

**Build PLUTO—eternal electronic marker**

HUGO GERNSBACK, Editor-in-chief ■ AUG. 50c

# Radio-Electronics

TELEVISION · SERVICING · HIGH FIDELITY

**Electronics Improves Hall Acoustics**

**Silicon Solar Cells—How They Work**

**Converge that Color TV Perfectly**

**40 AUDIO WATTS  
IN 40 OUNCES—**

**TOTALLY NEW TRANSISTOR AMPLIFIER**

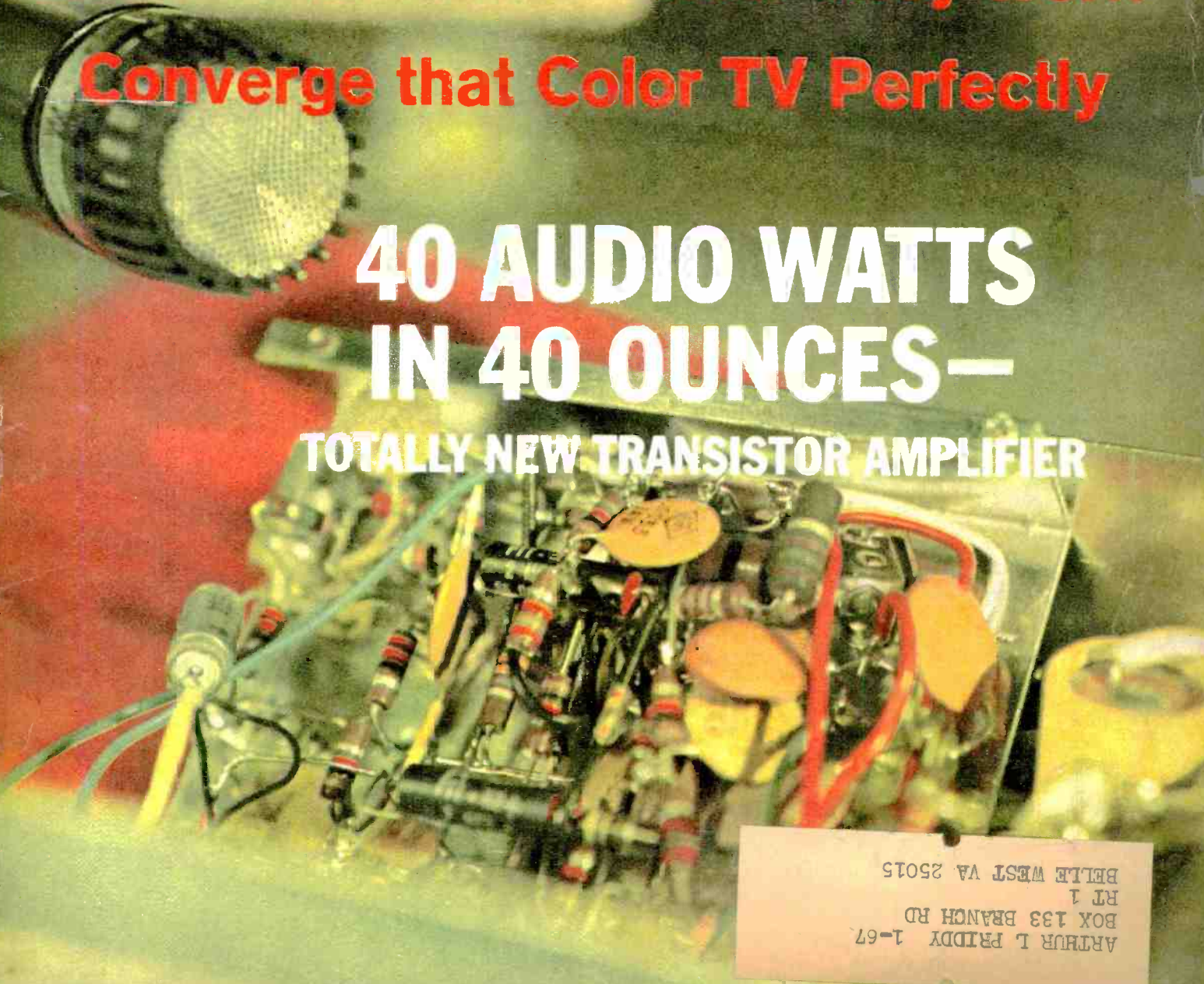

ARTHUR L. PRIDDY 1-67  
BOX 133 BRANCH RD  
RT 1  
BELLE WEST VA 25015



**BEST FOR YOU—  
IT'S MOST VERSATILE**

**TRIPLET**

**MODEL 850  
ELECTRONIC  
VOLT-OHMMETER**

**USES UNLIMITED:**

Field Engineers • Application Engineers • Electrical, Radio, TV, and Appliance Servicemen • Electrical Contractors • Factory Maintenance Men • Industrial Electronic Maintenance Technicians • Home Owners, Hobbyists

**MODEL 850 \$79.50**

**FACTS MAKE FEATURES:**

- 1** Long 7" easy-to-read scale.
- 2** .5 D.C. volt range for transistor circuits.
- 3** HIGH STABILITY. Meter connected in cathode circuit of 12 AU7.

High Input Impedance (11 MEGOHMS) and wide Frequency Ranges give this extremely versatile Electronic Volt-Ohmmeter considerable advantage in the measurement of DC voltages, AC RMS and Peak-to-Peak voltages. It measures directly the Peak-to-Peak values of high-frequency complex wave forms and RMS values of sine waves on separate scales. Exclusive Triplet BAR-RING instrument is fully self-shielded; high flux magnet and spring-backed jewels for ruggedness. Wired circuit.

**ADDED PROTECTION.** Meter is shorted out in OFF position for greater damping, meter safety during transit, electrically protected against accidental overload. ZERO CENTER mark for FM discriminator alignment, plus other galvanometer measurements.

New pencil thin test probe used for all functions: DC, AC, and ohms. No need to change cables. Beautifully styled case for professional appearance and functional utility, 7<sup>5</sup>/<sub>8</sub>" x 6<sup>7</sup>/<sub>16</sub>" x 3<sup>3</sup>/<sub>4</sub>".

Carrying handle can be used as a tester stand to place the tester at 25° angle for ease in reading.

Frequencies to 250 MC may be measured with auxiliary Diode. Probe, \$7.50 extra. DC voltages to 50 KV may be measured with auxiliary High Voltage Probe. \$20.50 extra.

**TRIPLET ELECTRICAL INSTRUMENT COMPANY, BLUFFTON, OHIO**

**CARRYING CASE**

Case 859—OP—Black leather  
Padded Carrying Case. \$19.50 Net



**RANGES**

8 DC VOLTS RANGES	0-.5-1.5-5-15-50-150-500-1500
7 AC RMS VOLTS RANGES	0-1.5-5-15-50-150-500-1500
7 PEAK-TO-PEAK VOLTS RANGES	0-4-14-40-140-400-1400-4000
7 RESISTANCE RANGES	0-1000-10,000-100,000 OHMS; 1-10-100-1000 MEGOHMS.

**FREQUENCY RANGE 15 CPS to 3MC; (Up to 250 MC with accessory diode probe available extra.)**

**INPUT IMPEDANCE DC Volts 11 Megohms; AC Volts minimum of .83 Megohms.**

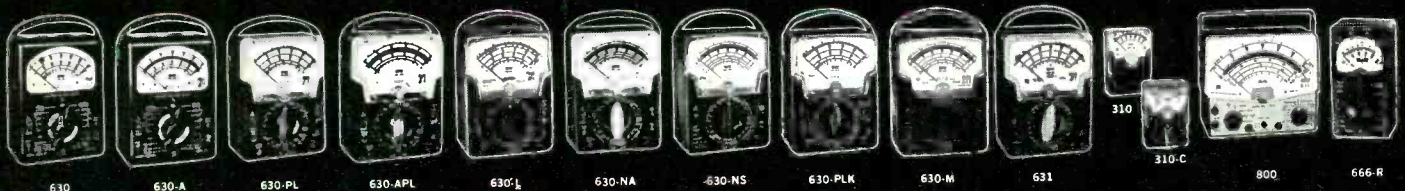

**THE WORLD'S MOST COMPLETE LINE OF V-O-M'S. AVAILABLE FROM YOUR TRIPLET DISTRIBUTOR'S STOCK.**



# The VHF-FM antenna that challenges all competition

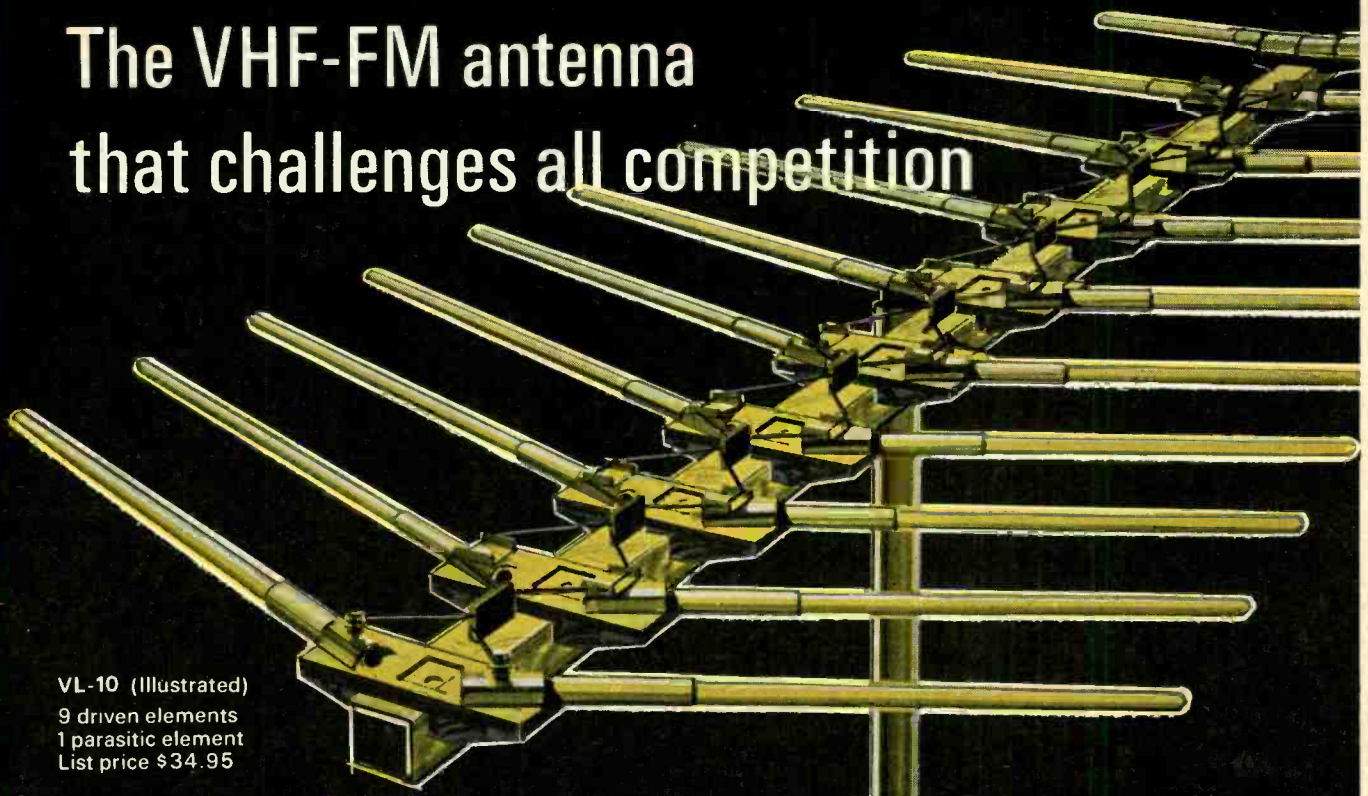

VL-10 (Illustrated)  
9 driven elements  
1 parasitic element  
List price \$34.95

## NEW **FINCO**® *Swept Element* "COLOR-VE-LOG" VHF-FM ANTENNA

Finco's Color Ve-Log challenges all competition on color or black and white reception and stands behind this challenge with a "Guarantee of Supremacy". The swept element design assures the finest in brilliant color and sharply defined black and white television reception – as well as superb FM monaural and stereo quality. FINCO precision-engineered features make these advanced-design antennas indispensable to good home sight-and-sound systems. And, of course, they carry the famous unconditional guarantee from the leading manufacturer in the field – FINCO. Promote the Color Ve-Log Antennas with pride, sell them with confidence, and profit handsomely.

Featuring Finco's Exclusive Gold Corodizing

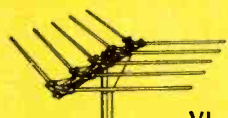

VL-5

5 element VHF-FM  
5 driven elements  
List price \$16.95

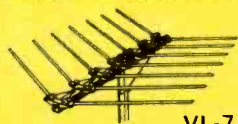

VL-7

7 element VHF-FM  
7 driven elements  
List price \$23.95



VL-15

15 element VHF-FM  
9 driven elements  
6 parasitic elements  
List price \$46.95

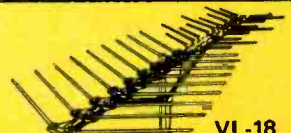

VL-18

18 element VHF-FM  
9 driven elements  
9 parasitic elements  
List price \$54.50

The FINNEY Company • 34 W. Interstate Street • Bedford, Ohio

Write for color brochure #20-307, Dept. RE

## GUEST EDITORIAL

- 31 Electronics and Programed Instruction.....Thomas Jaski

## ELECTRONICS

- 32 Solar Cells: Space Power.....Donald L. Stoner  
*How silicon cells work, and how they are made*
- 54 Electronic Pressure Cells Aid Civil Engineers.....James W. Essex  
*Pressure transducers keep tabs on stress in earth dams and pilings*
- 60 The Long Arm of Remote Control.....John W. Dietrich  
*How to drive a tractor without touching it*

## TELEVISION

- 39 Convergence by the ABC's.....Robert G. Middleton  
*Plagued by trios of lines and dots that won't merge? This will help*
- 47 Yoke Troubles.....Jack Darr  
*Pin them down and cure 'em*

## RADIO

- 34 Change Plus-Ground to Minus-Ground
- 52 CB I. F.'s on the Nose.....R. L. Conhaim  
*Accurate (.005% or better) alignment without special gear*
- 59 My Strangest Radio Repair Job.....James A. Fred

## TEST INSTRUMENTS

- 43 Look Inside an Amplifier.....R. E. Baird  
*Dynamic electronics demonstrator for clubs, schools or father-and-son sessions*
- 58 How to Wide-Band Your Scope.....Barry Turner  
*Rebuild its vertical amplifier and extend response to 4 mc*
- 64 Equipment Report: Triplett 630-M Volt-Ohm-Microammeter

## AUDIO-HIGH FIDELITY-STEREO

- COVER STORY 35 40 Watts in 40 Ounces! — The Two-State Amplifier.....Norman Crowhurst  
*Schematic and first construction details*
- 38 Magneto-resistive Microphones
- 44 A Concert Hall Gets a New Sound.....James Moir  
*Dozens of tuned mikes and speakers in the ceiling add warmth*
- 64 Equipment Report: Eico 3566 Solid-State FM Stereo Tuner-Amplifier

## GENERAL

- 20 Service Clinic.....Jack Darr  
*Testing Automatic Degaussers*
- 50 PLUTO Tells Where It Is.....Joseph Brown  
*Objects containing PLUTO are hard to steal or lose*
- 53 What's Your EQ?
- 56 A Voltage Doubler Doesn't Really.....Owen G. Patrick  
*Introducing the Patrick Machine—brilliant device to show that ac isn't so tough*

## THE DEPARTMENTS

12 Correspondence  
88 New Books  
75 New Literature

70 New Products  
80 New Semiconductors & Tubes  
4 News Briefs

82 Noteworthy Circuits  
66 Technotes  
86 Try This One  
53 50 Years Ago



Member,  
Institute of High Fidelity  
Radio-Electronics  
is indexed in  
Applied Science  
& Technology Index  
(Formerly  
Industrial Arts Index).

HUGO GERNSBACK, editor-in-chief and publisher. M. HARVEY GERNSBACK, editor. Fred Shunaman, managing editor. Robert F. Scott, W2PWG, technical editor. Peter E. Suthem, associate editor. Jack Darr, service editor. I. Queen, editorial associate. John J. Lamson, eastern sales manager. Wm. Lyon McLaughlin, technical illustration director.

GERNSBACK PUBLICATIONS, INC., Board Chairman Hugo Gernsback, Pres. M. Harvey Gernsback, Vice Pres.-Sec. G. Aliquo, Vice Pres.-Treas. Charles A. Raible



# Choose Your Tailor-Made Course in N.T.S. "PROJECT METHOD" ELECTRONICS!

Now! N.T.S. — one of America's oldest leading home-study and resident technical schools — offers you **GREATER CAREER OPPORTUNITIES IN ELECTRONICS**. N.T.S. "Project Method" home training lessons are shop-tested in the Resident School in Los Angeles. You work on practical job projects, learn to use shop manuals and schematics. Your N.T.S. training is individual. You proceed at your own pace. The Schools' practical methods, plus more than 60 years of experience, have helped thousands of students all over the world to successful careers. Prepare now for a secure future in one of 8 N.T.S. Electronics Courses designed to fit your own particular needs.



Work on the electronic "brains" of industry — computers, data processing and other automation equipment. Become a TV-Radio Technician, an electronics field engineer, or succeed in your own business.

## CHOOSE YOUR FIELD — INSURE YOUR FUTURE!

- 1 ELECTRONICS-TV-RADIO-SERVICING & COMMUNICATIONS** A basic course thoroughly covering fundamentals of electronics, radio, TV servicing and communications.
- 2 MASTER COURSE IN ELECTRONICS-TV-RADIO, PLUS ADVANCED TV & INDUSTRIAL ELECTRONICS** This course covers everything included in Course No. 1 plus Automation and every phase of the Electronics industry.
- 3 FCC LICENSE** Preparation for this government license essential for interesting jobs in radar, radio, television, communications, guided missiles, many others. Upon completion of this course, if you do not pass the FCC exam for a 1st Class Commercial Radiotelephone License your tuition will be refunded.
- 4 RADIO SERVICING (AM-FM-Transistors)** Train for radio sales and service with dealer or distributor.
- 5 TELEVISION SERVICING (Including Color)** Covers installation, adjustment, repair and servicing of black and white and color television . . . prepares you for your own sales and service business.
- 6 STEREO, HI-FI AND SOUND SYSTEMS** A growing field. Prepares you to build, install and service modern sound equipment for home or industry.
- 7 BASIC ELECTRONICS** Gives you the fundamentals you must know to build on for a future Electronics career. Also offers an excellent background for Salesmen, Purchasing Agents, and others in Electronics.
- 8 ELECTRONICS MATH** Simple, easy-to-follow instructions in the specialized math you need in many electronics jobs.

Most courses include Equipment Kits. THERE ARE NO KIT DEPOSITS. Everything included in your low tuition.

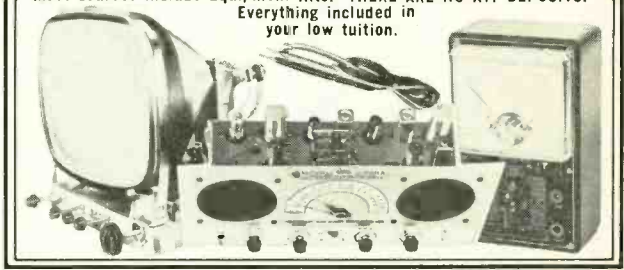

### CLASSROOM TRAINING AT LOS ANGELES

You can take classroom training in our famous Resident School at Los Angeles in Sunny Southern California. N.T.S. is the oldest and largest school of its kind. Associate in Science Degree also offered in our Resident Program. Check Resident School box in coupon for full details.

### HIGH SCHOOL AT HOME

Learn easily. New modern method. National also offers accredited high school programs for men and women. Take only subjects you need. Study at your own pace. Latest approved textbooks — yours to keep — everything included at one low tuition. Check High School box in coupon for information.



### MAIL COUPON TODAY FOR FREE BOOK AND SAMPLE LESSON

In Field of Your Choice. You enroll by Mail — and Save Money. No Salesmen: This means lower tuition for you. Accredited Member N.H.S.C.



## NATIONAL TECHNICAL SCHOOLS

4000 S. Figueroa St., Los Angeles, California 90037

Please Rush FREE Electronics "Opportunity Book" and actual sample lesson on course checked below:

- Electronics-TV-Radio Servicing & Communications
- Master Course in Electronics-TV-RADIO Advanced TV & Industrial Electronics
- FCC License
- Radio Servicing (AM-FM-Transistors)
- Television Servicing (Including Color)
- Stereo, Hi-Fi and Sound Systems
- Basic Electronics
- Electronics Math

Dept. 206-85

Name \_\_\_\_\_ Age \_\_\_\_\_  
 Address \_\_\_\_\_  
 City \_\_\_\_\_ State \_\_\_\_\_ Zip \_\_\_\_\_

- Check here if interested ONLY in Classroom Training at L.A.
- Check here for High School Department Catalog only.



## NATIONAL TECHNICAL SCHOOLS

WORLD-WIDE TRAINING SINCE 1905  
 4000 S. Figueroa St., Los Angeles, California 90037

RADIO-ELECTRONICS, August 1965, Volume XXXVI, No. 8. Published Monthly at Ferry Street, Concord, N.H. 03302. Second-class postage paid at Concord, N. H. SUBSCRIPTION RATES: U. S. and possessions, Canada: \$5 for 1, \$9 for 2, \$12 for 3 years. Pan-American countries: \$6 for 1, \$11 for 2, \$15 for 3 years. Other countries: \$6.50 for 1, \$12 for 2, \$16.50 for 3 years. Single copies: 50¢. © 1965, by Gernsback Publications, Inc. All rights reserved. POSTMASTERS: Send Form 3579 to 154 W. 14th St., New York 10011.



# NEWS BRIEFS

## NEW VIDEO TAPE RECORDER HAS INGENUOUS PICKOFF

A new video tape recorder with an ingenious method to couple to the TV receiver from which it records has been announced by North American Philips. It was, at the time, said to be the first helical-scan recorder to reach the market at under \$4,000.



The Norelco video tape recorder EL 3400.

The pickup system consists of a cylindrical capacitance plate inside a tube shield. This is placed over the last i.f. tube of a TV receiver, and picks up a 42-mc signal containing the video, sync and sound information. These are processed through a standard video detector, a 4.5-mc i.f. amplifier and a sound detector. Sync is tapped off in the usual manner, and video or sound are amplified conventionally.

For closed-circuit recordings, the audio and sync are recorded on separate tracks at the sides of the tape, and only the video information appears on the main track.

## ELECTRONIC IGNITION SYSTEM USES PHOTOCELL BREAKER

Instead of breaker points, a light beam is used in a transistor ignition system being tested by the Mallory Electric Co. of Detroit, on police cars, taxicabs and racing cars. The principle is somewhat similar to magnetic induction devices sometimes used in transistor ignition systems.

At the center of the breaker system is a small light bulb, lighted continuously from the time the ignition key is turned on. A cap mounted on the shaft in the distributor housing has slits around its circumference, so that as the cap rotates, light through

the slits shines on the photocell as the cap passes between it and the light.

The photocell output of 0.2 volt is amplified to 15 volts, 15 amperes, at a pulse width of about 1.2 milliseconds. These pulses are stepped up by the ignition coil to about 35,000 volts. The price of the system is \$150, but Mallory believes that the system will pay for itself, through reduced gasoline consumption, elimination of breaker points (and replacement) and all-around reliability.

## GARAGE-DOOR OPENERS JAM AIR NAVIGATION

The military services report that signals in the 230- to 290-mc band have experienced severe interference from garage-door openers. In the Los Angeles area alone, 58 interfering units were found in one week, and more than 100 have been closed down by the FCC during the past 6 months, according to Joseph Tippets, director of the Federal Aviation Agency, Western Region. Of the 58, only one was found to have been certified by the manufacturer as meeting Part 15 of FCC Rules and Regulations. Most of these openers were made before certification was compulsory. However, several were of current design.

The receivers are the source of interference. Many of them are super-regenerators, and they all operate 24 hours a day, whereas the transmitter is used only during the few seconds required to open a garage door. Only garage-door openers that operate in the 230- to 290-mc band constitute a hazard. This is a significant portion of the 225-400-mc uhf band assigned to military aircraft communications and navigational aids.

Members of the Automatic Door Openers Association who met in a national convention last May are concerned about the situation, and are assuring that all door openers manufactured in the future will be interference-free.

## HOME VIDEO TAPE RECORDER TO SELL FOR LESS THAN \$1,000

A home video tape recorder, complete with 9-inch TV receiver that is used as a recording and playback monitor, has been announced by Sony at a price of \$995.

The rotary scanning head of the recorder is the same type as that in



Sony's home video tape recorder.

the expensive tape recorders used by broadcast stations. Tape speed is 7½ inches per second, and the recorder uses 7-inch reels of tape ½ inch wide which can record 60 minutes continuously. Some models have a built-in timer that can record programs during the owner's absence.

Akio Morita, executive vice president and co-founder of Sony Corporation of America, stated that the Sony Videocorder would be ready for marketing early in August. "We think there is a very big future for the home video tape recorder," said Mr. Morita. "Perhaps several million will be in homes during the next five years." Operation of the machine resembles that of an audio tape recorder.

A \$350 camera outfit with which the owner can make his own TV recordings is also offered.

## "COMPACT" TV STATIONS PLANNED FOR UHF

TV channels 70-83 would be reserved for TV stations with 10-kw maximum power and a 300-foot antenna, under a new plan being studied by the FCC. The "compact" stations would be placed much closer together than permitted by the present allocations plan. The new service would be confined to smaller communities, and would not be placed within 25 miles of a city with a regular TV station.

## TELEVISION TRANQUILIZES CAGED GORILLAS

The most recent addition to the ranks of addictive television watchers are four gorillas at the Bronx Zoo. During most of last winter, they had a 16-inch television set.

The TV was installed when curator Joseph A. Davis Jr. noted that the animals, taken in from their outdoor quarters and confined in cages, became



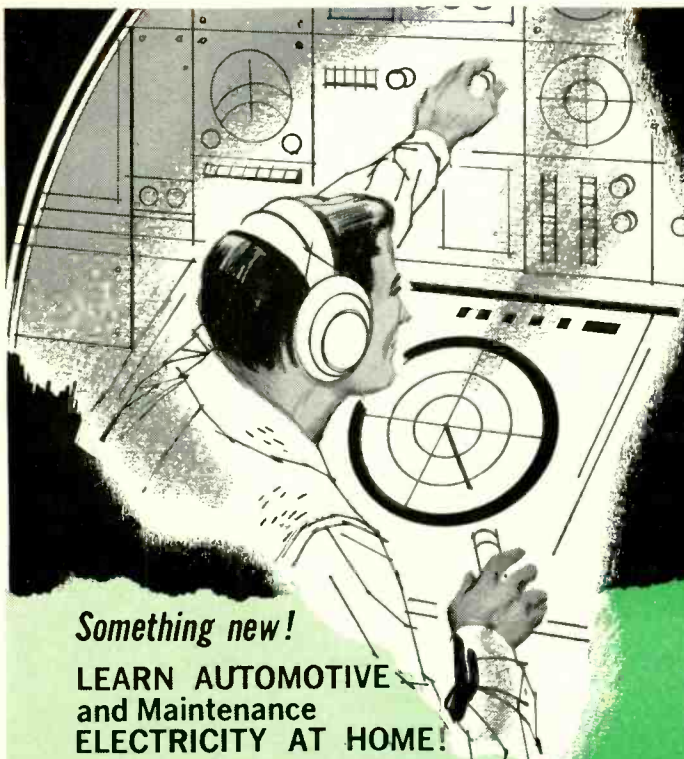

# 5,000 FIRMS HAVE EMPLOYED DeVRY TECH ELECTRONICS GRADUATES...

There Must be a Reason!

*Something new!*

## LEARN AUTOMOTIVE and Maintenance ELECTRICITY AT HOME!

Here's another great opportunity for the man who wants his own business or a bigger pay check with a brighter future. It is a NEW DeVry program that gives you the advantage of earning while you learn.

Prepare in spare time at home for profitable jobs which can take you all the way from trouble-shooting on the electrical systems of automobiles, marine engines, trucks, tractors and other gasoline engines, to the general maintenance of electrical equipment in the home or in light industry.

DeVry's new program "brings the classroom to your home" through the magic of AUDIO-VISUAL AIDS: Lectures recorded by DeVry instructors combined with colorful 8 x 10" transparencies to make learning easier. You get the advantages of "programmed" learning through modern texts which are also handy for future



reference. To develop practical skill, you get and keep valuable shop equipment and manuals. This includes building the brand-new DeVry Transistorized Automotive Analyzer and the DeVry Silicon Battery Charger — ideal "tools" for earning extra money as you go.

This new program covers the entire electrical systems in automobiles and other vehicles, including transistorized ignition systems, alternators and regulators, and other applications. In the maintenance field, it covers lighting, electric motors, controls, wiring — even transistors. The graduate from this program can be either a specialist as a troubleshooter on the electrical system of an automobile, or handle electrical lighting, heating, alarm and control systems. It is ideal for "one man" maintenance departments.

Check coupon at right and mail it today for FREE facts.

*Let Us Prepare You at Home or In  
One of Our Two Big Resident Schools  
for a Profitable Career in*

# ELECTRONICS

Across the continent, leading employers of personnel trained in electronics tell us that DeVry training is "Tops." Get the full story of DeVry Tech and the advantages it offers, by filling in the coupon below. The two free booklets pictured below tell of many fine opportunities for trained men in electronics: the great variety of jobs, from research, production, operation, maintenance and servicing of electronic equipment — to a neighborhood TV-radio sales and service business of your own. They'll tell you too, how DeVry has prepared men for good jobs with outstanding firms: on practical, "brass-tacks" problems with actual electronic equipment.

Here's good news: you don't need advanced education or previous technical experience to get started. If you can follow simple directions, you should be able to prepare with DeVry's help for real money in a field that may offer the opportunity of your lifetime.

**Employment Service:** With many employers so enthusiastic about DeVry Tech graduates, it's no wonder our Employment Service can help our graduates get started in electronics, or can assist them toward promotions later.

**FREE!**

SEND COUPON  
FOR BOOKLETS  
ON ELECTRONICS  
AS A CAREER



### DeVRY TECHNICAL INSTITUTE

4141 Belmont Ave., Chicago, Ill. 60641, Dept. RE-8-V

I AM INTERESTED IN ELECTRONICS. Please give me your two free booklets, "Pocket Guide to Real Earnings" and "Electronics in Space Travel"; also include details on how to prepare for a career in this field. The following opportunity fields (check one or more) interest me:

- |  |   |
|--|---|
| <input type="checkbox"/> Space & Missile Electronics | <input type="checkbox"/> Communications         |
| <input type="checkbox"/> Television & Radio          | <input type="checkbox"/> Computers              |
| <input type="checkbox"/> Microwaves                  | <input type="checkbox"/> Industrial Electronics |
| <input type="checkbox"/> Automation Electronics      | <input type="checkbox"/> Broadcasting           |
| <input type="checkbox"/> Radar                       | <input type="checkbox"/> Electronic Control     |

I AM INTERESTED IN AUTOMOTIVE AND MAINTENANCE ELECTRICITY. Please supply further information.

NAME \_\_\_\_\_ AGE \_\_\_\_\_

ADDRESS \_\_\_\_\_ APT. \_\_\_\_\_

CITY \_\_\_\_\_ STATE \_\_\_\_\_ ZIP \_\_\_\_\_

Check here if you are under 16 years of age.

Canadian residents: Write DeVry Tech of Canada, Ltd.,  
2095A 970 Lawrence Avenue West, Toronto 19, Ontario

ACCREDITED MEMBER OF NATIONAL HOME STUDY COUNCIL

## DeVry Technical Institute

Chicago • Toronto



# TUNER REPAIRS

Includes ALL parts (except tubes)...  
ALL labor on ALL makes for complete overhaul.

# \$950

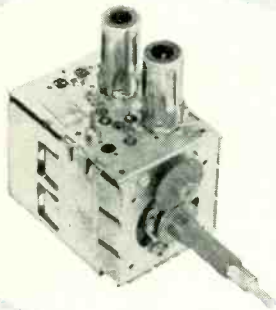

**FAST, 24-HOUR SERVICE**  
with FULL YEAR WARRANTY

Sarkes Tarzian, Inc., largest manufacturer of TV and FM tuners, maintains two completely-equipped Service Centers, offering fast, dependable tuner repair service. Tarzian-made tuners received one day will be repaired and shipped out the next. More time may be required on other makes. Every channel checked and realigned per manufacturer's specs. Tarzian offers full, 12-month guarantee against defective workmanship and parts failure due to normal usage. Cost, including all labor and parts (except tubes), is only \$9.50 and \$15 for UV combinations. No additional costs. No hidden charges. You pay shipping. Replacements at low cost are available on tuners beyond practical repair.

Always send TV make, chassis and Model number with faulty tuner. Check with your local distributor for Sarkes Tarzian replacement tuners, parts, or repair service. Or, use the address nearest you for fast factory repair service.



**SARKES TARZIAN, INC.**  
TUNER SERVICE DIVISION

Dept. 200  
537 South Walnut St.,  
Bloomington, Indiana  
Tel: 332-6055

Dept. 200  
10654 Magnolia Blvd.,  
North Hollywood, Calif.  
Tel: 769-2720

MANUFACTURERS OF TUNERS, SEMICONDUCTORS,  
AIR TRIMMERS, FM RADIOS, AM-FM RADIOS,  
AUDIO TAPE and BROADCAST EQUIPMENT

## NEWS BRIEFS continued

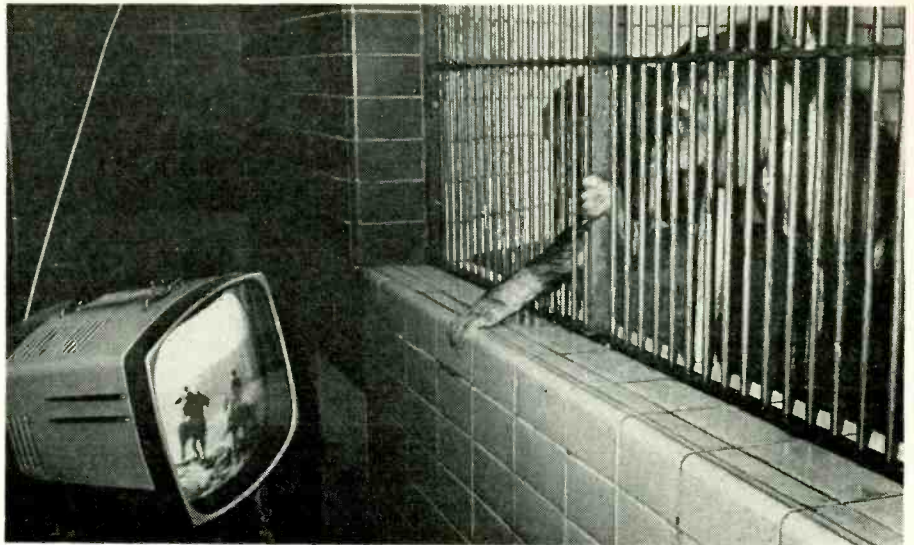

*New York Times photo*

*The gorillas watch one of their favorite programs—a Western.*

bored, cranky and quarrelsome. The TV changed all that. Only one of the gorillas showed any further tendencies to heckle his cage mates, and that, one keeper said, was "only during commercials."

Favorite programs for gorillas are any that show human forms moving about rapidly. They like cowboy-and-Indian and teen-age dance shows.

### LEAKY-COAX PHONE SYSTEM FOR NEW YORK SUBWAY

An experimental two-way radio network has been put into operation over an 8-mile stretch of the East Side IRT subway line in New York City. Transit police will use it to combat crime, and conductors and motormen

will be able to call in to warn of emergencies and deal with breakdowns and delays.

The equipment works in the 150-mc band. Signals are broadcast and picked up by a "leaky coax antenna" strung along the roof of the tunnel. It carries the radio waves from one handheld unit to another within about 300 feet of the antenna, in spite of the absorbing effect of the thousands of tons of steel in the subway.

### TUNNEL DIODES DETECT SOUND

High-frequency sound waves, up into the nanocycle region, have been detected experimentally with tunnel diodes. The diode has to be maintained in a superconducting condition, near absolute-zero temperature. The superconducting tunnel diode converts the microwave sound wave into a dc signal proportional to the energy density of the wave within the semiconductor material.

If this system can be developed further, it will be possible to convert microwave electromagnetic signals into sound waves, with a fantastic shortening of the wavelength, and consequent reduction of the size of the systems required for microwaves. A 10-gigacycle microwave signal has a wavelength of 3 centimeters, but converted into sound its wavelength would drop to about 3,000 Angstroms—100,000 times shorter.

### CALIFORNIA PAY-TV BAN RULED UNCONSTITUTIONAL

The California Superior Court ruled that the California law banning pay TV in the state (based on a referendum last November) is unconstitutional. The State Attorney General announced a decision to appeal the rul-

RADIO-ELECTRONICS is published by Gernsback Publications, Inc. Editorial, Advertising, Subscription and Executive offices: 154 West 14th Street, New York 10011.

Subscribers: When requesting change of address please furnish an address label from a recent issue. Allow one month for change of address.

ADVERTISING REPRESENTATIVES: East: John J. Lamson, Eastern Sales Manager, RADIO-ELECTRONICS, 154 West 14th Street, New York 10011, 212 AL 5-7755; Midwest: P. H. Dempers Co., 740 North Rush Street, Chicago, Illinois 60611, 312 MI 2-4245; Southeast: Neff Assoc., 15 Castle Harbor Isle, Ft. Lauderdale, Fla. 33308, 305 LO 6-5656; J. Sidney Crane, Assoc., 22 8 St., N.E., Atlanta, Ga. 30309, 404 TR 2-6720; Texas/Arkansas: Media Representatives, Inc., 2600 Douglas Avenue, Irving Texas 57060, 214 BL 5-6573; West Coast/Oklahoma: Husted-Coughlin, Inc., 1830 W. 8th Street, Los Angeles, Calif. 90057, 213 389-3132; Husted-Coughlin, Inc., 444 Market Street, San Francisco, Calif. 94111, 415 GA 1-0151; United Kingdom: Publishing & Distributing Co., Ltd., Mitre House, 177 Regent St., London W.1, England.



ing, a decision that surprised many because of Governor Brown's earlier criticism of the law.

**HUGO GERNSBACK  
SCHOLARSHIP AWARD**

The winner of the 1965-66 Hugo Gernsback Scholarship Award is Michael D. Lipshitz, a senior in the New York University College of Engineering. The \$1,000 grant is presented yearly to a student chosen by the university's College of Engineering faculty.



Mr. Lipshitz was born in New York City in 1945 and attended the Bronx High School of Science. He is active in WNYU, the college's radio station, and also engaged in a National Science Foundation Undergraduate Research Project in electroacoustical systems and sound transducers. A member of Eta Kappa Nu and Tau Beta Pi, he plans a career in audio or acoustical engineering.

**CALENDAR OF EVENTS**

14th Annual Convention, National Community Television Association, July 18-23; Denver Hilton Hotel, Denver, Colo.

17th Annual Vhf Picnic (Wabash Valley Amateur Radio Association), July 25; Turkey Run State Park, Ind.

31st Annual Midwestern Picnic and Hamfest (Hamfesters Radio Club), Aug. 8; Santa Fe Park, Chicago, Ill.

6th International Conference on Medical Electronics & Biological Engineering, Aug. 23-27; Tokyo, Japan

20th National Meeting, Association for Computing Machinery, Aug. 24-26; Sheraton-Cleveland Hotel, Cleveland, Ohio

Wescon (Western Electronics Show & Convention), Aug. 24-27; Cow Palace, San Francisco, Calif.

1965 International Antenna & Propagation Symposium, Aug. 30-Sept. 1; Sheraton Park Hotel, Washington, D. C.

Salon International de Radio et de la Television, Sept. 9-19; Hall Monumental du Parc des Expositions a la Porte de Versailles, Paris, France

International Conference on Thermionic Electrical Power Generation, Sept. 20-24; IEE, Savoy Place, London, England

# WHY risk your reputation with "just-as-good" capacitors?

When you pay little or no attention to quality in tubular replacement capacitors, you leave yourself wide open for criticism of your work . . . you risk your reputation . . . you stand to lose customers. It just doesn't pay to take a chance on capacitors with unknown or debatable performance records when it's so easy to get guaranteed dependable tubulars from your Sprague distributor!

## There's no "maybe" with these 2 great SPRAGUE DIFILM® TUBULARS!

The ultimate in tubular capacitor construction. Dual dielectric . . . polyester film and special capacitor tissue . . . combines the best features of both. Impregnated with HCX®, an exclusive Sprague synthetic hydrocarbon material which fills every void in the paper, every pinhole in the plastic film *before it solidifies*, resulting in a rock-hard capacitor section . . . there's no oil to leak, no wax to drip. Designed for 105°C (220°F) operation without voltage derating.



### DIFILM® BLACK BEAUTY® Molded Tubular Capacitors

The world's most humidity-resistant molded capacitors. Tough, protective outer case of non-flammable molded phenolic . . . cannot be damaged in handling or installation. Black Beauty Capacitors will withstand the hottest temperatures to be found in any TV or radio set, even in the most humid climates.

### DIFILM® ORANGE DROP® Dipped Tubular Capacitors



A "must" for applications where only radial-lead capacitors will fit . . . the perfect replacement for dipped capacitors now used in many leading TV sets. Double-dipped in rugged epoxy resin for positive protection against extreme heat and humidity. No other dipped tubular capacitor can match Sprague Orange Drops!

For complete listings, get your copy of Catalog C-616 from your Sprague distributor, or write to Sprague Products Company, 81 Marshall Street, North Adams, Massachusetts.



WORLD'S LARGEST MANUFACTURER OF CAPACITORS

65-132-83 RI



# ASSEMBLE YOUR OWN ALL-TRANSISTOR *Schober* ELECTRONIC ORGAN



3 NEW MODELS  
Recital \$1500  
Console II 850  
Spinet 550

This is the new, all-transistor Schober Console II...the most luxurious

"home-size" organ available today.

Full 61-note manuals, 17 pedals, 22 stops and coupler, 3 pitch registers, and authentic theatre voicing leave little to be desired. Comparable to ready-built organs selling from \$1800 to \$2500.

The pride and satisfaction of building one of these most pipe-like of electronic organs can now be yours...starting for as low as \$550. The Schober Spinnet, only 38 inches wide, fits into the smallest living room. The all-new, all-transistor Schober Recital Model actually sounds like the finest pipe organ; its 32 voices, 6 couplers, 5 pitch registers delight professional musicians...making learning easy for beginners.

AND YOU SAVE 50% OR MORE BECAUSE YOU'RE BUYING DIRECTLY FROM THE MANUFACTURER AND PAYING ONLY FOR THE PARTS, NOT COSTLY LABOR.

It's easy to assemble a Schober Organ. No special skills or experience needed. No technical or musical knowledge either. Everything you need is furnished, including the know-how. You supply only simple hand tools and the time.

You can buy the organ section by section...so you needn't spend the whole amount at once.

You can begin playing in an hour, even if you've never played before—with the ingenious Pointer System, available from Schober.

Thousands of men and women—teen-agers, too—have already assembled Schober Organs. We're proud to say that many who could afford to buy any organ have chosen Schober because they preferred it musically.

Send for our free Schober Booklet, describing in detail the exciting Schober Organs and optional accessories; it includes a free 7-inch "sampler" record so you can hear before you buy.

IN OUR 10TH YEAR

THE *Schober Organ* CORPORATION

43 West 61st Street, New York, N. Y. 10023

Also available in Canada, Australia, Hong Kong, Mexico, Puerto Rico, and the United Kingdom

THE SCHOBER ORGAN CORP., DEPT. RE-38  
43 West 61st Street, New York, N. Y. 10023

- Please send me FREE Schober Booklet and FREE 7-inch "sampler" record.  
 Enclosed find \$2.00 for 10-inch quality LP record of Schober Organ music. (\$2.00 refunded with purchase of first kit.)

Name \_\_\_\_\_

Address \_\_\_\_\_

City \_\_\_\_\_ State \_\_\_\_\_ Zip No. \_\_\_\_\_

## NEWS BRIEFS continued

### Introducing The New Rabbit's Foot® Antenna

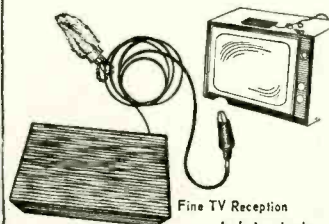

Fine TV Reception  
Isn't Just Luck

Indoor TV with rabbit's ears antenna can work pretty well at times. But signals have short wave lengths and they bounce from all sorts of things including people. This causes multiple images. It isn't reception that's the problem, it's too many signals that overlap causing flutters and ghosts.

The Rabbit's Foot antenna funnels these signals into a single one that's clear. Rabbit's Foot is a little block of walnut with a New Botagen Element inside. Now do away with those ugly, chrome Rabbit's ears and replace with Rabbit's Foot—your TV reception luck will change. A child can install it. It clips onto all sets. Complete with a real rabbit's foot..... \$6.95

Add 30¢ for shipping and handling

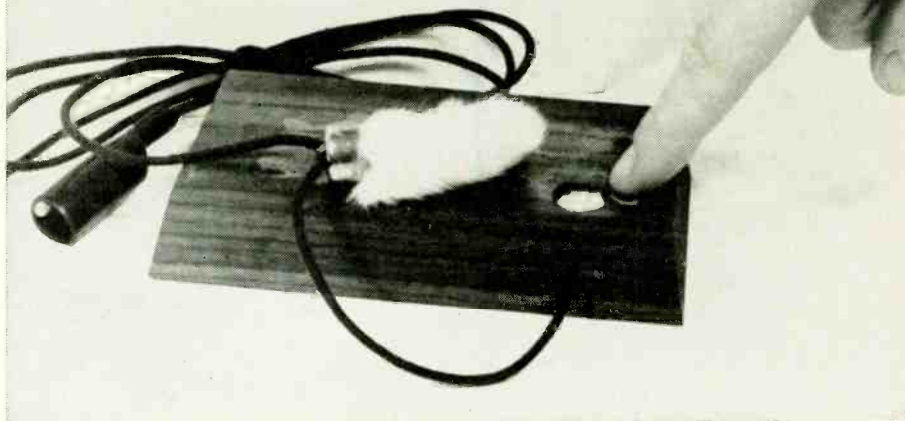

The Rabbit's Foot antenna with the plastic cover plate removed. Behind the antenna is a reproduction of a 3½ x 6-inch ad on page 24 of the Sunday, May 2 New York Times, placed by an elegant New York City hardware store. The same item has more recently been advertised by a well-known New York record and audio-component discount store.

### IF THE EARS ARE SO GOOD, MAYBE THE FOOT IS BETTER?

"Fine TV Reception Isn't Just Luck," says a newspaper advertisement for a new *Rabbit's Foot Antenna*. Yet the manufacturer seems to feel that a rabbit's foot may be helpful. It is hung (with no connection) onto a piece of fabric-insulated wire some 4 feet long with an alligator clip on one end. The other end disappears into a beveled walnut block covered on one side with a beautiful piece of sparkling plastic. (The photograph shows the block with the plastic removed.)

The block is supposed to contain a "New Botagen Element". The Element looks remarkably like wadded-up thin aluminum foil pounded into a 5/8-inch hole drilled into the block. The foil contacts the bared end of the 4-foot wire in the bottom of the hole.

The Rabbit's Foot antenna was

compared with a plain piece of wire 5 feet long. It did at least as well as the plain wire on most channels, and slightly better on some.

The whole device is yours for \$6.95. It replaces "ugly, chrome Rabbit's ears" and may bring you luck. If you feel you can pass up \$6.94 worth of luck, probably a piece of wire 5 feet long connected to your TV set would work about as well.

### VARIABLE-SPEED VIDEO RECORDER

A new portable TV recorder with a variable playback-speed control displays a television picture at normal speed, any degree of slow motion or stationary. It was announced by Precision Instrument of Palo Alto, Calif. The first 23 recorders have been purchased by the United States Air Force for use in teaching at eight training bases across the United States. END



# SOMEONE SHOULD DEVELOP AN EASY WAY TO LEARN ELECTRONICS AT HOME

## RCA INSTITUTES DID!

RCA introduces new CAREER PROGRAMS—beginning with the student-proved "AUTOTEXT" Programmed Instruction Method—the faster, easier way to learn. You start to learn the field of your choice immediately. No previous training or experience needed.

Pick the career of your choice—and RCA Institutes will do the rest! RCA's new, revolutionary "Career Programs" help you go directly to the career you want! You waste no time learning things you'll never use on your job! Each Career Program is designed to get you into the kind of job you want in the fastest, easiest possible way!

### SEPARATE COURSES

In addition, in order to meet specific needs, RCA Institutes offers a wide variety of separate courses which may be taken independently of the above Career Programs, on all subjects from Electronics Fundamentals to Computer Programming. Complete information about these courses will be sent with your other materials.

**CHOOSE A CAREER PROGRAM NOW**  
your first step to the job of your choice!

- Television Servicing
- Telecommunications
- FCC License Preparation
- Automation Electronics
- Automatic Controls
- Digital Techniques
- Industrial Electronics
- Nuclear Instrumentation
- Solid State Electronics
- Electronics Drafting

### RCA INSTITUTES BONUS EXTRAS

Only RCA Institutes offers you a Liberal Tuition Plan, one of the most economical ways to learn. Plus, you get top quality equipment in all kits furnished to you with your courses—yours to keep and use on the job. And now, RCA's NEW PROGRAMMED ELECTRONIC BREADBOARD GIVES YOU LIMITLESS EXPERIMENTATION—scientific laboratory procedures right in your own home! You build a working signal generator, AM Receiver, Multi-meter, Oscilloscope, and other valuable

equipment—all as a part of your course! Get the facts today!

**Classroom Training Also Available.** Day and Evening Classes are available to you in New York City at RCA Institutes Resident School. You may be admitted without any previous technical training; prep courses are available if you haven't completed high school. Coeducational classes start four times a year.

**SEND COUPON TODAY FOR COMPLETE INFORMATION. CHECK HOME STUDY OR CLASSROOM TRAINING.**

## RCA INSTITUTES, INC., Dept. RE-85

A Service of the Radio Corporation of America  
350 West 4th St., New York City 10014

RCA Institutes, Inc. Dept. RE-85  
350 West 4th St., New York, N.Y. 10014

Please rush me FREE illustrated book with information checked below. No obligation. No salesman will call.

Home Study  Classroom Training

Name \_\_\_\_\_ Age \_\_\_\_\_

Address \_\_\_\_\_

City \_\_\_\_\_ Zone \_\_\_\_\_ State \_\_\_\_\_

CANADIANS: Take advantage of these same RCA Institutes Courses at no additional cost. No postage, no customs, no delay. Fill out coupon and send in envelope to: RCA Victor Ltd., 5581 Royalmount Ave., Montreal 9, Quebec.



THE MOST TRUSTED NAME IN ELECTRONICS



# The new Amphenol 860 Color Commander cuts alignment time in half!

Ever finish a convergence job to find the raster off center. Lose convergence when you re-centered? Can't happen with the new Amphenol Color Commander, battery-powered, solid-state color generator. A special, single-crossbar pattern consists of one horizontal and one vertical line, crossing just where the center of the raster should be. No need to guess when centering the raster with this new pattern.

See dots before your eyes when you want only one to start static convergence? The 860 gives you that single dot, right at center screen. You'll be switching back to this important dot during dynamic adjustment to make sure you haven't gone off the track.

Even the old patterns offer something new. Line spacing in the crosshatch pattern is rigidly maintained for the 4:3 aspect ratio. You can rely on it for linearity, height, and width adjustments. The pattern gives you finely etched line width at normal brightness levels. What good is perfect convergence at reduced brightness if you lose it when the set's readjusted for normal viewing? This special crosshatch also eliminates receiver





fine-tuning error. Among the 860's nine useful patterns (most color generators have 5 or 6) are: multiple-dot, single vertical line, single horizontal line, vertical lines only, and horizontal lines only.

Finally, the Color Commander's unique color bar pattern (just three bars—R-Y, B-Y and—R-Y) simplify color adjustments. First you can get a rapid, overall check of color circuits. Then you can adjust color demodulator phase or pre-set the hue control and check its operating range. In each step, you know precisely how the color bars should look and how they should change during adjustment.

A new timing circuit eliminates instability and loss-of-sync problems. Silicon transistors maintain built-in precision and stability indefinitely. RF output is on channel 3 or 4, switch selected. An attenuator simulates weak-signal conditions. It has gun killer circuit. With 9 penlight cells, the Color Commander weighs 3½ lbs. In compact, leatherette carrying case, only \$149.95.

**The new solid-state Amphenol CRT Commander, Model 855**, checks all black-and-white or color CRT's with the same techniques used by tube

manufacturers. Variable G-2 voltage and choice of bias voltages permit you to simulate conditions found in TV receivers. Adjust electron guns to exact cut-off characteristics, check for emission, continuity, shorts, gas, and expected tube life. In color tubes, check for gun balance. The 855 rejuvenates CRTs where others fail. Features—AC operated, completely portable in matching leatherette case. Built-in burnout-proof voltmeter uses 50- $\mu$ a d'Arsonval movement. Screen and plate voltage and B+ distribution can be measured with direct probe on 1000-volt scale. Optional probe measures 2nd anode voltage to 50,000 volts. Filament voltage range, in 11 steps: 2.2 to 20 volts. Versatile 5-socket cable accommodates 7 different sockets, handles virtually every CRT without adapters. Complete with CRT Test Chart, \$89.95. See Color Commander test instruments at your Amphenol distributor.



**DISTRIBUTOR DIVISION**  
amphenol • borg electronics corporation  
2875 S. 25th Ave., Broadview, Ill. 60155





finger-  
tip avail-  
ability

# AEROVOX HAS 1212 EXACT REPLACEMENT TWIST PRONG AFH ELECTROLYTICS

Why fool with "jerry-rigged" electrolytics when there's an Aerovox exact replacement to give you the right rating and the right size? Aerovox actually stocks 1212 twist prong AFH electrolytics—this means off-the-shelf availability...not "we'll build it for you if you order it" delivery.

Available in singles, doubles, triples and quads, these popular types are now manufactured in new values for filter bypass applications in color TV as well as radio, black and white TV and amplifier equipment. Many values are now being used for industrial applications.

Aerovox AFH Twist Prong Electrolytics feature ruggedized prongs and mounting terminals, high purity aluminum foil construction, improved moisture resistant seal and 85°C operation. Here is the quality you need to protect your professional reputation.

Go to your Aerovox Distributor for a perfect electrolytic fit—he will deliver exactly what you want in less time than it takes to tell. Ask him for the new Aerovox Servicemen's Catalog #SE-565 or ask us. We'll be happy to send one your way.



**AEROVOX  
CORPORATION**

DISTRIBUTOR DIVISION, NEW BEDFORD, MASS.

Technical Leadership—Manufacturing Excellence

# Correspondence

## HOW DO TAPE RECORDERS WORK?

Dear Editor:

I enjoyed the article in the March issue of RADIO ELECTRONICS entitled "How Tape Recorders Work," by Raymond Smith. However, I believe a further clarification is necessary in the basic explanation of how the magnetic tape coating becomes magnetized.

In Mr. Smith's diagram, Fig. 1 below, he shows the magnetized tape as a series of small bar magnets, which is an excellent way of describing the magnetic effect. The diagram, however, is misleading in that it shows these bar magnets lying lengthwise along the tape.

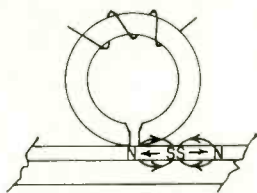

Fig. 1

This is a misrepresentation which could lead to some confusion in understanding the theory of operation. Actually the bar magnets should be represented as vertical magnets through the thickness of the magnetic coating.

As a further explanation, let us begin by showing the lines of flux at the gap of a recording head. (See Fig. 2, below.) As the magnetic coating passes the trailing edge of the recording-head gap, the magnetic particles become magnetized along the lines of flux, which are very nearly vertical at that point.

If we represent one of these minute permanent bar magnets with a vector whose point is the north end of the mag-

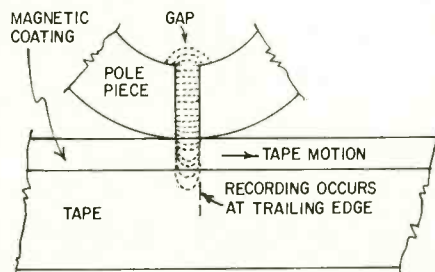

Fig. 2

net, and whose length is the strength of that magnet, then with a sine-wave input to the recording head, the resultant small bar-magnet representations in the magnetic coating would be as shown in Fig. 3.

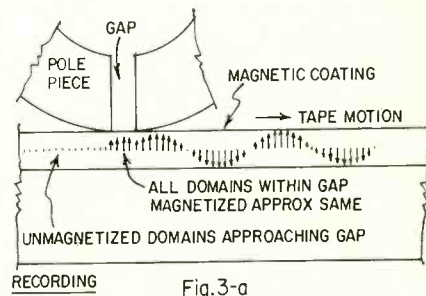
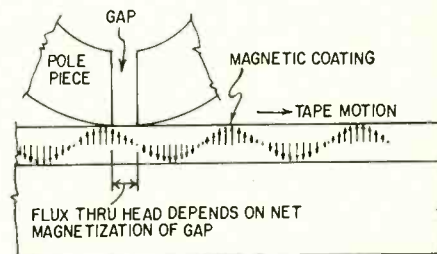

Fig. 3-a



PLAYBACK

Fig. 3-b

In the playback mode, as these small vertical bar magnets pass across the playback head gap, the flux lines from the tape enter the core and induce a signal voltage in the coil. This flux is determined by the net magnetization of all "bar magnets" within the gap region. Thus, in recording, the head-gap size is not as critical as in playback, since the final magnetization occurs only at the trailing edge of the gap; whereas in playback, head gap is extremely important, limiting high-frequency response to a frequency whose wavelength is twice the gap width.

I trust this explanation serves as a clarification without in any way minimizing the fine job Mr. Smith did in his article.

DONALD M. LAUNER  
TV Master Control Engineer, ABC-TV

## The author replies

Mr. Launer's theory is interesting. However, it does not apply to the general case I was attempting to illustrate. I think he has brought up a special case: that of surface recording of very short wavelength (high-frequency) signals.

My article and illustrations were based on what might be called classical longitudinal recording principles. As such, I chose to show the simple case where the majority of oxide particles within the useful field of the recording head are magnetized in the longitudinal direction. While this applies well to the long-wavelength (low-frequency) case,



# Why does one of these men earn so much more than the other?

More brains? More ambition?

No, just more education in electronics.

You know that two men who are the same age can work side-by-side on the same project, yet one will earn much more than the other.

Why? In most cases, simply because one man has a better knowledge of electronics than the other. In electronics, as in any technical field, you must learn more to earn more. And, because electronics keeps changing, you can never stop learning if you want to be successful.

But your job and family obligations may make it almost impossible for you to go back to school and get the additional education you need. That's why CREI Home Study Programs are developed. These programs make it possible for you to study advanced electronics at home, at your own pace, on your own schedule. You study with the assurance that what you learn can be applied on the job to make you worth more money to your employer.

CREI Programs cover all important areas of electronics including communications, servo-mechanisms, even spacecraft tracking and control. You're sure to find a program that fits your career objectives.

You're eligible for a CREI Program if you have a high school education and work in electronics. FREE book gives all the facts. Mail coupon or write: CREI, Dept. 1408C, 3224 Sixteenth Street, N.W., Washington, D.C. 20010

**Send for Free Book**

Accredited Member of the National Home Study Council

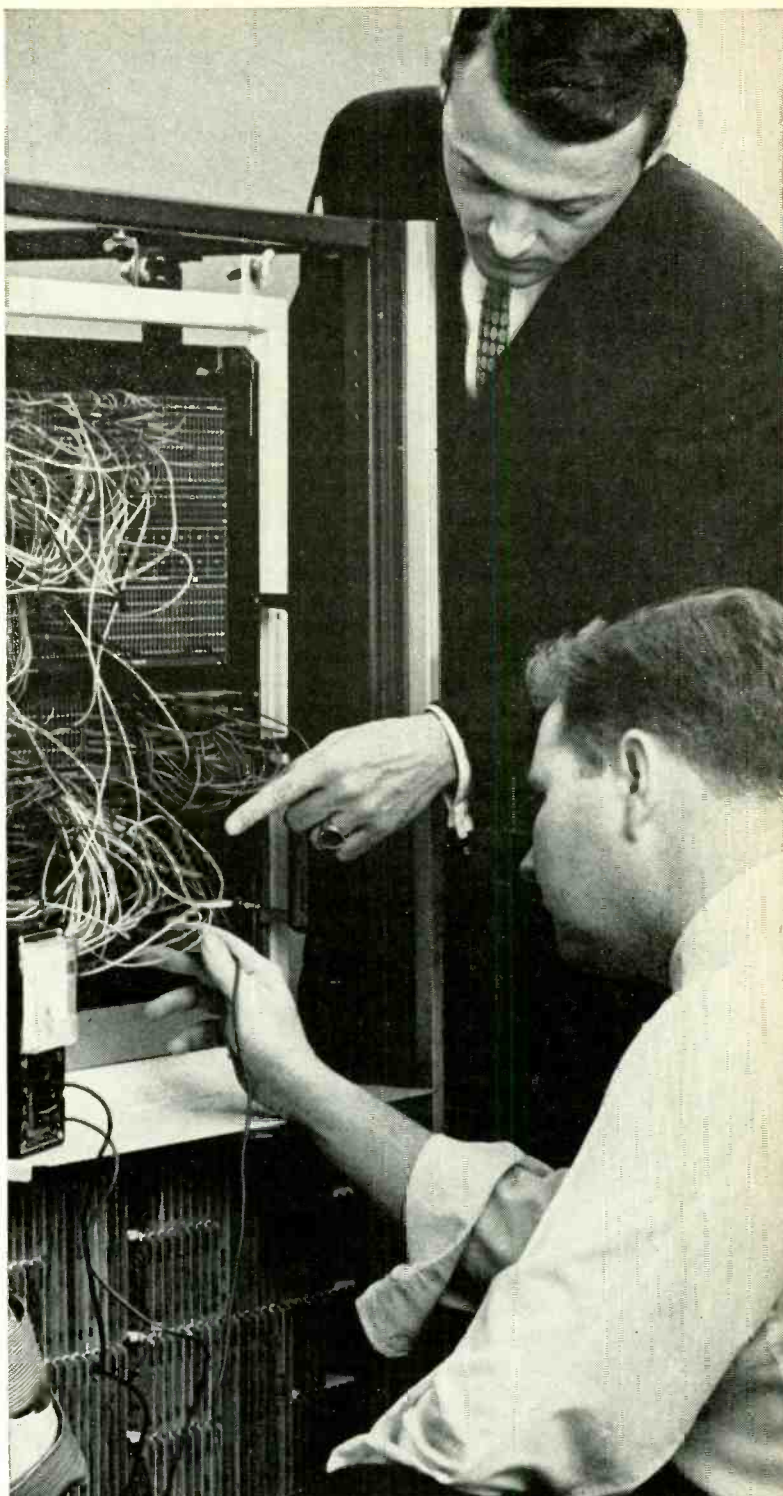

## The Capitol Radio Engineering Institute

Dept. 1408C, 3224 Sixteenth Street, N.W., Washington, D.C. 20010

Please send me FREE book describing CREI Programs in Electronics and Nuclear Engineering Technology. I am employed in electronics and have a high school education.

Name \_\_\_\_\_ Age \_\_\_\_\_

Address \_\_\_\_\_

City \_\_\_\_\_ State \_\_\_\_\_ Zip Code \_\_\_\_\_

Employed by \_\_\_\_\_

Type of Present Work \_\_\_\_\_



## CORRESPONDENCE continued

it is not nearly so correct for short wavelengths.

This is because most high-frequency magnetization takes place at or near the surface of the oxide coating, and the field lines from the head are nearly vertical at this point.

Coupled with this surface phenomenon during recording is the fact that magnetized particles near the surface are more readily resolved by the playback head. Thus, at limiting high frequencies, it is entirely possible that the

contribution of perpendicularly magnetized particles would exceed that of the longitudinally magnetized ones.

So we're both right, in a sense. Mr. Launer is correct for short wavelengths. I was correct for simplified theory and the long-wavelength case.

RAYMOND C. SMITH

### WATCH WHERE YOU STIMULATE!

Dear Editor:

The Solid-State Muscle Stimulator (June R-E, p. 42) can put your heart into fibrillation when improperly used. The device should *not* be used across the

upper portions of the back or chest, or in the area of the heart. It should not be used from one arm to the other, or from one arm to one leg. Currents as low as 5 ma will cause complete muscle control, and it may be impossible to move against the force of the current. This is of particular importance because your article shows the pads strapped on. Most commercial units do not strap pads on. This is because it is necessary to probe around to find areas that give the greatest effect with the least current.

Commercial pads are made of linen with several layers of felt underneath to hold water. This assembly is backed with sheet lead, which permits the pad to be molded to fit the body. The pads are usually soaked in salt water to improve contact.

WILL PIETTE  
General Service Co.

Milwaukee, Wis.

### OUR VOX IS CHANGING

Dear Editor:

One of your Noteworthy Circuits ("Vox for Tape Recorders," page 83 of the May issue) will be unstable as shown. There should be a several-megohm resistor from the plate of the 6AL5 to ground. The 4.7-megohm resistor serves no purpose.

The circuit was originally developed and authored by me under the title "Sure-Fire Voice Break-in," and was presented in an amateur radio magazine several years ago. It is a reliable circuit, but the change recommended should be made by anyone who builds it.

JAMES L. TONNE  
Roswell, N. M.

### MODIFIED INDUCTANCE CHECKER

Dear Editor:

Thank you for the inductance checker in the March issue by Mr. G. Posklensky. From that circuit, I built an inductance comparator and it works

### TAPE PLAYER FOR YOUR CAR . . .

Latest sonic boom is compact stereo tape-cartridge players for automobiles. Advantages over AM-FM are numerous—no interference, no fading, no tuning—and the programming of your choice. With well over a dozen brands (and more being announced almost every week), you can hardly tell the players without a score card. Be sure to read this thorough evaluation on available brands, complete with comparative chart.

COMING IN . . .

September  
RADIO-ELECTRONICS

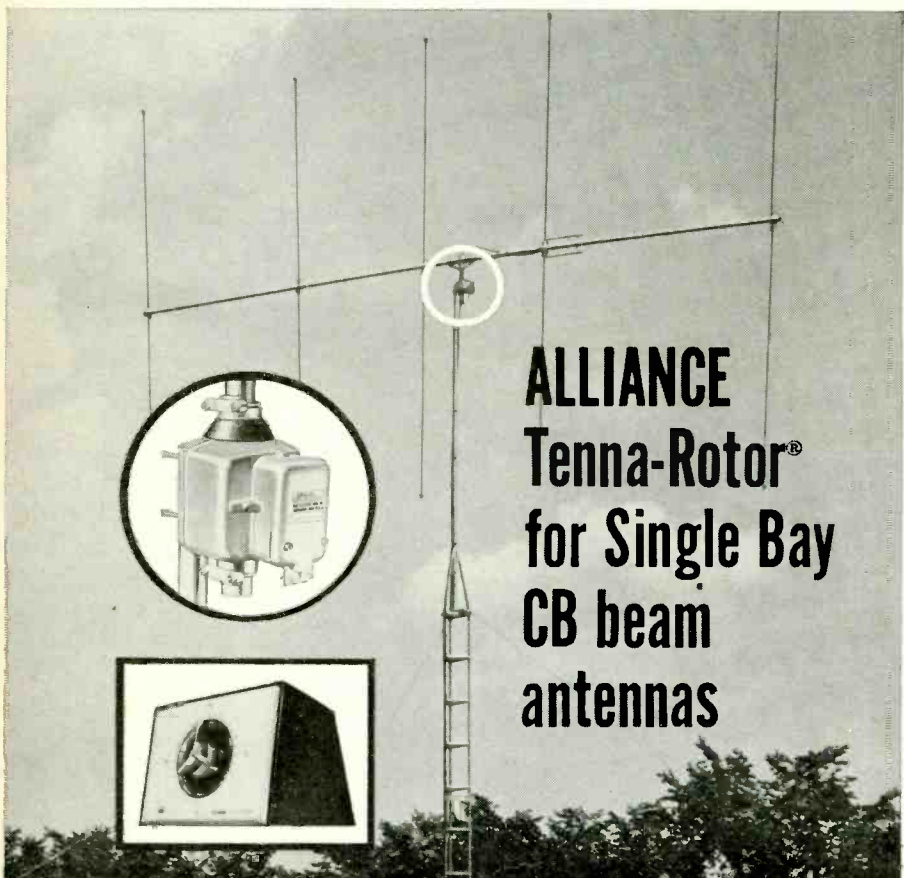

Tenna-Rotor stands up under severe conditions. Tests prove it is the strongest, most durable antenna rotator available for Citizens Band use on all single bay vertically polarized antennas up to six elements.

This latest Alliance Tenna-Rotor will turn heavy antennas and is designed to withstand wind velocities to 90 m.p.h. in accordance with E.I.A. wind loading standards. The patented rigid offset design distributes the load resulting in superior strength to weight ratio for greater ease of installation.

Features anti-windmilling, gearing and brake system to maintain positive positioning and eliminate overtravel. Unit, enclosed in a sturdy, ribbed die-cast zinc housing, is lightweight and simple to set up. If you can lift your antenna and put it on the Tenna-Rotor . . . it will support it, hold it and turn it.

- New Precision Machined Steel Drive Gear
- Greatest Positioning Accuracy Possible

The new Alliance transistorized automatic C-225 features a patented phase-sensing bridge similar to laboratory test equipment and is now available exclusively from Alliance for CB users. Affords automatic, stepless, synchronous pinpoint positioning accuracy throughout 360° of rotation that reduces or eliminates interference.

All this with noiseless control.



The **ALLIANCE** Manufacturing Company, Inc.  
(Subsidiary of Consolidated Electronics Industries Incorporated) Alliance, Ohio  
CSA approved





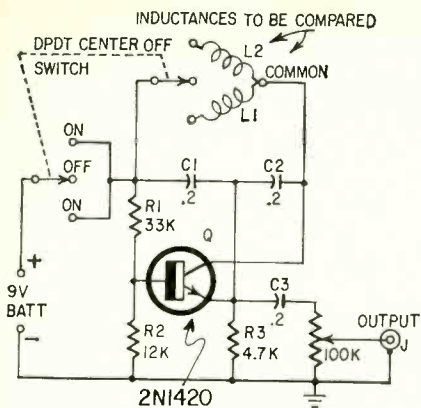

like a charm. I find the range is much greater than 5 to 600 mh—I have checked values from 5 mh to 20 h.

MELVIN T. HYATT

*Prairie Village, Kan.*

[The circuit of Mr. Hyatt's comparator is shown here. Note the 2-pole 3-position center-off switch, which replaces the two separate switches in the original, and his use of a 2N1420 transistor (Texas Instruments).—*Editor*]

#### ARE BASS NOTES NON-DIRECTIONAL?

Dear Editor:

Congratulations to Dr. Goldmark for the excellent guest editorial on high fidelity in the March issue of your fine publication. In particular, he makes the important point of relating this subject to actual listening experiences of the original sound. It is evident that Dr. Goldmark is a musician as well as a scientist.

There is one point which I should like to see clarified, and this is the commonly heard reference to the nondirectional characteristics of the bass register. The distribution pattern of a low tone from a woofer may be much less directional than the beam of a high tone from a tweeter, but how about the receiving end? As a member of a small musical organization, I can tell without looking where the tuba player is located, just about as well as the direction of the clarinet section.

No doubt there are many readers who would welcome some comment on this matter.

ERIC BARSCHEL

*St. Boniface, Man.*

#### AN AUTO MAN'S EXPERIENCE WITH TRANSISTOR IGNITION

Dear Editor:

I would like to answer Mr. James K. Hall, Jr.'s letter.

I am not an electronics engineer or a service technician. I am a repairman for the Ford Motor Co.

To begin, auto mechanics seem to be against any electronic gadget they don't know about. When I installed a

transistor ignition system in my car, my mechanic blew his top. Now he works on it if it needs work, but grudgingly. Apparently there are too many cars not equipped with electronic ignition for him to want to try to learn something new.

(I arrange my system so I can switch back to conventional ignition, just in case.)

Mr. Hall should have called his TV repairman—or the fellow who installed the transistor system.

Here are some suggestions to follow if you have transistor ignition:

1. Line up someone to fix it, just in case.

2. Always be able to switch back to the old Kettering system—have both systems complete.

3. Don't go to a garage for repairs on your transistor ignition.

4. Find a sharp, reliable technician.

5. Be sure any replacement transistors you use are meant for auto ignition. Cheap kinds won't stand the heat.

6. Get to be a do-it-yourselfer. Then you can fix anything you're big enough to work on.

7. Have your car power-tuned with a scope.

M. E. BABCOCK

*Blue Springs, Mo.*

END

## A Best Buy That's Become A Best Seller!



### SENTINEL 23 by EICO

#### 23 CHANNEL DUAL CONVERSION CB

All crystals provided for 23 crystal-controlled transmit & receive channels!

WIRED ONLY  
\$169.95

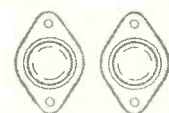

Transistorized  
12 VDC & 117 VAC  
dual power supply  
eliminates vibrator  
hash

Rugged 5-watt CB transceiver with "space-age" 23 channel frequency synthesizer. Gives you bullseye two-way communication in both fixed and mobile locations with equal ease. At your dealer now, the EICO Sentinel 23 (Model 779) is the new CB rig with every wanted and useful feature!

- Super-selective dual conversion superhet requires only 1/4 uV for 10db S/N.
- Crystal-controlled 6mc IF and three 455kc IF's.
- Effective automatic impulse noise limiter, wide-range AGC.
- Delta tuning for receiving off-frequency transmissions.
- Adjustable squelch and standby switch.
- Illuminated "S" meter/RF output meter.
- Single knob channel selector with illuminated dial.
- Converts to 3.5 watt PA system with remote speaker.
- TURNER 333 noise-cancelling ceramic p-t-t mike.
- Headphones/external speaker jack.
- Scuff-proof textured blue vinyl finished steel cabinet.
- Anodized extruded aluminum panel with polished edges.
- Black anodized, machined aluminum knobs.
- Convenient mobile mounting brackets.



For FREE Catalog and Sentinel 23 Spec. Sheet write to EICO, Dept. H, 131-01 39th Ave., Flushing, N. Y. 11352

**Discover the ease  
and excitement of NRI's**

**3 DIMENSIONAL  
METHOD**

**of ELECTRONICS  
TV-RADIO TRAINING**

**10 HOME-STUDY PLANS TO CHOOSE FROM**

Ask men whose judgment you respect about NRI's three dimensional method of home-study training. Ask about the new, remarkable NRI Achievement Kit. Ask about NRI custom-designed training equipment, programmed for the training of your choice to make Electronics come alive in an exciting, absorbing, practical way. Ask about NRI "bite-size" texts, as direct and easy to read as 50 years of teaching experience can make them. Achievement Kit . . . training equipment . . . bite-size texts . . . the three dimensions of home-study training; the essentials you must have to make

learning easier, more interesting, more meaningful. You get them all from NRI.

Whatever your interest . . . whatever your need . . . whatever your education . . . pick the field of your choice from NRI's 10 instruction plans and mail the postage free card today for your free NRI catalog. Discover just how easy and exciting the NRI 3-DIMENSIONAL METHOD of training at home can be. Do it today. NATIONAL RADIO INSTITUTE, Electronics Division, Washington, D.C. 20016.

**BEGIN NOW AN ABSORBING  
ADVENTURE—LEARN ELECTRONICS  
THE EASY NRI WAY—MAIL CARD TODAY**

**OUR 50TH YEAR OF LEADERSHIP**

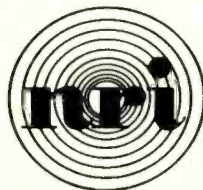

**IN ELECTRONICS TRAINING**



# 1 Start Fast with NRI's New Remarkable Achievement Kit

The day you enroll with NRI this new starter kit is on its way to you. Everything you need to make a significant start in the Electronics field of your choice is delivered to your door. It's an outstanding way of introducing you to NRI training methods . . . an unparalleled "first dimension" that opens the way to new discoveries, new knowledge, new opportunity. The Achievement Kit is worth many times the small payment required to start your training. No other school has anything like it. Find out more about the NRI Achievement Kit. Mail the postage-free card today.

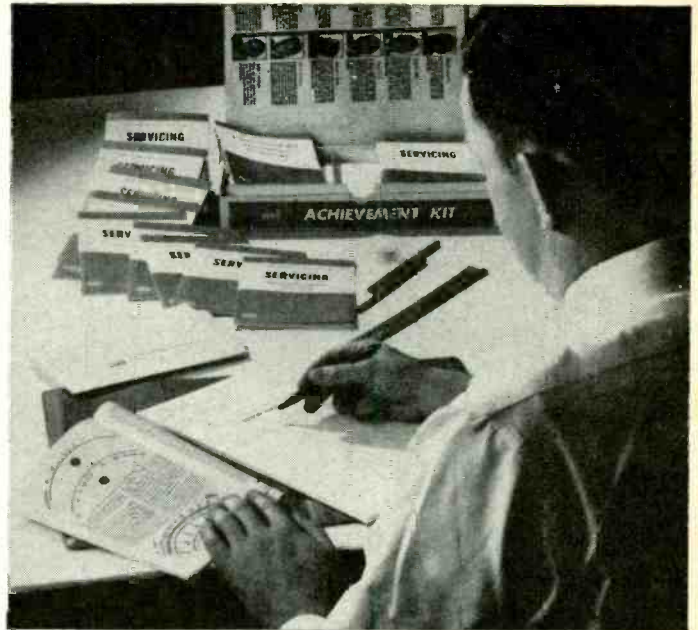

# 2 NRI "Bite-Size" Lesson Texts Program Your Training

Certainly, lesson texts are a necessary part of any training program . . . but only a part. NRI's "bite-size" texts are simple, direct, well illustrated, and carefully programmed to relate things you read about to training equipment you build. Here is the "second dimension" in NRI's training method. Here are the fundamental laws of electronics, the theory, the training of your choice, presented in a manner you'll appreciate. And in addition to lesson texts, NRI courses include valuable Reference Texts related to the subjects you study, the field of most interest to you.

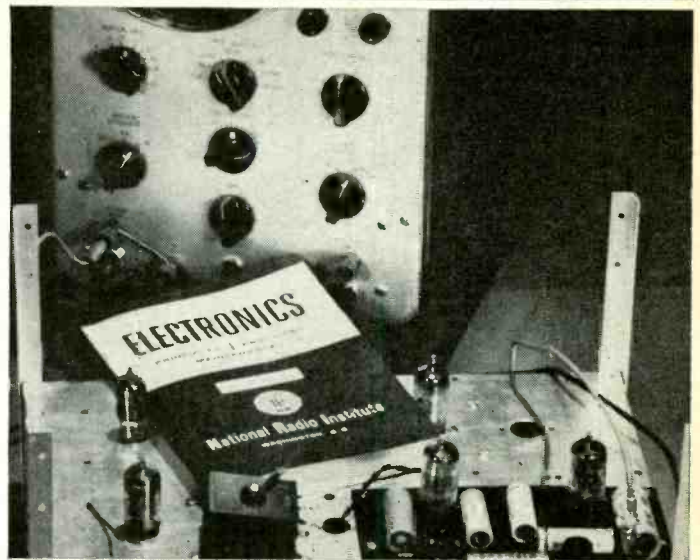

# 3 Custom-Designed Training Kits Make Learning Come Alive

Electronics becomes a clear and understandable force under *your* control as you get your hands on actual parts and build, experiment, explore, discover. Here is the "third dimension" . . . the practical demonstration of things you read about in NRI texts. NRI pioneered and perfected the use of training kits to aid in learning at home in spare time. *Nothing is as effective as learning by doing.* NRI invites comparison with equipment offered by any other school, at any price. Prove to yourself what three-quarters-of-a-million NRI students could tell you . . . that you get more for your money from NRI than from any other home-study Radio-TV, Electronics school. Mail postage free card for your NRI catalog. (No salesman will call.)

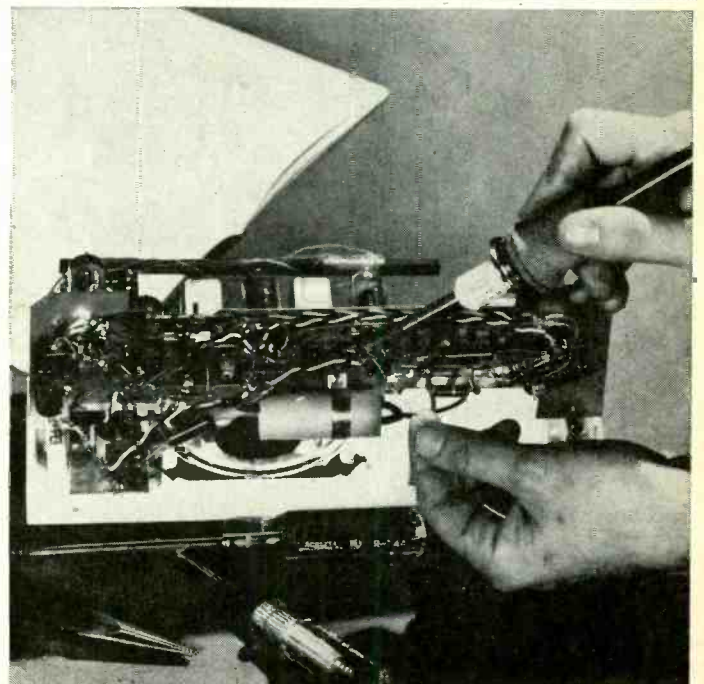

# SERVICE CLINIC

By JACK DARR Service Editor

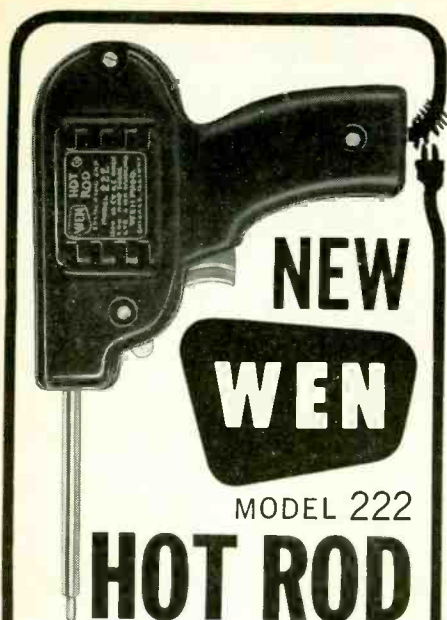

**NEW  
WEN**

MODEL 222

**HOT ROD  
GUN**

SOLDERING

The perfect answer to all Radio, TV and electronic soldering jobs.

222, with Wen's exclusive ATR (Automatic Thermal Regulation), is a power packed, lightweight precision instrument that gives you more than just dual heat. It gives you an effective and efficient range of heat up to 200 watts. The Wen Hot Rod Soldering Gun can deliver the heat-power found in a 200-watt soldering device on a current draw of only 110 watts surge and 55 watts working.

Feature for feature, there's not a better soldering gun to be found anywhere. Check 'em off.

- Exclusive ATR (Automatic Thermal Regulation) permits heat-power to be automatically adjusted to the correct level for the job being done.
- Tip automatically adjusts heat-power up to 200 watts.
- New CS 1200 heat element in the tip puts heat-power on the work.
- Economy performance—more heat-power, less current draw.
- Lighter weight, more compact—beautifully balanced.
- ONLY \$7.95

Model 222 K-5 Kit, with rugged custom fitted case, contains flat iron and plastic cutting attachments which seal plastic bags, remove wood dents and perform dozens of accessory jobs. Kit also contains fine soldering tip for delicate soldering jobs. Only \$11.95.

**WEN PRODUCTS, INC.**  
5810 Northwest Highway  
Chicago, Illinois 60631

This column is for your service problems—TV, radio, audio or general and industrial electronics. We answer all questions individually by mail, free of charge, and the more interesting ones will be printed here.

If you're really stuck, write us. We'll do our best to help you. Don't forget to enclose a stamped, self-addressed envelope. Write: Service Editor, Radio-Electronics, 154 West 14th Street, New York 10011.

## Testing Automatic Degaussers

A lot of the new sets are coming out with automatic degausser circuits. Like everything else, there will be times when we wonder whether the things are really working or not. Luckily for us, they're easy to check.

The schematic shows the basic circuit used in most of them: they are hooked up so that ac flows in the coil while the set is warming up. Then it is either disconnected or bypassed and has no effect during operation. (See "Automatic Degaussing," March 1965, p. 55.)

This gives us the check. With the set cold, shunt out the "switch" and turn the set on. Let it warm up, and then take off the shunt. You'll get a burst of current through the coil.

This will make "worms" on the edge of the screen. They won't be too prominent, but easily visible if you're watching. They won't last too long, so you'll have to be quick!

The basic operation is simple. A thermistor (the "switch" mentioned above) is hooked in series with the ac supply to the B+ rectifiers. It has a high resistance while cold and a much lower one when hot. So, when the set's first turned on, we get a rush of current through the low-resistance coils shunted across the comparatively high-resistance thermistor. Now, that gives us the required ac field, and we degauss the tube.

After the set warms up, the thermistor's resistance falls way down, so we get a very small ac drop across it. For better operation, a voltage-depend-

ent resistor is added in series with the coil. This works exactly opposite: with a high voltage across it, it has low resistance and vice versa. At first, this lets current pass; then, when the voltage drops, it helps to cut the current off almost completely.

Incidentally, here's one you can warn your customers about. When using any household appliance like a vacuum cleaner near the color set, never turn the motor off while the thing is close to the screen! Do exactly as we do with our degaussing coils: take it far away, then break the circuit. Otherwise, the suddenly collapsing magnetic field can magnetize the tube!

## Sync, brightness trouble, Zenith 19R20

A Zenith 19R20 won't come on in-sync horizontally, and it's unstable. Also, I have unequal brightness on the raster; the left half of the screen is brighter than the right half.—T.J., Norfold, Va.

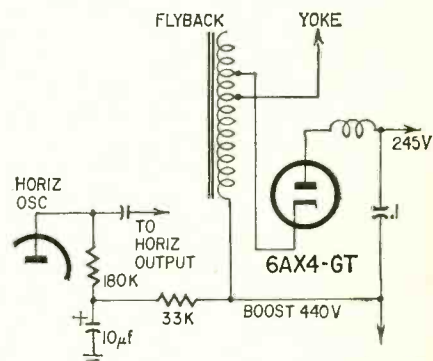
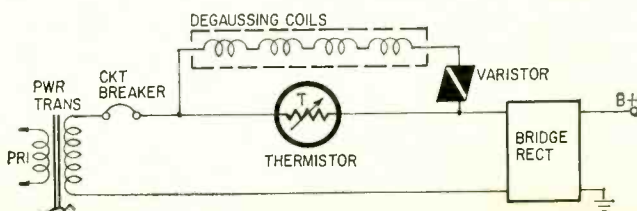

Fig. 1—Boost-voltage circuit may cause sync troubles and uneven brightness.

Check the boost circuit. There is a 10-µf electrolytic in the plate supply to the horizontal oscillator. If this is open or weak, it could be causing both these symptoms. Also, check the boost capacitor, the 0.1-µf between boost and B+ (Fig. 1). Leakage here could cause this kind of trouble.

I'd run a complete setup on the horizontal oscillator. Take off the sync

Simplest of several automatic degaussers.





and set up the oscillator to run free-wheeling. If it won't do that, there's a bad part somewhere; find it and replace it. In this condition, there are only a few parts left.

#### Color-bar generator kit: calibration

*I've built a color generator from a kit. On an RCA CTC9, I get good color bars, but I have trouble with the set on a color signal from the station. What's the matter?—M.H., Tahoe City, Calif.*

There's a good chance that your generator is slightly off calibration on its rf output. Since the set will make color bars on the generator, this means that it's OK. Since our "standard" must be the color signal from the TV station, there's only one possible answer!

Set up your generator and another color TV set. Tune in a color program. Disconnect the antenna, and use the TV set to calibrate your generator. You'll probably find this procedure somewhere in your instruction book, if you'll read it carefully.

#### Tube substitution in Zenith G402 radio

*I'm working on an old Zenith radio, a portable G402 Zenette. Uses 1R5, 1U4, 1S5 and 3V4 tubes. No service data available. Can I substitute a 1U5 for the 1S5? RCA's tube manual says I can, but I changed the base connections to fit the 1U5 and it didn't work! Why not?—A.S., Cherry Hill, N.J.*

The service data on this set are on the "Zenith 22-35" page of Rider's *Radio Troubleshooter's Manual*, Vol. 22. Electrical characteristics of 1U5 and 1S5 are identical. So the substitution should have worked.

Go back and recheck your wiring and, most especially, the plate load resistor and screen dropping resistor. If I remember this set, they used a rather

large resistor in the screen, and it used to increase in value. Then we lost volume and got bad distortion.

Be sure that the filament connections are right, and that the grid is not biased too heavily. The grid resistor is pretty big, too, and if it rises in value, we get too much bias, and the tube cuts off.

#### Intermittent shorts

*I've got an intermittent short in a Muntz 37B4. Blows the fuse. Can't find it.—C.T., Miami, Fla.*

Look for the time constant. If the

fuse blows inside of about 10 seconds, or as soon as the 5U4 heats up, it's likely to be in the B+ circuits. If it takes about 25-30 seconds, then it would be apt to be in the boost voltage circuits; it takes about this length of time for the damper and horizontal output tube to get good and hot.

Suggestion: take out all the "heavy-current" tubes: audio output, vertical output, horizontal output, damper. Now, turn the set on. If the fuse doesn't blow (since it's in the transformer primary: no HV fusing in this chassis), then you've cleared all the other tubes and stages. Now, replace the other

## ARTIFICIAL RESPIRATION FOR CRT'S

CREATES MORE PROFIT FOR YOU



Easy, professional way to check and correct B&W and Color Picture Tubes

#### TESTS AND REJUVENATES

- all picture tubes at correct filament voltage from 1 to 12 volts.
- all Hi G-2 and Lo G-2 picture tubes, including tubes that require as low a G-2 voltage as 30 volts.
- 110° tubes and the new 19" and 23" tubes.
- color picture tubes, including the new 90° 23" 23EGP22. Checks and corrects each gun of color tube separately.



### ALL-IN-ONE B&K CRT 445

THE INDUSTRY'S STANDARD  
Most Widely Used Today  
by Professional Servicemen

SAVES CUSTOMERS—ADDS SERVICE INCOME—MAKES NEW TUBE SALES EASIER

Does the job in a few minutes right in the home without removing tube from TV set.

Gives new life to weak or inoperative tubes. Checks for leakage, shorts, open circuits and emission. Removes inter-element shorts and leakage. Repairs open circuits and low emission. Restores emission and brightness. Life Test checks gas content and predicts remaining useful life of picture tube.

Quickly pays for itself.

Net, \$7495

See Your B&K Distributor for Demonstration, or Write for Catalog AP21-E

Subscribe to  
New  
Picture Tube  
Information  
Service



**B & K MANUFACTURING CO.**  
DIVISION OF DYNASCAN CORPORATION  
1801 W. BELLE PLAINE AVE. • CHICAGO, ILL. 60613  
Canada: Atlas Radio Corp., 50 Wingold, Toronto 19, Ont.  
Export: Empire Exporters, 123 Grand St., New York 13, U.S.A.

#### WHAT'S A DELAY LINE?

Delay lines are essential in color TV—vital to industry. You'll find them in radar, in computers. What do they do? How do they delay signals? Next month, Arthur Kramer explains electronic delay lines in detail. (Some of them are made of glass!)

COMING IN . . .

September  
RADIO-ELECTRONICS



## Need an Exact Replacement Control?

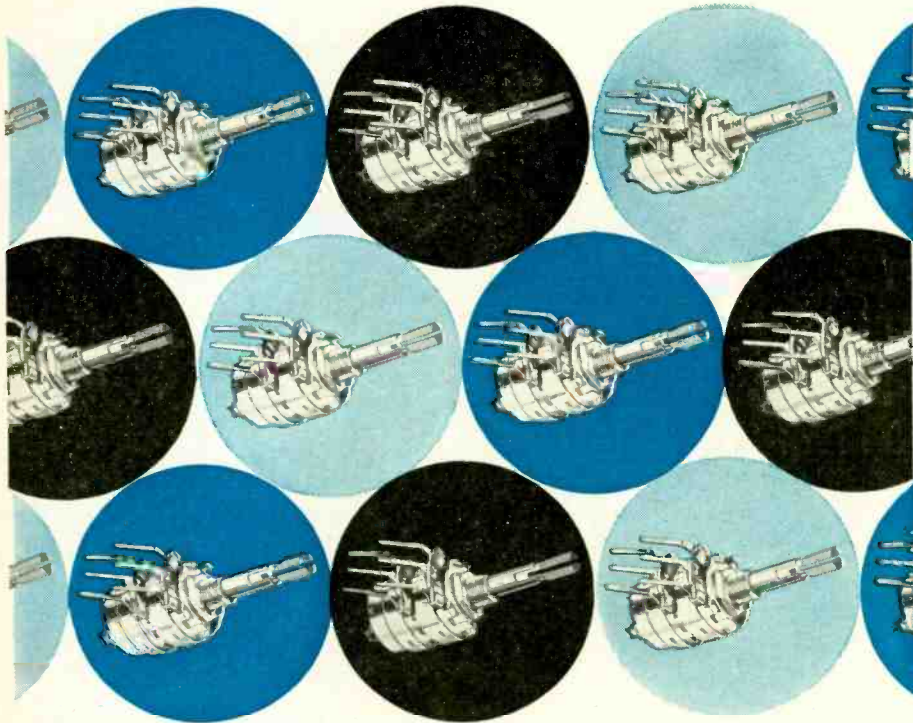

Your Centralab Fastatch® II Distributor  
Has Over

# 9 BILLION\*

In Stock!

\*With the Fastatch II system, your Centralab distributor can supply any of 9,938,500,000 different *exact replacement control* combinations. You'll see that these replacements look like the original, because they have:

- EXACT** length shafts for single, dual concentric and twin controls.
- EXACT** shaft end (round, half round, knurled, slotted, etc.)
- EXACT** mounting hardware (doghouse, twist-tab, reverse, etc.) and, of course, exact resistance and taper.

Although they look like the original, these controls will outperform the original—thanks to Centralab's patented snap-together *permanent-locking, anti-backlash* construction.

See your Centralab Fastatch II distributor whenever you need a replacement control. Whether for color or black and white TV, hi-fi, stereo, or radio, he can supply it!!

For additional information on the Fastatch II Control System, write to Centralab, Distributor Products, P. O. Box 591, Milwaukee, Wisconsin 53201, TWX: 414-731-8731. (In Canada: Centralab Canada Ltd., P. O. Box 400, Ajax, Ontario).



DIVISION OF GLOBE-UNION INC.

B6509

### SERVICE CLINIC continued

tubes, one at a time, beginning with the damper and horizontal output, and so on. When you find the one that pops the fuse, there's the trouble.

Might open some cathodes and hook a pilot lamp in series, just to see if this will help. If the lamp flares, then that stage is drawing too much current. Use something like the 150-ma No. 47.

### Green lowlights in RCA CTC5

*My RCA 21-01-7855 runs to green. The picture is green and white, instead of black and white. Color pictures seem to be pretty good. No one around here can figure it out. Help!—D.H., Pittsfield, Maine.*

First thing, although this has already been done, rerun the color temperature setup adjustments as given in RCA's instruction book 1957-T7. Basically, this trouble is due to the green gun conducting when it should be cut off (black screen). So, one of the adjustments is set too high, or there is a defect in the circuitry.

The most likely place for this would be in the green amplifier circuits; since you have dc coupling all the way through in such sets, a defect quite a way back can cause effects like this. Check plate resistors for correct value, tubes for grid emission, etc.

### Snow in the video i.f., Philco 49-1450

*I can't get the snow out of a Philco 49-1450. It's in the video i.f. Taking the tuner tubes out makes no difference in the snow; pull the first video i.f. tube and it's gone. Changed tubes, changed resistors, and checked agc; made no difference.—J.S., Florissant, Mo.*

This was a fairly common complaint on chassis of about that vintage. I notice that you did think of the agc; a lot of men overlook it, especially if the chassis has an AGC OFF switch like this one does!

Try changing the rest of the video i.f. tubes, especially the second. Also, check the screen and plate dropping resistors; they were the most common cause of this complaint. In some of them, adding a small bypass capacitor across the bias resistor in the cathode of the first stage helped. Don't overlook the chance of leakage in the coupling capacitor between the first and second i.f. tubes. Even a very minute leakage here will cause snow.

Other causes that have been found: corroded joints in the little rf chokes in the B+ feed line to the i.f., or in the i.f. coils and traps. Check their resistance, or simply shunt them with a piece of wire. This will kill the picture, in most



# GET IN ON THE **COLOR TV BOOM!**

## EARN BIG SERVICING PROFITS *with the know-how you get in*

# PHOTOFACT® COLOR TV COVERAGE

### PHOTOFACT COLOR TV COVERAGE AVAILABLE ON FOLLOWING BRANDS:

ADMIRAL	MOTOROLA
AIRLINE	MUNTZ
AMC	OLYMPIC
ANDREA	PACKARD-BELL
ARVIN	PENNCREST
BRADFORD	PHILCO
CAPEHART	RAYTHEON
CATALINA	RCA VICTOR
CBS-COLUMBIA	SEARS
CORONADO	SENTINEL
CURTIS MATHES	SETCHELL-CARLSON
DELMONICO	SILVERTONE
DUMONT	SPARTON
ELECTROHOME	STROMBERG-CARLSON
EMERSON	SYLVANIA
GENERAL ELECTRIC	TRUETONE
HOFFMAN	WESTINGHOUSE
MAGNAVOX	ZENITH

FOR PHOTOFACT FOLDER COVERAGE OF SPECIFIC CHASSIS MODELS in the above brands, check your Photofact Master Index and latest Supplement.

An average of 3 Color TV chassis is now covered monthly in current PHOTOFACT

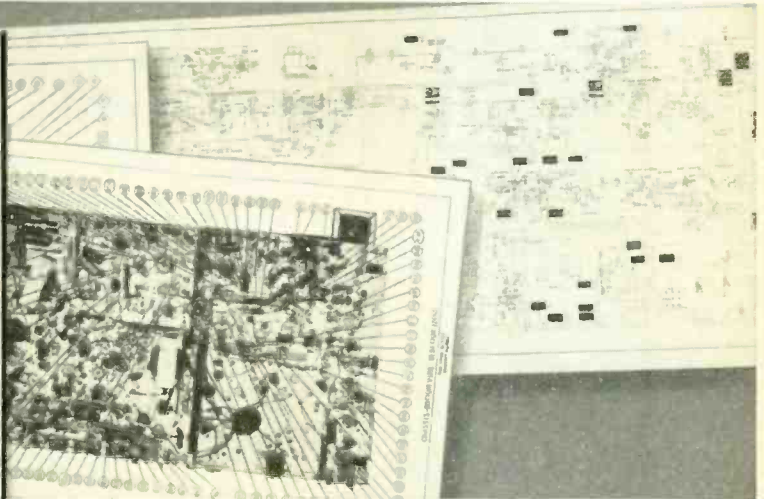

### HAVE EVERYTHING YOU NEED TO PERFORM EXPERT PROFITABLE COLOR TV SERVICING!

- Famous SAMS "Standard Notation" Detailed Schematics
- Chassis View Photos
- Disassembly Instructions
- Set-up Adjustments
- Full Alignment Data
- Resistance Charts
- Tuner Schematics
- Block Diagrams
- Waveform Diagrams
- Tube Placement Charts
- Complete Parts Lists

Plus dozens of other invaluable PHOTOFACT features

FOR THE COLOR TV COVERAGE YOU NEED, check your latest PHOTOFACT Master Index—the issue dated February, 1965 includes a special section listing all Color TV makes and models now covered in PHOTOFACT—so you can instantly locate the Color TV PHOTOFACT Folder you want.

See your Sams Distributor—he stocks all PHOTOFACT Sets to fill your requirements immediately.

## NOW MORE THAN EVER—PHOTOFACT OWNERSHIP PAYS OFF BIG!

### OWN A PHOTOFACT LIBRARY THE EASY-BUY WAY

Only \$10 down • 30 months to pay • No interest or carrying charges • Prepaid transportation • Add-on privilege of a year's advance subscription to current PHOTOFACT on the same Easy-Buy contract • Save 30¢ per Set—special \$1.95 price applies on Easy-Buy (instead of the regular \$2.25 price).

Deluxe new 4-drawer File Cabinet (full-drawer suspension)—available with your purchase of a PHOTOFACT LIBRARY consisting of 200 Sets (plus a selection of valuable Free extras!).

SEE YOUR SAMS DISTRIBUTOR  
FOR FULL DETAILS, OR MAIL COUPON

4 Ways to Select Your PHOTOFACT Library: 1. Complete your present Library. 2. Order a "Starter" Library. 3. Order by brand name and year. 4. Order a complete Library. See your Sams Distributor for full details, or send coupon below.

### HOWARD W. SAMS & CO., INC.

Howard W. Sams & Co., Inc. Dept. REF-8  
4300 W. 62nd St., Indianapolis, Ind. 46206

- Send FREE Photofact Cumulative Index.  
 Send full details on Easy-Buy Plan.

My Distributor is: \_\_\_\_\_  
Shop Name \_\_\_\_\_  
Attn. \_\_\_\_\_  
Address \_\_\_\_\_  
City \_\_\_\_\_ State \_\_\_\_\_ Zip \_\_\_\_\_

## SERVICE CLINIC continued

cases, but if it kills the snow too, look to see what has happened.

### Why "DO NOT MEASURE" on tube plates?

*Most service data don't give the value of the high voltage in a TV set. When they show the high-voltage rectifier tube, they say "Do Not Measure." Yet, it is important. This puzzles me! Why not?—A.C., Coraopolis, Pa.*

You'll find that lately most service data do give the high voltage, the dc high voltage, that is, on the ultor of the CRT. A lot of the older schematics didn't show this value.

There's a very good reason for saying "Do Not Measure" on such points as the HV rectifier plate, vertical output tube plate and horizontal output tube plate. While these points have a "nominal" dc voltage, for instance, the boost-voltage value on the horizontal output, there is *always* a very high pulse voltage there also.

Even on the vertical output plate, the lowest of them all, you'll find say 400 volts or so of dc, *but*—there will be very sharp spikes, pulses, etc., that can go as high as 1,200–1,500 volts! If you touch the probe of a voltmeter to such a

voltage, the high pulse values may puncture bypass capacitors across the input or even arc over the resistors in the input voltage divider. Once such a pulse voltage gets past the voltage divider at the input, where is it? Right: *across the very delicate meter movement!* You can figure out for yourself what will happen if we turn a 1,000-volt pulse loose in a 50-microampere movement. New meter.

While these voltages can be measured, it usually isn't necessary. For instance, we don't have to measure the pulse voltage at the plate of a 1B3 rectifier; if we have the right dc voltage at its output, measured with a high-voltage probe, then the plate voltage is OK!

### Low B+ voltage, Emerson C504A color TV

*I have voltage problems on an Emerson C504A color TV. All voltages read low, except the 125-volt line. I've checked for open capacitors by shunting, and for shorts: no avail.*

*Could this be the power transformer primary? If so, is there a standard replacement?—G.B., Fullerton, Calif.*

There are three causes for low B+ voltages: shorts, open filter capacitors and low ac line voltage. You have

checked the first two; be sure to check the last.

The total current drain of the B+ section of this set is given as 730 ma. I'd suggest breaking the B+ output circuit at the filter, and inserting a 1-amp dc meter to check this. This test will tell you whether the trouble is due to an overload or to low line voltage.

Your input filter capacitors won't have as much effect here as they would in the more common half- or full-wave rectifier circuits. In other words, an open input filter won't cause *as much* voltage drop by loss of "reservoir action" as it will in others.

I wouldn't suspect the power transformer, unless it's heating. There are only two things that can happen to a power transformer: an open winding or a shorted turn. Quick-check: disconnect all loads and hook up the transformer to a wattmeter. A good transformer, unloaded, will draw only about 2–4 watts. Anything more than this, say about 25–30 watts, means a shorted turn in one of the windings; this test is infallible, if all loads have been taken off.

### Frozen auto radio?

*My auto radio, installed last spring, worked fine. The car sat outside last winter, while the temperature went down to as low as -17°. Now the reception is weak and very noisy. The set's a hybrid tube-transistor of a good make. What do you think happened?—P. R., Chicago, Ill.*

It may be like the old tall story about the tunes that froze up in Paul Bunyan's trumpet, then thawed out and made it play all summer by itself!

Seriously, if moisture had condensed inside the radio, a hard freeze could have caused any of several things. Try this: substitute another speaker and another antenna. You can do this without taking the set out of the car. Moisture may have frozen inside the voice coil and warped the form; also, it may have frozen in the antenna base and broken an insulator or even the lead-in wire itself.

# Precise Scope Spectacular!

(only 7 and 8½-inch scopes—only triggered sweep scopes in this price range)

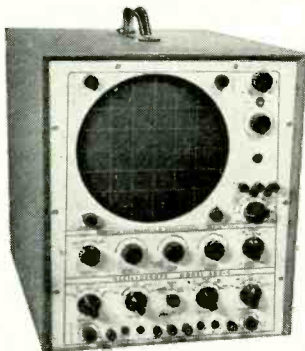

Four top quality scopes (kits or wired) including • two professional performance scopes the 7" Model 300C, K. \$169.95, W. \$222.95, and the 8½" Model 308, K. \$179.95, W. \$249.50, a low cost color scope, Model 3151, K. \$89.95, W. \$137.95 • a top value in a 5" general radio and TV scope Model 315, K. \$79.95, W. \$113.95. Prices slightly higher in West. Save now at your Precise distributor. For free 1965 catalog write:



PRECISE ELECTRONICS & DEVELOPMENT DIV. OF DESIGNATRONICS, INC.  
76 EAST SECOND STREET, MINEOLA, NEW YORK 11501

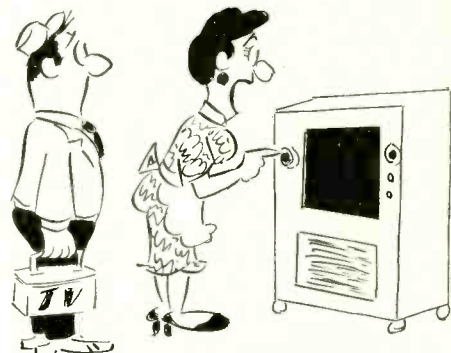

*"The trouble must be in this knob . . . when I turn it on nothing happens."*

RADIO-ELECTRONICS



If this doesn't help, then you'll have to pull the set out of the car and signal-trace it. Broken PC boards, tube sockets: anything could have been damaged under such conditions.

### Transistor ignition and resistance wiring

*My Buick Skylark has resistance type ignition wiring. I want to install transistor ignition. How much will the radio noise be increased if I remove this and use ordinary wiring?—P.G., Beverly, Mass.*

This shouldn't be necessary. One of the features of transistor ignition systems is the higher voltages available (Fig. 2 shows a typical comparison). So, since the only object of removing the resistance wiring would be to gain voltage at the plugs, why bother?

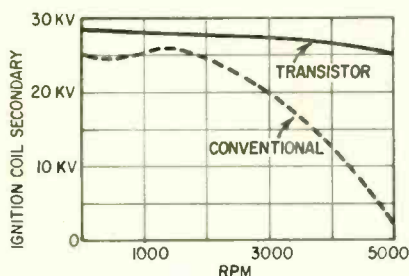

Fig. 2—Chart of coil output voltages with conventional and transistor ignition systems.

Actually, I have tested several different transistor ignition systems and found no difficulty at all in using resistance wiring. Also, they seem to have a lower level of "plug-noise" than conventional systems.

### Dc vs ac voltage readings

*I have low B+ voltage in an Admiral TV. I read 220 volts dc on the*  
*continued on page 30*

### NEW SEMI-SWEEPER PRODUCES WHATEVER FREQUENCY YOU WANT . . .

Here's a unique sweep generator that has no frequency till you give it one! Its stable transistor rf oscillator works with practically any inductance connected to its terminals, and a unijunction-transistor oscillator sweeps the rf oscillator at a widely variable rate. Works from below 100 kc to above 60 mc. Use for TV, AM, FM, for lining up crystal filters, for anything else you can think of!

COMING IN . . .

September  
RADIO-ELECTRONICS

AUGUST, 1965

meet the new  
**WINEGARD  
HOT-SHOT**  
Super Compact All-Band  
(UHF, VHF, FM)  
Color Antenna...  
Eliminates Ghosts  
Better than any  
other Metropolitan  
Type Antenna

Here's the antenna that replaces Conicals, Twin Vees, In-Lines and all Indoor antennas. It's Hot-Shot, the new antenna from Winegard that outperforms the others... yet lists for only \$8.80!

Designed specifically for all-band (UHF, VHF, FM) reception in metropolitan areas, Hot-Shot has a very high front to back and front to side ratio to eliminate ghosts more effectively than other antennas. Works on all bands to deliver life-like color, sharper black and white and distortion-free FM stereo. Easily installed, too, on roofs or in attics—you work with just one downlead. It even has Winegard's new Gold Vinylized finish to triple antenna life.

So don't give your customers the limited performance of an indoor or old fashioned outdoor antenna when for no more money than indoor types (\$8.80), you can give them the outstanding results of the all new Winegard Hot-Shot.

Ask your distributor or write today for Hot-Shot Fact-Finder #241. It's the hottest new all-band antenna for metropolitan and suburban reception areas.

**Winegard Co.**

ANTENNA SYSTEMS  
30131 Kirkwood • Burlington, Iowa

# You can earn more money if you have an FCC License

FCC Form 738 A

*The United States of America*

NUMBER  
P1-20-6490

**FEDERAL COMMUNICATIONS COMMISSION**

**RADIO TELEPHONE OPERATOR LICENSE**

**FIRST CLASS**  
(General Radiotelephone Certificate)

*This certifies that* \_\_\_\_\_ **TOMMY WILLIS DUFFY**

IS A LICENSED RADIO OPERATOR, AUTHORIZED, SUBJECT TO ANY SPECIAL ENDORSEMENT PLACED HEREON, TO OPERATE THE CLASSES OF LICENSED RADIO STATIONS FOR WHICH THIS CLASS OF LICENSE IS VALID UNDER THE ORDERS, RULES AND REGULATIONS OF THE FEDERAL COMMUNICATIONS COMMISSION, ANY STATUTE OF THE UNITED STATES AND ANY TREATY TO WHICH THE UNITED STATES IS A PARTY.

THIS LICENSE IS GRANTED UNDER THE AUTHORITY OF THE COMMUNICATIONS ACT OF 1934 AS AMENDED, AND THE TERMS AND CONDITIONS THEREOF AND OF ALL LEGISLATIVE ACTS, EXECUTIVE ORDERS, AND TREATIES TO WHICH THE UNITED STATES IS SIGNATORY, AND ALL ORDERS, RULES AND REGULATIONS OF THE FEDERAL COMMUNICATIONS COMMISSION, WHICH ARE BINDING UPON RADIO OPERATORS, ARE MADE A PART HEREOF AS THOUGH SPECIFICALLY SET OUT IN FULL HEREIN.

NEITHER THIS LICENSE NOR THE RIGHTS CERTIFIED TO HEREIN SHALL BE ASSIGNED OR OTHERWISE TRANSFERRED TO ANY OTHER PERSON.

PLACE AND DATE OF ISSUANCE: BUFFALO, NEW YORK - SEPTEMBER 11, 1963

DATE AND TIME OF EXPIRATION: SEPTEMBER 11, 1968 AT THREE O'CLOCK A. M., EASTERN STANDARD TIME.

SPECIAL ENDORSEMENT: SHIP RADAR ENDORSEMENT - SEPTEMBER 11, 1963 - BUFFALO, NEW YORK

  
ISSUING OFFICER

*Federal Communications Commission*



  
(Licensee)

  
(Issuing Officer)

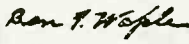
  
(Secretary)

NOT VALID UNTIL SIGNED

## Employers are paying good money for men holding FCC tickets. Read how to get yours:

When you hold a Commercial License issued by the FCC (Federal Communications Commission) you have written proof that you know and understand basic electronic theory and fundamentals. It's worth plenty . . . particularly to companies on the lookout for qualified electronics technicians. Here's how one of the country's leading office machine manufacturers rates men with FCC Licenses:

"An FCC License is an asset to any man looking to enhance his career in the field of electronics. At our Company, a licensed man is well-rewarded because an FCC License attests to his knowledge of electronics theory . . ."

Thousands of employers will tell you the same thing. Licensed men get the good jobs. They make more money

. . . move ahead faster . . . enjoy exciting, challenging work. What's more, they're needed badly in every field of electronics. Industrial electronics. Radio-TV Broadcasting. Aerospace. Electronics Servicing . . . including mobile and marine radio *plus* CB.

Yes . . . your opportunities are unlimited once you're carrying that FCC Commercial Ticket. AND CLEVELAND INSTITUTE OF ELECTRONICS CAN GET ONE FOR YOU! On the facing page, read how four ambitious men just like you have cashed in on CIE's sure-fire FCC Licensing Program. Read about CIE's exclusive money-back offer. And then send in the postage paid reply card. CIE will quickly send you complete FREE information. You will soon be on *your* way to a Commercial FCC License and the many rewards that go with it!



# These CIE men have good jobs

(they have Commercial FCC Licenses)



**Matt Stuczynski, Senior Transmitter Operator, Radio Station WBOE.** "I give Cleveland Institute credit for my First Class Commercial FCC License. Even though I had only 6 weeks of high school algebra, CIE's AUTO-PROGRAMMING teaching method makes electronics theory and fundamentals easy. After completing the CIE course, I took and passed the 1st Class Exam. I now have a good job in studio operation, transmitting, proof of performance, equipment servicing. Believe me, CIE lives up to its promises!"



**Ted Barger, Electronic Technician, Smith Electronics Co.** "I've been interested in electronics ever since I started operating my own Ham rig (K8ANF). But now I've turned a hobby into a real interesting career. Cleveland Institute of Electronics prepared me for my Commercial FCC License exam . . . and I passed it on the first try. I'm now designing, building and testing all kinds of electronic equipment . . . do a lot of traveling, too. It's a great job . . . and thanks to CIE and my FCC License, I'm on my way up."



**Chuck Hawkins, Chief Radio Technician, Division 12, Ohio Dept./Highways.** "Cleveland Institute Training enabled me to pass both the 2nd and 1st Class License Exams on my first attempt . . . even though I'd had no other electronics training. (Many of the others who took the exam with me were trying to pass for the eighth or ninth time!) I'm now in charge of Division Communications and we service 119 mobile units and six base stations. It's an interesting, challenging and extremely rewarding job. And incidentally, I got it through CIE's Job Placement Service . . . a free lifetime service for CIE graduates."



**Glenn Horning, Local Equipment Supervisor, Western Reserve Telephone Company (subsidiary of Mid-Continent Telephone Company).** "There's no doubt about it. I owe my 2nd Class FCC License to Cleveland Institute. Their FCC License Program really teaches you theory and fundamentals and is particularly strong on transistors, mobile radio, troubleshooting and math. Do I use this knowledge? You bet. We're installing more sophisticated electronic gear all the time and what I learned from CIE sure helps. Our Company has 10 other men enrolled with CIE and take my word for it, it's going to help every one of them just like it helped me."

## FCC LICENSE WARRANTY

A CIE FCC License Course will quickly prepare you for a Commercial FCC License. If you don't pass the FCC exam . . . on the first try . . . after completing your course, CIE will refund all your tuition. You get an FCC License . . . or your money back!

Two out of three men who took the 1st Class Commercial FCC License exam in 1964, failed.

Nine out of ten CIE-TRAINED men who take this exam, pass . . . the very first try!

And that's why CIE can back their courses with the warranty you see at the left. CIE-trained men know their stuff . . . because CIE AUTO-PROGRAMMED Home Study works!

Get started now. Send postage-paid reply card for free information about a plan that gets you an FCC License or costs you nothing!



**Cleveland Institute of Electronics**

1776 East 17th Street, Dept. RE-7, Cleveland, Ohio 44114



# One to BUILD

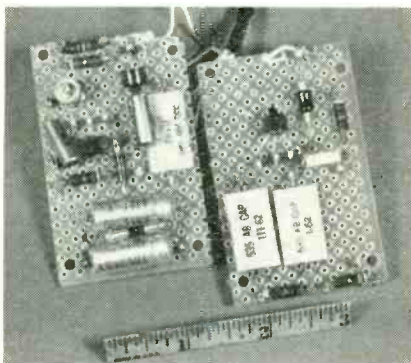

Now, a reliable auto tachometer you can build yourself! Here's the answer to the continuing problems you have with most engine-speed meters—varying battery voltage, changing spark-pulse shape, and the wide range of temperatures the unit has to live with. Designer Stephen Gross has solved all these difficulties in one inexpensive three-transistor circuit you can build. It works with any gas engine: 2-stroke or 4-stroke, 1 to 8 cylinders.

# One to BUY



Tape player for your car. Read about the latest sonic boom everyone's talking about—compact stereo tape-cartridge players for automobiles! Advantages over AM-FM are numerous—no interference, no fading, no tuning—and the programming of your choice. With well over a dozen brands (and more being announced almost every week), you can hardly tell the players without a score card. Be sure to read this thorough evaluation on available brands, complete with comparative chart.

# One to USE

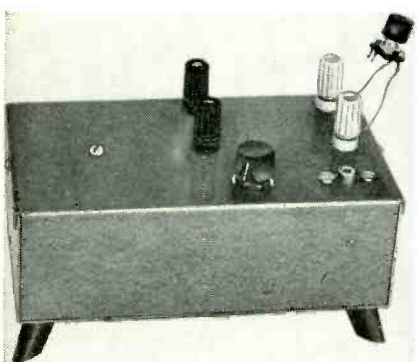

New semi-sweep generator produces whatever frequency you want. Here's a unique sweep generator that has no frequency till you give it one! Its stable transistor rf oscillator works with practically any inductance connected to its terminals, and a unijunction-transistor oscillator sweeps the rf oscillator at a widely variable rate. Works from below 100 kc to above 60 mc. Use for TV, AM, FM, for lining up crystal filters, for just about any other job you can think of!

Don't miss these musts in . . . September

# RADIO-ELECTRONICS

## SERVICE CLINIC continued

*5U4 cathode, 100 volts ac on the plates. Can't get any HV or raster—N.P., Orangevale, Calif.*

I know the first thing I'd check: That voltmeter! If you have 220 volts dc on the cathode, you *must* have more than 100 volts ac on the plates! So, check it against the ac line voltage, for example, to see if it's reading anywhere near right. (Personally, I suspect a bad rectifier in the meter!)

After this, check your input filter capacitor for opens, and the 5U4 tube.

## 8YP4 check-tube won't light

*I've got an 8YP4 check tube, and I've got problems with it. I hooked it up to an RCA 17PT-8071VU, and it would not light (the heater, that is). I made the adapter for it, but I think that's OK. What do you think?—R.C., Philadelphia, Pa.*

Well, I can see one thing: the 8YP4 has a 6.3-volt 600-ma heater while the 17CDP4 used in the RCA has an 8.4-volt 450-ma heater. This could be the answer, but it shouldn't keep the heater from lighting at all. Suggestion: go back and check continuity from the heater pins of the socket; in other words, through adapter, 8YP4 and all. Be sure that continuity is OK.

Actually, to get a "good match" in cases such as this where the currents aren't the same, you might even have to make up some kind of Rube Goldberg hookup: for example, a small, separate 6.3-volt transformer to heat the 8YP4, while the 17CDP4's heater is left hooked up in the original string. Complicated, but it would work.

## Vertical foldover at bottom in 41U Philco TV

*A 1958 Philco with a 41U chassis has a foldover at the bottom of the screen. Gets to about an inch in width. What's doing this?—A.F.B., Eureka, Nev.*

Philco has made a lot of 41U chassis—8L41U, 9L41U and so on. However, since you did say 1958 I picked the 9L41U since it was built then. If I missed, the basic trouble will still be the same.

Most common cause of this trouble is leakage in the coupling capacitor between the two halves of the multivibrator. Here, this would be the .033- $\mu$ f between pins 6 and 3 (plate and grid) of the 6CS7 tube. To check, lift the grid connection (turn the brightness down) and turn the set on. Now measure the dc voltage on the open end of the capacitor with a vtvm, on a low dc scale. If you read any voltage, replace the capacitor.

END



## Electronics and Programed Instruction

Guest editorial by THOMAS JASKI

A few years ago we heard a great deal of the major revolution in education that teaching machines were going to bring us. Today there is less interest in the machines and more on the *programed instruction* that makes them worth while. It has been established beyond a doubt that the machines themselves contribute little to the learning process, though they will eventually make a great difference in the organization of curricula. A complex computer may some day teach any number of programs simultaneously. What then, is programed instruction—the heart of this new teaching method?

At first glance it might appear to be a textbook chopped into small pieces called “frames” which are presented to the student one after another. It is not as simple as that. The program is a carefully constructed and *tested* presentation, designed to give the student the most learning with the least effort and time.

We know that a study situation is greatly improved when (a) the material is presented to the student in small, orderly steps, each step building on what has already been learned; (b) the student partakes actively, by writing or speaking answers, selecting or matching items, or accepting or rejecting an answer; (c) the student receives immediate feedback, learns whether he is right or wrong; (d) the student makes few errors; (e) the student sets his own pace.

Few of these conditions were realized in your high school days, and even fewer if you attended lectures at a university. The correspondence student is an even worse case. He struggles along by himself, sometimes weeks, to find out if he did answer correctly, and if not, what the correct answer is. He may have made wrong assumptions and built up on them before he learned he was wrong.

Programs avoid this kind of problem. They guide the error-making student back through the material, presenting it in a new way to give him another crack at the subject. If a student follows instructions systematically, studies the programs frame by frame, he can't help but learn and follow through, if it is a good program.

There are different forms of instructional programs. In the *linear program*\* each student takes the same path through the program, although some students may skip a few frames, while others must read “remedial” ones. In the *intrinsic program* (often in the form of a “scrambled book”) the path a student takes depends on how much he already knows in various areas of the subject matter. Some programs use a combination of these techniques.

To evaluate a student's progress it is important to keep

\*Currently available programs in electronics are all linear programs, available from correspondence schools and publishers.

track of his error rate and his score on periodic tests as he proceeds through the program. Here is where the computer can be useful. Visualize our future student taking a course in electricity. He carries no textbook, but perhaps a work-book to the study hall. Arriving, he checks out a magnetic disc, a roll of magnetic tape or a phono record. He then proceeds to a booth with a screen, some simple looking equipment and some buttons. He places his roll or disc in a slot and punches a few buttons to indicate his name and the course he is studying. In a few seconds he is asked a few questions about a previous lesson, to determine if he has remembered. He will answer by pushing one of a group of buttons, or drawing on the CRT screen with a “light pen.” As he draws, the screen will remain bright wherever he moves his light pen. When he finishes a second figure—the perfect answer—will appear on the screen, and he can compare his with it.

In the meantime the computer has checked his answers, determined if he is weak on any parts previously studied. If so, it will send him through the program frames on the subject, or through remedial frames. The student's performance on the test is recorded.

Program presentation on the screen may include drawings, movie film, still color pictures. Information and questions will come in written form on the screen, or aurally through speaker or headphone. Correct answers will bring fast progress: incorrect answers will cause the studying of more and more explanatory frames, as well as providing more practice. When the lesson is over, the student will remove his roll from the slot, check it in and leave, or get another roll for a different subject.

Relatively small and simple computers can do this job, since not all programs need be stored, only student progress. Fantastic? Not at all: this kind of computer-regulated programed learning is going on experimentally today. But that is not all.

Finding that computer technology creates no problem, but that the right kind of instructional programs are not available, scientists are now investigating the question: “Can computers be taught to construct programs?” The answer appears to be that they can, but the experimental programs so constructed were dry and uninspiring. It takes the little factors in interpersonal interchange, humor, picturesque use of language, amusing and colorful illustrations and a bit of whimsy to make programs digestible to human minds.

Rather than do away with teachers and instructors, computers will make it possible for a few teachers to deal with large numbers of students, to concentrate on those functions a computer cannot very well do (creative efforts, and such things as demonstrating chemical experiments). By removing the routine part of teaching, computers will not only make life easier for the students, who will learn better and in larger numbers, but they will also make the life of teachers more rewarding, more creative, more exciting. And they will help in no small measure to elevate our population to unprecedented levels of education and scientific achievement.

END

---

Thomas Jaski received his electrical engineering degree from the HTS Leeuwarden in Holland in 1939. An author of many articles for this magazine, he has specialized in bioelectronic and psycho-electronic subjects. Besides being a professional engineer in the State of California, he is an MS in psychology, and is now working in the field of programed instruction.

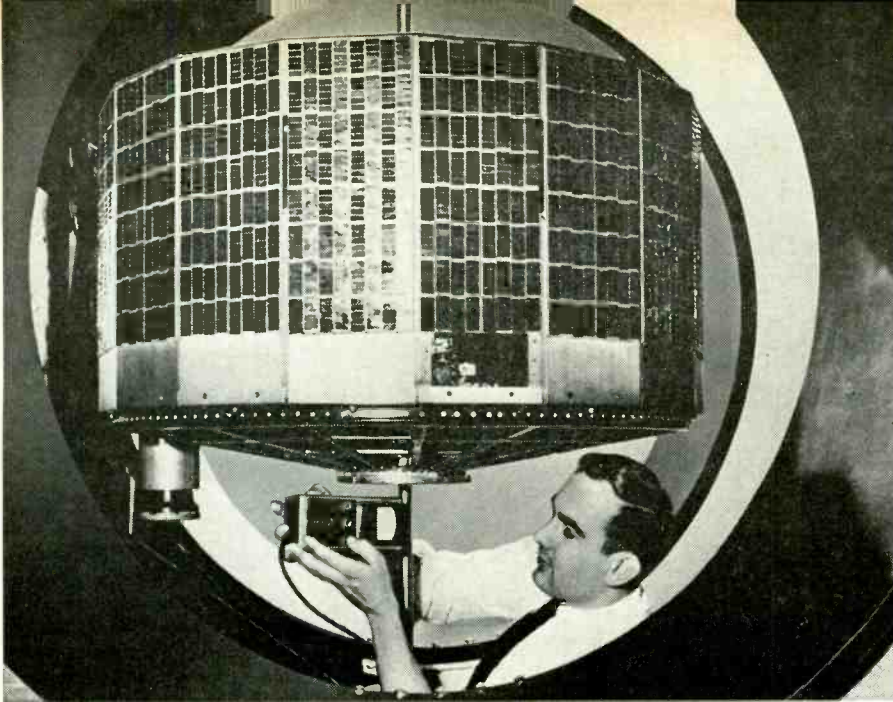

RCA

TIROS weather-eye satellite uses cloud-cover television scanning devices, powered by 9,000 silicon solar cells.

# SOLAR CELLS: SPACE POWER

What's behind these light, compact, efficient sources of electrical energy

By DONALD L. STONER

SPACE EXPLORATION HAS INTRODUCED A new term: *solar cells*—amazing devices that provide power for charging the battery systems in spacecraft.

The first satellite to use silicon solar cells was the Navy Vanguard I, launched March 17, 1958. It carried two transmitters, one powered by mercury cells and the other by silicon solar-energy conversion cells alone. Six clusters of 18 silicon cells energized a 20-milliwatt transmitter. Each cluster was mounted behind a window of Vycor glass for protection against micrometeorite bombardment.

In spite of the success of Vanguard I, the next dozen or so satellites (except for Sputnik III) used various chemical batteries such as mercury, nickel-cadmium, and silver-zinc. Then, on Aug. 7, 1959, Explorer VI was launched with four outstretched "paddle-wheels" lined with a total of 8,800 silicon solar cells. Explorer VI, with an instrument-crammed payload of 142 pounds, was one of the more spectacular of the US satellites and laid the

groundwork for large-scale use of silicon photovoltaic cells in space work.

## Silicon cells

A silicon cell is a wafer .02 inch thick, fairly brittle and available in sizes from  $\frac{3}{32}$  inch square to  $1\frac{1}{4}$  inches in diameter. The most extensively used size in satellites is 1 by 2 cm., which weighs about 0.2 gram—less than an equivalent volume of aluminum.

The 1 x 2-cm. silicon voltaic cell has been used by the tens of thousands to build up shingle panels or arrays up to several hundred watts capacity. One of these, a 26-square-foot panel of 10,640 cells, powered an electric automobile. Another standard configuration is the readout type. This is a multiple arrangement of small cells .08 inch wide, in a single row, and available with various numbers of individual cells.

The sensitive face of silicon photovoltaic cells is bluish black, with a narrow silvery collector strip serving as a positive terminal. The entire back of the cell serves as the negative terminal,

and is nickel-plated and tinned. Cells designed for use in satellites beyond the earth's atmosphere have a sensitive face with an iridescent blue appearance, which comes from a special thin cover glass cemented on the surface.

## How they are made

Only one element, oxygen, exists in greater quantity on the earth than silicon. However, it requires a highly developed technology and very specialized equipment to prepare silicon photovoltaic cells.

Purified intrinsic silicon, which liquifies at  $1,420^{\circ}\text{C}$ , is melted in quartz crucibles and doped with minute amounts of Group V elements, such as phosphorous, arsenic or antimony. An elongated single crystal of n-type silicon, about  $1\frac{1}{2}$  inches in diameter and as long as a sausage, is grown out of the molten silicon by first inserting a small seed crystal, then rotating and pulling at a slow regulated pace by a machine similar to a drill press. This was illustrated on the cover of the October 1963 RADIO-ELECTRONICS.

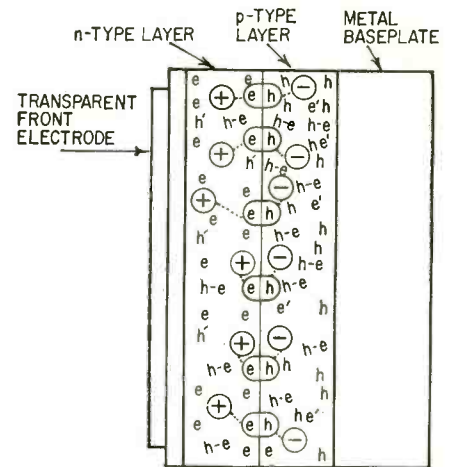

### LEGEND:

- e = mobile electrons (majority carrier).
- h = mobile holes (majority carrier).
- eh = majority carriers combined at junction.
- + = resultant positive ionic charge.
- = resultant minus ionic charge.
- h-e = hole-electron pair created by photon collision.
- e' = electron (minority carrier) from photon-excited hole-electron pair traveling toward positively charged n-side.
- h' = hole (minority carrier) from photon-excited hole-electron pair traveling toward negatively charged p-side.

Fig. 1—This simplified diagram applies to more than one kind of photovoltaic cell. Most work the same way.

After testing for resistivity, the elongated crystal is cut into  $\frac{1}{50}$ -inch-thick slices by a diamond-tipped circular saw. The slices are ground, lapped and chemically cleaned before they are placed in the diffusion chamber, a long quartz tube 3 inches in diameter running through a cylindrical electric furnace.

The slices emerge with a dark burnt



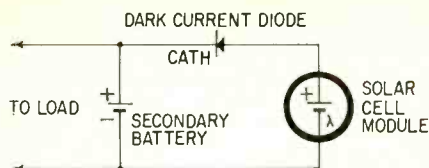

Fig. 2—Simple trick prevents charged batteries from discharging through solar cells during darkness. Current can flow through diode in only one direction.

appearance after heating in the chamber to 1,150°C in an atmosphere of boron trichloride. The boron compound has diffused into elemental boron, which in turn has diffused into the outer surfaces of the silicon wafer, creating a p-type silicon layer less than .0001 inch deep. The photovoltaic junction has now been created.

This p-layer, which becomes the positive terminal, must be electrically isolated, and the n-type silicon (now sandwiched in the middle) must be exposed for contact at the negative terminal. This is accomplished by grinding, sandblasting or chemical etching. By nickel-plating and tinning, a thin strip is formed on the p-layer to function as the positive terminal, and the n-type silicon is coated to form a substantial area that will function as the negative terminal.

#### How they work

The function of a silicon solar cell is to convert light energy falling on its surface to useful electrical energy. All practical photovoltaic cells comprise a junction of similar semiconductor mate-

rial. Depending on which elements (called doping agents) are added, the semiconductor will have an excess or deficiency of high-energy conducting electrons.

In a semiconductor, an electron deficiency is called a *hole* and has a positive charge. Because of this *positive* charge, material with an excess of holes is called p-type, while the material having an excess of electrons is called n-type. The holes in p-type material and the electrons in n-material respectively are called majority carriers, because they are in excess and the majority of current is carried by them. Conversely, the electrons in p-type and holes in n-type material, are called minority carriers.

Near the p- and n-junction, the majority carriers diffuse toward each other and unite, leaving a net deficiency charge on each side of the junction. Thus the n-type region, having lost electrons by combination across the junction, is now positively charged. Similarly, the p-type region becomes negatively charged. This creates an electric potential across the p-n junction. Not all the majority carriers will unite, for after a while the net charge across the junction attracts a counter-stream of minority carriers that tend to neutralize the effects of the charge created by the movement of the majority carriers. Nevertheless, the electric field at the p-n junction is of decisive importance.

Both the p-type and n-type materials, also contain many *valence* (outer-shell) electrons of lower energy that were left unaffected by the impurity doping. These valence electrons may be



Light-powered toy auto works from sun or lamp.

activated by heat or light and their conduction is called *intrinsic*. The opposite, *extrinsic* conduction, results from the impurity doping. This is the reason for the negative-temperature-coefficient resistance of semiconductors. As the temperature increases, the thermally excited valence electrons available for conduction continue to increase until they may completely mask the effect of the extrinsic conduction.

In ordinary metals, such as copper, the number of electrons available for conduction cannot be increased appreciably by temperature. The atomic structure of these metals is such that there is very little difference in energy levels between a valence and a conduction electron. On the other hand, as the temperature increases, the atoms vibrate faster, which reduces the average velocity of the current-carrying electrons and causes an *increase* in resistance.

A photon of light may collide directly with a valence electron. If this light is of short enough wavelength, it will impart enough energy to a valence electron to transform it to a high-energy conduction electron. This free electron will now be attracted by the field at the p-n junction and so will the associated hole, which was born simultaneously with the appearance of the photoelectron. The electron and the hole will travel in directions opposite to the direction of the majority carriers and this will define the direction of photoelectric current.

Fig. 1 (the cross-section of a selenium cell) shows in a simplified way that the photoelectrons travel toward the positively charged n-region and the corresponding holes toward the p-region. Therefore, if the photovoltaic cell is connected to an external load, the photocurrent flows from the p-type material

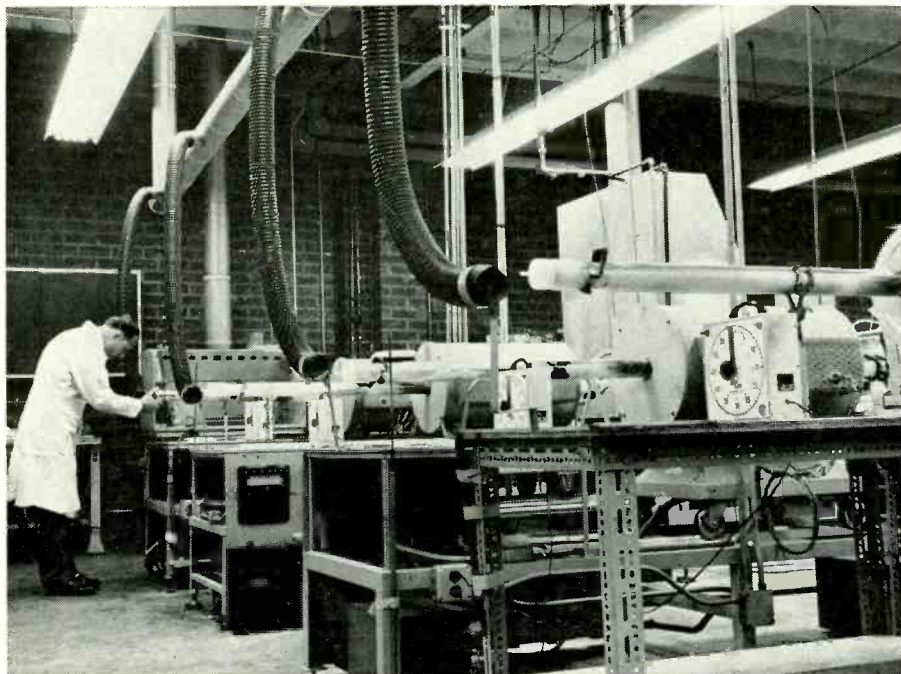

High-temperature fusion furnaces are part of production of p-n junction in solar cell silicon wafers.

International Rectifier



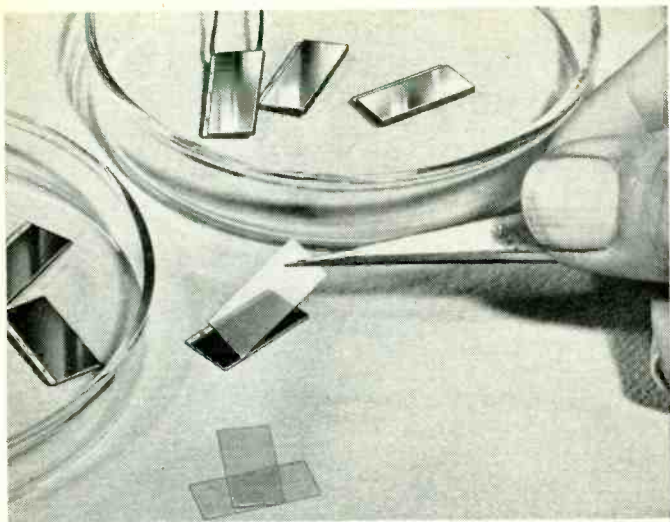

International Rectifier  
Filter-glass plates are cemented to silicon solar cells for outer space use, to protect them from harmful radiation.

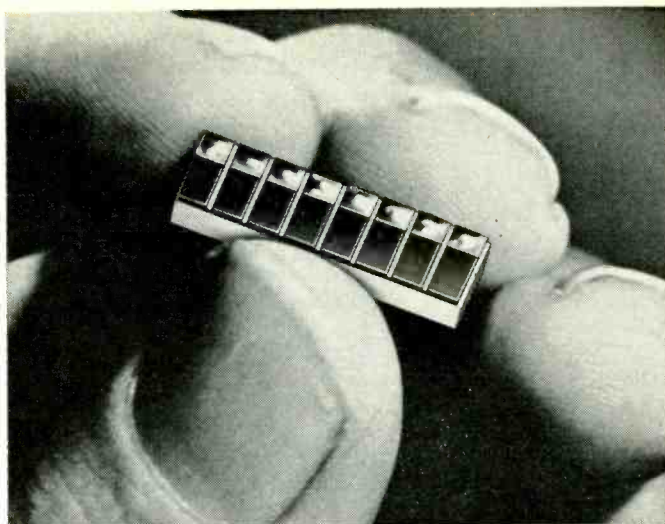

International Rectifier  
Silicon readout matrix cells "see" holes in punched cards used in data-processing systems.

through the load to the n-type material. (By convention, the direction of the electrons is considered to be opposite to the *direction of current flow*.) A silicon photovoltaic cell is constructed so that the sensitive face is the p-type region and is connected to the positive terminal.

The number of photoelectrons will be directly proportional to the radiant flux or illumination, since each photon can liberate only a fixed number of valence electrons. In the case of silicon, the fixed number is one. The short-circuit current is therefore directly proportional to the illumination and the illuminated area.

Solar cells can be used easily and directly for charging secondary batteries. Output voltage variation over a wide range of illumination is relatively small.

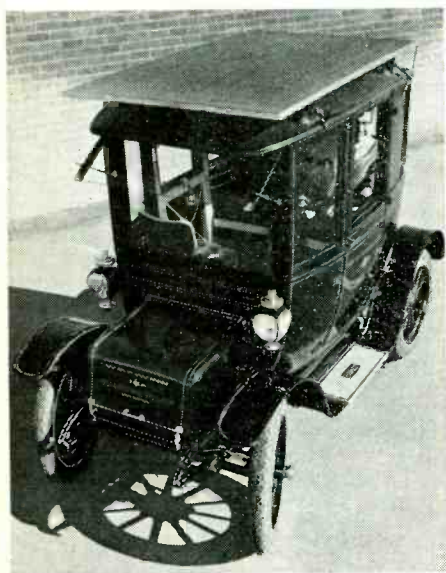

International Rectifier  
Sun-powered automobile—old, but life-size. 1912 Baker Electric is powered by 10,640 silicon solar cells, which charge its batteries.

Secondary batteries provide continuous service during darkness. Furthermore, they supply instant reserve power for short periods far beyond the capacity of the photovoltaic cells themselves.

For the longest service life, nickel-cadmium secondary batteries are preferred. Tests conducted by the Army Signal Engineering Laboratories have shown lives of 3,000 cycles or more for production-run nickel-cadmium cells.

It should be pointed out that, when solar cells are used to charge secondary batteries, a dark-current diode must be used in series (Fig. 2) to prevent the battery from discharging through the cells.

An article in the January 1965 issue of RADIO-ELECTRONICS gave a variety of simple experimental circuits powered by solar cells: oscillators, a receiver, relays and a complete light-beam communications system. END

## Change Plus-Ground to Minus-Ground

HAVE YOU BEEN UNABLE TO USE NEGATIVE-ground automobile accessories because of your positive-ground car? Many positive-ground foreign cars can be converted to negative-ground for American AM and FM radios, transistor ignition, electronic tachometers, etc.

All basic equipment such as lights, gages, starter motors and turn flashers will work equally well on either polarity. Polarity-sensitive equipment includes electronic tachs, transistor ignition, radios (most positive-ground accessory radios have a switch or shorting plug that converts them to negative-ground) and transistor voltage regulators.

To reverse polarity, disconnect the battery cables, turn the battery around and reconnect the cables. The cables or cable clamps may have to be exchanged since the battery terminals are different sizes.

Now briefly short the positive battery terminal to the field terminal (small wire, no capacitor) on the generator. This will reverse the magnetization of the field, converting the generator to positive ground.

The engine can now be started.

The ammeter should show a slight charge at idle and discharge at high rpm. Full charge means the generator polarity has not been reversed; try again. If this checks out okay, reverse the wires to the ammeter terminals (this isn't necessary if you're willing to read the ammeter backward). You're now driving a negative-ground car.

If after the conversion the ignition seems to misfire, it could be due to reversed high-voltage polarity to the spark plugs. This impairs ignition efficiency—electrons would rather jump from the hot inner conductor than from the relatively cold outer shell. The effect is small, and can be corrected by reversing the spark-coil primary leads.—Larry Baxter

[There are several types of fuel gages. Some are polarity-sensitive and may be damaged eventually or read incorrectly when polarity is reversed. Note the reading before and after the car's polarity has been reversed. If the reading is the same, the gage can be left as is. If the reading is off, then make a detailed circuit of the gage to determine if polarity reversal will damage it.—Editor] END





# 40 Watts in 40 Ounces!

## THE TWO-STATE AMPLIFIER

40 watts of audio power from the lighter socket in your car.

Highest-power "switching-mode" amplifier yet published.

By NORMAN CROWHURST

### COVER STORY

A PREVIOUS ARTICLE\* DESCRIBED THE steps that led to this new mode we have called Q-class, or two-state. Here we'll put the pieces together, solve one more problem that cropped up, and give you full construction details of an amplifier you can build for PA work.

When I put the drive and output stages together, a disappointing thing happened: the amplifier motorboated like crazy. I had a perfect drive waveform, according to my theory, and could modulate it beautifully, but when I connected the driver to the output, the whole thing motorboated. Why?

Some tests with the biggest capacitors I could lay hands on—thousands of microfarads—suggested that if I had a few farads (millions of microfarads) I might be in business. There had to be another way!

The cause of the instability, though it manifested itself as low-frequency motorboating, proved to be something happening within the ultrasonic periods. After each pulse is initiated by the multivibrator, the sawtooth discharge current does not change till the next pulse

\*July p. 54

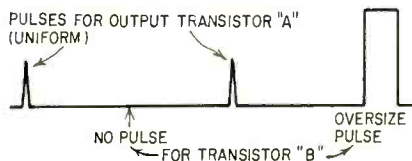

Fig. 1—One of the irregularities that occurred when the output stage was coupled to the drive stage.

recharges it. But the bias current is another matter.

The negative pulse feedback increased bias to terminate the pulse, but when the output stage was coupled to the same supply, the current it drew caused supply voltage to drop by more than the little n-p-n control transistor could compensate for. That is, without using more negative pulse feedback than could be allowed for its purpose of working *only* on minimum width pulses. So an increasingly high-intensity pulse loads down the supply voltage, until the bias change during a pulse period becomes insufficient to start a pulse. Then the supply charges up again until the voltages steady off enough for the sequence to start over.

Trying all kinds of values gave a critical combination or two that would stop the motorboating, but then a high-frequency effect occurred, at a period

that was a multiple of the ultrasonic period and thus audible as a whistle.

One form of this would let one output transistor take all the load, with big pulses, while the other would not "fire" because the circuit was still recovering from the big pulse. The other form would only fire every so many pulses: if it was one in four, then one output transistor would produce a big pulse every alternate ultrasonic period.

Sometimes one output transistor would produce regular pulses, but the other one would not, firing only on alternate pulses (Fig. 1). This led to the notion of applying an extra corrective signal derived from the output transistors, to "bias" the n-p-n transistor so

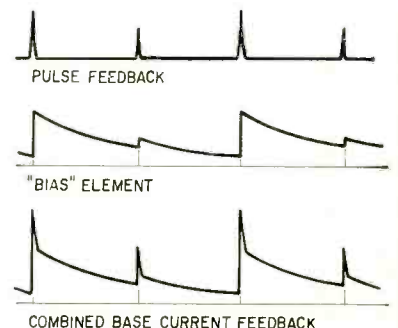

Fig. 2—Modification to the pulse negative-feedback stage to control irregularities.

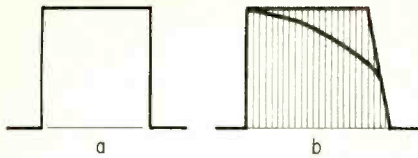

Fig. 3—Breakup of pulses that causes excessive dissipation: a—type of pulse desired; b—kind of breakup that occurred under circumstances described in text.

the negative pulse feedback would be just big enough to handle the situation at any time (Fig. 2).

This worked fine at quiescent, but

when I introduced modulation, instead of filling out with a variable width pulse, it multivibrated within the pulse, causing much increased dissipation in the transistors (Fig. 3). But I was getting there.

The final solution was to take all the pulse feedback from the same point—the output transistor collectors, via the diodes that enable a single pulse feedback to serve both “sides” (Fig. 4).

Fig. 4—Revised pulse negative-feedback circuit that eliminates irregularities of Figs. 1 and 3.

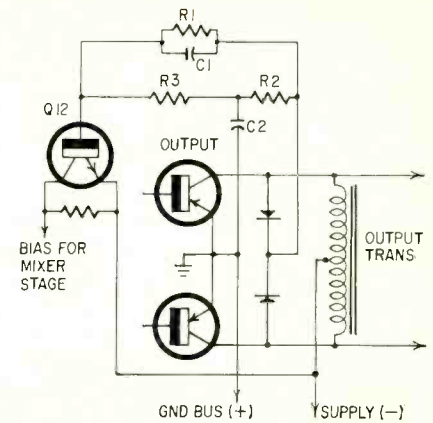
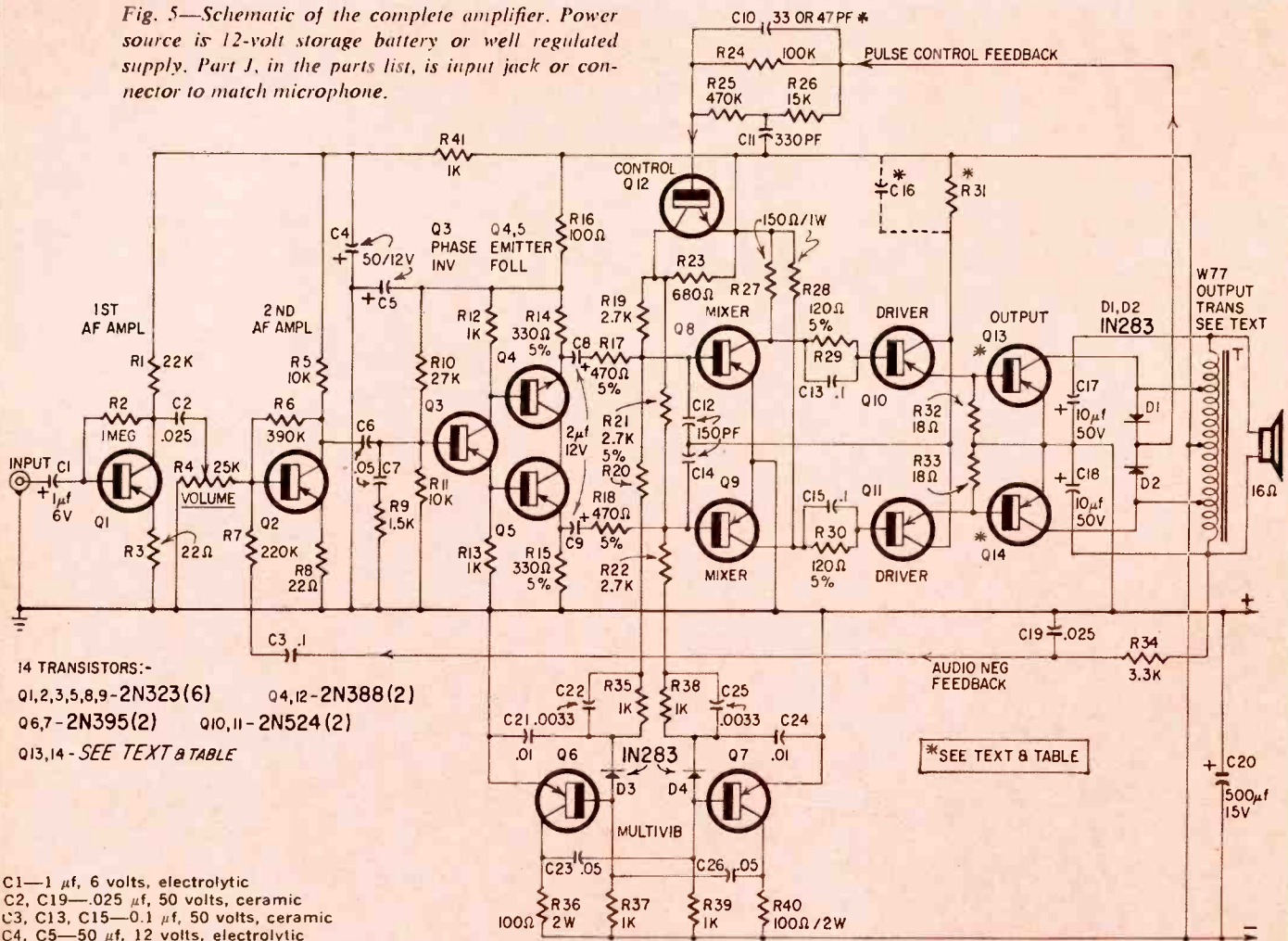

Fig. 5—Schematic of the complete amplifier. Power source is 12-volt storage battery or well regulated supply. Part J, in the parts list, is input jack or connector to match microphone.



- 14 TRANSISTORS:-  
 Q1,2,3,5,8,9-2N323 (6)    Q4,12-2N388 (2)  
 Q6,7-2N395 (2)    Q10,11-2N524 (2)  
 Q13,14-SEE TEXT & TABLE

- C1—1  $\mu$ f, 6 volts, electrolytic  
 C2, C19—.025  $\mu$ f, 50 volts, ceramic  
 C3, C13, C15—.01  $\mu$ f, 50 volts, ceramic  
 C4, C5—50  $\mu$ f, 12 volts, electrolytic  
 C6, C7, C23, C26—.05  $\mu$ f, 50 volts, ceramic  
 C8, C9—2  $\mu$ f, 12 volts, electrolytic  
 C10—see table  
 C11—330 pf, 1 kv ceramic  
 C12, C14—150 pf, 1 kv ceramic  
 C16—see table  
 C17, C18—10  $\mu$ f, 50 volts, electrolytic  
 C20—500  $\mu$ f, 15 volts, electrolytic  
 C21, C24—.01  $\mu$ f, 50 volts, ceramic  
 C22, C25—.0033  $\mu$ f, 50 volts, ceramic  
 D1, D2, D3, D4—1N283 (Sylvania)  
 J—2-conductor jack to fit microphone plug  
 Q1, Q2, Q3, Q5, Q8, Q9—2N323 (G-E)  
 Q4, Q12—2N388 (RCA)  
 Q6, Q7—2N395 (G-E, RCA)  
 Q10, Q11—2N524 (G-E)  
 Q13, Q14—2N1905 (RCA), 2N2832 (Motorola)  
 or 2N1046 (Texas Instruments) (See text  
 & table for choice)  
 R1—22,000 ohms  
 R2—1 megohm  
 R3, R8—22 ohms  
 R4—pot, 25,000 ohms, linear taper

- R5, R11—10,000 ohms  
 R6—390,000 ohms  
 R7—220,000 ohms  
 R9—1,500 ohms  
 R10—27,000 ohms  
 R12, R13, R35, R37, R38, R39, R41—1,000 ohms  
 R14, R15—330 ohms, 5%  
 R16—100 ohms  
 R17, R18—470 ohms, 5%  
 R19, R20, R21, R22—2,700 ohms, 5%  
 R23—680 ohms  
 R24—100,000 ohms  
 R25—470,000 ohms  
 R26—15,000 ohms  
 R27, R28—150 ohms, 1 watt  
 R29, R30—120 ohms, 5%  
 R31—see table  
 R32, R33—18 ohms  
 R34—3,300 ohms  
 R36, R40—100 ohms, 2 watts  
 All resistors 1/2 watt 10% except as noted

- T—Special output transformer, type W-77. Order stock No. 64 G 741, Allied Radio Corp., 100 No. Western Ave., Chicago, Ill. 60680. Price, \$4.07 plus postage  
 Chassis—two-piece aluminum box, 3 x 5 x 7 in. (Bud CU-3008A or equivalent)  
 Subchassis—open-end aluminum chassis, 4 x 4 1/2 x 1 in. (Bud CB-1618 or equivalent)  
 Cigarette lighter plug—(Schauer A-8412)  
 Transistor sockets (12)—mounting-ring type, with rings (Elco 05-3304 or equivalent)  
 Power-transistor sockets (2)—insulated type (Cinch-Jones 2-TS1 or equivalent)  
 Power-transistor mica insulating washers (2) for TO-3 (“diamond-shape”) transistors  
 Power cable—2-conductor heavy-duty rubber-covered cord; conductors not smaller than No. 16  
 Terminal strips, wire, miscellaneous hardware as specified in drawings



The parallel combination R1, C1 provides the basic negative feedback that controls amplitude of the pulse for low signal levels. Resistor R2, at the same time, charges C2 to a voltage depending on the magnitude and duration of the pulse. This capacitor then discharges through R3 at a rate that is long compared to pulse duration, but short compared to the highest audio frequency.

So current through R3 biases Q12 to vary the starting point at which the pulse through R1, C1 acts. If one transistor wants to give a bigger pulse than

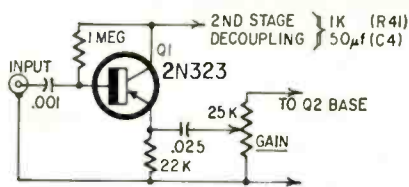

Fig. 6—High-impedance input stage, for use with ceramic microphone.

the other at the quiescent condition, the current through R3 tends to equalize them. When pulses get to the point where one side is width-modulated and the other side nonexistent, current through R3 permanently saturates Q12 until the audio waveform returns to a level where amplitude-modulated pulses are again needed.

Fig. 5 shows the complete circuit. What has not been shown before is Q1 and Q2, the audio stages at the front end; Q3, the phase inverter, followed by Q4 and Q5, back-to-back emitter followers (complementary) that feed audio to the mixer stage. Overall feedback is taken from the appropriate side of the output (the side that couples to Q14) back to the base of Q2. The values are chosen in just the same way as for overall feedback in any other type of audio amplifier circuit.

The input stage is designed to work with a microphone of 150 ohms impedance, or thereabouts, such as the Shure model 488B. If you want to use a ceramic type, the first stage can be made an emitter follower (Fig. 6)—a relatively simple change.

I made the circuit work with three types of output transistor, with slight changes. Least expensive was the RCA 2N1905. But this one has the least safety

margin against overvolting or overheating, because it switches more slowly than the other two types. To compensate for this, it needs a larger drive current and a slightly stronger negative feedback pulse.

As of this writing, the other two types are close in price. The Motorola 2N2832 has a maximum current rating of 20 amps, which means it could be driven harder, to get perhaps twice the power, with different load matching, but it needs more driving, because it has lower current gain.

The Texas Instruments 2N1046 has the highest current gain and the fastest switching time, which means it has the highest efficiency of the three and runs the coolest. Relative switching times are difficult to compare from the published data, because no data sheets give information in the same form.

The table shows what part values to use for each transistor type.

The skilled constructor and experimenter will have no difficulty, we hope, in making up a model from the information, schematics and parts list in this article. But for the person who wishes to be sure his model is as much like the prototype as possible, detailed wiring instructions will appear next month, with photos, layout drawings, and, finally, complete instructions for checking out

The Two-State Amplifier was tested by *Radio-Electronics* and found to work every bit as well as the author claims. Frequency response is deliberately restricted to the voice range—approximately 200 to 3,000 cycles. (The upper limit is determined by the switching frequency, 18 kc in this case, and, while there is no theoretical need for a 200-cycle low-frequency rolloff, that figure was chosen for best overall sound balance.) Distortion is not easily measured, because of the comparatively high 18-kc switching-signal component at the output. (Ordinary PA speakers will not reproduce 18 kc, nor is the level high enough for them to be damaged by it.) Listening tests indicated that the sound was crisp and clearly articulated.

The amplifier is somewhat sensitive to overvoltage under load and with signal. It should be operated from an automotive battery electrical system or other 12-volt source whose voltage does not rise suddenly when the load is removed.

The output transistors become only moderately warm at full power.

#### Changes For Different Output Transistors

If Q13 & Q14 are	R31 should be	C10 should be	C16 should be
2N1905	40 ohms	47 pf	omitted
2N2832	50 ohms	33 pf	omitted
2N1046	75 ohms	33 pf	.01 µf

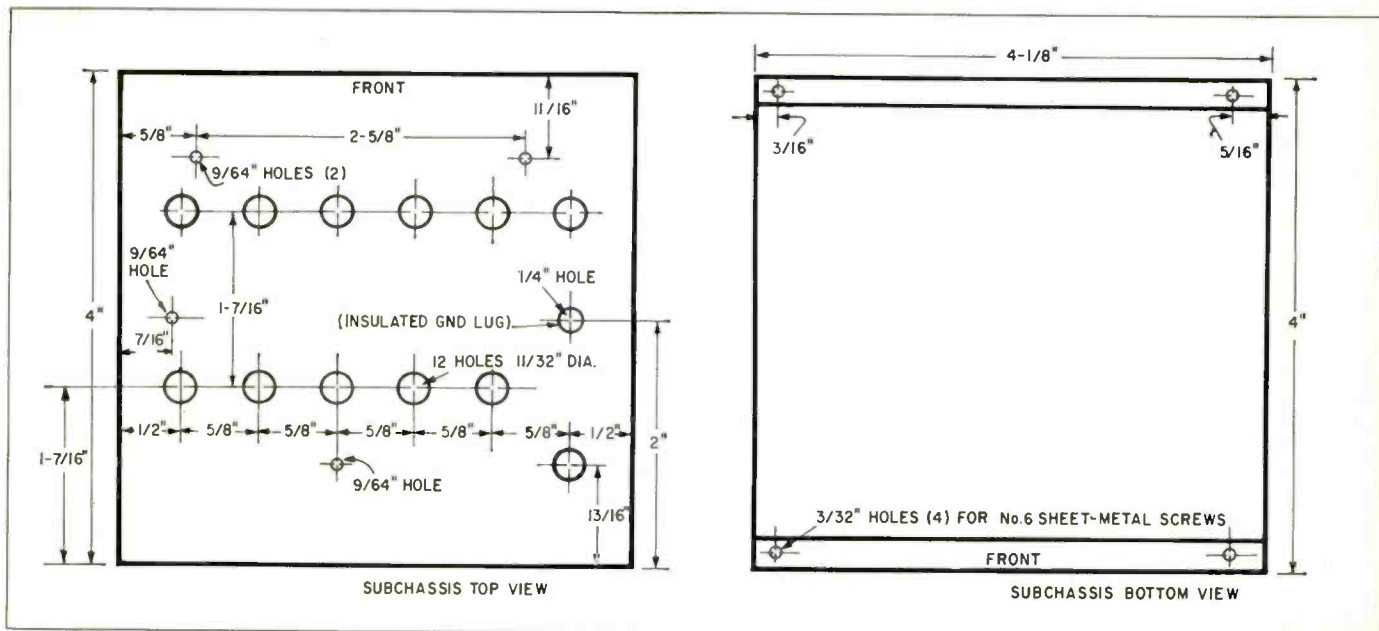

Fig. 7—Drilling guide for subchassis.

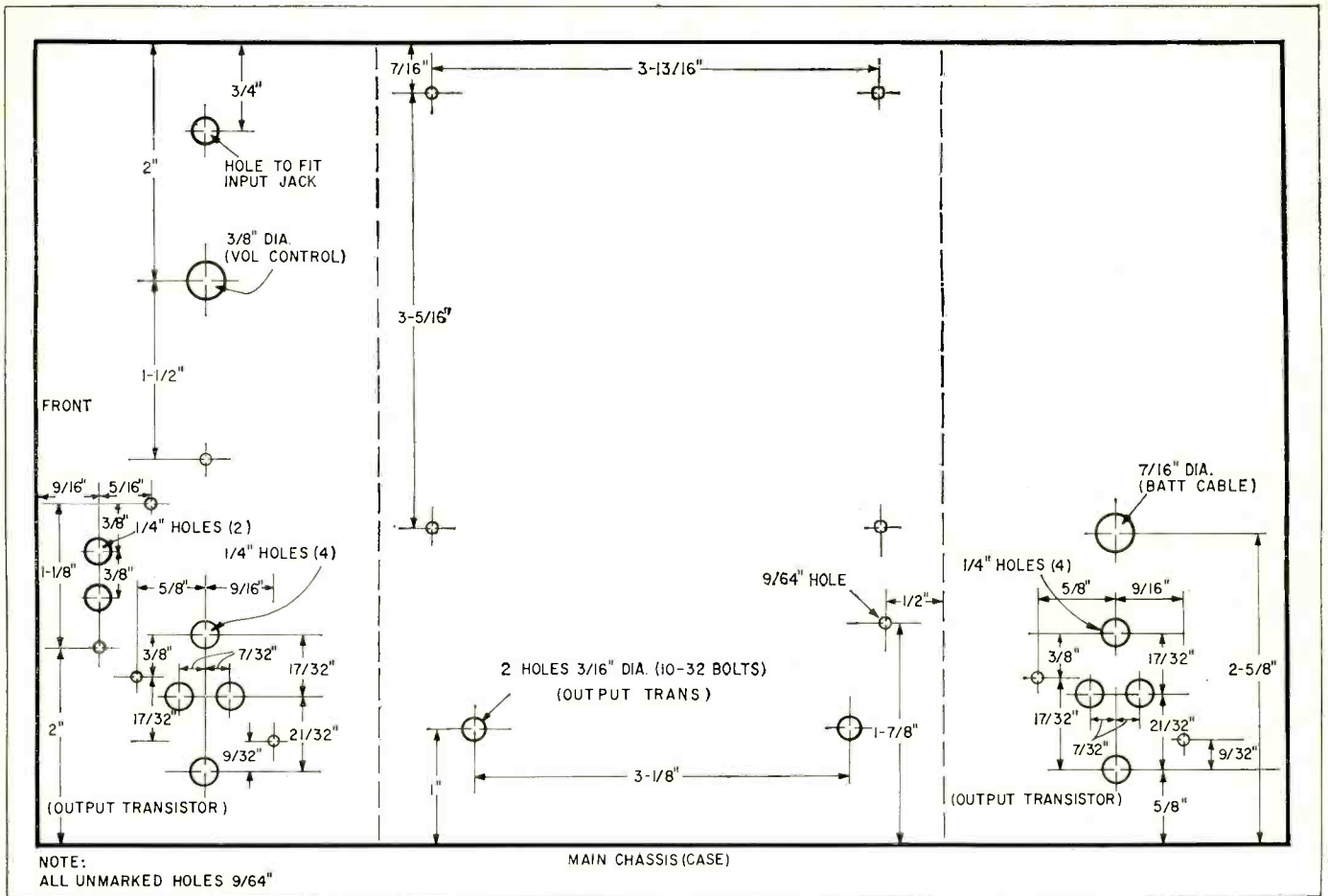

Fig. 8—Drilling guide for main chassis (case).

the amplifier.

If you order your parts when you've read this, they should arrive a little before the next issue of this magazine. You can then proceed to get the chassis ready and mount up the parts. The twelve  $1\frac{1}{32}$ -inch diameter holes in the subchassis (Fig. 7) take the transistor sockets. Arrange them with the emitter pins inward and collector pins

outward (toward the chassis sides).

On the main chassis (Fig. 8), the  $3/8$ -inch diameter hole near the input jack mounting hole (which is drilled to suit the type of jack chosen) is for the volume control.

Drill the output-transistor mounting holes very carefully according to dimensions shown (Fig. 8) and make sure that, when the sockets are mounted,

the transistor mounting screws and base and emitter pins cannot short to chassis.

In drilling the  $9/64$ -inch holes in the case to mount the subchassis, make sure they will align with the  $3/32$ -inch holes drilled in the flanges of the subchassis. But you will not need to mount the subchassis until you get the amplifier wired and tested. Wiring and testing details next month. **END**

## Magneto-resistive Microphones

MANY OF YOU HAVE PROBABLY HEARD about *magneto-resistance*, the property of a material whose resistance changes with the strength of an external magnetic field. That bismuth has a weak magneto-resistive response has been known for years. But recent discoveries show that certain semiconductors, such as indium antimonide doped with N-type impurity, are far more sensitive. Many new practical applications are now possible. Patent No. 3,109,985, issued to Heinz E. Kallmann of New York, N.Y., discloses a magneto-resistive microphone.

The magneto-resistive semiconductor is in the shape of a thin-walled cylinder (Fig. 1). Its outer diameter may

be  $1/4$  inch, length  $1/4$  inch and thickness .02 inch. Leads are attached to its ends. If an emf is applied, electrons tend to flow in straight lines from one end to the other. When a radial magnetic field is added (for example, directed toward the axis), the electrons move at right angles both to the emf and the field. Thus, they move in spirals around the cylinder. This increases the path length and hence also the resistance.

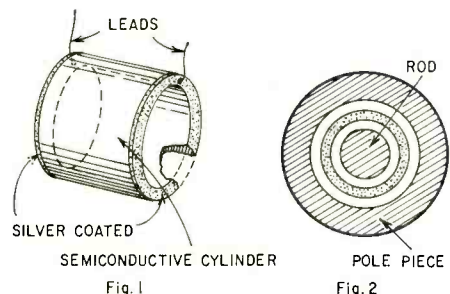

The cylinder is placed in an intense magnetic field. Fig. 2 shows it (shaded) between a surrounding pole piece and a magnetic rod (like a speaker voice coil). The flux density in this gap may be about 5,000 gauss. A diaphragm (not shown) is attached to the cylinder, to make it vibrate with sound waves. The slightest displacement of the cylinder changes the field strength affecting it, and this varies the resistance.

In one possible application, the leads from the cylinder terminate as a one-turn coil of a transformer primary. The secondary consists of many turns. The core (not shown) may be of permalloy. As the diaphragm vibrates, the dc through the primary is modulated, much as in a carbon mike and transformer circuit. Voltage is stepped up and the output can be amplified further. **END**



# CONVERGENCE BY THE ABC'S

Save time, temper and money by following these concise steps to perfect color-set convergence.

By ROBERT G. MIDDLETON

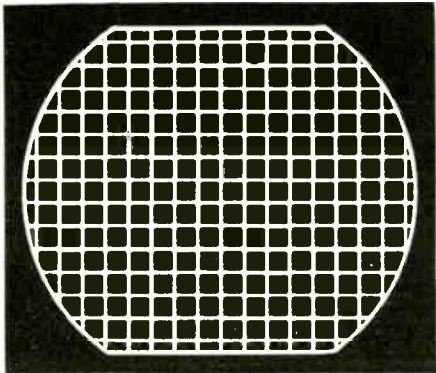
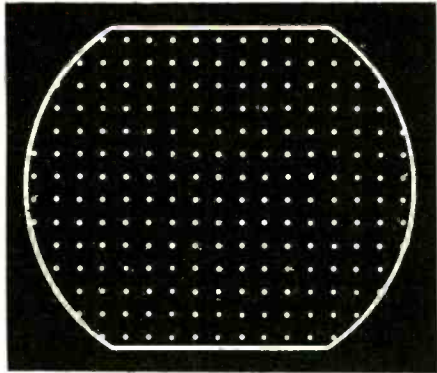
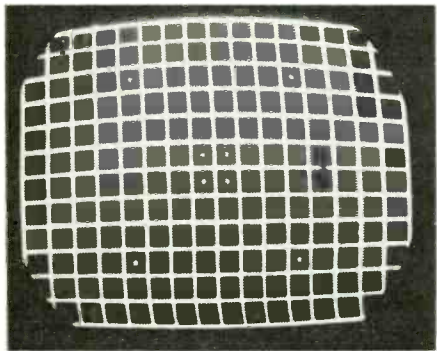

Fig. 1-a—Ideal crosshatch and dot patterns.



b—Practical patterns.

CONVERGING A COLOR PICTURE TUBE IS not easy, and probably never will be. Nevertheless, you can avoid wasting time if you have practical rules of thumb to follow. First of all, note the difference between ideal and practical convergence patterns. Fig. 1 shows that theory and practice do not quite agree. Lines and dots do not appear in straight rows because the picture-tube screen is curved. A crosshatch pattern in particular *might* be about as straight as a dog's hind leg at the top. This is because pattern generators do not have standard sync, and the horizontal oscillator is disturbed during passage of the vertical sync pulse. Sometimes you can adjust

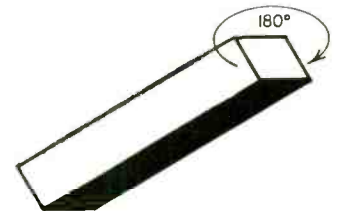

Fig. 3—Rotate magnet 180° to extend inadequate adjustment range.

the horizontal hold control critically to straighten out the dog leg; in any case, don't worry about it.

## Static-convergence-magnet action

The four static convergence magnets are shown in Fig. 2-a. The red, green and blue convergence magnets slide in holders; the blue lateral corrector magnet rotates. Color-dot motions and the magnet adjustments that cause them are depicted in Fig. 2-b. Remember two basic principles:

1. All color dots on the screen are moved the same amount by the static magnets.
2. Static convergence is *always* made *only* with reference to center screen.

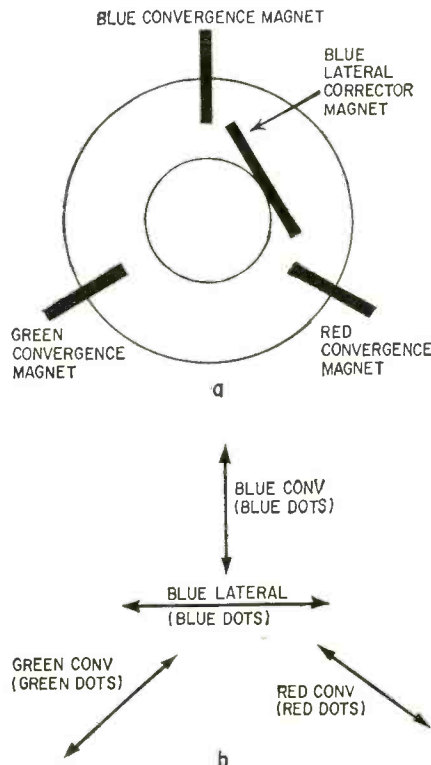

Fig. 2a—The four static convergence magnets. b—Color dot motions that result from adjusting the magnets.

Sometimes the color dots cannot be converged at center screen. Then observe which dot cannot be brought into position. If it is the green dot, say, take the green convergence magnet out of its holder, turn it 180° and put it back in the holder. Then you will have the adjustment range you need, unless the magnet is too weak (Fig. 3). Weak magnets must be replaced. Magnets weaken with age, from being dropped on a hard floor or being accidentally placed in a strong ac field. Remember that 180° rotation is required—if you make a mistake and rotate the magnet 90°, you will worsen the difficulty.

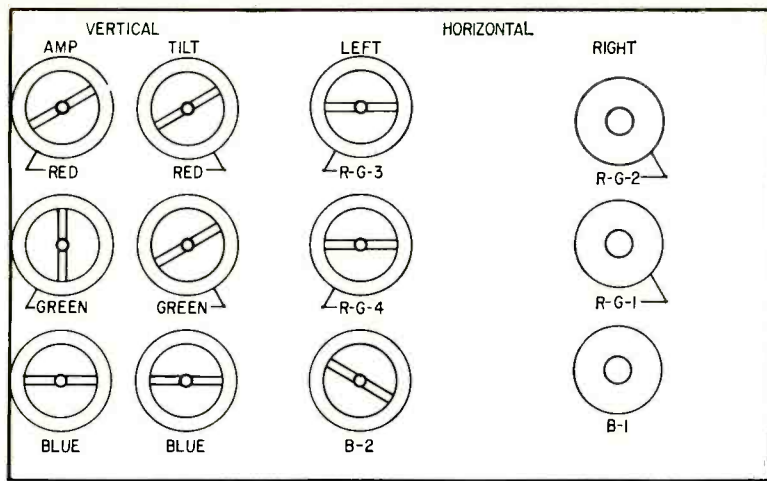

Fig. 4—Dynamic convergence controls.

Throughout the convergence procedure, you must return from time to time to the static magnets, and keep the dots at center screen converged. This is very easy. The difficult part comes next.

**Dynamic convergence adjustments**

In this article, we cannot cover all the many layouts of dynamic-convergence controls which have appeared in the past. Accordingly, one popular system, Fig. 4, will be discussed in detail. We selected the RCA CTC9. Its convergence controls and panel layout are duplicated in several RCA and RCA-designed chassis. Many earlier sets have the same controls in a different panel layout. There are 12 dynamic controls.

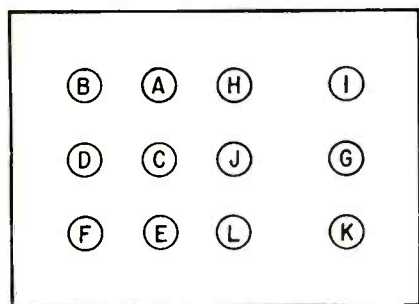

Fig. 5—Fig. 4 controls identified for ABC step-by-step convergence.

The terminology is rather technical, so forget it. Instead, dynamic adjustments will be explained by referring to Fig. 5, with a step-by-step identification. Thus you can follow an ABC procedure for minimum confusion. It also helps to work with two colors at a time, instead of three, whenever you can. Start like this:

1. Apply a dot pattern and adjust the static magnets for good convergence at center screen.

2. Kill the green gun. This can be done by connecting a 100,000-ohm resistor from the grid of the green gun to chassis ground.
3. Apply a crosshatch pattern, and adjust control A (Fig. 5) to con-

**Don't be alarmed—yet**

It is quite possible that you will have to turn control A to the extreme end of its range to get the correct pattern of Fig. 6—or it might happen that you can't quite make it. But don't be alarmed—yet. There is so much interaction among the controls that when some of the other controls are adjusted as required, A will probably have a normal range. So for the time being, merely bring the red and blue lines together as closely as possible, and proceed to the next step.

4. Adjust control B (Fig. 5) to improve the layover of the blue and red lines up and down center screen, as in Fig. 7. Touch up the blue lateral corrector, if necessary. You may need to touch up control A slightly, also.

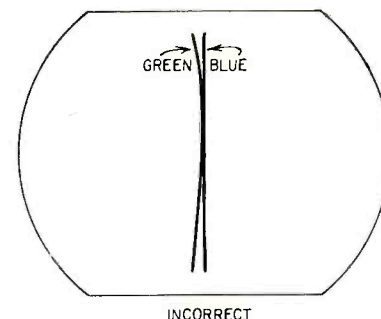
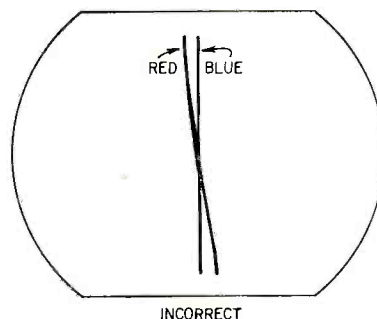
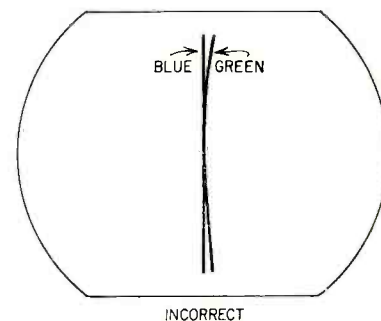
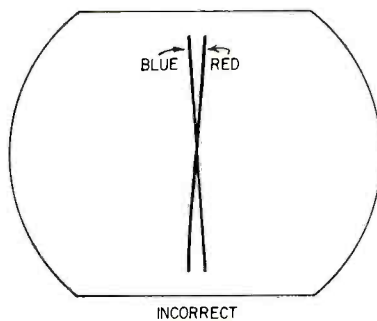
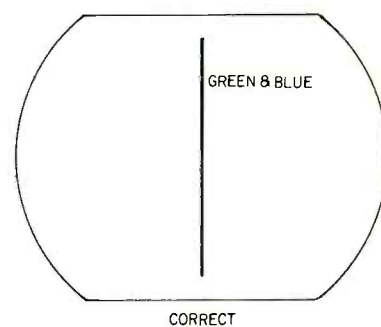
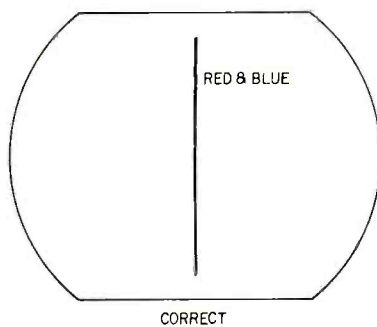
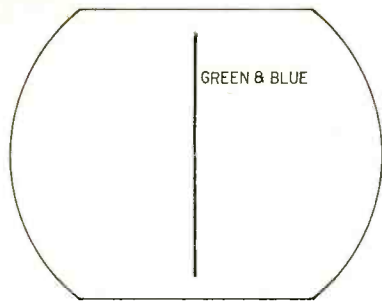

Fig. 6—First dynamic convergence adjustment.

Fig. 7—Second dynamic convergence adjustment.





CORRECT

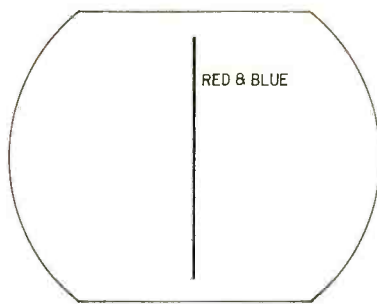

CORRECT

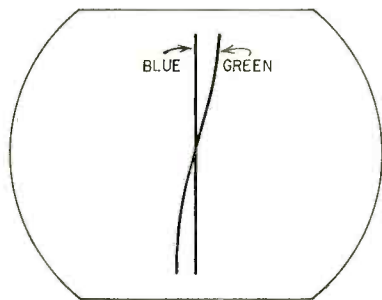

INCORRECT

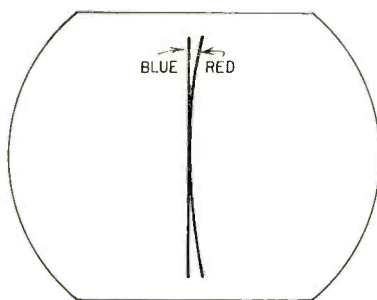

INCORRECT

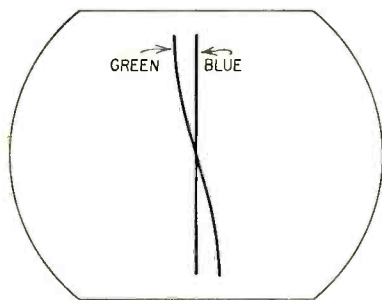

INCORRECT

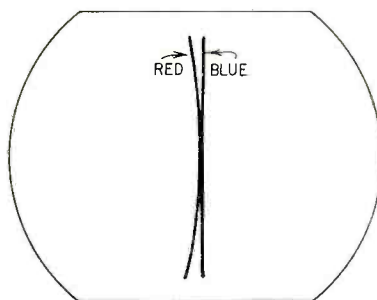

INCORRECT

Fig. 8—Third dynamic convergence adjustment.

Fig. 9—Fourth dynamic convergence adjustment.

### Now the green

No more adjustment of the red controls now. Instead, turn the green gun on and kill the red gun. Proceed:

5. Adjust control C (Fig. 5) to converge the green and blue lines up and down center screen (Fig. 8). As before, the blue line is our reference because its tilt is always the same. And don't worry—now—if you can't quite make it—just bring the green in as close as possible.
6. Next, adjust control D (Fig. 5) to improve the layover of the blue and green lines up and down center screen (Fig. 9). You might need to touch up the blue lateral corrector and control C slightly, for best layover.

### Look at all three

Now, turn on the red gun and look at all three colored lines down center screen. Most likely, the red line will not quite merge with the cyan (blue-and-

green) line, and you will need to touch up the red static magnet (and possibly the green static magnet also) to obtain a white line up and down center screen as in Fig. 10. Don't worry about the rest of the crosshatch pattern—we must disregard all portions of the pattern with which we are not concerned at the time. For a final check here, apply a dot pattern, to get a close look at static adjustments. Touch up the blue beam magnet and blue lateral corrector, if required, to get a nice white dot right in the center of the screen.

### Crossovers next

We are ready to tackle the crossovers at top and bottom of the screen. Apply a crosshatch pattern. Kill the blue gun and proceed to:

7. Observe whether the crossovers indicated in Fig. 11 are converged. If you are lucky, red and green crossovers will be converged at top and bottom. Chances are your luck has slipped a trifle, and controls A

and C (Fig. 5) must be re-adjusted slightly to get satisfactory crossovers. The rule is to make the crossovers correct with *both* controls A and C, not changing either control any more than you have to.

### Back to blue

You are done with green for the time being. Kill the green gun and turn the blue gun on. Look at the red and blue crossovers. If the crossovers are unsatisfactory (Fig. 12):

8. Adjust control E (Fig. 5) to make the crossovers at top and bottom as accurate as possible. Then, adjust control F. (Fig. 5) to improve the crossovers. Work back and forth between E and F for best convergence of red and blue.
9. Touch up the blue convergence magnet and the blue lateral cor-

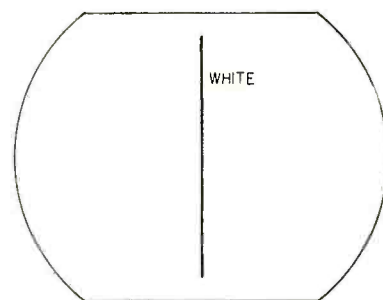

CORRECT

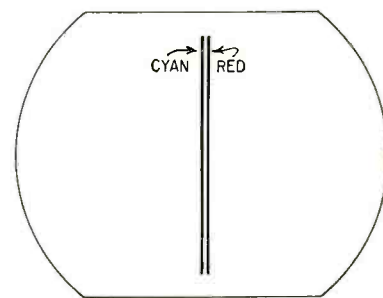

INCORRECT

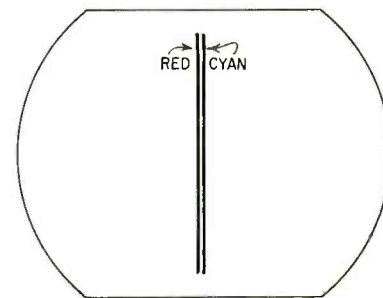

INCORRECT

Fig. 10—Static red magnet is adjusted to merge red and cyan lines.

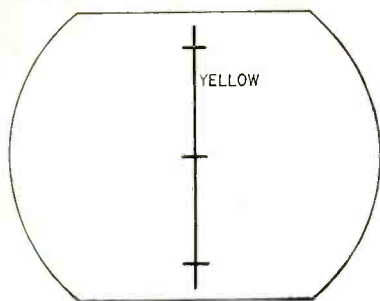

CORRECT

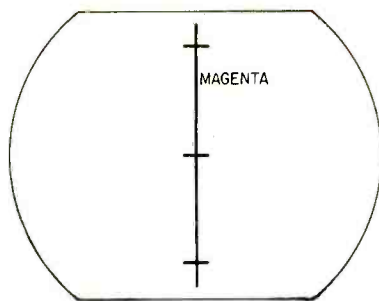

CORRECT

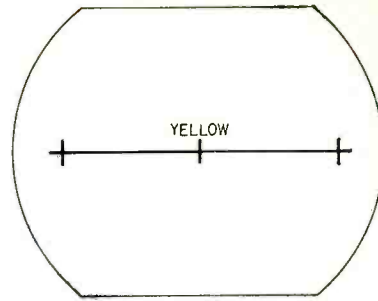

CORRECT

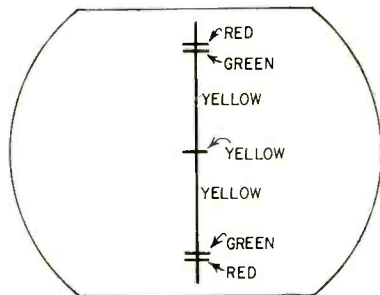

INCORRECT

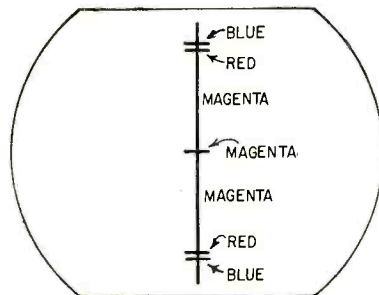

INCORRECT

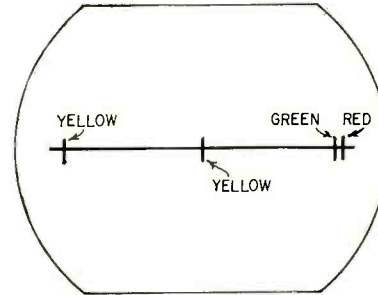

INCORRECT

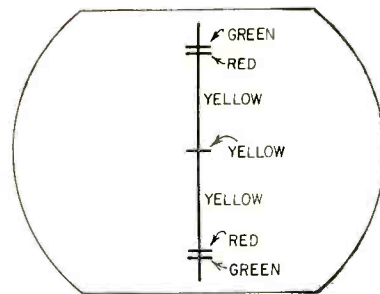

INCORRECT

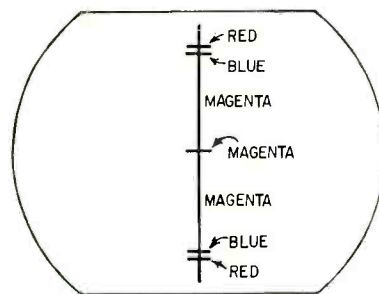

INCORRECT

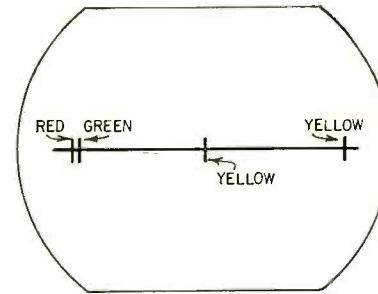

INCORRECT

Fig. 11—Crossovers, converged and mis-converged.

Fig. 12—Red and blue crossovers.

Fig. 13—Horizontal red and green crossovers.

rector as required to merge the three crossovers accurately. Turn the green gun on. Touch up the green convergence magnet, if necessary, to get white crossovers along the line up and down the screen. You may prefer to switch to a dot pattern for this.

### Whew! Now the horizontal line

Leave the vertical dynamic controls at this point, and check the horizontal dynamic controls. Kill the blue gun. Apply a crosshatch pattern. If the horizontal red and green crossovers are not correct (Fig. 13):

10. Adjust control G (Fig. 5) to converge the red and green crossover at the *right* side of the screen.
11. Adjust control H (Fig. 5) to converge the red and green crossover at the *left* side of the screen.

These two adjustments are easy as rolling off a log, compared with the

compromise adjustments before. But they may be insufficient to get complete crossover convergence. If so,

12. Adjust control I (Fig. 5) for crossover convergence at right screen.
13. Adjust control J (Fig. 5) for crossover adjustment at left screen. The horizontal crossovers should now be as accurate as you could want.

### Back to blue again

Now, turn the blue gun back on, and kill the green gun. Then,

14. Adjust control K (Fig. 5) to converge the red and blue crossovers at right screen.
15. Adjust control L (Fig. 5) to converge the red and blue crossovers at left screen

### Final checkout

Comes the moment of truth. Turn

the green gun back on, and switch to a dot pattern. Touch up the static convergence magnets, if necessary. You should see fairly good white dots over the screen area (except possibly at the extreme edges). Inasmuch as most technicians do not consider "fairly good" white dots really acceptable, portions of the procedure are repeated to improve overall convergence. If you are the fussy sort, you might want to repeat a smaller number of selected portions in the procedure a *second* time.

After you get the hang of it, you can size up a crosshatch pattern which is nearly in convergence and decide immediately whether the vertical or horizontal dynamic controls need attention, and which controls are farthest out of adjustment. This ability is the key to saving time, and making convergence jobs profitable. Experience proves that the main pitfall is failing to recognize clearly what each convergence control does, and then to concentrate on the pattern details that indicate whether the adjustment is correct. These ABC's should help you. END



By R. E. BAIRD

THE SLOW-MOTION FILM HAS LONG been an excellent technique for watching and teaching high-speed events. It would be nice if we could observe a tube or transistor amplifier in slow motion. Fig. 1 shows a demonstration setup for doing just that.

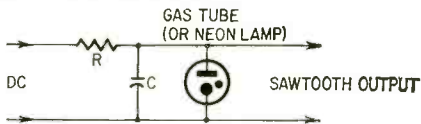

Fig. 2—Basic gas-tube relaxation oscillator runs free at frequency more or less proportional to  $RC$  ( $R$  in megohms times  $C$  in  $\mu f$  gives time constant in seconds). Supply voltage also affects frequency.

Everything centers on a Hewlett-Packard function generator which makes periodic waves down to a fraction of a cycle per second. With it, voltages and currents in a circuit can be observed as they change. In the photo, assume that grid voltage is increasing in the positive direction. We see plate current climbing also, plate voltage decreasing with respect to a dc zero, output voltage decreasing from an ac zero axis. This all happens at a rate the meters can follow exactly, and thus shows the phase characteristics of the different parts of the circuit. You can make a similar setup for a transistor amplifier. To someone just learning, this is a very effective and convincing demonstration.

Only a few specially equipped electronic training schools can afford a good function generator, though there are many reasons why a school ought to have one. Unfortunately, the price is too high for a high-school electronics or physics class. Actually all we need is some kind of ultra-low-frequency oscillator. It would be nice to have sine-wave, square-wave and triangular-wave output, as does the function generator, but at low frequencies the amplifier works the same regardless of the input wave shape. If you have a scope to hook to the input (or output), you can observe that the meters are following what is indicated on the scope.

Fig. 2 is the well known gas-tube relaxation oscillator, probably the simplest of all oscillators to explain. Its fre-

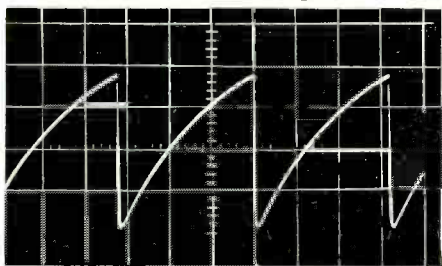

Fig. 3—Waveform from circuit of Fig. 2. Voltage rises in smooth curve to gas breakdown voltage, then falls almost instantly to de-ionization voltage level and begins rising again.

# Look Inside an Amplifier

Meters and a simple sawtooth-maker show students what really happens in an amplifier

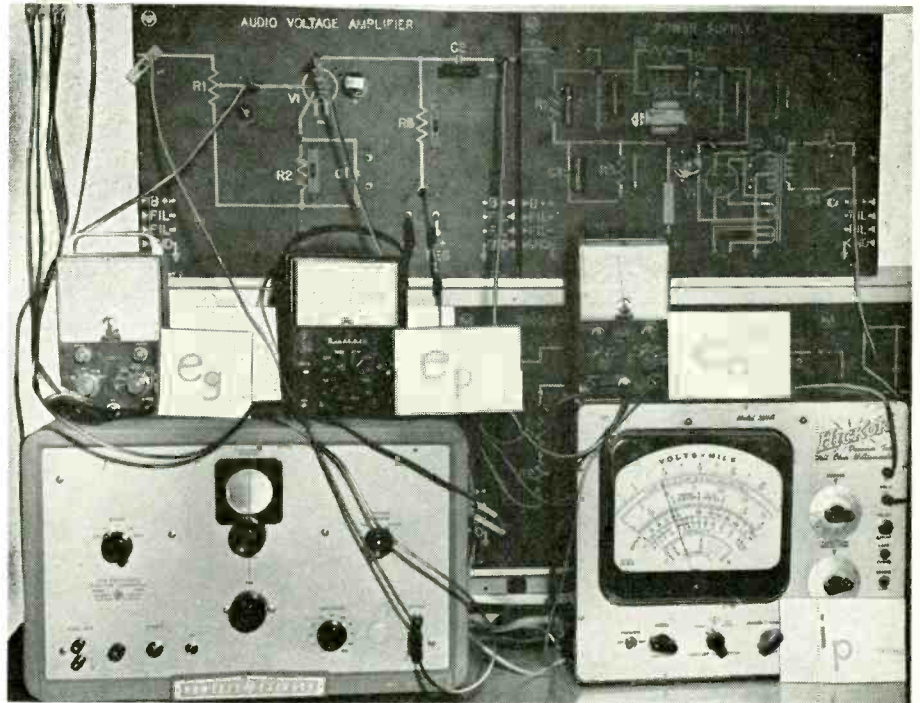

Fig. 1—Demonstration setup at author's Oregon Technical Institute. Function generator is versatile instrument, but not strictly necessary for these demonstrations.

quency of oscillation is based on  $RC = t$  (time constant), the time to charge a capacitor in series with a resistor to 63.2% of full charge.

With dc applied, the capacitor charges up to the breakdown voltage of the gas tube. At that instant the tube ionizes and becomes a very low resistance across the capacitor, which discharges rapidly to the point where the voltage across it is too low to keep the gas ionized, and the cycle starts over again. The waveshape is a modified sawtooth (Fig. 3). Fig. 4-a is a schematic of a complete demonstration setup for a vacuum tube and Fig. 4-b is for a transistor.

All voltmeters must be either

vtvm's or high-resistance multimeters. (Clubs can canvass members for vtvm's and other meters.) The oscilloscope can be added on the end. Observing the meters alone is enough to be educational! The relaxation oscillator has been rearranged in Fig. 4 so that it is possible to direct-couple to the grid or base. The wave shape is still the same and the voltage divider shown of 470,000 and 47,000 ohms gives about 1.5 volts peak to peak as input signal. The divider could be repropotioned for other values of signal voltage. The values of  $1 \mu f$  and  $1/2$  megohm with a NE-51 neon bulb give a frequency of about 1 cycle per second. END

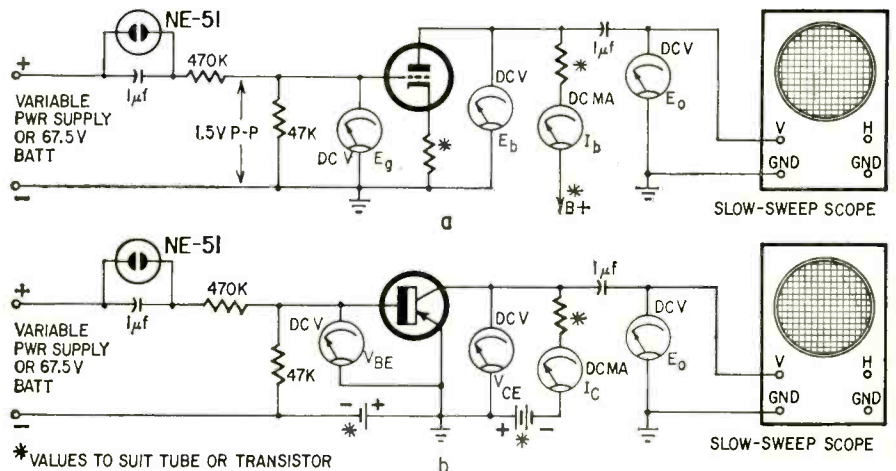

Fig. 4-a—Demo circuit for triode tube. (Values can be picked from RCA Receiving Tube Manual's Resistance-Coupled Amplifier Charts.) 4-b—transistor version.



# A CONCERT HALL GETS A NEW "SOUND"

How electronic "assisted resonance" improved a London concert hall's acoustics to bring raves from critics, musicians and acoustical experts

By JAMES MOIR\*

"GOOD ACOUSTICS" IS THE TARGET OF all architects lucky (or unlucky) enough to be commissioned to design a new concert hall. And one desirable attribute of a good concert hall is the "roundness", "fullness", "warmth" or "resonance" it gives to the music. All these words are used interchangeably to describe what an acoustician believes to be the result of having a reverberation time that is lower at middle and high frequencies than it is at low frequencies, but with absolute values appropriate to the size of the hall. Let's examine this more closely.

\*Acoustical consultant, Chipperfield, Herts., England

Acousticians indicate the extent to which the room adds reflection in terms of the room's *reverberation time*. This is a measure of the time taken for the intensity of a given sound to decay by 60 db. It is also roughly the time taken by a loud final orchestral chord to fall below the background noise in the hall. (For most of the music, only the first 10 to 20 db of the reflected sound will be heard above the sounds that follow directly from the orchestra. Nevertheless, the feeling of roundness and fullness is clearly present during the whole time.)

Experience suggests that there is an optimum reverberation time for any

hall. This depends on the volume of the hall, larger halls requiring a longer reverberation time. The optimum reverberation time also depends on the type of music being played.

It is believed that "roundness", "fullness" or "warmth" is dependent upon achieving the optimum time for the size of hall. But perhaps more important is achieving the correct reverberation time vs frequency. Halls have a "dry clinical tone" when the reverberation time in the band of perhaps 70-300 cycles is shorter than or equal to the reverberation time at and above 500 cycles.

Where the reverberation time proves to be longer than predicted ("live", "bright" or "reverberant" sound), there is a relatively simple solution: adding sound-absorbing material. The real difficulty arises when the reverberation time proves to be *shorter* than predicted ("dry" sound) because the ceiling, walls, floor or seats absorb more sound than was calculated.

It is not sufficient to install microphones and speakers in the hall to increase the loudness of the sound. *It is the absence of reflections that return to the listener some time after the direct sound from the orchestra that matters.* Thus, to achieve anything of value, it is necessary to control the time pattern of the returned sound. Many ways of doing this have been suggested, and some have been used to "improve" the reproduction from radio or to add "liveness" to TV studios necessarily deadened to allow good speech pickup. All common reverberation-altering techniques, like coiled-spring units or tape delays, provide a relatively *simple* pattern of artificial reflections, whereas the actual spatial and time pattern in a real concert hall is one of immense complexity.

A new method proposed by Mr. P. H. Parkin of the Building Research Station, London, uses the hall itself to provide the time delays and uses more than 100 simple channels to insure a complex reflection pattern.

## How it works

Each channel consists essentially of a microphone, amplifier and speaker, the microphone being inserted in a Helmholtz resonator tuned to pass only a narrow band of frequencies. Microphones and speakers are mounted in holes in the ceiling, the mike and speaker for any one channel being roughly 50 feet apart. If the amplifier gain is great enough, such a system will burst into oscillation at its tuned frequency. Below the point of oscillation, any impinging signal will build up in the channel as a result of acoustic feedback between the speaker and its associated microphone. When the impinging sig-

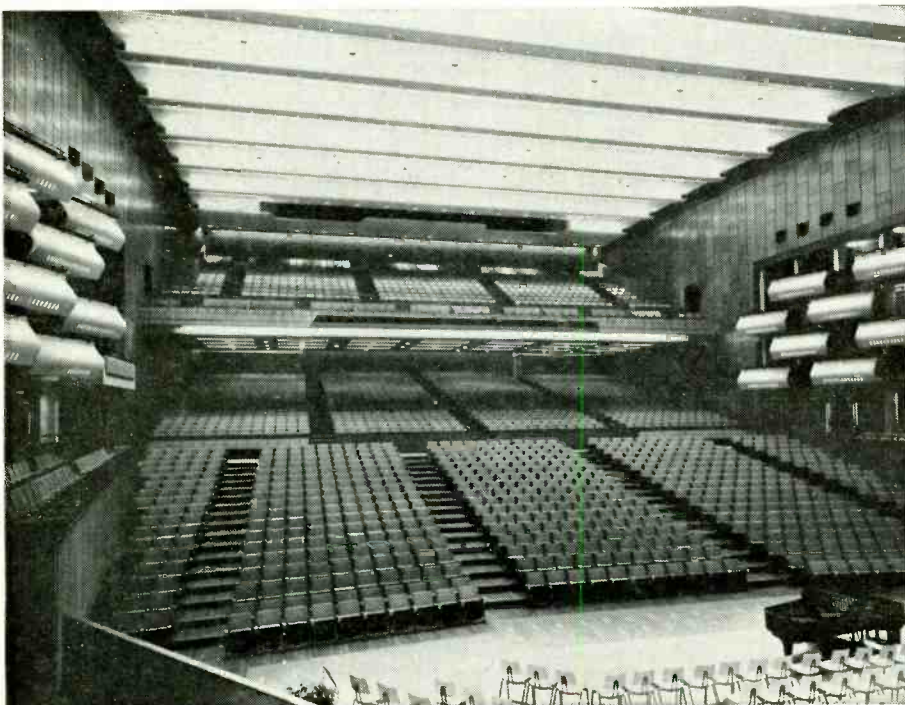

Royal Festival Hall, London, where electronic-acoustic experiments were carried out. The hall was designed in 1948.



nal ceases, the signal in the channel dies away exponentially to zero. The air in the hall between loudspeaker and microphone is part of the loop; thus the decaying acoustic signal is heard in the hall.

The efficiency of the coupling between any pair of units depends on where they are placed in the standing-wave system that has a frequency nearest to the tuned frequency of the channel.

This point needs some further explanation. Any enclosed space has a large number of acoustic resonances. In a room (three dimensions), there are three series of resonances, the lowest frequency in each series being the one for which the room length, width or height is one-half wavelength.

In addition to these first-order modes of resonance, any three-dimensional enclosed region has other series of resonances, the basic frequency in each series being determined by the combination of the width, height and length in pairs and in triplets!

For a typical hall there is an infinite number of resonant frequencies extremely close together even at frequencies as low as 50 cycles. Each mode of resonance has its own characteristic distribution of sound pressure over the enclosed space, although this is simple only at the basic frequency and its first few harmonics.

### Installing the units

So that any microphone-speaker pair will be as tightly coupled acoustically as possible, to prevent variations in overall gain that might cause oscillation, the microphone and speaker of each pair should be placed at points where sound pressure is highest for the design frequency of that channel.

Each channel must be operated just a few db below oscillation. Because each handles only a narrow band of frequencies, many are generally required. The total number depends on the width of the frequency band over which an increase in reverberation time is required. For the experimental installation in the Royal Festival Hall, London, it was decided to increase reverb time between 70 and 300 cycles. One hundred channels were installed, spaced roughly 3 cycles per second apart.

The microphones were tuned by mounting them in Helmholtz resonators consisting of a cylinder fitted with a sliding piston. These were constructed from Bakelized paper sheet and tube and gave a gain of 30-40 db. This is extremely important both in reducing the required amplifier gain and also in minimizing hum and noise picked up in the long microphone cables running back

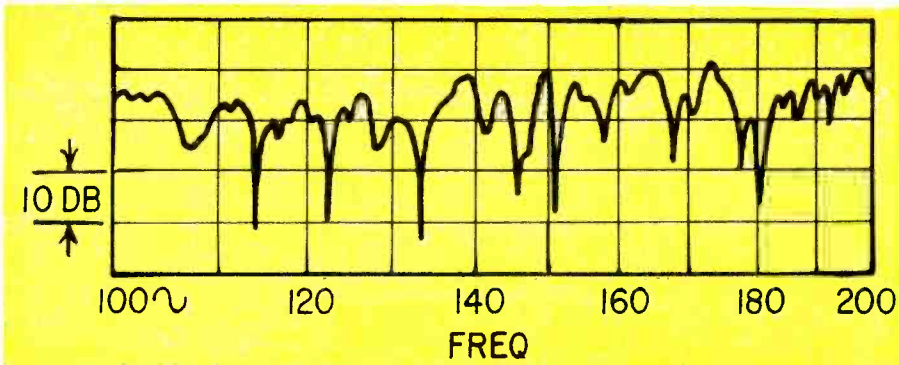

Fig. 1—Portion of a typical "transmission irregularity" curve between 100 and 200 cycles. The text explains its function.

to the central amplifier installation.

A narrow channel bandwidth allows the speaker system also to be tuned, and effective efficiencies around 80% were obtained from standard units. Speakers were tuned by adding a simple Helmholtz acoustic resonator to each. Except for the lowest ten channels, these were simple resonant boxes tuned by adjusting a slide over the port. For installation convenience, the low-frequency channels used pipe resonators, the frequency being adjusted by altering the length of the pipe.

Apart from the increase in efficiency, there are other advantages in tuning. The required amplifier power is reduced to about one-tenth, while distortion due to the speaker and amplifiers is virtually eliminated.

All the speakers and microphones were mounted over holes already existing in the plaster ceiling or in the sides of the long lighting trough running across the ceiling. (It was fortunate that a large number of openings had been left in the main ceiling to accommodate resonators to reduce the reverberation time! As it turned out, installing the main ceiling increased the total absorption at low frequencies by such an unexpectedly large amount that the absorbing resonators were never installed.)

Putting the system into operation proved a somewhat tedious process. The presence of steelwork, ducts and

conduits limited the positions in which speakers could be installed. In consequence, all the speakers were installed in accessible positions without respect to their position in the standing-wave system. A standard amount of audio power was then fed to the loudspeaker and a *transmission irregularity curve* (T.I.) taken between one speaker and four possible microphone positions. This curve is a plot showing the relation between sound pressure and frequency for constant electrical power into the speaker. It is the frequency response of the transmission path between speaker and microphone. Normally this is an extremely ragged curve with peaks that may be 20-30 db higher than an adjacent trough. A typical example is given in Fig. 1.

For channel stability, it is necessary to select a microphone position with a peak at the frequency to which the channel will be tuned. After some experience, it proved possible to find a suitable position for each microphone by merely exploring the possible positions with a sound-level meter. The microphone and speakers were then installed and tuned and a final curve taken to confirm that the T.I. curve was adequately peaked at the channel frequency. Reverberation time was then measured at each channel frequency and at several settings of the amplifiers' gain controls.

The normal reverberation-time-

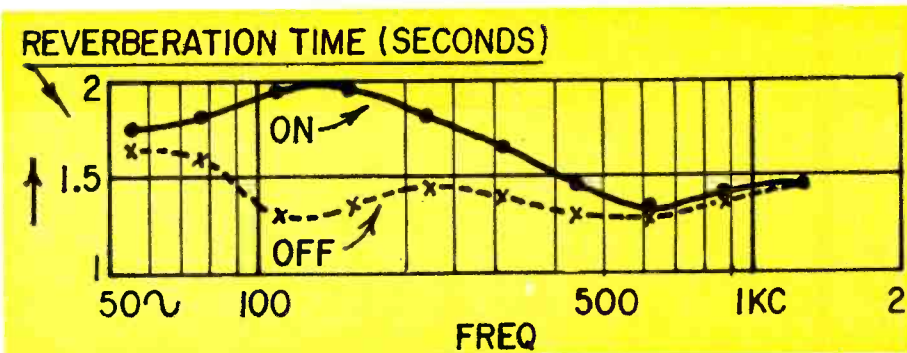

Fig. 2—Before and after: how the assisted resonance apparatus increased reverberation at frequencies where it was most needed.



frequency relation for the hall without an audience is shown in Fig. 2. The electronic equipment should raise the reverberation time to bring it into the "optimum" time range. Although this was easily possible, it was felt unwise to do this in a single step, so the reverb time was raised in stages to allow careful listening tests on a dozen or more concerts before it was raised to the next level. These tests extend over more than two months without raising any adverse comment or criticism.

During this time several favorable comments were made by various members of the many orchestras using the hall although they were not aware of the work in progress. One newspaper critic noted an improvement in the "warmth" of the hall but decided that this was the result of closing the organ screen. Several conductors commented to the general manager of the hall that they found it much easier to obtain a homogeneous blending and a more resonant and warmer tone. Similar comments have been made by a number of orchestral players and soloists.

On the afternoon of May 7, 1964, a demonstration was held. Music critics of all the leading newspapers and many leading conductors were present. A dozen or more selections were played, with and without the "assisted resonance" equipment in operation, to allow the critics to compare the "before" and "after" conditions with an interval of only a few seconds between. Reactions were either favorable or neutral, but there was no adverse comment. Experience suggests that when any change

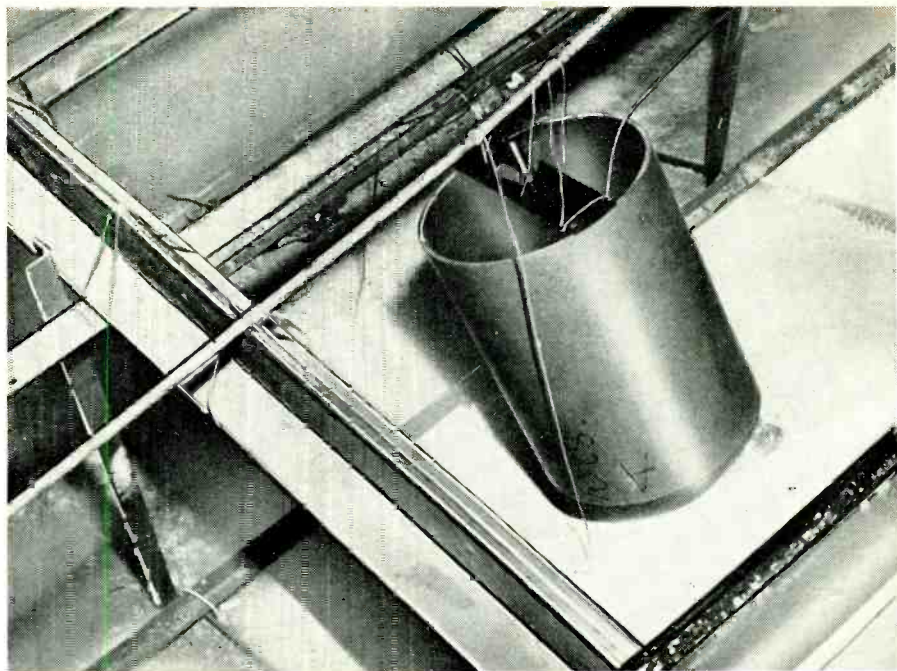

*Tubular Helmholtz resonator fitted to microphone above the ceiling of the Royal Festival Hall.*

in acoustics is made, 10-20% of the comment will be unfavorable whatever the change, particularly if the "before" condition has existed for long enough to allow listeners to become accustomed to it. Absence of unfavorable comment is therefore as significant as favorable comment.

My own feelings, after hearing about half a dozen concerts and rehearsals each week over the whole period of tests, were wholly favorable but I had some slight sense of disappointment that relatively large changes in

reverberation time did not produce a more obvious change. Each increase certainly increased the warmth, but the improvement in musical quality was not as great as I had expected.

The experimental work had to be terminated at the end of May (the hall was being closed for redecoration) but the improvement in the acoustics was considered to justify the installation of permanent equipment to increase reverb time electronically. Sufficient spare amplifier power will be provided to allow the reverberation time to be raised to something around 3 seconds at 100 cycles, if this proves advisable.

[In a paper submitted to the *Journal of Sound and Vibration* (British), Mr. P. H. Parkin, coauthor with K. Morgan, writes: "... there is not enough space in the ceiling for all the loudspeakers (perhaps 320) that would be necessary if we kept to one loudspeaker per channel for the whole frequency range, i.e. up to about 1,000 cycles. It has been decided that each loudspeaker shall do two frequencies; this means that the resonant boxes for the loudspeakers will be abandoned and larger power amplifiers will be needed. The intention is that there will be a number of 20-watt power amplifiers, each fed by two preamplifiers. Each preamplifier will of course be fed from a separate microphone, and will have its own gain control, phase-shifter, and provision for a plug-in filter."—*Editor*]

The concept of "electronically assisted resonance" is due to Mr. P. H. Parkin of the Building Research Station but I was privileged to be closely associated with the installation and commissioning stage.

END



*Two box type Helmholtz resonators (of lower Q than tubular type) fitted to speakers. "Funnel" between is lighting assembly.*



# YOKE TROUBLES

Knowing what to look for is a big help

By JACK DARR  
SERVICE EDITOR

HIGH-VOLTAGE PROBLEMS ARE PRETTY common in TV service work. Sometimes it seems that we spend our days drawing arcs to a screwdriver (or an unwary fingertip) from a 1B3 plate cap. Most of them are easy to find—bad tubes and so on. But now and then we run into a stumper. Probably the most popular in this class is yoke troubles. Everyone remembers the textbook picture of the wedge-shaped raster labeled yoke troubles or keystoneing. Well, you can find lots of yoke troubles beside this one. In fact, keystoneing can be caused by other things with a perfectly good yoke. For that matter, a defective yoke can show a perfectly straight-sided raster. (Narrow, of course.)

Raster distortion can be caused by yokes—shorted turns in windings, etc. But other troubles can cause the same symptoms. So we've got to go through the regular process of elimination to find out whether the yoke is bad or not.

## Basic circuitry

Yokes do two things. They furnish the horizontal sweep and also the high-voltage spike which is the source of the boost voltage. (The yoke, not the flyback, is where this pulse originates.) So there's a key clue for you: If everything else seems OK, but you get no boost at all, look for troubles in or around the yoke. You'll get the same B-plus reading on both plate and cathode of the damper tube when it's missing. Of course, troubles preceding the yoke circuit—weak horizontal output tubes, low B-plus, off frequency oscillators, and low drive—can cause the same symptoms, but these are usually easier to find.

The basic circuit of the yoke-flyback combination used in modern sets is shown in Fig. 1. The yoke windings are connected across a portion of the "secondary" of the flyback transformer (even if it happens to be an autotransformer), and the damper tube is connected across the yoke. This is true even though the damper cathode is most often connected to the next tap above the yoke—toward the horizontal output tube plate. Older sets sometimes used the direct-drive circuit in which the

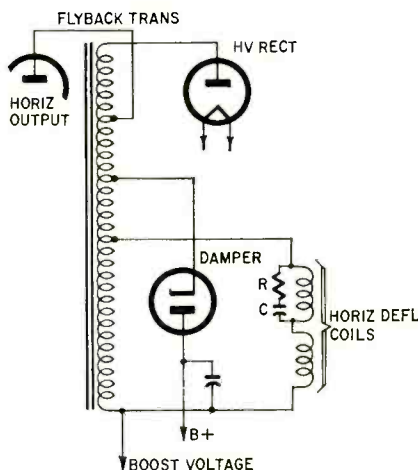

Fig. 1—Basic circuit of the yoke-flyback combination.

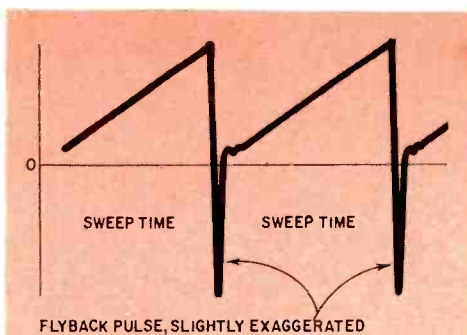

Fig. 2—Large pulse of reverse current is induced in yoke and flyback windings by collapse of sweep voltage sawtooth.

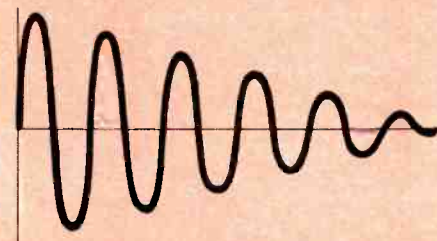

Fig. 3—Ringing, or oscillations set up in a resonant circuit by a single exciting pulse of current. The higher the circuit Q the longer the circuit rings.

yoke was connected at the bottom of the flyback, between this winding and B-plus.

## Circuit action

In normal operation, the pulse from the flyback is fed through the horizontal yoke winding. It builds up a large magnetic field in the yoke. When this collapses, a large pulse of reverse polarity is induced in the windings (Fig. 2). The yoke is a very high-Q winding that has an iron core. So is the flyback. When shock-excited by a large pulse of current, high-Q circuits will ring—oscillate at their fundamental frequency—and continue to oscillate until circuit losses have caused the current to stop flowing (Fig. 3).

The combination of yoke and flyback windings is a resonant circuit. The whole thing works exactly like a radio transmitter. The horizontal output tube and flyback are the final rf amplifier and plate tank, and the yoke is the antenna, to which we must transfer the maximum rf power to get the output we want. To get this output from a transmitter, we have to make the antenna circuit resonant at the carrier frequency so we can transfer maximum power to it. The same thing goes for the yoke. To get it up to maximum efficiency for generating the high voltage pulse in the flyback, we must make it resonant. This is not done to improve the horizontal sweep efficiency. That's taken care of by the horizontal output tube, mainly. The very sharp flyback pulse actually originates in the yoke and helps generate the pulse used to provide the high voltage for the crt. (The design of this circuit also affects the sweep, of course, but we'll deal with that later.)

So we make the yoke-flyback circuit resonant. At 15,750 cycles? No! It resonates at the flyback or retrace frequency. (Fig. 4). We use only the downward portion of the whole waveform, or the retrace time, which works out at somewhere in the vicinity of 70 kc. Note that this is not a harmonic of the horizontal sweep frequency, but all on its own. By making this resonant we get a higher-amplitude flyback pulse and more high voltage out of the flyback.

If our horizontal oscillator is oper-

ating away off frequency, the excitation to the yoke isn't going to be right and our efficiency goes away down. So does the boost voltage, the high voltage and everything else. This is something like trying to tune a 150-mc transmitter to a 59-inch low-band whip antenna. You'll never be able to get full rf output into a load that is mismatched. You get the same result when the yoke is not properly matched to the flyback when making replacements. The efficiency goes all to pieces and we can't get sweep, boost, etc.

Well, that's enough of the technical end. Now let's swing over into some practical servicing.

### Yoke ringing

This trouble always turns up on the left side of the raster. It appears as one, two or more lines about 2 inches from the left side of the screen. They look like vertical lines but, if examined closely, they seem to consist of small wiggles or bends in the scanning lines (Fig. 5). The bends are caused by a distorted horizontal scanning waveform and are more apparent on a blank raster.

The worse the ringing, the farther the lines extend across the screen and the more vertical lines there will be. In very bad cases, they may go all the way across the screen, but are always more intense at the left, fading gradually toward the right.

Watch out for "false-ringing" symptoms. There is one that can be readily confused with true yoke ringing, as the raster appearance is the same to a casual glance. This is shown in Fig. 6. However, if you pull the rf amplifier, it may go away entirely. If it does, it is caused by horizontal sweep energy getting into the rf stage or video i/f's. The most common cause is radiation from the yoke cable leaking into the transmission line between antenna terminals and tuner. To cure it, wrap aluminum foil around the yoke cable and ground it.

The key clue here is the appearance of the scanning lines. As you can see in Fig. 6, the lines are not bent but merely thinner at the point where they make the vertical lines. This is caused by the horizontal sweep spikes cutting off the CRT beam at that point, just as it would for a dark element in the picture.

Vertical lines of this type which appear on the left side of the screen always originate in the yoke circuits. Similar lines appearing on the right side of the screen originate in the flyback transformer or horizontal output tube. These are called spooks. Because of the difference in phase between primary and secondary in the flyback, the lines appear at different times during one horizontal sweep line. Fig. 7 shows the appearance of a typical yoke-ringing line on a test pattern. This one is caused by radiation into the tuner input. See the straight scanning lines?

The difference in phasing is illustrated in Fig. 8. Each section of the horizontal output supplies half of the horizontal sweep. So troubles appearing

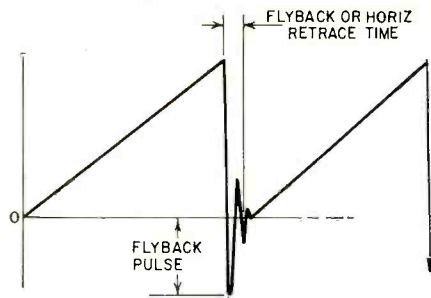

Fig. 4—Yoke-flyback circuit is made resonant at the retrace time, not at the horizontal sweep frequency.

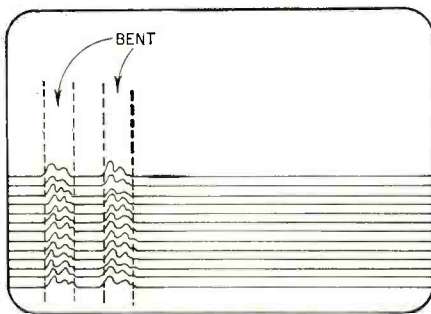

Fig. 5—Genuine yoke ringing. Scanning lines are bent, and trouble is in left half of screen.



Fig. 6—False ringing. Trouble is on left side, but scanning lines are straight. Vertical lines are caused by scanning lines being thinner, or completely missing.

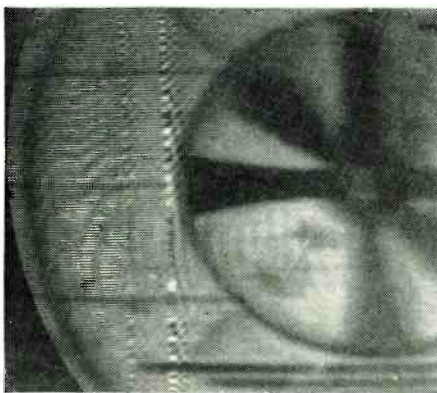

Fig. 7—False-ringing lines on a raster. Note straight scanning lines.

on either half of the screen can be pinned down by noting where they appear—left side, yoke; right side, flyback or output tube. (Barkhausen oscillations, slight trace of gas, etc.)

### Yoke servicing—substitution

Now, how do we pin down yoke troubles? Well, about the best way is substitution. If we come up with the standard symptoms of low high voltage (very small arc from the high-voltage rectifier plate), and especially no boost voltage (same B-plus voltage on both plate and

cathode of the damper tube), the yoke is suspect. You can use one of the sweep testers which have a variable inductance built in (Fig. 9) by disconnecting the yoke and hooking the inductor in its place. To test, connect your vtvm to the boost voltage, or a high-voltage probe to the high-voltage lead. Turn the set on, and set the variable inductor near the inductance value of the original yoke. If the yoke is bad, boost voltage will come back up to normal and high-voltage will return. You need only disconnect a maximum of three wires to make this test and, if the yoke is a plug-in type, it's simple.

This test can also be made with a spare yoke from stock. Select one as close to the original value as you can, although for test purposes anything within 20% of the original is fine. Incidentally, if the original yoke is left on the neck of the tube with the vertical windings still hooked up, turn the brightness down. You'll get a very bright vertical line if the high-voltage comes back, and you could burn the phosphor. The rated value of inductance is always given in the service data, or it can be looked up in a transformer catalogue if you have make and model number of the TV set.

There are actually only four troubles which are inside the yoke itself—open windings, shorts between horizontal and vertical windings, shorts in the anti-ringing network parts, and shorted turns in the windings. If you can't find an open yoke winding with an ohmmeter, don't bother to go any farther. (Although, come to think of it, there is one place you can be thrown a curve unless you're watching very closely. This is the paralleled windings used by G-E and several others. You'll have a couple of good clues here, though. One, you'll have a keystone and, two, the dc resistance will be exactly half of what it should be.)

Shorts between horizontal and vertical windings can be located with an ohmmeter. Watch out for the circuits with the vertical output stage tied to the center tap of the horizontal yoke windings, though. To be certain, disconnect all wiring to the yoke and recheck, looking up the circuit on the schematic to find out just how it is connected.

Shorts in the R-C networks are usually fairly easy to find as the capacitors and resistors have a tendency to burn up completely when they go. The appearance of the raster is your best clue. One test—disconnect the R-C network at one end and see if the raster goes back to "normal", with a ringing line or lines showing. If the original value is unknown, try different size capacitors across the top half, watching the ringing lines on the raster. When they disappear, you've found the correct-size capacitor.

Shorted turns can be hard to find, even with flyback testers, because of the low inductance of the yoke windings. It is often possible to make a comparison reading by checking a new yoke with the same inductance and comparing the two meter readings. Of course,



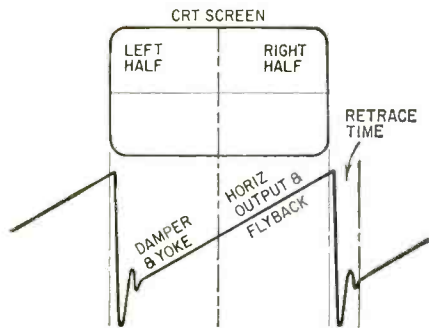

Fig. 8—Horizontal output tube contributes right half of each line of horizontal scan; damper tube and yoke inductance, left half.



Fig. 10—Partially shorted yoke in direct-drive circuit.



Fig. 11—Arc inside yoke. Radiation got into rf input.

while you're doing this, you could have connected the new yoke into the circuit and tested it in actual operation.

So, there are your test procedures. To recap briefly, run down the trouble until it is pretty apparent that it must be in either the yoke or flyback. By testing either of these you can find out what you want to know by elimination. If the yoke's good, then the flyback must be bad, and vice versa.

### Unusual troubles

Fig. 10 shows one unusual defect. This pattern was caused by a short to ground at the center tap of the horizontal yoke. We noted that sometimes this locked-in pattern did not appear, but we just got a narrow raster. This is in a direct-drive circuit.

Fig. 11 shows the result of another unusual one. This is a short across one half of the windings, with a fairly good sized arc being maintained. The resulting radiation of interference got into



Fig. 9—Sweep-circuit tester with variable inductance used for checking yoke for trouble.

the rf input, as we could tell by the very tiny piece of the test pattern visible near the left side of the screen.

As a final weird one, we once replaced a picture tube in a high-grade TV. When we turned it on, we were greeted with a series of continuous vertical stripes extending all the way across the screen. This mystified the whole crew no end. The set had been playing perfectly, and the old picture tube was merely weak.

Of course we started looking for something we'd done wrong—like leaving the ground off the dag coating, and

all sorts of very complicated troubles. After a bit of this, it dawned on us that this looked very much like yoke ringing. Slipping the back cover off the yoke disclosed a capacitor that had opened completely. It was very badly corroded from moisture; it looked like a small wad of salt! Evidently it had been hanging on by the skin of its teeth, with leads almost corroded in two, and the slight jarring it got while being moved from old tube to new one had finally broken it completely. So, if it looks like it might be yoke trouble, check it carefully and find out for sure. **END**

## SLIPPING DIAL-CORD HINTS

THE RADIO-TV SERVICE TECHNICIAN HAS always been plagued by slipping dial cords. Often he has ended up with a complete restringing job in cases where a suitable dial-cord dressing failed or decided to install a new cord—just to be on the safe side.

Tips discovered throughout the years by old-time technicians show that many cases of dial cord slippage can be corrected.

When the dial cord uses only one spring (Fig. 1), it's easy to tighten the cord. Remove the spring from its drum slot, twist the cord clockwise by revolving the spring to bring up the slack, and reinstall the spring in its slot. If the cord is still too loose, twist some more by repeating the above steps; and, if too tight, untwist a turn or so until the cord is no longer sluggish.

Where there is enough room on the drum, you can take up the slack by drilling a new mounting hole slot for the spring away from its original slot (Fig. 1). Sometimes you will find such slots already on the drum for just this job.

Where two sets of springs are mounted on the drum (Fig. 2), we can drill one or two hole slots for the

springs. A second method is to make loop knots where the cord is connected to the spring until the cord is tight.

These same tips will prove useful when installing new dial cords too. You know how easy it is to end up with a loose cord. Dial-cord dressing is most

REMOVE SPRING FROM SLOT & TWIST CLOCKWISE

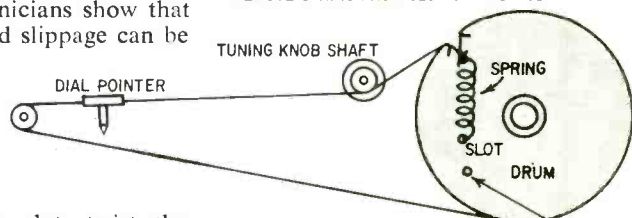

Fig. 1 DRILL NEW SLOT ABOUT HERE

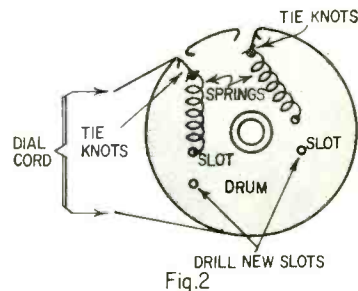

Fig. 2 DRILL NEW SLOTS

helpful, and these suggestions relate to cases where dressing just won't work. —George P. Oberto



# PLUTO Tells Where It Is

Build this Perpetual Low-power Unattended Transistor Oscillator as an electronic brand for valuable luggage, as a prize in treasure-hunts

By JOSEPH BROWN

YOU CAN PROTECT A VALUABLE PIECE of property against theft or loss in several ways. You may lock it up, you may guard it by human attention or with electronic control circuits or you may mark it as your property, as in branding cattle. Such a visible mark is only a means of adding a special characteristic to the electromagnetic radiation reflected by the object in the visible part of the spectrum.

But there is no need to confine the marking to the visible part of the spec-

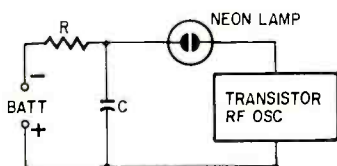

Fig. 1—Principle of PLUTO: simple neon relaxation oscillator keys rf oscillator to emit pulses once every second or so.

trum or to electromagnetic radiation reflected by the object. If we mark a valuable object by building a device into it which emits a characteristic radiation in the short-wave band, for example, we have two advantages over a visible sign. First, the "mark" is not readily detected by a thief, who might have some interest in preventing identification of the object. Second, an object containing a radio transmitter of some sort is not easily hidden. House walls, layers of soil, nonmetallic boxes or suitcases, which would conceal an object perfectly from

the searcher using visible light, would be very unsuitable hiding places for transmitter-marked objects.

The art of marking objects with simple battery-powered transistor transmitters has been known almost since the invention of the transistor. A golf ball with a built-in transistor transmitter, which could be located by means of a portable radio, was among the first practical transistor devices ever built. Soon after, police departments all over the world started to catch thieves with "planted" objects containing transistor oscillators.

But these simple oscillators, however effective they may be, have one disadvantage which makes them impractical for private use. They all require battery change from time to time if they are to operate with reasonable power. This is of no importance to a police department which puts a briefcase containing a transistor oscillator in a place where it is likely to be stolen. But if you want to equip your everyday briefcase with its own identifying beacon, your aim is to forget about the gadget until the day you discover that your briefcase is gone.

The answer to this problem is very simple. Just make the power drain on the battery so low that the useful life of the battery approaches its shelf life. But how can one get a useful signal from such a weak current? That is where PLUTO comes in. The name PLUTO is derived from *Perpetual Low-power Unattended Transistor Oscillator*. The trick by which reasonable rf field

strengths are generated with negligible battery drain consists in not operating the transmitter continuously. If you draw 1 microampere from a current source for 1 second, and store the energy in a capacitor, you can spend this "savings" in the form of 1 milliampere during 1 millisecond. That is the principle of PLUTO operation.

Fig. 1 shows the basic circuit of PLUTO. This pulse generator gives constant energy per pulse independent of internal battery resistance. When the battery approaches old age, the pulse repetition frequency decreases, but every pulse contains as much energy as it did when the battery was brand-new.

This "special" pulsing circuit is nothing else than a neon-lamp relaxation oscillator in which a transistor rf oscillator has been connected in series with the neon lamp.

The neon tube may be used for pulse generation due to a peculiar characteristic, which is mentioned for the benefit of the younger readers. If the voltage across the two electrodes of a neon lamp is below a certain value—the *firing voltage*—it acts like an almost perfect insulator. At the firing voltage, a visible red discharge forms between the electrodes, and internal resistance becomes very low. For continuous operation, therefore, a neon lamp always has to be operated with a series resistor to keep it from being destroyed by the current it suddenly draws as its internal resistance drops after firing.

If the voltage across an ignited neon lamp is lowered below the firing voltage, the discharge still persists. It is not until the voltage drops below the *extinguishing* (or *extinction*) voltage that the discharge stops. Usually the extinguishing voltage is several volts lower than the firing voltage.

Oscillations are generated by this process: Capacitor C is charged from battery BATT via resistor R. As soon as the voltage across C reaches the firing voltage of the neon lamp, a discharge current flows through the neon lamp and the transistor oscillator, discharging the capacitor through the resistance of the neon lamp and oscillator. This current persists until the voltage across the capacitor drops below the extinguishing voltage of the neon lamp. The capacitor then again begins to charge until it reaches the firing voltage, and so on.

For the practical circuit, R and C were chosen so that the device draws about 1  $\mu$ a from the battery. Repetition frequency of the pulses is about 1 per second. Every pulse consists of about 1 ma for a millisecond. Of course this device, which might be called a power transformer, is far from being without losses. Only a fraction of the energy drawn from the battery is converted into rf oscillations. A considerable part is used up in the neon-tube discharge

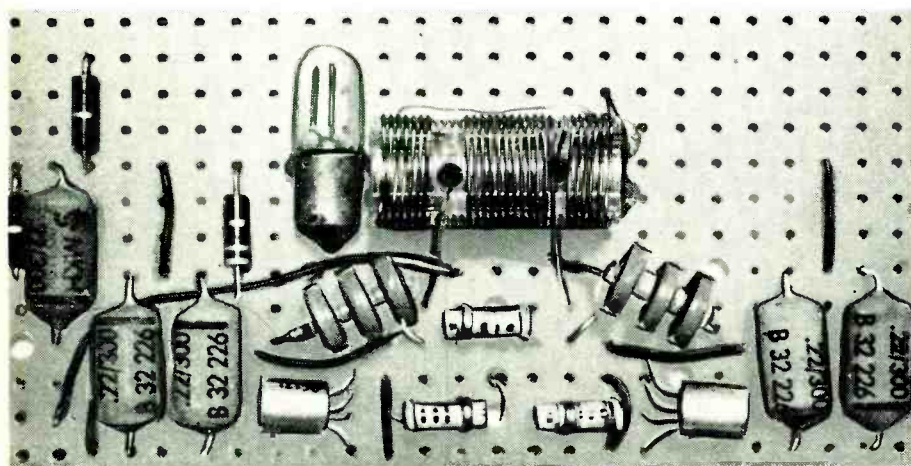

PLUTO prototype (no attempt was made to miniaturize it). It has been operating continuously for more than 2 years. Units in both photos were built in Germany with German parts.



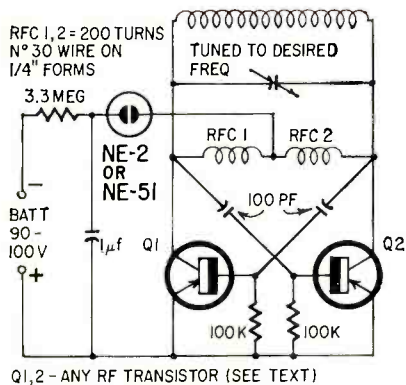

Fig. 2—Practical PLUTO. Q1 and Q2 can be almost any kind of transistor, depending on desired output frequency. To use n-p-n transistors, reverse battery polarity. Transistors should be of the same type.

and produces unwanted light as well as a tiny amount of heat.

This loss is made up by using a much higher supply voltage for the neon-tube oscillator than is used as a supply voltage for the transistor rf oscillator. One can afford to waste energy by using a more expensive high-voltage battery, as battery life is still considerably longer than that of a low-voltage battery loaded with a continuously running oscillator drawing a current comparable to the PLUTO's pulse current.

Let us assume that we have a small 100-volt battery, which is supposed to run 100 hours with a load of 1 ma. With a load of 1  $\mu$ a, it should run 100,000 hours, which is more than 10 years. In reality, the device will not work as long as that, because internal corrosion will ruin the battery before exhaustion.

An experimental PLUTO has been deliberately equipped with a discarded battery from a portable tube radio. This PLUTO has run 2 years without interruption on a battery which was already in the wastebasket. This example clearly shows the advantages of the PLUTO principle for any device which must maintain a constant rf amplitude over long periods, provided the rf energy is not needed as continuous oscillation.

Fig. 2 shows a complete PLUTO circuit. Though almost any transistor rf oscillator may be modified to work as a

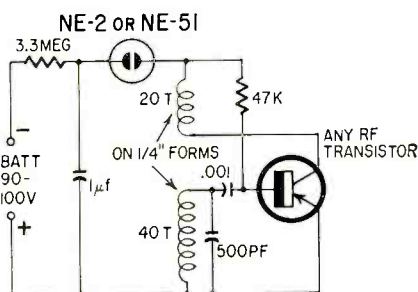
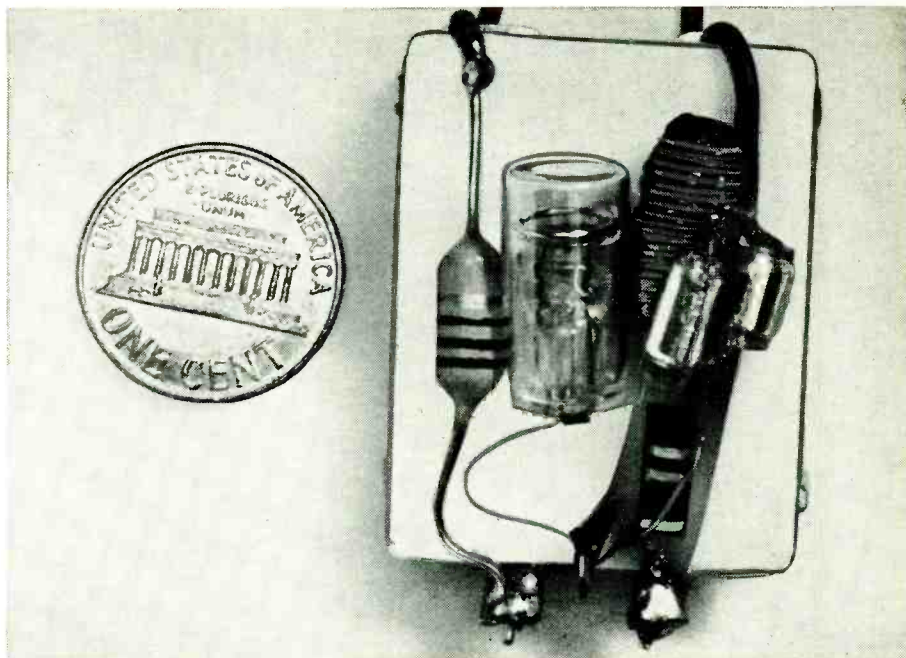

Fig. 3—Simpler PLUTO has fewer parts and is smaller, but less powerful. If you use glass- or plastic-encased transistor, you can wind coil around that.



Miniaturized PLUTO (circuit of Fig. 3). The 1- $\mu$ f capacitor is the base-plate; coil is wound around transistor.

PLUTO, this tuned multivibrator has been chosen because it needs no taps or feedback windings on the resonant circuit. Connect any L-C combination of reasonable Q to it, and it will oscillate at the frequency determined by the circuit, provided the frequency is not above the cutoff frequency of the transistors.

With OC171/2N1517 (Amperex) transistors, the device oscillated up to over 100 mc. These transistors were chosen only because they were available. Any transistors may be used if their frequency range extends to the frequency at which you want the PLUTO to operate. Power rating of the transistors is not critical, as the average power is very low.

Fig. 3 shows another PLUTO circuit, with fewer components. It can, therefore, be built smaller. A transistor enclosed in glass can serve as a coil form. The indicated L and C values are for the broadcast band. Due to the small size of the radiating coil, the range is considerably lower than that of the circuit shown in Fig. 2.

[The ease with which you can successfully conceal PLUTO depends a lot on the size of the largest component—the battery. You can use a single miniature 90-volt battery such as the NEDA No. 214, two No. 213's (at 45 volts each) or three 30-volt 210's. Some neon lamps can be fired with a 67½-volt battery. It may be necessary to use a separate battery pack connected to PLUTO through fine wires—Editor]

Now, about the practical operation of PLUTO. As soon as wiring is completed, it will start to emit short "ticks", about 1 per second, in the frequency band determined by the resonant circuit

of the rf oscillator. As there is no external antenna, there will be radiation only from the tank coil. The signal can be still picked up at a distance of about 20–30 feet with an ordinary portable radio. Of course, an additional antenna would increase the range considerably, but also might increase trouble with the FCC.

For theft and loss protection, PLUTO may be inserted in any object—a briefcase, a large book, or luggage. Due to the long battery life and relative cheapness of the other components, one might discard altogether the possibility of a battery change and encapsulate the whole device in a solid block of epoxy resin. If the purpose of such a radio-frequency emitting brick is demonstration, the epoxy resin should be transparent. If, on the other hand, the transmitting properties should be concealed, choose an opaque resin.

To locate a PLUTO somewhere around, just tune your portable radio to the PLUTO's frequency. Then move around slowly, until you hear the clicks. If your set has a directional ferrite rod antenna, you can locate PLUTO by getting fixes from different points. Otherwise just move in the direction of increasing intensity of ticks. PLUTO signals may also be received if the circuit is buried or is cemented into a wall. This gives a lot of possibilities for a Boy Scout treasure hunt, as well as for people who want to bury real treasures and find them again. A subminiature PLUTO, on the other hand, might be of some value for the amateur magician. A small plastic cube containing a PLUTO lends itself to amazing demonstrations of clairvoyance. END

# CB I.F.'s ON THE NOSE

Accurate (.005% or better) alignment without special gear

COMPARED TO TV, ALIGNING AN ORDINARY AM receiver is so simple the average service technician can do it with his eyes shut and one hand tied behind his back. Although CB receivers have no more complicated i.f. systems than broadcast receivers, the i.f. alignment is far more important. Since most CB transceivers have either crystal-controlled receivers or a combination of variable tuning plus crystal control, the flexibility in aligning the i.f.'s is sharply reduced, and aligning to the exact intermediate frequency is more important.

Where a receiver is tunable, it makes little difference whether an i.f. strip is aligned at center frequency or a little to one side. The passband is usually broad enough to take care of slight mistuning, or oscillator adjustments can be made to compensate for the difference. But, with fixed-tuned CB transceivers, sensitivity and selectivity can suffer and adjacent-channel interference can become troublesome when i.f.'s are even slightly misaligned.

It's all a simple matter of arithmetic. Assume the received signal is exactly on center frequency of 27.065 mc (channel 9). Further, assume that the receiver has a 455-kc i.f. and the oscillator is on the low side of the received signal. This would mean a receive crystal of 26.610 mc. With a perfect receiver crystal, any deviation from 455 kc in align-

By R. L. CONHAIM

ing the i.f.'s can cause less than ideal reception. When you realize that the usual service signal generator has an accuracy of ½% to 2%, the problem becomes acute. With a 2% generator a 455-kc setting can produce a signal anywhere from 445.9 kc to 464.1 kc. The receiver can be thrown off as much as one whole channel.

For this reason, manufacturers of CB equipment such as the Johnson Messenger specify an i.f. signal generator accuracy of at least 0.1%. Such generators are too expensive for average service use—the service technician doesn't usually do enough CB work to justify getting one. But there is a technique that will assure you of an accurate service generator, provided it is stable. You can determine that by beating it with any AM broadcast station. If, after warmup, the generator does not vary from zero beat with the broadcast station by more than 100 cycles, it is amply stable for CB use and, with the method outlined here, will be highly accurate.

## The method

AM broadcast stations are required by law to maintain their frequency within 20 cycles of assigned center frequency, therefore they make excellent frequency standards. The trick is to find

a station at the right frequency against which you can check i.f. settings for your signal generator. If the CB transceiver has a 455-kc i.f., all you need do is beat the signal with a broadcast station at 910 kc ( $2 \times 455$ ). If you can achieve zero beat and hold it, you will be least within 10 cycles of the i.f., or an accuracy of almost .002%! About 45 AM stations in the US operate on 910 kc. You can probably find one near you by referring to "North American Radio-TV Station Guide" by Vane A. Jones, published by Howard W. Sams, or to "Radio-TV Experimenter" (including "White's Radio Log") published by Science & Mechanics Publishing Co. What if the i.f. is not 455 kc? A good many are not.

What do you do about 1,650-, 1,680- and 1750-kc i.f.'s, all higher than broadcast-band stations?

Again, a little simple arithmetic shows the way. Let's take an i.f. of 1,750 kc as an example. If we divide 1,750 kc by 5 we get 350 kc. Set your generator at 350 and beat with a broadcast station at 700 kc ( $2 \times 350$ ). There is only one station in the country on 700 kc—WLW in Cincinnati. Since it operates at 50,000 watts, it can be heard almost anywhere in the US, especially at night. With the generator zeroed to WLW, leave the setting at 350 and align the i.f.'s. You will be using the fifth harmonic of 350, but in most generators fifth harmonic is strong enough. Where the receiver i.f. transformers show definite signs of having been tampered with, make your first adjustments with the signal generator set roughly to 1,750. Then go back and make final adjustments at 350 kc, which has been carefully set as outlined above.

The table indicates generator settings for all popular i.f.'s in CB superhet circuits. In each case, remember to leave the generator at the point where it is zeroed with the correct AM broadcast frequency. In some cases, you will find that an appropriate AM station cannot be received except at night, with an outdoor antenna and, preferably, an accurately calibrated AM receiver.

In beating with the appropriate AM station, keep the coupling from generator to receiver fairly loose. Direct

Broadcast Station Frequencies for Checking Signal Generator Accuracy

Intermediate frequency	Signal generator setting	Beat with broadcast station at*	Harmonic used to beat with AM station	Harmonic used to align i.f.
262 kc	262 kc	1310 kc	Fifth	Fundamental
266	266	1330	Fifth	Fundamental
455	455	910	Second	Fundamental
1650	330	660	Second	Fifth
1680	420	840	Second	Fourth
1750	350	700	Second	Fifth

\* In determining broadcast frequencies for checking i.f.'s not shown, remember AM frequency assignments are made at even 10-kc points.



connection to the receiver may load down the generator and cause its oscillator to "pull". You may also notice that changing the attenuation controls on the generator will cause a change in the beat frequency. If at all possible, use attenuator settings you will actually use during alignment.

In attempting to locate appropriate AM stations, you may not be able to hear their modulation, even at night. However, there is usually enough carrier to beat your generator against. If this is impossible, try other methods. You can, for example, use a surplus BC-221 frequency meter. With both the BC-221 and the signal generator loosely coupled to the AM receiver, set the receiver and BC-221 to the appropriate frequency and adjust the signal generator for zero beat. Other frequency meters can be used in the same way.

[The receiver is not necessary when you use a heterodyne-type frequency meter such as the BC-221 to check the signal generator. Plug a pair of phones into the BC-221 and loosely couple the generator's output to the fre-

quency meter's antenna post. Tune the signal generator for zero beat in the phones. If your BC-221 provides a modulated signal, forget about the signal generator. Use the frequency meter for i.f. alignment. The BC-221 hasn't an rf attenuator so set the signal level by adjusting the coupling into the transceiver's i.f. circuit.—*Editor*]

Some signal generators are equipped with crystal oscillators and external crystal sockets. These can be used for i.f. alignment with precautions. First, be sure the crystal was made for your signal generator. If possible, check the crystal against a broadcast station by the method discussed above. Second, some generators use crystals only for checking dial calibration of the variable oscillator. In such generators, leaving the crystal in the circuit for any length of time causes crystal heating from excessive drive, and the crystal frequency will change.

Aligning of the second i.f. stages in double-conversion sets presents no major problem. Since the second oscillator is usually crystal-controlled, the second

i.f. strip can be aligned by leaving the generator set for the first i.f., with the generator connection made to the first mixer grid or other indicated point.

Remember also that careful alignment is wasted if the receive crystals are not accurate. Unfortunately, some crystal manufacturers do not pay as close attention to receive-crystal tolerances as they do to transmit crystals, for which an FCC tolerance is specified. It is just as important that receive crystals be accurate, for best reception. Crystals should be checked with a frequency meter and should be within .0025% or better. Where CB is used for business purposes, maximum effectiveness can be got only by "netting". For this, the transmitter and receiver oscillators and intermediate frequencies of all units in the net should be as nearly alike as possible. Because most multichannel CB transceivers do not have adjustments for each channel, the "netting alignment" should be done on the one channel used most. With good crystals, all other channels will be sufficiently close for adequate communications. END

## WHAT'S YOUR EQ?

Conducted by  
E. D. CLARK

### Double Voltage

Being a handy fellow, for an experiment you make up a capacitor from a cookie sheet, Saran Wrap and a skillet. You want to charge this home-made capacitor to a potential of 200 volts, but you have only a 100-volt source.

It's possible to get the 200-volt potential on the capacitor without any additional equipment. How?—*Tom Jaski*

### Channel Selector

Charlie Ham, running a mobile rig located in the trunk of his car, wanted to be able to switch in four transmit crystals. He found two spare wires in the cable running from the remote head at the dashboard to his rig in the trunk.

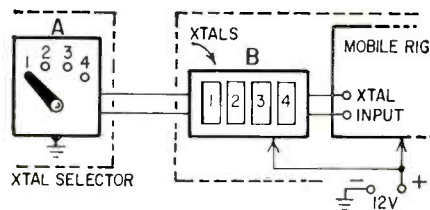

After digging through his junkbox, he came up with:

- 1—4-position, sp, rotary switch
- 2—silicon diodes
- 2—3pdt relays, 12-volt coils

His finished system is shown in the

diagram. What is the circuitry in boxes A and B?—*Arthur L. Erickson*

### What Frequency?

The diagram shows an earphone that produces a 1-kc audio output from a 1-kc input signal.

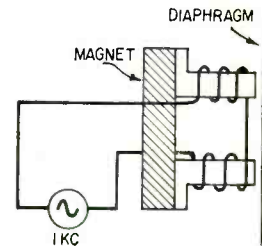

If the magnet is replaced with soft iron, what effect will this have on the frequency of the audio output?—*Olle Klippberg*

Three puzzlers for the students, theoretician and practical man. Simple? Double-check your answers before you say you've solved them. If you have an interesting or unusual puzzle (with an answer) send it to us. We will pay \$10 for each one accepted. We're especially interested in service stinkers or engineering stumpers on actual electronic equipment. We get so many letters we can't answer individual ones, but we'll print the more interesting solutions—ones the original authors never thought of.

Write EQ Editor, Radio-Electronics, 154 West 14th Street, New York, N. Y. 10011.

Answers to this month's puzzles are on page 87.

### 50 Years Ago

In Gernsback Publications  
In August, 1915  
Electrical Experimenter

Television—The Projection of Pictures Over a Wire  
Submarine "Wireless" Signaling  
An Interview with Guglielmo Marconi  
How to Build a Telautograph  
Wireless Relays and Amplifiers

### Radio-Electronics Is Your Magazine!

Tell us what you want to see in it. Your suggestions may make it a better magazine for the rest of the readers as well as yourself. Write to the Editor, RADIO-ELECTRONICS, 154 West 14th St., New York, N. Y. 10011.



Massive steel cofferdam, braced with I-beams, holds walls of this excavation and keeps them from caving in. Pressure cells fitted to beams can warn of excessive stress before a cave-in occurs.

# Electronic Pressure Cells Aid Civil Engineers

Continuous monitoring of stress and pressure in earth dams and excavations can avert disaster. Learn how it's done

IN A CITY IN SOUTHWESTERN ONTARIO, A sewage project called for constructing a foundation 25 feet below the mean water level of an adjacent river, and about 10 feet from the closest building. The base soil was dense, fine sand and there was certain danger of huge earth movements. The scheme couldn't have been adopted, if it hadn't been for pressure cells.

Undertaken jointly by the Civil Engineering Departments of McMaster University in Hamilton, the University of Waterloo and the National Research Council in Ottawa, who made the equipment available, the job was begun in the fall of '63. The electronic equipment used on the job, though it offers nothing new in the way of circuitry, is an ingenious application of known techniques.

A cofferdam (a watertight enclosure) of steel sheet-pilings was sunk into the ground, forming a square surrounding the area to be excavated. These piles stand about 50 feet high and are interlocked, one into another, forming a wall of steel.

At spots on the face of the wall are pressure cells, like the one shown in the photos. The cells are individually connected to a control box, which allows any one of 13 cells to be checked in turn, through a master cable to a metal

By JAMES W. ESSEX

cabinet which contains simply an amplifier, crystal and variable oscillators, a cathode-ray tube and a power supply.

The function of the device is to display changes in pressure at the cell faces by a pattern on the CR tube. With information gained from the pressure cells, we can judge more accurately the adequacy of the I-beams placed on lay-

ers within the cofferdam to shore up the walls and restrain the earth which otherwise would cave in. Excavation is carried on by buckets lowered between the squares formed by the I-beams.

The pickup head of the pressure cell works like the magnetic phono pickup in a hi-fi system, except that there is no needle to excite the magnetic field and induce an ac signal in the pickup coil. Rather, there's a taut steel wire (Fig. 1), set to vibrating by a pulse sent out by a discharge tube in the control unit. (See the photo which shows the dual-coil magnet piece—similar to an ordinary earphone—and its cover, in which two posts support the suspended steel wire which is approximately .010 inch in diameter.)

This cover, when put in place, allows the steel string to almost touch the pole pieces. Only a slight air gap separates it from them. A pulse from the control box "twangs" the wires. The pulse rate applied to the head can be varied.

There's sufficient pause after each voltage kick for the steel string to vibrate at the frequency determined by its tension. This is around 1,000 cycles normally. As pressure is applied to the face of the cell, bending it very slightly but enough to spread the posts, the string is

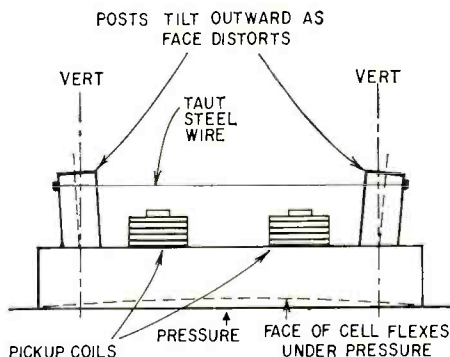
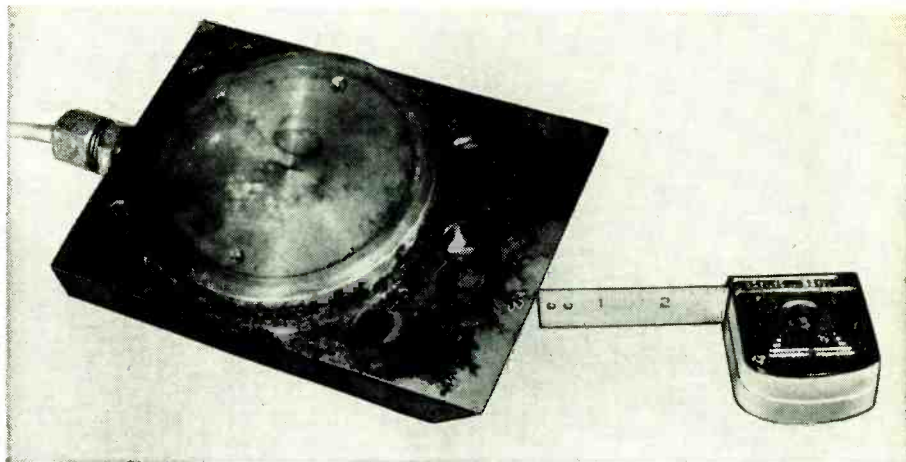

Fig. 1—Schematic cross-section of pressure cell shows how curving of face under pressure stretches taut steel wire, raising its natural resonant frequency.



tightened and its resonant frequency rises.

The control unit has facilities for comparing a variable oscillator frequency with a standard 1,000 cycles developed by a crystal. This operation establishes the basic, or reference, frequency and is noted by settings on a calibrated dial. The frequency of each cell in the lab during initial setup is noted on a chart. Because of the cells' construction they vary slightly (no one can tighten the steel string to a hair-splitting accuracy). Therefore, each cell is calibrated. The frequency is noted for zero pressure on the face. Then, as pressure is increased, the frequency goes up, and this is plotted on a graph. The operation is diagrammed in Fig. 2.



One of the pressure cells.

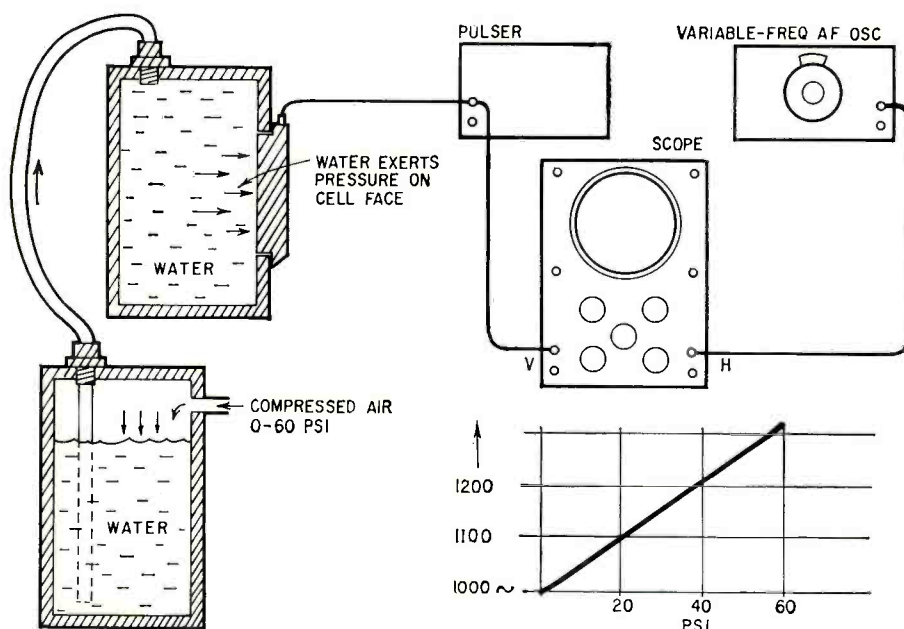

plot of pressure vs frequency can be prepared for each cell.

The number of pressure cells this unit can handle is limited only by the "switchboard" capacity ahead of the display unit and the money to invest in the cells. A good operator can monitor them continuously, reporting any sudden deviations in pressure in time to avert what might be a disaster.

The project described represents only the second in Canada (both in Ontario), the other having been done by N. R. C. in Ottawa. This indicates the experimental nature of the project. The Norwegians, I understand, who designed this type of unit originally, use it extensively.

I wish to acknowledge with thanks the help extended by Prof. N. Wilson, McMaster University, and Prof. Don Scott, Carl Christansen and P. Finn of the University of Waterloo. END

Fig. 2—Calibration setup. Cell is subjected to variable pressure from compressed air acting through water, and shock-excited by pulser. Output frequency from steel wire is compared with output from precisely calibrated audio generator by use of Lissajous patterns.

When the outgoing signal and the bounced-back signal from the cell are the same, the scope, set up to display a Lissajous pattern, shows a circle. To maintain this circle as the pressure on the cell (and its frequency) increase, the local oscillator must be adjusted accordingly. By reading the calibrated dial, a

Pressure cell, disassembled. Cap at right carries taut steel wire stretched between two posts. At left, body of cell holds magnetic circuit. Polepieces of coil assembly appear as two short, parallel black lines.

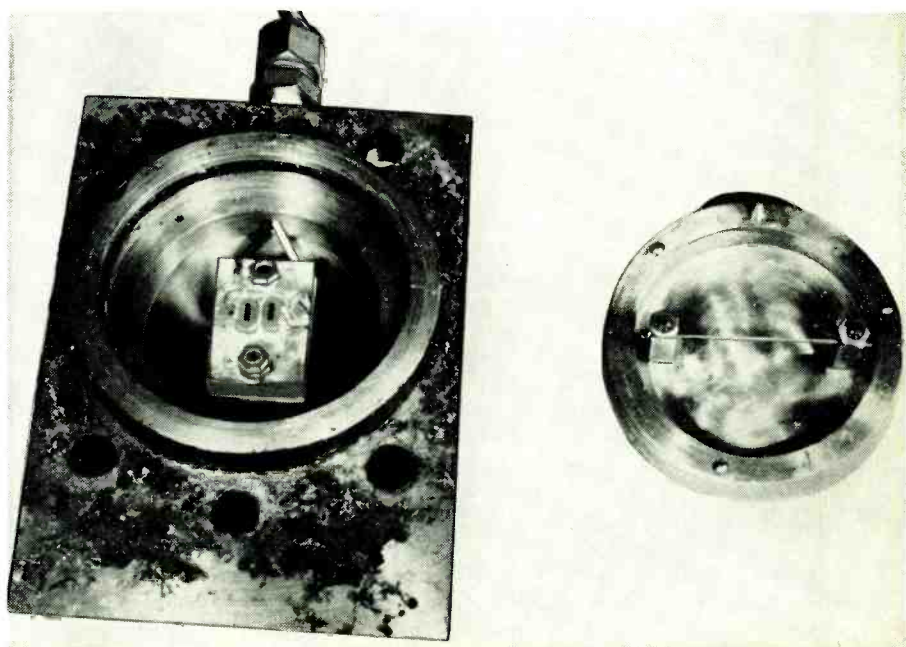
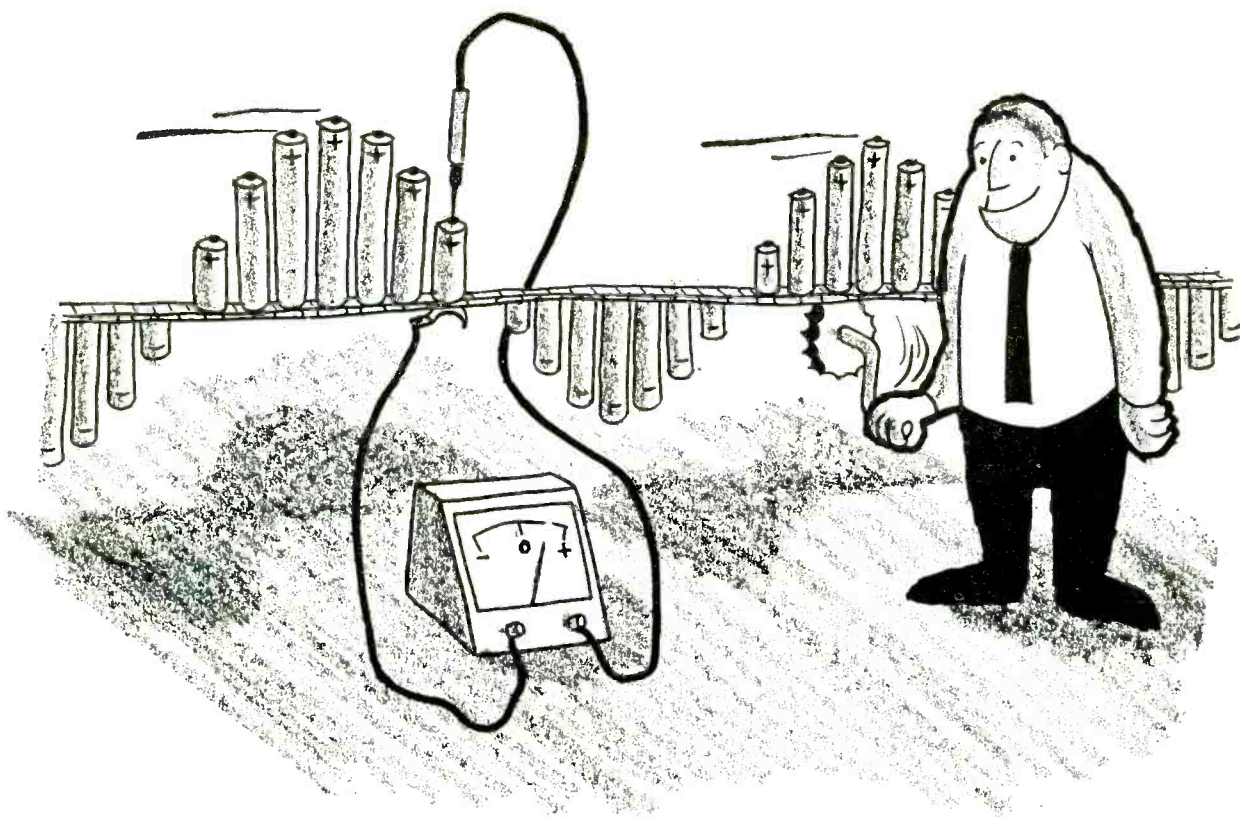



Fig. 1—The Patrick Machine.



# A Voltage Doubler Doesn't Really

A fanciful—and crystal-clear—approach to ac and voltage doublers

"YOU MEAN TO TELL ME THERE'S 330 volts coming out of that plug?" Jim pointed to a standard convenience outlet, shaking his head. "I just don't believe it!"

This fairly common reaction from an apprentice technician in my evening electronics class was prompted by a discussion of voltage-doubler circuits. His disbelief made me remember the problems I had as a student with the mysteries of ac, and I began to realize how unnecessarily complex we make these ideas.

We all use such phrases as "The root-mean-square voltage is equal to  $.707 E_{max}$ " or "The peak voltage is 1.41 times the effective value." These don't sound so bad, at least to the instructor, but how about this? "... if we consider this rotating vector to have a value of  $E_{max}$ , and its angular velocity is  $2\pi f$ , then clearly for any time  $t$  . . .," and all the rest of the instructorial gobbledegook! It's a wonder we don't bewilder ourselves, let alone those who are struggling with these ideas for the first time!

To all the perplexing terms and definitions we add yet another barrier to understanding. We put alternating current and direct current into tidy lit-

By OWEN G. PATRICK

tle separate compartments, implying that these are two kinds of current and that somehow different rules apply. So marked is this division that it has become a status symbol in the study of electronics. Students comment "Yeah, but wait till you get into ac. It's a lot harder!", or "You're still on dc. Ac is different."

Neither statement is altogether true, certainly not the first. The most difficult concepts we have all coped with, and probably still do, are the notions of what voltage, current and resistance *really* are. The second statement tends to mislead because there is absolutely no difference between the ampere or volt used in describing alternating and nonalternating currents. A clear understanding of the behavior of ac and the terms used to describe it is essential to understanding how voltage doublers and many other circuits work.

We might take another look at some of the basic concepts, stripped of the pedagogical verbiage, to see if we can describe more clearly and more simply these usually difficult ideas.

First, what yardstick do we use to

measure the behavior of ac? Of dc? We use the same volt, the same ampere and the same ohm.

If we look at some of the definitions of the volt, we find statements like "One volt is the electrical pressure required to force a current of one ampere through one ohm of resistance," or "One volt is the electrical pressure produced by a one-farad capacitor confining one coulomb of electrons . . .," or "One volt of opposing force is created by a one-henry inductor as the current intensity in it is changed by one ampere per second."

In these definitions the words "alternating current" or "direct current" are conspicuously absent. Then why the student's confusion? It begins with the ingredient of time, for an alternating current is really *current that changes voltage and polarity in a predictable way with the passage of time.*

Measuring alternating current is a little like trying to measure the height of a vigorous youngster while he is turning cartwheels on the front lawn. We can describe his height when he is upright and when he is standing on his head, but how do we measure him when he is horizontal and rotating?



To examine the nature of ac, like the youngest turning cartwheels, we need a way of stopping the action, at least momentarily, so we may determine how "tall" ac is and whether it is standing on its head or upright. For this purpose let's use our imaginations and conjure up a chain with some very special flashlight cells connected to it, cells with voltages proportional to their heights. We see them arranged as they are in Fig. 1, with a stationary position at one point along the chain for making observations. We can turn a crank and move the chain, bringing successive cells into position at our station.

The measuring device indicates the polarity and voltage of each of the cells. In this system the chain is the reference from which polarity and voltage are measured and the place of measurement is the reference for time. The station itself represents *now*. To its left are the events of the future; to its right, the events of the past. By turning the crank and measuring each cell as it comes into position we can relate the voltage and its polarity to time.

Stretching imagination to the breaking point, let's place a very large number of very thin cells on the chain so there are no gaps between them and their heights conform exactly to the curve only suggested by the cells in Fig. 1. By moving the chain at the proper speed, we can simulate the stuff that comes from the wall outlet.

If this fantasy gives us a reasonable picture of the nature of ac—of a continuously changing voltage with periodic changes of polarity—then how in the name of Ben Franklin can we give it fixed labels, like 110 or 220 volts?

### Equal work

We could tag ac with the voltage of the tallest cell. We do use that as one of ac's descriptive values and call it *peak voltage*. But there are two "tallest" cells, one positive, one negative. To solve that, we use two tags, one for each cell. Both have the same voltage and will cause the same current intensity, but in opposite directions and at different times.

More often used than peak voltages is a label for ac that compares it to dc. The basis for comparison is the ability

to do equal work. With such a standard, ac labeled "100 volts", applied to a resistance, must be capable of producing heat at the same rate as 100 volts of dc connected to the same resistance. *To do that, ac with a peak voltage of 1.41 times its labeled voltage* is required.

During the time when the voltage is greater than its labeled value, enough additional heat is generated to compensate for the time when it is less. It is this label of *effective voltage*, as it is called, that we mean when we refer to 110-volt outlets or 220-volt motors. This voltage is really only 70.7% of its maximum, or peak, and is mathematically the square root of the mean (average) of the squares of all the cells (instantaneous voltages) of either polarity (rms).

Let's develop our fantasy a little further. Suppose we could connect a lamp from the tallest cell above the chain to the tallest cell below the chain. We would then have the equivalent of a two-cell flashlight. That is, we would have twice the voltage of either cell alone. But to make this connection we must somehow span time, recalling that position along the chain represents time.

### Saving up voltage

Imagine two electron-storage tanks (capacitors) placed at our station. One has a contact posed above the chain, and the other a contact below. Both have their other terminals in contact with the chain. We now turn the crank and the cells move along. First one tank is connected and filled with electrons to the pressure of its tallest cell, and then later the other tank is charged to equal pressure by its cell. The storage property of these capacitors makes it possible for a voltage from the "past" to be retained for use in the "present" or "future." We now have a voltage from contact to contact that is twice the value of either of the tall cells. This is what a so-called "voltage doubler" actually does.

*Fig. 2—First one diode conducts, charging one capacitor, then (b) the other conducts and charges the other capacitor. In the meantime, the first capacitor holds its charge, so that at any instant the two charges are available in series (twice the voltage) to a load (c).*

If we now connect our lamp from one contact to the other, it will give off light as though it were connected to two cells. The only catch to this trickery is that, between contacts, the lamp is continuously discharging the capacitors, hence lowering the voltage.

The capacity of the tanks (*capacitance*, electrically speaking) must be large enough to supply the required amount of electrons to the lamp without significantly reducing their pressure between recharges.

Now let's return to reality and compare a real voltage doubler to the imagined. In Fig. 2 the two capacitors, C1 and C2, are the real storage tanks, and diodes D1 and D2 perform the function of the contacts. Capacitors C1 and C2 have a common connection to the voltage source just as they did to the chain in the imaginary, mechanical version. At a time when the "upper side" of the source is negative, diode D1 will pass electrons and charge C1 to the source's peak voltage. A short time later that side of the source will have turned positive and electrons will charge C2 through D2, also to the peak value. The lamp, connected across both C1 and C2, "feels" the pressure exerted by the charge in both capacitors, or twice the peak voltage of the source.

If our source happens to be the one commonly called "110 volts" (which should be 117 volts since this is the standard design value) and we calculate its peak voltage by multiplying 117 volts by 1.41, we get 165 volts. If we add one peak voltage to the other, as the doubler does, we have a total of 330 volts.

Of course, the lamp, or whatever the load may be, will attempt to discharge the capacitors and will not let this voltage remain constant. The average voltage will always be somewhat less than 330, depending on how large the capacitors are, how much current the load demands, how efficiently the diodes fill the capacitors, and last but not least, what the voltage at the outlet really is.

Jim, our student, heard this explanation and was finally convinced.

"Hey! I get it now! Thanks a lot, huh?" Then he grinned. "Man, like a voltage doubler doesn't really double, does it?"

END

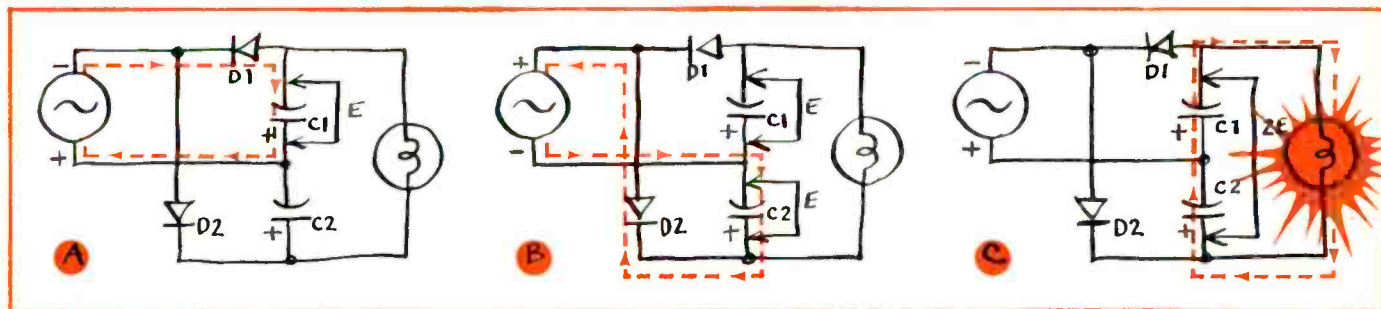

Sharp square waves, clean color bursts are routine on the screen with this wide-band, high-gain vertical amplifier

# How To Wide-Band Your Scope

By BARRY TURNER

MOST OF US HAVE WISHED AT ONE TIME or other that we could have bought a better scope. The vertical amplifier in an inexpensive scope just doesn't have the bandwidth for color work, for instance. Often the rest of the scope (high voltage, horizontal amplifier and time-base generator) are suitable. But when a color bar signal is applied to the vertical amplifier, a narrow-band amplifier just won't produce a usable pattern on the screen.

Let's start by seeing what we need. First, a trace about three-quarters of full screen height to make a good-size picture. Second, we should have about a 5-mc response—that is, our vertical amplifier should be able to amplify from some low frequency such as 30 cycles to 5 mc with the same gain all the way up.

The scope discussed in this story is a standard EMC (Electronic Measurements Corp.) 600. It is a good all-purpose one, and there are several like it on the market at about the same price.

The first step was to study the general layout of the scope. The two tubes used in the vertical amplifier were 12-AT7's, which meant there were two nine-pin sockets to work with. I decided to use 6BK7-B's. Then I had to find out if these tubes would produce enough deflection without another stage. They did—even with low inputs.

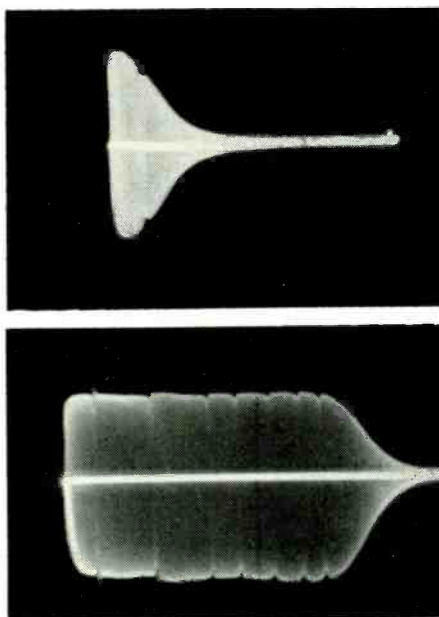

Swept scope response before (1) and after (2) rebuilding vertical amplifier. Marker notches are at 500-ke intervals.

I stuck to standard video-amplifier design throughout the circuits (Fig. 1). A "long-tail" phase inverter is used. The inverter grid is grounded for ac, and a degenerative cathode circuit couples both cathodes together. In the plate circuit, standard peaking coils are used.

The values are a good compromise between flat frequency response and adequate deflection.

This scope used vertical centering via the cathodes of the output stage. This had to be changed. I tied the plates of the cathode-ray tube to B-plus through a pair of 2.2-megohm resistors with a 1-megohm centering pot and two more resistors bleeding the B-plus to ground.

Start construction by completely stripping the vertical amplifier. Don't forget that the heater connections have to be changed for the 6BK7-B's (6.3 volts direct to pins 4 and 5). Wire the cathode circuits first, then the plate circuits with the peaking coils. Leave room for mounting the large coupling capacitors. They should not lie against the chassis but should be spaced away as far as practical—at least 1/4 inch.

B-plus to the stage was fed via a tie point on the original circuit. The original terminal strip was left in place—there were enough lugs for all connections. The peaking coils' leads were solid enough not to need tying down. Only one extra ground tie point was necessary, for C2 on pin 7 of V1.

(If your scope has octal sockets, try 6BL7's. Gain is much lower, but may be enough for your purposes. If you need extra gain, make adapter mounting-plates for the miniature sockets.)

The wiring is straightforward; no shielded leads were necessary in this scope and there was no overheating despite the slightly heavier current draw.

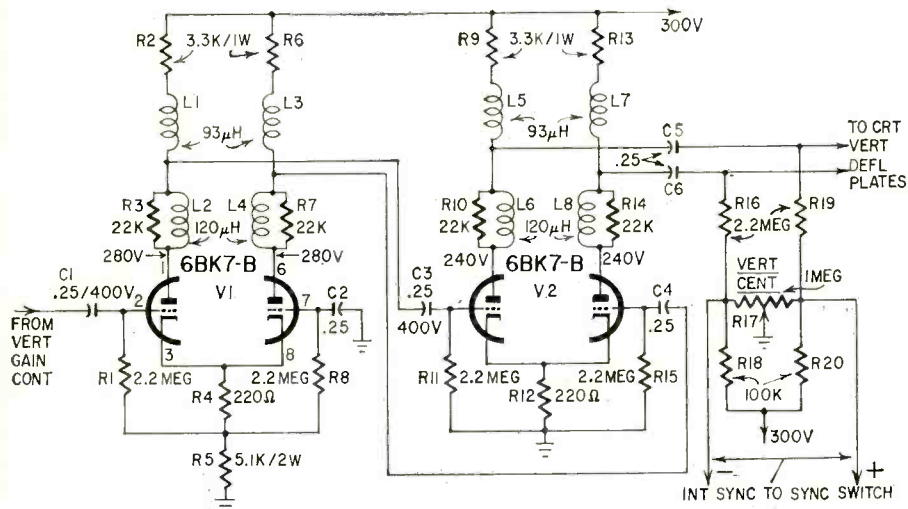

- C1, C2, C3, C4, C5, C6—0.25 (or 0.27)  $\mu$ f, 600 volts paper
- L1, L3, L5, L7—peaking coil, 93  $\mu$ h (J. W. Miller type 6177 or equivalent)
- L2, L4, L6, L8—peaking coil, 120  $\mu$ h (J. W. Miller type 6153; or use Miller type 6178, already supplied with 22,000-ohm shunt resistor, and omit R3, R7, R10 and R14)
- Miller coils are available from Allied Radio Corp., 100 N. Western Ave., Chicago 80, Ill., at 56¢ apiece plus postage.
- R1, R8, R11, R15, R16, R19—2.2 megohms
- R2, R6, R9, R13—3,300 ohms, 1 watt
- R3, R7, R10, R14—22,000 ohms
- R4, R12—220 ohms
- R5—5,100 ohms, 2 watts
- R17—pot, 1 megohm, linear
- R18, R20—100,000 ohms

All resistors 1/2 watt, 10% except as noted.  
V1, V2—6BK7-B  
Sockets, hardware, as required by scope being modified



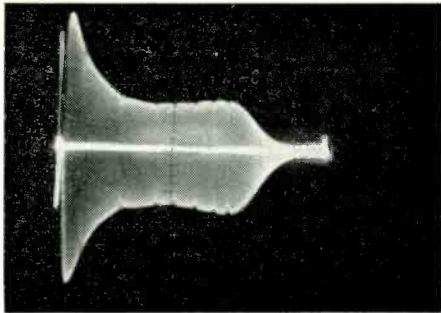

Larger-value plate loads will give more gain, but at sacrifice of extended high-frequency response.

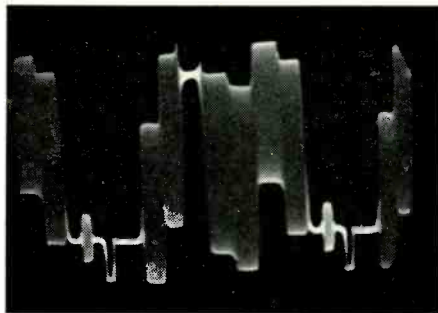

TV color burst as seen via new scope amplifier.

Fig. 2-a shows a simple frequency-compensated vertical input attenuator. With it, the converted scope's input impedance will be 1 megohm shunted by about 20-30 pf in the  $\times 1$  position, and 1 megohm shunted by much less capacitance in the  $\times 10$  position. Exact values of input capacitance will depend on lead lengths and dress, and so can't be specified exactly.

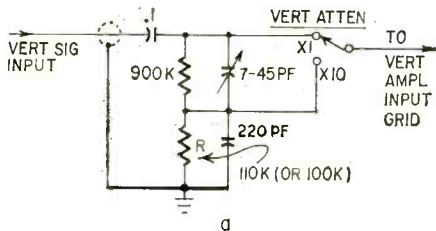
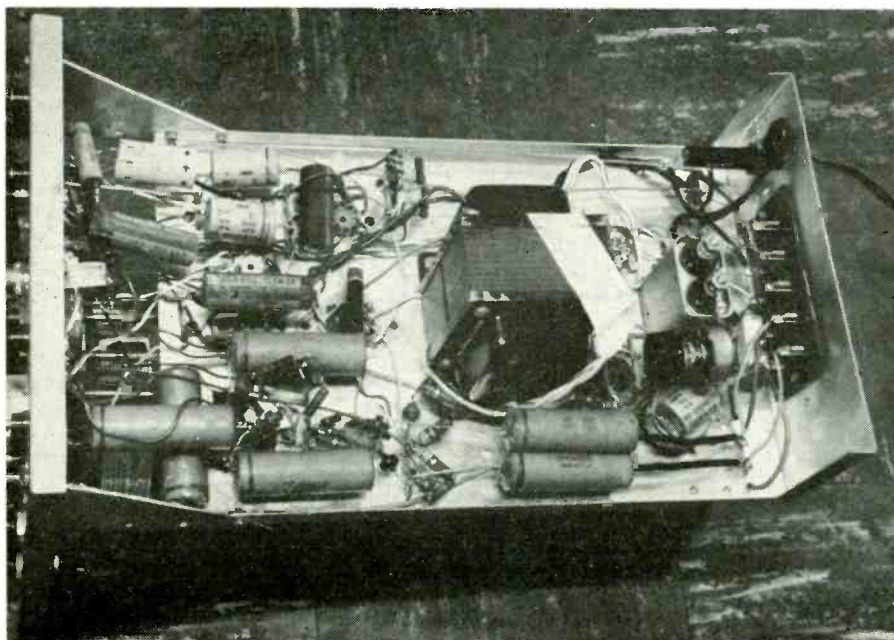
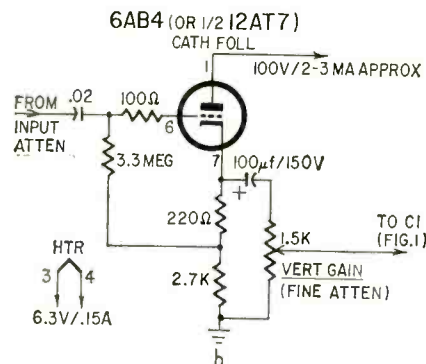

Fig. 2-a—Optional two-step input attenuator is compensated against high-frequency discrimination from stray capacitance. R should theoretically be 100,000 ohms, but finite load of following grid circuit makes about 110,000 ohms necessary for exact 10:1 attenuation ratio. Fig. 2-b shows simple one-tube cathode follower that allows using lower-resistance, non-discriminating variable resistor as fine (vernier) gain control. It can be added to any scope.



Most scope chassis have plenty of room for adding and rebuilding circuits. Rebuilt vertical amplifier stages described in this story are in left foreground.

resistance control (1,500 ohms), necessary to prevent high-frequency attenuation at mid-position settings.

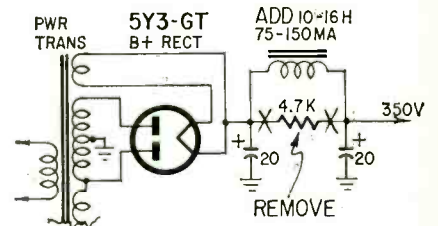

Fig. 3—Choke replaces first filter resistor for sharp, steady trace. Add a series R-C filter to drop B-plus to 290-300 for vertical amplifier. Check capacitors for adequate voltage ratings.

In the power supply, changing the filter resistor for a 10- to 16-henry choke at 75 to 150 ma (Fig. 3) will reduce ripple in the B-plus and give you a sharp, clear, steady trace. END

### My Strangest Repair Job

NOT TOO LONG AGO I DID THE STRANGEST radio repair job in all my 27 years of fixing radios. This radio was a Zenith Royal transistor portable.

Its teen-age owner was in his grandmother's barn lot painting some farm machinery and listening to his portable. A sudden summer thunderstorm came up and he grabbed the can of paint, the paint brush and the radio, mounted his bike and made for home.

When he got in the house, he saw green paint running down the side of the radio's leather case. He carefully wiped the paint off the case and set it up to dry. What he didn't know was that the enamel had run through the crack in the back cover and into the tuning capacitor. The trimmers were stuck together and more paint had run between the tuning capacitor plates.

I decided to see if I could clean the capacitor rather than buy a new one. I very carefully took it out of the chassis and removed the trimmer screws and mica insulators. Then I put it into a small can of lacquer thinner. After it soaked about an hour, I used pipe cleaners and pieces of cardboard to remove the green goo from between the plates, from the trimmer screws, plates and mica insulators, and from the frame. I dried it out carefully relubricated the ball bearings around the shaft and at its rear, and reinstalled the mica insulators and trimmer screws.

Several days later the boy's mother reported that the radio was playing rock and roll as well as ever. I'm wondering if she didn't wish it was still full of green goo.—James A. Fred



Union Switch & Signal

THIS FELLOW IS USING RADIO REMOTE control to operate that huge tractor way over there on the next page. He controls that mechanical monster without being exposed to danger and extreme heat. His shovel is unloading hot slag from an open hearth furnace. By operating the knobs and levers on the control box he carries, he can make the tractor work just as though he were in the cab.

To save precious heating time in ironmaking processes, it is necessary to remove slag before the furnace cools. Only by radio control can this be done safely and efficiently. The shovel operator can work in a place where he has a clear view of the job, avoiding hazard and discomfort.

This particular radio control system is manufactured by the Union Switch & Signal Div., Westinghouse Air Brake Co. in Swissvale, a suburb of Pittsburgh, Pa. All-transistor, light and portable, it is unique because of its compact construction and the large number of remote operations controlled. Designed to operate in the 150-mc frequency range, it controls 16 basic tractor functions either separately or in combination.

Because the system uses basic remote-control methods, it may—with minor changes—be applied to many other kinds of equipment. For example, it is used for remote control of unmanned locomotives in the switching yards of the Du Pont Chemical Works at Penn's Grove, N. J. The locomotive operator stands at trackside for a good view while coupling cars. The control system is used over a 1-square-mile area,

# THE LONG ARM OF REMOTE CONTROL

An example of one of industry's most valuable tools, and how it works

By JOHN W. DIETRICH

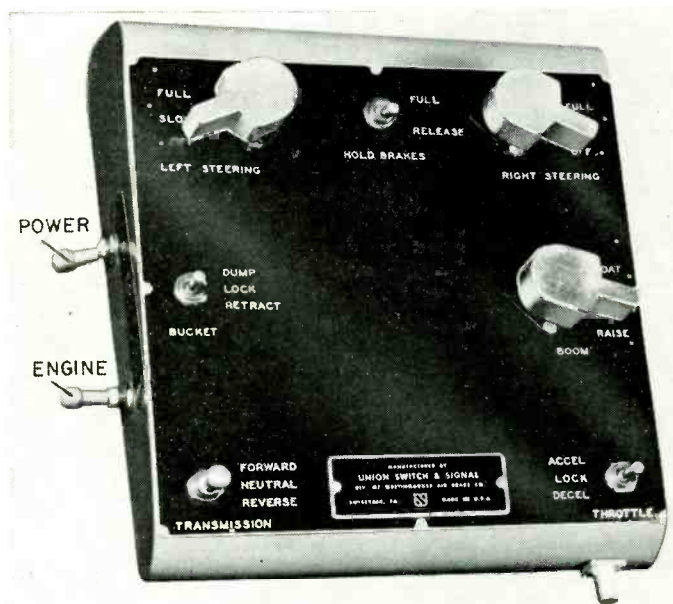

Union Switch & Signal

Fig. 1—The remote-control panel worn by the operator. It is hung so that he can read the control markings; they're upside down to an observer.

with nearly 15 miles of switching track through buildings of the chemical works. The 80-ton diesel-electrics are completely remote-controlled, even to ringing the bell and blowing the horn.

The portable controller weighs less than 5 pounds and is about a foot square by 3 inches deep. It contains a low-power transmitter, frequency-modulated by two or more tones and powered by a rechargeable 14-volt battery. The shoulder-strap harness contains a quarter-wavelength, flexible-wire transmitting antenna. The photo shows an operator wearing an improved antenna mounted on a safety helmet. Here the

antenna is in much better position to reduce signal loss and improve line-of-sight transmission.

A quarter-wavelength vertical receiving antenna is mounted on the tractor. The receiver is a double-conversion superhet, with crystal control and 19 transistors. The audio tones are amplified and rectified to supply 14 volts dc for tractor control relays. When energized by the correct tone, each relay operates air valves and mechanical linkage to produce the desired action.

Fig. 1 is a photo of the remote-control panel worn by the operator. Six controls are spring-return switches. They

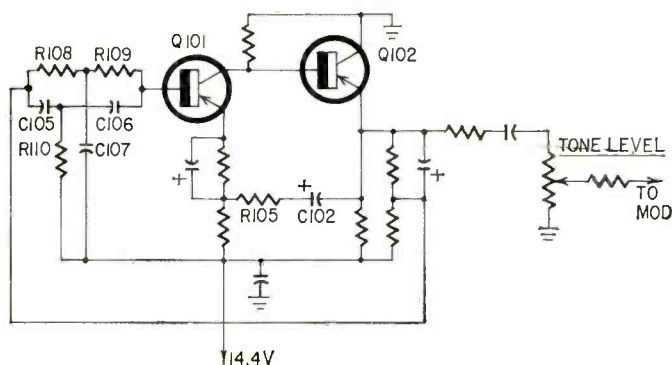

Fig. 2—One of the two-transistor tone generators in the system. Because of the bridged-T feedback loop, generators produce pure sine waves, free of interfering harmonics.



are turned to the desired function and held there until the tractor completes the action. When released, they return to normal, shutting off the transmitter and tone. When tone signals from the control cease, the tractor brakes are automatically applied through interlocked back-contacts of the tractor control relays, making the system fail-safe. Each switch position keys the transmitter on and supplies the proper tone for the desired action.

Twelve tones from 935 to 2,805 cycles are the tractor command signals. Each tone is separated from adjacent channels by 170 cycles. (Four tractor functions require dual tones.) The tractor transmission's forward and reverse control relays are interlocked so that operating both simultaneously puts gears in neutral for starting the engine.

The squelch-release tone is a "transmitter recognition" signal. Near 100 cycles, it is well away from other command tones and serves to remove audio squelch in the receiver. Like a combination lock, the receiver must have the right combination of incoming carrier tone frequencies before it responds. This minimizes the chance of stray interference causing wrong tractor commands.

### The electronics

The tone generators are in modules of less than 1 cubic inch. Each has two transistors in a twin-T R-C oscillator circuit. The circuit of one typical oscillator is shown in Fig. 2.

Capacitors C105, C106 and C107 and resistors R108, R109 and R110 form a twin-T filter. The R-C values set its rejection frequency. Output from Q102 feeds back through the filter to the input of Q101 and cancels amplification for all but one frequency. Therefore the amplifier has maximum gain at the filter rejection frequency only. Positive feedback through C102 and R105 causes oscillation at that frequency.

Level controls and isolation are used to match all tone output levels to the requirements of the modulator. Each control must be set to cause a 1-kc carrier-frequency deviation.

Varactor (voltage-variable capacitor) CR2003 produces frequency modulation by a very simple and direct method (Fig. 3). The diode junction ca-

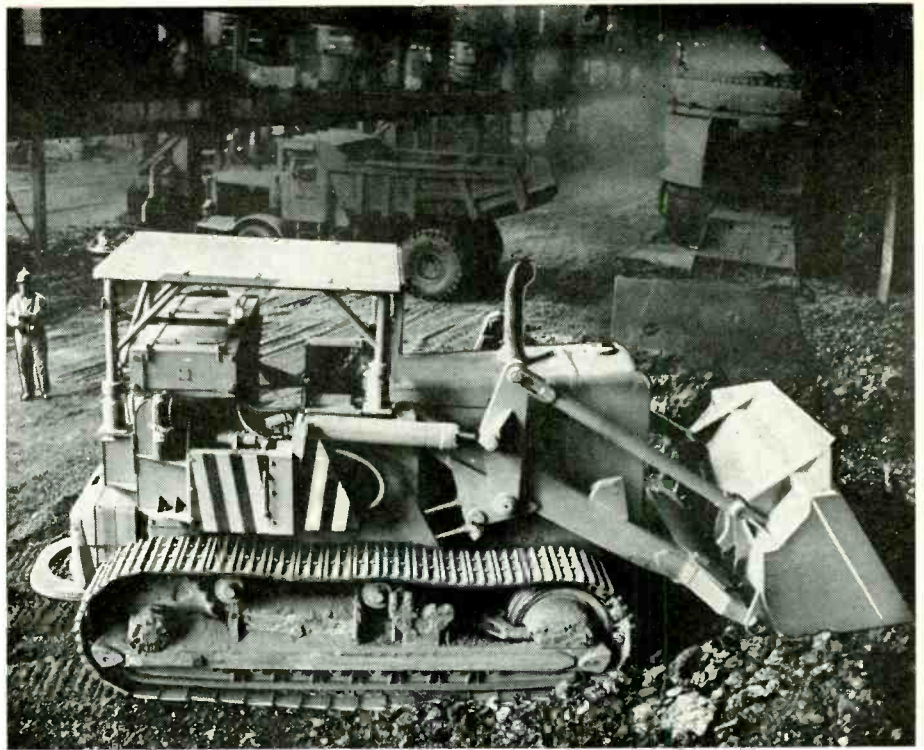

pacitance is adjusted to optimum linear value by setting R2039 for 2.5 volts dc at test point A. The modulator output voltage then causes capacitance change in CR2003 at an audio rate. Because CR2003 is in series with the crystal, the rf oscillator has an FM output. Final adjustment of R2039 sets carrier frequency correct within  $\pm 500$  cycles.

The rf oscillator itself is temperature-stabilized by dc bias. Capacitors C2001 and C2030 provide feedback to insure good crystal activity and stable oscillation. Oscillator output drives a transistor doubler to produce twice the crystal frequency.

Another varactor is used here as a very simple and highly efficient doubler (Fig. 4). Fixed bias through R2006 places operation of CR2001 at a nonlinear point of its operating curve. Rf excitation produces a voltage through CR2001 rich in second-harmonic distortion. Where efficiency is important, the varactor is well suited, for it is capable of a harmonic output near 80% of input.

The varactor output, at four times crystal frequency, is amplified by an emitter follower stage. Again a varactor

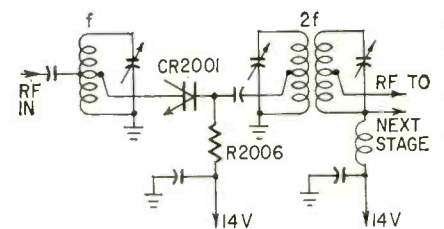

Fig. 4—A Varactor doubler stage in the transmitter.

doubler is used, this time to produce eight times crystal frequency.

The power amplifier is another emitter follower stage. It produces 500 mw at the 50-ohm output jack. A short coaxial cable connects from there to the antenna.

A rechargeable nickel-cadmium battery powers the controller. Rated at 14.4 volts, it allows 7 hours of intermittent operation before recharging.

A safety feature in the controller prevents accidental tractor commands if the operator falls: the ODD POSITION controls are two mercury switches in series with the battery cable. The operator may short them out with the BYPASS switch when an unusual operating position is necessary and deliberate.

The receiver is equally interesting because of its elaborate design for stability, crystal accuracy, high selectivity and high gain. Despite this, it is only 12 x 5 x 2 inches and weighs about 7 pounds.

The 50-ohm antenna input feeds the rf amplifier. An overload diode protects the input stage from excessive antenna signal.

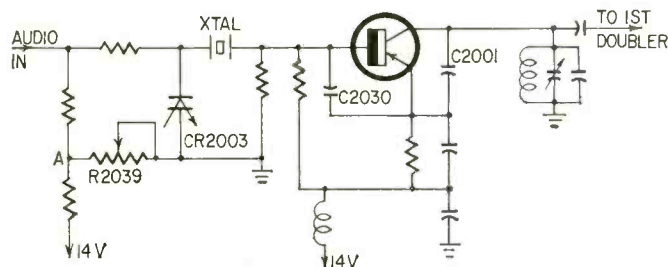

Fig. 3—The frequency-modulated crystal oscillator stage of remote-control transmitter.

The crystal oscillator circuit develops rf which is frequency-doubled and applied to first mixer, a mesa transistor. Mixer output is filtered to remove all unwanted signals.

The first i.f. amplifier receives a 23.5-mc signal. After two stages of amplification, the signal is mixed with the second oscillator signal. This second oscillator is crystal-controlled to produce a 1.9-mc i.f. Three stages of 1.9-mc amplification and limiting follow.

Limiter output is applied to the discriminator tuning circuit, which is temperature-compensated. Audio output voltage is also temperature-compensated to offset increased gain through the receiver with heat.

The 100-cycle transmitter recognition signal is applied through a narrow bandpass filter to the audio squelch circuit. Q403 (Fig. 5) acts as a variable resistance in series with the collector supply voltage of the second audio stage. In the absence of 100 cycles, Q403 acts as a high resistance. When tone is present, CR400 and CR401 rectify the ac voltage to forward-bias Q403. It is now a low resistance, so Q201's collector current flows and the signal passes through.

Tractor command tones are amplified in four stages, including a push-pull

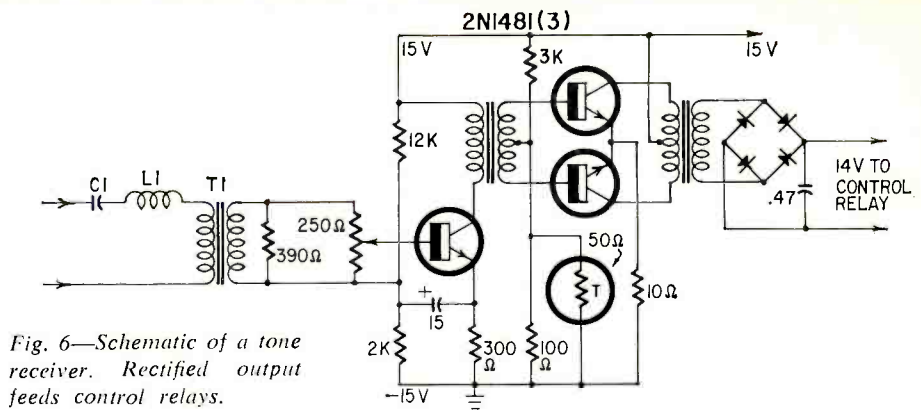

Fig. 6—Schematic of a tone receiver. Rectified output feeds control relays.

output stage. Output leaves the receiver through a twisted-pair line to the inputs of 12 tone receivers mounted in the tractor cab.

Fig. 6 shows a typical tone-receiver circuit. C1 and L1 series-tune the primary of T1 to a single command-tone frequency. The 12 tone amplifiers are each tuned within  $\pm 3$  cycles to accept only one audio frequency from the 13 incoming signals. Here each tone is amplified to a high level and applied to a bridge rectifier. The 14-volt dc developed is used to operate tractor control relays, each amplifier feeding one relay. Each relay applies the tractor battery

voltage to heavy pneumatic solenoids for tractor functions operated by compressed air. The tractor battery powers the control receiver during remote control.

A panel similar to that of Fig. 1 is mounted in the tractor cab for direct operation when desired. For direct operation, the tractor control relays are powered from the tractor battery instead of from the rectified tone voltage.

The small size and lightness of this system make installation a breeze. But remember that operation is primarily line-of-sight at 150 mc. It is important to mount the receiver antenna high and clear of obstructions. The antenna transmission line should be limited to 25 feet to minimize losses in the 50-ohm coaxial cable.

Although ruggedly constructed, the receiver should be mounted for minimum abuse, least dirt and lowest ambient heat. No license is required for the receiver installer, but an FCC license is required for service on the control unit. The transmitter is covered by Part II of the FCC Rules for Industrial Radio Services, Subpart L. END

Fig. 5—Receiver squelch uses 100-cycle tone to "open" second audio stage.

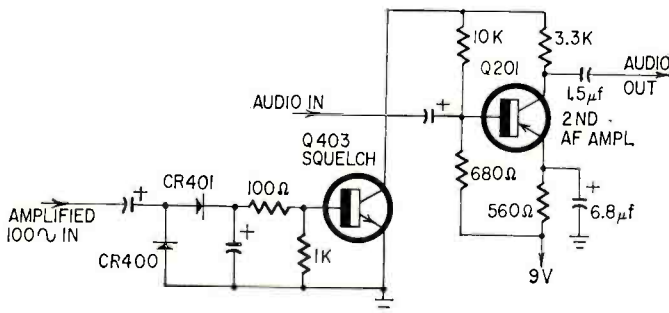

## Voltage Chart (and a Couple of Improvements) for the T-40/40

Mr. Daniel Meyer, designer of the T-40/40 transistor stereo amplifier and author of the article in the March issue describing it, has written us in answer to requests for voltage measurements and to questions about performance.

Note: Voltages given in the chart can vary 10% to 15% because of line-voltage and component tolerances, without degrading the amplifier's performance.

Mr. Meyer writes that he still has circuit boards for his transistor stereo preamp, described in the October 1962 issue of RADIO-ELECTRONICS. "It makes a fine preamp for this amplifier," he writes, "if the supply voltage is changed from 24 to 28 volts. This doesn't require any circuit changes, but it would help keep the noise figure down to change

R52 to 2,200 ohms. The higher supply voltage will give the required 2.5 volts output to drive the amplifier."

Some readers have reported that not all 2N1073's (Fig. 6 in the original article) work properly with R3 470 ohms. Mr. Meyer suggests changing R3 to 150 ohms, and says that then the circuit should work with the leakiest 2N1073 you can find.

He also suggests a "safety valve" in

the form of a silicon diode (1N645 or equivalent) connected across R13 in Fig. 2. It would prevent the current in the output stage from going to destructive values if something went wrong by conducting and limiting the voltage across the base-emitter junction of Q6.

Corrections to the original article have appeared on page 92 of the April issue, and on page 48 of the May issue.

END

OPERATING VOLTAGES ON T-40/40 AMPLIFIER (Measured with vtvm)

Transistor	Q1	Q2	Q3	Q4	Q5	Q6
Base	12.0	3.25	31.75	30	31	1.0
Emitter	11.25	2.5	31	30.25	30.5	.25
Collector	30.0	30	64	1.0	64	30.25



# LIVE BETTER ELECTRONICALLY with LAFAYETTE RADIO ELECTRONICS

## HI-FI AND CB EQUIPMENT Headquarters



Model HB-500  
**139<sup>50</sup>**  
99-3027WX

### NEW! LAFAYETTE 70-WATT COMPLETE AM-FM STEREO RECEIVER

Just Add Speakers and Enjoy FM, FM Stereo and High-Quality AM Reception

■ A powerful 70-Watt Amplifier plus Complete Preamplifier Control Facilities plus a Standard AM Tuner plus a sensitive FM Tuner plus an FM Stereo Tuner—all on One Compact chassis ■ Amazing FM "Stereo Search" Circuit Signals Presence of Stereo Broadcasts ■ Tuned Nuvistor "Front End" provides Greater Sensitivity, Lower Noise ■ Bar-Type Tuning Indicator for AM and FM ■ Variable AFC Control ■ Imported

TAKES REELS UP TO 7"



‡ adaptable to stereo playback

DYNAMIC MICROPHONE

### THE WIDELY ACCLAIMED LAFAYETTE RK-137A TAPE RECORDER

FEATURING **4**-TRACK STEREO PLAYBACK‡  
**4**-TRACK MONAURAL RECORD PLAYBACK

With Electronic Track Selector Switch, VU Recording Level Meter and Pause Switch For Instant Editing  
Includes Lightweight carrying case, dynamic microphone, output cable, 7 inch empty tape reel.  
● Two Speeds—3¼ & 7½ ips ● Pause Lever Provides Instant Stop for Editing ● Record—Erase Safety Switch ● Fast, Rugged Shift Lever Control ● Extension Speaker Jack ● High Impedance Monitoring Jack ● VU Meter Recording Level Indicator ● Electronic Track Selector Switch ● Specially Designed Heavy-Duty 6x4" PM Speaker ● Separate Erase and Record Heads ● Imported

Model LR-800  
**199<sup>50</sup>**  
99-0005WX



### Small... Quiet... Powerful! NEW! LAFAYETTE SOLID-STATE DUAL CONVERSION 5-WATT CB TRANSCEIVER

With Authentic Mechanical Filter

- ✓ Only 3" high—fits easily in any car
- ✓ Special multi-stage noise limiting circuit ends problem of mobile noise
- ✓ The same output as the most powerful tube unit yet uses only 1/50th of the battery power

The Perfect Unit For Mobile!

- 12 Crystal Transmit and Receive Positions ● 23 Channel Tunable Receiver With Spotting Switch ● 3-Stage Transmitter Rated For Full Legal Power ● Dual Conversion Receiver with 5/10 μV Sensitivity ● Multi-Stage Automatic Noise Limiting Circuit ● Rugged Silicon Mesa Transistors ● Compact—3"Hx11¼"Wx6½"D ● 12V DC Mobile Operation (Negative or Positive ground) ● 117V AC operation when used with Matching Solid-State AC Power Supply (Optional at \$16.95)

Model RK-137A  
**89<sup>50</sup>**  
99-1511WX



Model HB-400  
**169<sup>50</sup>**  
99-30Q1WX

### NEW! LAFAYETTE 23-CHANNEL 5-WATT CB TRANSCEIVER

Double Side Band Full Carrier

- ✓ 17-Tube Performance with 13 Tubes
- ✓ Low Noise Nuvistor "Front End"
- ✓ 5 Double-Tuned If Transformers
- ✓ Meets All FCC Requirements
- Frequency Synthesized Circuit Provides 23 Crystal-Controlled Transmit & Receive Channels—No Extra Crystals to Buy ● Continuous One-Control Channel Tuning ● Full 5-Watt Input ● Push-To-Talk Microphone & Electronic Switching ● Dual Conversion Receiver With 3/10 μV Sensitivity ● Delta Tuning Offers "Fine Tuning" of ±2.5Kc on Receive ● Illuminated "S" and RF Output Meter ● Variable Squelch, Variable Noise Limiter, AGC ● Built-in 117V AC & 12V DC Power Supply ● "Vari-Tilt" Mounting Bracket for Easy Mobile Installation ● Plug-in Facilities For Lafayette Selective Call Unit

With Advanced "Range-Boost" Circuit

# FREE! LAFAYETTE RADIO ELECTRONICS

1965 CATALOG NO. 650 516 PAGES!

See The Largest Selection in Our 44-Year History

- Stereo Hi-Fi — Famous Brands plus Lafayettes own Top-Rated Components
- Citizens Band Equipment
- Tape Recorders ● Ham Gear
- Radio's, TV's and Accessories
- P.A. Equipment; Intercoms
- Test Equipment ● Optical Goods
- Auto Accessories ● Musical Instruments

LAFAYETTE RADIO ELECTRONICS  
Dept. JH-5, P.O. Box 10  
Syosset, L.I., N.Y. 11791

Send me the FREE 1965 Lafayette Catalog 650 \$ enclosed; send me ..... (Prices do not include shipping charges).

Name.....  
Address.....  
City..... State..... Zip.....



# EQUIPMENT REPORT

## Triplet Model 630-M Volt-Ohm-Microammeter

Many disadvantages of a vtvm—need for a power source, drift, grounded case—are eliminated by the Triplet model 630-M volt-ohm-microammeter, yet it has nearly all the advantages, such as high input resistance.

Unlike a vtvm, the vom needs no warmup and has no zero drift since there are no amplifiers. Nor are they needed with a 1-megohm-per-volt sensitivity. The 630-M can measure currents of 20 nanoamperes (.02  $\mu$ a) and voltages as low as 5 mv.

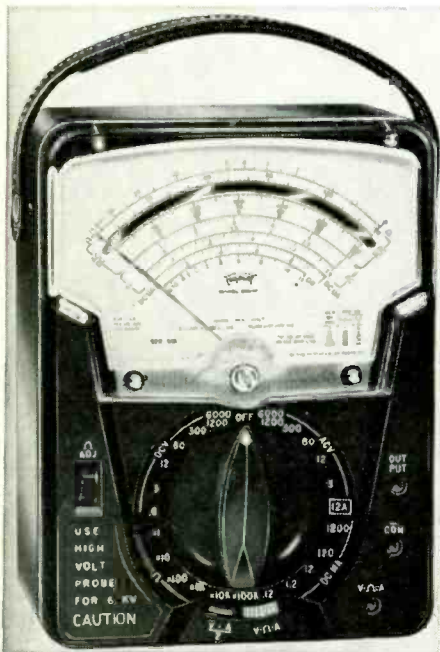

This is possible because of the taut-band meter movement. By doing away with the usual pivots, hairsprings and jeweled bearings (all of which produce friction) and using instead a stretched, hair-thin ribbon to suspend the coil and pointer, Triplet has made a 1- $\mu$ a full-scale meter movement rugged enough for a portable instrument with 1,000,000-ohm-per-volt sensitivity.

The delicate parts in a conventional d'Arsonval movement are similar to the balance wheel and hairspring in watches and small windup clocks—and you know what often happens when you drop a watch or clock: the pivots are shocked out of their bearing cups and the time-piece stops working. In the taut-band meter, the ribbon is securely anchored on both ends with the moving coil attached in the center—no pivots to slip out of place or get dirty or sticky, (nor to crack or change the amount of friction they present to the rotation of the moving-coil assembly.)

This reduced friction helps in other

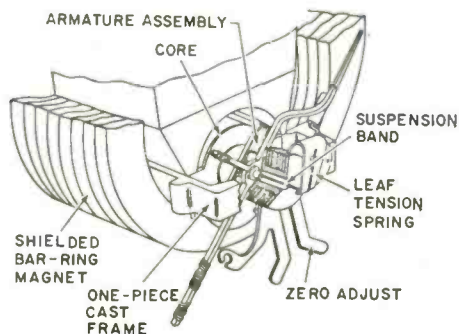

ways too. Measurements are more predictable, more repeatable. The accuracy of the Triplet model 630-M is higher than that of many other similar units of about the same price. The tolerance can be reduced to 1.5% of the full-scale reading for dc and 3% for ac. By comparison, a 20,000-ohm-per-volt vom is generally within 3%, sometimes 2% on dc. A vtvm is usually within 3% on dc and 5% on ac.

At 1-megohm-per-volt sensitivity, the input resistance of the 12-volt dc range is a little higher than that of a vtvm—most of which are 11 megohms for all ranges (some are 25 megohms with a low range of 5 volts full scale).

Actually the Triplet 630-M is a multiple-sensitivity instrument. A two-position selector switch changes the basic dc sensitivity from 500,000 to 1,000,000 ohms per volt. When the sensitivity is changed, the full-scale reading is changed, too. For example, the 12-volt full-scale range at 500,000 ohms per volt becomes 6 volts full-scale at 1,000,000 ohms per volt. (See the report on the Triplet 630-NS, which has a similar feature, in November 1963.)

The dual-sensitivity feature is not used on the 6 resistance ranges. Center-scale readings are 4.4, 44, 440, 4,400, 44,000 and 440,000 ohms. It is easy to read resistances of less than 1/2 ohm or more than 5,000,000 ohms (5 meg).

The sensitivity of the ac ranges is either 20,000 or 10,000 ohms per volt, depending on the position of the sensitivity selector switch.

The specifications list a total of 61 ranges (see list at end of report).

### Radio-Electronics Offers You A New Service

Starting with the September issue, *Radio-Electronics* will publish a *Readers' Service Page*.

By mailing in the postage-free business reply card on the *Reader's Service Page*, you will receive, at no cost to you, more information about products and services featured in *Radio-Electronics*.

*Radio-Electronics* will forward your requests to the companies, and they will send the material direct to you.

The accuracy of 1/5% is possible only when the mirror scale is used properly. The pointer must hide the reflected image to eliminate parallax that can reduce the accuracy of any reading.  
—Elmer C. Carlson

### MANUFACTURER'S SPECIFICATIONS

DC volts: 0.6-3-12-60-300 at 500,000 ohms/volt; 0.3-1.5-6-30-150 at 1,000,000 ohms/volt; 1200 at 125,000 ohms/volt; 600 at 250,000 ohms/volt  
AC volts: 3-12-60-300-1200 at 10,000 ohms/volt; 1.5-6-30-150-600 at 20,000 ohms/volt  
Db: -20 to +63 in 10 ranges  
DC microamperes: 1 at 300 mv; 60-600 at 300 mv; 120 at 600 mv  
DC milliamperes: 6-60-600 at 300 mv; 1.2-12-120-1200 at 600 mv  
DC amperes: 6 at 300 mv; 12 at 600 mv  
Ohms: R  $\times$  1-10-100 (4.4-44-440 at center scale)  
Megohms: R  $\times$  1K-10K-100K (4400-44,000-440,000 ohms center scale)  
Output: Capacitor in series with ac ranges  
Scale: 4.5 in. long at top arc. Black on white except 1.5 and 3 acv and ohms, which are red on white  
Battery: Self-contained. One Eveready 1.5V #950, or equivalent  
Weight: Approximately 4 lb.  
Price: \$199.50  
Triplet Electrical Instrument Co., Bluffton, Ohio 45817

## EICO 3566 Solid State FM MPX Stereo Tuner-Amplifier

This Eico receiver is an impressively complete package. It is obviously designed for the audiophile who loves good reproduction but is tired of twiddling, or for the music lover who wants a simple, reliable, clean-sounding unit.

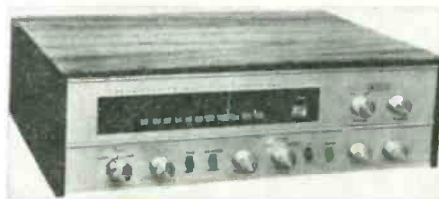

Next to the performance, which meets specs in every important way (and the specs are good), the most outstanding feature of the 3566 is the simplicity of its controls. Every feature that the average music listener could want is there, but there are no frills. For example:

The program source selector has only three positions: TUNER, PHONO and AUX. (When's the last time you used the tapehead input of your preamp?) There is a fourth source, but it is very sensibly switched by a separate slide switch marked TAPE-INPUT. Normally in the INPUT position, the switch passes any of the three program sources chosen by the selector. In the TAPE position, those are cut off and instead you hear tape playback (externally preamplified). This is good either for playing tapes in the ordinary way or for monitoring just-recorded sound via a separate playback head on your recorder (if your machine is a three-head design).

The MODE switch has only two posi-



tions: MONO and STEREO. (How often have you used the STEREO REVERSE, or the A or B position on your amplifier?) The power switch is separate from the volume control, so you can leave everything preset and simply turn on the power when you want to listen. Hardly vital, but a pleasant and inexpensive bonus—like “instant-on” television. All that remains are the usual bass, treble, volume and balance controls; a tuning knob, and three more switches: one that throws loudness compensation into the volume control, and one each for switching muting and afc in or out.

Now, how well does it perform? Very well. It is an exceptionally sensitive unit, and highly selective as well, with a comparatively steep-sided, flat-topped i.f. characteristic that is ideal for FM stereo reception and also makes tuning relatively easy and uncritical. There is a signal-level type tuning indicator, which serves almost as well as a zero-center meter as long as the i.f. stages and ratio detector are properly aligned. It also gives a rough indication of signal strength, which a zero-center meter can't do.

An item of particular interest with every FM tuner that uses transistors in its front end is how the tuner behaves with a strong signal. High sensitivity is not hard to come by, but it often makes the tuner vulnerable to cross-modulation near a powerful FM signal. The 3566 acquitted itself of all suspicion. I connected an rf signal generator across the antenna terminals (with an antenna connected also) through a pair of 150-ohm resistors, one in each leg. Cross-modulation (manifested by the appearance of the generator's signal at several points on the dial, and other spurious phenomena) did not appear until the rf level was over 10,000  $\mu\text{V}$ . A station outside the passband of the tuned antenna circuit is not likely to develop that kind of signal under ordinary conditions. Looks as though (with this receiver at least) some of the widely circulated fears about the susceptibility of transistors to cross-modulation can be laid to rest.

Audio quality and stereo separation are excellent. The amplifier puts out a legitimate 22 to 25 watts rms per channel (into 8 ohms) even with both channels driven simultaneously into separate loads. At extremes of the audio range, the power is down only 1 db or so.

Afc and muting are both extremely effective. The afc has what I call an “aggressive” quality—it seems to suck a station up and hold it fast over a broad space on the dial. From the performance of the receiver I'd guess that afc is provided for the sloppy tuners, the people who like to whip the knob around and expect to find a station there in perfect tune when it comes to rest. Drift, without afc, is negligible. The afc can, of

course, be disabled for tuning in weak stations. Muting works well but does kill a lot of the weaker stations. Almost unavoidable.

As a matter of design philosophy, Eico uses no devices except ordinary fuses to protect the output transistors from a short across the speaker terminals. The reasoning behind this is that an absolutely reliable protective system would cost unreasonably much, especially since the protection can be provided by the user, if he takes just a little more than ordinary care to avoid shorting the speaker leads, accidentally or otherwise. The operating manual for the 3566 includes an elaborate checkout procedure that must be followed religiously before plugging in the line cord. (To those who would count on the fuses to blow before the output transistors do: don't.) In case of an accident, Eico offers a replacement parts kit for \$5—their cost. It includes two output transistors, two bias-regulating diodes and two emitter resistors—the components most likely to vaporize under a short circuit.

Unfortunately there was no time to assemble the kit version of the 3566. It looks easy but time-consuming—as you might expect with 43 transistors. But Eico emphasizes that the finished kit needs no alignment except for adjusting the muting threshold. Front end, i.f. and multiplex are all preassembled, wired and aligned.

The Eico 3566 looks like and sounds like a delight to own. One of its nicest features is that it stays almost at room temperature even after hours of use, and its power consumption with no signal is only 25 watts! Find a tube receiver that'll match *that!*—Peter E. Sutherland

#### MANUFACTURER'S SPECIFICATIONS

**Amplifier and preamp**  
 IHF music power: 112 watts at 4 ohms, 75 watts at 8 ohms, 37.5 watts at 16 ohms (both channels)  
 RMS power: 52 watts at 4 and 8 ohms, 28 watts at 16 ohms (both channels)  
 Following measurements made with an 8-ohms resistive load:  
 Power bandwidth: 8 to 60,000 cycles (estimated) at 25 watts per channel; 20 to 20,000 cycles at 25 watts per channel, 0.5% distortion  
 IM distortion: 2% at 30 watts per channel, 1% at 25 watts per channel; 0.3% at normal listening level  
 Harmonic distortion: 0.5% from 20 to 10,000 cycles at 25 watts per channel  
 Frequency response:  $\pm 1$  db, 5 to 60,000 cycles  
 Hum & noise: 70 db below 10-mv input on magnetic phono, 70 db below rated power on other inputs  
 Sensitivity: 3 mv on mag. phono, 180 mv on other inputs  
**FM tuner & multiplex section**  
 Sensitivity (IHF standards): 2  $\mu\text{V}$  (30 db quieting), 2.7  $\mu\text{V}$  for full quieting (40 db)  
 Harmonic distortion (IHF standard): 0.5%  
 Frequency response: 1 db, 20 to 15,000 cycles  
 Channel separation: 40 db  
 Capture ratio: 4.5 db  
 Signal-to-noise ratio: 60 db  
 If & spurious-signal rejection: 80 db  
 19-kc suppression: 45 db  
 38-kc suppression: 55 db  
 SCA suppression: 40 db  
 Power requirements: 117 volts ac; 25 watts, no signal, 110 watts at full power  
 Cabinet dimensions: 5 $\frac{3}{4}$  x 17 $\frac{1}{4}$  x 13 $\frac{1}{4}$  with feet  
 Weight with cabinet: 22 $\frac{1}{2}$  lb  
 EICO Electronic Instrument Co., Inc., 131-01 39th Ave., Flushing, N.Y. 11352. \$219.95, kit; \$325, wired

## 3 WAYS TO BIGGER

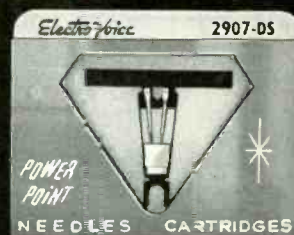

## NEEDLE



## CARTRIDGE PROFITS!

1. More “look-alike” exact replacement models than any other brand. Over 350 needles, 225 cartridges.
2. Easy-to-use reference material. E-V computer-printed catalogs make proper needle/cartridge selection easy, fast and accurate.
3. Highest standards. Rigid quality control and inspection cuts call-backs, gives full value to every customer.

Stock and sell E-V needles and cartridges for more profits. Pick up your FREE replacement guide at your nearby Electro-Voice distributor today!

**ELECTRO-VOICE, INC.**  
 Dept. 857E, Buchanan, Michigan 49107

**Electro-Voice**  
 SETTING NEW STANDARDS IN SOUND

# NEW LOWER PRICES ON HEATHKIT® CB!

Save \$20 On "Master Station"  
Transceiver!

Kit GW-42 **\$99<sup>95</sup>**

(was \$119.95)



- 5 crystal-controlled transmit & receive channels • Tunes 23 channels • 4-tone selective call • 6 or 12 v. DC, 117 v. AC • PTT mike, cables & crystals for 1 channel. 23 lbs.

Save \$15 On Selective Call Transceiver!

Kit GW-32A **\$69<sup>95</sup>**

(117 v. AC)

(was \$84.95)



- 5 crystal-controlled transmit & receive channels • Built-in selective call • PTT mike, cable & crystals for 1 channel • Kit GW-32D (6-12 v. DC) \$74.95. 5 lbs.

Save \$12 On 5-Channel Transceiver!

Kit GW-22A **\$47<sup>95</sup>**

(117 v. AC)

(was \$59.95)



- 5 crystal-controlled transmit & receive channels • PTT mike, cable & crystals for 1 channel • Kit GW-22D (6-12 v. DC) \$49.95. 13 lbs.

Save \$5 on 5-Channel Transceiver!

Kit MW-34 **\$84<sup>95</sup>**

(was \$89.95)

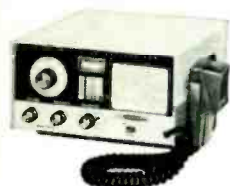

- Receives 23 channels • 1 front-panel transmit crystal socket • 5 crystal-controlled transmit & receive channels • 6-12 v. DC, 117 v. AC • PTT mike, cables, crystals for 1 channel. 16 lbs.

Save \$5 On  
1-Watt Walkie-Talkie!

Kit GW-52 **\$69<sup>95</sup>**

(pair \$129.95)



- Operates up to 3 miles • Battery charges from 117 v. AC or 12 v. DC • All-transistor circuit • Case, earphone, crystals 4 lbs.

## FREE CATALOG!



HEATH COMPANY, Dept. 20-8, Benton Harbor, Michigan 49023  
In Canada: Daystrom, Ltd., Cooksville, Ontario

Enclosed is \$\_\_\_\_\_ plus shipping. Please send model(s)\_\_\_\_\_

Please send FREE Heathkit Catalog.

Name \_\_\_\_\_

Address \_\_\_\_\_

City \_\_\_\_\_ State \_\_\_\_\_ Zip \_\_\_\_\_

Prices & specifications subject to change without notice. GX-141

# TECHNOTES

## SCOPE CHECKS ANTENNA ROTATORS

An antenna rotator and control box can be checked rapidly with an oscilloscope and an audio generator.

A large capacitor is used in the rotator control box, switched alternately from leg to leg of the motor to supply voltages in quadrature that drive the motor either right or left, depending on the relative phase. If the capacitor, motor windings and all other components are in good shape, a perfect circle on the scope screen will indicate that the voltages are indeed in quadrature (see the diagram). Any defect will be displayed as something other than a circle.

By modulating the beam with the line frequency (via the Z-axis terminal, if your scope has one), half the pattern can be blanked out. Flipping the direction switch will shift the pattern 90°.

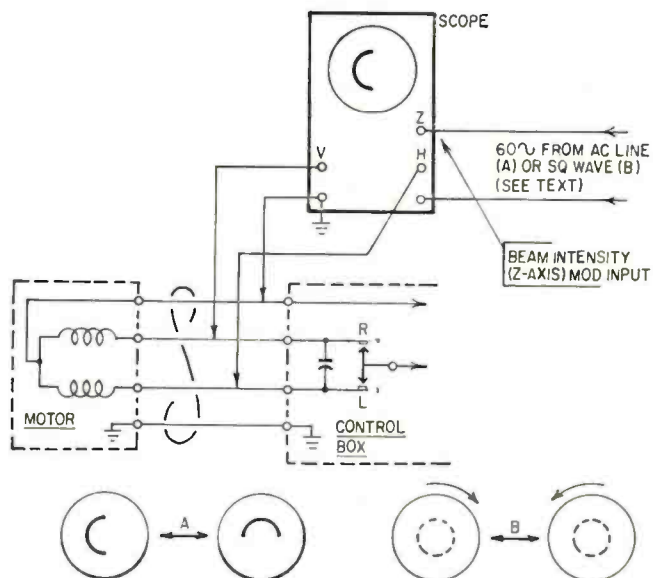

Another method is to modulate the beam with an audio sine or square wave. (A square wave is preferable because it gives sharper blanking.) As long as the generator is not tuned to the line frequency or some exact multiple of it, the pattern—a circle of bright spots or dashes—will rotate. Reversing the control switch will reverse the direction of the pattern's rotation, indicating that the rotator motor would also change direction.

Remember, initially, to remove the horizontal and vertical inputs to the scope alternately to set the gain controls equally, otherwise you won't get a perfect circle even if the rotator is all right.—M. P. Willoughby

## CANADIAN GENERAL ELECTRIC USING SARKES TARZIAN TUNERS

When you have to replace the fine-tuning wafer in one of these tuners, the job is much easier if you solder the ground lug from the wafer *after* the unit is reassembled. Drill a hole through the front plate where the old lug was soldered, straighten the bend in the new lug and reassemble the spac-



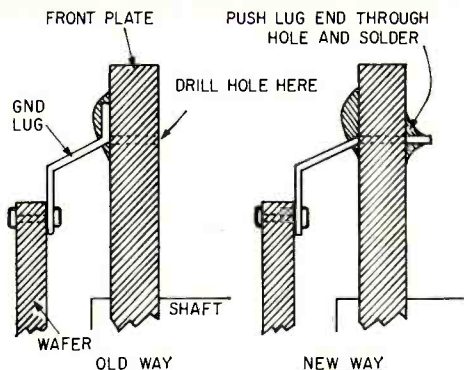

ers. Solder the upper coil to the new wafer before the front plate is replaced. When replacing the front plate, feed the ground lug through the drilled hole. Push the fine-tuning shaft into place (to align the wafer and prevent excessive pressure) and solder the ground lug.—*George Hrischenko*

### INSTANT INSTANT-ON

Customer complained that his 24-inch series string 24-inch Motorola had a fine picture only after it had been on a half hour or so. A series-string booster on the pix tube helped but not enough. The thing to do was, once the set was hot, to keep it hot. But you can't keep a set turned on all the time. As the next best thing, I put a 750-ma silicon diode across the ac switch. This gave the set an "instant-on" feature.

The customer still calls me up to ask how I did it and tells everyone I'm some kind of genius.—*Sid Elliot*

### WELDING TIMERS

When an automatic spot-welder, such as the Sciaky PMCO, fails to complete its cycle, the fault is usually in one of the program timers.

Short the switch terminals of each timer in succession. When you find one that does not cause the associated thyatron to fire in a second or less, it is defective.—*R. C. Roetger*

### PIONEER AMR 81 RECEIVER

When replacing pilot lamps in this popular imported amplifier, be sure that the rubber grommet that holds the lamp socket is not worn. A worn or broken grommet that allows the socket to short to the chassis will short out the dc hum-bucking voltage derived from the cathodes of the output tubes. This voltage is applied directly through a low-resistance balancing pot, so a short will remove bias from the output tubes, causing them to overheat and possibly damaging the output transformer. If necessary, replace the grommet and set it in place with service cement.—*Steve P. Dow*

### BATTERY SOLDERING IRON FOR BOATS

If you have ever had to solder a connection on a small boat while installing a radiotelephone or making repairs, you know how difficult it is to find a source of power to heat an electric soldering iron.

On small boats the power source is usually a 6- or 12-volt battery.

I don't like to use a torch because you never know when gasoline vapor will ignite.

So I bought a General Electric 6A210 6-volt soldering

# KIT OR ASSEMBLED!

Either Way, These HEATH Instruments Are Your Best Buy!

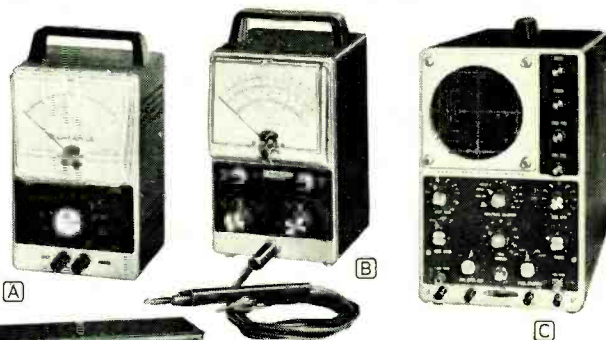

**(A) Heathkit IM-21 Laboratory AC VTVM.**  
• 10 voltage ranges—0.01 to 300 volts RMS full scale • 10 megohm input Z  
Kit IM-21, 5 lbs. . . . . \$33.95  
Assembled IMW-21 . . . . . \$52.95

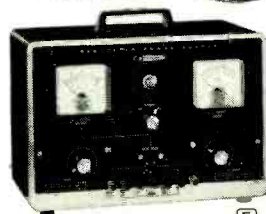

**(B) Heathkit IM-11 VTVM . . . Versatile!**  
• 7 AC, 7 DC, 7 Ohms ranges • Frequency response  $\pm 1$  db, 25 cps to 1 mc.  
Kit IM-11, 5 lbs. . . . . \$24.95  
Assembled IMW-11 . . . . . \$39.95



**(C) Heathkit Wide-Band Oscilloscope**  
• 5 mc bandwidth • Sweep 10 cps to 500 kc • 5" screen with graticule  
Kit IO-12, 24 lbs. . . . . \$76.95  
Assembled IOW-12 . . . . . \$126.95



**(D) Heathkit IM-13 "Service Bench" VTVM** • 7 AC, 7 DC, 7 Ohms ranges • Extra-large 6" meter • Gimbal mounting  
Kit IM-13, 7 lbs. . . . . \$32.95  
Assembled IMW-13 . . . . . \$49.95



**(E) Heathkit Variable-Voltage Regulated Power Supply** • Furnishes B+, Bias, & Filament voltages • Fully metered  
Kit IP-32, 16 lbs. . . . . \$56.95  
Assembled IPW-32 . . . . . \$84.95



**(F) Heathkit Audio Generator** • Switch-selected output—10 cps to 100 kc • Near-perfect sine wave  
Kit IG-72, 8 lbs. . . . . \$41.95  
Assembled IGW-72 . . . . . \$64.95

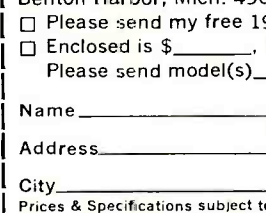

**(G) Heathkit "Solid-State" Regulated DC Power Supply** • 0.5 to 50 v. • Up to 1.5 amp. • Less than 150 uv ripple  
Kit IP-20, 13 lbs. . . . . \$72.95  
Assembled IPW-20 . . . . . \$114.95

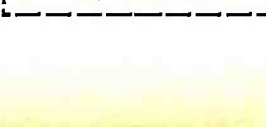

**(H) Heathkit Battery Eliminator** • Switch select 6 or 12 v. DC power • AC ripple less than .3%  
Kit IP-12, 20 lbs. . . . . \$47.50  
Assembled IPW-12 . . . . . \$59.95

### FREE CATALOG

Fully describes these at over 200 other different and exciting Heathkits and savings of 50% or more! Fill out the coupon below and send for your FREE copy today!

**HEATH COMPANY, Dept. 20-8**  
Benton Harbor, Mich. 49023

Please send my free 1965 Heathkit Catalog.  
 Enclosed is \$ \_\_\_\_\_, plus postage.  
Please send model(s) \_\_\_\_\_

Name \_\_\_\_\_  
(Please Print)

Address \_\_\_\_\_

City \_\_\_\_\_ State \_\_\_\_\_ Zip \_\_\_\_\_

Prices & Specifications subject to change without notice. TE-134

add an fm-stereo service center  
with this one new  
sencore unit!

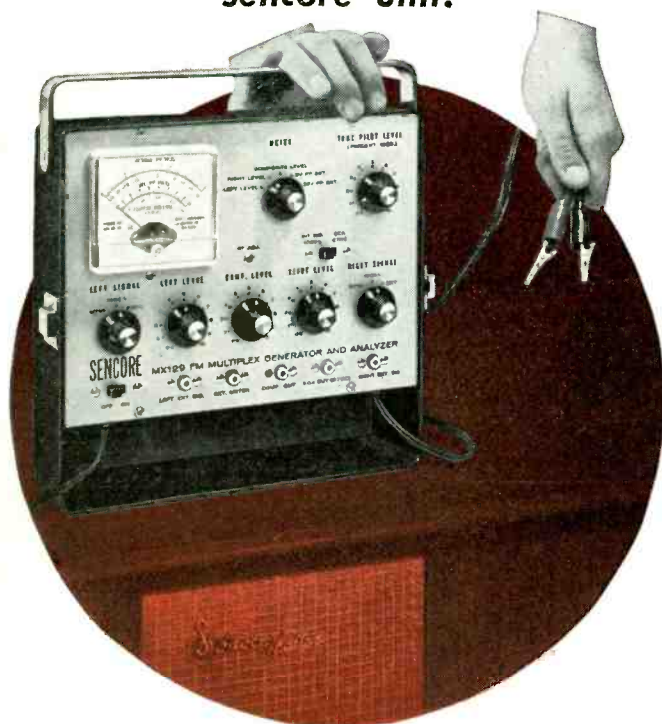

## THE SENCORE MX129 FM STEREO MULTIPLEX GENERATOR & ANALYZER

FM-Stereo growth continues to mount and is fast becoming as big a field as Color TV. This means more FM-Stereo service business for you, now and in the future. Is your shop equipped? It can be — completely and economically — with the MX129, the FM-Stereo "Service Center in a Case." The instantly stable, 19-Transistor, crystal controlled MX129 is the most versatile, most portable (only 7½ pounds), most trouble free and efficient multiplex unit on the market — just like having your own FM-Stereo transmitter on your bench or in your truck. Powered by 115 volts AC, it produces all signals for trouble shooting and aligning the stereo section of the FM receiver . . . can be used to demonstrate stereo FM when no programs are being broadcast. Self-contained meter, calibrated in peak to peak volts and DB, is used to accurately set all MX129 controls and as an external meter to measure channel separator at the FM-Stereo speakers. NO OTHER EQUIPMENT IS REQUIRED. only

**\$169<sup>50</sup>**

### SIGNALS AVAILABLE FOR ALIGNMENT, TROUBLE SHOOTING AND ANALYZING:

FM-RF carrier with composite multiplex audio signal with 38kc suppressed carrier, 19kc pilot and 67kc SCA signals • Multiplex signal formed by 60 or 1000 cycle internal tones or any external signal • Full control over left and right channel amplitude (modulation) • External 67kc SCA signal available for trap adjustment • Composite signals available for signal injection FM detector •

*professional quality — that's the difference!*

# SENCORE

426 SOUTH WESTGATE DRIVE • ADDISON, ILLINOIS

iron. It comes with a stepdown transformer and can be used on 117 volts ac in the shop. On a 6-volt boat I just eliminate the transformer and clip the leads direct to the battery. On a 12-volt boat, to drop the voltage to 6 volts and also have a bit of an extension cord, I figured out that 33 feet, 6 inches of Belden 8782 No. 24 AWG stranded two-conductor speaker cable works out perfectly.—*Sid Elliot*

### THREE GO/NO-GO CHECKS FOR LOCAL OSCILLATORS

These three quick checks to show whether or not a transistor radio's local oscillator is working need only a vtvm (25 megohms input resistance is better than 11, but 11 will do).

1. Measure voltage between base and emitter. If a p-n-p transistor is used, the base (in an oscillator) will be *positive* to the emitter; if an n-p-n transistor is used, the base will be *negative* to the emitter. If there is no potential difference, the oscillator is not working.

2. Connect the vtvm across the emitter resistor so the meter reads upscale. Short the tuning capacitor plates. If the meter drops to zero, the oscillator is working.

3. Check the rf voltage across the oscillator tank (or part of it)—usually less than 2 volts. Use an rf probe for this.

If one check leaves you in doubt, one or both of the others will make sure.—*E. L. Deschambault*

### DISTORTION IN GRUNDIG TK45 RECORDER

We have had several machines in with complaints of low audio and severe distortion. All machines were of the later types (the earlier type was without the additional ECC83/12AX7 in the amplifier). The stereo output stage in this machine consists of one ELL80, a dual pentode with a common cathode. Each section is used as a separate single-ended output tube. The distortion is common to both channels and is present on stereo or mono. The common cathode bias resistor was found to be open in all cases (R14, 160 ohms). It was replaced with a new 2-watt unit.—*Steve P. Dow*

### TAPE-HEAD SUBSTITUTE

When repairing tape recorder input circuits, it is often convenient to substitute some other transducer for the tape head. For ordinary heads, a 1,000-ohm magnetic earphone may be used. It will act as a microphone when the circuit is operating normally. Low-resistance heads may be replaced with a dynamic earphone of 16 to 50 ohms, such as a surplus R30, or by an old variable-reluctance pickup.—*James D. Lucey*

### BIG RESIDUAL READING ON HEATH AV-3 VTVM

I recently ran across a Heath AV-3 ac vtvm with a residual voltage indication, between 5 and 10% of full scale. This was constant at all ranges, even with the input shorted. The offset was varied only by reversing the line plug, indicating some stray pickup was involved.

The usual checks of power supply, tubes and components followed. Tubes were substituted, B+ filtering improved, and a silicon diode installed in place of the selenium one. No luck. The offset remained.

The situation had reached the point for considering exotic remedies, such as the injection of a 60-cycle at some bucking signal point. I tentatively coupled the grid of the first 12AT7 amplifier to one of the heater tiepoints through a



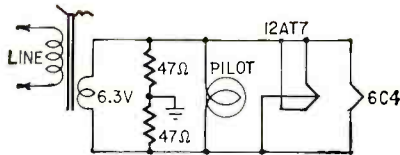

Fig. 1

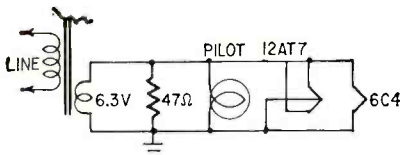

Fig. 2

small paper capacitor. Nothing happened. Was the capacitor too small? A .001 unit seemed adequate. I brushed the lead against the other heater tiepoint and the meter went off scale. What was this?

According to the schematic (Fig. 1) there should be about 3 volts at each tiepoint. Another (good) voltmeter showed a full 6 volts at one and zero at the other. In confirmation, one 47-ohm resistor was quite hot, its mate stone cold dead. Somewhere along the filament line was a short to ground, producing the situation of Fig. 2. The tube heaters were still being supplied with their proper voltage. But the heater-cathode-to-ground signal balance was quite upset . . . hence the meter offset.

The trouble was finally traced to a lead to the 6C4 preamplifier tube. Heat from soldering had weakened the wire's insulation and finally caused a short against the socket mounting screw head. It was probably only intermittent at first, curing itself with a rap on the case from some annoyed worker. Later on, the offset may have been taken for granted as some inherent quirk of the test equipment. Later on, this same trouble was found in another one of the same type meter, where the guilty wire had been stretched about a socket ground lug to dress it close to the chassis.—*F. W. Chesson*

### BUICK AUTO RADIO

This all-transistor Buick radio was intermittent, and wouldn't play above 1200 on the dial. The i.f. transformers were jiggled; the second i.f. was the culprit. I replaced it with a Delco 122E856.

The radio, with 12.6 volts applied to the power lead, would not oscillate above 1200 kc. The DS-25 transistor was unsoldered and tested. The result was about average, but I replaced it anyway. The radio returned to normal.—*Homer L. Davidson*

### COIL SPRINGS HELP KEEP GUYS TIGHT

I have always had trouble with guyed antenna jobs, because when they are guyed tight, constant vibration and tension from winds tend to loosen the anchors, which in my case are usually screwed down to the roof.

I have found that if I use a coil spring from an old flat bed, then pull the guys to the point where the springs just start to stretch, the problem is solved.

The springs are placed, one in each guy wire, between the anchor and turnbuckle.

I don't have to buy springs for this job, although most hardware stores carry them. Whenever I see someone discard an old spring frame, I just remove a few coils and store them away for future use.—*Jim Cavaseno* END

## BECOME A RADIO TECHNICIAN for only \$26.95

# BUILD YOUR RADIO

### CIRCUITS AT HOME

with the New Progressive  
**RADIO "EDU-KIT"®**

All Guaranteed to Work!

Reg. U.S.  
Pat. Off.

**PRACTICAL HOME RADIO COURSE** only **\$26.95**



### NOW INCLUDES

- ★ 12 RECEIVERS
- ★ 3 TRANSMITTERS
- ★ SQ. WAVE GENERATOR
- ★ AMPLIFIER
- ★ SIGNAL TRACER
- ★ SIGNAL INJECTOR
- ★ CODE OSCILLATOR

TRAINING ELECTRONICS  
TECHNICIANS SINCE 1946

- ★ No Knowledge of Radio Necessary
- ★ No Additional Parts or Tools needed
- ★ Excellent Background for TV
- ★ School Inquiries Invited
- ★ Attractively Gift Packed

### FREE EXTRAS

- SET OF TOOLS • RADIO & ELECTRONICS TESTER • ELECTRIC SOLDERING IRON • TESTER INSTRUCTION MANUAL • MEMBERSHIP IN RADIO-TV CLUB: CONSULTATION SERVICE • HI-FI GUIDE
- QUIZZES • TV BOOK • FCC AMATEUR LICENSE TRAINING
- RADIO BOOK • PRINTED CIRCUITRY • PLIERS-CUTTERS
- ALIGNMENT TOOL • WRENCH SET • CERTIFICATE OF MERIT
- VALUABLE DISCOUNT CARD

### WHAT THE "EDU-KIT" OFFERS YOU

The "Edu-Kit" offers you an outstanding PRACTICAL HOME RADIO COURSE at a rock-bottom price. Our kit is designed to train Radio & Electronics Technicians, making use of the most modern methods of home training. You will learn radio theory, construction, servicing, basic Hi-Fi and TV repairs, code, FCC amateur license requirements.

### THE KIT FOR EVERYONE

The Progressive Radio "Edu-Kit" was specifically prepared for any person who has a desire to learn Radio. The "Edu-Kit" has been successfully used by young and old in all parts of the world, by many Radio Schools and Clubs in this country and abroad. It is used for training and rehabilitation of Armed Forces Personnel and Veterans throughout the world.

The Progressive Radio "Edu-Kit" requires no instructor. All instructions are included. Every step is carefully explained. You cannot make a mistake.

### PROGRESSIVE TEACHING METHOD

The Progressive Radio "Edu-Kit" is the foremost educational radio kit in the world, and is universally accepted as the standard in the field of electronics training. The "Edu-Kit" uses the modern educational principle of "Learn by Doing."

Therefore, you will construct radio circuits, perform jobs and conduct experiments to illustrate the principles which you learn. You begin by examining the various radio parts included in the "Edu-Kit." You then learn the function, theory and wiring of these parts. Then you build a simple radio. With your first set, you will enjoy listening to required broadcast stations, learn theory, practice testing and troubleshooting. Then you build a more advanced radio, learn more advanced theory and techniques. Gradually, in a progressive manner, and at your own rate, you will find yourself constructing more advanced multi-tube radio circuits, and doing work like a professional Radio Technician.

Included in the "Edu-Kit" course are 20 Receiver, Transmitter, Code Oscillator, Signal Tracer, Signal Injector, Square Wave Generator and Amplifier circuits. These are not unprofessional "bread board" experiments, but genuine radio circuits, constructed by means of professional wiring and soldering on metal chassis, plus the new method of radio construction known as "Printed Circuitry." These circuits operate on your regular AC or DC house current.

In order to provide a thorough well-integrated and easily-learned radio course, the "Edu-Kit" includes practical work as well as theory; troubleshooting in addition to construction; training for all, whether your purpose in learning radio be for hobby, business or professional advancement; and a self-powered Dynamic Radio & Electronics Tester. The "Edu-Kit" also includes Code Instructions and the Progressive Code Oscillator, in addition to the F.C.C.-type Questions and Answers for Radio Amateur License training. You will also receive lessons for servicing with the Progressive Signal Tracer and the Progressive Signal Injector, and a High Fidelity Guide and Quiz Book. Everything is yours to keep.

### THE "EDU-KIT" IS COMPLETE

You will receive all parts and instructions necessary to build 20 different radio and electronics circuits, each guaranteed to operate. Our Kits contain tubes, tube sockets, variable electrolytic, mica, ceramic and paper dielectric condensers, resistors, tie strips, coils, hardware, tubing, punched metal chassis, Instruction Manuals, hookup wire, solder, selenium rectifiers, volume controls, switches, knobs, etc.

In addition, you receive Printed Circuit materials, including Printed Circuit chassis, special tube sockets, hardware and instructions. You also receive a useful set of tools, a professional electric soldering iron, and a self-powered Dynamic Radio & Electronics Tester. The "Edu-Kit" also includes Code Instructions and the Progressive Code Oscillator, in addition to the F.C.C.-type Questions and Answers for Radio Amateur License training. You will also receive lessons for servicing with the Progressive Signal Tracer and the Progressive Signal Injector, and a High Fidelity Guide and Quiz Book. Everything is yours to keep.

J. Stokatis, of 25 Poplar Pl., Waterbury, Conn., writes: "I have repaired several sets for my friends, and made money. The "Edu-Kit" paid for itself. I was ready to spend \$240 for a course, but I found your ad and sent for your Kit."

### UNCONDITIONAL MONEY-BACK GUARANTEE

The Progressive Radio "Edu-Kit" has been sold to many thousands of individuals, schools and organizations, public and private, throughout the world. It is recognized internationally as the ideal radio course.

By popular demand the Progressive Radio "Edu-Kit" is now available in Spanish as well as English.

It is understood and agreed that should the Progressive Radio "Edu-Kit" be returned to Progressive "Edu-Kits" Inc., for any reason whatever, the purchase price will be refunded in full, without quibble or question, and without delay.

The high recognition which Progressive "Edu-Kits" Inc. has earned through its many years of service to the public is due to its insistence upon the maintenance of perfect engineering, the highest instructional standards, and 100% adherence to its Unconditional Money-Back Guarantee. As a result, we do not have a single dissatisfied customer throughout the entire world.

### ORDER FROM AD - RECEIVE FREE BONUS RADIO & TV PARTS JACKPOT WORTH \$15

- Send "Edu-Kit" Postpaid. I enclose full payment of \$26.95.
- Send "Edu-Kit" C.O.D. I will pay \$26.95 plus postage.
- Send me FREE additional information describing "Edu-Kit."

Name \_\_\_\_\_

Address \_\_\_\_\_

**Progressive "EDU-KITS" Inc.**

1186 Broadway, Dept. 245-G  
Hewlett, N. Y.

(ATT: S. GOODMAN, M.S. IN EN., PRES.)

# NEW PRODUCTS

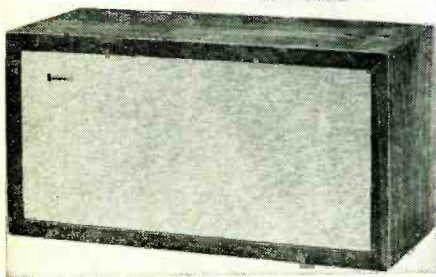

**3-WAY SPEAKER SYSTEM, Ultra-3.** Response from 35 to 19,000 cycles with crossover points at 1,000 and 5,000 cycles. Impedance 8 ohms. Tandem control adjusts high- and mid-range frequencies. Walnut veneer on 4 sides (can be used on bookshelf, divider, or floor), 23 $\frac{3}{4}$  x 11 $\frac{1}{2}$  x 9 $\frac{3}{4}$  in. Handles 32 watts of integrated program material.—LTV University, 9500 W. Reno, Oklahoma City, Okla.

**6-IN. VTVM KIT, KG-625,** features  $\frac{1}{2}$ -volt full-scale dc range. Dc ranges: 0-0.5-1.5-5-15-50-150-500-1,500 v full scale, with optional high-voltage probe to 25,000 v. Accuracy:  $\pm 3\%$  full-scale reading. Input resistance: 11 megohms to 1,500 volts. Ac rms ranges: 0-1.5-5-15-50-500-1,500 v full scale, separately calibrated scales for 1.5 and 5 v. P-p ranges: 0-4.2-14-42-140-420-1,400-4,200 v full scale, separately calibrated scales for 4.2 and 14 v; accuracy:  $\pm 5\%$  full-scale reading. Frequency response:  $\pm 1$  db, 30 cycles to 3

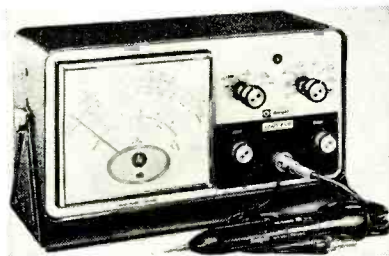

mc,  $\pm 3$  db, 30 cycles to 5 mc, to 250 mc with high-frequency probe. Ohmmeter ranges: 0-1,000-10,000-100,000 ohms; 0-1-10-100-1,000 megohms. Center scales: 10-100-1,000-10,000-100,000 ohms; 1 and 10 megohms.  $\frac{1}{2}$ -volt C-battery. Tubes: pre-aged 12AU7A with matched triode sections. 6AL5 full-wave rectifier. Power supply: transformer silicon diode rectifier.—Allied Radio Corp., 100 N. Western Ave., Chicago, Ill. 60680

**MARINE ANTENNA,** the *Silver Dolphin*, for CB boaters. 8 ft 5 in., brass parts chrome-plated, aluminum sections anodized. Hinge allows antenna to be laid parallel to deck. SWR of 1.5/1 or better over 23 channels. Matching transformer in waterproofed base.—Mosley Electronics, Inc., 4610 W. Lindbergh Blvd., Bridgeton, Mo. 63044



**DIGITAL READOUT CLOCK-MOVEMENT, Tymeter.** No. 130-12H: 12-hr readout; No. 131-24H: 24-hr readout.  $\frac{3}{8}$ -in. digits on 12-hr clock,  $\frac{3}{16}$ -in. digits on 24-hr clock, digits resettable individually. 110-120 v, 60 cycles ac. Available in 120 vac, 50 or 60 cycles; 240 vac 50 or 60 cycles; 115 vac 400 cycles. 3 x 5 $\frac{1}{2}$  x 3 $\frac{3}{4}$  in.,

2 lb.—Pennwood Numechron Co., 7249 Frankstown Ave., Pitts., Pa. 15208

**ELECTROLYTIC SUBSTITUTOR, ES132,** for transistor or vacuum-tube circuit. Provides 10 dual electrolytics from 2 to 250  $\mu$ f to operate from 2 to 450 volts dc. Can be used singly, as duals, or para-

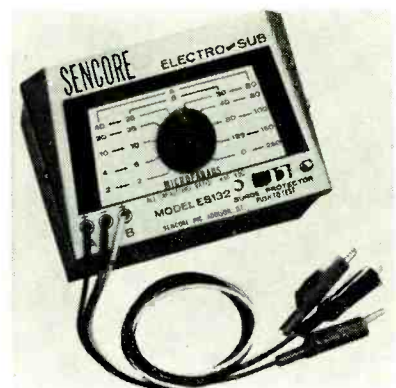

lled—up to 32 combinations. Steel case. Surge-protection switch also discharges electrolytic to prevent shock.—Sencore, Inc., 426 S. Westgate Dr., Addison, Ill. 60101

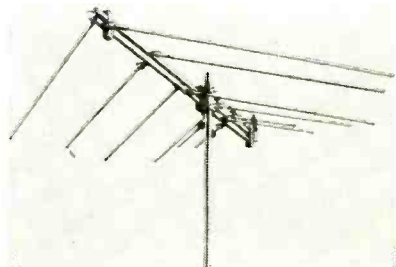

**LOG PERIODIC TV/FM ANTENNAS,** the *LPV-TV series* (3, 5, 7, 10, 13, 16, 19), have extremely narrow beam width across channels 2 to 13. Capacitor-coupled dipoles and directors enhance third-harmonic mode performance. Twin-boom feeder improves impedance match between low-impedance line and linear dipoles. Open-wire transformer brings impedance up to 300 ohms.—JFD Electronics Corp., 15th Ave at 62nd St., Brooklyn, N.Y. 11219

**STEREO ADAPTER CABLE, model 330G,** designed to plug directly into European 5-hole sockets or to interconnect preamps and crystal or ceramic high-impedance cartridges to many recorders. Includes European 5-pin type plug, two

## COMPLETE TUNER OVERHAUL

ALL MAKES — ONE PRICE



**9.95**

ALL MAKES  
ALL LABOR  
AND PARTS  
(EXCEPT TUBES)\*

ONE LOW PRICE INCLUDES ALL UHF, VHF, COLOR AND UV COMBINATION TUNERS

Simply send us the defective tuner complete; include tubes, shield cover and any damaged parts with model number and complaint. Your tuner will be expertly overhauled and returned promptly, performance restored, aligned to original standards and warranted for 90 days.

UV combination tuner must be single chassis type; dismantle tandem UHF and VHF tuners and send in the defective unit only.

Exact Replacements are available for tuners unfit for overhaul. As low as \$12.95 exchange. (Replacements are new or rebuilt.)

**CASTLE TV TUNER SERVICE, INC.**

MAIN PLANT: 5715 N. Western Ave., Chicago 45, Ill.  
EAST: 41 96 Vernon Blvd., Long Island City 1, N. Y.  
CANADA: 136 Main Street, Toronto 13, Ont.

\*Major Parts are additional in Canada



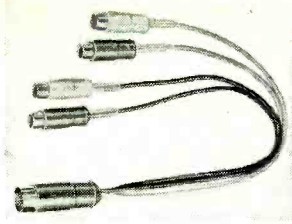

1-ft. lengths of shielded stereo cable, terminates in 4-color coded phono jacks.—Switchcraft, Inc., 5555 N. Elston Ave., Chicago, Ill. 60630

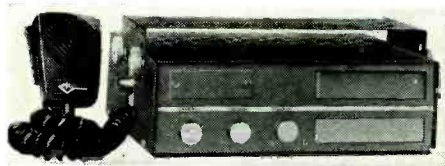

CB TRANSCEIVER, called *Contact Help*, with fixed channel for monitoring by emergency aid offices. Has special switch

position for H.E.L.P. (*Highway Emergency Locating Program*). 10½ x 3¼ x 8 in., less than 5 lb. Accessories include hand mike with push-to-talk button, 12-volt cord for cigar lighter plug-in, special theft-proof mounting bracket.—United Scientific Labs., 35-15 37th Ave., Long Island City, N.Y. 11101

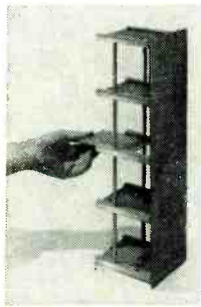

**CIRCUIT PACK-AGING KIT, VBK-8**, uses plug-in Vero-board with edge connectors that plug directly into automatically interconnecting motherboard. Allows direct electrical contact between connectors—circuit may be broken with Vero spot face cutter. Jumpers connect terminal of one connector to terminal of any other connector. Kit has 5 plug-in boards 3.4 x 5.1 in with gold-plated contacts, five 16-contact 0.2-in. connectors, and 5 x 18 in.

# LEARN ELECTRONICS FROM A-Z AT HOME!

Here's a complete self-training guide covering all the fundamentals you need to know for successful work in electronic circuits, including radio, television, industrial electronics and computers. Following basic coverage of electrons and electricity, the book clearly explains d-c circuits, magnetism, a-c circuits, vacuum tubes, and transistors. For each topic covered, examples are given that show how principles are actually applied.

## BASIC ELECTRONICS

NEW SECOND EDITION

BERNARD GROB RCA Institutes, N.Y.

660 pages, \$10.50

Enlarged and revised, this Second Edition gives basic principles and applications of today's electronics. Separate treatments of Ohm's law, series circuits, parallel circuits, and series-parallel circuits show how to apply d-c fundamentals. Electro-magnetic conduction, inductive reactance and capacitive reactance are described with all their uses in a-c circuits. Included are two new chapters on network theorems and complex numbers.

BUY THIS BOOK AT YOUR BOOKSTORE  
OR MAIL THIS COUPON

McGraw-Hill Book Co., Dept. 23-RE-85  
330 WEST 42 Street, N.Y., N.Y. 10036

Send me Bernard Grob's  
BASIC ELECTRONICS, Second Edition for 10 days  
on approval. In 10 days I will remit \$10.50 plus  
a few cents for delivery costs, or return book  
postpaid. SAVE MONEY: We pay delivery costs  
if you remit with coupon; same examination and  
return privilege.

NAME (print) \_\_\_\_\_

ADDRESS \_\_\_\_\_

CITY \_\_\_\_\_

STATE \_\_\_\_\_ ZIP \_\_\_\_\_

For price outside U.S., write McGraw-Hill Int'l., N.Y. 10036 23-RE-85

### Coming next month

## A New Free Service For Radio-Electronics Readers

Starting with the September issue, RADIO-ELECTRONICS will publish a Reader's Service Page.

You will be able to obtain, free of charge, more information or literature about products and services advertised or editorially featured in RADIO-ELECTRONICS, whether you seek information from one... a dozen... or more companies—simply by mailing in the business reply card on the Reader's Service Page.

RADIO-ELECTRONICS will forward your requests to the companies you have indicated, who will send the material directly to you.

You will find RADIO-ELECTRONICS' Reader's Service a great convenience and time-saver. Watch for this new free service starting next month. And take advantage of it!

# 50 easy-to-build Transistor Circuits

**Electronic Projects**  
FOR  
students, beginners,  
hobbyists

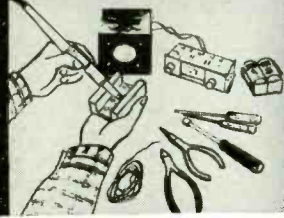

at your  
dealer  
**\$1.95**  
or mail  
coupon

100 pages of exciting transistor projects you can make with easy-to-get inexpensive parts. No technical knowledge needed—just the small tools shown. Tells you HOW TO: solder, recognize electronic parts, read electronic symbols. Clear pictorial and wiring diagrams make instructions easy. You can make: crystal radio, sun-powered radio, electronic megaphone, flashers, intercom, hi-fi tester, appliance tester, tachometer, stereo balance, code transmitter, and 40 other useful devices. A wonderful introduction to electronics. Published by Semitron, the leading professional line of semiconductors.

Order your SEMITRON Electronic Projects Book and parts from:

**ALMO RADIO**, 913 Arch St., Phila., Pa.  
Enclosed is \$\_\_\_\_\_ Send me  
copies of the Semitron 50-Projects Book  
postpaid.  
Name \_\_\_\_\_  
Address \_\_\_\_\_  
City \_\_\_\_\_ State \_\_\_\_\_ Zip \_\_\_\_\_

pierced mother-board, 5 pairs of plastic guides, tie rods and 12-in. spacers which may be cut to allow any desired distance between circuit boards.—Vero Electronics, 48 Allen Blvd., Farmingdale, N.Y.

**RUDDER POSITION INDICATOR KIT**, model MI-14, for large water craft, shows rudder position up to 40° port and starboard. Lets pilot compensate for current and wind by adjusting engines rather

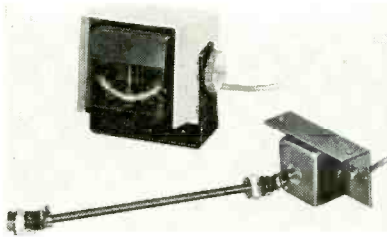

than rudder to maintain proper heading. Connects directly to rudder shaft, comes with 25 feet of connecting cable and 36-in. linking shaft. Aluminum case, gimbal mounting bracket. Voltage-regulated, operates on 6- or 12-volt storage batteries with nominal current drain of 300 ma. 4 lb.—Heath Co., Benton Harbor, Mich.

**82-CHANNEL TV TUNER SYSTEM**, with pushbutton uhf and preset vhf com-

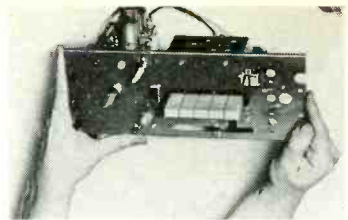

bined. System includes front mounting plate, connecting shielded cable, dropping resistor, vhf tuning and pushbutton actuating mechanisms, vhf/uhf tuner unit that mounts directly to receiver chassis. Front panel 4 1/2 x 11 3/16 in. Three systems: color, black-and-white and color with afc in the 82 channels.—Standard Kollsman Industries Inc., Tuner Div., 2085 N. Hawthorne Ave., Melrose Park, Ill.

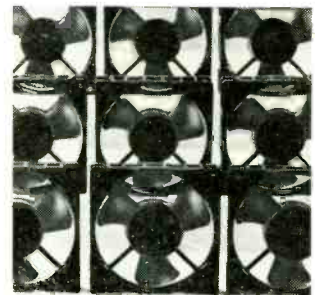

**MUFFIN FAN**, Mark 4. Static air delivery 100 cubic feet per minute; enclosed stator; Pyre-ML magnet windings; lubricated-for-life sleeve bearings; built-in heat sink. Four styles: skeleton, venturi, grille, filter. 4 1/2 x 4 1/2 x 1 1/2 in.—Rotron Mfg. Co., Inc., Woodstock, N.Y.

# NO COMPETITORS

Nobody else but **EMC** designs in so much value



Tube Tester Model 213

Compact, lightweight portability. Use it on the bench or in the field.

Full-view meter gives direct, clear-cut quality indications.

Full complement of sturdy sockets accepts compactron (12-pin), nuvistor, novar, 10-pin, 9-pin, octal, loctal, and miniature tubes.

Three heavy-duty controls for quick set-up of all tests. Check a fistful of tubes in the time it often takes to test one.

Precise programming. Only one socket per tube-base configuration prevents accidental plug-in.

12 slide switches for individual selection of tube pins provides versatility in testing, prevents obsolescence.

THE MODEL 213 saves you time, energy, money ■ Checks for shorts, leakage, intermittents, and quality ■ Tests all tube types including magic eye, regulator, and hi-fi tubes ■ Checks each section of multi-purpose tubes separately ■ Gives long, trouble-free life through heavy-duty components, including permanently etched panel ■ Keeps you up to date with FREE, periodic listings on new tubes as they come out ■ Your best dollar value in a tube tester. Available in high-impact bakelite case with strap: \$28.90 wired; \$18.90 in kit form. Wood carrying case (illustrated) slightly higher.



**ELECTRONIC MEASUREMENTS CORPORATION**  
625 Broadway, New York 12, New York  
Export: Pan-Mar Corp., 1270 B'way, N. Y. 1, N. Y.

**EMC, 625 Broadway, New York 12, N. Y.**

Rush me FREE catalog describing all EMC value-loaded test instruments and name of local distributor.

NAME \_\_\_\_\_  
ADDRESS \_\_\_\_\_  
CITY \_\_\_\_\_ ZONE \_\_\_\_\_ STATE \_\_\_\_\_

REC-8

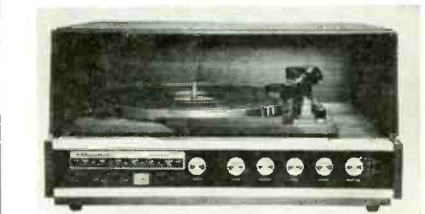

**MULTIPLEX FM TUNER** has been incorporated into Benjamin Stereo 200 phonograph system without increasing tabletop unit's size. Tuner includes tuning meter, automatic stereo switching, automatic stereo indicator light, afc switch. Slide-rule dial; 3:1 gear drive control. Inherent thermocompensated design.—Benjamin Electronic Sound Corp., 80 Swalm St., Westbury, N.Y.

**REEL-TO-REEL TAPE RECORDER**, the Wollensak 1288, plays horizontally or vertically, has walnut case with matching detachable bookshelf speakers. 4-track stereo and monaural record and playback, dual VU meters, tab controls, separate volume and tone controls for each channel, automatic shutoff, automatic tape lifters, built-in reel locks, fast forward and rewind with interlocking safety controls,





self-adjusting braking system.—3M Co., 2501 Hudson Rd., St. Paul, Minn. 55119



**SILICONE SPRAY.** *Sprayway*, release agent. Non-toxic, nonstaining, colorless, heat stable, nonflammable. Sprayed into plastic tubing or sleeveing, eliminates friction and drag when cable wire is inserted into tubing with or without breakout points.—Sprayway Inc., 7644 S. Vincennes Ave., Chicago, Ill. 60620

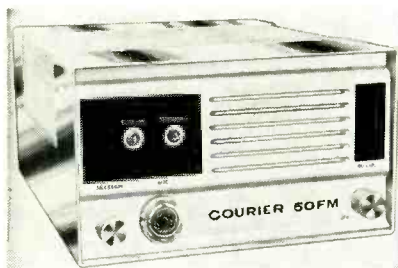

**2-WAY FM BUSINESS RADIO**, the *Courier 50FM*, operates in 25-to 50-mc range .50 watts power coverage over several thousand square miles, available with ac or 12-volt dc power supplies; FCC type accepted. Chrome cabinet.—E.C.I. Electronics Communications, Inc., 56 Hamilton Ave., White Plains, N.Y.



**BI-DIRECTIONAL WATTMETER**, the *ASWM-1*. Measures rf power. Accuracy of meter readings is  $\pm 5\%$  of full-scale calibration; also calibrated to read voltage standing-wave ratios directly. Measures incident or reflected power to 5,000 watts. 2 inserts provide coverage of commercial radio frequencies from 25 to 1,000 mc in 4 power ranges of 10, 50, 100 and 500

watts. Other inserts extend range to 2 mc.  $6\frac{1}{2} \times 7 \times 7\frac{1}{8}$  in., 7 lb.—Antenna Specialists Co., 12435 Euclid Ave., Cleveland, Ohio 44106

**THREE HEAD-BRACKET ASSEMBLY KITS**, to update tape cartridge recorders of *Fidelipac* and *Viking* type. *Quick Kit 114* uses 2 stereo heads, either 2- or 3-channel types—one head for program and cue record only; one head for program and cue play only. *Quick Kit 115* uses 2 mono heads—one head for pro-

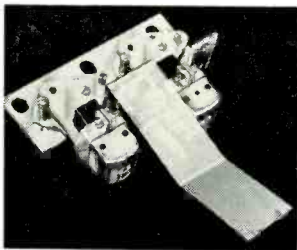

gram record/play; one head for cue record/play. *Quick Kit 117* uses one mono and one stereo head—a mono head for program record only; one channel of

#### WHEN YOU ORDER BY MAIL

Be sure to include your name and address. Type or print if you can—if not, write clearly. Don't send cash! Remit by check or money order. Mention you saw it in **RADIO-ELECTRONICS**.

## Are You A Slow Reader?

A noted publisher in Chicago reports there is a simple technique of rapid reading which should enable you to double your reading speed and yet retain much more. Most people do not realize how much they could increase their pleasure, success and income by reading faster and more accurately.

According to this publisher, anyone regardless of his present reading skill, can use this simple technique to improve his reading ability to a remarkable degree. Whether reading stories, books, technical matter, it becomes possible to read sentences at a glance and entire pages in seconds with this method.

To acquaint the readers of this newspaper with the easy-to-follow rules for developing rapid reading skill, the company has printed full details of its interesting self-training method in a new book, "Adventures in Reading Improvement" mailed free to anyone who requests it. No obligation. Simply send your request to: Reading, 835 Diversey Parkway, Dept. 448C, Chicago, Illinois 60614. A postcard will do. Please include your zip code.

## LOOK! A NEW ELECTRONICS SLIDE RULE with complete instruction program

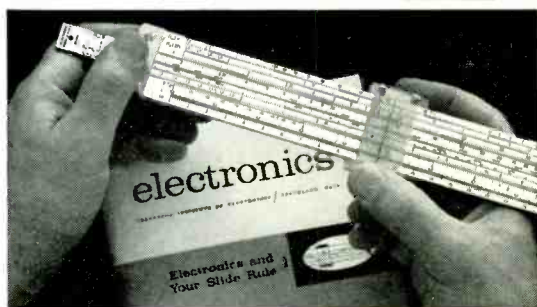

Here's a great *new* way to solve electronic problems accurately, easily . . . a useful tool for technicians, engineers, students, radio-TV servicemen and hobbyists. The Cleveland Institute Electronics Slide Rule is the only rule designed *specifically* for the exacting requirements of electronics computation. It comes complete with an illustrated Instruction Course. You get four **AUTO-PROGRAMMED** lessons . . . each with a short quiz you can send in for grading and consultation by CIE's expert instructors.

See for yourself. Learn how to whip through

all kinds of reactance, resonance, inductance, AC and DC circuitry problems in seconds . . . become a whiz at conventional computations too!

This all-metal 10" rule is made to our rigid specs by Pickett, Inc. . . . comes complete with top grain leather carrying case and Instruction Course. A \$50 value for less than \$20. Send coupon for **FREE** illustrated booklet and **FREE** heavy vinyl Pocket Electronics Data Guide. Cleveland Institute of Electronics, 1776 E. 17th St., Dept. RE-113, Cleveland, Ohio 44114.

**GET BOTH FREE!**



**ELECTRONICS**

**SLIDE RULE**

Send coupon today →

## Cleveland Institute of Electronics

1776 E. 17th St., Dept. RE-113, Cleveland, Ohio 44114

Send **FREE** Electronics Slide Rule Booklet. Special Bonus: Mail promptly and get **FREE** Pocket Electronics Data Guide too!

NAME \_\_\_\_\_ (Please Print)

ADDRESS \_\_\_\_\_ COUNTY \_\_\_\_\_

CITY \_\_\_\_\_ STATE \_\_\_\_\_ ZIP \_\_\_\_\_

A leader in Electronics Training . . . since 1934



# NEW

## UHF FIELD STRENGTH METER ADAPTOR

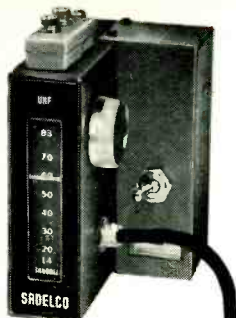

Why Shelve your present VHF Meter when you can Economically move up to the UHF Field with the new SADELCO UA-1 UHF ADAPTOR.

The UA-1 is a low noise, highly accurate UHF Receiver, individually calibrated for field strength measurements. Completely self-contained with its own regulated battery supply.

WILL WORK WITH ANY VHF METER.

Accuracy . . . plus or minus 2 DB  
 Input . . . . . 75 ohm • UHF Channels 14-83  
 Output . . . . . 75 ohm • 60 megacycles or Channels 2-3  
 Semiconductors . . . 3 transistors ;2 diodes

### SPECIAL FEATURES

- Weighs only 18 ozs. • Tunable plug-in probing antenna • UHF 300 to 75 ohm matching transformer • Holding Bar for quick snap on facility • Built in Battery Meter.

Price \$120.00 net



## PROVEN

A CHAMPION at only 3½ lbs.

### THE SADELCO MODEL FS-2

The World's Only Truly Compact (8¼" x 4½" x 3") Precision TV-FM Field Strength Meter IDEAL FOR: Field Surveys • Antenna Checking • Gain Measurements Accurately Calibrated in microvolts and DBs.

RANGE: Band 1 — Channel 2 to 6 plus FM  
 Band 2 — Channel 7 to 13  
 Band 3 — UHF Adaptor position

The Model FS-2 has a high accuracy of plus or minus 1.75 DB and compares favorably with meters costing over \$2000.

A Professional Instrument

UHF Adaptor Shown Mounted on Sadelco Field Strength Meter. (Can also be used as a Remote Signal Probe).

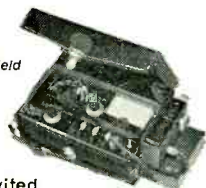

Jobber Inquiries Invited



Inquire about our Trial offer. Write to: SADELCO, INC. 601 W. 26th St. N. Y., N. Y. 10001 212 WA 9-2528

stereo head for program play only and second channel for cue record/play, permitting monitoring of program material while it is being recorded.—Nortronics Co., Inc., 8101 10th Ave. No., Minneapolis, Minn. 55427



500-WATT P.E.P. AMATEUR TRANSCEIVER, the SR-500 Tornado. Lower sideband used on 80 and 40 meters, and upper sideband on 20 meters. Dial calibration in 5-kc increments, accurate to less than 2 kc between 100-kc points after indexing. Vfo has 500-kc tunable range, stable within 300 cycles after warmup. Sensitivity: 1 mv for 20-db signal-to-noise. Audio response: 600 to 2,800 cycles at 3 db. Audio output 2 watts at 3.2 ohms. 13 x 6½ x 11 in., 13¼ lb.—Hallicrafters Co., 4401 W. 5th Ave., Chicago, Ill. 60624

SWITCHING MAT, type CVP 1723, switching elements heat-sealed in vinyl. 6-ft. lead wire. Rated to control up to 100-watt load, mats are best operated at 24 volts or less. 18 x 24 x ¾ in. Applications

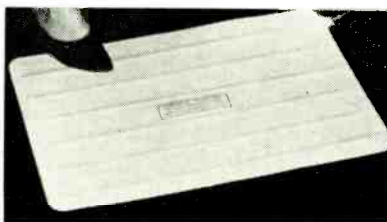

include burglar alarms, entrance annunciators, advertising display, automatic door operation, etc.—Tapeswitch Corp. of America, 545 Meacham Ave., Elmont, N.Y. 11003



OSCILLOSCOPE, the Primer-Scope Mark I, suggested for classroom or lab demonstration of ac and dc waveforms,

TV signal analysis, signal-tracing, peak voltage measurements, frequency and phase comparison of two signals. Sensitivity: 6 mv per division ac-coupled. Response: dc to 75 kc. Training manual. 3½ x 7 x 10.—Schaevitz-M.C.D., 2445 Emerald St., Philadelphia, Pa.



SCREWDRIVERS, Iron Man series, billed as strongest screwdriver made. Blade of 6150 chrome vanadium steel has polished nickel chrome shaft; is locked into handle. Lifetime guarantee.—Vaco Products Co., 317 E. Ontario St., Chicago, Ill.

SOLDERING IRONS COLOR-CODED. Using EIA color-code sequence, polyvinyl strain reliefs on power cords in range of 9 colors help identify



soldering irons from 12 to 700 watts. Coding is standard on irons with either 2-wire or 3-wire cord and plug, in all styles.—Hexacon Electric Co., 186 W. Clay Ave., Roselle Park, N.J. 07204

AM/FM/FM-STEREO TUNER-AMPLIFIER, model 1484. Power output 150 watts (75 per channel) IHF. Response: ±1 db from 20 cycles to 20 kc. Distortion: 3% total harmonic at rated power output. Channel isolation 30 db at 400 cycles. Hum and noise 60 db below rated output. AM: sensitivity, 50 µv/meter; bandwidth 8.5 kc at 6 db down; signal-to-noise 20 db with 100-µv-per-meter input; image re-



jection 60 db. FM: 2.5 µv for 30-db quieting, 1.8 µv for 20-db quieting, 2.0 µv at 3-db limiting level; AM rejection 35 db; image rejection 36 db; i.f. rejection 80 db; antenna input, 300 ohms balanced, 75 ohms unbalanced; stereo separation 36 db at 1 kc. 26 transistors, 15 diodes. Operates from 117 volts, 50 or 60 cycles. Stereo indicator light. 5¼ x 15¼ x 13¼ in., 18 lb.—V-M Corp., 305 Territorial Rd., Benton Harbor, Mich. 49023

All specifications from manufacturers' data



# NEW LITERATURE

# new SAMS BOOKS

**1965 SUMMER CATALOG, No. 654,** 144 pages, illustrations and specs on thousands of items from amateur gear to walkie-talkies. Index, fold-out order blank, credit-plan information.—**Lafayette Radio Electronics,** 111 Jericho Turnpike, Syosset, N.Y. 11791

**MOLDED ELECTRONIC TEST ACCESSORIES, General Catalog No. 10-65,** 28 pages, universal-punched, photos, specs, lists patch cords, cable assemblies, test leads, connecting leads, socket savers, test socket adapters. Includes typical applications.—**Pomona Electronics Co., Inc.,** 1500 E. 9th St., Pomona, Calif. 91769

**THERMISTOR QUIZ, No. 1,** single sheet, contains self-teaching features to increase knowledge of thermistors and their benefits as primary transducers.—**Fenwal Electronics, Inc.,** Applications Engineering Dept., 63 Fountain St., Framingham, Mass. 01702

**RECTIFIER COMPILATION, "Specific Data File-Rectifiers,"** 84 pages of technical articles and application data studies on subjects such as: series and parallel operation of silicon controlled rectifiers; the use of Klip-Sel transient-voltage suppressors; thermal considerations in the application of silicon rectifiers and controlled rectifier stacks; turn-on time of controlled rectifiers, and recommended customer test methods for power rectifiers. By the engineering staff of—**International Rectifier Corp.,** 233 Kansas St., El Segundo, Calif.

**NEEDLE CATALOG,** 32 pages, updated to include latest types of stereo needles. Contains pictures and specs on needle replacements for 36 brand names of cartridges ranging from Acos to Zenith.—**Jensen Industries,** Addison, Ill.

**PA SYSTEM Catalog No. B278,** Five varieties of portable, mobile and stationary public-address applications are described: the Sound Column Lectern, the Roving Rostrum, the Diplomat, the Sound Cruiser, the Ampli-Vox Background Music and Paging System. Specs and photos.—**Perma-Power Co.,** 5740 N. Tripp Ave., Chicago, Ill. 60646

**NEW PRODUCT BULLETIN, A-108,** printed in 4 languages, describes ultra-high-purity metals, solder preforms, core solders, printed-circuit materials. Also solder-flux guide chart.—**Alpha Metals, Inc.,** 56 Water St., Jersey City, N.J. 07304

**SEALED RELAYS Bulletin GEA-6628C,** 22 pages. Description, applications, ratings, specs and pricing information, dimensional drawings and mounting forms for 9 types of sealed relays.—**General Electric Co.,** Schenectady 5, N.Y.

**SUBMINIATURE INDICATOR LIGHTS Catalog L-157D,** 4-pages, looseleaf-punched. Diagrams and specs on complete line of one-terminal indicator lights for use in grounded circuits.—**Dialight Corp.,** 60 Stewart Ave., Brooklyn, N.Y. 11237

**NEW-PRODUCT SUPPLEMENT, 3-65,** 24-page catalog containing complete technical data on several new series of ultraminiature and miniature rotary switches and pushbutton switches; with rotary-switch reference chart; plus new sockets and module cases and headers.—**Grayhill, Inc.,** 561 Hillgrove Ave., La Grange, Ill. 60526

**AIRBORNE POWER-CONVERSION EQUIPMENT BROCHURE, Form T-26D,** Specs and application data on 23 models of Chatham transformer-rectifiers and new small "Y" series which have been qualified for more than 35 airborne applications.—**Tung-Sol Electric Inc.,** 1 Summer Ave., Newark, N.J. 07104

**POWER-SUPPLY BULLETIN 102B** describes 24 new models using 100% silicon semiconductors. All are system type units for semi-fixed (wide adjustment range) voltage ratings. Additions to RS series, they eliminate need for fuses or circuit breakers. 4 pages, specs and photos.—**Deltron, Inc.,** 4th & Cambria Sts., Philadelphia, Pa. 19133

**MUCON CAPACITOR CATALOG, Catalog A,** 12 pages, looseleaf-punched. Specs, curves on new line of ceramic capacitor elements for applications such as hybrid circuits where leads and coatings are not desired. Also on Hi-PuFs—monolithic capacitors for high capacitance in limited spaces, achieved with noble-metal electrodes in multilayered ceramic body fired as a unit.—**Republic Electronics Corp.,** 179 E. 7 St., Paterson, N.J.

**COMPACT SCREWDRIVER SETS Bulletin N365,** one sheet. Photos and specs on interchangeable blade sets for Bristol multiple-spline and Allen hex type socket screws.—**Xcelite, Inc.,** Orchard Park, N.Y. 14127

**OPERATIONAL AMPLIFIER CATALOG, Short Form no. 278,** describes complete line of all-silicon dc operational amplifiers, including differential input and output, single-ended and power-booster amplifiers.—**Burr-Brown Research Corp.,** PO Box 6444, Tucson, Ariz.

**KIT CATALOG, Supplement 800/54,** 40 pages, photos and descriptions of organs, color TV, AM, FM and short-wave radios, auto accessories, marine electronics, educational instruments, transistor stereo, etc.—**Heath Co.,** Benton Harbor, Mich. 49023

**DATA SHEET, The Ohmite News, Bulletin 504A,** has photos and specs of Ohmitran low-power variable transformer series, plus resistor data and some unusual scientific items.—**Ohmite Mfg. Co.,** 3603 Howard St., Skokie, Ill.

**PHOTOCONDUCTIVE CELLS BROCHURE,** 6-page foldout on T-4 300-mw-dissipation cells, featuring Sylvania's Blue Dot compound which changes to pink in case of damage to glass envelope. Curves and charts.—**Sylvania Electronic Components Group,** Seneca Falls, N.Y. 13148

**FULL LINE CATALOG, Switches, Potentiometers, Resistors,** 32-pages, punched. Photos, specs; includes composition-element potentiometers, wirewound-element potentiometers, power rheostats, sound-system controls, resistors, dials, switches, couplers, etc.—**Clarostat Distributor Div.,** Dover, N.H.

**CRYSTAL COMPONENTS CATALOG, Precision Frequency Regulation,** Bound section explains properties of crystals and manufacturing techniques. Inside back cover has pocket for inserts describing line of high- and low-frequency quartz crystals, filters, discriminators, tuning-fork and crystal oscillators, crystal and component ovens.—**McCoy Electronics Co.,** Mount Holly Spings, Pa.

**CONDENSED ELECTRON-TUBE CATALOG,** 26 pages, numerical index, specs on full line of tubes, including new cathode-ray and vidicon tubes. Loose-leaf punched. Write on company stationery.—**Amperelex Electronic Corp.,** Adv. Dept., Hicksville, N.Y. 11802

**APPLICATION NEWS SUPPLEMENT NO. 1,** 10 pages, includes index of articles from Signalite's *Application Newsletters*, Vol. 1, No. 1 through Vol. 2, No. 6, plus set of specs for new close-tolerance neon glow lamps.—**Signalite Inc.,** 1933 Heck Ave., Neptune, N.J.

**CATALOG No. 655,** 148 pages, photos, prices of 4,000 items for hobbyists, experimenters: do-it-yourself kits; solar energy materials; "Op Art" kits; industrial optics, tools, calipers, slide rules, photographic accessories, etc.—**Edmund Scientific Co.,** 105 E. Gloucester Pike, Barrington, N.J.

Any or all of these catalogs, bulletins, or periodicals are available to you on request direct to the manufacturers, whose addresses are listed at the end of each item. Use your letterhead—do not use postcards. To facilitate identification, mention the issue and page of RADIO-ELECTRONICS on which the item appears. UNLESS OTHERWISE STATED ALL ITEMS ARE GRATIS. ALL LITERATURE OFFERS ARE VOID AFTER SIX MONTHS.



## Know Your Signal Generator

by Robert G. Middleton. The newest book by this popular author offers, in his inimitably clear style, full and practical coverage of signal generators from A to Z—theory, operation, and applications. Explains basic principles of all types of signal generators; proceeds to explain generator accuracy, calibration, modulation, measurement of output voltages, harmonic amplitudes, and many other considerations. Includes dip meters, analyzers, radio test sets, and uhf and supersonic generators. Special chapter on FM stereo multiplex signal generators. Invaluable for service technicians, apprentices, hams, and hobbyists. 144 pages; 5½ x 8½". \$250  
Order KOG-1, only

**Two-Way Mobile Radio Maintenance (New 2nd Ed.)** by Jack Darr. This newly revised and updated guidebook includes coverage of the latest transistorized 2-way equipment. Here is a complete and extremely practical field servicing handbook, a valuable guide to planning, installing, and maintaining all types of 2-way mobile radio systems. The author's own first-hand experience gets you right to the heart of how to do the job the quickest and best way. Written in easy-to-understand language; illustrated with many on-the-job photos of 2-way equipment. 256 pages; 5½ x 8½". Order TWD-2, only \$495

## Second Big Printing! Color TV Guidebook

A special Howard W. Sams publication—the most complete and authoritative guide to color TV, servicing techniques, equipment required, and related subjects. General information includes outlook for color TV manufacturers, broadcasting networks, and technicians. Specific sections deal with starting a color TV service business, troubleshooting and repair techniques, antennas, color tube stocking, transistorized color TV, small-town color TV problems, new circuits and developments; building a color TV kit, and much more. The biggest dollar's worth of useful, practical color TV data available. 8½ x 11". \$100  
Order PFR-1, only

## Transistor Radio Servicing Made Easy (New 2nd Ed.)

by Wayne Lemons. Latest, completely updated edition of this practical how-to-do-it book. Explains only what you need to know to repair transistor radios (now including FM) with maximum profit. The on-the-job experience presented makes it the only book of its kind available. From the introductory chapter through the step-by-step explanations of bench-tested troubleshooting procedures, the text is written in servicemen's language. Explains how to find causes of noises, squeals, poor sensitivity and distortion; how to substitute transistors and check circuit performance; how to minimize "hard-to-find" parts problems. Includes a complete new chapter on FM transistor circuits. 144 pages; 5½ x 8½". Order TRE-2, only \$250

## Technical Speller & Definition Finder

by AETNA Miles. A practical reference, using an entirely new concept—gives the correct spelling, plus convenient sources for definitions and additional information on approximately 50,000 technical terms. Essential for secretaries, librarians, educators, authors, technicians, engineers, and others with scientific interests. Handy alphabetical listing has accurate spelling and definition key. Includes acronyms and their definitions. Trademarks are identified, and the proper spelling and typing form is shown. 288 pages; 5½ x 8½". \$595  
Order SDH-1 (hardbound), only  
Order SDS-1 (softbound), only 4.95

## HOWARD W. SAMS & CO., INC.

Order from your Sams Distributor today, or mail to Howard W. Sams & Co., Inc., Dept. RE-8, 4300 W. 62nd Street, Indianapolis, Ind. 46206

Send me the following books:  
 KOG-1     PFR-1     SDH-1  
 TWD-2     TRE-2     SDS-1  
 Send FREE Sams Booklist. \$\_\_\_\_\_ enclosed

Name \_\_\_\_\_  
 Address \_\_\_\_\_  
 City \_\_\_\_\_ State \_\_\_\_\_ Zip \_\_\_\_\_  
 My Distributor is \_\_\_\_\_  
 IN CANADA: A. C. Simmonds & Sons, Ltd., Toronto 7





# FREE

send today for your

## ALLIED 1966 CATALOG

*the most-used electronics catalog*

**508 VALUE-PACKED PAGES**

**send for  
it today!**

**SAVE MOST ON  
EVERYTHING IN ELECTRONICS**  
*including exclusive products  
and special values available only  
from **ALLIED***



**Knight  
KN-330 32-Watt FM-AM  
Multiplex Receiver**

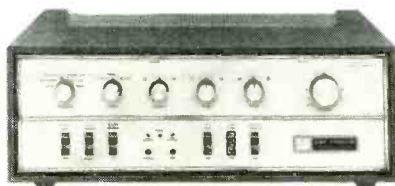

**Fisher TX-200 90-Watt  
Solid-State Stereo Amplifier**



**Lloyd's Deluxe  
9-Transistor  
Walkie-Talkie**

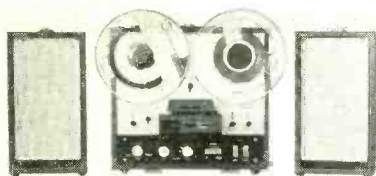

**Ok! Solid-State  
4-Track Stereo  
Tape Recorder**

**SEE WHAT'S NEW—  
SEE THE BIG VALUES!**



**Garrard  
Lab 80  
Automatic  
Turntable**



**Hallicrafters  
S-200 5-Band  
Short-Wave  
& AM Receiver**

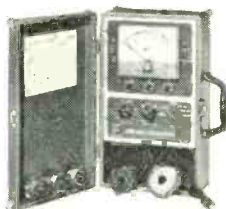

**B & K CRT 445  
Picture Tube  
Checker-  
Rejuvenator**

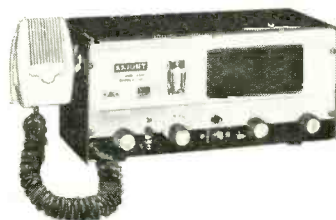

**Knight  
KN-2590  
Dual-Power  
CB 2-Way  
Radio**

### EASY TERMS

Use the convenient  
Allied Credit Fund Plan  
—over 24 months to pay

## ALLIED RADIO

*The World's Largest Electronic Supply House*

*satisfaction  
guaranteed or  
your money back*

RADIO-ELECTRONICS



# SPECIAL in your FREE 1966 ALLIED CATALOG

see what's new in the wonderful world of **knight-kits**<sup>®</sup>



KG-895 Superba Series  
120-Watt Solid-State  
Stereo Amplifier Kit. \$149.95

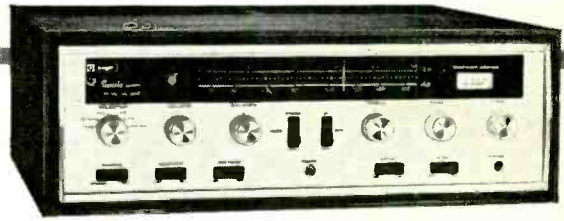

KG-964 Superba  
Series 64-Watt Solid-  
State FM-AM Stereo  
Receiver Kit.  
\$189.95

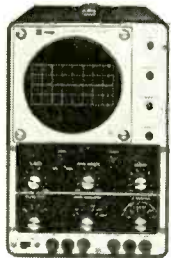

KG-635 5-Inch DC  
to 5.2 Mc Wide-  
band Oscilloscope  
Kit. \$99.95



KG-371 Solid-State  
Auto DC Power  
Timing Light Kit.  
\$19.95

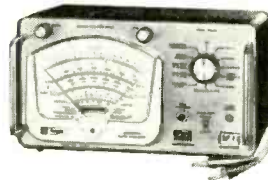

KG-375 Solid-State  
Universal Auto Ana-  
lyzer Kit. \$49.95



Safari-I Deluxe  
23-Channel Citizens  
Band Transceiver Kit. \$129.95



C-540 Low-Cost  
5-Watt Citizens  
Band Transceiver  
Kit. \$49.95



KG-221 FM Moni-  
tor Receiver Kit  
(police, fire, mar-  
ine, weather  
bands, etc.) \$39.95

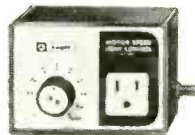

KG-201 Solid-State  
Motor-Speed/Light  
Control Kit. \$9.95

KG-415 Superba  
Series Professional  
Solid-State Stereo  
Tape Deck Kit.  
\$249.95



**Knight-Kit GUARANTEE:** Buy any Knight-Kit. Build it. Operate it. You must be satisfied or we refund your money.

**THERE IS A knight-kit FOR EVERY NEED!**  
easiest to build—enjoy big savings

- Stereo Hi-Fi
- CB 2-Way Radio
- Short-Wave
- Hobby Kits
- Test Equipment
- Automotive
- Intercom
- Amateur Gear

## FREE

Send today for your  
508-page Allied 1966  
value-packed catalog



send for your 508-page 1966 Allied Catalog

## FREE!

ALLIED RADIO, Dept. 2-H  
100 N. Western Ave., Chicago, Ill. 60680

Send FREE 1966 Allied Catalog

Name \_\_\_\_\_  
PLEASE PRINT

Address \_\_\_\_\_

City \_\_\_\_\_ State \_\_\_\_\_ Zip \_\_\_\_\_

# ALLIED RADIO

AUGUST, 1965

# "Which microphone should I use?"

- for tape recording
- for broadcasting
- for CB and ham
- for public address
- for any application...

**Free Booklet—**  
Everything You  
Want To Know  
About Micro-  
phones! Send  
Coupon Today!



**LTV UNIVERSITY**  
A DIVISION OF LING-TENCO-VOUGHT, INC.

Dept. RE-8, P.O. Box 1056, Oklahoma City, Okla.

Name \_\_\_\_\_

Address \_\_\_\_\_

City \_\_\_\_\_ State \_\_\_\_\_ Zip Code \_\_\_\_\_

# NEW SEMI-CONDUCTORS AND TUBES

## LOW-COST SILICON TRANSISTORS

Silicon transistors, only a few years ago, were very expensive toys indeed. (Many still are.) They were used almost exclusively in computers, industrial equipment or for high-frequency work, where high-temperature operation, reliability and low leakage were more important than cost.

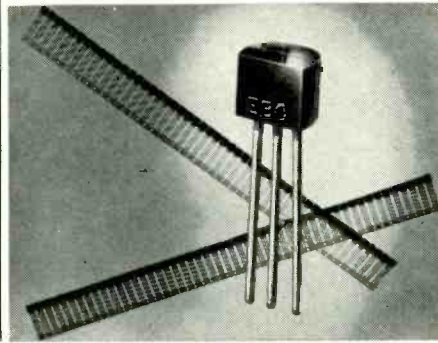

This past year has seen several lines of low-cost silicon transistors from several manufacturers, all aimed at everyday applications in radios, television sets and hi-fi amplifiers. Now Motorola has jumped in with four new lines of inexpensive plastic-packaged silicons, including both n-p-n and p-n-p types, for switching and amplifier applications.

One line, including n-p-n types MPS2923, -2924 and -2925, is intended for use in low-level i.f. and audio amplifiers, and all three transistors are priced under \$1. Another group includes n-p-n types MPS918 and MPS-3563, slightly higher in cost, meant for uhf amplifiers and oscillators. A third group contains two n-p-n high-speed switches for low-level logic functions, and the fourth group has three p-n-p transistors for low-level logic. These two lines are also priced under \$1.

The new packages are of pressure-formed black plastic with a D-shaped profile. The flat of the D makes it easier to mount the transistors on printed-circuit boards, and aids heat-sinking. The package is only a little more than 1/8 inch high, and the lead identification (E, B, C) is stamped right into the case.

Further information is available from the Technical Information Center, Motorola Semiconductor Products, Inc., PO box 955, Phoenix, Ariz. 85001.

# FABULOUS RECORD BARGAIN:

MUSICAL ENTERTAINMENT FOR THE WHOLE FAMILY ON SUPERB 12 INCH - 33 1/3 RPM LONG PLAY RECORDS IN HI-FI & STEREO

## Deluxe 10-Record Boxed Sets

only \$10<sup>.95</sup> EACH BOXED SET OF 10 LP RECORDS  
TWO SETS only \$21

Think of it! You get TEN superb 12" LP's in each handsome gift-boxed set . . . every set a complete collection of memorable performances by outstanding artists. Take your choice now at these fantastic money-saving prices. All records are engineered for the finest in listening pleasure. You have your choice of hi-fi or stereo. So act now, while supplies last, at these low prices.

**82 GREATEST COUNTRY & WESTERN SONGS** featuring Hank Locklin, Patsy Cline, Eddie Dean, Carl Belew, Ferlin Husky, Jan Howard, Jug Scott, T. Texas Tyler, etc. 10 LP's in all.

**TREASURY OF GREAT BROADWAY SHOWS**—10 LP's with full cast and orchestra; South Pacific; Sound of Music; Music Man; My Fair Lady; Porgy and Bess; 7 more.

**GREAT JAZZ OF ALL TIME**—10 LP's with Ray Charles, Tommy & Jimmy Dorsey, Jack Teagarden, Della Reese, Charlie Mingus, Lionel Hampton, Stan Getz, Kai Winding, many others.

**100 MOST REQUESTED SONGS OF ALL TIME**, pop favorites like "Nature Boy", "Tenderly", "Elmer's Tune", "Fascination"; 10 LP's, all Big Band Sound.

**100 GREAT PERFORMANCES**—in stereo only—Percy Faith, David Rose, Nat King Cole, Lena Horne, Billy Daniels, Mel Torme, Johnny Desmond, Art Van Damme, many more. 10 LP's to please everyone.

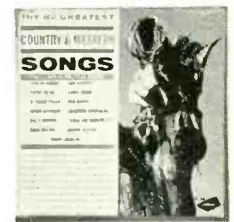
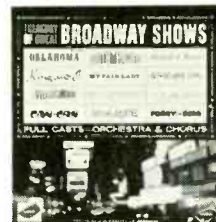

Hudson Specialties, Dept. RE-865  
160 West 14th Street, New York, N. Y. 10011  
Send me at once the Deluxe 10-Record Boxed Sets checked below. I enclose \$10.95 for one set; two sets \$21.

- Hi-Fi  Stereo
- Country & Western  
 Most Requested Songs  
 Broadway Shows  
 Great Jazz  
 Great Performances

Name \_\_\_\_\_ (Please print)

Address \_\_\_\_\_

City \_\_\_\_\_ State \_\_\_\_\_ Zip # \_\_\_\_\_



### G-E, RCA PROMISE COLOR CRT DEVELOPMENTS

Looks like wide departures from the standard 21-inch round and 23- and 25-inch rectangular color CRT's can be expected. Some variants have already appeared, and General Electric has begun pilot production of "an improved type of color television picture tube."

G-E President Borch described the new tube as an improved shadow-mask type, a simpler design than before. It uses bright rare-earth phosphors. G-E has no plans to sell the tube, and expects to use its entire production for its own color sets. No other details on this or any other possible G-E color tube are available at this writing.

RCA has begun distributing sample production quantities of its new 19-inch 90° rectangular color tube to set manufacturers. (This tube was first announced in RADIO-ELECTRONICS in the January issue, page 77.) The 19EYP22, with a laminated glare-free safety window, will cost manufacturers \$106; the 19EXP22, nonlaminated, is \$99.50. The shorter neck of the 90° design (about 7.2 inches shorter than the neck of the 21-inch 70° tube) is expected to inspire some new cabinet styles.

The RCA 19's contain new phosphors also, including an europium red and improved green and blue sulfide phosphors. They will use the same deflection and convergence components as the 25-inch 90° tubes.

### EXTREMELY HIGH-EMISSION CATHODES DEVELOPED FOR POWER TUBES

Cathode electron-emission densities of 10 amperes per square centimeter and higher at 1,000°C have been announced by General Electric Co. from a new cathode design. Present cathodes produce up to 2 amps per square cm at 1,000°C.

The high emission density is ascribed to a new refinement and combination of cathode materials (an alkali-metal/tungstate combination is used).

At the moment, high-emissivity cathodes will be used in beam type tubes, like klystrons and traveling-wave tubes, but they may also be practical for ordinary triodes and tetrodes.

The new cathode design is expected to increase the output of high-power tubes, reduce cathode size for a given output and increase tube life. If very high emission densities are not needed for a particular application, the cathode can be operated, with lower emission, at a reduced temperature.

### LOW-COST GERMANIUM POWER TRANSISTORS

A line of eight 7-ampere germanium power transistors—2N3611 through 2N3618—features low leakage, wide frequency response, high beta holdup, breakdown voltages from 30 to 75, and 85 watts power dissipation.

Prices of these Motorola transistors is quite low, beginning at \$1.15 (single quantity) for the lowest-voltage device and ranging up to \$2.37. All are in TO-3 packages.

Typical small-signal ac gain at 20 kc is 15 for all units, compared to 40 to 60 at 1 kc. This is not bad for rugged, inexpensive high-current germanium transistors, so these will appeal to audio builders as suitable for high-power amplifiers in many of the well known germanium-transistor circuits.

END

### New SEMI-SWEEPER produces whatever frequency you want . . .

Here's a unique sweep generator that has no frequency till you give it one! Its stable transistor rf oscillator works with practically any inductance connected to its terminals, and a unijunction-transistor oscillator sweeps the rf oscillator at a widely variable rate. Works from below 100 kc to above 60 mc. Use for TV, AM, FM, for lining up crystal filters, for anything else you can think of!

Coming in . . . September RADIO-ELECTRONICS

AUGUST, 1965

# Get the Best Matching Transformer Kit for Coax

## "COLOR-MATCH" by Winegard

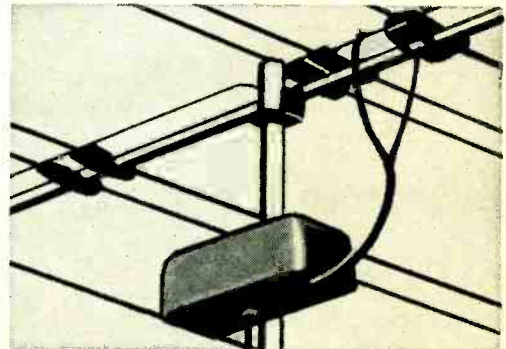

*The Convenient, Easy-to-Use Matching Transformer Kit for Quick, Permanent Coax Installations.*

75 ohm coaxial cable is the most permanent transmission line that can be used in a TV antenna installation. And, because it is shielded, it can be installed next to metal objects, run through conduit, and taped to the antenna mast without interfering with the TV signal. However, to install coax, you need the two matching transformers in "Color-Match".

Model T5911M Transformer mounts on or near the mast. It matches any 300 ohm antenna to 75 ohm coax cable. The T73 transformer mounts conveniently behind any TV set. It trans-

forms the signal back to 300 ohm impedance for a perfect match with the set. All mounting hardware and connectors are included.

When you use coax, be sure to use Winegard "Color-Match". Ask your distributor or write for spec. sheets. "Color-Match" is another convenience product for better TV reception from Winegard.

NOTE: When running 75-ohm coaxial cable in fringe areas, we recommend installation of Winegard 75-ohm Colortron Antenna amplifier Model AP275N—twin nuvistor, or model AP-275T—twin transistor to compensate for the

line loss inherent in all coax installations.

Model T-200 ONLY

\$8.25 LIST

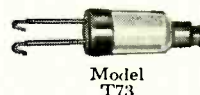
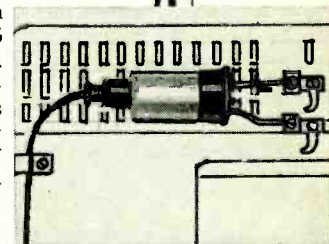

Model T73



Model T5911M



## Winegard Co.

ANTENNA SYSTEMS

3013J Kirkwood • Burlington, Iowa

# NOTEWORTHY CIRCUITS

## FAIL-SAFE AUDIO SQUELCH

Squelch is a most desirable feature in a receiver, particularly when the set is used to monitor channels where transmissions are intermittent. This simple oscillator type squelch can be added to most receivers with a minimum of modifications. It will make a great improvement in CB transceivers that do not have this feature.

The circuit, Fig. 1, consists of a voltage-controlled multivibrator that develops a signal that is turned on and off by the set's avc voltage. The output is

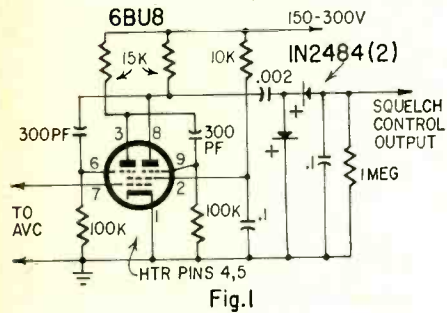

Fig.1

rectified to obtain the negative voltage used to cut off the set's first audio tube when no signal is coming in. When the avc voltage is low, the circuit develops about -20 volts. When the avc rises from zero to a predetermined level, say -3, the oscillator voltage drops suddenly to zero; the af amplifier operates normally and feeds the audio signal to the following stage.

G1 of the 6BU8 acts as the gating element, starting or stopping the multivibrator action between the plates and the suppressor grids. Output here is a square wave at about 170 kc. Rectified and filtered output provides the squelch control voltage.

With the constants shown, squelch output is 24 volts when the avc line is at ground potential, and falls to zero suddenly as the avc voltage reaches about -2.9. Raising the B+ voltage from 150 to 300 raises the output from -24 volts to -59, and shifts the cutoff point also from -2.9 volts to -7.6. At any plate voltage, the cutoff point, at which the oscillator stops generating output volt-

age, can be shifted by a factor of about 2.5 by varying the screen voltage, preferably with a potentiometer.

Power requirements of this circuit are about 10 ma at whatever plate voltage is used (150 or 300), 6.3 volts at 0.3 ampere for the heater, and 3 or more volts at perhaps 0.5  $\mu$ a (from the receiver avc system), for control purposes.

Customary connection of any generator type Codan (including this one) to the grid circuit of the first audio tube is shown in Fig. 2. Numerous obvious variations of this circuit, all performing the same function, are possible. Trouble will be experienced only if the avc voltage available from the signals which it is desired to receive is less than 3, or the first audio tube requires more than 20 volts for cutoff.

If, by some strange mischance, the multivibrator frequency (here about 170 kc) coincides with the set's i.f. or

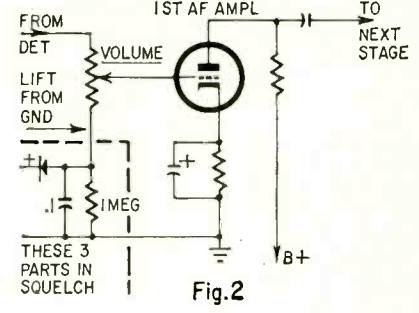

Fig.2

## MOVING DATE EXTENDED—SALE CONTINUES

FREE \$1 BUY WITH EVERY 10 YOU ORDER

Only applies to "\$1" Buys

FREE GIFT WITH EVERY ORDER

### \$200 HEARING AID—FOR \$5



Each HEARING AID is a Complete AUDIO AMPLIFIER and includes CRYSTAL MICROPHONE 3 SUBMINIATURE TUBES Superb Beige CABINET

TOP ITEM for Experimenter can be modified and converted to: RADIOS — INTERCOMS — TRANSMITTERS — SECRET LISTENING DEVICES — Etc. 5" x 2 1/2" x 1" — Shpg. Wt. 1 lb.

Complete as illustrated—incl. detailed informative SCHEMATIC DIAGRAM (less Earphone & Battery) ..... \$5

### HOTTEST VALUE EVER

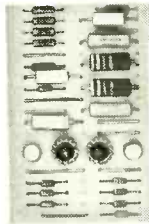

IBM COMPUTER SECTIONS Each Unit "cost IBM over \$5.00" 6 assorted Units we sell for \$1 are loaded with over 100 valuable parts.

6 for \$1  
70 for \$10

### STANDARD TV TUNER 41mc

Latest "GUIDED GRID" Compact Model — good for all 41mc TV's. All set for parallel — for series change the 6GK5 to a 3GK5.

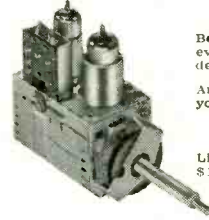

Best TUNER "Standard Kollsman, Inc." ever made — last word for stability, definition & smoothness of operation. An opportunity — to improve and bring your old TV Receiver up-to-date.

L-3", H-4", W-2"

List price \$35 — former reduced price \$15.97 — now cut in 1/2 to \$7.95.

COMPLETE with Tubes & Schematic ..... \$7.95

- |  |   |  |   |
|--|---|--|---|
| <input type="checkbox"/> 300—ASST. 1/2 W RESISTORS \$1<br>Top Brand, short leads, excellent          | <input type="checkbox"/> 100—ASST 1/4 WATT RESISTORS \$1<br>stand. choice ohmages, some in 5% | <input type="checkbox"/> 20 — ASSORTED TUBES \$1<br>Radio, Television and Industrial ..                          | <input type="checkbox"/> 2 — UNIVERSAL 2 1/4" PM \$1<br>SPEAKERS for Radios, Intercom, as multiple Speakers, etc. ....            |
| <input type="checkbox"/> 100—MOLDED TUBULAR COND. \$1<br>Top brand, short leads, excellent           | <input type="checkbox"/> 100—ASST 1/2 WATT RESISTORS \$1<br>stand. choice ohmages, some in 5% | <input type="checkbox"/> ALL AMERICAN TUBE KIT \$2<br>Top Standard Brand — 12BA6, 12BE6, 12AV6, 50C5, 35W4 ....  | <input type="checkbox"/> 50 ASSORTED MYLAR CONDENSERS \$1<br>Popular types .001 to .47 ...  |
| <input type="checkbox"/> 50—ASSORTED #3AG FUSES \$1<br>Popular assorted ampere ratings ..            | <input type="checkbox"/> 70—ASST 1 WATT RESISTORS \$1<br>stand. choice ohmages, some in 5%    | <input type="checkbox"/> 3 — TOP BRAND 35W4 TUBES \$1  | <input type="checkbox"/> 20 — EXPERIMENTER'S COIL \$1<br>"JACKPOT" assorted for 101 uses  |
| <input type="checkbox"/> 5—I.F. COIL TRANSFORMERS \$1<br>sub-min for Transistor Radios ....          | <input type="checkbox"/> 35—ASST 2 WATT RESISTORS \$1<br>stand. choice ohmages, some in 5%    | <input type="checkbox"/> 5—SYLVANIA 1U4 TUBES \$1<br>brand new Jan., individual cartons also serves as IT4 ..... | <input type="checkbox"/> 10—ASSORTED DIODE CRYSTALS \$1<br>1N34, 1N48, 1N60, 1N64, 1N82   |
| <input type="checkbox"/> 5 — AUDIO OUTPUT TRANSFORMER \$1<br>sub-min for Trans Radios                | <input type="checkbox"/> 50—PRECISION RESISTORS \$1<br>asst. list-price \$50 less 98% ..      | <input type="checkbox"/> 25 — SYLVANIA HEAT SINKS \$1<br>for Transistors, etc. ....                              | <input type="checkbox"/> 10—TOP BRAND TRANSISTORS \$1<br>—2N94, 2N404, 2N696, GT-2477   |
| <input type="checkbox"/> 4—TOGGLE SWITCHES \$1<br>SPST, SPDT, DPST, DPDT .....                       | <input type="checkbox"/> 20 — ASS'TED WIREWOUND \$1<br>RESISTORS, 5, 10, 20 watt ....         | <input type="checkbox"/> 100—MIXED DEAL "JACKPOT" \$1<br>Condensers, Resistors, Surprises ..                     | <input type="checkbox"/> 5—LINE FILTER COILS \$1<br>117v, 2.5mh, dual, many uses ..   |
| <input type="checkbox"/> 15—ASST. ROTARY SWITCHES \$1<br>all popular types \$20 value ....           | <input type="checkbox"/> 100—ASST. CERAMIC CONDENSERS \$1<br>some in 5% .....                 | <input type="checkbox"/> 100—BRASS FAHNSTOCK CLIPS \$1<br>popular type & size, plated ....                       | <input type="checkbox"/> 20—ITT SELENIUM RECTIFIERS \$1<br>65ma for Radios, Meters, Chargers, Transistors, Experiments, etc. .... |
| <input type="checkbox"/> CLEAN UP THE KITCHEN "JACKPOT" \$1<br>Big deal only one to a customer ..... | <input type="checkbox"/> 100—ASST. TERMINAL STRIPS \$1<br>all types, 1-lug to 6-lug .....     | <input type="checkbox"/> \$15.00 RADIO PARTS "JACKPOT" \$1<br>handy assortment .....                             | <input type="checkbox"/> FATHOM DEPTH PIECE OF \$1<br>EQUIPMENT loaded with fine parts  |
| <input type="checkbox"/> 50—RADIO & TV SOCKETS \$1<br>all type 7 pin, 8 pin, 9 pin, etc.             | <input type="checkbox"/> 25 — INSTRUMENT POINTER \$1<br>KNOBS selected popular types ..       | <input type="checkbox"/> 3 — ELECTROLYTIC CONDENSERS \$1<br>50/30-150v .....                                     | <input type="checkbox"/> 2—G.E. PIECES OF EQUIPMENT \$1<br>stacked with over 200 useful parts                                     |

BROOKS RADIO & TV CORP., 84 Vesey St., Dept. A, New York 7, N.Y. TELEPHONE COrtlandt 7-2359



that of some supersensitive local service, the frequency can be shifted by varying either the plate resistors or the grid coupling capacitors of the multivibrator. The operating frequency varies approximately as 1/RC.

Operation of this multivibrator squelch is satisfactory, consistent and apparently troublefree. Failure of the circuit stops only the squelch action, and does not disable the receiver audio system.—*Ronald L. Ives*

### NOVEL RADIO-INTERCOM CIRCUIT

I needed a simple intercom to be used as an electronic "baby sitter". The mike would be in the nursery and the speaker in the den where I spend many hours listening to the radio. My favorite receiver is a 1942 all-wave Silvertone model 7037. I decided to see if I could adapt it to work as a combined radio-intercom without relays or switching.

The diagram shows the circuit. The upper part is a simplified circuit of the receiver's audio system. R1, R2 and R3 replace the 15-megohm resistor in the grid circuit of the af amplifier. R4 and R5 replace the 500,000-ohm output grid resistor.

The microphone feeds a two-stage voltage amplifier. The output of the

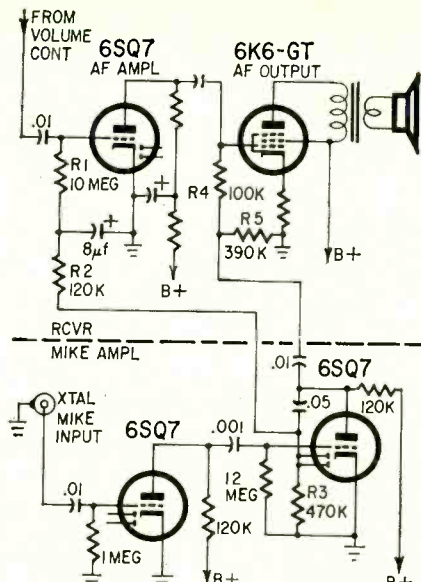

second stage is fed to the junction of R4 and R5. A portion of the amplified microphone signal is rectified by diodes in the second stage, to develop enough negative bias to cut off the af amplifier and prevent the broadcast signal from feeding through. The radio program is restored about 5 seconds after the mike signal ceases.

This old set has a large chassis with plenty of room for modifications. It used a 6SQ7 with the triode plate and grid

strapped together as the detector and avc diode. I installed a 1N34 germanium diode in the detector circuit and rewired the 6SQ7 as the first mike amplifier. I replaced the original speaker with a PM type and used its socket for the second 6SQ7. I use a crystal mike with about 40 feet of low-capacitance shielded audio cable.

This arrangement can be adapted to almost any modern receiver. You can use a high-gain miniature dual triode for the amplifier and a germanium diode to develop the negative control voltage. You may have to adjust the grid resistance in the set's af amplifier so the mike amplifier develops cutoff bias.—*Robert E. Flanagan*  
END

## BIG CATALOG

World's "BEST BUYS" in GOV'T. SURPLUS Electronic Equipment

FULL OF TOP QUALITY ITEMS—

Transmitters, Receivers, Power Supplies, Inverters, Microphones, Filters, Meters, Cable, Keys, Phones, Antennas, Chokes, Dynamators, Blowers, Switches, Test Equipment, Headsets, Amplifiers, etc., etc. **SEND 25¢** (stamps or coin) for **CATALOG** and receive **50¢ CREDIT** on your first order. Address Dept. RE.

FAIR RADIO SALES

P. O. Box 1105 • LIMA, OHIO • 45802

- |   |   |  |  |
|---|---|--|--|
| <ul style="list-style-type: none"> <li><input type="checkbox"/> CHAPT ZU DI MITZIA "JACKPOT" double your money back if not completely satisfied ..... \$1</li> <li><input type="checkbox"/> 1000—ASST. HARDWARE KIT screws, nuts, washers, Rivets, etc. .... \$1</li> <li><input type="checkbox"/> 1000—ASSORTED RIVETS most useful selected sizes ..... \$1</li> <li><input type="checkbox"/> 1000—ASSORTED WASHERS most useful selected sizes ..... \$1</li> <li><input type="checkbox"/> 250—ASST. SOLDERING LUGS best types and sizes ..... \$1</li> <li><input type="checkbox"/> 250—ASST. WOOD SCREWS finest popular selection ..... \$1</li> <li><input type="checkbox"/> 250 — ASST. SELF TAPPING SCREWS #6, #8, etc. .... \$1</li> <li><input type="checkbox"/> 150—ASST. 6/32 SCREWS and 150 6/32 HEX NUTS ..... \$1</li> <li><input type="checkbox"/> 150—ASST. 8/32 SCREWS and 150—8/32 HEX NUTS ..... \$1</li> <li><input type="checkbox"/> 150—6/32 HEX NUTS and 150—8/32 HEX NUTS ..... \$1</li> <li><input type="checkbox"/> 150—ASST. 2/56 SCREWS and 150—2/56 HEX NUTS ..... \$1</li> <li><input type="checkbox"/> 150—ASST. 4/40 SCREWS and 150—4/40 HEX NUTS ..... \$1</li> <li><input type="checkbox"/> 150—ASST. 5/40 SCREWS and 150—5/40 HEX NUTS ..... \$1</li> <li><input type="checkbox"/> 100 — ASST. RUBBER &amp; FELT FEET FOR CABINETS best sizes ..... \$1</li> <li><input type="checkbox"/> 10—ASSORTED SLIDE SWITCHES SPST, SPDT, DPDT, etc. .... \$1</li> <li><input type="checkbox"/> 10 — SURE-GRIP ALLIGATOR CLIPS 2" plated ..... \$1</li> <li><input type="checkbox"/> 5—ASSORTED TRANSFORMERS Radio, TV and Industrial ..... \$1</li> </ul> | <ul style="list-style-type: none"> <li><input type="checkbox"/> 10 SETS — DELUXE PLUGS &amp; JACKS asst. for many purposes .. \$1</li> <li><input type="checkbox"/> 10 — SETS PHONO PLUGS &amp; PIN JACKS RCA type ..... \$1</li> <li><input type="checkbox"/> 25—DUMONT MOLDED CONDENSERS .1—600v ..... \$1</li> <li><input type="checkbox"/> 10—6' ELECTRIC LINE CORDS with plug standard brands ..... \$1</li> <li><input type="checkbox"/> 4—50' SPOOLS HOOK-UP WIRE 4 different colors ..... \$1</li> <li><input type="checkbox"/> 50' — INSULATED SHIELDED WIRE #20 braided metal Jacket .. \$1</li> <li><input type="checkbox"/> 50' — HI-VOLTAGE WIRE for TV, special circuits, etc. .... \$1</li> <li><input type="checkbox"/> 200'—BUSS WIRE #20 tinned for hookups, special circuits, etc. .. \$1</li> <li><input type="checkbox"/> 50 — STRIPS ASSORTED SPAGHETTI handy sizes ..... \$1</li> <li><input type="checkbox"/> 100—ASSORTED RUBBER GROMMETS best sizes ..... \$1</li> <li><input type="checkbox"/> 50—ASSORTED PRINTED CIRCUIT SOCKETS best types .... \$1</li> <li><input type="checkbox"/> 3—1/2 MEG VOLUME CONTROLS with switch, 3" shaft ..... \$1</li> <li><input type="checkbox"/> 5 — ASST. 4 WATT WIRE-WOUND CONTROLS ..... \$1</li> <li><input type="checkbox"/> 20—ASSORTED VOLUME CONTROLS less switch ..... \$1</li> <li><input type="checkbox"/> 7—ASSORTED VOLUME CONTROLS with switch ..... \$1</li> <li><input type="checkbox"/> 15—RADIO OSCILLATOR COILS standard 456kc ..... \$1</li> <li><input type="checkbox"/> 20—ASST. PILOT LIGHTS #44, 48, 47, 51, etc. .... \$1</li> <li><input type="checkbox"/> 50 — WHITE TUBE CARTONS asst. for all 4 important sizes .... \$1</li> </ul> | <h3 style="text-align: center; margin: 0;">TV BARGAIN COLUMN</h3> <ul style="list-style-type: none"> <li><input type="checkbox"/> STANDARD COLOR TV TUNER Complete with Tubes ..... \$12</li> <li><input type="checkbox"/> COLOR TV VERTICAL OUTPUT TRANSFORMER standard type .. \$2</li> <li><input type="checkbox"/> 2—COLOR-TV CRT SOCKETS wired leads, for all color TV's .. \$1</li> <li><input type="checkbox"/> STANDARD VHF-UHF TV TUNER Complete with Tubes ..... \$12</li> <li><input type="checkbox"/> 10—ASST UHF TUNER STRIPS standard 16 to 67 \$50 value ..... \$1</li> <li><input type="checkbox"/> \$15.00 TELEVISION PARTS "JACKPOT" best buy ever .... \$1</li> <li><input type="checkbox"/> 4 — TV ALIGNMENT TOOLS most useful assortment ..... \$1</li> <li><input type="checkbox"/> 110° FLYBACK TRANSFORMER for all type TV's incl schematic ..... \$2</li> <li><input type="checkbox"/> 110° TV DEFLECTION YOKE for all type TV's incl schematic ..... \$2</li> <li><input type="checkbox"/> 90° FLYBACK TRANSFORMER for all type TV's incl schematic ..... \$1</li> <li><input type="checkbox"/> 90° TV DEFLECTION YOKE for all type TV's incl schematic ..... \$1</li> <li><input type="checkbox"/> 70° FLYBACK TRANSFORMER for all type TV's incl schematic ..... \$1</li> <li><input type="checkbox"/> 70° TV DEFLECTION YOKE for all type TV's incl schematic ..... \$1</li> <li><input type="checkbox"/> 4—DUMONT VERT OSC TRANS incl schematic for many TV uses ..... \$1</li> <li><input type="checkbox"/> 20—ASSORTED TV COILS I.F. video, sound, ratio, etc. .... \$1</li> <li><input type="checkbox"/> 20—ASSORTED TV KNOBS all standard types, \$20 value .. \$1</li> <li><input type="checkbox"/> 20—ASSORTED GRID CAPS for 1B3, 1X2, 6BG6, 6BQ6, etc. ... \$1</li> <li><input type="checkbox"/> 50—ASSORTED TV PEAKING COILS all popular types ..... \$1</li> <li><input type="checkbox"/> G.E. TV POWER TRANSFORMER 250ma, 300/360v, 6.3-9A, 5v-3A ..... \$4</li> </ul> | <h3 style="text-align: center; margin: 0;">MARKET SCOOP COLUMN</h3> <ul style="list-style-type: none"> <li><input type="checkbox"/> TRANSISTOR RADIO asst types, good, bad, broken, as-is, potluck ..... \$1.50</li> <li><input type="checkbox"/> 4—TRANSISTOR RADIO EAR-PIECES wired complete with plug ..... \$1</li> <li><input type="checkbox"/> TAPE RECORDER—assorted types good, bad, broken, as-is, potluck ..... \$4</li> <li><input type="checkbox"/> STANDARD 1/4W RESISTORS 10% 470, 1500, 6800, 15k, 100k, 2.2 meg, 5meg Your choice 100 for ..... \$1</li> <li><input type="checkbox"/> 3—ASST WEBSTER CARTRIDGES best types, complete with sapphires ..... \$1</li> <li><input type="checkbox"/> 25'—MICROPHONE CABLE Grey, deluxe, 2 conductor, shielded ..... \$1</li> <li><input type="checkbox"/> STANDARD TELEPHONE JACK or PLUG make telephone portable .. \$1</li> <li><input type="checkbox"/> TELEPHONE RECORDING DE-VICE place it under telephone .. \$1</li> <li><input type="checkbox"/> CRYSTAL LAPEL MICROPHONE high impedance, 200-6000 cps .. \$1</li> <li><input type="checkbox"/> 10 — ASST. RADIO ELECTROLYTIC CONDENSERS ..... \$1</li> <li><input type="checkbox"/> 7 — ASST. TV ELECTROLYTIC CONDENSERS popular selection .. \$1</li> <li><input type="checkbox"/> 50 — ASST. TUBULAR CONDENSERS .001 to .47 to 600v .. \$1</li> <li><input type="checkbox"/> 20—STANDARD TUBULAR CONDENSERS .047-600v ..... \$1</li> <li><input type="checkbox"/> 10—ASST DUAL CONTROLS for Radio, TV, Hi-Fi, Stereo, etc. .... \$1</li> <li><input type="checkbox"/> BONANZA "JACKPOT" not gold, not oil, but a wealth of Electronic Items—Money-Back-guarantee .... \$5</li> </ul> |
|---|---|--|--|

**IMMEDIATE DELIVERY** . . . Scientific light packing for safe delivery at minimum cost.  
**HANDY WAY TO ORDER:** Pencil mark or write amounts wanted in each box, place letter F in box for Free \$1 BUY. Enclose with check or money order, add extra for shipping. Tearsheets will be returned as packing slips in your order, plus lists of new offers.

Name .....

Address .....

Cost of goods .....

Shipping estimated .....

TOTAL .....

Please specify refund on shipping overpayment desired:  CHECK  POSTAGE STAMPS  MERCHANDISE (our choice) with advantage to customer



# Use these practical skill-building electronics handbooks to boost your income now!

# Which TWO do you want for only one dollar each

WITH TRIAL MEMBERSHIP IN THE ELECTRONICS BOOK CLUB:

Simply take 4 additional books within a year at low members' prices!

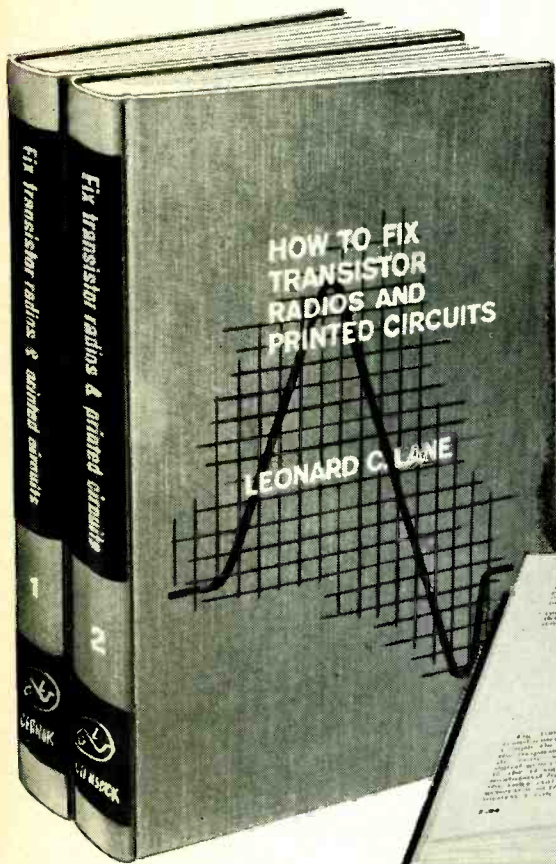

TAKE THESE TWO BOOKS OR ANY TWO DESCRIBED IN THIS ANNOUNCEMENT!

**96A, 96B: How to fix Transistor Radios and Printed Circuits by Leonard C. Lane**—This set counts as 2 books: Originally prepared as a complete course in servicing transistor radios. This two volume version treats every aspect of transistors, much of it new, original, unavailable anywhere else in book form. Hundreds of illustrations aid understanding. Completely covers semiconductor fundamentals, how transistors work, transistor types, amplifiers, RF and IF stages, printed circuits, specific servicing methods and techniques and many, many more subjects. Retail price \$9.90

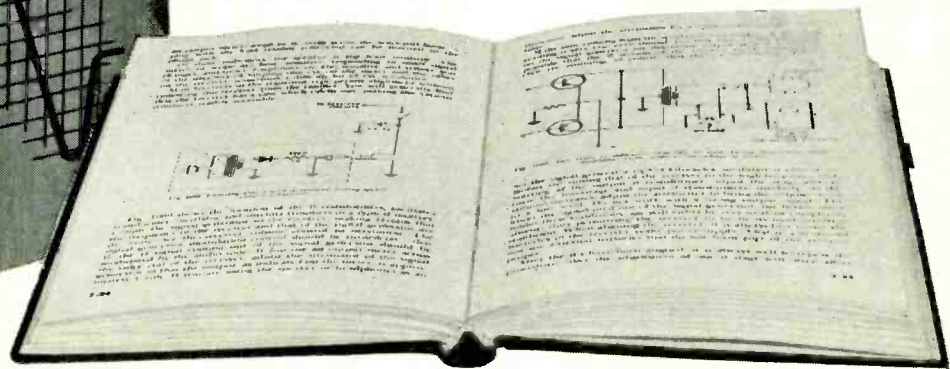

Take your choice of *any two* of these full-size, hard-bound, fully illustrated electronics handbooks for only \$1 each . . . with your trial membership in Gernsback Library's famous Electronics Book Club. *Never* has there been a *better time* to become a member. Now, you can see-for-yourself, *without risk*, the many important advantages you will enjoy. You'll be increasing your know-how and boosting your income while benefiting from the *very substantial savings* on every book you select.

### MOST USEFUL BOOKS YOU'VE EVER SEEN!

Whatever you want to know in electronics, there's a Club handbook to help you learn it quickly and economically. These manuals do *not* deal with vague theory. Each is a *working tool* . . . created to give you concrete help in a particular area of electronics. You get complete, concise, crystal-clear *answers* you can

use at once to solve practical problems. By broadening your knowledge and skills, you'll build your earning power and electronics enjoyment as well.

### BIG SAVINGS ON BOOKS YOU WANT!

Every other month the Club's News Bulletin will tell you about a significant new book on an important phase of electronics. The book may be on radio and TV servicing, test instruments, transistors, audio and hi-fi, industrial electronics, defense electronics, TV troubleshooting, electronics projects or on some other area of electronics that's of vital interest to you.

You may take this book if you wish or an alternate or none at all that month, since you need accept only four additional books within a year. *And the Club saves you up to 30% off retail prices* on the books you want.



# Save up to 83% INSTANTLY on the most valuable self-teaching electronics manuals you'll ever own!

Here is an astonishing offer from your Electronics Book Club: you get two outstanding electronics handbooks for only one dollar each—saving you up to 83% immediately, off the regular retail prices! Discover now, how helpful these books can be to *you, your job, your future*. Each volume gives you a complete background on a specific area of electronics. Here is everything you need to know to do any electronics job—from speedy repairs to troubleshooting to new experimental projects.

Every page of a typical Electronics Book Club selection is crammed with useful facts . . . about radio and TV servicing, TV troubleshooting, transistors, industrial controls, electronics communications, test procedures, AM/FM receivers, test equipment, servicing techniques, sweep oscillators, color TV problems, parts replacement, etc. The authors explain in careful detail, the most efficient, professional way to handle each problem. They give you a complete background—practical assistance you can use at once. Every function is shown by vivid hands-at-work photos, dramatic diagrams, easy-to-understand charts. All important “tricks of the trade” that play so great a part in successful servicing are presented completely and clearly. Here are manuals you will read and reread. They'll help you cash in on today's need for trained technicians.



107A, 107B: Radio Servicing Made Easy by Leonard C. Lane: This set counts as 2 books; originally a \$25 home study course; newest data on servicing; AM, FM, transistor; handy troubleshooting charts; Hardbound—Retail Price \$9.95

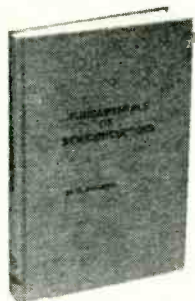

92: Fundamentals of Semiconductors by M. G. Scroggie: covers entire field—transistors, rectifiers, photoelectric devices, thermistors, varistors, etc. Hardbound—Retail Price \$4.60



104: Basic Radio Course revised, enlarged by John T. Frye: Ohm's Law, capacitance, tubes, transistors, etc. complete with servicing techniques. Hardbound—Retail Price \$5.75

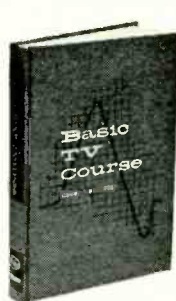

105: Basic TV Course by George Kravitz: Complete up-to-date guide including transistorized portables; circuit operation; sync methods, sweep systems, tuners, amplifiers; etc. Hardbound—Retail Price \$5.75



99: Industrial Electronics Made Easy by Tom Jaski: Operation, maintenance of industrial equipment, dielectric, induction, microwave heating; photoelectric, infrared, pressure, other transducers; Hardbound—Retail Price \$5.95



87: Practical Auto Radio Service & Installation by Jack Greenfield: How to handle bugs, service power supplies, tube types, hybrids, hints on installations, removal, etc. Hardbound; Retail Price \$4.60

115: Horizontal Sweep Servicing Handbook by Jack Darr: fast, simple ways to locate and repair troubles in sweep systems; practical shortcuts, tricks of the trade; Hardbound—Retail Price \$5.75

117: How to Build Tiny Electronic Circuits by Morris Moses: miniaturized electronics explained; components, equipment, devices, techniques, construction, repair hints; Hardbound—Retail Price \$5.85

57: The VTVM by Rhys Samuel: explains VTVM circuits, how they work, how to get most out of this electronic workhorse; troubleshooting; applications. Hardbound—Retail Price \$4.60

90: Hi-Fi Made Easy by Norman Crowhurst: frequency response, distortion, dynamic range, circuits, radio, records, pickups, microphones, speakers, woofers, tweeters, stereo. Hardbound—Retail Price \$5.00

98: Story of Stereo by John Sunier: Covers stereo on tape, film and discs; how to set up to get the most out of stereo; how to spot trouble, how to fix it; home and shop techniques; Hardbound—Retail Price \$5.00

71: Audio Design Handbook by H. A. Hartley: everything you need to create the perfect audio installation; facts on amplifier design, transformers, speakers, enclosures, filters, etc. Retail Price \$5.00

## THIS IS A VALUABLE COUPON:

It will bring you *any* two books on this page or the opposite, for only \$1 each, when you join the Electronics Book Club . . . and agree to take only 4 additional books within a year—out of a wide selection—at *low Club prices*. Thousands of others have already profited from membership. Discover now how you can profit too!

## ACT NOW—WITHOUT RISK!

Select your two introductory handbooks, for only \$1 each, right now. Clip and mail coupon today, while supplies last. *You will be protected* by this NO-RISK GUARANTEE: if you are not pleased when you examine the books, you may return them in 10 days and forget the matter. Mail coupon right away!

Gernsback Library Electronics Book Club  
Dept. RE-865, 154 West 14th Street, New York, N.Y. 10011

Please enroll me as a trial member of the Electronics Book Club and send me the TWO books whose numbers I have printed in the two boxes at right. Bill me only \$1 each, a total of \$2, plus shipping. If not pleased, I may return them in 10 days and this membership will be cancelled.



I need only accept as few as four additional books a year—and may resign any time after purchasing these four additional books. All selections and alternates will be described to me in advance, every other month in the Club Bulletin, and a convenient form will always be provided for my use if I do not wish to receive a forthcoming selection. You will bill me the special Club price for each book I take. This will be up to 30% off retail prices, plus a few cents postage.

INDICATE  
BY NUMBER  
THE BOOKS  
YOU WANT

Name ..... (please print) .....

Address .....

City ..... State ..... Zip .....

SAVE POSTAGE COSTS—enclose your payment of \$2 now and we will pay the postage. Same return guarantee privilege.



# TRY THIS ONE

## ADAPTER: MINIATURE MIKE CONNECTOR TO STANDARD PHONO JACK

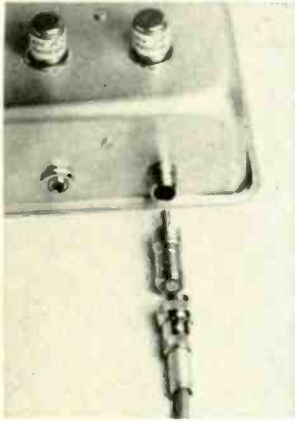

This little adapter lets you plug a miniature mike connector into a standard phono jack.

Remove the cable-protecting spring from a Switchcraft 5501M mike connector, and saw off the connector to a

length of about 1/2 inch. Solder one end of a short length of hookup wire into the pin of a standard phono plug. Insert the phono plug into the end of the mike connector, allowing the wire to pass through the mike connector and through the eyelet. The phono plug and mike connector are securely joined together with a couple of drops of solder. Clip off the excess wire, and solder the end into the eyelet of the mike-cable connector. The photo shows the completed adapter.

You can make this adapter more versatile by using a female mike connector instead of a male connector. The slide-back coupling ring on the female connector allows it to take either a male or female connector.—*Art Trauffer*

[New adapters for mating the many types of connectors are constantly being developed. Consult the latest Switchcraft and similar catalogs. You may be able to purchase a ready-made adapter for a few cents more than the cost of the parts.—*Editor*]

## FILTER FOR BATTERY ELIMINATOR

When testing 12-volt transistor car radios with a battery eliminator, a hum filter is a must. You can make a cheap one from your junk box.

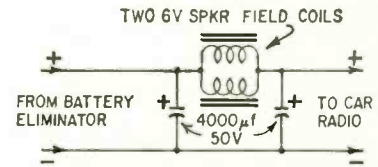

It consists of two 6-volt car-radio-speaker field coils, complete with yoke, and two 4,000- $\mu$ f 50-volt surplus filter capacitors. Mount the coil assemblies with their open ends butting and wire the coils parallel-aiding. The two coils in parallel provide maximum filtering with minimum voltage drop.—*Andy Maxim*

## FREE HIGH-VOLTAGE WIRE

Wire from the high-voltage-rectifier filament winding of a defunct fly-back transformer is well insulated stuff, useful for many rewiring jobs in a high-voltage cage and elsewhere.—*A. von Zook* END

**NEON AC/DC ELECTRIC TESTER**  
FOR HOME AUTO SHOP  
**Special! 59¢**

**Special!**  
With every \$10 Order  
**25¢**  
per tube  
(No Limit) from this list:  
6AG5 6SN7  
6AU6 6I6 6S4  
6AQ5 6K6 6W4

**Prestige & Success are yours as an ELECTRONIC EXPERT**  
FOR CORNELL CUSTOMERS ONLY by special arrangement with the publisher, these amazing bargains are available.

**COMPLETE RADIO SERVICING AND BASIC ELECTRONICS COURSE ONLY \$3.00**  
(\$2.50 + 50¢ packing charge)

**NEW PRACTICAL TV TRAINING COURSE ONLY \$3.50**  
(\$3.00 + 50¢ packing charge)

**Both above courses \$6.00**

**NEW! EASY TO USE! RADIO-TV/TUBE TESTER**  
TEST AND REPAIR TV & RADIO SETS APPLIANCES  
**\$2.89** plus 30¢ shipping

# CORNELL TUBES

## 1 YR. GUARANTEED

Mutual Conductance Lab-tested, Individually Boxed, Branded and Code Dated

33¢

100 TUBES OR MORE:  
**30¢ PER TUBE**

OZ4	6A55	6CD6	6K6	6X4	12BF6
1B3	6AT6	6CF6	6K7	6X8	12BH7
1J3 1K3	6AT8	6CG7	6Q7	7A7	12BL6
1H5	6AU4	6CG8	6S4	7A8	12BY7
1L4	6AU5	6CM7	6SA7	7B6	12C5
1T4	6AV6				12CA5
1U4	6AW8				12SN7
1X2	6AX4				12SQ7
3BZ6	6BA6				25L6
3DG4	6BC5				25Z6
5U4	6BD6	6CZ5	6SH7	7C5	35W4
5U8	6BG6	6D6	6SJ7	7N7	35Z3
5V4	6BJ6	6DA4	6SK7	7Y4	50L6
5Y3	6BL7	6DE6	6SL7	12AD6	24
6A6	6BN4	6DQ6	6SN7	12AE6	27
6A8	6B84	6EA7	6SR7	12AT7	77
6AB4	6BN6	6EAM5	6S7	12A7	78
6AC7	6BQ7	6F6	6UB	12A7	84 6Z4
6AC5	6BZ6	6GH8	6V6	12A7	5687
6AK5	6C4	6M6	6W4	12B6	6350
6AL5	6C6	6J5	6W6	12BD6	6463
6AN8	6C86	6J6	6W6	12BE6	7044
6AQ5					

Other tubes at low prices—send for free list  
NO SUBSTITUTIONS WITHOUT YOUR PERMISSION

**21 PICTURE TUBES**  
139¢ Yr. Guar.  
\* Aluminized  
Pay Dtd Deposit  
C.O.D. or Send Dtd  
with Order

**all purpose ELECTRONIC CLEANER**  
79¢ plus shipping

**SILICON RECTIFIERS**  
750 MA 400 P.I.V.  
**69¢ PAIR**

**DIODES / RECTIFIERS**  
39¢ per pack plus shipping  
**SENSATIONAL KIT VALUE!**

**SOLDERING GUN**  
SPECIAL LOW PRICE  
**2.99** plus 30¢ shipping

**Electronic SOLDER**  
SENSATIONAL VALUE! **29¢**

**TUBE CARTONS**  
HIGH GLOSS CLAY COATED  
PEEL AWAY BACK  
WITH GULLY IN  
DIAGONAL PARTITIONS

SIZE	FOR TUBE SIZE	PRICE PER 10 CARTONS	PRICE PER 100 CARTONS
MIN.	6AU6	29	2.89
LT.	6SN7	30	2.99
LT.	6044B	30	2.99
6	5046	69	7.99

**TUBE SUBSTITUTES** \$1.25

**ABC TV \$100**

**PICTURE EXPANDER** 99¢

**TERMS:** Add 3¢ per tube shipping. Orders under \$5.00 add 3¢ per tube shipping plus 50¢ handling. Canadian orders add approximate postage. Send 25% deposit on C.O.D. orders. No C.O.D. orders under \$5.00 or to Canada. No 24 hr. free offer on personal check orders **5-DAY MONEY BACK OFFER!**

**CORNELL ELECTRONICS CO.**  
Dept. RE 8 4217 University Ave., San Diego, Calif. 92105



# WHAT'S YOUR EQ?

These are the answers. Puzzles are on page 53.

## Double Voltage

You make up the capacitor from the cookie sheet and skillet with one layer of Saran Wrap. Charge the capacitor with the 100-volt source. Now, wrap Saran around the skillet handle and remove it from the assembly. Place a second sheet of Saran on the cookie sheet. Carefully replace the skillet, and you have a capacitor charged to 200 volts.

NOTE: Since the spacing between plates is doubled, the capacitance is halved. The charge (Q) remains the same, therefore, the voltage is doubled ( $Q = CE$ ).

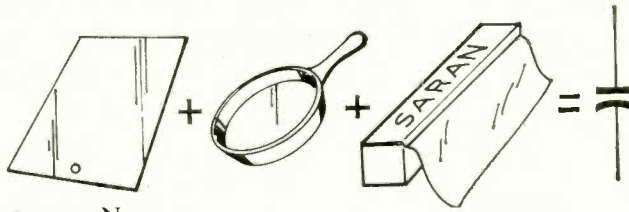

relay in position 2, neither relay in position 3, and both relays (via diodes) in position 4. This enables four switching operations with but two wires. The ground return for relay coils is through car frame.

(This solution is, of course, only one of several possible methods, each offering its own advantages.)

## Channel Selector

In operation, the rotary switch energizes one relay in position 1, the other

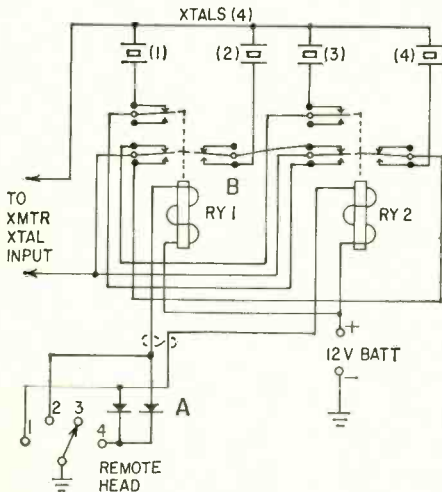

## What Frequency?

The audio output of the earphone is now 2 kc. Since the pole pieces and

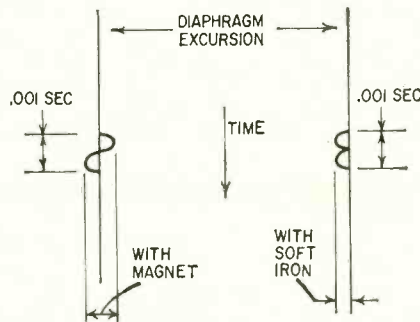

**CRYSTALS are not all the same!**

**INSIST ON TEXAS CRYSTALS BY NAME!**

If your dealer is temporarily out of stock or does not carry Texas Crystals, send us his name along with your order. Minimum order, check or C.O.D. is \$5.00. Add 5¢ per crystal for postage, 10¢ for air mail.

Texas Crystals quality is outstanding as evidenced by use in numerous government space projects where there's no compromise with quality, reliability or accuracy. The same dependable performance is yours for CB operation on all 23 channels at only \$2.95 per crystal.



Send for Free Catalog with Circuits

## TEXAS CRYSTALS

A Division of Whitehall Electronics Corp.

1000 Crystal Drive Fort Myers, Florida  
4117 W. Jefferson Blvd. Los Angeles, California  
Phone 813 WE 6-2109 Phone 213 731-2258

diaphragm are no longer magnetically "biased", the diaphragm (assumed perfect) follows each alternation or half-wave of the input signal, producing an output of twice the input frequency. END

## NOW . . . A RELIABLE AUTO TACHOMETER YOU CAN BUILD YOURSELF . . .

Continuing problems in most engine-speed meters are varying battery voltage, changing spark-pulse shape, and the wide range of temperatures the unit has to live with. Designer Stephen Gross has solved all these difficulties in one inexpensive three-transistor circuit you can build. It works with any gas engine: 2-stroke or 4-stroke, 1 to 8 cylinders.

COMING IN . . .

**SEPTEMBER RADIO-ELECTRONICS**

# ELECTRONICS

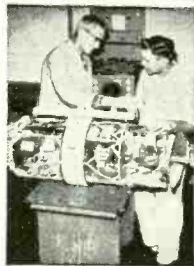

## Engineering-Technicians

Bachelor of Science Degree, 30 Months  
Save Two Years' Time

- Radio-Television Plus Color Technician (12 Months)
- Electronics Engineering Technology (15 Months)
- Electronics Engineering (B.S. Degree)
  - Electrical Engineering (B.S. Degree)
  - Mechanical Engineering (B.S. Degree)
  - Civil Engineering (B.S. Degree)
  - Architecture (B.S. Degree) (36 Months)

The Nation's increased demand for Engineers, Electronic Technicians, Radio TV Technicians is at an all time high. Heald Graduates are in demand for Preferred High Paying Salaries. Train now for a lucrative satisfying lifetime career.

Approved for Veterans

DAY AND EVENING CLASSES

Write for Catalog and Registration Application. New Term Starting Soon.

# HEALD'S

ENGINEERING COLLEGE

Est. 1863-102 Years  
Van Ness at Post, RE  
San Francisco, Calif.

Your Name .....  
Address .....  
City .....  
State .....

# NEW BOOKS

**WORLD'S FINEST**  
**5-CORE SOLDER**



**ERSIN MULTICORE**  
**NEW EASY DISPENSER PAK ONLY 69¢**

BUY IT AT RADIO-TV PARTS STORES  
MULTICORE SALES CORP. PORT WASHINGTON, N. Y.

**MOST-OFTEN-NEEDED 1965 RADIO DIAGRAMS** (Vol. R-25). M. B. Beitman, Supreme Publications, 1760 Balsam Rd., Highland Park, Ill. 60035. 8 1/2 x 10 1/2 in., 192 pp. Paper, \$2.50

The most recent compilation of manufacturers' diagrams and service information covering transistor and tube radios and audio amplifiers from the leading manufacturers.

**DICTIONNAIRE ANGLAIS-FRANCAIS**, by Henry Piraux. Editions Eyrolles, 61, Blvd. Saint-Germain, Paris Ve, France. 6 1/2 x 9 1/2 in., 362 pp. Paper, 38.90 francs

An extremely large and complete dictionary of electronics and words which might be used in connection with electronic equipment (atomics or plastics, for example). From English to French only.

**THE ELEMENTS**, by Samuel Ruben. Howard W. Sams & Co., Inc., 4300 W. 62 St., Indianapolis 6, Ind. 5 1/2 x 8 1/2 in., 112 pp. Paper, \$1.95

In this convenient little handbook, prepared by a man who is better known in electronics world as the inventor of the mercury cell and the dry electrolytic capacitor, each element is given a page. Elements are arranged alphabetically, from actinium to zirconium, with as many as 23 physical and chemical constants listed for most. Nine of the constants are repeated in easy-reference form at the top of the page, together with the name of the element and its symbol.

**PULSE AND SWITCHING CIRCUITS**, by Donald J. Ketchum and E. Charles Alvarez. McGraw-Hill Book Co., 330 W. 42 St., New York, N.Y. 10036. 6 x 9 in., 310 pp. Cloth, \$8.50

Practical circuits and test instruments are discussed and analyzed, with answers to some problems. Requires only basic electronics and elementary math.

**COLOR TV REPAIR**, edited by Martin Clifford in cooperation with the editors of RADIO-ELECTRONICS. Gernsback Library Inc., 154 W. 14 St., New York, N.Y. 10011. 6 1/2 x 9 1/4 in., 223 pp. Paper, \$1.25.

A compilation of material from such authors as Robert Middleton, Jack Darr, Art Margolis, Homer Davidson and others. Stresses the practical without omitting to explain the "how". Well illustrated with drawings and photographs.

**BASIC THEORY AND APPLICATION OF TRANSISTORS**. Dover Publications, Inc., 180 Varick St., New York, N.Y. 10014. 6 1/2 x 9 1/4 in., 263 pp. Paper, \$1.25.

This book is profusely illustrated and well organized. It begins with elementary semiconductor theory and progresses to amplifiers, oscillators, modulators, bias methods, etc. 240 illustrations (most are schematics). Reproduced from Army Technical Manual 11-690, first published in 1959.

**ANALOG COMPUTATION AND SIMULATION: LABORATORY APPROACH**, by Roger R. Jenness. Allyn & Bacon, Inc., 150 Tremont St., Boston, Mass.

Includes 25 lab studies of the computer and its applications. Written for advanced students and engineers.

**USING AN OSCILLOSCOPE**, by D. W. Easterling. Norman Price Publishers Ltd., Distributed by Sim-Tech Book Co., PO Box 69, Agincourt, Ont., Canada. 5 1/2 x 8 1/2 in., 80 pp. Paper, \$1.30

A British approach to the subject. Devotes considerable space to time bases (and the lack of them) and to radio and TV servicing.

**RADIO SERVICE TRAINING MANUAL**, by Richard F. Rice. Howard W. Sams & Co., Inc., 4300 W. 62 St., Indianapolis 6, Ind. 5 1/2 x 8 1/2 in., 288 pp. Paper, \$4.95

Troubleshooting charts, schematics with voltage readings, service techniques and test procedures, to speed up repairs of AM, FM, portables, auto sets and stereo.

**DICTIONARY OF ELECTRONICS, COMMUNICATIONS AND ELECTRICAL ENGINEERING (VOL. II, GERMAN-ENGLISH)**, by Harry Wernicke. Rohde & Schwarz, 8000 München 8, Mühlhofstr. 15, Germany. 6 1/4 x 9 in., 576 pp. Cloth, \$8.

Some 66,000 German technical terms rendered into English. Covers physics, astronautics, electronics, information theory, computers and mathematics. Several ingenious space-saving tricks have been used, making a compact volume with large, readable type. Volume I, an earlier edition, contains English-German vocabulary.

**THE ANALYSIS AND DESIGN OF ELECTRONIC CIRCUITS**, by Paul M. Chirlian. McGraw-Hill Book Co., 330 W. 42 St., New York, N.Y. 10036. 6 1/4 x 9 1/4 in., 570 pp. Cloth, \$11.75

Engineers and students at upper college level will find this an interesting and helpful book for explaining tube and transistor circuits, and design procedures.

**TRANSISTOR TELEVISION RECEIVERS**, by T. D. Towers. John F. Rider Publisher, Inc., 116 W. 14 St., New York, N.Y., 10011. 7 1/2 x 10 in., 194 pp. Cloth, \$6.95

This volume discusses the latest circuits used in American and foreign sets. Presenting typical schematics, it covers all sections of the receiver, explains operation and service techniques. British. END

## SILICON RECTIFIER SALE

IMMEDIATE DELIVERY  
FULLY GTD NEWEST TYPE  
AMERICAN MADE FULLY TESTED

750 MA-SILICON "TOPHAT" DIODES  
LOW LEAKAGE FULL LEAD LENGTH

PIV/RMS 50/35 .05 ea.	PIV/RMS 100/70 .07 ea.	PIV/RMS 200/140 .10 ea.	PIV/RMS 300/210 .12 ea.
PIV/RMS 400/280 .14 ea.	PIV/RMS 500/350 .19 ea.	PIV/RMS 600/420 .23 ea.	PIV/RMS 700/490 .27 ea.
PIV/RMS 800/560 .35 ea.	PIV/RMS 900/630 .45 ea.	PIV/RMS 1000/700 .60 ea.	PIV/RMS 1100/770 .75 ea.

ALL TESTS AC & DC & FWD & LOAD  
SILICON POWER DIODE STUDS

D.C. AMPS	50 PIV 35 RMS	100 PIV 70 RMS	150 PIV 100 RMS	200 PIV 140 RMS
3	.08 ea.	.12 ea.	.16 ea.	.22 ea.
12	.25	.50	.65	.75
35	.65	.90	1.25	1.40
50	1.50	1.75	2.20	2.60
100	1.60	2.00	2.40	3.00

D.C. AMPS	300 PIV 210 RMS	400 PIV 280 RMS	500 PIV 350 RMS	600 PIV 450 RMS
3	.27 ea.	.29 ea.	.37 ea.	.45 ea.
12	.90	1.30	1.40	1.65
35	2.00	2.35	2.60	3.00
50	3.25	4.00	4.75	6.00
100	3.60	4.50	5.25	7.00

"SCR" SILICON CONTROLLED RECTIFIERS "SCR"

PRV	7 AMP	16 AMP	25 AMP	PRV	7 AMP	16 AMP	25 AMP
25	.30	.50	.85	250	1.75	2.15	2.50
50	.45	.75	1.00	300	2.00	2.40	2.75
100	.80	1.25	1.50	100	2.40	2.75	3.25
150	.90	1.60	2.00	500	3.20	3.40	3.80
200	1.25	1.80	2.25	600	3.40	4.00	4.50

SPECIALS! SPECIALS!

100 Different Precision Resistors  
1/2-1-2 watt 1/2%-1% TOL \$1.50

2 amp 1000 Piv Silicon Power Rect. .70 ea.  
10 for \$6.50

T.V. Replacement Antenna List \$11.50 ea.

J. F. D. Supersensitive, 4 Sections Monopole  
Antenna, replacement for most sets \$1.25 ea.

Computer Grade Condenser 15,500 MFD  
15 VDC American Mfg. .75 ea.

Type IN34 DIODE GLASS .07 ea 100 for \$5

Money Back guarantee. \$2.00 min. order. Orders  
F.O.B. NYC. Include check or money order. Shpg.  
charges plus. C.O.D. orders 25% down.

Warren Electronic Components

230 Mercer St., N. Y., N. Y. 10012 • OR 3-2620

## fix ELECTRIC APPLIANCES

\$3 TO \$5 AN HOUR

FREE BOOK tells about it. Our complete, easy profitable spare-time or full-time business that course trains you for top earnings. At no extra pays \$3-\$5 hour - right at charge you get time-sav- home! 400 MILLION Ap- ing Appliance Tester. Get pliances now in use. Peo- FREE Book. FREE Sam- ple need them fixed. YOU ple Lesson! Mail coupon make good money doing now.

**FREE BOOK**

**FREE LESSON**

NATIONAL RADIO INSTITUTE, Appliance Div.  
Dept. 503-085, Washington 16, D. C.  
Send Free Book, Free Appliance Repair  
Course Lesson.  
Name.....  
Address.....  
City..... Zone..... State.....



# SCHOOL DIRECTORY

## Get Your First Class Commercial F. C. C. LICENSE QUICKLY!

Career opportunities in *communications electronics* are almost unlimited. Prepare now. Let Grantham train you—by correspondence, or by classroom and laboratory instruction. Get your *first class commercial F.C.C. license* in as little as 4 months, or at a slower pace if you prefer. Then, continue in more-advanced electronics training if you wish. Diploma awarded. Our catalog gives full details.

Learn how our training can prepare you for your F.C.C. license; write or telephone the School at any one of the teaching divisions listed below, and ask for "Catalog 57."

### Grantham School of Electronics

1505 N. Western Av., LOS Angeles, Cal. 90027  
(Phone: HO 9-7878)

408 Marion Street, Seattle, Wash. 98104  
(Phone: MA 2-7227)

3123 Gillham Road, Kansas City, Mo. 64109  
(Phone: JE 1-6320)

818-18th St., NW, Washington, D.C. 20006  
(Phone: 298-7460)

## GET INTO ELECTRONICS

V.T.I. training leads to success as technicians, field engineers, specialists in communications, guided missiles, computers, radar and automation. Basic & advanced courses in theory & laboratory. Electronic Engineering Technology and Electronic Technology curricula both available. Assoc. degree in 29 mos. B.S. also obtainable. G.I. approved. Graduates in all branches of electronics with major companies. Start Sept., Feb., 1968, campus. High school graduate or equivalent. Catalog.

VALPARAISO TECHNICAL  
INSTITUTE  
Department C. Valparaiso, Indiana



## A JOB or a POSITION?

The difference is **ELECTRONIC MATHEMATICS**

**NOW! A NEW WAY TO LEARN**—I. H. S. I. WAY. A complete home study course in electronic math to help you get the position you want—**MORE MONEY—MORE RESPECT**—**COURSE PREPARED BY COLLEGE PROFESSORS** who have lectured to thousands of men on math and engineering. You learn at home quickly, easily—**AS FAST** as you want.

**YOU SIGN NO CONTRACTS**—Pay only if satisfied—you owe it to yourself to examine the **INDIANA HOME STUDY INSTITUTE COURSE IN ELECTRONIC MATH**. **FREE BONUS**—if you join now, a refresher course in basic arithmetic.

Write for Brochure—No Obligation  
**THE INDIANA HOME STUDY INSTITUTE**  
Dept. RE-8, P.O. Box 1189  
Panama City, Fla. 32402

## B.S. degree in 36 months

Small professionally-oriented college. Four-quarter year permits degree completion in three years. Summer attendance optional. *Engineering*: Electrical (electronics or power option), Mechanical, Civil, Chemical, Aeronautical. *Business Administration*: Accounting, General Business, Motor Transport Administration. One-year Drafting and Design Certificate program. Graduate placement outstanding. Founded 1884. Rich heritage. Excellent faculty. Small classes. Well-equipped labs. New library. New residence halls. Attractive 300-acre campus. *Modest costs*. Enter Sept., Jan., March, June. For *Catalog and View Book*, write *Director of Admissions*.



### TRI-STATE COLLEGE

2485 College Avenue, Angola, Indiana



### Learn Electronics for your SPACE-AGE EDUCATION at the center of America's aerospace industry

No matter what your aerospace goal, you can get your training at Northrop Tech. in sunny Southern California.

**COLLEGE OF ENGINEERING.** Get your B.S. degree in engineering in just 36 months by attending classes year round. Most Northrop Tech graduates have a job waiting for them the day they're graduated!

**A & P SCHOOL.** Practical experience on real aircraft. One-year course prepares you for F.A.A. A&P certificate. **WRITE TODAY FOR CATALOG.**

**NORTHROP INSTITUTE OF TECHNOLOGY**  
1199 W. Arbor Vitae, Inglewood, Calif.

when it's time to think of college  
you should read this  
**FREE CAREER BOOKLET**  
about electronics at

## MSOE



**MILWAUKEE MS-237  
SCHOOL OF ENGINEERING**  
Dept. RE-865, 1025 N. Milwaukee Street  
Milwaukee, Wisconsin 53201

Tell me about an engineering career through residence study in:

Electrical fields  Mechanical fields

Name.....Age.....

Address.....

City, State.....

LEARN

## ELECTRONICS

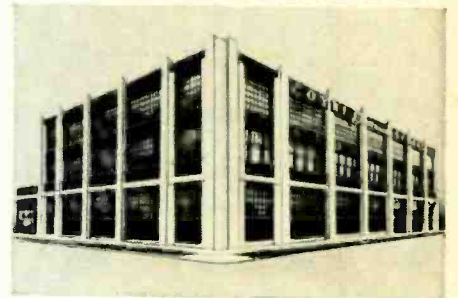

FOUNDED 1899

NOT-FOR-PROFIT

## COYNE ELECTRONICS INSTITUTE

Electronics Engineering Technology	—	Degree (2 Yrs.)
Electrical-Electronics Technician	—	Diploma (40 Wks.)
TV-Radio-Electronics Technician	—	Diploma (40 Wks.)
Combined Electronics Technician	—	Diploma (80 Wks.)
Practical Electrical Maintenance	—	Diploma (32 Wks.)
Practical Refrigeration Air Conditioning and Appliance Repair	—	Diploma (24 Wks.)
Specialized Industrial Electronics	—	Diploma (16 Wks.)
Introduction to Electricity-Electronics	—	Certificate (8 Wks.)
FCC First Class Radiotelephone	—	Certificate (100 Hrs.)

Special finance plans. Part time employment service while in school. Also Free graduate employment service.



Use this coupon to get our **FREE BOOK "YOUR OPPORTUNITIES IN ELECTRONICS"**  
**COYNE ELECTRONICS INSTITUTE, Dept. of Electronics C5-N**  
1501 W. Congress Parkway, Chicago, Illinois 60607

Name.....Age.....  
Address.....Phone.....  
City.....Zone.....State.....

Unlike most other schools, we do not employ salesmen

## EARN Electronics DEGREE

You can earn an A.S.E.E. degree at home. College level **HOME STUDY** courses taught so you can understand them. Continue your education, earn more in the highly paid electronics industry. Missiles, computers, transistors, automation, complete electronics. Over 27,000 graduates now employed. Resident school available at our Chicago campus—Founded 1934. Send for free catalog.

**American Institute of Engineering & Technology**  
1139 West Fullerton Parkway, Chicago 14, Ill.



**Engineering Technician**  
A.S. Degree—2 Years  
**Electronics Engineer**  
B.S. Degree  
Evening Courses Available

**ELECTRONIC TECHNICAL INSTITUTE**  
4863 El Cajon Blvd., San Diego, Calif.



# MARKET CENTER

## Rectifiers & Transistors

750 ma Silicon diodes "Epoxy" or "Top Hat"			Silicon Power Diode Studs 3 amps		
PIV	PIV	PIV	PIV	PIV	PIV
50	5¢	600	21¢	25	6¢
100	7¢	*700	25¢	50	8¢
200	10¢	*800	32¢	100	14¢
400	14¢	*900	40¢	150	16¢
500	18¢	*Top Hat only	200	22¢	All Tests

Full Leads. Tested. Guaranteed. American made

10 Watt Sil. Zener studs, 6-150v, any voltage 95¢ ea.  
 1 Watt Zener Diode Axial leads 6v-200v 50¢ ea.  
 Sil. diode stud 1500 PIV 300ma 50¢ ea.  
 18 Amp Stud Sil. Rect. 100 PIV 75¢ ea.  
 Hi-Voltage-Silicon epoxy diode, 2 1/2" x 3/8" x 1/2" Hoffman-3000 PIV-20Cma. \$1.49 ea.  
 Hoffman-6000 PIV-20Cma. \$3.49 ea.  
 Thermistor, glass bead, 1200 ohms, 600°F, 2/21.00  
 Sil. Power 2N1724—\$1.50; 85 watts

20 Watt Germanium (Internal and external heat sink)			
2N1038	28¢	2N1042	35¢
2N1039	35¢	2N1043	45¢
261040	45¢	2N1044	60¢
2N1041	60¢	2N1045	80¢

Light Sensitive Resistor  
75 ohms—10 meg. 100 volts, 150mw \$1.75 ea

2N1149	5 for \$1.00
2N650	49¢
HF Sil. 2N702-100mc 40¢; 2N703-150mc 60¢	

Light sensitive Power transistor TO-3 Case with circuit instructions—\$1.95 ea.

Philco Sil., NPN, 2N2479, new 3 for \$1.00  
 1N429, 6v Zener 30¢  
 HF Silicon tetrode, 3N35—75¢ ea.  
 2N243, Silicon power—4 for \$1.00  
 Sil. diodes, 1N200 series, assorted, new 15 for \$1.00  
 Ger. diodes, glass, new 15 for \$1.00  
 Nickel Cadmium Battery 9 1/2" oz. 2 3/4" x 3/4" x 4 1/2", 8 amp-hrs.—\$1.95 ea.

Varicap-voltage variable capacitor—47 pf at 4v., 4:1 new \$1.25 ea.

12 different pots 2-4 W	\$1.00
25 different power resistors to 50W	\$1.00

Silicon Controlled Rectifiers					
PRV	7 amp.	16 amp.	PRV	7 amp.	16 amp.
25	.28	.48	200	1.05	1.70
50	.48	.70	300	1.60	2.20
100	.70	1.20	400	2.10	2.70
150	.80	1.50	500	2.80	3.30
All Tests, Stud Type			600	3.00	3.90

Money back guarantee, \$2.00 min. order, include postage, Catalogue 25¢

ELECTRONIC COMPONENTS CO.  
Box 2902B Baton Rouge, La. 70821

## GENERAL

TV SERVICE ORDER BOOKS for use with your rubber stamp. Duplicate or triplicate. Low cost. Write for FREE 32 PAGE CATALOG and Special Rubber Stamp Offer. OELRICH PUBLICATIONS, 6556 W. Higgins, Chicago, Ill. 60656.

72 page Illustrated Government Surplus Radio, Gadgets Catalog 20¢. MESHNA, Nahant, Mass.

McGEE RADIO COMPANY. Big 1965 176-page catalog sent free. America's best values hi-fi amplifiers-speakers-electronic parts. 1901 McGee Street, Dept. RE, Kansas City, Mo. 64108.

BARGAINS OFFSET Presses, Varytypers Mimeograph Typewriters. Write DIXIEGRAPH, King, North Carolina.

Convert any television to sensitive Big-Screen Oscilloscope. Only minor changes required. No electronic experience necessary. Illustrated plans \$2.00. RELCO-A25, Box 10563, Houston 18, Texas.

BUILD TV CAMERA cheaper than ever! Send 10¢ for details. ATV RESEARCH, Dept. RE-11, Box 396, So. Sioux City, Nebraska 68776.

ORIGINAL Antique telephones, illustrated catalogue 20¢. TELEPHONE COMPANY, Turtle Lake, Wisconsin.

UNUSUAL Chemistry books, courses, kits! Rare chemicals, cheap! Catalog 25¢. NSOC, Box 94, Redwood City, Calif. 94064

KIT OF THE MONTH CLUB. Novel, new projects each month. Low Cost. Free information, LEADER ENTERPRISES, Box 44718-KC, Los Angeles, California 90044

SAFEGUARD PRIVACY! New instrument detects electronic "bugs", wire-tapping and snooping devices. Free information. DEE EQUIPMENT, Box 7263-E8, Houston 8, Texas.

## Canadians

CANADIANS Have you seen ELECTRON, Canada's own Service and Hobby magazine? Subscription \$3.50. ELECTRON, Box 796, Montreal, Canada.

GIANT SURPLUS BARGAIN PACKED CATALOGS. Electronics, Hi-Fi, Shortwave, Amateur, Citizens Radio, Rush \$1.00 (Refunded). ETCO, Box 741, Dept. R. Montreal, Canada.

CLASSIFIED COMMERCIAL RATE (for firms or individuals offering commercial products or services): 60¢ per word . . . minimum 10 words.

NON-COMMERCIAL RATE (for individuals who want to buy or sell personal items): 30¢ per word . . . no minimum.

Payment must accompany all ads except those placed by accredited advertising agencies. 10% discount on 12 consecutive insertions, if paid in advance. Misleading or objectionable ads not accepted. Copy for October issue must reach us before August 10th.

WORD COUNT: Include name and address. Name of city (Des Moines) or of state (New York) counts as one word each. Zone or Zip Code numbers not counted. (We reserve the right to omit Zip Code if space does not permit.) Count each abbreviation, initial, single figure or group of figures or letters as a word. Symbols or groups such as 8x10, COD, AC, etc., count as one word. Hyphenated words count as two words. Minor over-wordage will be edited to match advance payment.

## WANTED

QUICK CASH . . . for Electronic EQUIPMENT, COMPONENTS, unused TUBES. Send list now! BARRY, 512 Broadway, New York, N.Y. 10012, 212 WALKER 5-7000.

CASH, SONY TRANSISTOR TV's etc. swapped for G-R, H-P, L&N etc. equipment, special tubes, manuals, military electronics. ENGINEERING ASSOCIATES, 428 Patterson Road, Dayton, Ohio 45419.

Military surplus radios ARC-27 ARC-34 ARC-38 ARC-39 ARC-44 ARC-52 ARC-55 ARC-73 ARC-84 R-220C/ARN-21 51X-2/17L-7 RT-68/GRC. Test sets with ARM, URM, UPM, SG prefixes, Top cash dollar paid. SLEP ELECTRONICS, Drawer 178 Ellenton, Florida. 33532

4 Boonton Signal Generators Model 202B with Serial Numbers above No. 1000. Subject to test and approval. Call (212) EX 2-8900 Ext. 11 or write Dept. ML, FISHER RADIO CORP. Long Island City, N.Y.

15GP22 Color Kinescope. Rebuilt-Used (Operable). Reasonable. M. SASHKIN, 988 Stearns Dr., Los Angeles, California 90048

## EMPLOYMENT OPPORTUNITIES

CALIFORNIA EMPLOYMENT. Names and addresses of 500 Southern California electronics firms \$3. Air Mail \$4. SPINDLER, P.O. Box 103, Canoga Park, California 91305

## SERVICES

METERS—MULTIMETERS REPAIRED and calibrated. BIGELOW ELECTRONICS, Box 71-B, Bluffton, Ohio.

SPEAKER RECONING. Satisfaction Guaranteed. C & M RECON CO., 11 Witherspoon Street, Princeton, New Jersey

TRANSISTORIZED products dealers catalog, \$1. INTERMARKET, CPO 1717, Tokyo, Japan.

Fast, Transistor Radio Service, \$4.00 complete. Free, wholesale brochure. TWINLAKES ELECTRONICS. Leitchfield, Kentucky.

PROFESSIONAL BUSINESS CARDS Embossed. \$4.00 per M Postpaid. Samples free. LUMAR, Box 473, West Hartford, Conn. 06107.

NAMEPLATES, Decals, Signs, Plaques, Trophies, Badges. Write R. E. SETON, New Haven 15, Conn.

## MOTION PICTURES

SPECTACULAR '64 Indianapolis "500" Classic. 188' 8mm Eastman Color including fiery second lap crash \$11.95 postpaid. SPORTLITE "500" FILMS, 20-RE North Wacker, Chicago, Illinois 60606

**FREE CATALOG!**  
148 PAGES • NEARLY 4,000 BARGAINS  
OPTICS • SCIENCE • MATH



Completely new 1965 edition. New items, categories, illustrations. 148 easy-to-read pages packed with nearly 4000 unusual items. Dozens of electrical and electromagnetic parts, accessories. Enormous selection of Astronomical Telescopes, Microscopes, Binoculars, Magnifiers, Magnets, Lenses, Prisms. Many war surplus items for hobbyists, experimenters, workshop, factory. Write for catalog "EH".

### CLIP AND MAIL COUPON TODAY

EDMUND SCIENTIFIC CO., Barrington, N. J.  
PLEASE SEND ME FREE CATALOG "EH"  
Name \_\_\_\_\_  
Address \_\_\_\_\_  
City \_\_\_\_\_ State \_\_\_\_\_



# AUDIO - HI-FI

Component quotations-tapes Mylar 1800' post-paid \$1.59 each. BAYLA, Box 131RE Wantagh, N.Y.

WRITE for highest discounts on components, recorders, tapes, from franchised distributors. Send for FREE monthly specials. CARSTON, 1686-R Second Ave. N.Y.C. 10028

STEREO TAPE RENTALS for the discriminating listener. Free Catalog. GOLD COAST TAPE LIBRARY, Box 2262-Palm Village, Hialeah, Fla.

RENT STEREO TAPES—over 2,500 different—all major labels—free brochure. STEREO-PARTI, 1616 Terrace Way, Santa Rosa, Calif.

STEREO TAPES. Save up to 60% (no membership fees). We discount recorders, batteries, accessories, and mail pre-recorded tape prepaid anywhere that United States rates prevail. Free 60 page catalog. SAXITONE, 1776 Columbia Road N.W., Washington, D.C. 20009

TAPE recorders, Hi-Fi components, Sleep-learning equipment, Tapes, Unusual values. Free catalog. DRESSNER, 1523 Jericho Turnpike, New Hyde Park 5, N.Y.

HI-FI COMPONENTS, Tape Recorders, at guaranteed "WE will not be undersold" prices. 15-day moneyback guarantee. Two-year warranty. NO Catalog. Quotations Free. HI-FIDELITY CENTER, 1797 (R) 1st Ave., New York, N.Y. 10028

TAPE RECORDER SALE. Brand new, latest models, \$10.00 above cost. ARKAY SALES, 1028-E Commonwealth Ave., Boston, Mass. 02215.

TAPEMATES makes available to you ALL 4-TRACK STEREO TAPES—All Labels—postpaid to your door—at tremendous savings. For free brochure write TAPEMATES CLUB, 5280 RE West Pico Blvd., Los Angeles, Calif. 90019

LOW LOW QUOTES, DYNA. A.R. GARRARD E.V. HI-FI, Roslyn, Pa. 19001

## don't leave us behind WHEN YOU MOVE!

Postal regulations require that you pay extra postage on all magazines forwarded to you at a new address. Copies will not be forwarded free, and we cannot replace lost copies.

To insure delivery at your new address please notify us now, or at least 4 weeks in advance of your moving. Write in old and new address below, if possible include the address label from your last issue.

Thank you.

Please mail this form today to:

### Radio-Electronics SUBSCRIPTION DEPARTMENT

154 West 14th Street, New York, N.Y. 10011

NEW ADDRESS (Please print)

Name \_\_\_\_\_

Address \_\_\_\_\_

City \_\_\_\_\_

State \_\_\_\_\_ Zip \_\_\_\_\_

Attach label here or write  
OLD ADDRESS

Name \_\_\_\_\_

Address \_\_\_\_\_

City \_\_\_\_\_ State \_\_\_\_\_ Zip \_\_\_\_\_

# Compare these prices with all other prices for Brand New Tubes.

The largest stock of obsolete tubes in the USA at the lowest prices—COMPARE

# BRAND NEW UNITED'S FIRST QUALITY TUBES DISCOUNTS up to 80% OFF GUARANTEED ONE FULL YEAR! NOT USED! NO PULLS! WHY PAY MORE?

Type	Price	Type	Price	Type	Price	Type	Price	Type	Price	Type	Price	Type	Price	Type	Price
00A/UV	2.50	3DC4	1.35	6AJ8	1.95	6CY7	1.22	6J6	.72	8C57	.98	12FX8	1.27	19T8	1.25
01A	.80	3DK6	.92	6AK6	.94	6CZ5	1.59	6J7	1.85	8CK8	1.60	12G6A	.91	20S0	1.25
02A	.90	3DT6	.79	6AL3	1.00	6CZ5	1.95	6J8	1.25	8EB8	1.50	12OC6	1.15	21EX6	1.95
03A	1.35	3E7	1.42	6AL7	1.95	6D6	2.50	6J8	2.50	8EM5	1.19	12G6	1.46	21G5	1.49
04G	.85	3E7	1.42	6AL11	1.95	6D6	2.50	6J11	1.82	8E77	1.60	12GW6	1.15	21H8	1.65
082	.80	3E85	1.35	6AN6	1.25	6D6	2.50	6J8	1.95	8F7	.95	12H6	1.40	22B3	1.15
083	1.20	3F5H	1.95	6AN6	1.25	6D6	2.50	6J8	1.95	8G7	1.31	12J5	1.21	22B3	1.15
083	1.20	3F5H	1.95	6AN6	1.25	6D6	2.50	6J8	1.95	8H8	1.27	12J6	1.21	22DE4	1.15
083	1.20	3F5H	1.95	6AN6	1.25	6D6	2.50	6J8	1.95	8I8	1.27	12K5	1.45	22G6	3.25
083	1.20	3F5H	1.95	6AN6	1.25	6D6	2.50	6J8	1.95	8J8	1.27	12L6	1.21	25A4	2.50
083	1.20	3F5H	1.95	6AN6	1.25	6D6	2.50	6J8	1.95	8K8	1.27	12M6	1.21	25A4	2.50
083	1.20	3F5H	1.95	6AN6	1.25	6D6	2.50	6J8	1.95	8L8	1.27	12N6	1.21	25A4	2.50
083	1.20	3F5H	1.95	6AN6	1.25	6D6	2.50	6J8	1.95	8M8	1.27	12O6	1.21	25A4	2.50
083	1.20	3F5H	1.95	6AN6	1.25	6D6	2.50	6J8	1.95	8N8	1.27	12P6	1.21	25A4	2.50
083	1.20	3F5H	1.95	6AN6	1.25	6D6	2.50	6J8	1.95	8O8	1.27	12Q6	1.21	25A4	2.50
083	1.20	3F5H	1.95	6AN6	1.25	6D6	2.50	6J8	1.95	8P8	1.27	12R6	1.21	25A4	2.50
083	1.20	3F5H	1.95	6AN6	1.25	6D6	2.50	6J8	1.95	8Q8	1.27	12S6	1.21	25A4	2.50
083	1.20	3F5H	1.95	6AN6	1.25	6D6	2.50	6J8	1.95	8R8	1.27	12T6	1.21	25A4	2.50
083	1.20	3F5H	1.95	6AN6	1.25	6D6	2.50	6J8	1.95	8S8	1.27	12U6	1.21	25A4	2.50
083	1.20	3F5H	1.95	6AN6	1.25	6D6	2.50	6J8	1.95	8T8	1.27	12V6	1.21	25A4	2.50
083	1.20	3F5H	1.95	6AN6	1.25	6D6	2.50	6J8	1.95	8U8	1.27	12W6	1.21	25A4	2.50
083	1.20	3F5H	1.95	6AN6	1.25	6D6	2.50	6J8	1.95	8V8	1.27	12X6	1.21	25A4	2.50
083	1.20	3F5H	1.95	6AN6	1.25	6D6	2.50	6J8	1.95	8W8	1.27	12Y6	1.21	25A4	2.50
083	1.20	3F5H	1.95	6AN6	1.25	6D6	2.50	6J8	1.95	8X8	1.27	12Z6	1.21	25A4	2.50
083	1.20	3F5H	1.95	6AN6	1.25	6D6	2.50	6J8	1.95	8Y8	1.27	12AA6	1.21	25A4	2.50
083	1.20	3F5H	1.95	6AN6	1.25	6D6	2.50	6J8	1.95	8Z8	1.27	12AB6	1.21	25A4	2.50
083	1.20	3F5H	1.95	6AN6	1.25	6D6	2.50	6J8	1.95	9A8	1.27	12AC6	1.21	25A4	2.50
083	1.20	3F5H	1.95	6AN6	1.25	6D6	2.50	6J8	1.95	9B8	1.27	12AD6	1.21	25A4	2.50
083	1.20	3F5H	1.95	6AN6	1.25	6D6	2.50	6J8	1.95	9C8	1.27	12AE6	1.21	25A4	2.50
083	1.20	3F5H	1.95	6AN6	1.25	6D6	2.50	6J8	1.95	9D8	1.27	12AF6	1.21	25A4	2.50
083	1.20	3F5H	1.95	6AN6	1.25	6D6	2.50	6J8	1.95	9E8	1.27	12AG6	1.21	25A4	2.50
083	1.20	3F5H	1.95	6AN6	1.25	6D6	2.50	6J8	1.95	9F8	1.27	12AH6	1.21	25A4	2.50
083	1.20	3F5H	1.95	6AN6	1.25	6D6	2.50	6J8	1.95	9G8	1.27	12AI6	1.21	25A4	2.50
083	1.20	3F5H	1.95	6AN6	1.25	6D6	2.50	6J8	1.95	9H8	1.27	12AJ6	1.21	25A4	2.50
083	1.20	3F5H	1.95	6AN6	1.25	6D6	2.50	6J8	1.95	9I8	1.27	12AK6	1.21	25A4	2.50
083	1.20	3F5H	1.95	6AN6	1.25	6D6	2.50	6J8	1.95	9J8	1.27	12AL6	1.21	25A4	2.50
083	1.20	3F5H	1.95	6AN6	1.25	6D6	2.50	6J8	1.95	9K8	1.27	12AM6	1.21	25A4	2.50
083	1.20	3F5H	1.95	6AN6	1.25	6D6	2.50	6J8	1.95	9L8	1.27	12AN6	1.21	25A4	2.50
083	1.20	3F5H	1.95	6AN6	1.25	6D6	2.50	6J8	1.95	9M8	1.27	12AO6	1.21	25A4	2.50
083	1.20	3F5H	1.95	6AN6	1.25	6D6	2.50	6J8	1.95	9N8	1.27	12AP6	1.21	25A4	2.50
083	1.20	3F5H	1.95	6AN6	1.25	6D6	2.50	6J8	1.95	9O8	1.27	12AQ6	1.21	25A4	2.50
083	1.20	3F5H	1.95	6AN6	1.25	6D6	2.50	6J8	1.95	9P8	1.27	12AR6	1.21	25A4	2.50
083	1.20	3F5H	1.95	6AN6	1.25	6D6	2.50	6J8	1.95	9Q8	1.27	12AS6	1.21	25A4	2.50
083	1.20	3F5H	1.95	6AN6	1.25	6D6	2.50	6J8	1.95	9R8	1.27	12AT6	1.21	25A4	2.50
083	1.20	3F5H	1.95	6AN6	1.25	6D6	2.50	6J8	1.95	9S8	1.27	12AU6	1.21	25A4	2.50
083	1.20	3F5H	1.95	6AN6	1.25	6D6	2.50	6J8	1.95	9T8	1.27	12AV6	1.21	25A4	2.50
083	1.20	3F5H	1.95	6AN6	1.25	6D6	2.50	6J8	1.95	9U8	1.27	12AW6	1.21	25A4	2.50
083	1.20	3F5H	1.95	6AN6	1.25	6D6	2.50	6J8	1.95	9V8	1.27	12AX6	1.21	25A4	2.50
083	1.20	3F5H	1.95	6AN6	1.25	6D6	2.50	6J8	1.95	9W8	1.27	12AY6	1.21	25A4	2.50
083	1.20	3F5H	1.95	6AN6	1.25	6D6	2.50	6J8	1.95	9X8	1.27	12AZ6	1.21	25A4	2.50
083	1.20	3F5H	1.95	6AN6	1.25	6D6	2.50	6J8	1.95	9Y8	1.27	12BA6	1.21	25A4	2.50
083	1.20	3F5H	1.95	6AN6	1.25	6D6	2.50	6J8	1.95	9Z8	1.27	12BB6	1.21	25A4	2.50
083	1.20	3F5H	1.95	6AN6	1.25	6D6	2.50	6J8	1.95	10A8	1.27	12BC6	1.21	25A4	2.50
083	1.20	3F5H	1.95	6AN6	1.25	6D6	2.50	6J8	1.95	10B8	1.27	12BD6	1.21	25A4	2.50
083	1.20	3F5H	1.95	6AN6	1.25	6D6	2.50	6J8	1.95	10C8	1.27	12BE6	1.21	25A4	2.50
083	1.20	3F5H	1.95	6AN6	1.25	6D6	2.50	6J8	1.95	10D8	1.27	12BF6	1.21	25A4	2.50
083	1.20	3F5H	1.95	6AN6	1.25	6D6	2.50	6J8	1.95	10E8	1.27	12BG6	1.21	25A4	2.50
083	1.20	3F5H	1.95	6AN6	1.25	6D6	2.50	6J8	1.95	10F8	1.27	12BH6	1.21	25A4	2.50
083	1.20	3F5H	1.95	6AN6	1.25	6D6	2.50	6J8	1.95	10G8	1.27	12BI6	1.21	25A4	2.50
083	1.20	3F5H	1.95	6AN6	1.25	6D6	2.50	6J8	1.95	10H8	1.27	12BJ6	1.21	25A4	2.50
083	1.20	3F5H	1.95	6AN6	1.25	6D6	2.50	6J8	1.95	10I8	1.27	12BK6	1.21	25A4	2.50
083	1.20	3F5H	1.95	6AN6	1.25	6D6	2.50	6J8	1.95	10J8	1.27	12BL6	1.21	25A4	2.50
083	1.20	3F5H	1.95	6AN6	1.25	6D6	2.50	6J8	1.95	10K8	1.27	12BM6	1.21	25A4	2.50
083	1.20	3F5H	1.95	6AN6	1.25	6D6	2.50	6J8	1.95	10L8	1.27	12BN6	1.21	25A4	2.50
083	1.20	3F5H	1.95	6AN6	1.25	6D6	2.50	6J8	1.95	10M8	1.27	12BO6	1.21	25A4	2.50
083	1.20	3F5H	1.95	6AN6	1.25	6D6	2.50	6J8	1.95	10N8	1.27	12BP6	1.21	25A4	2.50
083	1.20	3F5H	1.95	6AN6	1.25	6D6	2.50	6J8	1.95	10O8	1.27	12BQ6	1.21	25A4	2.50
083	1.20	3F5H	1.95	6AN6	1.25	6D6	2.50	6J8	1.95	10P8	1.27	12BR6	1.21	25A4	2.50
083	1.20	3F5H	1.95	6AN6	1.25	6D6	2.50	6J8	1.95	10Q8	1.27	12BS6	1.21	25A4	2.50
083	1.20	3F5H	1.95	6AN6	1.25	6D6	2.50	6J8	1.95	10R8	1.27	12BT6	1.21	25A4	2.50
083	1.20	3F5H	1.95	6AN6	1.25	6D6	2.50	6J8	1.95	10S8	1.27	12BU6	1.21	25A4	2.50
083	1.20	3F5H	1.95	6AN6	1.25	6D6	2.50	6J8	1.95	10T8	1.27	12BV6	1.21	25A4	2.50
083	1.20	3F5H	1.95	6AN6</											



# MARKET CENTER

# ADVERTISING INDEX

RADIO-ELECTRONICS does not assume responsibility for any errors which may appear in the index below.

Aerovox Corporation (Distributor Div.)	12
Alliance Manufacturing Company, Inc. (Subsidiary of Consolidated Electronics Industries Inc.)	14
Allied Radio Corp.	76-79
Almo Radio	72
Amphenol Distributor Division (Borg Electronics Corporation)	10-11
B & K Manufacturing Co., (Div. of Dynascan Corp.)	21
Brooks Radio & TV Corp.	82-83
Capitol Radio Engineering Institute, The	13
Castle TV Tuner Service, Inc.	70
Centralab (Div. of Globe-Union, Inc.)	22
<b>CLASSIFIED</b>	<b>90-93</b>
Cleveland Institute of Electronics	26-29, 73
Cornell Electronics Co.	86
DeVry Technical Institute	5
EICO Electronic Instrument Co., Inc.	15
Electro-Voice, Inc.	65
Electronic Measurement Corp. (EMC)	72
Fair Radio Sales	83
Finney Co.	1
Gernsback Library, Inc.	84-85
Heald's Engineering College	87
Heath Company	66-67
International Crystal Mfg. Co., Inc.	94
Lafayette Radio Electronics	63
McGraw-Hill Book Co.	71
Mallory Distributor Products Company (Div. of P. R. Mallory & Co., Inc.)	Third Cover
Multicore Sales Corp.	88
National Radio Institute	16-19, 88
National Technical Schools	3
Poly Paks	93
Precise Electronics & Development (Div. of Designatronics, Inc.)	24
Progressive "Edu-Kits" Inc.	69
RCA Institutes, Inc.	9
RCA Electronic Components & Devices (Tube Division)	Fourth Cover
Reading Improvement Program	73
Sadelco, Inc.	74
Sams & Co., Inc., Howard W.	23, 75
Sarkes Tarzian, Inc. (Tuner Service Div.)	6
Schober Organ Corp., The	8
Sencore	68
Sprague Products Company	7
Tarzian, Inc. Sarkes (Tuner Service Div.)	6
Texas Crystals (Div. of Whitehall Electronics Corp.)	87
Triplett Electrical Instrument Company, The	Second Cover
United Radio Co.	91
University, LTV (Div. of Ling-Temco-Vought, Inc.)	80
Warren Electronic Components	88
Wen Products, Inc.	20
Winegard Co.	25, 81

<b>MARKET CENTER</b>	<b>90-93</b>
Edmund Scientific Co.	
Electronic Components Co.	
Music Associated	
Transistors Unlimited Company	

<b>SCHOOL DIRECTORY</b>	<b>89</b>
American Institute of Engineering & Technology	
Coyne Electronics Institute	
Electronic Technical Institute	
Grantham School of Electronics	
Indiana Home Study Institute, The	
Milwaukee School of Engineering	
Northrop Institute of Technology	
Tri-State College	
Valparaiso Technical Institute	

## SUB CARRIER DETECTOR



Add programs of commercial-free music thru your FM tuner. Detector, self-powered, plugs into multiplex output of tuner or easily wired into discriminator and permits reception of famous background music programs now transmitted as hidden programs on the FM broadcast band from coast to coast. Use with ANY FM tuner.

**WIRED UNIT \$75.00**  
KIT, with pretuned coils, no alignment necessary \$49.50  
crystal-controlled receivers available

**MUSIC ASSOCIATED**  
65 Glenwood Road  
Upper Montclair, New Jersey  
phone 744-3387 area code 201

METERS—Surplus, new, used, panel and portable. Send for list. HANCHETT, Box 1898 Riverside, Calif.

TV CAMERAS, transmitters, converters, etc. Lowest factory prices. Catalog 10¢. VANGUARD, 190-48-99th Ave., Hollis, N.Y. 11423.

PROFESSIONAL ELECTRONICS PROJECTS—Organs, Timers, Computers, etc.—\$1 up. Catalog 25¢, refundable. PARKS, Box 25565, Seattle, Wash. 98125.

BEFORE You Buy Receiving Tubes, Transistors, Diodes, Electronic Components & Accessories... send for Giant Free Zalytron Current Catalog, featuring all STANDARD BRAND TUBES all Brand New Premium Individually Boxed, One Year Guarantee—all at BIGGEST DISCOUNTS in America! We serve professional servicemen, hobbyists, experimenters, engineers, technicians. WHY PAY MORE? ZALYTRON TUBE CORP., 469R Jericho Turnpike, Mineola, N.Y. 11502

TRANSISTOR IGNITION! Coil, ballast 7.95 Free parts lists. TRANSFIRE Carlisle 20, Mass. 01741

ANY TV BONDED TUBE \$23.00. One year warr. (you keep the dud). Immediate delivery send check or money order. SAMSON KINESCOPE INC., 250 N. Goodman St., Roch. N.Y. 14607

NEED RESISTORS? Factory fresh, NAME BRAND, 1/2 watt, 10% standard carbon resistors. Any regular value from 10 ohms to 2.2 megohms, \$.05 each! Postpaid. Any quantity assorted. Minimum order \$1.00. TEPCO, Box 508, Tullahoma, Tenn.

TRANSISTORS, CAPACITORS, Sub-miniature electronic parts. Send for FREE CATALOG. ELECTRONIC CONTROL DESIGN COMPANY, P.O. Box 1432P, Plainfield, N.J.

Heatsinks! Designed for 40 watt push-pull transistor amplifier. Only \$1.25 plus 20¢ postage. 15¢ for catalog. FRANKS SCIENTIFIC CO. P.O. Box 1192, Corinth, Mississippi.

BUILD TRANSISTOR POWER TRANSFORMER 350V, 100M.A. for \$1.00. Booklet \$1.00. HERCO INTERNATIONAL, Box 113, Willowdale, Ontario.

Free wholesale catalog: Tubes, transistors, parts, equipment. Why pay more? ROYAL, Box 2591, El Cajon, California

PLANS ONE TUBE DX Shortwave kit (12,000 record) 24 pages—50¢. Experimenter's catalog 250 exclusive items—25¢, refundable. LABORATORIES, 1131-B Valota, Redwood City, California.

SCHEMATICS—\$1. Radio, Television. Prompt. BROWN's, 605 Naomi, Philadelphia, Penna. 19144.

TUBES, "Oldies", latest. Lists free. STEINMETZ, 7519 Maplewood, Hammond, Indiana. 46324.

RADIO & TV TUBES 33¢ each. One year guaranteed. Plus many unusual electronic bargains. Free catalog. CORNELL, 4217-E University, San Diego, California 92105

T U C O	All merchandise NEW	T U C O
TI 419, NPN silicon, 250 mw, 300 mc, 90 Hfe	.50	
TI 80297 NPN silicon, 100 volt, 4 watts, Stud.	1.23	
TI PET, Field Effect Transistor, SF2887	4.50	
Zener diodes, 1 watt, all voltages, 2 to 75 volts	1.00	
Rectifier, 25110, Intern'l Rect., 25 amp, 100 volt insulated, with hardware	1.25	
Precision sub-miniature Pots, 3% tol., 1K & 3.5K, Linear	.75	
Solid State power supply, 12 volt, 1 amp, regulated completely assembled and wired. Schematic	15.00	
SSO-15, UTC sub-min Transformer, Triad TZ-13	.75	
Write for Free Catalog		
TRANSISTORS UNLIMITED COMPANY		
462 Jericho Tpke. Mineola, N.Y. 11501. P17-7221		

## BUSINESS OPPORTUNITIES

PIANO Tuning learned quickly at home. Tremendous field! Musical knowledge unnecessary. Information free. EMPIRE SCHOOL OF PIANO TUNING, Dep't. RE Box 327, Shenandoah Station, Miami, Florida 33145. (Founded 1935.)

New scientific transistor instrument detects buried coins, treasures. Will detect gold, silver, copper, iron, etc. \$19.95 up. Free catalog. RELCO-A-25, Box 10563, Houston 18, Texas.

## BUSINESS AIDS

JUST STARTING IN TV SERVICE? Write for FREE 32 PAGE CATALOG of Service Order books, invoices, job tickets, phone message books, statements and file systems. OELRICH PUBLICATIONS, 6556 W. Higgins, Chicago, Ill. 60656.

1,000 Business Cards, "Raised Letters" \$3.95 postpaid. Samples. ROUTH RE12, 2633 Randleman, Greensboro, N.C. 27406.

## ELECTRONICS

FREE CATALOG of 200 special slide rules and calculating aids. DYNA-SLIDE, 600 South Michigan, Chicago, Illinois 60605



## EDUCATION/ INSTRUCTION

LEARN ELECTRONIC ORGAN SERVICING. New home study course covering all makes electronic organ including transistors. Experimental kits—schematics—trouble-shooting. Accredited NHSC-GI Approved. Write for free booklet. NILES BRYANT SCHOOL, 3631 Stockton Blvd., Dept. F. Sacramento 20, Calif.

HIGHLY—effective home study review for FCC commercial phone exams. Free literature! COOK'S SCHOOL OF ELECTRONICS, Craigmont, Idaho 83523.

FCC LICENSE in 6 weeks. First Class Radio Telephone. Results Guaranteed. ELKINS RADIO SCHOOL, 2603E Inwood, Dallas, Tex.

SLEEP LEARNING. Hypnotism! Tapes, records, books, equipment. Details, strange catalog FREE. RESEARCH ASSOCIATION, Box 24-RD, Olympia, Wash.

BROADCASTING, Communications Electronics taught quickly—resident classes; correspondence. Free details. Write: Dept. 4, GRANTHAM SCHOOLS, 1505 N. Western, Hollywood, Calif. 90027

# ZIP

stands for the Post Office Department's new Zoning Improvement Plan. When renewing your RADIO-ELECTRONICS subscription, or sending us a change of address, please let us know what your ZIP Code is. We'll add it to your address mailing plate ... and you'll get speedier delivery

service from the Post Office. By the way, when writing to us, address:

RADIO-ELECTRONICS,  
154 West 14 St.,  
New York, N. Y.  
10011



## Your HEART FUND fights them all



Heart Attack  
Stroke  
High Blood Pressure  
Rheumatic Fever  
Inborn Heart Defects

The time to sell is when you have a customer. And the place to sell is where you have some 155,000 customers—the classified pages of RADIO-ELECTRONICS

## CLASSIFIED ADVERTISING ORDER FORM

For complete data concerning classified advertising please refer to box elsewhere in Market Center section.

1	2	3	4	5
6	7	8	9	10
11	12	13	14	15
16	17	18	19	20
21	22	23	24	25
26	27	28	29	30
31	32	33	34	35

No. of Words { @ .30 Non-Commercial Rate } = \$  
 { @ .60 Commercial Rate }

Total Enclosed \$

Insert \_\_\_\_\_ time(s)

Payment must accompany order unless placed through accredited advertising agency 85

Starting with \_\_\_\_\_ issue

NAME \_\_\_\_\_

ADDRESS \_\_\_\_\_

CITY \_\_\_\_\_ STATE \_\_\_\_\_ ZIP \_\_\_\_\_

SIGNATURE \_\_\_\_\_

MAIL TO: RADIO-ELECTRONICS, CLASSIFIED AD DEPT., 154 WEST 14TH ST., NEW YDRK, N.Y. 10011

# 1¢ SALE!

- DISC CONDENSERS ... 30 for \$1 60 for 1.01
- PRECISION RESISTORS ... 30 for \$1 60 for 1.01
- PLANAR TRANSISTORS ... 4 for \$1 8 for 1.01
- 25 AMP RECTIFIERS ... 2 for \$1 4 for 1.01
- SWITCHING TRANS ... 15 for \$1 30 for 1.01
- ZENER REFERENCES ... 6 for \$1 12 for 1.01
- GERMANIUM DIODES ... 25 for \$1 50 for 1.01
- TOP HAT RECTIFIERS ... 25 for \$1 50 for 1.01
- TRANSISTORS ... 30 for \$1 60 for 1.01
- 10-WATT ZENER 30V ... 1 for \$1 2 for 1.01
- 2N1613 100MC TRANS ... 1 for \$1 2 for 1.01
- 4W PLANARS 2N497-98 ... 2 for \$1 4 for 1.01
- 3N35 TETRODE TRANS ... 1 for \$1 2 for 1.01

FREE  
**\$25** WORTH OF  
 • Transistors  
 • Diodes  
 • Rectifiers  
 • Knobs  
 • Condensers  
 • Coils, etc.  
 Include 25¢ for handling

**DOUBLE BONUS**  
 \$1 FREE  
 POLY PAK OF YOUR CHOICE

BOTH FREE WITH EVERY \$10 ORDER

## WORLD FAMOUS DOLLAR POLY PAKS

- 3 TRANSISTOR AUDIO AMP, tiny, wired .....\$1
- MAGNETIC REED SWITCH, glass sealed .....\$1
- 40 WORLD'S SMALLEST COND., to .05mf .....\$1
- 4 TRANSISTOR TRANSFORMERS, asst. worth \$25 \$1
- 1 FILAMENT TRANSFORMER, 117 to 6.3vct, 3A \$1
- \$25 RELAY SURPRISE, sealed, tiny types .....\$1
- 3 INFRA-RED DETECTORS, with leads .....\$1
- \$25 SURPRISE PAK: transistors, rect, diodes, etc. \$1
- 40 PRECISION RESISTORS, 1/2, 1, 2W, 1% values \$1
- 30 CORNING "LOW NOISE" resistors, asst. . . \$1
- 60 TUBULAR CONDENSERS, to .5mf, to 1Kv, asst \$1
- 40 DISC CONDENSERS, 27mmf to .05mf to 1KV \$1
- 60 TUBE SOCKETS, receptacles, plugs, audio, etc. \$1
- 30 POWER RESISTORS, 5 to 50W, to 24 Kohms. \$1
- 50 MICA CONDENSERS, to .1mf, silvers too! . . \$1
- 10 VOLUME CONTROLS, to 1 meg, switch too! . \$1
- 10" ELECTROLYTICS, to 500mf, asst FP & tubulars \$1
- 50 RADIO & TV KNOBS, asst. d. colors & styles . \$1
- 10 TRANSISTOR ELECTROLYTICS: 10mf to 500mf \$1
- 50 COILS & CHOKES, if, rf, ant, osc, & more . . \$1
- 35 TWO WATTERS, asst incl: A.B., 5% too! . . \$1
- 75 HALF WATTERS, asst incl: A.B., 5% too! . . \$1
- 60 HI-Q RESISTORS, 1/2, 1, 2W, 1% & 5% values \$1
- 10 PHONO PLUG & JACK SETS, tuners, amps . . \$1
- 50 TERMINALSTRIPS, 1 to 8 solder lug types . . \$1
- 30 "YELLOW" MYLAR CONDENSERS, asst val \$1
- 60 CERAMIC CONDENSERS, discs, nps, to .05 \$1
- 3 GEIGER COUNTER DETECTOR, tubes, assorted \$1
- 3 TRANSISTOR TRANS'TRS. 2N341, 42, 1W, npn \$1
- 85 WATT 2N424 PLANAR, silicon, TO-53 npn. \$1
- 85 WATT 2N1212 PLANAR, drift, 10mc, npn . . \$1
- 1 CONTROLLED SCR SWITCH, Transistron, TO18 \$1
- 10 SILICON TOP HAT RECTIFIERS, 50 to 400PIV \$1
- 2 2N721 PNP PLANAR, 2W, 75MC, TO-18 . . . \$1
- 2 2N735 NPN MESA, 500MW, 135MC, TO-18 . . \$1
- 2- CLAIREX PHOTO ELECTRIC CELL, CL607 . . \$1
- 2 500MC TRANS'TRS, 2N964, mesas, npn, TO18 \$1
- 4 PIN HEAD 2N790 NPN SILICON transtrs, TO18 \$1
- 4 2N43 OUTPUT TRANSISTORS, by GE, npn, TO5 \$1
- 4 2N333 NPN SILICON transistors, by GE, TO5 \$1
- 8, 2-6Amp RECT's, studs, silicon, 50 to 100V \$1
- 10 1000 MC-1N251 GERMANIUM DIODES . . . \$1
- 5 30MC TRANSISTORS, like 2N247, Sylvania . . \$1
- 5- —2N155 TRANSISTORS, or equals, TO3 cases \$1
- 2-800 MC, 2N709 NPN Silicon planar TO16 . . \$1
- 3 2N711 300MW, 300 MC, PNP MESA, TO18 . . \$1
- 15 1AMP 200V epoxy rectifiers, made by Sylvania \$1
- 2 25-AMP SILICON RECTIFIERS, 1-50V, 1-100V \$1
- 4 ZENER REFERENCES, 1N429, 6-volt, silicon \$1
- 10 ZENERS GLASS SILICON DIODES, axial, leads \$1
- 6 2N408 TRANSISTORS, TO1, npn, driver . . . \$1
- 2 2N718 NPN SILICON PLANARS, by Fairchild . \$1
- 4 2N219 TRANSISTORS, mixer-conv, TO22 . . . \$1
- 10 MICRODIODE STABILIZERS, epoxy, silicon . . \$1
- 2 2N706 500MW, 300MC NPN PLANAR, TO46 \$1
- 10 1000-MIL "CERAMIC" RECT, silicon, 50-400V \$1
- 10 POPULAR CK772 TRANSISTORS, npn, no test \$1
- 5 2N107 TRANS'TRS, by GE, npn, pop. audio pak \$1
- 10 PNP SWITCHING TRANSISTORS, 2N1305, TO5 \$1
- 10 NPN SWITCHING TRANSISTORS, 2N338, 440 \$1
- 15 PNP TRANSISTORS, CK722, 2N335, 107 . . . \$1
- 15 NPN TRANSISTORS, 2N335, 170, 440 . . . \$1
- 2N998 TYPE, 1000 GAIN, npn silicon, planar . . \$1
- "MICRO-T" TRANSISTOR, like TMT-1613. . . \$1
- 4 2N35 TRANSISTORS, npn, by Sylvania, TO22 \$1
- 4 "MICRO" TRANSISTORS, 2N131's, 1/16", rf \$1
- 4 CK721 TRANSISTORS, npn, aluminum case . . \$1

10¢ FOR OUR "SUMMER" BARGAIN CATALOG ON:  
 Semiconductors  Poly Paks  Parts

TERMS: send check, money order, include postage—avg. wt. per pak 1 lb. Rated net 30 days. CODs 25%.

# POLY PAKS

P.O. BOX 942R  
 SO. LYNNFIELD, MASS.  
 "PAK-KING" of the World





# SEE THE U.S.A.



Traveling by car to the distant corners of this great country of ours is becoming easier and takes less time than ever before. This year see the U.S.A. Visit the great national parks, the towering and majestic Rocky Mountains, historic New England, the seashore or the broad expanse of the midwest. No matter where you travel, International Citizens Radio transceivers can provide rapid emergency communication. International transceivers are designed and engineered to give reliable mobile service day in and day out under all kinds of conditions. The 1965 International transceivers have hybrid circuits which combine transistors and tubes for greater dependability. There is even one model which has built-in test circuits. You will have more fun traveling and a feeling of security with an International transceiver installed in your car for mobile communication. Write today for our catalog of Citizens Radio transceivers and accessories. Then see your nearest International dealer. He will assist you in selecting the best transceiver for your particular requirements.

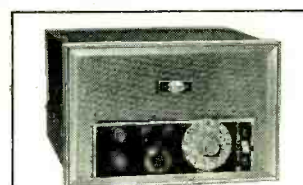

**MODEL 440**  
Citizens Radio Transceiver



**MODEL 660**  
Citizens Radio Transceiver



**MODEL 880**  
Citizens Radio Transceiver

FCC Citizens Radio license required.  
All use must conform with Part 95,  
FCC Rules and Regulations.

**INTERNATIONAL  
CRYSTAL MFG. CO. INC.**

18 NORTH LEE — OKLA. CITY, OKLA.



## What you should know about film resistors



If you've been looking inside some of the recent model television sets, chances are that you've noticed some unusual-looking resistors. Especially in the sizes readily identifiable as under 10 watts. You'll probably find them in spots where you're used to seeing small wirewounds.

There's a good reason. These are metal oxide film resistors. And the reason they're making such a hit is that they have as good stability and life as wirewounds—but they cost only about half as much in most values.

What's different about them?

First, they're made differently. A thin layer of tin oxide is evaporated onto a high quality ceramic rod, at high temperatures. A spiral groove is then cut, by a highly precise automatic machine, to produce a resistance path with the desired ohmic value. Then the end connections are applied and the whole works gets a coating of silicone finish. You can get a lot higher resistance values, size for size, than with wirewounds, because you're not limited by the problems of winding hair-thin wires. Top resistance for the 4, 5 and 7 watt sizes is 120,000 ohms; for 2 and 3 watts, 56,000 ohms. Standard tolerance is 10%.

Second, they behave differently. Their stability is really terrific. We've run them with on-off load cycling for 10,000 hours and measured changes of less than 1%. They'll take heavy brief overloads without damage, aren't bothered by humidity or vibration. And they're noninductive up to 250 mc. The name to ask your Mallory distributor for is the MOL film resistor. He has them in 2, 3, 4, 5 and 7 watt ratings, in popular resistance values. And when you need a higher wattage (up to 200 watts) ask him for Mallory vitreous enamel resistors—you can't beat them for cool operation and stable life.

Incidentally, Mallory MOL resistors have been used in a lot of the new radio and television sets. As an aid to service technicians, we have just printed a cross-reference list which shows, by set manufacturer and chassis number, the exact Mallory part numbers to use for each power resistor replacement. Get a copy from your Mallory distributor, or write Mallory Distributor Products Company, a division of P. R. Mallory & Co. Inc., P. O. Box 1558, Indianapolis, Indiana 46206.

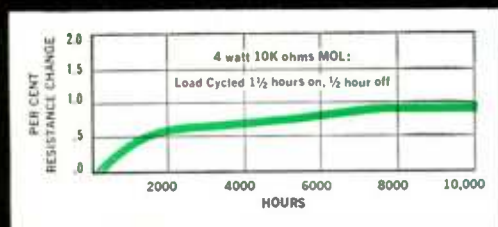

Typical stability test data: 10,000-hour load cycling test. Average resistance change is less than 1%!



## WHERE THE SILVERAMA® SCREEN BEGINS

### TV picture quality depends on precise control of phosphors

Television picture quality depends on the quality of the phosphor screen inside the faceplate. That's why every RCA Silverama replacement picture tube is completely rescreened—in the same painstaking manner and with the same precision—as RCA picture tubes produced for use in original equipment. Before receiving their new Silverama screens, reused glass envelopes are scrubbed completely clean and given a series of chemical baths internally to restore them to the peak of their optical capabilities.

RCA produces and develops its own screen phosphors. These are

formed by reacting solutions of zinc sulfate and zinc and cadmium sulfates with hydrogen-sulfide gas in this complex precipitator, (above). The resulting zinc sulfide and zinc-cadmium sulfide are then activated, fluxed, fired, washed, dried, and screened to form phosphors which emit blue and yellow light, respectively. These are carefully blended to produce phosphors that possess the pleasing "white", high light output, and uniform smoothness, which characterize RCA Silverama picture tube screens.

Make RCA Silverama your first choice in picture tubes.



Drying ovens remove moisture from phosphor

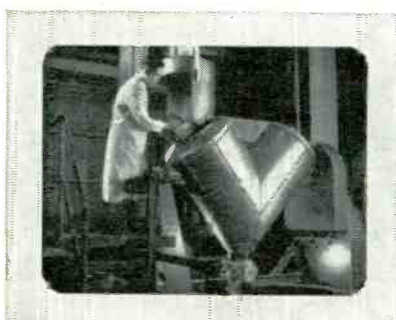

Phosphors are blended for best screen quality



Base materials are fired to form the phosphors

RCA ELECTRONIC COMPONENTS AND DEVICES, HARRISON, N. J.



The Most Trusted Name in Electronics