

RADIO DOINGS

RED BOOK OF RADIO

10¢
WEEKLY

*The Radio Authority
of the
Pacific Coast*



R. L. Rust, KGFH

Vol. XIII
No. 15

OCTOBER 7-13
1928

CROSLEY 1928-29 RADIO



Crosley Dynacone Dynamic \$ 27 Speaker

Again Crosley astounds the radio world with a true dynamic type speaker at about one-half the cost of any other speaker of equal quality.

The Dynacone reproduces the fundamental tones down to 30 cycles, with a superior curve over the entire range up to 7000 cycles, with a brilliance and clear separation of the various musical instruments never before heard in the moderate price speaker.

Other 1928-29 Crosley Winners:

6-tube A.C. Gembox Radio Receiver.....\$69
8-tube A.C. Showbox Radio Receiver.....\$85

Ask Your Nearest Crosley Dealer for a Free Demonstration

Exclusive California Distributors

KIERULFF & RAVENSCROFT

RADIO EQUIPMENT



1630-32
S. Los Angeles St.
LOS ANGELES

121-131
Ninth Street
SAN FRANCISCO

CROSLEY RADIO

"You're There With a Crosley"

*Here are a few of the Franchised Dealers who will gladly
Demonstrate the Complete Crosley Line for you*

LOS ANGELES

Downtown

Figuroa Radio Shop
937 W. Seventh St.
TUcker 7031

South

De Hoog Brothers
6120 S. Broadway
THornwall 0224

Southwest

L. A. Duncan
2891 W. Pico St.
EMpire 1141

Robinson Radio Shop
4528 So. Western Ave.
VERmont 6683

**Wesenberg Radio Music
Co.**
3915 S. Western Ave.
VERmont 7929

Southeast

Lord Hardware Co.
4525 Central Ave.
HUmbolt 9115

Washington-Vermont

Hamilton & Son
1558 Washington Blvd.
BEacon 0214

Westlake

Arcade Radio Studio
743 1/4 S. Alvarado
DRexel 6859

Alhambra

Fred B. Gillenwaters
127 West Main St.
Phone 2032

ANAHEIM

Radio Den
134 W. Center
Phone 975

GLENDALE

Shuck Music Co.
211 N. Brand Blvd.
Glendale 2329

INGLEWOOD

Mil Zillgitt
110 S. Market St.
Phone 23

LONG BEACH

John J. Sawyer
543 E. Anaheim St.
Long Beach 636-235

Reliable Radio Shop
200 E. 4th St.
Phone 636-450

Ward Bros. Radio Studio
2909 E. Anaheim St.
Phone 347-242

"You're There With a Crosley"



Eleanor Hayden, Harpist KFRC

The Belvedere

Two-tone walnut floor screen.

For A-Battery Operation \$45
AC Operation \$55

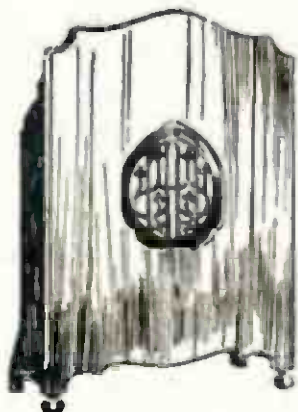

"Exquisite!"— a rendition by Eleanor Hayden in person.

"Exquisite!"— the same rendition over a Magnavox Dynamic.

Both are identical—both equally beautiful.

Such sensational realism is possible only with a dynamic. Among dynamics Magnavox stands foremost and for most.



THE MAGNAVOX COMPANY

Oakland, California

Chicago, Illinois

The New Air Era

It will seem very strange to twirl your dials after 3 a. m., November the 11th and find, with one exception, not a station in its customary place. Like the change from meters to kilocycles it will be hard to get used to—but how much better! It is the beginning of clear air lanes and standardization. Radio listening will increase unbelievably because of perfect reception. This increased use of receiving sets with its demand for the best entertainment obtainable will become so universal in America that broadcasting will necessarily reach a higher and more interesting plane than ever thought of before. Strong and insistent popular demand will accomplish tremendous improvements in every branch of radio.

Disregarding a few initial experiments in wireless voice transmission, radio is scarcely eight years old. Already there is over one billion dollars invested, seven million sets in use and a national commission created to regulate this young giant! Now that the air channels are protected from station interference there are millions who will buy sets because programs will come in perfectly. Squeals, howls and a bedlam of noise from wave interference for the average set are gone, and happily.

Though words of pessimism have already reached us concerning these new allocations it is borne in mind that this worthy plan is the solution after two years of intelligent survey by the Federal Radio Commission. It is a drastic step; and there will be many complaints, injunctions and law suits to restrain this Federal action, but the general plan will hold. Numerous last minute changes for betterment will be made so that the new list of stations given out now is only tentative and will not be reliable on November 11th.

On that date you will want a guide to tune in your favorite stations for they will arrive in strange places all over the dial. The RADIO DOINGS Call Book will be ready for you then. Last minute changes from Washington will be included in the accurate lists of cross-indexed stations with their power, locations and other information. A wonderfully clever and useful DIAL-LOG showing the positions of stations on *your* dials will be a feature. Western stations, foreign stations, every American station and other helpful tuning-in material will make this Call Book the best that RADIO DOINGS has ever published. Reserve yours now and we will have it delivered to your home just in time for November 11th.

Use this Coupon

Tear Here

Use this Coupon

25c

THE NEW RADIO DOINGS CALL BOOK

25c

Radio Doings, 407 East Pico Street, Los Angeles, Calif.

Please find enclosed 25c in stamps, money order, or cash. Send me the 1928-9 Call Book which contains the new listings and the DIAL-LOG. Have it reach me for use on November 11th.

Name.....

Address.....

State.....

RADIO DOINGS, October 6, 1928. Issued weekly at Los Angeles, Calif. Volume 13, No. 15. Subscription \$3.00 a year. Entered as second class matter, November 15, 1922, Los Angeles, Calif., Post Office, under Act of March 3, 1927.

MAGNAVOX *Dynamic* SPEAKERS



The D-6 Unit operates directly from the A Battery of your set and will absolutely render accurate Radio reproduction.

Equip your present phonograph with a Magnavox Dynamic Unit, making it the equivalent of an instrument that would cost at least \$1000.00.

A Complete Line of All Models

RADIO SUPPL

H. A. DEMAREST

912-914 S. BROADWAY VA.

LARGEST RADIO PARTS



D-6\$30.00
Operated on 6 Volts, D. C.

D-7\$30.00
Operated on 120 Volts, D. C.

MAGNAVOX *Dynamic* SPEAKERS



You won't want your present speaker after you hear the new Magnavox dynamic power speaker. The old one may seem satisfactory, but in reality it stifles and distorts reception. You can't imagine the difference—you must hear it. We have one on display—come in and hear it.

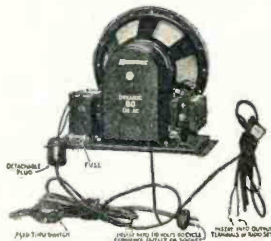

The Dynamic 80 Unit A.C. Model
\$40.00

On Hand—Immediate Delivery
Y COMPANY

PRESIDENT

6063 LOS ANGELES, CALIF.

JOBBER WEST OF CHICAGO

DAY-FAN

9 Tubes (Including Rectifier)



Self-evident quality in tone, and cabinet, that guarantees years of enjoyment. Newest improved radio in distinguished Console (with speaker)

In this set is an ideal balance of selectivity and sensitiveness.

To listen to this radio in your home is to realize clearly its tonal perfection—its ability to render faithfully the good things of the air.

This has one more active tube than most radio sets. It is this extra tube that gives Day-Fan the famed

Extra performance
Extra selectivity
Extra tone quality
Extra distance
Extra ease of tuning.

\$297.50
 Less tubes

Exclusive Southern California Distributor

C. C. LAWTON CO.

1125 Wall St.

WEStmore 3960

Los Angeles



The Refined Touch of Beauty

BEAUTY needs no halos—no songs of praise—to set it forth. Its own unconscious appeal—more forceful than the flow of high-sounding adjectives—gives it recognition wherever it is found.

And, Temple Speakers need no endorsement to earn recognition for their refined beauty. Nothing has been spared, either in design or manufacture, which would instill into them that delicate grace and harmony of lines which would make for pride of ownership. So Temple Speakers are welcomed into every home—they carry that refined touch of beauty which compels admiration—they create that feeling of satisfaction of a thing worth while.

Beautiful appearance alone does not tell the story, for coupled with their pleasing design is a tone quality—a realism of reproduction that has emblazoned the Temple name wherever radio is known.

Temple Speakers are ready for you in two different models. Model 15 is the refined and improved air column speaker—the same type of speaker upon which Temple success was founded—but now better than ever—price \$29.00.

Model 20 Temple Air Chrome represents a sensational new development in loud speakers. The open radiator consists of two sections instead of one, driven by the powerful Temple Double Action Unit, thus substantially increasing the volume and tonal range—price \$29.

Model 15
Temple Air Column Speaker \$29



Model 20
Temple Air Chrome Speaker

TEMPLE, INC.

Leaders in Speaker Design

1925 S. Western Ave. Chicago, U. S. A.

TEMPLE SPEAKERS

Southern California Distributor

C. C. LAWTON CO.

1125 Wall St.

WEStmore 3960

Los Angeles

Falck
Model 7B
\$199.50



The Price of the Falck Model 7B, illustrated here, includes Tubes, and a Genuine Magnavox Dynamic Speaker, Model 80.

How Can Such a Good Radio be Produced at a Price So Low?

This question is often asked of dealers and salesmen by people who have seen and heard the new Falck Radio models and have marveled at their exceptional quality and low prices. The superior performance is the result of painstaking attention to details given each radio by qualified radio engineers. Falck cabinets are designed by master furniture craftsmen. And the low prices are due to the economical operation of an efficient factory, located right here in Los Angeles.

You Don't Know **Real Radio Value**
Until you have Seen
and Heard the
Falck

Any of the dealers listed below will be glad to demonstrate the new Falck Radio to you in your own home, without obligating you in the slightest degree.

Los Angeles
ANGELUS RADIO SERVICE
2375 W. 5th St. YE 5658.
BIROSALL RADIO SHOP
8615 S. Vermont. YO 8842.
BRANDY GLASS & RADIO CO.
214 Alessandro St. OL 3515.
WALTER F. BROWNE RADIO STUDIO
4508-19 Hollywood Blvd. OL 4783.
A. W. COOPER
13154 W. 13th St. YE 0767.
GOLDEN GATE RADIO CO.
(West Coast Theatre Arcade)
3150 Whittier Blvd. AN 7983.
HOLMUND BROS. FURN. CO.
5707 S. Broadway. TH 4486.
L & V ELECTRIC CO.
8864 W. Pico. OX 1509.
PARAMOUNT RADIO & ELECTRIC CO.
5515 Santa Monica Blvd. ED 8473.
PEOPLES OUTFITTING CO.
3990-36 S. Vermont. VY 3143.
RED WING ELECTRIC SHOP
2101 Santa Monica Blvd. OL 1410.
GEO. R. SCHOFIELD, INC.
3350 Whittier Blvd. AN 7921.
M. N. WALKER ELECTRIC CO.
1222 Venice Blvd. 336-1331.
WEST STATES ELECTRIC CO.
5311 S. Broadway. AX 2786.
WHEELER'S SHOP ALL ELECTRIC
112 N. Avenue 58. GA 2208.
ALHAMBRA Alhambra Music House
105 E. Main St. Tel. 1754.
PASADENA: The Sons Shop
18 S. Raymond Ave. WA 2949.
REDONDO BEACH: Electric Radio Shop
(Paul Dick) Arada Bldg.
VERNON: Madury Music Co.
1320½ E. 35th St.

Designed and Built by
THE ADVANCE ELECTRIC CO.
1260 W. SECOND ST. LOS ANGELES



Falck

MODELS

Model 50—\$99.50
Six tubes—one-dial control—built-in speaker. Beautifully finished hardwood cabinets. Sound construction throughout.

Model 60—\$129.50
Six tubes—one-dial control. Improved built-in cone speaker. Completely enclosed in the same unusual walnut art cabinets used in the more expensive FALCK Models.

Model 7—\$160.00
Seven tubes—one-dial control. Semi-dynamic speaker. Beautiful walnut cabinet. Equipped with special switch for controlling low power for local reception and high power for distant reception.

Model 7B—\$199.50
The same as Model 7 but equipped with Magnavox Dynamic Speaker.

No. 20 of a Series



The Jensen Dynamic Speaker

reproduces with the same beautiful fidelity to the average radio set using a 112 tube as to the full undistorted output of 210 vacuum amplifiers. Finished in handsome burled walnut. Height 14 in., width 16 in., depth 12 in.

Type D 44 (6-volt operation) \$35.00
 Type D 45 (90-volt operation) 58.00
 Type D 44 A, C, (110-volt operation) 78.00
 Unit alone—for Radio or Phonograph installation, \$10.00 to \$55.00.

❖ ❖ ❖ It is
HEAR this
 a Jensen

After all — performance is what counts — and even though we could give you many reasons for superb performance of the Jensen Speaker — you would be best convinced by hearing it.

That is why it is too bad you cannot hear this adver-

JENSEN RADIO MFG. CO.
 212 Ninth Street

Exclusive Southern California Distributor
YALE RADIO ELECTRIC CO.
 1111 Wall St.

too bad that you can't
 Advertisement through
 Speaker



isement through a Jensen Speaker. For then you would realize the perfection of modern radio reproduction — and you would agree that the Jensen Dynamic Speaker has been and continues to be "The Finest in Radio."

Distributed in The West By

P. W. Gevin Co.
 1163 Front St., San Diego
 Stubbs Electric Co.
 78 Sixth St., Portland, Ore.
 Robert Weinstock, Inc.
 643 Mission St., San Francisco
 Harper-Magee, Inc.
 Fourth at Blanchard St.
 Seattle, Washington
 The Motor Hardware
 Equipment Co.
 San Diego, Calif.
 Pas. Wholesale Radio, Inc.
 Polson at 113 St.
 San Francisco

Oakland, Calif.

LOS ANGELES

JENSEN
DYNAMIC SPEAKER

.. The Finest in Radio ..

STARTLING ACHIEVEMENT

The SPARTON EQUASSONNE

An amazingly new and different development in circuits that will instantly open your eyes to the real magnificence of radio music. A complete revolution in radio science. No choice can be final until you hear the great Sparton EQUASSONNE.



Set Shown
at Right
79A
Complete
with Powerful
Speaker and
8 Tubes
\$242.50



Beautiful
Burl Walnut
Cabinet
in Period
Design
Made in
Sparton's
Own Factory

\$152.50 to \$925 Complete with Tubes

Wholesale Distributors

PACIFIC WHOLESALE INC.

WALTER M. ADAM
PRESIDENT

433 East Twelfth St., at Wall Los Angeles, Calif. WEstmore 4358

FARIN RAIN

"The Pathfinder of the Air"

The Authorized Sparton Dealers listed below will gladly demonstrate the new sensational Equassonne in your home without obligation.

Los Angeles

AMERICAN ELECTRIC CO. INC.
2409 S. Vermont Ave. BE 0676.
ANGELUS RADIO SHOP
1001 Santa Monica Blvd. OL 7745.
ASSOCIATED RADIO SERVICE CO.
411 Bowler's Bldg. OL 9255.
AVALON RADIO SHOP
8220 Avalon Blvd.

BARKER BROS.
7th and Figueroa. ME 1846.
6294 Hollywood Blvd. HD 4211.
BARROWS CO.
3545 Sunset Blvd. GR 2525.
BEDKMAN & ROUND, INC.
1279 S. Vermont Ave. VE 3874.

BIRCH-SMITH FURNITURE CO.
727 E. Hill St. AT 4121.
BOB BROWNS RADIO SERVICE
4338 S. Figueroa. HD 2192.
WALTER F. BROWN
1506 Hollywood Blvd. OL 4783.
C & O ELECTRIC CO.
1201 W. Santa Barbara. VE 2205.

GAYLORD RADIO & ELECTRIC
6818 S. Vermont Ave. TH 7015.
HARDING & GODDAN, INC.
152 N. Larchmont Blvd. HD 4753.
JENKENS RADIO CO.
8420 S. Broadway.

LA BREA RADIO CO.
5922 Wilshire Blvd. WH 2528.
LIVINGSTONE'S MIDWEST RADIO SHOP
4436 Melrose Ave. OL 5401.
MORTON & NORTON
2211 N. Broadway. CA 0188.

OTTO K. OLSEN
1550 N. Vine. OL 7704.
ROBINSON RADIO SHOP
4528 S. Western Ave. WE 8688.
MAX A. SCHIRESON
367 N. Main. VA 5007.

STANDARD RADIO CO.
417 W. Pico St. WE 1550.
TAN RADIO STORE
8405 Santa Monica Blvd. CR 8201.
VERMONT MUSIC CO.
820 S. Vermont Ave. DR 3229.
VICK'S FURNITURE CO.
5223 Wilshire Blvd. WH 1811.

WESTBROOK & HURST
5924 Pasadena Ave. GA 2950.
WILSHIRE MUSIC CO.
605 S. Western Ave. WA 3873.

Southern California

ANAHEIM:
Danz Piano Co., 102 W. Center
Krispe Music Co., Phone 1298.
AZUSA: Clayton's Radio Shop
120 E. Front Hill. Covins 283-34.
BAKERSFIELD: Unger & Jones
3180 1st St.

BALDWIN PARK: W. E. Walters
221 W. Covins Blvd. Covins 674-23.
BANNING: Bruce Barney
Box 325. Phone 225.
BELLFLOWER: W. W. Werner
381 Bonner St.

BEVERLY HILLS: Beverly Howe Co.
421 Beverly Dr. DX 7133.
BRAWLEY: Imperial Valley Howe Co.
BURLINGAME: Blue Oaks Radio Shop
325 E. Glen Oaks Blvd. Phone 726.
CALEXICO: Imperial Valley Howe Co.

DMING: Geo. Perry
1708 Fifth St. Phone 422-R-1.
COMPTON: Compton Music Co.
530 E. Main St. Phone 5235.
CORONADO: Coronado Radio Elec. Co.
1520 Grand Ave. Phone 690.
COVINA: Kirby Peyton
Phone 6002 or 3101.
CULVER CITY: Radio Electric Shop
7093 Main St.

DUNSMUIR: M. P. Myers
252 N. Crawford Ave. Phone 4146.
EL CAJON: Lynn Asplund Co.
Phone 811.
EL CENTRO: Imperial Valley Howe Co.

ENCINITAS: Wade M. Putnam
Phone 312.
ENCINO: E. R. Weber
17184 Ventura Blvd. Van Nuys 6011-22.
EUREKA: Young's Music Co.
428 E. Grand Ave. Phone 44.
FALGOUTO: E. S. Walton
FULLERTON: Nelson-Felling Music Co.
110 N. Knott.

GARDENA: Dan Soears
GLENDALE:
Russell-Pierce Furn. Co.
1800 S. Brand Blvd. Douglas 83.
Shook Music Co.
300 N. Brand Blvd. Phone 417.

GLENDRIDGE: Kirby Peyton
300 S. Alhambra Ave.
Covina 47062 or 7101.
HERMOSA BEACH: A. A. Estep
1327 Hermosa Av. Hermosa Beach 494.
HOLTVILLE: Imperial Valley Howe Co.

HUNTINGTON PARK: F. A. Dougherty
6234 N. Pacific Blvd. DE 4852.
INGLEWOOD: American Electric Co.
111 N. Merriot St. Phone 113.
LA CRESSENTA: La Cresenta Valley
Radio & Auto Shop.
2850 Mirfield Ave. Phone 834.

LA HARBOR: E. Lushin
Whittier 8520.
LA JOLLA: C. M. Measner
927 Silverado, Phone 859W.
LA MESA: Old Mill Service Station
Box 314. Phone 130-1.
LA VERNE: La Verne Radio Shop
Phone 417.

LONG BEACH: J. P. Anderson
2023 Wilshire Blvd. WH 1811.
Barker Bros.
222 American Ave. 647-57 or 614-04.
LONG BEACH: J. P. Anderson
102 Compton Ave., Belmont Station
Jersey Radio Shop.
167 American Ave. Phone 607-30.

LYNWOOD: F. A. Dougherty
6234 N. Pacific Blvd. DE 4852.
MORROWVILLE: Claude Chen Radio Store
80 E. California St. Phone 300.
MONTEBELLO: White Auto Elec. Co.
Phone 577.

NATIONAL CITY: Nelson-Smith Mercan-
tile Co. Phone 207-1.
OCEAN BEACH: Riverside Radio Co.
San Diego. Bayview 0213.
OILFIELD: W. W. Pifer. Radio Co.
142 Pier Ave. Santa Monica 613-25.
ONTARIO: R. J. Toboy
100 N. Pacific. Phone 829.

ORANGE: Coxson's Radio Shop
2000 N. Broadway. Ar. Phone 89.
OWENSBORO: Earl M. Hoas
2123 Sherman Way.

ORNARD: Geo. P. Austin
108 Fifth St. Phone 422-R-1.
PASADENA:
F. C. Nash & Co.
Colorado and Broadway. EL 3750.
Electro-Motive Corp., 317 E. Colorado
Phone 2845 and 3267.
POMONA: Harrison-Fitch Electric Co.
383 W. 2nd St. Phone 18-50.
PUENTE: M. Geraska
107 S. Main St. Phone 530-37.
REDWOOD BEACH: M. W. Costley
Phone 5413.

RIALTO: C. D. Young
138 E. Riverside Ave.
RIVERSIDE: Edwin E. Webb
1051 Taylor Blvd. Phone 199.
ROSEMAD: Rosemad Radio Elec. Co.
1017 Taylor Blvd. Phone 199.

SAN BERNARDINO:
Proton Electric Co.
184 Fourth St. Phone 241-22.
L. D. Spence, California Hotel
SAN DIEGO:
Edmondson Radio & Electric Co.
2314 Adams Ave.
Hancock Music Co.
2005 University Ave.
Harris Radio Co.
1104 Broadway. Franklin 3034.

The Radio Shop
746 Broadway. Main 5542.
Radio Radio Shop
490 1/2 St. Franklin 3170.
408 B St. Franklin 3170.

SAN DIMAS: Joe Walters
1011 Main St. Phone 1178.
SAN FERNANDO: Mission Pharmacy
1011 Main St. Phone 1178.
SAN JACINTO: Lloyd Record's Garage
Phone 102474.
SAN LUIS OBISPO: China's Electric
Shop. 952 Monterey. Phone 312-W.

SAN LEJANDRO: Pacific Radio Store
1103 Pacific Ave. Phone 428-W.
SAN JOSE: Radio Art Studio
Chula Vista 8712-R-5.
SANTA ANA:
Radio Store Elec. Corp.
303 N. Main St. Phone 2240.

Forsythe & Barker, 209 W. 6th St.
SANTA BARBARA: E. F. Rogers & Son
2223 Wilshire Blvd. Phone 300.
SANTA MONICA: Fred J. Bubbene
421 Santa Monica Blvd. Phone 355-32.
SANTA PAULA: The Radio Shop
Phone 455.

SIEGEL: Radio Shop
1000 Broadway. Phone 300.
VAN NUYS: Vanderhoff's Elec. Shop
224 Van Nuys Blvd. Phone 708.
VENTURA: J. C. Nevill
50 E. California St. Phone 200.
WHITTIER PARK: F. A. Dougherty
1005 N. Pacific Blvd. DE 4820.

WHITTIER: Farmer's Howe & Pant
Co., 109-11 N. Greenleaf Ave.
WILMINGTON:
Wilfrido Elec. Co.
119 W. Anaheim. Phone 1106.
Wilmington Hardware Co.
300-66 Atlantic Blvd.

Arizona

SMOYER: Imperial Valley Howe Co.
YUMA: Imperial Valley Howe Co.

New Lower Prices Utah Dynamic Speakers

Father of All Speakers



DYNOLA

A-C 110V.....\$65.00
 D-C 110V..... 55.00
 D-C 6V..... 55.00



Model "A100"
 110 A-C.....\$40.00



Model X-M Magnetic Cone
 \$14.00



Models
 D-200—110V D-C...\$30.00
 R-300— 6V D-C... 30.00

**D
Y
N
A
M
I
C
S

A
N
D

M
A
G
N
E
T
I
C
S**

BUY FROM YOUR JOBBER

Factory Representative

C. W. SMITH

WE. 9466

407 East Pico

Los Angeles, Calif.

Radio Topics of the Day

A Weekly Review of Radio News, Thought and Opinion

STATION ASKS FIVE DAYS HEARING—COULD USE A MONTH

There was consternation at the Radio Commission last week, when a wire of protest was received from Thomas P. Convey at St. Louis, reinforced by others from Senator Hawes of Wisconsin and Congressmen Cochran and Neidringhaus, protesting against the new assignment of Station KWK, owned by the Greater St. Louis Broadcasting Company, asking that five days be set aside for a hearing and adding that they had enough evidence to take a month.

Inasmuch as hundreds of stations will also ask to be heard, it isn't hard for the reader to figure out where this will lead to, especially if some of these stations, as they undoubtedly will, resort to legal action, which may be carried to the Supreme Court. That being true, members of the Commission are liable to be growing gray beards before the status of all the stations is settled.

WHAT THE NEW SET-UP MEANS

By Captain Guy Hill, Engineer,
Federal Radio Commission

The average listener will be interested to know just what improvement he may expect from the coming broadcasting allocation. The gain to the general public—and especially for the remote listener and farmer—will be that many more stations can be received clearly, without any heterodyne whistles or cross-talk. The increase in the number of stations received will, of course, vary, due to time of year and location of the listener, but the listener will be delighted in discovering the number of stations he can receive without interfer-

ence being present. Those listeners who like to try to pick up distant stations will find that there will be a large number of such stations that can be received without any interference, as there will be forty such stations on different frequencies and with no other stations on these frequencies to cause trouble.

Another important improvement will be that the listener as he tunes in to different stations will not get the same program repeated as often as at present, since the new allocation will require that stations on cleared channels must not give the same program on any two stations that are less than 300 miles apart. The Federal Radio Commission was instructed by law to make the radio broadcasting facilities equal for each of the five zones into which the country is divided.

NEW CHAINS PREDICTED VIA ELECTRIC REPRODUCTION

Despite the fact that up to now the idea apparently has not made much of a hit with the Federal Radio Commission great possibilities are held out by the sponsors of electrical reproduction for tying together without wires the hundreds of smaller broadcasters into vast chains.

Electrical reproduction it may be explained is broadcasting phonograph records without the aid of a microphone, but direct to the transmitter by means of an electric needle device.

The newest chain scheme seems to be to make a record of an advertiser's hour—like the Eveready for instance. Then to send this record to a hundred or more smaller stations and have it electrically reproduced and broadcast all over the United States at the same hour.

We are glad to send an additional supply of Applause Cards, if you have run out.



Metallized
WARNING!
-to Unlicensed Users of the Name
"POWEROHM"

"POWEROHM" is the name of a group of resistance units manufactured by the International Resistance Company for use in connection with high voltage radio and television apparatus.

This name has been duly registered in accordance with the requirements of the law and is solely and exclusively the property of the International Resistance Company in connection with the resistance units which it identifies.

Certain radio merchandise on the market is sold under one or more names which so closely resembles our trade-mark Powerohm that much confusion has been caused. We take this opportunity to warn all who infringe upon our trade-mark that legal steps immediately will be taken to prevent such practices and protect our property.

There is only one family of power resistance units made to the quality and accuracy

of DURHAM "POWEROHMS." They are made only by the International Resistance Company and are specifically and lawfully identified by the name "POWEROHM." All other resistance units not made by the International Resistance Company and sold under the name "POWEROHM" or misspelled imitations thereof are spurious substitutes.

Like DURHAM Resistors and Grid Suppressors, DURHAM POWEROHMS are made on the famous DURHAM Metallized principle and are supplied in a complete variety of ranges for every radio and television resistance requirement.

Follow the lead of the leaders in radio and tie-up with DURHAMS—Metallized Resistors, Grid-Suppressors and Metallized Powerohms—radio's leading resistance Units! Complete descriptive literature on the DURHAM line sent upon request.

DURHAM
METALLIZED
DURHAM

RESISTORS and POWEROHMS

INTERNATIONAL RESISTANCE CO., 2006 Chestnut St., Philadelphia, Pa.

THE STUDIO

Below—Jane Morse, blues, and Harry Foley, piano, are two featured entertainers from KMO, Tacoma, where they regularly entertain with an unusually good program of popular numbers. Miss Morse is to be featured Monday, Oct. 8, at 8 p. m., on KMO's popular hour.



At Left—Georgia Fifield has endeared herself to many thousands of Western listeners-in by her clever direction of one-act radio plays which she presents each Monday night from 7:30 to 8 over KNX. Miss Fifield is also featured on several other hours over the Hollywood station.

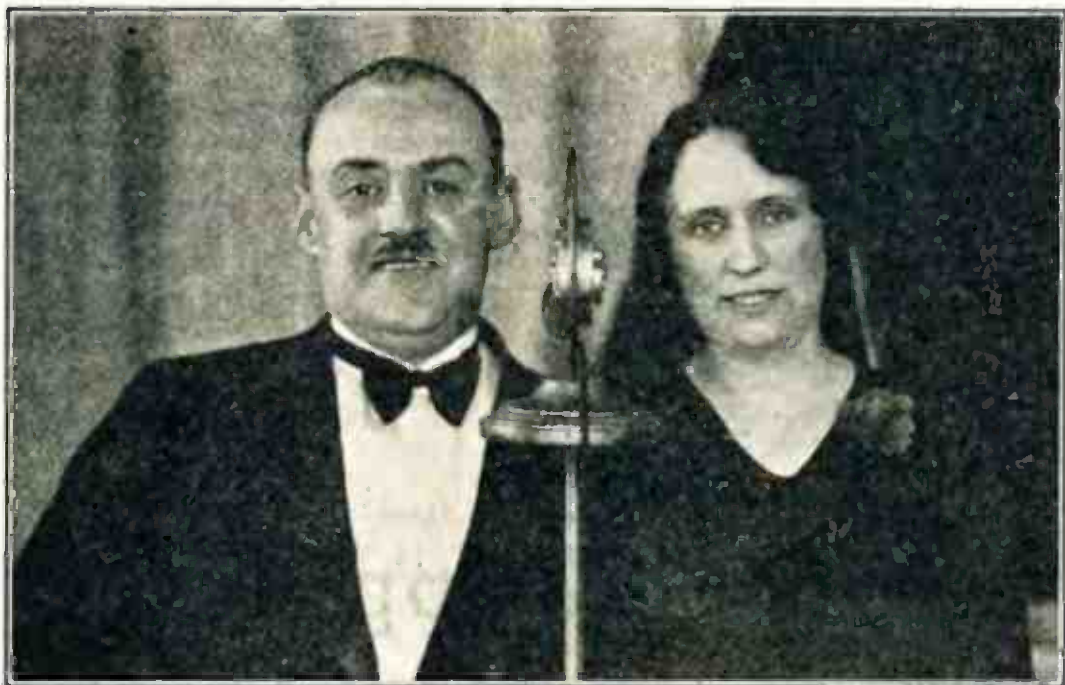



It is not necessary to declare aloud to the world that Commander Byrd is a man of remarkable achievement. ¶ Even though one had never read a line about him the merest checking up of his deeds and record would be sufficient to stamp his merit deep into your mind. ¶ And as with great men so with great products. ¶ Their very manner of existence and daily accomplishments tell all that the observer needs for appreciation and endorsement. ¶ Kolster Radio is a good example of this. ¶ Such faithfulness in tone quality, such extraordinary selectivity and such distinguished appearance have created by their presence in thousands of homes in every State, a powerful structure of confidence within the public mind. ¶ How natural that the Byrd Antarctic Expedition should order complete Kolster Radio equipment for its arduous service! Science recognizes science. ¶ Little wonder that one hears on all sides the quiet remark: "Oh yes, Kolster is a fine set."

"Drawn from the Crucible of Science"

KOLSTER RADIO



HAROLD G. JUNE
... experienced in army and air-mail flying, will be one of the pilots on the South Pole flight.



BERT BALCHEN
... Famous aide to Commander Byrd, is an important member of the South Pole Expedition.

California Distributors

John G. Rapp Corp.

1135 WALL ST.
LOS ANGELES

123 SECOND ST.
SAN FRANCISCO

? Questions and Answers ?

A Weekly Department Conducted by K. G. Ormiston, I.R.E.

QUESTION—Have a new Majestic. Can I put shield grid tubes in the RF stages to any advantage? Can regeneration be added without disturbing the original hookup?—J. D. R., Orange, Cal.

ANSWER—If a fellow has these "tinkering" tendencies, he should buy a kit and build up a set of that variety, whereupon it becomes simple for him to try out any and all of the ideas which he feels might improve the results. But, having bought a factory-built receiver, our advice is most certainly to leave it alone. The engineers who designed the set knew what they were doing—they did not use shielded grid AC tubes or incorporate regeneration for very good reasons. If I were to make a guess I would say that they felt that the AC shield grid tubes had not reached that state of development where they could be used as a commercial volume-production proposition. Regeneration is frowned upon by Mr. and Mrs. Public because it makes squeals and whistles. And since the factory-built receiver is, as a rule, designed to sell to Mr. and Mrs. Public and not to radio fans, the engineer's problem is to design a set which will appeal to and meet the requirements of the greatest number of people. And, as a finished product, it is a well-balanced mechanism which should not be tampered with. My advice would be to put the Majestic in the front room, where radio may really be enjoyed, and then get yourself a kit and a flock of tools, spread 'em out on the kitchen floor and hop to it! While the rest of the family are enjoying radio, you can have your "kick" trying out this and that.

QUESTION—What are the wave-lengths of the Japanese and Australian stations?—D. H. M., San Diego.

ANSWER—Some of our DX fans are a bit mixed up on the Japanese stations.

They were juggled around last spring and therefore the DX boys who hear a Jap and identify him by the wave-length rather than the actual announcement, are usually wrong. It's a Jap all right, but not the one you think it is! Here are the new wave-lengths according to the latest list furnished by the Department of Commerce at Washington:

JOAK—Tokyo—345 meters.

JOBK—Osaka—400 meters.

JOCK—Nogoya—360 meters.

JOFK—Hiroshima—353 meters.

JOGK—Kumamoto—380 meters.

There's another one, JODK, in Korea.

Who knows his new wave-length?

The Aussies are as follows:

2BL—Sydney—353 meters.

3LO—Melbourne—371 meters.

4QG—Brisbane—385 meters.

5CL—Adelaide—395 meters.

2FC—Sydney—442 meters.

2YA, Wellington, New Zealand, the fellow who has been the best all summer and still is the strongest, is on 420 meters.

QUESTION—What are the requirements for an amateur wireless operator's license?

M. McF., Los Angeles.

ANSWER—Address Bernard Linden, Supervisor of Radio, Custom House, San Francisco, and he will furnish you with full information, or inquire at the radio department of the Los Angeles Y. M. C. A., where license examinations are held by the supervisor.

QUESTION—What is the cause of motor-boating and how may it be remedied?

M. McN., Los Angeles.

ANSWER—Motor-boating is due to the feed back in an audio amplifier caused by the coupling of the plate circuits through the common B supply. It may be remedied by the use of an iron core choke of at least 10 Henries in the positive B lead to the amplifier with a 1 mfd. by-pass condenser connected from the set side of the choke to B negative.

Cunningham

RADIO TUBES



Choose
Wisely

**RADIO TUBE
PERFORMANCE**
*of unvarying
accuracy*

There are no "ifs" nor "ands" about your radio reception when your set is equipped throughout with new Cunningham radio tubes.

So uniform are their quality and performance, you can depend on them for faithful tone reproduction.

This monogram on the top of every Cunningham tube is visible proof of in-built integrity and quality.

Cunningham

RADIO TUBES

Give
**Perfect Reproduction
of Music and Voice**

*Distributed in Southern California by the Following
Los Angeles Jobbers:*

Yale Radio Electric Co.
1111 Wall St.

The Electric Corp.
1050 Santee St.

Ungar & Watson, Inc.
1363½ South Figueroa St.

Western Radio, Inc.
1224 Wall St.

Nat'l Radio & Sup. Co.
141-3 W. Washington Blvd.

Kierulff & Ravenscroft
1636 S. Los Angeles St.

Ray Thomas, Inc.
1248 S. Hope St.

Splitdorf-Bethlehem Co.
727 Venice Blvd.

**Stewart-Warner Sales
Company**
1366 S. Figueroa St.

**Graham Reynolds
Electric Co.**
300 E. 3rd St.

Herbert H. Horn
1629 South Hill Street

AERO COIL

SUPER-SENSITIVE INDUCTANCE UNITS

and the New

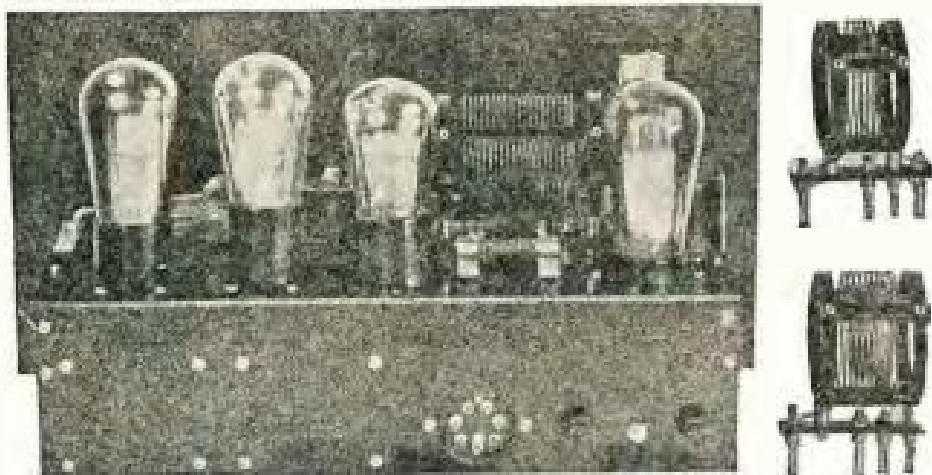

“INTERNATIONAL FOUR”

Non-Radiating!

Shield Grid R.F.!

Better Quality!

Simpler Control!

Greater Distance!

***Covers All Broad-
cast Waves!***

“It may be of interest to you to know . . . that 5SW (Chelmsford, England) has been received every afternoon . . . since March 19th . . . PCJJ at Eindhoven, Holland, comes in every Friday from 7 p. m. to 11 p. m. . . . 2NM at Caterham, England, on Sundays, Wednesdays and Fridays. . . . PCLL at Kootjwijk, Holland, about three days a week. Listened to 2FC at Sydney, Australia, from 6:30 a. m. to 7 a. m. Thursday morning. . . .”

The above statements are excerpts from an unsolicited letter received on May 27th by the Aero Products, Inc., from a satisfied user of a short wave set built around Aero Coils. This receiver was located in Western Pennsylvania and the letter advised that with two stages of audio, loud speaker reception was obtained about three days a week. The original letter can be seen at the offices of Aero Products, Inc., 4611 East Ravenswood Avenue, Chicago, Illinois.

Write for Further Information and Literature

Factory Representatives:

Henger-Seltzer Company, Inc.

711 East 14th St.
LOS ANGELES

1063 Howard St.
SAN FRANCISCO

SHORT WAVE CLUB

BYRD

For the benefit of our short wave club members who can handle the code, the following dope relative to the Byrd Expedition is of interest: Don Wallace, W6AM, hears from them quite regularly. Listened to WFBT, the supply ship Samson, last Monday evening. Came in very strong on 34 meters. Other calls used by the various units of the expedition are WFA, WFB, WFC, WFE, WFF and WFK.

CODE CLASS

The code class members have been sending in their copy and it is interesting to note that the first ten minutes of the very slow sending is received correctly by nearly all of the students. They write down the dots and dashes as heard and then later transcribe into letters and words. The second ten minutes is a little too fast for that process, and the code must be memorized to handle it. The third ten minutes is for the third-class members who can get from 8 to 10 words per minute. Now that you have all found the signals on the air, settle down to hard work with the code, listen in regularly Monday and Thursday evenings at 7:30 and send in your copy. It would help to connect up a dry cell, key and buzzer and practice sending the code in addition to receiving practice.

It is helpful to divide the alphabet up into groups which have a definite similarity. This will help memorize the symbols. For example, the letters which are made up of dots only are E, I, S, H and 5. Dashes only are T, M, O. Dots before dashes are A, U, V, and 4. Dots following dashes are N, D, B, and 6. Other groupings will occur to you which will be helpful.

6AM—LONG BEACH

Shortly after midnight last Saturday we rang the doorbell at 279 Molino, Long Beach, and were greeted by "Smiling" Don Wallace. Don is known in the "Ham" world, where he is quite famous, as 6AM. By the way, "ham" is a term which signifies amateur or, more particularly, radio telegraph amateur. It probably originated by an Englishman who pronounced it "hama-teur," and then "ham" for short.

Unfortunately, due to the lateness of the hour, Don's partner in the operation of his station (and everything else), was getting her beauty sleep, and so Mrs. 6AM did not attend the ham-fest which followed. Mrs. Wallace is a licensed operator, and well able to handle the station in Don's absence on business trips, and communicates with him via a small portable transmitter and receiver which he carries.

Our short wave club members will be particularly interested in 6AM because it is the station which is temporarily sending the code practice for Radio Doings, pending the construction of 6YD. The transmitting apparatus is shown in the accompanying photograph, together with 6AM himself, though how in Sam Hill the photographer caught him without his smile is more than we can figure out.

This station has been heard by other amateurs in all parts of the world—in fact, Don has communicated with stations in every continent on the globe in a single night! During our brief visit of a few early morning hours last Sunday, he conversed (by code, of course), with two amateurs in Australia, one in New Zealand, one in Ha-

(Continued on Page 42)

Royale

ROYALE—MODEL 82

Price, complete with tubes, \$169.50.

In beautiful United cabinet with sliding doors.

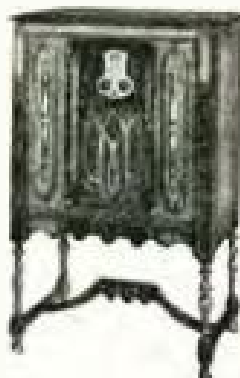

The Authorized Dealers listed below will be pleased to give you a demonstration in your home:

LOS ANGELES

AMERICAN MUSIC CO.
359 N. Main
BOB BROWN
4353 S. Figueroa
FIRESIDE RADIO
5531 York Blvd.
NAHRA FURNITURE CO.
507 N. Main
WALKER RADIO
5851 S. Vermont
WOLFE RADIO
547 S. Western Ave.

BELLFLOWER

BELLFLOWER ELEC. CO.
607 Somerset

BEVERLY HILLS

C. D. HUESTED
1226 Wilshire Blvd.

BURBANK

GLENOAKS RADIO SHOP
325 E. Glenoaks Blvd.

COVINA

COVINA MUSIC CO.
238 N. Citrus
ZUGS GARAGE
First and School Sts.

CULVER CITY

ED KRIST
516 Fay Ave.

HERMOSA BEACH

MUELLER'S DEPT. STORE
135 Camino Real

HUNTINGTON BEACH

BALES ELECTRIC SHOP
412 Walnut

HUNTINGTON PARK

POTTER RADIO
6513 S. Pacific

INGLEWOOD

AYLSWORTH ELECTRIC CO.
111 N. Market St.

LONG BEACH

O. S. PETERSON
642 American Ave.
COBLER RADIO CO.
216 Pine Ave.

LYNWOOD

WYLDE ELECTRIC CO.
11426 Long Beach Blvd.

OCEAN PARK

J. P. CONERUS
161 Pier Ave.

ONTARIO

M. P. PEARSON
318 Miramonte Ave.

ORANGE

K. M. CLAYPOOL
114 N. Glassell

PASADENA

MYERS DEPT. STORE
23-37 N. Raymond
CALIF. TIRE CO.
85 W. Colorado
SERVICE RADIO SHOP
1164 E. Colorado
CARROLL & CAUFIELD
2594 E. Colorado

PUENTE

L. T. HAMMERSLEY

POMONA

W. L. WILLIAMS
497 Second St.
NO BATTERY RADIO SHOP
223 N. Garey

PERRIS

H. E. SLAUGHTER

REDONDO BEACH

A. H. COSTLEY
202 S. Pacific

SAN DIEGO

SUNSET ELECTRIC CO.
Front and G St.
HOLCOMB'S RADIO SERVICE
730 F St.

SANTA ANA

PRESTON RADIO SHOP
211 E. Fourth

SAN BERNARDINO

LONG & ALLAN MUSIC SHOP
326 D St.

SANTA PAULA

KIT CARSON BATTERY & IGNITION
Main and Ojai

TAFT

TAFT ELECTRIC
325 Center St.

SOUTH PASADENA

JONES & CROSS
1020 Mission St.

WHITTIER

WHITTIER HARDWARE
114 S. Greenleaf

Exclusive Royale Distributors

C. W. Smith Co.

407 E. Pico St.

Suite 506

Tel WE. 9466

Los Angeles



STUDIO NEWS

Rae Silverman, singer of bluest blues, is to be heard over KGFJ on the noon request program and every night from 7 to 8.

KTBI, the Bible Institute, broadcasts a program for shut-ins every Monday morning at 10 o'clock.

Calmon Luboviski, master violinist, will play a novelty program of numbers that have never been on the air before over KNX. Sunday, October 7, from 9:00 to 10:30 p. m.

Eva Olivotti, soprano, will be heard over KMTR, as soloist with Loren Powell's Little Symphony Orchestra. Tuesday evening, October 9, at 8:00 p. m.

June Purcell and The Crockett Mountaineers will be the feature next Thursday evening from 8:00 to 9:00 over KEJK.

"The Sunshine Boys" of KFWB are dispensing an excellent brand of jazz music every morning from 7:00 to 9:30. Harry Q. Mills, Charles Beauchamp and Le Roy Kulberg are featured.

KNRC will broadcast all of the season's football games played at Loyola, which will include games with Gonzaga University at Spokane, St. Regis at Denver and the University of Arizona, beginning Saturday, October 8, at 2:30.

"The Big Bens." a five-piece, all-artist orchestra, sound the "Reveille" at 6:45 every morning, heralding the opening of Van's Pep Exercises given at KJR.

A feature of interest to radio fans and radio fraternity in general will be the Radio Technical Talks by N. E. Brown, one of the best known radio engineers in the industry. These talks will be given over KMIC every Thursday night at 7:00 p. m.

In response to numerous requests, Felix Orman will present series of talks covering the subject of "Making a Movie." Mr. Orman's talk on Motion Picture Acting will be given Thursday, October 11, at 2:45 over KFI.

Stanley Morrison, well-known clergyman, will conduct the KFRC Radio Fellowship Church every Sunday morning at 9:30 over KFRC. This church service is planned especially for the benefit of the aged and shut-ins.

Graham McNamee and Philip Carlin, NBC announcers, will share honors in the announcing of sixteen intercollegiate football games which the National Broadcasting Company will cover. The time and dates of the broadcasts and rebroadcasts will be announced later.

Once again, surprise and variety will be featured on the Tuesday night "You Never Can Tell" program which is broadcast over KQW at 8:00.

Tom Gerunovich and his Rhapsodizing Band will be heard over KFRC on Sunday, October 7, from 10:10 to 11:00 p. m.

Marguerite LeGrand, concert pianist, appears over KMIC every Tuesday night from 8:00 to 8:30.

The following political notices will be of interest to the radio public: Herbert Hoover, KPLA, KMTR, Saturday, Oct. 13, 5:30 to 6:30 p. m.; KGFJ—Minutemen every day for 5 minutes, 9:30 a. m., 3:00 p. m. and 8:15 p. m.; KSMR—Minutemen, every evening for 5 minutes; KMIC—Inglewood Minutemen, every evening; KFWC—Pomona Minutemen, every evening. Local radio dealers are arranging to tune in on all special programs. People down town can hear the speeches at any downtown music store, or at Hotel Cecil, 640 S. Main street.

CALL ONE OF THESE
MAJESTIC DEALERS

They Can Make IMMEDIATE Delivery

LIBERAL TERMS

BIRKEL MUSIC CO.

Home Demonstration Solicited

446 S. Broadway VA. 1241

DOWNTOWN

"Trade In Your Old Radio"

HARRY W. HARRISON, Inc.

Jonathan Club Bldg.

555 S. Figueroa St. TRInity 9777

HIGHLAND PARK

"Your Majestic will be the same wherever you buy it, but, only Holland can give you "Holland Service"

HOLLAND ELECTRIC

SHOP

Open Evenings

5632 Pasadena Ave. GA. 3912

Yes, We Demonstrate

BROOKS FURNITURE CORPORATION

AN. 7669

3555 Whittier Blvd.

Open Evenings

SOUTH WESTERN AVENUE

Free Demonstrations

Consent Terms

ROBINSON RADIO SHOP

Open Evenings

4528 S. Western VE. 6683

Demonstration Gladly

JENKINS RADIO STORE

Liberal Terms

8450-52 S. Broadway TH. 4460

SANTA BARBARA AVE.

RADIO ELECTRIC SHOP

Liberal Trade In—Terms to Suit

1428 W. Santa Barbara VE. 7440

SOUTHWEST

Specializing in Home Demonstration without any obligation whatsoever.

PACIFIC RADIO STORES

Trade-In Allowance Easy Terms

4705 S. Vermont VE. 9589

MONROVIA

Home Demonstrations Easy Terms

ARTHUR A. ROSS

504 S. Myrtle Phone Black 505

Open Evenings Saturday 'till 9 p.m.

INGLEWOOD

Home Demonstration Easy Terms

GLYNN ELEC. RADIO CO.

10404 Hawthorne Blvd.

Phone Inglewood 1330W

*See Us for Best Service
Open Evenings and Sundays*

More than a
Million Dollars

worth of
Majestic
Radio
sold in
September



Think of it! More than a million dollars worth of one make of radio purchased by Southern California radio enthusiasts in the 24 sales days of September. More than a full carload of Majestic all-electric receiving sets purchased every day.

This sales record will probably sound tremendously big if you are one of the people who have not yet heard Majestic Radio. After you do hear it... and enthuse over the surprising life-like tones made possible by the Majestic Dynamic Power Speaker, which is self contained in all Majestic models... After you see Majestic with your own eyes and admire the beautiful walnut cabinets... After you are told the sensationally low selling price of Majestic receivers made possible by volume production and lowered manufacturing costs... then you'll wonder why only a carload a day was sold in September.

We'll let you in on a secret. Our allotment was only 24 carloads. Majestic dealers could have sold more... and will in October. Ask your nearest Majestic dealer for the reasons for Majestic popularity and details about the remarkably easy plan on which it is sold.

SEE NEXT PAGE 

Trade News

Dynamic Europe

Europe has had its monarchic, socialistic, democratic and other "ic" tendencies, but now the whole works has gone dynamic. And this isn't political propaganda, either, it's facts, and substantiated by the new assembly room just added to the Magnavox factory in Oakland.

To satisfy the dynamic cravings of the wide world apart from these United States, which represents carloads and carloads of Magnavox speakers shipped to England, Germany, France, Africa, Australia, New Zealand and all points north, south, east and west, the plant in Oakland has been enlarged. We wormed this information out of no less a person than Mr. Flynn himself, the California sales representative for the Magnavox Company.

And so don't let anybody tell you anything different about the European situation—because you can take it from us, it's dynamic! In other words, those Europeans know their tone quality!

H. H. Horn Appointed Cunningham Distributor

Herbert H. Horn Company, the well-known radio and automotive jobber, located at 1629 South Hill Street, has just been appointed a Southern California distributor for Cunningham Tubes.

Mr. Horn states that he will carry at all times a complete stock of tubes to supply his large following of dealers.

The H. H. Horn Company is also distributor for the well-known line of Bremer Tully A.C. Radio Receivers, Silver-Marshall kits and parts, Temple Speakers, Flewelling, Insuline, Aero, National and Dresner Short Wave and Television kits, also many other nationally advertised lines of kits and parts.

Eveready Displays

A Unique Model

The new Eveready stand model AC Receiver is unique in that it is made of die cast aluminum finished in a dark green with routed silver striping.

It has a recessed control panel and is operated with one dial. This smartly



designed set can be used either as a table set, removed from the pedestal legs, or with the support as shown in the accompanying picture.

It employs seven tubes, which gives it a world of power and, with the Antenna Trimmer, allows great selectivity.

The Eveready line of receiving sets and speakers are distributed in Southern California by Reiman Wholesale Elect. Co., 218 E. Third St., Los Angeles, Calif.

Have you ordered your 1928-29 Radio Doings Call Book?
See Page 5.

MAGNAVOX

MAGNAVOX "Dynamic" SPEAKERS



*"And ev'ry voice is heard repeating
The merry burthen of glad song."—CARMEN.*

Sensational Tone Richness

Los Angeles Wholesale Distributors

C. C. LAWTON CO.
1125 Wall St.

LEO J. MEYBERG CO.
1022 Wall St.

SPLITDORF BETHLEHEM CO.
727 Venice Blvd.

WESTERN RADIO, INC.
1224 Wall St.

Trade News

McNamee With Advance

F. W. Falck of the Advance Electric Co., well-known Los Angeles manufacturers of radio equipment, announced this week that he had secured B. F. McNamee, well-known radio engineer, to assist in the designing and experimental division of the Advance Electric Co.

McNamee has earned an enviable reputation as a designer with three of the country's leading radio equipment manufacturers. During the war he was



B. F. McNamee

employed as chief engineer of the Morehead Laboratories, San Francisco, a concern well known to all old-timers in the radio and electrical business. While McNamee was with this firm they concentrated largely on filling big war contracts for vacuum tubes with the British and United States governments. McNamee has also been associated with the Magnavox Company and the Colin B. Kennedy Corporation, St. Louis, where he was retained as special designer of radio receiving equipment.

In addition to his work with radio

manufacturers, McNamee has the distinction of being the first radio newspaper editor on the Pacific Coast. He was in charge of the radio page of the San Francisco Chronicle in 1922. This was said to be the first exclusive radio section of any newspaper west of Chicago.

When interviewed, McNamee expressed great enthusiasm for the future development of the Advance Electric Company.

"The new Falck models introduced at the Radio Show are superior, in my opinion to any competitive sets on the market in the same price class," he said. "Steps are now being taken to increase production materially in order to keep abreast of the increased demand occasioned by the showing of the new models. In a completely equipped factory such as that of the Advance Electric Company, this will not be difficult to accomplish."



**For
Better
A. C.
Reception!**

Licensed by
Rider Radio
Corporation,
Pat'd 5-2-16,
7-27-26,
Pats. Pending.

PHASATROL

A True Balancing Device for
Radio Frequency Amplifiers

To secure clear reception in A.C. and Electrified Receivers, noise elimination is the most difficult problem to solve. Eliminate the squeals and howls caused by R.F. oscillations by installing Electrad Phasatrols in your power set. Very simple to install and adjustment is permanent. Price \$2.75 each. Write for free circulars and circuit data. Dept. R-10, 175 Varick Street, New York, N. Y.

ELECTRAD

Silver-Marshall 720 Screen Grid Six

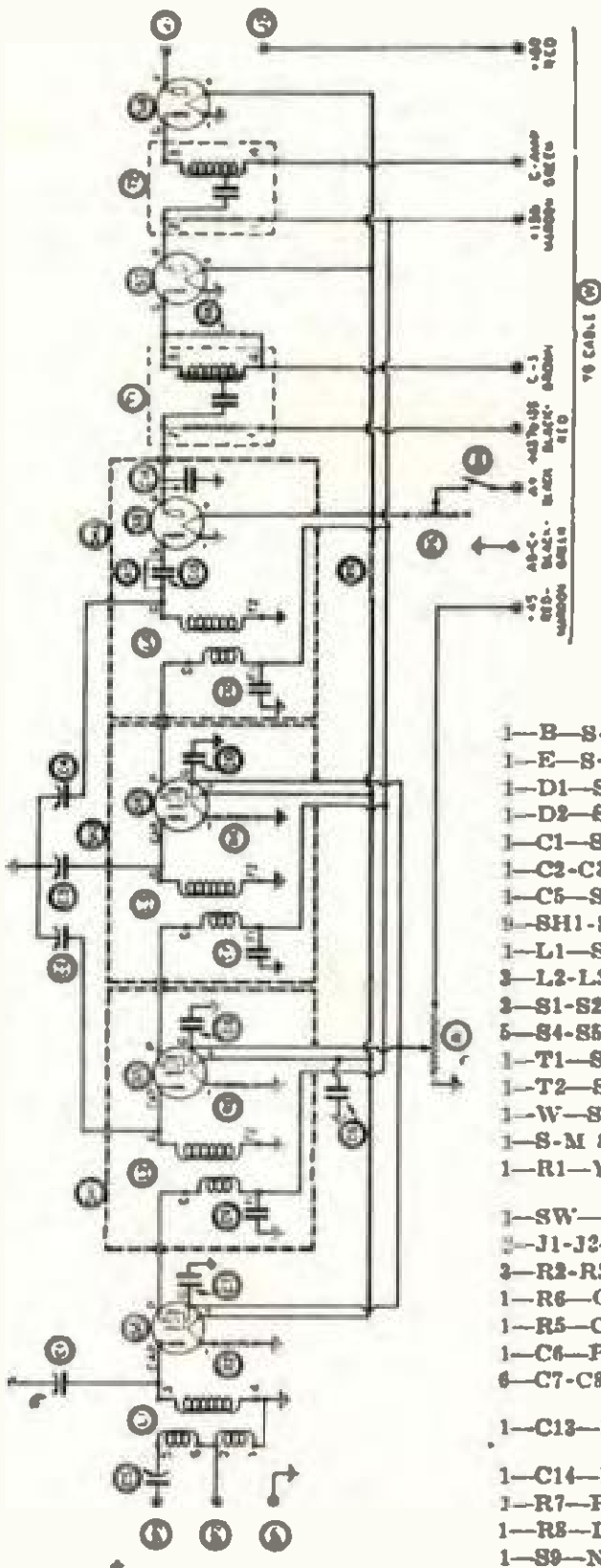

Here is the wiring diagram and complete list of parts for the new Silver-Marshall Screen Grid Six, known as the "720." This set was illustrated and described in last week's issue. Several have been built up already in Southern California, and reports of splendid performance are coming in.

The key numbers given in the parts list correspond to those in the diagram. This is the most economical of the kit sets offered this season, and certainly gives a lot of radio performance and quality for each dollar.

LIST OF PARTS

- 1-B-S-M 701 Universal pierced chassis.
- 1-E-S-M 809 dual control escutcheon.
- 1-D1-S-M 806L (left) vernier drum dial.
- 1-D2-S-M 806R (right) vernier drum dial.
- 1-C1-S-M 320R .00035 mfd. Universal condenser.
- 1-C2-C3-C4-S-M .00035 mfd. 3-gang condenser.
- 1-C5-S-M 342B .000075 mfd. midget condenser.
- 1-SH1-SH2-SH3-S-M 638 copper stage shields.
- 1-L1-S-M 140 antenna coil.
- 3-L2-L3-L4-S-M 132A plug-in RF transformers.
- 2-S1-S2-S3-S-M 612 5-prong tube sockets.
- 5-S4-S5-S6-S7-S8-S-M 511 tube sockets.
- 1-T1-S-M 255 first stage A. F. transformer.
- 1-T2-S-M 256 second stage A. F. transformer.
- 1-W-S-M 708 10-lead, 5-foot connection cable.
- 1-S-M 818 Hook-up wire (25 ft. to carton).
- 1-R1-Yaxley 53000, 3,000 ohm midget potentiometer.
- 1-SW-Yaxley 500 switch attachment.
- 2-J1-J2-Yaxley 420 insulated tipjacks.
- 3-R2-R3-R4-Carter RU10, 10 ohm resistors.
- 1-R6-Carter A6, 6 ohm sub-base rheostat.
- 1-R5-Carter H1 1/2, 1 1/2 ohm resistor.
- 1-C6-Potter 104, 1 mfd. bypass condenser.
- 6-C7-C8-C9-C10-C11-C12-Sprague 1/4 mfd. midget condensers.
- 1-C13-Polymet .00015 mfd. grid condenser with clips.
- 1-C14-Polymet .002 mfd. bypass condenser.
- 1-R7-Polymet 2 megohm grid leak.
- 1-R8-Durham .15 megohm resistor with leads.
- 1-S9-Naald 481XS cushioned tube socket.

Applause cards make it easy to show your appreciation for radio entertainment. RADIO DOINGS will mail you a quantity free on request.

\$500,000 to introducing a New Name a Great National

THINK of it! . . . Over half-a-million dollars to be invested by the Yale Electric Corporation to make November and December record-breaking profit months for its dealers . . . \$500,000 for advertising and selling, including seven startling color-pages in the Saturday Evening Post—dramatic big-space newspaper advertisements in 59 key cities—sensational radio programs over 21 important stations—striking window-displays and selling helps! . . . All tying in with a great \$10,000 Prize Contest that will send sales soaring and put plenty of rich sugar-frosting on the Dealer Cake!

Over 90,000,000 people—every section of the country—will be reached by this sweeping effort!—Week in and week out during the intensive two-months' drive this vast audience will be told about the amazing new features which have been added to the line—of the huge million-dollar plant which Yale has erected in Jersey City—of the new trademark which has been adopted: "BOND!"—This change of brand-name has recently been put into effect to avoid confusion with other products bearing the name "Yale."

BOND Flashlights and Batteries

will embody all the distinctive features which have given Yale products in the past their preeminence. And, in addition, new improvements which will still further enhance their value and appeal.

\$10,000 in Prizes to the Public!

So that the entire country may come to know thoroughly all the remarkable features about YALE-BOND Flashlights and Batteries and learn to identify them by their new name, we shall launch on November 1st the *Greatest Contest for Slogans ever Conducted by Any Concern in the Flashlight or Battery Industry.* \$10,000 in prizes will be distributed among 1,183 people—those who

be spent by YALE and a NEW LINE through PRIZE CONTEST!

submit the best slogans on the features of YALE-BOND Flashlights or Mono-Cells which they consider most important.

\$2,500 in Additional Awards to Dealers!
Every Retailer has a Good Chance to Win!

In addition to the \$10,000 customer prizes, we have appropriated \$2,500 for Dealer Prizes, to be distributed among those retailers extending the best cooperation during the Contest period. Any dealer in the country may enter this contest and any dealer—large or small—has an equal chance to win one of the big Cash Awards!—No puzzling tricks to it!

Contest planned directly to bring Customers into Your Store!

In each of the newspaper and magazine advertisements and in the radio broadcasting, only five of the six principal YALE-BOND features will be described. To learn about the sixth or "mystery feature," the public will be directed to a counter-card depicting this feature which can be seen only in the store of an authorized YALE-BOND dealer.

Also, we have prepared a special Contest Window Display—supplied free to authorized YALE-BOND Dealers—which is considered the most arresting and compelling thing of its kind ever put out. And here again the public is directed to come into your store to learn about the "mystery feature."

Moreover, in all the advertisements and in the window display, the public is directed to secure Contest Blanks through the dealer.

No expense has been spared in the whole campaign. Nothing has been overlooked to make it a big success for the dealer and the jobber. A wonderful new line of BOND Colored Flashlights has been brought out as additional bait for holiday business. Special advantages are being offered to all dealers handling YALE-BOND Radio "B" Batteries.—Millions of people all over the country will be keyed up to a high pitch of excitement over the big prize awards. It's up to you now to cash in to the fullest extent. Write today for further particulars.

BOND ELECTRIC CORPORATION

(Formerly Yale Electric Corporation)

Chicago JERSEY CITY, N. J. San Francisco
Manufacturers of Radio "A," "B" and "C" Batteries, Storage and Dry
Batteries, Flashlights, Mono-Cells

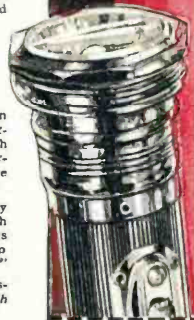

\$2500 in
Special Awards

for
**JOBBER
SALESMEN**

No hard work!
Easy to win!
Write
for particulars!



For Better Radio
Hammarlund
 PRECISION
 PRODUCTS



The Famous Hammarlund Midline Condensers

Universally approved by
those who "know their stuff"
in Radio.



The New Hammarlund Equalizing Condenser

Greatly improved and simplified. Mica dielectric and flexible phosphor-bronze spring plate, firmly riveted to bakelite base. Cannot short-circuit. Compact—fits small space. Direct attachment.

Made by
HAMMARLUND MANUFACTURING CO.
 New York, N. Y.

Factory Representatives

Henger-Seltzer Company

711 East 14th St., Los Angeles, California

1063 Howard St., San Francisco, California

Trade News

KFWB Receives Latest Type Microphone

Gerald King, manager of KFWB, and his assistant, Bill Ray, are most enthusiastic about the new Western Elec-



tric 47A Condenser Microphone. It is the very latest thing in transmission equipment and naturally it is their "pride and joy."

Acme Announces New Set

In announcing their new AC Receiver the Acme Electric and Manufacturing



Company of Cleveland believe they have a product that will meet the demands of the radio public.

It is self-contained, using three stages of Radio Frequency, two stages of Audio

Frequency and a Detector. The chassis and panel is a rigid, one-piece, pressed steel frame with power pact built in the chassis. The wooden cabinet is handsomely finished in beautiful cracked lacquer.

The Acme Electric and Manufacturing Company is one of the pioneers in the radio field. This company is better known as a manufacturer of A, B and C Power units, Trickle Chargers, Switches, A.C. Converters, Transformers and Chokes.

Kolster at South Pole

Radio entertainment at the South Pole will be provided by Commander Byrd for his expedition of 70 men to avoid the results of "all work and no play." Concerts will be heard from



several countries and in different tongues. The Commander is testing the set he is taking with him to link with a series of loud speakers of the type shown distributed around the quarters of his men.

Stations change in wavelength November 11th. You can find their position by using the 1928-9 Call Book. See Page 5.

MAGNAVOX

MAGNAVOX *"Dynamic"* SPEAKERS



"MAC," leader of
the famous broad-
casting "Haywire
Orchestra"

Infinitely Finer Reproduction

Los Angeles Wholesale Distributors

C. C. LAWTON CO.

1125 Wall St.

SPLITDORF BETHLEHEM CO.

727 Venice Blvd.

LEO J. MEYBERG CO.

1022 Wall St.

WESTERN RADIO, INC.

1224 Wall St.



Through the courtesy of the Sunset Mfg. Co. of Los Angeles, a Sunset Aerial will be given each week as first prize, and a Sunset Ground as second prize, for the two best DX letters. In addition, Radio Doings will send a special "Logging Graph" with Map and Distance Chart to the writer of each DX letter published.

FIRST PRIZE

SECOND PRIZE

DX Club:

I notice that in this week's Radio Doings you have opened the long wave DX Club, and call for letters. The following is a report of DX fishing on my seven-tube Federal, at my home in Glendale, on Saturday night, Sept. 22.

I started in at a few minutes past eleven and pulled in WENR, Chicago, without difficulty. Reception was excellent on the loud speaker, as good as ordinary local reception. A few minutes later—about 11:40—I played KFBU, Laramie, Wyo.—reception excellent (484 meters), and at 11:50 had no trouble getting WJJD, Mooseheart, Ill., on 365 meters. Shortly after this I played KFKA, Greeley, Colo. (249 meters), and KMOX, St. Louis (300 meters). I am making no mention of Coast stations, but just the rarer ones. I then spent about an hour trying to get the call letters of a station on about 223 meters—wobbling very badly, but finally gave it up. However, had good luck after 3:00 a. m. At this hour tuned in JOCK at Nagoya. As I had this station last year, verified, I held it only a few minutes. Tried for JOAK, but had no luck. However, at 3:10 got JOBK at Osaka, and held them until 3:30. A letter is on the way to them now. Just before 4 o'clock tuned in a station on approximately 345 meters, but reception was poor, and could get no call. (Was it one of the new Jap stations?) Reception of JOCK was fair (360 meters). Reception of JOBK was much better, clear, but some fading (385 meters)

After this, called it a night.

A. E. ARMSTRONG,
321 W. Myrtle St.,
Glendale, Calif.

(Ed. Note—See Page 21.)

DX Club:

Greetings—It is with great pleasure that I welcome the reopening of the DX Club.

I enjoy reading of the other fellow's log, and met some real DX fans last year.

The DX Club serves two purposes, one of friendship and the other of pointers on set operation and information of DX stations a great help to all of us.

I still use last year's set—a Radiola 20, Philco operated, 100-A speaker, 50-foot aerial, but moved from Inglewood to Hawthorne: seems a better location to get distance. Results from June, 1928, to now: Once or twice a month WBAP, Fort Worth, comes through now regularly; Sept. 14, WGN came through, and two nights ago, when KMIC was silent, got KGHL at Billings, Mont., a 250-watter, with good volume on 222 meters.

Log from June to now of DX stations are: WBAP, KFAD, KOA, KLZ, KFXF, KOW, KJR, KOMO, KGW, KOIN, KSL, KGO, KFWM, KLX, KTAB, KHQ, KPO, FFRC, KQW, KFWI, KEX, KWG, KFSD, KGB, KJBS, KYA, KFCR, KMO, KFBU, KFOA, WHO, WGN, CNRV, KGHL, and did any of you ever get KXA in Seattle on 535 meters? Have heard him for the last two weeks.

Well, good luck to all you DX fans, and drop me a line any time. I will be glad to swap letters, and I will sign off now.

Yours for DX, and more of it,

RAY SKAGGS,
Hawthorne, Calif.

(Continued on Page 90)

BT Counterphase 8—World's Greatest Radio—Sold with a Distance Guarantee. H. A. Everest, 7406 Melrose Avenue. OREGON 7402.

6AM Long Beach

(Continued from Page 25)

wali, one in Japan, and was getting warmed up for some real work when we reluctantly left. The New Zealand chap was a beginner who could hardly receive ten words a minute and was only using 45 watts power. He was obviously delighted with his contact with Long Beach.

The international communication system which the radio amateurs have built up is an amazing thing.

Their patience and persistence in developing such amazing efficiency in a wave-length field which was assigned to them because it was believed to be worthless, is a contribution to radio science of vital importance. While engineers backed by great resources endeavored to make possible long distance radio telegraphy by smashing through static and interference by means of great power (even up to 1000 kilowatts!) on the longer waves, the amateurs demonstrated that reliable communication over any distance could be maintained with an output of but a few watts on the very short waves. And so today the great corporations and governments are fighting for the short waves, and the amateurs who showed them how are being crowded into a few narrow bands.

Amateurs have transmitted half way around the world with one ordinary tube operating on dry batteries as the only power source. They are licensed

by the Government as operators and their stations are licensed and inspected. They have their national organization, the A. R. R. L., and local clubs and groups. They refer to the broadcast listener as a "B. C. L." and never as an amateur, for after all the BCL is like a spectator at a golf match, while the amateur is a golfer.

Don Wallace is chairman of the In-

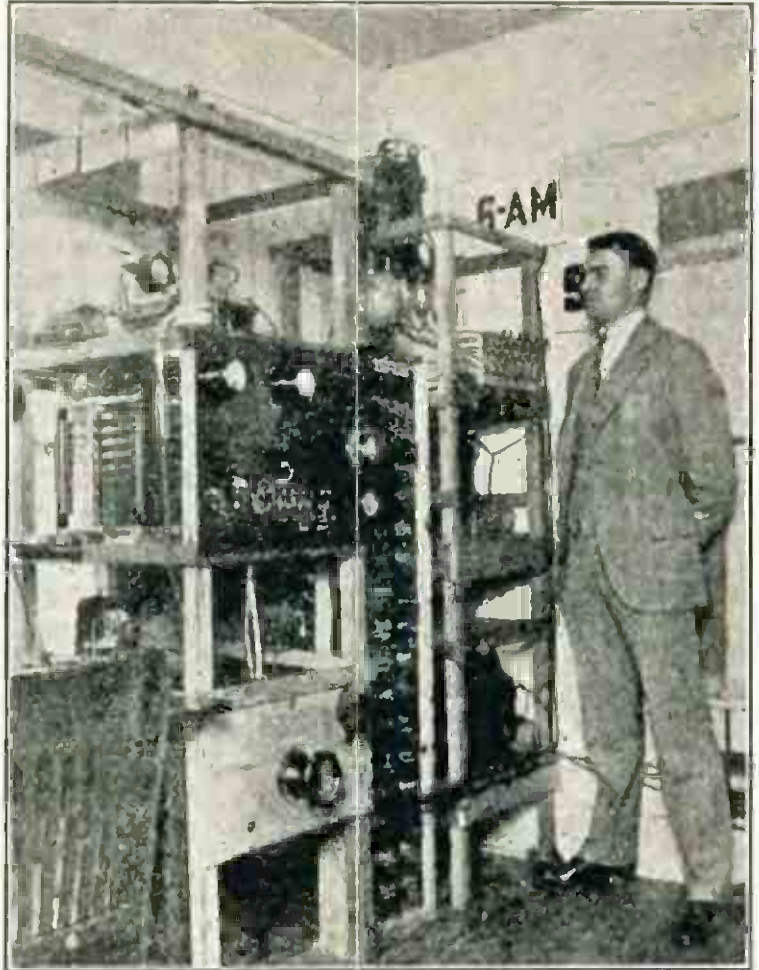

Don Wallace and His Radio Station

terference Committee of the Radio Trades Association of Southern California, and an industrious and popular manufacturers' agent during the day time.

Broadcasters throughout the country are busy working out new schedules to fit in with the reallocation plan, effective November 11th.

Creating a Sensation!

**10!
KC!**

**Selec-
tivity**



**Immediate
Delivery**

DE LUXE MODEL

Sargent-Rayment Screen Grid Seven

THE new Sargent-Rayment Screen Grid Seven has been designed to meet the exacting demands of long distance reception. The full power of four screen grid tubes is used. There are no oscillations, no howls, no squeals. Complete by-passing and choking of all common wires, heavy, rugged shielding of each stage, allow each shield grid tube to be worked to a maximum. The build-up of a weak DX carrier is amazing. Signals that would be entirely missed on a last year's receiver are amplified to give good volume on this set. Selectivity is greater than on anything heretofore available. The set cuts closer than 10 KC on most stations, and only in rare instances is more than 10KC required to completely tune out a powerful local. Long distance reception during the early evening when the locals are on is therefore easily possible.

Tone quality is unexcelled. We especially wish to call attention to the tone quality on DX stations. Due to the **TOTAL ABSENCE** of regeneration, the DX tone is better, clearer, sharper than ever heard before. Except for occasional background noise, a DX station is as clear as a local.

Complete Kit

Factory Wired

Standard Model.	\$130.00	Standard Model.	\$150.00
De Luxe Model.	140.00	De Luxe Model.	160.00

Distributed By

RADIO SUPPLY CO.

912-914 S. Broadway

H. A. DEMAREST, President
VA. 6063
WHOLESALE

Los Angeles, Calif.

"The Parts Warehouse of the West"

Here's New Radio Performance!!



DE LUXE MODEL

Sargent-Rayment Screen Grid Seven

Designed on the Pacific Coast to meet coast conditions, where selectivity requirements are more exacting than in Chicago or elsewhere. Many receivers which perform satisfactorily in Chicago are hopeless failures in Los Angeles and Francisco—hence the importance of special design for this territory.

The Sargent-Rayment Screen Grid Seven makes available the full power and amplification of four stages of sharply tuned screen-grid tubes—and the resulting sensitivity is such that the DX range is limited solely by the noise level. But noise alone does not make a good DX receiver—for if the locals cover the dials the extreme range is useless. In this receiver the selectivity is as great as the preservation of fine tone quality will permit. Speaking of tone quality . . . due to the fact that even on extreme distance there is no approach to oscillation, the total absence of

regeneration gives the same clear, sharp and undistorted speech and music on the far distant stations as available from the locals!

Special Notice

The De Luxe Sargent-Rayment Seven is put out exclusively by Radio Constructors Corporation and distributed to dealers by the jobbers here listed. The parts for this receiver are manufactured by Silver-Marshall, Inc., but the special finish is applied at Oakland, Calif. The standard model and De Luxe Model are identical except for the finish.

Prices

Standard Model, Grained Aluminum Finish Kit, \$130.00; Built-up, \$160.00
De Luxe Model, Brown, Crinkle-Craft Finish Kit, \$140.00; Built-up, \$160.00

Dealers: These jobbers can supply you with either the

Kü or Built-up Set:

SO. CALIFORNIA

Herbert M. Hora, Los Angeles
C. C. Lawton, Los Angeles
Radio Supply Co., Los Angeles
Radio Mfrs. Supply Co., Los Angeles
Radio Mfrs. Supply Co., Long Beach
Modern Electric Co., Anaheim
Williams and Kincaid, Santa Ana
Bennet Electric Co., San Diego

NO. CALIFORNIA

Offenbach Electric Co., San Francisco

Coast Radio Supply Co., San Francisco

Electric Supply Co., Oakland
Gilson Eleet. Supply Co., Oakland
Kimball-Usion Co., Sacramento

WASHINGTON

Wedel Company, Seattle
Harper-Maggio Ins., Seattle
Inland Radio Co., Spokane

OREGON

Universal Specialties Co., Portland

Stubbs Electric Co., Portland
Pac. Radio Sales Co., Oakland

COLORADO

Vreeland Radio Corp., Denver

IDAH0

Rupert Electric Co., Rupert
Reno Motor Supply Co., Reno

NEVADA

Peckard Service Sls., Albuquerque

UTAH

Land Radio Co., Fairview

Actual
Dial Settings
of Stations Logged
in One Evening
with the Sargent-
Rayment Seven!

In this test the receiver was located in Oakland within two miles of four powerful local stations. It is a positive indication of the degree to which the designers have combined great sensitivity with selectivity.

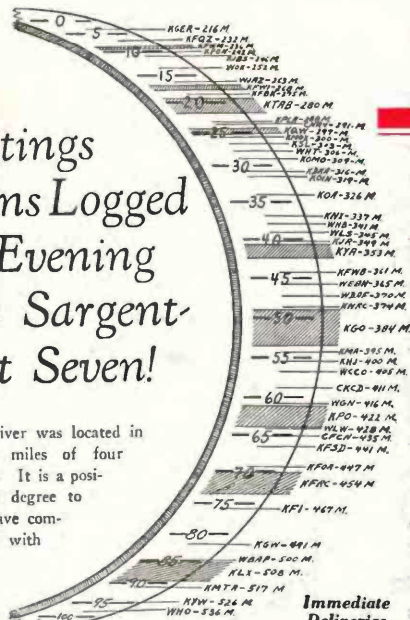

Write for
Booklet

Immediate
Deliveries

RADIO CONSTRUCTORS CORPORATION

357 Twelfth St. Oakland, Calif.

Sargent-Rayment Screen Grid Seven

WIRE WINDING SET UP: SEPARATE LEADS FROM EACH TERN ON U1222 SOCKETS TO POINT MARKED "A". ALSO RUN SEPARATE LEADS FROM EACH TERN OF U1222 SOCKETS TO POINT "B". THIS IS NECESSARY TO OBTAIN STABILITY OF U1222 STAGES.

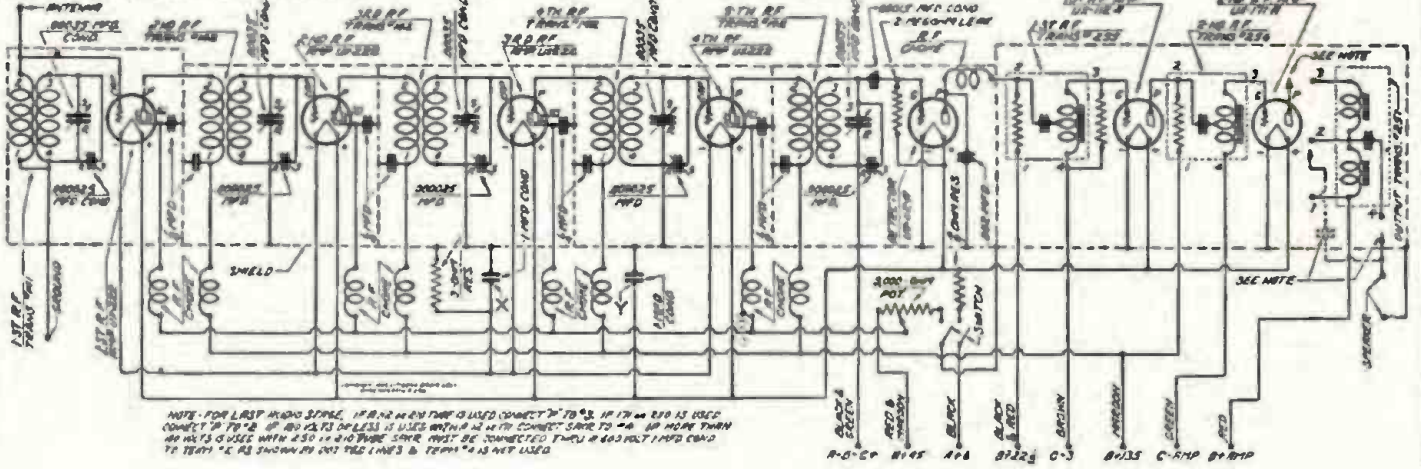

NOTE - FOR LAST HIGH STAGE, IF R-0-50 IS USED CONNECT "A" TO "B". IF 175 OHM 50 IS USED CONNECT "A" TO "B" AND "C" TO "D". IF 100 OHM 50 IS USED CONNECT "A" TO "B" AND "C" TO "D". IF 100 OHM 50 IS USED WITH 450 OHM 100 OHM SPKR MUST BE CONNECTED THROUGH 450 OHM 100 OHM CAP TO TERN "A". AS SHOWN ON THE LINES & TERN "A" IS NOT USED.

The Peer
of Them
All!

RADIO

MANUFACTURERS SUPPLY CO.

OPEN EVENINGS
UNTIL 9 P.M.
SATURDAY
UNTIL 10 P.M.

⚡ **10000** ⚡

SOUTH BROADWAY COR. 10TH ST.

OPEN EVENINGS
UNTIL 9 P.M.
SATURDAY
UNTIL 10 P.M.

Complete
Kits in
Stock

The Sargent-Rayment Seven

Sargent and Rayment, the inventors of the famous Infradyne circuit, have designed a new set employing screen-grid tubes in four stages of tuned radio frequency and many other unusual features. The generous use of chokes, by-pass condensers and shielding give the stability heretofore lacking in a tuned four-stage amplifier; the tremendous amplification of the screen grid tubes results in an unlimited DX range; the use of trimming condensers in each tuned circuit maintains the maximum in selectivity; and the new Clough

tuning of the antenna circuit. The four succeeding tuned circuits employ coil and condenser systems very similar to that of the antenna stage, of extremely low loss, high selectivity characteristics. The receiver has one major vernier drum tuning control supplemented by five small vernier knobs, one for each of the five tuned circuits. An on-off switch turns the receiver on and off. A volume control knob provides smooth control of volume from zero to maximum. The receiver is mounted upon a pierced aluminum

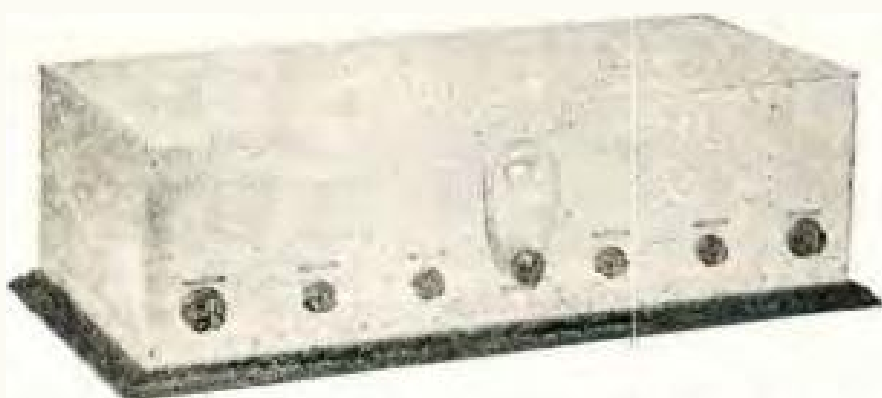

audio system is capable of very fine tone quality.

The set is essentially intended for the distance fan who requires the sensitivity which will go down into the noise level even on the quietest winter night, combined with the ability to play distance stations through a barrage of locals, and the best of tone quality under all conditions. It has one-dial control for ordinary operation, but is equipped with five trimmers for peaking the RF circuits in exact resonance on weak signals and where sharp selectivity is required.

The radio frequency amplifier circuits are most unusual, the antenna input stage employing a rejector type of wave filter to obtain very high selectivity and to allow single control operation by minimizing the reaction of different antenna characteristics upon the

chassis to which are assembled the partitions isolating each stage, and the front and back panels. All joints are made solid by an ample number of fastening screws and are lapped to provide positive shielding. The cover is removable for access to the interior of the set. The entire aluminum assembly, which provides both complete shielding and a cabinet for the receiver, is attractively trimmed off by a walnut base moulding on which the receiver chassis fits, and small control name plates.

The Sargent-Rayment Seven is a precision laboratory radio receiver. It has been designed throughout as such. It is like a battleship stripped for action, shorn of every piece of surplus gear. And it carries its own recommendation in its name.

The wiring diagram, complete list of parts, constructional information and detailed report of the set's performance in tests made by Radio Doings will be given next week.



Apex Table Model with Wrought Iron Stand and Apex Speaker

APEX RADIO

Better Performance at a Lower Price

You will never realize just how much trouble-free radio satisfaction your radio dollar will buy until you see and hear an Apex All Electric Receiver. Ask one of the many authorized Apex Dealers listed below to demonstrate in your own home, without obligation, the marvelous new Apex.

Los Angeles

Apollo Radio Shop
1707 N. Western Ave.

Walter F. Browne
4508 Hollywood Blvd.

Gus Brown Radio Store
1765 N. Cahuenga St.

Downtown Radio Co.
134 W. 7th St.

Acme Radio Store
709 So. Main St.

Electric Service Co.
4508 1/2 S. Vermont St.

El Sereno Service Co.
5319 Navarro St.

F. & H. Radio Shop
5011 York Blvd.

Fogil Radio Shop
310 W. 61st St.

W. L. Gaylord
6618 S. Vermont St.

Henry Radio Store
1277 N. Wilton St.

Jatho Radio Service
3410 Central Ave.

Jenkins Radio Shop
8452 S. Broadway

Kleinberger Co.
405 N. Main St.

Motley Elec. Service
7761 Santa Monica Blvd.

Paramount Radio Co.
5515 Santa Monica Blvd.

Pete's Radio & Electric Shop
6704 Elm St.

Quimby's Radio Service
1860 N. Vermont St.

Pico Radio Shop
4505 W. Pico St.

Radio Headquarters
7214 S. Broadway

Shane Hardware Co.
2906 Division St.

A. W. Townsend
3653 Edenhurst St.

Walker Radio Shop
5851 S. Vermont St.



Model 336

Apex Console Equipped with Famous Jensen Dynamic Speaker.

Southern California

ANAHEIM

C. A. Knapp
1101 Lincoln Ave.

BELLFLOWER

Moore's Radio Shop
427 Somerset St.

CORONA

Corona Hardware Co.
606 Main St.

ESCONDIDO

Young's Music Co.
128 E. Grand Ave.

GLENDALE

Richardson Furn. Store
1326 E. Colorado St.

HUNTINGTON BEACH

Frank Radio Service
222 1/2 Main St.

HUNTINGTON PARK

Huff's Furniture
6342 Pacific Blvd.

LONG BEACH

Mills Electric Co.
326 Pine Ave.

Kelm Radio
147 E. 4th St.

LA JOLLA

C. H. Messner Radio
927 Silverado Ave.

LOMITA

Calkin's Hardware Co.
Lomita, Calif.

NORTH HOLLYWOOD

Chas. F. Morrell
5437 Lanekahim Blvd.

OCEANSIDE

E. F. MacBeth Radio Store
Cor. Hill and Topeka Sts

ONTARIO

The Radio Shop
222 W. Holt St.

PASADENA

Thomas Radio Co.
697 N. Lake St.

SAN PEDRO

San Pedro Radio Co.
378 W. 6th St.

SANTA MONICA

Ed. Mathes
719 Broadway

RIVERSIDE

R. F. Austin
916 Main St.

Snyder Radio Shop
2595 New Magnolia Ave.

Roy Storie
Fendley Station

SANTA ANA

Marshall Radio Service
614 E. Fourth St.

Santa Ana Radio Co.
820 Fruit St.

SHERMAN

Preuss Road Radio Service
465 Robertson Blvd.

VENTURA

The Bartlett Co.
804 Main St.

Ventura Radio Sales & Service
79 S. Oak St.

WALNUT PARK

Smith Music Shop
2616 E. Florence Ave.

WILMINGTON

Driskill Furniture Co.
601 W. Anaheim Blvd.

Apex All-Electric Receivers Priced from \$87.50 to \$199.50 (Less Tubes)

Wholesale Distributors

YALE RADIO ELECTRIC COMPANY

1111 Wall Street

West Los Angeles 3351

Los Angeles, Calif.

LOG OF WESTERN STATIONS

CALL	Frequency In Kilocycles	Wave Lgths.	Power in Watts	STATION	LOG	CALL	Frequency In Kilocycles	Wave Lgths.	Power in Watts	STATION	LOG
SOUTHERN CALIFORNIA						KFWI	1120 268	500		San Francisco	
KMTR	580 517	500		Hollywood		KGA	1150 261	2000		Spokane	
KFI	640 469	5000		Los Angeles		KMO	1180 254	250		Tacoma	
KFSD	680 441	500		San Diego		KJBS	1220 246	100		San Francisco	
KHJ	750 400	1000		Los Angeles		KRE	1220 246	100		Berkeley	
KNRC	800 375	500		Santa Monica		KFIO	1220 246	100		Spokane	
KFWB	830 361	1000		Hollywood		KFJR	1230 244	500		Portland	
KNX	890 337	5000		Hollywood		KFWM	1270 236	500		Oakland	
KPPC	950 316	50		Pasadena		KPCB	1300 231	50		Seattle	
KPSN	950 316	1000		Pasadena		KZM	1300 231	100		Hayward	
KPLA	1040 288	500		Los Angeles		KGCL	1300 231	100		Seattle	
KTBI	1090 275	750		Los Angeles		KPQ	1300 231	50		Seattle	
KWTC	1100 273	100		Santa Ana		KFIF	1310 229	50		Portland	
KGEF	1140 263	1000		Los Angeles		KFBL	1340 224	50		Everett	
KFSG	1190 252	500		Los Angeles		KGTT	1360 220	50		San Francisco	
KEJK	1190 252	500		Beverly Hills		KFQW	1380 217	100		Seattle	
KFWC	1210 248	100		Pomona		KFEC	1400 214	50		Portland	
KGB	1210 248	100		San Diego		KFQU	1400 208	100		Holy City	
KFON	1240 242	500		Long Beach		KVOS	1430 210	50		Bellingham	
KFQZ	1290 232	250		Los Angeles		WESTERN STATES					
KELW	1310 229	250		Burbank		KLZ	850 353	1000		Denver	
KGEN	1330 225	100		El Centro		KOA	920 326	5000		Denver	
KMIC	1340 224	250		Inglewood		KFAD	930 322	500		Phoenix	
KGER	1390 216	100		Long Beach		KSL	990 303	1000		Salt Lake City	
KFVD	1390 216	250		Culver City		KFXF	1060 283	250		Denver	
KGFJ	1410 213	100		Los Angeles		KGEK	1140 263	10		Yuma	
KFCR	1420 211	100		Santa Barbara		KFCB	1230 244	125		Phoenix	
NORTHERN CALIFORNIA AND NORTHWEST						KDYL	1280 234	100		Salt Lake	
KXA	560 535	500		Seattle		KGAR	1290 234	100		Tucson	
KLX	590 508	500		Oakland		KFEL	1320 227	250		Denver	
KGW	610 491	1000		Portland		KFUP	1320 227	100		Denver	
KFBU	620 484	500		Laramie		KOW	1370 219	250		Denver	
KFOA	670 447	1000		Seattle		KPJM	1430 214	15		Prescott	
KFRC	680 454	1000		San Francisco		KGFH	1430 209	250		Pueblo	
KPO	710 422	1000		San Francisco		JOBBER'S SALESMEN THREE WANTED					
KWSC	760 394	500		Pullman		For selling good set line in Southern California. In replying, give full detail as to experience and salary or commission wanted. All information will be held confidential.					
KGO	780 384	5000		Oakland		Address S. D. E., Radio Doings					
KHQ	810 370	1000		Spokane		407 E. Pico St. Los Angeles					
KMJ	820 266	50		Fresno							
KYA	850 353	1000		San Francisco							
KJR	860 394	2500		Seattle							
KWG	870 345	50		Stockton							
KOIN	940 319	1000		Portland							
KOMO	970 309	1000		Seattle							
KQW	1010 297	500		San Jose							
KVI	1060 283	50		Tacoma							
KTAB	1070 280	500		Oakland							
KEX	1080 278	2500		Portland							
KFBK	1090 275	100		Sacramento							
KVL	1100 273	100		Seattle							
KOAC	1110 270	500		Corvallis							

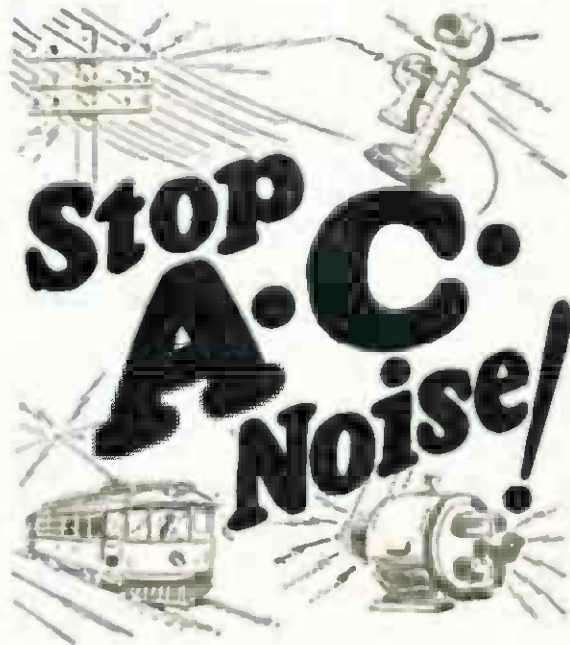

ALL over the country they are praising this wonderful improvement that blocks out line interference noise and radio frequency disturbances. Plug in a Falck Claroceptor between your receiving set and wall socket. You won't get any more of that man-made "static" from motors, street cars, telephones, electrical appliances, etc. An absolute necessity to clear reception in some locations. Also improves selectivity and distance.

A Falck Claroceptor requires no changes in your set. Measures just 3½x5½x2½ inches. Tested, proved. Get one right away—only equipment of its kind. At radio parts dealers, or write to factory for new descriptive folder FREE.



Falck CLAROCEPTOR

Manufactured by ADVANCE ELECTRIC CO.
1260 W. Second St., Los Angeles
JOBBER AND DEALERS. GET OUR PROPOSITION



Your Neighbors Will Pay You \$75⁰⁰ a week for Your Spare Time

You can easily sell them your spare hours for \$3 each by serving as "radio doctor," building them sets, selling them supplies at less than retail. A membership in the Association shows you how to cash in on Radio now and trains you for the \$3,000 to \$10,000 openings awaiting qualified men. The Association starts you in business if you wish. Investigate all it has done for others, all it can do for you. A MEMBERSHIP NEED NOT COST YOU A CENT.

Earn \$500 in Spare Hours

Our members are making big money with Radio. Werner Eichler, N. Y., earns \$50 a week—Lyle Follick, Mich., has earned \$500—F. J. Buckley, Mo.—makes as much as he receives from employer—All in spare time. Our members are starting radio stores, getting better positions, increasing their salaries, earning money spare time.

Act Now — for No-Cost Membership

Send post card for details of Special Membership Plan that need not—should not—cost you a cent, and our book, "Your Opportunity in the Radio Industry." It will show you how you can cash in on Radio now—and later.

Radio Association of America
Dept. RDA-10, 4513 Ravenswood Ave.,
Chicago.

Send me your book and details of your Special Membership Plan.

Name.....

Address.....

City.....State.....

Schedule of Western Stations Not Included in Detailed Program Section

Call Letters	Location	Freq. Ke.	W. L. Meters	Power Watts	Sunday		Monday		Tuesday	
					A. M.	P. M.	A. M.	P. M.	A. M.	P. M.
KFBL	Everett, Wash.	1340	223.7	50	11.00-12.00	8.00-9.30	9.30-10.45	4.00-10.00	9.30-11.15	4.00-5.00 6.00-9.30
KRE	Berkeley, Calif.	1300	230	100	7.00-11.30	2.00-4.30 7.00-8.00 10.00-12.00	7.00-11.30	2.00-4.30 7.00-8.00 10.00-12.00	7.00-11.30	2.00-4.30 7.00-8.00 10.00-12.00
KJBS	San Francisco, Calif.	1220	245.8	100		12.00-1.30 4.00-7.30	7.00-12.00	1.30-5.30 7.00-10.00	7.00-12.00	1.30-5.30 7.00-10.00
KGB	San Diego, Calif.	1210	247.8	500		9.00-12.00	9.00-10.30	12.30-6.00 9.00-12.00	9.00-10.30	12.30-6.00 9.00-12.00
KFWM	Oakland, Calif.	1270	236.1	500	9.45-11.00	12.30-2.30 7.30-9.20	10.00-11.00	12.00-1.00 5.00-10.30	10.00-11.00	2.00-3.00 5.00-10.30
KVL	Seattle, Wash.	1100	272.6	100	7.00-11.00			12.00-4.00 6.00-11.00		12.00-6.00
KFXF	Denver, Colo.	1060	282.8	250	8.00-9.00	8	9.00-10.00	6.00-8.30	9.00-10.00	6.00-8.00
KFAD	Phoenix, Ariz.	930	322.4	500	10.00-11.15	12.00-1.00	8	11.00-12.00	2.00-3.00 5.00-6.00 6.00-7.00	11.00-12.00
KXA	Seattle, Wash.	860	836.4	500	10.00-12.30	7.00-10.00	10.00-12.30	12.30-1.00	10.00-12.00	12.00-1.30 5.00-12.00
		Wednesday			Thursday		Friday		Saturday	
Call Letters		A. M.	P. M.		A. M.	P. M.	A. M.	P. M.	A. M.	P. M.
KFBL		9.30-10.45	4.00-5.00 6.00-10.00		9.30-10.45	4.00-5.00 6.00-10.00	9.30-10.45	4.00-5.00 6.00-10.30	9.30-10.45	4.00-5.00 6.00-9.30
KRE		7.00-11.30	2.00-4.30 7.00-12.00		7.00-11.30	2.00-4.30 7.00-8.00 10.00-12.00	7.00-11.30	2.00-4.30 7.00-8.00 10.00-12.00	7.00-11.30	2.00-4.30 7.00-8.00 10.00-12.00
KJBS		7.00-12.00	1.30-5.30 7.00-10.30		7.00-12.00	1.30-5.30 7.00-10.30	7.00-12.00	1.30-5.30 7.00-10.30	7.00-12.00	1.30-5.30 7.00-10.30
KGB		9.00-10.30	12.30-6.00 9.00-12.00		9.00-10.30	12.30-6.00 9.00-12.00	9.00-10.30	1.30-6.00 9.00-12.00	9.00-10.30	12.30-8.00 9.00-1.00
KFWM		10.00-11.00	1.30-3.00 5.00-10.30		10.00-11.00	2.00-3.00 5.00-10.30	10.00-11.00	2.00-3.00 5.00-10.30	10.00-11.00	6.45-10.30
KVL			12.00-4.00 6.00-11.00			12.00-6.00		12.00-4.00 6.00-12.00		12.00-6.00
KFXF		9.00-10.00	6.00-8.00		9.00-10.00	3.00-4.00 8.00-7.30	9.00-10.00	3.00-4.00 6.00-9.00	9.00-10.00	6.00-7.00
KFAD		2.00-3.00 5.00-7.00 8.00-10.00	11.00-12.00		2.00-3.00 5.00-7.00	11.00-12.00	2.00-3.00 5.00-7.00 8.00-12.00	11.00-12.00	2.00-3.00 5.00-7.00 8.00-10.00	
KXA		10.00-12.00	12.00-1.00 5.00-12.00		10.00-12.00	12.00-1.30 5.00-12.00	10.00-12.00	12.00-1.00 5.00-12.00	10.00-12.00	12.00-1.00 5.00-12.00

Steinite

ELECTRIC AC RADIO

Again--A Great Line at Sensational Prices!



Model No. 261—\$79.50

The Table Model, on the left, is simplicity itself! Neat—clean-cut—most compact of all. A cabinet of Tanguile, the most beautiful of all Philippine woods, richly finished in Duco. A six-tube tuned radio frequency receiver using AC tubes. Illuminated single-dial control, switch and antenna compensator — all grouped within the beautiful antique finished bronze escutcheon plate.

Also complete line of console models from \$125.00 to \$169.50. All models require 7 tubes, costing \$22.50,

Distributed by

NATIONAL RADIO & SUPPLY COMPANY

141 W. Washington

WE. 2748

Los Angeles

See One of These STEINITE DEALERS Today for a Free Demonstration

Los Angeles

**NINTH AND UNION
RADIO SHOP**
1605 W. 9th St.
DU. 4091

**RADIO EXCHANGE
& SERVICE**
4211 S. Broadway
AX. 6652

Long Beach
RADIO FAN
2631 E. Anaheim
Phone 318-250

**BOTHAMLEY
MUSIC**
1585 E. State St.
315-216

Hollywood

PAUL J. BRINDEL
6310 Selma St.
Special: Complete
Set with \$20 Speaker
\$102.00 — HE. 4525

San Bernardino

D. A. BLODGETT
470 Arrowhead

Venice

**C. L. GOFF RADIO
CO.**
1092 Washington Bl.
San. Monica 639-65

**El Segundo and
Hermosa**

JACK BREWER
139 Richmond St.
Phone 142

Whittier

J. D. STAHL
401-3 W. Phila.
423-283

Cucamonga

R. M. KINCAID

Schedule of DX Stations

This schedule of the powerful eastern and mid-western stations gives the signing-off hour in Pacific standard time. Inasmuch as these stations cannot be heard on the Pacific Coast until dark and they are all on the air at that time (except on silent nights), the DX fan is concerned only with the signing-off time.

Call Letters	Location	Freq. Kc.	W. L. Meters	Power Watts	Sun.	Mon.	Tues.	Wed.	Thurs.	Fri.	Sat.
WFAA	Dallas, Texas	550	545.1	500	10.00	8.00	10.00	8.00	8.00	8.00	10.00
KSD	St. Louis, Mo.	550	545.1	500	7.15	9.00	9.00	9.00	9.00	9.00	9.00
WHO	Des Moines, Iowa	560	535.4	5000	8.15	8.30	8.30	8.30	8.30	8.00	8.00
KYW	Chicago	570	526.0	2500	8.30	8.02	8.02	8.02	8.02	8.02	8.02
WFLA- WSUN	Clearwater and St. Petersburg, Fla.	580	516.9	750	S	9.00	9.00	9.00	9.00	9.00	9.00
WOW	Omaha, Neb.	500	508.2	1000	7.00	8.15	8.15	8.15	8.15	8.15	8.15
WBAP	Ft. Worth, Texas	600	499.7	5000	11.00	10.00	8	S	10.00	S	1.00
KTHB	Hot Springs, Ark.	600	499.7	1000	8.00	9.45	7.00	9.30	S	7.00	9.00
WEAF	New York, N. Y.	610	491.5	50000	8.45	8.00	7.30	8.00	8.00	8.00	8.00
WCFL	Chicago, Ill.	620	483.6	1500	7.30	10.30	10.30	10.30	10.30	10.30	10.30
WSB	Atlanta, Ga.	630	475.9	1000	6.15	8.45	8.45	8.45	8.45	8.45	8.45
KFNF	Shenandoah, Iowa	650	461.3	2000	8	6.00	6.00	6.00	6.00	6.00	6.00
KRLD	Dallas, Texas	650	461.3	500	9.30	10.30	10.30	10.30	10.30	10.30	10.30
WJZ	New York, N. Y.	660	454.3	40000	7.45	9.00	9.00	9.00	9.00	9.00	9.00
WJR	Detroit, Mich.	680	440.9	5000	10.00	10.00	10.00	10.30	10.00	10.00	10.30
WLW	Cincinnati, Ohio	700	428.3	5000	8.30	9.00	9.30	10.00	9.00	9.30	9.30
WOR	Newark, N. J.	710	422.3	5000	7.00	8.30	8.05	8.30	8.05	8.05	8.05
WGN- WLJB	Chicago, Ill.	720	416.4	500	8.00	10.00	10.00	10.00	10.00	10.00	10.00
WCCO	Minneapolis, Minn.	740	405.2	5000	8.30	8.00	8.30	10.00	9.00	10.00	10.00
WTAM	Cleveland, Ohio	750	399.8	3500	9.00	9.00	9.15	9.15	7.00	8.15	8.00
CYJ	Mexico City	750	400	1000	S	8.00	8.00	8.00	8.00	8.00	8.00
KWKH	Shreveport, La.	760	394.5	1000	10.00	10.00	10.00	10.00	10.00	10.00	10.00
WBBM	Chicago, Ill.	770	389.4	5000	10.00	8.45	9.00	9.00	9.00	9.00	10.00
WJBT	Chicago, Ill.	770	389.4	500	4.30	9.00	9.00	9.00	9.00	9.00	9.00
WGY	Schenectady, N. Y.	790	379	50000	7.30	9.00	9.00	8.00	9.30	8.00	9.00
WOC	Davenport	800	374.8	5000	8.15	10.00	10.00	10.00	10.00	9.00	8.00
WDAF	Kansas City, Mo.	810	370.2	1000	7.45	11.00	11.00	11.00	11.00	11.00	11.00
WEBB	Chicago, Ill.	820	365.6	500	6.00	S	11.00	11.00	11.00	11.00	11.00
KLZ	Denver, Colo.	850	352.7	1000	10.00	10.00	10.00	10.15	S	9.00	10.15
WWJ	Detroit, Mich.	850	312.7	1000	5.45	8.00	8.30	8.00	8.00	10.00	8.00
WLS	Chicago, Ill.	870	314.6	5000	S	7.00	S	8.30	5.00	9.00	10.00
WIB	Kansas City, Mo.	880	340.7	500	10.15	8.00	8.00	8.00	8.00	6.00	8.00
KFOB	Ft. Worth, Texas	900	331.1	1000	10.00	8.00	9.00	S	9.00	9.00	9.00
WRNY	New York, N. Y.	920	325.9	500	2.30	2.45	7.00	4.30	8.15	6.30	8.15
KOIL	Council Bluffs, Ia.	940	319	5000	10.00	10.00	11.00	11.00	10.45	11.00	11.00
KFAB	Lincoln, Neb.	940	319	5000	9.30	9.00	9.00	9.00	9.00	9.00	9.00
KDKA	Pittsburgh, Pa.	950	315.6	50000	7.30	8.45	8.30	8.30	8.30	8.30	8.30
WHT	Chicago, Ill.	980	305.9	5000	7.00	4.00	7.00	7.00	9.00	9.00	9.00
WGR	Buffalo, N. Y.	990	302.8	750	5.00	10.00	8.30	9.00	10.00	8.00	8.30
KSL	Salt Lake, Utah	990	302.8	1000	9.00	11.00	11.00	11.00	11.00	11.00	11.00
CNRV	Vancouver, Canada	1030	291	500	11.00	11.00	11.00	11.00	11.00	11.00	8
WENR	Chicago, Ill.	1040	288.3	500	8.00	9.00	9.00	9.00	9.00	9.00	10.00
KPAU	Boise, Idaho	1050	285.5	2000	S	S	10.00	S	10.00	S	10.00
WBAL	Baltimore, Md.	1050	285.5	5000	5.15	7.00	7.00	7.00	7.00	7.00	7.00
KFXP	Denver, Colo.	1000	282.8	800	S	7.00	7.00	7.00	7.00	7.00	7.00
WPG	Atlantic City, N. J.	1100	272.6	5000	6.30	8.00	8.00	8.00	8.00	8.00	8.00
KPAD	Phoenix, Ariz.	930	322.4	500	1.00	8.00	8.00	8.00	7.00	7.00	8.00
WJAZ	Chicago	1140	263.0	5000	7.00	9.30	9.30	9.30	9.30	9.30	9.30
KFKU	Lawrence, Kansas	1150	254.1	500	S	7.30	S	S	7.30	S	S
KDYL	Salt Lake, Utah	1280	234.3	500	10.00	10.00	10.30	10.00	10.30	9.30	11.00

The Sandar
Dynamic
Speaker
gives finer
Tone
than you've
ever heard
and takes
greater
Volume
than you'd

ever expect.
Listen.
Compare.
At your
Dealer's Now.
And think
of it!
Only
\$50 *for A.C.
or D.C.*

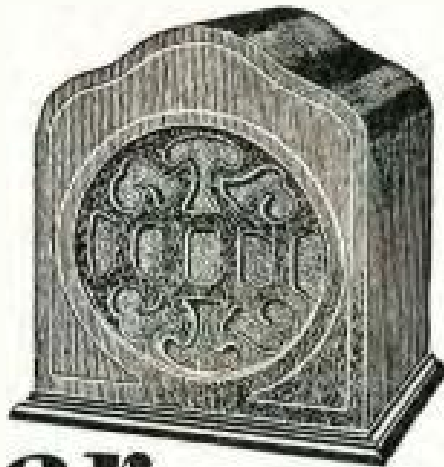

Sandar DYNAMIC

Distributed in the West by

SPOKANE
Spokane Hardware Co.

SEATTLE
Schram & Ware, Inc.
Seattle Hardware Co.

SAN FRANCISCO
W. E. & W. H. Jackson

PORTLAND
North West Auto Equip. Co.
Stevens & Rathkey, Inc.
J. M. Ward Co.

OAKLAND
W. E. & W. H. Jackson
LOS ANGELES
Illinois Elec. Co.



JENNINGS PIERCE
Announcer

**KFI KPO KGO
KGW KOMO
KHQ**

Charles H. Gabriel, Jr.
Program Director

Jennings Pierce
Chief Announcer

DAILY

9:00 p. m.—Time broadcast (except Saturday).
10:00 p. m.—The Trocadero's Dance Orchestra, except Monday.

SUNDAY, OCTOBER 7

1:30 p. m.—Melodies of the classics are to be played by the Peerless Reproducers as they present their afternoon's program. Two Wagner numbers will open this enjoyable program.
Broadcast over KHQ, KOMO, KGW, KGO, KPO and KFI.
3:00 p. m.—Sunday Afternoon Concert presents Colletto Manon, pianist, in her first appearance with the NBC System. Harold Dana, baritone, and August Plemeniak, oboist, and the National Concert Orchestra will also be heard.
Broadcast over KOMO, KGW, KGO and KFI.
4:30 p. m.—William Ford Manley is the author of the Biblical Drama story called "The Stolen Blessing," to be given at this time.
Broadcast over KHQ, KOMO, KGW and KFI.
6:15 p. m.—Frances Alda, soprano, and Mario Chamlee, tenor, will be heard from New York during the transcontinental Abcater Kent Radio Hour.
Broadcast over KHQ, KOMO, KGW, KGO, KPO and KFI.
7:30 p. m.—Oriental themes predominate in the program offered by the Whittall Anglo-Persiana during their broadcast.
Broadcast over KHQ, KOMO, KGW, KGO, KPO.
8:00 p. m.—A 60-minute program of classical music will be broadcast by the Standard Symphony Orchestra, under the direction of Nathan Abas.

MONDAY, OCTOBER 8

6:45 p. m.—Important new developments in the business activities of the world will be considered by Dr. Julius Klein at this time.
Broadcast over KHQ and KOMO.
7:00 p. m.—Henry M. Hyde's second talk on astronomy in a new series of RCA programs will be broadcast with the usual background of music.
Broadcast over KHQ, KOMO, KGW, KGO, KPO and KFI.
8:00 p. m.—Fourteen of Rudy Selser's own compositions will be played by the Shall Symphonists under Rudy's direction.
Broadcast over KHQ, KOMO, KGW, KGO, KPO and KFI.
9:00 p. m.—Gail Taylor, soprano, and Myron Niesley, tenor, will be the soloists for the "Song Painting" Program.
Broadcast over KHQ, KGO.

TUESDAY, OCTOBER 9

10:30 a. m.—Domestic Science will be the theme of the two chapters of the "Woman's Magazine of the Air" program.
Broadcast over KHQ, KOMO, KGW, KGO, KPO.
7:00 p. m.—"Show Folks" is the title of tonight's "Memory Lane" program and concerns the visit of a troupe of one-night stand actors in the little town of Goshen.
Broadcast over KOMO, KGW and KGO.
8:00 p. m.—"Manola," by Lecocq, will be presented by the Eveready program. Ethel Wakofield, soprano; Eva Gruninger Atkinson, contralto; Gwynn Jones, tenor, and James Isherwood, baritone, will sing the principal roles.
Broadcast over KHQ, KOMO, KGW, KGO, KPO and KFI.
9:30 p. m.—Amatzo's Gitanos will present their usual

program of light and joyous music.
Broadcast over KHQ, KOMO, KGW, KGO, KPO and KFI.

WEDNESDAY, OCTOBER 10

11:00 a. m.—A talk by Helen Webster, authority on matters of home science will be the feature of the "Woman's Magazine of the Air" broadcast.
Broadcast over KHQ, KOMO, KGW, KGO, KPO and KFI.
8:00 p. m.—Williams and Suzanne will provide another program of music and dialogue as the "Yellow Cab Gayeties" are broadcast.
Broadcast over KPO and KFI.
9:30 p. m.—Distinctly collegiate are the "Cheer with Isuan" programs. U. S. C. will be the background for the singing of collage songs.
Broadcast over KHQ, KOMO, KGW, KGO, KPO and KFI.
10:00 p. m.—Another group of happenings during the "Road to Romance" travel of Jack and Ethyl will be told at this time.
Broadcast over KHQ, KOMO, KGW, KGO, KPO and KFI.
9:30 p. m.—Midweek Concert featuring Edna May Hamilton, contralto, and Harold Dana, baritone, will be heard at this time.
Broadcast over KGW, KGO and KPO.

THURSDAY, OCTOBER 11

7:00 p. m.—Carrie Jacobs Bond, composer, will be presented to radio auditors during the Los Angeles studio program, "I Love You Truly" and "A Perfect Day" will be featured.
Broadcast over KFI (7:00 to 8:00) and KGW (7:00 to 7:30).
8:30 p. m.—Four vocalists and the National Concert Orchestra will participate in the Grand Opera Album program.
Broadcast over KHQ, KGW and KGO.
9:30 p. m.—"Good to the last note," the Maxwell House Coffee concert will be heard at this time. Irving Kennedy, tenor, is the soloist.
Broadcast over KHQ, KOMO, KGW, KGO, KPO and KFI.

FRIDAY, OCTOBER 12

5:35 p. m.—Play Park is the destination of Da-Ra-O and his friends in this trip to the Land of Health.
Broadcast over KHQ, KOMO, KGW and KGO.
5:00 p. m.—Wrisley Transcontinental Program direct from New York will regale listeners with the famous Wrisley reviews.
Broadcast over KHQ, KOMO, KGW, KGO, KFI.
8:30 p. m.—"Danse Macabre" will be played by four pianists during the General Independent Program.
Broadcast over KHQ, KOMO, KGW, KGO, KPO and KFI.
9:30 p. m.—Moon Magic creates an atmosphere of ethereal delight by the delicate and fantastic music which is presented in the period.
Broadcast over KHQ, KOMO, KGW and KGO.

SATURDAY, OCTOBER 13

7:00 p. m.—Dance music played by a 35-piece orchestra at New York will be broadcast through the NBC System during the Lucky Strike Hour.
Broadcast over KHQ, KOMO, KGW, KGO, KPO and KFI.
8:00 p. m.—Phil Cole will again act as master of ceremonies at the New Philco Theater, where a vaudeville program introducing many famous stars of the vaudeville stage will be broadcast.
Broadcast over KHQ, KOMO, KGW, KGO, KPO and KFI.
9:00 p. m.—"Hansel and Gretel," the Grimm fairy tale, is the dramatized "Golden Legend" to be heard at this time. Ted Maxwell makes the dramatization and directs the production and is responsible for the embellishment of the original simple tale.
Broadcast over KHQ, KOMO, KGW, KGO, KPO.
10:00 p. m.—Professor Herman Schnitzel will act as the master of ceremonies in the Big Show program. The usual NBC talent will perform.
Broadcast over KHQ, KGW, KGO, KPO (10:00 to 12:00) and KOMO (10:00 to 11:00).

Golden Bear AIR COLUMN **SPEAKER** 12 Sizes — WE. 2712 1929 Los Angeles St., L. A.



A · C · TUBES

The popularity of CeCo A.C. Tubes has been gained by their outstanding performance in clarity, sensitivity, and absence of A.C. hum, and—of prime importance—maximum operating life.

The CeCo line of A.C. Tubes embraces every existing type.

*Write for a copy of our booklet, "Getting the Most Out of Your Radio."
CeCo Tubes are for sale by best dealers everywhere.*

Factory Representatives:

B. KRUGER & CO.

500 N. Huntley Drive, West Hollywood

Phone OXford 3897

City Office and Showroom

608 Allied Crafts Building

407 E. Pico St., Los Angeles

The essential features of these programs are identical with those sent by the stations.



ROBERT HURD

KFI

Los Angeles, Calif.—640 Kc.

5000 WATTS—468.3 METERS
Radio Central Super-Station of Earl C. Anthony, Inc.
1400 S. Hope. Phone WE. 0331. After 5 P. M., WE. 0337

DAILY EXCEPT SUNDAY

- 8:00 a. m.—Shell Happy Time from KPO
- 9:00 a. m.—Sylvia's Happy Hour (except Monday, Wednesday and Friday).
- 12:00 noon—U. C. and U. S. Dept. of Agriculture Talks.
- 12:15 p. m.—Federal and State Market Reports.
- 1:00 p. m.—Talk on Traffic Violations (except Monday).
- 3:00 p. m.—Big Brother Ken (except Saturday).
- 10:00 p. m.—N. B. C. Dance Music (except Monday and Saturday).

- 4:30 p. m.—Harmony Trio.
- 5:30 p. m.—Nelle Callender Mills, violinist.
- 5:30 p. m.—Dr. Percy Wise Clarkson
- 6:00 p. m.—Gene Johnston's Music Box.
- 7:00 p. m.—Henry Starr, the Hot Spot of Radio.
- 7:30 p. m.—NBC—Democratic Political Program.
- 8:00 p. m.—NBC—Yellow Cab Co. program.
- 8:30 p. m.—NBC—Laugh with Isma.
- 9:00 p. m.—NBC—Associated Oil Co.
- 9:30 p. m.—KFI Symphonette.

THURSDAY, OCTOBER 11

- 9:00 a. m.—Musical program by Sylvia.
- 11:30 a. m.—Georgia O. George.
- 12:30 p. m.—Kenny and Ray; Sunny Three.
- 1:05 p. m.—Chas. Henri, piano and song.
- 1:15 p. m.—Miss Irene Kellogg talk, "Why Breathe."
- 1:30 p. m.—Elizabeth Cooper.
- 2:00 p. m.—Elsie Hammond and her banjo.
- 2:30 p. m.—Jean Talbot, piano and song.
- 2:45 p. m.—"American Motion Pictures in Europe."
- 3:00 p. m.—Alma and Adele Howell.
- 3:30 p. m.—Betty Thompson, contralto and pianist.
- 4:00 p. m.—Idell Harry Moyce and Hazel Dean Shively
- 4:30 p. m.—Arthur Belleville McCoid.
- 4:45 p. m.—Dr. H. Edward Myers.
- 5:30 p. m.—Griffith Jones, attorney.
- 5:50 p. m.—Federal Business Association.
- 6:00 p. m.—Republican Political Program—NBC.
- 6:30 p. m.—Red Wyatt and his uke.
- 7:00 p. m.—NBC—Los Angeles Studio program. Carole Jacobs Bond, Paul Roberts, Jean Egloff, Percoll Mayer and Margaret Kintz Duncan.
- 8:00 p. m.—Packard Concert Orchestra, Pryor Moore.
- 9:00 p. m.—KFI Symphonette.
- 9:30 p. m.—NBC—Maxwell House program.

FRIDAY, OCTOBER 12

- 10:00 a. m.—Betty Crocker Gold Medal talk.
- 10:30 a. m.—NBC—Woman's Magazine of the Air.
- 11:00 a. m.—Antonette Bush, violinist.
- 11:15 a. m.—Dr. Paul J. Dorosh, diet specialist.
- 12:25 p. m.—Franklin L. Graves talk.
- 12:45 p. m.—Alma Pratt Kohl, pianist.
- 2:00 p. m.—Rae Silverman and Esther Kahn.
- 2:30 p. m.—Wm. Don, English comedian.
- 3:00 p. m.—L. A. Fire Dept. Orch.; Dolly McDonald.
- 4:00 p. m.—Lee Fenton, baritone.
- 4:15 p. m.—Blanche Holmes, handwriting expert
- 4:30 p. m.—Betty Fallon in piano and song.
- 5:30 p. m.—Leon Reno's Kit Kat Club Orchestra.
- 6:00 p. m.—NBC—Wrigley program from New York.
- 7:00 p. m.—Pasadena Trio.
- 7:30 p. m.—NBC—Democratic Political Program.
- 8:30 p. m.—NBC—General Petroleum program.
- 9:30 p. m.—Cluderella and the Cross-eyed Bear.

SATURDAY, OCTOBER 13

- 9:00 a. m.—Musical program by Sylvia.
- 12:25 p. m.—Lonia F. Klein, harmonica player.
- 12:30 p. m.—Paris Inn Cafe Orchestra, E. E. Sheetz.
- 1:30 p. m.—Dicky Thomas, acc. by Berta Hill.
- 1:45 p. m.—Dr. Jain.
- 2:15 p. m.—Southern California vs. St. Mary's College football game, sponsored by Associated Oil Co.
- 3:00 p. m.—Dr. Walter W. Strong.
- 5:20 p. m.—Twrie Brothers, the Banjo Boys;
- 6:00 p. m.—Variety hall hour.
- 6:30 p. m.—Jeanette Rockwood Long, violin recital.
- 7:00 p. m.—NBC—American Tobacco Co.
- 8:00 p. m.—NBC—Philadelphia Storage Battery Co.
- 9:00 p. m.—KFI Symphonette.
- 10:00 p. m.—Packard Concert Orchestra.
- 11:00 p. m.—KFI Midnight Frolic.

- SUNDAY, OCTOBER 7**
- 10:00 a. m.—Morning services by L. A. Church Fed.
 - 11:00 a. m.—Third Church of Christ, Scientist.
 - 1:00 p. m.—Margaret Ruth Kernan, Marcus Markson.
 - 1:30 p. m.—NBC—Peerless Reproducers program.
 - 2:00 p. m.—Rocky Bernard, tenor; Jean Seacrest.
 - 2:30 p. m.—Bethel Temple Young People.
 - 3:00 p. m.—NBC, Musical program.
 - 4:30 p. m.—NBC, Biblical stories.
 - 5:00 p. m.—Alma and Adele Howell.
 - 5:30 p. m.—Walter Brown Murray, "Happiness."
 - 6:00 p. m.—Phyllis Campbell.
 - 6:15 p. m.—Wardner Wells, Economic talks.
 - 6:30 p. m.—NBC, Standard Oil Co.
 - 7:30 p. m.—NBC, Whittall Anglo Persians.
 - 8:00 p. m.—Packard Concert Orchestra; Pryor Moore.
 - 9:00 p. m.—NBC, Atwater Kent Co.
 - 9:30 p. m.—Norma Byington, soprano; Eleanor Ross.
 - 10:00 p. m.—Packard Six Dance Orchestra; Jean Dunn.

MONDAY, OCTOBER 8

- 1:05 p. m.—Det. Bretow, tenor; Noreen Ganille.
- 1:30 p. m.—Angies of the Air.
- 2:00 p. m.—Wilfred Butterworth, English tenor.
- 2:30 p. m.—Florence Norris, Astrologist.
- 3:00 p. m.—J. A. Fire Dept. Orch.; Dolly McDonald.
- 4:00 p. m.—Acolian Organ recital, Alex. Reilly.
- 5:30 p. m.—Senator George W. Cartwright.
- 5:45 p. m.—Edward H. Rust, nurseryman.
- 6:00 p. m.—Companella Male Quartet.
- 7:00 p. m.—NBC, R. C. A. Hour.
- 8:00 p. m.—NBC, Shell program.
- 9:00 p. m.—KFI Symphonette and Percoll Mayer.
- 10:00 p. m.—Night Cap Melodies, Packard Concert Or.

TUESDAY, OCTOBER 9

- 10:30 a. m.—NBC, Woman's Magazine of the Air.
- 11:30 a. m.—Georgia O. George.
- 12:25 p. m.—Doc Morris and his Uke; Sunny Three.
- 1:05 p. m.—Charles Henry, piano and song.
- 1:30 p. m.—Dr. Paul J. Dorosh, diet specialist.
- 1:45 p. m.—Aaron Gonzales, pianist.
- 2:15 p. m.—Garda Nord, soprano.
- 2:30 p. m.—Jack McGuire and Alice Stoddard.
- 3:00 p. m.—Marin Lohkar, contralto.
- 4:00 p. m.—Jeanette Warner, Katherine Lewis.
- 4:30 p. m.—Clarence Decker's Hawaiian Trio.
- 4:45 p. m.—Murel Knight, lessons in self-expression.
- 5:30 p. m.—Prof. Carl S. Knopf.
- 5:45 p. m.—Department of Commerce talk.
- 6:00 p. m.—La Mont Stetzer, baritone.
- 7:00 p. m.—Nick Harris, detective stories.
- 7:25 p. m.—Police Commissioner W. G. Thorpe.
- 7:45 p. m.—Bridge Lesson by June Snow.
- 8:00 p. m.—NBC—National Carbon Co. Eveready Hour.
- 8:30 p. m.—NBC—American Maltz Co.
- 9:00 p. m.—Packard Concert Orchestra, Pryor Moore.

WEDNESDAY, OCTOBER 10

- 10:00 a. m.—Betty Crocker Gold Medal talk.
- 11:00 a. m.—NBC—Woman's Magazine of the Air.
- 12:45 p. m.—A. A. Merry talks on current books.
- 2:00 p. m.—Chal Cathers, baritone; Lucile Ray
- 2:30 p. m.—Andy Lawless, tenor.
- 3:00 p. m.—Margaret Weatheringham and Coral Tilton, harmony duo.
- 3:30 p. m.—Miss Gunning, tenor; I. De Caluson Kaas.
- 4:00 p. m.—Neva Negus, bird warbler.

*See Page 56 for detailed program of National Broadcasting Company.

Copyright 1928 by Earle C. Anthony, Inc.

GILFILLAN

SALES & SERVICE — HEMPSTEAD 5590

139 N. Larchmont

Open Evenings

THE RICHEST TONE IN RADIO

Gilfillan Radio

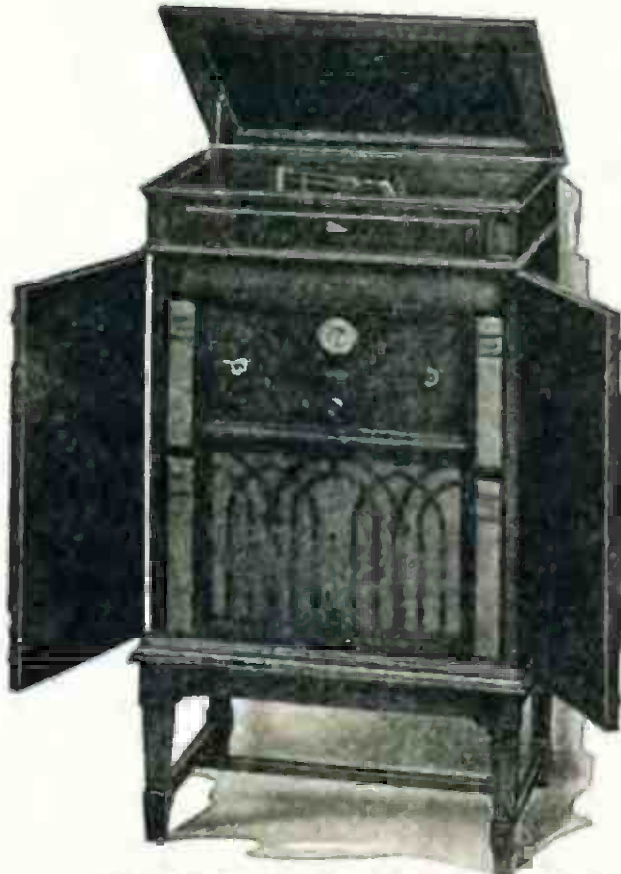

**The Finest
Music
Reproducing
Instrument
Ever Built!**

*Phono-Radio—7
tubes A-C operated
One Dial tuned.
C o m p l e t e l y
shielded. Push-pull
Amplification Elec-
tric Pick-up. Jensen
Dynamic Speaker—
the finest of every-
thing at a remark-
able price complete
with tubes, \$490.*

*Other models at
\$318 and \$388.*

Model 77 Combination Phonograph Radio

Has the widest range of rich, natural tone ever produced in radio. Simple turn of switch allows playing of records. You have never heard the equal of its brilliant, natural music. Built under license of RCA, Latour and Hazeltine patents and combining the best features of these with original ideas worked out in our laboratory. Here is the combination that the discriminating buyer has looked forward to.

**[Phone or write us for name of nearest Dealer where
you may hear and see this wonderful instrument.]**

**Gilfillan Bros. Inc., Los Angeles, San Francisco, Seattle
BUILT FOR WESTERN RECEPTION**

The essential features of these programs are identical with those sent by the stations.



E. K. BARNES

KHJ

Los Angeles, Calif.—750 Kc.

1000 WATTS—395.8 METERS

Don Lee Bldg., 7th and Bixel Sts. Owned and Operated by Don Lee, Calif. Dist. for Cadillac and LaSalle. Phone TR. 5411.

Glenn R. Dolberg
Night Time Director

E. K. BARNES
Daytime Director

Arthur Kay
Musical Director

C. M. C. Raymond
Commercial Director

Ernest G. Underwood
Technical Director

5:00 p. m.—Pacific States Savings & Loan Co. program
6:15 p. m.—Organ recital and vocalists.
8:00 p. m.—Sun Dodgers, with Charlie Wellman.
9:00 p. m.—Don Lee Symphony Orchestra.

TUESDAY, OCTOBER 9

9:00 a. m.—"The Meaning of the X Ray," by Dr. R. H. Swift.
11:00 a. m.—University of Southern California.
11:15 a. m.—Dr. Eugene Brown, talk on "Health."
11:15 p. m.—Celeste Ryus, concert pianiste.
12:45 p. m.—L. A. Adv. Club luncheon from Biltmore Hotel.
2:00 p. m.—U. S. G. Trojan Hour.
2:30 p. m.—Street and Highway Safety.
4:00 p. m.—Dr. Frank McCoy, health talk.
4:30 p. m.—Rabbi Edgar Magin's Hour.
7:00 p. m.—Overell Furniture Co. playlet, featuring Edward Murphy.
8:00 p. m.—Music Hour of Myrröhl.
9:00 p. m.—Dorado Club Silver Fizz Revelers, with Charlie Wellman.

WEDNESDAY, OCTOBER 10

11:00 a. m.—University of Southern California.
2:00 p. m.—Dr. Eugene Brown, Health talk.
2:30 p. m.—Los Angeles Public Library.
4:00 p. m.—Fred C. McNaab, Garden talk.
8:00 p. m.—Pacific States Savings & Loan Co. program.
9:00 p. m.—Elvis Ailman's Surprise Package.

THURSDAY, OCTOBER 11

11:00 a. m.—University of Southern California.
11:30 a. m.—Mother Spencer reads to the Veterans.
12:45 p. m.—Optimists' Club luncheon from Biltmore Hotel.
2:00 p. m.—Bureau of Public Safety, Los Angeles Police Department.
2:30 p. m.—Baron Keyes in "A Popular Song Review."
4:00 p. m.—Dr. Philip M. Lovell—"Care of the Body."
4:30 p. m.—"Uncle Jerry"—"Trip Through Funland."
7:00 p. m.—Inglewood Park Cemetery Ass'n.
8:00 p. m.—Ungar & Watson, Inc.

FRIDAY, OCTOBER 12

8:00 a. m.—Verdugo Woodlands Breakfast Club.
2:00 p. m.—U. S. G. Trojan Hour.
2:30 p. m.—Florence Dobinson, The Theater, Past, Present and Future.
4:00 p. m.—Los Angeles City Schools program.
4:30 p. m.—Council of International Relations.
7:00 p. m.—KHJ Concert Orchestra.
7:30 p. m.—Myrröhl Co. program.
8:00 p. m.—Continually program written by Van C. Newkirk.
9:00 p. m.—Dorado Club Silver Fizz Revelers with Charlie Wellman.
9:30 p. m.—Mexie Hour of Myrröhl.

SATURDAY, OCTOBER 13

8:00 to 12:00 noon—DARK.
2:30 p. m.—Football game from Univ. of So. Calif.
4:00 p. m.—Street and Highway Safety.
4:30 p. m.—L. A. City Playground Dept. program.
7:30 p. m.—Morrie Club, with Charlie Wellman.
8:00 p. m.—Robert Wildhack, The Radio Cartoonist.
9:00 p. m.—Cadillac-LaSalle Concert Orchestra.
12:00 midnight—The Marmakers, with Charlie Wellman.

DAILY EXCEPT SUNDAY

7:30 a. m.—Physical Culture Period by Dr. Philip M. Lovell.
8:00 a. m.—KHJ Early Birds (except Fri. and Sat.).
9:00 a. m.—Half hour of late recordings (ex. Saturday).
9:30 a. m.—"Have You Ever Heard?" (ex. Saturday).
10:00 a. m.—Agnes White—"At Our House" (ex. Saturday).
11:00 a. m.—Celeste Ryus, concert pianiste (ex. Saturday and Monday).
12:00 noon—Los Angeles Biltmore Hotel Concert Orchestra.
12:30 p. m.—World-Wide News, courtesy L. A. Times.
1:30 p. m.—Charlie Wellman's Request program.
3:00 p. m.—Matinee Melody Masters (except Monday).
4:00 p. m.—Lecture period.
5:30 p. m.—Story Man and His Air Castle (ex. Mon.).
6:30 p. m.—Don Lee Organ Recital (ex. Monday).
6:00 p. m.—Nightly Doings.
6:15 p. m.—Dinner music.
6:45 p. m.—World-Wide News, courtesy L. A. Times.
7:00 p. m.—Concert Orchestra and Soloists (ex. Tues.).
7:30 p. m.—Fyrol Half Hour of Happiness.
10:00 p. m.—Earl Burnett's Los Angeles Biltmore Hotel Concert Orchestra and Intermissions, through courtesy Ungar & Watson, Majestic Radio Dist.

SUNDAY, OCTOBER 7

9:30 a. m.—Late recordings.
10:30 a. m.—Morning services, First M. E. Church.
12:30 p. m.—Recordings.
6:00 p. m.—Nightly Doings.
6:45 p. m.—Evening Musicale, First M. E. Church.
6:45 p. m.—World-Wide News, courtesy L. A. Times.
7:00 p. m.—Evening services from First M. E. Church.
8:00 p. m.—Don Lee Symphony Orchestra.
9:00 p. m.—Cadillac-LaSalle Concert Orchestra.
10:30 p. m.—Vlanness Quintette.
11:00 p. m.—KHJ Dance Orchestra.

MONDAY, OCTOBER 8

11:00 a. m.—University of Southern California.
11:15 a. m.—Dr. Eugene Brown.
11:30 a. m.—"Old Man Opportunity."
2:00 p. m.—Elvis Ailman's Surprise Package.
3:00 p. m.—"Chain the Blues."
4:00 p. m.—George M. Lord, Western Air Express.
4:15 p. m.—M. D. Benesh, L. A. Co. Sheriff's Office.
4:30 p. m.—Marye Shannon Harrington, talk on "Problems of the Home."

MAJESTIC!

ATWATER-KENT

AXridge 1581

Service with a Smile
WATSON RADIO CO.

4411 S. Broadway

We are glad to send an additional supply of Applause Cards if you have run out.

WALTER BIDDICK — Phone WEstmore 9137
"A Complete Radio Program and Announcement Service"

BOSCH RADIO



Authorized Bosch Radio Dealers are now showing specially designed console illustrated, with its fine selected and patterned woods, rich carvings and beautiful finish, and are offering this console 28-A with Standard Bosch Radio Speaker and the Model 28 Bosch Receiver for \$220.00. Model 28-C, a similar



model with Dynamic Speaker, is \$260.00.

Bosch Radio Model 28—110 volt AC, Seven AC tubes and power tube. Single tuning, lighted dial. Solid mahogany cabinet. Price \$140.00. All prices are less tubes.

Authorized Bosch Radio Dealers are now showing the console Model 29B, specially designed for them with super-dynamic speaker and special high power speaker supply. Console has sliding doors, beautiful craftsmanship and selected woods. Bosch Radio Dealers are offering this console 29B with super-dynamic speaker and special high power speaker supply with Bosch Radio Model 28 Receiver for \$332.50.



Faithful reproduction is outstanding in the new Model 28 Bosch Radio Receiver—full toned, clear, great volume without distortion. See and hear Bosch before you buy.

From the dealer viewpoint Bosch Radio offers all that the public demands. Write for details.

AMERICAN BOSCH MAGNETO CORP.

Springfield, Mass. Branches: New York, Chicago, San Francisco, 1262-72 Post St.

Bosch Radio is licensed under patents and applications of R.C.A., R.F.L. and Lektophone

The essential features of these programs are identical with those sent by the stations.



NAYLOR ROGERS

KNX Hollywood, Calif.—890 Kc.

5000 Watts—337 Meters—Los Angeles Evening Express
Paramount-Lasky Studio, 5555 Marathon
"The Voice of Hollywood"

Phone HEMPstead 4101

Naylor Rogers
Manager and Program
Director

Glen Rice
Assistant Manager

N. D. Garver
Technical Engineer

9:00 p. m.—Calmon Luboviski, master violinist; Claire Mellonino, pianist, through the courtesy of the B. H. Dyas Company.

MONDAY, OCTOBER 8

11:00 a. m.—Georgia O. George courtesy program.
12:45 p. m.—Talk by Dr. A. Mackay Jordan.
7:00 p. m.—Carthay Circle Theatre courtesy program.
7:30 p. m.—One-act play directed by Georgia Field, through the courtesy of the Overell Furniture Co.
8:00 p. m.—Spiltdorf Radio courtesy program.
9:00 p. m.—Wurlitzer Music Co. courtesy program.

TUESDAY, OCTOBER 9

11:00 a. m.—French lessons by Edgard Leon.
2:30 p. m.—Beauty Talk, courtesy of Madam Marie.
4:15 p. m.—Riccardo, the psychic prince.
7:00 p. m.—Talk on popular Science by Dr. Mars Baume-
agrdt.
7:30 p. m.—Feature program.
8:00 p. m.—Hercules Gasoline Co., presenting "Tina and His Mule Hercules."
9:00 p. m.—Feature program.
9:45 p. m.—15 minutes with Gene Leonard, through the courtesy of the Gene Leonard Studios.

WEDNESDAY, OCTOBER 10

12:45 p. m.—Talk by Dr. A. Mackay Jordan.
2:30 p. m.—Talk on "Better Speech," by Mrs. David Hugh.
4:00 p. m.—Garden talk by Dewey R. Kruckeberg, through the courtesy of the Theodore Payne Nurseries.
6:00 p. m.—"Playgoers' Club, conducted by Wedgwood Nowell.
7:00 p. m.—Maytag courtesy program.
7:30 p. m.—Feature program.
8:00 p. m.—Brown Israel Co., presenting Bert Bulterworth and his Airdales.

THURSDAY, OCTOBER 11

11:00 a. m.—French lessons by Edgard Leon.
2:30 p. m.—Paul Higson.
4:00 p. m.—Louise Johnson, reading horoscopes.
7:00 p. m.—Feature program.
8:00 p. m.—Calmon Luboviski, master violinist; Claire Mellonino, pianist; through the courtesy of the Fitzgerald Music Co.
9:00 p. m.—Feature.

FRIDAY, OCTOBER 12

2:30 p. m.—L. A. Dist. Federation of Women's Clubs.
4:30 p. m.—Riccardo, the psychic prince.
7:00 p. m.—Feature program.
7:30 p. m.—New York Hat Store courtesy program.
8:00 p. m.—Royal Order of Optimistic Do-Nuts, through the courtesy of the Davis Perfection Bread Co.
9:00 p. m.—Gillmore Oil Co., presenting the Lion Tamers program.
9:45 p. m.—Broadcasting the main event from the Hollywood Legion Stadium, through the courtesy of Dan Parker, the Tailor.

SATURDAY, OCTOBER 13

6:00 p. m.—"Playgoers' Club, conducted by Wedgwood Nowell.
7:00 p. m.—Feature program.
8:00 p. m.—Announcement of services of L. A. churches.
8:05 p. m.—Feature program.
9:00 p. m.—Mr. and Mrs. Radio Skit.
9:30 p. m.—Feature program.
1:00 a. m.—The Midnight Express.

DAILY EXCEPT SUNDAY

6:45 a. m.—"Earlybirds," exercises given by Dr. P. M. Seixas.
7:15 a. m.—"Pep and Vigor," exercises given by Dr. P. M. Seixas.
7:45 a. m.—"Home Folks," exercises given by Dr. P. M. Seixas.
8:00 a. m.—Inspirational talk and morning prayer.
8:55 a. m.—Time signals from Washington, D. C., followed by birthday notices.
9:00 a. m.—Radio Shopping News, conducted by C. P. R.
10:00 a. m.—Town Crier of the Day's morning message.
10:30 a. m.—Kate Brev Vaughn, director of Household Economics Department of the Evening Express (ex. Fri. and Sat.).
12:00 noon.—Longines Time Signals thru the courtesy of the Geo. D. Davidson Company.
12:00 noon.—Musical program.
12:30 p. m.—W. F. Alder, travelogue.
1:30 p. m.—The Bookworm.
2:00 p. m.—Program given thru the courtesy of the L. A. Evening Express Classified Advertising Dept.
2:30 p. m.—Musical program.
3:00 p. m.—C. P. R.'s musical program.
4:15 p. m.—Lost and Found Announcements.
4:25 p. m.—Stock market reports.
4:45 p. m.—"Own Your Own Home," by Chet Mit-tendorf.
5:45 p. m.—Town Crier's Timely Amusement Tips.
6:00 p. m.—Dinner program presenting the KNX String Quintet under direction of Paul Finstein.
6:30 p. m.—J. B. Ransom Corporation presenting C. Sharpe-Minor at the organ from the Hotel Amb-
assador Auditorium.
7:00 p. m. and 10:00 p. m.—Longines Time Signals, courtesy of Geo. D. Davidson Co.
10:00 p. m.—Hotel Ambassador; Gus Arnheim's Coconut Grove Orchestra (ex. Fri.).
12:00 midnight.—Frank Sebastian's Cotton Club Cafe, through courtesy of Dorado Club Silver Fizz.

SUNDAY, OCTOBER 7

9:00 a. m.—Musical program by Chet Mit-tendorf.
10:00 a. m.—First Presbyterian Church of Hollywood.
1:00 p. m.—International Bible Students' Association.
2:00 p. m.—City Park Board, musical program.
5:15 p. m.—All Souls Church; Dr. Charles Aked.
6:00 p. m.—Talk by Ernest Holmes, through the cour-
tesy of the Institute of Religious Science and Phil-
osophy.
6:30 p. m.—First Unitarian Church.
7:00 p. m.—First Presbyterian Church of Hollywood;
Rev. Stewart P. MacLennan, pastor.
8:00 p. m.—Josef Rosenfeld's Concert Orchestra, from
the Ambassador Hotel.

WALTER BIDDICK — Phone WEStmore 9137
"A Complete Radio Program and Announcement Service"

ATWATER KENT
IN HOLLYWOOD
Expert Radio Service



Call GR 4876

HOLLY-ANGELES
MUSIC CO.

6611-HOLLYWOOD BLVD.

Over 900,000 Balkite Chargers Need This Authorized Replacement Rectifier



(A)
Type *LINK* for
Models N and
K Balkite Trickle
Chargers.

(B)
Type *BJ* for
Model J Balkite
Charger.

ELKON *the only authorized* Replacement Unit for Balkite Chargers

The Elkon Replacement Units and those made by the Fansteel Products Co. containing the Elkon Dry Rectifier are the only ones authorized for replacing the acid jars in Balkite Power Units.

No trouble in making the change—anyone can do it. And the difference! No fussing and messing with water and dangerous acids, with the Elkon Rectifier in place all trouble, attention and adjustment is eliminated for 5000 hours!

Increased efficiency, too. With the Elkon Replacement Units, the charging rate of Model K is increased from 4/10 of an ampere to 8/10; The Model N is increased from 8/10 to 1 ampere; and all of the charging rates of the Model J are increased 20%!

Solid, dry, self-healing, not affected by line surges, noiseless—truly the trouble-free rectifier.

ELKON, INC.

PORT CHESTER, N. Y.

Division of

P. R. MALLORY & CO., Inc.

ASK ABOUT THE OTHER ELKON RECTIFIERS, TOO

M-16 for "A" Eliminators and 3 ampere chargers, V-4 for trickle chargers—and this new EBH for replacing BH tubes in "B" Eliminators.



see a telephone switchboard—operators testing Elkon rectifiers and the seasoning boards in the background.

Radio Department, **ELKON, Inc.**
308 Fox Island Rd., Port Chester, N. Y.
Send me full information on Elkon
Radio Products
Name.....
Address.....

The essential features of these programs are identical with those sent by the stations.



GERALD G. STALEY

KMTR

Gerald G. Staley
Business Manager
Dean Metcalf
Publicity
Forbes van Why
Chief Engineer
Loren Powell
Program and Musical
Director

Chief Announcer

Hollywood, Calif.—580 Kc.

500 WATTS—515.9 METERS
KMTR RADIO STATION, 1028 N. Highland Ave. HOLLY 3026
The Official Broadcasting Station of the
Los Angeles Evening Herald.

TUESDAY, OCTOBER 9

- 10:00 a. m.—Georgia O. George courtesy program.
10:30 a. m.—Electrola recordings.
11:00 a. m.—Talk on "Intimate Impressions of Famous Stage Folk," by Marchal Millholland.
1:30 p. m.—Los Angeles Police Quartette.
7:15 p. m.—Golf Talk by Eddy Nunn, Golf Pro. of the Whitley Park Country Club.
9:00 p. m.—Light Operatic program featuring Loren Powell's Little Symphony and Eva Oldvott, light opera prima donna.
9:00 p. m.—F. J. Frederick courtesy program.

WEDNESDAY, OCTOBER 10

- 1:30 p. m.—Garden talk by Opal Scarborough through the courtesy of Germann's Seed and Plant Company.
3:15 p. m.—Hollywood Chamber of Commerce program.
3:45 p. m.—Talk on "Numerology," by Madame Effie.
4:00 p. m.—Carthay Circle Theatre program.
6:00 p. m.—Overell's Dinner-Hour Concert Orchestra, courtesy of Overell's Furniture Company.
7:15 p. m.—The Little Ant Man and Howard Clark, pianist and vocalist.
8:00 p. m.—Southern California Edison Company courtesy program, featuring their Symphonic Orchestra and assisting artists.
9:00 p. m.—Courtesy program.

THURSDAY, OCTOBER 11

- 10:45 a. m.—Dr. Paul J. Dorosh, "Diet Question Box."
1:30 p. m.—Louise Howatt, the "KMTR Happiness Girl."
7:15 p. m.—Department of Commerce talk by James H. Smalley.
7:30 p. m.—Pur-Pull Gasoline courtesy program.
8:00 p. m.—Loren Powell's Little Symphony and assisting artists.
9:00 p. m.—North American Building and Loan Association courtesy program.

FRIDAY, OCTOBER 12

- 11:00 a. m.—"Road Map of Life," by Florence Eve Hardy.
1:30 p. m.—Parke and Melford Serozen courtesy program.
4:15 p. m.—Talk on "Psycho-Analysis," by Walter Brown Murray.
7:30 p. m.—John Wright, the Right Tailor, courtesy program.
8:00 p. m.—Loren Powell's Little Symphony and assisting artists.
9:00 p. m.—F. J. Frederick courtesy program, presenting Henry Starr and his trio.

SATURDAY, OCTOBER 13

- 11:00 a. m.—Edward Lynn's Kiddies' hour.
2:30 p. m.—Broadcasting the football game.
7:15 p. m.—The Little Ant Man and Howard Clark, pianist and vocalist.
7:30 p. m.—Courtesy program.
8:00 p. m.—KMTR Melody Makers.
9:00 p. m.—Musical program.
10:00 p. m.—Maurice Menze's Dance Band from the El Patio Ballroom.

DAILY EXCEPT SUNDAY

- 7:00 a. m.—Louise Howatt's Happiness Hour.
8:00 a. m.—The New Idea Man's Wholesome Food Breakfast Club.
8:57 a. m.—Time signals from Washington, D. C.
9:00 a. m.—Mildred Kitchen of the Household Economics Department of the Evening Herald.
9:15 a. m.—KMTR Radio Press Agent Hour, featuring short business announcements and musical bulletins.
12:15 p. m.—Evening Herald news bulletins.
2:00 p. m.—KMTR Spanish Hour, announced by Senorita Luisa Lujan.
3:00 p. m.—L. Eddie Adams' Concert Hour (ex. Saturday).
4:30 p. m.—Optimist Dollars and Sense Hour.
5:00 p. m.—Shopping and musical program.
5:45 p. m.—Timely Topics, featuring amusement and cafe announcements.
6:00 p. m.—Dinner Hour program.
7:00 p. m.—Evening Herald news bulletins.
10:00 p. m.—George Redman's Roof Garden, Curley Hardwell's Orchestra.
11:00 p. m.—Maurice Menze's Dance Band from the El Patio Ballroom; correct time hourly through the courtesy of Muller Bros.

SUNDAY, OCTOBER 7

- 8:00 a. m.—The New Idea Man's Wholesome Food Breakfast Club.
9:00 a. m.—Electrola recordings, courtesy John Wright, the Right Tailor.
7:00 p. m.—Musical program featuring the KMTR Melody Ensemble.
8:00 p. m.—KMTR feature program, presenting Loren Powell's Little Symphony and assisting artists.

MONDAY, OCTOBER 8

- 10:45 a. m.—"Something About You," by Florence Eve Hardy.
1:30 p. m.—Parke and Melford, Serozen courtesy program.
6:30 p. m.—Howard H. Jones, Coach of the U. S. C. Football Team.
7:30 p. m.—Pur-Pull Gasoline courtesy program.
8:00 p. m.—Loren Powell's Little Symphony and assisting artists.
9:00 p. m.—Wurlitzer Music Company courtesy program re-broadcast.



EDMUND LYTTON

KEJK

Jean Campbell Macmillan
Literary Director
Edmund Lytton
Studio and Program
Director
Kenneth G. Ormiston,
Technical Director
Charles Rush
Transmission Engineer

Beverly Hills, Cal.—1190 Kc.

500 WATTS—252 METERS
Operated by Macmillan Petroleum Co.
Home Beautiful Exhibit Bldg.

- 7:00 p. m.—Book and Nook Period (except Friday).
9:00 p. m.—Dance program.

MONDAY, OCTOBER 8

- 7:30 p. m.—Red Seal Artists.
8:00 p. m.—Joseph Diskay, tenor; Helen Fraser Macmillan, soprano; KEJK Trio.

THURSDAY, OCTOBER 11

- 7:30 p. m.—Red Seal Artists.
8:00 p. m.—Crockett Mountaineers, songs and music from pioneer days; June Purcell, popular songs; William MacDonald, Scotch monologist.
9:30 p. m.—Request program.

FRIDAY, OCTOBER 12

- 7:00 p. m.—Opera reading.
8:00 p. m.—Santa Monica Glee Club; Helen Fraser, Macmillan, soprano; Kioff Harp Trio.
9:30 p. m.—Request program.

DAILY EXCEPT SUNDAY, WEDNESDAY AND SATURDAY

- 6:00 p. m.—Organ recital.
6:30 p. m.—Red Seal Artists (except Tuesday).

MORE POWER

BETTER TONE

and

LONGER LIFE

with the

SONATRON

171AC

NOW YOU can get improved results from your AC Set! Sonatron has created the 171 AC especially for the power tube socket in AC receivers—and the result is longer life, far greater volume and correspondingly improved tone. No re-wiring—simply take out the old 171 or 171A and put in the Sonatron 171 AC. Already thousands of these tubes are delivering amazing results throughout the country.

SONATRON TUBE COMPANY
CHICAGO NEW YORK



*— offered
only
by
Sonatron!*

SONATRON

THE WORLD'S LARGEST RADIO TUBE LINE

Wholesale Distributors: LISTENWALTER & GOUGH, Inc.
325 Fifth Street, San Francisco 819 E. First Street, Los Angeles

The essential features of these programs are identical with those sent by the stations.



GERALD KING

KFWB

Phone GL. 9481

Gerald L. King
Manager

Wm. Ray
Assistant Manager
Florence Israel
Program Arranger
Lottie Hewitt
Chief Technician

DAILY EXCEPT SUNDAY

- 7:30 a. m.—Jack Rinsonson's Sunshine Melody Boys.
9:30 a. m.—Characteristic Hour (except Wednesdays).
10:30 a. m.—Spanish program.
11:30 a. m.—KFWB Shopping Directory.
12:30 p. m.—Courtesy program (except Wednesday).
1:00 p. m.—Air Journal.
1:40 p. m.—Home Service program.
2:15 p. m.—Pacific Coast League baseball (ex. Mon.).
4:00 p. m.—Travel Tales.
4:45 p. m.—Radio Review.
5:45 p. m.—Town Tattler.
6:00 p. m.—KFWB Concert Quintet.
6:30 p. m.—Harry Jackson and entertainers from Fig's Whistle, Hollywood.
7:00 p. m.—Kolster Orchestra, courtesy John G. Rapp Corp., Kolster Radio Dist.
7:30 p. m.—Daily News (except Saturday).
8:00 p. m.—Time Signal, courtesy of New Haven Clock Co.
10:00 p. m.—Ray Fox Orchestra and Xavier Cugat and his Argentine Tango Orchestra from Montmartre.
11:00 p. m.—Timely Topics (except Tuesday).
Signs off at 11:30 (except Tuesday).
- SUNDAY, OCTOBER 7**
- 10:0 a. m.—Musical Program by courtesy of Dan Parker Tailor.
8:00 p. m.—Burr McIntoch, "The Cheerful Philosopher."
8:30 p. m.—Harry Jackson and his entertainers from Fig's Whistle, Hollywood.
7:00 p. m.—Xavier Cugat and his Argentine Tango Orchestra from the Montmartre Cafe.
7:30 p. m.—Program by courtesy of Lloyd K. Hillman.
7:50 p. m.—Daily News.
8:00 p. m.—Light Opera Hour by courtesy of the Overall Furniture Co., featuring Emma Kimmel, soprano; Charles Beauchamp, tenor, and Vincent Ponsati's Concert Orchestra.
9:00 p. m.—Program in honor of opening of Al Johnson's great Vitaphone production "THE SINGING FOOL," at Warner Bros. Hollywood Theatre.
11:00 p. m.—Time Timely Topics.
- MONDAY, OCTOBER 8**
- 11:00 a. m.—Housekeepers' Chat by Aunt Sammy of the U. S. Bureau of Home Economics.

Hollywood, Calif.—830 Kc.

1000 WATTS—361.2 METERS
WARNER BROS. MOTION PICTURE STUDIOS
Warner Brothers' Theater, 6425 Hollywood Boulevard

- 7:30 p. m.—The Screeners, courtesy Robt. S. Shrader.
7:50 p. m.—Jack Rinsonson's Sunshine Melody Boys.
8:00 p. m.—Program courtesy of Heine Van & Storage Co.
8:30 p. m.—Program courtesy of Warlick Music Co.

TUESDAY, OCTOBER 9

- 11:00 a. m.—Housekeepers' Chat by Aunt Sammy of the U. S. Bureau of Home Economics.
7:30 p. m.—Will Hardy, entertainer, by courtesy of Globe Ice Cream Co.
8:00 p. m.—Crosley Hour, presenting Crosley Revelers.
8:30 p. m.—Program by courtesy of Lloyd K. Hillman.
9:00 p. m.—Edgeworth Club program.
9:30 p. m.—Olympic Auditorium Boxing Bout.
10:30 p. m.—Ray Fox's Orchestra and Xavier Cugat and his Argentine Tango Orch. from Montmartre Cafe.
11:00 p. m.—Time Timely Topics.

WEDNESDAY, OCTOBER 10

- 8:00 a. m.—By remote control from Breakfast Club.
11:00 a. m.—Housekeepers' Chat by Aunt Sammy from the U. S. Bureau of Home Economics.
1:15 p. m.—Ray Fox's Orchestra by remote control from the Montmartre Cafe.
7:30 p. m.—L. A. Poles Quartet; traffic announcements.
8:00 p. m.—Xavier Cugat and his Orqueo; Carmen Costello, soprano; "Memories of Early California." Courtesy of Desmond's.
9:00 p. m.—Thos. Beauchamp, tenor, and Concert Orchestra.

THURSDAY, OCTOBER 11

- 7:30 p. m.—Will Hardy, entertainer, by courtesy of Globe Ice Cream Co.
8:00 p. m.—Neo Flying Cloud program presenting the crew of the Flying Cloud.
8:30 p. m.—Program presented by courtesy of the Weaver-Jackson Co.
9:00 p. m.—Vernon Richard, tenor, and the Federal Radio Orchestra.

FRIDAY, OCTOBER 12

- 7:30 p. m.—Gene Leonard, "Wizard of the Irons."
8:00 p. m.—Program by courtesy of Mills Shoe Co.
8:30 p. m.—Xavier Cugat, famous Spanish violinist; Carmen Costello, soprano; Ernie Kemp, Concert pianist.
9:00 p. m.—Sleepy Time Hour.

SATURDAY, OCTOBER 13

- 10:00 a. m.—Eastern Football Game.
12:30 p. m.—Spanish program.
8:00 p. m.—KFWB String Quartet, courtesy of Vine Street Theater.
7:00 p. m.—Program in honor of the Illustrated Daily News.
8:00 p. m.—Mona Motor Girls; LeRoy Kullberg and Ann Grey in popular songs.
9:00 p. m.—Leon DeLack's Quartet; Vernon Richard, tenor.

KPSN

Pasadena, California—950 Kilocycles

THE PASADENA STAR-NEWS
315.6 METERS—1000 WATTS

DAILY EXCEPT SUNDAY

- 12:00 noon—Music Period.
12:15 p. m.—Star-News Mid-Day News of the World.
4:30 p. m.—Tux Concert.

- 8:00 p. m.—Latest World News and Review.
8:15 p. m.—Record program.

SUNDAY, OCTOBER 7

- 10:45 a. m.—Morning services from the Pasadena Presbyterian Church.

Have you ordered your 1928-29 Radio Doings Call Book?
See Page 5.

ALADDIN Will Check Your Set FREE

Day and Night Service — Skilled Technicians

Call Empire 9518

4514 West Adams Street

Los Angeles, Calif.



Leaders in Speaker Design

REMEMBER way back to the days of the "goose-neck" horn?—that's when Temple engineers began developments on what is today one of the most outstanding designs in loud speakers

—the true compensated exponential air column. This technical language means nothing to the average purchaser, but it does mean something to know that Temple Speakers are not the results of mere ideas, but of careful, conscientious research and development in reproducer principles which are right.

In the Model 15 Air Column model has been built all of the improvements and refinements which these years have developed—it has a tone quality, a response to all frequencies and a capacity for handling strong signals that stamps it a masterpiece of design and construction.

Model 20 is a new sensational development in loud speakers. Again the same painstaking and careful Temple engineering and manufacturing skill offers a product worthy of the Temple name. Here the open radiator consists of two sections instead of one, driven by the powerful Temple Double Action Unit, thus substantially increasing the volume and tonal range.

A staff of nine graduate engineers, headed by Prof. Paul G. Andrea, and an electro-acoustical laboratory second to none in the country, make these outstanding Temple speakers possible. That's why Temple Speakers sell by comparison with anything the market offers at any price. That's why the name "Temple" is accepted and recognized wherever radio is known.

TEMPLE, INC.

Leaders in Speaker Design

1925 S. Western Ave. Chicago, U. S. A.



Model 20
Temple Air Chrome Speaker \$29.

TEMPLE SPEAKERS

Southern California Distributors

Herbert H. Horn Co.

C. C. Lawton Co.

National Radio & Supply Co.

Yale Radio Electric Co.



The essential features of these programs are identical with those sent by the stations.



MAEBELLE LESLIE

KPLA Los Angeles, Calif.—1040 Kc.

500 WATTS—288.3 METERS
Commercial Exchange Building, Eighth and Olive Streets
Official Station of the Los Angeles Examiner
Los Angeles, California

288.3 METERS—500 WATTS—1040 KILOCYCLES
1315 Commercial Exchange Bldg.
8th and Olive Streets

Phone TRInity 3202
A. MacDonald
Manager
Harry McCoy, Program
Mgr. and Night Announcer
Billy Barron
Director of Popular
Orchestra
Maebelle Leslie
Director of Concert
Orchestra
G. M. Sprague
Director of Transmutation
Omni Station of The Los
Angeles Examiner

8:00 p. m.—Royal Wallace and Doris Decker.
8:30 p. m.—Metropolitan Theater Revue.
9:00 p. m.—KPLA Concert Quintette with Emma Kimmel.

WEDNESDAY, OCTOBER 10

10:30 a. m.—Prudence Penny.
7:00 p. m.—Democratic National Committee news.
7:15 p. m.—Aretta and Little.
8:00 p. m.—KPLA Concert Quintette with Otto Floetz.
8:00 p. m.—Audrey Evans and her California String Quartette.
9:30 p. m.—Three Musketeers and Billy Barron.

THURSDAY, OCTOBER 11

10:30 a. m.—Clella Collins, business talks to women.
6:00 p. m.—Druggists Radio Association program.
7:00 p. m.—Democratic National Committee news.
7:15 p. m.—Premier String Quartette with Larry Hurd.
7:45 p. m.—Mahra the Great.
8:00 p. m.—KPLA Salon Orchestra with Harriett Larina.
9:00 p. m.—KPLA Dance Orchestra with Wint Cotton.

FRIDAY, OCTOBER 12

10:30 a. m.—Prudence Penny.
3:30 p. m.—Bureau of Public Safety Quartette.
6:00 p. m.—Druggists Radio Association program.
7:00 p. m.—Democratic National Committee news.
7:15 p. m.—Florentine Trio, semi-classics: Doris Decker and Katherine O'Neill.
8:00 p. m.—KPLA Concert Quintette with Hulda Dietz.
9:00 p. m.—Songs Pussers Revue, Novelty Fire.

SATURDAY, OCTOBER 13

10:30 a. m.—Clella Collins, business talks to women.
6:00 p. m.—Druggist Radio Association program.
7:00 p. m.—Democratic National Committee news.
7:15 p. m.—Frankie Callahan, Joan Weiborn, Katharine O'Neil and Royal Wallace.
8:00 p. m.—KPLA Quintette with Ralph Erwin.
9:00 p. m.—KPLA Dance Orchestra, diversities.

DAILY EXCEPT SUNDAY

7:30 a. m.—Recordings.
8:00 a. m.—Breakfast Frolic—request program.
11:00 a. m.—KPLA Diversities.
4:00 p. m.—Health talk, Miss Furman.
4:05 p. m.—Household, financial and shopping information.
6:00 p. m.—Druggists Radio Association program.
10:00 p. m.—George Eckhart's Cafe Lafayette Orchestra (except Saturday).

SUNDAY, OCTOBER 7

8:00 p. m.—KPLA Dance Orchestra with soloists.
MONDAY, OCTOBER 8
10:30 a. m.—Prudence Penny, courtesy of the Los Angeles Examiner.
11:00 a. m.—Diversities.
7:00 p. m.—Democratic National Committee news.
7:15 p. m.—Markie & Lawton, Melody Boys.
8:00 p. m.—KPLA Dance Orchestra with Leonard Van Itra.
9:00 p. m.—KPLA Salon Orchestra with Fred Leedom Scott.

TUESDAY, OCTOBER 9

10:00 a. m.—Clella Collins, business talks to women.
7:00 p. m.—Democratic National Committee news.
7:15 p. m.—Ex-Senator George Wilder Cartwright.
7:30 p. m.—Florentine Trio.



HARRY A. JAMES
Announcer

KELW

Phone Burbank 1192

Earl L. White, Owner

Harry A. James
Program Manager

Stuart F. Wainwright
Technical Engineer

Burbank, Calif.—1310 Kc.

MAGNOLIA PARK, 500 WATTS—228.9 METERS
"The White Spots of the San Fernando Valley"

9:00 p. m.—Rebroadcast Wurflitzer program.
10:00 p. m.—Leo Braun's Society Orchestra.

TUESDAY, OCTOBER 9

7:00 p. m.—Hollywood Duo; Frank Jocelyn, soloist.
8:00 p. m.—California String Quartet; Cliff Gunning, tenor; Lorraine Bergh, contralto.
9:00 p. m.—Ben Sears and wife, "Old Time Dancing"; Claude Burroughs, caller.

WEDNESDAY, OCTOBER 10

7:00 p. m.—Roy Tozer, baritone; Valley Instrumental Trio.
8:00 p. m.—California Banjo Boys; Cliff Gunning.
9:00 p. m.—Magnolia Park Trio; J. W. Brown, Jr.
10:00 p. m.—Featured Artists.

THURSDAY, OCTOBER 11

7:00 p. m.—Cyril Godwin, violin virtuoso; Florence May, concert pianist; Ira D. Morgan, baritone.
8:00 p. m.—Mission Quartet.
9:00 p. m.—Mission Trio and soloists.
10:00 p. m.—Novelty program.

FRIDAY, OCTOBER 12

7:00 p. m.—Harold Liberman Novelty Quartet; Ray Haddock, tenor.
8:00 p. m.—Neapolitan Trio; Otto Floetz, tenor.
9:00 p. m.—Walter Jutterly, baritone; Herbert Nennin, pianist; Ed Wise, concertina.
10:00 p. m.—Concert program.

SATURDAY, OCTOBER 13

7:00 p. m.—KELW Mixed Quartet.
8:00 p. m.—Kenney and Ray, duettists; Matt Lauder, Scotch comedian.
9:00 p. m.—California String Quartet; Jack Jenkins, crooning baritone; Eva Jenkins, whistler; Dorothy Earle, singing movie girl.
10:00 p. m.—Minstrels.

DAILY EXCEPT SUNDAY

7:00 a. m.—Louise Howatt's Happiness Hour, simultaneous broadcast with KNTR.
8:00 a. m.—New Idea Man's Wholesome Food Breakfast Club, simultaneous with KNTR.
10:00 a. m.—Audrey Evans, featuring Frank Jocelyn.
11:00 a. m.—World News and Panatrops.
5:00 p. m.—Itics and Ray Hour.
6:00 p. m.—California String Quartet.

SUNDAY, OCTOBER 7

10:45 a. m.—First Baptist Church, Glendale, by remote control.
7:15 p. m.—First Baptist Church, Glendale, by remote control.

MONDAY, OCTOBER 8

7:00 p. m.—Valry Sisters, duettists; Paul Kent, tenor; Ed Harold and Henrietta, novelty number.
8:00 p. m.—Artist Trio and Marie Gelder, contralto; Karola Landspach, accompanist.

Stations change in wavelength November 11th. You can find their position by using the 1928-9 Call Book. See Page 5.

RCA's Latest and Best

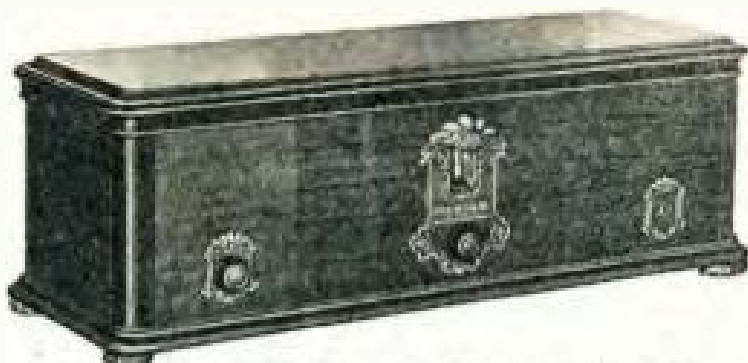

RCA Radiola 60 (without Radiotrons) \$175.00

THE RCA Super-Heterodyne, for five years the acknowledged leader in radio set design, has, in Radiola 60, been made a still finer instrument as a result of the continuous work of the two hundred engineers in the laboratories of RCA, General Electric

and Westinghouse. Not by virtue of its eight powerful AC Radiotrons alone, but also because of many new features in design, Radiola 60 outperforms other radio broadcast receivers with sensitivity, selectivity and tone fidelity that is amazing.

LOS ANGELES

Downtown

Barnes Music Co.
332 S. Broadway
TRinity 5223

Birkel Music Co.
446 S. Broadway
VAndike 1241

COLYEARS
507-511 So. Main St.
VAndike 1251.

Eastman Kodak Stores,
Inc.
510 S. Broadway
TRinity 0746

Martin Music Co.
734 S. Hill St.
TRinity 9621

Richardson's
730 West Seventh St.
TRinity 2303

Holland Electric Shop
5632 Pasadena Ave.
GARfield 3912

South

De Hoog Brothers
6120 S. Broadway
THornwall 0224

Southwest

C. & G. Electric &
Radio Company
1501 W. Santa Barbara
VERmont 5205

L. A. Duncan
2891 W. Pico St.
EMpire 1141

West Adams District

H. H. Walker
1323 Venice Blvd.
BEacon 1311

ALHAMBRA

Fred B. Gillenwater
Radio Studio
127 W. Main St.
Alhambra 2032

BELL

Baker Ave. Electric
4472 Baker Ave.
Phone DELaware 1871

PASADENA

Lee Radio Shop
922 E. Colorado St.
Wakefield 5951

Consult These Men, Too, for Expert Service on All Radiola Models

RCA Radiola

MADE BY THE MAKERS OF THE RADIOTRON

The essential features of these programs are identical with those sent by the stations.



DAVE WARD

KMIC

Inglewood, Calif.—1340 Kc.

250 WATTS—324 METERS
Chamber of Commerce Bldg., Inglewood, Calif.
Newspaper of the Air

Tel. TH. 1121
Owned and Operated by
James R. Fouch
Little Eddie Barnes
Studio Director and
Program Manager
Dave Ward
Announcer
"Doc" Harris
Asst. Announcer
A. F. Goldsborough
Technical Engineer
NEWS BULLETIN
HOURLY

- 7:30 p. m.—Cecilian Trio; John Dixon, baritone.
- 7:30 p. m.—Lainert Co. Orchestra.
- 7:45 p. m.—ATLY, S. B. Hahn.
- 8:00 p. m.—So. Calif. Music Co. presenting Marguerite LeGrande, pianist.
- 8:30 p. m.—Safeway Signal Orchestra.
- 9:00 p. m.—Frederick Finance program; re-broadcast of KMTR.

WEDNESDAY, OCTOBER 10

- 6:15 p. m.—Music Box Review.
- 6:45 p. m.—Cash Finance program.
- 7:00 p. m.—Carmel Kid Orchestra.
- 7:30 p. m.—Lainert Company Orchestra.
- 8:00 p. m.—May Co. program; re-broadcast KMTR.
- 9:00 p. m.—Professional tryouts.

THURSDAY, OCTOBER 11

- 6:30 p. m.—Music Box Review.
- 6:45 p. m.—Cash Finance program.
- 7:00 p. m.—N. E. Brown, radio technicalities.
- 7:15 p. m.—Westchester Market Orchestra.
- 7:30 p. m.—Safeway Signal Orchestra.
- 8:00 p. m.—Majestic Radio program; re-broadcast KHL

FRIDAY, OCTOBER 12

- 6:15 p. m.—Music Box Review.
- 6:45 p. m.—Westchester Market program.
- 7:00 p. m.—L. A. Police Quartet, with Sgt. Rosenbaker.
- 7:30 p. m.—Southern California Music Co. presenting Tom Derling, saxophone.
- 8:00 p. m.—Frederick's Finance Orchestra.
- 9:00 p. m.—Gilmore Oil program; re-broadcasting KNX.

SATURDAY, OCTOBER 13

- 6:15 p. m.—Music Box Review.
- 6:45 p. m.—Cash Finance program.
- 7:00 p. m.—Bergh Bros. Instrumental Trio.
- 7:15 p. m.—Judge Georgia Bullock.
- 7:30 p. m.—Safeway Signal Orchestra.
- 8:00 p. m.—Radio Section: Newspaper of the Air.

- DAILY EXCEPT SUNDAY**
- 8:00 a. m.—Breakfast Frolic with Little Eddie.
 - 9:30 a. m.—Cooking Hints by Mabel.
 - 12:30 noon—Dave Ward, the Office Boy.
 - 1:30 p. m.—KMIC Matinee Program.
 - 1:30 p. m.—Mabel of the Air.
 - 8:00 p. m.—Organ Recital—Marie Hocking, organist.

SUNDAY, OCTOBER 7

- 8:00 a. m.—Breakfast Frolic with Little Eddie.
- 9:30 p. m.—Rev. Henry Cox Culbertson, sermon.

MONDAY, OCTOBER 8

- 6:15 p. m.—Music Box Review.
- 6:45 p. m.—Cash Finance program.
- 7:00 p. m.—City of Inglewood program; Pastel Concert Trio.
- 8:00 p. m.—General Petroleum program; re-broadcast of KMTR.
- 9:00 p. m.—Wurlitzer program; re-broadcast of KMTR.

TUESDAY, OCTOBER 9

- 6:15 p. m.—Music Box review.
- 6:45 p. m.—Cash Finance program.



O. B. MILLS

KFWC

Pomona, Calif.—1210 Kc.

Phone 1147 347.8 METERS—100 WATTS
Elaborate Reynolds Studebaker Bldg.

Owned and Operated by
James R. Fouch
Oliver B. Mills
General Manager
E. L. Landsberg
Commercial Manager

- 8:00 p. m.—Old Reliable Orchestra, Jack Leighton, conductor.

TUESDAY, OCTOBER 9

- 7:00 p. m.—Dr. M. L. Weiner, Diet & Nerve Specialist.
- 7:15 p. m.—Studio novelties.
- 8:00 p. m.—Millard Owen, "One Man Band."
- 8:30 p. m.—Miss Baldwin, courtesy Brundage Acres, Ontario.

WEDNESDAY, OCTOBER 10

- 7:00 p. m.—Clover Kehoni and Frank Pierce, duets.
- 7:30 p. m.—Request program.
- 8:00 p. m.—L. & W. Service Corp. program.
- 8:30 p. m.—Carl Welfa, Ontario Shade & Linoleum Company.

THURSDAY, OCTOBER 11

- 7:00 p. m.—Old Reliable Orchestra, Jack Leighton, conductor.
- 7:30 p. m.—F. J. Trafton, educational talk to citrus growers.
- 7:45 p. m.—Lawrence Ipsen, bass baritone, and Miss Shewman.
- 8:00 p. m.—Margaretta Powers and Ted James, "Little Hills of Harmony."
- 8:30 p. m.—Harvey Studebaker, courtesy Monarch Metal Weather-strip Co.

FRIDAY, OCTOBER 12

- 7:00 p. m.—Miss Peggy DeLapp, concert soprano, and Miss Grace Swindt.
- 7:30 p. m.—Ralph Nye to popular ballads.
- 8:00 p. m.—De Fry's Old Time Orchestra.
- 8:30 p. m.—Popular request program.

- DAILY EXCEPT SUNDAY**
- 10:30 a. m.—Miss Baldwin, "KFWC Nightingale."
 - 11:00 a. m.—News Items (ex. Monday).
 - 11:45 a. m.—Merchants' Request program.
 - 6:00 p. m.—Merchants' Request Hour.
 - 8:45 p. m.—News Items, courtesy Los Angeles Record.

SUNDAY, OCTOBER 7

- 10:30 a. m.—First Christian Church, Pomona, Rev. Hutaler, pastor.
- 7:30 p. m.—First M. E. Church, Pomona, Rev. Reynolds, pastor.

MONDAY, OCTOBER 8

- 7:00 p. m.—Radio Picture Transmission.
- 7:30 p. m.—F. J. Trafton, educational talk to citrus growers.
- 7:45 p. m.—A. V. Storoz, Pomona Merchants Credit Association.

MAJESTIC RADIO

YOUR OLD SET TAKEN IN TRADE

BOB BROWN RADIO

Open Evenings
4353 S. Figueroa HLI. 2192

for just
a few cents more
The EVEREADY LAYERBILT



Now \$2.95 Eveready Layerbilt Medium Size "B" Battery No. 485, 45 cells. The longest-lasting Eveready of its size.



Now \$4.25 The original Layerbilt "B" Battery No. 486, 45 rolls. For heavy duty. The longest lasting of all Evereadys.

lasts weeks and months longer

To GET a genuine Eveready Layerbilt "B" Battery you need only pay a few cents more than you would for a cylindrical cell Eveready of the same size. The longer life built into the Eveready Layerbilt is worth much more to you than its cost. Every Eveready Layerbilt "B" Battery is built of flat cells, which occupy all available space within the battery case, avoid the waste spaces between the cylindrical cells in the older type of battery, and produce much more current.

That is why the Eveready Layerbilt lasts much longer than the cylindrical cell type of battery. The added life is far greater than you might suppose from the small extra cost.

There are two Eveready Layerbilts. One is the original No. 486, built for heavy duty, the longest lasting of all Evereadys and the most economical. It costs 25 cents more than a cylindrical cell Eveready of the same size. The other is the newer Medium Size Ever-

eady Layerbilt No. 485, which has the same dimensions as the cylindrical cell Eveready No. 772, but which lasts much longer, though costing only 20 cents more.

When you go to buy new "B" batteries, add just a few cents to what you would pay for a cylindrical cell Eveready, and get Eveready Layerbilts. They will bring you weeks and even months of extra "B" battery service.

NATIONAL CARBON COMPANY, INC.
New York  San Francisco

Unit of Union Carbide and Carbon Corporation

**Tuesday night is Eveready
Hour Night**

East of the Rockies
9 P. M. Eastern Standard Time
Through WEAJ and associated N. B. C. stations

On the Pacific Coast
8 P. M. Pacific Standard Time
Through N. B. C. Pacific Coast network

Layerbilt construction is a patented Eveready feature. Only Eveready makes Layerbilt Batteries.

The essential features of these programs are identical with those sent by the stations.



LARRY SNELL

KGFJ Los Angeles, Calif.—1410 Kc.

212.6 METERS—Washington Blvd. at Oak St.

"Keeping Good Folks Joyful Twenty-four Hours a Day"

Owned and Operated by
Ben S. McGlashan
Calvin J. Smith
General Manager
Duke Hancock
Assistant Manager
Thelma Kirchner
Program Director
Larry Snell
Announcer

Phones:
Westmore 7777
Westmore 7778

MONDAY, OCTOBER 8

12:00 noon—Rae Silverman, blues; Esther Kahn, pianist; Gene Perry, tenor.
2:00 p. m.—Studio program.
4:00 p. m.—Tryouts.
7:00 p. m.—Radiotising Twins.
10:30 p. m.—Hawaiian Trio; Scot Morrison, banjo and songs.

TUESDAY, OCTOBER 9

12 noon—Rae Silverman, blues; Esther Kahn, pianist; Gene Perry, tenor.
2:00 p. m.—Studio program.
4:00 p. m.—Bureau of Public Safety; L. A. Police Quartet.
7:00 p. m.—Radiotising Twins.
10:30 p. m.—Audrey Evans program; California String Quartet.
11:00 p. m.—Hawaiian Trio.

WEDNESDAY, OCTOBER 10

12:00 noon—Rae Silverman, blues; Esther Kahn, pianist; Gene Perry, tenor.
2:00 p. m.—Jesse Stafford and his Brunswick Recording Orchestra by remote control from Cinderella Roof Ballroom.
7:00 p. m.—Radiotising Twins.
12:00 midnight—Hawaiian Trio; Al Decker, uke and song.

THURSDAY, OCTOBER 11

12:00 noon—Rae Silverman, blues; Esther Kahn, pianist; Gene Perry, tenor.
2:00 p. m.—Studio program.
4:00 p. m.—Tavern Club Orchestra.
7:00 p. m.—Radiotising Twins.
10:30 p. m.—Hawaiian Trio; Veba Wood, blues.

FRIDAY, OCTOBER 12

12:00 noon—Rae Silverman, blues; Esther Kahn, pianist; Gene Perry, tenor.
2:00 p. m.—Studio program.
7:00 p. m.—Radiotising Twins.
10:30 p. m.—Hawaiian Trio; Charlie Cole, tenor; Rae Silverman, blues.

SATURDAY, OCTOBER 13

12:00 noon—Rae Silverman, blues; Esther Kahn, pianist; Gene Perry, tenor.
2:00 p. m.—Jesse Stafford and his Brunswick Recording Orchestra by remote control from Cinderella Roof Ballroom.
10:30 p. m.—Hawaiian Trio; Scotty Kirkpatrick and Stiles Sanford.
12:00 midnight—Saturday Nite Frolic.

DAILY EXCEPT SUNDAY

12:00 midnight—Nite Owl program.
7:00 a. m.—Breakfast program; Pastelle Concert Trio.
8:30 a. m.—Gordon Smith's Radiotising Service; Recordings.
9:30 a. m.—Popular recordings.
11:00 a. m.—Varied studio program.
12:00 noon—Your Favorite Request hour; Rae Silverman, blues singer; Esther Kahn, pianist; Gene Perry, tenor and uke.
1:00 p. m.—Semi-classical recordings.
4:30 p. m.—Studio program.
5:30 p. m.—Daily market reports.
6:00 p. m.—John Wright Orchestra.
7:00 p. m.—Gordon Smith's Radiotising Service; Radiotising Twins.
8:00 p. m.—Rae and Esther, blues.
8:30 p. m.—Jesse Stafford and his Brunswick Recording Orchestra by remote control from Cinderella Roof Ballroom.
10:30 p. m.—Music Box Hawaiian Trio.

SUNDAY, OCTOBER 7

12:00 midnight—Nite Owl program.
7:00 a. m.—Recordings.
10:00 a. m.—Southlanders Orchestra; Charlie Cole, tenor.
12:00 noon—Columbine Trio; Rocky Bernard, baritone.
1:30 p. m.—Hoot Gilman's Hawaiian Trio; Gladys Parrish, blues.
3:30 p. m.—S. A. Scherer Memory Contest; Esther Kahn, pianist.
4:00 p. m.—Sunday Afternoon Frolic.
5:00 p. m.—John Wright Orchestra.
7:00 p. m.—Recordings.



H. L. RUST

KGFH

H. L. Rust
General Manager

W. S. Brown
Sales Manager

Barret Cosby
Technician

DAILY EXCEPT SUNDAY

9:00 a. m.—Studio Program.
9:30 a. m.—Music.
10:00 a. m.—Shopping News, Records.
8:00 p. m.—News Items, Recordings.
MONDAY, OCTOBER 8
6:00 p. m.—Dinner music.
6:30 p. m.—Stockade Orchestra.
7:30 p. m.—Women's Christian Association; Eleanor Halpin, pianist; Catherine Halpin, violinist.
8:30 p. m.—Antonin's Dance Orchestra.
9:30 p. m.—Studio program.

TUESDAY, OCTOBER 9

11:30 a. m.—Pessy Korter, Prosperity.
11:45 p. m.—Music.

Glendale, Calif.—1140 Kc.

250 WATTS—263 METERS

Main Studio: Hotel Glendale, E. Broadway and Glendale Blvd.
Douglas 3326 Cor. E. Broadway and Glendale Blvd.

WEDNESDAY, OCTOBER 10

11:30 a. m.—Clifford A. Cole.
8:00 p. m.—Orchestra.
9:00 p. m.—Verdugo Serenaders; Monica Aloha, Mercedes Jordan, contralto; Juanita Thimm, soprano.

THURSDAY, OCTOBER 11

11:30 a. m.—Parliamentary Law Club.
11:45 a. m.—Parent-Teachers Talk.

FRIDAY, OCTOBER 12

11:30 a. m.—Dr. Juno K. Walton.
6:00 p. m.—Helen Branson, ballads; Florence Hatch, popular pianist.
6:30 p. m.—Bill Hatch's Hobo Orchestra.
7:30 p. m.—Hayzel Laxton, mezzo; Harry Marple, baritone; Glendale Harmony Trio.
8:30 p. m.—C. R. G. Hawaiians; Allen Dale, tenor; Alta Mae Paxton.
9:00 p. m.—Studio program.

SATURDAY, OCTOBER 13

6:00 p. m.—Major J. A. Smala, speaker.
6:15 p. m.—Curtis Orchestra.
7:00 p. m.—Alice Adams, pianist; Hazel Click and Billy Bookman, duets; Betty Cunningham, sec.
7:30 p. m.—Lola, psychologist.
8:00 p. m.—Theresa Lee, Mission soloist.
9:00 p. m.—Glendale Fire Department Orchestra.

Dealers—

We Are Now Making Deliveries on Our New

ALL ELECTRIC RADIO

A Set that is Filling a Long-felt Need in the *Low Price Field*, Constructed of *Only the Best* of Parts Throughout, Assuring You

“Maximum Satisfaction to the User with Minimum Servicing for the Dealer”

Just Glance at Some of the Outstanding Features of This Set!

Heavy Metal Chassis—Volume Control
Heavy Duty Power Pack—Special Rectifier Tube
Built-in Air Column Speaker
Heavy Duty Filter Condensers

Standard Parts Used Throughout and so Designed as to Permit Ready Access to All Parts

—◆—
Write, Phone or Call

POWELL MANUFACTURING CO.

LOS ANGELES

4009 South Western Ave.

Vermont 1619

The essential features of these programs are identical with those sent by the stations.



CLARENCE B. JUNEAU

KNRC

Frank N. Bull
Director
Wm. K. Sabransky
Musical Director
W. K. McCroery
Commercial Manager
Wm. Snyder
Technician
Doc Gray
Technician
Gerrie Middleton
Assistant Director

Santa Monica, Cal.—800 Kc.

500 WATTS—375 METERS
Municipal Auditorium, Ocean Park, Santa Monica, Calif.
Phone Santa Monica 63-101
Los Angeles Studio: Elks' Temple 95—Dunkirk 8154
Pickwick Broadcasting Corporation
Geo. H. Bowles, Vice Pres. and Genl. Mgr.
Clarence B. Juneau, Chief Transmission Engineer.

10:00 p. m.—Plantation Cafe Frolic; Henry Halstead's Victor Orchestra.

MONDAY, OCTOBER 8

8:20 p. m.—Berlita Method Spanish Lesson.
8:30 p. m.—Peggy Price, "Miss Pickwick."
7:00 p. m.—Glen Edmonds Air Theatre Play Boys; Rosalee Lane, blues singer; Jeanette Dace, pianist.
9:00 p. m.—Blu-Green Gas Boys; Hale Hooper, ballads; Loyce Whitman, blues.

TUESDAY, OCTOBER 9

8:20 p. m.—Ann Martin, Home Economics expert.
8:30 p. m.—Beverly Hills Male Quartet.
7:00 p. m.—Glen Edmonds Air Theatre Play Boys; Gladys Parish, blues singer; Polly Grant Hall, acc.
9:00 p. m.—Blu-Green Gas Boys; Hale Hooper, ballads; Loyce Whitman, blues singer supreme.

WEDNESDAY, OCTOBER 10

8:20 p. m.—Berlita Method Spanish Lesson.
8:30 p. m.—Studio Specialties.
7:00 p. m.—Glen Edmonds Air Theatre Play Boys; Peggy Price, "Miss Pickwick." Bill Sabransky, pianist.
9:00 p. m.—Blu-Green Gas Boys; Hale Hooper, ballads; Loyce Whitman, blues.

THURSDAY, OCTOBER 11

8:20 p. m.—Ann Martin, Home Economics expert.
8:30 p. m.—Peggy Price, "Miss Pickwick."
7:00 p. m.—Glen Edmonds Air Theatre Play Boys; Joe Bishop, guitar and songs.
9:00 p. m.—Blu-Green Gas Boys; Hale Hooper, ballads; Loyce Whitman, blues singer supreme.

FRIDAY, OCTOBER 12

8:20 p. m.—Berlita Method Spanish Lesson.
8:30 p. m.—Peggy Price, "Miss Pickwick."
7:00 p. m.—Glen Edmonds Air Theatre Play Boys; Vera Hamby, mezzo-contralto soloist.
9:00 p. m.—Blu-Green Gas Boys; Hale Hooper, ballads; Loyce Whitman, blues.

SATURDAY, OCTOBER 13

8:30 p. m.—Beverly Hills Male Quartet.
7:00 p. m.—Glen Edmonds Air Theatre Play Boys; Loyce Whitman, blues singer; Bill Sabransky, pianist.
9:00 p. m.—Blu-Green Gas Boys; Hale Hooper, ballads; Loyce Whitman, blues singer supreme.

DAILY EXCEPT SUNDAY
9:00 a. m.—KNRC Shopping Circle.
12:00 noon—Studio specialities.
1:00 p. m.—Shopping Review.
2:00 p. m.—Associated Press News from the Santa Monica Outlook.
2:30 p. m.—Santa Monica Municipal Band Concert (ex. Monday).
3:30 p. m.—Lois, the Mystic.
5:00 p. m.—Pickwick Pointers.
6:00 p. m.—Kiss' Mighty Organ.
7:00 p. m.—Glen Edmonds Air Theatre Play Boys and vocalists.
8:00 p. m.—Santa Monica Municipal Band Concert (except Monday).
9:00 p. m.—Gilmoro Oil Company program.
10:00 p. m.—Ralph Markey and his Musical Keys from Egyptian Ballroom.
11:00 p. m.—Plantation Cafe Frolic, featuring Henry Halstead's Brunswick Recording Orchestra and The Crusaders.

SUNDAY, OCTOBER 7

9:45 a. m.—International Bible Students' Association program.
10:45 a. m.—Pilgrim Lutheran Church Services.
2:30 p. m.—Santa Monica Municipal Band Concert (except Monday).
4:00 p. m.—Bible Questions and Answers.
4:30 p. m.—The Elks Mighty Organ Recital.
5:30 p. m.—Diaspora—IBSA program.
6:00 p. m.—Pilgrim Lutheran Church Services program.
7:00 p. m.—International Bible Students' Association.
8:00 p. m.—Santa Monica Municipal Band Concert.
9:00 p. m.—Jens Stafford's Brunswick Ballroom Orchestra from Egyptian.



BOB SWAN

KFQZ

Los Angeles, Calif.—1290 Kc.

232.4 METERS
1417 S. Figueroa St., Los Angeles, Calif. Westmore 3001.

Walter King, Gen. Mgr.
L. E. Taft, Studio Mgr.
Bob Swan, Announcer
Al Cajal, Studio Acc.
Monroe Manning,
Business Manager
Pearl Bestman
Program Director

10:00 p. m.—Orchestra; soloists.
11:00 p. m.—Old Time Song request.

MONDAY, OCTOBER 8

7:30 p. m.—Jeanette Warner; Harry Lamont; Ernest Jacobson.
8:30 p. m.—Ann Warren.
9:00 p. m.—Robert Stowe; Ralph Moore; Edith Isabel.

TUESDAY, OCTOBER 9

7:30 p. m.—Dick Wilson; Jim Crosby; Helen White.
8:30 p. m.—James Monte; Marie Gelder.
9:00 p. m.—Al Cajal request.

WEDNESDAY, OCTOBER 10

7:30 p. m.—Helen White; Silverstone Hawaiian Trio.
8:30 p. m.—Ann Warren.
9:00 p. m.—Hi Roxy and his Orchestra; Edlie Beale; Marshall Eiston.

THURSDAY, OCTOBER 11

7:30 p. m.—Jeanette Warner; Inez Ingram.
8:30 p. m.—Blaine Montgomery; Laura Redden.
9:00 p. m.—Novelty Syncopators; Oliver Pullerlin; Phyllis Craven.
10:00 p. m.—Auditions.

FRIDAY, OCTOBER 12

7:30 p. m.—Sammy Koren; Ethel Blecha.
8:30 p. m.—Dorothy Lewis; Mabel Springer.
9:00 p. m.—Lou Hinkel and Orchestra; Ralph Moore.

SATURDAY, OCTOBER 13

7:30 p. m.—Helen White; Inez Ingram.
8:30 p. m.—Al Cajal request program.
9:00 p. m.—Argo and Shriver; Margaret Thorpe.

DAILY EXCEPT SUNDAY
7:00 a. m.—Breakfast program.
10:00 a. m.—Panatropes and Shopping News.
12:00 noon—Studio program.
1:00 p. m.—Shopping News and Panatropes.
5:00 p. m.—Dinner program.
6:30 p. m.—Courtesy.
10:00 p. m.—Courtesy.
11:00 p. m.—Panatropes.

SUNDAY, OCTOBER 7
8:00 a. m.—Curry's program.
8:30 a. m.—Courtesy program.
12:00 noon—Panatropes request.
5:00 p. m.—Dinner program.
8:00 p. m.—Barrow's Majestic Hour.
7:00 p. m.—Harmony Trio; soloist.
8:00 p. m.—Dolly McDonald; Eddie Beale.
9:00 p. m.—Novelty Syncopators; soloist.

An Ideal Combination

Good Reception and RADIO DOINGS.

RADIO DOINGS is a weekly directory showing just what station to tune in for a favorite piece or program.

Concise and interesting topics covering the entire field of radio keep you posted weekly and furnish enjoyable recreational reading.

The progress of TELEVISION is covered thoroughly in the interesting non-technical style characteristic of our Technical Editor.

Short wave reception is given special attention each week. A code instruction class is now going on over W6YD under the auspices of RADIO DOINGS.

Accurate and up-to-date lists of stations with power, locations, wave lengths and other complete information is published in each edition.

This radio season promises more of interest and entertainment to you than ever before. Take full advantage of it with RADIO DOINGS to guide you!

SPECIAL OFFER

Use this coupon for your subscription order, and you will be sent a gold-imprinted leatherette binder. This attractive and durable gift is most useful in keeping pages of circuits, artist's photographs and other interesting features out of RADIO DOINGS.

**'THE PACIFIC COAST'S GREAT RADIO WEEKLY
DELIVERED TO YOUR HOME 52 WEEKS
FOR ONLY \$3.00
SAVE \$2.20**

RADIO DOINGS, 407 East Pico Street, Los Angeles, California:

I want the Binder. Enclosed is \$3.00. Please mail RADIO DOINGS each week for one year to my address.

Name.....

Address.....

The essential features of these programs are identical with those sent by the stations.

KFON Long Beach, Cal.—1240 Kc.

"Where Your Ship Comes In"
1000 WATTS—242 METERS—HANCOCK OIL STATION
Owned and Operated by NICHOLS & WARINNER, Inc.
220 E. Anaheim St.
CLARENCE GRARY, Announcer



CLARENCE GRARY
Announcer

DAILY EXCEPT SUNDAY

- 8:00a. m.—Tadpole Jones, The Buttercream Boy.
- 8:15 a. m.—Musical program.
- 9:00 a. m.—Novelty Music program.
- 9:30 a. m.—Organ Recital.
- 10:00 a. m.—"Shopping News"—Hugh A. Murti Co.
- 10:15 a. m.—"Devotional Period," except Saturday.
- 10:30 a. m.—Musical program.
- 11:30 a. m.—Press-Telegram morning news, Frank P. Goss.
- 12:00 noon.—Popular Dance program.
- 12:15 p. m.—Varied Musical.

- 4:00 p. m.—Press-Telegram afternoon news.
- 4:30 p. m.—Hancock Oil Co. Orchestra (every day).
- 6:00 p. m.—Lost and Found Announcements.
- 6:05 p. m.—Hancock Oil Co. Orchestra (every day).
- 8:00 p. m.—Press-Telegram evening news.
- 8:15 p. m.—Musical program.

DAILY EXCEPT MONDAY

- 2:30 p. m.—Press-Telegram presenting Long Beach Municipal Band.
- 3:05 p. m.—Adult Radio School (every day).
- 3:20 p. m.—Press-Telegram presenting Long Beach Municipal Band.

SUNDAY, OCTOBER 7

- 9:30 a. m.—Capitol Theatre Organ, Dick Dixon.
- 10:00 a. m.—Angeleno Abbey chimes.
- 11:00 a. m.—St. Luke's Episcopal Church, Rev. Perry Austin.
- 12:30 p. m.—Birket Music Co.
- 1:30 p. m.—Pacific Coast Club organ.
- 2:30 p. m.—Long Beach Municipal Band.
- 4:00 p. m.—Latest popular record releases.
- 6:00 p. m.—Radio Church of the Air.
- 7:00 p. m.—"Chrysler Program"—Concert Orchestra.
- 7:45 p. m.—First Church of Christ, Scientist.

MONDAY, OCTOBER 8

- 12:30 p. m.—Popular Songs of today.
- 12:45 p. m.—Piano selections.
- 1:00 p. m.—Red Seal Recordings.
- 1:15 p. m.—Jazz Band.
- 1:30 p. m.—Hawaiian program.
- 1:45 p. m.—Arkansas Traveler.
- 2:00 p. m.—Varied Musical program.
- 3:00 p. m.—Concert Orchestra.
- 7:00 p. m.—Suydam's Buttercream Schoolhouse.
- 8:00 p. m.—Goodyear Hawaiian Quartette and Double Eagle Twins.
- 9:00 p. m.—Rebroadcast KNX—Rudolph Wurlitzer Co.
- 10:00 p. m.—Chrysler Hour—Silver Spray Haymakers.
- 11:00 p. m.—Majestic Ballroom Orchestra.

TUESDAY, OCTOBER 9

- 1:00 p. m.—Kiwanis Club luncheon.
- 1:30 p. m.—Dance music.
- 6:45 p. m.—Dr. Williams (tuberculosis specialist).

- 7:00 p. m.—Musical program.
- 8:30 p. m.—Musical program.
- 9:00 p. m.—Breakers Hotel Orchestra.
- 9:30 p. m.—Rebroadcast KFWE—Olympic Auditorium.
- 10:30 p. m.—Breakers Hotel Orchestra.

WEDNESDAY, OCTOBER 10

- 1:00 p. m.—Rotary Club.
- 1:30 p. m.—Memory Lane.
- 1:45 p. m.—Dance music.
- 7:00 p. m.—"Tain's Pair of Kids."
- 7:30 p. m.—"Chrysler Hour"
- 8:15 p. m.—Pacific Coast Club Orchestra.
- 9:15 p. m.—Silver Spray Twin Ballrooms.
- 9:45 p. m.—Main Event, Wilmington Bowl.
- 11:00 p. m.—Breakers Hotel Orchestra.

THURSDAY, OCTOBER 11

- 1:00 p. m.—Health and Efficiency, Dr. Elmer S. Clark.
- 1:30 p. m.—Ballad Hour.
- 1:45 p. m.—Accordion and Banjo Records.
- 2:00 p. m.—Hawaiian and Black Crows.
- 7:30 p. m.—"Chrysler Hour."
- 8:30 p. m.—Musical program.
- 9:00 p. m.—"Studio Prolife."
- 10:00 p. m.—Eason Hawaiian String Quartet.
- 10:30 p. m.—Webster Dun-Art Piano Recital.
- 11:00 p. m.—Majestic Ballroom.

FRIDAY, OCTOBER 12

- 1:00 p. m.—Masonic Club luncheon.
- 1:30 p. m.—Popular Vocal selections.
- 1:45 p. m.—Jazz Band.
- 7:00 p. m.—Musical selections.
- 7:30 p. m.—"Chrysler Hour."
- 8:30 p. m.—Fireside Hour: Clarence Grary.
- 9:30 p. m.—Rebroadcast KNX—American Legion Stadium.
- 10:30 p. m.—Pacific Coast Club Orchestra.
- 11:00 p. m.—Majestic Ballroom.

SATURDAY, OCTOBER 13

- 4:30 p. m.—Uncle Happy's Kiddies.
- 4:45 p. m.—Majestic Ballroom Orchestra.
- 7:00 p. m.—Chocolate program.
- 7:30 p. m.—"Chrysler Hour."
- 9:00 p. m.—Breakers Hotel Orchestra.
- 10:00 p. m.—Pacific Coast Club Orchestra.
- 11:00 p. m.—Majestic Ballroom.

KWTC Santa Ana, Calif.—1100 Kc.

Studio at 1101 North Ross St., Santa Ana, California.

"The Garden of Eden Stations"
"Kum West to California"

272.8 METERS—100 WATTS
WESTERN ELECTRIC INSTALLATION



HAROLD MATHEWS

Owned and Operated by
Dr. John Wesley Hancock
Manager—Announcer
Telephone 1896

Edith C. Hancock
Program Manager

DAILY EXCEPT SUNDAY

- 6:00 p. m.—Dinner Hour: music news items, etc.
- MONDAY, OCTOBER 8
- 6:00 p. m.—U. S. Dept of Agriculture Bulletins.
- 6:30 p. m.—Garden Grove Free Methodist Church.
- 7:00 p. m.—Jess Goodman's Samson Cord program.
- 7:30 p. m.—Eastern Oil Co. Hawaiian Half Hour.
- 8:00 p. m.—Chandler's Music Store DeLuxe Trio.
- 9:00 p. m.—Musical Travelogue presented by Edna Burgo Paine.
- TUESDAY, OCTOBER 9
- 6:00 p. m.—Sol Gonzales' Spanish Half Hour.
- 6:30 p. m.—"Smiling" Eddie Marble's request hour.

WEDNESDAY, OCTOBER 10

- 6:00 p. m.—Program: Aunt Sammy's Household Hints.
- 6:30 p. m.—Moon Aerotype popular program.

THURSDAY, OCTOBER 11

- 6:00 p. m.—Merchant's Music Contest presented by Harold Mathews, featuring Hipmobile Concert Trio.
- 7:00 p. m.—Studio program.
- 7:30 p. m.—Italian program.
- 8:00 p. m.—James Willis Rice, violin; Arthur J. Smith, tenor; Mrs. James Willis Rice, acc.
- 8:30 p. m.—Program by Carolyn Haughton, pianist.
- 9:00 p. m.—Al Jasper, violin; the Haskin Twins, piano and song.

FRIDAY, OCTOBER 12

- 6:00 p. m.—"Frank" Wallace.
- 6:30 p. m.—"Smiling" Eddie Marble's request hour.

SATURDAY, OCTOBER 13

- 6:00 p. m.—Studio program.
- 7:00 p. m.—Merrilee Hour: Dreamland Lady.
- 8:00 p. m.—The Silverstone Quartet, directed by E. H. Elsner; Meba Elsner, accompanist.

The essential features of these programs are identical with those sent by the stations.



TOM SEXTON

KFSD San Diego, Calif.—680 Kc.

500 WATTS—440.9 METERS
"The Air Capitol of the West"
Telephone Main 8661

HARVEY T. COLLINS
President

TOM SEXTON
General Manager

DAILY EXCEPT SUNDAY

- 9:00 a. m.—Morning musical.
- 10:00 a. m.—Shopping hour.
- 11:00 a. m.—Service hour.
- 12:30 p. m.—Pipe-organ recital, Roma Lindsay.
- 3:15 p. m.—Spreckels outdoor organ, Ballboa Park.
- 4:15 p. m.—Studio program.
- 4:45 p. m.—San Diego Union and Tribune news items.
- 5:00 p. m.—Nightly musical review.

SUNDAY, OCTOBER 7

- 2:00 p. m.—International Bible Students.
- 3:00 p. m.—Theosophical Society.
- 8:30 p. m.—Hotel Del Coronado Concert Quartette, C. A. Gray.

MONDAY, OCTOBER 8

- 6:00 p. m.—Dinner concert, J. R. Townsend.
- 7:00 p. m.—Thearle Music Co. hour.
- 8:00 p. m.—Studio program.
- 9:00 p. m.—Woodmen of the World hour.
- 10:00 p. m.—American Legion Roundup.

TUESDAY, OCTOBER 9

- 6:00 p. m.—Dinner concert program.
- 7:00 p. m.—Valencia Park program.
- 7:30 p. m.—Studio program.
- 8:30 p. m.—Southern Title & Trust program.
- 10:00 p. m.—Jimmie Kerr's Orchestra.
- 11:00 p. m.—Plata Real Orchestra.

WEDNESDAY, OCTOBER 10

- 6:00 p. m.—KFSD Concert Trio, Leonardo Brill, director.
- 7:00 p. m.—Studio program.
- 7:30 p. m.—Theosophical Concert hour.
- 8:30 p. m.—Studio program.
- 9:00 p. m.—State College hour.
- 10:00 p. m.—Hotel Del Coronado Casino Orchestra.
- 11:00 p. m.—Hob Larson's Orchestra.

THURSDAY, OCTOBER 11

- 6:00 p. m.—Cramer's Baking Co. Trio.
- 7:00 p. m.—San Diego Police Department program.
- 8:00 p. m.—Unitarian Church program.
- 9:00 p. m.—Feature program.
- 10:00 p. m.—Jimmie Kerr's Orchestra.
- 11:00 p. m.—Plata Real Orchestra.

FRIDAY, OCTOBER 12

- 6:00 p. m.—Motor Hdw. & Equip. hour.
- 7:00 p. m.—Thearle Music Co. hour.
- 8:30 p. m.—Studio program.
- 10:00 p. m.—Kerr's Orchestra.

SATURDAY, OCTOBER 13

- 6:00 p. m.—San Diego Union and Tribune hour.
- 7:00 p. m.—Children's hour.
- 8:00 p. m.—Studio program.
- 9:00 p. m.—Pantaces hour.
- 10:00 p. m.—Hotel Del Coronado Casino Orchestra.
- 11:00 p. m.—Plata Real Orchestra.

*The Dawn
of Better
Music*

AEROFONIC

~~\$40.00~~
\$25

Manufactured Exclusively By
THE AEROFONIC COMPANY

Hill at 35th

HU. 5770

Los Angeles

The essential features of these programs are identical with those sent by the stations



AIMEE SEMPLE
McPHERSON

KFSG Los Angeles, Calif.—1190 Kc.

800 Watts—322.8 Meters. Angeles Temple, Echo Park. FI. 5121

"Four Square Gospel"

Aimee Semple McPherson
Founder, President
Roderick H. Morriss
Manager
M. E. Kennedy,
Technician
C. N. Tucker
Announcer
Esther Fricke
Temple Organist

DAILY EXCEPT SUNDAY

7:00 a. m.—Family Altar.
8:00 a. m.—Bible Study Hour (except Wednesday).
10:30 a. m.—Sunshine Hour.
11:30 a. m.—Noonday Musical, with Esther Fricke, organist (except Monday).

SUNDAY, OCTOBER 7

10:30 a. m.—Sunday Morning Worship, Hardy Mitchell.
2:30 p. m.—Devotional Message, Hardy Mitchell.
8:00 p. m.—Levina Bartolotti and Angelus Temple Silver Band.
8:30 p. m.—Evangelistic Service, Rozie Alford.

MONDAY, OCTOBER 8

11:30 a. m.—Blessed Hope Hour, Paul Myers & group.
5:30 p. m.—Vesper Hour, Organ Recital, Esther Fricke.

TUESDAY, OCTOBER 9
3:30 p. m.—Luther Plankenborn and Goodrear Branch Church.
4:00 p. m.—Classics Hour, Studio program.
5:00 p. m.—Blessed Hope Hour, Paul Myers & group.

WEDNESDAY, OCTOBER 10

2:30 p. m.—Divine Healing Service, Rozie Alford.
5:00 p. m.—Angelus Hour, Organ Recital, Esther Fricke.
7:00 p. m.—Noland Tucker and Angelus Temple Symphony Orchestra.
7:30 p. m.—Water Baptismal Service, Hardy Mitchell.

THURSDAY, OCTOBER 11

3:30 p. m.—Rev. Britton and Alhambra Branch Church Group.
4:30 p. m.—Book Lover's Hour, Noland Tucker.
5:00 p. m.—Blessed Hope Hour, Paul Myers & group.

FRIDAY, OCTOBER 12

3:00 p. m.—Rev. Bruftet and Pasadena Branch Church Group.
4:00 p. m.—Classics Hour, Studio Program.
5:00 p. m.—Organ Recital, Esther Fricke.

SATURDAY, OCTOBER 13

2:00 p. m.—Children's Happy Hour, Miss Estelle Jones.
5:00 p. m.—Sunday School Review.
7:00 p. m.—Levina Bartolotti and Angelus Temple Silver Band.
7:30 p. m.—Divine Healing Service, Rozie Alford.
8:30 a. m.—Jeanne and Joan Halamaeck, the Miracle Children.



HARRY P. HERDMAN

KTBI Los Angeles, Calif.—1090 Kc.

750 Watts—375.1 Meters—Bible Institute of Los Angeles

HARRY P. HERDMAN, Announcer, Phone ME. 6761

JOHN A. GLASSE, Director of Programs

HOWARD C. WILSON, Technician

GORDON E. HOOKER, Accompanist

DAILY EXCEPT SATURDAY AND SUNDAY

8:00 a. m.—Uncle Fred's Bible Children's Club.
8:30 a. m.—Devotional hour.
9:00 a. m.—Studio music.
9:15 a. m.—Daily Bible study.
11:30 a. m.—Music and Daily Scriptures.
1:00 p. m.—Studio Musical Program.

TUESDAY, OCTOBER 9

9:45 a. m.—Dr. W. E. Edmonds, Glendale Presbyterian
10:35 a. m.—Christian Philosophy.
1:15 p. m.—King's Business Question Box, Keith L. Brooks.
2:00 p. m.—Inspirational Message and Music.

WEDNESDAY, OCTOBER 10

9:45 a. m.—Christian Psychology.
10:35 a. m.—Doctrinal Lecture.
1:15 p. m.—Inspirational Message and Music.
2:00 p. m.—Visiting Pastor's Radio Ministry.

THURSDAY, OCTOBER 11

9:45 a. m.—News of Christian Work in the World.
10:45 a. m.—Christian Philosophy.
1:15 p. m.—Missionary Biographies, Rev. J. H. Hunter.
2:00 p. m.—Visiting Pastor's Radio Ministry.

FRIDAY, OCTOBER 12

9:45 a. m.—New Testament Word Studies, Dr. H. W. Kellogg.

10:35 a. m.—Dr. G. Campbell Morgan.

1:15 p. m.—Inspirational Message and Music.

2:00 p. m.—Visiting Pastor's Radio Ministry.

7:00 p. m.—International Sunday School Lesson.

8:30 p. m.—Dr. G. Campbell Morgan.

9:00 p. m.—Special Concert Hour.

Transformers and Choke Coils for A. C. Operation

Built to Your Own Specifications—Get Our Prices

8114 South Central

CRITTENDEN TRANSFORMER WORKS

Delaware 0561

The essential features of these programs are identical with those sent by the stations.



BERTHA I. BREWSTER
Program Manager

KGEB

Long Beach, Cal.—1390 Kc.

100 WATTS—215.7 METERS

435 Pine Avenue

Phone 632-75

Owned and Operated by C. Merwin Dobyas

JAY TAPP
Chief Engineer
HARVEY BREWSTER
Announcer

Bertha Brewster
Program Manager

CECIL FRY
Announcer

HAROLD BENDER
Technician

7:00 p. m.—Better English period.
7:15 p. m.—Jones Hawaiian Trio.
8:00 p. m.—Late News Bulletin from the Long Beach Sun.
8:15 p. m.—Shell Orchestra.
12:00 p. m.—Dobyas Footwear Blue Three.

TUESDAY, OCTOBER 9

1:00 p. m.—Dobyas Footwear Blue Three.
2:00 p. m.—Program from Cortland Gilmore Saxophone Conservatory.
7:00 p. m.—Book Lovers period.
7:15 p. m.—Music.
11:00 p. m.—Orchestra.

WEDNESDAY, OCTOBER 10

1:00 p. m.—Myrona DeGroot, reader.
1:30 p. m.—Studio program.
7:00 p. m.—Jury talk.
7:15 p. m.—Music.
8:00 p. m.—Julietta Burnett, soprano.
9:30 p. m.—Foster Rucker, baritone.

THURSDAY, OCTOBER 11

1:00 p. m.—Optimist Club program.
1:30 p. m.—Studio program.
2:00 p. m.—Voice clinic.
7:00 p. m.—Household Helps period.
7:15 p. m.—Music.
9:00 p. m.—Bernice Neal, violinist.
9:30 p. m.—Studio program.

FRIDAY, OCTOBER 12

1:00 p. m.—Studio program.
2:00 p. m.—Orchestra.
7:00 p. m.—Political Situation period.
7:15 p. m.—Music.
11:00 p. m.—Orchestra.

SATURDAY, OCTOBER 13

11:00 a. m.—Archie Long.
11:40 a. m.—Nature Study period.
1:00 p. m.—Studio program.
1:30 p. m.—Children's hour with Hargely Ann.
7:00 p. m.—Church announcements.
9:00 p. m.—Orchestra.

DAILY EXCEPT SUNDAY
11:00 a. m.—KGEB Devotional Period (except Sat.).
11:15 a. m.—Music.
11:30 a. m.—Daily Calendar and Announcements.
12:00 noon—Noon request program.
2:30 p. m.—Long Beach Municipal Band Concert (except Monday).
7:00 p. m.—Educational Period (except Saturday).
7:30 p. m.—Long Beach Municipal Band Concert (except Monday).
12:00 midnight—Dobyas Footwear Blue Three (except Wednesday, Thursday and Saturday).

SUNDAY, OCTOBER 7

9:30 a. m.—Taubman's Men's Bible Class.
10:45 a. m.—Classical music.
11:00 a. m.—First Presbyterian Church services.
12:15 p. m.—Music.
1:00 p. m.—Ursuline Wisner, contralto.
1:30 p. m.—Luana String Trio.
2:00 p. m.—Music period from Polytechnic High School, directed by Jane Stanley.
4:00 p. m.—Vocal program.
5:00 p. m.—Carlton Wood Ensemble.

MONDAY, OCTOBER 8

1:00 p. m.—Exchange Club program from the Hotel Virginia.
1:30 p. m.—Dobyas Footwear Blue Three.
3:15 p. m.—Child Psychology talk, Gladys Sanger Hayman.

STATEMENT OF THE OWNERSHIP, MANAGEMENT, CIRCULATION, ETC., REQUIRED BY THE ACT OF CONGRESS OF AUGUST 24, 1912

OF RADIO DOINGS, published weekly at Los Angeles, California, for October 1, 1928.

State of California, County of Los Angeles—ss.

Before me, a Notary Public in and for the State and county aforesaid, personally appeared G. W. Marshall, who, having been duly sworn according to law, deposes and says that he is the Business Manager of the RADIO DOINGS, and that the following is, to the best of his knowledge and belief, a true statement of the ownership, management (and if a daily paper, the circulation), etc., of the aforesaid publication for the date shown in the above caption, required by the Act of August 24, 1912, embodied in section 411, Postal Laws and Regulations, printed on the reverse of this form, to wit:

1. That the names and addresses of the publisher, editor, managing editor, and business managers are:

Publisher, Cloyd Marshall, Jr., 2288 Akyona Street, Los Angeles, California.

Editor, Cloyd Marshall, Jr., 2288 Akyona Street, Los Angeles, California.

Managing Editor, none.

Business Manager, G. W. Marshall, 2288 Akyona Street, Los Angeles, California.

2. That the owner is: (If owned by a corporation, its name and address must be stated and also immediately thereunder the names and addresses of stockholders owning or holding one per cent or more of total amount of stock. If not owned by a corporation, the names and addresses of the individual owners must be given. If owned by a firm, company, or other unincorporated concern, its name and address, as well as those of each individual member, must be given.)

Marshall & Company, Inc., 402 Allied Crafts Bldg., Los Angeles, California.

Cloyd Marshall, 2288 Akyona Street, Los Angeles, California.

Cloyd Marshall, Jr., 2288 Akyona Street, Los Angeles, California.

G. W. Marshall, 2288 Akyona Street, Los Angeles, California.

3. That the known bondholders, mortgagees, and other security holders owning or holding 1 per cent or more of total amount of bonds, mortgages, or other securities are: (If there are none, so state.) None.

4. That the two paragraphs next above, giving the names of the owners, stockholders, and security holders, if any, contain not only the list of stockholders and security holders as they appear upon the books of the company but also, in cases where the stockholder or security holder appears upon the books of the company as trustee or in any other fiduciary relation, the name of the person or corporation for whom such trustee is acting, is given; also that the said two paragraphs contain statements embracing affiant's full knowledge and belief as to the circumstances and conditions under which stockholders and security holders who do not appear upon the books of the company as trustees, hold stock and securities in a capacity other than that of a bona fide owner; and this affiant has no reason to believe that any other person, association, or corporation has any interest direct or indirect in the said stock, bonds, or other securities than as so stated by him.

5. That the average number of copies of each issue of this publication sold or distributed, through the mails or otherwise, to paid subscribers during the six months preceding the date shown above is: (This information is required from daily publications only.)

G. W. MARSHALL, Business Manager.

Sworn to and subscribed before me this 20th day of September, 1928.

(SEAL)

CLOYD MARSHALL, Jr.,

Notary Public in and for the County of Los Angeles, State of California.

(My Commission expires February 28, 1932.)

The essential features of these programs are identical with those sent by the stations.

KYA San Francisco, Calif.—850 Kc.



RUSSELL SHERWOOD
Program Director

"At the Golden Gate"

1000 WATTS—324.7 METERS

Headquarters at Leno's Wardwide Bldg.

CLAIR MORRISON, Manager RUSSELL SHERWOOD, Prog. Dir.

DAILY EXCEPT SUNDAY

- 8:00 a. m.—"The KYA Morning Glories," with music and songs
 9:00 a. m.—Sally Cooke, the "Better Home" Girl of KYA.
 10:00 a. m.—Musical program (except Tuesday and Friday).
 11:00 a. m.—"California Sunshine Hour."
 12:00 noon—News items direct from the Editorial Rooms of the Examiner (except Monday and Thursday).
 12:15 p. m.—Musical program (except Tuesday).
 3:00 p. m.—Bridge party.
 4:00 p. m.—Classical program.
 5:00 p. m.—Who's Who Program.
 6:00 p. m.—News from the Examiner.
 6:15 p. m.—The Golden Gate Crier (except Monday).
 8:30 p. m.—Klaine Goering Time Signal.
 10:00 p. m.—Tartan Time Signal.
 10:30 p. m.—Dance Orchestra (except Saturday).

SUNDAY, OCTOBER 7

- 10:00 a. m.—Miles Overholt, portraying the Examiner Comic Strip.
 11:15 a. m.—Temple Methodist Church.
 2:15 p. m.—Santa Clara vs. St. Ignace football broadcast.
 7:30 p. m.—Dr. Frederick L. Champett, feature writer.
 7:45 p. m.—Temple Methodist Church.

MONDAY, OCTOBER 8

- 7:30 p. m.—Democratic Committee broadcast over KYA and KPLA.
 7:50 p. m.—Honor Order of Optimalist Donuts, directed by Bert Butterworth.
 9:00 p. m.—Studio program.
 9:30 p. m.—Program presented by Dr. Huren L. Corley.

TUESDAY, OCTOBER 9

- 10:00 a. m.—Bell Laboratory program with Mary Elliot.
 10:15 a. m.—Recorded musical program.
 10:30 a. m.—Dr. Huren L. Corley.
 12:15 p. m.—Tuesdays Noon Club.
 2:00 p. m.—Habette, Fashion authority of Examiner.
 7:00 p. m.—Democratic Committee broadcast over KYA and KPLA.
 7:30 p. m.—Merchants Broadcasting Association prog.
 8:30 p. m.—West Coast Theater Prof.
 9:30 p. m.—Variety Hour with John Patrick, Melvin and Leo, and others.

WEDNESDAY, OCTOBER 10

- 11:40 a. m.—Dr. Julian R. Brandon.
 2:00 p. m.—Dr. Huren L. Corley.
 7:30 p. m.—Democratic Committee program over KYA and KPLA.
 7:50 p. m.—Studio program.
 8:30 p. m.—Address of Senator Robinson, Democratic candidate for Vice-President.

THURSDAY, OCTOBER 11

- 10:45 a. m.—Prudence Penny, household editor of the Examiner.
 11:40 a. m.—Dr. Julian R. Brandon.
 2:00 p. m.—Dr. Huren L. Corley.
 7:00 p. m.—Democratic Committee broadcast over KYA and KPLA.
 7:30 p. m.—Annette Thompson, Tom McKenna and Harney and Rose.
 8:30 p. m.—Studio program.
 9:00 p. m.—Dr. Frederick L. Champett of Examiner.
 9:30 p. m.—George Hepburn, Beale Rest. Fay and Pearl, and Chas. Wilkinson.

FRIDAY, OCTOBER 12

- 10:30 a. m.—Bell Laboratory program with Mary Elliot.
 10:30 a. m.—Dr. Huren L. Corley.
 7:00 p. m.—Democratic Committee broadcast over KYA and KPLA.
 7:30 p. m.—Studio program.
 8:30 p. m.—Edith Walker, LeRoy Cloris and others.
 9:30 p. m.—Matro Time Hour: Fred Souada, tenor, and Larry Stone.

SATURDAY, OCTOBER 13

- 10:30 a. m.—Dr. Huren L. Corley.
 7:30 p. m.—Democratic Committee broadcast over KYA and KPLA.
 7:30 p. m.—Billy Leonard and Mary Elliot in "Thirty Minutes of Nothing Too Serious."
 8:00 p. m.—Klaine Goering, Time Signal.
 8:30 p. m.—Old Times Hour with Ed Howlett, Marian Thompson, Rudy Farler, Dorothy and Kay, Fred Hagen, and Louise Hubert.
 9:00 p. m.—Variety Hour with Billy Leonard.
 10:00 p. m.—Radio Hour Frolic with Billy Sherwood at the "Mike," and a Revue of KYA Artists.

KLX

Oakland, Calif.—590 Kc.

P. D. Allen, Manager

Tel. Lakeside 6008, 13th and Franklin

Charles Lloyd, Program Director

DAILY EXCEPT SUNDAY

- 7:00 a. m.—Exercises.
 10:00 a. m.—Jean's Hi-Lights.
 12:00 noon—Standard time by Tribune ston.
 12:00 noon—George Otto's Twilana.
 1:00 p. m.—Jean Kent.
 2:30 p. m.—Jackson Recordings.
 3:40 p. m.—Baseball (except Monday).
 5:30 p. m.—Big Brother Bob's Club (except Monday, Friday and Saturday).
 6:00 p. m.—Hotel Oakland Concert Trio.
 8:30 p. m.—Bagpipians.
 7:30 p. m.—News broadcast.
 7:30 p. m.—Bagpipians.
 Time Signals throughout the day by courtesy of Alberta Candy Co.

SUNDAY, OCTOBER 7

- 5:30 p. m.—Chas. T. Bessner on Scottish Rite organ from new Scottish Rite Temple.

MONDAY, OCTOBER 8

- 10:30 a. m.—Martha Lee Home Economics hour.
 2:30 p. m.—Opportunity Hour.
 5:00 p. m.—Ambassador Laundry Co. program.
 7:00 p. m.—News broadcast.
 8:00 p. m.—Studio program.
 9:00 p. m.—Studio program.

TUESDAY, OCTOBER 9

- 10:30 a. m.—Martha Lee Home Economics hour.

- 4:30 p. m.—Chas. T. Bessner on Scottish Rite organ.
 9:00 p. m.—Studio program.
 9:00 p. m.—Familiar songs hit.

WEDNESDAY, OCTOBER 10

- 10:30 a. m.—Martha Lee Home Economics hour.
 4:00 p. m.—Chas. T. Bessner on Scottish Rite organ.
 8:00 p. m.—Educational hour.
 9:00 p. m.—Studio program.

THURSDAY, OCTOBER 11

- 10:30 a. m.—Martha Lee Home Economics hour.
 7:00 p. m.—News broadcast.
 9:00 p. m.—Studio program.
 9:00 p. m.—Dorian Trio.

FRIDAY, OCTOBER 12

- 10:30 a. m.—Martha Lee Home Economics hour.
 5:00 p. m.—Rastus and Professor I-Know-It, courtesy of Pacific Paint & Varnish Co.
 8:30 p. m.—Brother Bob's Club.
 7:00 p. m.—News broadcast.
 8:00 p. m.—Piano recital by Helen Wegman Parmelee.
 8:30 p. m.—David McAdam, tenor.
 9:00 p. m.—Dance program from Athens Athletic Club.

SATURDAY, OCTOBER 13

- 2:30 p. m.—Football broadcast.
 4:00 p. m.—Chas. T. Bessner on Scottish Rite organ.
 7:00 p. m.—News broadcast.

Arcturus Exhibits

Record Line of Tubes

At the Arcturus booth, at the Radio World's Fair, held at Madison Square Garden, New York City, during the week of September 15th, nineteen different types of A-C tubes, all standard production jobs, fitting every conceivable receiving requirement, were on exhibit. These tubes include low voltage replacement tubes as well as the standard Arcturus fifteen volt line. These include power and super-power tubes, half wave and full wave rectifiers, standard amplifying tubes, high mu tubes, shield grid designs, and four and five prong detector tubes, heater cathode and filament emitter types.

Particular interest has been stimulated by the Arcturus A-C shield grid tubes, the phenomenal amplifying characteristics of which have evoked engineering commendation, and the quick-acting 2.5 volt type 127 detector tube. The 127 tube is said to be a more sensitive detector than competing types and heats to operating temperature in seven seconds.

The entire line of Arcturus tubes are

designed for alternating current operation and represent the contribution of this relatively new independent tube manufacturer over the amazingly short but active period of one year. Arcturus today is the largest exclusive A-C tube manufacturer in the world.

Television Rights On Broadcasting Waves Questioned

There is a serious question as to whether television should be permitted in the broadcast band, even though it be accomplished within the present 10 kilocycle separation between channels. This is a question more of policy than of law, however, and its decision will rest with the Federal Radio Commission. In fact, the matter has already come before the commission, in an individual case.

The International Radiotelegraph convention of 1927 devotes a band to broadcasting as "radiotelephone communications intended to be received by the public." "Radiotelephone" does not include television, in the opinion of legal experts of the Commission.



PUBLIC ADDRESS
TYPE



CONDENSER



STANDARD BROADCAST
TYPE

M I C R O P H O N E S

On Display at RADIO SUPPLY CO., Los Angeles, and at
HERBERT H. HORN CO., Los Angeles

Manufactured by

UNIVERSAL MICROPHONE CO.

CHAMBER OF COMMERCE BLDG.

INGLEWOOD, CALIF.

The essential features of these programs are identical with those sent by the stations.



"MAC"

KFRC San Francisco, Calif.—660 Kc.

Owned and Operated by Don Lee, Cal. Dist. for Cadillac & LaSalle
1088 WATTS—454.3 METERS
1000 Van Ness, Telephone Prospect 100
"Keep Forever Radiating Cheer"

Harrison Holloway
Manager
Helen O'Neil
Program Director
Frank Moss
Musical Director
Alan N. Cormack
Engineer

DAILY EXCEPT SUNDAY

- 7:00 a. m.—Stamp Fitta. Courtesy Airfax Matron Mfra.
- 8:00 a. m.—Musical records program.
- 9:00 a. m.—Georgia O. Gurnee (except Saturday).
- 10:00 a. m.—Wyn's Daily Chat.
- 11:30 a. m.—Amateur Troups (except Saturday).
- 12:00 noon.—Sherman Clay concert.
- 2:00 p. m.—Matinee Concert, courtesy of Pacific Radio Trades (except Saturday).
- 3:00 p. m.—Matinee Orch. Concert (ex. Tues. & Thurs.)
- 4:30 p. m.—Organ recital by Theo. Strong (ex. Sat.).
- 5:15 p. m.—San Francisco Call, news items.
- 6:30 p. m.—Mac and his Gang.
- 6:20 p. m.—Town Topics.
- 8:30 p. m.—Embassy Theatre program (ex. Tuesday and Friday).
- 10:00 p. m.—Amos 'n' Andy
- 10:10 p. m.—Dance music.

SUNDAY, OCTOBER 7

- 9:30 a. m.—KFRC Radio Fellowship Church, conducted by Dr. Stanley Morrison.
- 10:00 a. m.—"Home Sweet Home" Concert.
- 12:00 noon.—Paulist Fathers' Old St. Mary's Church.
- 1:15 p. m.—Bosch Radio Concert.
- 3:15 p. m.—KFRC Studio Recital.
- 4:15 p. m.—Art Padden.
- 5:00 p. m.—"The Tea Time Three"
- 6:00 p. m.—Inspirational talk by Dr. Lous I. Newman
- 6:30 p. m.—Studio program.
- 7:00 p. m.—Robert Olson song recital.
- 7:30 p. m.—Cadillac-LaSalle Concert (Orchestra, direction of Frank Moss.
- 8:30 p. m.—Concert Orchestra with Edna Fischer solo.
- 9:30 p. m.—Tom Geranovich and his Roof Garden Orch.
- 10:00 p. m.—Amos 'n' Andy.
- 10:10 p. m.—Tom Geranovich and his Roof Garden orch.
- 11:00 p. m.—El Patio Dance Orchestra.

MONDAY, OCTOBER 8

- 4:00 p. m.—"Careers for Women."
- 4:15 p. m.—Talk by Physicist.
- 7:00 p. m.—Myrohi Musical Melody.
- 7:30 p. m.—Anti Preval Entertainers.
- 8:00 p. m.—"Blue Monday Jamboree."

TUESDAY, OCTOBER 9

- 11:00 a. m.—CHILD Diet.
- 4:00 p. m.—"Careers for Women" direction of Matilda Rosenfeld.
- 4:15 p. m.—Speaker from California Writer's Club.
- 6:30 p. m.—"Hobbs" noted sports authority.
- 7:00 p. m.—Mastor Quartette and Art Padden.
- 7:30 p. m.—White Cross Entertainers.
- 8:00 p. m.—Hans Candy Stores "Sweetheart Hour."
- 9:00 p. m.—"Fancies of Former Days" Carolans and Orchestra.

WEDNESDAY, OCTOBER 10

- 11:00 a. m.—Mary Lewis Haines Domestic Science Talk.
- 11:30 a. m.—Amateur Auditions.
- 4:00 p. m.—"The Observer" about new books and current topics.
- 7:00 p. m.—Coilian Trio.
- 7:30 p. m.—Anti Preval Entertainers.
- 8:00 p. m.—Herman Reinberg solo recital.
- 8:30 p. m.—Song Recital by Robert Olson.
- 9:00 p. m.—Western Motors Program.

THURSDAY, OCTOBER 11

- 11:00 a. m.—Studio Program.
- 11:30 a. m.—Mac and his Gang.
- 11:45 a. m.—Amateur Auditions.
- 4:00 p. m.—Popular Scientific Talk by Maynard Shipley
- 4:20 p. m.—Pan Fare by Fred Johnson of the Call.
- 5:30 p. m.—Mac and his Gang.
- 6:10 p. m.—Mac and his Gang.
- 7:00 p. m.—Myrohi Mirth and Melody.
- 7:30 p. m.—Mr. XYZ and his Alphabet.
- 8:00 p. m.—Concert Orchestra, Harry McKnight, Bob and his sister.
- 9:00 p. m.—"Tea Time Three."

FRIDAY, OCTOBER 12

- 11:00 a. m.—"Hints to Home Makers" by Aunt Martha.
- 2:00 p. m.—Matinee Concert Orchestra.
- 4:00 p. m.—Garden Talk by F. W. Davis.
- 6:20 p. m.—Town Topics.
- 6:30 p. m.—Pat Tracy, Sports Editor of the Call.
- 7:00 p. m.—Hot 'n' Cold Shows Program.
- 7:30 p. m.—Leigh Harline and White Cross entertainers.
- 8:00 p. m.—"Great Ladies."
- 8:30 p. m.—Shasta Firestone and the Sparklers.
- 9:00 p. m.—Cadillac-LaSalle Orchestra, Juanita Tenynson soloist.

SATURDAY, OCTOBER 13

- 10:00 a. m.—Studio Program.
- 11:00 a. m.—Amateur Auditions.
- 11:45 a. m.—Announcements of Sunday Church Services.
- 2:30 p. m.—Football Broadcast.
- 4:00 p. m.—Art Talk.
- 4:30 p. m.—Studio Program.
- 7:00 p. m.—Organ Recital.
- 7:30 p. m.—Anti Preval Entertainers.
- 8:00 p. m.—KFRC Concert Orchestra and Strollers.
- 8:15 p. m.—"Hobbies of Prominent Men."
- 8:30 p. m.—KFRC Concert Orchestra and Strollers.
- 9:00 p. m.—Hot Mark Hopkins Orchestra.
- 11:00 p. m.—Organ Program by Leigh Harline.

MEN!!

Repairing Are Always

With Complete Knowledge of Radio Service and

WANTED!!

Our Day and Evening Classes will fit you to successfully fill such a position.

Call—Write—Phone for Complete Information

RADIO COLLEGE OF CALIFORNIA

921 W. 6TH ST.

Employment Service

Vandike 0902

The essential features of these programs are identical with those sent by the stations.



CURTIS PECK

KPO San Francisco, Calif.—710 Kc.

1000 WATTS—422.3 METERS
HALE BROTHERS AND THE CHRONICLE
"The Voice of San Francisco"

Phone Kearney 784

J. W. Laughlin
Managing Director

Mrs. Frederick Crowe
Program Director

Curtis Peck
Technical Director

DAILY EXCEPT SUNDAY

- 6:45 a. m.—Health and Happiness Period.
- 8:00 a. m.—The Shell Happy Time.
- 9:30 a. m.—Debbide's Daily Chat.
- 10:00 a. m.—Mammy Sperry (ex. Tues., Thurs., Sat.).
- 11:30 a. m.—Ye Town Cryer.
- 12:30 noon—Time signals, scripture reading, etc.
- 12:30 noon—Lillian H. organ recital.
- 2:00 p. m.—House of Dreams (ex. Mon. and Sat.).
- 2:45 p. m.—Play-by-play broadcast of Pacific Coast Baseball Games (except Monday).
- 4:30 p. m.—Merton Hories and the Mission Sparklers (except Monday).
- 5:30 p. m.—Children's Hour.
- 8:00 p. m.—Hale Logue with music.

SUNDAY, OCTOBER 7

- 9:45 p. m.—Church services.
- 2:45 p. m.—Play-by-play broadcast of the Pacific Coast League baseball games for the Associated Oil Co.
- 6:30 a. m.—NBC.*
- 7:30 p. m.—Embassy Theatre concert.
- 8:00 p. m.—Organ recital by Uda Waldrup.
- 8:30 p. m.—Rudy Solger's Fairmount Hotel Concert Or.
- 9:00 a. m.—NBC.*

MONDAY, OCTOBER 8

- 10:00 a. m.—Art talk by Helen Gordon Barber.
- 1:00 p. m.—Program for Hale Bros., Inc.
- 3:00 p. m.—Physicists' program.
- 4:30 p. m.—Ye Town Cryer Service.
- 5:30 p. m.—Talk on Industrial San Francisco.
- 7:00 p. m.—NBC.*
- 9:00 p. m.—Percinia program.
- 9:30 p. m.—Studio program.
- 10:00 p. m.—KPO's variety program, featuring KPO's well known artists.

TUESDAY, OCTOBER 9

- 10:00 a. m.—Activity conducted by Ann Warner, domestic economist.

*See Page 86 for detailed program of National Broadcasting Company.

- 10:30 a. m.—NBC.*
 - 1:00 p. m.—Judy Jermaine song recital for Hale Bros., Inc.
 - 1:30 p. m.—E. A. Pierce & Co. stock market quotations.
 - 2:00 p. m.—House of Dreams.
 - 3:00 p. m.—Children's Hour by Big Brother of KPO.
 - 7:00 p. m.—Embassy Theatre concert.
 - 8:00 p. m.—NBC.*
 - 9:00 p. m.—Koster Radio Hour.
 - 10:00 p. m.—NBC.*
- WEDNESDAY, OCTOBER 10**
- 10:00 a. m.—NBC.*
 - 11:30 a. m.—Ye Town Cryer.
 - 1:00 p. m.—Hale Bros. program.
 - 7:00 p. m.—Studio program.
 - 8:00 p. m.—NBC.*
 - 10:00 p. m.—Gordon Henderson's Palm Court Dance Band.
 - 11:00 p. m.—NBC.*

THURSDAY, OCTOBER 11

- 10:00 a. m.—Ann Warner, domestic economist.
- 12:30 p. m.—Studio program.
- 1:30 p. m.—Hale Bros. program.
- 3:00 p. m.—Kosta Front, in World Topics on the Air.
- 7:00 p. m.—Federal Business talk.
- 7:45 p. m.—Sports-on-the-air by Harry Smith of the Chronicle.
- 7:30 p. m.—Merton Hories and the Mission Sparklers.
- 8:00 p. m.—Caswell Hour.
- 8:30 p. m.—Nathan Abas in a violin recital.
- 9:00 p. m.—NBC.*

FRIDAY, OCTOBER 12

- 12:45 p. m.—Commonwealth Club luncheon at Palace Hotel.
- 1:30 p. m.—Hale Bros. program.
- 7:00 p. m.—Embassy Theater Concert.
- 7:30 p. m.—NBC.*
- 9:00 p. m.—Alma Kirtling Quartet.
- 10:00 p. m.—Gordon Henderson's Palm Court Dance Band.
- 11:00 p. m.—NBC.*

SATURDAY, OCTOBER 13

- 10:00 a. m.—Activity conducted by Ann Warner, domestic economist.
- 1:00 p. m.—Hale Bros. program.
- 1:30 p. m.—E. A. Pierce & Co., stock market.
- 7:00 p. m.—NBC.*
- 9:00 p. m.—Gordon Henderson's Palm Court Dance Band.
- 10:00 p. m.—NBC.*



IRVING KRICK

KTAB Oakland, Calif.—1070 Kc.

Knowledge, Truth and Beauty
Official Pictwick Station
Owned and Operated by the Pictwick Broadcasting Corp.
MEL LE MON, Manager
ADA MORGAN O'BRIEN, Program Director
Teeth Avenue Baptist Church, 1418 Teeth Ave.
Telephone Merritt 0246
DAILY EXCEPT SUNDAY

- 9:00 a. m.—Hour of Prayer.
- 9:30 a. m.—Recordings.
- 12:00 noon—Organ Recital, Etsa Marvia Pomeroy.
- 4:00 p. m.—The Tea Hour, Elystan Trio.
- 5:30 p. m.—Dinner Hour Concert.
- 6:30 p. m.—Twilight Hour.
- 7:00 p. m.—Pomeroy Trio.
- 10:00 p. m.—Pictwick Serenaders.
- 12:00 a. m.—The Night Owl.

MONDAY, OCTOBER 8

- 8:00 p. m.—Educational Half Hour under direction of Prof. Linsley of Chabot Observatory and Mills College.
- 8:30 p. m.—The Elystan Trio, assisted by Roberts Fowler McDowell.

TUESDAY, OCTOBER 9

- 8:00 p. m.—Pictwick Trio, Doris and Pully.
- 8:30 p. m.—Miss Alice Shellenbarger will speak on "Innings from the Pen."
- 8:45 p. m.—Grace Adams Kent, Pacific Male Quartet.

WEDNESDAY, OCTOBER 10

- 8:00 p. m.—California Trilliums: Irene Lenoir, soprano.
- 9:00 p. m.—The Rainbow Trio.

THURSDAY, OCTOBER 11

- 8:00 p. m.—Prof. Kinsey of Mills College gives his weekly Travel Talk.
- 8:30 p. m.—The Happy Chappin, Nat Vincent and Harry Morton.
- 9:00 p. m.—The Elystan Trio.

FRIDAY, OCTOBER 12

- 8:00 p. m.—Speech on Christopher Columbus.
- 8:15 a. m.—Eloise Shannon, soprano; Irving Krick, pianist; Milliecent Benoit, mezzo contralto.

SATURDAY, OCTOBER 13

- 8:00 p. m.—Banquet of American Radio Relay League. Bernard Linden Radio Superstar, Master of Ceremonies.

The essential features of these programs are identical with those sent by the stations.



KGO Oakland, California—780 Kc.

5000 WATTS—304 METERS
PACIFIC COAST STATION, GENERAL ELECTRIC CO.
Phone Frodo 5000
537 Hotel St. Francis

DAILY EXCEPT SUNDAY

- 6:30 a. m.—California Home Life.
- 11:30 a. m.—Luncheon Concert.
- 12:30 noon, 5:00 p. m. and 10:00 p. m.—Telechrons Time.
- 12:30 and 1:00 p. m.—Stock and weather reports.
- 4:30 p. m.—Hotel St. Francis Dance Orchestra (except Monday).
- 6:30 p. m.—San Francisco and New York Stocks (except Wednesday and Saturday).
- 6:30 p. m.—News (except Saturday).
- 7:30 p. m.—Weather reports.
- 8:30 p. m.—Seasons Westminster Chimes.
- 9:30 p. m.—Time signals.

HOWARD MILKOLLAND

Announcer

SUNDAY, OCTOBER 7

- 11:30 a. m.—First Baptist Church service, Oakland.
- 1:00 p. m.—Forties Half Hour.
- 3:00 p. m.—NBC.
- 4:30 p. m.—Vesper Services, Grace Cathedral, San Francisco.
- 6:30 p. m.—NBC.
- 7:30 p. m.—Weather forecast.
- 7:50 p. m.—Whitall Anglo-Perkins.
- 8:30 p. m.—First Baptist Church service, Oakland.
- 9:30 p. m.—NBC.

MONDAY, OCTOBER 8

- 4:30 p. m.—"Everyday Living," Christian R. Madison.
- 5:30 p. m.—Aunt Detie; KGO Kidder's Klub.
- 6:30 p. m.—Telechron time.
- 6:30 p. m.—"What's Happening in the World," John D. Barry.
- 6:45 p. m.—NBC.
- 9:30 p. m.—General Electric program.
- 10:30 p. m.—Alaskan News Flasher, furnished by the United Press.

TUESDAY, OCTOBER 9

- 10:30 a. m.—NBC.
- 6:30 p. m.—"The Sterling Trambador."
- 7:30 p. m.—NBC.
- 9:30 p. m.—"The Miriam."

WEDNESDAY, OCTOBER 10

- 10:30 a. m.—NBC.
- 6:30 p. m.—Brenbrandt Trio.
- 7:30 p. m.—Agricultural program.
- 7:30 p. m.—NBC system political broadcast.

- 5:30 p. m.—Parliam Quartet.
- 6:30 p. m.—NBC.
- 9:30 p. m.—Concert program.
- 10:30 p. m.—NBC.

THURSDAY, OCTOBER 11

- 5:30 p. m.—Tom King detection stories.
- 6:30 p. m.—NBC system political broadcast.
- 6:30 p. m.—Studio concert.
- 7:00 p. m.—NBC.
- 7:30 p. m.—Vanderbilt.
- 8:30 p. m.—Maxwell House program.
- 9:30 p. m.—NBC program.

FRIDAY, OCTOBER 12

- 10:30 a. m.—NBC.
- 11:00 a. m.—Iverson Mills, baritone.
- 11:10 a. m.—Einer Martin, "Home Economics."
- 11:30 a. m.—Hector Hour, conducted by E. H.
- 4:30 p. m.—NBC.
- 5:30 p. m.—Weekly Financial Review, Theo. McMahon.
- 6:40 p. m.—Albertine Richards Nash, psychologist.
- 7:00 p. m.—NBC.
- 9:30 p. m.—Studio concert.
- 9:30 a. m.—NBC.
- 10:30 p. m.—Western Artist Series concert; Antonio de Grassi, violin; Wm. Deke, radio; Eva Garcia, piano.
- 11:30 p. m.—Hal Givrin's Hotel Oakland Dance Orch.

SATURDAY, OCTOBER 13

- 6:30 p. m.—Market reports, news and baseball.
- 6:30 p. m.—Herb Bodan's Orchestra.
- 6:45 p. m.—Weekly Sport Review, Al Sanders.
- 7:30 p. m.—American Tobacco Co. program.
- 9:30 p. m.—NBC.



TORRES WEIR
Announcer

KFWI San Francisco—1120 Kc.

500 WATTS—300 METERS
Radio Entertainment, Inc., 1122 Market Street
Telephone Market 1140

Chas. L. Peck
General Manager

Mildred L. Schneider
Program Director

- 9:30 p. m.—Semi-classical program.
- 10:30 p. m.—Dance music.
- MONDAY, OCTOBER 8**
- 10:30 a. m.—"The Dragon."
- 7:15 p. m.—Boster Business Bureau of S. F. Advertising Club.
- 9:30 p. m.—May Joseph-Kirald's Dramatic Playm.
- 6:30 p. m.—Studio program.
- TUESDAY, OCTOBER 9**
- 7:30 p. m.—Hank Blank.
- 9:30 p. m.—Surprise reception.
- WEDNESDAY, OCTOBER 9**
- 6:30 p. m.—Cecil James and Grace Moran.
- 6:30 p. m.—Bud Moran, baritone; Grace Moran, pianist.
- 7:10 p. m.—S. F. Chambers of Commerce.
- 9:30 p. m.—Dance Music.
- 12:30 p. m.—Glen and Well—The Life of the Party.
- THURSDAY, OCTOBER 10**
- 9:30 p. m.—Carl Tobin, tenor; Grace Moran, acc.
- 9:30 p. m.—Victor Navarretti, pianist.
- 9:45 p. m.—Harold Reed, the Versatile Entertainer, and Grace Moran, pianist.
- FRIDAY, OCTOBER 12**
- 9:30 p. m.—Dinner Hour program.
- 6:30 p. m.—Irene Smith, soprano, and associate artists.
- 7:15 a. m.—Tommy Thompson's Artistic Talk.
- 7:30 p. m.—Hank Blank.
- 9:30 p. m.—Andy and Jimmy, Harmony Team, and Dennis Lopez, pianist.
- SATURDAY, OCTOBER 13**
- 9:30 p. m.—Dance music.

- DAILY EXCEPT SUNDAY**
- 7:30 a. m.—Health Exercises by Cal King.
 - 8:30 a. m.—Musical Breakfast program.
 - 9:30 a. m.—Cal King's Country Store (ex. Mon.).
 - 9:30 a. m.—Charlie Glenn; News in Rhyme and Songs of Yesterday.
 - 10:00 a. m.—Musical program, weather forecast.
 - 12:00 noon.—40 minutes with Glen and Well.
 - 1:00 p. m.—Country Store (except Saturday).
 - 5:30 p. m.—Brunswick "New Hall of Fame" concert (except Tues. and Sat.).
 - 6:30 p. m.—Dinner Hour program (ex. Tues. & Sat.).
 - 7:00 p. m.—Sports Review by Sport Editor of S. F. Bulletin.
 - 8:00 p. m.—Studio program.
 - 10:00 p. m.—Police Report of Missing People (except Tuesday).
 - 10:30 p. m.—Dance music (ex. Tues.).
 - SUNDAY, OCTOBER 7**
 - 7:30 p. m.—First Church of Christ, Scientist, services.

The essential features of these programs are identical with those sent by the stations.



JOHN H. BARNET

KEX

Portland, Oregon—1080 Kc.

2300 WATTS—377.5 METERS
Owned by American Broadcasting Company
Terminal Sales Building

John H. Barnet
Program Director

Harry D. Procter
Commercial Manager

DAILY EXCEPT SUNDAY

- 9:30 a. m.—12 noon, 6 p. m. and 10 p. m.—Western Union time.
- 9:30 a. m.—Patric Cook, KEX Better Homes Girl.
- 10:00 a. m.—Morning Devotional Service.
- 10:15 a. m.—KEX Shopping Guide.
- 12:00 noon—Current Time; Dept. of Agri. Reports.
- 12:30 noon—Luncheon Concert.
- 1:00 p. m.—"Songs You Ought to Know." Alice Prindle and Thelma Lee.
- 1:30 p. m.—The Columbians (Monday).
- 2:30 p. m.—Song Recital (except Monday).
- 3:00 p. m.—Request Recordings.
- 4:00 p. m.—Concert Ensembles (except Monday).
- 5:00 p. m.—KEX Little Symphony Orch. (ex. Mon.).
- 6:00 p. m.—KEX Daily Hour.
- 7:00 p. m.—Dinner Dance concert (except Monday).
- 9:00 p. m.—KEX Little Symphony (ex. Mon., Tues.).
- 10:30 p. m.—Dance Frolic; Department of Agriculture reports; weather reports.

SUNDAY, OCTOBER 7

- 2:00 p. m.—KEX Little Symphony Orchestra.

- 3:00 p. m.—Recording Concert, "The Classics."
- 4:00 p. m.—Concert Ensemble; Sargent Patterson, baritone.
- 5:00 p. m.—Afternoon Musical; KEX Little Symphony.
- 6:00 p. m.—Multnomah Hotel Concert Orchestra; Leonard E. Becker, pianist.
- 7:45 p. m.—American Hearst Broadcast Committee Plan.
- 8:00 p. m.—Concert Ensemble; Alice Prindle, contralto.
- 9:00 p. m.—"Operatic Airs." KEX Little Symphony.
- 10:30 p. m.—Weather and Police Reports; News Flash.

MONDAY, OCTOBER 8

- 7:30 p. m.—Thos. O'Flynn, Irish tenor.
- 7:45 p. m.—Public Health Talk by Radio; Freddy Karshaw, pianist.
- 8:30 p. m.—The Tynd Chorus.
- 9:30 p. m.—The Columbians.

TUESDAY, OCTOBER 9

- 8:00 p. m.—Mel Blanc, comedian.
- 8:15 p. m.—Tulio Twins.
- 8:30 p. m.—Merry Maying Ramblers.
- 9:30 p. m.—"Secretville Review."

WEDNESDAY, OCTOBER 10

- 8:00 p. m.—Studio program.
- THURSDAY, OCTOBER 11**
- 8:00 p. m.—Catholic Truth Society lecture.
- 8:15 p. m.—Clyde Thompson, story teller.
- 8:30 p. m.—Western Light Opera Company.

FRIDAY, OCTOBER 12

- 8:00 a. m.—Big Bill Browne.
- 8:15 p. m.—Studio program.
- 8:30 p. m.—O. M. Plummer, General Manager of the Pacific International Livestock Exposition.

SATURDAY, OCTOBER 13

- 8:00 p. m.—Better Citizenship program.
- 8:30 p. m.—Studio program.



F. M. B.
Announcer

KGEN

El Centro, Calif. — 1330 Kc.

The Imperial Valley Station
225.4 METERS

Owned and Operated by
E. R. IREY and F. M. BOWLES
Medical Director, D. R. Deeble
Adv. Mgr., T. J. Arierbaugh
Chamber of Commerce Bldg., Phone 1100 or 47
E. R. Ireay, Technician

- 7:30 p. m.—Hits of the day; request program.
- 7:30 p. m.—Challenge program; L. V. Milk Producers Assn., Holtville.
- 8:00 p. m.—Old Timers request hour.
- 9:00 p. m.—John Deere Co. (dealers).
- 9:30 p. m.—Marsh Dry Cleaners.

WEDNESDAY, OCTOBER 10

- Wednesday silent.
- THURSDAY, OCTOBER 11**
- 8:00 p. m.—Twilight Concert program.
- 8:30 p. m.—Piggy Wiggly—All Over the World.
- 7:30 p. m.—Mona Motor Oil Hour; Edwar Bros. Co.
- 8:00 p. m.—Variety request program.
- 9:00 p. m.—Valley Lumber Co. program.
- 9:30 p. m.—The Quality program, Quality Dairy.

FRIDAY, OCTOBER 12

- 8:00 p. m.—Sunset Glow, Lullaby selections.
- 7:00 p. m.—Holtville Natatorium and Dance Pavilion.
- 7:30 p. m.—John Deere Co. (dealers).
- 8:00 p. m.—Around the World by Ear.
- 9:00 p. m.—The Blue and Gold hour, Richfield Oil Co.
- 10:00 p. m.—Hotel Aldrete and Just Inn, Spanish-Mexican hour.

SATURDAY, OCTOBER 13

- 12:00 noon—Kiddies' Hour.
- 8:00 p. m.—Around the World by Ear.
- 7:00 p. m.—Barbara Worth Garage, El Centro.
- 8:00 p. m.—Musical request hour.
- 9:00 p. m.—Variety program, request.
- 9:30 p. m.—Brawley Body Works program.

BT Counterphase 8 — World's Greatest Radio — Sold with a Distance Guarantee. H. A. Everest, 1032 North Ogden Dr. GRanite 9915.

The essential features of these programs are identical with those sent by the stations.



STEPHEN L. GAYLORD

KGW Portland, Oregon—610 Kc.

1000 WATTS—491.5 METERS
THE MORNING OREGONIAN
"Keep Growing Wiser"
DAILY EXCEPT SUNDAY

10:00 a. m.—Town Crier, weather reports, news items.
12:00 noon—Luncheon Concert.
6:00 p. m.—Dinner Concert (except Friday).
9:30 p. m.—Longitude Watchtime Signals.

WEDNESDAY, OCTOBER 10

7:15 a. m.—YMCA Health Exercises.
11:00 a. m.—NBC*
11:35 a. m.—The Town Crier.
12:00 noon—Luncheon Concert.
6:00 p. m.—Political Talk from KHQ.
7:00 p. m.—Studio program.
7:30 p. m.—"Half Hour of Happiness" KGW and KOMO.
8:00 p. m.—"Half Hour of Happiness."
8:30 p. m.—NBC*
9:30 p. m.—Studio Music.
10:00 p. m.—NBC*

THURSDAY, OCTOBER 11

7:00 p. m.—NBC*
7:30 p. m.—Book Chat by Richard U. Montgomery.
7:45 p. m.—Network concert.
8:00 p. m.—"Herbert's Deep Brucemela."
8:30 p. m.—NBC*
10:00 p. m.—"Sleepy Time" program.
11:00 p. m.—Dance Frolic.

FRIDAY, OCTOBER 12

7:15 a. m.—YMCA Health Exercises.
10:00 a. m.—NBC*
11:30 p. m.—Continuation of the Town Crier.
12:00 noon—Luncheon concert.
3:00 p. m.—NBC*
3:30 p. m.—Music.
6:00 p. m.—Dance Band.
8:00 p. m.—"Red and White Jesters."
7:00 p. m.—NBC*
10:00 p. m.—Profile of the Keep Growing Wiser Order of Root Owls.

SATURDAY, OCTOBER 13

7:00 p. m.—Concert from KOMO.
8:00 p. m.—NBC*

SUNDAY, OCTOBER 7

1:00 p. m.—NBC*
5:00 p. m.—Talk on Modern Science
8:15 p. m.—Studio program.
8:30 p. m.—NBC*
8:00 p. m.—Studio Concert.
9:00 p. m.—NBC*
9:30 p. m.—String Quartet.
10:00 p. m.—Little Symphony Orchestra.

MONDAY, OCTOBER 8

7:15 a. m.—YMCA Health Exercises.
8:45 p. m.—NBC*
9:00 p. m.—Smelter Furnace Concert from KGW thru KPTA.
9:30 p. m.—Studio music.
10:00 p. m.—Ben Seiling's Rogs and Collegiate.
11:00 p. m.—Studio Dance Frolic.

TUESDAY, OCTOBER 9

10:30 a. m.—NBC*
11:00 a. m.—Town Crier.
6:15 p. m.—Talk, "Portland's Problems" by Mayor Baker.
6:30 p. m.—Music.
8:45 p. m.—Dentistry Lecture.
7:00 p. m.—NBC*
7:30 p. m.—Buddy Sam.
8:00 p. m.—NBC*
9:00 p. m.—Schwabacher studio program, KOMO.
10:00 a. m.—Dance Frolic from KOMO.

*See Page 56 for detailed program of National Broadcasting Company.



PAUL CONNET
Announcer

KOIN Portland, Oregon—940 Kc.

1000 WATTS—319 METERS
Studio: New Heathman Hotel
Broadway at Salmon St.

C. H. Watson
Station Engineer

Paul Connet
Senior Announcer

Stan Spiegle
Junior Announcer
Publicity Director

8:00 p. m.—First Church of Christ, Scientist.
9:00 p. m.—Musical Comedy Hour.

MONDAY, OCTOBER 8

1:00 p. m.—U. S. Farm Forum.
6:30 p. m.—Druggists' hour.
7:30 p. m.—Henson Hotel Orchestra, under direction of Misha Peiz.
8:00 p. m.—Four Square Gospel Lighthouse Orchestra.
9:00 p. m.—Dance Twins.
9:30 p. m.—Studio program.
10:00 p. m.—Cole McKinley's Oregonians.

TUESDAY, OCTOBER 9

1:15 p. m.—Outdoors with the Scientist.
6:00 p. m.—"Better Flowers" talk.
8:15 p. m.—Oregon Humane Society.
8:30 p. m.—Tania Humation hour of Italian music.
9:30 p. m.—Night broadcast, courtesy American Legion.

WEDNESDAY, OCTOBER 10

8:00 p. m.—Studio.
8:30 p. m.—KOIN Players, direction Edris Morrison.
10:00 p. m.—Cole McKinley's Oregonians.

THURSDAY, OCTOBER 11

8:00 p. m.—Kream Twins.
8:30 p. m.—Maude Austin, Frank Taylor.
9:00 p. m.—Dance hour, soloists' program.
10:30 p. m.—Profile.

FRIDAY, OCTOBER 12

8:00 p. m.—Studio program.
10:00 p. m.—Cole McKinley's Oregonians.

SATURDAY, OCTOBER 13

After 8 a. m.—Silent for long-distance listeners.
11:00 p. m.—West Coast Theatre Frolic, direction of Georgia Stoll, from Broadway Theatre.

DAILY EXCEPT SUNDAY
8:30 a. m.—Housekeepers' Chat; Ruth Adamson.
10:00 a. m.—Town Topics, music; Yveta Waller.
11:15 a. m.—Louise Palmer Webber, Dietician.
11:30 a. m.—U. S. Dept. of Agriculture feature.
11:45 a. m.—Weather Report; Correct Time.
12:00 noon—Luncheon Concert, Heathman Hotel Organ.
3:00 p. m.—Portland News Matinee.
5:15 p. m.—Portland News Topic Tunes Time.
8:00 p. m.—Parker Realty Co. Organ Concert.
8:30 p. m.—Dinner Concert, Heathman Hotel Organ (except Monday).
7:00 p. m.—Henson Hotel Concert Orch. (ex. Mon.).

SUNDAY, OCTOBER 7

8:30 a. m.—Four Square Gospel service.
12:30 p. m.—Portland Theatre organ, Iris Wilkins.
8:00 p. m.—Parker Realty Co. Organ Concert.
8:30 p. m.—Dinner Concert on Heathman Hotel pipe organ.
7:00 p. m.—Henson Hotel Orchestra under direction of Misha Peiz.

The essential features of these programs are identical with those sent by the stations.



CARL E. HAYMOND

KMO

Tacoma, Wash.—1180 Kc.

500 WATT WESTERN ELECTRIC—254.1 METERS
Owned by KMO, Inc.
Hotel Winthrop

CARL E. HAYMOND
Manager and Chief
Announcer
J. A. MURPHY
Commercial Manager
JANE MORSE
Studio Director
MARGIE MAHON
Asst. Studio Director
J. O. KOLESAR
Chief Technician

DAILY EXCEPT SUNDAY

- 9:00 a. m.—KMO Early Birds.
- 9:30 a. m.—Boys' program.
- 10:00 a. m.—News Flashes and Time Signals.
- 10:30 a. m.—Home Economics.
- 10:45 a. m.—Town Crier and music.
- 5:15 p. m.—Sports Review.
- 5:30 p. m.—M. Y. M. C. Orchestra (except Tues., Thurs. and Sat.).
- 6:00 p. m.—Longing time signals.
- 6:00 p. m.—Dinner Hour program.
- 8:00 p. m.—Klaine Goering's time signals.

MONDAY, OCTOBER 8

- 7:00 p. m.—Tacoma Trunk Co. musical program.
- 7:30 p. m.—Navy Tex program—classical.
- 8:00 p. m.—Popular hour, featuring Jane Morse: Chain —KFOA, KFH, KTHR, KMA
- 9:00 p. m.—Book Chat by Mrs. Page Homser.
- 9:15 p. m.—Better Business Bureau.
- 9:30 p. m.—O. H. Clow program.
- 10:00 p. m.—Famous Name program.

TUESDAY, OCTOBER 9

- 7:00 p. m.—E. H. Kennedy, Oldsmobile program.
- 7:30 p. m.—Navy Tex program.

- 8:00 p. m.—Union Service hour.
- 8:30 p. m.—Central Motors program.
- 9:00 p. m.—Tommy Burns Frolic.
- 10:30 p. m.—Famous Name program.

WEDNESDAY, OCTOBER 10

- 7:00 p. m.—Tacoma Trunk Co. recording.
- 7:30 p. m.—Navy Tex program.
- 8:00 p. m.—O. H. Clow program.
- 8:30 p. m.—Famous Name program.
- 9:00 p. m.—Late release recordings.

THURSDAY, OCTOBER 11

- 7:00 p. m.—E. H. Kennedy, Oldsmobile program.
- 7:30 p. m.—Navy Tex program.
- 8:00 p. m.—Union Service hour.
- 8:30 p. m.—Central Motors program.
- 9:00 p. m.—Late recordings.
- 9:30 p. m.—St. Louis Dance program.

FRIDAY, OCTOBER 12

- 7:00 p. m.—Tacoma Trunk Co. musical program.
- 7:30 p. m.—Navy Tex program.
- 8:00 p. m.—Rental variety hour.
- 8:30 p. m.—Peoples Savings & Loan Association.
- 9:00 p. m.—Late release recordings.
- 9:30 p. m.—Navy's Ham Bone.
- 10:00 p. m.—Famous Name program.

SATURDAY, OCTOBER 13

- 8:30 p. m.—Famous Name program.
- 7:00 p. m.—E. H. Kennedy, Oldsmobile program.
- 7:30 p. m.—Navy Tex program.
- 8:00 p. m.—Union Service hour.
- 8:30 p. m.—Central Motors program.
- 9:00 p. m.—O. H. Clow program.
- 9:30 p. m.—Federal Bakery program.

SUNDAY, OCTOBER 14

- 10:45 a. m.—First Baptist Church.
- 8:00 p. m.—Hotel Winthrop Trio.

KPQ

Seattle, Wash.—1300 Kc.

Taft & Wasmer, Inc.
236.6 METERS—100 WATTS
ARCHIE TAFT and LOUIS WASMER, Inc., Owners
1107 Second Avenue Tel. EM 1433
C. A. Berger, Manager
Don Johnson, Announcer Norman Reiss, Engineer

DAILY EXCEPT SUNDAY

- 7:00 a. m.—Breakfast Program (except Monday, Wednesday and Friday).
- 10:00 a. m.—Market Suggestions (except Monday, Wednesday and Friday).
- 4:30 p. m.—Buyer's Guide (except Tuesday, Thursday and Saturday).
- 10:00 p. m.—Dance Music (except Tuesday, Thursday and Saturday).

SUNDAY, OCTOBER 7

- 9:00 a. m.—Sacred and concert records.
- 10:00 a. m.—Beauty hour.
- 12:30 p. m.—Orthophonic concert.
- 4:00 p. m.—Comedy program.
- 5:00 p. m.—Popular records.
- 5:30 p. m.—Pointers on attractiveness.
- 9:00 p. m.—Whitman Furniture Co. Home Hour.
- 10:00 p. m.—Babensack the Tailor; romance program.

MONDAY, OCTOBER 8

- 4:30 p. m.—Buyer's Guide.
- 5:30 p. m.—Rainier District program.
- 6:30 p. m.—Babensack the Tailor.
- 7:00 p. m.—Accordion and banjo recordings.
- 8:45 p. m.—Anna Helen Borstall, swimming talk.
- 9:15 p. m.—Home hour.

TUESDAY, OCTOBER 9

- 8:00 a. m.—Y. W. C. A. Setting-up Exercises.
- 8:30 a. m.—Shoppers' Service.
- 9:00 a. m.—Shoppers' Service.
- 9:10 a. m.—Road reports.
- 9:15 a. m.—Home hour.
- 10:30 a. m.—Buyer's Guide.
- 11:30 a. m.—Luncheon musicale.
- 1:00 p. m.—Rainier District.
- 2:00 p. m.—Varied recordings.

WEDNESDAY, OCTOBER 10

- 4:30 p. m.—Buyer's Guide.
- 5:30 p. m.—Rainier District.

- 5:15 p. m.—Home hour.
- 8:30 p. m.—Orthophonic concert.
- 8:45 p. m.—Anna Helen Borstall, swimming talk.

THURSDAY, OCTOBER 11

- 8:00 a. m.—Y. W. C. A. Health Rhythms.
- 8:30 a. m.—Margaret Bell, Shoppers' Service.
- 9:10 a. m.—Road reports.
- 9:15 a. m.—Home hour.
- 10:30 a. m.—Buyer's Guide.
- 11:30 a. m.—Sty's Hints.
- 12:00 noon—Organ recital, recorded.
- 1:00 p. m.—Rainier District program.
- 2:00 p. m.—Popular records.

FRIDAY, OCTOBER 12

- 4:30 p. m.—Buyer's Guide.
- 5:30 p. m.—Rainier District.
- 6:30 p. m.—Popular concert music.
- 7:30 p. m.—Red Sea Opera.
- 8:30 p. m.—Today's melodies.
- 9:15 p. m.—Home hour.

SATURDAY, OCTOBER 13

- 8:00 a. m.—Y. W. C. A. Setting-up Exercises.
- 8:30 a. m.—Margaret Bell, Shoppers' Service.
- 9:10 a. m.—Road reports.
- 9:15 a. m.—Home hour. Bargain bulletins.
- 10:30 a. m.—Bakker White, Food Specials.
- 10:30 a. m.—Buyer's Guide.
- 12:30 noon—Luncheon musicale.
- 1:30 p. m.—Popular recordings.

WALTER BIDDICK — Phone Westmore 9137
"A Complete Radio Program and Announcement Service"

The essential features of these programs are identical with those sent by the stations.



ARTHUR L. FRAM

KJR Seattle, Washington—860 Kc.

2500 WATTS—3485 METERS. Phone Main 1778

Operated by the American Broadcasting Co.

604 Home Savings Building, 1820 Westlake Ave.

Arthur L. Fram, Program Director, Clarence Clark, Engineer

DAILY EXCEPT SUNDAY

- 6:45 a. m.—Vim, Vigor and Vitality.
- 7:45 a. m.—Breakfast News.
- 8:00 a. m.—The Golden Hour Orchestra.
- 9:00 a. m., 12:00 noon and 10:00 p. m.—Pacific Standard Time Signals.
- 9:00 a. m.—Mary Crooke, KJR Better Homes Girl.
- 9:45 a. m.—Devotional Service.
- 10:00 a. m.—KJR Characteristic Hour.
- 10:30 a. m.—KJR Dream House.
- 11:00 a. m.—Variety Program.
- 12:00 noon—ABC Revellers, News.
- 12:30 p. m.—American Salon Orchestra, under direction of Francesco Longo (ex. Sat.).
- 1:30 p. m.—KJR Stringed Trio, directed by Kola Levenne (ex. Wed. and Sat.).
- 2:30 p. m.—Song Recital.
- 3:00 p. m.—American Symphony Orchestra, direction of Francesco Longo.
- 4:00 p. m.—Siesta Hour.
- 5:00 p. m.—Request Hour (except Tuesday and Friday).
- 5:00 p. m.—Special Announcements.
- 6:15 p. m.—Theatrical Review, News, Sports, etc.
- 6:30 p. m.—The Captivators (except Wednesday).
- 7:00 p. m.—Twilight Hour Program! American Salon Orchestra.
- 9:00 p. m.—American Salon Orchestra, under direction of Francesco Longo.
- 10:00 p. m.—Hotel Butler Rose Room Dance Orchestra.

SUNDAY, OCTOBER 7

- 10:00 a. m.—International Bible Students Assn.
- 11:00 a. m.—Sacred Concert.
- 2:00 p. m.—American Salon Orchestra.
- 3:00 p. m.—KJR String Trio, Kola Levenne, director.
- 4:00 p. m.—American Salon Orchestra (ABC).
- 5:00 p. m.—Cathedral Hour; Vesper Hour; Instrumental Quartet (ABC).
- 6:30 p. m.—Home Savings Building String Trio
- 7:00 p. m.—Novelty Hour; Murray and Harriet Show Host Band and the Masquerades.
- 8:00 p. m.—American Salon Orchestra.

MONDAY, OCTOBER 8

- 8:00 p. m.—KJR String Trio, Kola Levenne, director.

TUESDAY, OCTOBER 9

- 8:00 p. m.—KJR Dream House.
- WEDNESDAY, OCTOBER 10**
- 8:00 p. m.—American Salon Orchestra (ABC).
- THURSDAY, OCTOBER 11**
- 8:00 p. m.—American Salon Orchestra.
 - 10:00 p. m.—Hotel Butler Rose Room Orchestra, "A Night in Coffee Dan's."

FRIDAY, OCTOBER 12

- 8:00 p. m.—KJR Dream House.
- SATURDAY, OCTOBER 13**
- 8:00 p. m.—Melodians and Memories; the Reverie Hour
 - 9:00 p. m.—Vincent Knowles Orchestra (ABC).
 - 10:30 p. m.—Show Host Frolic (ABC).



GEORGE NELSON

KOMO Seattle, Wash.—970 Kc.

FISHER'S BLEND STATION
METROPOLITAN CENTER, SEATTLE

Telephone E167 5890

DAILY EXCEPT SUNDAY

- 10:00 a. m.—Inspirational Services.
- 10:15 a. m.—Y. M. C. A. Health Exercises.
- 10:30 a. m.—"What to Prepare for Dinner."
- 12:00 noon.—Farm Flashes, Grain Reports, Music, News (except Monday).
- 12:30 p. m.—"Constance Cook" and Rhona Marshall.
- 1:00 p. m.—Totem Concert Orchestra and Soloists.
- 4:45 p. m.—Silent Period.
- 5:00 p. m.—Kiddies' Program.
- 5:30 p. m.—Stocks and Bonds, News.
- 6:00 p. m.—Totem Orchestra and soloists (except Monday).
- 8:00 p. m.—N. B. C., Longline Time Signal.
- 10:00 p. m.—Totem Dance Orchestra. Late news flashes (except Saturday).

SUNDAY, OCTOBER 7

- 11:00 a. m.—Plymouth Congregational Church.
- 12:20 p. m.—Fifth Ave. Theater Organ Concert.
- 1:00 p. m.—Dum, Trio and Quartets
- 1:30 p. m.—NBC.*
- 2:00 p. m.—Homeaway Tabernacle.
- 2:30 p. m.—Totem Concert
- 3:00 p. m.—NBC.*
- 3:30 p. m.—Totem Concert Trio.
- 4:30 p. m.—NBC.*
- 5:00 p. m.—First Church of Christ, Scientist.
- 6:00 p. m.—NBC.*
- 9:30 p. m.—Totem Sunday Quartet; duos, trios
- 10:00 p. m.—Herbert Freese's Orchestra

MONDAY, OCTOBER 8

- 10:45 a. m.—Piano, Catherine Finney.
- 11:00 a. m.—Fifth Ave. Theater Organ Recital.
- 11:30 a. m.—"Blue Monday Joya"
- 6:45 p. m.—NBC.*
- 9:00 p. m.—Mueller Furnace Co. from KGW, Portland.
- 9:30 p. m.—Totem Concert Orchestra

TUESDAY, OCTOBER 9

- 10:30 a. m.—NBC.*
- 11:30 a. m.—Fifth Ave. Theater Organ Recital.
- 8:00 p. m.—NBC.*
- 6:30 p. m.—Totem Concert Orchestra.
- 7:00 p. m.—NBC.*
- 9:00 p. m.—Schwabacher hour, with KGW, Portland.

WEDNESDAY, OCTOBER 10

- 11:00 a. m.—NBC.*
- 11:30 a. m.—Fifth Ave. Theater Organ Recital.

*See Page 36 for detailed program of National Broadcasting Company.

- 12:00 noon.—Totem Concert Trio.
 - 6:00 p. m.—Totem Synco-Rhythmic; Jimmie & Bob.
 - 7:00 p. m.—Duets, Rhona Marshall and James Harvey.
 - 7:30 p. m.—NBC.*
 - 8:00 p. m.—Program originating at KGW, Portland.
 - 8:30 p. m.—NBC.*
 - 9:30 p. m.—Warner Bros. Picture Hour.
- THURSDAY, OCTOBER 11**
- 10:45 a. m.—Piano, Catherine Finney.
 - 11:00 a. m.—Fifth Ave. Theater Organ Recital.
 - 11:30 a. m.—Totem Concert Trio.
 - 7:30 p. m.—Program originating at KGW, Portland.
 - 8:00 p. m.—Totem Concert Orchestra; Totem Melodians.
 - 9:30 p. m.—NBC.*

FRIDAY, OCTOBER 12

- 1:00 p. m.—Duets, Witter and Wright; Totem Concert Orchestra.
- 2:00 p. m.—"Jimmie and Bob"; tenor, Art Lindsay.
- 3:00 p. m.—Mezzo Soprano, Rhona Marshall; baritone, Alec Campbell; Totem Concert Orchestra.
- 4:00 p. m.—"Jimmie and Bob"; soprano, Alice Maclean; Totem Concert Orchestra.
- 5:00 p. m.—Kiddies' program.
- 8:00 p. m.—NBC.*
- 9:00 p. m.—Totem Mixed Quartet; duets
- 9:30 p. m.—NBC.*

SATURDAY, OCTOBER 13

- 6:00 p. m.—Program joint with KGW, Portland, and KIQ, Spokane.
- 7:00 p. m.—NBC.*
- 11:00 p. m.—Fifth Ave. Theater Frolic.

The essential features of these programs are identical with those sent by the stations



CECIL P. UNDERWOOD
Chief Announcer

KHQ Spokane, Washington—810 Kc

1000 WATTS—379.2 METERS
LOUIS WASMER, INC., Standard Stock Exchange Bldg.
Telephone Main 4442

DAILY EXCEPT SUNDAY AND WEDNESDAY

- 7:00 a. m.—Bailey's Period of Pep and Callisthenics.
- 7:30 a. m.—Beauty Culture.
- 8:15 a. m.—Musical programs.
- 8:30 a. m.—Inland Empire Road Reports.
- 9:00 a. m.—Household Service—Tull & Gibbs.
- 9:57 a. m.—A & K Educational Talk.
- 10:00 a. m.—Sara Leigh's Hour with Women.
- 11:00 a. m.—Farmers' Service Hour (except Thursday).
- 12:00 noon—The Diamond Hour.
- 12:30 p. m.—Musical Program (except Tuesday).
- 1:00 p. m.—Miss Modern.
- 1:30 p. m.—Fun Facts.
- 2:00 p. m.—Washington Home Service Hour (except Tuesday and Friday).
- 3:00 p. m.—Kobler Concert.
- 3:30 p. m.—National Savings Thoughts.
- 4:00 p. m.—Stewart's Musical Program (except Tuesday).
- 4:30 p. m.—Bailey's Concert.

- 5:00 p. m.—Service Hour.
- 6:00 p. m.—Mahlon Merrick's Concert Orchestra (except Saturday).
- 6:30 p. m.—The Dough Boys (except Monday).
- 9:00 p. m.—Longitude Current Time.

SUNDAY, OCTOBER 7

- 10:30 a. m.—Children's Sunday School Program.
- 11:00 a. m.—Central Methodist Episcopal Church. Dr. T. W. Jeffrey, Pastor.
- 1:30 p. m.—NBC*
- 5:00 p. m.—Father's Concert.
- 8:30 p. m.—Religious services by the International Bible Students.
- 8:00 p. m.—NBC*
- 8:00 p. m.—Church of the Truth, the Rev. Erma W. Walsh, Pastor.
- 9:00 p. m.—NBC*
- 10:00 p. m.—City Service Concert.

MONDAY, OCTOBER 8

- 11:00 a. m.—Farmers Service Hour.
- 6:45 p. m.—NBC*

TUESDAY, OCTOBER 9

- 11:30 a. m.—Farmers' Service Hour.
- 10:30 a. m.—Woman's Magazine of the Air—NBC*
- 2:00 p. m.—Chamber of Commerce Luncheon.
- 4:00 p. m.—Musical Program.
- 7:00 p. m.—Musical Programs.
- 8:00 p. m.—Ever-Ready Sales Group.
- 8:30 p. m.—Don Amalio, NBC*
- 9:00 p. m.—Northwest Flyers.

*See Page 58 for detailed program of National Broadcasting Company.

- 10:00 p. m.—Dance music by Mahlon Merrick and his orchestra, playing in the Italian Gardens of the Davenport Hotel.

WEDNESDAY, OCTOBER 10

- 10:00 a. m.—Sara Leigh's Hour with women.
- 11:00 a. m.—NBC*
- 6:30 p. m.—The Dough Boys.
- 7:30 p. m.—Tom Mitchell Pyrolist—KGW
- 8:30 p. m.—NBC*
- 9:30 p. m.—Northwest Mines.

THURSDAY, OCTOBER 11

- 7:00 p. m.—Musical Program.
- 7:30 p. m.—Tom Mitchell Pyrolist—KGW
- 8:00 p. m.—Musical Programs
- 9:00 p. m.—NBC*

FRIDAY, OCTOBER 12

- 2:00 p. m.—Musical Program.
- 6:00 p. m.—NBC*
- 7:00 p. m.—Dinner Concert, Sports, etc.
- 7:15 p. m.—The Dough Boys.
- 7:30 p. m.—Democratic Campaign, NBC*
- 8:00 p. m.—NBC*
- 9:00 p. m.—Miss Spokane.
- 9:30 p. m.—NBC*

SATURDAY, OCTOBER 13

- 7:00 p. m.—NBC*



CARRIE ANDREW

KGA Spokane, Washington—1150 Kc.

200.7 METERS—3000 WATTS
Operated by the American Broadcasting Co., located in the Sun Life Assurance Building

Carrie Andrew
Announcer

H. E. Studebaker
Studio Manager

- 7:00 p. m.—A. B. C. Chain (except Wednesday).
- 7:30 p. m.—Correct Time.
- 8:00 p. m.—ABC Chain.
- 9:00 p. m.—Musical program.

SUNDAY, OCTOBER 7

- 11:00 a. m.—First Presbyterian Church Service.
- 2:00 p. m.—ABC Chain.
- 7:30 p. m.—Studio program.
- 7:00 p. m.—New Haven Westminster Chimes.
- 7:30 p. m.—First Presbyterian Church Services.
- 9:00 p. m.—ABC Chain.

MONDAY, OCTOBER 8

- 8:00 p. m.—ABC Chain.
- 10:00 p. m.—Studio program.

TUESDAY, OCTOBER 9

- 8:00 p. m.—Simpson's Old Timers.
- 9:00 p. m.—ABC Chain.
- 10:00 p. m.—Simpson's Old Timers.
- 11:00 p. m.—Musical program.

WEDNESDAY, OCTOBER 10

- 10:00 p. m.—Van Audie Hoffman Music Co. program.
- 11:00 p. m.—Musical program.

THURSDAY, OCTOBER 11

- 10:30 p. m.—Tranfused Orchestra.

FRIDAY, OCTOBER 12

- 11:00 a. m.—Dietetic Talk, courtesy Desert Hotel.
- 10:00 p. m.—Studio Program.

SATURDAY, OCTOBER 13

- 2:00 p. m.—Musical Program and Timely Topics.
- 3:00 p. m.—Mather Studio Organ Recital.

DAILY EXCEPT SUNDAY

- 6:45 a. m.—ABC chain setting up exercises.
- 9:00 a. m.—Time Signals.
- 9:00 a. m.—Betty Cooke, KGA Better Homes Girl.
- 10:00 a. m.—Classical Recordings.
- 10:30 a. m.—Morning Music for Housewives.
- 11:00 a. m.—Shopping Service; Music; Dietetic Talk.
- 12:00 noon—Time; Weather; U. S. Radio Farm School.
- 12:15 p. m.—Logan & Bryan Grain Quotations.
- 12:30 p. m.—Musical Programs.
- 1:00 p. m.—Van Audie Hoffman Music Co.
- 1:30 p. m.—Musical.
- 4:00 p. m.—Van Audie Hoffman Music Co.
- 4:30 p. m.—Business Announcements.
- 5:00 p. m.—Uncle Andy's Half Hour with Kiddies.
- 5:30 p. m.—Sullivan's Trio.
- 6:00 p. m.—Weather Forecast.
- 6:30 p. m.—Dinner Hour Concert.

The essential features of these programs are identical with those sent by the stations.

KFVD

Culver City, Calif.—1390 Kc.

250 WATTS—215.7 METERS
 4185 Minorva Ave.—Santa Monica 77115
 Operated by the Culver City Broadcast Co., the Official Station of the RADIO DISTRIBUTING CO., Distributors Freed-Eisemann Radol.
 Norman H. Marshall, Manager
 Marvin Adams, Chief Technician
 Chet Cathers, Program Director

DAILY EXCEPT SUNDAY
 9:00 a. m.—Recordings and announcements.
 4:00 p. m.—Recordings.
SUNDAY, OCTOBER 7
 6:00 p. m.—String Trio.
 7:00 p. m.—Floice Korth, Mickey Davey, harmony sisters
 8:00 p. m.—Ruby Weber, Cliff Wright, DeZia.
MONDAY, OCTOBER 8
 4:45 p. m.—Old Time Songs.
 5:00 p. m.—String Trio, soloists.
 6:00 p. m.—Adelaide Gossett-Joe Hechtal.
 9:00 p. m.—Jane Lee, Len Soule.
 9:30 p. m.—Jean Hadden.
 10:00 p. m.—Request Hour with Doc Morse.
TUESDAY, OCTOBER 9
 4:45 p. m.—Chet and Peggy in Sonolague.
 5:00 p. m.—Cliff Wright, Marguerite Guzman.
 6:00 p. m.—Elena Miller, Mae Bender.
 8:00 p. m.—Towers Academy of Fine Arts.
 10:00 p. m.—Earl Buehler, Ruby Tinsler.
WEDNESDAY, OCTOBER 10
 5:00 p. m.—I. J. Michaud, String Trio.

6:00 p. m.—DeZia, quartet.
 10:00 p. m.—C. Karl Jennings, concert baritone.
 10:30 p. m.—Soloists.
 11:00 p. m.—Ruby Weber, Esther Kahn.
THURSDAY, OCTOBER 11
 4:45 p. m.—Old Time Songs.
 5:00 p. m.—String Trio.
 6:00 p. m.—Armando Meus, violinist.
 10:00 p. m.—Jane Lee, Len Soule.
 10:30 p. m.—Eddie Johnson, guitar.
 11:00 p. m.—Sturdy Steers, Peggy Wade.
FRIDAY, OCTOBER 12
 10:00 a. m.—DeZia, quartet.
 4:45 p. m.—Chet and Peggy in Sonolague.
 5:00 p. m.—Marguerite Guzman, Cliff Wright.
 6:00 p. m.—Harmony Sisters, Yella Barber.
 9:00 p. m.—Jean Hayden, James Orr Dean.
 10:00 p. m.—Ruby Tinsler, Ed Lyttel.
SATURDAY, OCTOBER 13
 5:00 p. m.—String Trio.
 6:00 p. m.—Elena Miller, Mae Bender.
 10:00 p. m.—Doc Morse and his Uke.
 11:00 p. m.—Chet Cathers, Earl Buehler.

DX Club

(Continued from Page 41)

DX Club:

As I was reading my Radio Doings for this week I was certainly tickled to see the DX Club taken down from the shelf, dusted off and put to use.

My log as yet is very modest, but would like to submit those I have received since Sept. 1st:

WENR, WMAQ, KMA, KTNT, KSL, KJR, KOA, CNRV, KGW, KOIN, KEX, KOMO, WAAW, KFNF, and also received WJAX Sept. 17th, just a few days before the hurricane.

These stations have been received under difficulty, due to static, but I can't complain, as the DX season isn't even under way as yet.

Sincerely,

JOHN E. DIMOND,
 1735 San Pasqual St.,
 Pasadena, Calif.

DX Club:

After one year and ten months of fishing (in season and out of season) I finally landed a foreigner, other than Canada or Mexico. Listened to 3YA, Christchurch, New Zealand, sign off this morning at 2:10. For those who might wish to try for him will say that he is just between KIIJ and KWKH. Used 100 feet straight braided wire, with 6-tube Gillfillan No. 20.

A. W. CROSBY,
 8859 1/2 Alcott St., Los Angeles.

For good or ill, broadcasting is bound to exert an incalculable influence on the development of civilization. Unless the highest standards are maintained the persuasive influence of broadcasting may be damaging.

A. C. VOLTAGE CONTROL BOX

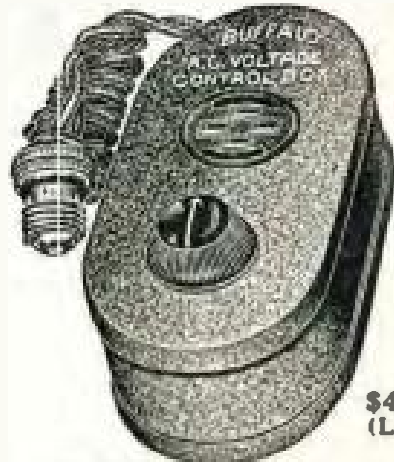

\$4.00
 (List)

A Dejur Product, operating efficiently on the AC set and on electrified installations. Voltage determined by observing heater element in detector tube.

Los Angeles Jobbers
 Radio Supply Co. H. H. Hara
 812-14 S. Hwy 1620 S. Hill St.
 Yale Radio Electric Co.
 1111 Wall St.
 Factory Representative
 F. H. Deardorf, 800 N. Spring St., L. A.

Timely Trade Topics

Mr. Jerry T. Hill of 823 San Fernando Bldg. has been appointed district manager for the DeForest Radio Company of Jersey City, New Jersey, and will specialize on the development of the local district for DeForest tubes.

Mr. W. T. Butterworth, of the Texola Radio Parlor at 638 North Western Avenue, Los Angeles, extends a general invitation to visit his new store. Superior service on Stewart-Warner and Cardinal sets is promised at all times.

B. J. DeJarnett, manufacturer of the D. J. Ground, of 4161 Mandlay Drive, Los Angeles, announces that the Pacific Wholesale, Inc., is now a distributor for the D. J. Ground.

A series of experiments recently made with Majestic All-Electric Radio receivers to determine the type of aerial and ground connections which most efficiently operate with this sensational radio have again proven the merits of the Bouldin Cage Antenna and the Preston Permanent Radio Ground, an antenna-ground combination that has been highly recommended by all radio engineers who have tested these products.

The Majestic experiments, made by Howard Threlgeld and F. A. Tischer, radio engineers on the staff of Ungar & Watson, Inc., Southern California distributors of Majestic Radio, produced results identical with those experienced by other engineers who were testing different makes of radio apparatus.

Officials of the Radio Test Laboratories, 3036 Fifth Avenue, Los Angeles, who distribute both the Bouldin Antenna and the Preston Ground, express themselves as much gratified with the results of the tests with Majestic radio and voice their opinion that this antenna-ground circuit will be in general use during the coming radio season, especially by radio fans who are trying

constantly to better their distance reception.

Harper's Radio Service of Alhambra has in operation a portable public speaking system that is very unique.

This apparatus has proved so efficient that most of the fairs throughout the state have found its services indispensable.

At the present time this "rolling" public address system, under the supervision of Mr. H. R. Harper, is in attendance at the Elks Convention and Circus at Santa Barbara, which will continue to October the 6th. The entire crowd is thus aware of everything that goes on at all times.

Radio and Music Trades Association of Seattle have adopted a Code of Ethics which they have printed on pocket size cards. These cards the members carry with them at all times and whenever a question arises as to terms and policy, the matter may be settled by referring to the Pocket Code.

The National Radio & Supply Company, 141 W. Washington St., Los Angeles, has been appointed Southern California distributor for Cuninghams tubes and will maintain a complete stock of the entire line at all times.

WANTED

Position as Program Manager and Musical Director. Years of experience in studio work. Excellent recommendations.

Box "B"

Radio Doings

JOS. GEFFEN, of the Green Specialty Company, wholesale jobbers in Radio Parts, died suddenly on September 25; interment made in Mt. Zion cemetery. Mr. Geffen had been associated with this company for the past seven years and was very popular with the Radio trade, by whom he will be greatly missed.

DO YOU KNOW THAT

A Stage of R. F. added to Silver-Marshall, Remler or Magnaformer Supers eliminates harmonics and increases Volume and Selectivity? Let me prove it to you.

Jack Cheney, 1759 W. 39th St.
Tel. UNiversity 6088 Los Angeles

The essential features of these programs are identical with those sent by the stations.



EARLE J. GLADE

KSL Salt Lake City, Utah—990 Kc.

1000 WATTS—302.8 METERS

"The Voice of the Inter Mountain Empire"

Earl J. Glade
General Manager
Lewis L. Lacey
Program Director
John N. Cope
Technical Director
Roscoe G. Grover
Chief Announcer

7:00 p. m.—"The Informal Blaze Miners."
7:30 p. m.—Doug. Iaitz and Larry Beaumont. "The Melody Boys."
8:00 p. m.—"The Jewel Box."
8:30 p. m.—"The Ariel Orchestra."

TUESDAY, OCTOBER 9

6:00 p. m.—National Political Broadcast from New York by the NBC.
6:30 p. m.—Salt Lake Police Department.
7:30 p. m.—Marguerite Turner, mezzo-soprano, and Cicily Adams, pianist.
8:00 p. m.—Half hour with the Old Timers.
8:30 p. m.—Harry E. Erickson, popular pianist.
9:00 p. m.—Claude Kiff and his Odeon Spanish Ballroom Band.

WEDNESDAY, OCTOBER 10

4:30 p. m.—National Political Broadcast from New York by the NBC.
6:30 p. m.—Better Business Bureau.
6:45 p. m.—Advice to the Home Gardener.
7:00 p. m.—Theora Lindgren. "The Blues Girl."
7:30 p. m.—"The Eight Four" Male Quartet.
8:00 p. m.—Plute Quartet.
9:00 p. m.—Concert Ensemble.
10:00 p. m.—Silent.

THURSDAY, OCTOBER 11

5:00 p. m.—National Political Broadcast from New York by the NBC.
6:30 p. m.—Informal program.
7:00 p. m.—Jordan Goodmansson, popular tenor, and his accompanist.
7:30 p. m.—Frank Cole and Donald Cope, violinists.
8:00 p. m.—John Kallias and his Hawaiian Trio.
8:30 p. m.—The Mormon Tabernacle Organ and Choir.
9:30 p. m.—Dance music, featuring Claude Kiff's Odeon Ballroom Band.

FRIDAY, OCTOBER 12

6:30 p. m.—"The Home Circle," Dr. Ray Durr.
7:00 p. m.—Lorel Berry, pianist.
8:00 p. m.—Chas. Lierly, tenor and Kyle Glasier, pianist.
8:30 p. m.—Music of Yesterday.
9:00 p. m.—Dance music, featuring Irving Webb's Imperial Six.

SATURDAY, OCTOBER 13

6:00 p. m.—NBC, Eastern Network, presenting B. A. Rolfe and his orchestra.
7:00 p. m.—The Brimley Brothers Quartet.
8:00 p. m.—"The Varsity Trio," instrumentalists.
8:30 p. m.—"Opportunity Hour."
9:00 p. m.—Dance music.
11:00 p. m.—KSL, Corbett Club.

DAILY EXCEPT SUNDAY

5:45 a. m.—Breville.
6:00 a. m.—Sitting-up exercises.
6:15 a. m.—Music for the early riser.
6:30 a. m.—Repetition of exercises.
6:50 p. m.—New York Stock Market and Chicago Grain Market.
7:00 a. m.—Inspirational period by "Optimo."
7:15 a. m.—An hour with the Masters of Melody.
8:00 a. m.—News Service for the Shopper.
9:00 a. m.—Items of interest to Madame.
9:30 a. m.—(Wednesday only), Helen Webster, Interior Decoration expert.
11:00 a. m.—Noon-hour Variety Broadcast.
1:00 p. m.—Popular Hour.
2:00 p. m.—KSL Concert Hour.
3:00 p. m.—"The Tiny Tots" hour with Uncle Roscoe and the gang.
4:00 p. m.—"Ye Olde Crow."
5:00 p. m.—Ogden Livestock Market.
5:30 p. m.—New York Stock Market.
6:00 p. m.—Utah and Salt Lake Mining Market.
6:05 p. m.—"Big Brother" and the children.

SUNDAY, OCTOBER 7

12:00 noon.—Noon Hour Broadcast, informal studio program.
1:00 p. m.—International Bible Students Assn. "Watch Tower" program.
2:00 p. m.—Mormon Tabernacle Services by direct wire.
2:30 p. m.—American Legion Americanization prog.
4:00 p. m.—"Deceitful Reproducers" Little Symphony.
7:30 p. m.—First Presbyterian Church Services by direct wire.
8:30 p. m.—Community Hour.
9:00 p. m.—L. D. S. Services from the studio.
10:00 p. m.—"Utah Loud Speakers," and the Melody Trio.

MONDAY, OCTOBER 8

6:30 p. m.—Informal program.

Stations change in wavelength November 11th. You can find their position by using the 1928-9 Call Book. See Page 5.

SILVER THE KING

24 Kt Gold
Pure Silver
Soft
Copper

Gosilco Super Aerial Wire

Gold over Silver on Copper

Greatly Increased DX Range. 35% More Volume—Clearer Tone—25% sharper Tuning—Non-Corrosive. Endorsed by Naval Research Laboratory, Major Mett, Ormiston. A permanent investment. No. 14, 100 ft., \$4.00; 75, \$3.25; 50, \$2.50. Pat. applied for. If dealer cannot supply you, write or phone us. Over 50,000 GOSILCO Aerials in use—There's a Reason.

GOSILCO RADIO PRODUCTS CO.
6420 Marbrisa Ave. DE. 3940 Huntington Park, Calif.

The essential features of these programs are identical with those sent by the stations.



FREEMAN H. TALBOT

KOA

Denver, Colorado—920 Kc.

500 WATTS—325 METERS GENERAL ELECTRIC COMPANY
Pacific Standard Time
"Rocky Mountain Broadcasting Section"

DAILY EXCEPT SUNDAY

- 11:30 a. m.—Time Signal.
- 11:31 a. m.—Weather, Stocks, etc.
- 11:15 a. m.—Organ Recital.

- 4:30 p. m.—Vincent Lopez and his Hotel St. Regis Dance Orchestra, NBC.
- 5:00 p. m.—Stocks, markets, livestock, etc.
- 5:25 p. m.—Road reports.
- 5:30 p. m.—Brown Palace Orchestra.
- 6:00 p. m.—Ipsan Troubadours, NBC.
- 6:30 p. m.—Palmdrive Hour, NBC.
- 7:30 p. m.—Democratic National Campaign address, NBC.
- 8:00 p. m.—The Novelty Shop.
- 8:30 p. m.—KOA Mixed Quartet.
- 9:00 p. m.—Denver String Quartet.

THURSDAY, OCTOBER 11

- 1:00 p. m.—A Recipe a Day.
- 3:05 p. m.—Thursday Afternoon Musicale.
- 3:30 p. m.—"The Morning Post Epigram."
- 3:45 p. m.—Musical program.
- 3:50 p. m.—Stocks, markets, etc.
- 3:55 p. m.—Road reports.
- 5:00 p. m.—Brown Palace Hotel Orchestra.
- 6:00 p. m.—Republican National Campaign address, NBC.
- 6:30 p. m.—Maxwell House Coffee Hour, NBC.
- 7:00 p. m.—Halsey Squart, NBC.
- 7:30 p. m.—Blue Danube Nights, NBC.

FRIDAY, OCTOBER 12

- 3:00 p. m.—A Recipe a Day.
- 3:05 p. m.—Housewives' matinee.
- 4:30 p. m.—Stocks, markets, etc.
- 4:55 p. m.—Road reports.
- 5:00 p. m.—Cities Service Orchestra and Cavaliers, NBC.
- 5:00 p. m.—Extension Service, Colorado Agricultural College, Fort Collins, Colo.
- 6:30 p. m.—Brown Palace Hotel Orchestra.
- 7:00 p. m.—Strangers-Carlson, NBC.
- 7:30 p. m.—Answers on Financial Questions.
- 7:35 p. m.—The Softball Scoreboard.
- 8:15 p. m.—The Artist's Studio—South Sea Scenes.
- 9:00 p. m.—The Music Album—Old Love Songs.

SATURDAY, OCTOBER 13

- 11:10 a. m.—Road reports.
- 12:30 p. m.—RCA Hour, NBC.
- 4:00 p. m.—Vincent Lopez and his Hotel St. Regis Dance Orchestra, NBC.
- 4:30 p. m.—Low White organ recital, NBC.
- 5:15 p. m.—"The World's Business," NBC.
- 5:30 p. m.—Preview of International Sunday School.
- 6:00 p. m.—Republican National Campaign address, NBC.
- 8:30 p. m.—Philco Hour, NBC.

- SUNDAY, OCTOBER 7
- 10:00 a. m.—Montview Blvd. Presbyterian Church.
- 12:30 noon—Sixty Musical Minutes, NBC.
- 1:00 p. m.—Genta Kozliska, soprano, and Winifred Young, pianist, NBC.
- 1:30 p. m.—National String Orchestra.
- 2:30 p. m.—Academy Hour, NBC.
- 5:00 p. m.—Dean and McCarty program, NBC.
- 5:15 p. m.—Cotton's Hour, NBC.
- 5:45 p. m.—Hoff-Schroeder organ recital.
- 6:30 p. m.—Montview Blvd. Presbyterian Church.

MONDAY, OCTOBER 8

- 7:30 a. m.—Democratic National Campaign address, NBC.
- 9:00 a. m.—Republican National Campaign address, NBC.
- 5:30 p. m.—Brown Palace Hotel Orchestra.
- 5:30 p. m.—Riverside Hour, NBC.
- 6:30 p. m.—Republican National Campaign address, NBC.
- 6:30 p. m.—Commodore Hotel Orchestra.
- 7:00 p. m.—General Electric hour.
- 8:00 p. m.—The Koa Hoons in "Money Sky."
- 8:00 p. m.—Horse Popular Trio.

TUESDAY, OCTOBER 9

- 7:30 p. m.—A Recipe a Day.
- 7:05 p. m.—Through the Opera Glasses, selections from "L'admet.".
- 4:30 p. m.—Vetera' Service, NBC.
- 4:30 p. m.—Memory's Garden, NBC.
- 5:00 p. m.—Stocks, markets, etc.
- 5:25 p. m.—Road reports, Motor Club of Colorado.
- 5:30 p. m.—Brown Palace Hotel Orchestra.
- 6:00 p. m.—Commodore Hotel Orchestra.
- 6:30 p. m.—Farm Question Box.
- 7:00 p. m.—Chequoy Club Eskimos, NBC.
- 7:30 p. m.—Answers on Financial Questions.
- 7:35 p. m.—Variety, the Spice of Life.
- 8:00 p. m.—Second U. S. Engineers' Band.
- 8:30 p. m.—Hotel Bennett Orchestra, NBC.

WEDNESDAY, OCTOBER 10

- 8:30 a. m.—Democratic National Campaign address, NBC.
- 9:00 p. m.—Republican National Campaign address, NBC.



FRED J. HART

San Jose, California—1010 Kc.

KQW

CALIFORNIA FARM BUREAU STATION
500 WATTS—256.00 METERS
FRED J. HART, Manager

SUNDAY, OCTOBER 7

- 10:15 a. m.—Sunday School lessons by Fred J. Hart.
- 11:00 p. m.—Morning Services, First Baptist church, conducted by Rev. Harold E. Harton.
- 7:30 p. m.—Evening Services, First Baptist Church.

MONDAY, OCTOBER 8

- 7:30 p. m.—Calif. Farm Bureau Evening Radio News.
- 8:00 p. m.—Salinas Community Program.

TUESDAY, OCTOBER 9

- 7:00 p. m.—Calif. Farm Bureau Evening Radio News.
- 8:00 p. m.—Surprise Program.

WEDNESDAY, OCTOBER 10

- 7:00 p. m.—Calif. Farm Bureau Evening Radio News.
- 8:30 p. m.—Mid-week Services, First Baptist Church.

THURSDAY, OCTOBER 11

- 7:00 p. m.—Calif. Farm Bureau Evening Radio News.
- 8:30 p. m.—Studio Program.

FRIDAY, OCTOBER 12

- 8:30 p. m.—San Jose Atwater Kent Contest.

SATURDAY, OCTOBER 13

- 6:30 p. m.—Calif. Farm Bureau Evening Radio News.
- 7:10 p. m.—Book diet by Herbert Corwin.

- DAILY EXCEPT SUNDAY
- 1:00 p. m.—Hart's Store half hour.
- 1:30 p. m.—The Friendly hour.
- 2:00 p. m.—The Style Chet.
- 4:00 p. m.—Sunshine Hour with W. K.
- 5:00 p. m.—Aunt Sammy talk; Home Economics (ex. Saturday).
- 5:30 p. m.—Pal's Big Brother Hour (ex. Saturday).
- 6:00 p. m.—Special radio features.
- 6:30 p. m.—Farmers' Exchange (ex. Saturday).

Radio Doings

Trade Mark Reg. U. S. Pat. Off.

New York Office
J. W. HASTIE
 155 East 42nd Street
 Vanderbilt 4661

Los Angeles Office
HORWOOD PUB. CO.
 407 East Pico Street
 Westmore 1401

San Francisco Office
CONGER & MOODY
 614-15 Hearst Bldg.
 Kearney 8483

CLOYD MARSHALL, JR.
Editor

K. G. ORMISTON
Technical Editor

GEORGE W. MARSHALL
Business Manager

MAJ. LAWRENCE MOTT
Associate Editor

Copyright, 1928, by Horwood Publishing Co.

CONTENTS

	PAGE		PAGE
The New Air Era.....	5	Silver-Marshall 720 S-G Six.....	35
Radio Topics of the Day.....	17	DX Club.....	41
The Studio.....	19	Sargent-Rayment Seven.....	47
Questions and Answers.....	21	Log of Western Stations.....	50
Trade News.....	32-34-39	Schedule of Western Stations.....	52
Short Wave Club.....	25	Schedule of DX Stations.....	54
Studio News.....	27	Timely Trade Topics.....	91

DIRECTORY OF DETAILED PROGRAMS

Call	Location	Meters	Page	Call	Location	Meters	Page
KELW..	Burbank, Calif....	228.9	68	KHQ...	Spokane, Wash. ..	370.2	89
KEX....	Portland.....	277.6	85	KJR....	Seattle.....	348.6	88
KFI....	Los Angeles.....	468.5	58	KLX....	Oakland.....	508	80
KEJK..	Beverly Hills, Cal.	262	64	KMIC..	Inglewood, Cal. ..	224	70
KFON..	Long Beach, Cal..	242	76	KMO...	Taroma, Wash. ..	254.1	87
KFQZ..	Los Angeles.....	232.4	74	KMTR..	Hollywood.....	516.9	64
KFRC..	San Francisco ...	454.3	82	KNRC..	Santa Monica....	375	74
KFSD..	San Diego, Cal....	440.9	77	KNX...	Los Angeles.....	337	62
KFSG..	Los Angeles.....	252	78	KOA...	Denver, Colo....	326	93
KFVD..	Culver City.....	215.7	90	KOIN..	Portland, Ore. ...	319	86
KFWB..	Hollywood.....	361.8	66	KOMO..	Seattle.....	309	88
KFWC..	Pomona, Cal.	221.1	70	KPLA..	Los Angeles.....	288.3	68
KFWI..	San Francisco ...	268	84	KPO...	San Francisco ...	422.3	83
KGA...	Spokane, Wash...	260.7	89	KPQ...	Seattle.....	230.6	87
KGEN..	El Centro, Cal....	225.4	85	KPSN..	Pasadena.....	315.6	66
KGER..	Long Beach, Cal..	215.7	79	KQW...	San Jose, Cal....	296	93
KGFH..	Glendale, Cal.	263	72	KSL...	Salt Lake City...	302.8	92
KGFJ..	Los Angeles.....	212.6	72	KTAB..	Oakland, Cal.	280	83
KGO...	Oakland, Cal.	384	84	KTBI..	Los Angeles.....	275	78
KGW...	Portland, Ore. ...	491.5	86	KWTC..	Santa Ana, Cal...	221.1	76
KHJ...	Los Angeles.....	399.8	60	KYA...	San Francisco ...	352.7	80
				National Broadcasting Co..	...		54

**THE PACIFIC COAST'S GREAT RADIO WEEKLY
 DELIVERED TO YOUR HOME 52 WEEKS
 FOR ONLY \$3.00—SAVE \$2.20**

Radio Doings, 407 East Pico Street, Los Angeles, California:
 Enclosed is \$3.00. Please mail Radio Doings each week for one year to my
 address. An attractive Leatherette Binder is sent with each subscription.

Name.....

Address.....

SILVER THE KING

24 Kt Gold
Pure Silver
Soft
Copper

Gosilco Super Aerial Wire Gold over Silver on Copper

Greatly Increased DX Range. 35% More Volume—Clearer Tone—25% Sharper Tuning—Non-Corrosive. Endorsed by Major Mott, Ormiston, Best, Cookaday, Garver of KNX. A permanent investment. No. 14, 100 ft., \$4.00; 75, \$3.25; 50, \$2.50. Pat. applied for.

Your Dealer Has It or Will Get It.

"Best by Navy Test"

Cunningham RADIO TUBES

All Types in Stock

C 11...\$ 2.50 Detector Amplifier	CX 301A.. 1.50 Detector Amplifier	CX 371A..\$ 2.75 Amplifier
CX 12... 2.50 Detector Amplifier	CX 310... 9.00 Power Amplifier	CX 374... 4.75 Voltage Regulator
CX 112A.. 2.75 Amplifier	CX 322... 6.50 4 Element Tube	C 376... 6.50 Ballast Tube
CX 220... 2.50 Amplifier	CX 326... 2.25 A. C. Amplifier	C 377... 1.75 Protective Tube
C 299... 2.25 Detector Amplifier	C 327... 4.00 A. C. Detector	CX 380... 4.25 Full Wave Rectifier
CX 299... 2.25 Detector Amplifier	CX 340... 2.00 Hi Mu Amplifier	CX 381... 7.50 Half Wave Rectifier
CX 300A.. 4.00 Detector		CX 350... 11.00 Power Amplifier

SM

Silver-Marshall Headquarters

A S-M 720 Custom Built Receiver will give you clear, distinct reproduction. Power to spare. Hear stations that you never had before.

HERBERT H. HORN

Established 1918

Westmore 6331

1629 South Hill Street

Los Angeles



APEX

RADIO

Let's Talk About Quality

APEX RECEIVERS employ the latest type improved NEUTRODYNE CIRCUIT. It is conceded to be the most efficient radio circuit yet devised, and practically all present day receivers now being offered, even those selling up to a thousand dollars or more, employ some variation of the famous NEUTRODYNE principle.

APEX engineers, using the NEUTRODYNE principle as a basis, have made many improvements, so that in presenting to you the APEX All Electric NEUTRODYNE you are offered a receiver as near perfect as present day engineers can devise.



Showing
Chassis
Construction

Apex
All-Electric
Receivers
from \$87.50
to \$199.50.
For List of
Authorized
Apex Dealers
See
Pages 48-49.

Rugged chassis construction—simplicity of tuning—mechanical and electrical excellence are outstanding features.

Real quality in spite of the moderate price asked for APEX RECEIVERS allows us to offer you the broadest guarantee ever made—

Should any APEX RECEIVERS prove defective in workmanship or material within a period of ninety days from date of purchase, your Apex dealer is authorized to exchange your set for a new one without cost to you.

Exclusive Wholesale Distributor

Yale Radio Electric Co.

1111 Wall Street

LOS ANGELES

Westmore 3351

This file including all text and images are from scans of a private personal collection and have been scanned for archival and research purposes. This file may be freely distributed, but not sold on ebay or on any commercial sites, catalogs, booths or kiosks, either as reprints or by electronic methods. This file may be downloaded without charge from the Radio Researchers Group website at <http://www.otrr.org/>

Please help in the preservation of old time radio by supporting legitimate organizations who strive to preserve and restore the programs and related information.