

New Super-Triplex; Multitone Loud Speaker Set

# Radio Digest

EVERY  
WEEK

# Illustrated

TEN  
CENTS

REG. U. S. PAT. OFF. & DOM. OF CANADA

Vol. VII

Copyright 1923  
By Radio Digest Publishing Co.

SATURDAY, DECEMBER 8, 1923

No. 9

## RADIO LOCATES DISEASE

### BLOOD COUNT DEVICE BOON TO HUMANITY

Canadian Physician's Invention  
Said to Diagnose by Rating  
Blood Stream

*Discovery Given Public*

Apparatus Which May Revolution-  
ize Medical Methods Pat-  
ented by Dominion

(By F. J. Huntley, Special Correspondent)

DETROIT.—What is declared to be a Radio invention which will diagnose human ills has been perfected, it was reported recently, by Dr. R. A. Waud of Highgate, Ont., a short distance from this city.

The discovery which in effect is similar in part to the reported application of Radio to the treatment or cure of diseases, as exclusively published by Radio Digest a few weeks ago, has attracted the attention of medical experts, especially of diagnosticians all over Canada and in a large part of the United States.

The Dominion government has issued a caveat (warning against infringement of patent) to Dr. Waud. The board of directors of the London, Ontario, medical school, where Dr. Waud made the greater number of his experiments, has arranged

(Continued on page 2)



Beryl Brown, soprano of the Chicago Civic Opera Company, has been heard this season in Verdi's "Aida" and Rimsky-Korsakoff's "The Snow Maiden" in minor but winsome parts

### HINT "BIG THINGS" IN SENATE PROBE

Federal Board's Findings in Search  
for Radio Monopoly Are  
Held up

WASHINGTON, D. C.—Whether the Federal Trade Commission has found a Radio monopoly or not in investigation of the Radio field for Congress, will not be known until the report is actually made to the Senate shortly after it convenes this December.

However, one of the members of the Commission who would not be quoted on the subject stated that the report would be a matter of very considerable interest to all Radiophans. It will be practically a complete history of the Radio industry up to the present time, from the time of its inception.

### WCAL BACK ON AIR AFTER STUDIO FIRE

NORTHFIELD, MINN.—The St. Olaf College station here, WCAL, is on the air again after an enforced vacation because of fire which destroyed the college chapel on September 22, and with it the broadcasting studio in the basement. A new studio has been constructed in the gymnasium.

To the left are presented two new acquisitions of the Civic Opera, both young American sopranos making their first bow to the public in grand opera. Standing nearest is Lucie Westen, who pleased as the "Forest Bird" in the recent production of Wagner's "Siegfried". Mary Fabian (in the lower corner), who possesses a promising voice, fills her parts with credit



# CHICAGO EXPOSITION DRAWS BIG CROWDS

## ANNUAL RADIO EXHIBIT IS ATTENDED BY NOTABLES

### Flewelling, DeForest and Other Famous Experts Take Part—\$7,000 in Prizes Awarded Listeners

CHICAGO.—Crowds so great that they exceeded in number, even at the start, the expectations of the management marked the second annual Radio show held in the Coliseum here recently. The daily attendance at the middle of the week's exposition was estimated at 20,000.

Exhibits of popular receiving sets and of accessories, of novel devices and of amateur sets for which prizes were awarded, and addresses by notables of the industry marked the show. Among the famous Radio experts who took part in the program was E. T. Flewelling, inventor of the circuit which bears his name. Dr. Lee DeForest, "father of Radio," who about twelve years ago while a clerk in Chicago, braved derision but persisted in his theory of electro-magnetic waves, was one of the "stars" of the exposition.

More than sixty home-built sets, among them an eleven-tube super-heterodyne, attracted attention. A \$2,000 hand-wrought solid silver receiving set was shown by the Federal Telephone and Telegraph company.

### Give \$7,000 in Prize Contest

Feature programs of the show were broadcast by the various stations in Chicago by means of sealed wires leading from the Coliseum. Stations KYW, Westinghouse, WDAP, Board of Trade-Drake Hotel, and WJAZ, Zenith-Edgewater Beach hotel, who had announced a popular voting contest to find out what the public wanted broadcast, brought an avalanche of votes from almost every state in the Union, from Canada, Mexico, Porto Rico, Hawaii, South America and Alaska. Prizes totaling \$7,000 in value, composed of receiving sets and accessories, were awarded those votes which tallied with numbers drawn during the exposition.

Station WJAZ reported the receipt, early in the contest, of 50,000 votes. Each of the other Chicago stations then received more than 15,000 votes. The aggregate number of votes received was 200,000. The contest was approved by the National Association of Broadcasters and when tabulated, is expected to reveal the manner in which Radio is developing the American mind, together with other important facts.

## ARMOUR INSTITUTE IS GIVEN STATION

### WPAD, Chicago, Transferred by Department Store to School of Technology

CHICAGO.—Station WPAD, owned by W. A. Wieboldt and Company, a department store of this city, has been given to the Armour Institute of Technology of Chicago, Dr. Howard M. Raymond, president.

Although a call signal has not been assigned to the new station it is operated under an experimental license as 9YL. Its range is 1,500 miles. The equipment is composed in part of five 250-watt tubes, three new motor generators and a power amplifier. J. A. Callanan, student, will be director of the station. Educational topics and musical numbers will form part of the new station's programs.

## RADIO LOCATES ILLS

(Continued from page 1)

for finances necessary to protect his device by patents throughout the world.

The apparatus will not be commercialized. In accordance with the ethics of his profession Dr. Waud, like Dr. A. C. Banting, (another Canadian) discoverer of insulin, specific for diabetes, will dedicate his invention to the public.

### Details Kept Secret

Details as to Dr. Waud's device have not yet been made known; in fact they are still held secret. But it is known that his contrivance may revolutionize existing methods of diagnosis.

Dr. Waud's invention is based on the effects of the human blood stream on Radio currents. It is understood that the rate of the blood current when registered by the Radio wave will serve to fix unerringly in the minds of diagnosticians the diseases of the patients under examination.

Experimenters in the Radio field in relation to the supposedly therapeutic values of the electro-magnetic air wave have known, for some time, that the nature of disease may be detected by its rate or mode of radiation. It is believed that Dr. Waud's invention is based along like lines.

## DANES LISTEN TO U. S. IN WEE HOURS

### WOC, Davenport, One of Favorite Stations Regularly Heard in Denmark

COPENHAGEN.—Enthusiastic Radio amateurs in Denmark are always endeavoring to catch broadcasting from the United States, even though this country lies in a somewhat more unfavorable position to receive American Radio messages than other European countries.

Now that it has become dark during the American sending hours, however, conditions for picking up American plants are much better than during the light summer evenings. Some of the Danish Radio amateurs have lately made it a practice to listen in for Americans at about 3 or 4 o'clock in the morning, Greenwich time. Recently several of these amateurs have reported getting different broadcasters in the United States. One station mentioned particularly often is Davenport, WOC. Orchestra music, soloists and speeches were plainly heard.

(Station WOC, Palmer School of Chiropractic, Davenport, Iowa, has been heard at much greater distances than this. Last winter a U. S. Army officer in Manila, Philippine Islands, reported picking up the program from where "the tall corn grows," a distance of over 11,000 miles. Only recently WOC was heard at Apia, Samoa, in the south central Pacific Ocean.—Editor's Note.)

A loud speaker is not an amplifier. Loud speakers that do increase the strength of signals have power amplifiers in them.

## Chicago's Rebroadcast Tests Are Successful

### Station WJAZ Receives and Re- transmits KYW's Grand Opera Program

CHICAGO.—Further experiments in rebroadcasting were conducted successfully here recently by Station WJAZ in conjunction with Station KYW.

Selections of grand opera broadcast by the latter plant were, by means of a lead from the back of the receiving set of WJAZ conducted into its transmitter and then rebroadcast.

The experiments proved, according to E. F. McDonald, Jr., owner of WJAZ, that although the music was transmitted by KYW on a 536-meter wave and retransmitted by WJAZ on a 447.7-meter wave there was no interference. Complimentary messages and letters were received by WJAZ from as far north as Duluth and south as far as Tulsa.

### Thousands Visit Philly Show

PHILADELPHIA.—When Philadelphia's second annual Radio show was held recently in the Arena, thousands of Radiophans in and around this city availed themselves of an opportunity of viewing one of the greatest collections of Radio apparatus ever gathered under one roof. The latest inventions, as well as apparatus that was in use twenty-five years ago and which figured largely in the development of Radio, were on display. One thing the old-time apparatus did was to dispel from the minds of many fans that Radio is in its infancy.

# CONTENTS

Radio Digest, Illustrated, Volume VII, Number 9, published Chicago, Illinois, December 8, 1923. Published weekly by Radio Digest Publishing Company, 123 West Madison Street, Chicago, Illinois. Subscription rates, yearly, Five Dollars; Foreign Postage One Dollar additional; single copies, Ten Cents. Entered as second-class matter at the postoffice at Chicago, Illinois, under the Act of March 3, 1879.

"All the Live News of Radio".....	1 to 9
Charts and Lessons in Dancing to Accompany Arthur Murray Broadcasts.....	5
An Evening at Home with the Listener In.....	8
Further Details of Miloplex Hook-Up.....	11
Advance Programs for Current Week.....	12
Single Tube Selective Long Distance Simplex.....	14
Simple Explanation of Radio for Everybody, Chapter VI, Part II—Vacuum Tubes, by M. W. Thompson.....	15
Editorials; Indi-Gest; Condensed, by Dielectric.....	16
Latest Development in Grimes' Inverse Duplex, Part III, Section II—How Howling Was Eliminated, by David Grimes.....	17
Super-Triplex Selective Receiver Construction, Part I—The Circuit, by H. J. Marx.....	19
Multitone Circuit Operates Speaker.....	21
Questions and Answers.....	22
Broadcasting Stations, Part I.....	23
Radio Illustrated, a Page of Pictures.....	24

## Looking Ahead

**How Does the Super-Triplex Strike You?** For selectivity combined with real volume, the triplex is a hard one for Radio engineers to improve. Building it? You should be. Better get started by getting your drawing board out and ordering a 12"x16" panel from your dealer. Then you'll be all set for Part II next week.

**Flewelling Has Some of the Most Original Ideas in Radio Design**—He's not tied down by convention but thinks out his own problems. Watch for his story next week. By the way, the Simplex Picture Diagram next week will give the beginner a tip on how to take the howling out of the Flewelling.

**Grimes Believes Crystals and Detector Tubes Are the Biggest Factors of success in reflex circuits.** Successful reception is dependent on rectification says the sage of the Inverse Duplex. He'll tell you why next issue.

**Ideas for the Experimenter's Laboratory**—A flock of valuable kinks worth knowing. Something extra for you next week.

**Ever Heard of a Push-Pull R. F. Amplifier?** No, of course not. But you will. Radio Digest is first with the latest. It's a knockout and soon to land.

**Aerials Galore But Few That Are Good**—Read what M. W. Thompson says about energy collectors (that's their Christian name) next week if you're in doubt.

**Dance Lesson Charts?** Sure, we'll give you Lesson V next week. And we'll tell you some more "dirt" about the music trust.

Newsstands Don't Always  
Have One Left

WHEN YOU WANT

# Radio Digest

YOU WANT IT!

BE SURE OF YOUR WEEKLY COPY  
BY SUBSCRIBING NOW

SEND IN THE BLANK TODAY

Publisher Radio Digest,  
123 West Madison St.,  
Chicago, Illinois.

Please find enclosed check M. O. for Five Dollars (Six, Foreign) for One Year's Subscription to Radio Digest, Illustrated.

Name .....

Address .....

City..... State.....

## KELLOGG CONDENSER



### Very true! rotor plates bolted at ends—no "shorts"

Now when it comes to condensers real radio bugs can appreciate this: heavy aluminum plates securely bolted across to assure uniform air space between the plates; a five-plate vernier gives "clean cut" tuning; heavy Bakelite end pieces make a rigid mounting; no "shorts" because it is impossible for plates to touch.

Here is a condenser that will be true to you. The price, which is always standard, is \$3.75 for 43 plate and vernier but that does not prevent the real radio rascal from having it wrapped up to take home—this very night. Another thing, this price includes dial and vernier knob.

Use—Is the Test

KELLOGG SWITCHBOARD  
& SUPPLY COMPANY  
CHICAGO

## Every Question ANSWERED for only \$1

At last you have under one cover  
a Complete Radio Handbook

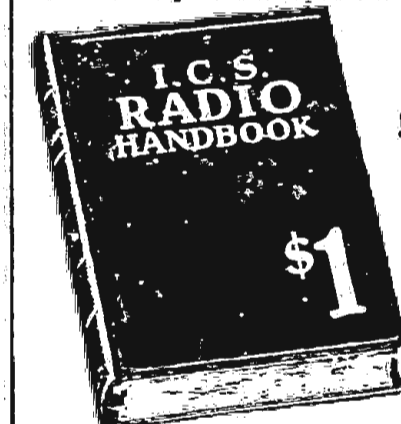

JUST OUT  
514 PAGES

Compiled by  
HARRY F. DART,  
B.S.E.E.

Formerly with the  
Western Electric  
Co., and U. S.  
Army Instructor  
of Radio.

Technically Edited by F. H. DOANE

NO more need you turn from book to book, hoping to find what you want. It is all here, in 514 pages crammed full of every possible radio detail. Written in plain language, by engineers for laymen. Clears up the mysteries, tells you what you want to know. A complete index puts everything within your reach in a few seconds.

**IT EXPLAINS:** Electrical terms and circuits, antennas, batteries, generators and motors, electron (vacuum) tubes, every receiving hook-up, radio and audio frequency amplification, broadcast and commercial transmitters and receivers, super-regeneration, codes, license rules. Many other features.

**Under one cover.** Yes, it is all in one volume of 514 pages of clear type with hundreds of diagrams and illustrations. Takes the place of eleven or more specialized texts, each costing from two to ten times the dollar you pay for this single book. Belongs in every radio-equipped home, on every amateur's table.

Send \$1 to-day and get this 514-page I. C. S. Radio Handbook—the biggest value in radio to-day. Money back if not satisfied.

TEAR OUT HERE  
INTERNATIONAL CORRESPONDENCE SCHOOLS  
Box 8276-D, Scranton, Penna.

I enclose One Dollar. Please send me—post-paid—the 514-page I. C. S. Radio Handbook. It is understood that if I am not entirely satisfied I may return this book within five days and you will refund my money.

Name .....

Address .....



# RADESE CODE LINGO AID HAMS TALKING

## LANGUAGE OF AMATEURS ALL THEIR OWN

### Brass Pounders Cut Language to Pieces in Effort to Save Time and Energy

Transmitting Radio amateurs and fans have originated, and are at the present time developing, a universal language of their own. It has even been intimated that some day this or a similar elaborated language may become useful to the peoples of the whole world as an abbreviated language for the written word.

Hundreds of Radiophans are now using many of the standard code terms and phrases in their writings, and several are successfully using it for making notes in their daily business.

There is nothing mysterious or remarkable in the code. It is very simple and not unlike the Phillips code, which is generally used by wire telegraphers in sending press despatches. This Radio code is based upon phonetic spelling, and in a long word many of the letters are deleted. For example, the word radiation in Radio code is cut down to but three letters—rdn.

#### List of Abbreviations to Date

Following is the latest list of the most prominent words in "Radese," used by every dyed-in-the-wool transmitting amateur:

Code Phrase	Code Phrase
fb... fine business	bv... have
om... old man	ruff... rough
ow... old woman	pt... point
br... bear or here	tubd... too bad
brd... beard	gess... guess
u... you	kg... know or no
wa... when	kw... know or kilowatt
ur... your	vy... very
spk... speak	cond... condenser
gud... good	freq... frequency
wrk... work	thot... thought
wkg... working	lmpt... important
wrkd... worked	pri... primary
bwsat... bow's that	sec... secondary
bw... bow	wv... wave
c... see	wl... well or will
cu... see you	wy... way
cuagn... see you again	betr... better
cul... see you later	gvg... giving
73... best regards	tea... thermocoupled amps
b4... before	cum... come
2nite... tonight	thr... there
or tnl... tonight	r... are
ltr... letter	ru... are you
sorri... sorry	cid... called
tt... that	cl... call
g... going	clg... calling
shud... should	rite... write
abt... about	dx... long distance
trub... trouble	tmw... tomorrow
wid... with	fr... for
gnd... ground	crd... card
rdn... radiation	nw... now
cntpse... counterpoise	pse... please
bt... by	tkx... thanks
hl... Radio laugh	tax... said
ml... my	sed... said
onll... only	aud... audibility
gv... give	cr... chemical rectifier
sum... some	ant... antenna
diff... difference	divr... deliver
enuff... enough	divd... delivered
cud... could	gt... get
lnpt... input	gm... good morning
88... love and kisses	gn... good night
abr... another	gd... good-bye
agn... again	msg... message
bt... but	wt... what
b... be	many... many
bk... break	mk... make
cnt... can't	nr... number
dat... don't	otr... other
dwn... down	red... received
da... day	stp... stop
ea... and	wix... wireless
ga... go ahead	wl... well

#### How to Memorize "Radese"

For readers who would like to memorize the abbreviations, an old trick is suggested. Obtain as many small slips of paper or cards, preferably cards, as there are abbreviations. In this case the number is 109. Then write the one abbreviation on one side of each card, and the corresponding phrase or word on the reverse side.

Shuffle the cards and read the abbreviation side of each of them, saying to yourself what the equivalent is. Then turn the card to see if you are correct. After running through the cards several times this way, turn the pack over, shuffle, and attempt to remember what the abbreviations are for the phrases and words you read on the unabbreviated sides of the cards.

This method of memorizing will be found very satisfactory and will accomplish the result in a short time.

## STOLEN: ONE RADIO STATION; COPS HUNT

ROLLA, MO.—The disappearance from this town of the entire apparatus at the amateur station operated by S. P. Stocking, call 9AZH, has resulted in a statewide search by police authorities. In two successive visits, probably planned by the same conspirators, every piece of this privately owned set, from a pair of lightweight phones to a 100-watt transmitter has vanished into the night.

## BOSTON'S ELKS TRY TO SPAN ATLANTIC

BOSTON.—WNAC gave its second annual All Elk Radio Night recently when Major Fanning and his crew again endeavored to get through to England, a feat accomplished on last year's Elk night. The program started at 9 p. m., Eastern time, and lasted beyond the time limit of last year, which was 5:15 next morning. WNAC holds a record for reaching England on a 100-watt set.

## SHE LISTENS TO "LIGHT" MUSIC



Is this one of the "foolish virgins"? She certainly doesn't look it, yet she has lamps without oil in plenty. You see it is a Radio set in lamp form and we never heard of oil improving reception. The unusual and rather attractive instrument covers a wide range and is up-to-date in every way. The loud speaker is concealed in the base. Photo by K. & H.

## BROADCAST PLAY IN 3 NIGHTLY EPISODES

### "Little Old New York" on Air as Well as Stage and Screen

DAVENPORT, IA.—While thousands are this week witnessing the first presentation of the famous historical comedy "Little Old New York" on the screen in Chicago and New York City, other thousands have been enjoying the stage version by Radio from the Palmer School of Chiropractic broadcasting station, WOC, located here.

When Amy Dennis and Eddie Waller, supported by the Grand Players were pre-

senting this famous play at the Grand Theater in Davenport, arrangements were completed by officials of the broadcasting station with the manager of the show to have the play broadcast by Radio.

The complete version was broadcast in three episodes on Monday, Wednesday, and Friday evenings of a recent week beginning at 11:30 Central Standard time each evening.

The Davenport station is one of the "old reliables" and is consistently heard in all parts of the United States and Canada. Thousands of Radiophans who tuned in WOC and heard the play broadcast, wrote the station expressing their thanks.

When soldering connections to jacks, do not let the flux run into the insulating segments, as it will form a good leak for Radio currents.

## AIRWAVES ON TRAIL OF FLEEING CONVICT

### LAY AIR TRAP FOR JAIL BREAKING ROBBER

#### Governor of Alabama Resorts to Radio When Sleuths Fail after Year's Hunt

BIRMINGHAM, ALA.—Will Radio be able to capture Roy Dickerson, noted bank robber, who escaped from prison November 14, 1922?

That's the question Governor W. W. Brandon is trying to determine. After a year's nationwide search for the noted bandit, engaged in by some of the best known detectives of the United States, Dickerson is as free today as he was on the day he mysteriously disappeared from Kilby Prison, Ala., one year ago.

At the request of Governor Brandon the following message was broadcast from stations at Montgomery and Birmingham on the anniversary of Dickerson's escape:

#### Broadcast Description of Fugitive

"Today, which is one year since the escape of Roy Dickerson, notorious bank robber, serving a 25-year term in the Alabama penitentiary, has been marked by the increasing of the reward offered for his recapture from \$400 to \$500. You are requested to notify your police officers of this information. Dickerson is 28 years old, height 5 feet 8 inches, weight 140 pounds, medium build, blue eyes, brown hair, medium complexion, fairly good teeth, smooth shaven, dresses well and is of pleasing personality; occupation, engine hostler and fireman; native Alabamian. He has tattoo of a five-pointed star near the base of the left thumb, dagger piercing flesh, eagle, five-point star with rays on left forearm, and other tattoo on right forearm."

#### Boasts No Jail Can Hold Him

Dickerson was serving a twenty-five year term for robbing the Phoenix-Girards Bank, at Girard, Ala., of over \$100,000 about three years ago. Dickerson's wife is serving a ten-year term in the Alabama penitentiary in connection with the bank robbery.

Dickerson was convicted of the bank robbery. He is said to have escaped from thirty-seven jails and penitentiaries in the United States, and boasts that there is not a prison in the world that will hold him. To Dickerson stone walls do not a prison make, or iron bars a cage.

"If detectives can't locate Dickerson, I wonder if Radio can?" Governor Brandon asked, as he sat in his office in the capital building at Montgomery. "Well I'm a great believer in Radio, and I'm going to try." And so he ordered the message broadcast, and is now waiting patiently for the results.

## BELIEVES SEEING BY RADIO NOT DISTANT

### WGR Manager Predicts Development of New Facility

BUFFALO, N. Y.—One of the interesting things about the Vincent Lopez Hotel Statler dance orchestra, which broadcasts almost daily from WGR, is its stunts. Anyone who has tripped the light fantastic to its tunes on the Statler ballroom floor knows that the stunts it pulls off are nearly as interesting as the music. In other words, putting it Vincentially, the Lopez stuff appeals to the eye as well as the ear.

When this orchestra goes on the air, if one could see it as well as hear it the enjoyment would probably be doubled. In discussing this peculiarity, M. A. Rigg, manager of WGR, predicted that the time was not far off when facilities for seeing as well as hearing Radiophone programs would be common.

Whether or not experiments were being made at the Federal Telephone & Telegraph Company of Buffalo which maintains WGR, Mr. Riggs did not state.

## THE ANTENNA BROTHERS

Spir L. and Lew P.

Patented by A. L. Brown

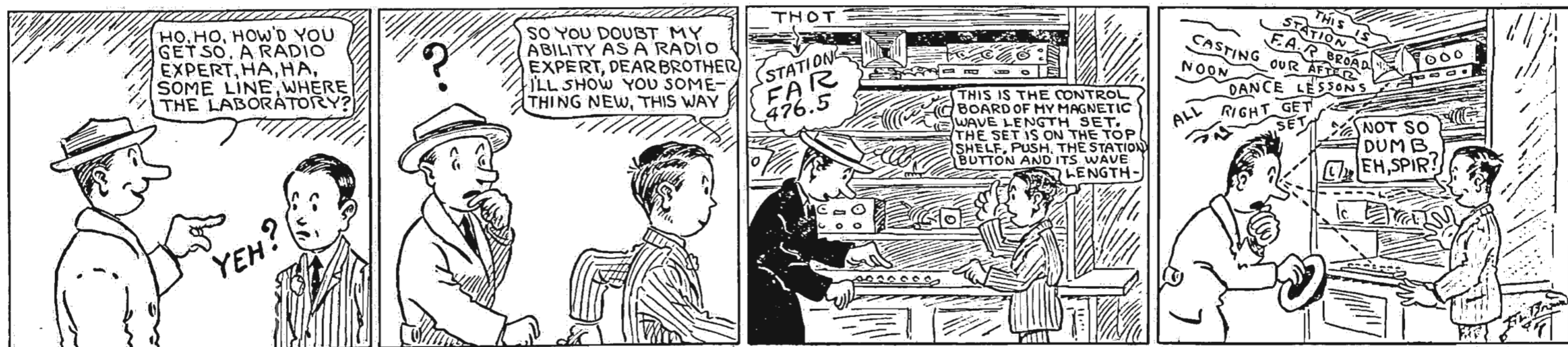



# 100 ARTISTS PLAY IN CONCERT SERIES

STATION WJZ BROADCASTS  
AMERICAN SOCIETY

Young Soloists to Make Symphonic  
Debut during Winter  
Season

NEW YORK.—The arrangements for what is probably the greatest presentation of symphonic music which Radio has yet attempted have been completed between M. R. Robinson of the American Orchestral Society and Station WJZ here, with the result that the station will broadcast by direct wire the entire series of fifteen concerts which the society, in co-operation with the New York Philharmonic Orchestra, has scheduled for the winter season. The first concert was given recently at Cooper Union, and the series continues at regular intervals until April 8, 1924.

### In Three Groups of Five Concerts

The fifteen concerts are classified in three groups of five each, the first five, which are given by the Orchestral Society for the New York Philharmonic Orchestra, and the second five, composing the annual series given by the Society to the Peoples' Institute, to be held in Cooper Union Auditorium, while the third group, the Children's Afternoon Concerts, will be given in Aeolian Hall. The ten Cooper Union concerts will be played by the entire Orchestral Society, over one hundred instruments in all, under the direction of Chalmers Clifton, while the Children's Concerts will be given by an orchestra of fifty-five picked members of the New York Philharmonic under the direction of Ernest Schelling.

### Schedule of Concerts

The Cooper Union concerts include the symphonic debut of several young American soloists of proven ability, and the programs will contain many compositions by young Americans in addition to thirty-two of the greatest symphonies. As the American Orchestral Society is composed solely of the finest of young American players, the concerts will present the absolutely best of American composers, artists, and instrumentalists. The concerts will be given on the fourth Sunday and the second Tuesday of each month.

## MUSIC HAS CHARMS FOR LORD RENFREW



Lord Renfrew while in Canada, but the Prince of Wales at home, this good looking chap is quite a Radiophan. The prince, although first interested in Radio in England, found "music hath charms" especially when tuned in while on his recent Canadian visit. He became quite fond of his American set

The educational series of Children's Concerts, under the direction of Ernest Schelling, will present the most famous symphonic compositions with musical explanation, and will include short biographical sketches of the composers. The first of this series will be given on the afternoon of January 8, and concerts will be continued on alternate Mondays thereafter.

THE

## AUDIOPHONE

TRADE MARK  
REG. U. S. PAT. OFFICE

Quality of reproduction such as only the original itself can equal. Speech that is so distinct that the voice heard is the actual voice of the speaker. Music that requires no tolerant imagination to be recognized as music of the finest type.

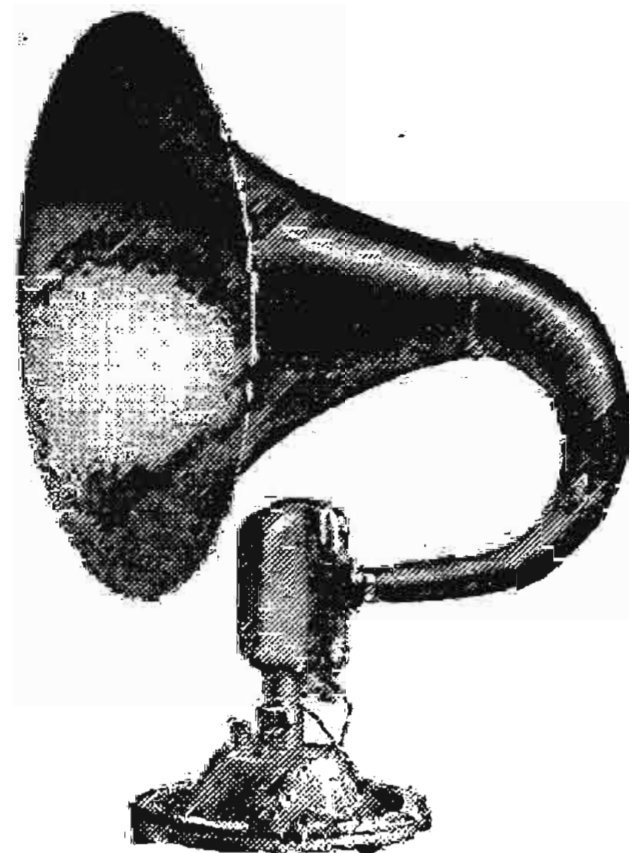

## Bristol's Single Stage Power Amplifier

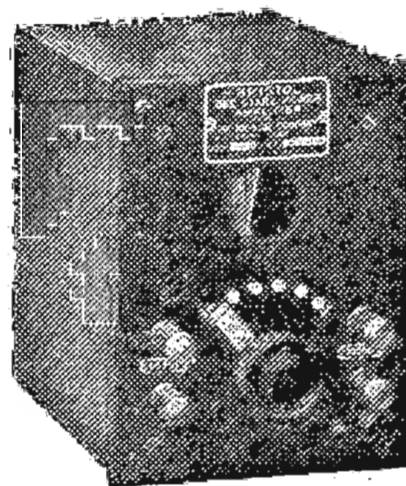

gives additional VOLUME with any two stage amplifier. No C batteries required. It provides the additional volume necessary to bring in very distant stations on the loud speaker.

Write for bulletin and address of the nearest dealer handling our instruments

## THE BRISTOL COMPANY

WATERBURY, CONN.

Boston New York Philadelphia Pittsburgh Detroit Chicago St. Louis San Francisco



### A Graduated Dial—

accurately calibrated in wavelengths enables you instantly to locate the program you desire.

### The New GREBE Broadcast Receiver

possesses many other advantages described in "Grebe Radio in the Well-Appointed Home." Ask your dealer or write us for a copy.

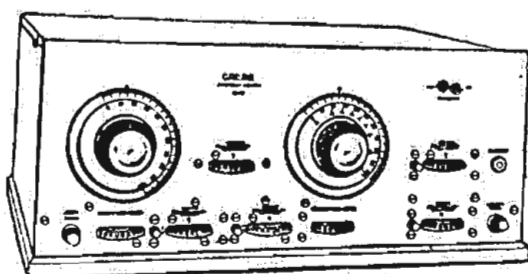

Licensed under  
Armstrong U. S.  
Pat. No. 1113149

A. H. GREBE & CO., Inc.

Richmond Hill, N. Y.

Western Branch—451 East 3rd St., Los Angeles, Cal.

## TAKE THE EXPENSE OUT OF

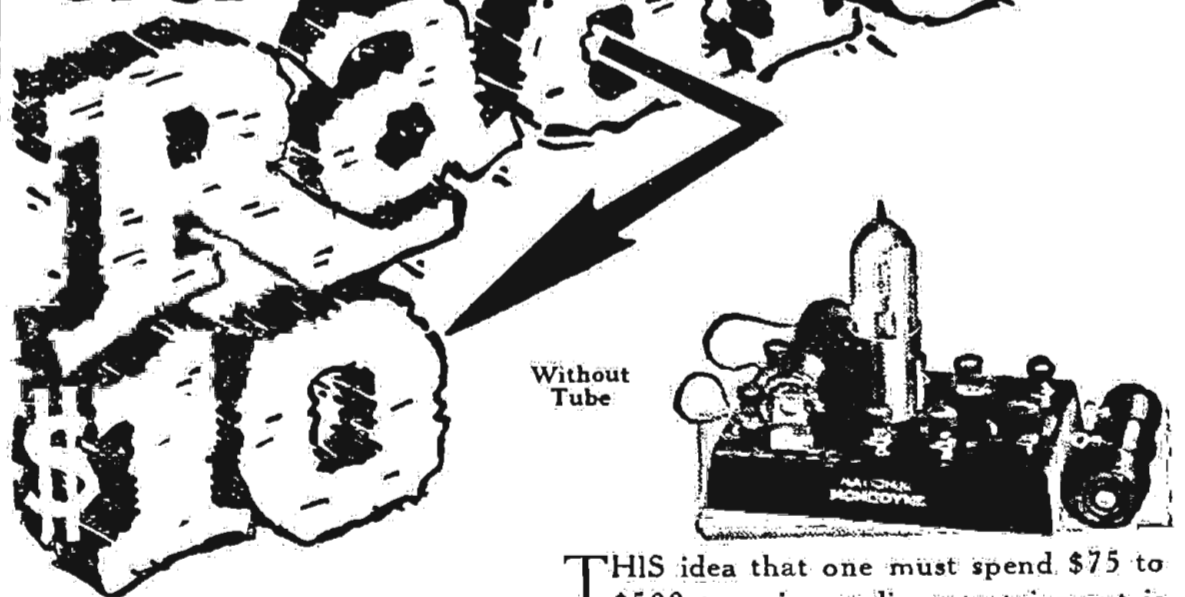

Without  
Tube

## NATIONAL MONODYNE TUBE SET MODEL GT-1

THIS idea that one must spend \$75 to \$500 to enjoy radio entertainment is all a big mistake. On the contrary, a ten dollar bill invested in a National Monodyne One Tube Set gives you results that equal and in most cases surpass the most costly sets.

You are welcome to full and positive proof of this statement, first, by hearing the Monodyne yourself, and second, by reading the unsolicited testimonials that pour in every day from all parts of the country.

### The National Monodyne has only One Tuning Control

It's simplicity in itself; no technical knowledge required. A child can operate it.

Sold by leading dealers, or if your dealer cannot supply you, write direct to

## NATIONAL AIRPHONE CORPORATION

16-22 HUDSON STREET

REG. U. S. PAT. OFF.

NEW YORK

# FANS THINK WELL OF DANCE LESSONS

## FAMOUS MURRAY COURSE BEING BROADCAST

Fourth Lesson's Charts Herewith—Save Them as Many Stations Are Now Giving Feature

Learn to dance by listening in! Radio Digest has perfected an arrangement with Arthur Murray, nationally known teacher of ballroom dancing, whereby Mr. Murray is broadcasting dancing lessons from WOR, J. Bamberger and Company, Newark, N. J., and a score of other prominent stations. Radio Digest exclusively will give the charts and instructions which apply to the lessons broadcast by Mr. Murray personally at WOR and by the other stations. WOR, WBAP, WNAC, WJW, WLAG, WREX, WJAS, WFI, KPO, CKAC, WSAD and KYW have recently started the series of lessons. The fourth lesson with charts is given below. These may be used in conjunction with the broadcast lessons. The complete course will occupy six lessons, one of which will be given each week. Save the lessons to use with the broadcasts.—The Editor.

### LESSON IV—THE CORTE

By Arthur Murray

LAST week was given charts and instructions for Lesson III—The Waltz. Week before last was given the footprint drawings and descriptions of the Chassé or Fox Trot and the Two-Step in the Fox Trot, these being the first two lessons. Mail has been very heavy from Radiophans requesting back issues of Radio Digest containing the charts necessary to fully benefit from my broadcasts. It may be necessary for Radio Digest later to reprint the earlier charts along with the more advanced lessons.

This week we will study the Corte, better known as the Promenade in the Tango Fox Trot. It is one of the most difficult steps in the Tango Fox Trot and should be studied and practiced very, very carefully.

Radio-dance-movie fans will recall the step danced by Rodolph Valentino in the film, "The Four Horsemen of the Apocalypse." The Promenade is the most beautiful part of this famous dance.

#### The Man's Part

Begin with the left foot and take four long, slow walking steps forward, 1, 2, 3, 4; these four walking steps are not a part of the Promenade, but it is advisable to do them before actually beginning the Promenade. They are necessary in order to make the step fit the music. Then—

### U. S. Investigators Report Tests of Receiving Sets

WASHINGTON, D. C.—The results of tests on Radio receiving sets made by the Bureau of Standards are given in a series of letter circulars now being issued. The first of this series is Letter Circular No. 90, which gives results of tests on certain electron tube receiving sets. The second, Letter Circular No. 93, describes the results of tests on receiving sets using crystal detectors. The third paper of the series, Letter Circular No. 102, has just been issued and described results of tests on a number of short-wave regenerative receiving sets. The receiving sets are referred to by arbitrary reference numbers rather than by a statement of the manufacturers' names and type numbers.

## CHARTS SHOW STEPS IN PROMENADE OR CORTE

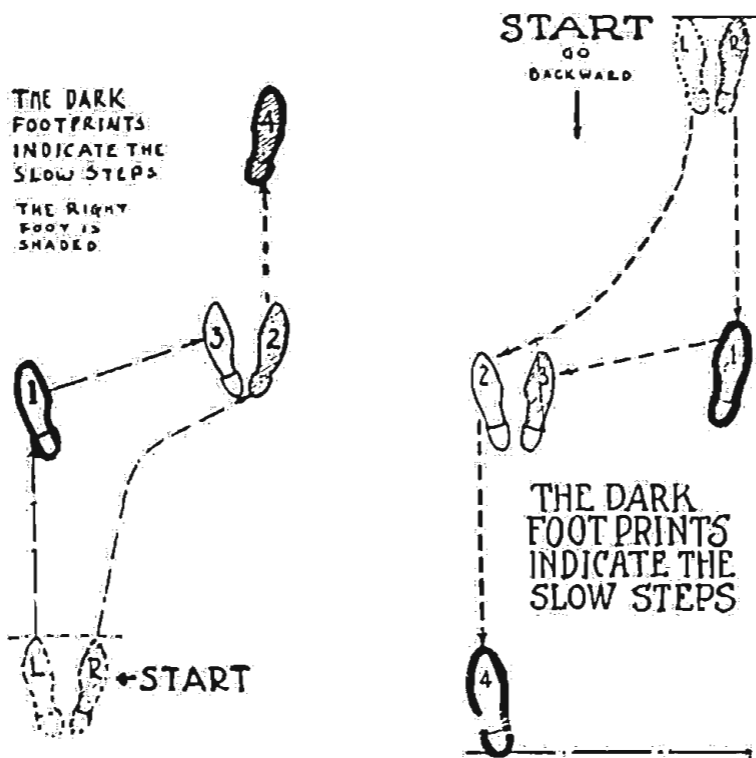

Figure 9

Figure 10

1. Take one SLOW walking step forward with the left foot;
2. Step forward quickly with right foot, moving it diagonally to the right, about fourteen inches to right of the left foot (see Figure 9);
3. Quickly draw left foot up to right, weight on left;
4. Take one slow step straight forward with right foot, weight on right. That's all.

### DON'TS FOR DANCERS

By Arthur Murray

Some people don't dance; they just fight it out.

Don't dance with your wife just once and then park her for the rest of the evening.

Don't hold the hand above the head. If you must indicate that you are a member of the Royal Straphangers' Brigade, wear a button.

Simply backing the girl around the room while the music is playing is not the ideal way of showing a girl a big time.

Don't hum or whistle. Be considerate of your partner. In any case the tune should be changed at least once every ten minutes. Hum in the same key with the orchestra, but don't attempt to drown their music.

Study the diagram and read these descriptions over again.

Remember that each time you take a step, place the weight down ON that foot. For instance, if you step forward or sidewise with the left foot, the weight must be placed ON the left foot.

Begin at the beginning and read the instructions very carefully. Practice this step for about an hour.

#### The Lady's Part

It is advisable for the lady to be thoroughly familiar with the man's part before doing her own. This gives her a better appreciation of what she is supposed to do. If you know the man's part, you can appreciate more readily what is expected of you in order to follow him.



Arthur Murray and Aileen Meehan demonstrating the fourth step in the Corte

The lady always begins with the right foot. Remember that in order to follow well you must take long steps. Begin with four long, slow walking steps. Then—

1. Take one long slow step backward with the right foot;
2. Step backward quickly with the left foot, placing it about fourteen inches to the left of the right foot (see Figure 10);
3. Quickly draw the right foot up to the left foot, weight on right foot;

4. Take a long slow walking step backward with the left foot, weight on left. That's all.

Note that 1 and 4 are slow steps, while 2 and 3 are done quickly.

Repeat from the beginning. Remember to study the man's instructions before learning the lady's part.

If you can do the Promenade, you will have no difficulty in learning any step in ballroom dancing.

(TO BE CONTINUED.)

**THE De Forest name** has been in the forefront of radio research for twenty-three years. De Forest invented the three-electrode vacuum tube which makes present-day radio possible. The sets and parts made today by the De Forest Company are worthy of the De Forest name.

DE FOREST RADIO TEL. & TEL. CO.  
Dept. R. D. 4 JERSEY CITY, N. J.

If Located West of Pennsylvania, Address  
DE FOREST RADIO TEL. & TEL. CO.  
Western Sales Division  
Dept. R. D. 4 5680 12th St., DETROIT, MICH.



## New Coto Compact Variable Air Condenser with Vernier

Type 3505  
.0005 Mfd.  
**\$5**

Type 3510  
.001 Mfd.  
**\$6**

Rugged and electrically efficient. Constructed on rigid metal plate from which condenser plates are perfectly insulated. Both rotor and stator plates are of copper, soldered firmly in place. Size only 2 7/8 x 2 7/8 inches. Positive, delicate vernier action.

If your Dealer cannot supply you, write us, giving his Name.

**COTO-COIL CO.**  
87 Willard Avenue Providence, R. I.

BRANCH OFFICES:  
Los Angeles, 329 Union League Bldg.  
Minneapolis, Geo. F. Darling,  
705 Plymouth Bldg.  
Atlanta, C. P. Atkinson,  
Atlanta Trust Co. Bldg.



### VISITING SONGSTRESS FERVENT RADIOPHAN



Georgette LeBlanc, Maeterlinck's gifted ex-mate, who won fame as the leading lady in most of his plays, is now on a concert tour of this country. She is an ardent Radiophan. Besides having broadcast several times her portable set never leaves her  
Keystone View Photo

### Two Radio Beacons in Use off Boston Harbor

BOSTON.—A system of Radio beacons, similar to those in use at Fire Island, Ambrose Channel Lightship and Sea Girt, for the benefit of New York bound shipping will soon be established for Boston bound ships. Two are in operation now, one at Nantucket Light, where the new lightship gives Radio direction signals, and the other at Boston Light, Boston Harbor. The third station is planned for Cape Cod. This means that a ship can find its own bearings from these stations.

### 170 Miles of Wire Link WGY, WJZ Broadcasts

#### Two of Largest Stations Join in Flashing Princeton Grid Game

NEW YORK.—A new union between two of the largest broadcasting stations in the country was announced recently after Station WJZ, Radio Corporation of America, New York City, and WGY, General Electric Company, Schenectady, New York, had broadcast the Princeton-Harvard football game direct from Palmer Stadium, Princeton, New Jersey.

The joint broadcasting, made possible by a special installation of 170 miles of land wire connecting the two stations, was exceptionally satisfactory. The installation will be used in the future for the dual broadcasting of events of major public interest from both New York and Schenectady simultaneously.

A two-slide tuning coil is more flexible than a one-slide.

### COLUMBIA ALL-CIRCUIT VARIOMETER

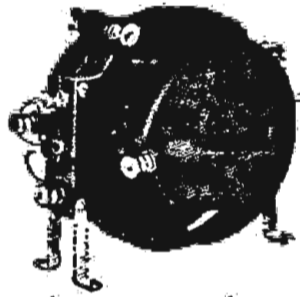

With split stators, providing for all present day circuits and permitting most future circuits in which a variometer may be used, this black bakelite moulded, green silk instrument is the one to buy. It is pig-tailed and built for selectivity. This

variometer can be used for MILOPLEX circuits.

Price \$5.50

Ask to see the nationally known Columbia line of licensed bakelite apparatus. Known satisfaction. A few more Columbia items:

- Moulded Bakelite Variocoupler.....\$6.00
- Geared Three Coil Mounting..... 5.00
- Geared Two Coil Mounting..... 3.50
- Inside Coil Mounting—"Vernier"..... 6.00
- All-Meter Variocoupler—150 to 2600 meters..... 7.00
- Mounted Coils, Coil Plugs, etc.

Write for our free literature

**COLUMBIA RADIO CORP.**  
157 NORTH UNION STREET, CHICAGO

#### Complete Parts for Miloplex Circuit—Cabinet Free

1 .0005 Variable Condenser, Vernier.....\$6.00	3 3/2-Inch Dials, each 75c.....\$2.25	1 B Battery, Burgess, 22 1/2 volt.....\$3.00
1 Estru Variometer..... 5.00	1 Potentiometer, 1850 ohms..... 2.20	3 Dry Cells..... 1.35
1 .00025 Variable Condenser..... 2.00	1 Rheostat..... 1.00	12 ft. sq. brass bus wire..... .30
1 Variable Grid Leak..... .75	1 Socket Bakelite Base..... .90	1 Set Readem Bind. Posts..... .75
1 .00025 Mica Fixed Condenser..... .40	1 Bakelite Panel 9x14x 1/2..... 2.50	
2 .002 Phone Condensers..... .80	1 DeForest D.V. 6 Tube..... 6.50	

**TOTAL .....\$35.70**  
Blue print FREE only with order for complete parts

#### Our Price Only \$28.50

#### Complete Parts for One Tube Reflex

1 Radiometer.....\$ 3.00	1 23 Plate Condenser..... 3.00
1 Tricoil Transformer..... 2.00	1 Audio Transformer..... 4.00
1 199 Socket..... .90	1 199 Tube..... 6.50
1 Baseboard, 7x9..... .25	1 7x9x 1/2 Bakelite Panel..... 1.25
1 Set Readem Binding Post..... .75	2 .002 Micon Fixed Condensers..... .80
1 Type B. B. Metal Detector..... 1.50	1 Cabinet, 7x9x8..... 2.50

**OUR PRICE ONLY .....\$22.45 TOTAL \$26.45**

#### Complete Parts RD 99 Long Distance Receiving Set

(See Radio Digest, September 29th issue)

3 Bakelite Base Sockets.....\$ 2.25	3 Rheostats..... 3.00
2 A. F. Transformers..... 8.60	2 Double Circuit Jacks..... 1.80
1 Open Circuit Jack..... .75	1 Estru Variometer..... 5.00
1 Variable Grid Leak and Condenser..... 1.00	1 .0005 Variable Condenser with Vernier..... 6.00
1 .005 Fixed Condenser..... .75	1 75-turn Honeycomb Coil, mounted..... 1.20
1 Single Coil Mounting..... .50	1 Set Readem Binding Post..... .75
1 Panel Bakelite, 7x16x 1/2..... 2.25	1 Cabinet, 7x16x8, fine mahogany finish..... 6.00

**OUR PRICE ONLY .....\$30.25 TOTAL \$39.25**  
and blue print. ONLY

#### Complete parts for a Neutrodyne Tube Set. Nothing extra to buy in parts. The complete parts are of the highest quality apparatus.

#### NEUTRODYNE

This is your opportunity to secure the parts for this famous set at a decided reduction in price. Nothing extra to buy, as this price includes all parts essential to build it..... **\$45.50**

Same parts complete with 1 UV-200 and 3 UV-201A Tubes; 2 22 1/2-volt large size B Batteries; 1 Storage A Battery; 110-ampere Baldwin Head Phones and Aerial Equipment..... **\$92.15**

This set would cost you \$181.65 if it was bought ready made.

#### Crystal Set Complete

With Phones, Aerial, Lead-in Wire, Insulators. An attractive Christmas Gift. Price, complete..... **\$8.50**

Above Set alone, without Phones or Aerial Equipment..... **\$2.50**

#### CABINETS

9x14x8, mahogany finish.....\$3.25	7x9x8, mahogany finish..... 2.75
7x21x8, mahogany finish..... 3.50	

**MUST SEND POSTAGE**

We Are Responsible Folks. Money Promptly and Cheerfully Refunded if You Are Not Satisfied

All Orders Mailed Promptly. Parcel Post Prepaid on \$5.00 or Over. No Stamps Accepted. Send Money Orders.

Quality Merchandise at Low Prices

## Economical Radio House

4600 Lincoln Avenue, Chicago

Every-thing in Radio Write Us

We Personally Guarantee All Goods

#### RADIO TALKS

Storage batteries, immediately after being charged, have a slightly higher voltage than that at which they are rated. To obtain the best results this means that the tubes are operated at a higher voltage and that the rheostat will have a different setting than when the storage battery is in operation at normal voltage.

*E. T. Flewelling*

# E. T. Flewelling Sockets

Flewelling Sockets will make your set better. They will assure better tone and more perfect reception. Many little noises that you have probably mistaken for tube noises will be eliminated (for very often these are socket noises and Flewelling Sockets are noise proof). This is because they are designed and made under the personal supervision of Mr. E. T. Flewelling. Mr. Flewelling's name protects you. You are assured that any part bearing his endorsement is tested and proven to be the best before it is placed on the market.

**BUELL MANUFACTURING COMPANY**  
2977 COTTAGE GROVE AVE.  
CHICAGO

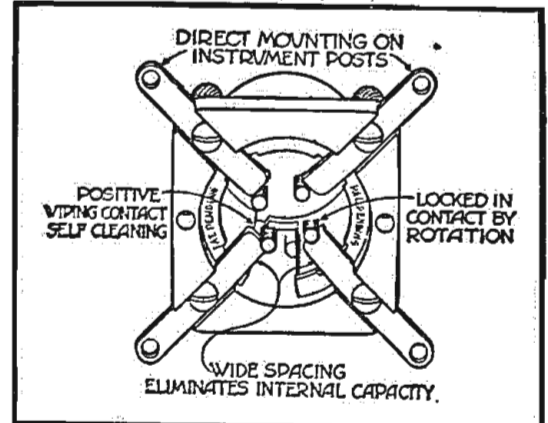

# \$1.00

At your dealers or post paid.

## RADIO AT N.Y. PRICES

### via Daily Parcel Post

The Prices Quoted Below Deliver Goods to Your Door

HOW TO ORDER—Write your order plainly; state number, description and price of items wanted. Send Post Office or Express Money Order, personal check or bank draft.

<b>STANDARD BRAND HEAD PHONES</b>	<b>WAVE TRAP</b>
C134 Brandes Superior.....\$ 4.95	Simplifies tuning. Eliminates interfering stations, thereby improving the selectivity of your set. Selects between conflicting stations. Special white quantity lasts.
C135 Dictograph..... 5.75	C131 Each.....\$4.95
C136 Baldwin Type "C" Double..... 9.85	<b>MOULDED BAKELITE VARIOMETER</b>
C137 Baldwin Type "C" Single..... 4.95	C79 Each \$4.95. List.....\$8.00
C138 Western Electric..... 10.50	A high grade instrument. Takes in the wave lengths from 250 meters to 800 meters. Table or Panel Mounting.
C139 Dietzen 3000 ohms extra special..... 3.95	<b>VERNIER VARIABLE CONDENSERS</b>
<b>RADIO SOLDERING IRON</b>	Specifications the same as above.
Indispensable for the man who builds his own sets.	C114—14 Plate Vernier with knob and dial.....\$2.95
C109.....\$2.50	C115—26 Plate Vernier with knob and dial..... 3.45
C133 Soldering Paste Tube..... 25	C116—43 Plate Vernier with knob and dial..... 3.95
<b>JACKS AND PLUGS</b>	<b>VARIABLE AIR CONDENSERS</b>
Jacks are polished nickel constructed with pure silver contacts.	These condensers are made of heavy aluminum plates, high grade bakelite ends.
C118 One spring open circuit.....\$ .39	C110—21 Plate, .0005 Mfd.....\$1.75
C119 Two spring closed circuit..... .49	C111—11 Plate, .0025 Mfd..... 1.25
C120 Round plug as illustrated..... .49	C112—3 Plate, .0005 Mfd..... .95
<b>MISCELLANEOUS</b>	C113—43 Plate, .001 Mfd..... 2.25
C163 Spaghetti Tubing per yard.....\$ .49	<b>PLATE CIRCUIT "B" BATTERIES</b>
C164 Synthetic Crystal..... .30	The highest grade of battery made at prices lower than they ever were sold before.
C165 Ground Clamps..... .17	C80—22 1/2 Volt Small.....\$1.15
C166 Black Rubber Binding Posts..... .05	C81—22 1/2 Volt Medium..... 1.45
C167 Nickel Plated Binding Posts, 2 for..... .05	C82—22 1/2 Volt Large..... 1.55
C168 No. 18 Annunciator Wire, half lb. coil..... .39	C83—45 Volt Medium..... 1.55
C169 6 ft. Phone Cord with Tips..... .79	C84—45 Volt Large..... 2.50
C170 20 ft. Extension Cord with Tips..... 1.95	C85—45 Volt Extra Large..... 3.50
C171 Wall Insulators, Porcelain..... .95	C86—360 Hour 1 1/2 Volt Twin Double Duty "A" Battery..... .75
C172 Tubular Porcelain, Lead-in Insulators, 6-in..... .10	
C173 Reinartz Coil..... 1.45	
C174 Cockaday Coil..... 2.42	
C175 2 in. Dial and Knob..... .25	
C176 3 in. Dial and Knob..... .35	
C177 4 in. Dial and Knob..... .49	

**Modell's**  
ESTABLISHED 1899

71 Cortlandt Street  
NEW YORK, N. Y.  
America's Greatest Radio Mail Order House  
ELEVEN NEW YORK STORES



## FINDS "REAL CAUSE" FOR FADING SIGNALS

POWER CHANGES BLAMED FOR ANNOYANCE

WGR Operator Discloses Result of His Research and Experiments

BUFFALO, N. Y.—Changes in potential in the power mains supplying the energy for Radio broadcasting and other forms of transmission, are the real cause for fading signals, often so disagreeable to the distant listener in, according to the statement of Edward Stanko, chief operator and announcer of Station WGR, the Federal Telephone and Telegraph Company, located here.

Mr. Stanko is quite convinced that his explanation of fading has been overlooked by many who have sought to solve the problem. His explanation follows:

"Many have given theories and explanations on fading of the signals of Radio stations. Some are sound and others imaginative. Those persons who have had experience with transmitters I am positive will agree with me.

### Power Main Changes Root of Evil

"After considerable investigation, and tests conducted by myself, I found that the most important part of determining the fading of signals, had not been taken into consideration.

"Most of the fading is due to the change in potential in the power mains which supply the current to the transmitter. Though not great, nevertheless it is there, and actual tests showed a marked rise or drop in the antenna, plates and grid circuits. With a 500-watt continuous wave transmitter, a rise of one-quarter of a volt increased the radiation one-half ampere. A drop of one-quarter of a volt, decreased the radiation as much as two amperes. The plate current varied about 150 milliamperes and the grid current varied about 150 milliamperes, according to the rise or drop of the potential.

"It can be easily seen that such a change in the current of the transmitter will effect the distance of reception and audibility of signals to a considerable degree."

If you have been getting stations and some evening do not get them, don't pull the set apart, as it might just have been a bad night.

## WBAP TURNS BACK 75 YEARS



G. C. Arnoux (in circle), or "G. C. A.," as he is known to the fans who tune in WBAP, and (left) E. L. Olds, or "E. L. O." on the air

Fort Worth, Texas, recently celebrated its seventy-fifth anniversary with a Diamond Jubilee, so naturally Station WBAP, the Star-Telegram, was called in to put the celebration on the air. During the festivities Fort Worth citizens dressed according to the fashion rife when the city was founded. Men wore chaps and "gats" as did their grandfathers, and the ladies donned calico and sunbonnets. Arnoux, chief announcer and program director, is "rolling his own" in the picture above, while Olds, day and early concert announcer also makes a good cowboy by carrying a lariat even to the studio so that he might rope and tie the "Mike" if it got too venturesome. Even a tribe of Comanche Indians was drafted for the jubilee and supplied a special Indian program from the versatile WBAP studio.

## U. S. Airwave Chief Plans Tour of All Nine Districts

WASHINGTON, D. C.—Chief Supervisor of Radio W. D. Terrell will make a swing around the country, eventually visiting each of the nine Radio districts. He recently made a trip to Detroit and Chicago, the eighth and ninth district headquarters. Within a month's time, he hopes to start West to visit Seattle and San Francisco and inspect the district headquarters there. Returning via New Orleans he will stop off there and in Atlanta, where the new fourth district offices were recently established.

## Los Angeles Show in February

LOS ANGELES.—The American Radio Exposition Company, which had the Radio Show at Grand Central Palace in charge, will stage the second annual Radio show on the Pacific Coast next February at Los Angeles. The last Western show was held in San Francisco.

## Railroad Messages Go by Air Successfully

Much of Line's Traffic Is Handled by Radio Plants

SPRINGFIELD, O.—Three Radio stations, located at points along the Detroit Toledo and Ironton railroad have been handling a portion of the road's traffic with great success for the greater part of a year, according to the reports of officials of the railroad company.

Some idea of the amount of traffic these stations are handling may be derived from the number of messages handled during a period of seventeen months: Springfield, 103,904; Dearborn, 95,993; Jackson, 8,904. Another Radio station at Northville, belonging to the Ford Motor Car Company, handled 2,113 messages during the nine months' period.

**FORMICA**  
A Laminated Phenolic Condensation Product  
SHEETS TUBES RODS

**RADIO PANELS**  
POLISHED BLACK FINISH

CUT PERFECTLY SQUARE TO ANY SIZE

1/32" THICK	1/2¢ PER SQ. INCH
1/16" THICK	3/4¢ PER SQ. INCH
3/32" THICK	1¢ PER SQ. INCH
1/8" THICK	1 1/2¢ PER SQ. INCH
3/16" THICK	2¢ PER SQ. INCH
1/4" THICK	2 1/2¢ PER SQ. INCH
3/8" THICK	4¢ PER SQ. INCH
1/2" THICK	5 1/4¢ PER SQ. INCH

SEND FOR COMPLETE PRICE LIST PROMPT ATTENTION TO MAIL ORDERS DEALERS PRICES ON APPLICATION

**STARRETT MFG. CO.**  
519 SOUTH GREEN ST. CHICAGO

# ACOUSTICOLA LOUD SPEAKER



PHONOGRAPH ATTACHMENT  
**\$10.00**

makes a high-grade loud speaker of any phonograph. Extra large size.

Wonderful adjustment lever tones down local stations and strengthens and clarifies weak signals from distant stations by instantly increasing or decreasing distance between poles and diaphragm. Just like focusing a camera.

## ACOUSTICOLA STANDARD MODEL

Same lever equipped, giant size unit with non-metallic horn, 21 1/2" high; bell 10" wide. **\$22.50**

## Acousticola Grand

**\$35.00**



With Cast Aluminum VIBRATIONLESS Horn—the world's finest loud speaker.

## TRIMM Head Phones

"PROFESSIONAL" **\$7.65** "DEPENDABLE" **\$5.00**

With every Trimm product we give a LIFETIME Guarantee. Write for folder.

**TRIMM RADIO MFG. CO.**

Dept. 63

24 S. CLINTON ST., CHICAGO

Eveready No. 764 "B" Battery, 22 1/2 volts, 3 3/4 inches long, 2 3/4 inches wide, 5 5/8 inches high, weight 2 1/2 lbs. Price \$2.25 everywhere



**EVEREADY**  
Radio Batteries  
—they last longer

The skyscraper "B" Battery is here!

New—this upright Eveready "B" Battery for cabinet or table where space is limited

Here is a new "B" Battery that stands on practically the same size base as the smallest Eveready "B" Battery, but towers above it in height and capacity.

It is twice as high, and will last you more than twice as long. And you pay only 50 cents more for the added capacity.

For portable sets, where smallest size and light weight are essential, the familiar favorite Eveready No. 763 is supreme at \$1.75. But where weight is not so important as space, buy the more than doubled service of the new upright No. 764 at \$2.25.

Fifteen vigorous cells give 22 1/2 volts. Two Fahnestock Spring Clip terminals.

For compact capacity, buy the new Eveready No. 764.

Manufactured and guaranteed by  
**NATIONAL CARBON COMPANY, Inc., New York, N. Y.**

**AN EVENING AT HOME WITH THE LISTENER IN**  
(SEE INSTRUCTIONS FOR USE BELOW)

Station and City	Mct	Monday	Tuesday	Wednesday	Thursday	Friday	Saturday	Sunday
CFCN, Calgary, Alta.	440	12:00-1:00	Silent	11:00-2:00	Silent	Silent	11:00-1:00	Silent
CKAC, Montreal, Que.	430	Silent	6:00-8:30	Silent	6:00-8:30	Silent	6:00-8:30	3:30-4:30
KDKA, E. Pittsburgh, Pa.	326	5:00-9:00	5:15-11:30	5:30-9:00	5:15-11:30	5:15-9:00	5:15-9:00	6:30-7:30
KDZE, Seattle, Wash.	435	10:30-12:30	Silent	10:30-12:30	Silent	10:30-12:30	Silent	Silent
KFAF, Denver, Colo.	360	9:00-10:00	9:00-10:00	Silent	8:30-9:00	9:00-10:00	9:00-10:00	Silent
KFL, Los Angeles, Calif.	469	8:45-1:00	8:45-1:00	8:45-2:00	8:45-1:00	8:45-2:00	8:45-2:00	10:00-1:00
KGW, Portland, Ore.	492	10:00-12:30	10:00-1:00	10:00-1:00	10:00-1:00	10:00-1:30	10:00-1:00	8:00-10:00
KHA, Los Angeles, Calif.	395	8:45-12:00	8:45-12:00	8:45-12:00	8:45-12:00	8:45-12:00	8:45-12:00	10:00-12:00
KPO, San Francisco, Calif.	423	10:00-12:00	10:00-12:00	Silent	10:00-12:00	Silent	10:00-2:00	10:00-12:00
KSD, St. Louis, Mo.	546	8:00-10:00	8:00-1:00	8:00-1:00	Silent	8:00-9:00	8:00-9:00	10:00-12:00
KYW, Chicago, Ill.	536	Silent	8:00-12:00	8:00-9:00	8:00-9:00	8:00-9:00	10:00-12:00	Silent
NAA, Radio, Va.	435	5:45-7:20	6:05-7:20	6:25-7:40	5:45-7:40	7:05-7:40	Silent	Silent
PWI, Havana, Cuba	400	Silent	Silent	7:30-10:00	Silent	Silent	7:30-10:00	Silent
WBAP, Fort Worth, Texas	478	7:30-10:45	7:30-10:45	7:30-10:45	7:30-10:45	7:30-10:45	7:00-7:30	5:00-6:00
WEAV, Columbus, O.	390	8:00-10:00	Silent	Silent	Silent	Silent	Silent	Silent
WEZ, Springfield, Mass.	337	5:00-8:00	6:30-8:00	5:00-11:00	6:30-8:00	5:00-11:00	6:30-8:00	5:45-8:30
WCAP, Washington, D. C.	469	Silent	6:30-7:30	Silent	9:00-11:00	Silent	6:30-11:00	6:20-7:20
WCBD, Zion, Ill.	345	8:00-10:00	Silent	Silent	Silent	8:00-10:00	Silent	2:30-5:30
WCK, Detroit, Mich.	517	7:30-9:00	7:30-11:00	7:30-9:00	7:30-9:00	7:30-9:00	Silent	6:15-7:15
WDAF, Kansas City, Mo.	411	8:00-1:00	11:45-1:00	8:00-1:00	11:45-1:00	8:00-1:00	11:45-1:00	Silent
WDAP, Chicago, Ill.	360	Silent	7:00-1:00	7:00-1:00	7:00-1:00	7:00-1:00	7:00-1:00	9:15-11:15
WDAR, Philadelphia, Pa.	395	6:30-9:55	6:30-7:00	6:30-10:00	6:30-7:00	6:30-12:30	6:30-7:00	Silent
WEAF, New York, N. Y.	492	6:30-9:00	6:30-9:00	6:30-9:00	6:30-9:00	6:30-9:00	6:30-9:00	6:30-9:00
WFAA, Dallas, Tex.	478	8:30-9:30	8:30-12:00	Silent	8:30-9:30	8:30-9:30	8:30-12:00	9:30-11:00
WFL, Philadelphia, Pa.	395	6:00-6:30	6:00-8:00	6:00-6:30	6:00-6:30	6:00-6:30	6:00-8:00	6:30-7:30
WGI, Medford, Mass.	360	Silent	6:00-7:30	6:30-8:00	6:00-7:30	6:30-8:00	6:30-8:00	7:30-10:00
WGR, Buffalo, N. Y.	319	5:30-11:00	5:30-7:45	5:30-11:00	5:30-7:45	5:30-11:00	5:30-7:45	2:00-3:00
WGY, Schenectady, N. Y.	380	6:45-9:00	6:45-9:00	Silent	6:45-9:00	6:45-10:30	Silent	5:30-6:30
WHA, Madison, Wis.	360	7:30-8:30	Silent	7:30-8:30	Silent	7:30-8:30	Silent	Silent
WHAS, Louisville, Ky.	400	Silent	7:30-9:00	7:30-9:00	7:30-9:00	7:30-9:00	7:30-9:00	4:00-5:00
WHAZ, Troy, N. Y.	380	8:00-9:30	Silent	Silent	Silent	Silent	Silent	Silent
WHB, Kansas City, Mo.	411	Silent	8:00-10:00	Silent	8:00-10:00	Silent	Silent	8:00-10:00
WHK, Cleveland, O.	283	5:00-5:30	5:00-5:30	5:00-5:30	5:00-5:30	5:00-8:00	5:00-5:30	7:00-8:30
WHN, New York, N. Y.	360	6:30-11:00	8:30-11:00	6:30-11:00	8:30-11:00	6:30-11:00	6:30-11:00	8:30-11:00
WIP, Philadelphia, Pa.	509	5:00-6:30	5:00-11:00	5:00-6:30	5:00-10:00	5:00-6:30	5:00-11:00	Silent
WJAR, Providence, R. I.	360	Silent	6:20-7:00	6:20-11:00	Silent	6:20-9:20	Silent	Silent
WJAX, Cleveland, O.	390	Silent	6:30-8:30	Silent	7:00-9:30	Silent	Silent	Silent
WJAZ, Chicago, Ill.	448	Silent	10:00-2:00	10:00-2:00	10:00-2:00	10:00-2:00	10:00-2:00	6:00-9:00
WJZ, New York, N. Y.	455	6:30-10:30	6:30-10:30	6:30-10:30	6:30-10:30	6:30-10:30	6:30-10:30	7:00-9:30
WKAQ, San Juan, P. R.	360	Silent	7:00-8:30	Silent	Silent	Silent	7:00-8:30	Silent
WLAG, Minn'pl's-St. Paul	417	Silent	Silent	9:15-10:45	Silent	9:15-10:45	9:15-12:30	7:45-9:15
WLW, Cincinnati, O.	309	8:00-10:00	10:00-12:00	8:00-10:00	10:00-12:00	Silent	Silent	Silent
WMAO, Chicago, Ill.	448	Silent	7:00-10:00	7:00-10:00	7:00-10:00	7:00-10:00	7:00-10:00	Silent
WMC, Memphis, Tenn.	500	8:30-9:30	8:30-12:00	Silent	8:30-9:30	8:30-12:00	8:30-9:30	Silent
WNAC, Boston, Mass.	278	Silent	7:00-9:00	8:00-10:00	7:00-9:00	7:00-9:00	8:00-10:00	5:30-7:30
WOAI, San Antonio, Texas	385	Silent	9:30-10:30	Silent	7:30-8:30	Silent	Silent	9:30-10:30
WOAW, Omaha, Neb.	526	9:00-11:00	9:00-11:00	Silent	9:00-11:00	9:00-11:00	9:00-11:00	9:00-11:00
WOC, Davenport, Ia.	484	8:00-9:00	Silent	8:00-11:00	8:00-9:00	8:00-9:00	9:00-10:00	7:00-11:00
WOO, Philadelphia, Pa.	509	6:30-10:00	Silent	6:30-10:00	Silent	6:30-10:00	Silent	Silent
WOR, Newark, N. J.	405	5:15-10:00	5:15-6:30	5:15-10:00	5:15-6:30	5:15-6:30	5:15-10:00	Silent
WOS, Jefferson City, Mo.	441	8:00-9:30	Silent	8:00-9:30	Silent	8:00-9:30	Silent	Silent
WRC, Washington, D.C.	469	7:00-9:00	Silent	7:00-9:00	Silent	7:00-9:00	Silent	Silent
WSAI, Cincinnati, O.	309	Silent	8:00-10:00	Silent	8:00-10:00	Silent	10:00-12:00	Silent
WSB, Atlanta, Ga.	429	8:00-12:00	8:00-12:00	10:45-12:00	8:00-12:00	8:00-12:00	8:00-12:00	7:30-9:15
WSY, Birmingham, Ala.	360	8:00-8:45	Silent	8:00-8:45	Silent	8:00-8:45	Silent	8:00-9:00
WTAM, Cleveland, Ohio	390	Silent	Silent	7:00-9:30	Silent	Silent	8:00-10:00	Silent
WWJ, Detroit, Mich.	517	7:30-9:00	7:30-9:00	7:30-9:00	7:30-9:00	7:30-9:00	Silent	4:00-5:00

Instructions for Use.—All the hours above are given in Central Standard Time. If your city uses Eastern Time, add one hour to each of the periods stated; if your city uses Mountain Time, subtract one hour; if your city uses Pacific Time, subtract two hours. This table includes only the evening broadcasts, and on Sunday, the late afternoon program.

Twenty-one English Radiophans have written WGY telling of successful reception of the Schenectady station's program during the last month.

**H - A - Z - E - L - T - I - N - E**  
**NEUTRODYNE**

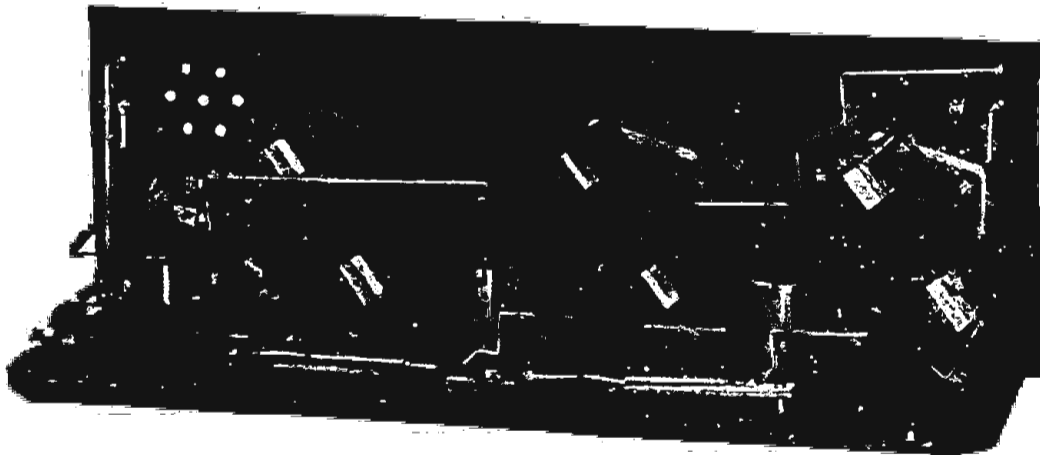

**Complete Parts for Reinartz Detector**

- Reg. Price      CONSISTING OF      Our Price
- 1.89 7x18 Formica Panel.....\$1.70
  - 1.00 Firth Socket ..... .45
  - 1.50 Howard Vernier Rheostat. 1.35
  - 3.30 23-Pl. Var. Condenser..... 1.45
  - 3.10 11-Pl. Var. Condenser..... 1.35
  - 1.50 3 Switch Levers ..... .75
  - .68 2 Doz. Switch Points..... .40
  - 3.00 Reinartz Coil ..... 1.95
  - 1.00 Freshman Variable Grid Leak and Condenser... .75
  - .80 8 Binding Posts ..... .40
  - .30 25 Ft. Hook-up Wire..... .20
  - .50 Baseboard for Mounting... .25
  - 1.00 Blueprint with Complete Instructions ..... .50
- REGULAR PRICE \$21.69**      **\$11.45**

Build a set where the numbers on the dials have a real meaning—

Complete parts for 3-tube Neurodyne consist of—

- 1 7x21x7/8 Drilled Formica Panel
- 1 Howard Rheostat
- 3 4" Radion Dials
- 3 John Firth Bakelite Sockets
- 8 Binding Posts
- 3 23 Plate Variable Condensers
- 1 Wave Control Neuroformer
- 2 R. F. Amplifying Neuroformers
- 2 Grid Neutralizing Condensers
- 1 .00025 Micon Condenser
- 1 Marco Variable Grid Leak
- 1 Base Board for mounting
- 25 Feet tinned copper bus bar wire and complete instructions for assembling and wiring.

4 Tube \$44.65      3 TUBE \$28.60  
5 Tube \$46.25

With FREED-EISEMAN or FADA Licensed Parts

All merchandise GUARANTEED by us to be of BEST QUALITY All mail orders shipped to you PROMPTLY



"The largest Radio Store in America"  
509 S. State St.  
Dept. RD-6  
Chicago, Ill.



**The Unexcelled Performance of Federal Standard Radio Products**

is the visual and audible evidence of the fine material and engineering skill which go into every Federal part. And the Federal guarantee is insurance of satisfaction to every Federal purchaser.

Federal head sets are one of the more than 130 radio products which Federal manufactures and guarantees. Your receiving set is no better than its weakest part. Insist on Federal.

Price 2200 OHMS  
**\$7.00**

**Federal Standard RADIO Products**



**—WILLARD—**  
WILLARD RADIO COMPANY  
291 BROADWAY,  
New York City  
"THE BEST FOR LESS"

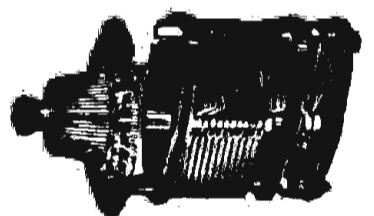

**FLEWELLING CIRCUIT**

EVERY PART COMPLETE  
2 honeycomb coils, 1 2-coil mounting, 2 coil plugs, 3 .006 condensers, 1 variable grid leak, 1 grid leak, 1 23-plate .0005 MFD. variable condenser, 1 Vernier rheostat, 1 tube socket, 8 binding posts, 20 feet bus bar wire, 1 3" dial and 1 high grade panel ALREADY DRILLED AS PER DIAGRAM IN BOOKLET OF INSTRUCTIONS SENT FREE. **\$11.95**  
Two-Stage Audio Frequency Amplifier—Parts complete in every detail for this Circuit—\$11.00  
Specify type of tubes you intend using

**CONDENSERS**

- 3 Plate Variable; value, \$1.75.....\$1.05
- 11 Plate Variable; value, \$2.50..... 1.20
- 13 Plate Variable; value, \$2.50..... 1.20
- 17 Plate Variable; value, \$3.50..... 1.85
- 23 Plate Variable; value, \$3.50..... 1.35
- 43 Plate Variable; value, \$4.50..... 1.95
- 13 Plate VERNIER; value, \$5.50.....\$3.75
- 23 Plate VERNIER; value, \$6.00..... 4.00
- 43 Plate VERNIER; value, \$6.50..... 4.25

- Filament Rheostat, 6 ohm..... .65
- Filament Rheostat, 20 ohm..... .80
- Filament Rheostat, 50 ohm..... .90
- With 2" Dial, 15c extra.

**AUDIO FREQUENCY TRANSFORMER—**  
Designed for use with W. D. 11  
Tubes, list, \$4.50; price..... **.75**

**BALL BEARING INDUCTANCE SWITCH—**  
value, 75c; special..... **.25**

V. T. SOCKETS—Nickel, brass sleeve, com-  
position base; value, \$1.00; special at..... **.40**  
**EXTRA SPECIAL—Telephone 3000 Ohms Head-**  
sets; \$9.00 value; reduced to..... **3.50**  
Vernier Dial Adjuster. List, 35c; special..... **.25**

**REINARTZ CIRCUIT**      EVERY PART COMPLETE

1 Reinartz wound coil, 1 tube socket, 1 rheostat, 1 23-plate .0005 MFD. variable condenser, 1 13-plate .00025 MFD. variable condenser, 3 inductance switches, 23 switch points and nuts, 6 switch stops and nuts, 8 binding posts, 2 3" dials, 1 variable grid leak, 1 .002 MFD. phone condenser, 23 feet bus bar wire, 1 high-grade panel ALREADY DRILLED AS PER DIAGRAM and complete instructions. **\$10.95**  
Two-Stage Audio Frequency Amplifier—Parts complete in every detail for this Circuit—\$11.00  
Specify type of tubes you intend using

**BEST QUALITY JACKS, Single Circuit;**  
value, 65c; special at..... **.30**  
Double Circuit; value, 90c; special at..... **.45**  
**MULTIPLE POINT INDUCTANCE SWITCH**  
with Knob and Dial (15 Switch Points).....**\$1.25**  
**LIGHTNING ARRESTERS** approved by underwriters ..... **.90**

**THREE-INCH DIALS—Unbreakable—heat**  
resisting composition—high finish; special..... **.90**  
**TWO-INCH DIALS—Same design—for rheo-**  
stats and potentiometers; special at..... **.25**  
**TELEPHONE PLUGS** ..... **.60**  
**FRESHMAN VARIABLE RESISTANCE**  
LEAK and MICA CONDENSER Combined..... **.75**

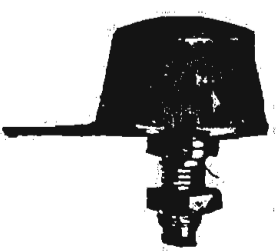

A Radio Set for Christmas—what other gift can offer even half the enjoyment and lasting pleasure? By building a set yourself you save considerable money. And besides, it's lots of fun and not a bit hard. Our service department will be glad to give you any information you need. Just drop us a line.

Every article advertised above is guaranteed by the manufacturer and by us—Mail orders filled immediately—transportation PREPAID on orders of \$5.00 or over east of the Mississippi River. Send cash, check or money order—absolutely no goods sent C. O. D.





# EXPOSE OF MUSIC TRUST PRINCIPLES

## ROSENTHAL OF A. S. C. A. P. MAKES MISSTATEMENT

### Tells Broadcasters in Meeting That WEAH Had Seen "Justice of Our Claim"—Proven Lie

The following article is one of a series which is being published with the express purpose of explaining to the Radio public the situation existing between the broadcasting stations and the American Society of Composers, Authors and Publishers. The series tells in detail the reasons why the National Association of Broadcasters was organized, and why certain popular songs, the copyrights for which are controlled by the "music trust," are not being broadcast.—The Editor.)

#### Part IV

MEMBERS of the National Association of Broadcasters have never been impressed by any amount of strict sincerity on the part of the American Society of Composers, Authors and Publishers, and they have their reasons. Granted that the average American will give and take a certain amount of bluff and enjoy it, yet he very promptly backs up and talks with much circumspection when addressing a body of men in a formal meeting, especially where convention reporters are carefully making a record of each word uttered.

**A. S. C. A. P. Does Not Fight Fair**  
The National Association of Broadcasters invited the American Society of Composers, Authors and Publishers, to send representatives of its organization to the meeting at the Drake Hotel, Chicago, on April 25, 1923. Appeared on the scene J. C. Rosenthal, General Manager, and E. S. Hartman, Chicago representative of the American Society of Composers, Authors and Publishers, who made a decidedly unfavorable impression on the men assembled, because of the arrogance of their discourse, and because of misstatements made.

The record shows that Mr. Rosenthal not once, but twice, said "The American Telephone and Telegraph company have already settled with us. They saw the justice of our claim. Why should not you?" etc.

**Rosenthal Invited to Leave Meeting**  
Now it so happened that the American Telephone and Telegraph company had a representative at the meeting under direct orders from New York City, and it was a matter of common knowledge to those who had investigated that the American Telephone and Telegraph company had not settled. Rosenthal and Hartman were thereupon asked to withdraw from the meeting. The executive officer having charge of Radio of the American Telephone and Telegraph was called on long distance and branded the statements made by Rosenthal as incorrect. It was this misrepresentation and bluff which caused broadcasters to give no further consideration to the demands of the American Society.

Again, on July 31, 1923, before Judge Lynch in Newark, in the case previously referred to, the Court report shows ex-Judge Haight, in arguing the case of the American Society, stated "The American Telephone and Telegraph have taken out a license with us." This was not true, and was not true on even as late a date as August 9, 1923.

#### Real Facts in the Matter

Now let us see what are the real facts. On August 9, 1923, the date this is written, which is three months and fourteen days after Rosenthal had made his incorrect statement in Chicago and nine days after ex-Judge Haight had made his state-

## MU-RAD DEALERS are making money!

And they don't find it hard to do it either. Why? Because the Mu-Rad Receiver itself does practically all the selling. A careful check on the sales of one Chicago dealer, proved that Mu-Rads are sold in 8 out of 10 competitive demonstrations!

### Write for Mu-Rad territory

Choice territory is still open to responsible, rated dealers. Kindly use your business stationery when writing for complete details.

Complete stock of parts  
WESTERN ELECTRIC COMPANY  
GENERAL RADIO COMPANY  
Write for Details and Discounts

Chicago Radio Apparatus Co.  
Jobbers of Good Radio Merchandise  
General Offices: 407 South Dearborn Street  
CHICAGO

ment in court, an officer of the American Telephone and Telegraph company stated that "No contract had been signed but that their legal department had a form of contract under consideration."

Why all of this beating around the bush? Why these intentional misstatements? Would not a truthful statement of the actual situation be strong enough for their purposes?

The American Society have harped upon this American Telephone and Telegraph matter until all are tired of hearing about it. Early last year a report was given to the Associated Press, which was printed in practically every newspaper of standing in the United States, stating that the American Telephone and Telegraph had taken out a license at that time, and quoting a large sum of money as the consideration. That report was entirely untrue and a knowing Radiophan does not need more than one guess to name the guilty parties.

(TO BE CONTINUED.)

Ask your Radio dealer for advice; he can probably tell you what you want to know and will be glad to do so. The manufacturer of your set is also willing to help you get the desired results.

# NEW YORK FIGHTS RADIO MONOPOLY

## CITY OFFICIAL COMBATS WESTERN ELECTRIC CO.

### Board of Aldermen Told That Concern's Tactics Prevent Construction of Plant

NEW YORK.—That New York City has been unable to erect its projected Radiotelephone broadcasting station because of the attitude of the Western Electric company which controls Radio patents was the recent charge of Commissioner Grover A. Whalen of the department of plant and structures in a formal communication to the board of aldermen.

#### Aldermen Order Plant

On July 19, 1922, a resolution was adopted by the board of estimate appropriating \$50,000 for the purchase and installation of equipment and for the construction of a complete Radiotelephone broadcasting station.

"In accordance with this action of the board," Commissioner Whalen's communication says, "proposals for bids were advertised and opened on Sept. 2, 1922. Only one bid was received, that of the Western Electric company, which was not accepted, in that it altered the terms of the specifications as advertised."

#### Monopoly Is Charged

"Exhaustive experiments have been conducted by the engineers of this department at the proposed site on the municipal building and at various other locations. The site of the municipal building was found to be unsatisfactory by test. After extended negotiations and the drawing of plans and proposals for other sites, this department has up to the present time been unable to execute the contract because of the continuous change of policy on the part of the Western Electric company. This company, through its control of Radio patents, is seeking to maintain a monopoly of the Radiotelephone broadcasting industry."

KDKA sometimes broadcasts on 100 meters. If the receiving set can get down that low, the listener won't be bothered by static.

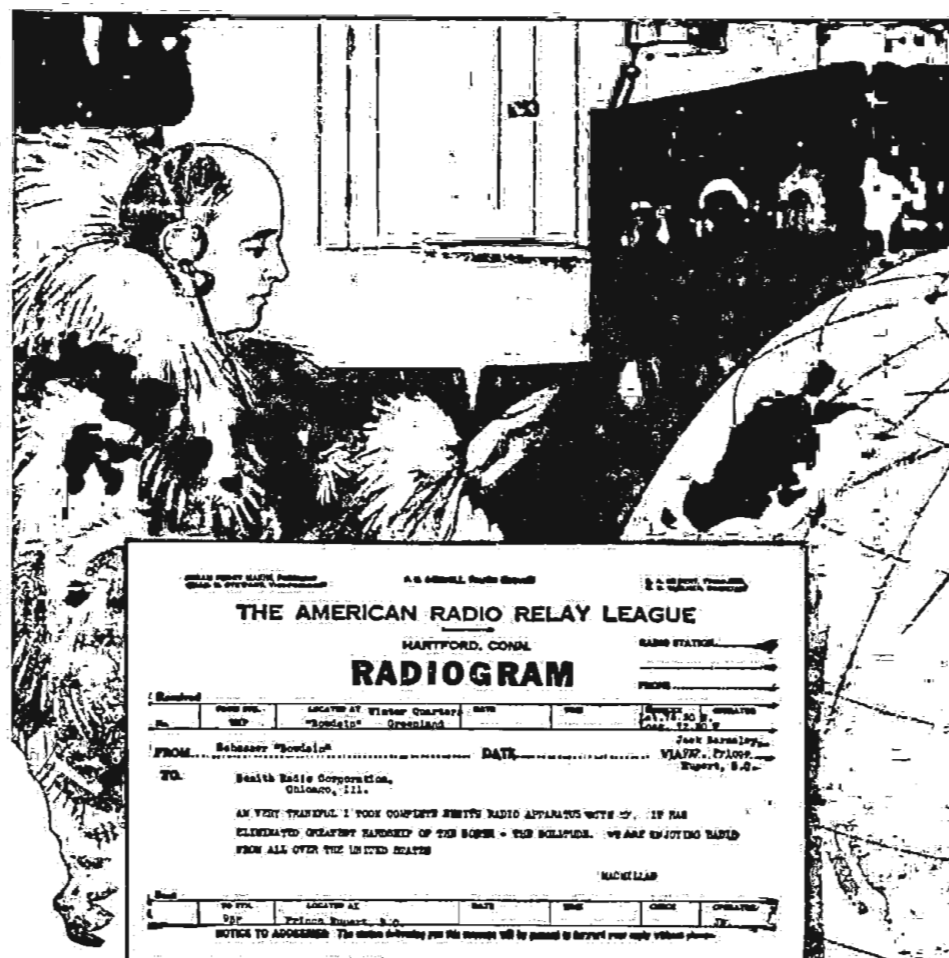

THE AMERICAN RADIO RELAY LEAGUE  
HARTFORD, CONN. RADIOGRAM  
TO: South Radio Corporation, Chicago, Ill.  
FROM: Secretary, National Association of Broadcasters, New York, N.Y.  
DATE: August 9, 1923

Inside the Arctic Circle, nine degrees from the North Pole, a little 89-foot schooner is frozen fast in the ice of Smith Sound. Aboard this schooner a group of brave men are enduring, as best they can, the desperate cold of the Arctic—cold that often drops to 60 degrees below zero. Human atoms in a boundless field of ice!

Cold is hard to endure, but far more terrible is the Arctic solitude—unbelievably oppressive. Radio, at length, has broken this spell forever!

### Concerts from Honolulu!

Daily, by means of powerful sending and receiving apparatus, the crew of the "Bowdoin" are in communication with relatives and friends in the far-off States. Daily they listen to concerts as far away as Chicago, Dallas, and Honolulu!

When the sanity, the very lives of one's shipmates may depend upon contact with the outside world, none but the **best** is good enough.

### Dr. MacMillan's Choice—the Zenith

Out of all the radio sets on the market, Dr. MacMillan selected the Zenith exclusively—because of its flawless construction, its unusual selectivity, its dependability and its tremendous reach.

Already his operator, on board the "Bowdoin" in Northern Greenland, has tuned in several hundred stations. You along the Atlantic who brag a little when you tune in Catalina Island—what would you say if you tuned in Hawaii from the Arctic Circle?

The set that Dr. MacMillan has is a standard Zenith receiving set. And you can do all that MacMillan does, and more, with either of the two new models shown at the right. Their moderate price brings them easily within your reach. Write today for full particulars.

Zenith  
Radio Corporation  
McCormick Building  
CHICAGO

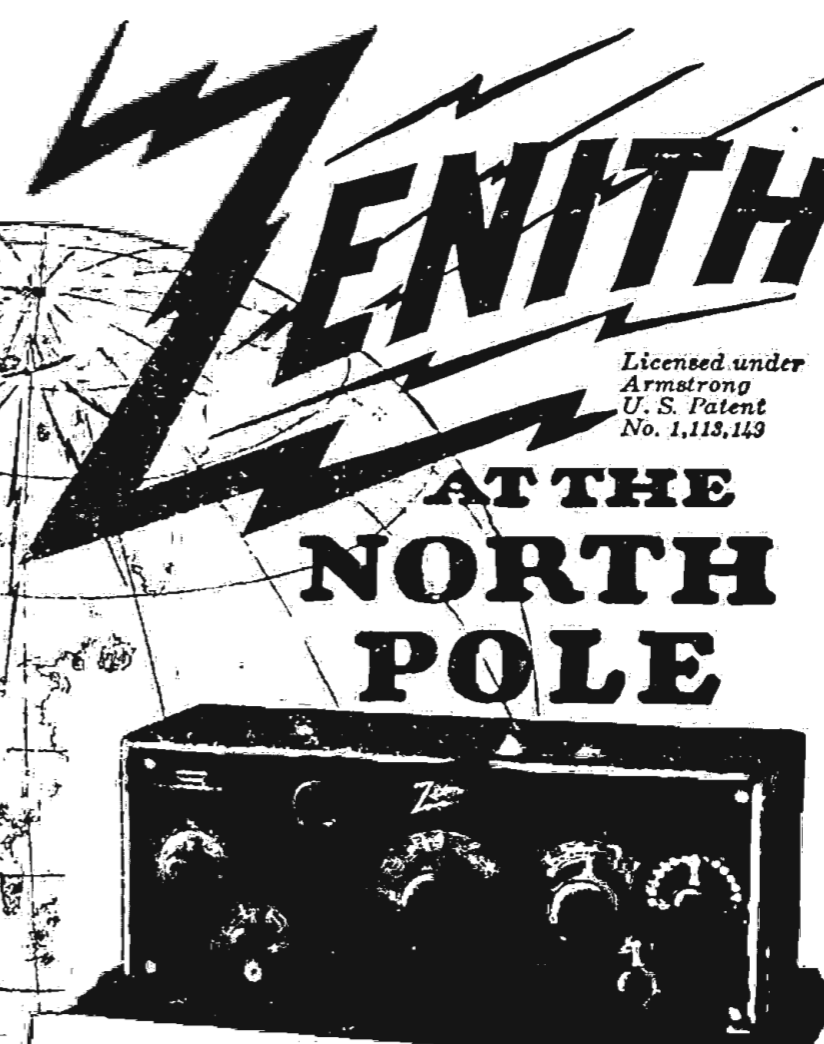

# ZENITH

Licensed under  
Armstrong  
U. S. Patent  
No. 1,115,143

## AT THE NORTH POLE

**Model 4R**—The new Zenith 4R "Long-Distance" Receiver-Amplifier comprises a complete three-circuit regenerative receiver of the feed-back type. It employs the Zenith regenerative circuit in combination with an **audion detector** and **three-stage** audio-frequency amplifier, all in one cabinet. Because of the unique Zenith "selector," unusual selectivity is accomplished without complication of adjustment. The Zenith 4R may be connected directly to any loud-speaker without the use of other amplification for full phonograph volume, and reception may be satisfactorily accomplished over distances **\$85** of more than 2,000 miles



**Model 3R**—The new Zenith 3R "Long-Distance" Receiver-Amplifier combines a specially designed distortionless three-stage amplifier with the super-efficient Zenith three-circuit regenerative tuner. Fine vernier adjustments—in connection with the unique Zenith aperiodic or non-resonant "selector" primary circuit—make possible extreme selectivity. **2,000 to 3,000 Miles with Any Loud-Speaker** The new Zenith 3R has broken all records, even those set by its famous predecessors of the Zenith line. Satisfactory reception over distances of 2,000 to 3,000 miles, and over, is readily accomplished in full volume, using any ordinary loud-speaker. No special skill is required. The Zenith is the only set built which is capable of being used with all present-day tubes as well as with any tubes that may be brought out in the future. The Model 3R is compact, graceful in line, and **\$160** built in a highly finished mahogany cabinet

ZENITH RADIO CORPORATION, Dept. E.  
328 South Michigan Avenue, Chicago, Illinois  
Gentlemen:—  
Please send me illustrated literature on Zenith Radio.  
Name \_\_\_\_\_  
Address \_\_\_\_\_



### HOOK-UP WITH SPLIT VARIOMETER

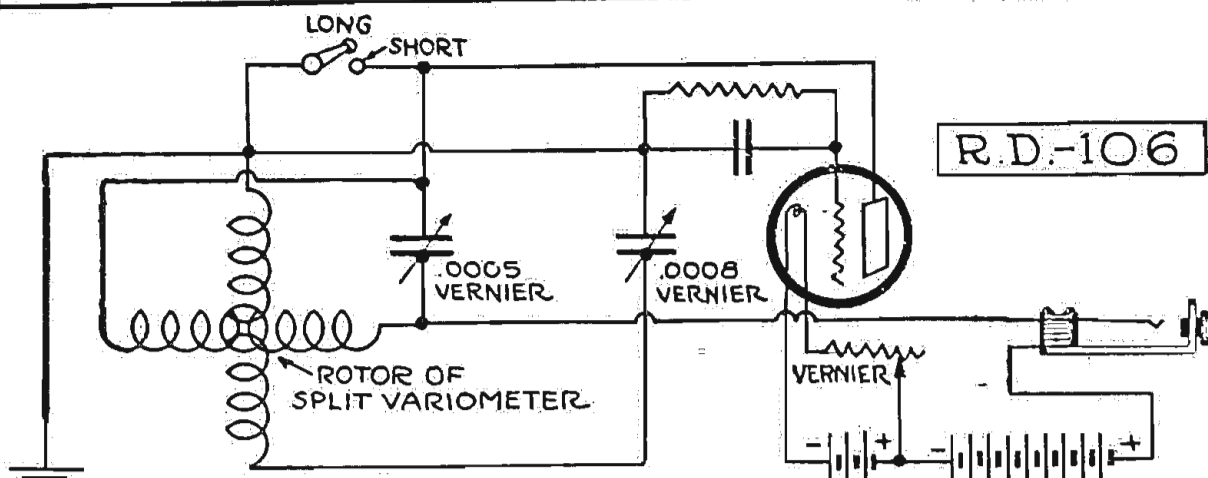

**S**PLIT variometers are going big. The idea of avoiding tapped inductances has proved valuable because of the lack of dead-end losses.

Here, then, is another split variometer circuit and it doesn't use an aerial, just a ground connection is sufficient and only three controls, the two variable condensers and the variometer coupling. The switch is used for the long and short wave control. The actual wave length range is dependent on the number of turns

of wire in the rotor and stator of the variometer.

The circuit is regenerative, gives good volume and has unusual selectivity. The filament rheostat is likely to be rather critical, so the use of a vernier type is recommended.

The plate battery voltage should be 22½ if a soft detector tube is used. With A tubes, 45 volts are usually necessary. The grid leak should have a resistance of one megohm and the condenser .00025 mfd.

### Transformer Hook-Up for Clear Strong Signals

I hook up my audio frequency transformer in a different way from that commonly used and get a much clearer and stronger signal.

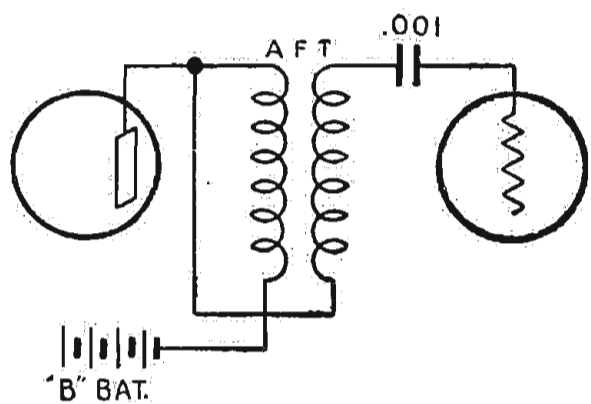

The lead from the inside of the primary

winding goes to the positive of the B battery; the lead from the outside of the same winding goes to the plate of the

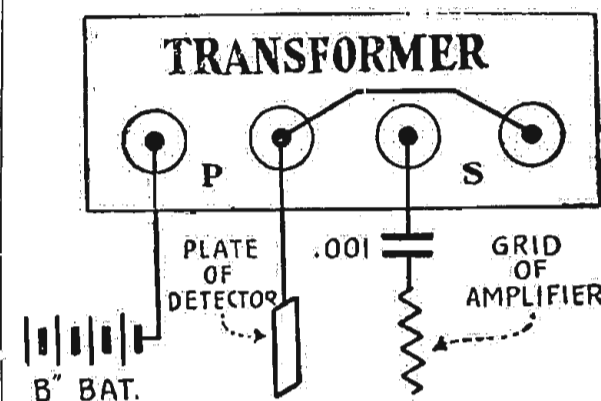

detector tube; the lead from the inside of secondary winding is connected direct to the outside lead from the primary, and the lead from the outside of secondary winding goes to the grid of the amplifier tube through a .001 condenser.—E. W. Mallernee, Battle Creek, Mich.

### Reception Queered by Crossing Power Lines

When something comes in over your set or whenever it seems to be acting queer, get in touch with some other fan and see if his set is acting the same way. Recently I could hear a grinding, popping, sputtering sound and at first thought it was in my set. However, when it ceased for part of a second or more, speech came in perfectly, and this presented a phase I could not account for. Another fan who uses a loop aerial was having the same trouble. We set about to find the trouble and located it a block and a half away where a 2,300-volt power line had crossed a 110-volt light line and would spark except when the wind blew them apart. This was a miniature "spark station" which would have given no end of trouble had it not been found.—J. B. Owen, Blair, Okla.

Too much regeneration spoils Radio reception.

### "Service that is certain"

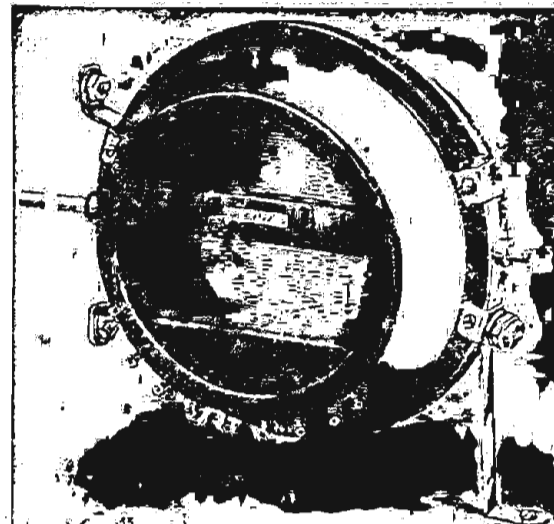

Langbein & Kaufman Variometers and Variocouplers .....\$8 ea.  
Finest Instruments in the world.  
Myers Hi-Mu Tubes.....\$4.35  
Amperite-Automatic Filament, eliminates Rheostat.....Unmounted, 70c; mounted, \$1.10  
All merchandise absolutely guaranteed.  
Shipped immediately on receipt of purchase price.  
**Radio & Mechanical Trade Corp.**  
23 Warren St. NEW YORK

### REINARTZ COILS

IMPROVED COILS MADE TO COVER NEW WAVE LENGTHS

- 21 tap coils.....\$1.00
- 16 tap coils......90

Above prices include coil mounting and also circuit diagram. Sent postpaid upon receipt of money order.

Attractive discounts to dealers.

KINLEY RADIO CO., Box 185, Detroit, Mich.

### REPEATER RADIO PHONE



2400 Ohms

### NEW REPEATER RADIO PHONE

Black Gun Metal Finish  
NICKEL TRIM

**\$3.50**

Better Than Most  
—As Good as Any

**Trial Offer** If your dealer is out of "Repeaters" send \$3.50 and dealer's name for complete set subject to refund in full within 10 days if not perfectly satisfactory.

**Moss-Schury Mfg. Co., Inc.**  
Radio Division  
2011-2015 Franklin Street, Detroit, U. S. A.  
Manufacturers of precision electrical devices

# SUPER VALUES

## WHAT'S NEW IN RADIO? HAZELTINES NEUTRODYNE

The ultimate receiver for local and long distance Radio concert reception

### THE MOST TALKED ABOUT SET OF TODAY

1. SIMPLICITY (A child can operate it)
2. SELECTIVITY (You can tune out local stations)
3. STABILITY (Always ready to entertain)
4. DISTANCE (Average range about 2000 miles)
5. NOISELESS (No squeals, no howls, no whistles)

Complete Parts for Building This Master Receiver **\$49.65**  
AS LISTED BELOW, ONLY

Stock No.	Quantity	Description	Price
201 A.	1	Bakelite panel, 24x7x½, drilled and engraved.....	\$ 6.50
202 A.	1	Baseboard, 23x6.....	.75
203 A.	5	Standard sockets.....	1.95
204 A.	3	Neutroformers.....	15.00
205 A.	2	Neutrodons.....	1.50
206 A.	2	High ratio transformers.....	11.10
207 A.	1	A. battery switch.....	.75
208 A.	3	4" Pathe dials, taper knob.....	2.10
209 A.	1	1 Plain rheostat.....	1.00
210 A.	1	Fada type 150 A. vernier rheostat.....	1.25
211 A.	7	Eby engraved binding posts.....	1.40
212 A.	1	Closed circuit jack.....	.80
213 A.	1	3 spring automatic jack.....	1.00
214 A.	27 ft.	Spaghetti tubing.....	2.10
215 A.	27 ft.	Bus bar.....	.25
216 A.	2	Condensers, .006 mfd.....	1.00
217 A.	1	Grid leak, 2 megohms.....	.50
218 A.	1	Grid leak and condenser, .00025.....	.60
219 A.	1	Package screws, nuts, terminals, etc.....	.10
220 A.	1	Fada instruction book.....	

Stock No.	Quantity	Description	Price
221 A.	5	Bonded tubes.....	\$22.00
222 A.	1	Seaman loud speaker, genuine Baldwin type C unit.....	12.75
223 A.	4	Columbia or Red Seal A battery.....	1.60
224 A.	2	45 volt B batteries.....	9.00
225 A.	1	Set complete aerial equipment.....	2.00

### OUR SPECIAL COMBINATION OFFER \$47.35

To each purchaser of the parts and accessories for the HAZELTINE NEUTRODYNE RECEIVER at the low price of \$97.00 we will, without cost to you, ship a Genuine HANES-ZENER special hand rubbed solid mahogany cabinet. Value \$10.00.

Each of the above parts are of the highest standard grade, and carry the HANES-ZENER guarantee and can be purchased separately at our special prices.

### Flewelling Circuit Complete

	List Price	Our Price
7x9 Radion Panel.....	\$ 1.15	\$ .90
23 Plate Var. Condensers.....	3.00	1.50
3 .006 Mica Condensers.....	3.00	2.00
C. R. L. Var. Grid Leak.....	1.85	1.30
Two Coil Honeycomb mount adjustable with knobs.....	4.00	2.55
50 Turn Honeycomb Coil.....	1.54	1.00
75 Turn Honeycomb Coil (Mounted).....	1.54	1.00
One tube socket.....	1.00	.40
Klosner vernier rheostat with dial.....	1.50	1.00
One three-inch Dial (Taper Knob).....	1.00	.25
8 Binding Posts.....	.80	.40
Baseboard for mounting.....	.75	.40
Complete Instructions for Assembly and Wiring.....	.50	.50

Regular Price .....\$21.63

**OUR PRICE \$13.20**

All the necessary screws, nuts and miscellaneous small parts which are necessary to complete the set are included in the above prices. Any part in either of these circuits may be purchased independently at the advertised cut prices.

### Reinartz Circuit Complete

	List Price	Our Price
Genuine Reinartz Coil endorsed by John L. Reinartz and bearing his signature. The only genuine coil for this circuit on the market. All others are imitations.....	\$ 2.50	\$2.00
One 7x10x2 Radion Panel.....	1.25	1.00
National Bakelite Socket.....	1.00	.40
Klosner Vernier Rheostat with dial.....	1.50	1.00
Two 23 plate variable condensers at \$3.00 each.....	6.00	3.00
Switch Points and Nuts.....	.80	.40
Six Switch Stop Points and Nuts.....	.40	.20
Freshman Grid Leak and Condenser.....	1.00	.65
Seven Binding Posts.....	.70	.35
25 ft. Tinned Bus Bar.....	.50	.35
3 Switch Levers with knobs.....	.75	.40
One Baseboard for mounting.....	.40	.25
One Fixed Phone Condenser.....	1.00	.25
One Single Jack.....		
Blue Prints with complete instructions for assembly and mounting.....	.50	.50

Regular Price .....\$19.05

**OUR PRICE \$11.05**

### LOUD SPEAKERS

List Price	Our Price	Description	List Price	Our Price
\$161.00	\$125.75	Western Electric 10-A.....	\$20.00	\$24.50
55.00	44.00	Western Electric 10-D.....	25.00	19.50
60.00	51.00	Magnavox Type R-3.....	25.00	19.50
35.00	29.50	Magnavox Type R-2.....	22.50	18.00
			28.50	23.50

### PHONES

List Price	Our Price
\$6.00	\$5.25
8.00	6.50
7.00	5.50

### TUBES

List Price	Our Price
\$5.00	\$3.95
5.00	3.95
6.50	5.75
6.50	5.75
6.50	5.75
6.50	5.75
6.50	5.75
6.50	5.75
6.50	5.75
6.50	5.75

### CONDENSERS

List Price	Our Price
\$1.80	\$1.90
5.00	2.50
5.50	2.75
3.00	1.50
2.80	1.90

### AUDIO TRANSFORMERS

List Price	Our Price
\$4.50	\$3.95
4.75	4.10
4.75	4.10
7.00	5.55
7.00	5.55

The Radio Mail Order House  
Known for Low Prices

WRITE FOR OUR CATALOGUE B



3 WEST 29TH STREET, NEW YORK CITY

Send Money Order,  
Including Postage



# Further Details of the Famous Miloplex Hook-Up

## Part X—The Heart of the Radio Circuit

By the Mystery Man

AND they are still selling bad pencils with erasers on them, which answers your troubles. No, somebody made a mistake. Maybe 'twas the King. Well, no matter, supposin' we blame it on Maggie. You can rub out the phone condenser on the King Diagram. It halnt got no business there. Sorry you had a dead set just 'cause of it. Atta baby! I knew you'd forgive me.

That fellow West was a surprise party wasn't he? Gee—wouldn't it be a Radio winter if we didn't have "fighters" like him who just won't let a little 2x6 circuit

minals. One each for each end of the stator winding, and one each for each end of the rotor. Of course using an ax is easier, but it makes such a messy job. Besides axes were never intended for any use but on chicken.

Another kick. Many write me (and they don't enclose stamped envelopes for reply either) telling they get a rather consistent ground hum. A ground hum may be grief to them but it's a whole story to me. The only reason for a ground hum is you are way shy on resonance. Don't ask me like one fine chap did. He wanted to know the name of the manufacturer of resonances, and still Maggie wonders why I'm staying out late nights. Hek, can a guy go to sleep trying to think up an answer to such a simple question? Certainly! Try and do it.

### The Heart of a Radio Circuit

You know it was either Mark Twain, Mark Anthony or Mark Time—one of the seven—who coined that famous saying now standard copy in all of Joe Miller's Joke Books, viz., "Where the heart is the lungs are close by" and coughed up a Radio truism. It's a fact, every Radio circuit has a heart, and many of them, volume enough to forever convince the deaf that they also have lungs. Yet, just the second any circuit goes blooie, do you feel around to see if its heart hasn't dropped out? Nay! Nay! but off you go to its ears, pedal extremities or some place—some place hunting around—guessing. Thanks to Radio, more often a guess finds the fly in the ointment.

Where is this circuit heart? And how can I tell a Radio circuit heart when I see one? Now listen, and then repeat three times—you listen also Mr. Barnes 'cause your circuit hearts are short-circuited.

### Its Definition

Ready? "The heart of any and all Radio circuits is that circuit of which the grid of the tube is one end, the plate of the tube the other, and—and the capacity from grid to plate, the missing link—the 'Mike' I call him—that makes or breaks any and all circuits if you don't know how to make him work for you."

### ANTENNA EFFICIENCY

Equip your aerial with dry gap insulators and keep it constant in all kinds of weather. Don't blame your set if your insulators are covered with snow or ice, which lets the electric current escape down the wet guy rope to the ground. \$1.50 each, check or money order. Write for descriptive bulletin.

THE ANTENNA INSULATOR COMPANY  
15 Bagley Street Pawtucket, R. I.

Speaketh the teacher, get that—it's going to be one of the questions in the exams.

Now look over your King or any other King and see if it has a heart—tack on signal tuning elements, signal receiving elements, pin on all the doodads you like—but forget to control or interfere with this heart circuit in the due performance of its work and you might as well advertise for help, or send the circuit, parts, tools and all to Maggie. On the other hand get that bigger, better idea that this "heart" and it alone is the one and only place in a circuit upon which all success or failure depends—know it and its function, why it functions, the "Why and Wherefores" of its existence—then Radio and the inherent value of a tube—a three-element tube—will appear in all of its marvelous simplicity.

Look at it. Study it as only six bucks worth of glass.

### Give More Details in Writing

That's the story this week. It's the biggest help I know. And now a word about my mail. Many—mercy, I say, too many—of you in writing give me so little information. Do this when writing: give me the make of each part, a careful sketch of your circuit, type and size of aerial, all of the essentials, and don't forget, enclose a stamped envelope for reply. I don't own the postoffice. Try answering thirty or forty letters a day. I know—it's O. K. I want to work 27½ hours a day but don't own the clock.

Maggie says, "Why not join the Union?" "Not a bad idea," says I. "Bad, say man! They wouldn't even let you wear a union suit." You know what I mean.

Atta baby! Now that you know the rules, the pen and ink business is dying.

### When Is a Vernier Not a Vernier?

And we will now forget postage stamps and swing onto vernier rheostats and variable condensers. When do you need a vernier rheostat? Never! Why do they build them? I don't know—unless well they don't know either. When do you need a vernier variable condenser? I mean the kind with a suburban extension of a plate or two on them. Well, let me see, you need one of them just about half or maybe seven-eighths—no it's one-half—as much as you do a vernier rheostat.

(Continued on page 14)

Gentlemen:

### Regarding the Miloplex:

Just a few words to compliment the originator of this circuit.

I built this set with practically junk parts, tried it out and then set it away, coming to the conclusion it was another freak hook-up, but not wholly condemning it.

Last night I put it into use again with two steps of amplification, and started tuning in.

I landed on WLAG, then KSD, WDAP, WJAZ, WSB and several others.

Today I tried it out at noon, with one wire counterpoise and aerial, landed on WEA, New York, broadcasting the ceremony of the Washington Memorial services. I was never able to receive from my location around noon, due to motors near by. I might say I am located right in the heart of this city in a flat three stories high, with higher buildings all around me.

All these stations came in with loud speaker intensity.

I must say for ease and simplicity in tuning, it is the best ever.

I am not rushing into print with this complimentary writing, but I want to say the originator started something big.

I also landed WGY on aerial alone tonight, without any ground.

Yours truly,

L. A. Coleman.

keep him from making every whistle spell "I'm Calling." The King works—if it don't it's you; Mr. Man: you and your parts, so tear into it. Don't let West carry away all the blue ribbons.

### How to Split Variometer

How do you split a variometer? Easy, just separate the connection between the stator and rotor, which will leave your variometer with four in place of two ter-

# Thrills from Radio

No. 6 of a Series Featuring Experiences of "ALL-AMERICAN" Users

## Heard 900 Miles on Loud Speaker

By Alex. C. Herro, Oconomowoc, Wis.

"I hooked the 'All-Americans' on the set, immediately upon receipt, and 'let her rip'.

"It worked fine. On the loud speaker I got many stations over 500 miles away, among them being KDKA, WMC, WGY, KSD—and W'BAF, Fort Worth, Texas, about 900 miles away.

"The last could be heard all over the house."

Don't spend time and money experimenting—over 300,000 radio enthusiasts, like Mr.

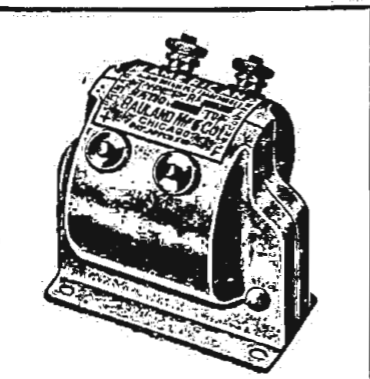

All-American Audio Frequency Transformers come in three ratios: 3:1, 5:1, 10:1.

Special Offer! "All-American diagram and circular describing Power Amplifiers; also Book of hook-ups containing 22 tested circuits. Send 4c in stamps or postage.

All the better dealers sell "ALL-AMERICAN"

RAULAND MFG. CO., 200 N. Jefferson St., CHICAGO  
PIONEERS IN THE INDUSTRY

AUDIO AND RADIO FREQUENCY

POWER AMPLIFYING INPUT AND OUTPUT

# ALL-AMERICAN AMPLIFYING TRANSFORMERS

Largest Selling Transformers in the World

**The RADIO-SHACK**

58 Dey Street - New York City  
Goods shipped C.O.D.  
Just pay the postman

EVERY ARTICLE SOLD ON WRITTEN MIDNEY-BACK GUARANTEE

The Convenient Way to Buy Radio

One of Six New York Stores

## High Quality at Low Prices!

**VICTOGRAND**

A loudspeaker as truthful in reproduction as it is beautiful in appearance. The base is finished in jet black, the tone arm is cast aluminum and the horn is of gold. Complete, no extra batteries required.

**\$9.95**

### TUBES

Each one is tested before shipment

RADIO CORPORATION OF AMERICA

WD 11	\$5.49
WD 12	5.59
UV 201A	5.59
UV 200	4.29

SUPERTRONS

Type WD 11	3.19
Type UV 201A	3.79

### "B" BATTERIES

Tested Fresh Batteries Only  
22½ Volt Variable

Reg. \$1.75	\$0.70
Reg. 2.50	1.25
Reg. 3.00	1.49

45 Volt Variable

Reg. 3.00	1.39
Reg. 4.00	2.29
Reg. 5.50	2.99

### TRANSFORMERS

ALL-AMERICAN

10-1 Reg.	\$4.75	\$4.30
5-1 Reg.	4.75	4.15
3-1 Reg.	4.50	4.00

ERLA REFLEX

No. 1 Reg.	\$5.00	4.25
No. 2 Reg.	\$5.00	4.25
Audio 3½-1 Reg.	\$5.00	4.25
Audio 2-1 Reg.	\$5.00	4.25
Brunswick Reg.	\$5.00	2.89

HEGEHOG AUDIO

3-1 Reg.	\$3.50	3.29
4-1 Reg.	3.50	3.29
6-1 Reg.	3.50	3.29

Use these transformers for the best results.

### CONDENSERS

Moulded Endplates and Sturdy Construction

11 pl. Reg.	\$1.75	\$0.99
23 pl. Reg.	2.50	1.49
43 pl. Reg.	3.50	1.89

Vernier with Dials

11 plate	\$2.75
23 plate	2.95
43 plate	3.25

### SPECIALS

Fada Type Rheostat, 6 ohm	\$0.39
Fada Type, 30 ohm	.49
Brunswick sockets with nickel top	.39
Slaction Sockets (moulded thorough)	.34
Slaction Moulded Variometer (150-600 meter) Reg.	5.50... 3.49

### Other Good Buys

Phone Plugs (round or flat)	25c
S. C. Jacks	23c
D. C. Jacks	37c
Spaghetti, 3 feet	11c
Bus Bar, 2 feet	3c
Tube Protectors ¼ or 1 amp	23c
Voltmeters	\$1.29



# "LILLIOM," "ANDREA CHENIER" AND

## These Stories Will Aid Opera Listeners

STORY OF ANDREA CHENIER, WMAQ DECEMBER 6

ON THE eve of the French revolution, Countess de Coligny gives a ball. Chenier, a young poet, enrages everyone except Madeleine, the daughter of the Countess, by reciting his radical poems. Gerard, the footman, admits a troop of beggars, announcing, "His Serene Highness, Prince Poverty," and is elected with them. Chenier attempts to save Madeleine from Gerard, now revolutionary leader. The two meet and fight. Although Gerard is hurt, he tells the crowd that he does not know Chenier and urges the latter to save Madeleine. Chenier is arrested and brought before Gerard. Although the poet pleads with the jury, and Madeleine offers her own life, Gerard cannot oppose the mob and Chenier is convicted. Madeleine, accompanied by Gerard, bribes her way into the Lazare prison, where Chenier is writing. Although Gerard appeals to Robespierre, he is unable to help him. In the morning Madeleine dies, gullotined with Chenier.

STORY OF CARMEN, KYW DECEMBER 8

CARMEN, a spy, is arrested for stabbing one of the factory girls and placed in Don Jose's charge, whom she bribes to release her. She is arrested for letting her while awaiting his release. Carmen meets Escamillo, a torador. When Don Jose comes out of prison, he quarrels with his superior officer for flirting with Carmen and is compelled to join a band of smugglers. Escamillo follows Carmen and the two men fight. They are separated by the gypsies and Carmen, while Don Jose is away at his mother's deathbed, Carmen and the gypsies follow Escamillo to Seville to watch a bull fight. Don Jose meets and kills her, just as the victorious torador comes out. In remorse he throws himself across her body.

—THE PROGRAM LADY.



Val McLaughlin (circle) bursts right through the bedtime story page and charms the WOC kiddies every Wednesday, Friday and Saturday with the "Sandman's Visit." The cast of Lilliom (center rectangle) rehearses for the WLW Radario production to be given Thursday, December 6. Left to right: "Lilliom," Charles W. Reaume; Mrs. Muscat, Olive Vail; "Julie," Helen McCoy

## Tuesday, December 4

KFI, Los Angeles, Calif. (Pacific, 469), 6:45-7:30 p. m., Concert, Gage Christopher; 10:00-11:00, Concert, Zoelner Conservatory.  
KGW, Portland, Ore. (Pacific, 492), 3:30 p. m., Jeanette P. Kramer, 8:00, Talk for farmers, Paul V. Maris; 10:00, Dance music, George Olsen's Metropolitan Orchestra.  
KJL, Los Angeles, Calif. (Pacific, 395), 2:30-3:30 p. m., Matinee musicale, Mrs. Ray Fisher, contralto; 6:45-7:30, "Sandman"; 8:00-10:00, "Sylinders of Sunshine"; The Three Selbys; 10:00-12:00, midnight, Art Hickman's Orchestra.  
KSD, St. Louis, Mo. (Central, 546), 8:00 p. m., Norman V. Dixon, baritone; Irene Slate, pianist; Mrs. N. D. Dixon, pianist; Addresses, H. E. Wiedemann, W. Guy Whitehead; 11:00, Silverman's Orchestra.  
KYW, Chicago, Ill. (Central, 536), 6:50 p. m., Children's bedtime story; 8:00-8:28, "The Farm Problem an International Problem," J. W. Coverdale; 8:35-9:30, Herbie Mintz, pianist; Frances Morrison, soprano; Ralph Elliott, tenor; Harriet Weeber, pianist; Joseph Izzo, flutist; Sallie Menkes, pianist; 10:00-12:30, Midnight Show; Wendell W. Hall, KYW's music maker; McVicker's Symphony Orchestra; W. Remington Welch, organist.  
WBAP, Fort Worth, Texas (Central, 476), 7:30-8:30 p. m., Henry Blewett's Orchestra of Denton; 9:30-10:45, Municipal Band of Alford; 10:00-11:00, WBZ, Springfield, Mass. (Eastern, 337), 6:00 p. m., Dinner concert, WBZ Trio; 7:00, "Winter Courses at College for Farmers," Director John Phelan of the Mass. Agr. College; 7:30, Twilight tales for the kiddies; "New Housekeeping," Agnes H. Craig; 8:00, WBZ Trio; Grace Loomis Kempton, soprano; 9:00, Bedtime story for grown-ups, Orison S. Marden.  
WDAP, Chicago, Ill. (Central, 360), 10:00 p. m., Rosemary Elmer, soprano; Erick W. Agard, tenor; Bob Cougle, pianist; Jack Chapman's Orchestra.  
WJAR, Philadelphia, Pa. (Eastern, 395), 12:00-12:30 p. m., Organ recital, William Klais, Stanley Theater; Arcadia Cafe Concert Orchestra, Feri Sarkozil, director; 2:00-3:00, Concert, Arcadia Cafe Concert Orchestra; 4:30, Piano recital, Edna Finestone; 7:30-7:45, Bedtime stories, Dream Daddy; 7:45-8:00, Dramatic review, Walter Greenough.  
WEAF, New York, N. Y. (Eastern, 492), 11:30-11:50 a. m., "Forecast of Motion Pictures," Adele F. Woodward; 5:00 p. m., Christmas program for children, Gimbel Brothers; 7:30, United Sports Talk, Thornton Fisher; 7:40, "Suction Bridge," Raymond F. Rode; 8:10, Marie S. Murray, soprano; 8:20, American Surety Co.; 8:30, Brooklyn Daily Eagle Talk; 8:50, James M. Rose, tenor; 9:00, World Mutual Casualty Insurance Co.; 9:30, National Carhide Comedy; 10:05, James M. Rose, tenor.  
WFAX, Dallas, Texas (Central, 476), 12:30-1:00 p. m., Address, DeWitt McLaughlin; 8:30-9:30, Mozart Choral Club; 11:00-12:00, Orchestra music and violin choir, A. A. DeMond and assisting musicians.  
WFI, Philadelphia, Pa. (Eastern, 395), 1:00 p. m., Meyer Davis Bellevue Stratford Orchestra; 6:30, Meyer Davis Bellevue Stratford Orchestra; 7:00, Bedtime stories, Cousin Sue; 8:00, Radio play, WFI Players.  
WGI, Medford Hillsdale, Mass. (Eastern, 360), 3:00 p. m., Amrad Women's Club Program, "Hospitality Talk," Marjorie Drew; Descriptive musicale, Chickering & Sons Co.; 7:00, "Alaska," Mr. Roberts.  
WGR, Buffalo, N. Y. (Eastern, 319), 12:30-1:00 p. m., George Albert Bouchard, organist; 4:00, Martha Gompf, harpist; Elise de Grood, violinist; 6:30-7:30, Vincent Lopez Hotel Stadler Dance Orchestra; 7:30, Digest of the day's news; Boy Scout Radiogram; Story from "The American Boy" magazine; 9:00, Ball room music, Hotel Stadler, annual hall, Society of Vocational Education.  
WGY, Schenectady, N. Y. (Eastern, 380), 2:00 p. m., "Early American Craftsman," Mrs. George B. Goodall; 7:45, Salvation Army Band; "Interesting Combination Reciters," R. E. Langley, Arthur Stone, cornetist; Albert Tompkins, euphoniumist; A talk on outdoor life, Jud Landon; Moncrieff Galloway, trombonist; James Ryan, cornetist.  
WHAS, Louisville, Ky. (Central, 400), 4:00-5:00 p. m., Strand Theater Orchestra; Walnut Theater Orchestra; Alamo Theater organ; 7:30-9:00, Ray Pfaff and his orchestra.  
WHN, New York, N. Y. (Eastern, 360), 2:15-2:30 p. m., James Kendis, composer and songwriter singing his own songs, assisted by Hal. Dyser at the piano; 4:30-5:30 p. m., "The Tangoland Serenaders," Jerry Schwarz, leader; 8:45-10:15 p. m., Charles Hathaway's Orchestra; 10:30-10:45 p. m., Ruth and Janet Meyer, jazz pianist and singer; 10:45-11:00 p. m., Charles Bourne, jazz pianist; 11:00-11:30 p. m., Shapiro Bernstein Music Co.  
WIP, Philadelphia, Pa. (Eastern, 509), 1:00 p. m., Organ recital, Karl Bonawitz, Germantown Theater; 3:00, Popular program, George Kelly and his Record Recording Orchestra; 6:05, Dick Regan and his WIP Little Symphony Orchestra; 7:00, Bedtime stories by Uncle Wip; 8:00, Dramatic review, Elliott Lester; 8:00, Dance music, Charlie Kerr and his orchestra.  
WJAZ, Chicago, Ill. (Central, 390), 7:30 p. m., Program arranged by the Cleveland News-Leader;

## Wednesday, December 5

KDKA, E. Pittsburgh, Pa. (Eastern, 326), 6:30 p. m., Pittsburgh Athletic Association Orchestra; 7:30, Literary program; 7:45, Children's period; 8:15, Address, Sanitation, Committee of the Allegheny County Medical Society; 8:30, KDKA Little Symphony Orchestra.  
KFI, Los Angeles, Calif. (Pacific, 469), 6:45-7:30 p. m., Detective stories, Detective Nick Harris; 10:00-11:00, Concert, California School of Artistic Whistling.  
KGW, Portland, Ore. (Pacific, 492), 3:30 p. m., Music by children; Story, Aunt Nell; 8:00, Ryhka String Orchestra; 9:00, Business Talk, James Albert; 10:00, Dance music, George Olsen's Metropolitan Orchestra.  
KHJ, Los Angeles, Calif. (Pacific, 395), 2:30-3:30 p. m., Cecilia Linn, soprano; Children's program, Vera Leavitt Owens; soprano; Priscilla Moran, screen juvenile; Bedtime story, Mrs. Rufus Wagner; Program, Victor Schertzinger, motion picture director and composer of "Marcheta"; 10:00-12:00 midnight, Art Hickman's Orchestra.  
KSD, St. Louis, Mo. (Central, 546), 7:00 p. m., Aberg's Concert Ensemble, Arne Arnesen, violinist; 11:00 Rodemich's Orchestra.  
KYW, Chicago, Ill. (Central, 536), 6:50 p. m., Children's bedtime story; 8:00-8:58, Wendell W. Hall, KYW's Music Maker; A. W. "Sen" Kaney; Sherwood School of Music; 9:15, The Public Shooting Grounds, "Gams Refuge Bill"; Book reviews, Llewellyn Jones.  
WBAP, Fort Worth, Texas (Central, 476), 7:30-8:30 p. m., Pearl Calhoun Davis, soprano; 9:30-10:45, George Freeman's Sooner Serenaders.  
WBZ, Springfield, Mass. (Eastern, 337), 6:00 p. m., Dinner concert, WBZ Quintette; 7:00, Radio course, Edward H. Goodrich; 7:30, Twilight tales for the kiddies; "Winter Care of Fruit Trees," William H. Wolf; Story for grown-ups, Orison S. Marden; 11:00, WBZ Quintette; Charles H. Young, tenor; Mrs. M. M. Thomson, pianist.  
WDAP, Chicago, Ill. (Central, 360), 10:00 p. m., Chicago Conservatory of Music; Jack Chapman's Orchestra.  
WJAR, Philadelphia, Pa. (Eastern, 395), 12:00-12:30 p. m., Organ recital, William Klais, Stanley Theater; Arcadia Cafe Concert Orchestra; 2:00-3:00, Concert, Arcadia Cafe Concert Orchestra; 7:30-8:00, Bedtime stories, Dream Daddy; 8:00, Dance music, Howard Lantini's Arcadia Cafe Orchestra.  
WEAF, New York, N. Y. (Eastern, 492), 11:00 a. m., Columbia University; 4:30 p. m., Mae Torrence, soprano; 5:00, Christmas program for children; Gimbel Brothers; 7:00, United Synagogue of America; 7:30, United Sports Talk, Thornton Fisher; 8:10, May Singh Breen, pianist; 8:15, Walter Vogel, baritone; 8:30, American Bond & Mortgage Co.; Walter Vogel, baritone; 8:50, Symphony Players; 9:50, Board of Education; 10:00, Jeanette and Mildred Boyd, soprano and contralto.  
WFAX, Dallas, Texas (Central, 476), 12:30-1:00 p. m., Address, Oscar O. Touchstone; music, "Red Head Gal."  
WFI, Philadelphia, Pa. (Eastern, 395), 1:00 p. m., Meyer Davis Bellevue Stratford Orchestra; 3:00, Boretta Kerk, Pianist; 6:30, Meyer Davis Bellevue Stratford Orchestra; 7:00, Talks from Snowball Land.  
WGI, Medford Hillsdale, Mass. (Eastern, 360), 6:50 p. m., Camp Fire Girls, Charles W. Casson, "Big Chief"; 7:15, "This Week's Judge"; 7:20, "Science up to Date," Scientific American; 7:30, "Books for Long Evenings," David M. Cheney; Concert Players, E. Chester MaDan, director.

## Thursday, December 6

KDKA, E. Pittsburgh, Pa. (Eastern, 326), 6:15 p. m., Grand Symphony Orchestra; 7:30, Weekly chat with farmers, Frank E. Mullen; 7:45, Children's period; 8:30, Concert, students of the studio of Lyman A. Perkins; Caroline Bracey, soprano; Arthur Ray Davis, tenor; E. Clair Anderson, bass; Mrs. L. Wallace Ohi, contralto; 11:30, Special late concert.  
KFI, Los Angeles, Calif. (Pacific, 469), 6:45-7:30 p. m., Concert, Los Angeles A. M. C. A.; 10:00-11:00, Concert, Wa-Wan Club.  
KGW, Portland, Ore. (Pacific, 492), 8:00 p. m., Dramatic program, Red Lantern Players; 10:00, George Olsen's Metropolitan Orchestra.  
KSD, St. Louis, Mo. (Central, 546), 8:00 p. m., St. Louis Symphony Orchestra, Rudolph Ganz, conductor; Max Stietendel, cellist.  
KHJ, Los Angeles, Calif. (Pacific, 395), 2:30-3:30 p. m., Matinee musicale; 6:45-7:30, Children's program; John T. Brown, harmonica player; Dickie Brandon, 4 years of age; 8:00-10:00, Woman's Choral Club of Pasadena; 10:00-12:00, Art Hickman's Orchestra.  
KYW, Chicago, Ill. (Central, 536), 6:50 p. m., Children's bedtime story; 8:00-8:20, Twenty minutes of good reading, Rev. C. J. Perrin; 8:30-9:30, Edison Symphony Orchestra, Morgan L. Eastman, director; Estelle Vernet, soprano.  
WBAP, Fort Worth, Texas (Central, 476), 7:30-8:30 p. m., Concert, Epworth League of Denton; 9:30-10:45, Fort Worth Euterpean Club.  
WBZ, Springfield, Mass. (Eastern, 337), 8:30 p. m., Twilight tales for the kiddies; Letter from the New

The charming "Carmen" is Alice Gentle. Above left is Fernand Anseau, who will sing "Jose" in the French opera. Tune in KYW Saturday, December 8. Once tuned in you'll stay till the final curtain.

England Homestead; 8:00, Miss Champagne, pianist; Beatrice Driscoll, pianist; pupils of Gustave Kratoch; 9:00, Bedtime story for grown-ups, Orison S. Marden.  
WDAP, Chicago, Ill. (Central, 360), 10:00 p. m., Percy Congdon's Orchestra; Jack Chapman's Orchestra.  
WJAR, Philadelphia, Pa. (Eastern, 395), 12:00-12:30 p. m., Organ recital, William Klais; 12:30, Arcadia Cafe Concert Orchestra; 2:00-3:00, Concert, Arcadia Cafe Concert Orchestra; 4:30, Piano solos, Edna Finestone; 7:30-7:45, Bedtime stories, Dream Daddy.  
WEAF, New York, N. Y. (Eastern, 492), 11:00 a. m., Special program for women; 4:00 p. m., Edgar Fairchild, pianist; 4:30, Maurice L. Seifstein, tenor; 5:00, Christmas program for children, Gimbel's; 7:00, Midweek services, N. Y. Fed. of Churches; 7:30, United Sports Talk, Thornton Fisher; 7:40, William Friedman, pianist; 8:00, Instruction talk, Ever-Ready Battery; Edna Fields, mezzo-soprano; 8:30, Bank of America; 8:50, Hearst's International Mag.; 9:15, William Sweeney, baritone; 9:30, Henry W. Tarr; Aida Quartette, trumpeter and player of horns; 10:15, Margaret Freer, mezzo-soprano; Jose Delaguerre, tenor; 11:00-12:00 midnight, Vincent Lopez Dance Orchestra.  
WFAX, Dallas, Texas (Central, 476), 12:30-1:00 p. m., "Education and Athletics," Ray Morrison; 8:30-9:30, Mrs. Albert Smith, soprano.  
WFI, Philadelphia, Pa. (Eastern, 395), 1:00 p. m., Meyer Davis Bellevue Stratford Orchestra; 3:00, Song recital, WFI Quartette, John Vandersloot, John Owens, Harold Simonds and Edwyl Lewis; 6:30, Meyer Davis Bellevue Stratford Orchestra; 7:00, Talks from Snowball Land; 8:00, Boy Scout Period; 10:10, Dance music, Meyer Davis Bellevue Stratford Orchestra.  
WGI, Medford Hillsdale, Mass. (Eastern, 360), 7:00 p. m., Evening musical, George Brinton Beal and Friends; Bedtime stories for parents, Alfred F. Whitman.  
WGR, Buffalo, N. Y. (Eastern 319) 12:30-1:00 p. m., George Albert Bouchard, organist; 4:00, Martha Gompf, harpist; Elise de Grood, violinist; 6:30-7:30, Vincent Lopez Hotel Stadler Dance Orchestra; 7:30, Digest of the day's news; Boy Scout Radiogram; Story from "The American Boy" magazine; 9:00, Ball room music, Hotel Stadler, annual hall, Society of Vocational Education.  
WGY, Schenectady, N. Y. (Eastern, 380), 2:00 p. m., "The Child Adoption League," Mrs. Andrew Vogel; 7:45, "Ship Propulsion," V. L. Wright; WGY Orchestra; Radio drama, "The Thirteenth Chair," WGY Players; Helen O'Neill, Rose Cohn; Will Crosby, Edward H. Smith; Mrs. Crosby, Mrs. R. P. Jecklyn; Roscoe Crosby, Maurice C. Randall; Edward Wales, Jerome Lovenheim; Mary Eastwood, Lola Sommers; Helen Trent, Margaret V. Smith; Grace Standish, Genevieve Liddane; Braddish Trent, John Loftus; Howard Standish, Barrington Havens; Philip Mason, Edward E. St. Louis; Elizabeth Estline, Arline Montgomery; Pollock, Frank Oliver; Tim Donahue, Charles S. Beames; Sergeant Dunn, Courtland Hopkins; Doolin, Burton Anderson.  
WHAS, Louisville, Ky. (Central, 400), 4:00-5:00 p. m., Strand Theater Orchestra; Alamo Theater organ; 7:30-9:00, Concert, Town Club of the Louisville Conservatory, Helen Elchenberger, director.  
WHN, New York, N. Y. (Eastern, 360), 2:15-3:00 p. m., Shapiro Bernstein Music Co.; 10:00-10:10, Bella Bart, astrologist; 10:30-11:00, Avon Society Orchestra; 11:00-11:15, James Kendis, song writer and composer singing his own songs; 11:15-11:45, Irving Berlin Music Co.  
WIP, Philadelphia, Pa. (Eastern, 509), 6:05 p. m., Dinner music, Dick Regan and his WIP Little Symphony Orchestra; 7:00, Bedtime stories by Uncle Wip.  
WJAZ, Chicago, Ill. (Central, 390), 8:00 p. m., Concert by the Shrine Band.  
WJAZ, Chicago, Ill. (Central, 447.7), 10:00 p. m. - 2 a. m., Ethel Manning, soprano; Samuel Pierson, pianist; Richard Lovridge, violinist; John Goin, pianist; Oriole Orchestra.  
WLV, Cincinnati, Ohio (Central, 309), 10:00 p. m., Modern Hungarian Radario Night; "Lilliom," Crevelley Radarians; Freda Slauter, violinist; Saida McAllister, pianist; Cincinnati Symphony Orchestra; 11:15, Ralph Long's Dance Orchestra.  
WMAQ, Chicago, Ill. (Central, 447.5), 7:00 p. m., Wheat Council—talk on "Toast," Rockwell Stephens; 7:45, "Andrea Chenier," opera at the Auditorium Theater by Chicago Civic Opera Company, broadcast on 345 meters, Mrs. Marx E. Oberndorfer, announcer; opera in Italian, music by Gioachino Rossini; libretto by Felice, four acts; Cast: Andrea Chenier, young poet, Guilfo Crimi; Charles Gerard, servant; Elizabeth Estline, Arline Montgomery; Pollock, Frank Oliver; Tim Donahue, Charles S. Beames; Sergeant Dunn, Courtland Hopkins; Doolin, Burton Anderson.  
WHAS, Louisville, Ky. (Central, 400), 4:00-5:00 p. m., Strand Theater Orchestra; Alamo Theater organ; 7:30-9:00, Concert, Town Club of the Louisville Conservatory, Helen Elchenberger, director.  
WHN, New York, N. Y. (Eastern, 360), 2:15-3:00 p. m., Shapiro Bernstein Music Co.; 10:00-10:10, Bella Bart, astrologist; 10:30-11:00, Avon Society Orchestra; 11:00-11:15, James Kendis, song writer and composer singing his own songs; 11:15-11:45, Irving Berlin Music Co.  
WIP, Philadelphia, Pa. (Eastern, 509), 6:05 p. m., Dinner music, Dick Regan and his WIP Little Symphony Orchestra; 7:00, Bedtime stories by Uncle Wip.  
WJAZ, Chicago, Ill. (Central, 390), 8:00 p. m., Concert by the Shrine Band.  
WJAZ, Chicago, Ill. (Central, 447.7), 10:00 p. m. - 2 a. m., Ethel Manning, soprano; Samuel Pierson, pianist; Richard Lovridge, violinist; John Goin, pianist; Oriole Orchestra.  
WLV, Cincinnati, Ohio (Central, 309), 10:00 p. m., Modern Hungarian Radario Night; "Lilliom," Crevelley Radarians; Freda Slauter, violinist; Saida McAllister, pianist; Cincinnati Symphony Orchestra; 11:15, Ralph Long's Dance Orchestra.  
WMAQ, Chicago, Ill. (Central, 447.5), 7:00 p. m., Wheat Council—talk on "Toast," Rockwell Stephens; 7:45, "Andrea Chenier," opera at the Auditorium Theater by Chicago Civic Opera Company, broadcast on 345 meters, Mrs. Marx E. Oberndorfer, announcer; opera in Italian, music by Gioachino Rossini; libretto by Felice, four acts; Cast: Andrea Chenier, young poet, Guilfo Crimi; Charles Gerard, servant; Elizabeth Estline, Arline Montgomery; Pollock, Frank Oliver; Tim Donahue, Charles S. Beames; Sergeant Dunn, Courtland Hopkins; Doolin, Burton Anderson.  
WHAS, Louisville, Ky. (Central, 400), 4:00-5:00 p. m., Strand Theater Orchestra; Alamo Theater organ; 7:30-9:00, Concert, Town Club of the Louisville Conservatory, Helen Elchenberger, director.  
WHN, New York, N. Y. (Eastern, 360), 2:15-3:00 p. m., Shapiro Bernstein Music Co.; 10:00-10:10, Bella Bart, astrologist; 10:30-11:00, Avon Society Orchestra; 11:00-11:15, James Kendis, song writer and composer singing his own songs; 11:15-11:45, Irving Berlin Music Co.  
WIP, Philadelphia, Pa. (Eastern, 509), 6:05 p. m., Dinner music, Dick Regan and his WIP Little Symphony Orchestra; 7:00, Bedtime stories by Uncle Wip.  
WJAZ, Chicago, Ill. (Central, 390), 8:00 p. m., Concert by the Shrine Band.  
WJAZ, Chicago, Ill. (Central, 447.7), 10:00 p. m. - 2 a. m., Ethel Manning, soprano; Samuel Pierson, pianist; Richard Lovridge, violinist; John Goin, pianist; Oriole Orchestra.  
WLV, Cincinnati, Ohio (Central, 309), 10:00 p. m., Modern Hungarian Radario Night; "Lilliom," Crevelley Radarians; Freda Slauter, violinist; Saida McAllister, pianist; Cincinnati Symphony Orchestra; 11:15, Ralph Long's Dance Orchestra.  
WMAQ, Chicago, Ill. (Central, 447.5), 7:00 p. m., Wheat Council—talk on "Toast," Rockwell Stephens; 7:45, "Andrea Chenier," opera at the Auditorium Theater by Chicago Civic Opera Company, broadcast on 345 meters, Mrs. Marx E. Oberndorfer, announcer; opera in Italian, music by Gioachino Rossini; libretto by Felice, four acts; Cast: Andrea Chenier, young poet, Guilfo Crimi; Charles Gerard, servant; Elizabeth Estline, Arline Montgomery; Pollock, Frank Oliver; Tim Donahue, Charles S. Beames; Sergeant Dunn, Courtland Hopkins; Doolin, Burton Anderson.  
WHAS, Louisville, Ky. (Central, 400), 4:00-5:00 p. m., Strand Theater Orchestra; Alamo Theater organ; 7:30-9:00, Concert, Town Club of the Louisville Conservatory, Helen Elchenberger, director.  
WHN, New York, N. Y. (Eastern, 360), 2:15-3:00 p. m., Shapiro Bernstein Music Co.; 10:00-10:10, Bella Bart, astrologist; 10:30-11:00, Avon Society Orchestra; 11:00-11:15, James Kendis, song writer and composer singing his own songs; 11:15-11:45, Irving Berlin Music Co.  
WIP, Philadelphia, Pa. (Eastern, 509), 6:05 p. m., Dinner music, Dick Regan and his WIP Little Symphony Orchestra; 7:00, Bedtime stories by Uncle Wip.  
WJAZ, Chicago, Ill. (Central, 390), 8:00 p. m., Concert by the Shrine Band.  
WJAZ, Chicago, Ill. (Central, 447.7), 10:00 p. m. - 2 a. m., Ethel Manning, soprano; Samuel Pierson, pianist; Richard Lovridge, violinist; John Goin, pianist; Oriole Orchestra.  
WLV, Cincinnati, Ohio (Central, 309), 10:00 p. m., Modern Hungarian Radario Night; "Lilliom," Crevelley Radarians; Freda Slauter, violinist; Saida McAllister, pianist; Cincinnati Symphony Orchestra; 11:15, Ralph Long's Dance Orchestra.  
WMAQ, Chicago, Ill. (Central, 447.5), 7:00 p. m., Wheat Council—talk on "Toast," Rockwell Stephens; 7:45, "Andrea Chenier," opera at the Auditorium Theater by Chicago Civic Opera Company, broadcast on 345 meters, Mrs. Marx E. Oberndorfer, announcer; opera in Italian, music by Gioachino Rossini; libretto by Felice, four acts; Cast: Andrea Chenier, young poet, Guilfo Crimi; Charles Gerard, servant; Elizabeth Estline, Arline Montgomery; Pollock, Frank Oliver; Tim Donahue, Charles S. Beames; Sergeant Dunn, Courtland Hopkins; Doolin, Burton Anderson.  
WHAS, Louisville, Ky. (Central, 400), 4:00-5:00 p. m., Strand Theater Orchestra; Alamo Theater organ; 7:30-9:00, Concert, Town Club of the Louisville Conservatory, Helen Elchenberger, director.  
WHN, New York, N. Y. (Eastern, 360), 2:15-3:00 p. m., Shapiro Bernstein Music Co.; 10:00-10:10, Bella Bart, astrologist; 10:30-11:00, Avon Society Orchestra; 11:00-11:15, James Kendis, song writer and composer singing his own songs; 11:15-11:45, Irving Berlin Music Co.  
WIP, Philadelphia, Pa. (Eastern, 509), 6:05 p. m., Dinner music, Dick Regan and his WIP Little Symphony Orchestra; 7:00, Bedtime stories by Uncle Wip.  
WJAZ, Chicago, Ill. (Central, 390), 8:00 p. m., Concert by the Shrine Band.  
WJAZ, Chicago, Ill. (Central, 447.7), 10:00 p. m. - 2 a. m., Ethel Manning, soprano; Samuel Pierson, pianist; Richard Lovridge, violinist; John Goin, pianist; Oriole Orchestra.  
WLV, Cincinnati, Ohio (Central, 309), 10:00 p. m., Modern Hungarian Radario Night; "Lilliom," Crevelley Radarians; Freda Slauter, violinist; Saida McAllister, pianist; Cincinnati Symphony Orchestra; 11:15, Ralph Long's Dance Orchestra.  
WMAQ, Chicago, Ill. (Central, 447.5), 7:00 p. m., Wheat Council—talk on "Toast," Rockwell Stephens; 7:45, "Andrea Chenier," opera at the Auditorium Theater by Chicago Civic Opera Company, broadcast on 345 meters, Mrs. Marx E. Oberndorfer, announcer; opera in Italian, music by Gioachino Rossini; libretto by Felice, four acts; Cast: Andrea Chenier, young poet, Guilfo Crimi; Charles Gerard, servant; Elizabeth Estline, Arline Montgomery; Pollock, Frank Oliver; Tim Donahue, Charles S. Beames; Sergeant Dunn, Courtland Hopkins; Doolin, Burton Anderson.  
WHAS, Louisville, Ky. (Central, 400), 4:00-5:00 p. m., Strand Theater Orchestra; Alamo Theater organ; 7:30-9:00, Concert, Town Club of the Louisville Conservatory, Helen Elchenberger, director.  
WHN, New York, N. Y. (Eastern, 360), 2:15-3:00 p. m., Shapiro Bernstein Music Co.; 10:00-10:10, Bella Bart, astrologist; 10:30-11:00, Avon Society Orchestra; 11:00-11:15, James Kendis, song writer and composer singing his own songs; 11:15-11:45, Irving Berlin Music Co.  
WIP, Philadelphia, Pa. (Eastern, 509), 6:05 p. m., Dinner music, Dick Regan and his WIP Little Symphony Orchestra; 7:00, Bedtime stories by Uncle Wip.  
WJAZ, Chicago, Ill. (Central, 390), 8:00 p. m., Concert by the Shrine Band.  
WJAZ, Chicago, Ill. (Central, 447.7), 10:00 p. m. - 2 a. m., Ethel Manning, soprano; Samuel Pierson, pianist; Richard Lovridge, violinist; John Goin, pianist; Oriole Orchestra.  
WLV, Cincinnati, Ohio (Central, 309), 10:00 p. m., Modern Hungarian Radario Night; "Lilliom," Crevelley Radarians; Freda Slauter, violinist; Saida McAllister, pianist; Cincinnati Symphony Orchestra; 11:15, Ralph Long's Dance Orchestra.  
WMAQ, Chicago, Ill. (Central, 447.5), 7:00 p. m., Wheat Council—talk on "Toast," Rockwell Stephens; 7:45, "Andrea Chenier," opera at the Auditorium Theater by Chicago Civic Opera Company, broadcast on 345 meters, Mrs. Marx E. Oberndorfer, announcer; opera in Italian, music by Gioachino Rossini; libretto by Felice, four acts; Cast: Andrea Chenier, young poet, Guilfo Crimi; Charles Gerard, servant; Elizabeth Estline, Arline Montgomery; Pollock, Frank Oliver; Tim Donahue, Charles S. Beames; Sergeant Dunn, Courtland Hopkins; Doolin, Burton Anderson.  
WHAS, Louisville, Ky. (Central, 400), 4:00-5:00 p. m., Strand Theater Orchestra; Alamo Theater organ; 7:30-9:00, Concert, Town Club of the Louisville Conservatory, Helen Elchenberger, director.  
WHN, New York, N. Y. (Eastern, 360), 2:15-3:00 p. m., Shapiro Bernstein Music Co.; 10:00-10:10, Bella Bart, astrologist; 10:30-11:00, Avon Society Orchestra; 11:00-11:15, James Kendis, song writer and composer singing his own songs; 11:15-11:45, Irving Berlin Music Co.  
WIP, Philadelphia, Pa. (Eastern, 509), 6:05 p. m., Dinner music, Dick Regan and his WIP Little Symphony Orchestra; 7:00, Bedtime stories by Uncle Wip.  
WJAZ, Chicago, Ill. (Central, 390), 8:00 p. m., Concert by the Shrine Band.  
WJAZ, Chicago, Ill. (Central, 447.7), 10:00 p. m. - 2 a. m., Ethel Manning, soprano; Samuel Pierson, pianist; Richard Lovridge, violinist; John Goin, pianist; Oriole Orchestra.  
WLV, Cincinnati, Ohio (Central, 309), 10:00 p. m., Modern Hungarian Radario Night; "Lilliom," Crevelley Radarians; Freda Slauter, violinist; Saida McAllister, pianist; Cincinnati Symphony Orchestra; 11:15, Ralph Long's Dance Orchestra.  
WMAQ, Chicago, Ill. (Central, 447.5), 7:00 p. m., Wheat Council—talk on "Toast," Rockwell Stephens; 7:45, "Andrea Chenier," opera at the Auditorium Theater by Chicago Civic Opera Company, broadcast on 345 meters, Mrs. Marx E. Oberndorfer, announcer; opera in Italian, music by Gioachino Rossini; libretto by Felice, four acts; Cast: Andrea Chenier, young poet, Guilfo Crimi; Charles Gerard, servant; Elizabeth Estline, Arline Montgomery; Pollock, Frank Oliver; Tim Donahue, Charles S. Beames; Sergeant Dunn, Courtland Hopkins; Doolin, Burton Anderson.  
WHAS, Louisville, Ky. (Central, 400), 4:00-5:00 p. m., Strand Theater Orchestra; Alamo Theater organ; 7:30-9:00, Concert, Town Club of the Louisville Conservatory, Helen Elchenberger, director.  
WHN, New York, N. Y. (Eastern, 360), 2:15-3:00 p. m., Shapiro Bernstein Music Co.; 10:00-10:10, Bella Bart, astrologist; 10:30-11:00, Avon Society Orchestra; 11:00-11:15, James Kendis, song writer and composer singing his own songs; 11:15-11:45, Irving Berlin Music Co.  
WIP, Philadelphia, Pa. (Eastern, 509), 6:05 p. m., Dinner music, Dick Regan and his WIP Little Symphony Orchestra; 7:00, Bedtime stories by Uncle Wip.  
WJAZ, Chicago, Ill. (Central, 390), 8:00 p. m., Concert by the Shrine Band.  
WJAZ, Chicago, Ill. (Central, 447.7), 10:00 p. m. - 2 a. m., Ethel Manning, soprano; Samuel Pierson, pianist; Richard Lovridge, violinist; John Goin, pianist; Oriole Orchestra.  
WLV, Cincinnati, Ohio (Central, 309), 10:00 p. m., Modern Hungarian Radario Night; "Lilliom," Crevelley Radarians; Freda Slauter, violinist; Saida McAllister, pianist; Cincinnati Symphony Orchestra; 11:15, Ralph Long's Dance Orchestra.  
WMAQ, Chicago, Ill. (Central, 447.5), 7:00 p. m., Wheat Council—talk on "Toast," Rockwell Stephens; 7:45, "Andrea Chenier," opera at the Auditorium Theater by Chicago Civic Opera Company, broadcast on 345 meters, Mrs. Marx E. Oberndorfer, announcer; opera in Italian, music by Gioachino Rossini; libretto by Felice, four acts; Cast: Andrea Chenier, young poet, Guilfo Crimi; Charles Gerard, servant; Elizabeth Estline, Arline Montgomery; Pollock, Frank Oliver; Tim Donahue, Charles S. Beames; Sergeant Dunn, Courtland Hopkins; Doolin, Burton Anderson.  
WHAS, Louisville, Ky. (Central, 400), 4:00-5:00 p. m., Strand Theater Orchestra; Alamo Theater organ; 7:30-9:00, Concert, Town Club of the Louisville Conservatory, Helen Elchenberger, director.  
WHN, New York, N. Y. (Eastern, 360), 2:15-3:00 p. m., Shapiro Bernstein Music Co.; 10:00-10:10, Bella Bart, astrologist; 10:30-11:00, Avon Society Orchestra; 11:00-11:15, James Kendis, song writer and composer singing his own songs; 11:15-11:45, Irving Berlin Music Co.  
WIP, Philadelphia, Pa. (Eastern, 509), 6:05 p. m., Dinner music, Dick Regan and his WIP Little Symphony Orchestra; 7:00, Bedtime stories by Uncle Wip.  
WJAZ, Chicago, Ill. (Central, 390), 8:00 p. m., Concert by the Shrine Band.  
WJAZ, Chicago, Ill. (Central, 447.7), 10:00 p. m. - 2 a. m., Ethel Manning, soprano; Samuel Pierson, pianist; Richard Lovridge, violinist; John Goin, pianist; Oriole Orchestra.  
WLV, Cincinnati, Ohio (Central, 309), 10:00 p. m., Modern Hungarian Radario Night; "Lilliom," Crevelley Radarians; Freda Slauter, violinist; Saida McAllister, pianist; Cincinnati Symphony Orchestra; 11:15, Ralph Long's Dance Orchestra.  
WMAQ, Chicago, Ill. (Central, 447.5), 7:00 p. m., Wheat Council—talk on "Toast," Rockwell Stephens; 7:45, "Andrea Chenier," opera at the Auditorium Theater by Chicago Civic Opera Company, broadcast on 345 meters, Mrs. Marx E. Oberndorfer, announcer; opera in Italian, music by Gioachino Rossini; libretto by Felice, four acts; Cast: Andrea Chenier, young poet, Guilfo Crimi; Charles Gerard, servant; Elizabeth Estline, Arline Montgomery; Pollock, Frank Oliver; Tim Donahue, Charles S. Beames; Sergeant Dunn, Courtland Hopkins; Doolin, Burton Anderson.  
WHAS, Louisville, Ky. (Central, 400), 4:00-5:00 p. m., Strand Theater Orchestra; Alamo Theater organ; 7:30-9:00, Concert, Town Club of the Louisville Conservatory, Helen Elchenberger, director.  
WHN, New York, N. Y. (Eastern, 360), 2:15-3:00 p. m., Shapiro Bernstein Music Co.; 10:00-10:10, Bella Bart, astrologist; 10:30-11:00, Avon Society Orchestra; 11:00-11:15, James Kendis, song writer and composer singing his own songs; 11:15-11:45, Irving Berlin Music Co.  
WIP, Philadelphia, Pa. (Eastern, 509), 6:05 p. m., Dinner music, Dick Regan and his WIP Little Symphony Orchestra; 7:00, Bedtime stories by Uncle Wip.  
WJAZ, Chicago, Ill. (Central, 390), 8:00 p. m., Concert by the Shrine Band.  
WJAZ, Chicago, Ill. (Central, 447.7), 10:00 p. m. - 2 a. m., Ethel Manning, soprano; Samuel Pierson, pianist; Richard Lovridge, violinist; John Goin, pianist; Oriole Orchestra.  
WLV, Cincinnati, Ohio (Central, 309), 10:00 p. m., Modern Hungarian Radario Night; "Lilliom," Crevelley Radarians; Freda Slauter, violinist; Saida McAllister, pianist; Cincinnati Symphony Orchestra; 11:15, Ralph Long's Dance Orchestra.  
WMAQ, Chicago, Ill. (Central, 447.5), 7:00 p. m., Wheat Council—talk on "Toast," Rockwell Stephens; 7:45, "Andrea Chenier," opera at the Auditorium Theater by Chicago Civic Opera Company, broadcast on 345 meters, Mrs. Marx E. Oberndorfer, announcer; opera in Italian, music by Gioachino Rossini; libretto by Felice, four acts; Cast: Andrea Chenier, young poet, Guilfo Crimi; Charles Gerard, servant; Elizabeth Estline, Arline Montgomery; Pollock, Frank Oliver; Tim Donahue, Charles S. Beames; Sergeant Dunn, Courtland Hopkins; Doolin, Burton Anderson.  
WHAS, Louisville, Ky. (Central, 400), 4:00-5:00 p. m., Strand Theater Orchestra; Alamo Theater organ; 7:30-9:00, Concert, Town Club of the Louisville Conservatory, Helen Elchenberger, director.  
WHN, New York, N. Y. (Eastern, 360), 2:15-3:00 p. m., Shapiro Bernstein Music Co.; 10:00-10:10, Bella Bart, astrologist; 10:30-11:00, Avon Society Orchestra; 11:00-11:15, James Kendis, song writer and composer singing his own songs; 11:15-11:45, Irving Berlin Music Co.  
WIP, Philadelphia, Pa. (Eastern, 509), 6:05 p. m., Dinner music, Dick Regan and his WIP Little Symphony Orchestra; 7:00, Bedtime stories by Uncle Wip.  
WJAZ, Chicago, Ill. (Central, 390), 8:00 p. m., Concert by the Shrine Band.  
WJAZ, Chicago, Ill. (Central, 447.7), 10:00 p. m. - 2 a. m., Ethel Manning, soprano; Samuel Pierson, pianist; Richard Lovridge, violinist; John Goin, pianist; Oriole Orchestra.  
WLV, Cincinnati, Ohio (Central, 309), 10:00 p. m., Modern Hungarian Radario Night; "Lilliom," Crevelley Radarians; Freda Slauter, violinist; Saida McAllister, pianist; Cincinnati Symphony Orchestra; 11:15, Ralph Long's Dance Orchestra.  
WMAQ, Chicago, Ill. (Central, 447.5), 7:00 p. m., Wheat Council—talk on "Toast," Rockwell Stephens; 7:45, "Andrea Chenier," opera at the Auditorium Theater by Chicago Civic Opera Company, broadcast on



# ARMEN," LEAD WEEK'S ATTRACTIONS



Mary Carter Toomey (circle), teller of bedtime stories for Station WFAA, the Dallas News and Journal, is society editor of the News and also builds many Radio sets. Having taught children, she knows how to tell stories they love. James Dale (left), as he appeared in "Loyalties," will lecture on "Galsworthy, His Life and Work," Tuesday, December 4, from WGR, Buffalo

the King, Vittorio Trevisan; Rousher, Desre Defrere; Fouquier Tinville, public attorney, Alfredo Gandolfi; Mathieu, a Sancelotta, called "Populo," Vittorio Trevisan; Incroyable, Jose Mojica; The Abbe, Lodovico Diviviero; Dumas, Pres. of the Tribunal, Alexander Kippis; Schmidt, jailer at St. Lazare prison, Gildo Morlatto; Major Domo, Milo Luka; Conductor, Giorgio Polacco.

WOC, Davenport, Iowa (Central, 484), 12:00 m., Chimes; 3:30 p. m., "Pathology of Bright's Disease," Karl G. Stephan; 5:45, Chimes Concert; 6:30, Sandman's visit; 8:00, P. S. C. Orchestra; V. B. Rochte, harpist.

WOO, Philadelphia, Pa. (Eastern, 509), 11:30-11:45 a. m., Organ recital, Mary E. Vogt; 12:00-1:00 p. m., Dinner music, Wanamaker Crystal Tea Room Orchestra; Robert E. Golden, director; 4:45-5:00, Organ recital, Mary E. Vogt.

WDR, Newark, N. J. (Eastern, 405), 2:30-2:45 p. m., Etta Porth, soprano; 2:45-3:00, Bertha Luck, contralto; 3:30-3:45, Etta Porth, soprano; 3:45-4:00, Bertha Luck, contralto; 6:15-6:30, Icicle; 6:30-7:30, Music While You Dine—Tom Cooper's Country Club Orchestra.

WWJ, Detroit, Mich. (Eastern, 517), 9:30 a. m., "Tonight's Dinner" Woman's Editor; 3:00 p. m., Detroit News Orchestra; 8:30, Detroit News Orchestra; Cathedral Male Quartet; 10:00, Dance music, Jean Goldkette's Orchestra; 11:00, Detroit News Orchestra.

## Friday, December 7

KDKA, E. Pittsburgh, Pa. (Eastern, 326), 6:15 p. m., Lucile Hale, organist; 7:15, Radio Boy Scout Meeting; 7:45, Children's period; 8:15, "The Outreach of the Early Church," Dr. R. L. Lanning; 8:30, Mathilda Bauer, soprano; Mrs. J. A. Greene, accompanist; Philip Porterfield, baritone; Leopold Tirtle, violinist; David Cohen, violinist.

KFI, Los Angeles, Calif. (Pacific, 469), 6:45-7:30 p. m., Concert, Harry Baisden and Orchestra; 10:00-11:00, Concert, Theron Bennett Concert Company.

KGW, Portland, Ore. (Pacific, 492), 8:15 p. m., George Olson's Metropolitan Orchestra; 9:00, "Oregon Resources," Alfred L. Lomax; 10:30, Hoot Owls with Pantages Frolic.

KHJ, Los Angeles, Calif. (Pacific, 395), 2:30-3:30 p. m., Matinee musical; 6:45-7:00, Children's program; Richard Headrick, screen juvenile; 7:00-7:30, Organ recital from First Methodist Church; 8:00-10:00, Polytechnic High Girls' Glee Club; 10:00-10:20, Art Hickman's Orchestra.

KYW, Chicago, Ill. (Central, 536), 6:50 p. m., Children's bedtime story; 10:00-12:30, Midnight Revue; Wendell W. Hall, KYW's Music Maker; Herbie Mintz, pianist; Walter Wilson, tenor.

WBAP, Fort Worth, Texas (Central, 476), 7:30-8:30 p. m., Concert by the Texas Christian University; 9:30-10:45, Orchestra of the Senior High School.

WBZ, Springfield, Mass. (Eastern, 337), 6:00 p. m., Concert, Harry Quintette; 7:30, "A Bear for Breakfast," Youth's Companion; 7:30, Twilight tales for the Kiddies; Current Book Review, R. A. McDonald; "Marketing the Farmers' Product," Richard Pattee; 11:00, WBZ Quintette, Byron Hayden, baritone; Myrtle Chapman, pianist.

WCBD, Zion, Ill. (Central, 345), 8:00 p. m., Treble Clef Chorus; P. B. Newcomer, cornetist; Edith Carey, contralto; Mrs. Blanche Reynolds Kesler, reader; L. J. Hire, violinist; Mrs. Harry E. Mayfield, soprano; Mrs. Blanche Bishop, pianist.

WDAP, Chicago, Ill. (Central, 360), 10:00 p. m., George R. Hill, Jr., Jack Chapman's Orchestra.

WDAR, Philadelphia, Pa. (Eastern, 395), 12:00-12:30 p. m., Organ recital, William Klais, Stanley Theater; 12:30, Dinner music, Arcadia Cafe Concert Orchestra; 2:00-3:00, Piano solo by Edna Finestone; concert, Arcadia Cafe Concert Orchestra; 7:30-7:45, Bedtime stories, Dream Daddy; 7:45, Book review, Doris Hyde; 8:00, Radio play, Walter Greenough; 8:00, Morning Glory Club Program, songs by Harry Glynn; dance music, Howard Lamin's Arcadia Cafe Dance Orchestra.

WEAF, New York, N. Y. (Eastern, 492), 4:00 p. m., Herman Levine, pianist; 4:30, Mrs. Sybil Griffith, soprano; 4:45, Della Rlordan, lady harpist; 5:00, Christmas program for children by Gimbel; 7:30, United Sports Talk, Thornton Fisher; 8:00, Abraham & Straus, chorus; 8:30, Louise Decker Scanlon, soprano; 9:30, Astor Coffee Orchestra. 12:30-1:00 p. m., "Outreach of the Early Church," Dr. Robert Stewart Hyer; 8:30-9:30, Band recital, Western Union Telegraph Company's Boys' Band.

WFI, Philadelphia, Pa. (Eastern, 395), 1:00 p. m.,

Meyer Davis Bellevue Stratford Orchestra; 3:00, Loretta Kerk, pianist; 6:30, Meyer Davis Bellevue Stratford Orchestra; 7:00, Bedtime stories by Cousin Sue; talks from Snowball Land.

WGI, Medford Hillside, Mass. (Eastern, 360), 3:00 p. m., Amrad Women's Club; "New System," Mrs. Evelyn Spencer; Edison program; 7:30, Charles L. H. Wagner, Radio Poet; Vocal selections, Marion E. Watson; Red Cross Health Talk, Henry Copley Greene.

WGR, Buffalo, N. Y. (Eastern, 319), 12:30-1:00 p. m., George Albert Bouchard, organist; 4:00, Martha Gomph, harpist; Elise de Grood, violinist; 6:30-11:30, Vincent Lopez Hotel Statler Dance Orchestra; 7:30, Digest of the day's news; 9:00, Concert, Jackson Glee Club.

WGY, Schenectady, N. Y. (Eastern, 380), 2:00 p. m., "Cross-Stitching and Last-minute Christmas Gifts"; 6:30, Children's program; 7:45, Wotan Zoellner, violinist; WGY Orchestra; 10:30 p. m., Hawaiian program; James Early, pianist; Pacific Hawaiian Trio; William Totterdale, tenor.

WHAS, Louisville, Ky. (Central, 400), 4:00-5:00 p. m., Walnut Theater orchestra; Strand Theater Orchestra; 7:30-9:00, Concert, Louisville Eight, Arthur Jackson, drummer; Paul Phelps, pianist; Murray Moore, banjoist; Griswald Glover, saxophonist; Donald Colburne, saxophonist; Robert Myers, cornetist.

WHK, Cleveland, Ohio (Eastern, 283), 9:00 p. m., Concert Program arranged by the Cleveland Radio Dealers' Association.

WHN, New York, N. Y. (Eastern, 360), 2:15-3:15 p. m., Indiana Five Orchestra; 9:30-10:00, Melo Club Dance Orchestra, H. W. Bolles, leader; 10:15-10:45, Fred Whitehouse Review; 10:45-12:00, Rex Serenaders.

WIP, Philadelphia, Pa. (Eastern, 509), 3:00 p. m., Popular program by singers from Remick studio; 6:05, Dinner music, by George Thomas and his Little Club Orchestra; 7:00, Bedtime stories by Uncle Wip.

WJAZ, Chicago, Ill. (Central, 447.7), 10:00 p. m., 2:00 a. m., L. K. Elberg, pianist; Howard Neumiller, pianist; Henrietta Blackwell, soprano; Gertrude Northwell, cellist; Oriole Orchestra.

WLW, Cincinnati, Ohio (Central, 309), 4:00 p. m., "MacDowell," Mildred Templeton Williams.

WMAQ, Chicago, Ill. (Central, 447.5), 4:30 p. m., Bush Conservatory; 7:00, Mrs. Frances M. Ford, "Wide Awake Club"; 7:30, Weekly musical lecture, Mrs. Marx E. Oberdorfer; 8:30, WMAQ, Dance Orchestra; 9:15, Cosmopolitan School of Music.

WOC, Davenport, Iowa (Central, 484), 12:00 m., Chimes; 3:30 p. m., "Nitrogen, the Creator and Destroyer of Life," C. A. Russell; 5:45, Chimes; 6:30, Sandman's visit; 7:00, "Is the Retail Dealer a Necessity or a Nuisance?" J. W. Gamble; 8:00, Kennedy Music Co.

WOO, Philadelphia, Pa. (Eastern, 509), 11:00-11:30 a. m., Organ recital, Mary E. Vogt; 12:00-1:00 p. m., Dinner music, Wanamaker Crystal Tea Room Orchestra; Robert E. Golden, director; 4:45-5:00, Organ recital, Mary E. Vogt; 7:30, Monologue, Ralph Blingham; 8:00, Organ recital, Mary E. Vogt; 10:10, Dance music, Adelphia Hotel Orchestra.

WOB, Newark, N. J. (Eastern, 405), 2:30-2:45 p. m., Carlyle T. Straub, reading original poems; 2:45-3:00, Gertrude Bronenkaht, soprano; 3:15-3:30, Dr. Harriet Van Buren Peckham, "Health Hints"; 3:30-3:45, Carlyle T. Straub, reading original poems; 3:45-4:00, Gertrude Bronenkaht, soprano; 6:15-6:30, Icicle; 6:30-6:45, Kenneth Kitchens Club Orchestra; 6:30-7:30, Man in the Moon Stories for Children; 7:00-7:15, Kenneth Kitchens Club Orchestra.

WWJ, Detroit, Mich. (Eastern, 517), 9:30 a. m., "Tonight's Dinner," Woman's Editor; 12:00 m., Jean Goldkette's Orchestra; 3:00, Detroit News Orchestra; 8:30, Detroit News Orchestra; Anne Campbell, Detroit News Poet; Laura Henkel, vocalist.

## Saturday, December 8

KDKA, E. Pittsburgh, Pa. (Eastern, 326), 12:30 p. m., Daugherty's Orchestra; 6:15, Westinghouse Band; 7:45, Children's period; 8:00, "Birds," George M. Sutton; 8:30, Westinghouse Band.

KFI, Los Angeles, Calif. (Pacific, 469), 6:45-7:30 p. m., Concert, Coral Atkins; 8:00-9:00, Filipino String Orchestra; 10:00-11:00, Concert, direction of Hugh Kirchhofer.

KGW, Portland, Ore. (Pacific, 492), 3:30 p. m., Music, by piano pupils of Lucille Cummings; story, Aunt Nell; 10:00, Dance music, George Olsen's Metropolitan Orchestra.

KHJ, Los Angeles, Calif. (Pacific, 395), 2:30-3:30 p. m., Program, piano pupils of Alice McComas Gray; 6:45-7:30, Children's program; 8:00-10:00, Hollywood Women's Club Chorus; 10:00-12:00, Art Hickman's Orchestra.

KSD, St. Louis, Mo. (Central, 546), 7:30 p. m., Missouri theater program.

KYW, Chicago, Ill. (Central, 536), 6:50 p. m., Children's bedtime story; 7:45, "Carmen," opera at the Auditorium Theater by Chicago Civic Opera Company, opera in French, music by Bizet, libretto after novel by Prosper Merimee by Meilhac and Halévy, four acts; Cast: Jose, Fernand d'Arleuil; Carmen, Alice Gen-Luka; Zuniga, Edouard d'Arleuil; Mercedes, Irene Hoff; Frasquita, Alice d'Arleuil; Marguerite, Irene Hoff; Escamillo, a Bull Fighter, Georges Baklanoff; Micaela, a peasant girl, Margory Maxwell; Dancairo, smuggler, Desirs Defrere; Remendado, smuggler, Jose Mojica; Lillas Pastia, an Innkeeper, Eugenio Correnti; Conductor, Giorgio Polacco.

WBAP, Fort Worth, Texas (Central, 476), 7:00-7:30

p. m., Review of the interdenominational Sunday School lesson, Mrs. W. F. Barnum.

WBZ, Springfield, Mass. (Eastern, 337), 7:00 p. m., Hotel Kimball Trio; 7:30, Twilight tales for the Kiddies; "Bringing the World to America," prepared by "Our World Magazine"; 8:00, Mrs. McCoy, pianist; William Flood, tenor; 9:00, Bedtime story for Grow-ups, Orison S. Marden.

WDAP, Chicago, Ill. (Central, 360), 10:00 p. m., Harmony Girls, Bob Brown, Fred Rose, Betty Holmes, Jack Chapman's Orchestra.

WDAR, Philadelphia, Pa. (Eastern, 395), 12:00-12:30 p. m., Organ recital, William Klais, Stanley Theater; 12:30, Dinner music, Arcadia Cafe Concert Orchestra; 2:00-3:00, Concert, Arcadia Cafe Concert Orchestra; 7:30, Bedtime stories, Dream Daddy.

WEAF, New York, N. Y. (Eastern, 492), 4:00 p. m., Carolinians Orchestra; 5:00, Christmas program for children, by Gimbel; 8:15, Grosskopf Trio; 9:00, W. S. Bryden, recitations; Oscar Taylor, baritone; 9:45, Ferdinand Wochsman, pianist; Lucky Strike Dance Orchestra; 11:00, Vincent Lopez Dance Orchestra.

WFAA, Dallas, Texas (Central, 476), 12:30-1:00 p. m., "Literary Lines," J. P. Comer; 8:30-9:30, Orchestra from the North Texas State Teachers' College; 11:00-12:00, Mrs. May Zigenbein, pianist.

WFI, Philadelphia, Pa. (Eastern, 395), 1:00 p. m., Meyer Davis Bellevue Stratford Orchestra; 6:30, Meyer Davis Bellevue Stratford Orchestra; 7:00, Talks from Snowball Land.

WGI, Medford Hillside, Mass. (Eastern, 360), 7:30 p. m., New England Business Problems, Arthur R. Currick, Music.

WGR, Buffalo, N. Y. (Eastern, Standard, 319), 12:30-1:00 p. m., George Albert Bouchard, organist; 4:00, Martha Gomph, harpist; Elise de Grood, violinist; 6:30, Vincent Lopez Hotel Statler, Dance Orchestra.

WGY, Schenectady, N. Y. (Eastern, 380), 9:30 p. m., Phil Romano's Rain-bo Orchestra.

WHAS, Louisville, Ky. (Central, 400), 4:00-5:00 p. m., Strand Theater Orchestra; Walnut Theater Orchestra; 7:30-9:00, Sylvian Trio, Fannie E. Stoll, violinist; Myrtle Chrisman, futeist; Evelyn Kaiser, pianist; Frank R. Doilens, tenor.

WHN, New York, N. Y. (Eastern, 360), 2:15-3:15 p. m., Fred Whitehouse Review; 3:45-4:30, Eddie di Lalla's Orchestra; 4:45-5:00, James Clarke in piano solos; 5:00-5:30, Harry Reiser and His Carolin Boys; 7:30-8:00, Melody Belles, the Clorox Gardens Girls Orchestra; 8:15-8:30, Beulah Wolf, 10-year-old singer; 8:30-8:45, Mr. and Mrs. Bobby Nolan, songs and recitations; 9:15-9:30, Hettie Tillett, contralto.

WIP, Philadelphia, Pa. (Eastern, 509), 1:00 p. m., Organ recital, Karl Bonawitz Germantown Theater; 3:00, Popular program, Fred Bowers and his Society Orchestra; 6:05, Dinner music, Greenwich Village Follies Serenaders; 7:00, Bedtime stories, Uncle Wip; 8:00, Science talk, Philadelphia College of Pharmacy professor; Charlie Kerr send his orchestra.

WJAZ, Chicago, Ill. (Central, 447.7), 10:00 p. m., 2:00 a. m., Betty Baxter, contralto; Carolyn Willard, pianist; Oriole Orchestra.

WMAQ, Chicago, Ill. (Central, 447.5), 8:00 p. m., Harmonical Technical High School Band; 9:00, Weekly musical review, Chicago Theater.

WOC, Davenport, Iowa (Central, 484), 12:00 m., Chimes; 3:30 p. m., "The Uses of Sulphur," C. C. Hall; 5:45, Chimes; 6:30, Sandman's visit; 9:00, P. S. C. Orchestra; V. B. Rochte, baritone.

WOB, Newark, N. J. (Eastern, 405), 11:00-11:30 a. m., Organ recital, Mary E. Vogt; 12:00-1:00 p. m., Dinner music, Wanamaker Crystal Tea Room Orchestra; Robert E. Golden, director; 4:45-5:00, Band Concert, J. W. C. I. Band; Organ recital, Mary E. Vogt.

WDR, Newark, N. J. (Eastern, 405), 6:15-6:20 p. m., Icicle; 6:20-6:30, Park City Male Quartet; 6:30-6:45, Lucille Rogers, soprano; 6:45-7:00, Icicle; 7:00-7:15, Lucille Rogers, soprano; 7:15-7:30, Fred Bendel, "Sports up to the minute"; 8:00-9:00, Eugene Ingram and his Orchestra; 9:00-9:15, Concert of 2 pianos by Frances and Elizabeth Adelman, courtesy Henry Rose; 9:15-9:30, "Laughology" monologue, M. Lynch; 9:30-9:45, Concert of 2 pianos, Frances and Elizabeth Adelman; 10:15-11:00, Four well known composers of popular music at 2 pianos.

WTAM, Cleveland, Ohio (Eastern, 390), 9:00 p. m., Regular Saturday evening dance program by the WTAM Orchestra.

WWJ, Detroit, Mich. (Eastern, 517), 9:30 a. m., "Tonight's Dinner," Woman's Editor; 3:00 p. m., Detroit News Orchestra.

## Sunday, December 9

KFI, Los Angeles, Calif. (Pacific, 469), 10:00-10:45 a. m., Services by L. A. Church Federation; 4:00-5:00 p. m., Concert presented by Federated Church Musicians.

KHJ, Los Angeles, Calif. (Pacific, 395), 10:00 a. m., Sermon; 10:30-12:30 p. m., Services, First Methodist Episcopal Church, Rev. Elmer E. Helms, pastor; Arthur Blakely, organist; 7:00-7:30, Arthur Blakely, organist; 8:00-10:00, De Luxe program.

KYW, Chicago, Ill. (Central, 536), 11:00 a. m., Central Church Service, Orchestra Hall, Dr. F. F. Shannon, pastor; 6:30, Excerpts from the New Testament, an American Translation by Prof. E. J. Goodspeed; William Z. Nourse; 7:00, Chicago Sunday Evening Club.

WBAP, Fort Worth, Texas (Central, 476), 11:00-12:15

p. m., Church services, First Methodist Church, Rev. J. W. Bergin, pastor; 5:00-6:00, Vesper concert.

WDAR, Philadelphia, Pa. (Eastern, 395), 2:30-4:00 p. m., Special program, popular classical selections, Arcadia Cafe Concert Orchestra, Fort Harkozel, director.

WBZ, Springfield, Mass. (Eastern, 337), 11:00 a. m., Church Services, Church of the Unity, Rev. Charles A. Wing, pastor; Philharmonic Male Quartet, Adelo Graves, harpist; Raymond C. Hodges, Int tenor; Howard I. Smith, 2nd tenor; William H. Lippmann, baritone; George B. Dowd, bass; Robert W. Field, organist; 8:45, Sunday vesper, Ernest Newton Izard, chime ringer; 8:30, Church services, St. Peter's Church, John H. Nolan, pastor.

WDAP, Chicago, Ill. (Central, 360), Drake Concert Ensemble and Soloists.

WEAF, New York, N. Y. (Eastern, 492), 2:45 p. m., N. Y. Federation of Churches program; 3:45, Dr. H. F. Hakes Cadman; 7:00, "The Fall of Jerusalem," Maj. Viola Gilbertson; 7:20, Capitol Theater Symphony Orchestra and Capitol Staff of Artists; 9:00, Skinner Organ Recital.

WFAA, Dallas, Texas (Central, 476), 6:00-7:00 p. m., Radio Bible Class, Dr. William M. Anderson, Jr., pastor; 9:30-10:00, Sacred Song Recital; 10:00-11:00, Jimmy Allen's Orchestra, Southern Methodist University Boys.

WGI, Medford Hillside, Mass. (Eastern, 360), 4:00 p. m., "Adventure Hour," Youth's Companion; 8:30, "World Unity," Greater Boston Federation of Churches; Music.

WGR, Buffalo, N. Y. (Eastern, Standard, 319), 3:00 p. m., Vesper services, Rev. O. E. Rutledge, Delaware Avenue Baptist Church; 4:00-5:00, Robert Munn, organist.

WGY, Schenectady, N. Y. (Eastern, 380), 10:30 a. m., Church services, First Baptist Church, Rev. Gordon H. Baker, pastor; 3:30 p. m., WGY Symphony; 7:30, Services, First Baptist Church.

WHAS, Louisville, Ky. (Central, 400), 9:57 a. m., Organ music; 10:00, Church services, Broadway Baptist Church, Rev. Dr. Russell J. Pirkey, pastor; Mrs. Roy N. Downs; 4:00-5:00 p. m., Sacred concert, Shawnee Christian Church Choir.

WHK, Cleveland, Ohio (Eastern, 283), 8:00 p. m., Instrumental and vocal numbers by the WIK Trio and favorite artists; 9:30, Chapel service, Glenville Presbyterian Church, Rev. A. H. Limouze, pastor.

WHN, New York, N. Y. (Eastern, 360), 5:15-5:30 p. m., Radio Five Dance Orchestra.

WIP, Philadelphia, Pa. (Eastern, 509), 4:00 p. m., Talks, auspices of Germantown Y. M. C. A.

WJAZ, Chicago, Ill. (Central, 447.7), 6:00-9:00 p. m., May Lapham, pianist; Marie S. Zenit, soprano; Oriole Orchestra.

WLW, Cincinnati, Ohio (Central, 309), 9:30 a. m., Sunday School service, Editorial Staff of Sunday School Publications, Methodist Book Concern; 11:00, Services, Church of the Covenant, Dr. Frank Stevenson.

WWJ, Detroit, Mich. (Eastern, 517), 11:00 a. m., Services, St. Paul's Episcopal Cathedral; 5:00 p. m., Detroit News Orchestra.

## Monday, December 10

KFI, Los Angeles, Calif. (Pacific, 469), 6:45-7:30 p. m., Coral Atkins.

WBAP, Fort Worth, Texas (Central, 476), 7:30-8:30 p. m., Guy Pitner & Brooks Morris; 9:30-10:45, Concert, John Tarleton Agri. College.

WDAR, Philadelphia, Pa. (Eastern, 395), 12:00-12:30 p. m., Organ recital, William Klais, Stanley Theater; 12:30-1:00, Arcadia Cafe Concert Orchestra; 2:00-3:00, Concert, Arcadia Cafe Concert Orchestra; 4:30, Piano, Edna Finestone; 7:30-7:45, Bedtime stories, Dream Daddy; 7:45-8:00, Moving Picture Review, James Nassau; 10:10, Dance music, Howard Lamin's Arcadia Cafe Orchestra.

WEAF, New York, N. Y. (Eastern, 492), 5:00 p. m., Christmas Program for children, Gimbel; 7:30, United Sport Talk, Thornton Fisher; 7:40, Lilyan M. Challenger, contralto; 8:00, Hoyle Fairchild; 8:20, United Cement Prod. Co.; Mary Wilderman, pianist; 9:00, Bank of America; Mary Wilderman; Long Island Grotto Band.

WFI, Philadelphia, Pa. (Eastern, 395), 1:00 p. m., Meyer Davis Bellevue Stratford Orchestra; 3:00, Caroline Hoffman, pianist; Ednyed Lewis, tenor; 6:30, Meyer Davis Bellevue Stratford Orchestra; 7:00, Talks from Snowball Land.

WGR, Buffalo, N. Y. (Eastern, Standard, 319), 12:30-1:00 p. m., George Albert Bouchard, organist; 4:00, Martha Gomph, harpist; Elise de Grood, violinist; 6:30, 11:00, Vincent Lopez Hotel Statler, Dance Orchestra; 7:30, Digest of the day's news; 9:00, Concert, mixed program, H. Messersmith & Sons, Niagara Falls, N. Y.

WGY, Schenectady, N. Y. (Eastern, 380), 2:00 p. m., "Christmas Plants and Flowers," Mrs. W. J. Cramb; WGY Orchestra; Mrs. Albert G. Kinum, Lois Hardesty, pianists; Lois B. Hardesty, soprano.

WHAS, Louisville, Ky. (Central, 400), 4:00-5:00 p. m., Walnut Theater Orchestra; "The Largest Aspect of World Affairs," Frederick Dixon.

WHAZ, Troy, N. Y. (Eastern, 360), 9:00 p. m., Lawrence Trio, Willard D. Lawrence, cellist; Eleanor Padley, pianist; Mrs. William T. Lawrence, soprano; Engineering talk, Dr. William Pitt Mason.

WHN, New York, N. Y. (Eastern, 360), 5:00-5:15 p. m., Edw. B. Marks Music Co.; 7:30-8:00, Sam Lanning's Roseland Dance Orchestra; 9:00-9:15, Alfred Dullin, Swedish pianist.

WIP, Philadelphia, Pa. (Eastern, 509), 3:00 p. m., Popular program, Hotel Walton Orchestra; 6:05, Potts Orchestra and Entertainers; 7:00, Bedtime stories and lullaby by Uncle Wip.

WLW, Cincinnati, Ohio (Central, 309), 4:00 p. m., Jennie Keht, pianist; Cincinnati String Quartet; "The Spiritual Teachings of the Younger Poets, Wilmar MacFarland; "Weeding and Watering," Prof. Tawney; 9:30, Crosley Theatrical Review; Roger Hill Dance Orchestra; Norma Reiss, singer.

WOO, Davenport, Iowa (Central, 484), 11:00-11:30 a. m., Organ recital, Mary E. Vogt; 12:00-1:00 p. m., Dinner music, Wanamaker Crystal Tea Room Orchestra; Robert E. Golden, director; 4:45-5:00, Organ recital, Mary E. Vogt; 7:30, Dinner music, Adelphia Hotel Orchestra; 8:00, Selections by WOO Orchestra; Robert E. Golden, director; 9:00, Organ recital, Mary E. Vogt; 10:10, Dance music, Adelphia Hotel Orchestra.

WDR, Newark, N. J. (Eastern, 405), 2:30-2:45 p. m., Mrs. Wm. Kent Lownsbury, pianist; 3:15-3:30, Mrs. Wm. Kent Lownsbury; 6:15-7:30, Harry Cox and his Hotel Robert Treat Orchestra; 8:00-8:15, "Current Motion Pictures," Alfred J. McCosker; 8:15-8:30, Rudolph Gruen, pianist; 8:30-8:45, "Jolly Bill Strenke"; 8:45-9:00, Rudolph Gruen, pianist; 9:00-9:15, Beth Treaskiss, contralto; 9:15-9:30, Gordon Stevens, baritone; 9:30-9:45, Beth Treaskiss; 9:45-10:00, Gordon Stevens; 10:00-11:00, Floyd's Dance Orchestra.

## World-Wide Use of Radio Laid Before Business Men

WASHINGTON.—A pamphlet on international communications, of considerable value to business men whose interests extend beyond the United States, has just been prepared by P. E. D. Nagle, communication expert of the Department of Commerce. The booklet reviews the present situation in world-wide cable and Radio communication, and publishes for the first time in this country, the provisions of the International Telegraph Convention of St. Petersburg and Lisbon. Under the title: "International Communications and the International Telegraph Convention," No. 121, of the Miscellaneous Series of Department of Commerce publications, Mr. Nagle's publication is available to the public from the Superintendent of Documents, Government Printing Office, Washington, D. C., at ten cents a copy.



"LILLIUM," "ANDREA CHENIER" AND "CARMEN," LEAD WEEK'S ATTRACTIONS

These Stories Will Aid Opera Listeners

STORY OF ANDREA CHENIER, WMAQ DECEMBER 6

THE era of the French revolution, the days of the guillotine, the days of the guillotine...

STORY OF CARMEN, KYW DECEMBER 8

CARMEN, a story, is arrested for stabbing one of the factory girls and placed in Don Jose's charge...

—THE PROGRAM LADY.

Tuesday, December 4

KFT, Los Angeles, Calif. (Pacific, 468), 8:45-9:30 p. m. Concert, Gage Christopher; 10:00-11:00, Concert...



Val McLaughlin (circle) hursts right through the bedtime story page and charms the WOC kiddies every Wednesday, Friday and Saturday with the "Sandman's Visit"...



Mary Carter Toomey (circle), teller of bedtime stories for Station WFAA, the Dallas News and Journal, is society editor of the News and also holds many radio sets...



Mary Carter Toomey (circle), teller of bedtime stories for Station WFAA, the Dallas News and Journal, is society editor of the News and also holds many radio sets...

W.A.R. Philadelphia, Pa. (Eastern, 335), 7:30-8:00 p. m. Church services; 8:00-8:30, Vesper concert...

W.A.R. Philadelphia, Pa. (Eastern, 335), 7:30-8:00 p. m. Church services; 8:00-8:30, Vesper concert...

Bedtime story, E. O. Johnson; Musical program, Faculty of the Cleveland Institute of Music...

The charming "Carmen" is Alice Carter. Above left, Fernand Amato, who will sing "Jose" in the French opera. Tune in KYW Saturday, December 8. Once tuned in you'll stay till the final curtain.

Meyer Davis Dellenre Stratford Orchestra; 3:00, Loretta Kerr, pianist; 6:30, Meyer Davis Dellenre Stratford Orchestra; 7:00, Radio stories by Cousin Sam...

W.A.R. Philadelphia, Pa. (Eastern, 335), 7:30-8:00 p. m. Church services; 8:00-8:30, Vesper concert...

Wednesday, December 5

KDKA, E. Pittsburgh, Pa. (Eastern, 326), 6:30 p. m. Pittsburgh Athletic Association Orchestra...

JUST A FEW LINES OUT THIS WEEK. PLEA note in WMAQ is also broadcast...

W.A.R. Philadelphia, Pa. (Eastern, 335), 7:30-8:00 p. m. Church services; 8:00-8:30, Vesper concert...

W.A.R. Philadelphia, Pa. (Eastern, 335), 7:30-8:00 p. m. Church services; 8:00-8:30, Vesper concert...

Thursday, December 6

KDKA, E. Pittsburgh, Pa. (Eastern, 326), 6:15 p. m. Pittsburgh Athletic Association Orchestra...

W.A.R. Philadelphia, Pa. (Eastern, 335), 7:30-8:00 p. m. Church services; 8:00-8:30, Vesper concert...

W.A.R. Philadelphia, Pa. (Eastern, 335), 7:30-8:00 p. m. Church services; 8:00-8:30, Vesper concert...

W.A.R. Philadelphia, Pa. (Eastern, 335), 7:30-8:00 p. m. Church services; 8:00-8:30, Vesper concert...

Friday, December 7

KDKA, E. Pittsburgh, Pa. (Eastern, 326), 8:15 p. m. Pittsburgh Athletic Association Orchestra...

W.A.R. Philadelphia, Pa. (Eastern, 335), 7:30-8:00 p. m. Church services; 8:00-8:30, Vesper concert...

W.A.R. Philadelphia, Pa. (Eastern, 335), 7:30-8:00 p. m. Church services; 8:00-8:30, Vesper concert...

W.A.R. Philadelphia, Pa. (Eastern, 335), 7:30-8:00 p. m. Church services; 8:00-8:30, Vesper concert...



# NS

dist Church, Rev. per concert  
 395), 2:30-4:00  
 ecclesiastical selections,  
 Harford, director,  
 7), 11:30 a. m.,  
 Rev. Charles A.  
 Quartet, Adrie  
 1st tenor; How-  
 Appmann, bari-  
 W. Field, organ-  
 ton Bagt, chime-  
 or's Church, John

Drake Concert  
 192), 2:45 p. m.,  
 am; 3:45, Dr. H.  
 Jerusalem," Maj.  
 heater Symphony  
 its, 9:30, Skinner

6:00-7:30 p. m.,  
 L. Anderson, Jr.,  
 ital; 10:00-11:30,  
 Methodist Univer-  
 tern, 360), 4:00  
 Companion; 8:30,  
 Federation of

dard, 319), 3:00  
 otledge, Delaware  
 Robert Muun, or-

80), 10:30 a. m.,  
 Rev. Gordon H.  
 shouy; 7:30, Serv-

2:57 a. m., Organ  
 roadway Baptist  
 pastor; Mrs. Roy  
 concert, Shawnes

8:00 p. m., In-  
 WIKK Trio and  
 Glenville Pres-  
 b, pastor.  
 5:15-5:30 p. m.,

9), 4:00 p. m.,  
 C. A.  
 6:00-9:00 p. m.,  
 soprano; Oriole

9), 9:30 a. m.,  
 Staff of Sunday  
 Concern; 11:00,  
 Fr. Frank Steven-

1:00 a. m., Serv-  
 5:00 p. m., De-

## er 10

6:45-7:30 a. m.,  
 476), 7:30-8:30  
 9:30-10:45, Con-

395), 12:00-12:30  
 a, Stanley Thea-  
 Orchestra; 2:00-  
 Orchestra; 4:30,  
 30-7:45, Bedtime  
 Sing Picture Be-  
 music, Howard

192), 5:00 p. m.,  
 bels; 7:30, United  
 Lilyan M. Chal-  
 lid; 8:20, United  
 on, pianist; 9:00,  
 an; Long Island

15), 1:00 p. m.,  
 extra; 3:00, Caro-  
 wis, tenor; 5:30,  
 extra; 7:30, Talks

ard, 319), 12:30-  
 organist; 4:00,  
 arood, Violinist;  
 Dance Or-

Concert,  
 Niagara  
 m.,  
 amb;  
 Har-

1 m.,  
 ct of

Law-  
 yanor  
 rano;

1 m.,  
 lin's  
 ullivan,

1 m.,  
 Potts  
 and

Jen-  
 "The  
 illmax  
 gney;  
 Dance

11:30  
 1 m.,  
 rches-

in re-  
 elphia  
 extra;  
 Mary  
 rches-

1 m.,  
 Mrs.  
 d his  
 parent  
 Ru-  
 nke";  
 Beth  
 bart-  
 ordon

1 m.,  
 d his  
 parent  
 Ru-  
 nke";  
 Beth  
 bart-  
 ordon

1 m.,  
 d his  
 parent  
 Ru-  
 nke";  
 Beth  
 bart-  
 ordon

1 m.,  
 d his  
 parent  
 Ru-  
 nke";  
 Beth  
 bart-  
 ordon

1 m.,  
 d his  
 parent  
 Ru-  
 nke";  
 Beth  
 bart-  
 ordon

1 m.,  
 d his  
 parent  
 Ru-  
 nke";  
 Beth  
 bart-  
 ordon

1 m.,  
 d his  
 parent  
 Ru-  
 nke";  
 Beth  
 bart-  
 ordon

1 m.,  
 d his  
 parent  
 Ru-  
 nke";  
 Beth  
 bart-  
 ordon

1 m.,  
 d his  
 parent  
 Ru-  
 nke";  
 Beth  
 bart-  
 ordon

1 m.,  
 d his  
 parent  
 Ru-  
 nke";  
 Beth  
 bart-  
 ordon

1 m.,  
 d his  
 parent  
 Ru-  
 nke";  
 Beth  
 bart-  
 ordon

1 m.,  
 d his  
 parent  
 Ru-  
 nke";  
 Beth  
 bart-  
 ordon

1 m.,  
 d his  
 parent  
 Ru-  
 nke";  
 Beth  
 bart-  
 ordon

1 m.,  
 d his  
 parent  
 Ru-  
 nke";  
 Beth  
 bart-  
 ordon

1 m.,  
 d his  
 parent  
 Ru-  
 nke";  
 Beth  
 bart-  
 ordon

WCBD, Zion, Ill. (Central, 345), 8:00 p. m., Treble Clef Chorus; P. B. Newcomer, cornetist; Edith Carey, contralto; Mrs. Blanche Reynolds Keeler, reader; L. J. Hire, violinist; Mrs. Harry E. Mayfield, soprano; Mrs. Blanche Bishop, pianist.  
 WDAP, Chicago, Ill. (Central, 360), 10:00 p. m., George R. Hill, Jr., Jack Chapman's Orchestra.  
 WDAR, Philadelphia, Pa. (Eastern, 395), 12:00-12:30 p. m., Organ recital, William Kluss, Stanley Theater; 12:30, Dinner music, Arcadia Cafe Concert Orchestra; 2:00-3:00, Piano solo by Edna Finestone; concert, Arcadia Cafe Concert Orchestra; 7:30-7:45, Bedtime stories, Dream Daddy; 7:45, Book review, Doris Hyde; 8:00, Radio play, Walter Greenough Players; 10:10, Morning Glory Club Program, songs by Harry Glyn, dance music, Howard Lanin's Arcadia Cafe Dance Orchestra.  
 WFAA, New York, N. Y. (Eastern, 492), 4:00 p. m., Herman Levine, pianist; 4:30, Mrs. Sybil Griffith, soprano; 4:45, Della Riordan, lady baritone; 5:00, Christmas program for children by Gimbel; 7:30, United Sports Talk, Thornton Fisher; 8:00, Abraham & Straus, chorus; 8:30, Louise Decker Scanlon, soprano; 9:00, Astor Coffee Orchestra.  
 WFAA, Dallas, Texas (Central, 476), 12:30-1:00 p. m., "Outreach of the Early Church," Dr. Robert Stewart Hyer; 8:30-9:30, Band recital, Western Union Telegraph Company's Boys' Band.  
 WFI, Philadelphia, Pa. (Eastern, 395), 1:00 p. m.,

KFI, Los Angeles, Calif. (Pacific, 469), 9:00 p. m., Concert, Coral Atkins; 8:00-9:00, Filipino String Orchestra; 10:00-11:00, Concert, direction of Hugh Kirchhofer.  
 KGW, Portland, Ore. (Pacific, 492), 3:30 p. m., Music, by piano pupils of Lucille Cummings; story, Aunt Nell; 10:00, Dance music, George Olsen's Metropolitan Orchestra.  
 KHJ, Los Angeles, Calif. (Pacific, 395), 2:30-3:30 p. m., Program, piano pupils of Alice McComas Gray; 6:45-7:30, Children's program; 8:00-10:00, Hollywood Women's Club Chorus; 10:00-12:00, Art Hickman's Orchestra.  
 KSD, St. Louis, Mo. (Central, 546), 7:30 p. m., Missouri theater program.  
 KYW, Chicago, Ill. (Central, 536), 6:50 p. m., Children's bedtime story; 7:45, "Carmen," opera at the Auditorium Theater by Chicago Civic Opera Company, opera in French, music by Bizet, libretto after novel by Prosper Merimee by Meilhac and Halévy, four acts; Cast: Jose, Fernand Anseau; Morales, Milo Luka; Zuniga, Edouard Cotreuil; Carmen, Alice Gentle; Frasquita, Alice D'Hermanoy; Mercedes, Irene Pavloska; Escamillo, a Bull Fighter, Georges Baklanoff; Micaela, a peasant girl, Margery Maxwell; Dancairo, smuggler, Desre Defrere; Remendado, smuggler, Jose Mojica; Lillas Pastia, an Innkeeper, Eugenio Correnti; Conductor, Giorgio Polacco.  
 WBAP, Fort Worth, Texas (Central, 476), 7:00-7:30

WLAN, Cleveland, Ohio (Eastern, 390), 9:00 p. m., Regular Saturday evening dance program by the WTAM Orchestra.  
 WWJ, Detroit, Mich. (Eastern, 517), 9:30 a. m., "Tonight's Dinner," Woman's Editor; 3:00 p. m., Detroit News Orchestra.

## Sunday, December 9

KFI, Los Angeles, Calif. (Pacific, 469), 10:00-10:45 a. m., Services by L. A. Church Federation; 4:00-5:00 p. m., Concert presented by Federated Church Musicians.  
 KHJ, Los Angeles, Calif. (Pacific, 395), 10:00 a. m., Sermon; 10:30-12:30 p. m., Services, First Methodist Episcopal Church, Rev. Elmer E. Helms, pastor; Arthur Biakely, organist; 7:00-7:30, Arthur Biakely, organist; 8:00-10:00, De Luxe program.  
 KYW, Chicago, Ill. (Central, 536), 11:00 a. m., Central Church Service, Orchestra Hall, Dr. F. F. Shannon, pastor; 6:30, Excerpts from the New Testament, an American Translation by Prof. E. J. Goodspeed, William Z. Nourse; 7:00, Chicago Sunday Evening Club.  
 WBAP, Fort Worth, Texas (Central, 476), 11:00-12:15

national communications, of considerable value to business men whose interests extend beyond the United States, has just been prepared by P. E. D. Nagle, communication expert of the Department of Commerce. The booklet reviews the present situation in world-wide cable and radio communication, and publishes for the first time in this country, the provisions of the International Telegraph Convention of St. Petersburg and Lisbon. Under the title: "International Communications and the International Telegraph Convention," No. 121, of the Miscellaneous Series of Department of Commerce publications, Mr. Nagle's publication is available to the public from the Superintendent of Documents, Government Printing Office, Washington, D. C., at ten cents a copy.



# SINGLE TUBE SELECTIVE LONG DISTANCE SIMPLEX

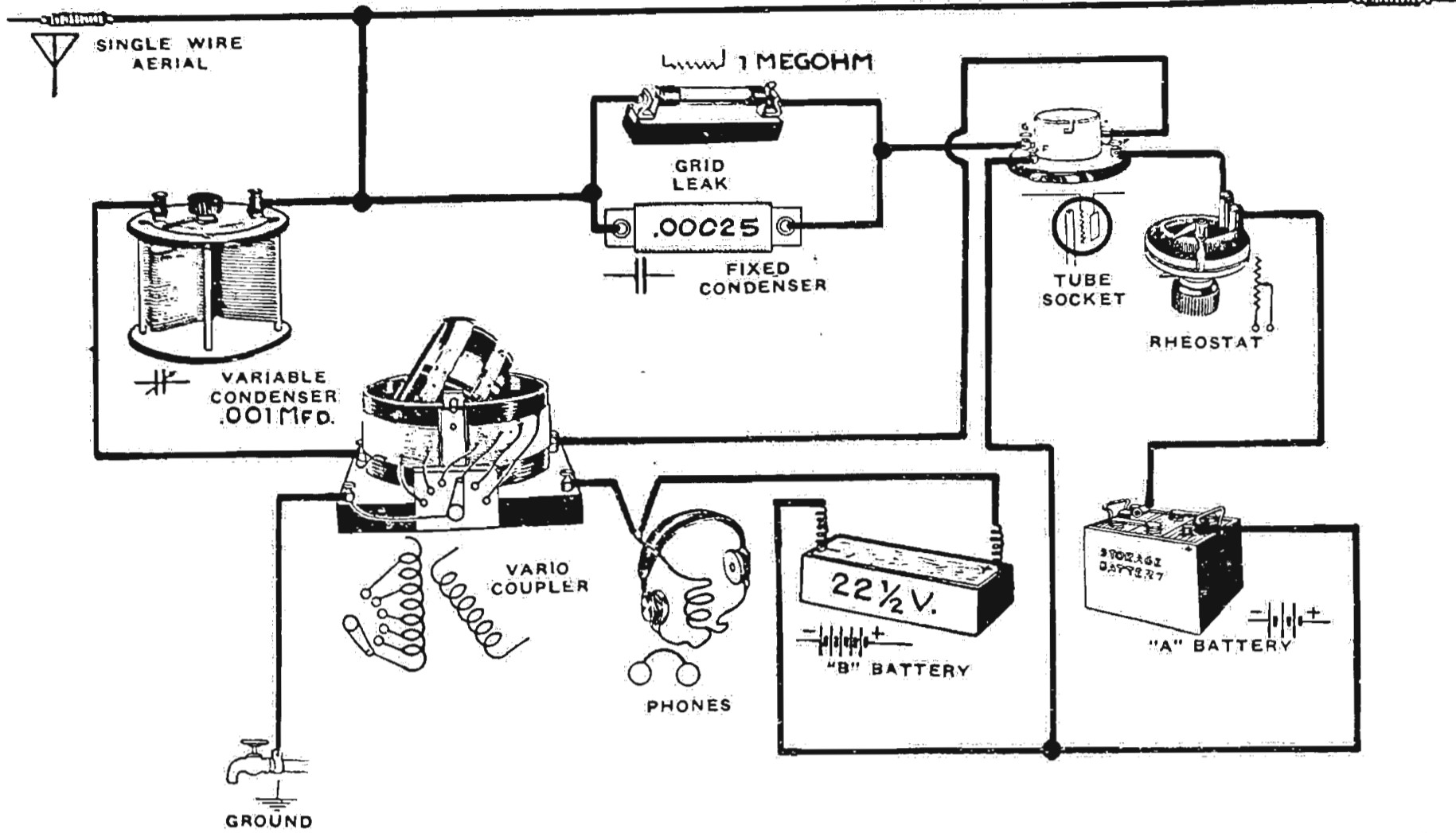

AS RADIO operator of Station 9CJ, East St. Louis, Ill., H. S. Wilhelm is interested in simple efficient receiving sets. He sent us a copy of his pet circuit and asks us to pass it along. It's simple stuff and will interest our new fans.

Here is what Mr. Wilhelm has to say: "This circuit presents a very simple one-tube set which is a go-getter, although I believe it has been published before in other magazines. I am sure any reader of the Digest who will give it a trial will be fully repaid by the results they obtain."

"I am located about three miles from KSD and am able to tune out this station and get other stations as far as 1,000 miles away. "The hookup is self-explanatory, but try changing the A battery leads for best results."

operating regenerative sets, use it wrong. They don't use it. Abuse it, is the word.

### Leave Rheostat Set

Armstrong invented the hook-up so he says, but it took Paul Godley to provide a means for handling it. Yes sir, if it's capacity feedback, do it with your condenser. If it's inductive, use your variable inductance. Either or both will do the trick, but don't try to force it through turning up your detector rheostat. Every detector tube has a filament brilliancy point at which it gives maximum results and this point positively is not critical. They all tell you to brighten your filament to just below or on the ragged edge of the "hiss point."

Do that Mr. Man and then tear the knob off. Leave it alone. Don't move it. Forget it! Mercy, if you must be a dial operator, if you just can't keep your hands off the baby, play with the other rotators, but leave that detector rheostat dial alone and more of you will tune in the auto band in southern California.

Let's eat!  
(TO BE CONTINUED.)

The actual daily transmission range of the high-power Radio telegraph circuits which terminate in the United States totals over 41,000 miles.

## TINY-TURN

### A New and Superior Vernier Control

TINY-TURN makes possible an exactness in tuning never before attained. It has a 30 to 1 gear ratio. No lost motion! The vernier turns in the same direction as dial; can be instantly disengaged, leaving dial free. INSTALLED ON ANY SET IN 3 MINUTES. Handsome nickel and black finish. We furnish counter display demonstrating boards.

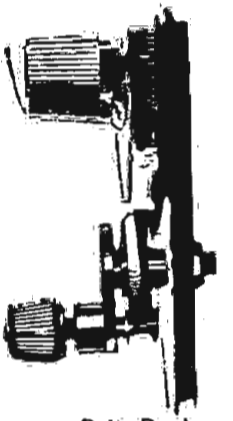

Price 75c

Pat. Pend. Side View showing friction drive against dial.

## DUO-SPIRAL

The Leading Loop Aerial with New Dial and Handle

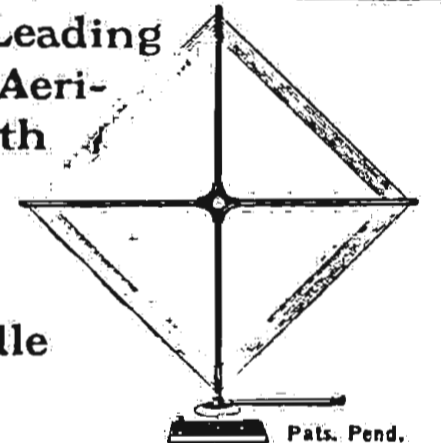

Top View of Base Showing Dial.

Pat. Pend.

Careful tests by radio engineers have proved the superiority of the DUO-SPIRAL loop. It is used exclusively by the largest manufacturers of radio frequency sets. It is trim and neat in appearance and handsomely finished. It rotates freely on its base. Adjustment is made easy by handsome dial and a long handle, which eliminates all body capacity effects. The green double silk covered wire is kept always taut by hidden springs. DUO-SPIRAL completely replaces roof antenna and ground and practically eliminates static.

24" Size \$8.50 - 12" Size \$7.50  
(These prices include NEW Dial and Handle.)

## LOOK-RITE

The Distinctive Binding Post

This handsome black and nickel finish Binding Post adds wonderfully to the appearance of your panel. LOOK-RITE is strong and sturdy throughout. Its concave metal base will stand tightening and prevents slippage. It fits any thickness of panel. Packed in cartons of fifty.



One-Half Actual Size

The above products (folders on request) are sold through dealers and jobbers. If your dealer cannot supply you, write us direct.

**RADIO UNITS INC**  
501 Webster Bldg., Chicago, Ill.  
Factory: Maywood, Ill.

## KING MILOPLEX

(Continued from page 11)

Too bad, but there is such a thing as a good variable condenser behaving itself from minimum to maximum and producing a straight line curve. If it just won't, then all the vernier plates you can pile on won't make it any more straight, and as a rule the addition of vernier plates very often turns an otherwise decent condenser into a Radio frequency leaker.

No son, they are not making filaments that are so touchy. If some fellow would make a plate battery vernier it would be worth—yes indeed—one plate battery

vernier is worth on the open market seventy times more than a vernier rheostat.

But how do you use the common, no doodad, vernier rheostat? Well, honest fans, most everyone, particularly those

**DEALERS**  
PROMPT SHIPMENTS  
LIBERAL DISCOUNTS

**COTO SPECIAL**  
Audio Frequency Transformer

\$2.50

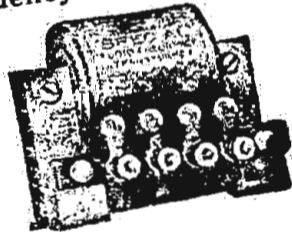

COTO-COIL Distributors

Note!! We are the largest exclusive Radio Jobbers in the Middle West

**HUDSON-ROSS**  
122 W. Madison St. Chicago

## B-T

BREMER-TULLY VERNIER TUNER

\$5.00



ORIGINAL 3 CIRCUIT COUPLER

If you want to eliminate local stations, get distance with volume and clearness never dreamt of before, cut in and out stations at will, all with simplicity of operation, buy a Bremer-Tully Vernier Tuner. Simple to install, connectous made to Binding Posts. Easily changed from one hook-up to another if desired.

Better Tuning  
B-T  
Price 10c

Better Tuning Tells you why and shows you how to get the best results. Unusually successful circuits described and illustrated with B-T photo diagrams. Sent on receipt of 10c. Free with each tuner.

**BREMER-TULLY MFG. CO.**  
532 South Canal Street CHICAGO

## RADECO SAFETY FUSES

(Patented)

Now available for DEALERS' SALE

Radio users have learned that Radeco Safety Fuses are a necessary tube protection—that their price (50 cents) is small compared with the great service they render.

The merit of the fuses, their low price and our extensive advertising have created a ready sale.

Up to now these fuses have been sold direct by mail, but the demand is so great that we want to distribute them in larger units through the trade channels. You will find Radeco Fuses a profitable item to add to your stock.

To assist you in handling them, we have made up attractive display boxes in colors containing an assortment of two dozen fuses.

Price per box (2 dozen fuses) \$12.00

Subject to Regular Trade Discounts  
ORDER TODAY

Radio Fans! Radeco Fuses can now be purchased at your Dealers.

**RADIO EQUIPMENT COMPANY**

New England's Oldest Exclusive Radio House

20 STUART STREET

BOSTON, MASS.



The Ideal Christmas Gift

For you who really love good radio Morrison Loud Speaker is the gift that is sure to please. Furthermore, you will show your good taste in selecting a present that is good for all the year.

Thousands of people are finding new radio possibilities with Morrison Loud Speaker. Harshness is eliminated, vibration forgotten once you attach Morrison to the tone arm of your

PHONOGRAPH Or Use It in a Good Horn

Full volume even with extreme amplification is assured you. There is just one point of adjustment—from soft to loud—and anyone can operate as well as an expert.

Complete with 5 Ft. Cord Nickel Plated Model \$10

Gold Plated Model \$15

Ask your dealer. If he hasn't any Morrissions in stock we will fill your order direct upon receipt of your letter.

Let us send you our new 2-color folder

DEALERS—Wire in at once for your requirements. Our discounts are generous.

**MORRISON LABORATORIES INC.**  
343 Jefferson Avenue East  
DETROIT, MICH.

**Morrison**

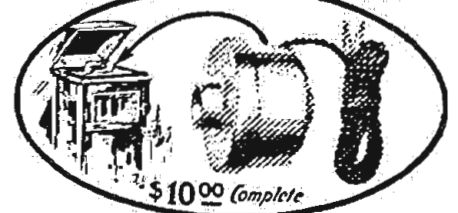

\$10.00 Complete

Loud Speaker



# Simple Explanation of Radio for Everybody

## Chapter VI, Part II—Vacuum Tubes

By M. W. Thompson

THE following article is the eleventh of a series for Radio beginners, written by Marvin W. Thompson, well known in air-phone circles for his understandable style of approaching his subject, and his ability as a Radio engineer. Mr. Thompson is now an associate editor on the staff of Radio Digest. A preliminary outline of the Chapters to follow is:

- Chapter VII—Antennas and Grounds.
- Chapter VIII—Regeneration.
- Chapter IX—Audio Frequency Amplification.
- Chapter X—Loud Speakers.

AT THAT time the construction of these consisted of a small square plate of metal held about  $\frac{1}{8}$  inch away from a single loop filament. The increased efficiency was at first hardly perceptible, but once the correct circuits and constructions had been determined they were amazing. Many unlooked-for effects soon appeared, the principal one being the emission of pure musical notes by the tube under certain conditions, and that these could be varied by altering the inductance and capacity of the circuit. This action was responsible for the name given the tube by DeForest's assistant and which it bore for many years—audion. The waves generated by the tube were musical and, of course, audible, and ions were responsible for them. Therefore, audible ions, or audion.

### Tube Uses

At their present stage of development let us see what vacuum tubes will do. They are veritable electrical acrobats, being able to perform stunts impossible to other electrical devices. A tube is, first, a wonderful generator of alternating current (current changing its direction of flow many times a second). If we feed direct current into the plate-filament circuit it will deliver, in the grid-filament circuit, current alternating over a wide range of frequencies, the rate varying with the constants in the circuit. Tubes used in this way generate the waves from a Radiotelephone transmitter. If we reverse the procedure and feed alternating current to the tube, it gives us pulsating direct current. Certain battery chargers are examples of this use of the tube on low frequencies; the grid in this case being omitted; the detector tube in any good receiving set utilizes this action of the tube on high frequencies.

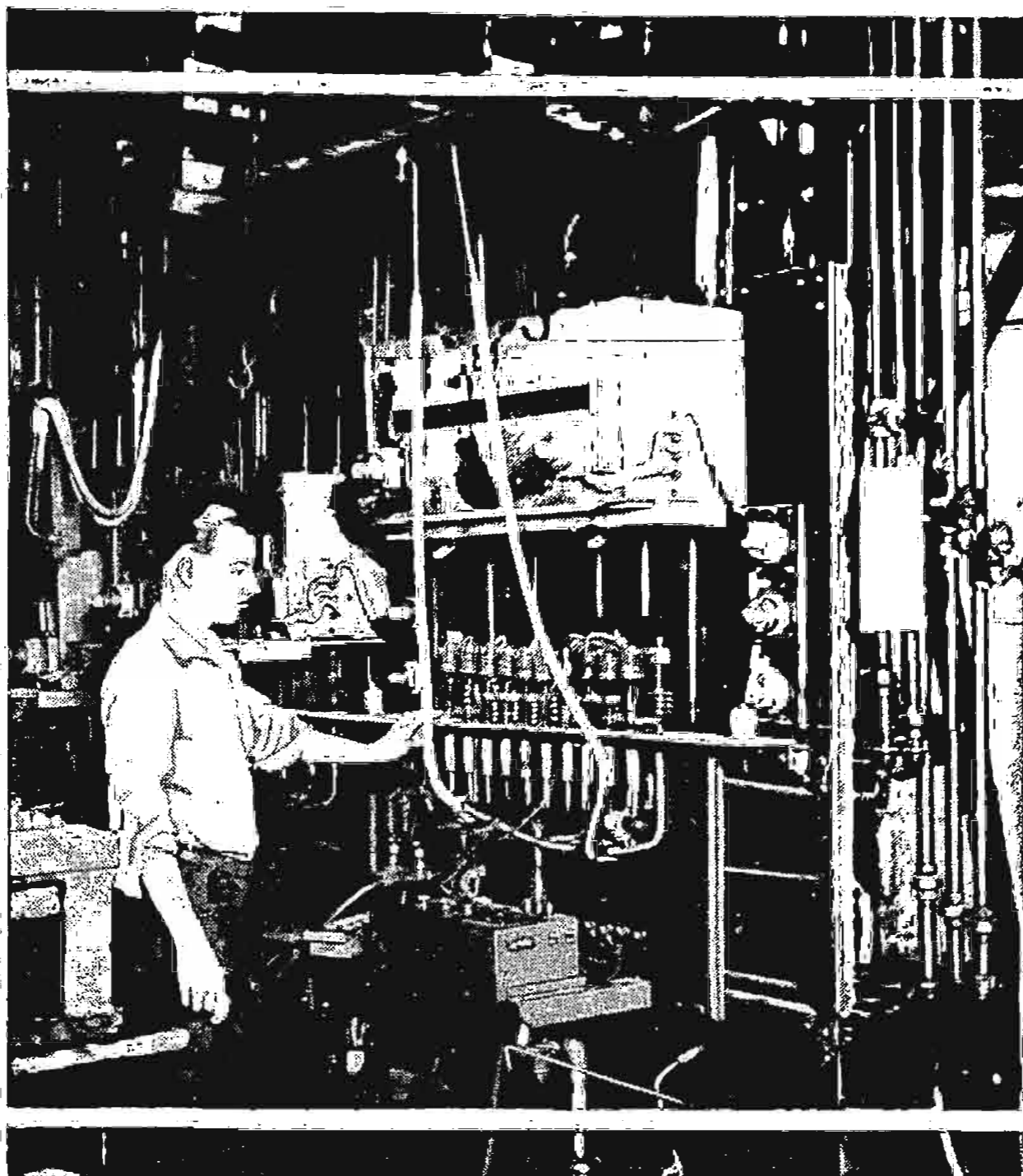

Evacuating the tubes. Special apparatus is used for this purpose, and ten tubes are exhausted at one time

this amplified fluctuating direct current is fed to tubes the same size as those generating the Radio waves and they "modulate" or impress the voice on the radiated waves. We thus have six separate

in all long distance telephone lines as a relay.

### Tube Manufacture

Let us now consider the construction of these tubes. Although the price of receiving tubes, which are essential for good reception and for amplification of any kind,

has been much reduced, it is still high and awaiting some means of manufacture that will eliminate much of the hard work before it can be reduced appreciably. Experienced production engineers are bending every effort to devising methods of manufacture that will permit more machine work and more rapid production. The personal equation plays a far more important part in the making of vacuum tube than in the making of any other piece of electrical apparatus generally used by the public.

The preliminary work and assembly of the filament and grid in a tube involve fourteen separate and distinct operations, each of which is a matter of careful, precise bending, twisting and joining of fine wires. To seal the lead-in wires of an ordinary lamp so that the base is air-tight is a comparatively easy matter but the sealing-in operation on a vacuum tube is a complicated process. Here four different lead-in wires must be carefully die-cut, placed in position and sealed without appreciable variation between tubes.

The fashioning of a filament is extremely difficult and very important. A piece of tungsten wire, fine as a human hair, must be cut and bent with an accuracy that does not permit even one percent of variation. The wire itself must be absolutely uniform in diameter and variations of .0001 inch cannot be passed. The grid wire must be wound around its support and welded into place. Although this is a machine job, it is anything but easy. Uniformity of shape is essential. The operator of a welding machine to do this work must have learned to apply uniform

(Continued on page 18)

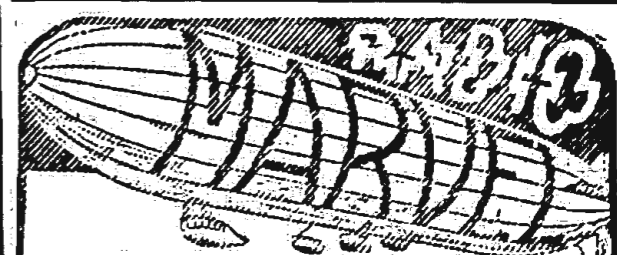

### MARVEL SPECIALS !!

- B BATTERIES, Quality Guaranteed**
- \$1.75 22 1/2 V. small ..... \$ .70
  - \$3.00 22 1/2 V. large ..... 1.20
  - \$4.25 45 V. medium ..... 1.69
  - \$5.50 45 V. large ..... 2.20
  - 6 Volt DX Tube, Guaranteed ..... 3.95
  - 1 1/2 Volt DX Tube, Guaranteed ..... 4.19
  - \$6.50 BIG FOUR CRYSTAL SET ..... 5.69
  - Complete with Nercos Phones ..... 8.09
- \$7.00 Pioneer Bakelite Varlocoupler ..... 4.95
  - \$2.50 183 Degree, 1200 meters ..... 1.92
  - \$6.50 Pioneer Bakelite Varlocouplers ..... 4.85
  - 13 Plate Vernier Condensers, Amco ..... 2.65
  - 23 Plate Vernier Condensers, Amco ..... 3.50
  - 13 Plate Vernier Condensers, Amco ..... 4.00
  - 7 Strand Copper Wire, 100 ft. Coils ..... .60
  - \$1.00 Saturn Automatic Plug ..... .80
  - \$17.00 6 Volt, 80 Amp. Battery, Guaranteed ..... 9.25
  - \$21.00 6 Volt, 80 Amp. Battery, Guaranteed ..... 11.75
  - \$6.00 Brandes Superior Phones, Gonure ..... 5.25
  - Nercos Phones ..... 2.45
  - \$10.00 Brunet French Phones, 4000 ohms ..... 6.50
  - \$18.00 Westinghouse Rectifier, Charger ..... 14.63
  - \$4.50 Thordarson High Ratio Transformer ..... 3.75
  - \$4.00 Thordarson Low Ratio Transformer ..... 3.25

Remittances must include Postage  
Send for our free monthly Price  
List DEPT. T. R. D.

**MARVEL RADIO CO.**  
132 NASSAU ST., NEW YORK

### RADIO CABINETS

- Direct from manufacturers in mahogany finish, one base board with each cabinet.
- |                      |                       |
|----------------------|-----------------------|
| 7 x 7 x 9.....\$2.50 | 7 x 7 x 21.....\$3.25 |
| 7 x 7 x 10.....2.65  | 7 x 7 x 24.....3.50   |
| 7 x 7 x 12.....2.75  | 7 x 7 x 26.....3.75   |
| 7 x 7 x 14.....2.90  | 7 x 7 x 28.....3.95   |
| 7 x 7 x 18.....3.05  |                       |

POSTPAID IN U. S.

Strongly constructed with grooves for panels. No fasteners or screws needed. Cash with order.

D. SUMNER

227 South Market Street, Dept. 21, Chicago



Welding the plates and grids, an operation done by experienced girls with the electric arc welder

The detector feeds the amplifier tube a slightly fluctuating direct current and this controls a comparatively powerful direct current in the plate circuits of the amplifier tubes, without change or distortion. The amplifying action of these tubes is also used in transmitters in this way: The voice fluctuations caused by talking into a microphone are not sufficiently strong to materially affect the powerful currents set up by the large tubes which generate Radio waves, so a small tube is utilized to amplify or strengthen these voice variations before they are impressed on the currents in the larger tubes. One more use of the tube should be mentioned: as a "modulator." Even though amplified, as just stated above, the fluctuations of current corresponding to speech would not sufficiently vary the Radio waves generated by large tubes, so

and distinct uses of the tube in Radio work, and besides these, it is also used



- E. MacDonald of Bangor, Me., received Wenatchee, Wash., on 1 tube Royal Portable Broadcast Receiver. One dial control. Takes all wave lengths. Complete parts, cabinet, instructions.....\$7.95
- Royal Portable 1 tube set assembled..... 10.00
  - Phones, batteries, tube, aerial, etc..... 9.75
  - Cockaday—Reinartz—Ultra-Audion circuits, panel, complete parts—Tube Free with each 13.67
  - 5 Tube ROYAL Neutrodyne (mounted)..... 49.47
  - ROYALTRON tubes, guaranteed. Standard base, 1 1/2 or 3 volt det. or amp. 6 V. amp. 3.95
  - Dietzen phones, 11st \$5, our price..... 3.75
- Write for Catalog  
**ROYAL MANUFACTURING COMPANY**  
Dept. 50 World Building, New York City

# PERFECTION

MAKE PERFECTION YOURSelves

<h3>ERLA REFLEX</h3> <p>Circuit Complete Operate a loud speaker on one tube with this wonderful set.</p> <ul style="list-style-type: none"> <li>1 Formica Panel 7x14 1/2. Panel 3/4 drilled, engraved &amp; polished</li> <li>1 Erla Reflex Transformer</li> <li>1 Pearlco Mid. Bakelite C'pl'r</li> <li>2 Switch levers</li> <li>1 Amco 23 Pl. Vern. Condenser</li> <li>1 Klossner Vernier Rheostat</li> <li>1 Crystal Detector with Crystal</li> <li>2 Bakelite Sockets</li> <li>1 Dial, 3 in. Improved Jack</li> <li>1 Dubiller Condenser #601</li> <li>1 Dubiller Condenser #002</li> <li>1 Erla Bezel</li> <li>8 Name Binding Posts</li> <li>12 Ft. Tinned Cop. Wire, No. 14</li> <li>6 Ft. Cambric Spaghettil</li> <li>12 Contact Points and Nuts</li> <li>2 Contact Stops and Nuts</li> <li>1 Franco Audio Transformer</li> </ul> <p>Our Special Price Complete</p> <p style="text-align: center;"><b>\$27.50</b></p>	<h3>COCKADAY</h3> <p>Circuit Complete</p> <ul style="list-style-type: none"> <li>1 Eastern Cockaday Coil</li> <li>2 Amco 23 Plate Condensers</li> <li>1 Panel 7x14 1/2</li> <li>2 Dials, 3 inch</li> <li>1 Bakelite Socket</li> <li>1 Tubular Leak, 2 Meg.</li> <li>1 Dubiller Condenser, .00025</li> <li>1 Klossner Rheostat</li> <li>8 Name Binding Posts</li> <li>2 Contact Stops and Nuts</li> <li>1 Diagram</li> </ul> <p>Our Special Price for Complete Cockaday Set</p> <p style="text-align: center;"><b>\$12.95</b></p>	<h3>NEUTRODYNE</h3> <p>5 Tube Set The Neutrodyne Circuit is the last word in Radio and is the best set that can be made today.</p> <ul style="list-style-type: none"> <li>1 Formica Panel 7x21</li> <li>5 Bakelite Sockets</li> <li>3 Neutrodymers</li> <li>2 Neutrodous</li> <li>2 Franco Audio Transformer</li> <li>1 "A" Battery Switch</li> <li>3 Dials, 4-inch</li> <li>1 Klossner Rheostat</li> <li>1 Amco Power Rheostat</li> <li>8 Binding Posts with Names</li> <li>3 Jacks</li> <li>27 Feet Spaghettil</li> <li>28 Ft. No. 14 Tinned Copper Wire</li> <li>2 Condensers, .006 Dubiller</li> <li>1 Grid Leak and Condenser, Freshman</li> <li>1 Dubiller Condenser, .002</li> </ul> <p>Special Price for Complete Parts for 5 Tube Set</p> <p style="text-align: center;"><b>\$32.50</b></p>
--	--	--

**PERFECTION RADIO CORP.**  
Mail Order Dept. 59 CORTLAND ST., NEW YORK CITY Add Parcel Post  
Do Not Send Stamps  
N. Y. Retail Stores: 78 Cortland St., 119 West 23rd St., 125 Chambers  
208 page complete Radio catalogue free with order of \$5.00 on request. Otherwise prepaid for 25 cents



# Radio Digest Illustrated

REG. U. S. PAT. OFF. AND COM. OF CANADA

Published by the Radio Digest Publishing Company, Inc.  
123 West Madison Street  
Telephone: State 4843, 4844, 4845  
Chicago, Illinois

E. C. RAYNER, Publisher

Chas. F. Smisor, Editor Evans E. Plummer, Managing Editor  
H. J. Marx, Technical Editor M. W. Thompson, Associate Editor

Eastern Representative, Jacob Miller, Times Bldg., Times Square,  
New York; Telephone Bryant 4909

Pacific Coast Representatives

E. J. Wood, 251 Kearney St., San Francisco  
Telephone Kearney 1472

H. M. Morris, 417 Western Mutual Life Building, Los Angeles  
Telephone 12011

Member of the Audit Bureau of Circulations



PUBLISHED WEEKLY

SUBSCRIPTION RATES

Yearly in U. S. and Possessions and Canada, \$5.00.  
Foreign postage, \$1.00 additional. Single copies, 10 cents.

Vol. VII Chicago, Saturday, December 8, 1923 No. 9

## What Broadcasting Means

**B**ROADCASTING means more than simply projecting sounds from an electrical device. Talking or singing into a transmitter is a simple process. To reproduce the voice or sounds from musical instruments without changing either is another matter.

The slightest error of voice or musical note, when amplified—as it must be in broadcasting—is necessarily magnified by such amplification, and this error is then objectionable distortion. To so perfect sending or broadcasting apparatus as to eliminate distortion has been the laboratory effort of all the better broadcasters.

## Farmer's Amusement

With a Radio Set the Winters Seem Shorter

**T**HERE is no great gap between the amusement likes and dislikes of the farmer and those of the city man. Hundreds of farmers write to tell the broadcasting stations how the concerts are tapped from the air over the orchards and pastures and how much they are enjoyed.

The Department of Agriculture maintains at Washington a remote control station in connection with the high-power station at Arlington, and the reports are spoken directly into the transmitter in the office. Thus a Radio news market service has been developed. About 150 Radiophone stations broadcast the agricultural information, which includes weather forecasts, crop reports, market reports and news. Farmers write to tell what they find of value, and give suggestions for other subjects to be sent through the air.

The long arms of Radio reach out and give the farmers a human touch of cheer, no matter how closed in they may be by rain or snow. The Radio set owner on the farm seemingly had his last winter shortened because of the entertainment he could enjoy at home.

## Universal Language

Music Is the Basis of Communication in All Tongues

**N**EVER in the history of the world has any invention been so eagerly, so rapidly, and so universally adopted as Radio. Three years ago it was an almost unknown art. Today millions are entertained by Radio. As a method of communication it has taken its place with the telephone, telegraph, and mail, but it is more than a method of communication. With the printing press and the moving picture, it is one of the three greatest factors in forming and influencing public opinion.

We may consider the future of broadcasting as an economic force, rather than try to foretell how invention may add to its further development.

The ability to communicate instantly and simultaneously with millions of people is not a power which will be lightly discarded. It suggests, with no strain on the imagination, a universal language and the vehicle for complete mutual understanding among the peoples of all civilized nations. Music is the universal language and fortunately music is the foundation of all broadcasting today.

Undoubtedly it will continue to occupy an important part of the programs, but it will be used with more artistic taste. The best in music will always be available so that public appreciation will become more exacting and the inferior and mediocre will be eliminated.

Religious services will continue to inspire the vast Radio audiences and particularly to cheer and comfort those who are incapacitated through age or infirmity. There will be established a unity of religious peoples which has never before existed.

Graded educational courses will be available at times convenient to those who labor in factories or fields, so that the world's standard in this respect may be greatly advanced by providing opportunities even for those isolated from educational centers or otherwise prevented from attending school or college.

## RADIO INDI-GEST

Page the S. P. C. A.

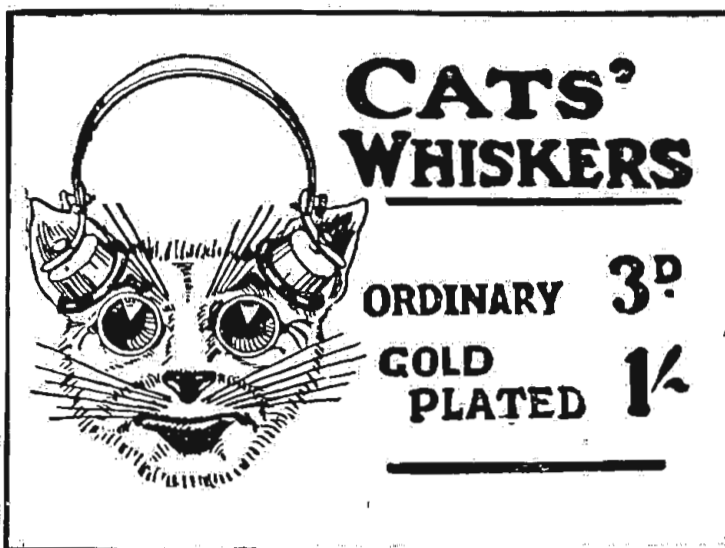

It is reported that when a London shopkeeper put the above poster in his window, two kindly old ladies stepped inside and told him that it was pure cruelty to poor cats to make merchandise of their whiskers; in fact, they were shocked to know that such cruelty existed. His lucid explanations of the term, however, won the day, and the two old ladies left with peace in their minds.

POSTER BY GILLIAMS.

### INDI-GEST KINKS? SEND A DOLLAR—

**T**HERE are many little Indi-Gest kinks worked out in the home that would hamper your fellow Radioknut and cause him much worry. Indi-Gest is very much interested in securing such material and is willing to accept a dollar for each kink printed. Send a stamped envelope so rejected copy may be returned. Under no circumstances will the dollar be sent back.

INDI-GEST KINKS DEPARTMENT

### A-B-C Lessons for Indigest Beginners Chapter XXV—Glandularly Speaking

BY GOSH

**Y**IS for youth,  
That Radio has most of,  
That makes it grow so fast,  
And have so much to boast of.

### The King Tried It the Same Way

The circulation manager hands us a letter from a bozo who managed to get locked in the hoosegow as a result of a misdemeanor and was therefore unable to get his weekly copy of Indi-Gest. Inasmuch as he was building the notorious Miloplex set, a series on how to build which he was reading (see back file of Indi-Gest for pictures of King and Queen Miloplex), he solicited the aforementioned circ. mgr. to send him the missing issue. He says he has company in the county cooler and that the Milo gives them quite a thrill as they listen in the steel cage. Any readers of Indi-Gest wishing to test their sets in steel cages, enclose envelope self-addressed and stamped, and full directions will be sent for getting wrapped up in a dungeon.

INDI.

### This Is a Good One to Know

She: "Jack, dear—am I really the first girl you ever kissed?"  
Jack: "Yes, indeed. I learned to do that the other night from a Radio lecture."  
PANTHER.

### He Doesn't Believe a Word of It



Voice over the Radio: "And now, little kiddies, what do you think Peter Rabbit answered?"  
FROM LIFE.

### The Charge of the DX Brigade

Batteries to the right of me!  
Batteries to the left of me!  
The struggle is terrible!  
Ruin and devastation on every side,  
The shrieks and roars of combat are deafening.  
What the outcome may be no one can foretell.  
My brain whirls as it views the scene.  
We have advanced too far to retreat,  
We must go on at any cost,  
The great problem that confronts us is—  
Can we make KPO or KDKA?  
RAY-DIO.

### Purely a Case of Cold Feet

Dear Indi: I hear by my friend's Radio (the waves still running off instead of onto my antenna) that silk stockings are going up on account of the earthquakes in Japan. 'Sall wrong—the silk socks are going up all right, but it's the chilly wind of winter, not any shimmies of Japan, that causes the elevation.  
SOOZZEE.



## Condensed

By DIELECTRIC

Frequently one looks to his daily paper to supply a detailed account of some discussion on a vital subject before a gathering of informed men, but portions of speeches will be missing. One great advantage of broadcasting meetings of various scientific and commercial bodies is the surety of reaching a vast audience of laymen with all that takes place (if the set works). A short time ago, every listener to WDAR, in Philadelphia, heard a discussion on the coal question at the meeting of the American Academy of Political and Social Science in that city. Such informing programs are of benefit to all listeners.

I really don't see that Radio broadcasting program directors have any reason to be disappointed with the listening public's response to their request for letters of advice regarding the class of programs desired. With each of the Chicago stations recalling to our notice about every other intermission, night after night, it was impossible for us to forget that at the Radio show prizes would be given for sending in letters and postal cards specifically dealing with this subject. It has been iterated and reiterated that in order to know what the listening public most desires to have sent through the air those sending it should be informed. There is variety enough, certainly, to suit any taste.

In the case of foreign visitors to this country during the past year, their utterances have been broadcast all over the country, so that you might hear what they had to say, even though your opinions differed radically from theirs. When Lloyd George spoke in the United States recently microphones were almost invariably placed so that his message was audible to many thousands not present at the many gatherings greeting him. It is sometimes well to listen to statements not altogether to your liking in order that you may be started to thinking—perhaps more clearly. On the eve of the celebration of Armistice Day, listeners-in were permitted to hear what Woodrow Wilson had to say to his fellow-citizens. In his case there can be no doubt of Radio serving as a more faithful barometer of his physical condition than any published statement regarding his health. Your phones, or loud speaker, showed the effort it cost him to speak—even for so short a time. Radio is stethoscopic.

The majority of broadcasting stations are very careful to select for their entertainers only those whose song or speech is of a refined character. Regardless of who may be listening, or to what station the receiving set is tuned, nothing will be heard unsuited to chaste ears. Well, yes, there may be an exception to that, particularly when an announcer has mislaid a bunch of telegrams—or an artist comments on his own mistakes. One evening I was listening to a station in Philadelphia and heard a well-known illustrator tell a fish yarn that excels in every attribute such yarns are supposed to have, and then listened to his request to "call me a liar." That epithet was good-natured and it was self-addressed, so it passes. His story was true, though it's hard to believe. Not all that the Radio carries is true—but it's clean.

All of us who delight in good music and wish to see a greater development of this fine art, are under obligation to station WMAQ, Chicago, because of the effort being made to encourage American composers in their work. In this contest, however, "jazz" and other popular forms of music are eligible to entry in the contest this station is carrying on for a period of four weeks. That, too, is admirable. It may help to evolve something better. When certain parties found that this and that feature of broadcast programs might be "cornered," they set to work to accomplish their end. At once counterefforts were made in behalf of the welfare of Radio audiences, which now appear to be meeting with success. A few would grab all, circumstances permitting.



# Latest Development in Grimes Inverse Duplex

## Part III, Section II—How Howling Was Eliminated

By David Grimes

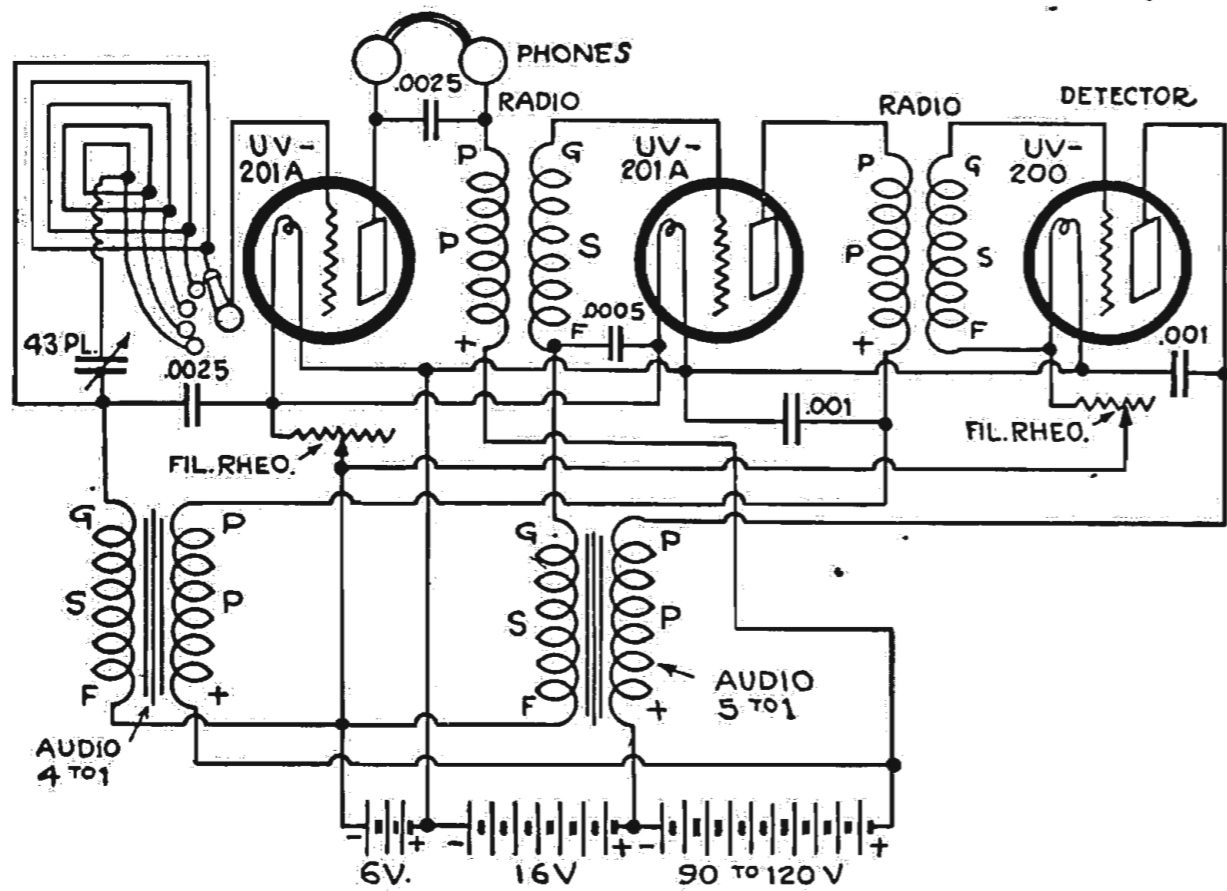

Figure 6—New Grimes circuit overcoming howl from self-capacity of first Radio transformer

ever, any standard Radio frequency transformer will act as a proper choke, if it is correctly connected. I would suggest that either its primary or secondary be used first with the unused winding left open. Then try connecting the two windings in series. If this results in less volume, one winding is opposing the other and should be connected oppositely with respect to the other winding. The two windings in series should give slightly greater volume than when one winding is employed. This

necessary when an additional stage of audio amplification is desired, and the details concerning it will be discussed in another article.

The changes discussed in this article were necessitated by the new and more efficient tubes. They constitute a definite improvement in the basic circuit, nevertheless, and should be incorporated even if the old tubes are still being used. The trouble resulting from the inherent capacity in the first Radio transformer

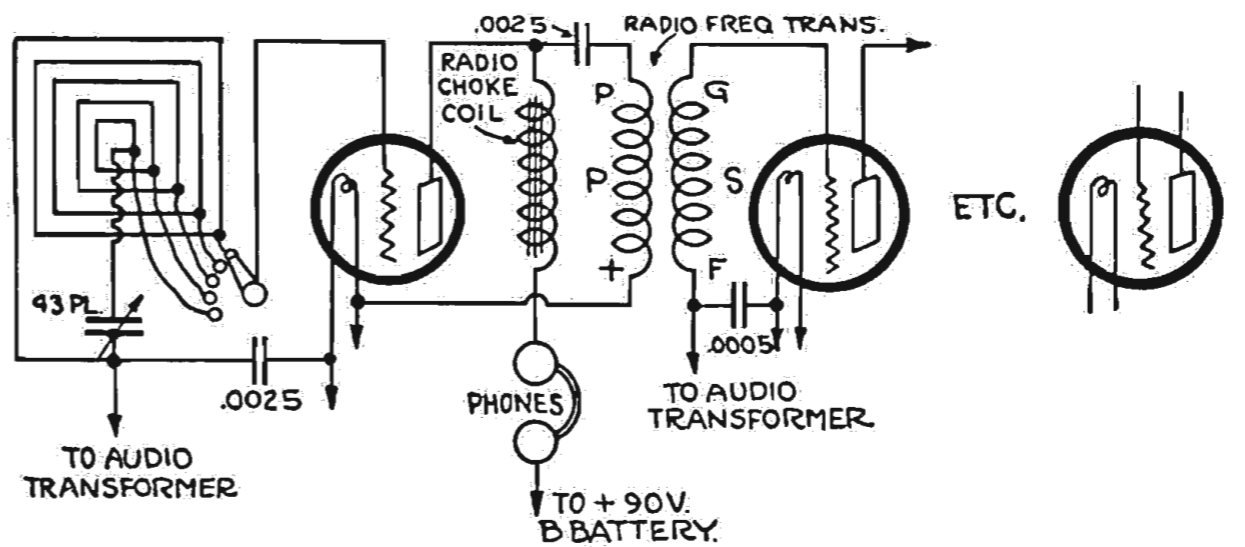

Figure 7—Grimes Inverse Duplex choke coil arrangement to prevent capacity howl in first Radio transformer

### CORRECTION

In the two illustrations accompanying the Inverse Duplex series in the November 24th issue a material mistake escaped our notice. Both drawings give the by-pass condenser in the loop circuit a capacity of .00025. This should be .0025. The use of the former condenser at this point will result in a howl.

capacity effects from the hands, and the adjustment of the set becomes critical. However, the set will work and the range is still very good, and this method is by far the cheapest. If it is desired to add one stage of audio amplification on this set, then other arrangements are best as more Radio energy is lost through the audio transformer to the filament than through the phones and body capacity of the operator. This will be taken up in a later article.

### Improved Circuit

An improvement on the above circuit is shown in Figure 7. As in most improvements, some expense is involved. It adds a Radio choke coil in the circuit, and unless one is experienced with such things, it is better to purchase it. At the present time no such choke is available. How-

arrangement will force all of the Radio currents in the plate of the first tube down through the first Radio transformer and into the second tube. This gives the set greater efficiency which will be noticeable in greater range of reception. It also frees the telephones from the Radio frequency energy making the operation of the set less susceptible to body capacity effects. This system is almost

always existed but until better amplification was gained in the new tubes, the trouble did not become objectionable when the recommended apparatus was used. With the new layout, the capacity still exists, but its effects are nullified. This nullification, it is believed, will permit the use of most of the standard Radio transformers with the standard tubes. (TO BE CONTINUED.)

THE arrangement previously described and shown in Figure 6 has one disadvantage. The Radio currents in the plate of the first tube have a tendency to pass into the telephones and thence to the ground through the body capacity of the person wearing them. Some of the Radio energy is thus lost and the range of the set is reduced a trifle. Also, the presence of Radio currents in the leads to the phones makes them very sensitive to

### Troubles and Don'ts

In place of flowers and fruits, small Radio sets are becoming the popular gifts to patients in hospitals. This is particularly true with regard to open air camps for tubercular patients, located in the vicinity of broadcasting stations.

To prevent a hum in the set, keep the electric wires away from apparatus. A droplight on the table where the set is located is sometimes responsible for a hum.

Never fasten an antenna permanently to the bough of a tree. Fasten it by means of a pulley, with a heavy weight at the end, which will keep it taut, yet will allow the tree to sway without breaking the wire.

All crystals can be injured by touching them with the fingers. It is best to handle them with tweezers or with a piece of

cloth and keep them in some kind of container when they are not in use.—Eric E. Leibner, St. Louis, Mo.



The new TWITCHELL AUXILIARY TUNER connected to your present set will enable you to bring in the long and short wave stations which your present set cannot get. It also cuts out all local stations so you may bring in distance any time without local interference. Copyrighted diagram of this tuner 50c, or with all parts \$9.00. Complete instrument in walnut cabinet, ready to use, \$15.00. Transportation prepaid.

MY HIGHLY IMPROVED REINARTZ brings in all important stations on this Continent loud, clear and without distortion. We dance to music from Atlanta and Los Angeles.

Build one of these wonderful 3 tube sets from my blueprint and specifications, price 50c, or with a complete and perfect double-wound spiderweb coil \$3.00 by mail. Picture of this set on a glass panel with every order. This copyrighted circuit is the most successful of any Reinartz modification yet produced, and is imitated the most. Thousands are in use. My W. D. II Circuit is especially designed for use with the "Pickle" tube and brings out the full value of that little tube as no other circuit can. Stations 1000 miles away come in clearly on one tube. This set is small, complete, portable. For the man who wishes the highest efficiency, this is the set to build. Price of blueprint and specifications, 50c, or with complete and perfect windings, \$3.00. Photo of set with every order. Sets built from these copyrighted plans will receive all broadcasting stations operating under the new laws. Their wave length range is from 170 to 800 meters. All goods prepaid. These instruments are easy to build, easy to operate. Everything clearly shown.

S. A. TWITCHELL  
1925 Western Avenue Minneapolis, Minn.



### Distributors for

- |                              |          |
|------------------------------|----------|
| Radio Corporation of America |          |
| Grebe                        | Magnavox |
| Atwater Kent                 | Burgess  |
| Brandes                      | Gould    |
| Murdock                      | Eveready |
| Nath. Baldwin                | Frost    |
| Western Electric             | Carter   |
| Acme                         | Dubilier |
| All American                 | Howard   |
| Signal                       | Eby      |
| Chelsea                      | Bradley  |
| Cutler-Hammer                | Jewell   |
| Western Coil                 |          |

and other manufacturers of high standing

We carry a comprehensive stock of the latest receiving sets, parts and supplies of the leading manufacturers, and ship from stock promptly.

FREE CATALOG Sent on Request

Dealers: Buy reliable equipment from a house of established reputation. Send for catalog of tested and approved apparatus and our discount sheet.

JULIUS ANDRAE & SONS COMPANY  
113 Michigan Street, Milwaukee, Wis.

# 1000 MILE



- What You Get
- Atlas Wonder Receiver
  - Brandes Head-phones
  - Cunningham Tube
  - A Battery
  - B Battery
  - Aerial
  - Ground Wire
  - Instruction Book
- COMPLETE NOTHING ELSE TO BUY

Range Ultra Audion Complete RADIO Outfit

9.95 CASH  
Reg. Value \$57.50  
This Book FREE

1000 mile range easily attained in favorable weather with this Atlas Wonder Single Tube Radio Set. Delivers beautiful concerts—melodies, operas, and market reports—every tone is clearly reproduced, every instrument retains its individuality. You will be thrilled with the wonderful results. Remember the outfit comes COMPLETE—nothing more to buy.

### Radio Dictionary FREE

One of the Atlas Wonder Radio Sets, completely built, can be had for only \$9.95 CASH, by one person in each community. You take absolutely no risk, as all Atlas supplies are sold with a positive guarantee of satisfaction. Don't fail to get this amazing offer. Do not send a penny—just your name and address and we will send you complete information. Our Big Radio Catalog explaining all about different sets and hook-ups comes FREE with the offer. You will want it, so don't delay. Get the amazing \$9.95 offer. Write TODAY.

ATLAS CUT RATE RADIO SHOP, DIV. 2, 345 S. Clark St., Chicago  
We operate three great retail stores in Chicago's Loop.

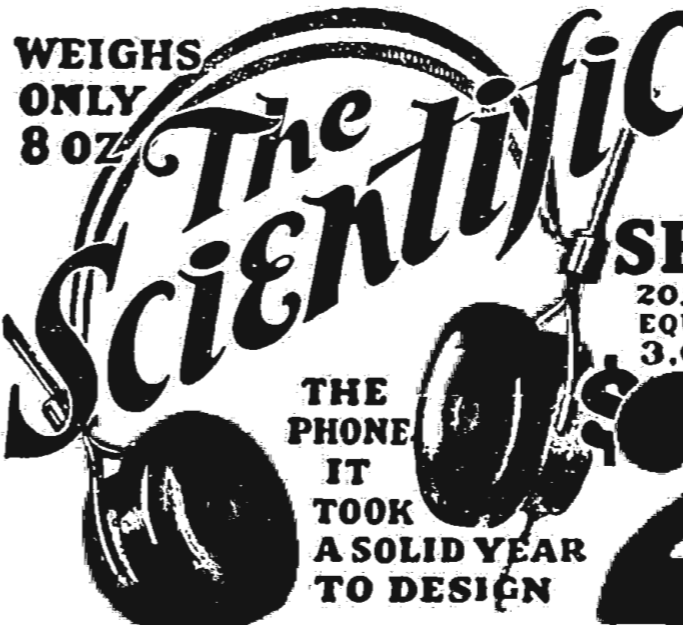

A \$200,000.00 COMPANY stands squarely back of the guarantee on every Scientific headset

### SEND NO MONEY!

20,000 TURNS Order TODAY  
EQUIVALENT TO 3,000 OHMS by Postcard

and Pay Postman on arrival  
LOUD SPEAKER UNIT \$1.95  
POST-PAID

We Guarantee The Scientific Headset to be the greatest value on the market. Try it for five days. If not satisfactory send it back and your money will be refunded immediately. Circular on request. Dealers wanted.

THE SCIENTIFIC ELECTRIC WORKS  
98 Brookline Ave. DEPT. W. BOSTON, MASS.



## RADIO FOR EVERYBODY

(Continued from page 15)

pressure, it sometimes requires two weeks to adjust a welder so that the operator can. The heat used in a welding machine is obtained electrically, and too much current will melt the very fine wires of the grid, while too little will not give it a good weld.

The plate, which is now usually made in the form of a cylinder surrounding the grid and filament, is punched from sheets of nickel or molybdenum. While its fashioning and welding are not quite as delicate operations as the grid work, they constitute almost a fine art. The last operation consists in anchoring the filament in place, and this "last" is by no means "least." It is one of the finer points of the job and must be done with much calculation, thought and steadiness of hand as the filament, while held firmly in place, must yet have sufficient play to allow for a small expansion when heated.

When the elements of the tube—the filament, the plate and grid—have been assembled and mounted within the glass bulb, the bulb must be exhausted of air. As an atom of air is as effective in blocking an electron as a truck is in stopping a motorcycle, it is essential that the process of exhaustion be carried to an extreme degree. Pumps of many types

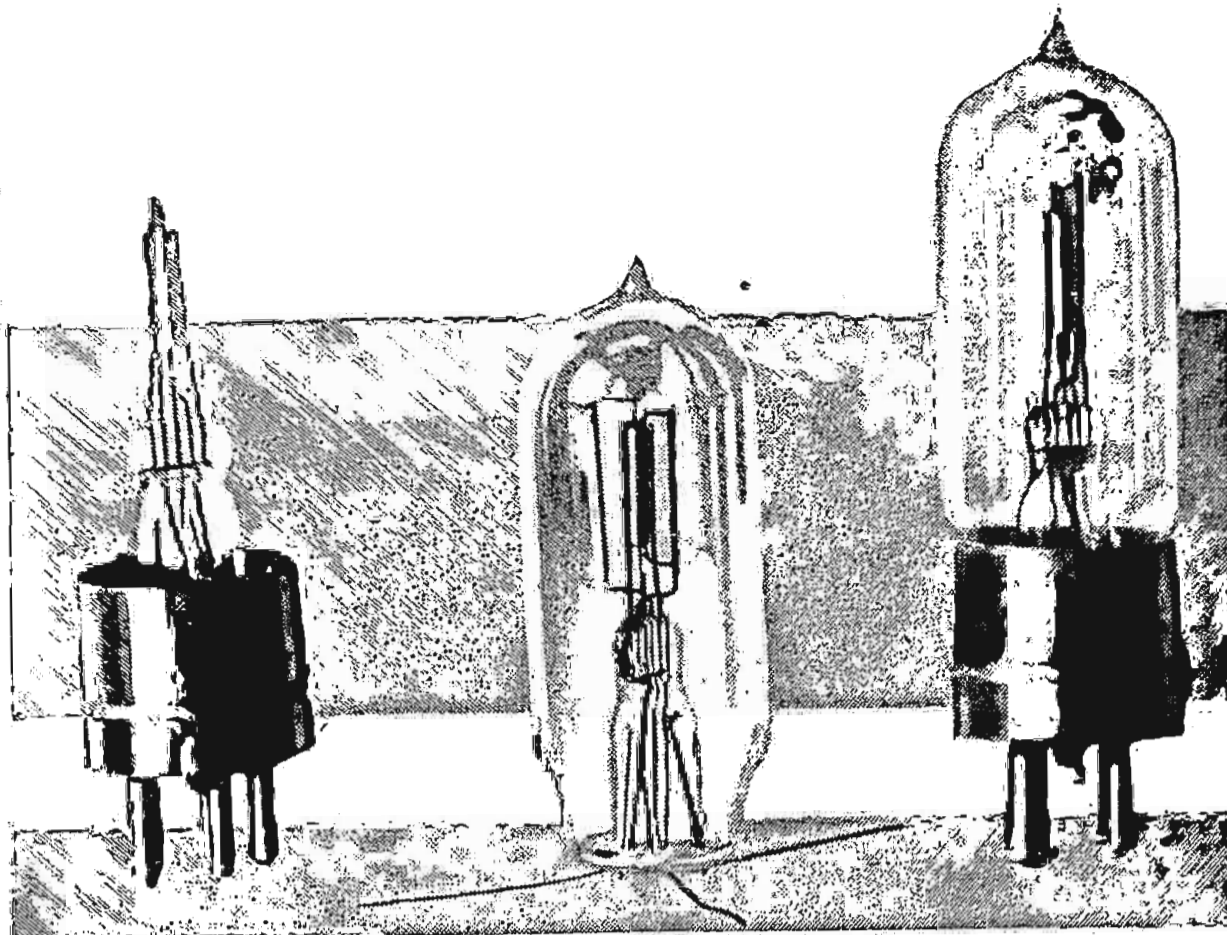

Three stages in the manufacture of a tube, showing the delicacy of the insides

is weak physically. The filament is its weakest point. Great care must be taken in removing the tube from its wrappings, in laying it down and in preventing it from rolling off a table, etc. The advanced Radio amateur has learned from costly experience to handle tubes as he would diamonds or dynamite—tenderly.

(TO BE CONTINUED.)

### Lock on Tube Lighting

Two good ways to prevent children from lighting the tubes of a set are as follows: Procure a key switch (such as used in houses as flush switches) and insert it in the panel, or in the end of the cabinet, and attach the negative side of an A battery or positive and negative side of the A and negative side of the B battery. Then it cannot be lighted unless the key is used.

An ordinary drawer lock can be used also, making the tumbler bear on a strip of spring brass. By using the positive of the A battery and the negative of the B battery together this cuts out both batteries.—H. A. Keys, Kinder, La.

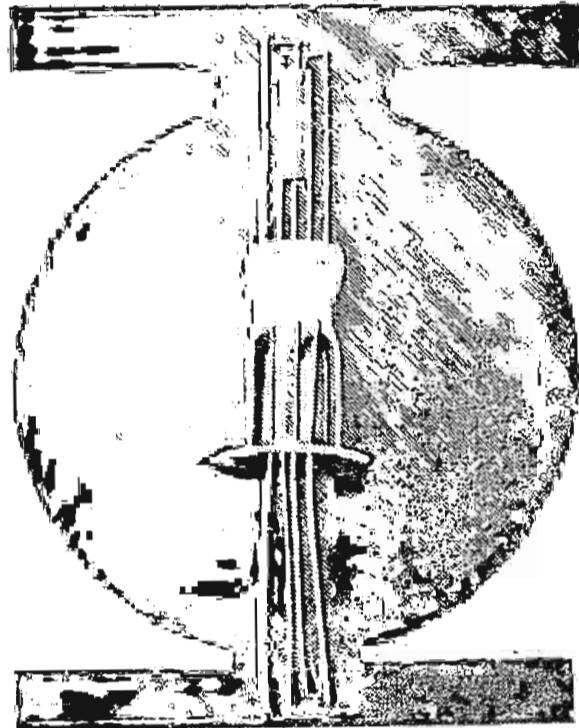

The filament, grid and plate welded to the support wires in the stem. This assembly must now be sealed in within the bulb

have been developed by manufacturers of these little lamps, most of them making use of mercury. So much for the construction of tubes.

The purchaser of a vacuum tube finds that it comes in a specially made cardboard box, and, in some cases, wrapped in soft cotton to protect it from jar or pressure. A tube, while extremely dependable in use and stable in operation,

Fifty assorted flathead solid brass machine screws, nuts, washers, copper lugs, 50c. Eight initialed binding posts, set, 60c. Twelve nickelled binding posts, 50c. All three items, \$1.50. RADIO LIST for stamp. All prepaid. Stamps accepted. Kladag Radio Laboratories, Kent, O.

**IF YOU CAN'T BUY THEM AT YOUR DEALER'S SEND DIRECT TO US**

"Red-Heads" are guaranteed radio phones. You run no risk when you buy them. Money back if, after 7 days' trial, you're not satisfied that they're the best receivers on the market at the price. Why not act right now and get a pair? It'll mean getting the maximum from broadcasting from the day you put them into use.

## RED-HEAD RADIO RECEIVERS

These remarkable head-sets are made by The Newman-Stern Co., one of the pioneer radio manufacturing houses in America.

JUST OUT

The new 1924 Model F

**\$6.50** PER PAIR Complete

This is the standard 3,000 ohm "Red-Head." The 1924 Model F has eleven improved features. Sensitive and fine-toned; aluminum case; famous brown-red caps; military headband; high-grade cord.

"Red-Heads" sent prepaid on receipt of price if you are unable to get them at your dealer's.  
**THE NEWMAN-STERN COMPANY**  
Dept. RD Newman-Stern Bldg. Cleveland

The new 1924 "Red-Head" Jr.

**\$5.00** PER PAIR Complete

The Junior Model has most of the quality features of the standard Model F here described. The resistance is 2,000 ohms per set instead of 3,000 ohms. A remarkable value.

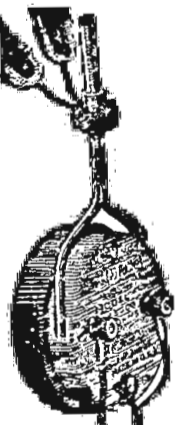

## Workman Radio Service

"THE ACCENT IS ON SERVICE."

14-16 Vesey St. NEW YORK

**VARIOCOUPERS**  
\$3.50 Workrite 180° Silk Wound.....\$2.95  
3.00 Mills 180° Silk Wound..... 1.95  
3.50 Fisher, Large, 90°..... 2.25  
2.75 Fisher, 180°..... 1.75

**VARIOMETERS**  
\$3.50 Workrite.....\$2.95  
5.00 Pathé Moulded..... 2.25  
3.50 Fisher, Large..... 2.65

**CONDENSERS**  
\$2.00 R. C. 11 plate.....\$1.05  
2.35 R. C. 23 plate..... 1.35  
2.75 R. C. 43 plate..... 1.65

**VERNIER CONDENSERS**  
\$4.00 R. C. 23 pl.....\$2.25  
5.00 R. C. 43 pl..... 2.95

**AUDIO TRANSFORMERS**  
\$5.00 Acme.....\$3.95  
5.50 Federal 226-W..... 4.35  
7.00 Federal No. 65..... 5.75  
7.00 Amertran..... 5.75

**PHONES**  
\$6.00 Brandes Superior.....\$5.25  
12.00 N. & K., Imported..... 5.50  
5.00 Nergo..... 2.50  
Ambassador..... 3.89  
6.00 Potter Precision Headset..... 4.25  
5.00 Diamond De Luxe Phones..... 3.50

Mail orders promptly attended to. All orders amounting to \$5.00 or more will be shipped prepaid. Will ship C. O. D. unless remittance accompanies order.

Write for our monthly bulletin of radio bargains at reduced prices.

## Hearse

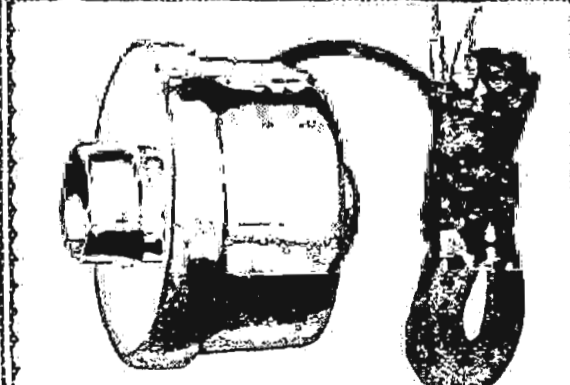

### Morrison Loud Speaker

Attaches to any phonograph or radio horn. Takes the rattle out of radio—realistically reproduces every signal with exceptional volume and clear, mellow tone.

SELLS FAST AT \$10

It's a big seller everywhere. Order now for the Holidays. We're headquarters for everything in radio. Big stocks—quick shipments. Get our big illustrated catalog B1001 and special discount sheet.

**WAKEM & McLAUGHLIN INC**  
225 E. ILLINOIS ST., CHICAGO

### Utilizing Flashlight Battery

With one-tube receiving sets designed for minimum size and weight, a flashlight battery may be used to light the filament. This battery will supply one hour's service a day for about one month.

### RADIO FANS

Tune in on station  
**WEAF** (New York)

every Thursday at 8.50 P. M. and listen to a story or article selected from

**HEARST'S INTERNATIONAL**

This is one of the most popular weekly features "on the air"

## FREE

Write for Free Copy of the Latest Radio Reprint. It contains a complete story from Hearst's International Magazine. Address Radio Editor, Hearst's International Magazine, -119 West 40th Street, New York City.

## WALNART

New  
**INDUCTANCE SWITCH**



Replaces switch points. Insures positive contact and better radio results.

Only one hole to drill in panel. 1 to 10 points.

Bakelite Knob and numbered dial. Position of contact always visible.

Terminals mounted on bakelite base. Can be used in small space.

Costs less than switch points and gives much better results.

Price  
**\$1.25**

ASK YOUR DEALER

Catalog mailed on request

**WALNART ELECTRIC MFG. CO.**

Dept. 412, 1249 West Van Buren Street  
CHICAGO

## The New Freshman CAPACITY FINDER

permits you to actually measure the condenser values necessary in your hook-up.



### FIND OUT

just what value of a condenser will give your hook-up the best results in the grid circuit, across the phones, in the antenna circuit, across transformers, battery circuits, etc.

31 different capacities in steps of .00005 up to .0015 possible with this combination.

Price **\$2.25**

including the 5 special Freshman Condensers

At your dealer; otherwise send purchase price and you will be supplied postpaid. Ask your dealer or write direct for complete instructions free.

**Chas. Freshman Co. Inc.**  
Radio Condenser Products

106 Seventh Avenue

New York

**CROSLY MODEL XJ RADIO RECEIVER**

**\$65**

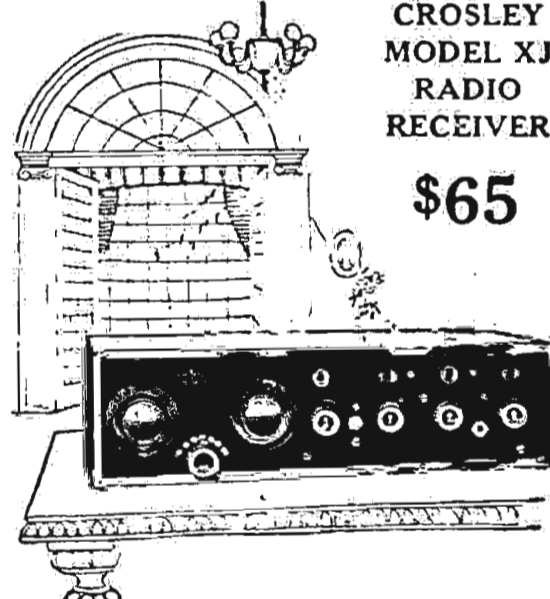

### Tune Out Local Interference

ENJOY the many interesting programs that may nightly be received from distant broadcasting stations.

With a Crosley Model XJ you can easily do this. This 4-tube radio receiver, consisting of one stage of tuned radio frequency amplification, detector and two stages of audio frequency amplification, is daily making new distance records.

Unsolicited letters from all parts of the country tell us of the farthest distant stations being brought in clearly and distinctly.

You, too, can enjoy the best programs if you own a Crosley Model XJ—Price only \$65.

Under actual tests, it has proven the most remarkable radio receiver ever offered to the public regardless of cost.

For Sale by Good Dealers  
Everywhere

**Crosley Manufacturing Company**  
POWEL CROSLY, Jr., President  
12492 Alfred Street, Cincinnati, O.



# Super-Triplex Selective Receiver Construction

## Part I—The Circuit

By H. J. Marx

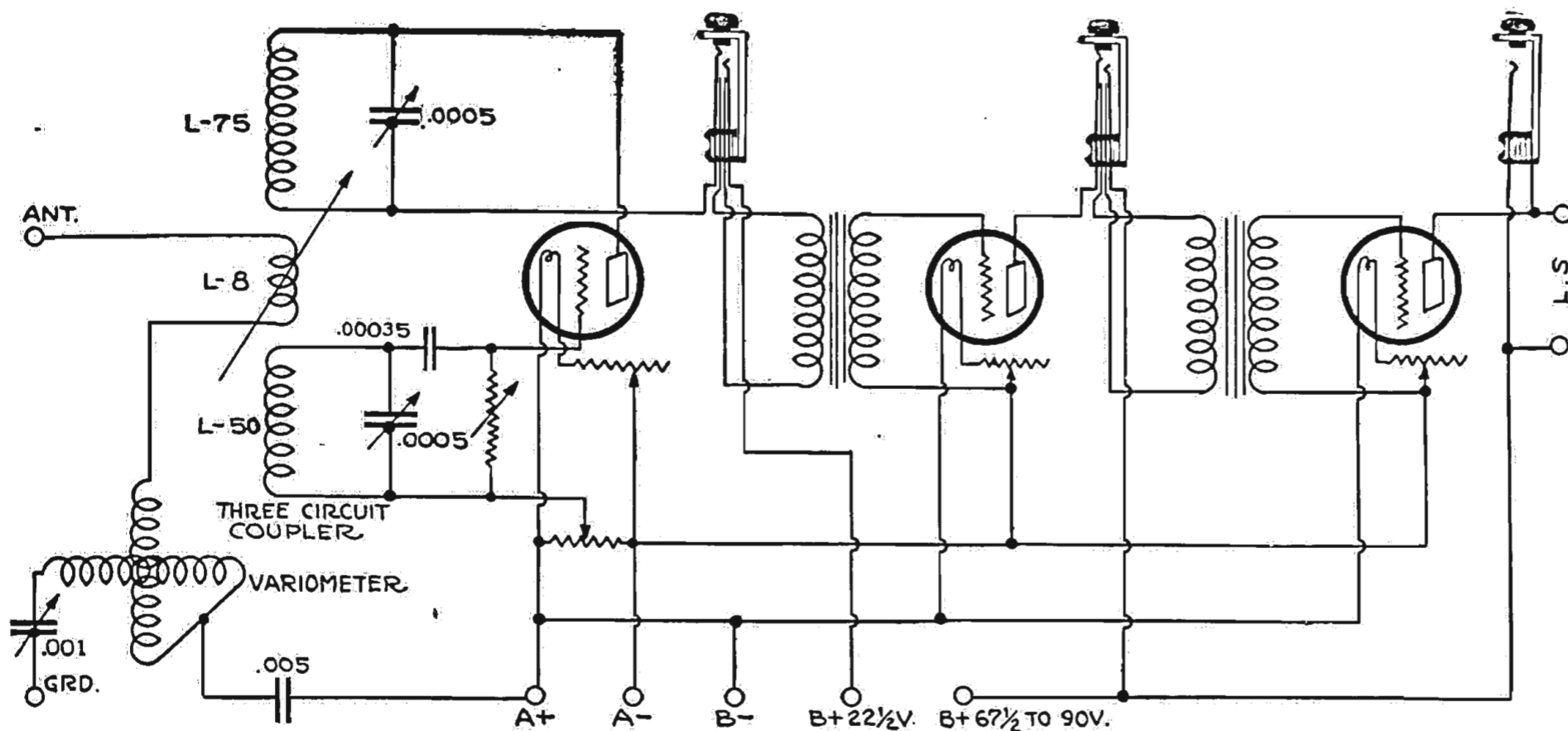

variable condenser across it; this is the 75-turn fixed winding on the coupler. The secondary consists of the 50-turn fixed coil and also has a .0005-mfd. variable condenser across it.

### The Primary Circuit

The primary circuit consists of three pieces of apparatus. The first is a .001-mfd. variable condenser on the ground side of a variometer followed by the 8-turn rotor of the three circuit coupler in series. The primary circuit is tuned by means of the variometer and the variable condenser, neither of which are unusually critical. The rotor of the special coupler permits a variable coupling between the antennae and balance of the circuits. This coupling is the means whereby unusual selectivity is made possible. Real efficient tuning, however, is entirely dependent on how well the operator becomes acquainted with handling this coupling control. He must learn to discriminate between stations and signals that require close coupling, and those where a loose coupling is of most advantage. That this coupling is effective is amply proved by the fact that even a strong local station can be cut out just (Continued on page 20)

HAVE you ever listened in on a long distance station and waited patiently for the call letters only to have one of the local stations suddenly open up with its introduction and drown out the other fellow? Exasperation but weakly expresses your feelings. Unfortunately it requires an unusual receiver to avoid this very common difficulty. In addition, in the attempt to overcome this, most often the volume of reception, in a simple form of circuit, is lost.

the remainder of the hook-up, or as in the Wizard Miloplex, the first circuit published, it may be concealed in the form of an integral part of the circuit. Regardless of its form or location in the circuit, the fact remains that selectivity is increased.

### Loop Aerial Kink

Only a short time ago the writer was operating with a loop aerial circuit. Naturally, as all tuning is centered in the loop condenser, selectivity is not entirely what it might be otherwise. The interference of one local station was so great as to entirely destroy the beauty of opera broadcasting from another station. As another loop aerial was on hand, the following experiment was tried out: A 23-plate variable condenser (.0005 mfd.) was shunted across the terminals of this second loop. No attempt was made to connect the second loop with the receiving circuit. It was set parallel to the loop on the set and as close as possible. As the interfering station was of a shorter wave length, the condenser across the second loop was set at maximum capacity and the set returned for the station desired. This entirely cut out interference.

Another procedure is to tune the set close to the interfering station before the second loop is placed into position; then

the second loop is put in and all the tuning is done with this condenser, leaving set tuning alone. This means of improvement of selectivity will be found very convenient in loop aerial reception. But where a tuning unit with an outdoor antennae is employed, we must go back to the first method.

### The Triple Circuit Coupler

Last week full details were given of the triple circuit coupler. This coupler is a special tuning unit combining a number of features developed for this circuit. The absorption coil, plate tuning coil or oscillating coil—call it what you want—is part of the plate circuit and has a .0005-mfd.

### LIST OF PARTS REQUIRED

- 1 Three-circuit Variocoupler.
- 1 Variometer.
- 1 Variable Condenser, .001 mfd.
- 2 Variable Condensers, .0005 mfd.
- 5 Dials, 3 inches.
- 1 Fixed Condenser, .005 mfd.
- 1 Fixed Condenser, .00035 mfd.
- 1 Variable Grid Leak.
- 1 Potentiometer.
- 1 Vernier Rheostat.
- 1 Double Rheostat.
- 3 Sockets.
- 2 Audio Transformers.
- 9 Binding Posts.
- 2 Double Circuit Jacks.
- 1 Single Open Circuit Jack.
- 1 Panel, 1/2 by 12 by 16 inches.
- 1 Sub-Panel, 1/2 by 16 by 6 1/4 inches.
- 1 Baseboard, 1/2 by 7 1/2 by 16 inches.

In building up the super-triplex, the four circuit tuner idea was first tried out and then discarded. The unusual success of the Miloplex circuits was due to the fact that a circuit commonly known as an absorption circuit was employed. It will be found that a circuit of this type always exists in any form of real selective hook-up. As in the Miloplex III, it may be a separate circuit with no connection to

### POST CARDS

A neatly printed post card for acknowledgment to broadcasting stations your reception of their entertainments. 2 dozen, 25 cents, postpaid. D. J. Spangler, Elkhart, Ind.

**UNOTROL**

\$ 11.90  \$ 11.90

### RECEIVER A Real One Tube Set

made of best material throughout. Mounted in high-grade mahogany-finished hinged-top Cabinet (as shown above).

**FULLY GUARANTEED**  
Wonderful Distance reported by Enthusiastic Owners  
Will Ship C. O. D.; postage paid east of Rocky Mountains

**AGENTS WANTED**  
To the Man Who Builds His Own: Write for our "BULLETIN OF RADIO PARTS AT BARGAIN PRICES." Standard Goods Only.

**Abalene Radio** 105 Audubon Ave. New York, N. Y.

**WE REPAIR YOUR VACUUM TUBES**

WD-11-12, UV-199, UV-201-A \$3.50 each  
C-301-A 2.75 each  
UV-200, C-300 3.00 each  
UV-201, C-301 3.50 each  
DV-6, DV-6-A 3.50 each

**ALL WORK FULLY GUARANTEED**  
Quick Service—Repaired Tubes shipped C. O. D.

**NEW TUBES**

A-399 (Type UV-199) \$4.10 EACH  
A-401-A (Type UV-201-A) \$4.10 EACH  
A-12 (Type WD-12) \$4.10 EACH

All the above Tubes guaranteed amplifiers and detectors. Shipped C. O. D., postage prepaid.

**Abalene Radio** 14 Vesey Street NEW YORK CITY

### The New METALELECTRIC SOLDERING IRON

Operates with the simplicity, ease & efficiency of a lead pencil on any electric current.

\$5.50

"WORTH IT"

**ACCEPTED** as the logical solution to Radio Soldering problems. An all-metal quality instrument with a worth-while guarantee.

Of your dealer or write

**Post Electric Co., Mfrs.**  
Dept. 509, 30 E. 42nd St. NEW YORK

**B-METAL**

The Crystal That Brought Joy to 100,000 Radio Users Last Season.

Sent on approval. Pay us when you are satisfied. That's how sure we are that it will please you. Just pass the good news on to a dealer so others may enjoy B-Metals too. Just send us the name of dealer who hasn't heard of B-Metal when remitting.

**50c**

**RADIO CRYSTAL**

The B-Metal type C fixed detector for your reflex set—try one and know

227 Oakmount Road, Toronto, Ont., Oct. 7th, 1923.  
B-Metal Refining Co., Detroit, Michigan.

**\$2.50**  
Dear Sirs:—Received your B-Metal Loud Talking Crystal and am more than satisfied with results obtained. Kindly find enclosed money order for 50c in payment for same. Yours very truly,  
J. B. LANGSTON.

**B-METAL REFINING COMPANY**  
3134 Trumbull Avenue, Detroit, Mich.  
Chicago Branch, 53 West Jackson Blvd.  
For Sale by All Dealers

**C REFLEX DETECTOR**

**World's Biggest Battery Bargain**

**FREE BATTERY FREE**

Hydrometer and "B" Battery FREE

**READ THIS SPECIAL CHRISTMAS OFFER. THEN ACT!**

Thousands of Radio Digest Readers will profit by this amazing offer. They will buy the famous 2-year guaranteed World Battery at the lowest price ever quoted. They will get a hydrometer and a "B" battery FREE. And they get the best battery built. It is "World" quality that makes possible our 2-year trouble-free guarantee. It is "World" quality that makes "World" owners "tell their friends." That's the best proof of performance any product can have.

**SEND NO MONEY**  
You need not send a penny. Just clip this ad and attach your name and address. The battery will be shipped to you the day your order is received. When the battery arrives, inspect it—read our 2-year guarantee before you pay one penny. Confine yourself to a protected from every angle—that the World battery price saves you 50%. Get the "B" Battery and hydrometer FREE. Order today.

**COMPARE THESE PRICES:**  
Special 200-hour Rechargeable Storage Batteries

2 Volt for WD-11 and 12 Tubes	\$ 5.00
4 Volt for UV-199 Tubes	5.00
6 Volt 60 Amp	5.50
6 Volt 80 Amp	10.00
6 Volt 100 Amp	12.50
6 Volt 120 Amp	14.50
6 Volt 140 Amp	16.00

5% Discount for Cash with Order.

**World Battery Co., Dept. L, 60 E. Roosevelt Rd., Chicago, Ill.**

**World** Send your order today.

**ROOT for RADIO!!**

Write for Our Bulletin

PHONES	PANELS (High Grade)
Baldwin-C .....\$8.25	7x10 .....\$ .75
Brandes ..... 5.25	7x18 ..... 1.35
Nerco ..... 2.75	7x24 ..... 1.75

RADION DIALS, 3", 30c; 4".....\$ .40

TRANSFORMERS	One Tube DX Set
All American .....\$4.00	SPECIAL FOR XMAS
Erla Reflex ..... 4.25	ORDER
Acme, Audio ..... 3.95	NOW .....\$15.00

We carry a complete line of standard parts and sets.  
Postage paid on orders of \$5.00 and over only.

**ROOT RADIO CO., Inc.**  
Dept. D. 2525 Broadway, New York



**SUPER-TRIPLEX**

(Continued from page 19)

...the coupling dial, although the remainder of the circuit may be very easily tuned to it.

**Type of Apparatus Required**

There are no set rules or restrictions on the type of apparatus required except that quality is essential. Occasionally we hear of a fan who gets Hawaiian Islands on a set constructed of 10-cent store apparatus. But don't take a chance that you are going to be one of the lucky fellows. If you're determined to make a receiving set of this type and want to feel positive that it will operate as efficiently as the original does, then save yourself a lot of trouble by purchasing and using only good apparatus. There are plenty of them on the market, and it requires no instructions as to what manufacturer's parts you should use. Fans have now reached that degree of experience that they can readily discriminate between good and bad.

Inasmuch as the three-circuit coupler was constructed of such type of winding as to give the lowest value of internal capacity, likewise it is recommended that the fan consider this in purchasing his variometer. The variable condensers should be of good quality, but vernier control is only required for the secondary. The vernier control rheostat is used on the detector tube. For the two amplifier tubes a double rheostat was used, consisting of two windings and two levers with a large and small knob in front for operating this receiver. This saved space and permitted a uniform layout, as will be noticed in the panel layout to be shown next week.

The potentiometer was a high resistance type similar to that required for the Miloslavskis circuits. This, however, is not essential except where dry cells are used for filament lighting.

A good quality variable grid leak is necessary. In glancing over the circuit an impression may be made that either the variable grid leak or the potentiometer is superfluous. Experimentation, however, did not indicate that it was wise to eliminate either.

(TO BE CONTINUED.)

**Hook-Up for Volume**

Condenser values are not very critical in this set but it is advisable to use those indicated. Coils may be varied. I use a 50-turn coil with 40 turns on the tickler. Spider web, honeycomb or a variocoupler

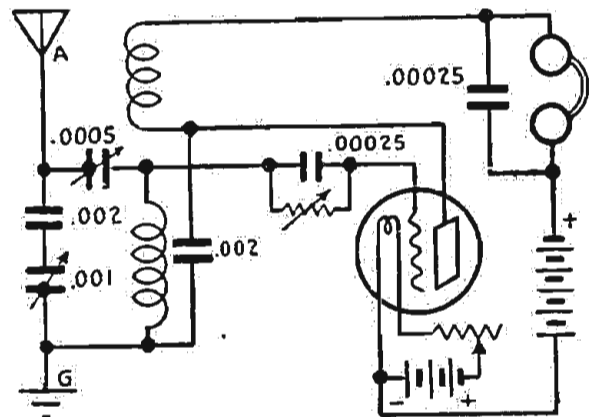

can be used. The coils may be made as follows: Primary 4 inches, and the tickler 2 1/2 inches in diameter. The secondary coil must be movable. It is best to tap the primary coil to get fine tuning. The grid leak is shown variable. After it is once fixed, it will be unnecessary to change it.—Bernard Smith, Denison, Tex.

**Radio Supplies at Cut Prices**

<b>CHARGERS</b>	
Handy (New Type).....	\$12.90
Homecharger.....	13.25
Genuine Tungar.....	15.75
<b>CONDENSERS</b>	
Crosley D.....	1.90
Bremer-Tully No. 23 Vernier.....	3.65
Bremer-Tully No. 43.....	4.39
New York Coil 11.....	1.19
New York Coil 23.....	1.45
New York Coil 43.....	2.25
Kellogg 11 Vernier & Dial.....	4.95
Kellogg 23 Vernier.....	5.65
Kellogg 43 Vernier.....	6.45
<b>COUPLERS AND VARIOMETERS</b>	
Kellogg Couplers.....	5.95
Kellogg Variometer.....	6.45
Dayton Fan Coupler.....	5.95
Dayton Fan Variometer.....	5.45
<b>PHONES</b>	
Western Electric.....	8.50
Baldwin.....	8.45
Blue Streak.....	3.39
Little Tattler.....	2.79
Frost 5000.....	2.85
<b>LOUD SPEAKERS</b>	
Dictogrand, New.....	19.75
B-3 Magnavox.....	24.75
M-1 Magnavox.....	24.80
A-1-B Magnavox.....	32.50
Western Electric 10-D.....	39.50
Western Electric 10-A.....	19.75
Western Electric Victrola Unit.....	7.65
<b>BATTERIES</b>	
Burgess No. 2156, 22 1/2 Volt, Large Size.....	1.85
Burgess No. 5306, 45 Volt, Large Size.....	3.45
Red Seal No. 6.....	.35
<b>TRANSFORMERS</b>	
Acme.....	3.69
All American (All Ratios).....	3.69
Federal, New Style.....	5.19
Bremer Tully Neutroformer.....	1.39
Dayton Fan.....	3.97
<b>RHEOSTATS</b>	
Jenkins Vernier, 8.5 or 30 Ohm.....	1.29
Pacont, 20 Ohm.....	.73
Dayton Fan, 30 Ohm.....	.63
Marco Vernier.....	1.19
Crosley Multistats.....	.63
<b>MISCELLANEOUS</b>	
Bus Wire, Sq. Tinned, 2 Ft. Lengths.....	.03
Spaghetti, 3 Ft. Lengths.....	.06
UV-199, 201A, WD-12, WD-11.....	5.10
UV-200.....	4.10
<b>CROSLLEY</b>	
Precision Ace.....	14.95
Crosley VL.....	21.25
Crosley XJ.....	48.75
Crosley XX.....	73.50

WRITE FOR AGENTS' PRICE LIST  
VALLEY RADIO SUPPLY CO.  
2206 Locust Street ST. LOUIS, MO.

**Calculating Current Flow**

**Finding Amperage in Circuit**

In Figure 1 is shown a simple circuit containing a battery and a resistance connected in series. For the sake of simplicity, the resistance of the connecting wires will be neglected. If the resistance and the voltage produced by the battery

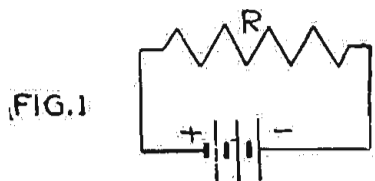

is known, all that is necessary to determine the quantity of current flowing in the circuit is to substitute the proper values in Ohm's equation. If the battery is a 6-volt battery and the resistance is 2 ohms, the solution for I will give us 3 amperes as the current flowing in the circuit.

**Complicated Circuits**

In Figure 2 a more complicated circuit is shown. Here several devices have been connected into the circuit in various arrangements of series and parallel. These resistances may represent various electrical instruments—lamps, heating elements and others.

The source of current is capable of furnishing a pressure of 100 volts.

In calculating the amperes flowing through the circuit, it is necessary to know the total resistance in it. The first step is to reduce those resistances which are connected in parallel to the value which a single resistance connected in their place should have to produce the same effect. In a water system this would amount to the same thing as substituting one pipe for three pipes.

**Resistance in Parallel**

When several resistances are connected in parallel, their total resistance is equal to the reciprocal of the sums of the reciprocals of the individual resistances. The reciprocal of a number is merely 1 divided by that number.

The sum of the reciprocals of the resistances between points a and b in Figure 2 is 1/2 plus 1/5 plus 1/10, or 3/10, the reciprocal of which gives 1.25. By using the same process, the resistance between points c and d is found to be 12/5 or 2.4 ohms.

We can now reduce this circuit to that shown in Figure 3 by substituting the above values for the various resistances shown in Figure 2.

Since the resistance of several resistances connected in series is equal to the sum of the resistances, the total resistance of the circuit of Figure 3 is equal to 23.65 ohms.

The current flowing in the circuit is therefore  $\frac{100}{23.65}$  or approximately 4.23 amperes.

It might be mentioned here that in all calculations where accurate results are desired, the answer should be left in

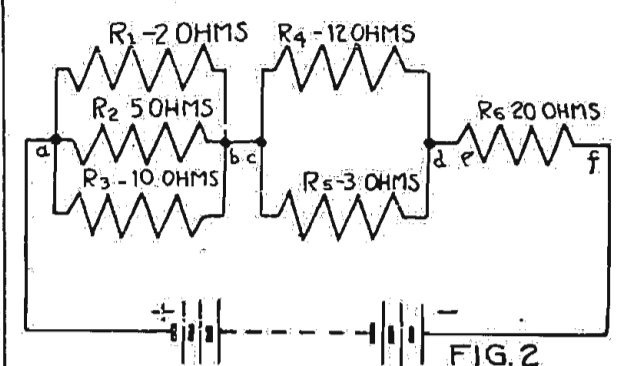

fraction form when the number is to be used in further calculations.

**Current Through Each Branch**

In flowing through the circuit shown in

**BUY DIRECT**  
SAVE DEALERS AND JOBBERS PROFITS  
WD-11, WD-12, UV-199, UV-201A \$5.43  
Radiotron Vacuum Tubes.....  
Branded "SUPERIOR" Phones.....\$4.76  
Battery Charger with  
"Tungar" Bulb.....\$9.38

**VARIABLE "B" BATTERIES**  
22 1/2 Volt.....\$1.24 45 Volt.....\$2.97

**VARIABLE CONDENSERS**  
11 Plate Regular.....\$1.28 11 Plate Vernier.....\$1.89  
23 Plate Regular.....1.44 23 Plate Vernier.....2.19  
43 Plate Regular.....1.59 43 Plate Vernier.....2.58

**AUDIO TRANSFORMERS**  
All-American (All Ratios).....\$3.82  
Jefferson "Star".....2.59  
Erie—3 1/2 to 1 and 6 to 1.....3.96  
Duplex "Push Pull" Type.....9.95

SEND FOR COMPLETE LIST  
Terms: Cash with Order or C. O. D.  
**SIMPLEX RADIO SUPPLY CO.**  
1806 Lafayette Avenue ST. LOUIS, MO.

Figure 2 the current divides in flowing through the divided circuits. The current flowing through each branch of a parallel circuit is inversely proportional to the resistance of the branch. In other words, a greater current flows through the lower resistance than through the higher resistance of a parallel circuit such as that between points a and b of Figure 2. To find the current flowing through each branch it is necessary to find the voltage across the terminals of each resistance, and then, knowing the voltages and the resistance, calculate the amount of current flowing through that particular resistance.

Although the current flowing between a and b divides and flows through resistance R<sub>1</sub>, R<sub>2</sub> and R<sub>3</sub>, we know that the total current flowing is  $\frac{100}{23.65}$  amperes. The voltage across ab therefore, by Ohm's law, is equal to the total resistance multiplied by the current, or

$$\frac{100}{23.65} \times 1.25 = \frac{125}{23.65}$$

or approximately 5.3 volts.

(Continued on page 21)

**Improved Ground Clamp**

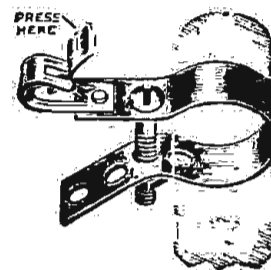

Equipped with Fahnestock Patent Wire Connectors

Easily Attached

No Soldering. For Radio Use Only

At Your Dealers

**Fahnestock Electric Co.**

Long Island City, N. Y.

**TRIGGER OF NEW YORK RADIO**

EVERYTHING SOLD ON MONEY-BACK GUARANTEE. WE HANDLE NO BOOTLEG MERCHANDISE.

<b>COCKADAY COMPLETE PARTS GUARANTEED \$12.50 ASSEMBLED \$17.50</b> Add \$2.50 to each for Cabinet	<b>ERLA REFLEX 3 TUBE BEST OF PARTS \$45.00 ASSEMBLED \$67.50</b>	<b>COCKADAY 3 TUBE Unassembled \$32.50 INCLUDE CABINET ASSEMBLED \$42.50 DISTANCE VOLUME SELECTIVITY</b>	<b>LOUD SPEAKER Bristol .....20.00 Atlas .....18.00 Magnavox ..30.00 Mercury .... 6.00 Music Master .....26.00</b>
---	---	--	--

Indoor Aerial.....\$1.75	Baldwin's Original.....\$8.50
Hydrometer......50	Jefferson Transformer.....2.75
Voltmeter, 50 Volts.....1.65	American Transformer.....5.50
Freshman Variable Grid and Leak......70	Acme Transformer.....4.25
Remler Moulded Variometer.....4.00	Wave Trap.....7.00
Fred-Eisemann 180° Coupler.....2.00	D. C. Charger.....5.75

We carry a complete line—from screws to sets.

You can purchase with an absolute guarantee. We carry no factory seconds or salvage merchandise. Goods shipped immediately. Please be sure to include postage on orders under \$10.00.

**TRIGGER OF NEW YORK**

160 EAST 59TH STREET, NEAR THIRD AVENUE, NEW YORK CITY

**LATEST, MOST EFFECTIVE RADIO "A" BATTERY**

SEND TODAY

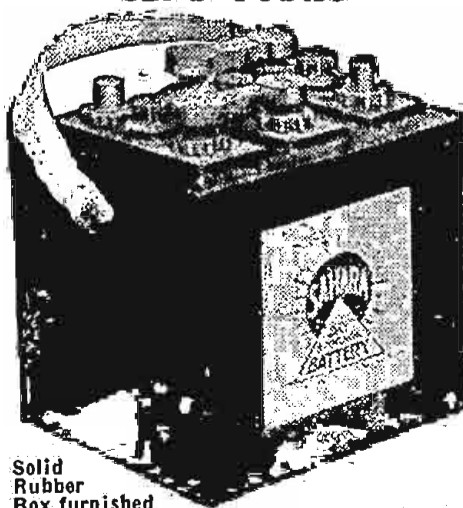

**Sahara Storage Battery—It's Dry**

Think of its advantages. There is no liquid acid to spill and ruin floors, rugs or creep up posts and ruin clothes—ideal for portable sets. Recharges quickly—easily—and cannot be harmed either by overcharging or drawing down too far. These exclusive features are what you want. We guarantee them. It is not a gelatin battery. It's dry and "chock full" of pep and life. Be the first in your town to have one of these remarkable batteries.

**Order Today—Send no Money**

We ship C.O.D., subject to your inspection, carrying charges to be paid by you. The price is \$25 if you order at once. Shipments made same day order is received. Remember there is no liquid—It's Dry. Orders are coming in fast. Get yours in today.

**SAHARA DRY BATTERY CO.**

Dept. A, PAWTUCKET, R. I.

DEALERS: There is a big business for you if you show this battery now. Send for discounts and get exclusive rights in your territory.

**Radiola Loud Speaker**

Model U. S.-1320  
Price \$36.50



**RADIOLA LOUD SPEAKER**

New—a loud speaker that brings music to the crowd as true and clear as one man gets it on the headphones. Nothing is lost—for its wide range gets all the overtones and partials. Nothing is added, for its horn is correct acoustically. The clear, rich tone of voice or instrument—pure and undistorted—with a knob to adjust the volume of tone at a touch. Have you heard it?

**Radio Corporation of America**

Sales Offices: Dept. 3602  
233 BROADWAY, NEW YORK  
10 S. LA SALLE ST., CHICAGO, ILL.  
433 CALIFORNIA ST., SAN FRANCISCO, CAL.

**Radiola LOUDSPEAKER**



# Multitone Circuit Operates Speaker

## Negative Reactance with Untuned Plate Circuit

A simple one or two-tube circuit which will operate a loud speaker with good volume is shown in the illustration. An untuned plate circuit is used, employing a hard tube, such as UV-201A, and

## CIRCUIT WITH ONE STEP A. F.

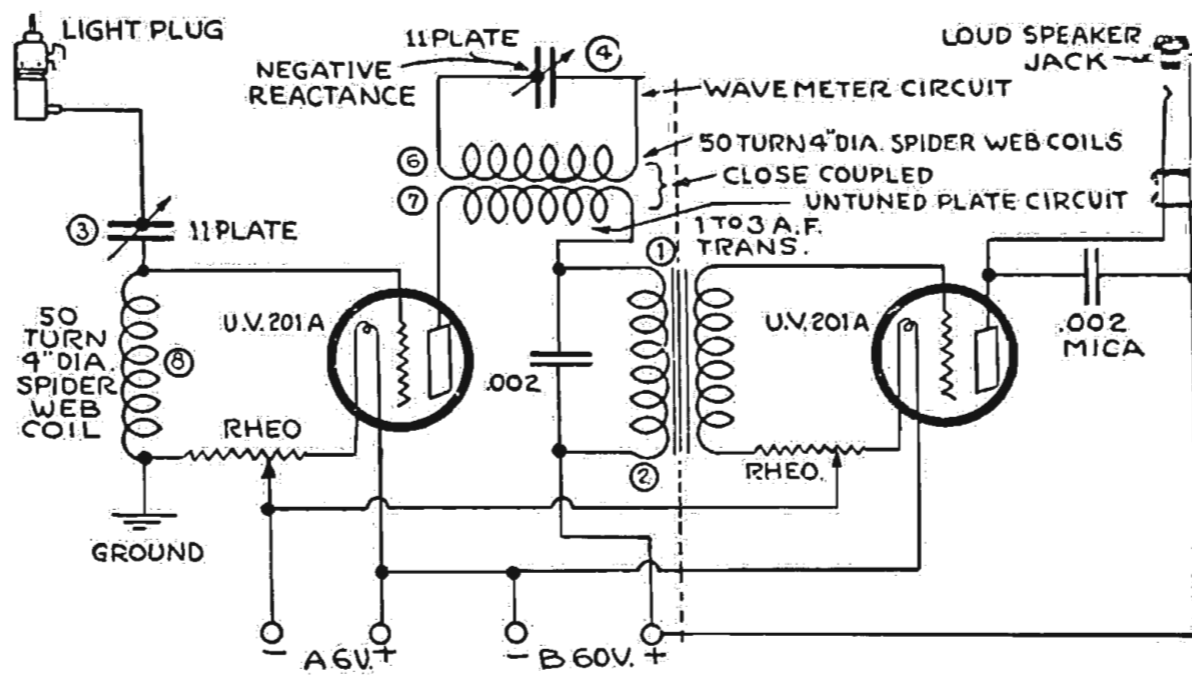

## WORKSHOP KINKS? EARN A DOLLAR—

THERE are many little kinks worked out at home that would aid your fellow Radio worker if only he knew about them. There are new hook-ups, new ways of making parts and various unique ways of operating sets that are discovered every day. Radio Digest is very much interested in obtaining such material. Send them in with full details, including stamped envelope, so rejected copy may be returned. The work must be entirely original, not copied. RADIO KINKS DEPARTMENT, Radio Digest, 123 W. Madison St., Chicago

amplification is obtained in a wavemeter circuit employing the principle of negative reactance.

Figure 1 shows the new circuit with a one-step audio amplifier added in place of phones at terminals 1 and 2. The set is easy to wire and inexpensive. It uses three 50-turn spider coils, 4 inches in diameter and wound with Number 24 ssc. wire, and two 11-plate condensers. No grid leak condenser is required. The set operates well on an indoor lighting socket plug, with input to loud speaker of Magnavox type. The antenna condenser and coil should be located at least 12 inches away from the wavemeter circuit, as coupling between these two parts of the circuit is detrimental. The two other spider coils are coupled closely. In use, 60-volt plate current is employed, and tuning is accomplished with antenna condenser 3 as usual, leaving condenser 4 of the wavemeter circuit at zero or other quiet position. The wavemeter circuit condenser, 4, is then turned up slowly until maximum amplification without squeal is obtained. It is also possible to use both dials for very sharp tuning to avoid local broadcasting. This is an economical set to build and operate, where loud speaker results are desired. The circuit is protected by patent rights and is distinguished from others in principle and performance. The inventor has no objection to private experimenters making non-commercial sets of this kind for their own private pleasure, but no manufacturing. The coils 6 and 7 should be at right angles to the coil 8, to avoid coupling.

Operation is obtained much on the principle of a vibrating water pipe which is started by a slight air leak in valve. The 60-volt B battery acts as the water pressure, and the wavemeter circuit causes the plate circuit to amplify without reference to the rest of the circuit, which can even be detuned therefrom considerably, if desired.—P. Edelman, St. Paul, Minn.

If you have a sewing machine motor and are bothered with noises in your set, find out whether the motor is running.

## "Kilocycle" Defined

In Radio, "kilo" means a thousand, and "cycle" means one complete alternation. The number of kilocycles indicates the number of thousands of times that the rapidly alternating current repeats its flow in either direction in the antenna in one second. The smaller the wave length in meters, the larger the frequency in kilocycles.

## CURRENT FLOW

(Continued from page 20)

This is called the voltage drop, or drop in potential across the resistance. Knowing this voltage across the terminals of the resistances between a and b, we can calculate the current flowing in any of the branches of the resistance group. If we

take R, for instance, to find I, we divide the voltage across the terminals,  $\frac{125}{23.65}$ , by

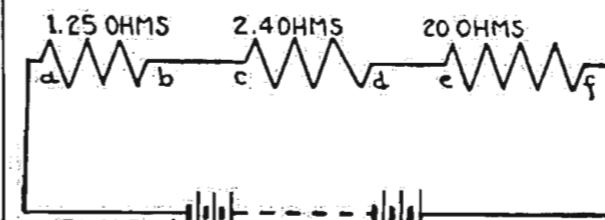

the resistance of the element, 2, and get 125

47.3

The contents of any other part of the circuit can easily be found in the same manner.

## Positive Results

ARE ASSURED WITH

Eastern Coil Sets for the COCKADAY CIRCUIT

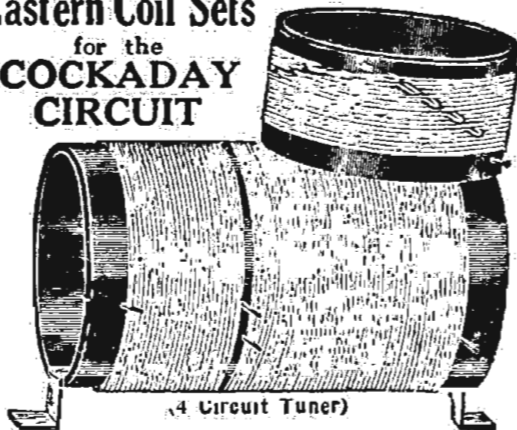

Now a standard, and in universal use, due to their efficiency in this wonder circuit. Made as per specifications of Mr. Cockaday, using No. 18 wire with D coil bank-wound

Complete Assembled Set of B, C and D Coils..... \$2.75

Hook-up directions and material list furnished free with each set of coils.

Mail Orders Filled. Dealers Communicate EASTERN RADIO MFG. CO. 22 Warren Street, Dept. R. D., NEW YORK, N. Y.

GENUINE EDISON ELEMENTS (new) for making "B" Batteries, obtained from U. S. Government. A positive and negative element—6c; glass tube—3c; all other parts at reasonable prices. Postage, etc., 50c extra per order. Free instructions. TODD ELECTRIC COMPANY, 109 West 23rd Street, New York.

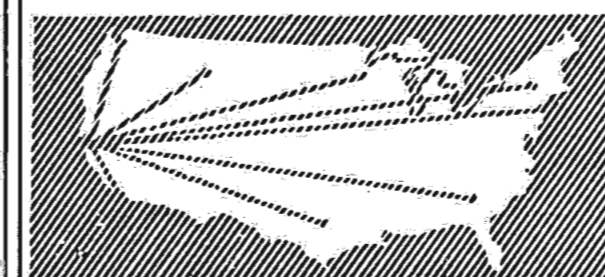

## ON ONE TUBE

Broadcasting from Atlantic Coast and Cuba heard in Calif. by users of the CROSS COUNTRY CIRCUIT. This range due to simplicity of set, and operation by one tuning control. Easy and cheap to build by any novice. Dry cell tubes may be used. Complete understandable instructions, full size blue print panel layout, assembly photo, etc., postpaid 25c; stamps accepted.

## VESCO RADIO SHOP

Box D-117 Oakland, Cal.

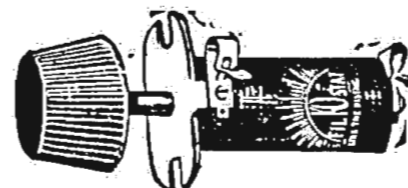

## MISSING WHAT YOU GET

YOUR set is probably bringing in DX stations you never hear because your rheostat cannot control your filament action. The Fil-Ko-Stat gives infinite adjustment and enables you to magnify the weak stations and bring them in strong and clear.

Full resistance 30 Ohms, adjusted to ALL TUBES. \$2 At All Dealers in High Grade RADIO SUPPLIES

"Avoid the use of inferior powdered carbon rheostats."

## FIL-KO-STAT

Made and Guaranteed by Dx Instrument Co., Harrisburg, Pa. Sole International Distributors. Radio Stores Corp., 218 W. 34. N. Y. City

## Strong B Battery with an A Battery Charger

Many Radiophans undoubtedly have storage B batteries that they have tired of keeping charged and in shape by the use of the electrolytic or chemical charger. The writer used one for a year until a month ago with no end of trouble. It is messy, inefficient and very bothersome. Finally, when my batteries would no longer take any charge at all, I tried using the two ampere rectifier. At first I tried charging six cells at a time. Of course this was too much and they started to boil. Then I tried twelve cells and watched them for several minutes and nothing happened. After charging them in this manner for a half hour I tested the battery and it registered 30 volts. It takes about 15 hours this way to bring a dead battery to full charge.—F. W. Lovgren, Virginia, Minn.

There are several types of crystal detectors, some of which are good and others are not. Get several and compare.



(Patent Pending) THE PERFECT SYNTHETIC CRYSTAL DETECTOR, SENSITIVE OVER ENTIRE SURFACE. No Hunting for "Spots." Loud and Clear. Endorsed by thousands of satisfied users. Sensitiveness Guaranteed. Price, Mounted..... 50c

14 K. GOLD SUPERSENSITIVE RUSONITE CATWHISKER. Permanent. Will Not Oxidize. Price..... 25c

RUSONITE REFLEX CRYSTAL. Manufactured Expressly for Reflex Circuits. Will Stand Up Under Heavy Plate Volt-100v. Guaranteed. Price, Mounted..... \$1.00

Order from your dealer or direct from RUSONITE PRODUCTS CORP. 15 Park Row New York, N. Y.

## CARTER "HOLD-TITE" Jacks



Perfect contact with plug always assured; Self-adjusting lock nut eliminates spacer washers.

PHOSPHOR-BRONZE SPRINGS (Low Resistance) INSULATION WESTINGHOUSE "MICARTA" (No Leakage) CONTACT POINTS PURE SILVER (Self-Cleaning)

"IMP" Cord Tip Jack 35c

Replaces binding posts for head conl. Can be used with standard cord-tips or "IMP" plugs.

Ask your dealer. Catalog of other new Carter Improved Radio Products on request.



## VERNI-TUNER

(Trade Mark) 3 in 1 Primary, Secondary and Variable Condenser NO TAPS NO INTERFERENCE

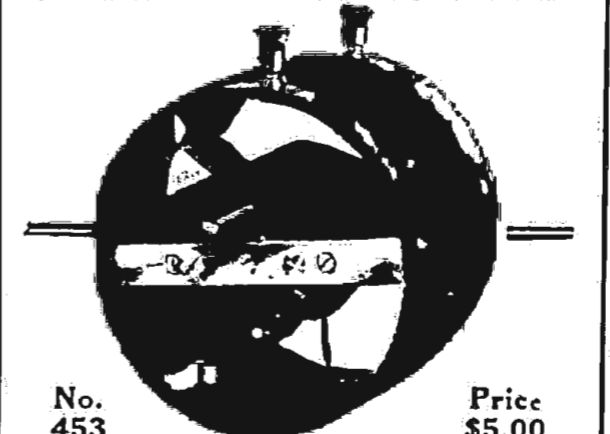

No. 453 Price \$5.00

Indispensable for Construction of Radio Sets Just add a rheostat and socket and you have a complete regenerative set. MOST SELECTIVE TUNER MADE Saves Labor—Space—Money Serves as the main tuning device for a regenerative circuits, reflex circuits and the Horne "Combined tuned radio frequency and reflex" circuits. Other units for Reinartz, Cockaday and other circuits. Booklets of 14 circuits free with each device. At your dealer or postpaid on receipt of purchase price. Write for leaflet. HORNE ELECTRIC & MFG. CO. Mercer & Colgate Sts. Jersey City, N. J.

Natural Re-PRODUCTION

Atlas AMPLITONE LOUD SPEAKER

Atlas Loud Speaker re-PRODUCTIONS are absolutely true to the original. The patented "double diaphragm" responds to every vibration intensity. Adjustable to your set and particular receiving conditions. Ask your dealer for a demonstration

\$25

Write for Booklet "R"

What have you accomplished with your Atlas Amplitone? Tell us about it.

Multiple Electric Products Co. Inc. ORANGE ST. RADIO DIVISION NEWARK, N. J.



# Questions and Answers

**Four Circuit and Neutrodyne**  
(5144) HVS, Columbus, O.  
Has a way yet been found to add R.F. to four circuit tuner?

Can the Neutrodyne method be added to the above?

Would you say the neutroformers had best be purchased or can they be home-made with good results?

What is the cause of only being able to receive when two taps are touched and nothing received when either are touched singly?

What is the proper brilliancy of 201-A tube when the full resistance of a 6-ohm rheostat is used?

If you were to use the process of elimination, where would you place the following for all-around broadcast reception: Neutrodyne, four circuit tuner or reflex?

Which would you advise one to build?

A.—Answering your inquiry we do not believe the employment of Radio frequency amplification with four circuit tuner will prove advantageous.

It would not be practical to use the Neutrodyne principle with the above circuit.

Neutroformers are not difficult of construction and could be made at home undoubtedly, but in view of patents we do not furnish details.

Five ohms' resistance is used with a 201-A tube. A 6-ohm rheostat can be used when turned about one-fifth on.

We are recommending the Reflex, Neutrodyne and Cockaday circuits comparatively in the order given.

A diagram showing method of adding two stages of audio frequency amplifica-

tion to circuit submitted appears on page eleven of July 21 issue of Radio Digest as Figure 44.

**RD-No. 95**

(5260) KC, La Crosse, Wisc.  
I would appreciate your answering the following questions regarding R. D. circuit No. 95:

Can a WD-11 tube be used with reasonable success?

Is the choke coil an iron core choke coil?

How can an outside aerial and a ground be used with this circuit?

Can two variometers of different sizes be used?

I shall use a 3 1/2 to 1 ratio Thordarson transformer. Will it give good results?

Please give me some data on the construction of a sensitive loop aerial to be used with this set.

Will the addition of a step of A. F. amplification make the use of a loud speaker possible?

A.—Answering your inquiries we are advising that a WD-11 tube will function with efficiency considering the current consumption.

Choke coil indicated is of the iron core or audio frequency type.

An outside antenna system can be employed merely by substituting a variocoupler for loop and making primary connection in the usual manner.

Variometers of different sizes can be used, if desired.

Three and one-half to one ratio transformer will be all right.

An efficient loop is accomplished in ten turns of flexible wire on a 3 foot square frame. Space wires at 1/2 inch.

Addition of one stage of audio frequency amplification will permit operation of a loud speaker.

**High Ratio Transformers**

(5176) FWC, Nebo, Ill.

I have an audio amplifier with two 9 to 1 ratio transformers. It gives pretty good results. The Western Electric Co. puts out transformers with much smaller ratio. What is the difference? Will the higher ratio transformers give better results than those with small ratio?

A.—Answering your inquiry, we are advising you that usually transformers of 10 to 1 and 3 to 1 ratio are recommended on first and second stages, respectively, in audio frequency amplification. The general experience is that with higher ratios distortion will occur. If you do not encounter this difficulty, there will be no other disadvantage in using those of 9 to 1 ratio.

What You Want. Everybody Likes It. A Fine Gift.

**"Where I Go By Radio"**

Handy, Unique and Complete Record Book Which Enables You to Keep for Reference When, Where and How You "Listened In" and What You Heard.

Special Features: Space for Recording Scores of Stations You "Pick Up." Every Line making an easy record of date, hour, weather conditions, station Call Letters, Location, Kind of Program, "Tuning In" combination, etc., by using Special Copyrighted Symbols; Pleasure of Keeping Records: How to Find Out Distances; How to Get Best Service; Call Letters of all Stations in United States, Canada, Cuba, etc.

Just What You Are Looking For. No More Scraps of Paper With Notes About Your "Pick Ups." Everything Kept in Convenient, Permanent Form. Great Ideal Every "Ra-Owl" and Housekeeper Endorse It.

Send \$1.00 Bill, Check or Money Order at Once and Get 2 Copies "Where I Go By Radio." Present Edition Only 50 Cents a Copy.

RADIO BOOK DEPT., PROGRESS PRESS, Union, S. C., U. S. A.

Please mail us names and addresses of all "Ra-Owls—The Wise 'Birds' Who 'Listen In' at Night."

**What About It?**

Isn't it about time to stop experimenting with multiple control circuits and build one that, combining ease of assembly and operation, loudness, clarity and selectivity of signals, as well as beautiful appearance, is excelled by none?

**THE ELGIN SUPER-REINARTZ RADIO RECEIVING SET**

Embodies all the advantages of the well known Elgin Reinartz (the set which was largely responsible for the popularity of this wonderful circuit) and many others. It is much louder, more selective, requires no storage battery, and can be used with excellent results on a short or loop aerial. It has brought in California stations two thousand miles from Elgin, clearly and without interference on a loud speaker with only one tube, and that while our powerful local station was broadcasting three miles away.

Could you ask for more? Write for circular giving one, two and three bulb hook-ups of this remarkable circuit. IT IS FREE.

ELGIN RADIO SUPPLY CO. 207 East Chicago Street ELGIN, ILLINOIS

**HAVE YOU SEARCHED FOR**

- Trips Circuit Tuner Units
- Aeriola Sr. Style Tuner Unit, 150-500 Meters
- Hi-Power Transformer with Split Tapped Winding
- Neutralizing and Tuned R. F. Cir. Transformers
- Reinartz Coils "New Static Reduced Winding"
- Resonance Wave Coils for Static Elimination
- Wavemeter and Wave Trap, Combined 150-600 Meter
- Edison (Signal Corps) Batteries and Elements
- New "Handy" Chargers for Any Voltage Battery
- 30 Henry Power Amplifier Chokes with 4 Valves
- Hi-Power Transformer with Variable Ratio
- "B" Bat. Protectors, Prevent Filament Burnout
- "B" Battery Voltmeters, 0-50 Volts
- Nathaniel Baldwin New Loud Speakers and Phones
- 200-300-400-500-600 Ohm Potentiometers
- 6-10-30 Ohm and "Universal" Rheostats
- Rheostat and Potentiometer Resistance Windings
- Bishop "Phantom Super" Tuner Units
- Variable Condenser Plate Cleaner
- Liquid Copper for Shielding Panels
- Quality Precision Var. Grid Leak, 0-10 Meg's
- Resla Core Solder (Never Use Acid or Paste)
- Hi-Quality Mica Fixed Condensers, Best Made
- Outfits of Parts for Any Circuit You Desire
- SEND FOR NEW DEALERS' LIST

QUALITY RADIO SHOP, Richmond, Ind.

**YOU DON'T NEED TUBES**

to hear concerts from distant cities. YOUR CRYSTAL SET will bring them in if you buy my plans and follow them. PEOPLE USING MY METHODS hear programs clearly from stations 400 TO 1000 MILES AWAY. No tubes, batteries or amplifying apparatus required. It may cost LESS THAN A DOLLAR to perfect YOUR set. EVERYTHING CLEARLY EXPLAINED in my copyrighted instructions selling for \$1.00. SATISFACTION GUARANTEED. Picture of my set and circular matter FREE. WRITE ME TODAY.

LEON LAMBERT  
501 South Volusia Wichita, Kansas

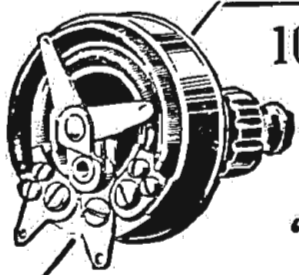

**100% EFFICIENCY**  
FROM YOUR TUBES with a PREMIER "MICROSTAT" (Trade Mark) SUPER-VERNIER RHEOSTAT

**\$3.00** and worth it.

THERE is no substitute for the Premier "MICROSTAT"—no other instrument that gives such perfect control of the current delivered to the filament of radio tubes. New principle—two windings in parallel; one 6 ohms, other 40 ohms. Absolutely noiseless. Infinite control—handles any tube. Capacity 3 amperes. Bakelite moulded—silver etched dial. Do not install a rheostat until you know all about the "MICROSTAT." Our Bulletin No. 90 explains it in detail. Send for it. It's FREE.

Ask for and insist on "MICROSTAT" at your dealer's.

Premier Electric Company  
3810 Ravenswood Ave. CHICAGO, ILL.

**TUBES \$5.55**

UV-199, UV-201A, WD-11, WD-12, DV-6

- Guaranteed Firsts in Original Packages
- ELECTRIC SOLDERING IRON, A.C. or D.C. \$2.28
  - \$5.00 Eria Reflex Transformer, No. 1 or No. 2. 4.68
  - 5.00 Eria Audio Freq. Transformer, special. 4.75
  - 4.75 All-American Transformers, any ratio, special. 4.12
  - 6.00 Manhattan Double Headphones. 3.95
  - 8.00 Brandes Superior Phones. 4.95
  - 3.00 Large 22 1/2 V. B Batteries, standard make. 1.93
  - 6.00 Large 45 V. B Batteries, standard make. 3.65
  - 6.50 Moulded Bakelite Variometers, split circuit. 4.85
  - 4.50 22 Plats Vernier Condens. .0005 mf. with dial. 2.95
  - 8.00 All-Wave Coupler, 150-5000 meters. 5.45
  - 180° Silk Variometers or Couplers. 1.50
  - Special Rheostats, 6, 20, or 40 ohms. 1.48
  - Rush Your Orders—Send for Free List—We Pay the Postage—Remit by Money Order

ROBERTS RADIO COMPANY  
138 N. La Salle St., Dept. 101, CHICAGO, ILL.

**RADIO BARGAINS**

REAL VALUES and the best of Merchandise. OUR PRODUCTS ARE GUARANTEED. We enable you to keep the cost of the building and upkeep of your set at the lowest figures and offer you only the most scientific and reliable products.

- SAVE ON RADIO**
- VARIOCOUPLER—180° Bakelite tubing, green silk wire. \$ 2.95
  - MOULDED VARIOMETER, green silk wire, special. 3.45
  - VARIOCOUPLER—180° Jaco special. 1.45
  - VARIOMETER—180° Jaco special. 1.45
  - VERNIER CONDENSER, 23 plate. 3.25
  - TRICOID REFLEX TRANSFORMER (Specify tube used). 1.85
  - UNITED AUDIO FREQUENCY TRANSFORMER, 5 to 1 ratio. 3.45
  - MAGNAVOX Loud Speaker. 29.75
  - HEAD PHONES, Long Distance. 4.95
  - 22 1/2 VOLT BATTERY. 1.45
  - PHONE PLUG, Special. .39
  - UV 199 SOCKETS. .69
  - ELECTRIC SOLDERING IRON. 2.45
  - RHEOSTATS 6, 20 or 40 ohm special. .48
  - POTENTIOMETER, 2000 or 4000 ohm. .69

We offer this extraordinary opportunity to buy your radio supplies at unheard of prices. Take immediate advantage by ordering TODAY. Send money order, cash or check.  
JACKSON RADIO COMPANY  
Dept. 121B, 639 W. North Ave., Chicago, Ill.  
For other bargains, write for our RADIO BULLETIN

**DUPONT PYRALIN SHELSTONE**

Loud Speaker With Nath. Baldwin Head Set Type C Perfect Results



Shelstone is made of Dupont's Pyralin, is transparent and one of the most attractive Loud Speakers on the market.

It is built differently to take advantage of the most correct acoustic principles and reproduces music and speech with a clear tone.

Loud Speaker with phones .. \$15.00

Loud Speaker postpaid . . . . . 3.00

Satisfaction guaranteed. C. O. D. or cash with order. Dealers write for discounts.

THE SHELSTONE COMPANY  
185 Clinton Avenue NEWARK, N. J.

**WD-11 and WD-12 Tubes Repaired**

- WD-11 or WD-12 . . . \$3.50
- C-300 or UV-200 . . . 2.75
- C-301 or UV-201 . . . 3.00
- C-302 or UV-202 . . . 3.50
- C-301A or UV-201A. 3.50
- Moorehead Detectors. 2.75
- Moorehead Amplifiers. 3.00
- DV-6 or DV-6A . . . . 3.00
- UV-199 or C-299 . . . 3.50

All tubes guaranteed to work like new

Mail Orders Given Prompt Attention "24 Hour Service"

Tubes Sent Parcel Post, C. O. D.

RADIO TUBE CORPORATION  
70 Halcey St., NEWARK, N. J.

**C-299 Tubes**

(05869) GG, Gifford, Ia.

Will six UV-299 vacuum tubes give better results when used in the Miloplex receiver than when used in a single or three circuit regenerative set?

A.—The C-299 tube will function with equal efficiency in either type of circuit.

Nearly 100 percent of Radio troubles is not knowing how to tune. Tuning the dials at random is only a hit-and-miss way.

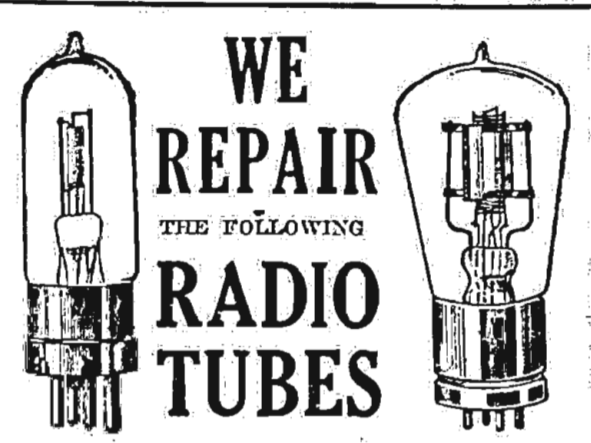

**WE REPAIR THE FOLLOWING RADIO TUBES**

Dealers and Agents write for Special Discount Mail Orders Solicited and Promptly Attended to

WD-11 {	OUR SPECIALTIES	{ 5 WATT
WD-12 {		TRANSMITTERS
UV-199 . . . . .	\$3.50	C-299 . . . . . \$3.50
UV-200 . . . . .	2.75	C-300 . . . . . 2.75
UV-201 . . . . .	3.00	C-301 . . . . . 3.00
UV-201A . . . . .	3.50	C-301A . . . . . 3.50
WD-11 . . . . .	3.50	WD-12 . . . . . 3.50
DV-6 . . . . .	3.00	DV-6A . . . . . 3.50
UV-202 . . . . .	4.00	C-302 . . . . . 4.00
UV-299 . . . . .	3.50	

H. & H. RADIO COMPANY  
P. O. Box 22-A  
Clinton Hill Station NEWARK, N. J.

**You Must Use**



**RHEOSTATS**

to get the best possible results from your set —no matter what type it is. They guarantee noticeable improvement in the reception obtained.



- 6 Ohms . . . . . \$1.00
- 20 Ohms . . . . . 1.25
- 30 Ohms . . . . . 1.30
- 25c extra with dial

Suitable for either table or panel mounting. Condensite base, high grade resistance unit, attractive knob. Adjustable shaft to any thickness of panel.

At all good dealers—or direct on receipt of purchase price. Also write for our complete literature.

AMSCO PRODUCTS, INC.  
416 Broome Street New York

**KEYSTONE RADIO LIGHTNING ARRESTERS**

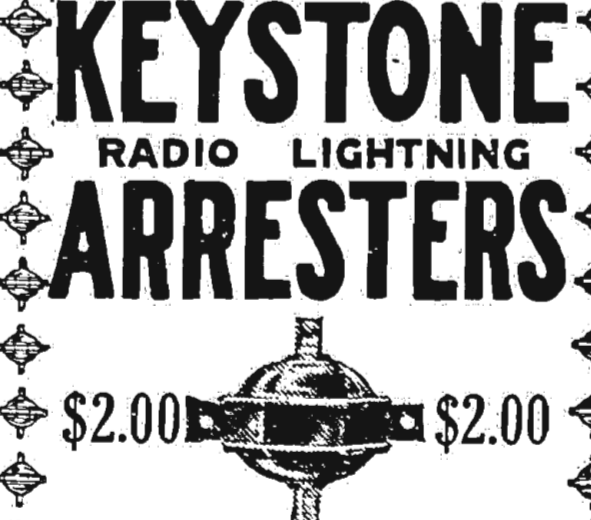

Should be on every aerial the year 'round. Provides highly efficient lightning and static protection for the home. Fully approved by Fire Underwriters. Can be installed outdoors. Has no vacuum to lose. Install one in your aerial lead now—be safe. This pioneer radio arrester is backed by 31 years' experience in lightning arrester design. For sale by Dealers everywhere, or sent postpaid for \$2.00. Write for circular.

Electric Service Supplies Co.  
17 & Cambria Sts. Philadelphia  
Monadnock Bldg., Chicago  
50 Church St., New York









# Radio Illustrated

"Baby Peggy," the juvenile star of the silver screen, during her recent visit to New York City, tried out Radio as one of her many new experiences in that metropolis. "Oh, I can hear Los Angeles, mamma," she exclaimed, as familiar sounds came to her ears, and as we see her here, she certainly looks a "mighty surprised baby" Int. Newsreel Photo

Anna Ludmila in dancing pose. Her youthful charm and beauty combined with superb grace of movement has won enthusiastic applause at every appearance and no doubt laid many a heart at her nimble feet

Another Marconi Radio wonder, the Otophone, which makes the deaf hear by means of a bone vibrator that takes the place of the human eardrum. Here two deaf persons are using the device Int. Newsreel Photo