

Radio Digest

EVERY WEEK

Illustrated

TEN CENTS

REG. U. S. PAT. OFF. & DOM. OF CANADA

Vol. VII

Copyright, 1923
R. D. P. Co. Inc.

SATURDAY, NOVEMBER 17, 1923

No. 6

MAY ELECT PRESIDENT



The popular program manager of KPO, Hale Bros., San Francisco, Ida Morgan O'Brien



Mildred Keats of the "Battling Butler" company entertained WOR listeners recently. If looks indicate voice we would like to hear her



Former prima donna of "Irene," Ursula O'Hare, often gives WHN listeners a treat

ALL U. S. LISTENS TO PHILHARMONICS

SERIES OF TEN CONCERTS TO BE BROADCAST

WEAF Will Send Educational Music into Thousands of Homes of Radiophans

NEW YORK.—Working in close cooperation with Clarence H. Mackay, Fred-eric A. Juilliard and Mrs. E. H. Harriman of the Philharmonic Society, the American Telephone and Telegraph Company announces that it will broadcast through Station WEAF the entire series of ten educational concerts to be given during the coming season in Carnegie Hall by the Philharmonic Society of New York, under distinguished conductors. The first concert was broadcast November 12.

Will Follow Lines of Last Season.
The directors of the Philharmonic Society have arranged an extensive educational program which, in addition to the concerts by the Philharmonic Society, includes lectures at school centers by Daniel Gregory Mason, of Columbia College, and children's concerts given by the American Orchestral Society.

The educational concerts given last year (Continued on page 2)

FARM BUREAU SEES FARMER AS U.S. HEAD

S. R. Guard Thinks Listening In Agriculturists Will Elect Chief Executive

Farmers to Have Station

By J. L. Newman, Staff Correspondent

CHICAGO.—Not only will Radio do more perhaps than any other agency to elect the next president of the United States, but it is likely to be the chief means of naming a farmer as the next tenant of the White House. This was the recent prediction, supported by those of noted publicists, of Samuel R. Guard, chief of the de-

(Continued on page 2)

Navy Tests Alertness of Ship and Shore Stations

Uses Three Cruisers, Battleships at Sea in Experiments

WASHINGTON.—The naval communication service is making extensive tests with Radio on three cruisers and a battleship now at sea. The tests are designed to determine the alertness of watch maintained by ship and shore stations, the maximum reliable range of ship's transmitters, the maximum range of reception from shore stations and the efficiency in handling codes.

The experiments are being conducted on board the battleship Colorado, operating off the Atlantic Coast; the cruisers Richmond, in the South Atlantic; Milwaukee in the South Pacific and Detroit in the Mediterranean. Similar tests will be undertaken on all new vessels when commissioned, and such of the fleet as are on detached service.

INVENTION WINS HIM \$500 PRIZE

"Wave Antenna" Device Brings Honor to Engineer Harold H. Beverage

NEW YORK, N. Y.—Harold H. Beverage, well-known Radio engineer, was tendered a vote of honor by the membership and board of officers of the Institute of Radio Engineers at their last meeting, for his contribution to Radio communication devices of the so-called wave antenna. Mr. Beverage was also presented with a cash prize of \$500, the Liebmann Memorial prize, this amount being the annual interest on an investment made by the late Col. Morris Liebmann, a well-known Radio engineer.

Each year this sum is given to the most deserving individual whose Radio inventions or developments are of outstanding practical importance and serve to materially enhance the progress of the art.

'BIRD CITY'S' BIRDS GIVE UP THE SHIP

WASHINGTON.—Radio rooms on vessels must not be used as aviaries. When a Radio inspector visited the S. S. Bird City recently, he found that the operator had given over his stateroom to a number of birds, which, despite the name of the vessel, is against the rules. The cabin was thoroughly cleaned and the bird tenants were ejected from their quarters.

LOPEZ DOES HIS OWN JAZZ ANNOUNCING

NEW YORK.—Vincent Lopez, whose orchestra is broadcast through WEAF here every Thursday and Saturday night, does his own announcing—something out of the ordinary. This feature presented the listeners in through the courtesy of Gimbel Brothers, is an hour's program from 11 to 12 p. m. Eastern time. Get it on your loud speaker and enjoy a good dance.

CLIP LAST COUPON WITH NEXT NUMBER

COLDER WEATHER CLOSES REWARD OFFER

All Letters Must Reach Digest Office Before December 1 to Be Eligible

SPECIAL REWARD OFFER

Coupon Number 25

This Special Reward Coupon appears each issue in Radio Digest until November 24. When sent in, accompanied by necessary remittance, according to the rules governing same, apparatus can be secured. See rules of offer below.

Save Me—I Am Valuable

The Special Reward Offer will be discontinued for the present season with the publication of Coupon Number 26 in the issue of November 24. This action has been deemed necessary as a result of the increased rush in business coming with the colder (and more favorable for Radio) weather.

All Radiophans contemplating taking advantage of the special offer must do so before December 1. All letters containing coupons and remittances for parts must reach the office of Radio Digest on or before that date. Such letters arriving after December 1 will be returned to the writer.

Lack of space requires the omission of the list of Radio parts obtainable. See issue of October 27 or November 3 for this list. One change, however, is to be noted. Articles in Class H must be accompanied by sixteen consecutively numbered coupons and \$3.40, instead of \$3.00 as given previously in the list.

Readers contemplating taking advantage of the special offer must remember that the coupons turned in for any item must be numbered consecutively, as for example, 16; 17, 18 and 19, or 18, 19, 20, 21, 22 and 23. The number of coupons necessary and the cash remittance, of course, depend on the item sought by the reader. There is no limit to the number of series turned in by any one reader.

Another point to be remembered by readers taking advantage of the offer is that checks and money orders will be accepted, but no cash or postage stamps.

FARMERS' VOTE ON AIR

(Continued from page 1)

partment of information of the American Farm Bureau Federation, headquarters Chicago.

"There never was a time in the history of this country," said he, "when the tiller was as well informed as now. This condition is due largely to Radio. The number of members in the American Farm Bureau Federation and allied organizations is 1,250,000. It is safe to say that most of them own or operate receiving sets. It is also conservative to estimate that the number of voters in these farmers' bodies is close to if not more than 2,000,000.

Farm Vote Strong Factor

"Political committees engineering the candidacies for the presidency will have to use Radio to reach not only the farmer, but every other voter. The great influence of the 'farm bloc' in congress, the strength of the agriculturalist in the legislatures, the awakening of the dominant political parties to the invincibility of the organized husbandmen, the ever widening scope of the farmer as a world factor—all these give to the people of the soil the balance of power in the political affairs of the United States, that is to say, of the civilized world.

"Armed with what is considered the decisive vote in affairs of state, the farmer must apply Radio to further his own aims. And those political machines which seek the influence of the farmer, that is, his vote, will need use Radio.

See Radio Elect Farmer

"So we are not dreaming wildly," continued Mr. Guard, "when we forecast that a farmer will be the next president of the United States.

"There is hardly a farmhouse in all the land, it is safe to say," Mr. Guard asserted, "in which there is not a Radio set. The farmer has arrived at the stage whereon he cannot do without Radio. He thus hears the market reports, in fact, depends largely on them; he hears the news of the world; he hears not only the officials of his own farm organization, but he hears the views of the world's statesmen.

"In Chicago, Station KYW spreads the affairs of the American Farm Bureau Federation over a wide area every Tuesday evening at 9 o'clock. We aim to form a chain of such stations, including those in Washington, New York City, Pittsburgh, Jefferson City, Mo., and Denver. By these means we shall be on the air every night excepting Sunday, preferably at the same hour—8 o'clock—so that farmers all over the United States may 'listen in' after the chores."

May Erect Chicago Bureau Broadcaster
As a part of the comprehensive scheme of the farm bureau and its associate bodies to educate the farmer as to economic and social conditions, a broadcasting station soon may be established in Chicago. "The transmitting plant will be owned by the bureau," Mr. Guard said. "The plan was discussed by our officials a few days ago."

The American Farm Bureau Federation, established in forty-six states of the Union, in 2,000 counties and in 15,000 townships, intends, too, by means of Radio to educate the farmers as to how co-operative marketing organizations may overcome speculation in raw food products. The tillers have already effected what is said to be the most powerful organization of its kind—the national co-operative grain marketing committee. What the committee does and intends to do is now broadcast and will continue to be disseminated by means of Radio.

"It would be well both for the farmer and the manufacturer of Radio receiving sets," concluded Mr. Guard, "to place on the market good sets say at \$15 each retail. The sale of sets at that price would be increased many times."

And thus, in the days to come in which a leader of the people will be chosen, there shall be heard throughout the land the voice of the farmer, a voice which all shall heed, a voice which shall not be stilled—Radio.

PHILHARMONICS START

(Continued from page 1)

by the Philharmonic Society will be continued along similar lines during the coming season. Five concerts will be given at Carnegie Hall on Monday evenings and five concerts on Wednesday evenings, Willem van Hoogstraten conducting on December 3 and 17 and January 21; Henry Hadley will direct the orchestra on December 31, and Willem Mengelberg will conduct the five Wednesday evening concerts on January 30, February 6 and 27, March 19 and April 2, all of which are to be broadcast by WEAF.

This is one of the most comprehensive and important educational programs in orchestral music yet to be presented to the Radio audience. The management of Station WEAF, in line with its policy of co-operating fully with the important musical organizations, will make a feature of the Carnegie Hall concerts. The music-loving public is indebted not only to the public-spirited directors of the Philharmonic Society, but also to the Victor Talking Machine Company, which has waived its contract rights in order that the educational work may be extended to the largest possible number.

Canada Plans Ship Safeguard

OTTAWA, ONT.—The Canadian Government is about to install a powerful direction-finding Radio station at Pachena, on the west coast of Vancouver Island, B. C., to protect ships of all nations entering the Straits of Juan de Fuca en route to American and Canadian ports. Numerous shipwrecks have occurred in this district, and it is expected that the new Radio beacon will enable vessels to determine their exact positions in foggy weather, avoiding many dangerous reefs thereabouts.

CONTENTS

Radio Digest, Illustrated, Volume VII, Number 6, published Chicago, Illinois, November 17, 1923. Published weekly by Radio Digest Publishing Company, 123 West Madison Street, Chicago, Illinois. Subscription rates, yearly, Five Dollars; Foreign Postage One Dollar additional; single copies, Ten Cents. Entered as second-class matter at the postoffice at Chicago, Illinois, under the Act of March 3, 1879.

"All the Live News of Radio".....	1 to 9
An Evening at Home with the Listener In.....	7
Single Tube Set for Long Distance Reception.....	10
How to Build a Three-Tube Miloplex Receiver, Part III—The Hook-Up Diagrams, by H. J. Marx.....	11
Advance Programs.....	12
Is This Super-Regenerative?—R.D.-103.....	14
Further Details of Miloplex Hook-Up.....	15
Editorials; Indi-gest; Condensed, by Dielectric.....	16
Latest Development in Grimes' Inverse Duplex, Part I—Reflexing with the Use of a Tube.....	17
Home-Made Multiple Phone Jack.....	19
Simple Explanation of Radio for Everybody, Chapter V—Capacities—Fixed and Variable, by M. W. Thompson.....	21
Questions and Answers.....	22
Broadcasting Stations, Part II—Station Schedules.....	23
Radio Illustrated, a Page of Pictures.....	24

Looking Ahead

John L. Reinartz, Famous Inventor of the Reinartz Circuit, has developed the simplest form of Reinartz circuit. His latest contribution to the Radio art will be given next issue. And, speaking of Reinartz sets, lots of our best Radio engineer friends told us we couldn't add Radio frequency amplification to a Reinartz. Like us, R. J. Benne of Burlington, Vermont, didn't believe everything he heard, so he turned around and did it anyway, and successfully. See his hook-up in next week's Digest.

Four-Circuit Fans, Make Way for the Three-Circuit Variocoupler—You've never heard of one? Of course not. It's the latest and best tuning circuit we have yet tried. H. J. Marx sprung it on us the other day. Talk about super-heterodyne. Say! It's almost as bad as all that, but the efficiency and selectivity of this new circuit places it in the leading rank of American Radio circuits. Full details to start soon. Mr. Marx completes his Miloplex construction series with the next article. The illustrations show clearly the beauty and workmanship displayed in the assembly of this set.

David Grimes Again Next Week—Read Mr. Grimes' second article of his series prepared especially for Radio Digest readers. He will give all the latest developments and tricks in his peculiar method of reflexing, the inverse process. Reflex circuit fans will find lots of interest in Mr. Grimes' articles.

The Mystery Man of the Miloplex Gets More Mysterious—He wants the subject matter of his next article kept a secret. So that's that. Buy next week's copy early and find out what his secret is.

Condensers and Capacity Explanations require considerable space, so Marvin W. Thompson's next article will continue on that subject. You like his writing? We thought you would.

Newsstands Don't Always Have One Left

WHEN YOU WANT

Radio Digest

YOU WANT IT!

BE SURE OF YOUR WEEKLY COPY BY SUBSCRIBING NOW

SEND IN THE BLANK TODAY

Publisher Radio Digest,
123 West Madison St.,
Chicago, Illinois.

Please find enclosed check M. O. for Five Dollars (Six, Foreign) for One Year's Subscription to Radio Digest, Illustrated.

Name

Address

City..... State.....

All the King's Horses
And All the King's Men
Couldn't Put the Condenser
Together Again

as many a radio man has found

when he took the front plate off a condenser to mount it. He had a sorry job on his hands—putting the washers and plates together again.

WALNART trouble-proof VARIABLE CONDENSER

Nothing like that can happen with a WALNART.

Walnart plates fit into a grooved rod—hence they cannot fall out or come loose.

We believe this is one of the reasons why we are working night and day to fill orders for Walnart Condensers (plain and vernier).

We also manufacture Variable Grid Resistance, tube sockets, standard and UV-199, vernier adjusters, inductance switches, etc., of highest quality. Ask your dealers to show them to you.

Write for illustrated folder.

WALNART ELECTRIC MFG. CO.

Dept. 409 1251 W. Van Buren St. CHICAGO

Radiola Loud Speaker
Model U. S.-1320
Price

\$36.50

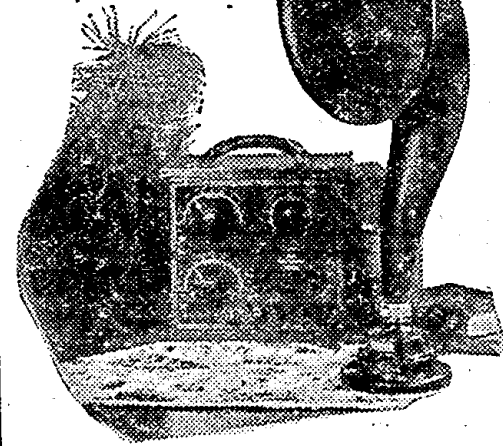

RADIOLA LOUD SPEAKER

New—a loud speaker that brings music to the crowd as true and clear as one man gets it on the headphones. Nothing is lost—for its wide range gets all the overtones and partials. Nothing is added, for its horn is correct acoustically. The clear, rich tone of voice or instrument—pure and undistorted—with a knob to adjust the volume of tone at a touch. Have you heard it?

Radio Corporation of America

Sales Offices: Dept. 3002
233 BROADWAY, NEW YORK
10 S. LA SALLE ST., CHICAGO, ILL.
433 CALIFORNIA ST., SAN FRANCISCO, CAL.

Radiola LOUDSPEAKER

BRITISH BROADCAST TRUST GUILLOTINED

POSTAL AUTHORITIES FEAR POWER GRANTED B. B. C.

British Broadcasting Company Could Have Required Fans Buy Its Apparatus to Get License

Carl H. Butman

WASHINGTON.—The British Postal authorities have succeeded in stopping what threatened to become a Radio broadcasting trust, which would also have controlled the sale of sets, refusing listening licenses to all except those whose sets were stamped "B. B. C.," including home-made sets.

The letters "B. B. C." stood for British Broadcasting Company, which through a recent arrangement between the government and the Radio manufacturing industry, was to have exclusive right to broadcasting in the British Isles. This company was to be financed from tariff payments on manufactured receiving apparatus and from license fees to be paid by listeners to the postoffice. It was a condition of the license that apparatus of foreign origin, with certain exceptions, would not be available for use under the scheme—all British-made apparatus being marked "B. B. C."

Criticizes System

In a recent report made to the British postmaster general, Major General Sir Frederick H. Sykes, chairman of the British broadcasting committee, said: "The system of marking apparatus and deriving revenue from broadcasting service from royalties on such apparatus gave the company a privileged position; we have had no proof that they have made any improper use of it; but the system is open to objection from several points of view, and should be abandoned as soon as possible."

The report admits that the company successfully established a broadcasting service of considerable merit, despite many difficulties, and was partly successful in ensuring that the demand for receiving sets during the initial period should mainly benefit British manufacturers, who established the service. But the scheme "has broken down in certain respects," the report adds, "largely owing to the unforeseen facility, cheapness and popularity of the construction of home-made sets."

Makes Recommendations

The broadcasting should be done under government license, it is believed by the committee, which agrees that the service of the B. B. C. should be continued for a definite period, subject to modifications of the license. "The government should keep its hands free to grant additional licenses," the report avers.

No part of the cost of broadcasting should fall upon the taxpayer, and the government should not endeavor to make a profit on the administration, the committee suggests. Revenues should be derived from receiving license fees.

New licenses, simple and uniform in type, are recommended to be placed on sale at postoffices without formalities. They would prohibit the use of "back-coupling" (re-radiating receivers), but put no other limitations on the apparatus allowed to be used, the report recommends.

Study Troubles and Cures in Massachusetts Course

BOSTON.—A ten lesson course in Radio reception and transmission under the auspices of the Massachusetts Department of Education has been started here. The classes are being conducted by Henry Bayard Phillips of the Massachusetts Institute of Technology, and are held there in the evenings. During the course Professor Phillips plans to discuss the construction, installation and operation of the essential parts of Radio transmitting and receiving apparatus. A feature of the work will be a study of the latest approved circuits, as well as common Radio troubles and remedies. This course will also be offered by correspondence to those who cannot attend the classes.

SINGER WARBLER TO MUSIC 1 MILE AWAY

NEW YORK.—Edith Bennett, concert star on the program of the Navy Day ceremonies at the recent Electric Exposition at Grand Central Palace, sang a group of classic and patriotic selections to a Radio accompaniment played by Rodney Saylor, pianist, and Armand Popper, violinist, at Station WHN, one mile away, and heard by the singer and her audience from a loud speaker.

DIMMED 'STARS' GO BACK TO BROADWAY

NEW YORK.—Actors and actresses who were favorites of the past generation of theatergoers, now enjoy the thrill of listening to the applause given to those who have taken their places. S. L. Rothapel, who puts the Capitol Theater on the air over WEAJ every Sunday night, has received a letter from the Actors' Fund Home, telling of their appreciation of such programs.

FACE COURT TEST ON MUSIC RIGHTS

EQUITY SNAG STILL IN 'THANK U' PATH

Fans Praise Shubert's Defiant Stand in Favor of "Caroline" Broadcast

BOSTON.—Although several thousand Radiophans were disappointed in not hearing the promised broadcasting by WNAC of excerpts from the "Thank U" company's program one Sunday night recently, because of a "run-in" with the Actors' Equity Association, they were repaid later by the brilliant program of numbers from "Caroline," now playing here, going out from the same station.

The Radio presentation of "Thank U" was stopped by Frank Gillmore, secretary of the Actors' Equity Association, who declared that if parts of the piece were broadcast the actors should receive one-eighth of their salary for the performance. Later he denied that he banned the performance, but the situation was such at the time of the scheduled program that the WNAC management thought it wiser to drop the performance.

Believes Broadcasting Helps Fame

Gillmore is quoted as saying later: "While I believe that broadcasting helps to make actors famous, it is the duty of the association to demand payment for the services of its members," although he admits that it has no control over the action of individual members.

In reply to this, John Shepard III said: "If Radio helps to make the actor famous, doesn't he automatically receive more money? The more fame the more money; and if broadcasting is helping to make the actor famous, why should the broadcasting station be asked to pay to make the actor famous?" And there the controversy rests.

There came near being another snag to trip the performance of "Caroline." Lawsuits based on the copyrights of the songs in the show were threatened by the local representative of the American Society of Composers, Authors and Publishers, who declared that broadcasting the music on which their members held copyrights would constitute a violation of the copyright law.

Shubert Takes Radio's Side

But Lee Shubert, owner of the show, declared that he held all rights to public performance of the music and had a right to send it out by Radio to the public as a public performance, even though the audience was not present within a theater.

The case will probably be tried in court as a test, as it involves a point never before brought up regarding the broadcasting of copyrighted music.

Hundreds of letters received by WNAC and the Shubert management show the public agree that "Caroline" is a real show and that Shubert is a "regular fellow." They also prove that broadcasting benefits a production, for fully ninety per cent of the writers promised to attend a performance shortly.

One letter contained the following significant sentence.

"If the theater people only knew how we Radiophans are guided in our selection of shows to see, they would join with the Shuberts and have more such wonderful music as 'Caroline' broadcast. . . . Our family has bought more records and songs from hearing them over the Radio than ever before."

Woman Artist Talks

NEWARK, N. J.—Jessie Tarbox Beals, renowned photographic artist, was heard recently on the program of Station WOR in an interesting talk in the series, "Half Hours with Successful Women." Mrs. Beals specializes in smiles at her studio and is a master of impressionistic photography, showing the souls of great cities.

In Prescott, Ariz., one of the hotels is to have a "Radio concert hall." All who care to come are invited.

TUNING IN ON EIFFEL TOWER



Tuning in on the Eiffel Tower? Yes, that was done at a recent Radio show. Not the Paris station, however, but a receiving set built into a faithful replica in miniature of the famous French edifice. The girl listening in "on the Eiffel Tower" is Miss Marie Saltysik K. & H. Photo

Winning New York Sets Enter in Chicago Show

Exhibit at Coliseum from November 20 to 25

CHICAGO.—The home-made receiving sets which won first and second prizes at the recent New York Radio show have both entered in the amateur contests to be a feature of the second annual Chicago Radio show to be held from November 20 to 25 at the Coliseum.

The set which won first prize in New York is of the portable type and has only

two controls. It was built by Oliver B. Parker of Brooklyn. The winner of the second prize was an elaborate outfit, which followed somewhat the lines of one of the well-known manufactured sets. It was built by James Dorothy of New York City.

These two sets, however, will have plenty of competition. Already more than three times as many sets have been entered in the Chicago show than were displayed in New York. The entries include sets built by amateurs from as far east as Lawrence, Mass., and as far west as Sacramento, Calif.

The amateur display will be placed in the Coliseum Annex inasmuch as the exhibits of the manufacturers and distributors will fill the entire Coliseum proper.

THE ANTENNA BROTHERS

Spir L., and Lew P.

He's Two Five-Millionths of 'Em



EXPOSE OF MUSIC TRUST PRINCIPLES

SMALL PERCENTAGE OF SONGSTERS ON ROLL

Broadcasters' Association Finds Name of Composers' Society Is Misleading

(The following article is one of a series which is being published with the express purpose of explaining to the Radio public the situation existing between the broadcasting stations and the American Society of Composers, Authors and Publishers. The series tells in detail the reasons why the National Association of Broadcasters was organized, and why certain popular songs the copyrights for which are controlled by the "music trust," are not being broadcast.—The Editor.)

PART I

THE executive offices of the National Association of Broadcasters are located at 1265 Broadway, New York City.

During the year 1922, broadcasters were going peacefully along their way, broadcasting whatever good music seemed to be desired by the listening public. From out of a clear sky came a demand by the American Society of Composers, Authors and Publishers, that they be forthwith paid a substantial sum of money, or that Radio stations cease broadcasting music, the copyrights of which were controlled by their members.

This demand surprised broadcasters beyond expression, because it had always been considered that a distinct service was being given to publishers when their musical numbers were sent over the air, and if anyone did any paying, it was the publishers who should pay broadcasters.

National Association Born

A meeting was called at the Drake Hotel, Chicago, on April 25 and 26, 1923, which was attended by most of the prominent broadcasters in the United States. The general manager of the Society of Composers, Authors and Publishers came from New York and addressed the meeting. His proposals, however, made a decidedly unfavorable impression upon the men assembled, and it was therefore decided to form the National Association of Broadcasters. Counsel was retained;

PIPE THIS, ARTISTS; HE LIKES YOUR ACT

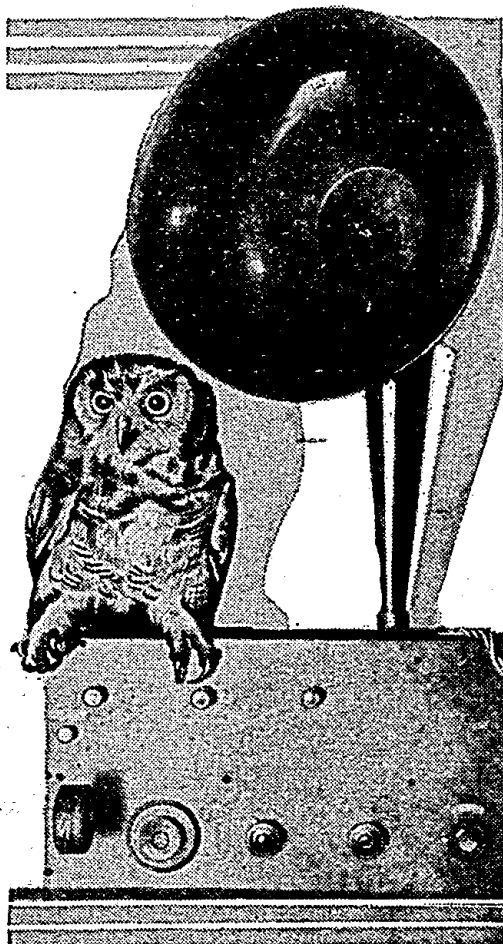

F. W. Lovgren, of Virginia, Minnesota, sends the above picture of his pet owl listening in. Mr. Lovgren says that the owl has become a wise Radiophan, and takes especial delight in roosting on the receiving set in this fashion when musical programs are being received. Who can go Mr. Lovgren one better with his or her pet?

Paul B. Klugh, who organized the Music Industries Chamber of Commerce, a very successful organization, took active charge of the affairs of the Broadcasters' Association, with the title of Executive Chairman. Offices were established in New York; plans were put into operation for the placing of the new organization upon a practical operating basis; a fund was

provided adequate to meet all financial requirements for a period of years, and a constitution and by-laws were adopted, embodying the following aims and purposes:

To foster and promote the development of the art of Radio broadcasting, and the interests of those engaged in any business, profession or industry relating or pertaining to Radio broadcasting; to re-

form abuses relative thereto; to secure freedom to its members from unjust and unlawful exactions; to procure uniformity, equity and certainty in customs and usages of trade and commerce relating thereto; to settle differences between the members and to promote a more enlarged and friendly intercourse between members; to secure co-operative action in ad-

(Continued on page 7)

Thrills from Radio

No. 3 of a Series Featuring Experiences of "ALL-AMERICAN" Users

I'VE TRIED 15 DIFFERENT MAKES

By W. R. Bradford, Little Meadows, Pa.

"The 'All-American,' I verily believe is the best transformer on the market. My location is on the shores of a lake surrounded by massive hills which virtually make it a pocket. Radio reception is very erratic and the signals weak.

"A friend sent me some 15 different transformers to try out. These were the best the market affords—Among them was a 10-1 'All-American' which was a revelation to me in performance.

"Contrary to expectations, there was not the slightest distortion at this high ratio—tone quality being in nowise degraded."

Why experiment?—over 300,000 radio enthusiasts like Mr. Bradford have already proved "All-Americans" best. And they are standard equipment on the better sets.

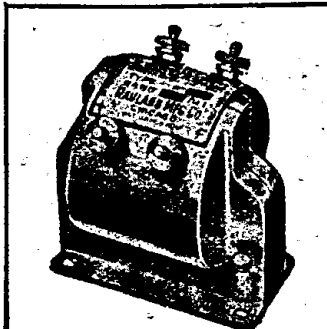

All-American Audio Frequency Transformer—comes in three ratios.

FREE!

All-American Book of tested hook-ups for getting new thrills out of your present radio outfit. Send 2c stamp for postage.

All the better dealers sell "ALL-AMERICAN"

RAULAND MFG. CO., 200 N. Jefferson St., CHICAGO PIONEERS IN THE INDUSTRY



AUDIO FREQUENCY

RADIO FREQUENCY

ALL-AMERICAN AMPLIFYING TRANSFORMERS

Largest selling Transformers in the world



Very Simple to Tune--

A DIAL, accurately calibrated in wave lengths, enables you instantly to locate the program you desire, when you own a

GREBE Broadcast Receiver

This instrument possesses many other advantages described in "Grebe Radio in the Well-Appointed Home." Ask your Dealer or write us for a copy.

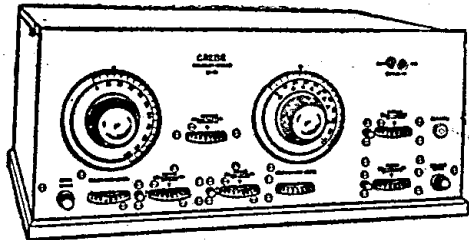

Licensed under Armstrong U. S. Pat. No. 1115149

A. H. GREBE & CO., Inc. Richmond Hill, N. Y.

Western Branch—451 East 3rd St., Los Angeles, Cal.

THE TRADE MARK AUDIOPHONE REG. U. S. PAT. OFFICE

Quality of reproduction such as only the original itself can equal. Speech that is so distinct that the voice heard is the actual voice of the speaker. Music that requires no tolerant imagination to be recognized as music of the finest type.



Bristol's Single Stage Power Amplifier

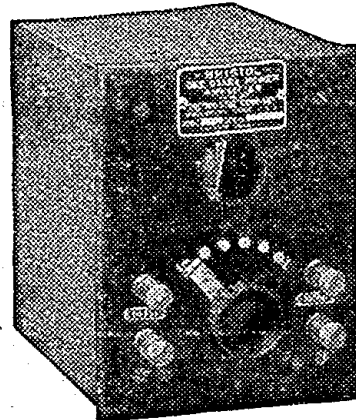

gives additional VOLUME with any two stage amplifier. No C batteries required. It provides the additional volume necessary to bring in very distant stations on the loud speaker.

Write for bulletin and address of the nearest dealer handling our instruments

THE BRISTOL COMPANY WATERBURY, CONN.

Boston New York Philadelphia Pittsburgh Detroit Chicago St. Louis San-Francisco

BROADCASTS PROVE AID TO STENOS

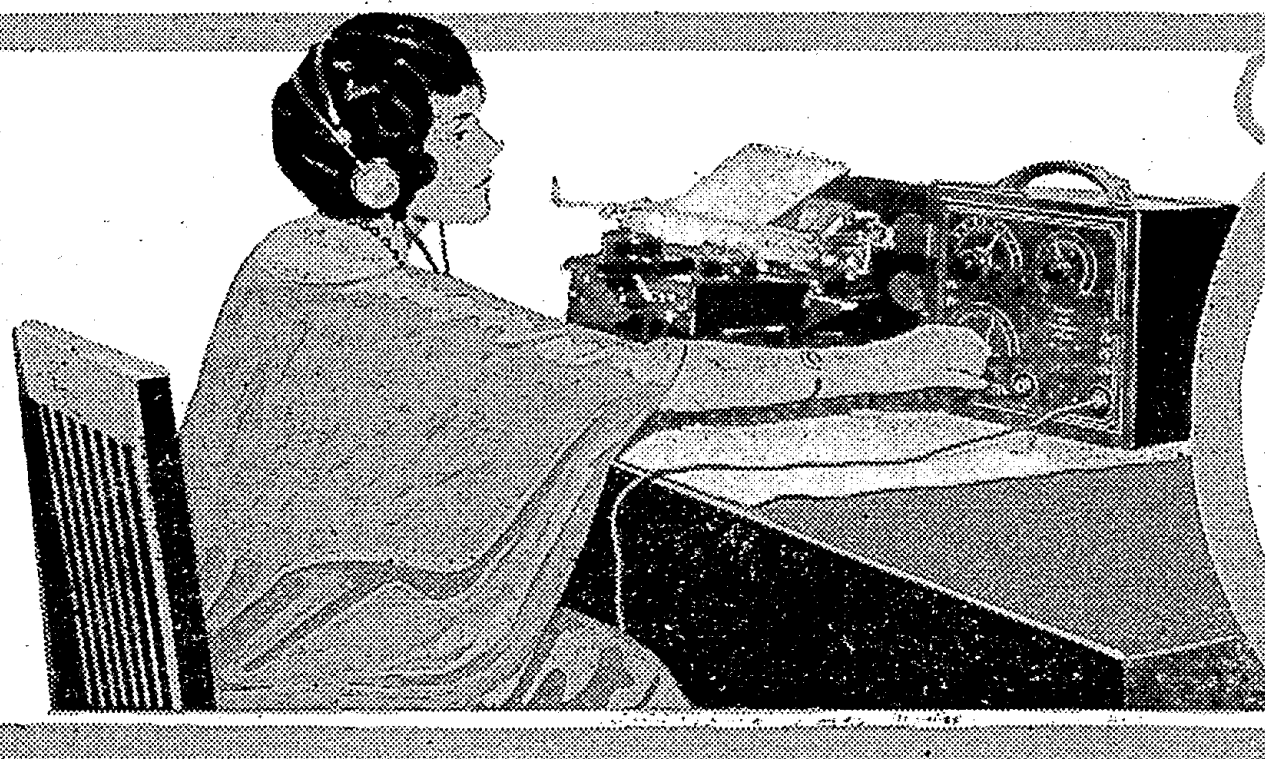

Commercial colleges are beginning to appreciate the facilities of Radio. Recently a shorthand speed contest was broadcast and received by the stenographers on their receiving sets. Several "pot-hook" schools are now advocating the use of broadcast talks, sermons, etc., as an

excellent means for their pupils keeping in practice and developing speed. Left, Miss Alice Post, tunes in for shorthand practice. Right, Earl Latham broadcasts a letter, which is in turn tuned in and taken down in shorthand by Miss Post
Photos by Int.

Stenos Gain Speed and Accuracy with Dictation Over Ether Waves

Radio Helps Typists Win Promotions—Variety of Subjects Heard over "Phones" Makes Practice Interesting—Differing Styles of Delivery Gives Valuable Shorthand Experience

NEW YORK.—Acquiring speed in taking shorthand dictation is the latest use for Radio. Already it has proved practical, and its possibilities are interesting stenographers, public schools and commercial colleges throughout the country.

A popular shorthand publication has directed the attention of Radiophan stenographers to the daily—and nightly—opportunity to transcribe in shorthand the great variety of material which comes over the Radio and thereby improve the accuracy of their work and increase their speed. Hundreds of student stenographers have tried it out with good results, and even larger numbers of shorthand writers, who have finished school and taken positions, have found it a means to keep their speed tuned up. "Nobody need get rusty who has a Radio," one stenographer wrote, "nor fail to get promoted to a better job for lack of practice."

Radio Nation-Wide Night School

The fact that so much of the broadcasting is in the evening may make Radio a sort of nation-wide night school.

One of the advantages of practice in writing the material which comes by Radio is the variety of subject matter—sermons, news reports, educational talks, business reports, travelogues, lectures,

book reviews—and the many different styles of delivery of Radio speakers. And the opportunities are open to shorthand writers in the most secluded hamlet or on the remotest farm provided they have satisfactory receiving sets.

As to the use of Radio by public schools and business colleges, the New York City Board of Education recently gave an interesting demonstration. In co-operation with Station WJZ and the Gregg School, the board held the world's first Radio shorthand contest. Provided with receiving sets, pupils in the shorthand classes in several important high schools took dictation from the Radio at eighty and one hundred words a minute. Prizes were awarded to the students who transcribed the dictation most accurately. The Bushwick High School in Brooklyn won first honors in the contest.

Good Sets Essential

The contest had an important additional result in demonstrating the necessity of good receiving apparatus both for school work of this kind and for good results by outside stenographers utilizing Radio for shorthand practice. Not one of the winged words must be missed, and every sound must be clear and undistorted. The blurring of "s" and "th" would spoil accurate transcription.

WGR GRADUATES FROM CLASS 'C' TO 'B' PLANT

Improvements Follow Admittance to Exclusive "Society"

BUFFALO, N. Y.—WGR has been graduated from Class C to Class B. The new license, came rather unexpectedly and designated the new wave length of 319 meters instead of 360, the wave length WGR has used for several months.

As a result of the admittance of WGR into the rather exclusive "society" of Class

B, several improvements in program and transmitting are planned. The next few weeks will probably see a great increase in sending radius on the part of WGR. Manager M. A. Rigg, Jr., and his assistants are jubilant over the B rating.

British Columbia Hears WGY

SCHENECTADY, N. Y.—F. C. Lloyd, of Crofton, Vancouver Island, British Columbia, recently reported reception of Station WGY of this city. This is not a distance record for the station, but it is the farthest point in the northwest that has been reported. Crofton is approximately 2,600 miles from Schenectady.

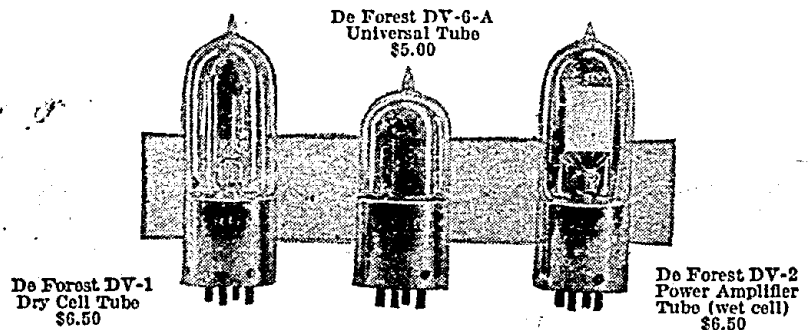

The More You Know About Radio The More You Rely on De Forest

Without Lee De Forest's discovery of the vacuum tube there would be no radio today. All radio broadcasting, all radio receiving by means of tube sets, rests on De Forest patents.

De Forest has been a pioneer in radio since 1900 and De Forest is a pioneer today. That is the reason for the great success of the De Forest Reflex Radiophone. That is the reason for the success of the new De Forest tubes—DV-1 Dry Cell Tube, DV-6-A Universal Tube, DV-2 Wet Cell Power Amplifier Tube.

If you want a radio receiving set with a range on indoor loop of from 1,500 to 3,000 miles, depending on atmospheric conditions; if you want simplicity of control, clear reception without distortion and without extraneous noise; if you want operation on either wet or dry cells—see the De Forest Reflex Radiophones at the De Forest agent's today.

The D-7A Reflex Radiophone is a three-tube set at \$125.00; the D-10 Reflex Radiophone has a drawer in its cabinet for dry batteries and is a four-tube set at \$150.00. No matter what you pay, you can't get greater radio satisfaction.

Whether you buy your set complete, or build your own from the laboratory tested De Forest parts, you can rely on De Forest, the greatest name in Radio.

De Forest Radio Tel. & Tel. Co. Dept. R. D. 3 Jersey City, N. J.

If located west of Pennsylvania address

De Forest Radio Tel. & Tel. Co.

WESTERN SALES DIVISION

Dept. RD. 3, 5680 12th St., Detroit, Mich.

De Forest Portable Reflex Radiophone type D-10, which operates on wet or dry cells, has a reception range of from 1,500 to 3,000 miles on indoor loop; has drawer for all necessary A and B dry cells, plus approx. Price \$150.00, mately 6% for transportation in territories west of Rocky Mountains.



Radio Catalogs Free Send a postcard for De Forest's Free Radio Catalog with full details and prices on sets, tubes, and parts.

De Forest products are sold only through exclusive agents, direct to the public for your protection. The De Forest Company will be glad to hear from representative dealers in various communities who wish to become exclusive De Forest agents.

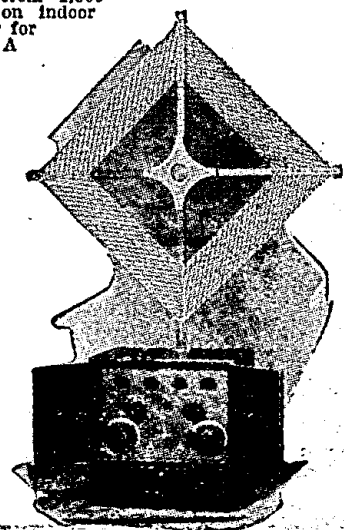

SAVE MONEY Radeco Safety Fuses

"The biggest little thing in radio"

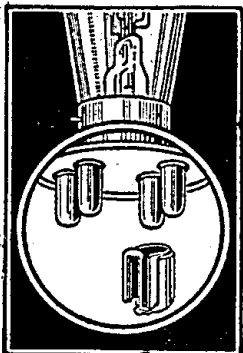

Price 50 cents each postpaid

RADIO experts recognize that some means of protecting the delicate filament of vacuum tubes is necessary. Thousands of tubes are needlessly burnt out each year. Radeco Safety Fuses have been developed to prevent this waste. They are endorsed by the leading radio publications. You can now absolutely protect the tubes of your set by slipping a Radeco Fuse on one of the filament terminals of each of your tubes.

Guaranteed not to interfere with the efficiency of your set. Save money by ordering today one fuse for each of your tubes. Mention type of tube.

Dept. 6

RADIO EQUIPMENT COMPANY 20 Stuart Street, Boston, Mass.

New England's Oldest Exclusive Radio House

Distributors of many other successful radio specialties DEALERS: We are going to appoint live distributors Write for our proposition and full details

READ WHAT ONE MAN SAYS

939 Dunlop Avenue Forest Park, Illinois

Radio Equipment Company, Gentlemen: About last January I purchased some of your Radeco Safety Fuses. I have never had cause to regret this purchase, because I believe it has saved me many dollars. So I am writing to thank you and will recommend them to my Radio friends. The fuses have not interfered in any way with the operation of my set, and you are entirely at liberty to use this letter as an "ad" for your product, if you should so desire. Wishing you success in your present enterprise, I am, Yours truly, Mr. Harvey F. Reese.

9/26/23

DICKENS CHARACTER ON AIR FROM WEAF



Interest in Dickens needs no stimulant, but if it did, to Mortimer Kaphan, the American character portrayer, would belong the credit for administering it. He has now enlisted the present-day miracle—Radio—in the aid of his wonderful interpretation of the famous author's characters. Here we see him as Little Nell's grandfather in the "Old Curiosity Shop." The broadcasting was done from WEAF, New York City

Lions' "Roar" Goes on Air for First Time at Newark

NEWARK, N. J.—For the first time over any Radio a meeting of the Lions Club of this city was broadcast recently from the studio of WOR as a novelty entertainment to listeners in. The Lions Club is a business organization similar to the Rotary Club and the Kiwanis organization. The Radio meeting was attended by approximately seventy-five members.

Roll call was followed by comedy songs and speeches after which a serious talk on business conditions in Newark was given by the Lions' president, Ben F. Jones. A "Radio" meal was served.

WHAZ Holds to Record as World Broadcaster

Cables from Europe Report Remarkable Reception

TROY, N. Y.—That the slogan of Station WHAZ at the Rensselaer Polytechnic Institute here, "The Transcontinental and International Radiophone Station broadcasting from the Oldest College of Engineering in America," adopted a year ago, is still justified as another season of distance Radio reception opens, is demonstrated by reports being received from Europe and all parts of North America. Referring to a single weekly program, twelve letters and cablegrams were received from various points in England. Except in the matter of names of entertainers the reports show remarkable fidelity to the program as presented.

VERNI-TUNER

(Trade Mark)

3 in 1 Primary, Secondary and Variable Condenser

NO TAPS NO INTERFERENCE

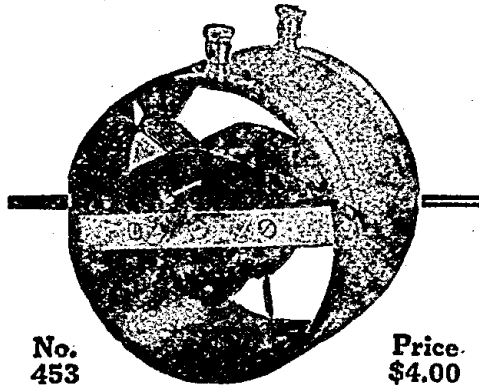

No. 453

Price \$4.00

Indispensable for Construction of Radio Sets Just add a rheostat and socket and you have a complete regenerative set.

MOST SELECTIVE TUNER MADE

Saves Labor—Space—Money

Serves as the main tuning device for all regenerative circuits, reflex circuits and the Horne. "Combined tuned radio frequency and reflex" circuits.

Other units for Reinartz, Cockaday, Flewelling and other circuits.

Booklets of 14 circuits free with each device. At your dealer or postpaid on receipt of purchase price. Write for leaflet.

HORNE ELECTRIC & MFG. CO. Mercer & Colgate Sts. Jersey City, N. J.

RADIO TALKS

Radio Frequency, Reflex and Super Circuits often refuse to work because of internal capacity in the set. Internal capacity, one of the greatest menaces to good reception, can be decreased or entirely eliminated by short, direct connections and wider spacing of connecting wires. Particular consideration should be given your sockets, for short spaced contacts are very often the cause of an otherwise good set working poorly. *E. J. Flewelling*

E. J. Flewelling Sockets

This socket is ideal for Radio Frequency and Reflex circuits. Positive self cleaning contacts—Elimination of internal capacity—Tube easily inserted and held firmly—Most direct mounting. These are the outstanding points wherein Flewelling Sockets differ from the ordinary socket. This means a more efficient set and better reception.

BUELL MANUFACTURING COMPANY

2977 COTTAGE GROVE AVE. CHICAGO

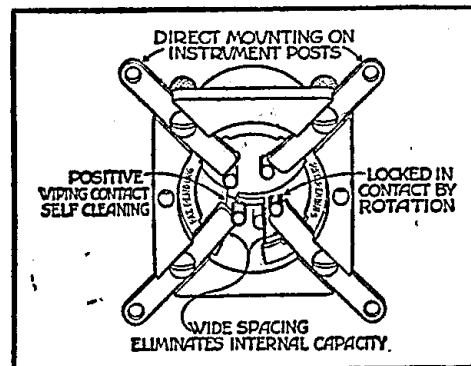

\$1.00 At your dealers or post paid.

YES! A RADIO FOR \$10.00

Don't Pay More—First See the



The Set with Only One Tuning Control

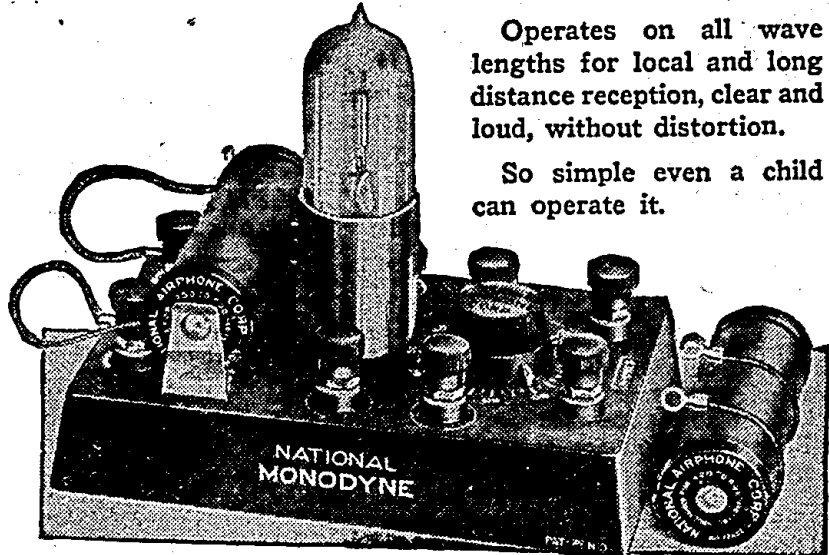

Operates on all wave lengths for local and long distance reception, clear and loud, without distortion.

So simple even a child can operate it.

If your dealer cannot supply you, write direct to



16-22 Hudson Street NEW YORK CITY

Federal Standard Head Sets

Professional expert radio operators, afloat and ashore, use Federal Head Sets because they're Federal Standard.

Federal Standard means perfect construction and utmost efficiency; it means perfectly matched pairs of phones that will get the utmost out of your Radio Set.

Ask for genuine Federal Standard Head Sets—no better can be bought.

Do not sacrifice efficiency of your Radio Set by using cheaper Head Sets.

130 Federal Standard Radio Parts offer the radio enthusiast a complete line of unqualifiedly guaranteed parts of the best quality.

List price 2200 OHMS

\$7.00



Federal Standard RADIO Products

EXPOSE OF MUSIC TRUST PRINCIPLES

SMALL PERCENTAGE OF SONGSTERS ON ROLL

Broadcasters' Association Finds Name of Composers' Society Is Misleading

(Continued from page 4)

vancing the common welfare of its members, and proper consideration and concentration of opinion upon questions relating thereto; to advocate the enactment of just and equitable laws pertaining to or affecting Radio; to support every movement to advance the Radio art; and to encourage and aid in the development of musical and literary genius, especially where such genius has not proper and just recognition.

Takes Measure of Antagonist

A survey was made of the American Society of Composers, Authors and Publishers, and it was found that:

1. Membership consisted, with but few exceptions, of a small percentage of the writers of words and music of ragtime, dance music, popular songs and musical comedies, and the publishers thereof.

2. The name of the organization was therefore found to be somewhat misleading, because representative American composers were not members, such as Harry Rowe Shelley; Harvey Worthington Loomis; Henry K. Hadley; Arthur Foote; Carrie Jacobs Bond; Horatio Parker; Charles W. Cadman; Rubin Goldmark; Williams Arms Fisher; W. J. Baltzell; Nathaniel Irving Hyatt; Homer A. Norris; Clifford N. Page; Henry F. Gilbert; Victor Harris; Charles Fonteyn Manney; Arthur Farwell; H. Leichter-Clough; John P. Marshall; David Stanley Smith; James H. Rogers; G. W. Chadwick; Ward Stephens; Samuel Richard Gaines; Cecil Forsyth; John H. Densmore; Mary Turner Salter; Alexander MacFayden; W. H. Neidlinger.

3. Nor were prominent American authors members, such as Sinclair Lewis; Edna Ferber; Joseph Hergeshelmer; Irvin Cobb; Fannie Hurst; Mary Roberts Rinehart; Sherwood Anderson; Emerson Hough; Christopher Morley; Arthur Train; Scott Fitzgerald; Carl Sandburg; Ernest Poole; Gertrude Atherton; Lee Wilson Dodd; Edgar Lee Masters; Samuel Hopkins Adams; Douglas Mallock, and Edith Wharton.

4. Nor were renowned and long established publishing houses members, such

WATCH SETS ITSELF BY RADIO



This watch automatically sets itself each noon via Radio and is the invention of Lieutenant John W. Isemann, U. S. N. R. F., who hopes to perfect a device to automatically correct and regulate chronometers of ships at sea thousands of miles from Arlington. The outfit consists of a miniature receiving set, containing a fixed cartridge detector and a "self-restoring coherer," which closes the circuit between a small storage battery in the set and a relay in the watch. The number of dashes of the time signal are exactly 270. A delicate escape wheel in the watch has 270 teeth and is rotated a tooth for a dash, until the snap mechanism is released and the hands snap to noon (or 11 p. m., as required). The watch may be adjusted to any signals. A tiny aerial of thirty feet of gold-plated wire is incorporated in the case, and intercepts the signals

Keystone View Photo

as Boosey; Doubleday-Page; John Church; Putnam; Ditson; Dutton; Schirmer;

Scribners; Fischer; Doran; Pond; Presser; Schmitt; Schubert; Summy; White-Smith; Wood, etc.

5. Their published membership showed 253 names of authors and composers out of a known list of over 5,000.

6. Their membership of publishers showed 33 names out of a known list of over 1,500.

7. The music of many popular songs has been written by song writers who were not members of the American Society of Composers, Authors and Publishers, proving beyond question that well known "hits" originate among the great number of song writers who are not members of the American Society. A few recent instances are: "Three O'Clock in the Morning," "Dardanella," "Yes, We Have No Bananas," "Love Sends a Little Gift of Roses," "Carolina Mammy," "When Will I Know," "M-A-Double-M-Y," and "Wonderful One." (These songs were quickly gobbled up by the publisher members of the American Society. If they, however, take over any songs which have been released by the National Association of Broadcasters, it must be subject to Radio rights previously conveyed to the broadcasters.)

Society's Music Not Better

When in full possession of these facts, the National Association of Broadcasters decided that there was certainly as much if not more desirable music outside of that which is controlled by the American Society of Composers, Authors and Publishers than that to which the society laid claim, and that the said American Society were in no position to make any concerted demands.

It must, of course, be conceded that more is heard of the music controlled by the American Society of Composers, Authors and Publishers, than that of the so-called independents for the simple reason that many of the publisher members of the American Society are old experienced hands at popularizing music. They employ professional staffs, song "pluggers," and through many expensive methods bring their songs to the ears of the people.

(TO BE CONTINUED.)

Vacuum Tubes Do Triple Duty With Erla Synchronizing Transformers

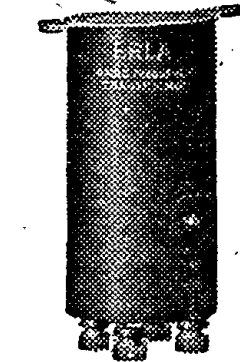
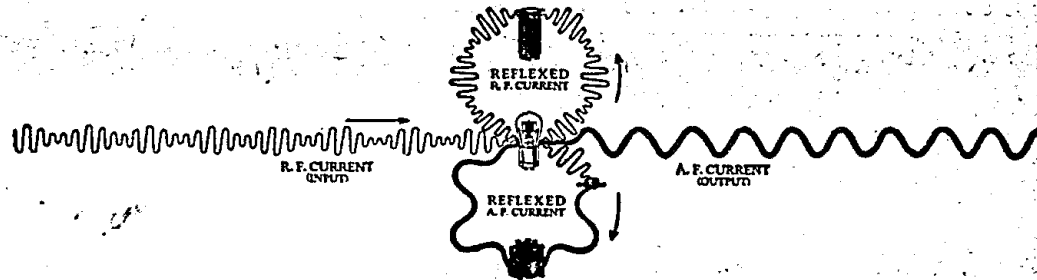

Perfect synchronization of received and reflexed r. f. currents make Erla radio transformers indispensable in reflex work. List, \$5

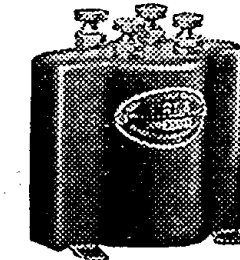

Rectified radio frequency and reflexed audio frequency currents are accurately synchronized by Erla audio transformers. List Price, \$5



Providing utmost sensitivity with perfect stability, the Erla fixed crystal rectifier is uniquely adapted for reflex work. List, \$1

For the first time, the full efficiency of vacuum tubes is completely utilized and brought under control.

In Erla reflex circuits, tubes do triple duty, providing simultaneous amplification of radio frequency, reflexed radio frequency and reflexed audio frequency currents. Yet, so precise is the manipulation of this complex current flow, that the tremendous gains resulting are achieved without a single deterrent flaw.

Not only do Erla reflex circuits demonstrate decisive superiority in range and volume, but they are also unequalled in selectivity, purity of reproduction, and ease of control.

Even the single-tube circuit provides far-flung loud speaker range, while the three-tube circuit surpasses costliest multi-stage amplifiers in transcontinental loud speaker reception. And the two-tube circuit is but a step behind.

Essential to the operation of these circuits, and the secret of their success, are Erla synchronizing radio and audio transformers. Providing perfect synchronization of received and reflexed currents having the same phase characteristics, they assure tremendously magnified amplification without trace of instability of distortion.

Complete working diagrams and description of perfected Erla reflex circuits are set forth in Erla Bulletin No. 14, obtainable gratis from leading radio dealers. Or write us direct, giving your dealer's name.

Electrical Research Laboratories
Dept. A 2515 Michigan Ave., Chicago



Dealers and Jobbers—Erla scientific progress steadily opens new avenues of trade and profit. Write for our liberal terms and discounts

AN EVENING AT HOME WITH THE LISTENER IN

(SEE INSTRUCTIONS FOR USE BELOW)

Station and City	Met	Monday	Tuesday	Wednesday	Thursday	Friday	Saturday	Sunday
CFCN, Calgary, Alta.	440	12:00-1:00		11:00-2:00			11:00-1:00	
CKAC, Montreal, Que.	430		6:00-8:30		6:00-8:30		6:00-8:30	3:30-4:30
KDKA, E. Pittsburgh, Pa.	326	5:00-9:00	4:00-8:00	5:00-9:00	5:00-9:00	5:00-9:00	5:00-9:00	6:30-7:30
KDZE, Seattle, Wash.	455	10:30-12:30		10:30-12:30		10:30-12:30		
KFAF, Denver, Colo.	350	9:00-10:00	9:00-10:00		8:30-9:00	9:00-10:00	9:00-10:00	
KFI, Los Angeles, Calif.	460	8:45-1:00	8:45-1:00	8:45-2:00	8:45-1:00	8:45-2:00	8:45-2:00	10:00-1:00
KGW, Portland, Ore.	492	10:00-12:30	10:00-1:00	10:00-1:00	10:00-1:30	10:00-1:30	10:00-1:00	8:30-10:00
KHJ, Los Angeles, Calif.	305	8:45-12:00	8:45-12:00	8:45-12:00	8:45-12:00	8:45-12:00	8:45-12:00	10:00-12:00
KPO, San Francisco, Calif.	423	10:00-12:00	10:00-12:00		10:00-12:00		10:00-2:00	10:00-12:00
KSD, St. Louis, Mo.	546	8:00-10:00	8:00-1:00	8:00-1:00		8:00-10:00	8:00-10:00	
KYW, Chicago, Ill.	538		8:00-9:00	8:00-9:00	8:00-9:00	8:00-9:00	8:00-9:00	
NAA, Radio, Va.	435	5:45-7:20	6:05-7:20	6:25-7:40	5:45-7:40	7:05-7:40		
WFAA, Havana, Cuba	400			7:30-10:00			7:30-10:00	
WBAP, Fort Worth, Texas	476	7:30-10:45	7:30-10:45	7:30-10:45	7:30-10:45	7:30-10:45	7:00-7:30	5:00-6:00
WBAV, Columbus, O.	390	8:00-10:00						
WBZ, Springfield, Mass.	337	5:00-8:00	6:30-8:00	5:00-11:00	6:30-8:00	5:00-11:00	6:30-8:00	5:45-8:30
WCAP, Washington, D. C.	469		6:30-7:30		9:00-11:00		6:30-11:00	6:20-7:20
WCBD, Zion, Ill.	345	8:00-10:00				8:00-10:00		2:30-5:30
WCK, Detroit, Mich.	517	7:30-9:00	7:30-11:00	7:30-9:00	7:30-9:00	7:30-9:00		6:15-7:15
WDAF, Kansas City, Mo.	411	8:00-1:00	11:45-1:00	8:00-1:00	11:45-1:00	8:00-1:00	11:45-1:00	
WDAF, Chicago, Ill.	360		7:00-1:00	7:00-1:00	7:00-1:00	7:00-1:00	7:00-1:00	9:15-11:15
WDAR, Philadelphia, Pa.	305	6:30-9:55	6:30-7:00	6:30-10:00	6:30-7:00	6:30-12:00	6:30-7:00	
WEAF, New York, N. Y.	402	6:30-9:00	6:30-9:00	6:30-9:00	6:30-9:00	6:30-9:00	6:30-10:00	6:30-9:00
WFAA, Dallas, Tex.	476	8:30-9:30	8:30-12:00	8:30-9:30	8:30-9:30	8:30-9:30	8:30-12:00	9:30-11:00
WFI, Philadelphia, Pa.	395	6:00-6:30	6:00-8:00	6:00-6:30	6:00-8:00	6:00-6:30	6:00-8:00	6:30-7:30
WGI, Medford, Mass.	360		6:00-7:30	6:00-7:30	6:00-7:30	6:00-8:00	6:00-8:00	7:30-10:00
WGR, Buffalo, N. Y.	319	5:30-11:00	5:30-7:45	5:30-11:00	5:30-7:45	5:30-11:00	5:30-7:45	2:00-3:00
WGY, Schenectady, N. Y.	380	6:45-9:00	6:45-9:00		6:45-9:00	6:45-10:30		5:30-6:30
WHIA, Madison, Wis.	300	7:30-8:30		7:30-8:30		7:30-8:30		
WHAS, Louisville, Ky.	400		7:30-9:00	7:30-9:00	7:30-9:00	7:30-9:00	7:30-9:00	4:00-5:00
WHAZ, Troy, N. Y.	380	8:00-9:30						
WHB, Kansas City, Mo.	411		8:00-10:00		8:00-10:00			8:00-10:00
WHK, Cleveland, O.	283	5:00-5:30	5:00-5:30	5:00-5:30	5:00-5:30	5:00-10:00	5:00-5:30	7:00-8:30
WHN, New York, N. Y.	360	6:30-11:00	8:30-11:00	6:30-11:00	8:30-11:00	6:30-11:00	6:30-11:00	8:30-11:00
WIP, Philadelphia, Pa.	609	6:00-6:30	5:00-11:00	5:00-6:30	5:00-10:00	5:00-6:30	5:00-11:00	3:30-4:30
WJAX, Cleveland, O.	390		6:30-8:30		7:00-9:30			
WJZ, Chicago, Ill.	448		10:00-2:00	10:00-2:00	10:00-2:00	10:00-2:00	10:00-2:00	6:00-9:00
WJZ, New York, N. Y.	455	6:30-10:30	6:30-10:30	6:30-10:30	6:30-10:30	6:30-10:30	6:30-10:30	7:00-9:30
WKAQ, San Juan, P. R.	360		7:00-8:30	6:00-7:00			7:00-8:30	
WLAG, Minneapolis, Minn.	417	7:30-10:00	7:30-10:00	7:30-12:30	7:30-10:00	7:30-10:00	7:30-12:30	7:45-8:45
WLW, Cincinnati, O.	309	8:00-10:00	10:00-12:00	8:00-10:00	10:00-12:00			
WMAQ, Chicago, Ill.	448		7:00-10:00	7:00-10:00	7:00-10:00	7:00-10:00	7:00-10:00	
WMC, Memphis, Tenn.	500	8:30-9:30	8:30-12:00	8:30-9:30	8:30-9:30	8:30-9:30	8:30-9:30	
WNAO, Boston, Mass.	278		7:00-9:00	8:00-10:00	7:00-9:00	7:00-9:00	8:00-10:00	5:30-7:30
WOAL, San Antonio, Texas	385		9:30-10:30		7:30-8:30			9:30-10:30
WOAW, Omaha, Neb.	526	9:00-10:00	9:00-10:00		9:00-10:00	9:00-10:00	9:00-10:00	9:00-10:00
WOC, Davenport, Ia.	484	8:00-9:00			8:00-9:00	8:00-9:00	9:00-10:00	7:00-10:00
WOO, Philadelphia, Pa.	509	6:45-10:00		8:00-11:00	8:00-9:00	8:00-9:00	9:00-10:00	
WOR, Newark, N. J.	405	5:15-10:00		5:15-10:00	5:15-6:30	5:15-6:30	5:15-10:00	
WQS, Jefferson City, Mo.	441	8:00-9:30			8:00-9:30			
WRC, Washington, D.C.	469	7:00-9:00		7:00-9:00		7:00-9:00		
WSAI, Cincinnati, O.	309		8:00-10:00		8:00-10:00		10:00-12:00	
WSB, Atlanta, Ga.	429	8:00-12:00	8:00-12:00	10:45-12:00	8:00-12:00	8:00-12:00	8:00-12:00	7:30-9:15
WSY, Birmingham, Ala.	360	8:00-8:45		8:00-8:45		8:00-8:45		8:00-9:00
WTAM, Cleveland, Ohio	390			7:00-8:30			8:00-10:00	
WWJ, Detroit, Mich.	517	7:30-9:00	7:30-9:00	7:30-9:00	7:30-11:00	7:30-9:00		4:30-5:30

Instructions for Use.—All the hours above are given in Central Standard Time. If your city uses Eastern Time, add one hour to each of the periods stated; if your city uses Mountain Time, subtract one hour; if your city uses Pacific Time, subtract two hours. This table includes only the evening broadcasts, and on Sunday, the late afternoon program.

GRIDIRON SCENES FLASHED OVER AIR

KYW SNATCHES UP EVEN SIGNALS OF TEAMS

Illinois-Chicago "U" Game Is Carried to Fans Who Stayed at Home

CHICAGO.—Football fans unfortunate to be unable to attend the Illinois-Chicago football game at Champaign, and who were also Radiophans, had a real treat recently when the game was picked up at Champaign by KYW microphones wired direct to the popular Chicago Westinghouse station and broadcast from here.

Announcer Harold A. Fall, assistant director of KYW, told every play direct from the new stadium, the opening of which was the big occasion of the day, which also was homecoming day for graduates of the University of Illinois. But besides Mr. Fall's announcing, one listening in to the game could almost tell just what was happening by the playing of the bands, cheers and umpires' whistles. Even the teams' mysterious signals were heard at times.

How Stunt Was Arranged

The broadcasting of the game was made possible by the latest type of equipment. Repeater or amplifier equipment had to be tested to meet very rigid requirements to insure the high quality of speech necessary for successful broadcasting. Special sealed wires were installed connecting the new stadium with KYW, which is located on the roof of the Edison building in Chicago.

The microphones used were selected from a large number, for only those giving a large volume of tone without noise or distortion could be used. The best wires in the Champaign to Chicago circuits were chosen out of all the lines available. They were of extra-large size to keep the drop in volume at minimum.

Operators, linemen and testers were stationed at frequent points along the line as an emergency measure to guard against any possible breakdown or interruption of the circuits.

When signals are too weak to operate a loud speaker, they are strong enough for several pairs of telephones.

ROOSEVELT'S SISTER SPEAKS OF HIS LIFE

The late President Roosevelt's sister, Mrs. Douglas Robinson, recently talked from WEAF on her brother's life K. & H. Photo



RADIO FEATURED AT GOTHAM SPARK SHOW

Fans Consider Electrical Pageant as Another Airphone Exhibit

NEW YORK.—The New York Electrical Exposition recently held in Grand Central Palace was, as far as the Radiophans were concerned, another Radio show. There was plenty of apparatus on display and many large companies were represented.

The Army had large space and showed all types of transmitters and receivers for use by artillery, aviation, cavalry, etc. A nice collection of tubes was also part of their exhibit showing all the different types of tubes which the army uses, from the little peanut tube to a big two-kilowatt transmitting tube.

—WILLARD—
WILLARD RADIO COMPANY
 291 BROADWAY,
 New York City
"THE BEST FOR LESS"

FLEWELLING CIRCUIT
 EVERY PART COMPLETE
 2 honeycomb coils, 1 2-coil mounting, 2 coil plugs, 3 .006 condensers, 1 variable grid leak, 1 grid leak, 1 23-plate .0005 MFD. variable condenser, 1 Vernier rheostat, 1 tube socket, 8 binding posts, 20 feet bus bar wire, 1 3" dial and 1 high grade panel **ALREADY DRILLED AS PER DIAGRAM in Booklet of instruction sent free. \$11.95**
 Two-Stage Audio Frequency Amplifier—Parts complete in every detail for this Circuit—\$11.00
 Specify type of tubes you intend using

CONDENSERS

3 Plate Variable; value, \$1.75	\$1.05
11 Plate Variable; value, \$2.50	1.20
13 Plate Variable; value, \$2.50	1.20
17 Plate Variable; value, \$3.50	1.85
23 Plate Variable; value, \$3.50	1.35
43 Plate Variable; value, \$4.50	1.95
13 Plate VERNIER; value, \$5.50	\$3.75
23 Plate VERNIER; value, \$6.00	4.00
43 Plate VERNIER; value, \$6.50	4.25

Honeycomb Coils, 50 turns mounted... \$.95
 Honeycomb Coils, 75 turns mounted... 1.00
 Double Coil Mountings... 2.45
 Triple Coil Mountings... 3.35
 Reinartz Coils, increased wave-length and mounting... 1.95

VARIOCOUPLER—Celeron Condensite and Litz Wire Wound Secondary; Value \$4.50. Special... \$2.25

AUDIO FREQUENCY TRANSFORMER—Designed for use with W. D. 11 Tubes, list, \$4.50; price... \$2.75

BALL BEARING INDUCTANCE SWITCH—value, 75c; special... \$.25

V. T. SOCKETS—Nickel, brass sleeve, composition base; value, \$1.00; special at... .40

EXTRA SPECIAL—Telephone 3000 Ohms Headsets; \$9.00 value; reduced to... 3.50
 Vernier Dial Adjuster. List, 35c; special... .25

REINARTZ CIRCUIT EVERY PART COMPLETE
 1 Reinartz wound coil, 1 tube socket, 1 rheostat, 1 23-plate .0005 MFD. variable condenser, 1 13-plate .00025 MFD. variable condenser, 3 inductance switches, 23 switch points and nuts, 6 switch stops and nuts, 8 binding posts, 2 3" dials, 1 variable grid leak, 1 .002 MFD. phone condenser, 23 feet bus bar wire, 1 high-grade panel **ALREADY DRILLED AS PER DIAGRAM** **\$10.95**
 and complete instructions...
 Two-Stage Audio Frequency Amplifier—Parts complete in every detail for this Circuit—\$11.00
 Specify type of tubes you intend using

BEST QUALITY JACKS, Single Circuit; value, 65c; special at... \$.30
Double Circuit; value, 90c; special at... .45

MULTIPLE POINT INDUCTANCE SWITCH with Knob and Dial (15 Switch Points)... \$1.25

LIGHTNING ARRESTERS approved by underwriters... .90

THREE-INCH DIALS—Unbreakable—heat resisting composition—high finish; special... .30

TWO-INCH DIALS—Same design—for rheostats and potentiometer; special at... \$.25

Filament Rheostat, 6 ohm... .65
 Filament Rheostat, 20 ohm... .80
 Filament Rheostat, 50 ohm... .90
 With 2" Dial, 15c extra.

TELEPHONE PLUGS... .60

FRESHMAN VARIABLE RESISTANCE LEAK and MICA CONDENSER Combined... .75

Half the pleasure of Radio is in building your own sets. Many pleasurable and profitable hours can be passed in this way. Our service department will be glad to give you any information you need. Just drop us a line.

Every article advertised above is guaranteed by the manufacturer and by us—Mail orders filled immediately—transportation **PREPAID** on all orders of \$5.00 or over east of the Mississippi River. Send cash, check or money order—absolutely no goods sent C. O. D.

Need tubes?—a good headset? Look these over carefully!

AUTOMATIC ELECTRIC \$10.00 Value Headsets

These headsets were formerly sold by the Automatic Electric Co., makers of telephone exchanges, at \$10 each. We bought their entire stock,—40,000 phones,—paid spot cash and because of this buying power (unequaled elsewhere in the radio field) we are able to offer you a \$10 headset for \$3.65. 30 years of experience have produced the Automatic Electric Headset. Coil is wound with about 6500 turns of No. 40 enamel coated copper wire. D. C. resistance 1600 ohms. Impedance at average music and voice frequency (800 cycles) 21,000 ohms. (Effective impedance rather than D. C. resistance is the big factor in a good headset.)

\$3.65

WESTERN ELECTRIC VT-2 Tubes 5 WATT "E" OR TYPE CW-931

About 1-3 of these 10,000 brand new, genuine Western Electric VT-2 Tubes that we bought from the U. S. Signal Corps have been sold. Radio men know that a genuine VT-2 Tube for \$7.45 is an unusual opportunity—a real "find"! These tubes may be used for RF and AF amplification and for CW, and phone transmitting. They have a higher amplification factor than any tube made! They are not Navy defects—released only as a surplus.

\$7.45

All merchandise GUARANTEED by us to be of BEST QUALITY All mail orders shipped to you PROMPTLY



"The largest Radio Store in America"
509 S. State St.
Dept. RD-113
Chicago, Ill.

RADIO AT N.Y. PRICES Daily Parcel Post

The Prices Quoted Below Deliver Goods to Your Door
HOW TO ORDER—Write your order plainly; state number, description and price of items wanted. Send Post Office or Express Money Order, personal check or bank draft.

Standard Brand Head Phones

B134 Brandes Superior	\$5.25
B135 Dictograph	6.75
B136 Baldwin Type "C" Double	9.85
B137 Baldwin Type "C" Single	4.95
B138 Western Electric	10.50
B139 Dietzen 8000 ohms extra special	3.95

Amplitone Loud Speakers
This speaker will give efficient results when used with any pair of Head Phones; highly nickel plated; 18 inches high.
B117\$3.95

Wave Trap
Simplifies tuning. Eliminates interfering stations, thereby improving the selectivity of your set. Selects between conflicting stations. Special while quantity lasts.
B131\$4.95

MISCELLANEOUS

B163 Spaghetti Tubing per yd.09
B164 Synthetic Crystal17
B165 Ground Clamps05
B166 Black Rubber Binding Posts05
B167 Nickel Plated Binding Posts, 2 for05
B168 No. 18 Annunciator Wire, half pound coil79
B169 6 ft. Phone Cord with Tips	1.95
B170 20 ft. Extension Cord with Tips05
B171 Wall Insulators, Porcelain10
B172 Tubular Porcelain Lead-in Insulators, 6-in.	1.45
B173 Reinartz Coil	2.42
B174 Cockaday Coil25
B175 2 in. Dial and Knob35
B176 3 in. Dial and Knob49
B177 4 in. Dial and Knob49

WOOD CABINETS
Highest grade Mahogany finish Cabinets. Hinged top. These cabinets are being sold at less than one-half regular value.
B57 Wood Cabinet; panel size 7"x10". Each... \$2.50
B58 Wood Cabinet; panel size 7"x12" 2.75
B59 Wood Cabinet; panel size 7"x14" 3.00
B60 Wood Cabinet; panel size 7"x18" 3.50
B61 Wood Cabinet; panel size 7"x21" 3.75
B62 Wood Cabinet; panel size 7"x24" 4.00

1 1/2 VOLT DIETZEN TUBE
Two-element Fleming valve effect; operates on one dry cell with or without "B" Battery; wiring diagram free with each tube.
B95 Dietzen Tube\$1.00
B96 Socket for Dietzen Tube... .40

Audio Frequency Transformers
The following transformers are guaranteed standard makes, and will produce very efficient results.
B63 Dietzen 3 to 1 Ratio.....\$3.95
B64 Dietzen 5 to 1 Ratio..... 3.95
B65 Dietzen 10 to 1 Ratio..... 3.95
B66 Acme Audio..... 4.25
B67 Amertran..... 5.95
B68 U.V. 712 R.C.A..... 5.75
B69 U.V. 714 R.C.A..... 5.75

Loop Aerial
B76. Can be assembled by anyone in five minutes; all wood parts, wire and binding posts included, complete.....69c

Plate Circuit "B" Batteries
The highest grade of battery made at prices lower than they ever were sold before.
B80—22 1/2 Volt Small.....\$1.15
B81—22 1/2 Volt Medium... 1.45
B82—22 1/2 Volt Large... 1.95
B83—45 Volt Medium..... 1.95
B84—45 Volt Large..... 3.50
B85—45 Volt Extra Large..... 3.50
B86—300 Hour 1 1/2 Volt Twin Double Duty "A" Battery..... .75

Modell's ESTABLISHED 1889
71 Cortlandt Street
 NEW YORK, N. Y.
 America's Greatest Radio Mail Order House
 ELEVEN NEW YORK STORES

MUSIC CONTEST TO FIND SONG WRITERS

WMAQ OFFERS FAME AND FORTUNE TO WINNERS

Prize Awards to Stimulate, Develop Latent American Talent—Woman Responsible for Idea

By J. L. Newman

CHICAGO.—So that the melodies now latent in the minds of the many nations which are fused in the crucible called America may be heard throughout the land, Station WMAQ, the Chicago Daily News, has begun a contest which, according to leaders in art, ranks well among similar cultural efforts. The competition will continue for sixteen or more weeks; only American citizens are eligible.

The aim of the competition is primarily the development of national musical talent. But there are many who see in the "match" a deadly blow at the efforts of organized music publishers to hinder the broadcasting of songs and other compositions.

To Rout Commercialism from Air

In establishing the contest WMAQ recognized the remarkable expansion of audiences in the United States, especially since the inception of Radio. There are said to be more than 7,000,000 Radio receiving sets in use almost every night. These bring into the homes especially a finer appreciation of music. It is this budding growth which Station WMAQ intends to cultivate. It is this flowering impulse which WMAQ intends to rid of organized commercialism.

Rules of the Contest

The rule of the competition that those who enter it must be born in the United States or else naturalized citizens, is considered most important. In this way Station WMAQ intends to adhere to its determination to advance and cherish American music.

The contest is divided into periods of four weeks each. There is a subcontest each week and a grand contest every fourth week to determine the merits of the compositions submitted.

The first period is devoted to popular or "jazz" song and dance music; the second period enables composers of ballads (vocal solos not of the so-called popular kind) to compete; the third is for band or orchestral music, and the fourth a repetition of the

JUDGES PONDER OVER COMPOSITIONS SUBMITTED



Circle insert: Judith C. Waller, director of Station WMAQ; judges at piano: E. E. Sheetz, Jr. (seated in front), widely known conductor, and Maurice Rosenfeld, music critic for Daily News; Eric DeLamarter (leaning over), assistant conductor of Chicago Symphony Orchestra; Arthur Olaf Anderson (at back), leading composer of Chicago
Photos by Daily News

first period. It is planned also to establish a contest (during a fifth period) for instrumental music for solos and for groups not larger than quintets.

Must Be Original

All compositions must be original, and never have been submitted to any pub-

lisher. All entries to the competition must be unsigned and addressed to the Music Contest Department, The Daily News, 15 North Wells street, Chicago; each must be accompanied by a sealed envelope containing the name and address of the entrant; those who desire the return of

their manuscripts should enclose sufficient postage.

When any of the compositions are published they are to become the property by copyright of The Daily News. If their publication runs into two or three edi-

(Continued on page 13)



AUDIO, RADIO PUSH-PULL TRANSFORMERS

TRANSFORMERS WHICH Really Transform! They Amplify

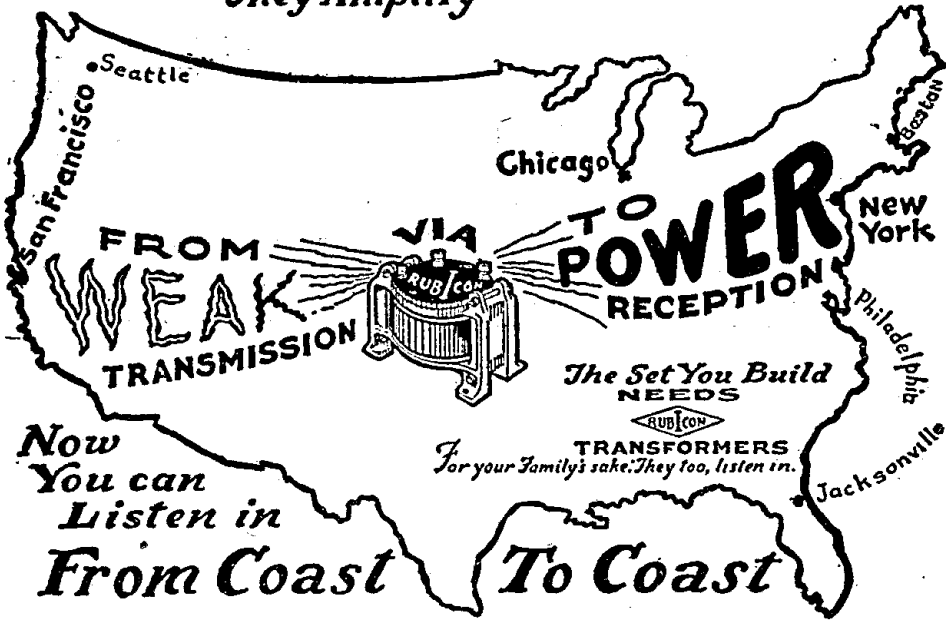

FOR SALE AT BEST RADIO DEALERS

GENERAL INSTRUMENT Co. 123 Liberty Street New York City

DUPONT MAKES New Pyralin Sheltone Loud Speakers

This New Pyralin-SHELTONE, made by DUPONT, gives greater volume—better tone and is more beautiful in appearance.

\$300



It is built differently to take advantage of the most correct acoustic principles and reproduces music and speech with a clear tone.

MADE EXCLUSIVELY FOR US

AT ALL DEALERS

Use the SHELTONE with ANY good phones and get wonderful results. We are distributors for Nath. Baldwin phones and the new Baldwin Loud Speaker.

Satisfaction guaranteed. C. O. D. or cash with order. Dealers write for discounts. DISCOUNT TO DEALERS

The Sheltone Company 185-189 Clinton Ave. NEWARK, N. J.

SINGLE TUBE SET FOR LONG-DISTANCE RECEPTION

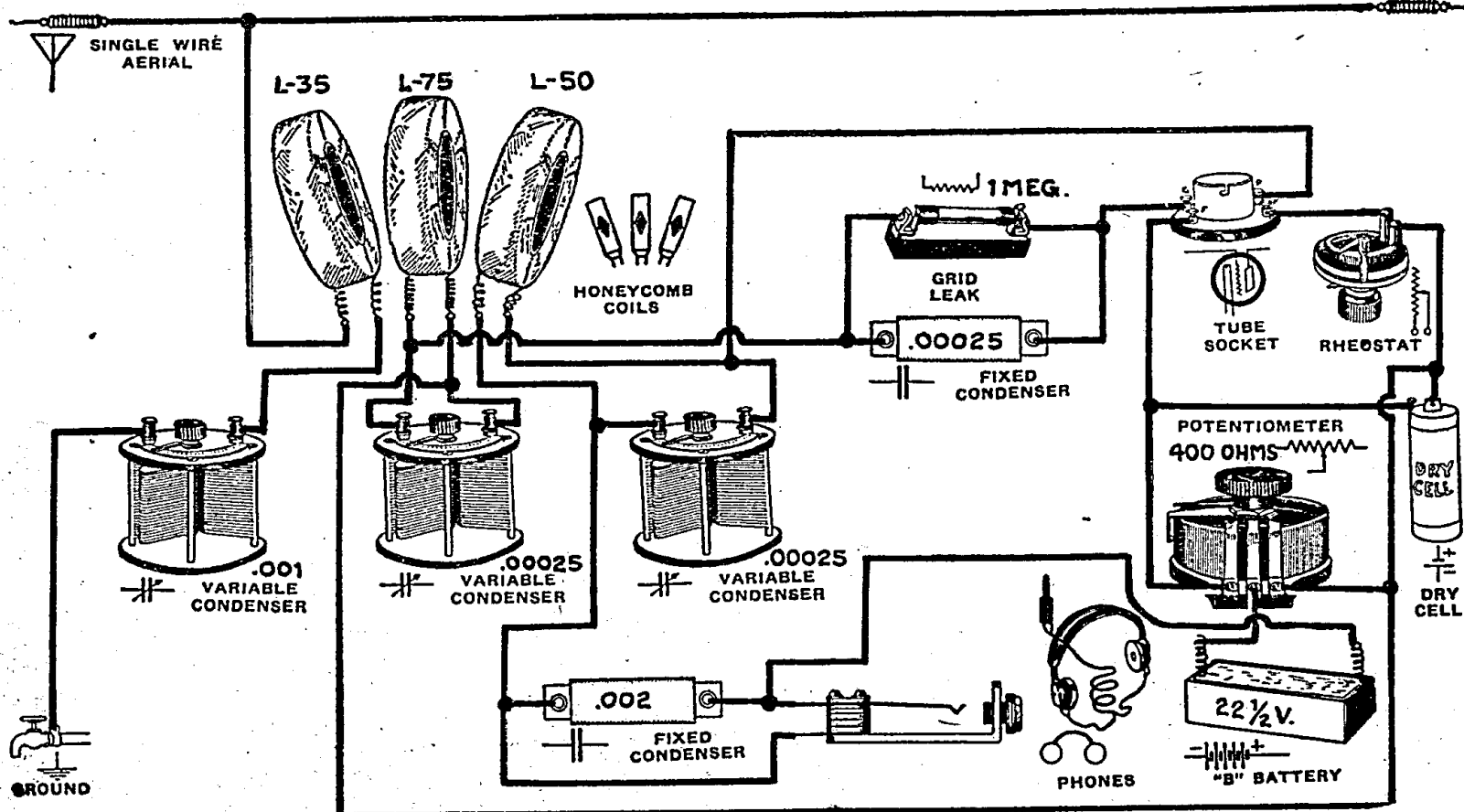

YES, sir, Mr. Martin C. Owens, of 4727 Gilpin street, Denver, Colo., tried this circuit and it's good, so we pass it on to you in the form of a Simplex diagram so anyone can understand it. He uses a WD-11 tube, but then let him tell you the story.

"I will try anything once and I will try anything twice," has been often said, but I go still further and say that I have tried different Radio hook-ups hundreds of times and have had various kinds of luck, resulting in either failures or successes, all of which I have in the end given up as not being as good in results as the diagram and parts herein described, where only one single tube is used, that enables me to get stations within the radius of 2,000 miles clear and distinct. The addition of two steps of amplification covers the entire Radio territory of America.

The diagram of the detector is very simple, and if wired as directed I am sure one can get as good results as I do myself. The honeycomb coils used are wound with number 22 dcc. wire and L-50 is reversed in the plate circuit. To do this properly, unscrew the coil from its socket and give it one-half turn without disconnecting the soldered leads, then tighten up back in place again, and the results will well pay for the trouble of reversing. Good parts to make this set are very essential, and should be purchased at a first-class Radio store that handles A1 goods from good manufacturers advertising in the Radio Digest."

Tuned and Untuned R. F.
Fans hearing of the expression "Radio frequency," generally think that by simply adding a one-step Radio amplifier to their tuners, distant stations will be easily tuned in. They will be disappointed with one step, as it actually cuts down the signal strength. Two steps shows some improvement over none at all, but one step of tuned Radio frequency, correctly built and operated, will give results better than or at least equal to two steps of untuned.

To retain long life tubes must be mounted with the filament in a vertical position.

Elements in Tubes
The three elements of the modern vacuum tube are the grid, plate and filament, which may be described as follows: The grid is a coarse metal mesh or a spiral of fine wire and is always placed between the filament and the plate. The plate is in the form of a perfect or flattened cylinder. Sometimes it is corrugated, but more often smooth. Usually it is the area of the plate that determines the capacity of the tube. The filament usually consists of a fine tungsten wire inside the plate and invisible from the outside. It glows with a deep red in some tubes, but with a brilliant yellowish white in others. When heated to the proper temperature it is the source of tiny electric charges called electrons, on which the operation of tubes depends.

The "height" of an antenna is the distance above the ground of its "middle point."

FORMICA
A Laminated Phenolic Condensation Product
SHEETS TUBES RODS
RADIO PANELS
POLISHED BLACK FINISH
CUT PERFECTLY SQUARE TO ANY SIZE
1/32" THICK 1/2¢ PER SQ. INCH
1/16" THICK 3/4¢ PER SQ. INCH
3/32" THICK 1¢ PER SQ. INCH
1/8" THICK 1 1/2¢ PER SQ. INCH
3/16" THICK 2¢ PER SQ. INCH
1/4" THICK 2 1/2¢ PER SQ. INCH
3/8" THICK 4¢ PER SQ. INCH
1/2" THICK 5 1/4¢ PER SQ. INCH
SEND FOR COMPLETE PRICE LIST
PROMPT ATTENTION TO MAIL ORDERS
DEALERS PRICES ON APPLICATION
STARRETT MFG. CO.
519 SOUTH GREEN ST. CHICAGO

REINARTZ COILS
IMPROVED COILS MADE TO COVER NEW WAVE LENGTHS
21 tap coils.....\$1.00
16 tap coils..... .90
Above prices include coil mounting and also circuit diagram. Sent postpaid upon receipt of money order.
Attractive discounts to dealers.
KINLEY RADIO CO., Box 185, Detroit, Mich.

1¢ SALE **THE RADIO SHACK** **1¢ SALE**
58 Dey Street, New York City
Written money-back guarantee with every purchase

MAKE 2 SETS FOR PRICE OF 1

1 1/2 Volt TUBES Satisfaction guaranteed. Fits standard socket. 1 FOR \$4.99 Ask to hear them.	2 For 5.00	SUPERTRON 6 V. TUBES Excellent as detector or amplifier. Draws 1/4 amp. Oscillates in all circuits. 1 FOR \$6.49 Ask to hear them.	2 For 6.50	1¢ SALE	KRONE PHONES 2200 Ohms. Standard make. Remarkable clearness and volume. Can be used with horn. Reg. \$6.50. 1 FOR \$5.89	2 Prs. For 5.90	TUBE PROTECTORS Impossible to blow your tubes if you attach these to your socket. 1 FOR 49c.	2 For 50c	
JACKS SINGLE AND DOUBLE German silver Contacts. Heavy Springs. nickel finish. Reg. 90c. 1 FOR 59c.	2 For 60c	PLUGS Torpedo or Flat Easy adjustment for phone cords. High finish. Perfect contact. Reg. \$1.25. 1 FOR 69c.	2 For 70c	3 IN. DIAL GREBE TYPE Remarkable value. Brass Bushing. Tapered Knob. Reg. 50c. 1 FOR 49c.	2 For 50c	SWITCH LEVERS Adjustable Arm Fada Type Knob. Heavy Nickel arm collar. Reg. 40c. 1 FOR 29c.	2 For 30c	TRANSFORMER Audio Frequency. Well known standard make. Ratio 4-1. Reg. \$5.00. 1 FOR \$4.99	2 For 5.00

THE NEW ERLA 12 PAGE REFLEX BOOK FREE

RHEOSTATS 30 ohm. complete with knob and dial. Reg. 75c. 1 FOR 59c	2 For 60c	LIGHTNING ARRESTORS Approved by underwriters. A necessity for your set. 1 FOR 74c.	2 For 75c	POTENTIOMETER 200 ohms; a necessity for every circuit. Easy mount, perfect contact. Reg. \$1.00. 1 FOR 89c.	2 For 90c	D. L. COILS 35-50-75 Just the sizes for Flewelling Circuit. Reg. 60c. 1 FOR 59c.	2 For 60c	VARIABLE GRID LEAK CONDENSER Panel type. Needed for proper results. 1 FOR 99c.	2 For 1.00
--	------------------	--	------------------	---	------------------	--	------------------	--	-------------------

All Parts Not Listed Also at Competitive Prices

COIL MOUNTS Double or triple. Beautiful high finish mounts complete, with pig tail wire. Reg. \$5.00. 1 FOR \$4.99	2 For 5.00	HYDROMETERS Very accurate. Packed in wooden moisture proof box. Reg. 75c. 1 FOR 59c.	2 For 60c	B BATTERIES 22 1/2 Variable Type Regular 1.75...1.39 Regular 2.65...1.99 Regular 3.00...2.49 45 V. Variable Reg. 3.00...2.89 Regular 4.00...3.49 Regular 5.50...4.99 All Fresh and Tested	2 For 1c MORE	VARIABLE CONDENSER 23 PLATE Sturdy construction. Perfect alignment between plates. Reg. \$3.00. 1 FOR \$1.99	2 For 2.00	VERNIER CONTROL For any Dial. Makes a Vernier out of any make condenser. Very efficient. Reg. 75c. 1 FOR 49c.	2 For 50c
--	-------------------	--	------------------	---	----------------------	--	-------------------	---	------------------

WRITE FOR CATALOG RADIO CONSTRUCTOR FREE WITH EVERY \$1 SALE WE SHIP C. O. D.
Expert Advice Free by Mail
Orders Shipped Same Day as Received
ENTIRE CONTENTS OF THIS AD COPYRIGHTED BY THE RADIO SHACK

KELLOGG JACKS

Jacks!
—high jacks
—low jacks
—that help the game

Oh, what we know about jacks! If we were to romp through our records I should venture to say we have sold jacks enough to make the side of the Court House look like a radiator hood on a Flivver. Yes! We have built hundreds of thousands of jacks for the most critical telephone work for years. If you need jacks and want to be absolutely sure they will deliver, just put "Kellogg Jacks" down on your order list. You can't go wrong. A thoroughly efficient, snug little job at \$1.10 a piece for 4 conductor Jacks

Use is the test

KELLOGG SWITCHBOARD & SUPPLY COMPANY
CHICAGO

How to Build a Three-Tube Miloplex Receiver

Part III—The Hook-Up Diagrams

By H. J. Marx

THE reaction to the three Miloplex circuits published was marked by some very unusual peculiarities. Frankly speaking, the reason for presenting the three circuits was this: The writer was informed of the unusual success with the first one, and naturally it was decided to assemble a set for test. When this was

This made it apparent that the final or King circuit could not be the only one presented for amplification.

Two Circuits

For these reasons two circuits are now published for use. The first one is the King itself, amplified. And for those who prefer the first, or Wizard Miloplex, the

The condensers used from the plates of the first two tubes to the positive B battery was also shunted across the secondary of the last audio frequency transformer.

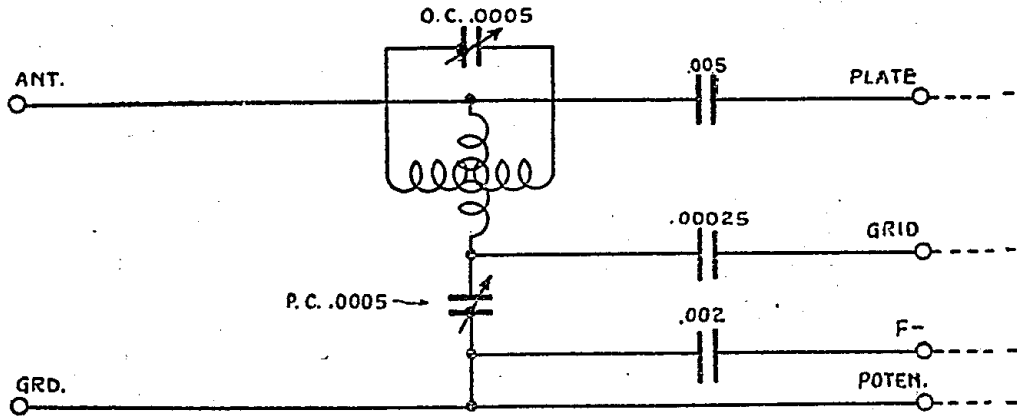

completed and passed on, the "Mystery Man" springs the jolt: "Oh, now I got a still better one." That meant starting all over again some more testing.

The completion of this second outfit was coincident with the introduction of the third circuit. Perhaps the Mystery Man would have sprung some more, but by this time the fans had started writing letters and now he's sweating blood trying to

second illustration of a three-tube circuit is given.

Inasmuch as the list of apparatus required is slightly different from that of the King three-tube circuit, a new list has been compiled. Remember, the list given on this page applies to the second circuit only. The parts needed for the first circuit were given in the first part of this series in the November 3 issue. The

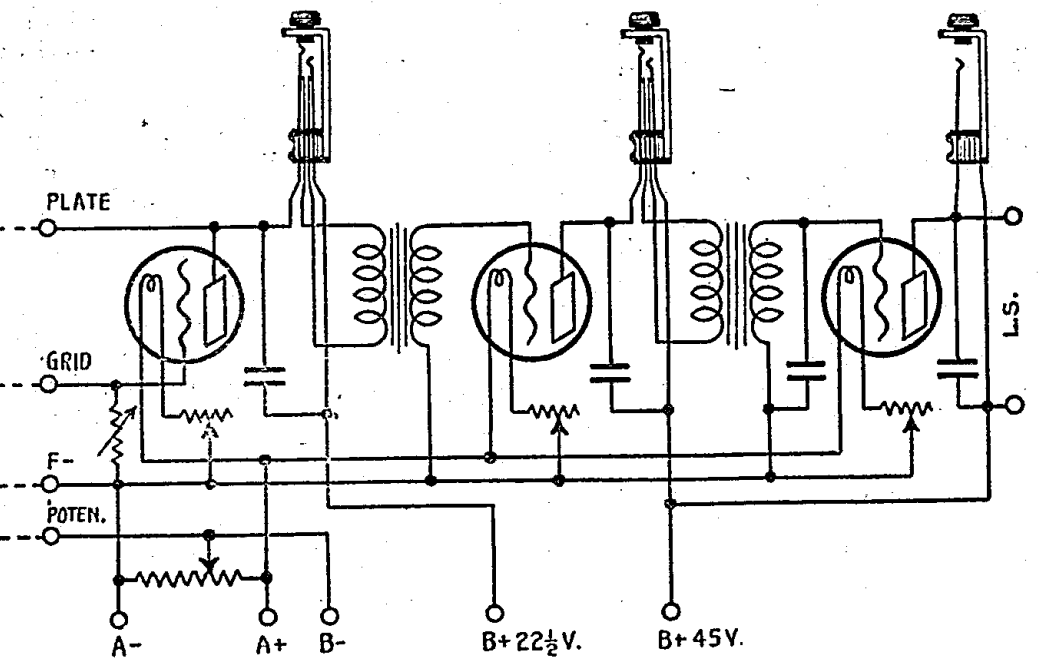

Above, Miloplex III circuit; Below, improved Miloplex I circuit

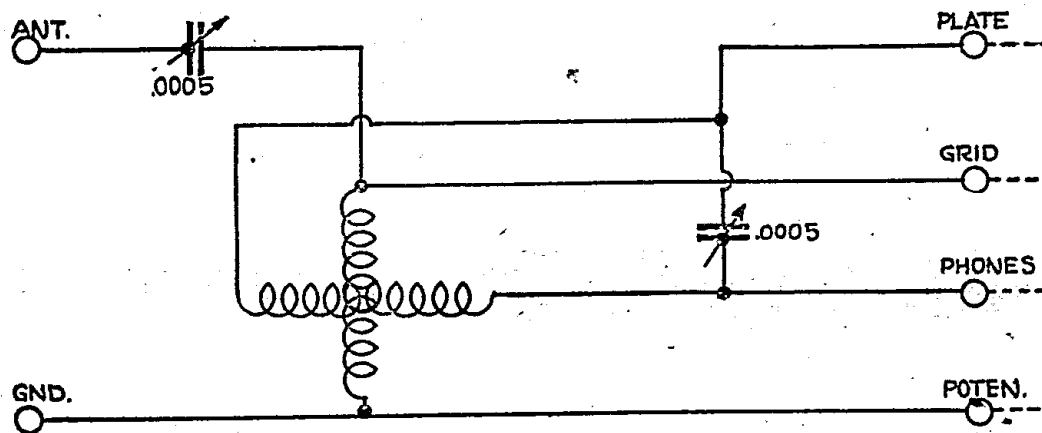

answer them all without thinking of any new Miloplex.

Now, to consider what happened when the fans tackled the circuits. Since all three circuits have been published, it's all right to tell this. All the letters received,

previously given instructions regarding the selection of apparatus, however, apply also to this second circuit.

Miloplex III

This circuit is practically the same as that presented by the Mystery Man, with the exception that a .005-mfd. fixed condenser has been added in the plate lead. This was found to assist the stability of the circuit and also to improve the tuning qualities.

No values are given for the by-pass condensers across the transformers, although they are given in the list of parts. It was found that with some transformers the values listed would not give satisfactory operation. This means it is up to the builder to try it out himself in order to get best results.

Fifty assorted flathead solid brass machine screws, nuts, washers, copper lugs, 50c. Eight initialed binding posts, set, 60c. Twelve nicked binding posts, 50c. All three items, \$1.50. RADIO LIST for stamp. All prepaid. Stamps accepted. Kladag Radio Laboratories, Kent, O.

tery terminals were both of .0015-mfd. capacity. The condenser from the plate terminal of the third tube to the positive B battery post has a capacity value of .0025 mfd. A .0001-mfd. fixed condenser

Improved Miloplex I
The second circuit, outside of the amplification stages, has incorporated some improvements upon the original Miloplex

(Continued on page 14)

LIST OF PARTS

- 1 Variometer.
- 2 Variable Condensers .0005 mfd.
- 3 Dials.
- 1 Fixed Condenser .00025 mfd.
- 1 Fixed Condenser .0015 mfd.
- 1 Fixed Condenser .0025 mfd.
- 1 Fixed Condenser .0001 mfd.
- 9 Binding Posts.
- 8 Single Connection Jacks
- 2 Panels 3/16"x7"x12".
- 3 Pieces Panel Stock, 3/16"x1 1/2"x4 1/8".
- 3 Brass Angles.
- 3 Rheostats, 20 Ohms.
- 1 Potentiometer, 1,850 Ohms.
- 1 Variable Grid Leak.
- 2 Double Circuit Jacks.
- 1 Single Open Circuit Jack.
- 2 Audio Frequency Transformers.
- 3 Standard Tube Sockets.
- 3 Vernier Adjusters.
- 2 Baseboards 1/2"x7 1/2"x12".

with rare exceptions, tell of fans who have had unusual results with one of the three circuits. In fact, the peculiar part of the whole situation is that each fan boasts of one of the three to the exclusion of the others.



(Patent Pending)

THE PERFECT SYNTHETIC CRYSTAL DETECTOR, SENSITIVE OVER ENTIRE SURFACE. No Hunting for "Spots." Loud and Clear. Endorsed by thousands of satisfied users. Sensitivity Guaranteed. Price, Mounted..... 50c

14 K. GOLD SUPERSENSITIVE RUSONITE CATWHISKER. Permanent. Will Not Oxidize. Price..... 25c

RUSONITE REFLEX CRYSTAL. Manufactured Expressly for Reflex Circuits. Will Stand Up Under Heavy Plate Voltage. Guaranteed. Price, Mounted... \$1.00

Order from your dealer or direct from RUSONITE PRODUCTS CORP. 15-Park Row New York, N. Y.

Improved Ground Clamp

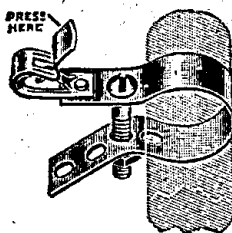

Equipped with Fahnestock Patent Wire Connectors

Easily Attached

No Soldering. For Radio Use Only

At Your Dealers

Fahnestock Electric Co.

Long Island City, N. Y.

2650 MILES

with ONE TUBE. Broadcasting from Atlantic Coast and Cuba heard in California by users of the CROSS COUNTRY CIRCUIT. This range is due to simplicity of set and operation as only one control is used for tuning. Easily and cheaply built. Dry cell tubes may be used. Complete instructions, with panel layout, assembly views, etc., postpaid for 25c. Or further information for red stamp. VESCO RADIO SHOP, Bx. 117, Oakland, Cal.



The Saturn "Above the Ordinary" Radio Products

"Automatic Plug" Connected—disconnected in a moment. Pulling tightens grip on cord tips. Lever instantly releases. Smooth, positive contact. Time and effort economized. Each Saturn Plug unconditionally guaranteed. Extra satisfaction at the same price. LIST PRICE \$1

Perfect Jack Rounded corner brass bracket, nickel plated. Spring German silver blades. Contact points of solid silver. Solder-flux compound on crow-foot offset of blades. Ready for quick connecting.

- List Prices
- No. 1 Single Circuit, Open.....50c
- No. 2 Single Circuit, Closed.....55c
- No. 3 Double Circuit, Closed.....70c
- No. 4 Single Filament Control.....75c
- No. 5 Double Filament Control.....80c

If your dealer cannot supply you send us your order direct

Write for Folder The SATURN Mfg. & Sales Co. 48 Beekman Street New York, N. Y.

IF YOU CAN'T BUY THEM AT YOUR DEALER'S SEND DIRECT TO US

"Red-Heads" are guaranteed radio phones. You run no risk when you buy them. Money back if, after 7 days' trial, you're not satisfied that they're the best receivers on the market at the price. Why not act right now and get a pair? It'll mean getting the maximum from broadcasting from the day you put them into use.

RED-HEAD RADIO RECEIVERS

These remarkable head-sets are made by The Newman-Stern Co., one of the pioneer radio manufacturing houses in America.

JUST OUT The new 1924 Model F \$6.50 PER PAIR Complete

The new 1924 "Red-Head" Jr. \$5.00 PER PAIR Complete

This is the standard 3,000 ohm "Red-Head." The 1924 Model F has eleven improved features. Sensitive and fine-tuned; aluminum case; famous brown-red ear caps; military headband; high-grade cord.

"Red-Heads" sent prepaid on receipt of price if you are unable to get them at your dealer's.

THE NEWMAN-STERN COMPANY Dept. RD. Newman-Stern Bldg. Cleveland

OPERA, PLAYS AND MUSICAL PROGRAMS

The Jewess

THE TWO operas you are to hear this week from KYW are similar in outline and are both written and sung in Italian. The plot of the Jewess is laid in Constance during the Middle Ages. Rachel, the Jewess, has been kidnapped and adopted by Eleazar, the Jew, although she is really the daughter of Cardinal Francesco di Brogni. Prince Leopold, who is engaged to the Princess Eudosa, carries on a clandestine love affair with Rachel disguised as a Jew. While he is in the little jewelry shop, Princess Eudosa comes to buy her lover a chain. This touches the false heart of the prince and he returns to her. However, Rachel and her father deliver the chain and see the prince. Rachel denounces him and both are condemned to die, because it is against the law for a Jew to marry a Christian. Touched by the pleading of Princess Eudosa, Rachel withdraws her charge. The prince's life is saved but the two Jews must die unless they will turn Christian, because they have conspired against the life of a Christian. As Rachel leaps into the seething cauldron of oil, Eleazar tells the Cardinal that she is his lost daughter. The opera ends with Eleazar also leaping into the cauldron and the Cardinal prostrate with the thought of the death to which he has condemned his own child.

Il Trovatore

IL TROVATORE is also built around the kidnapping of a child of noble birth, but this time Azucena, a gypsy, steals Manrico, the son of a Duke. Manrico falls in love with Leonora, a noble lady of Aragon, who also has for a suitor Count di Luna, the brother of Manrico. Not knowing their relationship both come to serenade the same lady and fight a jealous duel, in which Manrico is wounded. While Manrico is recovering from his wounds, Leonora thinking that her lover is dead, decides to take the veil. The Count plans to kidnap her before she enters the convent. Manrico and his followers prevent this but are in the end beaten by the Count who throws Manrico and his mother into prison. The prison songs of this opera are very famous. Leonora promises to marry the Count if he will free Manrico. While the Count is rejoicing over his promised happiness Leonora takes this news to her lover and dies in his arms. The Count in his anger has Manrico executed at once. As the Count stands in the palace, looking down into the courtyard, the old gypsy tells him he has killed his own brother.

Tuesday, November 13

KDKA, E. Pittsburgh, Pa. (Eastern, 326), 6:15 p. m., Dinner concert, Grand Symphony Orchestra; 7:45, Children's period; 8:15, Talk on trip to Europe; Dr. John Ewers; 8:30, Ham's Concertina Orchestra; J. Ham, concertina player; J. Berles, cornetist; W. Geminder, violinist; G. Hamm, banjoist; W. Wheeler, plays traps and drums; Thomas J. Durkin, tenor.

KFI, Los Angeles, Calif. (Pacific, 469), 6:45-7:30 p. m., Concert, Emma M. Bartlett, chairman of Public School Music, State Federation of Music Clubs; 10:00-11:00, Concert, courtesy of Mrs. J. Spenser-Kelly, president of Matinee Musical Club.

KGW, Portland, Ore. (Pacific, 492), 8:30 p. m., Talk Jeanette P. Cramer; 8:00, Talk for farmers, Paul V. Marrio; 10:00, Dance music, George Olsen's Metropolitan Orchestra.

KHJ, Los Angeles, Calif. (Pacific, 395), 12:30-1:15 p. m., Concert; 2:30-3:30, Matinee musicale; 5:45-7:30, Children's program; 8:00-10:00, John Henry Hopkins, cornetist; Burkman Brothers Hawaiian Quartette; Dr. W. C. Morgan, appearing through the courtesy of the Braum Corporation; 10:00-12:00, Art Hickman's Orchestra.

KSD, St. Louis, Mo. (Central, 546), 8:00 p. m., Program, Flower Shop Band; Addresses, Dr. George H. Moore, Lieut. R. P. Luther, H. H. Shackelford; 11:00, Dance music, Silverman's Orchestra.

KYW, Chicago, Ill. (Central, 536), 11:35 a. m., Table talk, Mrs. A. J. Peterson of Peoples Gas Co.; 2:35 p. m., Studio program; 6:50, Children's bedtime story; 8:01-8:25, Grand Opera: The Jewess in Italian; Cardinal Francesco di Brogni, pres. of council, Virgilio Lazzari; Princess Eudosa, niece of the emperor, Angelo Minghetti; Eleazar, Charles Marshall; Rachel, Rosa Ralska; Bugliero, provost of Constance, Desiro Defrere; Alberto, Gildo Morelato; A herald, Milo Luka; Ettore Panizza, conductor.

WBAP, Fort Worth, Texas (Central, 476), 7:30-8:30 p. m., Concert, Southwestern artists; 9:30-10:45, Novelty concert, auspices of N. McCarty Rubber Co.

WDAP, Chicago, Ill. (Central, 360), 1:40 p. m., Concert, Drake Concert Ensemble and Blackstone String Quintet; 7:00, Drake Concert Ensemble and Blackstone String Quintet; 10:00, Frederick W. Agard, tenor; Bob Cougle, pianist; Diana Tyson, contralto; Gladys Fingenbaum, soprano; Pauline Flisk, pianist; Jack Chapman's Orchestra.

WEAF, New York, N. Y. (Eastern, 492), 11:00-12:00 p. m., Special program for women.

WFAA, Dallas, Texas (Central, 476), 12:30-1:00 p. m., Address, DeWitt McCurray; 8:30-9:31, Charles Scovin, baritone; William Pennington, tenor; 11:00-12:00, Ruth Fabian, singer; Mrs. Clyde F. Magee, reader.

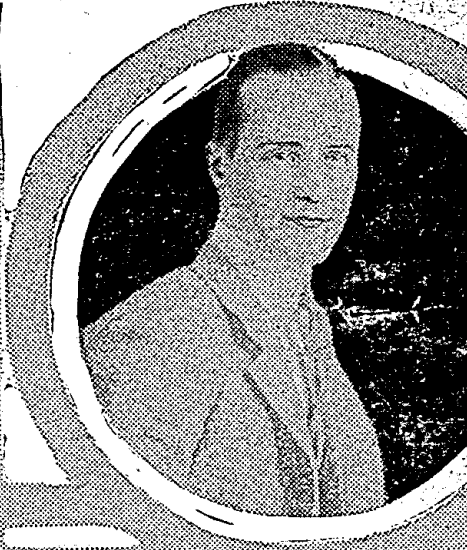

Tune in on KHJ, Wednesday, November 14, and hear Virginia Flohr (left), give you some real soprano solos. Chas. H. Wagner (above), Radio poet, is on WGI every Friday

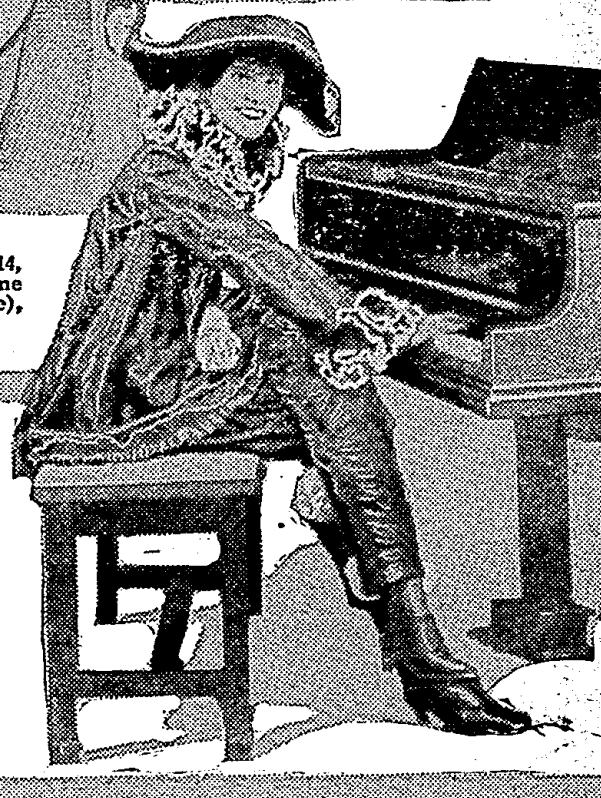

WFI, Philadelphia, Pa. (Eastern, 395), 1:00 p. m., Dinner music, Meyer Davis Bellevue Stratford Orchestra; 3:00, Short talk; 6:30, Dinner music, Meyer Davis Bellevue Stratford Orchestra; 7:00, Children's own half hour, Cousin Sue; 9:30, Radio play by WFI Players.

WGI, Medford Hillside, Mass. (Eastern, 360), 3:00 p. m., Amrad Women's Club; "Hospitality Talk," Ida B. Allen; Descriptive musicale, Chickering & Sons Company; 7:00, Evening musicale, Boston Y. M. C. A.

WGY, Schenectady, N. Y. (Eastern, 380), 2:00 p. m., "The Bear Story," Mrs. W. H. Rowney; 7:45, Radio drama, "The County Fair," WGY Players, Abigail Price, Helen Campbell; Otis Tucker, Edward H. Smith; Sallie Greenaway, Rose Cohn; Joel Bartlett, Edward E. St. Louis; Solon Hammerhead, Jerome Lovenheim; Tim, Frank Oliver; Tags, Lola Sommers; Bill Parker, Charles Baum; Cold Molasses, by himself; "Few Moments With New Books," William F. Jacob; WGY Orchestra.

WHAS, Louisville, Ky. (Central, 400), 4:00-5:00 p. m., Selections, Strand Theater Orchestra; "Just Among Home Folks"; Selections, Rialto Theater organ; 7:30-9:00, Concert, Miller's Entertainers, Jarric Miller, director and saxophonist; Keith Kanard, saxophonist; Cliff Eblen, pianist; Jimmie Curran, violinist; Leslie Smith, banjoist; Roy Brown, trombonist; Jack Kendall, tubaist; Gus Rapp, drummer; Reading: "An Interesting Historical Episode."

WHN, New York, N. Y. (Eastern, 360), 9:30-9:45 p. m., Mixed sextette of Corona Congregational Church; 9:45-10:15, Charles Hatloway's Orchestra; 10:15-10:45, Louis Barbey Trio; 11:00-11:30, Shapiro, Bernstein Music Co.; 11:45-12:00, Nicholas M. Piroso and His Orchestra.

WIP, Philadelphia, Pa. (Eastern, 509), 1:00 p. m., Organ recital, Karl Bonawitz, Germantown Theater organ; 3:00, Popular Song program; 6:55-6:45, Dinner music, Dick Regan and his WIP Little Symphony Orchestra; 7:00, Uncle Wip's bedtime stories and roll-call; 8:00, Special song recital; 10:15, Dance music, Charlie Kerr and his orchestra from Hotel St. James.

WJAX, Cleveland, Ohio (Eastern, 390), 7:30 p. m., Bedtime story, E. G. Johnson; 7:45, Program, Cleveland News-Leader; Spitalny's Orchestra in a program of popular dance numbers.

WJAZ, Chicago, Ill. (Central, 447), 10:00 p. m., 2:00 a. m., Estelle Sergeant, soprano; R. F. Elliott, tenor; Mary B. Smith, pianist; W. Brauer, cellist; Oriole Orchestra.

WJZ, New York, N. Y. (Eastern, 455), 3:00-4:00 p. m., Wanamaker concert; 4:00-4:10, Rex Schepp with banjo solos; 4:10-4:20, Nanchen Adams Rosan, soprano; 4:20-4:30, Rex Schepp, banjo solos; 4:30-4:50, Nanchen Rosan, soprano; 4:55-5:10, "Home Beautiful," Dorothy Ethel Walsh; 5:10-5:30, Ada Dubens, Rose Shelly, popular songs; 5:30-6:30, Program, MacMillan Company; 7:30-8:25, Warner Hawkins, pianist; "University of the Air," "Business Conditions, Dr. Warren Hickernell; 8:15-8:25, "Baseball and Banking," Henry R. Johnston; 8:25-11:30, Frank Jacob, tenor; "Etiquette" by Doubleday Page Co.; Elizabeth Gibbs, contralto; "Wild Animal Hunting," Charles Mayer; "Garden Talk," Peter Henderson Company; Hotel Astor Grill Orchestra.

WLW, Cincinnati, Ohio (Central, 309), 10:00 p. m., Program, Celeste Bradley, violinist; Rose Bradley, pianist; Thomas J. Bradley, baritone; Archie Bradley, boy soprano; Richards Quartette; Circle Orchestra.

WMAQ, Chicago, Ill. (Central, 447.5), 4:30 p. m., Program, pupils of Glenn Dillard Gunn School of Music; 7:00, Talk, Elsie Glamore, La Salle Extension University; Program, Chicago Consulate of Germany; 9:00, Ensemble music, Hotel La Salle Orchestra; 9:15, Weekly program, Lyon & Healy.

WOAW, Omaha, Neb. (Central, 526), 9:00-9:45 p. m., Hotel Fontanelle Concert Orchestra; 9:45-11:00, Program, colored artists, Edna M. Stratton, soloist; Clarence Desdunes, violinist; Lucy Allen, pianist; Irene Corcoran, soloist; Frances D. Gordon, pianist; Elizabeth Allen, singer.

WOC, Davenport, Iowa (Central, 484), 12:00 p. m., Chimes concert; 3:30 p. m., A. G. Hinrichs, lecturer; 5:45, Chimes concert.

WOD, Philadelphia, Pa. (Eastern, 509), 11:00-11:30 a. m., Organ recital; 12:00-12:35 p. m., Luncheon music, Anamaker Tea Room Orchestra, Robert E. Golden, director; 4:45-5:00, Organ recital, Mary E. Vogt.

WWJ, Detroit, Mich. (Eastern, 517), 9:30 a. m., "Tonight's Dinner," Woman's Editor; 9:45, "Ironing Day" program, Fred Shaw and Margery Richmond; 3:00 p. m., Detroit News Orchestra; Town Crier; Vocal program, Thaddeus Wronski and his pupils.

Wednesday, November 14

KDKA, E. Pittsburgh, Pa. (Eastern, 326), 6:30 p. m., Dinner concert, Pittsburgh Athletic Association Orchestra; 7:45, Children's period; 8:30, Little Symphony Orchestra; Irma McCall, soprano; Virginia Kendrick, contralto.

KFAE, Fullman, Wash. (Pacific, 330), 7:30 p. m., "How to Discover One's Aptitudes and Abilities," Dr. D. W. Hamilton; "Women and Clothes," Helen K. Robson; "Crop Improvement by Breeding," Prof. E. F. Gaines, music.

KFI, Los Angeles, Calif. (Pacific, 469), 6:45-7:30 p. m., Detective stories, Detective Nick Harris; 10:00-11:00, Concert, courtesy of Anna Priscilla Fisher, composer, featuring music of American composers.

KGW, Portland, Ore. (Pacific, 492), 3:30 p. m., Children's program; Piano solos, Fay Jackson, Edith Forman; Story, Aunt Nell; 8:00, Old-time dance music, Walker Brothers of Forest Grove; 9:00, Business talk, James Albert; 10:00, Dance music, George Olsen's Metropolitan Orchestra.

KHJ, Los Angeles, Calif. (Pacific, 395), 12:30-1:15 p. m., Concert program; 2:30-3:30, Matinee musicale; 6:45-7:30, Children's program; 8:00-10:00, Virginia Flohr, soprano; Ronald Faulkner, artist; 10:00-12:00, Art Hickman's Orchestra.

KSD, St. Louis, Mo. (Central, 546), 7:00 p. m., Program, Aberg's Concert Ensemble; Arno Arnesen, violinist; 11:30, Dance music, Rodemich's Orchestra.

KYW, Chicago, Ill. (Central, 536), 11:35 a. m., Table talk, Mrs. A. J. Peterson of Peoples Gas Co.; 8:00-8:30 p. m., Chicago Musical College; 9:05, Reviews of latest books, Llewellyn Jones.

PWX, Havana, Cuba (Eastern, 400), 8:30-11:00 p. m., General Staff Band of the Cuban Army.

WBAP, Fort Worth, Texas (Central, 476), 7:30-8:30 p. m., Concert, Sam Losh and pupil artists; 9:30-10:45, George Freeman's Sooner Serenaders.

WDAP, Chicago, Ill. (Central, 360), 1:40 p. m., Concert, Drake Concert Ensemble and Blackstone String Quintet; 7:00, Drake Concert Ensemble and Blackstone String Quintet; 10:00, Hugh B. Marshall, tenor; Jack Chapman's Orchestra.

WEAF, New York, N. Y. (Eastern, 492), 9:00-10:00 p. m., Broadway-King Company Dance Orchestra.

WFAA, Dallas, Texas (Central, 476), 12:30-1:00 p. m., Address, representative of the Dallas Chamber of Commerce.

WFI, Philadelphia, Pa. (Eastern, 395), 1:00 p. m., Dinner music, Meyer Davis Bellevue Stratford Orchestra; 3:00, Song recital; 6:30, Dinner music, Meyer Davis Bellevue Stratford Concert Orchestra; 7:00-7:30, Bedtime stories, Cousin Sue.

WGI, Medford Hillside, Mass. (Eastern, 360), 6:50 p. m., "A Message to Camp Fire Girls," Charles W. Casson; 7:15, "This Week Judge," 7:20, "Science Up to Date," Scientific American; 7:30, The Amrad Concert Players present two operettas: Fair Ellen, by F. Chester MacDan, director; "Some Home Problems," David McGregor Cheney.

WHAS, Louisville, Ky. (Central, 400), 4:00-5:00 p. m., Selections, Strand Theater Orchestra; "Just Among Home Folks"; Selections, Alamo Theater organ; 7:30-9:00, Concert, Mrs. John E. Harmon, Jr.; Reading: "An Interesting Historical Episode."

WHN, New York, N. Y. (Eastern, 360), 2:15-2:45 p. m., Gardens Orchestra; 8:00-9:30, Al King's Rajah Serenaders; 11:30-11:40, S. Jay Kaufman, talk on plays and art.

WIP, Philadelphia, Pa. (Eastern, 509), 3:00 p. m., Artist recital; 6:00-6:45, Dinner music, Jordan-Lewis Dance Orchestra; 7:00, Uncle Wip's bedtime stories and roll-call.

WJAZ, Chicago, Ill. (Central, 447), 10:00 p. m., 2 a. m., Program, Walo-Twitchell Piano Co.; Oriole Orchestra.

WJZ, New York, N. Y. (Eastern, 455), 3:00-3:15 p. m., Charles Bryden, tenor; 3:15-3:30, Stella Stamler, pianist; 3:30-3:45, Charles Bryden, tenor; 3:45-4:30, Harry W. Niles, bass; Stella Stamler, pianist; 4:30-5:45, Hotel Commodore Orchestra; 6:00-6:30, "Peter's Adventures Stories," Florence Smith Vincent; 7:30-7:45, Zella Seers; 7:45-8:00, "Review of Chorus," 8:00-8:45, Prudential; 8:00 p. m., 4:30, Cosmopolitan School of Music and Dramatic Art; 7:00, Georgena Faulkner, story lady; 7:30, Weekly lecture from Northwestern University; 9:00, Ensemble music, Hotel La Salle Orchestra; 9:15, Lindblom High School Orchestra.

WOAW, Omaha, Neb. (Central, 526), 9:00-11:00 p. m., Children's Orchestra, State School at Glenwood; E. R. Herrick, soloist; Three-minute talk on Glenwood Wayne D. Cheslo; Trumpet duet, Leslie Becker; Frank Cyphers; Vocal duet, J. D. Ironmonger, Helen Sydow; Helen Sydow, singer; Quartet, Mrs. Ed Marshall, Mrs. James Sawyer, Mrs. Clyde Rhoades, Mrs. Mel Stacey, Mrs. W. C. Rathke.

WOC, Davenport, Iowa (Central, 484), 12:00 p. m., Chimes concert; 3:30 p. m., Clyde G. Kern, lecturer; 6:30, Sandman's visit; 7:00, "Kitchen Arrangement," Edith Barker; 7:30, "Observation of Father and Son Week," Fred M. Hansen; 8:00, Edwin Swindell, organist; 10:00, Program, Kiwanis Club.

WOD, Philadelphia, Pa. (Eastern, 509), 11:00-11:30 a. m., Organ recital, Mary E. Vogt; 12:00-12:35 p. m., Luncheon music, Wanamaker Tea Room Orchestra; 4:45-5:00, Organ recital, Mary E. Vogt.

WOS, Jefferson City, Mo. (Central, 440.9), 8:00 p. m., "Overhauling the Tractor," Prof. M. M. Jones, music.

WTAM, Cleveland, Ohio (Eastern, 390), 8:00 p. m., WTAM Orchestra; Annette English, contralto; Gladys Mae Parsons, accompanist; Ben Silverberg, violinist; Clara Sharp, accompanist; H. M. Dunham, baritone; A. R. Willard, accompanist; Florence E. Beebe, pianist; Mrs. Emma Johnson Wise, soprano; Gladys Mae Parsons, accompanist; Max Schmitt, cellist, Comedy monologue; Chic Sale, star of "Common Sense."

WWJ, Detroit, Mich. (Eastern, 517), 9:30 a. m., "Tonight's Dinner," Woman's Editor; 9:30 p. m., Detroit News Orchestra; 7:00, Detroit News Orchestra; Town Crier; Hubert Haussler, bass; Amy Neuhold, soprano; J. B. Knight, bass.

Thursday, November 15

KDKA, E. Pittsburgh, Pa. (Eastern, 326), 6:15 p. m., Dinner concert, Grand Symphony Orchestra; 7:30, Weekly chat with the farmers, Frank E. Mullen; 7:45, Children's period; 8:15, Concert, Mrs. Ethel R. Tricke, soprano; Mrs. Alan B. Davis, pianist; Ernest W. Wright, tenor; Edward W. Koontz, pianist; Jack Thompson, humorist; 11:30, Midnight Frolic.

KFI, Los Angeles, Calif. (Pacific, 469), 6:45-7:30 p. m., Program, Y. M. C. A.; 10:00-11:00, Concert, Woman's Lyric Club, Mrs. W. V. Goodfellow, president.

KGW, Portland, Ore. (Pacific, 492), 3:30 p. m., Child training program; 8:00, Dramatic program, Doris Smith, director; 10:00, Dance music, George Olsen's Metropolitan Orchestra; Sarah C. Penny, pianist.

KHJ, Los Angeles, Calif. (Pacific, 395), 12:30-1:15 p. m., Concert; 2:30-3:30, Matinee musicale; 6:45-7:30, Children's program; 8:00-10:00, Florence Van Dyke, soprano; "Some Fundamentals in Physics," Professor John C. Shedd; 10:00-12:00, Art Hickman's Orchestra.

KYW, Chicago, Ill. (Central, 536), 11:35 a. m., Table talk, Mrs. A. J. Peterson of Peoples Gas Co.; 2:35 p. m., Studio program; 6:50, Children's bedtime story; 8:00-8:20, Twenty minutes of good reading, Rev. C. J. Perlm; 8:20-9:20, Musical program, courtesy of the International Harvester Co.; Herbie Mintz, pianist; Sallie Menkes, pianist.

WBAP, Fort Worth, Texas (Central, 476), 7:30-8:30 p. m., Concert, thirty-piece band of the North Texas Junior Agr. and Mech. College; 9:30-10:45, Program, University Club of Fort Worth.

WDAP, Chicago, Ill. (Central, 360), 1:40 p. m., Concert, Drake Concert Ensemble and Blackstone String Quintet; 7:00, Drake Concert Ensemble and Blackstone String Quintet; 10:00, John Stamford, tenor; Jack Chapman's Orchestra.

WEAF, New York, N. Y. (Eastern, 492), 11:00-12:00 p. m., Vincent Lopez Dance Orchestra.

WFAA, Dallas, Texas (Central, 476), 12:30-1:00 p. m., "The Man in Felt," Judge Hiram F. Lively; 8:30-9:30, Masonic musical program.

WFI, Philadelphia, Pa. (Eastern, 395), 1:00 p. m., Dinner music, Meyer Davis Bellevue Stratford Orchestra; 3:00, Song recital; 6:30, Dinner music, Meyer Davis Bellevue Stratford Orchestra; 7:00, Children's own half hour, Cousin Sue; 8:00, Radio Boy Scouts Corps; 8:45, Dance music, Jack Leroy and his Manhattan Melody Men from Cathay Tea Garden.

WGI, Medford Hillside, Mass. (Eastern, 360), 7:00 p. m., "Bits of Wisdom," George B. Deak; Musical program, George B. Deak and friends.

WGY, Schenectady, N. Y. (Eastern, 380), 2:00 p. m., "The Club Woman of the Twentieth Century," Mrs. Edward P. Press; 7:45, Music, Cluett Peabody & Co.; "A Goose Shooting Incident," Henry S. Watson; Margaret Conklin, Pianist; Arrow Double Male Quartet; Raymond F. Rooney, violinist; Charles Felter, tenor; "Sugar," C. A. Kelsey; Henry Loftingwell, baritone.

WHAS, Louisville, Ky. (Central, 400), 4:00-5:00 p. m., Selections, Strand Theater Orchestra; "Just Among Home Folks"; Selections, Rialto Theater organ; 7:30-9:00, The Ten Best Foster Songs, especially arranged and dedicated to WIAS by Zudie Harris Reinnee, sung by the Courier-Journal Quartette; Fannie Bess Morton, soprano; Mrs. K. W. Surman, contralto; K. W. Surman, tenor; Albion S. Cornwall, baritone; Mrs. Albion S. Cornwall, accompanist; Reading, "An Interesting Historical Episode."

WHN, New York, N. Y. (Eastern, 360), 2:15-3:00 p. m., Shapiro, Bernstein Music Co.; 9:30-9:45, Saranoff and his Wigwag Orchestra; 9:45-9:50, Benny Leonard; 9:50-10:00, Harry Richmond; 10:00-10:10, Belle Bart, astrologist; 10:10-10:15, Roy Cahnley's Orchestra; 10:30-11:00, Ben Burkhart's Highland Orchestra; 11:30-12:00, Marshland Dance Orchestra.

WIP, Philadelphia, Pa. (Eastern, 509), 3:00 p. m., Piano recital; 6:55-6:45, Dinner music; 7:00, Uncle Wip's bedtime stories; 8:00, Short talks and musical program; 8:30, Song recital.

WJAX, Cleveland, Ohio (Eastern, 390), 8:00 p. m., Concert program by the Oberlin Conservatory Trio, of Oberlin, Ohio; Mrs. Wm. Mason Bennet, piano;

JUST LINE THIS
TUE Ge
sulate
a pr
WMA
day I
you
ginia
tell
sound
she
haps
Amer
nothin
music
Miss
tell
mistak
can p
Thurs
sons
sharp
is pu
Mason
progr
Th
Fat h
Son's
will l
Wed
WOC
at W
As
always
and
shall
where
and I
know
what
Sunda
the R
Misso
Pris
Band
over
Dra
Radio
Playe
"Th
Fair",
ers.
We
WGI,
"Ruth
rad
Thu
The
Playe
An A
Play,
Cros
Sati
Rada
Conce
-THE-

MS FEATURE CURRENT WEEK ON AIR

Fred Smith (right), Radarist and director of WLW, has written "Farisada," adapted from the "Arabian Nights," and will produce it from the Cincinnati station Thursday, November 15. Mr. Smith is acclaimed the pioneer radio dramatist. Harry Erhart (left) is the Dream Daddy of Station WDAR, Philadelphia. He tells the little tots bedtime stories every evening.



The Harmony Girls (left) are weekly contributors to the Saturday night programs of WDAP, Chicago. Their piano-song "act" has gone over big with fans. Florence E. Beebe (right), pianist, will enrichen the program of WTAM, Cleveland, Wednesday night, November 14, with a group of solos



Fausto Alvarez (circle), tenor, is on the PWX program Saturday, November 17. Tune to 400



Mintz, pianist; Sallie Menkes, pianist; A. W. "Sen" Kane, specialty act.

WBAP, Fort Worth, Texas (Central, 476), 7:30-8:30 p. m., Father and Sons Day Concert; 9:30-10:45, Program, Texas Christian University.

WCBQ, Dallas, Texas (Central, 476), 8:00 p. m., Mixed quartet, Mrs. John D. Thomas, Mrs. G. R. Sparrow, M. P. Barton, John D. Thomas; L. J. Hite, violinist; Mrs. J. L. Hite, violinist; P. B. Newcomer, cornetist.

WDAP, Chicago, Ill. (Central, 360), 1:40 p. m., Concert, Drake Concert Ensemble and Blackstone String Quintet; 7:00, Drake Concert Ensemble and Blackstone String Quintet; 10:00, Cambridge Sisters; Rosemary Hughes; Jack Chapman's Orchestra.

WFAA, Dallas, Texas (Central, 476), 12:30-1:00 p. m., "Jesus, a Missionary," Dr. Robert S. Hyer; 8:30-9:30, Dallas Male Chorus, Paul Von Katwijk, director; Mrs. Albert Smith, soloist.

WFI, Philadelphia, Pa. (Eastern, 395), 1:00 p. m., Dinner music, Meyer Davis Bellevue Stratford Concert Orchestra; 3:00, Short talks and piano solos, Loretta Kerk; 6:30, Dinner music, Meyer Davis Bellevue Stratford Orchestra; 7:00, Bedtime stories, Cousin Sue.

WGI, Medford Hillside, Mass. (Eastern, 360), 3:30 p. m., Amrad Women's Club; "The Bee That Swarmed Alone," Dorothy E. Goodwin; Edison program; 7:15, "Small Bore Target Shooting," John J. Rowlands; 7:30, Selected verse, Charles L. H. Wagner, Radio Post; Myrtle Fordan Trio; Red Cross health talk, Henry Conley Green.

WGY, Schenectady, N. Y. (Eastern, 380), 2:00 p. m., "Home Made Oriental Buns"; 6:30, Children's program; 7:45, Travelogue address on Bermuda, Dr. Sigel Roush; WGY Orchestra; 10:30, WGY Orchestra; Peter Schmidt, clarinetist; Mrs. L. T. Stafford, soprano; Edward A. Rice, violinist; "Our Indestructible Soils," U. S. Dept. of Agri.; Ernest Burleigh, cellist.

WHAS, Louisville, Ky. (Central, 400), 4:30-5:00 p. m., Selections, Strand Theater Orchestra; "Just Among Home Folks"; Selections, Alamo Theater organ; 7:30-9:00, Concert, Swan Orchestra; Reading, "An Interesting Historical Episode."

WHK, Cleveland, Ohio (Eastern, 283), 9:00 p. m., Concert program arranged by the Cleveland Radio Dealers' Association; Musical numbers by the WHK Orchestra and popular entertainers.

WHN, New York, N. Y. (Eastern, 360), 2:15-3:15 p. m., Indiana Five Orchestra; 9:30-9:45, Juliette L. Selbeck, Soprano; 9:45-10:15, Jimmy Clarke Songbirds; 10:15-10:45, Ted Snyder Orchestra; 11:00-11:30, Fred Whitehouse Revue.

WIP, Philadelphia, Pa. (Eastern, 509), 3:00 p. m., popular dance music program; 7:00, Uncle Wip's bedtime stories and rollcall.

WJAZ, Chicago, Ill. (Central, 447.7), 10:00 p. m.-2 a. m., F. LeRoy Nelson, pianist; Irma Moschel, soprano; Edmund Brown, violinist; Orlo Orchestra.

WJZ, New York, N. Y. (Eastern, 455), 3:00-4:00 p. m., Hotel Astor Organ; 4:00-4:05, "Women's Wear"; 4:05-4:45, Zillah Buell, soprano; 4:45-5:45, Violin Recitals, pupils of A. Sinigalliano; 6:00-6:30, "Kiddle Stories," Agnes Leonard, with ukulele accompaniment; 7:30-8:15, Anna Robinson, lyric soprano; 7:45-8:00, "Looseleaf Current Topics"; 8:15-8:30 p. m., "Sports," Wm. J. Slocum; 8:30-8:45, Josephine Vollmer, pianist; 8:45-9:05, The King Sisters, formerly of "Irene"; 9:05-9:20, Josephine H. Vollmer, pianist; 9:20-9:30 p. m., "Children's Book Week," Marion Humble; 9:30-10:40, Anna Pinto, harpist; Loretta O. Connell, pianist; Loretta Federice, soprano; 10:40-11:00 p. m., "Near East Belle"; 11:00-11:30 p. m., Estelle Ashton Sparks.

WV, Cincinnati, Ohio. (Central, 309), 4:30 p. m., Special Matinee, Margaret Spaulding, director; Modern American Poets and Composers, Margaret Spaulding, Coda Disher, Kathleen Welshimer, Blanche Neel.

WMAQ, Chicago, Ill. (Central, 447.5), 7:00 p. m., "Wide Awake Club," Mrs. Frances Ford; 7:30, Weekly musical lecture, Mrs. Marx E. Oberdorfer; 9:00, Ensemble music, Hotel LaSalle Orchestra; 9:15, Bush Conservatory of Music.

WOC, Davenport, Iowa. (Central, 484), 12:00 m., Chimes concert; 3:30 p. m., C. C. Flanagan, lecturer; 5:45, Chimes concert; 6:30, Sandman's visit; 7:30, Y. M. C. A. Activities, Leland Ashe; 8:00, Artists from Maquoketa, Iowa.

WOO, Philadelphia, Pa. (Eastern, 509), 11:00-11:30 a. m., Organ Recital, Mary E. Vogt; 12:00-12:55 p. m., Luncheon music, Wanamaker Crystal Tea Room Orchestra; 4:45-5:00, Organ recital, Mary E. Vogt.

WOS, Jefferson City, Mo. (Central, 440.9), 8:00 p. m., Program, Faculty Girls, Christian College.

WWJ, Detroit, Mich. (Eastern, 517), 9:30 a. m., "Tonight's Dinner," Woman's Editor; 12:00 m., Dinner; 3:00 p. m., Detroit News Orchestra; 7:00, Detroit News Orchestra; Ann Campbell, Detroit News Poet; Bernhart Nippa, baritone; St. Mary's Church Choir.

KYW, Chicago, Ill. (Central, 536), 11:35 a. m., Table talk, Mrs. A. J. Peterson; 6:50 p. m., Children's bedtime story; 10:00-11:30, Late show; Herb

Aunt Nell; 10:00, George Olsen's Metropolitan Orchestra.

KHJ, Los Angeles, Calif. (Pacific, 395), 12:30-1:15 p. m., Concert; 2:30-3:30, Matinee musicals; 6:45-7:30, Children's Program, Oscar Sandstrom, pianist, 12 years of age, pupil of Ruth Thomas; 8:00-10:00, Franklin K. Matthews, Chief Scout Librarian, III Dab, will appear through the courtesy of the Suburban Estates Company; 10:00-12:00, Art Hickman's Orchestra.

KSD, St. Louis, Mo. (Central, 546), 8:30 p. m., Missouri Theater.

KYW, Chicago, Ill. (Central, 536), 11:35 a. m., Table talk, Mrs. A. J. Peterson; 2:00 p. m., University of Chicago vs. Ohio State University, football; 8:00-8:58, Grand Opera, H. Trovatore (In Italian), Leonora, a noble lady at the court of a Princess of Aragon, Rosa Raisa; Inez, her attendant, Elizabeth Kerr; Count of Luna, powerful young noble of Aragon; Giacomo Rimini; Manrico, a young chieftain of mysterious birth under the Prince of Biscay, Giulio Crimi; Azucena, a wandering Biscayan Gypsy, Cyrena Van Gordon; Ferrando, Captain of the Guard of Count Luna, Virgilio Lazzari; Ruiz, soldier in Manrico's service, Iose Hjelica; An Old Gypsy, Glido Morolotto; Messenger, Giuseppe Minerva; Pietro Cimini, conductor.

PWX, Havana, Cuba. (Eastern, 400), 8:30-11:00 p. m., Carlos Fernandez, pianist; Mr. Artemio, tenor; F. Alvarez, tenor; Messrs. Del Prado and Plans, baritone; Misses Plaza and Iturmendy, sopranos.

WBAP, Fort Worth, Texas. (Central, 476), 7:00-7:30 p. m., Radio Bible Class, Mrs. W. F. Barnum, leader.

WDAP, Chicago, Ill. (Central, 360), 1:40 p. m., Drake Concert Ensemble and Blackstone String Quintet; 7:00, Drake Concert Ensemble and Blackstone String Quintet; 10:00, Harmony Girls, Betty Holmes, Bob Brown, Jack Chapman's Orchestra.

WEAF, New York, N. Y. (Eastern, 492), 10:00-11:00 p. m., Lucky Strike Dance Orchestra; 11:00-12:00 midnight, Vincent Lopez Dance Orchestra.

WFAA, Dallas, Texas (Central, 476), 12:30-1:00 p. m., "How to Become Educated," J. O. Mahoney; 8:30-9:30, W. A. Green Choral Club, Earle D. Behrens, director; 11:00-12:00, Florida Morrison and assisting musicians in voice, violin and reading.

WFI, Philadelphia, Pa. (Eastern, 395), 1:00 p. m., Dinner music, Meyer Davis Bellevue Stratford Orchestra; 3:00, Song recital, WFI Male Quartet; 6:30, Dinner music, Bellevue Stratford Orchestra; 7:00, Bedtime stories, Cousin Sue; 8:00, Concert; 10:10, Dance music, Meyer Davis Bellevue Stratford Orchestra.

WGI, Medford Hillside, Mass. (Eastern, 360), 7:30 p. m., New England Business Problems, Arthur R. Curmick; Badario, Amrad Concert Players, F. Chester Madan; Union Chapel Choir, Quincy, Mass., Mrs. Florence Griffin, director; Delta Trio.

WJZ, Schenectady, N. Y. (Eastern, 380); 9:30 p. m., Dr. Romano's Rain-Boe Orchestra.

WHAS, Louisville, Ky. (Central, 400), 4:30-5:00 p. m., Selections, Strand Theater Orchestra; "Just Among Home Folks"; Selections, Alamo Theater Organ; 7:30-9:00, Hazel McClellan, soprano; Ruth Finley, accompanist; Guitlar and mandolin duets, Billy Hinkle and Jean Kohlhepp; Alvin Marcus, saxophonist; Reading: An Interesting Historical Episode.

WHN, New York, N. Y. (Eastern, 360), 2:15-3:15 p. m., Fred Whitehouse Revue; 3:45-4:45, Eddie di Lalla's Ideal Novelty Orchestra; 5:15-5:45, Harry Belafonte and His Caroling Melody Boys; 7:30-8:00, Melody Belles, the Clover Gardens Girl Orchestra.

WIP, Philadelphia, Pa. (Eastern, 509), 1:00 p. m., Organ recital, Karl Bonawitz, on Germantown Theater organ; 2:00-4:30, Play by play of University of Pennsylvania and Penn State football game; 7:00, Uncle Wip's Bedtime stories for children; 8:00, Song recital; 10:10, Dance music, Charlie Kerr and his orchestra from St. James Hotel.

WJAZ, Chicago, Ill. (Central, 447.7), 10:00 p. m.-2 a. m., Louise Winter, soprano; George C. Smith, baritone; Mable Stapleton, accompanist; Florence Gullans, accompanist; Dean Remick, pianist; Orlo Orchestra.

WJZ, New York, N. Y. (Eastern, 455), 2:00-5:00 p. m., Football game between U. S. Marines and Haskell Indians at Yankee Stadium; 5:00-5:30, Morris Goringod, baritone; 6:00-6:30, Uncle Wiggly Stories, Howard Garis; 7:30-9:00, Harry Glickman, violinist; Harper & Bros.; S. S. Aronson, pianist; "New International Interpreter"; 8:45-9:00, "Feeding Captive Wild Animals," Dr. W. Reid Blair; 9:00-10:30, Jewish Program, Rabbil Solomon Foster; 10:30-11:30, Stanislaw Dabrowski, violinist; 10:45-11:00, Estrella Mandolin Quartet.

WLW, Cincinnati, Ohio (Central, 309), 8:00 p. m., Special program, Esberger's Band; Helen Hofer, soprano.

WMAQ, Chicago, Ill. (Central, 447.5), 8:15 p. m., Armour Jubilee Singers; 9:00, Weekly musical revue, Chicago Theater.

WOC, (Davenport, Iowa (Central, 484), 12:00 m., Chimes concert; 3:30 p. m., C. C. Hall, lecturer; 5:45, Chimes concert; 6:30, Sandman's visit; 6:50, P. S. C. Orchestra; V. B. Rochte, baritone.

WOO, Philadelphia, Pa. (Eastern, 509), 11:00-11:30 a. m., Organ recital, Mary E. Vogt; 12:00-12:55 p. m., Luncheon music, Wanamaker Crystal Tea Room Orchestra; 4:45-5:00, Organ recital, Mary E. Vogt.

WTAM, Cleveland, Ohio (Eastern, 309), 9:00 p. m., Regular Saturday evening dance program by the WTAM Orchestra.

WWJ, Detroit, Mich. (Eastern, 517), 9:30 a. m., "Tonight's dinner," Woman's Editor; 3:00 p. m., Detroit News Orchestra; 5:00, Football scores; 7:30, Detroit News Orchestra.

Sunday, November 18

KHJ, Los Angeles, Calif. (Pacific, 395), 10:00 a. m.-12:30 p. m., Church service, First Methodist Episcopal Church, Rev. Elmer E. Helms, pastor, Arthur Blackley, organist; 7:00-7:30 p. m., Organ recital, Arthur Blackley; 8:00-10:00, De Luxe Program.

KYW, Chicago, Ill. (Central, 536), 11:00 a. m., Central Church service, Dr. F. F. Shannon, pastor; 6:30 p. m., Excerpts from The New Testament—An American Translation by Prof. Edgar J. Goodspeed, William Z. Nourse; 7:00 p. m., Chicago Sunday Evening Club.

WDAP, Chicago, Ill. (Central, 360), 9:15 p. m., Drake Concert Ensemble and soloists.

WFAA, Dallas, Texas (Central, 476), 2:30-3:30 p. m., Radio Bible Class, Dr. William M. Anderson, Jr.; First Presbyterian Church, 9:30-10:00, City Temple Singers; 10:00-11:00, Britling's Cafeteria Orchestra, Lou Goldberg, director.

WEAF, New York, N. Y. (Eastern, 492), 2:45-3:45 p. m., New York Federation of Churches; 3:45-5:30, Dr. S. Parkes Cadman, Bedford Branch, Brooklyn Y. M. C. A.; 7:20-9:00, Capitol Theater Symphony Orchestra and Capitol Staff of artists; 9:00-10:00, Sidner organ recital.

WFI, Philadelphia, Pa. (Eastern, 395), 7:30 p. m., Church services; 9:00, Organ recital.

WGI, Medford Hillside, Mass. (Eastern, 360), 4:00 p. m., Twilight Program "Adventure Hour," Youth's Companion; Joseph Costa, tenor; 8:30, "World Unity," Mass. Federation of Churches, Iran Nowlan; Paulsen String Quartette.

WGY, Schenectady, N. Y. (Eastern, 380), 10:30 a. m., Service, Emmanuel Baptist Church, Dr. Alfred W. Rogers, pastor; 3:30 p. m., Concert, WGY Symphony Orchestra; Leo Kilven, conductor; Maude Evans, soloist; 7:30, Service, Emmanuel Baptist Church.

WHAS, Louisville, Ky. (Central, 400), 9:57 a. m., Organ music; 10:00, Church service, First Presbyterian Church, Rev. Dr. Richard T. Gillespie; 4:00-5:00 p. m., Concert, Mrs. Jane Webster Murrell, director.

WHK, Cleveland, Ohio (Eastern, 283), 8:00 p. m., Sunday evening concert by the WHK Trio. Sermon from the Glenville Presbyterian Church, Rev. A. H. Limouze, pastor.

WHN, New York, N. Y. (Eastern, 360), 3:00-4:30 p. m., Christian Endeavor Union; 4:45-5:00, Jack Schwarz, baritone; 5:00-5:15, National Security Speaker; 6:15-6:30, Jack Berger's Orchestra.

WJAZ, Chicago, Ill. (Central, 447.7), 6:00-9:00 p. m., Harriet H. Seyl, Sopkin String Quartette, Orlo Orchestra.

WJY, New York, N. Y. (Eastern, 405), 2:30-3:15 p. m., Services, Board of Education of the Methodist Episcopal Church; 3:15-3:30, Edna C. Walter, pianist; 3:30-4:15, Vivian Lane, soprano; Edna C. Walter, pianist; 4:15-4:30, "Education Week," Dr. Walter L. Harvey; 4:30-5:00, Salvatore Cloffi, violinist; 6:00-6:30, Bubble Book Stories.

WJZ, New York, N. Y. (Eastern, 455), 11:00 a. m.-1:00 p. m., Services, St. Thomas Episcopal Church; 8:00-8:15, "The Annuals"; 8:15-10:00, Hotel Commodore Orchestra; 10:00-10:30, Wm. H. Crawford.

WLW, Cincinnati, Ohio (Central, 309), 9:30 a. m., Sunday School Service, Editorial Staff of Sunday School Publications, Methodist Book Concern; 11:00, Church services, Church of the Covenant, Rev. Frank Stevenson.

Monday, November 19

KFAE, Pullman, Wash. (Pacific, 330), 7:30 p. m., "Fattening Lambs," Prof. Howard Hackedorn; "What is Geology?" Prof. O. P. Jenkins.

KHJ, Los Angeles, Calif. (Pacific, 395), 12:30-1:15 p. m., Concert Program.

WFI, Philadelphia, Pa. (Eastern, 395), 1:00 p. m., Dinner music, Meyer Davis Bellevue Stratford Orchestra; 3:00, Piano solos, Loretta Kerk; 6:30, Dinner music, Meyer Davis Bellevue Stratford Orchestra; 7:00, Bedtime stories, Cousin Sue.

WGY, Schenectady, N. Y. (Eastern, 380), 2:00 p. m., "Coffee and Coffee Making," Edward Aborn; 7:45, Irene Cody, pianist; Helen Ryan, pianist; William Burke, tenor; Irene Nagle, pianist; "Glass," C. W. Fick.

WHAS, Louisville, Ky. (Central, 400), 4:00-5:00 p. m., Selections, Strand Theater Orchestra; "Just Among Home Folks"; Selection, Alamo Theater organ.

WHAZ, Troy, N. Y. (Eastern, 380), Program of Oldtime Songs and Melodies, Radio Male Quartet, Empiro Mixed Quartet.

WHN, New York, N. Y. (Eastern, 360), 4:30-4:45 p. m., Fred Fischer Music Co.; 7:30-8:00, Sara Lavin's Roseland Dance Orchestra; 8:00-9:30, Fair Service Operators Society Orchestra; 9:45-10:15, Ruth and Janet Meyer, jazz pianist and singer; 10:15-10:30, Alfred Dulin, Swedish pianist.

WIP, Philadelphia, Pa. (Eastern, 509), 3:00 p. m., Song recital; 7:00, Uncle Wip's Bedtime Stories for children.

WOO, Philadelphia, Pa. (Eastern, 509), 11:00-11:30 a. m., Organ recital, Mary E. Vogt; 12:00-12:55 p. m., Luncheon music, Wanamaker Crystal Tea Room Orchestra; 4:45-5:00 p. m., Organ recital, Mary E. Vogt; 7:45, Dinner music, Adelphia Roof Garden Orchestra; 8:30, Concert; 10:10, Dance music, Adelphia Hotel Orchestra.

WOS, Jefferson City, Mo. (Central, 440.9), 8:00 p. m., "Taxation," Prof. S. D. Gromer; Old Time "Break Down," or square dance dance program, A. E. Williams, director.

NEWS MUSIC CONTEST

(Continued from page 9)

tions, the composers will receive the usual royalties.

Prizes and Judges

Prizes totaling \$515 for each four weeks' period will be awarded in accordance with the following plan: Three prizes will be given each week, viz., \$50, first prize; \$25, second; \$10, third. The weekly prize winners will be entered in the grand contest for a first prize of \$100, and publication of compositions by the Boston (Mass.) Music Company; second prize, \$50; third prize, \$25. The total of prizes is to be \$2,500. Each composition which wins first prize in the grand contest will be published in sheet form by the concern named.

But perhaps the greatest prize, the most enviable honor, will go to those whose compositions are broadcast in recognition of merit by Station WMAQ. Only the winners will be broadcast. This will be done through the National Association of Broadcasters.

The judges of the contest are: Eric DeLamar, assistant conductor of the Chicago Symphony Orchestra; Arthur Olaf Anderson, leading composer of Chicago; and Maurice Rosenfeld, music critic of the Chicago Daily News. E. E. Sheetz, Jr., a widely known conductor, will assist in the judging of popular music.

And be it known that a woman, Judith C. Waller, director of Station WMAQ, conceived the idea of the contest which may lead America to an eternal musical shrine.

Friday, November 16

KDKA, E. Pittsburgh, Pa. (Eastern, 326), 6:15 p. m., Organ recital, Lucille Halek; 7:45, The children's period; 8:15, "Boy Scout Meeting by Radio," Richard Victor, scout master; 8:45, Morgan Quartet; Leo Kruczek, violinist.

KFAE, Pullman, Wash. (Pacific, 330), 7:30 p. m., "The Modern Battleship," Prof. R. D. Sloan; "Books for Winter Readings," Alice L. Webb; "Orchard Thinning," Prof. O. M. Morris; Program, Theta Upsilon Sorority; Alice Pike, soprano; Ruth Coates, violinist; Gladys Huebner, reader.

KFI, Los Angeles, Calif. (Pacific, 469), 6:45-7:20 p. m., Concert, Harry Baldwin's Orchestra; 10:00-11:00, Concert, the M. B. Concert Club.

KGW, Portland, Ore. (Pacific, 492), 3:30 p. m., "Child Nutrition," Margery M. Smith; 8:15, Studio program, George Olsen's Metropolitan Orchestra; 9:00, "Oregon Resources," Alfred Lomax; 10:30, Hoot Owls with Pantages Frolie.

KHJ, Los Angeles, Calif. (Pacific, 395), 12:30-1:15 p. m., Concert program; 2:30-3:30, Matinee musicals; 6:45-7:00, Children's program; 7:00-7:30, Organ recital, Arthur Blakely; 8:30-10:30, Monrovia Trio; Walter F. McEntire, lecturer; 10:00-12:00, Art Hickman's Orchestra.

KSD, St. Louis, Mo. (Central, 546), 8:00 p. m., Program, Mrs. J. Stoddard Robertson, contralto; Irene Moriarty, pianist; Adelaide Blase, violinist; Mario Louise Bulte, reader.

KYW, Chicago, Ill. (Central, 536), 11:35 a. m., Table talk, Mrs. A. J. Peterson; 6:50 p. m., Children's bedtime story; 10:00-11:30, Late show; Herb

Saturday, November 17

KDKA, Pittsburgh, Pa. (Eastern, 326), 1:30 p. m., Concert, Daughters' Orchestra; 5:15, Dinner concert, Westinghouse Band; 7:30, "Bringing the World to America"; 7:45, Children's period; 8:30, Concert, Westinghouse Band; Norman Porter, humorist.

KFI, Los Angeles, Calif. (Pacific, 469), 6:45-7:30 p. m., Concert, Theres Bessler, violinist; 8:00-9:00, The Arlington Five; 10:00-11:00, Special Concert, vocal.

KGW, Portland, Ore. (Pacific, 492), 3:30 p. m., Children's program, Webber's Juvenile Orchestra; Story,

IS THIS SUPER-REGENERATIVE?

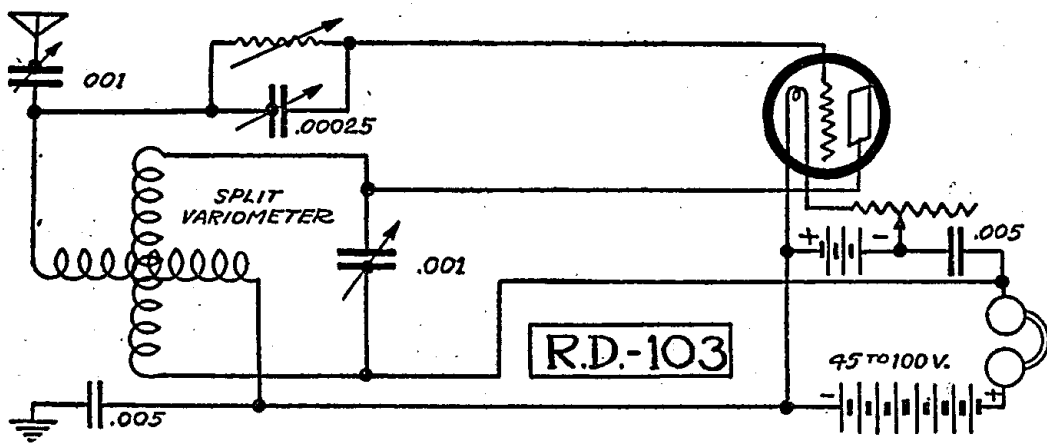

MR. E. C. HOFFMAN of 803 W. Superior Ave., Cleveland, Ohio, sends us his circuit with a title "Super-regenerative?" It has the characteristic whistle but strange to state is quiet, very selective and not affected by static. No wonder he is dubious. But he states frankly it's the best he has ever tried. Note that it resembles the original Miloplex somewhat.

He has asked us to pass it along with

the following suggestions. If it doesn't work just right, try reversing the rotor and stator leads. Tune the antenna condenser first; then the other controls, after which readjust the first. Values are apt to vary slightly for different tubes used. An amplifier tube is recommended.

The condenser between the phones and the negative filament battery should be tried at various values in order to get the best results.

THREE-TUBE MILOPLEX

(Continued from page 11)

Wizard. They are of minor importance and need no discussion.

The same conditions hold true for the addition of the condensers in the amplifying stages. No condenser was required from the plate of the first tube to the positive 22½-volt terminal. The values of the remaining condensers were kept the same as in the previous amplifier circuit.

Wiring

Be careful to check up all connections, as one little error, not always obvious, may suffice to stop all chances of reception.

The Mystery Man himself was in despair recently because one of his circuits wouldn't work. After a thorough examination the writer found one wrong connection and he, himself, found an omitted connection. The best of us fall down occasionally.

As often repeated, keep your leads short. In all Radio Digest diagrams crossed lines do not indicate a connection. All connections are marked with a heavy dot. Attention to this matter will solve the troubles of many and save the mail man a lot of work.

Watch your soldered joints; don't just paste them together with flux.

The illustrations of the completed set will help many fans with suggestions for wiring and tuning operations.

(TO BE CONTINUED.)

How to Stop Howling

If adjusting the filaments of an amplifier does not stop it from howling, try attaching a wire from the negative terminal of the battery used for lighting the filaments of the tubes to the ground post of the set. Should the howling continue, try grounding the iron cores of the amplifying transformers by attaching a wire to the cores and bringing it to the ground terminal.

RADIO FANS

Tune in on station
WEAF (New York)

every Thursday at 8.50 P. M. and listen to a story or article selected from

HEARST'S INTERNATIONAL

This is one of the most popular weekly features "on the air"

FREE

Write for Free Copy of the Latest Radio Reprint. It contains a complete story from Hearst's International Magazine. Address Radio Editor, Hearst's International Magazine, 119 West 40th Street, New York City.

THE UNOTROL (One Control) Broadcast Receiver

A Real One Tube Set. Made of best material throughout. In a Real Cabinet, with hinged top. High grade mahogany finish, hand rubbed. At a Real price. Will ship C. O. D.

Postage paid east of Rocky Mountains **\$11.90**

Set is Fully Guaranteed. Wonderful Distance Reported by Enthusiastic Users.

Dealers: Write for our proposition. Some good territories still open for bona fide Radio Dealers.

To the Experimenter and the Man Who Builds His Own: Write for Our Bulletin of Parts at Bargain Prices. Standard Merchandise Only.

Abalene Radio 105 Audubon Ave. New York, N. Y.

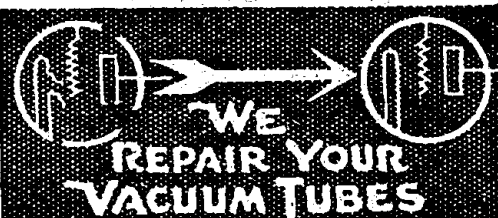

WD-11-12, UV-199, UV-201-A
C-301-A \$3.50 each
UV-200, C-300 2.75 each
UV-201, C-301 3.00 each
DV-6, DV-6-A 3.50 each

All Work Fully Guaranteed

Quick Service—Repaired Tubes shipped C. O. D. unless accompanied by remittance plus postage.

NEW TUBES

A-399 (Type UV-199) **\$4.10**
A-401-A (Type UV-201-A) **EACH**
A-12 (Type WD-12)

All the above Tubes guaranteed amplifiers and detectors. Shipped C. O. D., postage prepaid.

ABALENE RADIO 14 Vesey Street NEW YORK CITY

Large Size Wire Best
The largest wire practicable should always be used for winding coils for tuning circuits. It affords a much greater surface for the high frequency currents, aside from lower resistance. (Number 24 wire has more than 60 per cent greater high frequency resistance at 1,500,000 cycles than 20, and 26 more 100 per cent greater than 20.) Large wire also gives increased signal strength and greater selectivity.

Telephone Cord Kinks

Kinks in the phone cord should be straightened out every time they occur. A kink will soon wear through the cord fabric and expose the wiring. Later this may cause a short or open circuit.

B-T Gives

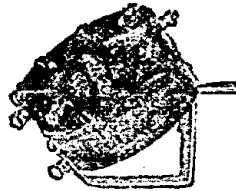

\$5.00

- 1 Vernier control hitherto unobtainable.
- 2 Unequalled results in single circuit regenerative Ultra Audion, etc.
- 3 Replaces Tapped Reinartz Coils.
- 4 Highly Selective and efficient for Reflex and R. F. Hook-ups.

Our new Booklet, "Better Tuning," will help you. It includes valuable information and new photo-diagrams. Sent on receipt of 10c—free with each tuner.

Bremer-Tully Mfg. Co.

532 South Canal Street, CHICAGO, ILL.



Super Vernier
RHEOSTAT
\$3.00

AND WORTH IT

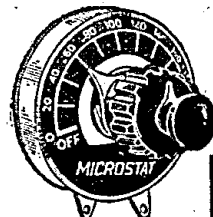

THERE is no substitute for the Premier "Microstat"—no other instrument that gives such perfect control of the current delivered to the filament of radio tubes. New principle—two windings in parallel—one 6 ohm—other 40 ohm. Absolutely noiseless—infinite control—handles any tube. Cap. 3 Amp. Bakelite moulded—silver etched dial. Do not install a Rheostat until you know all about the "Microstat." Our bulletin No. 90 explains it in detail. Send for it. It's FREE.

Premier Electric Company

3810 Ravenswood Ave. CHICAGO

Ask Your Dealer For
"MICROSTAT"

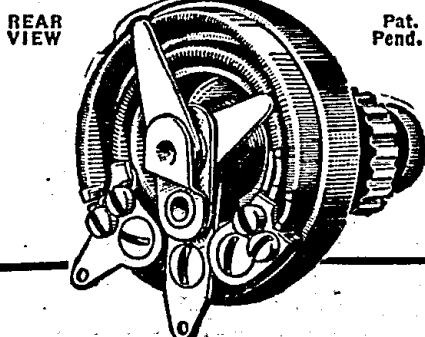

A NEW DISCOVERY!

EXTREME SUPER-REGENERATION is obtained without noises through

FRESHMAN

Variable Resistance Leaks

by connecting between plate and Grid of the tube as disclosed by the sensational **New Kaufman Circuit No. 2**



Panel Type

Absolutely
No Pencil
Markings



Base Type

Only the
Knob
Shows on
the Panel

Freshman Resistance Leaks are especially built for use as tuning instruments. Construction is such that they will withstand unusual usage. Freshman Leaks give an unbroken range of 180 degrees from 0 to 10 megohms. Absolutely guaranteed. Enables you to get stations you never heard before.

EITHER TYPE

Complete with either .00025 or .0005 mfd. Mica Condenser..... **\$1.00**
Without Condenser 75c
At your dealers—otherwise send purchase price and you will be supplied postpaid.

Ask your dealer or write direct for free diagram showing how you can convert your single tube circuit into the new sensational Kaufman Circuit No. 2.

Chas. Freshman Co. Inc.
Radio Condenser Products

106 SEVENTH AVE. NEW YORK

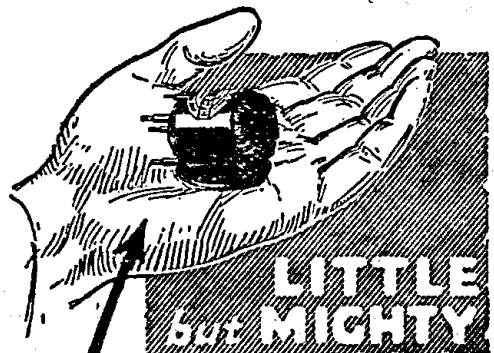

PREMIER "HEGEHOG" AUDIO Transformer

Little but mighty—a wizard for volume and tone quality. Look at the cuts. The view at the top shows the "HEGEHOG" as compared in size with the hand. The cut at the bottom shows it exact size. "Small" you say. Yes, but inside this "Little Wonder" you will find more efficiency, more reproduction volume and less distortion than found in any other Transformer regardless of size, price or design. The secret is in its patented construction. It is shielded 100% against foreign noises. Fully guaranteed. You'll want them in your next "hook-up," so get all the facts NOW. Our Free Bulletin No. 90 gives them fully. Send for it.

Premier Electric Company

3810 Ravenswood Avenue CHICAGO

Ask for and insist on
"HEGEHOG" at your dealer's
Price \$3.50

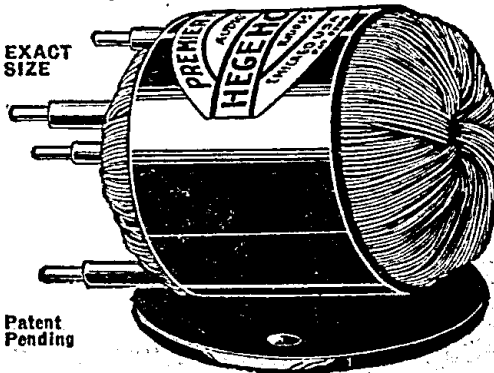

YELLOWTIP MICROMETER ADJUSTING

CRYSTAL DETECTOR Increases the Efficiency of Your Crystal Set



FINER tuning, clearest possible reception, constant adjustment until you wish to change, then—"A Twist of the Wrist—It's Set." Excellent for reflex and other circuits. Write for folder and name of your nearest dealer. **\$2**

Dealers and Jobbers—Write for Attractive Proposition
WHOLESALE RADIO EQUIPMENT CO.
Exclusive Factory Representatives
35 William Street, NEWARK, N. J.

MS FEATURE CURRENT WEEK ON AIR

Fred Smith (right), Radarist and director of WLW, has written "Farisada," adapted from the "Arabian Nights," and will produce it from the Cincinnati station Thursday, November 15. Mr. Smith is acclaimed the pioneer Radio dramatist. Harry Erhart (left) is the Dream Daddy of Station WDAR, Philadelphia. He tells the little tots bedtime stories every evening



The Harmony Girls (left) are weekly contributors to the Saturday night programs of WDAP, Chicago. Their piano-song "act" has gone over big with fans. Florence E. Beebe (right), pianist, will enrich the program of WTAM, Cleveland, Wednesday night, November 14, with a group of solos

Sunday, November 18

KHJ, Los Angeles, Calif. (Pacific, 395), 12:30-1:15 p. m., Church service, First Methodist Episcopal Church, Rev. Elmer E. Helms, pastor; Arthur Blakely, organist; 7:00-7:30 p. m., Organ recital, Arthur Blakely; 8:00-10:00, De Luxe Program.

KYW, Chicago, Ill. (Central, 536), 11:00 a. m., Central Church service, Dr. F. F. Shannon, pastor; 6:30 p. m., Excerpts from The New Testament—An American Translation by Prof. Edgar J. Goodspeed, William Z. Nourse; 7:00 p. m., Chicago Sunday Evening Club.

WDAP, Chicago, Ill. (Central, 360), 9:15 p. m., Drake Concert Ensemble and soloists.

WFAA, Dallas, Texas (Central, 476), 2:30-3:30 p. m., Radio Bible Class, Dr. William H. Anderson, Jr., First Presbyterian Church, 9:30-10:00, City Temple Singers; 10:00-11:00, Britling's Cafeteria Orchestra, Lou Goldberg, director.

WEAF, New York, N. Y. (Eastern, 492), 2:45-3:45 p. m., New York Federation of Churches; 3:45-5:30, Dr. St. Parkes Cadman, Bedford Branch, Brooklyn Y. M. C. A.; 7:20-9:00, Capitol Theater Symphony Orchestra and Capitol Staff of artists; 9:00-10:00, Skinner organ recital.

WFI, Philadelphia, Pa. (Eastern, 395), 7:30 p. m., Church services; 9:00, Organ recital.

WGI, Medford Hills, Mass. (Eastern, 360), 4:00 p. m., Twilight Program, "Adventure Hour," Youth's Companion, Joseph Coste, tenor; 8:30, "World Unity," Mass. Federation of Churches, Iran Nowlan; Paulsen String Quartette.

WGY, Schenectady, N. Y. (Eastern, 380), 10:30 a. m., Service, Emmanuel Baptist Church, Dr. Alfred W. Rogers, pastor; 3:30 p. m., Concert, WGY Symphony Orchestra; Leo Kilven, conductor; Maude Evans, soloist; 7:30, Service, Emmanuel Baptist Church.

WHAS, Louisville, Ky. (Central, 400), 9:57 a. m., Organ music; 10:00, Church service, First Presbyterian Church, Rev. Dr. Richard T. Gillespie; 4:30-5:00 p. m., Concert, Mrs. Jane Webster Turrell, director.

WIK, Cleveland, Ohio (Eastern, 283), 8:00 p. m., Sunday evening concert by the WIK Trio. Sermon from the Glenville Presbyterian Church, Rev. A. H. Limouze, pastor.

WHN, New York, N. Y. (Eastern, 360), 3:00-4:30 p. m., Christian Endeavor Union; 4:45-5:00, Jack Schwarz, baritone; 5:00-5:15, National Security Speaker; 5:15-6:00, Jack Berger's Orchestra.

WJAZ, Chicago, Ill. (Central, 447.7), 6:00-9:00 p. m., Harriett H. Seyl, Sopkin String Quartette, Oriole Orchestra.

WJY, New York, N. Y. (Eastern, 405), 2:30-3:15 p. m., Service, Board of Education of the Methodist Episcopal Church; 3:15-3:30, Edna C. Walter, pianist; 3:30-4:15, Vivian Lane, soprano; Edna C. Walter, pianist; 4:15-4:30, "Education Week," Dr. Walter L. Hervey; 4:30-5:00, Salvatore Cloth, violinist; 6:00-6:30, Bubble Book Stories.

WJZ, New York, N. Y. (Eastern, 455), 11:00 a. m., 1:00 p. m., Services, St. Thomas Episcopal Church; 8:00-8:15, "The Annals," 8:15-10:00, Radio Comedians Orchestra; 10:00-10:30, Wm. H. Crawford.

WLW, Cincinnati, Ohio (Central, 309), 9:30 a. m., Sunday School Service, Editorial Staff of Sunday School Publications, Methodist Book Concern; 11:00, Church services, Church of the Covenant, Rev. Frank Stevenson.

Monday, November 19

KFAE, Pullman, Wash. (Pacific, 330), 7:30 p. m., "Fattening Lambs," Prof. Howard Hackedorn; "What Is Geology?" Prof. O. P. Jenkins.

KHJ, Los Angeles, Calif. (Pacific, 395), 12:30-1:15 p. m., Concert Program.

WFI, Philadelphia, Pa. (Eastern, 395), 1:00 p. m., Dinner music, Meyer Davis Bellevue Stratford Orchestra; 3:00, Piano solos, Loreita Kerr; 6:30, Dinner music, Meyer Davis Bellevue Stratford Orchestra; 7:00, Bedtime stories, Cousin Sue.

WGY, Schenectady, N. Y. (Eastern, 380), 2:00 p. m., "Coffee and Coffee Making," Edward Aborn; 7:45, Irene Cody, pianist; Helen Ryan, pianist; William Burke, tenor; Irene Nagle, pianist; "Glass," C. W. Fitch.

WHAS, Louisville, Ky. (Central, 400), 4:00-5:00 p. m., Selections, Strand Theater Orchestra; "Just Among Home Folks"; Selection, Alamo Theater organ.

WHAZ, Troy, N. Y. (Eastern, 380), Program of Oldtime Songs and Melodies, Radio Male Quartet, Empiro Mixed Quartet.

WHN, New York, N. Y. (Eastern, 360), 4:00-4:30 p. m., Fred Fischer Music Co.; 7:30-8:00, Sam Lanning's Roseland Dance Orchestra; 9:30-9:50, Hal's Syncopated Jazz, pianist and singer; 10:15-10:30, Alfred Dulin, Swedish pianist.

WIP, Philadelphia, Pa. (Eastern, 509), 3:00 p. m., Song recital; 7:00, Uncle Wip's Bedtime Stories for children.

WOO, Philadelphia, Pa. (Eastern, 509), 11:00-11:30 p. m., Organ recital, Mary E. Vogt; 12:00-12:55 p. m., Luncheon music, Wanamaker Crystal Tea Room Orchestra; 4:45-5:00, Organ recital, Mary E. Vogt; 7:45, Dinner music, Adelphi Roof Garden Orchestra; 8:30, Concert; 10:10, Dance music, Adelphi Hotel Orchestra.

WOS, Jefferson City, Mo. (Central, 440.9), 8:00 p. m., "Taxation," Prof. S. D. Gromer; Old Time "Break Down," or square dance program, A. B. Williams, director.

NEWS MUSIC CONTEST

(Continued from page 9)

tions, the composers will receive the usual royalties.

Prizes and Judges

Prizes totaling \$515 for each four weeks' period will be awarded in accordance with the following plan: Three prizes will be given each week, viz., \$50, first prize; \$25, second; \$10, third. The weekly prize winners will be entered in the grand contest for a first prize of \$100, and publication of compositions by the Boston (Mass.) Music Company; second prize, \$50; third prize, \$25. The total of prizes is to be \$2,500. Each composition which wins first prize in the grand contest will be published in sheet form by the concern named.

But perhaps the greatest prize, the most enviable honor, will go to those whose compositions are broadcast in recognition of merit by Station WMAQ. Only the winners will be broadcast. This will be done through the National Association of Broadcasters.

The judges of the contest are: Eric DeLamar, assistant conductor of the Chicago Symphony Orchestra; Arthur Olaf Anderson, leading composer of Chicago, and Maurice Rosenfeld, music critic of the Chicago Daily News. E. E. Sheetz, Jr., a widely known conductor, will assist in the judging of popular music.

And be it known that a woman, Judith C. Waller, director of Station WMAQ, conceived the idea of the contest which may lead America to an eternal musical shrine.

Mintz, pianist; Sallie Menkes, pianist; A. W. "Sen" Kanev, specialty act.

WBAP, Fort Worth, Texas (Central, 476), 7:30-8:30 p. m., Father and Sons Day Concert; 9:30-10:45, Program, Texas Christian University.

WCBD, Zion, Ill. (Central, 345), 8:00 p. m., Mixed quartet, Mrs. John D. Thomas; Mrs. G. R. Sparrow, M. P. Barton, John D. Thomas; L. J. Hlre, violinist; Mrs. J. L. Hire, violinist; P. B. Newcomer, cornetist.

WDAP, Chicago, Ill. (Central, 360), 1:40 p. m., Concert, Drake Concert Ensemble and Blackstone String Quintet; 7:00, Drake Concert Ensemble and Blackstone String Quintet; 10:00, Cambridge Sisters; Rosemary Hughes; Jack Chapman's Orchestra.

WFAA, Dallas, Texas (Central, 476), 12:30-1:00 p. m., "Jesus a Missionary," Dr. Robert S. Hyer; 8:30-9:30, Dallas Male Chorus, Paul Von Katwijk, director; Mrs. Albert Smith, soloist.

WFI, Philadelphia, Pa. (Eastern, 395), 1:00 p. m., Dinner music, Meyer Davis Bellevue Stratford Concert Orchestra; 3:00, Short talks and piano solos, Loreita Kerr; 6:30, Dinner music, Meyer Davis Bellevue Stratford Orchestra; 7:00, Bedtime stories, Cousin Sue.

WGI, Medford Hills, Mass. (Eastern, 360), 3:30 p. m., Amrad Women's Club; "The Bee That Swarmed Alone," Dorothy E. Goodwin; Edison program; 7:15, "Small Bore Target Shooting," John J. Rowlands; 7:30, Selected verse, Charles L. H. Wagner, Radio Poet; Myrtle Fordan Trio; Red Cross health talk, Henry Copley Green.

WGY, Schenectady, N. Y. (Eastern, 380), 2:00 p. m., "Home Made Oriental Tunes"; 6:30, Children's program; 7:45, Travelogue address on Bermuda, Dr. Sigel Roush; WGY Orchestra; 10:30, WGY Orchestra; Peter Schmidt, clarinetist; Mrs. L. T. Stafford, soprano; Edward A. Rice, violinist; "Our Indestructible Sells," U. S. Dept. of Agr.; Ernest Burleigh, cellist.

WHAS, Louisville, Ky. (Central, 400), 4:00-5:00 p. m., Selections, Strand Theater Orchestra; "Just Among Home Folks"; Selections, Alamo Theater organ; 7:30-9:00, Concert, Swan Orchestra; Reading, "An Interesting Historical Episode."

WHK, Cleveland, Ohio (Eastern, 283), 9:00 p. m., Concert program arranged by the Cleveland Radio Dealers' Association; Musical numbers by the WHK Orchestra and popular entertainers.

WHN, New York, N. Y. (Eastern, 360), 2:15-3:15 p. m., Indiana Five Orchestra; 9:30-9:45, Juliette L. Seleck, Soprano; 9:45-10:15, Jimmy Clarke Songbirds; 10:15-10:45, Ted Snyder Orchestra; 11:00-11:30, Fred Whitehouse Revue.

WIP, Philadelphia, Pa. (Eastern, 509), 3:00 p. m., popular dance music program; 7:00, Uncle Wip's bedtime stories and rollcall.

WJAZ, Chicago, Ill. (Central, 447.7), 10:00 p. m.-2 a. m., F. Lelloy Nelson, pianist; Irma Moschel, soprano; Edmund Brown, violinist; Oriole Orchestra.

WJZ, New York, N. Y. (Eastern, 455), 3:00-4:00 p. m., Hotel Astor Organ; 4:00-4:05, "Women's Veil"; 4:05-4:45, Zillah Buell, soprano; 4:45-5:45, Violin Recitals, pupils of A. Singalitano; 6:00-6:30, "Kiddie Stories," Agnes Leonard, with ukulele accompaniment; 7:30-8:15, Anne Robinson, lyric soprano; 7:45-8:00, "Looseleaf Current Topics"; 8:15-8:30 p. m., "Sports," Wm. J. Slocum; 8:30-8:45, Josephine Vollmer, pianist; 8:45-9:05, The King Sisters, formerly of "Treason"; 9:05-9:25, Josephine H. Vollmer, pianist; 9:20-9:30 p. m., "Children's Book Week," Marion Humble; 9:30-10:40, Anna Pinto, harpist; Loretta O. Connell, pianist; Loretta Federico, soprano; 10:40-11:00 p. m., "Near East Relief"; 11:00-11:30 p. m., Estelle Ashton Sparks.

WLW, Cincinnati, Ohio. (Central, 309), 4:00 p. m., Special Matinee, Margaret Spaulding, director; Modern American Poets and Composers, Margaret Spaulding, Coda Disher, Kathleen Welshler, Blanche Neal.

WMAQ, Chicago, Ill. (Central, 447.5), 7:00 p. m., "Wide Awake Club," Mrs. Frances Ford; 7:30, Weekly musical lecture, Mrs. Mary E. Oberndorfer; 9:00, Ensemble music, Hotel LaSalle Orchestra; 9:15, Bush Conservatory of Music.

WOC, Davenport, Iowa. (Central, 484), 12:00 m., Chimes concert; 3:30 p. m., C. C. Flanagan, lecturer; 5:45, Chimes concert; 6:30, Sandman's visit; 7:00, Y. M. C. A. Activities, Leland Ashe; 8:00, Artists from Maquoketa, Iowa.

WOO, Philadelphia, Pa. (Eastern, 509), 11:00-11:30 a. m., Organ Recital, Mary E. Vogt; 12:00-12:55 p. m., Luncheon music, Wanamaker Tea Room Orchestra; 4:45-5:00, Organ recital, Mary E. Vogt.

WOS, Jefferson City, Mo. (Central, 440.9), 8:00 p. m., Program, Faculty Girls, Christian College.

WWJ, Detroit, Mich. (Eastern, 517), 9:30 a. m., "Tonight's Dinner," Woman's Editor; 12:00 m., Dinner; 3:00 p. m., Detroit News Orchestra; 7:00, Detroit News Orchestra; Ann Campbell, Detroit News Post; Bernhart Nippa, baritone; St. Mary's Church Choir.

Saturday, November 17

KDKA, Pittsburgh, Pa. (Eastern, 326), 1:30 p. m., Concert, Daughert's Orchestra; 6:15, Dinner concert, Westinghouse Band; 7:30, "Bringing the World to America"; 7:45, Children's period; 8:30, Concert, Westinghouse Band; Norman Porter, humorist; 7:00, KFI, Los Angeles, Calif. (Pacific, 469), 6:45-7:30 p. m., Concert, Theresa Bessler, violinist; 8:00-9:00, The Arlington Five; 10:00-11:00, Special Concert, vocal.

KGW, Portland, Ore. (Pacific, 492), 3:30 p. m., Children's program, Webber's Juvenile Orchestra; Story.

Aunt Nell; 10:00, George Olsen's Metropolitan Orchestra.

KHJ, Los Angeles, Calif. (Pacific, 395), 12:30-1:15 p. m., Concert; 2:30-3:30, Matinee musicale; 6:45-7:30, Children's Program, Oscar Sandstrom, pianist; 12 years of age, pupil of Ruth Thomas; 8:00-10:00, Franklin K. Matthews, Chief Scout Executive, III Dab, will appear through the courtesy of the Suburban Estates Company; 10:00-12:00, Art Hickman's Orchestra.

KSD, St. Louis, Mo. (Central, 546), 8:30 p. m., Missouri Theater.

KYW, Chicago, Ill. (Central, 536), 11:35 a. m., Table talk, Mrs. A. J. Peterson; 2:00 p. m., University of Chicago vs. Ohio State University, football; 8:00-8:58, Grand Opera: Il Trovatore (In Italian), Leonora, a noble lady at the court of a Princess of Aragon, Rosa Raisa; Inez, her attendant, Elizabeth Kerr; Count of Luna, powerful young noble of Aragon, Giacomo Rimini; Manrico, a young chieftain of mysterious birth under the Prince of Biscay, Giulio Crimi; Azucena, a wandering Biscayan Gypsy, Cyrena Van Gordon; Ferrando, Captain of the Guard of Count Luna, Virgilio Lazzari; Ruitz, soldier in Manrico's service, Jose Mojica; An Old Gypsy, Gildo Gimini, conductor, Giuseppe Milnera; Pietro

PWX, Havana, Cuba. (Eastern, 400), 8:30-11:00 p. m., Carlos Fernandez, pianist; Mr. Artemio, tenor; F. Alvarez, tenor; Messrs. Del Prado and Plana, baritone; Misses Plana and Iturmundi, sopranos.

WBAP, Fort Worth, Texas (Central, 476), 7:00-7:30 p. m., Radio Bible Class, Mrs. W. F. Barnum, leader.

WDAP, Chicago, Ill. (Central, 360), 1:40 p. m., Drake Concert Ensemble and Blackstone String Quintet; 7:00, Drake Concert Ensemble and Blackstone String Quintet; 10:00, Harmony Girls, Betty Holmes, Bob Brown, Jack Chapman's Orchestra.

WEAF, New York, N. Y. (Eastern, 492), 10:00-11:00 p. m., midnight, Vincent Lopez Dance Orchestra.

WFAA, Dallas, Texas (Central, 476), 12:30-1:00 p. m., "How to Become Educated," J. O. Mahoney; 8:30-9:30, W. A. Green Choral Club, Earle D. Behrens, director; 11:00-12:00, Florida Morrison and assisting musicians in voice, violin and reading.

WFI, Philadelphia, Pa. (Eastern, 395), 1:00 p. m., Dinner music, Meyer Davis Bellevue Stratford Orchestra; 3:00, Song recital, WFI Male Quartet; 6:30, Dinner music, Bellevue Stratford Orchestra; 7:00, Bedtime stories, Cousin Sue; 8:00, Concert; 10:10, Dance music, Meyer Davis Bellevue Stratford Orchestra.

WGI, Medford Hills, Mass. (Eastern, 360), 7:30 p. m., New England Business Problems, Arthur R. Curnick; Radarist, Amrad Concert Players, F. Chester Madan; Union Chapel Choir, Quincy, Mass., Mrs. Florence Griffin, director; Delta Trio.

WGY, Schenectady, N. Y. (Eastern, 380), 9:30 p. m., Phil Romano's Rain-bo Orchestra.

WHAS, Louisville, Ky. (Central, 400), 4:00-5:00 p. m., Selections, Strand Theater Orchestra; "Just Among Home Folks"; Selections, Alamo Theater organ; 7:30-9:00, Hazel McClellan, soprano; Ruth Finley, accompanist; Guffar and mandolin duets, Billy Hinko and Jean Kohlhepp; Alvin Marcus, saxophonist; Reading: An Interesting Historical Episode.

WHN, New York, N. Y. (Eastern, 360), 2:15-3:15 p. m., Fred Whitehouse Revue; 3:45-4:45 Eddie di Lalla's Ideal Novelty Orchestra; 5:15-5:45, Harry Reiser and His Carolin Melody Boys; 7:30-8:00, Melody Belles, the Clover Gardens Girl Orchestra, Concert; 10:10, Dance music, Meyer Davis Bellevue Stratford Orchestra.

WIP, Philadelphia, Pa. (Eastern, 509), 1:00 p. m., Organ recital, Karl Bonawitz, on Germantown Theater organ; 2:00-4:30, Play by play of University of Pennsylvania and Penn State football game; 7:00, Uncle Wip's Bedtime stories for children; 8:00, Song recital; 10:10, Dance music, Charlie Kerr and his orchestra from St. James Hotel.

WJAZ, Chicago, Ill. (Central, 447.7), 10:00 p. m.-2 a. m., Louise Peterson, soprano; George C. Smith, baritone; Mable Stapleton, accompanist; Florence Gullans, accompanist; Dean Remick, pianist; Oriole Orchestra.

WJZ, New York, N. Y. (Eastern, 455), 2:00-5:00 p. m., Football game between U. S. Marines and Haskell Indians at Yankee Stadium; 5:00-5:30, Morris Goringod, baritone; 6:00-6:30, Uncle Wigly Stories, Howard Garis; 7:30-9:00, Harry Hickman, violinist; Harper & Bros.; S. S. Aronson, pianist; "New International Interpreter"; 8:45-9:00, "Feeding Captive Wild Animals," Dr. W. Reid Blair; 9:00-10:30, Jewish Program, Rabbi Solomon Foster; 10:30-11:30, Stanislav Dabrowski, violinist; 10:45-11:00, Estrella Mandolin Quartet.

WLW, Cincinnati, Ohio (Central, 309), 8:00 p. m., Special program, Esberger's Band; Helen Hofer, soprano.

WMAQ, Chicago, Ill. (Central, 447.5), 8:15 p. m., Armour Jubilee Singers; 9:00, Weekly musical revue, Chicago Theater.

WOC, Davenport, Iowa (Central, 484), 12:00 m., Chimes concert; 3:30 p. m., C. C. Hall, lecturer; 5:45, Chimes concert; 6:30, Sandman's visit; 6:50, P. S. C. Orchestra; V. B. Koehne, baritone.

WOO, Philadelphia, Pa. (Eastern, 509), 11:00-11:30 a. m., Organ recital, Mary E. Vogt; 12:00-12:55 p. m., Luncheon music, Wanamaker Crystal Tea Room Orchestra; 4:45-5:00, Organ recital, Mary E. Vogt.

WTAM, Cleveland, Ohio (Eastern, 390), 9:00 p. m., Regular Saturday evening dance program by the WTAM Orchestra.

WWJ, Detroit, Mich. (Eastern, 517), 9:30 a. m., "Tonight's dinner," Woman's Editor; 3:00 p. m., Detroit News Orchestra; 5:00, Football scores; 7:30, Detroit News Orchestra.

Friday, November 16

KDKA, E. Pittsburgh, Pa. (Eastern, 326), 6:15 p. m., Organ recital, Lucile Halek; 7:45, The children's period; 8:15, "Boy Scout Meeting by Radio," Richard Victor, scout master; 8:45, Morgan Quartet; Leo Krizek, violinist.

KFAE, Pullman, Wash. (Pacific, 330), 7:30 p. m., "The Modern Battleship," Prof. R. D. Sloan; "Books for Winter Readings," Alice L. Webb; "Orchard Thinning," Prof. O. M. Morris; Program, Theta Upsilon Sorority; Alice Pike, soprano; Ruth Coates, violinist; Gladys Huebner, reader.

KFI, Los Angeles, Calif. (Pacific, 469), 6:45-7:30 p. m., Concert, Harry Balsden's Orchestra; 10:00-11:00, Concert, the K. M. B. Concert Club.

KGW, Portland, Ore. (Pacific, 492), 3:30 p. m., "Child Nutrition," Margery M. Smith; 8:15, Studio program, George Olsen's Metropolitan Orchestra; 9:00, "Luregon Resources," Alfred Lomax; 10:30, Hoot Owls with Pantages Frolic.

KHJ, Los Angeles, Calif. (Pacific, 395), 12:30-1:15 p. m., Concert program; 2:30-3:30, Matinee musicale; 6:45-7:00, Children's program; 7:00-7:30, Organ recital, Arthur Blakely; 8:00-10:00, Monrovia Trio; Walter F. McEntire, lecturer; 10:00-12:00, Art Hickman's Orchestra.

KSD, St. Louis, Mo. (Central, 546), 8:00 p. m., Program, Mrs. J. Stoddard Robertson, contralto; Irma Moriarty, pianist; Adalardo Blaise, violinist; Mario Louise Huite, reader.

KYW, Chicago, Ill. (Central, 536), 11:35 a. m., Table talk, Mrs. A. J. Peterson; 6:50 p. m., Children's bedtime story; 10:00-11:30, Late show; Herbie

IS THIS SUPER-REGENERATIVE?

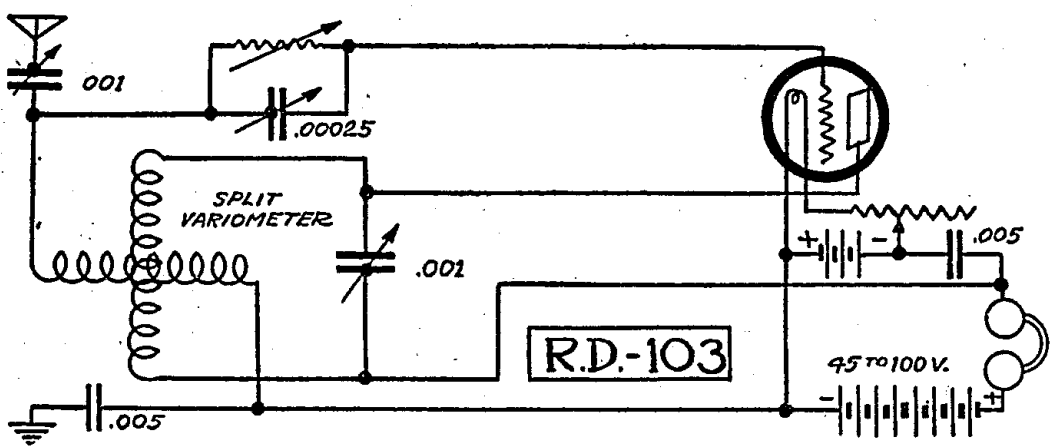

MR. E. C. HOFFMAN of 803 W. Superior Ave., Cleveland, Ohio, sends us his circuit with a title "Super-regenerative?" It has the characteristic whistle but strange to state is quiet, very selective and not affected by static. No wonder he is dubious. But he states frankly it's the best he has ever tried. Note that it resembles the original Miloplex somewhat.

He has asked us to pass it along with

the following suggestions. If it doesn't work just right, try reversing the rotor and stator leads. Tune the antenna condenser first; then the other controls, after which readjust the first. Values are apt to vary slightly for different tubes used. An amplifier tube is recommended.

The condenser between the phones and the negative filament battery should be tried at various values in order to get the best results.

THREE-TUBE MILOPLEX

(Continued from page 11)

Wizard. They are of minor importance and need no discussion.

The same conditions hold true for the addition of the condensers in the amplifying stages. No condenser was required from the plate of the first tube to the positive 22½-volt terminal. The values of the remaining condensers were kept the same as in the previous amplifier circuit.

Wiring

Be careful to check up all connections, as one little error, not always obvious, may suffice to stop all chances of reception.

The Mystery Man himself was in despair recently because one of his circuits wouldn't work. After a thorough examination the writer found one wrong connection and he, himself, found an omitted connection. The best of us fall down occasionally.

As often repeated, keep your leads short. In all Radio Digest diagrams crossed lines do not indicate a connection. All connections are marked with a heavy dot. Attention to this matter will solve the troubles of many and save the mail man a lot of work.

Watch your soldered joints; don't just paste them together with flux.

The illustrations of the completed set will help many fans with suggestions for wiring and tuning operations.

(TO BE CONTINUED.)

How to Stop Howling

If adjusting the filaments of an amplifier does not stop it from howling, try attaching a wire from the negative terminal of the battery used for lighting the filaments of the tubes to the ground post of the set. Should the howling continue, try grounding the iron cores of the amplifying transformers by attaching a wire to the cores and bringing it to the ground terminal.

RADIO FANS

Tune in on station
WEAF (New York)

every Thursday at 8.50 P. M. and listen to a story or article selected from

HEARST'S INTERNATIONAL

This is one of the most popular weekly features "on the air"

FREE

Write for Free Copy of the Latest Radio Reprint. It contains a complete story from Hearst's International Magazine. Address Radio Editor, Hearst's International Magazine, 119 West 40th Street, New York City.

THE UNOTROL (One Control) Broadcast Receiver

A Real One Tube Set. Made of best material throughout. In a Real Cabinet, with hinged top. High grade mahogany finish, hand rubbed. At a Real price. Will ship C. O. D.

Postage paid east of Rocky Mountains **\$11.90**

Set is Fully Guaranteed. Wonderful Distance Reported by Enthusiastic Users.

Dealers: Write for our proposition. Some good territories still open for bona fide Radio Dealers.

To the Experimenter and the Man Who Builds His Own: Write for Our Bulletin of Parts at Bargain Prices. Standard Merchandise Only.

Abalene Radio 105 Audubon Ave. New York, N. Y.

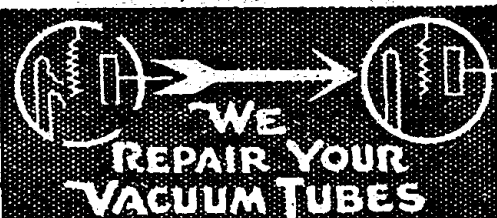

- WD-11-12, UV-199, UV-201-A C-301-A \$3.50 each
- UV-200, C-300 2.75 each
- UV-201, C-301 3.00 each
- DV-6, DV-6-A 3.50 each

All Work Fully Guaranteed

Quick Service—Repaired Tubes shipped C. O. D. unless accompanied by remittance plus postage.

NEW TUBES

- A-399 (Type UV-199) **\$4.10**
- A-401-A (Type UV-201-A) **EACH**
- A-12 (Type WD-12)

All the above Tubes guaranteed amplifiers and detectors. Shipped C. O. D., postage prepaid.

ABALENE RADIO 14 Vesey Street NEW YORK CITY

Large Size Wire Best
The largest wire practicable should always be used for winding coils for tuning circuits. It affords a much greater surface for the high frequency currents, aside from lower resistance. (Number 24 wire has more than 60 per cent greater high frequency resistance at 1,500,000 cycles than 20, and 26 more 100 per cent greater than 20.) Large wire also gives increased signal strength and greater selectivity.

Telephone Cord Kinks

Kinks in the phone cord should be straightened out every time they occur. A kink will soon wear through the cord fabric and expose the wiring. Later this may cause a short or open circuit.

B-T

Gives

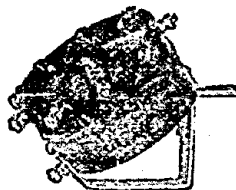

\$5.00

- 1 Vernier control hitherto unobtainable.
- 2 Unequalled results in single circuit regenerative Ultra Audion, etc.
- 3 Replaces Tapped Reinartz Coils.
- 4 Highly Selective and efficient for Reflex and R. F. Hook-ups.

Our new Booklet, "Better Tuning," will help you. It includes valuable information and new photo-diagrams. Sent on receipt of 10c—free with each tuner.

Bremer-Tully Mfg. Co.

532 South Canal Street, CHICAGO, ILL.



Super Vernier RHEOSTAT **\$3.00**

AND WORTH IT

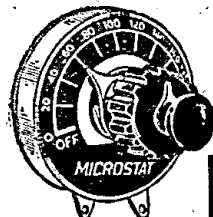

THERE is no substitute for the Premier "Microstat"—no other instrument that gives such perfect control of the current delivered to the filament of radio tubes. New principle—two windings in parallel—one 6 ohm—other 40 ohm. Absolutely noiseless—infinite control—handles any tube. Cap. 3 Amp. Bakelite moulded—silver etched dial. Do not install a Rheostat until you know all about the "Microstat." Our bulletin No. 90 explains it in detail. Send for it. It's FREE.

Premier Electric Company

3810 Ravenswood Ave. CHICAGO

Ask Your Dealer For "MICROSTAT"

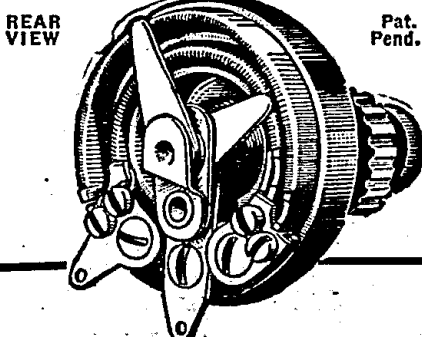

A NEW DISCOVERY!

EXTREME SUPER-REGENERATION is obtained without noises through

FRESHMAN

Variable Resistance Leaks

by connecting between plate and Grid of the tube as disclosed by the sensational **New Kaufman Circuit No. 2**



Panel Type

Absolutely No Pencil Markings



Base Type

Only the Knob Shows on the Panel

Freshman Resistance Leaks are especially built for use as tuning instruments. Construction is such that they will withstand unusual usage. Freshman Leaks give an unbroken range of 180 degrees from 0 to 10 megohms. Absolutely guaranteed. Enables you to get stations you never heard before.

EITHER TYPE

Complete with either .00025 or .0005 mfd. Mica Condenser..... **\$1.00**
Without Condenser 75c
At your dealers—otherwise send purchase price and you will be supplied postpaid.

Ask your dealer or write direct for free diagram showing how you can convert your single tube circuit into the new sensational Kaufman Circuit No. 2.

Chas. Freshman Co. Inc.
Radio Condenser Products

106 SEVENTH AVE. NEW YORK

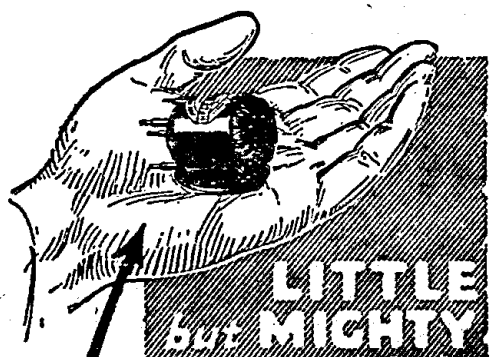

PREMIER "HEGEHOG" AUDIO Transformer

Little but mighty—a wizard for volume and tone quality. Look at the cuts. The view at the top shows the "HEGEHOG" as compared in size with the hand. The cut at the bottom shows it exact size. "Small" you say. Yes, but inside this "Little Wonder" you will find more efficiency, more reproduction volume and less distortion than found in any other Transformer regardless of size, price or design. The secret is in its patented construction. It is shielded 100% against foreign noises. Fully guaranteed. You'll want them in your next "hook-up," so get all the facts NOW. Our Free Bulletin No. 90 gives them fully. Send for it.

Premier Electric Company

3810 Ravenswood Avenue CHICAGO

Ask for and insist on "HEGEHOG" at your dealer's **Price \$3.50**

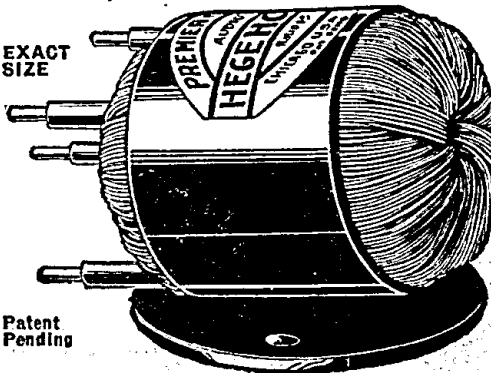

YELLOWTIP

MICROMETER ADJUSTING

CRYSTAL DETECTOR
Increases the Efficiency of Your Crystal Set



FINER tuning, clearest possible reception, constant adjustment until you wish to change, then—"A Twist of the Wrist—It's Set." Excellent for reflex and other circuits. Write for folder and name of your nearest dealer. **\$2**

Dealers and Jobbers—Write for Attractive Proposition

WHOLESALE RADIO EQUIPMENT CO.

Exclusive Factory Representatives 35 William Street, NEWARK, N. J.

Further Details of the Famous Miloplex Hook-Up

Part VIII—The Circuit Further Discussed by Experts

By the Mystery Man

SITTING at luncheon today in Chicago's wonderfully aggressive Electric Club, with five or six "Friendly Enemies," it was my pleasure to listen to a most interesting discussion upon the relative merits of tuning units. Of this crowd (it wasn't a party) four were engineers, one a circuit hound, the fifth a wise man who listened, and the sixth the man who made the King, and incidentally, several of you still are wondering whether the darn thing works or not.

Here, then, was a sure-fire crowd that wouldn't give or take an inch on their

from William Farr that's well worth repeating. Farr, they tell me, is a reflex wizard, while Forbes is a navy engineer with so many titles I had grave doubts as to whether his titles or his name would please you most. You know Forbes likes an argument; I believe our last tilt was "Whether you are modulating when you modulate or what bearing does the word Henry have with reference to Clay." But he's good enough to disagree with Mr. Marx and Mr. Farr, so that at least starts something.

Mr. Forbes will now speak:
"With the ordinary hook-up of the

coupled so that any reaction or change in one produces a very marked effect in the other.

"The reaction of either circuit on the other affects not only the value of the currents in the coils, as would be expected, but has an important influence on the frequency to which the circuits respond most vigorously. In other words, tuning the grid circuit to a given wave length impresses the oscillations occurring on that wave on the grid of the detector tube; these oscillations flow through the path formed by the winding of the variometer to ground end, also to negative filament.

"The oscillations flowing through the winding of the variometer do, by transformer effect, induce a current in the other winding of the split variometer (auxiliary circuit). Now, if the auxiliary circuit is not tuned to the wave length that the grid circuit is tuned to, resonance does not occur, and although you will apparently be in tune with the incoming signal, you will not get maximum results. These will only be obtained when the auxiliary circuit is exactly tuned to the same wave length as the grid circuit, at which point resonance occurs and maximum signal strength will result.

"A more direct method of observing this result is to place a hot wire ammeter or thermocouple in the circuit and note the changes in its readings as tuning is accomplished. Of course, the above action only holds true in its super-heterodyne form when the detector tube is set into oscillation. This will explain the tremendous increase in signal strength and tuning, selectivity, etc., when only the coupling of the two windings of the split variometer is varied."

That's what he said; if you don't believe it, tell him. You know they trap men in the navy to make public speeches in which all of the navy secrets are supposed to be exposed; and when they have

finished the oration one wakes up to the fact that they only showed you the black box wherein the secrets are hidden. I cannot digest it; yet, I quite appreciate that the explanation is as clear as possible. If you understand it, you're a better man than I am, Gunga Din.

Certainly I knew he would give me a theory that would be a bearcat, and I am most appreciative because many, many

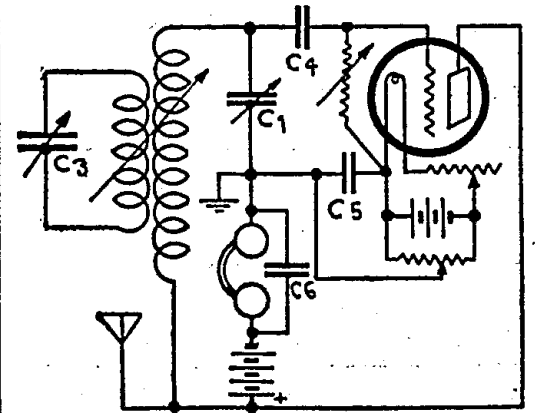

times have I sought his counsel and tried his patience.

Mr. Farr, say, Mr. Farr, no matter what I think about your theory—right or wrong—Maggie, the cook, said yours was the easiest understood, because you drew a picture of it, with bay windows on the house 'n' everything. And one dare not (Continued on page 20)

MILOPLEX VS. NEUTRODYNE

Dear Sir:

Three weeks ago I completed a neutrodyne, and since then have been working on the neutralizing condensers, trying to set them so that I could tune out a 500-watt local station. I have given up trying, and Sunday afternoon built the Miloplex. By 8:30 in the evening I was getting DX, while WEAN and WJAR, the loud, broad locals, were both going. I am located about twelve blocks from either station and, using an indoor aerial, had wonderful results with the Miloplex. This makes the eighth set I have built with the aid of Radio Digest, and all with success, but the Miloplex certainly has anything and everything that any of my friends or I have, beat for all that is desirable in a receiver.

With many kind thanks, I am,
Very truly yours,
Arthur I. Reichauer.

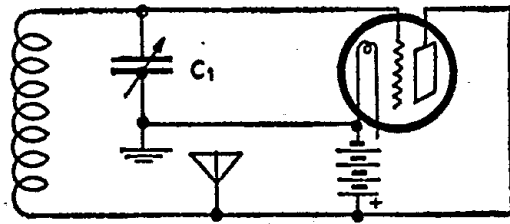

Miloplex, the incoming oscillations are impressed directly on the grid of the detector tube through a variable condenser; the other path is formed through one of the windings of a split variometer. The connection to the filament is through a small fixed condenser.

"An auxiliary circuit is formed by connecting the other winding of the split variometer in parallel with a variable condenser.

"The grid circuit is tuned by varying the variable condenser in series with the antenna; for future reference you will designate this condenser as C-1. The auxiliary circuit is tuned by varying the variable condenser (C-2).

"When two circuits are coupled they react on each other so that the current in each circuit is not the same as would be the case were the other circuit absent. The extent of the reaction is, however, very different in different cases. In the case under consideration the grid circuit and the auxiliary circuit are closely

personal opinion, battling" this way and that way over so simple a thing as a tuning unit.

What did they say? Well—why mince words—they each and all agreed that switch taps and inductance switches were about as essential on a tuning inductance as ear muffs on a canary—

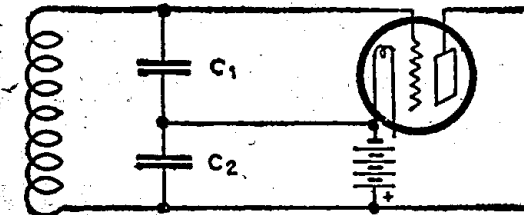

that's what they said; that's why we didn't use them on the King. I merely pass it on to you in support of some of my earlier statements.

Last week I digested Mr. Marx's theory of the Plexy, and now that friend Forbes has decided not to marry the girl, he has written me, and I'm giving you his theory, while among my numerous letters is one

RADIO HANDBOOK

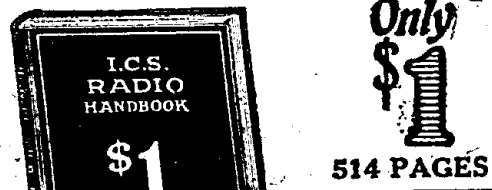

Just off the press! The greatest book on Radio ever written. Price only \$1. Filled with sound, practical, tested information for every radio fan, from beginner to hard-boiled owl. Written, compiled, and edited by men of national reputation. Every page tells you something useful—and there are 514 pages. Mail \$1 to-day and get this I. C. S. Radio Handbook before you spend another cent on parts. Money back if not satisfied

INTERNATIONAL CORRESPONDENCE SCHOOLS
Box 8278C, Scranton, Penna.

I enclose One Dollar. Please send me postpaid—the 514-page I. C. S. Radio Handbook. It is understood that if I am not entirely satisfied I may return this book within five days and you will refund my money.

Name.....
Address.....

ROOT FOR RADIO!!	
LOUD SPEAKERS	
Western Electric 10D.....	\$48.50
Mercury.....	7.50
PHONES	
Brands.....	\$5.25
Western Electric.....	8.25
Nerco (1-year guarantee).....	2.75
TRANSFORMERS	
All American (all ratios).....	\$4.25
Eria, Reflex.....	3.95
Acme.....	3.75
PANELS (High Grade)	
7x10.....	.75
7x18.....	1.35
7x24.....	1.75
Hydrometer.....	.35
Sockets.....	.35
Bus bar length.....	.03
Diags.....	3
Diags.....	4
We carry a complete line of all standard parts and sets. Let us know your wants. We can fill all your Radio requirements. We pay postage on orders of \$5.00 or over only. ROOT RADIO CO., Inc. DEPT. D, 2525 BROADWAY, NEW YORK CITY	

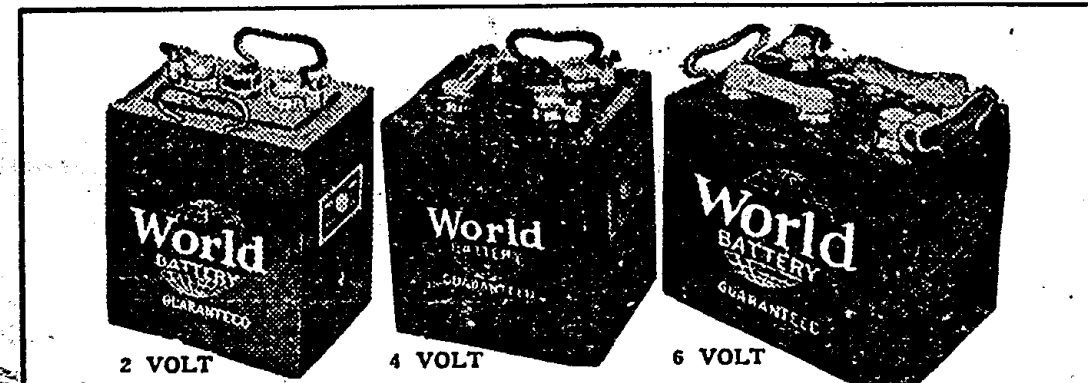

World Storage Batteries Save You 50% And You Get A Written 2-Yr. Guarantee

No better battery than the "World" can be built. That is why we can back it with the strongest guarantee written. We maintain the quality of our product. Our batteries have to be "right." And they are "right." Our tremendous steady increase in sales prove it. World Battery Owners "tell their friends." This is our best proof of performance.

Special 2 Volt Storage Battery.. \$5.00	6 Volt, 60 Amp.....\$ 8.50
For W.D. 11 and W.D. 12 tubes. Will run 200 hours on one charge. Rechargeable.	6 Volt, 80 Amp..... 10.00
Special 4 Volt Storage Battery.. \$8.00	6 Volt, 100 Amp..... 12.50
For U.V. 199 tubes. Same features as 2 Volt.	6 Volt, 120 Amp..... 14.50
	6 Volt, 140 Amp..... 16.00

Send No Money. Just your name and address. We ship C. O. D. subject to inspection or will allow 5% discount for cash with order. When the battery arrives C. O. D., read the 2-year written guarantee before you pay one penny. You are protected from every angle. Save 50% by acting while these prices hold.

WORLD BATTERY CO.
60 E. Roosevelt Road Dept. L Chicago, Illinois

B-METAL

The Crystal That Brought Joy to 100,000 Radio Users Last Season.

Sent on approval. Pay us when you are satisfied. That's how sure we are that it will please you. Just pass the good news on to a dealer so others may enjoy B-Metals too. Just send us the name of dealer who hasn't heard of B-Metal when remitting. **50c**

LOUD TALKING RADIO CRYSTAL

The B-Metal type C fixed detector for your reflex set—try one and know Gentlemen.—Some time ago I got from you one of your B-Metal Loud Talking Crystals and as you asked me to let you know how it worked, am writing to let you know that I am much pleased with it. It is more sensitive and louder than any detector I have used so far and these have been many—besides your product appears to stand up O. K. under my high plate voltage Eria requirements up to date. It is really a pleasure to have any Eastern Radio product come up to advertised promises. Yours truly,
EDWARD I. CHURCH.
B-METAL REFINING COMPANY
3134 Trumbull Avenue, Detroit, Mich.
Chicago Branch, 53 West Jackson Blvd.
For Sale by All Dealers

\$2.50

COTO-COIL DETECTOR

Coto Special Audio Transformers

Real Coto Quality at a Popular Price

DEALERS!
HAVE your jobbers let you in on this big seller? If not, write us, giving jobber's name.

A marvel of manufacturing economy. In finish, high grade materials and amplifying efficiency, actually superior to many transformers selling at \$5 and over. Ask your dealer to show COTO SPECIAL. If he fails you, send us his name and we will see that he is supplied.

COTO-COIL CO., 87 Willard Ave., Providence, R. I.

Pacific Coast Branch: 329 Union League Building, Los Angeles
Northwestern Branch: Geo. F. Darling, 705 Plymouth Bldg., Minneapolis
Southeastern Branch: C. P. Atkinson, Atlanta Trust Co. Bldg., Atlanta

Radio Digest Illustrated

REG. U. S. PAT. OFF. AND DOM. OF CANADA

Published by the Radio Digest Publishing Company, Inc.
123 West Madison Street
Telephone: State 4843, 4844, 4845
Chicago, Illinois

E. C. RAYNER, Publisher

Chas. F. Smisor, Editor Evans E. Plummer, Managing Editor
H. J. Marx, Technical Editor M. W. Thompson, Associate Editor

Eastern Representative, Jacob Miller, Times Bldg., Times Square,
New York; Telephone Bryant 4909

Pacific Coast Representatives

E. J. Wood, 251 Kearney St., San Francisco
Telephone: Kearney 1472

H. M. Morris, 417 Western Mutual Life Building, Los Angeles
Telephone 12011

Member of the Audit Bureau of Circulations

58
PUBLISHED WEEKLY

SUBSCRIPTION RATES

Yearly in U. S. and Possessions and Canada, \$5.00.
Foreign postage, \$1.00 additional. Single copies, 10 cents.

Vol. VII Chicago, Saturday, November 17, 1923 No. 6

Steinmetz the Wizard

The Passing of a Great Man in His Particular Field

HE LEFT a legacy to all of us. We cannot figure out in dollars and cents just how much each individual will be benefited, yet there was a portion dealt out to each one of us by Charles P. Steinmetz while he lived and worked. Yes! worked, for he demanded no salary; all he wanted was a drawing account, a place to live and a shop to work. If he had to think about money he could not work.

He was the author of many books, inventor of many devices, including the electric automobile and artificial lightning.

The passing of Dr. Steinmetz takes away a prominent figure in the electrical field. He had visions of transmitting power through the air and was the most advanced in this one particular thing, far ahead of any other person. We cannot calculate the eventual loss this man's untimely death may have been to us.

Ears May Be Bad

Health May Effect Hearing but Not Radio

A GERMAN scientist says that poor reception is not altogether to be blamed on the Radio set. It may be in your ears. This scientist further states that when you are feeling bad reception is poor, but when you feel good you can hear well. There is a difference of two hundred vibrations a second between the days when you feel bad and those when you are in good health.

That is some statement to make. If you feel right you can listen well, if not you cannot hear. We would rather believe that if reception is poor something is wrong with the set. It is true in some cases where a deaf person has regained his hearing by Radio, but there are exceptions to all rules.

Pay for Broadcasting

In What Way Shall Pay Come for Artists and Operators?

IT appears that the maneuvering carried on in England to pay for broadcasting is having its difficulties. They have a system whereby the owner of a receiving set must pay an annual tax of \$2, one-half of which the government retains, the other half going to the broadcasters. This has brought about a situation whereby the broadcaster controls the entire output. All sets manufactured and sold must have the approval of the government and the broadcaster gets 10 per cent of all sales. A home-made set stands no chance of approval, hence the owner cannot obtain a license. Naturally broadcasting has become a monopoly.

The general public did not like the restriction and the newspapers began a fierce attack on the broadcasting companies. The public stopped buying Radio sets and licenses and began making their own sets. The broadcaster could await the outcome but the small dealer had to close his doors. If the only solution to this problem be a tax, then it should be a just one and not given over to any special manufactured product or line of receiving sets.

In the United States there have been some broadcasting stations that adopted the policy of receiving fees for allowing the broadcasting of talks, lectures and speeches, and sometimes music. It is a very good thing for the industry in general and the great multitude of Radiophans that the practise is not at all general.

Broadcasting is not greatly different in effect from the reading pages of newspapers, periodicals and magazines. Those which are guided by fearless editors, who print only text matter that they believe to be correct, to be right and to be fair, are the publications that have the respect and following of their readers.

This has proved to be the case in the past. The greatest American magazines and newspapers in existence today are those which have not prostituted their reading pages for the benefit of any kind of interests.

RADIO INDI-GEST

FIFTEENTH ATTEMPT SUCCESSFUL

By Slathery Simpson

WALLA WALLA (By Indi-Gest Broadcaster Today).—You can't keep a good man down by mere failures. This noble thought was emulated today by Cam Era, Official Indi-Gest Staff Photographer and Boulevard Masseur, who succeeded, in his fifteenth attempt, at taking a picture of Mrs. King Milloplex, alias Queen Milloplex, alias Mrs. Mystery Man, alias Maggie the Cook. Not that the subject wouldn't pose. No, no! Far from that, but her peculiarly enlarged anatomy required specially imported rubber plates that would stretch, and also, that would stand the shock of the exposure.

The original fourteen plates saw her first and exploded with indignance. How the fifteenth plate was hoodwinked into registering this notorious person, how the camera struggled desperately to get away but succumbed at last to superior psychic powers, how the tripod became a bipod when it kicked off a leg in the struggle—all will be graven in the annals of the Walla Wallan photographic archives.

The facts remain that your humble correspondent is allowed the extreme pleasure of presenting this famous picture to READERS' OF INDI-GEST EXCLUSIVELY NEXT WEEK.

A-B-C Lessons for Indigest Beginners Chapter XXII—Ours Is Pig-Tailed

BY GOSH

V IS for variometer,
Just like a little pig's tail,
You twist it once too often
And your tube lets out a wail.

A Sacred Prize Fight at Last!

Dear Indi: On a recent Monday night I was listening in and heard Newark, N. J., reporting a prize fight by rounds. The account of the "mill" was becoming interesting, when Zion, Illinois, butted in. I could not tune WCBD out, so I adjusted the instrument until I could hear Zion and Newark equally well. This is what I heard:

Newark—"Bomash smashed Grebe on the nose, which brought the sap."

Zion—"This is our regular Lord's day service."

Newark—"Grebe replied with a vicious uppercut to the chin."

Zion—"Behold how pleasant it is for brethren to dwell together in unity."

Newark—"Bomash knocked Grebe through the ropes. Grebe came up smiling with a bloody face for more punishment."

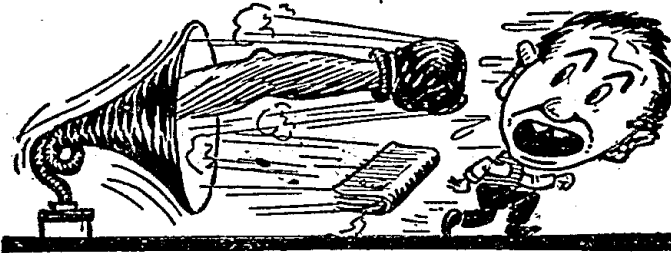

Zion—"It is like the oil which runneth down the beard, even Aaron's beard."

Newark—"Fourth round: Bomash sent a left to Grebe's head, which he dodged, only to receive a smash on the jaw, which came near putting him to sleep."

Zion—"Even to the hem of His garments."

Newark—"Both men bleeding freely and they have each received about all the punishment they can take."

Zion—"The choir will now sing 'Praise God from Whom All Blessings Flow'." FORBES BARN.

When Slo' Jo' Announces

I've lost nigh on a year, I fear,
Waitin' for things to hear,
"In one minute." "the next will be,"
"One minute please," he says to me.
And although it's gettin' late,
We just sit and wait and wait.
H. K. C.

He Thanks You from the Bottom of His Stomach

Dear Indi: Have been reading the articles by the Mystery Man concerning the Milloplex circuit, and it seems to me he must think of nothing else but eating. What's the matter, is his stomach trying to pull a McSwiney act?

Under separate cover you will find a nice juicy sandwich, give it to the Mystery Man, have him devour every crumb of it and then he can forget about his stomach for a while. The deuce with his cook, if he wants to discuss them why don't he write for the Ladies' Home Journal?

Another thing, remind him that I have informed the Salvation Army of his condition and they promise quick action in looking him up and giving him a big square meal. Yours till the Mystery Man gets enuf to eat,

FRANK KONWALSKI, Pres.
ALVIN A. AQUADRO, Secy.
Up-all-Night Radio Klub.

P. S.—I wonder if he ever heard of the song "Wanita"?

Our Parlor Story

A lady hard of hearing was listening in on the Radio in a friend's parlor one Sunday afternoon. The program being broadcast was a symphony concert. The visitor believed she was hearing a church service. After repeatedly hearing the announcement: "The next selection will follow in one minute," she remarked: "I'd hate to attend that church; they stop to take up a collection every minute." CROSBY WEEKLY.

We Will Try It and Tell You the Results

Dear Indi: I read with interest the phenomenon of Radio being a panacea in your late issue. But wouldn't it be awful if a cancer patient got tuned in on a jazz band or a T. B. wave or vice versa? Goo Goo.

Another Satisfied Customer



Condensed

By DIELECTRIC

Possibly a large percentage of listeners in do not understand the code signals, which so often interfere with perfect broadcast reception, although several broadcasting stations have been providing them with the ready means of learning the "dit-dah" language. To amateur Radio "bugs" much of the pleasure of tuning in lies in the ability to chat with a fellow fan in a distant state, or even in another country. Just recently a report came from Melbourne, Australia, that signals from American amateur Radio stations were received with remarkable strength. Why not add to the usefulness and entertainment of your receiving outfit by turning your attention to mastering code, so that you too may understand what amateurs say; that SOS signals may convey information when you stand by for particulars; that your service in time of need may be larger.

When Major General Squier, of the Signal Corps, discovered a method of transmitting speech and music over electric lighting wires, he set to work a group of men whose efforts have resulted in a new form of presenting entertainment to Radio listeners. The Wired Service Corporation, located on Staten Island, is carrying to 500 residents of the island a six-hour program daily, to be increased when the service is extended to New Jersey. Upon payment of a certain sum your set is installed and the programs come in. For a very small amount monthly you have the use of the set, with no batteries to bother with and a service department to keep it in order. Is this to be the solution of supporting broadcasting, at the same time eliminating bother with accessories?

Right along the line of broadcasting expense comes the news from the Actors Equity Association of their proposal to put Radio performances for theatrical companies on a paying basis. No longer are full companies of its members to give their services free at broadcasting stations. Individual artists may enhance their prestige via the studio of a transmitting station, if they so desire, without action from the association. There you are! The managers of broadcasting stations seem of a mind that this added expense cannot be borne. It appears to make no difference to the "Equityites" that broadcasting is free publicity. Well, it's a process of development and a solution to the support of broadcasting will ultimately be found. Wired wireless? Ask R. C. A.

Broadcasting station WNAC, the Shepard Stores, Boston, keeps a careful watch for features with an especial appeal to listeners in whereby they keep most of their large Radio audience contented. This station is one of the few giving play-by-play accounts of football contests between the big colleges. They broadcast recently, with orchestra, "Harmony March," written by Charles C. Webster of the American Woolen Company. This composition won the president's prize offered to employees of the company. You no doubt enjoyed Mr. Arnold's singing and are humming the song yet. What is new is Radiophoned.

From latest reports received the majority of you readers are having a far more comfortable time with your Radio than the MacMillan party aboard the Bowdoin bound north. Major Mott received a message at Avalon, Santa Catalina Island, Calif., from the Bowdoin announcing the position of the vessel as then eleven degrees from the North Pole. A very heavy snow with below zero weather and "the sun up for a few minutes today for the last time." The message also carried the welcome news of all hands being well. From a Radio standpoint this trip is one of considerable interest, as it was thought likely Radio communication could not be maintained within the vicinity of the Pole. Live and learn!

Latest Development in Grimes' Inverse Duplex

Part I—Reflexing with the Use of a Tube

By David Grimes

WHEN information concerning my Radio developments first started to escape through the press early last spring, Radio Digest made arrangements with me to write a series of articles on the Inverse Duplex. These were

first for Radio amplification and second for audio amplification. The idea of using the tube for reflexing was not new when I took it up. That idea was fully and basically covered by U. S. letters patent granted in 1914 to two Germans. An

last tube became overloaded long before the first tube was being used to its maximum efficiency. But this was not the only drawback.

The next difficulty was that the circuit tended to oscillate almost beyond all control. Many tests were conducted to locate the source of this oscillation, and it was finally found that the rectified Radio frequency currents in the output of the detector tube leaked through the audio circuit and were amplified at Radio frequency several times before being put back onto the grid of the detector tube again. This action is the same as that

times before placing them in the telephone receivers. A straight reflex circuit operating on a loop will pick up the 60-cycle hum from any electric wire in the house with considerable volume. In fact, the set may be used with great success for locating faulty or defective electric wiring in a dwelling. Needless to say, this is a big disadvantage when the set is used for Radio reception.

It is not often one shift or basic change in a circuit will overcome many difficulties. It usually requires at least one change per difficulty. But this was not so with the Inverse Duplex system. This

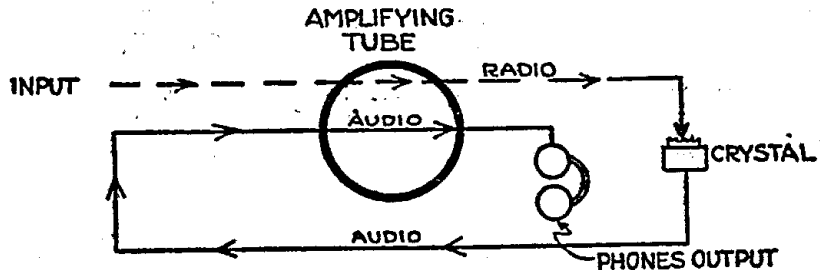

Original German reflex

well under way when letters began to pour in from previous "leaks," and these convinced me that I would either have to tell the full story or none at all. My partners at that time did not care to give out the full information; so I ceased putting out any further data. After some months of persuasion, they have come to the conclusion that our patent situation is

extended and more complicated system of duplexing or reflexing, using more than one tube, was later covered by patents granted to Marius La Tour, a Frenchman.

In the work conducted during the war on reflex circuits, it was found that all straight reflexing had three inherent disadvantages, and straight reflexing was the only kind known up to the time of my

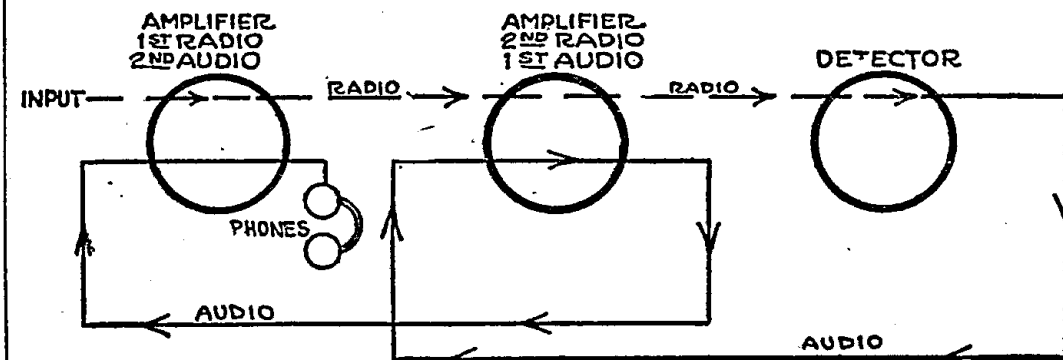

Grimes' Inverse Duplex system, reversed sequence

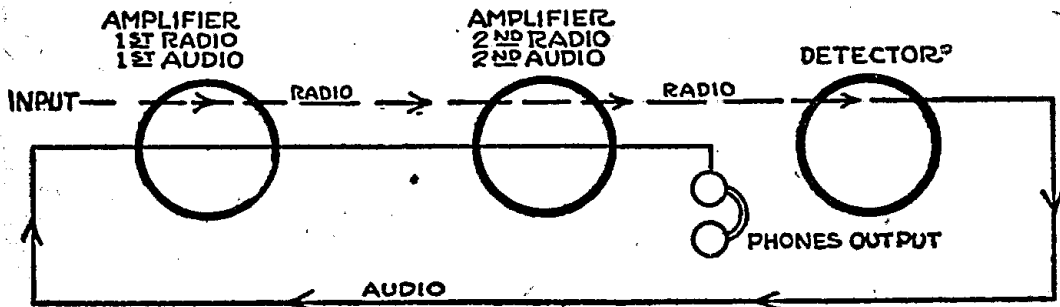

La Tour reflex, straight sequence

strong enough to warrant a complete release and that this is only fair to the man who wishes to "build his own."

This series of articles is not intended to give the constructional drawings, etc., as that would not be within my experience. The only type of Radio set which I work with at all is one wired up on a flat board with all apparatus readily accessible. No doubt there are many amateurs who have constructed successful Inverse Duplexes in cabinets and I will leave that field to them to explain. All the information given here will enable the student to duplicate the highly successful results I have obtained, providing he follows instructions and uses equipment that is not defective.

Before diving into the details and technique of the various circuits employing my system of reflexing, it is in order to give a brief outline of how the circuit was developed and what it is supposed to accomplish. Most inventions are not mere accidents, but are the results of months, sometimes years, of work. I believe it was Mr. Edison who said that all inventions were two per cent inspiration and ninety-eight per cent perspiration.

Inverse Duplex is one of those inventions that fall under the perspiration class. It was developed as a war necessity. It was the only answer to a very baffling problem. It successfully solved the dual use of vacuum tubes for ampli-

inverse development. The disadvantages may be briefly summarized as follows:

The vacuum tubes, were very easily overcrowded, as the first valve carried only the weakest Radio energy and also the weakest audio energy, while the last tube in the sequence was forced to handle both the strong Radio and strong audio amplification. Quite naturally, this

encountered when the receiver of a telephone is placed before the transmitter—a howl is produced. It is the same action as that which occurs in a regenerative circuit, only many times amplified. And finally there is a third trouble in which we are greatly interested if we have any 60-cycle electric currents in our homes.

This trouble is the ability of the straight reflex circuit to pick up audio frequency noises and amplify them many

system overcame the objections to the straight reflex, one right after the other—one, two and three. It is quite easily seen from Figure 1 that the difficulty with overloading has been solved, as with the Inverse system the tube carrying the

(Continued on page 18)

SPECIAL SALE

\$175.00 COMPLETE KENNEDY 3-TUBE RECEIVER **\$89.75**

Kennedy No. 281 Receiver and No. 521 Two-Step Amplifier, complete with Three WD-12 Radiotron Tubes, Two Dry Cells, Two 22-volt "B" Batteries, One Pair 3000 ohm Phones and Antenna equipment. Guaranteed new and first class. While a limited number last. **\$89.75**

- UV-201A, UV-199, WD-11, WD-12 Radiotrons \$5.28
- Murdock 3000 ohm Phones..... 2.95
- Brands Superior Phones..... 4.88
- 22½ volt Variable "B" Batteries..... 1.38
- 45 volt Variable "B" Batteries..... 3.38
- Air Core Neutrodyne Transformers, each 1.46
- Acme Type Audio Transformers..... 2.19
- Battery Charger with "Tungar" Bulb. 9.75
- Standard, 199 or WD-11 Sockets..... .48
- Atlas "Amplitone" Loud Speaker..... 18.96

All goods guaranteed as advertised. Send for complete list

SIMPLEX RADIO SUPPLY CO.
1806 Lafayette Ave. ST. LOUIS, MO.

COLUMBIA ALL-CIRCUIT VARIOMETER

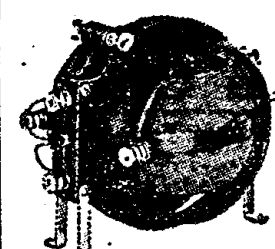

With split stators, providing for all present day circuits and permitting most future circuits in which a variometer may be used, this black bakelite moulded, green silk instrument is the one to buy. It is pig-tailed and built for selectivity. This variometer can be used for MILOPLEX circuits.

Price \$5.50

Ask to see the nationally known Columbia line of licensed bakelite apparatus. Known satisfaction. A few more Columbia items:

- Moulded Bakelite Variocoupler..... \$6.00
- Geared Three Coil Mounting..... 5.00
- Geared Two Coil Mounting..... 3.50
- Inside Coil Mounting—"Vernier"..... 6.00
- All-Meter Variocoupler—150 to 2600 meters..... 7.00
- Mounted Coils, Coil Plugs, etc.

Write for our free literature

COLUMBIA RADIO CORP.
157 NORTH UNION STREET, CHICAGO

Worksman Radio Service
"THE ACCENT IS ON SERVICE"
14-16 Vesey St. NEW YORK

VARIOCOUPERS
\$3.50 Workrite 180° Silk Wound..... \$2.95
3.00 Mills 180° Silk Wound..... 1.95
8.50 Fisher, Large, 90°..... 2.25
2.75 Fisher, 180°..... 1.75

VARIOMETERS
\$3.50 Workrite..... \$2.95
8.50 Remler, Moulded..... 4.45
3.50 Fisher, Large..... 2.65

CONDENSERS
\$2.00 R. C. 11 plate..... \$1.05
2.35 R. C. 23 plate..... 1.35
2.75 R. C. 43 plate..... 1.65

VERNIER CONDENSERS
\$4.00 R. C. 23 pl..... \$2.25
5.00 R. C. 43 pl..... 2.95

AUDIO TRANSFORMERS
\$5.00 Acme..... \$3.95
5.50 Federal 226 W..... 4.35
7.00 Federal No. 65..... 5.75
7.00 Amertran..... 5.75

PHONES
\$6.00 Brandes Superior..... \$5.25
12.00 N. & K., Imported..... 5.50
5.00 Nerco..... 2.50
Ambassador..... 3.69

Complete Parts for Cockaday Sets
Including 7x14x3/16 panel, Standard tested apparatus furnished throughout. **\$12.75**

Mail orders promptly attended to. All orders amounting to \$5.00 or more will be shipped prepaid. Will ship C. O. D. unless remittance accompanies order. Write for our monthly bulletin of radio bargains at reduced prices.

F. M. H. RADIO CO.
Room 985, Old Colony Bldg., Chicago

	Our List Price
Hegehog Transformers— (5-1, 4-1, 3-1).....	\$3.50 \$2.85
Federal (Type 65) Transformers.....	7.00 4.75
All-American Transformers— (10-1, 5-1, 3-1).....	4.75 3.75
3 Plate Condensers.....	1.75 .80
5 Plate Condensers.....	2.00 .95
11 Plate Condensers.....	2.25 1.05
17 Plate Condensers.....	2.50 1.15
23 Plate Condensers.....	2.75 1.25
43 Plate Condensers.....	3.00 1.50
14 Plate Vernier Condensers.....	5.00 2.75
22 Plate Vernier Condensers.....	5.50 2.90
44 Plate Vernier Condensers.....	6.00 3.00
B-Metal or Rusonite Crystal.....	.50 .40
Federal Phones.....	7.00 4.75
Little Tattler Phones.....	4.00 3.00
Howard Vernier Rheostat.....	1.50 1.05
Freshman Grid Leak and Cond.....	1.00 .75
Na-Aid De Luxe Socket.....	.75 .60
Federal Standard Socket.....	1.00 .75
Dials, 2", 3", 3½" for ¼" Shaft— List... 50c, 60c, 65c	Our Price... 22c, 24c, 26c

Hundreds of Bargains in All Standard Lines
We pay postage on all orders over \$5.00

RADIO TUBE CORPORATION
70 HALSEY ST., NEWARK, N. J.

WD-11 and WD-12 Tubes Repaired

WD-11 or WD-12..... \$3.50
C-300 or UV-200..... 2.75
C-301 or UV-201..... 3.00
C-302 or UV-202..... 3.50
C-301A or UV-201A. 3.50
Moorehead Detectors. 2.75
Moorehead Amplifiers. 3.00
DV-6 or DV-6A..... 3.00
UV-199 or C-299..... 3.50

All tubes guaranteed to work like new
Mail Orders Given Prompt Attention
"24 Hour Service"
Tubes Sent Parcel Post, C. O. D.

METALECTRIC SOLDERING IRON
Indestructible All-Metal Quality Instrument—"GUARANTEED"

Designed to meet the requirements of the discriminating assembler.

Interchangeable Tip
\$5.50
"WORTH IT"

Operates with the simplicity—comfort—ease and efficiency of a pen.

Of your dealer or write
Post Electric Co., Mfrs.
(Dept. 509) 30 East 42nd St. NEW YORK

You Must Use

AMSCO

VERNIER CONDENSERS

to get the best possible results from your set—no matter what type it is. They guarantee noticeable improvement in the reception obtained.

13 Plate	\$4.00
23 Plate	\$4.50
43 Plate	\$5.00

These Variable and Vernier Condensers will satisfy the most exacting. Perfect spacing, permanent adjustment, no iron used in construction. Whole white nickel finish. High maximum to minimum ratio.

At all good dealers—or direct on receipt of purchase price. Also write for our complete literature.

AMSCO PRODUCTS, INC.
416 Broome Street NEW YORK

Homemade Multiple Phone Jack Box

Connections Provided for Several Listeners

The box is made of wood with a front of bakelite. Inside of the box, between the lower part of the jacks and the bottom of the box, is placed a thin sheet of hard rubber obtained from a broken

WORKSHOP KINKS? EARN A DOLLAR—

THERE are many little kinks worked out at home that would aid your fellow Radio worker if only he knew about them. There are new hook-ups, new ways of making parts and various unique ways of operating sets that are discovered every day. Radio Digest is very much interested in obtaining such material. Send them in with full details, including stamped envelope, so rejected copy may be returned. The work must be entirely original, not copied.

RADIO KINKS DEPARTMENT,
Radio Digest,
123 W. Madison St., Chicago

photographic plate holder slide. This will serve to insulate the jacks in case any moisture should be absorbed by the wood.

The jacks and plugs should be wired in the same direction as the jacks and plugs on the set it is to be used with. Single closed circuit jacks are used with the phones in series when connected in this way.

A .001 mica condenser is shunted across the terminals. This is mounted on the outside of the box for convenience and for changing the capacity if found necessary. The tie cord of the terminals is placed under the condenser and a knot is tied to the end to keep it in place. The positive and negative posts are marked, and the wiring is continued through the jacks in the same direction on each one.—Victor A. Ulrich, San Francisco, Cal.

Automobile Battery Connection

The motorist usually places the battery in his car, thus saving the trouble and space taken up by a heavy A battery. As car batteries are nearly always under the floor of the car, you get your hands dirty and waste about five minutes every time you connect the set to go driving. This trouble is avoided by making a plug connection from the battery to the set that will fit the lighting sockets of the car. To connect the battery simply remove the bulb from the most convenient socket, which will probably be the one on the instrument board, and insert the plug from the set. The plug may be made from a burnt-out light bulb that fits the socket.

Break the glass and the sealing wax that holds it from the burnt-out bulb, saving only the brass shell and the small round disk that makes the contact at the center of the socket. To each of these solder one of the strands at the end of a piece of twisted light cord, long enough to reach from the set to the socket. Now, after making sure that the two wires of the cord do not short circuit and that the disk is in the same relation to the shell that it was before it was broken out, fill

BOX OF WOOD WITH BAKELITE FRONT

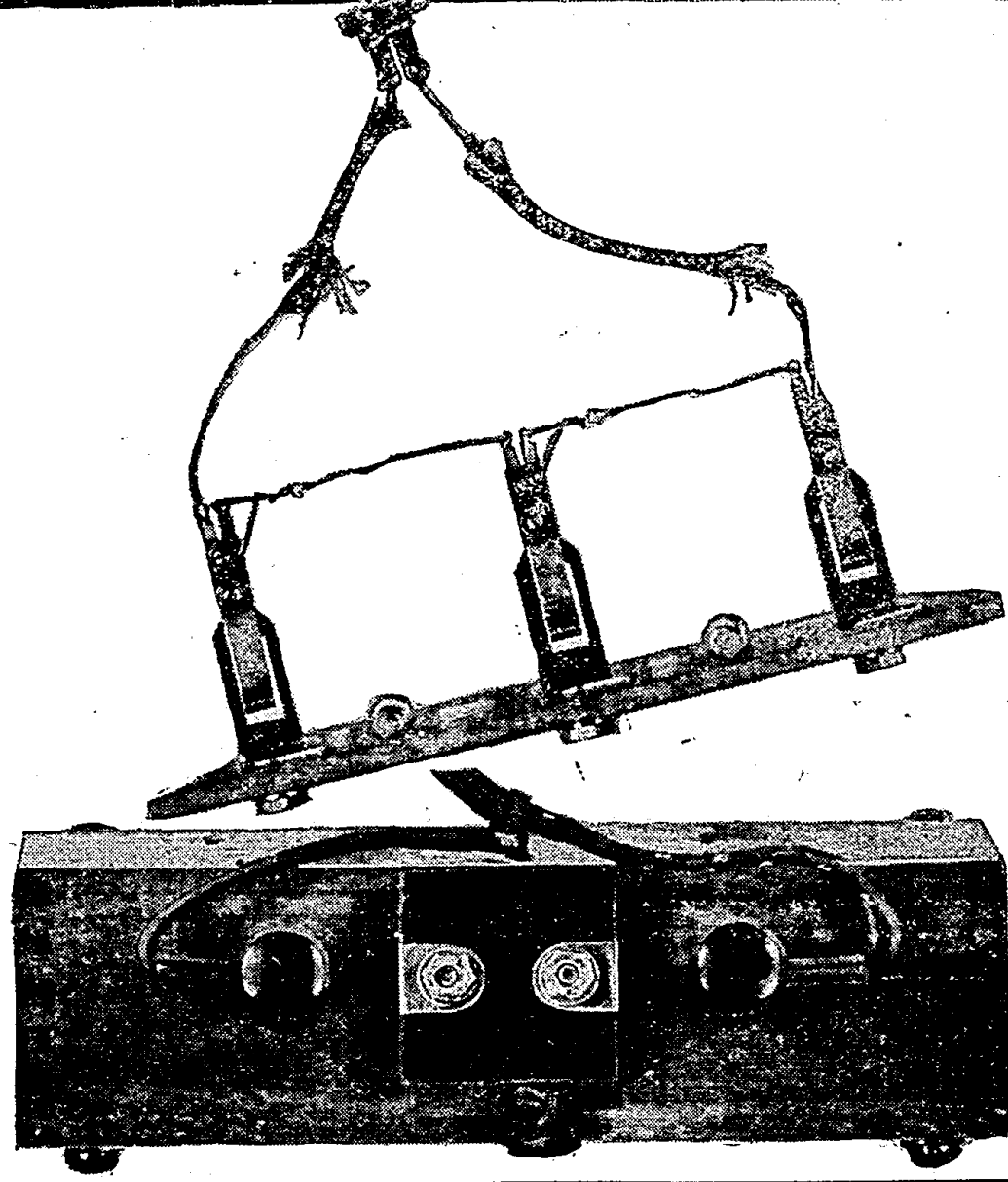
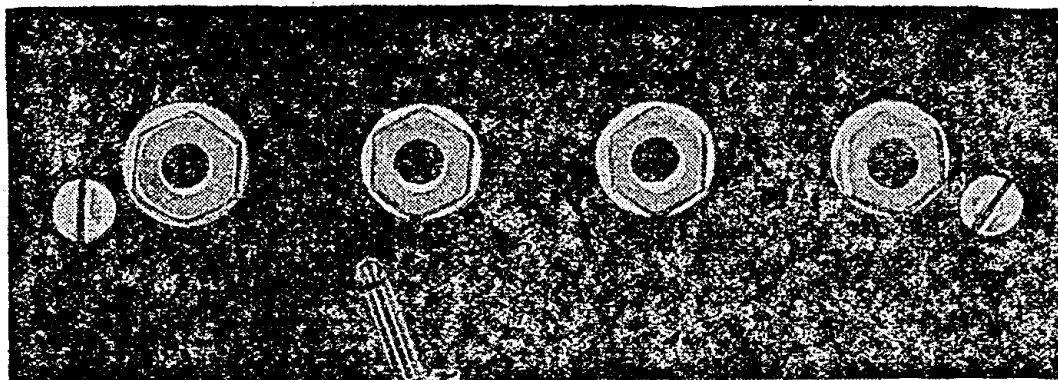

the shell with hot sealing wax, taking care to keep the disk in the correct position, so that it will make proper contact when inserted in the socket. Attach the other end of the cord to binding posts on the set and turn on the switch. The strands of the cord may have to be reversed at the binding posts before the plus and minus terminals of the battery are correctly matched with those of the set.—Robert T. Kennerly, Knoxville, Tenn.

Keep the storage battery fully charged and the top clean for best results.

How to Make Clips for Testing Out Circuits

Many times when trying out a new circuit it is not desirable to put in a full set of taps or make permanent connections. The clip that can be purchased in Radio shops is all right to use on battery terminals or heavy wire, but on small wire, like 26, 28 or 30, the wire either slips through the teeth or the space is too small. I have made a little clip with two

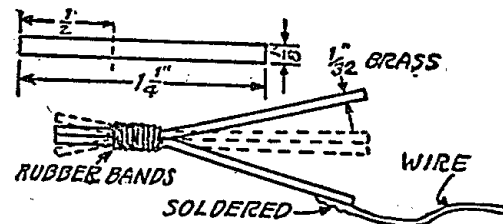

pieces of grass, binding them together with elastic bands. Any size clip can be made, from large to small size, and any tension by winding each side of the center as shown. This will clip on any size of wire.—Ray Oefinger, Bridgeport, Conn.

Special Sets Made to Order

Let us quote you on any circuit.

Send for Miloplex Price List

FORBES RADIO CO.

127 N. Dearborn St. Chicago, Ill.

Positive Radio Helps

For Storage Battery Tubes Use *Eveready Storage "A" Batteries.*

For Dry Cell Tubes Use *Eveready Dry Cell Radio "A" Batteries.*

For all Vacuum Tubes Use *Eveready "B" Batteries.*

EVEREADY Radio Batteries

—they last longer



FREE! Send for Circuit

New Cockaday Circuit --with the DIODE

A revelation in reflex work. The Diode replaces the crystal and overcomes all former difficulties with reflex circuits. Requires no adjustments for change of wave lengths. Gives you the clear reproductions of a crystal with the sturdiness and reliability of a tube. No "B" batteries required. Operates on less than 1/2 ampere from single dry cell. Easily adapted to Erla circuits. At your dealers or send purchase price and you will be supplied postpaid.

ELECTRAD, Inc.

428 Broadway NEW YORK

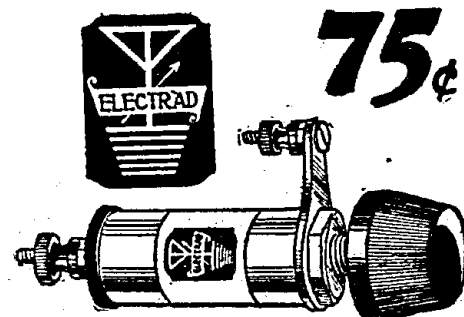

New Variohm

The latest invention in pressure grid leaks. Each movement gives a definite new resistance. Positively does the work where others fail. A gradual resistance over an entire range of 1/4 to 10 megohms. Eliminates circuit noises, is moisture proof, and non-microphonic. Ideal for use in Miloplex circuits. Guaranteed.

If your dealer cannot supply you, send remittance with your order to us.

ELECTRAD, Inc.

428 L Broadway NEW YORK

ELECTRAD



Natural Re-PRODUCTION

Atlas AMPLITONE

LOUD SPEAKER

Re-PRODUCTION so natural that even experts exclaim "Indeed a revelation," "nothing short of remarkable." Every voice inflection is faithfully reborn. Distortion made impossible by the marvelous, patented "double diaphragm." Ask your dealer for the final proof—a demonstration. Write for Booklet.

Complete with Connecting Cord **\$25**

TRADE MARK What have you accomplished with your Atlas Loud Speaker? Tell us about it.

Multiple Electric Products Co. Inc.
ORANGE ST. RADIO DIVISION NEWARK, N. J.

NEW MILOPLEX CIRCUIT

(Continued from page 15)

dispute a cook; her word may not be law, but, believe me, "Her word or you don't eat."

But, Mr. Farr, seeing as how I have given verbatim (big word) Engineer Forbes' theory, I think your theory is entitled to the same consideration, so here it is:

"The first accompanying diagram gives a simplified layout of an oscillating circuit of the capacity feedback type. This is very similar to the common oscillating circuit using a tapped inductance, except that in this case the capacity is tapped instead. No tuning is indicated, but tuning may be accomplished by making either or both feedback condensers variable or by leaving both of the feedback condensers fixed and tuning with a variable condenser shunted across them.

"The second shows the same circuit with the exception that the capacity provided by the aerial and ground has been substituted for the plate feedback condenser, and the circuit is tuned by varying the grid feedback condenser. On analyzing this you will find it to be identical with the Miloplex III circuit.

"The third diagram illustrates the Miloplex III circuit drawn in the same form as Figures 1 and 2 for the sake of comparison. It can be readily seen that condenser C₁ serves as the tuning condenser for the aerial circuit and C₂ for tuning the coupled circuit. C₃ is the regular grid condenser, C₄ a blocking condenser and C₅ a by-pass condenser for the phones.

"The circuit provided by the rotor of the variometer and the condenser C₃ is a tuned absorbing circuit such as used by Cockaday in his four-circuit tuner. This is very likely found necessary to control the oscillations in this circuit as the capacity feedback circuit is a powerful and persistent oscillator. By varying the coupling and wave length of this absorbing circuit, sufficient energy may be absorbed to prevent the circuit from oscillating.

"It might be interesting to note that this capacity feedback circuit forms the basis of the Colpitt circuit for C. W. transmission and also the Eaton circuit which was a popular receiving circuit several years ago.

"I trust you will find this to be the correct analysis of the Miloplex III, and that it will be of sufficient interest to pass on to your readers."

Mighty clear explanation, I'll say, including the diagrams. I rather believe, though, that Mr. Farr is somewhat influenced by precedent. So many parts of all Radio circuits of today comprise in their make-up fixed, tapped or variable oscillating or Eaton circuits, that to identify

one as functioning only as an absorbing circuit is difficult. You know all about the lawyer who said they couldn't put a man in jail—but that's where he was when the lawyer spoke.

This much I admit, that the Colpitts circuit, or to use the more common name, the ultra-audio, is very much alike, though not a twin of the Miloplex, and—now read carefully—that my use of the plate grid and primary is not new, for as the grid-plate capacity is not variable, it remains a constant regenerator irrespective of all other factors. Therefore, if we were to assume that the rotor in parallel with the variable condenser, as used in the King, were but an absorption circuit, it would appear logical that in operation it would absorb both from the grid, plate and primary circuits and cause a reduced signal strength, not decreasing regeneration in the least. Again, as an absorption circuit it would seem most proficient as an interference eliminator; but supposing we tune it below the desired frequency and the primary above the desired frequency, then learn what the beat note is.

Between this, that and putting on the feed bag, I've been galivanting around the country, leaning over counters here and there where Radio is sold, just to sort of get an earful of Plexy gossip. While here and there I have helped some who thought the connection dots in the drawings were made by careless flies. What'dya call it when you sneak around—oh, yes, Inocog; well, that's the way I went, and I'm going again, two or three times. Why? Because almost without exception, one or all of three things seems to be the trouble when the King isn't working, viz., the grid leaks were of the invariable kind; they had much too much wire, or the parts used "wouldn't part"—know what I mean? Then also trouble number four—oh, boy, wait until the Tech. Editor reads this—"Too many could not read the diagrams"—result, wrong connections. Once more, I repeat: Watch the dots.

With over 1,700 letters from friends and friendly enemies, how can I answer each of you? Some day I will; any fellow who takes the time to write me will receive a reply. When? Well, try answering 1,700 letters. I'll say it is.

It's mighty pleasing, though, to realize so many of you have made the King your pet. That's pay enough, because he is miserly indeed who has an apple and won't give anyone a bite, and I am also most grateful to Radio Digest. (Editor, do I get a raise for that?) But I do complain when a fan writes telling me the circuit never was any good, never can be, and several other "nevers." Funny, isn't it, when so many of you are getting coast-to-coast. So, here's my kicks to you

overnight builders: For nine long months, all that the King said to me was eat calls and squeaks, but I stuck. I licked it into talking plain English. Stick! There's a lot of Radio in the little fellow.

Next week, if Flewelling comes across, I'll give you his theory. After that the fun begins, because then I am going to run a couple of shooting-trouble stories, taking up points here and there that will help most.

(TO BE CONTINUED.)

The average life of a standard B battery is about nine months.

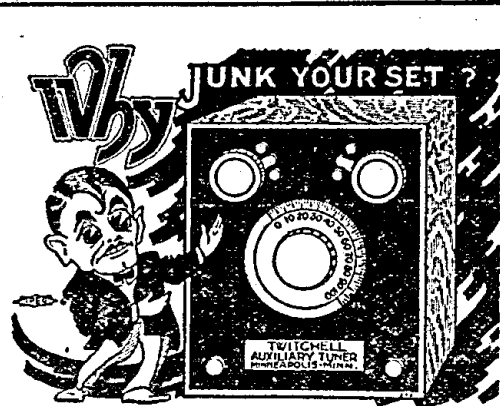

The new Twitchell Auxiliary Tuner connected to your present set will enable you to bring in the long or short wave stations which your present equipment cannot get.

Copyrighted Tuner diagram 50c, or with all parts \$9.00.

Complete instrument in walnut cabinet ready to use, \$15.00. Transportation prepaid.

My Highly Improved Reinartz brings in all important stations on this continent: loud, clear and without distortion. We dance to music from Atlanta and Los Angeles.

Build one of these wonderful 3-tube sets from my blueprint and specifications, price 50c, or with a perfect and complete double wound spiderweb coil, \$3.00 by mail. Picture of this set on a glass panel with every order.

This copyrighted circuit is the most successful of any Reinartz modification yet produced, and is imitated the most. Thousands are in use.

My W. D. II Circuit is especially designed for use with the "Pickle" tube and brings out the full value of that little tube as no other circuit can. Stations 1000 miles away come in clearly on one tube. This set is small, complete, portable. For the man who wishes the highest efficiency, this is the set to build. Price of blueprint and specifications, 50c, or with complete and perfect windings, \$3.00. Photo of set with every order.

These instruments are easy to build, easy to operate. Everything clearly shown.

Sets built from these copyrighted plans will receive all broadcasting stations operating under the new laws. Their wave length range is from 170 to 800 meters.

S. A. TWITCHELL

1925 Western Ave. Minneapolis, Minn.

Four Way Co.

Springfield, Mass.

New Model "4-Way" Switch Plug

PRICE:

\$1.50



SWITCH ON LOUD SPEAKER OR HEAD PHONES BY TURNING DIAL WITHOUT REMOVING PLUG FROM JACK. TWO HEAD

SETS MAY BE USED IF PREFERRED OR BOTH LOUD SPEAKER AND HEAD SET AT THE SAME TIME.

The new 1924 model "4-WAY" SWITCH PLUG

embodies many improvements, making the manipulation much easier. The improved Spring Locking Terminal Connections are far superior to binding screws. They form permanent electrical contacts which never work loose, as binding posts are apt to do.

New Single Radio Plug

PRICE: 50c



The finest yet produced

—employing our positive spring terminal connections that have proved so successful in our FOUR-WAY PLUG — never works loose.

See these beautiful plugs AT YOUR DEALER'S

Four Way Co.

Myrick Building SPRINGFIELD, MASS.

You Don't Need TUBES

to hear concerts from distant cities. YOUR CRYSTAL SET will bring them in if you buy my plans and follow them.

PEOPLE USING MY METHODS hear programs clearly from stations

400 TO 1000 MILES AWAY No tubes, batteries or amplifying apparatus required. It may cost

LESS THAN A DOLLAR to perfect YOUR set.

EVERYTHING CLEARLY EXPLAINED

in my copyrighted instructions selling for \$1.00. SATISFACTION GUARANTEED. Picture of my set and circular matter FREE. WRITE ME TODAY.

LEON LAMBERT

501 South Volusia Wichita, Kansas

MARVEL RADIO

THIS WEEK ONLY

FREE with Every \$10.00 Purchase and Over, a Rittler Knocked Down Portable Loop \$30.00 MUSIC MASTER LOUD

SPEAKER\$27.00

18.00 Westinghouse Bectigon Battery

Charger 14.63

Genuine Dilecto XX Bakelite

Panel, Any Size02

3/4" Thick, per square inch01 1/2

1/2" Thick, per square inch03

4.00 New Thordarson Low Ratio 3.25

4.50 New Thordarson High Ratio 3.75

UV-199 Transformers, High Ratio 3.25

Brandes Phones, Superior 5.25

Nereo Phones 3.00

10.00 Brunet French Phones, 4000 ohms. 6.50

ADVANCE B BATTERIES

Guaranteed to be of Highest Quality

1.75 22 1/2 V. Small75

3.00 22 1/2 V. Large 1.45

4.75 45 V. Small 2.00

5.50 45 V. Large 2.90

All Mail Orders Must Include Postage

MARVEL RADIO SPECIALTY CO.

132 Nassau St., New York City, Dept R. D.

DEALERS PROMPT SHIPMENTS LIBERAL DISCOUNTS

ERLA REFLEX



Erla Reflex 1 tube blue print.....25c

Erla Reflex 2 tube blue print.....35c

Erla Reflex 3 tube blue print.....50c

ALL PARTS IN STOCK

NOTE !!

We are the largest exclusive Radio Jobbers in the Middle West

HUDSON-ROSS 123 W. Madison St. Chicago

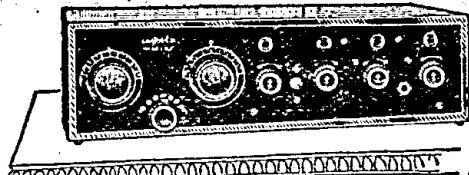

Crosley Model X-J \$65

DISPEL dull care during the fall and winter evenings with a Crosley Model X-J radio receiver. Enjoy, nightly, the concerts, speeches and other amusements that are sent out from New York, Honolulu, Cuba, Cincinnati and hundreds of other places.

For bringing in distant stations clearly and distinctly, no set can excel a Crosley Model X-J. It is a 4 tube radio frequency set, combining one stage of tuned radio frequency amplification, detector and two stages of audio frequency amplification.

Actual tests have proven it the most remarkable radio receiver ever offered regardless of price. See this beautiful instrument at your dealers. Complete catalog describing the entire Crosley line of instruments and parts will be sent free upon request.

Write for It Today.

Crosley Manufacturing Company

POWEL CROSLY, Jr., President

11493 Alfred St., Cincinnati, Ohio

Another Scoop Miloplex

Genuine parts as recommended by the inventor including the now

Famous SPLIT VARIOMETER

DEALERS ONLY Write for Dope

We are the largest exclusive radio jobbers in the middle west.

HUDSON-ROSS 123 W. Madison St. Chicago

Simple Explanation of Radio for Everybody

Chapter V, Part I—Capacities—Fixed and Variable

By M. W. Thompson

THE following article is the eighth of a series for Radio beginners, written by Marvin W. Thompson, well known in air-phone circles for his understandable style of approaching his subject, and his ability as a Radio engineer. Mr. Thompson is now an associate editor on the staff of Radio Digest. A preliminary outline of the Chapters to follow is:

- Chapter VI—Vacuum Tubes.
- Chapter VII—Antennas and Grounds.
- Chapter VIII—Regeneration.
- Chapter IX—Audio Frequency Amplification.
- Chapter X—Loud Speakers.

IN THE last chapter we considered inductance, one of the two essentials to a circuit which will handle Radio frequency currents. We will now take up the other—capacity. As was explained in an earlier chapter, capacity is the result of placing two metal surfaces in close proximity and in an electrical circuit. It frequently is present when not desired and in places where it is detrimental to efficiency. The distributed capacity present in a coil is an example; if two wires in a receiving set, in one of which there is a higher voltage than in the other, are run parallel and within 1/2 inch or so, a harmful capacity results.

On the other hand, properly placed and designed capacities are not only essential to tuning, but also useful in by-passing Radio frequency currents around resistances through which they could not pass, but which are necessary in the circuit either in the handling of direct current or current at lower frequencies.

Condenser vs. Storage Battery

Capacity is made up in units which, be they fixed or variable, are known as condensers. The condenser is the only genuine container of electricity. We put energy, in the form of electricity, into a storage battery but that energy is changed in form and stored chemically—it is no longer electricity. When the battery is connected to the filaments of our vacuum tubes, the chemicals react and recombine, and the stored-up energy is converted back into electricity and lights our tubes. The condenser stores electricity, as electricity, by permitting the entrance of an excess number of negative electrons on one parallel surface while there is a

dearth of these charges on the opposite surface, which is said to be positive. If the two surfaces are connected while this unstable condition exists, the negative electrons rush over to the other surface to bring it back to normal, and the condenser is said to be discharged.

Microfarads

Just as we have units of measurement for containers of other mediums, as the pint, quart, cubic inch and cubic foot, we must have units of measurement in regard to condensers. The farad is the largest unit used for this purpose, the name being composed of the first five letters of Faraday. Michael Faraday was a pioneer in the study of electricity. The farad is a tremendously large unit and a condenser of that capacity would be about as large as a good-size house, so a smaller unit, the microfarad, which is one-millionth of a farad is in use. In Radio work, this microfarad is still too great so we use the micromicrofarad which is one-millionth (.000001) of a microfarad. Radio condensers are made in such capaci-



Figure 35—The first step in reducing the size of the two surfaces of a condenser for compactness

ties as .00025 microfarad (mfd.), which is two hundred and fifty microfarads and spoken of as "triple-o-two-five"; or .001 microfarad (mfd.), which is one thousand micromicrofarads and spoken of as "double-o-one."

Multiplates

The simplest form of condenser is two square plates held about 1/8 inch apart, but this would have a very small capacity of about .00001 mfd. If we wish to increase the capacity, the natural thing to do would be to increase the area of the plates. This practice, however, could be done only up to certain limits and would not be compact. The usual practice is to cut up the two large plates and intermin-

gle the pieces as shown in Figure 35. This reduces two dimensions and increases the third. The arrangement shown in Figure 35 can be taken up to any number of plates.

Another method of increasing capacity is to place the plates closer together. The distance between surfaces is governed by the voltage in the circuit. In its

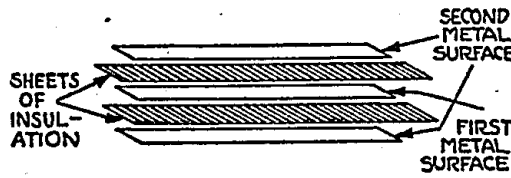

Figure 36—The second step toward compactness and greater capacity for a given plate area

attempt to neutralize unequal charges of negative electrons, electricity will jump through air and if we are using a rather high voltage the plates must be kept far apart—which reduces capacity. The next step, then, is to insert some form of thin insulating material between the plates so that the capacity will be greater for a given plate area and give better compactness (Figure 36).

Dielectrics

The material between plates, be it air or a solid material, is spoken of as the dielectric and its efficiency for this purpose is rated by a "dielectric value." Some materials, while they are excellent insulators, are very poor dielectrics; others are both excellent insulators and possessed of a high dielectric value. Much experimental work has proven mica to be the best material for use in condensers; it can be split very thin, possesses an extremely high dielectric value, and is a wonderful insulator. By alternating thin sheets of mica with thin sheets of copper and pressing the pile tightly together, a large capacity in a very small space may be

GENUINE EDISON ELEMENTS (new) for making "B" Batteries, obtained from U. S. Government. A positive and negative element—6c; glass tube—3c; all other parts at reasonable prices. Postage, etc., 50c extra per order. Free instructions. TODD ELECTRIC COMPANY, 109 West 23rd Street, New York.

had. These units are variable only in steps, as from .00025 mfd. to .0005 mfd. to .00075 mfd. to .001 mfd.; their capacity cannot be varied smoothly and evenly, which gave rise to the variable condenser.

(TO BE CONTINUED.)

Good Practice

When trying out a new circuit, it is advisable to lay out the parts on a neat board and draw the connection to the various parts with a pencil, then check up with the diagram. In this manner faults can be found before the set has been wired, which reduces the risk of having to destroy expensive parts.

80% of demonstrations result in sales for MU-RAD dealers

When a complete check on the radio sales of one Chicago store reveals that Mu-Rads are sold in eight out of ten competitive demonstrations, there must be a reason.

There is! Mu-Rad is easy to operate, uses an inside 2-ft. loop aerial, and is highly selective. Mu-Rad is guaranteed to receive at least 1000 miles.

Dealers: Write for Mu-Rad Proposition

Inquiries are solicited from responsible dealers only.

In order to help us weed out curiosity seekers, please use your business stationery in requesting this information.

We also carry a complete stock of WESTERN ELECTRIC CO. GENERAL RADIO CO.

parts. Write for details and discounts

Chicago Radio Apparatus Co.

Jobbers of Good Radio Merchandise
General Offices: 407 South Dearborn Street
CHICAGO

SPECIAL
(IMPROVED MODEL)
Direct From Manufacturer to Consumer
LOUD SPEAKER
Genuine Wood Fiber Horn (With Unit and Cord)
Entirely eliminates that annoying metallic sound. Positively the only WOOD FIBER HORN on the market today.
10-inch Bell with Standard Attachment: Complete. Height 24 inches. Colors, Black, Mahogany and Olive Green.
Price \$8.00
(For a limited time only.)
Delivered to any part of the United States and Canada
EMIL DECLYNE
15 Park Row, Room 2525, NEW YORK CITY
Send M. O. or C. O. D. Dept. R. D., Barclay 6298

MISSING WHAT YOU GET
YOUR set is probably bringing in DX stations you never hear because your rheostat cannot control your filament action. The Fil-Ko-Stat gives infinite adjustment and enables you to magnify the weak stations and bring them in strong and clear.
Full resistance 30 Ohms, adjusted to \$2 At All Dealers in High Grade RADIO SUPPLIES
"Avoid the use of inferior powdered carbon rheostats."
FIL-KO-STAT
Made and Guaranteed by:
Dx Instrument Co., Harrisburg, Pa.
Sole International Distributors.
Radio Stores Corp., 218 W. 34, N. Y. City

PERFECTION
MAKE PERFECTION YOUR SELECTION

N & K Phones. These are the new type N & K Phones made in Germany. They are, without question, the world's best phones. A limited quantity at special price.....	\$5.90	Atlas Loud Speaker—New Type. A loud speaker beyond compare. Adjustable tone. List \$25.00. Special	\$18.50
Brandes Phones. Superior	\$4.95	Amertran Transformers. List \$7.00. None better made.....	\$3.75
Reinartz. Complete parts for one tube set.....	\$10.50	Neutrodyne. Complete parts for 5 tube set. Exceptional value	\$32.50

PERFECTION RADIO CORP.
Mail Order Dept. 59 CORTLAND ST., NEW YORK CITY Add Parcel Post
Do Not Send Stamps
N. Y. Retail Stores: 78 Cortland St., 119 West 23rd St., 128 Chambers
208 page complete Radio catalogue free with order of \$5.00 on request. Otherwise prepaid for 25 cents

TRIGGER OF NEW YORK RADIO
EVERYTHING SOLD ON MONEY-BACK GUARANTEE. WE HANDLE NO BOOTLEG MERCHANDISE.

COCKADAY COMPLETE PARTS GUARANTEED \$12.50 ASSEMBLED \$17.50 Add \$2.50 to each for Cabinet	ERLA REFLEX 3 TUBE BEST OF PARTS \$45.00 ASSEMBLED \$67.50	COCKADAY 3 TUBE Unassembled \$32.50 INCLUDE CABINET ASSEMBLED \$42.50 DISTANCE VOLUME SELECTIVITY	LOUD SPEAKER Bristol20.00 Atlas18.00 Magnavox ..30.00 Mercury 6.00 Music Master26.00
---	---	--	--

Indoor Aerial\$1.75
Hydrometer50
Voltmeter, 50 Volts 1.65
Freshman Variable Grid and Leak70
Remler Moulded Variometer 4.00
Freed-Elsemann 180° Coupler 2.00
Baldwin's Original\$8.50
Jefferson Transformer 2.75
Amertran Transformer 5.50
Acme Transformer 3.75
Wave Trap 7.00
D. C. Charger 5.75

We carry a complete line—from screws to sets.
You can purchase with an absolute guarantee. We carry no factory seconds or salvage merchandise. Goods shipped immediately. Please be sure to include postage on orders under \$10.00.
TRIGGER OF NEW YORK
160 EAST 59TH STREET, NEAR THIRD AVENUE, NEW YORK CITY

Sterling Radio Devices
Put More Life in Your Set
Sterling's prestige for making delicately balanced instruments of rugged strength, immediately gave prominence to its radio products. Even in sets, assembled with Sterling parts by non-scientifically inclined individuals there is a perfection in radio receiving that surpasses results obtained from complete units.
THE STERLING MFG. COMPANY
2829 Prospect Avenue CLEVELAND, OHIO

FILAMENT RHEOSTAT
The resistance element is seated in a deep groove that insures permanent and smooth contact with the movable contact arm. There is a special Sterling Rheostat recommended for UV-199, UV-200, UV-201, WD-11, WD-12 and other tubes. Fine regulation to dispense with troublesome vernier.
Price \$1.00 and \$1.25

12 POINT ROTARY SWITCH
Designed to solve one of the most vexing problems of amateur and professional builders of radio sets. Eliminates unsightly front of board contact points, providing a complete unit for rear of panel mounting, to which variocoupler taps may be soldered. May be used with a voltmeter for reading voltage on individual tube filaments.
Price \$5.00

OTHER STERLING DEVICES
Portable Rectifiers Pocket Meters Filament Meters
Audio and Radio Frequency Transformers

Questions and Answers

Crystal Hook-Up

(5478) FPD, Newark, N. J.
 Kindly send me a hook-up of a crystal set using 1 variocoupler (10 taps), 1 23-plate variable condenser, 1 43-plate variable condenser (if necessary); 1 crystal detector and 1 phone condenser (.001 mfd.). Also please indicate on diagram

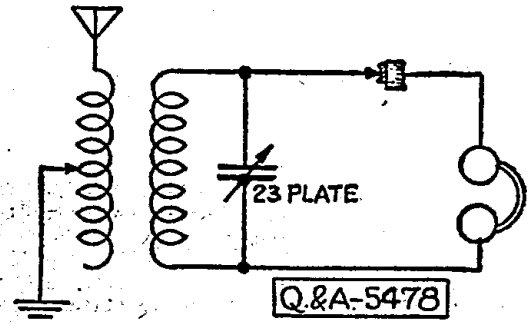

which wires are connected to the rotar plates of the variable condenser. If a 43-plate variable condenser is not necessary kindly state size required.

A.—We are herewith presenting a diagram of crystal detector circuit of your specifications.

Only one 23-plate condenser and no phone condenser is indicated.

Tuning Unit

(5152) WCB, Lynchburg, Va.
 Kindly give me correct number turns of wire in a short wave regenerative circuit with .001 mfd. condenser in series with aerial, using for coupler primary 4 1/4-inch diameter tube, coupler secondary, 3 1/2-inch diameter ball rotor. Plate and grid variometers are of wood type, 4-inch diameter primary, with 3 1/2-inch diameter ball rotor.

A.—Variocoupler for circuit of your specifications may be accomplished in 46 turns of number 20 dec. wire, tapped at every seventh turn for the primary, and 40 turns of number 24 or 26 dec. wire for the secondary. The variometer is wound full with number 20 dec. wire.

Circuit Selection

(5225) JRG, Decatur, Ind.
 Please answer these questions: I want to build a new Radio set. What circuit do you think is the best for loud, clear, selective reception? The set I have now

is using a variocoupler, two variometers and two stages of audio. It works better by using the rotor of the variocoupler for regeneration than by using variometers. Is a reflex circuit better?

A.—Answering your inquiry we are advising that the circuit of your description should prove very effective for long range reception with sufficient volume for employment of a loud speaker. It is our opinion that you may lack the tuning experience essential to effective operation of a three circuit receiver. However, once having gained it through an understanding of controls, etc., you will be well repaid.

The Reflex circuit is also very effective and will afford greater signal volume, although no greater receiving range.

On the whole, it is our advice to stick to your present circuit until you will have mastered its operation before passing an adverse decision upon it.

Patent Law

(5139) ALF, Red Bay, Ala.
 Please, let me know if it is against the patent law to sell a Radio set, assembled on a panel, but not wired. If it is against the law to solder the wire for a regenerative set; then, may I sell the panel and the instruments with wires soldered to each other but not connected, giving instructions how to do the connecting?

A.—We are not disposed to advise you in the matter of wiring circuits covered by patent rights for commercial purposes. While the plan suggested might not be considered as a violation of the letter of the law, it undoubtedly involves an evasion of the spirit.

Flewelling Condenser Values

(5203) VED, Tulsa, Okla.
 While looking over my back numbers of the Radio Digest I became interested in the series on the Flewelling—one condenser, flivver super, but found that one number was missing. I would appreciate the following information in your Q. and A. department:

What are the capacities of condensers, fixed and variable, in Flewelling one condenser super hook-up?

Would aluminum paint or tinfoil shielding be as efficient as a copper plate?

Could the rotor of the variocoupler be

bank-wound to secure the necessary number of turns?

Which is the best tube for this set; the WD-11, UV-199, UV-201-A or the C-301A?

A.—Answering your inquiry with reference to Flewelling circuit one condenser modification, we are advising that the variable condenser is of .0005 mfd., preferably vernier. The usual .006 mfd. blocking condenser is used, and a .00025 mfd. grid condenser are indicated.

Do not use aluminum paint for shielding panel. Tinfoil is recommended.

Rotor of variocoupler can be bank-wound, if necessary to accomplish the required number of turns.

A WD-11 or a UV-199 tube can be used

in this circuit, but either a UV-201A or C-301A are recommended for best operation. They are identical, and either will serve effectively.

WD11 and WD12 REPAIRED

ALSO OTHER TYPES OF TUBES for \$3.00

and guarantee them to work like new. We prepay parcel post back to you.

QUICK SERVICE

THOMAS BROWN CO.
 511-519 ORANGE ST. NEWARK, N. J.

"Service that is certain"

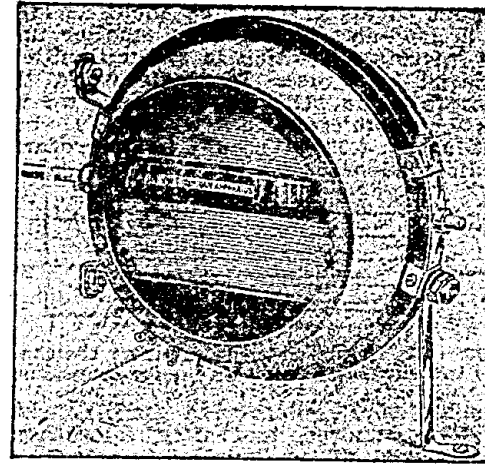

Langbein & Kaufman Variometers and Variocouplers.....\$6 ea.
 Finest instruments in the world.
 Myers Hi-Mu Tubes.....\$4.35
 Amperite-Automatic Filament, eliminates Rheostat.....Unmounted, 70c; mounted, \$1.10

All merchandise absolutely guaranteed.
 Shipped immediately on receipt of purchase price.

Radio & Mechanical Trade Corp.
 23 Warren St. NEW YORK

HIGHEST QUALITY SILVERTONE Lowest Price TUBES

OT SILVERTONE
 TONE—like a silver bell.
 VOLUME—unexcelled.
 LIFE—2000 to 3000 hours
 OPERATES—on dry cell or storage battery.
 THREE MODELS
 Voltage 2 3 5
 Bat consumption .06 15 25
 FULLY GUARANTEED
 One Price \$6.00 Everywhere
 Sold directly from factory to consumer through our own agents—no by mail. Literature free on request.
 Send no money—Pay the postman Money back, without question, if not exactly as represented.
 Manufactured by DeForest Tel. & Tel. Co. Exclusively for the O. & T. Electric Corporation
 1819 Broadway New York High class representatives wanted.

KEYSTONE RADIO LIGHTNING ARRESTERS

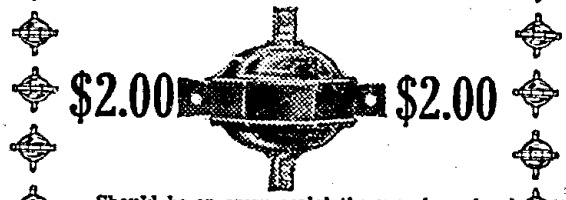

\$2.00 \$2.00
 Should be on every aerial the year 'round. Provides highly efficient lightning and static protection for the home. Fully approved by Fire Underwriters. Can be installed outdoors. Has no vacuum to lose. Install one in your aerial lead now—be safe.
 This pioneer radio arrester is backed by 31 years' experience in lightning arrester design.
 For sale by Dealers everywhere, or sent postpaid for \$2.00. Write for circular.

Electric Service Supplies Co.
 17 & Cambria Sts. Philadelphia
 Monadnock Bldg., Chicago
 50 Church St., New York

Morrison Loud Speaker
 \$10.00 Complete

SOME folks buy an EXPENSIVE receiving set AND then wonder why THEIR neighbor's cheaper SET sounds so clear and STRONG. Probably the NEIGHBOR has a MORRISON Loud Speaker ATTACHED to his PHONOGRAPH or horn. COSTS \$10.00 complete and REPRODUCES all BROADCASTING in NATURAL tones. No WONDER Morrison OWNERS brag about their CONCERTS. Dealers who SELL Morrissions don't HAVE any disgruntled CUSTOMERS. We will TELL you all about MORRISON in two-color CATALOG—ask for it.

Morrison Laboratories, Inc.
 343 East Jefferson Avenue, Detroit, Mich.

What About It?

Isn't it about time to stop experimenting with multiple control circuits and build one that, combining ease of assembly and operation, loudness, clarity and selectivity of signals, as well as beautiful appearance, is excelled by none?

THE ELGIN SUPER-REINARTZ RADIO RECEIVING SET

Embodies all the advantages of the well known Elgin Reinartz (the set which was largely responsible for the popularity of this wonderful circuit) and many others. It is much louder, more selective, requires no storage battery, and can be used with excellent results on a short or loop aerial. It has brought in California stations two thousand miles from Elgin, clearly and without interference on a loud speaker with only one tube, and that while our powerful local station was broadcasting three miles away.

Could you ask for more?
 Write for circular giving one, two and three bulb hook-ups of this remarkable circuit. IT IS FREE.

ELGIN RADIO SUPPLY CO.
 207 East Chicago Street ELGIN, ILLINOIS

EASTERN COIL SETS

for the COCKADAY CIRCUIT

(4 Circuit Tuner)

are now a standard, and in universal use, due to their efficiency in this wonder circuit. Made as per specifications of Mr. Cockaday, using No. 18 wire with D coil bank-wound

Complete Assembled Set of B, C and D Coils..... **\$2.75**

Hook-up directions and material list furnished free with each set of coils.

Mail Orders Filled. Dealers Communicate

EASTERN RADIO MFG. CO.
 22 Warren Street, Dept. R. D., NEW YORK, N. Y.

Carter Jack Switch

\$1.00

The best radio switch yet devised—easily mounted on panel—just like a jack—a quarter turn of the knob operates the heavy phosphor-bronze springs.

Furnished complete with "Off and On" name plate, knob and pointer.
 Made in four different spring combinations. Ask your dealer.
 Send for FREE wiring diagrams of various hook-ups; also complete catalog of other new improved Carter Radio Products.

Carter Radio Co.
 207 East Chicago Street ELGIN, ILLINOIS

WE REPAIR THE FOLLOWING RADIO TUBES

Dealers and Agents write for Special Discount Mail Orders Solicited and Promptly Attended to

WD-11	OUR SPECIALTIES	5 WATT	
WD-12		TRANSMITTERS	
UV-199\$3.50	C-299\$3.50
UV-2002.75	C-3002.75
UV-2013.00	C-3013.00
UV-201A3.50	C-301A3.50
WD-113.50	WD-123.50
DV-63.00	DV-6A3.50
UV-2024.00	C-3024.00
UV-2993.50		

H. & H. RADIO COMPANY
 P. O. Box 22-A
 Clinton Hill Station NEWARK, N. J.

A Precious Instrument for Local and Long Distance Tuning

2 IN 1 VARIABLE GRID CONTROL... **\$2.00**
 Worth \$10.00 for its efficiency

Patent Applied For

Micrometer adjustment as fine as 1/10,000 of an inch. Consisting of a variable resistance leak from 1/3 to 12 megohms and a variable condenser from .0002 to .0005. Shielded against all body capacity. Has no equal.

The variable condenser is especially designed for use in the grid circuit with a minimum of losses and micrometer adjustment. The variable resistance is of special design, different from all others in principal operation and construction. The combined unit has no sliding contacts to wear out, therefore insuring long life.

At all high class dealers
 Manufactured and guaranteed by

2 IN 1 RADIO & ELECTRIC CO.
 Mohawk Building, New York

Radiophone Broadcasting Stations

Corrected Every Week—Part II

CHALLENGE SUPPORTS LIST'S CORRECTNESS

ONE DOLLAR will be paid to every Radiophone reader of Radio Digest submitting the most errors in any one station's listing in the Directory of Radiophone Stations, which appears in four parts, serially continuously, on page 23. Letters must reach Radio Digest's office not later than one week from date of issue corrected. Readers are not limited to correcting one station. Turn in corrections for as many stations as you can find—if you can find errors! Use separate sheet of paper for each station submitted and place name and address on each sheet.

(NOTE.—The second part of the schedule list appears below. The first appeared last week and the third part will appear next week.)

KLZ, Denver, Colo. 360 meters. 1,000 ml. Reynolds Radio Co. Daily ex Sun, 7:30-8 pm, news, markets, bedtime story, Thurs, 8-9 pm, concert, Sun, 8:30-10:30 pm, concert, Mountain.

KMJ, Fresno, Calif. 273 meters. 800 ml. San Joaquin Lt. & Pr. Corp. Sun, 8-9 pm, music, Pacific.

KMO, Tacoma, Wash. 360 meters. 200 ml. Tacoma Times. (Love Electric Co.) Daily ex Sun, 6-7 pm, 9:15-10, concert, news, lecture, Pacific.

KNI, Roswell, N. M. 250 meters. Roswell Public Service Co.

KNT, Aberdeen, Wash. 263 meters. 600 ml. Grays Harbor Radio Co. Daily ex Sun, 7-8 pm, news, concert, Pacific.

KNV, Los Angeles, Calif. 256 meters. Radio Supply Co.

KNX, Los Angeles, Calif. 360 meters. Elec. Lighting & Supply Co.

KOB, State College, N. M. 360 meters. 500 ml. N. M. Agr. & Mech. Arts. Daily 11:55-12 m, 9:55-10 pm, time, reports, Mon, Wed, Fri, 7:30-8:30 pm, concert, Mountain.

KOP, Detroit, Mich. 286 meters. 1,500 ml. Detroit Police Dept. Slogan, "Safety First," Daily ex Sun, 1-2 pm, 6:30, reports, police information, emergency, Eastern.

KPO, San Francisco, Calif. 423 meters. 1,500 ml. Hale Bros., Inc. Daily ex Sun, 4:30-5:30 pm, music, Mon, Tues, Thurs, Sun, 8-10 pm, concert, lectures, Sat, 8-12 pm, music, Sun, 11-12:30 pm, church services, Pacific.

KQI, Berkeley, Calif. 360 meters. Univ. of Calif.

KQP, Hood River, Ore. 360 meters. Apple City Radio Club. Slogan, "Apple City of the West," Mon, Wed, Fri, 6:30 pm, music, Wed, 9 pm, special, Pacific.

KQV, Pittsburgh, Pa. 360 meters. 300 ml. Doubleday-Hill Elec. Co. Daily ex Sun, 12-12:30 pm; 4:30-5, 6-7 pm, Mon, Wed, Fri, 10-10:55 pm, concert, Fri, 4:30-5:15 pm, children's program, Eastern.

KQW, San Jose, Calif. 360 meters. 1,000 ml. Chas. D. Herrold. Daily ex Sun, 1-1:30 pm, Wed, 8-9 pm, concert, Pacific.

KRE, Berkeley, Calif. 273 meters. 600 ml. Daily Gazette. Mon, 8-10 pm, Wed, 9-10 pm, concert, Pacific.

KSD, St. Louis, Mo. 546 meters. 1,500 ml. St. Louis Post Dispatch. Daily ex Sun, 9:40 am, 10:40, 11:40, 12:40 pm, 1:40, 2:40, 4, 8, Tues, Wed, 12 midnight, concert, Thurs and Sun, silent nights, Central.

KSL, San Francisco, Calif. 360 meters. 50 ml. The Emporium. Temporarily discontinued.

KSS, Long Beach, Calif. 229 meters. 50 ml. Prest & Dean Radio Elec. Co., Radio Society of Long Beach. No regular schedule.

KTW, Seattle, Wash. 360 meters. 500 ml. First Presbyterian Church. Sun, 11-12:30 pm, 3-4:30, 7-9:30, church services, Pacific.

KUD, San Francisco, Calif. 360 meters. 1,500 ml. San Francisco Examiner. Slogan, "The Voice of the West," Daily ex Sun, 9-10 am, chat to housewives; 11-12, reports; 2:30-3:30 pm, lecture, news; 9 am, 12 m, 6:45 pm, weather reports, Sun, 9-10 am, 5-6 pm, news, Pacific.

KUS, Los Angeles, Calif. 360 meters. 300 ml. City Dye Works & Laundry Co. Discontinued temporarily.

KUY, El Monte, Calif. 360 meters. 500 ml. Coast Radio Co. Wed, 4-4:30 pm, Sat, 5-4 pm, Pacific.

KWG, Stockton, Calif. 360 meters. 1,500 ml. Portable Wireless Telephone Co. Daily ex Sun, 4-5 pm, news, concert, markets, Tues, Fri, 8-9 pm, concert, Sun, 2-3 pm, concert, Pacific.

KX, Modesto, Calif. 252 meters. 100 ml. Modesto Herald. Sun, 1-2 pm, Pacific.

KYO, Honolulu, Hawaii. 360 meters. Electric Shop. No definite schedule.

KYW, Chicago, Ill. 536 meters. 2,000 ml. Westinghouse Elec. & Mfg. Co. Daily ex Sun, Sat aft, 9:30 am, 10, 10:30, 11, markets; 10:55, 12, 11:05, weather; 11:30, news; 11:35, table talk; 12, 12:30, 1, 1:20, 2:15, 2:30, markets; 3, 3:30, 4, news; 4:15, markets; 4:30, 5, news; 6:30, markets. Daily ex Sun, Mon, 6:50, bedtime story, 8 concert, 9 special, Tues, Thurs, 2:35-3, musical frolic, Wed, Fri, 3:30, Sun, 11 am, 6:45-8:45, church services, Central.

KZM, Oakland, Calif. 360 meters. 200 ml. Western Radio Institute (Hotel Oakland). Daily ex Sun, 6:45-7 pm, news, Pacific.

KZN, Salt Lake City, Utah. 360 meters. 1,000 ml. Deseret News. Slogan, "The Center of Scenic America," Daily ex Sun, 8-9:30 pm, music, news, bedtime stories, etc. Mountain.

KZV, Wenatchee, Wash. 360 meters. 200 ml. Wenatchee Hattery & Motor Co. Daily ex Sun, 3:30-4:15 pm, weather, Mon, Wed, Fri, 1st to 15th each month, 8:45-9:30 pm, 15th to last each month, 8-8:45 pm, weather, Sun, 1st to 15th each month, 7:30-9 pm; 15th to last each month, 11 am-12:30 pm, church services, Eastern.

NAA, Radio, Va. 435 meters. 2,000 ml. U. S. Navy Dept. Daily ex Sun, 9:45-10:40 am, 12:25-12:40 pm, 1:45-2:20, markets, weather; 2:45-3 (Tues. only), Dept. Interior; 3:25-4:40, 5:05-5:20, markets, weather 10:05-10:20, weather, Mon, 6:45-8:20 pm, Dept. programs, Tues, 7:05-8:20 pm, Dept. programs, Wed, 7:35-7:45 pm, Dept. programs; 8:05-9:40, Marino Band, Thurs, 6:45-8:40 pm, Dept. programs, Fri, 8:05-8:40 pm, band concert, Eastern.

OA, Ottawa, Ont., Can. Dept. of Marine & Fisheries. Sat, 7:45-10 pm, music, entertainment.

PWX, Havana, Cuba. 400 meters. 1,500 ml. International Tel. & Teleg. Corp. Wed, Sat, 8:30-11 pm, music, Eastern.

WAAB, New Orleans, La. 268 meters. Valdemar Jensen.

WAAC, New Orleans, La. 485 meters. Tulane Univ. Fri, 7:15-7:30 pm, reports; 8-9:30, educational and entertainment program.

WAAD, Cincinnati, O. 360 meters. 200 ml. Ohio Mechanics Inst. No regular schedule, Central.

WAAG, Chicago, Ill. 286 meters. 300 ml. Chicago Daily Drapers Journal. Daily ex Sun, 8:40 am, 10:30, 10:45, 12:30 pm, Daily ex Sun, 12:45, 3, 4:30, live stock and weather reports, Central.

WAAK, Milwaukee, Wis. 230 meters. 300 ml. Gimbel Bros. Temporarily discontinued.

WAAM, Newark, N. J. 263 meters. 300 ml. I. R. Nelson Co. Daily ex Sun, 9:15-9:45 am, Daily ex Sat, 11-11:55 am; Mon, Tues, Wed, Thurs, 8-10:30 pm, music, Eastern.

WAAN, Columbia, Mo. 254 meters. Univ. of Mo. WAAP, Wichita, Kan. 360 meters. 500 ml. United Electric Co. Daily ex Sun, 12-12:30 pm, educational

program; 10:30 pm, weather, Tues, Fri, 8 pm, entertainment, Central.

WAAW, Omaha, Neb. 360 meters. 500 ml. Omaha Grain Exchange. Daily ex Sun, 9:45, 10:45, 11:45, 12:45-1:15 pm, 8, market reports; 8:15-9, music, Central.

WAAZ, Emporia, Kans. 360 meters. 250 ml. Hollister-Miller Motor Co. Tues, Thurs, 7-8 pm, entertainment. Temporary schedule, Central.

WABA, Lake Forest, Ill. 266 meters. 500 ml. Lake Forest University.

WABB, Harrisburg, Pa. 266 meters. Dr. John B. Lawrence.

WABC, Anderson, Ind. 229 meters. Fulwider-Grimes Battery Co.

WABD, Dayton, O. 233 meters. Parker High School.

WABE, Washington, D. C. 233 meters. Y. M. C. A.

WABF, Mt. Vernon, Ill. 234 meters. Mt. Vernon Register-News Co.

WABG, Jacksonville, Fla. 243 meters. 200 ml. Arnold Edwards Piano Co. Daily ex Sun, 3-4 pm, 5-6, music, Tues, Thurs, Sat, 8-9 pm, music, entertainment, Eastern.

WABH, Sandusky, O. 240 meters. Lake Shore Tire Co.

WABI, Bangor, Me. 240 meters. Bangor Ry. & Elec. Co.

WABJ, South Bend, Ind. 240 meters. 50 ml. The Radio Laboratories. Tues, Thurs, Sat, 6:30-7:30 pm, music, entertainment, Central.

WABK, Worcester, Mass. 250 meters. 50 ml. First Baptist Church. Sun, 10:30 am-12 m, Eastern.

WABL, Storrs, Conn. 233 meters. Connecticut Agri. College.

WABM, Saginaw, Mich. 254 meters. 500 ml. F. E. Doherty. Daily ex Sun, 12:15 am, news, markets, weather, stocks; 6, news, stocks, sports, music, Thurs, 8:30 pm, Sat, 10 pm, concert, Eastern.

WABN, La Crosse, Wis. 234 meters. Waldo O. Grover.

WABO, Rochester, N. Y. 252 meters. Lake Ave. Baptist Church.

WBAW, Lafayette, Ind. 360 meters. 100 ml. Purdue University. Mon, Fri, 7:15 pm. Special programs, Central.

WBAD, Minneapolis, Minn. 360 meters. Sterling Elec. Co.

WBAF, Moorestown, N. J. 360 meters. Fred M. Middleton.

WBAH, Minneapolis, Minn. 417 meters. 1,500 ml. The Dayton Co. Daily ex Sun, 12:30 pm, 1-1:30, 7-7:30, Mon, Thurs, 9:15-10:45 pm, Central.

WBAK, Harrisburg, Pa. 400 meters. 1,500 ml. Pennsylvania State Police. Daily ex Sun, 10:30 am, 1:30 pm, 5:45, police reports, fire protection, markets; 12 midnight, police reports, Mon, Tues, Fri, 7:30 pm, special, Eastern.

WBAN, Paterson, N. J. 244 meters. 200 ml. Wireless Phone Corp. Slogan, "The Silk City of America," Daily ex Sun, 9-11:30 am, 12:30-5:30 pm, Sat morn, only, Sun, 10-12 am, 2-5 pm, 7:30-10:30, Eastern.

WBAO, Decatur, Ill. 360 meters. 100 ml. James Millikin Univ. University activities. No definite schedule, Central.

WBAP, Fort Worth, Tex. 476 meters. 1,500 ml. Fort Worth Star-Telegram. Club, "Radio Truth League," Daily ex Sun, 10 am, 11, 12 m, 1 pm, 2, 2:30, 3, 4, markets, reports, weather, Mon, Tues, Wed, Thurs, Fri, 7:30-8:30 pm, 9:30-10:45, concert, Sat, 7-7:30 pm, Bible lesson, Sun, 11 am-12:15 pm, church; 5-6 pm, concert, Central.

WBAY, Columbus, O. 390 meters. 500 ml. The Ernor Hopkins Co. Slogan, "We Broadcast a Variety," Daily ex Sun, 12:30-1 pm, Mon, 8-10 pm, Central.

WBWA, Marietta, O. 246 meters. Marietta College. Wed, Fri evenings, lectures by faculty.

WBAX, Wilkes-Barre, Pa. 360 meters. 200 ml. John H. Stenger, Jr. Three nights of week, irregular.

WBAY, New York, N. Y. 492 meters. 1,500 ml. A. T. & Co. Experimental purposes only.

WBBA, Newark, O. 240 meters. 150 ml. Newark Radio Lab. Slogan, "The City in the Valley," Daily ex Sat, Sun, 6:30-7:30 pm, music, Sun, 1:30-4 pm, music, Eastern.

WBBC, Sterling, Ill. 229 meters. Sterling Radio Equipment Co.

WBBD, Reading, Pa. 234 meters. Bairbey Battery Service.

WBL, Anthony, Kans. 261 meters. 500 ml. T & H Radio Co. Mon, Wed, Sat, 8-9 pm, concert, lecture, Sun, 10 am, church service, Central.

WBS, Newark, N. J. 360 meters. 200 ml. D. W. May, Inc. Daily ex Sun 11-12 am, music; 1-2:15 pm, reports; 2:15-2:30 pm, music, reports, Tues, Thurs, Sat, 7:30-9:30 pm, program, Sun, 9-10:30 am, sacred music; 1-3 pm, program, Eastern.

WBT, Charlotte, N. C. 360 meters. 1,200 ml. Southern Radio Corp. Slogan, "Queen City of the South," Daily ex Sun, 10 am, 11:30 pm, weather, markets; 12 m, 5 pm, music, Tues, 8:30 pm, music, Fri, 11 pm, entertainment, Sun, 8 pm, church services, Eastern.

WBZ, Springfield, Mass. 337 meters. 1,000 ml. Westinghouse Elec. & Mfg. Co. Daily ex Sun, 7 pm, lectures; 7:30, children's hour; 7:45, markets, weather, lecture, Mon, Tues, Thurs, Sat, 8-9 pm, concert, Mon, Wed, Fri, 6-7 pm, concert, Wed, Fri, 11-12 midnight, concert, Sun, 11 am, church service; 6:45, chime vesper; 8:30, church service, Eastern.

WCAC, Fort Smith, Ark. 360 meters. John Fink Jewelry Co. Tests only.

WCAD, Canton, N. Y. 250 meters. 300 ml. St. Lawrence Univ. Daily, 11 am, weather, reports, time, Fri, 8 pm, program, Eastern.

WCAE, Pittsburgh, Pa. 462 meters. Kaufman & Baer Co., Pittsburgh, Pa. Daily ex Sun, 12:30 pm, news; 3:30, news, music; 4:30, reports, entertainment; 6:30, music; 7:30, news; 8:30, music, Sun, 3 pm, sermon; 6:30, music, Eastern.

WCAG, New Orleans, La. 268 meters. 200 ml. Clyde R. Randall. Mon, Thurs, 8-9 pm, concert, Central.

WCAH, Columbus, O. 236 meters. 500 ml. Entreklin Elec. Co. Slogan, "The Heart of Ohio," Daily ex Sun, 11:30-12:30 am, music, news, Tues, 7:30-9:30 pm, 11:30-1:30 am, concert, Columbus Philharmonic Society, Sun, 10-12:30, church service, Central.

WCAJ, Ute Place, Neb. 360 meters. 150 ml. Neb. Wesleyan Univ. Daily, 10:30 am, weather, Tues, 7 pm, Children's Hour, Thurs, 8 pm, music, lectures, Central.

WCAK, Houston, Tex. 360 meters. 100 ml. Alfred P. Daniel. Slogan, "Where Eighteen Railroads Meet the Sea," Wed, 8-10 pm, novelty program, Sun, 3-5, feature program, Central.

WCAL, Northfield, Minn. 360 meters. 500 ml. Dept. of Physics, St. Olaf College. No definite schedule.

WCAM, Villanova, Pa. 360 meters. Villanova College.

WCAN, Baltimore, Md. 360 meters. 100 ml. Sanders & Stayman Co. Daily ex Sun, 12-1 pm, Mon, Wed, 8-9 pm, Eastern.

WCAP, Washington, D. C. 469 meters. Chesapeake & Potomac Tel. Co. Tues, Sat, 7:30 pm, broadcast jointly with WEAJ, Thurs, Sat, 10-12 pm, dance music, Sun, 4, 7:20 pm, service.

WCAR, San Antonio, Tex. 360 meters. 1,500 ml. Alamo Radio Elec. Co. Mon, Thurs, Sat, 8:30-9:30 pm, concert, Central.

WCAS, Minneapolis, Minn. 246 meters. 500 ml. Wm. H. Dunwoody Industrial Inst. Slogan, "From the Flour City of the World," Mon, 7-7:30 pm, technical program, Tues, 8:15-9:30 pm, 9:30-10:45, on alternate weeks, music, lectures, Wed, 6:30-7 pm, radio problems, Thurs, 7-7:30 pm, code, radio problems, Central.

WCAT, Rapid City, S. D. 240 meters. 300 ml. S. D. State School of Mines. Daily ex Sun, 9:30 am, 12:30 pm, 3 pm, weather, reports, Wed, 7:15 pm, concert, Mountain.

WCAU, Philadelphia, Pa. 286 meters. 500 ml. Durham & Co. Daily 11:45 am, Tues, Fri, 7:30-8 pm, concert, Sun, 10:55 am, church services, Eastern.

WCAV, Little Rock, Ark. 360 meters. J. C. Dico Elec. Co. Tues, 8:30 pm.

WCAX, Burlington, Vt. 360 meters. Univ. of Vt.

WCAY, Milwaukee, Wis. 261 meters. 500 ml. Kesselman-O'Driscoll Music House. Daily ex Sun, 11 am, reports, Mon, Tues, Thurs, Fri, 7:30-8:30 pm, music, Tues, 10:30-11:30 pm, dance music, Sun, 7:30-9 pm, church services, Central.

WCAZ, Carthage, Ill. 246 meters. 250 ml. Carthage College. Wed, 9-10 pm, athletics, Central.

WCBA, Allentown, Pa. 280 meters. Chas. W. Heffner. Wed, 7:30-9:45 pm, Sat, Sun, 2-4 pm, 6-8, Eastern.

WCBB, Greenville, O. 240 meters. K. & K. Radio Supply Co.

WCBD, Zion, Ill. 345 meters. 1,500 ml. Wilbur Glenn Voliva. Slogan, "Where God Rules, Man Prospers," Mon, Fri, 8-10 pm, concert, Wed, Fri, 2:30-3:45 pm, service, Sun, 9-9:45 am, Bible School; 2:30-5:30 pm, church services, Central.

WCE, Minneapolis, Minn. 360 meters. Findley Elec. Co.

WCK, St. Louis, Mo. 360 meters. 500 ml. Stix, Baer & Fuller. Daily, 12-12:30 pm, 3-4:15, 5-5:30, Mon, Wed, Fri, 6:45-8 pm, concert, lecture, Central.

WCM, Austin, Tex. 360 meters. Univ. of Tex.

WGX, Detroit, Mich. 517 meters. 1,000 ml. The Detroit Free Press. Slogan, "The Call of the Motor City," Club, "Red Apple Club," Daily ex Sun, 2 pm, news; 2:15, spot reports; 2:50, weather, markets; 4:15, 4:30, 4:50, 6:15, markets, music, Daily ex Sat, Sun, 8:30-10 pm, week starting Dec. 11 and alternate weeks thereafter, concert, Tues, 10-12 pm, Club, Sun, 10:30 am, 7:15 pm, church services, Eastern.

WLD, Lindsborg, Kans. 360 meters. 200 ml. Wm. Louis Harrison. Tues, Thurs, Fri, 9:30 pm, entertainment, weather, Sun, 3:30 pm, vesper services, Central.

WDAE, Tampa, Fla. 360 meters. 500 ml. Tampa Daily Times. Wed, Fri, 8-10 pm, music, lecture, Eastern.

WDAF, Kansas City, Mo. 411 meters, 2,000 ml. Kansas City Star. Club, "Nighthawks," Daily ex Sun, 3:30-4:30 pm, music; 6-7, educational, bedtime story, etc.; 11:45 pm-1 am, Nighthawk Frolic, Mon, Wed, Fri, 8-10 pm, concert, Sun, 4-5 pm, music, Central.

WDAG, Amarillo, Tex. 263 meters. J. Laurance Martin. Tues, Thurs, 8-9:30 pm, music, Central.

WDAH, El Paso, Tex. 263 meters. Trinity Methodist Church South. Wed, Thurs, Sun, 7:30-8:30 pm, Mountain.

WDAI, Syracuse, N. Y. 246 meters. 200 ml. Hughes Radio Corp. Daily ex Sun, 12 m, reports, Eastern.

WDAK, Hartford, Conn. 261 meters. 150 ml. The Courant. Sat, 8 pm, concert, Eastern.

WDAL, Jacksonville, Fla. 360 meters. 250 ml. Florida Times Union. Daily, 11 am, weather; 4-5, 6-7 pm, music; 8-9, entertainment; 9:30, reports, Sat, 12-1 am, "The Midnight Aggravators," Eastern.

WDAO, Dallas, Tex. 360 meters. 300 ml. Automotive Elec. Co. Daily 1-1:45 pm, 7:15-8, Central.

WDAP, Chicago, Ill. 360 meters. 2,000 ml. Chicago Board of Trade, Drake Hotel. Daily ex Sun, every half hour from 9:30 am to 1:30 pm, quotations, reports; 6 pm, news, Daily ex Sun, Mon, 1:35, 7-8 pm, dance music; 10, concert, Sun, 9:15, concert, Central.

WDAR, Philadelphia, Pa. 335 meters. Lit Bros. Club. "Morning Glory," Daily ex Sun, 12-12:55 pm, music; 2-3 pm, 4:30-6, music, talks; 7:30-8 pm, Dream Daddy, Mon, 7:30-10:55, Wed, 8-11 pm, entertainment, Fri, 8-10:50, entertainment; 1 am, Club, Eastern.

WDAS, Worcester, Mass. 360 meters. Samuel A. Waite

WDAU, New Bedford, Mass. 360 meters. 500 ml. Industrial Union. Mon, Wed, Fri, 12:15-12:50 pm, industrial reports; 7:45-10 pm, music, Sun, 11 am-12:30 pm, 7-8 pm, church services, Eastern.

WDAK, Centerville, Iowa. 268 meters. 500 ml. First Nat'l Bank. Daily ex Sun, 11:30 am, reports, news, Mon, Thurs, 7:30-9 pm, concert, Central.

WDAY, Fargo, N. D. 244 meters. 300 ml. Radio Equip. Corp. Slogan, "The Biggest Little City in the World," Daily ex Sun, 9:30 am, weather, Tues, Thurs, Sat, 8-9 pm, concert, Sun, 10:30 am, church services, Central.

WDBK, Lancaster, Pa. 253 meters. Kirk Johnson & Co., Inc. Mon, Tues, Thurs, 8 pm, Eastern.

WDBF, Youngstown, O. 261 meters. Robert G. Phillips. Tues, Thurs, Sat, 8-9 pm, music, reports, Eastern.

WDM, Washington, D. C. 360 meters. 50 ml. Church of the Covenant. Sun, 11 am, church service; 8 pm, church service, Eastern.

WDT, New York City, N. Y. 405 meters. Ship Owners Radio Service & Premier Grand Piano. Discontinued temporarily.

WDZ, Tuscola, Ill. 273 meters. 100 ml. James L. Bush. Daily ex Sun, 9:30 am, 10, 10:30, 11, 11:30, 12 m, 12:30 pm, 1, 1:15, Chicago Board of Trade quotations, Central.

WEAA, Flint, Mich. 280 meters. 200 ml. Frank D. Keim. Slogan, "The Vehicle City," No definite schedule, Pacific broadcasts.

WEAB, Fort Dodge, Ia. 360 meters. 1,000 ml. Standard Radio Equip. Co. Daily ex Sun, markets every 30 min. from 8:40 am-12:20 pm; 5:15 pm, 10 am, 4 pm, road reports, Central.

WEAE, Blacksburg, Va. 360 meters. Polytechnic Inst. WEAF, New York City, N. Y. 492 meters. 1,500 ml. A. T. & T. Co. Slogan, "The Voice to the Millions," Mon, 4-5:30 pm, 7:30-10, Tues, Wed, Thurs, Fri, 11-12 am, 4-5:30 pm, 7:30-10, Sat, 4-5:30 pm, 7:30-11, Sun, 2:30-5:30 pm, 7:30-10, Eastern.

WEAG, Edgewood, R. I. 231 meters. Nicholas-Hine-Bassett Lab.

WEAH, Wichita, Kan. 244 meters. 500 ml. Wichita Board of Trade. Daily ex Sun, 9 am, 10, 11, 12 m, 1 pm, 2, market reports, Mon, Fri, 8-9 pm, music, Wed, 10-11:45, "Winter Garden Frolic," Central.

WEAI, Ithaca, N. Y. 286 meters. Cornell Univ. Irregular schedule.

WEAJ, Vermillion, S. D. 283 meters. Univ. of S. D.

WEAM, North Plainfield, N. J. 250 meters. 75 ml. Borough of N. Plainfield. No definite schedule.

WEAN, Providence, R. I. 273 meters. 50 ml. The Shepherd Stores. Daily ex Sun, 12-1, 4-5, 6-7, music, reports, weather, concerts, Tues, Thurs, 8:15-10, concert, Wed, 10:30-12 midnight, concert, Sun, 10:45-11:30 am, 7:30-8:45 pm, church service, Eastern.

WEAO, Columbus, O. 360 meters. 500 ml. Ohio State Univ. Daily ex Sun, 1-3 pm, reports, Tues, Thurs, 8-10 pm, lecture, concert, Central.

WEAP, Mobile, Ala. 360 meters. 50 ml. Mobile Radio Co. Daily ex Sun, 12 m, reports; 4-5 pm, music, Daily ex Sun, Mon, 7:45-8:45 pm, music, Sun, 3-3:50 pm, church service, First Mon of each month, 11 pm-1 am, concert, Central.

WEAR, Baltimore, Md. 360 meters. 200 ml. News & American Pub. Co. Tues, Thurs, Fri, 7-10 pm, music, weather, sports, Eastern.

WEAS, Washington, D. C. 360 meters. 200 ml. The Hecht Co. Temporarily discontinued.

WEAU, Sioux City, Ia. 360 meters. 300 ml. Davidson Bros. Co. Slogan, "The Heart of the Corn Belt," Daily ex Sun, 10 am, 11, 2 pm, 5, Mon, Wed, Fri, 8-9 pm, concert, Central.

WEAW, Houston, Tex. 360 meters. 700 ml. Will Horwitz (Iris Theater.) Slogan, "Where All the Oceans Meet All the Railroads," Daily ex Sun, 11 am, dinner hints, news; 12 m, music; 12:57-1 pm, time; 2:30 pm, music; 6 pm, news, Fri, Sat, 8-10 pm, concert, Sun, 11 am, 8 pm, church services; 9 pm, concert, Central.

WEB, St. Louis, Mo. 360 meters. 800 ml. The Benwood Co., Inc. Tues, 9-10:30 pm, Wed, 8-9:30 pm, Sat, 7:30-9 pm, 11 pm-1 am, Central.

WEV, Houston, Tex. 360 meters. 500 ml. Huriburt-Still Exco. Daily ex Sun, 10 am, 5:30 pm, weather, roads, Tues, Thurs, 8 pm, concert, Central.

WEW, St. Louis, Mo. 261 meters. 200 ml. St. Louis Univ. Daily ex Sun, 9 am, 10, 2, 5 pm, reports, Central.

WFAA, Dallas, Tex. 476 meters. 1,500 ml. Dallas News and Dallas Journal. Slogan, "Working For All Alike," Daily, 10:30 am, reports; 12:30-1 pm, address; 2:30-3:30, reports, news; 6:15-7, bedtime story; 6:45-7, sports, news; 8:30-9:30, concert, weather (silent Wed), Tues, Sat, 11-12 pm, music, Sun, 2:30-3:30 pm, Bible class; 9:30-11 pm, music, Central.

WFAB, Syracuse, N. Y. 234 meters. 500 ml. C. F. Service. Daily ex Sun, 8:30 pm, Sun, 9:30-10 pm, Service, Eastern.

WFAC, Poughkeepsie, N. Y. 273 meters. H. C. Spratt Radio Co. Temporarily discontinued.

WFAH, Port Arthur, Tex. 236 meters. 100 ml. Elec. Supply Co. Tues, Thurs, 10-11 pm, concert, Central.

WFAJ, Asheville, N. C. 256 ml. Hi-Grade Wireless Instrument Co. Temporarily discontinued.

WFAM, St. Cloud, Minn. 300 meters. 100 ml. St.

Cloud Daily Times. Daily ex Sun, 9:30-4 pm, markets, Mon, Wed, 7:30-9 pm, entertainment, Central.

WFAN, Hutchinson, Minn. 360 meters. 300 ml. Hutchinson Elec. Service Co. Slogan, "Gateway to the Ten Thousand Lakes of Minn.," Daily, 11:55 am-12:30 pm, program, news, time, weather, Tues, 8-10 pm, program, Special hours, Central.

WFAQ, Cameron, Mo. 360 meters. 300 ml. Missouri Wesleyan College.

WFAT, Sioux Falls, S. D. 360 meters. 500 ml. Daily Argus Leader. Daily ex Sun, 9:15 am, 11:15, 12:30 pm, 1:30, reports, music; 7:30, baseball, music, Central.

WFAV, Lincoln, Neb. 275 meters. 1500 ml. Univ. of Neb. Slogan, "The Home of the Cornhuskers," Daily ex Sun, 10 am, 12:40 pm, weather, Sat, 1-5 pm, football, Central.

WFI, Philadelphia, Pa. 395 meters. 1,000 ml. Strawberry & Clothier. Daily ex Sun, 10:15 am, reports; 1 pm, orchestra; 1:50 reports; 3-4:30, concert; 6:30, orchestra; 7-7:30, children's hour, Tues, Thurs, Sat, 8 pm, concert, Sun, 10:30 am, 7:30 pm, church services; 4:30, chapel service, Eastern.

WGAJ, Tulsa, Okla. 360 meters. Goller Radio Service.

WGAL, Lancaster, Pa. 248 meters. 35 ml. Lancaster Elec. Supply & Construction Co. Slogan, "Garden Spot of U. S. A.," Mon, Wed, Fri, 7:30-9 pm, concert, lecture, Sun, 3-3:30 pm, church service, Eastern.

WGAN, Pensacola, Fla. 360 meters. Cecil E. Lloyd.

WGAQ, Shreveport, La. 360 meters. 500 ml. Glenwood Radio Corp. Daily ex Sun, 12:30-1:30 pm, 6:30, 7:30, music, Sun, 11 am, 7:30 pm, church service, Central.

WGAR, Fort Smith, Ark. 360 meters. Southwest America. Discontinued temporarily.

WGAU, Wooster, O. 226 meters. Marcus G. Limb.

WGAW, Altoona, Pa. 261 meters. 300 ml. Ernest C. Albright. Slogan, "The home of the world's largest railroad shops," Tues, Wed, 9-11 pm, music, Sun, 9-10:30 pm, music, Eastern.

WGAY, Madison, Wis. 360 meters. 100 ml. North Western Radio Co. Daily ex Sun, 10 am, weather; 4:30, news, Mon, Thurs, 8:30 pm, concert, Sun, 3 pm, music, Central.

WGAZ, South Bend, Ind. 360 meters. 200 ml. South Bend Tribune. Daily ex Sun, 12:30-1 pm, markets, music, Mon, Wed, Fri, 7-8 pm, concert, Central.

WGI, Medford Hillside, Mass. 360 meters. 500 ml. Am. Radio & Research Corp. Slogan, "Amar, the Voice of the Air," Daily ex Sat, Sun, 12 m-1 pm, concert, Tues, Thurs, 7-8:30 pm, concert, Wed, Fri, Sat, 7:30-9:00, concert, Daily, 5:30-6:45 pm, Children's Hour, reports, codes, Tues, Fri, 3 pm, Amrad Women's Club, Sun, 4-5 pm, 8:30, church services; 10, concert, Eastern.

WGL, Philadelphia, Pa. 360 meters. 2,000 ml. Thos. F. J. Howlett. Irregular schedule.

WGR, Buffalo, N. Y. 319 meters. 1,000 ml. Federal Tel. & Teleg. Co. Slogan, "Key City of Industry," Daily, 10-45 am, weather; 12 m, organ music, Daily ex Sat, 8:30, 12:30 pm, 2:30, 4, 5, reports, Daily ex Sun, 6:30, music; 7, news, Mon, Wed, Fri, 9-11 pm, concert, Daily, 10:45 pm, weather, Fri, 8:45, road reports, Sun, 3 pm, vesper services; 4, organ, Eastern.

WGV, New Orleans, La. 350 meters. 400 ml. Interstate Elec. Co. Slogan, "Where the Mighty Mississippi Makes a Crescent Near the Gulf," Mon, Wed, Sat, 8-9 pm, 12-1, music, talks, Sat, 7:30-8:30 pm, Central.

WGY, Schenectady, N. Y. 380 meters. 1,000 ml. General Elec. Co. Daily ex Sun, 11:30-12 m, 5, 6, reports, time, sports, Mon, Tues, Thurs, Fri, 1-1:30 pm, 7:45, concert, Fri, 10:30 pm, special, Sun, 9:30 am, 6:30 pm, church service, Eastern.

WHA, Madison, Wis. 360 meters. 1,000 ml. Univ. of Wis. Mon, Wed, Fri, 7:30 pm, lectures, news, agrigrams, Central.

WHAA, Iowa City, Ia. 263 meters. 200 ml. Univ. of Iowa. No regular schedule.

WHAB, Galveston, Tex. 360 meters. 500 ml. Clark W. Thompson Co. Slogan, "The Gateway to the Southwest and Treasure Island of America," Daily ex Sun, 8:45 am, 11, 3:30 pm, 5, reports, music, news, Tues, Fri, 8 pm, entertainment, Sat, 8:20, special, Sun, 11 am, 7:30 pm, church service, Central.

WHAC, Waterloo, Ia. 360 meters. 100 ml. Colo Bros. Elec. Co. Daily, 6 pm, news, sports, Mon, Wed, Fri, 9:30 pm, concert, Sun, 11 am, church services, Central.

WHAD, Milwaukee, Wis. 280 meters. 1,000 ml. Marquette Univ. Wed, 7:30-8:30 pm, music, entertainment, Central.

WHAG, Cincinnati, O. 222 meters. 100 ml. Univ. of Cincinnati. No definite schedule.

WHAH, Joplin, Mo. 360 meters. 50 ml. Hafer Supply Co. Tues, Thurs, 8-10 pm; Sat, 10:30-11:30, Central.

WHAI, Davenport, Ia. 360 meters. 30 ml. Radio Equip. & Mfg. Co. Temporarily discontinued.

WHAK, Chikaskia, W. Va. 258 meters. 75 ml. Roberts Hdwe. Co. No definite schedule.

WHAM, Rochester, N. Y. 360 meters. Univ. of Rochester. Rochester Times-Union, Democrat and Chronicle. Daily ex Sun, 2 pm, 4:15, 6:50, 7, 7:30, 7:35, 7:40, Sun, 3:15, Radio Chapel, Eastern.

WHAP, Decatur, Ill. 360 meters. 100 ml. Otto & Kuhns. No definite schedule.

WHAQ, Washington, D. C. 462 meters. 75 ml. Semmes Motor Co. Mon, 7-8 pm, lecture on automobile upkeep, music, Eastern.

WHAR, Atlantic City, N. J. 231 meters. Paramount Radio & Elec. Co. Daily, 2-3 pm, 7-9, Eastern.

WHAS, Louisville, Ky. 400 meters. 1,500 ml. Courier Journal and Louisville Times Co. Daily ex Sun, 4-5 pm, 7:30-9, Sun, 9:27-10:45 am, 4-5 pm, church service, Mon night, silent, Central.

WHAV, Wilmington, Del. 360 meters. 200 ml. Wilmington Elec. Spec. Co. Slogan, "The First Broadcasting Station of the First City of the First State," Sun, 10-11 pm, Eastern.

WHAZ, Troy, N. Y. 350 meters. 2,000 ml. Rensselaer Polytechnic Inst. Slogan, "Transcontinental and International Broadcasting Station Located at the Oldest College of Engineering," Club, R. P. I. students, Mon, 9-10:30 pm, concert, educational talks, Transcontinental second Monday of each month, 12-1:30 am, music, Eastern.

WHB, Kansas City, Mo. 411 meters. 1,000 ml. Sweeney Auto & Electric School. Slogan, "Heart of America," Daily ex Sun, 8:

Radio Illustrated



Left, a scene from Shakespeare's "Twelfth Night" with Julia Marlowe and E. H. Sothorn as Viola and Malvolio. It was broadcast recently from a New York theater by WJZ. Above, machine that engraves radio panels. The operator holds in his left hand a "stencil" used to guide the cutter. Photo above © K. & H.

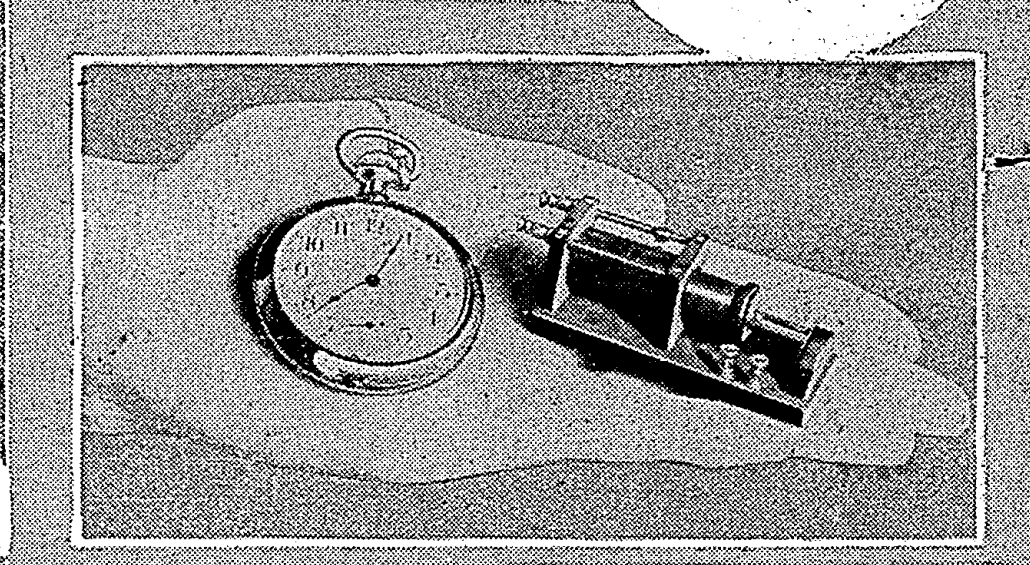

Above, loose coupler for receiver, said to be the smallest ever made, in the hand of its builder. Below, left, field radio station of U. S. Cavalry, and right, Mlle. Lenglen, famous tennis champion, telling fans about the game. Photo above, by K. & H. Below, left © U. & U., right K. & H.

