

# Radio Digest

EVERY WEEK **Illustrated** TEN CENTS

REG. U. S. PAT. OFF. &amp; DOM. OF CANADA

Vol. VI

Copyright, 1923  
R. D. P. Co. Inc.

SATURDAY, JULY 14, 1923

No. 1

## LEARN WHILE SLEEPING

### STATION MANNED BY PUBLIC IS PROPOSED

#### PHILADELPHIANS SUGGEST NATIONAL "CHAIN"

Plan Is Outgrowth of Chamber of Commerce Study to Effect Better Broadcasting

PHILADELPHIA.—Development of a central radio broadcasting station, to be owned and operated publicly as one of a chain which will extend throughout the country, is asked by representatives of the National Radio Chamber of Commerce in a proposal laid before the Philadelphia Chamber of Commerce.

Dr. Wilmer Krusen, chairman of the Municipal Affairs Committee of the Philadelphia Chamber, which has the proposal under consideration, has called a meeting of representatives of all local broadcasting stations to meet with his committee at the Chamber of Commerce.

Proposal for the establishment of a public broadcasting station is the outgrowth of much study by the National Radio Chamber in seeking to solve the problem of developing better broadcasting.

**Sees Great Public Service in Plan**  
"There are probably 50,000 broadcast receiving sets serving from 200,000 to 300,000 persons, in Philadelphia," according to a statement issued by the chamber. "This number is increasing rapidly because fair equipment is now within the reach of all. The mere presence in Philadelphia of such a station as we contemplate would undoubtedly serve to increase greatly public interest in radio and hence, correspondingly, the influence of the Philadelphia station.

"Such a station should be heard easily in half of the sets of the country, or not less than 1,000,000 sets, serving perhaps 4,000,000 persons. So rapid is the increase in the number of Radiophones that it is safe to say that within five years the voice of Philadelphia could and would be heard by half of the people of the United States.

"The public broadcasting station must and will be supported by the people whom it serves. We are presenting to Philadelphia the opportunity to lead the way in the great new development of this epoch-making art by establishing the first public broadcasting station in the United States, owned and operated by the public."

#### Giant Horn for City Park

ATLANTA, GA.—A giant loud speaker, fifteen feet long and big enough for a tall man to enter upright, amplifies the received municipal concerts broadcast nightly by the Atlanta Journal, Station WSB, for summer crowds at one of the city parks.

#### WONDER IF HONOLULU HEARD WOR WEDDING

NEWARK, N. J.—Word is being awaited as to whether or not Radiophans in the Hawaiian Islands and France picked up the wedding ceremony recently broadcast from Station WOR. The wedding in question was the ceremony which united Col. King Stanley, seventy, former Indian Scout and Miss Grace A. Raymond, forty-five.



It will go down in history that President Harding was the first president to use radio in speaking to the invisible public. His Alaskan trip is well dotted with speeches, many of which will be broadcast. Radio will keep him in close touch with things at home while in Alaska. He said, "It's a great stunt" after making a speech in a western state. The Presidential car is equipped with amplifying units and loud speaking horns, which broadcast the speaker's voice many blocks and it is easy for the crowds to hear the President from the observation platform on the train. Where speeches are made in halls the usual broadcasting takes place, and we all can hear it if we have long distance receiving sets. When the President and his party reach Alaska, their destination, only a thin piece of copper cable leading back to the States will let him know what is doing here. However, Radio will be used almost entirely on this trip.

### SUBCONSCIOUS MIND TAUGHT BY HEAD SET

Teach Naval Aviators Radio Code in Short Time—Speed Acquired

*Sleeping Mind Memorizes*

Principle Applicable to Other Fields—May Find Use in Schools of Country

By L. M. Lamm

WASHINGTON, D. C.—Are you having a hard time trying to learn the Radio code? Are you looking for an easy way to learn it? Is there something else difficult for you to grasp? Then go to sleep and let your subconscious mind learn it for you. That is the advice of Radio experts of the Navy Department. Experiments have been made and claimed to have been a success.

A novel plan for teaching the Radio code to student naval aviators at the Naval Air Station, Pensacola, Fla., has been under trial recently, according to officials of the Bureau of Aeronautics of the Navy Department, and reports received indicate the plan to be both practical and valuable.

**Learn While They Sleep**

The plan is to teach student aviators to receive code at high speed while they are asleep. The advantage claimed for the idea is that it enables the student to acquire facility in receiving the code in a fraction of the time that is ordinarily required. In recent tests made, say officials of the department, students who have been particularly slow in making progress with Radio practice have been saved from being dropped from the class at Pensacola.

The idea originated in the experience of Chief Radio Mate Phinney who is in charge of Radio instruction in the ground school at the Pensacola Air Station. In asking for a trial of his plan, Phinney cited his own case, and told of how in practicing receiving at the rate of thirty-five words per minute he fell asleep while the mechanical sender which he was using continued to send messages to him. When he awoke Phinney claimed that he was able to receive at the rate of thirty-five words, (Continued on page 2)

#### "RADARIO" COINED BY CROSLY PLANT WLW

CINCINNATI, O.—The word "Radario" is claimed to have been used first by station WLW, Crosley Manufacturing Company, this city. The term means Radio drama and was coined by WLW officials to describe the particular type of technique necessary for microphoning the invisible play. The station also claims the first Radio dramatist, Fred Smith.



FANS SAVE COUPONS FOR LARGER PARTS

LETTERS SHOW READERS TO BE SAVING SERIES

More Valuable of Standard Apparatus Goal of Special Award Enthusiasts—Many Cash in

SPECIAL REWARD OFFER Coupon Number 7. This Special Reward Coupon appears each issue in Radio Digest until further notice. When sent in, accompanied by necessary remittance, according to the rules governing same, apparatus can be secured. See apparatus list and rules of offer below. Save Me—I Am Valuable

With the publication of the seventh Special Reward Coupon for Digest readers many letters have been received which tell of the desire of fans to save the coupons for the more valuable pieces of apparatus in the offer list, such as those items catalogued under Classes E, F, G, and even H.

Many of these letters also indicate that the writers are saving more than one series of coupons. One fan told that he was saving four distinct series of coupons in order to secure audio and Radio frequency transformers in the Class H list. He is planning a set requiring two audio and two Radio frequency transformers and appreciates the saving made possible by the coupons.

It might be added here that there is no limit to the number of series turned in by any fan. Go as far as you like! And again, a series does not have to begin with coupon number one. Any series may begin with any coupon number, so long as it follows a consecutive series of numbers. All that is necessary in addition is the remittance called for in the particular class from which the item may be selected.

Rules to Remember

One point must be emphasized to those contemplating taking advantage of the special offer; that is, that the coupons turned in for any item must be numbered consecutively, as for example, 1, 2, 3, and 4 or 3, 4, 5 and 6. The number of coupons necessary and the cash remittance, of course, depend on the item sought by the reader. There is no limit to the number of series turned in by any one reader.

Another point to remember is that cash, checks and money orders but no postage stamps will be accepted. To make selection more simple the items have been divided into eight classes, each class depending on the number of consecutive coupons and amount of cash remittance necessary. The eight classes of items follow:

Class A Articles

For two consecutively numbered coupons and thirty cents (\$0.30) any one of the following articles will be sent: 1 Carter Imp Jack and Plug; 1 Carter 15-Ohm Resistance Unit; 1 Schindler .00025 mfd. Build-up Mica Condenser; 1 Schindler .0005 mfd. Build-up Mica Condenser; 1 Schindler .001 mfd. Build-Up Mica Condenser; 1 Schindler .002 mfd. Build-Up Mica Condenser; 1 Schindler .0025 mfd. Build-Up Mica Condenser; 1 Martin-Copeland Sta Put Plug; Walnut Standard Tube Socket; Walnut UV-199 Socket; Ray-O-Vac Dry Battery, 1 1/2 volts; Duhiller Micadons Type 601 (.0001, .00025, .0005, .001, .002, .0025, .003 or .004 mfd.); Premier Grid Condenser (.00025 or .0005 mfd.); Premier Variable Resistance; 1 Carter 25-ohm Resistance Unit; Standard Socket Adapter for Delta Midget Tube; Electrad Grid Leak (1, 1.5 and 2 megohms, with clips).

Class B Articles

For four consecutively numbered coupons and sixty cents (\$0.60) any one of the following articles will be sent: 1 Carter .04 mfd. Special Fixed Condenser; 1 Carter Jack Switch; 1 Carter Hold-Tite Jack, One Spring Open Circuit; 1 Carter Hold-Tite Jack, Two Spring Closed Circuit; 1 Carter Hold-Tite Jack, Three Spring Filament Control; 1 Carter Hold-Tite Jack, Four Spring Closed Circuit; 1 Carter Hold-Tite Jack, Five Spring Filament Control; 1 Puddin Variable Grid Leak with .00025 mfd. Condenser; 1 Federal Universal Phone Plug; 1 Federal Open Circuit Jack; 1 Federal Closed Circuit Jack; 1 Federal Double Circuit Jack; 1 Martin-Copeland Shur Grip Plug; 1 Martin-Copeland WD-11 Socket; 1 Martin-Copeland WD-11 Adapter; 1 Martin-Copeland UV-199 Socket; 1 Martin-Copeland UV-199 Adapter; 1 Martin-Copeland Pull Switch; 1 Martin-Copeland 5-point Inductance Switch; 1 Martin-Copeland Variable Grid Leak; 1 Martin-Copeland SPST Knife Switch; 1 Martin-Copeland SPDT Knife Switch; 1 Martin-Copeland DPST Knife Switch; 1 Martin-Copeland DPDT Knife Switch; Walnut Variable Grid Leak; Walnut Inductance Switch; Duhiller Micadons Type 600 (.0001, .00025, .0005, .001, .002, .0025, .003, .004, or .005 mfd.); Duhiller Micadons Type 610 (.001, .002, .0025, .003, .004, or .005 mfd.); Duhiller Micadons Type 601 (.006 mfd.); Duhiller By-Laws Condenser (.1, .25, or 5 mfd.); Premier Universal Tube Socket; Premier Radio Dial (3/16, 1/4, or 5/16 in. black or white face); Premier Universal Radio Jack, Open Circuit; Premier Universal Radio Jack, Two-Circuit Three Spring; Premier Universal Radio Jack, Two-Circuit Four Spring; Premier Universal Radio Jack, Filament Control Three Spring; Premier Switch Lever and 10 Points; Turney Spider Weh Coil (SW-20 with .038 milhenry inductance, SW-15 with .066 MH., or SW-20 with .300 MH.).

Class C Articles

For six consecutively numbered coupons and ninety cents (\$0.90) any one of the following articles will be sent: 1 Carter 6-Ohm Vernier Control Rheostat; 1 Carter "Tu-Way" Plug; 1 Federal Panel Mount Socket; 1 Federal 6-Ohm Rheostat; 1 Federal 3-Ohm (Power) Rheostat; 1 Amperite Automatic Filament Control (with mounting); 1 Martin-Copeland Marco Rheostat; 1 Martin-Copeland Series Parallel Switch; 1 Martin-Copeland DPDT Panel Switch; 1 Martin-Copeland 7-Point Inductance Switch; 1 Martin-Copeland 9-Point Inductance Switch; 1 Martin-Copeland 11-Point Inductance Switch; Walnut Variable Grid Leak with .00025 mfd. Condenser; Walnut Variable Condenser (3-plate .00006

(Continued on page 9)

LEARN WHILE SLEEPING

(Continued from page 1)

while previously he had been unable to catch more than twenty or twenty-five words. He advanced the theory that in a few hours of his slumber his subconscious mind had been trained to the higher speed.

Plan is Practical

When the proposition was first made to apply the test to student naval aviators in the ground school in Pensacola, officials of the Navy Department say that it was met with amused skepticism, but a practical test has convinced the skeptics that the plan is workable.

The matter of acquiring a speed of twenty words per minute has ever been a bugbear to students at the training station, it is said, and in a number of cases has seriously hampered their progress. This speed must be reached by the end of the six months' course in order for the student to receive a designation as pilot. In the last class to enter the ground school several students proved to be difficult subjects, and as a last resort the attempt was made to boost them to the required speed by sending radio code messages to them while they slept.

Applicable to Other Memory Work

Before turning in at night the student adjusts the receivers on his head which are used in the regular class. A regular watch is stood throughout the night by expert operators on the sending key and throughout the night they send at high speed—about ten words in excess of the student's capacity to receive. It has been found, according to the reports reaching the navy headquarters, that in his conscious hours the following day the student is able to receive messages at the speed they were sent to him while he was asleep.

In discussing his method Chief Mate Phinney claims that it has educational value in that memory tests which he has made have given astonishing results. Long passages of literature have been committed to memory in this manner that would otherwise have taken laborious effort extending over a long period of time. The belief was expressed that the scheme might be applied to other lines of

education and perhaps eventually would find use in the schools all over the country.

Cuban Station Owner Gives Long Distance Certificates

TUINUCU, CUBA.—Frank H. Jones, owner and operator of station 6KW, Tuinucu, Cuba, has a novel way of confirming the long distance reports of ambitious amateurs who write in to him, reporting reception of his broadcasts and requesting a check on the received broadcast.

On receipt of such reports, Mr. Jones checks up the report with the station log and issues a "Certificate of Long Distance Radiophone Reception," stating the date the record was accomplished, wave length used, type of apparatus employed at the broadcasting station, and a schedule of programs.

Majority of Radio Exports Go to Canada, Figures Show

WASHINGTON, D. C.—There were 128,026 pounds of Radio apparatus exported in April, valued at \$244,195, according to information just made public by the Department of Commerce. Of this apparatus, by far the largest quantity went to Quebec and Ontario, Canada, the exports to these provinces amounting to 33,319 pounds, valued at \$56,325. The second largest quantity went to Argentina, with Cuba and England being the countries to which the next largest quantities went.

Series of "Outdoor" Talks by Jud Landon, Broadcast

SCHENECTADY, N. Y.—For lovers of the field and stream WGY, the broadcasting station of the General Electric Company here recently inaugurated a series of "outdoor" talks. Jud Landon, nationally known devotee of the rod and gun, gives red-blooded talks for red-blooded men. He tells about the ways and the haunts of game fish; discusses in the language of the sportsman, such important things as bait, flies, tackle, rod and reel.

GIVE WORLD RULES ON RADIO IN WAR

NO BAN ON NEUTRAL SETS IN OWN TERRITORY

Belligerent Powers May Not Erect Station in Jurisdiction of Country at Peace

WASHINGTON.—International rules for the control and operation of Radio in time of war, as propounded by the Commission of Jurists at the Hague, were announced by the Department of State today.

These regulations, in the preparation of which Capt. Samuel W. Bryant, U. S. N., and Col. Geo. S. Gibbs, U. S. A., assisted American Commissioners Moore and Washburn, provide substantially that:

In time of war the working of non-belligerent Radio stations shall continue to be organized, as far as possible, in such manner as not to disturb the services of other Radio stations. Belligerent and neutral powers may regulate or prohibit the operation of Radio stations within their jurisdiction.

The erection or operation by a belligerent power of Radio stations within neutral jurisdiction constitutes a violation of neutrality on his part as well as on the part of the neutral power.

Neutral Power Need Not Restrict

A neutral power need not restrict or prohibit the use of Radio stations located within its jurisdiction, except to prevent the transmission of information destined for a belligerent concerning military operations and except as further prescribed. All restrictive or prohibitive measures taken by a neutral power shall be applied impartially by it to the belligerents.

Belligerent mobile Radio stations within a neutral State must abstain from all use of their Radio apparatus. Neutral Governments are bound to prevent such use.

The transmission by Radio by a vessel or an aircraft, whether enemy or neutral, when on or over the high seas, of military intelligence for the immediate use of a belligerent is deemed a hostile act and will render the vessel or aircraft liable to be fired upon. A neutral vessel or neutral aircraft which transmits, when on or over the high seas, information destined for a belligerent concerning military operations shall be liable to capture. The Prize Court may condemn the vessel or aircraft, if it considers that the circumstances justify condemnation. Liability to capture of a neutral vessel or aircraft on account of the acts referred to is not extinguished by the conclusion of the voyage or flight on which the vessel or aircraft was engaged at the time, but shall subsist for a period of one year after the act complained of.

Belligerent Control Over Neutrals

In case a belligerent commanding officer considers that the success of the operation in which he is engaged may be prejudiced by the presence of vessels or aircraft equipped with Radio installations in the immediate vicinity of his armed forces or by the use of such installations therein, he may order neutral vessels or neutral aircraft on or over the high seas, to alter their course to prevent their approaching the armed forces under his command; or not to make use of their Radio transmitting apparatus while in the immediate vicinity of such forces.

A neutral vessel or aircraft, which does not conform to such direction, exposes itself to the risk of being fired upon. It will also be liable to capture.

Neutral mobile Radio stations shall refrain from keeping any record of Radio messages received from belligerent military Radio stations, unless such messages are addressed to themselves. Violations of this rule will justify the removal by the belligerent of the records of such intercepted messages.

Belligerents are under obligations to comply with the provisions of international conventions in regard to distress signals and distress messages so far as their military operations permit. Nothing in these rules shall be understood to relieve a belligerent from such obligation or to prohibit the transmission of distress signals, distress messages and messages which are indispensable to the safety of navigation. The perversion of Radio distress signals and distress messages prescribed by international conventions to other than their legitimate purposes constitutes a violation of the laws of war and renders the perpetrator personally responsible under international law.

CONTENTS

Radio Digest, Illustrated, Volume VI, Number 1, published Chicago, Illinois, July 14, 1923. Published weekly by Radio Digest Publishing Company, 123 West Madison Street, Chicago, Illinois. Subscription rates, yearly, Five Dollars; Foreign, Six Dollars; single copies, Ten Cents. Entered as second-class matter at the postoffice at Chicago, Illinois, under the Act of March 3, 1879.

"All the Live News of Radio".....1 to 8
Drop a Nickel in the Slot—Hear Music..... 3
Survey of the Radio Patent Tangle, in Four Parts, Part I, by John B. Brady; An Evening at Home with the Listener In..... 4
"Back Stage" at the Stations..... 5
Flewelling Answers to Queries..... 6
This Week's Advance Broadcast Programs..... 7
Radiophone Broadcasting Station Directory, Part IV, State, City-Station Index..... 8
Editorials; Indi-Gest; Condensed by Dielectric..... 10
First Steps for Beginners in Radio, Chapter IX—Radio Frequency Amplification, by Thomas W. Benson..... 11
Phantom Circuit for Portable Set; Other Radio Workshop Kinks..... 12
How to Make a Camper's Portable Reflex Set, Part IV—Conclusion, by H. J. Marx..... 13
Morrow Double Regenerator; Hazeltine Neutrodyne Errata..... 14
Questions and Answers..... 15
Radio Illustrated, a Page of Pictures..... 16

Looking Ahead

A Trip Through WGY—next week with Vera Brady Shipman. Fans of the great Schenectady broadcaster will enjoy this story.

How Audio Frequency Amplification is Accomplished—and many other things about it will be told by Thomas W. Benson next issue in his instructive series for Radio beginners. Read Chapter IX, page 11, this week.

"Co-operative Competition" in the Radio Industry—will be continued next week by John B. Brady, a patent attorney well informed on the Radio situation.

A Photo Diagram of Another Standard Receiving Set—this time the Jones Symphony Receiver—will be in the July 21 issue. The understandable layout will no doubt be appreciated by Digest readers, as have the other photo diagrams of this series.

Tube Characteristics of the Northern Electric 215A—will be discussed by H. J. Marx in the July 21 issue. This little "pickle" tube has acquired popularity over night, scarce as it is.

And of Course the Other Regular Features—Flewelling Answers to Queries, Part I of the Radiophone Broadcasting Station Directory, Advance Programs, etc., will be in your copy of the Digest next week.

Have a Copy with You on Your Vacation

WHEN YOU WANT

Radio Digest

YOU WANT IT!

BE SURE OF YOUR WEEKLY COPY BY SUBSCRIBING NOW

SEND IN THE BLANK TODAY

Form for sending in blank today, including fields for Name, Address, City, State.

Northern Electric Peanut Tubes, Type 215A

DEALERS—ATTRACTIVE DISCOUNTS

NOTE: We are the Largest Exclusive Radio Jobbers in the Middle West

HUDSON-ROSS 123 W. Madison St. Chicago



# SIX BIG HUSKIES DO "FLORADORA" STUNT

## MACY EMPLOYEES STAGE UNIQUE OPERETTA

Bessie Barriscale's Brother Is Author-Hero of Musical Comedy Broadcast from WJY

NEW YORK.—Radiophans had an opportunity of hearing a unique musical comedy recently when "Onco Upon a Time," written and produced by employes of R. H. Macy & Co., Inc., was broadcast from Station WJY, New York.

Richard Barriscale, brother of Bessie Barriscale, film star, is author of the play and its hero. A number of tuneful songs written by Jack Straus, son of the president of Macy's, Harry Herman, Ralph Goldstein and Mr. Barriscale were rendered, among them: "When Dreams Come true," "Hearts Are Trumps," "Hitch Your Wagon to a Red Star," "He's Getting Better Day by Day," "You'll Think of Me Sometimes," "May-Ga-Lanka Blues" and "Nacy Mine."

The operetta was originally produced last month at the Central Opera House under the auspices of the Community Club, an organization of Macy employes.

**Beauty Chorus Attraction**  
A great deal of attention was attracted to it at the time by the Beauty Chorus, whose pictures were later featured in newspapers throughout the country.

Another hit was a burlesque on the Floradora Sextette by six husky delegates from the store's delivery department, who donned ballet costumes to lend an air of realism to their performance.

The play was condensed for broadcasting purposes by Miss M. C. Sidney, head of Macy's Department of Training, who was formerly on the stage.

Miss Kathleen Grealish, who played the double part of Sally and Irene, had been heard over WJZ before. So had William Francis. Both collaborated in the Christmas stories which were sent out by WJZ at that time.

# Radio Gospel Does Missionary Work

Clergymen Say Church Services Reach Many Thousands—Two Elderly Women Dress to "Attend"

SCHENECTADY, N. Y.—Local clergymen whose services have been broadcast now look upon the Radio station as a powerful gospel missionary. Words spoken in a church in the presence of a small group of people are given wings and travel to thousands of homes reaching the aged and the infirm and many who, but for the Radio, would not hear a church service. Village churches locked because of a shortage of ministers or inability to provide for a pastor regularly, now open their doors and the congregations worship with the Schenectady church membership via Radio.

### Dress to "Attend" Radio Church

After every service letters reach the pastor from all parts of the country. One clergyman was recently told of two elderly women, too feeble to go to church, who dress each Sunday in their best finery and sit at their Radio set, hats and gloves on, and devoutly listen to the service. During the scripture reading they follow the pastor in their bibles and at the offertory they solemnly place a modest offering in a plate at their side. At the end of the service the money is sent to the pastor who has been speaking to them.

A lumberjack recently wrote one of the Schenectady ministers that he had heard a church service for the first time in eleven years, and that it had taken him back to his "Sunday School Days". He was so impressed that he is getting a loud speaker so that the gospel message may be appreciated by others in the camp.

# PLAN TO PLACE RADIO IN CHARITY HOSPITALS

LOS ANGELES.—The Times of this city is promoting a very laudable plan to secure Radio sets for the inmates of charitable institutions and shut-ins or incapacitated individuals. The plan has been named the "Uncle John Radio Fund." All wishing to contribute to the fund should make checks payable to the "Uncle John Radio Fund," The Times, Los Angeles.

# FIRST SPECIAL PERMIT TO BOY TRANSMITTER

SAN FRANCISCO.—The first special amateur Radio license under the new Department of Commerce regulations is held by Lester Pickler, 18 years old, of San Ysidro, who is known to Radio amateurs of three continents through his Station 6Z1H. Colonel J. F. Dillon, United States Radio Inspector for the sixth district, granted him the license recently.

# STATIC BUG-A-BOO ON AIR VANISHING

## IMPROVEMENT BROUGHT BY NEW WAVE LENGTHS

Federal Inspection Officials Report Fans Getting Better Summer Results Than Ever

WASHINGTON.—Officials of the Commerce Department report that the schedule of new wave lengths for broadcasting stations has met with a cordial reception throughout the country, and that improvement in reception is noted almost everywhere.

All nine Radio Supervisors report satisfactory results in the allocation of the Class B and A wave lengths, stating that almost all listeners in are experiencing better reception than ever before in summer time, even with static interference at its height. Last summer, they point out, some five hundred stations were operating on 400 and 360 meters, whereas today the B stations have some nearly forty exclusive national waves, and the A stations have thirty-one waves assigned individually in the nine Radio districts.

The real success or improvement brought about by the wave allocation will not be fully appreciated until later in the fall, it is said.

### Many Stations Keep Old Wave Lengths

Over three hundred of the old stations continue in Class C, satisfied apparently to operate on 360 meters. Experts of the commerce department express some surprise at this condition; they hoped for early applications for transfers to Class A and B with independent wave lengths. Although no new stations are being licensed under Class C the fact that over three hundred stations, scattered all over the country, continue to transmit on the 360 meter wave tends to maintain interference which it was expected would be eliminated.

Speaking of static, a member of the Radio Section pointed out that if the "Radio receivers" would use shorter, single wire antennae and listen in on the shorter wave Class A stations, very little static interference would be noticed. Reception should be better, they say, as the equipment is not as susceptible to static. The use of loops and indoor aerials is also recommended.

# Writes Scenarios to Airphone Jazz

Rex Taylor Types Off Wesley Barry Picture with Country-wide Loud Speaker Accompaniment

HOLLYWOOD, CAL.—The motion picture director who employs a five-piece orchestra on the stage to get him and his actors into the proper moods or their various scenes, has nothing at all on the scenario writer these days.

Rex Taylor who is writing the screen version of "George Washington, Jr.", which is to be Wesley Barry's next feature picture for Warner Brothers, is now clicking his trusty "Underwood" to the accompaniment of some of our best known jazz orchestras. He has arranged to have Lyman's Orchestra from the Ambassador Hotel, "The Packard Six," Major's Orchestra from Ocean Park and other noted jazz organizations play nightly in the study of his Hollywood bungalow to provide proper inspiration for the rollicking comedy scenes he is developing in the George Co-han play.

A Radio receiver which Taylor has built himself is the means of bringing these various orchestras to him and he claims that with the cheerful strains from the loud speaker filling his comfortable study, he can accomplish a full day's work during the evening broadcasting hours without tiring him in the least.

# DROP COIN IN SLOT—GET MUSIC



Put a nickel in the slot and receive Radio broadcasts, is the latest Parisian Radio innovation. Automatic Radiophones are now being installed in French cafes, movies, hotel lobbies, ship cabins and other public places. Each apparatus is connected with a receiving set. Should music be unavailable, time signals are given out. When a coin is dropped in the slot (at the time concerts are on the air), connection is made and the listener in immediately enjoys music © K. & H.

# ETHER CONCERTS AID OPERA RECORD SALES

Radio Keeps Public Informed on Latest Disc Music

COLUMBUS, O.—Definite results have come from the broadcasting of operas recorded on records from WPAL, Superior Radio and Telephone Equipment Company. The operatic selections are given every other week. From eight to ten records produced by one artist are broadcast and many people either call in person or write for the records they have heard broadcast. Aside from the fact that this means of announcing the better things in music has proved a good stimulant for selling records, it has also been the means of informing the public on the availability of great works in the form of records.

# RADIO TO REPLACE SIGN TALK FOR DEAF

State School Plans Special Class to Train Students

JACKSONVILLE, ILL.—A deaf man who had not heard a sound in sixty years was able to hear music and the human voice by means of a Radiophone as the climax to a series of experiments conducted at the state school for the deaf here.

As a result of these experiments Col. O. C. Smith, managing officer of the school, announced that he was making preparations to conduct a class at the school next year, all pupils of which will be taught not with the old method of sign language and lip reading, but by use of Radio apparatus.

# THE ANTENNA BROTHERS

Spir L. and Lew P.

On the Forestry Service Wave

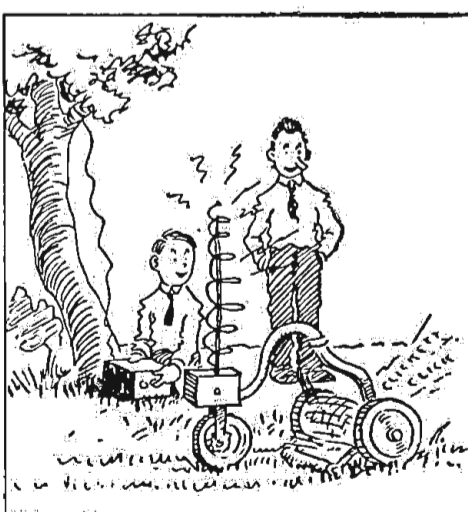



# SURVEYS INDUSTRY'S TANGLE OF PATENTS

## "Cooperative Competition" Leaves Maze of Stumbling Blocks for Independent Manufacturer

By John B. Brady

(Editor's Note.—Mr. Brady, a patent attorney of Radio repute, has achieved a remarkable survey of the network of patents, locking and interlocking the Radio industry in a veritable Gordian knot. His serial treatise on the patent situation will occupy four parts, of which this is the first.)

### PART I

THE RADIO industry can learn a great deal from its giant predecessor, the automobile industry, and perhaps amicably adjust the present chaotic situation arising out of the patents by a cross-license agreement to eliminate extended litigation. The automobile industry many years ago formed a National Automobile Chamber of Commerce which the manufacturers of different makes of cars joined and interchanged their patent rights on such a basis that production might go on unhindered with patent litigation.

### Pressing Small Manufacturer Out

The Radio patent situation for the smaller manufacturer on the outside of the big four looking in at the Radio Corporation is growing more acute each day. The Radio Corporation is bringing suits under its numerous patents and gradually pressing out the small manufacturer from his right of livelihood.

Glancing over the court records of only the past twelve months shows the Radio Corporation in litigation with the Radio Audion Company under the Fleming valve patent 803,684 in which they were successful in preventing the manufacture and sale of the Myer tubes when sold as detectors, although not when sold as amplifiers and oscillators.

### Get Myer Injunction

Upon the unsuccessful outcome of this suit the American Telephone & Telegraph Company sued the Radio Audion Company and DeForest Radio Telephone & Telegraph

Company on the DeForest amplifier patent 841,387 and grid patent 879,532 in which an injunction was obtained against the defendants. The Radio Audion Company appealed their case to a higher court. The Audion Company found the Radio Corporation circularizing the trade with unfair notices to the public having a tendency of damaging the business of the defendant, and as a result were successful in having this practice declared in contempt of court and collected damages from the corporation.

**R. C. A. After Small Manufacturers**  
An apparently aggressive policy has been adopted by the Radio Corporation against the small manufacturer in bringing a number of suits, among which is that against A. H. Grebe and J. H. Bunnell & Company under the DeForest patents 841,387 and 879,532 in the Federal Court for the Southern District of New York to prevent Grebe as manufacturer and Bunnell as distributor

(Continued on page 8)

## WLW Seeks Lost Dogs, Relatives and Flyers

### Even Fraternity Uses Airphone to Locate Missing Members

CINCINNATI, O.—Broadcasting stations are called upon to aid in all kinds of searches. Requests upon station WLW, have been most varied in their demands. For example, Colonel Graham Seton Hutchison, delegate from England to the Associated Advertising Clubs of the World convention at Atlantic City, was wanted by the Cincinnati Chamber of Commerce and, as he was flying around in an airplane from city to city on a speaking tour, it was difficult to locate him. The committee then sent a message to him via WLW and contact with him was finally made.

Search for members of the Chi Sigma Chi fraternity was made by Radio and everyone belonging to this fraternity was asked from WLW to send their names to the station. The great number of responses

## AN EVENING AT HOME WITH THE LISTENER IN (SEE NOTE BELOW FOR INSTRUCTIONS)

Station and City	Met.	Monday	Tuesday	Wednesday	Thursday	Friday	Saturday	Sunday
CFA, Toronto, Ont.	400	6:00-7:00	6:00-7:00	6:00-7:00	6:00-7:00	6:00-7:00	6:00-7:00	5:45-6:45
CFCN, Calgary, Alta.	440	10:00-11:00				11:30-1:30		11:00-1:00
CKAC, Montreal, Que.	430		6:00-9:00		6:00-9:00		6:00-9:00	3:00-4:30
KDKA, E. Pittsburgh, Pa.	360	5:00-9:00	5:00-9:00	5:00-9:00	5:00-9:00	5:00-9:00	5:00-9:00	6:30-7:30
KFAF, Denver, Colo.	360	9:00-10:00	9:00-10:00		9:00-10:00	9:00-10:00	9:00-10:00	
KFDB, San Francisco, Calif.	509	10:00-12:00		10:00-12:00		10:00-12:00		9:00-9:30
KFI, Los Angeles, Calif.	469	9:00-1:00	9:00-1:00	9:00-1:00	9:00-1:00	9:00-1:00	9:00-1:00	10:00-1:00
KGW, Portland, Ore.	492	10:00-2:00		10:00-11:00		9:00-2:00		9:00-10:00
KHJ, Los Angeles, Calif.	395	8:45-12:00	8:45-12:00	8:45-12:00	8:45-12:00	8:45-12:00	8:45-12:00	10:00-12:00
KPO, San Francisco, Calif.	423		10:00-12:00		10:00-12:00			
KSD, St. Louis, Mo.	546	8:00-12:30		8:00-10:00		8:00-12:30	10:00-12:00	
KYW, Chicago, Ill.	345		7:00-9:00	7:00-9:00	7:00-9:00	7:00-9:00	7:00-9:00	6:00-7:00
NAA, Radio, Va.	435	5:45-7:30		6:05-7:20	6:25-8:40	5:45-7:40	7:00-7:40	
PWX, Havana, Cuba	400			8:00-10:30				
WBAP, Fort Worth, Texas	476	9:30-10:30	9:30-10:30	9:30-10:30	9:30-10:30	9:30-10:30	7:00-7:20	3:30-4:30
WBZ, Springfield, Mass.	337	6:30-8:00	6:30-8:00	6:30-8:00	6:30-8:00	6:30-8:00	6:30-8:00	7:00-8:00
WCA, Detroit, Mich.	517	7:00-10:00	7:00-12:00	7:00-10:00	7:00-10:00	7:00-10:00		4:00-5:00
WDAF, Kansas City, Mo.	411	6:00-1:00	6:00-1:00	6:00-1:00	6:00-1:00	6:00-1:00	6:00-1:00	11:45-1:00
WDAJ, College Park, Ga.	360	7:30-11:30	7:30-11:30	10:30-11:30	7:30-11:30	7:30-11:30	7:30-11:30	7:30-11:30
WDAF, Chicago, Ill.	390		10:00-2:00		10:00-2:00		10:00-2:00	9:00-12:00
WDAK, Philadelphia, Pa.	395	5:30-9:00	5:30-6:00	5:30-9:00	5:30-6:00	6:00-1:00	5:30-6:00	
WEAF, New York, N. Y.	492	5:30-8:00	5:30-6:00	5:30-8:00	5:30-6:00	5:30-6:00	5:30-6:00	
WFAA, Dallas, Tex.	476	8:30-9:30	8:30-12:00	8:30-9:30	8:30-12:00	8:30-9:30	8:30-12:00	9:30-10:30
WFI, Philadelphia, Pa.	395	4:30-5:00	4:30-5:00	4:30-5:00	4:30-5:00	6:30-8:30	7:00-10:00	5:30-6:30
WGI, Medford, Mass.	360		7:30-9:00	5:45-7:30	8:30-10:00	8:30-10:00	7:30-9:00	8:30-10:00
WGM, Atlanta, Ga.	429	9:30-10:30	9:30-10:30	12:00-1:00	9:30-10:30	9:30-10:30	9:30-10:30	7:30-8:00
WGR, Buffalo, N. Y.	319	6:00-8:00		6:00-8:00		6:00-8:00		
WGY, Schenectady, N. Y.	380	6:45-9:00	6:45-9:00		6:45-9:00	6:45-11:00	7:00-8:00	6:30-7:30
WHA, Madison, Wis.	360	7:00-9:00	7:00-8:00	7:00-8:00	7:00-9:00	7:00-8:00	7:00-8:00	7:00-8:45
WHAS, Louisville, Ky.	400		7:30-9:00	7:30-9:00	7:30-9:00	7:30-9:00	7:30-9:00	
WHAZ, Troy, N. Y.	380	8:00-9:30						
WHB, Kansas City, Mo.	411		8:00-10:00		8:00-10:00			8:00-10:00
WHK, Cleveland, O.	360	5:00-5:30	5:00-5:30	7:00-8:45	5:00-5:30	5:00-5:30	5:00-5:30	7:00-8:00
WIP, Philadelphia, Pa.	509	4:00-5:30	5:00-10:00	5:00-5:30	5:00-5:30	5:00-5:30	8:10-10:00	
WJAX, Cleveland, O.	390		6:30-8:30		7:15-9:30			
WJY, New York, N. Y.	405		5:30-9:30		5:30-9:30	5:30-9:30		
WJM, Atlanta, Ga.	455	5:30-9:30	5:30-9:30	5:30-9:30	5:30-9:30	5:30-9:30	5:30-9:30	6:30-8:30
WKAQ, San Juan, P. R.	360		6:30-8:00		6:30-9:30	5:30-9:30	5:30-9:30	6:30-8:30
WLAG, Minneapolis, Minn.	417	6:30-10:30	6:30-10:30		6:30-10:30	6:30-10:30	6:30-10:30	7:30-8:30
WLW, Cincinnati, O.	309	7:00-9:00	9:00-11:00	7:00-9:00	7:00-10:00	7:00-10:00	7:00-10:00	7:30-8:30
WMAO, Chicago, Ill.	448		7:00-10:00		7:00-10:00			
WMC, Memphis, Tenn.	500	8:00-9:30	8:00-12:00		8:00-9:30	8:00-12:00	8:00-9:30	
WOAI, San Antonio, Texas	400		9:30-10:30		7:30-8:30			9:30-10:30
WOAW, Omaha, Neb.	526	9:00-10:00	9:00-10:00		9:00-10:00	9:00-10:00	9:00-10:00	9:00-10:00
WOC, Davenport, Ia.	484	7:00-8:30		10:00-11:00	7:00-8:30	7:00-8:30	9:30-10:30	7:00-9:00
WOO, Philadelphia, Pa.	509	6:00-9:00				6:00-9:00		
WOR, Newark, N. J.	405	7:00-10:00	5:15-6:30	7:00-10:00	5:15-6:30	5:15-6:30	7:00-10:00	
WOS, Jefferson City, Mo.	441	8:00-9:30		8:00-9:30		8:00-9:30		
WSAI, Cincinnati, O.	309		7:00-9:00		7:00-9:00		9:00-11:00	
WSB, Atlanta, Ga.	429	10:45-12:00	10:45-12:00	10:45-12:00	10:45-12:00	10:45-12:00	10:45-12:00	7:30-9:00
WSY, Birmingham, Ala.	360	8:00-8:45		8:00-8:45		8:00-8:45		7:30-8:30
WV, Detroit, Mich.	517	6:00-7:30	6:00-7:30	6:00-7:30	6:00-7:30	6:00-7:30		

Instructions for Use.—All the hours above are given in Central Standard Time. If your city uses Eastern Time, add one hour to each of the periods stated; if your city uses Mountain Time, subtract one hour; if your city uses Pacific Time, subtract two hours. If in addition your city is using Daylight Saving Time, add one hour to this result.

received from widely separated points in the U. S. showed that many of the members of this fraternity were owners of Radio receiving sets.

An alarm clock has been invented by a Frenchman which responds to a certain Radio wave length sent out by the Eiffel tower station.

### RADIO SPECIALS

- 3 Plate Vernier Condenser.....\$0.40
  - 13 Plate Variable Condenser......85
  - 23 Plate Variable Condenser..... 1.10
  - 43 Plate Variable Condenser..... 1.55
  - 2200 Ohm Phones, Guaranteed..... 2.95
  - 3000 Ohm Phones, Guaranteed..... 3.25
- Include Postage. Send Stamp for Complete List.  
ECONOMY RADIO CO., 132 Nassau St., N. Y. C.

## Calls on Radio to Add to Benefit of Churches

COLUMBUS, OHIO.—Believing that the Columbus Federation of Churches can be of greater general benefit than has been before possible, Rev. Walter A. King, executive secretary, has arranged with the Erner & Hopkins Company to broadcast weekly services over Station WBAV.

The services will be interdenominational and will be provided with the view of reaching many shut-ins who are often unable to attend the regular church services. Various religious leaders of Columbus will provide the programs.



**TULIP LOUD SPEAKER**  
The Horn Beautiful!

24" Complete .....\$18.00  
20" Complete ..... 16.50  
24" Without Unit..... 12.00  
20" Without Unit..... 10.50

Dealers Write for Discounts

**CONRAD MARX**  
23 Judge St., Brooklyn, N.Y.

Western Distributor,  
**FORBES RADIO CO.**  
127 N. Dearborn St., Chicago, Ill.

### Amrad Two Stage Amplifier

- Complete in mahogany cabinet. Wonder-ful buy. \$40.00 value. Limited quantity. **\$17.95**
- List Price Our Price
- \$25.00 Amrad Portable Set.....\$22.75
  - 40.00 Amrad Reflex Set No. 3366. Complete in mahogany cabinet..... 34.98
  - 20.00 CROSLLEY V. ONE TUBE SET..... 17.95
  - 42.25 Eria Reflex Circuit. Complete parts to build this set, including diagram. 27.95
  - 2.00 Filkostat..... 1.80
  - 1.00 25 Ohm Rheostat..... .65
  - .50 2" Dial..... .19
  - .50 Fada Switch Lever..... .18
  - 25.00 DX Crystal Set, complete with Phones, ready to "listen in." Bargain..... 8.95
  - 2.00 Gold Grain Detector (Panel Mtg.)..... .89
  - 2.50 Gold Grain Detector (Base Mtg.)..... 1.39
  - 1.00 Variable Grid Leak (0-5)..... .38
  - 2.50 11 Plate Variable Condenser..... 1.16
  - 3.50 23 Plate Variable Condenser..... 1.29
  - 5.00 43 Plate Variable Condenser..... 1.68
  - .25 Spaghetli, 3 ft. (any color)..... .08
  - 1.00 Rheostat..... .45
  - 11.50 U. S. NAVY TUBE..... 4.95
  - 6.50 Turney Spider Web Coils and Mtg..... 3.95
  - 3.00 Brach Lightning Arrestor..... 1.65
  - 1.25 Univermier with Dial (Splithair adj.) 1.08
  - 3.50 Lefax Radio Handbook..... 2.93
  - 12.00 NATHANIEL BALDWIN PHONES (MICA DIAPHRAGM)..... 8.35
  - 6.50 WD-II TUBES..... 5.45
- Everything guaranteed as firsts. Send for Special Price List. We pay the postage.
- RADIO SUPPLY STORES**  
254 West Stiegel Street, Mannheim, Pa.



# Nature

has given us many things to admire and use. But it requires "man made" devices to manifest the greatest wonders. For instance, RADIO.

In the Service Radio receiving set beauty and utility are exemplified in their highest form.

It adds beauty to your home and enjoyment through its loud, clear reception of distant music, speeches, etc.

The story of SERVICE RADIO will be told serially in this publication—or, if you prefer the entire story, write us for booklet, "The Story of Service."

## SERVICE RADIO SETS

are simplest to operate. They are made by a new concern composed of engineers and executives who have been connected with the most progressive producers.

DEALERS: Write for prices, terms and territory. Dealers' names will be published in our advertising.

"This is a TELEFORCE Product."

## SERVICE RADIO COMPANY

4727 Montgomery Road  
NORWOOD, OHIO

## The New Grebe Broadcast Receiver



**Point No. 2** A FOUR-TUBE RECEIVER in which you may use all kinds of tubes—in any desired combination. No storage battery unless you desire it. Just One of its Seven Points of Satisfaction

Licensed under Armstrong U.S. Pat. No. 1,113,149

Ask Your Dealer

A. H. GREBE & CO., Inc.  
Richmond Hill, N. Y.

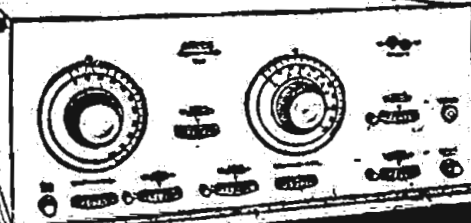



# "BACK STAGE" AT THE STATIONS



The photo at the left is that of Raymond Guy, well known to Radiophans as the "Jazz Announcer" of WJY, New York. In the center is the first feminine broadcast announcer of Washington, D. C.; Ruth Lukens, Station WIAY. Miss Lukens announces all the daytime numbers for the big department store station of Woodward and Lothrop. All kinds of things are sent out by WIAY, including music, baseball reports, bedtime stories and weather reports. Charles O. Fisher, in charge of the plant, says that it is very difficult to get a good ladies' voice for announcing, but Miss Lukens, he explains, is doing remarkably well. Walter C. Evans, right, chief engineer of KYW, Chicago, is the young man who keeps this equipment 100 per cent efficient. Evans grew up with head phones on his ears. Perhaps this is responsible for his creditable record in the Radio industry. Left Photo © K. & H.

## MUSSOLINI ACTS TO PRY OFF RADIO LID

### ITALY MAY SOON BEGIN BROADCASTING

Italian Fans Will Have to Pay Tax, Fixed by Wave Length of Sets

ROME.—The question of inaugurating a broadcasting service in Italy has been seriously discussed for the last year, but there was little hope of obtaining permission from the government for such a service until the matter recently was brought to the attention of the Premier himself, who promised to do his utmost to simplify the bureaucratic difficulties which had always surrounded any proposition regarding Radio.

The matter was placed in the hands of governmental experts, and they have devoted much time to outlining a program which, frankly, is not exactly what Italian Radio experts had hoped, but one must be satisfied that at least broadcasting has become a possibility and the wall of opposition which thwarted every Radio plan has been demolished by the Fascisti government. One company has agreed to pay a certain tax to the government in return for the permission of starting a broadcasting service throughout Italy.

#### Fans Must Pay Rent

This company is allowed to charge a certain amount to all subscribers, but unfortunately Radiophans and amateur inventors are not numerous throughout Italy at present. Heretofore they have not been encouraged, in fact, heavy fines have been imposed if private installations were placed on roofs or terraces of private dwellings.

It is hoped that with the broadcasting service Radiophans will increase in number, otherwise the project will be doomed to failure. The concession will be given to the Italian Marconi Wireless Company. They must undertake, according to the conditions laid down by the government, to supply a broadcasting service of news, concerts, etc., on a wave length which will vary from 200 to 400 meters.

## 1,100 Miles Covered with Only Ten Watts of Power

MARION, KANS.—Some unusual results have been accomplished by Station WRAD, a ten-watt broadcasting plant owned and operated by the Taylor Radio Shop, this city. Reports recently received from this station indicate that it has been heard in thirteen states and different points in Canada as far as Rokeby, Sask.

This record is unusual for a ten-watt Radiophone station, inasmuch as the service is regular and the distances covered constant.

As an example of the enormous amplification in Radio transmission from the minute variations in current in the microphone into which the speaker talks, to the amount radiated by a large broadcasting station. If a man's power could be amplified in the same proportion, he could move at one time 400 times the amount of freight handled on all the railroads of this country in a year.

## SUMMER PHOTOGRAPHS? EARN A DOLLAR—

SUMMERTIME means summer pictures. You and your camera can earn a dollar by sending the Digest out-of-doors photos involving the use of Radio in camp, the automobile, swimming, boating, canoeing, on the hike, playing golf, etc. Send such photographs with negatives and a few descriptive words, including a stamped, addressed envelope so that unsuitable pictures may be returned.

SUMMER PHOTO DEPARTMENT, Radio Digest, 123 Madison St., Chicago.

## Plane at Buffalo "Picks Up" Omaha

Flyer Hears Music 1,000 Miles Despite Storm—Use Aerial Length of Plane

BUFFALO, N. Y.—Radio receiving in an airplane was successfully demonstrated in the air over Buffalo recently by H. H. Howell, of the Howell Electric Company, of Buffalo and L. L. Irvine, former American ace and inventor of the Irvine plane shuttle.

The day of the demonstration was an extremely windy and stormy one. In spite of this fact, a concert was successfully received from Station WOAW, the broadcasting station of the Woodmen of the World, in Omaha, Nebraska, a distance of 1,000 miles. The program of the orchestra of the Rialto Theater, in Omaha, was received. Mr. Howell said the strong wind shifted the machine, cutting them out occasionally, but had it been a better day, there is not a doubt but what the entire program would have been received without the least break in the smoothness, as received on the ground.

The airplane was equipped with an antenna following the length of the plane and the frame of the machine for the ground.

## Mexico Spends \$200,000 to Lengthen Plant Ranges

MEXICO CITY.—The Mexican Government intends to change the apparatus used in its Radio stations from spark to continuous wave. With the present spark sets, it is reported that the Mexican stations can communicate only with two European stations; one, POZ, at Nauen, Germany and the other, Lafayette at Bordeaux, France. Equipment for four modern transmission stations of continuous-wave type have been ordered from Germany at a cost of \$200,000. They will be installed at Mexico City, Merida, Vera Cruz and Tampico. The old spark stations will be transferred to the Islas Marias; LaPaz, Lower California, Guadalajara, Jalisco and Acapulco, Guerro.

## Leviathan Sets Three Sea Airwave Records

Operators Received and Sent 75,000 Words on Trial Trip

NEW YORK.—In addition to making world speed records during the trial trip, the Leviathan established three marine Radio records for volume of traffic, range of transmission and reception and for operation of duplex telegraph and telephone system. The Radio operators received and transmitted an estimated total of 75,000 words, or 15,000 a day, the greater volume press dispatches.

From the first night out of Boston the Radio office was swamped with personal, official and press messages. E. N. Pickerill, chief Radio officer, and John R. Irwin, Anthony Tamburino and R. J. Green, operators, worked in four-hour shifts at the keys. In the tropical waters, where the static interfered the most and messages were heard indistinctly on land, three stations were directed to listen in. With more than a hundred correspondents on board, the passengers, among them some of the leading business and financial men of the country, yielded to the press on the question of order of dispatch.

Because of the pressure of business no effort was made on the trial trip to test the Radiophone equipment of the Leviathan. Mr. Pickerill had agreed to call up his wife in New York during the trip but had to give up the plan until the maiden voyage to Europe.

## WHO'S WHO IN RADIO INSPECTION SERVICE

Officers Listed to Guard Amateurs Against Fake Representatives

WASHINGTON.—Every amateur and broadcaster should know the officials of the Radio Section of the Department of Commerce in his district, so that he can get advice, keep in touch with new regulations and not be imposed upon by bogus representatives.

At headquarters in Washington, Chief Supervisor of Radio, W. D. Terrell is in charge under Secretary Hoover and Commissioner Carson. Mr. Terrell is assisted by W. E. Downey, Supervisor of Radio. In the nine districts with headquarters as shown, the following men are in charge:

District	Headquarters	Supervisor of Radio
1st	Boston	C. C. Kolster
2nd	New York	Arthur Batcheller
3d	Baltimore	R. Y. Cadmus
4th	Atlanta	R. Y. Cadmus
5th	New Orleans	Theodore G. Deiler
6th	San Francisco	J. F. Dillon
7th	Seattle	O. R. Redfern
8th	Detroit	S. W. Edwards
9th	Chicago	E. A. Beane

When there is more than one tuned circuit, each circuit must be equally tuned to secure resonance.

The ship doctor is having his troubles because of Radio. Not only has he the sick on his own vessel to care for, but he now receives many calls from ships which carry no doctor and send Radios for information.

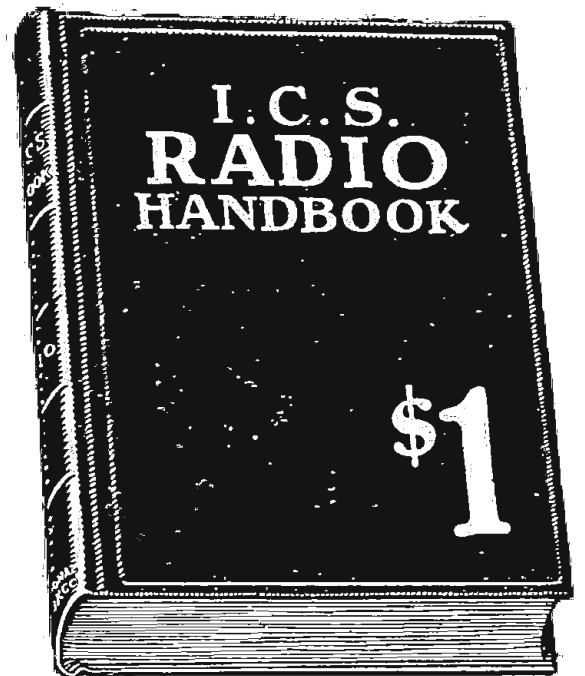

## At last! A practical authoritative book on RADIO

562 pages. Price only \$1.

Compiled by HARRY F. DART, B.S.E.E. Formerly with the Western Electric Co., and U. S. Army Instructor of Radio Technically edited by F. H. DOANE

THE most complete book of its kind ever published. Written, compiled and edited by practical radio experts of national reputation. Packed with concise, sound information useful to every radio fan—from beginner to veteran hard-boiled owl. Hundreds of illustrations and diagrams to make every point clear. Note this partial list of contents:

Different types of receiving and sending hook-ups, electrical terms, condensers, oscillating circuits, coupled circuits, induction coils, antenna systems, electric batteries, generators and motors, protective devices, crystal detectors, arc generators, transmitters, filters, wavemeters, radio experiments, International and Morse codes, commercial receiving sets, tables and data, radio transmitting and broadcasting stations (with call letters), Radio License Regulations, etc.

Send \$1 to-day and get this 562-page I. C. S. Radio Handbook before you spend another cent on parts. Money back if not satisfied.

INTERNATIONAL CORRESPONDENCE SCHOOLS  
Box 8278, Scranton, Penna.

I enclose One Dollar. Please send me—post-paid—the 562-page I. C. S. Radio Handbook. It is understood that if I am not entirely satisfied I may return this book within five days and you will refund my money.

Name.....  
Address.....

# STORM PUTS WIRES OUT—RADIO TO AID

## CYCLONE DISABLES TELEGRAPH IN ONTARIO

### All Land Lines Broken Down in Storm—Election Returns Made Despite Fact

By Albert H. Munday

TORONTO, ONT.—A striking instance of how Radio served a multitude of people when all other methods failed was evidenced recently when Station CFCA received and broadcasted election results of the Ontario provincial elections and in so doing recorded a scientific achievement. Not only did the presentation of results turn out as planned days in advance, but an unforeseen event which it seemed would prove a tragedy became a triumph for Radio.

For when a cyclone struck the province just as results were being received, killing two men, injuring five and causing a loss to property of well over a million dollars as well as isolating many of the leading towns, Station CFCA which had been broadcasting, brought its equipment into action to receive, in order to get via Radio the election returns from those sections of the country to which communication by wire had been destroyed. The wires were down throughout the Niagara peninsula and the western parts of Ontario. And in Toronto, in the East, and even in the isolated West, thousands of electors waited for the news. In telegraph rooms the instruments suddenly ceased and in telephone cabinets operators patiently waited at dead sets. Yet the storm's work had been ruthless and it seemed that it would be hours before the necessary communications would be established.

#### Announcer Asks for Complete Results

But in the silence of the CFCA's Radio studio the problem was being solved. The announcer stood by the microphone. He held a list of the ridings from which no returns had been received. He stood unspoken for a moment until the operator threw the current on, and then in slow and deliberate phrases he began:

"CFCA, the Radio station of the Toronto Star of Toronto, Canada, is making a request to all those listening in, particularly those in the vicinity of Hamilton and in the southwest part of the province, for results from constituencies that are either missing in whole or in large parts. The telephone wires have been blown to the ground and the only way to get the results is by the Radio."

In less than ten minutes a telephone message was received and the first returns were given by a young fan who had heard of results in one of the stricken districts. After a few minutes other reports were received. The broadcast of the election results proved to be one of the most efficient and quickest methods ever used in Canada.

## CUNNINGHAM TUBES REPAIRED

C-300 or UV-200.....	\$2.75
C-301 or UV201.....	3.00
C-302 or UV-202.....	3.50
C-301A or UV201A.....	3.50
WD-11 or WD-12.....	3.50
Moorehead Detectors.....	2.75
Moorehead Amplifiers.....	3.00
DV-6 or DV-6A.....	3.00
Also the new UV-199.....	3.50
NEW DX 1 1/2 VOLT TUBES.....	4.00

All tubes guaranteed to work like new. Mail Orders Given Prompt Attention "24 Hour Service" **RADIO TUBE CORP.** 55 Halsey Street Newark, N. J. TUBES SENT PARCEL PDST, C. D. D.

# FLEWELLING ANSWERS TO QUERIES

By E. T. Flewelling

(Editor's Note.—This department is written by Mr. Flewelling, the inventor of the famous super circuit. From the questions sent him each week care of Radio Digest, he picks the one considered most informative for all and answers it in this column.)

#### So-Called Flewelling Variations

(Submitted by F. S. W., Melrose, Mass.)

Question. I have built a Flewelling receiver and after working with it for some time I believe that I have improved upon the original circuit through the particular arrangement of the parts and the wiring. So far as I can see, the wiring diagram is the same as that published, yet if I change a single part I am afraid that I will lose the effects that I am securing such as Philadelphia, Troy and New York City without any antenna or ground. Can you explain why I am securing such wonderful results?

Answer. For approximately eight months the writer has been endeavoring to tell the public that the Flewelling circuit is not only capable of such results as you are securing but even better. A little comparison might help you to understand why this would be so. Take the case of a plain regenerative receiver. Although there are probably not more than a thousand makes of this type manufactured today that are working at the highest point of efficiency, yet any of them which are worthy of the name that they carry will bring in a powerful broadcast station, say 30 miles away without any antenna, and only a ground connection. Again, you will be able to pick them up on a small loop without any outside connection whatever. This distance of course varies with conditions. It is sometimes more or less, but if a plain receiver will do this (and I have seen them do it up to 50 miles away) what may we expect from a super-regenerative receiver? It makes no difference how super-regeneration (so-called) is accomplished, if we can improve on the plain regenerator, we most certainly have a mighty sensitive receiver. The Flewelling receiver stands as an entirely unique method of securing regeneration plus and you need have no fear that you will move about any part of your receiver. Not only should you secure the reception that you speak about but under favorable conditions you should do much better.

That you may know what to expect when your receiver is properly handled, etc., let me say that the powerful stations in Chicago may be received in your location any night in the week on the ground alone. This has been done over the period extending from November until March, during which time the writer was a resident of your neighboring town. Quite often you will get the Chicago stations, or others, without any ground or antenna and you may carry the set along the street while you are doing it as others have done before you.

A very interesting thing for those who care to experiment is to rewind the coils on their receiver (or preferably, use another set of coils) and try to bring in the 100 meter broadcasting that is being done. Roughly, theory tells us that the super-regenerative circuit, amplifying the shorter waves better than the longer, does so inversely as the square of the wave length, which means that the 100 meter stations would come in just so much easier. Practically, however, we find that the am-

plification is even greater than this, so you can see that there would be a decided advantage in bringing in these stations.

Let me, however, congratulate you upon the results that you have already received.

## Free Competition Now Inaugurated in Sweden

### Government to Erect Broadcasting Stations for Radio Company

WASHINGTON, D. C.—The proposed Swedish law for regulating Radiophony in that country recognizes the principle of free competition, with regard to the manufacture of Radio apparatus. It will permit amateurs to build their own sets, requiring only that these shall be constructed in accordance with certain regulations. The Telegraph Department does not contemplate limiting within narrow margins the wave lengths on which amateurs may receive.

In accordance with the proposed law the government is to erect the broadcasting stations and rent them to the Radio Telephony Company, which in turn will receive a rental from receiving stations.

## SPECIAL SUMMER OFFER!

### Type 400 MELCO RECEIVER

at

Distributors' Price of Only \$17.50

Regular List Price \$35. Two-stage amplifying unit for use with the Melco-400, also regularly costing \$35, now only \$17.50.

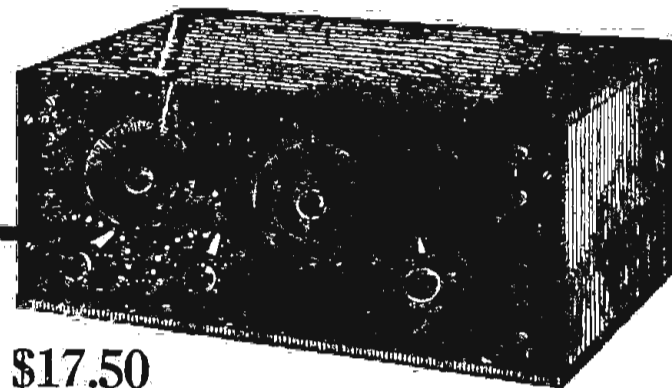

\$17.50

The Melco Type 400 Radio Receiver covers all broadcasting ranges thoroughly from 165 to 600 meters and assures a great degree of selectivity on the average small outdoor aerial. The Melco is the ideal summer set because it is least affected by electrical disturbances. Sold with our absolute money-back guarantee.

Shipped immediately on receipt of purchase price — F. O. B. N. Y.

Write for Descriptive Booklet **AMSCO PRODUCTS, Inc.**

Fairbanks Building

Broome & Lafayette St.

New York City

### DON'T PASS THIS—BUY



World Radio Batteries SAVE YOU 50% WRITTEN 2-YR. GUAR.

SPECIAL 2-Volt Storage Battery for WD-11 and WD-12 Tubes. Will give \$5 200 HOURS on single charge....

#### World-Radio-Batteries

Are unconditionally guaranteed

Because you deal direct with a manufacturer who is responsible for the performance and quality of the Battery.

6 Volts—60 Amps.,	6 Volts—100 Amps.,
\$10.00	\$14.50
6 Volts—80 Amps.,	6 Volts—120 Amps.,
\$12.50	\$16.00

Full Rating Guaranteed

MAIL YOUR ORDER TODAY. WE SHIP EXPRESS C. D. D. SUBJECT TO INSPECTION, OR WILL ALLOW 5% FOR CASH WITH ORDER. ALL ORDERS SHIPPED SAME DAY AS RECEIVED.

**WORLD BATTERY COMPANY,** 60 E. Roosevelt Rd., Dept. L, Chicago, Ill.



Make Your Set The Sensation of Your Town! with

## The RADIOXOR

Simple — Inexpensive — Certain

Can be attached to any set, operating head phones or loud speaker—crystal or Vacuum Tubes—Loop, Plug or Outdoor Aerial.

Send your name, address and type of set on a postcard for details.

Selling like wildfire, so act promptly. Orders filled in order of receipt.

**WILLART SALES COMPANY** World's Tower Bldg. 110 W. 40th St. New York City

# The New Grebe Broadcast Receiver

Point No. 3 The two chief factors of modern radio—Regeneration and Tuned Radio Frequency Amplification—find their first successful combination in this Receiver. Just One of its Seven Points of Satisfaction

Licensed under Armstrong U. S. Pat. No. 1,113,149

Ask Your Dealer

**A. H. GREBE & CO., Inc.** Richmond Hill, N. Y.



## PERFECTION

MAKE PERFECTION YOUR SELECTION

We Carry Only STANDARD Advertised Radio Equipment. Every Product Sold on a MONEY BACK GUARANTEE.

ACME PHONES Has no peer for receiving clear. List \$8.00. Our price.....	\$3.75
RHEOSTATS Cutter Hammer..... With Vernier.....	\$0.85 1.25
C. H. Potentiometer..... Klossner Vernier..... 2 Mica Diaphragms.....	1.25 1.20 1.25
NEUTRODYNE Complete parts for 3 tube Neutrodyne set. \$30.00. Complete parts for 4 tube Neutrodyne set, \$35.00.	
Nathaniel BALDWIN Phones—Genuine SINGLES AND CORD..... DOUBLES, CORD AND BANO.....	\$4.45 8.75
FLEWELLING CIRCUIT Complete parts, including Panel, Double Coil Mounting and 2 Honeycomb Coils. Mounted. ONLY Standard Equipment Used. Free Diagram.....	\$13.95
REINARTZ CIRCUIT Complete parts for this remarkable ablo set. Free Diagram.....	\$11.95
All American Transformers..... Eria Reflex..... Thordarson..... Westinghouse \$25.00 Aerola Jr. Set, without phones..... \$3.00 Brach outdoor arresters..... \$28.00 Tungar 5 amp.....	\$3.95 4.50 3.45 6.95 1.95 22.50
QUEEN'S VARIOCOUPERS OR VARIOMETERS.....	\$2.50

Perfection Radio Corporation, 59 Cortland St., New York City  
SIX NEW YORK RETAIL STORES—ADD PARCEL POST—DD NOT SEND STAMPS



# The Week's Advance Broadcast Programs

## Tuesday, July 10

**CFCA** (Eastern, Daylight Saving, 400), 8:00-9:00 P. M., Musical program, "Melodique," Star Orchestra; "The Dwarf," Arthur Fisher, baritone; "In the Garden of My Heart," W. Woods, cornetist; "España," Orchestra; "Jogging Along the Highway," Arthur Fisher; "Maytime," Orchestra; "Until the Dawn," W. Woods; Arthur Fisher, baritone; "Berceuse," "Prelude," Orchestra.

**KDKA** (Eastern, 326), 5:15 P. M., Dinner concert, Grand Symphony Orchestra; 6:30 P. M., Address; 6:45 P. M., Visit to the Little Folks, Dreamtime Lady; 7:20 P. M., Concert, King Hall Entertainers; Musical program, Mixed quartet, numbers, "Moonlight," "Fang," "The Miller's Wooing," "Fanning," "One Fleeting Hour," "Lee," "Good Evening"; Baritone solo, "On the Road to Mandalay"; Tenor solo, "Dear Heart"; Contralto solo, "Until"; Violin solos.

**KHJ** (Pacific, 395), 12:30-1:15 P. M., Concert, Mrs. R. E. Oliver, soprano, Ingrid Wicks, violinist; Ruby Wicks, pianist; Ruth Dougherty, whistler; 2:30-3:30 P. M., Musical program, featuring Mrs. R. E. Oliver, Ingrid Wicks, Ruby Wicks and Ruth Dougherty; 8:00-10:00 P. M., Christian Timmer and artist pupils.

**KSD** (Central, 546), 8:00 P. M., Concert, Grand Central Theater talent.

**KYW** (Central, Daylight Saving, 345), 1:35-2:00 P. M., Concert, furnished by Lyon & Healy Company; 5:50 P. M., Children's bedtime story; 7:00-7:58 P. M., Musical program, Cope Harvey's Orchestra; June Wilson Thrall, soprano; Martin Nelson, tenor; Lucille O'Brien, soprano; Hilda B. Farr, pianist.

**WBAP** (Central, 476), 9:30-10:45 P. M., Concert, Fred Ashoon and his Texas Hotel Orchestra.

**WBZ** (Eastern, 337), 7:30 P. M., Concert, W. H. Warner, bass; Grace Bosworth Clarke, contralto; Priscilla Paradis, violinist; 8:45 P. M., Bedtime story for grown-ups, Orison S. Marden.

**WDAF** (Eastern, Daylight Saving, 395), 12:00-12:54 P. M., Organ recital, Stanley Theatre; Dinner music, Arcadia Cafe Concert Orchestra; 2:00-3:00 P. M., Song recital; 4:30-5:55 P. M., Short talks; Talk on "Affairs of the Heart," Betsy Logan; 7:30-8:00 P. M., Bedtime stories, Dream Daddy.

**WDT** (Eastern, Daylight Saving, 405), 12:00-12:50 P. M., Daily message, Vaughn De Leath; "Page Padewski," Pete Wendling, pianist; "Bonnie," Hugo Frey, singer; "Dirty Hands," Dirty Face, Frank Marlin, singer; "Parantella," Joe Meyer, violinist; Songs, Robert H. Bowers; "Now That I Need You, You're Gone," "Magdel Yes, Ma'am!" Frank Marlin, singer.

**WFAA** (Central, 476), 12:30-1:00 P. M., Address, De Witt McMurray; 8:30-9:30 P. M., Recital, Belcanto Quartet; 11:00-12:00 P. M., Recital, W. A. Green Company.

**WFI** (Eastern, Daylight Saving, 395), 1:00 P. M., Dinner music, Meyer Davis, Bellevue Stratford Orchestra; 3:00 P. M., Concert, 3:45 P. M., Recital; 6:30 P. M., Meyer Davis Bellevue Stratford Orchestra; 7:00 P. M., Children's Own Half Hour, Cousin Sue; 8:00 P. M., Boy Scouts Radio Corps; 8:30 P. M., Musical program; 10:30 P. M., Dance music, Meyer Davis Bellevue Stratford Orchestra.

**WGY** (Eastern, 380), 1:00 P. M., Music and address, "The Women of One Hundred Years Ago," Mrs. C. A. Dingman; 7:45 P. M., Musical program, "Polonaise in A Flat," Elsie Waite, pianist; "Before You Came," "Starlight," Edward E. St. Louis, baritone; "Dawn," "The Bird with the Broken Wing," "O Heart, My Heart," "Pearl Adams, soprano; One-Act Playlet, "A Wall Street Romance"; "All for You," "Love Among the Roses," Edward E. St. Louis; "Rhapsody in G Minor," Ellen Vaita.

**WHAS** (Central, 400), 4:00-5:00 P. M., Concert, Mary Anderson Theater Orchestra; 7:30-9:00 P. M., Musical program, Mary Anderson Theater Orchestra; Claudine Yates, violinist; Hazel McClellan, soprano; Zither quartet, Louis Wegert, Herman P. Wegert; Mary Belle Bennett, reader.

**WIP** (Eastern, Daylight Saving, 509), 1:00-2:00 P. M., Organ recital, Karl Bonawitz, Germantown Theatre; 3:00-4:00 P. M., Artists' recital; 6:00-6:45 P. M., Dinner dance music; 7:00-7:30 P. M., Bedtime stories, Uncle Wip; 8:00 P. M., Short talks; Musical program; 10:10-12:00 P. M., dance music, Charlie Kerr's Cafe L'Algon Orchestra.

**WJAX** (Eastern, 390), 7:30 P. M., Concert, Cleveland News.

**WLW** (Eastern, 309), 10:00 P. M., Musical program, Peerless Dance Orchestra of Northern Kentucky; A. W. Vieve, baritone; "That Lullaby Croon," "I Want the Moon," Helen Hofer, soprano; Address, Powel Crosley, Jr.

**WMC** (Central, 500), 8:30 P. M., Program furnished by Lions Club; 11:00 P. M., Midnight Frolic.

**WOC** (Central, 484), 3:30 P. M., Educational talk; A. G. Hinrichs; 5:45 P. M., Chimes concert.

**WOO** (Eastern, Daylight Saving, 509), 11:00 A. M., Organ recital, Mary E. Vogt; 12:00-12:55 P. M., Luncheon music, Tea Room Orchestra; 4:45-5:00 P. M., Organ recital, Mary E. Vogt.

**WWJ** (Eastern, 517), 3:00 P. M., Concert, Schmenan's Band; 7:00 P. M., Concert, News Orchestra; The Town Crier; C. L. Hoot, bass; Mrs. Roy Smith, soprano; Hazel Taylor, pianist.

**KHJ** (Pacific, 395), 2:30-3:30 P. M., Matinee musicale; 6:45-7:30 P. M., Children's Hour; 8:00-10:00 P. M., Luxe Program.

**KSD** (Central, 546), 8:00 P. M., Concert, First Infantry Band.

**KYW** (Central, Daylight Saving, 345), 5:50 P. M., Children's bedtime story; 7:00-7:58 P. M., Musical program, courtesy Lyon & Healy; Cope Harvey's Orchestra; Wendell W. Hall, KXW's Music Maker.

**WBAP** (Central, 476), 9:30-10:45 P. M., Concert, Andrew Chapel, negro Methodist Church jubilee singers.

**WLW** (Eastern, 309), 8:00 P. M., Musical program, Zither duet, Ruth and Charles Hohe; Nau Ward, comedian; Guitar and mandolin selections, Al Zeff and sons; Lesson on swimming, Stanley Braunerger; Zither duo, Ruth and Charles Hohe; "I Love Life," "Fit for Fat," Mary Elizabeth Green, soprano; Guitar and mandolin selections, Al Zeff and sons; "Liszt Rhapsody, No. 9," Margaret Conway, pianist; "Concerto No. 9," Patricia and Margaret Conway, violinist and pianist; Mary Elizabeth Green, singer; "Heiro Kati," Patricia and Margaret Conway.

**KDKA** (Eastern, 326), 5:15 P. M., Dinner concert, Grand Symphony Orchestra; 6:45 P. M., Visit to the Little Folks, Dreamtime Lady; 7:00 P. M., "Macbeth," Rev. W. E. Kealy; 7:20 P. M., Concert, Esther Rose James, soprano, Adeline Ricketts Maud, reader, Joseph B. Fairman, violinist; Norman L. Rose, accompanist. Musical program, Soprano solo, "I Gathered a Rose," "Sing! Sing! Birds on the Wing," Nutting, "Angels Guard Thee," "Lullaby from 'Jocelyn,'" "Thou'rt Like a Lovely Flower," "Elogie," "Look Down, Dear Eyes," Reading selections.

**KHJ** (Pacific, 395), 2:30-3:30 P. M., Matinee musicale; 6:45-7:30 P. M., Children's Hour; 8:00-10:00 P. M., Concert, Gladys G. Hill, dramatic soprano.

**KYW** (Central, Daylight Saving, 345), 1:35-2:00 P. M., Concert, furnished by Lyon & Healy; 5:50 P. M., Children's bedtime story; 7:00-7:58 P. M., Musical program, courtesy of Salvation Army Staff Band; Cope Harvey's Orchestra; 8:00-8:25 P. M., "Twenty Minutes of Good Reading," Rev. C. J. Fernin, S. D., Head of Dept. of English, Loyola University.

**WBAP** (Central, 476), 9:30-10:45 P. M., Concert, Fort Worth artists.

**WBZ** (Eastern, 337), 7:30 P. M., Concert, Mme. Marguerite von Mizzi, contralto; Mrs. Alice P. Iluck, pianist; Ruth Dumond, soprano; N. J. Ferlole, tenor; Pauline Cebrell, pianist; 8:50 P. M., Bedtime story for grown-ups, Orison S. Marden.

**WDAF** (Eastern, Daylight Saving, 395), 12:00-12:54 P. M., Organ recital, Stanley Theatre; 2:00-3:00 P. M., Arcadia Cafe Concert Orchestra; 4:30-5:55 P. M., Talk, Betsy Logan; 7:30-8:00 P. M., Bedtime stories, Dream Daddy.

**WFAA** (Central, 476), 12:30-1:00 P. M., Address, "Why Be an American?" R. E. L. Sauer; 8:30-9:30 P. M., Hawaiian music, Grace and Edith MacDowell; 11:00-12:00 P. M., Musical program, under auspices of Bush & Gerts Piano Company of Texas.

**WFI** (Eastern, Daylight Saving, 395), 1:00 P. M., Dinner music, Meyer Davis Bellevue Stratford Orchestra; 3:00 P. M., Concert, Strawbridge and Clotier Male Quartet; 7:00 P. M., Children's Own Half Hour, Cousin Sue; 8:00 P. M., Musical program.

**WHAS** (Central, 400), 4:00-5:00 P. M., Concert, Mary Anderson Theater Orchestra; 7:30-9:00 P. M., Concert, Alvin Marcus and orchestra; Sunday School Lesson; Welfare talk, Mrs. Chas. B. Semple.

**WIP** (Eastern, Daylight Saving, 509), 1:00-2:00 P. M., Organ recital, Karl Bonawitz, Germantown Theatre; 3:00-4:30 P. M., Musical program; 7:00-7:30 P. M., Bedtime stories, Uncle Wip; 8:00-9:00 P. M., Musical program; 9:00-9:30 P. M., Organ recital, Karl Bonawitz.

**WJAX** (Eastern, 390), 8:00 P. M., Concert, Hotel Cleveland Orchestra.

**WLW** (Eastern, 309), 10:00 P. M., Musical program, Woody Dance Orchestra; Ed Decker, tenor; "When Song is Sweet," "Little Gray Home in the West," Elizabeth Jones, soprano; "At Dawning," "Calm as the Night," "Cincinnati Instrumental Trio; Comedy, "He Said and She Said"; "The Swan," "March Militaire," Trio; Woody Meyer's Dance Orchestra.

**WMC** (Central, 500), 8:30 P. M., Concert, Chisca Philharmonic Orchestra, Clara Ahern, director.

**WOC** (Central, 484), 3:30 P. M., Educational talk, Karl G. Stephan; 5:45 P. M., Chimes concert; 6:30 P. M., Sandman.

**WDO** (Eastern, Daylight Saving, 509), 1:00 P. M., Organ recital, Mary E. Vogt; 12:00-12:55 P. M., Luncheon music, Tea Room Orchestra; 4:45 P. M., Organ recital; 7:45 P. M., Dinner music, Hotel Adelphia Roof Garden; 8:30 P. M., Vocal selections; 8:45 P. M.-12:00, Dance music, Hotel Adelphia Roof Garden Orchestra.

**WWJ** (Eastern, 517), 3:00 P. M., Concert, Schmenan's Band; 7:00 P. M., Concert, News Orchestra; The Town Crier; Katherine Daniel, soprano; Edward Kelly, tenor.

(Continued on page 9.)

## What Time Is It?

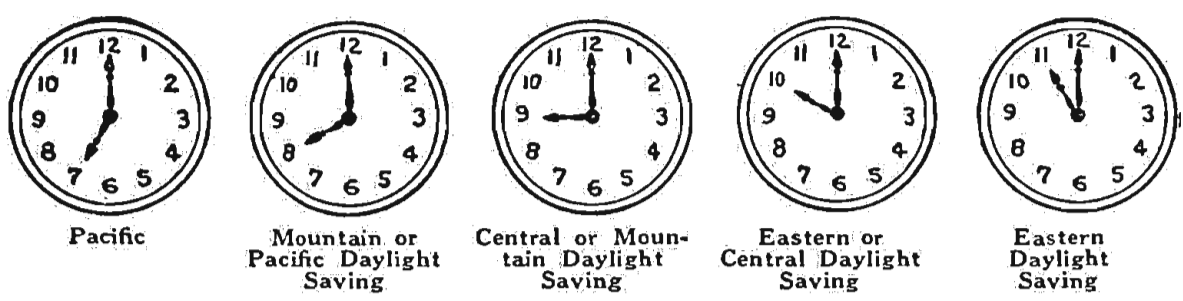

THE above clock dials are shown to clear up the misunderstanding which the various time bands and the Daylight Saving plan are creating. Although each dial registers time one hour ahead or behind of its neighbor, the exact period indicated on each dial is the same as that on every other. This chart will aid in the use of the advance programs and the schedules in the Radiophone Broadcasting Station Directory, both of which give the hours stated in the particular kind of time in use at each station. Only features are listed in the advance programs below. Much additional data and such parts of station schedules as are regular features week in and week out, will be found in the station directory which appears serially continuously on page eight.

**WBZ** (Eastern, 337), 7:30 P. M., Concert, Alice Powers, soprano; Willard Clark, baritone; Benjamin Buxton, pianist; "Reminiscences of Other Days," Mrs. Harry G. Kiltson; 8:50 P. M., Bedtime story for grownups, Orison S. Marden.

**WDAF** (Eastern, Daylight Saving, 395), 12:00-12:54 P. M., Organ recital, Stanley Theatre; 2:00-3:00 P. M., Dinner music, Arcadia Cafe Concert Orchestra; 4:30-5:30 P. M., Musical program; 7:30 P. M., Bedtime stories, Dream Daddy; 8:00 P. M., Musical program, Howard Lanin's Arcadia Cafe Dance Orchestra.

**WDT** (Eastern, Daylight Saving, 405), 12:00-12:50 P. M., Musical program, Laurence Dahm, pianist; Lena Lanza, soprano; Mary Moody, mezzo-soprano; Dorothy Donaldson, violinist; Dorothy Corbin, reader; 7:00 P. M., Recital, Arthur Kraft, tenor; Frank La Forge, pianist.

**WOC** (Central, 484), 3:30 P. M., Educational talk, Clyde G. Kerns; 6:30 P. M., Sandman; 8:00 P. M., Recital, Mrs. Frank A. Elliott, organist; 10:00 P. M., Musical program, Lorimer Foley, Ted Sloat, Mae Chambers, Dorothy Smith.

**WOO** (Eastern, Daylight Saving, 509), 11:00-11:30 A. M., Organ recital, Mary E. Vogt; 12:00-12:55 P. M., Luncheon music, Tea Room Orchestra; 4:45-5:00 P. M., Organ recital, Mary E. Vogt.

**WWJ** (Eastern, 517), 3:00 P. M., Concert, Schmenan's Band; 7:00 P. M., Concert, News Orchestra; The Town Crier; Vocal program furnished by pupils of John Watt.

## Thursday, July 12

**WFAA** (Central, 476), 12:30-1:00 P. M., Musical program, Meiba Theater talent.

**WFI** (Eastern, Daylight Saving, 395), 1:00 P. M., Meyer Davis Bellevue Stratford Orchestra; 6:30 P. M., Meyer Davis Bellevue Stratford Orchestra; 7:00-7:30 P. M., Children's Own Half Hour, Cousin Sue.

**WGY** (Eastern, 380), 7:45 P. M., Farmer's Night; "The Husking Bee," Cornhuskers Orchestra; "New Hampshire Home," James Montgomery, baritone; "Farmer Green," John T. Hill, reader; "The Boston Melody," Orchestra; Address, "The American Farmer and His Problem," W. W. Norton; "Old Oaken Bucket," "The Church in the Wildwood," Cowbell Four; Rube skit, "Just Before Train Time at Yaps Crossing"; "In the Shade of the Old Apple Tree," "Juanita," "Ford Song," Cowbell Four; "Barn Dance," Orchestra; "Down on the Farm," Seymour MacWilliams, tenor; "Barnyard Melody," Orchestra.

**WHAS** (Central, 400), 4:00-5:00 P. M., Concert, Mary Anderson Theater Orchestra; 7:30-9:00 P. M., Concert, under auspices of Carolyn Pell; Reading, "An Interesting Historical Episode."

**WIP** (Eastern, Daylight Saving, 509), 3:00-4:00 P. M., Song recital; 8:00-8:45 P. M., Dinner dance music; baseball scores; 7:00-7:30 P. M., Bedtime stories, Uncle Wip.

**CFCA** (Eastern, Daylight Saving, 400), 8:00-9:00 P. M., Musical program, "The Barber of Seville," Star Orchestra; "Homing," Mary Bothwell, contralto; "Viennese Melody," Mammie Roth, violinist; "Shepherd's Song," Orchestra; "The Song of the Open," Mary Bothwell; "Scenes Poetiques," Orchestra; Mammie Roth, violinist; "Blue Bells Drowsily Ringing," Mary Bothwell; "In the Shadows," Pirouette, Orchestra.

## Wednesday, July 11

**CFCA** (Eastern, Daylight Saving, 400), 8:00-9:00 P. M., Musical program, "Poet and Peasant," Star Orchestra; "Chant Triste," Jacques Sterin, cellist; "Loves a Merchant," Muriel Lomax, soprano; "Valse Bluette," "Entrance of the Boys," Orchestra; "Berceuse," Jacques Sterin; "Amina," Orchestra; Muriel Lomax; "In Love," Orchestra; "O Lovely Night," Muriel Lomax; "Yvonne," Orchestra.

**KDKA** (Eastern, 326), 5:15 P. M., Dinner concert, Little Symphony Orchestra, Victor Saudek director; 6:30 P. M., Review (continued) of J. M. Barrie's "What Every Woman Knows," Marjory Stewart; 6:45 P. M., Visit to the Little Folks, Dreamtime Lady; 7:20 P. M., Concert, Little Symphony Orchestra.

**Ritter Loop Aerial \$1**

Including wood parts—wire and binding posts. Can be assembled in a few minutes—Portable, requires little space, 36 inches across. Interference—Static—Lighting practically eliminated. Instructions with every SET. By Mail, 10c Extra.

Ritter Radio Company  
230 Canal Street, NEW YDRK

---

**CARTER AUTOMATIC RHEOSTAT**  
THE LATEST THE BEST

Eliminates first and second stage jacks. Decidedly simplifies amplification. Clock-spring pictail connection insures consistently reliable operation.

No. 3, 6-ohm, for UV-200 tube.....\$2.25 each  
No. 3-C, 20-ohm, for UV-201 tube.....\$2.50 each  
No. 3-D, 30-ohm, for UV-199 tube.....\$2.50 each

Write for Bulletin on Distinctive Carter Products.  
Carter Radio Co., 209 S. State St., Chicago.

**Freshman Fix-O**

A Fixed Resistance Leak Combination—4 in ONE

**Freshman Condenser Leak Mounting**  
**Freshman Fixed Leak SAFE-T HANDLE**

Price Complete **65c**

Furnished in any value of Resistance from 1/2 to 10 Megohms.

Separate Condenser and Mountings, 40c.  
Separate Leaks with Safe-T Handle, 30c.

At your dealers, otherwise send purchase price and you will be supplied postpaid.

**Chas. Freshman Co. Inc.**  
Radio Condenser Products  
106 SEVENTH AVE., NEW YORK

**B-T VERNIER TUNER**

Gives 100% improvement on REINARTZ CIRCUITS

Does away with soldered taps, switch points, etc. Easy to change to other circuits if desired. Photo Diagrams furnished—ask your dealer, or write for circular.

"IT'S A BEAUT"

**BREMER-TULLY MFG. CO.**  
532 South Canal Street CHICAGO

**THE LARGEST RADIO STORE IN AMERICA**

**BUILD YOUR OWN SET**

**THE LARGEST RADIO STORE IN AMERICA**

ACCORDING TO OUR INSTRUCTIONS  
RESULTS GUARANTEED—PANELS ON ALL SETS DRILLED—READY TO MOUNT

Complete Parts for Knocked-Down Receiving Set \$17.95	Complete Parts for Reinartz Sets \$11.45	Complete Parts for 2 Step Amplifier \$12.45
<b>CONSISTING OF</b> 2 Variometers.....\$10.00 \$3.90 1 Variocoupler..... 5.00 1.75 3 Bakelite Dials..... 3.00 .75 Remler Bakelite Socket..... 1.00 .45 Howard Rheostat..... 1.10 .80 Cunningham C-300 Detector Tube..... 5.00 4.45 Mahogany Cabinet..... 4.50 2.75 Genuine Formica Panel..... 2.25 1.75 8 Binding Posts..... .80 .40 Switch Lever..... .50 .25 12 Switch Points..... .40 .20 Freshman Grid Leak and Condenser Combined..... 1.00 .75 Complete Drawing for Assembly and Wiring..... 1.00 .50 Regular Price.....\$30.85 <b>Our Price \$17.95</b>	<b>CONSISTING OF</b> 7x18 Formica Panel.....\$1.89 \$1.70 Remler Bakelite Socket..... 1.00 .45 Howard Vernier Rheostat..... 1.50 1.35 23 Plate Variable Condenser..... 3.30 1.45 11 Plate Cuni Variable..... 3.10 1.35 3 Switch Levers..... 1.50 .75 2 Dozen Switch Points..... .80 .40 1 Schenohoven Reinartz Coil..... 3.00 1.95 Freshman Variable Grid Leak and Condenser Combined..... 1.00 .75 8 Binding Posts..... .80 .40 25 Feet Tinned Wire..... .30 .20 Baseboard for Mounting..... .50 .25 Blueprint with Complete Instructions for Assembly and Wiring..... 1.00 .50 Regular Price.....\$21.69 <b>Our Price \$11.45</b>	<b>CONSISTING OF</b> Can be used to amplify Reinartz, Flewelling, Short Wave Receiver, Crystal, Ultra Audion or any Receiving Set so that Loud Speaker or Phonograph can be used in place of Head Set. 7x10 Formica Panel or Other Suitable Size.....\$1.05 \$0.85 High Ratio All-American or Thordarson Transformer..... 4.75 3.95 Low Ratio Thordarson or All-American Transformer..... 4.50 2.95 2 Howard Rheostats..... 2.20 2.00 2 Remler Bakelite Sockets..... 2.00 .90 3 Double Facet Jacks..... 3.00 1.50 13 Binding Posts..... 1.30 .65 Baseboard for Mounting..... .30 .15 Regular Price.....\$20.10 Wiring Diagram, with Complete Instruction for Drilling and Assembling Panel..... <b>Our Price \$12.45</b>
<b>Complete Parts for Flewelling Circuit \$12.45</b> <b>CONSISTING OF</b> 6x14 Formica Panel.....\$1.26 \$1.10 23 Plate Variable Condenser..... 3.30 1.45 Three .006 Mica Condensers..... 3.00 2.25 CRL Variable Grid Leak..... 1.85 1.35 Remler Grid Leak..... .40 .25 2 Coil Adjustable Honeycomb Coil Mounting with Knobs..... 4.00 2.65 50 Turn Honeycomb Coil..... .75 .40 75 Turn Honeycomb Coil..... .80 .40 2 Remler Coil Mounts with Straps..... 1.20 .80 1 Remler Bakelite Socket..... 1.00 .45 Howard Vernier Rheostat..... 1.50 1.35 1 Bakelite 3" Dial..... 1.00 .25 8 Binding Posts..... .80 .40 1 Baseboard for Mounting..... .30 .20 1 Blueprint with Complete instructions for Assembly and Wiring..... 1.00 .50 Regular Price.....\$22.16 <b>Our Price \$12.45</b>	<b>Complete Parts for Ultra Audion Circuit, \$11.90 (Known as the Wonder Circuit)</b> <b>CONSISTING OF</b> 9x10 1/2 Formica Panel.....\$1.42 \$1.20 23 Plate Condenser..... 3.30 1.45 Bakelite Socket..... 1.00 .45 Special Ultra Audion Coil, plain or bank wound with tape..... 3.00 1.95 Howard Vernier Rheostat..... 1.50 1.35 CRL Grid Leak..... 1.50 .95 .0005 Micon Condenser..... .35 .25 2 Switch Levers..... .70 .50 18 Switch Points..... .50 .30 2 Switch Stops..... .10 .05 8 Binding Posts..... .80 .40 Genuine Solid Mahogany Cabinet, size 9x10 1/2, with hinged top..... 5.00 2.95 25 ft. Hookup Wire..... .20 .10 Regular Price.....\$19.37 Each order includes complete instructions for drilling, assembling and wiring. These construction plans are not drawn in schematic form but are drawn so that any one without any technical knowledge can follow with ease. <b>Our Price.....\$11.90</b>	<b>Complete Parts for Single Tube Reflex Circuit \$32.65</b> <b>CONSISTING OF</b> 43 Plate Vernier Variable Condenser.....\$7.00 \$3.95 Radion Loop Aerial..... 8.50 5.95 Cunningham C301-A Tube..... 9.00 5.95 Grewell Glass Enclosed Detector..... 2.00 1.65 Era Radio Frequency Transformer..... 4.50 3.45 All-American 5 to 1 Radio Audio Frequency Transformer..... 4.75 3.95 2-.001 Micon Condensers..... .70 .50 1-.002 Micon Condenser..... .45 .35 Howard Potentiometer..... 1.50 1.35 Howard 25 Ohm Rheostat..... 1.10 1.00 8 Binding Posts..... .80 .40 9x10 1/2 Formica Panel..... 1.42 1.20 9x10 1/2 Genuine Solid Mahogany Cabinet with Hinged Top..... 5.00 2.95 Complete instructions for drilling, assembling and wiring furnished so that any one with no technical knowledge can easily follow. Regular price.....\$45.22 <b>Our Price.....\$32.65</b>

**We guarantee all merchandise purchased of us. Mail orders receive immediate attention.**

BUY HERE FOR LESS  
**CHICAGO SALVAGE STOCK STORE**  
509 South State Street Dept. R. D. CHICAGO, ILLINOIS



# Radiophone Broadcasting Stations

## Corrected Every Week—Part IV

State, City, Call	State, City, Call	State, City, Call	State, City, Call	State, City, Call	State, City, Call				
<b>Alabama:</b> Auburn, WMAV Birmingham, WSY Mobile, WEAP Montgomery, WKAN	Gainesville, WKAY Macou, WMAZ Savannah, WBAO, WRAB	New Orleans, WAAB, WAAC. WVAG, WGV, WIAF, WWL Shreveport, KFDX, KFHF, WGAQ	Utica, KFGV York, KFDR	Norman, WNAD Okemah, WBAK Oklahoma City, WKY Okmulgee, WPAC Tulsa, WGAF, WLAL	Salt Lake City, KDYL, KZN				
<b>Arizona:</b> Phoenix, KDYW, KFAD, KFBC Tucson, KFDDH	<b>Idaho:</b> Boise, KFAU, KFDD, KFFB Kellogg, KFEY Moscow, KFAN	<b>Maine:</b> Bangor, WABI, WPAY Houlton, WLAN	<b>Nevada:</b> Reno, KDZK Sparks, KFFB	<b>Oregon:</b> Arlington, KFGL Baker, KFPA Corvallis, KFDJ Eugene, KFAT Hillsboro, KFPO Hood River, KFHB, KQP Marshfield, KFBH Medford, KFAY Pendleton, KFFE Portland, KPBQ, KFEC, KFIF, KGG, KGN, KGW Salem, KFCD	<b>Vermont:</b> Bellows Falls, WLAJ Burlington, WCAX Springfield, WQAE				
<b>Arkansas:</b> Fayetteville, KFDV Fort Smith, WCAC, WGAB Little Rock, WCAV, WEAX Pine Bluff, WOK	<b>Illinois:</b> Belvidere, WOAG Carthage, WCAZ Chicago, KYW, WAAF, WBU, WDAF, WIAZ, WMAQ, WPAD, WSAH, WVAZ Decatur, WBAO, WHAP Elgin, WTAS Lake Forest, WABA Mattoon, WQAL McLeansboro, WRAS Mt. Vernon, WABF Peoria, WJAN, WQAX Quincy, WCAW Rockford, WLAB Sterling, WBBC Tuscola, WJZ Urbana, WRM Zion, WCBD	<b>Maryland:</b> Baltimore, WCAO, WEAR, WKC, WNAV Frostburg, WPAQ	<b>New Hampshire:</b> Laconia, WKAU	<b>Virginia:</b> Arlington, NAA Blacksburg, WBAE Fortress Monroe, WNAW Portsmouth, WQAO Westhampton, WQAT	<b>Washington:</b> Aberdeen, KNT Bellingham, KDZB Everett, KFBL Lacey, KGY Neah Bay, KFHH Pullman, KFAB Seattle, KDZE, KDZT, KFHR, KHQ, KJR, KTV Spokane, KFDC, KFIO, KFZ Tacoma, BEL, KFBG, KFEJ, KGB, KMO Walla Walla, KFCE Wenatchee, KDZL, KZV Yakima, KFIO				
<b>California:</b> Altadena, KGO Bakersfield, KDZB Berkeley, KQL, KRE Del Monte, KLN El Monte, KUY Eureka, KNI Fresno, KML Hanford, KFBD Hollywood, KFAR Long Beach, KSS Los Angeles, KDZE, KFCL, KFL, KHL, KJS, KNN, KNV, KNX, KLS, KWH Los Gatos, KFHQ Modesto, KXD Oakland, KLS, KLN, KZM Richmond, KFCM Sacramento, KFBC San Diego, KDPT, KDYM, KFBC, KFFA San Francisco, KDZG, KDZX, KFDB, KPO, KSL, KUC San Jose, KFAQ, KQV San Luis Obispo, KFBE Santa Ana, KFAW Santa Barbara, KFJH Stanford Univ., KFGH Stockton, KJQ, KVG Sunnyvale, KJJ Taft, KFEB Venice, KFAV	<b>Indiana:</b> Anderson, WABC Brookville, WSAL Evansville, WAOU Greencastle, WLAX Huntington, WHAY La Porte, WRAF Marion, WIAQ Mishawaka, WQAO Muncie, WJAF South Bend, WABE, WGAZ West Lafayette, WBAA	<b>Massachusetts:</b> Boston, WNAC Dartmouth, WMAF Lowell, WQAS Medford Hillside, WGI New Bedford, WDAU Springfield, WBZ Worcester, WABK, WCN, WDS	<b>New Jersey:</b> Camden, WRP Gloucester City, WRAX Jersey City, WNO Moorestown, WBAF Newark, WAAM, WBS, WOB, WVAZ N. Plainfield, WEAM Ocean City, WIAD Paterson, WBAN Trenton, WMAL, WOAX	<b>Pennsylvania:</b> Allentown, WCBA Altoona, WGAU Clearfield, WPI Easton, WJAP Erie, WQAV Greene City, WSAJ Harrisburg, WABB Johnstown, WTAC Lancaster, WLBQ, WGAL McKeesport, WIK Parkersburg, WQAA Philadelphia, WCAU, WDAW, WFL, WGL, WIP, WJAT, WOO, WVAD Pittsburgh, KDKA, KQV, WCAE, WJAS Reading, WBBD, WRAW Scranton, WQAN, WRAY State College, WPAB Villanova, WCAM Wilkes-Barre, WBAX, WNAH	<b>West Virginia:</b> Clarksburg, WBAK				
<b>Colorado:</b> Boulder, KFAJ Colorado Springs, KFFQ, KFCK Denver, AA3, DN4, KDZQ, KEEP, KFAF, KFBL, KFEL, KFIC, KFLZ, KJZ Greeley, KFJD, KFKA Greeley, KFJD Gunnison, KFHA Lakeside, KFKH Pueblo, KFGB Trinidad, KFBS	<b>Iowa:</b> Ames, WOI Boone, KFGQ Burlington, WIAS, WLAT Cedar Rapids, WJAM, WKAA Centerville, WDX Council Bluffs, WPAF Davenport, WHAL, WOC Des Moines, KFBJ, WGF Dubuque, WQAK Fort Dodge, KFEE, WEAB Gladbrook, KFIC Iowa City, WHAA Lamoni, KFFV Le Mars, KFCY, WIAU Marshalltown, KFJB Newton, WIAH Oskaloosa, KFHL Sigourney, WOAD Sioux City, WEAU, WHAE Tinton, WIAE Waterloo, WHAC, WMAR, WRAN	<b>Minnesota:</b> Baudette, KFGY Duluth, WJAP, WJAT Hutchinson, WPAF Minneapolis, KFDD, KFEX, WBAD, WBAH, WCAS, WLAC, WRAB Moorhead, WPAU Northfield, WCAL St. Cloud, WPAF St. Paul, AV7, WAAH	<b>New Mexico:</b> State College, KOB	<b>Rhode Island:</b> Cranston, WKAP Edgewood, WEAG Providence, WEAN, WJAR, WRAH, WSD, WTAG	<b>Wisconsin:</b> Beloit, WKAW Kenosha, WQAR La Crosse, WABN Madison, WQAY, WHA Milwaukee, WAAK, WCAV, WHD, WIAO Neenah, WIAJ St. Croix Falls, WRAL Superior, WFAC Waupaca, WPAH				
<b>Connecticut:</b> Bridgeport, WKAN Hartford, WDAK New Haven, WPAJ Storrs, WABL Waterbury, WQAD	<b>Kansas:</b> Anthony, WBL Atwood, WEAD Beloit, WPAR Cheney, KFGP Emporia, WAAZ Hutchinson, WLAS Iola, KFID Liberal, WJAG Lindsborg, WDAD Louisburg, KFIL Manhattan, WTG Marion, WRAD Parsons, WQAJ Topeka, WJAG, WPAM Wichita, KFHI, WAAP, WEAH, WEY	<b>Missouri:</b> Butler, WVAR Cameron, WFAQ Cape Girardeau, WSAB Columbia, WAAW Independence, WPAG Jefferson City, WOS Joplin, WEAH Kansas City, WDAF, WBB, WJAJ, WQO Marshall, WJAT Moberly, KFEP Rockport, WMLD St. Joseph, KFHD, WEAK St. Louis, KFEZ, KFGI, KFIB, KSD, WCK, WEB, WEW, WMLY, WRAO Springfield, WIAI, WKAS, WQAB Tarkio, WIAT Webster Grove, WOAL	<b>New York:</b> Albany, WNY Amsterdam, WPAS Buffalo, WGR Canton, WCAD Cazenovia, WMLAC Ithaca, WEAJ Lockport, WJAK Newburgh, WCAE New York, KDOW, WBAJ, WDT, WEAF, WJX, WJY, WJZ, WJAW, WSAF Poughkeepsie, WPAF Rochester, WABO, WHAM Ridgewood, WHN Schenectady, WGY, WRL Syracuse, WDAI, WFAB, WLAH, WVAB Tarrytown, WRW Troy, WHAZ Utica, WSL Waterford, WFAQ	<b>South Carolina:</b> Charleston, WFAZ, WNAQ, WQAH Clemson College, WSAC Greenville, WQVY Orangeburg, WGAM	<b>Wyoming:</b> Casper, KFDF Douglas, KFEV Laramie, KFBU				
<b>Delaware:</b> Wilmington, WHAV, WOAT	<b>Kentucky:</b> Bowling Green, WNAB Frankfort, WQAK Lexington, WQAH Louisville, WEAS, WLAP Paducah, WIAR	<b>Montana:</b> Billings, KFCH Bozeman, KFDO Butte, KFAP Great Falls, KDYS Havre, KFBB	<b>Ohio:</b> Canton, WWB Cincinnati, WAAD, WHAG, WIZ, WLW, WMH, WSAI Cleveland, KDPM, WHK, WJAX Columbus, WBAV, WCAH, WEAO, WMAN, WPAL Dayton, WAI, WABD, WJAJ Fairfield, WJZ Granville, WJD Greenfield, WCBH Hamilton, WBAU, WRK Lebanon, WPG Lima, WQAC Marietta, WBAW Newark, WBBB Sandusky, WABH, WQAF Springfield, WNAF Staubenville, WTKA Stockdale, WJAK Warren, WLAZ Washington, C. O., WGAX Woster, WGAU Youngstown, WAAV, WDBF	<b>Nebraska:</b> David City, WRAR Fremont, WQAE Grand Island, KFJA Hastings, WQAY Kearney, KFHP Lincoln, KFDC, WFAV, WJAB, WKAC, WMAH, WQAP Norfolk, WJAG Oak, KFEQ Omaha, KFCZ, KFFX, WAAW, WIAK, WNAL, WOAW, WOU, WVW Rushville, WEAY Tecumseh, WTAU University Place, WCAJ	<b>North Carolina:</b> Asheville, WFAJ Charlotte, WBT Greensboro, WQAZ Raleigh, WLAC	<b>Tennessee:</b> Knoxville, WNAV Lawrenceburg, WOAN Memphis, WKN, WJMC	<b>Alaska:</b> Fairbanks, WLAY		
<b>Florida:</b> Jacksonville, WABG, WDAL Miami, WQAM Pensacola, WGAN, WLAV St. Petersburg, WSAG Tampa, WDAE, WHAW West Palm Beach, WKAH	<b>Louisiana:</b> Alexandria, KFFY Baton Rouge, KFGC	<b>North Dakota:</b> Fargo, WDAY, WPAK Grand Forks, WOAB Mayville, KFHU, WRAC Wahpeton, WJAW	<b>Texas:</b> Abilene, WQAO Amarillo, WDAQ, WRAU Austin, WCM, WNAS Beaumont, WJAM College Station, WTAU Dallas, KFFZ, WDAO, WFAA, WRR El Paso, WDAH, WPAF Fort Worth, WBAF Galveston, WHAB, WLAC Houston, WCAK, WEAT, WEV, WRAA, WSAV Laredo, WVAZ Orange, KFGX, WKAL Plainview, WSAF Port Arthur, WFAH San Antonio, AS6, WCAR, WAOI Stanford, WOAZ Tyler, WQAF Waco, WJAD, WLAJ, WWAC Wichita Falls, WKAF	<b>Utah:</b> Ogden, KFCEP	<b>Alaska:</b> Fairbanks, WLAY	<b>Hawaii:</b> Honolulu, KDYX, KGU, KYO Lihue, KFHS	<b>Porto Rico:</b> San Juan, WEAQ	<b>Canada:</b> Calgary, CHBC, CFAC, CFCN, CJCY Edmonton, CFCK, CJCA Fort Frances, CFPC Halifax, CFCE, CJCS Hamilton, CKOC Iroquois Falls, CFCH London, CFCX, CHCS, CIGGC, CKQC Montreal, CFCE, CHCX, CHYC, CJBC, CKAC Nelson, CIBC Ottawa, CHX, OA Regina, CKCK St. John, CJCL, CKCR Toronto, CFCA, CFYC, CHCB, CJCD, CJCH, CJCN, CJSC, CKCE, CKCK Vancouver, CFCE, CFYC, CHCA, CJCE Winnipeg, CHCF, CKCB, CKY, CKZC, CJNC	<b>Cuba:</b> Havana, PWX Tunucu, 6KW

### RADIO PATENT SURVEY

(Continued from page 4)

from selling receivers employing electron tube detector and amplifier circuits. Suit was also brought by the Radio Corporation against the same defendants under Langmuir patent 1,282,439, alleged to cover the grid leak; Lowenstein patent 1,231,764 on the Negative C battery; and Mathes patent 1,426,754, covering a resistance connected in the input circuit of a tube with a battery related therewith for bringing the grid to a different potential than the filament.

**Sues Under Assignments**

The Radio Corporation obtained the right to sue these defendants by a special assignment from the General Electric Company, owners of the Langmuir patent; and under the Lowenstein patent by an assignment from the American Telephone and Telegraph Company. The Western Electric Company assigned the Mathes patent to the American Telephone and Telegraph Company on November 11, 1922, and on November 13, 1922, the American Telephone and Telegraph Company transferred the right to sue these defendants to the Radio Corporation. The outcome of these suits will be of utmost importance to the industry and will decide whether anyone other than the Radio Corporation is entitled to vend a Radio receiving set.

**Supreme Court Gives Setback**

The only real setback experienced by the Radio Corporation since the series of suits was initiated occurred on February 19, 1923, when the Supreme Court of the United States handed down a decision in the Crown Die vs. Nye Tool Company suit, which meant that the Radio Corporation did not

have the right to sue for infringement or injunctions against the sale of alleged infringers of patents purely assigned or licensed to them. In such a suit, the Supreme Court ruled, the patentee himself must be the plaintiff or a co-plaintiff in the suit. However, the R. C. A. has been able in most cases to secure the co-operation of the actual inventors in its multitude of suits, so that the merry march of legal procedure still continues.

**List of Suit Victims**

The art has witnessed the Radio Corporation file suits under the Fleming valve patent 803,684, DeForest electron tube amplifier patent 841,387, and the DeForest grid patent 879,532, against literally dozens of small defendants. The list of victims includes some well known names, such as: A. F. Scheff; A. E. Reymann; S & N Radio Supply Company; Schweitzer & Schweitzer; M. A. Modell, et al.; John Firth & Company; Wireless Appliance Corporation; Independent Electrical Supply Company; Greenfield & Greenfield Radio Guild, Inc.; Federal Engineering Corporation and I. Gottlieb; all in the United States District Court for the Southern District of New York, and A. Rosasco, et al., in the United States District Court for the Eastern District of New York.

The industry has also witnessed the Wireless Specialty Apparatus Company, now a subsidiary of the Radio Corporation, file suits against the Freed-Eiseman Radio Corporation under the Pickard crystal detector

patent Re. 13,798, the Pickard cat whisker patent 1,104,073, and the Miessner cat whisker patent 1,104,065, including a similar suit against the Pinkerton Company and the Brinnell Company. Suits were also filed by the Wireless Specialty Apparatus Company against F. A. D. Andrea and the Magnus Electric Company, both in the United States District Court for the Southern District of New York, under the Pickard pyrite detector patent 933,263, the Miessner cat whisker patent 1,104,065, the Pickard cat whisker patent 1,104,073, the Pickard crystal detector patents 1,137,714, 1,225,852 and Re. 13,798. The Specialty Company has also sued the Patent Electric Company and R. H. Macy and Company under a number of crystal detector patents in the United States District Court for the Southern District of New York.

**Freed-Eiseman Gives Battle**

The Freed-Eiseman Radio Corporation filed counter suit in the New York Supreme

Court against the Wireless Specialty Apparatus Company for an injunction pendente lite to restrain the specialty company from publishing the trade warnings of patent infringement listing a great number of patents, whereas the subject matter of only a few of the patents warranted the attention of the trade. Freed-Eiseman were successful in this case both in the Lower Court before Judge O'Malley, and in the Appellate Court.

(TO BE CONTINUED)

### Kellogg Radio Equipment For Better Results

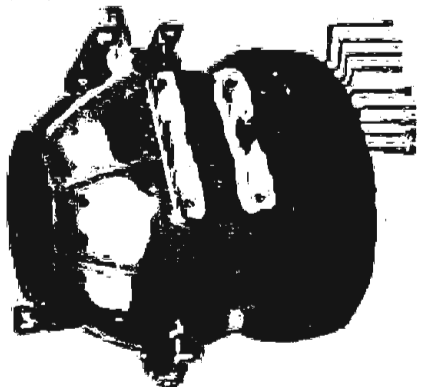

**VARIOCOUPLER**

The Kellogg variocoupler is of the same standard design as our variometer, being made of molded Bakelite, with reinforced construction.

For increasing the wave length from 500 to 2,500 meters, the Kellogg standard wound induction is added to the variocoupler.

It is arranged for either panel or base mounting. No. 501 Variocoupler ..... \$9.00  
With No. 502 Diamond Wound Coil, as shown in illustration ..... \$13.00

**Kellogg Switchboard & Supply Company**  
CHICAGO

### REFLEX

Erla Reflex Transformers  
DEALERS: SEND FOR LITERATURE  
NOTE: We are the Largest Exclusive Radio Jobbers in the Middle West

### HUDSON-ROSS

123 W. Madison St. Chicago

### Delicate Soldering

THE POST SOLDERING IRON  
Platinum Heating Unit—Interchangeable Tips—Universal Current  
(Large and Small)

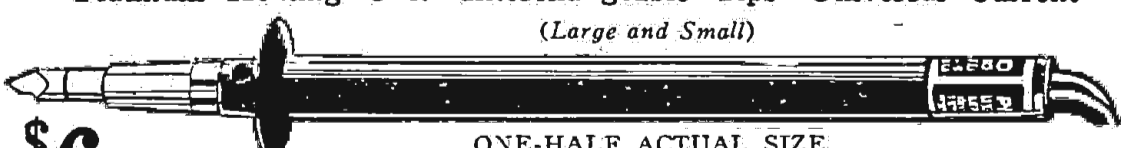

ONE-HALF ACTUAL SIZE  
Awarded Certificate of Excellency, N. Y. Evening Mail Radio Institute  
From your Dealer, or write  
**POST ELECTRIC COMPANY (Dept. 509), 30 E. 42nd St., New York**



ADVANCE PROGRAMS

(Continued from page 7)

Friday, July 13

CFCA (Eastern, Daylight Saving, 400), 8:00-9:00 P. M., Musical program, "Faust," Star Orchestra; "Brook Day," Maud Parsons, contralto; Harry Adaskin, violinist; "Intermezzo" from "Nadia," Orchestra; "Prohibitive Music," Maud Parsons; "Passepied," Orchestra; Harry Adaskin, violinist; "My Love and I," Maud Parsons; Selection from "The Lady of the Slipper," Orchestra.
KDKA (Eastern, 326), 5:15 P. M., Dinner concert. Grand Symphony Orchestra; 6:30 P. M., Farmer's Evening. Special farm program prepared by the National Stockman and Farmer; 6:45 P. M., Visit to the Little Folks. Dreamtime Lady; 7:20 P. M., Concert. Students from the Charles Le Sueur Studio.
KHJ (Pacific, 395), 2:30-3:30 P. M., Matinee musicale, arranged by the San Gabriel Chamber of Commerce, featuring the world-famous "Mission Play"; 6:45-7:30 P. M., Children's Hour; 8:00-10:00 P. M., Program arranged by the San Gabriel Chamber of Commerce.
KSD (Central, 546), 8:00 P. M., Opera, "The Gypsy Baron," Municipal Open Air Theatre.
KYW (Central, Daylight Saving, 345), 5:50 P. M., Children's bedtime story; 10:00-11:30, Musical program, Midwest Music House; Cope Harvey's Orchestra; Wendell W. Holl, KYW's Music Maker.
WBAP (Central, 476), 9:30-10:45 P. M., Concert, Rain-bow Girls' Chorus.
WBZ (Eastern, 337), 7:30 P. M., Concert, St. John's Glee Club; 8:50 P. M., Bedtime story for grown-ups, Orison S. Marden.
WDAR (Eastern, Daylight Saving, 395), 12:00-12:54 P. M., Organ recital, Stanley Theatre; 2:00-3:00 P. M., Arcadia Cafe Concert Orchestra; 4:30-5:55 P. M., Musical program; 7:30-8:00 P. M., Bedtime stories, Dream Daddy; 8:00 P. M., Special features from Stanley Theatre; Dance music, Howard Lanin's Arcadia Cafe Orchestra.
WDT (Eastern, Daylight Saving, 405), 12:00-12:50 P. M., Talk, "Esperanto," courtesy of the 16th Annual Esperanto Convention; Songs, Sara Segalowitz; Songs, Frank Marshall; Novelties, Harry Holliday; 11:00 P. M., Musical program, "Mad," "Runnin' Wild," "Seven or Eleven," Sherwood Orchestra; Songs, Vaughn De Leath; "Wonder If She's Lonely, Too," "Morning Will Come," "Red Head Gal," "Carolina Mammy," Orchestra; Songs, Vaughn De Leath; "The Thief," "You Gave Me Your Heart," "Yes, We Have No Bananas," Orchestra.
WFAA (Central, 476), 12:30-1:00 P. M., Address, Dr. Robert Stewart Hyer, Southern Methodist University; 8:30-9:30 P. M., Mrs. Clyde Magee, reader, and assisting musicians.
WFI (Eastern, Daylight Saving, 395), 1:00 P. M., Dinner music, Meyer Davis Bellevue Stratford Orchestra; 3:00 P. M., Concert; 6:30 P. M., Meyer Davis Bellevue Stratford Orchestra; 7:00 P. M., Children's Own Half Hour, Cousin Sue.
WGY (Eastern, 380), 7:45 P. M., Musical program, "The Spinning Wheel," "The Butterfly," Jennie Gurkin, pianist; "On the Sunset Line," Dorothy Golub, reader; "Mazurka," Samuel Gurkin, violinist; "Lithuanian Song," Elizabeth Reohr, soprano; "Rondo Capriccioso," Jennie Gurkin, Address, "American Common Sense," Charles Jarvis, Jr.; "Robin, Robin, Sing Me a Song," "There's a Lark in My Heart," Elizabeth Reohr; "Bolero," Samuel Gurkin, violinist; "Jimmie and the Brand New Baby," Dorothy Golub; "Ashea of Roses," "Serenade," Elizabeth Reohr; "Cradle Song," "Traumerel," Jennie Gurkin; 10:30 P. M., Musical program, "Soldier's Blood," "Dolgevillie High School Orchestra; "Poet and Peasant," Orchestra; "Life," Mrs. Albert M. Van Denberg, soprano; "Thoroughbred," Orchestra; "Air Varie," Sylvan De Lucco, clarinetist; "Old Folks at Home and in Foreign Lands," Orchestra; "Andante and Fugate Movements," from "Second Concerto," Daniel Green, Pianist; "Zampa," Orchestra; "Love Sends a Little Gift of Roses," Mrs. Albert M. Van Denberg; "Entrance of the Gladiators," "Stars and Stripes Forever," Orchestra.
WHAS (Central, 400), 4:00-5:00 P. M., Concert, Mary Anderson Theater Orchestra; 7:30-9:00 P. M., Concert, under auspices of Mrs. John Harmon, Jr.

WIP (Eastern, Daylight Saving, 509), 3:00-4:30 P. M., Dance music; 6:00-6:45 P. M., Dinner dance music; 7:00-7:30 P. M., Bedtime stories, Uncle Wip.
WDC (Central, 484), 3:30 P. M., Educational talk, C. E. Willett; 5:45 P. M., Chiuves concert; 6:30 P. M., Sandman.
WDD (Eastern, Daylight Saving, 509), 11:00-11:30 A. M., Organ recital, Mary E. Vogt; 12:00-12:55 P. M., Luncheon music, Tea Room Orchestra; 4:45 P. M., Organ recital, Mary E. Vogt.
WWJ (Eastern, 517), 3:00 P. M., Concert, Schmemman's Band; 7:00 P. M., Concert, News Orchestra; The Town Crier; Concert, Selucuan's Band.

Saturday, July 14

CFCA (Eastern, Daylight Saving, 400), 8:00-9:00 P. M., Musical program, "The Merry Wives of Windsor," Star Orchestra; "At Dawn," Naomi Wedd, soprano; "Melodie," Jacques Stern, cellist; "Pizzicato Polka," Orchestra; Naomi Wedd, soprano; "Prize Song," from "The Medalsinger," Orchestra; "Salut D'Amour," Jacques Stern; "Songs My Mother Taught Me," "Slumber Boat," Naomi Wedd; "Wiener Blut," Orchestra.
KDKA (Eastern, 326), 5:15 P. M., Dinner Concert, Westinghouse Band, T. J. Vestlue, Director; 6:45 P. M., Visit to the Little Folks, Dreamtime Lady; 7:20 Concert, Westinghouse Band, T. J. Vestlue, Director, Mrs. Nellie Sheets, contralto, Olive Cornham, soprano.
KHJ (Pacific, 395), 2:30-3:30, Matinee musicale; 6:45-7:30 P. M., Children's Hour; Bianca Blackburn, reader; 8:00-10:00 P. M., De Luxe Program.
KSD (Central, 546), 8:00 P. M., Concert, Missouri Theater talent.
KYW (Central, Daylight Saving, 345), 5:50 P. M., Children's bedtime story; 7:00-7:58 P. M., Musical program, Selections on Kimball Pipe Organ; Cope Harvey's Orchestra; 8:00-8:35 P. M., "Under the Evening Lamp," Youth's Companion.
WBAP (Central, 476), 7:00-7:30 P. M., Sunday School Lesson, Mrs. W. F. Barium, leader of the Barnum Bible Class of First Methodist Church.
WBZ (Eastern, 337), 7:30 P. M., Battle Day, Program by Professor J. Ernest Phillie of St. Joseph's Church; Concert, Chorus of St. Joseph's Church; 8:50 P. M., Bedtime story for grown-ups, Orison S. Marden.
WDT (Eastern, Daylight Saving, 405), 12:00-12:50 P. M., Talk, Vaughn De Leath; Hawaiian music, White Way Trio; Songs, Augusta Spett.
WFAA (Central, 476), 12:30-1:00 P. M., Address, "Current History Comment," Prof. Clyde Engleton; 8:30-9:30 P. M., Vocal program, pupils of Marie Altona; 11:00-12:00 P. M., Violin recital, Walter J. Fried with assisting musicians.
WHAS (Central, 400), 4:00-5:00 P. M., Concert, Mary Anderson Theater Orchestra; 7:30-9:00 P. M., Concert, Blue Bird Orchestra; Reading, "An Interesting Historical Episode."
WMC (Central, 500), 8:30 P. M., Concert, Brittling's Cafeteria Orchestra.
WDC (Central, 484), 3:30 P. M., Educational talk, C. C. Hall; 5:45 P. M., Chiuves concert; 6:30 P. M., Sandman; 9:30 P. M., Dance Program, P. S. C. Orchestra.
WWJ (Eastern, 517), 3:00 P. M., Concert, Schmemman's Band; 7:30 P. M., Concert, Schmemman's Band.

Sunday, July 15

WBZ (Eastern, 337), 7:30 P. M., Church services, conducted by Rev. G. Pitt Beers, pastor of the Park Memorial Church.
WFAA (Central, 476), 2:30-3:30 P. M., Radio Bible Class, Dr. William M. Anderson, Jr., pastor First Presbyterian Church; 9:30-10:00 P. M., Musical program, East Dallas Presbyterian Church; 10:00-11:00 P. M., Concert, Orchestra from East Dallas Presbyterian Church.
WGY (Eastern, 380), 9:30 A. M., Church services, First English Lutheran Church; Sermon, "Hidden Light," Rev. Herbert D. Shimer, First English Lutheran Church; 6:30 P. M., Church services, First English Lutheran Church; Sermon, "The Two Awakenings," Rev. Herbert D. Shimer.
WHAS (Central, 400), 9:57 A. M., Organ music; 10:00 A. M., Church Services, Calvary Baptist Church, Sermon, Rev. T. J. Barksdale, pastor; 4:00-5:00 P. M., Concert, under auspices of Isabelle Wetzelberger.

WMC (Central, 500), 11:00 A. M., Church services, St. Mary's Episcopal Church, Dean H. Noo; 4:00 P. M., Memphis-Chattanooga baseball game.
WWJ (Eastern, 517), 11:00 A. M., Church services, St. Paul's Episcopal Cathedral; 2:00 P. M., Concert, News Orchestra; 3:00 P. M., Concert, Schmemman's Band.

Monday, July 16

WDAR (Eastern, Daylight Saving, 395), 12:00-12:54 P. M., Organ recital, Stanley Theatre; 2:00-3:00 P. M., Song recital; Arcadia Cafe Orchestra; 4:30-5:55 P. M., Special musical features; Talk, "Affairs of the Heart," Betsy Logan; 7:30-8:30 P. M., Bedtime stories, Dream Daddy.
WFI (Eastern, Daylight Saving, 395), 1:00 P. M., Dinner music, Meyer Davis Bellevue Stratford Orchestra; 3:00 P. M., Song and piano recital; 6:30 P. M., Dinner music, Meyer Davis Bellevue Stratford Orchestra; 7:00-7:30 P. M., Children's Own Half Hour, Cousin Sue.
WGY (Eastern, 380), 7:45 P. M., Musical program, "Swing Song," Music Study Club Chorus; "First and Second Movements," "Seventh Concerto," Gladys Terriault, violinist; "Diamond Cut Diamond," Helen M. Abbott, reader; "Love Sends a Little Gift of Roses," "Just a Wearying For You," Anna D. Aston, soprano; "Bagatell," "Danse Negre," "Polonaise," Ruth S. Hardy, pianist; "Still as the Night," "Untel," Mildred C. Schilling, Marvin J. Roek, vocal duet; "The Bobolink," "If We Only Understood," In 1822," Helen M. Abbott, reader; "The Land of the Sky Blue Water," "Rose in the Bud," Mrs. Frank Catrivala, soprano; "The Bee," "Sonata in A Major," "First Movement," Gladys Terriault; "Eleanor," "For You," William A. Scott, tenor; "Bendemeer's Stream," Music Study Club Chorus; "Concerto in A Minor," Ruth S. Hardy.
WIP (Eastern, Daylight Saving, 509), 3:00-4:00 P. M., Song recital; 7:00-7:30 P. M., Bedtime stories, Uncle Wip.
WJW (Eastern, 309), 8:00 P. M., Musical program, Roger Hill Dance Orchestra; "It Was Not Thus To Be," Walter Phillips, baritone; Selections by orchestra; "Nola," "Caprice Espagnole," Anna Knova, pianist; "When Pa Pays the Monthly Bill," Catherine McPherson, reader; Xylophone solo, "Russian Rag," Anna Knova; "To Spring," "Rhapsody No. 11," Catherine McPherson, pianist.
WMC (Central, 500), 8:30 P. M., Concert, Hotel Gayoso Orchestra, Gaspar Pappalardo, director.
WDD (Eastern, Daylight Saving, 509), 11:00-11:30 A. M., Organ recital, Mary E. Vogt; 12:00-12:55 P. M., Luncheon music, Tea Room Orchestra; 4:45 P. M., Organ recital, Mary E. Vogt; 7:45 P. M., Dinner music, Hotel Adelpia Roof Garden Orchestra; 8:30 P. M., WOO Orchestra, Robert E. Golden, director; 9:30 P. M., Organ recital, Mary E. Vogt; 10:30 P. M., Dance music, Hotel Adelpia Roof Garden Orchestra, Walter Miller, director.

SPECIAL OFFER LIST

(Continued from page 2)

WFI (Eastern, 395), 1:00 P. M., Dinner music, Meyer Davis Bellevue Stratford Orchestra; 3:00 P. M., Song and piano recital; 6:30 P. M., Dinner music, Meyer Davis Bellevue Stratford Orchestra; 7:00-7:30 P. M., Children's Own Half Hour, Cousin Sue.
WGY (Eastern, 380), 7:45 P. M., Musical program, "Swing Song," Music Study Club Chorus; "First and Second Movements," "Seventh Concerto," Gladys Terriault, violinist; "Diamond Cut Diamond," Helen M. Abbott, reader; "Love Sends a Little Gift of Roses," "Just a Wearying For You," Anna D. Aston, soprano; "Bagatell," "Danse Negre," "Polonaise," Ruth S. Hardy, pianist; "Still as the Night," "Untel," Mildred C. Schilling, Marvin J. Roek, vocal duet; "The Bobolink," "If We Only Understood," In 1822," Helen M. Abbott, reader; "The Land of the Sky Blue Water," "Rose in the Bud," Mrs. Frank Catrivala, soprano; "The Bee," "Sonata in A Major," "First Movement," Gladys Terriault; "Eleanor," "For You," William A. Scott, tenor; "Bendemeer's Stream," Music Study Club Chorus; "Concerto in A Minor," Ruth S. Hardy.
WIP (Eastern, Daylight Saving, 509), 3:00-4:00 P. M., Song recital; 7:00-7:30 P. M., Bedtime stories, Uncle Wip.
WJW (Eastern, 309), 8:00 P. M., Musical program, Roger Hill Dance Orchestra; "It Was Not Thus To Be," Walter Phillips, baritone; Selections by orchestra; "Nola," "Caprice Espagnole," Anna Knova, pianist; "When Pa Pays the Monthly Bill," Catherine McPherson, reader; Xylophone solo, "Russian Rag," Anna Knova; "To Spring," "Rhapsody No. 11," Catherine McPherson, pianist.
WMC (Central, 500), 8:30 P. M., Concert, Hotel Gayoso Orchestra, Gaspar Pappalardo, director.
WDD (Eastern, Daylight Saving, 509), 11:00-11:30 A. M., Organ recital, Mary E. Vogt; 12:00-12:55 P. M., Luncheon music, Tea Room Orchestra; 4:45 P. M., Organ recital, Mary E. Vogt; 7:45 P. M., Dinner music, Hotel Adelpia Roof Garden Orchestra; 8:30 P. M., WOO Orchestra, Robert E. Golden, director; 9:30 P. M., Organ recital, Mary E. Vogt; 10:30 P. M., Dance music, Hotel Adelpia Roof Garden Orchestra, Walter Miller, director.

Class D Articles

For eight consecutive coupons and one dollar and twenty cents (\$1.20) any one of the following articles

PHANTOM PORTABLE CIRCUITS
Used on train or automobile. Set of four, \$1.00, or free with Radiotron or Cunningham tubes. RADIO CENTRAL, Dept. D, Abilene, Kansas.

RADIO VIA PARCEL POST AT N. Y. PRICES

Standard Parts Only, in Original Packing
NO SALVAGED GOODS SOLD
Where "Money Back Policy Prevails"

MARGO \$1.00 Vacuum Tube 1 Socket 1 1/2 Volt

Operates on one dry cell, either with or without B battery. Wiring diagram FREE with each tube. 10c extra for parcel post insured.

Table listing various radio parts and their prices, including phones, couplers, condensers, transformers, and miscellaneous items.

WESTINGHOUSE, JR. 6.95 .40
Aerex Crystal Set 7.95 .45
Victor Single Tube, completely assembled 12.50 .45
Victor Two Stage Amplifier 12.50 .45

RHEOSTATS
Klosner Vernier 1.25 .14
Bradleystat 1.49 .10
Union Radio .65 .08

SOCKETS
Bell V. T. & W. D. 11 89 .10
V. T. Bakelite 50 .10

LDUD SPEAKERS
King Amplitone Horn 4.95 .28
Reflex 9.85 .30
Phonaflex 15.00 .50

DIALS
2-inch (Bakelite) 25 .06
3-inch (Bakelite) 35 .08

Modell's ESTABLISHED 1929
191 Fulton St., Dept. F-21, New York City
9 New York Stores
America's Greatest Radio Mail Order House

will be sent: 1 Carter 20-Ohm Vernier Control Rheostat; 1 Schindler Radio Frequency Transformer; 1 Martin-Copeland 13-Point Inductance Switch; 1 Martin-Copeland 15-Point Inductance Switch; 1 Martin-Copeland 19-Point Inductance Switch; Walnart Variable Condenser (5-Plate .0001 mfd.); Ray-O-Vac No. 4151 B Battery, 2 1/2 volts; Ray-O-Vac Dry Battery, 3 cells 4 1/2 volts; Electrad Variolom, with micro condenser; Dubilier By-Pass Condenser (2 mfd.); CRL Variable Grid Leak with Condenser; Resistorometer (Type A or 2A).

Class E Articles

For ten consecutively numbered coupons and one dollar and fifty cents (\$1.50) any one of the following articles will be sent: 1 Carter 6-Ohm Automatic Control Rheostat; 1 Carter 20 Ohm Automatic Control Rheostat; 1 Decima 3-Plate Variable Condenser; Walnart Variable Condenser (13-Plate .00025 mfd.); Ray-O-Vac Dry Battery, 4 cells 1 1/2 volts; Dubilier Variolom (.0004 or .0006 mfd.); Resistorometer (Type B); Delto Midget Tube and Socket.

Class F Articles

For twelve consecutively numbered coupons and one dollar and eighty cents (\$1.80) the following will be sent: 1 Acme Pot-Rheo (potentiometer and rheostat); Walnart Variable Condenser (23-Plate .0005 mfd.); Ray-O-Vac No. 2151 B Battery, 2 1/2 volts; Dubilier By-Pass Condenser (3 mfd.); Premier Variable Condenser without dial (.00039 mfd.).

Class G Articles

For fourteen consecutively numbered coupons and two dollars and forty cents (\$2.40) any one of the following articles will be sent: 1 Federal 7-Plate Variable Condenser; 1 Federal 11-Plate Variable Condenser; 1 Federal 21-Plate Variable Condenser; 1 Federal Anticapacity Switch; 1 Decima Variable Condenser 11-Plate Walnart Variable Condenser (43-Plate .001 mfd.); Dubilier Variolom (.001 mfd.); Dubilier By-Pass Condenser (4 mfd.); Premier Variable Condenser with dial (.00078 mfd.); Premier Hegogog A. F. Transformer, 4 to 2 Ratio.

Class H Articles

For sixteen consecutively numbered coupons and three dollars (\$3.00) any one of the following articles will be sent: 1 Federal Audio Frequency Transformer No. 228 W; 1 Decima 23-Plate Variable Condenser; 1 Acme Audio Frequency Transformer; 1 Acme Radio Frequency Transformer (R-2, R-3, or R-4); Walnart Variable Condenser (13-Plate vernier); Ray-O-Vac No. 2301 "B" Battery 45 volts; Ray-O-Vac Dry Battery, 8 cells 1 1/2 volts; Dubilier Duratran (R. F. transformer); Premier Micrometer Variocoupler with dial; Premier Variable Condenser with dial (.0015 mfd.); Premier Variable Condenser with vernier (.0004 mfd.); Premier Hegogog A. F. Transformer, 10 to 1 Ratio; Premier Hegogog A. F. Transformer, Tube Socket Type, 4 to 1 Ratio; Turney Spider Web Coil Mount, Type B.

WE REPAIR YOUR VACUUM TUBES

WD-11, WD-12, UV-199, UV-201-A, C-301-A, \$3.50 each
UV-200, C-300, AP Detectors, 2.75 each
UV-201, C-301, AP Amplifiers, 3.90 each
UV-6, DV-6-A, 3.50 each
UV-202, 4.00 each

And Guarantee Them Equal to New
QUICK SERVICE include with your order remittance to cover repair plus parcel postage for one pound per tube. If preferred, tubes will be returned C.O.D. repair charges.

Abalene Radio 14 Vesey Street New York, N.Y.

Book Of 47 Hook-Ups by an Expert Radio Engineer. Forty-seven different ways of making your own set. Each hook-up designed by an expert radio engineer and was tested for accuracy. Every one of these hook-ups will give splendid results. Each hook-up contains detailed information on construction and operation. Thousands of these books are now in use by amateurs and professionals all over the United States. You will get more practical radio information and instruction from this book than from almost any other source. Send your order today. Enclose one dollar with order. ELS RADIO CO. 610 Randolph Bldg., Chicago, Illinois

WILLARD RADIO COMPANY 291 Broadway New York City
FLEWELLING CIRCUIT Every part complete, including drilled panel and book of diagrams and instructions \$11.95
REINARTZ CIRCUIT Every part complete, including drilled panel and book of diagrams and instructions \$10.95
Two-stage Audio-Frequency Amplifier. Every part complete for above circuits at \$11.00
CONDENSERS
3 Plate Variable; value, \$1.75 \$1.05
13 Plate Variable; value, 2.50 1.20
23 Plate Variable; value, 3.50 1.35
43 Plate Variable; value, 4.50 1.95
13 Plate Vernier; value, 5.50 3.75
23 Plate Vernier; value, 6.00 4.00
43 Plate Vernier; value, 6.50 4.25
Honeycomb Coils, 50 turns mounted .95
Honeycomb Coils, 75 turns mounted 1.00
Double Coil Mountings 2.45
Triple Coil Mountings 3.35
Reinartz Coils, increased wave length and mounting 1.45
Jacks, Single Circuit; value, 65c, special at .30
Double Circuit; value, 90c; special at .45
Multiple Point Inductance Switch with Knob and Dial (15 Switch Points) 1.75
Lightning Arresters, approved .90
Three-inch Dials, unbreakable, heat resisting composition, high finish; special .30

How to Make a Flewelling Receiver BLUE PRINTS for the construction of a Flewelling Receiving Unit and two step amplifier. ALL DETAILS FOR ASSEMBLY Description of apparatus and accessories and details of tuning. CABINET DIMENSIONS PANEL LAYOUTS LIST OF PARTS Send only money orders - no checks or stamps. Coins at your own risk. Book Department Radio Digest 123 W. Madison St., Chicago, Ill.
Modell's ESTABLISHED 1929
191 Fulton St., Dept. F-21, New York City
9 New York Stores
America's Greatest Radio Mail Order House



# Radio Digest Illustrated

REG. U. S. PAT. OFF. AND DOM. OF CANADA

Published by the Radio Digest Publishing Company, Inc.  
123 West Madison Street  
Telephone State 4844-4845  
Chicago, Illinois

E. C. RAYNER, Publisher  
Chas. F. Smisor, Editor  
Harry J. Marx, Technical Editor

Eastern Representative, Jacob Miller, Times Bldg., Times Square,  
New York; Telephone Bryant 4909

Pacific Coast Representatives  
E. J. Wood, 251 Kearney St., San Francisco  
Telephone Kearney 1472  
H. M. Morris, 417 Western Mutual Life Building, Los Angeles  
Telephone 12011



PUBLISHED WEEKLY

SUBSCRIPTION RATES  
Yearly.....\$5.00 | Foreign.....\$6.00  
Single Copies, 10 Cents

Vol. VI Chicago, Saturday, July 14, 1923 No. 1

## Interference Located

The Radio Amateur Is at Last Vindicated

OFFICIAL observations made by engineers of the Bureau of Standards for a period of seven months, and still being continued today, point to the fact that it is not the amateur that causes most of the interference to reception of concerts from broadcasting stations, but it is the broadcasting stations themselves.

Centering their observations on two broadcasting stations—one KDKA at Pittsburgh and the other WLB at Minneapolis—the engineers sought to discover the effect their messages had on nearby and distant receiving stations. They conclude that “the reliability of signals from a station first decreases and then rises as we increase the distance from that station.”

In their reports from between 200 and 1,000 receiving stations, monthly, the engineers were able to classify the sources from which interferences were being experienced. After tabulating these sources they showed that an average of 30.9 per cent of the interference came from other broadcasting stations, while amateurs with spark sets furnished 3.5 per cent of the trouble, and those with C. W. sets only 2.3 per cent.

## Simple Receiving Sets

Very Few Essentials Required in Circuits

WHAT are the absolute essentials of a Radio receiving set? The basic requirements for making Radio waves audible are two; an instrument to rectify the incoming waves and a receiver to turn the electrical energy into sound. The latter device is familiar to everyone. The rectifying is accomplished by a vacuum tube and apparatus used in conjunction with it, or in the simpler sets by a crystal of some suitable mineral, contact being made with a fine wire or metal surface.

While a detector and telephone receiver will receive the signals of a powerful station close by, even without an antenna, reception over moderate distances requires both the antenna and some device for tuning to the incoming wave. The variometer, the variocoupler and the variable condenser are among the more familiar instruments for tuning.

The simplest form of practical receiving apparatus is a crystal set which contains a detector, a coil of wire with a slider or switch to vary the number of turns in use and a small fixed condenser. This set with a normal antenna will receive broadcasting up to a distance of ten or fifteen miles. Occasionally stations several hundred miles away are heard on such sets using an outdoor aerial.

Vacuum tubes sets may be classified into groups such as non-regenerative, regenerative, Radio frequency and super-regenerative sets.

The circuit of the simple non-regenerative set is similar to that used with the crystal set, the chief point of difference being the use of the vacuum tube detector. The range of this set is somewhat greater than that of a crystal set and the inconvenience of adjusting the crystal is eliminated.

A large majority of the popular receiving sets today are of the regenerative type. They vary widely in detail, but all employ some variation of the feedback circuit developed by Major Armstrong. The Copp, Reinartz and many other popular circuits belong in this class. Distances exceeding 1,000 miles frequently are covered by the various regenerative receivers. The consistent range is several hundred miles.

Radio frequency amplification forms the basis of the third class of receivers mentioned. This form of amplification makes reception possible over great distances even with a loop or indoor antenna. Sets using Radio frequency amplification give remarkable results when properly handled, but it is difficult for the novice in Radio to obtain the same results as does the expert operator. Reflex and neutrodyne circuits come in the Radio frequency class, but often are satisfactory, and simple to operate.

## RADIO INDI-GEST

### SOCIETY NOTES OF WALLA WALLA

WALLA WALLA.—Rozee, author, Jennie Jerome and Goofey, co-authors of “In Search of a Kanoofis” left here last week on the annual weekly mail boat following their successful termination of the Kanoofis hunt. The Kanoofis, a beautiful thing, was boxed up in a gold-plated cage and will be exhibited in the States at all of the 336,782,195 National Radio Exhibitions, due to be held ere 1924 yawns. The departure was touching. The three were broke, so it was necessarily touching, very. Willie Bazoo, native basso (picture herewith), sang a tear-bringing farewell, entitled, “Properly Adjust Your Grid Bias With Your Potentiometer M'dear, For I'll Broadcast to You on Electromagnetic Waves When You're Gone.” (A trust song. Wotta we care about the trust?) The picture was taken of Willie just as he threw the dice on his parting shot. He parted with everything he had but it's warm in Walla Walla.



Willie Bazoo

The Walla Walla Chamber of Commerce is planning a drive for a greater Walla Walla. Of course, the Indi-Gest broadcasting station will come in for a large part of the advertising campaign. C. F. Jenkin's invention, Radio Movies, will be used to exploit and broadcast the beauties and grace of the unbleached and uneducated youthful maiden dancers. Sweet Cookie, premiere danseuse, is depicted. (Well what do you know about that?) Although she is here shown greatly reduced, she was formerly much larger but took Indi-Gest's broadcast weight-dissolving exercises. Sweet Cookie attributes all her grace to Al Brown, who drew her.



Sweet Cookie

The contest for a name for the Indi-Gest plant is growing very heated. Natives of Walla Walla are betting every bead on various contributors. Brambdin Bray, announcer, wants more names. Send 'em in now before the Christmas rush.

### SURPRESSED DESIRE

We oft'times have our secret desires  
And little dreams of life. (Do tell.)  
However, I've no thoughts of fame;  
Too late—I have a wife. (Lost hope.)

But just the same I have one wish  
Although I am not single, (Out, oui.)  
I hope some day to accomplish the  
Last line of this jingle. (Drive on.)

For four long weeks I've waded through  
A would-be poem, balmy, (Coo, coo.)  
That traveled to the South Sea Isles  
From the land of the salami. (Hot dog.)

I am a simple sort of man,  
A peace loving goofus, (How quaint.)  
But I would like to kick the pants  
Of the guy that wrote “Kanoofis.” (Zowie!)  
ROTOR E. GAPP.

Clipping from the New York Evening Mail tells just how careful Miss Eleanor Fitzgibbons is of her brand new pet flock of Jersey cows. Sez it, “Absolute cleanliness and Radio concerts are other items which go to make them (the cows) contented.” Never would we wish to dispute Miss Fitzgibbons' reference to the cows, but we say that this sounds like the opposite sex to us.

### A-B-C Lessons for Indigest Beginners

Chapter IV—A Brass Band Sleuth, So to Speak  
BY GOSH

D IS for detector,  
(Not of the Sherlock brand)  
That changes Radio wavelets  
Into “Skinktown's Marine band.”

### We'd Say, “Well, Georgie, How's Things?”

Indi: Do you think there must be blood on the moon when Station WOC broadcasts material like this?

SANDMAN (enthusiastically):  
“Now, little boys and girls, Betsy Ross heard a knock and she opened the door and there stood—why, whom do you suppose?—Why, there stood George Washington! Now, little boys and girls, what would YOU do if you heard a knock and opened the door and saw George Washington standing there—  
Yes, little boys and girls, what WOULD you do? I imagine that his presence on MY front porch would make me well—er—nervous, to say the least!  
LE MOQUEUR.

### How to Transform a Transformer

Dear Indi: (For your Kinks Department.) Having been troubled with an incessant induction for several weeks from a nearby leaky power transformer, I found I could eliminate the racket by placing a stick of picric acid behind said transformer and igniting same. This method is very effective.

P. S.: Excuse me, I forgot to enclose \$1.00. Maybe I can send it next Friday. Please send me a Kanoofis.  
EDDY CURRENTS.

Here lies Francis  
Alagonquin Kline.  
Who plugged in his phones  
On a high-voltage line.

### No, We Need Something Stronger

My Dear Sir: Having noted your anxiety over a name for your super bum broadcasting station at Walla Walla, I hasten to submit all the words in the unabridged edition of Webster's great work. This surely ought to win the grand prize with ease.  
AUNT ENNA.

### We'll Bite. What Is It?

Dear Indi: Hah! I have you at last. You thought you could get away with something when you let Jennie Jerome end the “Kanoofis” hunt by finding it in the form of the silk thread off the corner of a dark red Turkish towel. BUT Turkish towels have no silk threads. I know as a result of many Saturday night experiences. Now, tell the truth. What IS a Kanoofis?  
ALAGONQUIN TONSILS III.

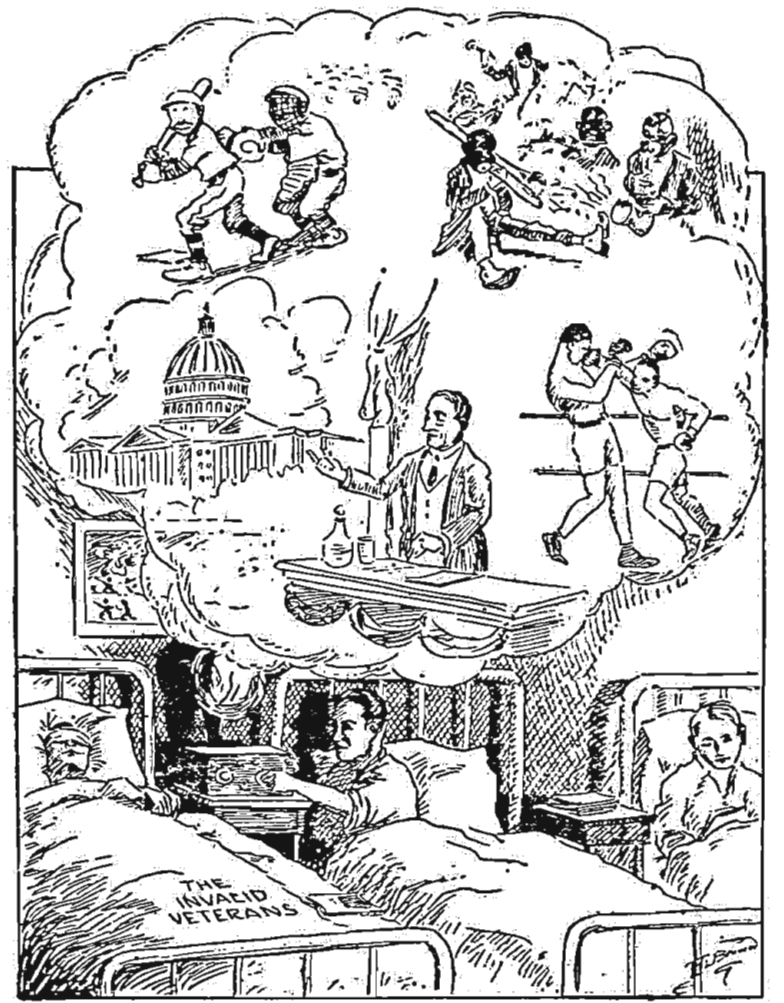

## Condensed

By DIELECTRIC

Another broadcasting station has been flattered in having a Wisconsin infant use their call letters to form the name Wallace Gordon Yadon. The initial letters will be recognized as associated with the popular Schenectady station WGY. In the south, not long ago, the call letters of a well-known station were used in naming a little girl “broadcaster.” In this case, it will probably be either an announcer or Radio operator. What has the station given its name-sake?

In the case of a shortage of engineers in some railway work, a Radio message broadcast recently brought a supply of college men who are pursuing courses in engineering. This is a pretty sure way of reaching those you are seeking, for the news is quickly spread and even though you are not the one fitted for the work your interest in the broadcast will lead to telling others who may not have receiving sets. It is surprising how seldom Radio is resorted to for this emergency when it is considered how effective it is.

In carrying on chess games between passengers aboard two ships nothing startling has been disclosed, except that the games may be called on account of losing contact with each other. This same form of pastime has been indulged among Radiophans ashore and has given the impetus to arranging contests of debating, etc., which not only enlarges the field of sport but carries it to the most modern arena—the expanse of air. It seems to me entirely possible that we shall learn of a new game to be played by certain passengers coming to our shores from abroad, which will consist of large paunches and various shaped bottles; the object being to empty as many of the latter as possible into the former before reaching the three mile limit.

It is yet entirely too early to presume a prediction that vertical antennae prevent static interference acceptable as fact. From the result attained by two men in California, who raised an antenna vertically by means of a kite, hope may be given to despondent summer fans. Experts have been working hard to find a real way in which the annoyance of static might be eradicated. None genuine has yet been found. We will await further experiments with the vertical idea before tearing down the aerials now in use.

Any fan living within a few doors of a single circuit operated by a new “bug” will readily appreciate the effectiveness of scrambled speech for preventing clear reception. The A. T. & T. made the announcement that they had successfully carried on experiments in transmitting messages unintelligible to any save the one with a set capable of unscrambling them. Privacy may be had, but at what expense? That is the point which most concerns us just now.

Many a watch, some grown to clock-like proportions and others still in their midgety, is unsheathed before the receiving set and made to conform with the time sent out from Arlington twice daily. This is an important feature in broadcasting and eliminates the necessity of having a wave length in tune with the naval station. Farmers especially profit from the broadcasting stations relaying the time signals. In Paris it has become impossible to transmit time accurately because of the vibrations in the city upsetting the delicate adjustments of the instruments. Hence they must take time to transport time to a less disturbing location.



# First Steps for Beginners in Radio

## Chapter IX—Radio Frequency Amplification

By Thomas W. Benson, A. M. I. R. E.

**BEGINNERS** will find the accompanying series by Mr. Benson very helpful in learning the rudiments of the popular science of Radiotelephony. The articles yet to appear are:

- Chapter X—Audio Frequency Amplification.
- Chapter XI—How Super Regeneration Is Accomplished.
- Chapter XII—Reflex Circuit Operation.
- Chapter XIII—About Headsets and Loud Speakers.
- Chapter XIV—Batteries Used in Radiophony.

**R**ADIO frequency amplification is a simple method of increasing the energy in the Radio receiving set before the signals are detected and the modulation wave made audible by a tube or crystal detector. Strictly speaking an amplifier of this type amplifies the carrier waves but should be so designed as not to distort the modulation wave. The advantage of this form of amplification lies in the fact that it will not amplify currents at audible frequencies and can therefore

kind of iron other than the softest, built up from very thin sheets. Iron core transformers are difficult to design for this purpose and those on the market are usually the result of cut and try methods. Air core transformers are easier to build and are often described in the technical press. They usually consist of two coils of fine wire wound close together on a wood or fibre form. The disadvantage of transformer coupling lies in the fact that a transformer operates efficiently over but a short band of wavelengths and when a wide range of wavelengths are tuned some means are required to change the inductance values of the windings on the transformers. Thus a certain make of transformer is rated to cover a wavelength range from 200 to 500 meters. As a matter of fact this transformer operates at its highest efficiency on a wavelength midway between these limits and when waves either side of that value are tuned the increase of energy per step of amplification is reduced.

### Radio Frequency Amplifiers

Just how a vacuum tube functions when acting as a Radio frequency amplifier may be explained, by Figure 40. Here is shown one stage of Radio frequency amplification coupled to a detector tube. It

tube where they are detected and made audible. Obviously the more effective this coupling can be made the more energy acts upon the grid of the detector tube and the louder will be the signals. When additional stages of amplification are used the same method of coupling is em-

extremely loose coupling. Its use is not advised beyond one stage as it makes the selectivity of the set so fine that it is difficult to pick up a distant station.

### Coupling Between Tubes

The use of resistance coupling between tubes for Radio frequency amplification

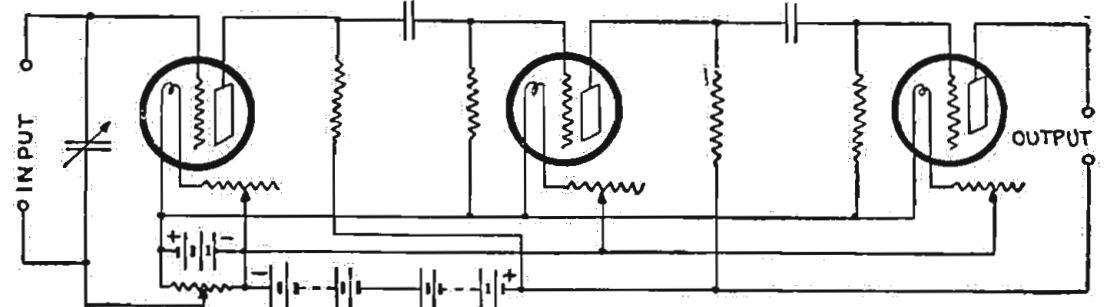

Figure 42—How resistance coupling is employed with grid leaks to control grid potentials

ployed between them. We must be careful, however, to keep the grid potentials of such a value as not to push the plate current over the bends in the curve. Should this occur the plate current wave will not follow exactly the grid current wave and distortion will result.

### Resonance Coupling

As a rule transformer coupling is not as efficient as impedance or resonance coupling. In Figure 41 is shown a circuit employing resonance coupling or tuned Radio frequency amplification between the first and second tube with transformer coupling between the second tube and detector.

It will be remembered in the chapter on regeneration it was shown that an inductance in the plate circuit would transfer part of the energy back into the grid circuit through a condenser. In a resonance coupling we have practically the same thing except that the energy is transferred to the grid of a second tube. The inductance and condenser shown connected between the positive battery and the plate form a tuned circuit.

When the set is functioning and the plate current of the first tube varies in synchronism with the grid currents the plate circuit is tuned to resonance by means of the variable condenser across the inductance. Due to the high impedance of this tuned circuit the resultant reactive effect of the inductance is transferred through the condenser to the grid of the second amplifier tube. The energy from the second tube is then passed on by the transformer to the detector tube. When a fixed impedance is used in this circuit it is connected in place of the inductance and variable condenser but has the limitation of functioning only over a narrow band of wave lengths similar to a transformer.

Tuned Radio frequency makes the circuit extremely selective and when used the simplest form of tuning may be employed in the aerial circuit. It acts in all respects like a two circuit tuner with

has not the disadvantage of working only over a narrow band of wave lengths but is not usually used for the reason that it is very inefficient on waves below 1000 meters. The principle on which this type of coupling works is similar to the others, utilizing a high resistance instead of a high impedance.

The transformers and tuned resonance amplifiers have a high impedance, that is, they offer a high resistance to the high frequency currents but have a low direct current resistance. This is, of course, due to the inductive action of the windings. The resistance coupling on the other hand offers a high resistance to both plate current and to the high frequency currents. A typical circuit using 2 megohm units as coupling between tubes is shown in Figure 42.

The operation of this circuit may be outlined thus: When put into operation there is a certain voltage drop across the coupling (Continued on page 14)

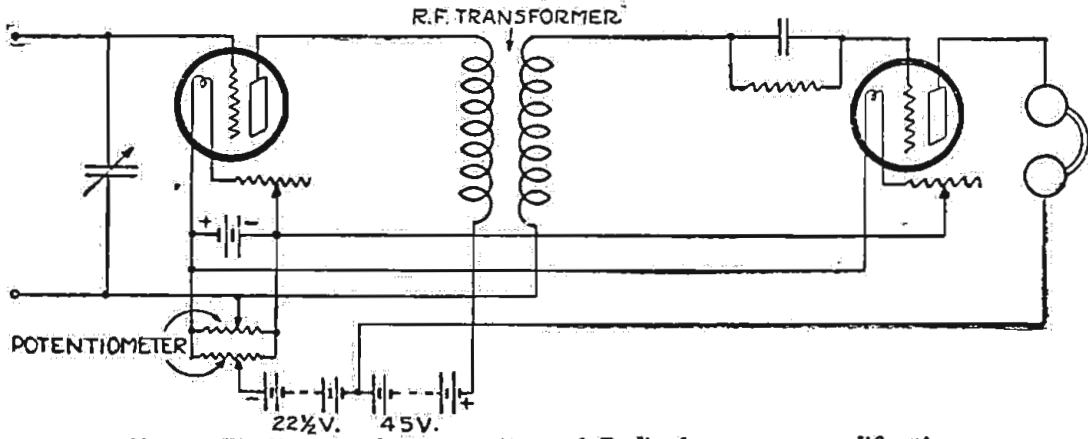

Figure 40—Showing how one stage of Radio frequency amplification is transformer coupled to detector

be carried further than audio frequency amplification which is limited to two or at best three stages. The other features of Radio frequency amplification are that it makes the set more selective and enables one to take advantage of the square law of the detector.

### Intensity of Impulses

It is a well known fact that certain minute Radio impulses will not cause a detector tube to function but after the impulses reach a certain intensity the response in the plate circuit varies approximately as the square of the grid potential change. Thus, when the grid charge is doubled the plate current change is four times as great. With Radio frequency amplification we can take an extremely weak signal and intensify it to a point where it will operate the detector tube at its highest efficiency. On the other hand audio frequency amplifiers can only am-

will be remembered in the chapter on the tube detector a curve was shown to illustrate that variations in grid potential would affect the plate current in a certain manner.

The curve of a tube when used as a Radio frequency amplifier with a high voltage on the plate will have practically the same shape but will be further to the left of the zero line and higher. When the tube is connected into a circuit like the one shown in Figure 40 the grid potential is adjusted by means of the potentiometer to such a value that the plate current is halfway down the slope of the curve. Now when a current flows in the aerial tuning circuit it will alternately impress negative and positive potentials on the grid.

When a positive potential is impressed upon the grid it will increase the slight positive potential already there and the

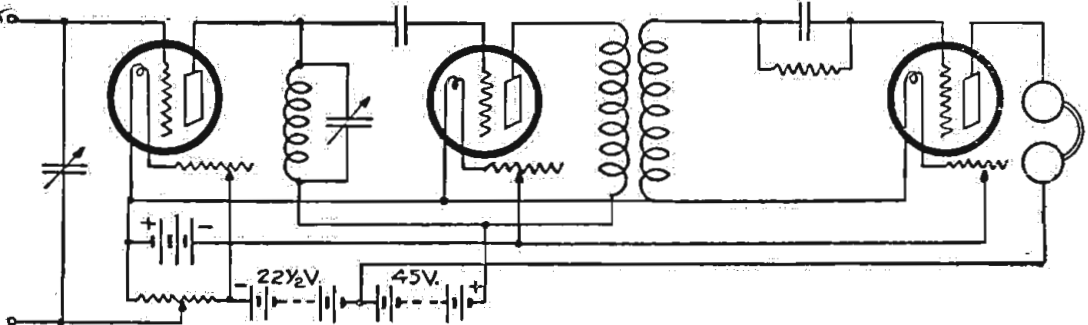

Figure 41—Showing two stage amplifier using tuned coupling in first stage and transformer in second

plify detected waves and weak signals that do not affect the detector are not heard at all.

There are numerous stumbling blocks in the way of obtaining high amplification per stage at Radio frequencies and for that reason more stages are necessary to obtain a given increase in energy at Radio frequencies than required at audio frequencies.

The chief obstacle is the high capacity existing between the elements in a tube itself. Actually this capacity is low but it is sufficiently high to cause trouble at Radio frequencies. This tube capacity can only be reduced by proper tube design so one has to get along the best way possible.

### Several Tubes in Cascade

The use of several tubes in cascade implies the use of some means of coupling the plate circuit of one tube to the grid of the next and we have three methods in common use for accomplishing this, namely, by transformer coupling, resonance, or impedance coupling or resistance coupling.

The first method makes use of small transformers either wound on a small finely laminated iron core or a nonmetallic form. The extremely high frequency of the currents forbids the use of any

plate current will be increased. When a negative potential is applied it will reduce the positive potential and less current will flow in the plate circuit. The plate current will then rise and fall in exact reproduction of the current flowing in the aerial circuit at Radio frequencies but of much greater values.

### Function of the Transformer

The function of the transformer is then to transfer these currents to the second

### POSITIVE RESULTS

are being obtained by thousands of satisfied users of the

### EASTERN COIL SETS for Cockaday Circuit

The remarkable features which are making this circuit more popular each day are its simplicity of construction and control—wonderful selectivity—distance records—clearness and loudness of reception, and the fact that all capacity squealing, interference, etc., are eliminated.

Made as per specifications of Mr. Cockaday, using No. 18 wire with D coil bank-wound.

COMPLETE SET OF B, C AND D COILS—PRICE ..... \$2.75

Hook-up, directions and material list furnished free with each set of coils.

Mail Orders Filled. Dealers Communicate

EASTERN RADIO MFG. CO. 22 WARREN STREET NEW YORK, N. Y.

**WE REPAIR**  
**WD-11, \$3.50**  
and OTHER  
VACUUM TUBES

Excepting  
VT-I and VT-II

MAIL ORDERS Solicited and Promptly Attended To

**H & H RADIO CO.**  
516 Clinton Avenue NEWARK, N. J.

**TWO SUPERSENSITIVE CIRCUITS**  
(Both Copyrighted)

My Highly Improved Reinartz brings in all important stations on both coasts and Mexican border, loud, clear and without distortion. We dance to music from Atlanta received on one loud Baldwin unit. Build one of these wonderful sets from my blueprints and specifications, price 50c, or with a perfect and complete double wound spiderweb coil, \$3.00 by mail. No other windings used. Photo of my set on a glass panel with every order.

This copyrighted circuit is the most successful of any Reinartz modification yet produced, and is imitated the most. Thousands are in use.

My W. D. 11 Circuit is especially designed for use with the "Pickle" tube and brings out the full value of that little tube as no other circuit can. Stations 1000 miles away come in clearly on one tube. This set is small, complete, portable. For the man who wishes the highest efficiency, this is the set to build. Price of blueprint and specifications, 50c, or with complete and perfect windings, \$3.00. Photo of set with every order.

Either set is easy to build, easy to operate. Everything clearly shown.

Sets built from these plans will receive all broadcasting stations operating under the new laws. Their wave length range is from 140 to 670 meters.

**S. A. TWITCHELL**  
1925 Western Ave. Minneapolis, Minn.

How to Make  
**a Reinartz Receiver**

Complete  
**BLUE PRINTS**  
for the construction of a Reinartz Receiving Unit and two step amplifier.

**INSTRUCTIONS FOR ASSEMBLY**  
Description of apparatus and accessories and details of tuning.

**WINDING A REINARTZ COIL**  
Cabinet Dimensions  
Panel Layouts  
List of Parts

Send only money orders—no checks or stamps. Coins at your own risk.

Book Department  
**Radio Digest**  
123 West Madison Street  
CHICAGO, ILL.

**Only 50¢**



# Phantom Receiver for Vacation Use

## Little Aerial Needed to Bring in Stations

By Leon W. Bishop, 1XP

One of the most interesting circuits for a single tube that may be constructed for vacation use and which may be used in

### WORKSHOP KINKS? EARN A DOLLAR—

**T**HERE are many little kinks worked out at home that would aid your fellow Radio worker if he only knew about them. There are new hook-ups, new ways of making parts and various unique ways of operating sets that are discovered every day. Radio Digest is very much interested in securing such material. Send them in with full details, including stamped envelope so rejected copy may be returned. The work must be entirely original, not copied.

RADIO KINKS DEPARTMENT,  
Radio Digest  
123 West Madison St., Chicago, Ill.

car or at camp and requires little or no aerial, is the phantom receptor. The circuit is the adaption of two Armstrong principles which really produce distance and clarity for a small constructional cost.

The success of any circuit depends upon the constants used, particularly this one which would seem to be a standard regenerative circuit but is completely changed by a large tickler and variable grid leak.

This circuit has been designed for the new wave bands of 2,000 to 550 kilocycles (150 to 545 meters) and includes the amateur. The circuit is more efficient on the shorter wave bands so it is possible to get the class A stations as loud as the class B, which is not possible with other types. Due to great flexibility the circuit will work equally well on phone, CW, ICW, and spark which will insure you of all classes of service no matter where you are.

#### Works Excellently on Short Aerial

When using this one tube circuit in a car with a 4-foot aerial it is equal to a three stage Radio frequency amplifier and detector. Due to the short aerial used it is possible to receive through bad static (QRN) and for this reason alone is of considerable value during the summer months.

The two best tubes to use are the UV-199 and UV-201A. The rheostat should have the resistance advised by the makers of the tubes. The B battery can be anywhere from 45 to 90 volts. The two fixed condensers .00025 and .002 mfd. should be of the mica dielectric type. The variable condenser should have from 17 to 23 plates (.0003 to .0005 mfd.)

#### How to Make Leak

The variable grid leak is important and should be variable over a range of from 50,000 ohms to 5 megohms. Several commercial types that were tried did not have the range claimed, so it might be advisable to build your own.

For that purpose purchase a ten cent roll of black picture binding paper tape whose dull black surface is slightly conductive and whose resistance can be readily lowered with an extra soft lead pencil. This grid leak can be arranged with a sliding arm or switch and contacts but it must be variable over a wide range and capable of fine adjustment.

#### Coupler Special Also

Like the grid leak, the coupler is of special design and the following values should be adhered to. The best combination to use is the rotor and stator of a standard coupler wound as follows. The tube (stator) should be wound with as large a wire as possible. Starting with 20 turns on the rotor side of the tube, tap every 10 turns until you reach 120 turns, which will leave 11 taps.

The rotor is also a real job for it is tapped in a similar manner. Start on one side of the rotor with 40 turns and tap



**THE PERFECT SYNTHETIC CRYSTAL DETECTOR, SENSITIVE OVER ENTIRE SURFACE. No Hunting for "Spots." Loud and Clear. Endorsed by thousands of satisfied users. Sensitiveness Guaranteed. Price, Mounted, 50c**

**14 K. GOLD SUPERSENSITIVE RUSONITE CATWHISKER. Permanent. Will Not Oxidize. Price, Mounted, 25c**

**RUSONITE REFLEX CRYSTAL. Manufactured Expressly for Reflex Circuits. Will Stand Up Under Heavy Plate Voltage. Guaranteed. Price, Mounted, \$1.00**

Order from your dealer or direct from

**RUSONITE PRODUCTS**  
15 Park Row New York, N. Y.

## ONE TUBE EQUALS 3 STAGES R.F.

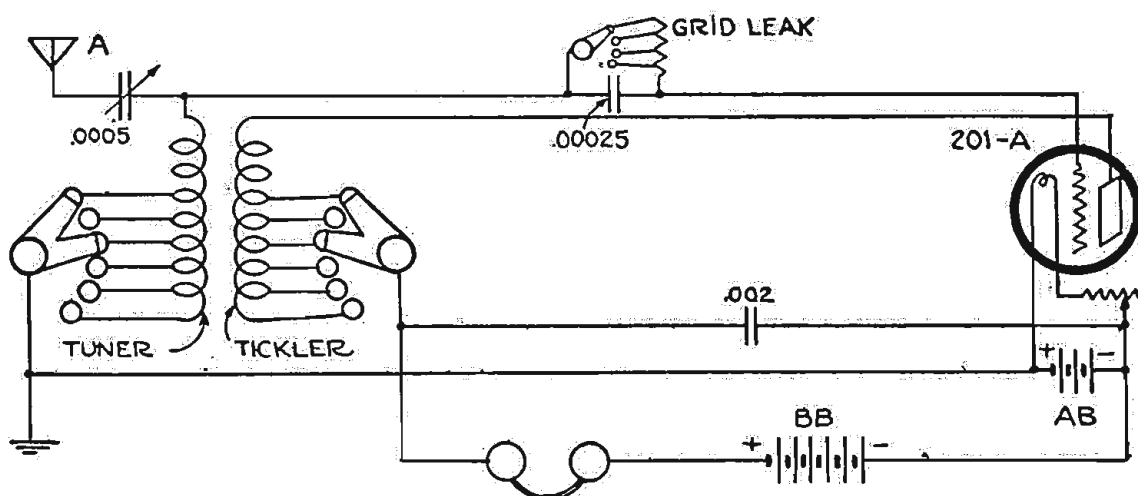

off every 10 turns until you have wound on 120 turns and you then will have 9 taps. These taps can be passed through the rotor shaft to switch points on the panel or a switch may be mounted on the rotor. Fine wire may be used on the rotor to accommodate the necessary 120 turns.

A warning is given against the use of shellac on the windings. Firm windings may be obtained by drilling holes at each tap off and binding the wires in them.

Do not use honeycomb coils. Either double or single switch arms may be used. The 180 degree types of mounting rotor can be used. Do not tap the coils any coarser than 10 turns, but finer if possible.

#### Operation of Circuit

The best antenna or collector system is to connect the variable condenser at point A to a good ground. No other connection is necessary. There are five adjustments on the set; the grid tuning coil, the tickler coil, the coupling between these coils, the variable grid leak, and the variable condenser. The filament rheostat is not critical so this is not regarded as an adjustment.

As the tickler coil and grid leak are increased, a super-regenerative condition will be met. The pitch of this note can be varied by the grid leak and should be adjusted until it is above the point of audibility and only a slight hiss is heard in the phones. At this point a wonderfully sensitive condition exists for all classes of phone and CW and will tune in contrastingly clear as compared with any single tube circuit.

A given wave length is tuned in by means of the variable condenser and grid circuit tuning coil. The tickler and grid leak are merely adjusted to conform to this condition. The resistance of the grid leak should be so arranged that it will give out a bad screech as it is increased and follow through an intermediate series of pure notes until it passes out of audibility, with a range of adjustment on either side.

The correct polarity of the tickler coil in the plate circuit will have to be tried out by reversing the leads until the best results are obtained.

#### Can Be Used as Transmitter

This is a standard circuit and may be used as such with an aerial and ground by reducing the tickler coil turns with the switch. With an aerial and ground the circuit can be used for transmission with a power tube and increased B voltage. All classes of super results may be obtained which makes it an ideal vacation outfit.

There are several aerial combinations that work well. One of the most interesting (Continued on page 14)

## Easy Way to Construct an Open Circuit Jack

The accompanying illustration will show how to make an open circuit jack, with a small piece of wood, some brass screws and a piece of spring brass about 3/8 inch wide, a short piece of brass tubing to fit the stem of a standard plug, which is threaded full length and is long enough to pass through the panel and have two thin nuts on both sides (unless the tubing can be strongly threaded into the panel itself, in which case the nuts may be eliminated).

The drawing is almost self-explanatory but it might be a good idea to put a thin coating of a good strong glue on the end of the wood block next to the panel, after

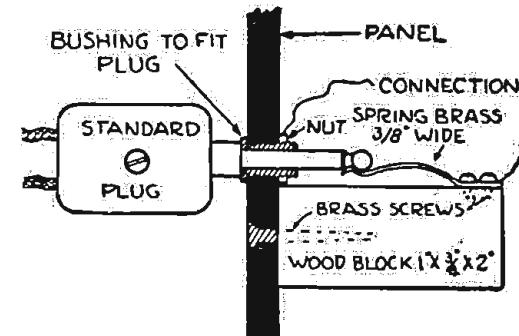

the block has been fitted and ready for the long brass screw inserted and tightened. This will prevent the wood block from turning.—C. W. Pomeroy, St. Louis, Mo.

#### A Suggestion

Wooden rotor balls, panels and paper tubes should be boiled in paraffin before winding to prevent shrinkage and to further improve their insulating properties.

#### Recharging Storage Cells

Both the filament and plate batteries should be tested at regular intervals to be certain that the voltage has not fallen below the value necessary to normal steady operation, as current variations resulting from run down batteries produce harsh notes in the receiving telephones resembling static disturbances. Storage batteries of the lead-acid type need recharging when the potential has dropped to 1.75 volts per cell. When the voltage of a block of B battery normally rated at 22.5 volts has fallen to 15 volts the battery should be renewed.

#### Resistance of Grid Leak

An important feature in securing proper operation of a detector tube is the resistance of the grid leak. A leak of the pencil mark type offers the advantage of being easily varied by increasing or decreasing the width of the mark and thus adjusting the resistance until maximum amplification is produced by the tube. Grid leak mountings which permit the interchange of resistances provide an easy method of experimentally determining the proper resistance for a particular tube, these resistances being obtained commercially in units varying from .05 megohm to 5 megohms.

**Crystal Tube Detector**  
Replaces crystal and cat whisker. Always set and alive, loud and clear. No more fishing for live spots. Guaranteed to detect perfectly. Simple to connect—full instructions. Needs no batteries and never burns out. Made of the famous B-Metal. Sold by all live dealers or can be ordered from

**The B-Metal Refining Co.**  
3134 Trumbull Avenue  
Detroit, Mich.

Price \$1.50

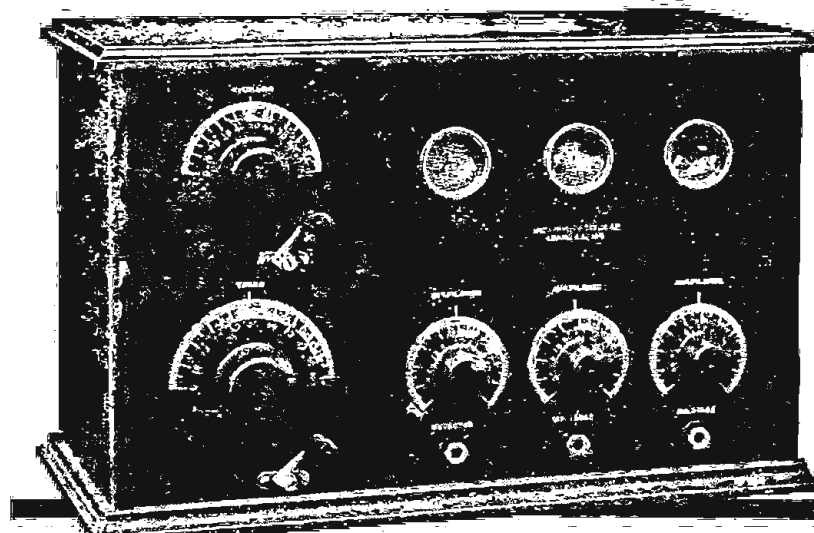

Michigan "Senior" Regenerative Receiver

### "Delighted"

It is almost uncanny, how that one word, "delighted," is repeated in the hundreds of letters we receive from users of "Michigan" Sets and Parts, as well as from the dealers who handle them.

A sense of relief and satisfaction is also expressed that, at last, they have discovered a Radio concern that *knows radio*, and which conducts its business in a business-like way.

#### Michigan Regenerative "Senior" and "Junior" Receivers

represent the latest and highest development of satisfactory long distance radio reception. All Michigan Receivers give superior results when used with any of the dry battery tubes now available.

They are licensed under Armstrong U.S. Patent 1,113,149 and pending letters Patent 807,388.

Send for Our Catalog.

**MICHIGAN RADIO CORPORATION**

GRAND RAPIDS, MICHIGAN

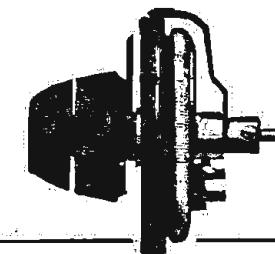

Michigan Accessories and Parts

Include two-stage amplifier, and a long line of highly perfected rheostats, variometers, variocouplers, plate condensers, grid condensers, etc.

Michigan Receivers are equipped with our patented *Split-hair Vernier Dial Control*. This device is also sold separately.

### FORMICA

A Laminated Phenolic Condensation Product  
**SHEETS TUBES RODS**  
**RADIO PANELS**  
POLISHED BLACK FINISH

CUT PERFECTLY SQUARE TO ANY SIZE

1/32" THICK	1/2¢	PER SQ. INCH
1/16" THICK	3/4¢	PER SQ. INCH
3/32" THICK	1¢	PER SQ. INCH
1/8" THICK	1 1/2¢	PER SQ. INCH
3/16" THICK	2¢	PER SQ. INCH
1/4" THICK	2 1/2¢	PER SQ. INCH
3/8" THICK	4¢	PER SQ. INCH
1/2" THICK	5 1/4¢	PER SQ. INCH

SEND FOR COMPLETE PRICE LIST PROMPT ATTENTION TO MAIL ORDERS DEALERS PRICES ON APPLICATION

**STARRETT MFG. CO.**  
519 SOUTH GREEN ST. CHICAGO



# How to Make a Camper's Portable Reflex Set

## Part IV—Wiring Details, Tubes to Use, Tuning, Conclusion

By H. J. Marx

**I**N WIRING this set the writer found it most convenient to put in all the battery leads first—running from the battery binding posts to the battery switch or direct to the sockets, rheostats and potentiometers. A little time should be spent in laying out these leads in the shortest, most direct and neatest manner. Contacts at terminals should be firm and solid; binding posts and thumb nuts should be locked in place if possible. A portable set gets a lot of knocking around which may loosen the connections. All soldered joints should be carefully and well made. Careless work will be a constant cause of trouble and will necessitate repeated opening of the set for repairs. A common source of trouble is the tendency to solder leads to fixed condens-

grid and plate leads are taken care of. Naturally these are the greatest trouble makers and care should be taken to see that they are made as short as possible and avoid parallel runs.

The wiring is completed with the addition of all by-pass condensers. Too many fans do not realize the importance of these condensers and that is usually where the trouble starts. Poor grades of condensers will cause lots of trouble. Since they are added last there is a tendency towards carelessness in the rush to complete the job. The writer has seen a number of sets where the sole trouble was due to such carelessness. Condensers touching other leads and apparatus change the circuit to such an extent that reception is either impossible or very unreliable.

A small loud speaker and the headphones also fitted into the battery compartment without crushing, thus making the set a completely portable unit including loud speaker and loop.

### Use of Outdoor Aerial

If desired, an outdoor aerial can be used by adding a variocoupler and connecting the secondary to the loop terminals of the set. The aerial and ground connections are then made direct to the primary.

### Tuning Operation

In tuning these circuits there are four types of controls to keep in mind. First, and naturally most important, is the variable condenser for tuning to wave length. The second set are the rheostats. These control the filament lighting and

the first Radio frequency tube and the other to control the feed back or reflexing of the audio frequency current into the grid circuit of the second tube. Both then have an adjustment not necessarily very critical which will balance the circuit as a whole. These adjustments vary slightly for different wave lengths but not so much as to make tuning difficult.

After the knack of setting the rheostats correctly is accomplished, the wave length control by means of the condenser is simple, but it is the potentiometers that often worry the beginner. Directions here are difficult since their setting varies with the tubes, the plate potentials and the rheostat settings. It is just a matter of a little experimenting.

(THE END.)

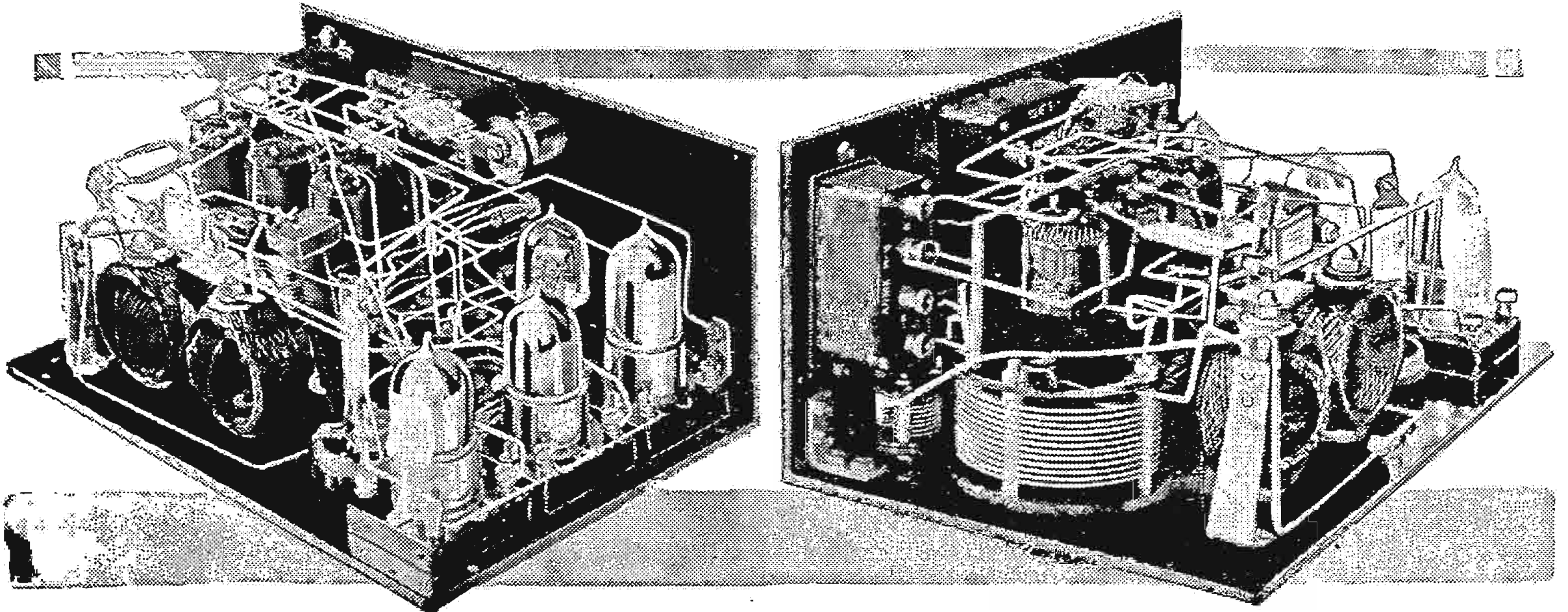

ers. This is permissible if the constructor is real handy with the soldering iron. Unfortunately the average fan is not sufficiently skilled to make a good soldered connection, with the result that when the heat is applied to the condenser terminals it is transferred to the plates and mica dielectric. This fuses and breaks down the condenser or alters its capacity value. It is best to use wire terminals fastened to the condensers with brass machine screws and nuts. The leads should be soldered to the terminals before they are bolted to the condensers.

The battery leads from the transformers should next be put in. After these the

plate battery voltage depends on the type of tubes used. In reflex circuits, regardless of the tube, it is best to try various plate potentials until maximum volume desired is reached or where the distortion begins. More than 90 volts will hardly be necessary. Four of the usual small size 22½ volt units will fit in across the battery section. Naturally the dry cell tubes were used. This called for two 1½ volt dry cells which are also placed in the battery compartment. For the terminals on the side panel, the small plug and jacks were used, thus permitting rapid connections to be made with the least amount of difficulty.

are therefore the main controls of electron emission. These can be turned on just a certain distance, beyond which the set spills over. This adjustment is varied somewhat in conjunction with the potentiometer adjustment. The rheostats then should be turned on to the point of quiet operation. The third controls are the potentiometers. These govern the grid potential and not only effect the volume, but also the clarity or modulation. They should not be advanced too far or reception will be distorted. The fourth set of controls are the variometers, since they have two distinct functions; the one to control the plate circuit oscillations of

### Core for Transformers

Radio frequency amplifying transformers using an air core have a natural period at which they should be operated to produce satisfactory amplification. The employment of a special type of high frequency iron for the core of these transformers results in obtaining increased voltage amplification and also permits the satisfactory use of the transformer on a greater range of wave lengths. Due to the fact that the use of an iron core has an effect similar to inserting resistance, the amplifier is prevented from setting up high frequency oscillations.

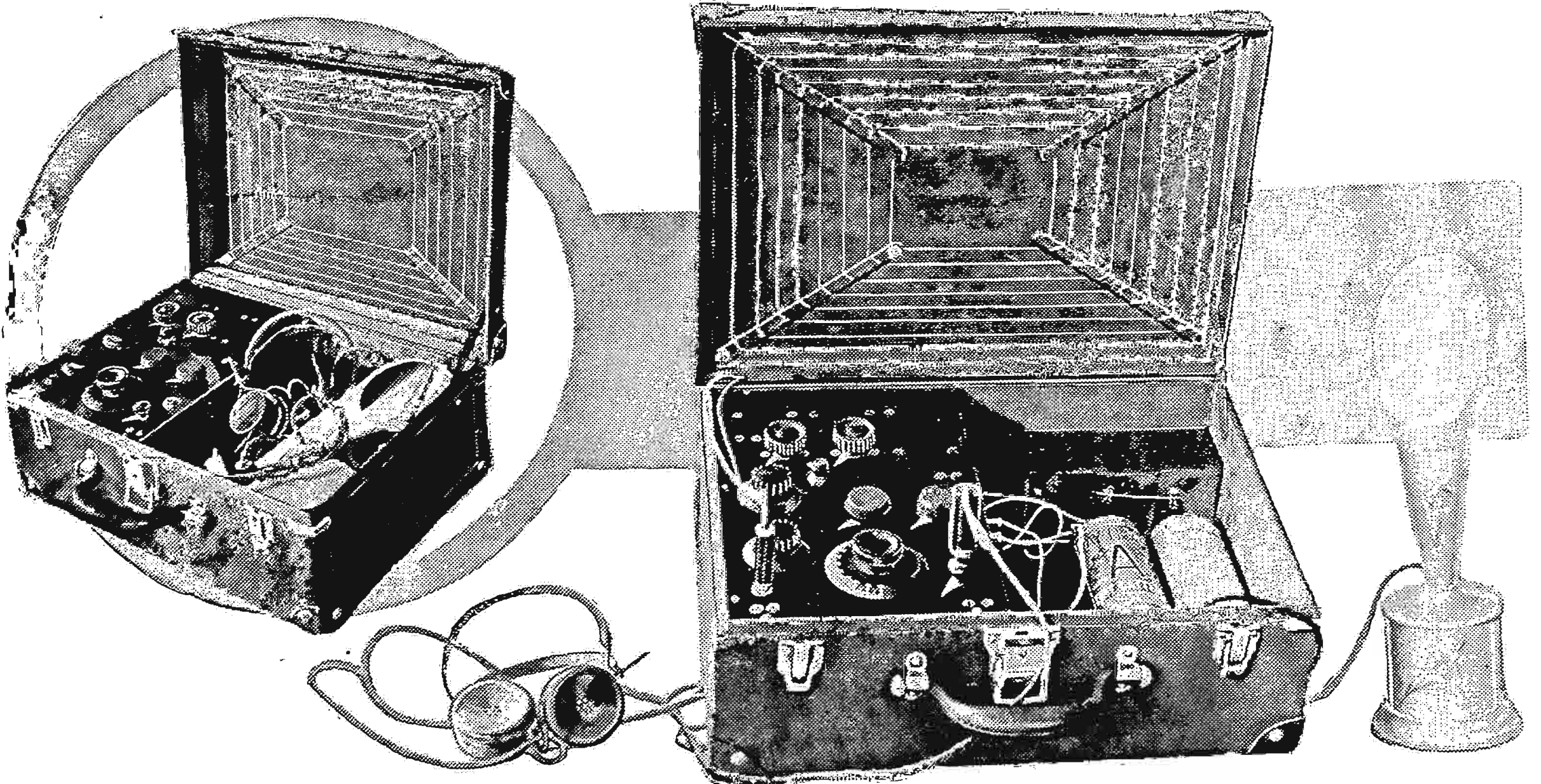



MORROW DOUBLE REGENERATOR

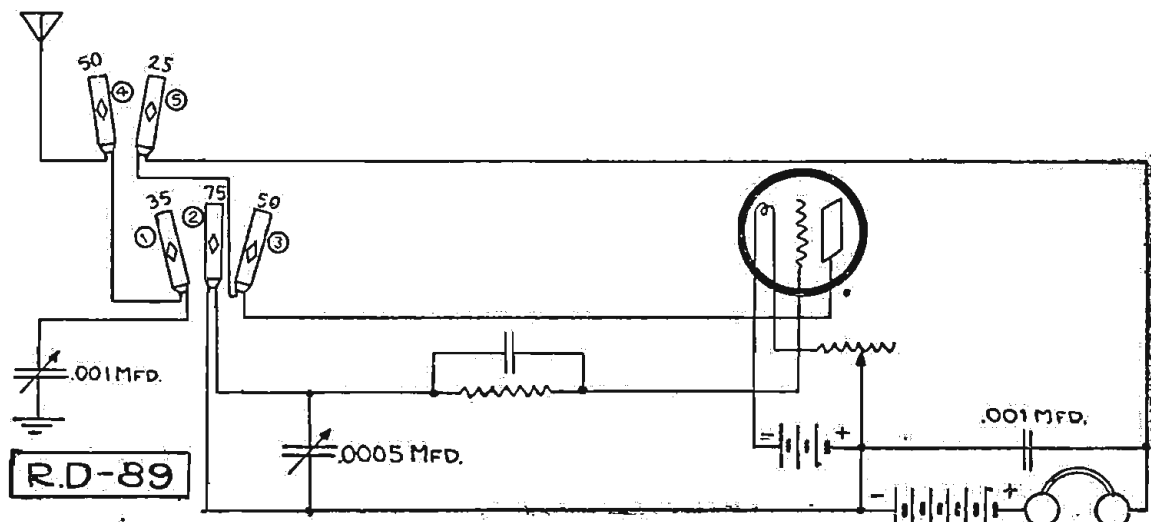

**D**R. B. F. MORROW, New York City, does a lot of experimenting with new hook-ups and when he gets something good he passes it on to us and the rest of the fans. Double regeneration has been tried a number of different ways, but there is always another method, so here it is for our experimental fans to use. It works all right!

Here is what the Doctor says:—  
 "Enclosed find another of my freak hook-ups for some of your readers to try these hot days. After all, if we don't keep on switching wires we'll never get anywhere, and just for fun I present the following arrangement of parts through which I get better results than I had before."  
 "The fundamental idea is not only for

feedback to the grid circuit, but make a separate feedback to the aerial circuit which gives me the theoretical combination of a triple circuit for selectivity and single circuit for volume.

"Coils 1 and 2 now have a transformer effect and throw to the grid energy which has been greatly built up by the feedback of coil 5 into coil 4. At first glance it would appear that the circuit is difficult to tune, which is not the case. I advise close coupling between coils 4 and 5, loose coupling between coils 1 and 2, and varying movements of coil 3. It is important in building the set to make sure that regeneration is obtained with both feedback coils or they will practically neutralize each other and then somebody is going to call me names."

FIRST STEPS IN RADIO

(Continued from page 11)

ling resistance and between the plate and filament of the tube.

Consider now that the grid of the first tube is made positive for half a cycle by the incoming waves. This draws more electrons out of the filament and reduces the resistance of the plate to filament part of the circuit.

The additional current flowing in the plate circuit increases the drop across the coupling resistance and this increase of voltage is impressed upon the grid of the second tube through the small fixed condenser. Thus the second tube further amplifies the wave, repeating the action through all the tubes.

Super-Heterodyne Circuit

This type of coupling is practically useless for short wave work by reason of tube capacities by passing part of the current and reducing the potential applied to the grids of the tubes. Its advantage lies in the wide range of waves over which it will work but they must be above 1000 meters. To overcome this Armstrong devised the Super-Heterodyne circuit. The principle of operation of this circuit is rather complicated but the idea is beautiful in its simplicity.

The first tube in the series is connected like a simple detector tube but the grid circuit is loosely coupled to a tube that is kept oscillating. The oscillations impressed upon the grid of the first tube are of such a frequency that they form a beat current with the carrier wave of the incoming signals.

This beat current is due to the waves of the two currents coinciding and then opposing at fixed intervals giving rise to a current in the plate circuit of the first tube that is of a lower frequency than the carrier waves received. This beat current is still at a Radio frequency, having a wave length of about 3,000 meters. At this wave length the current is fed into a series of resistance coupled amplifier tubes, usually five stages, and finally detected and passed through one or two stages of audio frequency amplification. By this means the resistance coupling is made to operate efficiently and such a receiver is considered the best it is possible to build at the present stage of the art.

Some Radiophans have excellent results with Radio frequency amplifiers while others seem to fail entirely when they attempt to build this type of apparatus, as in one case to the writer's knowledge where a fan installed a five stage amplifier and found his set worked better without it. Failure is usually the result of inattention to details and a little experimenting will often clear up the trouble.

General Rules Necessary

By following a few general rules good results are assured. Use only apparatus of known quality. Cheap instruments are usually worth just what they cost, if not less. Use only mica condensers and tube sockets that have all metal carrying parts well spaced from each other.

Where but one stage of Radio frequency is desired it is best to use a tuned type of coupling thus obtaining good efficiency and selectivity for the set. More stages can be employed using transformers if desired. Where one is willing to make the necessary adjustments two stages of tuned Radio frequency will prove highly satisfactory.

Tuned Radio frequency amplifiers have a tendency to self oscillation and this can be prevented by the use of potentiometers and by care in wiring. Keep the wires as far apart as possible, keep the leads short and let wires cross each other at right angles.

Some constructors shield their panels and instruments but from the writer's experience this is not always advisable. The use of a shield introduces capacity effects that sometimes renders the amplifier useless.

The better method is to build the amplifier without shielding, mounting the tubes and other apparatus well back from the panel and lengthening the control shafts. If body capacity is then troublesome the panel can be shielded as a last resort.

Hard Tubes Used

Hard tubes are used exclusively for Radio frequency amplifiers with a high plate voltage, 60 to 90 volts being used. For local reception where there is plenty of energy received a hard tube can be employed as a detector with a high plate voltage to give louder signals. Where distance is the goal a soft tube in the detector stage with a lower B battery is advised. Crystal detectors are often employed with these amplifiers and prove entirely satisfactory with two stages of audio frequency behind them to obtain loud signals. As a matter of fact a crystal detector gives clear reception with less trouble than a tube. The next chapter will take up audio frequency amplification and discuss the use of a crystal detector with both types of amplifiers.

(TO BE CONTINUED.)

GOOD PHANTOM CIRCUIT

(Continued from page 12.)

ing is to connect the point G to ground and touch the moistened finger to point A. For apartment houses two combinations can be used: (1) Connect the point G to ground and the point A to some metal object or a small aerial in the room; (2) Just connect the point A to ground.

To operate the set in a car connect the point G to the frame of the car through the steering wheel and the point A to the metal top or a small aerial in the top of the car.

When camping out the best collector seems to be a wire from the point A to a ground connection about 6 or 8 feet from the set. A short aerial may also be used. If this is a super it is far superior to

Electric Soldering Iron

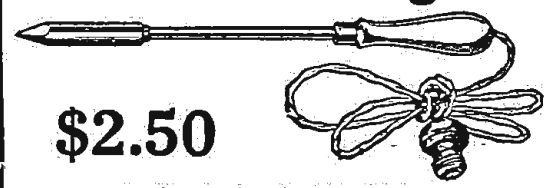

\$2.50

A. C. OR D. C. CURRENT

DEALERS—Attractive Discounts

NOTE: We are the Largest Exclusive Radio Jobbers in the Middle West

**HUDSON-ROSS**  
 123 W. Madison St. Chicago

HAZELTINE NEUTRODYNE ERRATA

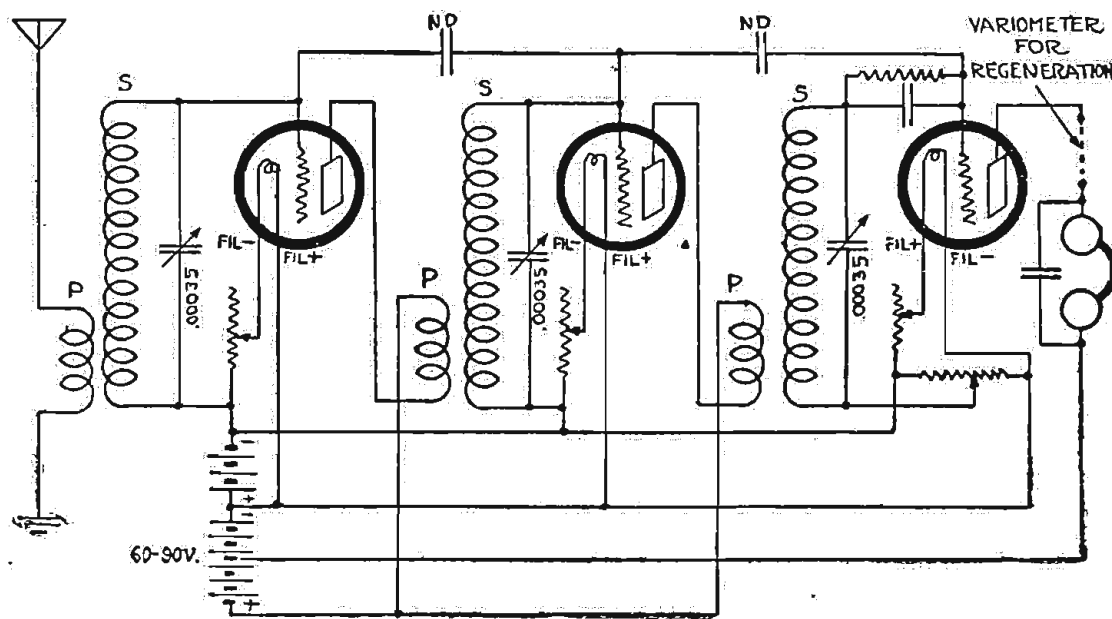

**I**N the June 30 issue of Radio Digest was shown a diagram for the construction of a two-step Radio frequency neutrodyne receiver. In this diagram the grid of the first Radio frequency tube was connected to the plate of the same tube by a short line which should have been omitted in the diagram shown above. This error

of commission may be corrected by breaking the lead described. The corrected diagram is illustrated herewith.

The Hazeltine neutrodyne circuit is proving quite popular to the great body of Radio experimenters on account of its remarkably high ratio of amplification on Radio frequency stages.

anything you have ever tried before in that line and it may be due to the fact that there are no large coils, condensers, or resistances to impede the real action of what a super might be if given a chance.

Mechanical Theory

You have often turned the variable condenser of a standard regenerative set up to zero and received an awful howl in the phones and said that the tube was spilling over. This is a negative charge that accumulates on the grid and leaks off in minute discharges which can be governed by a grid leak. These charges are negative so we can assume that the grid is negative most of the time and that an impressed EMF on the grid circuit would tend to build to infinity during the interval the grid was negative. This seems to prove out, as only a short aerial is required.

As the wave length is halved the amplification is squared by virtue of the increased frequency as compared with the rate of leakage. This may account for

the marked results on the shorter wave bands.

This circuit is the result of a year's experimental work on the ultra regenerator which was originally published in a Boston newspaper August 22, 1922. The work was carried out at Radio Station 1XP.

The French steamship line plans to equip all its passenger ships sailing out of New York with Radio receivers and amplifiers for the reception of broadcast programs.



Get a

Federal Standard HEAD SET

For every member of the family

Add to the pleasure you get out of Radio by permitting all the members of your family to enjoy it at once.

Federal Standard Head Sets are fully Guaranteed. Permanent magnets and a uniform air-gap give just the correct diaphragm action, perfect clarity of tone, and durable efficiency.

Scientific winding and the expert hand-workmanship of master craftsmen give exceptional range and power.

Get these guaranteed head sets from your dealer today and refuse to accept a substitute

Federal Telegraph and Telephone Co.

Factory: BUFFALO, N. Y.

Western District Office: 417 South Dearborn St., Chicago, Ill.



# Questions and Answers

### Distortion

(2478) MGS, Memphis, Tenn.  
I am using an Aerliola, Sr., detector and two stages of amplification using VT2 Western Electric vacuum tubes as amplifiers, 6-volt battery, and 90 volts on the plates of the amplifier. Music from the local station comes in much distorted and sounds just like the ring in a tin pan struck by a wooden instrument. Music from foreign outside stations such as WJZ, WOC, WHB, etc., comes in with a very tinny vibration, also renders the music disgusting to hear. I changed my 90 volts on the plates of the amplifiers to 45 volts and still the music is tinny both on ear receivers and loud speakers, regardless of the amount of amplification or reduction on the detector.

Listening in with my detector tube only the music comes in from the local station clear in tone and distinct, and no better could be desired, but as soon as the amplification is added distortion and the tinny vibration begins regardless of the quantity of power used.

My amplifying tubes are new and have signal corps VT2 Western Electric stamped across the base, therefore I believe them to be genuine.

The distortion evidently takes place in the amplification and not in the detector. Can you suggest a cause and a remedy for this condition as other owners in the city use 90 volts on the plates of the amplifier and are getting beautiful music from the local stations. It seems impossible for me to use more than 45 volts on the plates and get anything like good reception. I am also using Western Electric type 10D loud speaker.

A.—Noting specifications and difficulties of reception with receiver cited, will advise that it should employ 90 volts or over on the amplifiers.

While the distortion may be in the tickler we are more than inclined to believe that it is in the amplifying transformer, probably in the first stage. As a simple test try another transformer in your first stage and note if distortion ceases. If so, the transformer is at fault. Transformers frequently go wrong as the wire used in them is so small that they burn out easily.

### Non-Code Reinartz

(3570) AIA, Austin, Minn.  
I have constructed a Reinartz circuit receiver as per directions furnished in your special booklet on that subject. Using one WD-11 tube and an 80-foot antenna, I have enjoyed Radiophone programs from stations at Davenport, Iowa; Minneapolis, Minn.; Detroit, Mich.; Omaha, Neb.; and Kansas City, Mo. Seems to be working O. K. in that respect. However, one object in building this set was to be able to instruct my Boy Scout troop how to make similar sets with the primary object of affording them means of listening in on code messages. So far I have not heard the least sign of any dots and dashes. Kindly advise as to the reason for this and tell me what change, if any, can be made so I can get these code messages.

A.—Noting your specifications and requirements, we are advising the substitution of an 11-plate for 23-plate variable condenser in the secondary circuit and placing of 23-plate in place of 43-plate between the antenna and tickler coil and placing the 43-plate condenser in series with antenna, all of which is necessary to accomplish reception of code signals. This requires only the addition of an 11-plate condenser and shifting of those now employ in circuit. These combinations will also better receive on from 360 to 400 meters wave length. Code is transmitted by amateurs on a 200-meter wave length.

### Charger and Reinartz

(4129) RH, Seattle, Wash.  
I made a 98-volt 49-cell lead battery. I have been charging a 21-cell Edison 24-volt battery using a rectifier in three hours from the AC lighting current. Can I use the same system for the new battery?  
I notice your readers are interested in the Reinartz tuner. After changing and

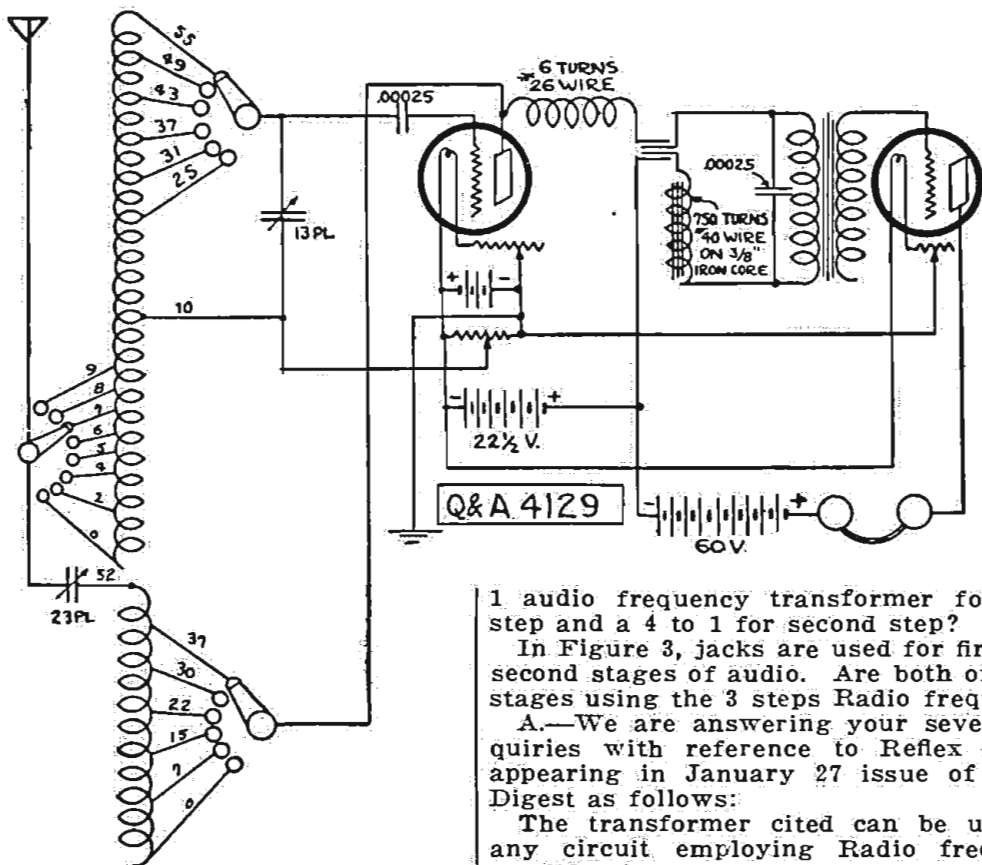

recharging my set and experimenting for 18 months I think I have the hook-up as near right as I can get it. We get some very good results on DX work.

I am enclosing hook-up, hoping to help some amateur like myself. If this hook-up is made properly it will give good results.

You do not need a grid leak but you do need a vernier on the 13-plate condenser and also the detector rheostat.

A.—Answering your inquiry with reference to battery charger for 98-volt 49-cell battery, we are advising that you can charge it in the same manner as used for the 24-volt battery. However, it will be necessary to divide the battery in two parts as its voltage is too high to be charged from 110 volts. Separate the cells so that one unit is of 24 cells and the other of 25 cells and charge these separately in the same manner as you are now using it with a 21-cell unit. A 60-watt lamp will serve as a resistance.

We are expressing our appreciation of your interest in behalf of readers of Radio Digest in submitting diagram of Reinartz circuit. We are pleased to pass it on to our readers.

### Reflex Transformers

(3092) AD, Chicago, Ill.  
I desire to build a reflex circuit as described in your valuable magazine of Jan. 27, page 13, either Figure 1 or Figure 2, and would like some help from you.  
I have an Erla R. F. transformer type

AB1, made of straight Radio frequency with the secondary circuit open through which audio frequency will not pass. Is there any place where I can use it in the three or four tube circuits in conjunction with other R. F. transformers?  
Will an all wave coupler be efficient in these circuits?  
Is there any advantage in using a 10 to

1 audio frequency transformer for first step and a 4 to 1 for second step?  
In Figure 3, jacks are used for first and second stages of audio. Are both of these stages using the 3 steps Radio frequency?  
A.—We are answering your several inquiries with reference to Reflex circuit appearing in January 27 issue of Radio Digest as follows:  
The transformer cited can be used in any circuit employing Radio frequency amplification.  
An all wave coupler would have no greater value than a short wave coupler.  
Both audio frequency transformers should be of four to one ratio.  
Referring to jacks: A stage of Radio frequency is cut out with each stage of audio frequency cut out. We are directing your attention to the fact that in Figure 3 the third jack is not connected correctly. A connection should be made from the first spring to the base of jack.

### Vacuum Tubes

(3031) LGC, Casper, Wyo.  
All text-books I have read say that when the grid is positive the greater the plate

current. Why? The usual answer is that it adds to the positive charge of the plate. But what is there to prevent the filament to grid current? Is there such, or is it so small as to be neglected?  
A.—Referring to vacuum tubes: It is true that when grid is positive the plate current is greater. The amount of current flowing from plate to filament depends upon the number of electrons which the filament radiates. If the grid is charged positive the filament radiates more electrons than if charged negative because a positive charge attracts a negative charge. Electrons are negative charges, and as the plate is charged more positive than the grid it does not allow the electrons to stop at the grid, but takes them on to the plate. This we trust is clear. There is, however, a slight accumulation of electrons on the grid—in order to avoid an excess of grid potential a grid leak is added to serve as a safety valve releasing the surplus or excess accumulation of electrons.

### Damage to Phones

Receiving telephones must not be connected in the plate circuit of a power amplifier, as serious injury to the windings will result. If the secondary of an amplifying transformer is connected in the power amplifier circuit so that it operates as a step down transformer, the receiving telephones may be connected to the primary winding and clear reception of signals may be obtained without damaging the receiving telephones.

An alarm clock has been invented by a Frenchman which responds to a certain Radio wave length when sent out by the Eiffel tower station.



ON APPROVAL FOR 30¢  
ZOBEL-STEIN LABORATORIES  
322 9TH ST. BROOKLYN, N.Y. SOUTH 2650

## Long Distance Crystal Set

We receive programs from Atlanta, Minneapolis, Davenport, Fort Worth, Dallas, Kansas City, St. Louis, Denver on Crystal without batteries. Usual crystal set requires only easy, inexpensive changes. Send stamp for further information or for copyright drawings and instructions. Everything clearly explained. Satisfaction GUARANTEED.  
Leon Lambert, 501 South Volusia, Wichita, Kan.

## a Chi-Rad Special!

### for W.D. 11 tubes—

Standard, threaded rubber, Willard's specially adapted for use with WD-11 Tubes. Supply current at 2 volts to one WD-11 Tube for 210 hours on a single charge. Rechargeable. Brand new, size 4x5 1/4 x 7 inches—Chi-Rad guaranteed.

2-Volt Willard Charged... \$7.50  
2-Volt Willard Dry..... 6.50

These same Willards can be adapted to deliver 8 volts for pure D. C. for C. W. Transmitters. Better than a generator because no filter is necessary. Much less expensive.

In lots of 40 (320 volts) \$160.00  
(Better prices on larger quantity)  
Specify dry or charged when ordering.

Chicago Radio Apparatus Co.  
415 S. Dearborn St. Chicago, Ill.

# Your Choice FREE

Bound Volumes  
Numbers Two, Three, or Four  
Postpaid by Parcel Post with One Year's Subscription to Radio Digest

65 Numbers

VOLS. TWO, THREE & FOUR  
Now Ready for Delivery. Parcel Post Prepaid, Each, Only \$2.00  
On account of the limited supply, the sale of these bound volumes is limited strictly to those readers of the Radio Digest who have subscribed for a year. One year subscription to Radio Digest and both bound volumes 2, 3 and 4..... \$7.00  
By subscribing now for one year to the Radio Digest you get both BOUND VOLUMES 2 and 3 or 3 and 4, 26 numbers, with 1 year's subscription, for \$7. One year subscription to Radio Digest and bound volumes 2, 3 and 4..... \$9.00  
ALL ORDERS MUST BE SENT DIRECT—No orders on this offer will be accepted through subscription agencies, news dealers or other sources. Check, money or express orders (no stamps) must accompany all orders.

13 Numbers in the Bound Volume  
52 Numbers in Year's Subscription

Greatest Collection of Radio Information Ever Published  
Reinartz Long Distance Circuit  
Ultra-Reinartz Circuit  
Flewelling "Fliver" Circuit  
Grimes "Inverse Duplex" Circuit  
Single Tube Reflex Circuit  
Armstrong "Super-Heterodyne" Circuit  
Two, Three and Four Tube Reflex Circuits  
A. B. C. Lessons for Radio Beginners  
In addition to these features these volumes contain many instructive articles, receiving set diagrams, how to make articles, new apparatus, pictures and illustrations, hook-up diagrams, broadcasting stations, technical articles and book reviews.

COUPON 7-14  
PUBLISHER, RADIO DIGEST,  
123 West Madison St., Chicago, Illinois.  
Please reserve me Bound Volume Number Two and also Number Three and one year's subscription to the Radio Digest, for which I am inclosing check—M. O. for Seven Dollars.  
Please reserve me Bound Volume Number Two or Three or Four and one year's subscription to the Radio Digest, for which I am inclosing check—M. O. for Five Dollars.

Name.....  
Address.....  
City..... State.....

PREMIER  
"HEGEHOG"  
TRADE MARK  
AUDIO  
FREQUENCY TRANSFORMER

PAT. PEND. HALF SIZE

MAXIMUM VOLUME  
MINIMUM DISTORTION  
100 PER CENT SHIELDED  
MOUNTS ANYWHERE

PRICE \$3.50

RATIOS—1 to 3, 1 to 4, or 1 to 5

The Most Efficient, Compact Transformer ever designed. Ask Your Dealer for the Premier "Hegehog."

Full Specifications on Request

Premier Electric Company  
Est. 1905  
3818 Ravenswood Avenue, CHICAGO, ILL.