

Radio Digest

Illustrated

50,000 COPIES EVERY WEEK

TRADE-MARK

Vol. 1. No. 3

Copyright, 1922,
E. C. Rayner

CHICAGO, ILL., SATURDAY, APRIL 29, 1922

PRICE TEN CENTS

RADIO SIGNALS SPIRITS

SCIENTIST DEFINES HUMAN RADIOPHONE

EVERY PERSON COMPLETE SET, SAYS DR. FREE

Nerve System of Man Like Receiving and Sending Stations, Declares Former Carnegie Technician

NEW YORK.—We now come face to face with the fact that brain and brain may communicate without speech. If this theory is true then the human being becomes a transmitting and receiving set of the Radiophone. Dr. E. E. Free lately of the Carnegie Institute says:

"Unquestionably the possibility of the solution of some of those problems contained in the relations of one human mind with another and the universe, which previously has seemed to be immeasurably remote, has become immediate.

"Cold, hard-headed science is beginning to accept phenomena which only recently it would have laughed at. Those electromagnetic waves which are the basis of Radio communication seem to be connected with the most astonishing of them.

Supernatural Explained?

"Marconi, discoverer of Radio telegraphy, has seemed to be a link between

(Continued on Page 2)

RADIO MAYSUPLANT FILM MAKER'S AID

Hollywood Producers Report Use of Airphone Increases Output and Heightens Efficiency

LOS ANGELES—Producers of motion pictures are making good use of the Radiophone. The Radiophone, they say, promises greater efficiency at less cost and threatens the jobs of the assistant directors. It supplants phonographs and studio orchestras. Marshall Neilan, noted director, has installed a Radiophone in his studio.

It is expected that the Radio will be of use also in the staging of "big scenes." Directors may use amplifiers to coach their companies in distant scenes.

RADIO SENDS PRAYER FOR BURIAL AT SEA

LOS ANGELES, CALIF.—Because the burial of a fireman at sea was delayed by lack of a liturgy the Radio operator of the ship Cape Roman waved an appeal broadcast and from the steamship Henry S. Groves received the solemn words of prayer. These were repeated over the body of the fireman which then was deposited in the deep.

SET "THAT SPEAKS WITH DEAD" CLAIMED BY CHICAGO EXPERT

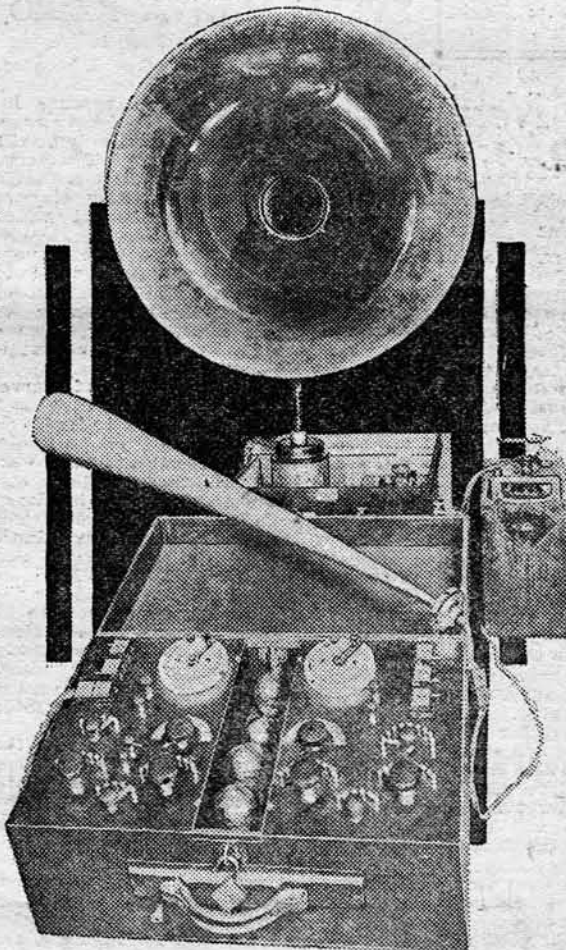

The Device Pictured Here, Known as the "Spirit Phone," Shows the "Trumpet" Lying Across the Cover of the Set. It Is Through This Horn That the Spirit Voices Pass, Says the Inventor.

JOKES AS VESSEL SINKS

Radio Operator Jests by Air Until Craft Is Engulfed

"We are sinking fast—stern first—can't hold up much longer—the skipper just dictated that and he ought to know—where did I put my hat—sorry, we can't wait any longer—have a pressing engagement with Davy Jo—"

These were the last words to be flashed by Radio from the ill-fated Norwegian steamship Grontoft, whose Radio operator jested with death as the water engulfed his apparatus.

The message, as written here, is recorded on the log of the steamship Ethonia, which reached the scene of the disaster some time after and reported, "No trace of wreckage." The engagement with Davy Jones was kept.

AKRON, OHIO.—Station 8UX, owned and operated by D. A. Hoffman of this city has discontinued broadcasting for the present. Operation will begin when a limited commercial license is received.

VEIL OF "GREAT BEYOND" IS LIFTED BY AIRPHONE, SAYS MEDIUM-INVENTOR

Most Marvelous Discovery Since World Was Begun Is Claimed by Chicagoan; Accident in Test Reveals the Super Amplifier That "Talks with Dead"

What was said to be the greatest discovery of the ages, a revelation so portentous as to challenge not only the most profound scientific theories but the most ancient and widely accepted divine presentments was that made known in Chicago during the 24th annual convention of the Illinois State Spiritualists' association.

The Radiophone has been perfected so that verbal communication with discarnate spirits, with those of the Great Beyond, has been established—this is the great discovery as announced during the convention. Recent tests with the super-Radiophone have enabled the living, it was said, to talk with those who have "passed on."

Thus by means of etheric waves the anguished longing of mankind almost from the beginning to converse with their beloved, to learn of the "life to come" from the noted and the lowly formerly of earth, has been answered, according to the assertions not only of physical but of spiritual savants.

"Spirit Phone" World's Goal

Declarations of religious leaders throughout the ages and, in recent times, the experiments of such scientists as Thomas A. Edison, Sir Oliver Lodge, Camille Flammarion and Sir Conan Doyle, of metaphysicians such as Mary Baker Eddy, Madame Blavatsky, Anna Besant and William T. Stead, and of philosophers such as Huxley and Haeckel, have been materialized, it was said, by the "spirit 'phone" of Henry Edward Burket, young electrician of Chicago.

By means of a Radiophone which he constructed, which he equipped with an amplifying device capable of "stepping up" 1,000,000 times or indefinitely higher, the voices of the spirit world have been plainly heard. It is likely, Burket told the spiritualists, of whose organization he is a member, that these conversations may soon be recorded like the sounds of a phonograph.

Burket's conclusions and apparatus are to be discussed during the international congress of spiritualists in London, July

(Continued on Page 2)

Radio Show to Feature Chicago's Exposition

Exhibitors' Association Plans Big Display at Pageant of Progress

The American Radio Exhibitors' association plans a show of Radiophones at the Pageant of Progress exposition in Chicago. Among the features will be "The Voice From the Clouds," a message from the ether without Radiophone receiving apparatus.

RADIO AN AID TO THRIFT

Cleveland Bank Increases Savings Deposits by Airphone

CLEVELAND, OHIO.—As a means of attracting attention to its spring campaign for savings depositors the Guardian Trust company of this city has installed in a window a Radio receiving set.

RED HAIR, BIG EARS GOOD RADIO ASSETS

NEW YORK.—Red hair and large ears are an asset rather than a drawback in Radiophony, it was shown here recently. Applicants thus equipped were selected to attend the naval militia Radio school by the naval recruiting officers. Red hair, the officers said, is indicative of alertness, and large ears are an aid in tuning radio instruments.

RADIO HAILS SPIRITS

(Continued from Page 1)

1-3. The experiments and achievements of other Radiophone explorers of the celestial regions, including John Slater, Jr., son of the noted spiritualistic medium of Oakland, Calif., Dr. A. Gelbert of Chicago, and Gustave Geley of Paris, are also to be analyzed. Prominent spiritualists are of the opinion, it is said, that soon psychic mediums the world over will be equipped with the spirit Radiophone.

Only Psychics Enabled to Hear

"Only those who are unusually psychic or magnetic, that is, spiritually sensitized, are enabled to hear the voices 'from the other side,'" declared Burket. In this he was supported by Colonel E. S. West of the United States army, a Philippine veteran, morale officer at Fort Leavenworth, one of the speakers during the spiritualists' convention, known throughout the world for his research.

"Until I have obtained a patent for my contrivance," continued Burket, "I shall not be in a position to detail its phases. The world may know that I have assembled the parts of a Radiophone then added a device which amplified sound to a very high degree."

Burket said his discovery was accidental. "I fumbled, a few evenings ago," he said, "the wires connecting my aerial. The wires fell away from the binding posts. I was astounded when I heard distinctly a male voice crying—'Hello, hello—why don't you step up faster?' Then I listened intently but the sounds became indistinct."

"Subsequent tests with my Radiophone, in the presence of a number of psychic persons, resulted similarly—voices were heard plainly although my apparatus was not connected with the aerial nor was it tuned with any sending set."

Burket's antenna and aerial are on the roof of the roominghouse in which he resides. The inventor admitted that his discovery might have been physical, the unfolding of a natural law. "But as a spiritualist and because of subsequent events," he declared, "I am sure the voices were those of spirits." While experimenting several years ago with a wireless 'phone Burket said he heard sounds which were not of this earth. "They were words spoken by a girl," he said. "She said quite plainly—'Hello, hello, Edward, why don't you answer?'" Burket said that only his intimates knew him as "Edward." Three years ago, Burket declared, tests by a Radiophone device resulted in the receipt of questions from what were believed to be nonmundane beings.

Thought Force Changes Frequency

"It is possible, it has been proved," he asserted, "that concentration of mind (thought force) will vary the frequency of etheric waves."

Burket's device is distinguished by what mediums call a trumpet to which is affixed an amplifier. The spirit sounds enter the trumpet, Burket said, and are reproduced or magnified by his apparatus.

Burket's investigations have been furthered by Colonel West. "It is quite probable," he said, "that the Radiophone soon will be used by mediumistic persons to communicate with the next world. There is nothing supernatural in this nor in any other phase of spiritualism." Colonel West said that each of his seven children is mediumistic.

There are said to more than 4,000,000 believers in spiritualism in the United States. Headquarters are in Washington, D. C.

Live Wire Kills Radio Fan

DETROIT.—The first fatality here in relation to radiophony was that in which Homer P. Chase, employe of the Ford Motor Company, while installing a receiving set in his home and erecting an aerial, was struck by a wire which had fallen across a high tension electrical strand. Chase was electrocuted.

Navy Air Chief Urges Radio

CHICAGO.—Rear Admiral Moffett, chief of the naval air service, has recommended the passage of a law requiring the use of Radio in passenger planes to prevent loss of life by accident. Recently a sea-plane floundered off the coast of Florida, resulting in the loss of five lives. Radio could have saved them, it was said.

Police Warn Pittsburgh "Fans"

PITTSBURGH, PA.—Almost everybody in Pittsburgh has gone "looney" over Radiophony. Many persons have been hitching airdials to anything handy, including poles and overhead structures which carry high power electric wires. Sharp warning has been issued by the police department against such practices.

High School Begins Radio Work

NEW PHILADELPHIA, OHIO.—A class of twenty-five juniors has begun to assemble equipment for the construction of a sending and receiving station at the high school. The juniors are studying Radio in all its phases.

Radio Hailed as Herald and Beacon by News and Coast Guard Experts

Tests by United States Passenger Ship Reveal How Dispatches May Be Sent Direct from Sea to Homes and How Craft Now Serving as Light Houses May Be Converted Into Saviors by Airphone

Thousands of "gobs" during the war struggled to obtain news by radio from the bulletin boards at the scuttlebutts. They thus learned to appreciate the Radiotelegraph. During the last few months they have become acquainted with the greater value of the Radiotelephone.

First Sea Story by Radio

From the ship America of the United States Lines recently was sent a news story by Radiophone at sea. According to the engineers present it was the inception of trans-sea telephony. The human voice, sent across the waves by means of the Radiophone, was transferred by ingenious devices instantaneously to land wires, thence to office and home 'phones. When the present system is extended and perfected dispatches, voiced at sea, may be sent directly to those for whom they are intended.

There is another form of Radio broadcasting which will be the means of saving many lives on sea and lake.

The most important work of the Radiophone is in connection with the Radio compass system. This method has already saved many lives and eliminated many days of delay in water navigation by making it possible for a ship to enter devious channels regardless of weather conditions.

Radio Signals Like Beacons

The system of signalling operates in a manner similar to those of Ambrose Channel and Fire Island light vessels at New York and the Sea Girt (N. J.) light

station. These beacons send out invisible electro-magnetic rays instead of light rays. Lighthouses are known to the mariner by their flashes; radio beacons are identified in like manner.

Ambrose Channel sends one dash; Fire Island a group of two dashes and Sea Girt a group of three dashes, with brief intervals between the groups.

Underwater Radio Predicted Savior of Ships in Storms

NEW YORK.—A new receiving apparatus developed by the radio division of the navy has underwater oscillators which recently enabled the battleship Ohio, lying 50 miles off the coast from Ambrose Channel lightship, to hear signals plainly.

The submarine bell of the lightship is heard by marines five miles away by means of a sound oscillator under water.

Leviathan to Have 740 Sets

NEW YORK.—Each of the 740 cabins of the Leviathan, greatest of all ships, now undergoing reconstruction for the United States Shipping Board, is to be equipped with a Radio receiving set.

EVERY MAN A RADIO

(Continued from Page 1)

the theoreticians and the laboratory scientists and between both and the great goal, not intentionally but because his cold, technical experiments have swept him, willy nilly, into the mysterious field.

"One is compelled to wonder if material science is not, indeed, to admit a fact a basis for most of the honestly claimed phenomena of the supernatural which hitherto it has denied.

"Physiologists now agree that nervous energy is electrical in nature. Burn your finger or move your toe and all authorities admit that the sensation of pain or through your nerves in the form of some feeble kind of electric impulse.

"So much for the nature of nerve-energy.

Relation of Nerve Energy to Radio

"Now note the relation of this to Radio. "In practical Radiophony rather powerful electrical disturbances must be employed, and, sometimes, sparks involving hundreds or even thousands of volts. The strength of Radio waves is in accordance with the strength of the electrical disturbances which set them in motion.

"The practical problem of Radio is the creation of a wave strong enough to be felt at a distance by man-made instruments which are crude and comparatively insensitive. Therefore the spark which is to travel far and still affect them must be the strong result of a considerable electrical disturbance.

"But this should not blind us to the fact that even low-powered disturbances create waves and that these move outward from their sources through the ether exactly as do high-pressure waves of practical wireless.

Proposes Experiment

"Suppose there should be arranged along the skin of a man or woman, an insulated wire paralleling one of the major nerves of the body, say, for instance, the sciatic nerve and its principal branches along the leg from toe to hip.

"Suppose this were connected with a powerful but very delicate, perfectly adjusted amplifying instrument, able to multiply Radio impulses by ten millions or perhaps one hundred millions.

"Then suppose a pin should be stuck into the toe of the person used for the experiment.

Human Radio Station

"Certainly a strong sensation of pain would be transmitted up that person's nerves to his spinal-cord and brain, a motor-impulse to jerk the toe backward instantly would be sent by his brain down the same motor-nerves.

"Both the pain-impulse and the order for the backward jerk would be electrical, each creating its feeble wireless wave. The nerve would be the sending station for the wave.

"Outside the body the insulated wire paralleling the nerve would act as a receiving station (in practical wireless the antennae) for this wave. A sufficiently powerful amplifier connected with the wire should enable reinforcement of the nerve-signal even to the point at which it would become audible through a telephone receiver.

"Of course all this would not be so simple as my description seems to indicate, but I believe the experiment, properly performed, would be successful."

Expert Visions New Fields for Radio

Westinghouse Manager Sees News Agencies and Business Men Use Wireless Phone

PITTSBURGH.—C. W. Horn, Radio manager of the Westinghouse Electric and Manufacturing Company here, says that the present stage of Radio broadcasting is only in its infancy. So far broadcasting has been confined to sending out such matter at regular periods as musical entertainments or occasionally market reports and speeches by prominent men. This is very interesting, but something more is needed to put broadcasting nearer to the limit of its possibilities Mr. Horn declares.

Undoubtedly the business man of the future will glance up at the clock when the stock market has closed, and being interested in certain issues, will reach over and throw a small switch and go on with his work while a loud speaker reads the stock reports. After hearing the reports in which he is interested, he will make a note of them and turn off the apparatus.

The future holds much in store for this field of endeavor and newspapers and other news agencies have not failed to note them. It will not be many years before people throughout the country will know what is taking place at Washington; will hear their representatives in either the House or the Senate debating on questions in which they are vitally interested; will hear the President reading his speeches to Congress and many other important events. When this time arrives it will be possible for the constituents of a senator or representative to know just how their servant in Congress is behaving.

Beware of Bootleg Vacuum Tubes, Brooklyn Warns

Brooklyn, N. Y.—Amateurs are being warned against the purchase of "bootleg" vacuum tubes, which are illegally manufactured in violation of patent rights held by the inventors. The "bootlegger" has no name stamped on it (it may have a forged name) and does not come in a box stating that it is licensed and by whom it is made. Some of the "bootleggers" will work and others won't. Five of the illicit tubes purchased in Brooklyn were tested and out of the total only one worked.

Sets Saved Many Lives at Sea

WASHINGTON, D. C.—Commander W. E. Reynolds, chief of the Coast Guard Service, says that the perfection of the Radio in life saving and in preventing ship disasters at sea is one of the wonders of the age. The veritable network of radio systems strung along the coasts saved untold lives last year.

Radio Digest Illustrated

Published Weekly by E. C. RAYNER, Publisher
123 West Madison Street, CHICAGO, ILLINOIS

SUBSCRIPTION RATES
Yearly.....\$5.00 | Foreign.....\$6.00
Single Copies, 10 Cents

Entry as second-class matter applied for at the postoffice at Chicago, Illinois, under Act of March 3, 1879.

Vol. 1 Chicago, Saturday, April 29, 1922 No. 3

CONTENTS

- Simple Instructions for Beginners, by Harry J. Marx 13
A description of the theory and operation of the Loose-Coupler and Variometer in simple language and its uses in the crystal detector and the vacuum tube receiving sets.
- Hook-ups for the Beginner..... 14
A loose-leaf sheet showing a number of different types of hook-ups for both the crystal and vacuum tube sets.
- Carrier Current Telephony and Telegraphy..... 12
Experts describe differences between various forms of wave guidance.
- Radio Receiving Sets..... 5
The first of a series of articles describing the essential parts of standard Radiophone receiving sets; a department of information exceedingly valuable to all interested in the airphone.
- Radiophone Broadcasting Stations..... 8-9
A revised directory of the stations throughout the United States, tabulated, with desirable information about each.
- Radio, Illustrated 16
A complete page of the latest developments in the use of radio.
- Questions and Answers..... 15
This department will smooth out the ruts in the path of the novice. A free service to readers which will solve their problems.
- Radio Signal Spirits..... 1
According to assertions of Chicago inventor he has so perfected the Radiophone as to be able to hear voices from "the other side;" said to be the greatest discovery of the ages and the most revolutionary.
- Editorials 10
- Radio Indi-Gest..... 10
A column of humor.

Looking Ahead

Benjamin F. Miessner, authority on Radio, author of "Radio Dynamics" and inventor of the "Electric Dog," will continue his informative series, "Characteristics of Vacuum Tube Amplifiers."

Harry J. Marx will give more of his "Simple Instructions for the Beginner," and the loose leaf sheets of the hook-ups of a number of difficult types of circuits.

Radiophone Broadcasting Stations will be larger and brought up to date. This feature is worth waiting for.

Famous Broadcasting Stations—the ones you hear—will be illustrated in every issue.

Radio Receiving Sets—simple illustrated descriptions of standard devices.

BE SURE TO GET RADIO DIGEST

It Will Be Hard to Find a Copy on the News Stands

SUBSCRIBE NOW!

SEND IN THE BLANK TODAY

Publisher,
Radio Digest, Illustrated,
123 West Madison St.,
Chicago, Illinois.

Please find enclosed check M. O. for Five Dollars for One Year's Subscription to Radio Digest, Illustrated.

Name.....
Address.....
City..... State.....

5,000 IN PITTSBURGH STORM SHOW DOORS

Cosmopolitan Crowd Defies Police in Attempt to See First Exhibition of Association

By Special Correspondent RADIO DIGEST

PITTSBURGH, PA.—So charged with interest, so important was the recent first semi-annual show in this city of the American Radio Exhibitors' association that the people not only of this city but of the United States, the Old World and even the Orient are eagerly awaiting announcement as to the next exposition.

5,000 at Show Opening

The show, opened the evening of April 11 on the 17th floor of the William Penn hotel, was attended by more than 5,000 persons. They were so keen to view the various developments in Radio devices that they defied the police and almost stormed the doors. More than 60 manufacturers and others identified with the industry displayed their wares or achievements. Even to the novice it was apparent that that although Radio was yet in infancy its possibilities were almost incredible.

One of the many features of the exhibition was the Radio concert by Station KDKA which daily formed part of the three-day program. Seemingly from the skies came entrancing strains. Noted vocalists and instrumentalists thus stirred the crowds and infused a bit of the mystic. Even those of the cosmopolitan throng who knew little of the game became alert when baseball scores from all over the country were delivered by Radiophone. How the birds of Pittsburgh conducted themselves was Radiophoned from a newspaper office to the exposition hall by George M. Sutton of Audobon Society of Western Pennsylvania.

An instructive phase of the program was that in which the board of fire underwriters demonstrated the proper method of installing an aerial. Bedtime stories for children and market reports also distinguished the program.

Those Who Exhibited

Among the exhibitors were Federal Telephone and Telegraph company, Buffalo, N. Y.; Signal Electric and Manufacturing company, Menominee, Mich.; Clapp-Eastman company, Cambridge, Mass.; The Workwrite Manufacturing company, Cleveland, Ohio; H. B. Eby manufacturing company, Globe Electric company and Crosby Manufacturing company, Cincinnati, Ohio; Exide Battery company, Philadelphia; Everett Electric company, New York; Hipwell Manufacturing company, Pittsburgh; Weston Electric Instrument company, Newark, N. J.; Universal Light company, Pittsburgh; Westinghouse Union Battery, Swissvale; Sperry and Bittner, Pittsburgh; Superior Engineering company, Pittsburgh; General Electric Supply company, Pittsburgh; General Radio Manufacturing company, Pittsburgh; Willard Storage Battery company, Cleveland, Ohio; Wireless Electric company, Pittsburgh; Lyradion company, Mishawaka, Ind.; Electric Service and Supply company, Pittsburgh; Pittsburgh Radio and Appliance company, Pittsburgh; Cook Electric Company, Chicago, Ill.; Columbia Radio company, Pittsburgh; Continental Fiber company, Newark, Del.; Meteor Radio Laboratories company, Piqua, Ohio; West Penn Radio company, Pittsburgh; Radiograph corporation, Pittsburgh; Penn Sales company, Pittsburgh; Englert Manufacturing company, Pittsburgh; Copperlad Steel company, Rankin, Pa.; Westinghouse Electric and Manufacturing company, Pittsburgh; American Radio and Research corporation, Medford Hillside, Mass., and the RADIO DIGEST.

BALL NEWS, PILLS, "GRUB" ON NEW MENU

CHICAGO.—The baseball season, opened a few days ago, offers a fertile field for the Radiophone, which enables the sending of various features of games directly from the diamonds.

Those unable to witness the games are enabled to hear its progress, even the rooting of the fans, by means of the Radiophone. Already many owners of pharmacies and restaurants are considering the installation of sets for the receipt of baseball news.

ARTS OF THE AIR MADE MORE BEAUTIFUL BY RADIOPHONE SET IN ORNATE CABINET



Among the Many Attractive Sets Which Held the Crowds at the Recent Pittsburgh Exposition Was That Depicted Here, Product of the Lyradion Company, Mishawaka, Indiana.

RADIO ON TUGBOATS NEW YORK SCHEME

ORDERS AND AMUSEMENTS PLANNED BY AIRPHONE

Lonely Life of Mariners, Causing Discontent, to Be Livened by Use of Receiving Devices

NEW YORK.—Radiophones are to be installed on several hundred tugboats owned by members of the New York Towboat Association, it was announced after a meeting of the organization. Radio apparatus already has been installed on two boats. Arrangements are being made to equip all tugs of the association before the opening of the summer season.

The first tug company to fit its boats with Radiophones was the Tice Towing Company, of 11 Broadway. The tug Nautic, Captain Cahill Kreiger, received its installation two weeks ago. Yesterday a group of members of the New York Towboat Exchange boarded the Nautic and put to sea. Benton Smith, chief engineer, who also operated the Radio outfit, tuned in and picked up a concert being broadcast from Newark, N. J., to which the visitors and crew listened more than an hour. Amplifiers were set up in the wheelhouse of the tug and also in its engine room. Stokers while shoveling coal are enabled to do it to a musical accompaniment, while the helmsman can have a concert as often as he cares to turn a switch.

A Radio set is to be installed today on the tug John Ruge, also owned by the Tice Towing Line. A part of the plan calls for installation of a sending station in the offices of the exchange, on the sixteenth floor of 11 Broadway. Officials of the company, in discussing their plan, pointed out that while the first consideration was increased efficiency of operation through the ability to telephone orders to tug captains within a radius of 200 miles from the main offices, much importance also had been attached to the psychological effect on the fleet personnel of providing entertainment such as the Radio telephone offers.

It was declared to have been long recognized that isolation during so large a proportion of their lives was in part responsible for discontented men. The belief is expressed that with amplifiers installed on all tugs there will be a general improvement in morale.

Three lines which will use Radiophone installation at once are the Dalzell Towing Line, the Russell Towing Company and the Moran Towing Company.

Radio Lowers Car Repairs in Detroit

Traction Company's Use of Airphone Speeds Maintenance and Reduces Number of Trucks and Crews

DETROIT.—After many experiments the streetcar company has found that by equipping emergency repair trucks with Radiophones, it could speed maintenance on the lines and thus lessen the number of trucks from three to two.

Heretofore it was difficult to communicate with the driver of a truck from the shops. The old method was to send a messenger but with the new equipment the message is flashed by Radio.

Radio Draws Soda Fountain Trade

NEWARK, N. J.—A feature of the drug store here is the Radiophone with a loud speaking amplifier. This, it is said, brings a larger volume of trade to the soda fountain. The customers listen to music while they are served with refreshments.

U. S. BILL TO RULE RADIO AERIAL IN THEATER LOBBY

Terms of Airphone Regulations Ready for Action by Congress

WASHINGTON.—In the recent parley as to the control of Radio the terms of the bill to place in the commerce department, administration of Radiophone communication were practically completed. Agreement has been reached.

Cleveland Amusement Place Draws Crowds by Means of Radiophone

CLEVELAND, O.—Instead of using an outside aerial in the State Theater here the owners have strung wires the length of the lobby, the largest in the city. Connections are maintained through brick walls.

THE ANTENNA BROTHERS

Spir L. and Lew P.

A LITTLE INTERFERENCE

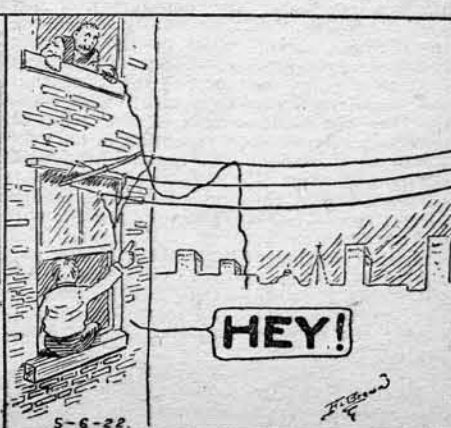
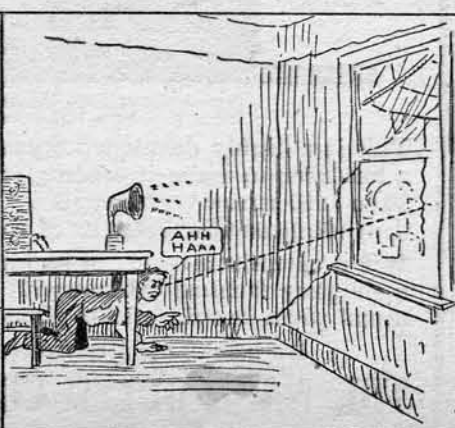
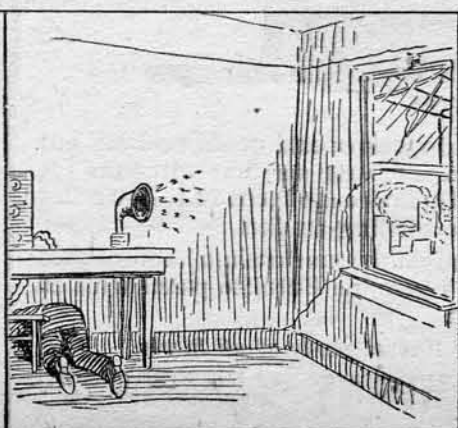

HOW TO KNOW MODEL RECEIVERS

RADIO DIGEST PRESENTS
FIRST OF SERIES

Illustrated Description of Essential Parts
of Airphones Forms Department
of Valuable Information

See Diagram Page 5

The photo shown on top illustrates the view of the unit as seen from the front with the various dials used for operation and tuning. The only connections to be made on the front of this unit is plugging of the receiver jack into any one of the three positions shown as Detector, First Stage of Amplification, and Second Stage of Amplification. In the illustration receivers are connected to the second stage taking full advantage of the amplifying power of the unit.

The lower view clearly represents the apparatus and the binding posts for connections as seen from the rear. The instruments are clearly identified and in addition, the usual hook-up convention is shown for the advantage of the beginner. No attempt has been made to show the internal wiring, because the amateur is not interested in that direction, and such information is available through our technical articles. Since all the connections are made to the binding posts shown in this view, and since these are confusing points in the setting up of the apparatus, our efforts will be directed towards simplifying that part of the procedure.

Installation

The antenna and its erection has been the subject of numerous articles in many papers and magazines, so we will start from the lead-in wires. Of course, proper attention should be paid to see that all leads are properly soldered and connected to the antenna, then let down and into the room where the set is installed. Avoid using too many turns and twists on the lead-in.

Make your run as straight, direct and simple as possible. Connect this antenna lead to the upper right hand binding post as shown; the lower right hand binding post is for the ground wire connection. This ground connection can be made to a radiator pipe connecting can be made to a pipe in the basement. In fastening on the ground clamp, make sure that the surface of the pipe has been well scraped and offers a clean electrical connection.

Batteries

The four binding posts on the left hand side are used for the battery connections; the "A" battery is a 6-volt battery of 60 amperes or more, the negative side of which is connected to the lowest binding post. In buying the batteries, the dealer will indicate to you the positive and negative terminals. The positive side is connected to the second binding post from the bottom. This "A" battery current is our filament lighting current and the flow to each tube is controlled by the filament rheostats of each tube.

This set can use either one or two "B" batteries as the buyer wishes. If a single "B" battery is used, it should be one of the 45-volt type with a 22½ volt tap; the negative is again connected to the bottom binding post, similar to the "A" battery. The positive end for the full 45 volts is connected to the top binding post; the terminal at 22½-volt tap, is connected to the second binding post from the top.

If two "B" are used one should be 22½ volts and the other 45 volts. The negatives of both are connected to the bottom binding post as before; the positive terminal of the 45-volt battery is connected to the top binding post, while the positive terminal of the 22½-volt battery is connected to the second binding post from the top.

This completes all of our connections and the apparatus is now ready for operation.

Tuning

Place the receivers on the head, set the rheostat knobs with the pointer to the extreme left and plug in on the detector jack. This automatically lights the detector bulb. Set the dials at the 50 point for the antenna condenser and coupler; now adjust the rheostat dial, gradually increasing the filament current until the soft purring is heard in the receivers. Increase the current to a point just before the time that the sound increases to a howling or hissing; try out various taps of the primary inductance knob until reception is noticed. Until the beginner is well acquainted with the operation of this set, it will be necessary to adjust the condenser dial at the same time. After a while the operator will discover which taps of the primary coil and what setting of the condenser dial are necessary for the proper wave length adjustment. Now adjust the coupler dial for the improvement of the reception; if necessary the detector rheostat can be readjusted.

Using the Amplifiers

Having tuned the detector units, pull out the receiver plug and insert in the first amplifying jack then adjust the filament

rheostat for the proper flow of current. Then repeat the operation for the second step. This concludes the tuning operation.

Suggestions

A few suggestions to be followed in this or in any other set:

1. Make sure that all wire connections are tight and cleaned.
2. Don't add unnecessary slack in your wires, and have an accumulation of twisted coils around the unit.
3. Don't try to increase the reception by starting howling because of too much current volt to the filament.
4. Before complaining that your set is no good, make sure that your part of the work is not open to criticism.

5. Don't expect good results with a poor aerial.

6. Don't run your aerial parallel to any high tension wires.

7. Unless you understand the subject thoroughly, don't try to improve the internal wiring of the unit. No manufacturer will stand behind his apparatus if you tamper with the connections.

8. Don't make additions to your set without proper advice on the subject.

9. Watch both batteries to see that they are in good condition.

10. Keep the level of the electrolyte in your storage battery above the plates by adding distilled or rain water when necessary.

"THEY'RE OFF" BY RADIO

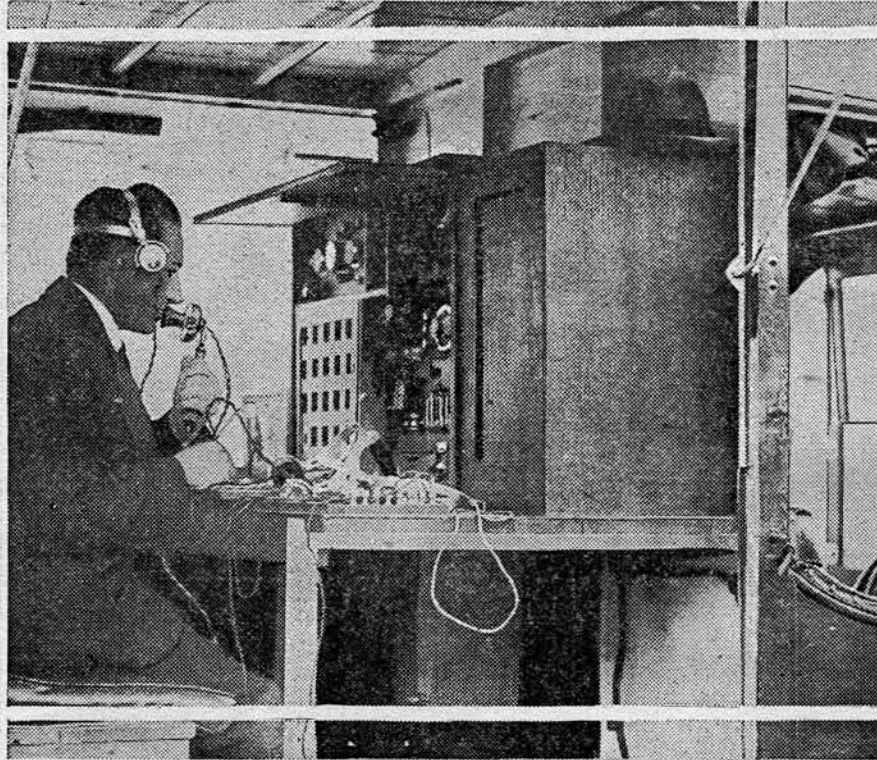

As the best way in which to handle crowds going to the races near London, the Government uses an airplane fitted with Radio which device handles traffic and prevents congestion of roads
© Kadel and Herbert

Will Radio Sour This Cow's Milk?

The old dinner bell on the farm may be scrapped now, according to the Talbots, a family of Florida farmers. When Daniel goes out to plow he straps his receiving set to the plow and puts the receiver to his ear.

And now and then the broadcasting stations are interrupted by Mrs. Talbot, who has a sending outfit at the house. She calls Hubby Talbot when it is time for dinner.

Makes Radio Code Records

As a result of the widespread interest in Radiophony, one manufacturer has recently brought out a set of double faced records for teaching the Continental telegraph code. Many people have purchased small outfits for listening in on the radio-phone concerts and news, and after the broadcasting has stopped for the evening, have tuned in and heard the familiar "buzz-buzz" of the radio telegraph messages being sent.

First Offering of the NEW

MorseOphone \$22.50

INSTRUMENT ONLY

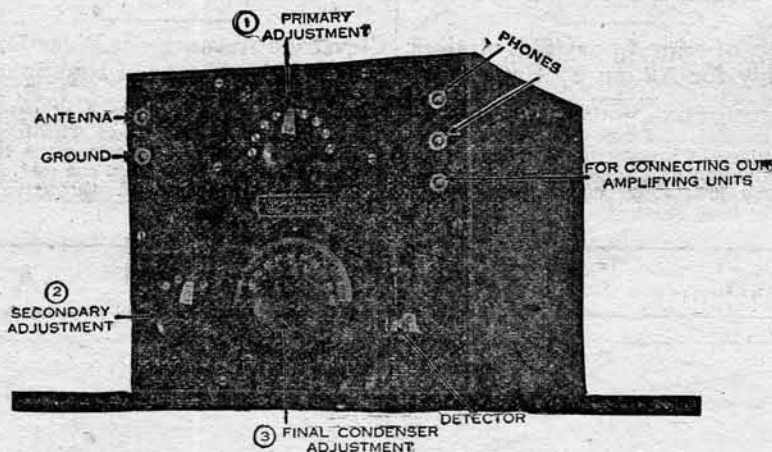

This is a highly developed crystal receiver and needs nothing but a head set to make it a complete receiving set that will tune for 50 to 1500 meter wave lengths. Its limits are from 10 to 500 miles depending on the strength of the sending station.

It is the handsomest set of its kind on the market in a hand-rubbed mahogany finished cabinet with a genuine Bakelite panel with all metal parts heavily nickel-plated.

We also carry a complete line of parts of all kinds

THE NASH-ODELL COMPANY 172 No. Franklin St. Chicago, Illinois

THOS. E. WILSON & Co.

Radio Department

IN STOCK TODAY

De Forest "Every Man" Crystal Detector Set, complete with Brandies phones \$25
De Forest Radiohome Receiver Set, with Cunningham Detector Tube and Frost 2000-ohm phones..... \$46

SUNDRIES and PARTS

Bradley Rheostats, the finest rheostat made for radio tube control \$1.85
Binding Posts, each 10c
Contact Points, per dozen 35c
Galena and Radiocite Crystals, mounted, 40c; unmounted..... 25c
Lightning Protector Brachs \$2.50
Battery Switches 15c
Fixed Phone Condensers 75c
Vacuum Tube Socket \$1.50

HEAD PHONES

Western Electric \$12.00
Kellogg 12.00
Frost 5.00
Tuning Coils, two-slide, complete \$4.50
Crystal Detectors, complete, mounted on hard rubber base, enclosed in glass tube..... \$2.50
Thordarson Amplifying Transformer \$4.50
The "Home Charger"—charge your own batteries at home \$18.50

THOS. E. WILSON & Co.

Monroe and Wabash
CHICAGO, ILLINOIS

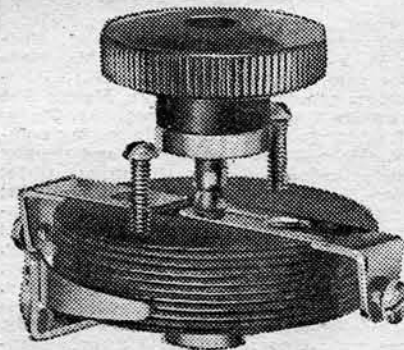

IN the reception of Radio signals of all classes, especially continuous wave and distant signals, the closest possible control of the detector tube filament temperature is extremely necessary. A compact and serviceable

RHEOSTAT

which gives this control has just been placed on the market,

The picture shows this rheostat mounted on a panel. As can be seen, the non-conductive drum is threaded, and in this thread is wound the required length of polished, non-corrosive resistance wire. When the knob is turned, the arm is rotated. This arm carries on its end a pivoted phosphor bronze contact tongue, the end of which follows the thread and consequently the resistance wire. In six revolutions of the knob, the tongue travels from one end of the resistance wire to the other, touching it at every point throughout its entire length. This gives the number of adjustments which is absolutely unlimited, and changes of one thousandth of an ohm are possible. In order to do away with the unnecessary turning of the knob, a simple cut-off is embodied in the rheostat. Adjacent to the point where the shaft makes contact with the lead-in arm, the shaft is grooved. When the knob is pushed in 1/8", the circuit is broken. When the knob is pulled out again (away from the panel), the circuit is made. In other words, the tube may be turned on or off without changing the setting of the rheostat. This lends great convenience in its operation.

J. E. JENKINS

59 E. Van Buren St. Room 605
CHICAGO, ILLINOIS

Radio Receiving Sets

SO THAT those interested in the various phases of Radiotelephony may learn especially about receiving broadcasts RADIO DIGEST presents here the first of a series of pictures of standard receiving sets.

EACH part is designated and named and its purpose is explained. All connections of aerial, ground and batteries are shown. Instructions for operation and tuning are given on page 4 of this issue.

BELOW are shown the front and rear of a standard receiving set manufactured by the Telephone Maintenance company of Chicago. This set is known as Telmaco Type TR-5.

Antenna

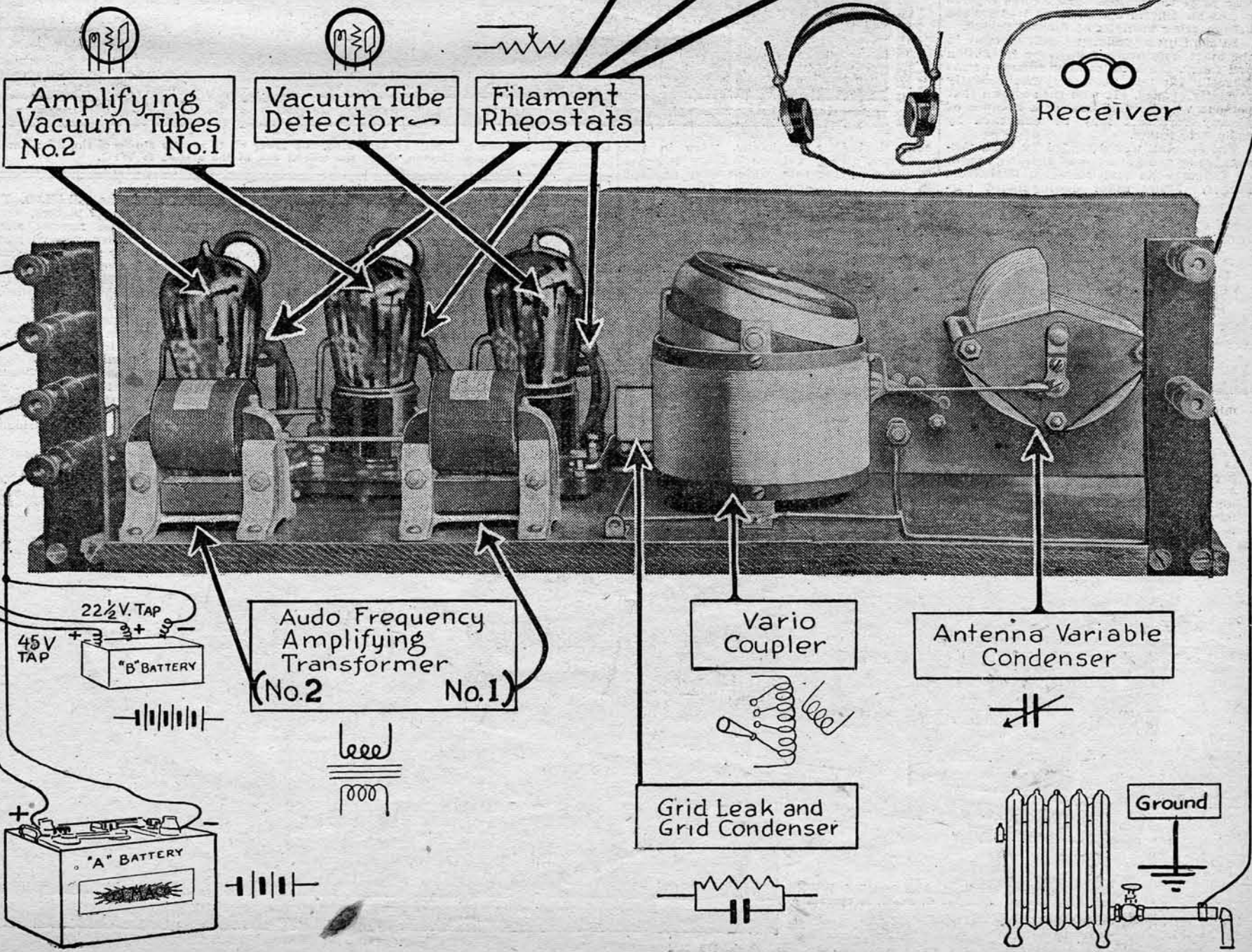
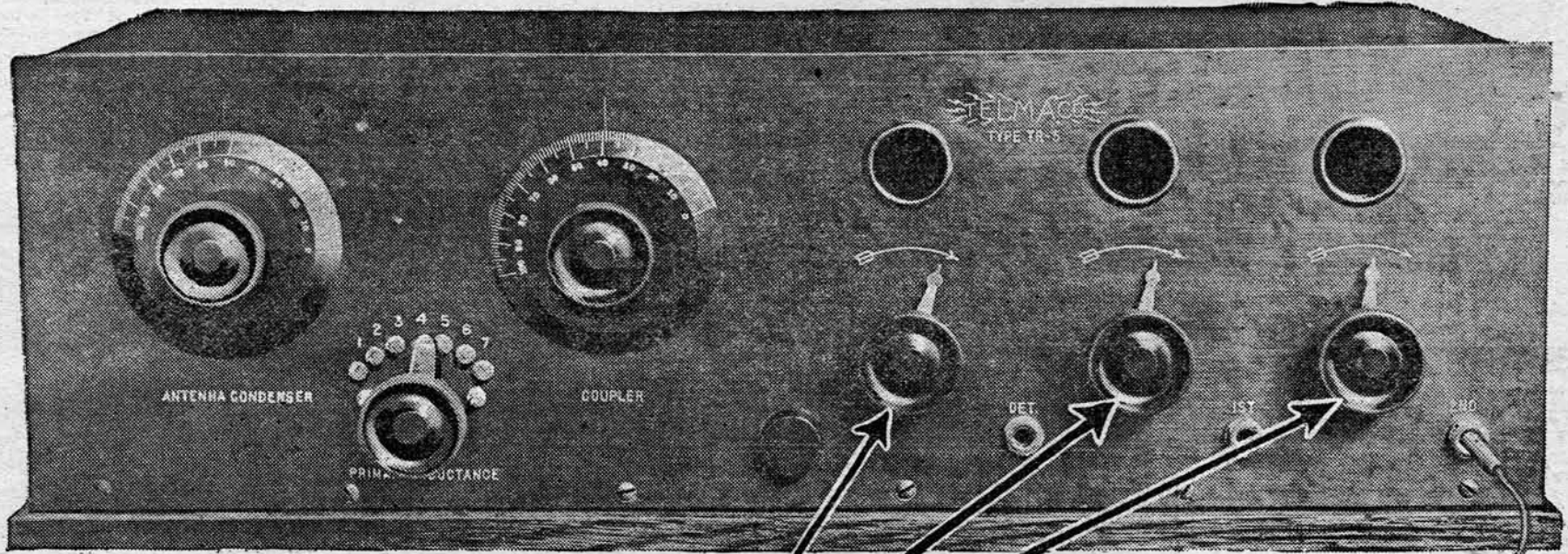

RADIO USED AS AN AID TO BUSINESS

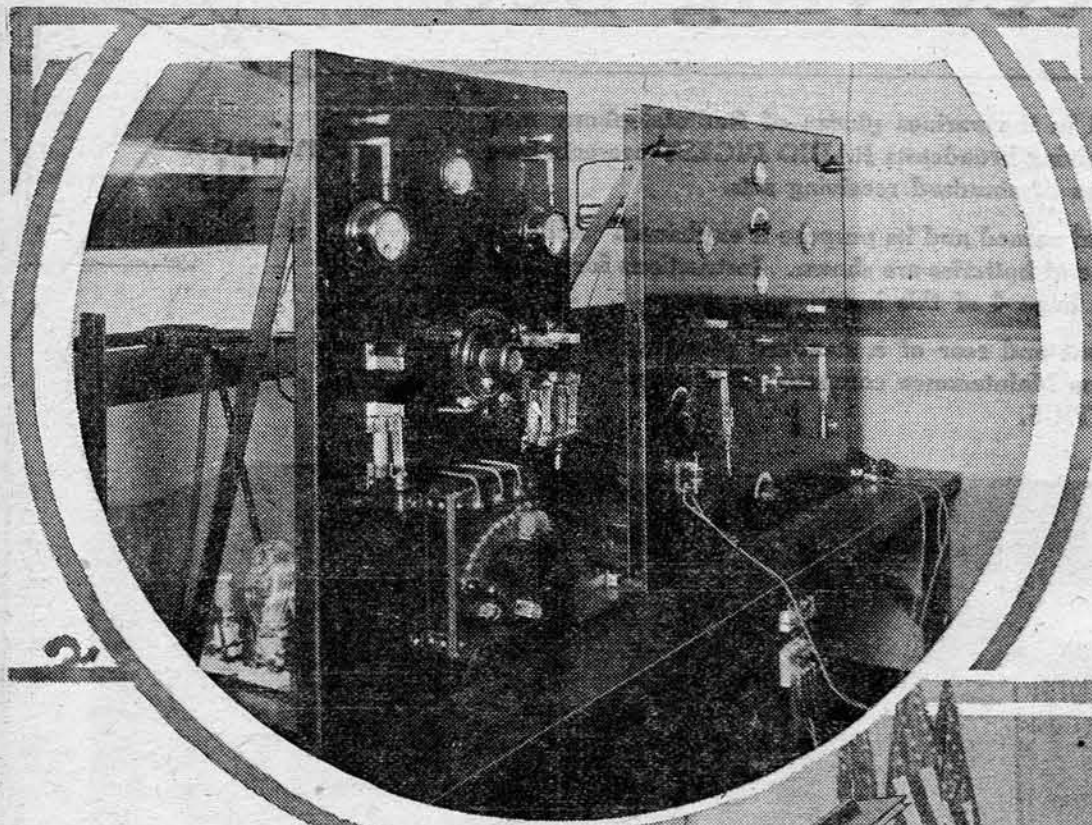

assembled in a sound-proof room far from the street. The walls were draped in blue corduroy as was the ceiling. This bizarre effect was heightened by the dim light of ornamental lamps. At one side curtains were draped. Behind these was a room filled with coils, tubes and transmitters.

In loud tones came the announcement: "This is WOH—Hatfield Electric company," which with songs by the Purdue University (Lafayette, Ind.) Glee club and selections by an orchestra were heard in Nebraska, Colorado, Missouri and Iowa.

Description of WOH

Here are the technical phases of WOH: Wave length, 360 meters; watts input, 250; normal range (receiving station

heard at a point in South America. The official call of the station is WRK. The length of its waves is 360 meters; the watt input is 1,000, normal range with crystal detector 50 miles, normal range (receiving station using one stage audio frequency amplification or its equivalent) 750 to 1,000 miles (heard by means of crystal detector in Texas), exceptional range—North, 300 miles; South, 2,000; East, 400 and West, 800 miles.

From eight to 10:30 o'clock (central time) in the morning on Monday, music and lectures on public health are broadcast. The program on Wednesday is like that of Monday with the addition of electrical and other news items. From 7:30 to 9:30 on Friday morning music is broadcast. The Saturday program, from 8 to 10:30 o'clock is like that of Friday, to which are added news features furnished by the General Electric company. During every other Sunday morning the services of Trinity Episcopal church are given, beginning at 10:45 o'clock, during the evening beginning at 7:30 o'clock. Trinity Episcopal, the Reverend H. Cowley, rector, was the second church in the United States to broadcast services. The first broadcasting was on Easter Sunday of last year.

In the Land of Mesquite

In Roswell, N. M., the Roswell Public Service company, of which Karl A. Stolf

STATIONS IN NEW YORK, NEW MEXICO DESCRIBED

Central West Sets Add Interest to Airphone Developments

From the teeming East, from the far-flung West and from the peaceful central valleys of the United States come reports of the successful operation of Radiophone broadcasting stations of diverse design.

In the City of Indians (Indianapolis) in the state heretofore famed for its fiction and fancy, the broadcasting station of the Hatfield Electric company was recently formally opened. It was then shown that persons who become downcast because of gloomy forecasts may be enlivened by radio broadcasts.

The opening was attended by such personages as the governor of Indiana, mayor of Indianapolis and Meredith Nicholson, author. Many other distinguished per-

sons, including musicians, were in the audience. They evinced intense interest in the receiving sets, which were encased in beautiful cabinets. The guests were

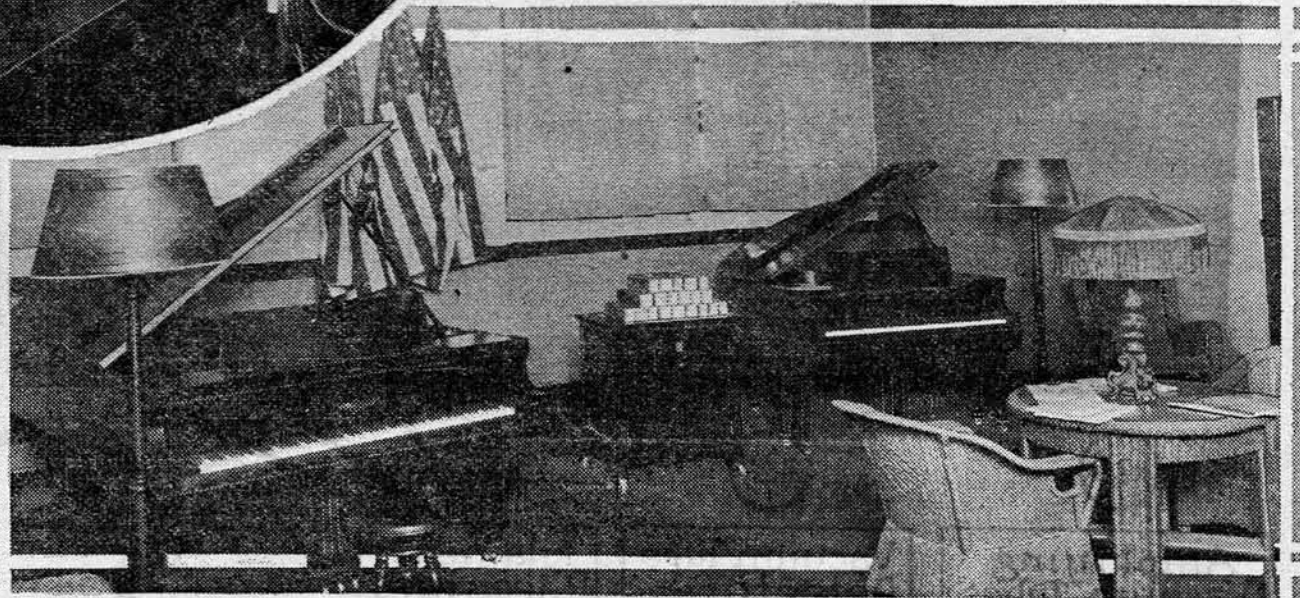

Upper picture shows transmitting apparatus, and lower photo reveals studio of the Rike-Kumler Store, Dayton, Ohio; the official call of the station is WFO.



© Kadel & Herbert
Raymond Ketcham, standing, who installed WWZ transmitting device. Douglas C. Smith is operating

using one stage audio frequency amplification or its equivalent), 250 miles; exceptional range, 700 miles in all directions.

The WOH daily program follows: From 10 to 11 a. m. and from 4 to 5 p. m. Monday, stock reports and brief concert; 8:30 to 10 p. m., musical numbers; on Tuesday the program is like that of the day previous excepting night features; the programs for Wednesday, Thursday and Friday are like that of Tuesday; the Saturday presentation is like that of Monday excepting that the short concert is given between 1 and 2 p. m.; on Sunday morning from 10 to 11 o'clock a musical program is presented. T. B. Hatfield is president of the company and Harrison Durant is chief of its radio division.

WBH, Hamilton, Ohio

By means of a tube detector and two-stages of amplification, the broadcasting station of the Doron Brothers Electric company in Hamilton, Ohio, recently was

is head, operates under the call 5ZAO. The station's wave length is 360 meters, watts input four 5-watt tubes, normal range (crystal detector) 40 miles, normal range (receiving station using one-stage audio frequency amplification or its equivalent) 1,100, exceptional range North 1,100 miles, South 300, East 900 and West 600 miles.

On Monday from 7 to 9 p. m. (mountain time) music, weather, stock and market reports and news are broadcast. The program on Tuesday is like that for Monday excepting the musical numbers. Wednesday's program is like that of Monday, and Thursday's like that of Tuesday. On Friday a program like that on Monday is given and on Saturday the presentation is similar to that of Tuesday. A sermon is broadcast on Sunday.

Among the chief broadcasting stations recently opened is that of the John Wanamaker department store in New York City. This station operates under the offi-

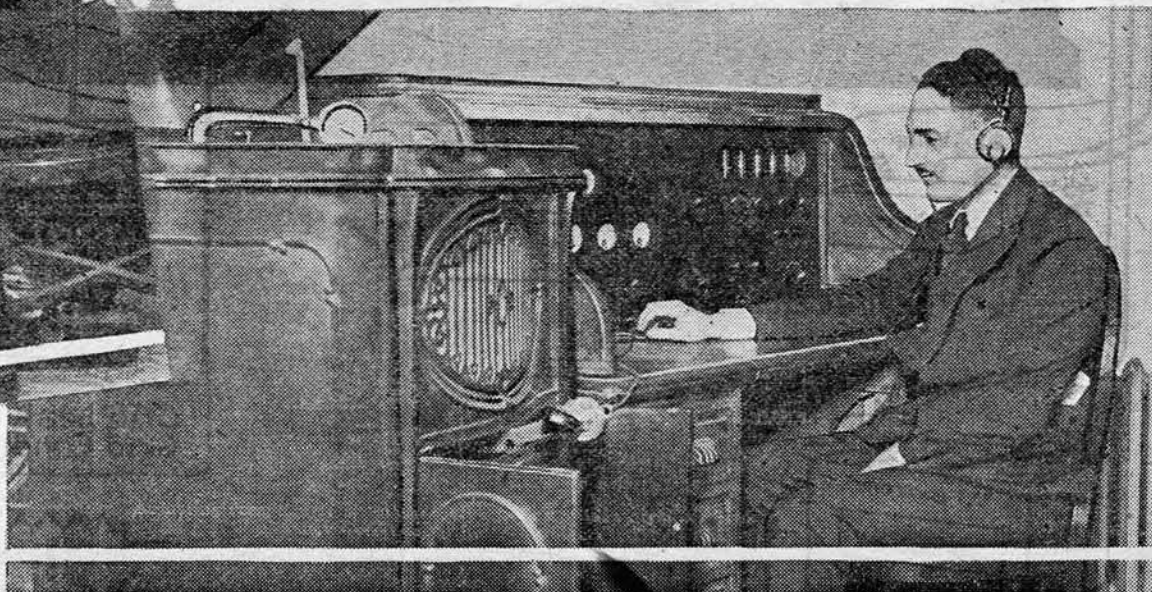

© Kadel & Herbert
Here is seen Douglas C. Smith, operator of WWZ broadcasting station, testing by means of phonograph

FIVE WELL-KNOWN STATIONS SHOWN

cial call WWZ. It broadcasts concerts and lectures to distant places in the United States. During the initial test, Douglas C. Smith, operator, used a phonograph with a microphone attached. During the war Mr. Smith was a chief radio electrician in the United States navy. Two ships on which he served, the army transport Santiago, and the Schuykill, were torpedoed by German submarines.

WFO, Dayton, Ohio

Another great department store which now is broadcasting is that of the Rike-Kumler company in Dayton, Ohio. The official call of the station is WFO. It is on the seventh floor of the building. The aerial, a six-wire inverted "L" on 15-foot spreaders, is on the roof. The aerial is suspended on two 55-foot poles. The lead-in comes through the roof down to the operating room. Roy S. Copp, operator, constructed the transmitter, which is composed of three 50-watt oscillators modulated by two 50-watt tubes. One 5-watt speech amplifier is used. The voltage generator is 1,000-volt, 1-K.W.D.C. generator.

Other Phases of Service

By means of chokes and eight microfarad condensers the hum is filtered out. The supply of filament is from a storage battery at present but later will be obtained from the generator.

Copp has put about four amperes in the

equivalent 300 miles, exceptional range, North fair, South good, West excellent. Since the station was opened cards have been received from Tampa, Fla.; Waco, Texas; Union, Neb.; Duluth, Minn.; Menominee, Wis.; Mt. McGregor, N. Y., and hundreds of other stations.

KDKA, Pittsburg

Station KDKA, Pittsburg, Pennsylvania, owned and operated by the Westinghouse Electric and Manufacturing Company was one of the first Radiophone stations to inaugurate broadcasting. Practically all the broadcasting done by KDKA at first was pioneering work. The case of the Radio church services is one instance. When the station was first started there was no

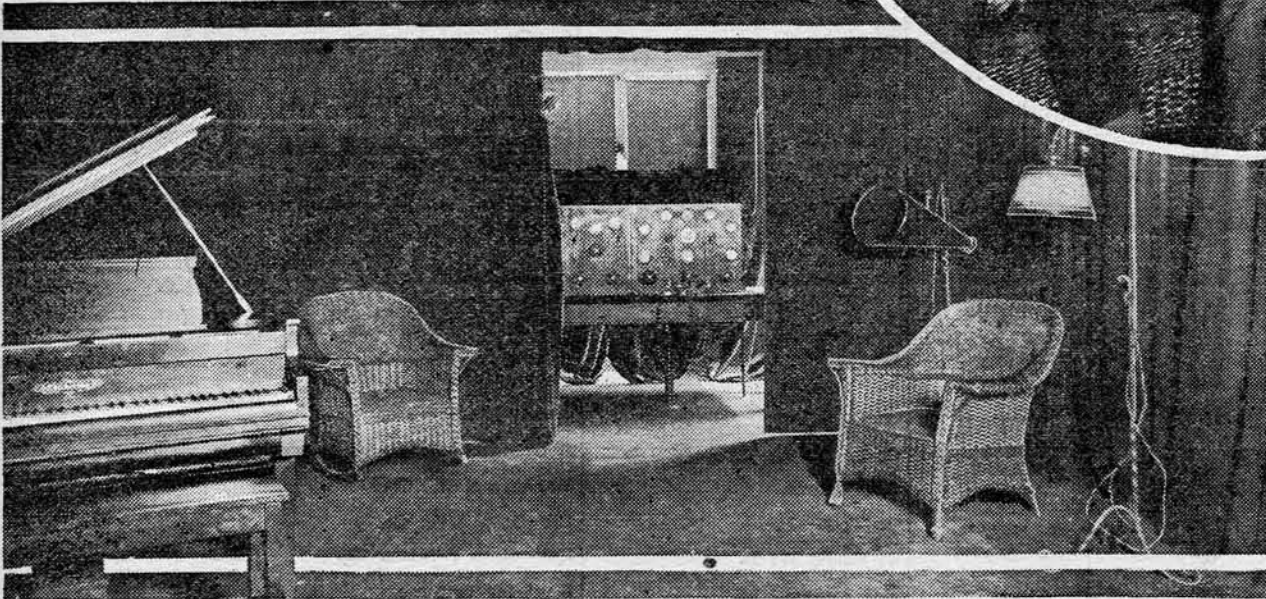
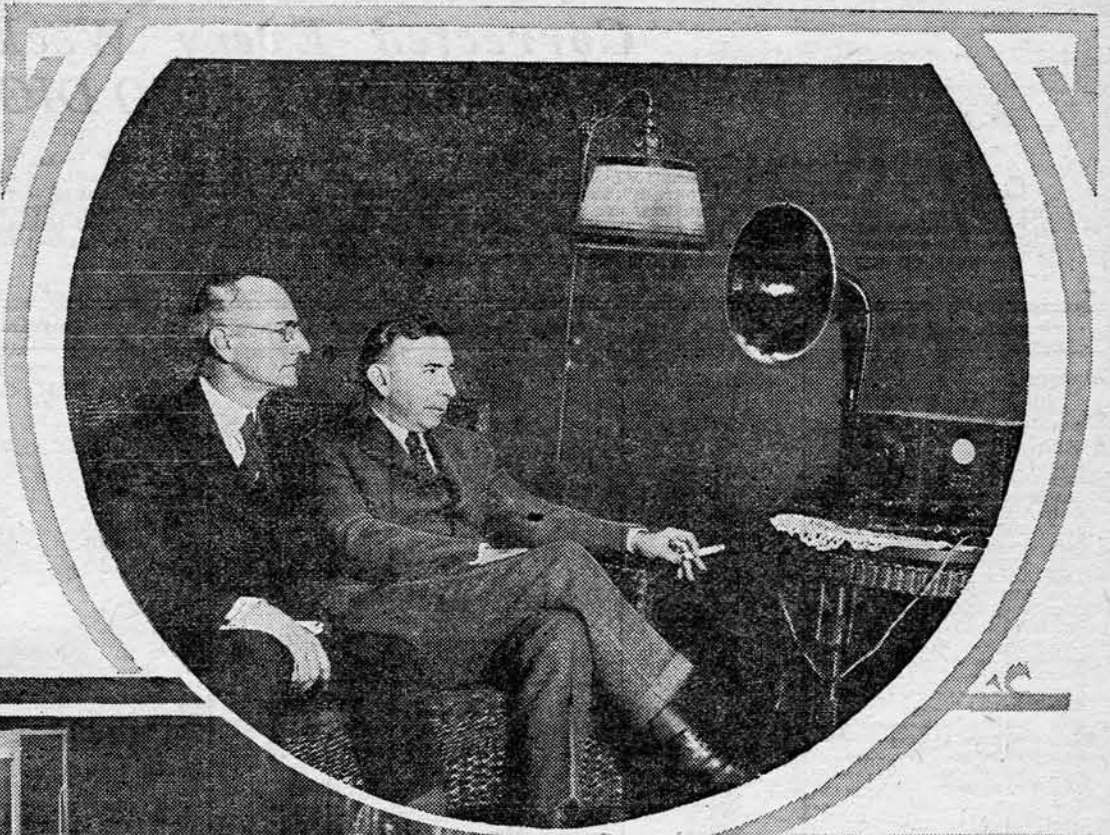

In the upper depiction are (from left to right) T. B. Hatfield, president of the company operating WOH, and Booth Tarkington, noted author; the lower photo shows the company's studio and part of its equipment.

and naturally caused quite a bit of comment.

Has Great Range

The range of KDKA is approximately 2,500 miles in all directions. To the north it has only been heard for a distance of 800 miles, but if there were more stations in northern Canada, this distance would undoubtedly be greatly increased. A letter was received recently from the U. S. Consul at La Guaira, Venezuela, telling of the remarkable clearness with which KDKA had been heard at that place on the evening of March 4. The Veneguellaan station was equipped with a vacuum tube detector and two steps of audio frequency amplification. La Guaira, Venezuela, is approximately 1,850 miles from Pittsburg.

KDKA broadcasts on a wave length of 360 meters and with 500 watts input.

antenna circuit with 800 volts on the plates, using the radiator system as a ground. The contrivance is supported by two large panels built by Mr. Copp.

In the studio, which is attractively decorated, are a grand and a reproducing grand piano. These instruments form part of the following daily programs of WFO: from 9 to 9:30 a. m. phonograph selections and news flashes on 360 meters; street market report at 9:15 a. m. on 485 meters. From 11 a. m. to noon music and news are given on 360 meters; market and weather reports at 11:30 a. m. on 485 meters (road conditions 360 meters). From 4 to 5 p. m. music and news flashes are presented on 360 meters; stock markets, grain and other crop reports and weather data at 4:30 p. m. on 485 meters (road conditions 360 meters). During Monday, Wednesday and Friday evenings from 7 to 8:30 o'clock, musical and educational programs are presented. Arrangements have been made for broadcasting on alternate Sunday mornings beginning at 11 o'clock the services of the First Lutheran and the First Presbyterian churches.

WFO uses a 1/2 K. W. input. The station's normal range with crystal detector is 100 miles, with receiving station using one stage audio frequency amplification or its

program developed for Sunday evening. It was suggested that church services be tried. There was no precedent for this method of Radio transmitting and consequently it was not known whether church services would broadcast well, or, indeed, if the churches would consent to the sending out of services.

Broadcast Religious Service

After some persuasion, permission was received from Calvary Episcopal Church, on Shady avenue, to broadcast its services. A district telephone line was installed between the church and the Radio station at East Pittsburg for this purpose. Four microphones were installed in the church to catch the voice of Edwin J. Van Etten, rector of the church, the choir, and chimes and the organ, and the entire service was first sent out January 2, 1921.

No one thing ever broadcasted by the Radio station has been so popularly received. Letters poured in by the score to the Radio division telling of the pleasure and benefit of this new departure in Radio. Newspapers in all parts of the country carried editorial announcement of the fact that church sermons were being broadcasted from Pittsburg through the medium of Radio telephone. This church service was the first to be wireless in the world,

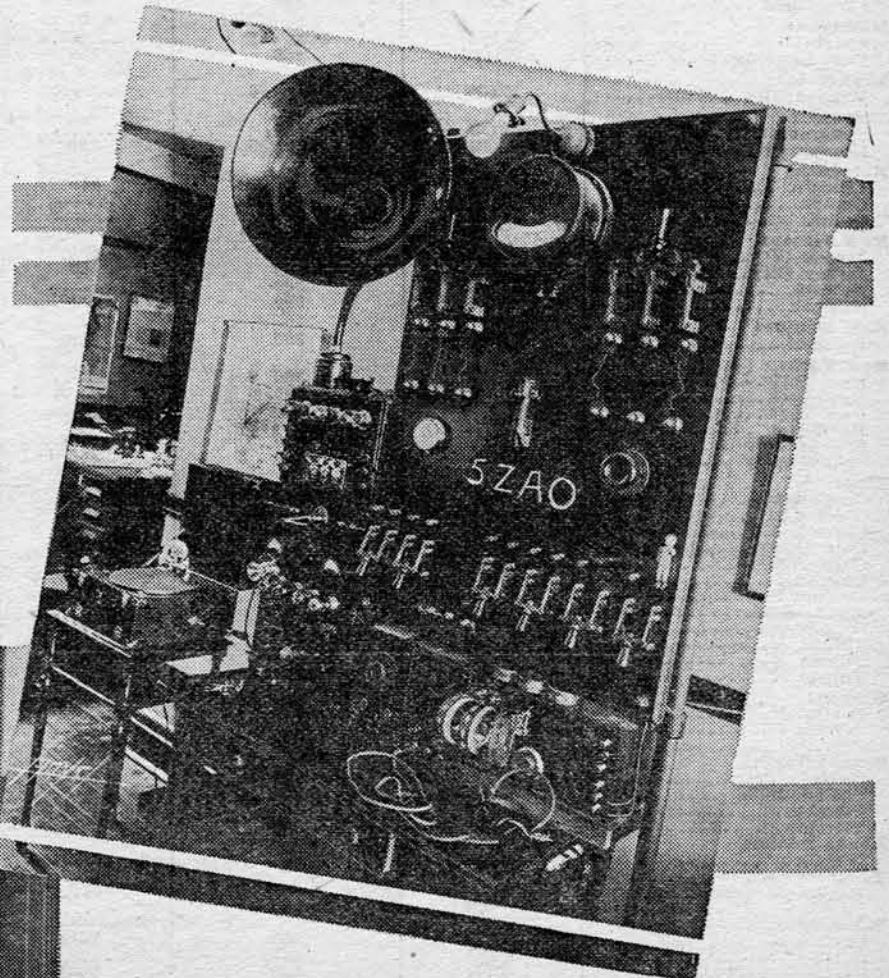

On the panel pictured above is the call 5 ZAO, the Roswell (N. M.) Public Service Company.

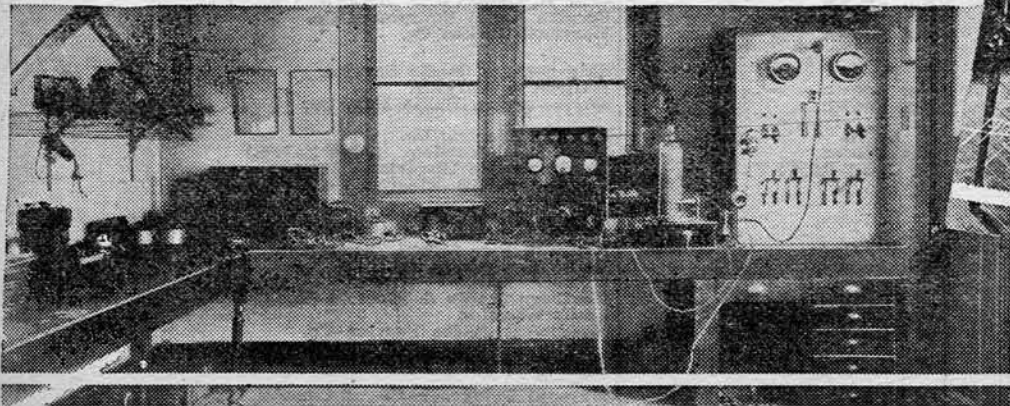

Striking view of the interior of WRK broadcasting station, Doron Brothers Electric Co., Hamilton, O.

Radiophone Broadcasting Stations

Corrected Every Week. Form
Copyrighted by RADIO DIGEST, 1922

Explanatory—In the following tabulation, RADIO DIGEST will attempt each week to make it easy for the reader to hear all the broadcasting stations in his vicinity. Hence the alphabetical classification, by states and then by cities, is used. Stations whose schedules of operating hours are known (those having C; N; R, etc., under "Program" in the following tabulation), are listed at the end of the table, alphabetically by call letters, under the head "Station Schedules." Having picked a station, use the "Station Schedule" list to learn its operating hours and what you will hear during the various hours. The following abbreviations are used in the "Program" column of the tabulation: A—agricultural bulletins, etc.; C—concerts; E—educational; F—fire; H—health reports; I—instruction (radio); L—lectures or speeches; M—market reports; N—news; P—police; R—religious; T—time signals; V—vaudeville or entertainment; W—weather reports. An asterisk (*) designates code telegraphy.

State and City	Call	Wave Lengths	Miles Range	Program	By Whom Operated
Alabama:					
Montgomery	WGH	360	1,000	W; R; E; A; M; C.	Montgomery Light & Water Power Co.
Arkansas:					
Pine Bluff	WOK	360	Not known.	The Pine Bluff Co.
California:					
Berkeley	360	C.	Maxwell Electric Co.
Gridley	KFU	360	500	C.	The Precision Shop.
Hollywood	KGC	360	300	C.	Electric Lighting & Supply Co.
Los Altos	KLP	360	1,500	C; N.	Colin B. Kennedy Co.
Los Angeles	KJS	360	Not known.	Bible Institute of Los Angeles, Inc.
Los Angeles	KOG	360	Not known.	Western Radio Electric Co.
Los Angeles	KQL	360	Not known.	Arno A. Kluge.
Los Angeles	KYJ	360	1,000	C; M; W; N.	Leo J. Meyberg Co.
Los Angeles	KZC	360	N; C.	Western Radio Electric Co.
Monterey	KLN	300; 360; 600	150	W; M; C.	Noggle Electric Works.
Oakland	KLS	360	150	C.	Warner Bros. (also operate 6XAM).
Oakland	KZM	360	1,500	N; C.	Hotel Oakland (Preston D. Allen).
Oakland	KZY	360	C; R; N.	Atlantic-Pacific Radio Supplies Co.
Pasadena	KLB	360	300	Not known.	J. J. Dunn & Co.
Pomona	KGF	360	C; N.	Pomona Fixture & Wiring Co.
Sacramento	KVQ	360	C; I.	J. C. Hobrecht (Sacramento Bee).
San Francisco	AGI	360	1,500	C; M; N; W.	Signal Corps, Presidio.
San Francisco	KDN	360	Not known.	Leo J. Meyberg Co.
San Francisco	KGB	360	C; N; L.	Edwin C. Lorden.
San Francisco	KSL	360	50	N; L.	The Emporium.
San Francisco	KUO	360	100	C.	The Examiner Printing Co.
San Jose	KQW	360	C.	Chas. D. Herrold.
Stockton	KJQ	360	N; M; C.	C. O. Gould.
Stockton	KWG	360	1,000	C.	Portable Wireless Telephone Co.
Sunnyvale	KJJ	360	N; W; C.	The Radio Shop.
Colorado:					
Denver	DD-5	340	1,500	C; N; W; L.	Reynolds Radio Co. (also operate 9ZAF).
Denver	KIZ	360; 485	1,000	N; W; C.	Fitzsimmons Hospital.
Denver	KOA	485	T; W; N.	Y. M. C. A. (W. H. Smith).
Connecticut:					
New Haven	WCJ	360	Not known.	A. C. Gilbert Co.
District of Columbia:					
Washington	WDM	360	R; L; C.	Church of the Covenant.
Washington	WDW	360	Not known.	Radio Construction & Electric Co.
Washington	WJH	360	250	L; C; V.	White & Boyer.
Washington	WWX	1160	600	W; M.	Post Office Department.
Washington	3YN	360	I.	National Radio Institute.
Georgia:					
Atlanta	4CD	200; 375	N; C; L.	Carter Electric Co.
Illinois:					
Chicago	KYW	360; 485	800	C; L; N; M; R.	Westinghouse Electric & Mfg. Co.
Chicago	WBU	360	1,000	P; F.	City of Chicago.
Rock Island	WOC	360; 485	Not known.	Karlowa Radio Co.
Indiana:					
Indianapolis	WLK	360	C; V; N; L.	Hamilton Mfg. Co.
Indianapolis	WOH	360	700	M; C.	Hatfield Electric Co.
Richmond	WOZ	485	300	C; M; N; W; L.	Palladium Printing Co.
Iowa:					
Des Moines	WGF	360	Not known.	Register-Tribune.
Iowa City	9YA	360	M; N.	University of Iowa.
Kentucky:					
Louisville	9ARU	200	200	N; I.	Darrell A. Downard.
Massachusetts:					
Medford Hillside	WGI	360	500	N; C; L; I; H; R; M.	Am. Radio & Research Corp. (also 1XE).
Springfield	WBZ	360	500	C; N; L; R; M; E.	Westinghouse Elec. & Mfg. Co. (also 1XAE).
Michigan:					
Detroit	WWJ	360; 485	1,000	C; V; N; M.	The Detroit News. (Was WBL.)
East Lansing	WHW	485	150	M; W.	Stuart W. Seeley.
Minnesota:					
Minneapolis	WLB	360; 485	W; M; C; N.	University of Minnesota.
Missouri:					
Jefferson City	WOS	485	M.	Missouri State Marketing Bureau.
Kansas City	WOQ	360; 485	300	M; W; C; L; R.	Western Radio Co. (Also operate 9XAB.)
Nebraska:					
Lincoln	9YY	375	300	C; N; M; W.	University of Nebraska.
Omaha	WOU	360; 485	Not known.	Metropolitan Utilities District.
Omaha	WOV	360	Not known.	R. B. Howell.
New Jersey:					
Jersey City	WNO	360	500	C; N; L.	Wireless Tel. Co. of Hudson Cy.
Jersey City	2IA	200	70	L; C; R.	Jersey Review.
Newark	WOR	360	Miscellaneous.	L. Bamberger & Co.
Newark	WJZ	360	2,000	N; L; C; W; A; R.	Westinghouse Electric & Mfg. Co.
New Mexico:					
Roswell	5ZAO	360	300	M; W; N; C.	Roswell Public Service Co.
New York:					
New York	WDT	360	Not known.	Ship Owners' Radio Service.
New York	WJX	360	Not known.	De Forest Radio Telephone & Telegraph Co.
New York	WYCB	1,450	N; C.	Amateur Radio Reserve.
Rochester	WHQ	360; 485	50	L; C; M; R.	Rochester Times-Union.
Schenectady	WGY	360	1,000	M; C; L.	General Electric Co.
Schenectady	WRL	360	800	C; R.	Union College. (Also 2XQ.)
Ohio:					
Cincinnati	WLW	360	1,200	C; L; N; R.	Crosley Mfg. Co.
Cincinnati	WMH	360; 485	1,000	C; N; L; W; V; M.	Precision Equipment Co. (Also 8XB.)
Cleveland	WHK	360	100	C.	Warren R. Cox.
Columbus	8BYV	200	C; N.	Electrical Specialty Co.
Columbus	8YO	275	T; M; L; N.	Ohio State University.
Dayton	WFO	360; 485	300	M; N; C; W; L; R; A.	Rike-Kumler Co.
Dayton	WA-1	360	Not known.	U. S. Army.
Fairfield	WL-2	360	Not known.	U. S. Army.
Hamilton	WRK	360	1,000	C; R; T.	Doron Bros. Electrical Co.
Toledo	WHU	360	Not known.	Wm. B. Duck Co.
Toledo	WJK	360	300	C; L; R.	Service Radio Equipment Co.
Toledo	WSZ	360; 485	Not known.	Marshall-Gerken Co.
Oregon:					
Portland	KGW	360	200	C; R.	Ship Owners' Radio Service.
Portland	360	Not known.	Hallock & Watkins.
Portland	360	Not known.	Northwestern Radio Mfg. Co.
Pennsylvania:					
McKeesport	WIK	360	500	C; L; R.	K. & L. Electric Co.
Philadelphia	WGL	360	Not known.	Thos. F. J. Howlett. (Also 3AWI.)
Pittsburgh	KDKA	360	1,000	N; C; L; R; V; T; M.	Westinghouse Electric & Mfg. Co.
Pittsburgh	KQV	360	750	C.	Doubleday-Hill Electric Co.
Rhode Island:					
Westerly	360	C; L.	Whitall Electric Co.
Texas:					
Dallas	450	N; W; C; R.	Police & Fire Signal Department.
Dallas	WRR	360	Not known.	Radio Equipment Co.
Washington:					
Seattle	KFC	360	700	N; C; V; H; L; R.	Northern Radio & Electric Co.
Seattle	KHQ	360	Not known.	Louis Wasmer.
Seattle	KJR	360	200	C; L; N.	Northwest Radio Service Co.
Wisconsin:					
Madison	WHA	360; 485	600	W; C; N; M; L.	University of Wisconsin.
Canada:					
Montreal	1,200	200	C; N; L.	Marconi Telegraph Co. of Canada, Ltd.
Toronto	450	Not known.	Canadian Independent Telephone Co.
Toronto	1,200	Not known.	Marconi Telegraph Co. of Canada, Ltd.

Your Directory—

To aid the beginner and to help him realize full benefits from his receiving station, RADIO DIGEST has compiled the foregoing list of radiophone broadcasting stations. To use the "radiophone directory" to its maximum advantage, the reader should note the broadcasting stations nearest, and attempt to tune them in at the wave lengths given.

Broadcasting stations with regular schedules of operating hours, are given below. Doubtless a few stations have been omitted inasmuch as their schedules have not been reported to RADIO DIGEST. These will be added as reported. The kind of program broadcast by a station during its various operating hours is also given.

In fact, the reader, by means of RADIO DIGEST'S radiophone directory, can pick out his favorite program, the station he desires, or the time which he prefers to listen in. Time, in the following list of stations having schedules, is always given in the time used in the city in which the station is located, as for example "KYW, Chicago, Illinois," indicates that the schedule of KYW is given in Central Standard time, the time which is in use in Chicago.

The stations are listed alphabetically by call letters. The list, therefore, acts as an index to the foregoing table:

Station Schedule

- AGI, San Francisco, Calif.**
Mondays, 7:00-9:00 P. M., concert and instruction in radio.
- DD-5, Denver, Colo.**
Daily except Sundays, 8:15 P. M., weather, news and concert. Thursdays, 8:15-9:30 P. M., special concert, and speeches additional.
- KDKA, Pittsburgh, Pa.**
Daily except Sundays, 10:00-10:15 A. M., 12:30-1:00 P. M., 2:00-2:20 P. M., 4:00-4:20 P. M., music; 7:30 P. M., bedtime stories; 7:45, news; 8:30-9:30, music and news. Saturdays, 3:00-4:00 P. M., concert. Sundays, 10:45 A. M., 3:00 P. M., and 7:30 P. M., church service.
- KDN, San Francisco, Calif.**
Daily except Sundays, 4:30-5:30 P. M., markets, news and concert; 7:10-7:30 P. M., financial news and weather; Mondays, 8:30-9:30 P. M., concert; Thursdays, 7:30-8:30 P. M., concert; Saturdays and Sundays, 8:15-9:00 P. M., concert.
- KFC, Seattle, Wash.**
Every day, eight hours, news, music and entertainment.
- KFU, Gridley, Calif.**
Mondays and Thursdays, 8:00-9:00 P. M., concert. Sundays, 3:00-4:00 P. M., and 8:00-9:00 P. M., concert.
- KGC, Hollywood, Calif.**
Tuesdays, Thursdays and Saturdays, 7:30-8:30 P. M., concert.
- KGW, Portland, Ore.**
Mondays, Wednesdays, and Fridays, 7:30-8:30 P. M., concert. Sundays, 7:30-8:30 P. M., church service.
- KIZ, Denver, Colo.**
Daily, 8:30 A. M., weather; 7:30 P. M., news; 9:00 P. M., weather. Sundays, 8:00-10:00 P. M., concert.
- KJJ, Sunnyvale, Calif.**
Tuesdays, 8:15-9:00 P. M., concert. Fridays, 7:30-8:15 P. M., concert.
- KJQ, Stockton, Calif.**
Wednesdays, 7:00-8:00 P. M., concert.
- KJR, Seattle, Wash.**
Daily except Sundays, 8:00-9:00 P. M., miscellaneous.
- KL B, Pasadena, Calif.**
Mondays and Fridays, 7:30-8:15 P. M., concert. Sundays, 3:00-4:00 P. M., and 8:00-9:00 P. M., concert.
- KL N, Monterey, Calif.**
Daily, 12:00-1:00 P. M., weather, markets and news; 7:00-8:00 P. M., concert.
- KL P, Los Altos, Calif.**
Mondays, 7:30-8:30 P. M., industrial news and concert. Thursdays, 8:30-9:00 P. M., concert. Sundays, 4:00-5:00 P. M., concert.
- KL S, Oakland, Calif.**
Daily, 12:00-1:00 P. M., concert. Saturdays, 7:30-8:15 P. M., concert.
- KO A, Denver, Col.**
Daily, 9:55-10:25, time and weather reports.
- KQV, Pittsburgh, Pa.**
Daily except Saturdays and Sundays, 4:30-5:00 P. M., concert. Mondays, Wednesdays and Fridays, 9:30-10:30 P. M., concert. Sundays, 1:00-1:30 P. M. and 4:00-5:00 P. M., concert.
- KQW, San Jose, Calif.**
Wednesdays, 7:30-8:15 P. M., concert. Sundays, 5:00-6:00 P. M., concert.
- KSL, San Francisco, Calif.**
Daily except Sundays, 10:00-11:00 A. M., concert and news; 2:00-3:00 P. M., concert and educational talk. Sundays, 2:00-3:00 P. M., concert and educational talk.
- KU O, San Francisco, Calif.**
Daily except Sundays, 3:00-3:30 P. M. and 5:30-6:45 P. M., news, etc. Sundays, 5:00-6:00 P. M., news, etc.

- KVQ, Sacramento, Calif.**
Daily except Sundays, 5:30-6:30 P. M., concert and news. Wednesdays and Saturdays, 8:00-9:00 P. M., concert.
- KWG, Stockton, Calif.**
Daily except Sundays, 4:00-5:00 P. M., news, concert and markets. Tuesdays and Fridays, 8:00-9:00 P. M., concert. Sundays, 2:00-3:00 P. M., concert.
- KYJ, Los Angeles, Calif.**
Daily except Sundays, 4:00-5:00 P. M., concert, markets, news and weather. Mondays, Thursdays and Saturdays, 8:00-9:00 P. M., same program.
- KYW, Chicago, Ill.**
Daily except Sundays, 9:30 A. M., 10:00 A. M., 1:20 P. M. and 2:15 P. M., stock quotations and markets; 2:15 P. M., 3:00 P. M., baseball; 4:15 P. M. and 6:30 P. M., news and markets; stock report summary; 7:30 P. M., children's hour; 8:00-9:00 P. M., concert; 9:00 P. M., news. Sundays, 3:30 P. M., church service.
- KZ C, Los Angeles, Calif.**
Daily except Sundays, 5:00-5:30 P. M., news and on Tuesdays, Wednesdays and Fridays, same hour, concert.
- KZ M, Oakland, Calif.**
Daily except Sundays, 7:15-7:30 P. M., news. Tuesdays, 7:30-8:15 P. M., concert. Fridays, 8:15-9:00 P. M., concert.
- KZ Y, Oakland, Calif.**
Daily except Sundays, 3:30-4:30 P. M., concert; 6:45-7:00 P. M., news; Wednesdays, 7:30-8:15 P. M., concert. Saturdays, 8:15-9:00 P. M., concert. Sundays, 11:00 A. M. to 12:15 P. M., church service; 3:00-4:00 P. M., concert.
- WBZ, Springfield, Mass.**
Daily except Sundays, 7:30 P. M., children's hour; 7:45 P. M., market, weather, lecture; 8:00-9:00 P. M., concert. Sundays, 3:00 P. M., and 8:00 P. M., church service.

Who Hears Broadcasting Stations Farthest?

TO STIMULATE long distance receiving, RADIO DIGEST ILLUSTRATED is starting a contest with its next number. If you can hear one of the broadcasting stations at a distance you consider remarkable, send in the evidence to this publication, care of the Broadcast Editor.

The receiving station hearing a given broadcasting station at the greatest distance, will, if ample evidence is submitted, be listed as the record holder along with the information on that station in the "Radiophone Broadcasting Stations" table. When another receiving station breaks the record listed, it will supersede the listing of the first station to "make" the table.

Caution! Don't send in your "record" unless you are fairly certain it is a real record.
—Broadcast Editor.

- WDM, Washington, D. C.**
Sundays, 10:30 A. M., church service; 3:00 P. M., lecture; 7:30 P. M., church service.
- WFO, Dayton, O.**
Daily, 9:00-9:30 A. M., concert and news; 11:00-12:00 A. M., music, news, markets, weather; 4:00-5:00 P. M., music, news, markets, agriculture, weather. Mondays, Wednesdays and Fridays, 7:00-8:30 P. M., music and lecture. Sundays, 11:00-12:00 A. M., church.
- WGH, Montgomery, Ala.**
Daily, 11:05 A. M., weather; 4:05 agricultural. 8:30-9:30 P. M., educational, agricultural, stock quotations and concert. Sundays, 8:30-9:30 P. M., religious program.
- WGI, Medford Hillside, Mass.**
Mondays, 8:15 P. M., news. Tuesdays and Thursdays, 8:15 P. M., children's hour. Wednesdays, 8:15 P. M., concert. Fridays, 8:00 P. M., radio instruction. Saturdays, news.
- WGY, Schenectady, N. Y.**
Daily except Saturdays and Sundays, 7:00 P. M., markets. Tuesdays, Thursdays and Fridays, 7:45-9:00 P. M., concert. Fridays, 11:30 P. M., concert and speech.
- WHA, Madison, Wis.**
Daily except Sundays, 12:30-1:00 P. M., weather, markets; Tuesdays, Thursdays, Fridays and Saturdays, 12:00-1:00 P. M., weather, markets, time; Tuesdays only, 8:00-9:00 P. M., concert; Fridays, 8:00 P. M., news; 8:15 P. M., 9:00 P. M., concert; Saturdays, 1:05-1:20 P. M., lecture.
- WHE, Cleveland, O.**
Daily, 1:30-2:00, 3:30-4:00, 8:00-9:30 P. M., concert.
- WHQ, Rochester, N. Y.**
Daily except Sundays, 12:00-12:15 A. M., music and news; 7:30-8:00 P. M., markets, bedtime stories, lecture; 8:00-8:30 P. M., music. Sundays, 3:00 P. M. and 7:30 P. M., church service.
- WHW, East Lansing, Mich.**
Daily except Sundays, 11:30-12:30 A. M., weather and markets.

- WIK, McKeesport, Pa.**
Daily except Sundays, 6:30-7:00 P. M. Tuesdays and Thursdays, 9:30-10:30 P. M. Sundays, 1:30-2:30 P. M. and 6:30-7:00 P. M.
- WJH, Washington, D. C.**
Tuesdays, 7:30-10:00 P. M., lecture and concert.
- WJK, Toledo, O.**
Daily except Sundays, 3:00-4:00 P. M., concert. Mondays, Wednesdays and Fridays, 7:30-9:00 P. M., concert, lecture, etc. Sundays, 7:30-9:00 P. M., sermon and concert.
- WJZ, Newark, N. J.**
Daily except Sundays, hourly from 11:00 A. M. to 6:00 P. M., music; 11:00 A. M., 12:00 M., 5:00 P. M. and 10:00 P. M., weather; 2:05 P. M. (except Saturdays), shipping news; 12:00 M. and 6:00 P. M. agricultural; 9:52 P. M., Arlington time signals. Tuesdays, 7:00 P. M., children's hour; 8:20-10:00 P. M., concert. Thursdays and Saturdays, 8:20-10:00 P. M., concert. Sundays, 3:00 P. M., church service; 8:20-10:00 P. M., concert.
- WLB, Minneapolis, Minn.**
Daily, 12:00 M., weather and stock quotations; 7:30 P. M., markets. Wednesdays, 8:00 P. M., concert.
- WLE, Indianapolis, Ind.**
Tuesdays, 8:00-8:55 P. M., concert; 9:00-10:00 P. M., vaudeville and news. Thursdays, 8:00-8:55 P. M., concert, lecture and news. Sundays, 8:00-8:55 P. M., concert, religious.
- WLW, Cincinnati, O.**
Tuesdays, Thursdays and Fridays, 8:00 P. M., music, news and lecture. Sundays, 8:00 P. M., church services.
- WMH, Cincinnati, O.**
Daily except Sundays, 11:00 A. M. and 4:00 P. M., weather and markets. Monday, Wednesday and Saturdays, 8:15-10:00 P. M., concert, lecture, vaudeville and news.
- WNO, Jersey City, N. J.**
Daily, 10:01 P. M., news, concert.
- WOH, Indianapolis, Ind.**
Daily except Sundays, 10:00-11:00 A. M., 4:00-5:00 P. M., stock reports and music; 8:30-10:00 P. M., music. Saturdays, 1:00-2:00 P. M., stock reports and music. Sundays, 10:00-11:00 A. M., music.
- WOQ, Kansas City, Mo.**
Daily except Sundays, 9:30 A. M., to 1:15 P. M., every half hour, markets; 11:30 A. M., 2:00 P. M. and 7:30 P. M., markets, weather and road conditions; 7:45-9:00 P. M., concert and vaudeville. Sundays, 7:00 P. M., church service.
- WOB, Newark, N. J.**
Daily except Sundays, 9:00 A. M., 5:00 P. M., hourly program.
- WOZ, Richmond, Ind.**
Daily except Sundays, 12:00-12:15 P. M., markets; 4:00-5:00 P. M., music, news, markets; 6:30-7:00 P. M., music, news weather and lecture.
- WRK, Hamilton, O.**
Mondays, Wednesdays and Saturdays, 8:30-10:30 P. M., music and news. Fridays, 7:30-9:30 P. M., music. Sundays, 10:45 A. M. and 7:30 P. M., church service.
- WRL, Schenectady, N. Y.**
Irregular programme.
- WRB, Dallas, Texas.**
Daily, 7:00 P. M., police news, sports, weather; 8:30-9:30 P. M., concert. Sundays, 11:00 A. M. and 7:30 P. M., church service.
- WWJ, Detroit, Mich.**
Daily except Sundays, 11:30-11:55 A. M. and 3:30-4:00 P. M., music; 7:00-8:30 P. M., concert, etc.
- WWK, Washington, D. C.**
Daily, 10:00 A. M., weather; 10:30 A. M., markets; 5:00 P. M., markets; 7:30 P. M. and 8:00 P. M., markets; 9:50 P. M., weather.
- 2IA, Jersey City, N. J.**
Wednesdays, 7:00-8:00 P. M., concert and lecture. Sundays, 7:00-8:00 P. M., church service and concert.
- 3YN, Washington, D. C.**
Daily, 6:30-7:30 P. M., radio instruction (code and radiophone).
- 4CD, Atlanta, Ga.**
Tuesdays, Thursdays and Sundays, 7:30-8:00 P. M., news and concert.
- 5ZA O, Roswell, N. M.**
Daily except Sundays, 7:00-9:00 P. M., weather, stock and news. Mondays, Wednesdays and Fridays, 7:00-9:00 P. M., music. Sundays, church service.
- 8BY V, Columbus, O.**
Mondays, Wednesdays and Fridays, 7:30 P. M., concert, news, etc.
- 8UX, Akron, O.**
Mondays, Wednesdays and Fridays, 6:30-7:30 P. M., concert.
- 8YO, Columbus, O.**
Irregular, time signals, news, markets, etc.
- 9A B U, Louisville, Ky.**
Mondays, and Wednesdays, in evening, police news, balance of week irregular.
- 9YA, Iowa City.**
Irregular, markets, news, etc.
- 9YY, Lincoln, Neb.**
Daily except Sundays, 10:10 A. M., markets and weather; 7:30 P. M., irregularly, music.

FIRST NEWARK SHOW MAKER OF HISTORY

DAILY PAPER SPONSORS CITY'S BIG EXHIBIT

Exposition Opened by Mayor Draws
Thousands for Four Days; Eight
Transmitting Stations Used

NEWARK, N. J.—Nothing in the history of this city has so interested or attracted its people as the first Radio show, sponsored by a daily newspaper here. The exhibit, in a leading hotel, was visited by thousands for four days. The opening speech, by the mayor of Newark, was broadcast by WOR (L. Bamberger and Company), an exhibitor.

Concerts, vocal and instrumental solos, recitations, weather and crop reports, market, stock and other news, government time signals, addresses and religious services were presented by the transmitting stations. Among these were WJZ (Westinghouse Electric and Manufacturing Company, Newark), WBZ (Westinghouse of Springfield, Mass.), KYW (Westinghouse of Chicago), KDKA (Westinghouse of Pittsburgh, Pa.), WVP (United States Signal Corps, Bedloe's Island, N. Y.), WGI (Radio Research corporation, Medford, Mass.), WGY (General Electric company, Schenectady, N. Y.), and WWJ (The News, Detroit, Mich.).

Among the exhibitors were:
American Radio Equipment Co.
L. Bamberger & Co.
Banister & Pollard.
Boonton Rubber Co.
Boy Scouts of America.
A. H. Corwin.
Dreyfus Sales Corp.
P. M. Drefus Co.
Exide Battery Co.
Essex Storage Battery Co.
Electric Mfg. & Sales Co.
Eastern Electric Supply Co.
Essex Manufacturing Co.
Essex Radio Service, Inc.
Franco Electric Corporation.
General Apparatus Co.
General Lead Battery Co.
Gerhing & Wellington.
Norman W. Henley Pub. Co.
Habne & Co.
Hintze Bros., Inc.
Harris Laboratories.
Hawkins Radio Store.
Irvington Varnish & Insulator Co.
Jewett Mfg. Corporation.
F. C. Kent & Co.
Krich Light & Electric Co.
Lindsay Metal Novelty Works.
Mills Radio & Electric Co.
Morscaw Radio Co.
Multiple Storage Battery Co.
D. W. May, Inc.
Newark Electrical Supply Co.
Nelson Radio Parts Co.
National Light & Electric Co.
Novo Manufacturing Co.
Poolinn Radio Co.
Radio Mineral Co.
Radio Mineral Co.
Radio & Model Engineering Co.
Radio Corporation of America.
Radio Supply Co.
The Radio Shop.
Martin H. Ray, Inc.
A. H. Redden.
Reily-Jotz Mfg. Co.
W. W. Reid, Inc.
Weston Electrical Instrument Co.
Wholesale Radio Equipment Co.
E. M. Wilson & Son.
Wintner Radio company.

GOOD PHONES NEEDED

Radio receiving outfits cannot be more sensitive than the phones used. Many beginners and even experienced amateurs fail to place sufficient importance upon phone selection.

The appearance of a pair of phones means nothing. Unless they are scientifically designed with perfect and mechanical correlation between their various working parts they cannot make the most of the weak currents that pass through them. It is in the phones that the delicate process of changing the electrical impulses into audible sounds, takes place.

In some apartment houses the ordinary telephone receivers have been pilfered by boys who are using the receivers on homemade apparatus. The telephone receiver of the ordinary kind is of little value to the Radio fan.

- Berkeley, Calif. (Hotel Claremont).**
Sundays, 1:00-2:00 P. M. and 6:00-7:00 P. M., concert.
- Denver, Colo. (Y. M. C. A.).**
Daily, 10:00 P. M., time signals, weather, news.
- Denver, Colo. (Fitzsimmons Hospital).**
Thursdays, 8:00-9:30 P. M., concert.
- Montreal, Canada (Marconi Station).**
Tuesdays, 8:00-9:30 P. M., concert, news.
- San Francisco, Calif. (The Emporium).**
Daily except Sundays, 10:00-11:00 A. M. and 2:30-3:30 P. M., concert.
- Westerly, R. I. (Whitall Elec. Co.).**
Daily, in evening, concert.

Radio Digest Illustrated

TRADE-MARK

E. C. RAYNER, Publisher
123 WEST MADISON STREET
TELEPHONE STATE 4844-4845
CHICAGO, ILLINOIS

New York Office - - - - - 453 Fifth Avenue Building
Detroit Office - - - - - 28 Rowland Building

58
PUBLISHED WEEKLY

SUBSCRIPTION RATES
Yearly.....\$5.00 | Foreign.....\$6.00
Single Copies, 10 Cents

Entry as second-class matter applied for at the postoffice at Chicago, Illinois, under Act of March 3, 1879.

In a new scientific field where many writers are contributing articles there will arise some controversy over the expressions of opinions and statements made from time to time. Some of these controversies may be taken into the courts for settlement. The priority of inventions may be claimed as well as the merits of some part entering into the construction of the radio apparatus. The Radio Digest is an outlet for these expressions and the publisher disclaims any responsibility for opinions or statements made in connection with radio apparatus. The news will be printed as it comes to us.

Vol. 1 Chicago, Saturday, April 29, 1922 No. 3

Lifting the Veil from the Future

Instructing and Entertaining the Public

THERE is no reason why entertainment should not be given to persons in railway stations. Some of the larger stations already have amplifiers for announcing the arrival and departure of trains. These may be used in connection with a receiving set that would produce news, music and other entertainment.

The commuter soon may be able to listen to news items; he will not have to read them in the usual dim light.

The common schools of today are crowded to capacity; for this reason the Radiophone may play an important part in education. Instruction may be broadcast and an unlimited number of pupils benefited.

The pace of today is much greater than a few years ago. To keep abreast or a little ahead the individual must have some mechanical means. While most of the things claimed for Radio may be impossible or not practicable many uses will be found that will become a part of the individual's daily life.

Will Radio Replace Newspapers?

Newspaper Items Follow Radio with More Interest

THE free distribution of news by Radiophone broadcasting stations has given many newspaper publishers food for thought. At present their instruments for receiving these messages are more or less of a novelty, but the publishers are wondering what the result will be when receiving sets become still more popular and used in many more homes.

It is thought by some that the first effect will come from the broadcasting of sporting events and reduce the sales of the evening papers. Once the score of a baseball game is known, the play-by-play synopsis doesn't interest many of the readers of the newspapers.

It is a known fact that a large number of the leading newspapers of the United States have tried out Radio for the sending and collecting of news. In some instances the publishers have discontinued the service, but this was not done on account of the growth of the Radiophone, but mainly because of the difficulty to get the initial news sent out to them. The paper gathering news did not always have facilities to reach Radio transmitting stations soon enough that items of importance could be sent out to the newspapers immediately.

Mr. Eaton, an executive of the Westinghouse Electric & Manufacturing Company, has said that Radio broadcasting of news will never be a competitor of the newspaper any more than it will supplant the telephone. It is true that an item of news can be broadcast to listening millions almost instantly, but such messages necessarily are sent out at set times. They reach only those persons actually listening in at the time, and the message must be stripped practically of all detail.

The only effect from a newspaper standpoint, of Radiophoning an important piece of news will be in the selling of more papers the next morning.

Radio on the Farm

Radiophone Is as Essential as Rain

THE Radiophone reaches its maximum in usefulness to the nation in agriculture much more than in any other industry. It not only makes the isolation of the people living on farms a thing of the past, but it brings to them the weather and market news, the prompt receipt of which plays a very important part in the production and distribution of crops.

During certain months in producing sections there is always some danger to the crops by frost. Radio warnings telling of any impending frosts can be flashed to the section. It is quite necessary that the farmer know the market conditions in order to have proper distribution of the farm products. If the farmer does not have prompt market information he cannot know when and where his produce is most needed. The over-supplied

and under-supplied markets may be made known to him quickly by Radio.

In an effort to secure a proper correlation of supply and demand, the Department of Agriculture has a crop and market reporting service that is regarded as the most efficient reporting system in the world. Market reporters in the principal producing sections and market corners are in daily touch with marketing activities.

The establishment of a national system of broadcasting agricultural news is therefore of vital importance. Radio brings the news to the farmer while it is still news and of value.

At the present time the Department of Agriculture with the cooperation of the Post Office Department and State and local institutions broadcasts daily weather, crop and market reports throughout the country by Radiophone and Radio telegraph. In recent years most of these reports have been sent out by Radio telegraph, which requires knowledge of abbreviations and codes on the part of the receiving operator. Thousands of amateur Radio operators receive these reports and distribute them in their immediate vicinity.

The Government Radio station at Arlington broadcasts weather reports and forecasts daily under the direction of the Department of Agriculture. These messages are sent in code and picked up by a network of officially designated Radio stations throughout the entire country, the receiving stations being equipped to transmit by voice the decoded message to thousands of anxiously waiting farmers. Thus a farmer by means of Radio keeps in touch with the pulse of the markets and changes in the weather. He knows with almost unerring certainty what to expect a week hence and the existing circumstances in the markets. This readily available news which is made possible to him has placed him on a footing where he is able to deal with the produce merchant and better his condition.

Aside from these services, local authorities use the Radiophone to deliver weekly lectures on seasonal problems that the farmer in the past had been left to work out alone. In addition he enjoys the nightly programmes, which since their inauguration have done so much to enliven the otherwise monotonous evening of the farm day.

Radiophone and Its Growth

Editorial Comment on the New Science

THE most inventive nation in the world is the United States. It is most receptive to new ideas and most willing to reward those who find something new. Throughout the ages the ether has been useless, apparently an unnecessary part of the terrestrial system, but it now offers one of the most valuable mediums for the transmission of thought, music and other communications.

In an obscure corner at the centennial exposition in Philadelphia in 1876, says Industry Illustrated, sat a young man who had devoted years of patient study and experiment to the model exhibited on a table in front of him. The crowds passed him with scant interest in the "toy" he was trying to bring to their attention. On the last day of the exposition, when the young inventor despaired of gaining recognition, a royal visitor recognized him as a person who had interested him some years before. By stopping to speak to the young man the kingly person brought a halt in the line. Many scientists stopped to examine the device, the first telephone of Alexander Graham Bell, the young inventor. [Less than 17 months ago the first news was broadcast by Radiophone and less than a year the first commercial station came into use; now there are a half million or more receiving stations. The new science owes its swift recognition to the approval of the ordinary man.]

The Marion (Ohio) Star says that the new science, Radiophony, affords mental relaxation of the most refreshing kind. Few of us realize the importance of a change in mental diet. An interesting diversion like Radio will add years to a man's life. One may experiment and invent to his heart's content.

Radio telegraphy is comparatively old, says the Nashville Banner, but Radiophones have been brought to their present state since the war. The government encouraged the use of the Radio during the war and recruited the ranks of its operators from amateurs. The Radio became a fad only a few months ago. Its increase in popularity may be judged by the statement from the government that there are now at least 700,000 receiving stations in use as compared with less than 50,000 nine months ago.

The Marine City Independent (Michigan) says "Is it just a spasm or are we facing a new era?" Indications seem very much to point to the latter. In spite of imperfections especially in the transmission of waves the Radiophone is fairly acceptable as it is.

In its comment on the Radiophone situation the Danville (Illinois) Press remarks that "just the other morning we woke and were amazed to find the world had gone crazy about the Radiophone. The Radiophone has corralled American enthusiasm; what was once purely a scientific instrument is rapidly becoming as common as the talking machine."

In an editorial in The Rustler (Basin, Wyoming) the viewpoint taken is that the Radio equipment needed for today does not call for the towers and the wires that have heretofore been used with the ordinary wireless. The equipment may be placed in the parlor, the wires hidden and run to a small aerial outside. The receiving instrument is but a small affair and its cost is nominal.

The Times (Emporia, Kansas) says that the Radiophone will outstrip the talking machine and even the motion picture because its potentiality lies nearer to the root of things. When the American farmer can be brought into conversational contact with the remotest part of the country, things are going to move. What is to happen to the local band when the boys and girls of every town and hamlet may dance to the music of the world's greatest masters of "jazz" as it is broadcast from a central point?

RADIO INDI-GEST

Now for a Radio Milk Bottle!

STUDENTS at Cornell University recently equipped a baby carriage with a life-size baby doll and a Radiophone receiving set. Parading down the streets of Ithaca, they tuned in and received the lullabies sent from a nearby station.

All mother needs now is a Radio control for the baby carriage which will guide the perambulator down the boulevards, entertaining the modern offspring with lullabies and feeding him from the Radio controlled

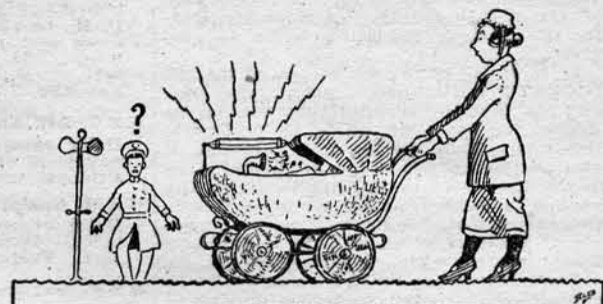

milk bottle, while mother—plays golf on the links or loses papa's monthly income at a friendly little game of bridge.

And (afterthought) wouldn't it be great to have a Radio controlled husband!

Fresh from the Backwoods—"You say that the messages come in over those wires," pointing to the aerial above the shack.

Operator—"You guessed it."

The Hick—"Well, I'll be darned. Here I've been watching it for two hours and nary a one did I see."

Has Hat Full of Radio Waves; Asylum Gets Him

The railroad agent at Port Jervis was approached by a badly scared man who complained that he had a "hat full of Radio waves" and did not know what to do with them. The police department was called, and when they had properly insulated the complainant a pair of keepers from the Binghamton State Hospital for the Insane accompanied their charge back to his "Radio wave proof castle."

The Radio Wave



I travel over land and sea
I travel far and wide,
The world is my dominion
As through the space I glide.

I carry news both bad and good
As on my way I roam,
Oft' to a sweetheart far away
Sometimes to Mother at home.

I've traveled to the tropics
Across the rolling main,
But someone's sure to take me
And send me back again.

I've been on ships that sail the sea
And reach a watery grave,
I cover the world and all therein
I am the Radio Wave.

Jack G. Forrest

Lights to See Messages Come In

She—"And why do you have all of those little electric lights inside of the box?" nodding toward the detector and amplifier.

He—"Just so that I can see the messages coming in, dear."

"Here's How"

Lives of great men all remind us,
We can make our lives sublime,
Build yourself a Radio outfit,
If you're out for a good time.
—"Chiquita."

"Are We Right?"

Ashes to ashes,
Dust to dust,
If the women don't get you,
Why the Radio must.
—"Chiquita."

When a Sleuth Isn't

No. Oscar, the detector is not a sleuth, and unlike Chicago "gumshoes," it requires no bullets to get its adjustment "shot."

2 K X MAKES NAME DURING GREAT WAR

AMATEUR HEARS SAYVILLE VIOLATE NEUTRALITY

2WG Described—Claimed to be the Largest Amateur Radiophone Transmitting Station

When Kaiser "Bill" started the big noise over in western Europe, he wasn't satisfied with keeping the fight on the wrong side of the Atlantic, but immediately started trouble here in the United States. One of his stunts was to use the Telephonken Company's powerful Radio station (German owned) at Sayville, Long Island, as an important link in his intelligence system. But he reckoned wrong.

T. W. Kilmer, Not Asleep

Hour after hour, day after day, T. Wendell Kilmer, owner and operator of station, 160 West 85th street, New York City, listened in on the messages which Sayville was transmitting. When deciphered, the messages proved very interesting reading for the secret service branch of the U. S. Department of Justice. The Sayville station was soon closed, and several important plans of Germany were intercepted.

Given Special License

As a result of his splendid work in intercepting the messages of Sayville, Kilmer was granted a special operating license and permit by the Navy department to keep his station in operation during the war, a concession held dear to the heart by any true blue amateur.

2KX is one of the pioneer amateur stations. It was one of the first in the second district to be licensed by the government. Below on this page is shown a picture of Kilmer at his station listening in with a loop type antenna. The steering gear, or hand wheel in front of and above his head, rotates the loop antenna so as to be in a plane with the station which is being listened for. Kilmer has a continuous wave transmitter with an input of 50 watts.

Station 2WG Believes in Neatness

The other amateur station picture shown below is that of 2WG, the station of Walter J. Garvey, located at 162 West 184th street, New York City. Garvey is a firm believer in the theory that neatness promotes efficiency, and the performance of his station does much to back him in his belief.

2WG has been heard in a good many states and has a normal working range of 1,800 miles. The transmitting outfit has an input of 500 watts, the continuous wave system being employed with key for code telegraphy and microphone transmitter for voice.

No Motor-Generator Used

Mr. Garvey does not use motor-generators to supply a direct current for his set. Whether he uses chemical rectifiers or vacuum tube rectifiers is a matter of conjecture, as his station's description does not state just what he does use. It emphatically states, however, that the system is a new "wrinkle" and that this feature will aid the science of Radio.

Often Broadcasts Program

It is probable that many owners of receiving sets have heard 2WG, as it is often employed in broadcasting. Lectures, musical programs and church services are but a few of the many broadcasts sent out by means of Mr. Garvey's transmitter.

It is claimed that 2WG is the largest amateur station in the United States. One would judge from the picture that the station was by no means in the mediocre class. Seven vacuum tubes are shown on the front of the panel, and there are three more at least hiding behind the cabinet below the loud speaker.

How to Make Radio Parts

Grid and Phone Condensers and Grid Leaks Described in Detail and Pictured So That Beginners May Learn Easily the Manner in Which to Fashion and Assemble the Best Airphone Sets

Grid and Phone Condensers

It is a simple matter to construct a condenser which can be used to shunt across the phones, or else be used for the grid condenser of a vacuum tube receiving set. The first thing you will need, is a number of sheets of tinfoil; the foil which is wrapped around cigarette packages will be all right, provided you do not tear it upon removing it from the package. Smooth the tinfoil out carefully, then, with a pair of shears cut two strips two inches wide, and three inches long. Next take some of the wax paper in which loaves of bread are wrapped, and cut three strips three inches wide, and four inches long.

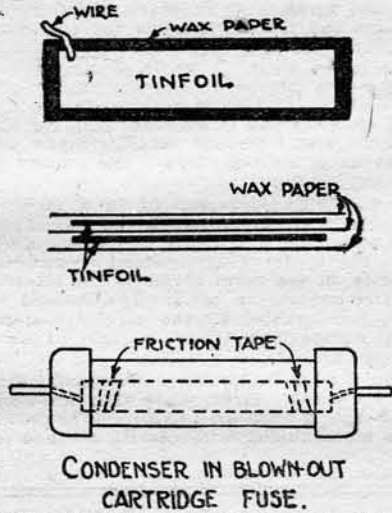

After that is done, lay a piece of the wax paper on a table, then a sheet of tinfoil, another sheet of wax paper, the other sheet of tinfoil, and then the last sheet of wax paper. Be sure that the tinfoil sheets do not touch each other as this will cause a short circuit.

Now take two pieces of wire three or four inches long, something similar to that which is used in the bell circuit in a house, and solder one on each piece of tinfoil. After that is done, firmly roll the whole thing up slowly into a small roll. Wrap a piece of electrician's friction tape around each end, then insert it into a cardboard mailing tube. When this has been done, dip the entire condenser into a pot of hot paraffine and let it cool. This will bind it firmly together.

The capacity of this condenser may be increased by adding more sheets of tinfoil and wax paper. Another good method of mounting this condenser is to take and place it in a blown-out cartridge fuse, soldering the wires to the heads of the fibre tube.

Radio for 'Busmen's Morale

NEW YORK.—The Fifth Avenue Coach Company has installed a Radiophone to entertain employees. The amplifier has been placed in the men's clubroom. The next move will be Radiophones in taxis, it is predicted.

How to Make Our Own Grid-Leaks

Although they can be purchased at very reasonable prices, the amateur is always fascinated with the idea of making parts

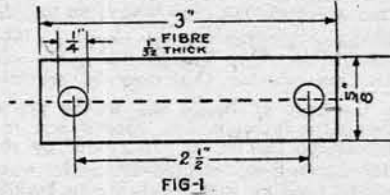

themselves. The grid-leaks as illustrated can be made at a cost of approximately 1 cent each and in addition have the advantage of permitting a variable adjustment.

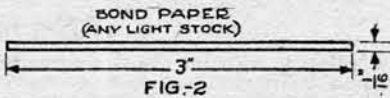

Figure 1 is made of fibre 1/2 of an inch thick; the 2 holes are punched with the ordinary office type of eyelet punch about 1/4 of an inch in diameter.

Figure 2 is the grid-leaks strip and is



made of narrow bands of any light weight bond paper dipped into a bottle of India drawing ink, such as Higgins. This is then left to dry. A strip 3 inches is inserted in the holes of the base as shown in Figure 3, and the eyelets are clasped in



as illustrated. Figure number 4 shows that a number of these leaks can be fastened together with 2 brass round head machine screws and nuts with the wire connections fastened at each end.

It is apparent that it is a simple matter to adjust our grid-leaks by adding or subtracting units as required until the reception is giving the best results.

WORTH WHILE BOOKS DEALING WITH RADIO

MAKING OF HOME SETS SPUR TO BEGINNER

Hook-Ups, Transmitters, Stations, Telegraphy Among Topics Listed for Benefit of Students

Home Radio. How to make and use it. By A. Hyatt Verrill. 75 cents, 12 full-page illustrations and diagrams.

This book is intended particularly for the amateur and for those who wish to know how to make and adjust Radiophones. The author has avoided technical terms and has aimed to make the directions plain and simple.

Radio Hook-Ups. By M. B. Sleeper. There are 82 circuits ranging from a simple detector and phone hook-up to those using several steps of amplification.

Design Data for Transmitters and Receivers. By M. B. Sleeper. There is crowded into this book valuable information in very little space.

Practical Wireless Telegraph. By Elmer E. Bucher. Price \$1.50.

Radio Engineering Principles. By Henri Lauer.

Wireless Telegraph and Telephony Simply Explained. By Alfred P. Morgan. Price \$1.50. A comprehensive treatise on this subject written in simple language.

A. B. C. of Vacuum Tubes in Radio Reception The. By Elmer H. Lewis. Ill. Pap. 75c.

Written for the novice in the art of operating Radio equipment.

Experimental Wireless Stations. By P. E. Edelman. Ill. \$3.00.

Directions for making simple wireless equipment for transmissions over long distances.

Construction of Radiophone and Telegraph receivers for beginners. By M. B. Sleeper. Ill. 75c.

Explanations for the person who wants to construct his own Radio set; illustrations, diagrams and full directions are given.

Radio for the Beginner

An up-to-the-minute book in plain language, presenting the principles of radio, the vacuum tube, radio tuning and helpful suggestions for the Beginner. Handy pocket size, substantially bound. Price..... \$1.00

Address: ALFRED FOWLER
19 Board of Trade, Kansas City, Missouri

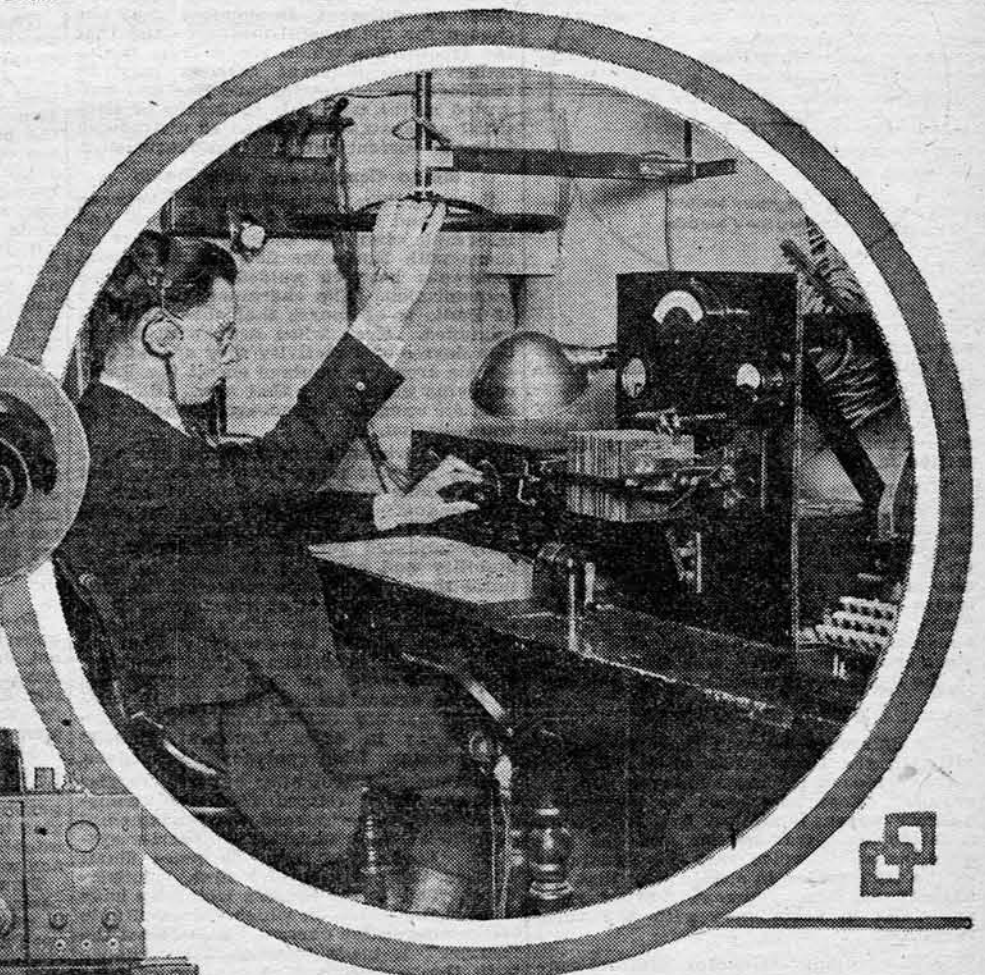
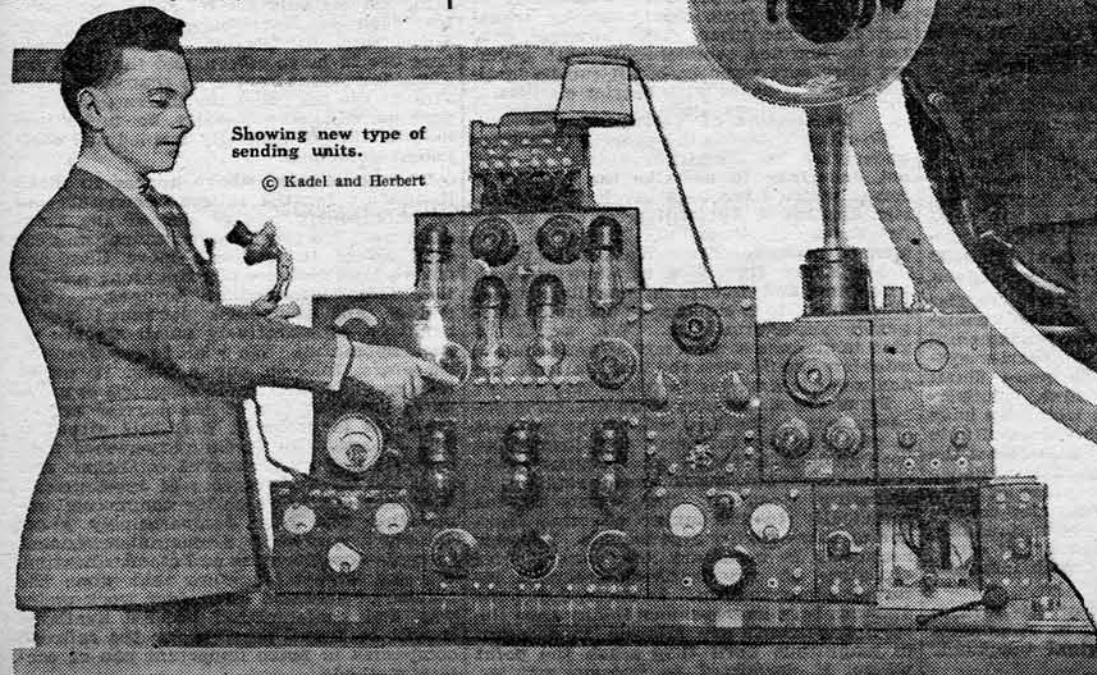

Carrier Current Telephony and Telegraphy

By E. H. Colpitts and O. B. Blackwell

Special to RADIO DIGEST

THE CONTINUATION of Benjamin F. Miessner's article, "Characteristics of Vacuum Tube Amplifiers" does not appear in this number of RADIO DIGEST ILLUSTRATED on account of Mr. Miessner's illness. Mr. Miessner will be able to continue his series in the next, the May 6th, number. In his next article, he will discuss the application of vacuum tubes to Radio receiving circuits.

It has been suggested to us that those who are responsible for railroad communications would be particularly interested in a statement regarding the carrier methods of telephone and telegraph operation.

In the April, May and June numbers of the Journal of the American Institute of Electrical Engineers, is given a fairly complete statement as to the history of this art, the fundamental principles which underlie it and the apparatus and methods which have been developed for carrying it out. We would refer you to that publication for a more detailed statement than is given here. In the present paper we are emphasizing certain features which we think will be of particular interest.

First, of all, let us make sure that we have the proper physical conception of carrier current transmission and understand the characteristics which differentiate it from ordinary wire transmission on the one hand, and from Radio on the other. Starting with fundamentals we all know that ordinary telephone and telegraph circuits make use of electromagnetic waves guided by wires. The wires play so important a part that we are likely to think of them as actually conveying the electrical energy. As a matter of fact, however, the energy is largely transmitted outside of the wires. To illustrate this we are indicating in Fig. 1 a cross-section of two (2) copper wires of the size used in the longest telephone circuits and spaced the usual twelve (12) inches. These wires weigh four hundred and thirty-five (435) pounds per wire mile. One large circle and two smaller circles have been so drawn on this diagram that 50 per cent of the energy transmitting over the circuit is transmitted within the inner circle; 49

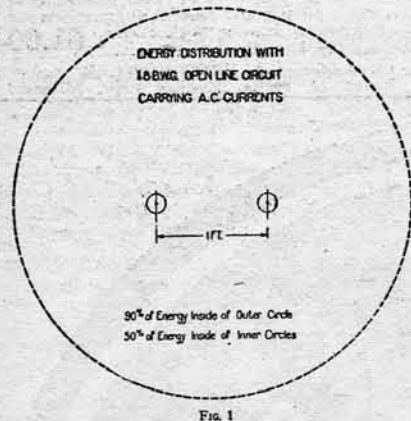

per cent. is transmitted between the inner and outer circles and 10 per cent. outside of the outer circle. The amount transmitted in the wire itself is negligibly small. (Energy dissipated in the wire should not be confused with energy transmitted in it.)

Now in the carrier system the electromagnetic waves are transmitted in just the same manner as those in the ordinary telephone circuit, although they are generally of higher frequency. The same circles in Fig. 1 show the distribution of energies around the wires for carrier currents. Both carrier and ordinary telephone and telegraph, then, use wire guided electromagnetic waves and do not differ in the mode of transmission over the line.

Here is the Difference

The difference between them lies primarily in the form given to the electric waves which carry the messages. In the ordinary telephone system, as you know, a direct current is allowed to flow through a microphone transmitter, and the frequencies of the voice vary the resistance of the transmitter in such a way that the amount of direct current flowing rises and falls in accordance with the voice variations.

In the ordinary telegraph a direct current is again used; this is broken into dots and dashes by the opening and closing of contacts.

In the carrier system a very similar process goes on except that instead of using a direct current an alternating current is used the volume of which is controlled in accordance with the variations of the Radiophone or other message being trans-

THE OPINION which follows is in answer to the inquiry by the RADIO DIGEST as to the guidance of radio waves. This explanation by John J. Carty, vice president, American Telephone and Telegraph company, New York city, one of the most renowned experts, is presented to the readers of RADIO DIGEST as a means toward increasing popular knowledge of the etheric transmission of intelligence.

A characteristic of Radio waves is that they are free waves, that is, are unguided. If they were guided they would no longer be Radio.

We have pointed out at various times that the electro-magnetic waves used in wired transmission are of the same nature as the electro-magnetic waves used in Radio transmission, that they are practically all outside of the wires themselves.

In the case of Radio the waves are allowed to become detached from the Radio transmitting station and spread out in all directions while in the case of wired transmission the waves are guided by the wires exactly to the desired point.

The guiding of electro-magnetic waves should not be confused with so-called directive sending and receiving in Radio. By multiple antennae or similar arrangement it is possible to cause Radio transmission or reception to be much stronger in a desired direction than in all other directions. This action however is carried out only at the place of transmission or reception while the wires of an ordinary circuit guide the waves throughout their complete course from the transmitting to the reception point. (Signed—John J. Carty.)

Summary

According to a recent thesis written by E. H. Colpitts and O. B. Blackwell, for the American Railway association, ordinary telephone and telegraph circuits make use of electro-magnetic waves guided by wires but as a matter of fact the energy is largely transmitted outside of the wires.

In the carrier system the electro-magnetic waves are transmitted in a manner similar to that of the ordinary telephone or telegraph circuit although the waves are generally of higher frequency. Both carrier and ordinary systems use wire-guided electro-magnetic waves; they do not differ in the mode of transmission over the lines. The difference between them lies primarily in the form given to the electric waves which carry the messages. In the carrier system an alternating instead of a direct current is used. The multiple message is enabled by the carrier system. In other words variations in the frequency of the current permits the sending of more than one message over the same wire.

Comparing the ordinary and the carrier systems with Radio the fundamental difference is that the latter's waves are guided by wires. Even when they are sent with a certain degree of directivity they spread over a wide area and impinge on all the Radio receiving sets in that area. Radio is an unguided broadcasting method of transmission.

In the ordinary system then we may say that we modulate a direct current. In the carrier system we modulate an alternating current.

An alternating current on which the signaling variations are thus impressed has come rather naturally to be regarded as the "carrier" of the signaling variations and therefore to be designated as the "carrier current." Thus the system has come to be designated as a "wire carrier system," or more simply as a "carrier" system. It is the use of the carrier principle which results in this very important advantage—several messages may be transmitted over one circuit.

This follows from the fact that carriers of different frequencies may be chosen for the several messages and that the frequencies which result from modulating these different carriers may be put together on a telephone line and separated at the terminals by means of electrical apparatus designated to distinguish between currents of different frequencies.

As to Comparison with Radio

So much then for the differences between carrier and the ordinary telephone and telegraph circuits. Comparing either of these with Radio we find a fundamental difference between guided and unguided transmission. The characteristic feature of Radio is of course that the waves are unguided. Even when sent with a certain degree of directivity they spread over a wide area and impinge on all the Radio receiving stations in that area. Radio is then an unguided broadcasting method of transmission.

In wire transmission the wires guide the waves, prevent them from spreading and deliver them to the desired receiving point. The conducting wires form electrical paths for the waves. These paths may be carefully adjusted for proper efficiency and stability and carefully balanced to minimize the amount of interference entering them and the amount of interference from them to other paths. This fundamental difference should be carefully kept in mind. It is unfortunate that the term "wired wireless" or "wired Radio" has to some extent been applied to the wire carrier system of transmission. Such terms say in effect "guided-unguided" transmission. They contradict themselves.

In thus distinguishing between carrier and the other related forms of transmission we have touched the fundamental principles which underlie the carrier systems. Looking at them in more detail we find that they involve first, "modulation." This is the process which we have already discussed, in which the amplitude of the alternating current which forms the "carrier" is made to vary in accordance with the variations of the voice of telegraph signals. For telegraphy this change in amplitude amounts simply to breaking the carrier current into "spurts" of alternating current interspersed with intervals of no current.

"Demodulation" consists of the reverse process of stepping back in frequency, thus giving back the original telephonic or telegraphic signals.

"Selection" is the third characteristic feature of the carrier system. This involves the use either of resonant electrical circuits for telegraph systems or of electrical filters for telephone systems. The electrical filter is a combination of coils and condensers so arranged that it will transmit any desired range of frequencies and practically shut out all frequencies outside of the range. By the use of filters at the terminals of a line different electrical circuits may be set up so that the frequencies corresponding to the several messages may be led into separate channels. In this way the separate messages are diverted to different subscribers with no interference between them.

Methods Used Are Similar

The methods used in arranging for two way operation, and the methods of using telephone repeaters in carrier systems, are similar in principle to the methods used in the ordinary telephone transmission. Carrier repeaters involve most of the problems in which those of you who are operating repeaters are familiar, besides certain problems peculiar to the high frequency field. There are, however, two advantages of carrier repeater operation which should be pointed out. (a) All the telephone or all the telegraph channels on a pair of wires may be amplified together in a single repeater without being selected one from the other. (b) It is possible, but with considerable sacrifice in the number of circuits, to use carriers of different frequencies for transmission in the two directions, thus avoiding the need of careful line balance at the repeater points. It would, of course, be perfectly possible to make similar arrangements with ordinary circuits by using a separate circuit for transmitting in one direction from that used for transmitting in the other. This, however, cannot be justified commercially with ordinary open wire circuits, but it can be justified in many cases with carrier circuits.

Description of Various Forms

So much then for the general principles underlying the carrier systems. I will not undertake to describe the particular forms which have been given to the carrier apparatus, but will refer you to the American Institute of Electrical Engineers' paper for that. We had the pleasure a short time ago of showing both telephone and telegraph installations at Harrisburg to a number of railroad telegraph superintendents. We would be glad to arrange so that any of you who are interested could visit the installation there and see the systems in operation.

From the standpoint of an operating superintendent, the line end of the problem is of particular interest. The first thing we find here is that high frequency currents attenuate much more rapidly in traveling along the line. This is due principally to the larger effective leakage at these higher frequencies. For this reason it is necessary to insert carrier repeaters at comparatively frequent intervals along the line. In determining the distance between repeaters in any case the carrier currents are allowed to decrease in magnitude until they reach the point where, if permitted to become smaller,

they would be interfered with by the slight disturbances which come into the line from static, from power systems, or from radio or other carrier systems.

Another problem which becomes of much larger importance in carrier operation, and which is perhaps the greatest difficulty in carrier transmission, is the effect of the short lengths of cable which it is impossible to entirely keep out of any open wire line. Such lengths come into the circuit in passing through cities or towns, at river crossings, etc. These short lengths of cable bring in very large high frequency losses, and also large electrical irregularities in the circuits at carrier frequencies. To overcome these difficulties as much as possible, loading has been developed and applied to cable circuits for carrier operation. It is necessary, however, to use special forms of coils and to space them less than 1,000 feet apart.

Here Is Another Problem

Another difficult line problem comes in when it is attempted to operate more than one carrier system on a pole line. The higher frequencies have a much greater tendency to pass from one circuit into another through the mutual capacities and inductances between circuits. This can be overcome as in ordinary circuits by transposing the different circuits against each other. The frequency of transposition and the difficulties of keeping the desired degree of precision are very much greater, however, with carrier systems. In some cases, even where it is attempted to operate a single system on a pole line, the amount of energy leaking into other circuits, without special transpositions, has been found sufficient to very greatly increase the attenuation loss in the carrier system.

The three problems noted above, which are (1) increased attenuation, (2) increased effect of lengths of cable, and (3) increased cross-induction, all become greater as the frequency is increased. It is for these reasons that the frequency range below 30,000 cycles has been exploited for carrier use by the Bell System.

With the system before you of so great technical interest, the thought which naturally occurs to you is "What use can we make of it in our railroad work?"

In the first place the carrier system as it now exists, is essentially a long distance proposition. This follows from the fact that there is involved very expensive terminal apparatus, where the transformation is made from the voice currents or signaling currents to the high frequency carrier currents. When this transformation has been made, the cost of intermediate repeaters to extend the range to which the currents be transmitted is comparatively small. Evidently it is not possible to economically place bridge stations on carrier circuits, since this involves again making the transition from the carrier frequencies to the voice or signaling frequencies.

As to Common Expense

An important part of the expense of a carrier installation is common to all the channels which are installed so that a channel placed singly would cost considerably more than would each of these or four channels put in at the same time. Carrier apparatus is necessarily complex and involves many features novel to an operating telephone or telegraph personnel. It is necessary, therefore, to build up a personnel having the necessary training in the special characteristics of these higher frequencies, and competent to maintain the new apparatus. For these reasons the telephone company is now considering carrier only for long distance service, such as Harrisburg to Chicago or Harrisburg to Detroit. The terminals here are in large offices, and the lines are along important routes so that the apparatus at the ends and the intermediate apparatus can economically be under the maintenance of specially trained and competent personnel.

The facts noted above appear to make it difficult for the railroad companies to advantageously use carrier at the present time. We presume you cannot, in general, afford to maintain more than one or two long distance circuits along a route free from intermediate bridges. The trained and competent personnel would handle a comparatively small amount of such apparatus. We wish to say frankly, therefore, that in our opinion it would take an unusual railroad situation to prove in the present use of the carrier apparatus. It is probable that this situation will change with further experience with systems under commercial conditions and with the further progress of development. With any art in which the commercial application has been comparatively short here is, as you know, a constant movement towards simplification and standardization. We can expect therefore that when the results of field and laboratory work under way and contemplated become available it will be found possible for the railroad companies to make important use of carrier methods.

Simple Instructions for the Beginner

By Harry J. Marx

The Vario-Coupler and the Variometer

CIRCUITS using two variometers and a vario-coupler have become most popular among the more advanced Radio fans. For this reason it is necessary that a detailed description of the operation and use of these two pieces of apparatus be furnished to readers of RADIO DIGEST.

In analyzing the vario-coupler we find that it closely resembles the loose-coupler described in our latest issue. We have as before a primary and secondary winding. In the loose-coupler the primary winding has a slider for tuning adjustments; in the vario-coupler the adjustments on the primary are usually controlled by means of taps and a switch. The taps are numerous to provide for as much range in adjustment as possible. Occasionally we find the primary furnished with a double contact switch, one to give rough adjustments, the other to give finer adjustments, that is to say, the one has taps perhaps for every 10 turns, while the other further subdivides one of these taps with a separate contact on each turn. The tuning is first adjusted on the contacts with 10 turns then is finely adjusted per turn through the other.

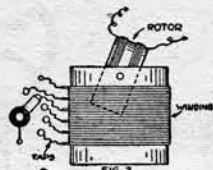
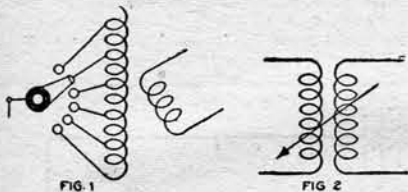

The Vario-Coupler

Figure 1 is the usual convention for the vario-coupler although that illustrated in Figure 2 is occasionally seen. Figure 1 shows the single switch arrangement for tapping the primary. Figure 3 is a picture view of the vario-coupler and illustrates how the secondary coil is pivoted inside the end of the primary tube. As shown the secondary coil is in a position at right angles to the primary coil; the inductive effect is low.

Vario-Coupler Operates Differently

In our latest issue I explained the difference between the loose-coupler and the vario-coupler. In the loose-coupler the inductance effect is controlled by sliding the secondary winding in and out of the primary winding but the vario-coupler has no sliding adjustment between the coils; it operates under a different mechanical adjustment. In this instance we rotate the secondary winding about its shaft on the inside of the end of the primary tube, then the secondary will receive the full inductive effect when the cores or insides of the tubes are in line; we control the variation as we turn it around from this original position.

The current flowing through the primary creates a magnetic field in the core of the primary; this magnetic field in turn induces a current in the secondary but the strength of this current varies depending on whether the secondary is receiving the full benefit of this magnetic field. As we turn the secondary around we are decreasing the number of lines of magnetic force that flow through the core of the secondary winding therefore we are decreasing the strength of the induced current.

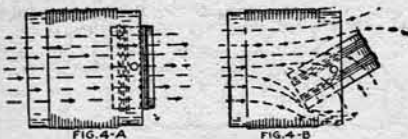

The Magnetic Field

This is illustrated in the Figures 4a and 4b by the dotted lines representing the magnetic lines of force. Of course we must realize that our current is alternating, giving us a constant change in polarity which corresponds to a constant breaking of the magnetic lines of force which is necessary to a constant induction and steady flow of current in the secondary.

The secondary coil of the vario-coupler has no taps or slide adjustment to vary the number of turns. For this reason the vario-coupler is usually used in conjunction with one or more variometers that control the tuning in the secondary circuits. This has been the cause of much

contention between the respective values of the loose-coupler and the vario-coupler and variometers.

Aspects of Both at Work

For short wave work we will find that the vario-coupler and the variometers make neat compact units for panel mounting while the loose-coupler is rather bulky and not as neatly adapted to panel mounting. If we want to increase the sizes for larger wavelengths it will be found that the loose-coupler may be expanded with less difficulty. The vario-coupler and variometers become too bulky for practicable purposes. Of course loading coils may be added but even here it will be found that the loose-coupler responds more readily to longer wavelengths. We must not overlook the fact that the ordinary amateur is more interested in the broadcasting of music and subjects of general interest and is therefore not very likely to aspire to very long wavelengths.

In tuning, the secondary is placed in the position of full inductance then the primary is adjusted through the tap switch, then the secondary is adjusted. Further adjustments are usually with the variometers and condensers.

As to the Variometer

The variometer as a rule is one of the persistent curiosities of Radio apparatus. Most amateurs have not tried to analyze fully its operation or its theory, yet it is actually a very simple device. It consists of two coils connected in series, the one turning inside the other. We receive the same effect and control of the induction as before but instead of two separate circuits we have only one. The coils of a variometer should both contain the same length and size of wire so that the induced current is the same as our initial current. Our initial current then goes through both coils but in addition we have the effect of the induced current in both coils of the series. Note here that we write of the effect of the induced current! This induced current may add to our initial current or it may subtract. If the current flows through both coils in the same direction the magnetic fields assist each other and the self induction of the variometer is at maximum. If the inner coil is rotated so that the current flows through the coils in opposite directions the magnetic fields oppose one another and the self induction is at minimum. The self induction of the variometer therefore depends on the relative positions of the coils; by the rotation of the inner coil a continuous variation of inductance may be obtained.

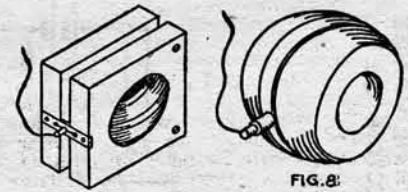
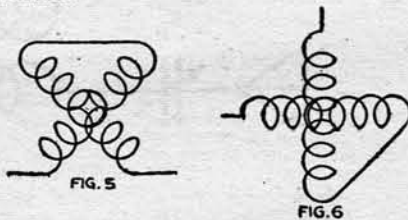

The Variometer

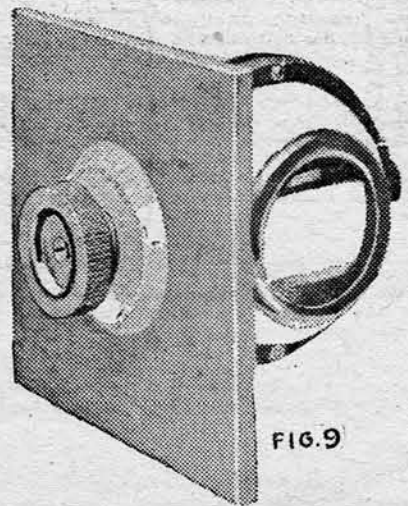

The Variometer

Figures 5 and 6 show the two conventions most used for variometers. The commercial variometer as obtained on the market is usually made with the wire

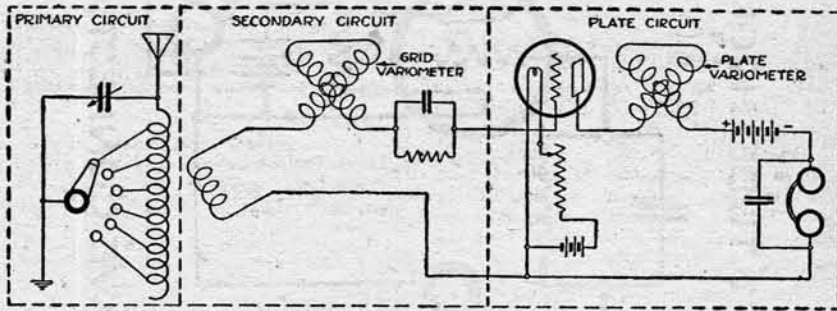

VARIO-COUPLER AND TWO VARIOMETER VACUUM TUBE HOOK-UP FIG. 12

Vario-Coupler and Variometers in Vacuum Tube Set

For receiving on wavelengths up to 600 meters the circuit using two variometers and the vario-coupler is by far most popular. It has been in use a long time; many will be found in the lists of amateur stations. To the beginner the numerous hook-ups that are now given are confusing; it is hard to select the one that is best suited. For receiving the broadcasting, with a vacuum tube set the one shown by Figure 12 cannot be easily surpassed.

It will be noted that the dotted lines do not indicate wires or connections but simply divide the hook-up into three separate circuits namely, the primary circuit, the secondary circuit and the plate circuit.

The primary circuit consists of the aerial, the ground, the variable condenser and the primary of the vario-coupler. After the filament current has been turned on this circuit is the first to be adjusted. This is done through the tapped switch on the primary and the variable condenser, worked either in conjunction or separately. After a little experimenting with the set the tap on the primary will be found that gives the best results for receiving any particular broadcasting station; this holds true of the variable condenser position.

The secondary circuit consists of the secondary coil of the vario-coupler, the grid variometer, grid leak and condenser, and the grid. This circuit is controlled by the setting of the secondary coil and the variometer. In tuning the secondary coil is first adjusted, then the variometer is used for more accurate control of the current flowing to the grid.

The plate circuit consists of the plate, the plate variometer, the "B" battery, the receivers and their condenser. The "A" battery, filament and rheostat is sometimes considered as a separate circuit controlled by the rheostat but it is essentially a unit inside the plate circuit. This circuit is controlled by the plate variometer; occasionally the voltage from the "B" battery is varied by tapping off different cells with a multi-point contact switch.

After all of the adjustments have been made it is advisable to go over each adjustment for a slight improvement through finer tuning. Tuning this circuit will not always be found a simple matter; it requires a little practice and much patience.

wound on turned wood blocks but we will also find them with the wires wound on formed bakelite and other compositions. An important feature is the necessity of keeping both coils equally balanced, with a minimum amount of clearance between the wires when rotating inside of one another. This makes it a rather difficult instrument to be made at home. Figure 9 illustrates the usual molded form of variometer for panel mounting. Figures 7 and 8 show the wooden type; Figure 8 shows the rotor as the rotating element is called. The wooden type is also adaptable to panel mounting.

Use with Crystal Detector Set

As shown in Figure 10 a variometer may be used with the crystal set only for close tuning in a very small range of variation in wavelength. The connection is similar to the single slide tuner. The only adjustment for tuning is the variometer but a variable condenser may be added in parallel across the variometer.

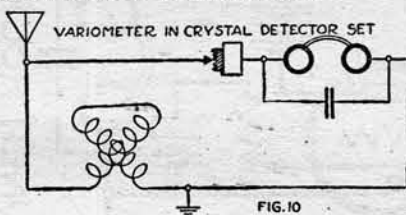

FIG. 10

In Figure 11 we show a very simple crystal set, using a vario-coupler. The wavelength and tuning range on this set is considerably better than the previous one. This too may be improved by the addition of a variable condenser in parallel across the primary of the vario-coupler or one in parallel across the secondary. The tuning is similar to that of the circuit with the loose-coupler shown in our latest issue.

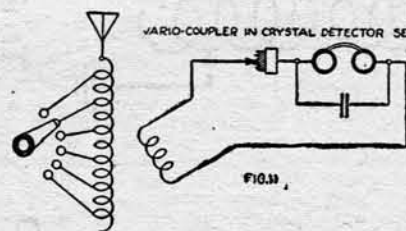

FIG. 11

How to Make Loud Speaker

By Jack Forrest

When the amateur has installed his set the next thing he usually thinks of is a loud speaker. All that is necessary to construct this loud speaker is a piece of stiff cardboard, sealing wax and a little perseverance.

The horn itself may be about 10 inches in diameter and two feet long. The smaller end rests on the ear-piece of the receiver with the hole in the horn just a little bit larger than the hole in the ear-piece. Do not let the horn rest on the diaphragm as it will greatly diminish the signals.

Cut the cardboard like that shown in the sketch, the outside radius about 18 inches and the inner circle about one or two inches. After the horn is cut out, carefully roll it up and glue the edges together, then place it against the ear-piece of the receiver. If the hole is too small, cut a little off the end with a pair of scissors.

When the small end is the correct size pour melted sealing wax around it thereby closing any space at the base of the horn and receiver. The best type of receiver to use with this horn is the Baldwin. This receiver is used practically in all the high priced loud speakers. Remember—the higher the resistance of the windings the better the receivers.

This horn will work best when using a vacuum tube detector and two stages of amplification although it will work on a

crystal set if the signals come loud enough in the receivers.

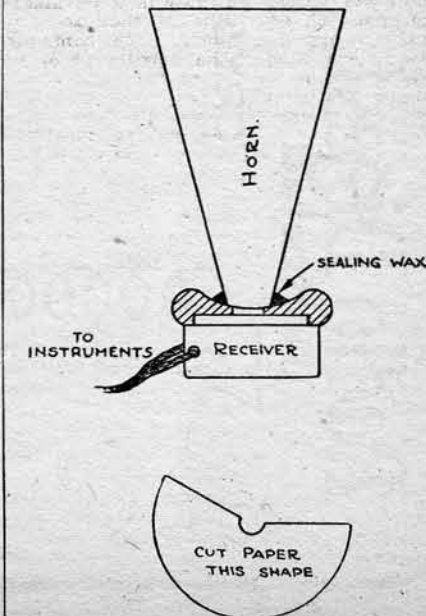

CRYSTAL

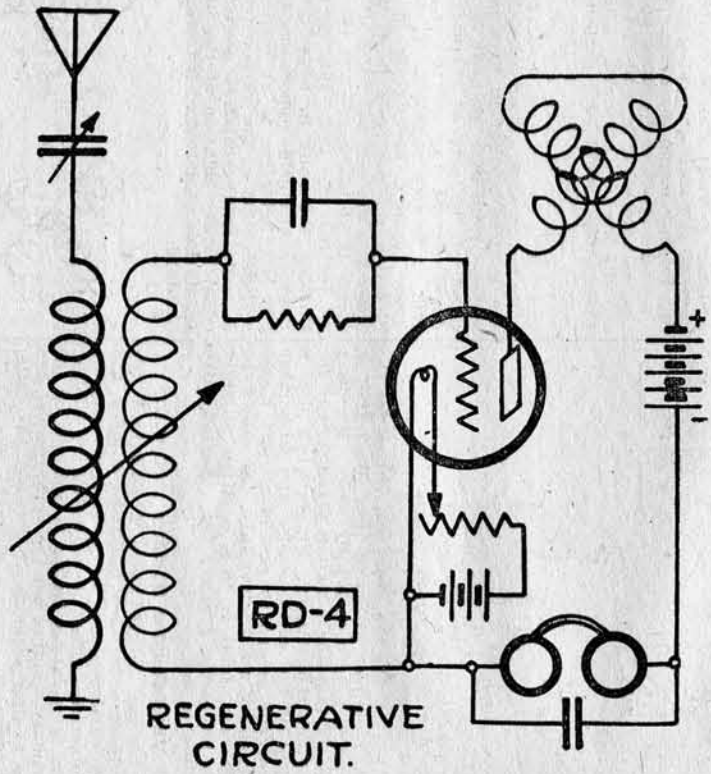
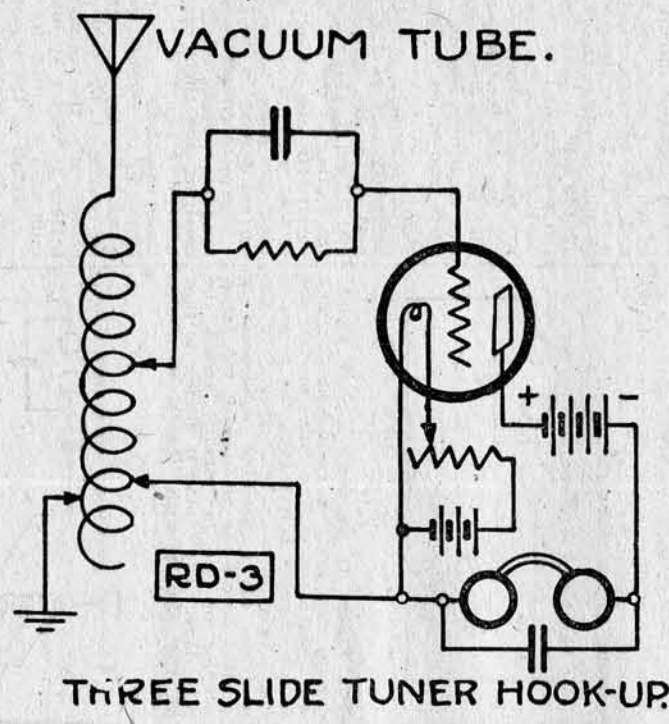
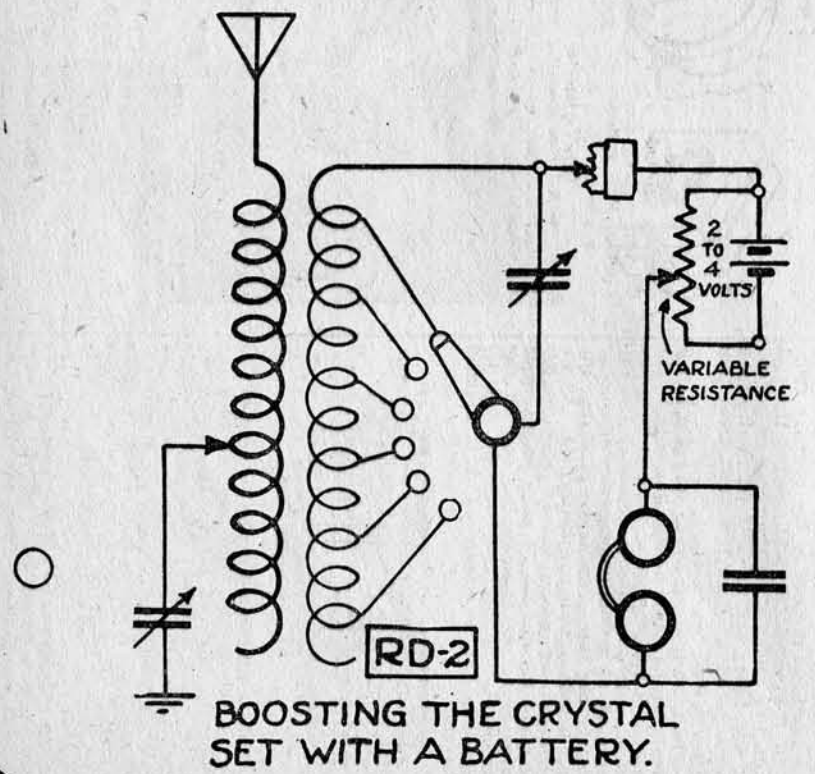
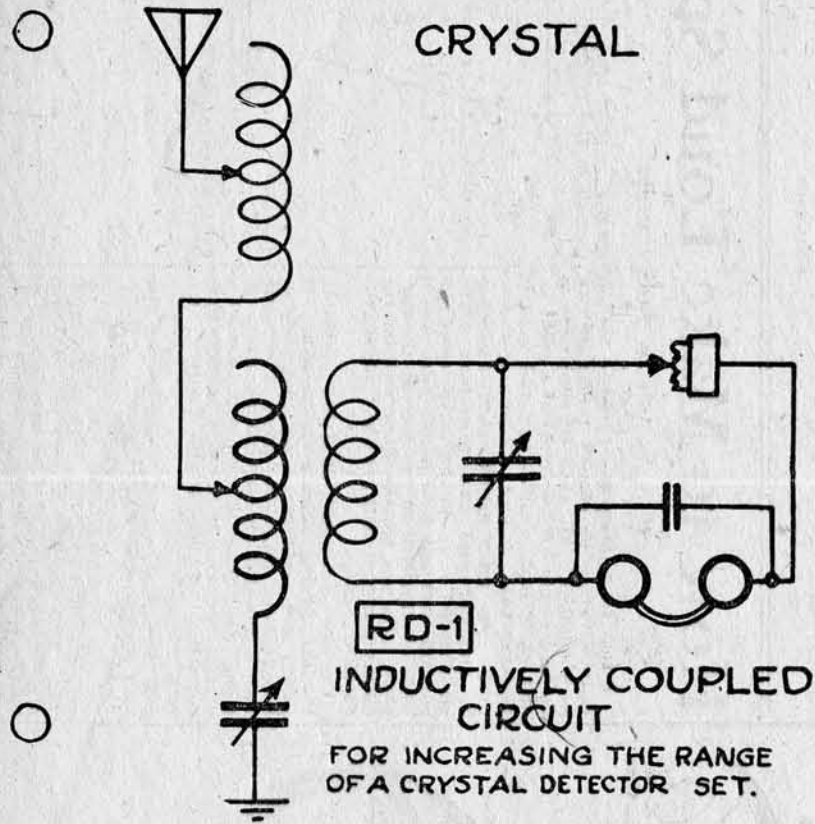

VACUUM TUBE.

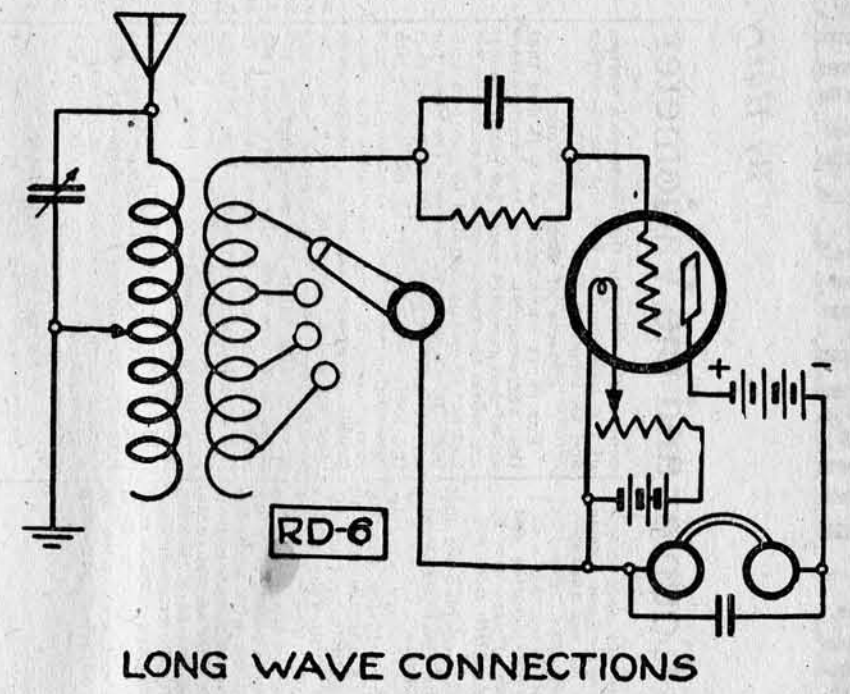
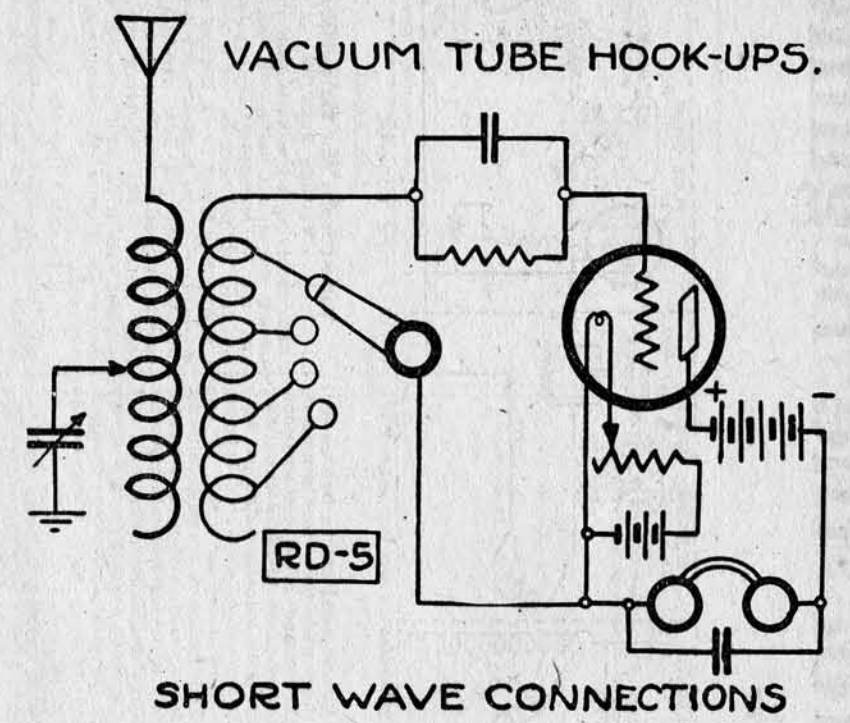

VACUUM TUBE HOOK-UPS.

HARRY J. MARX.

Questions and Answers

Radio Digest reserves the right to answer all questions either by mail or through these columns, as it sees best. It is necessary, when questions are sent, that the writer examine them to see whether he or she has furnished all the information required in order to answer the questions intelligently. The popularity of this column is indicated by the volume of correspondence we are receiving. We request your co-operation and patience in waiting for answers. All letters are answered in the order that they are placed in the mail.

Long Range Receiving Set

E. A. L.—Will you please advise me as to the best Radio receiving set in your estimation for use at Miles City, Montana? The nearest broadcasting station is Denver, Colo., about 500 miles in a direct line.

Ans.—I would suggest at least one step of Radio frequency amplification and two steps of audio frequency amplification. A good aerial and ground would be essential.

From Honeycomb Coils to Variometer and Variocoupler

R. J. C.—I like your paper; may I accept your invitation and ask a few questions concerning variometers and variocouplers? I am revising my panel and am changing from the honeycomb coils to variometer, etc. What is the combination most desired? How much more sensitive are two variometers and one variocoupler than a single variometer?

I have been using a set containing one five-plate condenser variable and one small variometer. I have a 43-plate .001 Mfd condenser, Radiotron UV 200, etc. Would you give me comparative estimates of efficiency adding another variable condenser, and without one, and hook-ups with the above mentioned tuning apparatus?

Ans.—I don't think there is any question or doubt that the variocoupler-variometer combination will be highly satisfactory to you. It hardly seems logical to compare that combination with a single variometer set. My article in this issue on this subject will help answer the question.

Your question relative to the gain in efficiency through the addition of more variable condensers is impossible to answer because I haven't enough details as to your aerial and other conditions of your apparatus. The article mentioned above gives you a good hook-up covering the equipment you mention. In addition we will have a number of loose leaf sheets as to numerous types of hook-ups with different apparatus in the following issues.

One Step Amplifier

C. W.—Please let me know whether you think the following diagram of a three layer bank coil with a tickler coil and V. T. detector and one step amplifier with one storage battery will work? I want to construct a 'phone set. I found the plans in a radio magazine but it did not include an amplifier with the set. Do you think I can hear the music with a loud speaker very good in a 15 by 15 foot room? I am making this set for a friend and want to make it a success. I bought your *Radio Digest* today; I think it is the best I have ever read. Your questions and answers interest me most.

Ans.—Sorry to say that the hook-up you sent in hasn't the slightest possibility of working. For example, where does the filament in your amplifier tube get its 6-volt current? Your letter came too late to insert a diagram; we will insert it in the next issue. With the proper hook-up your loud speaker could be plainly heard in the room of the size you mention.

Indoor Aerial

J. M. S.—A dealer informs me that with a \$75 DeForest receiving outfit I could hear Detroit programs even though my aerial is indoors, strung in my room in the hotel. Is this possible?

I have a \$25 Westinghouse set with which I hear the Chicago programs with the aerial mentioned. Would I be able to increase my hearing radius by stringing more wire? I have about 50 feet now.

Diagrams are given, requesting information as to which is best.

Ans.—I doubt whether you would be satisfied with the results; it would require at least two steps of amplification. Under perfect natural and atmospheric conditions it would be right but your room, in a hotel, does not impress me as favorable for reception with a loop aerial.

Instead of stringing more wire I suggest that you run one wire around the room, fastening it to the molding if possible. This will assist reception in all directions.

If this method is impracticable try running about six strands spaced ten to twelve inches apart across the room. You could not expect very much improvement with the \$25 set unless you install an outside aerial.

Radio Editor—Can I use 66 volts on an audiotron detector? Where is Station

W N O?—S. H. R. The audiotron detector is a hand-made affair, and some of the tubes will work as well on 8 volts as on 100. It all depends on the particular tube that you are using, as no two of them are exactly the same. If the tube starts to turn blue you will soon know that you have too much B battery. It is not particularly good for the tube, and you should cut down the B battery as soon as this happens. Station W N O is the Jersey Journal, located in Jersey City.

Radio Editor—I am making a variometer receiving set, but find that it will only work to 800 meters. How can I make a variometer that will tune to 3,000 meters?—Edgar Ellis. A variometer of this size is not very practicable to make, as it will be too large. You had better make a honeycomb coil set, as with this outfit you may tune up to any wave length by simply changing the coils.

Radio Editor—I have made a crystal set but all that I can receive are the spark signals. There are two elevated lines within a block of me. Will they make any difference?—William Kern. The elevated lines will not affect your set any.

ments of vacuum tubes. By connecting condensers and choke coils across the generator a fairly steady current can be secured providing the commutator of the generator has numerous segments. Local and stations up to several hundred miles distant can be received by this method, but as the current fluctuates quite often, this method is not used extensively.

Aerial

R. S.—I have a place to put an aerial up about 125 to 140 feet long and about 50 feet high. How many wires should I have? Is it best to have the end attached to sit lower than the other end?

A.—Very good results can be obtained by using a single wire with the dimensions stated. Yes, it is much better to have the free end higher than the end that lead is taken from, but in most cases this is not practicable.

Price of Set

W. S.—What is the price of a complete Radio set and where can one be bought?

An Invitation—

WHEN "stumped" write the Question Department of RADIO DIGEST. A self-addressed, stamped envelope should be enclosed ALWAYS, as not all answers can be published. Only those of general interest will be printed in these columns. Other questions will be answered by mail.

When your question is of a highly technical nature and cannot be readily explained, send sketches and diagrams along with it.

The services of a trained staff of Radio Engineers are at the command of every reader of RADIO DIGEST. Don't hesitate to send in your troubles and let RADIO DIGEST worry about them.

RADIO DIGEST, however, reserves the right to refuse to answer any question which might lead to litigation.

Your location has a lot to do with the reason you cannot hear any music. The best thing for you to do is to install a vacuum tube set, or you may have a poor crystal in the detector. You might try several different pieces of mineral, but the best you can hope for with the crystal set is very weak music.

Radio Editor—I would like to purchase a receiving set, but at the present time I feel that I would rather buy it on the installment plan, and would like to have you tell me where I can get a set on this plan.

—E. Lowe. Up to the present time this department does not know of any concern selling sets on the installment plan.

Radio Editor—Will I have to get permission to use the storage battery charger from the electric company? Why is it that I do not hear W Y C B?—W. D. M. No permission is needed to operate the battery charger; in fact, the company would like to see you use one, as it makes the meter go faster. We cannot tell you why you do not hear W Y C B, because you do not tell us anything about your set or show us the hook-up.

Radio Corp. Broadcasting Station

J. S.—Advises that he is informed that the new broadcasting station of the Radio Corporation, Westinghouse Company, will be located at the Hotel Pennsylvania and wants to know the opening date.

A.—We have no definite information as to the location nor the opening day of this station, but our readers may be assured that as soon as this information is available it will be published in *Radio Digest*.

"A" & "B" Battery

T. N.—What is the meaning of "A" battery and "B" battery?

A.—The "A" battery is usually a six-volt storage battery used for lighting the filament of the audion tubes and the "B" battery is usually a 22½-volt or multiple thereof battery used for supplying current to the plate of the tube.

Using a 7-Volt Generator

D. C.—Can I use a 7-volt DC generator set for the detector and amplifier tubes instead of a storage battery? If, not, why not?

A.—Yes, a 7-volt generator can be used to supply current for lighting the fila-

A.—Any Radio supply house can supply you with all equipment necessary for Radiophone reception.

Special Hook-Up

K. N.—How far can I receive the Radio broadcast on a machine like that on the enclosed diagram?

A.—The apparatus you mention is O. K. for stations up to 100 miles, but if long distance stations are to be received variometer connected in grid and plate circuits will increase the range at least five times and it will be much easier to tune in station due to the fact that the compensating wave will be heard first, and the voice located within a few degrees of that afterward.

Good Idea

Y. P.—Your paper is going to be something very timely and much appreciated. To begin with I am interested in obtaining a wireless telephone receiving set as an attraction for the Boy Scouts here. From this I am planning to lead to wireless telegraph receiving and sending later. Can you recommend an equipment of reasonable price, and mention where it might be purchased?

A.—You have certainly hit upon a good idea to interest the boys. You should have a regenerative receiver and a two-step amplifier for this work, as you are well located for receiving from both east and west broadcasting stations. This will cost about \$100 and can be purchased from any reliable electrical supply house.

Grounding

D. R.—I am not allowed to use an outside aerial. How do I ground the inside wires that run around the molding and where do they end?

A.—Connect one end of the wire to the aerial connection on your instrument, run the wire up to the picture molding, laying it out nice and straight so that it cannot be seen. The distant end is not connected to anything. The aerial must not be grounded, but the ground wire from your instrument can be connected to a radiator or water pipe, preferably the latter.

Purchasing Wire

S. W.—Where can I get No. 12 insulated copper wire?

A.—Try any electric supply house.

Two Stations On a Long Antenna

I. W.—I would like to know if two operators could use one antenna by having two lead-in wires?

A.—Yes, it is possible but better results would be obtained if an insulator were placed in the middle of the antenna, making two short antennae. You mentioned that the houses were 150 feet apart.

See Article on Loose Coupler

T. O.—Which is best with a crystal set, a vario-coupler or loose coupler? Can you use a loud speaker with a crystal set? Can Pittsburg be copied with one tube using single circuit tuner?

A.—Loose coupler is better with crystal set. Yes, a loud speaker can be used with a crystal set. Yes, Pittsburg can be copied with one tube on single circuit tuner.

Back Porch Aerial

C. R.—I live on the second floor of a three-story apartment. Would there be any objection to running an aerial between the posts on the back porch, to be taken down when not in use? Would sixteen feet be long enough for receiving purposes?

A.—You can put up a very good aerial on your back porch as suggested, but make it longer than sixteen feet if you can. Sixteen feet will give results with a good outfit, but if you can make it longer it will work better.

Variable Condenser

Radio Editor—Will you please tell me if a Connecticut variable condenser is all right to shunt across the secondary of a loose coupler? When I do this with mine it makes the telephone signals almost inaudible. Is arc different from C. W?—W. M. H. The condenser you speak of is all right for the purpose, but you will have to tune the set as well as the condenser to make the signals better. It should improve the set considerably. An arc station is not the same as a C. W. station.

A. Weinstein—Will a variable condenser in series with antenna take the place of a loading coil for increasing my wave length? Answer: No. The variable condenser will have just the opposite effect and will decrease your wave length.

Loose Coupler

Steve Love—I am making a loose coupler. Can you tell me how the connection between the primary and the secondary is made? Answer: There is no direct connection between the primary and the secondary coils. The current in the primary is transferred to the secondary by close proximity and not by contact. This transfer is known as induction.

Radio Editor—I have a loose coupler and a vacuum tube, but when I turn the filament on, the tube turns blue, what is the cause of this? Will it injure the bulb? What instrument will I use to make a tickler for this set?

A.—The bluing of the tube is caused by too much B battery. It is not particularly good for the tube. A variometer may be used in the plate circuit of your set, to give it regeneration. It will not work very well, however, and we would advise you to install a vario-coupler and two variometers for better results.

Wave Length of Tuning Coil

Radio Editor—Can I use the gas pipe for a ground connection? How can I find the wave length of a tuning coil? How can I tune to a desired wave length easily?—L. M. J. The gas pipe may be used, but it is not as good as the cold water pipe. At best the amateur can only estimate the wave length of a tuning coil, and the best way is to actually try the coil. You will know the wave length when you hear the broadcasting and also when you hear the ships. This will give you a good idea of the range of the coil. The only way to tune quickly to the desired wave length is to know your set. As you become more expert in handling the set you will not experience the least difficulty in tuning in any station you desire. It is simply a question of experience.

Receiving Transformer

M. Greene—Will you please tell me which is better, a three-slide tuning coil or a receiving transformer? Answer: The receiving transformer is far the better instrument.

Regenerative Set

Q.—Can I use the enclosed hook-up for the ground connection? What is the tickler coil used for in a honeycomb coil set if the set is not regenerative?

A.—Your hook-up is all right. The tickler coil is used in a set that is not regenerative.

Lightning Switch

Q.—I have a switch 15-amperes and 125 volts. Will it do for a lightning switch?

A.—No switch is necessary for an aerial for receiving. The switch you have is too small anyway. What is required is a small air gap of one-eighth inch or less for a vacuum lightning arrester.

© Fotograms
WHEN THE RADIO BUG GETS YOU, IT'S GOT YOU — Two amusements in one — Winifred Taylor must have her canter every morning but just can't "pass up" radio

Radio Illustrated



MODERN BABE
© P. & A.

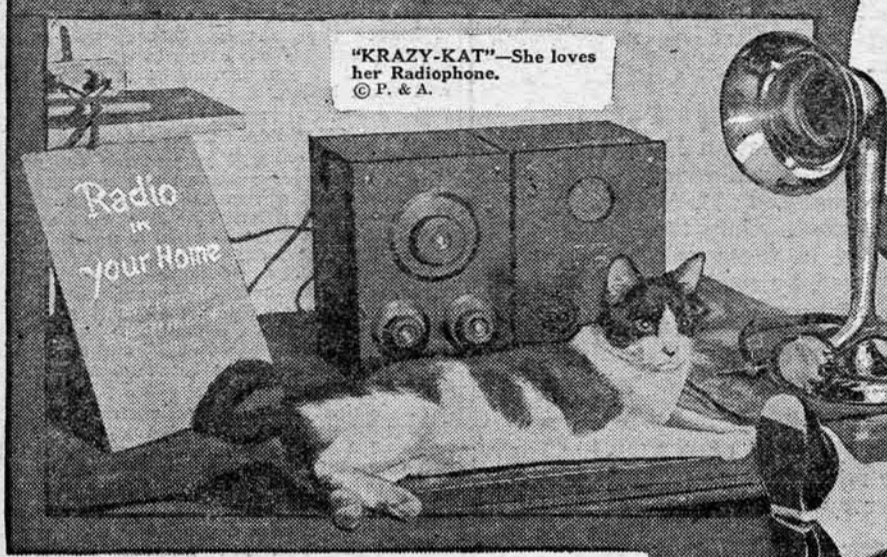

"KRAZY-KAT"—She loves her Radiophone.
© P. & A.

BABY HAS RADIO NURSE—The baby may be placed in a park on a bench and the nurse then turn to her knitting without keeping a constant watch on the child for with the receivers on the baby hears the concerts. Baby Alice Murray is getting her radio training early.
© Fotograms



AFTER YOU'VE SLICED ONE—Listen to radio.
© Fotograms

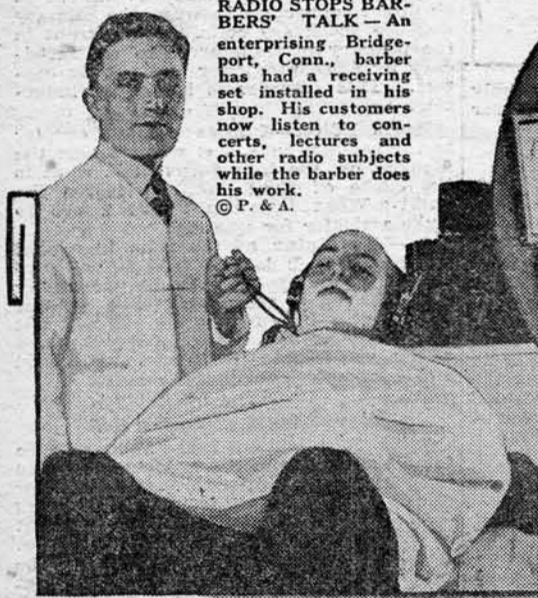

RADIO STOPS BARBERS' TALK—An enterprising Bridgeport, Conn., barber has had a receiving set installed in his shop. His customers now listen to concerts, lectures and other radio subjects while the barber does his work.
© P. & A.

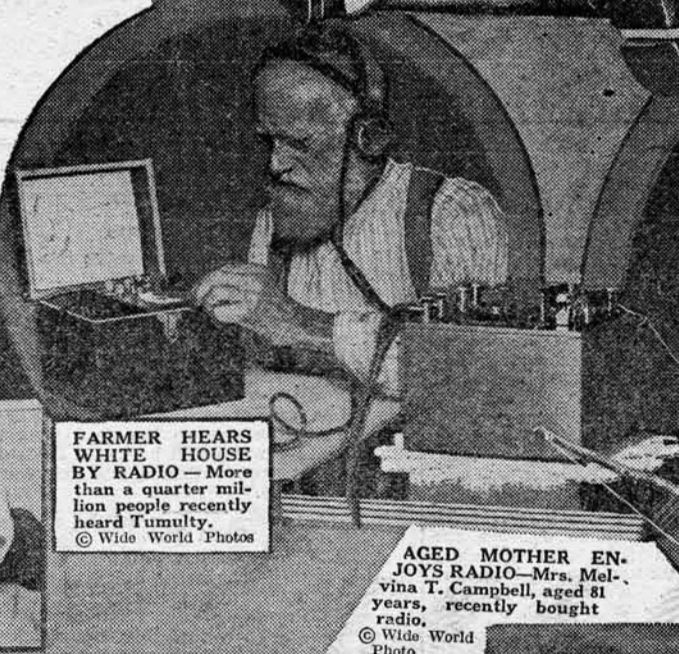

FARMER HEARS WHITE HOUSE BY RADIO—More than a quarter million people recently heard Tumulty.
© Wide World Photos



AGED MOTHER ENJOYS RADIO—Mrs. Melvina T. Campbell, aged 81 years, recently bought radio.
© Wide World Photo

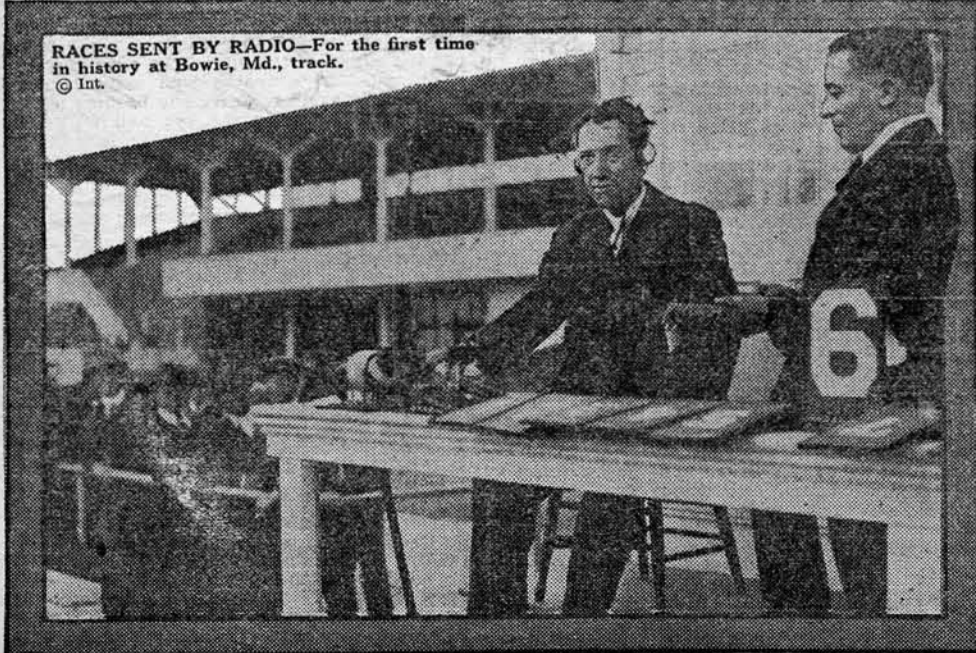

RACES SENT BY RADIO—For the first time in history at Bowie, Md., track.
© Int.



NO MORE LONE-SOME WAITING FOR BITES—Use radio.
© Fotograms

WHERE THE "WAVES" RULE—This girl has slipped into the bathtub but her radio's handy.
© Fotograms