

RADIO'S LIVEST MAGAZINE

OVER 175 ILLUSTRATIONS

Radio-Craft

Special
**RADIO
SERVICE**
Number

July

25 Cents

in United States
and Canada

HUGO GERNSBACK EDITOR



See Page 9

Everyman's Car-Radio Set — Public-Address and "Universal" Radio Tuner
Tube Characteristics with the "Ray" Tube — Service Man's Coil Tester

OVER 50,000 RADIO MEN READ RADIO-CRAFT MONTHLY

SENSATIONAL NEW SUPREME



2" OSCILLOSCOPES SET NEW PERFORMANCE RECORDS!

ONLY \$29.95
\$4.00 Down
\$4.14 FOR 7 MONTHS

Actual tests prove SUPREME 2" OSCILLOSCOPES far superior, more accurate, have four times larger screen area than the 1" kind!

SUPREME'S new 2" Oscilloscopes have created a sensation! In performance! In price! In value! And no wonder! Imagine a 2" Oscilloscope, actually using a 2" cathode ray tube (not a magnifying arrangement), that gives four times more effective screen area than the 1" kind—and yet costs even less than the average 1" Oscilloscope! In addition, you get extra, exclusive features found in no other instruments of similar price. What's more—

for less than 13c per day you can own one of these new 2" Oscilloscopes. This small amount is not for the life of your instrument but only during the few months that you are paying for it on SUPREME'S S. I. C. time payment plan—the world's easiest installment terms! Remember—one of these new 2" Oscilloscopes will cost you less than your cigarettes! See your parts jobber today!

VISUAL PROOF THAT CAN'T BE DENIED!

JUDGE THESE COMPARATIVE PHOTOGRAPHS YOURSELF!

This side-by-side comparison shows the same illustration reproduced both in 2" and 1" size. It portrays the demodulated output of the SUPREME Model 580 Signal Generator, obtained with a SUPREME 2" Oscilloscope which contains an actual 2" size tube (not a magnifying arrangement). Carrier frequency 600 kilocycles amplitude modulated at 400 cycles. Oscillogram made with vertical plates connected across demodulator stage load resistor of superheterodyne receiver. Judge for yourself which is clearer, more distinct, and which will give a more accurate reading. You'll place your vote for the 2" size!

MODEL 530—2" OSCILLOSCOPE

8 EXCLUSIVE features found in no other instrument of similar price!

1. The only 2" Oscilloscope at this price!
2. Exclusive SELECTIVE RETURN SWEEP ELIMINATOR for inclusion or rejection of power supply frequency return sweep!
3. Exclusive UNI-CONTROL allows separate control of two potentiometers from one shaft protrusion on the panel!
4. Exclusive ANTIQUE BRONZE PANEL!
5. Exclusive LIGHT WEIGHT and SMALL SIZE!
6. Exclusive "POWER ON" INDICATOR lamp!
7. Exclusive MAXIMUM FUNCTIONS with MINIMUM number of PANEL KNOBS!
8. Exclusive FLEXIBILITY OF CONTROL FUNCTIONS!

SPECIAL LOW INSTALLMENT TERMS ON SIGNAL GENERATOR-OSCILLOSCOPE COMBINATION

MODEL 535—2" OSCILLOSCOPE

10 EXCLUSIVE features found in no other instrument of similar price!

1. The only 2" Oscilloscope at this price!
2. Exclusive RETURN SWEEP ELIMINATOR for completely removing high frequency linear sweep return!
3. Exclusive SELECTIVE RETURN SWEEP ELIMINATOR for inclusion or rejection of power supply frequency return sweep!
4. Exclusive SNAP-LOCK SYNCHRONIZER for positive interlock between linear time base and incoming signal—Range 15 cycles to over 500 k.c.!
5. Exclusive UNI-CONTROL allows separate control of two potentiometers from one shaft protrusion—Grouping of controls eliminates groping for controls!
6. Exclusive ANTIQUE BRONZE PANEL!
7. Exclusive SMALL SIZE and LIGHT WEIGHT!
8. Exclusive MINIMUM number of PANEL KNOBS control MAXIMUM number of INSTRUMENT FUNCTIONS!
9. Exclusive "POWER ON" INDICATOR lamp!
10. Exclusive FLEXIBILITY OF CONTROL FUNCTIONS!

ONLY \$49.95
\$5.50 Down
\$4.95 for 10 Months



SOLD ON SUPREME S. I. C. TERMS—THE WORLD'S EASIEST INSTALLMENT TERMS!

SUPREME INSTRUMENTS CORPORATION

GREENWOOD, MISSISSIPPI

A FREE LESSON SHOWED BILL HOW HE COULD MAKE GOOD PAY IN RADIO



BILL, YOU'RE ALWAYS FOOLING WITH RADIO-- OUR SET WON'T WORK-- WILL YOU FIX IT?

I'LL TRY, MARY, I'LL TAKE IT HOME TONIGHT



I CAN'T FIND OUT WHAT'S WRONG-- GUESS I'LL MAKE A FOOL OF MYSELF WITH MARY



HELLO, BILL-- GOT A TOUGH ONE TO FIX? LET ME HELP YOU



HELLO JOE-- WHERE'VE YOU BEEN LATELY-- AND WHERE DID YOU LEARN ANYTHING ABOUT RADIO?

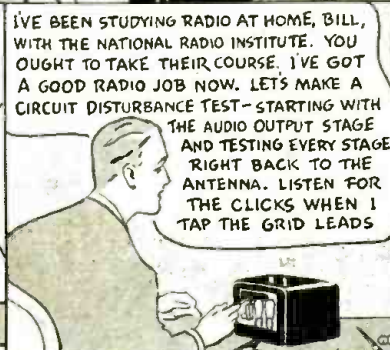

I'VE BEEN STUDYING RADIO AT HOME, BILL, WITH THE NATIONAL RADIO INSTITUTE. YOU OUGHT TO TAKE THEIR COURSE. I'VE GOT A GOOD RADIO JOB NOW. LET'S MAKE A CIRCUIT DISTURBANCE TEST-- STARTING WITH THE AUDIO OUTPUT STAGE AND TESTING EVERY STAGE RIGHT BACK TO THE ANTENNA. LISTEN FOR THE CLICKS WHEN I TAP THE GRID LEADS



SAY-- WHERE DID YOU LEARN THAT TEST? IT'S A GOOD ONE

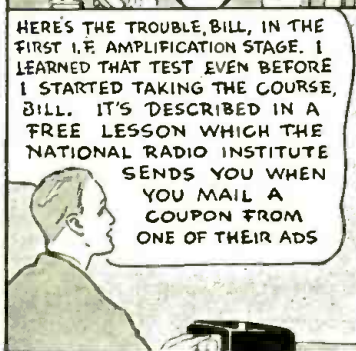

HERE'S THE TROUBLE, BILL, IN THE FIRST I.F. AMPLIFICATION STAGE. I LEARNED THAT TEST EVEN BEFORE I STARTED TAKING THE COURSE, BILL. IT'S DESCRIBED IN A FREE LESSON WHICH THE NATIONAL RADIO INSTITUTE SENDS YOU WHEN YOU MAIL A COUPON FROM ONE OF THEIR ADS



I'VE SEEN THEIR ADS BUT I NEVER THOUGHT I COULD LEARN RADIO AT HOME-- I'LL MAIL THEIR COUPON RIGHT AWAY

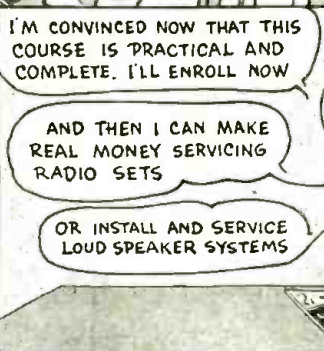

I'M CONVINCED NOW THAT THIS COURSE IS PRACTICAL AND COMPLETE. I'LL ENROLL NOW

AND THEN I CAN MAKE REAL MONEY SERVICING RADIO SETS

OR INSTALL AND SERVICE LOUD SPEAKER SYSTEMS



OR GET A JOB WITH A RADIO BROADCASTING OR TRANSMITTING STATION

AVIATION RADIO, POLICE RADIO, TELEVISION, ELECTRONIC CONTROLS-- RADIO IS SURELY GOING PLACES. AND THE NATIONAL RADIO INSTITUTE HAS TRAINED HUNDREDS OF MEN FOR JOBS IN RADIO

YES, I WILL SEND YOU MY LESSON ON RADIO SERVICING TIPS FREE TO SHOW YOU HOW PRACTICAL IT IS TO TRAIN AT HOME FOR A GOOD RADIO JOB



YOU CERTAINLY KNOW RADIO SOUNDS AS GOOD AS THE DAY I BOUGHT IT.

THANKS! IT CERTAINLY IS EASY TO LEARN RADIO THE N.R.I. WAY. I STARTED ONLY A FEW MONTHS AGO, AND I'M ALREADY MAKING GOOD MONEY. THIS SPARE TIME WORK IS GREAT FUN AND PRETTY SOON I'LL BE READY FOR A FULL TIME JOB

I HAVE TRAINED MANY MEN TO START A SPARE TIME OR FULL TIME RADIO SERVICE BUSINESS WITHOUT CAPITAL

Do you want to make more money? I'm so sure that I can train you at home in your spare time for a good Radio Job that I'll send you a sample lesson absolutely FREE. Examine it, read it, see for yourself how easy it is to understand even if you've never had any technical experience or training.

Many Radio Experts Make \$30, \$50, \$75 a Week

Radio broadcasting stations employ engineers, operators, station managers and pay up to \$5,000 a year. Spare time Radio set servicing pays as much as \$200 to \$500 a year. Full time Radio servicing jobs pay as much as \$30, \$50, \$75 a week. Many Radio Experts own and operate their own full time or part time Radio sales and service businesses. Radio manufacturers and jobbers employ testers, inspectors, foremen, engineers, servicemen, paying up to \$6,000 a year. Radio operators on ships get good pay and see the world besides. Automobile, police, aviation, commercial, Radio, and loud speaker systems offer good opportunities now and for the future. Television promises many good jobs soon. Men I have trained are holding good jobs in all these branches of Radio.

Many Make \$5, \$10, \$15 a Week Extra in Spare Time While Learning

Practically every neighborhood needs a good spare time serviceman. The day you enroll I start sending you Extra Money Job Sheets. They show you how to do Radio Repair jobs that you can cash in on quickly. Throughout your training I send you Plans and ideas that have made good spare time money--from \$200 to \$500 a year--for hundreds of fellows. I send you special Radio equi-

ment and show you how to conduct experiments and build circuits which illustrate important Radio principles. My training gives you practical Radio experience while learning.

Get My Lesson and 64-Page Book FREE--Mail Coupon. In addition to my Sample Lesson, I will send you my 64-page Book, "Rich Rewards in Radio." Both are free to any fellow over 16 years old. My book describes Radio's spare time and full time opportunities and those coming in Television; tells about my Training in Radio and Television; tells about my Money Back Agreement; shows you actual letters from men I have trained, telling what they are doing and earning. Find out what Radio offers YOU! MAIL THE COUPON in an envelope, or paste it on a penny postcard--NOW!

J. E. SMITH, President National Radio Institute Dept. 7GX Washington, D. C.

MAIL THIS NOW

J. E. SMITH, President, Dept. 7GX National Radio Institute, Washington, D. C.

Dear Mr. Smith: Without obligation, send me a sample lesson and your free book about the spare time and full time Radio opportunities, and how I can train for them at home in spare time. (Please write plainly.)

Name Age.....
 Address
 City State..... 14x1



Please Say That You Saw It in RADIO-CRAFT



HUGO GERNSBACK, Editor-in-Chief
 C. W. PALMER Technical Editor
 R. D. WASHBURNE, Managing Editor
 C. P. MASON Associate Editor

CONTENTS - JULY, 1937, ISSUE

Volume IX Number I

Editorial: Modern Radio Servicing.....Hugo Gernsback	5
The Radio Month in Review.....	6
A DeLuxe Service Shop on WheelsHermann Steiner, Jr.	8
The Service Man Takes a Holiday.....R. D. Washburne	9
New Profits for the Auto Mechanic in Radio In- spection.....A. R. Perong	9
Everyman's "Safety" Car-Radio Set for Custom Trade.....C. W. Palmer	10
Assembling a Simple Crystal Set.....N. H. Lessem	12
Correct Procedure for the Servicing BeginnerW. A. Woehr	12
Making the RADIO-CRAFT Simplified Carrier Inter- phone—Part II	13
How to Make a Hi-Fi P.A. and "Universal" Radio Tuner	14
A Universal-Service Test Speaker.....J. Abrams	16
Repair—Or, Replace That Defective Loudspeaker?M. E. Swift	17
"The Case of the Resort"—and Other Sound StoriesH. M. Bayer	17
An Excellent Coil-Testing Unit for the Service Man— Part I.....Walter L. Lyons	18
How to Check Condensers with an A.C. BridgeGlenn H. Browning	19
Taming Man-Made Static.....Charles Golenpaul	19
Vacuum-Tube Characteristics with the C.-R. TubeC. Bradner Brown	20
Servicing by Sight and Sound—Part I, Spot Ampli- fier Response Curves.....M. M. Brisbin	21
.....M. M. Brisbin	21
An Easily-Made Add-On Volume ExpanderL. A. de Rosa	21
ORSMA Members' Forum.....	22

Building an Interference Elimination Business—Part IHarry Kalker	22
Useful Radio Circuits.....	23
Operating Notes	24
The Latest Radio Equipment.....	26
A Combination V.-T. and Peak Voltmeter....S. Minsker	27
A 20,000 Ohms/Volt Analyzer Kit....M. N. Beitman	27
Build the RADIO-CRAFT 1937 Car-Radio Set—Part II	28
Test Equipment for the Service Man.....	29

RADIO SERVICE DATA SHEETS:

No. 202—Stromberg-Carlson No. 127 A.C.-D.C.	30
No. 203—General Electric Model E-51 Receiver	31
No. 204—Crosley Model C-516 (Chassis No. 506)	34
No. 205—Chrysler-Philco "Custom-Built" 1937 Car-Radio Set	35
Novel Radio Items.....	32
Useful Tools for Radio Servicing.....	33
How to Solder.....J. L. Brothers	36
Direct-Coupling in a 30-W. Beam Tube Amplifier— Part III.....A. C. Shaney	36
Technicians' Data Service.....	40
Book Reviews	64

THE AUGUST TELEVISION NUMBER

Whether or not you are interested in the newest tele-
 vision ideas here and abroad, we are sure you will want to
 read the many articles on radio reception, electronics and
 public address in August RADIO-CRAFT. Although this
 issue is our annual Television Number it also will contain
 articles on many other topics.

Read about—

- A New Television Advertising Sign
- A Cathode-Ray Aviation "Safety" Loop Antenna
- A 2-Tube Carrier Interphone

—in August RADIO-CRAFT.

Published by Radcraft Publications, Inc. Publication office: 29
 Worthington Street, Springfield, Mass. Editorial and Advertising
 Offices: 99 Hudson Street, New York City. Chicago Advertising
 Office: L. F. McClure, 919 North Michigan Avenue, Chicago, Ill.
 Western Advertising Office: Loyd B. Chappell, 530 West Sixth St.,
 Los Angeles, Calif.

Foreign Agents:

London—Gorrings American News Agency, 9A Green St., Leicester
 Square, W. C. 2, England.
 Paris—Messageries Dawson, 4 Rue Faubourg, Poissonniere, France.
 Melbourne—McGill's Agency, 179 Elizabeth St., Australia.
 Dunedin—James Johnston, Ltd., New Zealand.

RADIO-CRAFT is published monthly, on the first of the month preced-
 ing that of date; subscription price is \$2.50 per year in U. S. and Can-
 ada. (In foreign countries, \$3.00 a year to cover additional postage.)
 Entered at the post office at Springfield as second-class matter
 under the act of March 3, 1879.

Text and illustrations of this magazine are copyright and must not be
 reproduced without permission of the copyright owners.

Copyright 1937. Radcraft Publications, Inc.



"SERVICE MEN KNOW HOW VALUABLE GERNSBACK RADIO MANUALS ARE"

Over 90,000 Gernsback Official Radio Service Manuals and Handibooks are in Use Today—They Must Be Good!

Since 1931 radio men have bought Gernsback OFFICIAL RADIO SERVICE MANUALS—and today they are being purchased by more and more men for service work. The authentic material, easily accessible diagrams and complete service data make them invaluable to active and alert radio Service Men. *Without a Gernsback Manual with you on a service job, there's time and profit lost.* Your service kit or laboratory is incomplete without all the Gernsback OFFICIAL RADIO SERVICE MANUALS.



1936 OFFICIAL RADIO SERVICE MANUAL

Just packed with service data of sets manufactured during 1935, and 1936. There are SCHEMATIC DIAGRAMS of over 1,500 manufactured receivers showing speaker connections, power-transformer connections, R.F. and I.F. coil connections, phonograph connections, and other information. On all set diagrams, with few exceptions, the I.F. peaks are indicated, also socket connections. Notes on alignment procedure are printed with the diagrams, also for over 80% of the sets you will find OPERATING VOLTAGES. Assembly diagrams show the relationship of separate units to each other. A complete index of TRADE NAMES and their respective manufacturers is to be found in the 1936 Manual. A COMPLETE TUBE CHART includes information on hundreds of tubes. A LARGE CUMULATIVE INDEX contains all sets printed in the 1931, 1932, 1933, 1934, 1935, and 1936 Manuals.

1,200 PAGES * OVER 2,500 ILLUSTRATIONS
Looseleaf Binder—Stiff, Hard Covers
Size 9 x 12 Inches * Price \$7.00

1935 OFFICIAL RADIO SERVICE MANUAL

This edition is well noted for containing schematic diagrams and service notes for many older receivers. The volume is printed on a special "Bible Stock" and contains over a thousand pages, still it is only 1 1/4 inches thick. Conveniently rolls to fit into your pocket. Contains a vast amount of information on all-wave receivers, P. A. equipment, midget sets, auto-radio receivers, and test equipment.

OVER 1,000 PAGES * OVER 3,000 ILLUSTRATIONS
Looseleaf Binder—Flexible, Leatherette Covers
Size 9 x 12 Inches * Price \$7.00

1934 OFFICIAL RADIO SERVICE MANUAL

This manual contains values of I.F. transformers on superheterodyne receivers, valuable tube data, complete list of American Broadcast stations, free question and answer service, service material and schematic diagrams.

OVER 400 PAGES * OVER 2,000 ILLUSTRATIONS
Looseleaf Binder—Flexible, Leatherette Covers
Size 9 x 12 Inches * Price \$3.50

1933 OFFICIAL RADIO SERVICE MANUAL

The 1933 Manual features pictorial views of hundreds of commercial receivers with additional schematic diagrams, location of parts on chassis, values of intermediate frequencies, values of resistors and condensers and other valuable information for Service Men.

OVER 700 PAGES * OVER 2,000 ILLUSTRATIONS
Looseleaf Binder—Flexible, Leatherette Covers
Size 9 x 12 Inches * Price \$5.00

OFFICIAL RADIO SERVICE HANDBOOK

Here's the sensational new book on servicing. It is edited by J. T. Bernsley, well-known radio service authority. It covers over 500 radio topics and gives a complete description of the "Magic Eye." Contains a special section of 250 pages of Operating Notes. The book covers: Circuit Theory and Analysis; Modern Servicing and Test Equipment; Practical Short-cuts in Trouble Shooting and Repairs; Specialized Receiver and Installation Data; Modernization and Conversion Data; Social and Economic Problems of Service Men; and Operating Notes and Practical Data Listings.

OVER 1,000 PAGES * OVER 1,000 ILLUSTRATIONS
Beautiful Linen, Gold-Stamped Cover
Size 6 x 9 Inches * Price \$4.00

1932 OFFICIAL RADIO SERVICE MANUAL

Here is the volume which shows a step-by-step analysis of how to service any receiver. It is one of the early editions and covers many old sets.

OVER 1,000 PAGES * OVER 2,000 ILLUSTRATIONS
Looseleaf Binder, Flexible Covers
Size 9 x 12 Inches * Price \$5.00

1931 OFFICIAL RADIO SERVICE MANUAL

This is the first complete radio Manual published. It contains a comprehensive course for servicing radio sets. This course is invaluable not only to Service Men, but everyone interested in radio.

OVER 650 PAGES (Including Supplements) * OVER 1,500 ILLUSTRATIONS
Looseleaf Binder—Flexible, Leatherette Covers
Size 9 x 12 Inches * Price \$4.50

1935 OFFICIAL AUTO-RADIO SERVICE MANUAL

OVER 210 PAGES * OVER 500 ILLUSTRATIONS
Looseleaf Binder—Flexible, Leatherette Covers
Size 9 x 12 Inches * Price \$2.50

1933 OFFICIAL AUTO-RADIO SERVICE MANUAL

OVER 250 PAGES * OVER 500 ILLUSTRATIONS
Looseleaf Binder—Flexible Leatherette Covers
Size 9 x 12 Inches * Price \$2.50

YOUR RADIO JOBBER OR FAVORITE MAIL ORDER HOUSE SELLS GERNSBACK SERVICE MANUALS AND HANDBOOKS

Clip Coupon and Mail to **RADCRAFT PUBLICATIONS, INC., 99 HUDSON ST., NEW YORK, N. Y.**

RADCRAFT PUBLICATIONS, INC., 99 Hudson Street, New York, N. Y.		RC-737
Gentlemen: Enclosed you will find my remittance of \$..... for which you are to send me, POSTPAID, the Book or Manual which I have indicated at the right by a cross (x) in the panel.		<input type="checkbox"/> 1936 Official Radio Service Manual @ \$7.00
Name		<input type="checkbox"/> 1935 Official Radio Service Manual @ \$7.00
Address		<input type="checkbox"/> 1934 Official Radio Service Manual @ \$3.50
City	State	<input type="checkbox"/> 1933 Official Radio Service Manual @ \$5.00
(Send remittance in form of check or money order; register your letter if you send cash or unused U. S. Postage Stamps).		<input type="checkbox"/> 1932 Official Radio Service Manual @ \$5.00
		<input type="checkbox"/> 1931 Official Radio Service Manual @ \$4.50
		<input type="checkbox"/> 1935 Official Auto-Radio Service Manual (Including Supplements) @ \$2.50
		<input type="checkbox"/> 1933 Official Auto-Radio Service Manual @ \$2.50
		<input type="checkbox"/> Official Radio Service Handbook @ \$4.00

Please Say That You Saw It in RADIO-CRAFT

The First Three Installments

OF VOLUME 7 OF THE OFFICIAL RADIO SERVICE MANUAL

ARE NOW READY!



OVER
1,800
PAGES

★
OVER 3,000 ILLUSTRATIONS



RADCRAFT PUBLICATIONS, INC., 99 HUDSON STREET, NEW YORK, N. Y.

YOU DON'T HAVE TO PAY A PENNY IN ADVANCE FOR YOUR COPY OF VOLUME 7 OF THE GERNSBACK OFFICIAL RADIO SERVICE MANUAL!

SEND for Volume 7 of the GERNSBACK Official Radio Service Manual today. You can make use of it every day in your service work—and pay for it while you're using it. Three easy ways to get this new Manual are outlined in the coupon below. Two of the plans save you money. Don't delay—clip the coupon—fill it in and mail today. Within a few days you will receive by mail the first, second and third installments of radio's newest service Manual.

Here are the highlights of VOLUME 7

PUBLISHED SIMILARLY TO A MAGAZINE

The OFFICIAL RADIO SERVICE MANUAL (Volume 7) is being published in twelve installments—one installment being mailed every month to subscribers.

DEFERRED PAYMENT PLAN

This new Manual will be sold on the deferred payment plan. Complete details of this "pay-as-you-comple-your-manual" plan appears in coupon.

150 PAGES OF SERVICE DATA

Is sent to you every month. Each installment will never be less than 150 throughout the year.

MANUAL OF OVER 1,800 PAGES

The total amount of service data which you have received during the year exceeds any other service guide published.

CUMULATIVE INDEX EACH MONTH

The index accompanying the first installment lists all sets which appear in that section; the index mailed with the second installment lists sets appearing in both the first and second installments, and so on. You discard the previous index and use the new one furnished with each installment. With the final, twelfth installment, the Master Index which you receive will cover, not only the set data you received during the entire year's monthly service (which constitutes Volume 7), but, in addition, the sets listed in every GERNSBACK OFFICIAL RADIO SERVICE MANUAL since 1931.

OVER 3,000 ILLUSTRATIONS

The largest compilation of complete wiring diagrams, schematics and charts ever included in a single volume of any radio service Manual.

OVER 1,200 DIFFERENT MODELS

More wiring and schematic and other servicing diagrams will be included in Volume 7 than in any other Manual. At least 1,200 different models will be covered.

ALL FRESH MATERIALS—NO REHASH

And, most important, there will be no duplication of any material. In Volume 7 you will find material which has never appeared previously in the first six volumes.

MANY 1938 MODELS TO BE INCLUDED

At the end of a year's service (12 months), subscribers receive service data and diagrams on many advance 1938 models. This material would ordinarily appear in the 1939 Edition of the MANUAL.

NEW SERVICE DATA EACH MONTH

This new plan permits you to have in your possession service data just released. Previously, the material was a year old or more when it reached you. Service data on older receivers never before published in any other of the Gernsback Manuals, will be included in Volume 7.

COMPLETE SERVICE DATA

Data includes such valuable information as I. F. peaks, operating voltages, alignment procedure, chassis and tube socket layouts, values of components, lists of parts, and other vitally important service hints.

SERVICE DATA AND DIAGRAMS NOT LISTED ELSEWHERE

A considerably large portion of the data appearing in the monthly installments will not be found in any other radio service Manual . . . at least not for some time to come. This is an outstanding advantage of this new plan.

SIMPLE TO INSERT EACH INSTALLMENT

You literally "slip" them in . . . one installment on top of the other . . . without any fuss of arranging the pages numerically, alphabetically or otherwise. You merely open the binder and, with one single motion, slip the entire group of pages over the steel binding posts. You don't remove the pages thereafter, they stay in the binder for good. We've done all the filing work for you. . . . That's all there is to it! The specially compiled cumulative index (which you receive with each installment) does the rest. This index shows at a glance where any required information can be found.

EQUIVALENT TO TWO REGULAR SERVICE MANUALS

since the sets covered are those manufactured during the latter part of 1936, all in 1937 and many in early 1938. The second year (starting April, 1938) of this monthly service will begin with sets manufactured during 1938.

RADCRAFT PUBLICATIONS, INC. • 99 Hudson Street • New York, N. Y.

RC-737

Please enroll me as a subscriber to Volume 7 of the GERNSBACK Official Radio Service Manual and start sending me immediately the installments. I have marked below the plan which I prefer.

PLAN NO. 1

I enclose \$10.00 herewith, for which send me immediately, FREE OF CHARGE, a heavy, stiff binder, and the first three installments. Send me thereafter for nine consecutive months commencing July 1, 1937, regularly once a month, an average of 150 pages of Volume 7 of the OFFICIAL RADIO SERVICE MANUAL. These pages can be immediately filed into the binder. Both the binder and the monthly pages are mailed to me POSTAGE PREPAID. Total cost: \$10.00. THIS PLAN SAVES ME \$2.00.

PLAN NO. 2

I enclose \$3.50 herewith, for which send me immediately, FREE OF CHARGE, a heavy, stiff binder, and the first three installments. Send me thereafter commencing July 1, 1937, regularly once a month for nine consecutive months, an average of 150 pages of Volume 7 of the OFFICIAL RADIO SERVICE MANUAL. After I have received the 3rd, 6th and 9th installment, you are to bill me for \$2.50 in advance for the coming quarter making the total cost for the year's service \$11.00. THIS PLAN SAVES ME \$1.00.

PLAN NO. 3

I pay nothing in advance. Each month an average of 150 pages of the OFFICIAL RADIO SERVICE MANUAL will be delivered to me. I pay postman \$1.20 plus a few cents for C.O.D. charges each month for ten months. The eleventh and twelfth installments of the subscription will be delivered to me FREE OF CHARGE. You prepay shipping charges on all installments mailed to me. With the tenth installment send me FREE OF CHARGE a heavy, stiff binder.

I want the binder sent with the first installment, and will pay postman a total of \$2.40 plus a few cents for C.O.D. charges and \$1.20 per month for eight consecutive months thereafter. Under this plan, the tenth, eleventh and twelfth installments are delivered to me FREE OF CHARGE. TOTAL COST UNDER THIS PLAN \$12.00.

NAME ADDRESS CITY STATE

Send remittance by check or money order. Register your letter if you send cash or unused U.S. Postage Stamps.

Please Say That You Saw It in RADIO-CRAFT



"Takes the Resistance out of Radio"

Editorial Offices: 99 Hudson St., New York, N. Y.

HUGO GERNSBACK, Editor

Vol. IX, No. 1, July 1937

MODERN RADIO SERVICING

An Editorial by HUGO GERNSBACK

WHEN CLOCKS first were made, several centuries ago, they were constructed mainly of wood and most of the wheels as well as almost everything else connected with the clock, outside of the heavy lead weights, was also wooden. Such clocks had few parts and consequently any bright young man who knew something about mechanics had little trouble in repairing such clocks. But clocks kept on getting more complicated as time went on, and soon they were made entirely of metal. A little later on we had pocket watches, huge cumbersome pieces, that made good mechanics necessary but soon we had watchmakers and repair men who serviced and repaired such improved watches. More recently, timepieces have kept on getting more and more complicated, at the same time becoming smaller in size; no ordinary watchmaker of olden times could possibly take such a watch apart and put it together again, much less repair it, intelligently. Finally, when we have as we do today a watch which is smaller than a dime and which the ladies wear on their finger rings, it is easy to understand that only an A-1 watchmaker could possibly service and repair such a timepiece where it takes a good magnifying glass to even see some of the exceedingly fine pieces of its mechanism.

This parallel can be used in good stead in the servicing industry today. There was a time when any bright youngster with a pair of pliers and a screwdriver could service a radio set because after all they were still rather crude. But radio sets, the same as fine watches, have traveled on a parallel course of revolution.

Thus we find that radio sets are becoming more complicated every month. If you look at the underside of a chassis of a 1937 model radio set, it immediately becomes apparent that the old-time repair man could no more service, intelligently, such a radio set than a blacksmith could repair a ladies' wristwatch. Every available fraction of an inch is literally crammed with radio parts which themselves are getting smaller as time goes on. There is a bewildering array of colors stamped into the radio parts and often an equally bewildering array of colored cabling of the connection wires. Variable condensers, potentiometers, and other moving parts are built in such a manner that it takes an expert mechanic to handle them. Then we have the new dials, fearfully complicated in many ways, not only as to mechanisms but they are lighted by means of various electric pilot lamps, further complicating the radio set. Other sets with remote control call for still greater mechanical ingenuity and for still greater precision in workmanship.

I could go on at length to mention all of the complications and the great complexity of the modern radio set, but it all brings us to the same conclusion, that is, the modern radio set can no longer be serviced by a novice or even by a second-grade Service Man. It takes more than an ordinary radio man to do the modern radio set justice. He must not only be an expert in radio, but he must be a good mechanic as well. He must know something about physics, and he must be

a judge of the various materials which go into the manufacture of radio sets. And frequently, it happens that even a good Service Man must call in an associate in trying to properly and intelligently service a modern radio set. One may be an expert in radio, while the other may be a mechanical expert, and often both join in the labor when the set is in the shop, in order to properly service it.

And let no one think that radio sets are becoming less complicated. Neither watches, automobiles, nor typewriters became simplified as time went on, all became more complex, all more difficult in servicing, with each succeeding year. You may therefore expect radio sets to continue getting more complex as time goes on because more demands are made upon radio sets now than ever before. Only a few short years ago, people knew nothing about tone control, short waves, automatic tuning, remote-control operation, finger-hole-dial tuning, etc., whereas most modern sets have these improvements and many others besides. The sets of tomorrow will be far more complex and even the best scientific prophet cannot foretell how far this development will go. Thus, for instance, one of the adjuncts which will surely be added in the near future to our radio sets will be the radio applause or radio voting feature, whereby it will be possible for station owners to know how many sets are either on the air tuned in to their station or how many are voting for a certain radio program.

What has all of this to do with servicing? Simply this, that as time goes on servicing will not be the cinch it was years ago. It will call for radio-mechanics of the highest order, and this also fortunately for the radio servicing industry spells the death knell of the radio "gyp artist, who could repair a set for fifty cents." Unless the modern radio Service Man is well-equipped with instruments, he will be afraid to service a complicated radio set for fear that he will not be able to repair it at all. Of course, it is possible that we will always have that type of petty-radio larceny man, who when called in to service a radio set finds that the aerial wire has been disconnected from the binding post of the set, and he charges two dollars for some imaginary trouble. Or his brother in petty-crime, who tells his customer that all of the tubes are blown out, when as a matter of fact there is nothing the matter with them and perhaps only one of them has a bad contact.

I believe the time will come when no radio owner will be foolish enough to trust his set to every stray Service Man who isn't known in his community, because the owner will be afraid to trust a set to any one unless he is generally known to be *thoroughly reliable*.

Good Service Men will not be worried about the increasing complexity of radio sets because they have learned through long experience how to handle any situation that may arise. As for radio service gyps, we believe that their days are counted and it will not be long before they are automatically eliminated.

THE RADIO MONTH

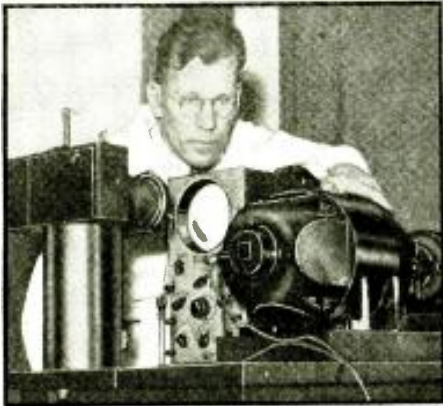

The Memnoscope "remembers" electrical impulses.

MEMNOSCOPE—AN ELECTRICAL BRAIN

AN oscilloscope, a camera (the two units combined constituting an oscillograph) and a peculiar motor-driven commutator having 147 separate segments each of which forms a tiny condenser were used, last month, to demonstrate the possibilities of making electrical devices "remember" electrical currents, in very much the same way as the human brain remembers.

The device, called the Memnoscope, was developed by the Westinghouse Research Labs. for recording trouble in Ignitron tubes which convert A.C. to D.C.

In action, the commutator of the Memnoscope is coupled by means of a coil to the circuits from the Ignitron. The commutator is revolved at a fast rate, and thus, each segment retains an image of a small portion of the current picked up in the coil, until it reaches a brush which draws off the charge. This charge is used to open the shutter of a camera focused on the end of a cathode-ray oscilloscope. Any failure of the Ignitron can thus be seen.



NAVY DEVELOPS "RADIO SPY"

IN a request before a Congressional Committee for appropriations, last month, the U.S. Navy disclosed the development of a "radio spy" by which enemy warships can be located or tracked over long distances at sea.

Rear Admiral Harold G. Bowen, engineer-in-chief of the Navy declined to make public details of the equipment—but it is suspected that the system uses micro-waves which are reflected by the distant vessels.

Flash!—While on the subject of secret inventions, it has been learned from a reliable source that a certain West Point Cadet has invented a means by which the entire short-wave spectrum can be blanketed with interference during war times, to prevent the use of these waves by the enemy for communicating purposes. The system has been tried on a small scale at the West Point radio station with fine success!

THE RADIO REFRIGERATOR

ANEW kink in merchandising was introduced, last month, with the introduction of a combined electric refrigerator and radio receiver, by Crosley.

The new unit contains the usual white refrigerator box, with all its gadgets and refinements—but the top, which is entirely separate and simply rests on the top of the refrigerator proper, is fitted with a 5-tube A.C. broadcast band receiver.

It has been said that 60 per cent of the housewife's time is spent in the kitchen, and from this statement the power of this refrigerator-radio scheme as a sales argument can be realized!

BROADCASTING FLASHES

IN a series of conferences with the Treasury department, a plan drafted by F.C.C.'s Commissioner George Payne to tax broadcasting stations on the basis of their power was "whipped into shape" for the House of Representatives.

Observations at the Mount Wilson Observatory indicate that the energy which causes fade-outs on the short-wave bands which has been attributed to Sun spots, comes from the Sun with the speed of light—or in other words, takes about 8 minutes to reach the earth.

The W.E. Co. placed a new program amplifier for radio stations on the market. The new unit features an automatic volume limiter (a type of reverse A.V.C.) which prevents over-modulation.

The Government of India, in installing new broadcasting stations in Calcutta, Delhi, Bombay and Madras decided to use 10 kw. short-wave transmitters because of the very bad static conditions on the broadcast band in that part of the world. To satisfy those few people using broadcast band sets, small 200 W. transmitters are re-broadcasting the short-wave signals—which is the reverse of the conditions in the U. S.

CRYSTAL MIKES CHECK VIBRATIONS

ANEW use for piezo crystals was announced last month by a well-known maker of these units. By mounting specially cut crystals on a propeller blade and using very fine leads with slip rings for connection, the torsional and bending strains due to vibration of the blade in motion can be detected.

Thus radio promotes airplane safety.

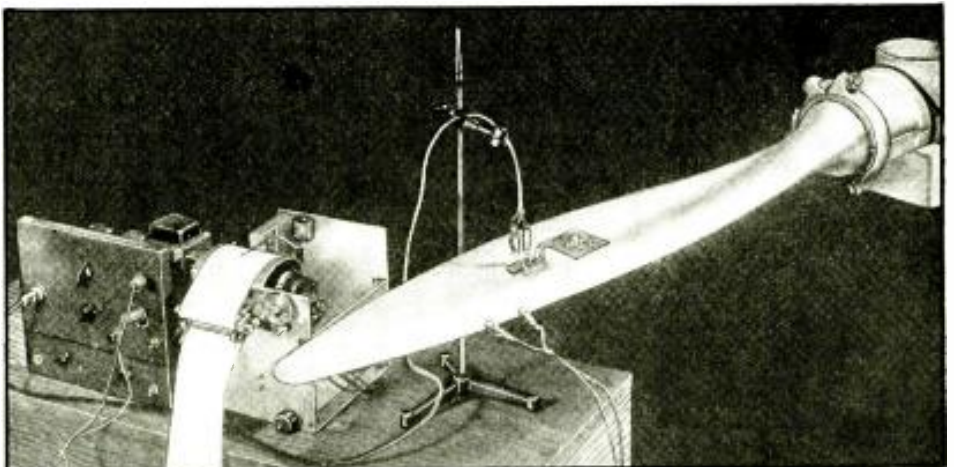

Above, piezo crystals record strains and torsions in airplane propellers. Left, the housewife will appreciate this addition, of a 5-tube radio receiver "section," to the electric refrigerator.

IN REVIEW

Radio is now such a vast and diversified art it becomes necessary to make a general survey of important monthly developments. RADIO-CRAFT analyzes these developments and presents a review of those items which interest all.

TELEVISION IN THE NEWS

CBS, not to be outdone by the efforts of NBC in the television field, made application to the F.C.C. last month, for permission to construct combined television and sound transmitters at the top of the Chrysler Building in New York. The station will equal the power of the television station now being constructed in Paris—30,000 watts.

As a direct result of the decision to use the Marconi system exclusively, in England, the price of television sets has been reduced by 30 per cent, including free installation.

R. A. Watson Watt, head of the Bawdsey Research Station of the Air Ministry in England announced the discovery of a new set of reflecting layers over the earth which reflect ultra-high frequencies. These layers are responsible for the "ghost" images which have been seen as "echo" pictures in the television screens of experimenters.

American Air Lines announced the successful use of "facsimile" devices in their ships—predicted in these columns.

RCA started back on the air with improved 441 line images with a promise that the experiments would continue well into the summer—good news!

Berlin is now enjoying (?) television operas.

AIR BEACON "MARKERS"

AS an added safety factor for pilots riding radio beams, the Bureau of Air Commerce began, last month, installing ultra-short wave "fan" type markers at certain distances from the major landing fields. These marker stations send out warning signals which tell the pilot how far he is from the landing field.

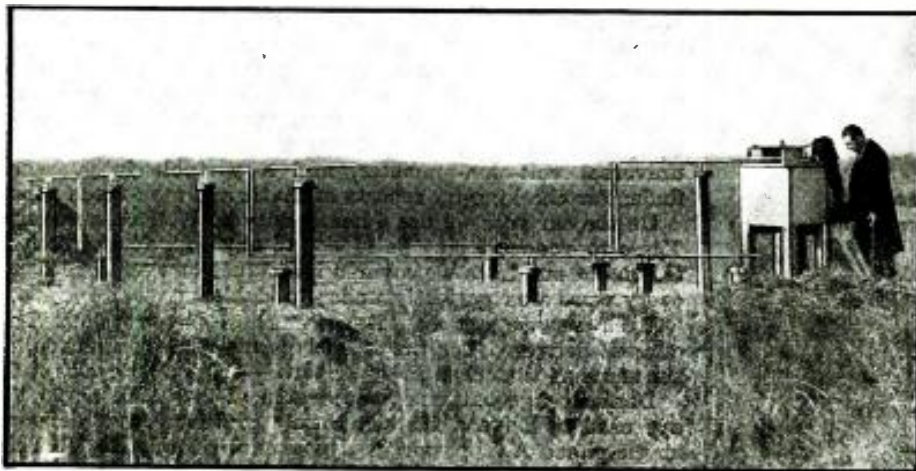

Above, the fan-type marker transmitters will promote safety in flying. Right, truck radio installation and repair is a new business for the Service Man.

PUBLIC ADDRESS IN SPAIN

AN interesting use to which a sound truck is being put in the bloody civil war in Spain was recounted in an issue of the *New Masses* last month.

The story tells of the Moors stationed behind a heavy stone barricade in the Rebel lines hearing the voice of one of their fellow-tribesmen telling in stentorian tones how they had been deceived by their officers—how the money they had received was worthless and the promises of independence for Morocco, false.

The voice was heard from a giant sound truck back of the Loyalist lines, which picked up the transmissions of radio station EAQ some 2 miles back of the lines and made the voice audible to the soldiers in the Rebel ranks.

The transmissions of EAQ on 9.4 megacycles have been heard over the entire civilized world.

TRUCK RADIO A PAYING LINE

ALTHOUGH a few auto trucks were fitted with the usual type of auto-radio sets within the past few years, there has been a notable lack of interest in this source of sales.

Within the past month or so, truck makers — notably Reo — have become conscious of the possibilities of added income from the sales of radio sets with their trucks. As a result, an entire line of Reo-Philco truck radio sets and equipment have been introduced, including special aerials and remote control heads to fit the dash boards of the new lines of vehicles.

Radio Service Men should investigate this new source of installation and repair work.

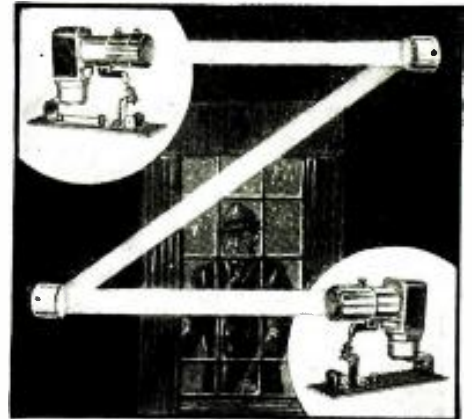

Infra-red beams effectively prevent intrusion.

A NEW INFRA-RED RAY ALARM

HOW an intricate net of invisible electric rays can be used effectively to snare burglars and kidnapers, and bring down the law upon them without their being aware of it, was demonstrated last month in New York City. Attempts to enter a 13,000 square foot area covered by the installation or to move from one zone to another were defeated at every turn!

The protectional device relies principally on the phototube, or "electric eye," to foil marauders. The protective network was made up of the beam from a standard automobile headlight bulb, from which all visible rays of the light spectrum had been filtered. By a multiple system of mirrors, this single invisible beam was reflected back and forth across a room, around corners, and at different levels and angles until the guarded area was completely protected against movement of a body in any direction.

(Continued on page 38)

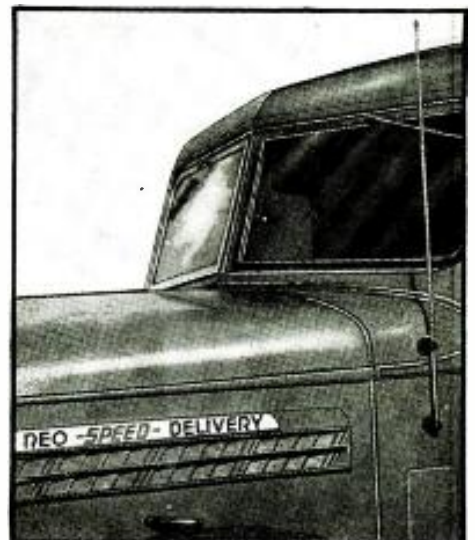

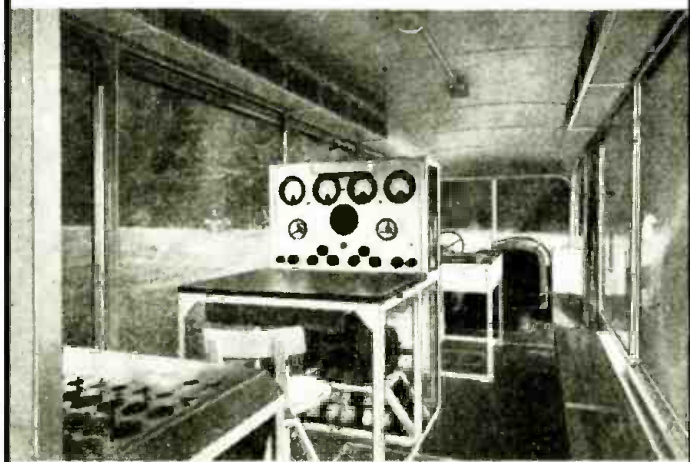
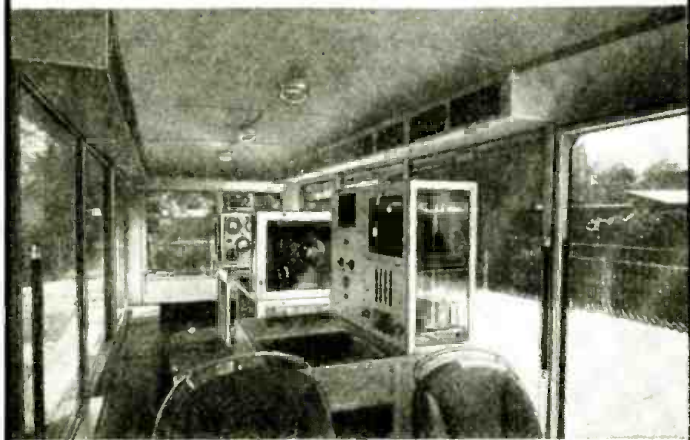
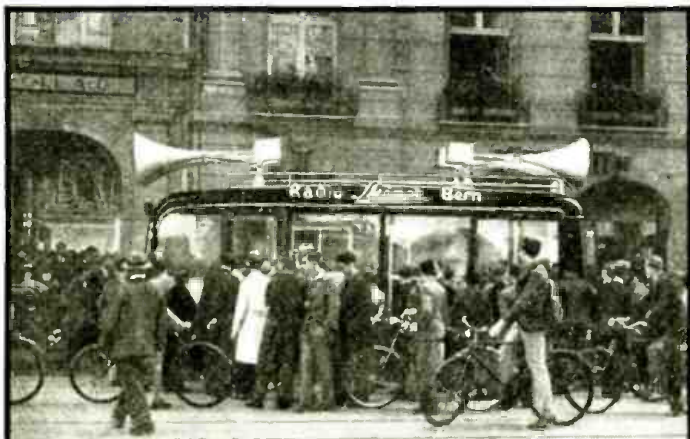

A DELUXE SERVICE SHOP ON WHEELS

A fleet of special trucks in Switzerland handles the service and public-address needs of over 100,000 customers.

HERMANN STEINER, JR.

IN SWITZERLAND you meet, everywhere, the blue Steiner-Service cars. They are the visible sign of a standard service organization which covers the whole country. These cars, one of which is shown here, pictorially, inside and out, are used by the Steiner service chiefs, officially tested radio experts, who check upon radio set installations, deal with receiver breakdowns and give technical advice to the listeners. Besides that, this great organization maintains modern-equipped service workshops in every big town.

The number of clients of this organization now numbers about 100,000 of the 400,000 licensed listeners in Switzerland. This amazing result—which American technicians would do well to analyze—is due to an ingeniously operated subscription system for radio sets, including all servicing.

These new service cars are equipped as a movable radio workshop, and in addition each one possesses a fine microphone and amplifier system for large P.A. work; a crowd of 100,000 and more persons easily may be covered. Every car has its own fixed district in which the clients are regularly visited—not only to effect repair but also, by periodical inspections, to avoid breakdowns.

At this "movable workshop" the clients' sets are thoroughly tested and cleaned, tubes are tested under operating conditions and weak ones immediately replaced by new ones.

TECHNICAL DATA

The Steiner Service and Public Address Car presents a complete radio workshop.

The instrument which most attracts public attention is the tube tester. This tester is furnished with 80 tube bases on which we are able to test every tube today in use. The tubes are tested under the same conditions as they are in the factory. Shorts, loose contacts, low emission, etc., and other defects are discovered very easily.

To be independent of the daily broadcast hours, the car carries a small service oscillator which covers the entire wave range from 14 to 2.500 meters. With this instrument we test every set for sensitivity, selectivity, amplification and dial alignment.

The P.A. system, which has an undistorted output of 100 W., is placed at a 3rd table. Inside this table is an electric turntable with crystal pickup. Also on this table is a commercial Rex Medium receiving set for reception of every broadcast program. In a corner is the requisite assortment of phono records; and a crystal "mike." Additional test equipment on the table includes a portable tube tester, a universal volt-ohm-ammeter, and a portable interference finder for checking-up reports of static and man-made noise.

On the car roof we use 4 heavy-duty 30-W. P.A. speakers. These reproducers may be turned in any desirable direction. On one of our tests we covered a distance of over 2½ miles; every word was perfectly understandable.

Each service car has its own small power plant. The current delivered, for the workshop and for illumination, is the same as that used in every town—220 V., 50 cycles A.C.

Dual storage batteries, each rated at 200 A.H. at 24 V., are used to drive a 1.1 kw. rotary converter that delivers single-phase A.C. power at a potential of only 15 V. This voltage is stepped-up by means of a transformer, to optional values of 110 to 220 V. To charge the storage batteries we

(Continued on page 41)

THE SERVICE MAN TAKES A HOLIDAY

Lakes, rivers and ocean beaches may be profitably patrolled by Service Men with suitably equipped boats.

R. D. WASHBURNE

UNLIKE the case celebre of the sailor on vacation who goes row-boating, the radio Service Man who, on his time off, undertakes to repair radio equipment at least has some monetary return to show for his industry.

But *Radio-Craft* goes a step further and makes the task really enjoyable in the suggestion, shown on the cover of this magazine and in the reproduction at upper-right, by combining the recreation of sojourning near summer resorts where boating is a feature, with the profitable service of extending to these boat owners the courtesy of radio repairs right at the respective private boat houses, yacht clubs, etc.; and, even, out on the water if necessary.

Radio-Craft will be greatly interested to hear from Service Men who may wish to put into practice this idea for bolstering the old bankroll.

The radio technician who aspires to

a profitable boat-radio repair service must be prepared not only to service innumerable types of radio receivers in all stages of repair and dis-repair but also should keep a weather eye open with a view to selling the boat owner on the idea of obtaining a more modern and effective radio set; and the possibility—or, in fact, probability—that his friends also will want to have a radio receiver installation.

The servicing tools required for a boat-radio repair service are identical to those required in servicing car-radio receivers. However the marine radio man will find that his average service charge will be greater than the customary level "on land" due to the fact that dampness raises havoc with radio equipment not specifically designed for marine use; and salt water in particular will exhibit pernicious effects that only the clever and painstaking radio man will be able to rectify.

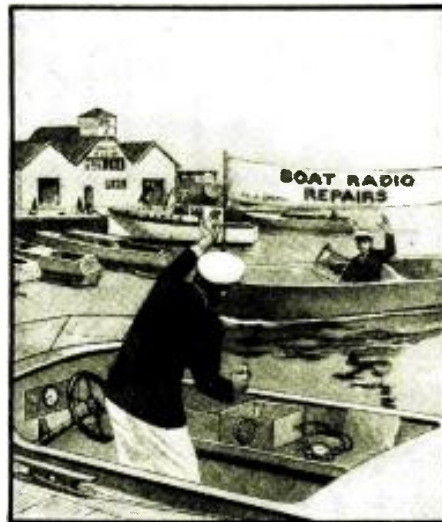

Pleasure and business are combined for the motor-boat enthusiast, this summer!

In addition to the repair angle there is also the matter of set installation which, in a boat, requires the technique of a Service Man experienced in taking into consideration all of the factors involved in placing the radio set and its controls in a manner that will be permanently satisfactory.

(See the article "Car-Radio Sets Afloat," on page 717 of the June 1935 issue of *Radio-Craft*.)

At this point we wish to stress a very important consideration. Do not expect to build up a boat-radio repair business
(Continued on page 38)

NEW PROFITS FOR THE AUTO MECHANIC IN RADIO INSPECTION

Here is the other side of picture—"the auto mechanic should also be the radio mechanic"—for consideration.

A. R. PERONG

IT IS A warm spring evening. You're out driving and stop at the red light.

Listen! From almost every car comes music. The auto-radio is here—and here to stay. Every day sees more and more cars equipped with them.

These radio receivers need regular inspection and tune-up, just as much as any other part of the car's electrical equipment. From the moment of its installation—a fact which many automobile owners do not know—the auto-radio is inextricably tied up with the entire car. It is not a separate unit but an integral part of the car's electrical system, which should definitely be serviced along with the rest of the car by a man with experience in automotive ignition and electrical systems.

A garage today that features one-stop radio and ignition system service, by experienced, dependable men, will save the car owner time, expense, and

build up a big new source of profit for the garage.

The most persistent offenders against perfect radio performance are not in the radio set but in the car itself. They are various forms of mechanical vibration. Such things as loose brake rods, oil lines, gas lines, cabling to the engine compartment, loose body, chassis and engine mounting bolts are all contributors to noises and disturbances heard over the radio system. They are all faults that a radio service station could never find, much less correct.

The entire electrical system must be right, too, to insure good radio performance. Distributor rotor and contact points, generator brushes, spark plugs and all light wiring, starting motor cables, generator cables, dash wiring and stoplight switches must be checked and put in perfect condition. A search must be made for leaky high-



A complete auto-radio checking unit.

tension cables and loose connections in the ignition system. An examination must be made to see whether paint or the like prevents good ground connections being made between the various parts of the automobile that form the ground connection. These poor connections will not be apparent in the operation of the car itself, as the voltage applied across the connection from the battery is enough to make sufficiently good contact for that purpose. However, when a radio receiver is installed in a
(Continued on page 39)



Fig. A. The driver does not have to look at the set!

EVERYMAN'S "SAFETY" CAR-RADIO SET FOR CUSTOM TRADE

A 6-tube auto set which consumes only 4 A. from the battery and is "button" tuned! A new series of low-drain tubes is used.

C. W. PALMER

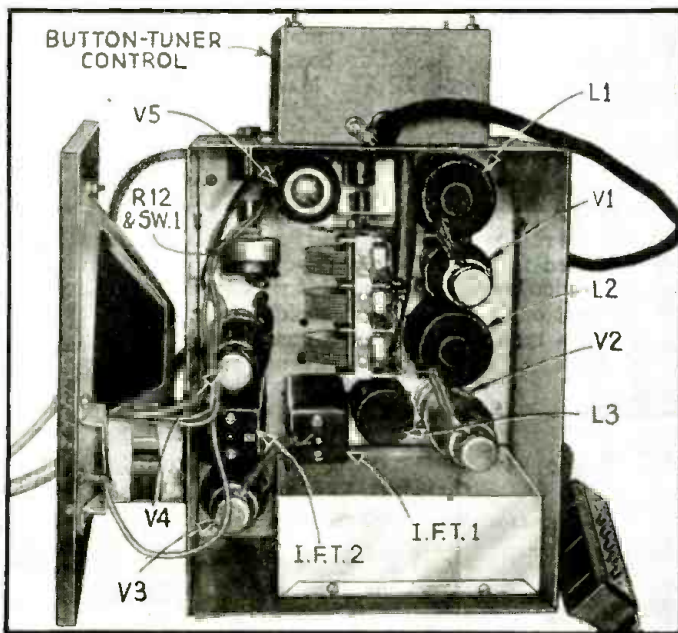

Fig. C. The front of the chassis showing parts layout.

A CAR-RADIO receiver for custom sales must have everything that the usual commercial auto set has, and yet have other characteristics or advantages which make it attractive to the class of buyer who wants something *different*.

For example, it must have all the sensitivity, volume and quality that is expected from a good manufactured set with other features such as delayed A.V.C. and so forth. Also, it must be modern in appearance and be fitted with the latest in tuning controls.

The set described here is designed with two major thoughts in mind. The first is *economy of battery current*. This is an important consideration if the set is to be used much, especially in view of the heavy over-loads which the car battery and generator are inflicted with in modern cars.

The second major consideration in the design of this set is *safety*. The car set must not absorb the attention of the driver. If it does, it is liable to become a menace to safe driving, especially in traffic.

DESIGN CONSIDERATIONS

The factor of low battery consumption is answered by the application of an entirely new series of 6.3 V. tubes not yet used in any commercial car set and which require only 0.15-A. of filament current instead of the usual 0.3-A. In addition, the battery supply utilizes a type of rectifier which does not have a hot cathode, thus effecting another economy

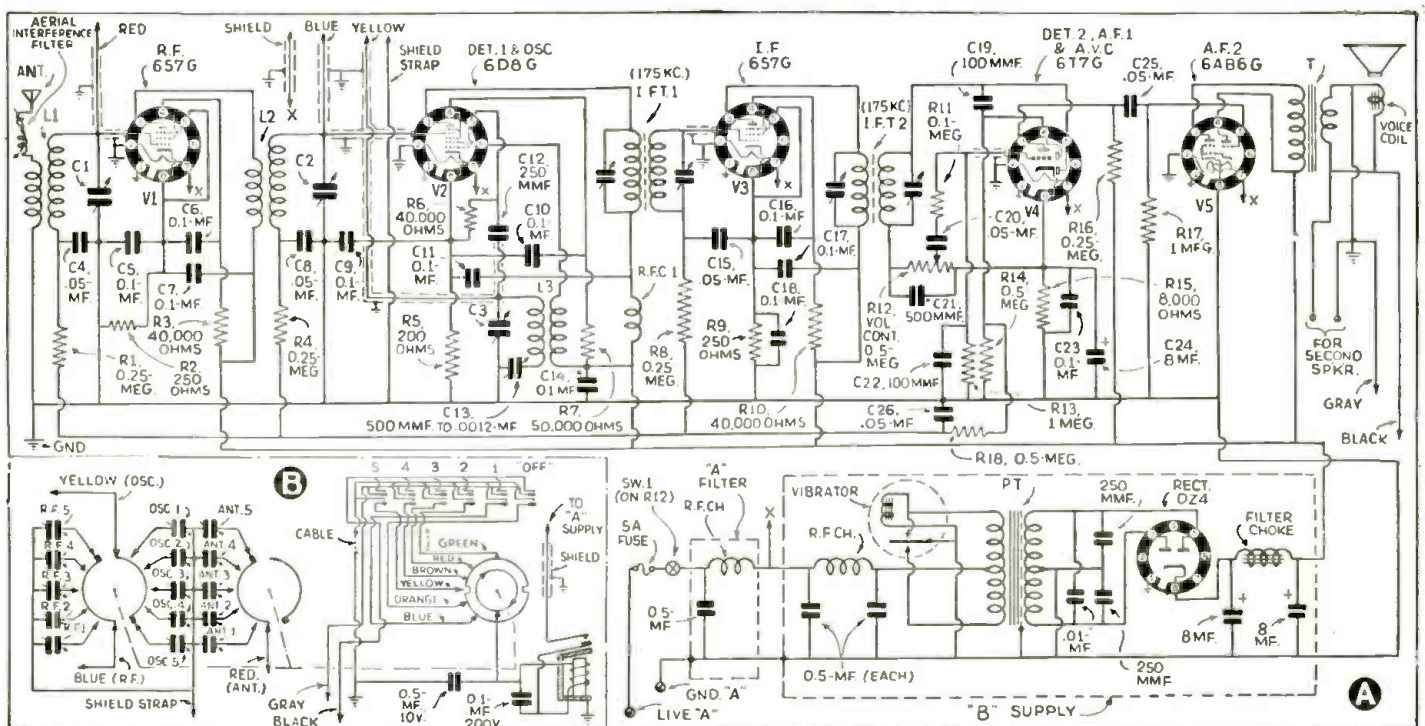

Fig. J. Complete schematic diagram of the set and the button tuner unit with the values of all parts indicated.

of battery drain. As a final blow to high current, a magic-magnet (high-coercive permanent-magnet) speaker with a fixed field magnet is used. These features help cut the total battery drain from 7 or 8 amperes required for the usual 6-tube car set to *slightly less than 4 amperes*. And this economy is accomplished without affecting the tone quality, sensitivity or gain of the set in any way.

The factor of safety in driving is answered in a novel way, by the application of a new type of tuning control which permits tuning in 5 local stations by simply touching buttons on a small, neat unit which either straps onto the steering column or mounts on the underside of the dash. This button tuner relieves the driver of any necessity to look at a dial as the buttons can be picked out instantly by touching them. Also, since the circuits controlled by the buttons are carefully adjusted in the alignment procedure, when the set is installed, this button tuner provides a *mechanical equivalent of automatic frequency control*—without the necessity of adding any additional tubes or parts to the set itself.

You have only to press the button lettered (depending upon location), let us say, WLW, and, presto!, the Crosley program is heard!

An examination of the circuit in Fig. 1 will show the essential facts about the receiver. Tube V1 is an R.F. pre-selector stage using a type 6S7G tube—similar in characteristics to the 6K7G. This is coupled to the frequency converter—a 6D8G which is similar to the 6A8. The I.F. amplifier stage uses another 6S7G which is coupled both in input and output with high-Q iron-core transformers, thus putting the major portion of the selectivity and gain in the I.F. amplifier where it belongs. A frequency of 175 kc. was chosen for this amplifier to further increase the I.F. amplification, and while the choice of this low frequency is attended with certain disadvantages, the resulting high gain and stability more than offset the disadvantages.

The I.F. amplifier is followed by a diode detector and high- μ triode A.F. amplifier—a 6T7G. This tube is similar to the type 75 tube, with the exception of a slight reduction in the triode gain, thus permitting a wider grid swing before grid current flows, with its accompanying distortion.

The 6T7G is followed by a 6AB6G direct-coupled triode which is similar to the 6B5 in design but having only 0.5-A. filament drain and an output of 3.5 W.

This completes the tube line-up with the exception of the power supply which is obtainable ready-to-install. This power supply uses a simple vibrator of the "parallel" type which has good life characteristics. A type 0Z4 metal tube is used to rectify the high voltage from the rectifier. This tube is similar to the old Raytheon BH and BA cold-cathode rectifiers, requiring no filament current.

An "A" line filter is mounted in the set between the battery line and the filament and plate supply. This prevents ignition interference from entering the set through

(Continued on page 44)

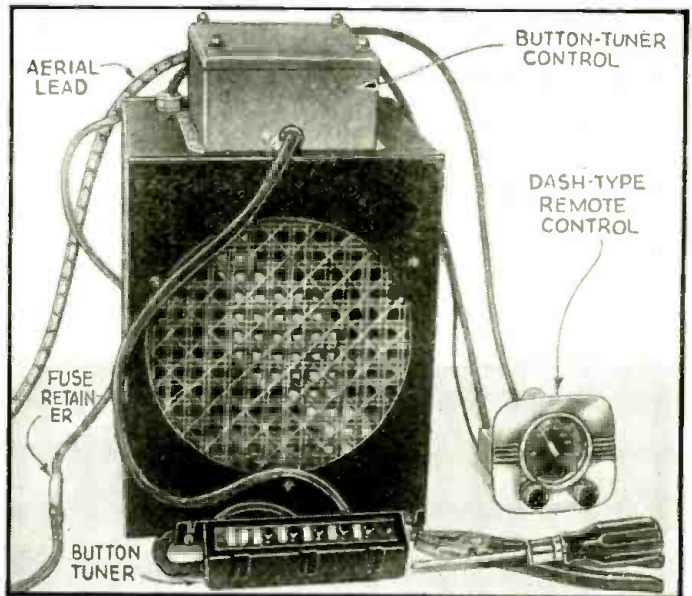

Fig. B. The set with remote control and button tuner.

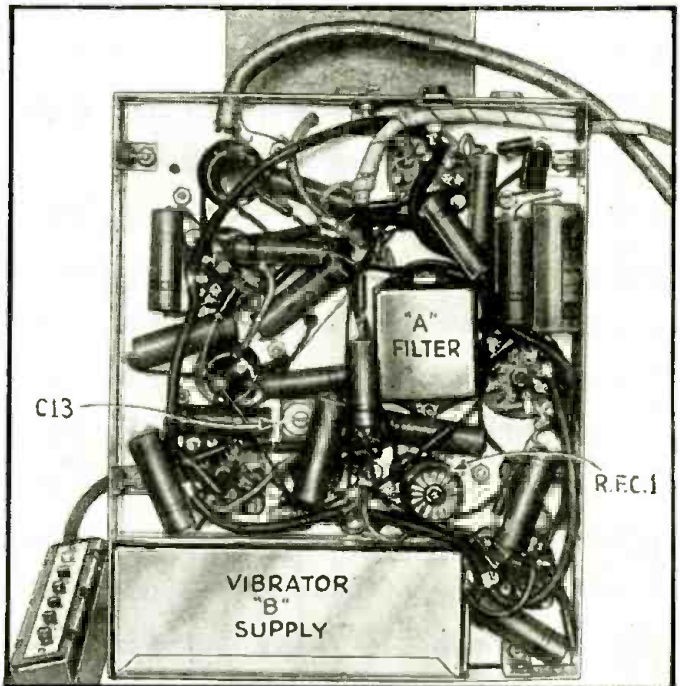

Fig. D. The back of the chassis showing the wiring.

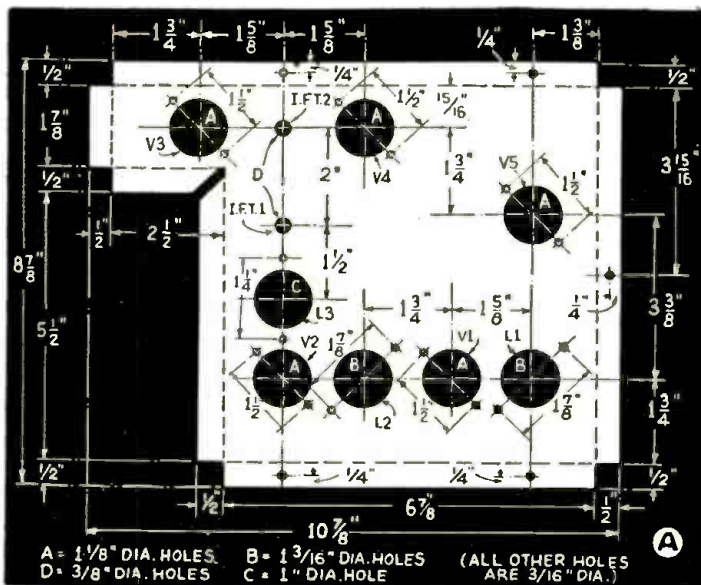
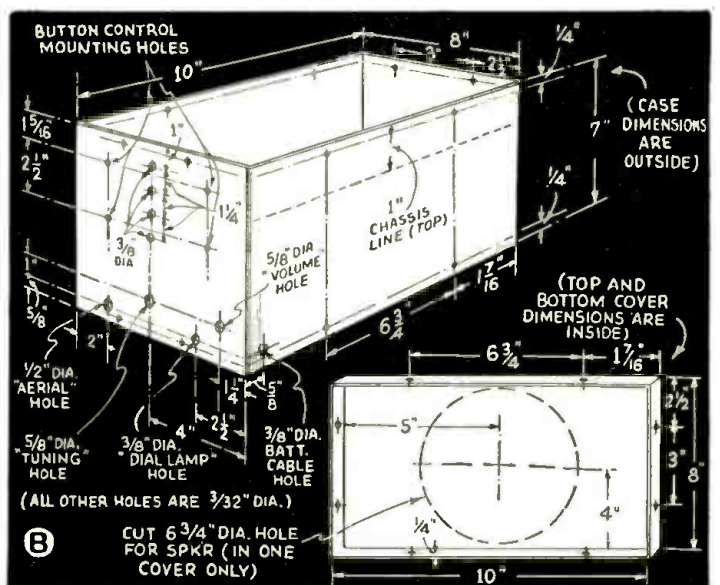
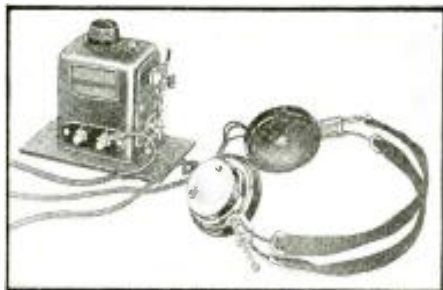

Fig. 2. Chassis and cabinet forming and drilling instructions. The drilling must be changed if the specified parts are not used.





ASSEMBLING A SIMPLE CRYSTAL SET

Beginners in radio will appreciate the simple and straightforward description of this radio set.

N. H. LESSEM

ONCE AGAIN it's the crystal set! Like a hobbing cork on a frothing, tumultuous sea, it persistently breaks through the turbulent waves of radio evolution to ride, mockingly, each crest. Multi-tube, complex radio receivers and the hundreds of modern new-fangled radio gadgets do not in the least detract from its popularity. In fact many of our timers revert to it occa-

sionally for sheer relaxation from the present furious gait of radio.

Yet, for more than any other reason, the crystal set owes its survival to the fresh class of beginners which crops up each year. For them it is the starting point in radio—the first stepping stone. To them it demonstrates, in a simple, easily-understood manner the fundamental theory of radio.

The crystal set described here is novel in that it is a modification of a simple, commercially-available unit—a "wavetrapp." The beginner, therefore, for his first set at least, need not be bothered with the construction of the actual components. Besides the wavetrapp, the only other parts necessary are: a 0.006-mf. (or "0 point double-0 six")
(Continued on page 38)

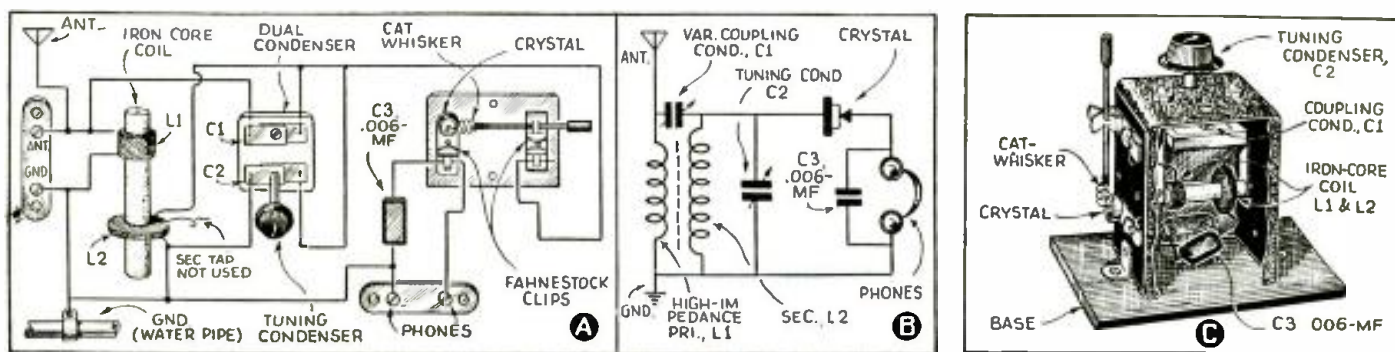

Fig. 1. A—picture diagram of the set; B—schematic circuit; and C—phantom view of the interior appearance and the crystal detector.

CORRECT PROCEDURE FOR THE SERVICING BEGINNER

Pitfalls in radio servicing may be side-stepped by the beginner who heeds the advice in this informative article.

W. A. WOHR

HAVING been in a position to observe the professional actions of many Radio Service Men for a number of years, the writer believes that the following information will greatly benefit those who feel they are not reaping as much of the harvest as they deserve.

To the busy Service Man, doing the job correctly in the least possible time means money in his pocket. Putting in 2

hours on one job when it normally should be done in 30 minutes, most decidedly represents a cash loss. On the other hand, a completed job that is not 100 per cent correct may mean a dissatisfied customer and a future loss of business. It all adds up, so let's take a few jottings from our notebook and see if we can give some of you fellows a lift. Remember, if you only find one useful idea in this whole article, it will

probably mean future dollars in your pocket.

ALIGNING PROCEDURE

First a word on aligning procedure. There is a right way and a wrong way and in case of doubt always use the set manufacturer's instructions—he designed the set and knows how it should be done. One thing many men do in-
(Continued on page 48)



Fig. A. Two views of industrious students of radio servicing at work in the shops of a large radio school.

MAKING THE RADIO-CRAFT SIMPLIFIED CARRIER INTERPHONE

A carrier 'phone plugs into the electric outlet—requires no inter-station wiring!

PART II

IN PART I the design of this unit was described in some detail—we will now proceed directly with the construction. The chassis is made from a piece of aluminum or sheet steel 6½ x 8 ins., front and rear drops being folded down along the 8-in. length to raise the chassis 1½ ins. The ends remain open.

The cabinet is a standard job readily available to the trade. Both the cabinet and the chassis are first drilled and pierced to layout drawing specifications.

Mount the speaker, with its output transformer above it, in position on the front panel as shown. Mount T1 to the left, the phone jack to the right, the send-receive switch and volume control beneath the jack and T1 respectively. Below the switch and control mount the "send" and "receive" indicating pilot assemblies, positioning the latter so that the terminals extend out toward but do not touch the back-folding side lips of the panel. Secure 2 right-angle supports with 2 in. legs from the nearest "five and ten cent" store and fasten these to the panel so that the chassis, when bolted to the free legs, will just clear the bottom plate of the cabinet.

Mount the various other components on or below the chassis, with I.F.T.1 positioned so that it will be near the "send-receive" switch when the chassis and panel are bolted together by means of the angle supports. One R.F. choke will be above chassis, one below. The filter choke Ch. will be above. Position sockets for short leads to associated components, secure them carefully with retainer rings, then fasten the chassis to the panel—remembering to keep a space of about 1 in. between the 2 metal units so that the pilot light sockets will have ample clearance and so that the nokoil speaker "pot" will not extend too far back and prevent installation of the tubes which are to be positioned behind it.

Refer to the layout drawing for tube placement and then wire-in all parts. No hard and fast rules suggest themselves here. Just remember that the chassis is not tied directly to "B minus," that condensers and resistors should be tied-down carefully to prevent their moving about and making unwanted contact, that we haven't much room to "play around" in, that a lot of connections may be made right at the send-receive switch and thus do away with the necessity for some otherwise long leads, that both "B minus" and "B plus" should be bypassed to chassis, that leads to the volume control and the control-grid of the 6F5 voltage amplifier should be shielded.

TESTS AND ADJUSTMENTS

Switch to "receive" and turn on the A.C. line supply by means of the switch on the gain control, R6. The green pilot should indicate an OK filament continuity with tubes, of course, in place. Test for a "B" voltage of about 110 at the input to Ch. and a filtered supply of something less than 100 at all plates and screen-grids. Set up an external and modulated signal at the desired operating frequency and tune I.F.T.1 for maximum level as indicated by strongest speaker reproduction. The modulation should be clear and distinct pushing well out and above any super-regenerative background noise. If it does not come out clearly and if simply a carrier is heard, check for detector circuit oscillation by tapping the control-grid terminal of the detector or one lug of R.F.C.1. A loud "plunk" will indicate oscillation and

(Continued on page 39)

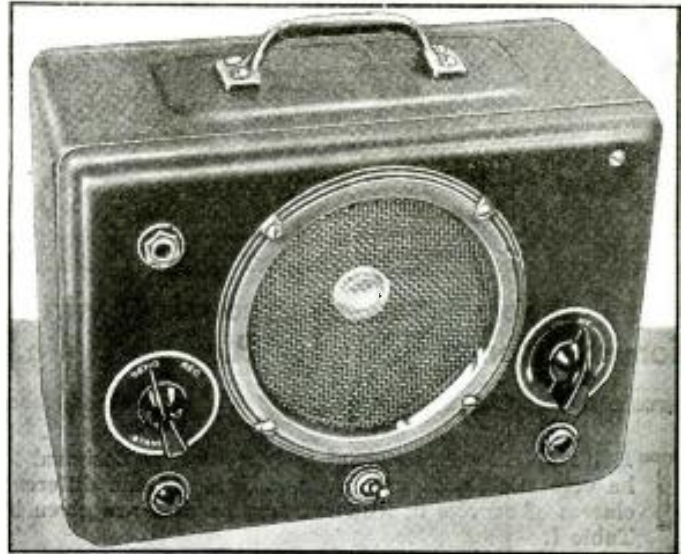

Fig. C. The front-panel appearance of the unit in its case.

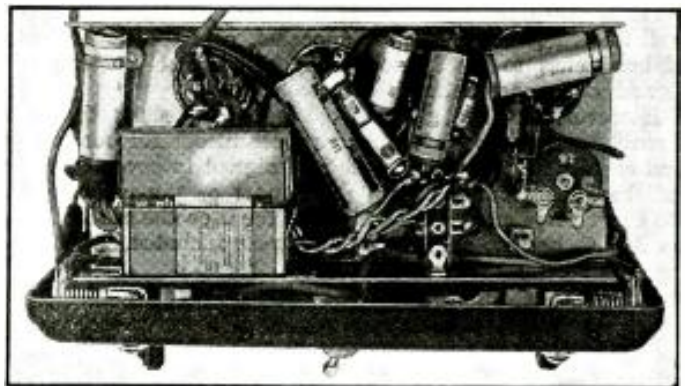

Fig. D. The positions of the parts under chassis are shown.

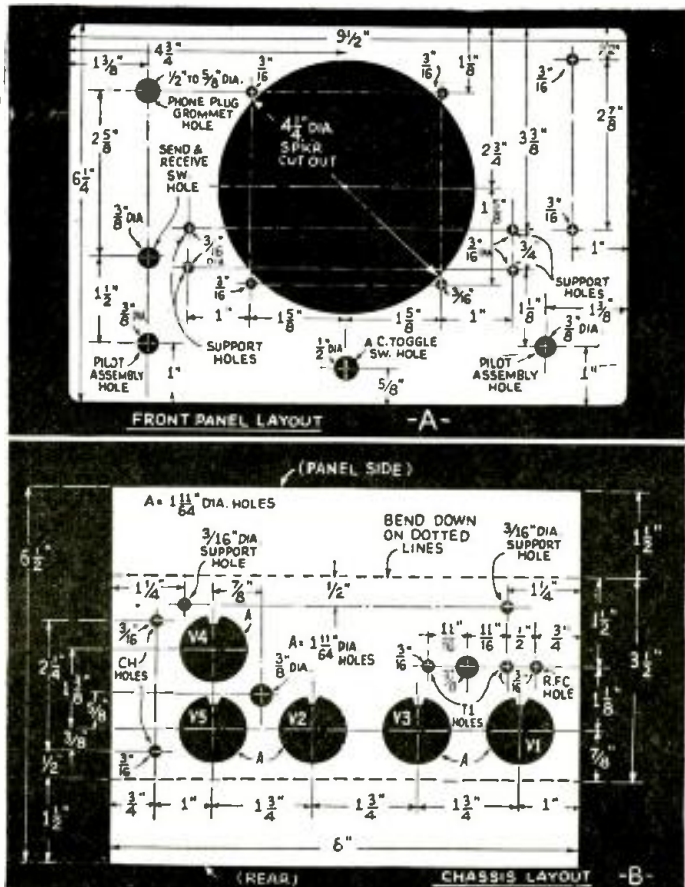
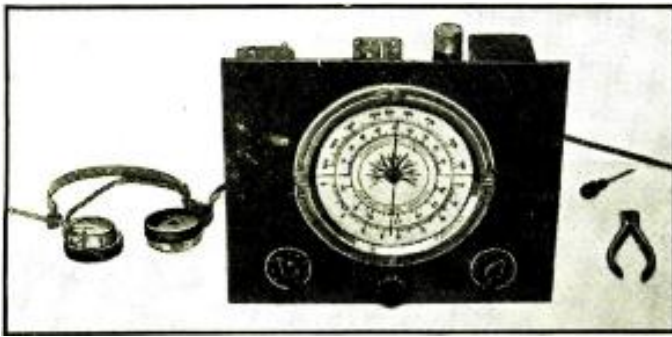

Fig. 3. Panel and chassis drilling and forming layouts.



HOW TO MAKE A HI-FI P.A. AND "UNIVERSAL" RADIO TUNER

Many readers have requested this construction data on a tuner for P.A. work, etc.

CHARLES SICURANZA

THE TUNER we are about to describe was designed to be versatile in its applications. Some of the different classes of service in which it may be used are given in Table I.

A study of the schematic diagram, Fig. 1, will show some interesting details. The superheterodyne circuit is used, because of its well known advantages. Almost equally as well known is the fact that superhet. sets can give plenty of headaches to the home-constructor, if not properly designed and constructed.

However, another glance at Fig. 1 will show that our circuit was stripped to the bare essentials for simplicity and ease of wiring. The tuner is designed to cover only the full broadcast band, plus a small part of the police band. No short-wave, no A.V.C. (nor need for it on the hi-fi locals), no A.F.C. and no frills whatever were included.

THE SIGNAL SEQUENCE

For the sake of pointing out the circuit features and parts, let us trace the path of a signal throughout the system. Starting at the antenna post the signal is applied to the high-impedance antenna coil L1, and also to one side of the volume control potentiometer. The signal is then applied across the tuned circuit of the 6K7 and amplified through the R.F. transformer, L2. The voltage gain in this R.F. stage averages over 50.

The amplified signal is next applied to the top cap (1st-det. section) of the 6A8 converter. The oscillator tuning section of the 6A8 operates at a frequency which is always 456 kc. higher than the received signal. Both frequencies are mixed, and then applied to the plate of the 6A8, where the tuned primary of the high-gain, iron-core, I.F. transformer selectivity differentiates the beat intermediate frequency from

TABLE I
Uses of the Hi-Fi P.A. and "Universal" Radio Tuner

- (1) As a high-fidelity tuner, built into a rack or panel amplifier. A swell for moderate-power stations.
- (2) As a high-fidelity tuner, built into, or placed on top of, old T.R.F. consoles with a good audio channel.
- (3) As an auto set, by changing the power transformer and adding a vibrator unit and an audio stage.
- (4) As a spare set using headphones, in homes where two or more persons want to listen to different programs.
- (5) As a remote control arm-chair tuner, using a good audio channel.
- (6) As a personal set for the near-deaf, using headphones or bone conductor.
- (7) Using two or more of these units for multi-channel work, as in hotels.
- (8) As a bedroom night-table set using headphones.
- (9) As a spare set for the kitchen, by adding a power tube and a small magnetic speaker.
- (10) As a comparison tester, for Service Men, etc.

the others. This transformer uses air-tuned trimmers. The gain is about 80 from the 6A8 plate to the 6J7 control-grid.

So far, it can be seen that the overall selectivity is good enough to separate most of the moderate-power stations, without attenuation of the higher frequencies. The signal is demodulated by the 6J7 biased 2nd-det., which has very desirable characteristics for this use. The constants chosen for the demodulator are such that they combine high sensitivity and high A.F. output for a given R.F. input. The demodulator stage gain is 110.

The plate circuit of the 6J7 has a shielded R.F. choke

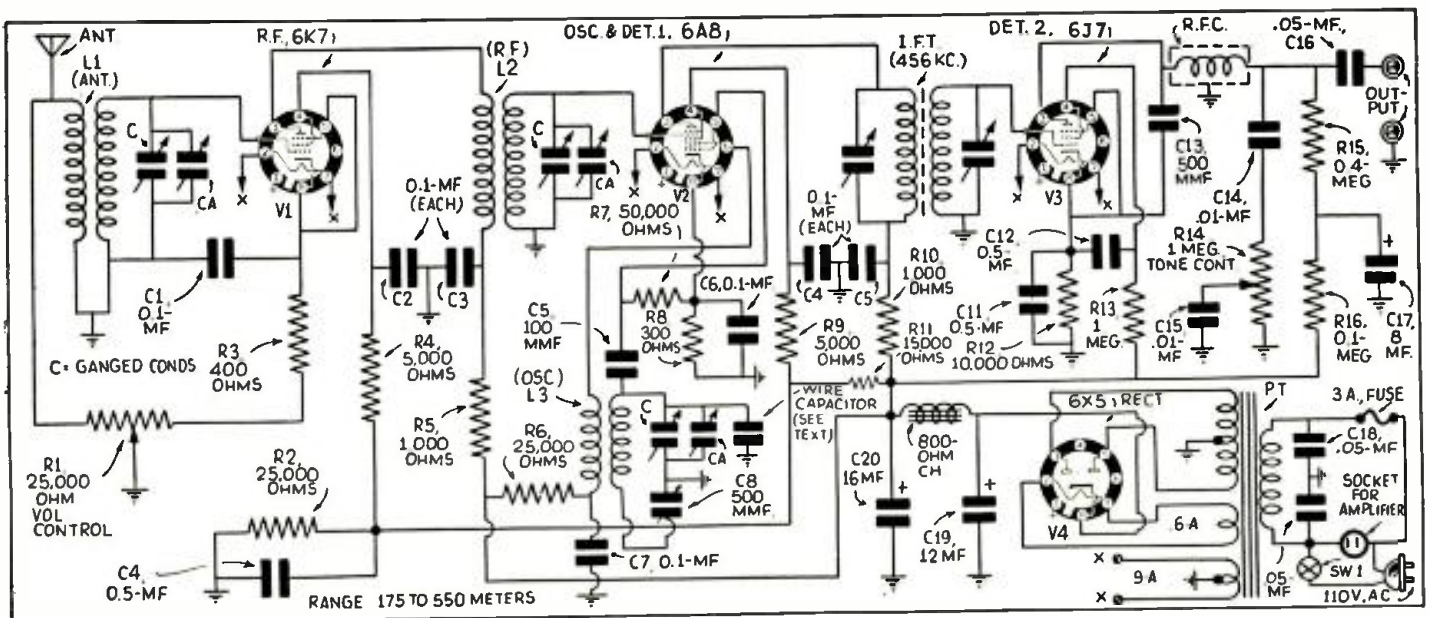

Fig. 1. The schematic circuit of the tuner, with all values.

to eliminate R.F. currents in the output. A tone control is placed in the 2nd-det. output to subdue static and vary the tone quality on certain types of music. The output tip-jacks are used either for headphones or connection to any audio amplifier.

We return for a moment to the volume control; the cathode of the 6K7 connects to one side of the potentiometer, R1, the center arm of which is grounded and the remaining arm connects to the antenna post as was mentioned above. This type of control is very effective because it takes the place of two separate controls, one in the cathode circuit and one across the antenna coil.

The power supply was especially designed for this unit. It consists of a small power transformer, which supplies 250 V. at 25 ma., a filter choke of 30 hy. at 25 ma. and 3 electrolytic condensers of the midget metal can type. The rectified A.C. is so effectively filtered that no sign of hum is present in the headphones.

An A.C. receptacle is placed across the power transformer winding for convenience. A dual line filter condenser is also connected across the A.C. line to reduce interference and noise. Connecting a single-pole, double-throw snap switch would enable the builder to use the A.C. line as an antenna or as a line filter, at his option.

Other circuit features are: the use of resistor condenser filters in the screen and "B plus" leads to prevent circuit coupling and insure stability and high gain.

The performance of this tuner is amazing, considering that only 4 tubes are used. For example, the A.F. output at the tip-jacks is usually high enough to drive a magnetic speaker at room-volume, from most of the local stations, here in New York City. As a further example, the detector output is sufficient to drive a single 6F6 to full output on all but the weakest signals.

It would be well to point out that there is a good possibility of overloading the first audio grid following the 2nd-detector when using any high gain amplifier with the tuner. This is so because of the fact that before the detector reaches its own overload point it is developing in the neighborhood of 17 V., A.F. This, obviously, is far too great a signal voltage to apply to a 6F5, for instance. The input circuit of the amplifier should therefore contain a variable gain control to regulate the input.

Hi-fidelity reception in our tuner is obtained in the simplest manner possible, without moving parts or switches. When properly aligned, the set just has enough selectivity to allow the side-band frequencies up to 6,000 cycles to get through. At the same time, however, the sensitivity is very good. The writer listened to KFI, Los Angeles (640 kc.), on headphones with a slight amount of interference from WSM, Nashville (650 kc.), on the adjacent channel. WEAJ (660 kc.) interfered slightly with WSM. A total of 68 stations were tuned in during a 2-hour tryout, at night.

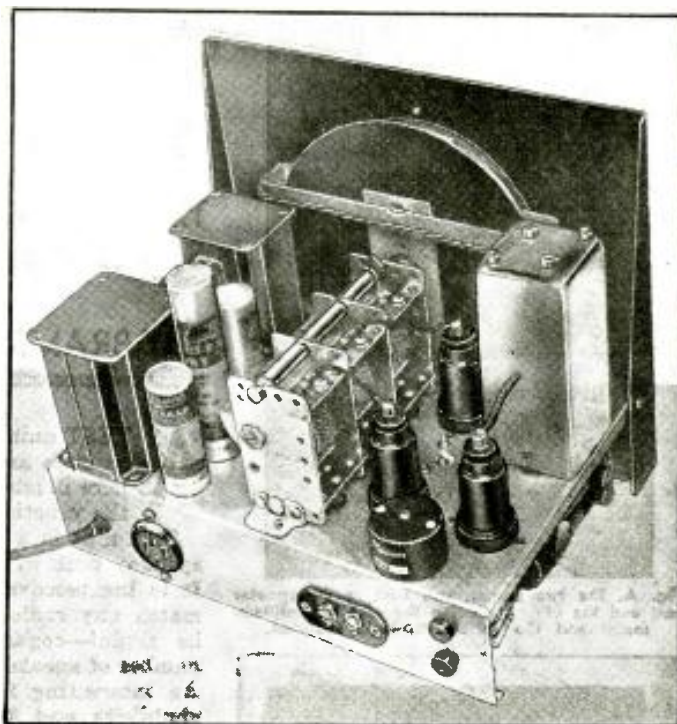

Fig. 8. The rear view of the chassis of the tuner.

LAYOUT DETAILS

As can be seen from the photographs, the tuner is compact without being crowded. The parts were laid out so that all "hot" R.F. leads would be very short. For instance, the lead from 6A8 plate to "P" lug on the I.F.T. is barely $\frac{3}{4}$ -in. long. The 3 coils are mounted underneath the chassis for several good reasons. The most important being that they are, in effect, doubly shielded when mounted this way.

The blank chassis specified should be drilled according to layouts given in Figs. 2 and 3. An ideal tool for the home constructor is the socket punch and circle cutter recommended in the List of Parts. The writer used the $\frac{3}{4}$ -in. punch for several of the holes required. The larger size (1 $\frac{3}{16}$ in.) was used to punch out all the socket holes and also the openings for the filter choke and A.C. receptacle. The circle cutter is needed to cut out the $5\frac{3}{4}$ in. hole for the dial on the front panel. These tools are practically indispensable to the home constructor for this type of work. Check the accuracy of the holes you drill by trying each part for correct fit and position. A little care at this stage will insure a finished product of precision appearance.

The front panel should not be touched until all the parts (Continued on page 42)

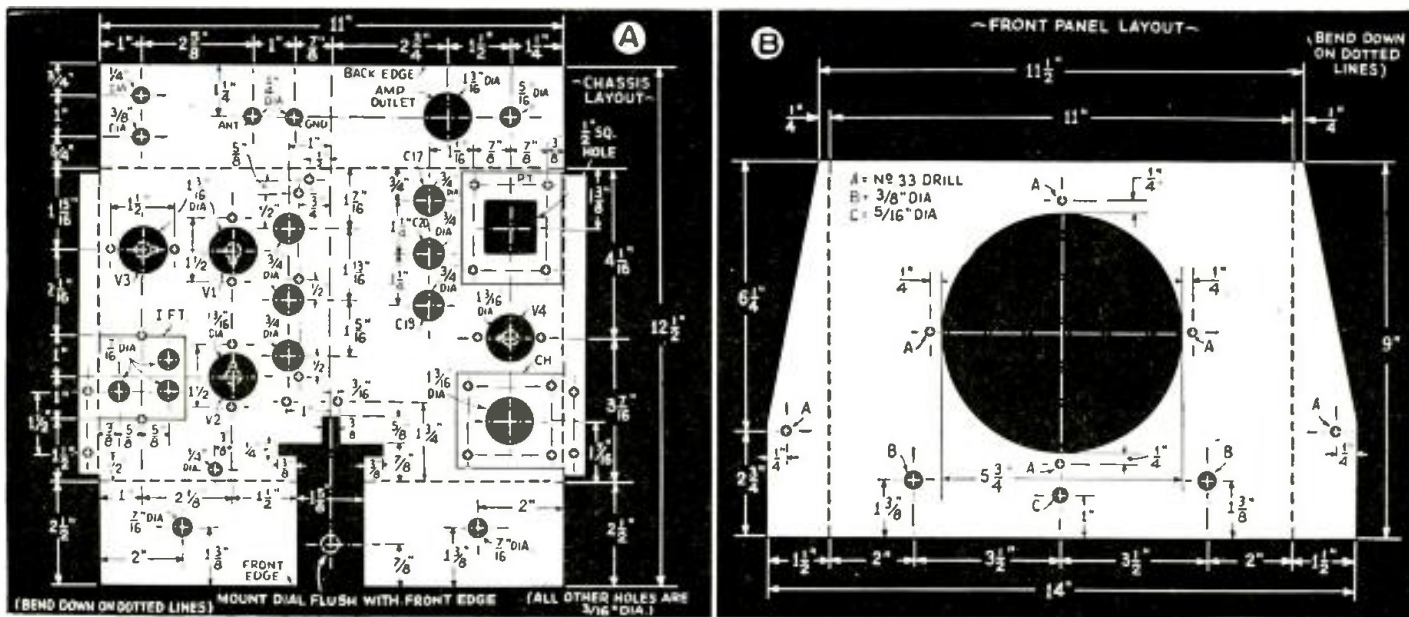

Fig. 2. The chassis drilling and forming layout and the panel drilling details. The mounting holes must be changed if substitute parts are used.

A UNIVERSAL-SERVICE TEST SPEAKER

The manager of a large radio service department tells Service Men how to make a new device that has many uses.

J. ABRAMS

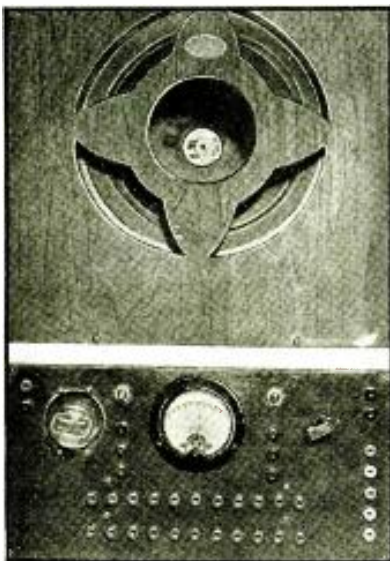

Fig. A. The two panels, one housing the speaker unit and the other mounting the rectifier, milliammeter and the various tip-jacks required.

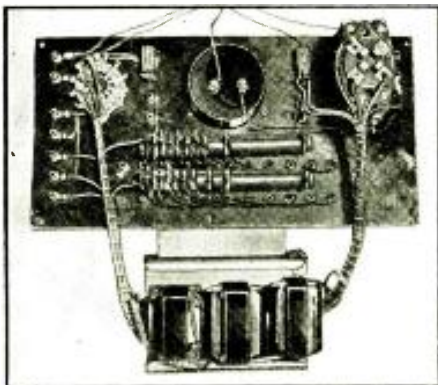

Fig. B. The rear view of the control panel. The left-hand transformer is the tapped output unit, that in the center the choke unit and the right-hand one is the power transformer.

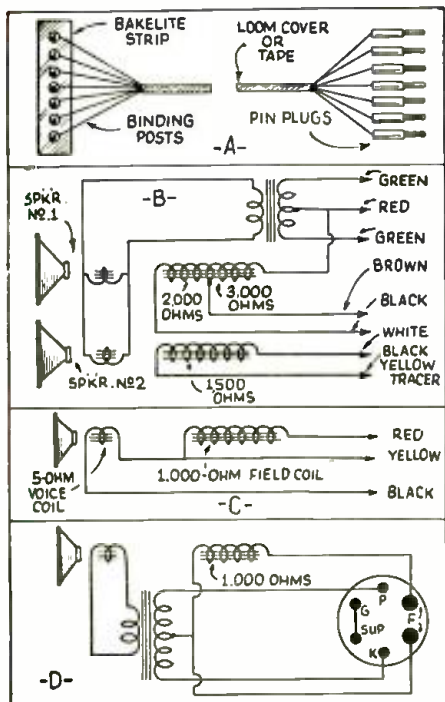

Fig. 2. Details of connections of the connecting cable, and various speaker connections. Tip-jacks, switches, tapped field coils, tapped resistors, a tapped transformer and a rectifier combine to make a versatile test unit that will pay for its cost in a short time. In fact, many Service Men will have on hand about all the components utilized in this device and thus the cost will be practically nil. A meter permits accurate check-up of operating current values. (The article includes considerable practical data on servicing reproducers.)

A TEST unit that will be a valuable asset to any radio repair shop is here illustrated and described for the practical Service Man.

This unit is a real "universal" loud-speaker that will not become obsolete. It is inexpensive to construct and can match any radio receiver made—or to be made!—regardless of the type or number of speakers it uses (or will use). An interesting feature is the extreme simplicity and flexibility which allows it to be used for countless other testing procedures. It can be employed for testing speakers, leakage in electrolytic condensers, insulation breakdowns, defective windings in A.F. transformers and intermittent shorts in R.F. and I.F. transformers. Other tests that can be performed with this instrument will be described later in this article.

Loudspeakers are easily damaged. Ask any radio man. The usual sad story, accompanied with many tears, is that an unexpected bump in the road merely scrambled a few chassis and speakers. The result is a costly trip to the speaker repair department for new cones.

In my case as the manager of a large radio service department I needed some device to eliminate the necessity of bringing the speaker into the shop. The vision of 2 or 3 poor unprotected speakers sharing the rear seat of each service car with a few husky chassis reminded me that cones are still quite expensive.

One hole in the street or a short stop resulted in a very nice conglomeration of radio-parts hash.

Reproducer trouble being rarely encountered in ordinary service work we found that the following tests would check a loudspeaker and obviate the need of taking it out of the cabinet.

PRACTICAL TESTING

Using an ohmmeter, check the field-coil, voice-coil and output transformer for short- or open-circuits. Then, a carefully put, casual question to the customer will disclose if there was any complaint regarding any cone rattle. If the output transformer is mounted on the speaker there is no need to open the voice-coil connections to check for continuity. The application of the small voltage in the ohmmeter to the primary of the transformer will cause a click to be heard if the voice-coil is all right even if there is no field excitation. This test can be made in less than 3 minutes.

The saving of time is another valuable feature. The usual time required to remove and install a single reproducer from an ordinary cabinet is about a ½-hour of hard labor. Then imagine a dual-speaker receiver in one of these new fangled cabinets and throw the watch away and get a calendar.

To fully understand the method of
(Continued on page 46)

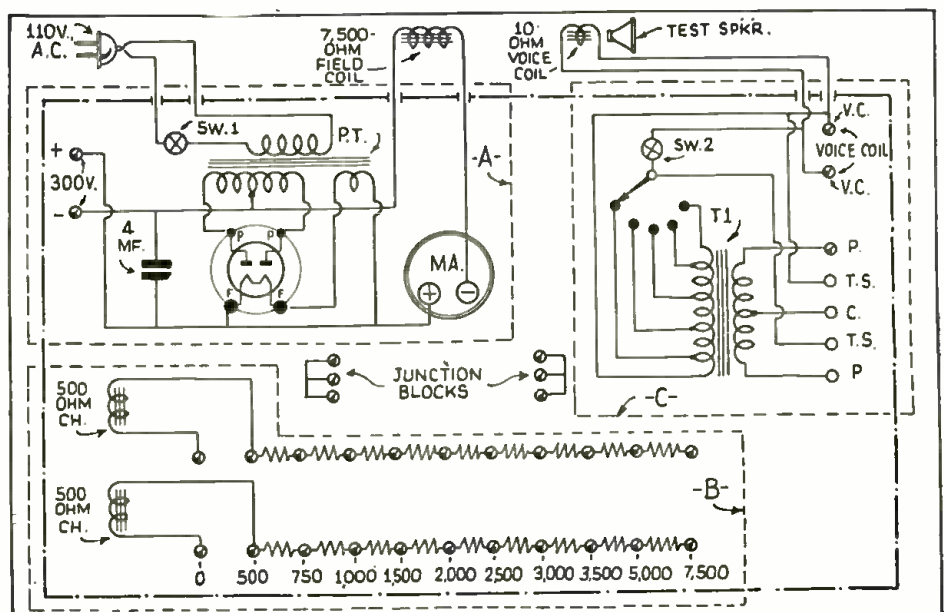

Fig. 1. The schematic circuit of the complete test speaker unit. The unit at A is the power supply; B is the substitute field circuit; C is the universal output coupling system devised by the author for coupling the unit to any set.

REPAIR—OR, REPLACE THAT DEFECTIVE LOUDSPEAKER?

Service Men, today, to "get by" must know how to "cut corners"—financially speaking; loudspeakers afford a good example.

M. E. SWIFT

THERE ARE several good reasons why it is usually better for the Service Man to replace a defective loudspeaker with a new one, rather than attempt to repair it.

After a loudspeaker has been in service for some time and goes bad, the trouble is usually not of a superficial nature—metal chips often find their way into the air gap; field or voice coils may burn out; the diaphragm may be torn; any one of a dozen troubles make it necessary to tear down and re-assemble the unit. The average Service Man has neither the time nor the tools for this work. Replacement diaphragms, unless obtained from the manufacturer, are seldom exact duplicates of the original. This may result in performance which is far from satisfactory. Even minor repair jobs, done in the shop, such as patching a torn diaphragm with tape—seldom completely satisfy the customer; he is usually interested primarily in performance, and if shown the advantages of a new speaker over his old one, will almost always be willing to pay the difference in price.

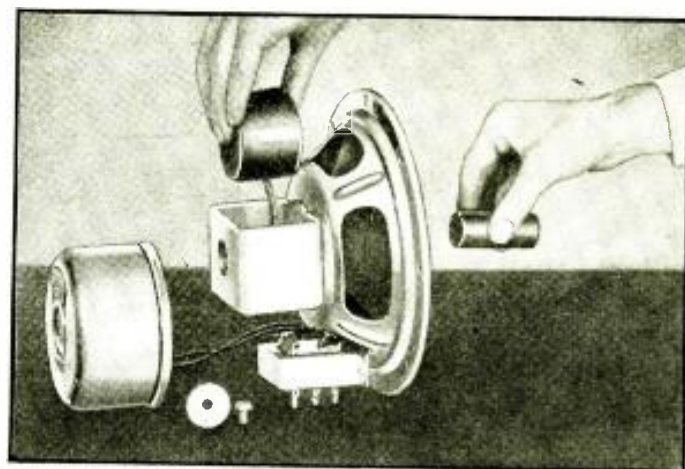

NEW DEVELOPMENTS

Because of improvements in magnetic structure and reductions in production costs, *replacement speakers* are now available at a reasonable price that are far superior in performance to units of a season or two ago. Many fine reproducers are constructed in such manner that the field coil can be changed without disturbing the alignment of the working parts. This results in a sizeable saving to the Service Man, since it reduces considerably the stock he must carry in order to cover the entire range of field resistances. When these speakers are purchased with universal output transformers, a further reduction in stock is realized. For most small shops 4 or 5 replacement speakers of this type will be sufficient; by having a couple of extra field coils for each on hand, almost any demand can be quickly and easily met.

When the Service Man is in a position to supply the
(Continued on page 45)

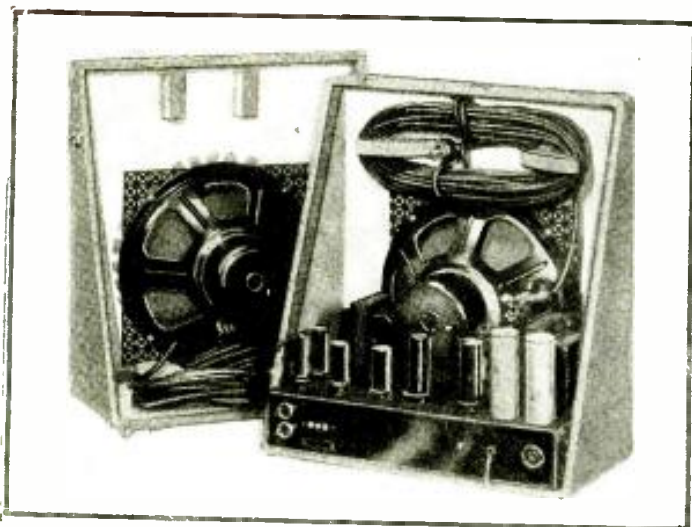

Fox Photo
A portable 20-watt sound system will enable the sound technician to master most of the outdoor problems he may encounter. The Lafayette unit illustrated comprises 1 case.

"THE CASE OF THE RESORT"—AND OTHER SOUND STORIES

The author's Book of Experience contains valuable pages on public-address Morals.

H. M. BAYER

that little talk, and several others along the same line, we arrived at a definite, rock-ribbed conclusion—The radio Service Man is extremely well aware of the fact that there is a tremendous field for the sale of sound equipment and its auxiliaries. As a matter of fact, he is tired of hearing this song played over and over again. But what he is willing to listen to, is the experiences of others—their sales and service problems and how they solved them.

The reason for this is very simple. He sells several receivers a week, and has been doing so for some considerable period (lucky boy!); sales experience in this case came quickly and with sufficient variety to preclude the necessity for extensive external study.

However, sales of public-address installations are not made several times a week. (We speak for the average service shop.) This makes each sale a complete study in itself; only rarely can a P.A. contract be handled exactly like some other sale of the past. And so the Service Man does appreciate hearing of the experiences of others; the sales, installation and service problems that arose and how they were solved, provided you omit all reference to "tremendous sales field," or any similar platitude used for mere space-filling.

(Continued on page 41)

WE HAD occasion, recently, to discuss radio and public-address sales with a technician who had a pretty significant axe to grind.

"I have read," he said with dangerous calm, "more than a 5-foot shelf of articles on selling public-address equipment. The greater majority of these articles spent a lot of time and effort convincing me that there is a tremendous field for the sale of sound equipment. You have no idea how convinced I am that there is a tremendous field for the sale of public-address equipment."

At this point he fixed us with a steely glint and viciously pounded the "No Sale" key on his cash register. "Now," he asked ominously, "what are you going to tell me?"

The rest of the conversation is unimportant. But from



Fig. A. Mr. Lyons with his coil and condenser test unit, checking a sample coil. While "Q" and "absolute gain" are important items in coil design it is sufficient, in production coil testing, to have a device such as this Comparometer (as the author calls the unit) which is calibrated in "per cent gain" only.

AN EXCELLENT COIL-TESTING UNIT FOR THE SERVICE MAN

Here's a "Comparator" design, taken from practical factory data, that every radio man will find useful.

WALTER L. LYONS

PART I

THE METER described in this article was intended to fulfill certain requirements in the production testing of a limited number of R.F. coils and condensers used in the radio receiver tuned circuit.

This "Comparometer", as we call it in the plant, is particularly adapted to the checking of I.F. and R.F. transformers as they must operate under receiver conditions. This is accomplished by feeding an R.F. current through the coil primary which method takes into account the effect of primary impedance upon the effective inductance and relative gain, of the tuned secondary, at both ends of the frequency spectrum over which the coil must operate.

Such measurement of the R.F. coils to be used in the several stages of a receiver at the lowest operation frequency is a quick check on the tracking of these coils while the high-frequency test reveals the presence of high distributed capacity or reflected reactance which may often serve to render a coil, such as an oscillator, useless.

While "Q" and *absolute gain* are important items in coil design, it is often sufficient in production coil testing to obtain comparative gain readings with respect to R.F. coil standards. For this reason, the Comparometer is calibrated in terms of *per cent gain* only. On inspecting the circuit, it will be apparent to the technician that features have been included in the design which make for the more accurate testing of antenna, R.F., oscillator and I.F. coils.

CONSTRUCTION

Figure 1 gives the placement of apparatus and important dimensions of the chassis which is constructed of cadmium-plated soft sheet iron. As Fig.

1A shows, the power transformer, supplying 6.3 V. to the tube filaments and high voltage to the 80 rectifier, is mounted on the rear of the chassis to save space and increase heat dissipation.

The oscillator utilizes a type 89 tube in a stable electron-coupled circuit comprised by C1, Cv and a universal-wound inductance L1, which has a tap for the cathode connection 100 microhy. from the ground (inside) end of the coil. These are all placed below the sub-panel in a well shielded compartment which also contains L3, a *sectionalized* R.F. choke and C9, which serves to flatten out the high-frequency and harmonic-voltage output of the oscillator. Frequency calibration of the oscillator dial (placed on the left end of the chassis) is accomplished by beating appropriate oscillator harmonics against known broadcast frequencies, using preferably a sensitive tuned-R.F. receiver. During this calibration, the vernier, Cv, is kept at the one-half maximum capacity position, which point should be marked permanently on the chassis.

R.F. AMPLIFIER

A 6D6 is used in a standard R.F. amplifier circuit. Among other functions, it feeds the primary of R.F. or I.F. transformers under test. The voltage output of the 6D6 is jointly controlled by Pot. No. 2 and Pot. No. 1, which latter controls the oscillator screen-grid voltage.

THE DETECTOR CIRCUIT

The "heart" of the meter is the low-loss tuned circuit L2-C2-C3. This is coupled to the control-grid of the 76 tube which serves as a rugged V.-T. voltmeter with a 0-1 ma. meter in-
(Continued on page 60)

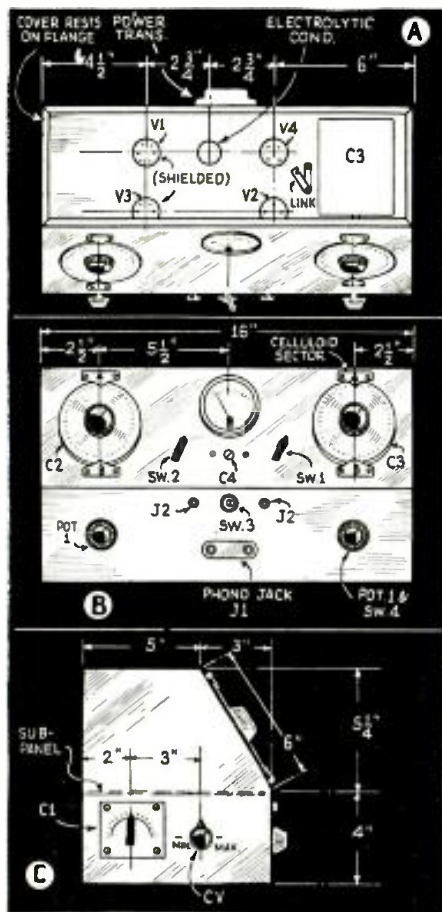

Fig. 1. Details of the cabinet and chassis, including the layout of the parts. Both the chassis and cabinet are made from sheet aluminum.

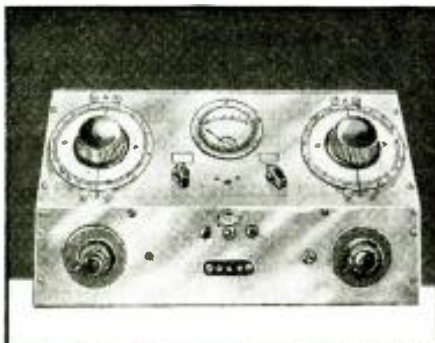

Fig. B. The appearance of the test unit, with its 2 dials can be seen in this view of the front of the instrument.

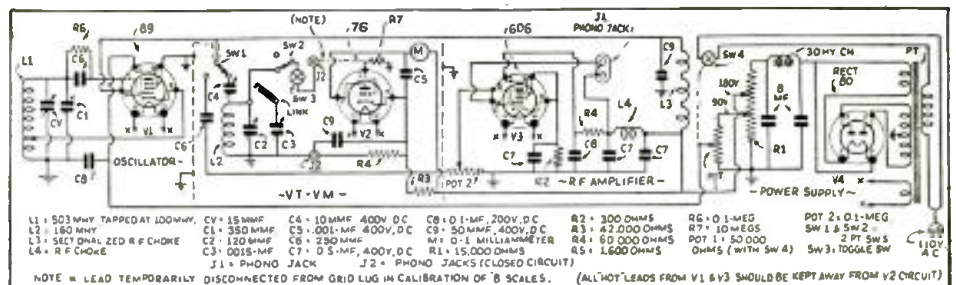

Fig. 2. The schematic circuit of the complete instrument including all necessary values. This instrument does not indicate the "absolute Q" but gives an indication of the gain in the coil. This may be either a percentage gain or a relative indication depending on the operation.

HOW TO CHECK CONDENSERS WITH AN A.C. BRIDGE

A Bridge Analyzer quickly conveys to the Service Man important condenser information he must know.

GLENN H. BROWNING

ALL SERVICE MEN realize that a condenser fault is one of the most common and sometimes one of the most baffling sources of trouble in a radio receiver.

Intermittent open condensers have caused many Service Men to spend hours in trying to determine the reason for a sudden drop in volume. Many times, normal operation may be temporarily restored by switching "off" and "on" the receiver. While this trouble cannot always be laid to a faulty condenser it is safe to assume that in the majority of cases such is the case. As a consequence the Service Man finds it almost essential to have in his workshop apparatus that will quickly, completely and accurately check all types of defects in electrolytic, paper and mica condensers.

ELECTROLYTIC CONDENSERS

The defects commonly found in electrolytic condensers are:

- (1) High D.C. leakage at operating voltage.
- (2) High power factor, even though the D.C. leakage is normal.
- (3) Complete or intermittent open-circuits.
- (4) Electrolytic action where the lead

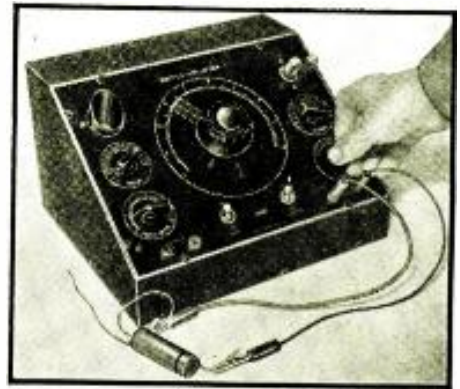

Fig. A. The Bridge Analyzer in operation.

is attached to the condenser, resulting in noise in the receiver.

(Continued on page 49)

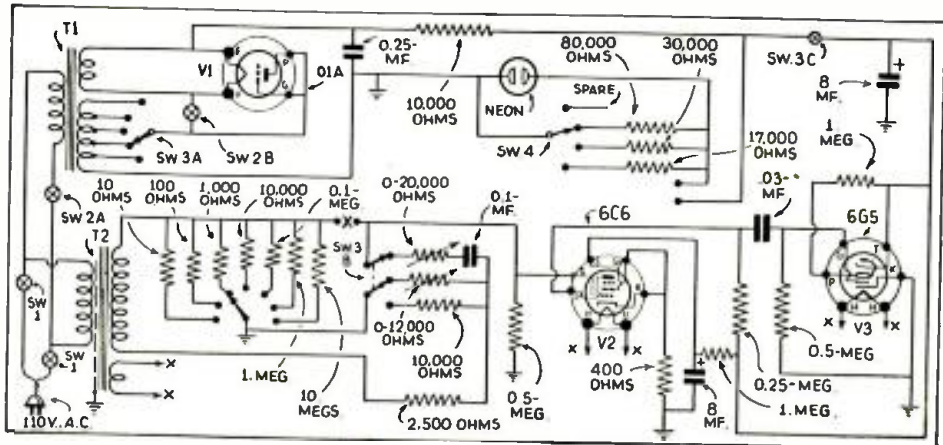

Fig. 1. The schematic circuit of the bridge including tuning "eye" and power supply.



TAMING MAN-MADE STATIC

The author answers questions, as to the why? and how? of interference, in the minds of Service Men.

CHARLES GOLENPAUL

RADIO RECEIVERS, as with human beings, become more susceptible of ailments as they become more refined and therefore more sensitive. Early crystal-detector sets were so insensitive that direct electrical contact with a buzzer was usually required to test the setting of the "catwhisker." Today, a buzzer a block away may cause a machine-gun rumble in a super-sensitive all-wave set! Hence the great problem of eliminating inductive interference at its source, if super-sensitive all-wave sets are to perform at their best.

CLASSIFICATIONS OF INTERFERENCE

There are 4 broad classifications into which interference normally falls, namely: (1) Natural static. (2) Interference originating in the receiver. (3) Interference from other stations or the neighbor's receiver. (4) Interference caused by electrical machinery.

The first classification is one over which we have a minimum amount of control. However, it is a matter of proportion. When our broadcast transmitters were rated at a few watts, the signals could not vie with Nature's own broadcasting efforts. The steady increase of transmitting power, together with the limitation of service areas, has resulted in a satisfactory balance between signal and static throughout the year. It is rare that radio reception is

impossible. Listeners located close to broadcast transmitters can operate even when lightning flashes are visible on the horizon.

When it comes to the second classification, it is for the set designer, builder and Service Man to guard against causes of noise. A faulty condenser can give rise to no end of noise which will be blamed on static, neighbors and everything else in creation except the real cause. Likewise

(Continued on page 52)

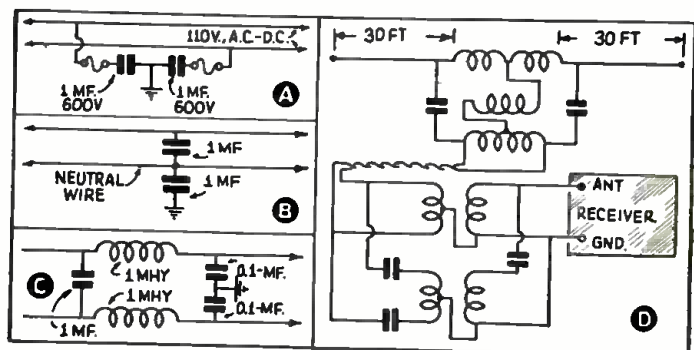

Fig. 1. Several types of line filters—A, B, and C; and an all-wave noise reducing aerial system.

VACUUM-TUBE CHARACTERISTICS WITH THE C.-R. TUBE

Actual dynamic characteristics of radio tubes may be determined by waveform-images on a screen.

C. BRADNER BROWN

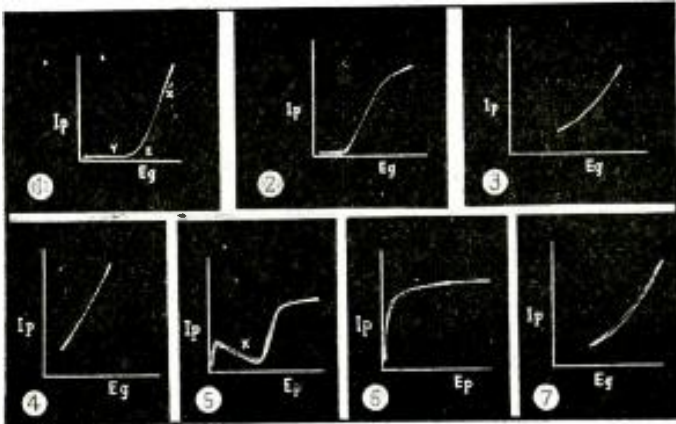

Fig. A. Contact photos of V-T. characteristics on a C.-R. tube.

OF ALL the interesting and ingenious uses to which the cathode-ray oscilloscope has been put in the last few years, none offers more room for investigation than the cathode-ray tube tester.

This latest use of the cathode-ray tube shows vacuum-tube characteristics on the fluorescent screen just as though they had been plotted from data taken in the most thorough fashion. Furthermore, and far more important, the actual dynamic characteristics are obtained.

DYNAMIC VS. STATIC TUBE TESTS

The difference between the "static" tube characteristics which represent the tube itself and the "dynamic" tube characteristics which represent its operation in a particular circuit can easily be seen by considering the effect of a grid voltage change on the plate current (or circuit characteristics) of a triode.

Increasing the grid voltage in the positive direction increases the plate current, but if the plate circuit contains a resistance load, this in turn lowers the plate voltage, which in turn tends to decrease the plate current. Thus, in general, less plate-current change will be obtained than the static characteristics show. From this, the value of testing the tube in its own particular circuit can be seen.

So much has been written about the cathode-ray oscilloscope in previous articles that no space for elementary discussion will be taken here. The instrument used by the author is the RCA model using the 3-in., type 906 cathode-ray tube.

A simple circuit which is adaptable to the study of tube characteristics is shown in Fig. 1. The connections to the oscilloscope are marked H, V and G.

The horizontal deflecting plates are connected through Sw.1 to either the grid potentiometer or the plate. At the same time, the vertical deflecting plates are connected through Sw.2 to either side of the plate load. Resistor R1 is a small variable resistance of several hundred ohms used as a milliammeter shunt to obtain a voltage proportional to the plate current.

To obtain the grid-voltage plate-current characteristic, Sw.1 is placed in position A with Sw.2 in position C.

A 60-cycle grid voltage is applied at Eg and R1 is adjusted to give a good vertical deflection with the vertical amplifier in the oscilloscope set at maximum. This will make use of as low a value of R1 as is possible, which will not materially affect the operation of the circuit.

Since the vertical deflections are proportional to the plate current and the horizontal deflections are proportional to the grid voltage, the cathode-ray beam will trace out the grid-voltage plate-current relationship curve on the fluorescent screen. And since this occurs over and over again at 60 times per second, it appears to be stationary on the screen.

The frequency of the grid voltage has no effect on the size or shape of the curve unless the plate load is inductive, in which case phase displacement will occur and the curve will be separated in 2 paths, one of increasing plate current and the return path of decreasing plate current. In a linear amplifier these 2 paths will form a perfect ellipse. Inasmuch as we are interested mainly in resistive loads, the curves shown here were all taken with a pure resistance as the plate load. In this case, a linear amplifier gives a straight line, the return path coinciding with the grid-voltage—plate-current curve.

WAVEFORMS OF A TYPE 6C5 TUBE

Figure A1 shows a 6C5 operated as a grid-bias detector with a -6 V. bias and a 90 V. plate potential. For a reasonably large swing, the plate current is proportional to the control-grid voltage as is shown by the straight portion of the curve marked X. The plate current cutoff is shown at Y, and the rectifying portion of the curve is shown at Z. For

small signals in the region of Z, considerable amplitude distortion will result since the plate current is not proportional to the grid voltage over this part of the curve.

Figure A2 shows the same tube operated at -1.5 V. bias. This should have represented a class A or linear amplifier but as can be seen, only a small section of the center of the curve fulfills these requirements. Plate current cutoff is still evident at the lower-left, and plate saturation is seen at the upper-right. It is evident that for faithful reproduction of A.F. signals, both these extremes must be avoided and the control-grid swing confined to the center or straight portion of the curve.

DATA ON A 6L6 BEAM TUBE

Figure A7 shows the result of operating a 6L6 beam-power amplifier into a 1,000-ohm load that is slightly inductive. Changing the output transformer matching to the speaker made the load practically non-inductive as is shown in Fig. A3, but this further lowered the load resistance causing the curved characteristic as shown. This condition would result in considerable 2nd-harmonic distortion which is quite disagreeable to the ear. It is largely eliminated in Fig. A4 by raising the load value to 5,000 ohms. The improvement is evident.

If the plate-voltage plate-current characteristics are to be investigated, Sw.1 is thrown to position B and the plate voltage swing adjusted by applying 60 cycles at Ep. An interesting comparison has been made in Figs. A5 and A6. In the first, the dynatron characteristics of the type 36 screen-grid R.F. amplifier are shown. The

(Continued on page 40)

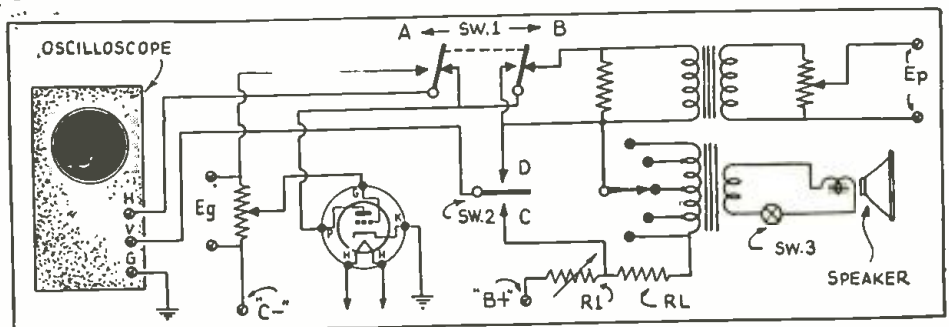

Fig. 1. The tube tester circuit with a triode type tube connected for characteristic test.

SERVICING BY SIGHT AND SOUND

PART 1 — SPOT AMPLIFIER RESPONSE CURVES

A factory technician gives the Service Man practical information on newest cathode-ray servicing procedure.

M. M. BRISBIN

DURING a recent series of factory lectures, entitled "Training the Ear for Radio Servicing," the

effect of changing circuit components in an A.F. amplifier was demonstrated. In order that the response curves of the amplifier could be noted by the audience, a demonstration device was used which would maintain the amplifier response curve on the screen of a cathode-ray oscilloscope. An outline of the operation of this device has been published but in response to requests for further information concerning its operation, it has been considered advisable to go more into detail.

Figure A shows the large demonstration board with the auxiliary apparatus connected in place. The amplifier under test is mounted on the rear of this board and its schematic diagram is on the front of the board. In this schematic diagram are various switches for changing the circuit. These switches are connected to the amplifier on the rear of the board and actually make the changes

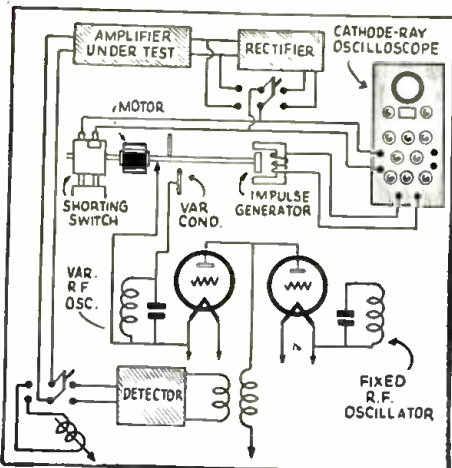

Fig. 1. A method of sweeping audio frequencies.

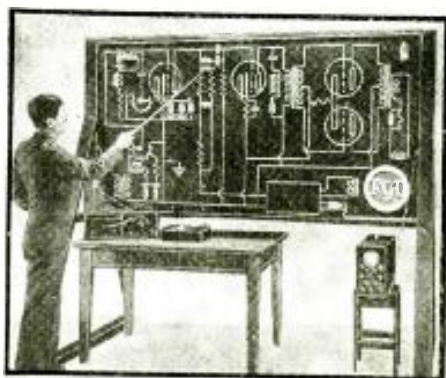

Fig. A. Radio men see and hear circuit actions, indicated on the schematic diagram. (Continued on page 51)

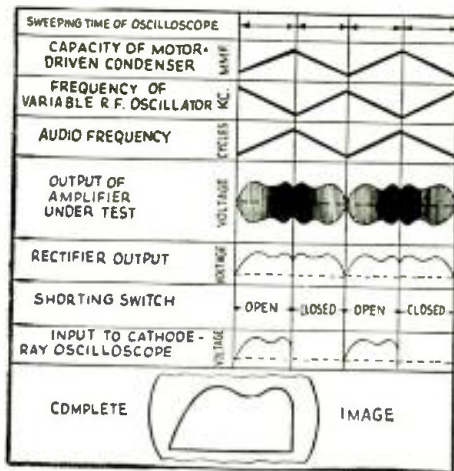

Fig. 2. Operations in sweeping audio frequencies.

AN EASILY-MADE ADD-ON VOLUME EXPANDER

A new, NON-DISTORTING "bridge" design permits obtaining any desired degree of A.F. volume expansion or compression.

L. A. DE ROSA

RECENTLY, two systems of expanding the signal in the audio channels of the receiver have appeared. Both systems were tested out in the factory laboratory with which the writer is connected and were found to be unsatisfactory in many respects.

Months of experimentation with all kinds of devices and systems, however,

has resulted in a modification—of one of the methods—which permits expanding the output of an amplifier as much as is desired with a minimum of power loss and at the same time introducing but a NEGLIGIBLE amount of distortion (as will be shown). PLEASE

NOTE THE CAPITALIZED WORD—
(Continued on page 54)

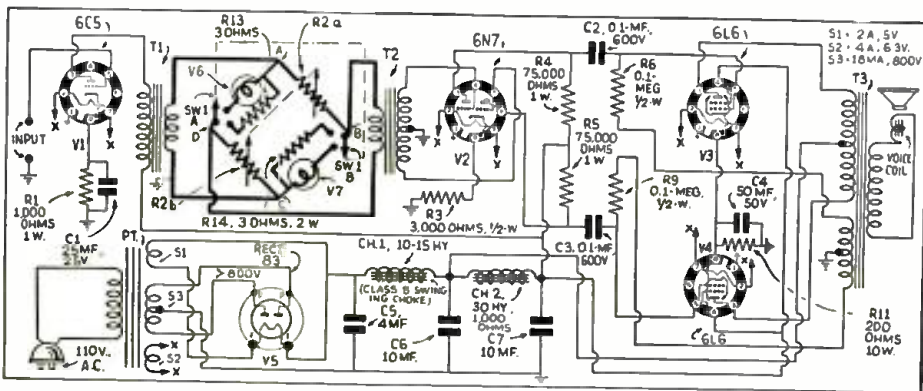
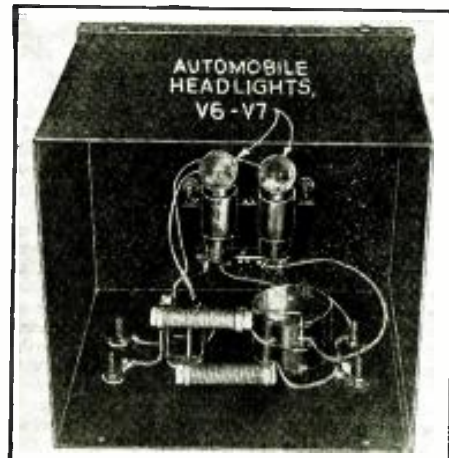

Fig. 1. The latest, corrected diagram of the new expander (heavy lines) connected in a beam-power amplifier.



Photo—Wholesale Radio Service Co.
Fig. A. Front view of the add-on expander.



Photo—Wholesale Radio Service Co.
Fig. B. Interior of the expander.

OFFICIAL RADIO SERVICE MEN'S ASSOCIATION, INC.

MEMBERS' FORUM

A department devoted to members and those interested in the Official Radio Service Men's Association. For mutual benefit, contribute *your* kinks, gossip and notes of interest to Service Men, or others interested in servicing.



Fig. A. Mr. Case's service emporium.

NOVEL TEST BENCH HAS "SNAP-OFF" EQUIPMENT

RADIO-CRAFT, ORSMA, Dept.:

Some of the other members of the ORSMA may be interested in the picture of my test bench I am enclosing. See Fig. A.

This bench is constructed of inexpensive pressed wood. The main feature of the bench being the quick portability of all test equipment and meters so that they can be "snapped off" for home servicing.

The several speakers are placed behind galvanized screen and impedance-tapped for all

sets; speakers can also be quickly "snapped off" for use with any amplifier.

The bench itself is well lighted and in addition has a hanging light of the old weight variety that will remain in any position.

The condenser tester is of a shop-made variety and tubes are tested with a Supreme Deluxe 89.

Parts and accessories are conveniently displayed in a show case in front of the technician. I will be glad to answer any questions that may be of interest.

RUPERT CASE,
Stockton, Kansas.

AN "AUSSIE" P.A. MAN SAYS "CONGRATULATIONS!"

RADIO-CRAFT, ORSMA, Dept.:

Before I start to tell you what I want, let me congratulate you on your "Anti-Howl Audio Amplifier" as described in the June and July 1936 issues of *Radio-Craft*!

Two weeks ago I had a mighty big P.A. job on hand; to feed political speeches to about 5,000 people in the town hall.

My own job, which uses type 2A3 tubes, sounded OK until I started to increase the gain and then—well I got perfectly disgusted with things.

My boss sent to Sydney for the parts, etc., for my amplifier and still I was skeptical.

I had it finished 7 hours before I had to

install it so I didn't have much time to give it a good test under various conditions.

Then! well, words cannot express the feelings that I felt when I heard it working in the hall. No blasting or having to man-handle the volume control at all; in fact next time I've got a job on I'm going to install it, switch it on, and then take the wife to the pictures, and collect it on the way home.

I get about 28 watts from it, but what watts! (No, that's not a pun.)

Well, whenever you hear from any so-called "critic" who reckons that the 6L6 is not a good tube, and that your circuits are not "up to snuff," refer him to me and I'll lock him up in my sound room and turn the job full on, then let him even try to utter a word!

(Continued on page 45)

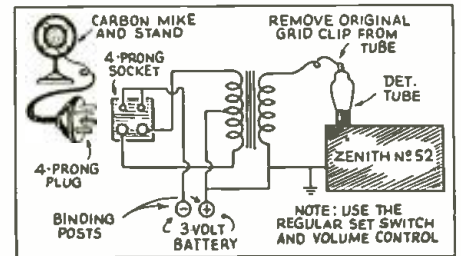

Fig. 1. A cheap P.A. amplifier adaptation.

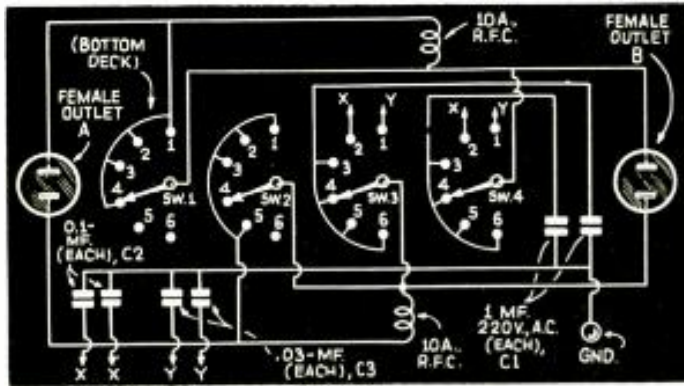

Fig. 1. The circuit of the Analyzer described.

BUILDING AN INTERFERENCE ELIMINATION BUSINESS

An "Interference Analyzer" will speed the servicing of man-made radio interference.
HARRY KALKER PART I

BEGINNERS in radio servicing as well as the advanced Service Man probably will be interested in a simple device, for checking interference-filter component values by means of the comparison system, that every technician who wishes to enter the profitable field of interference elimination should use as a basic tool.

Merely to discuss this tool—the Interference Analyzer, shown in Figs. A, B and 1—is to acquire an excellent background knowledge of just what constitutes the duties of an "interference servicer"; more general information on this topic (as to where to find prospective customers, how to approach them, etc.) will be taken-up in forthcoming Parts.

The simplest type of device for eliminating radio interference at the source (and one that is very often effective on household electrical appliances which draw little current) consists only of a filter condenser, C, connected to one side of the line of the appliance and grounded to the frame, as shown in Fig. 2A. Ordinarily a condenser of from 0.1-mf. to 1. mfd. will suffice. But, don't attempt to guess the correct capacity. Use an "interference analyzer," such as shown in Fig. 1. It will tell you *exactly* what value of condenser to install to eliminate the noise *entirely*.

Variations of the hook-up shown in Fig. 2A

should be tried on more troublesome cases of noise. Sometimes 2 condensers connected across the line and grounded to the frame of the appliance, as shown in Fig. 2B, will prove best. Again, it may be advisable to use an R.F. choke coil R.F.C., in series with the line as in Fig. 2C; or perhaps 2 chokes, or these in addition to the condensers, as in Figs. 2D and E, respectively.

In the past, it has been a slow, laborious procedure to determine the best filter arrangement. Using the trial-and-error system, the Service

Man had to connect one condenser and choke after another into the circuit until he found the right one. The Interference Analyzer now lends wings to this work by means of the following simple procedure:

(1)—Plug in clip lead adapter (a length of 2-conductor cord, with a male plug at one end and a clip on either lead at the other end) into "A" socket of Analyzer.

(2)—Connect clip leads of adapter to terminals of electrical appliance.

(Continued on page 50)

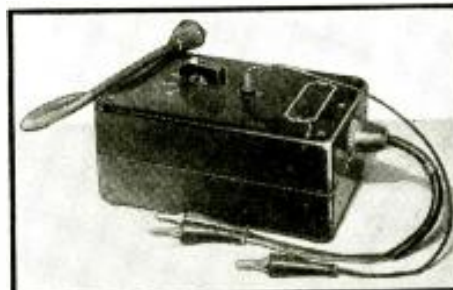

Fig. A. Exterior of the Interference Analyzer.

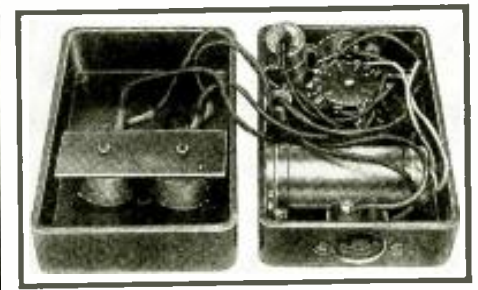
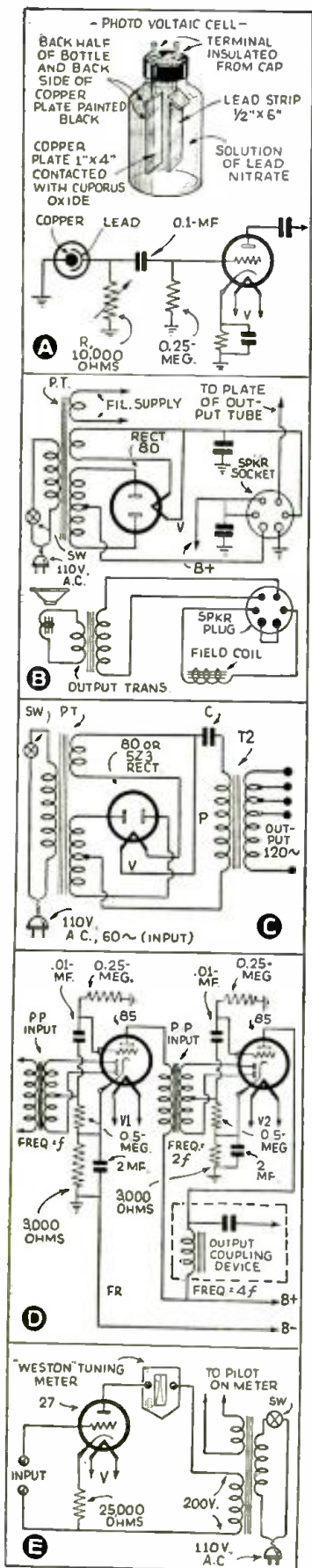

Fig. B. Interior of the interference unit.

AWARDS IN THE CONTEST
FIRST PRIZE \$10.00
SECOND PRIZE .. 5.00
THIRD PRIZE 5.00
Honorable Mention

USEFUL RADIO CIRCUITS

Experimenters: Here is your Opportunity to win a prize for your pet circuit idea, if it is new, novel, and useful.



FIRST PRIZE—\$10.00

Home-Made Photo-Voltaic Cell. My contribution is a home-made photo-voltaic cell for the experimenter. This cell changes varying light intensities into electrical impulses by varying the potential between the electrodes of a primary cell. The solution is made by adding 1 oz. of lead nitrate crystals to 1 gill of distilled water (4 gills = 1 pt.). An ordinary pickle bottle is used for a container. See diagram A. The electrodes used are a lead strip 1/2 by 6 ins. and a copper plate 1 by 4 ins. Heat the copper plate in a flame until the entire surface is coated with a black flaky substance called cupric oxide. (Use a blue flame instead of a yellow one, to avoid a deposit of soot.—*Editor*) Now wash the plate in a weak solution of ammonia water to dissolve the cupric oxide. This leaves a golden brown coating of cuprous oxide, which is light sensitive. The back half of the pickle bottle and the back side of the copper plate should be painted with black lacquer.

DONALD ROBERTS

SECOND PRIZE—\$5.00

Simple Method of Protecting Filter Condensers. It is probable that at some time or other almost every radio experimenter has absent-mindedly pulled the speaker plug out of a receiver and has consequently burned out or melted all the wax out of a set of filter condensers. The idea shown in diagram B does away with this possibility entirely. It will be noted that the speaker plug and socket have 2 extra connections. On the socket one terminal is grounded and the other is run to the center-tap of the power transformer, while on the plug the two extra terminals are merely connected together. When the speaker plug is pulled out, the center-tap of the power transformer is left ungrounded; so there are no abnormally high voltages produced across the filter condensers to burn them out.

HAL ANGER

THIRD PRIZE—\$5.00

Novel Frequency-Doubling Idea. Here is a frequency-doubling idea which I have found useful when a relatively small amount of power is required at a frequency higher than that of the available supply voltage. The circuit shown in diagram C, was used when a frequency of 120 cycles was desired to drive a small vibrator of a polarized type. The arrangement shown in diagram D is a variation which more readily adapts itself to multi-stage doubling but requires the addition of a power amplifier of some sort if other than a few milliwatts of power output is desired. The doubling arrangement is nothing more than a full-wave rectifier with output filter purposely omitted and a suitable A.C. output coupling device substituted in its place. A precaution to observe in the use of the circuit in diagram C is to be sure that condenser C has an adequate voltage rating. For safety, this condenser should have a D.C. voltage rating of at least 1.4 times the r.m.s. voltage delivered by the input transformer P.T. Con-

denser C should have a capacity of several microfarads—the higher the capacity the greater the current output. Transformer T2 in diagram C may be either a heavy-duty audio output transformer or a transformer similar to P.T. (or preferably a half-wave type) with the high-voltage secondary connected at P and various combinations of 110 V. winding and filament windings utilized to give desired output voltages. Standard audio components are entirely satisfactory for the circuit in diagram D and the output coupling can be of any type which will be suitable to feed into the following amplifier.

JOHN E. CLARKE

HONORABLE MENTION

Condenser Tester. Diagram E shows a circuit diagram of a useful radio servicing device. The job can be constructed very cheaply, in fact most of the components will be found in the Service Man's junk box. Owing to the advent of the "tuning eye" tube, the older tuning meters are being discarded and the device has been designed around a Weston Tune-a-Light meter. The plate voltage and grid bias resistor are selected to suit the tube used, so that with a free grid, the plate current will have a value of about 5 ma. which, with a Weston tuning meter, will cause the light beam to practically disappear. However, when the bias is applied to the grid by shorting the input terminals, the plate current will be reduced to about 0.5-ma. which will give nearly a full-scale light beam. Thus when the device is switched on, the light beam will disappear, but by connecting a high resistance between input terminals the bias is applied with a consequent appearance of the light beam. The job will detect leakages above 10 megohms, and I have found it very useful in detecting inter-element leaks in tubes and small-value coupling condensers. Condensers of a value of .01-mf. and over show a full light beam which gradually disappears as condenser charges up, the time varying from a second or two to several minutes with large-capacity condensers. The job will not give quantitative measurements, and care must be taken not to touch anything connected to the grid terminal while operating, as body capacity will give a false reading; also the grid terminal must be insulated with a good quality insulator as any high-resistance leak in the material will nullify results.

L. H. C. SMOUT
 Cahramatta, New South Wales.

HONORABLE MENTION

Simple Code-Practice Set. Two people may practice code in the same room using a single buzzer and 2 separate telegraph keys. No batteries are required. An ordinary bell-ringing transformer is employed. When one party is sending, the other party must throw his switch in order to short out his key, and vice versa. Works from the 110 V. 60 cycle house lighting circuits. See diagram F.

RICHARD GREY

(Continued on page 55)

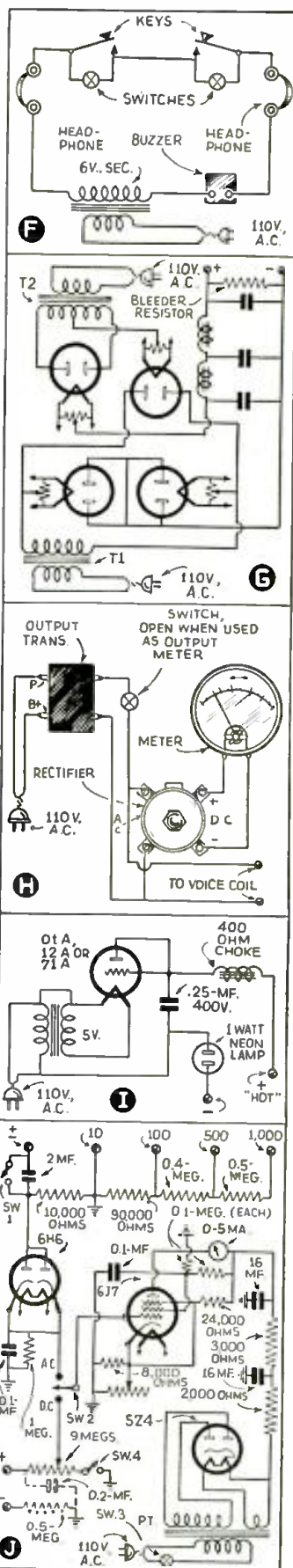

OPERATING NOTES

ANALYSES of RADIO RECEIVER SYMPTOMS

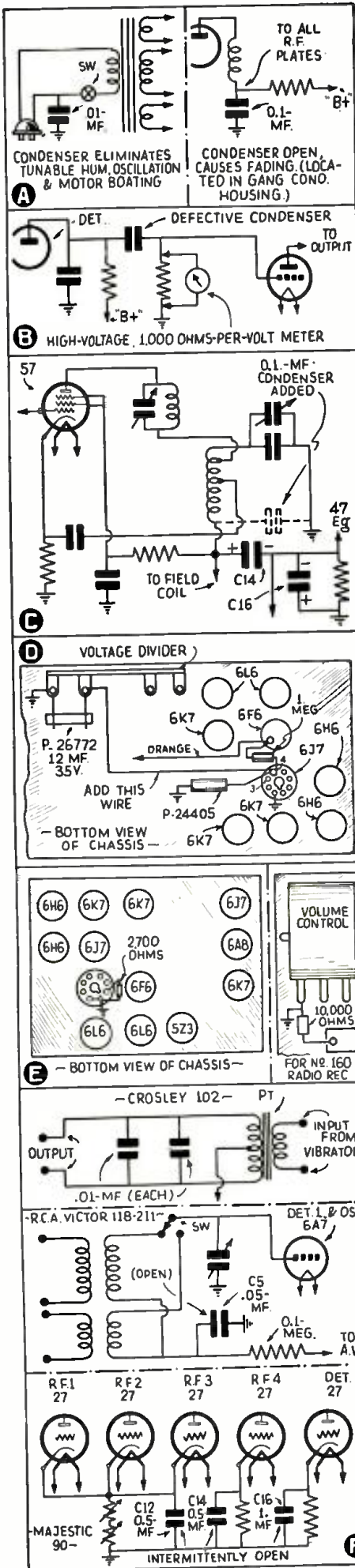

Fada Flashgraph 42. Oscillation and motor-boating between stations can always be eliminated by inserting a 0.01-mf. condenser between the 110-V. line and chassis—Fig. 1A. Fading on this model is usually traced to the coupling condensers of which there are two; for permanent repair both units must be replaced. Fading on this model is also traced to the R.F. plate bypass condenser as in Fig. 1A. It is located in the gang-condenser housing. The one with the red lead going to the R.F. coil is usually the defective one.

Zenith 70. When this set complaint is distortion on low-volume setting the usual cause is a leaky coupling condenser between the detector plate and first audio grid. The best method to check for this trouble is to connect the meter from the control-grid of the first audio to chassis. If there is a reading it indicates the coupling condenser is leaky. If there is no reading the coupling condenser is good. Use only a high-resistance meter when making this test.

IRVING ISKOWITZ

U. S. Radio & Television No. 400 Chassis. Here is an inherent fault in the circuit of the Gloritone model 24 (No. 400 chassis) that causes difficulty and is easily corrected. This circuit uses a 57 tube as a composite 1st-Det.—oscillator in which the tuned circuit of the oscillator is completed through the 8-mf. electrolytic filter condenser (C14) and a 4-mf. 20-V. electrolytic (C16). The trouble evidences itself by failure of the oscillator on the lower frequencies and severe audio frequency regeneration when the circuit breaks in or out of oscillation. This occurs until the set has thoroughly warmed up and may require more than an hour's time.

The difficulty is localized in the 4-mf. 20-V. electrolytic (C16), this condenser having a sufficiently high R.F. resistance at low temperatures to stop oscillation over part of the band. A 0.1-mf. tubular condenser, connected from the low-potential end of the oscillator to chassis, was found to be the smallest that would secure the desired results. This is illustrated by the dotted connections in the diagram. See Fig. 1C.

Increased selectivity is also a noticeable result of this change. Experience has demonstrated that the filter condensers should be replaced if

a complete reconditioning is desired. It is advisable, at least, to check them, preferably by measuring their power factor; although several of these chassis have operated satisfactorily many months after the proper bypass was provided.

A. S. Cox

Stromberg-Carlson 160-L Circuit. Variations in new 6J7 tubes have occasionally caused distortion in the automatic tone control circuit of the 160-L receiver, as first released. These tubes function correctly after "aging" a few hours. Also it has been found possible to eliminate this possibility of distortion with new or aged tubes by adding a wire, as shown in the illustration, to stabilize the screen-grid voltage. See Fig. 1D. This modification was put in effect at the factory in all 160-P and 180-L receivers, and in all 160-L produced after October 23, 1936.

Stromberg-Carlson No. 160 Receiver. Variations in characteristics of the 6K7 tube cause some tubes to draw excessive grid current, which may lead to (1) noisy volume control action as the volume knob is rotated; (2) low power output or "overloading"; and (3) excessive bass compensation at low volumes.

To prevent this, circuit changes are being incorporated in all of these receivers manufactured on or after October 9, 1936, and the same changes should be made in receivers in the field, where noisy volume control action is observed. State the circumstance and the necessary resistors will be supplied without charge.

Two changes are made (see Fig. 1E): (a) Replace the 1,000-ohm bias resistor with Part No. P-26338 (2,700 ohms) for increased bias. (b) Connect Part No. P-26345 (10,000-ohm) resistor across the bass compensating condenser, for smoother bass at low volumes. This connection is made from the volume control to a terminal nearby.

STROMBERG-CARLSON "SOLDER NUGGETS"

Crosley No. 102. Set dead, draws excessive current from "A" battery; either one or both vibrator condensers shorted. (These are accessible by removing side cover of vibrator housing, condensers connected across secondary of power transformer.) Replace with 0.02-mf. 1,600-V. tubular condenser. This is a common trouble with this set.

Fig. 1. Sketches of the circuit details discussed in the Operating Notes described on this page.

This is a common trouble with many makes of car receivers. It is recommended that you change the vibrator or buffer condensers every time you replace a vibrator. See Fig. 1F.

RCA Victor Model 118-211. Set had barely enough volume to play on local stations. A thorough check on all voltages, currents and point-to-point resistance measurements showed nothing wrong. The A.V.C. circuits were then suspected and an inspection of the schematic disclosed two likely places in the form of bypass condensers connected from the grid supply network to ground. A resistance check failed to show a shorted condenser, so the substitution method was used and it was found that the 0.05-mf. condenser (C5) bypassing the 1st-Det. grid-return from the automatic volume control to ground was open. It was also found that this was an intermittent condenser (I.F. 460 kc.).

Radiola Model 48. A common fault with this model is erratic cutting off to half-volume and back. The plates of the variable condensers in this model are made of a magnetic metal and iron filings from the bearings cling to the plates, shorting them at times. These small particles can only be seen with the aid of a strong light. The best way to remove these filings is to blow them out with about 200 lbs. of air.

Majestic Model 90. A very common trouble with this set is quick fading or snapping off to half volume. This is usually caused by one or more of the 3 bypass condensers bypassing the R.F. and detector cathode circuits. These condensers are all in metal cases, riveted to the inside of the side of the chassis. It is almost impossible to detect these condensers in the act of opening and closing since any kind of connections with test leads will result in normal operation for a short time. The only sure way to correct this trouble is to replace all 3 condensers with 0.5-mf. tubular condensers. Just as sure as you replace one and leave the other two in, you will be called back and have a nasty time explaining to the customer.

BINFORD OWENS

Philco 610, 620, 625, 630, 635. Fading at the low-frequency end of the broadcast band on these models, particularly the 610, has been traced to the padding condenser for the broadcast band. Stations from 900 kc. to 550 kc. may fade out or drift slowly. By re-setting the station selector or dial, signals are again heard until the frequency drift is as much as 50 to 60 kc. Leakage due to the presence of some foreign substance produces the difficulty. Remove the condenser and bathe in carbon tetrachloride for a moment or two.

Intermittent oscillation or noisy reception upon the slightest jar of the cabinet or chassis may be due to poorly grounded coil shields or loose grounding lug rivets. The coil shields are held in position by spaded clamps which lose their tension. These spades must be spread so that positive contact is secured. At other times, the rivets holding the space clamps to the shield-can loosen, culminating in the same complaint. The grounding lug rivets mentioned are those used for securing the tube sockets to the chassis, and which hold lugs in position to which different circuits are grounded.

Increased hum level on the model 630 is usually due to an improperly connected hum-bucking coil on the dynamic reproducer. Simply reverse either the voice coil or hum-bucking coil leads.

Philco 650, 650PX. The complaint of distortion at resonance, when strong signals are received, is almost always the result of insufficient A.V.C. voltage to the I.F. 78 tube. To reduce the controlling voltage to this stage, the manufacturer employed a 0.5-meg. resistor from the I.F. secondary return to ground or chassis. This is a small carbon unit located near the first I.F. transformer. Removal of the resistor from the circuit will correct the condition. A reading of 0.5-meg. from the control-grid of the I.F. 78 tube designates the trouble. See Fig. 1G.

Intermittent radio operation on the model 650 PX has been traced to a faulty phono-radio transfer switch. See Fig. 1H. This symptom will be manifested by the lack of screen-grid voltage on the R.F. and I.F. tubes, and is caused by poor contacts of the switch.

Philco 655. A slipping dial on this model is a frequent complaint and one easily remedied. The trouble is due to binding of the black cellu-

loid disc behind the dial face. After dis-assembling the dial, remove the black disc and ream its inside circumference slightly, so that undue friction against the dial collar is not present.

Philco 660, 665. When the long-wave band is found inoperative or weak with accompanying hiss, check the R.F. choke mounted upon the front wave-band switch section shield for an open-circuited condition. In every case, the open-circuit consisted of a break at the lugs, which is easily repaired.

Before replacing a shadowgraph tuning meter which is burnt out or open-circuited, the 0.05-mf. tubular condenser connected after the meter should be carefully tested for either a leaky or short-circuited condition. A defective condenser at this point will burn out the new shadowgraph unit because of excessive current, unless replaced. The condenser is located near the front of the chassis on the wave-band switch.

Very highly distorted, muffled or choked reproduction at any volume level is a complaint not uncommon with these models. By removing the grid bias from the 75 tube, which may be done by shorting out the 10-ohm section of the voltage divider in the rectifier secondary-return circuit, this condition may be cleared to a great extent but the volume control will have negligible effect. The trouble is due to a leaky blocking or coupling condenser between the plate of the type 75 tube and the grid of the type 42 driver. This unit is a 0.05-mf. black encaused condenser located near the type 42 driver tube socket. Since additional lugs on this condenser are used for terminal bracket purposes, unless a duplicate condenser is installed, it may be best only to disconnect leads to one side of the condenser and add a replacement unit.

BERTRAM M. FREED

Majestic 500. Sets of this model that refuse to operate over the entire dial can usually be remedied by replacing the small 50,000-ohm oscillator gridleak connected from oscillator-grid to cathode on 6A7. This resistor often increases in value several times.

Majestic 90. Weak reception on Majestic 90s, when all voltage and tubes check OK, can be caused by open-circuited 0.5-mf. bypass condensers. The two condensers in question are located on the side of the partition shield opposite the R.F. tubes. (Looking at the bottom). Sometimes the grounds of these condensers, which are soldered to the side of the can, snap, thus open-circuiting the condensers. The remedy is replacement or resoldering.

Zenith 705, 750. A common trouble in Zenith Model 705, 750, and other similar models is their failure to operate below 1,000 kc. This trouble will often be traced to an open section in the antenna coil. When this coil is open there is not sufficient energy picked up from the low end of the dial. This coil usually opens at the connecting lugs and is easily resoldered.

United Motors 4037. On United Motors model 4037 when the set is dead or very weak and the ammeter shows a drain of from 10 to 20 A., with the tubes, condensers, and vibrator checking OK, the trouble will often be traced to shorted turns on the primary of the vibrator transformer. The primary on these transformers consists of 4 layers of rather heavy wire and can be rewound quite easily. First make sure that the secondary is not shorted or grounded.

RCA Victor Model 120. When the circuit of this set model motorboats continuously, with no other signal audible, check for an open-circuited condenser in the 3-section electrolytic block at the right of the gang condenser. The offender is usually the screen-grid supply bypass. To prevent a callback the entire block should be replaced.

Atwater Kent 155. Weak, distorted signals on Atwater Kent Model 155 are often traceable to the 42 grid-return resistor. This resistor is a small 0.5-meg. metallized unit located right at the grid terminal on the 42 socket.

Silvertone Model 1592. Intermittent distortion in this set was finally traced to a shorting speaker field. This trouble was located by placing a low-range voltmeter across the field. When it shorted the voltage would drop to almost zero.

COMER H. BLACKBERRY

(Continued on page 60)

SERVICING QUESTIONS & ANSWERS

Service Men may write, requesting answers to specific service questions. Address inquiries to Service Editor. For questions answered by mail, a service fee of 25c per question is made. AN EFFORT IS BEING MADE TO MAINTAIN 48-HOUR SERVICE IN HANDLING THIS MAIL.

MOTOR BOATING

(7) Richard Strauss, N. Y. City.

Q. I have a Fada model 65 receiver, which intermittently motor-boats. Please advise the reason and remedy.

A. Motor-boating in this receiver can usually be traced to an open screen-grid bypass condenser. See Fig. 1A. We recommend replacing the defective unit with a 0.5-mf. 600 V. unit.

RESONANCE LIGHTS NOT FUNCTIONING

(8) Martin Block, Reading, Pa.

Q. About 2 months ago I purchased a G.E. model 115 receiver and was very pleased with it. Lately I have noticed that the focus lights which change from red to green to indicate when it is tuned properly are becoming less brilliant. How can this trouble be corrected?

A. In order to correct your trouble, it is advisable to check all the tubes first, paying particular attention to the 6K7 R.F. tube. It has been our experience that this complaint was always corrected by replacing the 6K7 R.F. tube.

CODE INTERFERENCE

(9) James Riley, Lansing, Mich.

Q. I have recently purchased a Grunow model 1191 receiver and am troubled a great deal by code, riding in on 710 to 570 kc. What can I do to correct this annoyance?

A. By purchasing a wavetrapp tuned to 460 kc. and connecting it in series with the aerial post on your set, this code interference will be greatly reduced. See Fig. 1B.

SET SMOKES

(10) Arthur Hall, N. Y. City

Q. About 6 months ago I purchased a G.E. E95 receiver, and until a week ago found it very satisfactory. I wanted to hear a program about a week ago and turned the switch on, and smoke started to emanate from the power transformer. I immediately shut it off. What I would like to know is whether it is essential to replace this power transformer.

A. The first thing to do is to check the 5Z4 rectifier tube. In all probability you will discover this to be the chief cause. If the set was turned off immediately, the transformer will not be impaired and will not need changing.

"MAGIC EYE" DULL

(11) Frank Morris, Bronx, N. Y.

Q. I have had an RCA 10K1 set for 3 months. During this time I have changed the "Magic Eye" 6E5 tube twice. What I would like to know is whether I will have to keep on replacing it every few weeks as in the past.

A. We are informed that the 6E5 "Magic Eye" is constantly being improved, therefore in our opinion it will not be necessary to change it so frequently in the future.

DISTORTION

(12) Edward Smith, Hartford, Conn.

Q. Please tell me the reason for distortion after

(Continued on page 53)

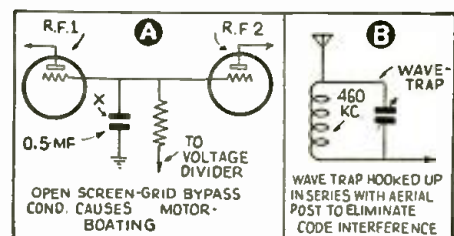
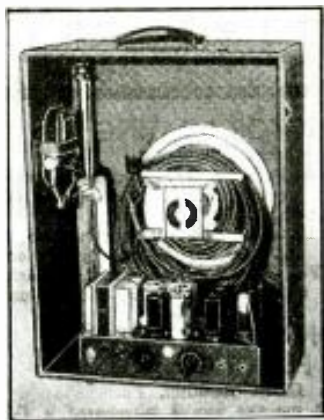

Fig. 1. Condenser defect; wavetrapp connection.

THE LATEST RADIO EQUIPMENT

This department brings to you each month the newest developments in electronic, radio and public-address equipment. Aggressive technicians use this department to keep posted on the newer and better ways of doing things.



Schools' portable recorder amplifier. Also OK for spot playback. (1389)



Low-priced oscilloscope. (1391)



New R.F. and I.F. wavetraps. (1394)

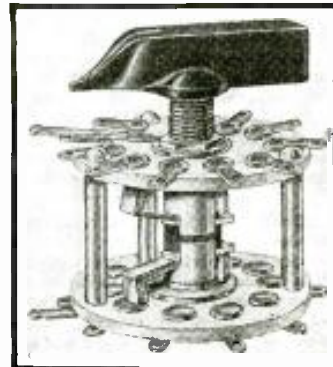

Low-loss, rugged switch. (1395)

HI-FI PORTABLE RECORDING AMPLIFIER (1389) (Universal Microphone Co.)

DESIGNED primarily for use in schools, etc., for the recording of exercises and lessons in languages, expression, pronunciation, etc., this high-gain, resistance-capacity coupled speech recording amplifier has been developed with the added convenience of portability.

Supplied complete with collapsible microphone stand, amplifier, velocity mike, 1-10-in. (or 2-8-in.) dynamic loudspeakers, cables and connectors, all within the carrying case. Unit includes built-in high- and low-frequency filter for tone regulation; low- and high-impedance input jacks; output for either 6- or 15-ohm cutting head; neon volume indicator; calibrated volume control. Hum-free, A.C. operation; spot playback if desired.

SELECTIVE INTER-OFFICE COMMUNICATOR (1390) (Operadio Mfg. Co.)

UNLIKE the model of the same make described last month in *Radio-Craft* this new model includes a control strip along the base that permits any one of 10 stations to be individually contacted. Once a

particular station has been signaled, and contact established, conversation may be conducted in absolute privacy—insofar as loudspeaker operation permits. A feature of this system, over those which do not require station-to-station wiring, is that high-quality voice reproduction may be obtained—a desirable characteristic where the interphone is to be used over extended periods.

NEW LOW-PRICED 3-IN. OSCILLOSCOPE (1391)

A TYPE 34-XH 3-in. tube is used in this new oscilloscope—which has been designed to sell for under \$55.

Although designed especially for the service engineer to be used in conjunction with any standard frequency modulator and oscillator or with any of the new designs of frequency-modulated oscillators, this instrument will serve the many purposes of a really efficient portable oscilloscope as well.

It has separately-controlled horizontal and vertical high-gain amplifiers, flat from 30 to 30,000 cycles; internal or external positive synchronization; high- and low-voltage power supplies (assuring brilliant pattern and no interaction of con-

trols); the amplified sweep permits observation of a single wave from 15 to 30,000 c.p.s.

AUTOMATIC-CONTROL WIND-DRIVEN BATTERY CHARGER (1392)

UP TO WIND velocities of about 20 m.p.h. this wind-driven generator delivers its maximum capacity. At speeds up to 60 m.p.h. the propeller is automatically tilted so that only enough propeller-area is presented to the wind to maintain normal output. A manually-operated pull-down wire tips the entire assembly to the off position in which it slips the entire airstream.

NOISE FILTER FOR ELECTRIC RAZORS (1393) (Solar Mfg. Corp.)

A NOISE-FILTER of the inductance-capacity type has been developed to eliminate the interference to radio reception caused by operation of electric razors. It takes only a second to plug the unit into circuit, between the razor's power cord and the wall receptacle. This low-priced, neatly-finished device should be an easy one for the Service Man to sell to his customers; a demonstration is all that's necessary to close the deal.

COMBINED B.C. AND I.F. WAVETRAP (1394) (Meissner Mfg. Co.)

A FERROCART (high-frequency iron) core is utilized in this newest wavetraps. It has two sections. One section (knob adjustment) resonates over the range of 1,720 to 700 kc., to eliminate interference from any particularly strong station within this frequency range. The other section (screw adjustment) covers a range of 400 to 700 kc. and thus will eliminate image-frequency interference within this band-width. Note that the two sections may be utilized simultaneously and for two different purposes, as mentioned above; or, these two sections may be connected in series to obtain resonance at any frequency between the extremes of 400 to 1,720 kc.

Service Men will be glad to know that a well-made device of this kind is now available.

LOW-LOSS, RUGGED SWITCH (1395) (Shallcross Mfg. Co.)

SEVERAL important features characterize a new switch designed to meet the most exacting demands in output meters, tube checkers, decade boxes, thermocouple

(Continued on page 56)



Selective-type interphone. Note:—Toggle switches permit simultaneously tying-in 4 stations. (1390)

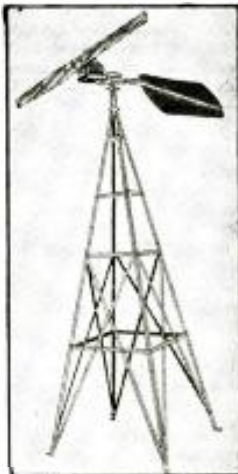

New wind-driven charger. (1392)

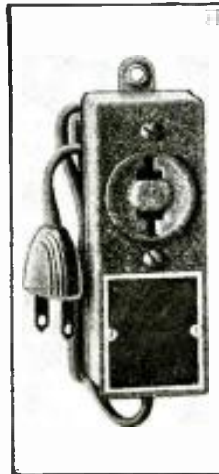

Razor noise filter. (1393)

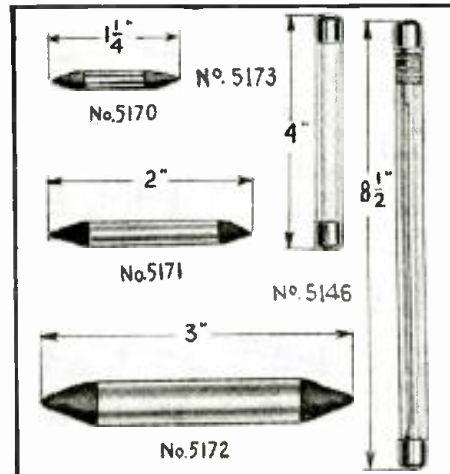

Two types of neon tubes. (1396)

A COMBINATION (AND SLIDE-BACK) V.-T. AND PEAK VOLTMETER

The functions, and what is probably the first published diagram with parts values, of a new test instrument.

S. MINSKER

LONG recognized as an indispensable laboratory instrument, the vacuum-tube voltmeter has now become a frequent service instrument for measuring C-bias, A.V.C., A.F.C., R.F. voltage, etc., where ordinary voltmeters of even the highest sensitivity will draw current and upset circuit conditions. This has been clearly shown in recent, detailed articles in *Radio-Craft* on the use of this type of test equipment.

A V.-T. AND "SLIDE-BACK" PEAK METER

An actual vacuum-tube voltmeter of the very latest type is here shown by photograph and diagram. It is a precision V.-T. voltmeter of improved practicability and ease of operation combined with a peak voltmeter of the *slide-back* type operating from an internal balancing voltage.

This instrument is offered to meet the

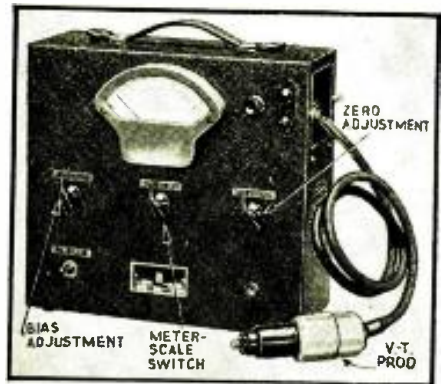

Fig. A. The meter and its probe or prod.

wide range of applications not satisfactorily filled by a vacuum-tube voltmeter, of the usual design, limited to the reading of root-mean-square potentials.

(Continued on page 61)

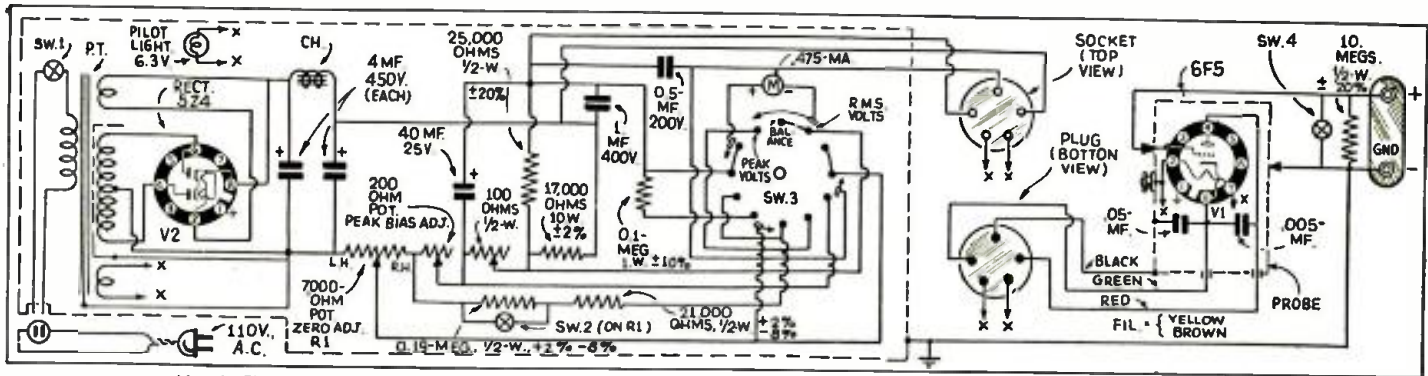

Fig. 1. This is believed to be the first published schematic circuit of the new meter to include electrical parts values.

A 20,000 OHMS/VOLT ANALYZER KIT

Diagrams for a high-resistance D.C. and A.C.-D.C. "Tester-Analyzer."

M. N. BEITMAN

THE NEW trend in servicing instruments is definitely in the direction of higher sensitivity.

The jump from low resistance to 1,000 ohms-per-volt, to 2,000 and now 20,000 ohms-per-volt instruments shows the service instrument manufacturers' reply to the Service Men's demand for sensitivity. But the rise of highly sensitive meters was not purely impulsive

on the part of the Service Men, it resulted from the development of new radio receiver circuits calling for more accurate adjustments and forbidding any excessive current drain during the tests.

Test operation under the above-mentioned conditions of 20,000 ohms/volt sensitivity has been made available in

(Continued on page 63)



Fig. A. The array of components that go to make up the Tester-Analyzer. The front view of the multi-scale meter (lower-left) is shown in insert.

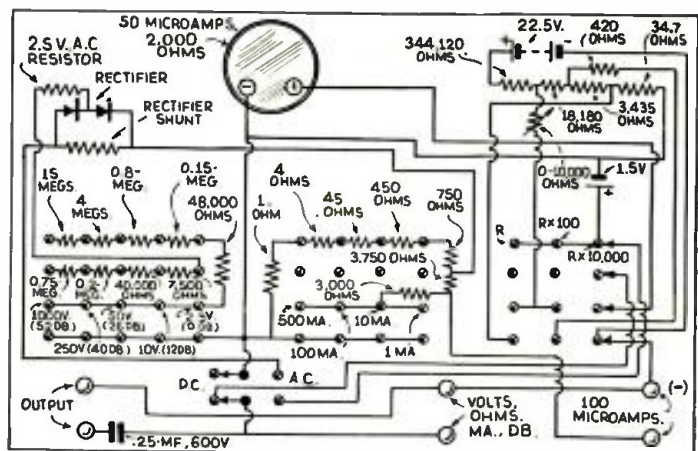
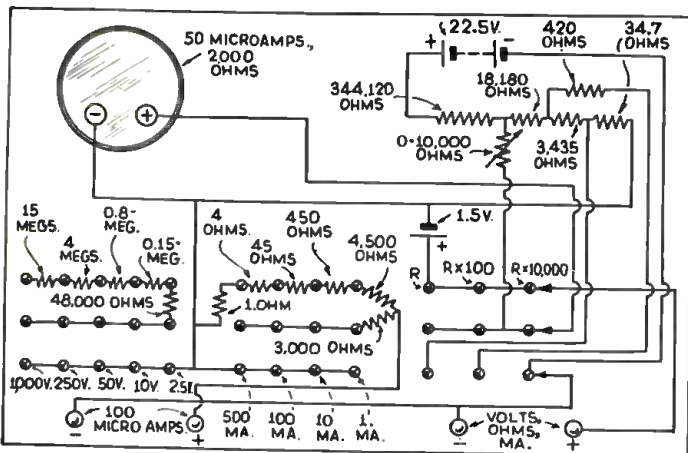

Fig. 1. Of two models, the D.C. type is shown by diagram, above, left; Fig. 2, above, right, diagrams the A.C.-D.C. Tester-Analyzer.

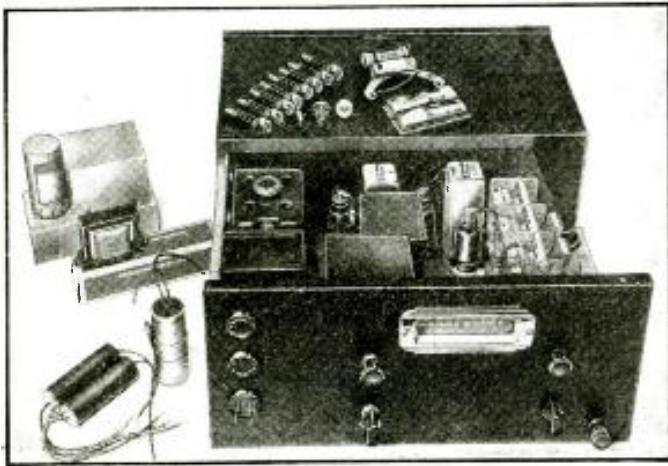

Fig. C. The completed set with accessories and vibrator "B" unit.

BUILD THE RADIO-CRAFT 1937 CAR-RADIO RECEIVER

Enjoy the pleasures of all-wave reception and automatic frequency control, in 1937.

PART II

AFTER THE constructor has decided, from the detailed descriptions given in Part I, just which types of power supply will be used and whether automatic frequency control, noise suppression, and a beat-frequency oscillator will be included in his set, the actual construction work can be started.

Incidentally, a complete description of the A.F.C., with the diagram of this part of the set will appear in Part III, in a forthcoming issue.

The construction of the "front end"—a complete R.F. coil assembly—will call for some exceptionally careful work and perhaps much more time than the reader might think.

THE INPUT "END"

First, the 3-gang switch must be taken apart, the spacers cut in two, the shield partitions formed and drilled and then installed between the switch sections, and the side piece bolted in to complete the job thus far. Next, the various coils must be wired in—self-supported from the switch sections. It would take a complete story to give all details as to proper placement, and we must simply refer you to the detail drawings on construction and layout and advise you to "hang up" the coils with solid No. 14 or 12 wire, keep the leads short, and place the higher-frequency windings as far as possible away from the shield partitions.

Wire in the trimmers on all but the ultra-high frequency coils, placing them wherever convenient and as close as possible to the inductances which they are to tune. Remember that they must be adjustable with the R.F. shield compartment in place under the chassis. Therefore they must be placed vertically, with the screw caps accessible from below the chassis. Connect the cap lugs to the A.V.C. or padder connection coil terminals and the bottom lugs to coil grid terminals.

Wire from coil to coil in each stage for "B plus," A.V.C., and other common coil leads, bringing the final leads out

through the side wall of the assembly or leaving them inside if they are to be connected to R.F. or mixer tube sockets. (These sockets will be inside the shield box when the assembly has been installed under the chassis.) In the R.F. and mixer compartments, wire-in R.F. coupling condensers (0.05-mf.) from common A.V.C. bus lines for each stage to some convenient point on the shield partitions and then solder leads to the partitions for connection up through the chassis to the variable condenser rotors. Connect leads for variable condenser stators (grid terminals) to the switch gangs, making the leads rather long so that they may be pulled up through the chassis later and before the assembly is fixed in position. Remember that it will be difficult to make changes and connections with the assembly installed, as coils and trimmers take up too much room. Do all this work in the very first place and test for continuity, etc., (Continued on page 58)

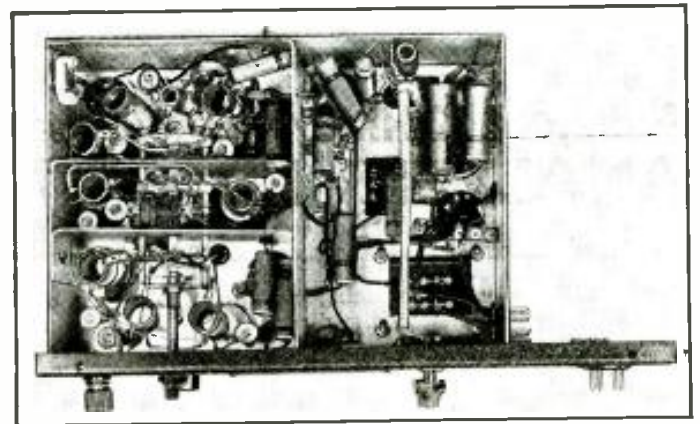

Fig. D. This under-chassis view shows the coil and switch mounting.

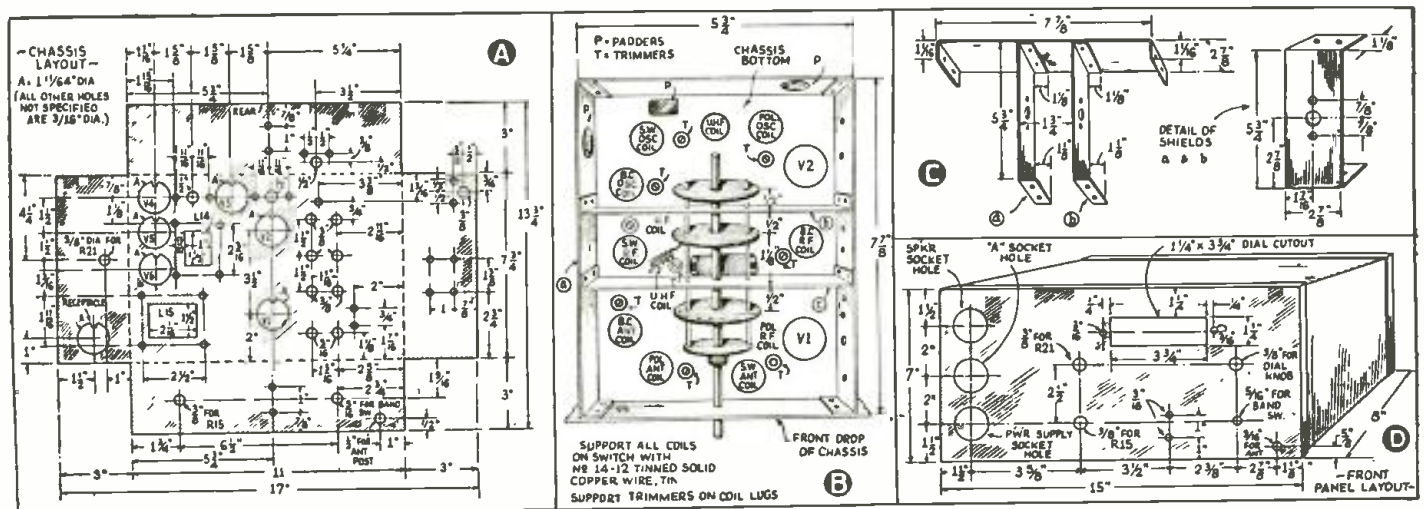
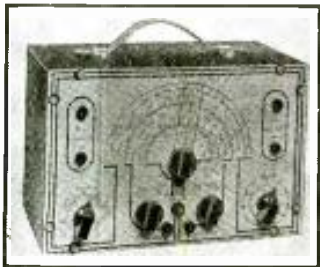

Fig. 3. Chassis, coil shield and metal container drilling and forming details. The band switch is taken apart and re-assembled as shown at B.

A brief review of a few new test instruments selected at random reveals that the trend continues toward precision and versatility.

TEST EQUIPMENT FOR THE SERVICE MAN



An A.C.-D.C. oscillator. External tests may be made. (1397)



New wide-range oscilloscope. (1398)

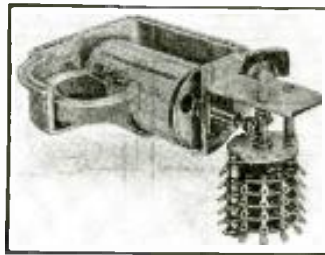

Bevel gears link the multi-point switch to the 12-scale mechanism. (1399)



View of the complete set analyzer, details of the 12-scale mechanism of which are shown in the companion illustration at left. (1399)

IT'S BEEN a long, up-hill climb but at last technicians seem to have awakened to at least some of the possibilities of that amazing device—the cathode-ray unit. Practically every large test-instrument manufacturer has brought out his particular version of cathode-ray servicing and test equipment, for 1937. Undoubtedly, 1938 will see continued progress along the same lines as those embodied in the C.-R. units shown on this page; the present status, and trend, of other types of test equipment also may be noted in the remaining devices discussed.

A.C.-D.C. SIGNAL GENERATOR

A FREQUENCY range of 100 kc. to 22 mc., all fundamentals, is available in the "oscimeter" here shown. Frequencies are read directly from a full-vision scale; accuracy is said to be 1 per cent on the broadcast and I.F. bands, and 2, on the higher frequencies. Modulation at 1,000 cycles is available.

Provisions are made for using this unit in making leakage tests of tubes and condensers; it serves also as a continuity tester. Separate R.F. and A.F. output posts afford additional external-test facilities.

(Superior Instrument Co.)
(1397)

SMALL-SIZE CATHODE-RAY OSCILLOSCOPE

OF SPECIAL importance, in connection with the instrument shown, is the frequency range of the sweep-circuit oscillator which covers the range of 1 cycle to 150,000 cycles per second. Device contains a built-in electronic frequency modulator. The C.-R. tube is the 1-in. metal type; it is particularly easy to follow the screen trace due to this tube being recessed. An effort has been made to simplify the control arrangement so that inexperienced persons may find it easy to secure good results in minimum time and with the least effort. Measurements: 11 x 9 x 7 ins. deep.

(1398)

A 12-SCALE SET-ANALYZER

MEASUREMENT of current, voltage and resistance from the receiver sockets is accomplished in the multi-scale instrument here shown by means of a 9-conductor cable and set of adapters; the point-to-point method of testing is employed.

The selector knob that controls the

scales at the same time switches the circuit to suit.

Most technicians will realize without lengthy explanation that having individual scales available to permit quick, accurate readings to be obtained under all test conditions is an almost invaluable design feature. For instance, suppose you want to check-up a soldered joint—how often will the available meter-scale give you a good reading on this fractional-ohm circuit? The new design hurdles this problem by including a sufficient number of scales to provide one which spreads 5 ohms over about one-half the range. Another point—the possibility of errors is greatly reduced since there is never any necessity for multiplying or dividing scale readings in order to determine values in a different range than the direct-reading one; thus, there is a scale for every range.

The movement is of improved, patented design using a laminated magnet with soft iron pole piece worked into rigid bridge assembly. Ranges: to 1,000 V., A.C. and D.C.; to 130 ma., D.C.; and to 2 megs.

(1399)

A.F. OSCILLATOR FOR CHECKING AMPLIFIERS

A SUFFICIENTLY strong signal is supplied by this A.C.-operated audio oscillator to permit checking weak amplifiers. Attenuation for the measurement of gain percentage is said to be extremely accurate and impedance matching is variable. A pure sine wave, without harmonics or other waveform distortion, is generated.

Frequencies: 100-250-500-1,000-2,000-3,000-4,000-5,000-7,500-10,000 cycles. Measures about 8 x 6½ x 4½ ins. deep; thus, it matches a companion series of units made by the same manufacturer.

(Triplett Electrical Instrument Co.)

(1400)

A.C.-D.C. MULTI-METER

SERVICE MEN, and even the general technician, will appreciate the exceptional convenience afforded in this newest in small-space multi-range meters—it's so compact it will slip into a pocket. Measures only 3 x 5¾ x 2 3/16 ins. deep. Previous instruments, by the same manufacturer, having the same general appearance lacked the built-in rectifier in this new model which permits A.C. measurements to be made.

Ranges: High Range—to 1 meg. with self-contained battery; Low weighs only 27 ozs.

Range reads to 1/10-ohm (low A.C. range reads to 1 V. for low-power output measurements). Voltage: 0-1-5-50-500-1,000 V., A.C.; 0-5-50-500-1,000 V., D.C. Current: 0-550 microamps., D.C.; 0-5-50-500 ma., D.C.; 0-5 A., D.C. Resistance: 0-500-50,000 ohms; 1. meg.

(Radio City Products Co.)
(1401)

2-UNIT SERVICING KIT

TWO UNITS, matched as to general appearance, have been introduced simultaneously by one manufacturer as complementary instruments for effective servicing of radio receivers.

The first unit is an inexpensive oscilloscope complete with 1-in. C.-R. tube. The second unit is a service oscillator, incorporating a greatly improved electronic sweep, which eliminates the need for a separate frequency modulator.

Oscilloscope

Outstanding among the features of the A.C.-operated oscilloscope are the following: full image with only 1.75 V. (r.m.s.); both vertical and horizontal amplifiers, individually controlled, flat from 30 to 10,000 cycles; linear timing axis in the same range. Utilizes 5 tubes; input power consumption, 50 W., cold (30 W., hot). With this instrument circuits may be accurately aligned, visually; all forms of distortion and hum checked; and modulation measured.

Test Oscillator

High output, negligible leakage (variable with frequency), and a sweep rate of 120 times per sec. (which eliminates flicker) are some of the features of the A.C.-operated test oscillator. Frequency range: 90 cycles to 32 kc. (in 6 ranges of fundamental frequencies) spread over a total scale length of 45 ins. Output control is a 3-step attenuator plus a continuously-variable unit. Utilizes 5 tubes. This signal generator is particularly valuable in servicing receivers of the high-fidelity type having flat-top I.F. stages and which therefore cannot be properly adjusted with an ordinary output meter; it may be used, in alignment applications with any type of cathode-ray oscilloscope.

Either unit measures about 14 x 9 x 7½ ins. deep.

(RCA Mfg. Co., Parts Division.)
(1402)

(Continued on page 59)

Name and address of any manufacturer will be sent on receipt of self-addressed, stamped envelope. Kindly give (number) in above description of device.



A.F. oscillator (100 to 10,000 cycles, pure sine wave) for checking audio amplifiers. (1400)

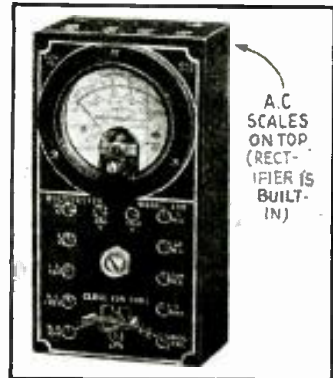

Pocket A.C.-D.C. meter. (1401)

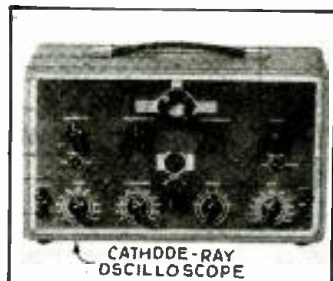

CATHODE-RAY OSCILLOSCOPE



TEST OSCILLATOR

A 2-unit servicing "kit." (1402)

STROMBERG-CARLSON No. 127, A.C.-D.C. CHASSIS (SET MODELS 127-H AND 127-M)

A 9-Tube Superheterodyne, Metal Tubes, 3-band (540-1,500 kc., 1,450-3,500 kc., 5.6-18 mc.) A.V.C., "Tri-Focal" (Cathode-Ray) Tuning, Permanent-Magnet Dynamic Loud Speaker.

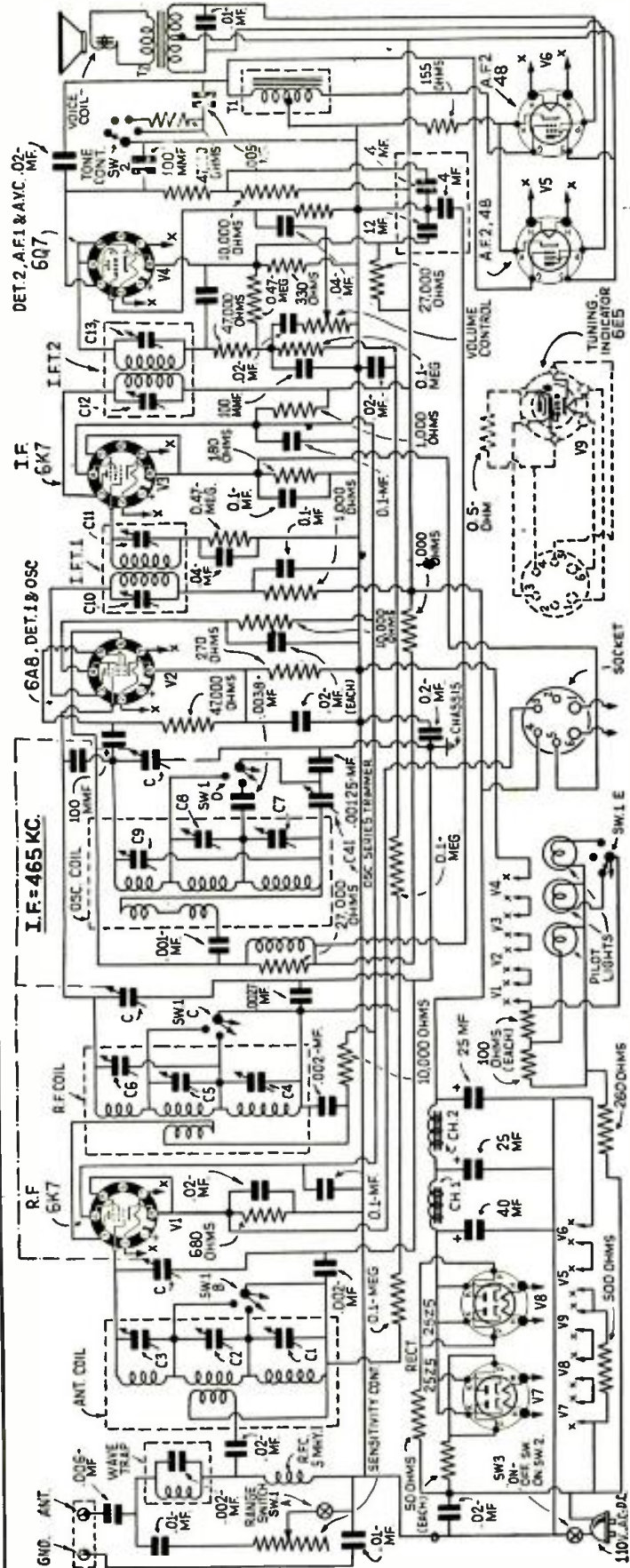

This is a universal A.C.-D.C. circuit. Note chassis is not the negative from which voltages are to be measured. Sensitivity control to be adjusted by Service Man for location. Tuning indicator is connected by plug at back of chassis. The "Tri-Focal" tuning indicator, V9, makes plug-in connection to the chassis.

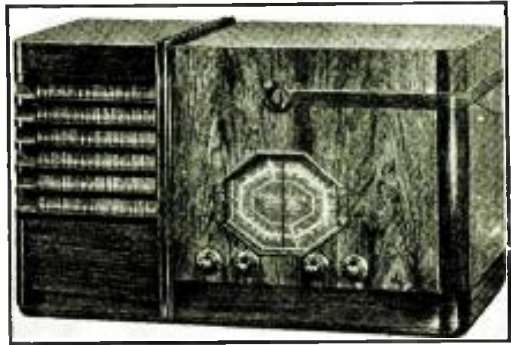

The 127-H, table model; the 127-M has a lowboy cabinet. 105-125 V., D.C. or 50-60 cycle A.C.

Voltage readings of set, with 120 V. on A.C. line (1,000 ohm/voltmeter) to heavy bus wire (negative grid-plate)—not chassis—are as follows:

Tube	3	4	5	6	7	8
V1	33	88	4	0	*24	4
V2	95	60	-7	95	*12	1 1/2
V3	90	88	2	0	*12	2 1/4
V4	450	0	0	88	*6	1

*A.C. voltage; on D.C. power line, lower D.C. reading will be had.
†Use 1,000-V. scale of meter.

Tube	1	2	3	4	5	6
V5	*61	106	106	0	17	*31
V6	0	106	106	0	17	*30
V7	*95	*116	112	116	*114	*70
V8	*120	*116	112	112	*116	*95
V9	*61	1/2	4	99	2 1/4	*67

*A.C. voltage; on D.C. power, lower. Receiver tuned to 1,000 kc.; no signal.
†Heater voltages (across terminals) *6 V., V1-2-3-4-5; *30, V5-6; *25, V7-8. Layouts of series heater circuits in lower left part of circuit diagram. Input power rating, 98 W.

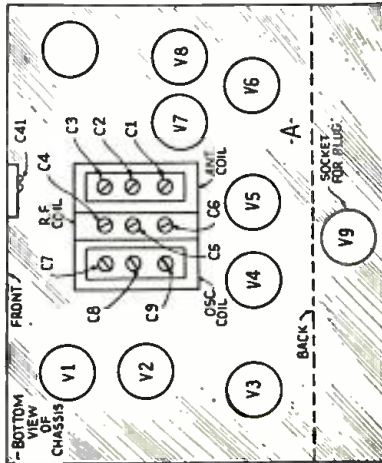
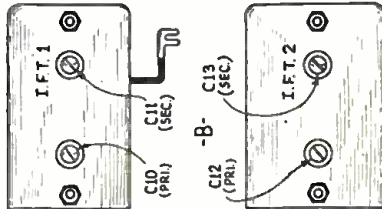
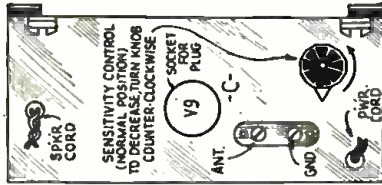

A, positions of R.F. trimmers; B, I.F. trimmers; C, back of chassis (turned on side).
kc., in this order, C13, C12, C11, C10.
The range switch connects, in series, 2 dial lamps at a time for proper illumination. Sensitivity control, at rear of chassis, is adjusted to give minimum interference from strongest nearby station. It is cut out on short-wave ("B", "C") range switch settings.

Alignments of R.F. circuits are to be made at following frequencies, in this order of trimming: "C" band, 17 mc., C9, C6, C3; "B" band, 3.4 mc., C8, C5, C2; "A" band, 1.4 mc. (1,400 kc.) C7, C4, C1. Then at 0.6-mc. (600 kc.) oscillator series aligner C41; at 1.4 mc. again, C7, C4, C1. Align I.F. amplifier at 465

GENERAL ELECTRIC MODEL E-51 RECEIVER

A 4-tube, A.C.-D.C. superheterodyne; dual band, broadcast range, 540-1,740 kc., short-wave range, 2.2-7.0 mc.; 6 1/2-in. dynamic speaker; power consumption, 45-W.; undistorted output, 0.3-W.; maximum output, 0.7-W.; intermediate frequency, 465 kc.; tone control.

The functions of the various tubes in the General Electric Model E-51 receiver are as follows: 6A8, oscillator and 1st-Det.; 6K7, I.F. amplifier; 6Q7, 2nd-Det. A.V.C. and first A.F. amplifiers; 25A6 audio power amplifier; 25Z6 rectifier with each section functioning as half-wave rectifier. The pilot light is a Mazda No. 46.

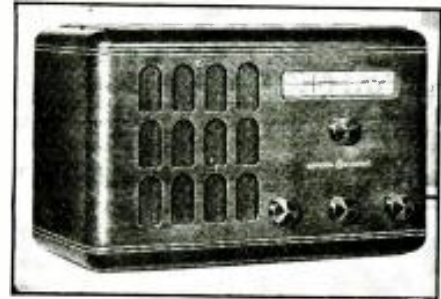

General Electric Table Model E-51.

The alignment frequencies for the General Electric Model E-51 are 465 kc. for the I.F. and 1,500 kc. for the broadcast band. In order to properly align this receiver, it will be necessary to have the following service tools:

1. Test oscillator capable of producing the above alignment frequencies;
2. Non-metallic alignment screwdriver;
3. Output meter. Trimmer locations as well as socket voltages are illustrated below.

The I.F. amplifier should be tuned to 465 kc.; set the test oscillator dial at this frequency. Turn the volume control to maximum and short-circuit the antenna and ground leads. Tune the receiver to a point where no signal comes in. Connect the test oscillator output between the 6A8 1st-Det. tube grid (V1) and the chassis. Connect the output meter across the cone coil of the speaker and adjust the oscillator output until a small deflection is observed on the output meter. The 4 I.F. trimmers are adjusted in the following sequence:

1. Secondary trimmer on second I.F. transformer, C17.
2. Primary trimmer on second I.F. transformer, C16.
3. Secondary trimmer on first I.F. transformer, C13.
4. Primary trimmer on first I.F. transformer, C12.

Throughout all adjustments the output should be maintained at a low level by decreasing the test oscillator output as the various stages are brought in line. After these adjustments have been made, the same procedure should be repeated as a final check. The I.F. alignment will then be complete.

The R.F. and oscillator transformers are aligned at 5x0 and 1,500 kc. With the tuning condenser plates fully meshed, line up the pointer and dial by adjusting the dial drive drum set screws so that the line at the extreme right-hand end of the dial is indicated.

Aligning the Broadcast Band: With the band switch in the clockwise position, set the tuning dial to 1,500 kc. Set the test oscillator at 1,500 kc. and adjust the oscillator trimmer for maximum output. Next, adjust the R.F. trimmer for maximum output, taking care that the output from the test oscillator is not high enough to overload any part of the set. After these adjustments, tune the set and the test oscillator to 5x0 kc. Adjust the broadcast padding condenser C7, for maximum output while rocking the tuning condenser back and forth until maximum output is obtained. The dial setting after this adjustment may not agree exactly with the frequency, but this is not important. To complete the broadcast band line-up, repeat the adjustment at 1,500 kc. as before.

Aligning the Short-Wave—2.2-7.0 mc. (2,200-7,000 kc.)—Band: No separate short-wave trimmers are provided on this receiver. The correct adjustment of the broadcast band automatically aligns the short-wave band.

Circuit diagram of General Electric Model E-51, showing values of all components.

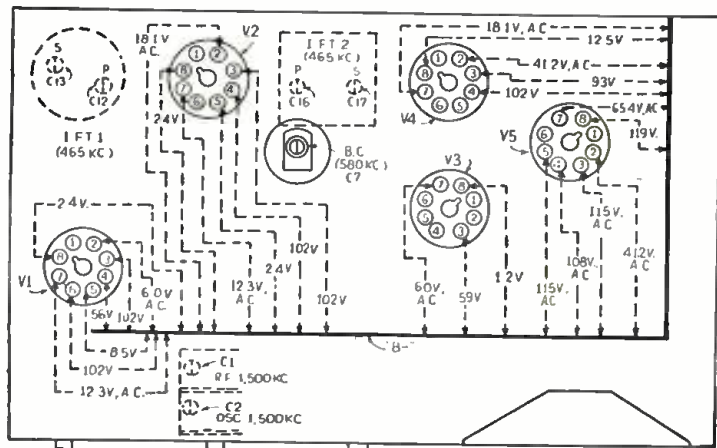
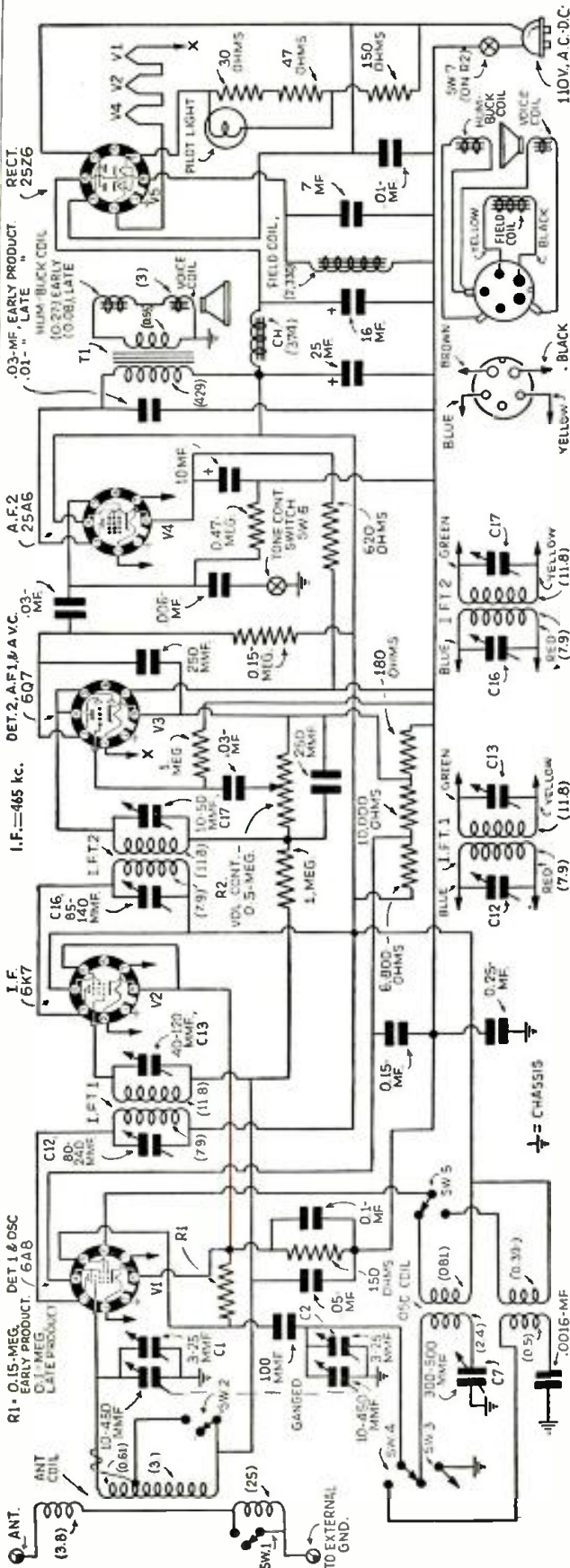

Voltage chart showing normal operating voltages of all tube elements, viewed from the under side of chassis. Trimmer locations are also indicated.

NOVEL RADIO ITEMS

The illustrations and descriptions on this page hardly do justice to these many ingeniously clever radio merchandising novelties.

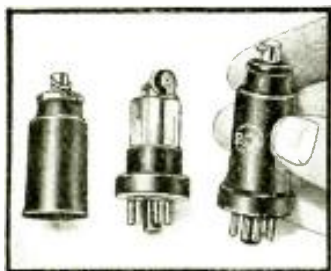

"Tube" lighter. (1380)



Service Man's pencil. (1381)

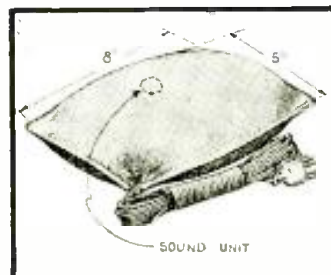

Music at ear-tip. (1382)

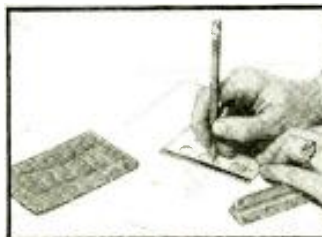

Make good diagrams. (1383)



Illuminated screwdriver. (1384)



Pocket slide-rule. (1385)

NUMEROUS interesting devices that do not fall into the ordinary categories of general radio equipment, testing apparatus, etc., are now available either as direct purchases or as premiums of some sort in connection with the purchase of radio equipment. Some of the more unusual of these devices which have made their appearance in the past are here shown for such interest as they may hold for the radio man. Names and addresses of manufacturers represented will be sent upon receipt of a stamped and self-addressed envelope. Kindly give (number) in the following descriptions.

A "Metal-Tube" Lighter. A new, novel "ciggy" lighter is made in the form of an octal-base tube of the screen-grid type. The lighter is made available by removing the shell of the "tube." (1380) RCA Manufacturing Co., Inc.

Color-Coded Service Pencil. More than ordinary utility is enjoyed in a new Service Man's pencil which incorporates (1) colored and numbered bands that rotate and may be aligned, as illustrated, to determine the electrical values of components in accordance with R.M.A. color codes; and, (2) a bakelite neutralizing tool that recesses into the pencil and is available by removing the entire cap which resembles a metal tube (removing only the shell of this "tube" reveals an eraser underneath which are contained replacement leads). (1381)

A Musical Pillow. Service Men should have no difficulty doing a nice sideline business wiring-in to existing radio sets: the new type of radio pillow here illustrated; hospitals, shut-ins, the hard-of-hearing and other markets for this pillow will be interested in the item because of its small size and low cost, and the individualized program-reception it affords. The pillow contains a small reproducer unit which radiates sound, to the surface of the pillow, through a resilient material containing hundreds of tiny passages. (1382) Eastern Radio and Television Co.

Radio Symbol Guide. Most radio men will welcome the new transparent celluloid stencil here illustrated. Its cut-out outlines make the drawing of radio symbols a pleasure

in more ways than one. (1383) Hygrade Sylvania Corp.

Flashlight Screwdriver. Here is a clever tool that combines an insulated metal blade set in a heavy glass base, with a flashlight whose rays are focused at the point of the blade. Clips into your pocket. Great for working in dark corners. (1384) Hygrade Sylvania Corp.

Circular Slide-Rule. Technicians who know enough arithmetic to work out an Ohm's law formula will want to own this new pocket slide-rule. Its effective length is 20 ins. Permits quickly making all those calculations, in multiplication, division, proportion, reciprocals, squares and square roots, that are the indispensable elements in constructing and servicing radio equipment of all types. (1385) Tavella Sales Co.

Radio-Set Tone Tester. The portion of this adaptor that extends from the knobs to its top may be rotated. This controls circuits, shown by diagram, that permit demonstrating, in 6 steps, the great difference in tone quality between types of radio receivers typical of the years 1927 to 1937. Coloramas simultaneously illustrate these respective types of sets. (1386) General Electric Co.

World-Wide Radio Station Index. Known as the "Roto-Log," this thumb-operated device lists over 1,600 long- and short-wave stations—tells time instantly at any point on the globe. Stations are listed by call letter, and by frequency and wavelength. Swell for checking station logs on dials, etc. (1386A)

"Pindex" Identifies Tube Terminals and Voltages. There has just been introduced a pocket-size, celluloid gadget that enables the Service Man to determine at a glance the manner in which the prongs are arranged, and the filament rated terminal voltage and current for over 60 of the most-used radio tubes. Corresponding data appear in respective windows as a card is slid back and forth. (1386B)

Illuminated Pencil. Ever had a yen to possess a pencil, that could be used in the dark, which would illuminate only the immediate area in which you were writing? Here 'tis. Fine for snooping in the dark corners of a radio set, too. The

(Continued on page 64)



Station data at thumb-tip. (1386A)

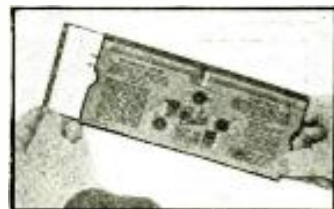

"Pindex" lists tube prongs. (1386B)



Write in the dark. (1387)

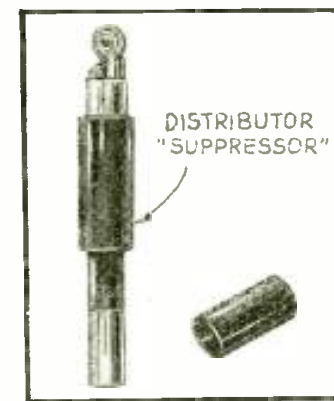

"Suppressor" lighter. (1388)



Tone demonstrator. (1386) The base of the demonstrator conceals the switch, etc. The circuit tells the story.

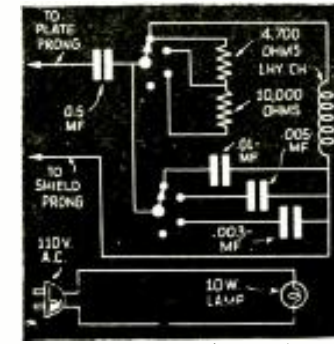

USEFUL TOOLS FOR RADIO SERVICING

The clever technician, in order to save him a few minutes here and a few minutes there, keeps himself well-posted on new tools. Many interesting ones are here described for the Service Man.



Literally blows out static! (1368)

PERHAPS not all these tools will interest all radio men, but, some of them will interest some members of the craft. Names and addresses of manufacturers represented will be sent upon receipt of a self-addressed, stamped envelope. Kindly give (number) in the following descriptions.

RADIO-SET BLOWER (1368)

SERVICE MEN now have available a radio blower that quickly chases dust and dirt—and thus, often, "static"—from the most inaccessible places in the radio receiver.

LIGHT-DUTY HAND-DRILL (1369)

HERE is an A.C.-D.C. hand-drill with trigger-type switch and continuous-operation lock, priced low enough to attract almost every radio set builder, Service Man and experimenter. The no-load speed of this 7-lb. drill is 2,950 r.p.m.

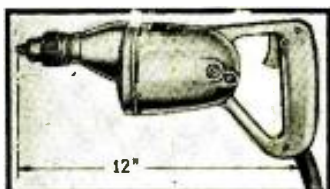

Electric drill saves time. (1369)

SERVICING CHASSIS CRADLE (1370)

ANY make or model of radio chassis may be held in any desired position for testing, aligning, repairing, replacing parts, etc., if the steel chassis cradle here shown is used.

BULLDOG-GRIP ELECTRIC PLUGS (1371)

SERVICE Men will want to replace their regular terminal plug with the special type here shown. A plunger causes the prongs to expand tightly against the receptacle. Prevents the soldering iron becoming disconnected in the middle of an important job—due to a wall plate in the customer's home that does not tightly fit the plug.



A plug with bulldog grip. (1371)

CIRCUIT BREAKER SUBSTITUTES FOR FUSE (1373)

NO NEED to delay repairs, in the service shop, to replace a

fuse blown by a defective instrument. Install a magnetic circuit breaker in a convenient spot. Available in instantaneous trip and time-delay action. Available types: drop on 50 ma. to 35 A.; time delay of 5 secs. to 8 mins.

WRINKLE-FINISH VARNISH (1374)

(General Cement Mfg. Co.)

GIVING a commercial appearance to home-built equipment (amplifiers, test equipment, parts, chassis, etc.) is no longer a problem to the custom constructor. A new "assist" in this direction for the technician is a varnish, available in black and colors, which wrinkles without requiring baking. Easily applied by brush or spray.

SERVICING GRAPHITE-LUBRICANT (1375)

IF THAT condenser shaft becomes a little tight give it a dose of finely-powdered graphite as here illustrated. The compressible celluloid tube is capped with a tiny nozzle.

WATER-PROOF INERTIA FLASHLIGHT (1376)

A BATTERY-OPERATED flashlight that does not use the usual type of off-on switch is now on the market. This flashlight is so completely water-proofed it may be submerged in water more than 24 hours without in the least affecting its operation. It is turned either on or off by a sharp snap of the wrist which operates a built-in switch utilizing principles of inertia.

SERVICING CHASSIS AND MALLET (1377)

A FIXED-ANGLE chassis made of heavy steel which may be used not only for bench work but also in connection with displays is here shown holding a radio set in position. A wooden mallet (insert), cushioned on both ends with rubber



New "safety" flashlight. (1376)



The chassis is fixed. (1377)



Letter your tools. (1375)



A clean-edge chassis cutter. (1379)

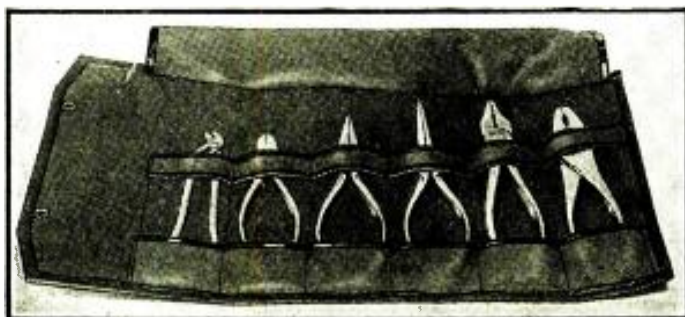

A kit of properly-selected, fine-steel pliers for radio men. (1379A)



New circuit breaker. (1373)



Wrinkle varnish. (1374)



Tubed graphite. (1375)

CROSLLEY MODEL C-516 [CHASSIS No. 506]

A 4-tube (and ballast) A.C.-D.C. superhet.; broadcast and some police bands, 540 to 1,725 KC; A.V.C.; 5-in. dynamic speaker, dual-purpose tubes.

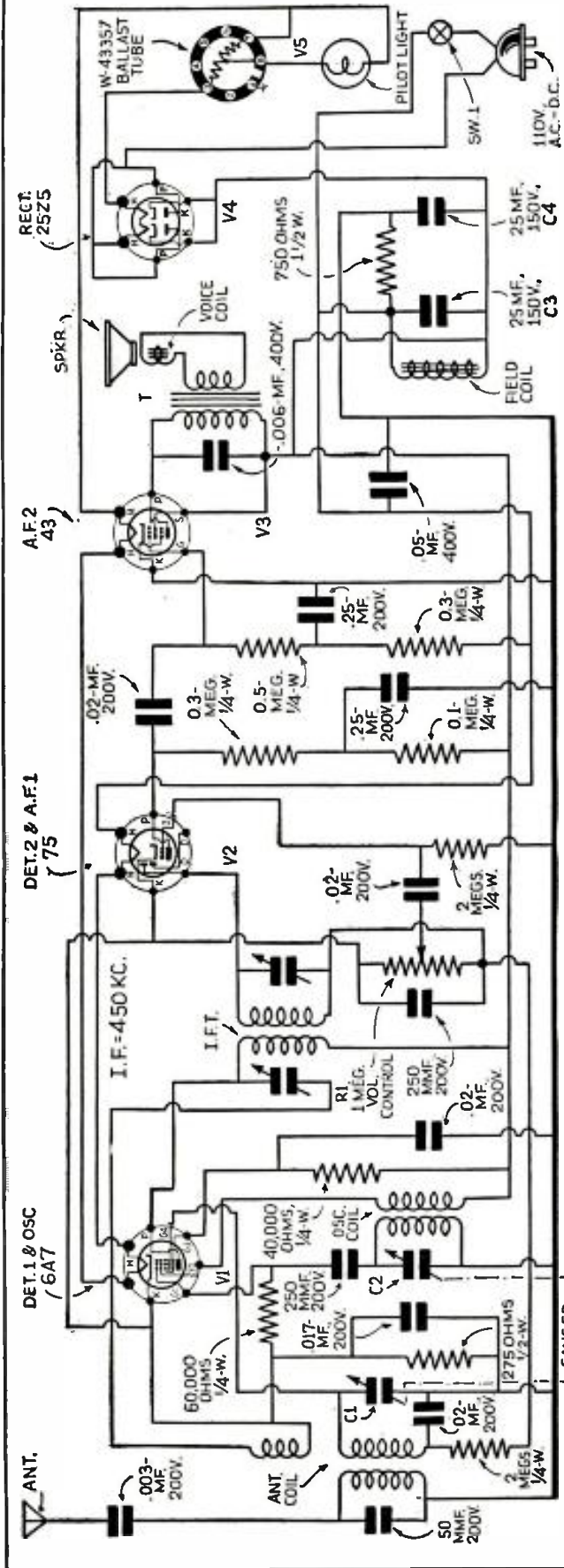

Circuit diagram of Crosley Model C-516 (Chassis Number 506) showing values of all parts.

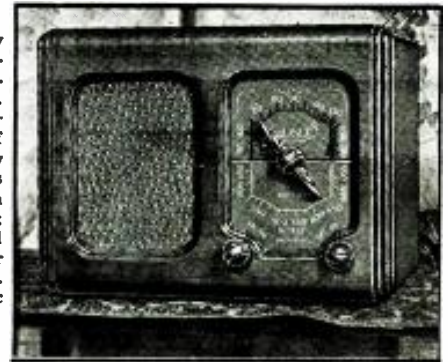

Crosley Model C-516 Mantel Set.

This model C-516 Crosley radio set is a 5-tube superheterodyne designed for operation on a 110 to 120 V. power supply, either A.C. or D.C. The tuning range of the receiver is approximately from 540 to 1,725 kilocycles (555 to 173 meters). Uses a 6A7 as oscillator and 1st-det.; a75 as A.V.C., 2nd-det. and A.F. amplifier; a 43 as power output and a 25Z5 rectifier. Utilizes a 5-in. dynamic speaker.

Tubes and Voltage Limits: The table shown below gives the functions of the tubes used, together with the voltage readings between the tube socket contacts and "B-". Voltage readings should be taken with a 1,000-ohm-per-volt, 250-V. voltmeter (except filaments) with volume control full on and no signal input.

Alignment Procedure: The chassis of this receiver is connected through a resistor to one side of the power supply and for this reason all test equipment should be thoroughly isolated in order that the power supply will not be short-circuited while attempting to align the receiver.

Connect one terminal of the output meter to the plate and the other terminal to the screen-grid of the 43 output tube. Be sure the meter is protected from D.C. by connecting a condenser (0.1-mf. or larger—not electrolytic) in series with one of the leads.

Tuning I.F. Amplifier to 450 kc.: (a) Connect the output of the signal generator through a 0.02-mf. condenser to the top cap of the 6A7 Oscillator—1st-det. tube, V1, leaving the tube's grid clip in place. Connect the ground lead from the signal generator direct to the receiver chassis but do not run a wire direct to ground. *Keep the generator leads as far as possible from the grid leads of the other screen-grid tubes.* (b) Set the station selector so that the plates of the condenser gang are completely out of mesh and turn the volume control to the right (ON). (c) Set the signal generator to 450 kc. (d) Adjust the I.F. trimmer condensers for maximum reading on the output meter. *Always use the lowest signal generator output that will give a reasonable output meter reading.*

Aligning R.F. Amplifier: (a) Connect the output lead from the signal generator through a 250 mmf. condenser to the antenna lead on the chassis. (b) Set the signal generator to 1,400 kc. (c) Adjust the station selector to 140 on the dial. (d) Adjust the trimmer located on the "OSC." section of the condenser gang for maximum output. (e) Adjust the trimmer located on the "ANT." section of the condenser gang for maximum output. (f) Readjust the station selector slightly for maximum output. (g) Repeat operation (e) for more accurate adjustments.

TUBE SOCKET VOLTAGE READINGS

Tube	Function	H	P	S	K	G2	G1	G4
6A7 (V1)	Oscillator 1st-Det.	6.5	100	40	1	100	-20	—
75 (V2)	2nd-Det. & A.F. Amp.	6.5	11	—	1	—	—	—
43 (V3)	Output	25.0	95	100	0	—	—	-20
25Z5 (V4)	Rectifier	25.0	—	—	100	—	—	—

Power output approximately 1 W.; power consumption approximately 50 W.; voltage drop across speaker field 120 V.; all readings taken on 117.5 V. A.C. power supply; all readings except filaments will be approximately 15 per cent lower on 117.5 V. D.C.

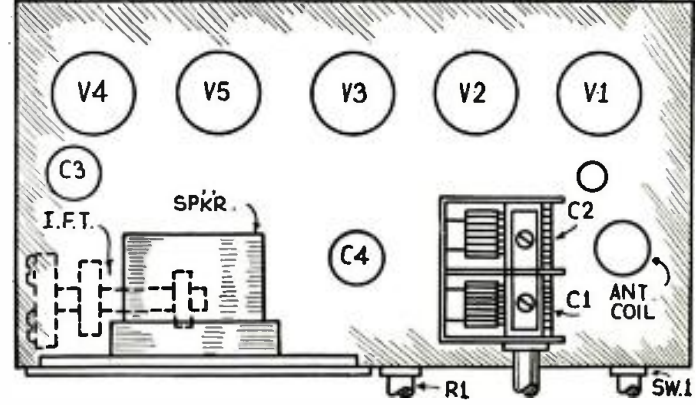

Chassis layout of Crosley Model C-516 showing location of tubes and major components.

CHRYSLER-PHILCO "CUSTOM-BUILT" 1937 CAR-RADIO SET (PHILCO CHASSIS C-1450)

Made by Philco (C-1450); 5-tube Superheterodyne; 6 V. D.C.; vibrator plate supply (optional); dual antenna connection; "courtesy" speaker connection; A.V.C.

This receiver is designed for Chrysler C14, C15, C16; DeSoto S-3; Dodge D-5, D-6, D-7; Plymouth P-3, P-4 models. The cars are also constructed to receive antennas, control panels, and additional speakers.

On models P-3, P-4, D-5, D-6, D-7, there is a connection of the "A" lead to the back of the ignition switch, on which there is a "Ga-Rad" terminal. When the motor is not running, turning the switch key to the extreme left permits the operation of the receiver. For other models, a lock switch, preventing unauthorized operation of the set, is an extra.

The set is normally furnished with the "Roadway" antenna, with which the pick-up is beneath the running boards. On the left side of the receiver housing is an antenna connector; if the "Skyway" antenna (installed on the roof, and running from windshield to below rear window) is used, two screws are taken out of the antenna connector and it is turned halfway round (Fig. F). The screws are replaced; a snap button cover taken off the antenna selector switch (Sw.1). The receiver is then mounted on its bracket; dash seal screw is taken from behind the swivel bracket (at bottom of receiver) and bracket secured to the dash. Antenna lead is then connected into conductor.

The control unit, installed from the rear of the panel, carries three control shafts, connected to the side of the receiver housing, as shown in Fig. E. The fused "A" lead runs from the upper left side of the housing to the "A" lead on the end of the receiver. The other battery lead, from the center of the housing, below the window, is cut to the proper length, and connected to the discharge side of the ammeter.

When the control knobs have been tightened on the shafts, and the shafts connected to their couplings on the receiver, by the casing nuts, the calibration of the tuning dial may be regulated. Turn the knob to right until a stop point is reached; then back all the way

in the opposite direction. Check against a station of known frequency; hold the dial at that frequency (with a rubber on the tip of a pencil) and tune exactly to the station.

To suppress ignition interference: screw the bakelite suppressor (interference condenser part 30-4007) on the distributor end of the distributor center lead cable; plug the distributor into the distributor cap. Install the generator condenser (part 30-4490) on the generator. It is mounted under the ground wire screw (center) and connected to the "A" terminal (thus putting it across the "A" supply) at the left. Do not connect to the other screw (right).

In cases of special trouble, ground the speedometer cable, oil line and temperature indicator tubes, where they enter the dash. No. 14 bare stranded wire is passed around the three tubes and grounded under one of the grommet cap screws. (Remove the paint from under the screw head.) It may also be helpful to connect a 0.5-mf. condenser to either the ignition switch or the ammeter (wherever it does most good), mounting the condenser on the flange of the instrument board.

In noisy locations, it is best to turn the middle knob (tone control) clockwise to Bass Note position, cutting down the high notes. Static, whether atmospheric or man-made, is amplified with the signal; and near electric power lines, or car lines, it may be difficult to bring in any but powerful locals. Since these require less amplification, the automatic volume control reduces amplification and with it the undesirable noise. Caution must be used to turn off the set completely, or the battery will discharge.

There are two models of vibrator: 41-3170-3 (Fig. B) and 41-3170-2 (Fig. D), connections of which are shown.

A 250-mmf. condenser has been added to this receiver, in later issues, as indicated in dotted lines, between filament of V1 and ground.

As a recommended accessory, the "Comfortone Courtesy" speaker has been designed. The back of the front seat, in all car models, is pierced to facilitate its installation. It therefore gives full volume to passengers in rear seats, without increasing it to inconvenience the occupants of front seats. It is connected (as shown in Fig. E) to a socket at the side of the receiver housing. Its connections are shown in Fig. C.



The permanent-magnet dynamic loudspeaker, behind the robe-rail, in use.



Installing the seat reproducer.

To install this speaker it is necessary to reach the speaker cut-out by removing the retaining bracket nuts, the front seat rear-cushion and peeling down the insulating material.

(Continued below.)

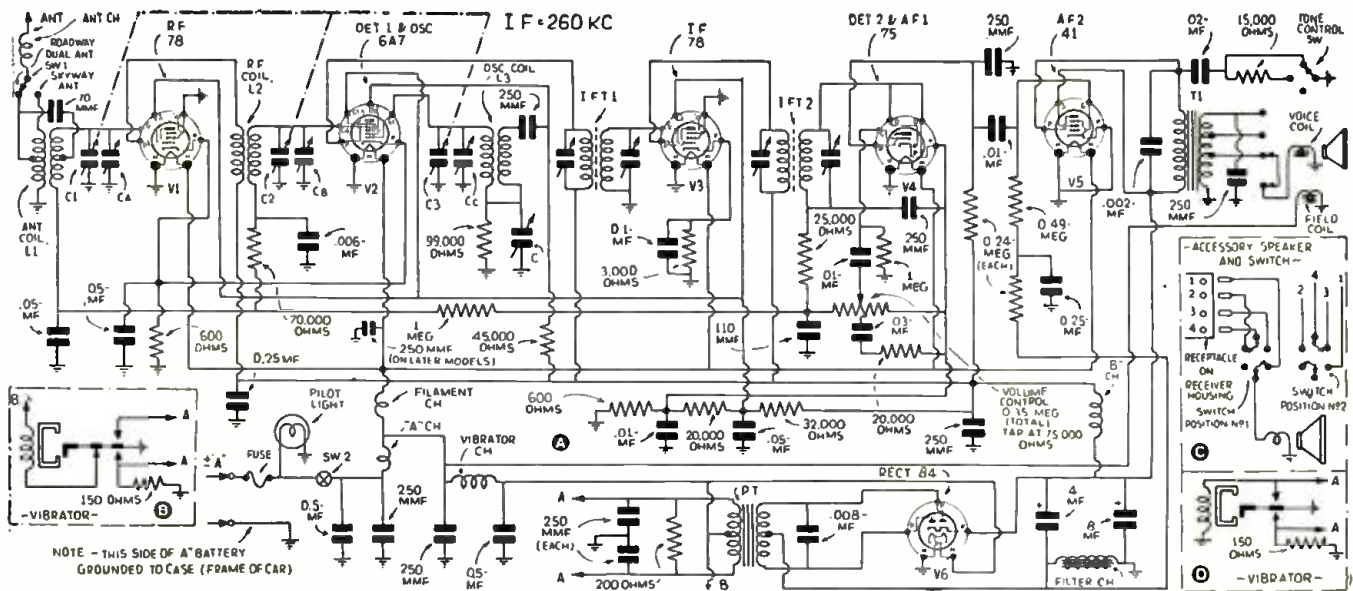

(Continued from above.) Using a sharp knife, cut through seat-back trim; use as guide, outside diameter of the cut-out.

Speaker cable threads, from receiver, under floor carpet along left side of floor tunnel to front seat and through hole in front seat center brace and along brace channel to 1/2-in. hole (to be drilled); photo shows wiring upward from this point.

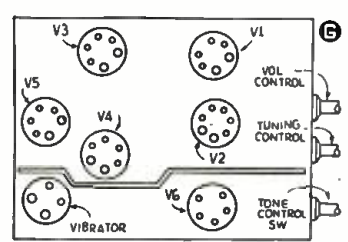
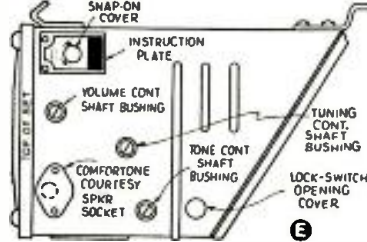
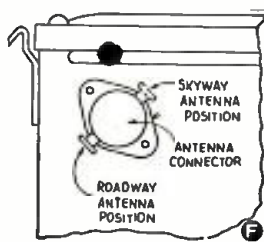



The correct angle to hold the iron is flat to the work.

HOW TO SOLDER

Tyro and expert technicians, alike, will appreciate the fundamental information on an important subject this article contains.

J. L. BROTHERS

SOLDERING is not difficult when certain facts are known. There is only one method of making a perfect, soldered joint. The pieces of metal to be soldered must be raised to the melting temperature of the solder used. It is most important to keep the soldering iron (Here's one of radio's paradoxes—the soldering "iron" is not an iron but a copper!—Editor) at the correct temperature. An "iron" too cold or too hot will not solder properly—if at all.

Temperature. The correct temperature

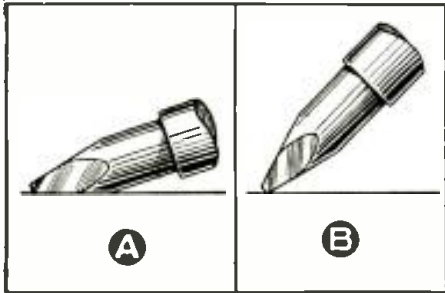

Hold the iron flat against the surface (A).

of the copper tip is indicated by the condition of the tinning. An experienced solderer knows by the appearance of the iron and by the "zip" it makes when brought into contact with the soldering flux and solder, just when the right temperature is reached. Only a little practice is needed to acquire this knowledge.

If the tip is overheating, there will be a tendency for the tin to burn off. That is, instead of the tinning on the copper tip remaining bright, it will become discolored and burn away permitting the bare copper to oxidize and consequently form a heat-insulating crust. The heat is thus prevented from melting the solder and raising the parts to the soldering temperature. Overheating can be prevented by disconnecting the iron from time to time as required.

Clean Metal. The metals to be soldered must be bright and clean, free from grease, dirt or oxide and preferably tinned (coated with pure tin or solder). Nickel-plated parts are very difficult to solder because nickel does not readily enter into solution with the solder, or "alloy" with it. Electro-plated tin parts

are not so satisfactory as those that have been hot dip-tinned because the solder tends to alloy only with the plating which frequently flakes off. There
(Continued on page 61)

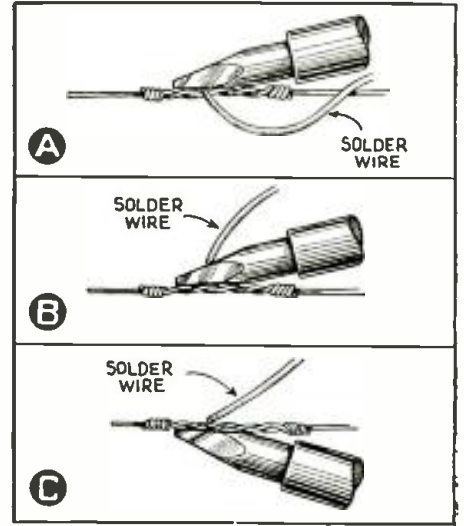

A and C are correct for resin-core solder.

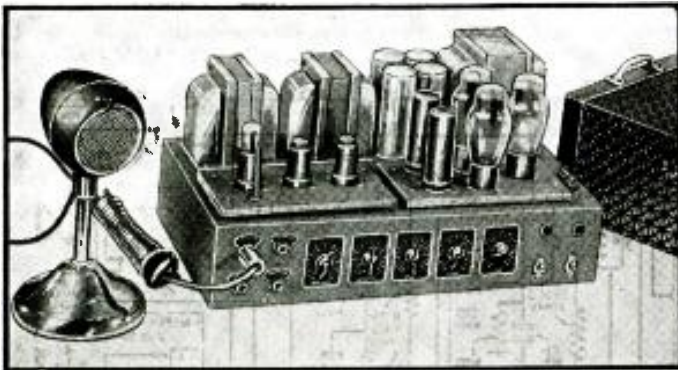

The appearance of the complete direct-coupled amplifier.

DIRECT-COUPLING IN A 30-W. BEAM TUBE AMPLIFIER

This hi-fi amplifier matches a specific microphone. Part II appeared in April issue.

A. C. SHANEY PART III

AFTER having carefully checked the "perfect and ideal" high-fidelity amplifier described in Parts I and II, the P.A. technician might say to the engineer, "So what?" And the engineer would probably reply, "With the advent of a true straight-line frequency, non-reactive amplifier, it becomes a relatively simple matter to design a real straight-line frequency response P.A. system by simply correlating the design of the microphone and loudspeaker in such way that the frequency response of these 2 units complement each other to provide, when connected to the amplifier, uniform pick-up and reproducing characteristics for the entire audio spectrum."

IMPORTANCE OF THE MICROPHONE

Naturally, the microphone is one of the very important determining factors

in such a system, and any discrepancy in its transducing ability would be exaggerated by the amplifier.

The ideal microphone is capable of converting all audio frequencies into

corresponding electrical impulses of equivalent amplitudes without waveform distortion. To accomplish this result, a new streamlined Bullet Micro-
(Continued on page 62)

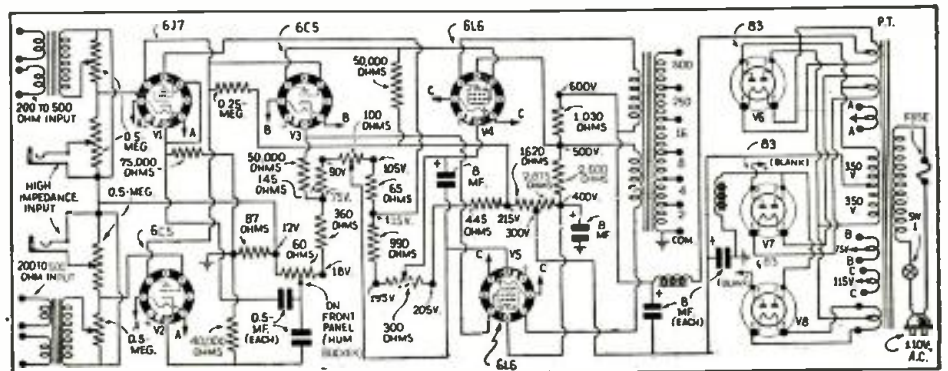

Complete schematic circuit of the amplifier described here and in previous Parts.

**RCA ALL
THE WAY**

RCA Radio News

RCA Manufacturing Company, Inc. • Camden, New Jersey
A Service of the Radio Corporation of America

**EVERYTHING IN
RADIO-MICROPHONE
TO LOUDSPEAKER**

To the consumer, RCA means high quality performance at low cost...To the radio man, RCA means easier selling, higher profits

ENJOY NEW RADIO THRILL!

*Thousands Getting New Pleasure
from Radio that's RCA All The Way!*

The air is full of thrills! Every hour of every day finds colorful, exciting programs being broadcast for you to hear—to enjoy!

As fine as these programs are—it's up to you to get the thrill of radio that's RCA All the Way—perfect performance beginning with the RCA microphone in the studio and coming to you with equal perfection from your RCA Victor receiver. Only by owning an RCA Victor radio can you get this thrill.

They Cost as Little as \$20

You can enjoy radio that's RCA All the Way at low cost with one of RCA Victor's new 1937 models! They are now on display at your RCA Victor dealer's store. Designed for every purse they cost as little as \$20. Among the many models priced below \$100 are several with RCA Victor's Magic Brain, Magic Eye, Metal Tubes. Every chassis is housed in a beautiful cabinet—and there is a large variety of cabinet styles—one of which is sure to catch your eye. At slightly higher prices are the fine models which feature RCA Victor's latest triumph—the Magic Voice.

But visit your dealer. See and hear these superb radios. Take particular notice of their thrilling performance. Then match them against any other radios of equal price—and RCA will win you!

RCA Victor Console Model 9K3... with Magic Voice, Magic Brain, Magic Eye, Metal Tubes. 530 to 22,000 kcs. Beam Power Amplification, Selector Dial, 9 tubes, \$134.95.



New Tube Manual!

The RC-13 Manual on RCA Radio Tubes gives service men complete information on all receiving tube types including Metal and G-Series tubes. Get your copy from your RCA tube distributor.

RCA Radiotron Check-up Restores Radio's Pep and Power

Radios, like anything else that's constantly in use, eventually tire and lose the efficiency which gave you outstanding performance when the set was new.

You can restore your radio's original pep and power—give it new life and "new set" tone by having your radio service man administer the cure-all of an RCA Radiotron check-up.

This check-up consists of 10 testing, cleaning and adjusting steps which cost you only \$1.50.

Get More Service Jobs— Push the Check-Up

If you're a service man you will discover, as hundreds of other men in your business have, that the RCA Radiotron Check-up Plan not only gives you additional service jobs but in addition, helps you sell parts, new sets and other appliances that you have for sale.

You will find the RCA check-up an easy service to sell. Because there's nothing unusual about check-ups in American life. People are accustomed to check-ups of all sorts. They know the value of check-ups. Therefore, a radio check-up is quite acceptable.

You get selling help, too, direct from RCA Radiotron. For full column advertisements are running in the Saturday Evening Post and Collier's every other week... newspaper ads are appearing in over 100 cities... the check-up is being featured with commercial announcements on a full hour Sunday radio program. And in every one of these advertising efforts RCA Radiotron is featuring you as the man to perform this check-up service. In addition, RCA Radiotron also offers you mailing pieces for your own use—mailing pieces that will include your own name and address and which will bring you directly to the attention of all your prospects. Secure yours today. Use them. Get behind this check-up service—and profit! You can get full details from your jobber, who will also beglad to tell you about the new RCA Radiotron Auto Radio Check-up.

This is P. A. Time— The Time to Cash In!

Warm weather and bright sunshine are here. And that means it's P.A. time—and the time for you to cash in on installations of public address systems.

Your prospects? There are many. This season of the year is ideal for outdoor installations such as in amusement parks, athletic fields, camps, resorts, swimming pools and "garden" night clubs.

The best way for you to get your share of this P.A. business is to offer prospects RCA equipment. Public address systems bearing the RCA trademark provide real quality. And that's only natural. For behind them are the years of experience RCA has gained as the world's leading maker of sound products.

RCA offers these portable P.A. models that will cover all your needs for the type of equipment. Both give you the sales advantage of the RCA name. All are literally packed with performance features that help make them easy to sell. All sell at modest cost—yet assure you good profits.

Get after the P.A. market today. Get your share of the profits that are in it. Push the RCA public address systems shown here—and win many installation jobs! Write us for free details.



RCA Portable Sound System PG-98... provides volume for audiences up to 1600 persons. 12 watts. RCA Velocity Microphone. Two Electro Dynamic Speakers. Easily accessible controls. Comes complete with six RCA Radiotrons.

RCA Portable Sound System PG-62-E... provides volume for audiences up to 3,000 persons. 20 watts. RCA Velocity Microphone with adjustable banquet stand. Two special Electro Dynamic Speakers. Provides for mixing voice with musical background. Comes complete with seven RCA Radiotrons.



In addition to these two systems shown above, RCA also offers another Portable Sound System, the PG-63-B—a 6-watt system providing volume for audiences up to 600 persons.

Please Say That You Saw It in RADIO-CRAFT

THE RADIO MONTH IN REVIEW

(Continued from page 7)

The system is extremely flexible in that the energy released by interfering with any beam can be used for various purposes, such as sounding an outside bell or siren. The type of installation made at the demonstration was unique and presaged more modern and effective methods. It automatically cleared a telephone line, dialed police headquarters, and transmitted a spoken message summoning aid. After this message had been repeated for a minute and a half, the device "hung up" and then called the telephone company, repeating its message for the same period as a check upon the first call. Having done this, it once more cleared the line and automatically placed the telephone back in service.

Previous protectional systems relying on the phototube have had to depend on a visible white

beam for reliable transmission of any considerable distances, or when reflected by more than a few mirrors. The 32-candlepower lamp employed in this demonstration was placed in a projector fitted with a special filter which transmitted only invisible rays of the infra-red band. The invisible beam was focused on the phototube through a special lens and holder connected to an amplifier using standard metal radio tubes. Because of its design, the system is responsive to minute current values set up in the phototube, making it possible to employ the beam over long distances, and to reflect it from mirror to mirror and effectively honeycomb a space with unseen "fences" of electricity.

Radio is making it harder and harder for lawbreakers to get away with anything.

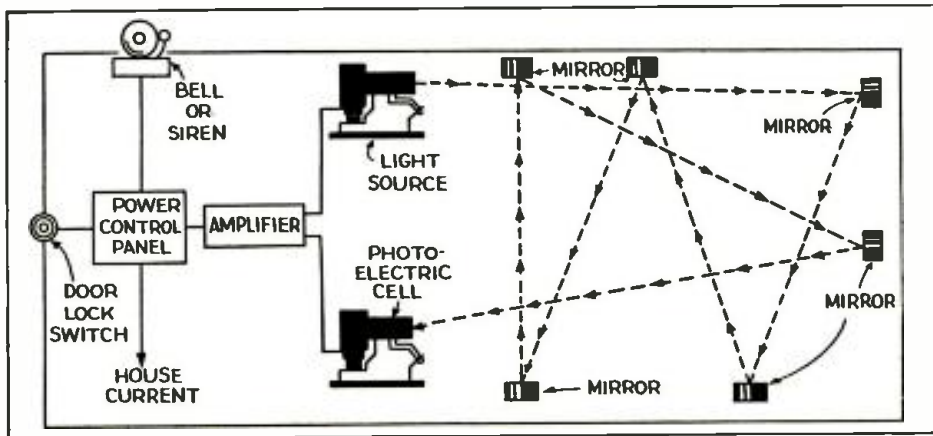

A simplified idea of how the "invisible" rays protect an area by crossed beams reflected from small mirrors.

ASSEMBLING A SIMPLE CRYSTAL SET

(Continued from page 12)

microfarad") fixed condenser, a galena crystal, and a crystal holder with attached "catwhisker."

TAKING THE FIRST STEPS

The first step in the construction of the crystal set is to "pull-down" the wavetrap; i.e., disconnect all wires and remove the "innards" from the metal can. Then proceed to rewire all the parts according to the picture diagram shown in Fig. 1A. For those who are able to and prefer to follow a schematic diagram, one will be found in Fig. 1B.

All the components of the wavetrap but one are utilized in the crystal set and that is the small fixed mica condenser. The value of this unit is too small for our purpose.

The small-diameter coil, L1 in the diagrams, becomes the primary winding of the antenna coil. The larger-diameter coil, L2, becomes the secondary. The tap on this coil is not used.

Both inductances are coupled by means of the smaller-capacity trimmer condenser, C1, the one with the screw adjustment. The other trimmer condenser, C2, the one with the extended shaft, is wired across coil L2. This condenser is the station selector.

The crystal and headphones are then wired into the circuit as shown in the pictorial and schematic diagrams. Connecting the 0.006-mf. bypass condenser across the phone terminals completes the wiring of the set.

HOW IT WORKS

This little crystal set was first tested in a modern steel building in New York City with a 20-ft. wire dangling from a window as an aerial. The results were remarkable, considering the circumstances. Five different stations were tuned-in with comfortable earphone volume. Several others were also tuned-in, but faintly. With a decent outdoor aerial they would have been much louder.

If upon completing the set you fail to receive any stations, try the following remedies:

- (1) Check the wiring against the diagrams for possible errors;
- (2) Clean the crystal detector by wiping the surface with a cloth dipped in ether or carbon tetrachloride ("cleaning fluid");
- (3) File the very tip of the "catwhisker", or snip it with pliers, to a very fine point to assure

good contact; (4) Try resetting the "catwhisker" on various points of the crystal surface in order to find the most sensitive spot; (5) Check the aerial and ground connections and the aerial itself.

To obtain good reception, a crystal set must be operated properly. Here is the procedure for operating this set.

Attach aerial, ground and phones to the set, making certain that all connections are secure. Tune-in a weak station and then adjust the coupling condenser, C1, with an insulated screw driver for loudest volume. Then readjust the tuning condenser for loudest volume. The coupling condenser need never be touched again so long as the same aerial is used. Finally, with a station tuned-in, "fish around" the surface of the crystal detector with the catwhisker until the most sensitive spot is found. This will usually manifest itself by an increase in signal strength. This adjustment need not be made frequently but should be made occasionally.

LIST OF PARTS

- One Meissner type 8048 wavetrap;
- One galena crystal;
- One crystal holder and catwhisker;
- One Cornell-Dubilier fixed mica condenser, 0.006-mf.;
- One baseboard;
- One pair of standard headphones.

THE SERVICE MAN TAKES A HOLIDAY

(Continued from page 9)

overnight. It may in fact be 2 or 3 seasons before the Service Man has succeeded in storming the citadels of the boatmen who own radio-equipped boats or who plan to equip their boats with radio receivers. Unlike the car-radio owner who has only to drive into a car-radio service station, the boat-radio owner finds it inconvenient to bring his problems to the Service Man. Therefore, it is up to the ambitious technician to capitalize on this fact by having instantly available a fully-equipped radio service boat to answer a radio repair SOS.



—says Mr. FRANCIS D. WARDNER

of the WARDNER RADIO ELECTRIC CO. of St. Paul, Minn. Thanks, Mr. Wardner, and because we understand you are one of the outstanding service men in the Northwest, we are doubly proud of your testimonial of confidence in Centralab. Since radio's pioneer days CENTRALAB has been building an outstanding "quality" control.



Service men everywhere are following Mr. Wardner's plan . . . by staying with CENTRALAB for ALL replacements.

Centralab

MILWAUKEE WISCONSIN
 BRITISH CENTRALAB, LTD.
 Canterbury Rd., Kilbourn
 London N.W. 6, England
 CENTRALAB
 118 Avenue Ledru-Rollin
 Paris XI, France

Save Money on everything you buy . . .



The New BARGAIN BULLETIN

Your Guide to Hundreds of Outstanding Values.

FREE Write today for this outstanding new BARGAIN BULLETIN—there is no obligation on your part. High quality merchandise at sensationally low prices! Radio Sets, Parts, Sporting Goods, Watches, Clocks, Typewriters, Cameras, Novelties and many other items at real savings to you. Fair Dealing—Prompt and Courteous Service, always. Send for your Free BARGAIN BULLETIN now, try us, and be convinced of our superior values and service.

RADIO CIRCULAR CO., INC.
 DEPARTMENT RC-7
 915 Broadway New York, N. Y.

NEW PROFITS FOR THE AUTO MECHANIC IN RADIO INSPECTION

(Continued from page 9)

car, it is desirable to maintain the metal parts of the car at the same ground potential so that, for instance, no radiation of the spark interference will flow from the engine block to the dash, thence to the frame of the car, in order to reach the lowest ground potential. A good electrical connection is as important as a good mechanical mounting.

All these things, of course, can be done easily with the aid of instruments designed for these purposes by leading automotive engineers. It only remains to add those equally important instruments specially built for radio service which will soon be the necessary equipment in every progressive shop.

An auto mechanic who knows ignition systems can pick up auto-radio service in a very short time. It is based on the same fundamental facts as the ignition system. Even the terms are those with which he is in daily contact—*ohms, amperes, volts*. So are *capacity and inductance*, the first being used in the designation of sizes of condensers used across the breaker points of the ignition system, the second being associated with the ignition coil. He will have no trouble at all in learning the ins and outs of auto-radio.

Stress the fact to every owner of an auto-radio receiver that the person to service his radio set is the man who services his car. For one is so inter-dependent upon the other, that unless there is perfect coordination, the best radio receiver in the world will prove a dud. This one-stop service will please him, save him time and money, and prove a surprisingly big and increasing source of profit to the garage.

Our Information Bureau will gladly supply manufacturers' names and addresses of any items mentioned in RADIO-CRAFT. Please enclose a stamped and self-addressed envelope.

MAKING THE RADIO-CRAFT SIMPLIFIED CARRIER INTERPHONE

(Continued from page 13)

show that the circuit is not super-regenerating, perhaps by reason of improper values for R9 and C2. REMEMBER THAT WE DON'T WANT OSCILLATION UNDER ANY CIRCUMSTANCES. WE DON'T EVEN WANT SUPER-REGENERATION IF WE'RE GOING TO HAVE TROUBLE WITH IT. If you can't get the set to regenerate properly without oscillation, tie the R lead from the R.F.C.2 switch section to R5 and discard C8 and R9. Plate voltage will be quite low, but the detector will still work efficiently.

Switch to "send". Here the red pilot should light up. Test for plate voltage. If this is as low as 50 and circuit corrections do not appreciably increase it, the 25A6 transmitting signal generator must be discarded and a 6J7 or 6C5 substituted. R.F.C.2, whatever the type of oscillator-circuit tube, must be effective at operating frequency and prevent any R.F. from wandering out of home pastures. Now connect a speaker voice coil to the secondary of Ch., if the latter is equipped with a winding for any voice-coil impedance match. Test for audio reproduction of impressed voice impulses by speaking into the "transducer" with the gain control at various positions. Clear articulation at all levels should result, with no evidence of hum, audio feedback, or R.F. mush. If speech sounds boomy and R9 and C8 are in use, decrease the value of C8 until low-frequency mike response is attenuated to the desired degree.

Remove the external speaker. If T1 "sings" at high audio-gain-control level and with or without impressed speech—(1) either R.F. and regenerating A.F. is playing heck with the works, or (2) the signal generator may not be oscillating and the load presented to the 25A6 modulator may be insufficient. Keep "playing around" until the generator is oscillating strongly and the audio system is entirely clear of undesirable effects. Set up a small receiver tunable to operating frequency and loosely coupled to the oscillating circuit and listen-in. If voice modulation can be distinctly and cleanly heard, we're ready to tie C7 to point Y and build up a second communicator unit.

CUT RATE OUTLETS

..... are places where
National Union Radio Tubes
AIN'T!

A nice comfortable feeling! We mean that secure, clean cut feeling a National Union Service Specialist has when he installs N. U. tubes. He knows he's gotten a fair price for premium quality merchandise. He's rendered a genuine service to a set owner and he's not going to be embarrassed by having his customer see N. U. tubes advertised in some gyp joint down the street as a loss leader.

No, Sir! National Union has kept the market clean for you. National Union tubes are not listed in cut price mail order catalogs. You won't find them in price slashing chain stores or department stores.

Your profit margin is reasonable when you sell at established list prices and National

Union has always felt that you are entitled to protection on it.

Remember these facts . . . the boys who are selling N. U. tubes are selling them with complete confidence . . . they're not running a chance of customer ill-will . . . because the set owner will never see N. U. tubes offered for sale with the heart cut out of the price!

This business of keeping the market clean for the Service Industry is only one of the reasons that N. U. is such an overwhelming favorite in the service field . . . Have you ever heard the entire National Union sales story? It will pay you handsome dividends to be tied up with N. U. Find out why . . . send the coupon below . . . NOW.

MEET US — at the NATIONAL RADIO PARTS TRADE SHOW
..... Booths 104 - 105 — Hotel Stevens - Chicago - June 10, 11, 12, 13

CLIP! . . . MAIL!

NATIONAL UNION RADIO CORP. of N. Y.
570 Lexington Ave., New York, N. Y.

RC-737

Who is the nearest N. U. distributor? I want to find out what N. U. can do for me.

Name

Street

City State



Be a RADIO EXPERT - Learn AT HOME

RADIO SPECIALISTS NEEDED

Modern receivers with their complicated circuit systems have knocked out the old time cut-and-try radio fixer. Trained men with up-to-the-minute knowledge are needed to service these new sets.

HERE IS YOUR OPPORTUNITY

Your possibilities of making money and getting ahead are limited only by your ability and skill—but you must know more than the other fellow. You must be a radio service specialist, as R.T.A. can train you.



FREE OF EXTRA COST
To start you making money without delay we equip you with this Circuit Analyzer and Point to Point Resistance Tester.

PRACTICAL TRAINING AT HOME

Our home study course is practical "shop and bench" training combined with a thorough set of practical lessons prepared by an experienced Radio Service engineer. Four working outfits are also furnished.

MAKE SPARE TIME MONEY

Our training is complete and practical. We show you how to make money almost from the start. The course can easily be made to pay its own way. Investigate now, write for free book of details.

WHAT R.T.A. STUDENTS SAY

Norwood, Ohio
I have connected with a large firm as Radio Service Manager and wish to extend my thanks for your help.

Joseph Rapten, Jr.

Yorkville, Ohio
From Aug. 1 to Dec. 7, 1936. I repaired 163 radios and put up 43 aerials which is very good for part time work while studying your course.

Chas. Koerber.

RADIO TRAINING ASS'N OF AMERICA
Dept RC-77, 4525 RAVENSWOOD AVE., CHICAGO

Please Say That You Saw It in RADIO-CRAFT

**Top
Quality
-ALWAYS!**



You take no chances with Raytheon tubes. When you make a replacement with Raytheons — you can forget them! Every Raytheon tube is top quality! Every one is precision engineered... built to give clear, true-toned reception, and extra long life. They won't bounce back! And every customer will be a permanent satisfied customer.

Because of their top quality, you'll find Raytheons practically everywhere! In U. S. Army, Navy and Aviation Communications. In major broadcasting chains. In thousands of amateur radio transmitters and receivers. In millions of home radio sets as original equipment. In leading auto radios, because of their sturdiness, uniformity and ability to withstand continuous shocks and rough usage. On thousands of dealers' and servicemen's shelves... and so on down the line.

So — when you handle or use Raytheons, you're not only in good company — but you know you're taking no chances.

ASK YOUR JOBBER



RAYTHEON PRODUCTION CORPORATION
 420 Lexington Ave. 55 Chapel Street
 New York, N. Y. Newton, Mass.
 445 Lake Shore Drive 555 Howard Street
 Chicago, Illinois San Francisco, Cal.
 415 Peachtree St., N. E.
 Atlanta, Ga.

RAYTHEON IS THE MOST COMPLETE LINE—ALL TYPES OF GLASS, OCTAL BASE, METAL, RESISTANCE AND AMATEUR TRANSMITTER TUBES.

TECHNICIANS' DATA SERVICE

JOSEPH CALCATERRA

DIRECTOR

A special arrangement between RADIO-CRAFT magazine and the publishers of this literature, which permits bulk mailings to interested RADIO-CRAFT readers, eliminates the trouble and expense of writing to each individual organization represented in this department.

2. HAMMARLUND CATALOG. Contains complete specifications, illustrations and prices on the Hammarlund line of variable and adjustable condensers; intermediate frequency transformers, coils and coil forms; sockets; shields; chokes and miscellaneous parts for broadcast, short wave and ultra-short wave reception and transmission. Also contains description and prices of the Hammarlund line of "Comet Pro" and "Super Pro" receivers.

5. ELECTRAD 1936 VOLUME CONTROL AND RESISTOR CATALOG. Contains 12 pages of data on Electrad standard and replacement volume controls. Truvolt adjustable resistors, vitreous wire-wound fixed and adjustable resistors and voltage dividers, precision wire-wound non-inductive resistors, center-tapped filament resistors, high-quality attenuators, power (50- and 150-watt) rheostats and other Electrad resistor specialties.

29. THE KEY TO SUCCESSFUL SERVICING. Four different types of combinations of courses on Radio Servicing, Public Address Work, and Television, developed by the Radio Service Institute, are described in this 24-page booklet. Complete information, including outlines of the courses and costs, is given. Two of the courses are designed for the more advanced and more ambitious Service Men who are anxious to get to the top of their profession. The other two courses are for less-experienced Service Men who want to advance more rapidly in the Radio Servicing Field. Please do not ask for this booklet unless you are interested in taking a course in these subjects.

53. POLYIRON COIL DATA SHEET 536. This folder contains complete catalog descriptions, specifications, prices, performance curves and circuits showing applications of the complete line of Polyiron radio components made by the Aladdin Radio Industries, Inc.

57. RIBBON MICROPHONES AND HOW TO USE THEM. Describes the principles and operating characteristics of the Amperite velocity microphones. Also gives a diagram of an excellent humless A.C. and battery-operated preamplifier.

65. THE 1937 LINE OF SUPREME TESTING INSTRUMENTS. This 24-page catalog gives complete information on the entire Supreme line of testing instruments, including the Model 535 Diagnostics; the Model 540 and 550 Radio Testers; the Model 500 Automatic; the Model 505 Tube Tester; the Model 555 Diagnosticscope and other Supreme oscilloscopes, tube testers, signal generators and multimeters. Complete details of the Supreme Easy Payment Plan for purchasing testing equipment on the installment plan are also given.

73. HOW TO ELIMINATE RADIO INTERFERENCE. A handy folder which gives very complete information on how to determine and locate the sources of radio noise by means of the Sprague Interference Analyzer. A description of the analyzer and method of using it is included, together with data on how to eliminate interference of various kinds once the source is located.

74. SPRAGUE 1936 ELECTROLYTIC AND PAPER CONDENSER CATALOG. Gives specifications, with

Radio-Craft Technicians' Data Service
 99 Hudson Street,
 New York City, N. Y. RC-737

Please send to me, without charge or obligation, the catalog, booklets, etc. the numbers of which I have circled below.

2	5	29	53	57	65	73
74	75	76				

My radio connection is checked below:

- Service Man operating own business.
- Service Man for manufacturer.
- Service Man for jobber.
- Service Man for dealer.
- Service Man for servicing company.
- Dealer.
- Jobber.
- Experimenter.
- Professional Set Builder.
- Amateur Set Builder.
- Short Wave Work.
- Licensed Amateur.
- Station Operator.
- Radio Engineer.
- Laboratory Technician.
- Public Address Worker.
- Manufacturer's Executive.
- Student.

I am a:

Subscriber Newsstand reader
 I buy approximately \$..... of radio material a month. (Please answer without exaggeration or not at all.)

Name

Address

City State
 (Please print name and address)

Avoid delay. The catalogs and booklets listed are now in stock and will be sent promptly as long as the supply lasts. Please use this coupon in ordering. The use of a letter causes delay.

list and net prices on a complete line of wet and dry electrolytic, and paper condensers made by the Sprague Products Co. for radio Service Men, set builders, experimenters and engineers. Information on the Sprague Capacity Indicator, for making capacity tests on condensers and in servicing receivers, is included.

75. SPRAGUE TEL-U-HOW CONDENSER GUIDE. A valuable chart, compiled by the Sprague Products Co. which tells the proper types, capacity values and voltages of condensers required in the various circuits of radio receivers and amplifiers, and how to locate radio troubles due to defective condensers. Includes data on condenser calculations.

76. FACTS YOU SHOULD KNOW ABOUT CONDENSERS. A folder, prepared by the Sprague Products Co., which explains the importance of various characteristics of condensers, such as power-factor, leakage, capacity and voltage in determining the efficiency or suitability of a given condenser to provide maximum filtering and safety in operation.

VACUUM-TUBE CHARACTERISTICS WITH THE C.-R. TUBE

(Continued from page 20)

area of reverse plate current due to secondary emission is seen at X. Figure A6 shows the improvement made when the type 39/44 screen-grid pentode is plugged into the same socket under the same conditions. The suppressor-grid has eliminated the secondary-emission phenomenon.

Whereas it has been the practice of designers to take the static tube characteristics and figure from them, it is now possible to set up the circuit in question and actually study the action of the tube and all its characteristics in operation. In present-day design where circuit constants are so complicated, with multi-element tubes and interlocking power-supply components, such a procedure is almost necessary. Then too,

when the study aims at elimination of distortion, the use of the actual characteristics of a vacuum tube in the particular circuit cannot be recommended too highly.

Not only can the cathode-ray tube testing equipment be used for design problems, but with small variations can be applied to the routine testing of tubes in production lines. By the use of a special type of synchronous switch perfected by the author and described in *Electronics*, June 1933, 2 or more tube characteristics can be compared by superimposing the curves. This will allow much more rapid and comprehensive tests to be made than heretofore have been possible because of the time involved.

Please Say That You Saw It in RADIO-CRAFT

"THE CASE OF THE RESORT"—AND OTHER SOUND STORIES

(Continued from page 17)

Accordingly, we are presenting several interesting public-address situations that actually occurred and from which much can be gleaned in the way of sales experience.

The Case of the Resort

Camp X—is a summer resort with a capacity of about 700. It comprises rows of small bungalows, a large dining hall, a sizable social hall (theatre and dance floor), golf and tennis facilities, a staff of capable technicians, the usual lake and, all-in-all, not a bad place for a Service Man to spend a week on an installation.

The original specifications recommended a system that employed the amplifier in the office where the calling mike was located. Cables were to be run overhead to loudspeakers in the dining hall, social hall, one facing the lake and another the golf course. One loudspeaker was allotted to the men's bungalows and another to the women's.

The project was quite ambitious. All speakers constituted a calling system for the office. During dining hours a mike was used in the dining hall for entertainment there; the mike line ran back to the amplifier in the office. The same system was to be used in the social hall in the evening. A mike line ran from the social hall to the office, some 600 ft., and the speaker cables carried the amplified business back from office to stage reproducers.

A portable mixer was to be carried to the dining hall and the social hall for use with the mikes in either place. Field and voice for all speakers followed the 3-wire cable system, with field supplies at the amplifier in the office. Other features included an R.F. tuner at the amplifier rack, spare amplifier for emergency and a portable record reproducing unit for mike-record mixing and fading.

The set-up looked swell on paper and so was OK'd for installation. Two weeks later the camp sky was darkened with cables and the entire office staff walked around training for the Best Diction Prize. The system worked—in a way.

Two times a day a harried technician lugged the mixer up to the dining hall for use there. In the evening it was set up for the band in the social hall, or backstage for sound effects. Another man had to sit in the office to control things at the amplifier.

Then, something was happening to quality—the long mike lines from the theatre and dining hall way over to the office amplifier were suspected. The ground on the mike cable shield at the office and that at the mike gave a differential reading. The social and musical directors tore their hair at the inflexibility of the system for hand and stare work—the office manager swore at the monitor on the office rack—the owner just swore.

It came sooner than was expected. The explosion rocked the windows at the P.A. establishment and sent a brace of engineers running up for another week's vacation with pay. And here is the solution. It should have been done in the first place; it constituted a bigger sale in terms of dollars and made every one happy.

The outdoor calling speakers were left in position, but a separate amplifier was used at the office for calling. Another amplifier was set up in the social hall; this unit mounted its own controls and served for the orchestra and stage.

The dining hall, likewise, was equipped with an amplifier suited to the hall's needs, and equipped with its own mixing panel—most amplifiers are so equipped anyway. Incidentally, here's a good tip; a simple fact had been overlooked in the original specifications—the enormous noise level of 700 dishes and metal eating tools going at the same time almost unbalanced the amplifier and the installation engineer. And, Oh yes, the wandering mike lines came down.

MORAL: The simplest way is generally the best way.

The Case of the Kitchen Call System

This one is really too simple, but it did create a slight stir and its solution will doubtless be of interest to all sound men. The locale of this plot took place in a restaurant. Specifications called for a conventional system using a loudspeaker in the kitchen and 4 microphones spaced equally along the sit-down counter so that 4 countermen could work more efficiently. A switch on each mike did the trick of throwing it into the circuit. Filaments and plates were on at all times.

Pride and tradition in one of the countermen caused him to attempt to sabotage the system; he insisted on roaring his "hamand" towards the kitchen as of yore instead of into the mike—but that's another story.

The catastrophe that started up the sirens in this case, occurred one noon-hour rush when two men simultaneously shouted their orders into the mikes. The chef's resultant of this composite order was too weird for words. True, 2 paralleled mikes did reduce the efficiency of output considerably, but enough trickled out of the speaker to bring about an incoherent phone message that almost caused an analyzer to jump off a test bench and gallop down to Ye Eate Shoppe unaided.

A bevy of technicians took to horse and made for the restaurant. When they arrived they found calm had descended again, albeit with mild complications. A system had been devised that served for the time being, but could not endure. Each man looked up and down the counter before shouting his order. At the time the technicians arrived, business had slowed down but the heads of two of the countermen continued to oscillate by momentum.

The mike switches were changed to incorporate another throw. When a man pressed his button a pilot light on each mike flashed, indicating that the system was in use. An independent circuit using a simple bell-ringing transformer for energy did the trick.

MORAL: Design your system for worst possible conditions.

The Case of Too Much Sound

This case marks a popular misconception of speaker placement for large areas. Two 6-ft. trumpets were used to cover the drill floor of a National Guard armory—one at each end of the floor. The amplifier had a considerable rating so as to over-ride the tramp and clatter of military drill.

When the set-up was demonstrated, the hall was empty except for the presence of the powers-that-be. They stood in the middle of the floor, beamed with satisfaction and murmured things about the wonders of science—it certainly was good and loud.

At the next drill night, troopers filled the floor and went about their business of "squads east and west." Suddenly the loudspeakers opened up. Several soldiers immediately under the trumpets remained standing by shoring themselves up with their rifles. A few in the middle of the floor merely staggered slightly; others, here and there, complained of hearing faint mumbblings.

After the Colonel hung up the receiver (and, boy oh boy, he was a soldier of the old school!), the bellow experts came down with a trailer full of smaller speakers. These were placed all around the floor so as to obtain good coverage of small areas rather than roaring coverage of very large areas as in the original installation. It worked.

MORAL: Where a little is good, a lot is not always better.

This article has been prepared from data supplied by courtesy of Wholesale Radio Service Co.

A DELUXE SERVICE SHOP ON WHEELS

(Continued from page 8)

use a D.C. generator which is independent of the car engine. This generator is driven by a 4-stroke, 2-cylinder gas engine.

The entire workshop is surrounded by a glass enclosure. Thus, the layman is able to get a good "action" idea of what constitutes a modern radio workshop.

This business of "bringing the mountain to Mohammed" in the form of a mobile servicing unit of course is not new to Radio-Craft readers—in fact, Radio-Craft proposed just such an arrangement several years ago. However, (1) the idea of combining a radio set and public address service in one, specially-designed automobile; and, (2) the idea of conducting the business behind glass so that the customer may follow the operations, both are money-making methods that we recommend to the worthwhile Service Man who can appreciate the customer-psychology involved.—Editor

Please Say That You Saw It in RADIO-CRAFT

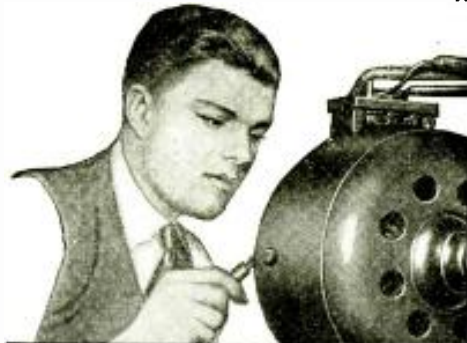

Amazingly Easy Way to Get into ELECTRICITY

Send Today for Details of

"Pay-After-Graduation" Plan

Don't spend your life never sure of a job. Let us prepare you for your start in a good paying field. Let us teach you how to prepare for positions that lead to good salaries in Electricity—NOT by correspondence, but by an amazing way we teach right here in the Great Coyne Shops you get a practical training in 90 days. Mail the coupon below. If you are short of money I'll send you all details of my "pay-after-graduation plan" where many get my training first and start paying for it 5 months after they start school and then have 18 months to complete their payments.

LEARN BY DOING—IN 90 DAYS

BY ACTUAL WORK—In the Great Coyne Shops

I don't care if you don't know an armature from an air brake—I don't expect you to! Coyne training is practical "learn-by-doing" training. Don't let lack of money hold you back from getting all details of my amazing plan.

MANY EARN WHILE LEARNING

If you need part time work to help pay your expenses, we may be able to help you as we have hundreds of others. When you graduate we'll give you lifetime employment service. And, in 12 brief weeks, in the great shops of Coyne, we train you as you never dreamed you could be trained... on one of the greatest outlays of electrical apparatus ever assembled... real dynamos, engines, power plants, autos, switchboards, housewiring, armature winding and many other branches of Electricity.

Electric Refrigeration Air Conditioning

Right now we are including additional instruction in Electric Refrigeration and Air Conditioning without extra cost so that your training will be complete and you can get into this marvelous, rapidly expanding field.

GET THE FACTS Coyne is your great chance to get into Electricity. This school is 38 years old—Coyne training is tested. You can find out everything absolutely free. Simply mail the coupon and let us send you the big, free Coyne book with photographs... facts... opportunities. Tells you how many earn expenses while training and how we assist our graduates in the field. No obligation to you. So act at once. Just mail coupon.

BIG FREE BOOK

Send for my big book containing photographs and telling the complete story—absolutely FREE.

H. C. Lewis



COYNE ELECTRICAL SCHOOL

500 S. PAULINA ST., Dept. B7-78, CHICAGO, ILL.

H. C. Lewis, Pres., COYNE ELECTRICAL SCHOOL
500 S. Paulina Street, Dept. B7-78, Chicago, Ill.

Dear Mr. Lewis: Without obligation send me your big, free catalog with facts about Coyne Training and details of your "Pay-Tuition-After-Graduation" Plan.

Name.....Age.....

Address.....

City.....State.....

SUCCESSFUL in
PERFORMANCE.. DESIGN..
CONSTRUCTION.. SALES..
say leading P.A. men

AMPERITE VELOCITY
ACHIEVES
UNIQUE RECORD
IN ACTUAL USE



Featuring..

1. Output increased 6 DB.
2. Triple shielded—against all RF or magnetic fields, entirely eliminating hum pickup.
3. Eliminates feedback troubles.
4. Excellent for close talking and distant pickup.
5. Acoustically designed to eliminate any possibility of cavity resonance.
6. Fitted with switch and cable clamp.

NEW! MODELS RBHn (High Impedance): RBMn (200 ohms) with Cable Connector and Switch

\$42.00 LIST

NEW! MODELS RBSn. RSHn. streamline: slightly lower output and frequency range than above, with switch only

\$32.00 LIST

Models RAL (200 ohms); RAH (2000 ohms). Built to Amperite standards: No peaks. Flat response. Triple shielded. Shock absorber. Swivel bracket

\$22.00 LIST

Finishes: All microphones have the new standard Gunmetal Finish. Available in Chrome, extra. \$1.00 List.

FREE: WINDOW DECAL advertising your SOUND SERVICE. Four-color design, 5 1/4 x 9 1/4. Write for it now.

AMPERITE Co. Cable Address: Altem, New York
 561 BROADWAY NEW YORK

AMPERITE Velocity **MICROPHONE**

FREE
 1937
RADIO
CATALOG

FREE

to Servicemen and hustling agents, our NEW 1937 Radio catalog, listing over 500 Nationally advertised home and auto Radios. We carry R. C. A. — Philco — G. E. — Zenith — Delco — Bosch — Motorola — Emerson — Detroit — Fada — Grunow and many others. The discounts we allow you range up to 50% from manufacturer's prices.

Become Our Representative

in your locality. Write for catalog, descriptive literature and confidential discount sheet to nearest office, Dept. D-2.

Modell's - Wholesale
 Radio Division

NEW YORK, N. Y. | CHICAGO, ILL. | ATLANTA, GA.
 58 Cortlandt St. 56 W. Washington St. 75 Forsyth St.

Nothing Equals
 THE NEW

KADETTE "EQUAFONIC"!

BELL-TESTED RADIO

KADETTE

INTERNATIONAL RADIO CORP., ANN ARBOR, MICH.

Get into **RADIO**
 REAL JOBS
 REAL PAY

Earn While Learning at Home!

Television, Photo Electric Cells, Public Address
 Many R.T.I. Trained Men make up to \$75 a week and more in full-time radio jobs—\$6-\$15 in spare time alone. More trained men needed. Learn at home by quick, easy

PHILCO
 CROSLEY
 ZENITH
 GRUNOW
 and 46
 other
 mfgs.
 endorse
 R-T-I

R-T-I WAY. Endorsed by 50 big concerns. Write for big Opportunity Book FREE. RADIO and TELEVISION INSTITUTE, Inc., 2130 Lawrence Ave., Dept. 22-B, Chicago, Ill.

HOW TO MAKE A HI-FI P.A. AND "UNIVERSAL" RADIO TUNER

(Continued from page 15)

have been assembled on the chassis. The height of the 3 protruding shafts (volume, tone and dial) should be measured from their centers to the bottom edge. If all is correct, then the front panel markings may be measured-off on the smooth back. Cut the large circle first, then drill the 3 shaft holes. Inasmuch as the front panel is 1 in. higher than we need, it is best to have a tinsmith cut off the excess on a power shears machine. At the same time, have him bend the two edges at 90 deg. angles as shown in the photograph. The finished panel will then be approximately 9 ins. high and 11 ins. wide. The tone and volume indicating plates are mounted by means of small escutcheon pins.

WIRING AND TESTING

The wiring comes next. A good method to follow is to wire one element of each tube at a time. For instance, wire all the shell prongs of the metal tubes to ground. Next, connect all cathodes, and so-on. This method eliminates a lot of checking and jumping back and forth.

The author never takes it for granted that a part is OK merely because it is new. So, if an ohmmeter is available, check the following items before mounting them on the chassis.

D.C. RESISTANCE

- | | |
|----------------------|---------------------|
| L1, Primary 20 ohms; | Secondary 6.5 ohms. |
| L2, Primary 65 ohms; | Secondary 6.5 ohms. |
| L3, Primary 2 ohms; | Secondary 3.2 ohms. |
| L4, Primary 8 ohms; | Secondary 8.0 ohms. |
| L5, 170 ohms. | |
| Ch., 800 ohms. | |

- | |
|--|
| T1, Primary 32 ohms. High-voltage secondary, 1,100 ohms, plate to plate. |
| Fl. winding (0.9-A.), 0.5-ohm. |
| Fl. winding (0.6-A.), 1. ohm. |

Check all resistors and discard any that are 20 per cent off their rated value. Also check the bypass condensers for shorts or leaks. Check the tubes.

When all wiring is complete, follow out the circuit for wrong connections and continuity. Turn the set on, do not use an antenna, turn dial to 1,700 kc. and volume on full, then check the voltage at each point as indicated below. Use 1,000 ohms/volt meter on 500-V. scale. All readings to chassis are given in Table II.

Tube Type	Pl.	S.-G.	Cath.
6X5	—	—	250 V.
6J7	22 V.	60 V.	5 V.
*6A8	230 V.	80 V.	—
**6A8	160 V.	—	2.7 V.
6K7	220 V.	80 V.	3 V.

*Pentode section. **Oscillator section.

If these voltages are more than 10 per cent off, check everything all over again.

Now we come to the subject of alignment. The I.F.T. should be accurately peaked at 456 kc. Upon this adjustment depends a great part of the sensitivity and selectivity of the set as a whole. If you haven't the equipment to do this job right, then by all means have it done by a competent technician.

If you have the equipment, the procedure is as follows: turn the set on, take the grid clip off the 6A8 and connect your oscillator to the top cap. The ground lead of the test oscillator should be connected to the tuner chassis. Connect an output meter or oscilloscope to the output tip-jacks at the rear of the chassis. The test oscillator should be accurately set on 456 kc. and the attenuator set for 1/3-deflection on the output meter. Peak the 2 air trimmers for maximum response, attenuating the test signal if the meter goes off scale.

Next, set the test oscillator to 1,600 kc., replace the 6A8 grid clip. Feed the test signal through a small mica condenser (100 mmf.) to the antenna post. The tuner dial should be set at 1,600 kc. and the 3 trimmers on the variable condenser should be screwed in tight all the way.

The antenna and R.F. trimmers should be unscrewed a little bit for maximum signal. It may be necessary to use additional capacity across the oscillator trimmer to bring the pointer to the exact line on the dial. The writer added about 3 mmf. by soldering a 4-in. piece of hookup wire to oscillator stator and wrapping 3 turns around the spacer bar. This wire may be seen in Fig. B, upon close inspection of the variable condenser section nearest the panel. This is the item, marked "wire capacitor," shown in Fig. 1, which is connected to condensers C and Ca. Note that although the other side of this "wire capacitor" is shown grounded, this is only a fictitious or effective ground and **DIRECT CONNECTION TO GROUND MUST NOT BE MADE.**

The low-frequency padder should first be screwed up tight and adjusted for maximum response at 600 kc. Rock the dial pointer slowly up and down while adjusting for the best peak. You will find that the high-frequency end may have shifted 10 or 20 kc., so go over the 3 trimmers again and then check 600 kc. again.

All this may sound hard but it really isn't. Our unit was all peaked in 15 minutes and rarin' to go.

Disconnect the test equipment and use either headphones or an amplifier for the air tryout. Connect an antenna not longer than 75 ft. to the set. As a rule, no ground wire is needed.

LIST OF PARTS

- One Meissner antenna coil, No. 6862. L1;
- One Meissner R.F. coil, No. 6864. L2;
- One Meissner oscillator coil, No. 4243. L3;
- One Meissner ferrocart I.F. transformer, No. 6643. 456 kc., L4;
- One Meissner shielded R.F. choke, No. 5592, 30 mhy., L5;
- One Meissner 3-gang variable condenser, No. 15122, 365 mmf.;
- One Meissner 6-in. dial, No. 1x246;
- One Meissner padder trimmer, No. D2500, 500 mmf., C8;
- One Kenyon power transformer, No. T249, T1;
- One Kenyon filter choke, No. T156, 30 hy., Ch.;
- Seven Aerovox tubular bypass condensers, type 484, 0.1-mf., 400 V., C1, C2, C3, C6, C7, C8, C10;
- Three Aerovox tubular bypass condensers, type 484, 0.5-mf., 400 V., C4, C11, C12;
- Two Aerovox tubular bypass condensers, type 484, 0.01-mf., 400 V., C14, C15;

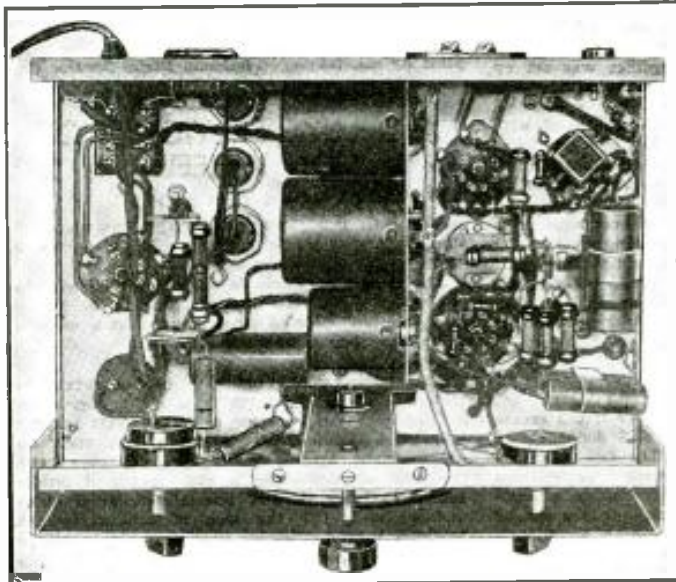

Fig. C. Under-side view. Note the coil mounting method used.

Please Say That You Saw It in RADIO-CRAFT

- One Aerovox tubular bypass condenser, type 484, 0.05-mf., 400 V., C16;
- One Aerovox dual tubular bypass condenser, 0.05-0.05-mf., 400 V., C18;
- One Aerovox electrolytic condenser, GLS 5, 8 mf., 450 V., C17;
- One Aerovox electrolytic condenser, GLS 5, 12 mf., 450 V., C19;
- One Aerovox electrolytic condenser, GLS 5, 16 mf., 450 V., C20;
- One Aerovox mica condenser, type 1467, 500 mmf., C13;
- One Aerovox mica condenser, type 1467, 100 mmf., C5;
- One General Electric type 6K7 metal tube, V1;
- One General Electric type 6A8 metal tube, V2;
- One General Electric type 6J7 metal tube, V3;
- One General Electric type 6X5 metal tube, V1;
- One General Electric molded rubber A.C. line cord;
- *Four terminal connectors, No. A-016;
- *One pair tip-jacks, No. 523, 1—red, 1—black;
- One Centralab volume control potentiometer, No. 72-102, 25,000 ohms, R1;
- One Centralab tone control potentiometer, No. 62-116, with switch, 1 meg., R14;
- One Centralab carbon resistor, 2 W., 15,000 ohms, R11;
- One Centralab carbon resistor 1 W., 25,000 ohms, R2;
- One Centralab carbon resistor, 1/2-W., 25,000 ohms, R6;
- Two Centralab carbon resistors, 1/2-W., 5,000 ohms, R4, R9;
- Two Centralab carbon resistors, 1/2-W., 1,000 ohms, R5, R10;
- One Centralab carbon resistor, 1/3-W., 1 meg., R13;
- One Centralab carbon resistor, 1/3-W., 0.4-meg., R15;
- One Centralab carbon resistor, 1/3-W., 0.1-meg., R16;
- One Centralab carbon resistor, 1/3-W., 50,000 ohms, R7;
- One Centralab carbon resistor, 1/3-W., 10,000 ohms, R12;
- One Centralab carbon resistor, 1/3-W., 400 ohms, R3;
- One Centralab carbon resistor, 1/3-W., 300 ohms, R8;
- *One antenna ground terminal strip, No. 2419;
- *One indicating plate (volume), No. 2450;
- *One indicating plate (tone), No. 2451;
- *Two pointer knobs, 1 1/4 in., No. 1155;
- *One black round knob, No. 1174;
- *Four octal wafer sockets, No. 1121;
- *One black wrinkle front panel, 10 x 11 x 1/16 ins., No. 3191;
- *One blank cadmium chassis, 11 x 7 1/2 x 2 1/2 ins., No. 1531;
- *Two socket punches, Nos. 755 and 757;
- *One circle-cutter, No. 775;
- *One piece aluminum for coil platform, 3 x 6 x 1/16 ins.;
- *One fuse mounting, No. 2340;
- *hookup wire, hardware, etc.
- *Names of manufacturers will be supplied upon receipt of a stamped and self-addressed envelope.

TRY TO MATCH THIS 12-WATT SOUND SYSTEM



Among new designs of moderate power, Model PA-712 rings the bell. It will handle audiences up to 1500 people, is suitable for churches, lodges, theaters, convention dinners, etc. Has the latest design features including beam tubes and multiple output arrangement for additional speakers.

Ultra portability . . . One case, 44 lbs., easily packed, easily carried. Easily set up too, and not critical on hum or microphonics.

At the price, Model PA-712 becomes a system that sound specialists can afford and can rent at a profit. It is modern in design too, and professional looking throughout. Ask to see it at your local jobbers.

WEBSTER CHICAGO

NOTICE TO DEALERS
 WEBSTER-CHICAGO, Section JU-10,
 5622 Bloomingdale Ave., Chicago, Ill.
 Without obligation please send me more
 information on Model PA-712;

- Portable housed in one sturdy carrying case.
- Amplifier is 12-Watt, 4-Stage, 7-Tube High Gain, Beam Type Design.
- Two 10" Permanent Magnet Speakers with Arrangement for Multiple Addi-
- Velotron Microphone.

LIST PRICE \$1100
 Complete

Sound Systems for _____

Name _____

Address _____

City _____ State _____

THIS POCKET VOLT-OHM-MILLIAMMETER DOES ALL YOUR D. C. TESTING

PRECISION BUILT \$10.80

• Model 735 has a Triplett D'Arsonval type precision instrument with easily readable scales. Ranges are 15-150-750 volts at 1000 ohms per volt; 1 1/2-15-150 M.A.; 1/2-1000 low ohms; 0-100,000 high ohms at 1 1/2 volts. Provisions for external batteries for higher resistance measurements. Has selector switch for all ranges and individual zero adjustment for resistance measurements.

ASK YOUR JOBBER—WRITE FOR CATALOG

READRITE METER WORKS
 716 College Dr., Bluffton, Ohio

... Without obligation please send me more information on Model 735. ... I am also interested in _____

Name _____

Address _____

City _____ State _____



Model 735
 Accuracy 2%
 Battery, Test Leads And Accessories Included

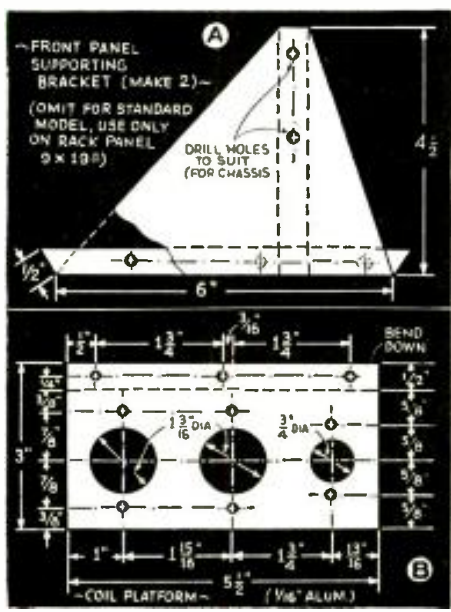

Fig. 3. Details of panel supports and coil rack.

Please Say That You Saw It in RADIO-CRAFT

EVERYMAN'S "SAFETY" CAR-RADIO SET FOR CUSTOM TRADE

(Continued from page 11)

MILLION

AC-DC VOLT-OHM MICROAMMETER



20,000
OHMS PER VOLT

AC-DC Volts 0 to 3-30-300-900. Ohms 0 to 10,000-30 Megohms. Microamperes 0-60-300. Milliamperes 0-30-300-600. High Torque Meter. Self-contained Batteries.

MODEL OM
29⁹⁵
NET

Model VO. Square meter without 60 micro-ampere scale, and Ohms to only 7.5 Megohms. Sensitivity 5000 Ohms per Volt.

\$19⁹⁵

MILLION RADIO AND TELEVISION LABORATORIES
559 N. UNION ST., CHICAGO, ILL.

TREASURE LOCATORS

BLUE PRINTS and INSTRUCTIONS

For Building the Following Treasure Finders and Prospecting Outfits

- Folder No. 1. Hughes Induction Balance Circuit
- Folder No. 2. Sensitive Hughes Induction Balance Circuit
- Folder No. 3. Single Super-Sensitive Hughes Induction Balance Circuit
- Folder No. 4. Radio Frequency Oscillator Circuit
- Folder No. 5. Audio Frequency Oscillator Circuit
- Folder No. 6. Combination Radio Transmitter and Receiver Circuit

With any one of these systems you can construct instruments to locate buried treasures, metal war relics, mineral deposits, subterranean water veins, buried gas and water pipes, lost objects, tools and treasures sunken in water, etc.

For each set of blueprints and instructions **\$1.00**
The complete set of six folders **\$5.00**
(Sent postpaid)

TECHNIFAX

Division 77C

558 W. WASHINGTON BLVD. CHICAGO, ILL.

CRYSTAL HEAD PHONES

SOUND CELL MICROPHONES

Information on request

THE BRUSH DEVELOPMENT CO.
3312 PERKINS AVE. CLEVELAND, OHIO

Advanced Home Study Training for SERVICEMEN!

"Radio Service and Public Address Work"

Technical training is no longer a "luxury"—it is a NECESSITY! R.S.I. training was prepared, and is being constantly revised, by experienced men FOR experienced men. No waste material—but a complete course that starts paying for itself right from the start. Start any time—take up to 3 years to complete. Pay as low as \$5 monthly!

WRITE TODAY FOR **FREE** BOOKLET "The Key To Successful Servicing"

RADIO SERVICE INSTITUTE
SUBSIDIARY OF CREI
Dept. RC-7, 3308 14th St., N.W., Wash., D.C.

the battery wiring. As additional precautions, the grid wires of the R.F., converter, I.F. amplifier and 2nd-detector tubes are shielded with large-size shielded loom.

All plate, screen-grid and cathode leads are carefully bypassed as close to the tube terminals as possible. This can be seen in the view of the underside of the chassis, Fig. D. This promotes stability and also aids in preventing any pick-up of ignition interference.

The button tuner consists of a control box which is mounted near the tuning condenser of the set and which contains a magnetic step switch and 15 mica condensers, three for each of the 5 stations (one for aerial tuning; one for R.F. tuning; and the 3rd for the oscillator).

The buttons on the control close the step switch thus connecting the mica condensers in parallel with the regular tuning condenser which is turned to the high-frequency end of the dial when the button tuner is in use. For tuning-in other stations besides these 5, the button tuner is turned off by touching the "off" button, and the regular remote tuning dial on the dash of the car is used in the ordinary way.

An 8-in. permanent-magnet dynamic speaker is mounted within the set, as shown in the photos, and a pair of tip-jacks are mounted on one side of the case to permit either an additional "header" or a "courtesy" speaker to be connected if desired. These tip-jacks are also handy if the set is used for picnics, etc., where it is desired to connect a speaker at a short distance from the car.

Three 3/8-in. holes are drilled on each side of the cabinet near the back to allow release of the pressure built up by the speaker cone excursions. If these holes are not made, the set will sound drummy and have an annoying cabinet resonance.

CONSTRUCTION

The entire set is built into a metal box 10 x 8 x 7 ins. deep. The box is made with removable covers on the front and back, and the chassis is mounted permanently in the box, the set being constructed right in the box. The removable covers permit easy access to the top and bottom of the chassis for any repairs and plenty of room for wiring and mounting parts when constructing the set. This novel method of constructing the set prevents rattles, and permits a more compact construction.

The chassis is set edge-wise in the cabinet, in the position in which it is mounted in the car. The tubes are thus mounted on their sides, which may raise a question in the minds of some builders. However, these tubes are made very rigidly to stand the abuse encountered in a car and as further assurance, engineers of the tube manufacturer were questioned on the subject before this construction was decided upon.

The photos and the chassis and box details give all the essential facts about the mounting and positions of parts, so a description of these operations will be dispensed with.

The wiring must be short and direct, with special attention given to well soldered joints. The vibration encountered by a car set necessitates construction which can not work loose. Lock washers must be placed under all mounting screws and parts which are supported on the wiring should have very short mounting wires and be mounted in such a way that they cannot sag and cause short-circuits.

The grid wires between the coils and the tubes of R.F., converter and oscillator tubes should be covered with shielded loom of the type used for car aerial wire shielding. This also applies to the control leads to the button-tuner unit. The use of this shielded loom will reduce any tendency to circuit oscillation because of the comparatively long wires to the button tuner, and will greatly lower the hum pick-up.

The type of remote control head used with the set will depend entirely on the type of car in which the set is to be mounted. The only stipulation about this control is to get one which matches the gear ratio of the auto-radio type tuning condenser and has a correctly calibrated dial.

ADJUSTMENT

When the set has been completely assembled, wired and checked, it should be aligned carefully with an accurate signal generator and output

meter (or better yet with an oscilloscope—which was the method employed by the writer). The I.F. alignment should be made with the oscillator tuning condenser shorted and the grid wire left on the converter tube, V2. The signal generator should be turned to the lowest output that can be picked up and should be further turned down if necessary, during the alignment operations, to prevent the A.V.C. from affecting the adjustments. The last I.F. trimmer (next to the 2nd-detector) should be adjusted first, followed by the others in turn, ending with the one nearest to the converter. The trimming of these I.F. coils should be repeated to be sure they are correct.

The signal generator should be connected to the aerial lead, next, and the dial turned to 1,400 kc. The 3 trimmers on the tuning condenser should then be adjusted for greatest signal strength. Last, but not least, the dial should be turned to 550 kc. and the padder condenser adjusted for greatest signal strength at the low-frequency end of the band. It is well to check the alignment at several points between, and bend the end plate of the oscillator section if necessary, to make the set track properly.

All these operations should be performed with the button tuner in the "off" position. In other words, the OFF button should be pushed first, and held down until the unit stops clicking. This disconnects the button tuner from the set and allows normal tuning at the remote control tuning head.

After the set has been properly aligned, the 5 local stations to be "button tuned" should be decided upon. The lowest frequency station should be adjusted first. Take the cover off the button tuner box on the top of the set, by removing the 4 acorn nuts. This reveals the 15 trimmers marked A1, R1, O1, A2, R2, O2, etc. The O1 (oscillator) trimmer should be turned, first until the desired frequency is tuned in, using the signal generator connected to the aerial and the output meter connected in the usual way. Follow this with the R1 and A1 trimmers. Then adjust the other 4 frequencies in the same way, touching the correct buttons in each case.

It is best to verify the adjustments of these trimmers, especially the aerial trimming adjustments, by connecting the regular car aerial to the set and making any slight readjustments needed to bring in the stations with greatest signal strength and best quality.

INSTALLATION

The set is mounted to the car with a single 3/8-in. bolt through the back cover, with sponge rubber pads in the 4 corners to prevent slipping and to cushion the mounting of the set to the fire wall of the car.

The battery cable and heavy shielded loom on the aerial wire should be carefully grounded in several places. The aerial "interference control" should be connected in the aerial lead, according to the instructions of the manufacturer. It should not be adjusted yet, however. Bypass the generator, the low-tension side of the distributor, the ammeter, the dome light and any other low-voltage wiring which passes through the fire wall. Bond all metal parts of the car—motor, fire wall, chassis, body, etc., carefully with heavy copper braid.

It is not usually necessary to use any spark-plug suppressors, though in abnormal cases an inductive-type suppressor may be necessary on the center lead to the distributor.

When all the above points have been taken into consideration, the set should be turned on as loud as possible at the point where ignition noise is worst and the aerial interference unit adjusted until the interference is balanced out. This unit picks up the ignition noise and feeds it back out-of-phase with the interference picked up in the receiver at the correct amplitude to cancel-out the interference in the set.

Incidentally, it is necessary for the cable between the button tuner and the tuner control box, on the top of the set case, to be very carefully shielded and grounded. Also, the box of the button tuner must be grounded with unusual care to the case of the set. Otherwise interference will be picked up when the button tuner is being used to tune in stations. If it is found that stations are accompanied with motor interference

Please Say That You Saw It in RADIO-CRAFT

when the button tuner is in use, but the same stations are free from this interference when tuned in by hand on the dial. It may be necessary to add an additional shielded loom over the cable between the button tuner and tuner control box. It may also be necessary to ground the tuner control box with a heavy braided copper strap to the battery cable shield in order to remove this interference. The double shielding should be tried as a final resort if careful grounding to the tuner control box fails to remove the ignition noise.

The unusual characteristics of this receiver, plus the ease of tuning-in local stations without taking your eyes off the road, and the extremely low battery drain should make it a good seller for those radio men who specialize in making custom sets for discriminating customers.

LIST OF PARTS

- One Meissner high-gain aerial coil, type 6*62, L1;
- One Meissner high-gain R.F. coil, type 6*64, L2;
- One Meissner oscillator coil, type 4242, L3;
- One Meissner Ferrocart 175 kc. I.F. transformer, type 5728, IFT-1;
- One Meissner Ferrocart 175 kc. I.F. transformer, type 5730, IFT-2;
- One Meissner 365 mmf., 3-section tuning condenser, 6:1 ratio (or as needed), C1, C2, C3;
- One Meissner Ferrocart 80 mhy. R.F. choke, RFC-1;
- One Meissner 500-12,500 mmf. padding condenser, type 15247, C13;
- Six Aerovox 0.05-mf. condensers, type 484, C4, C8, C15, C20, C25, C26;
- Eleven Aerovox 0.1-mf. condensers, type 484, C5, C6, C7, C9, C10, C11, C14, C16, C17, C18, C23;
- One Aerovox mica condenser, 250 mmf. type 1468, C12;
- Two Aerovox mica condensers, 100 mmf., type 1468, C19, C22;
- One Aerovox 500 mmf. mica condenser, type 1468, C21;
- One Aerovox electrolytic condenser 25 mf. 50 V., type PR50, C24;
- Four Continental Carbon 0.25-meg. 1/2-W. resistors, R1, R4, R8, R16;

- Two Continental Carbon 1/2-W. resistors, 250 ohms, R2, R9;
- One Continental 1/2-W. resistor, 200 ohms, R5;
- Three Continental Carbon 1/2-W. resistors, 10,000 ohms, R3, R6, R10;
- One Continental Carbon 1/2-W. resistor, 50,000 ohms, R7;
- Two Continental Carbon 0.5-meg. 1/2-W. resistors, R11, R18;
- Two Continental Carbon 1 meg. 1/2-W. resistors, R13, R17;
- One Continental Carbon 0.1-meg. 1/2-W. resistor, R11;
- One Continental Carbon 1/2-W. resistor, 8,000 ohms, R15;
- One Electrode potentiometer with switch 0.5-meg., type 203, R12;
- *One 0Z1-type vibrator "B" unit, 250 V., 50 ma.;
- *One "A" filter, type 4155;
- Two National Union type 6S7G tubes, V1, V3;
- One National Union type 6D8G tube, V2;
- One National Union type 6T7G tube, V4;
- *One type 6AB6G tube, V5;
- One Raytheon type 0Z4 tube, V6;
- One remote tuner (with correct ratio to suit tuning condenser);
- *One touch-o-matic tuner unit;
- *One 8-in. magic-magnet speaker with universal transformer;
- *Five octal sockets, type 1121;
- *One crackle-finish steel box, 8 x 10 x 7 ins., type 3502;
- *One interference control, type 4454;
- One 9 x 11 in. sheet of aluminum for chassis;
- Five ft. large shielded loom for aerial lead and control-grid shielding;
- One battery cable No. 12 wire, shielded, with fuse retainer;
- One double tip-jack for extra speaker;
- One single tip-jack for pilot light connection;
- One bayonet aerial connector;
- As needed, metal-cased condensers for ignition bypassing, etc.;
- One battery fuse 5 A.;
- One 3/4-in. bolt for set mounting;
- Hookup wire, screws, solder, sponge rubber, lock washers, etc.
- *Names of manufacturers will be supplied upon receipt of a stamped and self-addressed envelope.

ORSMMA MEMBERS' FORUM

(Continued from page 22)

Well, enough of this amplifier talk for the present, and now let's get down to business.

Firstly, kindly forward me as many "Answer Adv. post cards" as possible as I do not want to damage my *Radio-Crafts* by cutting the ads. out of them.

Secondly, will you please attend to the clippings enclosed, and do me a great favor, as you're on the spot, and I'm not.

In conclusion, may I wish you further success in 1937. Here's hoping you won't make any improvements to the Amplifier, as I'd hate to have to tear it down.

HAROLD N. KEOGH,
Inverell, N.S.W., Australia.

Thanks very much for your very kind words. It's nice to know that our carefully-prepared technical articles are of such international interest—and assistance.

A LOW-COST P.A. AMPLIFIER

RADIO-CRAFT, ORSMMA, Dept.:

As a member of the ORSMMA, I feel that it is about time that I passed along a little of the information that I have learned in the past 7 years of trying to do a good job in a short time and still be quite a distance from a quick source of supply.

I would like to offer the first suggestion to those members and service engineers who have occasion to require a cheap P.A. amplifier on short notice, and one that works surprisingly well. If you have an old Zenith No. 52 or any other make of similar layout and tube complement, do as follows:

Remove the grid cap from the type 21 detector tube. On top of the tin cover for the tuning condensers mount a 2-button "mike" transformer, solder a wire to one side of the secondary and ground this to the chassis of the set, and to the other side of the secondary solder a short shielded wire with a grid clip on it to reach the top of the detector tube (if the transformer is placed right, this wire will not have to be over

3 1/2 ins. long). Now mount beside the transformer a 4-prong socket and 2 binding posts, wire the 2 outside wires of the primary to the 2 filament prongs of the socket. The center of the primary should be grounded to the chassis of the set, now also ground one of the binding posts to the chassis and run a wire from the other post to the grid and on across to the plate prong (tying them together) of the socket.

Now connect a 2-button "mike" to a 4-prong plug with a button to each large prong and the mike frame to either of the small prongs; and 3 V. of battery to the binding posts. If everything is in good condition you will have a better amplifier than can be bought for many times the small cost of the "mike," stand, transformer, battery, 15 ft. of mike cord and incidentals. (The items mentioned above cost me \$6.85, and \$5.00 for the set.)

I used this amplifier in a theater of 600-person capacity for amateur night and with only the one speaker was able to get a good coverage at 3 ft. from the mike without turning it full on. And the best part of it is that the set is always ready to use as a radio receiver merely by changing the grid caps on the detector tube.

PHILIP HILLIKER,
Fleischmanns, N. Y.

REPAIR—OR, REPLACE THAT DEFECTIVE LOUDSPEAKER

(Continued from page 17)

customer a better speaker without delay at a reasonable price, he is rendering a service that will gain him a reputation for alertness and efficiency that will be reflected in increased business.

Our Information Bureau will gladly supply manufacturers' names and addresses of any items mentioned in *RADIO-CRAFT*. Please enclose a stamped and self-addressed envelope.

Please Say That You Saw It in *RADIO-CRAFT*



TALKING ABOUT P. A. WE'RE WILDCATS ABOUT REPUTATION

THE important thing in these days of hectic competition in the P. A. field is your reputation for quality merchandise. LAFAYETTE, realizing this, places emphasis on high quality components in every P. A. system which it designs, manufactures and sells. In thus protecting its own reputation, LAFAYETTE doubly secures the reputation of the engineer who sells and installs LAFAYETTE P. A. Systems. Only by the use of quality merchandise can the sound engineer insure his prestige. When you install P. A. be sure it's LAFAYETTE.



AGAIN LAFAYETTE engineers have produced a "year ahead" De Luxe amplifier! This system establishes a new "high" in fidelity of reproduction—a new "low" in price for a system of this type. "Highlights" include reverse feedback, automatic equalization, the new "Neo-Dial" (you can operate it in the dark), photo-cell input, and many other features. Model 131A—Less tubes, and screen. **\$29.50** YOUR COST

20 WATT PORTABLE SYSTEM
Complete with Tubes, Mike, Slip-in Case
\$82.95 READY TO OPERATE



HERE'S a compact portable P. A. system that will speedily earn its cost in rentals. Amplifier can be removed from case, enabling speakers to be hung or placed anywhere—ample power for large assemblages. Model 860-P... your cost complete with tubes and LAFAYETTE velocity mike, ready to operate, **\$82.95** NOTHING ELSE TO BUY!

Send for copy of FREE Catalog listing a full range of sound systems, radios, auto sets and 1001 other bargains. You cannot afford to be without it. Use coupon.

WHOLESALE RADIO SERVICE CO. INC.
NEW YORK, N. Y., CHICAGO, ILL., ATLANTA, GA.
100 SIXTH AVENUE, NEW YORK, N. Y. 301 W. JACKSON BLVD., CHICAGO, ILL. 430 W. PEACHTREE ST., N. W., ATLANTA, GA.
BROOKLYN, N. Y. NEWARK, N. J. JAMAICA, L. I.
343 E. 108TH ST. 215 CENTRAL AVE. 7th Floor, Main Street

WHOLESALE RADIO SERVICE CO., Inc.
100 Sixth Avenue, New York, N. Y.

Rush FREE Spring Catalog No. 68-3G7
NEW HAM CATALOG No. 66-3G7

Name.....
Address.....
City..... State.....



REX 6L6 BEAM AMPLIFIERS
 INCORPORATE HIGHEST STANDARDS OF ELECTRICAL AND MECHANICAL EFFICIENCY! FULLY MODERN!
 • Ingenious Construction (a radically new departure) provides far more satisfactory performance • May be operated upright (illustrated), horizontally, or mounted on a wall • Models available producing 14, 32, 50, 64, 96, 100, 128, 150, 200, 256 watts audio output, with only 2% Harmonic Content. (Distortion!)
 Inter-Office Amplifier Systems permit DUAL conversations simultaneously, no "press-to-talk" switches! Any number of stations!
NEW REX
 "LOUD-PHONE"
 • WRITE FOR OUR FREE CATALOGS •
REX AMPLIFIER SYSTEMS CO.
 148-156 West 23rd St., New York, N. Y.

SMALL ADJUSTMENT

The radio dealer had just succeeded in selling the most expensive all-wave phono-radio in his shop and was mentally spending the commission on the sale when his customer's voice brought him back to earth.
 "There's just one little adjustment I'd like you to make," she said.
 "Yes, madam?"
 "We do not have electric service," she told him, "so will you have it converted, please, for gas?"
 —from *New Outlook*

New ELGIN A.C.-D.C.
Volt-Ohm Milliammeter
 A compact tester that accurately tests A.C. voltages, D.C. voltages, D.C. Mills, and resistance.
 Reads obtainable; 0 5/50/500/1000 volts D.C., 0/5/50/500/1000 volts A.C., 0/5/50 and 500 Ma., 0/500/500000 ohms D.C. resistance. The unit can easily be adapted for use with oscillators as an output meter. **SHOULD BE PART OF EVERY SERVICEMAN'S AND EXPERIMENTER'S TEST KIT.**
 Net Price to Dealers, servicemen, and Dealers... **\$11.95**
 MODEL 801. Similar to above with the following readings: 0-5-50-500-1000 Volts D.C.; 0-500-500,000 Ohms.
 Net Price... **\$5.75**
TRY-MO RADIO CO., INC.
 85 Cortlandt St. New York City



A UNIVERSAL-SERVICE TEST SPEAKER

(Continued from page 16)

operation of this universal speaker we will take each part of the speaker separately and explain how each is used and made, and how the substitution for the original is accomplished.
 The first thing that we will deal with is the field coil of the speaker.

THE FIELD COIL

Field coils vary in resistance from 500 to 7,500 ohms with or without taps at intermediate values. Field coils are used as voltage dividers, filter chokes, bias resistors and output impedances.
 A tapped field coil seems the natural answer to all of these conditions, but it is not by any means. The first objection is that it is an expensive article to make up or buy. Secondly, we must take into consideration that our speaker arrangement must give us sufficient field sensitivity at all times so that we may be able to detect distortion or hum in the set on test. With a tapped coil we may not have sufficient excitation at all times and if we wanted to use it as a magnetic-reproducer substitute we would have to resort to an external field supply.
 The best method of substitution in these cases is to use a built-in field supply and thereby have full excitation for the test speaker at all times and use a combination of choke coil and tapped resistor for taking the place of the field coil in the set on test. The field supply circuit is shown in Fig. 1A and the substitute field circuit is shown in Fig. 1B.

The purpose of using the choke coil is to meet the conditions where the field coil is used as a filter choke or an output impedance. The resistance added to the choke coil will give a combination of the filtering effect and proper resistance of the field coil value that we need. The values shown in the diagram were found to meet all requirements. This arrangement is duplicated so that we can use it as 2 separate fields to meet the requirements found in a dual-speaker radio receiver.
 Multiple-speaker arrangements are merely 2 or more applications of the above-mentioned uses of the field coil combined in one set.
 For instance we will consider the Zenith model 444 radio set as an example. One speaker has a field coil of 5,000 ohms with a tap at 2,000 ohms used as a voltage divider. The second speaker is used as a combination filter choke and bias resistor with a value of 1,500 ohms.
 Another unusual speaker arrangement is the Fada reproducer for the model RA chassis. This set has a choke coil mounted on the frame of the speaker itself which is not connected to any of the components of the speaker.
 These 2 setups show the necessity of having 2 separate field-coil substitutes.
 Now we come to the signal part of the loud-speaker.

operation of this universal speaker we will take each part of the speaker separately and explain how each is used and made, and how the substitution for the original is accomplished.
 The first thing that we will deal with is the field coil of the speaker.

operation of this universal speaker we will take each part of the speaker separately and explain how each is used and made, and how the substitution for the original is accomplished.
 The first thing that we will deal with is the field coil of the speaker.

THE OUTPUT TRANSFORMER

Some sets have the output transformer in the chassis, others have it on the speaker frame. We must be able to match any combination of 1, 2 or 4 output tubes connected in push-pull or as single amplifiers.
 The solution to this is naturally a universal-type output transformer and a means of using it to couple to the test speaker or to eliminate it from the circuit in order to couple the signal directly to the voice-coil of the test speaker. The signal circuit is shown in Fig. 1C. By means of a 5-point selector switch in the secondary circuit we can match any type of output tube to the voice-coil of the test speaker.
 By the use of the proper connections to the primary of the output transformer we can match any circuit. Using the pin jacks marked "P" and "P" the signal input circuit is for a

single output tube. For push-pull circuits use "P" and "P" as the 2 plate connections and "C" as the center-tap. The use of pin jacks marked "TS" (transformer secondary) will be described later. To couple directly to the voice-coil as in cases where the transformer is in the chassis, open the secondary circuit by means of the toggle switch and connect the signal input to the 2 pin jacks marked "VC" (voice-coil). The use of a 10-ohm voice-coil in the test speaker provided the best overall sensitivity. A tapped voice-coil is not practical and to get a transformer to match the 10-ohm voice-coil to a 3-, 5-, or 20-ohm line from the set is unnecessary.

FIELD SUPPLY SYSTEM

The field supply system is simple enough but there are certain small changes made so that the power supply can be utilized for external testing uses.
 A small power transformer supplies filament and plate voltage for the rectifier. The tube used is a type 80 rectifier tube. A 4-mf. paper condenser is sufficient to filter the high voltage to the 7,500-ohm field coil of the test speaker. A small toggle switch turns on the 110 V. A.C. line when the universal speaker is in use. The milliammeter can be any type, accuracy and calibration is not important. The voltage is about 300 V., so it must have a range of at least 50 ma.
 Notice carefully that the meter is connected in series with the field coil only. The reason for this is that if the filter condenser shorts or any heavy current is taken from the pin jacks marked "Positive, Negative 300 Volts" the current through the meter, instead of increasing, will decrease and thereby prevent meter burn-outs and allow us to use a smaller range than would otherwise be practical.
 Now that we have duplicated the speaker unit of any radio set we should also be able to duplicate the connector systems of the different sets.

operation of this universal speaker we will take each part of the speaker separately and explain how each is used and made, and how the substitution for the original is accomplished.
 The first thing that we will deal with is the field coil of the speaker.

LOUDSPEAKER CONNECTION SYSTEMS

After a careful survey of the methods used for the link between the receiver and the reproducer unit we have found that the following cables provided a speedy and simple means of connection.
 For the sets having a female socket utilizing 4, 5, or 6 prongs, we use 3 separate cables with 4-, 5-, and 6-prong male plugs with the wires terminating in pin plugs for connection to the speaker test panel.
 For arrangements where there is just a speaker cable from the set to the speaker such as the Zenith 444, the cable from the set is connected to an insulated block which has 7 bindingposts to which a 7-wire cable is connected. This cable also terminates in pin jacks for connection to the speaker panel.
 For sets that have bindingposts to which the speaker cable is connected, such as the Majestic 70, we have a 4-wire cable with spade lugs on one end and pin plugs on the other.
 For sets using magnetic speakers we use a 2-wire cable with pin plugs on both ends. Occasionally we come across an offset female socket such as the Atwater Kent and some of the Philco sets used. The cable for this is quite simply made.
 Remove the prongs from an old tube base and solder them to one end of a 7-wire cable using 2 thick prongs and 5 thin prongs, the other end of the cable terminating in pin plugs. Now it is a simple matter to merely push the prongs into the socket in any odd position that any manufacturer may ever devise. Besides these cables a pair of leads with alligator clips on one

BURIED TREASURE!
 Find it with the New **GOLDAK RADIOSCOPE**
 Money Back Guarantee! Locates any metal including gold and silver sealed in glass. Guaranteed to detect deeper than any other device, regardless of price. Most advanced scientific design, based on original Radio Balance invented by Chilson. Write world's largest manufacturer of successful mineral locators for interesting information.
THE GOLDAK COMPANY
 1031 South Broadway Dept. RC, Los Angeles, Calif.

QUALITY recommends
Condensers by **SOLAR**
 WET... DRY PAPER MICA... THINNER
 Please Write for Details
SOLAR MFG. CORP. 599-581 Broadway New York City

WHY PAY MORE?
 ... when Radio City Products Co. offers you better testing equipment at far lower cost?
 • SEE YOUR JOBBER •
 WRITE TO DEPT. C FOR CATALOG
RADIO CITY PRODUCTS CO.
 88 PARK PLACE NEW YORK CITY "DEPEND ON DEPENDABLE"

Please Say That You Saw It in RADIO-CRAFT

end comes in handy. All the cables are shown in Fig. 2A.

A few tips on the construction of these cables will not be amiss here. Use a good insulated wire with a good amount of flexibility. Devise a color system so that you will be able to use the cables without tracing each wire every time it is used. The color system I use is simple and fast.

For the 4-prong plug cable I use a red wire for the plate, yellow wire for the grid, black with yellow tracer for the filament prong on the side of the grid and a black with red tracer for the filament prong on the side of the plate. For the 5-prong cable I merely add a blue wire for the cathode prong leaving the colors for the other prongs the same. For the 6-prong cable I add a blue with yellow tracer wire for the suppressor-grid prong. By this color system it is easy to identify the wires as they come out of the plugs.

These cables are connected to the speaker panel by means of pin plugs. Selection of the proper values are simply made by plugging into the proper pin jacks.

The idea of using selector switch arrangements was discarded. The possibility of insulation breakdowns in selector switches because of the high voltage in reproducer circuits and the comparative cost of multitap switches eliminated the idea. The pin jacks give better contact, more insulation, more flexibility, easier operation and best of all cost less. Another advantage of pin jacks is that each component part of the test panel may be used separately for other purposes.

In some speakers there is an internal connection between the signal and the field circuits and a wire from the set is connected to this connection. To meet this condition we use this simple method for connecting a single wire to two parts of the test panel. There are 2 sets of 3 pin jacks which are connected to each other as two trios. These are used as junction connectors so that a single wire from a cable can be plugged into one pin jack and by means of two short jumper leads with pin plugs on both ends, 2 leads can be brought out of the same wire by inserting them into the 2 remaining pin jacks of the trio. Two of these junction connectors are on the panel and have proven sufficient for all needs. Four jumper leads, each one the length of the panel, are used with the blocks.

HOW TO USE THE TEST SPEAKER

As an example of the operation of the universal speaker, we will use it to replace the twin speakers of a Zenith model 444 radio set. The description of the speaker system has been outlined before. The circuit diagram is in Fig. 2B.

The study of this complex speaker connection will reveal how the simpler circuits using only 1 speaker can be connected. The first thing to do is to connect the 7-wire cable from the chassis to the bindingpost strip of our 7-wire cable. Then following the colors through to the pin plugs we proceed as follows:—The 2 green wires go to the 2 jacks marked "P" and "P" on the output transformer. The red wire goes to one junction block and the jumpers coming out go to the "C" jack on the transformer and to the 5,000-ohm jack on the top row of the choke and resistor circuit. The brown wire goes to the 2,000-ohm jack. The black wire goes to the 0-ohm jack of the same row. The field of speaker No. 2 goes to the second row. The black and yellow tracer wire goes to the 0-ohm jack and the white wire goes to the 1,500-ohm jack. Turn on the field supply and switch in the voice-coil by closing both toggle switches and you are all set to go. The entire operation is done with very little practice in less than 1 minute.

Another example is the RCA R7. The circuit is shown in Fig. 2C. Using the same connector cable we connect the 3 wires from the set as follows: The black wire goes to the jack marked "VC." The yellow wire goes to the junction block from which one wire goes to the second "VC" jack and the other wire goes to the resistor jack marked 1,000 ohms. The red wire goes to the 0-ohm jack of the same row. Turn on the field supply and open the voice-coil switch to the transformer which is not being used. The time for the above connection is about 30 seconds.

A small card index system will prove a great help for some of the odd circuits such as the Majestic model 360 which has a 6-prong plug in which 2 prongs are shorted so as to open the 110 A.C. line to the set if the speaker plug is accidentally removed and so prevent damaging the filter condensers. The circuit of the repro-

ducer for this set is in Fig. 2D. The connection between the suppressor-grid and the grid prongs is made by utilizing the second junction trio.

This test unit can be used to test speakers by the following procedure. Connect a good radio set to the speaker panel in the regular manner. Then use the current supply from the panel by means of the two jacks marked "Positive, Negative 300 Volts" in series with suitable resistance from the unused row of field substitutes for the supply for the field of the speaker to be tested. Then connect the voice-coil of the speaker to the two pin jacks marked "TS" and match the transformer to the speaker by means of the 5-point selector switch. Now disconnect the main test speaker by opening the voice-coil toggle switch and the set will now feed its output to the external speaker which you wish to test.

TESTING RESISTORS, CONDENSERS, ETC.

When aligning a set connection may be had by putting the meter across the 2 jacks marked "TS" and by opening or closing the voice-coil switch you may have the aural indication or it may be cut out leaving the meter still in the circuit. The field supply unit with its meter also can be used as a type 80 tube tester by comparing the readings with a standard tube known to be in good condition.

The filter chokes on the panel may be used in set testing when trying to eliminate hum in radio receivers.

The resistors may be used to determine the correct value of open resistors in the voltage-divider system of a set by means of substitution.

For testing leakage, polarity and condition of electrolytic condensers the procedure is as follows: Connect condenser terminals to pin jacks marked "Positive, Negative 300 Volts" and note the meter action. If it goes down half-way it indicates that the condenser is either leaky or that the polarity is reversed. Now reverse the connections and if the meter goes half-way down again the condenser is leaky. If the meter shows no appreciable deflection then the condenser is all right. If the meter shows no deflection regardless of the polarity connection it is open. If it shows full downward deflection both ways it is shorted.

For insulation breakdown testing merely apply the high voltage to the circuit or part under test and watch the meter action. Intermittent shorts will show up readily at 300 V. and the meter will take sudden dips. This test is valuable for locating shorts from primary to secondary of A.F., R.F. and I.F. transformers, socket insulation breakdowns, intermittent coupling, filter or bypass condenser shorts and such. Another use of the high voltage is clearing shorts in variable and trimmer condensers caused by small burrs or filings. Apply the current to the condenser, first removing the lead from the condenser to the set, then rotate the condenser and you will hear and see the spark at the point of short-circuit between the plates. A complete short will show a full deflection on the meter.

CONSTRUCTION DATA

The construction of the entire unit is up to the builder. The circuit and arrangement of the parts is not critical and can be changed to suit the individual requirements. For instance in sections where direct current is used, a third row of field substitutes may be added and be made up of a heavy resistor so as to take care of the cases where the field of the set acts as the filament series resistor. In this case the resistor can be mounted away from the panel and leads brought to the panel because of the heat dissipated by such resistors.

The type of construction used by the writer was of the rack-and-panel type, where everything is mounted on the panel. This makes the entire unit very easy to mount and to take down for repairs if necessary. The entire test speaker can usually be built with parts usually found in the average junk box and if all the parts had to be bought then it still could be made for less than \$15.00. (The writer obtained the transformer from an old "B" eliminator. Unit P.T. may be a midget power transformer. Unit T1 is the universal-type output transformer.) This speaker set-up has been in use for 4 years now and has successfully overcome such tough jobs as the Sparton Triolian which uses 3 speakers.

Once this unit, with its saving in time on all kinds of work, is put in use one will wonder how he got along without it.

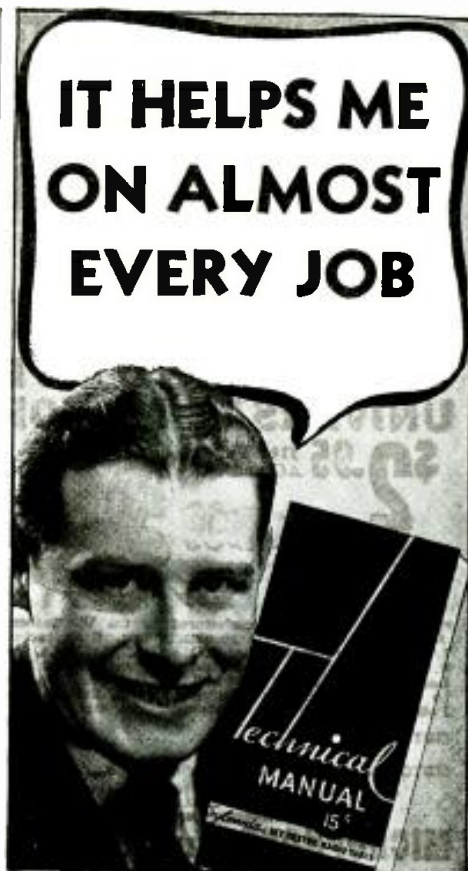

Are you one of the thousands of service men getting help from the new Sylvania Technical Manual? Get on the "band wagon" now!

If you knew how many thousands of service men are using this new Sylvania Technical Manual on almost every job you'd realize what a whale of a value it is for 15c!

This handy pocket manual contains 184 pages listing 193 tube types with important circuit application information on each—all about glass, metal and "G" type tubes as well as those for Majestic receivers... and full information on Sylvania "Ballast Tubes." Don't be without it! It's one of the handiest tools you could carry! Send the coupon and 15c—we'll do the rest.

SYLVANIA
Set-Tested Radio Tubes

HIGRADE SYLVANIA CORPORATION,
Emporium, Pa. RC-77

I enclose 15c. for which please send me a copy of the new Sylvania Technical Manual. I am (check below):
 Experimenter... Amateur... Call... Serviceman... Employed by dealer... Independent... Member Service Organization

Name

Address

CityState.....

Name of Jobber

Address

Please Say That You Saw It in RADIO-CRAFT

G.E. PHONOGRAPH MOTOR

Formerly Sold for \$15.00



Only \$4.95

VARIABLE speed induction type self-starting, 110 volt, 25 to 60 cycle, AC, with speed control. Plug and cord. Speed range from 5 to 200 R.P.M. Can be installed in place of old-fashioned, hand-winding speed motor. Also ideal for display turn table, and a hundred other uses. These General Electric Motors are brand new, in original factory cartons. \$4.95 G.E. Electric Phonograph motor as described. Shipping Weight—12 lbs.

WESTINGHOUSE UNIVERSAL MOTOR

\$2.95



Shipping Weight 3 lbs.

THESE Motors are manufactured by the Westinghouse Electric Co. They are absolutely new. Specifications: 1/30 H.P. operates on either A.C. or D.C., 110 volts, 5000 R.P.M. Rheostat can be used to vary speed. Height 3 1/4", Length 3 3/4", Width 1 1/4", Shaft 1/4" one inch long. Can be used to drive Sewing Machines, Models, Buffing Lathes, Polishing Head, Drills, Grindstones, etc., etc.

MOTOR only \$2.95
MOTOR with Arbor and 1/4" Chuck \$3.95
Add 25c for special packing and mailing anywhere in U. S. A.

MICROPHONE and RECEIVER

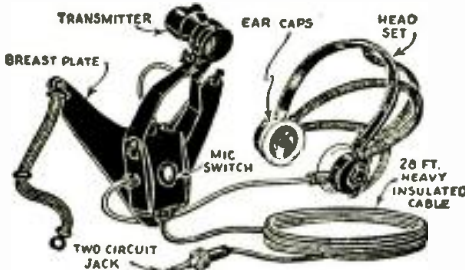

THIS Microphone and telephone headset outfit was built especially for the U. S. Navy Aviation Corps. The Holtzer-Cabot Electric Company contracted the outfit to Government specifications. The outfit consists of a low-impedance carbon microphone (transmitter), securely fastened to a metal breast-plate, and a set of heavy-duty, low-impedance earphones. A specially constructed switch on the back of the breast-plate controls the microphone circuit. The earphones are U.S.N. Utah type, attached to adjustable headband. Twenty-eight feet of very heavy weather and waterproof conductor cable is furnished. Current of not more than 10 volts should be used. A storage battery is the most satisfactory current supply. U. S. Navy Airplane-type Microphone and Receiver as described \$4.95 The shipping weight is 9 lbs.

WESTINGHOUSE POWER GENERATOR

Manufactured for U. S. Signal Corps
A.C. Electrical 200 Watt 110 V. AC Power



from a Windmill, from available Waterpower, from your Automobile, from your Motorcycle, from your Bicycle, Foot-pedal or Handcrank (for transportable Radio Transmitters, S. t. o n g Floodlights, Advertising Signs); do you want to operate AC Radio sets from 32 V. DC farm light systems; operate two Generators in series to get 200 V. AC; obtain two phase and three phase AC, etc., etc. 1/2 H.P. needed to run generator. There Are Over 25 Applications, such as: A.C. Dynamo light from eight to ten 20 Watt 110 Volt lamps. Short Wave Transmitter supplying 110 Volts A.C. for operating "Ham" transmitter. Operating 110 V. AC 80 Cycle Radio Receiver in DC districts. Motor Generator. Public Address Systems. Electric Sirens on motor boats, yachts, etc. Camp Lighting, etc., etc. Blue-Print, 22 x 28 in. and Four-Page 8 1/2 x 12 in. Instruction Sheets. Generator, as described including four replacement carbon brushes \$7.95 Shipping weight 18 lbs.

All merchandise in original packages—never used. Money-back guarantee.

We will forward Shipments by Express Collect if sufficient postage is not included.

WELLWORTH TRADING CO.
560 W. Washington Blvd., Dept. RC-737, Chicago, Ill.

CORRECT PROCEDURE FOR THE SERVICING BEGINNER

(Continued from page 12)

correctly is to align the I.F. in the wrong sequence. Always start with the I.F. transformer next to the 2nd-detector and adjust the condensers, in order, back toward the signal. And always work with the weakest possible output from the signal generator. This is the secret of a sensitive and selective aligning job. (A few manufacturers specify procedure that differs from the above.—Editor)

Those sets using tertiary (a third) windings on the I.F. transformers are usually designed to be aligned with the high-fidelity control in the "normal" position. The response curve is then broadened the proper amount on switching over to the high-fidelity side. If you have trouble in aligning some I.F. transformers, try shorting out the oscillator section of the gang condenser. Many times reaction between the set oscillator and the generator (that is, service oscillator) signal puts you on the wrong track and you may be aligning the I.F. to some beat-note harmonic.

Now a word to you new men—all troubles in a set cannot be found by analyzing, although a good many can. The trouble must be such that it affects some of the voltage readings we normally take. If it doesn't, our voltages won't show where the trouble lies. For example: an open antenna coil may cause weak reception, but it will not affect any of the set's voltages. Or perhaps we have an open voice coil—no voltage changes will take place, yet the set is "dead." Many more examples could be given, but I believe you get the idea by now.

Always check the tubes before you start looking for trouble in the set itself. Quite a large percentage of service work is simply replacing defective tubes. Present-day tubes require a pretty good tester if all the bad tubes are to be weeded out. A simple emission-type tester will catch most of them, but to get the real stubborn ones, use a power output type checker. This magazine some time ago published an article describing how to construct a tube tester using an oscillator circuit, the strength of oscillation indicating a tube's worth. This should catch most any faulty tube and personally we'd like to see another such article for metal tubes and all, with pre-calibrated settings. (How about it, fellows, how did you like that article, "The Meterless Tube Tester," in the January 1933 issue?—Editor)

A.V.C. CIRCUITS

Those A.V.C. circuits seem to be one big stumbling block for many men, when it comes to checking the action other than by a listening test. Since the bias on the I.F. tubes is generally controlled or varied by the A.V.C. voltage a check of the plate current of one of these tubes will give us a picture of the A.V.C. action. Normal plate current will exist with no signal, dropping to a lower value when a strong signal is applied. If you do not wish to use a meter for checking, an alternate method is to hook-in a "tuning eye" and observe its action. These "eyes" can be purchased complete with socket and leads ready to connect to any set having A.V.C., simple directions for attaching this unit being provided. If the set already has some form of tuning indicator, this will give us a direct check on the A.V.C. action. Many cases of failure can be traced to defective bypass condensers in this circuit, so give them a thorough check, especially for leakage.

ADDITIONAL TESTS

A good condenser tester, one using a sensitive meter for indications, is a very good investment for any Service Man. Coupling condensers should always be checked if the set seems less sensitive than normally, assuming everything else to be OK. Be as fussy as Aunt Matilda when it comes to checking these units for leakage, as the least little bit can upset a circuit and prevent normal action. Do not rely too much on the neon lamp method of testing these smaller capacities.

How many of you fellows have a good pair of headphones? They don't have to be expensive, as the ordinary 2,000 ohms-per-pair type constitute a very handy as well as a very sensitive indicator for testing. For aligning sets, using a weak signal from the test-signal generator, they are just the ticket. In fact many factory pro-

duction lines use this method. For a quick check of A.F. stages use a 0.25-mf. condenser in series with the phones and connect from chassis to any control-grid or plate terminal of the audio tubes. It's surprising how many different uses you will find for headphones in checking various circuits.

This next is perhaps familiar to the old timers, but will bear repeating. When replacing defective screen-grid bypass condensers, use ones having a 450-V. rating even though the service manual calls for one of 200 V. at this point. The reason is this: when the set is first turned on, the type 80 tube heats up quickly and starts delivering voltage before the heater tubes are drawing current and consequently for the first few seconds the "B plus" voltages are abnormally high. That is probably what caused the original bypass condensers to break down, so put in the higher-voltage ones and keep your customer.

And now for that general pain in the neck, the lowly midget. Many Service Men will not even work on them, due to the usual difficulty of convincing the customer that even if he did only pay \$9.85 for the set new, the service charge is still \$3.50 and should be paid. For those of you who will be doing this work, here are 3 common causes of trouble in midgets.

(1) Dried-out electrolytic filter condensers. If the plate voltage is 25 per cent or more below normal, chances are new filter condensers will put the set back on its feet. (2) The rectifier tube is another regular trouble maker and I believe the remedy is self-evident. (3) And last, watch those coupling condensers.

A quick way to check the oscillator of a super-het, to see if this portion of the circuit is oscillating, is to measure the rectified grid current. Disconnect the lower end of the oscillator gridleak resistor (the end opposite to the control-grid end) and insert a low-range milliammeter to read the current passing through this resistor. Normally it should be about 50 to 75 microamps., dropping to zero if oscillations cease.

WHAT ABOUT SERVICE PRICES?

So much for the technical hints and if all the above checks on your list of everyday events, then you are really up near the top. But how do you check on prices? How many of Uncle Sam's \$1 bills do you collect for a call to the other side of town? You may be an expert but are you cashing-in on it? As yet there is no standardization of service rates for the radio industry and it's high time there was.

All indications point to a charge of \$2.50 for a call and that is for the call only, parts, labor, etc., being extra. Many of the better Service Men only carry a tube tester and voltmeter into the customer's home. After all, a person's living-room is not a workshop so take the set back to your own shop for repairs, where you have the facilities to work on it properly. Charge a fair price for your work, at least \$2.00 an hour on straight labor with a minimum charge of 1 hour's work. Naturally exorbitant prices are out of the question so keep your rates in the professional class, because after all good radio servicing is a profession.

Now let's take a look at "you." How do you keep up-to-date with all the new changes and improvements continually being made? A very excellent method is to subscribe to 2 or 3 monthly radio magazines and trade journals. Look them over carefully, read the ads., see what is taking place and learn as much as you can about new ideas before they get on the market so you'll be ready for them when they do arrive.

Also pay some attention to your personal appearance. Never call at a customer's house in dirty or sloppy clothes. Neat appearance and a pleasant smile, along with prompt and courteous service at a fair price will get you a lot of business that the sloppy, surly, stalling competitor loses.

This article has been prepared from data supplied by courtesy of Coyne Electrical School.

CORRECTION NOTICE

Concerning the article "Build the Cyclops—A Beginner's 1-Tube Magic Eye Set" in the May 1937 issue—the "A"-voltage supply designated in both the schematic and physical diagrams should be 6.3 volts instead of 2 volts.

Please Say That You Saw It in RADIO-CRAFT

HOW TO CHECK CONDENSERS WITH AN A.C. BRIDGE

(Continued from page 19)

Leakage. High D.C. leakage under actual operation condition is usually the result of an electrical failure of the film which makes up the dielectric of the electrolytic condenser. This results in practically a short-circuited condenser and is readily determined by a D.C. test. However, this D.C. test should be made at or near the operating voltage, for the writer has known of cases, even in electrolytic condensers, where the film would withstand a low voltage such as would be impressed by an ohmmeter, yet would break down under the voltage applied to the filter circuit of the radio receiver.

Power Factor. Power-factor measurements on an electrolytic condenser give a very good idea of its condition. Power factors of greater than 20 per cent indicate that the filtering efficiency of the condenser is materially lowered. This is probably caused by a change in the structure of the paste or electrolyte which is the negative terminal of the condenser, for any current flowing in or out of the electrolytic condenser must pass through the above material and if its resistance is higher than normal there is a resultant loss which may be represented by a resistance in series with a perfect capacity. This dissipation of electrical energy causes the condenser to be less efficient in its filtering.

The power factor of a condenser is the resistance divided by its impedance.

Therefore, if R is the equivalent series resistance in ohms, C, the capacity of the perfect condenser in farads, and F the frequency, the power

factor equals
$$R \sqrt{R^2 + \left(\frac{1}{2\pi FC}\right)^2}$$

If the power factor of the condenser is less than 10 per cent the power factor reduces to $2\pi FCR$.

It will be noted that power factor is an A.C. measurement and may have no relationship to D.C. leakage. Of course, if the D.C. leakage is high, the power factor is also high. However, if the D.C. leakage is low, the power factor may or may not be normal.

Those interested in actually experimenting with different power factors in condensers used in filter circuits can, by adding a series resistance, make the power factor of the condenser any desired amount; for instance, to raise the power factor of an 8 mf. condenser 10 per cent at a frequency of 120 cycles, a series resistance of 16.6 ohms should be added. Proportionately larger resistance increases the power factor a proportional amount.

Open-Circuits. Complete or intermittent opens are one of the most difficult of the condenser faults to determine. The only satisfactory method is to obtain a measurement on the capacity of the condenser and then manipulate the leads or tap the condenser to determine whether or not its capacity changes under those conditions.

Electrolytic Action. Electrolytic action between the condenser leads and the condenser proper may be determined by bridge measurements. The ordinary procedure is to get an exact balance on the bridge, both in regard to the capacity of the condenser and its power factor. The electrolytic action developed between the leads and the condenser proper will tend to change this balance either in regard to power factor or to capacity or both with time. Consequently, it is only necessary to observe the visual balance in the Bridge Analyzer to be described to determine this condition.

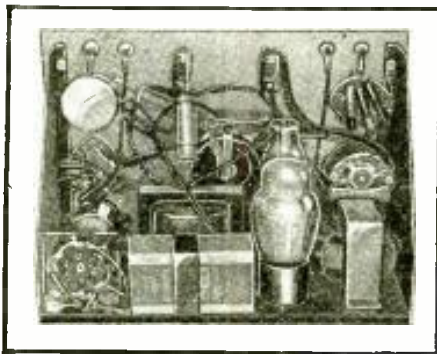

Fig. B. Interior of the A.C. bridge unit.

PAPER CONDENSERS (AND "DIELECTRIC HYSTERESIS")

- * The common faults in paper condensers are:
 - (1) Electrical failures due to a breakdown of the paper insulation.
 - (2) Complete or intermittent open-circuits.
 - (3) Higher than normal power factors.

Breakdown. Even though the condenser has failed, this breakdown cannot always be determined except near the operating voltage, for in some cases the original breakdown does not carbonize the paper used as the dielectric of the condenser sufficiently so that it will be indicated as substantially a short-circuit when tested at low voltages. However, at higher voltages ionization takes place and the condenser shows a very low resistance.

Open-Circuits. The open-circuits, intermittent or otherwise, may be determined in a similar manner as that described under ELECTROLYTIC CONDENSERS.

Power Factor. The power factor of a paper condenser is usually very low, normally ranging from about 1 per cent to less than 0.2-per cent. A paper condenser seldom has a power factor in excess of 20 per cent as failure practically always takes place before the condenser reaches this stage.

However, higher than normal power factors are a forerunner to electrical failure. When a paper condenser has a power factor of several per cent it is a definite indication that deterioration has taken place. Usually this deterioration is due to moisture. However, it may be due to carbonization of the paper caused by ionization in the voids of the dielectric.

If the high power factor is due to moisture this moisture has probably entered at the condenser ends. It is perfectly possible for one of the layers of paper used in the condenser to have its edges frayed a considerable amount more than the others. As a consequence, moisture will be taken up by this paper and transmitted into the condenser laterally. The transmission of this moisture between papers takes a very much longer period than the lateral transmission. As a result, one of the papers may be electrically damp while the other papers are substantially dry. The result of a D.C. test on such a condenser would indicate substantially a normal D.C. leakage resistance. However, a power factor test would indicate that the power factor was considerably higher than normal, the reason for this being that only one paper is wet and there is practically no D.C. leakage through the other papers. The loss in the condenser upon the application of alternating current would be considerably higher than normal due to what might be termed "dielectric hysteresis."

THE BRIDGE ANALYZER

The Bridge Analyzer was designed after a study of the above common defects in condensers.

(Continued on page 53)

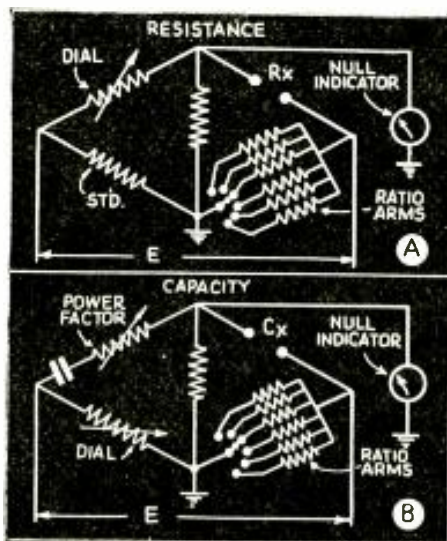

Fig. 2. Theoretical circuits of the capacity-resistance bridge.

Instruments by **TRIPLET**

... A Guarantee of **PRECISION and RELIABILITY**



MODEL 521 . . . 5" . . . Volt-Ohm-Milliammeter . . . One of Triplet's large line of electrical measuring instruments. Others available in 2 and 3 inch round and 3 and 4 inch square sizes. All standard ranges. Economically priced.

The new Triplet factory has daylight construction, it is air-conditioned throughout with temperature and humidity controlled. Especial measures have been taken to keep out dust, lint and microscopic particles . . . the enemies of precision accuracy.

The latest equipment makes possible the most modern processes for aging, relieving strains and stresses of materials and making the fine adjustments in assembly necessary for producing precision instruments.

No wonder. . . "Instruments by Triplet"—is a guarantee of precision and reliability.

WRITE FOR CATALOG



TRIPLET FACTORY—BLUFFTON, OHIO

The Triplet Electrical Instrument Co.
167 Harmon Ave., Bluffton, Ohio

Please send me more complete information on Triplet Model 521. I am also interested in

.....
Name
Address
City State

Please Say That You Saw It in RADIO-CRAFT

We Offer These Specials as Your YARDSTICK OF COMPARISON on P.A. EQUIPMENT



Heavy duty 12-inch aluminum projectors with heavy steel dome. Not to dealers. Only **\$3.18**



Send for Free catalog No. 62 and compare our values.

10 Watt "Versatile" system complete in leatherette carrying case—measures 14"x18"x16", including dynamic microphone. Nothing else to buy, sold only to dealers. Net Price **\$56.35**

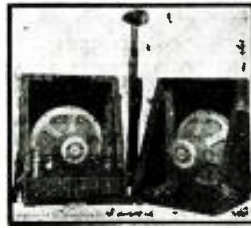

RADIO AMPLIFIER LABORATORIES, 59 Walker Street, New York, N. Y.

USEFUL REFERENCE DATA

The new 1937 catalog of Sprague Products Co. is of special interest to the radio Service Man who is not yet quite sure of just when and where to use particular types of replacement condensers. A "Tel-U-How Condenser Guide" contains a full-page tabulation of circuit analysis that clarifies the replacement problem; valuable supplementary data appear on other pages. Write to Radio-Craft for item No. 1419.

PHILCO SIGNAL GENERATOR

LIST PRICE \$22.50



A neat, brand new compact and accurate portable signal generator especially designed for adjusting standard broadcast and auto-radio sets. The Model 024 is the outstanding buy on the market in this type unit. Completely self-contained; operates from dry batteries (1—22½ volt standard battery and 1—Flashlight cell) and requires no outside power supply connection. Covers a range of 105 kc. to 2000 kc. ball-bearing tuning condenser makes for quick accurate operation.

MAIL ORDERS PROMPTLY FILLED

OUR PRICE **\$4.95**

PHILCO MODEL 024 Unit Measures 5x7x5 Shpg. Wgt. 6 lbs. F.O.B. N.Y.

EXTRA SPECIAL!

Genuine Astatic S-8 **\$4.95**
Crystal Pickup
THOR RADIO, Inc., 65 Cortlandt St. New York City

BUILDING AN INTERFERENCE ELIMINATION BUSINESS

(Continued from page 22)

(3)—Connect ground clip to Analyzer and to appliance frame.

(4)—If you cannot get to terminals of the appliance, cut into the supply lead so that the clip leads will be connected just as close to the device as possible.

(5)—Start the appliance operating. Then turn the Analyzer Selector Knob to Position No. 1. Listen on the customer's radio set (or your own portable radio receiver) to see whether this eliminates the noise. If not, then turn the Selector Knob to Position No. 2, and so on until you determine the filter arrangement that eliminates ALL of the noise.

In checking for noise, it is important that the Analyzer be connected directly to the terminals of the appliance (motor, vibrator, etc.) if at all possible. Otherwise there is apt to be a certain amount of interference radiated over the intervening line. If you cannot get to the terminals, cut into the supply line within a few inches of the terminals—just as close as you can get. Filter condensers should be installed at this same place in the line.

The type of interference analyzer here illustrated includes over 16 different filter combinations covering every type of filter circuit used in eliminating radio noises. (By disconnecting the ground connections it is possible to obtain 0.5-mf. from dual condensers C1; 0.05-mf. from dual C2; and, 0.015-mf. from dual C3.) See Fig. 1. Selector Knob Positions Nos. 1, 2 and 3 on the Analyzer include combinations to be obtained by the use of filter condensers only.

Selector Knob Positions Nos. 4, 5 and 6 give a variety of combinations which use both filter condensers and chokes of various sizes.

For instance, Positions Nos. 4 and 5 use 1 R.F. choke coil and Position No. 6 uses 2 R.F. chokes. Positions Nos. 4 and 5 are the same, except that the R.F. choke is in one side of the power supply line for Position No. 4 and in the other side of the line for Position No. 5. In connecting a filter to the appliance for permanent installation according to Position Nos. 4 or 5, the R.F. choke should be tried on both sides of the line to determine which is best.

In some instances better results are obtained by placing the R.F. chokes between the power supply line and the condenser. This is done by connecting the offending appliance into the Analyzer "B" socket and the supply line into the "A" socket.

USE OF LINE FILTERS

Occasionally a line filter will prove beneficial, especially where the radio-set antenna has a shielded lead-in and has been proved to be free of interference. In this case, simply treat the radio receiver as though it were a household appliance. Connect the Analyzer just as you would connect it to an appliance. Then determine the proper filter to use by rotating the selector knob until the noise is eliminated. Connect the ground wire of the filter to the receiver chassis or to the receiver ground, as circumstances dictate.

Heavy-Duty Equipment. Where the interfering appliance draws more than 10 A., no change in the procedure outlined will be necessary provided capacity filtering ONLY is required. In other words, if either Positions Nos. 1, 2 or 3 eliminate the noise, no chokes will be required and the current drain will make no difference.

However, if heavy-duty chokes are needed, these should be purchased separately and the capacities of the Analyzer employed to complete the job. Simply connect the Analyzer as you would for a straight capacity filter. Cut the wire to the appliance (motor, etc.) and connect the heavy-duty chokes into the circuit in series. Then try Selector Knob Positions Nos. 1, 2 and 3 to see which produces best results.

Heavy-duty chokes have not been incorporated into the Analyzer as they would add materially to its cost and the few jobs where they may be required can be handled satisfactorily and inexpensively in the foregoing manner.

Housing. Special boxes of sturdy metal construction to contain filter condensers and chokes used on interference elimination jobs are obtainable. These are marked and drilled for easy installation and insure a neat, efficient job. We strongly recommend their use. In some cases they are necessary to meet Underwriters' regulations.

Always remember to connect the filter devices as close to the offending appliance (motor, etc.) as possible. If you can attach them to the terminals or even inside of the frame of the appliance so much the better. In any event, never use a long lead to the filters. Every superfluous inch of lead wire may add to your troubles by causing radiation of the interference even after the filters have been installed.

This article has been prepared from data supplied by courtesy of Sprague Products Co.

FREE!
HAMMARLUND 25th YEAR RADIO CATALOG
The most complete catalog ever published with special illustrations, drawings, curves and a complete description of the famous 16 tube "Super-Pro." Write Dept. RC7-37.
HAMMARLUND MFG. CO., INC.
424-438 West 33rd Street, New York

P. A. is our business!
Your business is to obtain the best in **AMPLIFIERS and P. A. Equipment**
FREE CATALOG contains the greatest values ever offered. Consult us on your P.A. Problems, without obligation.
Amplitone Products Company
135 LIBERTY ST. NEW YDK. N. Y.

FREE RADIO AND PARTS CATALOG
Send for the new 1937 Spring ALLIED Radio Catalog—156 pages with Everything in Radio; 10,000 parts; 53 new All-Wave and Dual-Wave Knukht Radios with latest developments—Automatic Tuning, AFC, Tone Expansion, etc.; Amateur gear; Build-Your-Own Kits; test equipment; Public Address; books, tools, etc. Write for FREE copy!
ALLIED RADIO CORP.
Dept. 2-0, 833 W. Jackson Blvd., Chicago, Ill.

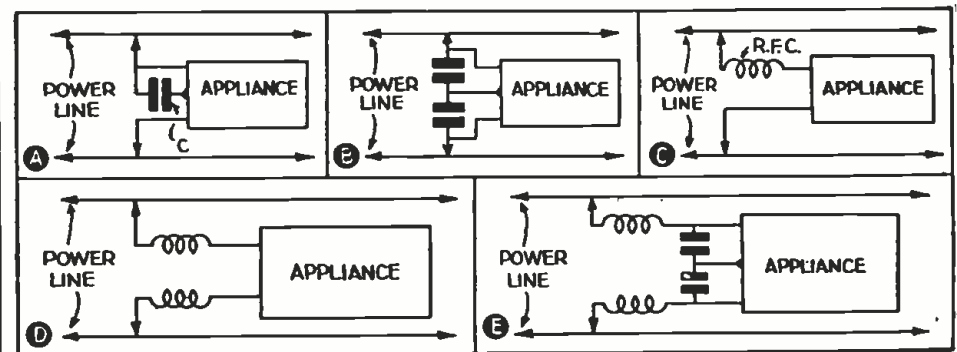

Fig. 2. Different types of interference filters attached to electrical appliances.

Please Say That You Saw It in RADIO-CRAFT

SERVICING BY SIGHT AND SOUND

(Continued from page 21)

The input to the amplifier is on the left and the output from the amplifier is on the right. In order that the operation of this equipment may be more clearly understood, refer to Fig. 1 which is a block diagram of the auxiliary apparatus.

In the lower-left corner of the diagram (and of the demonstration board) is a switch which is used to change the input to the amplifier so that it can be taken from a beat-frequency oscillator or from a phonograph pickup. The output of the amplifier connects to a rectifier and to a switch (shown directly underneath the rectifier) which applies to the cathode-ray oscilloscope either the direct or the rectified outputs of the amplifier. The units at the lower part of the diagram marked "Var. R.F. Osc.," "Fixed R.F. Oscillator," and "Detector" are units incorporated in a standard beat-frequency oscillator.

A beat-frequency oscillator operates by combining the output of two R.F. oscillators so that the difference of their frequency will be in the audio range and will be the frequency delivered to the amplifier under test. This audio frequency can be varied by varying the frequency of one of the R.F. oscillators.

AMPLIFIER TESTING PROCEDURE

To determine the characteristic of an A.F. amplifier, audio frequencies at constant voltage are applied to the amplifier and the variation of output at various frequencies is noted.

Ordinarily this is done rather slowly but to put the characteristic curve of the amplifier on the screen of an oscilloscope requires that this be done rapidly. In order to produce rapid variations of the audio frequencies, there is in parallel with the tuning condenser on one of the R.F. oscillators, a variable condenser which is so arranged that it can be rotated by a motor. This variable condenser is shown directly above the R.F. oscillator. In the position shown it is at minimum capacity. When the motor turns the shaft to which the variable condenser is attached, the frequency of the R.F. oscillator varies rapidly, and the output of the beat-frequency oscillator varies from a low audio frequency to a high audio frequency and then back again. This rapidly varying output is applied to the amplifier under test and the output of the amplifier is applied to the cathode-ray oscilloscope.

The timing of the oscilloscope is adjusted so that the image will sweep across the screen while the frequency is varying from its lowest point to its highest point. In order to hold the oscilloscope to its timing frequency, the impulse generator on the right-hand end of the motor shaft is connected to the synchronizing terminals of the cathode-ray oscilloscope. This produces a stationary image. In order that you Service Men may understand exactly what takes place, Fig. 2 will give a clearer idea of the sequence of operations.

SEQUENCE CHART

This chart may look a little complex but if followed carefully from the top down, its purpose may be realized.

The right side of the chart is divided into 4 equal sections. The width of these 4 vertical columns denotes the time required for the oscilloscope image to move across the screen. Inasmuch as the other operations are accurately timed to correspond to this sweeping operation, they can be drawn for the same intervals of time.

Next to the top of the chart is a line marked "Capacity of Motor-driven Condenser." Assuming that this condenser starts rotating at its point of minimum capacity, the capacity will increase as shown by the line to a maximum point, then decrease to a minimum point, increase to a maximum again and so on. This condenser being connected to one of the R.F. oscillators in the beat-frequency oscillator will cause the frequency of that particular R.F. oscillator to vary as shown in the second line. With the motor-driven condenser at its minimum, the R.F. oscillator will be oscillating at its maximum frequency and as the capacity of its condenser increases, the frequency of the R.F. oscillator will decrease, reaching a minimum at the same time the condenser reaches its maximum. The frequency of the oscillator will then increase as

the capacity of the condenser decreases, and so on.

If this variable R.F. oscillator beats against the frequency of the fixed oscillator, the A.F. produced will start at a minimum frequency. When the R.F. oscillator is at maximum the A.F. will increase as the R.F. frequency decreases. That is, when the R.F. decreases the oscillators are pulling farther apart which increases the A.F. output of the oscillator.

So it can be seen, on the 3rd line, that the frequency of the beat-frequency oscillator output will vary in the opposite direction to the frequency of the variable R.F. oscillator. If this varying audio frequency is applied to the input of an amplifier, the output of the amplifier will deliver a voltage which is considered as the characteristic of the amplifier under test. Starting with the low A.F. the amplifier does not put out much voltage.

The individual voltage waves are shown on the 4th line and they vary in amplitude as the frequency increases. When the frequency reaches its maximum point and begins to decrease, the same pattern is again made, only in reverse. That is, the pattern in the 2nd column is the reverse of the pattern in the 1st column. At the end of the 2nd column, the A.F. drops to zero. Beginning with the 3rd column the A.F. rises from zero to its maximum point and at the beginning of the 4th column begins to decrease going to zero again at the end of the 4th column.

If this voltage were applied to the cathode-ray oscilloscope, a pattern as shown on this chart would be a true picture of the amplifier characteristics. However, a single-line curve is more convenient to use. In order to get a single-line curve the output of the amplifier is applied to a rectifier. This rectifier cuts off the lower-half of the envelope pattern shown, which is the portion below the dotted line. When a small amount of filtering is applied to the output of the rectifier, the gap between the individual half-cycles can be filled in and will produce a smooth curve as is shown in the line labeled "Rectifier Output." This rectifier output is a true image of the outline of the upper portion of the pattern shown above. However, here again is something which is undesirable.

Operating the sweep oscillator and oscilloscope at the frequencies shown above, the image in the 2nd column will be superimposed on top of the image in the 1st column. This will result in 2 curves, one on top of the other, which do not coincide. In order to get the complete image desired, the curves must coincide. To do this a shorting switch is applied to the oscilloscope input which operates as shown in the next line. During the first sweep this shorting switch is open and allows the signal to be applied to the oscilloscope. During the next sweep it is closed. During the next it is open; and the next it is closed. Consequently, the input to the oscilloscope will be as shown in the bottom line.

For the first sweep the pattern will be shown on the screen but during the next sweep which is the reverse of the first, it will be short-circuited and only a straight line will appear on the screen. The 3rd sweep will be the same as the 1st and superimposed on top of it. The 2nd will be shorted-out making a straight line again. So, when these are all put together they will coincide and give the characteristic curve of the amplifier with the zero line drawn, at the bottom, as "Complete Image." This is the familiar type of curve which manufacturers publish in data books giving the performance characteristics of their amplifiers.

Analyzing this chart, it may be pointed out that the chart has been drawn to cover 4 successive sweeps of the oscilloscope. However, this only covers 2 complete revolutions of the motor-driven condenser mechanism. The complete image shown at the bottom of Fig. 2 is the type of view that appears on the screen of the cathode-ray oscilloscope. At the meeting where this equipment was used, variations in circuit characteristics were shown both visually and audibly. Visually on the screen of the cathode-ray oscilloscope and audibly by phonographic reproduction. (Service organizations interested in group-instruction of technicians may be interested to contact the author either directly or via Radio-Craft.—Editor)

This article has been prepared from data supplied by courtesy of RCA Manufacturing Co., Inc.

Please Say That You Saw It in RADIO-CRAFT

Well train **YOU QUICKLY**
for Good **FULL-TIME**
and **SPARE-TIME** Jobs in
ELECTRICITY



Train for a Better Job and a Future
Train in your Spare Time
by PRACTICAL Shop Methods
WITHOUT LEAVING HOME

Now, Electric Institute brings—**TO YOUR VERY DOOR**—practical training necessary for the rich rewards in Electricity. Keep your present job—no need to leave home—now you learn **ELECTRICITY** easily, practically—**BRIGHT AT HOME**—in your spare time.

PREPARE TODAY FOR OPPORTUNITIES AHEAD

Get into a real money making field where there are many opportunities in Electricity. There is no better way to succeed than to **TRAIN** for work in an industry that is expanding. New Electrical projects constantly mean more jobs for men with practical training. Almost every industry uses **TRAINED ELECTRICAL MEN**. Or you can own and operate an electrical business of your own.

Opportunities to Earn Up to \$5, \$10 a Week or More While Training

With this amazingly easy, fascinating method of **HOME SHOP TRAINING** it is possible to start **EARNING MONEY** almost at once. Do not confuse E. I. Training with dry, theoretical text book courses. Electric Institute tells you exactly **WHAT TO DO—THEN YOU DO the ACTUAL JOBS** with **ELECTRICAL EQUIPMENT** and **APPARATUS** which comes with your training at no extra cost.

Become a **TRAINED** man without leaving home or your present job—then be ready to step into a **REAL ELECTRICAL JOB**.

Money Back If Not Satisfied

You must be satisfied. We give you an agreement to return every cent you pay on tuition if, after completing our training, you are not satisfied in every way with our instruction, equipment or other services given you.

With our training, our graduates receive life time consultation service, employment service and many other features to help them succeed in Electricity.

Electric Institute is ready to show you the way in the great, growing field of **ELECTRICITY**—where trained men are **ALWAYS NEEDED**. Mail coupon **TODAY**—for big, free book of facts about this revolutionary **Practical Home Shop Training** and the tremendous opportunities in **ELECTRICITY**.

DIESEL ELECTRIC POWER, RADIO and REFRIGERATION

Take advantage of the opportunities awaiting trained men in these and many other branches of Electricity, with **ELECTRIC INSTITUTE** practical training. Mail coupon for complete facts about **ELECTRIC INSTITUTE**—it may be the turning point in your life.

FREE
ELECTRICITY

H. W. Petersen, President
Electric Institute, Inc.
Dept. 157H, Hinsdale, Illinois
Send Free Book with all facts about E. I. Home Shop Training.

Name.....Age.....
Address.....
City.....State.....

RUSH the COUPON—TODAY—BIG BOOK FREE

FACTORY TO YOU

NEW REMINGTON NOISELESS PORTABLE!



10¢ A DAY

Famous Remington Noiseless Portable that speaks in a whisper, only 10c a day, direct from factory. Standard keyboard. Automatic ribbon reverse. Variable line spacer and all the conveniences of the finest portable ever built. PLUS the NOISELESS feature. Act now. Send coupon TODAY for details.

You don't RISK a Penny
We send you Remington Noiseless Portable for 10 days' free trial. If not satisfied, send it back. We pay all shipping charges.

FREE Typing Course and Carrying Case
You will receive FREE a complete simplified home course in Touch Typing. Also FREE, a handsome, sturdy carrying case. No obligation. Mail coupon for full details—NOW

Remington Rand Inc., Dept. 189-7
815 Fourth Ave., New York, N. Y.
Tell me, without obligation, how to get a new Remington Noiseless Portable, plus Free Typing Course and Carrying Case, for 10c a day. Send Catalogue.

Name.....
Address.....
City..... State.....

Play Safe! Use The Word
NOKOIL
When Ordering Permanent Magnet Speakers

On broadcast as well as shortwave frequencies, in any location, you can eliminate "man-made" static with
NOISE-MASTER ALL-WAVE ANTENNA
Send for complete literature.
CORNISH WIRE CO., 30 CHURCH STREET, NEW YORK CITY

NEW GUIDE NOW READY!
Most complete volume control facts ever assembled in one book. Free with top (showing spec. number) of one Electrad volume control carton.
Write Dept. RC-7
175 Varick St., New York, N. Y.
ELECTRAD INC.

Learn SOUND RECORDING TALKING PICTURE PROJECTION TELEVISION-RADIO
Master training courses qualify you for good jobs. Practical, easy to learn. Newest equipment. 30,000 graduates. Earn room and board while learning. Couch R. R. fare allowed to L. A. Write for FREE BOOK. Address Dept. T-RC, 4000 S. Figueroa St.,
NATIONAL SCHOOLS - Los Angeles

"HAM" SPECIAL Standard Teleplex
A highly efficient code teacher using heavy specially prepared waxed paper tape, having two rows of perforations. Write for Free folder A7. We are the originators of this type instrument
Instrument with tapes prepared by expert and complete course, all for \$34.95. Without Oscillator. 72-76 Cortlandt St., N. Y. C.
TELEPLEX CO.

RADIOS..SAVE UP TO 50%
DEAL DIRECT...FACTORY PRICES! Many models to select from: AC-DC; All-Wave; Farm sets that operate like city radios! Your name and address on postcard brings you NEW Marshall Catalog in colors FREE. Get details of 30-DAY TRIAL plan and agent-user proposition!
GOLDSTONE RADIO CO.
Dept. 87, DEARBORN, MICHIGAN
30 DAY TRIAL \$6.98 UP
Free Catalog

TAMING MAN-MADE STATIC

(Continued from page 19)

with a faulty volume or tone control. If the set owner experiences excessive "static," the set may well be checked-over for offending components, loose joints in the aerial, or accidental contact between antenna and surrounding objects.

The third classification is of interest mainly to city dwellers, whose radio activities partake of the philosophy of sardines in a can. Dozens of aerials may clutter up the roof. Quite naturally, there is bound to be a certain amount of interplay between aerials and their sets, especially so if the sets are capable of regeneration or circuit oscillation without proper blocking means. Even though the old-time "squealers" are no longer commonplace, there are inexpensive superheterodynes capable of emitting a nice signal covering a quarter to half a mile radius. Here again, the Service Man must spot such interference and spike it.

But the bulk of the background noise confronting the present-day set owner originates with electrical equipment. Whenever a circuit is made or broken and a tiny spark appears, there is generated a damped radio wave. Now the whole question is whether that wave is to be trapped immediately before it can propagate over wire circuits and through space, or not. Because the wave is highly damped, it will cause interference at different frequencies by impact excitation.

The usual city apartment house is a veritable bedlam of man-made static noises. Electric bells and buzzers are great offenders, although thankfully at rare intervals. Elevator motors and contactors are probably the worst offenders, since they are constantly at work. If there is a doctor or dentist in the neighborhood with an X-ray machine or even an ultra-violet ray unit, the situation is one that is extremely difficult to remedy, for those two types of equipment constitute high-powered transmitters of troublesome waves.

TRANSMISSION OF INTERFERENCE

There are 4 ways for the inductive interference to reach the receiver, namely: (1) It may be radiated directly into space, especially if the source be quite powerful. (2) It may be conducted along power wires and reach the receiver that way. (3) It may be conducted along the power wires and radiated by them to the aerial. (4) It can be re-radiated by another conductor nearby.

Directly-radiated interference reaches the receiver by way of the antenna. It is, therefore, encountered with battery receivers as well as line-operated sets. Such interference should be suppressed at the source; but, failing in that, it is possible to overcome it by using a special antenna situated away from the interference zone and supplied by a noise-canceling lead-in. Since inductive interference usually does not extend more than 50 ft. from the source, the aerial can be swung clear of the building while the special lead-in passing through the noise zone will cancel-out any pick-up of its own.

Conducted interference can usually be reduced by means of a line filter. This is simply a pair of condensers connected in series across the line and center-tapped for a ground connection. Suppression at the source, of course, is a better procedure, for some of the interference may be radiated by the line and thus reach the set through the antenna, which gives us the 3rd classification. Obviously, if the interference hops off the wire into space, then we have plenty of trouble.

The fourth classification relates to a nearby aerial or wire which has picked up interference and is re-radiating it. It becomes a matter of shifting the nearby aerial or wire with relation to the set aerial, if unable to kill the trouble at its source.

NOISE-DETECTION PROCEDURE

Begin with the receiver. Make sure it is not guilty. Bad connections may cause a frying noise. Defective tubes may cause intermittent buzzing. These are often difficult to locate. The old test of disconnecting aerial and ground is not always reliable because some noises occur only when a signal is coming in. Tapping various parts of the set may help locate poor connections or faulty components. If possible, another receiver should be tried in exactly the same location.

Assuming that the receiver is blameless, disconnect aerial and ground, and short-circuit the aerial and ground binding posts with a short piece of wire. If the noise remains equally strong, it is of the second or conducted type.

If a battery-operated receiver is available, it serves to check interference caused by direct radiation or indirect radiation through power wires or adjacent aerial or wires. Interference radiated by the power line can usually be identified by tuning through the dial and down to the short waves. If the trouble becomes worse on the short waves, it is usually due to direct radiation and the source is probably within 50 ft. If the interference is worse on the long waves, the interference is probably carried along the power line and radiated by it. The source may then be several blocks away.

Again we repeat: the best cure is suppression at the source. But if that is impractical, then there are several things to do at the set end.

NOISE SUPPRESSION

If line noises originate outside the building, they may be kept out of the house wiring by the line-noise filter shown in Fig. 1A. Two paper condensers of 1 or 2 mf. each, rated at 600 V., are connected as shown, close to the point where the power line enters the building. Fuses should be inserted as an added protection. On A.C., the center-tap will be "hot" unless it is effectively grounded. An alternative circuit is indicated in Fig. 1B, but there is little danger of shock if the technician is careful to connect the ground first when installing the filter. It may be necessary to try several grounds. In any event, the ground wire must be kept as short as possible and should not be the same as that used for the receiver.

Where simple filters fail to turn the trick, a more elaborate arrangement such as shown in Fig. 1C becomes necessary. More than one section can be employed with different-size coils

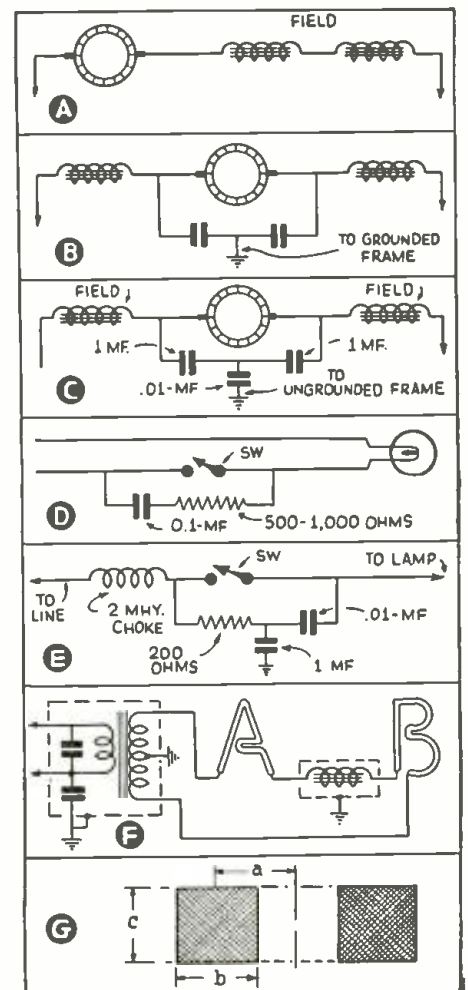

Fig. 2. Suppression of noise at the source.

Please Say That You Saw It in RADIO-CRAFT

so as to bring maximum attenuation in the center of different wave bands. Inductance values up to 1 millihenry have been employed for the broadcast band with condensers of 0.1- to 0.5-mf. These values are not critical. It is necessary to shield the filter carefully. Mounting the coils in inductive relation to each other helps the efficiency of the filter.

The 3rd measure the set owner can take is to employ a special noise-reducing antenna system. A typical layout of this general type is shown in Fig. 1D. In this case the aerial does all the work of picking up signals. The lead-in or downlead is inert as a pick-up, its sole function being that of a transmission line between aerial and set.

In the final analysis, however, suppression at the source is the best way out. In Figs. 2A, B and C we have the cure for electric motor noises. Electric motors of the series type, both A.C. and D.C., may be rewired from the circuit of 2A to that of 2B which makes the field serve as a choke. The center-tapped condensers are connected across the brushes—not across the line. If the frame of the motor is grounded the center-tap of the 2 condensers can return directly to the motor frame. When this is not feasible, the circuit of 2C is suggested. Dangers of shock are reduced by the additional condenser 0.01-mf.

Motors of the shunt type must have the condensers directly across the line which is also directly across the brushes. In all cases the wires should be short so as to prevent them serving as effective radiators. If condensers prove insufficient as suppressors, R.F. chokes heavy enough to carry the current, must be added as in Fig. 1C.

SWITCHES, FLASHERS, NEON SIGNS, ETC.

Noises caused by switches can be eliminated by the resistance-capacity filter shown in Fig. 2D. This is to be connected across the switch, not across the line. The proper sizes of resistor and condenser depend on current drawn by the circuit. In most instances, 500 to 1,000 ohms and 0.1-mf., respectively, will be found satisfactory.

Thermostat controls and flasher signs are nothing but switches and can be treated the same way. One circuit that has proven effective for flasher signs is shown in Fig. 2E.

Neon signs are notorious offenders in the matter of radio noises. If the neon sign is excited by high-voltage A.C., condensers can be fitted across the primary as in Fig. 2F. It is also effective to include a choke, properly insulated, in between the letters of the sign. If R.F. is used, the remedy is a narrow metal band around the glass tube near the middle of the sign, this band to be grounded.

SERVICING QUESTIONS & ANSWERS

(Continued from page 25)

my set is on about one-half hour. I own a Zenith model 6S152 receiver.

A. Distortion in this receiver is usually caused by a defective 6F6G power amplifier tube. These tubes are coming through greatly improved; therefore we believe they will last much longer.

2 SPOTS ON DIAL

(13) Oscar Heffner, New York City
Q. I own a Stromberg-Carlson model 68 receiver, and I am troubled with 2-spot tuning of WOR.

A. We judge from your inquiry that you must have one of the early 68 chassis with 175 kc. peaked I.F. transformers. By simple calculation you can determine the reason for 2-spot tuning of WOR. This station's wavelength is 710 kc. and therefore sets up a harmonic when mixed with the oscillator of your receiver on 1,420 kc. on your dial. The most practical remedy is to change the I.F. transformers to 465 kc. units. When you replace these transformers be sure to properly align them with an external oscillator.

S.-W. IMPROVEMENTS

(14) Thomas Silvester, Ossining, N. Y.
Q. Could you advise me how to increase the sensitivity of my receiver on short waves? I have a 1937 Philco set.

A. It is advisable to substitute your regular antenna with the new antenna kit made by the set manufacturer. This will greatly increase the sensitivity on short waves.

Diathermy machines, X-rays, violet rays and so-on are small radio transmitters and cause severe interference. The power line should be grounded at the source of interference by a filter similar to that shown in Fig. 1C. The directly radiated interference can only be stopped by a complete shielding of the room and filtering of all wires passing through the shield. If a power line filter is used at the machine, however, the special aerial will probably take care of the direct radiation.

The chokes should have a maximum of impedance over the tuning range of the receiver. In general, the larger the choke the better—if it does not have too much distributed capacity. Economic considerations and space limitations usually fix the size of the choke. Standard sizes for chokes have been anywhere between 100 and 1,000 microhenries.

In designing a choke the current carrying capacity of the wire should be taken in consideration. Since heavy wire means an expensive and large choke, the filter is often designed to carry no more than the current for a good-size receiver and care should be taken not to overload it. Table 1 shows the current-carrying capacity of several wire sizes as given by the National Board of Fire Underwriters, together with the maximum allowable number of watts on a 110 V. line.

The inductance of multilayer coils of square cross-section, Fig. 2G, is given by the equation:

$$L = \frac{.8a^2N^2}{6a + 9c + 10b} \text{ microhenries}$$

where N is the number of turns and all dimensions are in inches. The most efficient coil is had when $b = c = .667a$. If one assumes these relations they can be inserted in the above equation and after some mathematical juggling be put in the following form

$$a = \sqrt[5]{52.6 \frac{L}{d^2}}$$

$$b = c = .667a$$

$$N = .44a^2d^2 = bcd^2$$

d is the number of turns per inch and can also be found in Table I.

TABLE I

Size, B.&S.	Safe current	Power on	Turns-per-in.
Gauge	(Amperes)	110 V. line	Enam. D.C.C.
10	25	2,500	9.6 8.9
12	20	2,000	12.1 11.0
14	15	1,500	15.2 13.6
16	6	600	19.1 16.7
18	3	300	23.9 20.2

This article has been prepared from data supplied by courtesy of Aerovox Corporation.

HOW TO CHECK CONDENSERS WITH AN A.C. BRIDGE

(Continued from page 49)

The function of this bridge is to determine the condition of electrolytic and paper condensers, both in regard to D.C. leakage values and power factor.

The bridge consists of a network so designed as to measure capacity from 10 micromicrofarads to 100 microfarads; power factors from 0 to 50 per cent; D.C. resistance values from 1 ohm to 1 megohm; and D.C. leakage of electrolytic and paper condensers under actual voltage operating conditions. The D.C. voltage impressed on the condenser for leakage tests may be varied by the operator from 35 to 550 V. D.C. leakages in electrolytic condensers may be measured as well as D.C. leakages of paper and mica condensers.

The diagram shows the schematic circuit of the Bridge Analyzer and a simplified diagram of the bridge network used. In order to cover a large range of capacity and resistance a 7-point decade switch is employed which is a multiplier on the main dial. This main dial has a scale of $8\frac{1}{2}$ ins. so that the values of capacity and resistance may be accurately determined.

A 6G5 electronic visual-indicator tube is used as a null indicator instead of the customary headphones, the "eye" opening at balance.

The Service Man and experimenter, it is believed, will appreciate this device which enables him to accurately determine the condition of all condensers in a radio receiver.

Our Information Bureau will gladly supply manufacturers' names and addresses of any items mentioned in RADIO-CRAFT. Please enclose a stamped and self-addressed envelope.

Now—a high-powered—



Radio Engineering Library

New
The Library now comprises a revised selection of books culled from latest McGraw-Hill publications in the radio field.

—especially selected by radio specialists of McGraw-Hill publications

—to give most complete, dependable coverage of facts needed by all whose fields are grounded on radio fundamentals

—available at a special price and terms.

These books cover circuit phenomena, tube theory, networks, measurements, and other subjects—give specialized treatment of all fields of practical design and application. They are books of recognized position in the literature—books you will refer to and be referred to often. If you are practical designer, researcher or engineer in any field based on radio, you want these books for the help they give in hundreds of problems throughout the whole field of radio engineering.

5 volumes, 3064 pages, 2000 illustrations

1. Glasgow's PRINCIPLES OF RADIO ENGINEERING
2. Hund's PHENOMENA IN HIGH-FREQUENCY SYSTEMS
3. Chaffee's THEORY OF THERMIONIC VACUUM TUBES
4. Terman's MEASUREMENTS IN RADIO ENGINEERING
5. Henney's RADIO ENGINEERING HANDBOOK

10 days' examination. Special price. Monthly payments. \$25.00 worth of books cost you only \$21.50 under this offer. Add these standard works to your library now; pay small monthly installments, while you use the books.

SEND THIS ON-APPROVAL COUPON

McGraw-Hill Book Co., Inc.
330 W. 42nd St., New York, N. Y.

Send me Radio Engineering Library, 5 vols., for 10 days' examination on approval. In 10 days I will send \$2.50, plus few cents postage, and \$3.00 monthly till \$23.50 is paid, or return books postpaid. (We pay postage on orders accompanied by remittance of first installment.)

Name

Address

City and State

Position

Company RC-737

AUTO-RADIO Re-Installations

1,016,313 NEW JOBS
Get Your share of them!

Field estimates reveal a vast new market for dealers and service men in transferring old radio sets to new cars—modernizing, replacing, converting.

TRANSFER ANY SET TO ANY CAR

With patented UNIVERSAL CONTROLS you can get your full share of this valuable new business. Installations are made quickly and easily—without cutting or drilling the dash.

Pre - Assembled!

UNIVERSAL gives you a pre-assembled, single-unit control to fit any car radio— together with the proper plate to perfectly match the instrument board.

Send for the Catalog TODAY!

Universal DASHBOARD CONTROLS

UNIVERSAL CONTROLS, INC.
21-07 48th Ave., Long Is. City, N. Y.

Please send your new Catalog F-1.

Name

ADDRESS

Dealer Service Man Jobber

Please Say That You Saw It in RADIO-CRAFT

Our New Address

GREN PARK COMPANY

1229 PARK ROW BLDG.
NEW YORK, N. Y.

RADIO MEN always need accessories for the service bench or kit. Here are a few tools which come in handy for any repair job. On just one or two service jobs you'll be repaid their nominal cost.

FLEXIBLE SHAFT SCREWDRIVER

Use this FLEXIBLE SHAFT SCREWDRIVER—the screwdriver that actually goes around a corner—in your service work. It reaches many awkward places where a screw cannot be reached by a straight or offset driver. Has a thousand and one uses—ideal for repairing radios, refrigerators, automobiles, oil burners, machinery, shop equipment, electrical appliances, vacuum cleaners, marine equipment, household jobs, etc. The FLEXIBLE SHAFT SCREWDRIVER has a shaft of laminated steel wire—tempered, chromium-plated fittings—fluted, hard—wooden handle—length overall 8".



PRICE, **\$1.00**
POSTPAID

FLEXIBLE DRIVE SOCKET SET

The most practical socket set ever developed for radio work—ideal for "hard-to-get-at-places." Set consists of 10" Flexible Drive with six (6) removable sockets having hex openings in the following sizes:

3/16" 1/4" 5/16" 3/8" 7/16" 1/2"

The FLEXIBLE DRIVE SOCKET SET is similar in construction to the screwdriver. With each socket set is included a FREE steel carrying case. PRICE, **\$3.00**



POSTPAID

SHOCK-PROOF SCREWDRIVERS

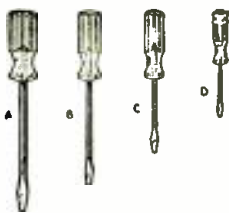

The finest set of shock-proof screwdrivers available for radio men—this set of four (4) screwdrivers has transparent, unbreakable, shock-proof handles, and is equipped with tempered steel blades. Blade sizes are: A—5" x 1/4" B—4" x 3/16" C—3" x 3/16" D—2" x 1/4". Set of four (4) screwdrivers. PRICE, **\$1.50**

POSTPAID

GREN PARK COMPANY

1229 Park Row Bldg., New York, N. Y.

CLIP MAIL COUPON TODAY

GREN PARK COMPANY RC-77
1229 PARK ROW BLDG., New York, N. Y.

Gentlemen: Enclosed you will find my remittance of \$..... for which please send me, POSTPAID, the equipment indicated by the cross (X) below:

() FLEXIBLE SHAFT SCREWDRIVER @ \$1.00
 () FLEXIBLE DRIVE SOCKET SET @ \$3.00
 () SHOCK-PROOF SCREWDRIVERS @ \$1.50 per set (Set of four)

Name

Address

City State

AN EASILY-MADE ADD-ON VOLUME EXPANDER

(Continued from page 21)

WE MEAN IT!

Another advantage of this modified system is the fact that if a class AB output stage is used, it will operate on the "A" portion of its plate characteristic except for the peak powers, thus keeping the harmonic distortion to a negligible value at ordinary volumes.

Like its progenitor as used in one make of present-day commercial radio receiver, its fundamental operation is based on the change of resistance of an enclosed tungsten filament as its temperature is raised by the passage of a large current. Two bulbs are connected in a Wheatstone bridge arrangement as shown by heavy lines in Fig. 1. (A complete 30-W. amplifier is shown for the convenience of readers who may wish to see exactly how the new modified expander connects into a practical amplifier circuit.) When the voltage across points A and C is increased, the current in both sides of the bridge is increased and more heat is evolved in the lamp filament causing a rise in temperature, and, because of the high temperature coefficient of this wire, an unbalance occurs causing a current to flow between the B and D terminals of the bridge.

THE NEW MODIFICATION

The modified expander circuit differs from the commercial type in that the former circuit is always operated at low levels and near its balance point. This is accomplished by inserting the expander proper after the first tube of the audio amplifier, and following it by additional audio amplification and the output stage.

If a voice coil were connected across points B and C as is done in one of the commercial systems now in use, then in order to obtain a moderate amount of expansion, an enormous loss may be expended across the elements of the Wheatstone bridge. This fact also places a practical limit to the expansion possible. Should a Wheatstone bridge be operated with a large unbalance, two opposite resistance arms must be increased or decreased quite a bit before there is an appreciable change in the unbalance current.

A bridge operated near its balance point, however, requires but a small change in resistance of two diametrically opposite arms to cause a huge increase in unbalance current. Since the change in resistance of a bulb filament is limited by its temperature coefficient, then, in order to secure a large increase in unbalance current by a minimum increase in input voltage, the bridge should be operated at a point very close to balance. In fact, if the bridge is balanced and the slightest unbalance occurs, the ratio of increase will be infinite since it was originally zero and the resultant value no matter how small, when divided by zero, results in infinity.

Another advantage in operating the bridge near balance is the increase in time lag which results therefrom. The bulbs, V6, V7, used in the bridge require an appreciate time to heat up and change their resistance. This fact is advantageous since it introduces a delay and does not allow all the expansion to occur on one or two lobes of the signal wave. If the system responded instantly to changes in impressed voltage, the result would be a peaked wave, highly distorted and containing large odd-order harmonic components.

The time lag required to keep the odd-harmonics down to tolerable values is dependent both on the frequency and amplitude of the lowest tone which is impressed on the expander. This time lag is determined by the mass of the filament and by the operating temperature of the filament. Since a very hot bulb takes less time, proportionately, to become cool than one heated to a lower temperature, the bulbs should preferably be worked at lower power levels. This will make the time lag proportionately greater for the same filamentary mass.

OPERATION NOTES

Almost any degree of expansion or compression is possible with this bridge arrangement. (The commercially-available expander-adaptor illustrated in Figs. A and B has a control range of 30 db. from any given level.—Editor)

The amount of change is determined by the setting of the variable resistors, R2a, R2b. If the bridge is balanced for a just-audible signal, then any slight increase in signal amplitude will result in a huge change in contrast. If the resistance values of R2 are made less than the

resistance values of lamps V6-V7 at low volumes then the expansion will not be as great. If on the other hand, the resistance of the rheostat arms is made greater than the bulb resistance, then an increase in signal amplitude will result in a decrease in output and compression will result.

Since this expander circuit is capable of practically any degree of expansion, care must be taken not to use too much expansion, since this will result in unnatural reproduction. Remember that until broadcast transmitters incorporate compressor circuits, the use of an expander at the receiving end is apt to be a bit disappointing, especially if the control man at the transmitter is over-zealous.

The schematic arrangement of the apparatus as used in the laboratory model is shown in Fig. 1; which depicts the latest circuit improvements (as of May 1st), in this system. The output of the radio receiver or phonograph pickup is impressed on the control-grid of a 6C5, V1. The output of V1 is in turn, by means of a step-down transformer, impressed on the bridge circuit. The bridge proper, as connected in this model, consisted of two 6-8 V., 3 candlepower automobile lamps and a dual rheostat consisting of two 5-ohm sections on a common shaft. The output of the bridge is fed through a step-up transformer to the control-grids of a 6N7 which, in turn, feeds a pair of 6L6s arranged to operate as a push-pull class AB amplifier and capable of delivering 34 W. to the speaker if the power supply is well regulated.

The constructional details are quite simple and should be easily gleaned by inspection of the schematic shown by heavy lines in Fig. 1. The transformer, in order to assure a good overall frequency response, should be selected with care. Unit T1 may be an output transformer which was made to match a very low voice coil impedance. For T2, the transformer used was one made to match a velocity microphone to push-pull grids. A set-up using an output transformer of the type made to work a push-pull stage to a voice coil, however, was tried for T2 and gave satisfactory results. The transformers T1 and T2 should be capable of operating at levels of from plus 19 to plus 20 db., that is, less than 1 W.

In the expander bridge, if the dual 5-ohm control is not procurable 2 rheostats may be substituted, the only difference being that the adjustment of the bridge will be a bit more difficult with 2 controls.

A photograph showing the arrangement of the expander proper is illustrated in Figs. A and B. The actual expander circuit takes up very little room and can easily be connected to practically any receiver. (The photos were made available by courtesy of Wholesale Radio Service Co.—Editor)

If a driver stage is used to swing the grids of the output stage, then the bridge, with its associated step-down and step-up transformers, may be inserted ahead of the driver. In many cases, the 1st audio can be replaced by a tube suitable as a driver and the expander inserted in the input to the driver. In cases where the audio section of a receiver is obsolete, the transformers may be replaced by resistance coupling and the old output tube or tubes used as drivers, immediately following the expander, feeding a pair of push-pull 6L6s.

LIST OF PARTS

- One universal-type output transformer, high plate impedance to 1.5- or 2.5-ohm secondary load, T1;
- One universal-type output transformer (functions well, as a mike to push-pull grids unit, if operated reversely), T2;
- One output transformer (for 6L6s in class A prime to voice coil), T3;
- Two automobile headlight bulbs, 3 candlepower, 6 to 8 V., V6, V7;
- One Electrad tandem control, No. 6608, 5 ohms (individual 10-ohm rheostats, part No. 204-W, may be used instead) each resistor, R2a-R2b;
- Two Electrad resistors, 3 ohms, 2 W., R13, R14;
- One Wholesale Radio Service Co. metal cabinet, size 6 x 5 1/2 x 5 1/2 ins. deep;
- One Wholesale Radio Service Co. lot of miscellaneous parts (binding posts, escutcheon, knob, D.P.D.T. snap switch, etc.).

This article has been prepared from data supplied by courtesy of Electrad, Inc.

Please Say That You Saw It in RADIO-CRAFT

USEFUL RADIO CIRCUITS

(Continued from page 23)

HONORABLE MENTION

How to Obtain High Voltage from Several Broadcast-Receiver Power Transformers. "Hams" and experimenters often want high plate or D.C. voltages. This can be supplied by using ordinary good broadcast-receiver power transformers, wired in a bridge circuit which, in conjunction with 83s or some other mercury-vapor rectifier tube, give a D.C. output nearly equal to the A.C. voltage of the power transformer. See diagram G. Now to further increase the voltage, wire the high-voltage filament of the bridge rectifier to center-tap of next power transformer. You will then have the voltage of No. 2 added to No. 1. You can make two bridge circuits like No. 1 and get still higher voltages, wiring them in series, of course. All filament windings to rectifiers must be separate. They can be part of the same power transformer, but separate filament transformers would be less likely to have any breakdown trouble. By these circuits the voltages are raised but the transformers are not overloaded.

HUBERT BUSSARD

HONORABLE MENTION

A Home-Made Output Meter. A good output and A.C. meter can be made from a tuning meter which can be picked up for about 25c. taken from a Majestic 60-A receiver. The rectifier is an Elkon type, cut down to get a more sensitive reading. For A.C. readings, an old output transformer is used and the meter is then calibrated against a standard model. It may also be used as an output meter to line up I.F. and R.F. stages, etc. The A.C. side of the rectifier is connected directly to the voice coil. See diagram H.

FRANK KOLLATT

HONORABLE MENTION

Good Home-Made Condenser Tester. After experimenting for the last couple of weeks, I have found a circuit that will test condensers from 10 mmf. to 100 mf. and give a fairly accurate test. I used an old filament transformer from a Majestic "B" eliminator, a 1 W. neon lamp, a 0.25-mf. 400 V. bypass condenser, a 400 ohm choke, and a type 01A tube as a rectifier. In addition to testing condensers, this unit can also be used as a continuity tester. See diagram I.

E. O. COLE

HONORABLE MENTION

Versatile Vacuum-Tube Voltmeter. I wish to present an A.C.-operated, flexible, vacuum-tube voltmeter of entirely original design, simplicity and proven worth. I use this meter in service work, and it was used as an output meter "on the line" in one of the local radio manufacturing companies, comparing favorably with the specialized equipment used for this purpose. The 6J7 metal tube is used because the response is linear from 2 to 5 ma. (with circuit constants used) so that the measured voltages may be read directly from the meter scale. The ranges are 10, 100, 500 and 1,000 V. A.C. and 0-13 V. D.C. (with use of the 9 meg. potentiometer, the D.C. range may be extended much higher and still have linear response). Frequency error is small up to 200 or 300 kc. I have used it to measure output of an all-wave oscillator. Some of the uses of this meter are: measuring A.C. voltages from transformers; A.V.C. voltages; bias on audio tubes at the grid, and when tapped high-resistance voltage dividers are used; output meter (from plate to ground or across voice coil); gain in final stages of a receiver; etc. In some cases an A.C. operated V.-T. voltmeter will induce a terrific hum in a receiver when A.V.C. voltages are being measured. There are a number of things which can be done to cure this: (1) change the power transformer of the V.T. voltmeter (which may have leakage or too high a capacity between primary and secondary, etc.); (2) insulate all grounds from the chassis, including insulated mounting of the filter condensers of V.T. voltmeter; (3) insert a resistance and capacity filter in the ground lead of the D.C. section of the V.-T. voltmeter (see diagram J); (4) reverse line plug; (5) remove external ground from receiver and line bypass condenser (if there is one).

WILLARD CHANEY

ELECTROLYTICS for your every CIRCUIT REQUIREMENT

THERE is no electrolytic replacement required for the servicing of the modern A.C.-D.C. receiver that cannot be successfully accommodated by either the types KR or JR dry electrolytic capacitors.

The type KR series is enclosed in a round aluminum container with convenient wire terminals and stud and bolt mounting, for sub-panel wiring. The type JR is assembled in a handsome silver container and provided with convenient wire leads and mounting feet. Both the KR and JR series is available in single, dual and multiple capacity combinations.

For a neat, profitable job and complete customer satisfaction standardize on C-D electrolytics. Complete catalog free on request.

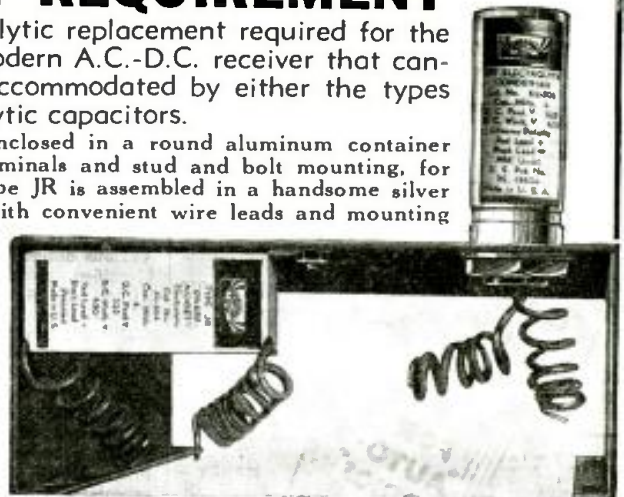

WORLD'S LARGEST MANUFACTURER OF CONDENSERS

CORNELL DUBILIER

CORNELL-DUBILIER CORPORATION
1014 Hamilton Blvd.
So. Plainfield, N. J.



3-Tube Short Wave Radio

Only \$3.25

(less tubes, phones, unwired)

A REAL, powerful 3 tube short wave set that readily brings in amateurs, police calls, broadcast stations, experimental and foreign stations with good volume under fair conditions. THE WORLD AT YOUR DOOR!

A dependable receiver which is guaranteed to give results. Operates entirely from the AC or DC house current. Simple to build and easy to operate. Beautiful, black shivel finish cabinet and instruction furnished. wave-length range 12-600 meters. An ideal set for the beginner who wishes to learn the thrill of short wave reception.

THREE TUBE BATTERY SET, less tubes, phones, unwired \$2.95.
TWO TUBE BATTERY SET, less tubes, phones, unwired \$2.00.

KITS wired, extra 75c.
Tubes, each 50c. Broadcast band coils (2), extra 95c. Cannonball double headphones \$1.35.

FREE: New 1937 Catalogue

of Short-Wave receivers, transceivers, 5 meter apparatus, and summer portable sets; send stamp to cover mailing costs on your copy.

NOTE: Kits are factory assembled by us and are ready to wire by merely following a simple diagram. No holes to drill or parts to mount.

20% deposit required on C.O.D.'s

EILEN RADIO LABORATORIES

ON THE BOARDWALK
ATLANTIC CITY
HOTEL
KNICKERBOCKER
IN THE HEART OF ALL
RESORT ACTIVITY

FIREPROOF CONSTRUCTION
AMERICAN & EUROPEAN PLAN
SALT WATER BATHS

ROOM AND BATH FROM \$3.50
AMERICAN PLAN FROM \$6.00

C. HENRY LANDOW, Manager

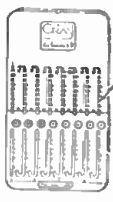

Vest Pocket Adding Machine

Sturdy Steel Construction. Lifetime Pocket Companion. Adds, Subtracts, Multiplies, Divides. Capacity, 999, 999.99. A real machine—guaranteed 5 years. Send name and address. We ship immediately. On delivery, pay postman \$2.50 (plus few cents postage). (Foreign countries send cash.)

Free Trial \$2.50

Your money back after 10 days trial if not satisfied. Thousands of satisfied users. Total Send for Special Offer Cost for to agents.

TAVELLA SALES CO., 21 West Broadway, New York, N. Y.

BS-5 6-TUBE BAND SWITCH RECEIVER

12 to 600 meters



A powerful sensitive receiver covering the entire wave-length span of 12 to 600 meters in 5 steps. NO PLUG-SWITCH are used. Simply turn the wavelength selector within this range.

PRICE, complete with 6 tubes, cabinet, wired, ready to use \$16.95

BS-5 KIT, of necessary parts, including detailed instructions, less tubes, cabinet, unwired \$10.95

SPECIAL: Complete kit, cabinet, tubes and instructions, unwired \$14.95
(If metal tubes are preferred to glass type, add \$1)

Dept. RC-7, 136 Liberty Street, New York, N. Y.

TWO WAY COMMUNICATION



List Price
\$15.00

Per Station

SEND FOR COMPLETE CATALOG OF RECORDING MACHINES, BLANK DISCS, MICROPHONES, ETC.

UNIVERSAL MICROPHONE CO. LTD.
424 Warren Lane, Inglewood, Calif., U. S. A.

Inter-phones, office to office, factory, shipping depts., house to garage and hundreds of other uses. Positive in operation. Simple to install. Modern in appearance. Any number of 'phones to same line.

(Dealers and jobbers write for discount)

HAVE YOU SOME SPARE ROOM

a basement or garage where you can do light work? We can offer you a profitable proposition casting 5 and 10c Novelties, Ashtrays, Toy Automobiles, etc. as Manufacturer for firms of many years standing. No experience necessary as we furnish full instructions with moulds. If interested in devoting your spare or full time to profitable work and you mean strictly business write AT ONCE for full details as we are now closing 1937 arrangements for supply of our goods.

METAL CAST PRODUCTS CO.
Dept. 26, 1696 Boston Road, New York, N. Y.

Please Say That You Saw It in RADIO-CRAFT

Amazing New Gadgets Speedup YOUR SERVICE WORK

GHIRARDI'S NEW POCKET TROUBLE SHOOTERS
SAVE TIME • SAVE LABOR • SAVE MONEY!

The author of "RADIO PHYSICS COURSE" & "MODERN RADIO SERVICING" now gives you 2 NEW "GADGETS"—eyeletted, pocket-size TROUBLE-SHOOTER CARDS that list all common radio set troubles—tell you exactly what tests to make—give quick remedies for every case!

Cleverest, Handiest, Trouble-finders Ever Conceived!

You'll marvel at the genius and simplicity of these wonderful "lightning" trouble finders. Just a flip of a card and the problem's solved!

FOR "HOME" AND "AUTO" SETS

Each gadget for its type of set gives all common trouble symptoms— "Hum," "Weak," "Noisy," "Inoperative," "Intermittent," "Fading," "Oscillating," "Distortion,"—with instant tests and remedies.

50c PER COPY

The "Twain Gadgets" may pay you their cost on the first service call!

MONEY BACK IN 5 DAYS IF NOT SATISFIED!

RUSH THIS COUPON NOW!

RADIO & TECHNICAL PUBL. CO., Dept. RC-77
45 Astor Place, New York, N. Y.

Enclosed find \$_____ Rush the "Gadgets" checked below at 50c each. If not satisfied I am privileged to return them within 5 days, and get my money back.

"HOME RADIO" GADGET "AUTO RADIO" GADGET

Name _____
Address _____
City _____ State _____

These new gadgets will be ready for shipment June 21st.

SIGNAL GENERATORS KITS and COMPLETE

COIL KIT SW-1. Complete 6-coil and switch assembly, mounted and wired on machined bakelite strips for 400,000 mfd. variable. Covers 90 kc. to 31 mc. on fundamentals. Wt. 1 lb. \$3.77

FOUNDATION KIT SW-1A. Consists of 6 coils and switch, tuning condenser, metal-etched panel with all scales, Delta transparent bakelite pointer with knob, and directions. Wt. 3 lbs. \$6.93

COMPLETE KIT SW-1B. All parts in kit SW-1A, also modulation transformer, 3 sockets, 300 ohm line cord, drilled and tapped bakelite strip for mounting c. i. s., volume control, knobs, all condensers and resistors, sub-panel, hardware, toggle switch, pin-jacks, crackle-finished steel cabinet with handle, 3-645 metal tubes and directions. Wt. 5 lbs. \$13.45

COMPLETE WIRED & TESTED SIGNAL GENERATOR, less tubes. Wt. 6 lbs. \$14.15

COMPLETE GENERATOR, lined-up to its tubes, ready to plug-in as shown \$15.95

WRITE FOR DESCRIPTIVE CIRCULARS
DELTA RADIO COMPANY
135 Liberty Street Dept. RC-7 New York, N. Y.

LEE Correspondence Courses in RADIO and ELECTRICAL ENGINEERING

ELECTRICAL ENGINEERING Get good grasp of electrical field. Prepare yourself, at Low Cost, for secure future. Modern, simplified, you can understand quickly.

RADIO ENGINEERING Extra fine course in radio, public address, photo-electric work. Trains you to be super-service man, real vacuum tube technician. Exper. kits furnished. Diploma on completion. Tuition, \$25. Get copies of school catalogs, student magazines, complete details. SEND NOW!

FREE

LINCOLN ENGINEERING SCHOOL, Box 931-31, LINCOLN, NEBR.

Play Safe! Use The Word

NOKOIL

When Ordering Permanent Magnet Speakers

RIDER MANUALS

NOW IN SEVEN VOLUMES

JOHN F. RIDER, Publisher 1440 Broadway, New York City

THE LATEST RADIO EQUIPMENT

(Continued from page 26)

banks, analyzers, etc. The volume and surface leakage is held to 10¹² by the use of a ceramic switch plate. Unit is available in either single or double deck, with brass or silver contact points. The switch is of small-space type and is very rugged.

and series resistors. Many important applications for this type of tube include transmitter adjustments, R.F. measurements, current readings, and radio-receiver output meters.

NEW NEON TEST LAMPS (1396)

(Sundt Engineering Co.)

CLASSIFIED as *electrodeless* and *current-measuring* types, two new groups of neon lamps have made their advent on the market. Various designs of each are illustrated. They are identified, as to voltage to glow on A.C., as follows: No. 5170, electrodeless, 400 V.; No. 5171, electrodeless, 550 V.; No. 5172, electrodeless, 1,000 V.; No. 5173, test probe, 1,000 V.; No. 5146, tuning wand, 110 V.

The *electrodeless* tubes operate on the same principle as a condenser. Electrons flow between the 2 metallic caps deposited on the outside tips of the tube, with the neon gas acting as a conductor between the 2 metallic caps. In normal practice, the current/light ratio is very high, especially when the frequency is about 5,000 cycles; current drain rarely exceeds 4 micro A.

Because of their high impedance, these tubes may be operated in circuits of very high voltages and low currents without causing any appreciable change in the normal operation of the circuit. Many important applications for this type of tube are diathermy output indicators, transmitter and R.F. pilot lights, insulation and condenser testing, and automobile ignition testing.

The *current-measuring* type is of the internal-electrode glow-tube type. The length of glow along the 6-in. electrode is a measure of the current passing through the tube. For this reason, it may not only be used for D.C. measurements, but also for indicating the relative current in R.F. circuits. The intensity of the current will cause a bright glow to creep up within the tube along the electrode. In direct-discharge work, however, the current passing through the tube must be limited to less than 10 ma. This may be accomplished by use of the proper shunts

MIKE STAND (1404)

(Amperite Corp.)

THIS MIKE stand merits special attention in view of its radical departure from previous designs. Placing a microphone horizontally lowers the center of gravity and this makes the stand unusually stable. The leaf spring suspension acts as an excellent shock absorber. The microphone may be rotated in practically any position; horizontally for pulpit, desk and foot-light installations.

SOUND-CELL MIKE (1405)

(The Brush Development Co.)

BY TIPPING at about a 45-deg. angle the "cue ball" sound-cell assembly shown in phantom view in May 1936 *Radio-Craft*, page 675, important advantages are obtained. In addition, the sound cell itself has been improved so that the output (-60 db.) is the highest of any sound cell so far produced. Available with line matching transformer.

DYNAMIC MIKE (1406)

(American Microphone Co.)

A PRESSURE-TYPE dynamic microphone suitable for either close or distant pick-up, in indoor or outdoor installations. Measures only 3 1/2 x 2 1/2 ins. dia.; wide frequency response; high- or low-impedance matching; semi-directional.

VARI-VOLT TRANSFORMER (1407)

(General Electric Co.)

THIS TRANSFORMER will supply the service bench with an output of 250 W. max.; toggle switches control the output voltage ranges of 0

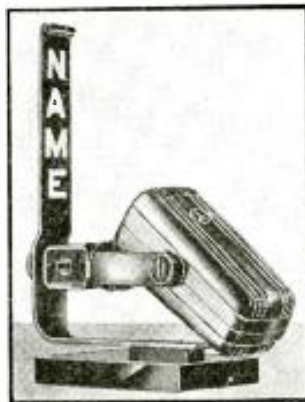

Mike stand. (1404)



Dynamic mike. (1406)



Pilot mounting. (1409)



Tapped transformer. (1407)

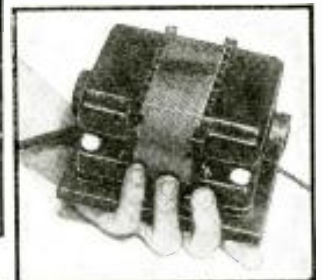

D.C.-A.C. converter. (1410)



Crystal mike. (1405)

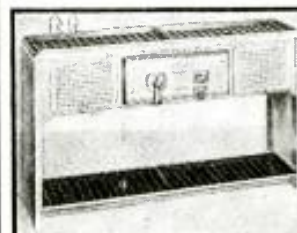

Charging table. (1408)



110-W. amplifier! (1411)

Please Say That You Saw It in RADIO-CRAFT

to 256 V. in 2 V. steps or from 0 to 128 V. in 1 V. steps.

CHARGING SET-UP (1408)

(General Electric Co.)

FOR THE car-radio or rural-radio Service Man who wants to do his own battery charging there is now available a 12-battery "charging shop" which incorporates every necessary unit.

PILOT MOUNTING (1409)

EQUIPMENT builders and Service Men will be interested to know that there is now available a pilot light mounting with a bull's eye that is removable for pilot light replacement from the front of the panel!

TRAILER CONVERTER (1410)

CONVERTERS for changing 6 V. D.C. to 110 V. A.C. for running radio sets in trailers, automobiles, at summer camps, etc., are now available.

110-W. AMPLIFIER (1411)

A 4-STAGE amplifier terminating in 4-6L6s provides 70 W. self-bias or 110 W. fixed-bias; total gain, 110 db. This 2-chassis amplifier is dimensioned for rack mounting. High impedance input; universal line and voice coil outputs. Also available for amateur service with a Vari-match modulation transformer.

NEW COMMUNICATOR (1412)

THE DESK-TYPE microphone-loudspeaker is shown at left, and the amplifier (of the system) at right, in this view of one make of inter-communicators. The mike-speaker is mounted at a 45-deg. angle in a cast aluminum housing 7 x 5 x 4 ins. high. The amplifier incorporates 1-6J7, 1-25A6 and 1-25Z6; overall gain, 86 db.; output level, approx. +22 db.; frequency response, +1 db. Various selective and non-selective arrangements are available. Requires inter-station wiring; operates on 110 V. A.C.-D.C.

THE "BELFONE" (1413)

A REPRESENTATIVE unit in a complete line of Belfone inter-office communication units is illustrated. A ruby pilot light on top indicates the operative position. Provision is made for an earphone for use in private conversation. The usual treadle-type talk-listen control is provided. Both selective and non-selective operation are available. The inter-station wiring plugs-in; the system operates on 110 V. A.C.-D.C.

THE "COMMUN-O-PHONE" (1414)

A MASTER amplifier and a group of talk-receive units constitute this office communication installation. A pilot lamp lights as a busy signal for the duration of the conversation. A slight additional charge is made for converting the system into a 2 or more channel arrangement permitting more than one conversation at once; the pilot light giving a busy signal only if they are all in use at the same time, with the addition of a busy tone to indicate the called station as being in use. A Commun-O-Phone with automatic switching, that includes up to 40 stations, 2 channels and calling all stations at one time (blanket), also is available.

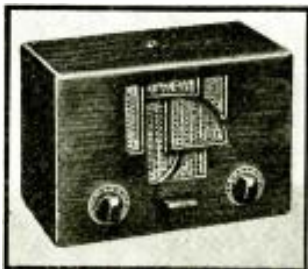

Above, a Belfone inter-communication unit. (1413) Right, a talk-receiver station of the selective-type Commun-O-Phone system. (1414)

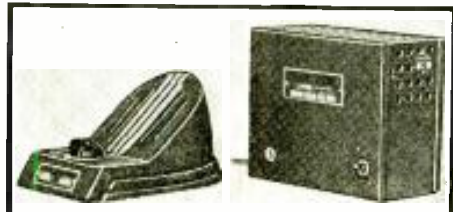

A well-designed interphone system. (1412)

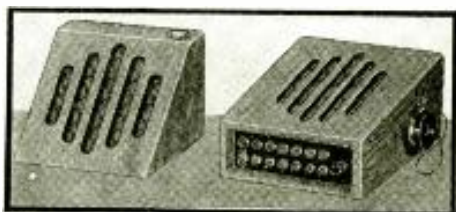

Left, common-talk unit; right, selective and private unit. (1415)

NEW INTERPHONE (1415)

BOTH a model A, shown at left, and a deluxe B type shown at right are available from a well-known manufacturer of sound equipment. The model A system utilizes a common amplifier and a push-button on the top-right surface of the desk unit. The deluxe job is provided with a secrecy earphone and up to 6 sub-stations and control switching system.

A NEW BOOKLET

Of interest to the technician and the rabid short-wave enthusiast is the new folder describing the new Super-Pro just published by The Hammarlund Manufacturing Co., Inc. This folder contains valuable technical data concerning this new "communication type" receiver which is of general interest to radio technicians—aside from the particular receiver described. Write to Radio-Craft for your copy of this folder—ask for No. 1403.

CORRECTION ITEMS

May Radio-Craft, pg. 670, contained a slight discrepancy concerning the crystal microphone, item No. 1328, that has been called to the attention of Radio-Craft by The Brush Development Co. Item C in the illustration referred to as cellophane instead is specially-prepared paper.

June Radio-Craft, pg. 714, carried a most regrettable trinity of errors—a transposition of credits which was not caught in time to make correction. Correction credits are: B. & O. radio installation, Crosley Radio Corp.; Evanston, Ill., police ambulance radio installation, General Electric Co.; meteorograph radio balloon, National Carbon Co.

"CELL" OR "BATTERIES"?

In order to get a check-up from an authoritative source concerning the proper use of the terms *cell* and *battery*—which are used indiscriminately by most radio men (a single No. 6 drycell usually being called a "doorbell battery")—Radio-Craft requested from National Carbon Co. a comment in this connection. The reply, from their Mr. L. S. Fox, follows:

"Definitions from Webster's New International Dictionary:

"Cell—a cup, jar or other vessel, containing electrodes and an electrolyte for generating electricity."

"Battery—an apparatus for generating voltaic electricity, consisting of one or more cells."

"Thus, a single cell may be called a 'battery' correctly. However, the definition commonly used in the battery-manufacturing industry is that a battery consists of TWO OR MORE cells! It is recommended that a single unit be termed a *cell* and a combination of two or more cells be called a *battery*."

LEARN RADIO
the Easy way
with Ghirardi's Complete
RADIO PHYSICS COURSE
972 Pages \$4.50 8 Illus.
only 4.00

The world's greatest collection of radio knowledge all in one book! 4 sound volumes—Ghirardi's famous course used by thousands of students in 82 different countries. With this one book you can quickly master RADIO, ELECTRICITY and SOUND. Clear! Up-to-date! Complete! Inexpensive!

PARTIAL LIST OF SUBJECTS
Sound, Speech and Music, Electron Theory, Electric Current, Electrical Units, Ohm's Law, Batteries, Magnetism, Electromagnetism, Electromagnetic Induction, Inductance, Condensers, Alternating Current Circuits, Filters, Electrical Measuring Instruments, Electromagnetic Radiations, The Broadcast Station, The Receiving Station, Vacuum Tubes, Radio Frequency Amplification, Superheterodyne Receivers, R.F. Amplifier and Coil Design, Audio Amplification, Loud Speakers, Battery-Operated Receivers, Power Supply Units, Electric Receivers, Auto and Aircraft Receivers, Phonograph Pickups, T.A. Systems, Short-Wave Reception, Photoelectric Cells, Television, The Antenna and Ground, Testing and Servicing, Sound Motion Pictures, Appendixes, 856 Review Questions for Self-Study.

MAIL NOW! Money-back Guarantee.

Radio & Technical Publishing Co.,
45 Astor Place, New York, Dept. RC-77
 Encl. find \$4 for RADIO PHYSICS COURSE, 1937 ed., (Foreign \$4.50)
 Please send free circular "P".

Name

Address

A NEW HIGH QUALITY SWITCH

The Shallcross Rotary Instrument Switches are designed for high voltage, high frequency and high insulation applications.



These switches can be made with any number of contact points up to fifteen, shorting or non-shorting, can be furnished with suitable insulation for metal panels, ganged in two or more decks, 1/4" shaft, single hole mounting. Ideally suited for band switching, high resistance voltmeters, multi-range instruments, etc.

Send for Bulletin 530-P for details.

SHALLCROSS MFG. COMPANY

Electrical Measuring Instruments and Accurate Resistors

700 MAC DADD BOULEVARD
COLLINGDALE, PA.

NEW—JUST OUT!

GADGETS
MAGAZINE
JULY 1937
HUGO GERNSBACH
Editor
IN THIS ISSUE
**\$ FORTUNES \$
IN GADGETS**
150 ILLUSTRATIONS
DEPARTMENTS IN THIS
MAGAZINE
THE MONTH'S
LATEST GADGETS
NEWEST GADGET PATENTS
GADGET PATENT ADVICE
HOW TO MAKE YOUR OWN GADGETS
25 Cents * \$3 A YEAR
NEW YORK, N. Y.

The world's only magazine on this subject. Contains 150 illustrations of the latest and best gadgets, novelties, and specialties. A veritable gold mine of information which you can not get in any other way.

Every month, GADGETS sends you not only America but the entire world for the newest, most useful articles of this type, including the latest gadget and novelty patents.

Don't fail to read the article **FORTUNES IN GADGETS!** Learn how inventors become rich in inventing or devising simple gadgets!

If your newsdealer cannot supply GADGETS MAGAZINE send 25c to

GADGETS Magazine
99-R Hudson Street, New York N. Y.

CLASSIFIED ADVERTISEMENTS

Advertisements in this section are inserted at the cost of twelve cents per word for each insertion—name, initials and address each count as one word. Cash should accompany all classified advertisements unless placed by a recognized advertising agency. No less than ten words are accepted. Advertising for the August, 1937, issue should be received not later than Monday, June 7, 1937.

DOGS

TERRIERS; ALSO BULL PUPS. SHIP ANYWHERE. Bob Tonn, Dallas, Texas.

SWL CARDS

SWL CARDS. GREAT FOR REPORTING THE stations you hear. Bunch of samples and RST chart for five cent stamp. WIBEK, 16 Stockbridge, Lowell, Mass.

RADIO COURSES

RADIO OPERATING: Prepare for Gov't License Exam. ● **RADIO SERVICING:** Including Short Wave ● **AMATEUR CODE** ● **ELECTRONICS** ● **TELEVISION** ●

Day and Evening Classes—Booklet Upon Request
New York YMCA Schools
4 W. 84th Street, New York City

RADIO REPAIR CEMENT

"THE ORIGINAL SPEAKER CEMENT"
Used for replacing speaker cones, mending old, rattling, or torn cones, sealing adjustments, cementing loose tube bases, grid caps, coils, leads etc. Dries fast, vibration proof, waterproof, invisible aid to Service Men. See your jobber, if he cannot supply you, write us. List price 50c for large bottle. Send for FREE circular of complete line.
GENERAL CEMENT MFG. CO.
(Radio Div.) Rockford, Illinois

WHILE THEY LAST!

12" Magnavox Speakers with Curvilinear Cone—900 ohm field. Complete with output transformer to match a single **\$2.89** Pentode Tube (47, 2A5, etc.)
No COD Shipments—Shipping Wt. 8 lbs.
Write for Our New Spring Flyer
ARROW SALES COMPANY
631 WASHINGTON BLVD., CHICAGO, ILL.

BUILD THE RADIO-CRAFT 1937 CAR-RADIO RECEIVER

(Continued from page 28)

before installing.

Drill and cut the chassis. Then install and wire in all components *except* the R.F. assembly. Put the variable condenser and the oscillator padders in place, at least, as these items cannot be installed after the coil assembly has been bolted-in. Wire up both R.F. and mixer sockets completely, too, as it will be almost impossible to do so with the coil assembly preventing accessibility of terminals.

Do not elevate the tuning condenser more than 1/4-in. above the chassis, as it will touch the top of the cabinet. Rubber faucet washers will lift the component just about the right amount and will be quite advisable as a means of taking up shock and preventing condenser plate vibration and microphonics.

Install *both* the specified dial (if it is desired) and the gear reduction unit for the remote control on the condenser's 3/8-in. shaft—making sure that both are of 6-1 ratio. Place the front panel in proper line and secure it to the chassis by means of the audio volume control shaft nut and a couple of machine screws. Bolt the genemotor (or the substituted vibrator power supply assembly) securely inside the cabinet and to the left, leaving room for connections from the sockets and male receptacle on the front panel. Proper hookup data for sockets, chassis, and power supply of either type are given in one of the accompanying diagrams.

THE VIBRATOR POWER SUPPLY

It might be noted that complete vibrator-type power supply assemblies are available which will give up to 100 ma. at 300 V. and may be substituted for the genemotor specified if the builder prefers. Both the genemotor and the vibrator units will afford excellent service if well made and adequately rated.

To those builders who desire to use a single pentode audio stage and a vibrator job affording the required power for the complete receiver (about 60 ma. under such conditions), some vibrator data will be welcome. One such vibrator is pictured, and information given now will relate to that particular job as shown.

Figure 6 gives the circuit and component values. This type of power supply system is of the self-rectifying type, is compact, exceptionally efficient, and affords long vibrator life. It will supply approximately 250 V. at 50 ma. of filtered D.C. power when connected to a storage battery delivering 6.3 V. at the center-tap of the transformer primary. If a somewhat higher voltage is required at considerably lower current it would simply be necessary to adjust the load conditions of the receiver so that lower current would be drawn from the pack. (The most advisable thing to do would be to reduce the current drain of the 6F6 pentode.) If, on the other hand, a higher current on the order of 60 or 70 ma. is required, the receiver circuit might be left "as is," with some slight decrease in "B" voltage below 250 the result.

If such a vibrator supply is required, measurements should be taken with an input voltage of 6.3 at the transformer center-tap. It may be necessary to have the battery on charge to obtain this voltage, but if a charger is not available and the input voltage at the center-tap is 6 V. or 5.7 V. output voltage and current

will be 5 and 10 per cent lower than normal, respectively, and calculations of performance may be still made by correcting readings by the 5 or 10 per cent.

ADJUSTMENTS

1. Connect the receiver to a "B" battery power supply or A.C. pack designed to give 250 to 300 V. D.C. at 100 ma. Match the speaker properly to the output transformer, add an antenna, switch to the broadcast band and align the I.F. to 456 kc. If signals are heard we are ready to trim the high-frequency stages.

2. Alignment: Broadcast—align at 1,600 kc., pad at 600 kc.; Middle Freq.—align at 6,000 kc., pad at 1,800 kc.; Short-Wave—align at 18,000 kc.

3. Substitute genemotor or vibrator power supply. Note total current drain and output voltage at no-signal, low-signal, and high-signal levels. If current drain on peaks at high level exceeds 100 ma., increase 6C5 driver bias until the strongest local signal will not cause this drain.

4. Install the receiver in a car, if only temporarily. Note whether or not vibrator or genemotor noise is in evidence when the receiver is operating on the higher-frequency bands. If such noise is heard, remove the receiver and add such auxiliary audio filter components as are necessary to effective suppression of the unwanted impulses. Generally an additional 8 mf. condenser from "B plus" to ground will do the trick—but if this alone isn't sufficient a dual electrolytic and a filter choke of 400 ohms or so value and designed to pass the current which our receiver draws at full-signal may be required.

It will be found that every precaution must be taken to thoroughly suppress ignition and other car electrical system interference if satisfactory performance is to be had on the higher-frequency bands. Wheel-static suppressors, the usual spark plug and distributor suppressors, the usual filter condensers at the coil and ammeter, etc., and all the other more or less customary items may be employed. Desirable and additional items are a dome light filter and filters in both the antenna and "A" feed leads.

Building this receiver is going to be quite a job. But don't let that scare you. It will work with surprising efficiency when in operation and will be well worth the business of constructing it. Further, we can guarantee it to meet every requirement of that exacting customer who wants "the bestest of the best," as Ben Bernie would have it.

STATIC SUPPRESSION IN ALL-WAVE CAR-RADIO SERVICE

There are 4 general types of interference met with in auto-radio service—three of which become of increasing seriousness as the tuning range of the receiver is extended to and through the higher frequencies.

(1) The first of these is that caused by high-tension spark discharge, generator commutator arcing, low-tension breaker point noise, dome-light radiation, and spark static from windshield wipers, clocks, heaters, fans, and various motor-driven and electrically-powered items constantly or occasionally used in the car. The usual spark suppressors, distributor suppressor, coil- and other high- and low-tension bypass condensers, and dome-light filter which are customary to the average good B.C.L. band set installation will, if they are at all effective, work well regardless of the frequencies to which an all-wave job tunes. Proper shielding of antenna lead-in and nearby low-tension lighting wires helps here.

(2) The second is metal-to-metal noise caused by poor connections throughout the auto chassis and body and calling for extra-careful attention where short-wave stations are to be received with a high-sensitivity receiver such as this *Radio-Craft* 1937 Car-Radio Receiver. The shielding and bonding which are required to eliminate last traces of ignition interference will help in suppressing this type of noise but, as we have just stated, unusual care must be exercised to insure against any possibility of both ground-to-ground "scratch" and any difference of potential between various metal parts. Flexible bonding from bulkhead to motor block and drive-shaft torque tube, from bulkhead instruments to radio-set mounting bolt, and from all free metal parts to a common ground point may be required. *Be very careful with bonding, and if*

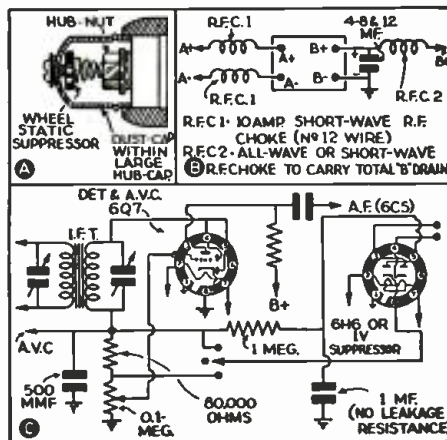

Fig. 4. Interference suppression (A and B) and a noise suppressor (C).

Please Say That You Saw It in RADIO-CRAFT

good ignition noise suppression has been effected and the antenna is properly shielded, no more noise will be encountered on short waves than that brought in on the average home all-wave receiver.

(3) The third is static interference made apparent only when the car is in motion, which is caused by road-surface, wheel, and tire frictional-electricity discharge, and which really makes one sit up and take notice during short-wave reception. Torque tube and muffler tail pipe grounds will be imperative here, as well as some sort of effective means of grounding the transmission. Wheel-static suppressors, installed in all 4 wheels as shown in Fig. 4A (mounted on standard dust caps within the regular hub caps), will eliminate tire static.

(4) The fourth is interference in the form of genemotor or vibrator power supply "hash." Some of this type of noise may be eliminated by increasing the size or number of audio filter components in the "B plus" lead from power pack to receiver. Such increase is not always effective, however (larger than customary audio filter chokes may be for that matter inadvisable with heavy "B" current drains and because of increased voltage drop across them and lower "B" output), and it is therefore advisable to secure or build a power supply which in itself is very carefully filtered, say to give proper service with 5-meter receivers. Most of the noise is more apparent than actual (so far as its source at the dynamotor or eliminator is concerned), and is really set up by radio-frequency disturbances which get into the 6 V. input and "B plus" leads to the receiver. Nothing under the sun but R.F. chokes will help here, and it is suggested that one be placed in the "B plus" wire from the power unit to the set proper, with perhaps an additional 4, 8 or 12 mf. filter capacity directly across the supply output. Such a choke may be any convenient item of guaranteed effectiveness at all frequencies to which the receiver is to tune and of current carrying capacity something greater than full receiver drain at full output. Radio-frequency chokes in both "A" battery leads to the power unit may be required, each built to carry 10 A. or so and effective at least on the shorter wavelengths—where R.F. interference is found to be of high order in sum total effect. See Fig. 4B.

There is no reason on earth why an all-wave, high-gain receiver, connected to a suitable an-

tenna, will not give excellent performance in automobile service provided the suggested precautions are taken to eliminate static and other interference.

With the antenna grounded, the set should run perfectly quiet. With the antenna connected properly, noise should be found (that picked up from other than strictly local sources) and may be suppressed by trimming the antenna circuit to resonance somewhere in the noisiest short-wave band (say the regular short-wave band) and by careful alignment of the tuned circuits on ALL bands. Peak efficiency in the R.F. stage will always bring up the signal-to-noise ratio, of course, and it might be advisable in some instances to remove the A.V.C. from this stage so that the tube used with it will operate at all times at full conductance. The use of a simple noise suppressor circuit in the receiver might be a very desirable added refinement. Figure 4C shows such a circuit—easily adapted to the Radio-Craft 1937 Car-Radio Receiver.

LOCAL REGULATIONS

Some city or state ordinances prohibit the operation of car-radio receivers in certain portions of the frequency spectrum below the broadcast band—those used or reserved for police mobile communications in particular. It will be wise for the builder of an all-wave auto job to make sure of local regulations—or, of course, state laws—before constructing his receiver, and to then eliminate such coils as would tune to the prohibited bands, or to make such changes as would prevent these coils from tuning to the "taboo" points. As the most interesting band is the regular short wave, tuning from 19 to 50 meters approximately, and as this band would hardly be affected (make sure of it, however!), we can still have our all-wave receiver and do away with the intermediate band entirely.

It is of course advised that the user of an all-wave car-radio set play around with the short-wave bands only when the car is not in motion—or where circumstances are such as to permit his giving entire attention to the wheel and the road. "Fishing for DX" while driving is a dangerous and altogether improper business, and the writer of this article wants to go definitely on record as to the great importance of that fact. "Safety of the road"—for the driver and for the "other fellow"—must command every attention, recognition, and respect.

TEST EQUIPMENT FOR THE SERVICE MAN

(Continued from page 29)

TUBE TESTER

Employs an English-reading fan type meter with "Bad-?Good" scale. This unit which is light and compact for shop or field use, checks all 4, 5, 6, 7 small and large, octal and most transmitting tubes with an emission test. A neon short test is included.

Low cost consistent with dependable operation is the feature of this instrument.

(Superior Instrument Co.) (1416)

5,000 OHMS/VOLT METER

A high-resistance A.C. and D.C. meter having scales of 0-3-30-300-900 V. A.C., 0-3-30-300-900 V. D.C., 0-300 microamperes, 0-3-30-300-600 ma. D.C., db. power-level scale, direct reading, 0-10,000 ohms, 0-10 meg. ohmmeter, all housed in a handy case 7 1/2 x 5 x 3 1/2 ins. deep and

having a special high-torque movement and built-in test leads. A handy unit for the Service Man and P.A. technician.

(Million Radio & Television Labs.) (1417)

A.C.-D.C. SERVICE OSCILLATOR

A 6-band signal generator covering the frequencies from 90 kc. to 31 megacycles. The tubes are external to the case and the line-dropping resistor is in the line cord so that the interior of the case is not heated by these units. This increases the stability of the instrument over other makes which have the tubes and resistor near the coils where they can be raised in temperature. A separate 400-cycle oscillator provides modulation.

(Delta Radio Co.) (1418)



Low-cost tube checker. (1416)



Volt-ohm-current meter. A power level scale directly in db. is included for power measurements. (1417)



Stable signal generator. (1418)

Please Say That You Saw It in RADIO-CRAFT

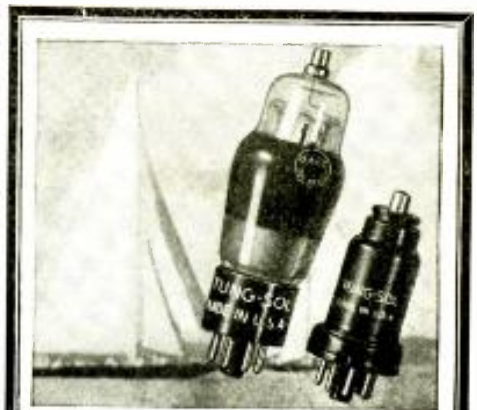

Smooth Sailing with TUNG-SOL

Every retail advantage which the radio dealer has ever hoped to find is included in the TUNG-SOL CONSIGNMENT PLAN: No cash investment at any time—an adequate, up-to-the-minute stock—full-profit protection—and remittance only after tubes are sold.

You may have the required qualifications to join the thousands of Tung-Sol Retail Agents who are making real money selling radio tubes. Write for name of your nearest Tung-Sol wholesaler.

TUNG-SOL

Flow radio Tubes

TUNG-SOL LAMP WORKS, INC. Radio Tube Division, NEWARK, N. J.

COMPLETE STANCOR KIT

- 4 OSCILLATORS
- Straight Pentode
- Tritet
- Jones
- Bi-Push
- 2 BUFFER DOUBLERS
- Triode
- Dual Triode
- 4 AMPLIFIERS
- Single Triode (T20 or Type 10)
- Push-Pull Triode (T20 or Type 10)
- Single Pentode (RK-39 etc.)
- Push-Pull Pentode (Bi-Push)
- Forty-Eight Combinations



48 CIRCUIT COMBINATIONS FOR \$49.95

Here's a natural for the medium-power amateur. 4 Oscillators . . . 2 Buffer-Doublers . . . and 4 Amplifiers . . . 35 to 120 watts input . . . ALL FROM A SINGLE KIT. The kit includes circuits for the most recently released tubes . . . and circuits on older types of tubes that you probably have in your shack.

The new Stancor "48-C" Kit contains all the parts you need FOR EVERY CIRCUIT—less crystal, tubes and meter.

COMPLETE SCHEMATIC BLUE PRINTS FREE WITH EVERY KIT

STANDARD TRANSFORMER CORPORATION 850 BLACKHAWK STREET • CHICAGO

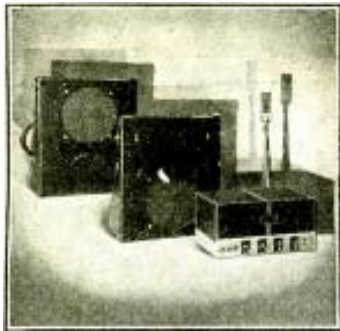

DESIGNED for PERFORMANCE

Newest engineering features are incorporated in the 1938 line of ACA High-Fidelity Amplifiers. Models for all applications. Power outputs ranging from 10 to 1000 Watts. Available in portable, semi-portable, mobile and permanent systems. Special universal amplifiers operate from 6 volts D.C. or 110 volts A.C. *Backed by a 5 Year Guarantee.*

Write for FREE latest catalog

Mr. A. C. Shaney will gladly help you plan any type of P.A. installation. Send complete details for free expert advice.

AMPLIFIER CO. of AMERICA
37 West 20th Street New York, N. Y.

ELECTRIC EYES

Be the first in your community to install electric eye devices and reap a rich reward. Simple electric eyes for opening doors, announcing people in offices, safety protection across doorways and many other uses can be bought at low cost. \$10.00 cash with order or C.O.D. brings you a marvelous electric eye complete with caesium photo cell. Operates from 110 volts AC or DC. Money back guarantee. If no satisfied return unit to us in good condition within 10 days and money will be refunded. We can supply photo electric equipment for any purpose, sorting machines, grading machines, traffic counters, laundry counters, oil burner safety controls and many other devices. A postcard will bring complete information for any special applications.

ELECTRONIC PRODUCTS COMPANY, St. Charles, Illinois



Majestic & Grigsby-Grunow, original and genuine factory radio and refrigerator service. We have purchased all of the assets formerly belonging to Grigsby-Grunow. All parts, service replacement units will carry regular factory guarantee. Buy only through our authorized distributors, dealers or ourselves. **GENUINE MAJESTIC PARTS & TUBES.** Write for prices. **G & G GENUINE MAJESTIC REFRIGERATOR & RADIO PARTS SERVICE.** 5801 Dickins Avenue, Chicago, Illinois.

Play Safe! Use The **Word**

NOKOIL

When Ordering Permanent Magnet Speakers

RADIOS 1/2 OFF!

Buy direct. New line of ZEPHYR WORLD-WIDE all-electric, battery and auto radios, 5 to 15 tubes. All latest features. Buy at WHOLESALE PRICES. MONEY-BACK GUARANTEE. Earn extra money with our Agent-User Plan. Write for FREE CATALOGUE.

ZEPHYR RADIO COMPANY
13141 Hamilton Ave. Detroit, Michigan

30 DAYS TRIAL

BEAM POWER KITS

These basic fully shielded units will enable you to construct the latest 6L6 Beam Power Amplifiers utilizing inverse feedback. Circuit diagram supplied.

32-Watt Power Transformer.....\$3.95
Universal Output Transformer.....2.25
Input Push-pull Transformer.....1.95
First Filter Choke.....1.85
Second Filter Choke......75

Order direct from this list!
SPECIAL TRANSFORMERS PROMPTLY BUILT TO ORDER—SEND SPECIFICATIONS FOR PRICES.

INTERNATIONAL TRANSFORMER COMPANY
39 West 20th Street New York City

BE OUR AGENT!

BIG PROFITS FOR RADIO MEN

Sell our complete line of 16 MM and 35 MM motion picture equipment for theatres, institutions, clubs and home use. We have everything. Tremendous field; liberal profits. Write TODAY.

S. O. S. CORP. 636-RA Eleventh Ave., N.Y.C.
CABLE—SOSOUND, N.Y.

BOOK REVIEWS

RADIO SERVICING. by M. N. Beitman. Published by Supreme Publications. Size, 8½ x 11 ins., 17 pages. Price, 50c.

This book contains short-cuts and money-making ideas and undoubtedly will interest many beginners in radio servicing. This publication is of little interest to experienced Service Men, as the chapter headings indicate: 100 Common Radio Faults; Tuning Mechanism Out of Order; Condenser Replacement; Power Transformers; Alignment Adjustment; Money in Modernization; Extra Speakers Present Real Money Making Possibilities; Public Address Offers Real Profits to Service Men; Tube Testers.

RADIO SERVICE BUSINESS METHODS. by John F. Rider and J. Van Newenhizen. Published by RCA Manufacturing Co., Inc. Size, 6 x 9¼ ins., 218 pages. Price, \$3.00.

Here is the first authoritative volume to analyze and explain the best known present-day methods and procedure of conducting a radio service business. Primarily the authors seek to help the radio service engineer, unfamiliar with bookkeeping, maintain an orderly accounting system which will keep him constantly informed of his financial progress with the minimum expenditure of time and effort. This book was originally offered as one of the units of a 3-Point Service System Plan which was designed to help the radio Service Man get more business, simplify his handling of it and organize his procedure. Undoubtedly, for many this book will mean the difference between a success or a failure in independent radio servicing.

Part I, by John F. Rider, contains 6 chapters discussing practical angles of managing a servicing business. Part II, by John Van Newenhizen, contains a foreword and 9 chapters on proper accounting procedure. A 5-page index of Part II is included. The author of Part I is a well-known technician. The author of Part II is an accountant and auditor of long experience in the radio field.

FOUNDATIONS OF WIRELESS. by A. L. M. Sowerby. Published by Iliffe & Sons, Ltd. Size 5 x 7½ ins., 260 pages. Price, approx. \$1.25.

Although this volume is by an English writer the radio man will have no difficulty in "translating" the text into the more familiar "American" in which "valve" becomes vacuum tube, etc. Of special interest to your review editor was the considerable amount of information the author has been able to compress into the limited number of pages in discussing the design factors involved in radio receiver design. Anyone adding this book to their technical library will be rewarded with a reference work that contains all the fundamental information necessary to the proper design of efficient radio receiving equipment.

The table of contents is much too extensive for reproduction in its entirety here, but the complete contents of a representative chapter are given below.

The Superheterodyne and Its Frequency-Changer: Need for Selectivity; Principle of Superhet.; Principle of Frequency-Changer: Two-Valve Frequency-Changer: Single-Valve Frequency-Changer; Conversion Conductance; Oscillator Ganging; Whistles.

This book is a little too technical for the out-and-out beginner inasmuch as the author credits the reader with at least a nodding acquaintance with technicalities. The book has appeal mainly as general reading and reference for the technician who has graduated from the kindergarten stage. The author's use of corollaries is most intriguing.

NOVEL RADIO ITEMS

(Continued from page 32)

flashlight portion uses 2 cells. The pencil-end switch will lock closed. (1387).

Distributor-Suppressor Lighter. Any radio man would be fooled by the realistic appearance of this, seemingly, distributor-type "interference suppressor." Remove the top-half shell, though, and it's ready to be flipped into flame. (1388)

ADVERTISERS' INDEX

A	
Allied Radio Corporation.....	50
American Microphone Company.....	61
Amperite Corporation.....	42
Amplifier Co. of America.....	64
Amplitone Products Company.....	50
Arrow Sales Company.....	58
B	
The Brush Development Co.....	44
C	
Central Radio Laboratories.....	33
Classified Section.....	58
Cornell-Dubilier Corporation.....	55
Cornish Wire Company.....	52
Coyne Electrical School.....	41
D	
Delta Radio Company.....	56
E	
Ellen Radio Laboratories.....	55
Electrad, Inc.....	52
Electric Institute.....	51
Electronic Products Co.....	64
G	
G & G Genuine Majestic Refrigerator and Radio Parts Service.....	64
Gadgets Magazine.....	58
General Cement Mfg. Company.....	58
The Goldak Company.....	46
Goldstone Radio Company.....	52
Grenpark Company.....	51
H	
Hammarlund Mfg. Company.....	50
Harrisburg-Sylvania Corp.....	47
I	
International Radio Corporation.....	42
International Transformer Co.....	64
K	
Kenyon Transformer Co., Inc.....	61
Kretz Knickerbocker.....	55
L	
Lancaster, Allwine & Rannell.....	62
Lincoln Engineering School.....	56
M	
McGraw-Hill Book Company.....	53
Metal Cast Products Company.....	55
Million Radio & Television Labs.....	44
Modell.....	42
N	
National Radio Institute.....	1
National Schools.....	52
National Union Radio Corp.....	39
New York YAI&CA Schools.....	53
P	
The Plan Shop.....	62
R	
RCA Institutes, Inc.....	61
RCA Manufacturing Co.....	37
Radio & Technical Pub. Co.....	55, 57
Radio & Television Institute.....	52
Radio Amplifier Labs.....	54
Radio Circular Company.....	54
Radio City Products Co.....	36
Radio Publications.....	62
Radio Service Institute.....	41
Radio Training Assoc. of America.....	39
Radiotek Company.....	63
Raytheon Production Corp.....	40
Readrite Meter Works.....	43
Remington Rand, Inc.....	52
Rex Amplifier Systems Co.....	46
John F. Rider.....	56
S	
S.O.S. Corporation.....	61
Shaleros Mfg. Company.....	57
Solar Mfg. Company.....	46
Sprayberry Academy of Radio.....	Inside Back Cover
Standard Transformer Corp.....	59
Supreme Instruments Corp.....	Inside Front Cover
T	
Tavella Sales Company.....	55
Technifax.....	44
Telex Company.....	52
Thor Radio, Inc.....	50
Triplet Elect. Instrument Co.....	49
Try-Mo Radio Co., Inc.....	46
Tung Sol Lamp Works, Inc.....	59
U	
Universal Controls.....	53
Universal Microphone Co., Ltd.....	55
W	
The Webster Company.....	43
Wellworth Trading Company.....	48
Weston Electrical Instrument Corp.....	Back Cover
Wholesale Radio Service Company.....	45
Wright, DeCostor, Inc.....	52, 56, 63, 64
Z	
Zephyr Radio Company.....	64

(While every precaution is taken to insure accuracy, we cannot guarantee against the possibility of an occasional change or omission in the preparation of this index.)

NOW IS THE TIME TO CASH IN ON THE MOST SENSATIONAL HOME TRAINING PLAN IN THE HISTORY OF RADIO



Make Me Prove that YOU Can Make Good in RADIO

MY TRAINING ACTUALLY SETS YOU UP FOR BUSINESS

RIGHT NOW!.... Is the Time to Get Started in an Industry That is Making Fortunes for Live, Wide Awake Men.

THIS new and different kind of Training does more than teach you about all branches of Radio. It teaches you Radio business methods—it sets you up ready for an actual start in business—and it backs up every step of your training with **REAL PROFESSIONAL RADIO EQUIPMENT!**

No matter what kind of Radio Training you take, it is absolutely necessary that you have equipment of this kind BEFORE you are ready to start making real money.

Sprayberry Training brings it to you almost at the start—teaches you just how to use it under actual working conditions. Upon completion you have **COMPLETE** business and technical training **PLUS** the needed equipment to enter business at once for full or part time profits—or to start off on a career in any one of Radio's specialized fields such as Public Address, Auto Radio, Commercial Radio, Broadcasting, etc.

ACT TODAY

Get Into Radio — An Industry That Shows a Profit NOW!

Radio is going ahead by leaps and bounds. And now **TELEVISION** is on its way!

Today is the time to get started—and Sprayberry Training will start you right. Investigate at once! I will show you how an investment of only 17c a day—just about the cost of a pack of cigarettes—can mean a real future for you in one of the fastest-growing professions in the world.

EARN UP TO \$25 A WEEK WHILE LEARNING—READ WHAT THESE MEN SAY



A. H. LANOIE, Northbridge, Mass., writes: "Since enrolling I have cleared a net profit of more than \$130 in spare time alone, and I am not half through the course yet. Honestly, I cannot understand how you can give so much 'dope' for so little money."

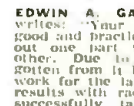

EDWIN A. GAMMON, Auburn, Maine, writes: "Your course is so thoroughly good and practical that it is hard to pick out one part that is better than any other. Due to the knowledge I have gotten from it I have been deluged with work for the last month, achieving good results with radios which had been unsuccessfully tackled by other service men. You deserve all the credit, and I can't tell you how much I appreciate your course."



WALTER DAVIS, Baltimore, Md., writes: "Thanks to the Sprayberry Practical Course for which I would not take any think or any price, I am now making an average of from \$10 to \$25 per week in spare time work, and if this keeps up I may go in for full time radio servicing and sales. Thank you again."

F. L. Sprayberry
SPRAYBERRY'S MASTER SERVICE COURSE
For Servicemen Only

A new 45 lesson Course on Radio Service work. Describes the actual how to do it way. Practical, modern and easy to understand. Every serviceman needs this Special Service Course. Nothing like it in print. Represents years and years of experience at actual Radio Service work.

SEND TODAY FOR CATALOG. FILL IN COUPON BELOW—CATALOG DESCRIBES BOTH COURSES.

Terms as low as \$3 per month

YOU GET THIS BIG PROFESSIONAL OUTFIT

This set is the real thing: New "Electric Eye", Set of famous Rider Manuals, Experimental Kit, Tool Kit with Replacement Parts, etc., and big USEFUL Triplet Tester—the kind of equipment real service men use to do real jobs.



NOW SEND FOR FREE BOOK!

My free book has started hundreds of men on the road to success in Radio and happiness in life. It's crammed with facts you can't afford to miss—filled with **TRUE STORIES** of men that I put into Radio. Get this book and read it. If others can succeed in Radio, so can you—it's all in getting started right. So get the right start **TODAY**—mail this coupon for **YOUR** copy of this great **FREE BOOK!**

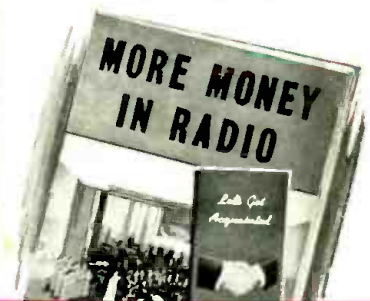

MAIL COUPON TO WASHINGTON TODAY

SPRAYBERRY ACADEMY OF RADIO,
 F. L. Sprayberry, President,
 Office No. 20-H, University Place, N. W.,
 Washington, D.C.

Please send me, without obligation, "More Money in Radio" and complete facts about your new type of training.

NAME (Ave)

ADDRESS

CITY STATE

Paste this coupon on a penny postcard and mail **TODAY**.

PREVIEW DOUBLE FEATURE

BOOTHS 40-41, RADIO PARTS SHOW, CHICAGO

THE *New*
MODEL 775
**WESTON
SERVISSET**

...Combining the Model 772
ANALYZER and the new,
matched Model 773
TUBE CHECKER!



Features:

1. Complete, modern servicing combination in a solid, polished-wood case of finest construction! Real luggage handles.
2. Contains the famed Model 772 and the new, matched Model 773 Tube Checker.
3. Model 773 perfected emission type tester . . . tests tubes under standardized load resistance . . . big, sensitive meter.
4. Improved noise test . . . all electrodes. Neon short check . . . while tubes are hot. Cathode leakage test.
5. Wired for rotating filaments . . . spare socket . . . obsolescence forestalled!
6. New, exclusive rapid-reference tube chart.
7. Model 772 has big WESTON Meter . . . sensitivity 20,000 ohms-per-volt . . . resistance ranges up to 30 megohms . . . current as low as 1/2 microampere. Wide range of usefulness . . . including all receivers, P. A. systems, television, sound movies, photo-cell circuits, etc.

Model 775 combines the Model 772, 20,000 ohms-per-volt Analyzer . . . with the new, matched Model 773 Tube Checker . . . in a handsome, solid-wood case of finest construction. Model 773 also used as counter tube seller.



A *New*
**CONCEPTION IN
COUNTER TUBE SELLERS!**

Entirely different! Commands instant attention in this striking, polished solid-wood case. Conveys to customers the impression of true, scientific accuracy. Instrument also fits the single and combination carrying cases. Quickly interchangeable. Note the new Weston rotator-type tube chart. You 'spot' your tube instantly. Charts easily replaceable.

See this modern servicing unit at the show, or return the coupon for complete details.

Weston Electrical Instrument Corporation,
599 Frelinghuysen Avenue, Newark, N. J.

Send data on Model 775.

Name

Address

City State

WESTON Instruments can be purchased under the WESTON deferred INVESTMENT PLAN!