

J U N E 1 9 2 9

# RADIO

# BROADCAST

PUBLISHED FOR THE RADIO INDUSTRY



**TRADE  
SHOW  
ISSUE**

**SPECIAL FEATURES IN THIS ISSUE**

**Where Are We Going in Cabinet Design?**

**Testing Methods for Radio Dealers**

**What the Manufacturers Offer this Season**

**Other features: Loud Speaker Trends . . . What the Licensing Groups Offer . . . Radio Shop Practise . . .  
Help for Dealers in Choosing Lines . . . The New Inductor Speaker . . . A Useful Vacuum-Tube Voltmeter**

**T H I R T Y F I V E C E N T S**

**DOUBLEDAY, DORAN & CO., INC. ♦ GARDEN CITY, NEW YORK**

# Cunningham

## RADIO TUBES



Be guided by a name that has meant absolute tube integrity for the past fourteen years. The name is Cunningham—choice of the American home.

*Cunningham Booth No. 5, R M A Trade Show, Congress Hotel, Chicago, June 3-7*

**E. T. CUNNINGHAM, Inc.**

NEW YORK

CHICAGO

SAN FRANCISCO

DALLAS

ATLANTA

*Manufactured and sold under rights, patents and inventions owned and/or controlled By Radio Corporation of America*



  
**PILOT**  
**DOUBLE-DUTY**  
**SHORT-WAVE BAND**      **BROADCAST BAND**  
**SUPER WASP**  
 TUNED SCREEN GRID      14 TO 500 METERS

# Announcing-PILOT'S NEW Radio Thrill!

This is what R. S. Kruse says:

“In my opinion no receiver manufactured today is better suited to the amateurs’ 1929 need than is the Pilot Super Wasp.”

## World's Finest S-W Set

The Super-Wasp Kit combines in one receiver Short-Wave and Broadcast Reception from 14 to 500 meters.

Not merely a shield grid stage of doubtful value in front of a regenerative detector—but a scientifically engineered receiver with a *tuned* screen grid circuit that provides a gain of from 4 to 20 over the entire amateur spectrum. The SUPER WASP takes the applesauce out of most “QSA-5” reports.

Selectivity is enhanced without tuning complications. The shield grid stage really TUNES! With this receiver you can unscramble the fones on the 80 meter band. These definite superiorities have been achieved without undue circuit or mechanical complications.

Note:—Illustration shows half of shields removed

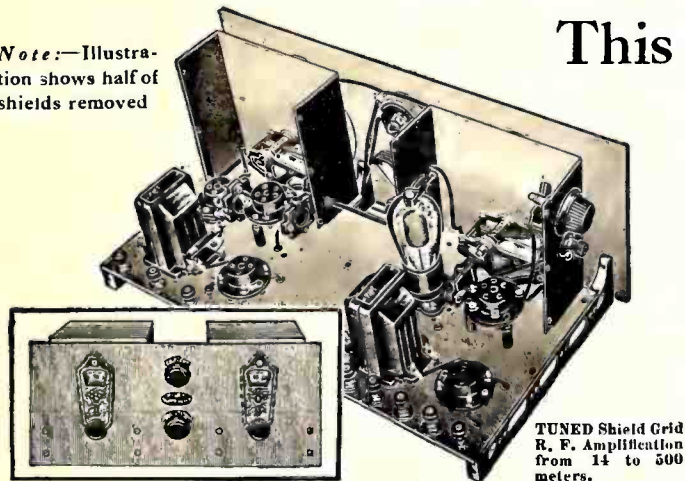

TUNED Shield Grid  
R. F. Amplification  
from 14 to 500  
meters.

### Here's What You Want to Know about the SUPER WASP

The Pilot Super Wasp Kit comes to you complete, with panels and cans accurately drilled and fitted, and with full scale blue-prints. Can be assembled in one evening. The short direct leads, required in hooking up, are indicative of its *efficient simplicity*.

The set is completely shielded eliminating all band capacity effects. *The regeneration control, once set, is consistent over any amateur band.* There remain only two tuning controls—following degree for degree.

A complete set of r. f. and detector plug-in coils comes with each kit, covering all wavelengths from 14 to 500 meters, with a generous overlapping.

One stage of S-G amplification *that tunes and amplifies!* Two stages of audio. 14 to 500 meters with plug-in coils. Two controls over *any* amateur band. Completely and individually shielded. 6 v. A, 9 v. C and 135 v. B. The finest amateur S-W set in the world. Also a splendid broadcast receiver. So simple, the beginner can build it. So effective, the veteran ham cannot afford to be without it.

PILOT SUPER WASP KIT      \$29.50  
(Catalog No. K-110)      *(Slightly higher West of the Rockies)*  
Including 2 sets of 5 coils each, full-sized blue-print and complete assembly data.

Send for Radio Design

50c. brings you one year's subscription to "Radio Design". Quarterly Magazine, chock-full of latest Radio, Short Wave and Television Developments. "Radio Design", 103-E Broadway, Brooklyn, N. Y.

Name .....

Address .....

City..... State.....

The Pilot Super-Wasp is made in World's Largest Radio Parts Plant

**PILOT ELECTRIC M'FG. CO**  
 323 BERRY ST.  **BROOKLYN, N.Y.** **INC.**  
 ESTABLISHED 1908      TRADE MARK REG.



# McMURDO SILVER

# Announces

# Silver



And now, at last, comes Silver-Marshall's entry into the complete RCA—licensed radio receiver field with SILVER RADIO—the most sensational development since a.c. tubes revolutionized radio.

1929 is a Screen-Grid year. Its pace will be set by the new type radio that is SILVER RADIO—so original and so advanced technically as to be *utterly different from any other manufactured receiver*. For SILVER RADIO comes from a designer, a laboratory, and a factory that have *mastered* Screen-Grid technique—and *proved* it by chalking up unbroken records with the Sargent-Rayment Seven, and the famous Screen-Grid Sixes.

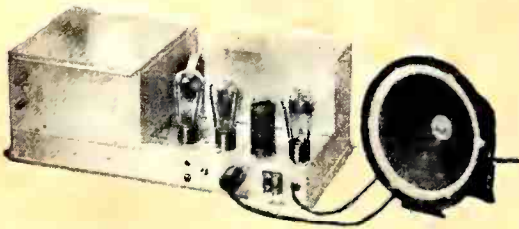

The SILVER RADIO chassis and speaker above is made complete in the new home of Silver-Marshall pictured below—the third largest exclusive radio plant in the Chicago area. The eight-tube Model 30 chassis (as furnished in Model 60 Lowboy and Model 95 Highboy) contains the fully shielded, non-oscillating Screen-Grid r. f. amplifier, with band selector, Screen-Grid power detector, push-pull power amplifier and A, B, C, and speaker power supply. It is a marvel of mechanical and electrical engineering. In all comparative tests so far, no other radio has been found which can even equal its performance.

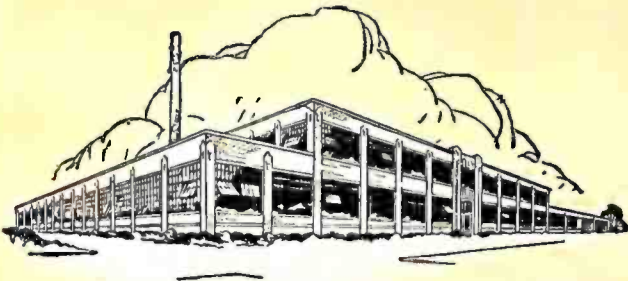

SILVER RADIO is nothing if not *new*. It is first to *eliminate all antenna installation*. It is first to use *three* 224 a. c. Screen-Grid tubes as r. f. amplifiers with *band-selector tuning*, followed by a *fourth* Screen-Grid tube in the newest type of power detector circuit. SILVER RADIO is first to use a pair of 245 power tubes in push-pull; first to use a *matched-impedance* dynamic speaker. And SILVER RADIO is first also with a startling development—the *Overtone Switch*, which brings out all the beauty of ordinarily-lost high notes as does no other radio—yet cuts them out at will to reduce static in bad weather. And prices—SILVER RADIO is first with prices so low that they actually make you gasp, even though they are made possible by tremendous production.

**SILVER-MARSHALL, Incorporated**

**SM**

**"Silver on Radio is like**



# Radio

Just as a.c. tubes changed the "fashion" in radios from battery to light socket in 1927—just as surely will SILVER RADIO revolutionize public demand in 1929. For you know that the amazing new features of SILVER RADIO spell *revolution* in radio results—for distance, for selectivity, tone, convenience, and low cost.

Appreciation is due, and is in full measure given, to the many friends whose use and recommendation of S-M products has pushed SILVER-MARSHALL up into the position of dominating leadership in the parts field, now to launch forth, from one of the largest radio plants in America, the self-contained SILVER RADIO receivers. And Silver-Marshall has kept faith with these friends—SILVER RADIO is just the outstandingly superior product that they have always expected from the S-M laboratories.

*SILVER RADIO will be distributed through leading jobbers to franchised dealers in exclusively allotted territories—backed by an unprecedentedly large newspaper advertising allowance per set, to "break" in the early summer. Dealer demonstrations are being arranged now, and franchise applications are being received.*

**6443 W. 65th St., Chicago, U. S. A.**

***Sterling on Silver***"

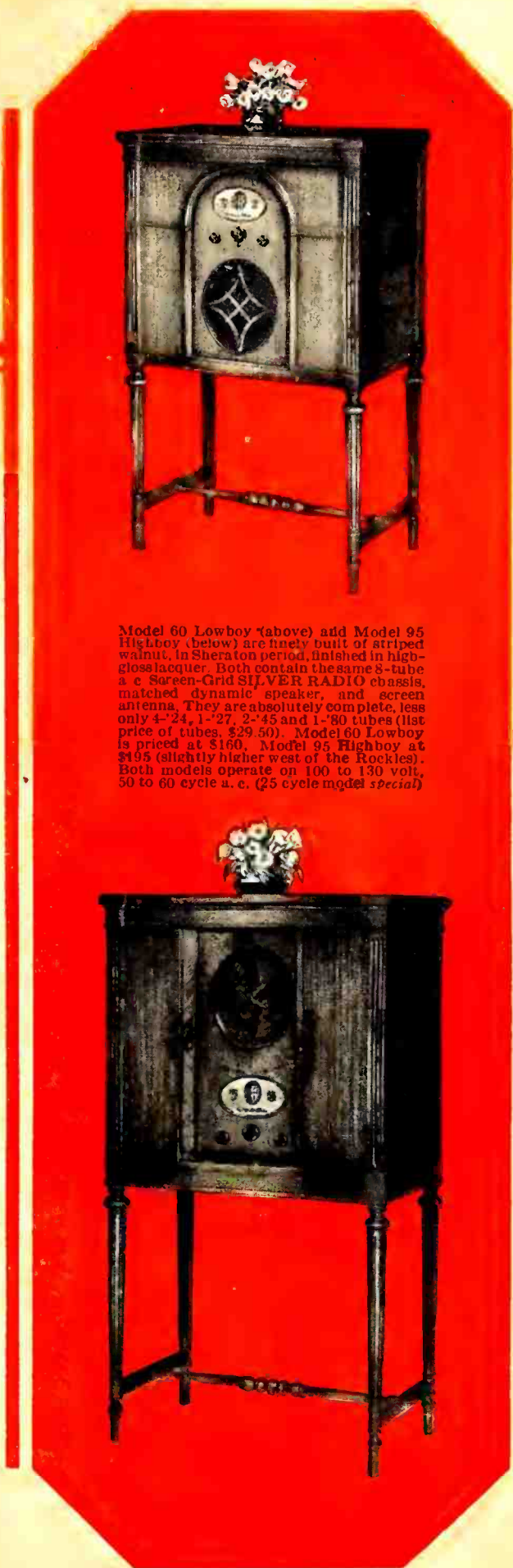

Model 60 Lowboy (above) and Model 95 Highboy (below) are finely built of striped walnut, in Sheraton period, finished in high-gloss lacquer. Both contain the same 8-tube a.c. Screen-Grid SILVER RADIO chassis, matched dynamic speaker, and screen antenna. They are absolutely complete, less only 4-24, 1-27, 2-45 and 1-80 tubes (list price of tubes, \$29.50). Model 60 Lowboy is priced at \$160. Model 95 Highboy at \$195 (slightly higher west of the Rockies). Both models operate on 100 to 130 volt, 50 to 60 cycle a. c. (25 cycle model special)

SILVER-MARSHALL, Inc.  
 6443 West 65th Street, Chicago, Ill., U. S. A.  
 Send me the dope, and tell me where I can see and hear it—I'm interested.

Name.....  
 Address.....  
 City..... State.....

# SPEED

## RADIO TUBES

TESTED and APPROVED by Landay Brothers

AND BY THE  
METROPOLITAN  
PUBLIC

Thousands of radio fans saw  
**SPEED RADIO TUBES**  
tested before their eyes

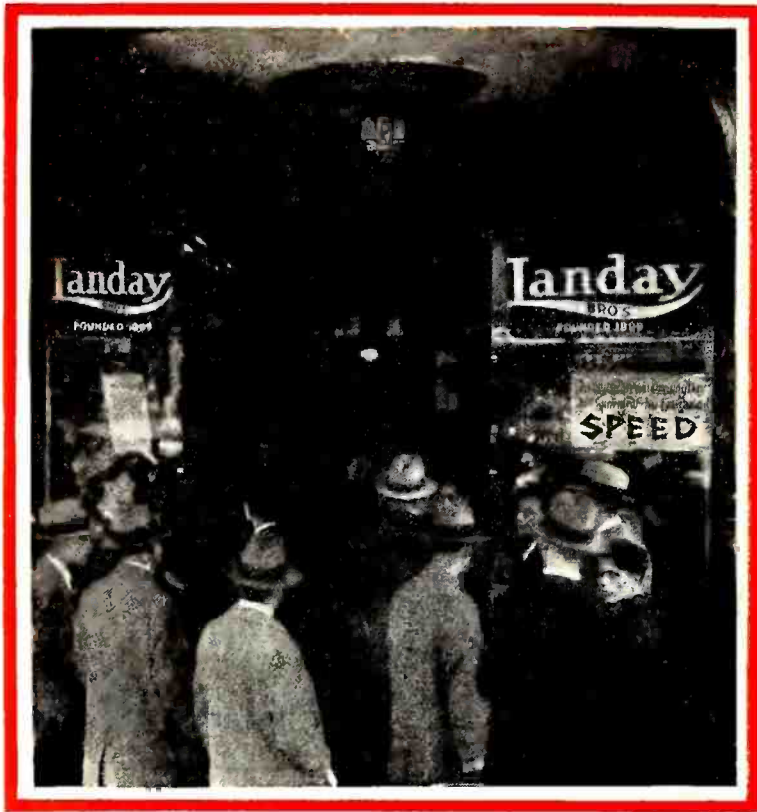

**L**ANDAY BROTHERS, one of the largest radio outlets in the East, tested **SPEED** Tubes, found they were everything we said they were, and then some, and put their o. k. on the **SPEED** Tube Line.

Then Landay showed New York why they chose **SPEED**. All day Saturday,

April 27th, thousands of radio users milled into Landay's to see the laboratory tests on **SPEED** Tubes. "How did it go?" we asked Landay. "It was a great **SPEED** day," they said. (and it certainly looked like it from the sales figures they showed).

But we expected **SPEED'S** success. Every place **SPEED** has gone, it has gone over with a resounding bang. Why not, when the line is right — right in price, right in quality, right all the way through. There's a **SPEED** Tube for every radio and every radio need.

**SPEED** — short, snappy, easy to remember. A far-flung advertising campaign — Saturday Evening Post, newspapers and fan magazines — will engrave it in every mind — make **SPEED** just another word for Tube. Now's the time to check into the best money-making tube proposition in the field.

# SPEED

CABLE RADIO TUBE CORPORATION

80-90 N. Ninth St., Brooklyn, N. Y.

MAKERS OF RADIO TUBES SINCE 1924





# SM

## S-M Reduced Prices Mark a New Era Of Confidence

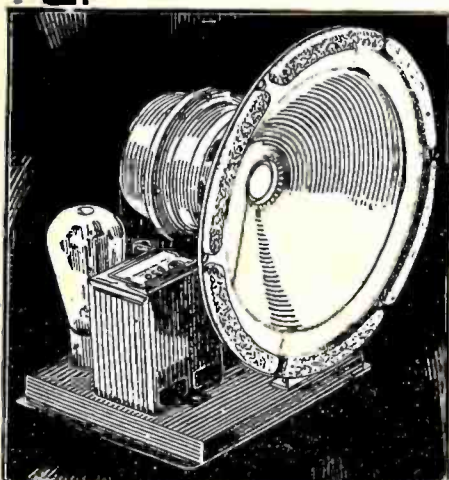

### YES— Something Happened in Speakers When the S-M Appeared

The new S-M speaker is fast becoming as famous an audio product as Silver-Marshall's immensely popular Clough-system audio transformers. So accurately designed is this new speaker unit that it eliminates all objectionable hum as well as "drummy" tones, and brings out both low and high pitches with a fidelity hitherto unobtainable. Two types: 851 for 110-volt d.c., \$29.10 net. 850, for 50-60 cycle 105-120 volt a.c. (using 1-'80 tube), \$35.10 net.

FOR a long time Silver-Marshall has felt that the "list price" method of pricing prevalent in the radio parts business was not conducive to public confidence, and that it should be discarded in favor of an honest and straightforward policy. The situation today is that fully 95% of all radio parts sold go to professional setbuilders, service men or experimenters with commercial connections, who buy at a fictitious "list" price less a discount, usually about 40%. As this discount is available thru, actually, millions of mail order and jobber catalogues, to any and every buyer, the list price is indeed fictitious, and serves no purpose except to destroy confidence.

For this reason Silver-Marshall, as America's largest parts manufacturer, believes that the time has come to "clean house" in the industry—alone if necessary. Therefore, effective April 15th, all S-M list prices were reduced about 40%, so that the new list prices are now about the net prices available to all. No "dollars and cents" change is made—an outworn fiction only is discarded. Henceforth, the professional setbuilder and service man will never be embarrassed when, after selling a set, he is confronted by his customer with a net price catalog. There will be only one selling price on S-M apparatus—the new "net-list," at which consumers, setbuilders, and professional setbuilders can all buy.

This change is intended to, and will, protect service stations and professionals, who, buying parts at the same prices their customers obtain, have their profits insured by a fair and generous differential (to cover their labor) between the cost of parts to their customers and the cost of factory wired sets.

S-M believes that this frank and open policy will insure confidence among those it is designed to protect and help—the consumer, the setbuilder, the service station and jobbers, for it protects the professional from cut-price competition, consequently makes selling easier, and inspires confidence, not mistrust, in his customer.



### S-M Power Amplifiers With Clough-System Tone

Operating entirely from the a.c. light socket, and using the famous S-M Clough-system audio transformers, these amplifiers give the very finest reproduction at auditorium-volume obtainable on the market today.

S-M 690, to reach 2000 or more people, has three stages (last two push-pull); supplies 6 to 12 or more dynamic speakers. Fading control on panel, and three-point switch for record—microphone—radio input selection. Uses 1-'27, 2-'26, 2-'50, and 2-'81 tubes. Price, less tubes, \$147, net.

S-M 679, to reach 1000 or more people, has two stages; supplies 2 to 4 or more dynamic speakers. Binding posts for microphone—radio—record pickup input. Uses 1-'26, 1-'50, 2-'81 tubes. Price less tubes, \$81, net.

S-M "PA" type amplifiers are available for all larger experimental installations at surprisingly reduced prices, as shown in our new April 15th catalog.

S-M's monthly publication, *The RADIOBUILDER*, is mighty interesting reading these days. Issue No. 12 (April, 1929) contained a forecast of band selector tuning as it will characterize 1930 receivers; also a timely discussion of the "one-stage" audio trend. If you are not getting the *RADIOBUILDER*, be sure to send the coupon—and send it anyway for the new S-M April catalog, containing new low S-M list prices, which are net.

Authorized S-M Service Stations have made money this season, and still bigger opportunities are opening up for them. Ask us about the Service Station appointment.

**SILVER-MARSHALL, Inc.**  
6403 West 65th St., Chicago, U. S. A.

Silver-Marshall, Inc.  
6403 W. 65th St., Chicago, U. S. A.

.... Please send me, free, the new April S-M Catalog; also sample copy of the *RADIOBUILDER*. For enclosed..... in stamps, send me the following:

- .... 50c Next 12 issues of *The Radiobuilder*
- .... \$1.00 Next 25 issues of *The Radiobuilder*
- .... S-M DATA SHEETS as follows, at 2c each:
- .... No. 1. 670B, 670ABC Reservoir Power Units
- .... No. 2. 685 Public Address Unipac
- .... No. 3. 730, 731, 732 "Round-the-World" Short Wave Sets
- .... No. 4. 223, 225, 226, 256, 251 Audio Transformers
- .... No. 5. 720 Screen Grid Six Receiver
- .... No. 6. 740 "Coast-to-Coast" Screen Grid Four
- .... No. 7. 675ABC High-Voltage Power Supply and 676 Dynamic Speaker Amplifier
- .... No. 8. Sargent-Rayment Seven
- .... No. 9. 678PD Phonograph Amplifier
- .... No. 10. 720AC All-Electric Screen-Grid Six.
- .... No. 12. 669 Power Unit (for 720AC)

Name.....

Address.....



# THE NEW RADIO SET TESTER

See it at the R.M.A. convention

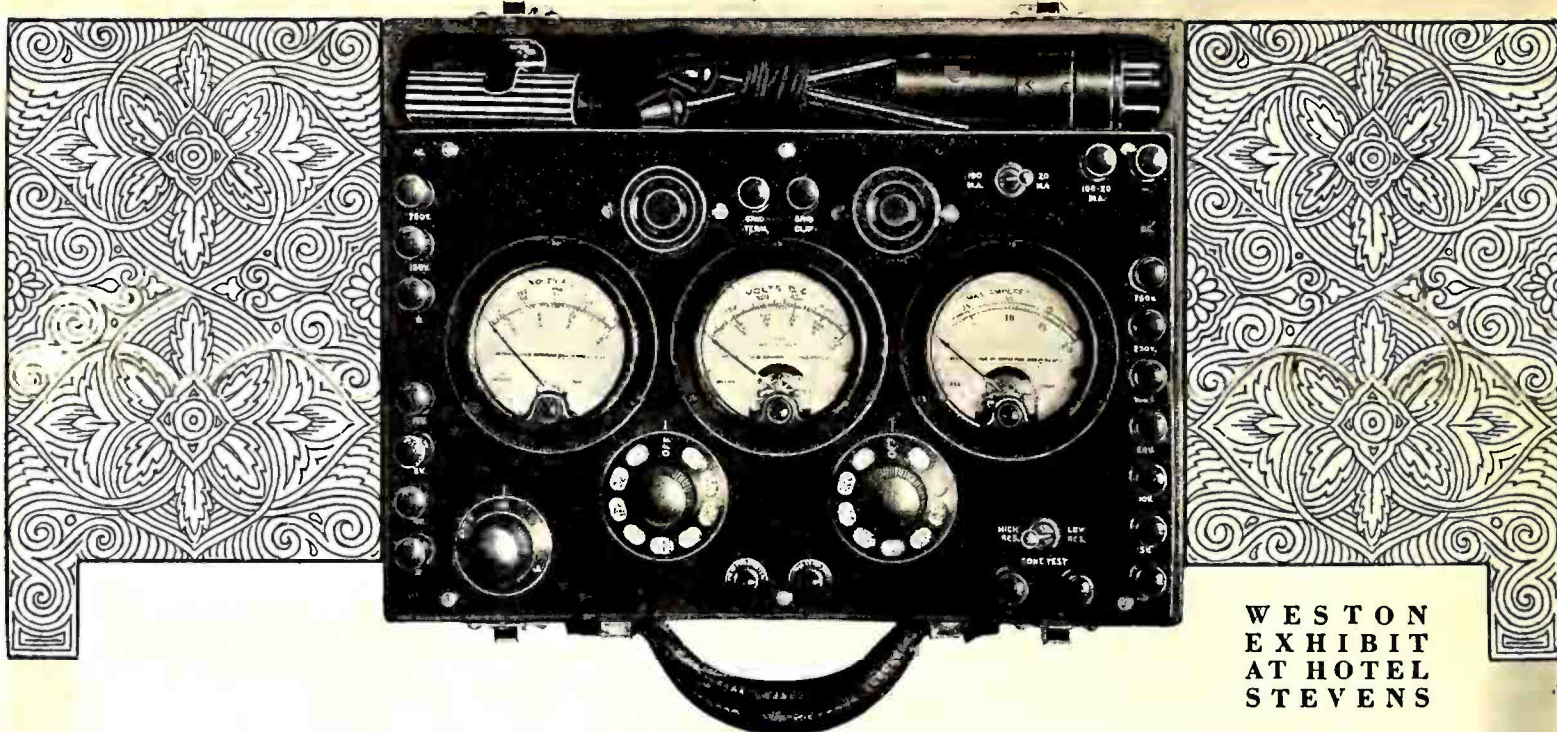

WESTON  
EXHIBIT  
AT HOTEL  
STEVENS

The radio industry is familiar with the Weston Model 537 Radio Set Tester—for A. C. and D. C. receivers. Service men hailed it with great acclaim a year ago, noting its many advantages over the Weston Model 519—for D. C. only.

And NOW—here is another great advance—the Weston Model 547—incorporating many additional features to meet the service testing requirements of radio's latest developments. And there have been many since the last R. M. A. Convention. But with this NEW SET TESTER radio servicing is still further

simplified, even taking into account the number of new tubes, sets and circuits. Space won't permit description here—nor would words alone do this new set tester justice. You must see it for yourself—operate it—try to think up some service problem it can't solve. Try as you will the Model 547 will give you a quick and accurate answer every time. Convenient—complete—light and rugged. Handsome in appearance—and it will yield you handsome profits. It will increase your business and your prestige. **YOU CAN BANK ON IT!**

## OUTSTANDING FEATURES OF THE MODEL 547

*First of all it is a WESTON—assuring you exquisite workmanship and complete service reliability. It is provided with three instruments—all 3 1/4" diameter and furnished with bakelite cases. Carrying case, removable cover, panel and fittings are also made of sturdy bakelite.*

**A. C. Voltmeter**—750/150/16/8/4 volts. The three lower ranges are brought out to the Tester plug, and all five ranges are brought out to binding posts. 750 volt range is for testing secondaries of power transformers. 16 volt range is to provide for 15 volt A. C. tubes. Operations have been reduced—only one selector switch being necessary.

**D. C. Voltmeter**—High range increased to 750 volts. Other ranges—250/100/50/10/5—all six ranges brought out to binding posts and Tester plug.

**D. C. Milliammeter**—Double range—100/20 M. A. provides for lower

readings with better scale characteristics. **Tests**—On A. C. sets the heater voltage and plate current can be read throughout the test while the D. C. voltmeter may be indicating plate bias or cathode voltage.

Self-contained, double-sensitivity continuity test provided. This can also be used for measuring resistance as well as testing for open circuits. Grid test can be made on A. C. or D.C. screen grid tubes—also the '27 tubes when used as a detector—without the use of adapters.

Two sockets on the panel—UY tube adapters eliminated.

**Weston**  
PIONEERS  
SINCE 1888  
**INSTRUMENTS**



# NEW, REVOLUTIONARY, A YEAR AHEAD

## Largest Pick-up Ever Put on the Market

The Best Theatre Pick-up is the largest, heaviest and most powerful pick-up available to the general public. Naturally, to get power you must have size. And with size you must have weight. The Best Suspension Bridge Counter-Balance makes it possible to use this weight with but the weight of a feather on the delicate record.

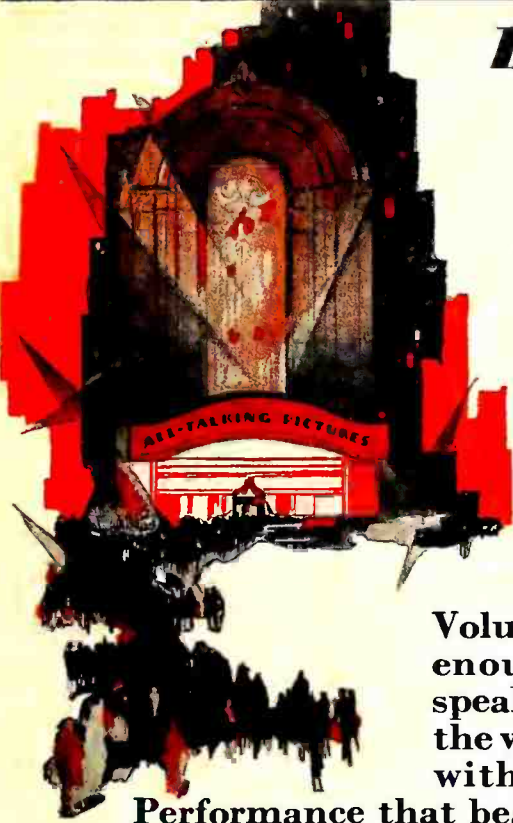

## Thunderous Volume!

Volume . . . thunderous volume . . . enough to tax the capacity of any speaker . . . and yet you can cut down the volume to the barest whisper. And without the slightest distortion!

Performance that beggars description, so much better than ordinary pick-ups, that there is no comparison.

## Know the Best by the Box

Individually packed in the most sumptuous display box known to the Radio Industry. To place one of these display boxes on your counter, is to sell it. Complete with volume control and adapter for four or five prong tubes (in case the set does not have a phonograph jack).

List price \$17.50, with long arm for Theatre Records \$20.00.

**BEST MANUFACTURING CO.**  
1200 GROVE ST., IRVINGTON, N. J.

## COUNTER BALANCED!

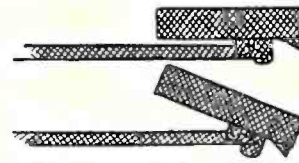

The Best Theatre Pick-up, is built like a suspension bridge. So delicately is it balanced, that only a feather weight is placed on the record. When finished playing a record, simply tip the head — it stays — no danger of ruining record or woodwork. Perfect balance does it.



# The BEST Theatre PICK-UP

For Home and Theatre

Best Manufacturing Company,  
1200 Grove St., Irvington, N. J.

Send us complete information on the following:—

- Best Theatre Pick-up
- Best Theatre Dynamic

Name .....

Address .....

.....



# RADIO BROADCAST

VOL. XV. NO. 2



PUBLISHED FOR THE RADIO INDUSTRY

WILLIS KINGSLEY WING . . . . . Editor  
KEITH HENNEY . . . . . Director of the Laboratory  
HOWARD E. RHODES . . . . . Technical Editor  
EDGAR H. FELIX . . . . . Contributing Editor

## Contents for June, 1929

Frontispiece - - - -	<i>Interesting Pictures of the Month</i>	68
The Trend in Cabinet Design - - - -	<i>R. H. Langley</i>	69
The March of Radio - - -	<i>An Editorial Interpretation</i>	72
Can Radio Become a Style Product?	Regarding Direct Radio Advertising Tube Makers Sign R.C.A. License	
Improvements in 1929-30 Receivers	<i>Views of Leading Executives</i>	74
Pick-Ups—A Worth-While Accessory - - - - -		77
What the Licensing Groups Offer	<i>Hazeltine, R.C.A., R.F.L., and Technidyne</i>	78
What They Say - - - - -	<i>The Month's Best Letters</i>	80
Judging the Merits of a New Set - - - -	<i>Harry Alter</i>	81
Progress in Loud Speaker Design	<i>Four Acoustic Engineers</i>	84
1929—The Year of 100,000,000 Tubes - - - - -		85
A Game for Radio Dealers - - - - -	<i>S. Gordon T. Parks</i>	86
Radio Shop Practice - - - - -	<i>Mary Texanna Loomis</i>	87
In the Radio Marketplacc - - - - -	<i>Items of Trade Interest</i>	90
The Radio Dealer's Note Book - - - - -		93
The Inductor-Dynamic Loud Speaker - - - -	<i>R. H. Dreisbach</i>	94
Routine Plate Circuit Testing - - - -	<i>John S. Dunham</i>	96
"Radio Broadcast's" Set Data Shcets - - - - -		99
The Spartan Receivers	The Freshman Model QD-16-S	
All-American Mohawk Receiver		
Strays from the Laboratory - - - - -	<i>Keith Henney</i>	101
Trends in 1929 Receiver Design	Humps in Audio Transformers	
Data on Electrostatic Speakers	Short-Wave Schedules	
How Much is an Engineer Worth?	Resourcefulness of an Engineer	
Power Requirements in England	Dr. Goldsmith Resigns as Editor	
The Experimenter's Armchair - - - - -	<i>Robert S. Kruse</i>	103
A German Portable Receiver	A 110-volt Potentiometer	
An Improved Oscillator	The I.R.E. Patent Digest	
Miniature Current Transformer	Letters are Welcome	
"Radio Broadcast's" Home-Study Sheets - - - - -		105
No. 23. Radio-Frequency Oscil-lators	No. 24. Measuring Capacity	
A Simple Two-Tube V.T. Voltmeter - - - -	<i>Howard E. Rhodes</i>	107
Improvements in the 227 Tube - - - -	<i>F. X. Rettenmeyer</i>	108
Complete List of R. C. A. Licensees - - - - -		108
Broadcast Engineering - - - - -	<i>Carl Dreher</i>	109
The Serviceman's Corner - - - - -		110
Radio Broadcast Laboratory Information Shcets	<i>Howard E. Rhodes</i>	116
No. 283. Hum-Voltage Character-istics	No. 285. Frequency Vs. Capacity and Inductance	
No. 284. Hum-Voltage Character-istics	No. 286. Frequency Vs. Capacity and Inductance	
	No. 287. Protecting Meters	

The contents of this magazine is indexed in *The Readers' Guide to Periodical Literature*, which is on file at all public libraries

## . . . among other things

HERE WE are at the start of another radio season. How will it compare with other seasons? What are the manufacturers' offerings? What are the trends? In short, how is the radio world going? In the issue now before you, we have tried to provide answers to most of these questions, written by those who are in a large measure responsible for our present advancement.

THE PRICE tendency this year is perhaps the most obvious: manufacturers are giving more value for less money in 1929 than they did in 1928. The sets, from those in the lowest price class to those selling for the highest figure, give improved performance and are generally better values. At least one leading maker offers in his list price the entire receiver equipment: set, loud speaker, cabinet, and tubes. This, in our opinion, is a step of great importance and we believe the practice in time will become more general. The radio sets themselves, although they do not differ materially from those offered in previous years, are definitely improved in exterior appearance. "Beneath the hood," they contain a great number of improvements, which, while not sensational, represent engineering advance, and show that the design engineers have not been idle. All receivers are basically the same yet each has its individual technical points of difference. The engineers now know how to measure these differences and can tell exactly what the real performance of the set is. Models are now thoroughly tested, measured, taken apart, redesigned, and put together again before being put into production and offered to the dealer and to the public. Radio manufacture, in short, is a much more exact operation than ever before. From this, the entire industry benefits, and the public, praises be, receives more for its investment.

HOWARD W. DICKINSON, formerly executive vice-president of the George Batten Company, and a nationally known authority on merchandising problems, begins a series of intensely interesting articles in the July RADIO BROADCAST. These articles, warmly personal and sympathetic, will offer some new and distinctly helpful ideas on radio selling. In addition to many other helpful articles for those who sell radio, our technical section in July will contain the finest line-up of material it has ever been our pleasure to present. For the first time anywhere, we offer in that issue complete technical descriptions of three well-known commercial receivers; a splendid article on loud speaker measuring methods; definite data on the 245-type tube, and numerous other special features.

—WILLIS KINGSLEY WING.

TERMS: \$4.00 a year; single copies 35 cents; All rights reserved. Copyright, 1929, in the United States, Newfoundland, Great Britain, Canada, and other countries by

DOUBLEDAY, DORAN & COMPANY, INC., Garden City, New York

MAGAZINES . . . . .  
COUNTRY LIFE . . . . . WORLD'S WORK . . . . . THE AMERICAN HOME . . . . . RADIO BROADCAST . . . . . SHORT STORIES . . . . . LE PETIT JOURNAL . . . . . EL ECO . . . . . WEST BOOK SHOPS (Book of all Publishers) . . . . .

NEW YORK: <LORD & TAYLOR, JAMES MCCREERY & COMPANY, PENNSYLVANIA TERMINAL, 166 WEST 32ND ST., 848 MADISON AVE., 51 EAST 44TH STREET, 420, 526, and 819 LEXINGTON AVENUE, GRAND CENTRAL TERMINAL, 10 WALL STREET> ATLANTIC CITY: <2807 BOARDWALK> CHICAGO: <75 EAST ADAMS STREET> ST. LOUIS: <223 N. 8TH ST. and 4914 MARYLAND AVE.> CLEVELAND: <HIGBEE COMPANY> SPRINGFIELD, MASS: <MEEKINS, PACKARD & WHEAT.

OFFICES

GARDEN CITY, N. Y. NEW YORK: 214 MADISON AVENUE. BOSTON: PARK SQUARE BUILDING. CHICAGO: PEOPLES GAS BUILDING. SANTA BARBARA, CAL. LONDON: WM. HEINEMANN, LTD. TORONTO: DOUBLEDAY, DORAN & GUNDBY, LTD.

OFFICERS

F. N. DOUBLEDAY, Chairman of the Board; NELSON DOUBLEDAY, President; S. A. EVERITT, Vice-President; GEORGE H. DORAN, Vice-President; RUSSELL DOUBLEDAY, Secretary; JOHN J. HESSIAN, Treasurer; LILLIAN A. COMSTOCK, Ass't Secretary; L. J. McNAUGHTON, Ass't Treasurer



# RAYTHEON

RAYTHEON has done something more than imitate the design of other tubes. Raytheon has made a very real contribution to radio.

## RAYTHEON *was FIRST*

To produce a practical, heavy duty rectifier tube for B-elimination.

*And when Raytheon brought out a full line of A. C. and receiving tubes, RAYTHEON was FIRST*

To anchor receiving tube elements at the top with mica, increasing rigidity and uniformity of performance.

To produce a long-life, quick-heating tube for A. C. operation.

## *And RAYTHEON ALONE*

Builds a tube of FOUR-PILLAR CONSTRUCTION, cross-anchored top and bottom—a tube so sturdy that its laboratory-tested performance cannot be changed by the shocks and knocks of shipment and handling.

In addition to the many outstanding improvements and patents which can be used by Raytheon *only*, Raytheon will benefit by all R. C. A. tube patents, present and future.

Due to the license granted Raytheon—*jobbers and dealers can sell these high-quality tubes with no danger of legal entanglements or "frozen" stock.*





# EVEREADY RAYTHEON

## *THE NEWEST NAME IN RADIO*

NATIONAL CARBON COMPANY, Inc., now controls production and sale of licensed Raytheon Tubes. This combines not only the names, but facilities of these two companies.

Effective June 1, 1929, Eveready Raytheon Tubes will be produced and merchandised under the control of the great Eveready organization.

Plant enlargements are now under way. Additional equipment is being installed. Production of Eveready Raytheon Tubes will be enormously increased. An adequate supply is assured.

Eveready Raytheon is a large individual division of the National Carbon Company, Inc., and will have all of the usual aggressive Eveready advertising and merchandising activities back of it. Extensive Publicity . . . Broadcasting . . . Advertising.

This means increased opportunities for present Raytheon dealers. Additional franchises will be allotted. There will be full co-operation with the trade.

Plan now to take full advantage of this great new development in the radio tube market. Be sure to order an adequate stock of Eveready Raytheon Tubes.

**NATIONAL CARBON COMPANY, INC.**  
New York, N. Y.

*Branches: Atlanta, Chicago, Kansas City, Long Island City, San Francisco*

*Unit of Union Carbide  and Carbon Corporation*

# EVEREADY RAYTHEON



# EVEREADY RAYTHEON

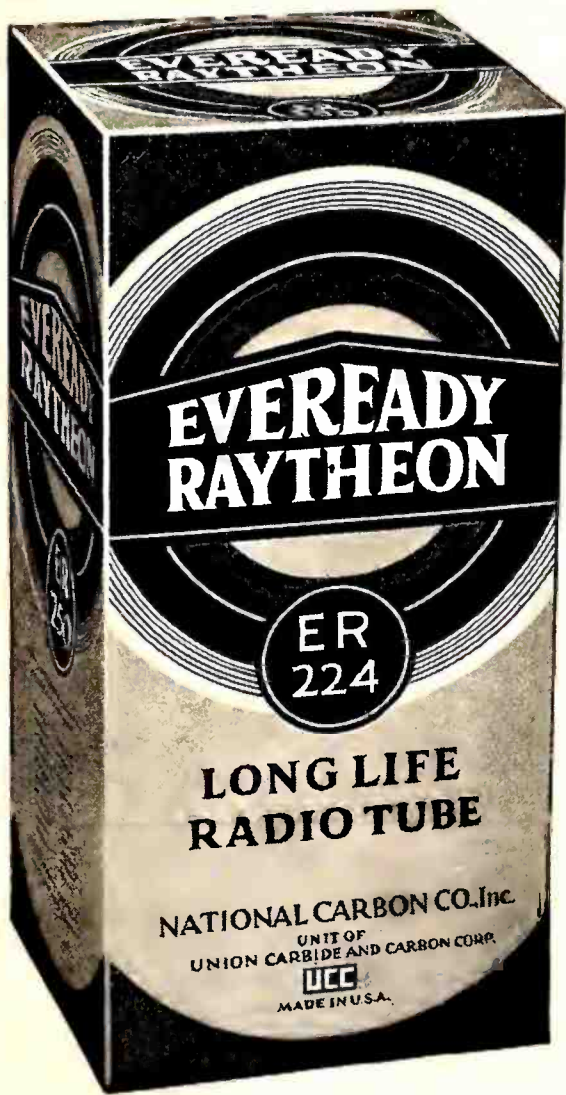

EVEREADY Raytheon Tubes will be sold in this package, made in the Eveready colors—red, blue and gray. It brings the prestige of two well-known names together in a striking display.

The change in name will mean even more than a great expansion of production and distribution. In addition to the specialized activities of the famous Raytheon laboratories at Cambridge, Eveready Raytheon will have the benefit of all research and development facilities of the National Carbon Company, Inc.

Eveready Raytheon will continue to lead in radio tube development. As an Eveready Raytheon dealer, the many developments in principle and design which are constantly in progress in the Eveready Raytheon laboratories assure you of radio tubes abreast of the moment . . . ahead of it.

Don't miss this opportunity to profit by all that Eveready Raytheon will have to offer you. Get in touch with your jobber or distributor today.

**NATIONAL CARBON COMPANY, Inc., New York**

*Branches: Atlanta, Chicago, Kansas City, Long Island City, San Francisco*

*Unit of Union Carbide  and Carbon Corporation*







**EVEREADY  
RAYTHEON  
PACKAGE**

*and great new*

**ER 224**

*Screen Grid Tube*



*Eveready Raytheon Tubes are a  
complete line*

- |                 |                     |
|-----------------|---------------------|
| ER Rectifier BH | ER 240              |
| ER Rectifier BA | ER 280              |
| ER 201-A        | ER 281              |
| ER 200-A        | ER 226              |
| ER 112-A        | ER 227              |
| ER 171-A        | ER 224              |
| ER 210          | ER Type A Cartridge |
| ER 250          | Rectifier           |
| ER 245          | ER Photo-cell       |
|                 | ER Kino Lamp        |

*ER 224 tube with exclusive four-pillar  
construction, cross-anchored top and  
bottom*



# Announcing

# TRIAD

## RADIO TUBES

Achieved at last — the tube perfection for which the radio world has waited! Exhaustive research, a radically new engineering process, greatly advanced laboratory methods, a care in production and testing which has never been known before — from all these has been created an infinitely higher standard in tube quality, a standard which only Triad Tubes offer! Tests have proved their unparalleled clarity of tone, their longer life and their greater sensitivity and volume. ▲▲ Back of every Triad Tube is the personal guarantee of a group of pioneers in the radio industry, whose integrity and resourcefulness has been proved through years of intimate contact with both trade and public. ▲▲ Their product, the result of a conviction that better tubes could be manufactured, now makes possible a greater and more economical enjoyment of radio reception!



GEORGE COBY  
*President*

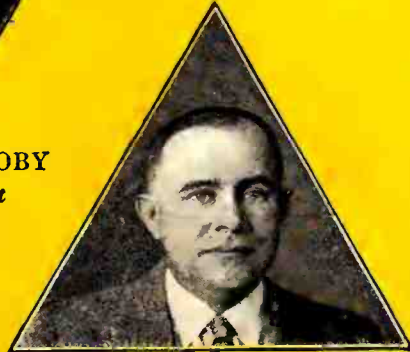

ELY EGNATOFF  
*Treasurer*



WILLIAM CEPEK  
*Secretary*



HARRY H. STEINLE  
*Vice-President and  
General Sales Manager*



“Quality ▲ Service ▲ Durability”





# Dealers!



**T**RIAD brings you a definite, well-planned policy of sales cooperation. Unequaled quality, a continuous supply, prompt deliveries, close factory contact—in short, every possible bit of assistance will be yours. A tremendous advertising, radio and publicity campaign has been launched that will make Triad the world's most popular tube. Tie-up material will be provided to each dealer in any quantity desired. And there is a generous profit margin with Triad—one that will bring real satisfaction to you with every sale. A greater tube business with greater profits is waiting for you in 1929 with Triad. Write or wire now for the special sales and merchandising proposition we have arranged for you!

## The Triad Line—Complete!

A complete line of A. C. tubes is included in the Triad line—also D. C. types, Special Purpose tubes and Television and Photo Electric Cells. The Triad Line enables you to meet your customer's demand instantly—and Triad quality assures absolute satisfaction with every sale.

*The TRIADORS will broadcast a popular program every week over a national network. This selling cooperation will mean a steady consumer demand for Triad Tubes.*

## Triad Publicity

**Broadcasting:** Fifty-two weeks of broadcasting over a national network, have been arranged. A famous orchestra, stars of the stage and concert world, elaborate presentations of varied nature—all these and many other features will sell Triad Tubes in the homes of every radio owner.

**Newspapers and Magazines:** An extensive national newspaper and magazine campaign will keep the Triad line constantly before the reading millions in 1929 and 1930. This powerful advertising, together with interesting publicity items will aid materially in building a steady consumer demand.

**Dealer Helps:** Attractive window strips, fliers and broadsides for counter or mailing purposes, plates and matrixes for local advertising—these are only a few of the many merchandising helps available to every Triad dealer. Every possible aid will be extended in helping the individual dealer to tie up with the national newspaper and radio campaigns.

### New! "Tube Insurance"

A certificate is enclosed with every Triad Tube, guaranteeing thoroughly satisfactory service. Here is a unique and valuable Triad merchandising feature! It means satisfaction to both customer and dealer—and a saving in the dealer's selling time and expense. Remember—only Triad offers "TUBE INSURANCE".

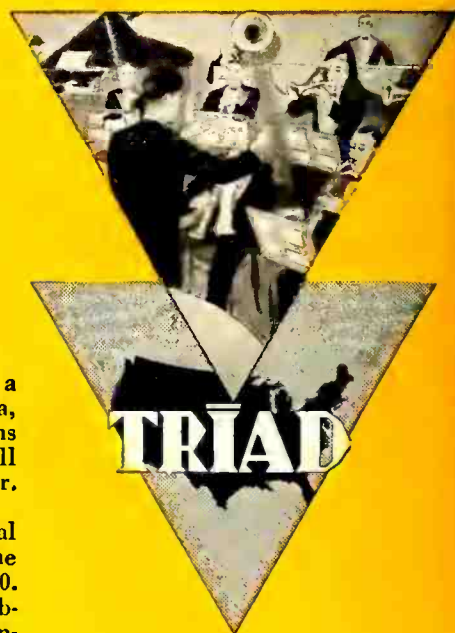

*"The Tube in the Triangular Box"*



The Triad box itself is of tremendous merchandising value. Its unique shape and design lend themselves easily to spectacular displays. Your trade will soon learn to "Ask for the tube in the triangular box."



NEWSPAPER AND MAGAZINE ADVERTISEMENTS



DEALER'S HELPS



# Seven Seas Console

## First With A-C Shield Grid Tubes

ONCE again Leutz leads, introducing the first A/C Console to use the superior A/C Shield Grid Tubes. The result—a superior Console which will meet all competition, 100% shielding, wide spacing between radio frequency transformers and metal and unit construction contribute to make up the finest in radio for the coming season—the new Seven Seas Console by Leutz.



## Unit Construction

THE electrical equipment is divided into four separate units: 1, chassis; 2, power amplifier; 3, power pack; 4, dynamic loud speaker. Two 210 tubes in the push-pull amplifier. Three A/C Screen Grid Tubes in the radio frequency amplifier. All heater tubes including one in the detector circuit and one in the first audio stage and a full wave rectifier using two 281 tubes. Here is a radio into which are incorporated the new features of 1930 radio with an unusually perfect audio amplifier. Highest quality dynamic speaker used.

A RADIO that defies competition. A sales leader for the dealer who wants something better than the ordinary to sell. Investigate the Seven Seas Console by Leutz.

### Features:

A/C Operation  
Single Dial  
Dynamic Speaker  
Push-Pull Audio  
2/210 Power Tubes  
100% Shielding  
Adjustable Selectivity  
Shield Grid Tubes  
Heater Type Tubes  
Unit Construction  
9 Tubes  
Maximum Range  
Tremendous Volume  
Perfect Reproduction  
Walnut Console

FRANCHISE APPLICATIONS ARE INVITED

from established dealers

LITERATURE ON REQUEST

## C. R. LEUTZ, Inc.

LONG ISLAND CITY, NEW YORK, U. S. A.

CABLES: "Experinfo"—New York

West Coast Representative

B. J. HOWDERSHELL

Detwiler Bldg., 412 W. Sixth St., Los Angeles



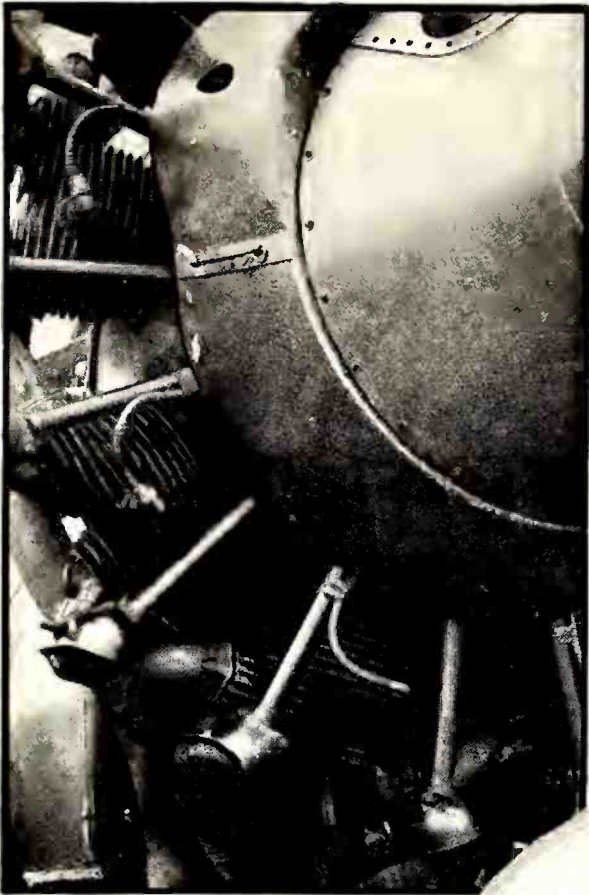

The U. S. Bureau of Standards has equipped an airplane as a laboratory for testing radio beacon signals at night and during foggy weather. On the right is shown the equipment installed in the plane.

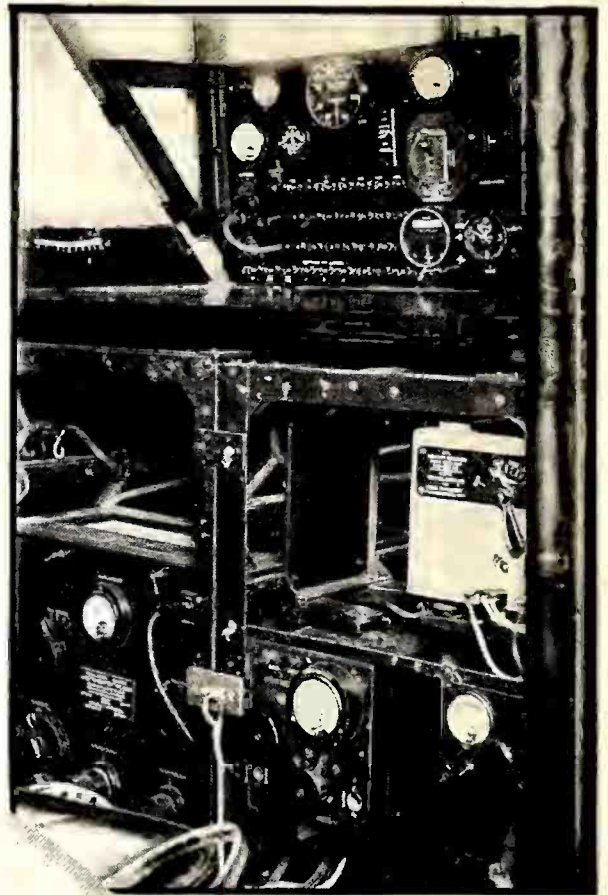

In the "flying laboratory" shielding is used as shown above to prevent the ignition system from causing interference with the reception of beacon signals.



Guglielmo Marconi seated in front of an array of radio receiving and transmitting equipment of the vintage of 1901 is shown in an old picture on the left.

View of the dignified modernistic exterior of the Motala (Sweden) broadcasting station.

This attractive new building houses the complete equipment, including studios, of station WENR, Chicago, Ill.



## INTERESTING RADIO PICTURES OF THE MONTH



## How Can Radio Satisfy the Public's Artistic Demands?



RALPH H. LANGLEY, Director of Engineering, Crosley Radio Corporation, says, "Radio . . . is an even greater improvement over the old phonograph than the automobile over the horse and buggy. Surely it is entitled to the same beauty and distinction of design. . . . We need new and honest treatments . . . which make no apology to the past. . . ." Mr. Langley, when in charge of receiving set design for the General Electric Company, was responsible for the first super-heterodyne models with sealed "catacombs."

---

## THE TREND IN CABINET DESIGN

---

By R. H. LANGLEY

*Crosley Radio Corporation*

**W**HERE HAVE the modern designs for radio sets come from, and where are they going to? Is there any definite history back of our present radio cabinets, and can we think of them as final, or will there be further developments? These are interesting and important questions, worthy of careful examination.

Radio receivers (they used to be called "wireless receivers") have been built for a great many years. Back in those early days a receiver consisted of but few parts, and they were fastened down to a board, so that the connections would stay in place. It may be somewhat of a surprise to know that our present highly complicated receivers are built on this same plan. To be sure, there have been tendencies away from this arrangement, but to-day, apparently, we are back again at first principles.

The first step away from the "breadboard" design was the introduction of a front panel, with some of the devices mounted on the panel and some on the base. One of our well-known manufacturers has a patent on this construction. Then came sets in which the panel replaced the base completely, and everything was mounted on it. Hundreds of thousands of receivers of this type were built and sold, and many of them are still in service.

The desire to conceal all the wiring, which at best was unsightly, was the probable reason for the return to the base mounting for all the parts. The old "breadboard" has been replaced by a punched steel chassis, and all the wiring is inside this base. In most modern sets, the a.c. power unit is also mounted on this same steel base, and this form can perhaps be regarded as the highest development in design.

The relation of the loud speaker to the present status of set design is also interesting. Why is the loud speaker still a separate device? The fact is that, in spite of all that can be said about the advantages of having the loud speaker at some different point in the room from the receiver itself, the present arrangement is an inheritance from the earlier days, which we have not yet discarded. It is a relic for which we seem to have some sentimental attachment. The day is probably close at hand when we shall forsake this time-honored division of our equipment and build the receiver and speaker in one unit.

### *Early Receiving Methods*

**I**N THE EARLY days the only method of hearing radio signals was by use of head telephones, and these had to be at the end of a cord so that the operator could wear them. For some time after broadcasting started, head telephones were used exclusively. When the loud speaker came, it was used for some time interchangeably with the head phones, and a jack was provided by which either might be plugged in. To-day the use of head phones has almost disappeared, but the loud speaker still dangles at the end of a cord, and even in the cabinet sets, is a separate device, mounted independently in the cabinet.

The dealer to-day likes to sell a complete equipment, in one ensemble, at a "complete" price, and the buyer undoubtedly prefers to buy it that way. It is closely parallel to the "completely equipped" automobile which we buy to-day, as against the separate purchase of a dozen necessary accessories, which was the rule a few years ago. To provide this completeness in radio sets, the manufacturer (or in some cases the dealer)



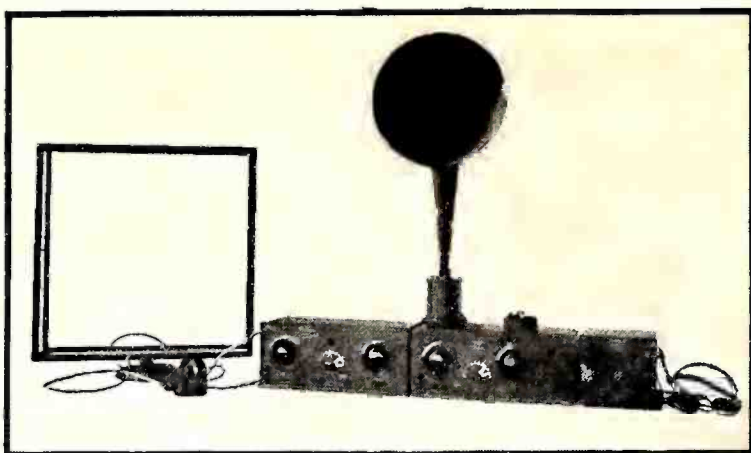

*The type of radio cabinet which was popular in 1923.*

mounts the radio set and the loud speaker into a wood cabinet, but the loud speaker is manufactured as a separate instrument, and the receiver itself is designed and manufactured as though it were to be placed alone on a table. It is probable that at least 80 per cent. of the sets sold in 1928 were mounted in floor-type cabinets, but neither the sets nor loud speakers were designed specifically for this arrangement.

Here again we find the reason in tradition rather than intention. Until recently, all radio receivers obtained their power supply from batteries. It is only within the last year that a.c.-operated receivers have dominated the market. The old battery-operated sets required space for the batteries, and this, more than anything else, was the justification for a relatively large piece of furniture. A compartment in the bottom of the cabinet, usually reached from the rear, was provided for the batteries, and was made high enough so that the numerous connections that had to be made when the not infrequent battery renewals were necessary could be accomplished with reasonable ease.

The radio cabinet of to-day is large enough to take a complete set of batteries. This empty space, surrounded by beautiful woodwork, is shipped across the continent, and the buyer pays the freight. It will never contain anything but air. Perhaps we shall always be content to buy half-empty furniture, but no other piece in the modern home can justify such inefficient use of space.

### *Causes of Present Design*

**T**O SUMMARIZE our examination of the present status of design, we can record three facts: first, that the set itself is not yet adapted to the housing in which it is placed; second, that the loud speaker can, and probably will, be combined with the set; and, third, that there is every reason to expect more compact designs, no less artistic, but better suited to the none too generous proportions of the modern home.

Perhaps a more adequate basis for our feeling that the cabinet designs of to-day will undergo further changes and improvements can be found in the automobile. Surely it is not like the horse-drawn vehicle that preceded it. It has but two points of similarity. It runs on four wheels and is arranged so that the passengers may sit down. But the wheels themselves are very different, with their huge tires, and the steering mechanism is different. The bodies, analogous to our radio cabinets, have no precedent in the past. They are beautiful beyond the richest dreams of the old coach builders, and, most important, they are completely and perfectly adapted to the chassis on which they are mounted, the mechanism which they house, and the use to which they are put. They express in every line, the speed, the comfort, and the convenience of a new method of transportation.

Our radio sets may be regarded as a means of transportation into the realms of music. The automobile will take us to the concert hall, the radio set will bring the concert to our homes. But why should it resemble the phonograph, which was the best that an earlier period could provide to give us the pleasures of music? Radio, in the wealth of its possibilities, is an even greater improvement over the old phonograph than the automobile is over the horse and buggy. Surely it is entitled to the same beauty and distinction of design.

Motor cars to-day are much smaller than they were a few years ago; their size has been reduced to the minimum necessary for proper performance. In the same way and for the same reasons we may expect the radio set to grow smaller.

There are two factors not so closely associated with the



*One of the earliest designs of commercial console radio cabinets.*

story of gradual development, yet having an important bearing on the cabinet designs of to-day. The first of these is the question of style. When we buy furniture, we select from a large number of samples, each expressing a different artistic treatment. If it is a library table we want, there are dozens of them, and our final choice is usually influenced by some slight detail of design. It is necessary for the dealer to have this wide assortment, and after we are once in the store, it is no longer a question of whether we will buy a table, but which one we like the best.

To a very large extent, radio sets are, and perhaps must be, purchased on this same basis of choice between cabinets. We seem to take for granted that all sets are about alike in performance, regardless of the name of the manufacturer. We will, of course, choose between those having the technical features we have been told are essential; we want a set having at least so many tubes, and with the popular type of loud speaker, and operated from the a.c. lines. But beyond this it is almost entirely a question of cabinet design.

It is this style element that makes it necessary for each dealer to carry a wide variety of models. But no manufacturer, in the present state of the industry, can attempt to offer a



*New Design Needed*

sufficiently complete choice of cabinet models in his own line, each built complete in his own factory. It would mean large investments in inventory, not only on his part, but also on the part of his jobbers and dealers, and the progress of the art is so rapid that the less popular models in such a line would have to be closed out at sacrifice prices, before technical advances in design made them entirely unsalable.

*Solving the Problem*

**T**HIS DIFFICULTY is avoided, or at least minimized, by allowing the dealer to make the installation of set and loud speaker in the cabinet. He can carry an assortment of empty cabinets, and a stock of standard sets and loud speakers, and make up the combinations as they are sold. This method, however, gives the manufacturer two new problems. How can he be sure that the combinations thus made will function properly? He will certainly be blamed if they do not. And again, in order to prevent the obsolescence of the cabinets in which his jobbers and dealers have invested, he must see that each new model is so designed that it can be installed in the cabinets previously used. This makes improvements in technical design difficult and slow.

The furnishings and decorations for the living room are chosen with care and deliberation. Here the guests will be entertained and here the radio set must be placed. *It must fit into this picture harmoniously, attracting attention neither because it is much finer than the other pieces, nor because it is obviously not as good.* It is almost impossible to have it accurately "match" them. It is going to be an "odd piece" at best. It is the necessity for creating cabinet designs that will meet this difficult requirement that gives the furniture craftsmen their greatest problem.

Table types of radio sets are to-day housed to a very large extent in metal cases. The number of such sets sold leaves no question of their acceptability. The necessity for unsightly batteries is gone, and a small table-type receiver, perhaps on a wrought-iron stand, can be fitted into the living room in such a way as to add to the effect of the decorative scheme. It makes no pretense at matching the furniture but it may well be in complete harmony with floor lamps and fixtures.

The demand for floor types, however, cannot be neglected. If these are to be done in metal, rather than wood, any attempt to imitate the beauty of wood veneer must be skillfully done. The possibilities for decorative treatment of metal are almost limitless. Automobile designers have created out of metal, forms both beautiful and satisfying, completely abandoning the types and motifs of earlier vehicles. There is no reason to doubt that radio designers will soon accomplish an equally distinctive and gratifying result. The tendency toward smaller forms, and toward the assembly of set and loud speaker in a single unit, will help in the complete adaptation of the equipment to its housing, and in producing types much finer from an artistic and decorative standpoint.

The same search for new forms in decoration which has brought about the "modern" types of furniture and furnishings, will find expression in radio designs. It is not to be expected, however, that such types will dominate, regardless of the fact that they are well suited to the treatment of metal. Rather, I believe, we may look forward to the creation of types as different as the automobile, and equally pleasing whether they are surrounded by strictly modern, or by the more-conservative and well-established forms of furniture.

**T**HE GREEKS have been criticized for trying to portray draperies in their statuary. Stone was not a suitable material in which to picture linen and silk. This same objection is valid to-day against an improper combination of material and treatment. Decorative schemes must be suited to the material in which they are to be executed, and no form in one material which could be better done in another can be regarded as good. Thus, metal cabinets and cases call for new and honest treatments, which need make no apology to the past or to other materials, but which in themselves are satisfying and beautiful.

If any of us knew what these new forms would be, we would be building them to-day. It must not be inferred that the cabinets of to-day can be regarded as bad. Some of them are poor, to be sure, but many are excellent, and they all express this very search for something better which I have attempted to outline, and in a few we can read the tendencies which will mature to-morrow. Each new cabinet, in a sense, is an experiment in art, and it will succeed or fail, partly on the excellence of the equipment which it houses, but to a much greater degree because of the discriminating taste of the buyer in choosing, from an artistic standpoint, the furnishings for his home. In the results of these tests the designers will read the outlines for the offerings of another season.

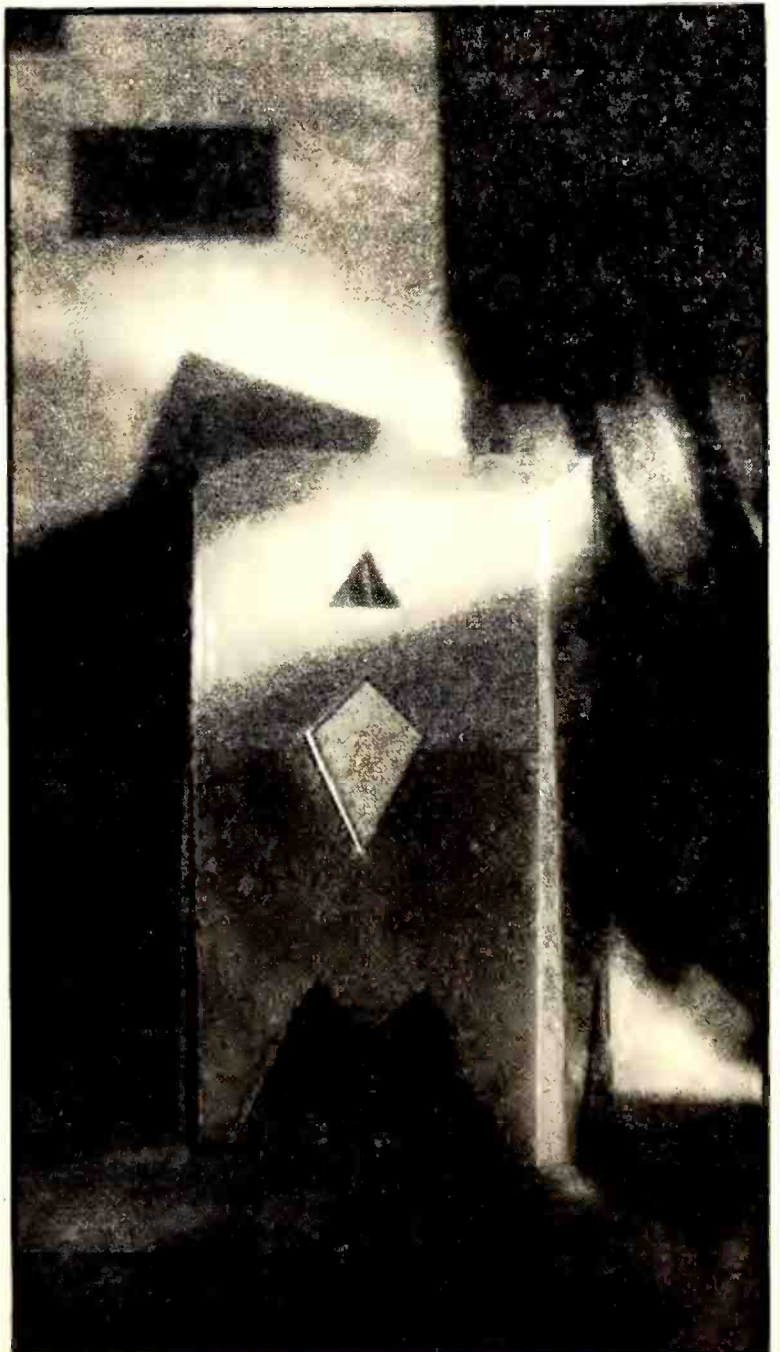

Designed and photographed by Larry June  
An imaginative design suggested by this article and made  
by a Radio Broadcast staff artist.



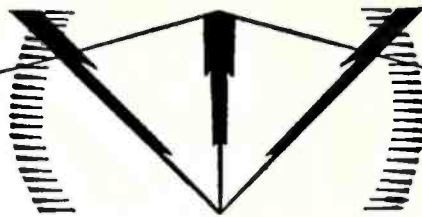

## Can Radio Become a Style Product?

**R**ADIO RECEIVERS are sold to two classes of purchasers: first, new prospects who have not previously possessed radio receivers, comprising new families, older families that have reached an improved economic status or become approachable through lowered prices, and those converted to radio because of improved performance, better available broadcasting programs, and simplified operation and maintenance; second, the replacement market, consisting of enthusiastic radio followers who appreciate the improvement in modern radio receivers as to performance, appearance, and ease of maintenance, effected since their own was purchased.

Both of these markets are now at a peak and sales resist-

ance in them is at a minimum. Ten million out of our twenty-four million families have been sold radio and we are doubtless at the steepest part of the increase-of-listeners' curve. The group which are out of reach of the radio market for economic reasons, those not reached by good broadcasting, and those who object inherently to the artificial character of radio entertainment, are becoming a larger and larger percentage of the unsold market, so that, as in the automobile field, the new prospect market is becoming a smaller factor and sales resistance is increasing.



Investigation in major cities, where good broadcasting has been available for a period of years, reveals the astounding fact that over 80 per cent. of the sales made by certain high-class stores, concentrating on the more expensive market, are replacement sales, and the average in such centers is well above 60 per cent. for all classes of stores. Unquestionably, the replacement market is becoming the mainstay of the industry, although there will always be new prospects by reason of the formation of new families or improved economic position of older ones.

The factor which determines the turnover of the replacement market is the percentage of existing owners who renew their radio investment each year. The replacement market, like the new sale market, is also at its major rate of increase.

We cannot continue to expect as radical improvements so definitely obsolescing existing radio receiving sets in future years as the parade of fundamental improvements which we have had for successive years in the past. It is obvious that the improvements of the more recent seasons, such as push-pull amplification and electrodynamic reproducers, already represent a marked diminution in sales power over those of the earlier years. They are, in fact, engineering styles rather than fundamental improvements because their performance could probably now be equalled by the devices which they displace. They are not new or recently invented; they have simply been well exploited as radical improvements

and have been adopted as essential to good performance. From an engineering standpoint, the expectancy of replacement due to engineering improvement alone may soon fall from two years to five years within a relatively short time, unless visual reception becomes an influence tending to replace broadcast receivers, and that represents a sixty per cent. reduction in the replacement market!

Unless radio becomes a style product, therefore, we will soon face increased sales resistance in the new purchaser market and a diminishing rate of replacement. Style in outward appearance must fortify the advantages of each new season's products so that owners of serviceable but old-style receivers will be tempted to turn in their equipment long before it is rendered hopelessly obsolete by engineering improvements.

The style factor has become the main reliance for maintained turnover in the automobile market. Substantial price reductions have tapped new economic strata and broadened the field of prospects, but these reductions have required huge increases in production to maintain substantial profits.

It is the pride appeal of modernity rather than real improvement in performance which stimulates the replacement trade of the automotive market; the effect of wear on performance provides the excuse for discarding a car before its service life is exhausted. Thus, the style appeal is supported and encouraged to the point that saturation is no threat to continued sales. The motor car is the symbol of the owner's economic and social status. It stands as a living advertisement in front of his door.

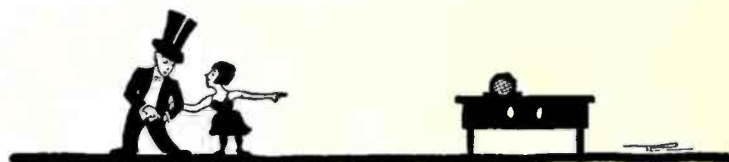

Can radio adopt the pride appeal and make the owners of old receivers replace them, even though the performance of the sets they purchase is only superficially superior to that of the sets they discard? Perhaps engineering improvement cannot continue to be sufficiently radical to force resale turnover at the present rate. Style, therefore, must be definitely introduced to lend support to engineering improvement. To build up the pride appeal is much more difficult for the radio industry than for the automobile trade, because wear is not an aiding factor and the radio receiver does not advertise its owner's financial status as effectively as does the automobile. Instead, the receiver has a modest place in the living room and is subject to about the same style influence as is the living room furniture. We have had but one non-engineering style change since radio began; the substitution of the unit console for the table-type receiver.

While the radio industry grows at its present rate, with both new customer and replacement markets at their peak, it may advantageously lay the foundation for maintained rate of replacement sales. The radio receiver is only moderately well adapted to becoming a style product but unless



style comes to the aid of maintaining replacement turnover, only engineering improvement will remain as the means of keeping up the growing production rate.

### Regarding Direct Radio Advertising

**M**OST LISTENERS have doubtless appreciated the excellent dance orchestra which punctuates the advertising announcements broadcast by the Lucky Strike people on Saturday nights through the N. B. C. chain. They have become so hardened to the blatant advertising which characterizes a number of so-called good-will programs that they automatically become deaf when the announcer's voice starts. This fact alone accounts for the few protests registered against radio advertising and minimizes the negative reaction which would otherwise be felt by its sponsors as well as their listeners.

By and large, experienced users of the larger chains observe wisdom and restraint in their announcements but there has been, nevertheless, a steady lowering of standards in radio advertising. Those few which exceed the bounds of propriety, however, embolden others to transgress further and further into the realm of direct radio advertising, with the inevitable consequence that an increasing number will search the dials for less offensive programs or shut off their sets altogether. It must be remembered that the listener, unlike the reader of the printed page, is seriously inconvenienced by undesired advertising. He must rise from his comfortable seat by the fireside when silly announcements destroy the program value of the channel to which his set is tuned and he must then find a more attractive and intelligently conducted feature on another frequency. When reading a magazine or newspaper, one glance is sufficient to distinguish between education, entertainment, and undesired advertising.

The managers of broadcasting stations are unfortunately faced with high pressure from radio advertisers, spending large sums of money, for greater and greater concessions, while the listener remains relatively inarticulate. He will remain so as long as he can find satisfactory entertainment on other channels when the offering on one is distasteful. If the blatant advertising vogue, however, becomes universal, the loss of following will no longer be confined to the audiences of unintelligently presented features, but to all broadcast presentations. The fact that direct advertising programs bring satisfactory return encourages this type of presentation, but reliance on returns is deceiving as long as there is available no measure of the unfavorable reaction engendered by misuse of the radio medium. With 80 per cent. of WEAf's time sold between seven and ten P.M., as nearly as we could calculate it for a recent week, and nearly as good a percentage of revenue-producing features on many of the leading stations, there is every reason for observing the utmost caution to guard against the insidious influence of "radio advertising halitosis." The logical outcome of the unfortunate



tendencies gradually developing is an undermining of the good-will influence of radio advertising, a mutual loss to listener, manufacturer, broadcaster, and advertiser.

That this trend is recognized as dangerous to the progress of broadcasting by station managements is indicated by the position taken by several committees of the National Asso-

ciation of Broadcasters at their meeting held in Chicago last March. Their committee on ethics recommended that all programs after six P.M. shall be of an entertainment and good-will character and that "commercial announcements" shall be barred after that hour. Many of the lesser stations disregard their obligations to the public's entertainment needs

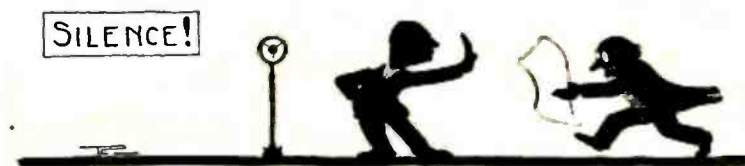

and they will discover that adherence to their association's recommendation is the most effective way to increase audience following and thereby their revenue. The code of ethics for the guidance of station managements which was adopted by the committee also advised all broadcasters to prevent the broadcasting of matter which is regarded as offensive, fraudulent, deceptive, obscene, or information regarding products which may be injurious to health; to ascertain the financial responsibility and character of their clients; to stop the broadcasting of statements derogatory to others; and to follow strictly the regulations of the radio law of 1927.

To the listener, who has tired of the growing abuse of the microphone by the radio advertiser, this code may not appear sufficiently stringent, but it must be remembered that it is the work of the broadcast station managements themselves and that it frowns on many of the current practices so detrimental to program standards.

The radio industry is to be congratulated upon the constructive character of the activities of its trade association in the broadcasting end of the business. It is, by such wise and far-sighted recommendations, demonstrating its capacity for leadership in the field.

### Tube Makers Sign R.C.A. License

**T**HE FIRST independent tube manufacturer to sign the R.C.A. tube license agreement is the Raytheon Manufacturing Company and a number of independents it is said, may follow shortly. The \$50,000 minimum annual guarantee will prove a stumbling block for many of the minor manufacturers in the field, but several of the better-known makers made sufficient tubes last year to meet this figure. Delay is being experienced in several instances in securing signature to the agreement because the prospective licensees are themselves the sponsors of promising improvement and process applications and patents which they feel should be taken into account. Furthermore, with the unfavorable adjudication of the tipless tube and tungsten rolling process patents, considerable encouragement has been given to the belief that the R.C.A. position is not impregnable. It requires a major adjudication, corresponding to the Alexanderson cascade tuned-circuit patent in the receiver field, to win the wholesome respect of the vacuum-tube industry and to precipitate a rush of the field to sign the license. With such a vast and diversified research force to draw upon, there is little doubt that some such adjudication will take place with a consequent further enrichment of the R.C.A. royalty account. A useful by-product of licensing the field on the R.C.A. basis will be the discomfiture of various vacuum-tube manufacturers of a low order of competence which should result in a corresponding improvement of the technical standards of the vacuum-tube products offered the consumer through a certain type of unscrupulous though rather well-patronized radio outlets.—E. H. F.



## Fourteen Leading Manufacturers Describe

# IMPROVEMENTS IN 1929-30 RECEIVERS

### A-C DAYTON COMPANY

FORD STUDEBAKER, Chief Engineer: In designing our receivers for the 1929-30 radio season we have endeavored to combine the following features: selectivity, tone quality, sensitivity, volume, and ease of control. The "pre-selection" method of tuning, which is the most practical for obtaining maximum selectivity without critical characteristics, has been incorporated in the receiver. In order to obtain sensitivity we are using a five-stage r.f. amplifier with a very flat amplification curve. Grid-bias power detection is employed with the output of the detector feeding directly into a push-pull output a.f. stage employing two 245-type tubes. Among the other features which have been built into the set are complete static and magnetic shielding, electrolytic filter condensers which preclude the possibility of breakdown, single-control tuning, a simple positive volume control, a single switch to control the set and loud speaker, devices which provide for any type of loud speaker, a switch which permits instantaneous change from radio reception to phonograph, and a multi-plug which provides a ready means of connecting the integral units. Individuality is maintained by really different cabinet combinations.

### BALKEIT RADIO COMPANY

GLENN L. ALSPACH, President and General Manager: One of the most important features of our 1929 receivers is the new dynamic loud speaker which is more sensitive, more brilliant across the entire tonal range, and fully capable of handling the entire volume of the receiver without distortion. In the new Balkeit console receivers five stages of r.f. amplification and a 245-type output tube are employed. Particular attention has been given to the acoustical features of the cabinet in order to insure full volume without distortion. These cabinets have rigidity of construction with ample baffle area, and interfering elements in their structure have been avoided. Another feature of the receivers is dependability and freedom from routine attention. In other words, in the new Balkeit we have striven to make available to the user a high order of selectivity, sensitivity, and tonal quality, at the same time employing improved methods of construction which assure complete satisfaction. It is a balanced set without extremes, its cabinet blending with its surroundings.

### BREMER-TULLY MFG. COMPANY

R. E. SMILEY, Vice President: With the recent announcement of the purchase of the capital stock of the Bremer-Tully Manufacturing Company by the Brunswick-Balke-Collender Company, there is placed at the disposal of this company a combination rarely

found. This company has always been famous for turning out splendid radio receivers, and our receivers, which will be offered for sale this year, will combine a rare degree of selectivity, sensitivity, and true fidelity of tone. Coupled with these superior qualities to be found in our radio receiver will be finer cabinet work with designs made to fit into the home on the basis of beauty and utility.

These factors, very much in line with the radio trends of 1929, together with keen merchandising policies, will give to the public, a type of product that will insure pleasure and satisfaction in every way.

### THOMAS A. EDISON, INC.

ARTHUR L. WALSH, Vice President: Greater volume without distortion, the accomplishment of uniform amplification over the entire wave-band, and the advent of the 245 tube, are the outstanding developments of the 1929 radio season. The desirability of having uniform amplification over all graduations of the scale has been an engineering ideal for a long time. That it is now consummated I regard as the engineering accomplishment of the year. Uniform at all dial settings as to selectivity and sensitivity, with faithful reproduction, the best examples of the new radio receiver bring to the public excellent instruments at moderate prices.

Edison Radio embodies these latest ideas in receiver design, including the correct utilization of the 245 tube. The Edison chassis includes two of the 245 tubes in push-pull (the combined undistorted power output equalling that of a single 250-type tube at voltage usually employed), three of the 227 indirect-heater-type tubes used as radio-frequency amplifiers, two 227 tubes employed as detector and as first audio-frequency amplifier, and a 280 tube as rectifier.

The new Edison Radio line, with a single chassis and models varying only in cabinet design, is the finest that can be built.

### FEDERAL RADIO CORPORATION

L. W. JAMES, Assistant to the President: Compactness of radio receivers seems to be the trend for 1929. Simplified circuits requiring a minimum of servicing, yet maintaining good fidelity and improved sensitivity and selectivity is another outstanding feature of the new sets. There is also an increasing demand for provision for phonograph pick-up units. Federal's new receivers, notably the model K, lends itself to the desire for compactness. The use of a.c. screen-grid tubes and push-pull amplification increases the amplification and reduces the complications of the circuits. Good fidelity is maintained through the use of a dynamic loud speaker. The cabinet design meets the demand of the apartment-



Ford Studebaker, chief engineer, A-C Dayton Co.



Glenn L. Alspach, president Balkeit Radio Co.



house dweller for small size and is in good taste. The new model M is unusually selective and sensitive. It is sturdily constructed with a steel chassis base which assures rigidity and protection in shipping. The receiver is very successful in picking up distant stations and in reproducing all programs with fidelity. Provision is made in the chassis for attaching a phonograph pick-up jack.



*R. E. Smiley, vice president, Bremer-Tully*

**FREED-EISEMANN RADIO CORPORATION**

**JOSEPH D. R. FREED, President:** The Freed Radio places its public appeal upon its price as well as on its selectivity and sensitivity. It is possible to achieve the latter or the former but to have attained them both is something of which we may be proud. Freed Radios are all neutrodyne sets

of four or five tuned stages. In each we have included a low-loss variometer which in some sets acts as one stage in itself and in other circuits is connected with the detector circuit to obtain finer tuning and greater selectivity.

The more expensive sets make use of the new 245-type tubes in push-pull with 250 volts on their plates. In the popular-priced set we make use of 171A tubes in push-pull, three 126's, in the radio-frequency stages, one 127 as detector, and one 127 in the first audio stage.

We do not use the screen-grid tubes because our tests have not proven them to be of value as they give only increased volume. There is little doubt that new devices may be perfected in the years to come but our policy will always be that untested apparatus must be kept out of our circuits until we have found them fool proof.

**CHAS. FRESHMAN COMPANY**

**CLARENCE A. EARL, President:** The line of Earl radio receivers for the season of 1929-30 contains an a.c. console model that meets every price appeal. All but the most expensive models are also available for d.c. operation, and special receivers are made for 25-cycle operation. The complete line includes five receivers ranging in size from a small table model to a nine-tube dynamic-equipped console receiver. The most important feature of the Earl receivers is that they are of "service-proof" design; that is, rugged construction has been used throughout on all models. Protection has been placed where it is needed, pressed-steel frames house most of the equipment, and the end plates of each condenser section are of heavy brass. One main tuning drum is used on all models with selectivity being achieved by a small variometer. By use of either an inductor-dynamic or moving-coil-dynamic loud speaker, together with the utmost refinement in the circuit design of the audio-frequency stages, true reproduction of the full musical range has been obtained.



*Curtiss Abbott, sales manager, Eveready*

**NATIONAL CARBON COMPANY**

**H. CURTISS ABBOTT, Sales Manager, Radio Division:** In developing the new Eveready receiver the aim of the engineering staff was to produce a set which would not only be more stable and sensitive, but which would also give reliable service every day of the year. Greater stability and sensitivity has been achieved through substituting a variable inductance coil for one of the four tuned circuits. One-dial control is accomplished by mounting this coil on the shaft which turns the three-gang condensers. Mechanically, the new Eveready set is so sturdy and rugged that the chances of derangement during transportation and later in use are reduced to a minimum. The foundation which supports the chassis is a deep steel box-section member. Wherever weight is to be supported, metal, usually steel, is used. Insulation is not used to bear the weight of parts. All exposed parts of the chassis are finished with baked enamel, and the chassis itself seals the set against humidity. The receiver is available in a number of beautiful walnut cabinets.

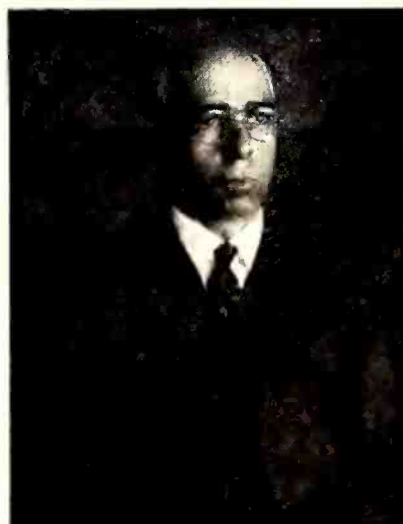

*Walter E. Holland, chief engineer, Philco*

**PHILADELPHIA STORAGE BATTERY COMPANY**

**WALTER E. HOLLAND, Chief Engineer:** The present trend in radio receivers is toward still better fidelity, simpler and more rugged design that will minimize servicing, greater beauty, and tuning scales calibrated in kilocycles. To meet these demands Philco have developed two a.c. receiver chassis, which will be mounted in three types of console cabinets and one table cabinet. An improved Philco electrodynamic loud speaker with a 9" seamless fabric cone will be used with all models.

Improved fidelity is obtained by using two 245-type tubes in a push-pull circuit, while acoustical improvements in cabinet construction have eliminated booming and other undesirable resonance effects. Trouble-free construction is obtained by providing the receiver and power units with bottom terminals and mounting all on one rigid base of drawn steel. A bottom plate is employed to protect, seal, and shield the "live" parts and wiring. A further simplification is obtained in one model by taking advantage of the characteristics of the new a.c. screen-grid tubes. In this model the number of tubes has been reduced to a total of six, and certain parts have been eliminated, thus simplifying the construction and wiring. The new eight-tube receiver provides the utmost selectivity combined with sensitivity and good tone quality. The tuning scales of Philco receivers are marked with "kilocycle channel numbers."

**SILVER-MARSHALL, INC.**

**McMURDO SILVER, President:** In designing Silver Radio, an attempt was made to incorporate into it every worthwhile feature that would go to make a really fine receiver.



The principal technical features to be found in our receivers are a.c. screen-grid tubes for increased distance and stability, band-selector tuning for improved selectivity and the diminution of sideband cutting, a.c. screen-grid power detector for increased power output and improved fidelity, push-pull power output stage with new 245-type tubes to provide ample undistorted output, dynamic loud speaker of improved high-frequency response, elimination of usual antenna installation which is replaced by a small antenna contained in the console housing the set and loud speaker, and automatic regulation of fluctuating power line voltages.

In S-M receivers will be found an "overtone switch," which cuts down the response to high tones at will.

Two models are available, one a lowboy, at \$169.00 list, and the second a highboy with sliding doors, at \$195.00 list. Both are of simple, semi-Sheraton design. Striped walnut, finished in gloss lacquer, is used in both models.

**STROMBERG-CARLSON TELEPHONE MANUFACTURING COMPANY**

RAY MANSON, Vice President and Chief Engineer: Trends in radio receiver construction point to detailed improvements only, and not to any radical changes in fundamental design. The worth-while trends center around improvements that make for better reproduction, as prospective purchasers of new radio receivers now realize that in the last analysis, the only object in owning a radio receiver is to obtain accurate and natural reproduction of what is going on before a distant microphone.

One of the means for obtaining improved reproduction is the use of the new UY-224 a.c. screen-grid tube and the new UX-245 power tube. Three of these new a.c. screen-grid tubes used with four tuning stages increase the amplification possible up to the detector circuit, allowing for improved detector action, such as linear power detection with automatic grid bias.

This year there are four new Stromberg-Carlson receivers, each of which makes use of three of the new a.c. screen-grid tubes. All of these models use the new linear power detection with automatic grid bias, working directly into a power output system employing the new UX-245 tubes.

**VICTOR TALKING MACHINE COMPANY**

H. C. GRUBBS, Vice President: Victor has waited until 1929 to introduce its own radio receiver because we desired to give the public an instrument which would be as close to perfection as engineering ability could devise. Victor Radio and Radio with Electrola is unique in design, appearance, and performance. It is not an assembled set in any respect. A cabinet of exceptional beauty is made of rich walnut veneer. The receiver is a power-operated, completely shielded, tuned radio frequency set of the antenna type, utilizing ten

tubes. A mechanical system of micrometer adjustment, which we call "Micro-Synchronism," is employed and this feature permits a precision alignment of the chassis and a high degree of sensitivity and selectivity. Tuning is accomplished with a super-automatic device operating over a full-vision illuminated dial calibrated in kilocycles. The power amplifier employs a balanced push-pull circuit with two 245-type tubes. There is a harmonic modulator which allows the owner to get more or less emphasis on bass notes as he prefers. The dynamic loud speaker is of greatly improved design. The combination radio-instrument is equipped with an improved Electrola, induction disc motor, 12-inch turntable, and a newly designed electric pick-up unit. Victor Radio is very easy to service; it is made up of four individual units any one of which may be disconnected instantly.



Ray H. Manson, chief engineer, Stromberg-Carlson.

**THE ZENITH RADIO CORPORATION**

THOMAS H. ENDICOTT, Zenith Radio Corporation: The introduction of the new Zenith models which will make their appearance at the Chicago trade show will feature, foremost, the popularizing in the price of several Zenith receivers. This is made possible because of the increased manufacturing facilities brought about by the overwhelming demand of the public for high-grade radio receivers.

The Zenith Corporation now makes all of the parts and also the cabinets used for their receivers. Our new cabinet plant is equipped with especially designed automatic machinery of entirely different construction from the

type used in the average furniture factory.

The newest design in screen-grid tube circuits will be incorporated in all of the new models for 1929-1930. Improved "Automatic Tuning," will also be found on all models.

**COLUMBIA PHONOGRAPH CO., INC.**

HARRY A. SUMMERS, Research Division: The trend in radio receivers for the 1929-30 season is in the direction of reduction of cost by means of simplification as far as it may be

carried without sacrifice of performance. Coupled with this is a reduction in the number of tubes used, which gives simplicity in service and manufacture, resulting in lower cost on both these items.

Our receivers for 1929 respond to these trends, being moderately priced and highly compact. These sets employ 327-type tubes in all sockets except the power stage which uses two 345-type tubes in push pull. In this way we obtain a power output equal to a pair of 210 tubes without the use of high voltages and with resulting economy of parts. The new dynamic loud speakers which we use in these sets do not over accentuate the low frequencies and high frequencies are reproduced at more nearly normal levels. This has been accomplished by redesigning the motor and by the use of a Burtex diaphragm.



H. C. Grubbs, vice president, Victor.



Thomas H. Endicott, Zenith Radio Corp.



## PICK-UPS—A WORTH-WHILE ACCESSORY

**T**HE MARKET for phonograph pick-up units is increasing. Radio dealers everywhere are finding that this accessory is helping them toward greater profits. Shops handling only radio sets have found that carrying an electromagnetic pick-up device enables them to sell not only this accessory, but also electric and spring motors and complete turntable assemblies, and in many cases portable phonographs on which the pick-up unit is installed and used in connection with the amplifier system of the radio set. And shops handling phonograph records also have found that the sale of pick-up units definitely increases their sales of records.

The Yorkville Radio Company, 147 East 86th Street, New York, finds that the sale of pick-up units has been greatly increased by the practice of set manufacturers in recent years of affording provision for the connection of these units. Sidney Vorzimer, manager of the Company says: "In our experience, we find that it is very easy to sell customers buying a new radio set with a phonograph pick-up jack, the necessary unit. Furthermore, we make the sale, as an accessory, at the same time the set itself is sold.

"Our average customer pays about \$8 for the unit. Some, of course, prefer a higher-priced unit, and we are glad to sell the more expensive units, not alone because of a higher unit of sale but because the more expensive units give better performance.

"Most of our customers who are interested in a pick-up unit do not care to use it with an old phonograph which they may have," adds Mr. Vorzimer. "I believe that these users have let the dust gather on that old phonograph cabinet so long that they would much rather purchase a compact little motor and turntable assembly which can be located close to the radio set than to revive the old phonograph.

"The average price our customers pay for pick-up unit, turntable assembly, etc.," Mr. Vorzimer says, "is about \$20, although, of course, we sell a respectable number of more expensive complete units."

The best prospects are not owners of old sets which can be adapted to use a phonograph unit, but the purchasers of new sets. The Yorkville Company has found more success in selling units *with* new sets than in selling the pick-up unit to the customer on a later visit to their store.

One of the most interesting results of the wide use of phonograph pick-up units by Yorkville customers is that it



Sidney Vorzimer, manager,  
Yorkville Radio Co., Inc.

increases the market for new set sales. Customers who have enjoyed the adaptability of their radio set and phonograph when in separate units can readily be interested in a combination radio-phonograph set where the radio and phonograph are housed together in an attractive cabinet.

After the customer has been interested in the widened world of music and all the entertainment offered by the new electrically-cut phonograph records, the price of the pick-up unit, motor, and turntable assembly is not a seriously limiting factor.

The Yorkville Company does not concentrate on one line of pick-up units, but handles five different makes.

Many dealers are interested in a summary of the best sales arguments which have been employed successfully by others in selling the phonograph pick-up devices in the retail store. Here are some of the high lights:

Stress the merits of *new* electrical phonograph recordings.

Explain how the phonograph pick-up unit provides *with* the radio set a *complete* home entertainment unit.

Emphasize the fact that *with* the pick-up unit and the radio set the user can repeat at will his favorite selections.

Show how the pick-up is really an inexpensive accessory to the radio set.

And—don't fail to *demonstrate* to the customer.

The advantages of the dealer pushing the sale of pick-up units are many. The dealer—if his store is exclusively radio—can reap many repeat sales through stocking records. Pick-ups sell records and records sell pick ups. The customer who has bought a pick-up unit to use with his old set is always a good prospect for a new combination radio-phonograph unit. The set-owner who uses a phonograph pick-up unit steadily is an increasingly good customer for replacement tubes.

The dealer should find a phonograph pick-up unit the means of extending the summer use of the radio set in localities where broadcasting service is still poor during the summer months. This advantage was found by RADIO BROADCAST particularly important in the Southern states. Many musically inclined listeners have acquired elaborate libraries of electrically-cut records which they play through their radio sets, when reception conditions are not at their best.

On page 87 of this issue appears a list of the leading phonograph pick-up units with full data. Dealers who wish further information direct from the manufacturers should write on their letterhead and one letter to RADIO BROADCAST will bring full information on all the lines.



## WHAT THE LICENSING GROUPS OFFER

### HAZELTINE'S POSITION IN FIELD

**T**HE HAZELTINE CORPORATION was organized in February, 1924, for the purpose of licensing radio and other manufacturers primarily under the patents of L. A. Hazeltine. Previous to the formal organization of the Corporation, licenses under the Hazeltine patents were granted. Receiver manufacturers have been licensed since March, 1923.

Now eighteen radio manufacturers in the United States are licensed. In addition, the American Telephone & Telegraph Company and the Western Electric Company each have acquired rights under this patent structure.

Hazeltine patents are used by foreign manufacturers as well. In England, Marconi's Wireless Telegraph Company, Ltd., holds a license for the British Isles and possessions; in Australia, Neutrodyne, Pty. has been organized and has seven Australian manufacturing licensees. In Canada, DeForest-Crosley is the only manufacturer so licensed but many United States manufacturers who hold rights to these patents make sets in their Canadian branches.

The Hazeltine Corporation has licensed set makers under certain LaTour patents and has also licensed other manufacturers, not in the radio field, under certain other LaTour patents, notable among these are some X-ray manufacturers.

The Hazeltine Laboratory has been serving the licensees of the Corporation ever since the inception of the parent organization. This laboratory, headed by W. A. MacDonald as chief engineer, is constantly engaged in studies with the purpose of developing new circuits and methods of value to the licensed manufacturing companies. The research division of the laboratories is separate in purpose but is directly concerned with the problems incident to receiver design and production. This division is an extremely important part of the laboratory and, in the solution of the many problems of this practical nature which continually arise in manufacturing plants, does much to simplify and improve production processes.

The purpose of the Corporation and the value which the licensee companies are expected to receive from their royalty payments is not merely to give passive permission to make radio sets using certain patented circuits, but to give a continual technical service and advice. The licensees are always free to consult with the Hazeltine engineers. The degree of use which any licensee company makes of the Hazeltine technical service, of course, varies with the company. In some instances, the laboratory has completely engineered and designed a



*W. A. MacDonald, chief engineer, Hazeltine Laboratory.*

receiver for a licensee company and in many others, they have been called in consultation by the engineers of the company. In this way, many important radio manufacturers have found the more or less detached and disinterested technical service of this Corporation of distinct value to them. And this aid has been reflected in the ultimate manufactured product which reaches the customer's home as a set made under Hazeltine patents: in better performance through engineering consultation, in greater value for less money through improvements and economics of manufacture.

—EDGAR RICKARD, *President.*

### THE R.C.A. LICENSE POLICY

**W**HEN THE Radio Corporation was formed in 1919, it acquired through various cross-license agreements from the General Electric Company, Westinghouse Electric and Manufacturing Company, United Fruit Co., and American Telephone and Telegraph Company a very substantial patent situation with regard to the manufacture of broadcast receivers for use in the home. The Radio Corporation decided, in 1927, to extend licenses to a good many radio manufacturers rather than adopt the policy of extensive patent litigation for enforcement of its patent rights.

One of the most important things that radio manufacturers as a whole have been seeking during the past few years is prestige. A large portion of their effort in advertising, sales promotion, and direct sales has been devoted to impressing trade channels and the ultimate consumer that they were building on a solid foundation and were in business to stay. The taking of a license from the Radio Corporation was, in the opinion of many, the biggest thing a manufacturer could do to impress the people concerned that they were building for the future of the industry.

A radio manufacturer to-day practically has to guarantee immunity to his trade from patent difficulties. There are two methods open to him—taking a license for his product, or demonstrating to the trade that he will bear the expense of such suits as may be filed against him or his trade channels. The R.C.A. license policy has almost completely settled this situation for most jobbers and dealers.



*A. F. VanDyck, manager, Technical and Test Department, R. C. A.*

The Radio Corporation has made available the services of its engineering staff through its Technical and Test Department, to all of its licensees. This service is merely an advisory one but is much appreciated by the licensees. Licensees have expressed themselves as being considerably helped in their planning and development work by

I-1



this service. All new vacuum tubes as they are introduced from time to time are available to licensees for experimental work for several months before they are generally released to the trade. About twice a year the R.C.A. has technical meetings with its set licensees at which time subjects of mutual interest are discussed.

It is a very interesting fact that the retail prices of radio sets have not gone up in the past two years, notwithstanding the fact that during that time the industry has completely changed over from battery-operated sets to the now popular set operated directly from the lighting circuit in the home. This means that the consumer's dollar is purchasing considerably more than it did two years ago. In addition to the mechanical features involved, the consumer's dollar is also purchasing greater value in the way of loud speakers and cabinets.

**THE R.F.L. PROGRAM**

**T**HE LETTERS "R.F.L." seen so often in the advertisements of well-known radio manufacturers, stand for Radio Frequency Laboratories. This company began business in a small laboratory at Boonton, New Jersey, about seven years ago, shortly after popular radio broadcasting was begun. For several years, laboratory research on a variety of electrical communication problems was carried on, including the development of certain amplifier circuits for use in broadcast receivers. Licenses to build sets were then issued to five manufacturers who believed that group-research would produce more and more inventions, and could be made to pay.

The aim of R.F.L. has been to gather together a group of qualified scientists and specially trained radio engineers, and to direct them on problems connected with the design and development of broadcast receivers. Inventions which come from these research workers are turned over to the group of licensees who make practical use of them.

The work comprises two major divisions—Research and Engineering Service. The Research Division endeavors to keep a little in advance of the known science of radio, and to commercialize its research to the extent of furnishing something new and practical for the licensees to manufacture. The Engineering Division keeps up with the advance in the art, helps the licensees with their production problems, and furnishes all the technical facts necessary to keep them fully informed about their own product and its relation to the contemporary art. In addition to this, it often renders special technical assistance on matters outside the scope of set design.

Engineering concerns itself with the present, Research with the future, yet the two are interdependent. The relation is not unlike the building-up process in a regenerative amplifier. The most difficult step is to get research started, and then it must be fed financially for several years, with the help of administration and engineering, before it pays dividends. The idea of group-financed research is based upon the prin-



*R. W. Seabury, president,  
R. F. L.*

ple that two people with limited research budgets can do more than twice as much operating together as they can operating separately. R.F.L. represents a unique reduction to practice of this idea, and the success and growing reputation of these laboratories is evidence of its economic soundness.

R.F.L. is not a manufacturing corporation, but primarily a research and patent holding company, and, as it goes on doing

its share of development work in the radio industry, it would seem that the vision of the founder is likely to be fully realized.—

*RICHARD W. SEABURY,  
President*



*Lester L. Jones, president,  
Technidyne Corporation*

**TECHNIDYNE'S OFFERINGS**

**T**HE TECHNIDYNE CORPORATION, in 1929, will continue its research into circuit and apparatus design in the way it has followed since its inception. That is, by employing inventive,

analytical, and design skill. The word Technidyne itself signifies our place in the radio picture; it comes from the two Greek words, *technikos* and *dynamas*, signifying "technical power."

Looked at from the inside, the organization is a place where imagination, invention, and creative ability can flower. Looked at from the outside, it is an institution on which the relatively small producer may lean for those services otherwise beyond his reach. In addition to this important service, it has already developed resources capable of supplementing those of the largest producers.

Our management is free from the direct burden of production and sales problems, and can centralize attention on the well rounded growth of this "technical power." This means simply that our personnel is more actively interested in producing ideas and circuits than in apparatus using these ideas and circuits. While we are not interested primarily in construction or production, believing that our problem is to provide our licensees with something to build, yet we go much further than the usual laboratory in that we engineer our inventions to the practical point and are able to assist the manufacturer in the design of practical production models. Also, we have produced a number of inventions which tend to reduce production problems and in developing our circuits we always keep in mind the requirements of practical production.

The advantages, as we see it, of being free from production difficulties are manifold. We can look into the future more calmly, and into the past achievements of other inventors with more certainty of completely covering the literature if we are not harassed by problems that must be solved within the next day or so.

The engineers of Technidyne have always aimed at ideas leading to patents that were free from difficulty in litigation. Our engineers must know what has already been accomplished. An invention that is really only a copy of another person's idea, is never litigation-free; it is always in hot water.

Our personnel and our policies are guided by the desire to aid our licensees in their present problems, and to provide them with the output of our imagination in the future.

—LESTER L. JONES, *President.*

L-2



# what they say



## Carries Only One Line of Sets

**A**T SOME TIME or other every radio dealer debates with himself over how many lines it is advisable for him to stock at one time. Some are of the opinion that they can satisfy the demands of every customer by having a large variety of makes and models while others believe that they can obtain best results by concentrating on products of one maker. In this connection a letter from a dealer in Coffeyville, Kansas, is of interest.



To the Editor:

We have secured very gratifying results for the past two years by specializing on one line of radio receivers. We operate under an exclusive franchise and carry all models of this manufacturer. Before adapting this policy we stocked from three to four makes of receivers at all times but we found that it was practically impossible for a dealer in a town of the size of ours to carry more than one line and make money.

Our experience with vacuum tubes may also be of interest to you. Originally we stocked only one line, but, in order to protect ourselves at the time when the tube shortage became acute, we were forced to add other lines. At present we carry a fairly complete stock of three lines.

RALPH T. FLOREA

## How to Make Service Pay

**T**HERE HAS been considerable controversy among our contributors and readers concerning the type of testing equipment which is best suited to the requirements of the outside serviceman. In his series of articles, B. B. Alcorn advocated a simple, inexpensive, portable test-set for the small radio dealer's serviceman, stating that the high cost of more elaborate equipment is an important objection. On the other hand, John S. Dunham advises all radio dealers to invest in a complete tube- and set-checker, and he claims that such apparatus will pay for itself within three months on the basis of increased efficiency. The following letter from a reader in Pine Bluff, Ark., gives the opinion of a Majestic dealer on the subject.



To the Editor:

I have just finished reading the letters of John S. Dunham and B. B. Alcorn in March, 1929, RADIO BROADCAST and wish to express myself as in hearty accord with the views of Mr. Dunham. I entered the radio profession last June as an unknown dealer and borrowed money to buy my first set. In my determination to make a success of the business I decided that I must provide good service, and I felt that knowing—not guessing—what was wrong with a radio would not only save time but make the customer feel that I had an idea of what I was doing. Therefore, after selling two sets, I invested \$75 in a set-tester. This more than paid for itself in a very short time.

Since buying the set-tester I have sold 121 receivers and made over 600 service calls. In my opinion it would have

been impossible for me to have accomplished this without complete and accurate testing apparatus. When I make a test I know what is wrong and, therefore, as a rule, I am able to repair the trouble quickly. Besides, what would you think of a doctor who came to see you and left his kit at home? Even though you had faith in him, you would be inclined to think that you were not getting your money's worth because he would be guessing instead of testing.

I do not regret a single cent that I spent on my tester and I think it should be one of the first purchases—if not the first—a radio dealer should make.

DAVID WHITE.

## Merits of No-Charge Call

**M**OST RADIO dealers hold up their hands in horror when the subject of no-charge service calls is mentioned. Many of these men view their entire service department as an unfortunate liability which cannot be avoided and they believe that they must charge for everything in order to "break even." However, R. Ross Wilson, a dealer in Knoxville, Tenn., considers the question from a different angle:



To the Editor:

Each year during the summer months I make an inspection of every set sold in the past season by my concern. Whenever necessary I rebalance and reneutralize these sets, replacing tubes, and generally placing the receiver in first-class condition. This is to maintain the customer's interest in radio during the summer months, as he has been told that decent reception is impossible at this time of the year. This work is also successful in providing an excellent list of prospects, selling a good number of tubes, retaining our customer's good will, and it assures us that he will be a booster and not a knocker. We are not charging a cent for this service other than the cost of any parts or tubes which may have to be replaced. This idea is not only practical but is also paying substantial dividends.

When I entered the retail field I decided that the average prospect and customer was like the dealers I had met—he wanted to be sure of receiving good service. Therefore, I make it a point to make my own installations, regardless of whether it is a sale or demonstration, as in this way I am able to show the prospect that I am familiar with my line and am not afraid to roll up my sleeves and work. While making an installation I explain to the customer why I do certain things and before I leave his home I make sure that he thoroughly understands the operation of the receiver. Three or four days after installing the set I call again to make sure it is operating satisfactorily, and this gives me an opportunity to learn the names of friends and neighbors who have heard the set. All of this free service requires considerable time but it keeps me well supplied with prospects and it gives me a booster with every sale.

R. ROSS WILSON.





*Harry Alter, president, Harry Alter Company, Majestic distributors in Chicago.*

## *Knowing Your Line Facilitates Selling*

---

# JUDGING THE MERITS OF A NEW SET

---

By **HARRY ALTER**

*President, Harry Alter Company, Chicago, Ill.*

*As Told to Edgar H. Felix*

**T**HE PROCESS of testing a radio receiver by a dealer or jobber, when the first sample of a new model is delivered, almost invariably consists of hastily plugging in the candidate for sales records at the nearest light socket, connecting up any antenna that happens to be at hand, and then listening to a number of local programs in tense admiration. A few, more particular, may indulge in a slightly more exhaustive test, installing the receiver in their homes so that they may enjoy a little aimless dial twiddling.

These hap-hazard procedures are indeed a compliment to the confidence which the dealer has in the reputation of a manufacturer but such casual observation of performance is hardly an illuminating test. I do not advocate any exhaustive engineering examination because, in most instances, it is neither practicable nor necessary. But, if a dealer is to qualify himself to appreciate fully the merits of a new line, a systematic and comprehensive testing procedure, faithfully carried out, may be of inestimable value. Only by actual experience and intimate knowledge of the performance capabilities of a receiver is it possible to present the advantages of ownership to the prospective purchaser in a clear, concise, forceful, and convincing manner.

The testing procedure suggested is based upon the combined experience of a number of technical advisors of the largest jobbing organizations in the industry. The tests are qualitative rather than quantitative and require facilities which are almost invariably available.

A prime consideration in securing a reliable judgment is that a comparison with known performance be made

under standard conditions. Receivers are, therefore, usually tested in the home of a technically qualified employee or executive rather than in the place of business of the dealer or jobber. It is essential that standard conditions, to which the expert is accustomed, be maintained. Usually a standard receiver is permanently installed at the testing location and this, when comparisons are made, should be equipped with new tubes in the same manner as the new receiver to be tested. The most satisfactory results are obtained if a quick change mechanism is available for rapidly switching from the known receiver to the new. This requires not only switching antenna and ground, but preferably the reproducer element as well. Both receivers should be completely wired up through the switching system so that antenna, ground, and reproducer may be instantly changed from one receiver to the other. With alternating-current tubes, filaments on both receivers should remain switched in constantly so that instant comparison is possible.

Three series of tests are suggested: first, tone quality; second, selectivity; and third, sensitivity. These are the three fundamental factors of performance which are readily compared. These tests should first be made through a common reproducer system and, if the receivers are equipped with their own reproducers, the tests should then be repeated with each receiver utilizing its own loud speaking device.

The usual process in fidelity tests is to tune-in to a program which involves the lower notes. If considerable volume is obtained with such program material, the reproduction is generally classed as satisfactory. This is, however, only a partial test because receivers are frequently designed which



do not overload on the lower frequencies but fail to reproduce satisfactorily and in their proper proportion the overtones which lend the distinctness to different instruments of the orchestra and are of especial importance in obtaining clear articulation of speech. A comparison test is excellent indication of the relative audio-frequency range of two receivers. Judgment, however, should also be passed upon the ease with which the low notes are handled as well as the frequency range of the audio system. Freedom from overloading under conditions of normal reception can be detected readily by an experienced ear which perceives manifestations of overloading as tendency to rattle and resonate. More than one receiver has an audio system which tends to oscillate at the low notes, giving it a slight effect of persistence which is even pleasing with certain types of music, such as organ and cello, but is decidedly detrimental to good articulation and brilliance.

Considerable assistance may be had in this process if a milliammeter is placed in the plate supply of either the output stage or the entire plate supply. If the milliammeter tends to fluctuate while low notes are being reproduced with good volume, it is definite indication that overloading is experienced. Another method, which has been used successfully, is to connect a fixed condenser of one microfarad or more across the loud speaker terminals. The higher frequencies pass more readily through such a condenser than the lower. With some receivers, a one-microfarad condenser so connected makes little difference even in the articulateness of speech, while with others, having faithful amplification not only of the lower frequencies but of the high frequencies as well, there is a marked falling off in clarity. To one not trained in detecting the contribution of the higher frequencies and overtones, this procedure presents a simple, if crude, method of by-passing them so that their effect can be observed by comparison. Compensating adjustment of volume control should, of course, be made before and after connecting the condenser in order that the comparison be made under similar conditions.

Speech is the most ready source for determining the presence of the higher frequencies. Although most of the volume of speech is given by frequencies below 1500 cycles, understandability or articulation is very largely a matter of the higher frequencies. The violin and the soprano voice are also excellent means for determining the presence or absence of amplification at the higher frequencies.

The fidelity tests suggested outline means not only for making a general judgment of the reproduction but for

determining the total range of tone amplified by the receiver, checking overloading, and comparing the relative amplification of the lower and higher frequencies. No systematic examination of the receiver's performance fails to include all of these factors.

### Tests for Selectivity

TESTING FOR selectivity is too easy and simple to be worthy of detailed description. So long as a standard antenna system is used and the convenience of a comparison switch is available, the procedure is obvious. In almost all locations, high-powered stations are available so that the dial range covered by a strong signal is readily observed. The antenna system used with a receiver should be a normal one and no valid test can be made with an antenna of excessively long or short dimensions. A short antenna gives satisfactory results even with a receiver having unsatisfactory selectivity, while

a long one handicaps even the best of receivers. An average antenna, 75 to 100 feet in length, should be used.

Every location has its individual possibilities for testing selectivity, such as the reception of a particular distant station on a channel neighboring one assigned to a local, which gives an index to the performance of a receiver. One who is called upon to pass judgment on receivers should be familiar with these characteristics of his location by frequent observation so that judgment may be passed with any receiver. For example, in the New York area, reception of WLW through WOR is usually an indication of excellent selectivity, but only familiarity with the particular points and distance at which the test is made makes this a specific criterion of a receiver's selectivity.

The three points upon which definite judgment as to selectivity should be based are as follows: first, the dial range covered by the nearest high-powered transmitter; second, the nearest channel upon which a distant station may be heard neighboring on the highest-powered local signal; and third, with the receiver set for maximum volume, determination of the loudest station, restricted sufficiently by the selectivity of the receiver so that a distant station may be heard on the neighboring channel without interference.

Comparison tests offer an easy method of judging sensitivity. It must be remembered that tested and measured tubes must be used in sensitivity tests. Also conditions must be observed simultaneously when comparing two receivers because periodic changes take place in the effectiveness of the transmission medium. The advantage of familiarity with

**HENRY W. JONES & SONS**  
RADIO SALES AND SERVICE

**P E R F O R M A N C E T E S T**

Receiver... *Super-Hattadyne* Model... *70 m.*  
Tested by... *R. M. K.* Date... *5/6/28*

	OUR STAND-ARD	THIS SET
(a) Tone Quality		
(1) LOW FREQUENCIES		
(a) Range test, by comparison, with organ, cello and tympani...	<i>Good</i>	<i>Ex</i>
(b) Overloading, with program featuring lower frequencies, such as organ, symphony orchestra, male quartette		
(2) HIGH FREQUENCIES		
(a) Observe articulation with speech, brilliance with violin and soprano voice...	<i>Good</i>	<i>Good</i>
(b) By-pass high frequencies through 1 mfd. across reproducer and compare relative loss	<i>6</i>	<i>4</i>
(b) Selectivity		
(1) Compare dial ranges covered by nearest high-powered stations	<i>30 ch.</i>	<i>20 ch.</i>
(2) Observe nearest channel to high power local that a distant station can be heard	<i>fair</i>	<i>Good</i>
(3) Observe comparative performance by finding nearest high-powered station which does not interfere with reception of distant station ten kilocycles above or below it	<i>fair</i>	<i>Good</i>
(4) Compare selectivity at high frequency end of band with middle and lower frequencies		
(c) Sensitivity		
(1) Compare volume of distant stations throughout dial range, utilizing knowledge of local reception conditions	<i>Good</i>	<i>Ex</i>
Power Supply		
(1) Measure voltage supplied each tube with set checker and correct line voltage input adjustment	<i>112 volts a.c. input</i>	
Voltages A <i>1.5 - 2.5</i> B <i>45 - 70 - 250</i> C <i>6 - 50</i>		
Mechanical		
(1) Dial control for rigidity and positive action	<i>Good</i>	
(2) Chassis construction for ease of removal from cabinet	<i>fair</i>	
(3) Accessibility of filter condensers and audio transformers	<i>Good</i>	
(4) Color coding of wiring and means provided for continuity tests	<i>Yes</i>	
(5) Gang Condensers for mechanical strength and connections to rotors	<i>Ex</i>	
(6) Accessibility of compensating capacities on gang Condensers for service purposes and inaccessibility to user	<i>Ex</i>	
(7) Rigidity and bonding of shieldings	<i>Good</i>	
(8) Accessibility of hum balancer	<i>Good</i>	
(9) Absence of exposed delicate parts	<i>None</i>	

Dealers will find a chart of this type helpful in studying the merits of a new receiver.



reception conditions at the test point is obvious, but even this is not sufficient to produce positive judgments unless switching arrangements are available which make instantaneous comparison of the attained volume with a given signal possible. With such facilities, tuning in a distant station on two receivers and switching quickly from one receiver to another makes a simple and satisfactory test of radio-frequency amplification.

These performance tests are easily made and give a direct comparison of the factors which determine the service a receiver will give to the consumer. A chart of the type shown on page 82 permits the systematic rating and reporting of this series of tests.

Having completed the performance tests, examination should then be made of the voltages delivered by the receiver's power supply under various conditions. Usually some means is supplied for adjusting voltage input to the power supply for two or more effective line voltages. By means of a good set-checker, the grid and plate voltages supplied each tube should be measured with the input voltage supply properly adjusted. The examination should determine that none of the tubes are operated above their rated voltage. High potentials particularly should not be tolerated because this causes rapid deterioration of tubes in the hands of the consumer and gives exceptionally good performance with respect to selectivity and sensitivity only when the tubes are new. Superiority in these respects, so attained, is certain to cause trouble later because purchasers will soon complain of short tube life.

### Mechanical Examination

THE RECEIVER should next be subjected to mechanical inspection, preferably aided by the service instruction manual supplied by the manufacturer. The dial-control mechanism should be inspected carefully by applying friction at a convenient point on the condenser drum and observing if there is any play or slip when the knob is turned. Rheostats should work smoothly. Gang condensers should be of rigid construction and the contacts between the rotors should be inspected carefully to assure a permanent electrical connection. For convenience in servicing, the ease with which the chassis and the power supply is removed is of importance. The service manual and the chassis itself should be examined to see if simple wire codes are used so that routine tests may be easily made. Condensers in the power pack and audio transformers should be readily removable and convenient test points should be available. The hum balancing means should be accessible, while the means used to balance the gang condensers should

be such that they are accessible to the serviceman but not to the set-owner. The chart also contains a table to aid in making a systematic mechanical inspection.

The experienced dealer knows that convenience in servicing conserves profit and maintains customer satisfaction. Considering the receiver solely from the performance standpoint, without giving thought to future service which may be necessary, has often led to the adoption of a line which may sell readily but which absorbs much of the profit earned by sales because of later service expense. Therefore, the mechanical inspection is most essential as service accessibility and means of detecting and shooting trouble is of considerable importance. While the mechanical inspection should be made with this point in view, general mechanical design should not be overlooked. Rigidity in the chassis, sturdy variable condensers, well anchored wiring, firm shielding compartments, and absence of exposed delicate parts should be observed.

I am certain that dealers inspecting a new line will be greatly aided by following a systematic and comprehensive procedure in making their tests. Furthermore, they will find themselves much better equipped to make a compelling and accurate presentation to prospects of the capabilities which their favorite lines possess.

## TRADE MAGAZINE PREJUDICES

*IT IS a common idea—all too common—that trade magazines must never talk of technical matters. Such conservatism can be justified up to a certain point, but beyond that, it is harmful. Since their beginning, trade magazines have stressed certain aspects of selling, such as window displays, summer campaigns, over-the-counter selling, etc., to the exclusion of all other matters. Indeed trade magazines, are commonly regarded as properly containing nothing else. Other aspects, such as the semi-technical angle (less important but still deserving some attention), have been neglected completely.*

*Look at the set advertising in the various trade magazines. Do you not find such statements as, "245-type tubes in push-pull;" "automatic voltage regulation;" "screen-grid tubes;" "dynamic loud speaker;" and "band-pass tuning?" These are technical facts—and salesmen use them. And there are other technical things about radio receivers equally effective in sales, that have never been explained in merchandizing language.*

*Take a specific case—for example, a Sparton receiver.*

*As a salesman, do you know in what way Sparton sets are essentially different from any other receivers? On page 99 of this issue will be found an article in which the unusual characteristics of the Sparton are clearly indicated. Read it. Read the article on the Radiola 60 series on page 15 of the May issue, another example of the same type of article. And, after reading them, let us know what you think of them.*

—THE EDITORS.

## NOTES ON BROADCASTING

AN INDICATION of the interest in fight broadcasts is given by a statement of the New York Edison Company. During the Sharkey-Stribling bout, broadcast from Miami, Florida, current consumption began to rise above the normal load at nine o'clock, had risen to 25,000 kw. over that in use on ordinary nights by ten o'clock, soared to 40,000 kw. about the time the fight ended at 10:30, and reached a maximum of around 54,000 kw. at 11 P.M. A lot of late staying up must have been caused because the load did not return to normal until one A.M.

SENATOR NYE, of North Dakota, will offer a bill for the erection of a Government radio broadcasting station to radiate debates of Congress on important issues. In view of the N.B.C. offer to broadcast important debates over networks and the impossibility that Nye's one station can reach an appreciable part of the listening public, the project is as wasteful as it is useless.

LICENSE HAS been applied for by the Freshman Company to erect two experimental television transmitters at their plant in Clifton, N. J., according to J. D. R. Freed, vice-president of the company.



## PROGRESS IN LOUD SPEAKER DESIGN

### NATHANIEL BALDWIN, INC.

E. W. SMITH, Research Department: Fundamental and accurate data on vibration instruments has enabled manufacturers to set a new standard in moving-iron reproducers as regards efficiency. A very satisfactory response is now obtained with a reduction of the "peaks" that have characterized the performance of these instruments hitherto.

The Baldwin line reflects all the improvements enumerated in a new moving-iron instrument. The improvements are listed as follows: one-piece cast-aluminum frame, laminated pole pieces and armature, new double permanent magnets which offer nearly twice the magnetic flux of the old type, and an improved "Burtex" acoustic diaphragm.

### JENSEN RADIO MFG. COMPANY

PETER L. JENSEN, President: Loud speaker manufacturers that employ competent and progressive engineering staffs will present to the trade this year new models of dynamic (moving-coil) loud speakers somewhat better in every respect than the 1928 models. The main improvements are made along the following lines: greater dependability on high power; larger cones with consequently less motion for the same output of sound; eliminating stresses and danger of breakdowns; larger voice coil capable of carrying 250 push-pull input without overheating, and finally and most important extending the response to include more of the higher voice frequencies.

The voice coil problem has been overcome in the new 1929-30 model Jensen dynamic loud speakers by the use of aluminum wire. As aluminum has about 60 per cent. the conductivity of copper and only about 30 per cent. its weight, its employment gives the required increase in current carrying capacity without correspondingly adding to the weight of the moving parts.

The Jensen Concert Speaker employing a lighter movable system has a response well above a frequency of 5000, and the "boom-boom" characteristic of many dynamic loud speakers has been entirely eliminated without the sacrifice of the pleasing true low notes. It employs a shallow 9 $\frac{1}{4}$ " cone.

Due to the increased demand, dynamic loud speaker manufacturers have been able to plan more economical production this year by being assured of a larger output and set manufacturers can procure good dynamic speakers at a cost probably not exceeding 25 per cent. over the cost of a good magnetic unit.

### OXFORD RADIO CORPORATION

FRANK REICHMAN, Radio Sales Division: Dynamic loud speakers will hold the front rank in loud speaker styles during 1929. The dynamic loud speaker has proven its merit and

with another year of development behind it outranks, in fidelity of performance, any other design. Practically all of the leading set manufacturers are planning on using dynamic loud speakers exclusively.

Dynamic speakers will be ever so much lower in price due to set manufacturers incorporating in the power pack of the set the means for supplying the field current to the speaker. This eliminates almost half of the manufacturing cost of the loud speaker proper. However, this means the speaker and the set have to be engineered and sold together.

Oxford loud speakers this year will be available in every type of dynamic. This will include all d.c. models for set manufacturers. The line will also include "hum free" a.c. models in both the dry rectifier and tube types, and theatre models designed to operate on the most powerful amplifiers. All types are made in two sizes, the 9" and 11".



*Frank Reichman, Radio Sales Division, Oxford Radio Corp.*

Cabinet manufacturers, this year, are designing their cabinets as "baffle boxes" quite as much as beautiful furniture. They realize that the dynamic loud speaker is not a complete operating instrument

without its "baffle" and that the cabinet is the "horn," and is an essential, vital part of the loud speaker.

### STROMBERG-CARLSON TELEPHONE MFG. COMPANY

RAY MANSON, Vice President and Chief Engineer: Last year, the dynamic type (moving-coil) loud speaker came into its own, due to the small space required for a powerful driving unit. Many detailed improvements have been made in this type of unit which provide for increased audio-frequency range and increased electrical efficiency. This result will be obtained by various detailed improvements, such as the use of larger diameter driving cones, more flexible supports for the cone, lighter weight cone materials, the use of stiffening means in the cone structure, etc. The so-called "magnetic" (moving-iron armature type) loud speaker also will be offered in greatly improved forms, which are sure to give better reproduction than many of the dynamic loud speaker offerings of last season. Condenser-type loud speakers will be available as a commercial product before the end of 1929 and no doubt will create considerable interest.

Stromberg-Carlson loud speakers meet these trends in a full line of improved "magnetic" types, model Nos. 14, 15, 16, and 17, and in an improved electrodynamic floor model, known as the No. 25. All of these loud speakers use "large diameter" cones of special construction, arranged to provide the correct frequency range for natural reproduction of speech and music, and a combination electrical and mechanical system which provides high efficiency of sound output as compared to electrical input



*Peter Jensen, president, Jensen Radio Mfg. Co.*



Replacement Sales for 1928 Increased 77% . . . Estimated Replacement Sales for 1929 Will Increase 80%

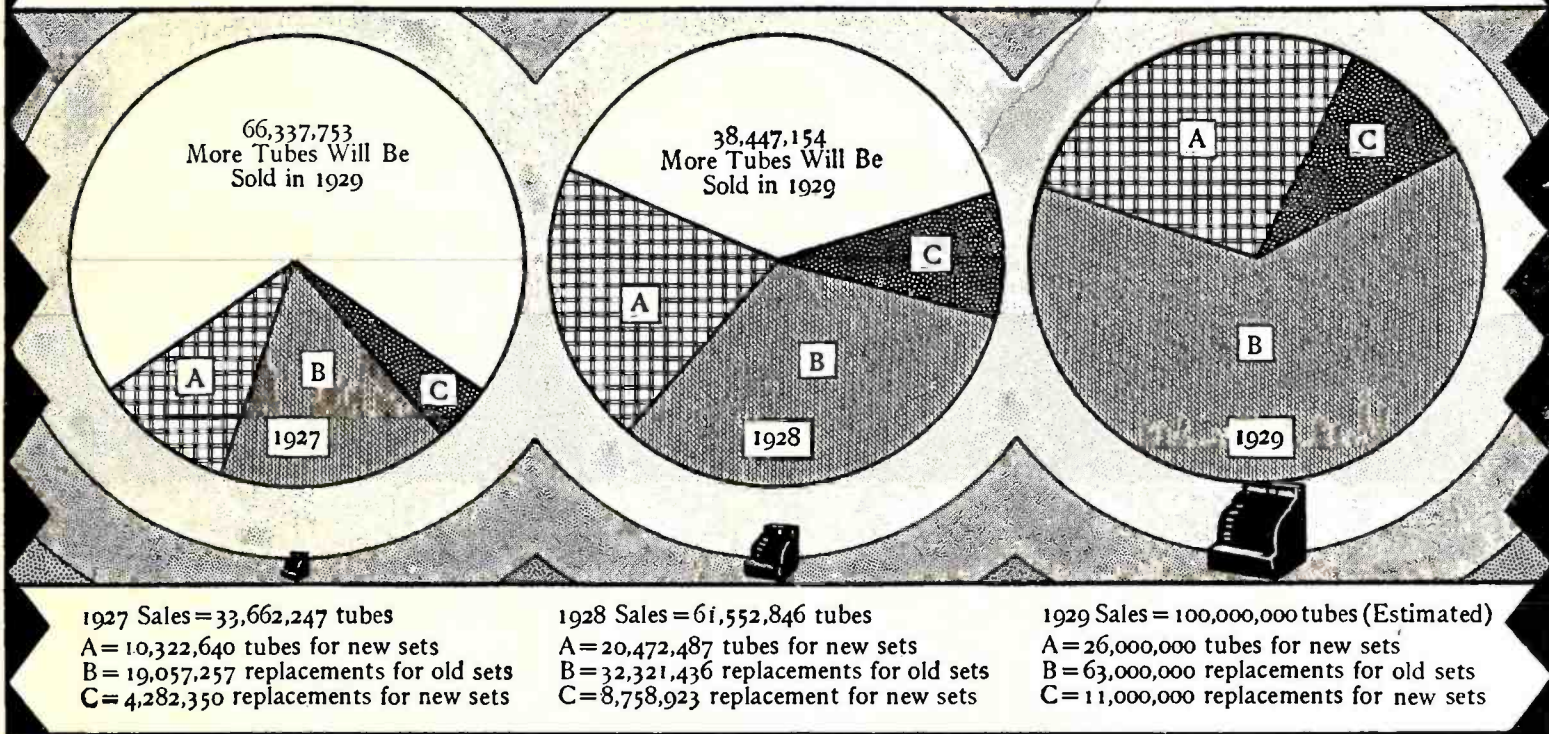

## 1929—THE YEAR OF 100,000,000 TUBES

**E**STIMATES OF tube sales during 1929 indicate that dealers may expect an increase of at least 60 per cent. in this part of their business—and, as every dealers knows, this will represent an appreciable part of his yearly increase in revenue. Why this great increase?

Tubes from reliable manufacturers do not, as some customers still believe, fail prematurely. The reason for the accelerated growth in the tube replacement market comes from but one cause—the use of more radios more hours per day. This in turn is caused by the increase in “time on the air” taken by both national and local broadcasters; by the increased number of stations which may be received without interference; by the improved fidelity of transmission and reception; by the rapid betterment of the quality of programs; and by the fact that the moment a radio receiver operated directly from the lamp socket is installed, its user is freed from worry about whether his batteries will need replacement or charging if he works the radio too hard. The result is he listens more than he did before.

The charts at the top of this page show the extent to which the tube market increased last year, and the expected sales for the current year. (These charts show the various purposes for which the tubes are purchased, such as tubes for use in new receivers, replacement tubes for receivers sold during the current year, and replacement tubes for old receivers.) The fact which is instantly apparent is that the replacement market is growing by leaps and bounds; much faster than the market created by the sale of sets.

Let us consider a few facts, contributed by a recent survey of the National Broadcasting Company. This survey shows that 68 per cent. of the radio owners use their set on an average of at least two hours per day, 44 per cent. use their sets at least three hours per day, and 24 per cent. use their sets more than four hours per day. These figures have been found to hold true irrespective of the section of the country, occupation, or social standing of the individual.

These data, taken in March, 1928, prove that listening to the radio is becoming increasingly popular. More recent surveys indicate that to-day, June, 1929, radio entertainment is even more popular and that many families are using their sets five hours or more a day, or a total of approximately two thousand hours per year! This, in turn, means that many set-owners have to buy at least two complete sets of tubes for their receivers each year (see chart below), and it explains why the replacement tube market is increasing with such rapid strides. And what could be more natural than this increase when it is realized that the better stations are now on the air from 6:45 A.M. until midnight and that over 600 stations are broadcasting?

Better programs, better radio receivers, more stations on the air, widespread acceptance of the radio as a source of entertainment, news, and education, all point toward a still greater use of the receiver than has been customary.

All of these factors should be appreciated by the dealer in radio tubes, and should be pointed out to the irate customer who insists that the tubes in his new a.c. set are ready for the wastebasket much sooner than is proper.

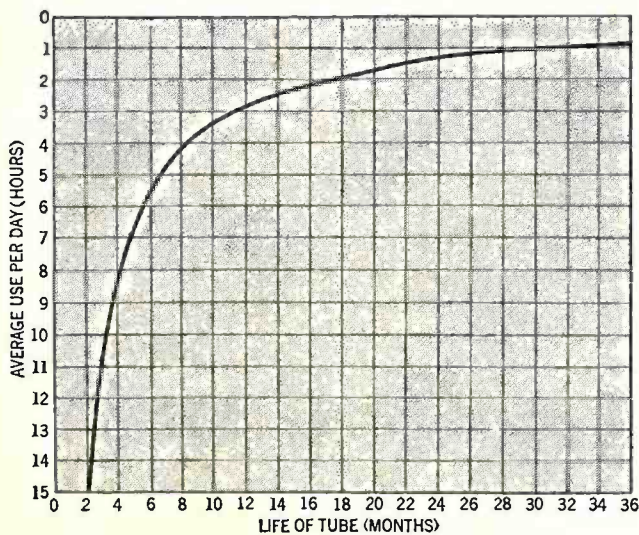

Showing how tube life varies with use.

I-3



# Determining Your Firm's Degree of Perfection

## A GAME FOR RADIO DEALERS

By S. GORDON T. PARKS

President, Parks & Hull, Baltimore, Md.



S. Gordon Parks

HERE IS a list of questions which dealers will find profitable to examine. Take the list and note your answers, "yes" or "no," in the margin—play it as a game, if you like. But the writer feels that this is more than a game—every dealer can with profit use these questions as an aid in taking mental stock of his organization.

The idea of this little game is briefly this: you read the questions carefully, and indicate your answer with a check mark for "yes" and an "X" for "no." After going through the entire list in this way, look at the answers in smaller type at the bottom of the page. These answers, in the experience of the writer, are those which would be made by a one hundred per cent. perfect dealer.

By comparing your answers with this theoretical ideal you will be able to determine readily how closely your organization approaches perfection. And then, what is more important, by concentrating on the problem of making the wrong things right, you will be able to improve your standing in a manner that will be reflected in increased sales and a higher degree of customer good will. And, best of all, you can make this test in perfect privacy, with no one but yourself viewing the outcome, be it good or bad. What happens afterward is up to you.

The hundreds of Atwater Kent dealers who are clients of the writer's firm expressed great interest in this game, which was published in our house organ, *Parks Hullings*, and I am glad to present these questions to a far wider group: for the thousands of other radio dealers who are readers of *RADIO BROADCAST*.

And now, on with the game!

### The Questions

1. Do you reserve about 5 per cent. of your expected gross sales to be used for advertising?
2. Does your advertising in newspapers consist of two or three feature display advertisements per season, rather than regular and consistent efforts?
3. Does your newspaper advertising consist of display advertising used consistently throughout the season?
4. Do you use billboard advertising?
5. Do you advertise over your local broadcasting station?
6. Do you use direct mail advertising, such as the "Tone in the Home" campaign and the "Donnelly Post Card" campaign?
7. Do you use to the fullest extent the window-trimming aids available to you through your jobber?
8. Do you change your window display weekly?
9. Do you maintain at all times an attractive store display of a representative line of sample stock?
10. Do you make full use of the various dealer helps which are available to you?
11. Do you stress the real talking points of the lines you handle?
12. Do you make a practice of knocking merchandise that you do not carry?
13. Do you keep well posted on programs and broadcast features in order to be able to tell prospective customers what they will hear if they buy a radio set?
14. Do you spread your sales efforts over a half-dozen different lines?
15. Do you concentrate on three or less, well-chosen lines?
16. Do you carry consigned merchandise?
17. Do you carry an adequate staff of outside salesmen the year 'round?
18. Do you maintain a staff of outside salesmen during the winter season, cutting that staff down to little or nothing during the summer?
19. Do you demonstrate in the prospect's home?
20. Do you demonstrate only in the store?
21. If your antennas are erected by an outside firm, do you caution your installer to see that the job is properly done?
22. Does your serviceman see that all inside connections, particularly the ground connection, are carefully made?
23. Do you follow up all sales to make sure that the customer is satisfied; and to obtain all possible prospects from this source?
24. Do you answer all service calls as speedily as possible, and as near to the promised time as can be done?
25. Do you maintain adequate service equipment to render service with efficiency and satisfaction to the customer, and with the lowest possible cost to yourself?
26. Do you render free service, except on tubes, for ninety days—thereafter making a fair nominal charge for time and material?
27. Do you train your servicemen to sell accessories such as new tubes, power units, and extra loud speakers, in the course of their regular work as well as to obtain the names of people who have shown interest in the customer's set that is being serviced?
28. Do you maintain your service department so that it is self-supporting and not a drain on your profit and loss account?
29. Do you maintain a clear, up-to-date system of service records so that your billing can be done quickly and fairly, and so that your sales staff can periodically examine the records for live prospects for the sale of a new set?
30. Do you offer favorable terms to those customers of good standing who cannot afford to pay cash?
31. Do you accept small down payments from customers whom credit investigation shows to be worthy of trust?
32. Have you a standing order card on file for new merchandise?
33. Do you hold regular meetings of your organization to discuss new sales efforts?
34. Do you insist that your sales and service staff keep in touch with the progress of radio by reading regularly one or more good trade papers?

### The Answers

(Read these *after* you have checked your own replies in the margin of this page.)

The perfect dealer—yes indeed there are many of them!—would answer "Yes" to all of the questions with the exception of the following, to which the reply should be "No": Numbers 2, 12, 14, 16, 18, and 20.

And now just a final suggestion to help you make more money and achieve more good will: if you are not letter-perfect make this game serve you by an effort to see how closely you can approach the ideal. Keep the questions and their solution in some convenient place where you can check them over from time to time to determine how quickly you are progressing. You will find, without a doubt, that the more closely you approach the ideal rating, the greater will be your success. *Give it a trial and see!*





General view of test bench in the laboratory of the Loomis Radio College.

## Practical Pointers on Servicing

# RADIO SHOP PRACTICE

By MARY TEXANNA LOOMIS

President, Loomis Radio College

**I**N A PREVIOUS article we gave some pointers on "Running a Small Radio Shop" and a description of a service shop in Washington, which had been chosen as a model for other small radio stores. In this article we aim to go more into detail concerning the actual methods used in the servicing branch of the radio business. As stated before, the serviceman, if he is to be successful in his work and make friends for his employer, must be trained in his business. The day of the "just-picked-it-up" serviceman is over.

With the shop properly equipped and running with at least two capable servicemen, one for outside work and one for shop work, a single service job would consist of the following:

- (1) Call received by telephone asking for service.
- (2) Service ticket made out and serviceman starts out on call.
- (3) Serviceman calls at house and checks antenna, ground, loud speaker, tubes, and everything outside set chassis. If any trouble is found during these tests he makes the necessary repair immediately.
- (4) When all wiring, apparatus, etc., outside the chassis either checks o.k. or has been repaired or replaced, the serviceman proceeds to check voltages and current in the set as follows:  $E_p$ ,  $E_g$ ,  $I_p$ , and  $E_f$ . He also tests the set for operation, provided the set is working, and checks on selectivity and sensitivity. If set checks o.k. and customer is satisfied with results of such minor repairs or replacements as could be made at the house, he is requested to sign a ticket stating that service is completed and satisfactory. This ticket must be turned

in at the office of the shop by the serviceman. If he collects money, this must be signed, accounted for, stating amount, and serviceman must give receipt to customer. If, in the house tests, the set chassis or power unit showed trouble which could not be handled at the house, it should be removed from cabinet or console and taken to the shop for repairs. *It is not good policy to make extensive repairs in the home of the customer, as it often has a bad effect psychologically for the customer to see the set "all torn to pieces."*

(5) When the set or chassis is brought to the shop to be serviced, it is properly tagged and placed on the "incoming" shelf, to be taken up in its turn. It should not be left standing there long enough to accumulate dust.

(6) When the "inside" man takes up this set, he makes thorough tests of all circuits and parts, with the idea of locating defects. The part, or circuit, found to be the cause of trouble is then repaired and the set is checked thoroughly for performance. When perfectly satisfactory, the set is marked "repaired" and placed on the "outgoing" shelf for delivery to the customer.

(7) The repaired set is returned to the hands of the "outside" man, who delivers and installs it, testing it on an outside station in the presence of the customer. If the customer is satisfied, the serviceman obtains a signature to the statement that the set is operating satisfactorily. As before, if any money is exchanged, this must be handled carefully as described in a preceding paragraph.

In connecting the set at the customer's house and in making final tests, everything should be checked again, as this often brings to light some minor defect that might become worse in time and require another service call. This policy



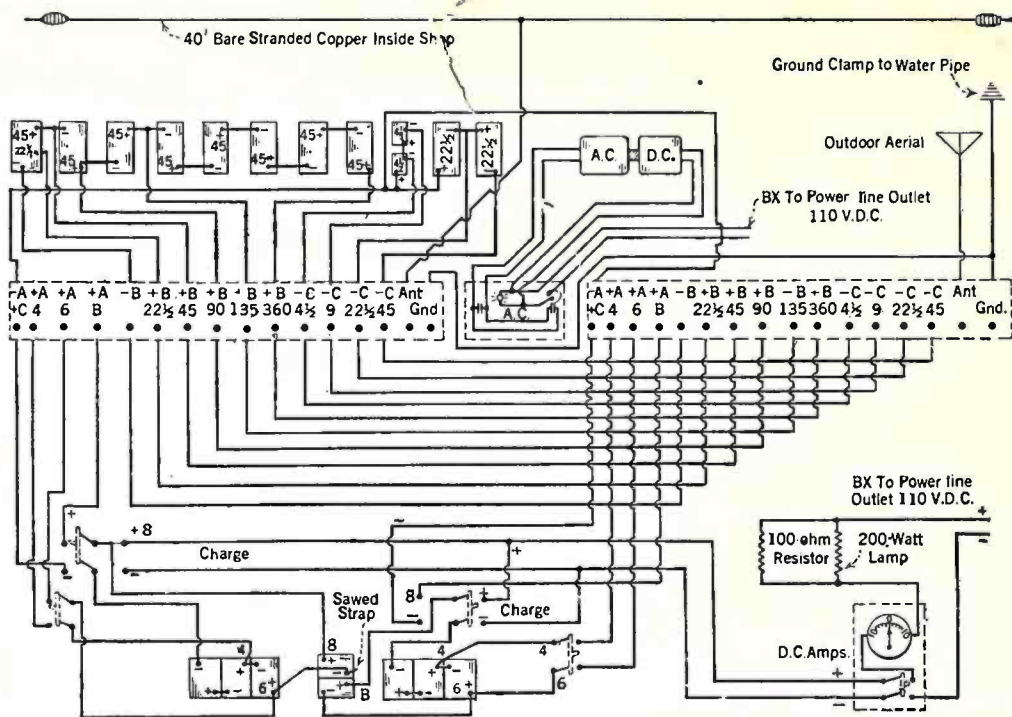

Fig. 1—Wiring diagram of the test bench pictured on page 87

keeps no-charge service calls at a minimum and develops confidence for the shop and men employed by it.

While individual cases frequently arise, calling for ordinary common sense in the handling, the following list of troubles and probable causes may be considered a general guide:

**No  $E_p$ :** Bad B batteries, bad power pack, open plate circuit. The latter may be due to a burned-out plate resistor, a burned-out transformer coil, or a poor or broken connection. A shorted by-pass condenser, or bad rectifier tube, in case of an electric set.

**No  $E_g$ :** Bad C battery, or open grid circuit which may be due to burned-out grid resistor, burned-out transformer coil, or bad connection. In electric sets where  $I_p$  through a resistor gives  $E_g$ , check plate circuit also.

**High  $I_p$ :** Wrong C bias (too low or reversed), shorted tube, shorted plate resistor, or wrong connection batteries or power pack.

**No  $E_f$ :** Bad filament battery, bad power pack, open rheostat, or bad connection.

### Testing Equipment

THE TESTING APPARATUS employed, and the cost of it, is largely a matter of choice with the shop-owner. A large amount of expensive equipment is not actually required in order to conduct a successful servicing business, if such apparatus as is purchased is well chosen. Each outside serviceman must have a neat box with a small number of carefully selected tools. Superfluous tools only get in the worker's way. The kit should contain two styles of pliers, wire-scraping knife, soldering iron, two screw drivers, and a couple of octagonal wrenches.

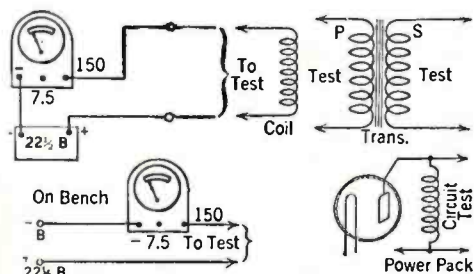

Fig. 2—Voltmeter continuity testing.

If one of the screw drivers is magnetized it will be a great help. This is easily accomplished by inserting the blade inside of a coil of about 50 turns of No. 18 insulated wire which is connected across the terminals of a six-volt battery and closing the circuit for a few minutes. It can also be done by holding the screw driver, with a good tight grasp, against the field of a d.c. motor while running. A small mirror, such as carried in women's hand bags is often very useful in looking at crowded wiring and connections under circumstances where it is not desired to disassemble the set, and this is small and of light weight. [A dentist's mirror might prove even more satisfactory—*Editor*.] Besides the tool kit, the outside serviceman should carry an assortment of standard tubes in a separate box, and a

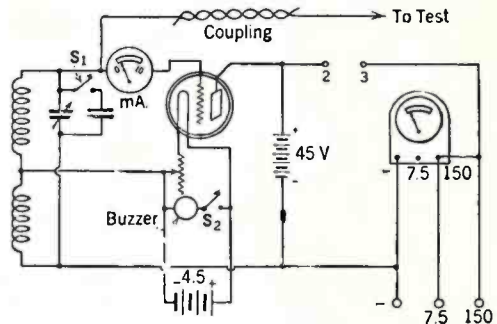

Fig. 3—Oscillator-voltmeter test combinations.

standard tube- and set-tester, or set of testing meters.

Inside the service shop, there should be one completely outfitted work bench for every three or four outside men. In our former article we showed a picture of the actual layout of a service-shop bench which is in continual practical commercial use. The heading picture of this article gives a general idea of the double test bench in use in the Loomis laboratory. This is located in the center of the room in order to permit students to gather around it while trouble-shooting demonstrations are going on. Otherwise it would be much better backed up against windows. A complete wiring diagram of this table is shown in Fig. 1. Batteries and a.c. generator are installed beneath the bench, with wires brought up through drilled holes to conveniently arranged terminals.

If the workers like, a permanently installed arrangement of testing meters may be mounted on a bakelite or metal panel and added to such a work bench. This has some advantages, and some disadvantages, depending on individual preference. A few models of complete testing tables, factory built, are on the market. One made by a well-known firm contains seven meters mounted on a steel panel 24 by 42 inches, placed horizontally across two wooden posts 36 inches high. The meters are as follows: 0-7.5 volts d.c.; 0-75 volts d.c.; 0-150-300 volts d.c., 1000 ohms per volt; 0-15-150 d.c. milliamperes; 0-4-8-16 volts a.c.; 0-250-750 volts a.c.; and 0-1.5-15 microfarads. Binding posts and switches are provided so that each meter may be used individually and for all ranges. The panel is wired up with a tube socket and a long cord with a tube-prong plug at the end. By means of these, each circuit in a radio set may be tested with the tube in a socket. Outlets may be connected to a 110-volt 60-cycle line. Voltage may be read and a radio set then plugged into the outlets. The 750-volt a.c. range is for testing the high-voltage secondary winding of a power pack and the capacity meter is useful for determining condenser values and in

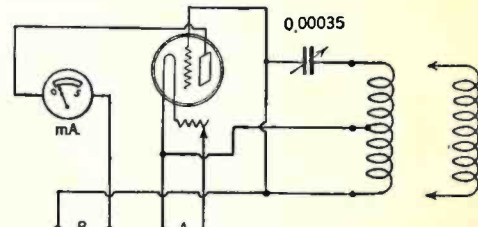

Fig. 4—Diagram of the oscillator tester shown in Fig. 5.

locating condenser shorts. The bench described above is the Jewell radio test bench, No. 580, price \$278.50

### Standard Testing Methods

IT WOULD BE RATHER out of the question, in an article of this space, to undertake to cover tests on every known make of receiver. Individual tests for various makes of sets, and specific uses of various standard test sets, are at all times available from manufacturers. Each receiver requires its own particular tests, and the makers, in their service manuals, thoroughly explain the correct way of making tests which are best adapted to the characteristics of their machines. In addition to this information some test-set manufacturers supply with their testers complete testing data for every standard receiver.

Certain tests apply in a general way to all sets, regardless of make. These may be set forth as follows: **Test for plate voltage:** Touch leads from a high-voltage voltmeter to the plate and filament prongs of each tube socket, with the set connected to its usual power supply. If no voltage is indicated, there is an open circuit in a transformer coil or a shorted by-pass condenser in the circuit attached to the plate prong of that tube. If several tubes show no plate voltage there may be a broken or loose connection. If a power pack is used, the output voltage of this should be checked, and, if trouble is indicated there, the power pack needs to be overhauled.

**Locating open circuit:** If the power input to the set is o.k., and a voltmeter gives no reading as referred to above, the same voltmeter may be employed in locating the open which is probably the reason for no voltage on the plate of the tube. The open may be either the primary of an audio-frequency transformer, a coil in the



radio-frequency stage, or a broken lead to coil or tube. To test for an open circuit in any transformer coil, place the voltmeter, in series with a 22½-volt battery, across the section to be tested. No voltage reading indicates an open. If a reading is obtained, this shows that connections or coils are not open. The test tells nothing about shorts.

**Locating short-circuit:** Any coil or piece of electrical apparatus has some resistance and, therefore, should show a voltage drop. A lower voltage reading will be obtained when testing through a coil than when the ends of the test clips are touched together. When the leads are touched together, the full voltage of the battery is read, but when the leads are placed across a piece of apparatus the battery voltage, less the volt drop across the coil, is read. If *no drop*, not even a small one is shown, a short is indicated. A fairly low resistance voltmeter should be used for this test so that enough current will flow to give a readable drop across apparatus under test.

**Testing condensers:** In testing condensers for shorts or breakdown, the same test for open circuits will apply. In this case, however, a reading will indicate that the condenser is shorted. A condenser in good con-

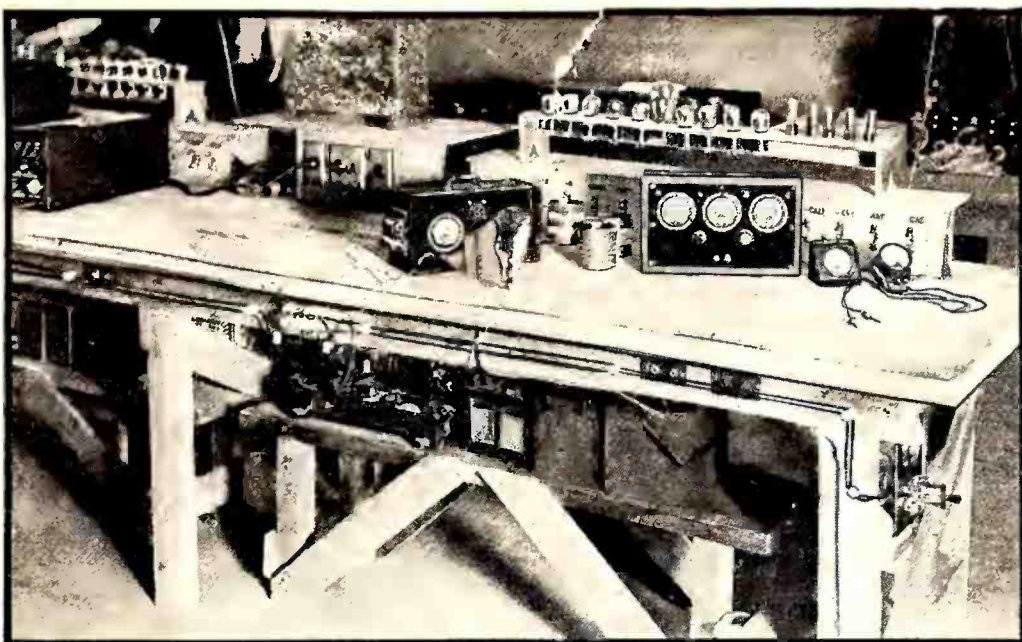

Fig. 5—View of the test bench, oscillator, and tube-tester described in this article.

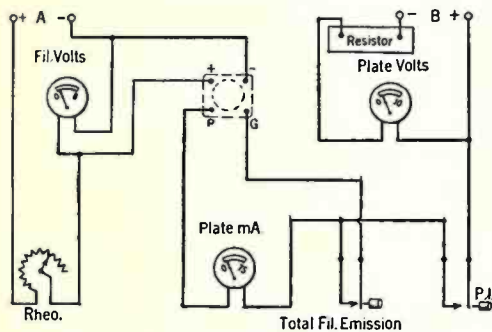

Fig. 6—D. C. tube-tester circuit.

dition is an absolute block to direct current. Therefore, if a reading is obtained, the condenser is bad. This test is made best with a high potential, say about 135 volts, as occasionally a condenser will test o.k. on low voltage but will break down when the set-operating potential is applied to it. Bad by-pass condensers will create short-circuits in grid and plate supplies and, therefore, will show up by a zero plate or grid voltage reading.

With a double-range portable voltmeter, and the shop work bench wired up as shown in Fig. 1, the voltmeter may be connected to the permanent battery clips for series readings. Or, if the bench is busy, a separate battery and the portable meter may be used at another location.

### Tube- and Set-Tester

SEVERAL GOOD tube- and set-testers of standard types are on the market. It is generally safest to purchase such apparatus from one of the well-established concerns. Many testing sets, some standard and others more or less novel, may be made profitably in one's own shop or laboratory. A combination voltmeter and oscillator, as shown in Fig. 3, is a convenient piece of equipment for use in a service shop. Its uses are to test voltages and to provide signals during hours when there is no broadcasting. Only the best materials and meters should be used, and it should be made as small and light as possible. The coil, for the condenser values shown, may consist of No. 30 d.c.c. wire tightly wound on a form 1.75 inches in diameter, to 250 turns and tapped at the center. After being wound, the coil should be coated with collodion to hold the wire in place. Meters and other parts should be arranged to make the leads as short as

possible. If a 199 tube is used, the batteries may be placed inside the box. A 4½-volt C battery will suffice for the filament, and a small-sized B battery may be used for the plate. These will last a long time. Note that the B battery functions both as plate power for the oscillator and for operating the voltmeter in making continuity tests. The oscillator must be calibrated from a suitable standard. The following paragraphs describe some tests that can be made with this test-set.

To use the apparatus as a straight high-frequency oscillator, insert tube, throw switch S<sub>1</sub> to "on" position, and couple test lead to a receiver. Coupling may be increased or decreased by changing the amount of wire twisted together in the lead. At resonance between tester and receiver the greatest "dip" in the grid milliammeter will be noted, but coupling should be loosened enough to prevent the dip from pulling the oscillator off the frequency to which it is set. The oscillator

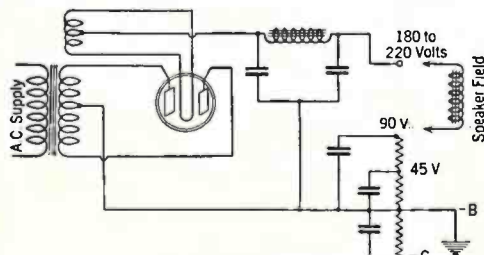

Fig. 7—Typical B and C supply unit of an a.c. receiver.

may be modulated for audibility by closing S<sub>2</sub> and causing the buzzer to vibrate.

Continuity and voltage-drop tests may be performed with the oscillator shown in Fig. 3 by connecting the circuit and resistance coil, or other piece of apparatus being tested, to posts 2 and 3. This places the B battery and the high range of the voltmeter scale in series with the circuit or part to be tested. A practical serviceman would gradually discover a number of other ways to employ this set advantageously.

A slightly different oscillating set for testing purposes is seen at the left in Fig. 5. A diagram of this is given in Fig. 4. It is self-explanatory. The milliammeter, in the plate circuit in this set, gives an indication of resonance by dipping. With this apparatus calibrated for standard frequencies, it may be used with a single coil of wire having no center tap for in-

dicating resonance as a pick-up wave-frequency meter. With the center-tapped Hartley coil it is useful as a "driver." For instance, in checking on the coils and condensers of the different stages of a neutrodyne receiver, if the milliammeter dips the same amount for each stage, when tuned to resonance with each tuned circuit, this is an indication of continuity through each coil, the dip being caused by absorption into the coil circuit. If each tuned circuit tests the same, this also shows that they are properly designed to tune to the same frequency. The batteries are mounted inside the oscillator cabinet.

At the right of the oscillator, in Fig. 5, is a tube-tester, made and used by students of the Loomis Radio College. This is a standard arrangement of plate voltmeter, plate milliammeter, and filament voltmeter. Something of the kind is indispensable in every radio service shop. Weston meters, type 301, flush, were used. The resistor is made to be used with the plate voltmeter and is supplied with it by the manufacturer. Some difficulty was encountered in locating suitable jack switches, or push-button jacks, for this set. These were finally devised from parts of telephone jacks, the "push-buttons" consisting of the knobs and brass shafts of Eby binding posts. With the filament rheostat adjusted to show a voltmeter reading of the correct filament voltage, the milliammeter reading of plate current, for various plate voltages, indicates the condition of the tube. If desired, a meter of the same make, showing filament current could be included in such a tester.

The tests described apply to all types of receivers, but, due to the differences in circuit design, as indicated in Figs. 7 and 8, a.c.-operated receivers also require additional tests. However, these are beyond the scope of the present article.

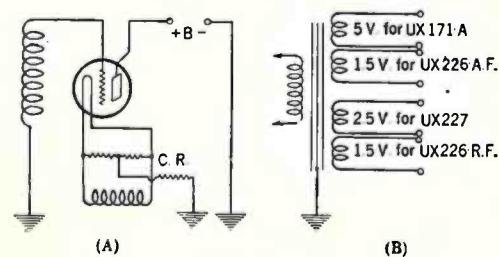

Fig. 8—(A) Method of obtaining negative C bias; (B) usual system of securing filament voltages in an a.c.-operated receiver.



# IN THE RADIO MARKETPLACE

News, Useful Data, and Information on the Offerings of the Manufacturer

## Personal Notes

**J. K. I. CODY**, formerly general sales manager of the National Cash Register Company in Japan, has been appointed general sales manager for the Gold Seal Electrical Co., Inc., New York. Edward R. Fiske, formerly assistant general sales manager of the Ceco Mfg. Co., of Providence, R. I., is now general field supervisor of Gold Seal.

**JOSEPH L. RAY**, vice-president and general sales manager of the Radio Corporation of America, has been elected to the board of directors of the Victor Talking Machine Company.

**DOMINIC F. SCHMIT** has been appointed chief engineer of E. T. Cunningham, Inc., New York, succeeding Roger M. Wise who is now with Grigsby-Grunow. Before his connection with Cunningham, Mr. Schmit spent three years in the research laboratory of the General Electric Co., at Schenectady, in research and development work on radio receiving tubes. Mr. Schmit was born in Port Washington, Wis., and was graduated with a B. S. in E. E.

**KENNETH W. JARVIS**, formerly a member of the engineering staff of the Crosley Radio Corporation, at Cincinnati, Ohio, has joined the Sterling Manufacturing Company, of Cleveland, Ohio, as chief engineer of the radio division.

**WILLIAM C. ALLEY**, formerly managing editor of our excellent contemporary, *Radio Retailing*, has joined the staff of R.M.A. as merchandising manager. His headquarters will be in the New York office at 11 West 42nd Street.

**PROF. REGINALD A. FESSENDEN**, bearer of one of the best-known names in radio, has joined the staff of Grigsby-Grunow, makers of Majestic Radio, as consulting engineer. It was announced that, "while Prof. Fessenden's work will be directed mainly toward developing television apparatus, his experience in radio tube manufacture and set design will be of value."

**R. F. LOVELEE** has been appointed assistant sales manager of the Federal Radio Corporation, Buffalo. Mr. Lovelee has been with the company since its first connection with radio. He is a graduate of the University of Michigan in electrical engineering, worked in the Chicago laboratories of Western Electric and later in the engineering department of Federal at Buffalo.

**THE WOOD CABINET CORPORATION**, 196 Lexington Avenue, New York, has just been formed by T. J. Molloy to take over the business of the Wood-Molloy Co. A sales force of 50 men will cover the trade with low- and medium-priced cabinets in about 15 models of conventional design, interchangeable for all makes of radio receivers. These cabinets will be sold direct to dealers.

**ARTHUR L. WALSH** has been appointed vice-president and general manager of the radio and phonograph division of Thomas A. Edison, Inc. The new Edison radio-

graph is an important unit in the line and will include provisions for playing the new needle-type Edison record which can be played on any phonograph. Hill-and-dale Edison records will remain in production.

**SPARTON ANNOUNCES** that Frank S. Purviance is now district sales representative in the Michigan-Indiana territory.

**D. J. QUINN**, formerly Western sales manager for Sonatron, has been appointed vice-president in charge of sales. Other changes in titles have made Nathan Chirelstein, chairman of the board, Harry Chirelstein, president, and R. L. Marshall, in charge of testing and shipping is now secretary of the company.

## News of the Industry

**GRIGSBY-GRUNOW** announces the formation of the Majestic Corporation, 120 South LaSalle St., Chicago, to finance the paper of its authorized dealers in connection with time sales of Majestic sets. The office is in charge of H. C. Straus.

**ARCTURUS RADIO TUBE COMPANY**, Newark, N. J., announces an increase in production schedule from 17,500 tubes daily to 45,000 per day. A new factory has been occupied and will add 111,000 square feet of floor space to the 45,000 square feet already in use in other plants.

**STROMBERG-CARLSON**, of Rochester, N. Y., has started operations in their new factory which covers 28 acres and provides 360,000 square feet of floor space. Radio sets and telephone equipment will be produced.

**THE TRANSFORMER CORPORATION OF AMERICA** is now located at 2301 South Keeler Ave., Chicago, Ill.



The new Bosch model 30 radio-phonograph combination.

**P. R. MALLORY AND CO., INC.** announces the purchase of a factory in Indianapolis which is expected to be in complete operation by October 1 and will house the manufacturing activities of Elkon, Inc. and the Knapp Electric Co. The new plant has a floor area of about 200,000 square feet and will house the general sales offices, although a New York sales office will be maintained and complete stocks of Knapp and Elkon radio products kept on hand.

**FEDERAL RADIO**, of Buffalo, announces that the Sanford Motor Supply Co., of Williamsport, Pa., will become exclusive wholesalers for Federal.

**THE POLYMET MFG. CO.**, of New York, have purchased the Strand and Sweet Mfg. Co., Winsted, Conn., makers of fine copper magnet wires. Polymet purchased recently the Coilton Mfg. Co.

**EXPANSION IN THE CROSLY** manufacturing facilities is reported from Cincinnati where an additional plant to cost \$750,000 is expected to double the present production of receivers. At present 3800 people are employed in the plant.

**THE ACME ELECTRIC AND MFG. CO.** of Cleveland, has increased its capital stock and changed its name to Acme Radio & Electric, Inc. In 1928, the company began producing a.c. receivers and now has 1700 dealers, an increase of 1200 over a year ago, according to an announcement.

**THE RAYTHEON MANUFACTURING COMPANY**, of Cambridge, who manufactures a complete line of radio receiving tubes and rectifiers, is soon to take over a new factory in Watertown, Mass., with about 160,000 square feet of floor space. When fully equipped this factory will turn out about 30,000 tubes per day.

## New Receivers Announced

**THE RADIO CORPORATION OF AMERICA** announces a new six-tube a.c. receiver, the Model 33. It utilizes four 226-, one 227-, and one 171A-type tubes and a 280-type rectifier. A new R.C.A. loud speaker, the 100-B, is used. This loud speaker is of the magnetic type and it fits into a border groove on top of the radio set. The list price of the Model 33 is \$77.50 and the list price of the 100-B is \$22.00.

**THE GRAYBAR Model 311** is the latest receiver of the Graybar Electric Company. The list price is \$77.50. The Graybar loud speaker lists at \$22.00. The circuit uses six tubes in a tuned r.f. arrangement.

**THE NEW EVEREADY** receivers were announced recently by the National Carbon Company. Model 31 is a table type listing at \$115; model 33 at \$210; model 32 at \$175, and model 34 at \$225. All of the receivers use the same chassis which is a seven-tube set plus a rectifier.

**THE EARL** radio receivers are a product of the Chas. Freshman Company, Inc. The Model 22 Earl lists at \$99.50 less tubes. It is an eight-tube set of the neutrodyne type with four tuned circuits, push-

I-A



pull amplification, and an inductor loud speaker. The Model 32 lists at \$169.00 and is similar to the 22 except for the loud speaker which is of the moving-coil type.

THE NEW STEWART-WARNER Series 900 Console, consisting of a table-type receiver and a Stewart-Warner Dyphonic loud speaker, lists at \$113. With an electrodynamic loud speaker the combination sells for \$123.25. The set utilizes seven tubes plus a rectifier. In the output stage two 245-type tubes are connected in push-pull.

THE AMERICAN BOSCH MAGNETO CORPORATION has announced their new Bosch radio-phonograph combination, Model 30. The new combination uses nine tubes and lists for \$475.00. The cabinet is 47½ inches high, 36 inches wide, and 9¼ inches deep and contains two record racks. The turn table is operated by a General Electric induction motor equipped with an automatic stop. Contained in the cabinet is a Bosch super-dynamic loud speaker.

THE SIMPLEX RADIO COMPANY announces a new eight-tube receiver. The set uses five 227-, two 245-, and one 280-type tubes. The illuminated dial is calibrated in kilocycles. The set contains a phonograph jack and a built-in light-socket antenna. The console model complete with dynamic loud speaker lists at \$150.50 less tubes.

Miscellaneous New Apparatus

THE STEVENS MANUFACTURING CORPORATION announces the design of a new diaphragm utilizing a special shape which is said to decrease distortion produced by ordinary cone diaphragms. The new diaphragm is made of Burtex, which is a special diaphragm material manufactured by this corporation.

THE POOLEY COMPANY, cabinet manufacturers, have designed two special cabinets, models 8200 and 8400, for use with the Atwater Kent Model 46 receiver and the Atwater Kent electrodynamic loud speaker, Model F-2-c.

THE THORDARSON MANUFACTURING COMPANY manufactures a special transformer, type T-2903, designed for use in conjunction with the moving-coil loud speakers to replace transformers supplied with these units.

THE CLAROSTAT MANUFACTURING COMPANY, INC. manufactures a complete line of wire-wound resistors. Fixed resistors are available in sizes from 1 to 3000 ohms. Center-tapped resistors designed for use across the filament circuits of a.c. tubes are available in either fixed or adjustable types in sizes from 6 to 500 ohms.

THE POTTER COMPANY manufactures a dynamic loud speaker filter, a device designed for use with a.c.-type loud speakers to decrease the hum. The filter is connected directly across the field winding. The price is \$4.75.

THE JENSEN RADIO MANUFACTURING COMPANY announces a new Imperial model loud speaker, consisting of a Jensen auditorium-type dynamic loud speaker mounted in a special cabinet which acts as a baffle. The cabinet was designed by Everett Worthington. Models for operation on either 110 volts a.c. or d.c. can be obtained. The a.c. Imperial model lists at \$100.



Louise Homer, Metropolitan Opera Star, listening to the new Victor Radio with Electrola, Model R. E. 45.

THE JEWELL ELECTRICAL INSTRUMENT COMPANY'S new a.c. tube-checker, type 210, operates from the a.c. lines and will check all types of tubes including rectifiers. The panel of the tester carries an a.c. voltmeter, a d.c. milliammeter, and a selector switch to give a.c. potentials of 1.1, 1.5, 2.5, 3.5, and 7.5 volts.

INSULATED TEST handles useful to servicemen or in radio laboratories are manufactured by the Metropolitan Mfg. and Electric Company, Chicago. The test handles complete with leads list for \$1.25.

A NEW PHONOGRAPH pick-up has been announced recently by the Best Manufacturing Company. The Best theatre pick-up is counterbalanced so that just enough weight bears on the record for the needle to track perfectly. It is packed in a three-color display box with volume control and a universal adaptor for use with sets not having a phonograph jack. Price, \$17.50.

THE HOYT RADIO SERVICER, Model 600, is a compact portable set-tester for making tests on all modern radio receivers. It contains a high-resistance voltmeter for measuring d.c. potentials with voltage scales of 12, 120, and 600 volts. The milliammeter in the instrument has two scales,



New Atwater Kent radio cabinet by Pooley.

one of 30 and the other of 120 milliamperes. The a.c. voltmeter has three scales, 3, 9, and 150 volts. Provision is made for testing all types of tubes, including rectifiers.

A NEW DYNAMIC loud speaker, Model SP-29, is announced by the Stevens Manufacturing Corporation. To supply field current, a 280-type rectifier tube is used in conjunction with a filter system consisting of 5-mfd. condensers and a 30-henry choke coil. The input transformer is arranged so that the loud speaker may be used with all types of power tubes, either singly or in push-pull.

Items of Interest

THE AMRAD CORPORATION manufactures Mershon condensers which are at present being used in the power units of a considerable number of well-known receivers. Mershon condensers consist of rolled aluminum electrodes in a copper case, these electrodes being covered by an oxide film. These condensers have the advantages that they provide a large capacity in a small space and they are also self-healing; that is, if they break down due to the application of excessive voltage, they immediately reheal and are not affected permanently by the break down.

Mershon condensers are now being used by the following manufacturers:

- Automatic Radio Mfg. Co., Boston, Mass.
- Balkeit Radio Co., North Chicago, Ill.
- Browning-Drake Co., 110 Brookline St., Cambridge Mass.
- Colonial Radio Corp., Long Island City, N. Y.
- Crescent Radio Mfg. Co., Minneapolis, Minn.
- Crosley Radio Corp., Cincinnati, Ohio
- DeForest Radio Corp., Toronto, Canada
- France Mfg. Co., Cleveland, Ohio
- High Frequency Laboratories, Chicago, Ill.
- Howard Radio Co., South Haven, Mich.
- Jordan Elec. Mfg. Co., Minneapolis, Minn.
- National Company, Malden, Mass.
- H. J. Power Radio Corp., Medford, Mass.
- Sleeper Radio & Mfg. Co., Long Island City, N. Y.
- Sparks-Withington Co., Jackson, Mich.
- Sterling Mfg. Co., Cleveland, Ohio
- A. C. Dayton, Dayton, Ohio

LUMINATOR, INC., 1730 South Michigan Ave., Chicago, has issued an interesting catalog describing a portable standing lamp made by them which provides strong indirect illumination for rooms. Irving Davis, of their sales department says many radio dealers are handling this item, selling the product as a sideline.

IT WAS ANNOUNCED by Atwater Kent that representatives of 22 radio cabinet makers have arranged to supply a complete line of cabinets for Atwater Kent sets and loud speakers this year, giving a range of more than 30 different types from the popular priced models to the most elaborate. These cabinet makers expect to furnish their product for more than one million A-K sets during the year, i.e., from May, 1929, to May, 1930.

THE CHARLES FRESHMAN COMPANY, INC., has applied for two television broadcast channels for experimental purposes. The transmitters will be located at the company's new plant at Clifton, New Jersey.

THE ENGINEERING DIVISION OF R. M. A. recommends that, for the convenience of the buyer, the tubes in a receiver be designated to indicate which are strictly "radio" tubes and which are accessory to the performance of the set. Thus, the tubes in an average a.c. set would be indicated 6-1. The first six tubes indicate the measure of performance of the set and the number separated by a dash shows how many rectifier tubes and those used similarly are

1-5



employed. By totalling the two figures the entire number of tubes employed is apparent.

THE GENERAL ELECTRIC COMPANY has sold to the Russian government the world's largest high-voltage rectifier. This giant rectifier is of the mercury-vapor type and supplies an output of 758 kilowatts at 15,000 volts. Eighteen mercury-vapor rectifier tubes are used. The sale was negotiated under a contract calling for several items of radio apparatus including a 20-kilowatt short-wave transmitter.

DUDLEY WILCOX, treasurer of the Ajax Electrothermic Corp., Trenton, N. J., advises us that he has available for presentation before engineers' clubs or societies copies of a film dealing with high-frequency electric furnaces. The film shows the melting and pouring of metals in charges of from one ounce to several pounds, clearly indicating the method of operation and the way in which electricity is applied in the furnace charge.

EFFECTIVE APRIL 1, the Radio Corporation announces, loud speaker No. 103 is reduced in price to \$30 and No. 106 to \$65. This is a reduction of \$7.50 and \$23.00, respectively.

*Of Engineering Interest*

THE E. F. JOHNSON COMPANY, of Waseca, Minnesota, sells a complete line of microphones and accessories, transmitting tubes, inductances, insulators, and filter condensers. The microphone is of the stretched-diaphragm, two-button, carbon type and lists at \$67.50.

THE SILVER-MARSHALL COMPANY'S public-address amplifier, type 690, is designed to supply sufficient power, when fed by a microphone, a radio set, or phonograph pick-up, to operate up to twelve dynamic loud speakers, according to the manufacturer. The amplifier employs three a.f. stages. The first audio amplifier tube is a type 227, in the second stage 226-type tubes are used in push-pull, and in the output stage are two 250-type tubes in push-pull. The amplifier is stated to have a comparatively flat characteristic from 50 to 5000 cycles. Price, completely wired, \$245.00.

A CALIBRATED LEVEL indicator panel has been designed by J. E. Jenkins and S. E. Adair. The net price, complete except for tubes and batteries, is \$250.00 f.o.b. Chicago. The panel gives a wide



Joseph L. Ray, vice president and general sales manager, R. C. A.

range of level readings from -10 DB to +20 DB in steps 2 DB deep. The panel is exceedingly useful in determining the output of an amplifier or in making a frequency characteristic run. The input transformer in the device has a flat characteristic up to 6000 cycles. It has the advantage over other level indicating systems that it is direct reading and that it produces practically no change in load when its own settings are altered.

DATA ON INTERFERENCE PREVENTION

CIRCULAR LETTER No. 182 issued by the Bureau of Standards, Department of Commerce, Washington, deals with elimination of certain types of interference with radio reception which have been found serious in some areas. Some subjects covered are power line induction, sparking apparatus, location of interference sources, commutators, bell ringers, and smoke precipitators.

NEW STROMBERG-CARLSON SET

THE STROMBERG-CARLSON COMPANY'S new receiver, No. 611, contains several improvements in design that result in better detection and audio reproduction. Three stages of r.f. amplification using the new a.c. screen-grid tubes are used. From these tubes tremendous amplification is obtained and there is impressed

on the input to the power detector an r.f. voltage at least thirty times greater than would be obtained from an r.f. amplifier using three 227-type tubes. The power detector has a linear characteristic which eliminates distortion obtained from ordinary "square-law" detectors. The output of the detector feeds into a 245-type power tube. The use of only one a.f. stage not only improves the quality by eliminating some possible distortion in the audio amplifier but also results in less a.e. hum. The receiver is single controlled and is equipped with a phonograph pick-up jack.

BRUNSWICK BUYS BREMER-TULLY

THE BREMER-TULLY COMPANY, of Chicago, has been purchased by the Brunswick-Balke-Collender Company. This brings to Brunswick licenses to use patents controlled by RCA, Meissner, Hazeltine, and Latour. The new line of Brunswick radio sets and Brunswick radio-panatropes will "establish price levels to insure Brunswick dealers a mass market opportunity so essential to successful merchandising," it was announced.

HILER AUDIO SYSTEM LICENSEES

THE ZENITH RADIO CORPORATION, of Chicago, is the only receiver manufacturer licensed to use the Hilier audio system. Parts and accessory manufacturers who are now licensed are: General Radio Company, Ford Radio and Mica Corporation, American Specialty Company, Leslie F. Muter Company, and Kenneth Harkness, Inc.

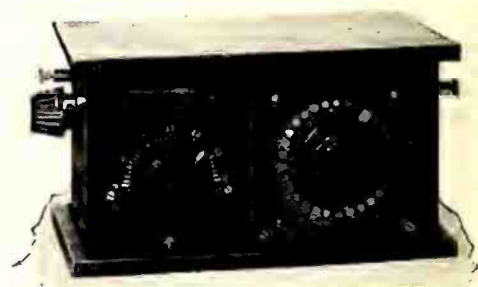

The winner in the Ludlow Radio Company's "Oldest Set Contest."

PRICE OF UX-245 REDUCED

EFFECTIVE APRIL 15, the price of the new power-amplifier Radiotron, the UX-245, was reduced from \$4.25 to \$3.50, the Radio Corporation announced. "Although this tube was announced during the early part of March," officials of the Radio Corporation state, "it has already created a demand in excess of preliminary production estimates. The resultant increase in the production schedule has effected a corresponding reduction in cost of manufacture, making the new price possible."

A WISCONSIN DEALER'S NOVEL CONTEST

An interesting contest was held recently in Madison, Wis., by the Ludlow Radio Company. M. H. Ludlow, president, called for the registry of the oldest set in town. The first prize was a complete a.c. receiver. "The prize-winning set will be kept as a curiosity," said Mr. Ludlow, "and through the contest we gained a number of prospects for new sets." Some of the old-timer sets which were registered in the contest were Radiola 3, Clapp-Eastham C-23, Grebe C11-9, deForest, Custer Airbug, and A. C. Gilbert. RADIO BROADCAST was asked to act as adviser in deciding the contest.

We should be interested to hear from other dealers who have successfully carried out similar contests with details of the re-



This attractive window display was employed by the Ludlow Radio Company to create interest in their "Oldest Set Contest."

I-6



sults and, if possible, pictures of the displays which they employed in connection with the stunt.

NEW BALKEIT SALES POLICY

THE NEW PRESIDENT of the Balkeit Radio Company, North Chicago, Illinois, is Glenn L. Alspach. Mr. Alspach comes to Balkeit from the Gilfillian Radio Company of Los Angeles where he was treasurer and general manager. The Board of Directors of the Balkeit Company now includes: J. M. Troxel, E. F. Radke, J. C. Baker, W. A. Strong, E. G. Booz, and B. V. Becker. The entire capital stock of the company is owned by the Fansteel Products Company.

Balkeit announces a direct-to-dealer distribution policy. "The groundwork of the new Balkeit sales policy has been laid," said Mr. Alspach, "and among the field sales representatives are Harold W. Goldstein, western Pennsylvania, West Virginia, and part of Ohio; M. C. Curtis, Chicago and northern Illinois; Herman Hollander, Missouri and eastern Kansas; and Gifford Horenstein, Connecticut." Signed contracts for more than 50,000 receivers are now in hand, it was announced, and the minimum production for the year is expected to be 100,000 sets.

NEW TECHINIDYNE LICENSEE

THE NEW A.C. DAYTON SETS, demonstrated at a recent meeting for sales managers of distributing branches at the Dayton factory, will be made under the Technidyne patents, it was announced by Ford Studebaker, chief engineer. The new set, known as the "Navigator," will em-



Arthur L. Walsh, vice president and general manager, Radio and Phonograph Division, Thomas A. Edison, Inc.

ploy only one stage of a.f. which is a push-pull circuit with two 245-type tubes.

R. F. L. LICENSEES

THE RADIO FREQUENCY LABORATORIES, Boonton, N. J., have licensed the following radio set companies under their patents, according to R. W. Seabury, president of the Laboratories:

- American Bosch Magneto Corp.
- Grigsby-Grunow Co.
- Kellogg Switchboard and Supply Co.
- National Carbon Company
- Stromberg-Carlson Telephone Mfg. Co.
- Standard Radio Mfg. Corp., Ltd., Toronto

LICENSEES OF THE HAZELTINE CORP

FROM JACK BINNS, treasurer of the Hazeltine Corporation, 42 Broadway, New York, we have secured the following list of the licensees of that organization:

- All-American Mohawk Corporation
- Amrad Corporation
- American Telephone and Telegraph Co.
- F. A. D. Andrea, Inc.
- Breiner-Tully Mfg. Co.
- Crosley Radio Corp.
- Chas. Freshman Co., Inc.
- Freed-Eiscmann Radio Corp.

- Gilfillan Bros., Inc.
- A. H. Grebe and Co., Inc.
- Howard Radio Company
- King-Hinners Radio Co.
- Philadelphia Storage Battery Co.
- Stromberg-Carlson Tel. Mfg. Co.
- United States Radio and Television Co.
- Western Electric Co.
- deForest-Crosley, Ltd., Toronto.
- King Quality Products, Ltd., Bridgburg, Ont.
- Workrite Radio Ltd., Brantford, Can.
- Louis Coen, Wireless Pty., Ltd., Australia
- Suttons, Ltd., Australia
- Melbatone Radio Co., Ltd., Australia
- Werring Radio Co., Ltd., Australia
- Metropolitan Elec. Co., Ltd., Australia
- Marconi's Wireless Telegraph Co., Ltd., London

The Radio Dealer's Note Book  
NO. 4. PHONOGRAPH PICK-UP UNITS

Free—Complete Information\*

ACCURATE summaries of useful information are constantly of value to those radio folk who deal with the public. This sheet, one of many on various subjects to follow, sets down collected information on phonograph pick-up units. The dealer or serviceman can remove this part of the page for his notebook or he can have it photostated.

This month's "Notebook" contains a list of manufacturers of phonograph pick-up units together with the list price and data on accessories. When a phonograph pick-up unit is used to play phonograph records in conjunction with a radio receiver, a volume control separate from that on the receiver is usually required. This device is generally a variable resistor connected across the pick-up unit. Some pick-up units are supplied with a volume control and in other cases, as indicated in the table, the volume control must be purchased separately. The simplest way to connect a phonograph pick-up to a radio receiver is by means

of an adapter, the detector tube being removed from the set and the adapter plugged into the detector socket. An arrangement which is perhaps somewhat better is to connect a jack across the primary of the first a.f. transformer and the leads from the pick-up unit are connected to a plug which is pushed into the jack when one desires to play phonograph records. If the customer has available an old phonograph, he can frequently attach the pick-up unit to the existing tone arm. If a phonograph with a tone arm is not available, however, it is necessary to purchase a pick-up unit that is supplied complete with a tone arm.

\*As a service to readers, the Editors have arranged that dealers may obtain complete information on all the devices listed in the table by writing to the Service Department of RADIO BROADCAST and asking for data on phonograph pick-up units. All requests must be written on a business letterhead or a card must be enclosed to identify the writer as a dealer or serviceman.

Name of Manufacturer	Price	Specifications
Alden Mfg. Co.	\$ 5.00	Complete with adapters but without volume control or tone arm.
Allen-Hough Mfg. Co.	\$ 7.50 \$ 8.50	Available in nickel-plated and gold-plated models. Complete with adapters and volume control but without tone arm.
Amplion Corp. of America	\$16.50	Complete with adapters, volume control, and tone arm.
Audak Co.	\$15.00	Complete with adapters and volume control, but no tone arm.
Best Mfg. Co.	\$17.50	Complete with adapters, volume control, and tone arm.
Brooklyn Metal Stamping Co.	\$10.00	Complete with adapters and volume control, but no tone arm.
Buckingham Radio Corp.	\$10.00 to \$19.00	Available in many different models with and without accessories. Special manufacturer's models can be obtained.
Carryola Co.	\$ 7.50	Complete with adapters and volume control, but no tone arm.
Crosley Radio Corp.	\$15.00	Complete with adapters, volume control, and tone arm.
Electrical Research Labs. (Erla)	\$13.00	Complete with volume control and balanced tone arm. Adapter \$2.00 extra.
Gordon Co.	\$11.50 \$12.50	Available in two models, with or without accessories.
Nathaniel Baldwin, Inc.	\$11.50	With tone arm but no adapter. Volume control \$2.50 extra.
Signal Electric Mfg. Co.	\$13.00	Complete with adapters, volume control, and tone arm.
Stromberg-Carlson Telephone Mfg. Co.	\$25.00	Complete with adapters, volume control, and tone arm.
United Air Cleaner Co.	\$10.00	Complete with adapters, volume control, and tone arm.
Utah Radio Products Co.		Complete with adapters, volume control, and tone arm.
Webster Electric Co.	\$12.50 \$17.50	Complete with adapters and volume control, but no tone arm. \$17.50 model includes tone arm.
Pacent Electric Co.	\$12.00 \$15.00	Complete with volume control, a.c. and d.c. adapters, but no tone arm. Complete with volume control, a.c. and d.c. adapters, and counterbalanced tone arm.

I-7



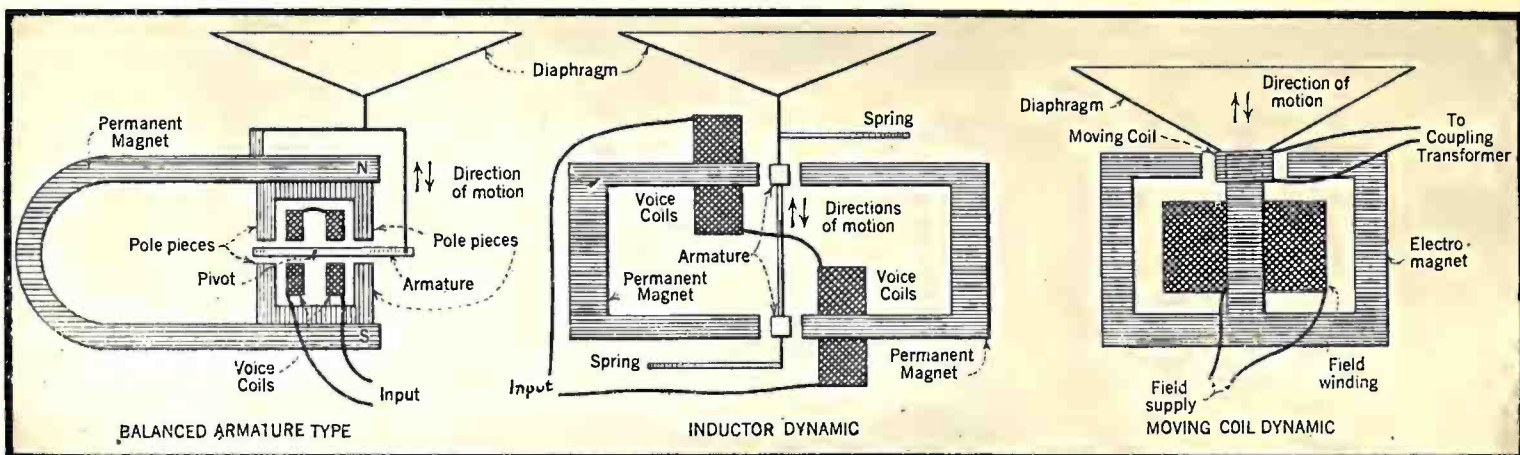

The above schematic drawings show clearly that the inductor-dynamic loud speaker motor differs both in construction and principle of operation from the balanced-armature and moving-coil types of loud speaker driving units.

## A New Trend in Reproducer Design

# THE INDUCTOR DYNAMIC LOUD SPEAKER

By R. H. DREISBACH

Farrand Manufacturing Company

A NEW DYNAMIC loud speaker, the "Inductor Dynamic," has recently made its appearance in the radio field. This is the result of some three years work by C. L. Farrand and has now been perfected to such a degree that it has surpassed the previous hopes of the inventor.

This loud speaker, in the author's opinion, has several decided advantages over the moving-coil dynamic; it requires

loud speaker with that of the balanced-armature type. To alleviate the possibility of this mistake it may be well to point out the disadvantages of the balanced-armature type which are not present in this new loud speaker.

In the case of the balanced-armature type, the distance between the armature and the pole face is varied. The magnetic force exerted on the armature varies inversely as the square of this distance and the force exerted on the armature by its spring support varies inversely as this distance. From this we see that an element of distortion has entered into the operation of this type of motor. For the balanced-armature motor to be comparatively sensitive this gap between the armature and pole face must be quite small, but then the spring supporting the armature must be made quite stiff to prevent the armature from "flopping" against the pole face. This necessary stiffness impairs the operation of the motor at the lower frequencies; consequently, the design of a balanced-armature motor is a compromise between these two evils. The other obstacles found in the design of

balanced-armature units concern spring resonances and the fact that the apex of the cone does not move in a straight line but follows an arc.

### Features of Inductor Type

ALL OF THESE undesirable features are absent in the inductor dynamic. In this new loud speaker the gaps between the armature and the pole faces remain

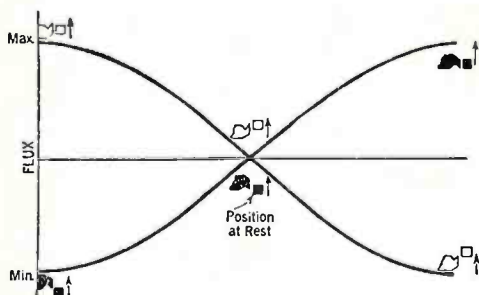

Fig. 1—If the flux in the two magnetic circuits were 180 degrees out of phase there would be no restoring force.

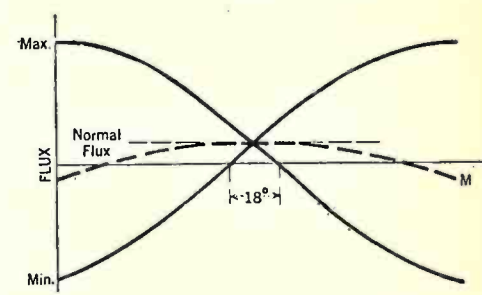
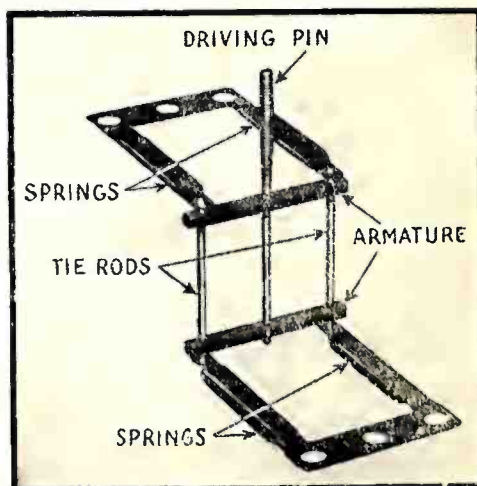

Fig. 2—In practice, a restoring force (see dotted line) is created by shifting the phase of the fluxes 18 degrees.

no d.c. excitation for its field and experiments indicate that it is more sensitive and more efficient at the lower frequencies.

As its name may imply, the construction and principle of operation of the inductor loud speaker is a new departure from the dynamic loud speaker as known up to the present time. [The term "dynamic" is here used by the author to denote force or motion. Dynamic is usually associated with moving-coil loud speakers but in its general meaning it is equally applicable to all types of loud speakers.—Editor.] Unlike the moving-coil dynamics, the inductor utilizes two U-shaped permanent magnets to supply its fixed magnetic field instead of requiring some external source of energy to supply this field. Instead of the usual moving coil, the armature is of moving iron and is composed of two separate bars connected by tie rods working between its respective pole faces. Because the armature is of moving iron the reader may be prone to confuse the operation of this



The construction of the armature assembly of the inductor loud speaker is clearly illustrated above.

constant and the area by which they overlap is varied. The restorative force in an inductor loud speaker is magnetic and is a restorative force rather than a restraining force, the latter being the case with the spring of a balanced-armature motor. The inductor unit must necessarily have a spring support for the armature but the primary function of this spring is to hold the gap constant, and not to supply the restorative force but to leave that function to the magnetic force.

The driving motor is an induction motor with reciprocating action instead of rotary action. Consider Fig. 3. The armature assembly rides freely between the pole pieces,  $P_1$  and  $P_2$ . The coils,  $C_1$  and  $C_2$ , are connected in series. A current flowing through the windings in the direction indicated will increase the flux through the pole legs  $P_1$  and decrease the flux through the pole legs  $P_2$ . The flux, seeking the path of least reluctance, exerts a greater force on the armature bar  $A_1$



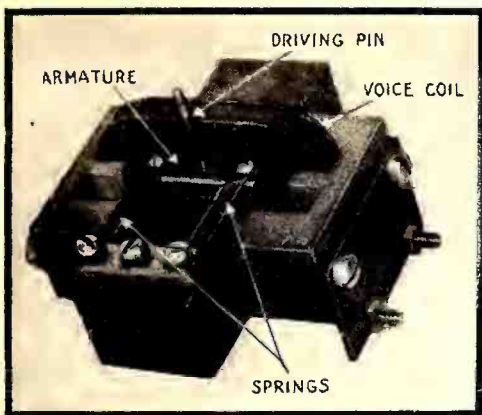

View of the inductor loud speaker motor with the permanent magnets removed.

than on the armature bar  $A_2$ , thus moving the armature in the direction indicated. On the reverse of the cycle the armature moves in the opposite direction in the same manner. The pole legs are cut to the shape indicated to reduce the leakage flux and to bring the greatest flux density to the most desired point.

If the inside spacing between the armature bars is equal to the center to center spacing of the pole faces, the flux in the magnetic circuit  $P_1A_1P_1$  varies  $180^\circ$  out of phase with the flux in the circuit  $P_2A_2P_2$  as the armature is moved to its two extremes. This is shown in Fig. 1, where the flux in the two paths is plotted against the displacement of the armature. The sum of these two curves is a straight line. This would give extreme sensitivity but there would then be no magnetic restoring force. If the armature bars are brought slightly closer together, a distance corresponding to 18 electrical degrees, the resulting curves will be those shown in Fig. 2. The sum of these two curves is the curve M, representing the change in total flux. This shows that the total flux is greatest when the armature is in its "at rest" position and represents the magnetic restoring force, or, if you will, the "magnetic stiffness." This is the design used in practice.

Another explanation of the action in fewer words is that the opposite forces on the two armature bars cause the armature to rest at a middle position which we might call its "magnetic center." The flow of voice currents in the coils causes this "magnetic center" to shift and the armature moves along with the "magnetic center."

It is now apparent that any d.c. component flowing in the windings would change the position of the armature by moving it to one side or the other, thus reducing its limit of motion in one direction. For this reason there must be no d.c. flowing through the windings, thus making it necessary to use an output transformer or a choke and condenser. However, if the loud speaker is to be used on a push-pull amplifier, a third

lead may be taken from the windings at the point where the two coils are connected together and used as the mid-tap of the windings. This corresponds to the mid-tap on the primary of the usual output transformer. The d.c. which flows through the windings in this manner does not upset the "magnetic center." On the contrary it should be in such a direction as to aid the permanent flux through the poles. Doing away with the output transformer in this manner does away with its attendant losses and the gain is readily noticed by the ear.

Operating Data

IT HAS BEEN found that matching the impedance of the inductor dynamic to that of the amplifier with which it is to be used is of greater importance than it

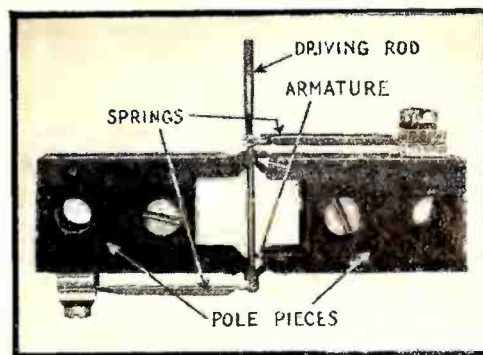

Cutaway picture showing the placement of the armature between the pole faces of the magnet.

speaker has too high an impedance for that of the amplifier with which it is used, the efficiency is lowered at the higher frequencies and increased at the lower frequencies. Since the loud speakers are made in four different models, each having a different impedance, this feature affords the listener the chance to pick a loud speaker which will give the balance of high and low frequencies which is most pleasing to him.

Many moving-coil dynamics rely upon a mechanical resonance to give the impression that the loud speaker is reproducing the lower frequencies. The high efficiency of the inductor dynamic at these frequencies makes it unnecessary to depend upon any such "false bass." In fact, the resonance has been placed below sixty cycles. The springs supporting the armature are of very thin stock (0.008") and the entire armature assembly including springs, weighs but 4.5 grams as compared to 8 to 15 grams for the usual moving-coil dynamic. It is at the lower frequencies that the greatest difference is found between the two types of loud speakers. With an input of 15 db at 30 cycles the inductor motor moves a ten-inch cone one-eighth inch.

The moving-coil dynamic is so inefficient from a standpoint of field excitation that it requires a heavy field structure of a coil and magnet whereas the inductor dynamic is so much more efficient that with two permanent magnets it will give the same output that may be obtained from a moving-coil dynamic using from ten to fifteen watts in the field. It would have been highly desirable before the advent of the inductor dynamic, if it were possible, to build a moving-coil dynamic loud speaker with permanent magnets. This was tried here and abroad unsuccessfully, as, due to the inefficiency of the field system, between 20 and 35 pounds of permanent magnets were necessary. To supply the power to the field of a moving-coil dynamic it has been common practice to use a rectifier which has introduced an objectionable hum in the loud speaker. The inductor dynamic does not add any additional hum to that of the set.

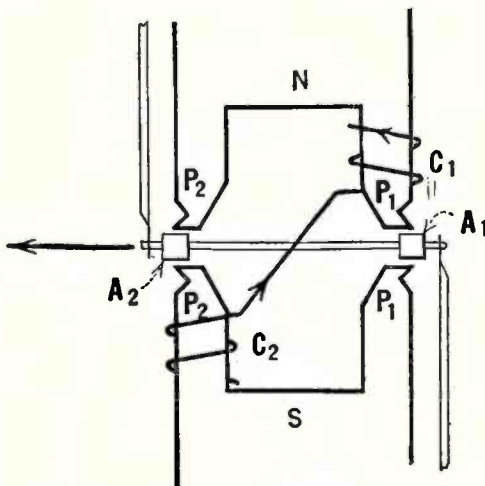
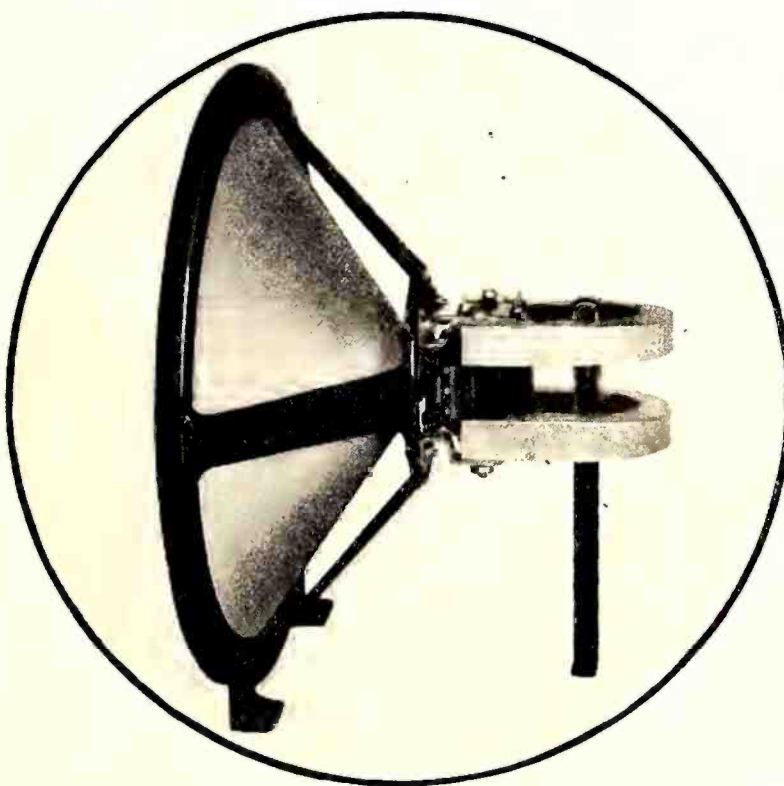

Fig. 3—Schematic diagram explaining the principle of operation of the inductor loud speaker.

was with the moving-coil dynamic. The impedance of the moving-coil dynamic may be varied over quite a wide range before the ear will detect any great change in operation. However, this is not the case with the inductor dynamic. If the loud



View of an inductor loud speaker motor with a paper cone attached. This loud speaker, of course, must be placed behind a baffleboard for best results.



## ROUTINE PLATE CIRCUIT TESTING

By JOHN S. DUNHAM

QRV Radio Service, Inc.

FROM THE standpoint of the amount of service required, the plate circuits of a radio receiver are more important than the filament and grid circuits. That is so because more apparatus is associated with the plate circuits than with the other circuits. We have the primaries of a.f. and r.f. transformers, a.f. and r.f. chokes and by-pass condensers, interstage and output jacks, and a loud speaker. With battery-operated sets we have B batteries. In socket-powered receivers we have voltage dividers, variable resistors if the power supply is an external B-power unit, filter chokes, by-pass and filter condensers, rectifier tubes, buffer condensers if the rectifier is of the gaseous type, and the high-voltage secondary winding and primary winding of a power transformer.

Plate circuits are also of greater importance to the serviceman because the voltages employed are of a higher order than those in the filament and grid circuits. The comparatively high potentials are the active cause of open audio transformers, loud speaker coils, and filter chokes. They are responsible for the breaking down of by-pass and filter condensers. They cause shorts and leakage paths through insulation. Because of all that, the serviceman must spend a great deal more time studying plate circuits and the functions and behavior of the included apparatus than it is necessary for him to spend studying the comparatively simple and abbreviated filament and grid circuits.

### Routine Tests

WE HAVE mentioned before the value of routine in circuit testing, and the following of a routine when testing plate circuits is exactly as important as its application to other circuits or other work of any kind. Tests should start at the sockets, with very few exceptions. Continuity, as well as voltage tests which can be made from the sockets should be made under the load of the tube which belongs in the particular socket, and with all the other tubes in their respective sockets. In socket-powered receivers, and in battery-operated receivers when the B batteries are partially exhausted, the voltage across any tube rises as the remainder of the load is removed by taking other tubes out, an effect which is especially pronounced in modern socket-powered receivers using the series system of voltage division. What we desire to determine by a voltage test is not the no-load voltage, but the voltage under the normal working load of all the tubes. In past years, before the general advent of the high-resistance meter for service work, the meters used constituted a load greater than the normal load of any one tube and some times greater than the total tube load. The high-resistance meter, either as a single unit or incorporated in a test set, usually requires one milliampere for full-scale deflection, which constitutes a load that is negligible in comparison with the load of the tubes. Therefore, the meter has a negligible effect on the voltage across the tubes or across any one tube.

There are some troubles in radio receivers



The Arrow Electric Company, Jersey City, N. J., make a feature of their completely equipped service laboratory. This view of the showroom shows the neat test panel of the laboratory in the background.

ers that do not show up under no-load conditions, but do show up plainly under the normal load. Intermittent opens sometimes fall into that class, and high-resistance joints, such as one where rosin has gotten under a large proportion of the solder at a soldered joint, are practically always in that class. In some cases high-resistance shorts also act the same way. For example, assume that a by-pass condenser across a load has broken down in such manner that its d.c. resistance remains high. Suppose the load which that condenser constitutes is about equal to the load of a 171A tube across whose supply it is connected. In that case a voltage test at the tube socket with the tube removed would show normal voltage. With the tube in, however, the total load on the supply circuit would be twice that for which it was designed, and a voltage test across it at the socket would show a voltage considerably below normal. Whenever you can do so, make your voltage and continuity tests under normal load conditions.

Many of the troubles in a receiver can be determined definitely without testing further than the sockets, by the employment of general knowledge of circuits and their behavior under given conditions, in conjunction with a clear analysis of the various items of evidence presented by the tests at the sockets. If, after each separate test is made, the serviceman will stop before going on to the next, and think out exactly what the result of that one test means in relation to the problem he is attacking, he will in most cases save himself a lot of unnecessary testing, and a lot of valuable time.

For example, if an  $E_p$  test at a detector socket shows no voltage, or fluctuating voltage, but the same test at the first a.f. socket shows normal steady voltage, the trouble is obviously not a general one having to do with the whole plate supply, but is confined solely to the detector supply circuit. If, however, an  $E_p$  test at the first a.f. socket does not show voltage, but a test at the detector socket does, the trouble is not thereby confined to the first a.f. local supply, because in most sets, regardless of type of power supply, the plate supply to the first a.f. and all the r.f. tubes is a common one. In that case it becomes necessary to test at one of the r.f. sockets to determine whether the trouble has to do with that common supply, or is confined to the branch of that common supply which goes to the first a.f. tube.

If tests show lack of  $E_p$  at two sockets whose plate supply is common, and normal or slightly high voltage is found at other tubes whose supply is not common to those two, those facts are very definite evidence. If the set is a battery operated one, the trouble must exist between the battery and the point where the common lead branches to the several tubes supplied. If the set is socket powered, the trouble must exist between the voltage divider and the branching point.

### Open Circuits

WHEN  $E_p$  does not appear at the socket or sockets of one of the usual three branches of the total plate supply, and the cause is an open, part of the load



on the supply has been removed. The effect on the voltage at the remaining tubes is the same as that which would be obtained if part of the total load were removed by taking tubes out, or by any other means. The voltage rises, to a degree that depends upon the percentage of load removed and the regulating effect of the various drops in the supply system. In battery-operated sets, the rise will be very slight when the B batteries are fresh, but may be noticeable if they are old. The degree of rise in voltage which occurs in socket-powered receivers is roughly a function of the cost of the supply system. The cheaper it is the higher will the voltage rise. When the thoughtful serviceman finds the condition described, he knows that the *only* trouble he has to find is an open.

When more load is added to the normal load of a supply, the terminal voltage at the load is lowered. If a test for  $E_p$  at one branch of the total load does not show voltage, but the voltages at other sockets are *lower* than normal, there are just two possible causes of that lowered voltage. The most probable one is that the load on the supply has been increased, by the breaking down of the by-pass condenser across the section of the supply which does not show voltage. The other possible cause is partial failure of supply, which, in socket-powered receivers, would mean failure of the rectifier tube in ninety-nine out of a hundred cases. If that were the cause, lack of any voltage at the socket or sockets of one branch of the load would mean a coincidental open in that branch, having no bearing on the rectifier trouble. If the rectifier is thermionic, serious overloading will often—but not always—be visually evident by the fact that the plate is red. Gaseous rectifier tubes do not show that evidence, and as the overload caused by a broken down by-pass condenser may not be sufficient to redden the plate of a thermionic tube, the best way to be sure about it is to disconnect one side of the suspected condenser. If the trouble were there, voltage conditions would then return to normal. If the by-pass condenser is connected within the set proper, instead of directly across the voltage divider within the power pack, overload caused by its breaking down can be determined by measuring the total plate current with a

milliammeter in the minus-B lead between the set and power pack. The point to be emphasized, however, is that the evidence gained at the sockets themselves, without going further, is ample justification for the assumption that the sole trouble is the breaking down of that particular by-pass condenser. The alternative of an open in the part of the load circuit which shows no voltage, and a poor rectifier tube at the same time, is a rare coincidence in actual practice.

Assume that  $E_p$  tests at the sockets do not show voltage at any of them. In a battery-operated set it can mean only one of two things. The most probable one of those two is an open in the minus-B lead. The other, which occurs rarely, is totally dead B batteries. In his sixteen years of experience with them, the author has not seen more than a dozen times three, or even two, *totally* dead B batteries connected to a radio receiver. In a socket-powered receiver, the condition can mean an open in the minus-B lead, in the plus-B lead somewhere between the rectifier and the voltage divider, in the rectifier or the transformer secondary winding, or it can mean a broken-down filter condenser. The latter is far more frequent. The question of whether the trouble is an open or a short across the filter system through one of the condensers, can be determined often without further tests. Sometimes the shorting path does not immediately become a continuous metallic one, but is a practically continuous flash-over between plates within the condenser, which is clearly audible as a crackling noise. If the rectifier is thermionic its plate or plates will usually become red, when a dead short exists. If the tube is the gaseous type, a short across its output will sometimes be evident by accentuated humming of the transformer and also noticeable humming of the tube itself. The plates of a gaseous type rectifier tube do not get red hot even with the tube passing as much as an ampere of current.

### Tests for Short Circuits

IF NONE OF those evidences of a short exists, then actual circuit testing becomes necessary. The easiest and quickest way to decide the question is to put a 4.5-volt C battery in series with a voltmeter across the output of the filter, from the

negative to the positive side, *with the power off*. If a full or practically full reading is obtained, a short must exist. If a low reading is obtained it means that the circuit is completed only through the resistance of the divider. If no short exists, the trouble must be an open.

If the C-battery test shows the shorted condition, then each condenser must be tested individually to determine which one is the offender. That may be done by disconnecting one side of each in turn. When one has been disconnected, turn on the power and test for voltage at the filter output. If approximately normal voltage appears, the disconnected condenser is obviously the bad one. The condensers may be further tested by subjecting them momentarily to the voltage supplied at the place in the filter where they are normally connected, and then shorting them with pliers or screwdriver. If a good fat spark occurs, the condenser is not broken down. If it is suspected that the condenser is leaky although not entirely broken down, charging it and letting it stand for ten minutes or more before shorting it will answer that question. If the average filter condenser holds practically its full charge that long, it is in good condition. If it does not hold its charge that long, it should be replaced.

Abnormal  $I_p$  through any tube, with normal or low  $E_p$  and normal filament voltage, is a plate-circuit manifestation of trouble which may, or may not be an actual plate circuit trouble. In any set, it means insufficient C bias. In battery-operated sets, and practically all sets using external B-power units, the trouble is exclusively a grid circuit one. But in all socket-powered receivers—with the exception of series-filament jobs and a very few others—the C-bias resistor is actually in the plate circuit in addition to being in the grid circuit. If that resistor is shorted there will be no C bias and the  $I_p$  will go up. If it is open there will be no  $I_p$  at all, a case which we shall discuss further, later in this article.

In battery-operated sets, if  $E_p$  tests at all sockets show slight but irregular fluctuation accompanied by hissing and frying noises from the loud speaker, and the voltages are low, it is conclusive evidence, in most cases, that the batteries have outlived their useful span and must be replaced. If the same fluctuation and noise occurs when the voltage shows the batteries to be fresh, then the evidence points either to a varying resistive joint in the minus-B lead, or a defective B battery. It is fairly common to find brand new B batteries that are noisy, or have open sections, among the very cheap makes, but rare among the good makes. It *never* is economy to buy or use anything but the best batteries obtainable.

If  $E_p$  fluctuation is observed at one socket, but the voltage at others is steady, that set of conditions is valuable evidence. If the fluctuation is at an r.f. tube socket, it points to a resistive joint as the most probable trouble. It rarely means trouble in the primary of the following r.f. transformer. If the fluctuation is at the detector socket or an a.f. socket, or an i.f. socket of a "super" with iron-core transformers, it points to the primary winding of the following transformer, or in rare cases to the loud speaker coils if no output transformer is used. In most cases loud speaker coils open completely when they do go, without any interval of intermittency.

### Transformer Breakdowns

THE STUDY of the causes of breakdown in iron-core i.f. and all a.f. transformers is an interesting one. It is too lengthy to discuss in this article, but an excellent

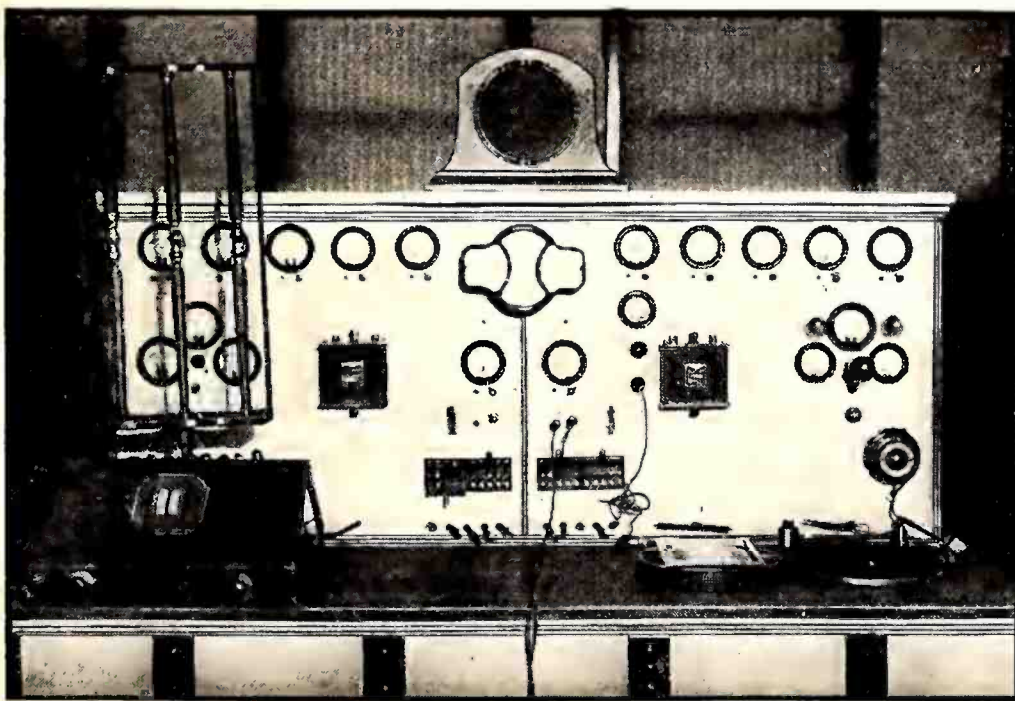

The up-to-date radio test panel and work bench pictured above was designed and constructed by G. R. Prell, service manager for the Southern General Electric Supply Company, Oklahoma City, Radiola distributors.



discussion of the subject, by Herbert M. Isaacs, is scheduled to appear soon in RADIO BROADCAST. Suffice it to say here that the conditions which cause trouble in iron-core transformers are so different in air-core transformers as to practically exempt them from that sort of trouble, and consequently they have an indefinitely long life. Iron-core transformers, on the other hand, have a relatively short life. In its relation to practical servicing, the trouble in iron-core transformers is such that, when a transformer starts to become noisy, we know definitely that it will become progressively noisier and will finally open. Sometimes, when the noise has just started, it will be very intermittent and may occur only at intervals of hours or even days. Sometimes fairly high voltage impressed directly across the terminals of such a transformer will not open the winding, and will sometimes apparently clear up the trouble. But because of the nature of the cause of that trouble, it will always recur, and transformers which have shown any evidence of that condition always ought to be replaced immediately.

In socket-powered receivers, other than those operated from external B-power units (sets originally designed for battery operation) and those having series filaments, the grid-bias resistor of a particular tube, or a group of tubes whose plate supply is common, is in the plate circuit. It is not part of the supply system, but is part of the load on the supply, as it is between the most negative end of the supply and the filament. The filament is positive with respect to the negative end of the supply by the amount of drop across that resistor. If the resistor is open, a test at the socket from plate to filament will not show any voltage, but a test from grid to filament will show the voltage that is the IR drop across the meter itself. The meter is then acting as a substitute for the bias resistor. On the other hand, if there is an open at any other point in the plate circuit, no voltage will be obtained testing from the filament to either plate or grid, because there can be no drop across the C-bias resistor unless plate current is flowing. All that makes it important to remember three things when servicing that predominant type of a.c.-operated set. First, that normal C-bias voltage can be obtained only when a good tube is in the socket, and that no grid voltage at all will be registered if there is no tube in the socket. Second, that if no voltage is obtained from plate to filament, but voltage is secured from grid to filament, the trouble can only be an open grid-bias resistor. Third, that if voltage is absent across both plate to filament and grid to filament paths, the trouble is not in the grid resistor, but is elsewhere in the plate circuit, except in extremely rare cases when opens might appear in two parts of the circuit simultaneously.

If any of the foregoing is not quite clear to any serviceman who has read it, the way to make it clear and to make it a useful

part of his working knowledge is to draw a diagram of the circuits involved, represent the conditions graphically, and study it until he is thoroughly familiar with the possibilities described. Then he will know a great deal more about it than he would if such a diagram were reproduced with this article. That is an observation that holds true for the study of any problem in any circuit. When one doesn't clearly

of divider, if detector voltage is not obtained, but the other voltages are normal or high, so that we know the trouble is not due to the additional load caused by the breaking down of the by-pass condenser connected from the detector tap to minus B, the open must be between the detector tap and the next higher voltage tap, for the detector voltage does not depend on a drop between its tap and minus B, but on the difference between the drop from that tap to maximum plus B and the drop across the whole supply from minus to maximum plus B. Most dividers have a section from the detector tap to minus B, but for a purpose other than that of furnishing drop for the detector voltage. If voltage is not obtained from minus B to the tap which is next to the detector tap, towards the plus end, and we know from other evidence that the voltage at the next higher tap (usually maximum B plus) is high, then the open must be in the section

### SYMBOLS IN COMMON USE

*The following is a list of radio abbreviations most frequently used as a kind of technical shorthand. It should be posted for convenient reference in every serviceman's shop.*

SYMBOL	MEANING
$E_B$	B supply voltage
$E_p$	Voltage at plate of tube
$E_c$ or $E_g$	Grid-bias voltage
$E_f$	Filament terminal voltage
$I_p$	Plate current
$I_g$	Grid current
$I_f$	Filament current
$R_p$	Plate resistance of tube
MU ( $\mu$ )	Amplification constant of tube
$G_m$	Mutual conductance of tube
$R_L$	Load resistance in plate circuit of tube
DB	Transmission unit
IR	Current times resistance

understand a set of conditions that are found in a receiver, draw a diagram of the circuits involved and study the possibilities as they are governed by the circuit arrangement and the effects which have been observed. Drawing diagrams for the purpose of studying a particular problem, or as an exercise in learning the circuits of a receiver, is a very profitable pursuit.

between the intermediate tap and the maximum. If the open does exist there, then both the intermediate and detector taps will show open. That particular open is another trouble which may be determined definitely, in the vast majority of cases, by thoughtful testing at the sockets.

The section of the divider between the detector tap and minus B is added so that there will be a continuous path for current through the divider from plus to minus, thus providing a slight load on the supply system even when the set itself is not drawing any current, as would be the case with all the tubes removed, or if the set were entirely disconnected. If there is no load across the supply system, no current is being drawn from the system and the IR drops across the rectifier tube and transformer secondary are negligible, with the result that the peaks of the a.c. voltage at the terminals of the secondary of the supply transformer are impressed across the filter condensers. The peaks of sine wave a.c. voltage have an amplitude of roughly 1.4 times the average or r.m.s. value. If the no-load terminal voltage of the transformer secondary is, for example, 400 volts to supply 180 volts from plate to filament of a 171 after the drops in the rectifier tube, chokes, output transformer, C-bias resistor, and the transformer itself have been subtracted, the peak voltage impressed across the filter condensers when no load exists across the filter output will be approximately 400 times 1.4, or 560 volts. If even a light load of the order of 5 or 10 milliamperes is across the output of the filter system, the IR drops across the tube and transformer secondary increase, the voltage impressed on the first filter condenser will be much less than the maximum peak voltage, and that on the succeeding condenser or condensers will be still less by the amount of drop across the chokes preceding them, which means that with a minimum load provided the condensers need not be constructed to withstand as high a voltage as they would were a no-load condition possible.

RADIO SET ANALYSIS										
OWNER <i>H. J. Marshall</i>		ADDRESS <i>1015 Prairie Ave., City</i>		DATE <i>Aug. 15 '27</i>						
NAME OF SET <i>6 tube tuned R.F., with eliminator</i>										
TUBE NO. IN ORDER	TYPE OF TUBE	POSITION OF TUBE 1st, R.F., DET., ETC.	READINGS, PLUG IN SOCKET OF SET						NORMAL PLATE M.A.	PLATE M.A. GRID TEST
			TUBE OUT OF TESTER		TUBE IN TESTER					
			A VOLTS	B VOLTS	A VOLTS	B VOLTS	C VOLTS			
1	201-A	1st R.F.	5.2	95	5.0	90	0	5.3	11.1	
2	201-A	2nd R.F.	5.2	95	5.0	90	0	0.2	0.3	
3	201-A	3rd R.F.	5.2	95	5.0	90	0	5.2	10.8	
4	201-A	Detector	5.6	95	5.0	45	0	1.7	5.5	
5	201-A	1st audio	5.4	0	5.0	0	4.5	0	0	
6	171	2nd audio	5.2	157	5.0	150	41.0	5.0	off scale	
7										
8										
9										
10										
SUGGESTIONS OR CHANGES MADE <i>New tube in socket #2. Repaired break to plate of 1st audio tube socket. Boosted B voltage on last tube.</i>										
BY <i>Smith Radio Shop - A.R. West</i>										

After servicing a receiver the wise serviceman fills out a chart of the type illustrated above. This saves considerable time on the next call. This form is supplied by Jewell.

### Servicing B-Power Units

THE problem of finding opens in a B-supply unit of any kind is not a tremendously difficult one. It means simply going from one point to the next, eliminating sections of the circuit until the right one has been located. In the voltage divider itself, one must have some knowledge of how the circuit works. For example, in the commonly used parallel type



## THE SPARTON RECEIVERS

THE SPARTON EQUASSONNE RECEIVERS are especially interesting for they use two devices—a band-pass selector in combination with an untuned radio-frequency amplifier—which are to be found in few other radio receivers.

A Sparton Equassonne receiver contains three separate sections, a "selector unit," an "amplifier unit" and the "power converter." The selector unit picks out the signals from the station to which the user desires to listen, the amplifier unit amplifies and detects these signals, and the power converter amplifies the detected signal sufficiently so that satisfactory volume may be obtained from a loud speaker connected to the output of the power converter. This briefly is the way this set works. It differs from ordinary tuned r.f. receivers in the several ways.

In a tuned r.f. set the incoming signals are amplified by the r.f. amplifier tubes and the selecting is accomplished by the r.f. transformers connected between the successive r.f. amplifier tubes. The desired signal is, therefore, selected as it passes through the r.f. amplifying system. In the Sparton circuit all the selecting is done at one point and then, after the desired signal is completely separated from all the undesired signals, it passes to the r.f. amplifier unit to be amplified.

The r.f. system in an ordinary tuned r.f. set will fail to amplify unless all the stages are tuned to the desired signal. In the Sparton set it is not necessary to tune the r.f. amplifier, for without adjustment it is capable of amplifying any signals (in the broadcast band) that may be impressed on its input. In the Sparton sets one simply tunes the selector to the desired signal and then the amplifier unit automatically does its work of intensifying the particular signal that has been selected.

The last tube in the amplifier unit is the detector. It is of the plate-detection type and is provided with sufficient plate and grid voltage so that it may supply, without overloading, 20 volts or more at audio frequency to the transformer in its plate circuit. The a.f. output from the detector passes into the primary of the audio transformer, and the secondary of this transformer feeds the grid circuit of the power tubes, which, in many of the models, are connected in push pull. This Sparton receiver, therefore, contains only one stage of audio-frequency amplification in contrast with the two stages ordinarily used in broadcast receivers. It is possible to use one stage instead of two because the r.f. amplifier unit has sufficient gain and the detector has sufficient load capacity so that a single transformer is all that is required to step up the a.f. voltage to a value sufficient to operate the power tubes at their maximum output.

The plate circuits of the power tubes contain an output transformer and the secondary of this transformer feeds the moving coil of the dynamic loud speaker used in some of the models. The plate current of the tubes also passes through the field coil of the dynamic loud speaker and the 40 or 50 mA. obtained in this way is sufficient to excite the winding.

The preceding paragraphs have described in a general way the operation of these excellent receivers. Let us now examine in more detail the operation of the selector and amplifier units.

Before entering a detailed discussion of the selector unit, it is advisable to consider, in a general way, the intimate relation between selectivity

and fidelity. The perfect radio receiver would be capable of tuning-in any station without interference from any other stations. This is the ideal condition at which set designers aim. Unfortunately, however, as the selectivity of an ordinary tuned r.f. receiver is increased the fidelity tends to decrease, because the selectivity of the r.f. amplifier tends to suppress partially certain essential parts of the receiver signal. When this occurs the fidelity of the output is effected adversely, being apparent by an absence of high frequencies. The problem

band cutting and the steep sides provide excellent selectivity. Such a characteristic—flat top and steep sides—results, however, only when the circuits are tuned accurately to the same frequency. With these circuits it is, therefore, quite important that the coils be matched carefully and the tuning condensers be ganged accurately.

The entire selector section is contained in a single metal box and if any part of it becomes defective the unit may be removed from the set and replaced by another selector unit, the job of removing the defective unit and substituting a good unit taking not more than fifteen minutes.

The amplifier unit which contains five r.f. amplifier tubes and a detector has an overall gain which is considerably more than that of many ordinary tuned r.f. receivers. The circuit of the amplifier is very unusual but no details regarding its operation are available at this time. The amplifier unit like the selector unit can, when defective, be removed from the set and replaced by another amplifier unit.

The fact that any of the three sections of the set may be removed quickly and replaced by a good unit makes the servicing of the set a very simple matter. When a dealer gets a call to service a Sparton receiver, the serviceman sent on the job merely needs to determine which of the three units is defective. He then replaces it with a good unit and takes the defective unit back to the store to repair it at the first opportunity. By

means of a simple series of tests it is possible to determine quickly which unit is defective. For example, to detect a defect in the selector unit it is simply necessary to remove the antenna wire from its usual location and connect it instead to the connection between the selector and the amplifier units. With the antenna in this position, signals from all the local broadcasting stations will be heard in a jumble provided the amplifier and the power converter are in good condition. When signals cannot be heard with the antenna connected to its usual position ahead of the selector the serviceman has a definite indication that the selector is at fault. He then proceeds to remove it and replace it with a good unit. In this way the customer is not deprived of the use of his set while the selector unit is being repaired.

It is seldom that one finds in a single receiver as many unusual characteristics as are contained in the Sparton sets. In the preceding paragraphs several of these features have been described in detail. The following is a rather complete list of all the special characteristics of Sparton sets:

- (a) Sparton receivers contain a band-pass selector
- (b) An untuned r.f. amplifier
- (c) A power detector which gives much less distortion than is obtained from the usual type of weak-signal detectors.
- (d) A single stage of a.f. amplification rather than two stages as used in the conventional receivers
- (e) A phonograph pick-up jack so that the set may be used in conjunction with a phonograph pick-up unit to permit the electrical reproduction of phonograph records
- (f) A dynamic loud speaker supplied from tubes with sufficient output to insure high-quality reproduction.
- (g) A tapped power transformer so that adjustment may be made to compensate differences in line voltage, an arrangement permitting the operation of all the tubes at maximum efficiency.

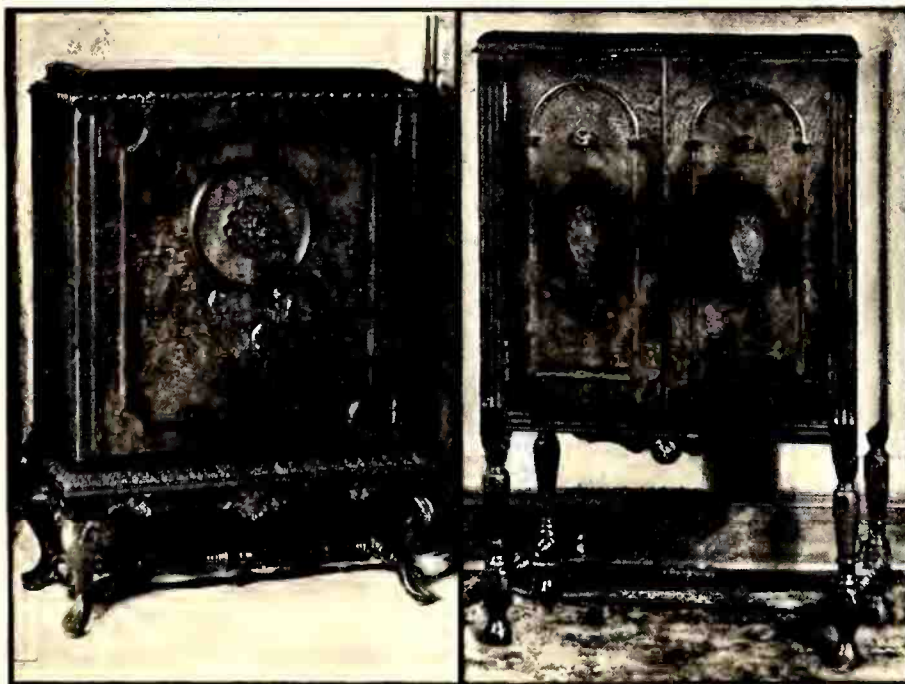

Two new cabinet models used for housing Sparton receivers.

has been to design an r.f. selecting system that will give adequate selectivity but which will not suppress any essential parts of the incoming signal. In the Sparton receivers this has been accomplished by the use of a "band-pass" filter. The term band-pass is applied to the selector unit because its characteristics are such that it passes a band of frequencies just wide enough to contain all the essential components of the audio signal.

The band-pass selector in the Sparton sets is responsible in no small degree for the good quality which may be obtained from the set.

The selector unit consists of four tuned circuits. If the connections to these tuned circuits were traced it would be noted that a small coil, is connected in series with two of the tuned circuits. Now it is a characteristic of two circuits each tuned to exactly the same frequency that, when they are coupled together by any means (as for example a small coil), the response curve of the two circuits together is quite different from either circuit alone. Either circuit alone would give an ordinary resonance curve—a sharply peaked curve that cuts sidebands resulting in the loss of some of the higher audio frequencies. Both circuits together, however, produce a curve with a flat top and very steep sides. The flat top effect prevents side-

### DO YOU KNOW—?

*What the important features of the new radio receivers are? See page 74.*

*How you can increase profits by selling phonograph pick-up units? See page 77.*

*That you will sell many more tubes during 1929 than you did during 1928? See page 85.*

*What the trends are in radio cabinet design? See page 69.*

*How to arrange most efficiently your service department? See page 87.*

*The important facts about Sparton radio receivers?*



# ALL AMERICAN-MOHAWK RECEIVER, MODELS 60-61-62-65-66

This all-electric receiver uses six tubes with a 171A-type tube in the output circuit. The volume control is a 75,000-ohm variable resistor connected across the tuned circuit feeding the detector tube. The circuit consists essentially of three stages of r.f., one

stage of which is untuned, a detector, and two stages of a.f. amplification. It should be noted that the power transformer is equipped with an extra socket for a dynamic loud speaker and that the primary is tapped for high and low line voltages.

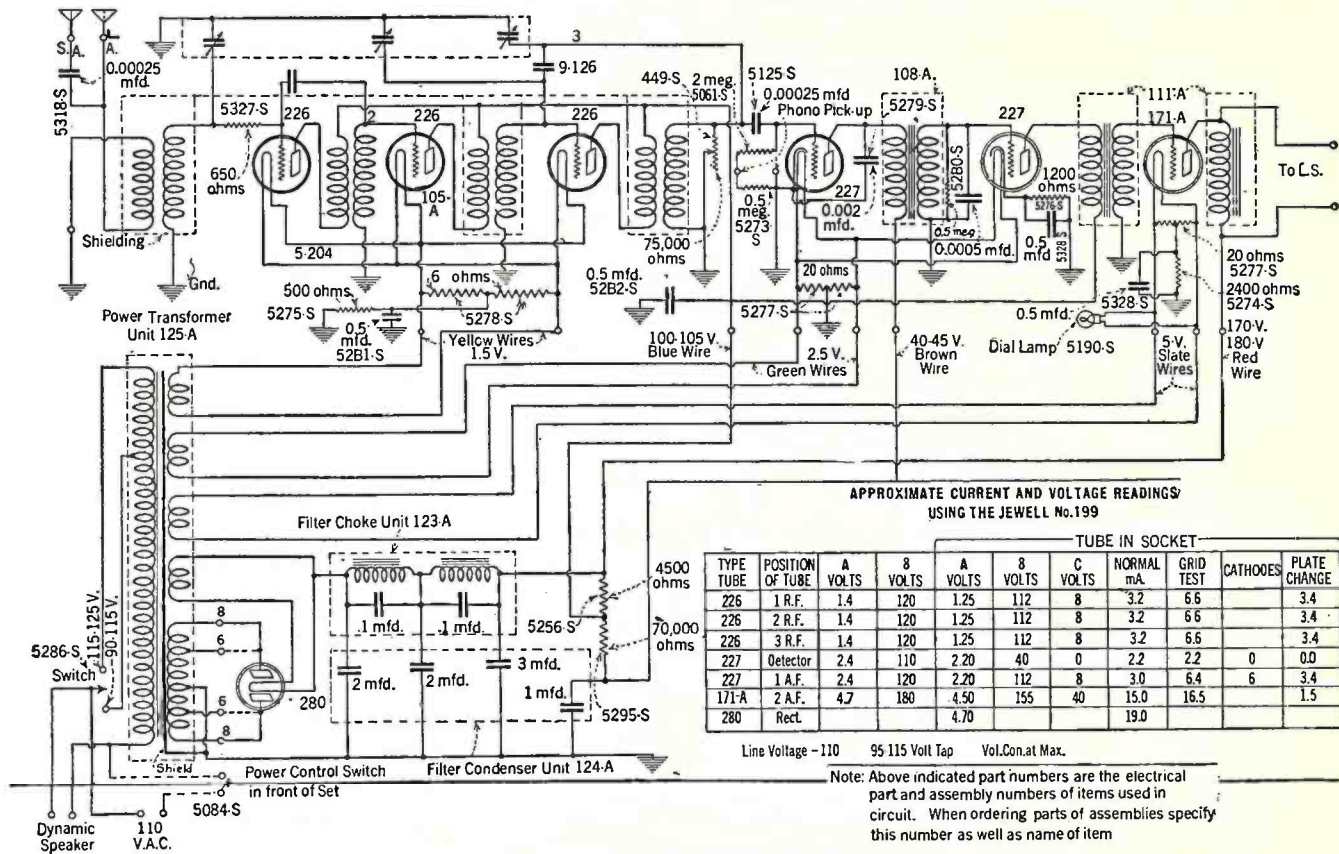

## FRESHMAN MODEL QD-16-S

This receiver consists of a stage of screen-grid amplification using a 222-type tube, a grid leak and condenser type detector, and a two-stage transformer-coupled audio amplifier, the output of which feeds into a dynamic loud speaker. Some regeneration is introduced into the circuit by the small variable condenser C<sub>1</sub>. Two tuned

circuits are used between the output of the screen-grid tube and the input to the detector circuit. The set, therefore, contains three main variable condensers, and a 40-mfd. midget condenser is connected across the first tuned circuit to permit accurate tuning for the reception of distant stations.

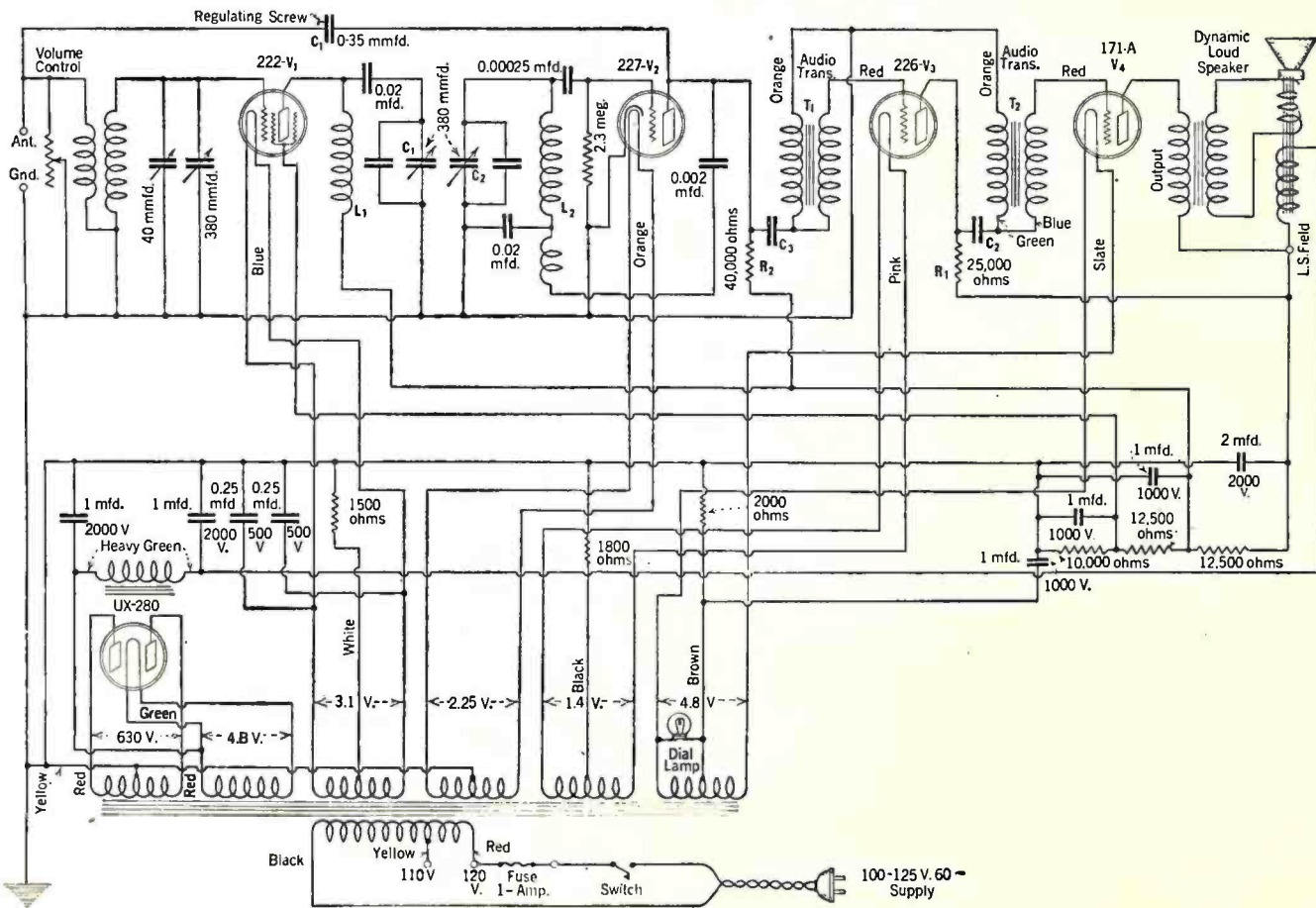



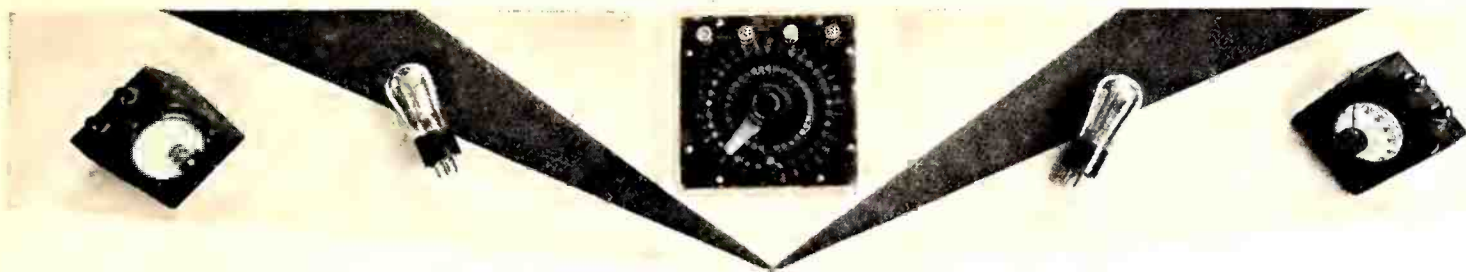

## STRAYS *from* THE LABORATORY

### Trends in 1929 Receiver Design

WHETHER OR NOT the majority of receivers sold during 1929 will be engineered for screen-grid tubes is a question that only time can answer. The attitude among some manufacturers is as prevailed at the time the a.c. tubes were first announced, "Let George do it." When several manufacturers merchandise a screen-grid receiver that stays sold, the others will no doubt scramble to get their own screen-grid sets out of the laboratory and on to the dealers' shelves.

It is certain that 1929 will see the general adoption of the 245-type power tube, and indications are that most up-to-date receivers will use two of them in push-pull. Many receivers seem to be including some sort of band-pass tuning, some as preselectors and some between tubes as coupling circuits. Many receivers will have but one stage of audio, and of those which use screen-grid tubes, the majority will require but a very small antenna for loud speaker operation from distant stations.

The average sensitivity of receivers built in 1928 was of the order of 50 microvolts per meter; those built in 1929 will probably be ten times as sensitive, 5 mv/m.

The advantage of uniform sensitivity over the broadcast band is a talking point (and a good one, we believe) of several manufacturers. Whether or not this uniform sensitivity means uniform selectivity, we do not know. This would be more of an advantage than uniform sensitivity, in our opinion.

Some receiver manufacturers feel that the problem of getting a.c. screen-grid tubes in sufficient quantities and of sufficient uniformity will militate against the widespread use of this new addition to the tube line. Tube manufacturers, on the other hand, see no great difficulties in the way of building these more complicated structures. They feel that the experience gained in the production of the heater-type tube will cut down the time of experiment on the newer tube, and, that when manufacturers are ready for the tubes with the additional grid, they will be ready.

Some manufacturers have discovered that they will require the same number of tubes when the screen-grid type are used, as in 1928, and, therefore, that the advantage in making a screen-grid-tube set is only one of sales appeal. On the other hand, at least one manufacturer is ready to advertise that his receivers will not be screen-grid-tube equipped, and others have discovered that the same performance can be secured from a four-tube set using the a.c. screen-grid tubes as is now possible from six tubes. Such a receiver

will have two screen-grid r.f. amplifiers, a 227-type power detector, or a screen-grid detector, and one stage of a.f. amplification. Will such a receiver have sufficient selectivity? That is the question everyone asks.

With an equal number of tubes it ought to be possible to design a receiver that, with a small antenna or loop, would bring in as much program enjoyment as an older set with a large outside antenna. We hope

The following are among the subjects discussed in "Strays" this month:

*Trends in 1929 Receiver Design*  
*Data on Electrostatic Speakers*  
*How much is an Engineer Worth?*  
*Power Requirements in England*  
*Humps in Audio Transformers*  
*Short-Wave Schedules*  
*Resourcefulness of an Engineer*  
*Dr. Goldsmith Resigns as Editor*

the advertising departments will not offer the screen-grid receivers as being more free from static and other unwanted racket. If they are loop operated, considerable discrimination against unwanted signals, broadcasting, or static may be secured. A blanket statement, however, that the screen-grid tube will make a set freer from undesired noise is too good to be true.

### Gossip About Electrostatic Loud Speakers

AS IN THE CASE WITH the a.c. screen-grid tube, some manufacturers will and others will not use the newest type of loud speaker, the electrostatic type. Some observers claim it is more sensitive; others say it is "down." It is generally agreed that its space requirements cannot be made much less than a dynamic from an

equal performance criterion, and that the chief cause for worry is how long it will stand up in service. The fact that rubber, or some other insulating material, must be subjected to atmospheric changes, to the continuous static field across it, etc., means that it is difficult to get up accelerated life tests in order to find out how long the device will stand up.

If the condenser-type loud speaker were cheaper, or more sensitive, or better looking, or more durable, or if it had a better frequency characteristic, the technical part of the trade would be interested. If the condenser-type loud speaker proves to be merely a good sales argument, the technical people will pass it by. It is difficult to believe, however, that some good will not come from the work that has gone into its development. We have the highest regard for the engineers and physicists at the Riverbank Laboratories.

### How Much is a Chief Engineer Worth?

HOW MUCH IS A chief engineer worth? Let us suppose a manufacturer pays his chief engineer \$10,000 a year and that he makes 100,000 receivers. This engineer is responsible, more or less, for the expenditure of money for the raw materials, for the design, and for the production of these sets. Thus, he gets about ten cents per set for his work. Now, if the receiver is made under a license agreement, it pays not less than 7½ per cent. (\$7.50 on each \$100 set), and, if it goes into a big cabinet which brings the price to \$200, the licensor gets \$15.00 although the chief engineer still receives only ten cents. What is the moral of this story? We don't know.

### Power Required by English Loud Speakers

AN EXTRACT FROM A letter from C. L. LYONS, of Claude Lyons, Ltd., Liverpool, radio and electrical distributors, casts some light on the power requirements for various types of loud speakers used in England at the present time. According to Mr. Lyons, who has conducted many tests to determine what his clients desire in the way of volume:

1. Dynamic loud speakers require about 750 milliwatts,
2. Large cone loud speakers, 15 inches in diameter, require 350 milliwatts,
3. Diaphragm-driven horn loud speakers, more or less obsolete, 250 milliwatts,
4. Small cone loud speakers, 7 to 15 inches in diameter, need about 250 milliwatts.

Mr. Lyons expressed surprise at the fact that many American technical articles mention power outputs as

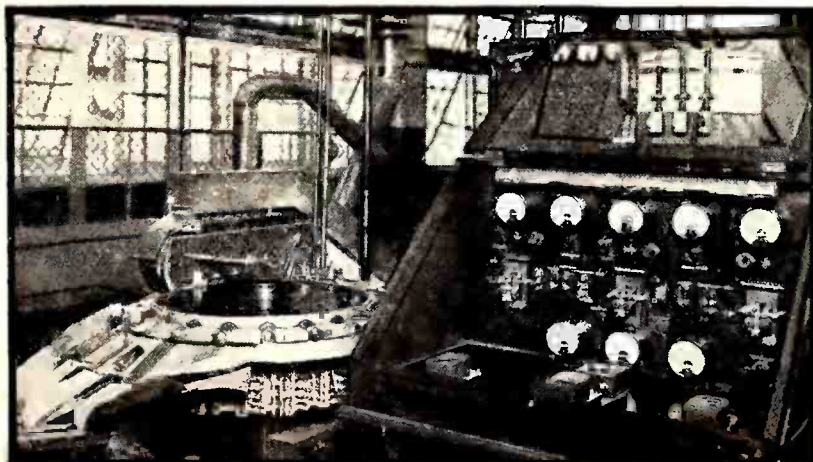

View of an automatic tube-testing apparatus used by Westinghouse. At the right is shown the control cabinet panel and at the left the automatic feeding system



low as 50 and 100 milliwatts as standard volume levels. He does not take into account the fact that these are levels desirable for laboratory measurement and that people in general in this country desire much more power output than these figures. The tendency, if anything, is to about double the power requirements that he mentions as desirable in England. At least 1.5 watts is now considered as necessary for average homes.

**Humps in a.f. Transformer Characteristics**

ANYONE WHO HAS MEASURED the voltage across a good a.f. transformer when various input frequencies at the same voltage are put into its primary winding will remember the hump that occasionally takes place somewhere between 4000 and 10,000 cycles. Why is this hump?

A transformer may be considered as Fig. 1, in which the primary and secondary leakage inductances are represented in series with the primary and secondary resistances and the previous tube resistance, and across this circuit is the mutual inductance between primary and secondary—which should be high—shunted by the capacity of the windings, the leads, and the tube input, and followed by a perfect transformer. Now all of this is a series circuit which may become resonant to some audio frequency. If so, the voltage across C will rise, and the transformer characteristic will show a hump in the neighborhood of this resonant frequency. If the "Q",  $L_2/R_2$ , of the circuit is high the hump may become high enough for the entire system to sing. If the Q is low, which may be due to high-resistance windings or a high-resistance tube, the hump may be quite small. Thus, a good transformer, which will be stable when worked out of a 201A-type tube, may sing when worked out of a 112-type tube.

Increasing the plate resistance, then, cuts down the peak. Putting an inductance in series with the primary lowers the frequency of the peak. Increasing the capacity across the secondary lowers the frequency of the peak. Putting a resistance in series with the grid lead cuts down the hump.

At low frequencies this series leakage reactance is small compared to the mutual reactance. The response at low frequencies, then, is a function of how great this impedance is compared to the tube resistance. (See Fig. 2) If the mutual inductance of the transformer is high compared to the plate resistance of the tube, the low-frequency response will be good. If a poor transformer with low mutual is used, or if the tube resistance is high, the response at low frequencies may become quite bad, and, in fact, may become markedly peaked in the neighborhood of 1000 cycles. If a good transformer, the Samson Symphonic for example, is worked out of a screen-grid tube some such curve as that in Fig. 4 will result.

The series resonance hump at high frequencies can be cut down by a resistance near the grid of the tube. If carried far enough, the high-frequency response will begin to droop. If the resistance is in the filament side, as for C-bias purposes, the high frequencies will be reduced because

the capacity current, Fig. 3, must flow through this resistance and sets up a voltage across it which is out of phase with the desired voltage across the grid-filament input.

WELLINGTON W. MUIR, of Lockport, N. Y., who probably has more "DX" records than any other consistent listener in this country, submits the following data on short-wave broadcasting.

The Chief Engineer at Bandoeng, Java, will be pleased to receive reports from those hearing the following phone transmitters: PLE, 15.74 meters, PLF, 17.40 meters, and PLG, 18.88 meters, daily from 7 to 11 A.M. (E.S.T.); PLR, 27.80 meters, daily from 11 A.M. to 2 P.M.; PLG and PLE, Wednesdays from 5:30 to 7:00 A.M. The Société Française Radio-Électrique, 79 Boulevard Haussmann, Paris, will be pleased to receive reports from those hear-

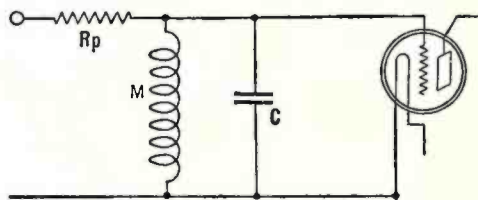

Fig. 2

ing the following phone transmitters: FW4, 24.50 meters; FW, 15.55 meters; and Buenos Aires, 15.02 meters. The radio station at Matala, Sweden, will be pleased to receive reports from those hearing their short-wave station on 98.90 meters, daily from 11 A.M. to 5 P.M. PCJJ, 31.30 meters, Eindhoven, Holland, will be pleased to receive reports. This station operates on the following schedule: Thursday 1 to 3 P.M. and 6 to 10 P.M., Friday 1 to 3

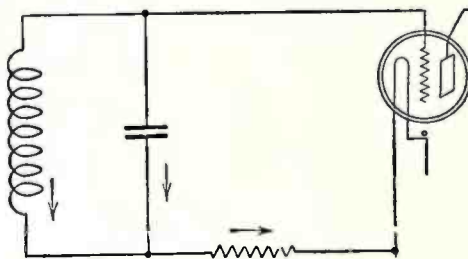

Fig. 3

P.M. and 8 to 12 P.M., and Saturday 12:01 to 1 A.M. All of the hours given above are in Eastern Standard Time."

A WELL-KNOWN RECEIVER manufacturer in the Middle West decided to go in for the 250-type of amplifier tube but discovered that no greater volume could be obtained from the set than with

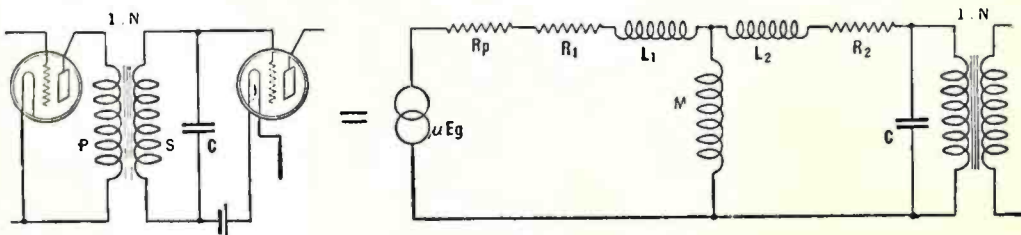

Fig. 1

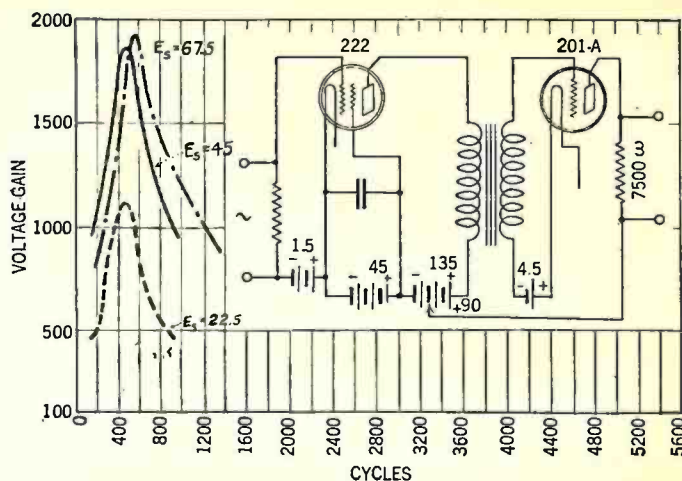

Fig. 4

a 171-type power tube. The trouble was lack of plate voltage. The manufacturer called in a consulting radio engineer and the following is the result. The receiver had eight tubes. The engineer went over the entire receiver and finally secured better results from seven tubes. This left one extra socket on the chassis. He put a 226-type tube in this socket, made it into a two-element rectifier, and supplied the bias for the 250 from it. This added 60 volts to the plate of the 250. The result was a seven-tube receiver with the performance of the eight-tube set, a 250-type tube with 300 volts on its plate, and plenty of volume.

THE INABILITY of Dr. Alfred N. Goldsmith to serve longer as Editor of the *Proceedings of the Institute of Radio Engineers* is a matter of regret which all members of the Institute share. Despite the difficulty of obtaining a constant supply of good material in the midst of intense rivalry, and considerable secrecy, among radio laboratories and manufacturers, and the labor involved in presenting this material in the proper form, Dr. Goldsmith has served for sixteen years as Editor of the *Proceedings*.

A cursory glance through papers presented during those sixteen years indicates why the bound copies of the *Proceedings* have come to be the cover and contents of every radio engineer's library. These papers are signed by such names as Marconi, Armstrong, Poulson, Hazeltine, Pickard, Cohn, Stone, Zenneck, Austin, Morecroft, Pierce, and others, including Dr. Goldsmith.

IN JANUARY "Strays" we gave some empirical formulas whereby the inductance of multilayered coils, solenoids, and helical coils could be calculated. The dimensions were given in inches. When the dimensions are given in centimeters the following formulas will give the inductance. We are indebted to HAROLD F. SCHWEDE, of Chicago for them:

$$L_n = \frac{0.315 a^2 n^2}{6a + 9b + 10c} \mu h; L_s = \frac{0.394 a^2 n^2}{9a + 10b} \mu ah;$$

$$L_h = \frac{0.394 a^2 n^2}{8a + 11c} \mu h$$

Where  $L_m$  = Inductance of multilayer coil  
 $L_c$  = " " solenoid "  
 $L_h$  = " " helical "

In the above formulas a, b, c, and N are as shown on page 170, January RADIO BROADCAST.

—KEITH HENNEY



# THE EXPERIMENTER'S ARMCHAIR

By ROBERT S. KRUSE

## An Improved Oscillator

SO MUCH FOR European practice. Let us now return to the United States; in fact, to a point just a bit north of the center thereof. This must serve as an introduction for LOUIS F. LEUCK, of Lincoln, Nebraska, who describes for us a general-purpose oscillator of more than usual merit. It holds calibration, may be used as a mere "driver," as an "oscillating wavemeter," as a trans-

mitter "tone checker," as a "tuning meter," or as a receiving heterodyne. Furthermore, it is very simple, easy to construct, and inexpensive. The device with all these virtues is simply a self-contained battery-driven oscillator with circuit precautions against the effects which usually produce the worst changes in calibration. The following description is quoted in part from a longer description which unfortunately cannot be given in full.

Mr. Kruse's "Armchair Chats" this month include the following:

- A German Portable Set
- An Improved Oscillator
- Miniature Current Transformer
- A 110-volt Potentiometer
- The I. R. E. Patent-Digest
- Letters are Welcome

mitter "tone checker," as a "tuning meter," or as a receiving heterodyne. Furthermore, it is very simple, easy to construct, and inexpensive.

The device with all these virtues is simply a self-contained battery-driven oscillator with circuit precautions against the effects which usually produce the worst changes in calibration. The following description is quoted in part from a longer description which unfortunately cannot be given in full.

The circuit is the balanced-bridge version of the Colpitts circuit, and was developed by Willis Hoffman of the Burgess laboratories. Examination of Fig. 2 will show that if the coils  $L_1$  and  $L_2$  are alike we will have a balanced bridge whenever capacities  $C_1$  and  $C_2$  are equal. There will, accordingly, be no tendency for radio-frequency current to flow from point A to point B and very little tendency for it to flow by way of the plate supply from point C to point B. The choke,  $L_c$ , can usually be short circuited without producing any effect. To obtain this condition approximately in transmitting or receiving practice is entirely possible by simple mechanical precautions.

In Mr. Leuck's oscillator,  $C_1$  and  $C_2$  are the halves of a reconstructed receiving condenser which, in its new form, has two rotor sections connected together by the common shaft and meshing into separately insulated stator sections. The spacing has been doubled to improve stability of calibration.  $L_1$  and  $L_2$  are halves of the same split coil wound on a ux tube base whose prongs act as terminals. The bypass condenser,  $C_3$ , and the vacuum-tube socket are connected directly to the coil socket without any intervening wires whatever. As long as the coil is pushed clear down in the socket and the tube is not changed, the tuned system, therefore, remains stable and unchanged. In support of this point, Mr. Leuck says. . . "To get an idea of the meter's ability to retain its calibration the wavemeter was calibrated

from 9xL. A month later the receiver was set on the wavelengths at which 9xL was about to transmit according to its published schedule. This was done by means of the wavemeter (i.e., the oscillator here discussed.) The signals from 9xL came in without retuning the receiver on fully half the points. This was better than could rightfully be expected, since 9xL maintains an accuracy of only  $\frac{1}{10}$  of 1 per cent." (This is the guaranteed accuracy but 9xL actually does better on much of its work.)

The bridge circuit, together with the small size of the coils and other parts, makes the meter as free from hand-capacity effects as one could wish. Shielding is entirely unnecessary and useless. The device was accordingly mounted in an old Crosley receiver case. The front of the panel has but three objects mounted on it, a good vernier dial, the filament switch, and a pilot light. The pilot light has but one object in life; when it is included even the most absent-minded person can hardly forget to turn off the filament switch.

## RANGE COVERED

"The meter described was intended to cover the amateur bands with generous margin above and below. Its fundamental range is 32 to 50 meters. Since the oscillating receiver and this wavemeter both produce harmonics, the wavemeter is readily usable to determine wavelengths from 16 to 25 meters and from 64 to 100 meters. A 12-volt plate battery (several



This new miniature current transformer has been developed by Weston, seemingly for the experimenter.

BY WAY OF departing a bit from the discussion of our own affairs, let us take a look at the German portable broadcast receiver called the "Radio-Baron." It is made by Lorenz who innocently was the cause of our great crop of "wiggle-wound" coils of a few years ago.

The "Radio-Baron" normally lives in a carrying case and is self contained. A multiplicity of adjustments is provided unlike our American practice. First of all the loop is wound around the frame in two layers separated by half an inch. The high inductance thus provided is necessary for the upper wavelength range of the set, which tunes-in the long-wave European broadcasting stations. A tap switch on the panel permits dropping down to the usual range. The circuit is a double-detection one (super-heterodyne) and the two tuning controls are operated by a double drum dial of standard design. Filament power is supplied by a small "dry" storage battery and controlled by the usual rheostat and switch, the latter being on the panel and the former at the back of the set. Grid and plate voltages are supplied by a combined dry-cell B and C battery. Since the highest potential available with a new battery is 90 volts, the last audio tube is special, having an additional grid. It is not a screen-grid tube but is, I believe, a pentode which provides a moderate amount of power output without resorting to a power plant in our customary fashion. The highest potential ordinarily used by the Baron is 60 volts. Circuit variations in plenty are provided for; in addition to the range-change switch there is a lever for altering the coupling to the oscillator, a control for adjusting regeneration in the i.f. system, and provision for operating the set with 4, 5, or 6 tubes! Just what the last device does to the circuit cannot be discovered without wrecking the set. The empty sockets are jumpered by means of a double-ended plug cord. Presumably, the purpose is to save tubes and batteries on local reception.

The loud speaker is peculiar. The rather large diaphragm is of something resembling celluloid and is driven from the center. It is, however, neither flat nor conical but of some curved form, possibly logarithmic.



The "Radio Baron," a self-contained loop-operated portable receiver of German manufacture.



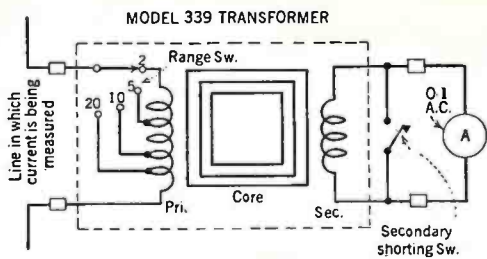

Fig. 1—Schematic diagram showing method of connecting the miniature current transformer.

C batteries or one 22-volt tapped C battery) gives plenty of "poke" to make the last named range useful. The fundamental wave is then almost too strong. Oscillations will occur when only 6 or 9 volts are used on the plate. Too much plate battery brings out the unwanted odd harmonics. A battery potential of 22.5 volts is more than should be used. Harmonics more remote than those named can be used but they are rather weak."

CURVE SHEET

When using a variable condenser having two rotor sections and two stator sections, each of 4 plates and double-spaced, the tuning range shown on the curve sheet is obtained with a 23-turn coil of No. 28 wire space-wound on a UX tube base. The coil is split, hence each section has 11½ turns. In case the meter is to cover a higher band of wavelengths the UX base will prove too small. Its size can be increased by means of a tube that will just slip over the base, and such a tube may be secured with small screws. However, ready-made forms of sufficient size are now obtainable.

By plotting the dial readings against both wavelength and frequency we have a combination wavemeter and frequency meter. The curve chart is also an instrument for converting wavelengths to frequencies, and *vice versa*. For example, suppose we wish to know the frequency corresponding to a wavelength of 43 meters. We find (wavelength) 43 meters on the left of the chart, follow the ordinate to the right until it intersects the wavelength curve, then follow downward until we intersect the frequency curve, then to the right again, and read off the frequency—7000 kilocycles. For such conversions the dial reading does not concern us.

The curve sheet shown is for a particular meter. It covers only the one band since, when the meter is used in the band above or below, it is only necessary to multiply or divide the reading by 2.

CALIBRATION

To calibrate such a meter it is necessary to secure a sufficient number of points from the transmissions of standard-frequency stations such as 9XL and wvv.

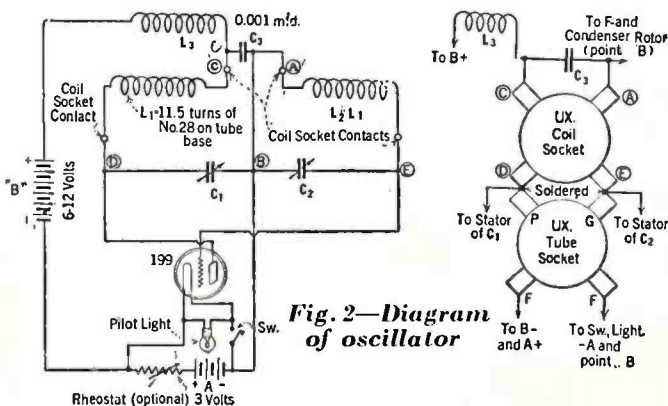

Fig. 2—Diagram of oscillator

Commercial stations whose wavelengths are known may also be used. The method is as follows: first tune-in the standard signal on an oscillating receiver and adjust the tuning controls to zero beat. Then (without touching the receiver) tune the oscillator until it produces zero beat with the receiver and standard signal. Record the wavelength and oscillator setting and proceed to the next point. Since the second harmonic of both receiver and oscillator is easily distinguished by its strength, points may be obtained also from signals of half or twice the wavelength at which calibration is desired. The receiver, of course, is tuned to the signal and the oscillator to half or twice the wavelength so that the fundamental of one beats with the second harmonic of the other.

USES OF THIS METER

Besides serving most of the ordinary purposes of an oscillator, the meter is of aid in locating stations whose wavelengths

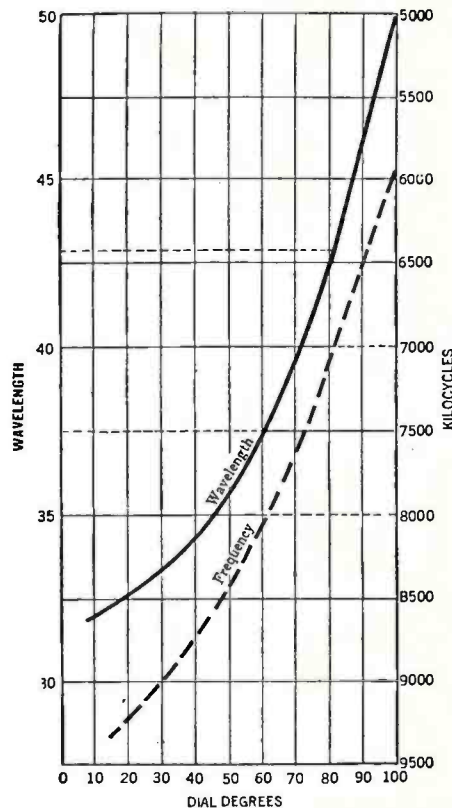

Fig. 3—Calibration curves of Mr. Leuck's oscillator.

are known, it comes in handy when building or altering a short-wave receiver, and is useful in adjusting the wavelength and tone of a transmitter carrier. In doing the latter it is useful to listen to a harmonic of the transmitter while beating it against the receiver and one of the frequencies of the meter. Mr. Leuck suggests, however, that "if one feels it imperative to listen on the transmitter fundamental, this may be done after the oscillator has been equipped with a pair of phones and the sensitivity sufficiently reduced by enclosing the oscillator bodily in a metal shield such as a tin bucket. The phone cord may emerge through a hole in the bucket lid and," Mr. Leuck dryly adds, "it is necessary to devise an extension to the tuning knob to reach outside the pail or else put an assistant inside to do the tuning."



A convenient wire-wound potentiometer for 110-volt circuits.

Miniature Current Transformer

FOR THE particular use of the experimenter, seemingly, Weston has just offered a miniature current transformer (type 539). With a single one-ampere a.c. ammeter, such as the type 528, it makes possible measurement of any current from 0.2 to 200 amperes. For currents below 1 ampere the meter is used alone. For currents from 1 to 20 amperes the meter is connected as shown in Fig. 1 and the primary switch is set to the proper range. For larger currents—up to 200 amps.—the line itself is treaded through the "window" of the core.

If the line is put through once the maximum of the meter range represents 200 amperes, if twice—100 amps., and if 4 times—50 amps. Even if we assume that we will use only the upper ¼ of the meter scale we can obtain the following ranges, which have liberal overlaps. 0.2-1, 0.4-2, 1-5, 4-20, 10-50, 20-100, 40-200. The rather awkward range of 13.3-66.6 amps. (obtained with three conductors through the window) may be omitted.

Most current transformers have their ranges disturbed and their insulation burned if the secondary is left unloaded (meter off) while current flows through the primary. The size and design of the 539 largely prevents this but a shorting switch (See Fig. 1) has been provided as a precaution.

A 110-Volt Potentiometer

THERE IS much peace of mind in being able to apply voltage gradually instead of "slamming it on." A recent temporary need for a variable a. c. voltage resulted in the acquisition of a Ward Leonard "Vitrohm" potentiometer of a pattern which may be left continuously across a supply potential as high as 125 volts a.c. or d.c. It is known as catalogue No. 64304A and has a resistance of 250 ohms. There are 22 contact points and the slider covers two at a time, thus providing 20 steps with sparkless transfer. Obviously, the device may also be used as a rheostat. It costs less than a single UX-210 and may easily save much more.

The I. R. E. Patent Digest

IT IS REGRETTABLE that the patent digest has gone from the pages of the I. R. E. *Proceedings*. Having asked some dozen or so of the members, I find confirmation of my feeling that the ordinary member read this digest with interest, found it stimulating, and looks forward to the time when it will again be possible for Mr. Brady to furnish this review.

Letters are Welcome

LETTERS or informal papers to be read or discussed in "The Experimenter's Armchair" are welcome. They should be addressed to Robert S. Kruse, RADIO BROADCAST, Garden City, N. Y., and should refer to these pages by title.



# RADIO-FREQUENCY OSCILLATORS

A VACUUM TUBE will not only amplify and detect radio- and audio-frequency waves but it will also generate them. How does a tube oscillate? What are the controlling factors, how much power can be obtained from it, how can it be adjusted to give maximum power output, maximum efficiency, etc.?

Consider Fig. 1. It represents the apparatus in one of the oldest and most famous experiments in radio science. It is a condenser which is permitted to discharge through an inductance and a resistance. Usually the greatest part of the resistance of such a circuit is the resistance of the spark gap. When photographs of such a spark are made on a rotating mirror, it will be seen that the spark does not jump the gap all in one leap, but that it oscillates back and forth, at one instant going through the gap from A to B, and in the next instant going from B to A. The number of times per second these oscillations occur, depends upon the values of L and C, and the total number that take place before they eventually die out depends largely upon R. If the resistance is high, only a few oscillations take place, Fig. 2A, and if the resistance is low, many oscillations take place, Fig. 2B. If the resistance could be reduced to zero, continuous oscillations or waves (cw) would take place (see Fig. 2C); there would be no tendency for them to die out, and if a negative resistance could be added, the system would even supply a certain amount of radio-frequency power to an outside circuit without the oscillations dying out.

Consider now an amplifier tube. The tuned circuit is in its plate circuit and it is coupled to the grid circuit through a tickler coil. Suppose the condenser in this tuned circuit is discharged through the coil and the series resistance. This discharge current sets up a voltage across the inductance which induces a voltage on the grid of the tube equal to  $M\omega IL$ , where M is the mutual inductance between the two coils,  $\omega$  is 6.28 times the frequency, and IL is the current through the coil. This voltage will be amplified and applied to the tuned circuit again. If this amplified voltage is greater than the original discharge voltage

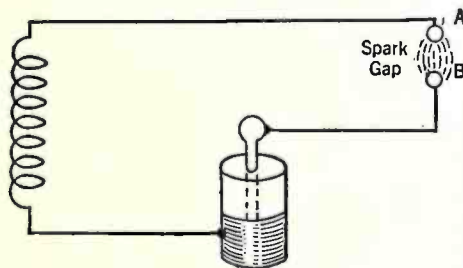

Fig. 1—A coil, a Leyden jar, and spark gap—this was the first transmitter.

across the inductance, oscillations will be built up in this circuit, and will continue at an amplitude depending upon the circuit constants. If the amplified voltage is less than the original discharge voltage, the oscillations in the tuned circuit will be prolonged, but cannot continue forever. If the returned voltage is just equal to the original discharge, the oscillations cannot increase in value, the circuit will be in an unstable condition, and cannot supply any power to another circuit.

The plate current of such a tube consists of the average or d.c. value taken from the plate battery plus the a.c. variations just as in an ordinary amplifier tube. In other words, an oscillating tube may be thought of as a self-excited amplifier. The grid voltage depends upon the strength of the oscillations and the coupling between tickler and plate coil. This grid voltage drives the plate circuit into producing corresponding plate-current variations. This a.c. plate current produces an a.c. voltage across the tuned circuit, and thereby produces a current that circulates between coil and condenser.

How much can the a.c. plate current be? Suppose the plate current curve is as shown in Fig. 4. When oscillations start, the a.c. plate current is small. If the operating point is such that the average value of current taken from the plate battery, which is the current read by a d.c. meter, is midway between zero and the saturation current, B, or the maximum permitted by the C bias and a.c. grid voltage, then the maximum variations from this average must be  $I_s/2$ . Thus we have a plate current varying from twice the d.c. value to zero. This is an a.c. current whose maximum value is equal to the d.c. plate current and whose ef-

fective value is  $I_{d.c.} \times 0.707$ . The plate current is also equal to the grid voltage multiplied by the mutual conductance of the circuit—which we shall assume is the  $G_m$  of the tube. Thus,

$$i_p = e_g \times G_m \quad (1)$$

$$= I_{d.c.} \quad (2)$$

$$\text{or } e_g = \frac{I_{d.c.}}{G_m} \quad (3)$$

This is the a.c. grid voltage which is amplified in the tube, and placed across the tuned circuit thereby setting up an oscillatory current in it. Normally this oscillatory current is about 20 times as great as the d.c. plate cur-

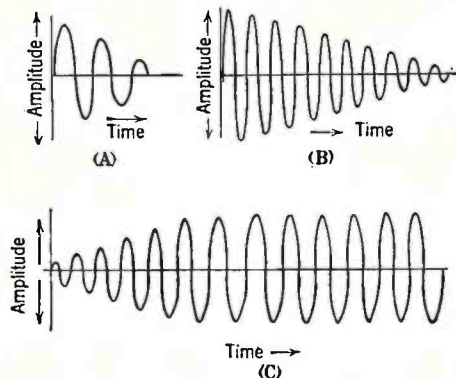

Fig. 2—(A) A highly damped wave; (B) a slightly damped wave; (C) a continuous wave.

rent. This current induces an a.c. grid voltage on the grid coil, and the process goes on ad infinitum. This oscillatory current can be calculated from

$$e_g = IL \frac{M\omega}{eg} \quad (4)$$

$$IL = \frac{I_{d.c.}}{G_m \times M\omega} \quad (5)$$

The power in the oscillatory circuit is equal to

$$P_{osc} = (IL \times .707)^2 r \quad (6)$$

where r is the resistance of the tuned circuit. This power will be a maximum when the effective resistance of the tuned circuit,  $L^2\omega^2/r$  or  $L/Cr$  is equal to the tube plate resistance. The power into the tube from the B batteries is the product of the d.c. plate current and the d.c. plate voltage. The efficiency of the circuit is the ratio between the power in the oscillatory circuit and the total power taken from the B battery.

$$P_{total} = E_p I_p \quad (7)$$

$$Eff = \frac{P_{osc}}{P_{total}} = \frac{(IL \times .707)^2 r}{I_p E_p} \quad (8)$$

### Conditions for Oscillation

If the mutual inductance or coupling between grid and plate coils is varied, it will be found that the tube will oscillate over a certain range in coupling, but not at either greater or less coupling than this range of values. The conditions for oscillations are

$$M \text{ must be greater than } \frac{1}{\mu} (L \times C \times r \times R_p) \quad (9)$$

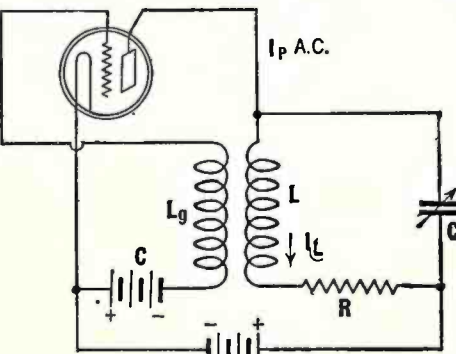

Fig. 3—A standard grid-tickler transmitting circuit.

which may be written approximately as

$$M > \frac{L}{\mu} \quad (10)$$

Problem: In the Laboratory an inductance of 387 microhenries was tuned by a condenser to 1225 meters,  $f = 245$  kc. A tube with a  $\mu$  of 8 was connected to it in a tuned plate circuit (Fig. 3). Resistances were added to the tuned circuit, and the plate current and oscillating current were read. The values of total circuit resistance, plate current, and oscillating current are given below.

Total resistance	$I_p$ (mA.)	$I_{osc}$ (mA.)	$P_{total}$	$P_{osc}$	Eff.
25	9	250			
35	16	230			
38	19	200			
40	22	100			

### Procedure

1. Calculate the power taken from the plate battery ( $E_p = 200$ ) from (7) at each value of total resistance and fill in the table above.
2. Calculate power in oscillating circuit from (6). Since the meter read the effective value of the current, it will not be necessary to multiply by 0.707 to get the correct value of IL.
3. Calculate the efficiency of the circuit for each value of total oscillatory circuit resistance.
4. Calculate the effective resistance of the tuned circuit,  $L^2\omega^2/r$  or  $L/Cr$ .
5. Assume that the plate resistance of the tube is equal to the effective resistance of the tuned circuit when the maximum power is transferred to the latter, and therefrom determine what the plate resistance of the tube in this experiment was.
6. From (10) calculate the value of M in microhenries for oscillation.
7. Remembering that  $G_m$  equals  $\mu/R_p$ , calculate the  $G_m$  of the tube.
8. From these values of  $I_p$  (d.c.), mutual

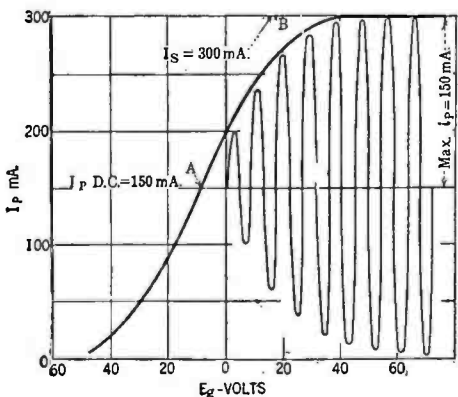

Fig. 4—How oscillations build up in a transmitting tube.

conductance, and mutual inductance, calculate the oscillating current at each value of total resistance and see how it checks the values given in the table above.

9. At each value of resistance, calculate the a.c. grid voltage from (4).

10. From (4) and (1) calculate the a.c. plate current for each resistance value and see how it checks the d.c. plate current.

Note. Do not worry if the values you calculate do not check very closely the values as measured in the Laboratory. The mathematics which you use in the above formulas are only true when the d.c. plate current is adjusted and the feed back is arranged so that a sine wave is generated. In this experiment, it is probable that a very poor wave form was generated, and that with no added resistance the d.c. plate current was equal to the peak value of the a.c. current. It will be most nearly equal to it when the tube is acting nearly 50 per cent. efficient, however.

When a tube has a large C bias and is worked far down on its plate current curve, it cannot generate sine waves. It becomes more efficient, however, and this is why an amateur can push 200 watts into his 50-watt tube without burning holes in the plate. The circuit is more efficient—he is using a large grid leak—and more power goes into the load than is used up on the plate, but he is doing this at the expense of a pure wave form. He is filling the ether with harmonic radiations and he need not be surprised if he gets a card from someone who has identified his call in the 20-meter band, although his wavemeter says his wavelength is 40 meters.



# MEASURING CAPACITY

THE ESSENTIAL PARTS of every tuned circuit, of which radio receivers are made, are capacities and inductances. "Home-Study Sheet" No. 20 told how to build a standard inductance for the home laboratory or shop; this "Home-Study Sheet" gives some of the fundamental facts about condensers.

## Capacity Measurements

Eliminating the slight effect of the edges, the capacity of two opposing conducting surfaces, as in Fig. 1, is given by the simple equation:

$$C = \frac{0.0885 S}{T} \text{ micromicrofarads}$$

S is the area of one plate, and T the distance apart, both in centimeters. If the dimensions are in inches, the formula is:

$$C = \frac{0.225}{T} S \text{ micromicrofarads}$$

If the space between the plates is occupied by any other insulator (called the dielectric) than air, the above values must be multiplied by the dielectric constant of the material used. For mica this constant may vary from 4 to 8, for glass from 3 to 10, and for waxed paper from 3.5 to 3.75.

For example, the capacity of the condenser in Fig. 1 is 88.5 mmfd.

To the experimenter these formulas have little practical application except to afford some means of estimating capacities. In the usual form of variable air condenser accurate measurements would be extremely difficult, if not impossible. We are, therefore, dependent on some known capacity for a standard. No reliance whatever can be placed in the stated capacities of the many small fixed condensers on the market, the error not infrequently being as great as 50 per cent. The G.R. 347 variable condenser may be had at a reasonable cost, and carries a scale reading directly in micromicrofarads from zero to 500 or 1000. The upper end of the scale of this condenser could be accepted with assurance of a very fair degree of accuracy, and the instrument is well adapted to laboratory work as it is inclosed in a metal shield. In any case, see to it that the condenser chosen is of the straight-capacity-line type, has a maximum capacity of not less than 500 (preferably 1000) micromicrofarads, has very durable bearings, has no stop to prevent the plates from revolving completely, and has the dial firmly secured to the shaft. It is also desirable to have a condenser with some sort of fine vernier that can be disconnected, as many times the condenser will be used for approximate determinations when a vernier would be quite inconvenient. At other times, when using loose coupling and absolute resonance is necessary, the vernier cannot be too sensitive.

If the experimenter is fortunately in a position to have his chosen condenser calibrated for him at about ten points, his troubles may be ended quickly. A curve should then be laid out on squared paper having ten lines to the inch. The resulting capacity readings may then be tabulated opposite each of the one hundred points of the dial, such a tabulating being much more convenient for general use than a curve.

## Standard Condensers

Standard laboratory condensers of the variable type generally carry a label stating the values at ten different points. If access can be gained to one of these at a near-by college, school, or electrical establishment, the values should be transferred to the new condenser by

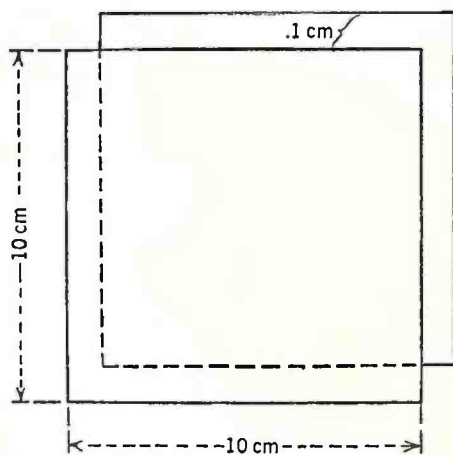

Fig. 1—Schematic drawing of a simple condenser.

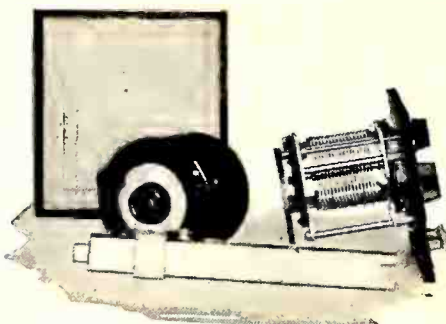

Fig. 2—Two calibrated variable condensers. The ten-inch slide rule shows their comparative size and the chart shows the usual type of calibration curve.

means of the substitution method. Set the standard condenser on one of the points at which it has been calibrated. Connect it to terminals "Y" of the bridge ("Home-Study Sheet" No. 21) and then balance it with an extra variable condenser connected to the "X" terminals at a 1:1 ratio, or, if a third condenser is not available, use a fixed condenser and the slide-wire. When a perfect balance is secured, replace the standard (connected to "Y") with the new condenser, and adjust it carefully until it is in balance; i.e., until its capacity equals the known value of the standard condenser. Have the leads to the condensers fairly long, and

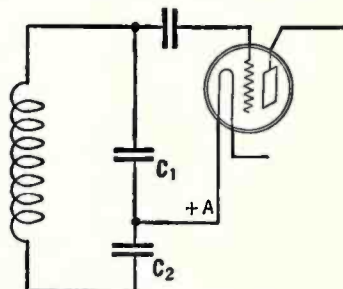

Fig. 3—The circuit used in problem No. 3.

maintain them in the same relation throughout the comparison in order that their capacities will remain constant. The new condenser should be compared at least twice to each of the known values of the standard condenser, using different settings of the slide-wire and capacity. The advantage of this method is that its accuracy is not affected by any errors in the bridge.

When making measurements of capacities on a bridge, the laboratory worker must remember that a condenser has a negative reactance, and so the ratio used in determining the capacity of a condenser in terms of a standard must be reversed. Thus, if resistance or inductances were measured on a bridge, and the two lengths of a slide-wire which gave the ratio between the standard and the unknown resistance or capacity were A/B, when capacities are measured and the balance is obtained, the proper ratio to use is B/A. Thus, if the lengths of slide-wire to balance two inductances, L<sub>x</sub> and L<sub>s</sub>, are 4/5,

$$\frac{L_x}{L_s} = \frac{4}{5} \text{ or } L_x = \frac{5}{4} L_s$$

when capacities are balanced by this ratio, the correct value of

$$C_x = \frac{4}{5} C_s$$

At this point it would be appropriate for the experimenter to familiarize himself a little further with his equipment and at the same time experimentally verify the rule for combining two condensers in parallel or series.

## Formulas

In the first case the capacities are merely added, and the demonstration of this fact simply requires the measurement of the two capacities separately and then comparing their addition with the measured capacity of the two connected in parallel.

The resultant capacity of two condensers of

capacities A and B in series is the reciprocal of the sum of the reciprocals or

$$\frac{1}{\frac{1}{A} + \frac{1}{B}} \text{ or } \frac{A \times B}{A + B}$$

Thus, if both capacities are 1, then the resultant is obviously  $\frac{1}{2}$ . To verify this, measure each capacity separately, and then compute the resultant, which may then be compared with the measured value of the two condensers connected in series.

While the expression, the reciprocal of the sum of the reciprocals, sounds rather deep, the reason for it is very simple, and requires no mathematical demonstration to show why it should be so. The reactance of a condenser is decreased as the capacity is increased, so that the reciprocal is proportionate to the reactance. The sum of the reciprocals then is, therefore, simply adding two series resistances, as it were, and represents the total reactance. To get this back into terms of capacity again, we merely turn the expression upside down.

While a variable condenser of 0.001 mfd. will generally be found sufficient, it is desirable to calibrate two or three fixed condensers of larger values, for which purpose the usual square mica condensers, securely held together by two eyelets, are satisfactory. In making such determinations do not use the slide-wire at too great a ratio—say not over 5:1. When the measurement of large values is necessary, it is better to measure a condenser of intermediate value, and then proceed from it to the higher value.

For the measurement of a very small capacity, such as the minimum of a variable condenser, it is advisable to connect it in parallel with the calibrated condenser, set at about half capacity. With the bridge, balance this combination against any available condenser, and note the dial reading. Disconnect the small condenser, and balance again. The difference between the two readings will be the desired capacity.

## Problems

Problem 1: Two condensers, each of 200 mmfd., are connected in parallel. What is the resultant capacity? If one is 200 and one is 400 mmfd., what is the resultant capacity?

Problem 2: The condensers described above are connected in series. What is the resultant capacity?

Problem 3: In a certain receiver circuit it is necessary to ground the tuning condenser to the filament of the tube but it is not permissible to ground the coil. This can be done by connecting another condenser into the tuned circuit, as in Fig. 3. Must C<sub>2</sub> be large or small compared to C<sub>1</sub>, so that the tuning range of the circuit will not be altered appreciably? For example, if C<sub>1</sub> is 500 mmfd., how large should C<sub>2</sub> be?

Problem 4: An antenna has an effective capacity of 0.0002 mfd. How much capacity must be added in series to reduce this capacity to 0.00015 mfd.? If the inductance in the antenna has not been changed, what is its natural wavelength now?

Problem 5: Two plates 10 cm on a side are separated by 3 mm of dry air. What is the capacity of the condenser? Suppose a sheet of mica, dielectric constant = 6, is put between the plates. What is the capacity now?

Problem 6: A fixed condenser across a given inductance has a capacity of 1000 mmfd. and tunes the inductance to 1000 meters. A variable condenser having a maximum capacity of 1000 and a minimum capacity of 25 mmfd. is placed in series with it. Plot the wavelength against added series capacity. (Note: Wavelength in meters = 1.884 LC where L = μh and C = mmfd.)

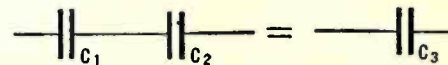

$$C_3 = \frac{C_1 \times C_2}{C_1 + C_2} = \frac{1}{\frac{1}{C_1} + \frac{1}{C_2}}$$

Fig. 4—Capacity formula for condensers in series.

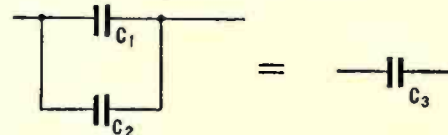

$$C_3 = C_1 + C_2$$

Fig. 5—Capacity formula for condensers in parallel.



# A SIMPLE TWO-TUBE V. T. VOLTMETER

By HOWARD E. RHODES

Technical Editor

ONE OF THE most useful instruments to be found in a radio laboratory is the vacuum-tube voltmeter—it is practically an indispensable piece of apparatus in many measurements on circuits and parts used in radio receiving sets. In its simplest form it consists of a tube and meter connected as indicated in Fig. 1A, the B and C potentials being such that the tube is operated on the lower bend of its  $I_p-E_g$  characteristic, so that any voltage impressed on the grid produces an increase in plate current. However, unless a very sensitive measuring instrument is used in the plate circuit, this arrangement has the disadvantage that its sensitivity is not very great; with a 200-microampere meter it is generally impossible to read, with good accuracy, any potential below 0.6 volt. A second disadvantage is that the calibration of the instrument is quite sensitive to changes in the A, B, or C battery voltages.

An unusual form of vacuum-tube voltmeter which does not have these two disadvantages was constructed recently in the Laboratory. This instrument has been used with very satisfactory results for some time and its construction is described in this article. The voltmeter was designed especially for making measurements on phonograph pick-up units, but it is equally suitable for any measurements at frequencies between about 60 and 8000 cycles. However, the usefulness of this meter is limited to audio frequencies because it incorporates a one-stage a.f. amplifier which has a flat characteristic between 60 and 8000 cycles.

## Features of Meters

THE CIRCUIT diagram of the voltmeter is given in Fig. 4. It consists essentially of a simple one-tube voltmeter with a stage of audio-frequency amplification ahead of it. From the stage of amplification, a voltage gain of about eight is obtained, and the sensitivity is consequently increased by a factor of eight, so that when using a 200-microampere meter at M we can now read potentials down to about 0.1 volt

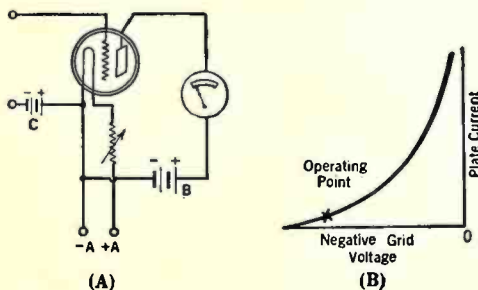

Fig. 1—(A) a simple v.t. voltmeter circuit; (B)  $I_p-E_g$  curve of tube showing operating point of meter.



View of the two-tube breadboard-type vacuum-tube voltmeter constructed in the Laboratory.

and, by means of multipliers, up to about 4 volts—a voltage range of 40, corresponding to about 32 dB. By adding a stage of amplification we have, therefore, overcome one of the disadvantages of the simple voltmeter, i.e., lack of sensitivity.

Independence of changes in A, B, and C voltages is obtained by supplying all of these potentials from a single battery.

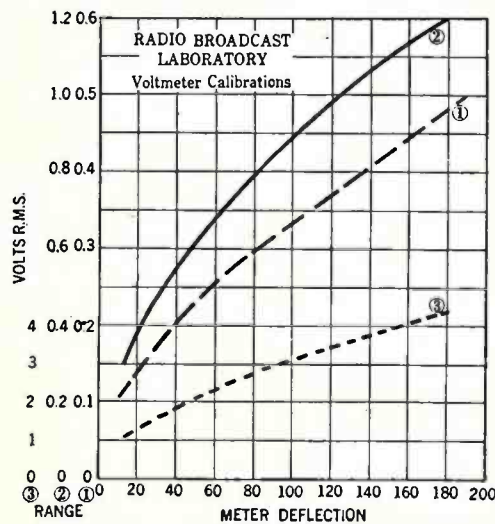

Fig. 2—Calibration curves of the v.t. voltmeter described in this article.

By adjusting a single resistor,  $R_3$ , it is always possible to set accurately all the voltages so that a single calibration is correct over a long period of time.

The voltmeter uses two 199-type tubes with their filaments connected in parallel and supplied from a single 45-volt B battery—in the Laboratory a 45-volt storage battery was used. In the plus lead from the battery are connected three resistors,  $R_1$ ,  $R_2$ , and  $R_3$ , the total resistance of these three units being such as to permit about 120 mA. to flow through the circuit—each tube filament takes 60 mA. The voltage drop across the 300-ohm resistor,  $R_1$ , supplies a plate potential of  $300 \times 0.12$  or 36 volts to the plates of the

tubes. A C-bias potential of 2.4 volts for the grid of the first tube is supplied by  $R_4$ , a 20-ohm resistor in the A-minus lead to the tube. A 66-ohm resistor,  $R_5$ , supplies a C bias of 8 volts to the grid of the second tube. The tubes are resistance coupled, the plate resistor being  $R_6$ , a 50,000-ohm unit, the grid resistance,  $R_7$ , 1 megohm, and the coupling condenser, C, with a capacity of 0.01 mfd.

The steady plate current from the last tube is about 150 microamperes, and, in order that the entire scale of the meter may be used, it is necessary that the steady current be balanced out. This is accomplished by connecting a rheostat,  $R_2$ , in series with the plus lead and utilizing the

voltage drop across it to send a current around through  $R_8$ , a 4000-ohm resistor, and the meter, M. The direction of this current is opposite to that of the plate current and, by adjusting the position of the slider on the rheostat  $R_2$ , we are able, therefore, to balance out the steady plate current and bring the pointer of the meter back to exactly zero.

In operating the voltmeter it was found that if the resistance of  $R_3$  was slightly reduced, so that more current flowed through the circuit, the reading of M increased; if the resistance was increased the pointer on M moved back passed the zero point. This fact affords a simple and accurate method of adjusting the instrument to the correct operating point. The battery potential may vary from 40 to 50 volts and it will always be possible to adjust the voltmeter correctly by simply adjusting  $R_3$  so that the pointer is at exactly zero. It has been found possible to set up the voltmeter in the Laboratory and, with this single adjustment, exactly to duplicate a calibration made several months ago.

## Voltage Range

THE VOLTAGE RANGE of the instrument was increased by connecting several resistances,  $R_9$ ,  $R_{10}$ , and  $R_{11}$ , in series across the input terminals. With the lead from the grid connected to terminal No. 1 a calibration corresponding curve 1 in Fig. 2 was obtained. Curves 2 and 3 were obtained by connecting the grid lead to terminals 2 and 3, respectively.

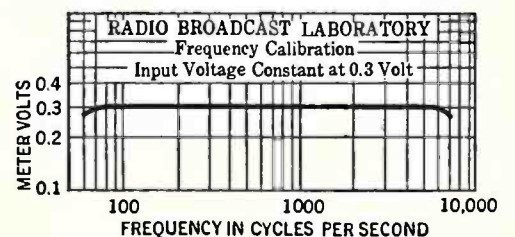

Fig. 3—Frequency characteristics of the v.t. voltmeter designed by the writer.



The frequency calibration curve is given in Fig. 3. It is practically flat from 60 to 8000 cycles—which we considered the useful range of the device.

The fact that a high resistance,  $R_7$ , is in the grid circuit of the second tube introduces a rather unusual characteristic. It has been found that as soon as an a.c. voltage, sufficient to swing the grid positive so that grid current flows, is impressed across the grid of the second tube, the reading of the plate meter,  $M$ , begins to decrease instead of increase. This characteristic prevents damage to the meter in case excessive a.c. input is applied to the voltmeter—this is certainly an advantage. The disadvantage of this arrangement is that false readings may be obtained unless it is realized that the meter is being overloaded. The decrease in plate current produced by overloading can be prevented by using a choke coil in place of  $R_7$ , but the coil must have a very high inductance to prevent a decrease in gain at the low frequencies. A coil with an inductance of between 100 to 200 henries will probably be found satisfactory. The coupling con-

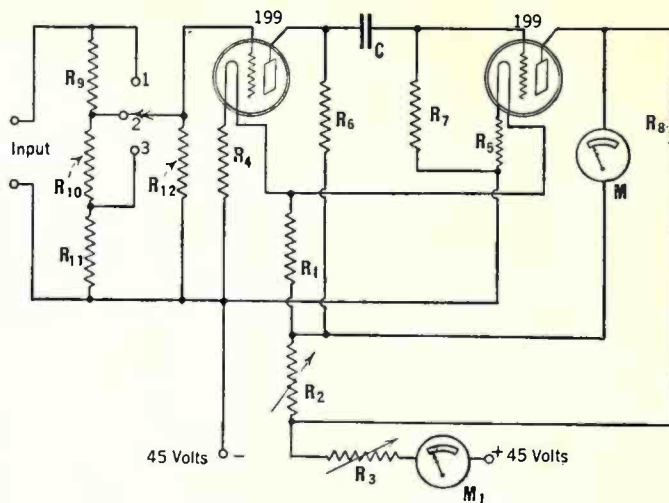

Fig. 4—Schematic diagram of the v.t. voltmeter pictured on page 107.

denser, when using a choke, may have to be increased to about 0.5 or 1 mfd.

The Laboratory's meter has been constructed on a baseboard as indicated in the picture. There is nothing unusual about either the parts or their arrangement on the board—except possibly that we would suggest that a Patent or G.R.

rheostat be used for  $R_2$ , since these are the only rheostats we know of that can be fastened directly to the baseboard. A wood screw should also be passed through the center hole which normally holds the shaft. When the correct adjustment of  $R_2$  has been determined, this screw will serve to hold securely the arm of the rheostat at the correct adjustment.

List of Parts

THE FOLLOWING is a complete list of the apparatus selected for the construction of the v.t. voltmeter described in this article:

- $C_1$  One Sangamo fixed condenser, 0.01-mfd.;
- $R_1$  One Ward-Leonard fixed resistor, type 507-93, 300-ohm;
- $R_2$  One rheostat, 2-ohm;
- $R_3$  One Centralab power rheostat, 150-ohm;
- $R_4$  One Frost fixed filament resistor, 20-ohm;
- $R_5$  Three Frost fixed filament resistors connected in parallel, two 20-ohm and one 25-ohm units;
- $R_6$  One Durham Metallized resistor, 50,000-ohm;
- $R_7$  One Durham Metallized resistor, 2-megohm;
- $R_8$  One Ward Leonard fixed resistor, type 507-29, 4000-ohm;
- $R_9$  One Durham Metallized resistor, 0.25-megohm;
- $R_{10}$  One Durham Metallized resistor, 0.1 megohm;
- $R_{11}$  One Durham Metallized resistor, 50,000 ohm;
- $R_{12}$  One Durham Metallized resistor, 1-megohm;
- $R_{13}$  Two sockets;
- Falnestock clips, etc.

NEW 227-TYPE TUBE OF IMPROVED CONSTRUCTION

By F. X. RETTENMEYER  
Chief Engineer, F. A. D. Andrea, Inc.

DURING THE PAST SEASON dealers may have received quite a few complaints from purchasers of a.c.-operated radio receivers. The owners of these sets state that they frequently hear an annoying hiss and buzzing noise in the loud speaker. The cause of this noise has been traced by tube engineers to the 227-type detector tube. Fortunately, this trouble is not caused by the new tubes which are now available, but many of the old type are still in use.

If a 227-type tube is examined, it will be noticed that the heater and its insulation extends above the cathode by a small amount and it has been found that the noise described above is due to the fact that the exposed portion of the

insulating material collects a charge which builds up to a certain potential and then discharges to the cathode. This discharge, which is identical in action to that found in a leaky condenser, causes a buzzing type of interference which may occur at more or less regular intervals and which sounds not unlike radio-telegraph interference. In addition, the exposed portion of the heater sometimes introduces a certain amount of noise into the radio circuits by virtue of its effect on the tube space current. Both of these defects have been eliminated in the 227-type tubes now being manufactured. The cathode has been extended in the new tubes to the end of the insulation on the heater and it acts to shield the entire heater circuit from such interference.

The type of interference mentioned

above is, of course, present in all electric receivers but it is much more apparent in those sets which have good a.f. systems. That this must be the case is at once apparent when it is considered that a great many musical instruments produce characteristic tones of the same pitch as the interference (i.e., cymbals, castinets, bells, triangles, and the overtones of the violin). Further, the s's and th's of speech are hissing sounds which are vitally necessary for good articulation and are very similar in character to the above types of interference. To limit the range of reproduced speech and music so that the crackling and hissing noises would not appear would mean that the quality would be seriously marred, and a receiver is good only when it faithfully reproduces all the audible frequencies broadcast.

COMPLETE LIST OF R.C.A. LICENSEES

THE FOLLOWING is a complete list of the manufacturers licensed to operate under the patents of the Radio Corporation of America.

RECEIVING SET LICENSEES

The manufacturers listed below are licensed under the R.C.A. receiving set patents. Those manufacturers marked with an asterisk (\*) are also licensed under the power supply and amplifier licenses, and those marked with a dagger (†) are licensed under the electric phonograph patents.

- All-American Mohawk Corp.,\*† Chicago, Ill.
- American Bosch Magneto Corp., Springfield, Mass.
- Amrad Radio Corp.,† Medford Hillside, Mass.
- F.A.D. Andrea, Inc.,† Long Island City, N. Y.
- Atwater-Kent Mfg. Co., Philadelphia, Pa.
- Bremer-Tully Mfg. Co.,\*† Chicago, Ill.
- Buckingham Radio Corp.,\*† Chicago, Ill.
- Colonial Radio Corp.,† Long Island City, N. Y.
- Columbia Phonograph Corp., Chicago, Ill.
- Consolidated Radio Corp.,\*† (two Divisions)
- Wells-Gardner & Co., Chicago, Ill.
- Arborphone Division, Ann Arbor, Mich.
- Crosley Radio Corporation,\* Cincinnati, Ohio.
- Day-Pan Electric Co., Dayton, Ohio.
- Gulbrausen Co.,\*† Chicago, Ill.
- Electrical Research Laboratories, Inc.,\*† Chicago, Ill.
- Federal Telephone Mfg. Co.,\* Buffalo, N. Y.

- Freed-Eisemann Radio Corp., Brooklyn, N. Y. and Chas. Freshman, Inc., New York, N. Y.
- Gilfillan Bros. Inc.,\*† Los Angeles, Cal.
- A. H. Grebe & Co. Inc.,\* Richmond Hill, N. Y.
- Grigsby-Grunow Co.,\*† Chicago, Ill.
- Howard Radio Co.,\*† Chicago, Ill.
- Kellogg Switchboard & Supply Co., Chicago, Ill.
- Colin B. Kennedy Corp.,† Chicago, Ill.
- King Manufacturing Corp.,\* Buffalo, N. Y.
- Kolster Radio Corp.,\* Newark, N. J.
- Philadelphia Storage Battery Co.,\*† Philadelphia, Pa.
- Silver-Marshall, Inc.,† Chicago, Ill.
- Splittorf Radio Corp.,\*† Newark, N. J.
- Steinite Manufacturing Co.,\* Atchison, Kansas.
- Stewart Warner Speedometer Corp.,\* Chicago, Ill.
- Stromberg Carlson Telephone Mfg. Co.,\*† Rochester, N. Y.
- Temple Corp.,\*† Chicago, Ill.
- United States Radio & Television Corp.,\* Chicago, Ill. (three divisions)
- Apex Electric Mfg. Co., Chicago, Ill.
- Case Electric Company, Marion, Ind.
- Continental Radio Corp., Ft. Wayne, Ind.
- Walbert Radio Corp.,† Chicago, Ill.
- Zenith Radio Corporation,\* Chicago, Ill.

POWER SUPPLY AND AMPLIFIER LICENSEES

The following list includes manufacturers licensed under the R.C.A. power supply and amplifier patents. Other manufacturers licensed under these patents are the receiving set licensees (listed above)

which have been marked with an asterisk (\*).

- American Transformer Co., Newark, N. J.
- Autorad Electric Corp., Detroit, Mich.
- I. H. Eby Mfg. Co., Philadelphia, Pa.
- Electrad, Inc., New York City.
- Enterprise Mfg. Co. of Pa., Philadelphia, Pa.
- Farrand Mfg. Co. Inc., Long Island City, N. Y.
- Federal Radio Corporation, Buffalo, N. Y.
- Ferranti Inc., New York, N. Y.
- General Radio Co., Cambridge, Mass.
- Gray Products, Inc., Poughkeepsie, N. Y.
- Kingston Products Corporation, Kokomo, Ind.
- Martin Copeland Company, Providence, R. I.
- National Company, Inc., Malden, Mass.
- Radio Receptor Co., New York, N. Y.
- Sterling Manufacturing Co., Cleveland, Ohio.
- Thordarson Electric Manufacturing Corp., Chicago, Ill.
- J. S. Timmons Co. Inc., Philadelphia, Pa.

ELECTRIC PHONOGRAPH LICENSEES

Manufacturers licensed under the electric phonograph patents are those marked with a dagger (†) in the above list of receiving set licensees.

VACUUM-TUBE LICENSEES

The Raytheon Manufacturing Company Cambridge, Mass., is the only tube manufacturer which has thus far been granted a license to operate under the R.C.A. vacuum-tube patents.

I-8



# BROADCAST ENGINEERING

BY CARL DREHER

## Volume Control in Broadcast Transmission

THE PROBLEM of effective amplitude control in broadcast transmission is an old one which has been discussed from the beginning and which has not yet reached a final solution—although a satisfactory answer appears to be in sight. The necessity for it arises through the great range of variation characteristic of acoustic problems, and the fact that electrical machinery and conditions in general are not readily adapted to such a range.

A symphony orchestra which is being broadcast may emit ten million times as much sound energy at one time as another. Even if the range is only one million, it is not readily handled in the transmission chain following the microphone. The maximum amplitude must be set to pass through the various amplifier units without overloading. If, then, the minima are left as they enter the microphone, these portions of the transmission will drop below the inescapable noise level of the equipment itself (tube hiss, etc.), extraneous disturbances in transmission (cross-talk on wire lines, induction, etc.) and noise in reception originating in similar ways. The remedy is to compress the range of variation within such limits that it will fit into the design of the equipment, neither falling to a level where noise becomes objectionable, or overloading any part of the system, while retaining the essential characteristics of the original sound output with its artistic values.

The usual method adopted is the use of a manually operated voltage divider, otherwise known as a "gain control" or "volume control." This is inserted at some point in the transmission chain, as between amplifier stages. The total resistance of the potentiometer is usually 400,000–600,000 ohms, and the taps are so arranged that each step corresponds to a change of 2 DB, sometimes 3 DB. Steps of 2 DB correspond to about 25 per cent. voltage changes. The calibration holds only when no current is drawn by the circuit element ahead of the potentiometer.

### VOLUME INDICATORS

Such an amplitude control is usually used in conjunction with a volume indicator. This is simply a tube rectifier acting as a peak voltmeter. It may also be calibrated in DB. The task of the broadcast operator is to watch the indicator and to turn down the gain control when the meter indicates over-shooting, while when the volume drops too low he must raise the level. He is assisted, in some cases, by a view of the action at the pick-up point, while on other jobs he may have to work blind. He may have a musician working with him to indicate what is going to happen, so that the operator may be prepared for changes. Rehearsals, of course, are a great help. The job is well done when changes in volume are confined to an irreducible minimum, effected in advance of the instant when they become necessary, and not made so abruptly that the at-

tention of critical listeners is disturbed. These are difficult requirements.

An automatic volume control in place of the manually operated form, or in conjunction with the latter, was proposed some years ago as a solution, and it is probable that the next few years will witness its adoption in high-grade broadcast operation.

### AUTOMATIC CONTROL

The best known form of automatic volume control is the radio-frequency type used to maintain constant output in a radio receiver with varying field intensity, when a relatively distant station is being picked up. Such devices are usually operated by the carrier wave, variations in carrier intensity being compensated for by inverse changes in radio-frequency amplification. The operation of such a system is described by Harold A. Wheeler in a paper on "Automatic Volume Control for Radio Receiving Sets," in the *Proceedings of the Institute of Radio Engineers*, Vol. 16, No. 1, January, 1928. Mr. Wheeler shows a receiver with four neutralized radio-frequency stages, followed by a two-element rectifier with filter circuits arranged to separate the direct and audio-frequency components of the pulsating rectified voltage. The audio components are led through a manually operated gain control to the audio amplifier, which comprises four stages. The direct component of the rectified voltage is led back to the radio-frequency train as an automatic grid bias. Fig. 1, reproduced from Fig. 2 of Mr. Wheeler's paper, shows the circuit. With the circuit constants shown the rectifier reacts on the grids of the radio-frequency tubes in  $\frac{1}{4}$  second, so that the system is almost capable of wiping out the inherent audio-

frequency variations of sound. This time constant is, of course, controllable.

### ANOTHER AUTOMATIC DEVICE

More recently G. L. Beers and W. L. Carson, in a paper on "Developments in Super-heterodyne Receivers," published in the Vol. 17, No. 3, (March, 1929) *Proceedings of the Institute of Radio Engineers*, describe an automatic volume control, the circuit of which is here reproduced in Fig. 2. In this case the grid of the volume control tube is connected in parallel, through a coupling condenser, to the grid of the second detector of the super-heterodyne receiver. The voltage drop across a resistor in the plate circuit of the detector furnishes additional negative bias for the amplifier tubes, reducing the sensitivity of the receiver. The circuit constants are chosen to obtain the desired smoothing out without affecting the audio-frequency quality of reproduction. By means of the manual control on the grid of the volume-adjustment tube the degree of control may be set at any desired value. By increase of the bias on this tube a larger grid swing is permitted in the audio detector before the automatic volume control action comes into play.

The general principle of automatic volume controls for broadcast transmission is similar to that of the radio-frequency devices described, but some modifications are required. The method may utilize part of the input to an amplifier, which, after rectification, yields a d.c. component for control purposes either through grid or plate circuits of the amplifier. By means of a manual adjustment the audio gain control may be set to reduce the intensity range instead of smoothing it out altogether, since in broadcast transmission it is not desired to deliver a constant output with varying input, but merely to bring up the low portions, or reduce the peaks, within certain limits. This may be done by setting the automatic gain control so that it does not function except on peaks above the allowable level, or, alternatively, permitting it to operate at a low level to bring up the amplification as required. In either case the time constants must be chosen to give a rapid response, of the order of a tenth of a second.

It is probable that the automatic volume control for broadcast transmission will be useful only in conjunction with a carefully handled manual control. One reason for this is that announcements, in good broadcast practice, are transmitted well below the level of peaks in the music, a form of discrimination which cannot be expected from anything but a human operator. There is no reason, however, why the operator cannot throw a key, for instance, to lower the over-all gain 4–6 DB for speech, while the advantages of the automatic volume control are utilized during the musical intervals of the broadcast.

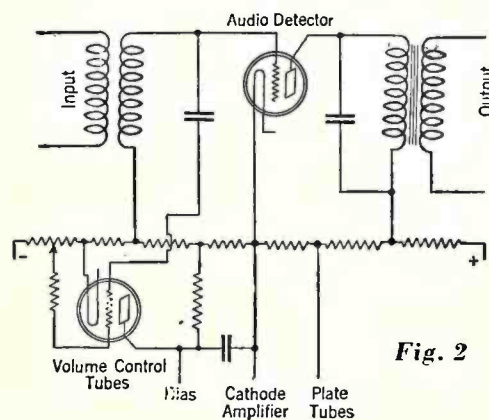

Fig. 2

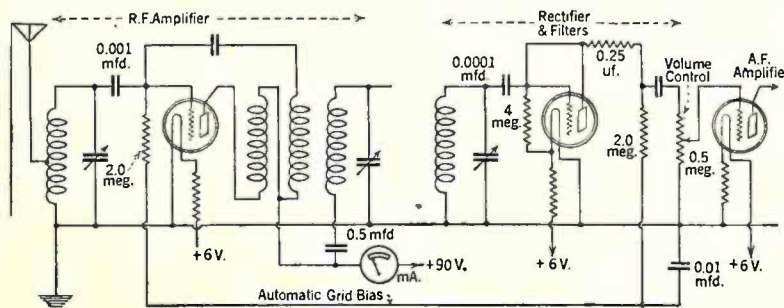
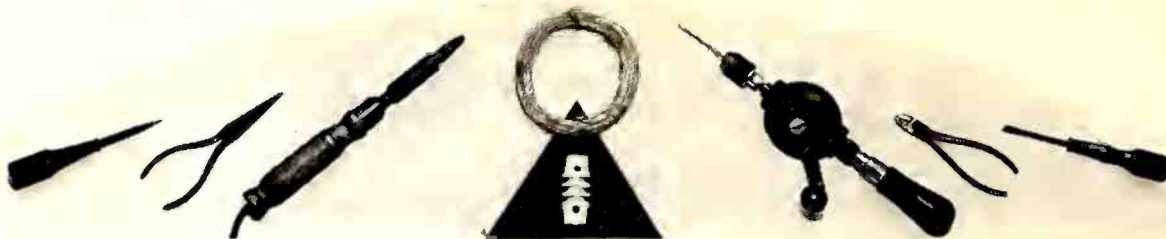

Fig. 1





## THE SERVICEMAN'S CORNER

**I**N "THE SERVICEMAN'S CORNER" for May, we considered the simplest and most inexpensive types of radio testers. We publish below a compromise between these more elementary models and the high-priced commercial instruments. The compromise, however, is merely one of price. The outfit described below is as elaborate and efficient as any portable equipment can well be. The contributor is F. W. HOWARD, radio electrician, of 444 Lakeview Avenue, Pitman, New Jersey.

A standard service test set: "The following description of a set- and tube-tester constructed by the writer may serve to bring encouragement to some brother serviceman to whom a set-tester and a seat on the Stock Exchange mean the same thing.

"The total cost of this outfit need not exceed \$25.00, even if every part of it has to be purchased new, and, as a matter of fact, nearly every serviceman will find a good part of the necessary equipment lying around his shop.

"Reference to the drawing will give the panel layout of the instruments, the dotted rectangle at the bottom representing the C battery, which is placed upside-down under the panel, and held in position by strips of the brass, which are in turn screwed to the brass frame.

"The mounting for the 0.1 meg. resistor is also fastened to the under side of the panel, between the meters and switches, E and F. The writer strapped this mounting between the top screws of the two Weston meters, thus avoiding the necessity of having screw heads showing on the face of the panel, but this is a matter of personal choice.

"The connections are shown in the diagram. Here it will be noted that each of the four switches has the direction of its throw indicated by double-pointed arrows, with an asterisk showing the position given on the panel layout. This might be termed the normal position for tests on d.c.-tube sets.

"In operation, connection is made between the tester and the socket of the set under test by means of a two-foot cord having tips on one end and a plug on the other. Plugs should be made up for all types of tubes. The writer has three plugs, for x base, y base, and v (standard) base. For testing uv-199 bases, or wd-11 type, use adapters which may be purchased at any parts store. In the case of uv-199, wd-11, and uv-201A tubes, it will also be necessary to use adapters in the sockets on the tester. The writer was unable to purchase one of the latter adapters, so he made one by bolting a standard uv-type socket to the top of a ux-tube base, connecting from prongs to springs with short pieces of wire. This serves to test uv-201A-type tubes. For testing uv-199 and wd-11 tubes, socket adapters were found which fitted into the uv socket of the homemade adapter.

"It is advisable to use different colors for the wires between plugs and tips, having corresponding wires of each cord of the same color. Thus, a solid blue would be —fil., blue with red tracer +fil., yellow grid, red plate, and for uv base, white cathode.

"These cord pins fit into the tip-jacks at the top of the panel, No. 2 being minus fil., No. 3 plus fil., No. 4 grid, No. 5 plate,



*The Modern Radio and Equipment Company, of Buffalo, N. Y., installed a public-address system at the aviation show in exchange for booth space.*

and No. 6 cathode. Nos. 1 and 4, with switch F thrown to normal (right) position, permit using the C battery as a source of low voltage d.c. for continuity tests, in connection with an external meter, or the same thing may be done using jacks Nos. 1 and 2, with switches D and E in normal (left) position, whereupon pushing button J gives a reading on the d.c. voltmeter if the external circuit is closed.

"It will be noted that switch D is a reversing switch for the d.c. voltmeter, which is very useful in testing certain types of sets, such as Radiola 20 and 25, where every other socket has reversed filament connections.

"Switch E shifts voltmeters, which is about the only necessary change between testing a d.c. and an a.c. set.

"Switch F cuts the local C battery into the grid circuit, thus making it possible to test a tube for "grid swing" in a socket which normally has no bias. This grid-swing test is made by pushing button J with switch G in its normal (right) position, thus connecting the plate circuit through the milliammeter. If it is deemed inadvisable to short the bias in this manner, switch F may be thrown to the center position, opening the grid circuit.

"Throwing switch G to the left position makes a high-reading voltmeter out of the milliammeter, with a reading of 100 volts per mA., and an accuracy plenty good enough for most tests. In this test position, button K gives cathode voltage, and button L gives plate voltage.

"Inductance switch H is a multiplier for the d.c. voltmeter, giving 2½, 5, and 10 times normal readings. Inductance switch

M is a shunt connector for the milliammeter, giving 2, 5, and 10 times normal. The writer wound these shunts by taking a shield-shaped piece of thin fiber which was anchored under the terminal nuts of the Weston meters. This fiber was pierced with several parallel lines of small holes, and the resistance wire passed in and out of these holes. For the multiplier resistance it is advisable to obtain some very small wire, as considerable resistance is necessary.

"The writer carries his tester in a cash box which measures 13" × 9½" and is 4" deep. The brass supporting frame is therefore made 3½" high, and the full length of the tester, the "runners" having felt strips shellacked to their under sides, to prevent scratching the customer's furniture. The 9½" width of the box allows room to carry a 201A-, a 226-, a 227-, a 171A-, a v-199-, and an x-199-type tube in a line between front of box and side of tester, which serve to keep the tester from rattling around, and also insures a spare of each of the common types of tubes.

"The list of parts, with designations corresponding to those on the plan of the panel and on the circuit diagram, is as follows:

- A—0-7 Beede a.c. voltmeter;
- B—0-10 Weston d.c. voltmeter;
- C—0-10 Weston milliammeter;
- D and G—Yaxley three-pole, double-throw, center position jack switch;
- E and F—Yaxley single-pole, double-throw, center position jack switch;
- H and M—Yaxley four-point inductance switch;
- J, K, and L—Pearl center push button;
- S—Eby sub-panel-type four-prong socket;
- SS—Eby sub-panel-type five-prong socket;
- 1-6—Yaxley tip jacks;
- 7" to 12" hard-rubber panel;
- 4' of ¾" × ¼" brass strip;
- ½-volt C battery;
- 100,000-ohm 2-watt Tobe Veritas resistors and mounting;
- Resistance wire from old 200-ohm potentiometer or equivalent.

### Miscellaneous

**S**OME helpful information on Zenith Sets: "When a Zenith model 11-E or 14-E or even a 16-EP gets so that the volume does not remain steady after a station has been tuned-in, it is very often caused by the rotary plates of the gang condenser becoming loose on the shaft.

"I have found a great number of Zeniths with this ailment and I find that a very efficient way of repairing a set of this type



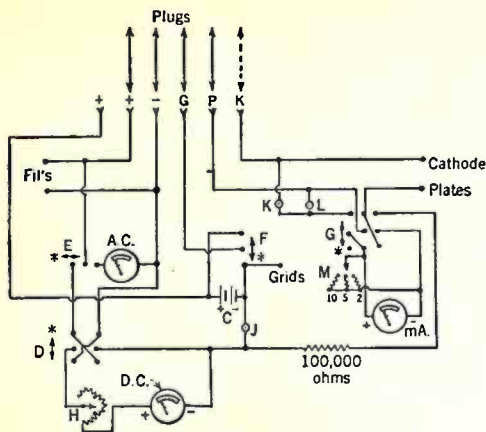

Schematic diagram of Mr. Howard's test set.

is to solder a piece of No. 22 hard-drawn brass wire across all of the rotary plates and ground the wire to the adjustment nut on the left end of the condenser shaft. The wire should be fastened under this adjustment nut first and then wrapped around the shaft once, forming a spiral, or pig-tail, before it is extended across and soldered to each of the rotary plate gangs.

"This will generally improve the operation of the set about 30 or 40 per cent.

"Another thing about the model 11-E and 14-E Zenith that needs a lot of attention is the balancing of the condensers. This, of course, should be done with a good oscillator. I find that the best volume and tone quality may be obtained by setting the second and third r.f. stages approximately two meters lower, and the detector stage) approximately three meters higher, (at 300 meters) than the antenna stage. If the four condensers are all set alike it will make the set so sharp that the tone quality will be affected materially."

A. D. WOODYATT, Marshfield, Ore.

An unusual case of distortion: "The writer recently ran into a case of distortion which is, he believes, a bit out of the ordinary. The owner of a Majestic Model 70 receiver complained of oscillation and distortion on all frequencies and a check of the set disclosed the fact that the r.f. plate voltages were too high and the plate voltage at the output was too low. The set was removed from the cabinet, checked carefully, and found o. k. as was the power-pack. The dynamic loud speaker was then checked and it was found that the field winding was shorted. As the field in this particular dynamic acts merely as a choke across the 96-220 volt output of the power-pack it would, of course have produced the above effect."

W. P. ERICKSON, Omaha, Neb.

Visual checking of resonance in ganged circuits: A visual means of indicating re-

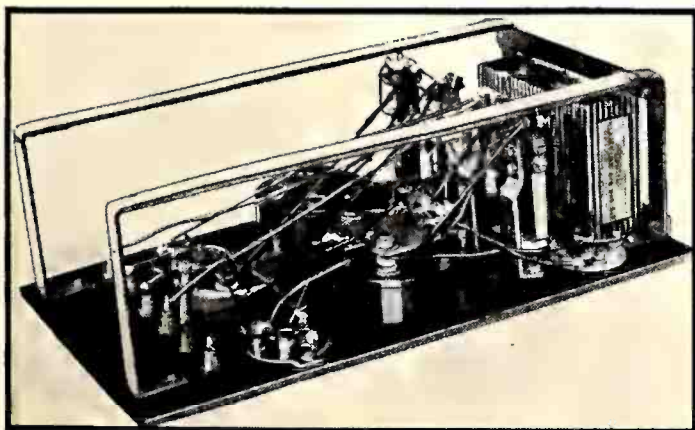

The arrangement of parts on the rear of the tester panel is shown clearly in this picture.

sonance in radio-frequency sets can be arranged simply by placing a low-reading milliammeter in the detector output. The deflection on the meter will be changed by the strength of the carrier wave applied to the grid of the detector tube.

With a given carrier wave, greatest deflection on the meter will denote resonance in the tuning of the set.

In the grid condenser and leak method of detection the deflection on the meter will read downward. In the plate method of detection the deflections will read upward. The meter range should be 0-2 mA.

M. CHERNOW, Polyphase Radio Laboratories, New York City

Insulating lacquer in an A.-K. set: This was encountered in an Atwater Kent model 30 six-tube single-control receiver. This receiver while playing perfectly would suddenly drop in volume. The A battery and connections, power unit, set, and antenna were found o.k. With the set operating, it was found that by pressing on the condenser associated with the detector tuning coil the above condition would obtain.

On the condensers in this set there are two screws which go through the bakelite end piece and screw into the stationary grid

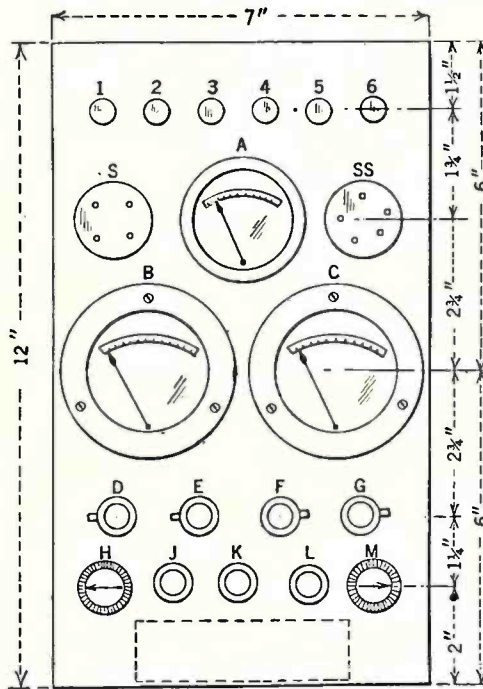

Panel layout of tester showing exact layout of parts.

condenser is connected, and from the other the grid end of the tuning coil is connected. All brass screws in these sets are lacquered and it was found that the screw connection to the grid end of the coil was causing a high-resistance connection due to the lacquer. The lacquer was removed with a file and the set performed as it should.

H. WEIMER, Finkle Electric Shop, Appleton, Wis.

Accuracy of Small Meters

THE ACCURACY of small meters has often been the subject of service controversy. L. C. NICHOLS, manager of the New York Weston

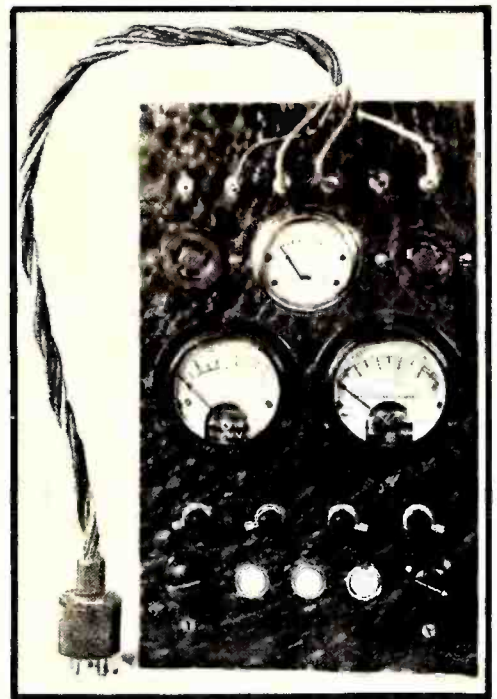

Front view of test set showing test plug and cable.

office, writes us in reference to the more popular Weston voltmeters and milliammeters. "Models 528, 476, and 517 are all provided with etched-metal scales and on such instruments, whether d.c. or a.c., it is our custom to state the guarantee as 2 per cent. of full scale to allow for slight discrepancies between instruments which develop in the process of manufacture and assembly. The scale being fixed for any particular range we, of course, cannot calibrate for these slight discrepancies.

"When considering direct-current measurements the Model 433 is correct well within 1 1/2 per cent. of full scale. The other instruments may have errors as high as 4 to 5 per cent., the amount varying to some degree with the scale. Briefly, the low-range instruments are more sensitive to residual magnetism than the higher ranges in any of the models referred to.

"The values given are considerably beyond any errors we have been able to detect, but it is our policy to state these inaccuracies rather high to avoid possible extended correspondence or dissatisfaction on the part of any customer.

Business Kinks

FRANK J. SHANNON, of Shannon and Wynkoop, radio service and Radiola specialists, of Philadelphia, Pa., gets right down to earth on several vital points of servicing.

"We charge a time rate of two dollars per labor hour on radio service calls. As Philadelphia is so spread out that traveling time and expense mounts up somewhat, we charge traveling time on remote calls—some of our Philadelphia calls are twenty miles by auto from our shop and yet still within city lines. In cases where customer does not care to have us proceed after diagnosis and recommendations we have a minimum charge of two dollars. As to accessories, we charge the current list price—if they want cheap products and prices they can go to 'Radio Row' and take their chances. We, as a rule, always repair a set completely in the customer's home—whoever takes the original phone call requests the name of the radio, trouble as diagnosed by customer, and name and type of accessories. Then the man who makes the call carries accessories to cover probabilities of that particular set or sets.



We put in audio transformers and other such parts right on job, and collect the cash then and there. By the way, getting your cash on the job is an important item. The person taking the job over phone tells new customer our terms—CASH. I learned this important point quickly upon entering repair business, for it's a job in itself to collect a radio repair bill. The excuse is that the radio is unsatisfactory, even if you've left a considerable amount of new accessories. Then too, there's a chance that while you're waiting payment over a long period that these 'tricky' customers will expect you to fix set as a 'reinspection'—don't forget they have yet to pay for the original job. Then, another important feature to the repair service is to have good high-class men out on the job. After all, it's not the name of the repair company that the customer cares about, but it's the high-class work done by the good repairman you send out. Then I find that no matter how many cards I leave on a job the customer will misplace them so as to have difficulty in reaching me in future. I've made up my mind not only to leave a card in the set but also to paste a label under the receiver cover, if possible."

*Demonstrating Equipment*

I AM ENCLOSING a snap shot of a baffle arrangement I am using in conjunction with an S-M 720 screen-grid six and a phonograph pick-up for demonstrating purposes. An awkward object, but a delight to listen to! I find good demonstrating equipment the best possible sort of publicity and advertising."

H. WILSON, Jamestown, N. Y.

*D. C. Installations*

HOWARD T. CERVANTES, service manager for Haynes Griffin, New York City, comments interestingly on d.c. installations.

"During the past few years we have installed a great many sets using d.c. A- and B-power units without much success. This was unquestionably due to the poor design of this d.c. equipment. The choke coils and B-power units are, in a great many cases, too small, and in nearly every



H. Wilson, of Jamestown, N. Y., believes in using high-grade demonstrating equipment.

case there is insufficient bypassing. This, I believe, contributed largely to the resultant poor success.

"For example, it is impossible to substitute a d.c. B-power unit for 90 volts of B battery and get the same results. Our most recent experience with a device of this kind was the Ward Leonard d.c. A, B, C eliminator with which you are probably familiar. This is probably the best outfit that has been developed for this purpose, although the Abox condenser is quite a nuisance, requiring refilling and seemingly not maintaining its capacity for any great period. This change in capacity caused a change in load, either decreasing or increasing the output.

In general, these d.c. outfits have been anything but satisfactory. As you are probably aware, the greater part of our clientele is located in the d.c. district and this season we have had very good success with the d.c. sets that were put on the market last fall. We have had very few complaints of poor quality with these receivers. The better types are using either push-pull or parallel audio systems, and some of the higher priced models employing the dynamic loud speaker are comparable in every way with their corresponding models in a.c.

"I would say that our greatest problem in the installation of these sets has been from line interference. We find that in the majority of installations it is necessary for us to erect an antenna having sufficient proportions to give a pick-up great enough to get good strong signals that will ride over and above the line noises. We find it next to impossible to get good results with an indoor antenna. With elevators, motors, relays, refrigerators, and other such devices, the average apartment house in New York City is a veritable noise factory.

"In some cases we have attempted to



This picture shows the baffle arrangement which Mr. Wilson uses for demonstrating purposes.

clear up this noise by the use of a so-called noise filter at the set, without any success whatever. The only place to tackle this is at the source. Most of the filters on the market are good for small motors and refrigerators but we haven't found anything to eliminate other noises except the erection of a good long antenna."

STATEMENT OF THE OWNERSHIP, MANAGEMENT, CIRCULATION, ETC., required by the Act of Congress of August 24, 1912, of RADIO BROADCAST, published monthly at Garden City, New York for April 1, 1929. State of New York, County of Nassau.

Before me, a Notary Public in and for the State and County aforesaid, personally appeared John J. Hessian, who having been duly sworn according to law, deposes and says that he is the treasurer of Doubleday, Doran & Co., Inc., owners of Radio Broadcast and that the following is, to the best of his knowledge and belief, a true statement of the ownership, management (and if a daily paper, the circulation), etc., of the aforesaid publication for the date shown in the above caption, required by the Act of August 24, 1912, embodied in section 411, Postal Laws and Regulations, printed on the reverse of this form, to wit:

1. That the names and addresses of the publisher, editor, managing editor, and business managers are: *Publisher*, Doubleday, Doran & Co., Inc., Garden City, N. Y.; *Editor*, Willis Kingsley Wing, Garden City, N. Y.; *Business Managers*, Doubleday, Doran & Co., Inc., Garden City, N. Y.

2. That the owner is: (If owned by a corporation, its name and address must be stated and also immediately thereunder the names and addresses of stockholders owning or holding one per cent. or more of total amount of stock. If not owned by a corporation, the names and addresses of the individual owners must be given. If owned by a firm, company, or other unincorporated concern, its name and address, as well as those of each individual member, must be given.) F. N. Doubleday, Garden City, N. Y.; Nelson Doubleday, Garden City, N. Y.; S. A. Everitt, Garden City, N. Y.; Russell Doubleday, Garden City, N. Y.; George H. Doran, 244 Madison Avenue, N. Y. C.; George H. Doran, Trustee for Mary Noble Doran, 244 Madison Ave., N. Y. C.; John J. Hessian, Garden City, N. Y.; Dorothy D. Babcock, Oyster Bay, N. Y.; Alice De Graff, Oyster Bay, N. Y.; Florence Van Wyck Doubleday, Oyster Bay, N. Y.; F. N. Doubleday or Russell Doubleday, Trustee for Florence Doubleday, Garden City, N. Y.; Janet Doubleday, Glen Cove, N. Y.; W. Herbert Eaton, Garden City, N. Y.; S. A. Everitt or John J. Hessian, Trustee for Josephine Everitt, Garden City, N. Y.; William J. Neal, Garden City, N. Y.; Daniel W. Nye, Garden City, N. Y.; E. French Strother, Garden City, N. Y.; Henry L. Jones, 244 Madison Ave., N. Y. C.; Sanford G. Etherington, 50 East 42nd St., N. Y. C.; Stanley Rinehart, Jr., 1192 Park Ave., N. Y. C.; Donald Macdonald, Garden City, N. Y.

3. That the known bondholders, mortgagees, and other security holders owning or holding 1 per cent. or more of total amount of bonds, mortgages, or other securities are: (If there are none, so state.) NONE

4. That the two paragraphs next above, giving the names of the owners, stockholders, and security holders, if any, contain not only the list of stockholders and security holders as they appear upon the books of the company but also, in cases where the stockholder or security holder appears upon the books of the company as trustee or in any other fiduciary relation, the name of the person or corporation for whom such trustee is acting, is given, also that the said two paragraphs contain statements embracing affiant's full knowledge and belief as to the circumstances and conditions under which stockholders and security holders who do not appear upon the books of the company as trustees, hold stock and securities in a capacity other than that of a bona fide owner; and this affiant has no reason to believe that any other person, association, or corporation has any interest direct or indirect in the said stock, bonds, or other securities than as so stated by him.

5. That the average number of copies of each issue of this publication sold or distributed, through the mails or otherwise, to paid subscribers during the six months preceding the date shown above is . . . . . (This information is required from daily publications only.)

(Signed) DOUBLEDAY, DORAN & COMPANY, Inc.  
By John J. Hessian, *Treasurer*.

Sworn to and subscribed before me this 4th day of March, 1929.

[SEAL.] (Signed) Frank O'Sullivan  
Notary Public Queens County No. 1501  
Certificate filed in Nassau County  
Term expires March 30, 1920



# 3

# new tubes



## from the De Forest laboratories

To meet the requirements of the modern Screen-Grid Radio Sets—the De Forest laboratories have developed the improved “high vacuum” screen-grid Detector-Amplifier, Audion 424. It has the usual amplification factor of 420, eliminates all hum and crackle and will give new performance standards with screen-grid sets.

Another development of the De Forest Laboratories is a perfected humless Audion 427, the improved A. C. Heater type detector which gives to sets operated by socket power, the same purity of tone that characterizes battery sets and reduces the



**AUDION 424**  
*The 2½ Volt A. C. Humless Screen-Grid Detector-Amplifier.*



**AUDION 427**  
*The Humless A. C. Heater Type Detector-Amplifier.*



**AUDION 445**  
*The 2½ Volt A. C. Power Tube.*

heating time to 10 to 15 seconds.

The third achievement of De Forest Engineers is Audion 445 — an A. C. Power tube that produces an amazing purity of tone with freedom from distortion under heavy loads.

Visit us in June at the Chicago Radio Show (Booth No. 12 and also Suite 410 at the Blackstone Hotel) and learn more about the perfected De Forest “high vacuum” Audions, the only radio tubes with 23 years history behind them.

**De Forest Radio Company**  
Jersey City, N. J.

# de Forest AUDIONS

“HIGH VACUUM” RADIO TUBES



# Performance - insured

Radio performance can be no better than the performance of each component part.

Your finest engineering efforts are defeated unless each purchased part performs precisely as your specifications require.

The T·C·A standard of quality is your best insurance that these important units, at least, will function as you would have them.

*Look us up at the Radio Show and let's talk it over. Booth No. 64D. Demonstrations at Room 516, Stevens Hotel.*

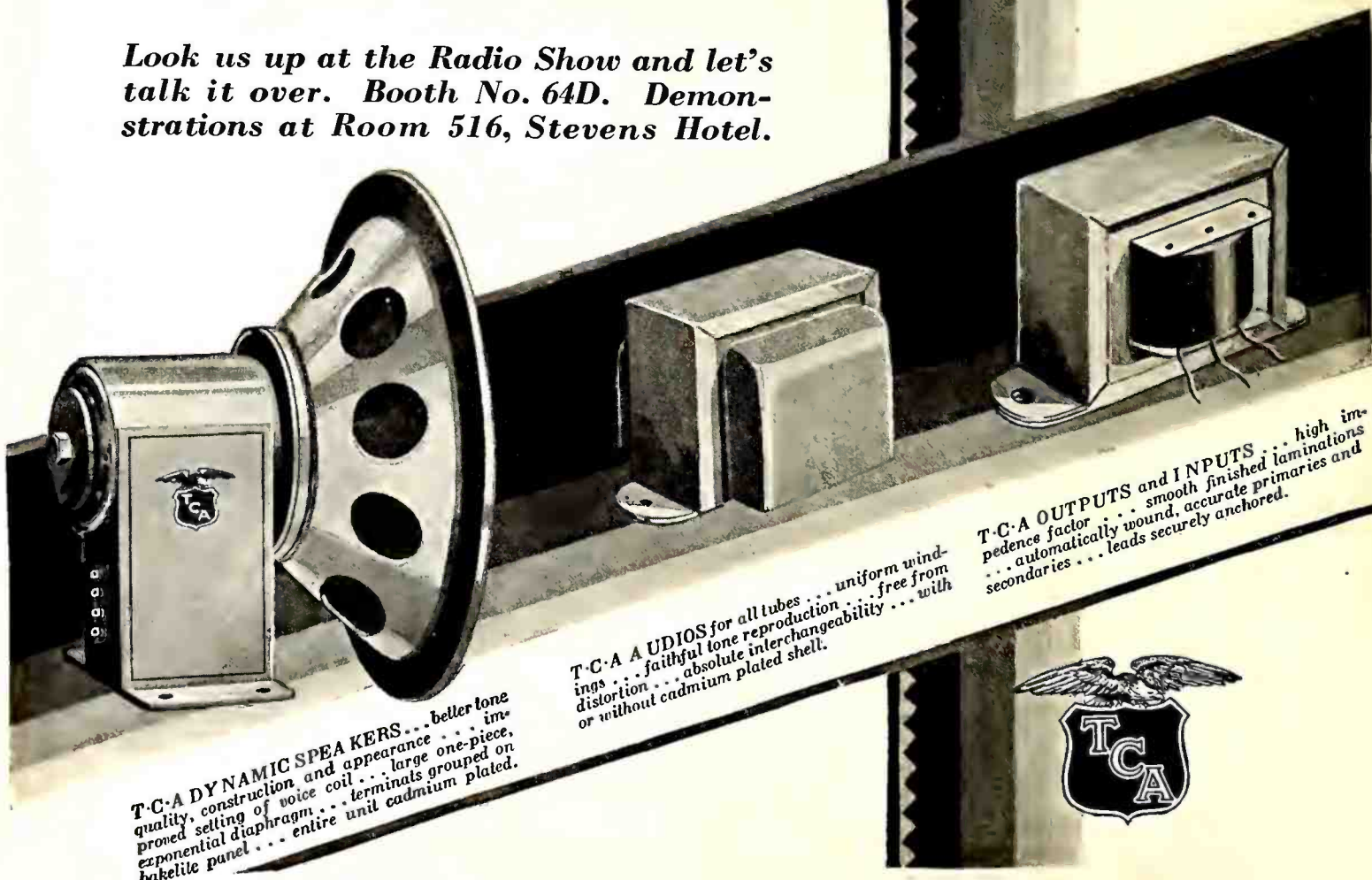

**T·C·A DYNAMIC SPEAKERS**... better tone quality, construction and appearance... improved setting of voice coil... large one-piece, exponential diaphragm... terminals grouped on bakelite panel... entire unit cadmium plated.

**T·C·A AUDIOS** for all tubes... uniform windings... faithful tone reproduction... free from distortion... absolute interchangeability... with or without cadmium plated shell.

**T·C·A OUTPUTS and INPUTS**... high impedance factor... smooth finished laminations... automatically wound, accurate primaries and secondaries... leads securely anchored.





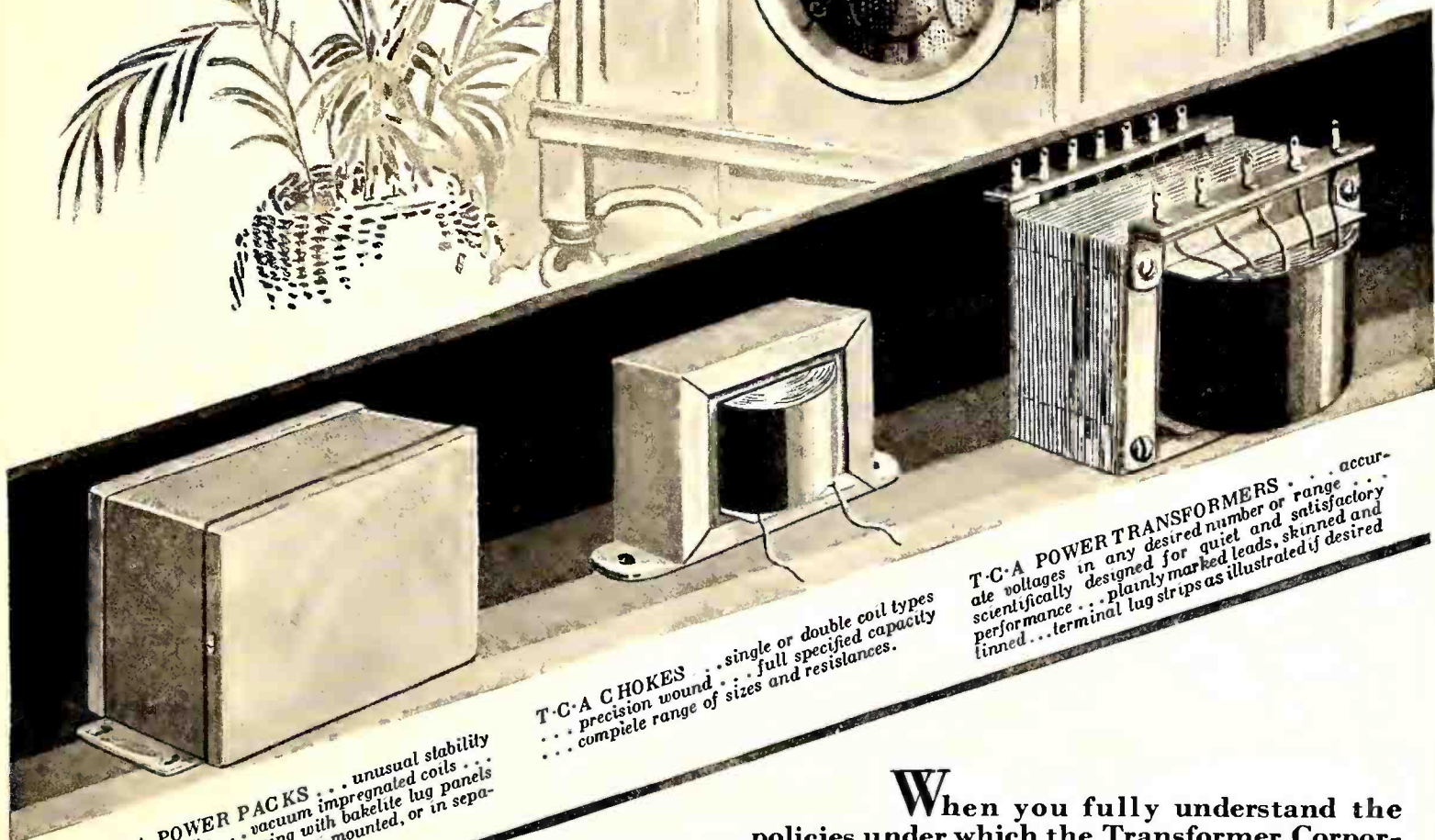
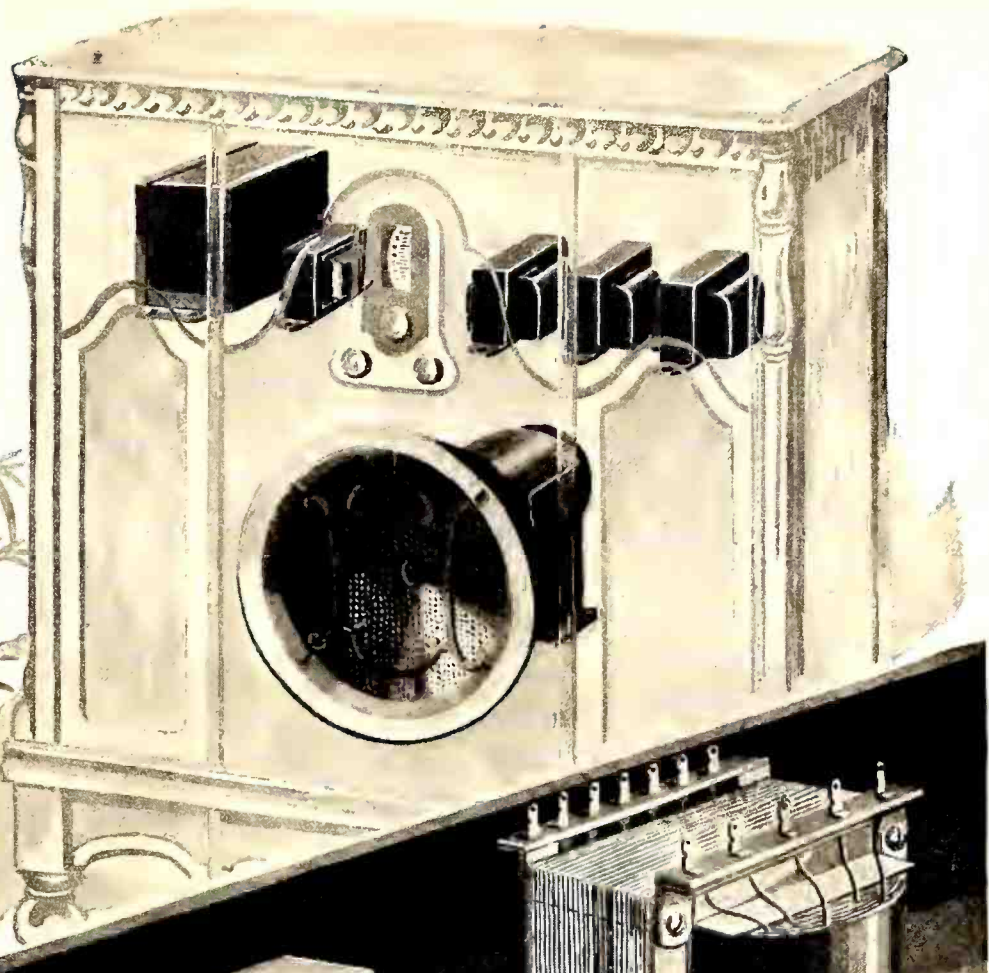

**T·C·A POWER PACKS** . . . unusual stability and durability . . . vacuum impregnated coils . . . cadmium plated housing with bakelite lug panels . . . furnished complete, semi-mounted, or in separate units.

**T·C·A CHOKES** . . . single or double coil types . . . precision wound . . . full specified capacity . . . complete range of sizes and resistances.

**T·C·A POWER TRANSFORMERS** . . . accurate voltages in any desired number or range . . . scientifically designed for quiet and satisfactory performance . . . plainly marked leads, skinned and tinned . . . terminal lug strips as illustrated if desired

Core laminations are all of special soft steel of high magnetic capacity, and separated by a silicate treatment that raises their value. Blanks are clean cut and free from burrs. Cadmium plated shields supplied if desired. All leads securely anchored, and insulated leads thoroughly skinned and tinned for rapid handling and perfect soldering.

Complete data and samples available. T·C·A engineers will gladly assist in your audio and power supply developments.

**W**hen you fully understand the policies under which the Transformer Corporation operates, you will concede that our claims for T·C·A products are reasonable and conservative. Specialization, we all know, has its advantages. It makes intensive and critical engineering possible. It has enabled us to perfect our product to a point where a large demand has developed. We have built millions of units. This volume has encouraged us to build and install special machinery, more accurate and more speedy than human hands. T·C·A Transformers meet the quality requirements of your engineers, as well as the price requirements of your production department. Transformers and dynamic speakers have much in common from a manufacturing standpoint. So the T·C·A Dynamic was a natural development for this organization. And the same precision through controlled quantity production that made T·C·A transformers and power packs standard in the country's finest sets, is securing a quality in T·C·A Dynamics that is receiving quick recognition. They are a real contribution to the industry.

**THE TRANSFORMER CORPORATION OF AMERICA, CHICAGO, ILL.**  
2301 - 2319 So. Keeler Ave.



**Tone  
Quality-  
Sensitivity  
Volume and Clarity**



*all this  
and more  
by using*

**CeCo  
Radio Tubes**

**I**f you're *tone conscious* you'll sense the finer, purer tone quality that CeCo's provide...the greater sensitivity they give the set ...the greater volume without distortion they afford.

What you will discover also (after you've enjoyed them clear to the end of their long, useful life) is the many extra months of perfect service CeCo's provide.

Hear a set of CeCo Tubes today—most good dealers have them.

*Listen to the sparkling program of music and comedy by the CeCo Couriers Monday Evenings—8:30 Eastern Daylight Saving time over WOR and the Columbia Broadcasting System.*

**CeCo MANUFACTURING CO., INC.**  
PROVIDENCE, R.I.

**Used By Millions**

# The Radio Broadcast LABORATORY INFORMATION SHEETS

By HOWARD E. RHODES

**T**HE aim of the RADIO BROADCAST Laboratory Information Sheets is to present, in a convenient form, concise and accurate information in the field of radio and closely allied sciences. It is not the purpose of the Sheets to include only new information, but to present practical data, whether new or old, that may be of value to the experimenter, engineer, or serviceman. In order to make the Sheets easier to refer to, they are arranged so that they may be cut from the magazine and preserved, either in a blank book or on 4" x 6" filing cards. The cards should be arranged in numerical order.

Since they began, in June, 1926, the popularity of the Information Sheets has increased so greatly that it has been decided to reprint the first one hundred and ninety of them (June, 1926-May, 1928) in a single substantially bound volume. This volume, *Radio Broadcast's Data Sheets*, may now be bought on the newsstands, or from the Circulation Department, Doubleday, Doran & Company, Inc., Garden City, New York, for \$1.00. Inside each volume is a credit coupon which is worth \$1.00 toward the subscription price of this magazine. In other words, a year's subscription to RADIO BROADCAST accompanied by this \$1.00 credit coupon, gives you RADIO BROADCAST for one year for \$3.00 instead of the usual subscription price of \$4.00.

—THE EDITOR.

No. 283

RADIO BROADCAST Laboratory Information Sheet

June, 1929

## Hum-Voltage Characteristics

(226-AND 227-TYPE TUBES)

**I**T IS becoming increasingly common to find that most recent models of various well-known receivers use 227-type tubes in all the sockets rather than only in the detector socket with 226-type tubes in the r.f. stages and in the first a.f. stage. To explain this trend in receiver design the statement is generally made that 227-type tubes produce less hum than 226-type tubes. This is true—but it isn't an explanation. Why the 227 is a better tube is indicated by the curves on "Laboratory Sheet" No. 284 taken from the *Cunningham Tube Data Book*.

Curve A is for a 226-type tube and shows the relation between the hum voltage in the plate circuit of one of these tubes as a function of the plate current. The minimum hum voltage indicated by this curve is about that obtained from a 226-type tube under normal conditions. If, however, the plate voltage increases or decreases somewhat there is a rapid increase in the amount of hum. If the plate potential were 90 volts and the bias about 6 volts minimum hum would be obtained, but a 10- or 15-volt decrease in plate voltage would double the hum output.

Curve B shows a comparison between the 227- and 226-type tubes with reference to hum.

This curve shows hum output as a function of the accuracy of the center-tapped resistor connected across the tube's filament. It should be noted that the 227-type tube is affected only slightly by an unbalance of the center-tapped resistor whereas the 226-type tube necessitates the use of a very accurate center-tapped resistor. Specifically, the curve shows that if the resistor is unbalanced ten per cent. the hum voltage from a 227-type tube is increased very slightly. On the other hand, a ten per cent. unbalance in the resistor across the 226-type tube causes the hum voltage to increase from a minimum of 10 millivolts to about 600 millivolts!

The rather recent improvements in radio receivers—in loud speakers particularly—has made it especially important that everything possible be done to keep the hum output at the lowest possible level. The hum is not only annoying, as of itself, but it also has an apparent effect on the fidelity. When stimulated by a tone such as a hum, it is difficult for the ear to hear other tones of the same or nearly the same frequency and so we get an apparent reduction in low-frequency response. This technically is known as the "masking effect" of one tone on another.

No. 284

RADIO BROADCAST Laboratory Information Sheet

June, 1929

## Hum-Voltage Characteristics

(226-AND 227-TYPE TUBES)

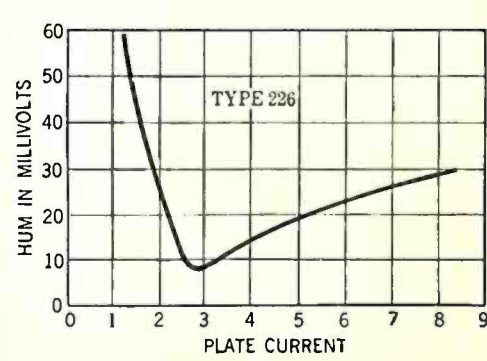

(A)

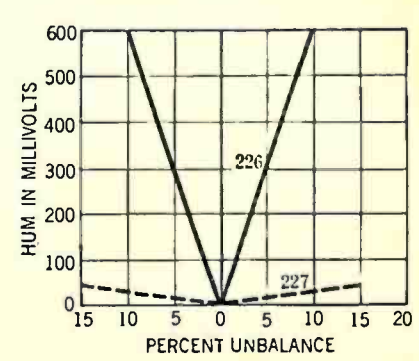

(B)



# PAM Breaks Another Record

All Chicago records for 100% leasing broken by PAM-equipped apartment

An apartment in the Lake Lane



Lake Lane Apartments Chicago



TELEPHONES BE BE

## RADIO CONTRACTORS

NOT INCORPORATED  
DESIGN—INSTALLATION—SERVICE  
2029 N. Spaulding Avenue  
CHICAGO

ESTIMATES FURNISHED  
WORK GUARANTEED

February 5, 1929.

Samson Electric Company,  
Canton, Massachusetts.

Attention of Mr. R. W. Cotton, Sales Mgr.  
Gentlemen:

Enclosed are a few photographs of the radio system which we installed at the new Lake Lane Apartment Hotel at 6214 Winthrop Avenue, here in Chicago, for which we had you build the special power amplifiers.

Everyone who listens to this installation marvels at the perfect tone quality. The reproduction in every apartment is equal to that of a latest model \$300 receiving set. What greater tribute can be paid to the quality of your Samson Amplifiers?

Combined with this tone quality is power. For instance, a few days ago in mid-afternoon we tuned in WLW, Cincinnati, through our barrage of local broadcasters and furnished this program to all the rooms. We are also proud to have completely eliminated cross-talk, usually found on installations with a choice of programs.

Radio was featured in advertising the Lake Lane Apartments, and the speed with which the Hotel was 100% leased, is without precedent.

Thanking you for your co-operation, and with all good wishes, I am  
Yours very truly,

RADIO CONTRACTORS

Roy Baumann

RB. AE

RADIO SERVICE TO EVERY ROOM THRU MASTER CONTROL SET—CHOICE OF PROGRAMS  
ALSO PUBLIC ADDRESS SYSTEMS

**Samson Electric Co.**

MEMBER  
**RMA**

MANUFACTURERS SINCE 1882

Main Office:  
CANTON, MASSACHUSETTS

Factories at  
CANTON & WATERTOWN



PAM 19  
Price, without tubes, \$175.00



# Where PERFORMANCE Counts!

Technical data and fine descriptions may help,—but in the final analysis, nothing counts like—PERFORMANCE!—And you can rely on *Electrad* for that.

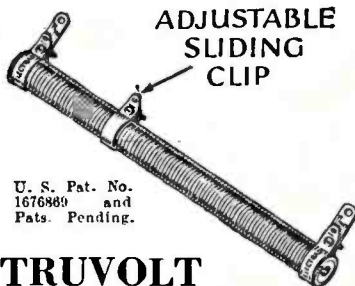

U. S. Pat. No. 1676869 and Pats. Pending.

## TRUVOLT

### All-Wire Resistances

Nothing better for Eliminator or Power-Pack construction. Distinctive design that insures accurate values, cool, safe operation and ENDURANCE that cuts down service and replacement expense. The sliding clip, an exclusive *Electrad* feature, provides easy, convenient variability. 22 stock sizes. Also Variable Truvolts with same features.



U. S. Pat. No. 1034103-1034104 and Pats. Pending.

## Super-TONATROL 5-Watt Volume Control

You no longer need compromise on a volume control. You can now plan to use any reasonably high voltage and depend on *Electrad's* new 5-watt volume control to handle it perfectly without strain. A new principle throughout—smooth as velvet—and with longer life than you'll ever demand of it.

Can be made with a variable or tapered curve with practically any desired rating.

Sample and laboratory graphs to any established manufacturer. Test it in your own way.

ELECTRAD, INC., Dept. R B 6  
175 Varick St., New York, N. Y.

Please send me data and sample of—Truvolt Resistance—Super-TONATROL.

Manufacturer .....

Address .....

City .....

State .....



No. 285

RADIO BROADCAST Laboratory Information Sheet

June, 1929

## Frequency Vs. Capacity and Inductance

IN "LABORATORY INFORMATION SHEET" No. 286 are given a group of curves indicating what capacity is necessary to tune a circuit to a given frequency when using a coil of known inductance. The curves are applicable to broadcast frequencies and the capacities cover the range of sizes ordinarily used in such receivers.

The curves were calculated by substituting in the formula.

$$f = \frac{159,200}{\sqrt{LC}}$$

where  $f$  = frequency in cycles per second

$C$  = capacity in microfarads

$L$  = inductance in microhenries

The curves were calculated for various frequencies between 500 and 1500 kc. A few examples will indicate quite clearly how the curves are used.

Example. What size condenser is necessary to tune to 600-kilocycles with a 200-microhenry coil? To determine this we locate the vertical line corresponding to 200 microhenries and follow it to the 600-kilocycle line and it is found that this point corresponds to 0.00035 mfd.

which is the capacity necessary to tune the coils to 500 meters.

Example. To what frequency will a circuit tune if it consists of a 250-microhenry coil and a 0.0004-mfd. condenser? The unknown frequency in this case is determined by finding the intersection of the vertical line corresponding to 250 microhenries and the horizontal line corresponding to 0.0004 mfd. They intersect at the line corresponding to 500 kilocycles which is the frequency to which they would tune.

Example. How much inductance is required in parallel with a 0.0003-mfd. condenser to tune to 1500 kilocycles? Determine the intersection of the horizontal line corresponding to 0.0003 mfd. with the transverse line corresponding to 1500 kilocycles. The intersection is found to fall on the vertical line corresponding to 38 microhenries which is the required value of the coil's inductance.

If it is desired to make calculations of inductance, capacity, or frequency for values above or below the broadcast bands, the formula given at the beginning of the sheet may be used. It is simply necessary to substitute the known quantities and solve for the unknown.

No. 286

RADIO BROADCAST Laboratory Information Sheet

June, 1929

## Frequency Vs. Capacity and Inductance

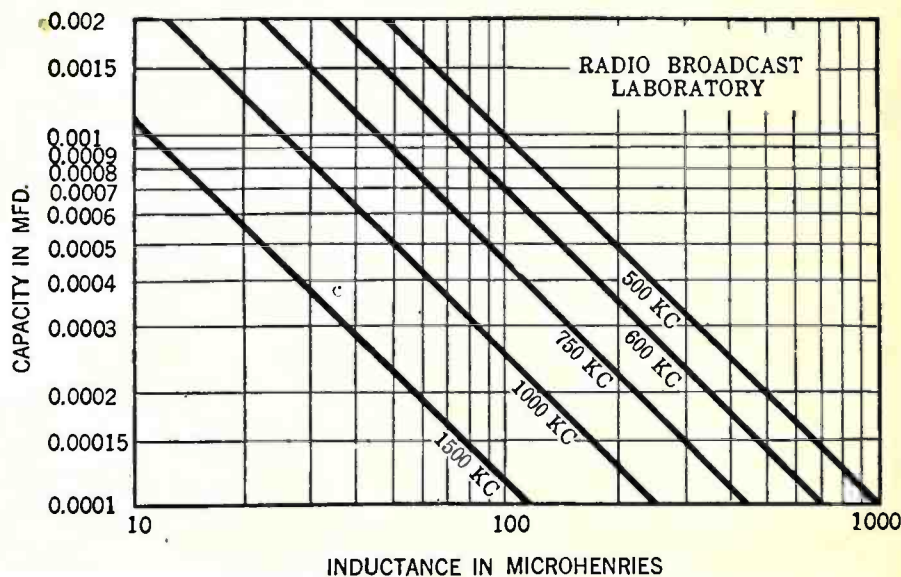

No. 287

RADIO BROADCAST Laboratory Information Sheet

June, 1929

## Protecting Meters

SEVERAL READERS have written us and requested suggestions on how to protect a milliammeter in a set-tester or tube-tester from damage in case there is a defect in the circuit of the device being tested which would permit sufficient current to flow through the meter to damage it.

The simplest way of protecting the meter is by the use of the arrangement indicated in sketch A on this sheet.  $M$  is the meter to be protected and it is protected by the shunt circuit consisting of  $R$  and the switch  $S$ . The switch,  $S$ , is the type which is usually used as a volt-meter switch; it normally remains in a closed position and must be held in the open position by hand. The resistance,  $R$ , should have a value such that, with the switch closed and maximum rated current of the meter flowing through the circuit, the meter gives a very small deflection. For example, suppose that the meter had a range of 10 milliamperes. The procedure would be to pass 10 mA. through the meter so that the meter read a maximum and then to place across the meter a resistance such that the meter deflection decreased to, say, 0.5 mA. Now when we use the instrument in which the meter is located we first note the reading of the meter with the switch

closed (its normal position) and if the meter reads more than 0.5 mA. we will know that excessive current is flowing through the circuit and the meter will be overloaded if the switch,  $S$ , is opened. If the meter reads less than 0.5 mA. it will be safe to open the switch.

Another good method of protecting a meter is by the circuit arrangement in B. In this sketch  $R_2$  is a rheostat with a resistance of about 10 ohms. The procedure here is to start with the arm at the right and then to move gradually the arm to the left end. If as this end is approached the meter needle goes off scale it is an indication that current in excess of what the meter can read is flowing through the circuit.

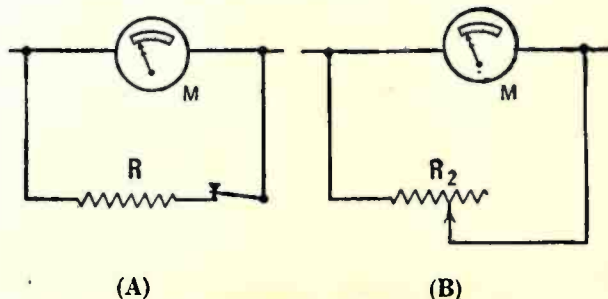



the most Complete  
Comprehensive and  
Authoritative  
RADIO HANDBOOK  
ever published!



## Practical Radio Telegraphy and Telephony

By RUDOLPH L. DUNCAN

Director Radio Institute of America

and CHARLES E. DREW

Instructor in Radio and in charge of Electrical Division, Radio Institute of America

This book contains over 900 pages of practical information for SHIP, SHORE, and BROADCAST OPERATORS, RADIO ENGINEERS, and AMATEURS. It is an ideal "Wireless Operators' Handbook" and a complete text for students of Wireless Communication.

26 chapters—a progressive record of the latest 1929 practice—make this Radio Handbook indispensable for the practical radio man. Principles, methods and equipment are described in language readily understood by both the expert and the novice, and illustrated profusely with more than 460 clear and illuminating diagrams and photographs.

The authors are two of the foremost teachers of the subject in the country. The book is the product of the School Division of the Radio Corporation of America and therefore represents the last word on the subject.

Never before has such a wealth of practical and usable data been collected in book form for the use of the many thousands for whom Radio is the most fascinating subject in the world.

Price \$7.50

Send in this coupon at once . . . and examine the book at our expense.

### A WILEY BOOK

Free Examination Coupon

John Wiley and Sons, Inc.  
440 Fourth Ave., New York

Gentlemen: Kindly send me on ten days' free examination, Duncan and Drews' "Radio Telegraphy and Telephony."

I agree to remit the price (\$7.50) of the book within ten days after its receipt or return it postpaid.

Name.....

Address.....

Position or Reference.....

Subscriber . . . Yes . . . No . . . R.B. 6-29



## A New Tube + Transformer once more Establish a Brand, New Standard of

Power



Tone

No. 994 for use with  
The new UX-245 Tube

Remember when the UX-250 Tubes came out? What a tremendous leap Radio Made.

From rasping, indecipherable noise to soft, human reality. Radio critics took a new lease on life; cynics who scoffed at radio became fans overnight; and a few set manufacturers, who were first to grasp the significance of the new Volume Tone standard, became leaders in their industry.

Refinement now begins. UX-245 Tubes are perfected. In the Dongan laboratories engineers have worked, urged on by their own enthusiasm, to develop exactly the right Power Amplifier Transformer, as a necessary companion piece to the new Tube. No. 994 Transformer is the answer: It synchronizes with the Tube—with resulting Power and purity of Tone that delight the most demanding.

### The Finest Type of Power Amplifier

with UX-245 Tubes use

No. 994—Power Amplifier Transformer.....	\$12.00
No. 2189—Push Pull Output Transformer.....	12.00
No. 3107—Straight Output Transformer.....	12.00
D-946 —Standard Condenser Unit.....	22.50
No. 5554—Double Choke, use in Filter Circuit.....	11.00

These Dongan Parts are available now. Equip your receiver with this new amplifier—and enjoy still another of Radio's greatest advancements.

Send check or money order. Further details on request

### DONGAN ELECTRIC MANUFACTURING CO.

2991-3001 Franklin Street  
Detroit



This is a good time to subscribe for

### RADIO BROADCAST

Through your dealer or direct, by the year only \$4.00  
DOUBLEDAY, DORAN & CO., Inc. GARDEN CITY, N. Y.

**The Ounce of Prevention**

AMPERITE automatically prevents "A" current fluctuations, lengthens tube life, improves set operation. Entirely unlike fixed resistors. A type for every tube—battery or A. C.

*Radiall Company*  
50 FRANKLIN ST., NEW YORK

FREE New "Amperite Blue Book" gives latest construction data.  
Write Dept. RB-6

**AMPERITE**  
REG. U.S. PAT. OFF.  
The "SELF-ADJUSTING" Rheostat



### Wire Your Home for Radio

For every radio need, in brushed brass or Bakelite. Fit standard electrical switch or outlet box. Single plates and in gang in many combinations

No. 135—For Loud Speaker.....	\$1.00
No. 136—For Aerial and Ground. . .	1.00
No. 137—For Battery Connections. . .	2.50
No. 138—For A C Connections. . . . .	1.00

(Bakelite, 25c additional per plate)

YAXLEY MFG. CO.

Dept. B. - 9 So. Clinton St., Chicago, Ill.



# ONLY CENTRALAB makes resistances like these

The construction and design of a variable resistance is of as great importance as the mere fact that it possesses a certain resistance and will carry a specified current load. **CENTRALAB** design is such that the resistance unit not only will handle the power but also vary it in a manner so as to derive the greatest efficiency from the receiving set or power unit.



### CENTRALAB RADIOHMS

In following resistances:  
0-2,000 ohms, 0-50,000  
ohms, 0-100,000 ohms,  
0-200,000 ohms, 0-500,000  
ohms. List price...\$2.00

The following features distinguish **CENTRALAB** variable resistances of the Graphite Disc type:

Rocking Disc Contact	Noiseless, smooth and easy adjustment
One turn of knob gives complete variation	Constant resistance
Insulated shaft and bushing	Rigidly built; fully guaranteed

Made in two and three terminal units to be used as Volume Controls, Radiohms and Potentiometers. Special resistance tapers can be had for any circuit. Send for interesting booklet "Volume and Voltage Controls—Their Use."

## CENTRAL RADIO LABORATORIES

24 Keefe Avenue

Milwaukee, Wisconsin

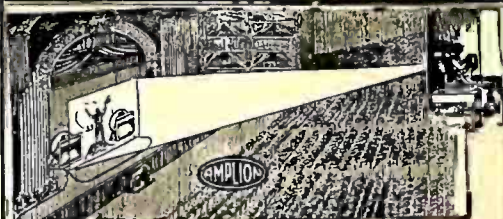

### PUBLIC ADDRESS SYSTEM

installed with **AMPLION** sound equipment give

### SUPERIOR PERFORMANCE

with a background of 42 years of success in the acoustic field **AMPLION** is prepared to offer public address equipment of unsurpassed dependability for theatres, hotels, clubs, auditoriums, hospitals, railroad depots, county fairs, etc.

*We have ready for immediate delivery and quick installation group address equipment as follows:*

- AMPLION EXPONENTIAL 10 FT. AIR COLUMN HORNS.**
- AMPLION GIANT DYNAMIC AIR COLUMN UNITS.**
- AMPLION ELECTRIC PHONOGRAPH PICK-UPS.**
- AMPLION EXCITERS.**
- AMPLION MICROPHONES.**
- AMPLION "AMPLIFIERS.**
- AMPLION "TRANSFORMERS.**

*AMPLION is the ONE place in America where you can purchase the complete installation or any part of the equipment as desired.*

Write for new catalog and profitable **Amplion** proposition to competent engineers.

#### WANTED

We need **RADIO ENGINEERS** in all parts of the country for making Public Address Installations. If interested, file your name, address, training and experience, together with references, with  
**PUBLIC ADDRESS DEPT.**

**Amplion Corp. of America**

133 W. 21st Street

New York

## AEROVOX BUILT BETTER CONDENSERS AND RESISTORS

### Takes Out the Hum in Any Dynamic

**I**N spite of the many methods utilized to eliminate the hum in A. C. dynamic speakers, many of the best dynamics still have a hum which is sufficiently pronounced to be objectionable, especially during lulls in the program while waiting for announcements.

You will be surprised at the completeness with which an **Aerovox 1500 mfd. "A" condenser**, connected across the field coil or across the rectifier output, will eliminate the hum and increase the sensitivity of the speaker.

Complete details and comparative data, showing the results obtained when using these condensers to eliminate hum, will be furnished on request.

#### Send for Catalog

containing detailed descriptions and complete specifications of all **Aerovox** products. Free on request.

#### The Research Worker

contains, each month, valuable information on radio design. It will be sent free on request.



## Potter RR-245 Condensers

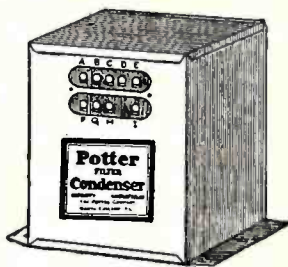

for  
Successful  
Operation  
of R-245  
Power  
Compact

Get one to-day and enjoy the beautiful tone the 245-type tube gives **\$19.75**

### Potter Dynamic Speaker Filter

Will reduce the hum in an A.C. operated speaker using low voltage rectifier **\$4.75**

**T-2900** Condenser Block for the single 250 type tube amplifier. **\$20.00**

**T-2950** Condenser for the push-pull 250 type tube amplifier. **\$22.50**

**T-2098** Condenser Block for single 210 type tube amplifier. **\$20.00**

**T-280-171** Condenser Block for power pack with 280 type tube rectifier. **\$18.00**

**SM-673** Condenser Block for Silver-Marshall power amplifier and power supply units. **\$20.00**

## The Potter Co.

North Chicago, Illinois

A National Organization at Your Service

## Jenkins & Adair Level Indicator Panel Type B (Calibrated)

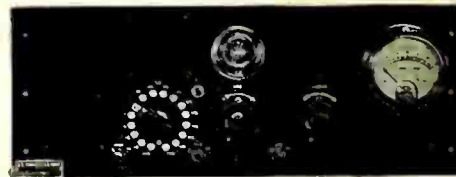

For Broadcasting, Electrical Recording, and Power Speaker Systems

The Type B Level Indicator Panel is designed for direct reading of the voice level on any 500-ohm telephone circuit, the range being from minus 10 TU to plus 20 TU, in steps of 2 TU each. The parts consist of an accurately built input transformer, a specially designed potentiometer, a filter retard and condenser, and direct current galvanometer calibrated for this work.

The use of this panel is essential wherever a specific level must be maintained. The calibration is highly accurate, and cannot alter while the tube constants remain normal. The potentiometer is built up of nichrome wire units, held to an accuracy of 1/10 of 1%. The panel is extremely simple in operation, is direct reading in TU's, and minimizes the change of load on the measured circuit when the level settings are changed. This last feature is a great improvement over present types.

The dimensions of this panel are 19 x 7 1/2 in. It is of 5/16 in. black sanded bakelite and weighs, complete, 18 lbs. It operates on 12 volt A battery and 135 volts B battery, and requires a 102E tube (not furnished by us). The parts of this panel are NOT sold separately. Bulletin 8 gives a more complete description and will be mailed on request. The net price in the United States and Canada is \$250.00 f. o. b. Chicago.

**J. E. JENKINS & S. E. ADAIR**  
Engineers

1500 N. Dearborn Parkway

Chicago

U. S. A.

Manufacturers of Recording Amplifiers



**Stop  
A.C.  
Noise!**  
**Improve  
Selectivity!**

**PLUG** in a Falck Claroceptor between wall socket and radio set and eliminate "static" from motors, street cars, telephones and electrical appliances. This new improvement by a pioneer radio parts manufacturer grounds and thus blocks out line interference noise and radio frequency disturbances. *Also improves selectivity and distance.* Requires no changes in set. Measures just 3½ x 5½ x 2½ inches. Thousands now all over America use the Claroceptor for clearer A. C. reception. Get one right away—at radio parts dealers. Write for descriptive folder.



\$7.50 complete with cord and plug

**Falck  
CLAROCEPTOR**

Built by **ADVANCE ELECTRIC CO.**  
1260 W. Second St. Los Angeles, Calif.  
JOBBERs and DEALERs, GET OUR PROPOSITION

**attention  
service men**



A quality replacement audio transformer for the service man. Possesses the same high degree of performance which characterizes all Thordarson audio units.

Provides highest amplification consistent with quality reproduction.

**Unique Mounting Feature**—The mounting bracket of this transformer is designed to fit all standard mountings without the necessity of drilling additional holes. May be mounted either on end or side or may be used as bracket to support sub-panel.

**Remember:** Thordarson radio transformers are Supreme in musical performance.

R-100 - - - List Price \$2.25  
**THORDARSON ELECTRIC MFG. CO.**  
Transformer Specialists Since 1895  
Huron, Kingsbury & Larrabee Sts., Chicago

**THORDARSON**  
replacement  
audio transformer

**T e s t e d . . .  
. . . t e s t e d ,  
t e s t e d a g a i n ,  
a t e v e r y s t e p  
i n m a n u f a c t u r i n g**



**P**RECISION in production methods keeps Arcturus quality at the peak.

Every manufacturing process is checked by relentless tests, revealing every defect that might cause faulty performance.

"Go-and-No-Go" gauges, sensitive meters, high-powered microscopes and accurate chemical analysis replace all human guesswork in making Arcturus tubes—

insuring uniformity in materials and construction, uniformly fine performance throughout Arcturus' long life.

Critical engineers and set manufacturers approve the correct design and careful construction of Arcturus *Blue Tubes*. They know that A-C sets give the most satisfactory service, the best reception, with Arcturus Tubes in every socket.

[ *Engineering Facts Have a Utility Significance to the Broadcast Listener* ]

**ARCTURUS  
BLUE <sup>A-C</sup> LONG-LIFE TUBES**

ARCTURUS RADIO TUBE COMPANY ~ Newark, N. J.



**ELECTRIC  
TUBE BASE  
BRANDERS**

*Impress Neat,  
Clean Letters  
into  
your  
Bases*

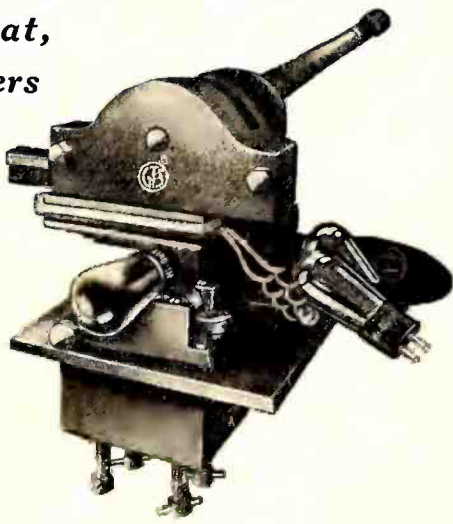

**HAND OPERATED  
THE LATEST AND BEST  
Machines for Marking Bases**

*Power Driven*

*Designed and Built by*

**GEORGE T. SCHMIDT, Inc.**  
4100 Ravenswood Ave. Chicago, Ill.



# PICKING OUT IMPERFECT TUBES



is easy with our Type 443 Mutual Conductance Meter. This readily made measurement shows up incorrect spacing of the elements as well as faulty filament emission.

Demand this test of the tubes you buy and make it on the tubes you sell.

*Bulletin 443-T Describes It.*

## GENERAL RADIO COMPANY

30 State Street  
Cambridge, Massachusetts

274 Brannan Street  
San Francisco, California

# AERO-CALL



The  
Shielded  
Filtered

Short Wave Converter

*Factory-Built, Ready to Plug  
Into Any Present Radio Set*

The Aero 1929 Converter is a compact factory-built short-wave adapter equipped with special short-wave coils. It is designed for both A.C. and D.C. sets. Operates on A.C. or D.C. sets without motorboating, by an auxiliary filter system control, an exclusive feature (patent applied for.) It can be plugged into any regular radio set. This amazing radio instrument now makes it possible for you to reach 'round the world. (Geo. Morcroft of Pa. received England, Australia and Holland on his initial test.) Permits you to enjoy international programs and many others from coast to coast that your regular receiver cannot get. What a thrill it is to plug this into a tube socket on your regular set and instantly be in another world! No change or wiring required. All complete, ready to operate, tubes and coils hidden, no apparatus in sight, except the neat, golden-brown, compact metal cabinet in crackle finish. Size, 9 x 5 1/2 x 2 1/2 in. Cushioned feet.

The only converter we know of that really works on all sets. Two models—A.C. and D.C. Write for Catalog and literature, or send \$25.00 less 40% and name of your jobber.

*New Aero Supplement now ready. Ask for it.*

Model A, without tube,  
for A.C. sets . . . . . List  
Model D, without tube,  
for D.C. sets . . . . . List

**\$25.00**

**AERO PRODUCTS**  
INCORPORATED

6411 E. Ravenswood Ave. Dept. 269  
CHICAGO, ILL.

# Universal Resistance!

BY means of the adjustable micrometric resistance obtained with the Clarostat, the radio service man can instantly obtain the precise resistance for best results in any radio circuit. Clarostat means *universal resistance*—hand-fitted to the requirements.

The Clarostat line includes a wide range of variable resistors, ranging from tiny Grid Leak and Volume Control types, to giant Power and Super-Power types for high-power amplifiers and auditorium installations. Also includes the Hum-Dinger—a perfected hum balancer for A-C tube circuits, and complete assortment of improved wire wound strip resistors.

There is even a refined socket antenna plug in the Clarostat line, which will generally equal a good antenna in performance—just the thing for temporary receiver installations, or as a tonic for poor reception.

In short the Clarostat line is to the radio service man what the first aid kit is to the doctor. Be prepared for all emergencies: include Clarostats in your repair kit!

Write for literature describing the complete line of Clarostats and how the various types are applied to service problems. And if you have any special resistance problems, do not hesitate to call upon our engineering staff for co-operation.

CLAROSTAT MFG. CO., Inc.

Mem. R.M.A. Specialists in Radio Aids  
284-7 N. 6th St.  
Brooklyn, N. Y.

# Whatever You're Building...

*from a Crystal Set . . to the  
17 tube "Hoofus-Doofus"*

**it'll be that much better  
for using Polymet Products**

and that goes for the man who builds one set for his family or the manufacturer who turns out thousands every day. It all comes down to this—"You can't make a silk purse out of a sow's ear". In the same way, a good radio, to be and to continue to be a good radio, must start with good parts; e. g.—Polymet Products.

We know that you'll find them well-made, uniform, carefully tested, accurately rated and thoroughly dependable, because that's the only way they leave our plants.

*Filter Blocks, By-Pass Condensers . . .  
Bakelite Mica Condensers . . . Resistances*

POLYMET MANUFACTURING CORPORATION

837 E. 134th St.  
New York City



"Visit our booth"  
No. 76, at the  
R. M. A. Show."

**POLYMET PRODUCTS**

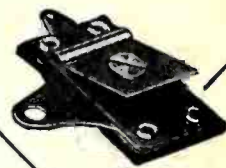

# The Ideal Condenser for Equalizing

For balancing the sections of a multiple condenser—for neutralizing oscillations in radio-frequency amplifiers—for antenna coupling to improve selectivity. Ruggedly built with Bakelite base mount, mica dielectric and phosphor bronze spring plate, safe—cannot short. Compact—fits in small spaces. Lug for direct attachment. Two sizes:—35 mmfd. and 70 mmfd.

*Write Dept. R B 6 for descriptive  
folder of Hammarlund Products.*

HAMMARLUND MFG. CO.  
424-438 W. 33rd St., New York

For Better Radio  
**Hammarlund**  
PRECISION  
PRODUCTS





\$65

**NEW GEMBOX AC  
ELECTRIC 7 TUBE**

The DYNACONE is a different type of power speaker that takes its field current from the set which operates it. This employment of the armature principle of actuation has improved reproduction to a marked degree. Each tone is true in its relation to every other tone of the audible scale.



\$25

**IMPROVED  
DYNACONE**

**GEMBOX**

The GEMBOX has three stages of radio frequency amplification, detector, 2 audio with 171-A power tube in last stage and a rectifying tube—7 tubes in all. Shielded—illuminated dial—power output tube—Mershon condenser in power supply—AC electric operation. All modern, up-to-minute quicksale features.

Installed with the Dynacone in the—

**GEMCHEST**

You have the smartest radio set on the market, and at a price that makes quick sales. The GEMCHEST design is adapted from the Chinese Chippendale—three exquisite color combinations—Mandarin red with bronze gold hinges and fittings—Nanking green with rose gold—Manchu black with white gold. Stylish—new—individual—perfectly fitting into modern home interiors.

The SHOWCHEST is the same but is equipped with the 8-tube SHOWBOX receiver selling at \$109.

Both the GEMCHEST and SHOWCHEST come equipped with the Improved Dynacone.

The Crosley JEWELBOX selling at \$105 is another wonderful value.

**The Crosley Radio Corporation**  
Dept. 20 Cincinnati, Ohio  
Powel Crosley, Jr., President  
Owners of WLW—The nation's station  
Montana, Wyoming, Colorado, New Mexico,  
and West prices slightly higher.  
*Prices quoted do not include tubes*

**THE  
SMART GEMCHEST**

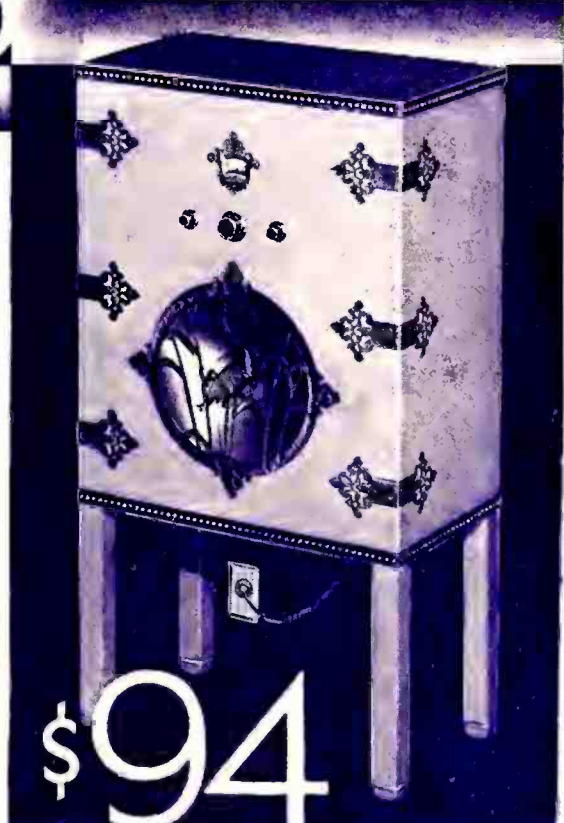

\$94

THE·WORLD'S  
THREE·GREAT  
RADIO·VALUES

**CROSLEY RADIO**



**A Radiotron  
for every purpose**

- RADIOTRON UX-201-A  
*Detector Amplifier*
- RADIOTRON UV-199  
*Detector Amplifier*
- RADIOTRON UX-199  
*Detector Amplifier*
- RADIOTRON WD-11  
*Detector Amplifier*
- RADIOTRON WX-12  
*Detector Amplifier*
- RADIOTRON UX-200-A  
*Detector Only*
- RADIOTRON UX-120  
*Power Amplifier*
- RADIOTRON UX-222  
*Screen Grid Radio  
Frequency Amplifier*
- RADIOTRON UX-112-A  
*Power Amplifier*
- RADIOTRON UX-171-A  
*Power Amplifier*
- RADIOTRON UX-210  
*Power Amplifier Oscillator*
- RADIOTRON UX-240  
*Detector Amplifier for  
Resistance-coupled  
Amplification*
- RADIOTRON UX-245  
*Power Amplifier*
- RADIOTRON UX-250  
*Power Amplifier*
- RADIOTRON UX-226  
*Amplifier  
(A. C. Filament)*
- RADIOTRON UY-227  
*Detector Amplifier  
(A. C. Heater)*
- RADIOTRON UX-280  
*Full-Wave Rectifier*
- RADIOTRON UX-281  
*Half-Wave Rectifier*
- RADIOTRON UX-874  
*Voltage Regulator Tube*
- RADIOTRON UV-878  
*Ballast Tube*
- RADIOTRON UV-886  
*Ballast Tube*

*The standard by  
which other vacuum  
tubes are rated*



*Look for this mark  
on every Radiotron*



**RAY H. MANSON**  
Chief Engineer, Stromberg Carlson Telephone Mfg. Co., 1911



"Experiment with every type of vacuum tube has convinced us of the superiority of RCA Radiotrons. We not only use them for testing the performance of Stromberg Carlson Instruments, but recommend them for use in all of our sets."

*Ray H. Manson*

When you purchase a quality receiving set be sure it is equipped with genuine RCA Radiotrons. If you will replace all of the tubes in your set with RCA Radiotrons once a year at least, you will get the finest reception the instrument affords.

**RCA RADIOTRON**

RADIO CORPORATION OF AMERICA • New York • Chicago • Atlanta • Dallas • San Francisco

**"Never out of stock on RCA Radiotrons —we carry the complete line." This is the kind of dealer advertising that builds tube business, brings in steady profits, and gives the radio dealer a reputation for dependability. Radio customers choose the stores that are known to carry the full line of RCA Radiotrons—all the time.**

Superior resources of research and manufacturing guarantee to RCA Radiotrons the finest possible quality in vacuum tubes. They are the standard of the industry—and so accepted by both the trade and the public.



The national magazine advertisement reproduced at the left is one of the 1929 Radiotron series, each of which carries the signature of a leading radio manufacturer.

RADIO CORPORATION OF AMERICA • NEW YORK • CHICAGO • ATLANTA • DALLAS • SAN FRANCISCO

**RCA RADIOTRON**

**RADIOTRONS ARE THE HEART OF YOUR RADIO SET**