

Popular Radio

AUGUST, 1922

Fighting Fire by Radio

How the airplane scouts of the Forest Service are saving millions of dollars for Uncle Sam

15¢



How Machines Are Controlled by Radio--How to Make a Variable Condenser--The Law and the Radio Amateur--What Your "Call Letters" Mean--How the Sun Helps Wireless--Radio and the Law

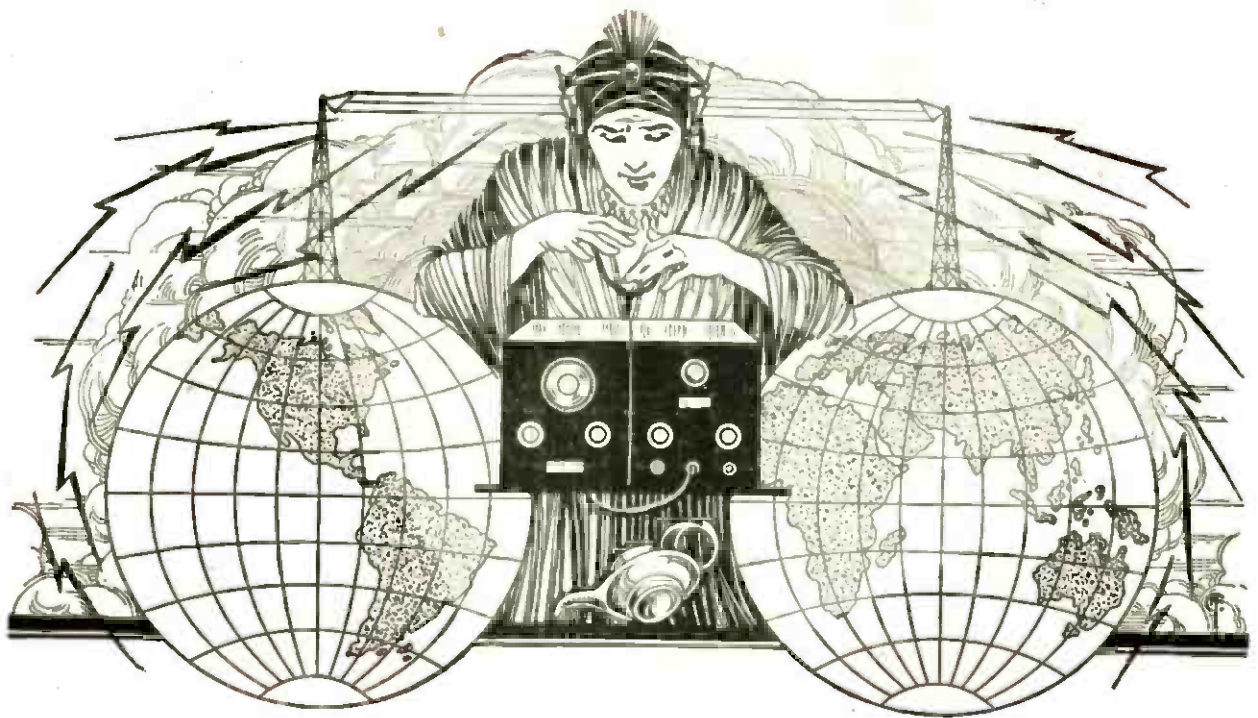

The Magic of Radio Brings Together the Ends of the World

Among the triumphs of inventive genius which have brought the miracles of radio into the lives and homes of millions of people, none so precisely meets the exacting requirements of this new science as the

Westinghouse Type RC Receiver

As national distributors of the products of leading manufacturers of radio equipment, we are at all times in position to make immediate quantity deliveries on this superior and popular instrument, as well as

Westinghouse Aeriola Grand
Westinghouse Aeriola Sr.
Westinghouse Aeriola Jr.

Write us today for descriptive pamphlets and full information concerning radio equipment of every kind.

20th CENTURY RADIO CORPORATION

National Distributors

Executive Offices, 565 Fifth Avenue, New York, N. Y.

Straus Building, Suite 710

Telephone, Murray Hill 6548

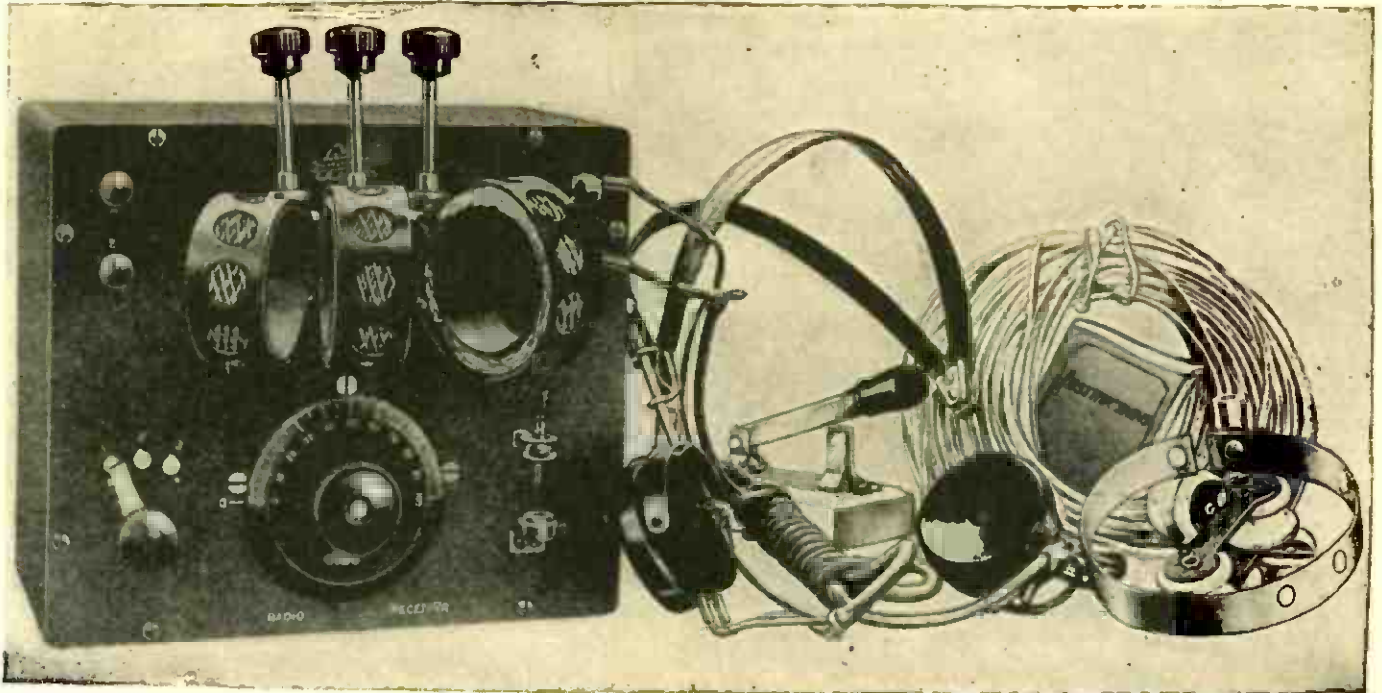

ABC Radio Crystal Receiving Set No. 5000 \$14.75

AS the result of a fortunate *quantity purchase*, we are able to offer this regular \$25.00 outfit direct to the consumer at a saving of \$10.25.

For a limited time only, we can supply this wonderful ABC Crystal Receiving Set at special introductory price of \$14.75.

This beautifully constructed and efficient cabinet receives wireless music, speeches, etc., at a distance of 15 to 25 miles—just right for Tampa residents.

By adding extra units later on, you can possess a fully equipped station second to none.

ABC Radio Crystal Receiving Set

No. 5000, with three coils (cabinet as illustrated). Price . . . \$14.75

ABC Radio Crystal Receiving Set No. 5000 with Completion Package (as illustrated) consisting of aerial wire, insulators, 2000 ohm Murdock head phones with improved Signal Corps type headband, ground clamp and ground switch—a complete receiving station. Price complete, \$22.25.

Send Postal Order or certified check today in order to get your set at this special price.

WIRELESS EQUIPMENT CO., Inc.

32 Austin Street

Newark, N. J.

POPULAR RADIO



VOLUME I

CONTENTS for AUGUST, 1922

NUMBER 4

(Cover design by Harry Townsend)

| | |
|--|-------------------------------|
| The President Talks to the Nation by Radio..... | Frontispiece |
| Fighting Fire by Radio..... | Arthur Chapman.....Page 233 |
| How Machines Are Controlled by Radio..... | Henry Smith Williams..... 242 |
| Why the Sun Makes Possible Long-Distance Wire- less | E. E. Free..... 249 |
| The Law and the Radio Amateur..... | Charles H. Kesler..... 256 |
| How Radio Circuits Are Coupled and Tuned..... | Laurence M. Cockaday..... 265 |
| Simple "How" Articles for the Beginner—No. 4 | |
| What "Call Letters" Mean..... | William E. Moore..... 269 |
| The Latest Developments in Radio Frequency Am- plifiers | Arthur H. Lynch..... 274 |
| Radio on Your Pleasure Boat..... | Paul McGinnis..... 280 |
| How to Make a Variable Condenser..... | A. Hyatt Verrill..... 284 |
| The Foolish Fear of Lightning..... | Edgar H. Felix..... 288 |

DEPARTMENTS

| | |
|--|-----|
| What Readers Ask..... | 292 |
| Broadcasts | 296 |
| More Short Wave Bands for Broadcasting. | |
| The Best Home-Made Amateur Station in America | |
| Radio Helps Aviators in Making Landings | |
| The World's Best Code Operator | |
| Radio Beacons Send Out Warnings At Sea | |
| One More "Smallest" Tube Set | |
| Will Trains Be Controlled by Radio? | |
| The First Use of Radio in a Balloon Race | |
| Spreading the Gospel by Radio | |
| An Amazing Feat of a Receiving Set | |
| Radio Weather Signals Are Dimming the "Weather Eye" | |
| Hints for Amateurs..... | 301 |
| Adventure in the Air..... | 303 |
| I Pick Up an Old Friend in Mid Ocean.....Canadian Operator | |
| Romance by Radio.....Anonymous | |
| The Shortest Long-Distance Record.....C. A. Briggs | |
| Radio Traps a Thief.....E. H. Felix | |
| Grandma Listens In.....Ralph Somers | |

VOLUME I

AUGUST, 1922

NUMBER 4

Published monthly by Popular Radio, Inc., 9 East 40th Street, New York, N. Y., telephone number Vanderbilt 9985; H. B. Emerson, President; E. R. Crowe, Vice-President; P. O. Batch, Treasurer. Price, 15 cents a copy; subscription \$1.50 a year in the U. S., \$1.75 in Canada; elsewhere \$2.00 a year, payable in advance. The International News Company, Ltd., No. 5 Bream's Bldg., London, E. C. 4 sole distributors in England. Entered as second-class matter April 7, 1922, at the Post Office at New York, N. Y., under the act of March 3, 1879. Copyright, 1922 and title registered as a trade-mark by Popular Radio, Inc. Printed in U. S. A.

KENDALL BANNING, Editor

LAURENCE M. COCKADAY, R.E., Technical Editor

WITH the completion of our splendid new factory at Richmond Hill, N. Y., the Grebe high standard of quality will be maintained —and the production quadrupled!

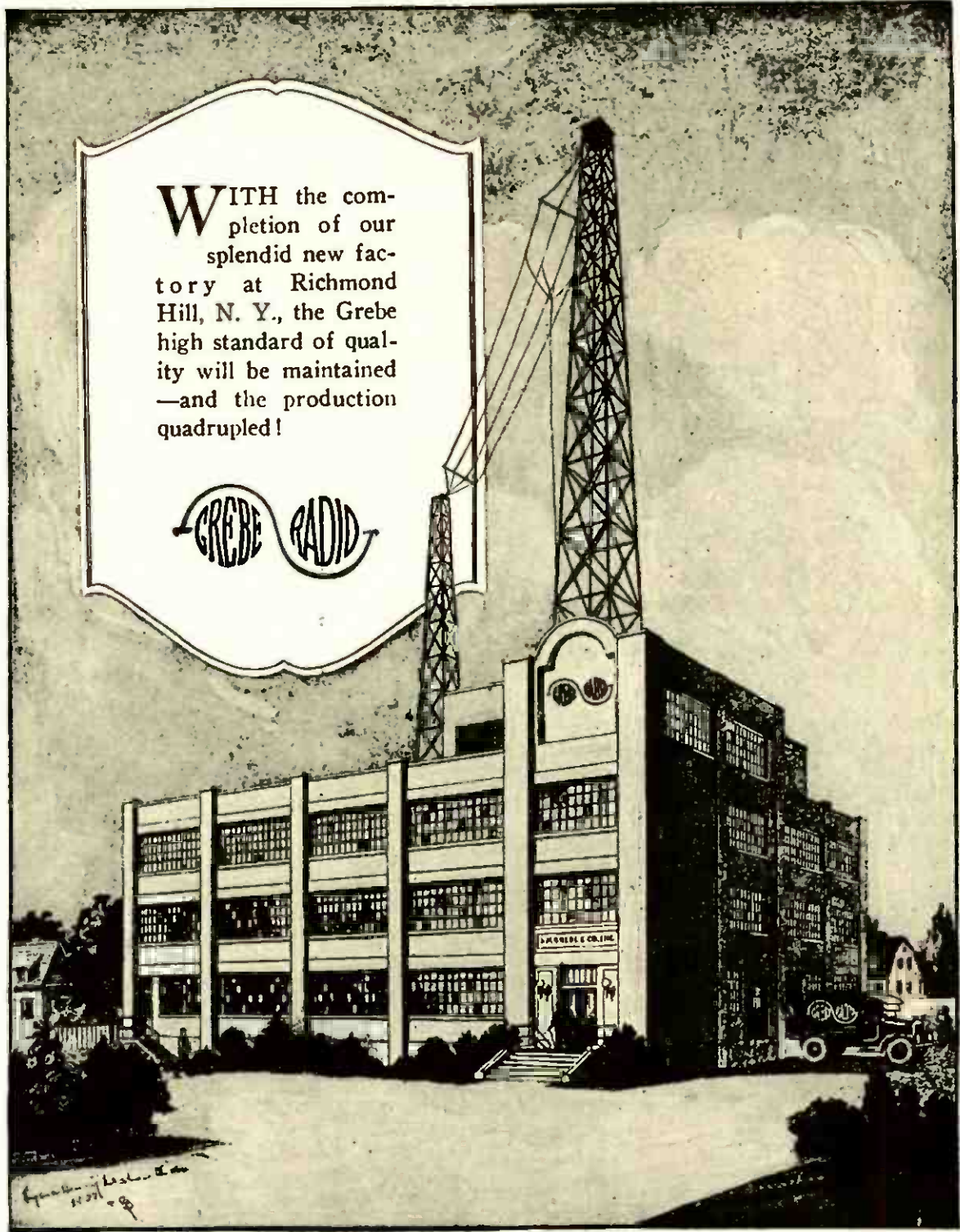

A PAGE WITH THE EDITOR

NOT in many months has any magazine article stirred up the radio fans as did the startling *There Are No Ether Waves* by Dr. Charles P. Steinmetz, in our July number. Now that the distinguished Doctor has disposed of the ether wave theory, the next logical step is to put forward a constructive explanation of the phenomenon of radio, to take its place. And that is exactly what Dr. Steinmetz has promised the Editor to do. Needless to say, his article will appear in POPULAR RADIO.

* * *

Just before this number went to press Major General George O. Squier, the famous father of "wired wireless," came on from Washington and posed for his portrait which will be reproduced in full color on our September cover—the number that will contain an article by the General himself. The artist was none other than Joseph Cummings Chase, whose portraits of American soldiers are known throughout the world.

* * *

THOSE of our readers who have been deriving both pleasure and profit from the *Simple "How" Articles for Beginners*, by Laurence M. Cockaday (our Technical Editor), appearing in these pages, will be glad to know that much of this material may now be obtained in book form. Mr. Cockaday's volume "Radio Telephony for Everyone" has just been published, and judging from the early reviews, the book threatens to become a real best seller. But it ought to; just see who wrote it!

* * *

THE radio world received a real thrill last month when Major Edwin H. Armstrong demonstrated his wonderful new receiving set before the Institute of Radio Engineers in New York. Major Armstrong showed what his apparatus could do and how it did it. In a near issue of POPULAR RADIO will appear a specific, detailed and profusely illustrated article that will tell our readers *how to make it*.

* * *

THE way in which this article has been prepared is characteristic of the policy of POPULAR RADIO in the assembling of its technical articles. First, our Technical Editor actually made the set in his own laboratory. Then he installed it and conducted a series of careful tests upon it. When it was at last approved, the set was photographed in detail and diagrams were made of its parts. And not until then did the Technical Editor write the article.

Can anyone suggest a more thoroughly practical method of producing the kind of "how to make" articles that we are publishing?

* * *

THIS number of POPULAR RADIO which you are holding in your hands contains 100 pages—a growth of 16 pages over our number of four months ago. So rapidly is the magazine developing, indeed, that plans are now under way

for making substantial additions to our next number. Yet the price remains only 15 cents—40 percent less than any other monthly radio magazine.

* * *

OUT in the remote places where the radio fan has time to settle down and really read his magazines, one acquires a discriminating sense of values. "I wouldn't take a dollar for my June number of POPULAR RADIO," writes J. J. Wills of Pine Castle, Florida, "—unless I could get another copy."

* * *

EVEN in Cuba the radio fan is carefully looking them over. "I have been buying all the magazines that are received in Havana," confesses David E. Masnata, "and none of them supply what the amateur wants to know so satisfactorily as POPULAR RADIO. A couple of days after your copies are placed on sale here they are sold out."

* * *

IN less than five days after our July number appeared on the newsstands our Advertising Manager received the following letter:

"Up to the moment of writing we have received orders for more than Two HUNDRED of our \$1.00 combinations, from our one-eighth page advertisement in your current issue. Increase my advertising space for your next number."

BRILLIANTONE RADIO PRODUCTS.

Our advertisers may find themselves in the position of the country storekeeper who complained to a would-be customer; "Naw, we don't keep Blank's tools; it's no use. We used to, but they always sold out."

* * *

SOMETIMES the "fame that comes over night" happens in real life. It happened years ago to Ellis Parker Butler, whose story "Pigs Is Pigs" has become a classic of wit and humor. But even that is no funnier than his story "I Install My Own Radio Set"—in POPULAR RADIO for September. And the story is not "just made up"; it is really true! Anyone who has ever put up his own set has a real treat in store.

* * *

WHAT kind of articles would you, Mr. Reader, like to see in this magazine? What articles do you enjoy best? From what articles do you profit most? How can we make this the most interesting and the most helpful and popular radio magazine in the world? If you have a suggestion, will you not send it along to the Editor?

Kendall Banning
Editor, POPULAR RADIO

For this Broadcasting Receiver thousands have been waiting

EVER since broadcasting became the vogue, there has been a demand for a receiver which would fill a whole room with music of perfect tone quality but which would be so simple that anyone could tune in by moving a single lever.

This ideal has at last been realized in the Aeriola Grand—the supreme achievement of present-day radio.

When you hear the voice and the music that come from the Aeriola Grand it is as if the lecturer or singer at the broadcasting station were in your presence. The whole family listens and marvels.

The Aeriola Grand stands unrivaled not only as a radio receiver but as a piece of cabinet work.

Prices

- Complete with mahogany stand, storage battery, battery charger, antenna equipment and all accessories\$409.50
- Without stand, storage battery, charger and receiving antenna equipment 325.00
- With stand, but without storage battery, charger and antenna... 350.00
- Mahogany stand only..... 35.00

See the Aeriola Grand at your nearest dealer

Before you buy any receiver, secure a copy of the book "Radio Enters the Home." It tells the real story of radio and will help you to get the most out of this new art. 128 pages—over 200 illustrations—35c a copy. At your dealer or write direct to

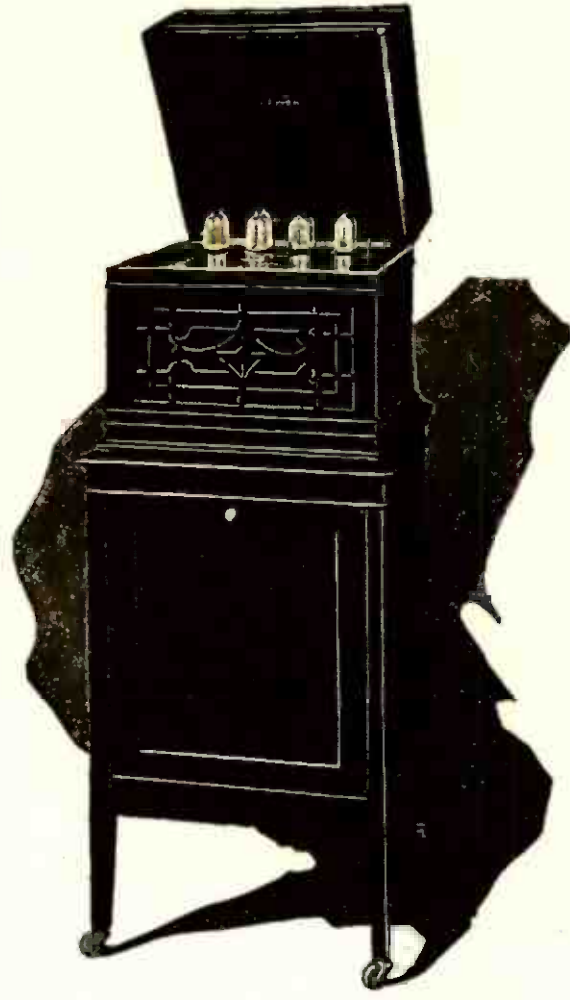

What the Guests Heard at the Jacksons' Aeriola Grand Party

- Baseball scores
- Dance Music
- Songs by a great ballad singer
- Lecture on the "Wedding Ring. Past and Present"
- A story by a famous author
- Chamber music by a noted string quartet
- The whole opera "Cavalleria Rusticana" with explanations
- News of the day
- Weather forecast for the following day



Sales Dept., Suite 2067
 233 Broadway, New York, N. Y.
 District Office
 10 So. La Salle St., Chicago, Ill.



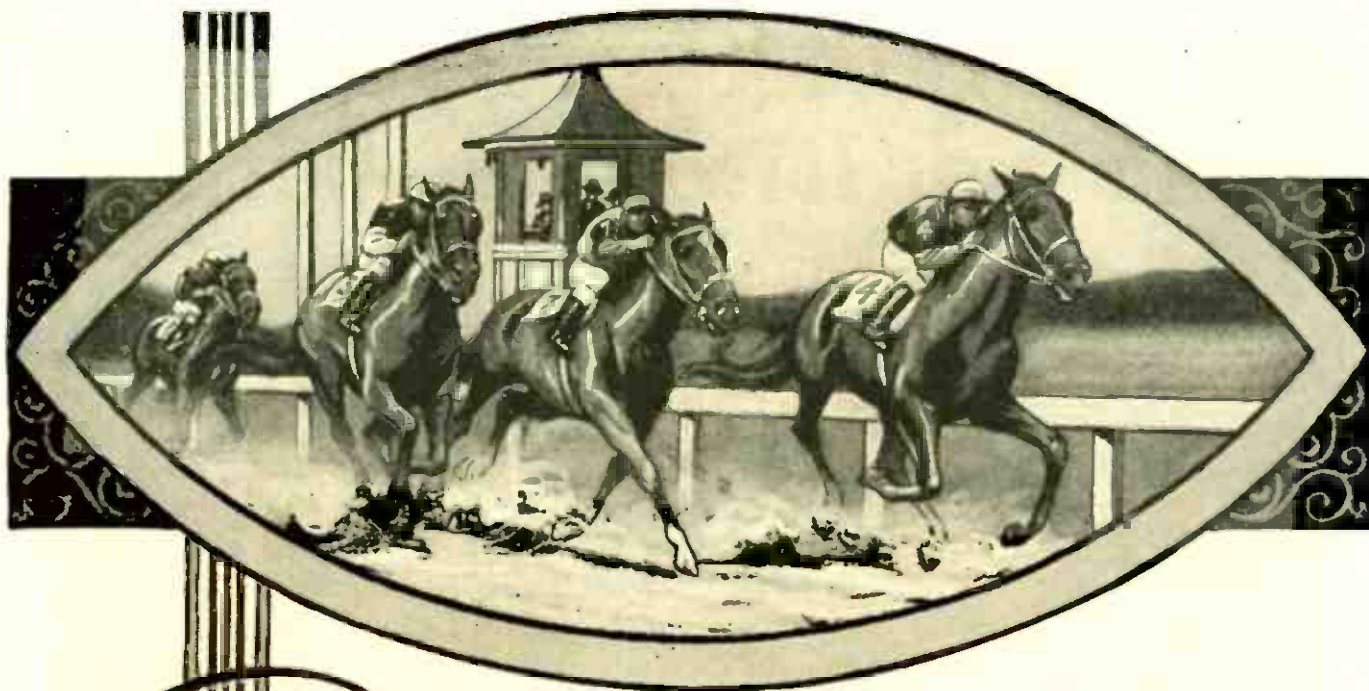

We're off!!!



OFF the beaten path and on the trail to a worthwhile goal. "Thoroughbred Apparatus" has been constantly winning new friends and has hung up some enviable records as a quality leader in radio apparatus.

Our goal is *unwavering superiority*, and we intend to come under the wire with "Thoroughbred Apparatus" in the lead of the radio field.

On June 1st we moved into our new factory. Now, with greatly increased facilities, we are prepared to handle your orders as they come. Write for our interesting offer to reliable dealers.

"Thoroughbred Apparatus" consists of: Moulded Variometers, Vario-couplers, "Read 'em" Binding Posts, 17 styles, Amplifier Panels, Detector Panels, Variable Condensers, Fixed Condensers, Binding Posts, Contact Points and Stop Pins, Switch Levers, Dials, Single Sockets, Rheostats, Crystal Detectors.

THE MARSHALL-GERKEN COMPANY

Jackson & N. 12th Street, Toledo, Ohio

Thoroughbred Apparatus



WHAT WILL BE THE FUTURE OF BROADCASTING?

"RADIO broadcasting as now conducted may pass. I think that it will. But it will pass into something bigger and better, into something more useful to men and to society."

George O. Squier

MAJOR GENERAL, UNITED STATES ARMY

Speculation concerning the future of radio broadcasting is widespread; opinions vary as to how it may develop. For the next issue of POPULAR RADIO General Squier, the famous father of "wired wireless", has written a significant and a prophetic article that is of commanding interest to every radio fan in the country.

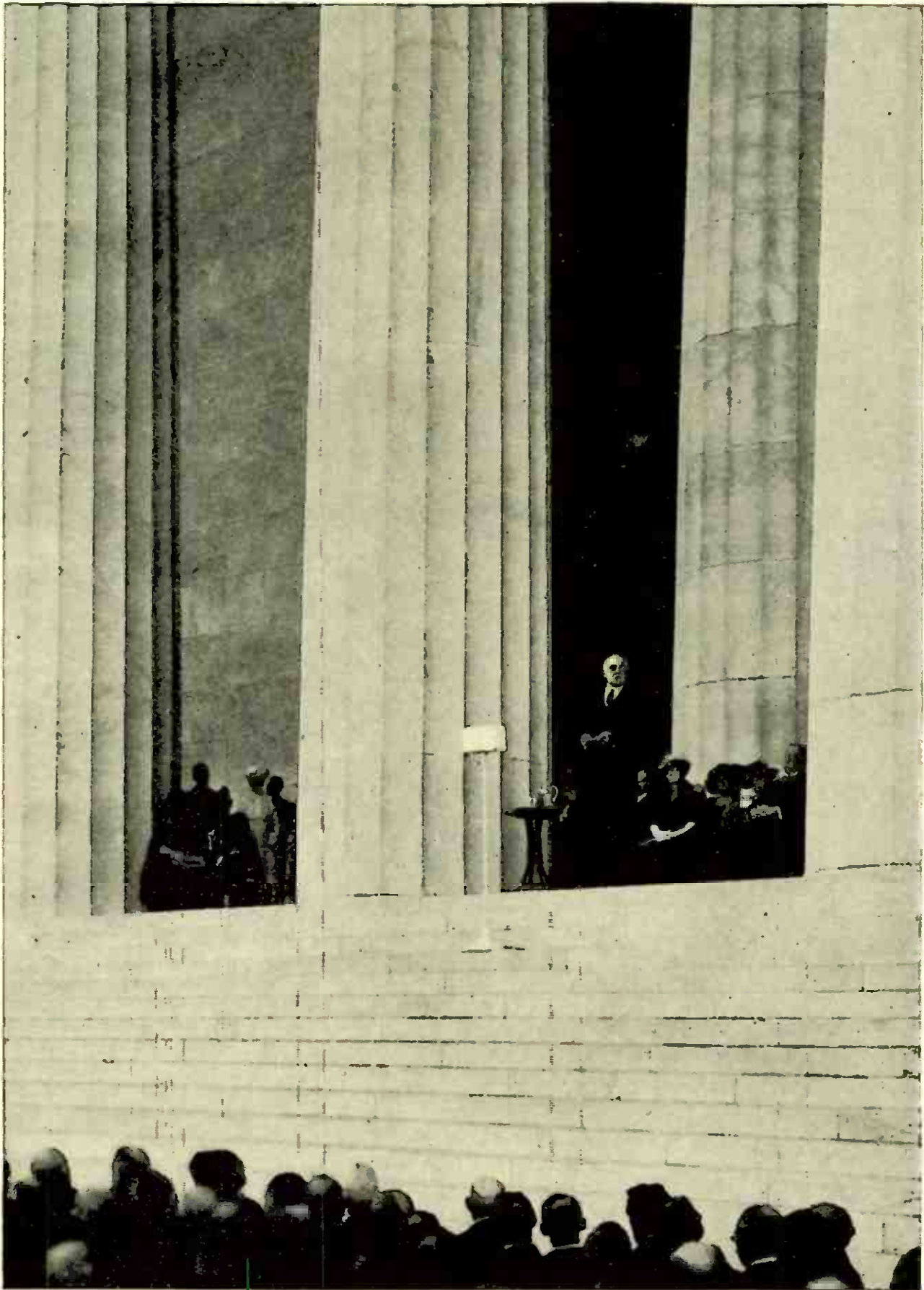

Harris & Ewing

**THE PRESIDENT SPEAKS TO THE GREATEST RADIO AUDIENCE IN
THE WORLD**

At the dedication ceremonies of the Lincoln Memorial the President addressed an audience of about 50,000 people. But in front of him was placed a microphone that transmitted his voice to two radio stations—one at Anacostia and one at Arlington—which broadcasted the voice at wavelengths of 412 and at 2,650 meters respectively.

Popular Radio

VOLUME I

AUGUST, 1922

NUMBER 4



Fighting Fire *by* Radio

How Modern Science Is Reaching Into the Remote Wilderness to Safeguard Millions of Dollars Worth of Public and Private Property from the Flames

By ARTHUR CHAPMAN

“THE fire has us surrounded. I’m going to dismantle the radio set and take it on a raft, out on the lake, and see if I can’t save it.”

Such was a vocal message received by a Forest Service radio operator at Lolo Hot Springs, Montana, from the operator at Beaver Ridge, Idaho, across the main range of the Bitter Root Mountains, in August, 1919, at the height of a disastrous season of forest fires.

The stations mentioned were the first ones to be installed by the United States Forest Service to demonstrate the possibilities of permanent radio lookouts in forest fire work. Effective service had been rendered in California, Oregon and Washington by airplanes equipped with radio, communicating with field stations, but these lookout stations in Montana and Idaho were for continuous service. They had been equipped under the greatest difficulties, on account of their location in rough, high ground where ordinary telephone construction was next to impossible. They had been rendering efficient service for more than a month. To have one of the stations wiped out would be regarded as a calamity.

Without a thought of his own danger, the operator at Beaver Ridge, with flames advancing upon his post from every side, dismantled the radio set and carried it down the hill to a small lake, where he built a raft to float it.

Through a combination of lucky circumstances the rangers who were fighting the fire were enabled to keep the radio station from being destroyed. As soon as it was certain that the danger was over, the operator floated his radio set back to shore and had the outfit once more taken back to the lookout station and the outside world was soon being apprised by wireless of conditions in the Beaver Ridge area.

This is only one of many incidents that have enlivened the youngest branch of the Forest Service since radio has been introduced in the work of fire fighting.

In airplane fire patrol work, which has been done extensively and successfully in the Pacific Coast states, radio has improved the one unsatisfactory element—that of reporting fires. Parachutes with messages attached were too uncertain. Carrier pigeons released from the air and reports by telegraph or telephone after

landing proved too slow in comparison with the work achieved by systems of lookouts, with specially built lines. In the first official reports to the Forest Service concerning airplane patrol work, the use of wireless was urged as a vital necessity. This need, with others, was so well met that at the conclusion of the last six months of 1919, following a systematic use of airplane patrol with radio, it was reported: "Airplanes are as necessary now to the Forest Service as boats to the Navy."

Six patrol routes covering National Forest areas of high value in California were mapped out and twice each day six Curtiss airplanes covered the greater part of 6,000,000 acres of rough, mountainous, heavily timbered country. The average non-stop run was 160 miles; the average round trip 320 miles. Many fires were discovered, located and reported in advance of the regular Forest Service detection organization, and in addition to performing these duties the regular fire patrol proved of great value in reporting the progress of fires. The patrol observers communicated by radio to the base stations and from there to the ground patrols by telephone. In five months, from June to October, inclusive, 202,009 miles were covered by airplane, and 442 fires discovered, 27 of which were reported in advance of the regular forest patrols and independent of them.

While the development of radio in the aircraft patrol was being carried on, the Forest Service was not overlooking the opportunities of wireless at established points in the National Forest. The Service has created many lookout stations at suitable points in forest areas. These stations are connected by telephone with the offices of the forest supervisor. When an observer at such a station sees a fire, the location is telephoned to headquarters. If the fire appears to be serious, a general alarm is sent to district headquarters and a large force of fire fighters is sent to the scene.

These telephone lines to lookout sta-

tions in the National Forests have been constructed at great expense. Most of them have, of necessity, been built through wild and rugged country, sparsely inhabited. Such lines are often threatened with destruction by fire. Sometimes they are destroyed, in spite of all that can be done to save them, and the costly work of installation must be begun over again. Also the stations may be cut off for weeks and new fires may start in other parts of the forest, without being reported. It is like putting out the eyes of the Forest Service when these stations are disabled.

A case in point, which could not have happened had radio been installed, took place last summer in the Clearwater National Forest, where fires were very destructive. More than ninety miles of ordinary telephone line was destroyed, the trees from which the wire was suspended were burned and the wire itself was melted by the heat. Quick communication was at an end and the efficiency of the fire fighting organization was correspondingly diminished. It took more than a week to restore telephone communication with every resource of the Forest Service officials devoted to that end.

Such a halting of communication at the very crisis of a fight against forest fires is in sharp contrast with the incident related at the beginning of this article. With no line of wire communication to worry about, the radio operator at Beaver Ridge who transplanted his outfit to safety on the lake, while the flames went by, was in a distinctly advantageous position.

With no idea of getting the necessary pioneer work accomplished in establishing radio stations, R. B. Adams, Telephone Engineer for Districts No. 1 and No. 4 of the Forest Service, was delegated in the summer of 1919 to study the subject and to ascertain what equipment was best for the purpose. Wireless experts of the War and Navy Departments were consulted and the plants of the leading electric companies were visited in order



From a photograph made for POPULAR RADIO

A RADIO SCOUT OF THE AIR

Few forms of government service offer more adventuresome experiences than the "Forest-Fire Air Patrol" of the Northwest, whose daily flights of several hundred miles over valuable timber tracts not only locate fires before they get far under way but direct the work of the fire fighters below.

to secure the best information possible.

After full consideration, what are designated as SCR-67A wireless telephone sets, used by the U. S. Signal Corps, were decided upon as most promising for the Forest Service in its experimental work in the mountains. Two of those sets were secured and taken to the field for a test of their efficiency. One set was installed at Mud Creek ranger station, near Lolo Hot Springs, Montana. It was determined to erect the other set at Beaver Ridge, which, though only twelve miles by air route from Lolo Hot Springs, is in another state and across a mountain range and is thirty miles distant by trail.

During the preliminary test work, Adams had personal charge of the Mud Creek station and that at Beaver Ridge was handled by his assistant, Everett Cutting. Working in the face of apparently

insurmountable obstacles, these men did not quit until they had proved that the radio station had an important place in forest protection work. Theirs was the enthusiasm of an abiding faith, and they demonstrated resourcefulness in overcoming unlooked-for problems which cropped out at every turn.

Transportation presented unusual difficulties at the outset. Carrying delicate instruments by pack train over almost impassable trails for thirty miles is something to tax the patience of the most enthusiastic scientist. One of the worst tasks was to pack the cumbersome storage batteries that had to be used at each station. The two stations had been made ready for business, antennae installed, signals agreed upon, and other details attended to, but no storage batteries had arrived at the Beaver Ridge terminus.

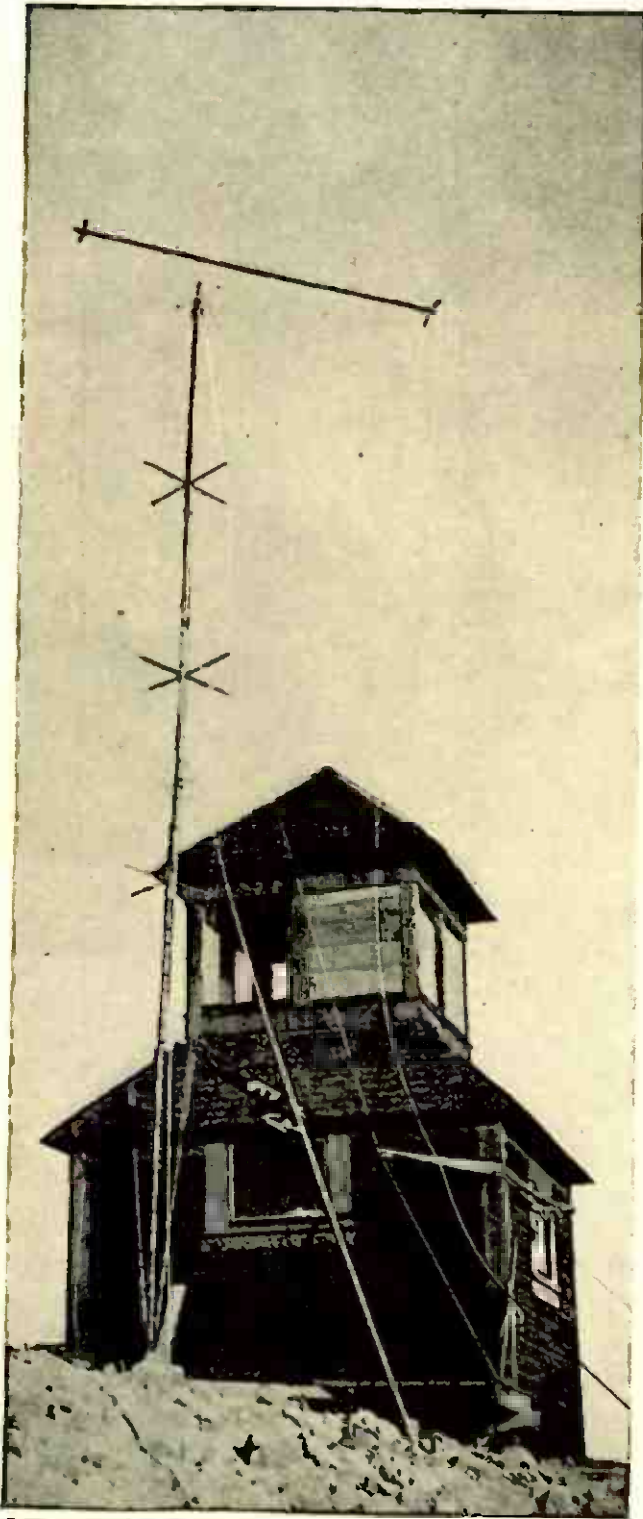

© Underwood & Underwood

A RADIO LOOK-OUT ON MT. HOOD

Located 11,250 feet above sea level, this station of the Forest Service receives and transmits reports of forest fires within a radius of many miles.

Word came at last from the packers, indicating to some slight degree the troubles that had been encountered. Three times the Beaver Ridge battery was lost or destroyed in transit. Pack horses had slipped off the trail and packs had become displaced and gone rolling down the

mountainside. On the final trip the battery was all but lost, but finally recovered and the pack train struggled on its way and all equipment was delivered.

Antennae hung high on convenient pines, the storage batteries were all in place, and from out of the air the Mud Creek station heard the welcome call, "Hello, Mr. Adams," sent by Operator Cutting from Beaver Ridge—the first telephone call ever transmitted by the Forest Service by radio in the administration of the National Forests. This was on the morning of July 19, 1919. The sets remained in operation and were used for every purpose the telephone would be called for until the last of August, when the temporary removal of the Beaver Ridge set took place as described.

The "hello girls" at modern telephone exchanges, who feel that fireproof buildings equipped with electric lights and fans and steam heating plants and upholstered furniture, to say nothing of restaurants and gymnasiums, probably would be horrified at the primitive surroundings under which these first radio operators in the Forest Service were compelled to work. At both the Mud Creek and Beaver Ridge stations the wireless sets were established in field tents. The flicker of coal oil lanterns afforded the only illumination at night. The operator's seat was a soap box, and the instrument desk was a cracker box. The heat of summer days was sometimes lessened by a wind which menaced the frail canvas "office" of the operator. Under these pioneer conditions Adams and Cutting carried on their work during one of the most disastrous fire seasons on record.

While the sending radius of the sets used was not great, the receiving ability was practically unlimited and wireless messages from many distant points were picked up by the lonely stations astride the Bitter Roots. Perhaps Beaver Ridge was the first place in the inter-mountain region to know that Admiral Rodman's flagship had safely passed through the Panama Canal, for the Forest Service op-



Photo by courtesy of the U. S. Forest Service

A PACK TRAIN OF RADIO EQUIPMENT PENETRATES THE GREAT FORESTS.

To pack and transport into the heart of the timber districts of the great Northwest antennae, storage batteries and delicate receiving and transmitting apparatus presents a problem that taxes the patience even of the most enthusiastic scientist.

erator in the mountain wilderness had picked up the naval radio message announcing the fact.

As a result of this first season's work, additional equipment was secured the next year through the Navy Department, in the form of 50-watt telephone transmitting sets. These were used during the summer of 1921 successfully between Buffalo Hump and Warren, Idaho, a distance of from 40 to 45 miles. Prior to the installation of the radio between Buffalo Hump and Warren it required nearly two days to get a message between those two points. With the radio in use, fire calls were handled between those points in about four minutes.

The big problem confronting the Forest Service, according to Mr. Adams, is power. It is necessary to carry everything in the "back country" by pack horse, and, as the weight a horse can carry is limited to 150 pounds, special equipment had to be designed in the form of gasoline charg-

ing plants to secure adequate power for charging storage batteries.

Some radio engineers were of the opinion that considerable trouble might result from placing the sets in mineral zones and heavy timber. No such trouble developed, though one set was located in a hole in a heavily mineralized country and the other was in the midst of dense timber and also was close to another mineralized zone.

The power problem at the Forest Service stations was not solved without considerable experimenting. Finally there were used 270 No. 2 Burgess dry batteries, connected in series, to secure the 350-volt plate current required. This did away with the motor generator entirely. However, for the right solution of the power problem, some form of generating equipment similar to the Delco lighting system will have to be used in this mountain wireless work. Gasoline-driven engines, air motors, and different forms of

hydroelectric power developed are all possibilities in this connection. Diverse conditions in different localities no doubt will call for the utilization of all these various methods of generating power. The one to be adopted at any particular station must be determined by local conditions.

One valley in the Cleveland National Forest had been a constant source of fires of suspicious origin, until airplane patrol was established. The knowledge that an airplane operator in forest patrol work has a powerful telescope and radio at his command cannot fail to have a beneficial effect on that type of incendiary whose specialty is starting forest fires in order

to be put on the government's payroll to fight the very flames for which he is responsible.

The airplane patrol work in the National Forests was undertaken by the Air Service Branch of the War Department, with Air Service personnel and equipment and at Air Service expense, at the request of the Forest Service and with the cooperation of that department and the Signal Corps. Radio on the airplanes themselves and at the bases is handled exclusively by the Air Service; all other radio is handled by the Signal Corps. An officer of the Forest Service acts as liaison officer at each base and receives all reports by radio or by pilots landing, which



Photo by courtesy of the U. S. Forest Service

THE FIRST MAN TO USE RADIO IN FIGHTING FOREST FIRES

Facing what at first appeared to be unsurmountable obstacles, R. B. Adams, engineer for Districts No. 1 and No. 4 of the Forest Service, undertook to establish radio service in the wilderness of Montana early in 1919. This picture shows the original set on which was received the first radio message ever transmitted in the administration of the Forest Service.

reports he in turn transmits to the forest supervisors.

The value of radio has been proved not alone in reporting fires but in directing the operations of fire fighters. The best example of this use of radio occurred at the Mill Creek fire, covering some 12,000 acres in the Lassen National Forest. A portable radio receiving set was taken to the fire line by truck and by pack horses. A special airplane was detailed to the fire, to perform two duties, the first being to circle the entire fire, report conditions and direct the fight so far as possible, the second duty being to patrol the fire line.

With the receiving set directly on the fire line, and with the use of the liaison officer for a part of the time, and the most experienced observer during the remainder of the duration of the fire, it was found possible to get practical directions from the plane regarding the best disposal of the fire-fighting crews.

The airplane patrol of the fire line was determined upon as the best means of conserving the available force of fire fighters. During the progress of the fire there was from ten to fourteen miles of fire line to watch. Men were scarce and the fire was uncontrolled on the other side. It was determined to take every available man from the fire line and concentrate the entire force on the other side of the fire. The ship came down to an altitude just above the tree-tops and made a detailed patrol of these fourteen miles of fire line. The radio reports of the operator were relied upon absolutely. If he reported the fire line as clear, the men were all kept at the big task of fighting the fire on the other side. But if a radio report came back to the effect that the fire had broken over, or was about to do so, men were sent to the threatened point on the fire line and the danger was averted. This is the first time, as far as Forestry officials know, that a successful patrol of a fire line has been made—and this would not have been possible had it not been for radio.

The advantages of radio for quick re-

ports were demonstrated following unusually severe lightning storms on the Lassen forest. Thirty-two fires were started by lightning in one district within two days. Similar airplane reconnoissances were made on the Klamath and the Plumas forests after severe lightning storms, with excellent results from the wireless reports.

Locating a forest fire "accurately" in Forest Service parlance means within a quarter of a mile of the actual scene of the fire. This is not as easy as it sounds, even when the locating is done from an observation station where the operator has powerful glasses and scientific instruments to aid him in his work. District Forester Paul G. Redington reports that 33 percent of the fires discovered by the airmen operating out of Mather Field in California, and reported by radio, were located "accurately." An additional 19 percent of the fires reported were within a half mile of their actual locations. Ten percent were located by the Air Patrol before the forest rangers knew of their existence, and eighty-three fires, or 42 percent of the total, were reported by radio while the airplanes were in flight. Fifty-eight percent, therefore, were reported after the airplanes had landed.

In Oregon seven airplanes were assigned to the Eugene base and four to the Medford base—all equipped with radio sets. The first sets furnished by the Signal Corps were found to be of too low receiving power to be as effective as was desired. New sets were furnished and the patrols kept in constant touch with each other. During the first season of operations in Oregon, local amateur wireless operators caused considerable annoyance by sending messages while the machines were in flight, but as soon as their attention was called to the trouble in receiving fire reports most of them refrained from using their instruments during patrol periods.

A radio-telegraph transmitting outfit designed by the Signal Corps of the United States Army, labelled as type

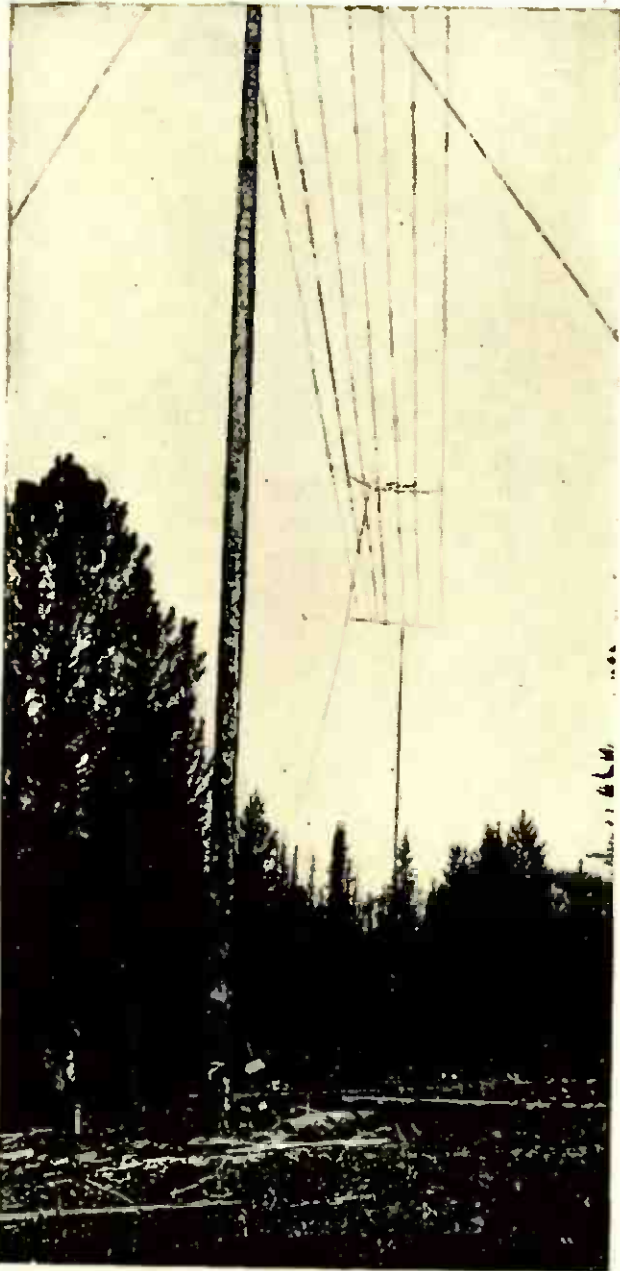

Photo by courtesy of the U. S. Forest Service

AN ANTENNA IN A REAL WILDERNESS

Erected in the Nez Perce forest. The poles are 98 feet high with a 210-foot span; the seven antenna wires are spaced 2 feet 10 inches apart.

SCR-73, is employed on fire-detection aircraft. The equipment is of a damped-wave design, obtaining its power from a self-excited inductor type alternator. The latter is propelled by a constant speed airfan or possibly a fixed wooden-blade airfan designed for training purposes. The alternator, rotary spark gap, potential transformer, condenser and oscillation transformer are self contained in the stream-line casing of the alternator. The latter is customarily mounted on the underside of the fuselage where the pro-

PELLER spends its force in the form of an air stream. The only units included inside the fuselage are the telegraph sending-keys, field and battery switch, dry battery in its holder, variometer, and antenna reel.

This type of transmitter conforms to the description of being a simple rotary gap, indirectly excited spark, provided with nine taps on the inductance coil of the closed oscillating circuit. Nine different wavelengths are possible, and five varying toothed discs for the rotary spark gap yield five different signal tones. These two variations afford forty-five different combinations of wavelengths and tones. Thus, it is feasible to press into service a series of airplanes for detecting forest fires in a restricted area without interference putting in its discordant work.

The wavelengths and tones of this transmitting set are brought into harmonious operation when the airplane is on the ground. Once the machine leaves the earth, this apparatus is not available to either the pilot or observer. The only adjustment effected in the air is that accomplished by a variometer mounted in the fuselage which brings the open oscillating circuit into harmony with the closed circuit as indicated by the maximum current reading on a hot wire ammeter in the variometer box. There is no battery to go "dead" or other auxiliary units to fail. The hot wire ammeter tells whether or not signals are being radiated.

A two-way radio-telephone set is employed on an airplane at each sub-base for directing the fire-fighting crew at big conflagrations. A Signal Corps design, bearing the number 68-A, is used for this purpose, the outfit having a wavelength range from 215 to 450 meters. A special constant voltage generator supplies the power for transmitting and for heating the essential vacuum tube filaments. Other accessory units of this radio-telephone outfit are: a filter box, a radio set box, an interphone set box for affording communication between the pilot and observer, two head sets and tele-

phone transmitters, with the necessary connecting cords.

A damped wave airplane receiving set, known as Signal Corps design No. 54, was installed on the ground at the forest supervisor's headquarters in each National Forest. Here reports of detection of fires were received from airplanes making semi-daily patrols. This receiving outfit involves the use of both primary antenna and secondary circuits. These may be tuned by means of the variable capacitance and variable inductance found in both circuits. Across the secondary condenser is connected the detector and telephone circuit. A separate buzzer circuit is installed in the cover of the box to excite the set when adjusting the crystal detector.

An airplane assigned as a forest-fire patrol submits its radio equipment for thorough inspection before leaving the ground. In advance of its departure from the vicinity of the airdrome, the patrolling airplane is required to call the radio station and obtain its "O. K.," which signifies that both the radio installation on the flying mechanism and ground wireless apparatus are functioning satisfactorily. The machine then soars along its well-defined route, sending back by wireless its observations according to pre-arranged time schedules.

This knowledge from out of the sky by the medium of ether is received both at the base of the Air Service and at the receiving headquarters of the Forest Service over which the plane chances to be flying at that particular time.

With the arrival of the machine at another base, ordinarily for the purpose of the pilot and observer eating dinner, the list of observations is forthwith deposited with the wireless operator who transmits the reports by wireless to the main headquarters. This act serves as a verification of the report previously dispatched by radio from the machine while on its observation tour.

The main question concerning the development of radio as an aid in the ad-

ministration of forests is: What is the Forest Service going to do, exclusive of any aid from other departments? In airplane patrol, dependence must naturally be placed upon other branches of government service. This support may be withdrawn, through necessity, at a most inopportune time. Consequently it is felt by Forest Service officials that the substantial development of radio must come from within the Service itself. They are planning for and looking forward to the addition of equipment of their own.

Adams' work in Montana and Idaho, under District Forester Fred Morrell, seems to afford a foundation for substantial development. He has demonstrated that it is possible to equip radio stations successfully in the most isolated regions. Wherever any sort of a trail can be built, the rest can be left to that gifted and patient individual, the master of the pack train, who has not yet disappeared from the West.

The losses that can be prevented by radio communication, either from lookouts or aircraft, will soon pay many times over for any cost of installation and maintenance. The value of only three of the great National Forests is estimated at nearly \$63,000,000. From 1910 to 1917 inclusive there were 5,313 fires in all the National Forests, burning 1,163,756 acres of timber annually valued at \$3,758,356. On state and private lands, from 1915 to 1917, 2,873 fires occurred, burning 8,052,945 acres of timber, a loss of \$9,875,000, not including the losses suffered in the great Minnesota fire.

Radio seems to mark the next great step to be taken in forest conservation in this country. With radio reports being sent from permanent lookout stations and from airplane patrols, giving the exact locations of fires in their incipiency, and with radio operators in airplanes hovering above forest conflagrations and directing the work of the fire fighters below, it seems that science has spoken its final word in forest preservation—and has spoken in actual voices from the clouds.

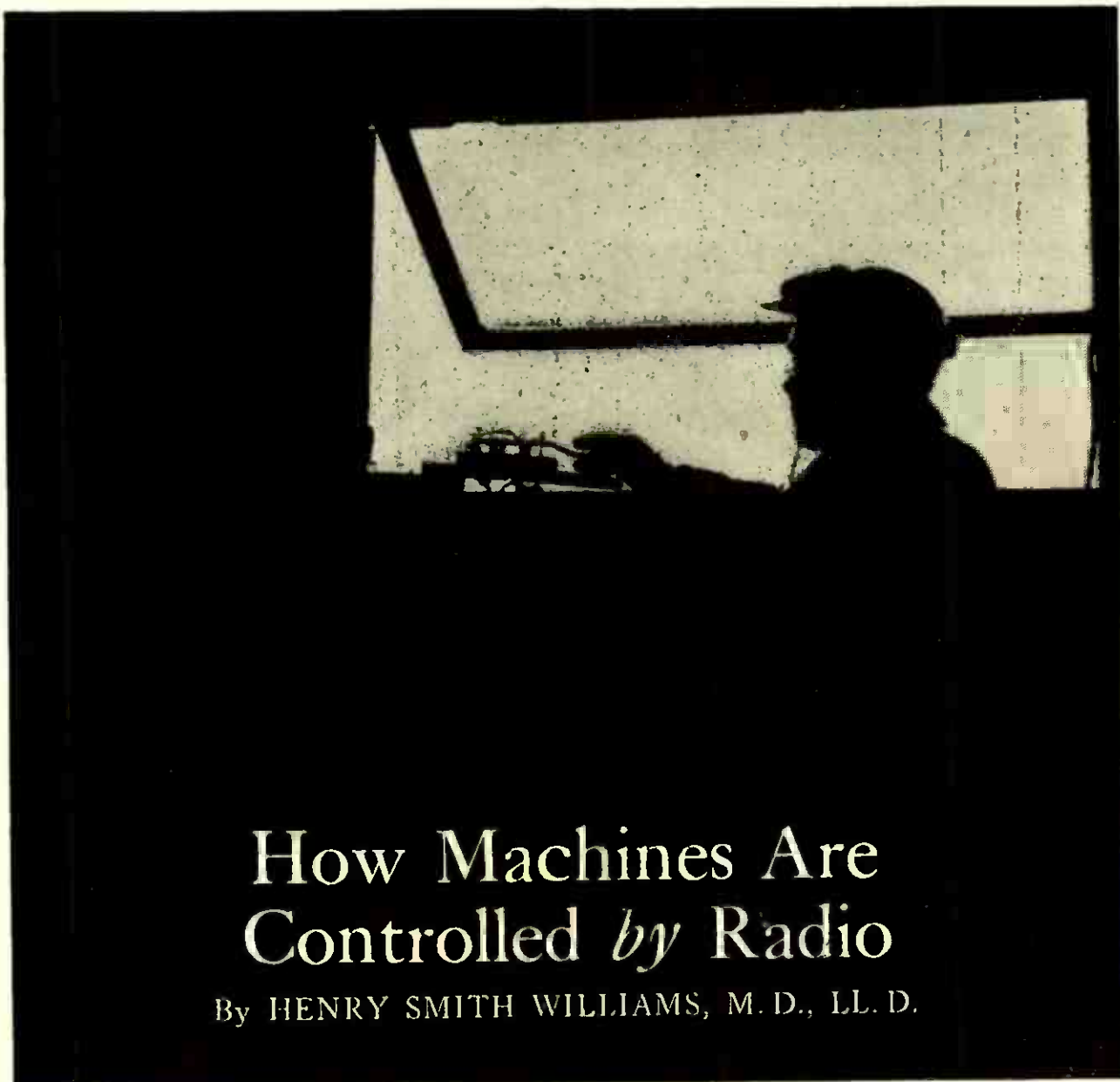

How Machines Are Controlled *by* Radio

By HENRY SMITH WILLIAMS, M. D., LL. D.

International

For Over a Quarter of a Century Boats, Motor Cars, Torpedoes and Airplanes Have Been Directed by Wireless Impulses—This Article Describes the Mechanism of One of the Latest of These Devices

NO radio apparatus exhibited in New York has attracted anything like the popular attention bestowed on Mr. E. P. Glavin's mystifying little automobile that is controlled by wireless.

I use the word "mystifying" advisedly, even though there is no secret as to the way in which Mr. Glavin accomplishes the wonder. A wonder it remains, however, even after the fullest explanation. The greater your knowledge of radio, in fact, the more fully you will agree to that.

You see Mr. Glavin standing at the side of the room, a solid-figured man with gray hair and strong, thoughtful face; you are at once struck with his resemblance to that other wizard in the field of electricity, Thomas A. Edison. The little automobile, somewhat boat-like in shape and with a mast that heightens the resemblance, stands in the middle of the floor. It is indeed a prosaic looking vehicle; its metal covering might give the impression that it is a model of some

new type of armored "tank." At a distance, your only clue to its real character, is supplied by the coil of wire that ascends as a spiral about five or six inches in diameter that winds about the mast from bottom to top, where there is a little electric signal light. On closer inspection you might see within the open body of the vehicle a series of electric batteries and sundry mechanical devices,

but even that glimpse would probably make you not much the wiser, even if you are a skilfull mechanic. About the only obvious feature is a central wheel, the rim of which projects into the body of the little car, to which the propelling mechanism is attached. The single front wheel, it may also be noted, serves to guide the vehicle to left or right, just as a bicycle is guided. But there is no bicycle

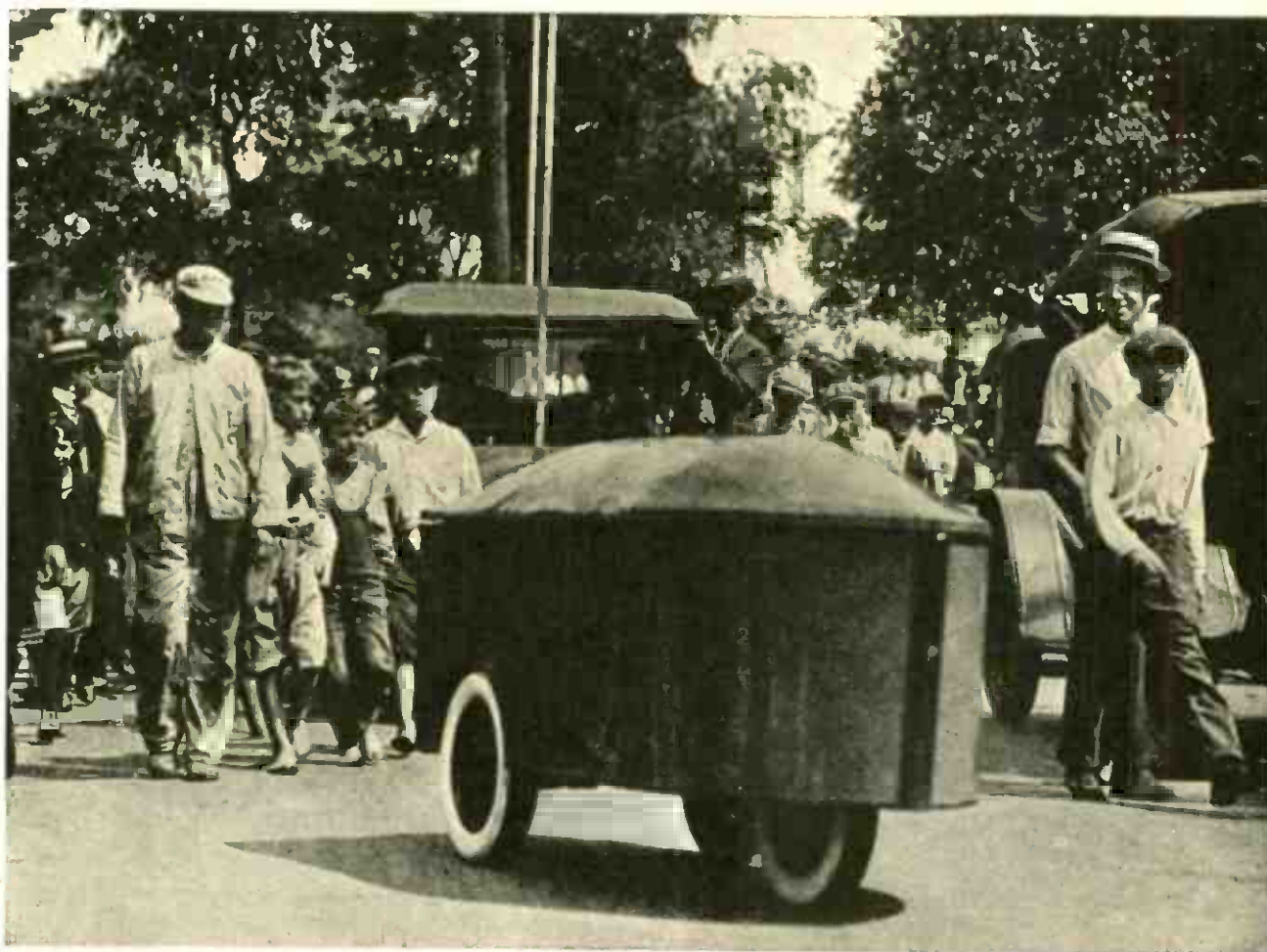

© Underwood & Underwood

A SMALL "TANK" WINDING ITS WAY THROUGH CROWDED TRAFFIC

A spectacular demonstration of a radio-controlled automobile—the fore-runner of a radio-controlled tank—was given in the streets of Dayton, Ohio, on August 5, 1921, at an hour when the traffic was heaviest. This car was developed by Captain Raymond E. Vaughan, Chief of the Radio Branch of the Engineering Division of the Air Service, U. S. A. at McCook Field. The car was eight feet long, three feet high and two and a half feet wide. It was propelled by motor and storage batteries at a speed ranging from four to ten miles an hour, and was controlled entirely by wireless signals transmitted from an automobile that followed in its rear; Captain Vaughan states "the controls would be effective at a distance of 50 miles and could be operated from an aeroplane as well as from the ground." It was stopped, started, reversed, steered; made to blow a horn, ring a bell and fire a pistol by the pressure of buttons on an automatic transmitter that sent out various combinations of dots and dashes that caused certain controls in the car to function. The "brains" of Captain Vaughan's car is the selector—an apparatus about as large as a saucer which decodes the combinations of dots and dashes and puts the desired controls in operation within a quarter of a second. Any one of the twelve controls can be made operative in less than one second. The possibilities for operating war-machines on the same principle give these demonstrations a prophetic significance.

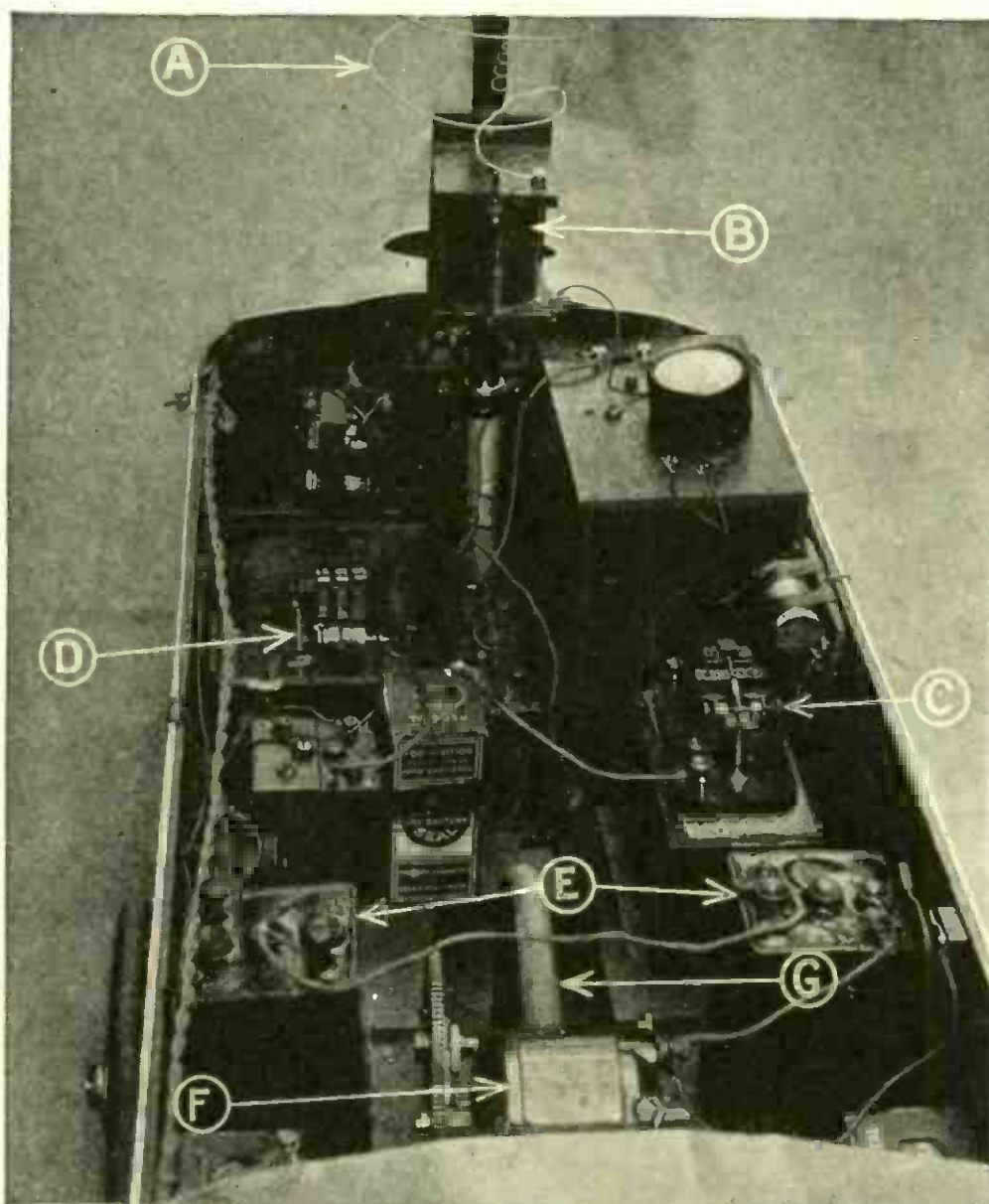

From a photograph made for POPULAR RADIO

INSIDE INFORMATION ON THE CONTROLS OF THE RADIO CAR

The essential working parts, by means of which the vehicle is controlled, are as follows: A is the spiral antenna; B is the tuning coil; C is the sensitive relay operated by the feeble radio currents; D is the control switch which is set into action by the closing of the contacts of the relay; E are the storage batteries which furnish the electrical power to the motor F, and G is the propelling wheel.

handle or other mechanism in sight by which the wheel might be turned.

Mr. Glavin, standing perhaps twenty feet away from the car, raises his hand. You note that the signal light at the tip of the mast flashes, but nothing more tangible happens. Another slight motion of Mr. Glavin's hand. Now the car starts forward and begins its strange journey. It glides along at a moderate pace, like a tank leisurely charging the mass of spectators, but before it reaches them it circles to the left, and moves back

toward the point from which it started.

Mr. Glavin's face is impassive, but from time to time he lifts his hand with a little movement as of salutation; each time he does so you note that the car changes its course. It circles to right as well as left; it cuts a big figure eight; with seeming intelligence it turns its prow just in time to avoid collision with the spectators.

I chanced to be standing beside Mr. Glavin on one of the occasions when the car was making such a journey.

"Now I will have it come around and stop right in front of us," he remarked quietly. A wave or two of the hand and the thing was done! It was hard to avoid the feeling that this weirdly responsive little vehicle, as it circled about and came toward us and stopped respectfully four or five feet away, was manifesting actual intelligence and consciously responding to the mandate of its master.

There was a time when an exhibition like that would have been labeled "wizardry," and an interpretation would have been put upon the word that would have boded ill for the exhibitor. The word "wizardry" still applies, but it now has scientific instead of superstitious implications. The medieval interpretation would

have condemned the inventor for consorting with evil spirits, the modern interpretation explains that he is juggling with electromagnetic waves in the ether.

There is, as I have said, no mystery about the method of operating Mr. Glavin's device. Every observer is aware that the little car makes its pilgrimage under radio control. Everyone knows that when the director lifts his hand he is merely signalling to the radio operator a short distance away. The operator touches a telegraph key connected with an ordinary transmitting apparatus that operates in connection with a short two-wire aerial. Everyone knows that the electromagnetic waves sent out from the aerial are caught up by the receiving coil that is spiraled to the mast, thus constituting a receiving antenna, and that it is the impulse thus coming to the radio apparatus stored within the body of the little car that determines its movements.

But this knowledge does not take away the mystery. To see that little vehicle, under no man's hand, start and move about in an intelligently directed path, stop, and start again and finally make its way to the stall that is its temporary home, and stop there—quite as a horse makes its way to its own stable—is to witness a scientific miracle that yields place to few others in genuine mystery. The

THE GLAVIN "MYSTERY MOTOR CAR"

The motive power is furnished by a storage battery; electromagnetic waves from the aerial throw the current in and out of circuit. How this is done is the essence of the device.

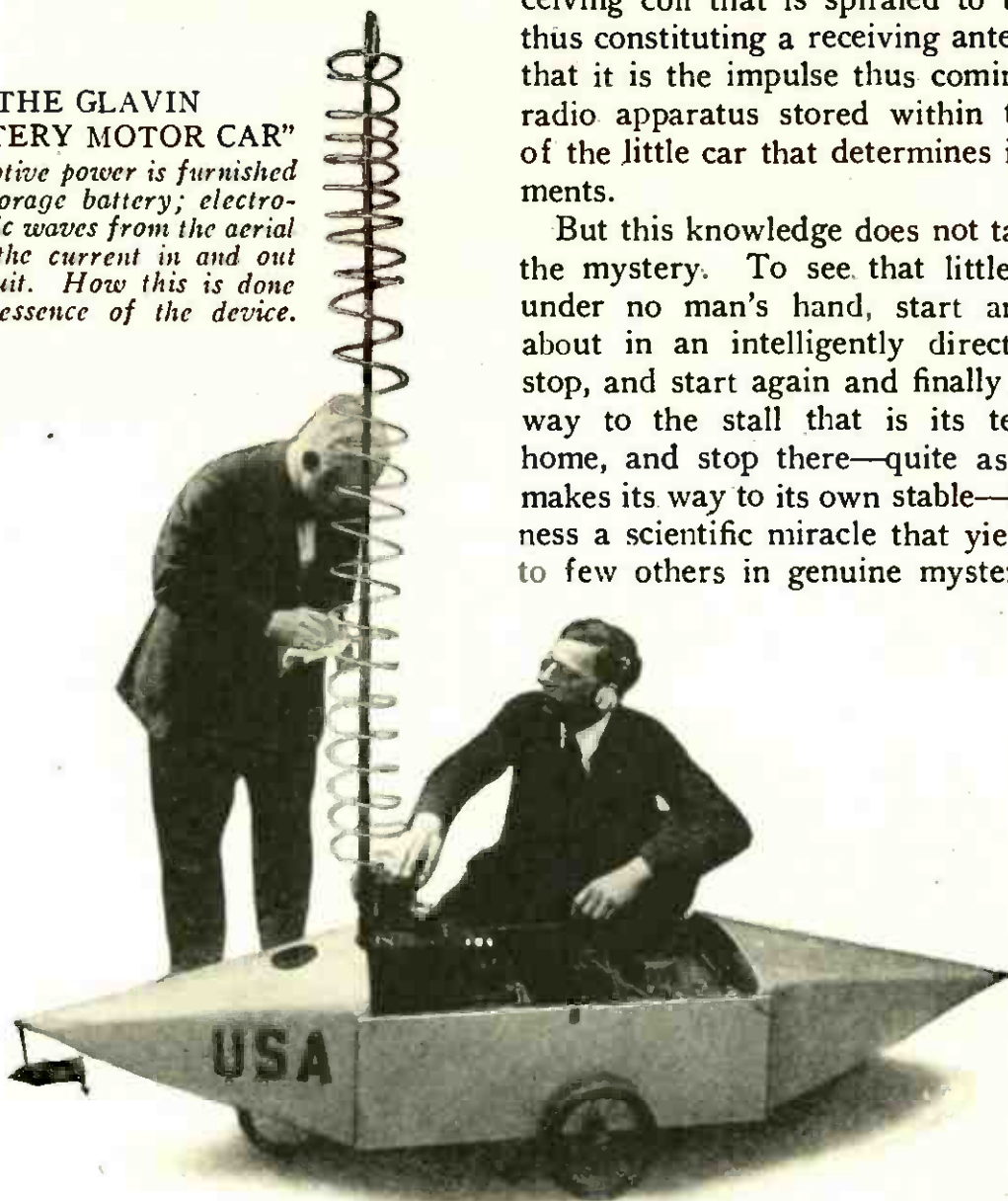

From a photograph made for POPULAR RADIO

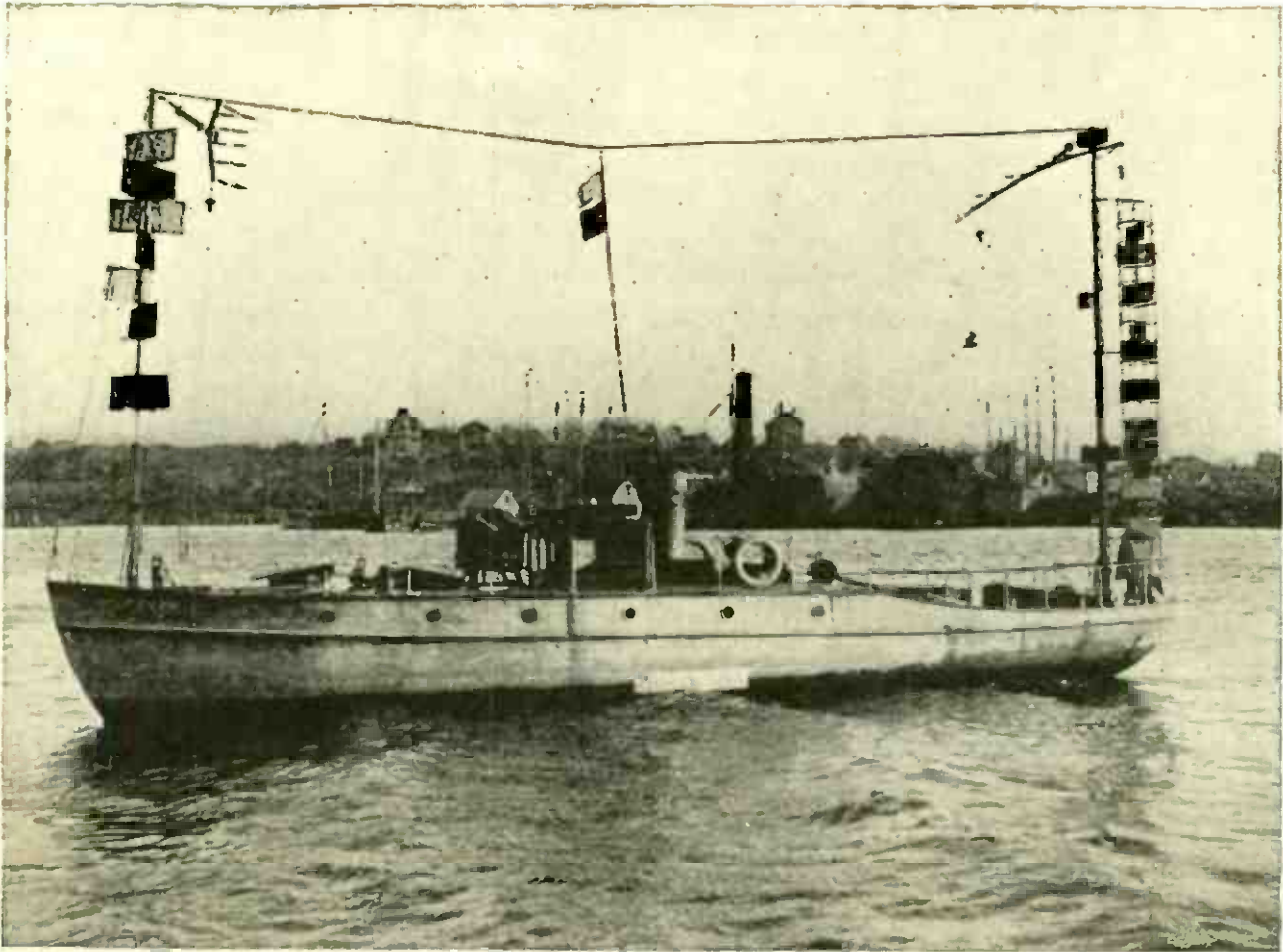

International

A FORE-RUNNER OF A RADIO-CONTROLLED NAVY

Several years ago the youthful "wizard" of Gloucester, Mass., John Hays Hammond, Jr. attracted world-wide attention by demonstrating how a yacht could be directed by radio impulses sent over a distance of several miles. These experiments were followed by the development of radio-controlled torpedoes.

builder of radio apparatus can tell how the thing is done in mechanical terms. The mathematician can calculate the energy involved. But no man can give what could properly be called a full explanation of the mystery.

It is possible, of course, to go a little more into detail as to the precise steps of the series of processes by which a wave of the hand appears to be translated into the propulsion of a vehicle—not only appears to be, but really is so transplanted, if we accept words in their proper meaning.

But what takes place within the mechanism of the vehicle when the wireless impulse is received from the transmitting aerial?

At the outset it must be understood that the radio waves which determine

the activities of the little car do not supply the energy of propulsion. By no possibility could they do that. The electromagnetic waves that come from the aerial could no more turn the driving wheel and propel the vehicle than could the same feat be accomplished by those other electromagnetic waves termed rays of light which pass from Mr. Glavin's hand to the eye of the operator of the radio-telegraphic key. The radio waves convey more energy than the light waves, to be sure; but in no conceivable way could they convey enough energy to propel a vehicle weighing eight pounds, let alone eight hundred.

Most of the observers are well aware of that. They understand that the actual propulsion of the wireless car is effected by a storage battery which is a part of

the internal mechanism of the car itself. A little dynamo that differs in no essential from the dynamos that propel other electrically-driven vehicles—from automobiles to trolley cars—metamorphoses the energy of the storage battery to energy of molar motion—and turns the wheel. The electromagnetic waves from the aerial serve only the function of the motorman on the trolley car, they throw the electric current in or out of circuit.

It is the way in which this is accomplished, however, that constitutes the essence of Mr. Glavin's invention.

This statement does not do full justice to the problem. It is necessary not merely to throw on and shut off current, enabling the car to start and stop (which is all that the motorman on the trolley is called upon to do), but it is necessary

also to provide for the lateral guidance of the car, a duty of which the motorman is relieved by the railway irons. The feat of Mr. Glavin's radio-automaton might better be likened to the task of the automobile driver who not only starts and stops his car but turns it to right and left.

Mr. Glavin labored with this problem for nine years before he solved it to his satisfaction. The inventor himself would probably qualify that phrase and say that he labored nine years before he got the car to operating as it now does, and that even now he feels that he has made only a tentative solution of the problem and is by no means satisfied with it as an ultimate achievement.

But the present achievement is notable enough to satisfy most inventors and to



HE LABORED NINE YEARS TO MAKE HIS RADIO CAR WORK

Not so many generations ago this inventor, E. P. Glavin, would have been condemned for consorting with the evil spirits that propelled and guided his miniature motor car. Modern science, however, knows that he is merely juggling with electromagnetic waves in the ether—until ultra-modern science disproves the existence of ether and proclaims another explanation of the phenomena of radio.

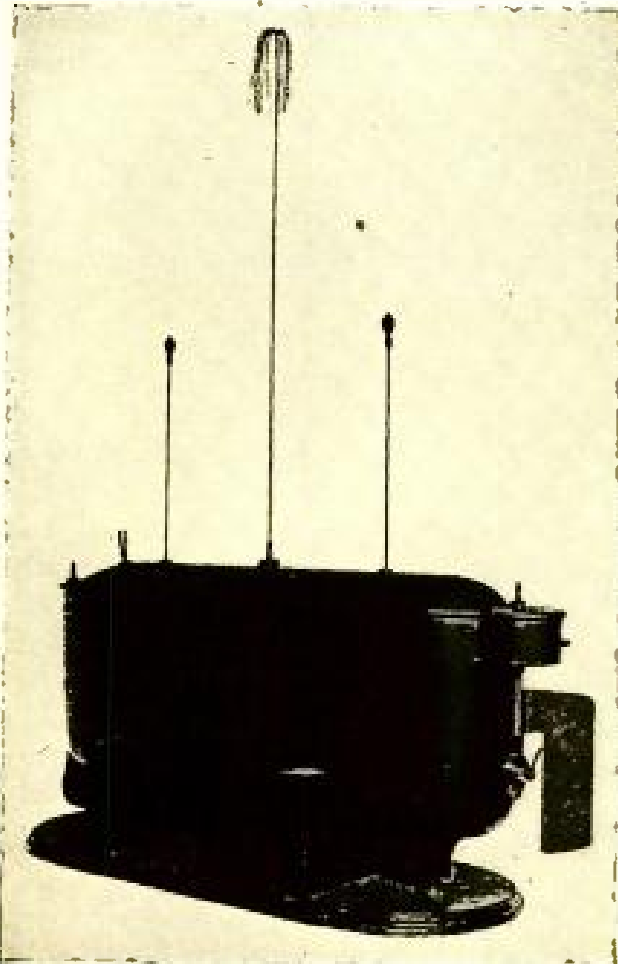

TESLA'S FAMOUS "TELAUMATON"

As far back as 1895 Nikola Tesla gave demonstrations in New York of this radio-controlled boat. It was eight feet long, and was operated in a large tank. The inventor made the boat go through many evolutions, turn lights on and off and fire miniature guns—to the consternation of the public to which radio was practically unknown.

excite the wonderment of all beholders. The mechanism involved, so Mr. Glavin assures us, is relatively simple; important mechanical devices almost always are simple when perfected. In this case, the mechanism that shunts the current from one circuit to another consists of a small drum actuated by an electromagnetic dog-and-ratchet arrangement. Released by one signal, the drum rotates enough to bring a brass collar in contact with poles of the battery, thus establishing a circuit that lights the electric lamp at the top of the mast head. A second signal releases

the drum and permits it to turn into the next position, where another brass collar establishes the circuit that enables the dynamo to actuate the propelling wheel. The motorman has turned his lever and established the circuit, and the car is in motion.

Now comes the third signal, and this (while leaving the propulsive current in circuit) permits another shift of the drum, bringing into action an electrically-driven power that turns the guiding wheel to the left. The car now circles to the left until the next signal brings the wheel back again; then it will go straight ahead again until the sequential signal turns it to the right.

There are twelve signals in the entire series, and the successive shifts of the drum necessarily take place in an unvarying sequence. Straight ahead—turn to the left—straight ahead on a new tangent—turn to the right—straight ahead on a new tangent—turn to the left—and so on. There is no way of changing the succession of the signals.

Nevertheless, the car can be made to take any desired course—as can the man-driven automobile. If Mr. Glavin wishes the car to make its first turn to the right instead of to the left, he merely gives three signals in rapid succession after the vehicle is under way. The three signals can be given in less than a second's time with the result that the drum will shift so rapidly, that the left-turn circuit and the back-to-center circuit are passed before the wheel has fairly begun to respond and the turn-to-right circuit appears to have been directly established. In other words, the undesirable signals were "jammed" and rendered inoperative.

Such, then, are the essentials of Mr. Glavin's invention. In a sense it is simple, yet of all radio marvels, few are more thought-provocative than this.

Q*The next article by Dr. Williams will describe the latest experiments in the transmission of radio impulses over wires and the amazing applications and possible developments of this phenomenon in our every-day life—including the use of telephones on moving trains.*

Why the Sun Makes Possible Long-Distance Wireless

As every radio operator knows, sunlight appears to have a blanketing effect upon radio communications. But the energy exerted by the sun's light also drives into the earth's atmosphere the solar dust which creates the "Heaveside layer" or "wireless screen," which is a tremendous advantage. This article tells how and why.

By E. E. FREE, Ph.D.

LONG distance wireless is one of those impossible things which has been done.

In the early days of radio-telegraphy the experts wrote convincing papers to prove that the transmission of wireless signals across the ocean was impossible, that it would require an impossibly large power. That it couldn't be done.

And then Marconi did it. Accomplished the impossible. Sent signals across the Atlantic with a small fraction of the sending power that the experts said would be necessary.

Transoceanic wireless became an everyday matter. Presently the signals from European stations were detected in Australia—clear on the other side of the earth. These were actual accomplishments. Yet they were "impossible," and contrary to all theory. Obviously it was time to revise the theory.

This is the story of how a new theory has been formulated and tested, how wireless experts came to believe that the whole matter is explained by an action of the sun, by solar dust shot out from the sun's surface and caught in the upper levels of the earth's atmosphere. Were it not for this dust, this beneficent solar bombardment of our atmosphere, the most



From a photograph made for POPULAR RADIO

HE MAKES COMET TAILS IN HIS LABORATORY

In order to demonstrate that light exerts pressure, Prof. Gordon Ferric Hull of Dartmouth College, in collaboration with Dr. Ernest Fox Nichols, devised the "comet tube" shown in this picture. This tube demonstrates how fine dust is driven sideways by light, as in the cases of comet tails. This action of light pressure drives dust from the sun into the earth's atmosphere, thus making long-distance radio communication possible.

powerful known wireless station would reach only a few hundred miles instead of the 12,500 miles which it does reach, a distance half way around the earth.

First we must see why the ordinary theory of wireless waves made long distance transmission seem impossible.

The ether waves which carry wireless messages are supposed to go outward from the sending station in every direction through space, to spread in an ever-growing sphere, just as the water-wave on a pond spreads in an ever-widening circle. The farther the wave has to go the weaker it becomes. Most of the energy supplied to it by the sending station, is lost in space. Only the tiniest fraction of this energy reaches the receiving station and is picked up. For practical wireless communication to be possible the original wave has to be strong enough so that this final tiny fraction of the wave picked up by the receiving station retains enough energy for perception.

Now the actual energy of this fraction in any given case can be calculated theor-

etically from the intensity of the wave at the sending station, the distance, the size of the receiving antennae, and from other details. For an actual instance of transmission between the great sending station at Nauen, near Berlin and the Panama Canal, the received current was theoretically calculated by Dr. L. W. Austin as about six ten-millionths of one microampere.

Was this the actual current received? Far from it. The actual current was 1.3 microamperes, over two million times stronger than it should have been theoretically.

This was a help for the practical wireless men. Something in the ether was helping them out. It was not so simple for the theorists. They had the job of finding out what this helpful something was.

Obviously it was something which de-

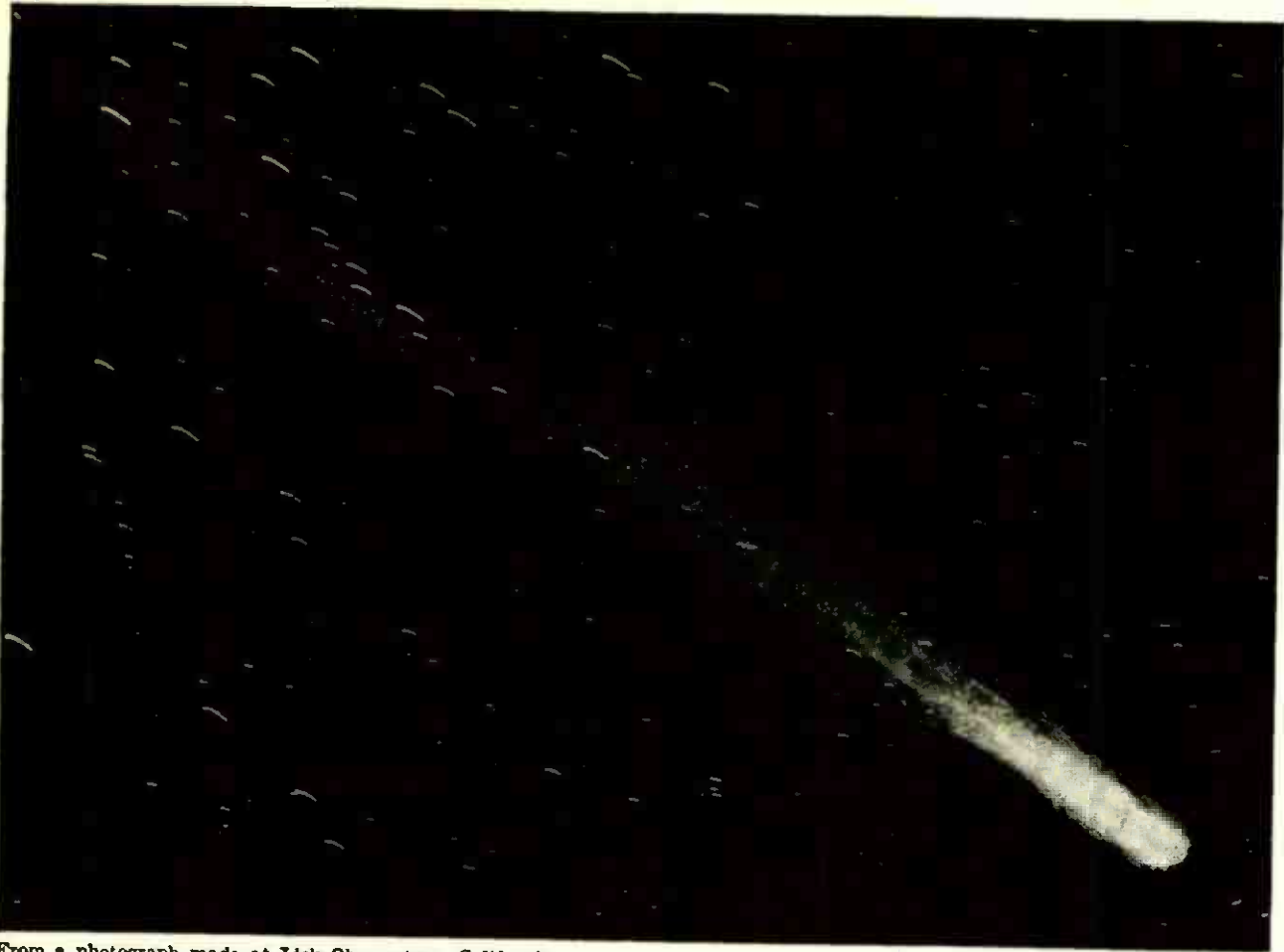

From a photograph made at Lick Observatory, California

THE LIGHT OF THE SUN MOVES THE COMET'S TAIL

The minute dust-particles of which a comet's tail is composed are driven backward by the pressure of sunlight. To this phenomenon of light much of the radio communication on the earth is made possible.



From a photograph made at Mt. Wilson Observatory, California

THE ORIGINAL SOURCE OF THE "WIRELESS SCREEN" AROUND THE EARTH

This is a photograph of a "solar prominence," or in other words, a storm of fire on the sun. This particular storm is driving the white-hot flames 100,000 miles high; sometimes these prominences are 300,000 miles high. It is the dust driven outward by such disturbances that reaches the earth and forms what Dr. Fleming calls a "wireless screen."

creased the loss of wireless energy out into space. The waves were held close, somehow, to the earth's surface. In the words of Dr. J. A. Fleming, speaking last Winter before the Royal Society of Arts:

"The upshot of the whole matter then is this: Long-distance radio-telegraphy, say, round one-quarter of the circumference of the earth, would certainly be quite impossible but for some force operating to compel the waves to follow round the earth's curvature and not glide quickly off it."

This conclusion, the conclusion that ether waves are tied somehow to the curvature of the earth, that they bend with it and follow it instead of being de-

ported into space, has just received strong confirmation from the experiments of Lieut. Guierre of the French Navy. Lieut. Guierre has been cruising about in the ocean near Australia and has been observing the clearness with which he could pick up the signals from the great French stations at Lyons (14,000 meters) and at Nantes (9,000 meters) located approximately on the other side of the earth.

He finds that the signals from Lyons are much stronger when his receiver is exactly opposite Lyons, exactly through the earth from Lyons. That is, when the receiving station (Lieut. Guierre's ship) is exactly at the antipode of Lyons. The same is true of the signals from Nantes. They are stronger at the exact antipode

of Nantes, at the other end of the earth.

It is evident that the ether waves from Lyons or from Nantes bend around the earth in all directions, and curve inward finally toward a point exactly opposite the sending station. At this point, this antipode, they reinforce each other. The waves which came around one way, over America, reinforce those which came the other way, over Europe and the Indian Ocean. Hence the signals are strongest exactly where the waves meet, exactly at the antipode.

No one doubts nowadays that the ether waves do bend this way around the earth, that wireless follows the earth's surface as flies crawl about an orange. The question is *why?*

The latest answer is found in the solar theory of the possibility of long distance wireless, thanks to Dr. J. A. Fleming, whom I quoted. He suggests that the solar dust creates far up in the earth's atmosphere a layer which conducts electricity, a layer which imprisons the wireless waves and makes them follow about the earth. Terrestrial wireless, says Dr. Fleming, is transmitted almost entirely

in the non-conducting skin or shell which lies between this conducting layer of the upper atmosphere and the surface of the earth.

The idea that particles of dust are shot out by the sun and reach the earth is not new. Many physicists have worked out this idea, notably Dr. Svante Arrhenius of Sweden. The cause is the intense disturbance on the sun's surface in addition to what is called the "pressure of light." In an earlier article in this magazine* I discussed the matter of solar disturbance and explained how the tremendous and continual storms on the incandescent surface of the sun force up great columns of glowing gas, of iron and carbon and other elements that are all so hot that they are gases and not solids, as they are on earth.

These glowing gas clouds cool off a little when they get far enough up from the sun's surface. The iron vapor condenses to tiny droplets of molten iron and then cools to tiny particles of solid iron. Other elements do the same. Far above the sun's surface, thousands or

* See POPULAR RADIO for May, 1922.

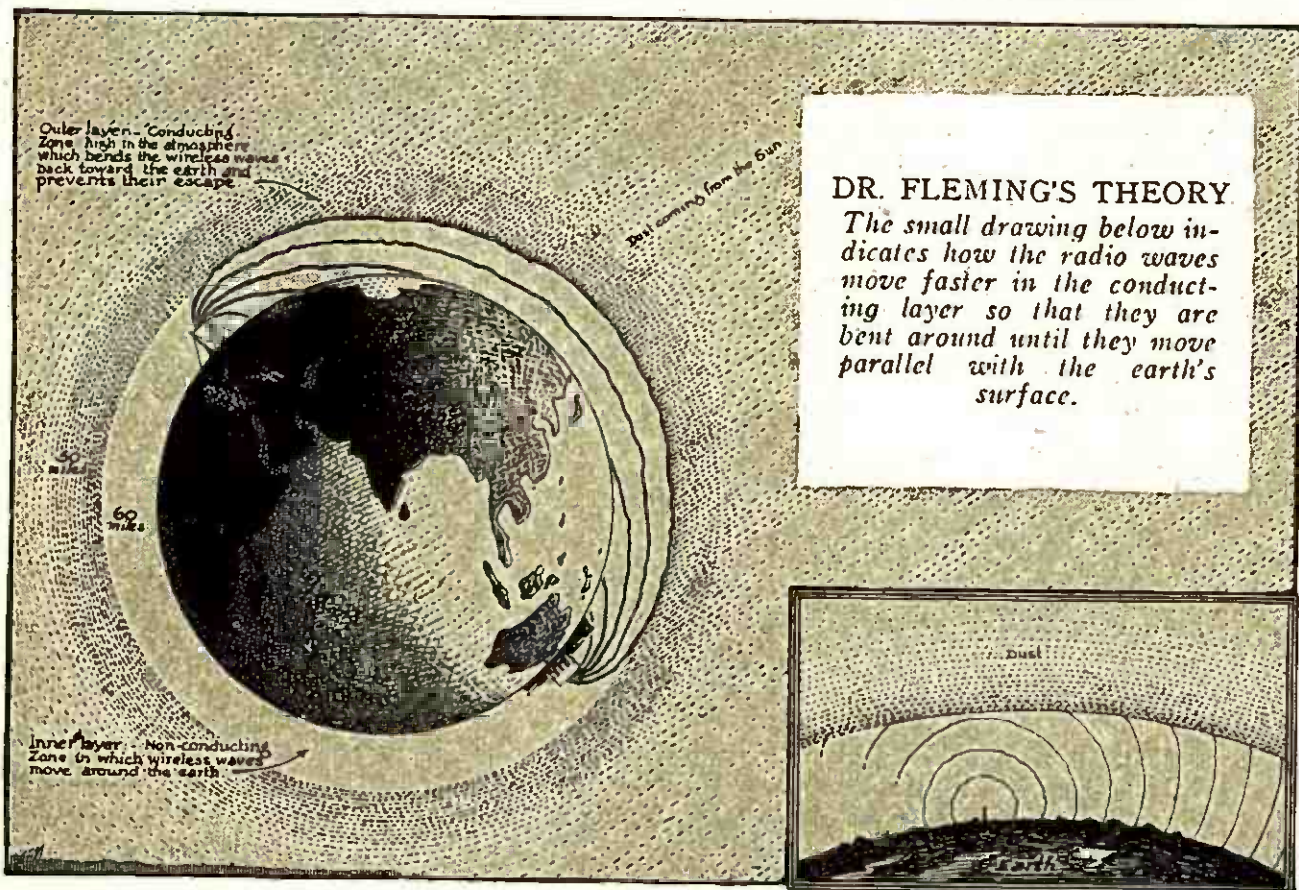

DR. FLEMING'S THEORY

The small drawing below indicates how the radio waves move faster in the conducting layer so that they are bent around until they move parallel with the earth's surface.



From a photograph loaned by the Smithsonian Institution, Washington

HOW SUN RAYS ARE USED FOR COOKING MEALS

An example of what the scientists call "the utilization of solar energy" is demonstrated in this device that converts sunlight into heat. The same radiant energy that operates this stove drives the solar dust earthward.

hundreds of thousands of miles above it, there is believed to be a cloud of such very fine dust. The particles of this cloud, most of them, fall back slowly toward the sun, to be again melted and vaporized and driven up by other storms into the condensing region where the solar heat begins to yield to the cold of space.

But not all of these dust particles fall back into the sun. Some of them are so small, indeed, that they are pushed farther out from the sun, pushed out by light. This is where the "pressure of light" applies. That light can exert a pressure you can see by observing the apparatus consisting of a glass globe with little metal vanes in a vacuum, common in opticians' windows. These vanes revolve rapidly because the black sides of

them, one side of each vane is always blackened, are pushed backward by the effect of light. The pressure of light on very fine dust particles is not exactly the same as this, but it has the same effect. The particle is pushed outward from the sun. If the particle is very small and consequently very light, it is pushed outward with great velocity, perhaps as much as five hundred or a thousand miles per second.

It is believed that such particles are being shot out constantly by the sun in all directions; they are being pushed out by sunlight. Some of these particles reach the earth, or rather the earth's atmosphere. Most of them do not sink to the earth's surface, because they are too small. The earth has a protective blanket of air and very fine particles cannot fall

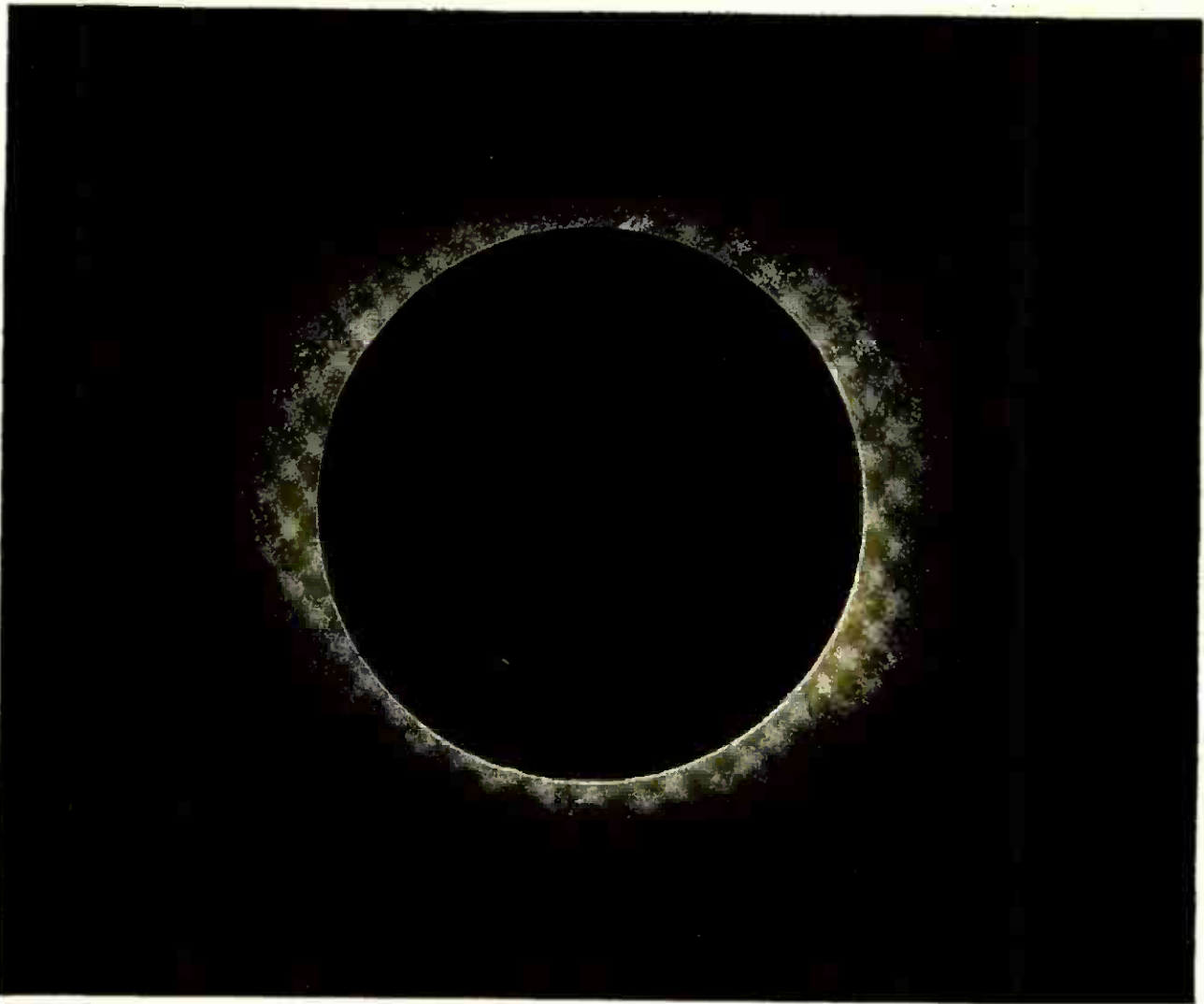

From a photograph loaned by Lick Observatory, California

WHERE THE "SOLAR DUST" GETS ITS START

This photograph of an eclipse of the sun shows the surrounding glow or "corona," which consists in part of great clouds of vapor and dust hundreds of thousands of miles high. This is the source of the solar dust.

through this. You have seen how dust motes seem to float in a beam of sunlight. Really they are floating in air, or only seem to float; in absolutely still air they will ultimately sink to the ground. They sink very slowly.

These dust motes are many thousands of times larger than the tiny dust particles received from the sun, which will not sink in air at all. They float in it forever, as a cork floats in the sea. High in the air there is a layer of them, thinks Dr. Fleming, a permanent layer, a layer which provides the conducting protective screen about the earth included in the wireless theory.

In a sense this dust-filled layer is the upper surface of the atmosphere, but it must not be thought of as a definite dis-

tingent surface, like the surface of the sea. The density of the air decreases as one rises from the earth's surface, but it decreases gradually. The air merely becomes thinner and thinner as one goes up; above five or six miles the air is too rare to support life. Above ten or fifteen miles its chemical composition begins to change. At fifty or sixty miles above the earth's surface the air is unlike the air we know and breathe. It is very thin; by earthly standards it is practically a vacuum. It contains no oxygen and only a little nitrogen. Mainly it is hydrogen and helium, the lightest of known gases. These are the gases with which we fill balloons. And when we do so the balloons start upward, upward toward the brothers of their own family, toward the

atmosphere levels where these gases belong.

It is these greatly rarified higher levels of hydrogen and helium which are believed to stop and hold the solar dust particles. Thin and tenuous as the atmosphere is at this level, it is nevertheless sufficient to stop the infinitely tiny dust particles, to prevent them from falling further earthward. And all these particles, coming as they do from the intense electrical disturbances of the sun, are charged with electricity. They create a charged, an electrified layer. An electrified layer of gas is always a conducting layer, one competent to conduct electricity, to stop and reflect the wireless waves.

This forms the wireless screen which Dr. Fleming believes to lie about the earth. The solar dust, all of it electrically charged, is shot out toward us, is caught and stopped by the upper levels of our atmosphere and produces there an electrically conducting layer.

There are, of course, many other details for speculation. The probable thickness of the electrified layer; the separation of positively and negatively charged particles; the possibility of conducting layers or clouds below the main layer, with the relation of these to static; the effects of sunlight and shadow upon this conducting layer.

The essence of the theory is simple. Beneath the conducting layer, in a fifty or sixty mile skin of air between the wireless screen layer and the earth's surface, we operate our wireless. Wireless waves cannot get out. Long distance wireless is possible for this reason. These wireless waves have to stay in this wireless skin about the earth and keep their energy for the receiving station, and

not waste it uselessly in empty space.

But, you say, why worry about all these matters of conducting layers and wireless screens? Long distance wireless really works. Who cares why it works?

The scientist cares. He cares for the sake of knowledge, even if utility seems improbable. But in this case utility for this knowledge is far from improbable. Understanding some natural phenomenon is the first step toward using it. If we can learn more exactly the nature of Dr. Fleming's wireless screen we may feel pretty sure of being able to use it. For instance, variations in it and in the relating conducting layers or clouds below it probably cause the great differences in wireless range between day and night as well as the differences from day to day or with the seasons. The condition of the screen has much to do, probably, with interferences by static.

Knowledge of just how the screen works, of just how it keeps wireless waves to their proper paths around the earth, will go far to solving one of the greatest problems of practical wireless—the problem of maintaining uniform transmitting conditions for twenty-four hours a day and three hundred and sixty-five days a year.

Then there is another matter. There are proposals that we should try to signal Mars by wireless. If this is tried, how are we to get our signals through the wireless screen about the earth? Such signals would be forced back earthward, just as ordinary wireless waves are. No way of avoiding this difficulty is known, but doubtless the wireless engineers will have learned one by the time the signalling of Mars is actually attempted for new discoveries are common in radio.

Q Every experienced radio amateur in the country knows of Prof. J. H. Morecroft, the wireless expert of Columbia University. In the next issue of POPULAR RADIO will appear his article (the first of a series), that will treat of a vital function of the vacuum tube—a subject on which Pro. Morecroft is a foremost authority.



*Surprising and Important Bits of Information Con-
of Radio Messages—an Article that Every*

SOME evening when you are listening in on the radio and you happen to pick up a message that is of peculiar personal interest to you—that may even be about you—but that is specifically addressed to someone else, do not think that the message belongs to you, or that even the substance of it belongs to you. And don't think that you are at liberty to divulge it to anyone else, either, for you are not—legally.

In fact, the law states specifically that such a message does not belong to you any more than another person's mail belongs to you. To be exact section nineteen of the Radio Laws provides as follows:

SECRECY OF MESSAGES

Nineteenth. No person or persons engaged in or having knowledge of the operation of any station or stations, shall divulge or publish the contents of any messages transmitted or received by such station, except to the person or persons to whom the same may be directed, or their authorized agent, or to another station employed to forward such message to its destination, unless legally required so to do by a court of competent jurisdiction or other competent authority. Any person guilty of divulging or publishing any message, except as herein provided, shall, on conviction thereof, be punished by a fine of not more than two hundred and fifty dollars or imprisonment for a period of not exceeding three months, or both fine and imprisonment, in the discretion of the court.

This statute is penal. Its violation upon conviction results in a fine, imprisonment or both, but its violation does not give a right of action by a person damaged against another in a civil action.

Furthermore, this statute, just because it is penal, must be strictly construed. The fact that no decisions involving this statute have been recorded is indeed a compliment to the high moral characters of the numerous persons who have listened in on messages and who have not divulged or published them.

As an example of a possible violation of this statute, for instance, let us assume that the United Press transmitted a news item by radio to the newspaper *Cleveland Leader*. In this case, no one who happened to listen in on the radio message would be at liberty to publish or divulge its contents except to the addressee. On the other hand, if such a news item were broadcast—that is, if it were not directed to anyone in particular—it would not be a violation of the statute to divulge it.

Again, suppose the Associated Press, which has thousands of members, should broadcast (in a limited sense) a news item not to one paper but to all of its members, the message, even though it did not specify each member by name (which would not be practical), might be pro-

the Radio Amateur

By CHARLES H. KESLER

Member of the Bar of the District of Columbia

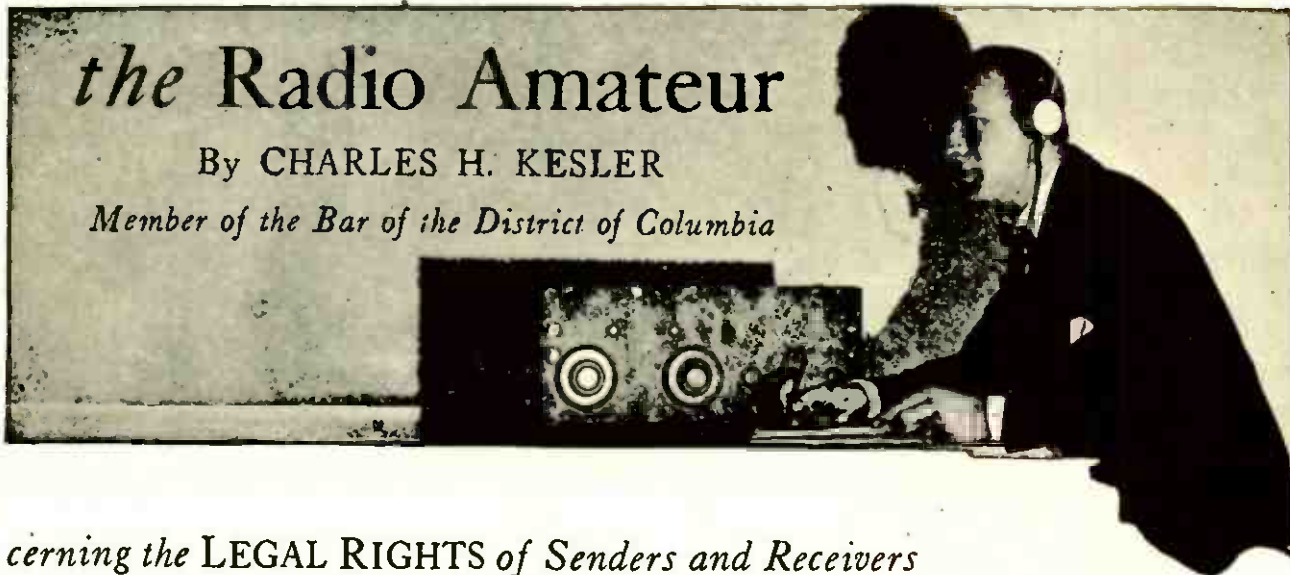

*cerning the LEGAL RIGHTS of Senders and Receivers
Owner of Radio Apparatus Should Read*

tected if it were transmitted with a notice like this:

"For Associated Press members only."

Would a person who divulged this message in a newspaper that is not a member of the Associated Press be liable under this statute? Certainly this is a point which would test the argumentative skill of counsel for both the state and defendant.

These are but the first of the many legal problems that the radio is thrusting upon us. And many of these problems concern the radio amateur, both directly and indirectly. Questions of law are being asked that have not yet been answered by the courts. Can I legally use this set or that set in receiving? Can I legally repeat news, lectures, songs, dramas or other information which I receive while listening in? In my business and social relations can I enforce contracts or agreements that I make by radio? Is there any way of preventing by legal action this confounded interference which prevents me from hearing the songs and lectures which are being transmitted?

The users of transmitters also have their problems. What type of transmitter am I allowed to use by law? Where can I establish my transmitter? Can I transmit copyrighted material? What wavelengths can I use? When can I transmit?

How powerful may be my transmitter? What kind of information can I transmit? In other words, to what extent can I interfere with the clear reception of the numerous receivers now in use?

The present radio laws are inadequate to control present radio communication. We hear complaints on all sides about interference and the inability to hear what we want to hear on account of the undesired noises and the conflict of wave with wave. Chaos reigns where law and order should reign. The receivers buzz and grind; music is superimposed on music. A lecture on prohibition becomes entangled with an advertisement for yeast. All this confusion in the ether is due to the very nature of radio communication and to the character of the electromagnetic waves that are transmitted. We can not blame the waves nor can we blame the intelligence behind the transmitters because there is no one to control and regulate them.

Is the problem of regulating all this traffic up to the State or to the Federal Government?

In this country the several states, each of which is a sovereign, have formed a confederation known as the United States of America or the Federal Government. The powers of the Federal Government are designated in and limited by its Con-

stitution. It remains to be seen if the control of radio and the enactment of laws relating thereto be primarily a matter for the Federal Government or for each State.

Article I, Section 8, of the Constitution provides that Congress shall have power:

To regulate commerce with foreign nations, and among the several states and with the Indian tribes.

To promote the progress of science and useful arts, by securing to authors and inventors the exclusive right to their respective writings and discoveries.

To provide for the general defense by raising and maintaining an Army and Navy and to provide rules relating thereto.

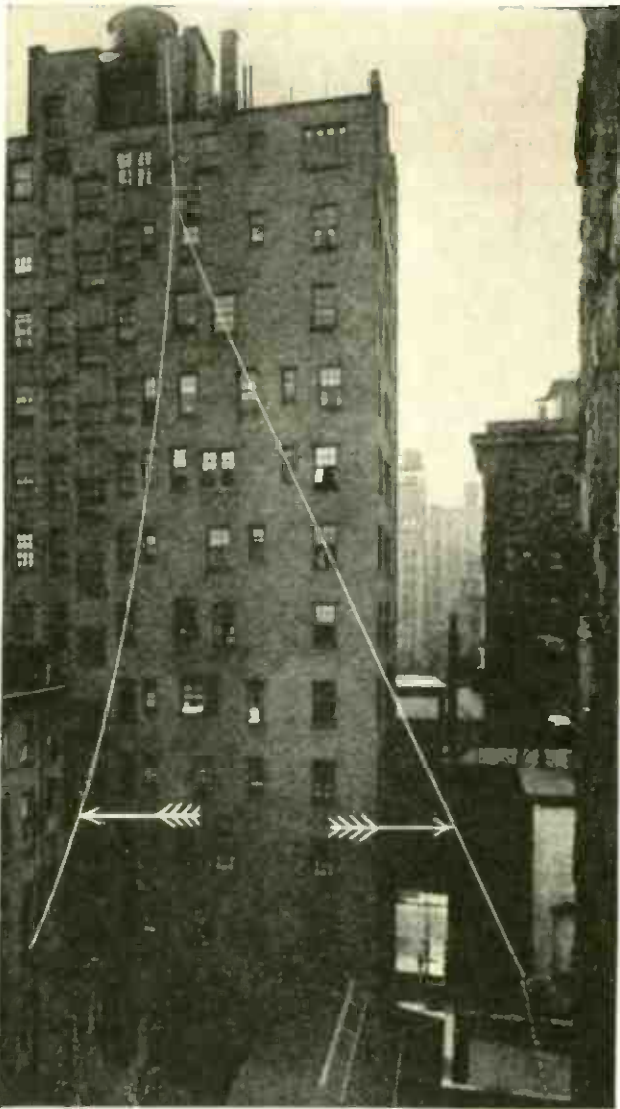

From a photograph made for POPULAR RADIO

WHEN A "LICENSE" IS REQUIRED

The owner of a radio set has no more right to run an antenna over a neighbor's property than he has a right to run a pipe-line or a railroad over it—until he gets oral or written permission.

As the Federal Government under the commerce regulations clause has assumed legislative control of the railroads and telegraph and telephone lines operating from one State into another and among the several States, so also it has assumed control of and made regulations and laws relating to radio because radio by its very nature is of a character which is bound to extend from one State into another and is of special value in commerce and on the sea.

It is a situation that indeed requires government control and regulation and its necessity arises by reason of the nature of radio communication.

While telephonic conversations and telegraphic messages are transmitted along wires without interference with each other, radio messages are radiated for miles in all directions in space. When several are being simultaneously transmitted, one may and usually does interfere with another. This makes reception difficult unless the wavelengths of the several signals differ. But it should be noted that when hundreds of stations are sending, several of them may be sending on the same wavelength. These invisible waves vary from a few hundred meters to thousands of meters, and the power of the transmitters vary from one-quarter or one-half K. W. to two K. W. and five K. W. and more, whereby the messages may be transmitted a few miles or thousands of miles across States and even across oceans. The interference of one transmitter with another, or (legally expressed) the interference of one person's radio rights with those of another, is clearly within the regulation of the Federal Government.

It is, therefore, within the jurisdiction of the United States to protect the lives of its citizens upon the high seas by requiring the installation of radio sets on ships and providing for the regulation thereof. Again, it is within the jurisdiction of the United States to make such regulations as are necessary to prevent radio transmitters or receivers from



George Grantham Bain

THE BROADCASTING OF COPYRIGHTED MUSIC IS RAISING MANY LEGAL PROBLEMS

Amateurs who have been entertaining their audience gratis by transmitting copyrighted selections have not been "giving public performances for profit." But how about the large, commercial stations maintained by manufacturers and sellers of radio equipment?

interference with each other and with the sets of the Army and Navy. Also, in view of the public and non-secret character of information transmitted by radio, it is within the power of Congress to regulate as to the secrecy of messages and even to protect by suitable copyright laws the music, writings and creations of authors and to regulate the sending of such material by radio for the amusement, information and recreation of the general public.

And, finally, while justly protecting the property and other rights of individuals, it should be the policy of a government of the people, such as ours, to promote the general welfare and happiness of all by such regulation of radio that the use of the thousands of receivers now established may be enjoyed to the fullest extent.

The present radio laws of the United States are found in an Act approved July

23, 1912, amending an Act approved June 24, 1910. These laws are of very little interest to persons who have merely receiving sets and do not transmit. This Act requires the installation of sets on boats, provides rules for their use, and requires licenses of different grades for operators of transmitters, both commercial and amateurs.

But the particular point of law that the Federal Government brings to the attention of the radio amateur—a point so far-reaching in its application as to justify the government in publishing a copy of the law in its post offices—touches upon the ownership of the messages sent by radio.

Consider, for example, the civil side of the question as to who owns the radio messages; that is, of the property rights of one person or organization in news and his remedy against another person who

violates these rights. The principles involved here are either of an equitable character or statutory.

News as such is as free as the ether through which it is transmitted. As the word "news" denotes, information comes from the North, East, West and South and is again radiated or transmitted in all directions for the information of man and his intellectual development. Hence it would be against public policy for the state to grant to anyone, persons or organizations, a monopoly on news.

As the rule is proved by its exceptions, so also there arise cases in which the general rule as to news is modified by the courts. We all have the idea of what is just and equitable. So in the relation of man to man, the courts will protect the distribution of news by an organization like the Associated Press, for example, against unfair methods of competition or against the unjust and inequitable methods of a competitor—such, for instance, as causing a breach of trust by an employee or client of the news distributing organization.

One case decided by the Supreme Court of the United States is that of *Board of Trade vs. Christie Co.* (198 U. S. 236). In that case, the Board of Trade at Chicago distributed grain quotations by ticker to customers under a written agreement to keep it confidential. The Christie Co. by means amounting to a breach of these confidential terms, redistributed these quotations to its customers. The court enjoined the Christie Co. The incident is of interest to the radio amateur because similar principles would apply to radio transmission of news in so far as the facts are approximately the same. The question, however, is rather academic, owing to the non-secret character of radio transmission and the large number of receivers now in use.

News items and ideas are not copyrightable as such. But the literary style or garb in which said news and ideas are expressed is copyrightable. Lawfully copyrighted matter cannot be reproduced

or published by an unauthorized person, even though received by radio, unless it is changed into a non-copyrighted form. And this brings up a point of law that sooner or later will affect the broadcast programs that use copyrighted material.

The following classes of writings may be copyrighted: books, periodicals, newspapers, lectures, sermons, addresses, dramatic or dramatico-musical compositions, and musical compositions.

A copyright may be secured by first publishing the work with the copyright notice upon it and then applying to the Registrar of Copyrights for a certificate. In cases when the writing is not to be printed for general sale and circulation (as in the case of sermons and lectures), manuscript copies are deposited with the Registrar of Copyrights.

The copyright not only covers the original work of the author as printed, and gives him the exclusive right to print and sell it, but if it be a musical work, to deliver or authorize the delivery in public for profit. The author also has the exclusive right to make records for phonographs and player pianos.

Thus it is clear that most of the radio listeners can remain in that condition of mental relaxation that is summarized by the expression "I should worry." The liability for infringement of copyrights is on the person who transmits—unless the transmitted material is reproduced unchanged by the listener by publication or delivery in public for profit.

The development of our present copyright laws offers a good example of the lagging of the laws behind material development and shows how difficult it is to protect rights in property by legislation as conditions change. Under the copyright laws in force in 1908, the Supreme Court decided in the case of *White-Smith Co. vs. Apollo Co.* (209 U. S. 1) that perforated rolls of mechanical piano players reproducing musical selections do not infringe a copyright on the selections. The laws were subsequently amended to include such records and also moving pic-

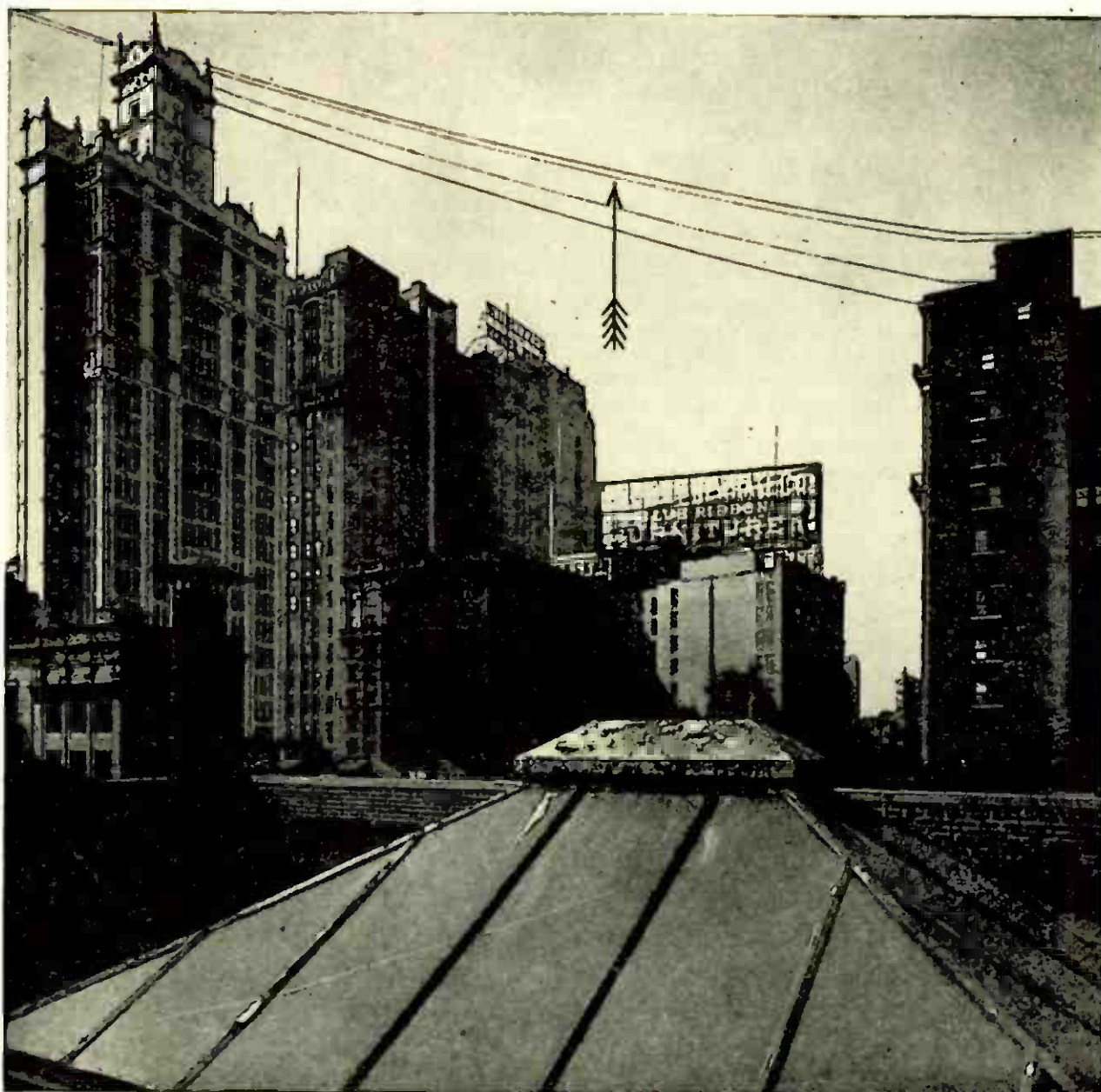

From a photograph made for POPULAR RADIO

ANTENNAE THAT REACH ACROSS CITY STREETS ARE LADEN WITH LEGAL COMPLICATIONS

Only a franchised company is permitted by law to string an aerial over a city street; permits to do so are not granted to private parties. The wires in the above picture caused a vast amount of trouble in New York before the right to string them up was finally determined legally

ture of films then in the early stages.

Likewise, the present practice of broadcasting music, lectures, and news may soon show that under our present laws certain rights or interests are not properly protected by laws now in force. These laws will then be amended or new laws made.

The laws relating to agreements and contracts made by radio will presumably be the same as now apply to such transactions by telephone and telegraph. Such agreements, in so far as they meet the

requirements of the Statute of Frauds of the several States, are enforceable. It may be of interest to a layman to know that, although agreements, contracts and sales are made daily by radio, telegraph and telephone which are otherwise lawful, yet they are not enforceable in a court because certain statutory regulations have not been complied with. That is, the court will not enforce the contract, no matter how many witnesses one may have, unless the transaction is made according to the required form.

Such statutes, known as the "Statute of Frauds," are in force in most States and are based on a similar statute passed in the reign of Charles II in 1677.

Section seventeen of this Statute provides that

"No contract for the sale of goods, wares and merchandise above a specified price is enforceable except the buyer accept part of the goods and actually receive the same or give something in earnest to bind the bargain or in part payment or that some note or memorandum of the bargain be made and signed by the parties to be charged or their agents."

Hence contracts of sale made by radio are not enforceable until part of the goods are actually received and accepted by the buyer or until he pays something down or unless there is a written memorandum. Goods can be ordered by radio and when accepted and received the contract of sale is binding. Or money can be transmitted by radio, and the contract of sale would then be binding and enforceable. When the contract is entirely unexecuted a memorandum must be made or such agreements of sale by radio are not enforceable unless they are later ratified in writing. However, countless agreements of sale are made daily by wire or radio in which the parties rely on the honesty and moral uprightness of each other for the execution, even though in a suit such agreements would be unenforceable.

Other laws touch upon the radio amateur—and his neighbor—more directly. For instance, one cannot trespass on a

neighbor's property and attach an aerial to his house, barn, tree or other fixture without his consent. One has no more right to do this than to run a pipe or a telephone line or a railroad over his property without his consent. And permission to mount an aerial on property may be given by parol or in writing; such consent is called a license. Licenses are revocable by the owner of the property; they terminate upon the sale of the property and are personal to the parties. When such licenses are granted care must be exercised to mount the aerial properly so as not to cause damage to the property. Under the Statute of Frauds, a conveyance of an interest in land must be in writing. When it is desired to secure permanently the right to install and maintain an aerial on the property of another, a formal deed must be made, conveying the right and interest; otherwise it is a mere license.

Recently in a western state some angry neighbors hauled an amateur into court for allowing his spark transmitter to buzz and sing—as if it could do anything else and work! They claimed that the transmitter was noisy and caused them great discomfort. The judge, however, it appears, was for the amateur and he held that the noise was not a nuisance because it was a noise which we must get used to, even though we do not like it.

The radio laws now in force, although

Form 908

NOTICE

DEPARTMENT OF COMMERCE
BUREAU OF NAVIGATION
RADIO SERVICE

SECRECY OF MESSAGES—FALSE SIGNALS

The act of Congress to regulate radio communication, approved August 13, 1912, provides in the nineteenth regulation and in the seventh section, respectively, as follows:

Nineteenth. No person or persons engaged in or having knowledge of the operation of any station or stations, shall divulge or publish the contents of any messages transmitted or received by such station, except to the person or persons to whom the same may be directed, or their authorized agent, or to another station employed to forward such message to its destination, unless legally required so to do by the court of competent jurisdiction or other competent authority. Any person guilty of divulging or publishing any message, except as herein provided, shall, on conviction thereof, be punishable by a fine of not more than two hundred and fifty dollars or imprisonment for a period of not exceeding three months, or both fine and imprisonment, in the discretion of the court.

Sec. 7. That a person, company, or corporation within the jurisdiction of the United States shall not knowingly utter or transmit, or cause to be uttered or transmitted, any false or fraudulent distress signal or call or false or fraudulent signal, call, or other radiogram of any kind. The penalty for so uttering or transmitting a false or fraudulent distress signal or call shall be a fine of not more than two thousand five hundred dollars or imprisonment for not more than five years, or both, in the discretion of the court, for each and every such offense, and the penalty for so uttering or transmitting, or causing to be uttered or transmitted, any other false or fraudulent signal, call, or other radiogram shall be a fine of not more than one thousand dollars or imprisonment for not more than two years, or both, in the discretion of the court, for each and every such offense.

(TO BE POSTED IN RADIO STATIONS)

So important does the Federal government regard the laws that specify the ownership of radio messages that it posts this warning in the radio stations of the country

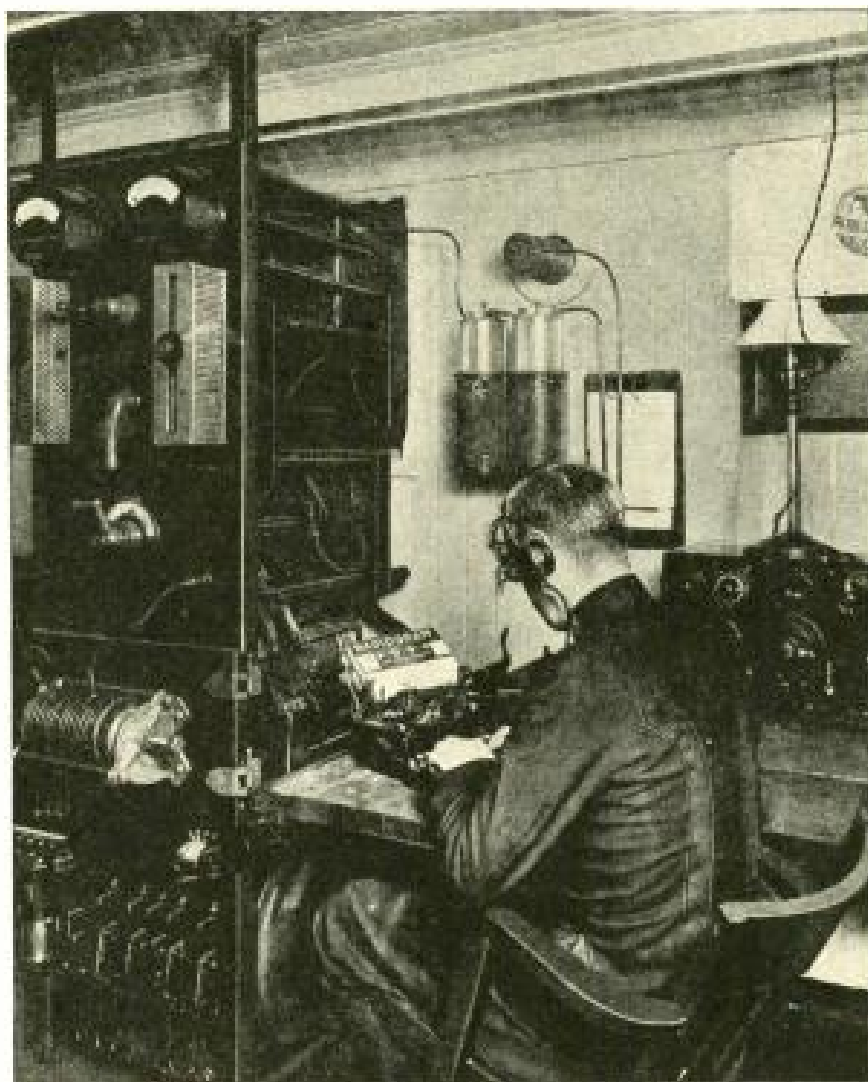

THE FEDERAL LAWS REQUIRE RADIO SETS ABOARD VESSELS.
In the protection of the lives of its citizens upon the high sea, it is within the jurisdiction of the government to state what ships shall be equipped with sets and how those sets shall be used.

they regulate the location of transmitters and the wavelengths at which they may be operated, are entirely inadequate to control radio transmission as it exists today. Steps, however, have been taken to clothe the Secretary of Commerce with sufficient authority to effectually control and regulate radio transmission for the benefit of the users of radio receivers.

The first step for the formation of new laws was recently taken by a conference of experts on radio, in Washington, for the purpose of outlining and analyzing the present radio transmitting situation, and to determine how radio communication may be regulated for the purpose of reducing interference to a minimum.

The new radio laws which will be

passed will not affect the users of receivers, except to make more enjoyable their use of the radio—unless the listener is using a type of receiver which transmits interfering waves while receiving. When these regulations are in force, offenders who overstep their assigned wavelengths and cause interference will be found and punished by the radio air police.

Other laws that touch the radio amateur are the patent laws. These are not primarily designed for the benefit of the inventor; they are intended to promote general welfare by encouraging the development of the useful arts, giving to the inventor a reasonable compensation for his work or creation. One phase of the patent laws relates directly to the users

of receivers. The person who uses an unlicensed receiver that is covered by a patent may be sued for infringement, even though he did not make the set.

The user, however, usually buys his receiver from a manufacturer without a thought of patents; even though he is using an infringing receiver there is very little probability that he will be sued, either because the patentee does not know of the infringement or because the patentee prefers to sue the manufacturer or distributor and thereby obtain larger damages.

It has been proposed that it would be a great scheme to devise a patented transmitter which would send a peculiar wave, capable of being received only by a peculiar and patented type of receiver. The owner of the patent on this apparatus could thus broadcast matter which could be received only by the patented receiver which of course the patentee would sell. All other types of receivers on the market would thus become or be "junk" as far

as the new station would be concerned.

As the situation now is, while one manufacturer of apparatus bears the expense of broadcasting to the users of its receivers, yet other manufacturers indirectly benefit by this broadcasting because the users of other types of receivers can also listen in on the broadcasted matter. Is this fair? Presumably it is. As yet no constitutional amendment has been made requiring us to use cotton in our ears.

Should the type of secret broadcaster be allowed by law if it is ever developed? Probably not, as it utilizes a public medium for entirely private ends and may cause interference. The recent conference in Washington resolved as follows:

RESOLVED, That it is the sense of the conference that radio communication is a *public utility* and as such should be regulated and controlled by the Federal Government in the *public interest*.

If radio communication is to remain or be a "public utility" no monopoly on broadcasting for the benefit of the few could be tolerated.



© Kadel & Herbert

A RADIO SET IN A SAFETY RAZOR BOX

Some day we will consider a pocket radio set as much of a necessity as a watch. Here is another ingeniously devised receiver made by a boy in New York, Sidney Kasindorf, who with the use of a variable condenser, a tuning coil and a crystal detector can hear the big station at Newark without trouble.

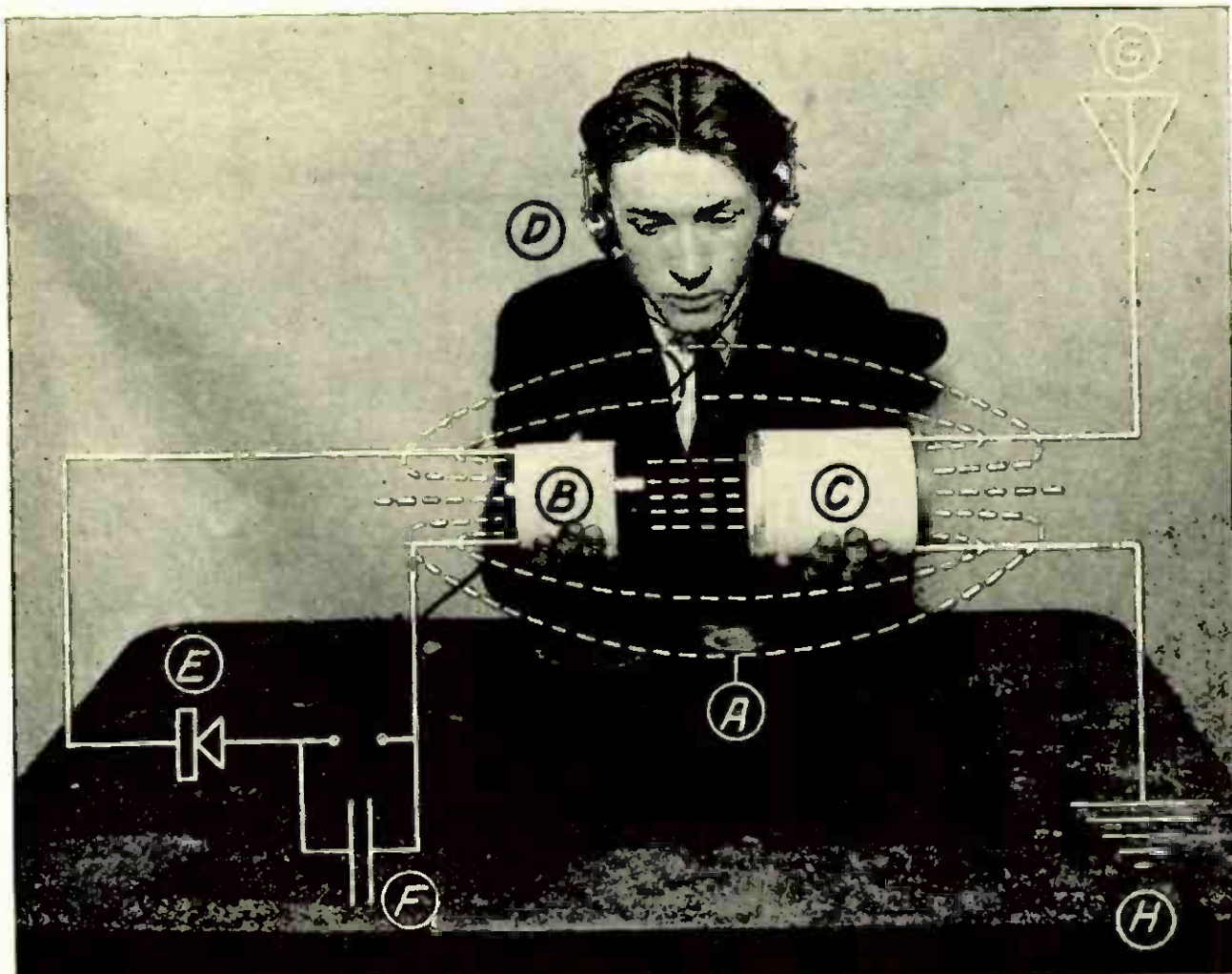

From a photograph made for POPULAR RADIO

WHAT THE MAGNETIC ENERGY CIRCULATING AROUND YOUR RECEIVING COILS LOOKS LIKE

If the human eye could perceive lines of electromagnetic force, it would see the phenomenon shown in this diagram. A are the lines of force generated by the primary coil C, which induce currents in the secondary coil B. D are the head telephones; E the crystal detector; F the fixed telephone condenser; G the antenna and H the ground connection.

How Radio Circuits Are Coupled *and* Tuned

Simple "How" Articles for the Beginner—No. 4

By LAURENCE M. COCKADAY, R. E.

RADIO currents of high frequency are usually generated in some form of closed circuit, which is tuned by varying either the inductance or the capacity in the circuit or both. These currents must, however, be supplied to the antenna circuit, in some way or other, before they can be used for the propagation of Hertzian or radio waves through space, thus making possible radio telegraphy and telephony.

The device used for this purpose is called a "transformer." When it is used for transmitting it is usually called an "oscillation transformer," and when used in a receiving set, it is known as a "loose coupler" or "variocoupler."

Before we take up the devices used for high frequency currents, let us study the ordinary low frequency transformer such as is used for lighting our homes.

Such a transformer consists of three

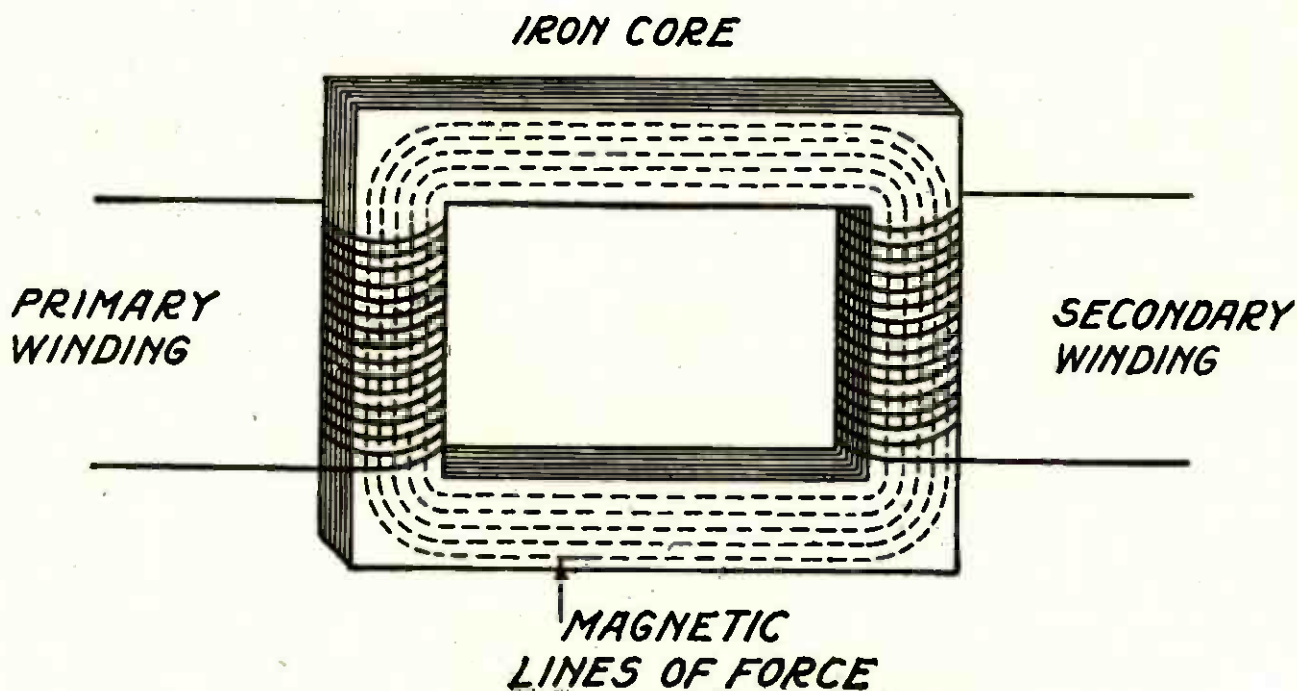

FIGURE 1

How an ordinary transformer transfers electric current from one circuit to another by means of two coils and an iron core.

main parts; a primary winding, a secondary winding, and an iron core. The core is usually made of iron sheets built up in the form of a square "ring," or hollow square. The primary winding is then wound over one side of this square, using the iron for a core, and the secondary is wound over the opposite side of the square, also using the iron for the core. Such a transformer is shown in Figure 1.

Now if we cause an alternating current or a pulsating direct current to flow through the primary winding, by connecting the two ends of the primary wire to an alternating current generator or a direct current generator, with a device for breaking up the direct current into impulses, we will cause the iron core of the

transformer to become magnetized. The magnetic flux will flow around through the square rings, and the direction of its flow will be governed by the direction of the current flowing through the primary coil.

We have already learned that if insulated wire is wound on a soft iron core and a current of electricity is caused to flow through the winding, the core will become magnetized. If a similar winding and core were suddenly to be placed near enough to a permanent magnet for the iron core to become magnetized externally for an instant, the reverse action would take place, and a current would thus be induced in the winding.

To return to our transformer; when the core is magnetized by the current flowing through the primary winding, the magnetic flux flows around through the core and passes through the center of the secondary winding. At this instant a current is induced in the secondary winding that corresponds exactly with the current that flows through the primary winding. This effect is called electromagnetic induction. The primary winding changes the electric current into magnetic energy; the core carries the magnetic energy around

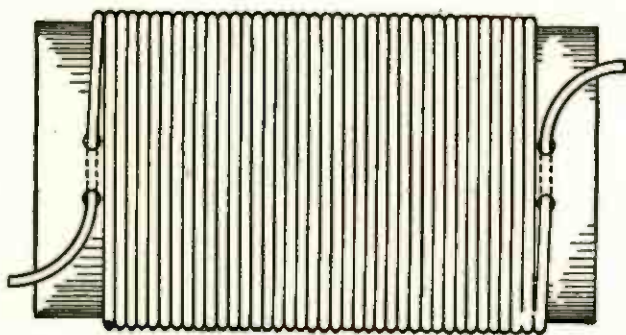

FIGURE 2

A coil of the type used for transferring currents from one radio circuit to another.

to the secondary coil, and the secondary changes the magnetic energy back into an electric current.

In this way electric currents can be transferred from one circuit to another without any actual connection between the wires of the two circuits. When two circuits are thus connected together by means of a transformer, they are said to be "coupled" together.

Radio circuits are also coupled together in much the same manner, but the transformers used for coupling radio circuits do not have iron cores. They use air cores. Iron cores are used with low frequency currents, while for high frequency currents air cores are used.

In transformers used for coupling radio circuits, the windings are wound on insulating tubes. Such a coil is shown in Figure 2.

If we take two such coils, one for the primary and one for the secondary and place them end to end as shown in Figure 3A, and cause a radio current to flow through the primary coil, the magnetic field surrounding the primary coil will envelop the secondary coil, passing through it and causing a current to flow through the secondary coil.

If, however, we should place the sec-

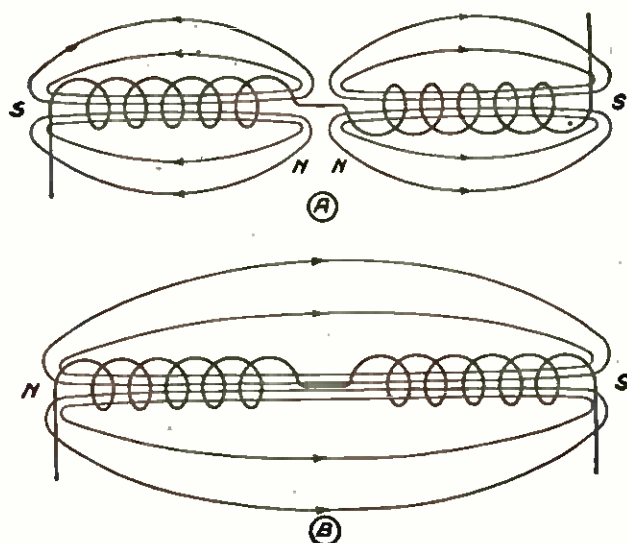

FIGURE 4

A shows two coils connected in series with the windings opposing; with this connection the coils respond to low wavelengths. B shows the coils with the windings additive. This device is called a variometer.

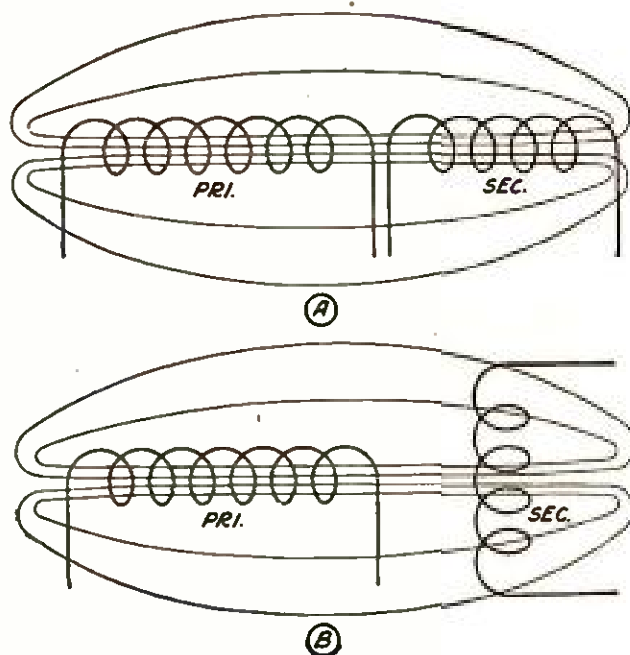

FIGURE 3

A shows two coils placed in inductive relations to each other; large currents are induced in the secondary from the primary. B shows the coil in non-conductive relation. This device is called a loose coupler.

ondary coil at right angles to the primary coil as in Figure 3B, there will be little or no current induced in the secondary coil as the magnetic flux does not flow in the proper direction through it. In most radio sets, the secondary winding rotates, and by rotating the knob on the set which is attached to this coil, the coupling is varied. The reader will now understand what he is doing when he varies the coupling on his set.

In some sets the secondary coil slides in and out of the primary coil, and the coupling is varied in this way. When the secondary coil is in a position that allows all of the magnetic flux to flow through it, the two circuits thus coupled are said to be "closely coupled," and when the secondary coil is placed in a position that allows little or no magnetic flux to flow through it, they are "loosely coupled." When a transmitting or a receiving set is coupled loosely to the antenna circuit, it sends out a sharper wave or receives with much sharper tuning, than a set that is closely coupled.

An oscillating circuit such as that described in the last article of this series,

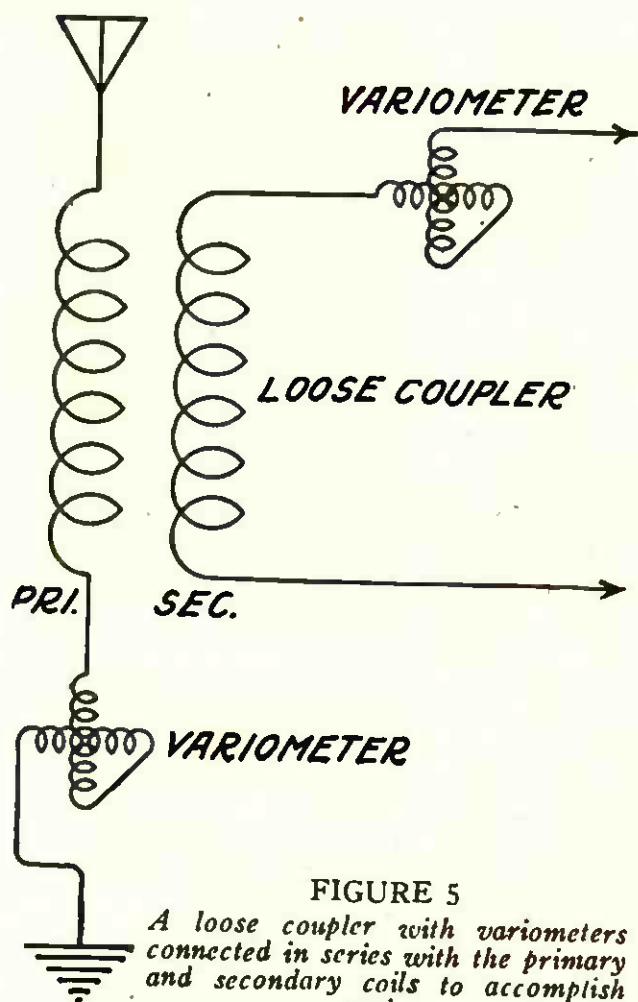

FIGURE 5
A loose coupler with variometers connected in series with the primary and secondary coils to accomplish tuning.

comprises a condenser, a spark gap, and an inductance or coil. The coil serves a double purpose. It tunes the circuit to the desired wavelength, and also serves as the primary coil of an oscillation transformer. The secondary coil receives the oscillations from the primary coil by electromagnetic induction, and at the same time tunes the antenna circuit. The secondary coil is connected in series with the antenna and ground. In this way the antenna circuit is energized and the Hertzian waves are emitted from the antenna.

A variometer, which consists of two coils connected in series, is often used for tuning a circuit. One coil is stationary and is called the "stator;" the other coil rotates inside it and is called the "rotor." In using this device to tune a circuit, when the coils are rotated so that the electromagnetic fields of the two coils are opposing, (as in Figure 4A), the two fields acting against each other do not allow any electromagnetic energy to be stored up, or in other words their mutual induction is theoretically zero.

A coil of this type set in this position would respond to very low wavelengths. If the rotor be turned so that its field be additive with the stator, as shown in Figure 4B, the two fields will act with each other to store up electromagnetic energy, and the mutual induction will be at a maximum. In this position the variometer will respond to a high wavelength.

By slowly rotating the rotor from the first position to the last mentioned position, the variometer can be used for tuning and will pass through the various wavelengths that it is designed to listen in on. The variometer is used for tuning in receiving sets, and Figure 5 shows two variometers used to tune the primary and secondary circuits of a receiving set. The other two coils shown in the circuit are the primary and secondary coils of the loose coupler, or variocoupler.

Thus we see how the coil is used in radio circuits, and that it serves the double purpose of tuning the circuits while at the same time it couples them together, or transfers the electricity from one circuit to the other.



"THE NEWSPAPER THAT COMES THROUGH THE WALLS OF YOUR HOME"

Do you know that at the present time there is a daily newspaper that has no printing press, no plates, no pictures and no type? Its news is sent out to its subscribers by radio. Do you know that there is another newspaper that maintains a radio-equipped motor car that is a licensed sending station in which it sends out its reporters to cover news items in places where telegraph wires are not accessible? Read about these new and strange features of the modern newspaper in the next issue—written by Homer Croy, who (properly enough) comes from Missouri.



From a photograph made for POPULAR RADIO

THE MAN WHO ASSIGNS THE CODE NAMES

His official title is "chief of the Radio Service, Department of Commerce;" his name is W. D. Terrill—known to radio amateurs throughout the country.

What "Call Letters" Mean

By CAPT. WILLIAM E. MOORE

EVERYONE who has ever listened in on the radio—and there are few left who have not—is familiar with the formula that every sender uses when he introduces himself into the world of the ether.

First of all he asks "all clear?" Only he doesn't ask it in exactly those terms. He uses the same expression that the golfer uses; he queries "fore?" Or else he uses the code signal:

" . . . "

If he finds that he is not intruding

upon a conversation; if no one warns him to keep out; the sender then proceeds to call the station he wants by repeating its call letters three times, thus:

"2AQB 2AQB 2AQB."

And then he follows up by identifying himself by his own call letters:

"De2XK 2XK 2XK."

What do these call letters mean? Who assigns them? What do the numbers and letters signify?

The number 2 in both of the above calls indicates that the sending station is

an amateur station located in the Second Area. There are nine areas in the United States altogether. The call letters "2AQB" thus make clear the status of the station and its general location; a reference to the booklet, "Amateur Radio Stations of the United States," issued by the Department of Commerce, identifies the sender as William A. Mackay of Coytesville, New Jersey.

The sending station call number indicates that it is also an amateur station and that it is also located in the Second Area. But the letter X marks that station as unique among amateurs, for that letter is reserved exclusively for experimental stations that have special privileges. And the K identifies the particular station within this classification. A reference to the printed list of licensed stations shows that the station is located in New York City and is owned by Laurence M. Cockaday.

Whenever the letters X, Y or Z follows a numeral, the amateur station may be identified as an experiment station, a school or institute, or an amateur radio relay station, respectively.

Similarly, all call letters that begin

with W and N belong exclusively to Uncle Sam; the letter K belongs to him only in part. They were first officially assigned to him at an international conference held in 1912, when the letters of the alphabet were distributed among the nations of the world for such purposes. How Uncle Sam makes use of these three letters is his own concern.

This division of the alphabet among the great powers of the world—a division which is still unknown to the masses of the people of the participating nations—began at London on the occasion of the International Radiotelegraphic Conference and was completed at Berne, Switzerland, on the day of the beginning of the World War, August 1, 1914. The London Conference sat to consider the regulation of radio communication between the nations of the world. At that gathering, mandates for international call letters were distributed among the conferring powers.

But the delegates to London made only a partial allotment of call letters to those countries that signed the convention; this work was completed later by the International Bureau of the Telegraphic

| | | | | | | | | | | | | | | |
|----------|---|---|---|---|---|---|---|---|---|---|---|---|---|---|
| W | A | B | C | D | E | F | G | H | I | J | K | L | M | |
| A | | | | | | | | | | | | | | |
| B | | | | | | | | | | | | | | |
| C | | | | | | | | | | | | | | |
| 1 | A | B | C | D | E | F | G | H | I | J | K | L | M | N |
| A | | | | | | | | | | | | | | |
| B | | | | | | | | | | | | | | |
| C | | | | | | | | | | | | | | |
| D | | | | | | | | | | | | | | |
| E | | | | | | | | | | | | | | |

FIGURE 1: THE "W CHART" ON WHICH CALL LETTERS FOR COMMERCIAL STATIONS ARE DETERMINED

In each of the squares is written the name and address of the station to which the call letters are assigned, beginning with the first square, which is designated as WAA. On the chart below the amateurs call numbers and letters are determined, beginning with the call letters 1AA.

FIGURE 2
The four-letter call chart beginning with KDAA (at top) and the amateur experiment-station chart (below).

| | | | | | | | | | | | | | | | |
|---|---|---|---|---|---|---|---|---|---|---|---|---|---|---|---|
| | | A | B | C | D | E | F | G | H | I | J | K | L | M | N |
| 1 | X | | | | | | | | | | | | | | |
| | Y | | | | | | | | | | | | | | |
| | Z | | | | | | | | | | | | | | |
| 2 | X | | | | | | | | | | | | | | |
| | Y | | | | | | | | | | | | | | |
| | Z | | | | | | | | | | | | | | |

Union at Berne, when by the consent of the associated nations it modified and added to the previous allotment of call letters.

The call letters distributed by the Berne Bureau now constitute the basis for every signal that is sent out by a government or commercial radio operator anywhere in the world. That the twenty-six letters of our alphabet can be shifted about to form a sufficient number of combinations to furnish call signals for so many radio stations is at first thought astonishing. But when one considers that the United States of America is getting along without difficulty on something less than three call letters, one realizes that the rest of the world ought to be able to do fairly well on the remaining twenty-three letters.

Thus it was that in the distribution of the alphabet among the peoples of the earth the letters N, W and K fell to the lot of Uncle Sam. This statement must be slightly modified, however, for K is not wholly our own. We divide ownership with Germany.

At this point, perhaps, it should be explained that the service regulations of the International Radiotelegraphic Convention provide that the call letters of stations in the international system must be formed of a group of three letters (now sometimes extended to four) which shall

be distinguishable from one another. The call letters allotted to the United States comprise all three and four letter combinations beginning with the letter N, all those beginning with the letter W, and all combinations from KDA to KZZ, inclusive.

The K combinations from KAA to KBZ belong to Germany.

One might think, if he were not broadly informed in matters pertaining to this fascinating new field of communication, that the numerous commercial and government stations in America would quickly absorb all the possible letter combinations beginning with N, W and K. If so, he has another surprise in store when he learns the almost limitless possibilities of combinations within the alphabetical boundaries. In allotting the letters internally the government first turned over the letter N entirely to the Navy Department. Even that does not complete the whittling down process, for the combinations from WUA to WVZ and from WXA to WZZ are reserved for the United States Army. What remains is the commercial allotment.

We have, then, three national sources of control over the distribution of call signals. The Navy Department orders the distribution of signals for the Navy vessels and shore stations: the War

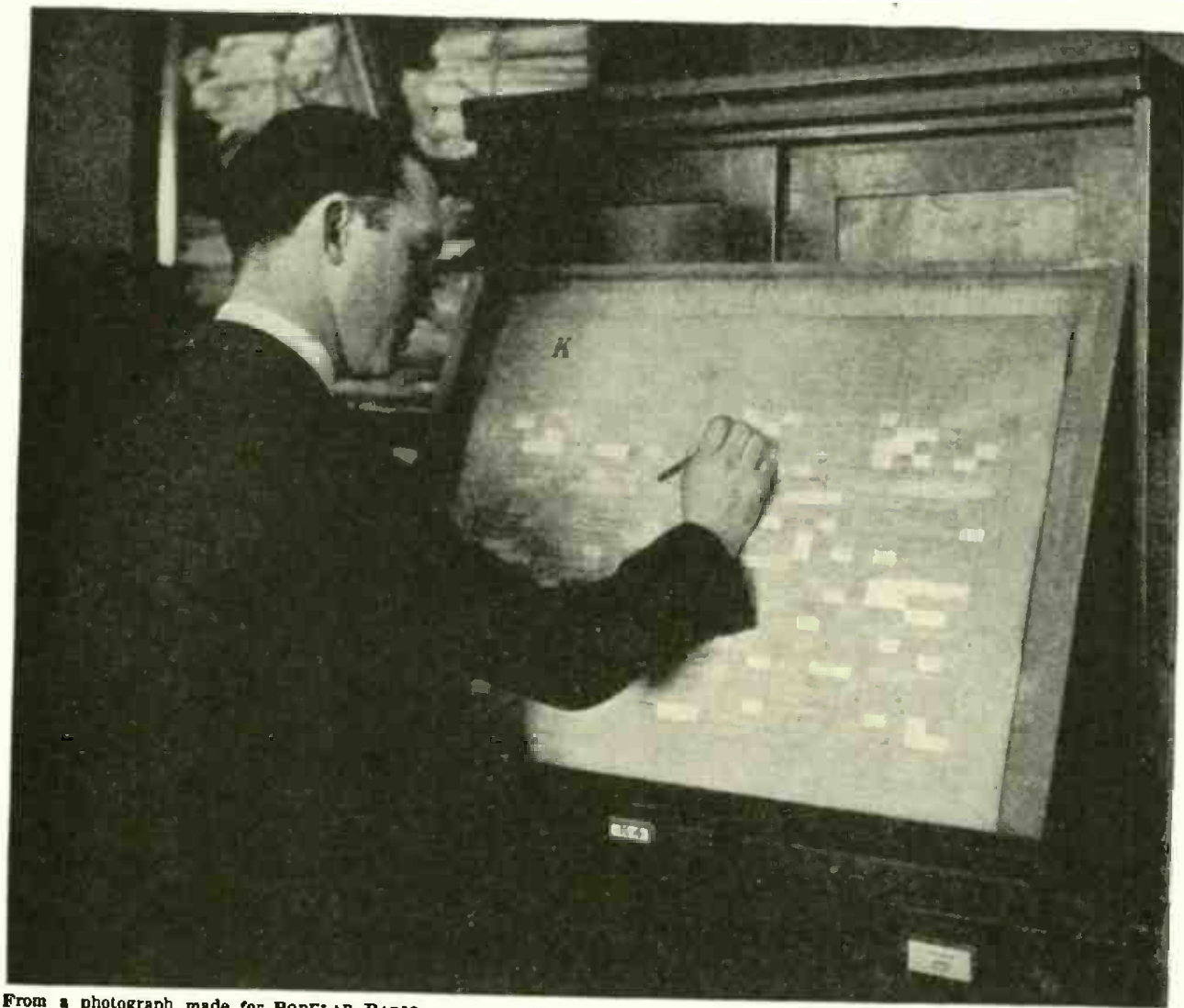

From a photograph made for POPULAR RADIO

A STATION ON THE K CHART GETS A CODE NAME

The country is roughly divided into an eastern and a western section. Commercial stations in the western half are listed on the K chart; the W chart records the stations located in the eastern half of the country.

Department controls certain W groups, and the Radio Service of the Bureau of Navigation of the Department of Commerce has supervision over what remains of the W groups and of those K groups not assigned to Germany. The Radio Service of the Department of Commerce assigns all call signals for amateurs, commercial land radio stations, commercial ship radio stations, and the so-called special stations.

The assignment of call signals to amateur sending stations is in a class by itself, but for commercial radio purposes the United States is divided roughly in halves by the Department of Commerce. West of an imaginary line running north and south through the center of the country each station is given a letter com-

bination beginning with K. East of the central line call signals begin with the letter W. Thus the signal of the Alaska Packers' Association of Clark's Point, Alaska, is KHG, while the call signal of the International Radio Telegraph Co., at Belfast, Me., is WNN. There are some exceptions to the rule, but in principle all Atlantic Coast stations begin with W and all Pacific stations with K.

In order to avoid confusion the assignment of signal calls by the Department of Commerce is recorded upon charts, known as K Charts, W Charts, and District Charts. The latter are for amateurs and specials. These charts are laid off in squares, 27 spaces wide and 27 spaces deep, as shown in the illustrations. Across the top of each chart, be-

ginning in the second column, run the letters of the alphabet in their ordinary sequence. The letter at the top of each column thus indicates every square in the column's depth. Beginning at the second square from the top of the left hand column of the chart the letters of the alphabet range downwards—a letter for each horizontal column. This is a familiar arrangement for code charts, permitting the designation of any square in the chart by means of the letters at the top and side of the intersecting columns. It will be noted that such an arrangement reserves the square in the upper left hand corner of the chart for the first call letter.

On such a chart, then, (Figure 1) the square in Chart W at the point of intersection of vertical column A and horizontal column A would be indicated thus: WAA. If it were desired to indicate the square similarly located on Chart K, the symbol would read KAA.

Suppose the Smith Manufacturing Co. enters an application for a radio license and asks for the allotment of a call signal for its station. Assume that the Smith Manufacturing Co. is located on the Atlantic Coast and is the first applicant to the Department of Commerce for a call signal. If a license is granted, after inspection, the name of the company is written in the square on the W Chart where the vertical column A intersects the horizontal column A. The company is then notified that its call signal is WAA. As long as the Smith Manufacturing Co. retains its government radio license its name remains in the WAA square as a record at the Department of Commerce. Should it give up its license the call signal would be reassigned to another license holder in Atlantic territory whose name would be written into the square WAA.

When the government runs out of three letter combinations, as it has in some instances, the process of doubling the call letters begins. This is indicated on the Department of Commerce charts

by dropping a two letter symbol into the upper left hand square, as shown in Figure 2.

In handling the allotment of call signals to the 15,000 or more amateur transmitting stations in this country the government employs a different system, disregarding the international alphabetical list of call letters. For greater ease in handling the volume of amateur business, as every amateur knows, the Department has divided the country into nine districts. There is a radio inspector in each of these districts who handles directly the applications of amateurs for licenses and call signals. Whenever a license is granted the call signal follows automatically.

The radio inspector gives the amateur a numerical call number instead of an international call letter. This number corresponds with the number of the district. The First District, for example, comprises all the New England states. The charts for that district are known as No. 1 Charts, a diagram of which is shown in Figure 1. The numerical charts are laid off in alphabetical columns in the same manner as the international letter charts.

Mr. W. E. Heckman, of Auburndale, Mass., for instance, appears to have been the first applicant for a license and call signal in the First District, so we find that his call signal is 1AA. The latest recorded applicant in the New England territory is Henry M. Wallingford, of West Somerville, Mass., and his call, being far down the alphabetical list, is 1WZ. The University of California Radio Club, at Berkeley, is in the Sixth District; its number is 6BB.

As the experienced amateur knows the identity of a radio station becomes so intimately tied up in its call letters that it is hard to think of the sender by name.

William A. Mackay is not generally known by that name to his radio amateur friends; some of them, indeed, may never have heard his name at all. He is "2AQB."

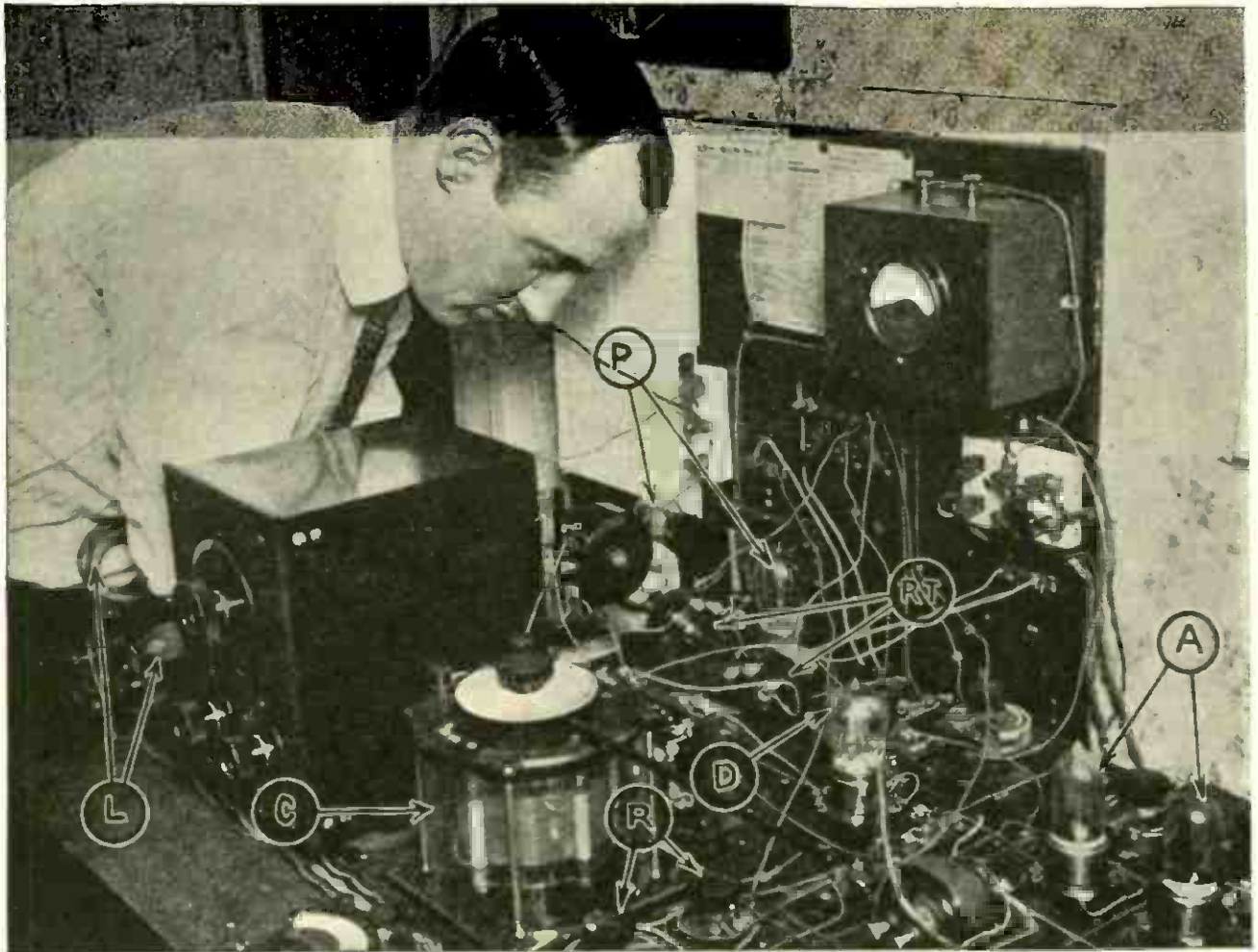

From a photograph made for POPULAR RADIO

TESTING OUT NEW AMPLIFICATION CIRCUITS

In this experimental hook-up L shows the honeycomb coils; C the tuning condenser; R the two filament rheostats; D the detector tube; P the radio frequency amplifiers; A the audio frequency amplifiers, and RT the radio frequency amplifying transformers.

THE LATEST DEVELOPMENTS IN

Radio Frequency Amplification

How It Is Being Used For Strengthening the Reception of Weak Signals Without Materially Increasing Strong Signals and For Reducing Static.

By ARTHUR H. LYNCH

THERE are two distinct kinds of amplifying circuits used for radio receiving. The first (which is the more common), is called "audio frequency amplification" because the currents that pass through the various units vibrate at comparatively low frequencies within the range of audibility. These currents when passed through the windings of a telephone receiver magnet cause the telephone diaphragm to vibrate in synchronism

with their own vibration. Amplification of the audio frequency character is used where the building up of an energy sufficient for the production of a loud signal is desired. The second kind is called "radio frequency amplification."

Radio frequency amplification is designed to fill an entirely different need and its use should not be misunderstood. Radio frequency amplifiers should not be used alone when a loud signal is de-

sired. They should be used to build up the weak impulses from the receiving antenna circuit in order that the detector tube may function satisfactorily.

In vacuum tube receiving circuits (or in crystal receiving circuits for that matter) the detector tube or crystal, as the case may be, operates as a rectifier, permitting current to pass through it in one direction and refusing to permit it to pass in the opposite direction. This rectifier action changes the rapidly vibrating electrical waves that are picked up by the receiving antenna into pulsating vibrations of lower frequencies which may be transformed into sound waves through the functioning of the telephone receiver.

The operation of a crystal or vacuum tube detector depends upon a number of varying features, not the least of which is the natural condition of the mineral or crystal itself, and the energy of the incoming signal. In order to have any type of detector operate satisfactorily as a rectifier the incoming signal should be rather strong. Of course strong signals, as they are understood today, are entirely different from the strong signals of the past.

When receiving outfits are located near

a radio broadcasting station, ample signal strength may be secured by the use of the detector alone and this comparatively strong signal may be built up by the use of audio frequency amplifiers to sufficient strength to operate loud speaking devices—providing an outdoor antenna is used. If the receiving station is more remote and the signal weaker, however, it is necessary to build up the incoming signal by means of radio frequency amplification. This building up is done satisfactorily by the methods described here.

There are certain limits to the value of radio frequency amplification. Once the signal from a transmitting station has been built up to a certain point, increasing the number of stages of this type of amplifier does not result in an increase of the signal strength. For this reason it is possible, when radio frequency is employed, to build up a weak signal without building up a comparatively stronger signal in the same proportion, permitting the operator to copy the weaker signal, and reduce the interference from the stronger station, within fixed limits.

When radio frequency amplification is applied to a loop or frame antenna, it provides, even with this small energy ab-

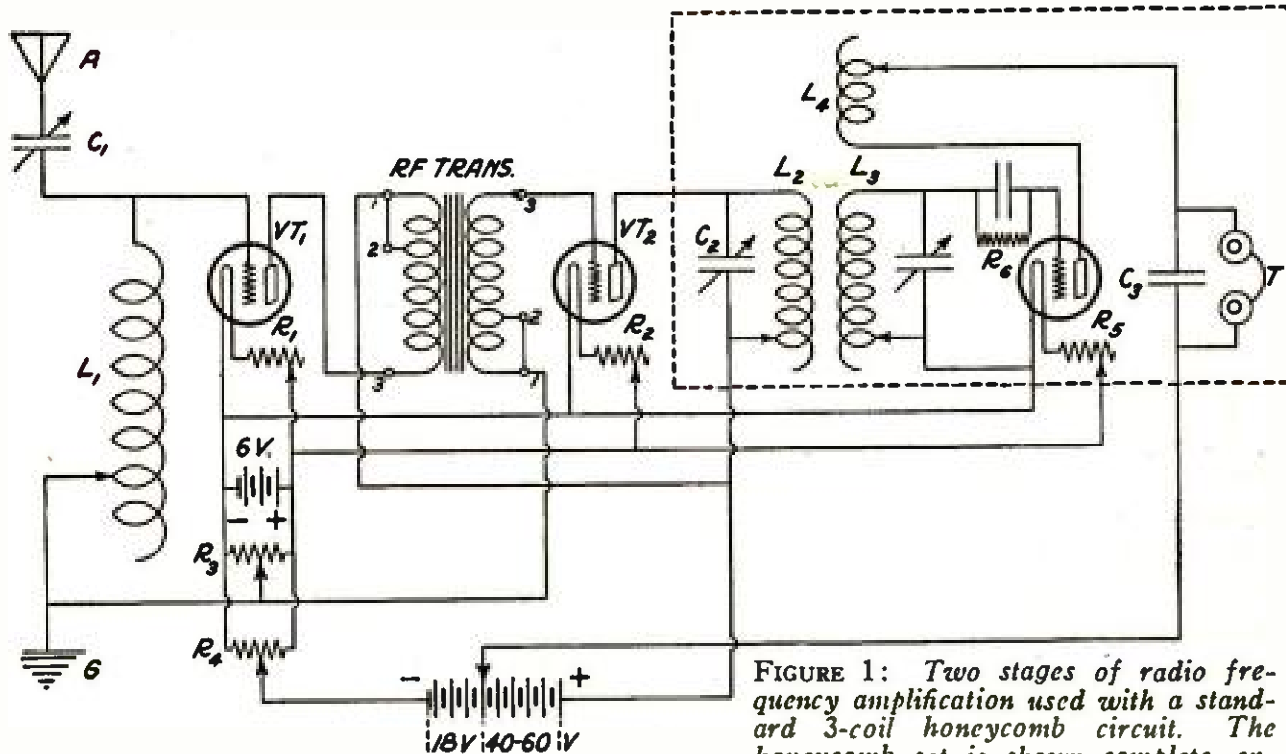
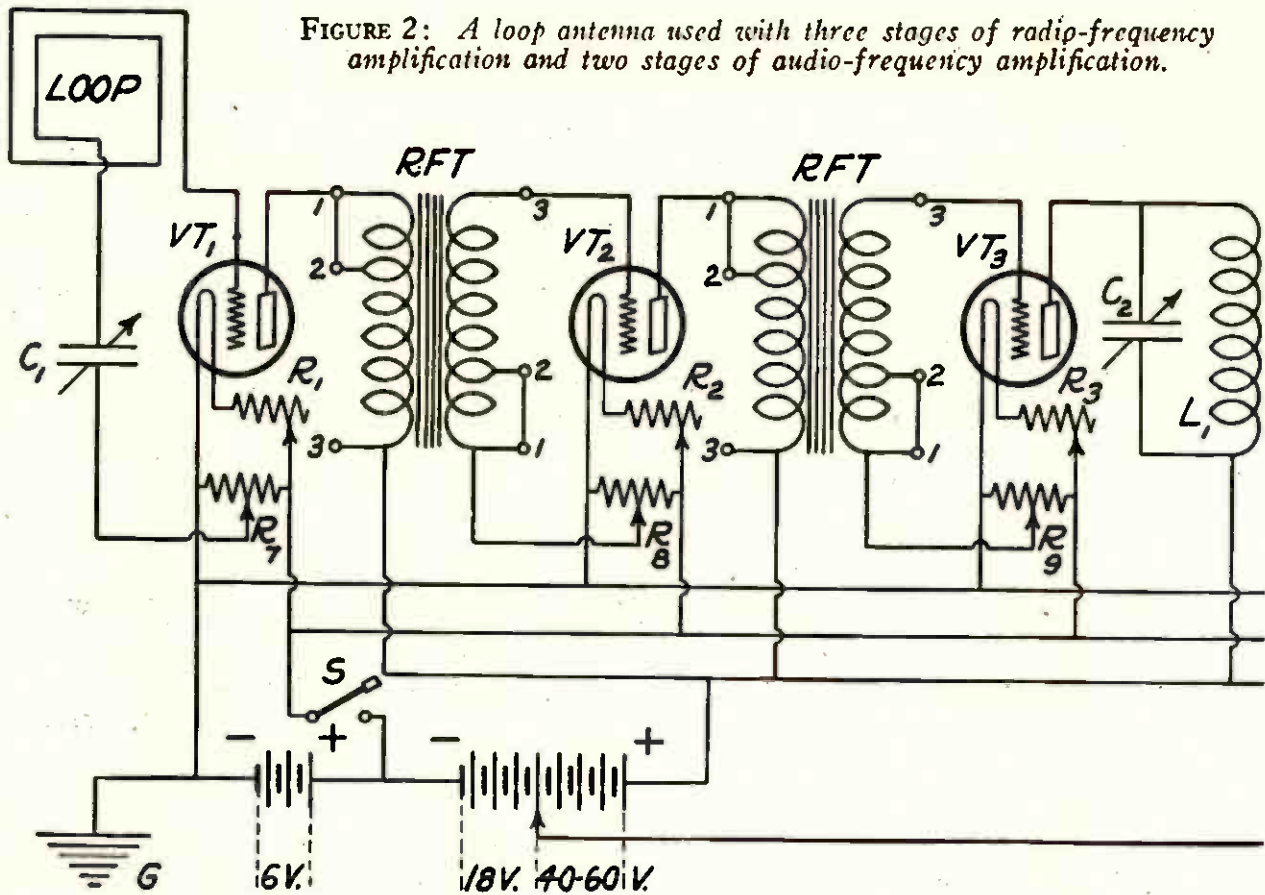

FIGURE 1: Two stages of radio frequency amplification used with a standard 3-coil honeycomb circuit. The honeycomb set is shown complete, enclosed by the dotted lines.



sorber, an intensity strong enough to actuate the detector tube over comparatively long distances. By the addition of audio frequency amplifiers this signal may be built up to a strength sufficient for the operation of a loud speaker.

When more than two stages of audio frequency amplification are employed there is a tendency for the signals, especially if they are radio telephone signals, to become distorted and sometimes unintelligible. For this reason it is generally more advantageous to employ enough radio frequency amplification to permit the proper operation of the detector, adding not more than two stages of audio frequency amplification to produce a loud signal.

Where radio frequency amplifiers are used in conjunction with a suitable loop antenna and tuning elements, two or three stages in cascade permit the copying of European stations.

Heretofore, when radio frequency amplifiers have been employed, it has been found that their use involved transformers of different designs for the different ranges covered by the receiving set, so

that in order to cover a wavelength range of 200 to 5000 meters two or three transformers were necessary with each stage of amplification. If three stages were employed it necessitated the use of six to nine different transformers. Today this is not necessary, for a radio frequency transformer may be secured with a wavelength range of 200 to 5000 meters and another covering a range of 5000 to 25,000 meters is now on the market. These two transformers cover all the wavelengths used in present-day reception.

The circuits illustrated here by no means cover the various applications of radio frequency; rather are they pointed out as typical of a class of circuits which should suggest themselves to the experimenter. Some circuits that have been given publicity show radio frequency amplifiers used with single circuit tuners; this method, however, is not the most satisfactory because there is a tendency on the part of the receiving outfit to radiate energy.

Figure 1 is a typical circuit that employs one radio frequency transformer in conjunction with a standard regenerative

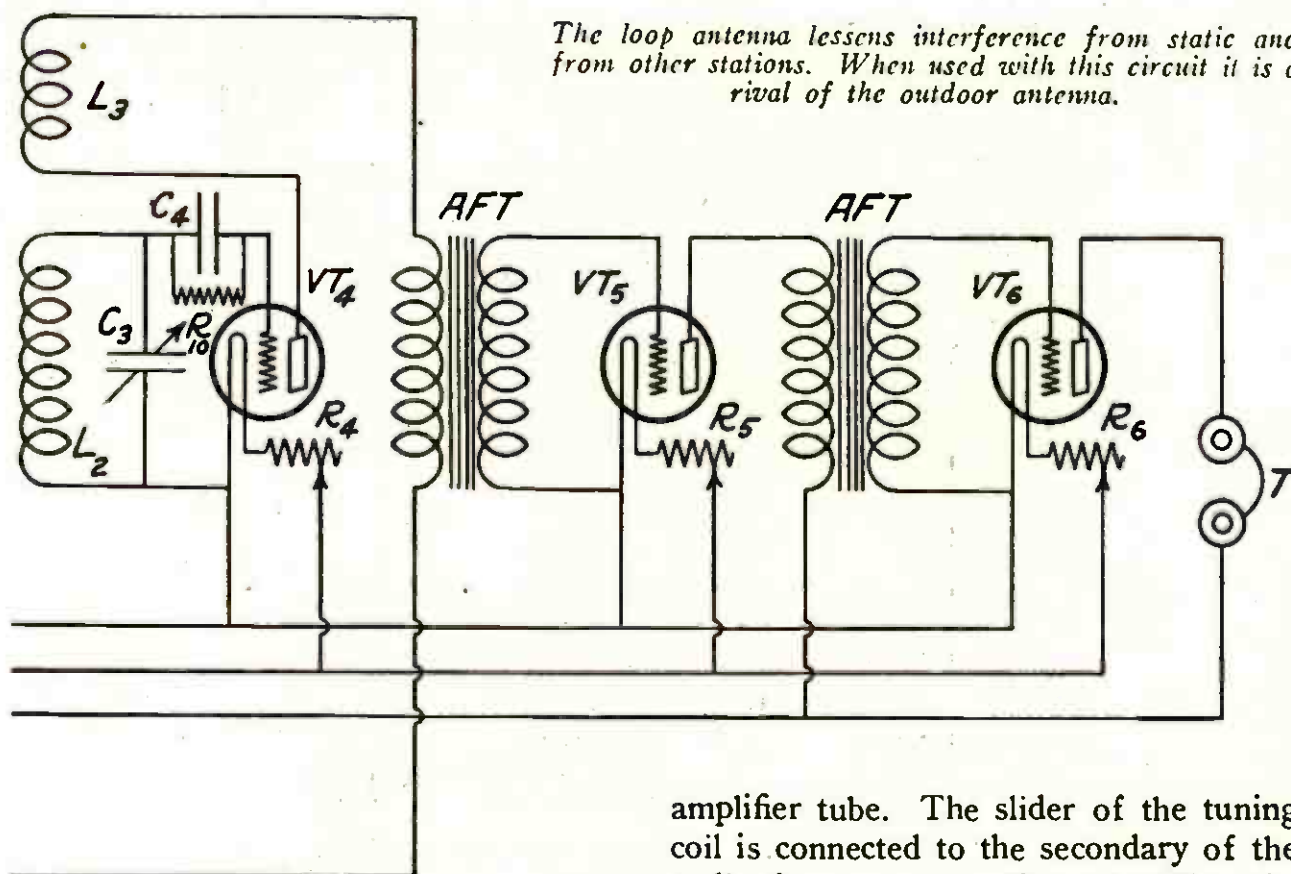

The loop antenna lessens interference from static and from other stations. When used with this circuit it is a rival of the outdoor antenna.

receiving circuit. The regenerative receiver itself is enclosed by the dotted lines. It will be noticed that two radio frequency amplifying tubes are employed; this is done because the first tube is used in conjunction with a standard radio frequency transformer, with a wavelength range of 200 to 5000 meters, while the second amplifying tube is connected in the primary circuit of the loose coupler or vario coupler used in the regenerative receiver. This primary, instead of being connected to the antenna and ground systems as is ordinarily the case, is shunted by a variable condenser. In this case the primary with its variable condenser and the secondary with its variable condenser, form the primary and secondary of one stage of tuned radio frequency amplification.

The difference between this circuit and most regenerative receiver circuits, therefore, is found between the antenna and ground systems and the vacuum tube detector. A variable condenser C1 is connected in series with a single slide tuning coil between the antenna and the ground. One end of the tuning coil is led directly to the grid of the first radio frequency

amplifier tube. The slider of the tuning coil is connected to the secondary of the radio frequency transformer. This circuit acts as an energy absorber and the small currents picked up by it are amplified through the two stages of radio frequency before they are passed to the secondary tuning circuit and the vacuum tube detector. It should be noted that in this circuit two standard "A" battery potentiometers are employed; one of them is used to regulate the plate potential of the detector tube and is shunted across the "A" battery with its movable contact in series with the plate battery, to which connection is generally made at the 18-volt tap. This potentiometer is indicated by "R4" in the diagram. "R3" is another standard "A" battery potentiometer, similarly shunted across the "A" battery with its movable contact connected to the antenna absorbing circuit and the secondary of the first radio frequency transformer. The potentiometer in this instance acts as a stabilizer and its proper manipulation results in eliminating undesirable noises which would undoubtedly occur without it. The values of the various instruments can be easily determined by experiment, however the values of capacities and inductances for long waves

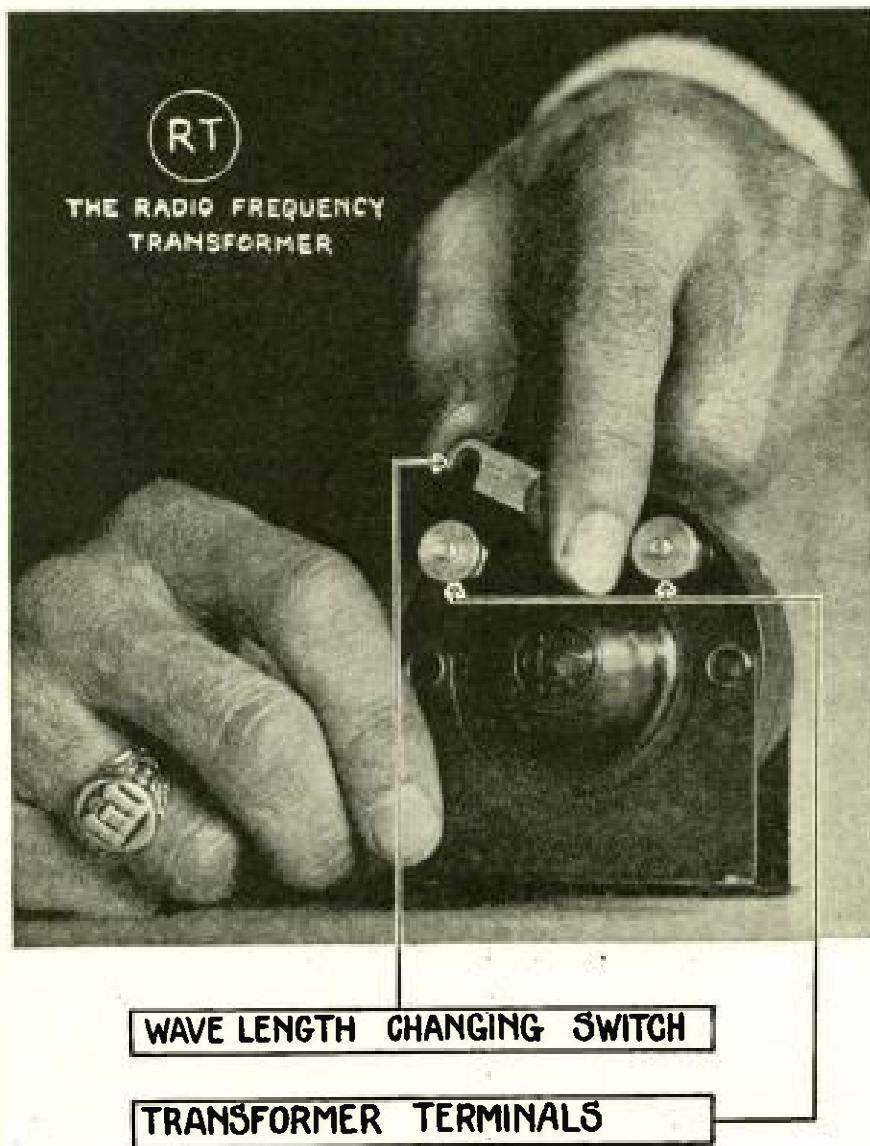

must necessarily be increased materially.

Figure 2 shows a method for using a loop antenna with several stages of radio frequency amplification and two stages of audio frequency amplification. For ordinary broadcasting reception or amateur reception a satisfactory loop antenna may be made by winding five or six turns of lamp cord (untwisted) upon a frame three feet square and about six inches wide, No. 14 B. & S., spacing each turn one-half inch between wire centers and providing a tap on each turn for regulation on the inductance of the loop.

With a circuit of this character, employing as it does three stages of radio frequency amplification, a signal of slightly greater intensity is obtained than is possible with an average outdoor antenna and the detector tube alone. This

arrangement, however, is susceptible to little interference because of the very marked directional characteristics of the loop, which will respond to signals from a given direction only; that is, the direction in which the loop points. Interference from various transmitting stations as well as static is materially reduced where a loop antenna is employed. The action of the audio frequency part of the circuit is similar to audio frequency applied to practically any other circuit and is merely used for the building up of great enough signal intensity to actuate a loud speaker.

In loop reception it may be readily seen that a number of stages of radio frequency are necessary for bringing about the same result which would be possible with a single detector tube and an outdoor



Brown Brothers

A CROSS-THE-CONTINENT RECEIVING STATION

With a loop aerial (which may be less than a foot in diameter) and with but a single radio-frequency amplifier, signals may be received over hundreds of miles; with additional stages of amplification signals may be received for thousands of miles.

Radio on Your Pleasure Boat

Some of the Ingenious Ways for Installing Your Receiving Set on Small Craft that will Enable You to Enjoy Wireless Programs on Your Vacation

By PAUL MCGINNIS

WHEN the owner of a modern pleasure boat breaks away from the city for a cruise, he has a host of ethereal friends to entertain him. He no longer fears the weather man, for although a fog can shut out the scenery and a rain can make him seek cover, his radio receiver makes his trip a successful vacation.

In fact, one motorboat enthusiast who takes religious care of his engine and would rather see a good coat of paint on his boat than a stylish coat on his back recently remarked that the first consideration in planning a cruise was his radio set.

His immaculate boat was of secondary importance.

He was one who would listen to the purr of his engine like a piano tuner at work. Perhaps that was why he strained in many peculiar shapes beneath his boat to place a strip of copper along the keel from stem to stern before it went into the water for the season.

He knew that a square foot of copper plate, fixed to the bottom of the boat, would serve all practical purposes, especially in salt water, but he knew also that naval vessels had been equipped with the

strip of copper to form the ground connection, and he wanted the best.

"I might strike a heavy sea which would throw a small plate out of the water," he explained.

Some who have smaller boats or canoes, or who take apparatus from their homes to use temporarily on their boats, have found it more convenient to drop some kind of metallic weight into the water to make a ground connection. Where the weight has a foot or more of surface ex-

posed to the water, it has proved itself fairly efficient. In some cases the propeller has formed a fairly good ground when the ground wire has been connected to the engine.

The trailing wire form of antenna has perhaps been the most valuable recent development in using radio sets on small boats. An insulated wire dropped over the side of the boat has been made to work quite as well as the expensive type strung between masts.

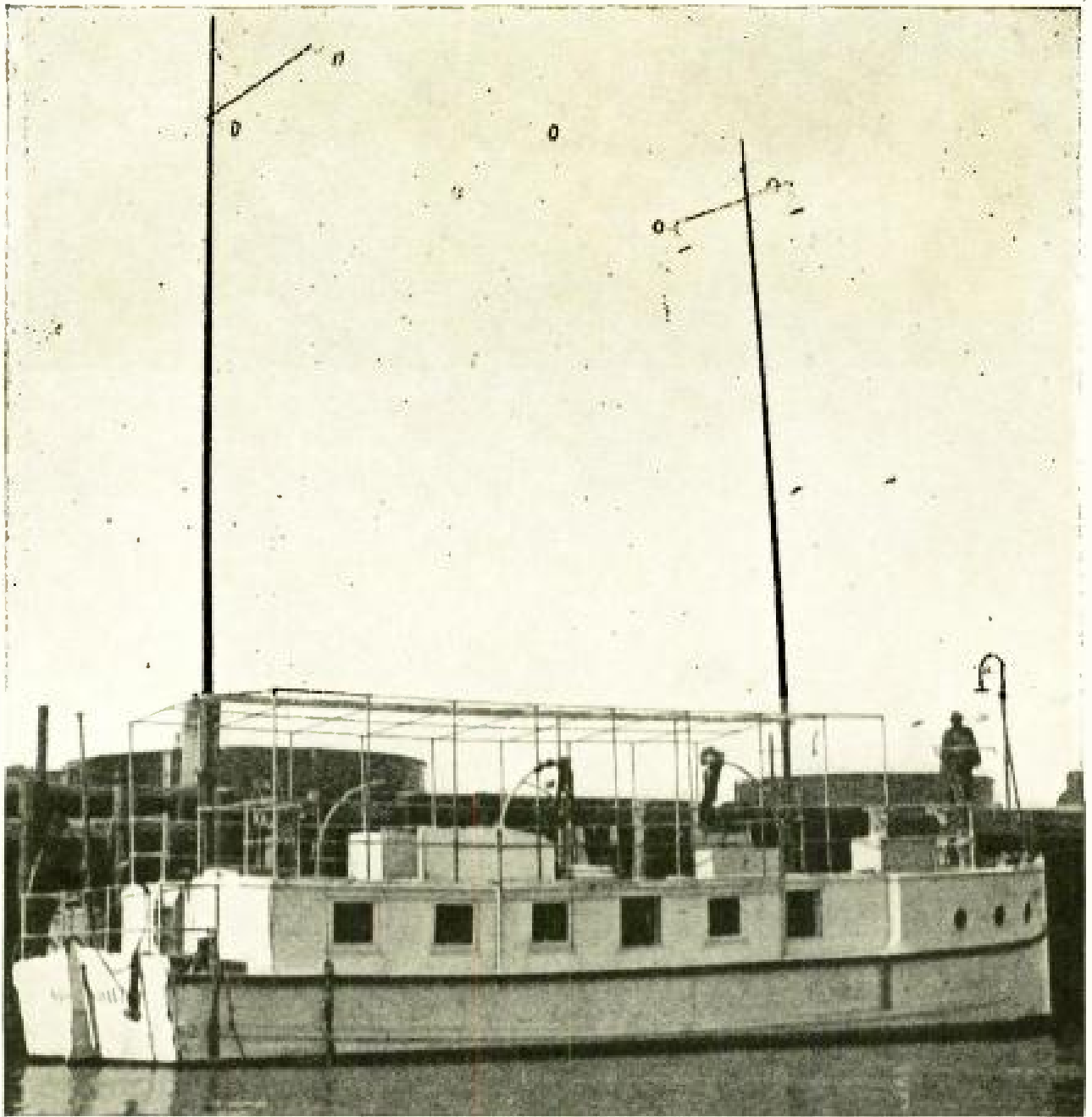

International

MASTS MAKE EXCELLENT ANTENNAE

On this pleasure launch the "masts" are merely aeri-als; the antenna wires are strung between them and connect with the prow. Such an arrangement gives a small vessel the same radio range as an ocean-going liner.



AT SEA—BUT IN TOUCH WITH HIS OFFICE

With a square foot of copper attached to the bottom of the yacht to serve as a ground and a single-masted aerial, Col. Hugh C. Willoughby has long used the "Sea Otter" as both a receiving and transmitting station.

The end of the wire must be insulated so that no part of the antenna can come into connection with the water. This can be done by wrapping the end with rubber tape and dipping it in paraffine, or by applying two patches used to mend inner tubes for automobile tires. Rubber covered wire will last longest in the water.

The boat need not be in motion when the trail antenna is used, as it will receive the radio impulses when hanging straight down from the boat. Deep water is not necessary, for the wire may be allowed to rest upon the ground. A practical length is 75 feet.

The T type or the inverted L type of antenna, strung between two masts, is the ideal arrangement, but almost as good results have been obtained with an aerial brought down from a single small mast



Photos by Edwin Levick

of the kind commonly built upon motor-boats or small yachts.

About the famous Belle Isle, near Detroit, Mich., the phonographs on canoes have found rivals in radio sets and broadcasted programs. The custom of hearing music on the water while the relaxing business man reclines on soft cushions and paddles his canoe silently through canals and under rustic bridges has received a new impulse with the coming of radio.

The canoe is often a most efficient receiving station, and when smaller boats are made, they will also be stations when they reach the hands of the inventive American amateur.

The trail antenna is valuable to the canoeist, but other types are used successfully. When the canoe is equipped with a sail, the aerial problem is solved by a simple arrangement on the mast.

Perhaps the most successful type for the canoe is the loop antenna, consisting of about a dozen turns of wire around a frame some three feet in diameter. If the skipper of the canoe is a good navigator and can determine his bearings, the loop can be pointed in the direction of the desired sending station, when it will not only tune out other stations sending at the same time, but pick up less static interference than any other form of antenna.

Another form of loop antenna has been successfully made by running an insulated wire along the sides of the canoe and along the keel. With such an antenna, one end of the canoe must be kept pointed directly at the station.

The loop antenna has great possibilities when used with vacuum tubes. With two stages of audio-frequency amplification and several stages of radio-frequency amplification, a loop much less than a foot in diameter can pick up stations in Europe.

A visit to the boat clubs of the Hudson River shows that there are two classes of member, those who have equipped their boats with radio and those who are planning to do so. Even the commodore of the rockingchair fleet, that aged person who is a sailor only in spirit and who



A TINY STATION—BUT IT WORKS

This compact little outfit both receives and sends radio messages. The power is furnished by four dry cells; the trailing antenna is dropped over the side of the canoe on the left.

rocks in contentment on the club veranda, is either enjoying the clubhouse radio receiver or starting an agitation to install one.

Complete transmitting apparatus is sometimes condensed into such a small form that it can be operated in a canoe or rowboat with the aid of dry cells.

Receiving sets, practical on small pleasure boats, need not take up more room than a camera. With a simple aerial and ground connection, such a set can pick up transmitting stations more than twenty-five miles away.

Smaller receiving sets are found practical in the race among amateurs for the invention of the smallest, and while the canoeist can carry his in his vest pocket, it is quite likely that the bather will soon have a set for the breakers.

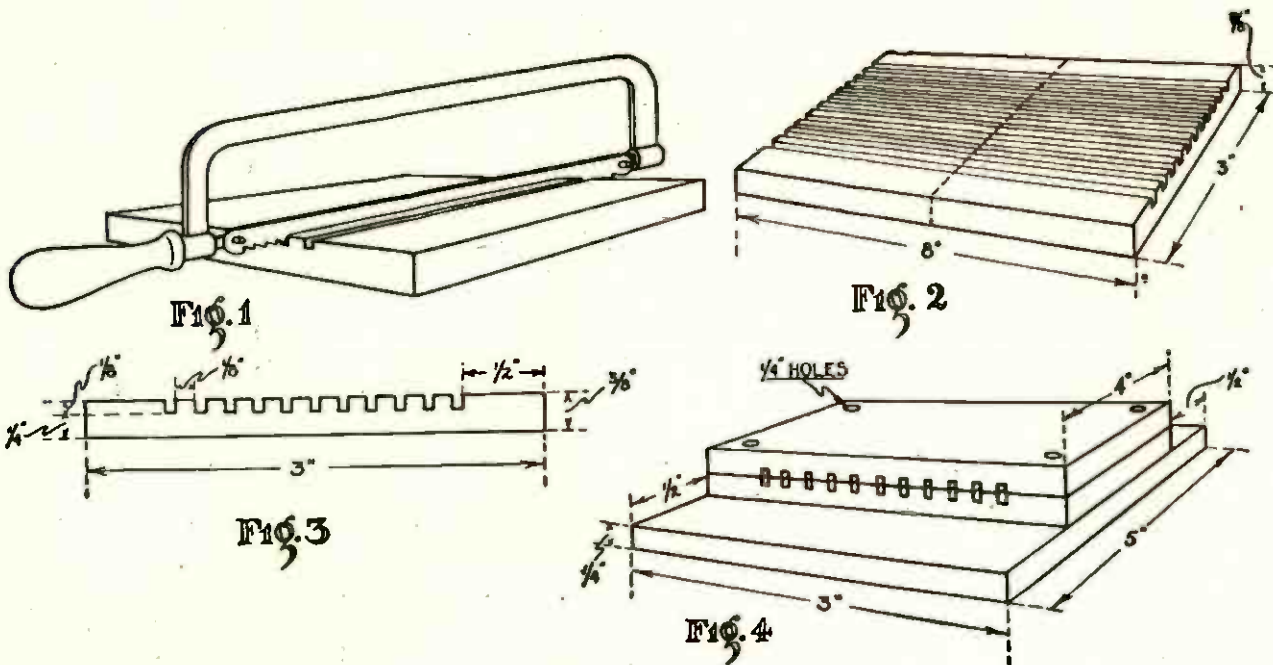

How to Make a VARIABLE CONDENSER

Simple and Easily Understood Directions for Building This Useful Device at Home at About Half the Cost of a Ready-Made Instrument

By A. HYATT VERRILL

ONE of the most useful instruments used in radio sets, whether of the crystal detector or vacuum tube type, is the variable condenser. Unfortunately these devices are expensive and many beginners are prevented from experimenting with them and from improving their sets because of the additional cost. But an efficient variable condenser which will serve every purpose for the average set may be made at home at a cost of less than half the price of a ready-made instrument. No particular mechanical skill or technical knowledge is necessary to construct this condenser, but if it is to prove successful and satisfactory the fan must expect to take some pains with the task and to work accurately.

If you own a hack saw, a screwdriver, a bench vise, a $\frac{1}{8}$ -inch drill, a pair of tin shears or ordinary strong scissors you will not require any other tools, although

you will be able to do a little neater job and may save a few pennies if you have a set of small screw taps and dies and a soldering set. The supplies you will need are:

A piece of Bakelite or some similar insulating composition about 3 inches by 8 inches in size and $\frac{3}{8}$ of an inch thick:

A piece of wood, Bakelite, or fibre $\frac{1}{4}$ -inch thick and 3 inches by 6 inches in size:

Sheet aluminum $\frac{1}{32}$ of an inch thick and large enough to give you 11 pieces, each 2 inches by 3 inches in size:

A small piece of $\frac{1}{32}$ -inch or $\frac{1}{16}$ -inch brass about $\frac{1}{2}$ -inch wide and 2 inches long:

Two binding posts (those from an old dry battery will do very well):

Nine or ten washers for $\frac{1}{8}$ -inch screws, $\frac{5}{32}$ -inch thick. If you cannot secure exactly this thickness have a tinsmith cut

them from sheet copper or brass of the right thickness or else get some $\frac{1}{4}$ -inch and some $\frac{1}{32}$ -inch washers and use these together to make up the $\frac{5}{32}$ -inch required:

Three $\frac{1}{8}$ -inch brass screw-headed bolts, $1\frac{1}{4}$ or $1\frac{1}{2}$ -inches long, with nuts:

Four $\frac{1}{8}$ -inch brass screw-headed bolts, $4\frac{1}{4}$ -inches long with nuts. If you cannot obtain these, get $\frac{1}{8}$ -inch brass rod and either thread the ends yourself or have it done at the nearest garage or machine shop.

The first step is to mark off carefully eleven parallel double lines on the piece of Bakelite 3 inches by 8 inches in size. To do this accurately you must use either a straight edge and a pair of dividers or T-square or a right angle triangle, as the entire efficiency of the condenser will depend to great extent upon the care and accuracy with which you do this.

Draw a line $\frac{1}{2}$ -inch from the 8-inch edge of the Bakelite, running the line the length of the block. Then, exactly $\frac{1}{32}$ of an inch from this draw another line, or if you prefer, scratch the lines with a sharp steel point.

Exactly $\frac{1}{8}$ of an inch from this second line draw a parallel line and $\frac{1}{32}$ of an inch from this draw another line. Continue in this way until you have eleven of the double lines each $\frac{1}{32}$ of an inch apart and with each pair of these separated by a space of $\frac{1}{8}$ inch.

Now comes the most difficult part of the entire operation, cutting grooves or notches where the $\frac{1}{32}$ -inch spaces are marked. However, if you go about this

in the right way you will find it simple.

Get a narrow strip of brass or iron about $\frac{1}{8}$ -inch thick with a perfectly straight edge and bend the two ends at right angles so the inside distance from end to end is 8 inches. Place this on the Bakelite block (as shown in Figure 1) and clamp the block and the metal strip between the jaws of a vise with the edge of the metal strip along one of the pencil lines or scratches. Then, using this as a guide, cut a slight notch $\frac{1}{8}$ -inch deep with a hack-saw that has a tooth clearance of $\frac{1}{32}$ -inch. Loosen the block and strip, move the latter to the next double line and cut another groove. Continue until the entire eleven notches or grooves are cut, when the block should appear as in Figures 2 and 3. If, however, you have no large vise in which to clamp the block in this way, you may secure the Bakelite or fibre to a bench; by using a little care you will be able to make the grooves easily.

When the grooves are done, measure off 4 inches on the 8-inch side of the block and saw the block into two equal portions across the grooves. Then mark off a line $\frac{1}{2}$ an inch from the edge of the 3 by 5-inch piece of wood or fibre and draw a line parallel with the 3-inch edge. Take the two halves of the grooved block, place them face to face, (adjusting them so that the grooves are absolutely in line, as in Figure 4), place them with one edge on the line along the other block as shown and clamp the three firmly in a vise. Then, with your $\frac{1}{8}$ -inch drill make four holes through all three blocks,

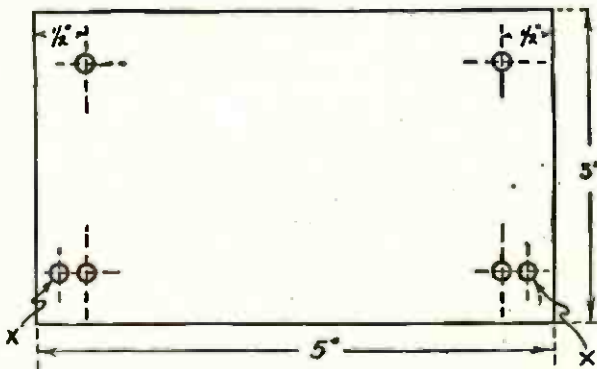

FIG. 4A

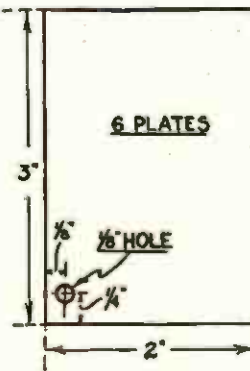

FIG. 5

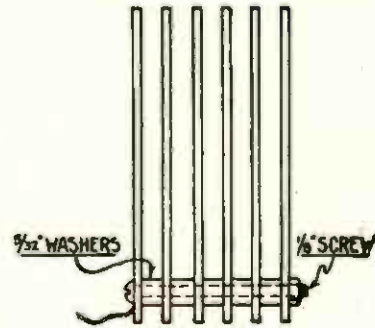

FIG. 5A

drilling about $\frac{1}{4}$ of an inch from the outer corners of the grooved blocks, and drill two more holes through the two projecting corners of the larger block, as in Figure 4 A (XX).

Next, mark off eleven rectangles on the sheet aluminum having each rectangle 2 inches by 3 inches in size. If you have trouble cutting the metal take it to a tin-smith and let him cut the pieces for you, as they must be true, square and all of exactly the same size. Then, clamp six of these together in a vise and bore a $\frac{1}{8}$ -inch hole through one of the corners, $\frac{1}{8}$ -inch from one edge and $\frac{1}{4}$ -inch from the other, as shown in Figure 5.

Then clamp the other five plates together and bore two holes at the corners as shown in Figure 6, keeping the holes $\frac{1}{4}$ -inch from each edge. Lay these last aside for the present and slip one of the $1\frac{1}{4}$ or $1\frac{1}{2}$ -inch bolts through the hole in one of the plates with the single hole. Slip a $\frac{5}{32}$ -inch washer, (or a $\frac{1}{4}$ and a $\frac{1}{32}$ -inch washer, according to which you use), over the bolt, put on another plate, then another washer until all the plates are on the bolt and are separated by washers as shown in Figure 5 A.

Twist a short length of wire around the screw under the head, and thread a nut loosely on the opposite end, then place the plates upright on a level surface so that all are in line and tighten on the nut with your fingers until the plates and washers bind and are fairly firm.

Now place these plates connected by the bolt in the grooves on one of the

pieces of Bakelite with the end where the screw comes flush with one end of the block and with the screw head and wire at the lower corner. Then place the other piece of grooved Bakelite on the plates; be careful to adjust them until they fit in the grooves. Then slip the four long $\frac{1}{8}$ -inch bolts through the holes in the four corners of the blocks and screw the nuts on firmly, thus clamping the plates in the grooves. In doing this however, do not use so much pressure that the plates will buckle under the strain but screw down the nuts little at a time, first on one and then another, until the plates are firmly secured. When this is done, tighten up on the nut of the bolt which holds the plates together, place a binding screw in the hole in the corner of the larger block, connect the wire from the plates to this and the whole should then appear as in Figure 7.

Now take the strip of brass $\frac{1}{2}$ -inch wide and 2 inches long and bend the ends at right angles so as to leave exactly $\frac{3}{4}$ of an inch between the ends inside of Figure 8. Bore a $\frac{1}{8}$ -inch hole through each of these ends and another $\frac{1}{8}$ -inch hole through the brass strip in its centre. In this last hole, secure a short brass rod or brass bolt. If a bolt is used it may be fastened by means of two nuts as shown in Figure 8, or it may be soldered as preferred. On the other end of this rod place an insulating knob of some sort.

Now take the five remaining aluminum plates and place them on bolts exactly as you did the first six, slipping

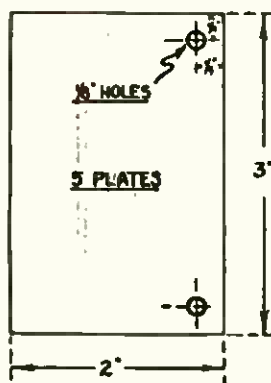

FIG. 6

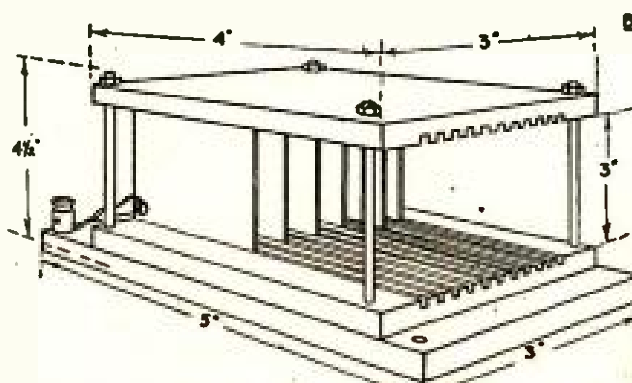

FIG. 7

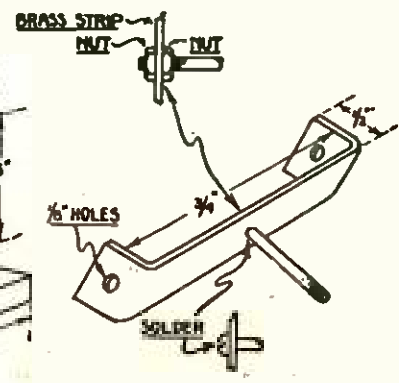

FIG. 8

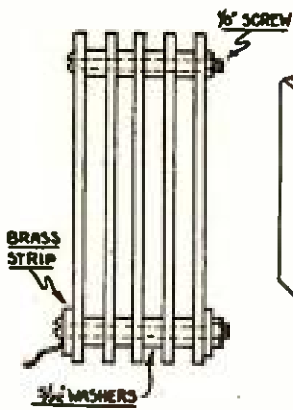

FIG. 9

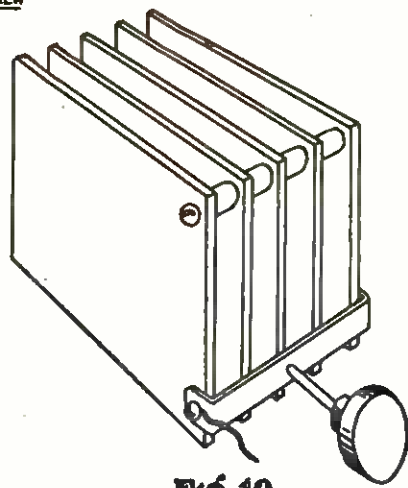

FIG. 10

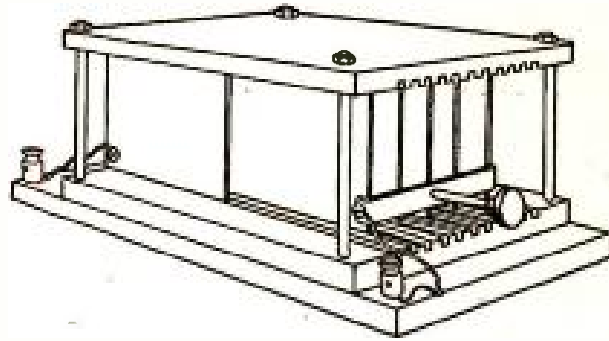

FIG. 11

a plate, then a washer and then a plate on the bolts, as in Figure 9. Place one bolt first; before screwing on a nut place the other bolt. This should be passed through one end of the brass strip bearing the knob, then through the plates and washers and finally through the other end of the strip, as shown in Figure 10. Finally twist a piece of flexible wire around the bolt under the head and tighten the nuts firmly.

Now, if you have done your work accurately, it is only necessary to slide the five plates into the grooves between the first six, connect the flexible wire from the sliding plates to a second binding post and your condenser should look as in Figure 11, and be ready to connect with your set. Test it first to be sure it is not short circuited.

If you find that the sliding plates bind in the grooves, you may loosen the nuts on the long bolts that hold the blocks to-

gether and place thin cardboard washers under them until the plates slide readily. If the trouble lies in the spacing of the plates or grooves you may readily adjust the plates by placing very thin brass or copper washers or shims between the plates if they are too near together or by filing down the 5/32-inch washers if the plates are too far apart. Even if your grooves are unequally spaced you will have no difficulty in adjusting the plates to fit them, for by filing off the washers in one place and adding shims in another you can make the plates farther apart or nearer together at will.

Although this eleven-plate condenser will have ample capacity for the average set, you may at times require a large one. By merely adding to the size or number of plates and making the necessary alterations in the dimensions of the other parts you can build a variable condenser of any desired size or capacity.



IS RADIO RE-MAKING CIVILIZATION?

GEORGE CREEL, the world-famous publicist and writer, thinks that it is—and says so with characteristic emphasis in the September issue of POPULAR RADIO. "When the citizens of one country learn at first hand by radio what the citizens of another country are doing and thinking," he says, "politicians will have a sad time attempting to play on ignorances and outworn hates. Real news is about the best binder the human family has ever developed. We proved it during the war—and we proved it by radio." And then he reveals an unwritten chapter of American history in which radio played a stirring and a vital part.



The Foolish Fear of Lightning

Brown Bros.

If your antenna wires are not grounded, they may become loaded with static electricity and cause a "corona discharge" during a thunder storm. This phenomenon may appear terrifying—but it is entirely harmless.

By EDGAR H. FELIX

NEW inventions bring new fears. The bill to license construction of the first railway into London was vigorously and vociferously opposed in Parliament and by the press because the people feared the vibration of trains within the city would shake down every building in London within two years.

New Yorkers feared that the first voyagers on Fulton's steamboat would go to the bottom of the river instead of riding on its surface.

A Boston physician who tried to introduce anæsthetics into the operating room was mobbed because the people feared such use would affect the soul.

The world changes but little in its fears. A new invention today awakens fears similar to those of the past. Radio salesmen say people fear that lightning will be attracted to their homes if they install broadcast receivers; and it has been predicted by one ridiculous "pro-

phet" that, as greatly increased numbers of antennae are put up for use, lightning will destroy a good part of our cities."

During a thunderstorm recently I inquired for the manager of a large downtown New York City store who had just installed a radio department.

I was not, however, immediately allowed to talk with him, for he was excitedly giving instructions to have the lightning switch for the indoor antenna put in the grounded position. His words were repeated by his secretary: "He says make it snappy or lightning may strike the store any minute and set it on fire."

If lightning were thus attracted, the brass railings for the offices, the typewriters and every other metal object in the department store should be hurriedly dumped out into the streets with the first indication of every thunderstorm. The people in that store were in no more danger from the remote possibility of

lightning being attracted by that indoor antenna on the lower floor of the steel building than they were in danger of the possibility of an army of African jungle gorillas walking in upon them at that moment.

When an intelligent and otherwise well informed radio department manager worries about lightning in such a case under such conditions, what may not be the worry of men and women in the homes where new broadcast receiving sets have been installed?

If this should spread, the telephone companies might find a new high peak of traffic just before thunderstorms due to broadcast enthusiasts telephoning home to make sure the lightning switch is in the grounded position. This is a thoughtful precaution but it offers little protection against a lightning discharge. If the conditions were such that lightning would strike anywhere near that home, it would strike there—antenna or no antenna.

Lightning, like other dangers we face, appears worse than it is. Of course, the probability of danger has been well advertised from the standpoint of public safety by the Board of Underwriters and from the business standpoint by manufacturers of lightning arresters.

Fears disappear with knowledge of the facts. The facts that relate to the possibility of lightning striking an antenna are of two groups: facts of experience and facts of science.

As to facts of experience:

After twenty years of radio, there are but few cases on record of antennæ being struck by lightning. It is nonsense to attribute to a radio antenna the power to attract or change the course of a lightning discharge of billions of volts and millions of amperes.

Here are a few of the facts of science:

Most visible lightning discharges take place between clouds of different potentials. If every flash seen during a storm were grounded to earth in the form of a direct discharge, a thunderstorm would

invariably be accompanied by tremendous damage, but instead of this, most of the charges gathered on clouds are dissipated through a continuous stream of leakage between the earth and the clouds. Nature with her usual foresight, always accompanies high humidity and heavy rain with a highly charged cloud atmosphere. In this way she punctures the insulation of air between the clouds and the earth by a continuous stream of minute



Keystone View Co.

YOUR ANTENNA PROTECTS YOUR HOUSE

It no more attracts lightning than does a tree; if a bolt does by chance hit the antenna, it acts as a lightning rod.

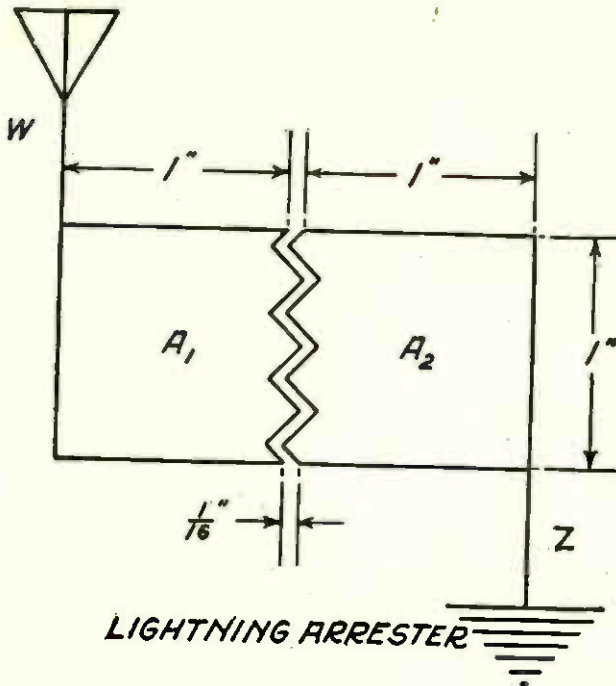

An air gap lightning protector can be made of two pieces of brass plate shaped as shown above. These should be mounted on a suitable insulating base and the receiving set should be connected across W and Z.

conducting bodies, each highly charged. Some of these continually discharge through the antenna system, as is evidenced by that unpleasant noise which we call static. Thus, there is a continuous conducting path between a cloud and the earth, resulting in a lightning flash only when extremely high charges are present. When such a discharge takes place, a current of millions of amperes and billions of volts drain the cloud of its charge.

A thunderstorm, then, clears away the charges on the clouds in two ways; first by a continuous stream of charged rain-

drops and conducting ions; and second, by direct discharges, such as take place between the electrodes of a spark gap. The latter is usually preceded by a collection of charges from nearby clouds until sufficient potential has been collected by some one cloud to break its way directly to the earth through a space of from one and a half to two or more miles.

An electric charge sufficiently strong to break through a space of that distance is of such intensity that its course is influenced very slightly by the relatively small attraction of a piece of antenna wire. Moreover, a grounded antenna is at the same potential as the earth itself.

Since the potential of the antenna is practically the same, the only other assumption that might make it seem that an antenna might be an attraction for a lightning discharge is the fact that the antenna is nearer the cloud than the surface of the earth. The cloud is from 7,000 to 11,000 feet away. The ordinary receiving antenna for broadcasting is seldom more than a hundred feet in the air. A hundred feet more or less travel for a charge of billions of volts is not sufficient to make such a charge change its course as much as twenty feet in order to find such a little path of less resistance. In the few cases known of lightning striking an antenna, it is certain that it would have struck at that very spot if no antenna had been there.

The actual ionized path established by

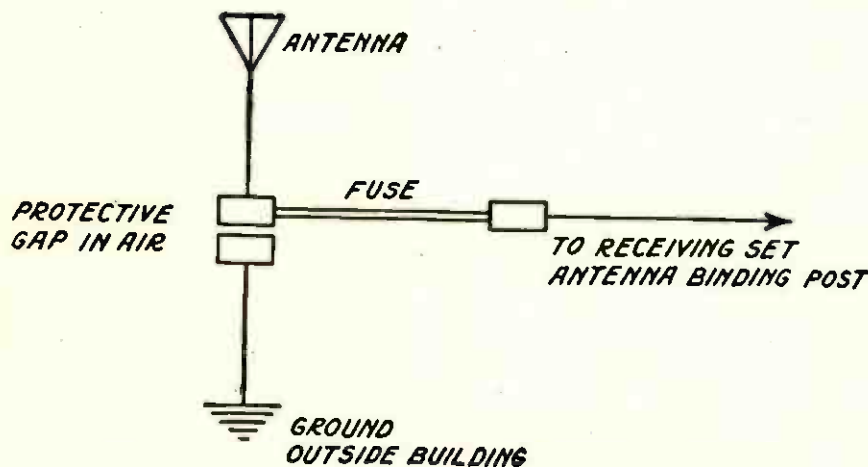

This lightning protector has a fuse leading in to the instruments. If lightning should strike, the long fuse would blow out and the electrical discharge would take place through the gap.

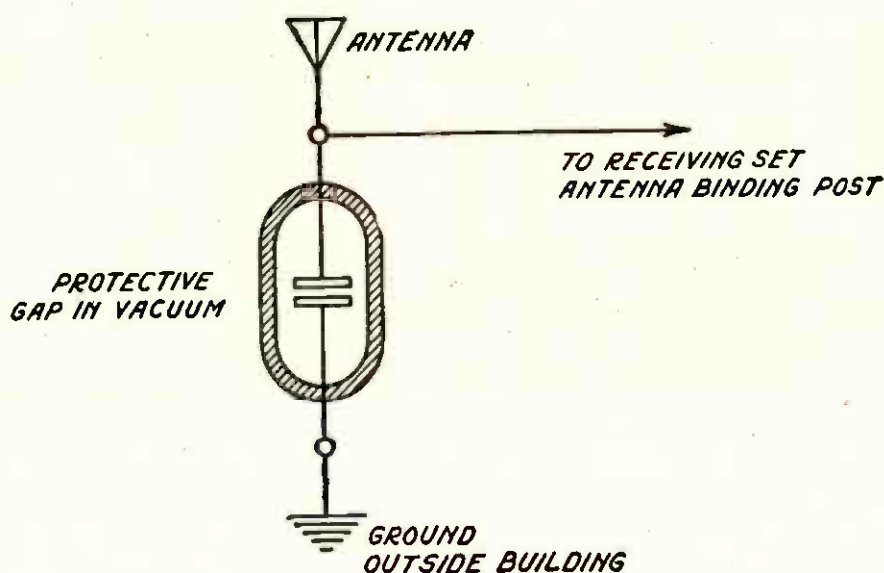

A VACUUM TYPE OF LIGHTNING ARRESTER

The instruments are connected to the antenna and ground as usual, with the gap shunting the windings. Any electrical surges that gather on the antenna immediately cause a discharge across the gap in the vacuum.

a direct cloud discharge is at the most but a few inches in diameter. Surrounding this ionized path of direct discharge, there is a large accompanying discharge, perhaps several miles in area. This entire area is influenced by the terrific current grounded by the lightning discharge. Sensitive receiving sets are greatly affected by this for several miles around—perhaps anywhere within a radius of scores of miles. It is against this sympathetic discharge that we take our main precautions.

The lightning arrester dissipates such charges with certainty and safety even though the antenna is not grounded, and so forms actual protection, similar to that of the time-honored lightning rod.

The lightning arrester is a safety gap designed with such electrodes that a charge on the antenna of over 500 volts is grounded with the greatest possible facility. Whenever a charge of sufficient voltage is collected on the antenna, a spark discharge takes place across the toot-like electrodes of the arrester gap.

Against an actual discharge—that is, lightning striking at a particular place—there is no real protection possible.

Since the actual ionized path of such a direct cloud discharge is but a few inches in diameter the owner of a broad-

cast receiving set should not expect his particular little antenna with no especial attracting features to be picked out. He would be as much an egotist as an old maid in her little back yard holding out an up-turned thimble, confidently expecting that when but one rain-drop falls from a cloud two miles away, it will so distinguish her as to direct its way to her thimble when it might as easily fall anywhere else within the State.

In planning lightning protection, make certain that your antenna is protected by a grounding device as required by the Board of Underwriters. This protects you against damage occasioned by any discharge taking place through the antenna either because of natural leakage or because of indirect cloud discharges and lightning discharges nearby. By having the grounding device properly installed the insurance on the property is protected. A radio set that is properly set up with antenna and with ground connections made in the correct way, affords better protection against lightning than if it were not installed. There is absolutely no justification for the hysterical fear that a radio installation will "draw" lightning—no more justification than in the case of the child's fear that some grinning hobgoblin will jump out from the dark.

WHAT READERS ASK



THIS department is conducted for the benefit of our readers who want expert help in unravelling the innumerable kinks that puzzle the amateur who installs and operates his own radio apparatus. If the mechanism of your equipment bothers you—if you believe that you are not getting the best results from it—ask THE TECHNICAL EDITOR.

THE flood of inquiries that has poured in upon the Technical Editor has not only furnished evidence of the need of this department; it has also necessitated a system of handling the correspondence that will insure the selection of and answer to only those questions that are of the widest application and that are, consequently, of the greatest value to the greatest number of our readers. Our correspondents are, accordingly, asked to cooperate with us by observing the following requests:

1. Confine each letter of inquiry to one specific subject.
2. Enclose a stamped and self-addressed envelope with your inquiry.
3. Do *not* ask how far your radio set should receive. To answer this inquiry properly involves a far more intimate knowledge of conditions than it is possible to incorporate in your letter.

The questions that are not of sufficient general interest to warrant publication in this department will be answered personally. Many of these questions are being answered by referring the correspondents to items that have already been printed in these pages. To get the full benefit of this service, therefore, *save your copies of POPULAR RADIO.*

QUESTION: Please tell me if two receiving sets can be used on the same antenna. I have an antenna 170 feet long, stretched between two trees. One tree is in my neighbor's yard and he would like to listen in also. Would it be better to place a breaker in the centre of the antenna so that my neighbor could use one-half 85 feet long and I the other half?

W. W. BLAUVELT

ANSWER: The second method would be the better. Place an insulator at the center of the 170-foot antenna wire, thus splitting it up into two antennae of 85 feet each.

QUESTION: On page 59 of the May issue of POPULAR RADIO is a diagram of a honeycomb set for receiving high-powered undamped stations. Can this set be made to receive concerts on 360 meters? What size honeycomb coils should be used?

J. J. MILLER

ANSWER: This set may be used for broadcast reception. The coils should be: Primary L-35, Secondary L-50 and Tickler L-75. A crystal detector can be used for concert reception, but the results will not be as good as with a vacuum tube, as the crystal detector is not as efficient a rectifier as the vacuum tube.

* * *

QUESTION: I am interested in the hookup of a set I saw in your department; you mentioned that it was capable of receiving foreign high-powered stations. Does this mean telegraph signals or concerts within this range? Would the set shown on page 60 of your May number receive concerts?

B. BOUCHIER

ANSWER: The first set will receive undamped telegraph stations within the range mentioned. The set described on page 60 is meant for short wavelength reception and is capable of receiving concerts over a range of 300 miles, if conditions are favorable.

* * *

QUESTION: I have an induction coil, about 6 inches long and 2 inches in diameter. Can I hear anything on it if I use it for the tuner in a radio receiver? If so how will I connect it?

JOS. I. BROWN

meter is a single circuit inductance which is variable, and the variocoupler is a two circuit inductance, the secondary winding of which is of a fixed value and the primary winding is variable by taps. We cannot answer questions as to distances a set will receive.

* * *

QUESTION: Would I increase the range of the set described in the June issue of POPULAR RADIO if I put in a loose-coupler or a variocoupler in the hookup instead of the coil?

FLOYD GIBSON

ANSWER: This would increase the selectivity or tuning ability of the set considerably, and the distance range slightly.

* * *

QUESTION: Please send me a diagram of a set for receiving broadcasting that does not use a crystal detector.

CURZON FERRIS

ANSWER: We are publishing on this page a diagram of a simple tuning coil that is connected up with a vacuum tube detector. We believe this will be simple enough for you to construct. See Figure 4.

* * *

QUESTION: Is there any way to fix a tinfoil shield to a wooden panel for a regenerative circuit?

EDW. H. BUCHER

ANSWER: You may accomplish this by using shellac as a glue to be applied to the tinfoil. The tinfoil should then be pressed on the back of the panel and smoothed out. The tinfoil should be cut away where the instrument binding posts touch or pass through the panel. The ground binding post, however, should be connected to the shield.

QUESTION: Will I be able to receive music from a good broadcasting station, within a five-mile radius, with the crystal set described in the May issue of POPULAR RADIO? Could I hear music from that distance with a single wire aerial about 30 feet high?

L. P. CLARK

ANSWER: You should be able to hear the music satisfactorily with the set mentioned with the single wire antenna at this distance.

* * *

QUESTION: How far under favorable conditions, would you be able to hear with a set as described by A. Hyatt Ver-rill in the June issue of POPULAR RADIO? What is the cost of a good variocoupler? What is the function of the variometer, and what is the cost of a good one?

G. G.

ANSWER: The set described should work reliably over a distance of 50 to 75 miles. The variometer is a continuously variable inductance and is used for tuning a circuit to resonance. A good variometer or variocoupler can be obtained at a price between \$7.00 and \$10.00.

* * *

QUESTION: I am interested in radio and wish to qualify as an operator. Will you please acquaint me with some Correspondence School that will furnish me with this training?

P. CHRISTENSEN

ANSWER: There are several good schools of this kind; the one nearest to you is the National Radio Institute, Washington, D. C.

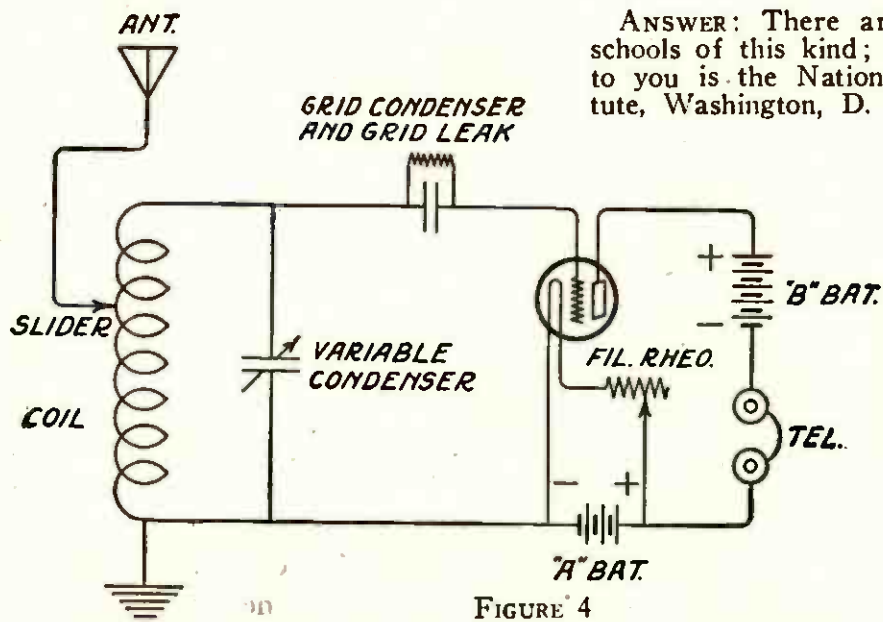

FIGURE 4

A simple and practical hook-up employing an audion detector, a single slide tuning coil and variable condenser.



ITEMS of general interest that you ought to know; bits of information of practical usefulness to every radio amateur.

More Short Wave Bands For Broadcasting

MORE short wave bands for broadcasting, nominal fees for licenses, and provision for permits before erection of transmitting stations are among the changes incorporated in a bill just passed by Congress. All that is needed now to put these changes into effect is the approval of the Senate.

More liberal provisions for broadcasting on short wavelengths are provided in the bill which gives broadcasting by the Federal and state governments and public institutions exclusive rights to the wavelengths from 485 to 495 meters. This is essentially the same wave used for government weather, crop and market reports now. Those who live away from the seacoast will have a larger variety of radio waves to utilize under the recommendations. The band from 285 to 485 meters is assigned to private and toll broadcasting, but the zones from 285 to 315 and from 425 to 475 meters will not be used in regions near the coast because of the chance of interference with marine radio communication. For similar reasons the experts have limited government and public broadcasting on 650 to 700 meters to 400 or more miles from the seacoast, and similar broadcasting on 700 to 750 meters must not be done nearer to the coast than 200 miles.

By the establishment of a new band

of wavelengths from 100 to 150 meters for the exclusive use of private and toll broadcasting, the experts foresee the establishment of short range broadcasting. It is expected that this will be a development of the future; that due to the fact that few radio receiving sets as they are now made can receive radio waves shorter in length than 200 meters, it will be possible to establish radio entertainment service on the basis of renting receiving sets adjusted to a particular wavelength. The use of shorter wavelengths will introduce new problems into radio apparatus manufacturing and will also allow the establishment of a large number of low-power, short wavelength transmitting stations in a small area. Each city will be able to have its own transmitting station of this character and will operate without interfering with other stations.

Reasonable fees that will help to pay the increased cost of radio regulation are proposed in the bill. It also provides for permits before a transmitting station is erected rather than after it is erected and before it begins to operate as is now the case.

The Best Home-Made Amateur Station in America

IN a small town in New Mexico, isolated from the active radio world by broad deserts and high mountains, an amateur has built a wireless station which has been awarded the Herbert Hoover

cup for 1921 for being quite the best product of amateur skill.

Louis Falconi, known as 5ZA to amateurs who have heard him in every part of the country, was chosen by the American Radio Relay League because of the ingenuity he displayed in making a large part for his apparatus, electrical efficiency of the set, transmitting range, receiving performance, observance of radio law, ability of the operator to handle messages, amount of traffic handled and completeness of the station log. For several years his station has been the chief connecting link between the Mississippi Valley and the western coast, and he has been heard in every state but Maine. He communicates with ships both on the Atlantic and the Pacific Oceans and is consistently heard as far away as in the Hawaiian Islands.

The difficulty in getting proper radio supplies was the mother necessity which made Falconi the inventor of many parts used in his set which now not only includes a spark transmitter but a con-

tinuous wave transmitter, I. C. W. telegraph and radiophone. The phone has been heard as far east as Indiana and in many other distant states.

It was Falconi's station which connected Chicago with Los Angeles last summer when a message was relayed from Hartford, Conn., to Los Angeles, Calif., and a reply returned to Hartford in six and a half minutes.

Radio Helps Aviators in Making Landings

A NEW method of helping airplanes to locate the landing field and come to earth safely with the use of radio has been developed by the Bureau of Standards after several years of study. Radio direction finders and other devices have been in use for a long time to assist airplanes in landing during the night, in the fog, or at other periods of poor visibility. The usual method of using radio for this purpose is to transmit from any ordinary elevated antenna at the landing field radio signals which are received on a direction finder carried by the airplane. This



Fotograms

THE WORLD'S BEST CODE OPERATOR

When Theodore McElroy took down code messages at the rate of 56½ words a minute with but one error at a recent radio show in New York, he won the title of "champion radio code operator of the world," and was given a silver cup as evidence of his skill.

method gives the direction of the landing field, but it does not tell accurately the distance from the plane to the field.

The aviation experts of the army and navy have long wanted a method that will give a signal heard over a comparatively large area when the airplane is at a high altitude but which is localized within a small area when the plane is near the ground. A large horizontal coil tuned to 500 cycles was tried by the Bureau of Standards but did not prove satisfactory. Experiments were then made with radio frequency waves, and two horizontal coils, one above the other and with current flowing in opposite directions, were used. A fairly high radio frequency,

such as 300 kilo-cycles or a wavelength of 1,000 meters, was used in this case. The signals that radiated from the two coils were the strongest for an airplane flying in a given horizontal plane whenever the airplane was within a comparatively small ring-shaped area located above the landing field.

Radio Beacons Send Out Warnings at Sea

SO successful have proven the five radio beacons with which the Department of Commerce has been experimenting for sending out warning signals to ships in fog and heavy weather, that five more stations have been authorized. The new beacons will be installed at Boston, Nantucket, Cape Charles, Columbia River and Puget Sound.

Foreign ships are being equipped with direction finders to enable them to tell the direction of the warning beacons, and foreign authorities are watching America lead the world in this new development of the science of navigation.

At present the five stations which stand watch on our coast are located at Ambrose, Fire Island and Sea Girt near New York and on the light ships off Cape Hatteras and San Francisco. The radio signals are sent by automatic devices which operate at regular and frequent intervals.

Will Trains Be Controlled By Radio?

WILL the next step in "safety first" railroading be routine radio communication between train and dispatchers? This is the question that is being asked by those who see the future significance of the Interstate Commerce Commission's final orders to forty-nine railroads to establish automatic train control devices on their lines before January 1, 1925.

The first trains ran "wild" with no other control than that of the engineman. When two trains used the same track in opposite directions, the first control was



Kadel & Herbert

ONE MORE "SMALLEST" TUBE SET
This "peanut tube" receiving apparatus, which is said to have a range of 75 miles, weighs less than 1½ pounds. It won first prize for its young maker, Sterling G. Sears, at a New York radio show, where it was adjudged the most suitable small set yet devised for use by the police.



U. S. Signal Corps

THE FIRST USE OF RADIO IN A BALLOON RACE

Radio in free ballooning was used for the first time in the national balloon race which was won by Major Oscar Westover, who covered a distance of 850 miles—300 miles farther than any of the other contestants. Major Westover used fifteen feet of copper wire screening like that ordinarily used for windows, for lining the balloon basket and to form the ground; the aerial—a single strand over a hundred feet long—was dropped from the side of the basket. With a two-stage receiving set of the common commercial type stations were heard a thousand miles away. Code messages were received successfully, and weather reports reached the balloon regularly at noon and midnight.

through synchronized watches. Watch failure or an engineer's impatience often resulted in a head-on collision. Then came the telegraph and the red light and its resulting intermittent communication between dispatcher and engineer. As the air brake was perfected and speeds and weights were increased, the block signal system, and later the automatic interlocking signal system came into use, extending the intercommunication between dispatcher and train. Now comes the automatic train control to insure that engineers will do with their trains what the signals indicate they must do. Yet with the best of signal systems and the most reliable of automatic control the fact remains that a fallible human being is propelling an engine at tremendous speed with only intermittent communication with those who might warn him of danger or tell him why he should stop.

The use of radio would keep engineers and conductors in continuous touch with all stations on the right of way. Its installation by legal enactment is believed by many to be as inevitable as was that of the air brake, the block signal and now the automatic train control. Its coming seems to be only a matter of time.

Spreading the Gospel By Radio

CHURCH authorities have been quick to seize upon the radio as a medium for spreading Christian propaganda; presumably it is only a matter of a short time when the Jewish, Buddhist and other faiths will follow suit. The broadcasting of church services has already become a more-or-less fixed institution and no longer has elements of novelty except in its special applications; one of these comes from a church in Syracuse, whose pastor has just announced that all the

shut-in members of his congregation will be furnished with receiving sets at the church's expense, to enable his parishioners to listen-in on his weekly sermons that are broadcasted from station 8BNY. Still more recently comes the announcement that the station WJZ at Newark has undertaken to broadcast the Bible at the behest of the American Bible Society. Thousands will hear this new program.

Will the warfare between the various religious sects that have marked the history of the world be now lifted into the ether? Will the government authorities eventually have to step in to regulate proselyting?

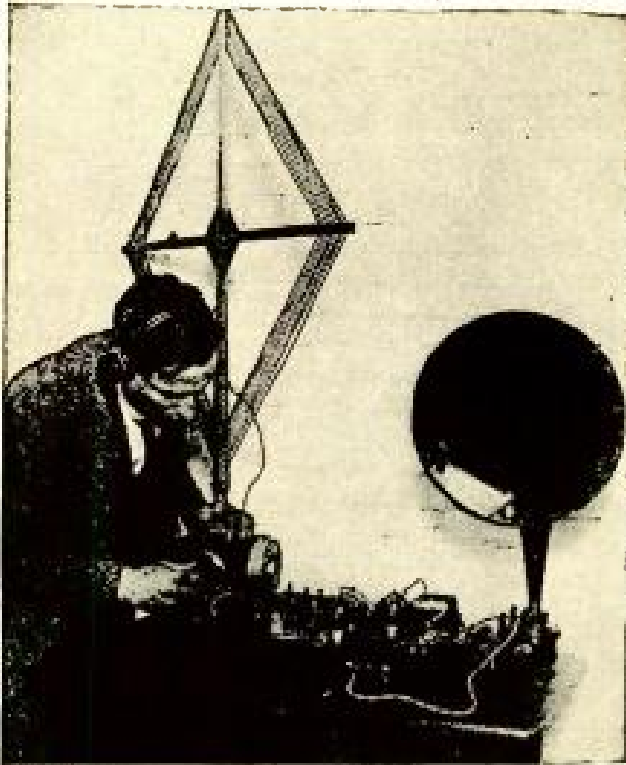

© Kadel & Herbert

AN AMAZING FEAT OF A RECEIVING SET

A remarkable demonstration of the impending development of receiving apparatus was recently given in New York by Edward H. Armstrong, the distinguished scientist. With a small loop antenna, his set gave results comparable with that of the common type of set connected to an outside antenna. Wonderful results were obtained with no antenna at all, and the interference from other stations and from static was practically eliminated. An extraordinary feature of the "super-regenerative circuit," as it is called, was the use of only three vacuum tubes, which gave the same amplification as the ordinary receiving set with nine tubes. In the course of his demonstration Mr. Armstrong filled the large auditorium with music from WJZ at Newark.

Radio Weather Signals Are Dimming the "Weather Eye"

ANOTHER charge may now be lodged against radio by the old-school romanticists—it is undermining the authority of the sea captains by taking away from them their traditional jobs of forecasting the weather.

The new order of things has just been inaugurated along the Pacific Coast, where definite and scientifically accurate data on weather conditions is broadcasted from Alaska to Mexico for the special benefit of mariners.

To the radio compass bearing service, established a year ago for the purpose of giving masters of vessels accurate compass bearings by radio, has been assigned the task of broadcasting the weather "dope" twice a day. The reports, originating in San Francisco at the Bureau of the Weather Department and sent out from the radio station at that point, are picked up and relayed by more than a score of other stations. The first report went out on a wavelength of 4659 meters; it was picked up at the naval radio station at the Los Angeles Submarine Base and was relayed to Alaska, British Columbia and Canadian points, Washington and Oregon; Honolulu also picked up the reports and broadcasted them to vessels within range of the Hawaiian station. A regular schedule has now been worked out; the morning bulletin is to be served daily at noon (75th meridian time) at a wavelength of 4650 meters C. W. The evening bulletin will be flashed at ten thirty at a wavelength of 1908 meters D. R.

The bulletins are divided into two parts and invariably begin with the letters USWB. The first part consists of surface weather conditions based upon observations taken at 8 A. M. and 8 P. M.; and of upper air observations taken in the afternoon of the date of distribution. The second part of the bulletins consists of synopses of general atmospheric pressure distribution.

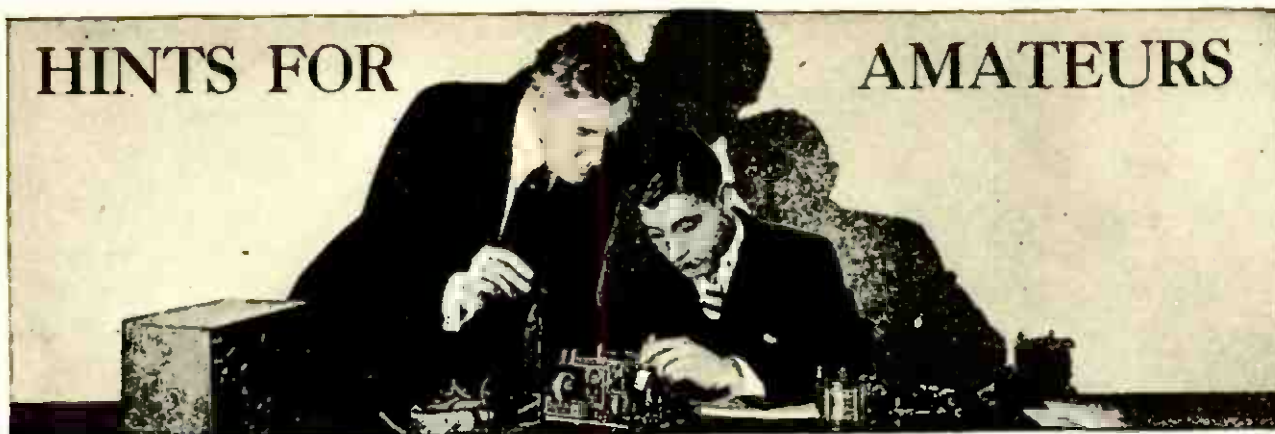

THERE are numerous ways of installing the antenna in the summer time when one is away in the country, but the method that first suggests itself, in case there is no tall building to hitch it to, is to fasten the antenna between two tall trees.

This is a good idea, even if many of us have tried it out with results that were not altogether satisfactory. That is because the tree in the summer has its veins filled with sap. The tree in this condition is in itself a veritable antenna.

If we install our receiving antenna close up to the branches of the tree, the tree will absorb the energy that would ordinarily be induced in the antenna, and the antenna would get little or none of its rightful electrical energy, and we would hear weak signals or no signals at all.

Keep your antenna at least ten to twenty feet away from trees or branches of trees. This may be done by fastening one end of a rope or wire of ten or twenty feet in length to the tree, and fastening the insulator on the other end of the rope. Then fasten the antenna wire to the insulator. Do the same thing on the other end of the antenna, and you have your antenna supported efficiently between the two trees without being close enough to the trees to sustain losses by absorption.

* * *

HONEYCOMB coils absorb moisture in damp weather, and this causes leakage. The coils may be dried out and made moisture-proof by immersion in melted paraffine until all bubbling has ceased. If the coil is of the unmounted type the ends

of the coil should be tied fast with a string, as the sealing wax that they are fastened with will melt in the paraffine and the coils will unwind unless the ends are tied.

* * *

KEEP your storage battery filled with distilled water so that the plates are always covered, and your battery will retain its charge longer and its life will be considerably lengthened. Do not add acid to your battery, as only the water evaporates.

* * *

WHEN you connect batteries to other radio instruments, you may avoid trouble if you take the following precautions: connect the wires first to the instruments in the proper way, and then when you are sure that everything is correct, connect one of the free ends of the wires to the correct terminal of the battery. Then take the remaining wire and quickly touch it to the remaining terminal of the battery. If the bulbs do not light up or if they light up too brilliantly for an instant, you know there is something wrong, but there will be no harm done. If you connect the battery first, the two free ends might touch together and cause a short circuit.

The same rule applies when disconnecting a battery from apparatus; disconnect the battery first and then disconnect the wires from the apparatus. This may be more easily remembered in the form of a rule: Do all your connecting and disconnecting of apparatus with no voltage on the apparatus.

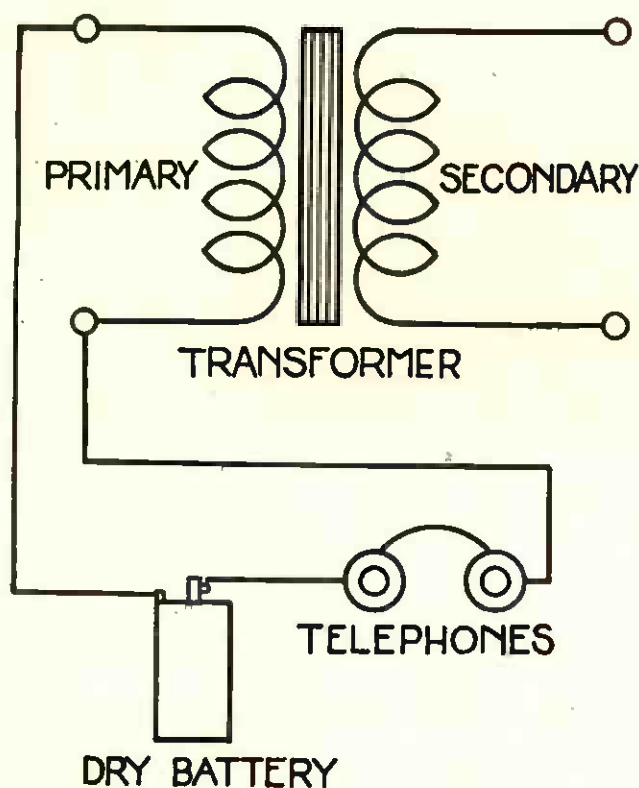

FIGURE 1

A circuit for testing an amplifying transformer for a burned-out winding. One of the wires leading to the windings is touched on the transformer terminal; if the winding is continuous a sharp click will be heard in the telephones.

A GRID leak may be made by cutting a piece of cardboard into a piece about one inch square, and covering it with a uniform layer of india ink. After it has dried, cut this piece in half and bore two holes in one of the pieces one half an inch apart. In these holes insert brass 6-32 machine screws, flat-headed, and fasten them tight with nuts on the other side. One screw will be one terminal and the other screw will be the other terminal of the grid leak, while the india ink will form the resistance. This resistance may be varied by cutting the strip narrower and narrower while listening after each cutting to see if the signals are getting weaker or stronger with the changes in resistance. A record may be kept of the different widths; then when the maximum results are recorded and further cutting begins to decrease the strength of signals, the second piece of cardboard may be cut to the correct size and the grid leak connected to the set for permanent use. The grid leak should

be connected either across the grid condenser, or from the grid of the tube to the negative filament connection.

* * *

A GOOD way to test out an amplifying transformer to find out if it is open-circuited, is to connect one end of the winding to one terminal of the head telephones. Then, with the telephones on the ears, touch the other terminal to a dry cell which is connected to the other end of the winding of the transformer. If the transformer winding is all right a clicking noise will be heard in the telephones. Then try the same thing with the secondary winding of the transformer. If no clicks are heard, one of the windings of the transformer is "open." A circuit for making this test is shown in Figure 1.

* * *

THE sensitivity of an audion tube sometimes may be increased by placing a large horse-shoe magnet in a certain position so that the poles of the magnet are on each side of the tube. This probably is due to the magnetic effect upon the moving electrons that flow across from the filament to the plate. The amateur experimenter will find this a good field for him to investigate as he may hit upon some new idea along this line that will be an improvement upon the present-day vacuum tube. Needless to say, if this should be the case, his fortune would be made.

* * *

A DETECTOR tube will not work efficiently as an amplifier, as it will not stand as high a plate voltage as the amplifier tubes. Its only point of difference from the amplifier tube is that it has not been evacuated to such a high degree of vacuum; some gases are allowed to remain in the tube. It is this gas that will not allow the application of a higher plate voltage, as the gas ionizes, and makes the tube steadily conductive from the filament to the plate. A blue glow can be seen in the tube when this takes place. Use an amplifier tube for amplification.

ADVENTURE IN THE AIR



WHAT is the biggest thrill YOU ever got over the radio? Have you ever picked up a call for help? Or located a lost friend—or helped to run down a fugitive, or listened in on a conversation of peculiar personal interest to yourself? For every anecdote, humorous or grave, ranging from 50 to 300 words in length, the Editor will pay upon acceptance. Address contributions to Editor, ADVENTURE IN THE AIR DEPARTMENT, 9 East 40th Street, New York City.

I Pick Up an Old Friend in Mid Ocean

WHY is it that such a large percentage of the "adventures" that reach the Editor come from operators who have been at sea? Perhaps because the call of the great waters is heard most keenly by those who are quickest to recognize an adventure when it comes their way.

All was quiet when I relieved the first operator at midnight. Only an occasional splash of static broke the stillness of the radio world on the Atlantic.

Shortly after one o'clock I heard a chap testing; apparently he was just putting in the time and listening to the noise of his own spark discharge.

For something to do, or maybe to assist in keeping awake in the course of my watch, I started up and called him, asking whither he was bound. He answered immediately and named a northern port. I had been there possibly half a hundred times and the name of that city called back many pleasant memories—for the girl lives there. It almost made me feel that the fellow was a friend of mine when he named his destination.

He was a beautiful sender and it was a pleasure to work with him. We became chummy in a radio way, and "o.m." (old man) occurred frequently in our exchange of commonplace words.

After we had talked a while, taking care to keep within regulation topics, he said; "Say o.m., your sending sounds familiar. What is your name?"

I told him, and I nearly fell out of the chair when he replied, "Well Holy Smoke! This is Henderson who sat behind you in High School

and who left with you from our home town to get our first ships."

You can imagine my surprise at "meeting up" with a friend I had not seen nor heard of for three years. I had tried to locate him but I could get no trace of him.

Two weeks later I received a letter from him, and the old friendship was renewed.

CANADIAN OPERATOR

Romance by Radio

AFTER reading the following item that came from Canada, the Editor understood why the contributor preferred to remain anonymous:

About a year ago a local station was giving concerts by radio. One evening, after a couple of selections (one of which was a solo by a young woman), the operator asked for some one who was listening in to give a report on the articulation. I called him up by phone and did so, after which I asked permission to speak to the young artist. My request was granted. She was a very nice young woman, and I was soon chatting with her with animation. I made her promise to sing for me by radio. But I had overlooked possible consequences.

After one or two selections the operator came to the radiophone and called me several times; he announced that Miss Blank would like to speak to me. She came to the transmitter and said twice:

"Hello 3XX; I am going to sing a love song for you."

There were half a dozen people in my station at the time, and I sought desperately to turn out the filaments, but they would not let me. I was too confused to catch the song, but my visitors were having a rare time at my expense. As soon as the last words of the song died away several spark stations opened

up with "Hi Hi" as a sort of grand finale. After the concert several stations called me and asked embarrassing questions.

The next morning when I went to the front door to pick up the morning paper, I found that some wag had written on the front of the house, in large characters, "3XX; I love you." The paper had an interesting account of the concert of the previous evening, and I read the cheering news that the program had been heard about 150 miles and by several thousand persons.

That cured me. The next time I do any flirting it will not be done by radio.

ANONYMOUS

The Shortest Long Distance Record

NOW and then some stations are given up by their owners and the calls are assigned to others who may be many miles away from the previous users. A fan who hears a call may therefore be misled as to its whereabouts in looking it up in the call-book—as in the following case:

A station in Washington was recently assigned an old call which we will designate as 3AB; it had previously belonged to a station at Norfolk, Virginia. Near to it is another station, which we will call 3BTD, which had just started up. The following communication was heard the other night when these two stations got in touch with each other:

3BTD: "Yes, your signals are coming in very strong, old man. How are mine?"

3AB: "Yours are coming in strong. Have you a telephone?" (3AB wanted to tell 3BTD that he was out of hours for local work.)

3BTD: "No, I have no telephone. This is ——— at ——— Street, Washington, D. C. Are you 3AB of Norfolk, Va.? Your signals come in steady and strong here."

3AB: "No, I am in the city. See you later; good-bye!"

These stations were so close together that if the operators had poked their heads out of their windows they could have carried out their conversation by shouting!

C. A. BRIGGS

Radio Traps a Thief

SOMETIMES the wireless has been used in unexpected ways—ways to which the underworld has not yet adapted itself. For instance:

For several years a department store organization that has one store in New York and another in Philadelphia handled much of the traf-

fic between the two stores by radio at a considerable saving in telegraph tolls.

One day I was calling on a friend at the office of the New York store. Word had just been sent up that a customer had charged to her account a valuable fur and wanted to leave the store with it at once. Because of the large amount involved, approval was desired by the salesman before the customer left the premises.

The credit man was consulted; at the same time a radiogram was filed to the Philadelphia credit department. The customer was kept waiting by various subterfuges on the part of the salesman. The true reason for the delay could not, of course, be given, for it might result in the loss of a valuable account.

The answer from Philadelphia came before the report from the credit office located on the same floor. A brief telephone conversation—and an indignant woman was ushered in, assisted by the strong arm of a detective. A messenger came in from the New York credit department and reported the account satisfactory. My friend smiled to me.

The woman had not counted on radio. The message revealed that the lady whose name was signed to the charge slip was at that moment in the Philadelphia store. Thanks to radio, a theft was prevented and a clever impostor exposed.

E. H. FELIX

Grandma Listens In

WHAT happens when an inexperienced hand tries to tune in on the receiver is told in this item that comes from Albany, New York:

Grandma made a startling discovery the other night. She had often taken the head phones to listen in on a broadcasted program, but she did not know what code signals sounded like.

My cousin Henry had just erected a station, and we were in communication with him for the first time. Grandma was much elated when I was actually talking to Henry through the air. Although his code signals were faint they were distinguishable, and I let Grandma take the phones to hear Henry for herself. She listened for some time but said she could hear nothing. I turned the knobs of my condenser and my variable inductance for better adjustment, but still she frowned. I concluded that the trouble was with her hearing, so I began to couple in a second vacuum valve to make the signals stronger.

As I went about finding the proper wires and connections, Grandma took it upon herself to turn the knob of the inductance, as she had seen me do. She tuned the set so broadly that dozens of stations could be heard.

"Ralph!" she exclaimed. "Someone is broadcasting a cat fight!"

RALPH SOMERS

Q The story of the first human being to receive and to send a radio signal—the pioneer scientist who ante-dated the great men whose names are household words today—will be told in the next number of POPULAR RADIO.

“WORKRITE RADIO PARTS WORKRITE”

These Standard High-Grade Instruments At New Low Prices

WorkRite Super Variometer

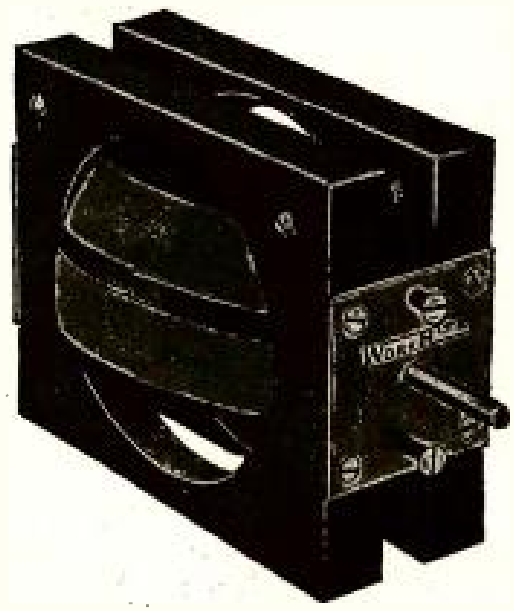

The WORKRITE VARIOMETER is made from finest quality mahogany and will not warp. Beautiful finish. Binding posts are placed between stators. Both connections made by double spring contacts. Has $\frac{1}{2}$ " shaft. All windings are perfectly made, and connections cleverly concealed. Easy to mount on panel with two screws furnished. All metal parts made from brass, highly polished and nicked. Substantially built throughout. Just the right number of turns and air space to make it very sensitive and to tune extremely sharp.

WORKRITE VARIOMETER packed in attractive box, \$5.25. With Dial, \$6.00.

WorkRite 180° Super Variocoupler

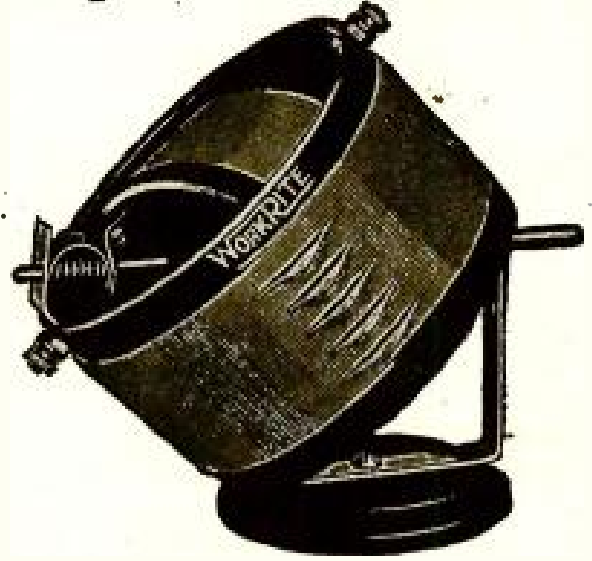

The WORKRITE VARIOCOUPLER represents perfection in getting all dimensions and number of wire turns just right. Tunes twice as sharp as the ordinary 90° coupler. Most any coupler will work, but few will "WorkRite."

Both primary and secondary are made from Formica. Contacts are formed by double springs, eliminating scratching noises. All metal parts are made from highly polished brass and nicked. Shaft $\frac{1}{2}$ ". Easy to mount on panel.

Leading radio engineers have pronounced WorkRite Variometers and Couplers the best they have ever tested.

WORKRITE VARIOCOUPLER packed in attractive box, \$5.00. With Dial, \$5.75.

WorkRite Super Rheostat

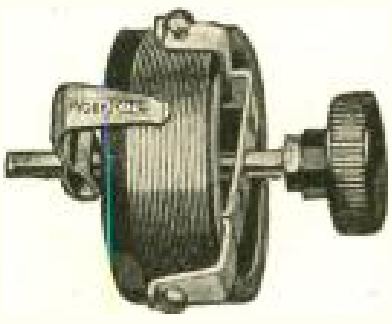

Here is a REAL Rheostat—something entirely new and very much needed. Can be instantly changed from $6\frac{1}{2}$ ohms resistance to zero by simply pushing in the knob, or you can have fifty thousand different adjustments by turning the knob. Any radio man can appreciate what this means on a detector tube when working on DX signals or concerts. All metal parts made from brass, nicked and highly polished. The special resistance wire is non-corrosive, non-rusting and does not change in resistance through change in temperature. Screws for mounting on panel furnished. The WorkRite Rheostat is really remarkable in its performance and is easily worth twice the price asked. No set should be without it. Price, \$1.50.

We also manufacture several other Radio Parts: Write for circular. Accept no substitutes for. "WORKRITES"

THE WORKRITE MFG. CO.

Main Office and Factory, 5522 EUCLID AVENUE, CLEVELAND, O.
Branch Office, 2204 MICHIGAN AVENUE, CHICAGO.

DE FOREST RADIO PARTS

For Those Who Build Their Own

De Forest Parts contain the same high quality and superior workmanship as are embodied in the well-known De Forest Radiophone* Receiving Sets. Insist upon De Forest when purchasing the following instruments:



"I'm Glad We Own A Radiophone"

Rheostats
Switches
Grid Leaks

Condensers
Coil Mountings
Duo-lateral Coils

Tube Receptacles
Crystal Detectors
Microphones

* Registered U. S. Pat. Off.

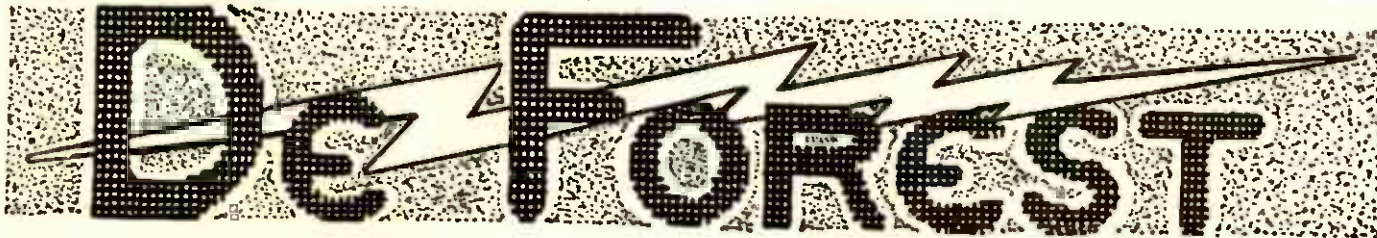

"Famous for Dependability"

DICTOGRAPH HEADSET



Look for the World-Famous Name "Dictograph"

ALL over the world "Dictograph" stands for the finest and most sensitive equipment made for transmitting and receiving sound.

The Dictograph Radio Head Set is the product of the same experience that has made the Detective Dictograph, the Acousticon for the Deaf and the Dictograph System of Telephones the world's standard for sensitive receiving, scientific accuracy and fine construction. Dictograph reputation is your guarantee of supreme quality.

The Dictograph Head Set improves any receiving set, whether Crystal Detector, Regenerative, or Non-Regenerative. Ask for it at your dealer's.

DICTOGRAPH PRODUCTS CORPORATION
220 West 42nd Street New York.
Ready soon—the Dictograph Radio Loud Speaker

3000 Ohms



Price \$12.00

NOVO "B" BATTERIES FOR RADIO

22½-45 & 105 VOLTS



NOISELESS
DEPENDABLE
GUARANTEED

ASK YOUR DEALER

NOVO, MANUFACTURING CO.
424-438 W. 33rd ST.
NEW YORK

531 SO. DEARBORN ST., CHICAGO.

RADIO

PARTS

CROSLEY

MANUFACTURING CO., CINCINNATI, O.

Improved Radio Units of proven efficiency and moderate price

Crosley Rheostats complete with knob, pointers, etc. Constructed for mounting on panels up to $\frac{3}{8}$ " in thickness—wound with non-corrosive resistance wire. 7 ohms resistance. Carries 1 ampere without heating. Suitable for detector and amplifier tubes. Price 60c.

Crosley Model "B" Variable Condenser is proving to be a much more efficient condenser than the plate type. Having no appreciable body or hand capacity it is easier to tune in C.W. and I.C.W. than with any other type. .0005 M.F. capacity. Size $1\frac{3}{8}$ " x $3\frac{3}{8}$ " x $3\frac{1}{2}$ ". Price without knob or dial, \$1.75.

Crosley V-T Socket

For all radio purposes, unbreakable—heavy porcelain. Bayonet catch deeply imbedded. Soldering irons will not melt. Base and panel mounting—an exclusive Crosley feature. Retail price, 60c.

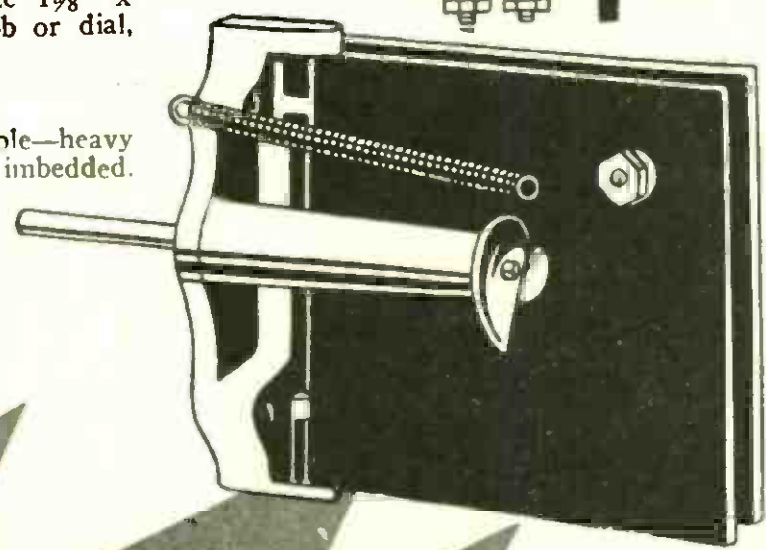
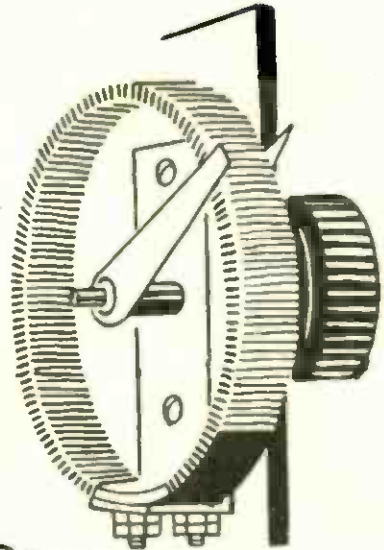

"Better costs less"

OTHER CROSLEY UNITS

- Transformers
- Vario Couplers
- Vario Meters
- Taps
- Switches
- Binding Posts
- Cabinets
- Batteries

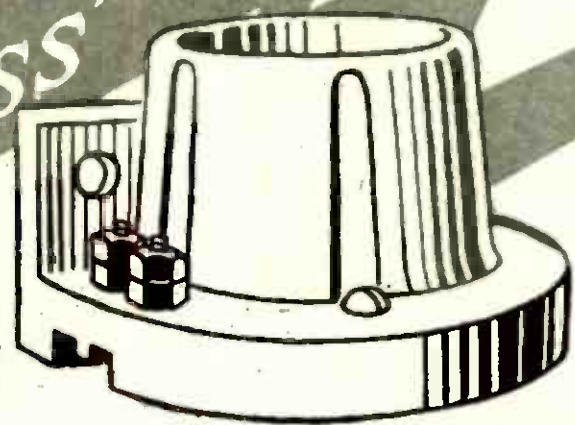

SEND FOR CATALOG PR-822

Illustrates and describes full Crosley line of Radio Receiving Apparatus and Radio Parts

Send for Catalog

Because You Hear With Both Ears



Two men talk to you at the same time. They utter the same words at exactly the same moment. Yet, because their voices are different you concentrate on the words of one.

So it is with an unbalanced radio headset. You concentrate on one of the two unequal telephones.

Because you have two ears, because it is better to use them both in listening to broadcasted music, Brandes Superior Headsets have *Matched-Tone* phones.

MATCHED-TONE is a trade-mark registered in the U. S. Patent Office

C. BRANDES, INC.

Wireless Headset Specialists

237 LAFAYETTE STREET

NEW YORK, N. Y.

RADIO INVENTIONS

WE shall be pleased to have you consult us with regard to patenting any new radio equipment which you may develop. Two members of our staff of attorneys, formerly with the Western Electric Company, specialize in patents relating to the radio art.

Office consultation particularly invited.

MUNN & COMPANY

634 Woolworth Building . . . New York City
Hanna Building . . . Cleveland, Ohio
Tower Building . . . Chicago, Ill.
Scientific American Bldg., Washington, D. C.
Hobart Building . . . San Francisco, Calif.

Variable Condensers

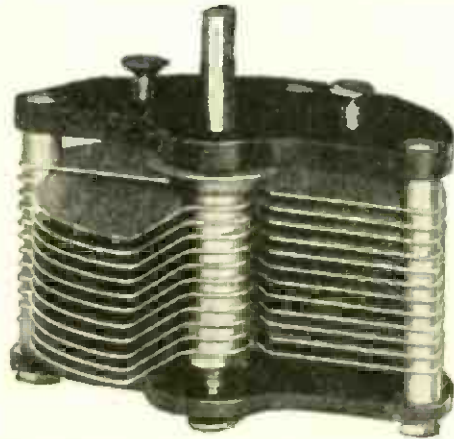

Variable condensers to be efficient must be well made. Loose joints or faulty construction soon allows the plates to get out of alignment and decrease their efficiency. A seasoned organization backed by a half million dollar equipment have placed the United Condensers in the front rank with radio engineers the country over.

| | |
|---------------------------|--------|
| Prices—43 plate | \$4.50 |
| 23 plate | 4.30 |
| 11 plate | 4.00 |

without dial or knob.

Liberal discounts to jobbers and dealers.

We invite correspondence with Radio Manufacturers who are interested in using our facilities and services for manufacturing Radio Equipment.

United Manufacturing and Distributing Company

536 Lake Shore Drive

Chicago, Ill.



"Stop those back fence concerts"

THE yowls of a prowling Tommy are as mere love-songs beside the ear-splitting howls of a perturbed radio set (and you'll be surprised how often one gets perturbed without the calming influence of the proper Amplifying Transformer).

Most any transformer can amplify sound, but it will also amplify the stray fields which produce howling and distortion. It takes the Acme Amplifying Transformer with its specially constructed iron core and coil to put an end to the "back-fence" concerts. Only when you add the Acme do you get the realistic tone and volume so markedly absent in the ordinary radio receiving set.

The Acme Radio Frequency Transformer greatly increases the range of any receiving set, either vacuum

tube or crystal detector type. The Acme Audio Frequency Transformer produces not only volume, but reality of tone. It is indispensable to the satisfactory operation of loud speaking devices. The combination of one or more stages of Acme Radio and Audio Frequency Transformers assures the maximum of range, of volume and of reality in tone.

The Acme Apparatus Company, pioneer radio engineers and manufacturers, have perfected not only Radio and Audio Frequency Transformers as well as other receiver units and sets, but are recognized as the foremost manufacturers of Transmitting Apparatus for amateur purposes. Sold only at the best radio stores. The Acme Apparatus Company, Cambridge, Mass., U. S. A. New York Sales Office, 1270 Broadway.

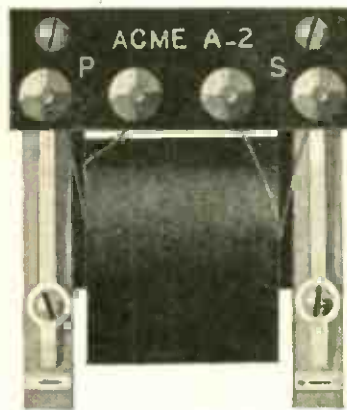

Type A-2 Acme Amplifying Transformer, price \$5 (East of Rocky Mountains)

ACME

for amplification

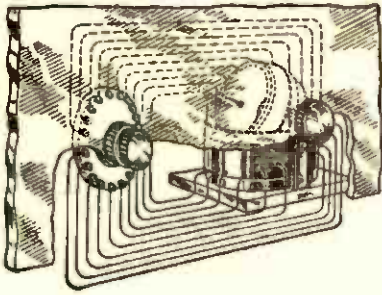

Installation with Variocoupler

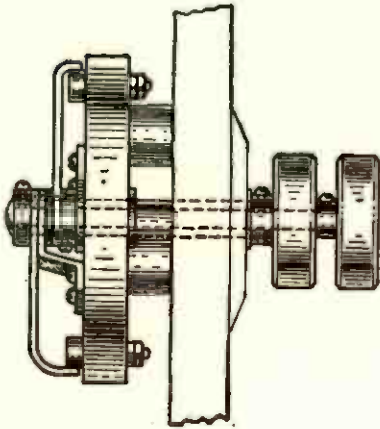

Side view showing mounting on panel

SELECTOR

A selective radio contact switch. For varying the number of turns in any kind of radio tuning coil.

The SELECTOR can be mounted on coupler or coil direct, thus reducing leads to a minimum. Short leads and positive contact in radio instrument wiring are not only necessary, but are imperative for highest efficiency.

The SELECTOR combines these essential features and in addition is compact, positive, and will give that commercial appearance to your panel.

Price \$4.25 Postpaid

Norris Electric Specialties Co.

Incorporated

126 Liberty Street, New York

TELEPHONE RECTOR 6669



**Wire This Receiving
Set Yourself And Save From
\$25 to \$35**

When the parts listed below have been connected, you will own a vacuum tube detector and 2-step amplification receiving set which will equal those retailing at \$70 or more.

- | | |
|---------------------------------|----------------------|
| 1 Mahogany Cabinet 27 1/2" x 9" | 3 Klossner Rheostats |
| 1 Hard Rubber Panel (Drilled) | 1 3-Coil Mounting |
| 1 Grid Leak & Condenser | 3 Honeycomb Coils |
| 1 .001 Mfd. Condenser | 3 Standard Sockets |
| 1 .0005 Mfd. Condenser | 2 3 1/2-inch Dials |
| 1 Single Jack | 10 Binding Posts |
| 1 Double Jack | All Wire |
| 2 Acme Transformers | |

Price \$46.00

Send your name and address to us and we will send you these assembled parts C. O. D., with the understanding that you may return them to us within 10 days if unsatisfactory.

STAR RADIO CORPORATION
2510-A Grand Concourse New York City

Positive Contact **KAPACITON** Permanent Capacity
COMPRESSED, BAKED, SEALED
INDIVIDUALLY TESTED
KONDENSERS
ARE BETTER CONDENSERS!

Phone Grid*. Grid with fixed leak. Grid with detachable and variable leak (Pat. Pen.). All capacities

Indeed, We Do

make a *good* condenser, a *bully good* one, we mean—an engineering product, not a toy. The best of that type that's made now, if you'll let's be personal. **AND WHEN BETTER ONES ARE MADE, WE'LL MAKE THEM.**

EQUIP WITH KAPACITONS

You'll Find They Are

SOLD BY THE BEST JOBBERS AND DEALERS!

Meironsky

ESTABLISHED 1910

JERSEY CITY, N. J.



Radio Dealers:

Here's your magazine. RADIO MERCHANDISING concerns itself only with the problems of the manufacturer, distributor and dealer. It does not attempt to cover "fan" interest except from the dealer viewpoint. With a corps of several hundred correspondents covering every important city in the United States, comprehensive market reports will be maintained in the offices of the publication which will show the available market in any particular territory. This service will be of the greatest possible value to the executives of manufacturing concerns and will aid them in pre-determining the points of absorption for their products.

Regular Departments

Sales Help for the Dealer
 New Apparatus and Supplies
 Men of the Industry
 Field Correspondence
 Territorial Report
 General News of Dealer Interest
 Buyers' Guide

Special Features

What Is a Radio Retail Stock?
 Store Signs and Window Displays
 Dealers as Radio Fans
 How Long Will it Last?
 Boy Buyers of Radio
 How Shall the Electrical Store Meet Competition?
 Radio and the Musical Dealer

RADIO MERCHANDISING IS PUBLISHED TWICE A MONTH. NO LIVE DEALER OR DISTRIBUTOR CAN AFFORD TO MISS A COPY

(Tear coupon off here and mail today)

Radio Merchandising,
 342 Madison Avenue, New York

Enclosed please find \$3.00 for which enter my subscription to Radio Merchandising for one year.

Name

Address

Trade Mark **BKUMA YRLSBUG** Reg. Ap. For

Attentive Beginners Who Use

Dodge One Dollar Radio Short Cut

Do Arrive

HONOR ROLL giving Names, Addresses, Radio Calls, of Beginners who mastered Code in 30 minutes to 2 hours and now hold licenses as Radio Operators mailed free on request.

Mail to

C. K. DODGE, DEPT. B, MAMARONECK, N. Y.

JOY-KELSEY CORPORATION
Manufacturers
RADIO EQUIPMENT
4021 West Kinzie St. Chicago Ill.

CUSTOM TAILOR MADE
TO FIT YOUR INDIVIDUAL CAR



Made in our custom shops after your order is received. We ship ordinarily in 2 or 3 days. Perfect fit guaranteed when correct name, year and model of car is given. You can easily apply it yourself. We furnish instructions and all necessary tacks, welts and fasteners.

\$4.00 and up
Parcels Post Paid

Our Catalog No. 10, with samples, is free for the asking.

LIBERTY TOP & TIRE CO., Dept. R-4, Cincinnati, O.

SEND FOR THE INTERNATIONAL CATALOG
Factory to Consumer direct— **PAY ONLY ONE PROFIT**



Our net price list of auto bodies and body supplies at Wholesale Prices. Save big money by buying Direct from Factory

For Ford and Chevrolet, Dodge, Maxwell, and Overland Four—prices from \$27.85 up

International Body Works 914 W. Ohio St., Chicago, Ill. Dept. 11

AUTO-OWNERS WANTED



To introduce the best automobile tires in the world. Made under our new and exclusive **Internal Hydraulic Expansion Process** that eliminates **Blow-out—Stone-Bruise—Rim-Cut** and enables us to sell our tires under a

10,000 Mile Guarantee

We want an agent in every community to use and introduce these wonderful tires at our astonishingly low prices to all motor car owners. Write for booklet describing this new process and explaining our amazing introductory offer to owner agents.

Hydro-United Tire Co.
Dept. 247—Chicago San Francisco Pittsburg, Pa.

Speed Up Your Production

by sawing bakelite, formica, brass, copper, carbon, or wood on a

Junior Bench Saw



A precision machine especially adapted to the rapid and accurate production of small duplicate parts. All metal construction. Top 10" x 13", elevates for grooving, tilts 10 degrees for beveling. Saws 1 1/2" stock. Easily driven by 1/4 hp. or 1/2 hp. motor. Attachments for grinding and sanding. Special saws for bakelite, brass, etc., furnished from stock. **\$28.75**

Junior Bench Saw with guides and one 6" wood saw \$60.00. Motor Driven Unit as shown, mounted on iron base with 1/4 hp. ball-bearing motor, belt tightener, belt, cord, plug, and switch, \$60.00. Write for fully illustrated circular.

Manufacturers and amateurs will be interested in our Handlathes, Junior Bench Drill, Handisaw and Ball-Bearing Motors.

W. & J. BOICE, Dept. 608, 114-23rd ST., TOLEDO, OHIO



Solder Your Connections

for best results. Get the "Wonder" a Self Heating Iron. Use it anywhere without stove. No workshop complete without it. Cheap to operate. Generates own vapor in two minutes. Absolutely safe — a child can operate. Nothing to get out of order. Use it as a blow torch also. Boxed complete with solder, salomoniac and full soldering directions. **Send No Money** — just your name and address on a post card. When the postman delivers, pay him \$2.50.

Dealers—a big seller, write for proposition.

North Shore Radio Works, Dept. C-605
810 Davis Street, Evanston, Ill.

MYERS WONDERFUL SEWING AWL

TOOLS IN HANDLE



The Awl For All

A complete repair shop in itself. Sews anything heavy or light, leather shoes, harness, buggy tops, canvas, belts, etc. **\$1.00 Postpaid.**

C. A. MYERS COMPANY, 6345 Woodlawn Ave., Chicago, Ill.

Of Immediate Importance to Advertisers

These Temporary Rates of

| | |
|----------|----------------|
| \$120.00 | a page |
| 65.00 | a half page |
| 35.00 | a quarter page |
| .70 | an agate line |

were based on an estimated sale of 50,000 copies.

By the time the June issue went to press the print order had been successively increased to 150,000. For July the edition was more than 175,000. But—until the new rate card is actually in the mails, the publishers must accept, at the above rates, all advertising we offer them. In the meantime, we believe advertisers who contract for space will buy on a rising market of exceptional strength.

POPULAR RADIO

Represented by

E. R. CROWE & CO., Inc.
9 East Fortieth Street New York
A. B. DeLACY
in charge of advertising

The Man-Day Circuit is covered by Patents Pending

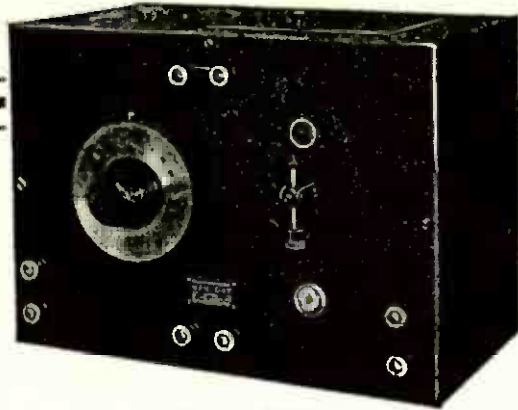

The Man-Day Circuit is covered by Patents Pending

Type CDR-1

The Man-Day Radio

is called by those who know most about radio the "greatest receiver in existence," yet it is only \$25.00.

GREAT advances have been made in radio in the last few months, but none more important or impressive than the Man-Day. The big advance step in the Man-Day is its circuit—a circuit which is responsible for the sensitiveness and sharpness of this receiving set. Our rectifying mineral has 93% to 95% rectification properties compared to galena with 65% to 70%. It has never been available for amateur use. The U. S., British and Canadian governments have paid from \$37.50 to \$50.00 for each crystal alone, since 1911—they used padlocks on their sets. It cannot burn out and is set in—not removable. Extra Minerals \$2.50.

Type CDR-1 is a complete Man-Day Radio outfit, *guaranteed to receive clearly 35 miles from the larger broadcasting stations.*

This receiving outfit is mounted in an open top cabinet. We invite your inspection. Bakelite Panel, satin finish, with push-button for buzzer, handsome hand-rubbed cabinet. Price \$25.00.

- Pittsburgh 360 miles**
- Schenectady 155 miles**

Our MDA-1 detector and amplifier with Jack control can be added at any time and increased range guaranteed about 4 to 8 times.

At our branch and experimental station at Lynbrook, L. I., on a 65-foot aerial and CDR-1 tuner, we receive from the following stations consistently:

- Deal Beach 36 miles**
- WJZ Newark 28 miles**

You can readily see that our guarantee of 35 miles will be far exceeded.

Type TRB-1 is a tube receiver efficient as the CDR-1, but requires only the turning up of the tube for reception. Price \$38.00.

Type MDA-2 is a 2 step Jack control amplifier to match TRB-1 receiver. Reception up to 500 miles with this combination. Price \$48.00.

Type MDA-1 is a detector and 1 stage amplifier built identical to our other units. Jack control. Price \$38.00.

Liberal discounts to dealers and jobbers off the list prices.

MAN-DAY RADIO CORPORATION

135 West 33rd Street, New York City

Lynbrook, L. I.
New York

190 St. Catherine West
Montreal, Canada

POPULAR RADIO INSTITUTE

Radio equipment of manufacturers is now being tested and approved by the

POPULAR RADIO INSTITUTE
9 EAST FORTIETH STREET
NEW YORK

All equipment submitted is tested as promptly as possible and returned to sender with Institute report. There is no charge for the report, but transportation costs must be paid by the manufacturer.

A list of manufacturers whose equipment has been approved will be published in an early issue of **POPULAR RADIO**.

RAND McNALLY

RADIO MAP OF UNITED STATES

COMPLETE — COMPREHENSIVE — ACCURATE

A MAP of the United States showing the Government Radio Stations, the Broadcasting Stations and the Commercial Radio Stations by distinctive symbols. The call letters of each station are given, also the wave lengths of each. The Radio Districts are shown with their numbers.

Alphabetical lists of stations and alphabetical lists of call letters are included.

Extracts of the Radio Communication Laws of the United States are printed on the reverse side, also other information of general interest.

A thorough knowledge regarding the stations now operating will increase the pleasure derived from your activities in Radio. This map is an essential item of the equipment of everyone now interested in Radio.

The Rand McNally Radio Map of the United States is 27x26 inches in size, printed in colors and folded to convenient pocket form with attractive cover.

Price 35c Each

Sold by Dealers or supplied direct upon receipt of remittance.

DEALERS: Send for sample on your letterhead and request details of our proposition. The Rand McNally Radio Map will prove a valuable addition to your stock of Radio Supplies.

Rand McNally & Company

NEW YORK
42 E. 22nd Street

Map Headquarters

CHICAGO
536 S. Clark Street

Now Ready—A Loud Speaker That Is a Loud Speaker

Made by the makers of the celebrated Callophone loud speakers, used in offices and factories many years before there was any broadcasting.

CALLOPHONE
REG. U. S. PAT. OFFICE

Radio Products

Specially adapted to amateur radio work giving perfect tone quality and surprising volume. Will easily fill a large room or hall. Operates on one, two or three stages of amplification.

Not to be confused with loud speakers which are merely a head phone with a horn, this instrument is specially designed, patented and built for loud reproduction. Solid mahogany piano-finished base, perfect modulating horn, complete with flexible cable ready to connect, requiring no separate battery or attachments.

See it.—Hear it! You will not realize the full possibilities of a real loud speaker until you hear the Callophone.

*Leading dealers everywhere
are ordering rapidly.*

**Callophone
Radio Products**
151 Grand Street
New York

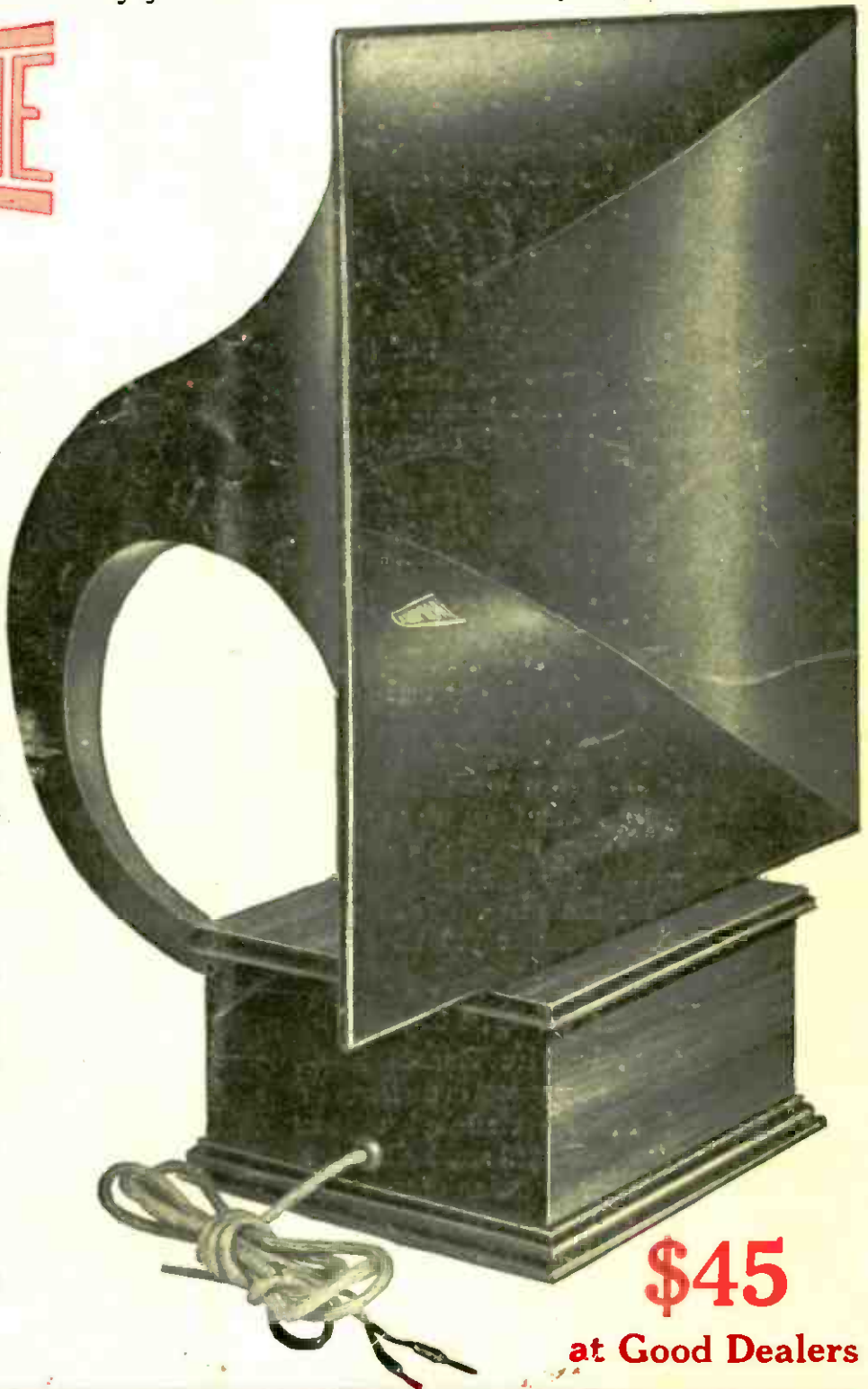

\$45

at Good Dealers