

PRICE 10 CENTS

IN THIS ISSUE

INVENTIONS OF EDISON
ELECTRIC LIGHTS AND MODEST PURSES

POPULAR ELECTRICITY

Trade Mark

IN PLAIN ENGLISH

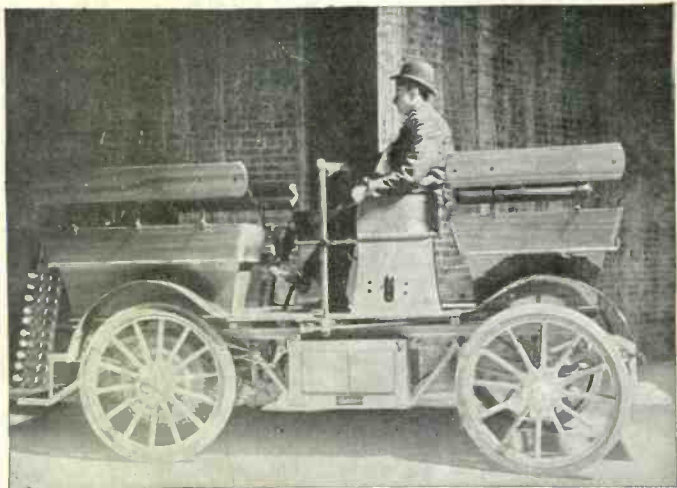

Copyright, 1909, by Waldor Fa-bett

CHAUFFEUR TO THE SENATE

Vol. II.

MAY 1909

No. 1.



\$410.00 BUYS ALL THE MATERIAL IN THIS BARN

An illustration from our "Book of Plans"

A modern up-to-date barn, one of many illustrated and fully described in our free "Book of Plans." It can be readily constructed by an ordinary mechanic with the aid of our simple plans & specifications, furnished free of charge. In referring to this design mention "J F 1."

Building Material Greatest Offer

EVER PUBLISHED!

FREE BUILDING HOUSE AND BARN PLANS!

The Chicago House Wrecking Co. is the most wonderful institution in the world. We offer you an opportunity to make an enormous saving in the purchase of building material and supplies of every kind. Read our new 1909 offer carefully. It is something that every man with an immediate or prospective building idea must carefully consider. We say that, quality considered, we can undersell any concern in existence on any lumber or building material needed for construction of any house or building.

100,000,000 Feet of New Lumber at Wrecking Prices!

We purchased direct from the Mills, at various Forced Sales, thousands of carloads of high-grade, first-class, brand new Lumber. We bought it at sacrifice prices and we are offering it for sale at a reasonable margin of profit. This is an opportunity of a lifetime to buy the very best Lumber manufactured at prices less than the dealer or jobber can ordinarily buy it for.

As to quality, rest assured nothing better is manufactured. Don't listen to what unscrupulous dealers may tell you. Our material is guaranteed to be clean, new, fresh lumber — not wrecked material in any sense of the word — just as good as you can buy anywhere and it is sold under a positive, binding guarantee that protects you absolutely.

We don't ask for money in advance. You can buy it without sending one cent of money with your order. All we require is a guarantee as to your responsibility. Money refunded if material is contrary to our representation. We have a capital stock and surplus of over \$1,000,000.00. We refer you to any bank or banker anywhere. Or you can write direct to the Great Stock Yards Bank, The Drovers Deposit National Bank of Chicago.

\$650 Buys all the Material to Build This House!



THIS IS AN EXACT PHOTOGRAPH OF OUR WONDERFUL \$650 HOME. That means we will furnish you all the Lumber and Building Material needed to construct it. Write for our "Book of Plans," which gives details showing exactly which material is furnished. Mention Design "J F 5." This is only one of many other designs shown in our grand "Book of Plans."

NOTE THE PRICES!

Red Cedar Shingles	\$3.00
White Pine L'th	
No. 1—32-in..	1.75
Roof Sheathing	14.50
2x6—12 ft.....	15.50
4-in. White Pine	
Lap Siding...	16.50
4-in. Flooring..	16.00
Pt. Sh'th'g L'th	16.00
Fencing, 6-in..	18.00
2x6—22 ft.....	19.00
Ceiling, 5/8x4-in	14.50
2x8—18 ft.....	19.00
Drop Siding....	16.00
2x10—12 ft....	18.00
2x12—20 ft....	19.50
Barn Boards...	19.50
Cl'r 1/4 S. Flo'r'g	30.00
Ye'll w P'pr Sid.	15.00

¶ Prices are, per thousand, in carload shipments only, F. O. B. Chicago, for 30 days only. All material guaranteed new.

Send Us Your Lumber Bill for Our Estimate!

¶ We urge you to send us your carpenter's bill for our estimate. Have him make up a list of every single item you will need and send it to us. We guarantee to go over it carefully and itemize it fully and to send you a clear concise statement of just what we will furnish and the prices will be so low as to secure your order. You can include in your list of material everything needed; that means even plumbing and heating material, furniture, rugs, etc.

FREIGHT PREPAID OFFER

¶ We make our quotations Freight Prepaid. That means delivered free of all charges to your railroad shipping point. No trouble with the Railroad Companies for you. We assume every possible risk. We guarantee safe, sound and prompt delivery and if any material reaches destination damaged, we make good at once and assume all your claims against the Railroad Co.

NOTE THE PRICES!

Barn Sash.....	\$ 0.36
Storm Sash.....	.70
Stall Sash.....	.21
Hot Bed Sash..	1.55
Windows.....	.50
Panel Doors....	.50
Window Frames	1.25
Door Frames...	.50
Base Angles...	.02
Corner Blocks..	.02
Base Blocks....	.03 1/2
Stair Rails.....	.07
Porch Balusters	.05
Porch Rail.....	.03
Cottage Wind's.	3.52
Porch Columns.	.65
Blinds.....	.66
Porch Brackets	.06
H'd w'd Mantels	5.00

¶ Prices are subject to quick acceptance, and all material guaranteed brand new, standard grade and quality.

Send for Our Free Catalog No. 891

We publish a book of some 500 pages, containing a general record of our goods and showing millions of dollars worth of merchandise secured by us at Sheriff's Sales, Receivers' Sales and Manufacturers' Sales. It lists Building Material and Supplies, Machinery, Hoop and Wire, Structural Material, Hardware of all kinds, Furniture and Office Fixtures, Belting and Rubber Hose, Plumbing and Heating Apparatus, Pipe, Valves and Fittings, Wire and Manila Rope, Electrical Apparatus, Safes and Vault Doors, Tanks, etc., etc.

In addition to this General Catalog we publish a "Book of Plans," It shows illustrations of modern houses and barns; gives illustrations from life as well as floor plans; it explains our unique offer to furnish all material needed to construct any buildings shown in our book. You can get a complete set of plans, specifications and bill of material for \$2.00. Or, furnished free with your order. We also publish a Furniture Catalog showing handsome designs in Household Goods, Furniture and Office Supplies. Write us your wants. We can save you big money. We illustrate rugs, carpets and linoleum in exact colors. Ask for Catalog No. 891. We have an immense stock of Imported Oriental Rugs. Write for prices.

CHICAGO HOUSE WRECKING CO., 35th & Iron Streets, CHICAGO

CHICAGO HOUSE WRECKING CO., CHICAGO

Send me free of all cost your Wonderful Catalog and Building Offer, as advertised, I saw your advertisement in Pop. Electricity

Name.....

Town.....

County..... State.....

R. F. D. No. 539

17 JEWEL \$14.50 ON ELGIN 14 - CREDIT



WRITE TODAY for our Big Free Watch Catalog. It tells all about our Easy Credit Plan and how we send Elgin 19 Jewel B. W. Paymoud and 21 and 23 Jewel Elgin Veritas everywhere on Free Trial without security or one cent deposit. **Positive'y Guaranteed** to pass any Railroad Inspection.

Let me send you this High-Grade, Genuine Elgin 17-Jewel Watch in Hand Engraved Case on Free Trial

This watch has 17 genuine ruby jewels, micrometric regulator, patent Breguet hairspring; is Factory tested, finely finished throughout and regulated to the second.

P. S. HARRIS,
President Harris-Goar Company.
Mr. Harris and the Harris-Goar Co. are well known to the publishers of this magazine and we take pleasure in recommending them.—Publishers.

Its Our Big Special this month at \$14.50

We ask no security and no interest—just plain honesty among men. Our Elgin Watches are so well known and our CREDIT PLAN so Easy, Simple and Fair, that no matter where you live or how small your wages, we will trust you, so that you and every honest man and woman can own a High-Grade Elgin Watch in a beautiful Guaranteed 25-year Gold Case and wear it while paying for it in such small payments that you never miss the money.

Every Watch Sent Prepaid NO MONEY DOWN

You assume no risk whatever in dealing with us, because before you buy or pay one cent, we place the watch right in your own hands and let it do its own talking. Elgin Watches are made strong and accurate. They will stand hard usage and last a lifetime. This is the reason we can send them on approval and Guarantee Safe Delivery. If we were handling a flimsy, off-brand watch we could not make this guarantee and sell them on credit.

You cannot afford to buy an Unknown, Off-Brand Watch at all!

You cannot afford to buy a watch of any kind until you have our Catalog and Prices, for we are the LARGEST WATCH HOUSE IN AMERICA.

We Sell Only Genuine Elgin Watches, and our Catalog contains the True Factory Description of every High-Grade Elgin Watch made. It is Free.

BARGAINS FOR WOMEN

EVERY woman should send for our Free Catalog, because it will pay you to have our Prices and Easy Credit Plan. It enables you to buy Diamonds, Watches, Solid Gold Jewelry, Silverware, etc. and pay for them out of your pin money. **Write Today for Catalog. Do it now!**

HARRIS-GOAR CO.

Just Your Name and Address on a Postal or the COUPON

will bring you our **BIG FREE CATALOG** and a photograph and history of the Elgin Factory, the Largest in the World.

HARRIS-GOAR Co.,

1231 GRAND AVENUE,
KANSAS CITY, MO.

JUST YOUR NAME AND ADDRESS WILL DO.
HARRIS-GOAR CO., 1231 Grand Avenue Kansas City, Mo.
Please send me your Free Catalog of Elgin Watches and I will include facts on Elgin Watches. Also your Easy Credit Plan of buying Elgin Watches No Money Down, \$2.00 a Month.

NAME _____
POST OFFICE _____
STATE _____
R. F. D. _____

POPULAR ELECTRICITY

THE BABY TORCH

The Smallest, Most Compact, Durable and Efficient Torch Made

Electricians, Bell Hangers, Automobilists, Machinists, Dentists, Chemists, Plumbers, Engineers, Locksmiths, Telephone Repair Men, Telegraph Repair Men, Bicycle Repair Men.

It is scientifically constructed of the best materials obtainable to meet the demand for a truly efficient tool bag torch. It is small and portable but does its work as well as the largest, most elaborate torch made. **Tank is only 3 inches high and 2 inches in diameter.**

Lights with a match. Burns without Air Pressure. No pump or other complicated part to get out of order, become worn, or be replaced. If you use any kind of a blow-pipe flame you need a "BABY TORCH." Sent Postpaid \$1.25.

Throws a
four inch
Flame.



H. W. HARROLD,

Valparaiso, Ind.

FOLLOW THE POINTERS

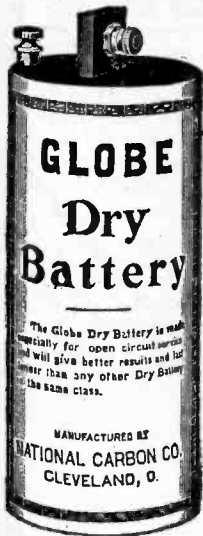

If you want the BEST low price dry cell made for

Electric Bells, Annunciators, Gas Lighters, Operating Small Motors, etc.

Price in lots of 12 or more 13½¢ each

If you are carrying on experiments in which wet or dry cells have to be used our Battery catalog will prove of interest. Sent Free to all who mention this publication.

**NATIONAL CARBON CO.
CLEVELAND, OHIO**

For our Mutual Advantage mention Popular Electricity when writing to Advertisers.

ONE YEAR FREE

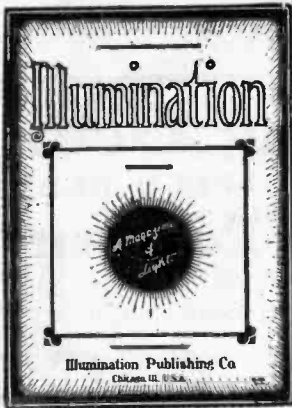

YOU are interested in light or you would not be reader of "Popular Electricity."

YOU want to gather as much valuable information in connection with the subject as you can.

YOU want to keep in touch with every branch of the lighting industry, learn as many new things about it and get as many new ideas as possible.

"ILLUMINATION" is devoted exclusively to the subject of light, its production, distribution, sale and use. It is the one magazine in which you can get all of the news of every branch of the industry, read the thoughts of the men who are leaders in every department of the business and keep in touch with the progress of the world pertaining to light.

WE WILL SEND YOU "ILLUMINATION" FREE

for one whole year if you will get two of your friends to subscribe at 50c a year. Send a one dollar bill with the names and addresses of two others besides yourself and we will enter the three subscriptions for one year each.

OR we will give YOU three years subscription to your address for \$1.

REMEMBER that "ILLUMINATION" costs 10c per single copy and is a **monthly** publication. This is a proposition you cannot afford to let slip.

ACT NOW, before you lay this magazine down.

ILLUMINATION PUBLISHING CO.
324 DEARBORN STREET, CHICAGO

Liberal commissions paid agents in all parts of the country. Secure good territory for yourself before it is all assigned.

S. P. E.
ILLUMINATION,
Chicago

Please send me your magazine to the address below for three years, for which I agree to pay you \$1.

Name.....
Street No.....
Town.....
State.....
Firm.....
Position.....

POPULAR ELECTRICITY

THE
OK

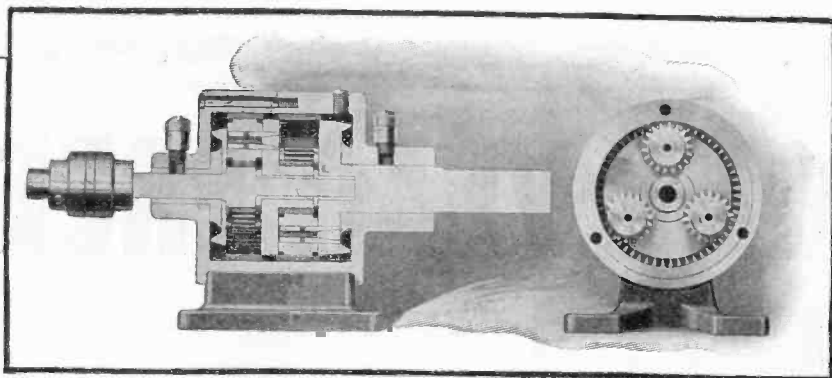

THE
OK

Speed Reducing Gear

A COMBINATION COUPLING AND SPEED REDUCER

Efficiency Over 90 Per Cent

1-8 H. P. to 50 H. P.

Write us your wants and let us tell you more about it

D. O. JAMES & CO.

351 W. Monroe Street, Chicago

The Del Electric Curling Iron



¶ A new and practical electrically heated device for curling the hair. The only electric curling iron that will produce marcel, pompadour, puff and wave effects. ¶ This iron is self contained—requiring no separate device for heating, thereby insuring absolute cleanliness. ¶ Attaches to any lamp socket by means of cord and plug. ¶ When the iron is sufficiently hot, turn off the current, the cord may be detached and the iron will remain hot for some time. This leaves you free to act without chance of the cord getting in your way. Will be found most convenient when traveling.

Price, \$3.75 complete.

SOLD BY ALL FIRST-CLASS
DEALERS

Del Sales Company, ⁹⁸ Jackson Blvd. Chicago

For our Mutual Advantage mention Popular Electricity when writing to Advertisers.

DIM-A-LITE

Gives a
**High, Low or Medium
 Light**
 as desired



THE DIM-A-LITE is not a lamp that will burn out and have to be replaced, but a plug device that will last as long as any socket. Easy to attach—merely screw it into the socket like a lamp and screw any standard Edison base lamp into it. At the low position it **REDUCES CURRENT 70%** and at the medium position 20%. A light saver for any room.

PRICES:

Gun Metal	\$1.00
Brush Brass or	} . . \$1.25
Oxidized Copper	

Postage Prepaid.

**FEDERAL
 ELECTRIC COMPANY**
 124 W. Lake St., Chicago

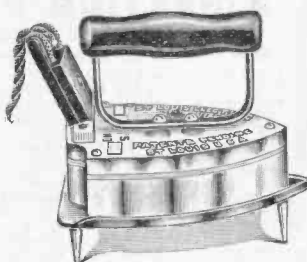

OUR No. 305, 6-LB. STANDARD.

The Peacemaker

Model for 1909 is a beauty. It will sell. The style, finish, balance and workmanship are perfect. Its service satisfactory to the most critical and exacting.

When an Electric Iron has met the requirements of the Commercial Laundry and the Factory, as the **PEACEMAKER** has, it will satisfy the demands of all users.

The tests made of the **PEACEMAKER**, have been the nine hours a day—constant use—heavy work tests; where solid strength, endurance, efficiency and economy had to be combined to cover the need.

All of these have been met; not for a short time, but for so long a time that a new record has been made in the life of Electric Sad-Irons.

Write and let us show you what the users say.

The largest Laundries of the Middle West say: "*It is the most satisfactory, the most durable and most economical we have ever used, and we have tried every leading make.*"

The largest Clothing Factory west of the Mississippi River says: "*It is the only Electric Iron that we ever tried that got hot enough, staid hot enough and gave us no trouble with repairs.*"

We make a six-pound double-pointed Iron that is a beauty and is as good as it looks, and a great seller.



OUR No. 307, 6-LB. DOUBLE POINTED.

We will ship you, for trial, any Iron we make, weighing under 8 pounds, charges prepaid, for \$4.00, which you can return at our expense after 30 days' use, if you do not care to buy.

We have the Iron you want, and believe an introduction will result in a lasting good will.

Special inducements to Dealers and Central Station Managers.

ST. LOUIS ELECTRIC HEATING COMPANY
 1305 Pine Street ST. LOUIS, MO.

POPULAR ELECTRICITY



A HEATING PLANT FOR YOUR HOME

SOLD DIRECT TO YOU AT MANUFACTURER'S PRICE

Don't say you can't afford a heating plant for your home until you GET OUR PRICES. They will surprise you—and we furnish plants in such convenient form that you can INSTALL THEM YOURSELF, if you want to—or have a handy man to do it at day laborer's wages. It costs you nothing to have us make an estimate for you—and we not only save you about 50 per cent in the cost, but we GUARANTEE SATISFACTION. You take no chances. We write it in the contract that our plant will supply the temperature required in each and every room, and hold ourselves in readiness to supply, free of all cost, all materials, should it be needed to bring the plant up to our guarantee. Should the plant at any time within one year prove a failure, or unsatisfactory to you, we will refund the entire purchase price upon the return of the plant to us. We will make you (free) complete working drawings, showing the size of pipes to use at every part of the plant and how to place the fittings, so that you can't go wrong. We will cut all large size pipe for the mains and will lend you an entire outfit of tools to do the work. You cannot get a better plant, even if you pay twice as much. It will pay you to write for our Information Blank. Then give us a sketch showing the arrangement of your rooms, or furnish us with the architect's plans, and we will figure out the exact amount of material needed and our price.



\$135 Is all it costs for a hot water heating plant for this 2-1/2-room cottage. 6 radiators. A total of 215 ft. of radiation and a 400 ft. cast iron sectional heater, together with all the necessary pipe and fittings; radiator valves, gold bronze covering, and, in fact, every bit of material needed.



\$180 A first class hot water heating plant, for this 8-room house for \$180. 8 radiators, a total of 300 ft. of radiation, a 500 ft., cast iron, sectional heater, gold bronze, all the necessary pipe and pipe fittings; radiator valves, covering & everything needed.



\$247 This large 11-room house supplied with all the material for a hot water heating plant for \$247. 475 feet of radiation in 11 radiators and a 700 ft. cast iron, sectional heater, gold bronze and all the necessary pipe and pipe fittings, radiator valves, and covering; in fact, every bit of material needed.

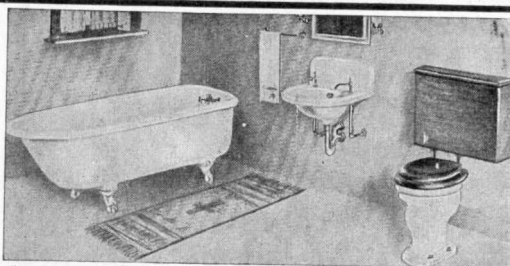
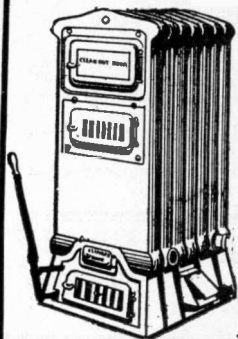

\$39.00 HIGH GRADE BATH ROOM FIXTURES

For this Complete Set of We Sell Direct to the Consumer

This is our No. 5 bathroom combination, regularly listed in our catalog for \$45. We are making a special offer to readers of Popular Electricity on this of \$39. The Bath Tub is 5 ft. long, 30 ins. wide, white porcelain enameled inside and over the rim, and is trimmed complete with full nickel trimmings. The Lavatory is cast iron, heavy white porcelain enameled and trimmed complete with full nickel trimmings. The Closet is high-grade, sanitary, vitreous siphon wash down bowl with polished oak copper lined tank and seat and cover to match. All parts high-grade. This offer is for a limited time only. Other Bathroom Outfits from \$24.50 to \$125.00

THE PROBLEM SOLVED

You can have Modern Sanitary Plumbing installed in your home at very low cost, for our "All Iron Pipe" System enables any handy mechanic, without previous experience, to do the work.

DON'T BE HELD UP

for an exorbitant sum in order to possess these conveniences, for we will sell you the material at lowest wholesale prices. There is no mystery about the pipe work for plumbing. It makes no difference—whether in a city, where you have running water and sewerage, or in the country, where you have to provide your own water system and dispose of your own sewerage, you can have these improvements. We will sell you all the material of all kinds needed, make you working drawings, and tell you how to do the work.

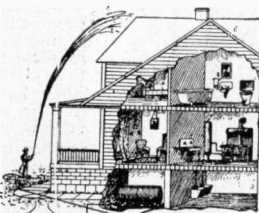

Pneumatic Water Supply Systems

We will furnish you with a complete pneumatic or air pressure water supply outfit that will

furnish you running water the same as city water works. Prices range from \$40 upward. We will furnish you complete house plumbing outfit like shown in this picture, including the pneumatic water supply system, the bath room outfit, the kitchen sink and range boiler; and all the pipe and pipe fittings to install from \$125 upward.

JUST SEND US A PLAN

of your house for our free estimate of all the material required to put in these modern conveniences.

READY ROOFING

95 Cents per Square Galvanized Rubber and Asphalt

We offer the entire lot of factory mill ends of prepared roofing strictly high grade, brand new, at less than cost of manufacture. There are from two to four pieces of galvanized rubber or asphalt roofing to each roll of 108 sq. ft. This is \$2 and \$3 grades of roofing.

CENTRAL M. & S. CO., CHICAGO.

The hot water heating plant purchased from you for my 11-room house, which I installed, following your plans, is thoroughly satisfactory. I have no difficulty in heating my house from 75 to 80 degrees in coldest weather. I expect to purchase quite a few plants room outfit with the necessary piping to connect it all up. I did all the work myself and the entire outfit works perfectly. Five to 10 minutes pumping twice a week supplies all the running water we want. I think almost any man would be able to follow your plans and do the work.

CENTRAL M. & S. CO., CHICAGO.

I am much pleased with the hot water heating plant, the pneumatic water supply system, the bath room outfit and kitchen sink that I purchased from you for my home. Every part of this plant is thoroughly satisfactory. We have extremely cold winters here; but the heating plant heats the house perfectly. In purchasing this from you, I saved about \$400.00. Very truly yours,

JOHN GASMAN, Bark River, Wis.

CATALOG No. 123 BARGAIN BUILDING MATERIAL, including bath room and plumbing supplies, heating apparatus, pipe and fittings, poultry netting, wire fencing roofing materials, etc. FREE.

Central Machinery & Supply Co.

2593 Archer Avenue, Chicago

Guarantee: The key note of our business is EVERY ARTICLE GUARANTEED AS REPRESENTED AND TO BE SATISFACTORY. Your money will be cheerfully refunded for any article not entirely satisfactory.

For our Mutual Advantage mention Popular Electricity when writing to Advertisers.

POPULAR ELECTRICITY

IN PLAIN ENGLISH

HENRY WALTER YOUNG, Editor

Vol. 11.

MAY 1909.

No. 1.

CONTENTS

	Page		Page
Chauffeurs to the United States Senate and Tunnel Through Which They Travel (Frontispiece)		Receiving Distance	40
HOW SENATORS RIDE TO WORK.....	1	Condenser and Detector.....	40
Fire Engine Warning Signal.....	3	Electrolytic Detector	40
ELEMENTARY ELECTRICITY. CHAPTER 13. By Prof. Edwin J. Houston.....	4	Condenser	40
Striking Electric Sign.....	9	A B C Receiving Set.....	40
Electric Swinging Door.....	9	Telephone Induction Coil.....	40
GASOLINE CARS SUPPLANTED BY ELECTRICITY	10	ELECTRICAL MEN OF THE TIMES. Henry L. Doherty.....	41
Experiments with High Voltage Current. By H. L. Transtrom.....	12	ELECTRICITY IN THE HOUSEHOLD....	42-45
Early Electric Locomotive.....	14	IS ELECTRIC LIGHT TOO DEAR FOR MODEST PURSES? By William Kelly..	42
The Tungstolier	15	The Electrotherm	45
TRAINING A FIRST AID CORPS.....	16	JUNIOR SECTION	46-53
Klaxon, The X-Ray of Sound.....	19	CONSTRUCTION OF A LAMINATED MOTOR. By Milford J. Whinney.....	46
New Electric Furnace Product.....	19	Cost of Operating Electric Apparatus....	48
Destroying Street Car Tickets.....	20	HOME MADE ELECTRIC HEATER. By P. J. O'Gara.....	49
STANDARD ELECTRIC TIME SYSTEM....	20	General Plan for Home Made Rheostat....	50
Eye Comfort	22	Smallest Electric Launch.....	51
A New Illuminant.....	22	SWITCHBOARD STORIES—WHY HARVEY MOVED. By C. Tuels.....	52
Signal to Prevent Car Accidents.....	23	Lynn Marsh, the Boy Telegrapher.....	53
Electric Current Consumption in New York..	23	QUESTIONS AND ANSWERS.....	54-61
All Day Service in Small Cities.....	23	Electrolysis of Water.....	54
INVENTIONS OF EDISON—A CLASSIFICATION. By Joseph J. O'Brien.....	24	Ammeter Shunt	55
Control of Moving Picture Arcs.....	26	Telephone Receiver Wire.....	55
Radio Adjustable Telephone Holder.....	27	Transformer and Motor Connections.....	56
THE DICTOGRAPH. By Joseph B. Baker..	28	To Make a Commutator; Switchboard Connections; Lightning Arrester.....	57
TRACKLESS TROLLEYS OF VIENNA....	30	Magneto Generator	58
Cigar Lighter	31	Arc Lamp Resistance.....	58
POPULAR ELECTRICITY WIRELESS CLUB	32-40	Burglar Alarm Circuit.....	59
CONSTRUCTION AND OPERATION OF SPARK COILS. PART 1. By V. H. Laughter	32	Magnet Coil Winding.....	59
WIRELESS TO LINK AMERICAN UNIVERSITIES	36	A Closed Circuit Cell.....	59
How to Make an Electrolytic Detector... 37		Telegraph Key and Relay.....	60
3,000-Mile Equipment for Washington.... 38		Arc Lamp Rheostat.....	60
Japan's Marvelous Aerograms.....	38	Effect of Lines of Force.....	61
Spark Coil Design.....	38	Winding Small Drum Armatures.....	61
Four-Inch Spark Coil.....	39	NEW ELECTRICAL INVENTIONS.....	61-63
Spark Coils	39	Electric Light Fixture.....	61
Receiving Ability; Detectors.....	39	Renewing Dry Cells.....	61
Sending Helix	39	Electric Safety Razor.....	62
Condenser; Interrupter	39	Harper's How to Understand Electrical Work. By Wm. H. Onken, Jr. (Book Review)	63
Sensitiveness of Receiving Apparatus.... 40		Illumination (Book Review).....	63
		SHORT CIRCUITS	64-65
		ELECTRICAL DEFINITIONS	66

ISSUED MONTHLY BY POPULAR ELECTRICITY PUBLISHING CO., Monadnock Block, Chicago, Ill.
 YEARLY SUBSCRIPTION, \$1.00 CANADIAN, \$1.35; FOREIGN, \$1.50; SINGLE COPY, 10 CENTS

No additional copies will be sent after expiration of subscription except upon renewal.

Entered as Second Class Matter April 14, 1908, at the Post Office at Chicago. Under the Act of March 3, 1879.

Copyright 1909 by Popular Electricity Publishing Co., Chicago, Ill.

GET THIS \$1200.00 NEXT MONTH! WHAT A BLESSING TO ALWAYS HAVE MONEY IN ABUNDANCE.



You can, it's easy. **Hundreds Getting Rich the "New Way."** Said to be world's greatest and surest money maker. One man actually made \$1281.00 IN ONE MONTH, \$51.50 IN 15 MINUTES, \$800 IN 8 DAYS. Not a fairy tale, fake or humbug, but absolutely true—sworn statement. New, wonderful discovery. Causing great enthusiasm. Readers, listen, see, read how this invention has made, is making thousands of dollars for others:

Does \$1200 Monthly "My sales \$1281.00 one month, \$1118.00 another. Best thing ever sold. Not one complaint from 2000 customers." **SWORN STATEMENT BY INTEREST YOU?** M. G. STONEMAN, MONT.

"SOLD \$2212.00 IN 2 WEEKS. Not one dissatisfied user." writes Korstad & Mercer, Minn. "My sales \$1680.00 IN 73 DAYS," writes C. D. Rasp, Wis. "Canvassed 60 PEOPLE—GOT 55 ORDERS. Sold \$320.00 in 16 days," writes W. H. Reese, Pa. "Enclosed order for \$115.00 FIRST DAY'S WORK. Best thing I ever worked," writes L. H. Langley, N. D. "Everybody thinks apparatus finest thing. Sold 15 one afternoon," writes Miss Eva Edwards, Nev., after ordering 73. "I averaged \$164.25 WEEKLY for three months, undoubtedly best line on market," writes J. W. Beem, Kas. "Finest seller I ever saw, catches the eye. Don't want anything better. SELL 8 OUT OF 10 HOUSES," writes Wm. Maroney, Okla. "A man that can't sell your outfit couldn't sell bread in a famine, send 48 more," writes J. B. Cashman, Minn. "I make \$100 DAILY," writes J. Sevegne, N. Y.

HUNDREDS, MEN AND WOMEN TELL OF WONDERFUL SUCCESS equipping town and farm homes with Allen's Portable Bath Apparatus. 50,000 already sold. Acknowledged best thing ever happened for humanity. Nothing like it. Gives every home a modern bath room for only \$5.00. Think of it! Costs nothing to operate. Used wherever water in any form exists. So energizes water that 1 gallon does more than tub full old way. Gives cleansing, friction, massage, shower baths all together or separately. Cleanses almost automatically. Makes bathing 5 minute operation. Only clean, running water touches body—no immersion. No tubs, buckets, bowls, wash-rags or sponges—no plumbing. Insures cleanliness without drudgery—prolongs life—prevents disease. Small but mighty—carried in grip. Endorsed by famous Battle Creek Sanitarium and other celebrated authorities. Most popular, easiest, quickest, surest selling household article going.

Let us give you an appointment worth \$40.00 to \$60.00 weekly plus freedom from drudgery, long hours, wage earning, bossism, job hunting. We want more **AGENTS, SALESMEN, MANAGERS,** either sex, at home or travelling, all or spare time to fill orders, appoint, supply, control sub-agents. Hustlers getting rich. **EXPERIENCE UNNECESSARY.** Simply supply enormous demand already made—that's all. Every customer anxious to boost your business. No easier, quicker, certain way to make money. **Exciting business—big profits—popular goods, guaranteed by an old reliable \$50,000.00 house—no competition—exclusive territory—co-operation and assistance.**

CREDIT GIVEN—SEND NO MONEY—only your name and address on a postal card today for world's greatest agency offer, valuable booklets, credit plan, proofs of phenomenal success—**ALL FREE. COSTS NOTHING TO INVESTIGATE. MEET US THAT FAR ANYHOW.**

"SEE IT ENERGIZE."
Sec. view Comb, Portable and Bathroom Outfit.

THE ALLEN MFG. CO., 1499 ALLEN BLDG., TOLEDO, OHIO.

WATCH THIS PAGE

When your subscription expires, you will find a renewal blank enclosed here. You should fill out and return same with remittance at once to avoid missing a number. Positively no copies mailed on any subscription after same expires unless renewed, and we cannot agree to begin subscriptions with back numbers.

No matter when your subscription expires, it will pay you to avail yourself now of this

Special Offer For Renewal Subscribers Only

YOUR CHOICE OF THE FOLLOWING VALUABLE ELECTRICAL BOOKS

HANDY ELECTRICAL DICTIONARY,
DYNAMOS AND ELECTRIC MOTORS
AND ALL ABOUT THEM,
WIRELESS TELEGRAPHY.

FREE

PRIVATE HOUSE ELECTRIC LIGHTING,
TELEGRAPHY AND HOW TO LEARN IT,
HOW TO MAKE ELECTRIC BATTERIES
AT HOME.

with \$1.00, (Canada \$1.35, Foreign \$1.50) for your renewal.

POPULAR ELECTRICITY is getting better right along—increasing in popularity with each issue. It is becoming more and more the magazine you can't afford to be without. You intend to renew—of course! Better do it now while this special offer is in force. It may be withdrawn at any time. Address

POPULAR ELECTRICITY PUBLISHING COMPANY, Monadnock Block, CHICAGO.

PUBLISHER'S PAGE

INVENTIONS OF EDISON

In this issue Joseph J. O'Brien gives a classification of the inventions of Edison. "Future fame" he says, "will rest largely on the art test, and not on the military test, and by this test Edison is greater than Caesar." Though the truth of this statement may be evident to some, there are many who have very little conception of the great scope of Edison's work. They think of him, perhaps, as the inventor of the electric incandescent lamp or of the phonograph—his greatest productions. But they do not know that his inventive genius has been felt in the fields of photography, glass production, fruit preserving, ore manipulation, electric traction, office appliances and a great many others. In short, Mr. O'Brien's classification shows that Edison's work has extended into 18 groups of main arts under which are 103 sub-divisions of main arts, the total number of separate patents being 858. These figures are astonishing, and the classification altogether makes very interesting reading.

BOUND VOLUMES

Calls for back numbers of the first volume of Popular Electricity have been insistent, although, unfortunately, we have been unable to fill many of the orders owing to the fact that several of the editions have been exhausted. That requests are still coming in for copies as far back as No. 1, Vol. I indicates that many are seeking to complete their volumes with a view to binding them up into permanent form for future reference. We are sorry that we cannot comply with all these requests, but we can be of assistance to some who are particularly anxious to preserve complete files, as we have a limited supply of bound volumes containing the first 12 numbers. These will be supplied at a moderate price—first come, first served.

Those who desire a complete index to the first volume may obtain one upon request. Regular subscribers have already received them, but as they were not included in the newsstand edition there are no doubt many regular buyers of the magazine who have complete files to which the index will be a valuable addition.

IS EVERYBODY HAPPY?

To make Popular Electricity a magazine interesting and valuable to old people and young people, to the electrical engineer and the layman, in short, to the whole reading public interested in any shape or manner in electricity, has been the aim of its publishers. That success has been found in this attempt is abundantly proven by the mail that comes to this office every day of the year. Here are a few examples:

The president of a large electric light plant in Iowa says: "We have no doubt that after the subscribers get in the habit of taking your magazine they will continue to do so, as there is no question but what it is a good magazine and interesting to the old as well as the young." The secretary of a large telephone company writes: "Personally I value the magazine very highly and wonder that you are able to get so much good information for the money as you are doing." This from a member of an electrical supply company: "Now we have at least ten men, that I know of, in our employ who are subscribers for your magazine, and we consider it one of the best magazines of its kind that we have been able to get hold of."

From the general readers come such expressions as these: "Popular Electricity is the best electrical magazine I ever read; I read quite a number;" "Your magazine I cannot praise too highly. There are so many meaty things on Electricity (on which I am very weak) that touch me in a hungry, tender spot, that I am like the boy with the mixed bag of nuts. Don't know which I like best, all good." "I have just finished reading the January issue of Popular Electricity (the first one I have had the pleasure of reading) and will say that it is the best thing I have ever read on the subject."

RENEWALS: The date on the wrapper of your magazine shows the issue with which your subscription expires. No additional copies will be mailed after the expiration of a subscription, except upon renewal. Since each issue is printed a month before the date which it bears, renewals should be sent in at least four weeks in advance, in order that no copies be missed.

POPULAR ELECTRICITY



**What's the Use of Working for \$15.00
Per Week When You Can Be Your
Own Boss and Earn
\$200.00 PER MONTH?**



This is the average earnings of more than 500 of our customers who are operating and demonstrating our Wonder Cannon Automatic Photo Button Machine.

Only \$30.00 Cash required to start you in this profitable business.

Our \$30.00 outfit is complete and includes Wonder Cannon, Tripod, 1000 plates, 1 Gross Gilt Frames and enough Developing Powders for one month's work.

Our Cannon takes, develops and finishes Photo Button in 30 seconds, ready to wear.
No experience required.

Can be set up in 20 seconds, ready to operate. A big money maker at Fairs, Carnivals, Picnics or Celebrations. Sent upon receipt of \$5.00; balance C. O. D.

THE CHICAGO FERROTYPE CO.

Room 103 Ferrotype Building, Congress and Laflin Sts., Chicago, Ill.

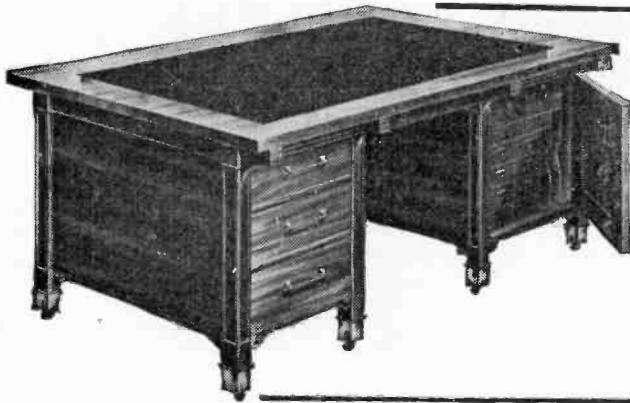

AN INSPIRATION!

To refit your office with "Andrews Quality" Office Furniture is a good one. Improves your business, nerves and bank account.

Try it!

A. H. Andrews Co.

174 Wabash Avenue, CHICAGO

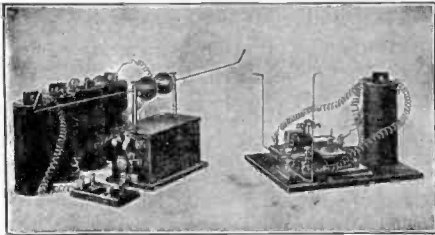

THE BEST YET IN WIRELESS!

Outfit Complete \$12.25

A real working equipment which gives fine results up to three miles. If you are experimenting in wireless why waste time, money and patience building delicate apparatus that may not work?

Why not get to sending messages at once?

Send 4 Cents for Catalogues and Sample Burning Wire.

B. M. MEYERS ELECTRICAL HOUSE, Evansville, Wis.

**GET
WISE**

SAVE MONEY! Here's Your Chance!

MODERN ELECTRICAL CONSTRUCTION, by Horstman & Tousley. A reliable, practical guide for the beginner in electrical construction, showing the latest approved methods of installing work of all kinds according to safety rules of National Board of Underwriters. Fully Illustrated. Black leather binding. Price \$1.50. A few slightly soiled copies (don't hurt book a bit) for \$1.00. First come, first served.

Popular Electricity Publishing Co., Book Dept., Monadnock Bldg., Chicago, Ill.

For our Mutual Advantage mention Popular Electricity when writing to Advertisers.

You should own an Electric Iron

EVERY ELECTRIC-LIGHTED HOME should have its Hot Point Electric Iron. This is true whether you do your own ironing, or servants do it, or it is sent out

The Hot Point Electric Iron is absolutely safe—no risk to user or property. It attaches to any light socket—simply take out the light bulb and screw in the plug at end of flexible connection.

The current is carried into the iron by the switch plug at rear of iron. As soon as this is inserted the iron begins to heat. In two or three minutes you begin to iron and iron continuously.

In a few minutes more the iron will get so hot that you can pull out the plug (requires almost no effort) and iron for some time without further current. When the iron begins to cool, put back the plug for a few minutes.

It is as easy as that.

The stand is attached to rear of iron. Simply tip iron up on the heel when not in use. The handle never gets hot (no holder). The point of the iron is always hot—therefore you iron right up into the pleats and folds; and work with the entire face of the iron.

No heat in the room—no soot or dust—no fuss or bother. Simply iron when you want to, in any room in the house.

The 6 pound Hot Point Electric Iron will do the heaviest domestic work. And the lightest—because you have absolute control of the temperature. There are two models. Both fully guaranteed against electrical troubles.

The handsomest—the sturdiest—the most efficient electric iron. Costs only 3 to 5 cents for an hour of continuous ironing, which means as many pieces ironed as in an hour and a half with any other method.

Two Models—Standard and Automatic.

All we have said above applies word for word to both the **Standard** and the **Automatic** Hot Point Irons.

The **Automatic** Hot Point Iron is exactly the same as the **Standard**, except that we have added a device which automatically switches off the current before the iron becomes overheated. Should you forget to pull out the switch plug when leaving this iron, the automatic device will attend to it. Fire risk entirely done away with. Our **Automatic** is the only electric iron with an automatic temperature control. The only absolutely safe iron.

PACIFIC ELECTRIC HEATING CO.

Main Office and Factory: Ontario, Cal.
Eastern Factory: 63-65 W. Washington St. Chicago, Ill. Send order to nearest point.

Central Station Managers and Dealers.

This is but one of the many advertisements we are running. We want to turn orders in your town to you. Order samples at wholesale, subject to 3 days approval. State number you will be able to use and we will name special quantity price. Give voltage.



How to Get A Hot Point Electric Iron.

IN hundreds of cities the Lighting Company distributes Hot Point Electric Irons to its customers.

Remember—there is no other iron with the hot point—the cool handle—the attached stand. No other with the automatic control.

If your Lighting Company cannot supply you probably the leading Electrical Supply, Hardware or House Furnishing store can.

Order direct from us, if you prefer. Use coupon below. Iron will be delivered to you without further trouble.

The **AUTOMATIC** is not made smaller than 6-lb. The **STANDARD**—4, 5 or 6-lb. We recommend the 6-lb. for household work.

Be sure to give voltage. If uncertain, call up your Lighting Company or Dealer.

Every Iron Fully Guaranteed.

A number is stamped on every iron at the factory, and a record kept of that iron. It is guaranteed by us to the Lighting Company or Dealer. They guarantee it to you. This covers defects in material and electrical trouble of every kind.

We will deliver to you, all charges prepaid anywhere in the United States, one 4, 5 or 6-lb. **STANDARD** Iron for \$5.00; or one 6-lb. **AUTOMATIC** Iron for \$6.00.

Fully Approved by National Board of Fire Underwriters

PACIFIC ELECTRIC HEATING CO.

ONTARIO, CAL. CHICAGO, ILL. (Address nearest office.)

Please send me for particulars about Hot Point Electric Irons.

Send me charges prepaid, 1 Standard Hot Point Iron, \$5.00

1 Automatic Hot Point Iron, 6.00

(Draw pencil through one not wanted.)

Enclosed is check in payment of some.

Name.....

Street..... Voltage.....

City..... State.....

I enquired about it of.....

For our Mutual Advantage mention Popular Electricity when writing to Advertisers.

Cigarette Rolling Made Easy

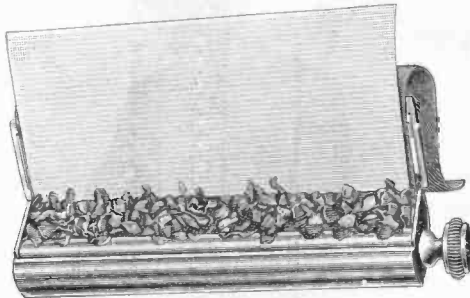

(Patented)
Place tobacco and paper as shown above.

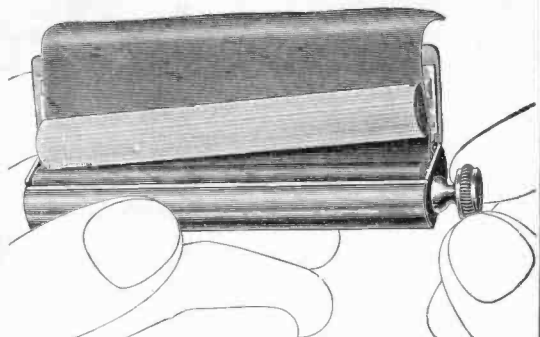

Close cover, moisten paper, turn knob and cigarette is finished, as shown.

**Quicker than by hand—No waste of tobacco—Perfectly formed
Actual saving more than pays for machine in short time**

The **GEM CIGARETTE ROLLER** is the only machine that rolls a perfectly formed cigarette from any tobacco or paper.

Price 25 cents Prepaid, if not satisfied your money will be returned.

THOUSANDS IN USE—CUSTOMERS DELIGHTED.

AGENTS AND DEALERS WRITE FOR TERMS.

SIGARET ROLLER WORKS, 42 W. Quincy St., Chicago, Ill.

ELECTRICAL WORKERS

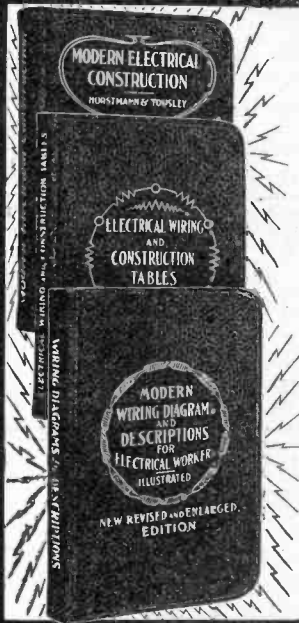

A Complete Electrical Workers' Library Positively Up-to-Date and Written for THE MEN WHO DO THE WORK

There is little that is theoretical, nothing historical, but everything useful and practical. ¶ Just what is needed to be known and nothing to confuse. The authors are men who are brought in daily contact with electrical workers and who, therefore, are conversant with their needs and with the best methods of presenting the various subjects.

MODERN WIRING, DIAGRAMS AND DESCRIPTIONS

Describes everything used in general practice; bells, burglar alarms, batteries, dynamos and motors, meters, automobiles, arc and incandescent wiring, telephones, testing, trouble, etc. ¶ Fits the owner for any kind of electrical work.

Each diagram and explanation complete in itself, not requiring any previous knowledge of the subject to be able to understand it. A complete collection of diagrams covering every class of construction with which the electrical worker will be brought in contact.

A book that can be carried on the job. ¶ Settle disputes and arguments.

ELECTRICAL WIRING AND CONSTRUCTION TABLES

This book contains the only practical alternating current wiring table published. Here is the old formula for drop in voltage:

$$\sqrt{[(E. X. P. F.) + (I. X. R.)]^2 + [(E. X. I. F.) + L.]^2} = E'$$

To do intelligent work you must use this formula to find the size of wire needed or consult the tables in this book. In the past most people have guessed. This book gives tables by which the proper size wire may be found without the use of mathematics. The tables do all the figuring.

Trigonometry, algebra and the extraction of the square root are not necessary with these tables. ¶ Over 100 pages of tables. Single, two and three phase; any distance, any loss, any power factor, any voltage, any efficiency, 25, 60 and 125 cycles. All that are needed; none that are not needed. ¶ Will save, in time saved, their cost many times over. ¶ The tables showing the proper size wire to use according to the Underwriters' table of carrying capacity minimize the possibility of costly errors.

MODERN ELECTRICAL CONSTRUCTION

The practical workman's handbook. ¶ Written by men in daily touch with the best class of work and the latest wrinkles. ¶ For those who desire to pass civil service examinations, gain admittance to the unions, become first-class wiremen, know all the tricks of the trade. ¶ Detail information on all construction work. ¶ Every page full of practical information; nothing else. ¶ Strictly up-to-date. ¶ Per set of three volumes, bound in full Persian Morocco leather, red edges, round corners, \$4.00. Single volumes, each, \$1.50. ¶ Sent to any address, all charges paid, upon receipt of price. **FREDERICK J. DRAKE & CO., 216 Fisher Building, Chicago, U. S. A.**

For our Mutual Advantage mention Popular Electricity when writing to Advertisers.

2c a Week Pays Wash Bill!

Electricity or Water-Power Does the Work

Write for
FREE Book

Just a "Twist of the Wrist" Starts or Stops the Machine!

The 1900 Motor Washers are now at work in thousands of homes. They are doing the work formerly done by women, at a cost of 2 cents a week for power! Saving thousands upon thousands of dollars in wash bills. Saving worlds of wash-day troubles. Leaving the women free to do other work while the machines are doing the washing.

The 1900 Motor Washer

Washes a Tubful in Six Minutes!

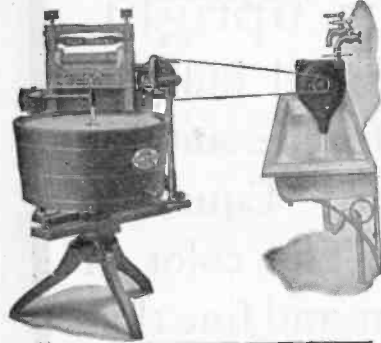

1900 Water Motor Washer
Can be connected with any water tap instantly

Handles heavy blankets or dainty laces.

The outfit consists of the famous 1900 Washer with either Electric Motor or Water Motor. You turn on the power as easily as you turn on the light, and back and forth goes the tub, washing the clothes for dear life. And it's all so simple and easy that overseeing its work is mere child's play.

A Self-Working Wringer Free With Every Washer

The motor runs Washer and Wringer. We guarantee the perfect working of both. No extra charge for Wringer, which is one of the finest made.

Write for FREE BOOK and 30 Days' FREE TRIAL OFFER!

Don't doubt! Don't say it can't be done! The free book proves that it can. But we do not ask you to take our word for it. We offer to send a 1900 Motor Washer on absolute Free Trial for an entire month to any responsible person. Not a cent of security—nor a promise to buy. Just your word that you will give it a test. We even agree to pay the freight, and will take it back if it fails to do all we claim for it. A postal card with your name and address sent to us today will bring you the book free by return mail. Address, The 1900 Washer Co., 3339 Henry St., Binghamton, N. Y. Or, if you live in Canada, write to the Canadian 1900 Washer Co., 355 Yonge St., Toronto, Canada.



1900 Electric Motor Washer
Can be connected with any ordinary Electric Light Fixture

Hotel Cumberland

NEW YORK

S. W. Corner Broadway at 54th Street

Near 50th St. Subway, 53rd St. Elevated and all Surface Lines.
Ideal Location near Theatres, Shops and Central Park.



HARRY P. STIMPSON, Formerly with Hotel Imperial. R. J. BINGHAM, Formerly with Hotel Woodward

NEW and FIREPROOF

Strictly First-Class Rates Reasonable.

\$2.50 with Bath
AND UP

Restaurant Unexcelled
Prices Moderate

Send for Booklet

10 Minutes Walk to 20 Theatres

ROBERT P. MURPHY, Prop.

HOTEL ALBANY

41st Street and Broadway, New York

Remodeled, Handsomely Furnished New Throughout



Absolutely Fireproof. In the heart of the City
500 Rooms. 300 Bath Rooms. European Plan.
Cuisine Unexcelled. Gentlemen's Cafe, Ladies' Restaurant and Moorish Rooms. Popular Prices.
Plenty of life—but Homelike.

\$1.00 PER DAY AND UP
SEND FOR BOOKLET.

Meet me at the College Inn, under the Albany, New York's Leading Rathskeller, a place to eat, drink and be merry. Music.

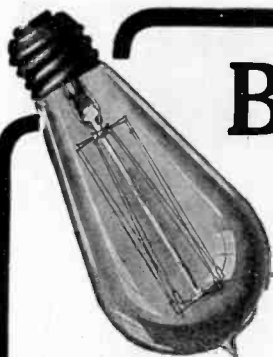

Burns Satisfactorily in any position—

At an angle—pendant
—horizontal or upright.

This is the new 40 watt
small bulb Sunbeam
Tungsten Lamp.

The 25 watt and small bulb 40 watt styles will fit any shade or fixture suitable for 16 c. p. carbon filament lamps. Equal life on either a. c. or d. c. circuits. The color of the Sunbeam Tungsten is so clear and fine that pale blue and pale pink can be distinguished under the rays of this lamp as readily as by sunlight.

LIST PRICES

	Clear	Frosted	Standard Pkg. Quantity
25-watt regular	\$0.85	\$0.90	100
40-watt small bulb	1.00	1.05	100
40-watt regular	1.10	1.15	50
60-watt "	1.40	1.47	50
100-watt "	1.75	1.85	24
250-watt "	3.50	3.70	12
No. 1 Meridian 40-watt	1.50	1.50	24
No. 2 Meridian 60-watt	1.75	1.75	24

Sunbeam Incandescent Lamp Co.

Established 1889

MANUFACTURERS

Members of the National Electric Lamp Assn.

CHICAGO

NEW YORK

TORONTO

The Practical House Cleaner



We want to send this machine to every housekeeper in America who uses electricity, that she may prove for herself that it will thoroughly clean any room in a few minutes. All we ask is that you send your name and address.

The Hoover Electric Suction Sweeper

does more than any vacuum cleaning system. Unlike all other systems, it is not necessary with the Electric Suction Sweeper to first sweep the floor with a broom to remove pins, match sticks, etc., that lodge in the pipes and stop them up. Nine-tenths of the work required from a cleaning machine is on the floor. There is little need for dusting when you use the Electric Suction Sweeper—it takes up and holds the dust without scattering it about the room. Yet we furnish attachments, at small extra cost, that do clean portieres, curtains, furniture and bed clothes. The work of spring house-cleaning becomes a pleasure with the Electric Suction Sweeper.

The Electric Suction Sweeper sells for considerable less than any good vacuum system, and costs but a little more than a good range, sewing machine or other household convenience that would not give as much satisfaction.

If you would like to try this machine at our expense—we pay express charges and make delivery to your home.

Send name and address today to

Electric Suction Sweeper Co., Dept. 27, New Berlin, Ohio

A SCHOOL WITHIN ITSELF

the careful student comprehends the complete designing, care and operation of a dynamo or motor, and I chapter on electric automobiles, outlining their construction, care and operation, and all about storage batteries and how to handle them. Each subject is carefully written and to the point. After a student studies a subject, he is questioned on that subject in such a manner as to bring clearly to his mind the points he needs to know regarding same. A Dictionary in

back of book will enable him to learn the meaning of any electrical word, term or phrase used in this book, as well as hundreds of others in common use. All required tables necessary in the study are in it.

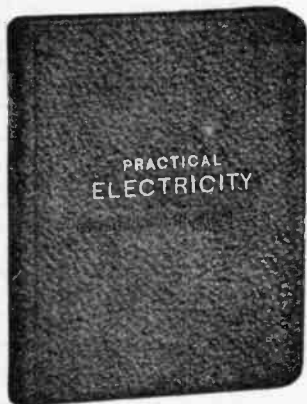

TABLE OF SUBJECTS:

<p>Chapter I—Wiring. II—Electric Batteries, Electric Plating. III—Magnetism. IV—The Magnetic Circuit. V—Magnetic Traction. VI—Magnetic Leakage. VII—Energy in Electric Circuit. VIII—Calculation of Size of Wire for Magnetizing Coils. IX—Calculation of EMF's in Electric Machines. X—Counter EMF. XI—Hysteresis and Eddy Currents.</p>	<p>Chapter XII—Armature Reaction. XIII—Sparking. XIV—Winding of Dynamos and Motors. XV—Proper Method of Connecting Dynamos and Motors—Self Excitation. XVI—Diseases of Dynamos and Motors, their Symptoms and How to Cure Them. XVII—Arc and Incandescent Lamps. XVIII—Measuring Instruments. XIX—Alternating Current. XX—Automobiles.</p>
---------------------------------------------------------------------------------------------------------------------------------------------------------------------------------------------------------------------------------------------------------------------------------------------------------------------------------------------------------------------------------------	--------------------------------------------------------------------------------------------------------------------------------------------------------------------------------------------------------------------------------------------------------------------------------------------------------------------------------------------------------------------------------

A Dictionary of over 1,500 Electrical Words, Terms and Phrases, giving a brief meaning of all which are in common use.

\$2.00 PER COPY — FOURTH EDITION — 20,000 COPIES SOLD.

The offer we make of refunding money if book is not satisfactory upon examination is AN UNUSUAL ONE in connection with the sale of a book. But we have no fear of its return. Your decision will be what thousands of others have been. Money would not buy it if it could not be duplicated. We could print testimonials by the hundreds. It is best to order now and be your own judge of its merits.

THE MORTIMER BOOK CO.,

160 Washington St., Chicago, Ill.

For our Mutual Advantage mention Popular Electricity when writing to Advertisers.

POPULAR ELECTRICITY



Makes and burns its own gas and produces a pure white, steady, safe, 100 candle power light. No wick, smoke, dirt, grease or odor.

THE "BEST" LIGHT

Lighted instantly. Over 200 styles. Agents wanted. Write for catalog

THE BEST LIGHT CO.
280 E. 5th St., Canton, O.



TYPEWRITERS

All Makes, \$10 Up. CASH OR TIME. Rented Anywhere—Rental Applied. SENT ON TRIAL—FREE.

Tell us what you want and what you expect to pay and we will ship you one for trial and examination. All fully guaranteed

Economy Typewriter Exchange, 74 Washington St., CHICAGO, ILL.

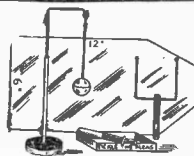

Wonderful 12x6" **ELECTROPHOROUS** and apparatus.

Two rubs gives a stinging 3 inch spark to the hand, 6 inch to a Metal Conductor, charges Leyden Jar, Lifts and holds up a 9 inch 4 oz. tin pie plate. \$1.25

Send for our great Catalogue.

HERTZIAN ELEC. CO., 1009 E. 42d St., Brooklyn, N. Y.



ALCOHOLISM

For allaying the feverish desire for drink, and in sustaining those who wish to give up the liquor habit

EARL'S ANTOL TREATMENT is daily receiving the grateful testimony of those whom it has benefited. No absence from business, no inconvenient conditions or bad after effects. Correspondence strictly confidential.

The Cost is Very Moderate
Write at once for Free Booklet.

JOHN C. EARLE, 161 Gates Ave., Montclair, N.J.
Sole Agent for U. E. A. and Canada.



Electric Motor Watch Charm

A genuine Electric Motor, inclosed multipolar type. Runs 2000 revolutions per minute. Highly polished and plated. A powerful "Pocket Battery" with every outfit. Postpaid, \$1.00.

DESPATCH MFG. CO.
112 N. First St., Minneapolis, Minn.

WIRELESS TELEGRAPHY

USING A CROW-BAR ON A WATCH is like trying to work your wireless without our CARBORUNDUM DETECTOR. It is as sensitive as any, yet so hardy that you can receive while you toss it in the Air. NO ADJUSTING—consequently—NO BOTHER. It Works Where It's Put. Price—\$1.00. Telephone receiver 1000 ohms, with cord, \$2.75. The famous FIVE MILE OUTFIT, a complete sending and receiving station. Price \$9.15. This outfit contains our 14-inch coil, Carborundum Detector, etc. 14 inch coil, each, \$5.90. 2 inch coil, each \$7.75. Send stamp for large illustrated circulars. All goods guaranteed.

INTERNATIONAL WIRELESS CO., Dept. E. LIMA, OHIO.

MAKE MIRRORS AT HOME

Big profits, with little outlay. One 18x36 in. mirror costs \$2.00 to \$500. You can silver a glass this size for 20c. Send 50c in stamps or money order and we will send you explicit directions how to do it; also how to emboss, grind, foil, gold leaf, frost chip and make imitation stained glass. How to transfer photos on glass, bore holes in glass and cut skylights.

GEORGE L. PATTERSON & CO.
2214 Monticello Avenue MORGAN PARK, ILL.

TELEGRAPHY

The Omnigraph Automatic Transmitter combined with standard key and sounder. Sends you telegraph messages at any speed. 5 styles, \$2 up. Circular free.

OMNIGRAPH MFG. CO.
39 H. Cortlandt St., New York



DO YOU LIKE TO DRAW?

THAT'S ALL WE WANT TO KNOW

Now, we will not give you any grand prize—or a lot of free stuff if you answer this ad. Nor do we claim to make you rich in a week. But if you are anxious to develop your talent with a successful cartoonist, so you can make money, send a copy of this picture, with 6c in stamps for portfolio of cartoons and sample lesson plate, and let us explain.

The W. L. EVANS SCHOOL OF CARTOONING
325 Kiagramore Bldg., Cleveland, Ohio.



Ayes All Steel Vises

Wood Workers Vise, Durable, Handy, Simple and Cheap. Price \$2.50 weighs 15 lbs., fully guaranteed, returnable if not pleased.

AYES & COMPANY,
59 Ellen St., Chicago.



Gem Motor 75c

Practical and substantial. Will run small mechanical toys on one cell dry battery. Has adjustable brushes and extra large field coil. Best on market. Only 75c. Postage 15c.

TREMBLY ELECTRIC CO. 2
Centerville, Iowa



LATEST POCKET LIGHT

with the new High Candle Power—Tungsten More Light Lamp, 5000 Flashes per battery Nickel plated, lock switch double lens. To acquaint every reader with the merits of our most highly perfected goods will send anywhere this New Flashlight ready for use for 75c, or with 2 extra New Refillable Batteries prepaid for only \$1—Illustrated Catalogs of latest Electrical Novelties at lowest prices Free. Favorable discounts to dealers. We are Headquarters for electric novelties that satisfy. **ELECTRIC NOVELTY CO., Mfgs. and Imp. Washington Nat'l Bank Bldg., Pittsburg, Pa.**

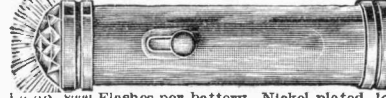

"Don't Cuss The Telephone"

Because your line is noisy. Buy a "Wasatch Induction Killer," and be happy. Made for all kinds of noisy lines.

"IT STOPS THE BUZZ"

Sent by mail postpaid for \$1.50. Every telephone user needs one. "Agents Wanted." "Patent Pending."

WASATCH ELECTRIC SERVICE CO., (Inc.)
46 Post-Office Place, Salt Lake City, Utah.

ANYTHING ELECTRICAL

A 2ct. stamp secures Our latest catalogue—100 pages of Electricity—Electric Novelties, Motors, Dynamos, Wireless Outfits, Transformers from \$1 to \$150 and upwards, Electric Heating Devices, Great German Toys, Etc., Etc.

J. J. DUCK 428 St. Clair St. Toledo, O.

For our Mutual Advantage mention Popular Electricity when writing to Advertisers.

Everything for Furnace Work



On Free Trial At Our Expense
Until Jan. 1st, 1910

Our story is quickly told. We will send you a Hess Steel Furnace and complete heating outfit, including pipes, registers, fittings and everything needed, for from \$25 to \$100 less than you can buy from dealers, and deliver it at your station, freight prepaid. You may place the purchase price in the hands of your local banker who will hold the money until Jan., 1st, 1910, while you test the heater.

These
Important
Heating
Books
FREE



If the test is not satisfactory to you in every way, you may return the goods at our expense and have your money back, we to pay cost of removal and freight charges both ways. Ask us more about it. There's money in it for you. Our great co-operative plan makes you a partner in our success. We explain this with every estimate. This offer also applies to heating equipments for all buildings. We manufacture and sell from our Factory direct to you.

No 45
**"Leader" Steel
Furnace**

Price \$49 Pipes and Registers Extra
Delivered any station east of Omaha and north of the Ohio River.

Heating Plans Free! Write for Booklets!

Send us a rough sketch of any building that you wish to heat and—without any charge or obligation on your part, we will have our experts prepare a simple, clear plan, which you can easily understand, showing every detail of the furnace, pipes, registers, etc., in their proper places, with the exact cost to you of the complete equipment.

The Hess Furnace will burn any fuel. Besides any kind of coal, or wood—chips, twisted straw, corn cobs or any other waste fuel can be utilized and money saved.

Our free booklets, "Modern Furnace Heating" and "These Bear Witness," give valuable information about heating any building perfectly and economically. Write today for these booklets.

Hess Warming & Ventilating Co.,
912 Tacoma Bldg., Chicago



\$1.04 a Year for your Washing

¶ Ever stop to figure the great saving in money, health and energy by using an Automatic Electric Washer. ¶ It saves the woman's hands; stops the lame back, does away with the disagreeable features in the home that constantly arise on wash-days—just turn on the current for a few minutes and your washing is done. ¶ The simplest Electric Washer on the market and the most reliable—guaranteed to do cleaner work in less time and at less expense than any other Electric Washer on the market. Don't hesitate to ask us about it. There is a lot to be told that will interest you and save you money.

Automatic Electric Washer Co., Newton, Iowa

For our Mutual Advantage mention Popular Electricity when writing to Advertisers.

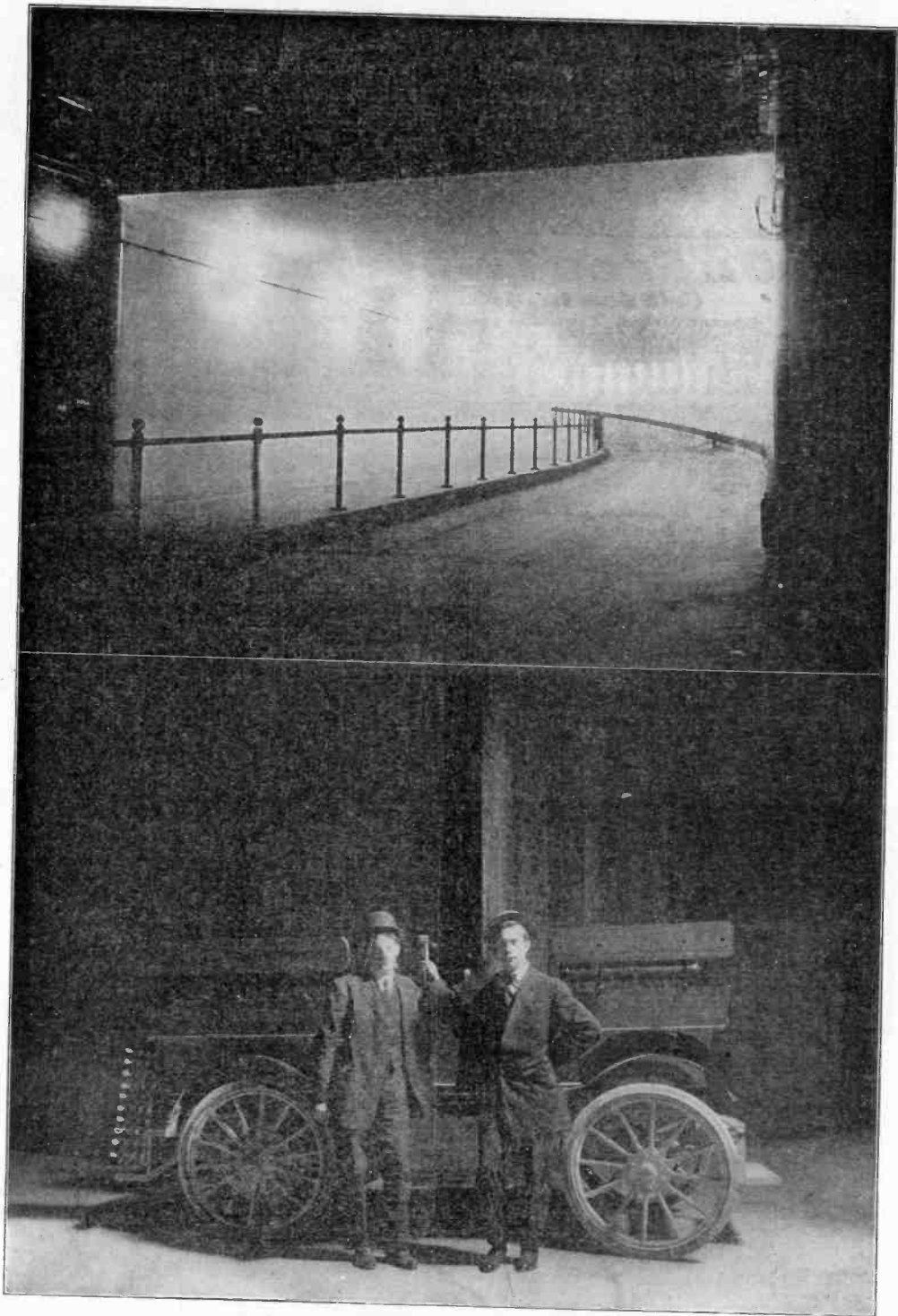

CHAUFFEURS TO THE UNITED STATES SENATE AND THE TUNNEL THROUGH WHICH SENATORS RIDE.

Copyright 1909, by Waldon Fawcett.



POPULAR ELECTRICITY

IN PLAIN ENGLISH



VOL. II

MAY 1909

No. 1

HOW SENATORS RIDE TO WORK.

BY WALDON FAWCETT.

The oddest automobile line in the country has recently been placed in operation in the capital city of the nation. Indeed, it is more than this. It may safely be said that it is not only distinctive among all installations of commercial motor cars but is quite the most novel transportation system of any kind in the world. The vehicles that comprise its rolling stock are unique, and finally, it has for passengers the most distinguished body of men that regularly ride on any such semi-public conveyances.

This innovation is an electric motor car line that connects the United States Capitol and the recently completed Office Building of the United States Senate, operating in a subway nearly one-third of a mile in length. In this electric-lighted tunnel are in operation electric automobiles of special design which regularly make the trip from terminal to terminal in one minute or less, carrying ten or eleven of the nation's lawmakers, or friends and constituents who may have business with them.

At present this most up-to-date of motor car lines is in operation only between the Capitol and the Senate Office Building, but it is planned to shortly extend the underground transportation system and have a similar line of cars operating between the halls of Congress and the new Office Building of the House of Representatives, which is located about as far distant from the Capitol as is the Senate Building, but in the opposite direction. The tunnel by which the House of Representatives Building is

accessible from the Capitol is a duplicate of the S-shaped "tube" leading to the Senators' working quarters.

Work began several years ago on the two marble office buildings—each costing \$3,000,000—for the use of the Senators and Representatives, respectively, these, the largest office structures in the world having been made necessary by the limited amount of space in the Capitol proper, which limitations, taken in conjunction with the constant increase in the number of legislators made it impracticable for more than a fraction of the whole number of Congressmen to have their private offices in the big white-domed building. Almost from the moment that it was decided to build a huge "annex" on either side of the Capitol there was discussion as to the best means of conveying the lawmakers quickly between their office buildings and the Capitol. Obviously an up-to-date system must be devised for it is frequently necessary for Congressmen to make a quick trip in order to vote on a bill upon which a roll-call is demanded or meet other like urgent contingencies.

The first decision reached by Mr. Elliott Woods, Superintendent of the Capitol, was that the various buildings must be connected by tunnel, for, in the vicinity of the Capitol, as elsewhere, Washington is a city of magnificent distances and Capitol Hill is particularly exposed in inclement weather. The tunnel provided, there arose the problem of transportation within the "tube." Various solutions were proposed, including moving

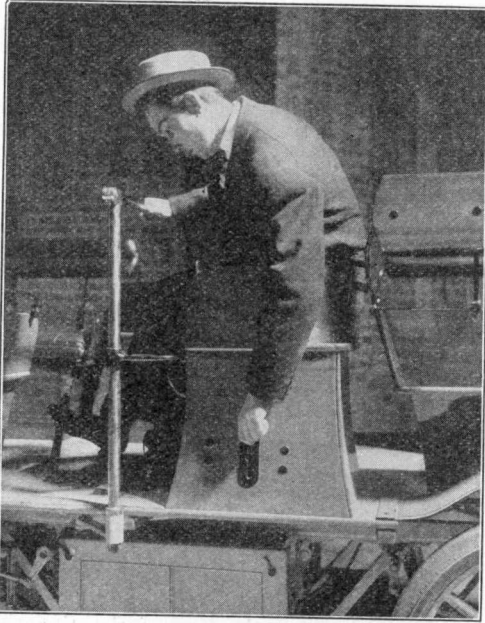

Copyright, 1909, by Waldon Fawcett
SIDE VIEW OF ELECTRIC VEHICLE.

sidewalks and miniature electric cars operating on a double-track system. Finally, however, after full investigation the officials gave their preference to a line of automobiles, electrically operated. These traverse a concrete roadway which is of sufficient width for two of the machines to pass at any point in the tunnel. A sidewalk, protected by a heavy iron guard rail, extends the length of the tunnel, parallel to the roadway, and pedestrians may get aboard the motor cars at any point in the tunnel, although it is expected that the autos will not make stops between the terminals except under unusual circumstances.

The motor cars, which derive their propulsive energy from five-horsepower storage batteries, were built for a contemplated speed of 12 miles per hour. It has been found that in actual service the average elapsed time required for a round trip is two minutes. The journey from the Capitol to the Office Building is made in 40 seconds, but nearly twice as much time is consumed in the return trip, owing to the fact that the entire journey is up-grade, and more especially by reason of the circumstance that the cars are, in effect, running backward on the return journey. Owing to

the limited space at the terminals and a desire to keep these novel shuttle-cars in continuous operation, the cars are not turned upon completion of each trip. Thanks to the special design of the car with seats along the sides, this mode of operation entails no inconvenience upon the passengers, but when the drive wheels are in front it is more difficult to steer and the chauffeur operates at a slower speed, which, combined with the slight grade, lengthens the time of the journey to the Capitol over that of the trip in the opposite direction.

The exigencies above mentioned were in great measure responsible for the design evolved for these new Capitol motor cars, which are radically different from anything else ever manufactured. To adopt a homely simile, this new style auto might be compared to two dog carts, placed end to end, and linked by a platform on which is the operator's seat, or rather seats, for there have been provided for the chauffeur two individual seats on opposite sides of the car and facing in opposite directions. When the end of a run is reached the driver changes seats and is thus constantly fac-

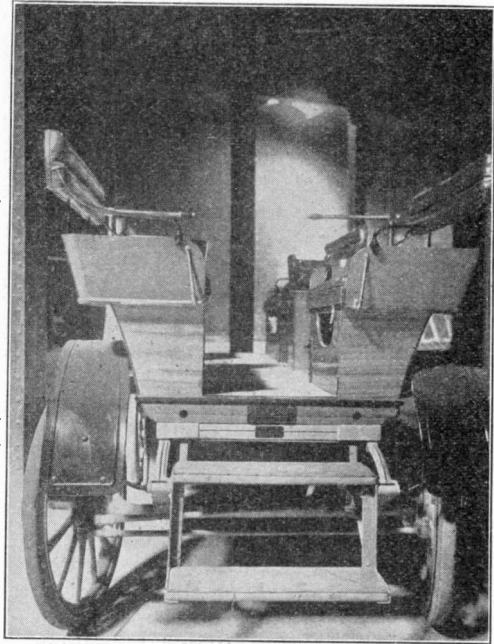

Copyright, 1909, by Waldon Fawcett.
END VIEW OF ELECTRIC VEHICLE.

ing to the front, although the machine is not turned around.

Six passengers can be accommodated in the seats at one end of the car and four passengers in the seats at the opposite end. In "rush hours" a passenger can always be accommodated in the vacant operator's seat (if he is content to ride backward) thus bringing the capacity up to eleven, excluding the chauffeur. The bodies of the Capitol autos are finished in a smart tan tint and upholstered with brown leather, a color scheme that was selected as harmonizing with the plastered walls of the tunnel.

The motor cars for the Capitol cost in the neighborhood of \$5,000 each, and it is contemplated that eventually four of them will be in operation between the Capitol and the Senate Office Building and probably a greater number between the Capitol and the Representatives' Building, owing to the fact that nearly four hundred Representatives, and an equal number of private secretaries and clerks to the Congressmen must be provided for as regular patrons.

The charging of the batteries of the Capitol motor buses is done at night, and it is not necessary to remove either the vehicles or the batteries from the subway for this purpose, the charging being done at the electric power plant which supplies light, elevator power, etc., to the Capitol and Office Buildings, and which is in the basement on the level of the subway.

FIRE ENGINE WARNING SIGNAL:

Fire engines, as they come rushing out of the barn drawn by half frantic horses, are not easily controlled. They emerge from the doors so suddenly that street cars passing in front of the barn cannot be stopped in time. So sometimes there are collisions.

In order to warn motormen when such danger is liable to occur an ingenious signal is used in Rochester, N. Y., at the corner of Platt and State streets, where there is a fire engine station. The picture shows the signal, which has two vanes. The view is down State Street, while the engine house door is on Platt street, not shown in the picture.

When the fire apparatus leaves the fire engine house the horses run over a contact maker, which is placed in the floor just ahead of the front wheel, and this completes a circuit in the signal box, starting the semaphore arms in rotation. The signal is so timed that it will run for about two minutes continuously, and then stop automatically, thus giving time for the fire apparatus to cross State Street in safety.

Mounted in the end of the semaphore arm are incandescent lamps which show red for night service.

Current for tripping the signal is taken from the 110-volt lighting circuit,

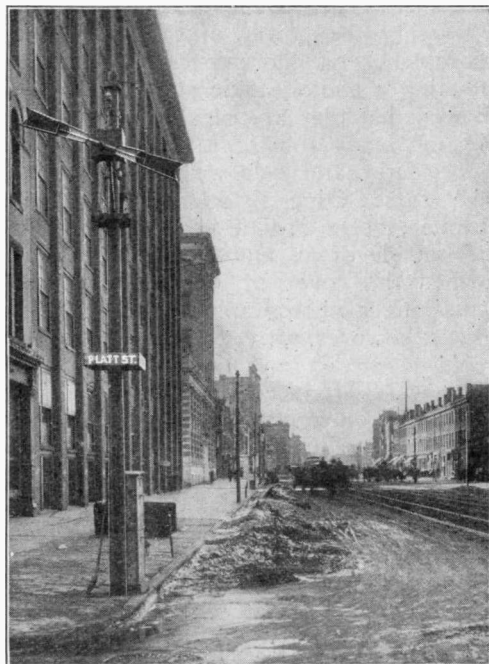

FIRE ENGINE WARNING SIGNAL.

while the current for whirling the signal is taken from the trolley.

Another signal which is installed at Main Street E. and Stillson Street, consists of a device for shutting off the trolley current at some distance on each side of the danger point. It acts on nearly the same principle as a circuit breaker and is contained in a box suspended between the trolley wires. It is tripped by the wheels of the fire-engine, as in the previous case.

ELEMENTARY ELECTRICITY.

BY PROF. EDWIN J. HOUSTON, PH. D. (PRINCETON).

CHAPTER XIII.—THE X-RAYS.

Reference has been made in the preceding chapter to the fact that by making the portion of the walls of a Crookes' tube against which the cathode rays strike, a thin plate, or, as it was also called *window*, of metallic aluminium, Lenard succeeded in causing some of the cathode rays to pass out of the tube into the air. These rays, called the Lenard rays, are luminous for a short distance from the aluminium window.

Lenard discovered that these rays carry a small charge of negative electricity, possessing the power of causing phosphorescence or fluorescence, as well as affecting a photographic plate. He also showed that they are capable of passing through many substances opaque to ordinary light, and even went so far as to take some faint shadow pictures of opaque or semi-opaque bodies placed on the outside of an aluminium plate that formed the cover of a light-tight box containing a photographic plate. These effects, however, were so feeble that they failed to attract any marked attention. They were produced by Lenard in the year 1894, or considerably after the observations by Plucker, Hittorf, Goldstein and Crookes referred to in the last chapter.

It was not until a later date, 1895, that attention was called to a somewhat similar phenomenon produced in the neighborhood of that portion of a cathode tube against which the rays strike. This discovery, made by Prof. W. C. Röntgen, of Wurtzburg, Bavaria, was regarded by the scientific world as of such importance that its announcement created the greatest excitement, and in a few weeks led to the repetition of the experiments at practically all places that had received information concerning them.

Röntgen had been making some observations on phosphorescence. Knowing the power of the cathode rays to excite this variety of radiation, he had in his laboratory a Crookes' tube through which electric discharges were passing.

He had darkened his laboratory; and, in order to prevent the light produced by the Crookes' tube from passing into the room, had carefully covered the outside of the tube with several thicknesses of black paper.

Among some of the substances in which Röntgen had been exciting fluorescence was a sheet of paper covered with a chemical salt known as tungstate of calcium. Happening to place this sheet of paper in the neighborhood of the Crookes' tube, he was greatly surprised to observe that it suddenly began to emit fluorescent light. Assuming, as a matter of course, that the light from the Crookes' tube was escaping through cracks or openings in the black paper, he carefully examined the tube and again arranged its covering until he was convinced that now at least no light could escape. To his surprise, however, the fluorescence of the tungstate-covered paper continued. He was, therefore, forced to the conclusion that there had been produced in the Crookes tube, by the bombardment of the cathode rays against the glass, an entirely new variety of radiation that possessed in a marked degree not only the power of passing through substances ordinarily opaque to light, but after such passage of also producing both fluorescence and phosphorescence, as well as affecting a photographic plate.

For want of a better name Röntgen proposed the name of the X-rays, or the unknown rays, for this peculiar variety of radiation. The selection of this name was in accordance with the usage in algebra of representing an unknown quantity by the letter X. This name, X-rays, has been generally retained in science, although the rays are frequently known, after their inventor, as the Röntgen rays.

It will be observed that unlike the Lenard rays, the X-rays produce no immediate effects on the eyes. If, therefore, an active Crookes' tube were covered with blackened paper, so far as the

sight was concerned, there would be no way in which the presence of the X-rays could be observed by the unassisted eye. If, however, a fluorescent substance were placed in their path, it would immediately become luminous. In a similar manner a photographic plate is also instantly affected.

As already remarked, the cathode rays are not produced until a certain high vacuum is reached. The additional discovery was made shortly afterwards that when this high vacuum exceeded a certain value, the amount of X-radiation produced was greatly decreased.

It may occasion some surprise that Lenard's discovery of rays that were able to pass through substances opaque to light and produce fluorescence, phosphorescence and photographic effects, so signally failed to arouse the attention of scientific men as was occasioned by Röntgen's discovery. There was, however, this difference. Lenard discovered an effect, so faint in its intensity that it could only be observed in the immediate neighborhood of the aluminium window. It was therefore without any practical value. Röntgen's discovery, on the contrary, was of a radiation of such intensity in its penetrating power, that it was capable of producing its curious effects at considerable distances from its source.

When Röntgen demonstrated that the X-rays possessed such penetrating power that they could readily pass through inch boards of wood, a thousand pages of an ordinary book, or two packs of playing cards, and still be able to produce fluorescence, phosphorescence, or photographic effects, it is not surprising that the announcement instantly commanded the close attention of the entire scientific world. Not only because there was something apparently uncanny in the ability to see what was otherwise invisible, but especially because in addition to this, it was found that the X-rays possessed the wonderful power of readily passing through the flesh, blood and soft tissues of the human body, so as to permit its bony skeleton as well as some of its internal organs to be examined. The world at large recognized that these rays would afford a wonderful aid in

medical diagnosis. Therefore the discovery attracted universal attention.

Suppose, for example, as represented in Fig. 86, that a screen consisting of a sheet of paper or other substance transparent to X-rays, covered with a fluorescent substance, such as tungstate of calcium, or platino-barium-cyanide, is placed at the larger end of a stereoscope with the fluorescent surface turned towards the inside. Then if one hand of the experimenter is held outside the box near the fluorescing plate, or as it is called the fluorescent screen, and his eyes placed at the opening in the smaller end, a picture will be seen on the screen of the bones or other opaque integuments of the hand when X-rays are permitted to fall on the outside of the hand.

In a similar manner, if, as repre-

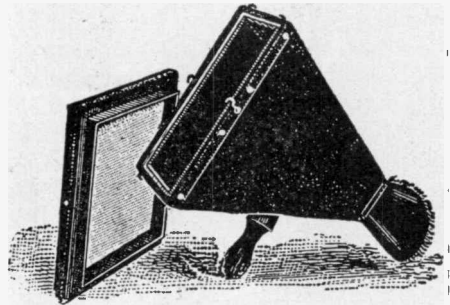

FIG. 86. PLATINO-BARIUM-CYANIDE SCREEN.

sented in Fig. 87, X-rays are passed in a nearly dark room through the human body as represented, and a large screen covered with a fluorescent substance is placed near the back of the person standing in front of the source of X-rays, there will be seen on the screen, the fluorescent surface of which is turned from the body, a shadow picture of its skeleton and other semi-opaque parts.

In this picture the X-ray tube is shown with the X-radiation thrown from one-half of its surface, and its terminals connected with the terminals of an electro-static induction machine provided with Leyden-jar condensers.

The fluorescent pictures above referred to exist only while the rays are passing. It is easy, however, to produce permanent pictures. To do this it is only necessary to employ a sensitive photographic plate, wrapped with several

thicknesses of blackened paper so as to be thoroughly opaque to ordinary light and placed on a table with its sensitive surface upward below an excited X-ray tube, as shown in Fig. 88, so that the rays may fall freely on the paper. Before the current is passed through the tube the hand is placed as shown on the paper, between the sensitive surface of the plate and the X-ray tube. Under these circumstances, only those portions of the plate are affected where the rays

like a pistol ball, a needle, pin, or other body, that had been accidentally introduced below the surface.

In the above example, the high-pressure electric source employed for the operation of the X-ray tube is a Ruhmkorff induction coil capable of producing a 15-inch spark through free air.

The intensity of the effects produced by X-rays varies not only with the character of the vacuum in the X-ray tube, but also with the intensity of the electric

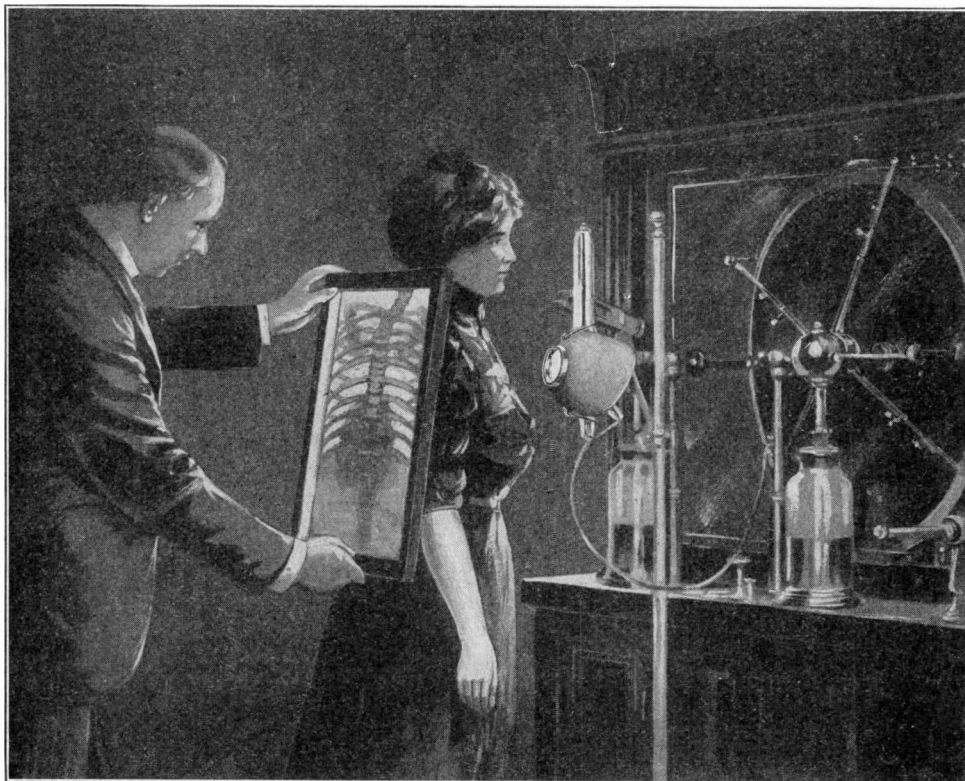

FIG. 87. AN X-RAY SHADOW PICTURE.

pass freely through the flesh, blood and other transparent tissues, while the bones, and other opaque or semi-opaque tissues cast shadows on the plate. Consequently, the negative so produced is employed for printing a picture. Such a picture of the foot and shoe is seen in Fig. 89.

It will readily be understood how great an aid an X-ray photograph, like the above, would afford a surgeon in locating the presence of a foreign body

discharge. If, however, too great a bombardment of the cathode rays is permitted to fall against the wall of the tube, the glass may be rapidly melted, thus destroying the tube. In order to avoid this, instead of permitting the cathode rays to fall directly on the wall of the glass tube they are caused to strike against a piece of highly refractory metal such as platinum, placed opposite the cathode. Such a piece of metal is called an anti-cathode, and can

safely be exposed to a bombardment that is capable of raising its temperature to incandescence. An X-ray tube provided with an anti-cathode contains also a cup-

vided with a cathode (C) composed of hammered aluminium in the form of a concave reflector of such dimensions that the cathode stream is focused on the

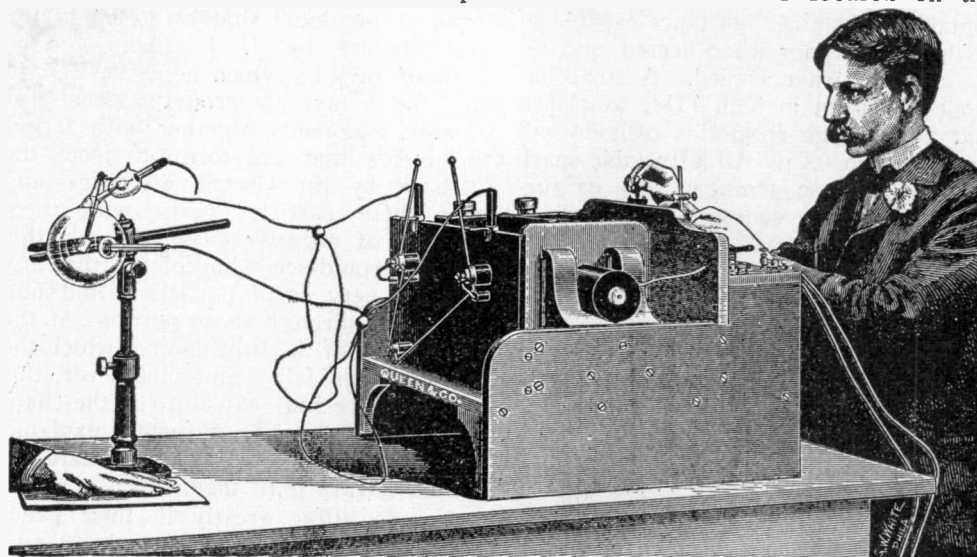

FIG. 88. TAKING A RADIOGRAPH OR X-RAY PICTURE OF THE HAND.

shaped terminal that focuses the rays on a point on the surface of the anti-cathode, thus insuring a sharper shadow picture than if the X-rays were thrown off from an extended surface.

Various forms have been given to X-ray tubes. In some, arrangements are provided whereby the extent of the vacuum may be regulated, thus permitting the most effective vacuum to be readily obtained; for, it can be shown that after a somewhat prolonged use the vacuum in the tube increases to such an extent as to render it practically inoperative unless a gradual leakage may occur into the tube.

The Queen self-regulating X-ray tube represented in Fig. 90, is suitable only for use with the currents like those obtained from an induction coil or a static induction machine. It consists of a large bulb (B) that forms the X-ray tube proper, and a smaller bulb (D) communicating with (B), so arranged that it can automatically lower the vacuum in (B) should it become too high to produce X-rays. The construction and operation of the self-regulating X-ray tube are as follows:

The X-ray tube proper (B) is pro-

vided with an anti-cathode (A) or anode formed of platinum. The outer end of the cathode is represented at (K).

(B) is exhausted to such a high vacuum that initially no discharge will pass



FIG. 89. A RADIOGRAPH OR X-RAY PICTURE.

through it. The bulb (D) on the contrary, is exhausted to a low Crookes vacuum. A small pear-shaped bulb (X) communicates with the bulb (B) and contains a chemical substance capable of giving off a vapor when heated, and re-absorbing it when cooled. A small cathode is placed in bulb (D), so placed that a discharge from this cathode will heat the bulb (X). An adjustable spark point (P), is so arranged that its further end can be swung to any desired

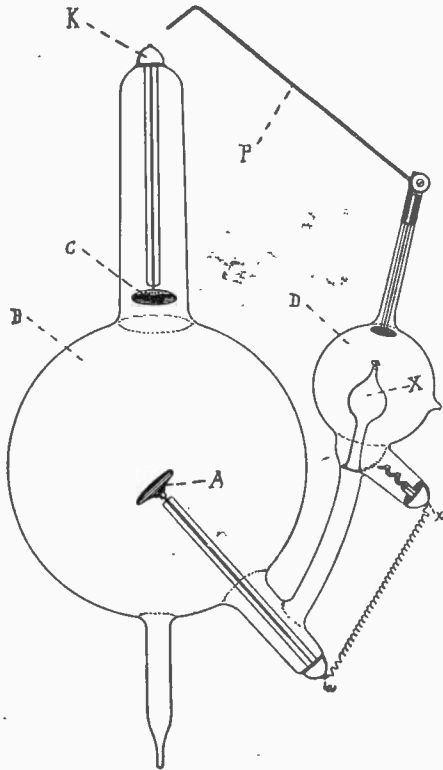

FIG. 90. QUEEN SELF-REGULATING X-RAY TUBE.

distance from the terminal of the main cathode (C) at (K).

When the self-regulating tube is first employed the discharge cannot pass through the bulb (B), on account of its high vacuum, but readily passes from (K) to (P) through the bulb (D). Heating the bulb (X) it causes vapor to be given off from the substance it contains. This vapor entering the main bulb (B), lowers its vacuum so as to permit the cathode rays to be discharged from the cathode (C), which falling on

the anti-cathode (A) cause it to become a source of X-rays.

The exact nature of the X-rays is unknown. There would appear to be little or no doubt that as stated in the last chapter by J. J. Thomson, the cathode rays by which both the Lenard and the X-rays are produced consist of minute fragments together with larger fragments that are torn off from the cathode by the electric discharge and that these particles carry with them charges of negative electricity. If this is so it would seem improbable that any but the very small particles could find their way through those portions of the glass walls of the tube against which the cathode rays fall. Since, however, this will be more fully explained in the chapter on radio-activity, a further explanation will be deferred as to the character of the X-rays until then.

X-rays differ greatly in their penetrating power according to the condition of the vacuum of the X-ray tube and the electric pressure employed for its operation. The penetrating power, however, and the ability to produce X-ray photographs, will vary with the distance from the tube. Neglecting losses by absorption provided they are produced from a point source, the penetrating power will be inversely as the square of the distance.

The most sharply defined X-ray photographs are produced when the rays come from a point rather than from a surface.

As regards the character of the sensitized plate employed in X-ray photography, it has been found that certain emulsions are especially sensitive to this form of radiation, so that the best results are obtained by the use of plates especially prepared for the purpose.

Care must be taken to avoid too prolonged an exposure of the body to an active X-ray tube for this character of radiation, like sunlight, possesses the power of setting up a severe inflammation that may result in suppuration and sloughing of the tissues. A curious difference, however, exists between the position of the parts affected by sunburn, the name given to such inflammations when caused by sunlight, and X-ray

burns or dermatitis, or that caused by exposure to X-rays. Sunburns are limited to the outer surface of the body. X-ray burns affect principally a portion of the surface of the bones called the periosteum. This is to be expected, since the flesh and other tissues covering the bones permit the X-rays to readily pass through them, and fall almost as freely on the bones as if all the flesh and blood had been removed, and the bones were directly exposed to the radiation.

X-ray burns are often exceedingly severe, and may necessitate the removal of an arm, or a leg, or even cause death. What makes it all the more difficult to avoid such burns is the fact that a comparatively long time generally elapses between the exposure and the setting in of the inflammation. For example, several weeks may elapse before the inflammation shows itself. With proper care, however, X-ray examinations and X-ray photographs can be made by comparatively short exposures, so that no serious results to the patient need occur. It is different, however, with the operator, who is apt to suffer severely from over-exposure. When, however, care is taken to protect the body by shields of lead plates, and to avoid unnecessary exposure to direct radiation from the X-ray tube, no serious results need occur.

(To be continued.)

STRIKING ELECTRIC SIGN.

The electric coffee sign shown in the picture is so realistic that it would almost give you a thirst, so to speak. The sign is 21 feet wide and 32 feet high, and is erected on a prominent corner in Atlanta, Ga.

The border is outlined by three rows of lights—red, white and green—the colors changing about 20 times a minute. The immense letters of the wording, "Luzianne Coffee" have also three rows of lights, red, white and green, and, together with the border, are flashed consecutively red, white and green, and then all colors at once. Lights in the remainder of the lettering are all white and burn continuously.

The picture on the sign represents an ante-bellum "Mammy" pouring her cof-



STRIKING ELECTRIC SIGN.

fee and a bank of lamps are so arranged and operated by flasher, that the steam which is continually arising from the cup and pot gives a beautiful cloud effect, while the stream of coffee being poured from the pot is plainly visible. The sign contains 1,350 two-candlepower incandescent lamps.

ELECTRIC SWINGING DOOR.

Revolving doors leading into the Hotel Astor in New York are now operated by electricity instead of by hand. A doorman whose duty it used to be to swing the glass doors by main strength, now does his work with no greater exertion than is needed to press a button.

He stands in the hotel lobby some distance from the doors. In his hand he holds an electric button attached to a wire. The other end of the wire is connected with the door swinging apparatus. When anybody approaches the doors from either the street or the lobby side the doorman presses the button and the doors swing round.

GASOLINE CARS SUPPLANTED BY ELECTRICITY.

There is an interurban railway 20 miles in length extending from Kansas City, Mo., in a southwesterly direction to Olathe, Kan., that is of more than usual interest from the fact that it affords an example of the abandonment of the gasoline-operated motor cars, which attracted considerable attention a few years ago, in favor of the straight overhead electric trolley system. For several years the road was operated with the gas-electric system of motive power, in which each motor car is a complete power station, with gasoline engines driving electric generators, supplying, in turn, electricity to operate the motors. But it was decided, after careful consideration, that the straight electric system offered advantages in economy, attractiveness to the public and reliability of operation, and so the road was "electrified," the electric service going into operation the first of this year.

No unusual conditions presented themselves in planning and building the electrical equipment. The line extends from the intersection of Thirty-ninth Street

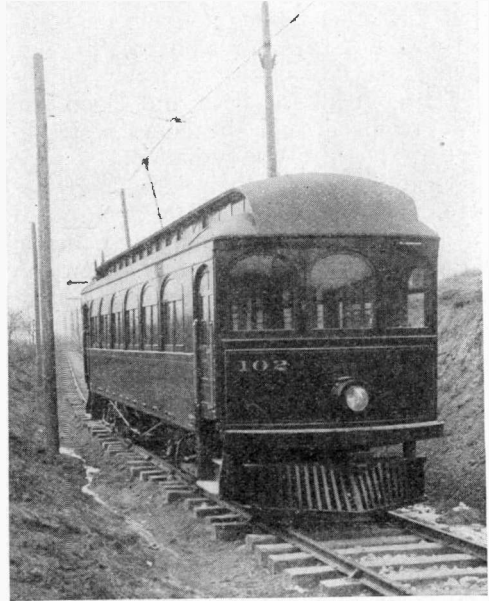

MISSOURI AND KANSAS INTERURBAN RAILWAY CAR.



POWER HOUSE OF THE MISSOURI AND KANSAS INTERURBAN RAILWAY.

and the state line in Kansas City, where it is connected with the local street railway system, along a ridge known as the Old Santa Fe Trail, through the villages of Overland Park and Lenexa to Olathe. There are no bridges and no grades steeper than $1\frac{1}{2}$ in 100, except at a hill near Olathe, where the grade is 4 or 5 in 100. The tracks of the Missouri and Kansas Interurban Railway Company, which built the road, are laid on private right-of-way exclusively, with 70-pound rails and white-oak ties.

The ordinary 600-volt direct-current

without "feeders," which are usually employed in electric railway work. This wire is of copper and is of the size known as No. 0000. It is suspended from brackets on poles on the tangents or straight stretches of track, but on curves the cross-suspension system is used; that is, poles on each side of the track support cross wires, to which the trolley wires are attached.

As the power house is about thirteen miles from the Olathe end of the line, there is a considerable "drop" in the electromotive force or electrical pres-

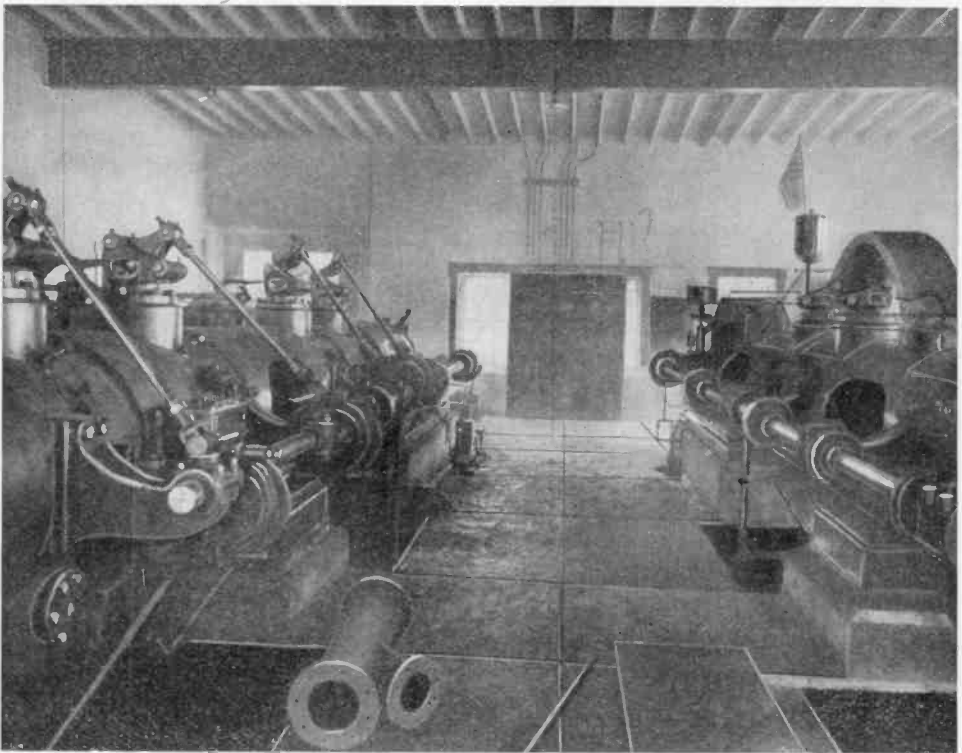

GAS ENGINES FOR DRIVING RAILWAY DYNAMOS.

system is used. Power is supplied to the line by a power station at Overland Park, about seven miles from Kansas City. Electricity is generated by two dynamos of 260 horsepower each, driven by gas engines direct coupled. The gas supply is obtained from gas wells on the company's property, and there is also a connection with the mains of the company furnishing power gas to Kansas City. The electricity is fed directly into the overhead trolley wire,

sure. Owing to the considerable current used and the comparatively low pressure at the start, the 600 or 625 volts at the power house is not more than about 440 volts at the end of the line, the loss being represented by energy consumed in overcoming the resistance of the large copper wire for this distance. And it is just at this point, too, that the voltage should be at its highest in order that the motors may work at their greatest efficiency in climbing the

hill. It may be explained that the power plant was not placed at the midpoint of the line because the car-barns were located on the company's property at Overland Park in the time of the gasoline cars.

To overcome this "drop" a storage-battery station is in operation near the Olathe end of the line. This is arranged to "float" on the line, as the engineers express it. The line pressure, 440 volts, is used to charge the battery, which is discharged as needed at 600 volts. Of course, as something can not be made out of nothing, the voltage is "boosted" at the expense of some current, but as amperes are plentiful and volts are what are needed, the arrangement is entirely satisfactory.

Prominently shown in the exterior picture of the power house and car barns at Overland Park is an elevated water tank. This is part of the water-supply system. A motor-driven pump forces water from a spring about 2,000 feet distant up into the tank, whence the

water is distributed about the plant as needed. The gas engines in the power plant are water-jacketed to keep them cool, and from this tank the circulating water is obtained.

The passenger cars used on this line are large and handsome. They are 44½ feet long and will seat 52 persons, 12 in the smoking compartment. Four 40-horsepower motors, on two trucks, propel each car. The cars are designed to operate in one direction only, and the motorman's cab is arranged at one side of the front end of the car. This gives passengers a practically unobstructed view through the front of the car, at the same time securing maximum seating capacity and a front exit.

From the Kansas City terminal the cars are operated for a distance of about three miles to the center of the city by the Metropolitan Street Railway Company of Kansas City. The business of the interurban road has been greatly increased since the electrification.

EXPERIMENTS WITH HIGH-VOLTAGE CURRENT.

BY H. L. TRANSTROM.

Two different effects are produced at the terminals of a high-voltage transformer which are very interesting to study. In the first illustration, the discharge resembles a flame as from a burning match but much larger.

When the terminals are charged to the full voltage, and the discharge is not allowed to pass, it is called static, meaning that the charge is in a state of rest. The voltage is then at the maximum, but as soon as the pressure breaks down the high resistance of the air, the air is heated to incandescence which lowers its resistance to a few ohms. The voltage correspondingly decreases to a fraction of the voltage which existed before the resistance of the air-gap was broken down. The flame is very hot and assumes a yellow color because of the presence of sodium in the air. If the terminals are composed of copper the flame is bluish and the cotton covering gives it a reddish tinge.

The characteristic inverted V-shape of alternating discharges of a high voltage

transformer is due to the heating of the particles of air which causes them to rise, drawing the flame upwards to a height of several inches, depending on the voltage, amount of current flowing and the shape of the terminals. The "horn" lightning arrester is based on this principle, two terminals of heavy copper wire being set quite close together at the bottom but spread apart at the top so that the draft of air blows out any arc that may form by the line current after the lightning has passed through it to the ground.

If a condenser, such as a leyden-jar or any high voltage condenser is shunted across the terminals, the flame discharge ceases and assumes a more startling form. The flame discharge is practically noiseless and gives a very ordinary light, but the condenser discharge produces a roar like a miniature thunder clap and yields a dazzling light very much like lightning. To the eye each discharge appears to be a single spark, but it has been proved, when analyzed

by a very rapid picture taking device, that it is made up of several sparks alternating with almost inconceivable rapidity.

To understand this consider the action of the pendulum. When given its initial energy, necessary to raise it to one side a certain height, and then released, it drops to its position when at rest but does not stop there because of its inertia, swinging to a height almost as great in the opposite direction and then back and forth, each succeeding swing a little shorter than the one preceding until it comes to rest at a vertical position. The reason it comes to rest is that the friction of the pivot and the air resist its motion, otherwise it would continue to swing indefinitely.

The electrical inertia is vastly greater than the inertia of the pendulum, so when the condenser surfaces are given their initial charge from the secondary of the transformer, they discharge through the high resistance air gap, from the positive

discharge only in the opposite direction, repeating this until the charge cannot bridge the air gap. Each discharge is a little weaker than the one preceding, as were the strokes of the pendulum, due to the loss of energy dissipated by the light, heat and sound.

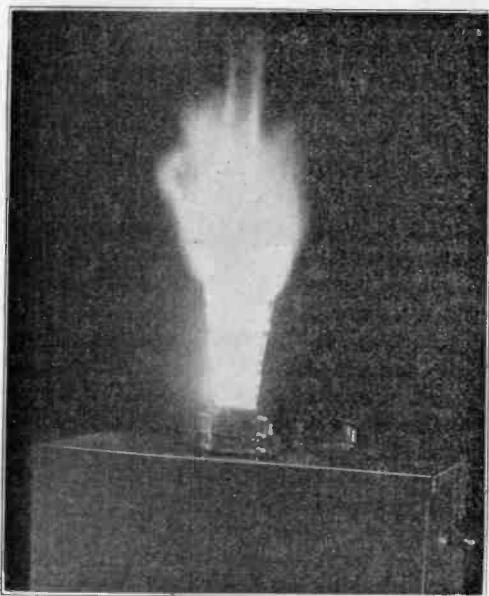

CHARACTERISTIC V-SHAPED DISCHARGE.

plate to the negative. The former, because of its inertia, overdischarges and causes the negative to become positive and the positive, negative. If the air gap is not too long the plates will again

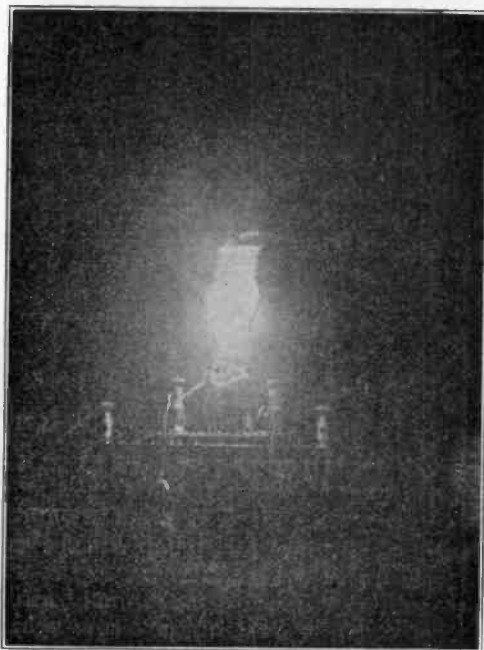

DISCHARGE WITH CONDENSER ACROSS TERMINALS.

The longer the pendulum the less frequently will it swing, and the larger the capacity of the condenser, the less the frequency of the discharges, therefore a small condenser gives a higher frequency than a large one.

When one charge has been dissipated in the spark the transformer again charges the plates to a high voltage and the discharge is repeated.

If the condenser is small enough and the air-gap through which the spark jumps short enough, the condenser can be charged and discharged several times during one alternation of the transformer. If the discharge of the condenser is permitted to pass through a suitable coil of wire in series with the spark gap and a secondary of suitable construction is placed in a proper position to it, we have what constitutes a Tesla coil and induced high frequency current.

EARLY ELECTRIC LOCOMOTIVE.

One of the first electric locomotives put in operation for commercial purposes is shown in the picture. It was constructed in Wisconsin and shipped to Derby, Conn., and there put into immediate use for the hauling of freight between the towns of Ansonia and Derby, and was the only means of hauling freight or expressage from the busy manufacturing town of Ansonia to the Derby docks, the marine shipping point for the Naugatuck Valley.

The Naugatuck Valley Steamboat

in them. The first run was made on the morning of April 30, 1888, from Ansonia to Derby.

Soon after the freight service was inaugurated it was found that the railway company could operate passenger service to replace the horse cars that were plying between Birmingham (now Derby), East Derby and Ansonia, so they had a car constructed of a somewhat similar design to that of the freight service, only the motor was mounted in one end of the car, and the rear was used for passengers. To the motor shaft was

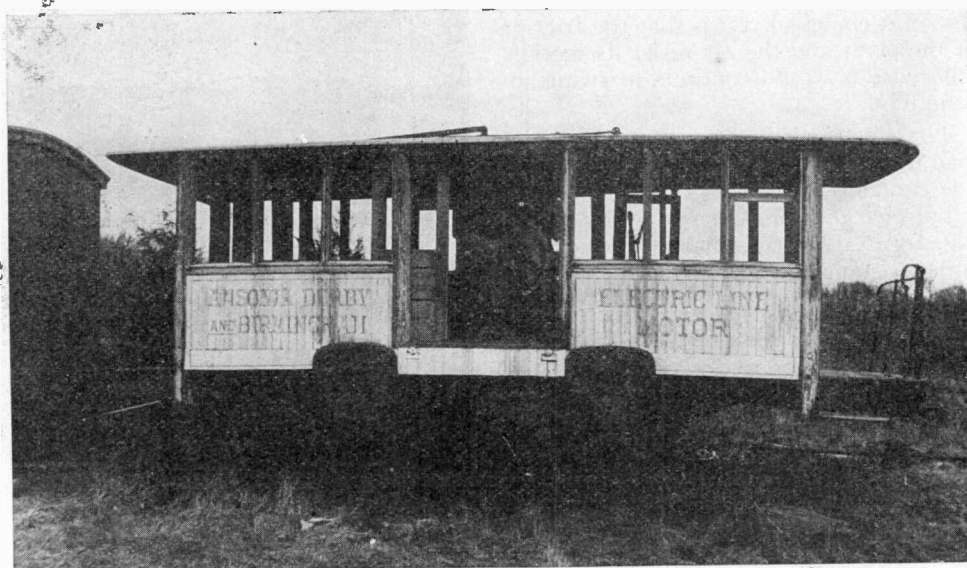

EARLY ELECTRIC LOCOMOTIVE.

Company used to ply between the cities of New York and Derby, furnishing means for conveying freight between the manufacturing towns of the valley and all commercial points, and this freight was hauled by trucks drawn by horses until electric transportation was installed.

The motor car was among the first of its kind to be built, and the motor was constructed very clumsily, occupying a large portion of the car. The remaining space was devoted to the controlling apparatus, brakes, etc. The motor car and trailers were constructed very low, owing to the necessity of passing beneath some low bridges or trestles; and this made it impossible to stand erect

attached a union, meshing into a large gear; this gear was mounted upon a steel counter shaft, carried by broad bearings solidly attached to the bottom of the motor, so that the center of the motor shaft was always true with the counter shaft. Attached to this were two sprocket wheels which in turn were connected to two sprockets of larger dimensions and attached to the front axle, the means of propulsion being a steel chain between the sprockets. The motors were of 15 horsepower and the cars would run about 40 miles an hour on level ground.

One of these historical motor cars, as shown in the illustration, is now on exhibition at Pine Rock Park, Connecticut.

THE TUNGSTOLIER.

The tungsten lamp is here to stay for the simple reason that it gives a near approach to sunlight at a current consumption of $1\frac{1}{4}$ watts per candlepower. But the lamps cannot be put up in a haphazard manner. Some have tried to do this to their sorrow. They have taken old-fashioned fixtures and tried to shorten them and hammer them into shape to

way a tungsten should hang. These requirements are very well attained in the "tungstolier," an example of which is shown in the picture. The particular type illustrated is what is known as the folding tungstolier, that is, its arms work on hinges and may be closed up like an umbrella. It may therefore be shipped and stored in a small, compact package. When it is put into service its arms pro-

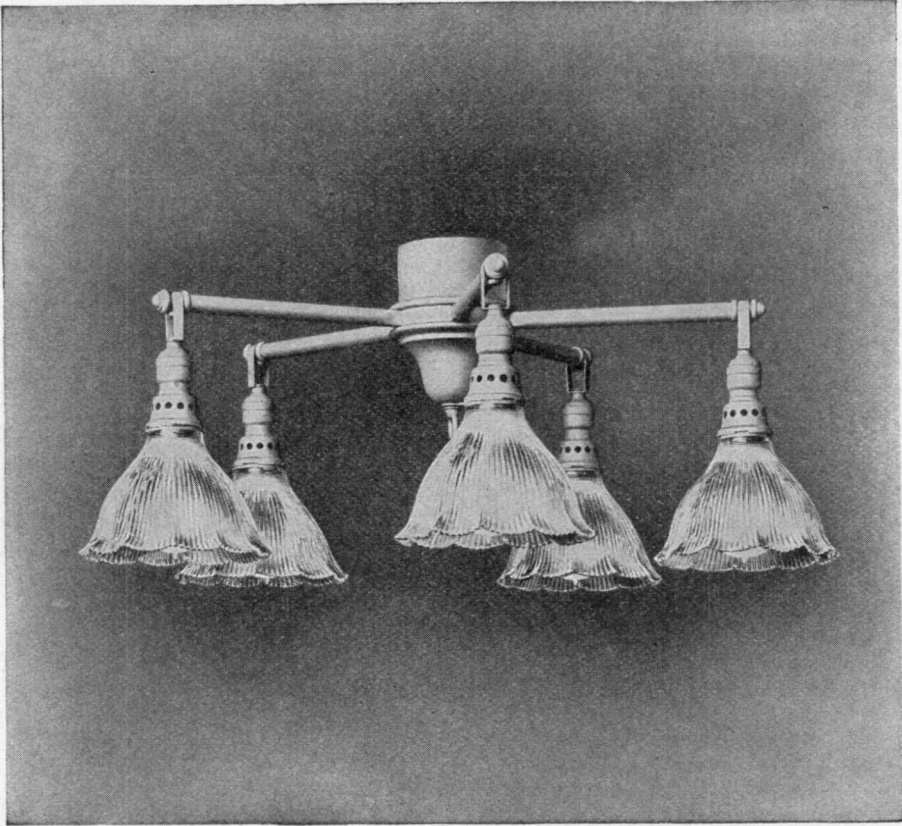

THE TUNGSTOLIER.

fit the requirements of the new lamp, with the result that the final cost has been greater than to have installed suitable fixtures at the start.

The principal requirements necessary to obtain the most efficient service from tungsten lamps are prismatic reflectors properly to diffuse and distribute the powerful light; a properly designed fixture to carry the lamps and reflectors, and a simply and substantially constructed link to suspend the lamp in a vertically downward position, which is the

ject outward and give a firm and rigid support. The sockets for the lamps, which also carry the shades, are then hung to the arms. The fixture comes already wired, it being only necessary to connect the wires in the stem to the outlet wires and to fasten it to the ceiling.

There are more than seven million telephones in regular service in this country and during the past year more than 7,500,000,000 messages were sent over the wires.

TRAINING A FIRST-AID CORPS.

How many men know how to act when a live wire is sizzling and sputtering around the sidewalk? Who among us could jump to the rescue of some unfortunate who has stepped on a current-carrying third rail? Neither live wire or still more lively rail are likely to suspend business while an expert is sent for, and it is someone's duty to act quickly in such an emergency if lives are to be saved. But saving another's life at the expense of one's own is a sacrifice that does not appeal to the average citizen and visions of sudden death by the method that is becoming the popular one for sending murderers to the great beyond are disturbing factors to the greatest hero among the spectators of an electrical horror.

The demon of the dynamo, however, loses much of his power to paralyze would-be rescuers when knowledge steps in to point the way to safe as well as quick action in rescuing victims of such accidents. This is regarded by the directors of our great railway systems as so self-evident a fact that concerted steps are now being taken to establish a national society of first aid to electrical victims. It is hoped that the work now in progress will in time become so widespread that never will a live wire get loose on one of its rampages or the third rail grip an unsuspecting wanderer in the forbidden paths of our railway lines without some bystander having sense and presence of mind sufficient to do the right thing at the right moment and with sufficient celerity to effect a rescue.

The work has been progressing so quietly that few are aware that this new "first aid" movement is in progress. The



HOW TO REMOVE A VICTIM FROM CONTACT WITH A CHARGED WIRE OR THIRD RAIL.

railways have had expert lecturers going the rounds of work shops and yards, gathering the men in their dinner hour or whenever there is a good chance for an audience and teaching them systematically how to deal with electrical accident cases.

One of the first lessons imparted, naturally, is how to tear the victim of a live wire or third rail accident from the clutch of the terror that lives in the metal. To take the live wire first: The men are taught that the way to detach this wire from the body of the man who has been shocked into helpless unconsciousness is for two of the bystanders to pull off their coats and twist them into a rope. One coat will do if the job of making a rope of two is likely to take too long. The two men run to the scene of the accident, holding between them the rope of coats. Passing this over the wire they can pull it away from the man on the ground without receiving any shock themselves. While they hold the wire away the victim can be dragged from the scene of danger. The coat idea is only advanced because a coat is the handiest thing to use. There is no time to run for a rope. A man can peel his coat off in a second, and having learned the lesson it will occur to him to do this at the first intimation of the need of a rescue.

In the third rail accident the men are told that if they will approach the victim with some caution and grasp him by the slack of his coat he can be dragged from the deadly rail without danger to the rescuer. Or he can be pried from the embrace of the current that is taking his life by means of a wooden bar or any piece of wood that is long enough for the purpose.

It is assumed by the lecturers that the victim will fall across the rail, for almost all third-rail accidents happen this way. A man stepping on the rail drops like a log and naturally drops right into the jaws of death. Now it does not follow that third rail contact kills at the first shock. The voltage is not sufficient to instantly render lifeless a strong and healthy man. It will kill a weak man, in all probability, at the first shock, but even in his case there is a possibility that

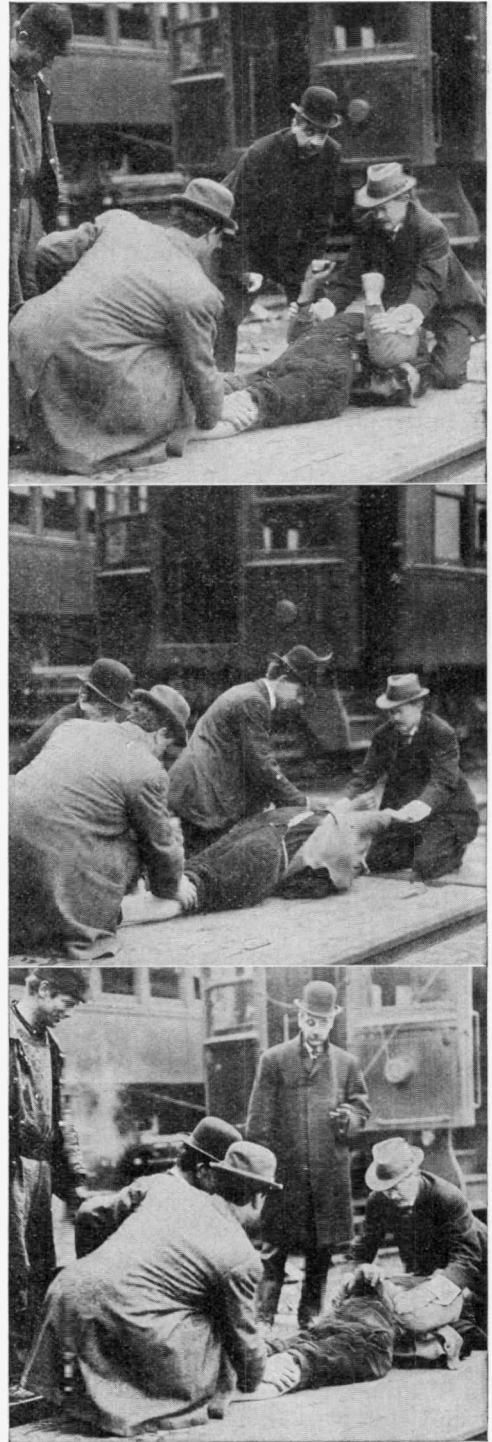

METHODS EMPLOYED IN RESUSCITATION FROM ELECTRIC SHOCK.

quick action may save him. In the past the unlucky individual who has stepped on this concealed death trap has remained there to be shocked to death. In the future it is hoped there will be some "first aid" expert at hand to prevent such a calamity.

The methods to be used in rescuing victims of electrical accidents are not all that is taught at these first aid lectures. The men are instructed how to go to work when the unconscious man or woman lies prone and still and apparently lifeless. Quick treatment in such cases is as necessary as it is when some swimmer has been dragged unconscious from the waves.

Some of the accompanying pictures, showing a lecture in progress, illustrate

arms are brought from the side of the chest to a line straight with the body until they meet over the head. Then they are brought sharply down again. The next movement is to bring the arms in a straight line to the side of the walls of the chest. Then they are pressed over the lower ribs to expel the air drawn in by the previous operations.

An additional lesson, one that has no connection with the saving of life, but which is important to the men who work where live wires are, is the teaching of the use of a hose during a fire.

Many of the men who work in the danger zone know that when a fire breaks out there is not only the risk of contact with broken live wires to be feared, but that the mere playing of a

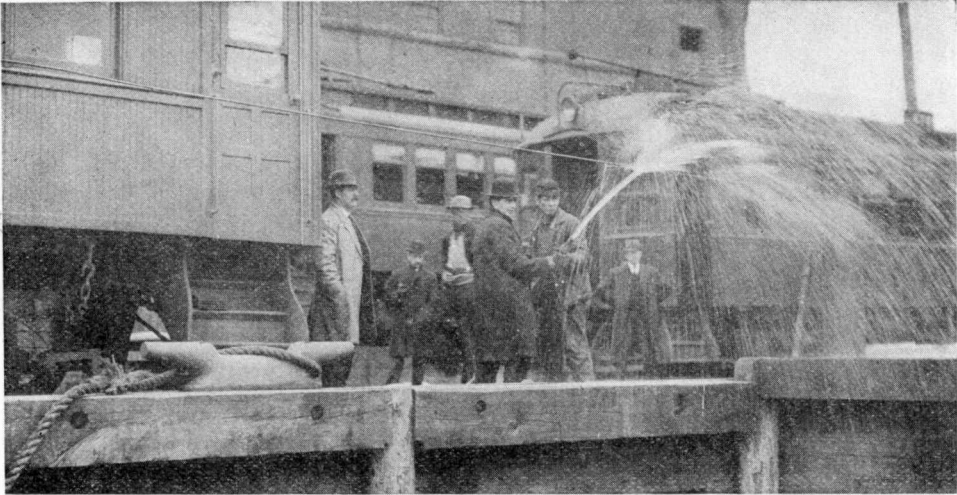

TEACHING THE USE OF A HOSE IN THE NEIGHBORHOOD OF LIVE WIRES.

the methods of treatment very plainly. The patient is first placed on his back with a coat under his shoulders to permit the head to fall back. His clothing is loosened at the neck and his sleeves and trousers rolled up. While one man is doing this another is examining the man's mouth to see if the tobacco he may have been chewing at the time of the accident has not slipped down his throat, or his false teeth, if he wears them, are not choking him. If ice is handy this is rubbed on the spine.

Another man during this time can be moving the arms of the patient in the proper way to restore respiration. The

hose on a live wire will give a man a shock that is far from pleasant, to say the least. The men are taught during the lectures how closely they can approach with a hose the vicinity of a live wire. At a distance of seven feet five inches the current from a live wire has not enough power to harm a man who is at the end of a hose from which water is pouring on the wire. If he approaches cautiously he can come within two feet of the wire with the hose pipe without encountering dangerous current, provided his heart is sound.

The lectures are a regularly recognized part of the railway work, paid lec-

turers being employed to educate the men. Those men who learn how to be electrical "first aiders" pass the knowledge on to their associates, and so the work is spreading fast and satisfactorily.

KLAXON—THE X-RAY OF SOUND.

"A creation in discord" is an appropriate phrase to apply to that strange, penetrating and most startling tone combination produced by the Klaxon, the latest

end of the shaft is a toothed wheel, the teeth striking a knob attached to a vertical diaphragm situated in the horn part. The vibration of the diaphragm produces the sound—the most unusual and startling roar that ever greeted human ears. It is only necessary to push a button and turn on the current from the battery which operates the motor. The small illustration shows the exterior of one type of the Klaxon with wires to connect it to the battery.

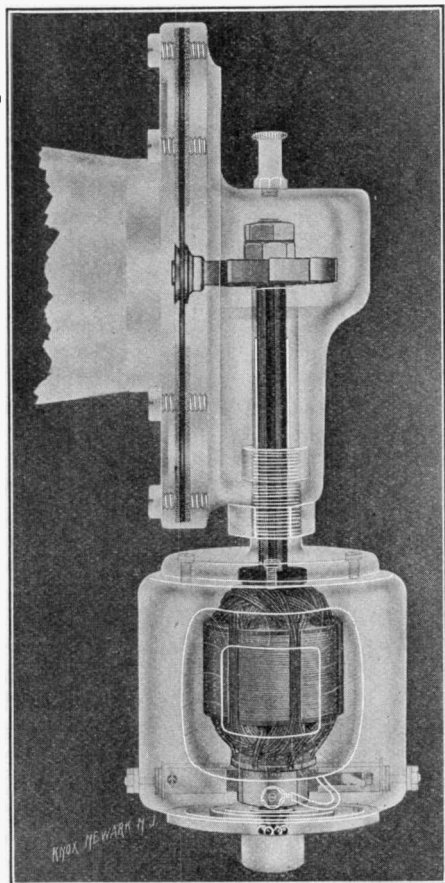

INTERIOR MECHANISM OF THE KLAXON.

automobile warning signal. In appearance the Klaxon is not unlike the ordinary automobile horn, but it is much different inside, being operated by an electric motor instead of air.

One of the illustrations shows the interior mechanism. In the base is a small motor on a vertical shaft which revolves at a tremendous speed. On the upper



KLAXON HORN COMPLETE.

The note of the Klaxon drowns every other sound in its vicinity. It cuts through fog readily, and carries to great distances in fair weather. For this reason it is an ideal motor-boat signal. It provides for a long-drawn or sharp-short note and starts or stops instantly. You can install it on either side, in any position you wish, and operate it from any section of your boat.

NEW ELECTRIC FURNACE PRODUCT.

A new material has recently been produced in the electric furnace to take the place of platinum for heating elements in electric cooking and heating devices. The new product is called silundum, and is produced by subjecting carbon to the vapor of silicon. The result is a silicified carbon which is similar to silicon carbide and has many of the same properties. It resists temperatures of 1,600°C. and does not oxidize, nor is it affected by acids. As a conductor of electricity its resistance is said to be several times greater than that of carbon.

DESTROYING STREET CAR TICKETS.

Traction companies are much interested in a new ticket destroying device which runs by electric power and literally "chews up" used tickets by the thousands, converting them into a salable product in the shape of waste paper, to be sold to paper mills or for packing purposes.

This machine is so simple that it can

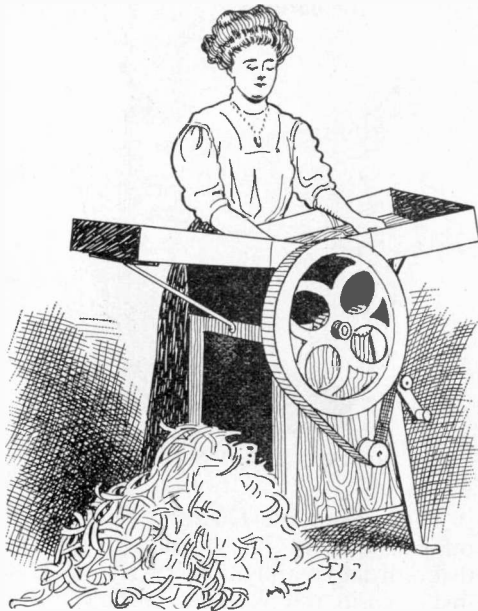

TICKET DESTROYER.

be operated by an office boy or girl. While in operation it occupies a space of two feet by four feet. The feeding boards or tables are hinged and may be dropped down out of the way when not in use. There are two of these tables enabling two operators to feed at the same time, thereby increasing the capacity.

Enclosed in the bottom of the frame is a $\frac{5}{8}$ horsepower motor, the operation of which will not be attended by any disagreeable noise in the office. Sixty circular knives of high grade steel $\frac{11}{32}$ inch thick are placed on two parallel shafts geared together by cut gears. Each knife is interchangeable. In case of injury to any one of these knives by a piece of metal passing between the rolls, it can be replaced at very small cost.

STANDARD ELECTRIC TIME SYSTEM.

Punctuality is essential to discipline, system and economy in all departments of life. To aid people to be punctual electricity is used in scores of ways, but even the people in whom these various systems are designed to stimulate promptness do not understand their mysterious working.

A modern electric time system consists essentially of a perfectly made, electric, self-winding master clock, which performs the dual function not only of keeping very precise time itself, but of controlling electric impulses to various other time keeping devices of which the system is composed.

The illustration shown herewith represents, diagrammatically, a master clock from which radiate electric circuits controlling time stamps; secondary clocks, which keep the exact time of the master clock, a tower clock motor for operating the clocks in a tower or steeple, and a program clock, which is sometimes used in schools. Electrically operated whistles may be added to the system and many other applications will suggest themselves.

One of the most interesting features of the system is the program clock, which may be used for a great variety of purposes, such as automatic signal work and the automatic starting and stopping of machines. This program clock drives paper ribbons which are perforated for the hours and minutes that signals should be given and thus permit electric circuits to be made through the perforations to the signal apparatus, as the ribbons slowly unwind. One program clock may control from one to eight independent and distinct circuits of signals with any number of bells on each circuit. Furthermore, the program clock is capable of automatically changing the program from day to day by cutting out a program on Sundays or giving any combination of programs that may be desired.

These program clocks have found many useful applications in schools for ringing signals for the dismissal of classes, changing of study periods, etc. There is, however, a wide, economic field for them in industrial work,

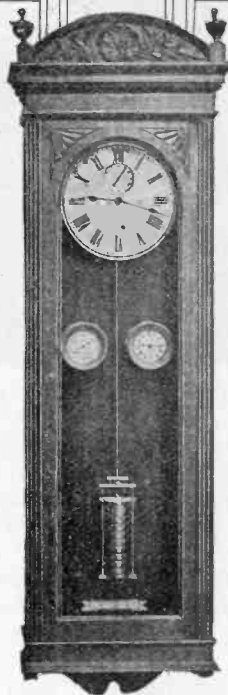
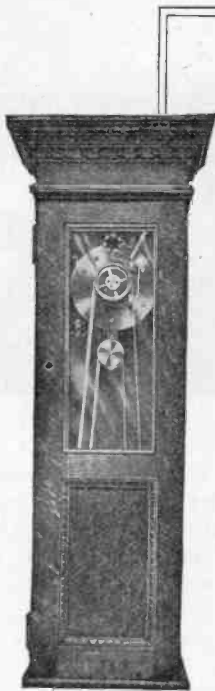
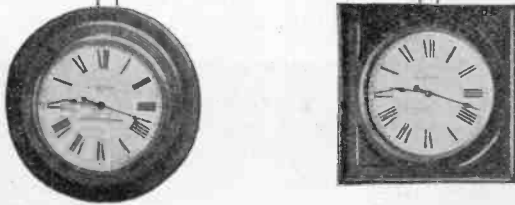
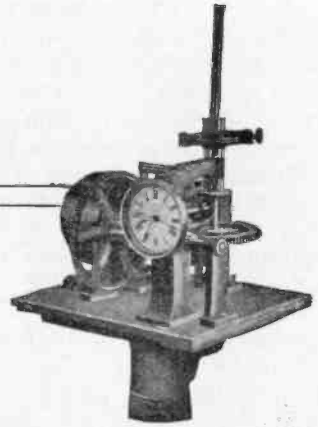
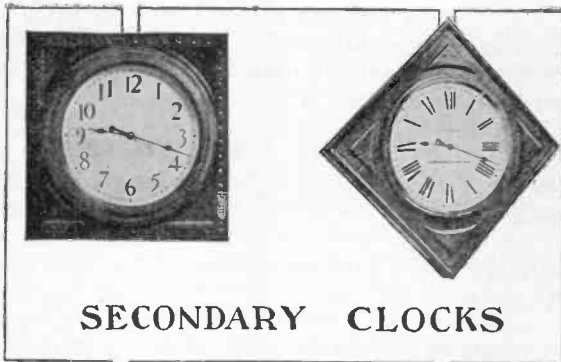

TO MASTER CLOCK BATTERY

SOME APPLICATIONS OF THE STANDARD ELECTRIC TIME SYSTEM.

EYE COMFORT.

The new method of indirect illumination, called the "I-comfort" (eye comfort) system, which was described in the December issue of Popular Electricity, is now made in what is known as the "adaptable" form; that is, the peculiar inverted reflectors are so arranged that they may be attached to the ordinary lighting fixtures without changing the latter, thus making the new system "adaptable" to the old. The system is meeting with favor in many instances where heretofore it has been difficult properly to illuminate the working plane,

but that it lessens the tendency to irritability, and one working under such conditions must be physically and mentally better at the day's end.

A NEW ILLUMINANT.

Plates of aluminum alloy used as electrodes form a new kind of electric lamp that is said to promise efficient and economical lighting. Trial was made with an alloy much used for motor castings and containing 90 per cent of aluminum, the remaining 10 per cent being chiefly copper and tin, with some manganese, iron and zinc and traces of silicon. Im-



INDIRECT ILLUMINATION IN OPTICAL GOODS STORE.

as in counting rooms and places where large clerical forces are employed. It is said that by this system the glare on the books and papers is entirely eliminated.

The accompanying picture shows the "I-comfort" system of lighting applied to a large optical goods store. Adaptable are here used on what were old-style electroliers, the new reflectors throwing the light up on the ceiling from whence it is reflected evenly.

The chief claims made by adherents of the indirect system of illumination are that it not only removes the cause of eye distress and frequent headaches, thereby conserving the bodily energy,

mersed in a solution of common borax such electrodes stand a current gradually brought up to 250 volts. The current causes the electrodes to glow like white hot iron in water without the sparking of pure aluminum, and with a lowered voltage an opal colored light was produced giving the effect of a building lighted with many concealed lamps. Beyond 200 volts small, shifting sparks appeared over a white surface. The glow resembles the light sometimes seen about wires carrying current of very high tension, but in this case there is a static discharge of electricity through the thin film of aluminum oxide coating the plates.

SIGNAL TO PREVENT CAR ACCIDENTS.

A prolific source of street car accidents is for a person to alight from the rear platform, pass around the rear end of the car and step onto the next track right in front of a car coming from the opposite direction and necessarily hidden from view until too late. Its bell may be clanging, but so also may be eight or ten others in the vicinity of a busy corner, and in the rush and turmoil it is so easy to be thinking of other things besides a mere street car.

A device which will prove efficient in preventing this particularly prevalent form of accident has been thought out by Mr. A. O. Nichols of Omaha, Neb. It consists of a signal bell mounted on the

ALL DAY SERVICE IN SMALL CITIES.

Time was when electricity was used almost entirely for lighting purposes. During the hours between dusk and daybreak the electric lighting plants ran the generators at their greatest capacity to take care of the thousands of lights burning in the streets, the shops and factories, the offices and homes. But as soon as old Sol peeked above the eastern hills the electrical engineer in the power house opened a switch and the arc lamps in the streets instantly went out, though the red hot tips of the carbon electrodes glowed for a few seconds in the morning light. In a few minutes more another switch was turned and the lights for the houses and buildings were turned off



EXTERIOR VIEW.

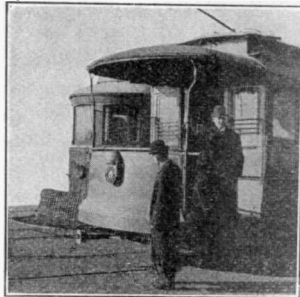

SIGNAL IN OPERATION.



INTERIOR VIEW.

rear of the car and operated with a push button by the motorman up in front. When the latter sees a car approaching on the parallel track while his own car is standing still, he rings the signal bell as long as there is any danger. This calls the attention of people passing the rear end of the stationary car to the approach of a car on the other track. The bell casing also bears, in plain letters, the following: "Look Out for Car on Other Track," which is illuminated at night by an electric lamp.

ELECTRIC CURRENT CONSUMPTION IN NEW YORK.

The New York Edison Company has about 65,000 customers on its lines extending over Manhattan Island and the Borough of the Bronx. Current is fed through 81,000 meters to an equivalent of 6,000,000 lamps. The electric motors taking current from the company figure up about 186,000 horsepower.

and the great generators soon stopped with no work to do during the daylight hours. The engines stopped running, the machinery stood motionless, the fires were banked, the steam pressure went down, while the engineer and his assistants killed time in cleaning up the different machines and polishing the brass fixtures, or went home to sleep.

But electricity has found so many new fields of employment in the past few years, and has come into such general usefulness in the shop, office and household by day that nearly every public electric power plant in towns of any size at all is now running day and night. The time has arrived when the power plants can earn nearly as much during the day as they do during the night. The electrical energy which was exclusively used for lighting purposes in the past is now recognized as the ideal source of power and an important factor in the heating world.

INVENTIONS OF EDISON—A CLASSIFICATION.

BY JOSEPH J. O'BRIEN.

Edison and invention are two words that have become almost synonymous in the minds of millions. As America has led the world in the volume of invention, so Edison has led in the volume of inventions produced by individuals.

Out of millions of experiments with nature things and with man things this nation has been developed into its present state of greatness. All the wonderful industrial arts of our time are the results of human experience organized by human experiments and developed into the organized knowledge of human science. The experiment is the instrument of invention and the product of experiment is art. Without art man would have remained uncivilized. Civilization, then, is the social effect of art, and since art is the product of invention, civilization is the elaborated effect of human invention.

Future fame will rest largely on the art test and not on the military test, and by this test Edison is greater than Cæsar. A great deal of exaggeration and a great deal of misrepresentation concerning the inventions of Edison have been indulged in. The scope of his work has been carried beyond truthful bounds by some, while it has been seriously underestimated by many writers who occupy positions of authority. In the *Encyclopedia Americana* it is stated: "More than three hundred patents have been issued on his inventions." This statement was 50 per cent wrong at the time it was published.

Other men have invented more complicated machines than Edison has; other men have solved tremendously difficult inventive problems. But in the volume of output; in the persistency of endeavor; in the brilliancy of experimental resolution, Edison stands forth as the inventor-leader of our time and our period—the wizard of experiment. It was Edison who subdivided the elusive electrical current, in the face of negatively figuring mathematicians, and brought the incandescent lamp out of the field of laboratory speculation and into that of commercial use and success.

An achievement which is of infinitely greater importance to the world than the erection of time wearing pyramids of little utilitarian value.

The production of a successful incandescent lamp demanded efficient current generating machines, efficient distributing systems, efficient control systems, and practical manufacturing and business methods. The problem was not merely one of carbonizing bamboo and durable lamp construction, but of economical, gas-competing illumination. Accordingly the entire field of seen possibilities was overhauled by the inventors, with Edison, the master experimenter in the lead. The influence of the successful incandescent lamp upon the entire field of electrical endeavor has never been fully established, but it is now recognized that the science of electrical engineering owes its greatest stimulus to the development of the successful incandescent lamp, which is made up of a bulb having a vacuum and a high resistance conductor therein. The incandescent lamp not only brought about the development of the science of electrical engineering and gave rise to whole industries embracing billions of invested capital, but rendered possible the modern stage, the wonders of which we are only beginning to see.

It was Edison who invented the continuous photographic film which has now been elaborated into an ever expanding art of photographic illustration. This art has brought a world of knowledge to every class and compelled the reform of opinion-ribbed art notions. This art has brought distant cities and peoples to our feet and made world-study a pleasure to the most indifferent. The moving picture theaters are now an established amusement feature of every city, and it is estimated that over forty million tickets are sold each week. Who can estimate the influence of this work upon the minds, hearts and relations of men? We cannot even appreciate it as yet.

John Philip Sousa says that the phonograph gave us "canned music."

Certainly. So did photography give us "canned" images and movements. So did type give us "canned" knowledge and "canned" history. In fact this work of canning things, of canning records, images, memories, tones, songs, voices, movements, events, forms a very vital part of the work of civilization. Since it is by art man advances it is by man's efforts in preserving and experimenting with art that art advances, and the advance of both involves the transmission of intelligence.

In order that the general scope of Edison's work might be better understood I have classified the patented inventions of Edison, and for the first time here give the general results of this classification in the following table. This classification does not attempt to give all of the many details of Edison's inventions, but does give the reader an accurate idea of the fields into which Edison has worked with results.

NAME OF ART.	MINOR ART.	PATENTS
Electrical Power Machinery.	Generators, Motors, Regulators, Governors, Machine parts.	123
Electrical batteries.	Storage batteries, Generating Batteries, Thermo-electric batteries, Processes of manufacture, Manufacturing aids, Battery parts, Gas manipulation.	64
Measurement of Electricity.	Meters, Controlling temperature of.	17
Distribution of Electricity.	Systems of distribution, Conductors, Fuse blocks, Junction box, Lightning arrester. Converters.	60
Electrical Communication.	Telegraphy, art of, Telegraph circuits, Telegraph instruments, Telegraph instrument parts, Telephony, Telephone instruments, Telephone circuits, Telephone parts, Signaling, Signaling instruments, Signaling boxes.	178
Electrical Illumination.	System of electric light, Incandescent lamps, Arc lamps, Fluorescent lamp, Filaments, Manufacture of filaments, Manufacture of lamps, Vacuum pump, Carbonizer, Thermal regulator, Safety conductor, Lamp parts, Electric chandler, Conductors, Cut-outs.	190

Electric Traction.	Electric railway, Electric locomotives, Propelling mechanisms, Railway systems, Turn tables, Trolleys, Insulation, Handling cable cars.	22
Phonographs.	Phonographs, Blanks, Phonograph parts, Phonograph dolls, Manufacturing blanks, Manufacturing tools.	98
Electroplating and Electrometallurgy.	Metal plating, Tools for plating, Electrolytic composition, Electric welding, Metabolizing iron.	11
Ore Manipulation.	Magnetic ore separators, Method of ore separation, Magnetic ore controlling, Grinding Machines, Ore conveyors, Screening, Crushing machines, Extracting ores, Mixers, Briquet making, Composition brick, Compressing dies, Making cement, Cement kilns, Cement, Drier	65
Photography.	Kinetoscope, Kinetographic camera, Kinetoscopic film.	4
Office Appliances.	Electrographic vote recorder, Autographic printing, Typewriting machines, Addressing machines, Autographic stencils, Stencil pens.	9
Journal Bearings and Gearing.	Expansion pulleys, Lubricating journal bearings, Shafting, Vehicle wheel, Dustproof bearings, Dustproof swivel gearing, Magnetic belting.	9
Glass.	Process of making glass, Apparatus for making glass.	3
Compressed Air.	Reheating compressed air.	2
Wire drawing.	Method of drawing wire.	1
Fruit preserving.	Vacuum fruit preserving.	1
Weighing.	Automatic weighing apparatus.	1

SUMMARIES.

Total groups of main arts.....	18
Total subdivisions of main arts.....	103
Total number of patents.....	858

The above classification is the first of its kind that has ever been published and deserves particular consideration for this, if for no other reason. It places in a concrete shape the inventions of Edison and enables the layman to readily ascertain what fields the "Wizard" has invaded with patent results. The electrical character of Edison's work is seen at a glance. Telegraphic

work led to the vote recorder, to the stencil pen, which in turn opened up the way for various office appliances, and to the larger field of telephonic invention. Telephonic work led to phonographic work, while general work with the electromagnets led directly to the magnetic ore separator. The magnetic ore separator opened up the field of mining and cement, which now promise some new wonders. The electric lamp led to generators, distributing systems, meters, regulators and manufacturing processes. As a by-product of vacuum work we have Edison's contribution to the art of fruit preserving by means of a vacuum. The generation of electrical energy and the commercial exploitation of that energy compelled work on storage batteries, which work continues without interruption.

The entire work of Edison presents a consistent evolution of things electrical in nature or in relation, and if one attempts to trace this work beyond the years of our time he will find it leading to the workshops and laboratories of Europe; to the "dancing frog" of Galvani; the "electric pile" of Volta; the magnet of Sturgeon; the discoveries of electro-magnetism; dynamic generation, and the differences between insulators and conductors. Without the magnet and the battery Edison could not have built up his magnificent work and it is to Europe that we owe these vital contributions.

CONTROL OF MOVING PICTURE ARCS.

Arc lamps for moving picture machines operate on approximately 35 volts and 40 amperes. Now 35 volts is way below that of the usual lighting circuit, which is about 110 volts. Therefore, the arcs cannot be operated directly across the light wires without the use of a device called a rheostat. The latter contains a lot of iron wire of high resistance connected in series with the arc lamp to keep too much current from flowing through the latter. But the rheostat itself consumes current which costs money, and besides, gives out a lot of heat which is uncomfortable in the close quarters usually occupied by the operator.

A device designed to eliminate the rheostat is called the Compensarc, shown in Fig. 1. This is on the order of a transformer to reduce the voltage of the lighting current to a value suitable for

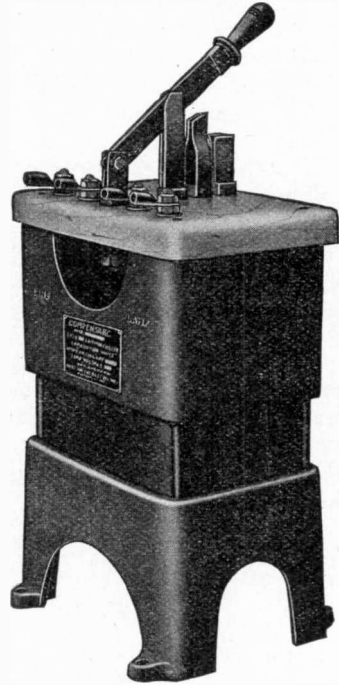

FIG. 1. THE COMPENSARC.

the arc lamp. Unlike the ordinary transformer, however, it is provided with various adjustment features to maintain the arc of a constant strength and uniform

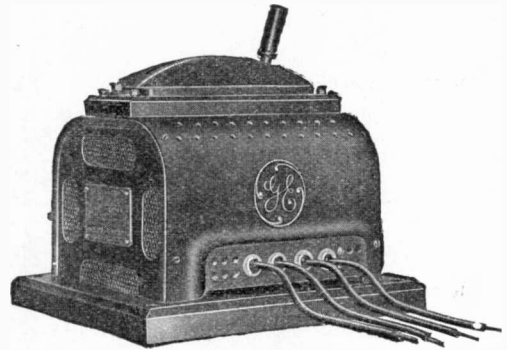

FIG. 2. ECONOMY-ARC.

quality so essential to the production of clear and steady pictures.

Another apparatus known as the Economy-arc, Fig. 2, is also a saver of

light bills. The regulation made possible by this device overcomes varying conditions such as result from different densities of films and different distances between lamp and screen. For the convenience of the operator the attachment wires are brought out through porcelain bushings in the casing, and each pair is marked, one "line" and the other "lamp," so that wrong connections cannot be made.

RADIO ADJUSTABLE TELEPHONE HOLDER.

The Radio adjustable telephone holder is the latest invention of Kempster B. Miller and Samuel McMeen of the firm of McMeen & Miller, telephone engineers. It is adapted to any make of desk telephone and can be mounted on a desk or table or on the wall or floor. By a simple and easily adjusted device which clamps around the upper part of the telephone the latter is flexibly suspended from the arm, always in a vertical position. The arm in turn can be moved around in any position, up or down or sidewise and will stay perfectly balanced in any position.

Some of the advantages of this unique holder are the following: Permits one telephone to serve four people without getting up from their desks; when not in use the telephone is off the desk and out of the way; can be used standing up or sitting down; holds the instrument always in a vertical position unless the user desires to tilt it while talking.

The convenience of a movable holder for the telephone can only be appreciated after it has been in actual use. The ordinary desk telephone, with its usually tangled cord, will occupy about a

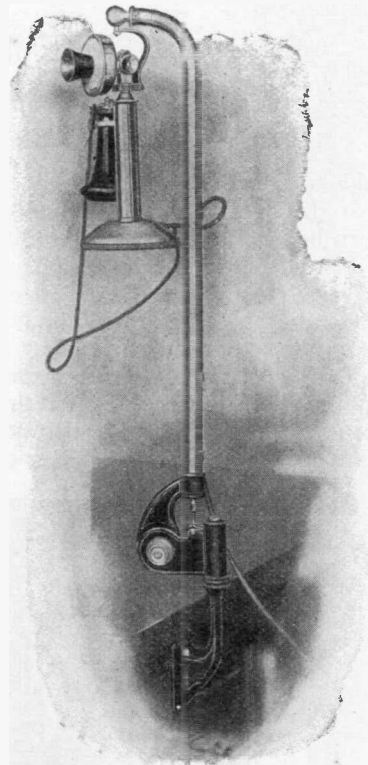

RADIO ADJUSTABLE TELEPHONE HOLDER.

square foot of desk space and is always in the way. An unlucky move will often push it off onto the floor, and the result is a broken mouthpiece if nothing more serious.

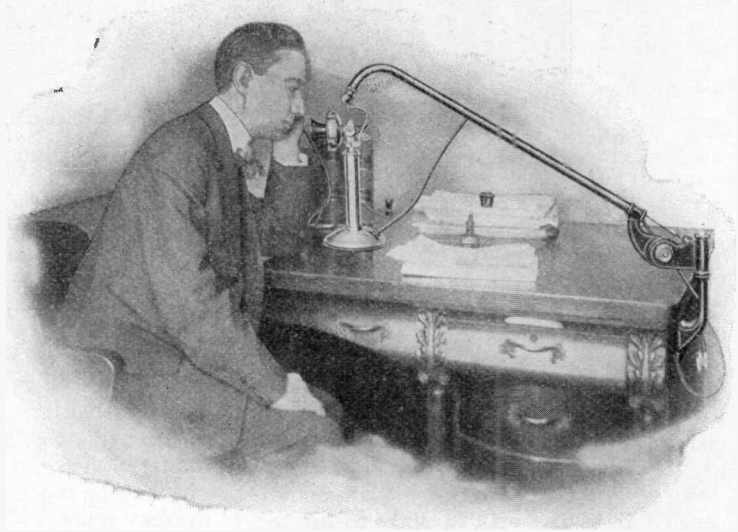

RADIO TELEPHONE HOLDER IN USE

THE DICTOGRAPH.

The Last Word in the Conservation of Business Energy.

BY JOSEPH B. BAKER.

How to conserve the time and attention of the overdriven executives of the modern business world is a serious problem. In the great organizations of today the utmost efficiency of operation must be attained. This iron condition of success has a particular bearing in the matter of the countless written and oral communications of all kinds that are carried on. In the life-and-death struggle of competition, every day is a day of bat-

to summon them from another room. Second, for things that need not be done on the instant, he may dictate instructions to a phonograph for writing or execution later. Third, for things not needing to be written for him, he may pick up a telephone and talk with people in his own building, in other parts of the city, or in distant cities.

All these three ways of imparting the mind of the executive involve wasting his

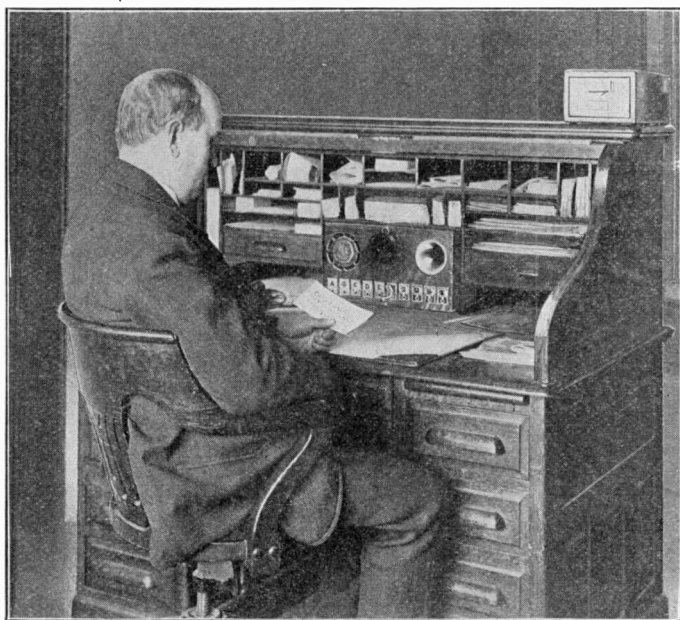

PRESIDENT OF A LARGE COMPANY DICTATING THROUGH THE DICTOGRAPH.

tle in which he holds the supreme command. Should not the contact between the giving of his orders and their intelligent obedience be as direct and close as it can possibly be made?

Let us examine briefly the different ways that the busy executive ordinarily has at his disposal for impressing the decision of his master mind upon others, to be by them transmuted into action.

First, for things requiring immediate service, he may speak directly to his secretary, managers, or other assistants, in the same room, or he may press a button

time and attention; they are little leaks of his valuable dynamic energy scattered through his day of five to seven hours, and making a large aggregate loss.

The first way is the most wasteful. Suppose he needs his secretary, acting as his personal stenographer. If he prefers to have the secretary constantly nearby, in his private office, there is direct communication to be sure, but this time-saving may be more than offset by the intermittent noise of her typewriter. But if she is in an adjoining room there is the time she takes in coming into the office

in answer to the call—including the few seconds consumed in gathering up her note-book and pencil, and perhaps also taking a letter out of her machine, arranging her papers, or making a memorandum. Whatever the time is, an irreducible minimum of seconds is lost in this way which is an unconscious irritation to the executive, who "wants what he wants when he wants it."

The second way—the use of the phonograph—is helpful to some extent, and has a field of usefulness. But the utter lack of the human element is often objectionable; and the only way the machine saves a man's time is by enabling him to give his dictation at his convenience without requiring the presence of the typist.

The intercommunicating telephone system is a time-saver, but has no application to dictation. From the viewpoint of the busy executive it has the serious objection of holding him up pretty completely from other activities for the time being.

How can all this waste of time and energy in the machinery of business communication be abolished? For the busiest man, carrying the heaviest responsibilities, the clock goes 'round just as fast as for the idlest and least burdened. Is not some better, freer route to the minds and hands of his assistants possible?

The solution of the problem is the Dictograph, an instrument which eliminates all the "lost motion" between the executive and his subordinates by establishing immediate oral communication with them without the ordinary transmitter to be talked into, or a receiver to be held to the ear. Impressing his mind is reduced to the simplest conceivable process—mere unencumbered vocal utterance.

The Dictograph, as it appears on the executive's desk, consists of a small box containing an extraordinarily sensitive transmitter and a loud-speaking receiver. An ear-piece receiver is also provided. On the front of the box are a number of simple electric switches and signals. That is all there is to the "master station."

Even less pretentious are the "sub-stations" which are installed on the desks of the subordinates and each of which is connected by wire to the master station, where it terminates in a switch and sig-

nal. The sub-station consists only of a transmitter and an ear-piece receiver. The latter may be held against the ear by a head-band, like that used by telephone operators, so as to leave both hands free to manage note book and pencil.

In using the Dictograph no "Central" is necessary. In fact the manipulation is so simple as to leave almost nothing to describe! The executive does everything by direct vocal utterance, without having to approach a telephone instrument, in fact freed entirely from the paraphernalia of the telephone. A simple movement brings the subordinate's ear and voice to receive and acknowledge instructions spoken in an ordinary tone. To dictate a letter, for example, one touches one of the little levers on the Dictograph box. This signals the stenographer, and her reply emanates from the box just as though she were actually sitting beside one's desk, though in reality she is sitting at her own desk in another room. One then proceeds with the dictation, speaking right out into the air in the customary way, every word being heard and taken down by the stenographer at the other end of the wire. If the dictator wishes, he may get up from his chair and walk about the room while dictating, speaking part of the time with his back turned; yet every syllable is caught by the stenographer through the sensitive electric ear on her employer's desk. Should secrecy of reply be desired, he may silence the loud-speaking receiver and use the ear-piece instead.

A demonstration of the Dictograph gives to a busy man a vivid realization of how many of his ideas have been evaporating, how much of the freshness and vigor of his letters have been lost. Then there is the secrecy attained. The physical presence of a stenographer or other persons in the private office has a dampening effect under some circumstances. Many a business deal has gone awry because the principals felt unable to talk freely.

Where this system is installed conferences may be held over the wire without any of the conferees leaving their desks. The system lends itself no less admirably to more formal conferences. A master station on the board-room table at a Di-

rectors' meeting enables any of the directors to speak with any one in the establishment—to obtain needed information, receive messages, etc.—without leaving his associates, or losing touch with the proceedings.

The apparatus, which is made by the National Dictograph Company of New York, has already been installed in several prominent banks, trust companies and large commercial institutions in New York, Chicago and elsewhere.

TRACKLESS TROLLEYS OF VIENNA.

By trackless trolleys are meant electric buses or automobiles which follow the pavements or country roads as an ordinary road vehicle but which derive their current from an overhead trolley wire, as in the case of a street car which runs upon rails. They have not been operated with success in this country, but in

til midnight. With three cars running, 2,700 passengers are carried without difficulty on Sundays. Only 10 seconds are required for interchanging the trolley cables at the meeting of the cars, this being done at any point on the line.

It is maintained that the two 20-horsepower motors on these omnibuses may

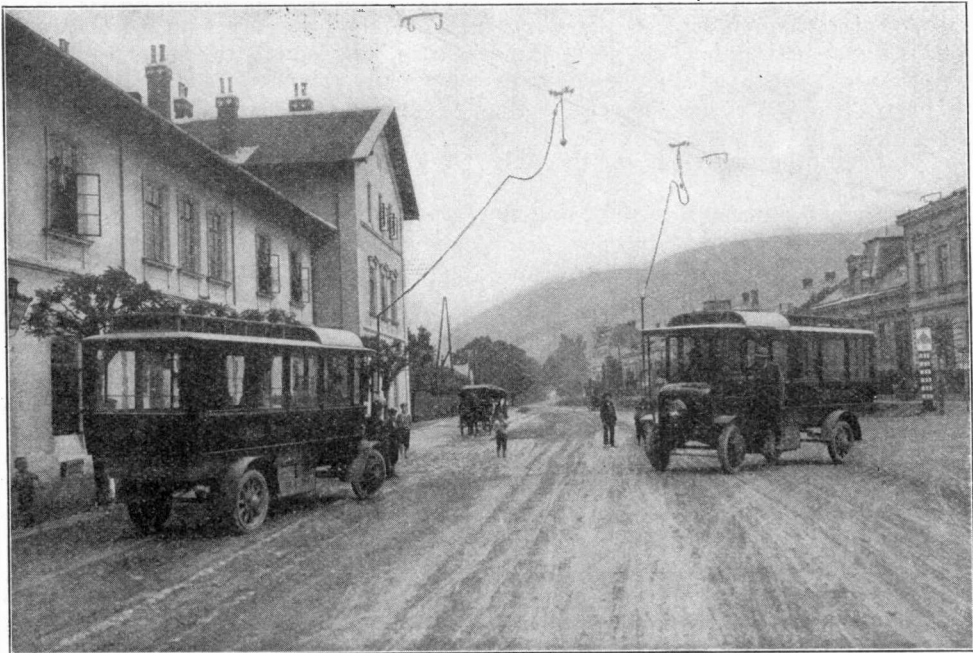

TRACKLESS TROLLEY OMNIBUSES.

Europe there are a number of systems in use which are apparently economical, due, no doubt, to the excellent road beds that there prevail. One interesting line of this character is at Weidling, near Vienna, Austria, and is 2.3 miles long, with gradients as great as 7 per cent.

There are five trackless trolley cars or omnibuses in service, each carrying 21 passengers. About 100 miles are run daily from 5 o'clock in the morning un-

be overloaded to double their usual output, in emergencies, without getting dangerously hot. The cars weigh only 2.5 tons each, and this small weight, compared with the load carried, has an important bearing on road surface wear, rubber tire wear, and consumption of current.

This trackless trolley system is the invention of Ludwig Stoll of Vienna, and among the strong claims made for the

system are its simple, rapid, silent and smooth running, as well as its freedom from breakdowns and interruptions of service.

Current is collected by a little wheeled arrangement which runs along on the trolley wires and from which flexible conductors depend, conducting the current to the car. There are two trolley wires, one positive and the other negative.

It is stated that the trolley runs with little or no sparking, the wheels running on ball bearings, and the pull of the cable acting upon a very short lever-arm. The center of gravity of the trolley is very low, so that there is no deviation of the trolley in spite of strong transverse pull, the conducting cable being long enough to follow the car. There is an upper sliding knot tied up on the pendulum weight, as shown in the illustration, and stretched by means of a spring from the latter. There is also provided a cable roller with 30 or 40 feet of cable which is let out or rolled up by means of a spiral spring.

By the use of these two appliances the car is allowed to run on the whole width of the roadway, to turn out in overtaking or meeting automobiles or other vehicles and accommodate itself to every form of traffic. When two trackless trolley cars meet the motormen simply interchange the trolley cables by detachable contact boxes, this being a decided advantage over a single track electric railway on which much time is lost in waiting at passing points.

EARTH CURRENTS.

Great local differences in the electrification of the earth are known to exist, and a German engineer suggests that with better knowledge it may be possible to make mining for electricity as profitable as digging for coal or metals. In experiments in two comparatively shallow borings, he has obtained weak currents between a small rod of brass or iron immersed in the water of the pit and a similar rod buried near the surface. He urges that contractors, mining companies and others take up the problem, and perform such experiments as testing the current between a 60-foot copper cylinder at the bottom of a boring of

thirty thousand feet or more and a similar cylinder buried in moist ground at the surface, also investigating the charges to be obtained from long iron pipes buried in the ground.

CIGAR LIGHTER.

No doubt the desk telephone, which is so indispensable in all offices, suggested the unique design of the cigar lighter shown herewith. This lighter is made with a substantial base and the heating

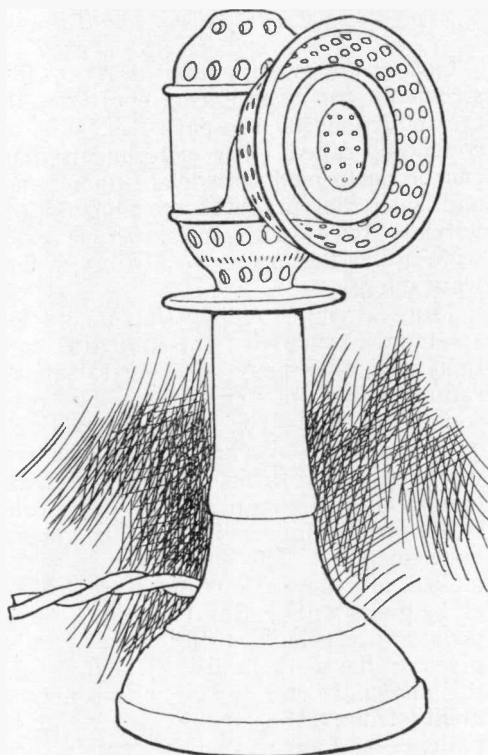

CIGAR LIGHTER.

element is contained in a projection on the side which looks very much like a telephone mouthpiece. The wires from the lamp socket lead into the base and being flexible permit the lighter to be moved around readily over the counter or showcase.

To demonstrate that the electric chair does not kill, but makes victims comatose, it is said that a New York man, Charles Quill, allowed 1,800 volts to pass through his body. Quill was not injured in the test.

POPULAR ELECTRICITY WIRELESS CLUB.

Membership in Popular Electricity Wireless Club is made up of readers of this magazine who have constructed or are operating wireless apparatus or systems. Membership blanks will be sent upon request. This department of the magazine is devoted to the interests of the Club and members are invited to assist in making it as valuable and interesting as possible, by sending in descriptions and photographs of their equipments.

SPARK COIL CONSTRUCTION AND OPERATION.

BY VICTOR H. LAUGHTER.

PART I.

One of the most popular electrical instruments for experimental purposes is the induction coil or spark coil, as it is commonly called. The experiments that can be performed with it are numerous, and since the practical introduction of wireless telegraphy, it has come into wide use as the means for setting up the wave energy.

More attempts are possibly made by amateurs to construct the induction coil than any other piece of electrical apparatus and with poorer results. The reason is obvious. The induction coil requires careful work, and parts which are designed to work in conjunction with one another to obtain results. This rule is not usually followed out by the casual experimenter. The insulation is overlooked, and the various parts are selected by guess work. Results are of course poor, and the builder of the coil finally gives up the work in disgust. However, this need not deter anyone with ordinary ability from taking up the work, for if patience and care are used satisfactory results may be obtained.

As the same plan of construction is followed out with all spark coils, only one size will be described here, but dimensions of the other sizes will be given. The amateur may then construct any other size by following out the same general plan.

The spark coil complete constitutes the following parts: Iron wire core; primary winding; insulating tube; secondary winding; vibrator, and condenser. The complete parts as connected up for use are shown in Fig. 1, in which (A) represents an iron wire core, (B) the primary winding, (C) the insulating tube and (D) the secondary winding. The

complete vibrator is made up of parts (G), (M) and (F). (H) is the condenser and (I) the battery. Before going into the construction it would be advisable to study out the action which takes place in a spark coil in operation, as this will give a clearer idea of the parts

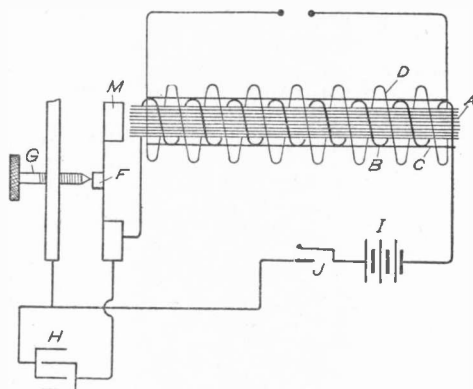

FIG. 1. GENERAL CONSTRUCTION OF A SPARK COIL.

involved. We have the core (A) which is a circular bundle of soft iron wires. Over the core is wound the layers of heavy wire known as the primary winding, and over the primary a large number of turns of small wire known as the secondary. The two windings are insulated from one another by the tube (C). The primary winding leads down to the battery at (I) and to key (J), and from the opposite side of the key (J) to the metal post which supports the screw (G). The screw (G) is platinum tipped and rests against the second platinum contact (F), which is mounted on a brass spring strip bearing the soft metal disk (M) fastened on the end. This strip as shown is connected to the remaining

terminal of the primary winding. The secondary terminals lead up to binding posts mounted on the top of the coil case.

When the key (J) is closed the current circulates from the battery (I) around the windings over the iron core and completes the circuit through the contacts (F) and (G). The electrical current flowing through the primary winding sets up magnetic effects in the core, which extend out in invisible lines through the secondary winding. As the disk (M) is of soft iron it is susceptible to magnetic effects and will be attracted towards the coil (A). The disk in its forward movement pulls the spring which breaks the circuit at the contact (F). The current now ceases to flow, and as the core is magnetic only as long as the current flows, the pull on the disk is released, allowing it to fly back to its original position only to repeat the operation over again. At each "make and break" a pressure of several thousand volts is induced in the secondary winding, this action being due to the high ratio of the secondary to primary turns. The current induced in the secondary flows to the terminals and jumps the spark gap. The length of the spark gap the current will jump is largely determined by the adjustment of the "make and break" device, commonly called the vibrator. The condenser (H) connected across the vibrator contacts serves a useful purpose. The spark at the contacts would be very large and hot and would soon melt the platinum if it were not for the fact that the condenser takes up this spark in the form of a charge and in turn discharges back into the primary winding.

Now that the operation of the coil and parts used have been described, the actual construction will be taken up.

In view of the fact that the amateur prefers a coil that can be used for nearly all ordinary laboratory work, one of the four-inch size will be described. A coil of this size can be used for wireless telegraphy up to a distance of 10 to 20 miles, and for X-ray work, lighting Geisler tubes and numerous other purposes.

CORE.

The core is usually one of the most neglected parts of the coil, whereas, it is one of the most important features. The

desired feature of the core is that it should be made of very soft and small iron wire, cut to the exact length, with as many pieces forced into the bundle as possible. In all cases the wires should be well annealed. The reason for using a large number of small wires for the core, in place of a solid iron body, is that a core of the first named type is capable of taking on and losing the magnetic effects much quicker than a core of the same metal in a solid body. That is, the solid core would not take on and unload the magnetic effects as fast as the vibrator worked, which would result in a weak and stringy spark. We have this same action in a condenser in a slightly different sense, which will be explained later. A core built up of a large number of small wires is said to be of the laminated type, and we find the principle of lamination extended to other electrical instruments.

A core for the coil in view should be 10 inches long, $1\frac{1}{8}$ inches in diameter, built up in a circular bundle of soft iron wires. In view of the important part the core plays and the difficulty experienced in building it up, the writer would recommend that the amateur buy it complete, as the cost will not exceed 50 cents. However, some may prefer to perform the actual construction. First get a sufficient quantity of No. 22, well annealed, soft iron wire to form a bundle $1\frac{1}{8}$ inches in diameter, the wires being previously cut to the proper length and made straight. To form the core first roll a tight flexible paper tube to the desired diameter and glue. Fill the tube as full as possible with the core wires and roll with pressure between two boards. This will cause the wires to cling more closely together. Remove the tube and force in more wires, continuing the operation until the tube is full and has taken on a circular shape. Next wrap the tube from end to end with unwaxed shoemaker's thread, making the respective turns fit evenly and neatly together. Over the thread is now wrapped about 15 layers of thin porous tissue paper, and the whole boiled out in a half and half mixture of paraffine and beeswax, for at least 30 minutes, or until all bubbles cease coming to the surface.

The primary winding is made up of

two layers of No. 14 single cotton covered magnet wire wound on the core continuously to within $\frac{3}{4}$ inch of each end. A lead about four inches long should be left unwound to connect to the vibrator and battery. The respective turns of the primary winding should be made as neatly as possible, for kinks, etc., will to a certain extent impair the working efficiency.

The completed core and primary winding is illustrated in Fig. 2. When completed as shown the boiling out process is gone through again.

THE INSULATING TUBE.

The insulating tube for the small size coils up to $1\frac{1}{2}$ -inch sparks can be made

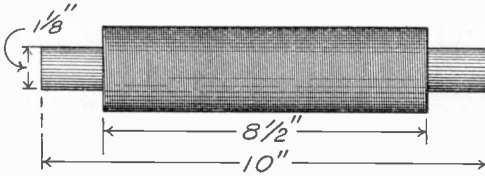

FIG. 2. COMPLETED CORE AND PRIMARY WINDING.

by winding several layers of paper to a tube of the desired size and boiling out with paraffine. But for the larger sizes a tube of hard rubber is recommended. The insulating tube for our proposed coil should have a total length of $9\frac{1}{2}$ inches, $1\frac{3}{4}$ -inch inside diameter, and $2\frac{1}{8}$ -inch outside diameter. The tube, however, should make a neat fit over the primary winding, and if any additional space remains between the two, fill in with paraffine.

THE CONDENSER.

While it will be some time before we come to the point where the condenser is put in actual use, since the drying out process takes several days, it should be constructed at the present time so that when the rest of the work is finished the condenser will be ready for use.

The condenser will require about 3,000 square inches of tin foil as the total area. The sheets can be cut up in 6 by 8-inch sizes, as this will reduce the number of sheets, over a smaller size. However, any other size can be used. As the sheets will run 48 square inches to the sheet this will necessitate 64 such sheets, giving a total of 3,082 square inches of foil, al-

lowing the extra number of inches for losses involved in cutting and assembling.

The dielectric or insulating medium which separates the foil sheets from one another should be selected with care. A good grade of thin bond paper cut in sheets of 8 by 10 inches makes an excellent insulating medium.

For building up of the condenser a baking pan about 12 inches wide, 14 inches long and two inches deep will be needed, also four pounds of paraffine wax, and a common squeegee print roller. Sixty-four strips of foil 1 by 3 inches are cut, to be used for the connecting strips of the respective foil sheets.

The pan is placed on a stove and the paraffine heated until it is in a boiling state. It is advisable to place the pan containing the paraffine in a second larger pan, with water poured around, as this will prevent the paraffine from becoming overheated and catching fire.

A number of paper bond sheets are now placed in the pan and boiled for about 30 minutes. The sheets are removed and held up by the different corners so that the superfluous wax will run off as evenly as possible. Lay the sheet down on some flat smooth object and place on it, in the center, a sheet of the foil. This will allow a one-inch margin around the edges. One of the foil connecting strips is now placed on, in such a manner that one inch rests on the foil sheet, and one inch clear of the paper. The squeegee print roller is run over the foil with some pressure, which makes the paper and foil adhere more closely together and forces out the superfluous wax. This operation must be carried on while the wax is still soft.

The next sheet of paper is taken from the wax pan and made to fit over the first and the foil sheet as neatly as possible. The second foil sheet is placed on and rolled down as before, but the connecting strip is led out to the side, opposite from the first. That is, if the first strip leads out to the left-hand side, the second should lead out to the right-hand side. This is made clear by reference to Fig. 3. The heavy black line (A) represents the insulating medium, and the line (C) the foil and connecting strip.

Owing to the fact that condenser capacity should be varied until the best re-

sults are had, the condenser should be divided up into banks, and more or less of these banks are cut into the circuit until the point has been reached where the spark is flowing across the terminals with the maximum value.

A very good division can be made by dividing up the condenser into two banks

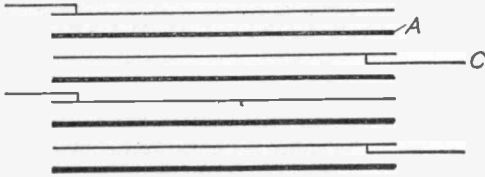

FIG. 3. GENERAL PLAN OF CONDENSER.

of 16 sheets each, one of eight and two of four. This will give a large regulation and allow the condenser to be used for other purposes than across the vibrator contacts of the spark coil.

Considering that the 16 sheets have been built up according to the method stated, the condenser is ready to be mounted. However, it should be clamped between two boards with considerable pressure, and left over night. This will close up all air spaces, which to a large extent are responsible for punctures across the foil sheets.

As the exposed ends of the foil strips are very delicate and liable to be broken when handling, thin brass strips one inch

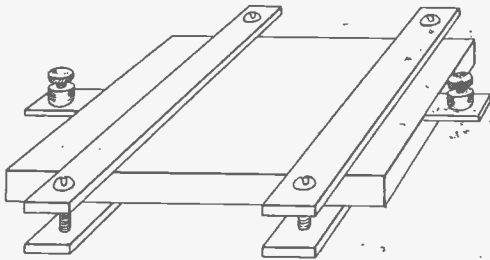

FIG. 4. COMPLETED CONDENSER.

wide and two inches long should be folded over the exposed portion, and holes punched through and binding posts screwed therein.

The condenser is now placed between two thin oak boards, which neatly cover the surface, and additional strips placed over and screwed together at each end, which will clamp the boards tightly in place. The completed condenser is illus-

trated in Fig. 4. The total number of banks can of course be clamped together in this manner, and this is recommended where it is desired to mount the whole in one case.

After the building up of all the different banks, a case is provided in which the whole number can be placed, and the plug contacts mounted on top so that the different adjustments can be quickly made by the operator. A convenient and simple method for making the plug connections is shown in Fig. 5 (aa) represents two of the banks built up of 16 sheets each, (B) one of eight sheets and (CC) two of four sheets. As will be noted the leads from one side of the condensers are all connected to one wire in common and connection for the opposite side is made

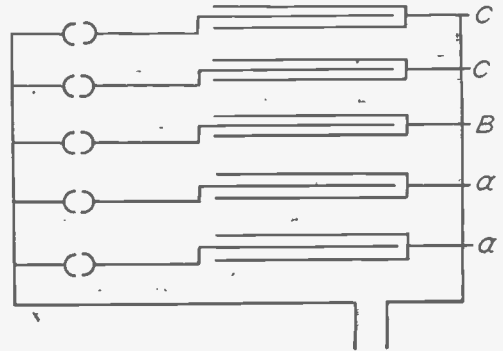

FIG. 5. CONVENIENT METHOD OF MAKING PLUG CONNECTIONS.

by inserting plugs in the various plug contacts. The exact method of mounting is left to the builder's needs and means. By following this general plan the amateur should have no difficulty in constructing a condenser for any size coil, as any changes to be made in the size of the parts, from the dimensions given, would in no way affect the working efficiency.

For small size coils the rolled type of condenser is sometimes used. The construction of such condensers is very simple. Two long strips of foil are placed over one another with a strip of paraffine paper between, and rolled up into a solid body with terminals left out for connecting. However, this type is not as efficient as the type previously described. The condenser, as previously stated, in this respect resembles the iron wire core.

To give efficient results the condenser should be capable of taking on and discharging the sparks at the vibrator contacts as fast as the latter operates. Where the rolled type is used it takes a long time for the condenser to absorb the

spark, and a certain amount of the energy leaks through and is lost during the cycle. With the alternate layer type the charge and discharge is made rapidly and a better spark is had.

(To Be Continued.)

WIRELESS TO LINK AMERICAN UNIVERSITIES.

Princeton leads the way in 'a new project the object of which is to link by wireless the principal colleges and universities of the country. Princeton has an outfit, set up in Science Hall, which is the first of a chain of these up-to-date equipments that will make it possible for a conversation to be carried on

gram or the delay of communicating through the medium of the mail.

One afternoon a chess game by wireless was carried on between the students of Princeton University and the experts of the ships at the Brooklyn Navy Yard. Naval men are keen players of the game, for the leisure that is found at sea is en-

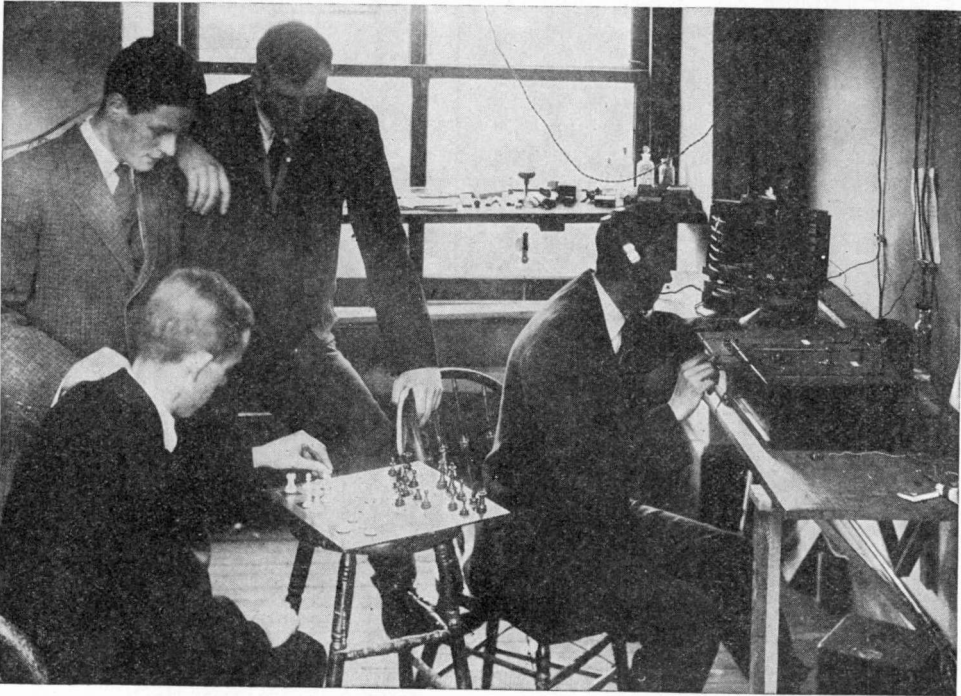

CHESS GAME PLAYED BY WIRELESS.

with other seats of learning when they have equipments. An inter-collegiate chess series might be conducted through the air, students could exchange views on athletic matters and questions of import to the debating societies and other scholastic organizations, all without the expense of a tele-

couraging to the development of chess students. The game was carried on entirely by wireless and was followed with lively interest by spectators at both stations.

When the other colleges have installed the wireless outfit, chess by this means will become a regular feature of

the competitive program of the universities. There is no difficulty in the way. During the game referred to a student who was a "wireless" expert sat with the receiver at his ear and called off the moves as fast as they were made. The method was far quicker than the cable game, for the moves were recorded by wireless to a man who sat a few feet from the board and by him were passed on verbally to the player.

"The future program," said a student who has been largely instrumental in rigging up the wireless plant at Princeton, "is to have a receiving station at the athletic field so that the results of athletic games can be made known instantly, and reported during the progress of the game, by the students themselves. This wireless station will be a permanent thing. At all big games we now have the regular telegraph installed so that the spectators can be kept informed of the progress of events at other grounds that are interesting, but there are minor days when the telegraphic machinery is not there to give us this information, and with our own plant we can keep posted on everything that goes on without having to depend on outside sources.

"If there are important events in progress at Franklin Field, for instance, and it is not possible for many of the men to attend them, those interested in the results can gather at the hall in which our wireless is placed and keep in touch with the situation every minute without any expense to themselves or the college. What a boon this will be only college men know.

"We are longing for the time when other universities will have their wireless outfits working. At present we practice on the ships in New York harbor, on our friends of the Navy Yard, and with any operator that we catch idle. There are numbers of ships in harbor whose operators are glad to get in conversation with anyone to while away the tedious hours, and we exchange conversation with these chaps, and occasionally pick up one who plays chess. But there is a growing feeling of resentment among the regular operators against idle wireless men who throw conversational messages on the air. It interferes more

or less with the carrying on of legitimate wireless business and the air is becoming so surcharged with these 'Good morning, have you used Bear's soap?' messages that there is talk of legislation to protect the regular companies.

"For this and other reasons we are looking forward to the time when the inter-university conversation by wireless will be an accomplished fact. Then we shall drop the Jack Binnses of the harbor and converse only with our own."

HOW TO MAKE AN ELECTROLYTIC DETECTOR.

One of the things which a "wireless enthusiast" is always looking out for is a good detector, and it will be found by experience that the electrolytic gives the

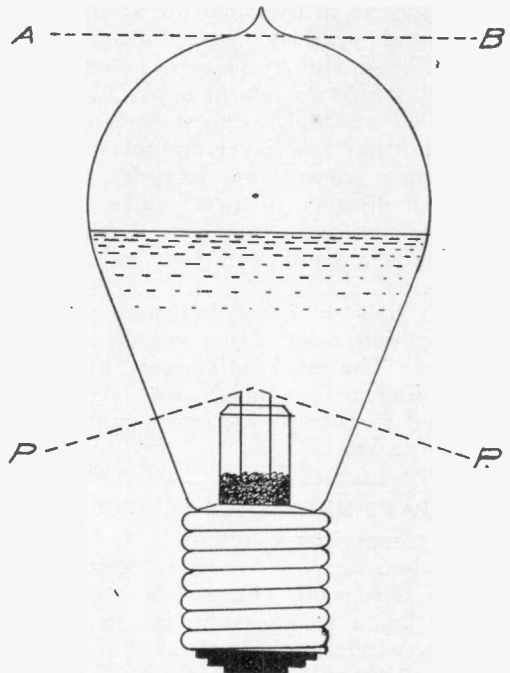

most satisfactory results. Here is the description of one which gave the writer very good results, being very inexpensive yet efficient:

Take a five-candle power lamp globe and break the tip off as shown by the dotted line (A B) in the cut. Smooth off any rough edges with an alcohol lamp and break off the fine filaments and turn the platinum points in till they are about one-sixteenth of an inch apart. Now

screw the globe into a wall bracket and screw the whole on to a suitable base.

Next fill the globe about two-thirds full of a solution made by dissolving one part sulphuric acid to four parts water. Connect up as you would any electrolytic detector. Under ordinary conditions the detector will work very well.

F. ERSKINE HENEY.

3,000-MILE EQUIPMENT FOR WASHINGTON.

The new wireless tower and equipment at Washington, D. C., will have a radius of 3,000 miles. So say the specifications upon which bids are made by the various wireless construction companies. The specifications also state that the messages are not to be interrupted by atmospheric disturbances or by interference with neighboring stations.

At the same time the department asked for bids for two sets of apparatus to be installed on naval vessels to be capable of transmitting and receiving messages at all times, seasons and latitudes, to and from a distance of 1,000 miles, and to receive messages from the Washington station at a distance of 3,000 miles at all times.

The bids submitted indicated a lively competition, seven firms submitting proposals. The most satisfactory of these, according to the officials, was one which offered to furnish apparatus and tower for \$182,600.

JAPAN'S MARVELOUS AEROGRAMS.

A recent press dispatch from San Francisco says: "Across 4,700 miles of ocean, aerograms have been received from Japan by operators in the United States wireless telegraph station in this city. Although they have been unable to reply to the call from over the seas, they have watched with growing interest the efforts of the Japanese to get into communication with the United States through other means than the cables and ships.

"This marks a record for receiving wireless messages. It was nearly four months ago that James Watkins, chief operator, and R. Lawrence McLaurin, the night operator, were surprised one night to catch strange signals from ap-

parently a great distance seaward. Japan, with more powerful sending apparatus than is found in any other wireless station in the world, flashed her signals through almost a sheer 5,000 miles. But Japan does not know her voice was heard and will not until this news is sent to the land of the mikado.

"For weeks and weeks the Japanese had been calling and Operators Watkins and McLaurin heard, but could make nothing of it. Honolulu heard, too, and at the same instant, by comparing notes. The two stations reached the conclusion that the signals came from Japan."

WIRELESS QUERIES.

ANSWERED BY V. H. LAUGHTER.

Spark Coil Design.

Questions.—(A) I would like to know if a $1\frac{1}{8}$ inch core, 15 inches long, will be large enough for a spark coil, with eight miles of No. 36 wire in the secondary and two layers of No. 16 wire in the primary. (B) What current in volts and amperes would run same? (C) What size spark would I get? (D) If the core and primary winding are not right, would like to know what to use to get the best efficiency from the coil.—A Reader, Napa, Cal.

Answers.—(A) Yes.

(B) A battery giving 12 volts will operate the coil satisfactorily. Figuring the diameter of single cotton covered No. 16 wire as .055 inches and the average diameter of cylinder wound as $(1.125 + .055)$ 1.18 inches, approximately 146 feet of wire (two layers) having a resistance of .58 ohms is used.

E 12
— or — gives C equal to 20.5 amperes.

R .58
But a point often misunderstood is that E

— gives a larger current than enters the R primary, because a large reduction is made by the self-induction of the primary coil. We can hardly go farther into this question in this department.

(C) About a three-inch spark with a condenser of 150 sheets, 9 by 9 inches.

In Questions and Answers Department, November issue, 1908, see answer

to question (B) of A Reader, Seattle, Wash.

(D) Little data and few formulas and rules are recorded to give the relation between transmitting power, dimensions, and constants for coils. In practice each manufacturer experiments until he finds the conditions necessary for his particular purpose. A closer compliance to what standard data is available, allowing one inch of core to project at each end to reduce magnetic leakage, would be to use two layers of No. 14 wire on the primary and five pounds of No. 33 wire on the secondary.

Four Inch Spark Coil.

Question.—Will you kindly tell how to make a four-inch jump spark coil, with dimensions and size and amount of wire.—J. C. R., Leominster, Mass.

Answer.—Length of core, $14\frac{3}{4}$ inches; diameter of core, $1\frac{1}{2}$ inches; primary wire, No. 12 B. & S. gauge, two layers; secondary wire, No. 33, ten pounds. Condenser: 200 sheets, 9 by 9 inches; battery voltage, 16. See "Construction of a Two-Mile Wireless Outfit," November issue, for further hints.

Spark Coils.

Questions.—(A) In winding a one-inch spark coil with number 32 wire instead of 36 what will be the difference? (B) Does a telegraph set have to be equipped with a relay and how is the relay used? (C) How much wire is used to construct a gas lighting spark coil? E. F. R., Rahway, N. J.

Answers.—(A) The spark will be reduced in length to a large extent but this will be especially valuable for use in wireless telegraphy.

(B) The telegraph relay is not absolutely essential to a short distance telegraph set but it is a very necessary addition for long distance work. It is used to open and close a local circuit containing a sounder, and is operated by the very slightest current coming in over the main line.

(C) Gas lighting coils are divided into a number of different types and it would be necessary for you to state your question more clearly before we could give you an answer.

Receiving Ability; Detectors.

Questions.—(A) From how far would the following outfit receive: Auto-coherer; 1,000 ohm receiver; 60 foot aerial, and tuning coil? (B) Which is the best silicon of electrolytic detector?—K. W. W., Fort Scott, Kans.

Answers.—(A) Up to 50 or 100 miles.

(B) The electrolytic is the more sensitive.

Sending Helix.

Questions.—(A) How is a sending helix made and what is the principle? (B) If a one-inch coil is immersed in oil how much current can safely be used with it and what kind of oil should be used?—C. R. K., Little Rock, Ark.

Answers.—(A) The sending helix can be made by winding 10 turns of No. 6 bare copper wire on a frame 10 inches in diameter and 10 inches in height. The respective turns offer a high choking effect to the high tension currents and will allow of a large range of regulation to be had within a short length.

(B) A coil can carry so much current and no more. Immersing the coil in oil would in no way make the primary turns more conductive. However, the better the insulation the more perfect the coil will be from the electrical standpoint.

Condenser; Interrupter.

Questions.—(A) Which are the best, Leyden jars or paper condensers on the primary of a four-inch coil? (B) Is it necessary to use Leyden jars in the secondary circuit to fatten the spark for wireless work? (C) Explain the mercury interrupter and how it works? Could it be used with the battery current? (D) Would No. 14 aluminum wire do for use in constructing a tuning coil? (E) Could you tell me the nearest wireless station to Chicago?—F. H., Chicago, Ill.

Answers.—(A) A Leyden jar is the more efficient type of condenser, but for use across the vibrator contacts in the primary circuit, the paper type will answer and is usually employed.

(B) Yes, either a Leyden jar or some other type of high frequency condenser.

(C) Mercury interrupters are of many different types and to describe the various kinds would require more space than can here be given. One of the most common types consists of a vibrating contact operated by motor which works in and out of a pot of mercury. Such interrupters can be used with batteries as well as with power circuits.

(D) Yes, but the size is rather large. We would recommend No. 22 tinned copper wire.

(E) Detroit.

Sensitiveness of Receiving Apparatus.

Question—Would the receiving set described on page 635 of your February issue pick up messages from the commercial stations three and four hundred miles from Cincinnati?—H. S. B., Cincinnati, Ohio.

Answer.—We hardly think that this detector would pick up messages from stations this far away. With a suitable aerial and a liquid detector this would be possible.

Receiving Distance.

Questions—(A) How far should I be able to receive with the following equipment: Zinc-ite and copper pyrites detector, tuning coil, 40 foot aerial, condenser and telephone receiver? (B) What size spark coil is necessary to send up to five miles and how can I make it? (C) Kindly give me the directions for making a 20-mile wireless set.—E. K., Washington, D. C.

Answers.—(A) From 25 up to 100 miles.

(B) We refer you to the article, "Construction of a Two-Mile Wireless Outfit," in the November, 1908, issue, which described a coil that will send up to five miles under good conditions.

(C) A twenty-mile wireless set would constitute a tuned sending and receiving equipment, using a liquid detector and a four-inch coil which will be fully described in the serial on spark coils beginning in this issue.

Condenser and Detector.

Questions—(A) What is the purpose of a condenser? (B) Can the fine wire in a detector be any other than platinum? (C) How can an induction coil be constructed cheaply? (D) What is a coherer used for.—J. N., Wappingers Falls, N. Y.

Answers.—(A) The condenser is used to cut down the static interference, and to a certain extent increases the strength of the received signals.

(B) Other kinds of wire are being employed at the present for special experimental work, but the platinum is to be recommended.

(C) We refer you to the series of articles beginning in this issue under the title, "Spark Coil Construction and Operation."

(D) The coherer is used to detect wireless waves.

Electrolytic Detector.

Question—How many volts are needed to work an electrolytic detector in series with two 75 ohm telephone receivers?—E. I. W., New York.

Answer.—The voltage necessary to operate the liquid detector is exceedingly low. A dry cell giving one volt will answer.

Condenser.

Question—Is a condenser absolutely necessary in a wireless sending apparatus? If so, for what purpose will an ordinary one made from a brass tube answer?—W. G., Chicago, Ill.

Answer.—A condenser is not necessary in the sending end unless the set is of the tuned circuit type. We would not recommend a condenser made from a brass tube for use in the sending circuit. However, it could be used in the receiving side to an advantage.

A. B. C. Receiving Set.

Questions—(A) Can a telegraph sounder be used in place of a receiver in connection with the A. B. C. receiving set? How many ohms should the telephone receiver have? (B) How high should an antenna be to send up to three hundred feet with the one-half inch spark coil? (C) How many dry cells can be used on a one-half or three-fourths inch spark coil?—R. B. McC., Jenkintown, Pa.

Answers.—(A) A telephone receiver only can be used. Any type of telephone receiver will answer.

(B) From 30 to 40 feet high.

(C) Not over four or five should be used.

Telephone Induction Coil.

Questions—(A) I have a battery telephone coil and would like to know if it could be used in connection with wireless telegraphy. (B) I have two coils that belong on an electric light tester. Would these be of any use? (C) What would be the distance a $\frac{1}{4}$ inch spark coil could send messages if connected with a 50-foot aerial?—J. L. D., Cambridge, Mass.

Answers.—(A) The coil you have on hand would be useless in wireless telegraphy. It is too small to try to change it into a spark coil and too large for a receiving transformer.

(B) No.

(C) Up to one-fourth mile under good working conditions.

ELECTRICAL MEN OF THE TIMES.

HENRY L. DOHERTY.

A pioneer exponent of the "new business idea" in electric central station practice is Henry L. Doherty of New York. To be so identified with a movement of the most far-reaching benefit to the central station business might well be cause for great pride on the part of any man. But no man, perhaps, can "stand prosperity" and the praises of his fellow men better than Mr. Doherty. He is unspoiled by success, for he has a level head.

Henry Latham Doherty was born in Columbus, Ohio, in 1870. His education was of the self-acquired variety and most practical in its nature. When twelve years of age he entered the employment of the Columbus Gas Company and remained there, in various capacities from office boy upward, until 1896, when he went to Madison, Wis., as manager of the Madison Gas and Electric Company.

In 1897 Mr. Doherty became a member of the National Electric Light Association, at that time devoted to technical work, and at best rather an easy-going institution. It was Mr. Doherty's idea that such an association should be more than a mere body for the discussion and preservation of data and records of physical developments. He believed that it should be made a moral force to sustain its members in their efforts against competition and to devise new ways and means for educating the public in the use of electricity and to assist the central stations in their plans to secure new business intelligently. His efforts in the association did not at first meet with favor, for he was young and the older members rather

resented his aggressiveness. But he gradually found supporters until finally, in 1901, he was elected to the presidency of the association, and from that day its real success began. With one bound Mr. Doherty became practically dictator of the organization and indisputable leader of the majority, and the mandates that were issued by the association became assertive and forceful.

The story of Mr. Doherty's work in

Denver, where he placed the Denver Gas and Electric Company on a sound basis, raising it from the position of a heartily despised corporation to that of a subject of great municipal pride, is well known, and has been told in a previous issue. But this is only one example out of many instances in which he has rehabilitated the affairs of a broken down light company and made it a potent factor in the upbuilding of a city. As a result he is now the moving spirit in a large number of

lighting companies throughout the country.

All through his successful business career Mr. Doherty has been a firm believer in advertising for the building up of central station business. And his conception of advertising is by no means a narrow one, but a great, broad gauge plan whereby the people are brought to know of the advantages and economies of electric current through systematic educational campaigns, through public and private demonstrations, newspaper advertising, direct advertising, lectures, electrical shows and expositions, and a hundred and other ways which his able lieutenants might devise.





ELECTRICITY IN THE HOUSEHOLD

IS ELECTRIC LIGHT TOO DEAR FOR MODEST PURSES?

BY WILLIAM KEILY.

"Give a dog a bad name and hang him," is an old saying, and it is exemplified by the fact that many persons still labor under the delusion that the cost of electric lighting in the home is so

ing was urged on the undeniable ground of quality rather than price.

People generally do not realize, however, the really wonderful development in the art of producing and mar-



IN EVERY HOUSE ON THIS STREET ELECTRIC LIGHTS AND FLAT IRONS ARE IN USE.

high as to be prohibitive to all except the well-to-do. It is not strange that this is the case, for in the early days, and up to say 10 years ago, the ideal illuminant was, indeed, comparatively expensive, and its use for residence light-

keting electricity which has been made in the last decade. The improvement is not only in the design of electrical machinery, to prevent losses; not only in betterment of the means of transmitting the current, for the same purpose; not

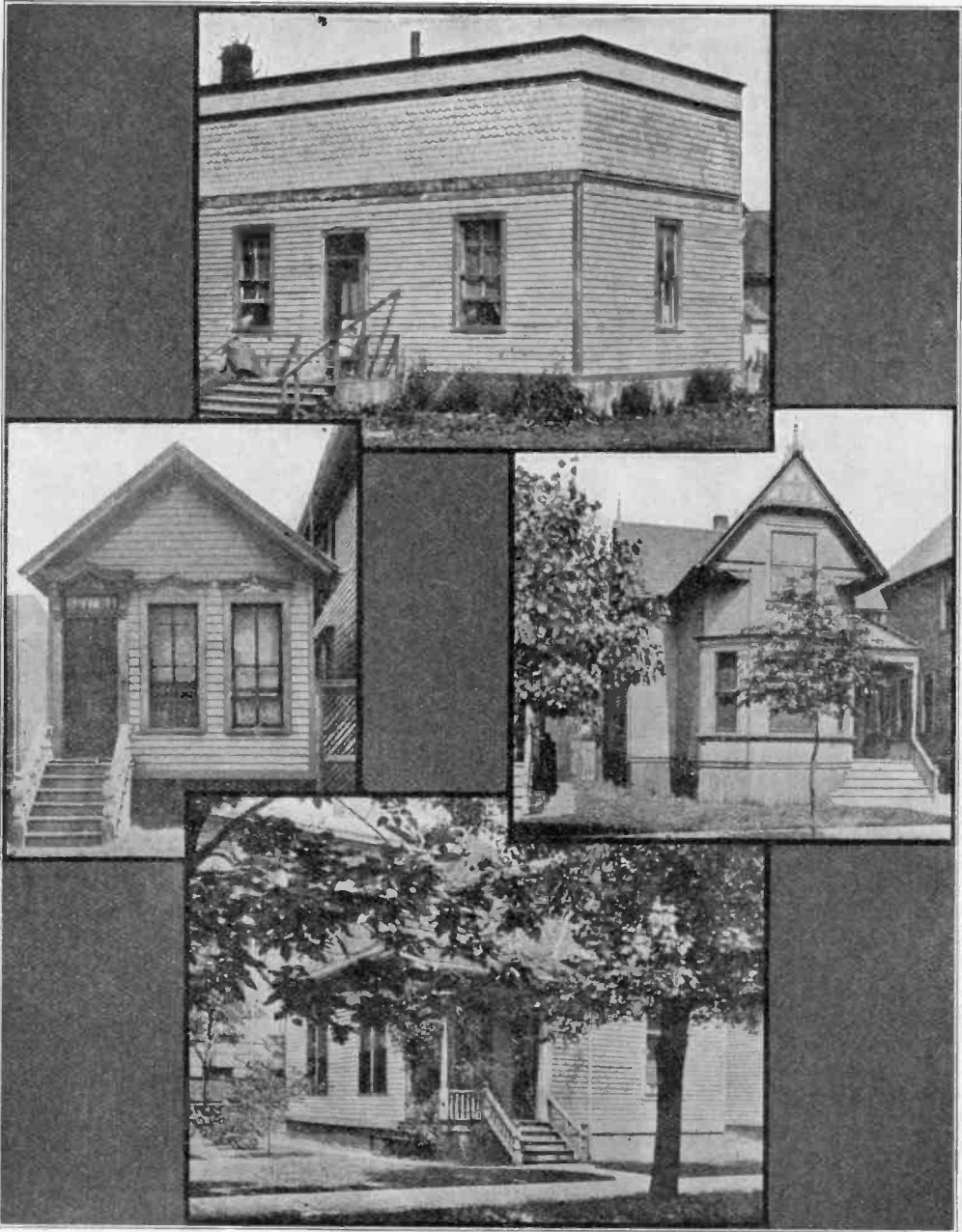

THESE ARE MODEST HOMES. EVERY OWNER FOUND ELECTRICITY NOT ONLY CONVENIENT BUT AN ACTUAL ECONOMY.

only in the use of high-efficiency lamps and reflectors, which produce two or three times as much light for the same consumption of current; not only in the remarkable economies effected by modern prime movers (the machines which drive the generators of electricity), such

as steam turbines and gas engines; not only in the greatly extended use of waterpower—but more than all these causes, even, the change is due to the education and enlightenment of the electric-light man himself.

The average manager of a public elec-

tric-lighting plant is no saint. He is just a "hustling," hard working American business man who is trying to get the best possible return from the property in his charge. But he takes a broader, more serious view of the relation of a public-service corporation to its public than he once did. He strives to please the people, not to antagonize them. And in selling electricity he has discovered that it pays best to produce his product in large quantity to secure the advantage of low cost of production; to sell large quantities to attain the heavy load on the station which this policy makes necessary, and to sell at low price to secure the big demand.

This may seem to be a self-evident business proposition, but in the central station industry it is not so simple as it appears. There are troublesome questions of "load factor," interest charge on idle machinery, "maximum demand," "readiness to serve," extensions of lines (especially important where only underground construction is permitted), cost of customers' meters, cost of house wiring, etc., which cannot be gone into here, and these make the fixing of equitable electric lighting rates a perplexing problem indeed. But the general tendency, as the men and methods in the electric lighting business improve, is toward cheaper prices. In Chicago, for instance, the rates for electricity are now only about 40 per cent what they were 10 years ago.

At 10 cents a kilowatt-hour electricity is considered to be about as cheap as gas for lighting, and in many places electric energy can be bought, even by the small consumers, at a lower price than this. Often there is a primary rate higher than the figure given and a secondary rate considerable lower, and the cottage or small-apartment customer can secure the advantage of the lower rate by a wise use of his lights, which the central station company will be glad to explain to him, for it enables the company to make a better use of its facilities and to stand ready to serve more customers. Sensible co-operation between customer and company is mutually advantageous.

In many small towns there are no gas plants, and here the electric light competes with kerosene lamps. This is true

too in workingmen's homes in larger cities. Electricity has proved itself able to meet this challenge, and in households where every cent counts. One reason for this is that of late years kerosene oil has constantly risen in price, while electricity has decreased. Another is that the labor and inconvenience of keeping up the oil supply and filling and cleaning the lamps is to be added to the cost of the oil.

Four rather haphazard examples of what is actually being done in supplying electricity to the homes of people of scanty or moderate means under commercial conditions in towns and cities in the Middle West may be given. It is to be noted that in every case the current sold is generated by steam power.

In Cadillac, Mich., the central station company has 300 customers on its books (or had last August, when the statement was made publicly) whose wages do not exceed more than two dollars a day. These workingmen can afford electric light and the company can afford to sell it to them, or of course it wouldn't do it. The company gets from \$9 to \$15 a year from each consumer of this class.

Dubuque, Iowa, has an up-to-date electric lighting management, and here a carefully prepared educational campaign has been carried on to convince householders of moderate means that electricity is not to be regarded as a luxury for the rich. During the last eight months more modest homes have been equipped electrically than during any previous period of several times that duration. Here it is found that the possibility of using the electric flatiron is a great attraction toward the electric service. Where housewives do their own ironing, they find the electric flatiron a great labor-saver. It is significant that in East Dubuque, a small suburban village of workingmen's houses, there is proportionately more residential lighting (electrical) than in prosperous Dubuque, across the river.

Residence lighting has always been an important branch of the business of the electric lighting company in Detroit, which is to be expected, perhaps, in that city of beautiful homes. The rapid growth of the business, however, dates

only 10 years back. Now there are over 12,000 residence customers of all classes. In this city a large number of cottages as well as more pretentious houses are electrically lighted. This business is taken from kerosene competition. Usually the cottage householder who uses electric light in Detroit owns his own home. This city has many districts consisting of rows of small houses, called terraces, where each cottage is owned by its occupant. Such owners prefer electric light because of the saving in maintenance of wall decorations and ceilings. Several large property holders specify in their rental leases that electricity shall be used exclusively for lighting by the tenants. This policy was adopted without action on the part of the central station company. The average monthly bill for residence electric lighting in Detroit is \$2.32.

Chicago has about 30,000 householders living in small houses or apartments who are customers of the electric lighting company. In an ordinary seven room apartment perhaps 20 lamps will be installed, although the number varies to suit individual requirements. Formerly a minimum monthly payment of one dollar was required, but this is no longer asked, and many bills are made out for less than that sum. But, taking the general run, the monthly cost of electric light in the small homes of Chicago may be said to range between \$1.15 and \$2.50 net. There has been a great increase in this class of business within the last few years, stimulated by steadily decreasing rates for electricity.

Of course the price of electricity varies widely in different localities, affected by local conditions. Some managements are less anxious for residence business than others. Some, using the "white coal" of waterpower, are able to sell electrical energy more cheaply than others who have to burn coal hauled perhaps a long distance. The prevailing rate of interest on money, cost of labor and several other things, such as the character of the community served, whether industrial or otherwise, all have their influence on the commercial price of electricity to small residence users. But it is believed that the facts and fig-

ures given in the dispassionate survey of the situation made in this article show that, in most places, the man who can afford to pay from 75 cents to \$2.50 a month for the lighting of his home can have the use of electricity, with its great advantages of healthfulness, cleanliness, cheerfulness and convenience.

THE ELECTROTHERM.

The Electrotherm is a light, flexible pad composed of wires insulated and protected with asbestos and designed to perform the function of the old-fashioned hot water bottle. It is arranged for attachment to an ordinary electric light socket, and when so connected, the pad offers sufficient resistance to the current to produce a constant and absolutely uniform degree of heat as long as the current is turned on. A regulating switch

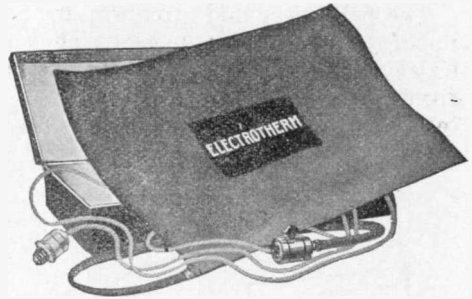

THE ELECTROTHERM.

is provided by which a low, medium or maximum degree of heat may be obtained at will, by simply turning the key.

In pneumonia cases the value of the Electrotherm is especially apparent for the reason that the most potent influence in the treatment of this disease is bodily application of a steady, continuous heat.

In consequence of resulting danger from the disturbance of the patient, and the change in temperature caused by changing the application when a hot water bottle is used, physicians have reluctantly been compelled to forego this most efficient influence. In such cases the Electrotherm is indispensable, obviating as it does, all these objections and furnishing the only method for an application of a regulated heat for an indefinite period.

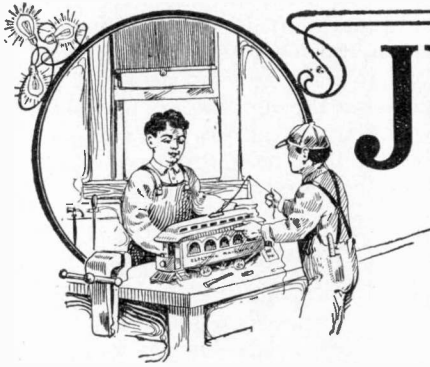

JUNIOR SECTION

CONSTRUCTION OF A LAMINATED MOTOR.

BY MILFORD J. WHINNEY.

I have constructed the electric motor here described, and have found it to work admirably. It is a unique little machine embodying as it does a laminated field and armature.

The field piece and armature are built up of 30 sheet iron pieces. The material for this purpose may be obtained from a tinsmith, or by heating old tin cans until the solder melts, when they may be pulled apart and straightened

forced into it. Cut out the disk carefully with an ordinary pair of scissors, and file off any burr that may remain around the hole. Use this as a pattern for laying off the remaining 29 pieces.

Having cut 30 pieces, now bind them together with twine, to hold them in place until the wire is wound on. Turning now to the field magnet, Fig. 2, lay off as per drawing and cut 26 pieces as shown by the solid lines and four pieces

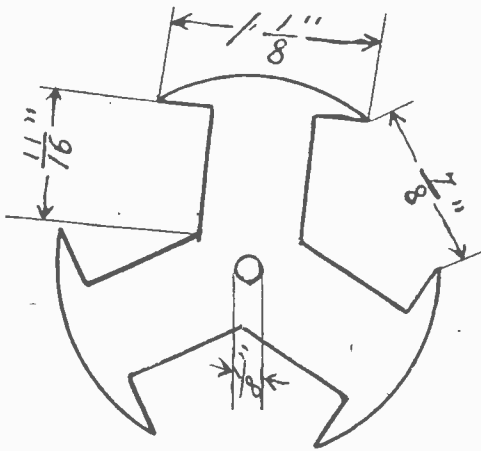

FIG. 1.

into flat sheets, as the so called "tin" of which cans are made is simply sheet iron coated with tin, and will answer the purpose. Carefully lay out an armature disk, the shape and size shown, Fig. 1. In one of the sheets, punch a small hole accurately in the center and enlarge by reaming with the tang of a file until a one-eighth inch wire nail can just be

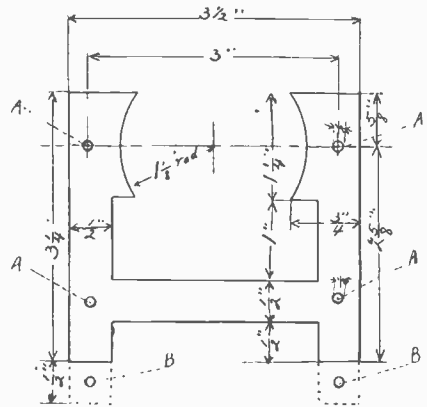

FIG. 2.

with the extensions shown by the dotted lines. These extensions are afterward bent out at right angles and form ears for securing to the base-board.

Assemble the sections of the field by putting two pieces with the extensions, on each side of the 26 pieces, then clamp the sections in a vise and drill four one-eighth inch holes in them at (A, A, A, A), Fig. 2; also drill a one-eighth

inch hole in the extensions at (B, B). The field sections are now bolted together with four small one-eighth inch bolts passing through the holes (A, A, A, A).

The bearings, Figs. 3 and 4, are cut from heavy sheet brass. The holes for

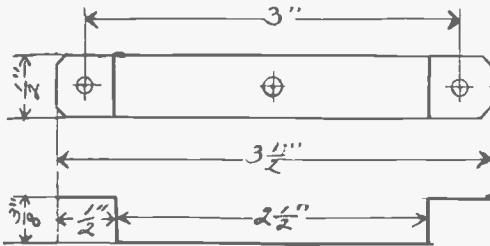

FIGS. 3 AND 4.

the armature shaft should be of such a size as to allow it to revolve freely but with no shake. The holes in the ends are the same diameter as those in the field pieces, one-eighth inch.

The armature is assembled by forcing the disks onto the shaft, Fig. 5, which is

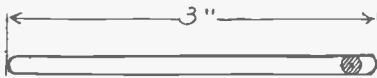

FIG. 5.

made from a wire nail one-eighth inch in diameter and three inches long, the head having been cut off and the ends nicely rounded.

The commutator is made of a piece of wood as shown in Fig. 6, the hole either being drilled through or burned

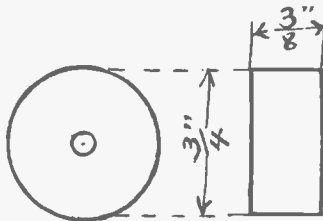

FIG. 6.

with a red-hot wire so that it is a tight fit on the shaft.

The commutator segments, Fig. 7, are cut from thin sheet copper or brass and fastened to the wooden cylinder by bending down the lugs. Leave about one-

sixteenth of an inch between each segment.

The brushes are cut from the same sheet copper or brass as in Fig. 8, and are fastened by small screws to the brush holder, a wooden block made to

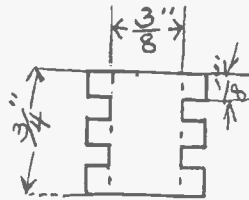

FIG. 7.

the shape and size shown in Fig. 9.

Now wind the field magnet with about one-half pound of No. 18 gauge single cotton covered magnet wire, first wrapping a layer of writing paper around the

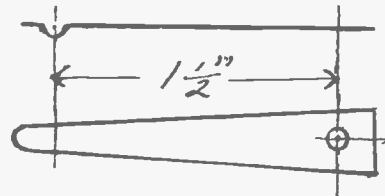

FIG. 8.

sharp corners. Five layers of wire are enough, and a free end three inches long should be left at the beginning and end of the winding for connections, one end

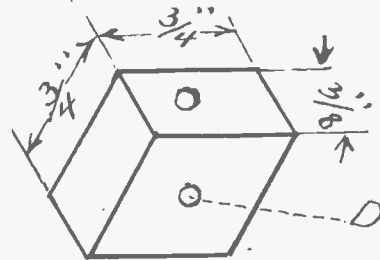

FIG. 9.

is connected to a binding post and the other to the lower brush when the motor is assembled.

Having finished winding the coil, cover it with one layer of adhesive tape, as this helps to protect it.

Wind the armature as shown in Fig.

10, first wrapping on a layer of paper. Wind each pole with four layers of No. 22 single cotton covered magnet wire, winding always in the same direction. Connect the inside layer of one winding to the outside layer of the next, continuing thus until there are three connections, each consisting of two wires (A) and (B), Fig. 10, which must be scraped for a distance of about one inch from the ends and twisted together, as shown at (C). Then connect the three twisted ends, one to each of the three segments of the commutator, by a drop of solder.

Then assemble the motor by fastening the bearing strips to the field with the small bolts passing through the holes (A, A, A, A), Fig. 2, also put a few washers or short coil of bare copper wire

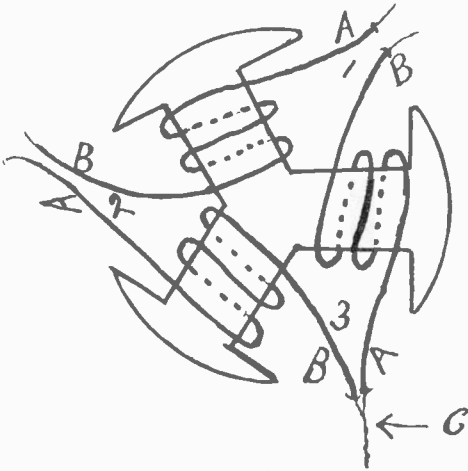

FIG. 10.

on the shaft to keep the armature in place between the pole pieces.

The brush holder, Fig. 9, is fastened to the front bearing, Fig. 3, by a small bolt passing through a hole made in the bearing, and one made in the wood block at (D), Fig. 9.

Having assembled the motor and properly connected it the circuit will be through the field coil to the lower brush, then through the brush and commutator segment around the armature, out through the opposite segment and brush to the battery.

Two cells of battery will run the above motor at a good rate of speed, but with a few more cells more power may be obtained.

COST OF OPERATING ELECTRIC APPARATUS.

Experimenters who use electric light current often desire a means of determining the cost per hour of operation of a certain piece of apparatus. If direct current is used, this is a simple matter, since direct current ammeters, as are used for batteries, are cheap and easy to procure. But alternating current ammeters are expensive and complicated, and therefore not available in modest laboratories. Happily there is a way, used by the writer, by which the cost of alternating current may be determined, and which does not require any extra apparatus. It is by means of the lighting company's meter.

All, or nearly all, alternating current meters have an opening in front, under the dial, through which the armature or rotor may be seen. This rotor makes a certain number of revolutions per minute in proportion to the amount of current used, and when no current is being used by the consumer, the rotor is stationary.

First of all the number of revolutions per minute that the rotor makes when a known current is being used must be counted; then the apparatus, the cost of operation of which is to be determined, is connected up, and the revolutions per minute of the rotor counted again. The ratio of the speed in the latter case, to the speed in the former, is the same as the ratio of the two costs, and since the cost in the former case is known, that in the latter may be computed.

To give a particular example. The writer's meter, a five ampere integrating watt-meter, has a rotor which makes four revolutions per minute when one 16 candle-power lamp is burning. Since a 16 candle-power lamp costs one-half cent per hour (at the rate here prevailing), taking one-half ampere at 110 volts, those four revolutions per minute correspond to one-half cent per hour. When a small motor was operated, through resistance, on the 110-volt current, the rotor of the meter made twenty revolutions per minute. The ratio of speed was twenty to four, or five to one, and since this is the ratio of cost, the current cost five times one-half cent per hour or two and one-half cents per hour.

LOUIS H. ROLLER.

HOME-MADE ELECTRIC HEATER.

BY P. J. O'GARA.

A home-made electric heater which is nearly as efficient as a factory made heater may be constructed by any ingenious boy. The material necessary for its construction is not expensive and only a few tools are needed.

Procure six porcelain bushings 18 by $13/16$ inches and wind each one with 25 feet of No. 26 "Climax" resistance wire. The turns should not be allowed to touch each other, and may be kept apart by putting on a thin coat of plaster

lower terminals should in like manner be brought out to the lower contact screw. The upper and lower coils should have their other terminals connected together right across the end. The nearest pair of coils should now have their left hand terminals connected to the snap-switch; and the farther pair should in like manner be connected to the other snap-switch. With this arrangement three heats may be obtained by turning the snap-switches on or off.

After the plug and snap-switches have been connected with the coils, two tin

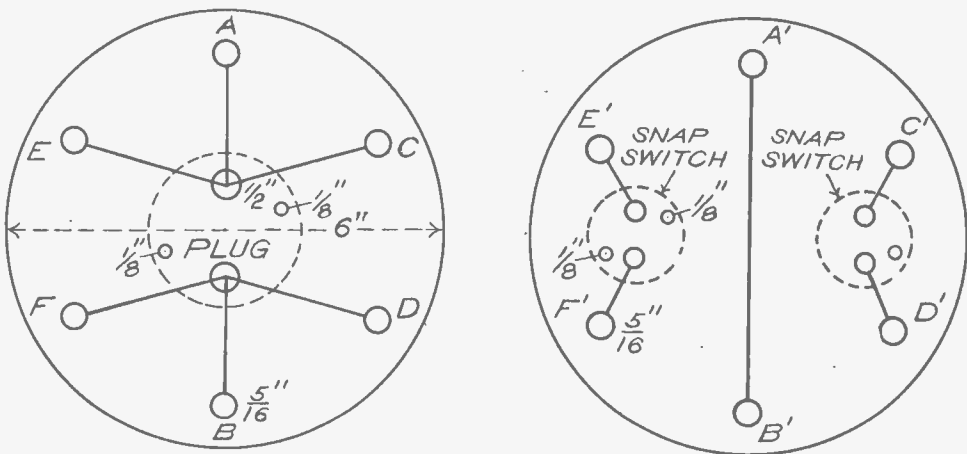

FIGS. 1 AND 2. ARRANGEMENT OF PLUG AND SNAP SWITCHES IN ELECTRIC HEATER.

of Paris on one side. It is not necessary to entirely cover the wires with it. Cut out two disks of tin or other thin sheet metal six inches in diameter, and punch six $5/16$ inch holes at equal distances and within $3/4$ inch of the outside edge. Also punch holes through which to lead out the wires, as well as others for the attachment of the plug and snap switches. Then cut out two disks of asbestos the same as the metal disks. The diagram of these disks is shown in Figs. 1 and 2. Cut off six lengths of $5/16$ inch rod iron 20 inches long and thread these lengths at both ends for about one inch. Then assemble the parts as shown in Fig. 3. The attachment plug is shown at the right while the two snap-switches are at the left. The terminals of the three upper coils should now be brought out and fastened under the upper contact of the plug; and the three

disks the same diameter as the other disks are fitted over the ends and held in place by small machine screws. These are not absolutely necessary, but they cover up the nuts which hold the parts together, making the apparatus have a more finished appearance. Cut a piece

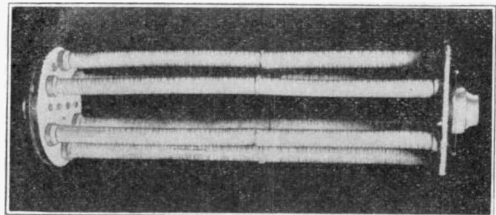

FIG. 3. HOME-MADE ELECTRIC HEATER.

of asbestos just long enough to fit in between the two heads, and wide enough to just cover the three coils. This

is necessary in order to protect the floor from excessive heat, since the heater rests in a horizontal position. As shown in Fig. 4, a protective covering made of a piece of perforated sheet metal

total capacity. Attachment is made to the ordinary lamp socket by means of a piece of lamp cord and a plug.

In case that it is desired to wind the heater for 220 volts, each coil should be

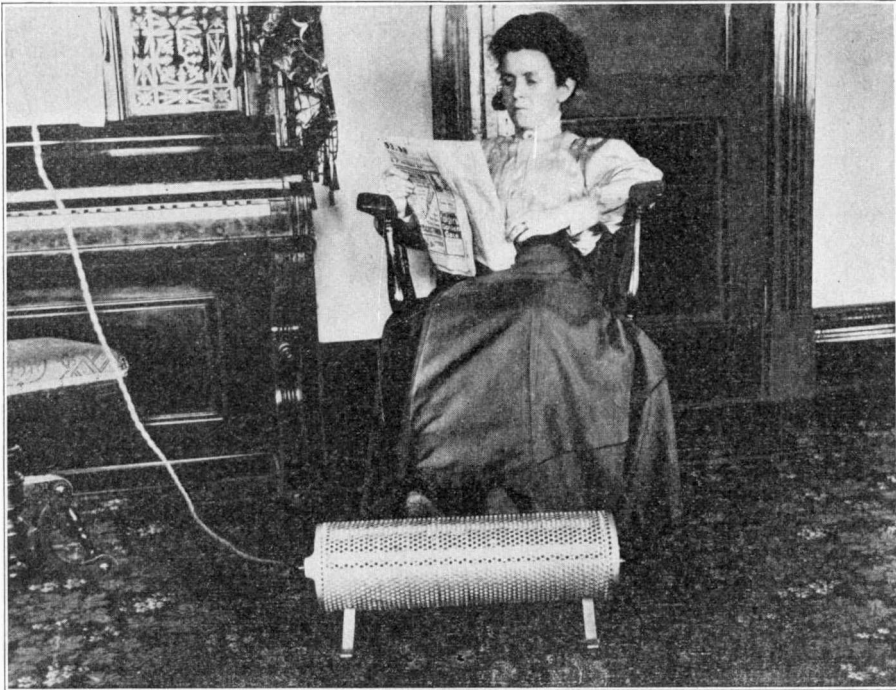

FIG. 4. ENJOYING THE COMFORTS OF THE ELECTRIC HEATER.

20½ inches long and 19¼ inches wide is now fitted over the coils, and held in place by the bolts which also attach the legs to the heater. The legs are made of ⅝ inch strap iron bent into the form shown in Fig. 4. Since the bolts, which attach the legs to the cover, also pass through the bottom sheet of asbestos, there is no chance of the coils slipping out. In case the perforated sheet metal cannot be obtained at a hardware store there are always discarded sheets to be found at a flour mill, where perforated zinc screens are used for milling purposes.

This heater is constructed for a voltage of from 110 to 120, which is the ordinary voltage of most incandescent lighting circuits. When turned on full the heater consumes about 600 watts, or that of 12 incandescent lamps. With the two snap-switches turned off, it takes about 200 watts, or one-third the

wound with No. 29 "Climax" resistance wire having the same length as before.

GENERAL PLAN FOR A HOME-MADE RHEOSTAT.

This rheostat can be made by anyone having a few carpenter's tools. The frame and fittings may be varied to suit the current regulated, and worked out in accordance with the plans. A hardwood panel of the required size lined with ⅛-inch asbestos on the back should be provided to support the resistance coils (E). The panel should be mounted 12 inches from the wall on metal brackets. All screw heads should be countersunk. The following material is needed: Porcelain knobs (K); porcelain bushings or loom (P); strip of ¼-inch asbestos (N); ¼-inch asbestos board (T); two copper plates (D), ⅝-inch thick; strong steel spring (S); common door hinge (H); copper straps (C);

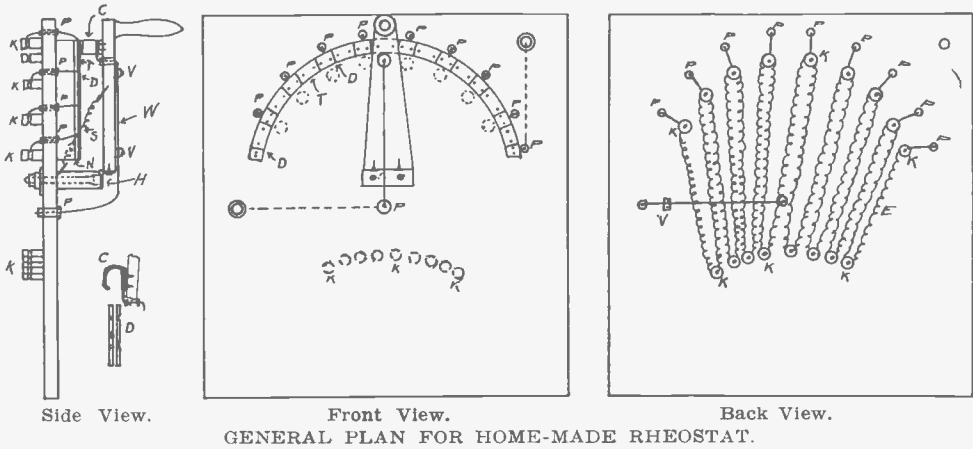

porcelain cleats (V). Enough hardwood should be provided to construct the revolving part under hinge (H), the arc of the circle for contacts (D), and the arm and handle.

As seen in the back view, the distance between the upper and lower knobs (K K) may be increased or diminished to provide room for the necessary wire resistance. When the arm is on the contact (D) the circuit is open. The arm should have a hardwood peg as a stop at starting and running positions and also an additional peg to hold the arm in the

running position. This part of the device may be arranged to suit the ideas of the builder.

Eight steps are provided in cutting out the resistance. Use Ohm's law, $C = \frac{E}{R}$ to determine C at each step, E and R being known. For convenience in figuring wire resistance, it may be noted that the resistance of copper wire is $10\frac{1}{2}$ ohms per circular mil foot; iron wire, 6 times as much; nickel, 8 times, and German silver, 13 times as much.

SMALLEST ELECTRIC LAUNCH.

Probably the smallest electric launch ever constructed is the one shown in the picture. It is the handiwork of a boy 18 years of age, John Elliott Jenkins, of Chicago. Young Jenkins is studious al-

but the electric launch is the most skillfully executed of them all.

The launch is $7\frac{1}{2}$ inches long, with a $1\frac{3}{8}$ -inch beam and a depth of $1\frac{1}{4}$ inches. The picture shows its size as compared

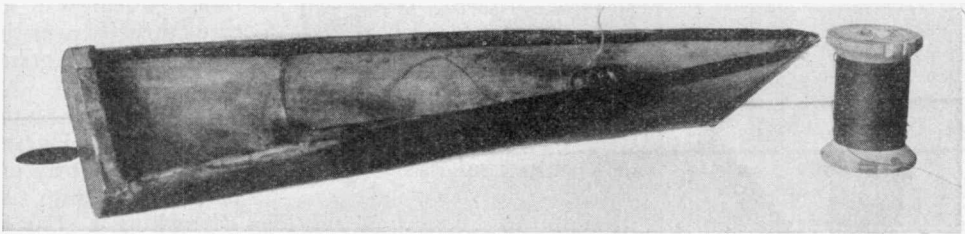

SMALLEST ELECTRIC LAUNCH.

most to the extent of being retiring, and is never so happy as when let alone and allowed to satisfy his craving for electrical experimental work. He has constructed a great many ingenious devices,

with an ordinary spool of thread. It is made principally of shellaced paper, with a few little bits of wood here and there for stiffening. The propellor shaft is part of a hat pin, with tiny blades care-

fully mounted, and this shaft is driven by a most curious little motor only three-quarters of an inch high and with wires almost as fine as hairs. The armature of this motor is about half as big as a

good sized hazlenut. But for all this, the boat will run, although it is so small that it cannot carry its own battery, unless a very small special one be built for the purpose.

SWITCHBOARD STORIES.

WHY HARVEY MOVED.

BY C. TUELLS.

Harvey Jackson was truly in love with his work. He had just completed his college course of four years at one of our eastern universities, and was now starting in to get his practical experience in the largest electrical manufacturing concern in the world, where he was receiv-

The city of Lynn wasn't a large city, consequently Harvey experienced little trouble securing a room in the center of the business section, still keeping financially within his limited means. His first months of experience were spent in the arc lamp department of the manufactur-

ing concern where for a while he was kept busy breaking up old lamps, after which he went to the testing bench and later up to the experimental room. The experimental room was a veritable wonderland to Harvey and it was not long before his inventive genius began to crop out. His time at the shop was mostly taken up with routine work, but he used to spend his evenings developing his new ideas in his little down-town room, which was located directly over the largest dry-goods store in town.

One day at the shop, while Harvey was trying out an experimental lamp, he conceived the idea of making a style of lamp that would use less current and give much more light; so that evening in his little room he started in to investigate his idea. With the aid of some old lamp parts and the shop scrap-barrel and a few evenings of persevering work he had his model lamp completed and all ready to test, but, blinded by his enthusi-



THE WIRE TAPPING WAS A GREAT SUCCESS.

ing the munificent sum of 18 cents an hour. Eighteen cents an hour did not seem much to Harvey after his brilliant years at college, especially as it was coupled with 10 hours a day of steady and sometimes very hard work. But experience was what Harvey was after and he was getting it every hour—with the 18 cents an hour thrown in.

asm, he had overlooked the fact that an arc lamp could hardly be a success on a low voltage and much over-worked incandescent circuit, so, though his lamp was now ready, it was useless unless he could get a higher voltage circuit on which to try it out.

Dejectedly he sat looking out of the window, thinking how his success was being nipped in the bud, when his eye caught the series arc light wire directly under and within reach of his window. There is an old adage that reads, "Fools rush in where angels fear to tread"—Harvey tapped the wire. The tapping was a great success, mechanically if not morally, and the brilliant rays from his highly successful lamp completely drowned his guilty conscience. It was necessary for him to keep his blinds closed so that the intense light would not attract attention from passers-by in the street below, but that was easily done, and for many nights he experimented with and perfected his new idea.

One pleasant Saturday evening soon after his invention was developed he was trying to still further increase the efficiency of his lamp, when suddenly (to this day Harvey can't explain how) he accidentally opened the circuit or else grounded it.

Harvey's room was immediately plunged in darkness; so also was the whole street traversed by that particular line. Some one immediately sent a rush call to the electric light company and soon the emergency wagon was thundering down the street towards the dry goods store—and Harvey. The young inventor began to figure how things were coming out and hastily threw open the window and started to disconnect his tapping wires, but he was just in time to be too late, for, as he was removing his second wire a vigilant lineman spied him as he pulled it into the window.

It didn't take Sherlock Holmes' power of deduction to trace the trouble to Harvey's room by way of the window, and soon a store manager, a lineman and a policeman were having an extremely personal interview with a much embarrassed young man, which resulted in his paying a twenty-five dollar fine in the local court next day, and indirectly in the appearance of a sign in the fatal window which read—"To let."

LYNN MARSH, THE BOY TELEGRAPHER.

At 11 years of age Lynn Marsh is one of the best telegraph operators along the line of the Baltimore & Ohio South-Western Railroad. He has been handling the key ever since he was nine years old. He isn't in charge of an office, but his father, W. W. Marsh, is the agent and operator at Winton Place, and Lynn often "sits in" for his father, handling the key like a veteran.

"I started to learn telegraphy when I was nine years old and I expect to be the best telegraph operator in the country



LYNN MARSH AT THE KEY.

when I grow up," declares the youthful knight of the key.

The boy operator is known by nearly all the telegraph operators along the line of the railroad and they all like to take "stuff" from the key of the young expert. Lynn has worked a newspaper wire for an eight-hour turn, but he prefers the click of the railroad message to that of the newspaper story.

The war department has confirmed the report that ex-President Roosevelt is carrying to Africa with him two rifles whose sights are equipped with small electric lights to enable accurate shooting at night. These sights are the invention of a Chicago man, and are at present undergoing an exhaustive trial by the war department.

QUESTIONS AND ANSWERS.

Readers of Popular Electricity are invited to make free use of this department. Knowledge on any subject is gained by asking questions, and nearly every one has some question he would like to ask concerning electricity. These questions and answers will be of interest and benefit to many besides the one directly concerned. No consideration will be given to communications that do not contain the full name and address of the writer.

Electrolysis of Water.

Questions.—(A) Is there any definite way to figure the amount of hydrogen gas liberated from water by a known current of electricity? (B) What voltage is the best for the decomposition of water? (C) How are the oxygen and hydrogen gases carried off and compressed? (D) Will you show how such apparatus may be constructed? C. C. V., Pittsburg, Pa.

Answers.—(A) One ampere-hour will set free 12.8 cubic inches of oxygen and 16.3 cubic inches of hydrogen.

(B) Water slightly acidulated with sulphuric acid decomposes with the application of three volts. The real decomposition of pure water has been found to begin at 1.08 volts.

(C) The generated gas may be carried by pipes into a bell receiver having the lower end immersed in water similar to the storage tanks used by illuminating gas companies. The bell may be weighted to secure the desired pressure. Pipes leading to the bells should be equipped with stop valves.

(D) Many different apparatuses particularly of German make have been patented but we do not know of any large plant in commercial operation in this country. We are informed that two or three plants are in operation in Europe. Apparatus for laboratory purposes is shown in Fig. 1, and consists of a glass U tube and a rubber connection to the reservoir (R). By raising and lowering (R) various pressures of (H) and (O) may be obtained. The electrodes (P P) are of sheet platinum. The leading-in wires are of the same metal. The liquid used should be by volume, six parts of water and one part sulphuric acid. This will produce oxygen rich in ozone. The above apparatus or similar outfits are sold by firms supplying schools and colleges with laboratory material. Figs. 2, 3 and 4 give a general design of a commercial outfit said to have been successfully operated in Germany. The whole resembles a filter

press. In the designs, (E) is a lead plate acting as a double electrode, (D) is sheet asbestos forming the electrode

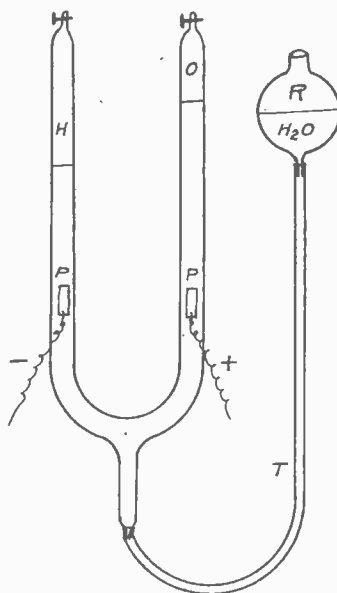

FIG. 1. LABORATORY WATER ELECTROLYZER.

spaces, and at the point where the lead plates would come in contact pieces of rubber are laid on the asbestos. Supply pipes should be of iron or lead with couplings and cocks of bronze. The whole apparatus must be well insulated from the ground and from metal connections to gas pipes. Tests to determine this should be made. The pipes (H) and (O) run to their respective electrode chambers, (H, H, H) and (O, O, O). Each plate, Fig. 4, has at the top and bottom in its thick edges, two holes, (H, O) and (W, W₁). The water pipes connect with the funnel supply. Plates, rubber sheeting and asbestos are held together by a hand wheel device shown in dotted lines. Every alternate plate respectively is connected to the +

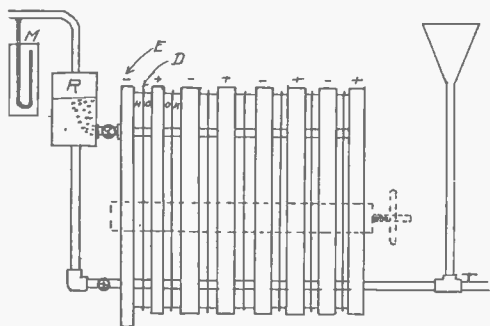

FIG. 2. WATER ELECTROLYZER—SIDE VIEW.

and — side of the supply circuit by connections which should be provided but not here shown. Pressure in both leading-off pipes should be kept the same and manometers (M) placed as shown.

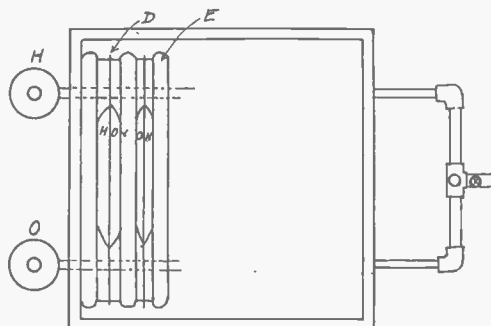

FIG. 3. WATER ELECTROLYZER — TOP VIEW.

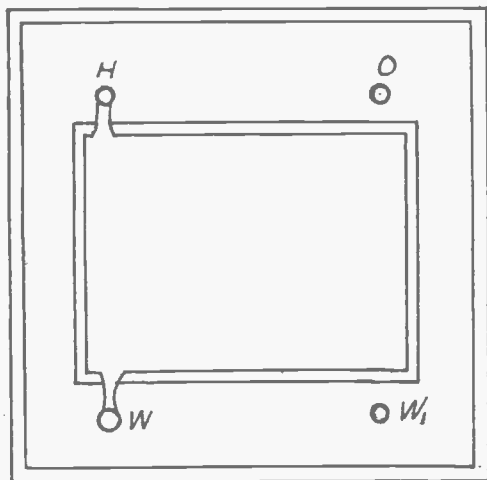

FIG. 4. SINGLE ELECTRODE OF WATER ELECTROLYZER.

The gas when used for medical purposes may be purified by passing it through a red hot porcelain tube. The purity of the gas may be also tested by leading a little of it through a rubber tube into a test tube filled with water and inverted in a dish of water. As soon as gas has displaced the water a match may be lighted under the mouth of the tube. Hydrogen burns quietly. Oxygen should not ignite. If the apparatus takes too little current, test the voltage between the plates. If a chamber shows no pressure a short circuit may have occurred. If the voltage is high the chambers may be empty, possibly by stopping up the channels.

Ammeter Shunt.

Question.—How are ammeter shunts calculated?—F. F., Milwaukee, Wis.

Answer.—The diagram shows the connections for a shunt ammeter. (K)

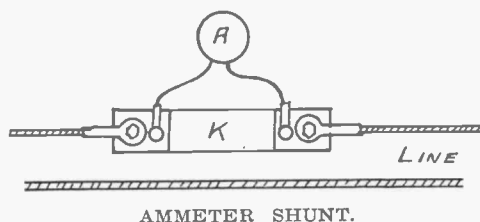

is a conductor in series with one side of the line and having a low temperature coefficient. Hence the drop in voltage across (K) is proportional to the current passing. (A) is a low reading sensitive voltmeter which measures this drop. If the resistance of (K) is .002 ohms and the instrument reads .5 volts,

$$\text{by Ohm's law } C = \frac{E}{R}, \text{ or } \frac{.5}{.002} = 250$$

amperes. Shunts and ammeters are built to measure certain maximum currents and are so named.

Telephone Receiver Wire.

Question.—How much and what size wire should be used to wind a telephone receiver pole?—E. A. R., Rockford, Ill.

Answer.—The resistance of a single pole receiver is about 75 ohms. Use 180 feet of No. 36 B. and S. gauge, or 114 feet of No. 38 single cotton covered wire. In double pole receivers the resistance of each coil is about 50 ohms for each coil. Use 120 feet of No. 36 wire or 75 feet of No. 38 wire.

Transformer and Motor Connections.

Questions.—(A) Please give diagram for connecting a three-phase alternating current motor to service, the primary being 2,200 volts and the secondary 110 volts. (B) How many transformers should I use?—W. C., Sulphur Springs, Ark.

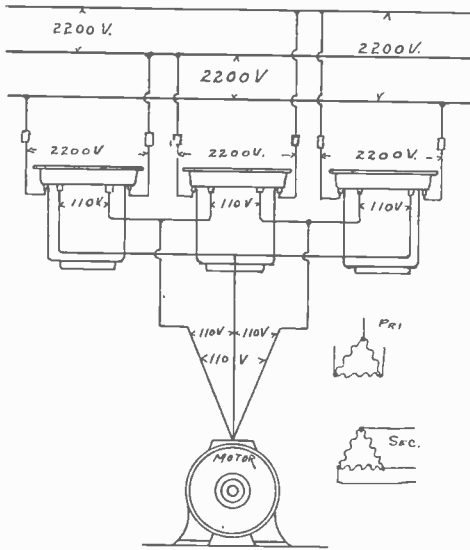

FIG. 1.

commonly used than any of the others. The primaries as shown are delta connected. The pressure in the primary of each transformer is the same as the pressure on the mains, and the secondary pressure is one-twentieth of this. By this method it is plainly evident that if one transformer blows its fuse or breaks down, the other two will be able

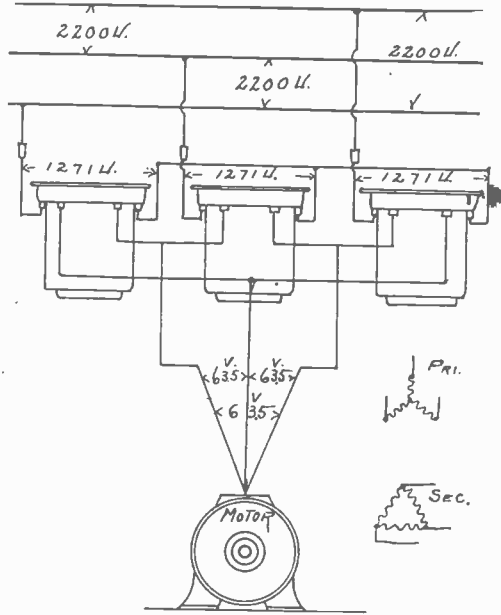

FIG. 3.

Answers.—(A) In making the following calculations it has been assumed that the ratio of transformers in all three diagrams is 20 to 1. The connections shown in Fig. 1 are more

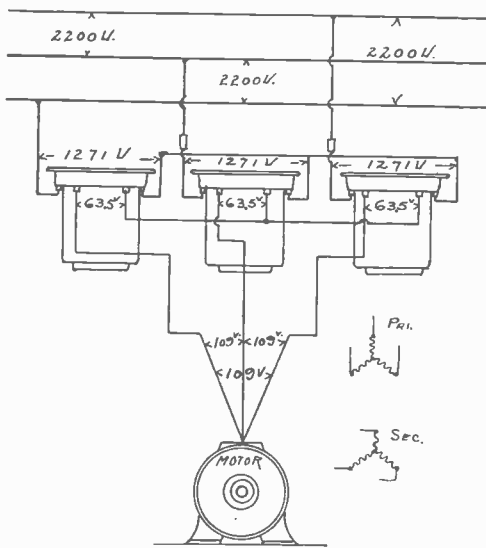

FIG. 2.

to carry the load with safety if it is reduced somewhat.

In Fig. 2 the primaries and secondaries are Y connected as shown. In this method the voltage in the primary of the transformer is the voltage of the mains divided by the square root of 3 or 1.73. The pressure across the secondary main equals the pressure of the secondary of one transformer multiplied by 1.73. The advantage of this way of connecting is that the voltage across the primary coils is less than the line voltage, which is a very important consideration in the matter of insulation when transformers are connected to very high voltage mains. The same advantage is gained also when the connections are made as shown in Fig. 3.

(B) The number of transformers shown in each diagram answers your question.

To Make a Commutator; Switchboard Connections; Lightning Arrester.

Questions.—(A) How would you make commutator segments for a small dynamo? (B) Will you give diagram showing how to wire a generator switchboard? (C) where and how are lightning arresters connected to outgoing lines? W. S., Concord, N. H.

Answers.—(A) Referring to Fig. 1, two cylinders (H) of hard wood may

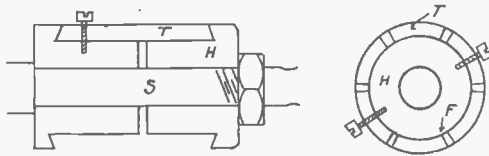

FIG. 1. CONDENSER.

be bored and turned as shown. The ring (T) of which commutator is made may be placed on the cylinder, made in halves so this can be done. The whole is driven on a lathe mandrel (S) and the

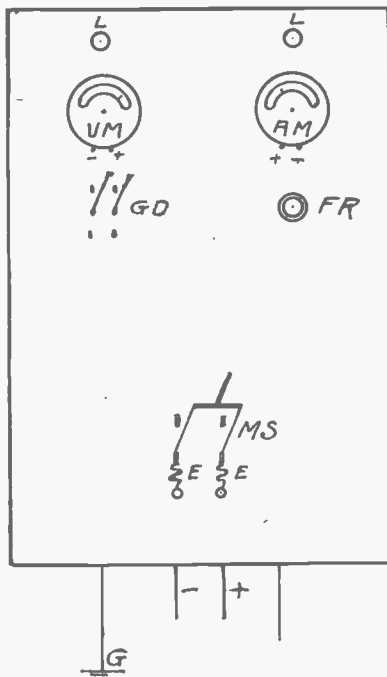

FIG. 2. D. C. SWITCHBOARD—FRONT.

nut shown, tightened. After turning and making the segments by sawing, the cuts (F) should be filled by strip mica or hard wood strips.

(B) Figs. 2 and 3 show front and

back view of a switchboard in which (E, E) are fuses on leads from the generator, (G D) is a voltmeter ground detector equipped with single-pole double-throw knife switches, (G) is ground for same. Voltmeter connections are shown with fuses (which should not be over six amperes) protecting the voltmeter

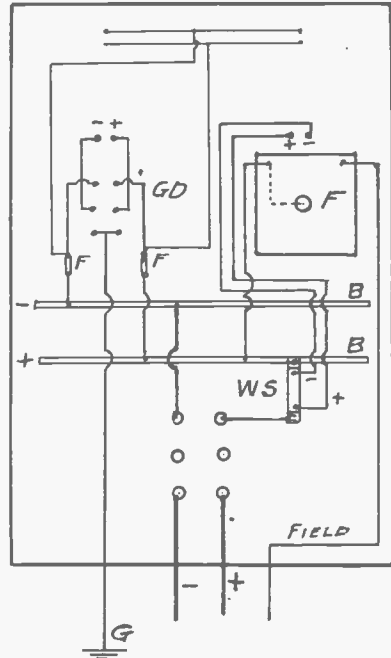

FIG. 3. D. C. SWITCHBOARD—BACK.

and two pilot lights (L, L). The ammeter is connected to a Weston shunt (W S). The shunt field rheostat (F) is shown as connected from the positive bus (B), and through this the field current is controlled. The other end of the field wire after passing around the cores is connected to the negative brush at the machine.

(C) Fig. 4 shows connections (D, D) for lightning arresters. These points should be chosen near the place where the wires enter the station. The choke coils (C, C), owing to the supposed high frequency of the lightning discharge and the self-inductance of the coils, choke back the discharge, the same passing preferably down through the arresters to ground. The arresters should be located away from the board. Not less than No. 6, B. and S. gauge copper wire

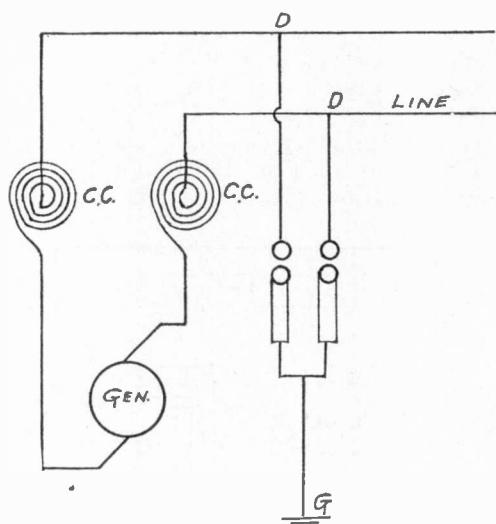

FIG. 4. LIGHTNING ARRESTER CONNECTIONS.

should be used, runs being free from kinks, coils, and sharp turns. The ground wire from the arresters should not be run in pipe. The ground plate should be fairly heavy sheet copper plate having at least four square feet of surface, buried in damp soil or soil kept so artificially. The ground wire should be riveted and soldered to the ground plate.

Magneto Generator.

Questions.—(A) Could I make a battery motor out of a telephone generator? (B) If I made a dynamo out of a telephone generator by putting a commutator on it, would I have to rewind the armature?—C. E. P., Smithshire, Ill.

Answers.—(A) Magneto generators ordinarily give from 60 to 75 volts. To run one at the high speed usual as a motor would require too many cells. A commutator would be necessary and the armature would have to be rewound for low voltage, six or eight volts. The permanent magnets also vary in flux produced. In a given generator, therefore, turning at a certain speed, the voltage will depend upon the number of turns of wire in the armature. Find by experiment how many turns of wire on the armature will give six or eight volts on an open circuit, then use the largest wire which this number of turns will allow.

(B) Not if you want 60 or 75 volts and a small current.

A 125-Cycle Motor on 60 Cycles; Windin^g Armature.

Questions.—(A) In the December, 1908, issue of Popular Electricity I read how to change a motor running on 125 cycles so it would run on 60 cycles. I used 150 feet of No. 23 wire on each pole piece. The fan operates, but at slow speed, and also vibrates with a humming noise. (B) How would you wind a drum armature having 36 slots?—W. W., Chicago, Ill.

Answers.—(A) The latter part of the answer to J. E. D. in issue referred to answers part of your question. The humming is due to parts of the motor being "in tune" with the frequency or alternations.

(B) Wind as follows:

Coil No.	Starts in Slot No.	Ends in Slot No.
1	1	18
2	19	36
3	7	24
4	25	6
5	31	12
6	13	30
7	3	20
8	21	2
9	27	8
10	9	26
11	33	14
12	15	32
13	23	4
14	5	22
15	11	28
16	29	10
17	35	16
18	17	34

Arc Lamp Resistance.

Questions.—(A) What size of German silver wire and how much of it will be needed for resistance in an arc lamp using $\frac{3}{8}$ -inch by 12-inch carbons? (B) For a flaming arc?—T. W. P., Chicago, Ill.

Answers.—(A) A constant potential direct current enclosed arc lamp requires about 80 volts at the arc and four amperes on a $\frac{3}{8}$ -inch carbon. A resistance of eight ohms, or one and one-third pounds of No. 14 German silver will give the necessary resistance for 12-inch carbons.

(B) A constant potential direct current flaming arc lamp is adjusted for 45 volts at the arc and a consumption of 10 to 12 amperes. A proportional decrease in resistance as noted in (A) is required.

Burglar Alarm Circuit.

Questions.—(A) Kindly explain how I may arrange a burglar alarm so as to have one large outside bell, one small inside bell and a switchboard for the equipment. (B) What are considered an electrician's helper's tools? H. G. B., Jersey City, N. J.

Answers.—(A) The diagram shows connections for a closed circuit alarm, windows (W), relay (C), and gravity battery (G). Armature (A) is normal-

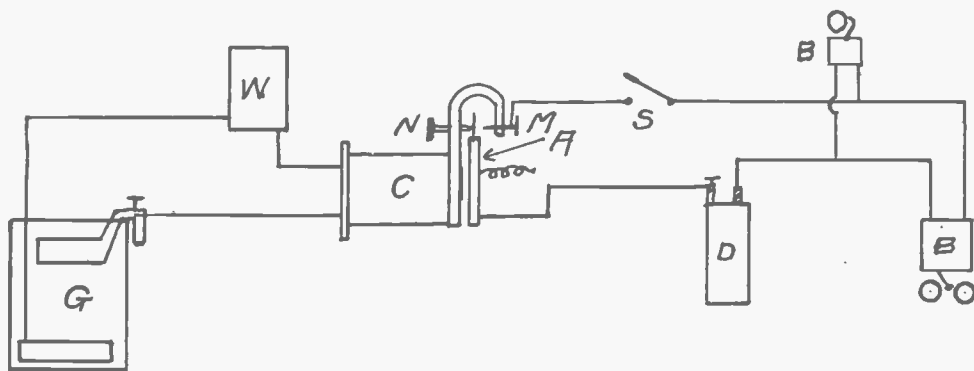

BURGLAR ALARM CIRCUIT.

ly held in contact with point (N). If circuit (W G C) is broken, relay (C) releases (A) and the spring causes contact to be made at (M) which is insulated from (N). If switch (S) is closed bells (B) ring until circuit (W G C) is closed or (S) opened. (S) and (C) could be placed on a neat wooden board and the position of (A) would indicate the condition of window circuits.

(B) We do not know that any certain tools are so designated, but other things being equal the electrician's helper would be most efficient if he has the following: One rule, 2 foot; one clawhammer, No. 13; one blow lamp; one B. and S. pocket wrench, No. 4; one screw-driver bit; one set (2) Champion screw-drivers; one large screw-driver, 12 inch; one ratchet brace, No. 33; bits, $\frac{1}{4}$, $\frac{3}{8}$, $\frac{1}{2}$, $\frac{5}{8}$, $\frac{3}{4}$, $\frac{7}{8}$, 1 inch; one Clarke expansive bit, $\frac{7}{8}$ to 3-inch; one gimlet bit; one wood countersink; one extension drill; $\frac{3}{8}$ inch, length 24 inches; one long or extension gimlet; one cold chisel, $\frac{3}{4}$ inch; one wood chisel; one brick drill; one pair line pliers, 8 inch; one splicing clamp; one soldering copper, No. 3; one plumb bob; one hack saw, 10 inch; one saw, 20 inch.

Magnet Coil Winding.

Question.—Please tell me how to make a magnet coil that I may connect across 110 volts, the coil to be only one inch long. C. M., Richmond, Ind.

Answer.—Wind a bundle of iron wires with two layers of oiled paper. Upon this wind 1,000 feet of No. 30 silk-covered wire. The current through the coil when across a 110-volt circuit will be about one ampere.

A Closed Circuit Cell.

Question.—How can I make a wet, closed circuit cell other than a bichromate cell? J. A., Council Bluffs, Ia.

Answer.—The Gordon cell is made as follows: Provide a glass or porcelain jar six inches in diameter and eight inches high, with a tin or fiber tight fitting cover. In this jar suspend by an iron rod, insulated through the cover, a tin cylinder pierced full of small holes. Fasten to the outside of this cylinder down near the bottom three porcelain supports to hold and insulate a ring of zinc. To this zinc fasten a rubber covered wire and bring this wire up through cover. Brass connectors may be fastened to the upper ends of the iron rod and rubber covered wire. These are the battery terminals. Fill the jar with six pints of water and slowly add $1\frac{1}{2}$ pounds of caustic soda. Now immerse the cylinder containing $2\frac{3}{4}$ pounds of oxide and around which is the zinc ring. Pour a little paraffine oil on the surface and securely fasten the cover in place. This cell gives a steady current of two amperes at seven-tenths volts or five amperes at five-tenths volts. Copper oxide, zinc, and caustic soda are required to renew the cell.

Telegraph Key and Relay.

Questions.—(A) How can I make a telegraph key? (B) How can I make a relay of high resistance?—J. L. B., Elizabeth Port, N. J.

Answers.—(A) Fig. 1 shows the working parts of a telegraph key. The circuit through the key may be traced

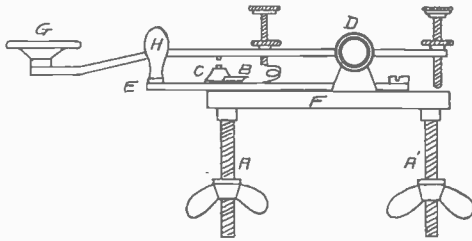

FIG. 1. WORKING PARTS OF A TELEGRAPH KEY.

from leg (A) to anvil (C) which is insulated by a hard rubber bushing and plate from base (F). With the key pressed down the current passes to trunnion (D), to base (F), and to leg (A'). (E) is a circuit closer by which the frame (F) through a metal strip (B) closes circuit through the anvil (C) and leg (A) when key is not in use. Connections are made to legs (A) and (A').

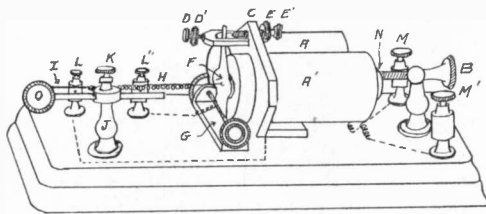

FIG. 2. TELEGRAPH RELAY.

The contact points are platinum, and (G) and (H) are of hard rubber. The rest of the instrument is of brass.

In Fig. 2 of a telegraph relay (A A') are the coils surrounding two soft iron cores, connected by a yoke (N) at one end, and adjusted by set screw (B), (A A') being adjustable through frame (C). The soft iron armature (F) operates on a trunnion held in place by a brass base (G). (D D') and (E E') are adjustment screws with lock nuts, (D D') being

tipped with hard rubber. A sliding rod through (J) held in place by a set screw (K) controls the tension of the spring (H) when (O) is adjusted. Parts except as noted are of brass, the whole being mounted on a wooden base. Connecting wires are run in grooves in this base. Binding posts (M M') are connected to a local battery and sounder, the circuit of which is closed by the armature. The coils (A A') are usually enclosed in hard rubber cylinders. Regarding the building of the coils, divide between two spools 2,900 feet of No. 30 B. and S. gauge wire. Place in each coil a soft iron core connected at one end by a yoke. Join the coils together so that if stretched in a straight line along the yoke forming a bar magnet, the wire will be wound in the same direction throughout. Together these coils will have a resistance of 300 ohms approximately.

Arc Lamp Rheostat.

Questions.—(A) I have a rheostat on an arc lamp taking about 45 amperes. The wire in the rheostat is German silver, No. 10 B and S gauge. The coils are exposed and after some twenty minutes' run the coils get red hot, causing a breakdown about once a month. Could I inclose this rheostat in an oil proof air tight box filled with crude petroleum to prevent heating and breakdown?

(B) Would the oil serve to cut my resistance down?

(C) Would there be any danger of fire?

(D) Will you give a diagram of a transformer stepping 110 volts down to 55 volts and capable of delivering 40 to 60 amperes?—W. A. McD., St. Louis, Mo.

Answers.—(A) No. 10 German silver wire (18 per cent nickel) has a carrying capacity of $8\frac{1}{2}$ amperes. Increase the size of the wire and in the same proportion increase the length. This will keep the resistance the same as now, but increase the carrying capacity. It is not advisable to cool the rheostat with petroleum.

(B) No.

(C) The Fire Underwriters' laboratories do not approve the oil cooled rheostat because they believe it increases the fire hazard.

(D) The specifications for the design of a transformer such as you suggest hardly come within the scope of this department.

Effect of Lines of Force.

Question.—I have a galvanometer made of a coil of wire, inside of which is a pocket compass. When I connect this galvanometer across the primary of an induction coil having a make-and-break contact the needle will gradually commence to revolve. What is the cause? M. B. G., New York City.

Answer.—When a current is passed through a coil of wire, magnetic lines of force are built up inside the coil. Any magnetic metal inside this coil will try to place itself in the path of these lines longitudinally. In the case you describe the magnetic lines are made and then die out because the interrupter on the coil makes and breaks the circuit. When the circuit is made the needle seeks to place itself along the path of the lines, which lines immediately disappear, leaving the needle to swing on around until

the next pull is impressed upon it. The speed is regulated by the speed of the make and break.

Winding Small Drum Armature.

Questions.—(A) Armature, $2\frac{1}{8}$ inches in diameter and $2\frac{7}{8}$ inches long. How much and what size wire should I use to get 50 volts, armature to be drum wound? (B) Does a six-segment commutator require 12 slots in the armature?—A. Curtis, Cleveland, Ohio.

Answers.—(A) With field coils in shunt, provide 12 slots and 12 segments, the slots being $\frac{1}{4}$ inch wide by $\frac{1}{4}$ inch deep. Use 14 ounces of No. 22 wire on armature and $2\frac{3}{4}$ pounds of No. 24 wire on the field coils.

(B) There may be six, 12, 18, or so on, slots (some multiple of six) in the armature.

NEW ELECTRICAL INVENTIONS.

ELECTRIC LIGHT FIXTURE.

A device for raising and lowering electric incandescent lamps has been patented by William Amstalden of Amador City, Cal. As shown in the cut it contains a drum which winds up and unwinds the cord. The drum is provided with a spring and ratchet arrangement,

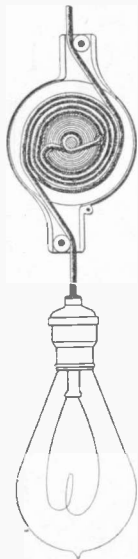

ELECTRIC LIGHT FIXTURE.

similar to that of a curtain roller, which permits of the lamp being adjusted at any desired height.

RENEWING DRY CELLS.

It is well known that dry batteries commence to deteriorate from the time they are made and that therefore it is always a matter of uncertainty in purchasing a cell whether it will continue to be efficient for several months or only for a few days. At the present time, as soon as the voltage of such a cell falls below a certain amount, the cell must be discarded and a new one bought. The purpose of an invention made by H. B. Ramey of Alexandria, Va., is to enable such a cell to be revived with very little trouble and slight expense so that its period of usefulness will be extended for a length of time at least equal to that for which it could be used if put in service immediately after its manufacture.

The invention consists, broadly speaking in applying to the exterior of the cell a casing carrying a dry electrolyte which, upon the application of moisture, sets up a chemical action with the exterior zinc surface of the cell and, the

latter being perforated, causes electrical action to be again produced.

The casing or cup consists of an external waterproof casing and an internal absorbent lining. A sheet of the absorbent paper of the proper size, to form a cylinder of the desired diameter, is impregnated with a solution containing ten parts of muriate of ammonia, four parts of bichromate of potash and ten parts of

rain water. Chemical action will then immediately be produced between the outer surface of the zinc and the electrolyte contained in the porous lining of the cup and the terminals of the cell will show practically the same voltage as it did when it was new. By replenishing the water from time to time, say once a month for example, the life of the cell can be prolonged for a considerable time.

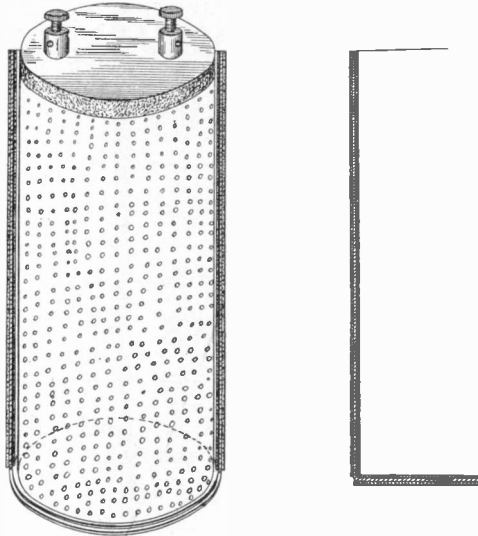

RENEWING DRY CELLS.

chloride of sodium. This sheet is then dried, preferably by passing it between rollers which serve to incorporate the chemicals firmly and to extrude the excess of water, and is wrapped around a wooden cylinder of appropriate diameter. It is then coated externally with a waterproofing paste. Around this is then wrapped a coating of Manila paper, the end of the cup being formed by placing a disk of similar paper at the end of the cylinder in the inside and folding the sheet of Manila paper over it.

The usual external casing of paper is next removed from the cell and the zinc surface cleaned. After wiping off the surface the zinc is perforated in a number of places with a small sharp instrument and the coal tar in the top of the cell is removed by tapping around the edge with a hammer. The cell is then placed within the prepared cup and the top is filled with clean water, preferably

ELECTRIC SAFETY RAZOR.

The latest application of electricity to be suggested is an electric safety razor, and Luigi Brunacci of New York, N. Y., has secured a patent on the idea. The device, as shown in the cut, consists

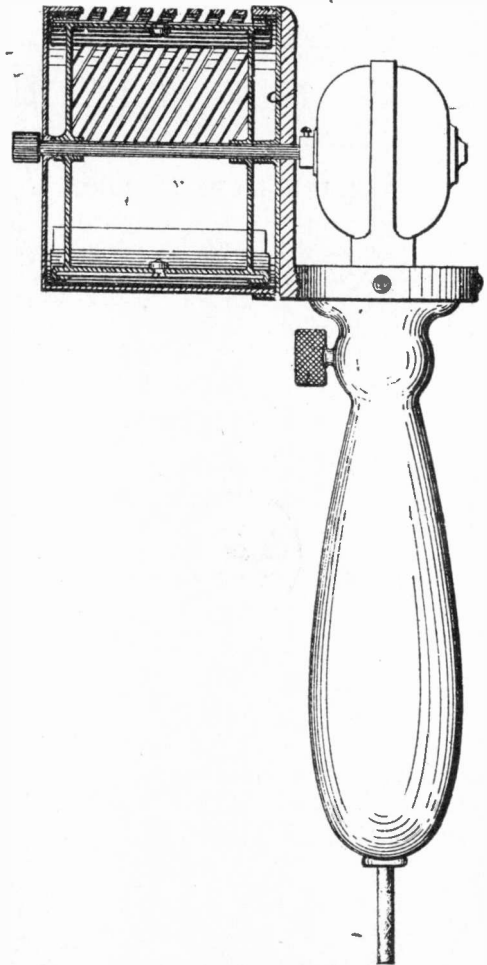

ELECTRIC SAFETY RAZOR.

of a handle, on the end of which is mounted a very small electric motor whose shaft projects through a barrel-like casing. On the shaft inside the casing are mounted revolving arms which carry two razor blades, the keen edges of which just skim the interior surface of the casing. Diagonal slots are cut through the casing and as the latter is passed over the face the hairs protrude through the slots and are cut off by the blades.

BOOK REVIEWS.

HARPER'S HOW TO UNDERSTAND ELECTRICAL WORK. By William H. Onken, Jr., and Joseph B. Baker. New York: Harper & Brothers, 1908. 359 pages, with 171 illustrations. Price, \$1.75.

Far off in the distant West the sun beats down on the snowcapped mountains. Rivulets of water flow down the sides, joining others on their way, until at last the swelling tide is met by a wall of steel and concrete. Fighting against this man-made barrier, the water at last finds a small opening leading to a canal which winds its way along the mountain-side. Suddenly it comes to a precipitous height and plunges down through steel tubes to the power house far below. Emerging from its narrow prison the maddened water seeks to escape, and in its outward rush it brushes aside the blades of the massive water turbine attached to an electric generator. A switch is thrown and the next instant a million lights spring into being in cities over 200 miles away. Along the route of the transmission lines hamlets, villages, towns and cities feel the pulse of this restless energy. Let that pulse stop beating and all progress is stopped.

How to understand this new and wonderful force—electricity—is a problem which is now occupying the minds of people in the ordinary walks of life. A few decades ago it was only the most venturesome engineers who were seriously studying the subject; a few generations ago only some dozens of pioneers in science contemplated it seriously. Of all the theoretical and experimental work that has been done in these years and which will be done in the future, little will be understood by the layman. But to become conversant with

the practical things which are now being done electrically is the desire of every intelligent person who wishes to keep abreast of the times in the age in which he is living.

There is very little of the theoretical in this book, but it answers so many of the practical questions in electricity so clearly and concisely that to the non-technical public it will be found both interesting and instructive. For instance, it tells you how electricity is made. It is easy to push a button and get a light, but the reason and the source of this power is to most people a mystery. Then in the same simple way the application of this power to lighting, heating, transportation, farming, mining, etc., is explained.

ILLUMINATION.—Another field of business endeavor has been invaded by a trade paper, and, with the appearance of the initial number of *Illumination*, which is just now being circulated, a new publication that will cater to the interests of those engaged in the field of lighting and fixtures is launched. The initial number presents a very striking appearance, and the sub-title gives an additional clew to the nature of the publication—"A Magazine of Light." In the first number, Mr. E. G. Cowdery, manager of the People's Gas Light and Coke Company, writes his ideas of "Gas as an Illuminant." Emily Calvin Blake, a well-known magazine writer, begins a series of articles dealing with the early history of the various means of lighting. Waldon Fawcett tells for the first time the story of the use and development of the new illuminant, "Lusol," which is being extensively experimented with by the French government. Lem F. Parton, who has just returned from an extended tour throughout all of South America, takes up this interesting portion of the western hemisphere and shows where there are great possibilities for the location of power and lighting plants. In the make-up the magazine presents a very unique and high-class appearance. It is well edited and well printed, and if appearance counts it should prove to be a winner. H. B. Shontz is manager and Wesley A. Stanger is editor. The home office of the magazine is in the Monon Building, Chicago.

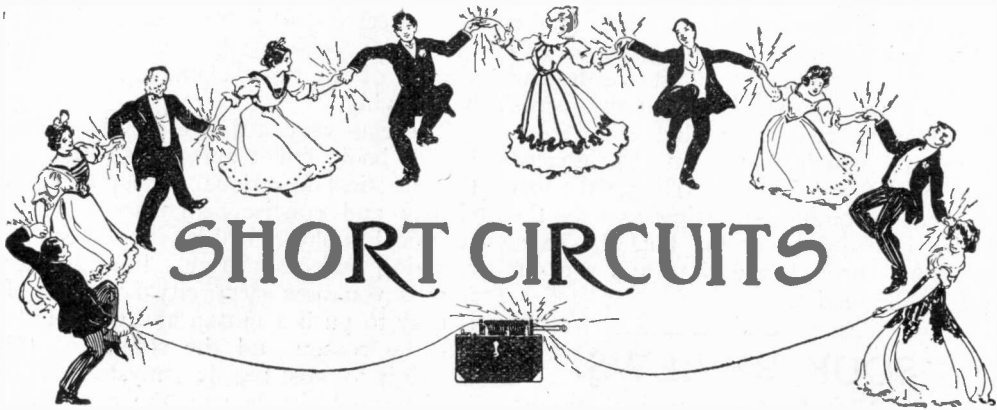

SHORT CIRCUITS

Willie Vet—"What's an army endurance test, ma?"

Mother Vet—"Living with your pa the first few days after he gets his pension money."

I shot an arrow in the air, it went in the distance, I know not where, till a neighbor said that it killed his calf, and I had to pay him six and a half (\$6.50). I bought some poison to slay some rats, and a neighbor swore it killed his cats; and rather than argue across the fence, I paid him four dollars and fifty cents (\$4.50). One night I set sailing a toy balloon, and hoped it would soar till it reached the moon; but the candle fell out on a farmer's straw, and he said I must settle or go to law. And that is the way with the random shot; it never hits the proper spot; and the joke you spring that you think so smart, may leave a wound in some fellow's heart.

Never having taken a sea trip, Mr. Cobb one day conceived the idea of making a voyage to New York. Accordingly he sailed from Boston in a small schooner.

The first day out a storm was encountered and Mr. Cobb became violently sick, but after several hours he mustered up courage and strength to look out upon the troubled waters.

As he looked from the side of the little ship up the trough of the sea, it seemed very smooth to him. The captain's cutting of the waves was "senseless," he told himself.

But as this mad steering continued, the unhappy passenger finally crawled out, on hands and knees, to where the captain stood at the wheel, and raising his voice above the din of waves and wind, shouted:

"Man, man, keep in the ruts, keep in the ruts!"

A young theologian named Fiddle

Refused to accept his degree.

"For," said he, "'tis enough to be Fiddle

Without being Fiddle D.D."

"Oh, I couldn't love him!"

"Why not?"

"He wears a wig!"

"The very idea!"

Then the dear creature removed two rats, some puffs, a coronet braid, a pompadour and a switch, and sat down to peruse a novel.

Mother (indignantly)—"You naughty boy! Stop pulling that poor cat's tail."

Little Innocent—"I'm not pulling it. I'm only holding on. The cat is doing the pulling herself."

"Well, good-bye, dear!" said Mr. Trueboy to his beloved spouse. "I must go and dictate those letters—twenty-six of them—so you mustn't expect me home very early."

"All right," was the response. "But I wish you wouldn't work so hard."

Half an hour later Mr. Trueboy entered his club and sat down, with three others, at a card table.

"Just a moment, you fellows, before the first hand is dealt. I've got to keep my word with my wife. One of you just take down what I dictate: 'A b c d e f g h i j k l m n o p q r s t u v w x y z.' There! Those letters are off my mind!"

A recent church notice in Manchester, England, read: "A potato pie supper will be held on Saturday evening. Subject for Sunday evening, 'A Night of Agony.'"

"I had to sell my auto, but I haven't missed it yet."

"How's that?"

"You can get most of the sensation by cleaning rugs."

Old Mr. Flaherty was a general favorite in the little town where he lived. The doctor was away during the early part of the summer and did not hear of the old man's death. Soon after his return he met Miss Flaherty and inquired about the family, ending with:

"And how is your father standing the heat?"

Johnny's mother gave him two five-cent pieces—one for candy, the other for the Sunday-school collection.

Light-hearted, he was tossing the coins in the air on his way to the church, when suddenly one eluded his grasp and disappeared through a cellar grating. Down on his knees he peered into the dark pit, only to realize his loss. Then looking thoughtfully, first into his hand, next at the cellar steps, he remarked: "Well, there goes the Lord's nickel!"

"Why are you so sad?" an acquaintance asked a young man whose aunt had just died. "You never appeared to care much for the poor lady." "I didn't," said the youth dolefully; "but I was the means of keeping her in a lunatic asylum during the last five years of her life. She has left me all her money, and now I've got to prove that she was of sound mind!"

Breathes there a man with soul so dead who, when outdoors he pokes his head on days like these, says not, "I wish I had the time to take a fish?"—Washington Herald.

Oh, yes; I know a chap who is so blooming lazy that, gee whiz, he has no fond desire to roam, but drinks the "bait" and stays at home.—Houston Post.

Alpine Hotel Manager (to the man who has the telescope for hire)—"The Kaiser is coming here to-morrow. Be careful to say nothing to him about the majesty of the mountains."

A sign hung in a conspicuous place in a store in Lawrence reads:

"Man is made of dust. Dust settles. Are you a man?"

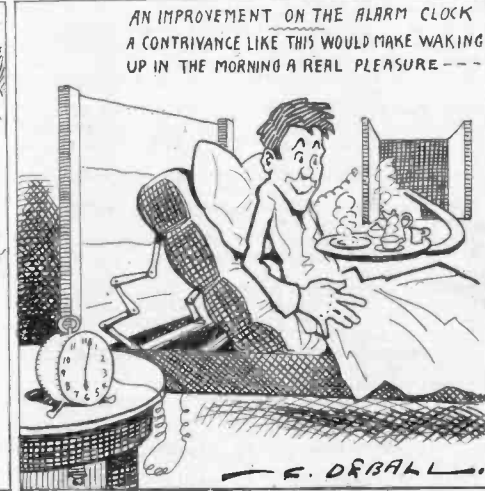
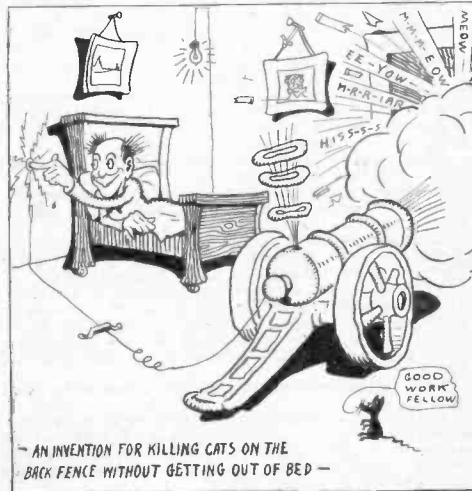
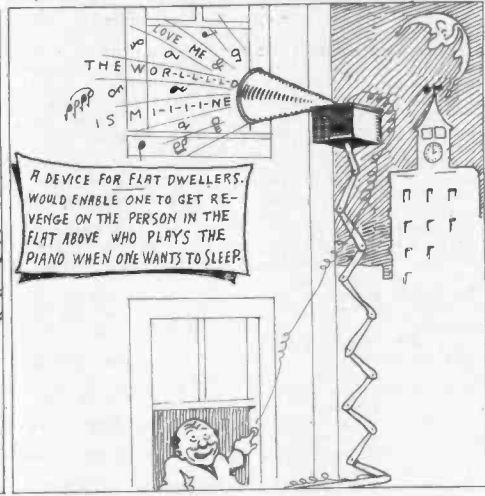
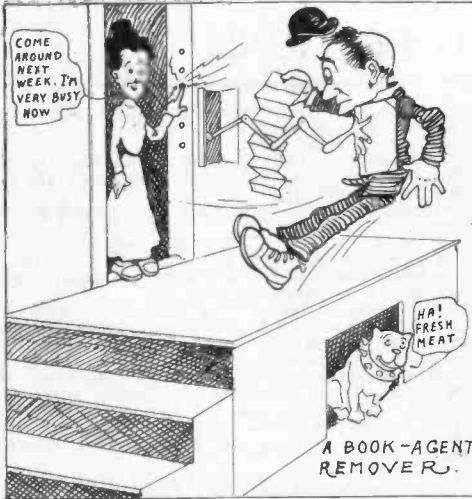

ELECTRICAL DEFINITIONS.

- Accumulator.**—Storage battery.
- Alternating Current.**—That form of electric current the direction of flow of which reverses a given number of times per second.
- Ammeter.**—An instrument for measuring electric current.
- Ampere.**—Unit of current. It is the quantity of electricity which will flow through a resistance of one ohm under a potential of one volt.
- Ampere Hour.**—Quantity of electricity passed by a current of one ampere flowing for one hour.
- Anode.**—The positive terminal in a broken metallic circuit; the terminal connected to the carbon plate of a battery.
- Armature.**—That part of a dynamo or motor which carries the wires that are rotated in the magnetic field.
- Branch Conductor.**—A parallel or shunt conductor.
- Brush.**—The collector on a dynamo or motor which slides over the commutator or collector rings.
- Bus Bars.**—The heavy copper bars to which dynamo leads are connected and to which the out-going lines, measuring instruments, etc., are connected.
- Buzzer.**—An electric alarm similar to an electric bell, except that the vibrating member makes a buzzing sound instead of ringing a bell.
- Candle Power.**—Amount of light given off by a standard candle. The legal English and standard American candle is a sperm candle burning two grains a minute.
- Capacity, Electric.**—Relative ability of a conductor or system to retain an electric charge.
- Charge.**—The quantity of electricity present on the surface of a body or conductor.
- Choking Coll.**—Coil of high self-inductance.
- Circuit.**—Conducting path for electric current.
- Circuit-breaker.**—Apparatus for automatically opening a circuit.
- Collector Rings.**—The copper rings on an alternating current dynamo or motor which are connected to the armature wires and over which the brushes slide.
- Commutator.**—A device for changing the direction of electric currents.
- Condenser.**—Apparatus for storing up electrostatic charges.
- Cut-out.**—Appliance for removing any apparatus from a circuit.
- Cycle.**—Full period of alternation of an alternating current circuit.
- Diamagnetic.**—Having a magnetic permeability inferior to that of air.
- Dielectric.**—A non-conductor.
- Dimmer.**—Resistance device for regulating the intensity of illumination of electric incandescent lamps. Used largely in theaters.
- Direct Current.**—Current flowing continuously in one direction.
- Dry Battery.**—A form of open circuit battery in which the solutions are made practically solid by addition of glue jelly, gelatinous silica, etc.
- Electrode.**—Terminal of an open electric circuit.
- Electromotive Force.**—Potential difference causing current to flow.
- Electrolysis.**—Separation of a chemical compound into its elements by the action of the electric current.
- Electromagnet.**—A mass of iron which is magnetized by passage of current through a coil of wire wound around the mass but insulated therefrom.
- Electroscope.**—Instrument for detecting the presence of an electric charge.
- Farad.**—Unit of electric capacity.
- Feeder.**—A copper lead from a central station to some center of distribution.
- Field of Force.**—The space in the neighborhood of an attracting or repelling mass or system.
- Fuse.**—A short piece of conducting material of low melting point which is inserted in a circuit and which will melt and open the circuit when the current reaches a certain value.
- Galvanometer.**—Instrument for measuring current strength.
- Generator.**—A dynamo.
- Inductance.**—The property of an electric circuit by virtue of which lines of force are developed around it.
- Insulator.**—Any substance impervious to the passage of electricity.
- Kilowatt.**—1,000 watts. (See watt.)
- Kilowatt-hour.**—One thousand watt hours.
- Leyden Jar.**—Form of static condenser which will store up static electricity.
- Lightning Arrester.**—Device which will permit the high-voltage lightning current to pass to earth, but will not allow the low voltage current of the line to escape.
- Motor-dynamo.**—Motor and dynamo on the same shaft, for changing alternating current to direct and vice versa or changing current of high voltage and low current strength to current of low voltage and high current strength and vice versa.
- Multiple.**—Term expressing the connection of several pieces of electric apparatus in parallel with each other.
- Multiple Circuits.**—See parallel circuits.
- Neutral Wire.**—Central wire in a three-wire distribution system.
- Ohm.**—The unit of resistance. It is arbitrarily taken as the resistance of a column of mercury one square millimeter in cross sectional area and 106 centimeters in height.
- Parallel Circuits.**—Two or more conductors starting at a common point and ending at another common point.
- Polarization.**—The depriving of a voltaic cell of its proper electromotive force.
- Potential.**—Voltage.
- Resistance.**—The quality of an electrical conductor by virtue of which it opposes the passage of an electric current. The unit of resistance is the ohm.
- Rheostat.**—Resistance device for regulating the strength of current.
- Rotary Converter.**—Machine for changing high-potential current to low potential or vice versa.
- Secondary Battery.**—A battery whose positive and negative electrodes are deposited by current from a separate source of electricity.
- Self-inductance.**—Tendency of current flowing in a single wire wound in the form of a spiral to react upon itself and produce a retarding effect similar to inertia in matter.
- Series.**—Arranged in succession, as opposed to parallel or multiple arrangement.
- Series Motor.**—Motor whose field windings are in series with the armature.
- Shunt.**—A by-path in a circuit which is in parallel with the main circuit.
- Shunt Motor.**—Motor whose field windings are in parallel or shunt with the armature.
- Solenoid.**—An electrical conductor wound in a spiral and forming a tube.
- Spark-gap.**—Space between the two electrodes of an electric resonator.
- Storage Battery.**—See secondary battery.
- Thermostat.**—Instrument which, when heated, closes an electric circuit.
- Transformer.**—A device for stepping-up or stepping-down alternating current from low to high or high to low voltage, respectively.
- Volt.**—Unit of electromotive force or potential. It is the electromotive force which, if steadily applied to a conductor whose resistance is one ohm, will produce a current of one ampere.
- Voltage.**—Potential difference or electromotive force.
- Volt Meter.**—Instrument for measuring voltage.
- Watt.**—Unit representing the rate of work of electrical energy. It is the rate of work of one ampere flowing under a potential of one volt. Seven hundred and forty-six watts represent one electrical horse power.
- Watt-hour.**—Electrical unit of work. Represents work done by one watt expended for one hour.

CLASSIFIED ADVERTISING

Rates, 40 cents per agate line, cash with order, nothing less than 3 lines.
Advertisements should be in our office on or before the 2d preceding date of issue.

Help Wanted.

WE EXPECT to have positions for a number of men as automobile car drivers, and interurban railroads; only sober and reliable men need apply; experience unnecessary; send four-cent stamp for applications. The Western Transportation Company, American Nat. Bank Bldg., St. Paul, Minn.

WANTED—Railway mail clerks, clerks at Washington, customs clerks. Yearly salary \$800 to \$1,600. Short hours. Annual vacation. No "layoffs." Salary absolutely certain twice each month. Examinations everywhere, May 15th. Over 2,000 appointments to be made during 1909. Everyone over 18 eligible. Country residents eligible. Common education sufficient. Candidates prepared free. Write immediately for schedule. Franklin Institute, Dept. D 66, Rochester, N. Y.

WANTED—Responsible men and strong boys at Los Angeles. Fair pay while mastering trade of plumbing, bricklaying or electricity in months instead of years. No expense for instruction. Write quick. United Trade School Contracting Co., Los Angeles.

Patents.

PATENTS. H. W. T. Jenner, patent attorney and mechanical expert, 608 F Street, Washington, D. C. Established 1883. I make an investigation and report if patent can be had, and the exact cost. Send for full information. Trade-marks registered.

PATENTS—Advice and books free. Highest references. Best results. I procure patents that protect. Watson E. Coleman, Patent Lawyer, 612 F St., N. W., Washington, D. C.

PATENTS SECURED — Inventor's Pocket Companion free. Send description for free opinion as to patentability. W. N. Roach, Jr., Metzertott Bldg., Washington, D. C.

Agents Wanted.

WANTED—One hustler in every concern employing any number of men to represent Popular Electricity. Here is your chance to double your income without interfering with your regular work. Others are making \$2.00 to \$5.00 a day and there is no reason you cannot do what others are doing. Give name of your company and number of employees, name of your superintendent or foreman and we will send free, samples and outfit. Address Circulation Mgr., Popular Electricity, 1252 Monadnock Block, Chicago.

AGENTS. Our \$2 adding machine is making a tremendous hit, good territory unoccupied. Smith Supply Co., B.-6, Los Angeles, Cal.

LAST CHANCE to get "Practical Lessons in Electricity" with a year's subscription to Popular Electricity for only \$1.25 (Canadian, \$1.60; foreign, \$1.75). See special offer elsewhere in this issue. Act quick if you don't want to miss this. Popular Electricity Pub. Co., Book Dept., Monadnock Block, Chicago, Ill.

BIG MONEY FOR AGENTS. A few more "live ones" wanted in every locality. The most liberal proposition ever offered. Write for particulars. State line of business or where employed. Positively no postals will be given attention. Popular Electricity Pub. Co., Book Dept., Monadnock Block, Chicago, Ill.

Inventions.

EXPERT AND SUCCESSFUL inventor will develop ideas and inventions, build models, make drawings and give general advice in perfecting and marketing inventions. Long experience. Circular free. L. Casper, 638 No.

Schools.

\$200 TO \$600 MONTHLY EASILY MADE fitting eye glasses. Short, easy mail course. Reduced tuition. Big demand for opticians. Write to-day for free "Booklet O." National Optical College. St. Louis.

For Sale.

FOR SALE—Complete set of castings, with blue prints of $\frac{3}{4}$ h. p. gasoline stationary engine; includes governor and timer, screws, etc. \$10. Comet Motor Works, 17 W. Madison St., Chicago, Ill.

THOUSANDS OF PRACTICAL FORMULAS, 15c each. We can tell you how to make or mend anything. Consulting Chemists, Box 217, Redlands, Cal.

FOR SALE—Amateurs, make your coils with a slide wire bridge. Drawings and instructions, 50 cents. No toy. Cost, \$3.00. Advance Bridge Co., 125 E. Jefferson St., So. Bend, Ind.

FOR SALE—A large quantity of No. 34 single silk magnet wire at \$1.50 per pound; any address prepaid; nothing less than one-half pound. Geo. E. Glasser, Charlotte, N. Y.

EXCHANGE OR SELL your motors, generators, steam and gasoline engines, cameras, magic lanterns, phonographs, printing press, musical instruments, real estate or anything of value, new or second-hand. Send 4c stamp for best trading plan known. National Exchange Co., 929 Olive, St. Louis, Mo.

THREE THOUSAND FORMULAS—My 368-page volume of recipes and trade secrets, cloth bound, only 40c prepaid. Worth dollars. Satisfaction guaranteed. Wiley Sanderson, Dept. E, Ypsilanti, Mich.

SNOW scenes. Views from one of Maine's most picturesque places. 5 ft. snow. 6 actual photo-cards, highly polished, 50c. Suitable for framing. C. Stanley, L. B. No. 5, Dixfield, Me.

POPULAR ELECTRICITY

CLASSIFIED ADVERTISING.

(CONTINUED.)

Busintss Opportunities.

INVESTORS' NOTICE—Invest \$5.00 or more and become an original organizer of the South Bend Mining and Milling Company, who hold options on grand "Tungsten properties;" an investment of each \$5.00 secures 100 shares of stock. Invest to-day. For further information address South Bend Mining and Milling Company, Neitzel Block, South Bend, Ind.

500% PROFIT seems incredible, don't it? Send us 10c silver for copy of our folder, "How to Make Money Making Mirrors." Money returned if not satisfied. Economy Chemical Co., Box P-805, Ludington, Mich.

Wireless.

WIRELESS EXPERIMENTERS. 1200 OHM receivers, each \$3.00. Wound with copper wire and very sensitive. First 25 sold will be fitted with nickel plated headband. W. C. Getz, 345 N. Charles St., Baltimore, Md.

CARBON WIRELESS DETECTOR sent prepaid upon receipt of 50c. Simple, sensitive and strong. Dept. Q, 357 E. 46th St., Chicago.

WIRELESS TELEGRAPHY—Send twenty-five cents, coin, to-day and receive by return mail complete instructions, with diagrams, for making a complete sending and receiving station. Among instruments described are 1-inch coil and two different types of receivers. Box 519, Lima, Ohio.

THE NEW SILICON DETECTOR will increase your receiving radius 500%. Only type sold to experimenters authorized by owners of Silicon patents. Infringers prosecuted! Send for special price list. W. C. Getz, 345 N. Charles St., Baltimore, Md.

WIRELESS. One-inch spark coils, specially made for wireless. Fat hot spark. Regular \$6.00. Special this month \$4.50. Also larger coils. A B C Wireless Specialty Co., 111 Broadway, New York.

Miscellaneous.

ALL SAFETY RAZOR BLADES 2½c each. Double edged blades a specialty. We sterilize, resharpen and return your own blades better than new. Send address for convenient mailing package. Keenedge Co., 87 Keenedge Bldg., Chicago.

YOU WANT THIS. "Conversations on Electricity," by Prof. Joseph G. Branch, the well-known electrical engineer and author. An elementary work expressly for students and engineers, written in dialogue form, giving a vivid idea of the subject and making a strong impression on the mind of the reader. Easy to understand. Elucidates the alternating current—its nature and applications—in an unusually clear manner. 282 pages, handsomely bound, profusely illustrated with cuts and diagrams. Price \$2.00 postpaid. Special price for thirty days only, \$1.75. Add this to your electrical library before this offer expires. Popular Electricity Pub. Co., Book Dept., Monadnock Block, Chicago, Ill.

AMATEURS READ THIS. 200 WATT DY-NAMO—Rough castings, \$4; blue prints, 50 cents. If castings are ordered within thirty days after prints, price of prints refunded. LEE, HARRIS & CO., Box 41, Jamestown, N. Y. Photo for 2-cent stamp.

Miscellaneous.

POCKET COMPEND. OF ELECTRICITY—272 pages, cloth bound, indexed, only 40c prepaid. Satisfaction guaranteed. Wiley Sanderson, Dept. E, Ypsilanti, Mich.

BLAKE'S ELECTRICAL CONNECTING CORDS meet want of ready means of connecting complicated apparatus using moderate currents. Indispensable to electrical workers. Soft, flexible, different colors for easy tracing, spring-clip attachments. In 20, 30, 40-inch lengths. Prices 10, 15, 20c each. W. Blake, 253 Blake St., New Haven, Conn.

BOYS—BOYS—This is for you, and those who like boys. "The Boy Electrician," by Prof. Erwin James Houston. A book every boy will enjoy and learn something from. 326 pages—10 full page illustrations. Price \$1.50—or free for only three paid yearly subscribers to Popular Electricity. Popular Electricity Pub. Co., Book Dept., Monadnock Block, Chicago, Ill.

SAFETY RAZOR BLADES sterilized and sharpened better than new; 2 cts. each. 5 years' success. Send for blade box and circular. Electro Stropping Co., 122 Shelby St., Detroit, Mich.

NEW MAGNET WIRE, sizes from 24 to 39, at amazing low prices. Write for prices. New storage batteries, 6-60, \$7.50. Walter W. Hartman, Clay Center, Kansas.

EVERYONE USING DRY BATTERIES send 25c for scientific instructions. Renew exhausted batteries cheaply; last long as new. Fairmount Telephone Co., Leightons Corners, N. H.

MAKE MIRRORS AT HOME. Big profits with little outlay. One 18x36-in. mirror costs \$2.00 to \$5.00. You can silver a glass this size for 20c. Send 50c in stamps or money order and we will send you EXPLICIT DIRECTIONS how to do it; also how to emboss, grind, foil, gold leaf, frost chip and make imitation stained glass. How to transfer photos on glass, bore holes in glass and cut skylights. George L. Patterson & Co., 2214 Monticello Ave., Morgan Park, Ill.

THREE THOUSAND FORMULAS. My 368-page volume of recipes and trade secrets, cloth bound, only 40 cents, prepaid. Worth dollars. Satisfaction guaranteed. Wiley Sanderson, Dept. E, Ypsilanti, Mich.

SNOW scenes. Views from one of Maine's most picturesque places. 5 ft. snow. 6 actual photo-cards, highly polished, 50c. Suitable for framing. C. Stanley, L. B. No. 5, Dixfield, Me.

MEDICAL AND SPARK COILS repaired. Send stamp for full detail drawings on a medical or spark coil. Price 50c. Address J. Lockie, R. 1718, Marquette Bldg., Chicago.

MAGIC POCKET TRICK FREE. Catalogue included, send 4c in stamps. Magic, Dept. 17, 270 W. 39th St., New York.

WANTED—One hustler in every concern employing any number of men to represent Popular Electricity. Here is your chance to double your income without interfering with your regular work. Others are making \$2.00 to \$5.00 a day and there is no reason you cannot do what others are doing. Give name of your company and number of employees, name of your superintendent or foreman and we will send free, samples and outfit. Address Circulation Mgr., Popular Electricity, 1252 Monadnock Block, Chicago.

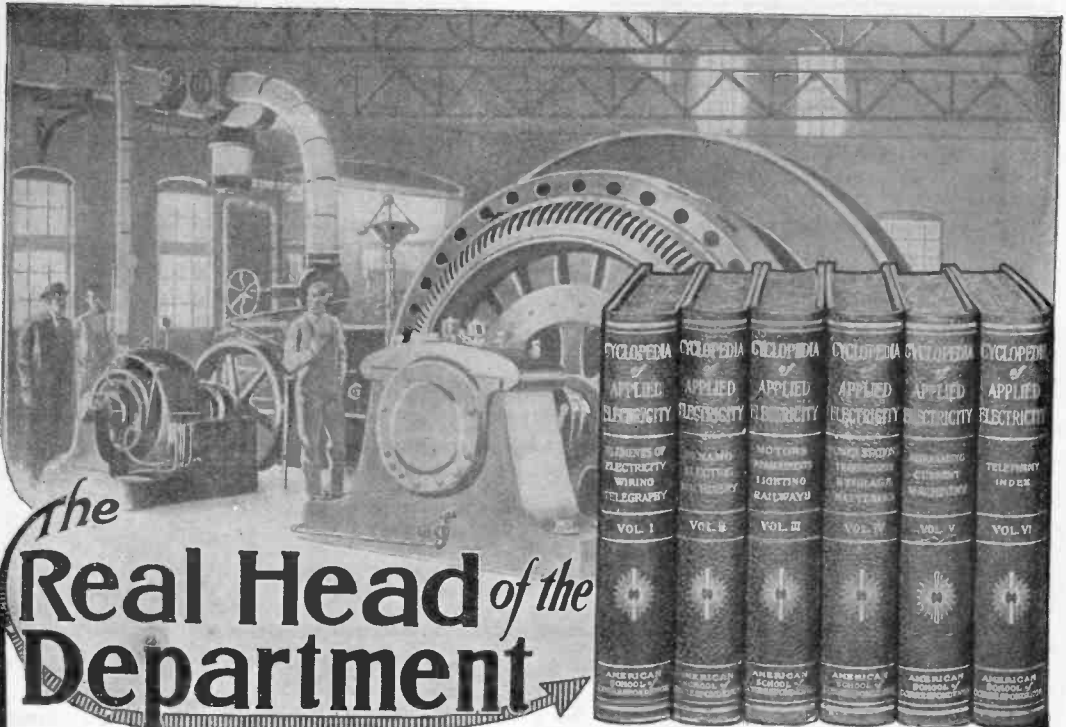

The
Real Head of the
Department

The Cyclopedic of Applied Electricity

is a storage battery of electrical knowledge. It is charged right up to the minute with reliable information—it is the real head of the department because it contains the work and knowledge of over thirty practical electrical engineers, experts and teachers. This work contains a complete record of their experiments, discoveries and observations. Just the information that the head of any electrical department should have at his finger tips for ready reference.

YOU CAN ADD THIS KNOWLEDGE TO YOURS AT HALF PRICE IF YOU ORDER PROMPTLY

To introduce this great work, we will fill orders for the next thirty days at \$18.60 per set, payable \$2.00 after examination and \$2.00 per month. The regular price is \$36.00. Order promptly. The half price edition is limited.

EXAMINATION FREE! It won't cost you a dollar to examine the books. Just fill in the coupon. The books will be sent to you absolutely FREE of charge. You can return them at our expense if not satisfactory.

These six big volumes contain 2,896 pages, covering 4,000 different topics. Hundreds of special photographs, diagrams sections, condensed tables and formulas. Page size 7 x 10 inches. Printed in large, clear type on special paper; substantially bound in half red morocco.

PARTIAL SYNOPSIS OF CONTENTS:

Electric Wiring—Electric Telegraph—Wireless Telegraphy—Telautograph—Theory, Calculation, Design and Construction of Generators and Motors—Types of Dynamos and Motors—Elevators—Direct Current Motors—Direct-Driven Machine Shop Tools—Electric Lighting—Electric Railways—Alternating Current Motors, etc.—Single Phase Electric Railway—Management of Dynamos and Motors—Power Stations—Central Station Engineering—Storage Batteries—Power Transmission—Alternating Current Machinery—Telephony—Automatic Telephone—Wireless Telephony—Telegraphone, etc.

With this special offer we will also include as a monthly supplement a year's subscription to the

TECHNICAL WORLD MAGAZINE

This is a regular \$1.50 monthly covering present day scientific facts and inventions. An ideal magazine for the home because it is just enough different from the others to make it interesting. Fill in the coupon to-day—don't wait for to-morrow.

AMERICAN SCHOOL OF CORRESPONDENCE
 CHICAGO, U. S. A.

FREE OFFER COUPON

P. E.
 5-C9
 A. S. of C.

Please send me Cyclopedic of Applied Electricity for five days' free examination. Also T. W. for one year. I will send \$2 within five days and \$2 a month until I have paid \$18.60; otherwise I will notify you and hold the books subject to your order. Title not to pass until fully paid.

NAME.....
 ADDRESS.....
 OCCUPATION.....
 EMPLOYER.....

POPULAR ELECTRICITY

TEN THOUSAND TELEGRAPHERS WANTED
by railroads, commercial companies and Wireless Companies. Only schools in America teaching

WIRELESS TELEGRAPHY

We operate fifteen Wireless Stations. Main Line R. R. Wires in each one of our Institutes.
Supervised by R. R. Officials. Write for prospectus.

NATIONAL TELEGRAPH INSTITUTE

Cincinnati, Ohio Philadelphia, Pa. Memphis, Tenn. Davenport, Iowa Columbia, S. C. San Francisco, Cal.



ILLUSTRATING

--Law--Pharmacy--Cartooning--Shorthand--Bookkeeping--Nursing--Journalism--Telegraphy--Penmanship
Taught by mail and in our resident schools. Founded 1850. Income increased while learning. Graduates everywhere. Write for our free booklet--tells all. State course desired.

NATIONAL CORRESPONDENCE SCHOOLS 42 N. Penn'a St., Indianapolis, U. S. A.

**BIG
PAY**

**PLUMBERS, BRICKLAYERS and ELECTRICIANS
EARN \$5.00 A DAY AND OVER.**

We can teach you any of these trades in from 2 to 3 months by Practical and Individual Instruction and enable you to secure a well-paying position upon graduation. Write today for free catalog.

COYNE 253 Tenth Ave., NEW YORK
NATIONAL TRADE SCHOOLS 825 N. Ashland Ave., CHICAGO

**SHORT
HOURS**

**KELLOGG HOUSE
TELEPHONES**

Save Time. Send for Folder 4-S

KELLOGG SWITCHBOARD & SUPPLY CO., CHICAGO



**SEND FOR MY BOOK
STRONG ARMS**

FOR MEN, WOMEN and CHILDREN
10c in stamps or coin

Send for my booklet containing 20 illustrated exercises for developing and beautifying SHOULDERS, ARMS and HANDS without apparatus. Reg. price 25c.

Prof. ANTHONY BARKER

School of Physical Culture
1290 Barker Bldg., 110 W. 42d Street, New York

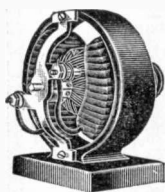

DYNAMO - MOTOR \$3.85

(A Dynamo and Motor in One)

As a dynamo it will light 40 candle power, operate induction coils; charge storage batteries; decompose water; electroplate, etc. As a motor, will operate sewing machine, jeweler's lathe, emery wheel, circular saw, advertising devices, and other useful appliances. Send stamp for catalog. Nos. 11 and 12 of new things electrical.

ARROW ELECTRIC CO.
103 South Canal Street, Chicago, Ill.

BOYS! SEE HERE!

A book for live young Americans—interesting—instructive. The Boy Electrician, by Edwin Hames Houston. Prof. Houston has a world-wide reputation as an electrician and inventor, and knows what boys want. 326 pages—ten full-page illustrations. Price \$1.50 or free for three paid yearly subscribers to Popular Electricity.

Popular Electricity Pub. Co., Book Department,
Monadnock Block, Chicago, Ill.

W. H. CRUMB & COMPANY

Engineers :: Contractors

Telephone Engineering and Construction
Plans, Specifications and Estimates
Promptly Furnished.

835 Monadnock Bldg., Chicago, Ill.

Let Us Make Your Metal Parts

We make anything to order—Stampings, Sheet Metal work—anything a good machine shop should do—we do—because we're good ones. We publish "The Silent Partner." Ask for a sample copy. Write us.

THE GLOBE MACHINE & STAMPING CO.
3610 Hamilton Avenue, N. E., Cleveland, Ohio

AGENTS PORTRAITS 35c, FRAMES 15c,
sheet pictures 1c, stereoscopes 25c,
views 1c. 30 days credit. Samples and Catalog Free.
Consolidated Portrait Co., 290, 110 W. Adams St., Chicago.



MAGIC TRICKS Our latest illustrated book tells you how to do all kinds of tricks GET ONE and shine as a star entertainer among your friends. Price only 25c Send for catalog.

PEERLESS TRICK AND NOVELTY CO.
Dept. D, 3146 & 3148 State St., Chicago, Ill.



HAWAIIAN DIAMONDS

brilliantly. Heavy tooth belcher ring, guaranteed 10 years, 14k. gold filled.
Price each, \$1.25; doz., \$13.50
Sent C. O. D., 1/2 deposit in advance.

Sold direct to you. Do not pay retail prices! You can make 200% profit on sales as we sell samples at wholesale prices. Beautiful flashing stones. Permanent. Send for catalog.
W. H. HOLLISTER & CO. MASONIC TEMPLE, CHICAGO, ILL. Dept. M

For our Mutual Advantage mention Popular Electricity when writing to Advertisers.

AUGUST ISSUES WANTED

The August 1908 edition of Popular Electricity has been exhausted. In order to obtain a supply for binding, etc., we will pay **25 CENTS** each, for issues of that date, until the required number are obtained. Must be in perfect condition, covers and all.

POPULAR ELECTRICITY PUB. CO.

**MONADNOCK BLOCK,
CHICAGO, - ILLINOIS.**

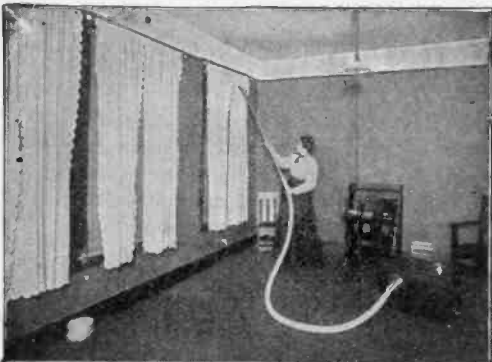

The "LITTLE GIANT" ELECTRIC PORTABLE SUCTION CLEANER

For Cleaning Carpets, Rugs, Mattresses, and Curtains.

Removes every particle of dust from Books, Pictures, Shelves, Draperies, Portieres, etc.

Costs less than one cent per hour to operate.
Price, complete, \$85.00

SEND FOR LITERATURE

PACIFIC SUCTION CLEANER CO.

322 POST ST., SAN FRANCISCO, CAL.

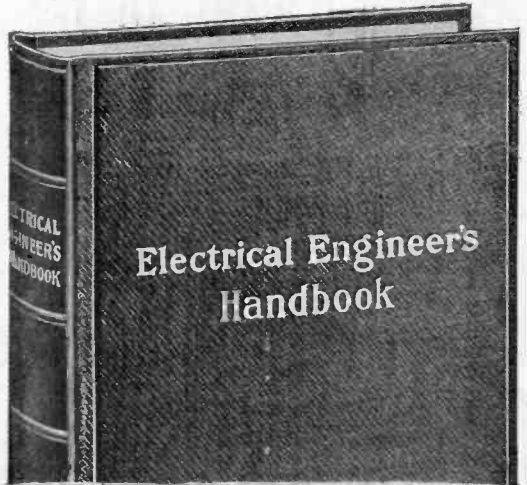

Special Offer

The I. C. S. Electrical Engineers' Handbook contains more practical information about the electrical engineering profession and allied trades than any other book of its size in existence. It is a Little Giant Encyclopedia of information compiled from the courses of the International Correspondence Schools which were written by the best experts in the country.

This book is not only of value to men in higher positions but can be successfully used by workers in subordinate positions in these trades on account of the fact that it is readily understood without a knowledge of higher mathematics. It contains rules, formulae, tables and diagrams of connections that are most generally used by wiremen, dynamo attendants, foremen of construction, managers, engineers, and superintendents of power stations, and superintendents of electric-lighting and electric-railway systems, and manufacturers and dealers in electric apparatus and supplies.

OUR SPECIAL OFFER: To better introduce the value of I. C. S. Instructions to members of these trades we will send this book containing 420 pages, 262 illustrations, bound in cloth with gilt top and title, and regularly sold at \$1.25 to anyone sending us the coupon below and

Act NOW!

50c

**INTERNATIONAL TEXTBOOK COMPANY,
Box 1102-P, Scranton, Pa.**

I enclose 50 cents for which please send me one copy of your "Electrical Engineers' Handbook."

NAME

STREET AND NO.

CITY..... STATE.....

Good for 75 cents.



I WANT TO TEACH YOU TELEGRAPHY

either through my private correspondence course at your home or at my residence school. Telegraphy offers more opportunities for steady, profitable, fascinating employment and advancement to the highest salaried positions than almost any other occupation. There is a good demand today for competent telegraphers, and now is the time to learn telegraphy.

MY AUTOMATIC SELF-TEACHER will teach you at your home during your spare hours. It is to telegraphy what the phonograph is to foreign language study. I furnish a complete set of records with each machine, a 264 page cloth bound book

"THE TELEGRAPH INSTRUCTOR," written by myself and in fact everything required to learn telegraphy at home.

MY RESIDENCE SCHOOL IS THE LARGEST IN AMERICA, and expenses are lower than anywhere else. Now, if you are at all interested in the study of telegraphy, let us become acquainted.

WRITE ME TODAY for catalog containing information of both courses. **IT IS A FIELD YOU OUGHT TO ENTER.**

G. M. DODGE,

Foster Street, VALPARAISO, INDIANA

QUALITY INSURANCE

Means the elimination of faults in your Product by **RIGID TESTS.**

Shrewd manufacturers do not jeopardize their trade by shipping half-developed goods. Careful purchasers buy subject to specifications and tests.

We are the medium for satisfactory dealings. We make all manner of electrical and photometrical tests and furnish you with exact and dependable data.

Electrical Testing Laboratories

80th St. and East End Ave.,

NEW YORK, N. Y.

Pilley's Combination Flue Brush and Scraper

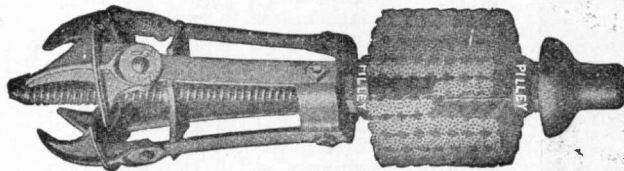

is made of the very best steel wire and in the very best and strongest manner. Every brush is guaranteed, so that if it is not just what we represent, you lose nothing.

WRITE FOR CATALOG

Pilley Packing & Flue Brush Mfg. Co., 612 S. 3d St., St. Louis, Mo.

Instructions in Wireless Telegraphy

SEND 25c for the best wireless instruction book ever published. Tells you how to construct your own spark coils, relays, coherers and tapping keys, etc. Non-technical; everybody can understand it. Complete instructions.

We also manufacture and deal in all kinds of electrical apparatus at low prices, and are the only manufacturers of the famous Joerin Third Relay, with which many marvelous experiments can be performed. Send 5 cents in stamps for catalogue.

ELECTRICAL EXPERIMENTERS SUPPLY COMPANY

Successors to Joerin Electric Novelty Co.

Room 500, 622 Wells Street, Chicago, Ill.

EASY WAY

NEW INVENTION—NOTHING ELSE LIKE IT.
CLEANS FAMILY WASH in 30 to 50 minutes
WHILE YOU REST

No rubbing. No chemicals. No motor, electricity, water power, springs, levers or wheels.

DOES IN ONE OPERATION THE WORK OF WASH BOARD, WASHING MACHINE, WASH BOILER.

Less time; almost no labor; no injury to clothes.

Customers everywhere praise it—Lauretta Mitchell, O. writes: "Done big washing with Easy Way in 45 minutes. Sold 3 ready." D. N. Curtis, Okla.—"Washes white and colored clothes and blankets equally well." (Orders 12.) Mrs. Fred Reynolds, Mass.—"I do three washings with Easy Way every Monday; get them out before noon." F. E. Post, Pa., writes: "Done

TWO WEEKS WASHING IN 45 MINUTES. Clothes cleaned without rubbing."

J. W. Meyers, Ga., orders 12 more, says: "Easy Way greatest invention for womanhood, forever abolishing that miserable washday. Sells itself."

SEE HOW SIMPLE—DIFFERENT, EASY, operated on any stove. Add water, then soap then clothes. Move knob *only occasionally*. In 8 to 10 minutes first batch clean. Next batch same way, same water. In 30 to 50 minutes family wash clean. Cleans white and colored clothes, woolens, laces, bed clothes.

NO RUBBING OR INJURY—ALL METAL, durable, light in weight, sanitary. Nothing to warp, crack, break, or get out of order. Easily handled, always ready. Child or weakly woman can handle it. Solves servant problem. Saves drudgery, time, clothes, labor, fuel, health, looks. Laundries clean clothes without rubbing—Easy Way does same at your home. No experiment. 100,000 already sold.

FREE SAMPLE To Agents. A. G. Witt, Pa., "Received Easy Way yesterday; sold 4 today—not out after orders."

We want managers, agents, men or women, home or traveling, all or part time to exhibit, take orders and appoint agents. Easy Way new article, not worked to death. Best seller out. Every family wants one. People wild to see it demonstrated; buy without being asked, and throw away costly washing machines to use it. **Only 2 sales a day means \$36.00 a week profit.**

Price only \$6.00 ready for use. Sent anywhere. Not sold in stores. *Get one for your own use.* **GUARANTEED SATISFACTORY** or your **MONEY REFUNDED.** Send for Free Sample offer, special agents' proposition, etc. **Cost nothing to investigate.** Send name and address anyway for full description. Write today.

HARRISON MFG. CO.

932 Harrison Building, Cincinnati, Ohio.



AGENTS GETTING RICH

R. O. Cowan, N. Y., placed 13 in 6 hours—(profit \$39.00.) Mrs. J. Brown, sold 10 in 3 days—(profit \$30.00.) K. J. Blevins, O., writes: "Made 7 calls, sold 5 one day!"—(profit \$15.00.) R. H. Latimore, Pa., writes: "Sold 4 this morning. Never yet turned down." Mrs. Gerrish, Mont., ordered sample, then 1 dozen, then 100—(profit over \$300.00.) **Just shipped 1000 Easy Ways** to one agent in Russia. N. Boucher, Mass., orders 75 more, says: "Everybody wants one. *best business I ever had.*" A. S. Verrett, La., sold 8 in one day—(profit \$74.00.)



WANTED--A RIDER AGENT in EACH TOWN and district to ride and exhibit a 1909

Model "Ranger" bicycle furnished by us. Our agents everywhere are making money fast. *Write for full particulars and special offer at once.*

NO MONEY REQUIRED until you receive and approve of your bicycle. We ship to anyone, anywhere in the U. S. *without a cent deposit in advance, prepaid freight,* and allow **TEN DAYS' FREE TRIAL** during which time you may ride the bicycle and put it to any test you wish. If you are then not perfectly satisfied or do not wish to keep the bicycle you may ship it back to us at our expense and *you will not be out one cent.*

FACTORY PRICES We furnish the highest grade bicycles it is possible to make at one small profit above actual factory cost. You save \$10 to \$25 middlemen's profits by buying direct of us and have the manufacturer's guarantee behind your bicycle. **DO NOT BUY** a bicycle or a pair of tires from *anyone at any price* until you receive our catalogues and learn our unheard of *factory prices* and *remarkable special offers* to rider agents.

YOU WILL BE ASTONISHED when you receive our beautiful catalogue and study our superb models at the *wonderfully low prices* we can make for 1909. We sell the highest grade bicycles for less money than any other factory. We are satisfied with \$1.00 profit above factory cost. **BICYCLE DEALERS**, you can sell our bicycles under your own name plate at double our prices. Orders filled the day received.

SECOND HAND BICYCLES. We do not regularly handle second hand bicycles, but usually have a number on hand taken in trade by our Chicago retail stores. These we clear out promptly at prices ranging from \$3 to \$8 or \$10. Descriptive bargain lists mailed free.

TIRES, COASTER-BRAKES, single wheels, imported roller chains and pedals. **DO NOT WAIT**, but write today and we will send you *free* by return mail our *large catalogue*, beautifully illustrated and containing a great fund of interesting matter and useful information; also a *wonderful proposition* on the first sample bicycle going to your town. It only costs a postal to get everything. **Write it now.**

MEAD CYCLE COMPANY

Dept. P 251

CHICAGO, ILL.

POPULAR ELECTRICITY



If you want a good piano we save you from \$100 to \$300 by our direct factory-to-purchaser system.

WING PIANOS

are *made by us*, in our own factory. They are *sold direct from our factory and in no other way*. Every unnecessary cost is eliminated. Every dollar spent with us is piano value through and through—the best that 40 years of study and experience can produce. The *lowest, factory-price* consistent with an artistically and musically perfect instrument.

THE WING TONE is so sweet and deep it is in a class of its own. Thousands of customers yearly write and tell us so. "Pure and sweet; every note clear and musical; responsive to the lightest touch, yet possessing great volume and power, without a trace of harshness"—this describes the tone of the WING PIANO.

—THE WING WAY—

We will place a WING PIANO in any home in the United States on trial entirely at our expense, without any advance payment or deposit. If, after 20 days' trial in your own home, it is not satisfactory, we take it back. *Nothing to be paid by you before it is sent, when it is received, or when it is returned.* You are under no more obligation to keep the piano than if you were examining it at our factory. Every expense and all risk is ours, absolutely. *Easy installment payments, if you desire them.*

When you buy a piano at retail you pay the retail dealer's store rent and other expenses; you pay his profit and you pay the commission or salary of the agents or salesmen he employs. We make the WING PIANO and sell it ourselves. We employ no agents or salesmen. When you buy the WING PIANO you pay the actual cost of construction plus only our small wholesale profit. This profit is small because we sell thousands of pianos yearly. Most retail stores sell no more than 12 to 20 pianos yearly and must charge from \$100 to \$300 profit on each. You can calculate this yourself. These dealers get as much profit on their cheap pianos as on the standard high grade ones. As the cheap pianos cost less than half, they "talk up" and push the cheap pianos—but often call them high grade.

Pioneers of the direct plan of piano selling, our unparalleled success has brought forth many imitators, but no competitors, either as to the excellence of our product or the integrity and economy of our methods. Forty years of daily increasing business and 45,000 satisfied and enthusiastic buyers testify to this.

Ask a Wing customer what he thinks of Wing Pianos and Wing methods. We will send you names in your locality for the asking.

Our commercial standing and references will guarantee you that our word is good and contract gilt-edged. The publishers of any prominent magazine will also tell you this.

The WING PIANO is broadly guaranteed in writing for 12 years.

FREE EVEN IF YOU ARE NOT READY TO BUY
WRITE OR SEND THE COUPON TO-DAY

WING
& SON

370-391

W. 13th St.,
New York

Send to the name
and address written
below, your Free
Books without any cost
or obligation on my part.

"The Book of Complete Information
About Pianos."

A copyrighted book of 152 pages with many illustrations. A complete reference book on the piano subject. History of the piano, descriptions of every part, how to judge good and bad materials, workmanship, etc. *Teaches you how to buy intelligently. You need this book.*

Free for the asking from
the old house of

WING & SON 370-391 W. 13th St.,
New York

THE MARVELOUS INSTRUMENTAL ATTACHMENT

If you choose, and without extra cost, your piano can have this wonderful addition. Imitates perfectly the mandolin, guitar, harp, zither, and banjo. Music written for these instruments, can be played just as perfectly by a single player on the piano as though rendered by an orchestra. It is an integral part of the instrument; does not take in any way from its tone or value as a piano and prolongs the life of the strings and action.

For our Mutual Advantage mention Popular Electricity when writing to Advertisers.



**The New
20th Century
Ice Cream
Freezer and
Crusher**

A complete ice cream plant in one machine—electrically driven. No belts or pulleys. Requires small space. Why not make your own ice cream and save money? The ideal freezer for confectioners and druggists. Made in 2 sizes—20 and 40 quart. Write for catalogue and prices.

R. A. Dewsberry, Chicago, Ill.
46 N. Morgan Street

TELEPHONES SPREADING CONSUMPTION

Have you ever estimated YOUR chances of escape from the deadly clutches of

THE GREAT WHITE PLAGUE!!!

They are easily estimated and you would find them alarmingly small. Consumption killed 1,500,000 persons during 1908, 200,000 of whom died in the United States. One-third of all deaths between the ages of 20 and 45 are caused by consumption; according to these official estimates over six million persons now living in the United States will die of consumption. This makes your chance of escape less than 1 to 15 and the subject of prevention should be of interest.

Consumption is a communicable germ disease largely spread by the sputum of those affected, which dries, mingles with dust and floats around in the air we breathe. It is bad enough for a consumptive to expectorate on the street but absolutely criminal for him to use an undisinfected phone. In the open the winds scatter the dust and germs, the sun kills many of them, but when a consumptive uses an undisinfected phone scores of small particles of sputum carrying thousands of germs of consumption are projected right into the interior of the mouthpiece in the act of speaking. They are carried into a small dark confined space measuring about one cubic inch where no friendly winds can reach to scatter them and where no sunlight can penetrate to kill them, on the contrary they are constantly warmed and moistened by the breath of those who use the phone which forms an ideal incubator where they multiply in enormous numbers, as has been repeatedly proved by scientists. The germs of consumption imprisoned in the mouthpiece of the phone have only one way of escape, through the open mouthpiece and when you place your mouth close to the phone and in conversation inhale deeply you may draw them right into your lungs by the thousand. You cannot prevent consumptives using the phone because thousands are infected for weeks and months before they or any one else recognizes their complaints as consumptive and before their disease has been diagnosed as tuberculosis, but YOU CAN remove all danger of infection through your phone by equipping it with a DIOZO Phone Disinfecter at a cost of only 50 cents a year and advise your friends to do likewise. Write for free booklet on DIOZO as a factor in the prevention of disease. Parker Chemical Co., Chicago.

ELECTRICITY Will Do Your PUMPING

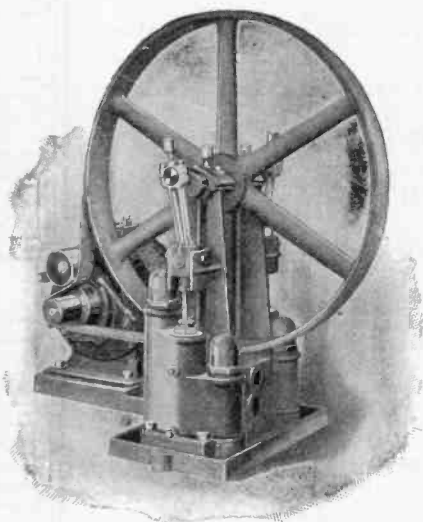

**In Homes, Apartment
Houses, Office Buildings,
Suburban Residences.**

The Sanitary Electric Pump will run on any 110 Volt current. Perfectly Safe, lasts a life time.

Pumps 50 gallons per minute. Operates with less power and sells for less money per gallon delivery than any other.

Write and ask us all about it.

SANITARY PUMP COMPANY

100 Canal Street,

Dayton, Ohio.

AN invitation to residents of Chicago and out-of-town visitors is cordially extended by the Commonwealth Edison Company to visit its beautiful Exhibition Rooms—**Electric Shop**—doubtless one of America's most artistic and elaborate show places.

Situated adjacent to the shopping district, visitors are at all times welcome to the conveniences afforded by this permanent home for the exhibition of modern light, power and heat.

Aside from the display of lamps, unequalled in the West for artistic and exclusive designs, **Electric Shop** affords an exceptional means for information as to the manifold electrical conveniences and comforts in the home and the application of electrical power to all manner of commercial uses.

Cor. Michigan and Jackson Blvds., Chicago

Refinish a Piece of YOUR Furniture at OUR Expense

Let us send the
Materials Free



WE WANT a sample of wood finishing done with our preparations in your home. We will send the materials to do the work. Here they are:

A bottle of Johnson's Electric Solvo to quickly remove the old finish—

A bottle of Johnson's Wood Dye (you to choose the color from our 14 different shades) to color the wood—

A sample of Johnson's Prepared Wax to give that beautiful "hand-rubbed" effect—

And our illustrated guide book for home beautifying which includes complete color card and tells how to finish and refinish wood.

No doubt you have some piece of furniture that you prize highly, yet do not use on account of the worn condition of its finish, or because it does not harmonize with other furniture or decorations.

Use this outfit, which we want to send you free, for refinishing it, and you will be surprised to learn how easily the work is done and the beauty of the result.

May we send you these three packages, and the valuable six-color book, free at once? Learn from the test the beautiful effect obtained from the use of

Johnson's Wood Dye

It is not a mere stain. It is a deep seated dye—sinking into the pores of the wood and bringing out the beauty of the grain. When finished with Johnson's Prepared Wax you have a permanent finish of real beauty and most artistic effect. We want to give you these three packages at once, absolutely free. You can either send us your name and address on a postal or in letter requesting them or use coupon below printed for your convenience.

Johnson's Wood Dye comes in 14 Standard shades:

- | | |
|------------------------|-----------------------------|
| No. 126 Light Oak | No. 130 Weathered Oak |
| No. 123 Dark Oak | No. 131 Brown Weathered Oak |
| No. 125 Mission Oak | No. 132 Green Weathered Oak |
| No. 140 Manila Oak | No. 121 Moss Green |
| No. 110 Bog Oak | No. 122 Forest Green |
| No. 128 Light Mahogany | No. 172 Flemish Oak |
| No. 129 Dark Mahogany | No. 178 Brown Flemish Oak |

Half-pints 30c; pints 50c. Johnson's Prepared Wax 10c and 25c packages. Also sold in large sizes. For sale by all leading paint dealers. Send coupon today to

S. C. Johnson & Son, Racine, Wis.

"The Wood Finishing Authorities"

Please Use This FREE COUPON — one sample bottle of Johnson's Wood Dye, shade No. 126, one bottle of Johnson's Electric Solvo, and a sample of Johnson's Prepared Wax.

I accept your offer of Free Booklet Edition PE-3

Name.....
Address.....

I usually buy my paint at store of
Name.....
Address.....

**One Maid Does the Work of Four Men
Cleans Everything—Anywhere**

Portable, Light and Efficient for Private Homes, Hotels, Hospitals, etc.

**THE "POSITIVE" ELECTRIC
VACUUM CLEANER**

Has a range of from 6 to 12 inches vacuum. It is set to operate on 8 inches at the nozzle. It will thus remove all the dust and dirt from inside, under and on top of carpets, rugs, etc., without injury or wear to the finest fabrics Turkish rugs, etc. It is operated from any electric light socket. Simply screw in the plug and turn on the current, same as you would a light bulb. It takes only about one-quarter the current of any other machine. Costs about 2 cents per hour for electricity. It is mounted on ball-bearing, roller swivel, rawhide casters, and can be wheeled from room to room.

It is light in weight (weighing about 100 pounds), and can readily be carried up and down stairs. It is always ready for instant use. It is not a toy, but a powerful complete machine, doing all the work of a \$3,000 plant. It has no valves to wear out and make a noise. It is practically noiseless. Makes about as much noise as a sewing machine. It has no expensive parts to wear out. It will last a lifetime with ordinary use and care, without repairs. It is practically "fool proof." It is simple and can readily be operated by any housemaid. It is an ornament, finished in highly polished oak. Cabinet can be left in a room or stored away in a closet. Looks more like a silver chest than a machine. A bag cannot be used on our Positive Vacuum Machine. It will pull the dirt right through a bag. We guarantee that our Positive Cleaner will take up dust from any rug that has just been cleaned by any other machine.

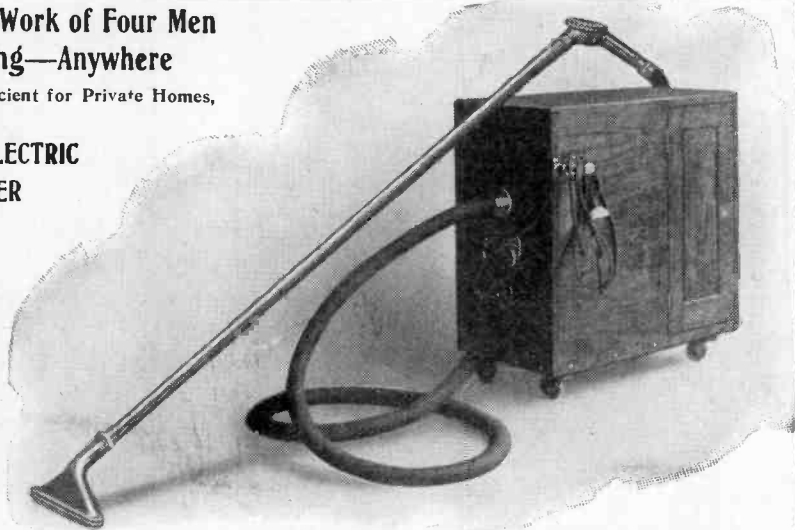

Manufactured Only by **ELECTRIC CLEANER COMPANY** Write for Catalog at once.
General Sales Offices: 1657-58-59 Monadnock Block, CHICAGO, U. S. A.

Don't Be a Wage Slave

**Make \$3,000.00 to \$5,000.00 a Year
Be a Doctor of Mechano-Therapy**

Are you tired of working for wages which barely keep body and soul together? Have you the ambition to enjoy the profits of your own labor? To gain social prominence and financial independence? To go forth among your fellow men with your head up—an honored and respected citizen of your locality? Have you thought of going into business for yourself?

THEN SEND FOR OUR FREE BOOK

Entitled "How to Become a Mechano-Therapist." It tells how every man and woman, with an ordinary, common school education, can acquire a profession within a few months which will insure financial independence for life. **GET OUR BOOK**—it costs you nothing.

WHAT IS MECHANO-THERAPY?

Mechano-Therapy is the art, or science, of treating disease without drugs. It is similar to Osteopathy, but far superior, being the latest, up-to-date method of treating disease by the Natural Method. It heals as Nature heals—in accordance with Nature's laws. The Mechano-Therapist is a drugless physician. His medicines are not drugs, but scientific combinations of food, circumstance, idea, water and motion. He is skilled in compelling the body to DO ITS OWN HEALING with its own force, rather than with poisonous drugs of the old school practitioner.

CAN I LEARN IT?

Have you asked yourself this question? We answer unhesitatingly, YES.

If you have so much as an ordinary, common school education you can learn.

You learn if you have the ambition to better your condition.

We can teach you in a very short time, so you may enter this profession—when you do, you begin to make money.

We supply all lessons and necessary text books free of cost to you. No apparatus is used. You do not even need a place to work. All you require is your two hands. Certainly you can learn. The free book tells all.

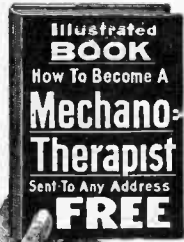

SEND FOR THIS BOOK TODAY, IT IS FREE

We Teach You in Your Own Home

We can teach you an honorable and profitable profession in a few months, which will insure your financial independence for life, making it possible to have an income of \$3,000 to \$5,000 a year. We teach you by mail, in your own home, without interfering with your present duties. No matter how old you are. Any day's business experience—salaried men, who could see nothing in the future but to become Ostrized, and laboring men, who never realized that they had within themselves the ability to better their conditions. Write for our FREE book, which explains all—today.

person—man or woman—with just an ordinary school education, can learn Mechano-Therapy. It is easy to learn and results certain. **AMERICAN COLLEGE OF MECHANO-THERAPY, Dept. 761, 120-122 Randolph Street, Chicago, Ill.**

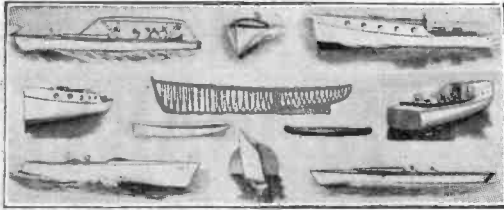

Build YOUR OWN BOAT—Save $\frac{2}{3}$

Any one can put together my knock-down boats or build a boat from my paper patterns. If you want to know how it can be done.

Send for my 1909

Catalog No. 22 today

I can supply you with the framework for your boat, shaped, machined, every piece fitted and ready to put together, for less money than most lumber dealers charge for suitable rough lumber.



YOU TAKE NO RISK I absolutely guarantee that you will be perfectly satisfied with everything you purchase of me, or your money will be instantly refunded.

C. C. Brooks.

It shows 100 new models.

Today there are more boats built by inexperienced amateurs using my system, than by all the boat factories.

I can save you (1) the boat builder's profit; (2), labor expense; (3), big selling expense; (4), $\frac{1}{2}$ of the freight. **Figure it out yourself.**



I can save you two-thirds on high grade Mission furniture shipped knock-down, in sections, not in pieces.

Put the K. D. Sections Together Yourself



As you receive it—with cushions made ready to drop in place. Just six joints to put together.

Every piece is of selected solid oak, massive, simple, always in good taste, and of a style that never changes.

C. C. BROOKS, Pres., BROOKS MFG. CO.
4205 Ship Street, SAGINAW, MICHIGAN, U. S. A. Est. 1901.
Originators of the Knock-Down System of Boat Building and Home Furnishing.

Do You Hear Well?

The Stolz Electrophone—A New, Electrical, Scientific and Practical Invention for those who are Deaf or Partially Deaf—

WAY NOW BE TESTED IN YOUR OWN HOME. Deaf or partially deaf people may now make a month's trial of the Stolz Electrophone at home. This personal practical test serves to prove that the device satisfies with ease, every requirement of a perfect hearing device. Write for particulars at once, before the offer is withdrawn, for by this personal test plan the final selection of the one completely satisfactory hearing aid is made easy and inexpensive for every one.

This new invention, the Stolz Electrophone (U.S. Patent No. 763,875) renders unnecessary such clumsy, unsightly and frequently harmful devices as trumpets, horns, tubes, ear drums, fans, etc. It is a tiny electric telephone that fits on the ear and which, the instant it is applied, magnifies the sound waves in such manner as to cause an *astonishing increase in the clearness of all sounds.* It overcomes the buzzing and roaring ear noises and, also, so constantly and electrically exercises the vital parts of the ear that, usually, the natural unaided hearing itself is gradually restored.



Mrs. C. Lidecka, 238 12th Ave., Maywood, Ill., wears an Electrophone

Less conspicuous than eyeglasses

What Three Business Men Say: The Electrophone is very satisfactory. Being small in size and great in hearing qualities makes it preferable to any I have tried and I believe, I have tried all of them. M. W. HOYT, Wholesale Grocer, Michigan Ave. and River St., Chicago. The Stolz Electrophone Co., Chicago, Ill. Gentlemen—

I have used your Electrophone since July 1908. It enables me to hear speakers over 50 feet away. Without it I could not hear their voices. It has improved my natural hearing at least 50%, and has stopped the head noises which were so annoying. Refer to me at any time. Yours truly, E. P. ROGERS, Suite 908-159 LaSalle St., Chicago, Ill.

I have now used your Electrophone over a year, and know that it is a first-class, scientific hearing device. Without it people have to shout directly in my ear to make me hear. With it, I can hear distinctly when spoken to in an ordinary tone. Best of all, it has stopped my head noises, which were a terrible aggravation. LEWIS W. MAY, Cashier, 100 Washington St., Chicago. Write to or call (call if you can) at our Chicago offices for particulars of our personal test offer and list of other prominent endorsers who will answer inquiries. Physicians cordially invited to investigate aurists' opinions. Stolz Electrophone Co., 1854 Stewart Bldg., 7th floor, Chicago. Branch Offices: Philadelphia, Cincinnati, Seattle, Los Angeles, Pittsburg, Louisville, Cleveland, Indianapolis, Des Moines, Toronto. Foreign Office: 82-85 Fleet St., London, Eng.

“1900” Dry Cells



ARE the Batteries of Merit. Eighteen years of successful operation make them of

Known Quality

Manufactured by

The Nungesser Electric Battery Co.
CLEVELAND, OHIO

General Sales Office:
128 West Jackson Boulevard
CHICAGO

Send No Money

JUST YOUR ADDRESS



In order to prove that Rheumatism, Indigestion, Constipation, Neuralgia, Deafness, Nervousness, Paralysis and Insomnia, in fact any ailment or pain due to congestion or poor circulation can be promptly relieved in your own home without drugs or medicines, we want to send you a **Vibro-Life**

Vibrator Free

Express Prepaid

YOU decide whether to buy it or return it, and it costs you not one cent unless you keep it. Fully guaranteed. Try it ten days, then if you are fully satisfied with the benefit received, buy it; otherwise return it and we will pay the express charge. **Send no money now**—just fill in and mail the coupon. This offer and special price is for a limited time only, so write at once.



EUREKA VIBRATOR CO.,

Suite 552 E No. 1269 Broadway, New York City.
Or Box 682, Brantford, Ontario, Canada.

I am interested in your Free Trial Offer, also free booklet on Health and Beauty.

NAME.....
ST. AND NO.....
CITY.....

OFFER EXTRAORDINARY

Through a Special Arrangement with the Publisher we are able to Offer **FOR THIRTY DAYS ONLY**

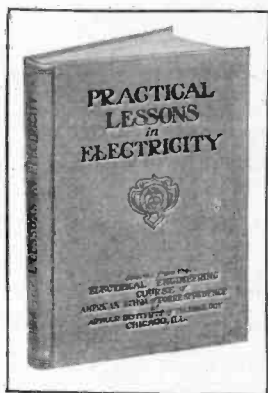

PRACTICAL LESSONS IN ELECTRICITY

Regular Price, \$1.50

For Only **75cts.** (Add 15cts. for Postage)

JUST HALF PRICE PRACTICAL LESSONS IN ELECTRICITY is a working guide to the fundamental principles of electrical science and approved American practice by the following well known authorities on electricity; F. B. Crocker, E. M. Ph. D., Head of Department of Electrical Engineering, Columbia University, Past President, American Institute Electrical Engineers; H. C. Cushing, Jr., Consulting Electrical Engineer, and Lawrence K. Sager, S. B.; M. P. L., Patent Attorney and Electrical Expert.

The work includes special treatises on the construction, installation and care of the various commercial types of storage batteries, and approved methods of installing conductors for the transmission and utilization of electricity for power, lighting, heating, bell signaling and other purposes.

275 pages; 6 1/2" x 9 1/4"; handsomely bound in red cloth with 150 illustrations.

No one interested in electricity should be without it. **ACT AT ONCE** and get this book for **half price**.

SPECIAL So many requests have been received to extend our Special Offer to give one years' subscription to POPULAR ELECTRICITY and "Practical Lessons in Electricity" for \$1.25 (Canadian \$1 60 Foreign \$1.75) that we have decided to extend it another thirty days, but this offer positively expires with the special offer above described on May 15.
WRITE TODAY
Use the coupon, state whether you wish subscription with book or book alone.

POPULAR ELECTRICITY PUBLISHING COMPANY,
Monadnock Block, Chicago, Illinois.

Gentlemen:—Enclosed please find \$..... for which send me

..... as per your special offer in POPULAR ELECTRICITY for May.

Name,.....

Street and Number.....

Town..... State.....

C O U P O N

Will you accept \$5⁰⁰ a day for your services?



Whatever your present employment may be—whether you are a man or a woman—this offer is open to you.

You can establish yourself in a pleasant, profitable and permanent business that will pay you more than \$5.00 a day at the start—and will pay you as much more as you care to make.

You can learn this business in less than a week—and make good money while you are learning it. You will have practically no competition.

You Take no Risk Whatever

You will invest no money in this business until you are absolutely sure you can earn the money at it. You therefore run no risk of losing money. You are paid well for all you do.

You know the principle of the vacuum cleaner. It sucks up dirt and dust from floors, carpets, rugs, furniture, walls, woodwork, etc., and takes all the dirt and dust out of the house—quickly, easily, economically.

It makes housecleaning the work of hours instead of the work of days—and it does the work ten times as thoroughly as any other method.

How The Business Increases

Every housewife who has a rug, a room or a house cleaned by this process, is so thoroughly satisfied that she tells her friends about it.

You get their orders. They tell their friends—and you get more orders.

You get the work month after month, season after season, year after year. The more customers you get—the more they get for you.

Duntley Standard Vacuum Cleaners

embody every principle and every improvement known in the vacuum cleaner business—and combine all these advantages in a portable machine, weighing about 50 pounds, that can be easily carried from room to room, or house to house.

You can take one of these machines into a residence and remove every particle of dust and dirt, from every room, without taking up carpets or rugs—without removing furniture—without taking down curtains or portieres—and do it in one-tenth time it could be done otherwise.

What This Invention Means

Before the invention of the Duntley Portable Standard Vacuum Cleaner, this work could only be done with a big, cumbersome, costly wagon apparatus—yet these wagon outfits earned for their owners immense profits.

The Duntley Portable Standard Vacuum Cleaner does the same work that the big wagon outfits do, and costs only a fraction as much originally and much less to operate. It will therefore, pay you far larger profits.

My Pay From Profit Plan

I want one good, earnest, honest, active man or woman in every city or town—no matter how small—where residences are lighted by electricity, to engage in the Duntley Vacuum Cleaner business, on the "Pay from Profit Plan."

I will establish you in business—show you how it is done—enable you to make good money while you are learning it—and assure you an income of at least \$5.00 a day.

Or, should you want a Duntley Standard Vacuum Cleaner for use in your own home, I will prove its value, its economy, and its necessity to you—and give you an opportunity to use it, at my expense.

Let me Prove These Truths

I do not ask you to invest one dollar. All I ask is that you fill out the coupon below, and let me prove to you the truth of every statement here made.

This offer is made to you—now—today—it is your great opportunity to start in a new business—in a coming business—in a profitable business—in a business of your own, that will grow bigger each year. Fill out and mail the coupon right now.

J. W. Duntley, President

Duntley Mfg. Co., 303 Dearborn St., Chicago

Fill out and mail this coupon today

J. W. Duntley, Pres., 303 Dearborn St., Chicago. P.E.

Dear Sir:—Tell me how I can earn \$5.00 or more a day with a Duntley Standard Vacuum Cleaner, on your "Pay from Profit Plan."

Name

Street and No.

Town

State

Occupation

Will you engage in business yourself?

Or, are you interested for use in your home?

POPULAR ELECTRICITY

The WORLD Is YOURS For \$3.00

**TECHNICAL WORLD MAGAZINE } BOTH FOR
and the }
NEW PEERLESS 12-INCH GLOBE } \$3.00**

The regular price of THE TECHNICAL WORLD MAGAZINE is \$1.50 a year, but it's worth far more. You could not duplicate the Peerless Globe for \$6.00. We have, however, purchased many thousands in order to bring this great bargain opportunity within the reach of our patrons and friends.

New Peerless 12-inch Globe



Height 20
Inches.

—the latest globe on the market, lithographed in ten permanent oil colors. The stand which is made of oak, weathered finish, is more up-to-date and far superior to the old-style iron base. The ball, or globe proper, is finished with high-grade varnish and is, therefore, impervious to water. It can be kept bright by an occasional wiping with a damp cloth.

TIME DISC—By means of a time disc at the north pole, time at any point in the world may be instantly approximated by noting the time at the point where observation is made.

ISOTHERMAL LINES—The isothermal lines are represented by red and blue lines for January and July and at various intervals the mean temperature for three months is noted.

The **ANALEMMA**—Just west of Mexico is the Analemma representing a figure eight. This is divided into months and the months, in turn, into days, and shows just where the direct rays of the sun strike the earth for every day in the year.

NOTE. The globe weighs eight pounds when packed ready for shipment. The subscriber must pay the freight or express charges when delivery is made.

Technical World Magazine
Chicago, U. S. A.

Pop.
Elect.
5-09
ORDER
BLANK

Technical
World Magazine
Chicago, U. S. A.

For the \$3.00 enclosed please send me The
Technical World Magazine
for one year, and the 12-inch
Peerless Globe, as advertised.

Name.....

St. Address.....

City.....State.....

**THE NEW
INCOMPARABLE
PEERLESS
VIBRATOR**

HAS
NOTHING BUT
GOOD POINTS
MAY WE SHOW YOU
ONE?

**MANHATTAN
ELECTRICAL SUPPLY
COMPANY**

188 5th Avenue, CHICAGO
17 Park Place, New York

We Want a Representative In Your Shop

¶ We have a plan by which farming can be done on a large scale and pay small investors very large returns.

¶ We farm in TEXAS *the land of opportunities*, where you can harvest some crop every month in the year.

¶ It will pay every one to investigate and secure an interest with us. *Full particulars free.*

¶ You can make \$100 a week representing us without leaving your present occupation. Try it.

National Farm & Land Co.
Dept. A. ST. LOUIS, MO.

TO BECOME A
SUCCESSFUL ELECTRICIAN
STUDY MECHANICAL DRAWING

WHY? BECAUSE IT teaches you the fundamental principles of mechanical construction, design and operation. ALSO TRAINS YOUR MIND; develops your ability to think,—to conceive of,—to understand and use your mental ability. That's the point,—USE YOUR MENTAL ABILITY—it brings success in any useful employment.

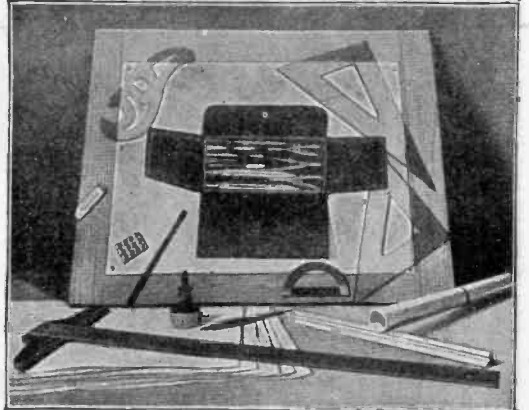

Are you in the kind of Position that you like?
Do you wish to get more pleasant work?
Do you want to become able to get more money?
Are you putting in long days at hard work?

The "FREEPORT IDEA" of Home-study is a big improvement in Correspondence Instruction;—you can now get the help you know you need; get it in interesting personal letters and worded in plain English. You will enjoy studying Architectural or Mechanical Drawing THE WAY WE TEACH IT, because you begin by doing actual drawing and go step by step, quickly and easily into practical work. We furnish the above drawing outfit.

If you are ambitious, but dissatisfied or misplaced (no matter who or where you are) mark a cross (X) on the attached coupon to show what position you would like to get, fill in your name, address, etc., tear off the coupon and mail it to us.

FREEPORT CORRESPONDENCE SCHOOLS
905 Rice Bldg., Freeport, Ill.

I would like the position before which I have marked a cross (X). Please explain without cost to me, how I can get such a position and be sure to hold it.

..... Mechanical Draftsman Manual Training Instr.
..... Sheet Metal Draftsman Bookkeeper
..... Architect Advertiser
..... Architectural Draftsman Stenographer
..... Architectural Designer Steam Engineer
..... Carpenter and Joiner Stationary Fireman

NAME.....AGE.....
CITY.....STATE.....
ST. or R. F. D.....OCCUPATION.....

We will show you how to TRAVEL THE ROAD TO PROSPERITY.

EXCELSIOR AUTO CYCLE

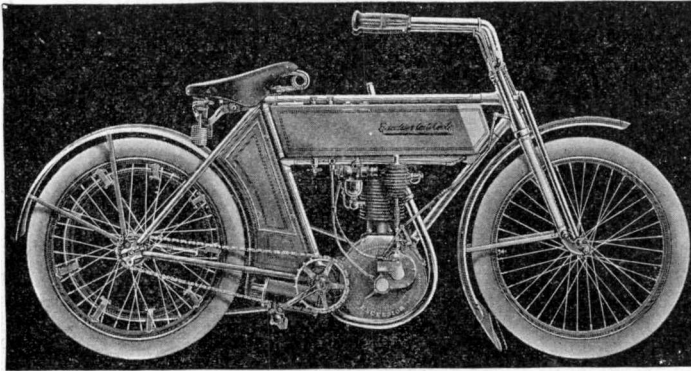

The Machine Without a Weak Spot

Tried in Every Big Road Event of 1908, and made good every time.

PERFECT SCORES

In every Reliability Run, including the F. A. M. New York-Chicago and many others.

The big, powerful motor, broad, flat belt drive, positive lubricating system, scientifically designed, straight line frame, low, comfortable saddle position, and other valuable features, make this a perfect mount for touring and hard service, as well as for pleasure riding in cities or on good roads.

POSITIVELY RELIABLE, ECONOMICAL, POWERFUL, SPEEDY AND SAFE

Three Models, all described in our new catalog MC-129. Write for it today.

EXCELSIOR SUPPLY COMPANY

Established 1876.

233-237 RANDOLPH STREET, CHICAGO, ILLINOIS

Will You Accept This Business Book if We Send it Free?

Sign and mail the coupon below. Send no money! Take no risk!

One hundred and twelve of the world's master business men have written ten books—2,079 pages—1,497 vital business secrets, ideas, methods. In them is the best of all that they know about

- | | | |
|----------------|-------------------------------------------------------|-------------------------------------------------------------|
| -Purchasing | -Salesmanship | -Position-Getting |
| -Credits | -Advertising | -Position-Holding |
| -Collections | -Correspondence | -Man-Handling |
| -Accounting | -Selling Plans | -Man-Training |
| -Cost-keeping | -Handling Customers | -Business Generalship |
| -Organization | -Office Systems | -Competition Fighting |
| -Retailing | -Short-cuts and Methods for every line and department | and hundreds and hundreds of other vital business subjects. |
| -Wholesaling | | |
| -Manufacturing | | |

A 9,059-word booklet has been published describing, explaining, picturing the work. Pages 2 and 3 tell about managing businesses great and small; pages 4 and 5 deal with credits, collections and with rock-bottom purchasing; pages 6 and 7 with handling and training men; pages 7 & 12 with salesmanship, with advertising, with the marketing of goods through salesmen, dealers and by mail; pages 12 to 15 with the great problem of securing the highest market price for your services—no matter what your line; and the last page tells how you may get a complete set—bound in handsome half morocco, contents in colors—for less than your daily smoke or shave, almost as little as your daily newspaper.

Will you read the book if we send it free? Send no money. Simply sign the coupon.

The System Co., 151-153 Wabash Ave., Chicago

If there are, in your books, any new ways to increase my business or my salary, I should like to know them. So send on your 16-page free descriptive booklet. I'll read it. 178-5

Name _____
 Address _____
 Business _____
 Position _____



RUSSIAN PROCESS STROPS

At Half Price
Buy of the Maker

Send 98 cents for the best Strop made. Money refunded if not satisfied.

Illinois Razor Strop Co.

60 Wabash Ave., Chicago.

"TELEPHONY"

☐ Is a handsomely illustrated, ably edited, weekly exponent of one of the most marvelous of modern American industries.

☐ Twenty years ago the Telephone was a curiosity. Today it is a Business Necessity. Practically indispensable, even in the Social and Domestic affairs of the Nation. ☐ The Independent Telephone Field alone represents an investment of over \$500,000,000, while more than \$25,000,000 is expended by it annually for supplies.

☐ Here is a field affording young men of ability and ambition greater opportunities than almost any other vocation which they can possibly adopt. ☐ Engineering, Contracting, Inventing, Manufacturing, Construction, Maintenance, Management and other departments of Telephone work reach out with open arms inviting the talented youth of today to become the prosperous leader of tomorrow.

→ Easy to Learn at Home ←

☐ All of the fundamentals of Telephone work can be readily learned at home by any bright young man through the reading of good books and the careful perusal of the one great medium of the Telephone industry, "Telephony."

☐ "Telephony" is a weekly publication which covers every phase of the Telephone business. ☐ In the course of a year "Telephony" presents over 4000 printed pages or the equivalent of more than 40 of the ordinary sized \$1.50 books. ☐ The subscription price of "Telephony" is \$3.00 a year, but readers of Popular Electricity can secure it at a special rate of \$2.00 temporarily by employing coupon blank herewith.

☐ We also present below a list of some of the leading Telephone books all of which "Telephony" is prepared to furnish, postage prepaid, for prices indicated after each. ☐ Insert above your name, when ordering, either the word "Telephony" or the title of the book you want.

BOOK LIST

A. B. C. of the Telephone, J. E. Homans.....	\$1.00
American Telephone Practice, K. B. Miller.....	\$4.00
Electrical Instruments and Testing, N. H. Schneider.....	\$1.00
Handy Electrical Dictionary.....	\$0.25
Modern Electrical Construction, Horstmann & Tousley.....	\$1.50
Modern Wiring Diagrams, Horstmann & Tousley.....	\$1.50
Telephone Principles and Practice, G. W. Wilder.....	\$2.00
Telephone Construction, Installation, Wiring, Operation and Maintenance, W. H. Ratcliffe and H. C. Cushing, Jr.....	\$1.00
Telephone Construction, Methods and Costs, C. Mayer.....	\$3.00
Telephony, A. V. Abbott (6 Vol.).....	\$6.00
Telephony, W. C. Boyrer.....	\$3.00
And Paul Lutzke's Great Telephone Story, "A Fight with an Octopus".....	\$0.25

COUPON—Cut out and mail today

**TELEPHONY
PUB. CO.**
Monadnock Block
CHICAGO, ILL.

Gentlemen: I enclose herewith \$..... for which please send me.....

**Write for Our Telephone Book
Catalogue, Free**

Name.....
St.....
City.....
State.....
(Popular Electricity)

— The —

Omaha Electrical Exposition

May 6th to 15th 1909

In the Omaha Auditorium

This will be the most complete and most beautiful Electrical Show ever held west of Chicago.

Grand and original scheme of illumination, with unique and attractive arrangement of exhibits.

This is the one great opportunity of the year to reach the Electrical Supply Merchants and Electrical Contractors of the Great West.

Booths substantially built and ready for exhibits on May 3d. Show opens May 6th.

For space, prices, and all other information, address

**J. M. GILLAN, Manager,
OMAHA, NEB.**



TRAINING Outweighs Long Service

There is no better proof of this than the everyday scenes of long-service *untrained* employees at the beck and call of younger men who occupy the big positions because of their training. It's a case of Training vs. Long Service—with the odds all in favor of the *trained* man.

Get out of the untrained rut. Mark the attached coupon and let the International Correspondence Schools of Scranton tell you how you can qualify for a better position. How you can protect yourself against servitude in your old age. How you can become *an expert at your chosen line of work*. No necessity for leaving home. No books to buy. Mark the coupon. It will bring you advice and information worth dollars to you. Marking the coupon puts you to no expense and places you under no obligation. Mark it **NOW**.

HOW THE I.C.S. RAISES SALARIES

That the Business of the I. C. S. is to Raise Salaries is shown by the monthly average of 300 letters *VOLUNTARILY* written by students reporting salaries raised and advancement won through I. C. S. help. During October the number was 274.

So long as you can read and write there's an I. C. S. way by which you can succeed in life. Let the I. C. S. tell you what it is.

MARK THE COUPON NOW.

SALARY-RAISING COUPON

INTERNATIONAL CORRESPONDENCE SCHOOLS
Box 1102, Scranton, Pa.

Please explain, without further obligation on my part, how I can qualify for employment or advancement in the position before which I have marked X

Bookkeeper	Mechan. Draughtsman
Stenographer	Telephone Engineer
Advertisement Writer	Elec. Lighting Supt.
Show Card Writer	Mech. Engineer
Window Trimmer	Plumber & Steam Fitter
Commercial Law	Stationary Engineer
Illustrator	Civil Engineer
Civil Service	Building Contractor
Chemist	Architect Draughtsman
Textile Mill Supt.	Architect
Electrician	Structural Engineer
Elec. Engineer	Banking
	Mining Engineer

Name _____
Street and No. _____
City _____ State _____

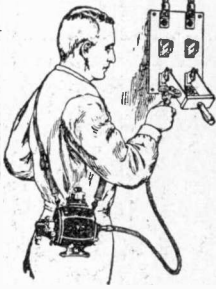

ELECTRIC PORTABLE POLISHING MACHINE

Consists of small motor with straps for crwinging over operators shoulder and on the armature shaft of the motor a flex shaft is provided, at the end of which is a holder for rotary polishing discs, buffs, etc. Useful for polishing signs, railings and other brass work. Also in the garage central station, etc.

ELECTRICALLY OPERATED AIR COMPRESSORS

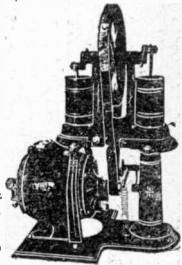

For Garages, Saloons, Central Stations, Air Brush work, etc. etc. Single and double cylinder types. Automatic pressure regulators.

We make a line of small electric lathes and a variety of other electric specialties. Write for circulars and price.

VICTOR ELECTRIC CO.

55-61 Market St.

CHICAGO, ILL.

RING WITHOUT BATTERIES

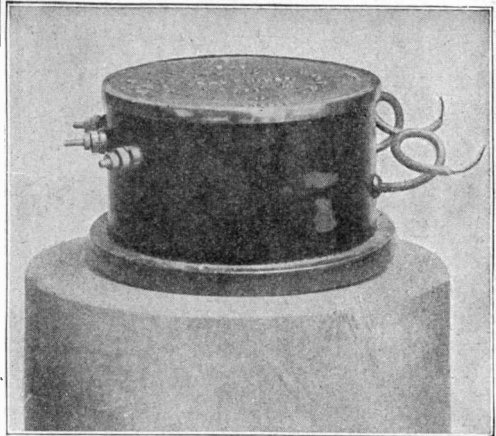

The Rollinson Bell Ringer

will operate buzzers, door bells, hotel calls, elevator calls, automatic gas lighters, etc., from an ordinary 110-volt lighting circuit, without the use of batteries.

The bell ringer is made in three sizes, all three taking 100 to 130 volts from the line and changing it to 6-13-19 and 8-16-24 volts respectively for supplying the bell circuit. Using alternating current, the device may be said to operate without cost for current.

MOHAWK ELECTRIC CO., Albany, N. Y.



HELP-A-PHONE

How often do you have important conversations over your phone?

How often have you failed to hear distinctly?

The Help-a-Phone is just what you need where the noise of the typewriter, the buzz of conversation or the rattle of machinery interferes with the accurate and satisfactory hearing of messages.

Makes telephoning possible under any condition. Makes whispered conversations possible on local lines.

Offices, homes and shops where it has been in use report that it is invaluable. Money cheerfully refunded if you are not satisfied. State in ordering whether it is to fit a Bell or other instrument. Sent on receipt of price \$3.50.

If you are not interested as a telephone user send to us for a few facts and figures on the Help-a-Phone as an agency proposition. We have men and women who are coining money.

Western Help-a-Phone Company, 56 5th Ave., Chicago, Ill.

CHAS. E. GREGORY, Pres.

POPULAR ELECTRICITY



Excel Electric Laundry Irons,

Electric Universal Coffee Percolators, Chafing Dishes, Tea Pots, Tea Kettles, Nursery Food Warmers, Cereal Cookers, and many other useful Electric Appliances, described in our attractive catalogue "H."
The next mail will bring it if you write us.

All "Excel" Appliances
GUARANTEED

"Excel" in durability, attractiveness and efficiency.
Lowest in price.
We desire to quote discounts to leading Electrical Houses.

EXCEL ELECTRIC HEATING CO.
237 Broadway, New York City, N. Y.

We
Protect
The
TRADE



Dealers—Send us your name at once,
we want to send you **FREE**
our Catalog 15.

Write at once.

R. Williamson & Co.
Manufacturers of
Electric and Combination
Fixtures and House
Lighting Supplies.
Washington & Jefferson Sts., Chicago



PAT. APPLD FOR

WIRELESS EXPERIMENTERS ATTENTION

Our **Circuit Detector** will be a most valuable addition to your equipment. Just the instrument for testing your apparatus and connections. Detects all circuit and connection troubles.

Makes an **Ideal and Reliable Wireless Operator's Head Receiver.**

Complete—with high grade receiver—leather covered head band—battery and 5 foot green cord.

Sent Prepaid—to any part of the U. S. or Canada on receipt of \$2.50. Our watch case style "W" telephone receiver sent **Postpaid** on receipt of 80 cents.

Three foot cords for same 20 cents.

We are the Manufacturers. **Send Us Your Orders.**

Wm. J. Murdock & Co., 40 Carter St., Chelsea, Mass.

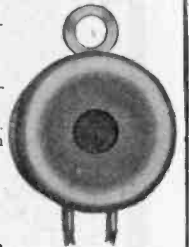

DIAMONDS ON CREDIT

20% DOWN—10% PER MONTH

Why wait for your Diamond until you have saved the price? Pay for it by the Lyon Method. Lyon's prices are fully 20% lower than any others. Lyon's Diamonds are guaranteed perfect blue-white, imported in the rough, cut and polished here to save import duties and middlemen's profits. A written guarantee accompanies each Diamond. You have the option for exchange at any time at full purchase price. All goods sent prepaid for inspection. 10% discount for cash. **Send now—today—** for our catalogue No. 2, splendidly illustrated. *Established 1843.*
J. M. LYON & CO.
71 Nassau St., New York



For our Mutual Advantage mention Popular Electricity when writing to Advertisers.

POPULAR ELECTRICITY



Summer Comfort in the Office

You wouldn't do without an electric light anywhere because of its trifling cost. The General Electric fan costs no more to operate.

Summer heat is reduced at a cost less than that for lighting winter's darkness. Summer makes less demand for electric light. You should give yourself and office employees the benefit by enjoying the comfort given by General Electric fans.

Neglected Wastes Takes the Dividends

No man can keep alert to the vital elements of business details if he is oppressed by the heat or depressed by foul air. The General Electric fan will help him by dispelling both.

Mistakes are all Lost Motion

The one who makes mistakes is not so much to blame as the one who permits conditions that favor mistakes. The General Electric fan keeps the air fresh and cool and the worker keen and accurate.

The 1909 design of the General Electric fan merits your exclusive attention. Its many points of superiority are easily recognized—noiseless operation—even distribution of air over a large area—little space occupied—little current consumed—speed can be varied to produce a gale or zephyr at command—designs adapted to all ventilating and cooling purposes—and so, many points, too numerous to mention here, have been taken care of by the General Electric Company. You benefit more than you know when you buy a General Electric fan.

A beautiful Catalog No. 4632T illustrating these fans is available for those interested.

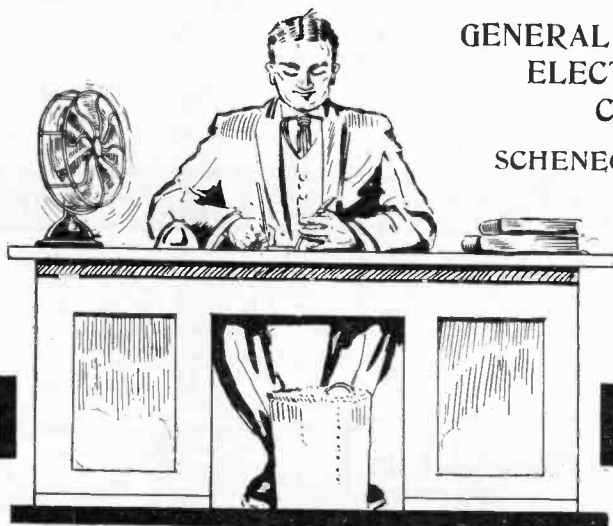

GENERAL
ELECTRIC
COMPANY

SCHENECTADY,
NEW
YORK

2117

For our Mutual Advantage mention Popular Electricity when writing to Advertisers.

POPULAR ELECTRICITY

LET US FIGURE

on all your Electrical Work. Some of the largest contracts on Electrical work in the country have been performed by us.

WE INSTALL

Power and Light Plants. Generators and Motors, Electric Light and Power Wiring for Factories, Churches, Schools, Colleges, Theatres, Office, Store and Residence Buildings.

Estimates cheerfully furnished for this class of work in any part of the U. S.

WE MANUFACTURE

Switchboards, Panelboards, Steel Cutout Cabinets, Junction Boxes, Service Switch Boxes, Theater Stage Plugs, Experimental Switchboards and Appliances for High Schools and Colleges. Newgard receptacles and other electrical specialties.

All Electrical work at the Chicago Electrical Show installed by us.

Manufacturers of the Famous "Newgard" Waterproof Receptacle and Globe.

HENRY NEWGARD & CO.
30-32 West Monroe St., Chicago, Ill.

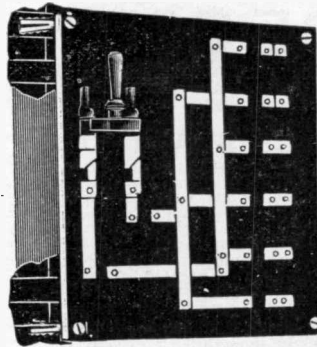

**Secured
By Star
Screw
Anchors**

Finish your work up neat, strong

and clean with Star Screw Anchors —or in heavy work with Star Expansion Lag Screws or Star Expansion Bolts.



This is the Star Screw Anchor to use: drill a hole in wall and insert; run screw through fixture and on into the anchor; as the screw tightens the anchor expands and holds as long as the wall stands.

Catalogue and Samples on request.

STAR EXPANSION BOLT CO.
BAYONNE, N. J.

25c BOOKS

Our 25c Electrical Books are immensely popular

Here are some of the Titles

- Electricity
- Dry Batteries.
- Electrical Circuits and Diagrams, (Part 1) Direct Current.
- Electrical Circuits and Diagrams, (Part 2) Alternating Current.
- Electric Bells and Alarms.
- Modern Primary Batteries.
- Experimenting with Induction Coils.
- Induction Coils. How to Make and Use Them.
- Simple Experiments in Static Electricity.
- The Wimshurst Machine.
- Alternating Currents, Simply-Explained.
- Small Accumulators.
- Small Electrical Measuring Instruments.

All Fully Illustrated

Mailed postpaid upon receipt of price

Send for full List of over 60 Titles **FREE**

SPON & CHAMBERLAIN
123 E. Liberty St. NEW YORK

Intercontinental University

BOARD OF DIRECTORS

Includes Justice DAVID J BREWER, U. S. Supreme Court; Hon. MARTIN A. KNAPP, Chairman Interstate Commerce Commission and Senator CHAUNCY M. DEFEW, EDWARD EVERETT HALE, Co-founder.



Hon. David J. Brewer



Hon. Martin A. Knapp



Edward Everett Hale
Ask for Catalog 22
State course
wanted

Instruction by mail in practically all lines of business, science and education. Law-Bookkeeping—Accounting—Civil Service—Engineering—Mechanical Drawing—Business Letter Writing. 160 separate courses. To be well educated is to be well paid. We will help you to a better place in life

Intercontinental University
1444 "L" Street,
Washington, D. C.

Please send the year book and catalog

I am interested in

For our Mutual Advantage mention Popular Electricity when writing to Advertisers.

"I MADE \$88.16

first 3 days" writes Mr. Reed of Ohio. Mr. Woodward earns \$170. a month. AGENTS all making money. Mr. M. L. Smith turned out \$301.00 in two weeks. Rev. Crawford made \$7.00 first day.

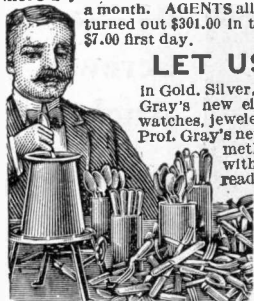

LET US START YOU

In Gold, Silver, Nickel and Metal plating. Prof. Gray's new electro plating machine plates on watches, jewelry, table ware and all metal goods. Prof. Gray's new Royal immersion process, latest method. Goods come out instantly with fine brilliant, beautiful thick plate ready to deliver - no polishing or grinding. Every family, hotel and restaurant wants goods plated.

AGENTS HAVE ALL THEY CAN DO—

people bring it. You can hire boys to do the plating as we do. Men and women gather work for small quired—we teach you. Outfits ready for work when received. Materials cost about 10 cents to do \$1.00 worth of plating. Demand for plating is enormous. WE ARE RESPONSIBLE and guarantee everything.

Call or write today. Our new plan, testimonials, circulars and SAMPLE FREE. Don't wait. Send us your address anyway. Gray & Co. Plating Works, 1176 Gray Building, Cincinnati, Ohio.

Thor the motorcycle supreme
THE AUTOMOBILE OF THE MASSES

Speed 5 to 60 miles an hour. Fast enough for the most daring; slow enough for the most cautious. Governed and controlled entirely with the handle grips—mechanism concealed and protected. Easily mastered by a novice. Practical for pleasure or business. Can outdistance fastest automobiles and all rival motor cycles. Takes any mountainous road at slow or high speed. The **Thor**, without any repairs, was the only one of 9 contestants to complete the 1,116-mile cross country endurance test of Chicago Motor Cycle Club.

Models—\$150 to \$300. Motors—2½ H. P. to 6 H. P.

Agents Wanted in Every City and Town.
Largest Motor Cycle Plant in America. Over 10,000 **Thor** motors in use. Features not on any other motor cycle. Catalogue with our liberal proposition free.

AURORA AUTOMATIC MACHINERY COMPANY,
Dept. C. Aurora, Illinois, U. S. A.

COLUMBIAN ENGRAVING CO.
HALF TONE ZINC ETCHING & ILLUSTRATING
331-335 DEARBORN ST. CHICAGO

PHONE HAWKESON 2976

THE AMERICAN SOCIETY OF ELECTRICAL STUDENTS.

All Students of Electrical Engineering, Physics, and the Mechanic Arts, are invited to become Charter members of the above Society.

The Society will hold Annual Conventions, own its own Information Bureau, and will publish and issue to its members a Monthly Bulletin of the latest Achievements in the Arts and Sciences, and topics of interest to Students. Charter Membership fee, \$2.00 and Annual dues, \$2.00.

For further particulars, and address all applications for membership to

Louis E. Walkins, M. & E. Engr. Brockton, Mass.
P. O. Box 204, or No. 140 Belmont Street, Brockton, Mass.

Big Profits Printing Window Cards and Signs

EASY TO OPERATE
SIGN-WRITER PRESS

Easy Terms No Experience Necessary

SIGN WRITER PRESS COMPLETE, \$45
including three sizes metal type, 500 blank cards size 6x6 to 10x18 inches, 2 inking rolls and plates, 2 tubes best ink, black and red. A practical machine, size 20x20x8. Weight 68 lbs. Shipping weight with complete outfit, 160 lbs. Every merchant daily needs attractive display signs, cards and price tickets for store and window advertising. Press prints any size card to 28 inches. Two or more colors printed at one time. No experience necessary. Easy payments. Terms: \$25 cash, \$10 per month for three months. Free catalog.

AUTOMATIC PRINTING PRESS COMPANY
403 Crilly Block, Chicago, Ill.

LEARN TO DRAW

Artists and draftsmen make \$20 to \$100 a week. Pleasant, refined, fascinating work for men, women boys and girls. We guarantee proficiency or will refund tuition.

Illustrating, Cartooning, Commercial Designing taught by artists trained in American and European Schools. Instruction adapted to each student's needs. Advisory Board of world's best artists approves lessons. Test Work Sent FREE to ascertain individual talents and needs. State course wanted. You assume no obligation. Mechanical, Architectural and Sheet Metal Pattern Drawing also taught successfully. **ACME School of Drawing**, 237 South St. Kalamazoo, Mich. If interested, ask about the **ACME RESIDENCE SCHOOL IN KALAMAZOO**

JUST OUT

Low-priced 3-lb Mop; turn crank to wring; hands keep clean. Women all buy; 150% profit to Agents. Cost 40c dozen lots; retail at \$1 each; exclusive territory given; send for free catalog.

U. S. MOP CO. 604 Main St. Leipsic, O.

BARODA FLASH LIKE GENUINE
Day or night. You can own a Diamond equal in brilliancy to any genuine Stone at one-third the cost.

BARODA DIAMONDS IN SOLID GOLD RINGS
stand acid test and expert examination. We guarantee them. See them first, then pay. Catalogue Free. Patent Ring Measure included for FIVE two-cent stamps.

THE BARODA COMPANY,
Dept. 40, 220 North State St., Chicago

For our Mutual Advantage mention Popular Electricity when writing to Advertisers.

NEW BOOKS FOR BOYS

A book that the boy will eagerly devour. Shows him what he can do with his own hands, and accomplish results with inexpensive materials. Tells how to make simple batteries, induction coils, telephones, wireless telegraph apparatus, and hundreds of other interesting and instructive articles.

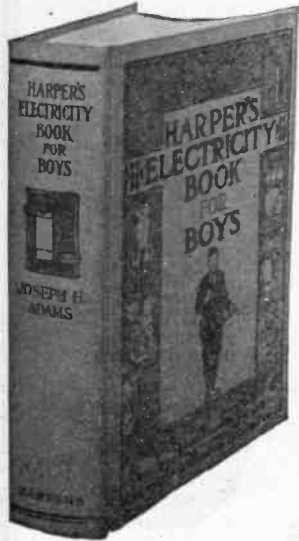

Explains briefly and in simple language the workings of electricity in its daily application and has an appendix of electrical terms and phrases. Every boy should have this book. 407

pages with 274 illustrations. Price, \$1.75. Given free for three paid subscriptions to

Popular Electricity

Presents the subject in a way that makes it both interesting and instructive and easily understood by young people. Describes vividly the invisible wonders of the mysterious world of magnetism.

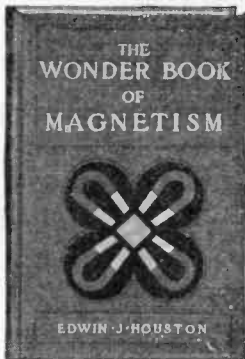

Fascinating as a fairy tale. Delights both young and old. 325 pages, 77 illustrations. Price \$1.50. Given free for three paid subscriptions to

POPULAR ELECTRICITY

Enclosed find.....please send
 (Name book.)
 Name
 Address
 City.....
 State

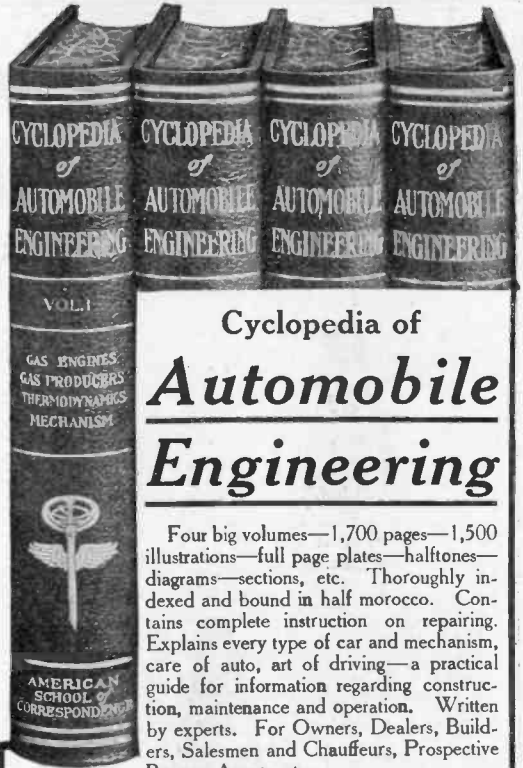

Cyclopedia of Automobile Engineering

Four big volumes—1,700 pages—1,500 illustrations—full page plates—half-tones—diagrams—sections, etc. Thoroughly indexed and bound in half morocco. Contains complete instruction on repairing. Explains every type of car and mechanism, care of auto, art of driving—a practical guide for information regarding construction, maintenance and operation. Written by experts. For Owners, Dealers, Builders, Salesmen and Chauffeurs, Prospective Buyers, Agents, etc.

Free Introductory Offer:

EXAMINE THESE BOOKS AT OUR EXPENSE. We will send you a complete set by prepaid express. Keep them five days—give them a thorough and careful examination. If you do not wish to keep books advise us and we will have them returned at our expense. If you keep the books send us \$2.00 in five days and \$2.00 a month until special introductory price of \$12.60 has been paid. Regular list price \$24.00.

PARTIAL LIST OF CONTENTS:

Automobile Operation—Care—Trouble—Breakdown—Repairs—Automobile Power Plants—Cooling and Oiling Systems—Ignition Systems—Spark Coils—Buying a Motor Car—Gasoline, Electric and Steam Cars—Tires—Puncture—Accessories—Driving—Motorcycles—Gas and Oil Engines—Fuels—Care of Gas Engines—Electricity—Storage Batteries—Direct Current Motors—Mercury Vapor Converter—Primary Batteries—Steam Engines and Boilers—Valve Gears—Indicators, etc.

Order promptly and we will include FREE for one year, as a monthly supplement, the TECHNICAL WORLD MAGAZINE, a regular \$1.50 monthly, full of interesting scientific topics written in popular form.

FREE OFFER COUPON

American School of Correspondence, Chicago, U. S. A.

Please send set Cyclopedia of Automobile Engineering for 5 days' free examination; also Technical World for 1 year. I will send \$2.00 within 5 days and \$2.00 a month until I have paid \$12.60; otherwise I will notify you and hold the books subject to your order. Title not to pass until fully paid.

NAME
 ADDRESS
 OCCUPATION
 EMPLOYER

Pop. Elect. 5-09

POPULAR ELECTRICITY

Our Regular Stock of Tungsten Multiple Lamps

IS UNEQUALED BY ANY OTHER MANUFACTURER



25 Watt
The Smallest

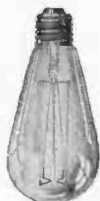

40 Watt
(small bulb)



40 Watt



250 Watt
The Largest—



60 Watt



100 Watt



PROMPT DELIVERY AND BEST QUALITY
CHARACTERIZE

G-I TUNGSTEN LAMPS

Write for Descriptive Bulletin No. 6D

The General Incandescent Lamp Company
Cleveland, Ohio.

SAN FRANCISCO OFFICE
403 Atlas Bldg.

ST. LOUIS OFFICE
1434 Syndicate Trust Bldg.

KANSAS CITY OFFICE
509 N. Y. Life Bldg.

NEW YORK OFFICE
30-32 E. 20th St.

CINCINNATI OFFICE
225 E. 4th St.

SEATTLE OFFICE
223 Colman Bldg.

For our Mutual Advantage mention Popular Electricity when writing to Advertisers.

Want To Sell More Electric Current?

The demand for electric current can be greatly increased by advertising the advantages of electric power and light.

For years we have prepared and placed such advertising for the largest Central Electric Stations in the Country.

We will be glad to show you what we have done for them, and what we can do for you.

Wm. D. McJunkin
Advertising Agency
Business Builders

167 Dearborn St. Chicago

"Vesta" Pocket Electric Lantern

**DRY STORAGE
BATTERY**
**TUNGSTEN
BULB**



This is not a toy but is a practical portable lantern designed in response to an increasing demand for a safe powerful light where the use of gasoline oil or a candle is dangerous.

The battery is so made that it can be carried in the hip pocket without inconvenience and will give an exceptionally clear, white light from 12 to 15 hours on one charge.

Recharging can be done at small cost and the batteries will last for many months if properly cared for.

Write for further information.

Price \$5.00

VESTA ACCUMULATOR CO.
1338 Michigan Ave., Chicago, Ill.



Something
for
Everybody
An Invention for
the People
To See it is
to Want it

Tungsten Adapter

For Burning Tungsten Lamps on
Any Fixture

Only one difficulty has stood in the way of the universal adoption of the Tungsten lamp—it must be burned in a vertical position—and many fixtures and sockets are not installed with this in mind.

The Benjamin Tungsten Adapter disposes of this "vertical difficulty" in less than a minute's time. It is as inexpensive as it is simple.

While the necessity for buying fixtures is thus obviated, old ones are not infrequently improved in appearance by the changed position of the lamps.

Let us tell you more about it.

BENJAMIN ELECTRIC MFG. CO.
42 W. Jackson Blvd, CHICAGO

Electrical Testing So You Can Understand It.

Are you limited in the knowledge of Electrical Testing?

Are you spending lots of time and money looking for troubles that you could locate and clear with the apparatus you now have at hand, or could make, if you only knew how.

It is wonderfully simple when you understand the principle.

We tell it to you so you can make even difficult tests the first time.

Our language and drawings simply make you see the theory and then you cannot make a mistake.

For 25 cents we can furnish you information on Electrical Testing subjects, written in a non-technical manner so that you can advance in this line of work to the rank of an expert. The information is worth many times the price and you cannot afford to be without the newest practical schemes. Money refunded if not satisfied.

Enclosed find 25 cents for which send me the following instructions.

- | | |
|---------------------------------------------------------------------------------------|---------------------------|
| 1. How to locate telephone cable trouble with a voltmeter. | 25c for each instruction. |
| 2. How to test telephone lines by ear. | 1..... |
| 3. How to wire your voltmeter to make all manner of tests and locations. New methods. | 2..... |
| 4. How to make loop tests with a Wheatstone bridge. | 3..... |
| | 4..... |

Name.....
Address.....
City.....

Middleton Bros. 1361 Monadnock Block, CHICAGO, ILL.

Which Man Will You Be?



The man that works in the factory or store, or keeps the books, or does the office work, is not the one that draws the big pay envelope. It is the man that **sells the goods**; there is no limit to what he can earn. Good salesmen earn anywhere from

\$1,000 to \$10,000 A Year

and expenses. We will teach you to be a high-grade Salesman by mail in eight weeks and our **Free Employment Bureau** will assist you to secure a position as a Traveling Salesman with a reliable firm. We received calls for salesmen from 3,000 firms last year, and assisted hundreds of our graduates to secure good positions where a great many of them have earned from \$100 to \$500 a month and expenses and some of them even more than that. We are receiving hundreds of new calls for salesmen for the summer and fall rush. If you are ambitious and want to enter the most independent, best paid, pleasant profession in the world, where you can increase your earning from two to ten times, our free book, "*A Knight of the G-19*" will show you how. Write (or call) for it today. Address nearest office.

Dept. 158 **National Salesmen's Training Association,**
New York Chicago Minneapolis * Kansas City San Francisco

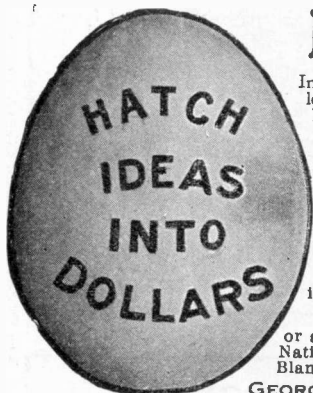

Make More Money

Increase your personal earnings or those of your business by learning the modern method of business promotion. If you are handicapped by the small salary of a narrow, crowded line of work, prepare for one of the varied well-paid positions in the great profession of advertising. If you are a business man and want to increase the volume and profits of your business

Learn Advertising

We provide expert, practical instruction in writing, planning and managing retail, mail-order, trade-paper or ask-the-dealer advertising, agency work and soliciting. To prove the superiority of our instruction we offer the mail course on

30 DAYS FREE TRIAL

or an evening **FREE** in New York. Write for particulars. National advertisers should ask for Business Analysis Blank for planning campaigns.

GEORGE FRANK LORD, INC., 333B 4TH AVE., NEW YORK

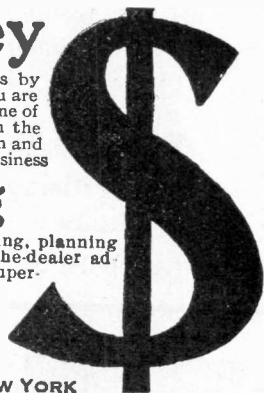

U. S. or CANADIAN PATENTS

\$25.00

We pay all expenses and disbursements except Government fees

ASSOCIATES throughout Continental Europe, Great Britain, the Colonies, South America and Canada enable us to investigate and prosecute foreign interests with dispatch.

Our Pamphlet No. B for the asking.

THE INDUSTRIAL LAW LEAGUE, Inc.
170 Broadway, NEW YORK CITY, N. Y.

A Practical Book—for Practical Men

Electrical Wiring and Construction Tables, by Henry C. Horstman and Victor H. Tousley. Saves tedious calculations. Every wireman, foreman, engineer, contractor, architect should have a copy. Bound in full Persian morocco. Handy size for coat pocket. Price \$1.50. A few handled copies, good as new, for \$1.00 each. Get yours while you can. Won't last long.

POPULAR ELECTRICITY PUBLISHING COMPANY, Book Department
Monadnock Block, Chicago, Ill.

For our Mutual Advantage mention Popular Electricity when writing to Advertisers.

IF YOU HAVE
RHEUMATISM
 sign and mail this coupon to
MAGIC FOOT DRAFT CO., Dept. 540F
JACKSON, MICH.

Name.....
 Address.....

Return mail will bring you a \$1.00 Pair of Magic Foot Drafts to try Free. Read below.

Upon receipt of above coupon we will send you by return mail, prepaid, a regular \$1.00 pair of Magic Foot Drafts, Michigan's Great External Cure for Rheumatism of every kind—chronic or acute—Muscular, Sciatic, Lumbago, or Gout. No matter where the pain or how severe. Then, and only after you have give them a thorough trial and are fully satisfied with the benefit received, you can send us One Dollar. If not, you pay nothing. You decide and we take your word.



FREDERICK DYER, Corresponding Sec'y.

Magic Foot Drafts have been sent on approval to many hundreds of thousands, and no one paid us a cent until after trying them. Isn't this evidence that the Drafts are a remarkably certain cure? Surely you cannot go on suffering when such a cure will be sent you to Try Free for simply mailing the above coupon. They are curing even old chronics of 30 and 40 years suffering. Will you try them? Then just mail the coupon with your full address to Magic Foot Draft Co., 540F Oliver Bldg., Jackson, Mich. Send no money—only the coupon. Write today.



EVERY ONE interested in Electricity needs—should have Handy Electrical Dictionary, vest pocket size. 224 pages, 48,000 definitions, seven pages of diagrams. Cloth binding. 25cts; Red leather, gilt edges, 50cts. Special price 30 days only, 40cts prepaid. Order today.

Popular Electricity Publishing Company
Book Dept., Monadnock Bldg., Chicago, Ill.

Cure Yourself

Right at Home With

Vibration



Health is waiting for you! Perfect, abounding, glowing health—such health as you have not known for years, perhaps. And without the aid of doctors, drugs or medicines! No matter what ails you; no matter even if your case has been pronounced incurable—**don't give up hope!**

Vibration, the marvel of the 20th century, has cured uncounted thousands of people who thought they were hopeless invalids.

THE WHITE CROSS ELECTRIC VIBRATOR

is the greatest boon that suffering humanity has ever known. It gives life and health, strength and beauty to all. It sends the good red blood leaping and coursing through your veins, puts new life into disused muscles and nerves. It shakes the disease **right out of your system.**

The White Cross Electric Vibrator is the only instrument in the world which enables you to make use of the three great natural forces, Vibration, Faradic and Galvanic Electricity—right in your own home! It is a perfect Massage Vibrator and Medical Battery combined for less than the usual price of either.

VIBRATING CHAIR FREE With a simple attachment you can transform any chair into a perfect Vibrating Chair. You can take Vibratory treatments and Swedish Movements right in your own home, that physicians and sanitariums charge \$2 to \$3 a piece for.



CURES THESE DISEASES:

- | | | |
|-------------|------------------|-----------------|
| Head Ache | Asthma | Heart Trouble |
| Catarrh | Neuralgia | Deafness |
| Insomnia | Erasms | Stomach Trouble |
| Indigestion | Weak Eyes | Skin Diseases |
| Weakness | Nervous Debility | Scalp Disease |
| Rheumatism | Constipation | Lumbago |

All these and dozens of other chronic and acute diseases can be instantly relieved by Vibration and Electricity.

Valuable Book Given Away

Send us your name and address on the attached coupon at once and we will mail you a copy of the famous book, "Health and Beauty," absolutely free and postpaid. Tells how to prevent and cure disease and become healthy, hearty, happy and beautiful in a natural way. No matter how well you are now, you need this book. It has saved thousands of lives—it may save yours. No obligations—just your name and address.

SIGN THE COUPON

Get the free book at once. Let us tell you about our liberal Free Trial Offer. Get our special 60 day introductory discount. Learn how you and all you loved ones can get well without drugs or doctors. Remember, no obligations, just name and address. Get the free book today.

1165
Lindstrom, Smith Co.,
 253 La Salle St.,
CHICAGO, ILL.

Without obligations on me, please send me free your free book "Health and Beauty," Special Reduced Price Offer and Complete Catalog.

Name.....
 Address.....

LINDSTROM, SMITH CO.
 253 LaSalle St. CHICAGO
 Dept. 1155

POPULAR ELECTRICITY

IF YOU WANT THE BEST VIBRATOR MADE BUY THE AMERICAN

**NO FREE TRIALS—
BUT**

**YOUR MONEY
BACK** on request
at any time with-
in six months of
the date you pur-
chase, either
through your deal-
er or from us direct
if you will simply
say that you are
not satisfied.

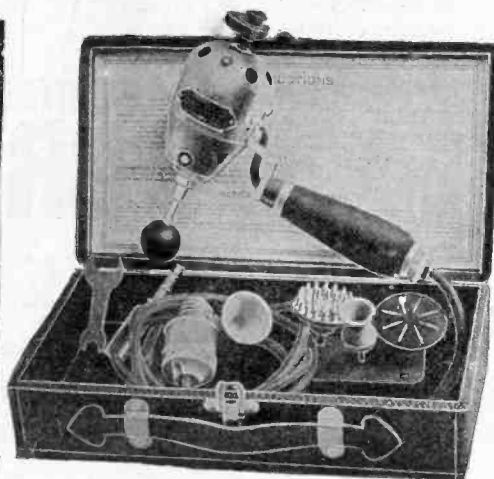

**ONCE THE AMERI-
CAN VIBRATOR**

is in your home,
you will never part
with it. Unlike
the so-called vibra-
tors sent you for
one week free trial
on approval, The
American is just as
good as new after
years of constant
use.

Made and Sold at a Price That Pays for Perfection, not Cheapness

No other vibrator nearly so good from a technical, medical or commercial viewpoint. There are a hundred reasons why the American Vibrator is best and should be in every home.

Send for our Free booklet and learn all there is to be known on the subject of vibrators and their uses.

CENTRAL STATION MANAGERS AND DEALERS—We are developing a remarkable distributive plan for your benefit. Write for details.

Southern Illinois Electric Company

ANYTHING ELECTRICAL

508-12 Missouri Ave.,

East St. Louis, Illinois

For our Mutual Advantage mention Popular Electricity when writing to Advertisers.

POPULAR ELECTRICITY



PROMOTED!

☐ Don't worry about the boss not having his eye on you and noticing the improvement in your work. Remember he is human—he is on the lookout for good men. His success, and the firm's depends on his ability to select the right man.

☐ If you are a little better than the other man—if you know more about your work than he does, do you suppose the boss will pass you by and boost the other fellow?

☐ You wish you had a better job. You wish you knew more, then you could do more and earn more. Fill in the blank form below and let us tell you how these wishes can be realized.

☐ Our advice, based upon the experience of our successful students and graduates will cost you nothing. It may start you right and change your whole future.

☐ The American School of Correspondence is an educational institution. We employ no agents or collectors. The merit of our work makes this unnecessary.

☐ Advice regarding the work you wish to take up and our complete Bulletin will be sent for the coupon. There's no obligation attached to this—mail it to-day.

WE HELP MEN HELP THEMSELVES

AMERICAN SCHOOL of CORRESPONDENCE
CHICAGO, U. S. A.

FREE INFORMATION COUPON

American School of Correspondence:
Please send me free your Bulletin of engineering information and advise me how I can qualify for position marked "X."

- | | |
|--------------------------|--------------------------------------|
| ... Electrical Engineer | ... Telephone Engineer |
| ... Draftsman | ... Heating and Ventilating Engineer |
| ... Civil Engineer | ... Plumber |
| ... Mechanical Engineer | ... Architect |
| ... Stationary Engineer | ... Hydraulic Engineer |
| ... Structural Engineer | ... Textile Boss |
| ... Municipal Engineer | ... Sheet Metal Pattern Draftsman |
| ... Railroad Engineer | ... College Preparatory Course |
| ... Structural Draftsman | ... Sanitary Engineer |

NAME
ADDRESS
OCCUPATION

P. E. 609.

For our Mutual Advantage mention Popular Electricity when writing to Advertisers.

POPULAR ELECTRICITY

THE SOUTHERN
ELECTRICAL AND INDUSTRIAL
EXPOSITION

will be formally opened at the
ARMORY in LOUISVILLE

BY

PRESIDENT WILLIAM HOWARD TAFT

who will press a button in Washington
starting the machinery on

MONDAY, APRIL 12, AT ONE O'CLOCK

For twelve days, April 12 to 24, there will be exhibited:

The product of the factories of the leading electrical concerns of the United States.

The product of the big industrial enterprises of the country and of the cities of Louisville, Jeffersonville and New Albany.

The product of the retail stores of Louisville, exemplifying the merchandising advantages offered by the merchants of the first city in the State.

Marconi's Wireless Telegraph.

Two concerts daily by Natiello and his band.

There will be scores of other attractions in booths, including an electric clock, the largest in the world, in a most brilliantly illuminated Armory.

To which the public is invited. The admission at the door will be 25 cents. For space apply to

A. TRACKMER, Secretary.

POPULAR ELECTRICITY

Are You Using Central Station Power?

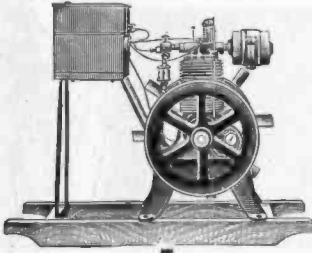

IF NOT—A WHITE LILY GAS ENGINE should be your first thought when you BUILD YOUR OWN POWER PLANT.

Stands up under the severest tests. Guaranteed free from imperfections in workmanship and material.

Let us give you the benefit of our Knowledge on Gas Engines when applied to Electric Power Plants.

Our 30 days' free trial, which is the only way our Gas Engines are sold—ought to convince you that the White Lily Gas Engine is the only Engine for your needs. We have data on Installing Power Plants which will interest you greatly.

White Lily Mfg. Co., 1549 Rockingham Road, Davenport, Iowa.

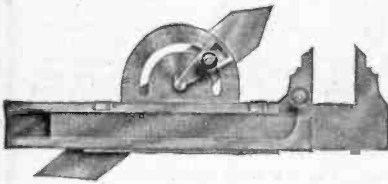

16 to 1.

FOR SALE AT ALL LEADING HARDWARE STORES, OR SENT DIRECT, POSTAGE PREPAID, **\$1.15.**

Wiet-Goethe Combination Gauge and Caliper Rule

You can carry more than sixteen ACCURATE TOOLS in your vest pocket.

Every High grade mechanic should have one of these tools.

Chicago Steel and Brass Works

1700 Fisher Building

Chicago, Illinois

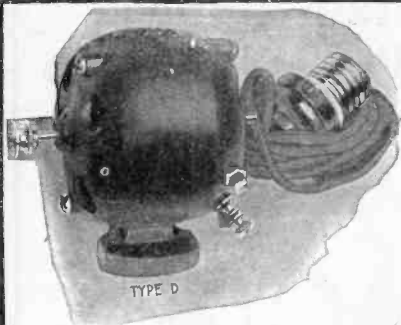

TYPE D, \$5 00 Express prepaid.

WIZARD TOY MOTORS

For alternating and direct current 110 volts—Just use your electric light socket—The most substantial and powerful toy motor on the market.

Wizard Motors operate on Any Light Circuit; simply hook into the light socket; plug and cord with every order. We make all kinds of Toy Motors. Write for Circular 27.

THE WIZARD COMPANY,

Cor. Dearborn and Randolph Sts. CHICAGO, ILL.

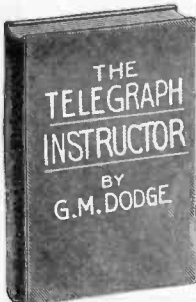

75c TO KNOW HOW TO BE A COMPETENT TELEGRAPH OPERATOR

Best "Plain English" treatise on the art of Telegraphy. The Demand Exceeds the Supply for good Operators, so be fit.

Regular price of Telegraph Instructor is \$1.00; for thirty days only we will send it to any address prepaid for only 75c.

POPULAR ELECTRICITY PUBLISHING CO., Monadnock Bldg., Chicago

For our Mutual Advantage mention Popular Electricity when writing to Advertisers.

POPULAR ELECTRICITY

DIAMONDS on CREDIT

20% DOWN — 10% PER MONTH

Why wait for your Diamond until you have saved the price? Why not have the use and pleasure of same immediately and pay for it by the Lyon Method? Lyon's prices are fully 20% lower than any others. Lyon's Diamonds are guaranteed perfect blue-white, imported in the rough, cut and polished here to save import duties and middlemen's profits. A written guarantee accompanies each Diamond. You have the option for exchange at any time at full purchase price. All goods sent prepaid for inspection. Send now—today—for our Catalogue No. 2., splendidly illustrated. *Established 1843.*



J. M. LYON & CO. • 71-73 NASSAU ST. NEW YORK

BUSINESS PROMINENCE SOCIAL SUCCESS WEALTH

The Master Key

Stop Forgetting MEMORY

My book: HOW TO REMEMBER, sent free to readers. It opens the doors of wealth and achievement with the master key that fits all locks.

"You are no greater intellectually than your memory"

There is nothing difficult about my method. You can study anywhere, at any time, in spare moments. I have taught more than 40,000 people how to remember. My method teaches you how to remember things you have seen, read and been told about, increases business capacity, income, social standing—also how to remember faces, names, business details, studies—develops will, concentration, personality, self-confidence, conversation, public speaking, writing, etc. Write today for free copy of my interesting book—"How To Remember"—and see how simple my memory training really is. Address

DICKSON MEMORY SCHOOL, 929 Auditorium Building, Chicago

HOTEL EMPIRE



WE OFFER YOU THE MOST DELIGHTFUL

HOTEL ACCOMMODATION AT MODERATE COST

BROADWAY, (LINCOLN SQUARE) AND 63D ST. **NEW YORK CITY**

All surface cars pass or transfer to door Subway and "L" stations, one minute

ALL MODERN IMPROVEMENTS

Rooms, with detached bath, . . . \$1.50 per day up
 Rooms, with private bath, . . . 2.00 " "
 Suites, with private bath, . . . 3.50 " "

W. JOHNSON QUINN, Proprietor

Steel Pulley for Power Houses

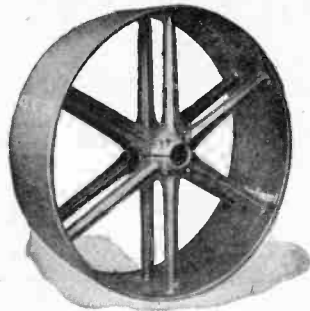

The Only Steel Pulley Made

that has sufficient structural strength to be made in large sizes and all sizes; have metal bushings so that they never slip on the shaft—all are split and are very easy to erect—being all metal, dampness does not effect them—are always in running balance.

We want to tell you more about this.

ONEIDA STEEL PULLEY CO.
 105 S. Clinton Street, CHICAGO, ILL.



24 HOURS OF DAYLIGHT

The "I" Comfort System of Indirect Illumination is the most practical and efficient method for **Lighting Halls, Offices, Assembly Rooms, Residences, Etc.**

This system affords a nearer approach to daylight than any other method of artificial illumination, yet it involves no greater current consumption than for the direct lighting systems in general use. One 100-Watt Tungsten lamp is ample for a room like the above—15 feet square, with light ceiling and dark walls. 1200 installations giving perfect satisfaction. Write for our testimonials. Our new catalog contains information of direct value to you. A line to

**C
O
M
F
O
R
T
S
Y
S
T
E
M**

us will put you in touch with greatest idea of up-to-date illumination.

National X-Ray Reflector Co. 247 E. Jackson Boulevard, Chicago.

THORDARSON'S WIRELESS TRANSFORMERS

High Potential or step-up transformers, as powerful as a 10-inch induction coil, for wireless telegraphy, charging condensers, ozone generators and other experimental purposes. 250 watt capacity.

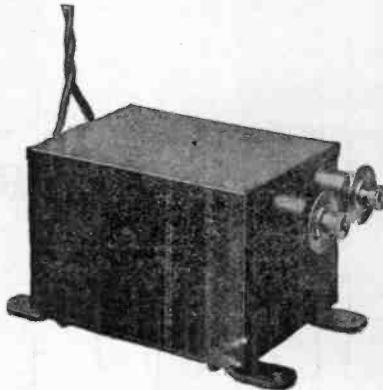

Can be run from any alternating current lamp socket.

We are equipped to furnish transformers up to 100 K. W. capacity. Any secondary voltage desired. Quotation on request.

Cash Price, \$22.00

Thordarson Electric Mfg. Co.
151-157 South Jefferson Street, CHICAGO.

Let Us Send YOU A **Monarch Vibrator** ON APPROVAL

Guaranteed to be the most powerful, durable and practical vibrator of its size made.

These vibrators contain complete, perfect **Electric Motors**, and are made to run on their own dry cells or to attach to electric light socket like a lamp. Fully adapted to professional requirements, yet the **most economical and satisfactory for home use**. Light, compact, noiseless; motionless handle. To prove our strong claims for the **Monarch**, we send it prepaid **TO TRY FREE**

Don't buy a vibrator without careful consideration of every one of the above points, including scope of guaranty.



For Beauty

intended perfections. Helps to restore to nature's intended perfections. Removes wrinkles and facial blemishes. If too thin, it brings the blood and develops fullness of the neck, arms or deficient parts, by building new flesh. If too stout, it brings the blood to wash away adipose tissues. Splendid for the scalp, for the complexion and after shaving. Prevents dandruff, irritation, falling hair, baldness.



For Health

Furnishes passive exercise to parts which suffer from congestion, the cause of all disease, bringing the rich, purifying blood in quick response to its swift pulsations, and restoring normal functions. Soothes excited nerves and brings sweet, refreshing sleep.

Let us send you a vibrator, prepaid, without a cent in advance, so that you may know for yourself the wonderful benefits of vibration when given by a high grade machine. Liberal allowance for old machines in exchange. Our new Book, "Health and Beauty Without Medicine," with illustrations from life, FREE. Write to-day. Address

MONARCH VIBRATOR CO., 544 Security Building CHICAGO, ILLINOIS

LET US SEND YOU THIS IRONER FOR 30 DAYS' FREE TRIAL



to convince you that the "Simplex" will do your ironing better than any laundress can do it by hand in 1-5 the time without tiring effort. The ironer cost only 1½ cents an hour to heat.

It is furnished to operate by hand or power. Write today for our booklet that tells you more about it.

AMERICAN IRONING MACHINE COMPANY, 30 Lake St., Chicago

Do You Want to Be WELL?

Do you lack that vigor and strength that comes with abundant health? Need of vitality causes most disease. ELECTRICITY will give you better blood and splendid regular circulation—fresh energy—NEW LIFE. Don't depend on drugs.

THE NEW



Wireless Battery

(Electricity in Tabloid Form)

is the new invention that physicians use and prescribe because it is compact, simple, safe and DEPENDABLE. A Pocket Battery in a polished metal case—no wires, cords, plugs or liquids—just fits the hand. Small but potent, lasts a lifetime and cannot get out of order.

INVALUABLE FOR RHEUMATISM, NEURALGIA, ASTHMA, INSOMNIA and all nervous troubles and diseases caused by sluggish circulation.

BEAUTY MASSAGE and ELECTRIC BATHS administered by means of the WIZARD WIRELESS are effectual, pleasant and enjoyable. The finest natural complexion beautifier ever discovered. Healthy, active skin is necessary to both health and beauty.

FOR HAIR AND SCALP a special electric brush goes with every Wizard Wireless. Better than gallons of tonics—clean, quick and easy to use.



Will You Try One Free?

We have a special offer to make responsible people. WRITE TODAY for our free approval plan and our new booklet on Home Treatment.

The Genesee Electric Mfg. Co.
106 Sterner Bldg., FLINT, Mich.

Let Us Tell You

WHY

The Electric Fire Place is

Convenient,
Safe, Clean
and Economical.

Install it
anywhere

No chimney
needed.

Write now
for catalog.



RATHBONE & PANIGOT COMPANY

Patentees and Sole Makers

Grand Rapids - - Michigan

THE "National"

A
PORTABLE
VACUUM
CLEANING
MACHINE

combining efficiency, practicability and economy. Can be attached to any electric light socket.

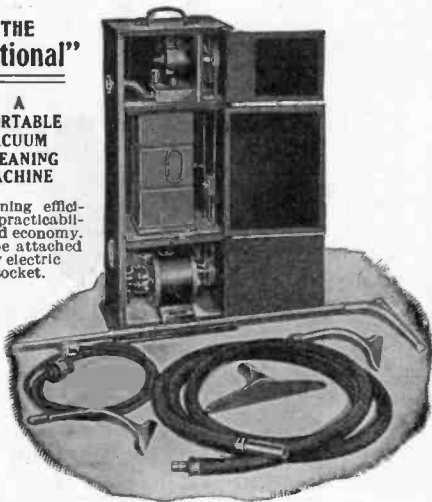

EFFICIENT Because it thoroughly accomplishes its purpose.
PRACTICAL Because of its simplicity and compactness.
ECONOMICAL Because of its minimum cost of maintenance and operation.

Growing concerns and responsible parties wanted for agents. (Exclusive territory given. Price Complete \$100.00. Send for Catalogue and Particulars

NATIONAL VACUUM COMPANY
30 Broad Street, " " NEW YORK

Don't Take Chances

with so-called electric washing machines still in the experimental stage.

We have been making an excellent line of Cylinder Washing Machines ever since 1903. If you buy the

SANITARY PARAGON Electric Washer and Wringer

(Made of Metal Throughout)

you are certain of a *reliable* machine which embodies all the essential features of *durability, efficiency and service.*

The **Paragon** is conceded by laundry experts and leading engineers to be the Acme of Perfection and mechanical ingenuity.

Before buying any washer do not fail to send for our illustrated Catalog A14.



1909
Model

**PARAGON
MFG. CO.**

3619-23 Ashland Ave.
CHICAGO

ELECTRICITY

Did you ever stop to think just how much has been accomplished with this "something of which we know so little."

It is only lately that public attention has been directed to its value as a curative agent especially in such diseases as

**RHEUMATISM LUMBAGO
NEURALGIA SCIATICA**

and the results that have been accomplished have astonished even the most sanguine.

As a result of the study and investigation which this Company has been making under the direction of Expert Electro-therapists, we have been able to place on the market

ELECTRO-ROL

a perfect combination of Faradic electricity and Vibration or massage.

The Electro-Rol is *so simple* that a child can use it without danger, *so effective* that Physicians and Masseuse have adopted it in their practice, and the price is so reasonable that it is within the reach of every family.

We want to send YOU our booklet and Body chart so you will know more about the Electro-Rol and what it will do for you in pain or sickness. A postal will bring our reply.

OLIVER MFG. CO. Inc. 1021 Walnut St., PHILADELPHIA, PA.

The Plunket Jr.

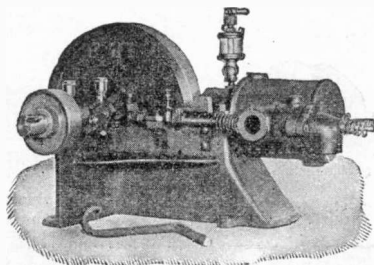

A HIGH-GRADE, HALF HORSE POWER GAS ENGINE.

Weight 68 lbs. Water Jacketed Four Cycle
For Laboratory, Shop or Home, efficient, simple,
durable

(Equal to two extra men about the place)

Perfectly governed so a wide range of speeds is always at operator's command.

Use City Gas, Natural Gas, Gasoline, Alcohol.

Send for catalogue and prices

J. E. PLUNKET

47-49 So. Jefferson St.

CHICAGO

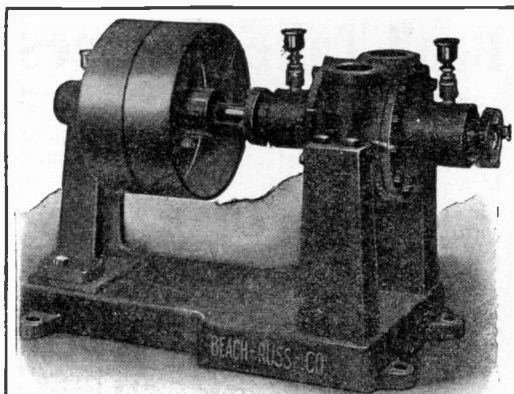

DIRECT-CONNECTED SLOW-SPEED ROTARY ELECTRIC PUMP

Automatic, silent, primes itself, has positive action on the water. Will pump any liquid that is free from grit. Arranged with tank switch to control operation, starting when tank is two-thirds empty and stopping when water is at proper level. A most durable pump, all wear being easily taken up. For use in Tanneries, Laundries, Dyers, Hotels, Institutions and Private Houses.

Let us quote you on Rotary Pumps for all purposes, Vacuum Pumps, Pressure Blowers, Blower Burners, Flat Irons.

BEACH-RUSS CO. 214 Fifth Ave., Chicago.

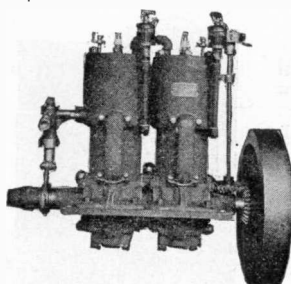

Marine Gasoline Engines

From 1½ to 15 H. P.

3 H. P. Engines, complete with Boat Fittings, (no tank or pipes), \$59.00.



Sterling Engine Company

29 South Clinton Street
CHICAGO, ILL.

**THE WIZARD
MESSAGE VIBRATOR**

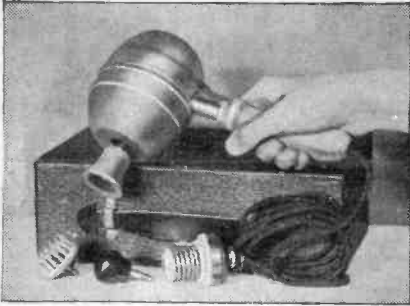

Better than most Vibrators selling at three times its price.

Investigate the "Wizard" before purchasing other makes Operates on both Alternating and Direct Current 110 Voltage. Has the switch in the handle.

Aluminum Case, Maple Handle. Green Silk Conductor Cord. Scalp, Face, and Body Applicators.

Small and neat leatherette covered case.

WE ALLOW EVERY DEALER A GOOD PROFIT.
Price, \$7.50.

The Wizard Co., Chicago.

SPECIAL SALE

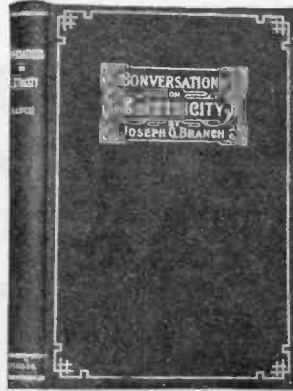

**Conversations in
Electricity**

By JOSEPH G. BRANCH, B. S., M. E.

The author deals with the subject of electricity in a clear and *elementary* way, in order to familiarize the student with the *Principles* of electricity before attempting to show how these principles are applied in practical work.

The book is written in dialogue form, thus giving a vivid idea of the subject and leaving a strong impression on the mind of the reader.

Special attention is paid to the alternating current, its generation and application, owing to its daily increasing use.

The book contains 282 pages, with 105 illustrations, and is strongly and handsomely bound in green cloth, gilt embossed.

A valuable addition to any library. Your list of electrical books is not complete without this volume.

Regular Price - - - - \$2.00

Special, one month only, \$1.75

Don't miss this offer.

Popular Electricity Pub. Co.

Book Dept.

Monadnock Bldg., Chicago

We Cure Eye Troubles



SEND FOR OUR **Free Eye-Book** THEN TREAT YOUR OWN EYES

It doesn't matter what your eye trouble is, or how serious or chronic it may be, this great Eye-Book will show you how to treat your own eyes at home. No Knife. No pain. No trouble. Not necessary to see a doctor.

Our book about eyes sent free, tells all about it; things you ought to know, but which your doctor has never told you, and contains letters from many who have been cured.

A postal card will get the book and we will give you our free advice if you will write us a short description of your case.

Write now while you think about it. Address

North American Eye Specialists

2477 North American Building

CHICAGO, ILL.

3 Years to Pay

for the celebrated

Meister PIANO



The best piano in the world at \$175

\$1 Weekly or \$5 a Month

No cash payment down. No interest.
No freight charges. No extras.

30 Days Free Trial

In Your Own Home
and We Pay the Freight

We want you to sample this piano for a month to convince you that it is the best piano in the world at \$175. We guarantee a saving of \$100 or more on each instrument. Rothschild 10-year guarantee bond with each piano.

We don't want a cent from you until you are satisfied. If you don't want the piano we will send for it. We own the Meister Piano Co. outright, and instead of paying 30% to 40% commission to agents we

Sell Direct from Factory to You

Send now for the Meister Piano Book. It's FREE. It shows all grades of Meisters, \$175.00 \$225.00, \$255.00 and \$285.00. Beautifully done in colors. A postal card will bring it.

ROTSCHILD & COMPANY

303 State Street, Chicago, Ill.

ELDREDGE ELECTRIC MFG. CO.

MANUFACTURERS OF

**ELECTRICAL
MEASURING
INSTRUMENTS
& SPECIALTIES**

26 P. O. Square,
SPRINGFIELD, MASS., U. S. A.



Just Turn The Faucet



and have the week's wash done in one-half the time, by water pressure.

No backaches or wash women! The "SIMPLEX" works perfectly on 20 lbs. or more. A real convenience. Sold complete or separate. Motor to be attached to your hand machine for \$12.50.

AGENTS—Is motor sells because it washes clothes. Buy proposition; nothing like it. Women will like it. Send for booklet and state territory desired. Now's the time.
SIMPLEX WASHER CO., Milwaukee, Wis.

WANT A BARGAIN? GET THIS!

Electrical Railroading as applied to Steam Railways by Sydney Aylmer Small. 924 pages. Fully illustrated. Handsomely bound in black leather, gilt embossed. A GREAT BOOK. Complete, authentic. Regular price, \$2.50. A few copies only slightly shelf worn (hardly noticeable) for \$1.90 while they last.

Popular Electricity Publishing Company, Book Dept.,
Monadnock Block, CHICAGO, ILL.

LEARN TELEGRAPHY

Start right. Get *The Telegraph Instructor* by C. M. Hodge. Best "Plain English" treatise on the art ever published. For beginners or practical men. 260 pages. Fully illustrated.

Regular price \$1.00. Special till May 15 only, 75c prepaid.
POPULAR ELECTRICITY PUBLISHING CO.
Book Department Monadnock Block, Chicago, Ill.

A SHINE FOR A GENT

If you have a little capital and want to establish yourself in a profitable, permanent and substantial business, write us at once about our

Electric Automatic Shoe Polisher



A practical, effective coin operating shoe cleaner and polisher. Can be installed in stores, depots, public places, in fact any where. Unsurpassed money-maker. Draws trade wherever installed.

COST OF OPERATING, 1c PER
100 SHINES

Not a cheap penny slot machine, but a practical necessity in a class by itself.

ORGANIZERS & AGENTS WANTED with some capital for local operation. **BIG PROFITS.**

ACT QUICKLY:

WRITE US TO-DAY

ELECTRIC SHOE POLISHER CO.
1314 Great Northern Building, Chicago

PATENTS = PATENT ATTORNEYS

PATENTS Secured Promptly and with special regard to the legal protection of the invention
HAND BOOK FOR INVENTORS AND MANUFACTURERS SENT FREE UPON REQUEST

C. L. PARKER, Patent Lawyer

Patents, Caveats, Trade Marks, Copyrights, Reports as to Patentability, Validity and Infringement.
 Patent Suits Conducted in all States.

REFERENCES: American Tire Co., Automatic Vending Machine Co., Lippincott Pencil Co., International Ore Treating Machinery Co., Globe Machine and Stamping Co., Metal Manufacturing Co., Builders Iron Foundry, Morgan Machine and Engineering Co., Berkshire Specialty Co., Stewart Window Shade Co., Macon Shear Co., Acme Canopy Co., Oaks Manufacturing Co., Cox Implement Co., Columbus Buggy Co., National Index Co., Handy Box Co., Iron-Ola Co., By-Products Chemical Co., Alabama Brewing Co., National Offset Co., Antiseptic Supply Co., Floor Clean Co., Fat Products Refining Co., Richmond Electric Co., Railway Surface Contact Supplies Co., National Electric Works, Modern Electric Co.

Mr. Parker on November 1, 1903, after having been a member of the Examining Corps of the U. S. Patent Office for over five years resigned his position to take up the practice of patent law.

Address 12 **McGILL BUILDING** - - - - **WASHINGTON, D. C.**

Samuel G. McMeen Kempster B. Miller

McMeen & Miller

Patent Solicitors and Patent Experts

In connection with our telephone engineering practice we make a specialty of securing electrical patents for inventors, and of giving expert advice in patent matters. We also have facilities for marketing meritorious electrical inventions.

1456 Monadnock Block,
 CHICAGO

787 Market Street,
 SAN FRANCISCO

PATENT SENSE

and PATENTS THAT PROTECT
 yield our clients enormous profits. Write us for PROOF. Inventors lose millions through worthless patents. E. S. & A. B. LACEY,
 Dept. 52, Washington, D. C. Estab. 1869.

THE INVENTOR'S UNIVERSAL EDUCATOR
 TELLS ALL ABOUT PATENTS,
 HOW TO SECURE THEM. HAS

600 MECHANICAL MOVEMENTS
 also 50 PERPETUAL MOTIONS

Every inventor should have a copy. Price \$1.00 by mail.
 Address _____

F. G. DIETERICH, Uray Bldg., Washington, D. C.

PATENTS SECURED. Inventor's Pocket Companion free. Send description for free opinion as to patentability. W. N. Roach, Jr., Metzertott Building, Washington, D. C.

PATENTS

are the greatest source of profit; patent your idea before someone else does; a valid patent, granting as it does, a monopoly is an excellent business foundation; it is also a salable piece of property. I have constant demand for good patents; inventors with good practical ideas write. I will patent and market your inventions. **BOOK FREE.**

SANDERS, 115 Dearborn St., Chicago Ill.

PATENTS

TRADE MARKS AND COPYRIGHTS
SECURED OR FEE RETURNED

Send model or sketch and description of your invention for free search of the U. S. Patent Office Records.

Our Four Books mailed Free to any address. Send for these books; the finest publications ever issued for free distribution.

HOW TO OBTAIN A PATENT

Our Illustrated 80 page Guide Book is an invaluable book of reference for inventors and contains 100 mechanical movements illustrated and described.

FORTUNES IN PATENTS

Tells how to invent for profit and gives history of successful inventions.

WHAT TO INVENT

Contains a valuable list of inventions wanted and suggestions concerning profitable fields of invention. Also information regarding prizes offered for inventions, among which is a

PRIZE OF ONE MILLION DOLLARS

offered for one invention and \$10,000 for others

PATENTS THAT PAY

Contains fac-similes of unsolicited letters from our clients who have built up profitable enterprises founded upon patents procured by us. Also endorsements from prominent inventors, manufacturers, Senators, Congressmen, Governors, etc.

WE ADVERTISE OUR CLIENTS' INVENTIONS FREE in a list of Sunday Newspapers with two million circulation and in the *World's Progress*. Sample Copy Free.

VICTOR J. EVANS & CO.

(Formerly Evans, Wilkens & Co.)

Main Offices, 615 "F" Street, N.W., Washington, D. C.

PATENTS THAT PROTECT AND PAY

Advice and Books Free. Rates Reasonable. Highest References. Best Services.

WATSON E. COLEMAN, Patent Lawyer
 612 F St. N. W., WASHINGTON, D. C.

POPULAR ELECTRICITY

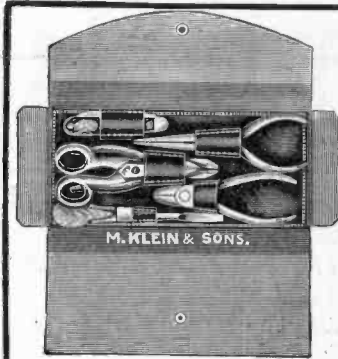

No. 403 K

KLEIN'S

Now Electrician's
Pocket Tool Kit

This tool-kit contains a selection of Klein tools such as have been found indispensable to the practical telephone man. It is of convenient pocket-book style, with a firm metallic clasp. Send 3c in stamps for 65 page catalogue. Special prices quoted on request. Write for new catalogue.

**Mathias Klein
& Sons**

Sta. U. 3, Chicago, Ill.

A Battery Bargain

A 6 Volt, 60 Ampere Storage Battery
GUARANTEED 1 YEAR

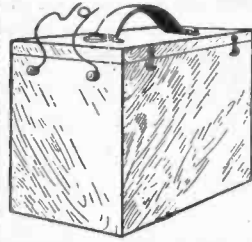

\$9.75

Selling regularly
at \$22.50

S. BREAKSTONE

900 Fisher Building
CHICAGO, ILL.

ELECTRICITY
Practically and Individually
TAUGHT

Our pupils actually handle the tools and machinery.—Instructors stand beside them, directing, criticising and showing them how to work.—Day and Evening sessions.—Call and inspect our school and equipment or write for prospectus.

New York Electrical School
36 West 17th Street, New York

OSTER No. 1 1/2 A DIE STOCK



Cuts 1/2, 3/4, 1, and 1 1/2 inch Pipe or Conduit.
Right or left, or both.

Can be set for over or under size as easily and quickly as standard.

Ask for price delivered.

THE OSTER MFG. CO.

2180 East 61st Street

CLEVELAND, O.

**Fractional Adding and
Subtracting Rule**
Price
\$1.00

A practical, useful and time-saving device for students in engineering schools, machine designers, mechanical and civil engineers, etc. Adds and subtracts fractions for you, eliminating tiresome figuring and insuring absolute accuracy. You can't make a mistake. Full directions for using. Your money back if not in every way satisfactory. Endorsed by leading instructors in mechanical schools, and by practical mechanical men in all fields. Send today. Price \$1.00. Address

BURGESS & SAUERBERG
801 Kortlander Building GRAND RAPIDS, MICH.

ELECTRICAL HANDBOOKS 10 CENTS EACH

- 1 How to Make a Dynamo.
- 2 How to Make a Telephone.
- 3 How to Make an Electric Motor.
- 4 How to Make a Storage Battery.
- 5 How to Make a Wilmshurst Electric Machine.
- 6 How to Make a Magneto Machine.
- 7 How to Make a Medical Induction Coil.
- 8 How to Make a Pocket Accumulator.
- 9 How to Make a Plunge Battery.
- 10 How to Make a Voltmeter.
- 11 How to Make a Galvanometer.
- 12 How to Make a Hand Dynamo.
- 13 How to Make a Talking Machine.
- 14 How to Make a 1-8 H. P. Dynamo or Motor.
- 15 How to Make a Toy Motor.
- 16 How to Make an Electric Bell.
- 17 How to Make a Telegraph Instrument.
- 18 How to Wind Armatures.
- 19 How to Wind Field-Magnets.
- 20 How to Make an Ammeter.
- 21 How to Make a Thermostat.
- 22 Motor Rotation.
- 23 How to Make an Electric Soldering Iron.
- 24 How to Make a small Electric Heater.
- 25 How to Make an Electric Furnace.
- 26 How to Make Hand Feed Arc Lamp.
- 27 How to Make a Jump Spark Coil.
- 28 How to Make a Rheostat.

All Books ILLUSTRATED with Working Drawings.

E. BUBIER PUBLISHING CO., - LYNN, MASS

ACCURATE, COMPACT, INEXPENSIVE



**Voltmeters
Ammeters and Volt-Ammeters**

Send for complete Catalog No. 14 of portable and switchboard types, with directions for testing.

L. M. PIGNOLET, 78 Cortlandt Street, NEW YORK



Robert Pocket Meters

For general battery testing
Dead-Beat Accurate, Durable, Guaranteed
Send for Catalogue

Volt-Ammeters
0-3 Volts, 0-30 amperes, \$6, incl. 1'th'r case
0-6 Volts, 0-30 amperes, \$6, " " "
0-12 Volts, 0-30 amperes, \$6, " " "

Ammeters
0-30 amperes, incl. 1'th'r case

Volt-Meters
0-3 Volts, - - - \$4, incl. 1'th'r case
0-6 Volts, - - - \$4, " " "
0-12 Volts, - - - \$4, " " "

ROBERT INSTRUMENT CO.
68 Shelby St., Detroit, Mich.

ELECTRICIAN @ MECHANIC

is a magazine which will help you. It is a practical monthly for every one who wants to learn about electricity, or who uses tools. Its articles tell you how to make dynamos, engines, wireless telegraph apparatus, furniture, models, etc. It is the only magazine of its kind in the world.

EDITORS

FRANK ROY FRAPRIE, M.Sc.Chem. Prof. A. E. WATSON, E.E., Ph.D.
M. O. SAMPSON

REGULAR FEATURES

Electricity. Practical and simple articles on electrical science, new applications and history, all illustrated. How to make dynamos, motors, batteries, all kinds of electrical apparatus. How to wire for bells and electric lights, install telephones, etc.

Mechanical Articles. How to use lathes and machine tools. How to use tools of all kinds. Forging, metal working, soldering, brazing, plating, etc. How to build gas engines, steam engines and other machines. All about gas engines and flying machines. Illustrated articles on everything new in mechanical progress.

Woodworking and Manual Training. How to build mission furniture. Wood finishing, staining, polishing, etc. Woodwork joints and cabinet making. How to make useful and handy articles of wood. Mechanical drawing, etc.

Wireless Telegraphy and Telephony. Full information of all that is new in wireless. Any one can build a wireless station from our descriptions. Our Wireless Club has nearly a thousand members in America and even beyond the seas.

*All articles written in simple language for everybody to read. \$1.00 a year. Three months' trial, 20c.

SPECIAL THIRTY DAY OFFER

For Thirty Days Only, or until our stock of back numbers is exhausted, we offer twelve back numbers and a full year's subscription for \$1.35. Money orders only; no stamps accepted.

Sampson Publishing Company. 1140 Beacon Building
BOSTON, MASS.

Success Is Within Your Reach



The unprecedented demand prompted the Publishers to issue a popular paper bound pocket edition of this dollar book to sell at 10 cents per copy, 104 pages, 16 chapters. It is practically a text book and should be the seed to a fortune to the man or woman with brains and earnestness of purpose, desirous of accumulating money. More individuals owe their financial success to the laws contained in this book than to any other known source.

MONEY IS THE BEST PARTNER

a man can have, and the best friend a woman can have. It will work for you through health and sickness and stand by you through thick and thin. If you are unable to accumulate money, if your money is idle, if you want it to earn more than savings bank interest, if you want to invest it safely and profitably, or if you want to improve your financial condition generally, you should secure this book without delay and learn the laws governing financial success.

The Book is plainly written, easily understood, and deals with

The definition of money and its uses.

The exercise of judgment in making investments.

How to develop the qualities essential to financial success.

How to create and realize the desire for better financial circumstances.

You cannot afford to be without this book, as it places within your own hands the means of starting you on the road to a broader career and financial independence.

Regular edition, bound in limp leather, silk lined, \$1.00 per copy. Special paper bound edition, 10 cents per copy, mailed post paid on receipt of stamps or silver.

How to guide your ambition and utilize your latent abilities.

How to concentrate upon your aim, and persist until you achieve it.

How to make money safely and judiciously, etc., etc.

SEND YOUR ORDER NOW

The Fiduciary Company, Publishers,

965 Tacoma Building, CHICAGO, ILL.

For our Mutual Advantage mention Popular Electricity when writing to Advertisers.

POPULAR ELECTRICITY



Wm. H. Crane



Mable Hite



David Warfield



E. S. Willard



Cecil Lean



Florence Holbrook



W. W. Hinshaw



Trixie Friganza



Joseph Sheehan



Frank Gotch



John Kling

THESE 22 STARS

And many more use and endorse the Swedish Electric Vibrator.

Copy of letters from them stating what it has done for them mailed FREE to any address.

This Vibrator is a **Gymnasium, a Physician, a Beauty and Health builder and Youth Restorer, all in one.** It gets right down to the centers of **Natural Stimulation and Revitalizes you Permanently.** No bad after effects as with drugs. It **Reaches the Nerve Basis,** increasing the flow of **Nervo Fluids.** It **Exercises, Strengthens, Revitalizes,** gives **New Energy, Soothes and Rests** you, all at the same time, by reason of its wonderful **50,000 Penetrating Vibrations** per minute and its **Perfect Rhythm.**

"HEALTH, STRENGTH, ENERGY ARE CONDITIONS OF HARMONIOUS VIBRATION." "Disease is interrupted or discordant vibration."

The Swedish Electric Vibrator will give you the **Perfect Rhythm** of health. It will **Unclog** the bowels in **Two Minutes.** It will **Recharge, Revitalize and Re-energize** a fagged man or woman. A few touches with the Vibrator will **Cure Any** headache. It will touch the morphic nerve and soothe the most restless to sleep.

It will **Bring** the bloom of youth to faded cheeks—**The Kind That Won't Come Off.**

It will loosen the scuff and dandruff, cause the hair cells to resume **healthy** action; **Brings** the life-giving blood to the scalp and apparently **Resurrects** the dead hair cells and follicles as **Plenty of New and Glossy Hair** is the result.

It will cure **any** case of Rheumatism.

It will do and cure a thousand and one things that we would like to tell you **How** it does and **Why.** Don't be skeptical. Write us about **Any** ailment or condition and we will give you free advice **JUST HOW** to effect a cure or **Correct** a condition.

We have a **Book** of many pages, **Illustrations, Charts, Diagrams** and Instructions in **Plain English** which we will mail **Free** to any address.

OUR DIAMOND MEDAL Vibrators are operated by batteries or electric light current. The most **Efficient and Powerful** Vibrator of **Any** size or price. The **Only** Vibrator with a **Perfect Rhythm.** A Vibrator without a Rhythm is like a ship without a rudder.

GUARANTEED FOR FIVE YEARS. PRICES Within the Reach of All.

SWEDISH ELECTRIC VIBRATOR COMPANY

502-640 Farragut Avenue, CHICAGO, ILL.

For our Mutual Advantage mention Popular Electricity when writing to Advertisers.

POPULAR ELECTRICITY



Elsie Janis



Kyrle Bellew



Mabel Taliaferro



Joe Weber



Battery Current Operated Vibrator for use where electric light current is not available. Batteries and all come in this portable case.



Showing Battery Vibrator and fine point Applicator.



Julia Sanderson



Showing Vibrator proper with Vacuum Cup Applicator.

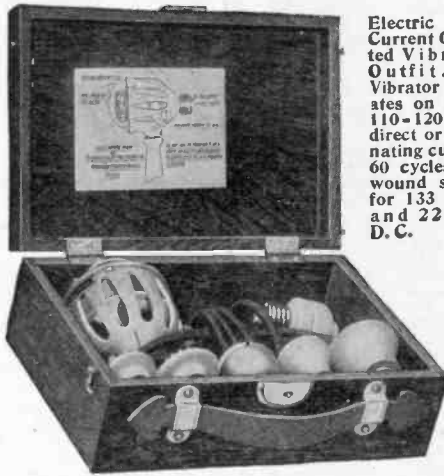

Electric Light Current Operated Vibrator Outfit. This Vibrator operates on either 110-120 volts, direct or alternating current; 60 cycles also wound special for 133 cycles and 220 volt D. C.



Harry Bulger



Camille D'Arville



O. Overall



Mordecai Brown



Frank Chance



Michael Donlin

For our Mutual Advantage mention Popular Electricity when writing to Advertisers.

Webster's New \$8.50 Encyclopedic Dictionary FREE with each of the First Hundred Orders!

MAGNIFICENT 1909 EDITION OF THE

New Americanized Encyclopedia

First in Wealth of Learning, First in Weight of Authority, Latest in Date of Publication

Fifteen massive volumes, sumptuous binding; 10,000 double-column pages, 100 superb maps, 37,000 biographical references, hundreds of illustrations, colored plates of the rarest beauty



"An intellectual ocean whose waves touch every shore of thought."

\$1.00 Secures the Set.
Sent Free for Examination

A Home University
A College Education
A Huge Library

The King of All Encyclopedias, at Prices Never Before Approached

You have always meant to get an encyclopedia—every intelligent man does. NOW IS THE TIME. The possession of this latest and greatest of all ENCYCLOPEDIAS puts you ten years ahead of your less enterprising neighbor. Other books tell you about ONE thing; this tells you about EVERYTHING. It covers every phase of human knowledge, discovery, experience, and belief. All gallant deeds and stirring scenes, all victories of brain or brawn, all marvels of science and invention, all the glorious achievements that have made history luminous and civilization possible are found in the 10,000 teeming pages of these splendid volumes. Can YOU afford to do without it?

Its Matchless Authority. The most brilliant thinkers of the century are enrolled as its contributors. Its writers include such men of world-wide fame as Matthew Arnold, James Bryce, John Morley, Andrew Lang, St. George Mivart, Canon Farrar, Edmund Gosse, John Stuart Blackie, Leslie Stephen, Edward Freeman, Lord Kelvin, Robertson Smith, Sir Norman Lockyer, Thorold Rogers, Saintsbury, Swinburne, Simon Newcomb, John Fiske, Cardinal Gibbons, John Bach McMaster, Admiral Melville, Thomas B. Reed, Carroll Wright; and these, with hundreds of others equally famous, give it an authority so overwhelming, so incomparable, that it reigns without a rival in the realm of scholarship.

Special Half Price Offer. To emphasize the issue of the 1909 edition of this magnificent work, we are making, for a limited time only, a special introductory offer at just ONE-HALF the regular price. The cloth set we price at \$37.00, the half morocco at \$46.00. Moreover, with each of the first hundred orders to reach us we will send absolutely FREE Webster's Huge New Encyclopedic Dictionary, retailing regularly at \$8.50. It is bound in full sheep, marbled edges, gold stamped and indexed. This combination of the world's most famous Encyclopedia and equally famous Dictionary gives you a magnificent reference library of enormous extent and unmatched value.

Send No Money Now. Sign and mail the attached coupon and we will ship you a complete set for five days free examination. You can return them AT OUR EXPENSE if they fail to give you entire satisfaction. We pay all transportation charges. Should you decide to purchase them, then send us \$1.00 as first payment and pay the balance at the rate of \$2.00 per month for the cloth and \$2.50 per month for the half morocco.

Do Not Delay. At these phenomenal prices the introductory sets will vanish like magic. It is the opportunity of a lifetime. Enrich your mind, adorn your library, delight your family with this stupendous work.

WRITE TODAY. Remember. No risk! No obligation!
You purchase only if satisfied.

The Booklovers' Society

156 Fifth Ave.
New York City

NAME.....

ADDRESS.....

If you prefer the cloth edition, alter \$46.00 to \$37.00 and \$2.50 each month to \$2.00.

P. E.
Apr. '09

THE
BOOKLOVERS'
SOCIETY
156 Fifth Avenue,
New York

Please send me for examination prepaid a complete set of the New Americanized Encyclopedia in half morocco binding at your SPECIAL HALF PRICE offer of \$46.00. If the set is satisfactory, I agree to pay upon the purchase price the sum of \$1.00 in cash within 5 days after receipt of goods and \$2.50 each month thereafter for eighteen months. Title to remain in The Booklovers' Society until full purchase price has been paid. If the books are not satisfactory, I am to notify you promptly and hold them subject to your order. Also send me Webster's New Encyclopedic Dictionary, which I am to receive absolutely FREE should I retain the set.

**THE KIMBLE VARIABLE SPEED
SINGLE PHASE A. C. MOTORS**

Send for Catalogue R

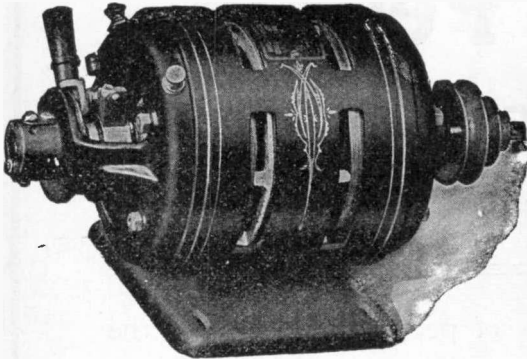

- 1/2 H.P., 110 Vts., 60 Cycle.....\$27.00
- 1/2 H.P., 110 Vts., 60 Cycle..... 50.00
- 1 H.P., 110 Vts., 60 Cycle..... 60.00

All Motors Guaranteed 2 Years.

KIMBLE ELECTRIC CO.

617 West Adams Street
CHICAGO



A Testing Set

Anyone Can Operate Tests and Locates all troubles in Telephone and Telegraph lines, Cables, Switchboard, Instruments, etc.

Write for information
MIDDLETON BROS.
Electrical Testing Instruments
1861 Monadnock, Chicago

**FRY
DRAUGHTING
TABLES**

For years Fry Patent Draughting Tables have been the standard. There are none better at any price. Style B shown in the illustration is very complete, with foot rest, swing instrument drawer and sketch box. Has adjustment for attaching to either side. The top can be raised without raising frame. Suitable for sketch, perspective and careful work. When not in use folds up and can be set in small space. Made durably from best material; iron standards adjustable to desired height. Write to-day for descriptive matter our entire line of draughting-room furniture. The quality and price is right.

FRITZ MFG. CO., 93 Alabama St., Grand Rapids, Mich.

**Send for one of these
32-Page Books To-Day**

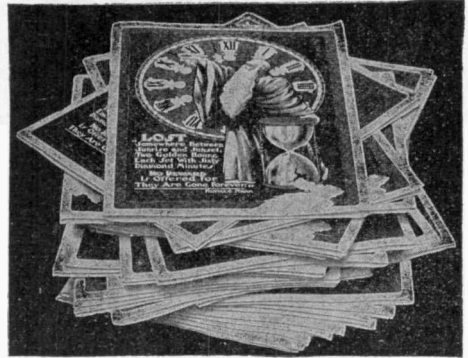

Our Booklet No. 80 contains valuable information for every person interested in Inter-communicating Telephones and Private Branch Exchange Systems for use in—
HOME — OFFICE—FACTORY
BANK — HOSPITAL — HOTEL



“QUALITY APPARATUS”

We make the greatest variety of Telephones for any kind of service and Switchboards for any size system. Consult us regarding any telephone requirements.

Ask for Booklet No. 80—Second Edition
Sent free upon application to either office.

**STROMBERG-CARLSON
TELEPHONE MFG. CO.**

CHICAGO, ILL. KANSAS CITY, MO.

There are over 1,100,000 “S-C” Telephones in use

150,000 People— Attended the ELECTRICAL SHOW at Chicago Last Year

THIS throng was made up of people interested in the development of electricity; particularly from the consumer's standpoint.

The development of this marvelous force together with the great strides made in the manufacture of electrical accessories used in the home, in the office, in the factory and on the farm, has made it vitally important that the manufacturer of electrical accessories, the jobber and the supply house should be interested and support the Electrical Show which takes place in Chicago next year.

It is the general opinion that all who have exhibited at this show have received benefits which they could never have secured in any other way. The public has become interested in the exploitation of their products to the extent that the demand made upon the manufacturer to supply the consumer of electric current has been greater than ever before.

The location for exhibitors in the Coliseum is a vital point in the success of their exhibit. By reserving space considerably ahead of time you will be able to secure your desired position in the hall.

Electrical Trades Exposition Company
Monadnock Block :: :: CHICAGO, ILLINOIS



**\$1.00 Down—and
\$1.00 a month for 2 mos.**

will secure you this set of Electrical Books worth over **FOUR DOLLARS**—or secure 6 paid subscribers to Popular Electricity and we will send them to you **FREE OF CHARGE.**

First Steps in Electricity or Electricity for Beginners

For the beginner in the Electrical Trade this book is what you want.

Electricity Made Simple

Just the book for beginners and electrical workers whose opportunities for gaining information on the branches of electricity have been limited

The Electrical Handy Directory

This little Directory gives you the definition of all electrical words and terms

Easy Experiments in Electricity and How to Make Them

The very latest and most valuable work on Electricity for the amateur or Practical Electrician published

P. E. May '09

Gentlemen:
Enclosed find \$1.00 for which send me your group No. 1 of books. I promise to pay the balance—\$2.00—within 2 months, at \$1.00 per month. Title not to pass until books are paid for in full.

NAME.....
STREET & No.....
TOWN.....STATE.....

New Invention!

Nothing Else Like It

THE MOST WONDERFUL STOVE EVER INVENTED

Consumes 395 Barrels of Air to One Gallon Common Kerosene Oil

Causing Great Excitement Wherever Exhibited

Fuel drawn principally from atmosphere. Uses 395 Barrels of air while consuming one gallon of oil. Wood and coal cost money, ONLY FREE FUEL IS AIR. Supply unlimited. No trust in control. Air belongs to rich and poor alike.

Harrison's Valveless, Wickless, Automatic Oil-Gas and Air Burner Stove

Automatically generates gas from kerosene oil, mixing it with air. Burns like gas. Intense hot fire. Combustion perfect. To operate—turn knob—oil runs into burner—touch a match: it generates gas, which passes through air mixer, drawing in about a barrel of air to every large spoonful of oil consumed. That's all. It's self-regulating, no more attention.

For more or less heat simply turn knob. There it remains until you come again. To put fire out turn knob, raising burner—oil runs back into can, fire's out. As neat perfection as anything in this world. No dirt, soot or ashes. No leaks—nothing to clog or close up. Ideal for summer use. No wick, not even a valve, yet heat is under proper control.

D. CARN Ind., writes: "It costs me only 4¢ cents a day for fuel." L. NORRIS, Vt., writes: "The Harrison Oil-Gas Generators are wonderful savers of fuel, at least 50 to 75 per cent. over wood and coal." E. ARNOLD, Neb., writes: "Saved \$4.25 a month for fuel by using the Harrison Oil-Gas Stove. My range cost me \$5.50 per month, and the Harrison one \$1.25 per month. Objectionable features of other stoves wiped out."

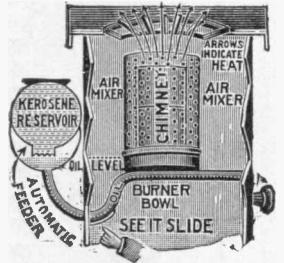

Sectional Cut of Generator. Same heat all day or all night.



Not like Those Sold in Stores

Ideal for cooking, roasting, baking, ironing, canning fruit, pic-nics, cottages, camping, also for heating houses, stores, rooms, etc., with radiating attachment. No more carrying coal, kindling, ashes, soot and dirt. No hot, fiery kitchens. Absolutely safe from explosion. Not dangerous like gasoline. Simple, durable—lasts for years. Saves expense, drudgery and fuel bills.

ALL SIZES, PRICES LOW—\$3.25 and up. Sent to any address. Send no money—only send your name and address. Write today for our 30-day trial offer—full description—thousands of testimonials. 1909 Proposition. Circulars FREE.

Exciting Business for Agents

SALESMEN—MANAGERS—MEN OR WOMEN at home or traveling, all of paid orders, appoint agents. MESSRS HEAD & FRAZER, TEXAS, write: "Enclose order for \$81.00. RUSH. Sell like hot cakes. SOLD 50 STOVES IN OUR TOWN." B. L. HUESTED, MICH., writes: "BEEN OUT ONE DAY AND SOLD 11 STOVES." This patent new, NOTHING LIKE IT. Demand enormous. Agents reaping great harvest. When operated people stop on street, leave their homes, places of business, miss trains to watch this generator—excites curiosity—watch it as though a thing of life. Show a dozen—sell ten. WRITE TODAY FOR SPECIAL AGENTS' NEW PLAN. SEND NO MONEY. World unsupplied. Get in early for territory.

THE WORLD MFG. COMPANY

7202 World Bldg., Cincinnati, Ohio



Principal and 10% Dividends Guaranteed

10,000 shares of the 10% participating preferred stock of the Balch Publishing Company, guaranteed as to principal and dividends, are herewith offered for subscription at \$10 per share, par value, subject to following:

TERMS

Plan A—Cash in full payment when subscribing.

Plan B—25% with subscription, balance in 3 equal monthly payments.

Plan C—10% with subscription, balance in 6 equal monthly payments.

No subscription for less than 5 shares will be accepted. Make checks and Money Orders payable to Balch Publishing Company.

DIVIDENDS

Commence from the date on which stock is paid in full, and will be paid by check semi-annually on March 1 and September 1 of each year.

GUARANTEE.

The Preferred annual dividend of 10 per cent is guaranteed for 3 years, and the repayment of the principal with a premium of 5 per cent is guaranteed on demand at the end of 3 years. In the event of Mr. Balch's death prior to the expiration of the 3 years, the full amount due under the guarantee becomes payable in cash, a special fund having been provided for that purpose by insurance on Mr. Balch's life. The Guarantee appears on every stock certificate.

Profits in Magazine Publishing.

Frank A. Munsey started in the magazine business with a capital of \$40; his business now pays a profit of \$1,000,000 a year. The stock of the S. S. McClure Company is

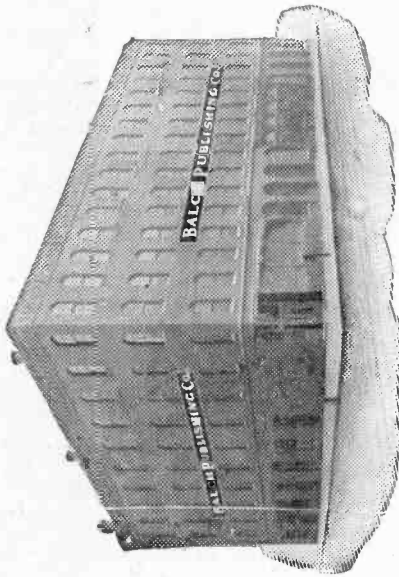

Building at Kinzie Street and Dearborn Avenue, occupied by Balch Publishing Company.

REFERENCES.

Numerous references of the most substantial character will be furnished on request.

GENERAL INFORMATION.

The Balch Publishing Company is an Illinois Corporation, doing business in Chicago and highly regarded locally. The entire capital is \$150,000, of which \$50,000 is common stock owned by Mr. Frank O. Balch. There are no bonds, mortgages or prior liens of any kind.

The Company owns and publishes "Home Life," a mail-order monthly magazine with a circulation of 900,000 copies per issue and an advertising patronage approximating \$25,000 per month. The magazine is known to every advertising agency in the United States and is

Right at Home

A few names of associates and business friends in Chicago who have subscribed for the "Home Life" shares:

- T. C. Frederick, Treasurer Bedford Quarries Co.
- Geo. Gillette, Attorney.
- D. W. Gaylord, Adv. Manager Balch Publishing Co.
- H. A. Bingham, Sales Manager Pilcher-Hamilton Paper Co.
- H. A. Bowman, President Bowman Auto. Adding Co.
- John Arthur Dixon, Asso. Editor Chicago Record-Herald.
- Wm. E. Duff, Circul. Mgr. Balch Publishing Co.
- Alfred Bersbach, Treasurer Manz Engraving Co.
- John Hindman, President Colonial Mercantile Co.
- Right Rev. Samuel Fallows,

considered one of the best. A full list of names is given on page 10.

The business has been established a number of years and is now paying at the rate of about \$85,000 per annum. The capitalization of the Company is extremely low, the proceeds from the sale of the 10,000 Preferred Shares are to be used for the purpose of improving the magazine to the extent of making it the highest grade mail-order publication in the country.

While dividends of only 10 per cent are guaranteed, the Preferred Stock participates in all earnings the same as the Common Stock and may be confidently expected to pay from 25 per cent to 100 per cent per annum. Any increase in the rate of dividends will effect a proportionate increase in the value of the shares.

Considering every phase, we believe that no sounder or more profitable investment was ever offered to the public through the columns of the press. The business is successfully established and the entire proposition rests upon the firm foundation of "what it has done" and "is doing now," not upon "what it proposes or expects to do."

Preferred Stock participates in all earnings the same as the Common Stock and may be confidently expected to pay from 25 per cent to 100 per cent per annum. Any increase in the rate of dividends will effect a proportionate increase in the value of the shares.

Fill out and mail either the attached coupon or application.

Balch Publishing Company

51 Dearborn Avenue, Chicago, Ill.

It is decidedly worth your while to look into this without delay. There are only 10,000 shares at \$10 each. They are offered for sale in the columns of our own monthly magazine, "Home Life," having a circulation of 900,000 copies per issue, and through the columns of several other standard publications with a combined circulation of over a million; it is therefore expected that the entire issue will be promptly subscribed.

APPLICATION

BALCH PUBLISHING COMPANY,
51 Dearborn Avenue, Chicago, Ill.

Subject to your guarantee I herewith subscribe for.....shares of your 10% Guaranteed Preferred Stock at \$10 per share on plan.....and enclose herewith \$..... as required under the said plan, agreeing to pay the balance if any, according to your terms. Certificate is to be issued me as soon as full payment is made.
Please acknowledge receipt.

Date..... Name..... Address.....
Please write plainly.

COUPON

BALCH PUB. CO.,
51 Dearborn Ave., Chicago, Ill.
Please mail me a free copy of "Home Life" and your booklet containing references and complete information about the 10% shares.

Name.....
Address.....

- W. J. Thompson, Manager Ellis Co.
- Arthur E. Swett, Swett Adv. Agency.
- E. C. Bode, Adv. Mgr. Chicago Examiner.
- J. E. Dunning, Supt. Printing Dept. Balch Pub. Co.
- Leon F. Titus, Banker.
- H. E. Groth, Treasurer Mahin Advertising Co.
- S. F. Marchant, Treasurer Pilcher-Hamilton Paper Co.
- J. B. Ott, President Ott Printing Co.
- Robert C. Harell, President Steamfitters' Supply Co.
- W. A. C. Smith, Manager The Ohio Quarries Co.
- M. Rothschild, Manager Chicago House Wrecking Co. And others as prominent.

Thor-Electric

WASHWOMAN
HOUSEMAID
LAUNDRESS
MAN-OF-ALL-WORK

ALL
IN
ONE

Washes and wrings by electricity without packing the clothes in a wad, as many other washers do—keeps the water hot during the wash—and with its UNIVERSAL ROD, operates the ironing machine, the ice cream freezer, the grindstone and performs countless other household tasks.

Does Everything But Hang Out the Clothes.



The New Way of Washing Clothes

Sent on 30 Days Free Trial

Write Us for Free Booklet.

1203-159 S. Jefferson St.
CHICAGO

Hurley Machine Co.

2303 Flatiron Bldg.
NEW YORK