



45635

# POPULAR COMMUNICATIONS

OCTOBER 2007

## Celebrating 25 Years We Look Back...And Ahead

- **Reminiscing About Shortwave Highlights, pg. 10**
- **Alice Brannigan Returns, pg. 14**

**PLUS...**

**The Hobby's Past: Heathkit's History, pg. 17**

**And Its Future: A Weather Station, Ham Radio, GPS Trio, pg. 28**

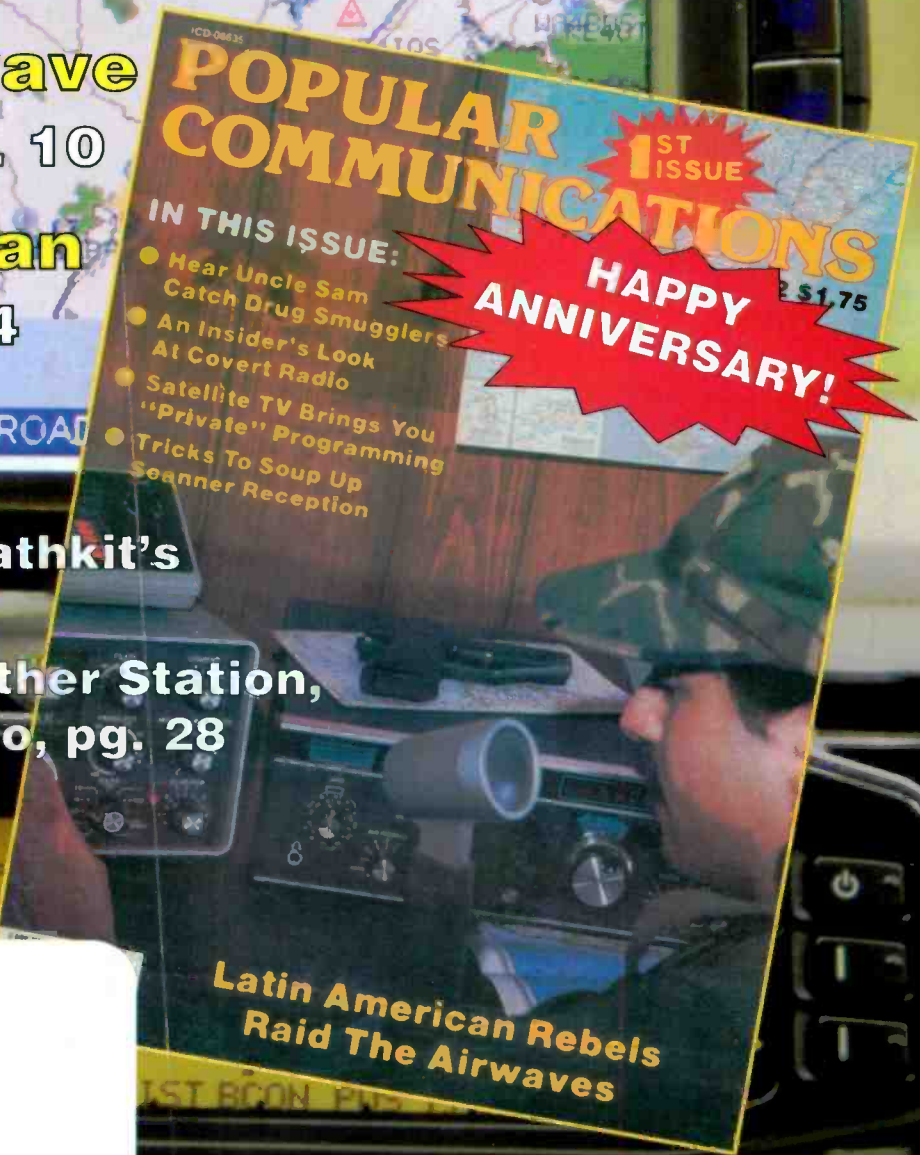

**POPULAR COMMUNICATIONS**  
1<sup>ST</sup> ISSUE  
\$1.75

- IN THIS ISSUE:**
- Hear Uncle Sam Catch Drug Smugglers
  - An Insider's Look At Covert Radio
  - Satellite TV Brings You "Private" Programming
  - Tricks To Soup Up Scanner Reception

**HAPPY ANNIVERSARY!**

**Latin American Rebels Raid The Airwaves**

\*\*\*\*\*SCH 5-DIGIT 66061  
 02 000380028 2902 2710  
 MR. DAVID C STEARNS KCODAA  
 2639 W WHITNEY ST  
 OLATHE KS 66061-6011





# THE PROFESSIONAL STANDARD

The compact desk-top VR-5000 is Yaesu's most versatile Communications Receiver ever! With ultra-wide frequency coverage and a host of operating features, you'll be on top of the monitoring action with the VR-5000!

- CONTINUOUS FREQUENCY COVERAGE: 100 kHz ~ 2.6 GHz / LSB, USB, CW, AM-Narrow, AM, Wide AM, FM-Narrow, and Wide FM (cellular frequencies are blocked)
- 2000 MEMORY CHANNELS / 100 MEMORY GROUPS
- DUAL RECEIVE
- DIGITAL SIGNAL PROCESSING / BANDPASS FILTER, NOISE REDUCTION, NOTCH FILTER, NARROW CW PEAK FILTER (Optional DSP-1 requires)
- REAL-TIME SPECTRUM SCOPE
- WORLD CLOCK WITH UTC/LOCAL SETTINGS
- PRESET SHORTWAVE BROADCAST STATION MEMORY BANK
- EXTENSIVE SCANNING CAPABILITY/SMART SEARCH™

## ● AND MUCH, MUCH MORE . . .

- "RF Tune" Front-end Preselector (1.89-1000 MHz)
- 20 dB Attenuator for strong signal environments
- IF Noise Blanker
- DVS-4 Digital Voice Recorder (option) with two memories of up to 8 seconds each
- 10.7 MHz IF Output Jack
- Field Strength Meter
- Audio Tone Control
- All-Mode Squelch Control for silent monitoring
- Password-protected Panel and Dial "Lock" feature
- Display Dimmer/Contrast Control
- Clone Capability for copying memory information from one VR-5000 to another
- Personal Computer Interface Port
- Two Antenna Ports
- Audio Wave Meter provides display of incoming signal's wave characteristics

## COMMUNICATIONS RECEIVER

# VR-5000

0.1~2599.9999MHz\*  
LSB/USB/CW/AM-N/AM/  
WAM/FM-N/WFM  
\*Cellular blocked

Enjoy the wide world of communications monitoring with the action-packed VR-5000, available from your Yaesu Dealer today!



### Wideband Receiver VR-120D

- Wideband Coverage: 0.1-1299.995\* MHz AM/FM/Wide-FM
- Rugged outdoor-ready case construction
- Ultra-long battery life
- BNC-type antenna connector
- Straightforward 4-button operation
- Versatile 640-channel memory system



### All-Mode Wideband Receiver VR-500

- Frequency coverage : 0.1-1299.9995 MHz\*\*
- Modes : NFM,WFM,AM,USB, LSB, CW
- Multiple Power Source Capability
- Polycarbonate Case
- Real-Time 60-ch\* Band Scope \*Range 6 MHz / Step 100kHz
- Full Illumination For Display And Keypad
- Convenient "Preset" Operating Mode
- Front-end 20 dB Attenuator

For the latest Yaesu news, visit us on the Internet:  
<http://www.vertexstandard.com>

Specifications subject to change without notice. Some accessories and/or options may be standard in certain areas. Frequency coverage may differ in some countries. Check with your local Yaesu Dealer for specific details.

**YAESU**  
Choice of the World's top DX'ers™

Vertex Standard  
US Headquarters  
10900 Walker Street  
Cypress, CA 90630 (714)827-7600



# Universal Radio — Quality equipment since 1942.



*etón*

E1 XM

OPTION

The **etón E1 XM** is the world's first radio that combines AM, FM, shortwave and XM Satellite radio into one ultra high-performance unit. The E1 is an elegant confluence of performance, features and capabilities. The look, feel and finish of this radio is superb. The digitally synthesized, dual conversion shortwave tuner covers all shortwave frequencies. Adjacent frequency interference can be minimized or eliminated with a choice of three bandwidths [7.0, 4.0, 2.5 kHz]. The sideband selectable Synchronous AM Detector further minimizes adjacent frequency interference and reduces fading distortion of AM signals. IF Passband Tuning is yet another advanced feature that functions in AM and SSB modes to reject interference. AGC is selectable at fast or slow. High dynamic range permits the detection of weak signals in the presence of strong signals. All this coupled with great sensitivity will bring in stations from every part of the globe. Organizing your stations is facilitated by 500 user programmable presets with alpha labeling, plus 1200 user definable country memories, for a total of 1700 presets. You can tune this radio many ways such as: direct shortwave band entry, direct frequency entry, up-down tuning and scanning. Plus you can tune the bands with the good *old fashioned* tuning knob (that has *new fashioned* variable-rate tuning). There is also a dual-event programmable timer. Whether you are listening to AM, shortwave, FM or XM, you will experience superior audio quality via a bridged type audio amplifier, large built in speaker and continuous bass and treble tone controls. Stereo line-level output is provided for recording or routing the audio into another device such as a home stereo. The absolutely stunning LCD has 4 levels of backlighting and instantly shows you the status of your radio.

Many receiver parameters such as AM step, FM coverage, beep, kHz/MHz entry etc., can be set to your personal taste via the preference menu. The E1 has a built in telescopic antenna for AM, shortwave and FM reception. Additionally there is a switchable antenna jack [KOK] for an external antenna. Universal also sells a PL259 to KOK antenna jack adapter (#1052 \$14.95) as well as a sturdy angled Lucite radio stand (#3873 \$16.95).

The E1 comes with an AC adapter or may be operated from four D cells (not included). 13.1"W x 7.1"H x 2.3"D Weight: 4 lbs. 3 oz. We are shipping latest production. Get a **Free YB-300PE** with your E1 for a limited time.  
E1 XM Order #0101 \$499.95

 **AUDIOVOX**  
CNP2000



The Eton E1 is XM ready, so you may purchase the Audiovox CNP2000DUO XM antenna module at any time. It has a 25 foot cable. (An optional XM-EXT50 50 foot extension cable is also available #4905 \$39.95.)  
CNP2000DUO Order #0072 \$58.95

**Note:** The CNP2000 DUO antenna module and XM subscription are sold separately. Activation and monthly subscription fee required for XM.

**GRUNDIG** YB-300PE

**FREE**  
Receive a **FREE**  
**Grundig YB-300PE**  
with your Eton E1  
purchase!



The **Grundig YB-300PE Professional Edition** covers: AM, FM stereo and shortwave from 2.3-7.8 and 9.1-26.1 MHz. Tune via Direct keypad entry, 24 memories, Band button, scanning plus Up and Down tuning. The YB-300 PE features a large LCD display with display lamp for momentary illumination. Other refinements include: 24 Hour Clock, DX-Local Switch, sleep timer, Scan and Lock. The side of the radio features the DC input jack, the external antenna input jack and earphone output jack. Includes an AC adapter, vinyl carrying case, carrying strap, plug in external wire antenna, Manual and stereo earphones. Operates from three AA cells. Titanium colored case 5.9 x 3.5 x 1.25 inches 13 oz. Originally introduced at \$99.00.

YB-300PE Order #0300 \$49.95

► Purchase your Eton E1 from Universal Radio before 12/31/07 and receive a **FREE Grundig YB-300PE** with your order!

*etón* E5

**FREE**  
Receive a **FREE**  
**Grundig FR-200**  
with your Eton E5!



The **etón E5** is a world class portable radio covering long wave, AM, FM and shortwave. It offers SSB-Single Side Band, 700 memories, keypad entry, scanning and a 24 hour clock timer. You also get: Line Output, Local/DX Switch, Wide-Narrow selectivity and external SW antenna jack. Operates from four AA cells (not supplied) or the included AC wall adapter. Comes with a manual, wrist strap, protective case, wire antenna and ear buds. 6.675 x 4.125 x 1.125" 12.2 oz. One year limited warranty.

List \$169.95 Order #0055 \$149.95

► Purchase your Eton E5 from Universal before 12/31/07 and receive a **FREE Grundig FR-200 AM/FM/SW wind-up emergency radio** with your order!

**universal  
radio inc.**

**Universal Radio, Inc.**  
6830 Americana Pkwy.  
Reynoldsburg, Ohio  
43068-4113 U.S.A.

800 431-3939 Orders & Prices  
614 866-4267 Information  
614 866-2339 FAX Line  
dx@universal-radio.com

**www.universal-radio.com**

► Visit our website for more exciting new and used shortwave radios.

- Visa
- MasterCard
- Discover
- JCB
- Prices and specs. are subject to change.
- Special offers are subject to change.
- Returns subject to a 15% restocking fee.
- Prices shown do not include shipping.



# Contents

## POPULAR COMMUNICATIONS

Volume 26, Number 2

October 2007



14



17



28



### Features

- 10 Recuerdos...**  
Looking Back 25 Years For Shortwave Memories by Gerry Dexter
- 14 Alice Brannigan Tracks A Wandering Broadcaster**  
An Old Friend Rejoins Us For A Double Dose Of Radio Nostalgia  
by Alice Brannigan
- 17 Heathkit—From Airplanes To Educational Courses**  
Pop-Comm Takes A Fond Look At  
Another History by Randy Kaeding, K8TMK
- 22 Masters Of Scanning**  
Four Innovators Who Helped Shape Our Hobby  
Look Back—And Ahead by Ed Muro, K2EPM
- 36 Domestic Broadcasting Survey, 9th Edition**  
Accurate, Affordable—Essential—DX Information  
Is As Close As Your Keyboard by Richard A. D'Angelo

### Columns

- 28 A Weather, Ham Radio, GPS Trio Radio Resources
- 30 Grouping Channels Into Banks! ScanTech
- 39 A Speaker Test Jig For Your Service Bench The Wireless Connection
- 44 World News, Commentary, Music, Sports, And Drama At Your Fingertips World Band Tuning Tips
- 48 Another Milestone In Pop'Comm's History—The 301st Gerry Dexter! Global Information Guide
- 56 Twenty-Five Years Back Into The Future The Propagation Corner
- 62 Software-Defined Radios: The Next Generation Broadcast Technology
- 66 Happy Anniversary! Utility Communications Digest
- 74 The Carrier Current Ghost Shannon's Broadcast Classics
- 79 Podcasting: Talk Radio And Educational TV For Hams!  
Plus The Real Dope On Coax Ham Discoveries
- 84 A Bathroom With A View The Loose Connection

### Departments

- 4 Tuning In—An Editorial
- 6 InfoCentral—News, Trends, And Short Takes
- 8 Washington Beat—Capitol Hill And FCC Actions Affecting Communications
- 9 Our Readers Speak Out—Letters
- 46 Power Up—Radios & High-Tech Gear

### On The Cover

Popular Communications is a quarter of a century old, and we turn our gaze both forward and back. In the foreground of this month's cover is what greeted readers of our premier issue; in the background is a technical marriage made in heaven: AvMap's G5 GPS and Kenwood's TM-D710A. Just add a weather station for the ultimate storm chasing mobile system.

Visit us on the Web: [www.popular-communications.com](http://www.popular-communications.com)



# Tap into secret Shortwave Signals

Turn mysterious signals into exciting text messages with the MFJ MultiReader™!

MFJ-462B  
**\$189<sup>95</sup>**

Plug this self-contained MFJ Multi-Reader™ into your shortwave receiver's earphone jack.

Then watch mysterious chirps, whistles and buzzing sounds of RTTY, ASCII, CW and AMTOR (FEC) turn into exciting text messages as they scroll across an easy-to-read LCD display.

You'll read interesting commercial, military, diplomatic, weather, aeronautical, maritime and amateur traffic . . .

## Eavesdrop on the World

Eavesdrop on the world's press agencies transmitting unedited late breaking news in English -- China News in Taiwan, Tanjug Press in Serbia, Iraqi News in Iraq -- all on RTTY.

Copy RTTY weather stations from Antarctica, Mali, Congo and many others. Listen to military RTTY passing traffic from Panama, Cyprus, Peru, Capetown, London and others. Listen to hams, diplomatic, research, commercial and maritime RTTY.

## Super Active Antenna

"World Radio TV Handbook" says MFJ-1024 is a "first-rate easy-to-operate active antenna...quiet...excellent dynamic range...good gain...low noise...broad frequency coverage."

Mount it outdoors away from electrical noise for maximum signal, minimum noise. Covers 50 KHz-30 MHz. Receives strong, clear signals from all over the world. 20 dB attenuator, gain control, ON LED.

Switch two receivers and auxiliary or active antenna. 6x3x5 in. Remote has 50 feet coax. 3x2x4 inches. 12 VDC or 110 VAC with MFJ-1312, \$15.95.

Switch two receivers and auxiliary or active antenna. 6x3x5 in. Remote has 50 feet coax. 3x2x4 inches. 12 VDC or 110 VAC with MFJ-1312, \$15.95.

MFJ-1024 **\$149<sup>95</sup>** 54" whip, 50 feet coax. 3x2x4 inches. 12 VDC or 110 VAC with MFJ-1312, \$15.95.

## Indoor Active Antenna

Rival outside

long wires with this

tuned indoor active

antenna. "World

Radio TV Handbook"

says MFJ-1020C is a

"fine value... fair

price... best offering to

date... performs very well indeed."

Tuned circuitry minimizes inter-

mod, improves selectivity, reduces

noise outside tuned band. Use as a

preselector with external antenna.

Covers 0.3-30 MHz. Tune, Band,

Gain, On/Off/Bypass Controls. Detach-

able telescoping whip. 5x2x6 in.

Use 9 volt battery, 9-18 VDC or

110 VAC with MFJ-1312, \$15.95.

## Compact Active Antenna

Plug

this com-

act MFJ

all band active antenna into your

receiver and you'll hear strong, clear

signals from all over the world, 300

KHz to 200 MHz including low,

medium, shortwave and VHF

bands. Detachable 20" telescoping

antenna. 9V battery or 110 VAC

MFJ-1312B, \$15.95. 3 1/4 x 1 1/4 x 4 in.

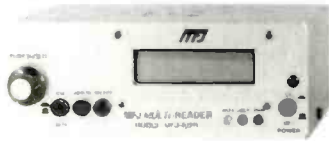

Listen to maritime users, diplomats and amateurs send and receive error-free messages using various forms of TOR (Telex-Over-Radio).

Monitor Morse code from hams, military, commercial, aeronautical, diplomatic, maritime -- all over the world -- Australia, Russia, Japan, etc.

Monitor any station 24 hours a day by printing transmissions. Printer cable. MFJ-5412, \$11.95.

Save several pages of text in memory for later reading or review.

## High Performance Modem

MFJ's high performance PhaseLockLoop™ modem consistently gives you solid copy -- even with weak signals buried in noise. New threshold control minimizes noise interference -- greatly improves copy on CW and other modes.

## Easy to use, tune and read

It's easy to use -- just push a button to select modes and features from a menu.

It's easy to tune -- a precision tuning indicator makes tuning your receiver easy for best copy.

It's easy to read -- front-mounted 2 line 16 character LCD display has contrast adjustment.

Copies most standard shifts and speeds. Has

MFJ AutoTrak™ Morse code speed tracking.

Use 12 VDC or use 110 VAC with MFJ-1312D AC adapter, \$15.95. 5 1/4 W x 2 1/2 H x 5 1/4 D inches.

## WiFi Yagi Antenna -- 15 dBi 16-elements extends range



16-element, 15 dBi WiFi Yagi antenna greatly extends range of 802.11b/g, 2.4 GHz WiFi signals. 32 times stronger than isotropic radiator. Turns slow/no connection WiFi into fast, solid connection. Highly directional -- minimizes interference.

N-female connector. Tripod screw-mount. Wall and desk/shelf mounts. Use vertically/horizontally. 18W x 2 1/4 H x 1 1/4 D inches. 2.9 ounces.

MFJ-5606SR, \$24.95. Cable connects MFJ-1800/WiFi antennas to computer.

Reverse-SMA male to N-male. 6 ft. RG-174.

MFJ-5606TR, \$24.95. Same as MFJ-5606SR but Reverse-TNC male to N-male.

## Eliminate power line noise!



MFJ-1026  
**\$189<sup>95</sup>**

Completely eliminate power line noise, lightning crashes and interference before they get into your receiver! Works on all modes -- SSB, AM, CW, FM, data -- and on all shortwave bands. Plugs between main external antenna and receiver. Built-in active antenna picks up power line noise and cancels undesirable noise from main antenna. Also makes excellent active antenna.

## MFJ Antenna Matcher

Matches your antenna to your receiver so you get maximum signal and minimum loss. MFJ-959C

Preamp with gain control boosts weak stations 10 times. 20 dB attenuator prevents overload. Select 2 antennas and 2 receivers. 1.6-30 MHz.

9x2x6 in. Use 9-18 VDC or 110 VAC with MFJ-1312, \$15.95.

## High-Gain Preselector

High-gain, high-Q receiver preselector covers 1.8-54 MHz.

Boost weak signals 10 times with low noise dual gate MOSFET. Reject out-of-band signals and images with high-Q tuned circuits. Push buttons let you select 2 antennas and 2 receivers. Dual coax and phono connectors. Use 9-18 VDC or 110 VAC with MFJ-1312, \$15.95.

Dual Tunable Audio Filter

Two separately tunable filters let you peak desired signals and notch out interference at the same time. You can peak, notch, low or high pass signals to eliminate heterodynes and interference. Plugs between radio and speaker or phones. 10x2x6 inches.

MFJ-1045C **\$79<sup>95</sup>**

MFJ-752C **\$109<sup>95</sup>**

## MFJ Shortwave Headphones

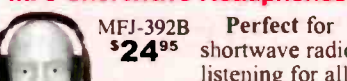

MFJ-392B  
**\$24<sup>95</sup>**

Perfect for shortwave radio listening for all modes -- SSB, FM, AM, data and CW. Superb padded headband and ear cushioned design makes listening extremely comfortable as you listen to stations all over the world! High-performance driver unit reproduces enhanced communication sound. Weighs 8 ounces, 9 ft. cord. Handles 450 mW. Frequency response is 100-24,000 Hz.

## High-Q Passive Preselector

High-Q passive LC preselector boosts your favorite stations while rejecting images, intermod and phantom signals. 1.5-30 MHz. Preselector bypass and receiver grounded positions. Tiny 2x3x4 in.

MFJ-956 **\$59<sup>95</sup>**

Super Passive Preselector

Improves any receiver! Suppresses strong out-of-band signals that cause intermod, blocking, cross modulation and phantom signals. Unique Hi-Q series tuned circuit adds super sharp front-end selectivity with excellent stopband attenuation and very low passband attenuation and very low passband loss. Air variable capacitor with vernier. 1.6-33 MHz.

MFJ-1046 **\$109<sup>95</sup>**

MFJ Shortwave Speaker

This MFJ ClearTone™ restores the broadcast quality sound of shortwave listening. Makes copying easier, enhances speech, improves intelligibility, reduces noise, static, hum. 3 in. speaker handles 8 Watts. 8 Ohm impedance. 6 foot cord.

MFJ-281 **\$12<sup>95</sup>**

## MFJ All Band Doublet

102 ft. all band doublet covers .5 to 60 MHz. Super strong custom fiberglass center insulator provides stress relief for ladder line (100 ft.).

Authentic glazed ceramic end insulators and heavy duty 14 gauge 7-strand copper wire.

MFJ-1777 **\$49<sup>95</sup>**

MFJ-1777 Ship Code A

## MFJ Antenna Switches

MFJ-1704 **\$69<sup>95</sup>**

MFJ-1702C **\$29<sup>95</sup>**

MFJ-1704 heavy duty antenna switch lets you select 4 antennas or ground them for static and lightning protection. Unused antennas automatically grounded. Replaceable lightning surge protection. Good to 500 MHz. 60 dB isolation at 30 MHz. MFJ-1702C for 2 antennas.

## Morse Code Reader

Place this pocket-sized MFJ Morse Code Reader near your receiver's speaker. Then watch CW turn into solid text messages on LCD. Eavesdrop on Morse Code QSOs from hams all over the world!

MFJ-461 **\$89<sup>95</sup>**

MFJ-108B, \$21.95. Dual 24/12 hour clock. Read UTC/local time at-a-glance. High-contrast 5/8" LCD, brushed aluminum frame. Batteries included. 4 1/2 W x 1 D x 2 H inches.

MFJ-108B, \$21.95.

MFJ-108B, \$21.95.

MFJ-108B, \$21.95.

MFJ-108B, \$21.95.

MFJ-108B, \$21.95.

MFJ-108B, \$21.95.

MFJ-108B, \$21.95.

## Dealer/Catalog/Manuals

Visit: <http://www.mfjenterprises.com> or call toll-free 800-647-1800

1 Year No Matter What™ warranty • 30 day money back guarantee (less s/h) on orders direct from MFJ

**MFJ** MFJ ENTERPRISES, INC.  
300 Industrial Pk Rd, Starkville, MS 39759 PH: (662) 323-5869  
Tech Help: (662) 323-0549  
FAX: (662) 323-6551 8-4:30 CST, Mon-Fri. Add shipping. Prices and specifications subject to change. (c) 2006 MFJ Enterprises, Inc.



*Twenty-five years is a good long time for pretty much any human endeavor. Lasting so long shows a real commitment. In the case of Popular Communications, which celebrates that mark this year, it's evidence of the commitment of a large group of people—the readers, writers, advertisers, staff—who have been, and still are, part of something vibrant. As we embark upon our 26th year, we continue our part in the commitment to deliver a quality publication that's informative, timely, and (most of all, I hope) fun.*

*One score and five years ago (we keep trying to come up with different ways to say it!), Tom Kneitel, the pivotal force behind what would develop into Pop'Comm was already well known in the hobby world as an author, publisher, and delightfully irreverent iconoclast. And what a force he was. Under his stewardship, Pop'Comm broke new ground, gained a large and loyal readership, and carved an influential place in the communications hobby overall. That's why it's such an honor for me this month to turn this page over the man behind the plan so many years ago.*

*And, frankly, it's also a blast to have Alice Brannigan back for an anniversary visit. And to read Gerry Dexter's recuerdos, or reminiscences, of the hobby during those early years of Pop'Comm. Sentimental readers will also want to check the history of another pivotal force in the hobby, Heathkit. Then, taking us into the future, we have some other pretty influential people musing about where we're headed in "The Masters Of Scanning."*

*But that's enough from me. At this point, I'll let TK, as we affectionately know him, take over as we introduce this special anniversary issue.—EL*

## A Twenty-Five Year Milestone

by Tom Kneitel, W4XAA, Senior Editor

**T**he years seem to have flown by, but it was a full quarter of a century ago that we put out the first issue of the magazine we lovingly refer to as *Pop'Comm*.

Publisher Dick Ross and I had spent several years kicking around the concept and possibilities of bringing out a monthly magazine fully dedicated to the hobby of communications monitoring. Both of us had grown up with magazines such as *Popular Electronics*, *Electronics Illustrated*, and *Radio News*. Each of them devoted several pages per month to monitoring, but not enough to satisfy the appetites of listeners. And, of course, by the 1980s, all three had become pretty much extinct.

Our mutual vision was that our proposed publication should appeal both to shortwave listeners and those who monitored scanners. It should cover new products, a dash of history, and be offered with style, humor, and flair.

We made dozens of lists of possible features, monthly potential authors, and hoped-for advertisers. We wondered how a magazine would be received within the hobby.

Being a writer and not a businessman, I was the impetuous one, ready to jump right in with both feet. My theory was, as publisher of *CQ* magazine, Dick already had a production, advertising, and office staff of experienced people. I felt everything we needed was already in place.

Fortunately, Dick was a businessman who exercised caution. He kept making all sorts of spreadsheets, charts, calculations, cost estimates, and plans. He got quotes from printers. Dick estimated our chances of surviving at least long enough until the publication finally clicked. He surveyed potential advertisers to get their views. This entire process practically drove me batty. Eventually, there came a time when Dick decided my enthusiasm and incessant bugging him trumped all of his meticulous calculations. We decided to just go ahead and do it.

That's when we realized that our baby, which we had always referred to as "the magazine," had no name. We made several

lists of possible names, but nothing seemed to exactly capture the essence of what we had envisioned. It finally came down to two possibilities: *Communications Illustrated* and *Popular Communications*. As soon as we zeroed in on the correct name, everything fell right into place.

Our target date was September, 1982. That left us the luxury of taking our time gathering story and column ideas, and contacting authors. Looking back over our early issues, I see names such as Gerry Dexter and Gordon West, two prolific sources of information who have contributed to the success of *Pop'Comm* from the beginning right to the present. Throughout the years we've been able to present writings from other authorities, such as Harry Helms, Alice Brannigan, and the late Havana Moon.

Communications has seen many changes during the magazine's years, including new digital modes, cellular phones, trunking, restrictive monitoring laws, and the ever-present Internet. We have followed all of these.

Over the decades, *Pop'Comm* has attracted a loyal following of readers. Our readers contribute a large percentage of the material used in the magazine, including photos, loggings, and entire articles. There is an active side-hobby of collecting back issues. Certain issues have become rather scarce and enjoy brisk trading at those rare times they show up on eBay.

I'm proud to say that, through e-mail, snail mail, and personal contact, I have gotten to know countless *Pop'Comm* readers. They are as dedicated, loyal, friendly, and unique a group as any monthly magazine could hope to have. It's like a big family that includes the folks on the editorial staff of the magazine, and even the office staff here.

It has been a wonderful experience putting out *Pop'Comm*, with occasional times when there are highlights worthy of special note. As we mark our quarter-century milestone, we head

(Continued on page 78)

# RCR-22

FM / AM / Aux-In PLL Synthesized Tuning  
Atomic Clock Radio



The clock starts by connecting to the atomic clock in Boulder, Colorado to set the most accurate time keeping technology currently available. Once the signal is found it will synchronize every hour to ensure that it is the right time, every time. Once the clock is set you can program the dual alarms to wake you to your favorite AM or FM station or take advantage of the Humane Waking System that begins with a low volume beep and gradually increases in intensity to slowly wake you instead of receiving a firm jolt that the others provide.

With its intuitive design you have the ability to select the days of the week you wish the alarms to wake you, meaning you never need to worry about being woken up on the weekends, or forgetting to turn the alarm on during the week. Once you set it, you can forget it. It also features Sangean's Super Capacitor that provides memory and alarm memories for up to 1 hour during a power disruption, eliminating the need for a battery backup.

For the ambitious power nappers of the world the clock features a NAP function that can be set to wake you in 10 minute intervals up to 2 hours without re-setting the alarms so that you can get the most of your power nap. There is also a handy sleep timer that allows you to fall asleep listening to your favorite radio station from 15 minutes up to 2 hours. And with the Aux-input you can connect your iPod™ or a CD player to enjoy your favorite soothing sounds CD or digital music collection to fall asleep.

With all these features, it is truly the easiest last Alarm Clock Radio you will ever have to buy. Just set it and forget it... but with all these features, why would you?

Inside the box you will find the RCR-22, the detachable atomic clock receiver, owners' manual, and a 1 year warranty.

- PLL Synthesized Tuner.
- 14 station presets (7 FM, 7 AM).
- Radio Controlled clock (Available for CE, UK, USA or Japan).
- Adjustable sleep timer (15-120 min.).
- Adjustable nap timer (10-120 min.).
- HWS buzzer (Humane Waking System).
- Adjustable alarm buzzer level.
- Week Day selection.
- Easy to read LCD.
- Alarm set LED indicator.
- Dimensions (W X H X D): 6 1/2" X 3 2/16" X 6 3/4"
- Weight: 2 lb 2 oz.

## SANGEAN

A WORLD OF LISTENING

Sangean America, Inc.  
2651 Troy Avenue, South El Monte, CA 91733  
Tel: 888.SANGEAN Fax: 625.579.6806  
e-mail: [info@sangean.com](mailto:info@sangean.com)  
[www.sangean.com](http://www.sangean.com)



# News, Trends, And Short Takes

## Radio Six International Returns To Shortwave And Mediumwave

Effective August 11—right around the time this magazine went to print—Scotland's only independent international broadcaster, Radio Six International, was to return to shortwave with a resumption of its Saturday morning broadcast on 9290 kHz beamed to Europe, the Far East, and Pacific regions.

The program, transmitted every Saturday between 0700 and 0800 UTC, will be relayed from the 100-kW facility at Ulbroka, Latvia, as well as from the 2.7-kW mediumwave transmitter on 945 kHz in Riga, Latvia. The station has recently expressed reservations about the effectiveness of shortwave transmissions, and is available 24 hours a day on the Internet at [www.radiosix.com/](http://www.radiosix.com/) as well as via satellite and FM in various parts of the world at certain times of day.

## VOA Delano To Close At End Of Summer

Another international broadcasting shortwave site was to have closed at the end of the current shortwave broadcast season. The American Federation of Government Employees, Local 1812, said the Broadcasting Board of Governors announced the closure of the Delano, California, transmitting station. The closure was scheduled for last week of October, 2007. Employees will remain on the payroll until January 5, 2008.

## VOA Expands Broadcasts To Somalia

The Voice of America (VOA) has added 30 minutes to its daily Somali radio broadcast, providing a full hour of live, up-to-the-minute news and information to listeners. VOA Somali currently airs from 1600 TO 1700 UTC, with a repeat broadcast at 1700 UTC.

The additional half hour, 1630 to 1700 UTC, includes a wider variety of listener interactives, such as call-ins, roundtable discussions, and debates on topics ranging from health, education, and youth to business and development. Weekend programming will offer in-depth discussions and interviews focusing on the interests and needs of Somalis.

VOA's Somali Service was launched on February 12, 2007. Broadcasts are available on AM 1431 kHz, FM, and shortwave radio frequencies 13580 kHz, 15620 kHz, and 1431 kHz. The 1700 UTC broadcast repeats on HornAfrik (88.8 FM in Mogadishu), a VOA-affiliated station.

## Exiled Ethiopian Orthodox Church Launches New Radio Broadcast

The exiled Holy Synod of the Ethiopian Orthodox Tewahedo Church launched a weekly radio broadcast to Ethiopia on July 2, 2007. The broadcasts are every Monday from 1600 to 1700 GMT on 15260 kHz and will include bible teaching, church news, as well as reports and discussions on current social, political, and other issues of national importance. The Holy Synod

is led by Abune Merkorios, whom followers consider the legitimate patriarch of Ethiopia. He went into exile when the Tigrean People Liberation Front came to power in 1991.

## Zimbabwe Jamming Equipment Backfires

Zimbabwe government radio jamming equipment reportedly purchased in China has backfired, gagging its own new shortwave project, Voice of Zimbabwe (VOZ), sources at the station revealed. The ambitious station, set up to counter Western broadcasts, is said to be battling to recruit qualified personnel to run its operations, while its few employees are still in Harare instead of moving to Gweru where it was due to be housed. Sources said the equipment was believed to be made up of three jammers installed at Thornhill, a military airbase and government communications center in the Midlands.

The plan was to block a perceived negative publicity campaign from outside radio stations, such as Voice of America (VOA) funded by the U.S. State Department; SW Radio, which beams from London; and Dutch-funded Voice of the People (VOP), among others. The jamming equipment has prevented VOZ from starting regular operations due to the self-signal interception going on at the station.

The country has four state-controlled FM radio stations and one shortwave, VOZ, which appears to be struggling against the tide. The government announced two months ago that the station would run trial broadcasts for three weeks on 5975 kHz and 4828 kHz, but the trials were a major flop owing to the jamming machinery from China.

## ABC-Australia To Investigate Breast Cancer Among Employees

The Australian Broadcasting Corporation plans to conduct investigations into the frequency of breast cancer among women in all its studio complexes across the country. The move follows the release of a final report into the high rate of breast cancer cases at the ABC studios in the western Brisbane suburb of Toowong.

All staff at Toowong were relocated just before Christmas last year after a study found female employees reported breast cancer at a rate of up to 11 times higher than the general working community. The new report says there could be something in the working environment at Toowong that could have contributed to the observed breast cancer risk, and which could also be present in similar ABC studio complexes.

## Deutsche Welle Starts Regular DRM Service To South Asia

Since July 2, Deutsche Welle has been broadcasting regular DRM transmissions in English beamed to South Asia from its relay station at Trincomalee, Sri Lanka. Shortwave transmissions are at 0500 to 0600 UTC on 12005 kHz and 0800 to 0858 UTC on 12070 kHz (both 90 kW, beam 345 degrees). There's also a DRM transmission on mediumwave 1548 kHz at 0100 to 0200 UTC (100 kW, beam 035 degrees). ■



# Big Savings on Radio Scanners

## Uniden® SCANNERS



### Bearcat® 796DGV Trunk Tracker IV with free scanner headset

Manufacturers suggested list price \$799.95  
**CEI Special Price \$519.95**  
 1,000 Channels • 10 banks • CTCSS/DCS • S Meter  
 Size: 6.15" Wide x 6.91" Deep x 2.38" High

**Frequency Coverage:** 25.0000-512.0000 MHz., 806.0000-956.0000 MHz. (excluding the cellular & UHF TV band), 1,240.0000-1,300.0000 MHz.

When you buy your Bearcat 796DGV TrunkTracker package deal from Communications Electronics, you get more. The GV means "Great Value." With your BC796DGV scanner purchase, you also get a **free deluxe scanner headphone** designed for home or race track use. Headset features independent volume controls and 3.5 mm gold right angle plug. The 1,000 channel Bearcat 796DGV is packed with features to track Motorola Type I/II/III Hybrid, EDACS, LTR Analog Trunk Systems and Motorola APCO 25 Phase I digital scanner including 9,600 Baud C4FM and CQPSK. Also features control channel only mode to allow you to automatically trunk many systems by simply programming the control channel, S.A.M.E. weather alert, full-frequency display and backlit controls, built-in CTCSS/DCS to assign analog and digital subaudible tone codes to a specific frequency. In memory, PC Control and programming with RS232C 9 pin port (cable not supplied), Beep Alert, Record function, VFO control, menu-driven design, total channel control and much more. Our CEI package deal includes telescopic antenna, AC adapter, cigarette lighter cord, DC cord, mobile mounting bracket with screws, owner's manual, trunking frequency guide and one-year limited Uniden factory warranty. For maximum scanning enjoyment, order magnetic mount antenna part number ANTMMBNC for \$29.95. For complete details, download the owners manual from the [www.usascan.com](http://www.usascan.com) web site. For fastest delivery, order on-line at [www.usascan.com](http://www.usascan.com).

### Bearcat® BCT8 Trunk Tracker III

Manufacturer suggested list price \$299.95  
**CEI Special Price \$169.95**  
 250 Channels • 5 banks • PC Programmable  
 Size: 7.06" Wide x 6.10" Deep x 2.44" High  
**Frequency Coverage:** 25.0000-54.0000 MHz., 108.0000-174.0000 MHz., 400.0000-512.0000 MHz., 806.0000-823.9950 MHz., 849.0125-868.9950 MHz., 894.0125-956.0000 MHz.

The Bearcat BCT8 scanner, licensed by NASCAR, is a superb preprogrammed 800 MHz trunked highway patrol system scanner. Featuring TrunkTracker III, PC Programming, 250 Channels with unique BearTracker warning system to alert you to activity on highway patrol link frequencies. Preprogrammed service searches makes finding interesting active frequencies even easier and include preprogrammed police, fire and emergency medical, news agency, weather, CB band, air band, railroad, marine band and department of transportation service searches. The BCT8 also has preprogrammed highway patrol alert frequencies by state to help you quickly find frequencies likely to be active when you are driving. The BCT8 includes AC adapter, DC power cable, cigarette lighter adapter plug, telescopic antenna, window mount antenna, owner's manual, one year limited Uniden warranty, frequency guide and free mobile mounting bracket. For maximum scanning enjoyment, also order the following optional accessories: External speaker ESP20 with mounting bracket & 10 feet of cable with plug attached \$19.95. Magnetic Mount mobile antenna ANTMMBNC for \$29.95.



### Bearcat® BCD396T Trunk Tracker IV

Suggested list price \$799.95/CEI price \$519.95  
 APCO 25 9,600 baud compact digital ready handheld TrunkTracker IV scanner featuring Fire Tone Out Paging, Close Call and Dynamically Allocated Channel Memory (up to 6,000 channels), SAME Weather Alert, CTCSS/DCS, Alpha Tagging. Size: 2.40" Wide x 1.22" Deep x 5.35" High

**Frequency Coverage:** 25.0000-512.0000 MHz., 764.0000-775.9875 MHz., 794.0000-823.9875 MHz., 849.0125-868.8765 MHz., 894.0125-956.0000 MHz., 1240.0000 MHz.-1300.0000 MHz.

The handheld BCD396T scanner was designed for National Security/Emergency Preparedness (NS/EP) and homeland security use with new features such as **Fire Tone Out Decoder**. This feature lets you set the BCD396T to alert if your selected two-tone sequential paging tones are received. Ideal for on-call firefighters, emergency response staff and for activating individual scanners used for incident management and population attack warning. **Close Call Radio Frequency Capture** - Bearcat exclusive technology locks onto nearby radio transmissions, even if you haven't programmed anything into your scanner. Useful for intelligence agencies for use at events where you don't have advance notice or knowledge of the radio communications systems and assets you need to intercept. The BCD396T scanner is designed to track Motorola Type I, Type II, Hybrid, SMARTNET, PRIVACY PLUS, LTR and EDACS\* analog trunking systems on any band. Now, follow UHF High Band, UHF 800/900 MHz trunked public safety and public service systems just as if conventional two-way communications were used. **Dynamically Allocated Channel Memory** - The BCD396T scanner's memory is

organized so that it more closely matches how radio systems actually work. Organize channels any way you want, using Uniden's exclusive dynamic memory management system. 3,000 channels are typical but **over 6,000 channels are possible** depending on the scanner features used. You can also easily determine how much memory you have used and how much memory you have left. **Preprogrammed Systems** - The BCD396T is preprogrammed with over 400 channels covering police, fire and ambulance operations in the 25 most populated counties in the United States, plus the most popular digital systems. **3 AA NiMH or Alkaline battery operation and Charger** - 3 AA battery operation - The BCD396T includes 3 premium 2,300 mAh Nickel Metal Hydride AA batteries to give you the most economical power option available. You may also operate the BCD396D using 3 AA alkaline batteries. **Unique Data Skip** - Allows your scanner to skip unwanted data transmissions and reduces unwanted birdies. **Memory Backup** - If the battery completely discharges or if power is disconnected, the frequencies programmed in the BCD396T scanner are retained in memory. **Manual Channel Access** - Go directly to any channel. **LCD Back Light** - A blue LCD light remains on when the back light key is pressed. **Autolight** - Automatically turns the blue LCD backlight on when your scanner stops on a transmission. **Battery Save** - In manual mode, the BCD396T automatically reduces its power requirements to extend the battery's charge. **Attenuator** - Reduces the signal strength to help prevent signal overload. The BCD396T also works as a conventional scanner to continuously monitor many radio conversations even though the message is switching frequencies. The BCD396T comes with AC adapter, 3 AA nickel metal hydride batteries, belt clip, flexible rubber antenna, wrist strap, SMA/BNC adapter, RS232C cable, Trunk Tracker frequency guide, owner's manual and one year limited Uniden warranty. Not compatible with AGEIS, ASTRO or ESAS systems. Order on-line at [www.usascan.com](http://www.usascan.com) or call 1-800-USA-SCAN.

### More Radio Products

Save even more on radio scanners when purchased directly from CEI. Price includes delivery in the continental USA excluding Alaska.

Bearcat 898T 500 channel TrunkTracker III base/mobile.....	\$209.95
Bearcat 796DGV Digital 1,000 ch. TrunkTracker IV base/mobile.....	\$519.95
Bearcat BCD396T APCO 25 Digital scanner with Fire Tone Out.....	\$519.95
Bearcat 246T up to 2,500 ch. TrunkTracker III handheld scanner.....	\$214.95
Bearcat Sportcat 230 alpha display handheld sports scanner.....	\$184.95
Bearcat 278CLT 100 channel AM/FM/SAME WX alert scanner.....	\$129.95
Bearcat 248CLT 50 channel base AM/FM/weather alert scanner.....	\$104.95
Bearcat 244CLT 30 channel base AM/FM/weather alert scanner.....	\$94.95
Bearcat 92XLT 200 channel handheld scanner.....	\$105.95
Bearcat 72XLT 100 channel handheld scanner.....	\$89.95
Bearcat BR330T handheld shortwave/scanner with Fire Tone out.....	\$274.95
Bearcat BCT8 250 channel information mobile scanner.....	\$169.95
Bearcat 350C 50 channel desktop/mobile scanner.....	\$96.95
AOR AR16BQ Wide Band scanner with quick charger.....	\$199.95
AOR AR3000AB Wide Band base/mobile receiver.....	\$1,079.95
AOR AR8200 Mark IIIB Wide Band handheld scanner.....	\$594.95
AOR AR8600 Mark II Wide Band receiver.....	\$899.95
Deluxe Independent Dual Volume Control Racing Headphone.....	\$29.95
Scancat Gold For Windows Software.....	\$99.95
Scancat Gold for Windows Surveillance Edition.....	\$159.95

### Bearcat® BC246T Trunk Tracker III

Suggested list price \$399.95/CEI price \$214.95  
 Compact professional handheld TrunkTracker III scanner featuring Close Call and Dynamically Allocated Channel Memory (up to 2,500 channels), SAME Weather Alert, CTCSS/DCS, Alpha Tagging. Size: 2.72" Wide x 1.26" Deep x 4.6" High

**Frequency Coverage:** 25.0000-54.0000 MHz., 108.0000-174.0000 MHz., 216.0000-224.9800 MHz., 400.0000-512.0000 MHz., 806.0000-823.9875 MHz., 849.0125-868.9875 MHz., 894.0125-956.0000 MHz., 1240.0000 MHz.-1300.0000 MHz.

The handheld BC246T TrunkTracker scanner has so many features, we recommend you visit our web site at [www.usascan.com](http://www.usascan.com) and download the free owner's manual. Popular features include **Close Call Radio Frequency Capture** - Bearcat exclusive technology locks onto nearby radio transmissions, even if you haven't programmed anything into your scanner. **Dynamically Allocated Channel Memory** - Organize channels any way you want, using Uniden's exclusive dynamic memory management system. 1,600 channels are typical but **over 2,500 channels are possible** depending on the scanner features used. You can also easily determine how much memory is used. **Preprogrammed Service Search (10)** - Makes it easy to find interesting frequencies used by public safety, news media TV broadcast audio, Amateur (ham) radio, CB radio, Family Radio Service, special low power, railroad, aircraft, marine, racing and weather frequencies. **Quick Keys** - allow you to select systems and groups by pressing a single key. **Text Tagging** - Name each system, group, channel, talk group



ID, custom search range, and S.A.M.E. group using 16 characters per name. **Memory Backup** - When power is lost or disconnected, your BC246T retains the frequencies that were programmed in memory. **Unique Data Skip** - Allows the BC246T to skip over unwanted data transmissions and birdies. **Attenuator** - You can set the BC246T attenuator to reduce the input strength of strong signals by about 18 dB. **Duplicate Frequency Alert** - Alerts you if you try to enter a duplicate name or frequency already stored in the scanner. **22 Bands** - with aircraft and 800 MHz. The BC246T comes with AC adapter, 2 AA 1,800 mAh nickel metal hydride batteries, belt clip, flexible rubber antenna, wrist strap, RS232C cable, Trunk Tracker frequency guide, owner's manual and one year limited Uniden warranty. For more fun, order our optional deluxe racing headset part #HF24RS for \$29.95. Order now at [www.usascan.com](http://www.usascan.com) or call 1-800-USA-SCAN.

### Buy with Confidence

### Order on-line and get big savings

For over 37 years, millions of communications specialists and enthusiasts worldwide have trusted Communications Electronics for their mission critical communications needs. It's easy to order. For fastest delivery, order on-line at [www.usascan.com](http://www.usascan.com). Mail orders to: Communications Electronics Inc., P.O. Box 1045, Ann Arbor, Michigan 48106 USA. Price includes \$30.00 UPS Ground shipping/handling/insurance per scanner to a street address in the continental USA excluding Alaska. Add \$20.00 shipping for all accessories. For shipments to Canada, Puerto Rico, Hawaii, Alaska, Guam, P.O. Box, APO/FPO, USPS Priority Mail or UPS 2 business day delivery, add \$30.00. Michigan residents add sales tax. No COD's. For Bearcat scanners your satisfaction is guaranteed or return item in unused condition in original packaging within 61 days for refund, less shipping charges. 10% surcharge for net 10 billing to qualified accounts. All sales are subject to availability, acceptance and verification. Prices, terms and specifications are subject to change without notice. We welcome your Discover, Visa, American Express, MasterCard, IMPAC or Eurocard. Order toll free, call 1-800-USA-SCAN or 1-734-996-8888 if outside Canada or the USA. FAX anytime, dial 1-734-663-8888. Dealer and International inquiries invited. Order your radio scanners from Communications Electronics today.

For credit card orders call  
**1-800-USA-SCAN**  
 e-mail: [cei@usascan.com](mailto:cei@usascan.com)

**www.usascan.com**  
 PO Box 1045, Ann Arbor, Michigan 48106-1045 USA  
 For information call 734-996-8888 or FAX 734-663-8888  
Price schedule effective January 2, 2006 AD #10206 © 2006 Communications Electronics Inc.

**COMMUNICATIONS ELECTRONICS INC.**  
 Emergency Operations Center

Visit [WWW.USASCAN.COM](http://WWW.USASCAN.COM) • 1-800-USA-SCAN



# Capitol Hill And FCC Actions Affecting Communications

## FCC Revises 700 MHz Rules, Sets Auction Parameters

In a Second Report & Order adopted July 31, the FCC revised the 700-MHz band plan and service rules “to promote the creation of a nationwide interoperable broadband network for public safety and to facilitate the availability of new and innovative wireless broadband services for consumers,” according to a Commission news release.

And, in a move applauded by public safety agencies, the Order established a framework for a 700-MHz Public Safety/Private Partnership between the licensee for one of the commercial spectrum blocks and the licensee for the public safety broadband spectrum. The release stated,

As part of the Partnership the commercial licensee will build out a nationwide, interoperable broadband network for the use of public safety. This network will facilitate effective communications among first responders not just in emergencies, but as part of cooperative communications plans that will enable first responders from different disciplines, such as police and fire departments, and jurisdictions to work together in emergency preparedness and response. Under the Partnership, the Public Safety Broadband Licensee will have priority access to the commercial spectrum in times of emergency, and the commercial licensee will have preemptible, secondary access to the public safety broadband spectrum.

Among the guidelines established for the long-anticipated 700 MHz auction are “anonymous” bidding procedures, in which any information that indicates specific applicants’ interests in the auction, including license selections and bidding activity, is withheld until after the close of the auction. The Commission will also use “package bidding” procedures when auctioning the 12 licenses in the Upper 700-MHz Band C Block to assist bidders seeking to create a nationwide footprint.

## DoD, FCC, And ARRL Address Interference To Military Radar

Alleging a growing number of interference complaints, the U.S. Air Force has asked the FCC to order dozens of amateur radio 70-centimeter VHF repeater systems on both coasts to “either mitigate interference to the Pave Paws radars or shut down,” according to a report from the American Radio Relay League.

The in-band interference from amateur radio fixed FM voice repeaters has increased to an unacceptable level, the U.S. Department of Defense said. Pave Paws radars (PPRs) are used for national security functions, including early detection of water-launched missiles.

The ARRL said it is working with the DoD to develop a plan to address the interference. More than 100 repeater owners/trustees have received letters of notification. Fifteen repeaters within less than 100 miles of Otis Air Force Base on Cape Cod, Massachusetts, and more than 100 repeaters within about 140 miles of Beale Air Force Base near Sacramento, California, are impacted.

The Amateur Radio Service is a secondary user in the 420-

to 450-MHz band. “As such, amateur radio licensees, jointly and individually, bear the responsibility of mitigating or eliminating any harmful interference to the primary user, which in this case is the Government Radiolocation Service that includes the DoD Pave Paws systems,” according to the ARRL.

“The letters sent to affected repeater owners/trustees give them an up-to-date briefing on the ongoing negotiations with the U.S. Air Force, as well as outlines the DoD’s plan,” the League said. “The DoD has indicated a willingness to try a mitigation proposal, but they have also indicated their need is for these issues to be resolved sooner rather than later.” All interference is to be resolved no later than August 1, 2007.

Beginning in August 2007, and continuing on a periodic basis, the DoD is to have a follow-up engineers’ study at each PPR site “to ensure corrective actions have been taken and to ensure that successful mitigation continues.”

The League has also been in contact with the FCC. “They have the ultimate responsibility for enforcing any mitigation plan, up to and including ordering specific repeaters to shut down operations. The FCC is aware of the complex nature of this problem and the mitigation strategy being proposed by the DoD,” the ARRL said.

## House Rejects Attempt To Eliminate Federal Funding For Public Broadcasting

The Association of Public Television Stations (APTS) welcomed the House of Representatives’ overwhelming rejection of an attempt by Representative Doug Lamborn (R-Colo.) to eliminate federal support for Public Broadcasting. By a vote of 357 to 72, the House defeated Rep. Lamborn’s proposed amendment to the FY 2008 Labor, Health and Human Services, Education and Related Agencies Appropriations bill.

APTS President and CEO John Lawson praised the House action, stating “A bipartisan majority of 230 Democrats and 127 Republicans affirmed the view of millions of Americans that public broadcasting is essential.”

Representative Earl Blumenauer (D-Ore), co-chair of the 110-member House Public Broadcasting Caucus, said in opposition to the amendment: “Public broadcasting is culture, it is education, it is public safety. Indeed, this is the backbone in many parts of the country of emergency communications network...Public broadcasting is providing a voice for America, a noncommercial independent voice that is too often sadly lacking. It isn’t available anywhere else in the gazillion channels on our cable networks.”

## North Carolina Governor Signs Antenna Bill

North Carolina Governor Mike Easley in late June signed HB1340—the Amateur Radio Antenna bill—into law, making the state the 25th in the country to pass a state model of the FCC’s 1985 PRB-1 regulation.

The bill was introduced in February and was passed unanimously by both the House and Senate. The law, which takes effect

*(Continued on page 83)*



## OUR READERS SPEAK OUT

Each month, we select representative reader letters for "Our Readers Speak Out" column. We reserve the right to condense lengthy letters for space reasons and to edit to conform to style. All letters submitted must be signed and show a return mailing address or valid e-mail address. Upon request, we will withhold a sender's name if the letter is used in "Our Readers Speak Out." Address letters to: Edith Lennon, Editor, Popular Communications, 25 Newbridge Road, Hicksville, NY 11801-2909, or send email via the Internet to editor@popular-communications.com.

### We Can Move Mountains...

...literally. This letter was sent to author Janice Laws concerning her recent article "Life's A Trip, Log It." The geographic sleight of hand was ours, not Janice's. We apologize to the great state of West Virginia and any errant hikers still out there.

Dear Janice:

Your article in the July Pop'Comm about our radio finds on the road was interesting. However, please note that the caption under your picture on Spruce Knob is incorrect; that mountain is in West Virginia, and not Virginia. It's the highest mountain in that state, and I've hiked there several times. I was able to access our Winchester, Virginia, repeater on 146.820 MHz from there using a 2-watt handheld transceiver. An amateur repeater is located on Spruce Knob, and it's a favorite spot for hams on Field Day.

Perry Crabill, W3HQX  
Winchester, VA

### Just Can't Get Enough...

The following letter was sent to Pete Bertini, our "Wireless Connection" columnist.

Dear Pete:

Thank you, I love little projects like yours. As small as they are, they teach quite a lot.

You may want to pass this on in the chain of command: I wish there was a magazine devoted to nothing but homebrew stuff, and I wish your website had a forums section!

Frank  
Via email

Dear Frank:

Or maybe in book form...?

Editor

Dear Editor:

I really wanted to write and thank you

for all the great stuff you put in your magazine. I pick it up whenever I can find it on the newsstand, but sometimes it's sold out.

I especially like Gerry Dexter's column because he has so many great logs. And I also love reading Shannon's column. Her radio nostalgia's always so interesting.

Keep it up...

David G.  
Via email

Dear David:

We absolutely intend to. And maybe it's time you subscribed. We wouldn't want you missing any more of Gerry or Shannon.

Editor

### For New Orleans Gone By

Dear Editor:

I went to the local bookstore last night and bought your August issue because of the New Orleans article by Roberto Dabdoub ("Listening To The Echoes Of Katrina"). I read the article and am very glad you published it. The article provides a glimpse of what happened and did not happen due to Katrina. About half of everything I know in the city had been flooded (my boyhood home, grade school, high school, and both colleges among other places), some have not recovered and some are no longer there.

Having been born and raised there, I feel sadness when I read an article about New Orleans' lack of restoration progress. New Orleans will never be the same. I wish the article could have gone into even more detail about the dynamics of communications in New Orleans.

Dan  
Via email

Dear Dan:

The dynamics of the communications, and lack thereof, is a topic that will be examined and re-examined for a long time to come, both in these pages and in the larger public debate. It was that tragic.

Editor

# POPULAR COMMUNICATIONS

## EDITORIAL STAFF

Edith Lennon, N2ZRW, Editor

(E-mail: editor@popular-communications.com)

Tom Kneitel, W4XAA, Senior Editor

Richard S. Moseson, W2VU, Editorial Director

(E-mail: w2vu@popular-communications.com)

## CONTRIBUTING EDITORS

Rich Arland, W3OSS, Homeland Security

Peter J. Bertini, K1ZJH, Restoration/Electronics

Kent Britain, WA5VJB, Antennas And Accessories

Bruce A. Conti, AM/FM Broadcasts

Gerry L. Dexter, Shortwave Broadcast

Richard Fisher KI6SN, Capitol Hill News

Bill Hoefler, KB0ULJ, Aviation Communications

Tomas Hood, NW7US, Propagation

Shannon Huniwell, Classic Radio

John Kasupski, KC2HMZ, Utility Communications

Kirk Kleinschmidt, NT0Z, Amateur Radio

Ron McCracken, WPZX-486/KG4CVL, REACT

D. Prabakaran, News

Bill Price, N3AVY, Humor/Communications

Ken Reiss, Technical/Scanning

Bob Sturtevant, AD7IL, Puzzles and Trivia

Tom Swisher, WA8PYR, Military Monitoring

Jason Togyer, KB3CNM, Cartoons

Gordon West, WB6NOA, Radio Resources

## BUSINESS STAFF

Richard A. Ross, K2MGA, Publisher

Arnold Sposato, N2IQO, Advertising Manager

Emily Leary, Sales Coordinator

Sal Del Grosso, Accounting Manager

Doris Watts, Accounting Department

Melissa Gilligan, Operations Manager

Cheryl DiLorenzo, Customer Service Manager

Ann Marie Auer, Customer Service

## PRODUCTION STAFF

Elizabeth Ryan, Art Director

Barbara McGowan, Associate Art Director

Dorothy Kehrweider, Production Director

Emily Leary, Production Manager/Webmaster

Hal Keith, Technical Illustrator

Larry Mulvehill, WB2ZPI, Photographer

A publication of



CQ Communications, Inc.  
25 Newbridge Road  
Hicksville, NY 11801-2953 USA

Offices: 25 Newbridge Road, Hicksville, NY 11801. Telephone (516) 681-2922. FAX (516) 681-2926. Web Site: <http://www.popular-communications.com/> Popular Communications (ISSN-0733-3315) is published monthly by CQ Communications, Inc. Periodical class postage paid at Hicksville, NY and additional offices. Subscription prices (payable in U.S. dollars): Domestic—one year \$32.95, two years \$58.95, three years \$85.95. Canada/Mexico—one year \$42.95, two years \$78.95, three years \$115.95. Foreign Air Post—one year \$52.95, two years \$98.95, three years \$145.95.

U.S. Government Agencies: Subscriptions to Popular Communications are available to agencies of the United States government, including military services, only on a cash with order basis. Requests for quotations, bids, contracts, etc. will be refused and will not be returned or processed.

Entire contents copyright © 2007 by CQ Communications, Inc. Popular Communications assumes no responsibility for unsolicited manuscripts, photographs, or drawings. Allow six weeks for change of address or delivery of first issue.

Printed in the United States of America.

Postmaster: Please send change of address to Popular Communications, 25 Newbridge Road, Hicksville, NY 11801.



# Recuerdos...

## Looking Back 25 Years For Shortwave Memories

by Gerry Dexter

“**R**ecuerdos” is one of the titles on Stan Kenton’s brilliant “Cuban Fire!” The album notes say the word means “reminiscences.” When *Pop’Comm*’s erudite editor, Miss Edith, phoned suggesting I do something like this for our 25th Anniversary that’s the term she used to describe the concept.

Now, going back 25 years by relying on *my* memory is a dangerous business, akin to high-wiring it without a net or a balance bar! Fortunately my shortwave library contains enough historical material to provide numerous thought starters, so there’s no need to rely on my sieve-like retention ability. Having said that, I do have some *recuerdos* of my own.

### It Begins...

Then-editor Tommy Kneitel called to offer me the shortwave broadcast column in the late summer of 1982. So it’s from that point and through the early part of ’83 where we’re going to rummage through the memory vault to see what we find.

The first thing that comes to mind is how much action and excitement there was! A couple of SWBC weekly newsletters, fed by some of the world’s most knowledgeable and experienced DXers, kept us on top of things. Beyond those we had the monthly club bulletins, of which there were several, as well as weekly DX programs. And if the news involved a really hot tip there was always the telephone. (No, we didn’t have to dial an operator and ask her to place the long distance call!)

Anyway, it seemed that every week there was something new to be heard. Including frequent unidentifieds, which could sometimes take days or even weeks of monitoring and detective work to figure out. (We didn’t have the World Wide Web to rely on.)

Sixty meters was simply alive with Latins. One weekly listed logs from 13 Bolivians alone! If you doubled the number of active—and hearable—Bolivians today I don’t think you’d come up with even half that many, although the *World Radio TV Handbook* listing is still long.

But “Sixty” wasn’t merely Latin Land. Indonesian domestics, Indian regionals, Aussies, PNGs (Papua New Guinea, for you newcomers), and certainly the Africans left their mark! Cameroon had four or five regionals based in different cities. Radiodiffusion Togolaise on 5047? Pick your evening and you’d hear them signing on at 0530. Not all were snap receptions, of course. 5047’s cousin at Lama Kara on 3222 was a rarity.

\*Capitol Jazz CDP 7 96260 2

*Gerry Dexter, Pop’Comm’s shortwave broadcast guru, has been with the magazine since its inception.*



Another piece of history: the author, in an undated photo, doing what he loves.

**RADIO DENMARK**

Copenhagen, 10/15, 1957

DEAR LISTENER,

Your report of 8/17 1957 concerning our broadcast on 9520 kc/s, 31.51 m, 50 kw, call letters OZFS, at 0340-0400 GMT on 7/29 1957, beamed to North Americans hereby verified.

Sincerely yours,

*Paul Berg*  
(SHORTWAVE DEPT)

Radio Denmark was still active on shortwave in the early 1980s.



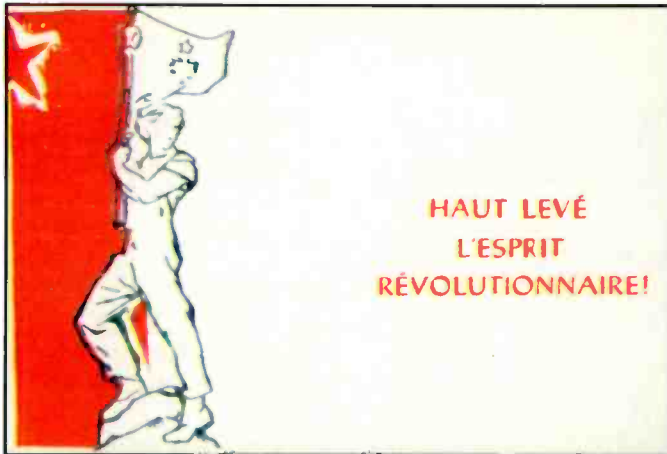

A good way to punish a naughty kid was to make him listen to a Radio Tirana announcer read from the works of Albanian strongman Enver Hoxha.



The "Listening Post" shack just before the column began. I do miss the Rascal—that's the big guy on the right.



Twenty-five years ago Swiss Radio was still going strong.



You had to beg Radio Moscow to put sites on its QSL cards.

Likewise Burundi on 3300 and Rwanda on 6055 (before the DW relay went into business there).

## Global Goings-On

Just as it does today, shortwave broadcasting reflected the world political situation. Then, as now, Cuba was a prime target for clandestines. La Voz del Cuba Independiente y Democrática (CID) was active with multiple services on several channels. The lower end of 7 MHz was home to a ragtag collection of more or less amateur clandestines—some operated by not-so-nice people who had occasional run-ins with the law or the FCC or

Castro's agents in Miami, or were actually involved in acts of sabotage against the regime. Radio Abdala, Radio Cuba Libre, Torch of Marti, and La Voz de Alpha 66 were some of the more active, although you couldn't predict which night any of them would be on, if at all.

Nicaragua and El Salvador were hot items in Washington, and there was a lot of radio activity surrounding both as left wing losers fought for "the people." Radio Venceremos, Radio Quince de Septiembre, Radio Farabundo Marti, La Voz de Nicaragua Libre, Radio Miskut and Radio Sandino were broadcasting on behalf of one side or the other. Radio Impacto in Costa Rica, a "commercial" station lacking any discernable advertis-

ing, ran a lot of political material against the left-wing rebels. Many came to the general conclusion that Impacto's funding was suspect, to put it delicately.

The year 1982 saw Argentina invade the Falkland Islands. After Argentine forces landed, the almost-never-heard Falkland Islands Broadcasting Station was taken off the air, disappointing the many DXers still seeking their first log. After the British victory FIBS returned, but only briefly before the shortwave outlet was shut down. (The BBC continued to broadcast its weekly "Calling the Falklands" program until just a year or so ago.)

Clandestines were buzzing around here, too. Argentina had a station called "Liberty" up on the 16-meter band that aired Beatles tunes, mixed with warnings to the British troops to turn their ships around and go home. DXers quickly nicknamed the lady host "Argentine Annie." It didn't take long for Britain's radio response. The BBC relay station at English Bay on Ascension Island soon began broadcasting a specially created Radio Atlantico del Sur (Southern Atlantic).

An ocean removed, KYOI in Saipan was about to come on the air and prove again that no one had yet figured out a way to make advertising-driven shortwave broadcasting work. It closed after just a couple of years and was purchased by Herald Broadcasting, which hoped to advance its Christian Science radio mission. Alaska's KNLS had just been completed and was about to sign on for the first time. It, of course, is still going strong.

## Other Voices

More memory makers: The jointly operated BBC/Deutsche Welle relay on





Radio Senegal was a regular every night on 4890.



Britain's Radio Atlantico del Sur was active during the Falklands War.



La Voz del CID was one of the main anti-Castro clandestines.

Adamov answering listener mail, begging for site QSLs from Mrs. Eugenia Stepanova. The other USSR services were nearly as well heard. We'd listen to Radiostansiya Rodina (Homeland), Radio Mayak (Lighthouse)—remember their "Midnight in Moscow" IS?—Radiostansiya Atlantika, Radio Tiky Okean (Pacific Ocean), Radio Peace and Progress, and Radio Magdallanes, beamed especially for Chile. And who could forget those "fascinating" readings of the works of strongman Enver Hoxha on Radio Tirana?

## Gone, But Not Forgotten

I could go on for many pages about the stations that we were hearing back then, but are long gone now. Do we miss them? Yes! Do we long for those days? Are you kidding? But as Stan Kenton used to say when asked about the early days of his orchestra: "Nostalgia isn't what it used to be!"

There's no doubt that shortwave has changed and lacks some of the excitement and romance it had for those of us who were active 25 years ago. Yet today, even with its faults, I think most find that it still calls to us. So, if those assumptions are true, then you and I have just two choices: 1. pull down the antenna, sell the receiver, trash the QSLs, and take up rope collecting; 2. dive in even deeper! Spend more time at the radio, upgrade equipment, support editors (me, for example!), and let stations know you listen to and appreciate their efforts, and do what you can to promote short-wave listening.

Me? I think I'll take a spin through 31 meters. ■

Montserrat was still active. The Polish Solidarity union had a program on the Dominican Republic's Radio Clarin. Speaking of Clarin, Radio Earth, then in its germination period, would eventually end up on Clarin—as Radio Discovery. Radio Senegal in Dakar on 4890 was still around. Swaziland had Swaziland Commercial Radio, operated by a Missouri-based company. In Haiti there was Radio Citadelle on 6155, in addition to the famous 4VEH.

Radio Denmark was still active—and broadcast direct from Denmark, no less. Mexico sported XEWW-La Voz de la America Latina, along with several others, including Su Pantera (The Panther) on 6105. There were actually two broadcasters in Antarctica. So, in addition to the frustration involved in trying for Radio Nacional Arcangel on 15476, you could get the same result with AFN-McMurdo on 6012.

Who can forget Radio Tahiti on 6135, 11825, and 15170? Who, back then, did not have the thrill of listening to grass-

skirt music flowing and swaying late on a snowy night? Or haunting huaynos running non-stop deep into the dark on Radio Andina, Peru.

## Names Of Yore

Sometimes just the station names held a fascination. There was The Voice of the Free Sons of Yemeni South! The Voice of the Broad Masses of Eritrea, a clandestine back then but legit now. And China's odd Beihai Fisheries Station (one DXer parodied it as the "BBC Scottish Fisheries Station"—and even had a t-shirt made up!). One of my favorites was the Voice of the Resistance of the Black Cockerel, run by Jonas Savimba's UNITA resistance party in Angola.

## Chilly Receptions

And don't we all so miss the "good old days" of the Cold War? Hearing Radio Moscow with that old smoothie Joe



**KENWOOD**

Listen to the Future

# KENWOOD

## TM-D710A

DATA COMMUNICATOR 144/440MHz  
FM Dual Bander



**A Star is Born**

Get Yours Today...See your local dealer for availability.

**KENWOOD U.S.A. CORPORATION**  
Communications Sector Headquarters  
3975 Johns Creek Court, Suite 300, Suwanee, GA 30024-1265  
Customer Support/Distribution  
P.O. Box 22745, 2201 East Dominguez St., Long Beach, CA 90801-5745  
Customer Support: (310) 639-4200 Fax: (310) 537-8235

**INTERNET**  
Kenwood News & Products  
<http://www.kenwoodusa.com>  
ADS#30407





# Alice Brannigan Tracks A Wandering Broadcaster

*For This Special Occasion, Pop'Comm Talked An Old Friend Into Rejoining Us For A Double Dose Of Radio Nostalgia*

by Alice Brannigan

**T**he early years of broadcasting were a bit chaotic. Stations were born, only to perish shortly thereafter. The government kept changing which agency was in charge of broadcasters, and it kept shifting the regulations and frequency assignments. From 1922 to 1941, things were in a state of flux.

Stations kept changing their locations to find the largest audience. They struggled to get more airtime and advertisers, and to avoid interference. Some regularly changed their call letters and transmitter power. Confusion reigned. A listener needed not only a good receiver, but also a scorecard just to keep track of this kaleidoscope. Many newspapers refused to carry station information out of fear that the blossoming broadcasting industry would siphon off readers and advertising revenue.

In 1921, KDKA became the first licensed commercial broadcast station. By 1922, there were more than 600 commercial and non-commercial church, college, newspaper, store, hotel, and personally owned stations in the United States. Even some hams had set up their own little unauthorized stations. Hams used homemade equipment, and even some low-powered licensed broadcasters tended to use equipment they had built themselves.

## Call It Casual

Keep in mind that most early broadcasters were informal little operations run by only a couple of people. The majority of stations ran between 10 and 100 watts, seeking to serve only their immediate neighborhoods. They could usually make do with small homebrewed transmitters and rooftop dipole antenna systems. Such stations had the ability to pick up and change locations on a whim and at the drop of a hat. Licenses to broadcast were pretty easy to obtain in those days, and lots of folks wanted to get in on this novel new technology.

It's always fascinated me to watch this constantly changing scene with all of its twists and turns. Let's focus in on one particular early station and watch its serpentine trek through the decades, via assorted call letters and locations.

## Two Guys From Brooklyn

In late 1926, the Brothers Faske (Arthur and Leo) obtained a license to operate a 100-watt station, WBKN, in Brooklyn,

*Not that she needs an introduction to most of you, but Alice Brannigan was the author of countless radio nostalgia pieces for Pop'Comm.*



*Here's our very own Alice Brannigan as she appeared on our June 1987 cover.*

New York. WBKN was assigned full use of the quiet frequency of 1030 kHz, and promptly set up shop in a couple of rooms in the Municipal Bank Building at 1525 Pitkin Avenue. It was in the heart of the Brownsville section of the city. They had built the transmitter. WBKN dubbed itself "The Voice of Community Service" and commenced with music from live performers and phonograph records.

All was bliss for a few months until the Federal Radio Commission decided that WBKN's frequency had been reallocated to Canada. The station was kicked off that channel and relegated to 1220 kHz, where it would have to divide air time on the frequency with several other one-lung local stations, WBMS, WIBI, and WWRL.

Its schedule was a patchwork quilt. WBKN was silent on Sundays. On Mondays and Fridays it operated noon to 1 p.m., and 3 to 5 p.m. Tuesdays it had the channel from 10 p.m. to



# GREETINGS

from

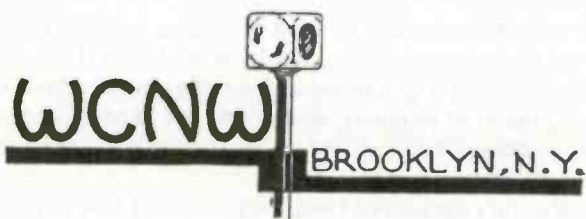

YOUR VALUED REPORT . . . . .  
DATED 11/22/34 AT 1:20 A.M.  
CHECKS WITH OUR LOG.

IN EXTENDING THIS VERIFICA-  
TION, MAY WE ASK YOU TO TUNE  
IN AGAIN.

VERY TRULY YOURS

W C N W  
1500 K/C

*Arthur Fiske*

The Brooklyn Station with the Championship Punch

100 W.

*Here's the QSL card WCNW sent to listeners.*

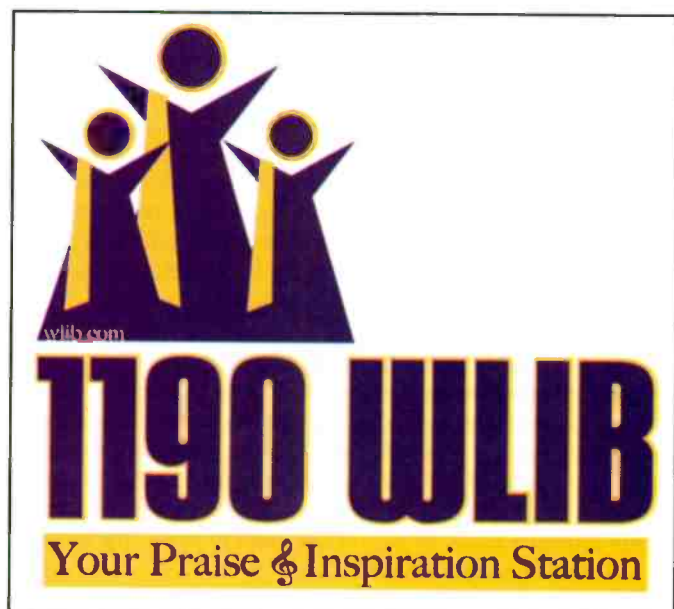

*This is the logo currently used by WLIB.*

midnight. Wednesdays it was on from midnight until 2 a.m. Thursdays and Saturdays it ran 6 to 8 p.m.

Things went well on 1220 kHz, but in 1927, the FRC decided that the four stations should all move to 1500 kHz. This made the Faskes decidedly unhappy. They squawked that 1500 kHz was the "graveyard" channel at the high-frequency edge of the broadcast band. Arthur grumbled it couldn't even be tuned in on some older and cheaper receivers.

## Wagons West!

In 1928, after only two years in the shadow of Brooklyn's Ebbets Field, Arthur and Leo Fiske pulled the plug on WBKN and moved it 20 miles west to the seaside resort village of Long Beach, Long Island. They kept the slogan "The Voice of Community Service," adding that the station was "The Municipal Broadcasting Station of Long Beach." The station changed the call letters to WCLB. With studios in the Ocean Crest Hotel, on the boardwalk, the station remained on 1500 kHz, sharing airtime with WBMS, WGOP, and WWRL. By 1929, its channel partners were WL BX, WMBQ, and WWRL. Programming consisted of music, talk shows, and sports.

When WCLB's license expired during the summer of 1929, the FRC refused to grant it a renewal. The station's owners protested and managed to get the license reinstated in April of 1930. But it was nearly over for the Fiske Brothers' seaside idyll.

## Return Of The Prodigal Son

The Great Depression made for lean times in Long Beach. So, in April of 1931, Arthur Fiske decided to pack up his beach



*Today, WLIB 1190-AM, New York's "first 24-hour inspiration station, shares studio space with sister station WBL5-FM on Manhattan's Park Avenue.*



togs and transmitter and return his little station to the very same digs on Pitkin Avenue, Brooklyn, where he had begun back in 1926. The station was still on 1500 kHz, but changed its call letters to WMIL, dubbing itself "Brooklyn's Premier Independent Station." WMIL split time on the frequency with WLBX, WMBQ, and WWRL.

Arthur Faske then got a brainstorm. What a crazy guy! He tried to convince the FCC to kick WLBX off the air and relinquish ITS airtime to WMIL. When that idea crashed, Faske's Plan B was to move WMIL to 1300 kHz, replacing WFAB on that channel. The feds regarded that concept as the worst plan since *Plan 9 From Outer Space* (look it up if you don't know).

In 1933, Arthur Faske got permission to change the call letters to WCNW and to finally increase the station's daytime power to 250 watts (still 100 watts at night, however). WCNW called itself "The Brooklyn Station WWith the Championship Punch."

### A New Image

The year 1935 saw Faske move his station's facilities to a new location on Flatbush Avenue.

In 1941, when the government extended the high-frequency edge broadcast band from 1500 kHz to 1600 kHz, it moved WCNW there. Faske decided to accept his fate and tell listeners it was the first frequency on their dials. WCNW still shared airtime with WWRL. The fact was, after 15 years of hard service, WCNW's homebrewed transmitter had acquired the irk-

some habit of wandering off its assigned frequency and, even worse, simply shutting itself down altogether.

By then, the FCC had had it up to here with the fickle Mr. A. Faske and his antics. Neither was the agency particularly amused by WCNW's assorted technical disasters. The agency sought to shut down the station. Amazingly, Faske not only managed to keep his license, he even convinced the FCC to allow him to change frequency and run 1 kW on 1190 kHz.

The WCNW programming was varied and even ethnic, with an assortment of religious, sports, and talk shows directed at Asian and black listeners. In fact, it called itself "The Voice of the Negro Community."

In the early summer of 1942, Faske sold WCNW to his general manager, E. Goldofsky. Faske stayed aboard as the chief engineer. The new owner promptly changed the station's call letters to WLIB, calling it "The Voice of Liberty." He also opened up studios in Manhattan.

Goldofsky formatted WLIB with classical music, and the station became a popular staple on the New York radio dials. WLIB was so successful that, in 1944, it was purchased for a quarter of a million dollars by the owners of *The New York Post* newspaper.

### WLIB Gets The Blahs, Then The Good News

By 1949, however, WLIB found itself knee deep in financial trouble and had to be sold at the bargain price of \$150,000. The new owners changed to a varied ethnic format to appeal to Spanish, Yiddish, Greek, and black audiences. As time passed, WLIB's programming relied primarily upon its coverage to black audiences, and the studios were moved to Harlem in 1962.

In 1971, WLIB was sold again. By that time it had become the most popular station in New York serving the black and Afro-Caribbean audiences. WLIB now used the slogan "Your Praise and Inspiration Station." In 1994, the FCC allowed WLIB to operate with 50 kW (30 kW at night). It currently shares studio space with sister station WBLS-FM on Manhattan's Park Avenue.

### A Well-Deserved Thank You

It's was a long and eventful road getting from WBKN to WLIB, and I want to thank our friends at *Broadcast Pro-File* for their invaluable assistance in researching the history of these stations. *BP-F* maintains extensive and highly detailed histories of virtually every American broadcast station that ever existed. Copies of these reports are available at a very nominal cost. Write them for their free catalog, and be sure to tell them Alice, or Shannon, sent you. Their address is *Broadcast Pro-File*, 28243 Royal Road, Castaic, CA 91384-3028.

### Franks For The Memory

Did you ever see the Oscar Meyer *Weinermobile*? It looks like a giant hot dog on a roll. Next time it comes to town listen for its low-power FM broadcast station on 88.3 MHz. About all it plays is that annoying Oscar Meyer jingle, and you can hear it only within a block or two of the vehicle. Now, try to get a QSL from that unique station!

That's about it for now from here in Radioville. It was a great pleasure spending time with all our *Pop'Comm* readers again. I hope you enjoyed it, too. ■

## NEW FROM CQ!

### CQ HF Operator's Survival Guide

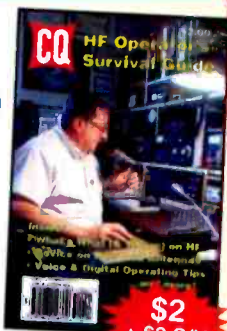

A practical, hands-on getting started guide for newcomers to high-frequency (shortwave) Amateur Radio. Among other topics, this book discusses the characteristics of each HF ham band and explains which is best and when, basic HF operating practices, choosing your first HF transceiver, antenna basics and various HF modes and operating activities. There's also an HF band chart!

**Receive this booklet FREE  
with a 3-year subscription to  
CQ Amateur Radio magazine.**

**CQ Communications**  
25 Newbridge Rd., Hicksville, NY 11801  
Phone 516-681-2922  
[www.cq-amateur-radio.com](http://www.cq-amateur-radio.com)



# Heathkit—From Airplanes To Educational Courses

## Pop'Comm Takes A Fond Look At Another History

by Randy Kaeding, K8TMK

Over the past 50 years or so a number of companies have marketed products for the communications hobbyist. Some of these companies no longer exist, while others have changed their marketing targets. In either case, many of them have essentially been forgotten. One company, Heath Company, was once considered “the largest manufacturer of electronic kits.”

Although Heath Company no longer makes Heathkits, it does still hold a special place in the hearts of those who ever built one of its products. Many of us can still remember verifying the seemingly never-ending pile of parts against the parts list. We can also still remember the whiff of smoke as each part was soldered, even the whiff of the occasional burnt finger when we got too close to the soldering iron. But by far the greatest pleasure was when we first turned the unit on and it actually worked!

True, Heathkits have not been manufactured for over 15 years, but many are still in use today. Just look at any photograph of someone's hamshack, and you'll probably find at least one Heathkit.

This month, as *Pop'Comm* celebrates its own history, we also take this opportunity to remember, and celebrate, the history of the beloved company that made Heathkits.

### A Man With A Plan

The story of Heath Company begins with a man named Edward Bayard Heath, who was born in 1888. Ed was so fascinated with flying that he built his own airplane at the age of 21 in a family-owned machine shop in Chicago. His dream was to produce an affordable lightweight airplane so the average person could also enjoy flying. The company Heath went on to found became known as the Heath Aeroplane Company.

One of the ways Heath made his airplanes affordable was to produce them in kit form. In 1926 one of his popular designs, the Parasol, was available in both assembled and kit form. Eventually, the Parasol could also be purchased in several stages of assembly. Soon, Heath saw that he could increase his airplane sales by starting a flying school, thereby attracting more potential customers.

*Randy Kaeding, K8TMK, joined Heath Company in 1970 as an audio technician, and later worked as a technical writer. He's currently Course Architect for Heathkit Company. Recently, Randy and several former employees formed the Heathkit Amateur Radio Group, obtaining the appropriate callsign W8KIT.*



*A very early, undated Heath Company catalog.*

Tragically, Heath was killed in 1931 during a test flight of a new design. Without his leadership—and in part because of a new Department of Commerce regulation against building aircraft at home—the company went downhill and moved from Chicago to Niles, Michigan. By 1935, the company was bankrupt. A few Parasols still exist today, mostly in museums.

### A Resurgence

Fortunately, the company did not end with Heath's death. In 1935, an engineer named Howard E. Anthony bought Heath Company in an auction—for a mere \$300! Howard was not a rich man, but he was ambitious, curious, and also interested in electronics and flying. Anthony moved his company to Benton Harbor, Michigan, and renamed it Heath Aircraft Company. He began to buy surplus materials, such as aircraft parts, including aircraft radio equipment and all kinds of other electronic parts. One of his first electronic products was a low-cost, easy-to-





*Ed Heath in his pontoon plane.*

Amateur Radio, Audio Components, Test Equipment, Automotive, Television, Computer Products, and General. The company also briefly added a Furniture product line and a Lighting and Security group, which did business under the Heath/Zenith and Reflex brand names. Heath Company-owned Prokit Electronic Company in Hong Kong manufactured the lighting and security products.

In 1974, Heathkit Educational Systems was formed and is the only division of the company that remains today.

In 1979, Schlumberger sold Heath Company to Zenith Radio Corporation for 63 million dollars, which signaled a major change in direction for the company. Zenith's emphasis was on the company's very successful and profitable computer business, and so Zenith Data Systems (ZDS) was formed. As the company grew to around 2,000 employees, it became obvious that more space was needed yet again. A new large building was built directly across the street from the original building on Hilltop Road in St. Joseph. This building housed the ZDS engineering department. As the company continued to grow, a large shipping warehouse was leased about a mile to the south.

## Changing Trends Lead To A Decline In Interest

By the mid 1980s, the kit business began to fail. This was partly due to changing interests, foreign competition (you could buy a similar, or better, assembled product for less money than a kit would cost), and the public's desire for

install aircraft radio, the Model MA-4A, which was designed for Heath by the Meissner Company.

Anthony's interests quickly shifted from aircraft products to electronic products, and the company began to recover. In 1947, Howard designed a 5-inch oscilloscope from surplus parts and offered it in kit form for \$39.50. This was the first Heathkit. The oscilloscope was quickly followed by a vacuum tube voltmeter for \$24.50 and a signal generator for \$19.50. When surplus parts became unavailable, they were replaced with brand new parts.

The first kit manuals were very abbreviated and written for people with a technical background. As interest grew, however, especially among non-technical people, the kit manual greatly expanded so that almost anyone could build a Heathkit. One of the company's mottoes was "We won't let you fail."

1958 and expanded many times between 1960 and 1968. And, by the way, a large photograph of Howard Anthony is still proudly displayed on a wall in the current office area.

In 1961, Daystrom merged with Schlumberger Limited and formed the Schlumberger Products Corporation, which later changed its name to Veritechnology Electronics Corporation. The company continued to grow during the 1960s and 1970s, and the interest in Heathkits became so great that around 55 Heathkit retail stores were opened at strategic locations in the United States, plus a few in Canada and Europe, making it much easier for potential customers to see the actual product and get it right away.

Around this time, Heath offered some 400 kits in the following product lines:

## Another Tragedy, Another New Beginning

By 1954, the company grew so much that it occupied at least seven buildings. Moving materials back and forth between buildings was so inefficient that Anthony contracted a company to build a new plant in nearby St. Joseph, Michigan. After these plans were in place, Anthony left on vacation and, ironically, was also killed in an airplane crash. This temporarily stalled the expansion plans while Anthony's widow, Helen, found a suitable company to continue the Heathkit legacy.

In 1955, Helen sold the company to Daystrom, Inc., which continued the expansion. The new building on Hilltop Road in St. Joseph was completed in

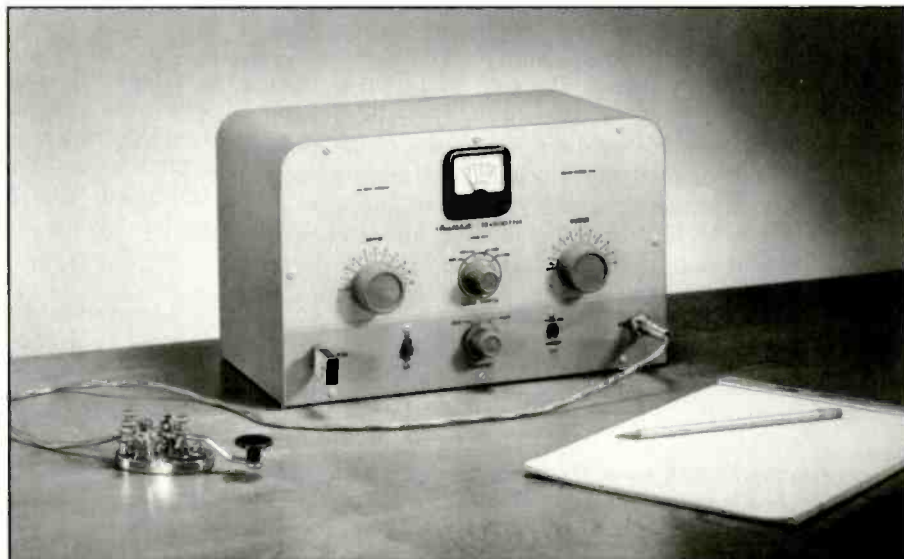

*Heath's AT-1 was the first amateur radio transmitter kit.*



# HEATH DEC.-JAN. FLYER

## ELECTRONIC SPECIALS

The Christmas rush moved us under heading the December Flyer to prepare the December-January Flyer—the issues will be placed however. Our shipping department did not and when we placed the flyer before Christmas nearly every order was on the way and on Saturday before everyone received their gifts on time. Our bridge on the matter of 1998 our orders are shipped within 48 hours after received but in the case of our little, the Christmas season for Christmas we will not be getting an order but we will not exceed a week or two days.

**The BEST NEWS OF THE MONTH!**

### The 1918 5 INCH HEATHKIT OSCILLOSCOPE

The helpful suggestions of those who have assembled Heathkit Oscilloscopes have made possible many improvements. The new model is lighter, smaller and more compact with improved sweep circuitry, linear amplifiers and amplified assembly and wiring. Customers are finding that assembling these kits is really fun and a good education and that's more than they think they have a quality instrument so good an easy one to get at only about one third the cost of factory built instruments.

**LOOK WHAT YOU GET...**

1. Heavy single part electrolytic tubes (200, 100, 600's, 500 750's and 800's), transformer, etc. the screen and base up wire.
2. Beautiful veneer panel, grey anodized metal and aluminum all packed, formed and section plated.
3. Detailed blueprint, instructions and layout drawings. All you need is a soldering iron, screw driver and pliers.
4. See output size (10" x 13" x 19" line).
5. Frequency associated vertical and horizontal amplifiers are 600's and are binary plus or minus 100 from zero frequency to 50 Hz.

These supply with all fitted accessories supplies 1200V magnetic and 750V positive making 1500V available for the tube.

7. Sweep generator supplies 15 volts to 50 Hz sweep.

**Not here ELSE TO BUY \$39.50**

APP SHIP WT. 95 LBS

---

### BC 645 GENERAL ELECTRIC TRANSCEIVER

We've told you about the BC 645 before but now have added for more information. The BC 645 covers the ultimate band (40-475 kHz) without change and is approved for licensing by the FCC on an international basis for the only commercial mobile from any home, hotel, restaurant, airplane, etc. It contains a two tube receiver (600 50's, 600 100's, 600 200's, 700's and two 750's) with a five tube transmitter (1 500's, 600's, 700's, 750's) and operates from 12 or 24 V D.C. with a speaker available at \$5.00 or from 110 V A.C. with the transmitter power supply as apply at \$11.95.

These beautiful sets meet the Government over \$200.00 and are a steal while they last at \$127.00. Complete instructions and diagrams are provided and operate weight is 20 pounds max.

**\$14.95**

**2 FOR \$27.00**

### BC 645 ACCESSORIES

240V A.C. Power Supply Kit \$11.95  
T-32 Table Microphone 2.95  
Microphone Transformer 1.95  
5" PM Speaker with 6F6 Output Transformer 2.80  
Antenna Cable R.G. 8 U 4.45  
BC 645 Dynamotor for 12 or 24 V Operation 3.95

**KITTING VIEW**

“instant gratification.” The majority of the public simply did not want to spend time building a kit. In addition, to put more features in a smaller package, the industry was quickly switching to a surface-mount technology approach that was too hard for most people.

In an attempt to rekindle interest in kit building, however, Heath Company designed several “starter kits.” These were very simple kits that took a very short time to assemble and contained some educational value by explaining in detail how the device worked. Unfortunately, the idea never really took off.

In 1989, Groupe Bull headquartered in France acquired Heath Company as part of its acquisition of ZDS for 650 million dollars. You’ll note that the value of the company increased a little more than tenfold in only 10 years. At this time, the kit business, ZDS, Veritechnology, the Heath/Zenith Lighting and Security business, and Heathkit Educational Systems remained in the Hilltop buildings. Prokit Electronics Company was also part of the Groupe Bull acquisition.

Because the computer business was bringing in by far the most revenue, it became increasingly difficult to get new designs through the company’s shared resources (drafting, computer-aided design, etc.). So, in March of 1991, Heath Company (all except ZDS) moved into its own newly renovated building, a former K-Mart, located at 455 Riverview Drive in downtown Benton Harbor, Michigan. The idea was that these businesses would become a stand-alone company and not be so hindered by the control ZDS had over the shared resources. In addition, the company would be more attractive to a potential buyer.

A few months after the move, Heath Company began phasing out the failing kit business and the retail store program. The only companies that remained were Heathkit

Cover of 1948 catalog showing the first Heathkit—a 5-inch oscilloscope.

# If you enjoy Amateur Radio ...you'll enjoy **CQ**

It's a different kind of ham magazine. Fun to read, interesting from cover to cover, written so you can understand it. That's **CQ**. Read and enjoyed by thousands of people each month in 116 countries around the world.

It's more than just a magazine. It's an institution.



CQ also sponsors these world-famous award programs and contests: The CQ World-Wide DX Phone and CW Contests, the CQ WAZ Award, the CQ World-Wide WPX Phone and CW Contests, the CQ World-Wide VHF Contest, the CQ USA-CA Award, the CQ WPX Award, the CQ World-Wide 160 Meter Phone and CW Contests, the CQ World-Wide RTTY Contest, the CQ 5 Band WAZ Award, the CQ DX Award, CQ iDX Award, CQ DX Field Award, CQ DX Marathon and the highly acclaimed CQ DX Hall of Fame.

## SUBSCRIBE TODAY!

CQ The Radio Amateur's Journal  
25 Newbridge Road, Hicksville, New York 11801  
Phone: 1-516-681-2922

**For Fastest Service FAX 516-681-2926**



	USA	VE/XE	Foreign
1 Year	<input type="checkbox"/> 36.95	<input type="checkbox"/> 49.95	<input type="checkbox"/> 61.95
2 Years	<input type="checkbox"/> 66.95	<input type="checkbox"/> 92.95	<input type="checkbox"/> 116.95
3 Years	<input type="checkbox"/> 96.95	<input type="checkbox"/> 135.95	<input type="checkbox"/> 171.95





*An aerial view of the main Hilltop Road building in St. Joseph, Michigan, circa 1980.*

Education Systems, the Lighting and Security business, and Prokit.

Much of ZDS's success had been due to its winning several large government contracts. But with the loss of a major contract, and price competition from Compaq and Dell, this business also began to fail. Both buildings on Hilltop Road were eventually sold, and the shipping warehouse was vacated.

Four years later, Groupe Bull, now doing business as Bull Systems, Inc., sold Heath Company to HIG Capital

Management, Inc., based in Miami. HIG was a private investment firm that acquired small- and medium-sized companies. Some time later, Groupe Bull sold ZDS to Packard Bell/NEC.

## Today

In early 1998 the Lighting and Security group, Prokit, and the Heath Company name were sold to DESA International of Bowling Green, Kentucky. HIG retained only Heathkit



*Production area in the current Riverview Drive building, where some assembly is performed.*



Heathkit Company employees, 2007. The author is in the back row, center, in the blue shirt. (Photo by April Moschioni)

Educational Systems and the Heathkit name, which officially became Heathkit Company, Inc. The "new" Heathkit Company was actually comprised of two companies: a property management company (the Riverview building) and Heathkit Educational Systems. A year later, HIG sold the Riverview building to Benton Harbor Charter Schools, and the Heathkit Company to a private investment group. Due to the sale, Heathkit Company leased about half of the building from the school.

The Heathkit Company was sold again in 2006 to a private individual who still owns it today. The current company still leases half of the Riverview building from the school and has about 25 employees. It mostly sells technical education hardware and manuals through distributors to vocational and post-secondary schools. Most of the educational courses are computer-related in some way.

One of the most recent products was a course in RF-ID (Radio-Frequency Identification), a technology that may eventually replace bar code labels because the contents of a box that contains many items can be read without opening the box. The anti-theft sensors that many stores install at their doors are also a form of RF-ID.

The company also recently began a new Life Sciences series of courses, and by the time you read this article, this author will have finished up a Biomedical Instrumentation course that includes an electronic trainer, nine circuit-specific training modules, and a lab manual consisting of hands-on experiments. For more information about these and other

courses, visit the Heathkit website at [www.heathkit.com](http://www.heathkit.com)

## And For The Nostalgia Buffs...

We hope you enjoyed this look at the development and, for many of us very sad, decline of one of the most important influences on our hobby. Thank you, Heath Company.

And for those of you who just can't get enough of this bit of history, you can find information about older Heathkits by subscribing to an information website at [www.tempe.gov/lists/control.aspx?list=HEATH](http://www.tempe.gov/lists/control.aspx?list=HEATH). Just follow the simple instructions to subscribe to the list. But keep in mind that this website is not supported by the Heathkit Company, and the company is not responsible for any information shared there. ■

## RentScanner.com



- Try before you buy
- One week to one month
- AR8200MKIII, PRO-96, BCD396T
- Starting at \$23

[www.rentscanner.com](http://www.rentscanner.com)

### ELECTRIC RADIO MAGAZINE

Tired of modern radios you can't work on and are hard to understand? ER is the monthly magazine for you! Send \$1 for a sample to:

ER, PO Box 242,  
Bailey CO 80421-0242  
720-924-0171 or email:  
1Editor2@indra.com  
[WWW.ERMAG.COM](http://WWW.ERMAG.COM)

# ATOMIC TIME

1010 Jorie Blvd. #332  
Oak Brook, IL 60523  
1-800-985-8463  
[www.atomictime.com](http://www.atomictime.com)

**ADWA101 - \$49.95**

**14" LaCrosse Black Wall WT-3143A \$26.95**  
This wall clock is great for an office, school, or home. It has a professional look, along with professional reliability. Features easy time zone buttons, just set the zone and go! Runs on 1 AA battery and has a safe plastic lens.

**Digital Chronograph Watch ADWA101 \$49.95**  
Our feature packed Chrono-Alarm watch is now available for under \$50! It has date and time alarms, stopwatch backlight, UTC time, and much more!

**WT-3143A - \$26.95**

**WS-8248 - \$64.95**

**LaCrosse Digital Alarm WS-8248U-A \$64.95**  
This deluxe wall/desk clock features 4" tall easy to read digits. It also shows temperature, humidity, moon phase, month, day, and date. Also included is a remote thermometer for reading the outside temperature on the main unit, approx. 12" x 12" x 1.5"

1-800-985-8463  
[www.atomictime.com](http://www.atomictime.com)  
Quantity discounts available!

**WS-9412U - \$19.95**

**LaCrosse WS-9412U Clock \$19.95**  
This digital wall / desk clock is great for travel or to fit in a small space. Shows indoor temp, day, and date along with 12/24 hr time, apx 6" x 6" x 1"

Tell time by the U.S. Atomic Clock - The official U.S. time that governs ship movements, radio stations, space flights, and warplanes. With small radio receivers hidden inside our timepieces, they automatically synchronize to the U.S. Atomic Clock (which measures each second of time as 9,192,631,770 vibrations of a cesium 133 atom in a vacuum) and give time which is accurate to approx. 1 second every million years. Our timepieces even account automatically for daylight saving time, leap years, and leap seconds. \$7.95 Shipping & Handling via UPS. (Rush available at additional cost) Call M-F 9-5 CST for our free catalog.



# Masters Of Scanning

## Four Innovators Who Helped Shape Our Hobby Look Back— And Ahead

by Ed Muro, K2EPM

**T**he radio hobby and technology in general have grown by leaps and bounds over the last 25 years, so much so that I don't think we could ever have imagined the changes that have taken place. In celebration of 25 years of *Popular Communications*, I thought it would be fitting to take a retrospective look at the past 25 years in the scanning hobby, with an eye also toward where we are today and where we may be headed. To help me, I reached out to some of the "movers and the shakers" in this hobby to get their impressions on where we've been and where we're going. We'll meet them shortly, but first I wanted to spend a few moments on the developments of the past couple of decades as I see them.

### A Quarter Century Of Change

When we talk about advancement in technology over the last 25 years, we talk about it on several levels.

First, there are what I call the "monitoring targets." These are the people or agencies we listen to on our scanners. Technology has changed the equipment they use, sometimes forcing change in the equipment we use to listen to them.

For instance, years ago, you'd often find agencies using one frequency for the base to dispatch on and another frequency for the mobile units to talk back on, in many cases the mobiles couldn't hear each other! So, you'd have to program both frequencies in your scanner. For the most part, those days are over. Repeaters came along and changed that. And today agencies are no longer using one or two frequencies; now they have "systems."

Second, there's what I call "the end user"; in other words, us, the scanner hobbyists. As agencies moved to 800-MHz trunked systems, scanners had to evolve to cover that frequency. Then they evolved another step to follow the conversations within the trunking protocols. Later, as new types of trunked systems appeared, they had to adapt to monitor those types of communications. The most recent advancements have been the ability to monitor APCO 25 digital systems and to interface with computers for either programming or computer-aided scanning.

Finally, there's how we hobbyists gather the data we need to monitor various agencies and how we communicate with each other. When I started in this hobby the only way to get frequency data was to buy a copy of *Police Call* at RadioShack, mail away for one of Tom Kneitel's books from CRB Research, or go to a local CB Shop or RadioShack and see if they had a printed sheet of local frequencies. Sometimes those sheets were free, sometimes a dollar or two.

*Ed Muro, K2EPM, has been a radio hobbyist since his early teens. He served three terms as vice-president of the Long Island Mobile Amateur Radio Club and is a public information officer and VE for the ARRL.*

As far as communicating with each other went, there were two ways—and they were both *s-l-o-w*. There were many radio clubs that printed newsletters so members to exchange information, and there was the good-old U.S. Mail. Many people made life-long friends writing letters back and forth. I still have a folder full of some of my favorite letters. Well, my friends, something called the Internet changed all that.

That, in a nutshell, is where the last 25 years have taken us in the scanning hobby. At this point, I'll hand the mic to the experts of the hobby and let them share their viewpoints.

— • • • —

### Mark Meece, N8ICW

First, we talk with Mark Meece, N8ICW, who's been a hobby mainstay in the greater Cincinnati, Ohio, area for as long as I can remember. His involvement with the Cincinnati/Dayton Area Monitoring Exchange (MONIX) and the Association of North American Radio Clubs (ANARC) has helped countless hobbyists.

*Ed:* How did you get involved in the radio hobby?

*Mark:* I have been fascinated with radio since I was quite young. My first memory is tuning around on multi-band radios my mom had. I would search for anything two-way I could hear—police, aircraft, etc. One Christmas my mother gave me a Realistic Pro-53 8-channel crystal scanner, I soon migrated to the Pro-2002, the first 50-channel programmable scanner from RadioShack. I was hooked from there on out. I have my mother to thank for pushing me into the hobby. I had no idea I would ever be this involved in it.

*Ed:* What do you think of the advancements in technology?

*Mark:* When I think back to the early '80s and scanners such as the Bearcat 250 and Bearcat 300, with a channel capacity of about 50 frequencies, that had to be programmed by hand, costing between \$300 and \$400, and then I look at what \$400 can buy you today...1,000 or so channels, trunking, alpha tags, and computer programmability...I have to think we are in somewhat of a better position. Yet, others will

*Mark Meece, N8ICW, speaks at the 2007 Winter SWL Festival in Kulpville, Pennsylvania.*



argue that technology has excluded a lot of people who don't want to take the time to learn how to use the new equipment. We heard stuff like this before: "Oh, it's so much easier to program an old 16-channel scanner by hand."

The worry has always been, that as public service communications progressed technologically, that we as hobbyists would eventually be shut out, but that has not been the case at all. The hobby side of technology has kept pace.

Fifteen years ago I could tell you the user of a specific frequency within 100 miles of my home just by glancing at the frequency. If anything, I am now spoiled by alpha tags. I love looking at the scanner and seeing the screen tell me whom it is I am listening to.

As for computer programming, these days it is just about the only way to go to program your scanner. As the proud owner of both the Pro-96 and Pro-97 I actually enjoy creating files for areas I visit. A hobbyist named Don Starr has written some wonderful user-friendly, low-cost software programs for scanners, such as those I just mentioned. Also with the higher amount of memory available in current scanners, to hand-program 1,000 channels could cause carpal tunnel syndrome to set in.

That being said, however, don't rely 100 percent on computer programming. Always learn how to program your scanner manually, so when you are out in the field you can change things on the fly quickly...

[T]here are people who will go into a store, buy the latest gadget—not just scanners mind you, this can practically be applied to anything electronic these days—and they get home, take it out of the box, turn it on and expect it to be set up and working for them immediately. They want immediate gratification, but the radio-monitoring hobby doesn't work that way.

Some of the newcomers to the hobby just do not realize there is research involved. In this day and age we have a wonderful source of info called the Internet, so there is no excuse for not finding information on scanning receivers, frequencies, reviews, clubs, etc.

*Ed:* Many people know you from your involvement in MONIX and with the MONIX Frequency list and web page. What is MONIX and how has it evolved?

*Mark:* MONIX stands for the Cincinnati/Dayton Area Monitoring Exchange. It started out in 1983 as a frequency list on a 300-baud BBS (computer bulletin board.) The premise was that if you downloaded the list you had to add to it a frequency not already on the list. I decided to add everything I had collected from my eight years of monitoring and that more than doubled the size of the list. From there it has grown almost exponentially. It now stands at just over 100 pages.

Around October 1990, we started a weekly amateur radio net on a local repeater and started monthly meetings. We were fortunate that one of our members was an engineer at the now historic Voice of America Bethany Relay Station in West Chester, Ohio. We held our meetings there until the government closed the facility in 1994.

In 1997 I created the MONIXWeb site at [www.siscom.net/~nmeece/monix.html](http://www.siscom.net/~nmeece/monix.html) and one of our other members created a sister site that holds the frequency list at [www.monix.net](http://www.monix.net). We also have a Yahoo group list at <http://groups.yahoo.com/group/MONIX>.

The club is mainly for the benefit of hobbyists in and around the Cincinnati/Dayton area, including Northern Kentucky, Southeastern Indiana, and West Central Ohio. However, anyone can feel free to join us. I think what has been the main dri-

## RSGB Books from



### VHF/UHF Handbook

Edited by Dick Biddulph, M0CGN  
RSGB, printed 2002., 317 pages.

One of the most complete guides on the theory and practice of reception and transmission on VHF/UHF band. Hundreds of Illustrations and photos.

Order: RXVUH **\$35.00**



### Packet Radio Primer

By Dave Coomber, G8UYZ & Martin Croft, G8NZU  
RSGB, 2nd Ed., 1995, 266 pages

Detailed practical advice for beginners. Completely revised and greatly expanded to cover developments in this field and beyond bare basics into advanced areas such as satellite operations.

Order: RSPRP **\$16.00**



### Amateur Radio Mobile Hdbk

RSGB, 2002, 128 pages.

Covers all aspects of this part of the hobby. Operating techniques, installing equipment in a vehicle and antennas, maritime, and even bicycle mobile.

Order: RSARMH **\$21.00**



### Practical Receivers for Beginners

By John Case, GW4HWR

RSGB, 1996 Ed., 165 pages

Selection of easy-to-build receiver designs suitable for amateur bands (including microwaves) and simple fun projects and test equipment.

Order: RSPRN **\$24.00**



### HF Antenna Collection

RSGB, 1st Ed., 1992, 233 pages.

A collection of outstanding articles and short pieces which were published in Radio Communication magazine during the period 1968-89. Ingenious designs for single element, beam and miniature antennas, and comprehensive info on feeders, tuners, baluns, testing, modeling and more.

Order: RSHFAC **\$16.00**



### Practical Antennas for Novices

By John Heys, G3BDQ

RSGB, 1st Ed., 1994, 52 pages.

How to build simple but efficient antennas for each of the Novice bands up to 434MHz plus ancillary equipment to ensure they're working!

Order: RSPAN **\$12.50**



### Digital Modes for All Occasion

By Murray Greenman, ZL1PBPU

RSGB, 2002 Ed., 208 pages.

Simply the most "complete" book on Digital Modes available. Over 100 illustrations!

Order: RSDMFAC **\$27.50**

View more RSGB Books on our web site  
[www.cq-amateur-radio.com](http://www.cq-amateur-radio.com)

Shipping and Handling: US and Possessions \$5.00 for the first book, \$2.50 for the second, and \$1 for each additional book. **FREE SHIPPING ON ORDERS OVER \$75.00** (merchandise only). Foreign - Shipping will be calculated by order weight and destination and will be added to your credit card charge.

**CQ Communications Inc.**

25 Newbridge Rd., Hicksville, NY 11801

516-681-2922; Fax 516-681-2926

Order Toll-Free 800-853-9797



ving force for MONIX all these years is that our members are always on the lookout for something new and unknown.

*Ed:* You also were heavily involved in ANARC and spent time both on the ANARC Board of Directors and as Chairman. What was ANARC?

*Mark:* ANARC was the Association of North American Radio Clubs, an umbrella of member clubs across North America, mainly Canada and the United States. It was formed in 1964 at a time when some radio clubs that were somewhat in close competition with each other were bickering and causing dysfunction in the radio-monitoring hobby. ANARC set up a series of goals to help promote closer ties and the interchange of ideas and information among the member clubs and to be a liaison between hobbyists, broadcasters and radio equipment manufacturers.

At one time there were 15 or so member clubs. A seven-member Board of Directors governed ANARC, with one [member] acting as Chairman. The Board of Directors [comprised] members of the member clubs in ANARC each serving two-year terms. A group of three would be elected one year and a group of four would be elected the following year.

My first experience with ANARC was sitting in as a guest at a Board of Directors meeting during the 1990 Dayton Hamvention. At the urging of Dave Marshall, the managing editor of the All Ohio Scanner Club, I ran for and was elected to the ANARC Board in 1994. In 1996 I was elected Chairman of ANARC, I held that post until late 2004. In 2005 with dwindling member club support and participation, the Board of Directors decided that ANARC had fulfilled its original purpose and was no longer needed, so ANARC was dissolved after 41 years of service.

*Ed:* Given the explosion of the Internet, instant messaging, iPods, and other emerging media, where do you see the radio hobby 25 years from now?

*Mark:* I see it without wires! Programming your radios wirelessly, sharing signals, and freely exchanging information wirelessly no matter where you are. We now have a few different types of data that can be monitored via radio. I envision that becoming more the norm than the exception. Keeping information with us, was once in printed form, will be carried around in our pockets electronically. Podcasting, while not very timely, can be an excellent way to promote the hobby and offer tips and tricks to radio monitoring. The future has no limits. I think our hobby will continue to keep pace technologically.



### Rich Carlson, N9JIG

Next, we visit with Rich Carlson, N9JIG, a scanning legend in the Chicago area, largely stemming from his work with CARMA. Rich explains that organization.

*Ed:* How did you get started in the hobby?

Rich: My dad was a police officer in the town I grew up in. He bought me a scanner from a friend of his so I would stop pestering him to ride in his squad car! It was an original Regency 8-channel VHF-Hi only scanner, which I ended up smoking years later in a high school electronics class. I bought an identical unit a couple years ago and will attempt to get crystals to match the original layout from almost 40 years ago.

# 2 CQ calendar 2

15 months of value January 2008 through March 2009

This year's calendar brings you 15 spectacular color images of some of the biggest, most photogenic shacks, antennas, scenics and personalities from across the country!

Calendars include dates of important Ham Radio events such as major contests and other operating events, meteor showers, phases of the moon, and other astronomical information, plus important and popular holidays. The CQ Ham Radio Operators calendar is not only great to look at, it's truly useful, too!

Calendar orders will ship on 10/08/07. You will not be billed until your order ships.



## CQ Communications, Inc.

25 Newbridge Road, Hicksville, NY 11801

Call 1-800-853-9797 or FAX 516-681-2926 • [www.cq-amateur-radio.com](http://www.cq-amateur-radio.com)







Here's Rich Carlson, N9JIG, in his shack.

*Ed:* In your opinion how has the hobby evolved over the years and where do you see it going?

*Rich:* The scanning hobby has turned so much toward computers, so much so that it is unusual to meet a scannist that isn't on-line. Scanners themselves have done a good job of keeping up with the technology. Every time there is a new advance in radio technology some people say it will be the end of scanning.

I remember when UHF T-Band came about in the Chicago area, you could not get crystals above 470 MHz, and people said that we would never be able to listen to the PD again. Well, that obstacle was overcome. A few years later it was 800 MHz, then trunking, then digital. Each time the scanner manufacturers have produced radios to monitor these modes and frequencies.

For the future I think that SDR [software-defined radios] and further integration of computers and scanners are going to be the norm. Right now just about every mid-range and high-end scanner is computer programmable, and many are computer controllable. Radios like the OptoCom, WinRadio, and PCR series radios that rely on computers will evolve to be more accessible tools.

I can also see a future generation of scanners that will replace the buttons of the keyboard with a dynamic display. When you need to program in a frequency the touch screen will display a number pad. When you need to program a description the display will show a predictive text alpha keyboard. When you need to adjust the volume, squelch, or other parameters the display will show those controls. During scan and reception the display will show the description and scan status, etc. With memory prices so cheap, you can have hours of built-in recording/play-back or almost unlimited channel capacity.

*Ed:* How do you think technology has changed the way radio enthusiasts gather and exchange information?

*Rich:* This goes back to computers. Before the Internet and computers took over the world, scannists gathered information individually and in small groups. Several friends and I produced "Scanner Lists" for our areas and shared information among ourselves. To get frequencies for a new area you went to a local scanner store or RadioShack and they always had a list of channels so they knew what crystals to stock. Sometimes they would run off a copy for you, even if you didn't buy a crystal.

Later came commercial scanner directories, with *Police Call* and *Scanner Master* books predominant. Eventually these com-

mercial guides couldn't compete with the Internet and free information. Sites like CARMA [Chicago Area Radio Monitoring Association] and Radio Reference have made it easy to share information and provide an easy and fast way to update and correct it.

*Ed:* What is CARMA and how it has evolved?

*Rich:* CARMA started out as a dozen or so RCMA [Radio Communications Monitoring Association] members that wanted to get together and socialize. This evolved into the Chicago Chapter of RCMA, which was the largest chapter outside of California. This in turn evolved into CARMA after RCMA had some issues and eventually folded. CARMA started actively seeking out additional members, posting fliers in radio stores, going to hamfests, and embracing the Internet. We grew the club from a dozen or so members to over 1,400. With monthly get-togethers and occasional tours and picnics we try to provide the opportunity to meet other scannists and share our knowledge base.

A year or so ago Ted Moran, one of the Directors of CARMA, started sharing his listing of data on a town-by-town basis around the Chicago area, inviting other members to add to and update his info. This evolved into the CARMA Profiles that we have expanded to cover all 102 counties in Illinois, as well as every controlled airport and a dozen or more other specialty profiles. These Profiles are available for free at [www.carmachicago.com/](http://www.carmachicago.com/) profiles and have really helped out hundreds of scanner users.

CARMA uses a Yahoo Group (<http://groups.yahoo.com/group/carmachicago>) to conduct most of the day-to-day club business, such as meeting announcements and information exchange. We have a public web page at [www.carmachicago.com](http://www.carmachicago.com) where anyone can share our Profiles and see information about CARMA. We also have regular meetings on alternate months at a local restaurant as well as informal "Friday Nighters" at varying locations to sit down and shoot the breeze on whatever someone wants to talk about.

CARMA has taken a lead role in cooperation with local law enforcement, Fire, and EMS agencies and has unprecedented cooperation with many of these agencies. Since hundreds of our members are police officers, firefighters, dispatchers, or other public safety professionals and volunteers, our members can see things from both sides of the microphone.

*Ed:* Law enforcement officials, as well as politicians, often disagree about the public's right to monitor radio communications. Some support it; others want to encrypt everything and keep their communications secure. Your thoughts?

*Rich:* Obviously, I take the position of the public's right to monitor, if not I better find a new hobby. When discussing this subject I always try to bring up two points:

First, with the public having the ability to listen to police communications it makes them more aware of their surroundings. There might be a certain element of crime that the local citizen might not be aware of had they not heard it on the scanner. It also gives law enforcement an extra set of eyes and ears...how many times have we heard that a local citizen helped the cops catch a fugitive because they heard the call on the radio and then spotted someone matching the description.

You will have those officials who will chomp at the bit when they hear they can migrate over to a digitally encrypted trunked system, and then you have others, such as the Delaware State Police, who stream their dispatch audio right on their own website. I also remember a county somewhere in Georgia who ran their communications audio over one of the local cable TV channels.



My opinion is that if you don't want someone to hear something then it probably should not be said. With that in mind, and based on almost 30 years experience in law enforcement, I know there are times when the public's right to listen is subordinate to officer safety, and encryption or other methods of secure communications are necessary. These days, with digital cell phones and Nextels being impossible for anyone other than the NSA to easily monitor, most police officers have a quick and simple method of keeping inappropriate radio traffic off the air.

There are going to be times when a scanner will be used as a tool to commit a crime, just as any other device can be perverted for illegal use. The outright banning of or requiring a difficult to acquire permit for a scanner doesn't stop the criminal, it just makes life difficult for law-abiding scannists. Judicious use of encryption or other communications methods and cooperation with local scannists is a much more effective method of operation.

In Downstate Illinois, Champaign County posted its frequency and talkgroup list on the Internet for scannists to view, and the system isn't even operational yet! They understand that it wouldn't take long for scannists to figure it out. This is an enlightened attitude, similar to that of the Delaware State Police. Accordingly, scannists have to respond in a positive way. By staying out of the way of responders, not repeating information overheard on the scanner, and just using common sense, scannists can ensure the continued support of these agencies, and hopefully others will follow suit.

---

### Gene Hughes, *Police Call*

Some time back I had a conversation with Gene Hughes, the former editor and publisher of the *Police Call* series of frequency directories, which reached the end of its lifespan with the 2005 edition. We talked about how he came to found that influential publication.

*Ed:* You've been involved with two-way radio communications for a long time. How did you get started?

*Gene:* I got into the radio business in 1960 selling two-way radios. Along with my partner, I formed a company that sold, serviced, and installed two-way radios. By the time I sold my share of the business in 1987 we had 55 employees.

*Ed:* What was the inspiration for *Police Call* and how did it all begin?

*Gene:* When I was 12 years old, in the early 1940s, I was given a portable radio. One day I was tuning around the band between stations and I heard a woman's voice giving out addresses and talking about guns and various crimes. I realized I was listening to the dispatch side of LAPD's radio communications on an image of their frequency of 1730KC.

In the early 1960s I started measuring exact radio frequencies using a Lamken meter. I kept detailed records of this, and my wife started asking me what I was going to do with all this data. I quipped that I could probably find someone to buy this information. So, in 1963, I published my first frequency directory, which consisted of about eight to 12 pages. I went door to door to various radio shops and ham radio dealers in the area hawking my book, and eventually it sold around 800 copies. The next year I realized that some revisions needed to be made, so I came out with my second edition in 1964.

Around 1970 or 1971 I got together with George Switlyk, who became our data manager, and he was able to come up with

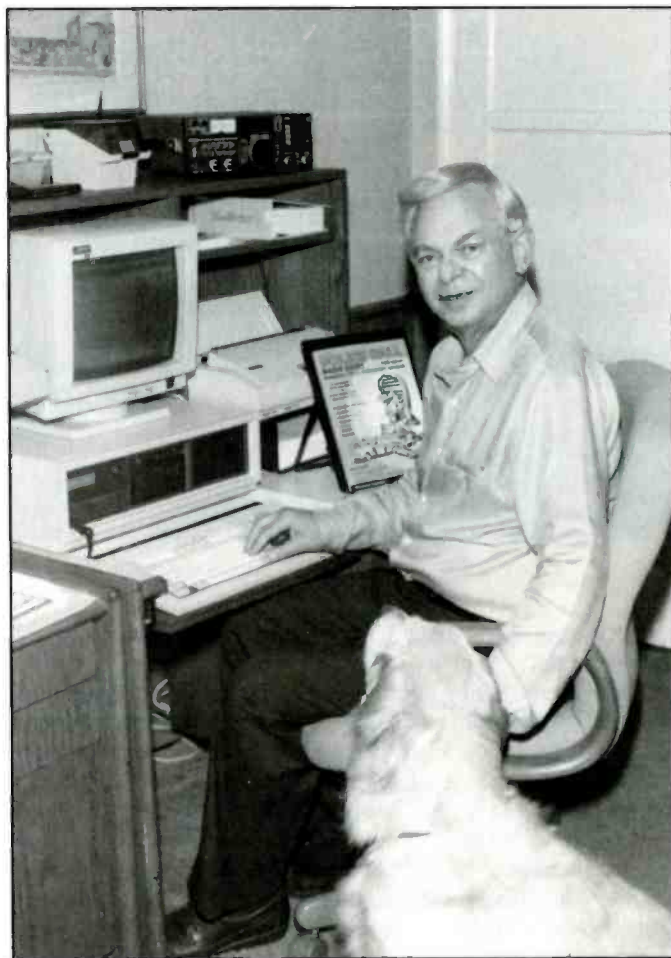

*Gene Hughes, editor and publisher of Police Call, in an undated photo.*

software to format the information that we needed to publish. That is when we came out with our first nationwide edition. When the first programmable scanners came out the book really took off, and that's when we formed our relationship with RadioShack.

*Ed:* What was involved with gathering the information you needed to publish?

*Gene:* In the early days we actually had an office at the FCC. When licenses were issued they would be put on display and our personnel would copy down the information we needed. Today, the FCC publishes this information on the Internet. Toward the end of our run our customized computer programs would extract the information we needed. Additionally, the "Beyond Police Call" section of the book was being handled by Rich Barnett before he took over all of the editing.

---

*Police Call* had quite a following of loyal readers who contributed information year in and year out. It reached the end of its lifespan with the 2005 edition, but it was one heck of a run. Evidently RadioShack did what any business would do, and made a decision not to continue carrying the book based upon market factors. Today, in his spare time Gene is a Special Reserve Officer with the Los Angeles Police Department. He volunteers at the desk at the Wilshire Station of the LAPD and also gives lectures on crime prevention.—EM

## Lou Campagna, N3TMA, Scanner Digest

Lastly, we chat with Lou Campagna, N3TMA. Lou previously published a regional frequency directory for the Philadelphia area and was closely associated with the North East Scanning News (NESN). Today he is the publisher of the online e-zine, *Scanner Digest* (see ScannerDigest@usa.com).

*Ed:* How did you get involved in the radio hobby?

*Lou:* My first scanning experience was to monitor the busy Philadelphia Fire Department using a crystal-controlled 4-channel VHF portable scanner radio. I monitored fire dispatch, emergency band (extra alarms).

Fire-ground and the Rescue band (medic units) and I was set. Nothing could get better than this as I had the ability to monitor the entire fire communication system. Little did I realize that there was more to come.

*Ed:* What do you think of the advancements in technology?

*Lou:* Actually the way information was shared was very crude compared to the way we now exchange the very same information, and that was by good-old U.S. mail. That's right, a group of early scanner enthusiasts

exchanged photocopied sheets of frequencies that were then sent out to a dozen or so hobbyists. After a few months of mailing various frequency lists, you had enough information on hand to program your scanner. Today, the Internet provides an instant way for hobbyists to exchange data and most of the frequency information is available on webpages for free.

*Ed:* Where do you see the radio hobby 25 years from now?

*Lou:* I see the computer to be the backbone of a scanner enthusiast's shack for years to come. Whether the computer is used to help program the radio or is used together with monitoring the management of frequencies, it is a perfect marriage between radio monitoring (audio) and information gathering.

Additionally, the enjoyment of scanner monitoring can even be done without the scanner radio as more websites support the popular audio streams of your favorite public safety agencies. Today a scanner buff in California can use a computer to effectively monitor a two-alarm building fire in midtown Manhattan via the live stream.

So long as there's an interest in what's going on, I feel that there will still be a group of core enthusiasts who will use whatever tools and methods are readily available to accomplish their tasks. Albeit more expensive, many of the joys that were experienced back in the 70s can still be enjoyed today with the help of computers.

There always seems to be a period of concern when public safety radio systems deploy new methods of communications, but eventually the technology is made available to the hobbyists through the redesign of scanning equipment and it is hoped that the spirit of the hobby continues forever. ■



Lou Campagna, N3TMA, publisher of the online e-zine Scanner Digest.

# RSGB Books

now available from



## Antenna Toolkit 2

By Joe Carr, K4IPV  
RSGB & Newnes, 2002 Ed.

256 pages. A definitive design guide for sending and receiving radio signals. Together with the powerful suite of CD software included with this book, the reader will have a complete solution for constructing or using an antenna; everything but the actual hardware!



Order No.: RSANTKIT2

\$40.00

## The Antenna File

RSGB. ©2001. 288 pages. Order: RSTAF

50 HF antennas, 14 VHF/UHF/SHF antennas, 3 receiving antennas, 6 articles on masts and supports, 9 articles on tuning and measuring, 4 on antenna construction, 5 on design and theory, and 9 Peter Hart antenna reviews. Every band from 73kHz to 2.3GHz!

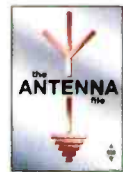

Order No.: RSTAF

\$32.00

## VHF/UHF Antennas

By Ian Poole, G3YWX

RSGB, 2002 Ed, 128 pages. This great new book investigates the exciting area of VHF and UHF antennas. VHF and UHF bands provide an exciting opportunity for those wishing to experiment, while the antenna sizes at these frequencies do not occupy great amounts of space.



Order No. RSVUANT

\$23.00

## RSGB Prefix Guide

By Fred Handscombe, G4BWP

RSGB 8th Ed., 2007 80 pages. This complete guide to prefix identification and information has been fully updated. The guide provides a listing of prefixes and their entities along with additional info including a prefix's continent, CQ Zone, ITU Zone, latitude and longitude and much more. You'll also find a newly added index of countries and their call sign allocations divided by continent.



Order No. RSPFXG

\$19.95

## Antenna Topics

by Pat Hawker, G3VA

RSGB, 2002 Ed. 384 pages. This book is a chronological collection of selections of G3VA's words over the years. Hundreds of areas and subjects are covered and many a good idea is included.



Order No. RSAT

\$29.00

### Shipping and Handling

US and Possessions - Add \$5.00 for the first book, \$2.50 for the second, and \$1 for each additional book.

**FREE SHIPPING ON ORDERS OVER \$75.00** (merchandise only).

Foreign - Calculated by order weight and destination and added to your credit card charge.

**ALLOW 3 TO 4 WEEKS FOR DELIVERY**

**CQ Communications Inc.,**  
25 Newbridge Rd., Hicksville, NY 11801  
516-681-2922; Fax 516-681-2926  
Order Toll-Free 800-853-9797  
View more RSGB books at  
[www.cq-amateur-radio.com](http://www.cq-amateur-radio.com)



## A Weather, Ham Radio, GPS Trio

**K**enwood has upgraded its TM-D700A dual-band data communicator to the new, more data-powerful TM-D710A. AvMap Navigation's G5 personal navigator displays *all* North America, and simply plugs into the Kenwood D710A to provide an unsurpassed APRS bi-directional navigator, with new search and rescue navigation capabilities. Add a Peet Bros. or Davis weather station, and you have the ultimate storm chaser mobile system—*no computer required!*

"Search and rescue ham operators will quickly spot some of the new SAR features in the Kenwood D710A transceiver with built-in terminal node controller," said Don Arnold, W6GPS, AvMap North American sales manager for amateur products.

"Storm chasers now have a transceiver that can take Peet Bros. or Davis Instrument weather sensors and interface them with a direct data feed to the new Kenwood D710A *without* tying up an additional laptop for mobile applications," added Arnold, also pointing out the bi-directional color mapping capability of the new AvMap G5 touch screen GPS, which simply plugs into the new Kenwood D710A, the older D700A, and the still-popular Kenwood TH-D7A handheld.

### A Technical Marriage

It's not often that a ham radio transceiver manufacturer takes a step solely dedicated to working with ham radio emergency responders and actively supports another brand of GPS and weather data peripherals. But Kenwood's ham radio product manager, Phil Parton, N4DRO, *knows* the importance of an integrated ham radio *system*, having spent time involved in SAR, as well as working directly with ham radio emergency volunteer responders to help support them.

"I work all of the ham shows myself to hear, firsthand, what the ham radio volunteer emergency responders need to better perform their functions," said Parton, who's based out of Kenwood USA's headquarters in Suwanee, Georgia. Little will get lost in the translation with daily meetings between Parton and the Japanese



*The new dynamic APRS duo from Kenwood and Avmap.*

radio engineers who report to corporate headquarters in Japan.

This product mix of dual-band TNC (terminal node controller) data communicator with weather and APRS attachments is also a labor of love for Arnold. He traveled to the AvMap factory in Italy to work up the technical marriage between the AvMap G5 and the Kenwood equipment, using his own SAR skills to help develop the combinations for "off-the-shelf" weather monitors to do double duty, without a computer. The result is a great tool for mobile storm chasers!

"Imagine storm chasers in Oklahoma spotting a nearby twister, with their Kenwood VHF/UHF mobile transceiver automatically relaying ground atmospher-

ic measurements as well as their vehicle's location, speed, and direction," said Arnold, showing off the five-inch, trans-reflective color touch screen AvMap G5, now loaded with a fresh new TeleAtlas database covering all of North America.

The AvMap G5 and the new D710A (or older Kenwood D700A) support bi-directional APRS data exchanges, with all plug-in cables included with the AvMap. "You can see the callsigns of other stations around you, such as other weather spotters squawking their positions on APRS," explained Arnold. "This little GPS will graphically show you the dirt road to meet up with other APRS stations nearby, and even alert you if another station strays into your guard-zone circle."



View live weather information from your Peet Bros. or Davis weather station.

For the SAR tracker, the combination of the Kenwood portable TH-D7A and the battery-operated AvMap GPS makes an unbeatable trailblazer for total APRS and mapping functions. With backlighting turned off on the AvMap color mapping GPS receiver, you have several hours of internal battery capability to conduct thorough grid searches. And for all-day, or night, operation with the GPS backlit, a 3-amp-hour belt battery pack will power the Kenwood handheld and the AvMap GPS for approximately 12 hours. But, said Arnold, "The bigger the battery, the longer it will last."

"For weak-signal ham radio operators, the AvMap will read common grid squares and sub-grids, with bi-directional capability for receiving APRS positions of

other radio operators around you, plus make quick on-road or off-road calculations on how to rendezvous with other nearby APRS operators," said Arnold.

The AvMap G5 has a 20-channel GPS Sifir III engine and antenna system built in, as are the rechargeable batteries. A single data cable, with supplied plugs, interfaces the AvMap G5 to the Kenwood portable D7A, the mobile D700A, or brand new D710A. The only other cable the AvMap could use might be an external 12-volt source, which is included with all G5 AvMap GPS systems.

The AvMap G5 receiver sensitivity (-159 dBm) is unbelievable. In certain environments where most GPS equipment won't function, the AvMap G5 will begin to show satellite reception bars on



Don Arnold, W6GPS, testing the new AvMap Navigation's G5 GPS with the Kenwood TM-D710A.

all satellites in view. Within about a minute, it has enough signal strength to develop a position accurate to 20 feet, thanks to WAAS (Wide Area Augmentation System) differential signal corrections. A proprietary compact flash card for the new G5 now includes compressed TeleAtlas mapping of all the United States plus Canada and Puerto Rico. There is no need to purchase additional mapping products or Points of Interest databases.

The new Kenwood TM-D710A with its weather reporting ability was previewed at the 2007 Dayton Hamvention. It's similar in size to the Kenwood TM-D700A dual-band data communicator, but is even more powerful. Here, at a glance, are just some of the features you'll get:

- Built-in TNC
- 50W on VHF&UHF
- Dual color green or amber backlit LCD
- Sky Command II+
- APRS with many more features
- APRS weather beaconing (requires Peet Bros. or Davis weather station)
- Built-in sound card interface
- EchoLink ready
- Free programming software at [www.kenwoodusa.com](http://www.kenwoodusa.com)

SAR agencies will appreciate the various conversions of the raw GPS datastreaming from the AvMap G5. Not everyone uses the same grid location system, and the output of the G5 AvMap equipment lends itself to customizing alternate SAR coordinate systems. Certainly the inclusion of the internal TM-D710A software to decode weather station datastreams would benefit both fixed station and mobile applications, neither needing a running external computer system.

The simple serial cable connection from the weather station to the TM-D710A would provide an automated APRS weather signal for everyone to view on their own APRS radio equipment.

## Make A Call

All three systems—weather, radio, and GPS—are currently sold by your local or catalog ham radio dealer. Call for complete system pricing and get set for improved data signaling! You can also check out all the buzz on the user group site hosted by moderator Jim Keck, Jr., N6JIM, at [http://groups.yahoo.com/group/Avmap\\_G5\\_APRS/](http://groups.yahoo.com/group/Avmap_G5_APRS/).



# Grouping Channels Into Banks!

Last month we looked at ways to get started in the scanning hobby, and hopefully had a few pointers for getting you off on the right foot. This month, I thought we'd continue our "getting started" theme with a discussion of how to organize the channels in your new radio.

Even advanced users will argue about this topic. That's because there are probably as many variations on the basic methods for organizing your scanner as there are scanner enthusiasts. But there are also some basics we can cover to get you thinking about what would work best for you. I'll apologize in advance if I left out your favorite method, but they only give me so much space.

## Why Care?

Why should you care about any of this? Can't you just grab the radio and start putting things into the next available channel? Well, yes, you can, but it will make it much harder to zero in on something specific when you want to. You may not have run into this problem yet, but you will, trust me.

If some big event happens in your town, you're going to want to listen to specific things and, just as importantly, turn other specific things off for a short time. If there's a big fire, you'll want to listen mostly to the fire channels and lock out the chatty mall people, or even the police departments outside the immediate area. If there's a bank robbery, you probably don't want the scanner stopping while they dispatch an ambulance to an accident.

Yes, you can use the individual channel lockouts, and you may need to do some of that, too. But the banks on most scanners are easy to turn off and on and will also give you some indication that they're off or on. Individual locked-out channels can stay hidden for a long time before you notice that you haven't heard something for a while.

Most of the organizational methods I've seen boil down to separating the channels by the type of service that uses them (police, fire, medical, ham, etc.) or by area (all of the "east stuff" in one bank, "west stuff" in another, etc.). Quite

frankly, I hadn't really given it a whole lot of thought until I started messing with computer control systems and it became possible to reorganize banks quickly and easily. Now I think good organization can add a lot to your enjoyment of the hobby, and it pays to do some planning about how you can sort your frequencies. (See "Banks To Consider" for a quick glance at what I mean.)

## Sorting By Service

I myself have always been pretty much a service fan. I had all the county police channels in one bank, city in another, state and outlying areas in another. Then I'd have a bank for fire. Then it depended on the radio as to how much room I had to put together any others. This method works quite well if you're interested in a particular department or section of scanning, or if you seldom listen to a particular service but want to have them handy for when something does happen (assuming, of course, that you have open banks to store them in). This method also works well for scanning from a fixed location, say mostly at home.

The primary disadvantage of this method comes to light when you get into

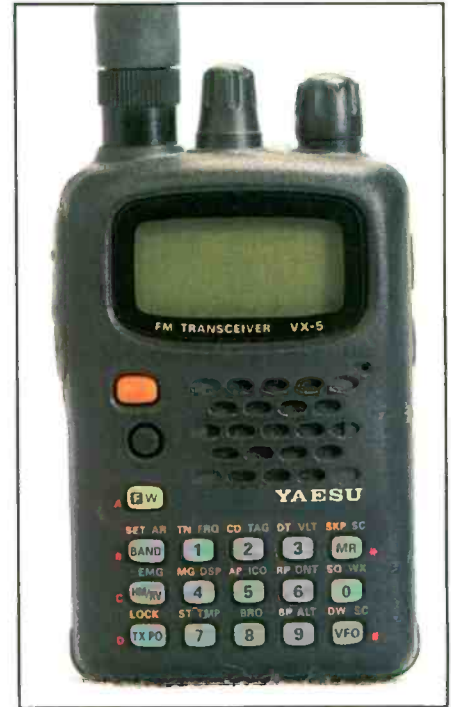

Many hams use handheld transceivers for double duty, listening to both ham and public service frequencies. Most handhelds don't have banks, though, so it can be a bit tricky to switch back and forth from ham mode to scanner mode. But it is workable if you only want to carry one radio.



This early base receiver from Yaesu was one of the first high-quality communications receivers for the scanner market. Unfortunately, it was a terrible scanner without computer control. ScanCat was born to meet the needs of owners of this receiver!

a busy environment. If you have a busy police department with several channels, it's entirely possible that your scanner can be held up for quite some time plowing its way through, stopping here and there as it goes. Perhaps some of the channels are not of much interest, but if they are grouped together by service, you'll probably have them active. You can easily get tied up on some major event in the police bank and miss some other event in another bank.

Of course, there's no complete cure for this, but you can mitigate the damages a bit by planning. And another radio doesn't hurt, either. Eventually, if there's enough traffic, you'll either have to give up listening to some channels or add another radio just to have a chance of hearing what's happening.

Trunktracker radios have made this quite apparent. Of course, the trunktracker receivers from Uniden and RadioShack can only listen to one trunked bank at a time. If you want to listen to conventional traffic at the same time, you *must* have another radio. True, there are lots of complaints and dissatisfaction regarding this, but while it would be nice to only have to carry one radio while mobile, there are some good reasons it works this way.

The first is technical: the radio would have to reacquire the data channel every time it re-entered the trunked bank, and you'd lose quite a few seconds of time while this took place. New products on the horizon may eliminate this from consideration, but for now, it's our only option.

The other reason that I've come to appreciate is that with any size trunking system at all, the volume of traffic on that system pretty much precludes using the radio for any serious scanning outside the system anyway. Our system, for instance, is tied up full time with just dispatch channels. In my area (St. Louis), even if you don't listen to all the districts, the radio stays pretty busy with dispatch, tac channels, car-to-car, etc. I really don't believe that you would hear much of anything outside the trunked system even if it were possible, and our trunked system isn't all that large compared to some cities.

## Geographically Speaking

The other popular method of organizing, as I mentioned, is by area. All the south side stuff in one bank, all of the north in another. This means that probably some channels will have to be duplicated, like mutual aid and point-to-point channels that are in use no matter where you are. Things like fire dispatch and medical services may also not follow clean geographic lines and have to be duplicated as well.

Seem like a waste of channels? Well, back in the old days of four- and 16-channel scanners, I would have agreed. Of course, most of the four- and 16-channel radios don't have banks anyway, so that point is moot. However, with today's 200-, 400-, and even 1000-channel radios, some duplication begins to be a little more tolerable, and even make some sense at times.

Another case in point. My county is divided into five precincts. Each of the precincts has its own dispatch channel. There's a detective channel, a car-to-car channel, and an emergency channel that are shared county wide. As I mentioned earlier, I used to keep all the police channels in one bank and scan them all full time. The problem is that scanning in the car, particularly with a handheld, if I'm up in the north precinct, I can't hear much of what's going on in the south one—it's simply too far away to get much but static. That's not much fun to listen to.

## Banks To Consider

Here are a few ideas to get you started. This list is by no means exhaustive, of course.

### Service:

Police	Casinos
Fire	Unknown or Experimental
Medical	Schools
Media	Railroads
Aviation	Busses/Taxis
Military	All the Time Stuff
Ham	Mutual Aid/Shared
Business	frequencies
Malls	Maritime, Lake, River

### Geographic:

City	Outstate
County	Your City
Local	Neighboring city
North, South, East, West	Precinct or District

### Special Banks:

Airport Problems	Major Media Event
Parade/Fair	Sports Event
Rail Accident	Severe Weather
Major Vehicle Accident	Natural Disaster
River/Lake/Ocean Incident	Major Fire
Industrial Incident	Riot or Other
VIP Visit	Civil Disturbance
Jail or Prison Incident	Concert or Theater Event

In addition, there are many municipalities (somewhere around 80) within the county, some of which have their own police departments and some of which do not. Some of the municipalities that do have their own departments also have their own dispatch, but some contract that out to other departments, or even the county. The county has an additional two channels dedicated just to these municipalities, one for



*This unique arrangement from Uniden and RadioShack separated the bank switches and labeled them with alphabetic characters. Later versions of this radio had 20 banks: 10 numeric and 10 alphabetic. Nice feature, and more banks!*



**ADVANCED SPECIALTIES INC.**  
 Orders/Quotes 1-800-926-9HAM  
[www.advancedspecialties.net](http://www.advancedspecialties.net)

**BIG ONLINE CATALOG**

BCD996T  
 6000 Channel Digital Trunking Scanner

**UNIDEN BEARCAT DIGITAL SCANNERS • CB • AMATEUR • RADIOS & ACCESSORIES**

ALINCO • YAESU • GALAXY  
 • RANGER • COBRA

(201)-VHF-2067  
 114 Essex Street, Lodi, NJ 07644

Closed Sunday & Monday

**POWERPORT**

**Gearharness**  
 Hands free transport for your handheld and other gear.



**Leather & Neo Pouches**  
 Custom sizes to fit your handheld.



**Radio Wallet**  
 Travel case for your handheld and accessories.



[www.powerportstore.com](http://www.powerportstore.com)



**WE'RE ON THE WEB**

Check out our Web site at:

[www.popular-communications.com](http://www.popular-communications.com)

**FREE SAMPLE COPY!**

**ANTIQUE RADIO CLASSIFIED**

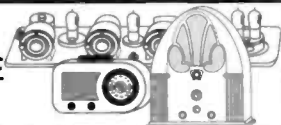

*Antique Radio's Largest-Circulation Monthly Magazine*

Articles - Classifieds - Ads for Parts & Services  
 Also: Early TV, Ham Equip., Books, Telegraph, 40's & 50's Radios & more...

Free 20-word ad each month. Don't miss out!

1-Year: \$39.49 (\$57.95 by 1st Class)  
 6-Month Trial - \$19.95. Foreign - Write.  
 A.R.C., P.O. Box 802-T14, Carlisle, MA 01741  
 Phone: (978) 371-0512; Fax: (978) 371-7129  
 Web: [www.antiqueradio.com](http://www.antiqueradio.com)

north side stuff and one for the west group. So, in addition to listening to the county precinct I'm in, I also have to follow these municipal channels, and there are a bunch.

So I got the bright idea, why not give each precinct a bank? It could include the precinct channel, any municipalities in that precinct that I care to listen to, the fire dispatch channels that cover that area and the shared channels that I want to listen to most of the time. In addition, I created a bank of all fire, one for air stuff (when I'm near the airport at lunch time), and one or two left over for experimental stuff or special events.

I simply switch banks on and off like I used to with channels, but now I'm not missing all the action on other frequencies in the area. The trade off is that there's a lot of duplication in my scanner, and there are several banks with very few channels in use. Oh well...it does the trick for me.

**Event Scanning**

A friend of mine groups many of his scanner banks by event. He has a handful of channels that he likes to listen to all the time and dedicates one or two banks in one of his scanners to those, mostly grouped by geography. It's mainly local stuff that he's interested in tracking. The rest of the banks in his radios are dedicated to one type or another of special event scanning, some of which border on services.

For instance, there's a bank for severe weather events. Any time during the year that severe weather threatens, he flips this bank on and immediately has access to the highway department, weather observation channels, ham radio frequencies that are used for storm spotting, etc.

You can make almost a hobby out of this type of thinking. Consider an event

that is likely to occur in your area. What would happen, say, if the president came to your town? Okay, if you live in the District of Columbia, this won't be very challenging, but if you live somewhere else, well, just think about it. What kind of frequencies might be active because of a VIP visit? Would a likely visitor receive secret service protection? They're mostly encrypted, so you can't listen to them, but activity on those channels might tip you off that something was about to happen.

Would your local police have a role? Sometimes they're used to provide traffic control and other assistance. What frequencies might they use? How about medical services, or fire? News coverage? You can fill up a bank pretty quickly with good possibilities.

Now, depending on where you live, you might have to wait a long time to see just how good your guesses were. But once the event happens, it can be quite a lot of fun, and your prior preparation can get you in on the action just a bit earlier. Particularly if you have more than one radio and can dedicate a bank to channels you don't need very often, it can be really enjoyable to plan. Even if you can't spare a bank, you can think about the frequencies and write them down somewhere. That way, you'll have the planning done and if you hear something happening you can reprogram quickly. You do have a list of the frequencies that are normally in your scanner, don't you?

Another possible event might be if a factory, school, or other major facility near you had a major function or occurrence. It could be a celebration of some sort, could be a disaster situation. What frequencies would be in use? What outside agencies might be called in? If you're within a reasonable distance to any large facility, chances are that you'll be able to hear its day-to-day radio operations, most

**Frequency Of The Month**

Each month we ask our readers to let us know what they're hearing on our "Frequency Of The Month." Give it a listen and report your findings to me here at "ScanTech." We'll pick a name at random from the entries we receive and give the lucky winner a free one-year gift subscription, or extension, to *Pop Comm*. The latest winner of a free subscription is **David Heard, N5SRC, of Kingwood, Texas**. Congrats, David.

Our frequency this month will be **39.70**. Have a listen and let me know what you hear, even if it's nothing. It's a low-band frequency, so it may surprise you if conditions are right. Don't forget to include your address for the now monthly drawing of a one-year subscription! Also, please put the frequency in the subject line or on the envelope. You can email your submission to [radioken@earthlink.net](mailto:radioken@earthlink.net), or send the information to Ken Reiss, 9051 Watson Rd. #309, St. Louis, MO 63126.

of which are probably very boring. But if something happens, having those frequencies handy might get you information that you wouldn't otherwise have until the news at 11:00 (or ever). In the event of a major disaster, like a chemical spill, that could be very good information to have in advance. Hopefully, you'll never get to test that out, but it's fun to plan, anyway. And maybe you'll encounter a smaller event or drill you can test things out on.

### What Approach Do You Use?

As you can see, there's no one right answer to this. It depends a lot on the kind of events you're likely to see in your area, as well as how much you want to listen to. There's a balancing act between scanning too much so that you can't really follow anything, and listening only to one channel so you follow all that traffic, but miss everything else.

A lot of people use multiple radios to overcome some of the limitations of capacity versus time to scan through the list. I've also discovered that my mobile needs are completely unrelated to what I listen to at home. I've solved the mobile problem with the geographic method. At home, I'm still working on a geographic/event system that works, but I'm getting there...

How's your system working? Write in and let us know. ■

### Twenty-Five Years Ago

As *Pop'Comm* enters its 26th year, it's a good time to look back at the hobby. Twenty-five years ago, the digital scanner was just becoming popular. They were expensive, but you didn't have to have a \$5 crystal for every channel that you wanted to listen to. RadioShack still sold the crystals in most of their stores, just in case you had one of those old radios. Many were programmed by setting patterns of switches, but the direct entry scanner had just come onto the market so you could type the frequency into the radio from a keypad. This was a fantastic improvement!

The personal computer industry was just getting started with computers like the Apple IIe and the RadioShack TRS-80. Trunking systems didn't exist, nor did the computing power to make them a reality. Likewise, digital modulation was simply not viable until the computing technology caught up.



Just about the time *Pop'Comm* first came along, so did this 50-channel radio from RadioShack. It was one of the first with actual banks of 10 channels, each of which could be switched on and off easily with the numbered keys at the far left on the keypad.

# Pop'Comm October 2007 Reader Survey Questions

This month we'd like to ask you about your interest or involvement in amateur radio. Please use the Reader Survey Card and circle all appropriate numbers. Thanks for participating.

I am a licensed ham .....	1
I am not a licensed ham .....	2
I am not a licensed ham but would like to get my license...3	
I am not a licensed ham and have no interest in pursuing it.....4	

### I hold the following class license

Novice.....5	
Technician (including Tech Plus).....6	
General.....7	
Advanced.....8	
Amateur Extra.....9	
I am not a licensed ham.....10	

### How long have you been a ham?

As long as I can remember.....11	
Since the restructuring of 2000 made it simpler.....12	
Since the elimination of the code requirement in February 2007.....13	
I am not a licensed ham.....14	

### I am involved in the following aspects of ham radio:

Ragchewing.....15	
DXing.....16	
Contesting.....17	
Digital Modes.....18	
Mobile Operation.....19	
Field Day.....20	
Homebrewing.....21	
Volunteering/Public Service.....22	

### I currently own one or more of the following amateur radios:

Handheld transceiver.....23	
Base/mobile transceiver.....24	
I own no ham radio equipment.....25	

### I intend to buy one or more of the following amateur radios:

Handheld transceiver.....26	
Base/mobile transceiver.....27	
I have no intention of buying ham radio equipment.....28	



# Domestic Broadcasting Survey, 9th Edition

***Accurate, Affordable—Essential—DX Information Is As Close As Your Keyboard (But You Can Print It, Too)***

by Richard A. D'Angelo

*Editor's Note: The material in this reference review initially appeared in the June 2007 issue of the NASWA Journal. We're reprinting it here as a service to our readers (it's just so darn important!). It has been edited for style and is reprinted with permission.*

**F**inding useful, current, accurate DX references in the electronic world isn't as easy as it should be. There are numerous providers of radio broadcasting information in the marketplace today, many of them offered for free, but a lot of them are not of a high quality. The latest *Domestic Broadcasting Survey 9* ("DBS-9") [May 2007, ISSN 1399-8218], once again edited by Denmark's world-renowned DXer Anker Petersen, is one resource that does not disappoint.

Published in May by the Danish Shortwave Club International ("DSWCI"), the *DBS* continues to be the top annual publication devoted to tropical and domestic band shortwave broadcasting stations. The DSWCI offers the *DBS* in electronic form (PDF format), which provides for a substantial reduction in price over a paper version, thereby increasing its value and speed of delivery. Either way you will be receiving and using an important DX resource produced by an international array of top shelf DXers that will prove its worth to you time after time.

Richard D'Angelo is the Executive Director of the North American Shortwave Association (NASWA) and a member of the club's Executive Council.

As in past years, a copy of the press release can be found on the DSWCI website at [www.dswci.org](http://www.dswci.org). By clicking on the Domestic Band Survey, you will see the color front page of "El Condor Pasa" played at the archaeological market in Raqchi, Cusco, Peru, taken by Anker during his Latin America tour and sample listings from this year's *DBS* along with reviews from last year's edition. Anker's cover photos for the *DBS* continue to provide the local flavor associated with a domestic listening market.

The DSWCI turned 50 years old this year. It has a worldwide membership of experienced shortwave listeners scattered in about 35 different countries all over the globe. Anker draws upon the knowledge and skills of the DSWCI's international array of top-flight DXers to produce a unique and extremely valuable hobby resource. In addition to the club's extensive monitoring activity, the new survey is also based upon many official sources and DX bulletins with A07 schedules included when available. Over the years, the DSWCI has published some of the best non-commercial hobby references available to the shortwave listener. The electronic *DBS-9* continues this grand tradition. It is an essential reference for serious shortwave listeners and DXers.

This is the ninth year that the DSWCI has incorporated its invaluable tropical band survey into a broader survey that includes all domestic shortwave broadcasting. The old "Tropical Band Survey" ("TBS") portion of this publication, which has been tops in the field of shortwave broadcast lists for many years, is in its 35th year. Because most of its members devote most of their DXing time to domestic broadcasting stations on the tropical and



domestic  
broadcasting  
survey

9<sup>th</sup> Edition, May 2007  
ISSN 1399-8218

*Edited by Anker Petersen*



### Samples From Domestic Broadcasting Survey 9

C	4750	1	UGA	Dunamis R, Kampala	1500-1700 E, 1700-1900 Vn. rlg. Later on 9 hours daily	APR07
A	4754,9	10	B	R Imaculada Conceição, Campo Grande, Mato Grosso do Sul	(Oct-Feb) 24 h P rlg, d -4755,4; n 4755, ex R Educação Rural	APR07
A	4755	0,5	PRU	R Huanta 2000, Huanta, Ayacucho	0900-1325v 2200-0200v S/Quechoa, alt. Fq's: 4746,9(ID) and 4751,8	APR07
C	4755,2	0,5	FSM	Pacific Missionary Aviation (PMA), Pohnpei	r tests 0730-1400* E	MAR07
A	4760	8,5	IND	AIR Port Blair, Brookshabad, Andaman & Nicobar Islands	Southern Sce: 2355-0300 1030-1700(SS -1730) E/Hindi/ Sanskrit/ Nicobarese/ Telegu/ Bengali/Tamil/Malayalam, E nx 2335(local) 0035 1230 1530, Hindi ID: "Yeh Akhasvani Port Blair-he". 0125-0130 Sanskrit, 1030-1100 Nicobarese, 1100-1130 Telegu, 1130-1200 Tamil, 1200-1230 Bengali. (= 7115)	FEB07
B	4760	10	IND	R Kashmir, Leh, Ladakh, Jammu and Kashmir	(Apr-Oct 0130) 0212-0400/0415 1200-1700 (Sa-1730) E/Hindi/Urdu/ Laddakhi/ Kashmiri. Hindi ID: "Akashvani Leh", "Radio Kashmir". E nx 0245. (= 6000). Part of AIR Network.	FEB07
D	4760	1	LBR	ELWA, Monrovia	0600-0800 1800-2300 (Su -2230) E/Vn rlg	MAY06
B	4760	50	SWZ	TWR, Mpangela Ranch	FS: Nov-Mar: 1600-1700 P/Tshwa/Shangaau/Ndau	FEB07
B	4763,1	-	BOL	R Chicha, Tocla, Nor-Chichas, Potosí	1015v-1700 2100-2400 S/Aymara, S ID: "Radio Chicha, eco de bolivianidad", "Radio Chicha, desde Tocla, en el departamento de Potosí, transmitiendo en 4760 kilociclos, onda corta y 100,5 MHz FM" JAN07	
D	4900	50	CHN	Voice of the Strait, Fuzhou, Fujian	Nov-Mar: 2225-2400 1200-1700 Amoy; replaced Feb 2007 by 6115	NOV06
B	4900	50	IND	AIR Guwahati A, Assam	North Eastern Sce. Alternative frequency for 4940	MAR07
C	4905	1	B	R Anhanguera, Araguaína, Tocantins	[Oct-Feb] 24 h P, relays "Araguaia FM" and "Rede Somzoomsat, Fortaleza", "Rádio Anhanguera, a sua melhor música"	DEC06
C	4905	5	B	R Nova Relógio, Rio de Janeiro	[Oct-Feb] 0730-0300 P rlg with time checks in background, sl: "A Nossa Rádio". Very irregular	JAN07
A	4905	50	CHN	Xizang PBS, Lhasa, Tibet	2100-1800v (not Tu 0600-1000) Tibetan, exc. W 0700-0720 1630-1650 E, and relays of CNR8 MS: D 2300-2400 0400-0500 1300-1400 Tibetan // 4920 5240 6130 7385. E ID: "This is Holy Tibet, China Tibet People's Broadcasting Company"; ck 6010(MS ID)	APR07
B	9720	150	CHN	China Business R, Xi'an, Shaanxi	0000-1000 C // 9530 9810 11685 11915 12080, ck 3985(ID)	JAN07
A	9720	5	PRU	R Victoria, Lima	24 h S/P, sl: "La Voz de la Liberación" // 6020,2; n 9720, d 9720,1-9720,4	APR07
B	9730,8	50	BRM	Myanma R, Yangon, Yegu	(SS 0245-)0330-0700 Bamar, 0700-0730 E,(= 5985(ID) 7185)	AUG06
C	9743,3	10	INS	RRI Sorong, PP	RRI Cabang Muda : 0115-0800 Bahasa Indonesia, often relays RRI Jakarta // 9680 11860; (= 4874,6)	DEC06
B	9745	60	BHR	R Bahrain, Ras Hayan	General Px: 24 h A, ID's: "Huna al Bahrain", "Idhaat mamlakat al Bahrain", ck 6010	JAN07
B	9745	100	EQA	HCJB, Pifo	Regional Sce: 2100-2300 Quichua // 6080; also FS	DEC06
B	9745	250	TWN	Voice of Han Broadcasting Network, Kuanyin	0655-0105 C to Mainland China, ID: "Hansheng Kuangpo Tientai, Kuanghua chih Sheng"	DEC06

#### Category 4: Covert broadcasts by opposition groups via own or local transmitters.

Code	kHz	kW	To	Station	Schedule (UTC), remarks	Last log
D	4375	-	IRN	Voice of Iranian Revolution,	1520-1627v Kurdish // 3880v (ID + details),d 4330-4395 jumping possibly via No. Iraq 5 kHz. Jammed	DEC06
A	4375	-	IRN	Voice of the Communist Party	1725-1855v (Fr -1915) Farsi // 3880 (ID + details); d 4330-4395 of Iran, possibly via No. Iraq jumping 5 kHz. Jammed	APR07
C	4675	-	IRN	Voice of Free Kurdistan	0230v-0430v 1630-1830v Sorani (Iranian) Kurdish, ID: "Dengi Azadi Kurdistan", d- 4670	FEB07
B	4860	-	IRN	Voice of Iranian Kurdistan, via Al-Sulaymaniyah, No. Iraq	0245v-0430 1430-1600v Kurdish, 0430-0500 1600v-1700v Farsi, // 3970(ID's), but unsynchronous; d 4835-4900. Jammed	APR07
B	6300	20	MRC	National R of the Saharan Arab Democratic Republic, Rabouni (near Tindouf), Algeria	0700-0800v(Fr-1000v) 1800-2300 A, 2300-2400 S // 1550 MW. A ID: "Idha'at al-wataniyah li al-jumhuriyah al-arabiyah al-sahrawiyah al-dimuqratiyah". Operated by Polisario, d 6208-7460	APR07



international shortwave bands, many years ago the DSWCI decided to expand the traditional tropical band survey to include stations broadcasting to a domestic audience. Consequently, the DSWCI now publishes a superb, comprehensive reference of domestic shortwave broadcasting.

The *DBS-9* covers all active stations broadcasting to a domestic audience between the frequencies of 2300 kHz and 30,000 kHz. Part 1 is the 35th edition of the "TBS," covering all active broadcasting stations in the 2300- to 5700-kHz range. Part 2 covers the domestic stations on the international bands above 5700 kHz broadcasting to a national radio audience. Part 3 includes active clandestine broadcasting stations with schedules and identifications that enhance the value of the *DBS-9* to the serious shortwave radio monitor. Part 4 contains deleted frequencies between 2 and 30 MHz, which have not been reported as heard during the last five years, but may reappear.

A valuable, unique feature of the *DBS-9* is the right hand column called "Last Log." This column shows the last month and year prior to the April 30th deadline when a particular station was reported logged by a DXer somewhere in the world. This gives the listener a reasonable indication of the audibility of the shortwave broadcasting station.

## Updated And Confirmed

As part of the updating process, most frequencies that have not been heard in the last year have been deleted from the list and moved to a section at the end of the survey, Part 4 as discussed above, for stations deleted since July 2002. This updating procedure makes the *DBS* current and very user friendly.

My own personal monitoring and checking confirms that the 2007 edition of the *DBS* continues the tradition of providing very accurate and extremely useful information for the DXer. Consequently, it makes an extremely valuable addition to the references and published resources hobbyists maintain in pursuit of elusive DX station catches.

To assure reliability, each of the 1,050 station frequencies has been confirmed on the air by the club's extensive assemblage of worldwide monitoring experts since the last publication through the April 30th closing date. Stations confirmed as being active are marked with an "A" (regular), or "B" (irregular), or "C" (sporadic) in the list. A "D" means the station is likely inactive. This simple coding system provides valuable information when tuning the

bands while trying to get a handle on rare, exotic DX catches. As a result of monitoring, most of the frequencies already have been confirmed as being active in 2007.

Two years ago the "Tropical Bands Monitor" ("TBM") feature was added as a regular update to the *DBS*. Its introduction provided a readily available electronic update of broadcasting stations below 5700 kHz; it has been a big success. This website-based feature, which is updated each month, helps keep the *DBS-9* current. I download the latest version each month—it is usually available three or four days after the close of the previous month—and use it as a ready guide to what is being heard around the world on the domestic frequencies. This service alone is worth more than the price of the *DBS* itself. I can't overemphasize the value the "TBM" adds to the *DBS*. Together they form an indispensable package of DX reference sources.

DSWCI members also receive periodic updates issued in the *Shortwave News* bulletin published by the club and through its electronic *DX Window*. These extra services keep the domestic band survey accurate and up to date. Details about becoming a DSWCI member are available at the club website. The electronic, PDF-format membership option substantially reduces the cost of being a member by reducing the printing and postage costs.

## Easy, Indispensable Resources

The *DBS* and "TBM" are high-quality shortwave broadcast DX resources made available at a very reasonable price. The combination of high quality and low price make the *DBS* and "TBM" unbeatable in today's global resource reference marketplace. If you listen to domestic broadcasters, the *DBS-9* and the monthly updates through the "TBM," are "must-haves" while tuning the bands. This is the first resource I pack when attending French Creek DXpeditions. I can't imagine DXing the shortwave bands without a copy of the *DBS* and the latest update of the "TBM" at my side.

How easy is the *DBS* to use? Simple, the *DBS* is very straightforward and easy to use. The first column provides the reception code, A, B, or C as previously described. The second column lists the frequency. The third column provides the station transmitter output. The fourth column designates the broadcasting country utilizing the International Telecommunications Union (ITU) country code abbreviations (for those not familiar with these

abbreviations, a complete list of ITU country codes is given on page 3 of the *DBS*). The fifth column provides the station name and/or call letters and location. The sixth column provides transmission times and other useful information about the station, such as operating schedules during Ramadan for Middle East and Indonesian stations. Other useful features for easy station identification are the parallel frequencies and station ID sentences. The final column is the "Last Log" feature previously described. (See "Samples From Domestic Broadcasting Survey 9.")

Also, the survey includes a listing of Indonesian provinces and special districts, which is extremely useful for DXers with an interest in that part of shortwave broadcasting world. As the sunspot numbers slowly move up, I expect to be tuning more Indonesian stations during our upcoming DX season.

## How To Get Yours

The 40-page A-4 size *DBS-9* is available in electronic form in PDF-format and is about 500 kB. It is available via email for only U.S. \$7.00, EUR 5, or 5 International Reply Coupons ("IRCs"). The limited print edition is available for only U.S. \$12.00, EUR 10, or 10 IRCs.

The *DBS-9* can be ordered direct from the club treasurer at the following address:

DSWCI, c/o Bent Nielsen, Egekrogen 14, DK-3500 Vaerloese, Denmark

The 2007 edition of the *DBS* continues the excellent tradition of being a very useful and reliable DXing resource that should be in the shack of every active shortwave radio monitor. I use the *DBS* on a regular basis while tuning the bands. I can't imagine DXing without this at my side, especially while on DXpeditions.

While some enjoy operating a computer while tuning the bands, I print out a hardcopy to use, thereby eliminating an electronic device from the shack while listening. During French Creek DXpeditions, my copy of the *DBS* is in constant use! The PDF-format *DBS* is incredibly inexpensive and extremely useful. The monthly update to the "TBM" keeps things current.

At only U.S. \$7.00, the electronic *DBS* continues to be the best buy of any hobby resource on the market today. You must have the new *DBS*, which is an outstanding piece of DX hobby research. This is a necessity for any DX shack and is highly recommended, so order a copy to enhance your DXing sessions. ■

# A Speaker Test Jig For Your Service Bench

Last month's simple extension cord project permitted keeping a set's large and delicate electro-dynamic speaker in the cabinet while the chassis was being serviced and aligned. Having to remove a large 12-inch dynamic speaker from a console is a chore; and once the paper cone is exposed, it's amazing how sharp objects are inadvertently drawn to them! Who needs the extra expense of having a speaker reconed—especially when the damage was self-inflicted and so avoidable!

Unfortunately, while not all manufacturers used speaker plugs on the chassis rear apron, Zenith, along with a few others, was kind enough to do so. Most Zenith sets used a conventional five-pin wafer tube socket for the speaker. For whatever reason, pin three wasn't used, and it is often missing on the speaker plug. The same five-pin socket was used on sets that used single-ended (S-E) and push-pull (P-P) audio output stages. The field coil is connected between pins one and five; note that Zenith wires the rectifier tube cathode to pin five. Pin one is the filtered B+ for the radio. The audio transformer primary is connected between pins two and four.

For those sets with P-P audio transformers, the audio transformer center tap was usually connected to pin one of the socket (filtered DC from the field coil.) Other brands used "hard-wired" speaker leads, or oddball speaker connectors mounted to the frame of the speaker. I've even seen six-pin arrangements used. For the latter, most of us eventually find enough *junkers* (radios beyond reasonable restoration due to extreme damage or missing rare parts) to provide the donor parts to make up those oddball cables as needed.

## A Speaker Test Jig

Early radio repair shop service benches often incorporated either commercially bought or homemade (many were often built into the bench) test speaker jigs to reduce the technician's bench time. Time saved was money earned for the busy high-volume repair shops! I've seen several of the commercial units up for auction in the past, but the final sales prices usually ended up being a little too steep for my liking. Alas, the woes of competing in a global auction site often lead to such frustrations!

I decided to make my own speaker substitution box, and I also thought that it would be a good construction project that others might also enjoy and find useful. So let's go over the various sections needed to make a speaker test jig and discuss what they do. We'll also discuss some possible changes that could be included to make a fancier and more versatile unit. But remember, simpler is often better, and our objective is for a unit that is easy to use and inexpensive; after all it is intended for intermittent service work and not long-term radio listening. (See Figure.)

## Field Coil Substituting

First, we'll need to find a means to substitute the field coil assembly used on early electrodynamic speakers. The field coil



*Photo A. Here's an inside view of my speaker test jig. The speaker, audio transformer, and many of the other smaller parts were salvaged from a non-repairable junk Heath T4 signal tracer. Note the long threaded spacers that provide a means to attach the front panel to the enclosure. All wiring and parts must be able to withstand voltages in excess of 500 VDC.*

provided two important functions in the radio circuit. First, the field coil inductance worked as a filter choke for the power supply filtering—it reduced the residual AC artifacts from the first filter capacitor. The field coil also generated the strong, fixed magnetic field needed for the voice coil's magnetic field to work against to move the paper cone.

It would be impractical to exactly duplicate the inductance and DC resistance of each field coil that might be encountered in our a test jig; but it is effective and easy to use just an array of power resistors to match the DC value of the field coil resistances. Fortunately, the field coil DC resistances are shown on the schematics in the Rider manuals, making our lives a lot easier.

Some filtering will be lost since the resistance alone will provide less filtering action than the winding inductance; this means there may be some hum heard in the speaker. But, what is important is that the DC operating voltages will be close to what they should be. That's more important than a small increase in background audio hum for our brief test period needs.

## Finding The Right Power Resistor

As I mentioned, a cursory scan of a random selection of sets taken from my Rider *Volume VII* yields the following sampling of DC ohm reading values for various field coils: 275, 380, 400, 425, 700, 1100, 1875, and 2600 ohms. It would be possible to switch in several power resistors, selected perhaps to offer 20-percent overlapping resistances between say 100 and 3000 ohms, but that would involve a lot of resistors and an involved switching arrangement. If available, a decade power resistance substitution box would do well here! The Clarostat model 240-C would be an ideal choice; and these venerable workhorses are



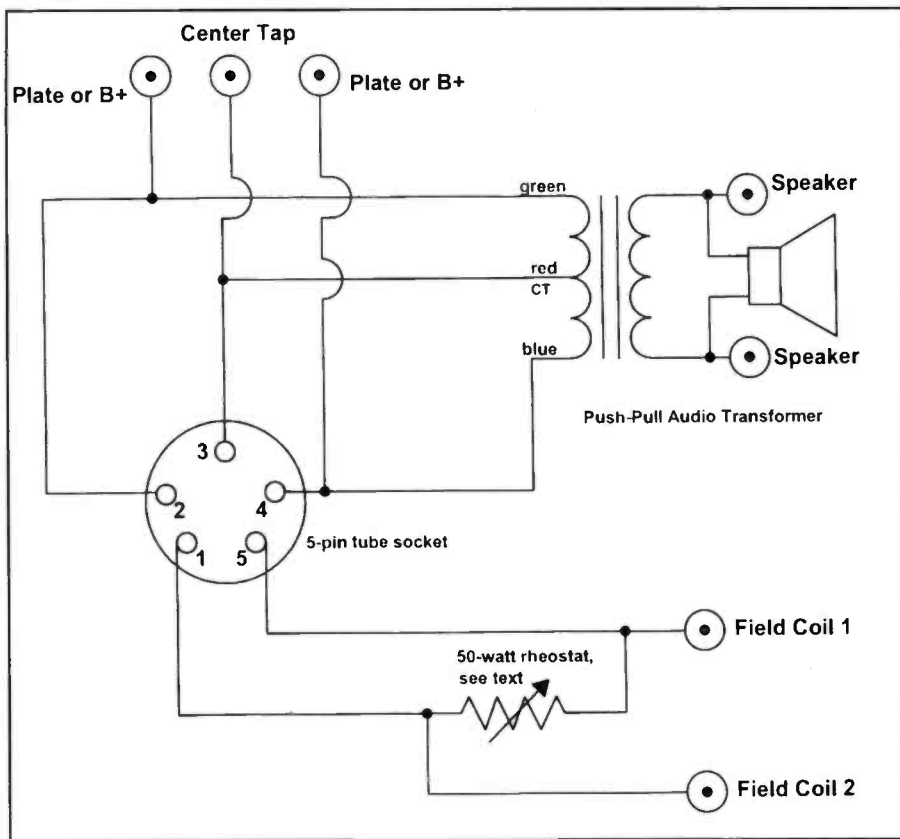

Figure. This schematic shows how I wired up the test speaker. The unit is provided with binding posts and a five-pin socket. The socket can be used with jumper cables for chassis that use a speaker socket, while the binding posts are used for sets with flying leads that are soldered to the speaker.



Photo B. The completed speaker test jig is housed in a salvaged Heath T4 signal tracer enclosure. I painted the front panel to hide the old control markings. I added extra binding posts to bring out the rheostat, speaker, and audio transformer connections for flying lead hookups. A five-pin socket permits the use of custom extension jumper cables made up for the more common sets.

often spied at ham auctions or on the surplus markets—keep your eyes open for one! The downside is that they take up a bit of bench real estate.

Remember that the field coils get warm when the set is running. They are dropping voltage and producing heat energy due to “I-squared R” losses. A field coil will give different resistance measurements depending on its temperature—the resistance value per foot for the fine gauge wire used for the field coil windings increases with temperature.

### An Ideal Solution

Why not use a power rheostat for the field coil substitution? A rheostat would allow almost infinite resolution for resistances within its range. Fair Radio’s website shows a 2500-ohm, 50-watt power rheostat (Fair Radio part number is RHEO-50-2500, and it goes for under four dollars) that would be ideal for this application.

What wattage resistor is needed? Let’s be conservative and assume that the maximum B+ current will be less than 100 mA.

The power formula to find wattage when current and resistance are known is  $Watts = I^2 R$ . This formula gives us the heat produced by the different field coil resistances for a 100-mA current. For field coil resistances between 100 and 3000 ohms, the wattage will proportionally increase from 1 watt to over 30 watts! Allowing for a two-to-one safety margin, the Fair Radio 50-watt, 2500-ohm rheostat is within reasonable limits for our needs.

Keep in mind that, although the rheostat is rated at 50 watts, the power rating for these devices will proportionally decrease as their resistance is reduced. On the other hand, the heat energy being dissipated will also be proportionally less!

### Speaker Transformer Conundrums!

The next problem to be solved is what to use for an audio output transformer! Remember there are several variables at work here that should be taken into account since the test jig will need to accommodate sets with different tube load impedances, as well as push-pull

and single-ended output designs. For those who wish to obsess about such things, fancy audio transformers with tapped primary and secondary windings are made by Hammond. RadioDaze is a Hammond distributor, so you can visit their website for more information on these products. (Contact info for Radio Daze and other suppliers is given at the end of the column.)

Those transformers, combined with some fancy switching, can be set to match almost any radio output stage configuration that will be encountered—a range that could vary between 1000-ohms Z to 10,000-ohms Z. Again, let’s keep it simple and down to earth. For our needs a basic audio transformer designed for push-pull audio will provide satisfactory results when used in either a pull-pull output or single-ended output stage—with some reservations!

Here’s what we need to consider. Visualize the primary winding on a P-P transformer as being a continuous winding with a center tap for the B+. Each tube is drawing the same quiescent Class A idling current through the windings. *The*

standing DC currents on each half of the winding produce a magnetic field that cancels the other out! Single-ended audio transformers must be designed to handle the resulting magnetic field, which limits the transformer's audio power due to core saturation.

I suggest using a good-sized transformer—one with an 8-watt or greater rating—for this project. The Hammond HX-125-J would be my choice if I had to buy one, otherwise a push-pull audio transformer salvaged from an older amplifier or radio will do fine. Remember, the plan is to get the radio aligned and tested with minimum fuss on the bench.

## Putting It All Together!

I had picked up three Heath model T4 signal tracers for an earlier column on signal tracing techniques. Two of them were restored using parts from the third unit.

If you remember, these units have a built-in speaker and P-P audio transformer, with front-panel jacks, and were designed for speaker substitution! Basically they're already one-half of what is needed for a speaker test jig. The old T4 provided many of the needed components: these parts included the audio transformer, speaker, enclosure, and binding posts.

Photos A and B show how it was put together. Unneeded parts were removed from the old signal tracer chassis and saved for future use. Nothing is wasted at the "Wireless Connection" headquarters—I already have plans for the power transformer. The Heath speaker and Heath audio transformer and jacks were left on the panel, but everything else was removed. The Heath transformer probably has a reasonable DC current rating for SE service despite its small size, otherwise I doubt that the Heath engineers would have used it. I used two long threaded spacers to provide a means for attaching the front panel to the enclosure. Normally this is accomplished by the internal chassis, which is not used for this application.

I had a smaller 10,000-ohm, 25-watt rheostat on hand, so that's what I'm using for the present time for illustration purposes. The 50-watt Fair Radio rheostat is on my wish list for my next Fair Radio order and is a far better choice! The small rheostat shown in Photo A is at maximum ratings with 50 mA of current, and it doesn't have the needed wattage to handle larger sets.

Note that I also added a pair of binding posts for the field coil rheostat. The front panel now sports two binding post jacks for the speaker: three for the audio transformer primary windings and center tap, and another two for the rheostat. These binding posts permit attaching fly leads from a chassis directly to the unit without using the socket. They also permit other tricks, such as using a banana plug jumper to connect the one side of the field coil to the speaker transformer center-tap for push-pull Zenith sets that are connected with an extension cable to the five pin socket.

Having the speaker audio on front panel binding posts provides an easy means for hooking up an AC voltmeter or vacuum tube voltmeter for alignment. The added binding posts take care of the unused front panel holes. An old dial plate covers the slide switch cutouts, one of which was enlarged for mounting the rheostat. These can be seen in the front view shown in Photo B. You can either make up a calibrated dial plate with markings showing the resistance settings, or you can use an ohmmeter to preset the rheostat to the needed resistance before hooking things up.

The vacant eye tube opening on the front panel was fitted with a five-pin tube socket to facilitate using different plug-in speaker extension cables for different radio configurations. For P-P Zenith sets, simply connect a jumper wire between the binding posts for the filtered B+ and audio transformer CT. This will connect the transformer CT to pin 1 on the speaker jig's socket.

Unfortunately, I had planned to make the unit compatible with the extension speaker cables discussed in our last column. However, this raised some safety issues. Using a male-type chassis plug on the front panel would accommodate the female end of the extension cable, but then there would be high voltages on those exposed pins if the binding posts were used for the hookup instead! The use of a female socket means that a double-male cable is now needed; and it must be connected to the speaker test jig first! This prevents exposing high voltages on the pins of the plug that goes to the test jig.

But, of course, nothing can be made foolproof, so always handle this sort of equipment with the greatest respect and care! Filter capacitors can hold a charge for quite a long time. Always assume high voltages are present, even if the radio has been unplugged for days. Pay attention to

## Track Hurricanes Tornadoes and Flash Floods

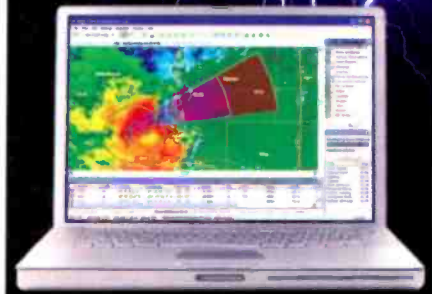

### SWIFT WX Professional 2.7

*"It's not too often we can buy a software program and truly say its really worth the money and more importantly, does what it says it will do. If you are a spotter or a weather enthusiast, the battery of features and tools found in SWIFT WX has no peers."*

Tony Amato, KR4UQ  
Virginia RACES State EOO  
NWS SKYWARN Spotter Since 1992

*try it free for two weeks!*

[www.swiftwx.com](http://www.swiftwx.com)

what you're doing, and don't work on electronic equipment when you're tired or distracted!

## A Better Mousetrap?

That's it for this month! I hope this project is something you'll find useful on the bench. I know many of you will expand on the basic version I've presented; photos and ideas for improvement are always welcome!

We'll be back in December. Until then, keep those soldering irons hot, and those old tube radios glowing! ■

### Resources

*Antique Electronics Supply*  
6221 S. Maple St., Tempe, AZ 85283;  
Phone: 480-820-5411; Fax: 800-706-6789; Web: [www.tubesandmore.com](http://www.tubesandmore.com).

*Fair Radio*  
2395 St. Johns Rd., Lima, OH 45804;  
Phone: 419-223-2196; Fax: 419-227-1313; Web: [www.fairradio.com](http://www.fairradio.com).

*Radio Daze, LLC*  
7620 Omnitech Place, Victor, NY 14564;  
Phone: 585-742-2020; Fax: 800-456-6494; Web: [www.radiodaze.com](http://www.radiodaze.com).



NEW PSR-500



Shown Actual Size

(145mm H x 65mm W approx. excluding projections)

# TAKE CO

Frustrated by your digital trunking scanner? Let GRE put you back in control with the all new PSR-500!

Public safety radio systems have become very sophisticated in recent years, and the digital trunking scanners you use to monitor them have become a lot more complicated. GRE puts you back in control with the PSR-500 Advanced Digital Scanner!

The PSR-500 features GRE's exclusive Object Oriented User Interface, which gives you unprecedented ease of use in the field. But don't let that fool you – behind the user friendly face of the PSR-500 you'll find the most powerful digital trunking scanner available.

The PSR-500 lets you scan the way YOU want to scan. You can scan trunking talkgroups, conventional channels, even search configurations and Spectrum Sweeper setups – all at the same time, and all with one-handed ease-of-use! And, you can group as many as 1,800 "scannable objects" any way you see fit using GRE's powerful Scan List grouping system. Your objects can be members of as few or as many Scan Lists as you want, and there's even a Favorites Scan List that allows you, within a press of one button, to quickly access and scan a subset of the objects programmed into the scanner. YOU get to decide!

The PSR-500 is a professional quality digital trunking scanning receiver. It is designed for use by media organizations and public safety users, yet it is so easy to use that even beginners will be up and running in no time at all!

Available mid-October, call your favorite amateur radio or scanner dealer now to get on their PSR-500 list - be the first to take control of your scanning!



COMING SOON FROM GRE! >>>



**PSR-100**  
Handheld Scanner  
200 CH  
SAME(FIPS) / Weather alert  
5 One Touch Service Searches  
Skywarn  
Spectrum Sweeper  
PC Programmable  
Backlit LCD Display

© 2007 GRE America, Inc., 425 Harbor Blvd., Belmont, CA 94002

tel: (650) 591-1400 fax: (650) 591-2001 email: scanner-sales@greamerica.com web: www.greamerica.com

All specifications are subject to change without notice or obligation.

# CONTROL WITH GRE!

## Features

### Intuitive "Object Oriented" User Interface Design

- Designed for ease of use, yet powerful enough to satisfy the most sophisticated experts. Common data entry, browsing and control methods are used for non-trunked conventional channels, trunking talkgroups, search configurations and Spectrum Sweeper setups. The radio grows with you - you can start out with a small, easy to manage configuration, then expand it whenever you need to.

### Powerful and Flexible Scan List Functionality

- Allows you to arrange, group and scan objects according to your preference, with no limit to the number or types of objects in a Scan List, and no limit to the number of Scan Lists an object can be a member of.

### Menu Driven Programming with Context Sensitive Help

- Each menu item provides a few lines of help text that provide assistance with programming and using the scanner.

### Upgradeable CPU and DSP Firmware

- You can easily keep your radio current with software enhancements as they become available with free upgrades from [www.greamerica.com!](http://www.greamerica.com!)

### Flexible Free-Form Memory Organization

- Memory is assigned as objects are created using a sophisticated internal file management system. You are not constrained to traditional bank/channel scanner memory layouts. No memory is wasted as a result of bank/channel programming constraints. The scanner has sufficient main memory capacity to store over 1,800 conventional channels, trunking talkgroups, search configurations and Spectrum Sweeper objects in any combination, providing ample capacity for more sophisticated hobbyists and professionals while keeping the database size manageable for beginners.

**GRE's Exclusive V-Scanner Technology** - Allows you to save complete radio configurations within the radio, for recall into main memory as needed in the field. This is similar to having a laptop computer and programming software available anytime. You can use V-Scanners to store configurations for different geographical areas or usage styles. Twenty-one V-Scanner Folders are provided, each capable of storing over 1,800 objects.

Total memory capacity of main memory combined with V-Scanners is over 39,600 (1,800+37,800) objects!

**Multi-System Trunking** - Scans most common trunked radio system signaling formats, including Motorola, EDACS Standard, EDACS Narrow, LTR and P25 trunked radio networks. Talkgroup call and individual call monitoring are supported. Supports trunking operation in virtually any land mobile radio band, including 700 MHz and the new Federal 380 MHz band!

**P25 NAC Functionality** - Much like CTCSS and DCS with analog signals, P25 Network Access Code (NAC) is used to provide selective squelch operation on conventional P25 digital channels. GRE's PSR-500 Advanced Digital Scanner will detect the NAC that is being used on a P25 conventional digital channel, and will allow you to program NAC codes to block transmissions that do not have a matching NAC, including analog traffic on the same frequency!

**Remote Control Capability** - Can be used with third party application software to remotely control the scanner from a personal computer.

**Exclusive ALERT LED** - Programmable tri-color LED can be configured to illuminate or flash when certain objects are active. Eight user-defined colors and brightness levels can be specified from thousands of possible combinations. Provides visual alerts when certain objects are active, e.g., blue can be used to signal activity on a primary police call, red for fire, etc."

**Audible alarms** - Programmable audible alarms can be configured to sound when certain objects are active. Can be used in conjunction with, or separately from, the ALERT LED described above.

### GRE's Exclusive Automatic Adaptive Digital Tracking

- When monitoring Motorola and P25 digital systems, instantly adapts the digital decoder to the digital modulation format of the transmitted signal, then analyzes the digital signal 50 times each second and adapts to any subtle changes caused by multipath or fading. No cumbersome manual adjustments are required.

**GRE's Exclusive Digital AGC** - Instantly compensates for low audio levels that are very common on digital systems. The radio is easier to listen to, and provides you with a more enjoyable scanning experience.

### The Best Subaudible Squelch Decoder in the

**Scanning Industry** - CTCSS and DCS subaudible squelch coding is processed by the same powerful DSP chip that is used for P25 digital decoding. Provides fast and reliable decoding of subaudible squelch signaling with squelch tail elimination.

**High Speed PC Interface** - Uses GRE's 30-3290 USB cable in full duplex mode at 6 times the speed of previous scanner models for PC transfer and 8 times the speed of previous models for radio-to-radio cloning.

**Powerful Spectrum Sweeper** - Quickly sweeps the scanner's frequency ranges for transmissions from nearby transmitters.

**Real-time Signal Strength Indicator** - Shows relative strength of received signals.

**Trunking Control Data Output** - Streams decoded trunking control data from your PSR-500 to a personal computer for use with popular third party trunking control channel monitoring software. No slicer needed! Also streams NOAA weather radio SAME alert data!

**High Contrast LCD Display** - Provides one row of dedicated icons, and four rows of 16 characters for programming and scanning operations.

**SAME and All Hazards Weather Alerting** - GRE's PSR-500 Advanced Digital Scanner can operate in dedicated SAME weather alerting mode, and alert you to severe weather and other hazards in the specific area(s) that you select, or, the scanner can check your local NOAA weather frequency periodically, even while scanning, and alert you when an All Hazards alert occurs.

**SKYWARN Storm Spotter Functionality** - Provides instant, one button access to frequencies used by storm spotter networks. You can monitor storm conditions as they occur, and become aware of dangerous conditions before the media or emergency management officials are able to announce them to the general public.

**Sleek, Compact Case Design** - Has a Large Speaker for adequate volume in most environments, and is designed for one-handed operation for ease of use.

### PSR-600 Digital Trunking Desktop/Mobile Scanner

Same features as PSR-500 in desktop/mobile style!



### PSR-200

#### Desktop Scanner

200 CH  
SAME(FIPS) / Weather alert  
5 One Touch Service Searches  
Skywarn  
PC Programmable  
Backlit LCD Display  
And MORE!



### PSR-300

#### Triple Trunking Handheld Scanner

Motorola Analog, EDACS, LTR  
1,000 CH / 1,500 TGID  
CTCSS / DCS  
20dB attenuator  
SAME (FIPS) / Weather alert  
Skywarn  
Spectrum Sweeper, and MORE!



### PSR-400

#### Triple Trunking Desktop/Mobile Scanner

Motorola Analog, EDACS, LTR  
1,000 CH / 1,500 TGID  
CTCSS / DCS  
20dB attenuator  
SAME (FIPS) / Weather alert  
Skywarn  
Spectrum Sweeper, and MORE!



# World News, Commentary, Music, Sports, And Drama At Your Fingertips

This listing is designed to help you hear more shortwave broadcasting stations. The list includes a variety of stations, including international broadcasters beaming programs to North America, others to other parts of the world, as well as local and regional shortwave stations. Many of the transmissions listed here are not in English. Your ability to receive these stations will depend on time of day, time of year, your geographic location, highly variable propagation conditions, and the receiving equipment used.

AA, FF, SS, GG, etc. are abbreviations for languages (Arabic, French, Spanish, German). Times given are in UTC, which is five hours ahead of EST, i.e. 0000 UTC equals 7 p.m. EST, 6 p.m. CST, 4 p.m. PST.

UTC	Freq.	Station/Country	Notes	UTC	Freq.	Station/Country	Notes
0000	7555	Voice of America Relay, Kuwait		0300	7440	Radio Ukraine International	
0000	6145	Radio Nederland Relay, Bonaire		0300	11920	RTV Marocaine, Morocco	AA
0000	6090	Radio Bandeirantes, Brazil	PP	0300	6185	Radio Educacion, Mexico	SS
0000	9440	Radio Prague, Czech Republic		0300	5010	Radio Nationale Malagasy, Malagasy	Malagasy
0000	6035	La Voz del Guaviare, Colombia	SS	0300	15495	Radio Kuwait	AA
0000	6000	Radio Havana Cuba	SS	0300	13760	Voice of Korea, North Korea	FF
0030	7415	WBCQ, Maine		0300	13730	Radio New Zealand	
0030	10330	All India Radio	HH	0300	4780	RT Djibouti	FF
0030	9870	Radio Austria International		0300	7475	Voice of Greece	Greek
0030	15250	CVC International, Australia	II	0300	15240	Radio Australia	
0030	4717	Radio Yura, Bolivia	SS	0300	6090	Caribbean Beacon, Anguilla	
0030	4965	Radio Alvorada, Brazil	PP	0300	4885	Radio Clube do Para, Brazil	PP
0100	7250	Voice of Russia	RR	0300	6010	La Voz de su Concencia, Colombia	SS
0100	6010	Radio Sweden, via Canada	Swedish	0300	12015	Voice of Islamic Rep. of Iran	AA
0100	9440	Radio Slovakia International		0300	3396	Radio Zimbabwe	
0100	9460	Voice of Turkey	TT	0300	9815	Adventist World Radio, via UAE	
0100	9715	RDP International, Portugal	PP	0300	4930	Voice of America Relay, Botswana	
0100	9770	Radio Budapest, Hungary	HH	0330	15420	BBC Relay, Seychelles	
0100	6973	Galei Zahal, Israel	HH	0330	3250	Radio Luz y Vida, Honduras	SS
0100	11780	Radio Nacional Amazonia, Brazil	PP	0330	11590	Kol Israel	
0100	7345	Radio Prague, Czech Republic		0330	3240	Trans World Radio, Swaziland	vern
0100	4834	Radio Maranon, Peru	SS	0400	7275	RT Tunisienne, Tunisia	AA
0130	4052	Radio Verdad, Guatemala	SS	0400	9865	Radio Farda, USA, via Morocco	Farsi
0130	4780	Radio Buenas Nuevas, Guatemala	SS	0400	9705	La Voix du Sahel, Niger	FF
0200	9665	Voice of Russia, via Moldova		0400	5960	Radio Japan, via Canada	JJ
0200	5890	Radio Thailand, via USA		0400	9700	Radio Bulgaria	
0200	6536	Rdf. La Voz del Rondero, Peru	SS	0400	7260	RT Algerienne, Algeria, via England	AA
0200	4819	Radio Quito, Ecuador	SS	0400	9970	RTBF, Belgium	FF
0200	11915	Radio Gaucha, Brazil	PP	0400	5910	Marfil Estereo, Colombia	SS
0200	6135	Radio Santa Cruz, Bolivia	SS	0400	5025	Radio Rebelde, Cuba	SS
0200	6150	Radio Record, Brazil	PP	0400	15185	All India Radio (Goa)	HH
0200	5014	Radio Altura, Peru	SS	0400	4810	Radio Transamericana, Mexico	SS
0200	11800	RAI Italia	II	0400	1000	WWVH, Hawaii	
0200	15560	Vatican Radio, via Russia	Hindi	0400	7210	Radio Fana, Ethiopia	Amharic
0200	4828	Zimbabwe Broadcasting Corp.	vern	0430	3810	HD2IOA, Ecuador	SS time
0230	15385	Voice of America Relay, Philippines	CC	0430	9925	Voice of Croatia, via Germany	Croatian
0230	7230	Radio Slovakia International	SS	0430	3320	Radio Sondergrense, South Africa	Afrikaans
0230	11710	RAE, Argentina		0430	11980	Voice of Turkey	TT
0230	7270	Radio Cairo, Egypt		0500	9575	Radio Medi Un, Morocco	FF
0230	5915	Radio Zambia		0500	4770	Radio Nigeria	
0230	7260	Voice of Turkey	TT	0500	4777	RTV Gabonaise, Gabon	FF
0300	7305	Vatican Radio		0500	6160	CKZN, Newfoundland	
0300	6055	Radio Exterior de Espana, Spain	SS	0500	5005	Radio Nacional, Equatorial. Guinea	SS
0300	7390	Channel Africa, South Africa		0500	7380	Trans World Radio, via Albania	

UTC	Freq.	Station/Country	Notes	UTC	Freq.	Station/Country	Notes
0530	5030	Radio Burkina, Burkina Faso	FF	1600	13675	Radio Austria International, via Canada	
0530	9515	Radio Sultanate of Oman	AA	1600	11570	Radio Pakistan	
0600	9620	Channel Africa, South Africa		1700	12035	SW Radio Africa, via England	
0600	9615	Radio New Zealand International		1700	15690	Radio Taiwan International, via France	
0630	4845	Radio Mauritanie, Mauritania	AA	1730	11735	Radio Romania International	
0700	7125	Radio Conakry, Guinea	FF	1730	9750	Radio Japan, via England	JJ
0700	6030	CFVP, Canada		1730	17680	CVC - La Voz, Chile	SS
0730	9525	Cotton Tree News, Sierra Leone, via Ascension	irregular	1730	12160	WINB, Pennsylvania	
0799	9525	Star Radio, Liberia, via Ascension Is.		1800	11875	Radio Nacional Venezuela, via Cuba	SS
0800	4915	ABC No. Territories Service, Australia		1800	15345	RTV Marocaine, Morocco	AA
0800	7355	KNLS, Alaska		1800	15580	RDP International, Portugal	PP
0900	4939	Radio Amazonas, Venezuela	SS	1800	13820	CVC International, via Germany	SS
0900	9600	Radio UNAM, Mexico	ss	1830	15475	Africa No. One, Gabon	FF
0900	3310	Radio Mosoj Chaski, Bolivia	SS	1900	9785	Voice of Turkey	
0900	5035	Radio Aparecida, Brazil	PP	1900	15120	Voice of Nigeria	
0930	9625	Radio Cancao Nova, Brazil	PP	1900	17810	Radio Nederland	
1000	3280	La Voz del Napo, Ecuador	SS	1900	15630	Voice of Greece	Greek
1030	9965	T8BZ, Palau	CC	1900	15085	Voice of Islamic Rep. of Iran	FF
1030	15190	Radio East Africa, Equatorial Guinea		1930	11750	Adventist World Radio, via South Africa	Hausa
1030	4780	Radio Cultural Coatan, Guatemala	SS	1930	11705	Radio France International	FF
1100	9930	KWHR, Hawaii		1930	11810	Radio Jordan	AA
1100	9930	Open Radio for North Korea, via Hawaii	KK	2000	11695	Radio Budapest, Hungary	HH
1100	4750	Radio Republik Indonesia-Makassar	II	2000	17630	Africa No. One, Gabon	FF
1130	6050	RT Malaysia/Asyik FM		2030	11735	Radio Tanzania-Zanzibar	Swahli
1200	9650	KBS World Radio, South Korea		2030	13720	Radio Tirana, Albania	Albanian
1200	9845	Voice of America Relay, No. Marianas		2100	11625	Radio Exterior de Espana, Spain	
1200	9280	Family Radio, via Taiwan	CC	2100	12085	Radio Damascus, Syria	various
1200	9740	BBC Relay, Singapore		2100	7285	China Radio International, via Albania	
1200	7200	Radio Bulgaria	Albanian	2100	12035	Voice of America Relay, Sao Tome	
1200	9400	Far East Broadcasting Corp., Philippines	CC	2130	11895	Deutsche Welle Relay, Rwanda	
1230	11500	Voice of Russia via Tajikistan	Hindi	2130	17615	China Radio International, via Chile	PP
1230	9430	FEBC International, Philippines	CC	2200	9790	Radio Romania International	
1230	9525	Voice of Indonesia	II	2200	15600	Radio Taiwan International, via Florida	
1230	17660	Voice of Africa, Libya, poss. via France		2200	11850	Trans World Radio, Guam	Indonesian
1300	7485	Trans World Radio, Guam	CC	2200	15110	Radio Kuwait	AA
1300	9335	Voice of Korea, North Korea		2200	9990	Radio Cairo, Egypt	
1300	11895	BBC Relay, Singapore		2200	15345	RAE, Argentina	SS
1300	9580	Radio Australia		2200	13700	China Radio International, via Canada	SS
1300	9485	Shiokaze, Japan, via Taiwan	various	2200	9780	Republic of Yemen Radio	AA
1300	9780	KNLS, Alaska		2200	9900	Radio Varna, Bulgaria	BB; Sun-Mon
1300	9690	Voice of Nigeria		2200	7190	RT Tunisienne, Tunisia	AA
1300	11975	Adventist World Radio, Guam	JJ	2230	13775	Voice of America Relay, Thailand	CC
1300	13745	Trans World Radio, Swaziland		2230	9745	HCJB, Ecuador	Quechua
1330	15240	Radio Sweden		2230	6200	Radio Bulgaria	SS
1330	15265	Radio Solh, England	Dari/Pashto	2230	5930	Cyprus Broadcasting Corp.	Greek; wknds
1330	11585	All India Radio	HH	2300	6300	Radio Nacional de la RASD	AA/S
1330	11750	BBC Thailand Relay		2300	15585	Radio Free Asia, via No. Marianas	CC
1330	21655	RDP International, Portugal	PP	2300	15640	Deutsche Welle, Germany, via Russia	GG
1400	11760	Radio Havana Cuba	SS	2300	11855	Radio Aparecida, Brazil	PP
1430	17780	RAI Italia, Italy	II	2300	15445	Radio Canada International	SS
1430	11730	Radio Japan		2300	7170	China Radio International, via Mali	CC
1530	13765	Vatican Radio		2300	11750	China Peoples Broadcasting Station	CC
1530	13775	Radio Austria International, via Canada		2330	9875	Radio Vilnius, Lithuania	
1600	17560	BSKSA, Saudi Arabia	AA	2330	15630	Voice of Greece	Greek
1600	12133	AFN/AFRTS, Florida					
1600	15580	Voice of America Relay, Morocco					
1600	12050	Radio Cairo, Egypt	AA				



## New, Interesting, And Useful Communications Products



Crosley Radio's Explorer 1 XM Satellite Radio is housed in a handsome wooden cabinet.

### Crosley Radio's Explorer 1 XM Satellite Radio

Crosley Radio is now offering the Explorer 1 satellite radio-ready tabletop sound system (Model CR224). Features include XM readiness; portable audio readiness (simply plug in your portable audio device or MP3 player); AroundSound (three speakers and ported bass provide surround sound effect); AM/FM/XM radio; digital tuner; station presets; bass and treble controls; LED display; digital alarm clock; dual independent alarms; tuned port enclosure; auxiliary input/output; headphone jack; battery backup; and ultra-compact remote control.

The Explorer 1 is housed in a paprika or black wooden cabinet that measures 6.125 x 11.8125 x 8.125 inches (HWD) and features beveled aluminum accents. It weighs approximately 9 pounds and retails for \$249.95. XM \$12.95 monthly service subscription and required antenna sold separately (XM service only available in the 48 contiguous United States).

For more information, visit [www.crosleyradio.com](http://www.crosleyradio.com).

### Hemisphere GPS's Crescent V100/V110 GPS Compasses

Hemisphere GPS recently introduced its new Crescent V100 and V110 GPS Compasses. These all-in-one vector products provide precision heading and positioning for marine navigation and a variety of other applications. Crescent V100 Series GPS Compasses are practical, affordable, accurate, and reliable alternatives to traditional gyro compasses. A rugged, maintenance-free smart antenna design combines the company's Crescent Vector board and two multipath-resistant antennas, all housed in a 1.6-foot enclosure for simple installation and portability. The Series provides better than 0.3° heading accuracy and includes SBAS (Satellite-Based Augmentation System) differential capable of providing better than 24-inch positioning accuracy.



Hemisphere GPS's Crescent V100 Series GPS Compasses provide precision heading and positioning for marine navigation and other applications.

The Crescent V110 incorporates a beacon differential option. Both models feature integrated gyro and tilt sensors, which deliver faster startup times, smoothed heading output, and continuous heading updates for up to three minutes during temporary loss of GPS signals. Hemisphere GPS' exclusive COAST technology is also included in order to maintain sub-meter positioning during temporary loss of differential signal.

The Crescent V100 sells for \$2,895; the Crescent V110 for \$3,295. For more information, visit [www.hemispheregps.com](http://www.hemispheregps.com). For sales, email [precision@hemispheregps.com](mailto:precision@hemispheregps.com), or contact Hemisphere GPS's headquarters at 4110 9th Street S.E., Calgary, Alberta, Canada T2G 3C4; Phone: 403-259-3311; Fax: 403-259-8866; Email: [info@hemispheregps.com](mailto:info@hemispheregps.com).

### MFJ Single-Band Rotatable Mini-Dipole Kits

MFJ has just added to its extensive product line several single-band rotatable mini-dipole kits. You can use these inexpensive, lightweight, isolated mini-dipoles when space is limited for temporary or permanent installations. Rotate to null



MFJ's inexpensive, lightweight, isolated mini-dipole kits are available for 75, 40, 20, 17, 15, 10, and 6 meters.

QRM/noise and to focus your signal. The kits include two HF sticks of your choice and an MFJ-347 mini-dipole mount.

Models are available for your favorite bands: MFJ-2275 (75 meters); MFJ-2240 (40 meters); MFJ-2220 (20 meters); MFJ-2217 (17 meters); MFJ-2215 (15 meters); MFJ-2210 (10 meters); and MFJ-2206 (6 meters). The retail price is \$49.95 per band.

The MFJ-347 Mini-Dipole Mount attaches to a mast up to 1 1/4-inch O.D. and is manufactured of heavy-duty solid aluminum. Isolated dipole elements let you insert balun or coil up coax to isolate the feedline. According to the company, you get a true balanced dipole that prevents RF on coax shield, eliminates pattern distortion, reduces noise pickup and RFI radiation from coax, and provides deep dipole end-nulls for nulling out interference.

The MFJ-347 retails separately for \$19.95

The MFJ-347 and MFJ-22XX are protected by MFJ's No Matter What one-year limited warranty. To order, receive a free catalog, or for your nearest dealer, contact the company at MFJ, 300 Industrial Park Road, Starkville, MS 39759; Phone: 800-647-1800; Fax: 662-323-6551; Web: www.mfjenterprises.com.

## Self-Study Course Teaches Accessing And Interpreting Real-Time Weather Data On-line

While not a product *per se*, here's something an awful lot of our readers will find extremely valuable. Storm-Prep, a new public education initiative, offers an

illustrative self-study course titled "Anticipating, Recognizing, and Preparing for Deadly Weather." You don't need to be a meteorologist to learn how to interpret real-time weather data to recognize and prepare for the variety of weather hazards that occur each year. This course demonstrates how to use the Internet to access and interpret radar imagery, satellite imagery, and other taxpayer-funded weather data, and even sky clues, to recognize the potential for, or the imminent threat of, deadly weather. The course focuses on tornadoes, large hail, damaging winds, floods, lightning, hurricanes and tropical storms, winter storms, dense fog, and extreme heat and cold.

According to course developer Pete Wolf (a professional meteorologist who has focused on local research and meteorologist training initiatives), "real-time weather data can be accessed on-line at no cost, but without any instruction regarding data interpretation. This course provides that instruction. It teaches a skill that anyone can learn, and promotes a beneficial real-time Internet application."

The course registration fee is \$39—about the cost of a textbook—and includes priority mail shipping. For more information, visit [www.storm-prep.com](http://www.storm-prep.com).

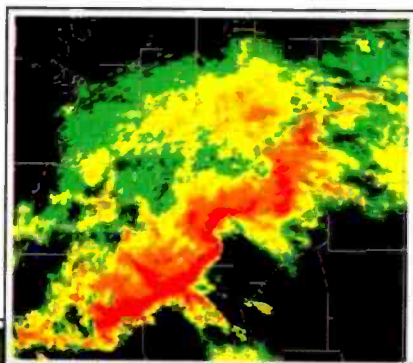

Wolf  
**STORM-PREP**  
"Making Weather Less of a Surprise!"

Screen shots from Storm-Prep's self-study course, "Anticipating, Recognizing, and Preparing for Deadly Weather."

## INFORMATION & ORDERING WWW.SCANCAT.COM

INTERNET DOWNLOADS AVAILABLE  
**ORDER TOLL FREE**  
**888-722-6228**

### Special

ScanCat-Lite-Plus.....	Reg. \$29.95
Mr. Scanner FCC CD-ROM.....	29.95
Nat-Com's FCC Scancat Files.....	9.95
Bonus Disk Of Frequencies.....	15.00
	<b>\$84.85</b>

**NOW \$54.95**

**PLUS FREE** Scanning Magazine(s)  
(Current Issues While Supplies Last)

## SCANCAT®

Since 1989, The Recognized  
Leader in Computer Control

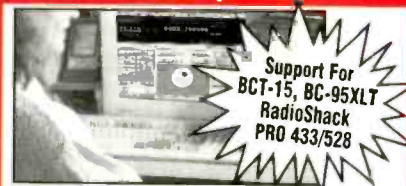

Once you use SCANCAT with YOUR radio, you'll NEVER use your radio again WITHOUT SCANCAT!

### ScanCat-Lite-PLUS

Limited Time \$29.95 Intro Special

Program Your Scanner

As Easy As 1-2-3-CLICK!

SC-Lite Supports PRO-83, PRO-95, PRO-96, BC246 & over 15 more Trunking Scanners

### Scancat-Gold for Windows

Version 8.50 \$99.95

Supports all radios in ONE program - share files with all radios.

Two Scanning modules:

A Simple Basic Module - for beginners

**Plus**—An Advanced Scanning System for the "experts".

### Scancat-Gold for Windows-SE -

\$159.95

All the features of our "Standard Scancat" plus additional functions.

- Long term logging of frequencies to hard drive.
- Record Audio to hard drive using sound card.
- Improved spectrum analysis with several great graphical analysis screens.

### Skysweep Decoder Software



Advanced Digital  
Signal Processing  
Software For  
HF/VHF Applications

All you need is any  
Windows® soundcard  
demo on our website

JUST OUT  
NEW  
VERSION

## COMPUTER AIDED TECHNOLOGIES

P.O. Box 18285 Shreveport, LA 71138

ORDERS: (318) 687-4444 FAX: (318) 686-0449

Info/Tech Support: (318) 687-2555

(9 a.m. - 3 p.m. Central M-F)

INTERNET DOWNLOADS AVAILABLE  
INFORMATION & ORDERING  
WWW.SCANCAT.COM



# Another Milestone In Pop'Comm's History— The 301st Gerry Dexter!

**T**en and ten plus five. Two dozen and one. XXV. A quarter century. A silver anniversary. A generation. There are several ways to indicate the number "25." This month we can employ another: "Popular Communications!" I'm guessing you were made aware of the happy occasion well before you arrived on this page, but at the risk of sounding like a late night per-inquiry TV commercial: "But wait! There's more!"

Marching along all the way, this column also celebrates the start of its 26th year! It was "The Listening Post" back when the magazine's first issue appeared, and then many years later it acquired the more "modern" name used today. Yours truly is privileged and honored to have been at the helm from Day One. Lessee—that comes to three hundred columns! As I write this 301st, I wouldn't begin to attempt to tally the number of loggings that involves, but it has to run deep into five figures; in fact, it might very well be scratching at 100,000! So my oft-repeated thanks again go out to all who have submitted their monitoring results over the past years. Bravo to all of you, past and present!

Now we move straight ahead, with more shortwave news and loggings as we continue to celebrate this fascinating medium and look forward to the 30-year mark ahead.

It looks as though some sort of special U.S. shortwave to Venezuela is in the works. Such has been proposed in Congress, although not in any detail. It may take the form of a special program as part of the VOA or perhaps become a "Radio Free Venezuela" type of thing. We'll wait and see.

Last month I mentioned CVC International and the speed at which it seems to have grown over its few years of activity. No sooner did the page show up on the newsstands than CVC stumbled. Word has it that it suddenly discontinued all broadcasts relayed by sites in Germany. The relays from Meyerton, South Africa, have also been cancelled. This narrows things down to

CVC just using sites in Tashkent and Yerevan (Armenia) plus its main Darwin, Australia, site. No explanation was given so we're left puzzling over what will happen when CVC takes control of the Julich, Germany, site it purchased last year

It seems that GBC, the Ghana Broadcasting Corporation, aka Radio Ghana, is not currently active on shortwave. The normally heard 4915 frequency has been silent. I suppose it's run into technical problems. Its transmitter is quite old and probably hasn't been maintained as well as it should have been—a common problem for many African broadcasters.

It may have been somewhat expected, but it was still a surprise to learn that HCJB is soon to cease all shortwave transmitted from within Ecuador. Obviously it couldn't find a new and practical in-country transmission site, a move made necessary by the expansion of Quito's airport. If this cessation hasn't happened just yet, I'd guess it will when the new B-07 broadcast season goes into effect near the end of October. The change will make Ecuador much more of a challenge to log. This is truly a sad and disturbing development.

## Reader Logs

Here are this month's logs. All times are in UTC. Double letters are language abbreviations (AA = Arabic, SS = Spanish, GG = German, etc.). If no language is mentioned the broadcast is assumed to have been in English (EE).

**ALGERIA**—RT Algerienne, 7260 via Skelton at 0359 open with instrumental. 5+1 pips, anthem and woman beginning the Holy Koran program. //9540-Woolferton. (D'Angelo, PA)

**ANGUILLA**—Caribbean Beacon, 6090 at 0303 with religious commentary. (MacKenzie, CA) 11775 with University Network pgms at 1805. (Charlton, ON)

**ARGENTINA**—RAE, 11710 at 0235 with DX tips, ID, classical

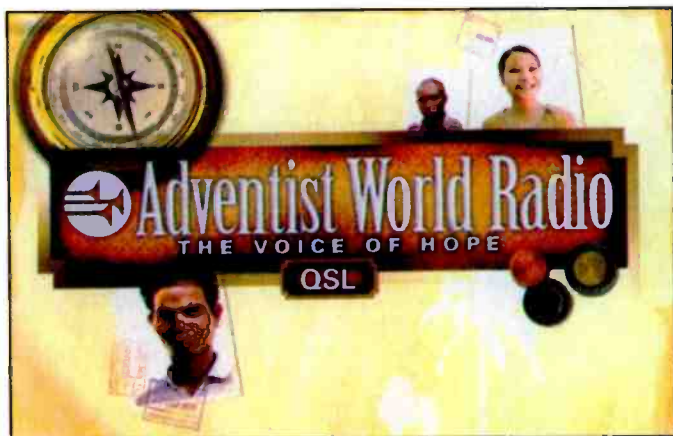

Adventist World Radio seems to have an inexhaustible supply of QSL card designs. Ah, if all the broadcaster QSL policies were just half this good! (Thanks Rich D'Angelo, PA)

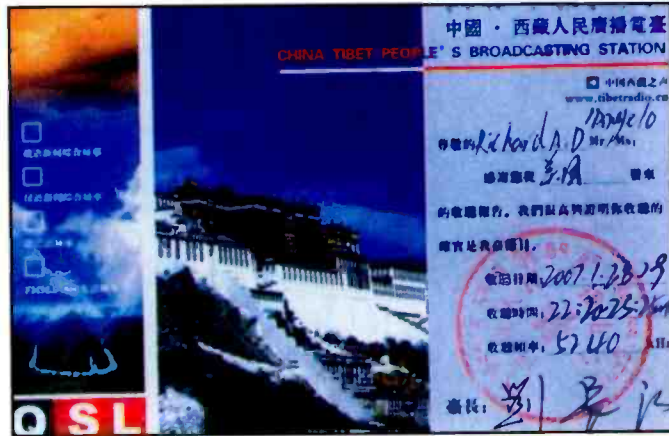

There was a time when there was no way you could get a Tibet QSL out of China. Now they have their own card, sent by email! (Thanks Rich D'Angelo)

## Help Wanted

We believe the "Global Information Guide"—month after month—offers more logs than any other monthly SW publication! (387\* shortwave broadcast station logs were processed this month!) Join the fun and add your name to the list of "GIG" reporters! Send your logs to Gerry Dexter, 213 Forest St., Lake Geneva, WI 53147 or via email to [gdex@genevaonline.com](mailto:gdex@genevaonline.com) (see the column for formatting tips). Deadline is the 25th of each month.

*\*Not all logs get used; there are usually a few which are obviously inaccurate, unclear, or lack a time or frequency.*

music. Close down anmts at 0254, IS, IDs in SS. (D'Angelo, PA) 15345 in SS at 1815. (Charlton, ON) 2205. (Alexander, PA) 2215. (Linonis, PA)

**ASCENSION**—BBC Atlantic Relay, 17885 in listed Hausa at 1935. (Brossell, WI) 21470 with *African Sports World* at 1640. (Wood, TN)

**AUSTRALIA**—Radio Australia, 9580 at 1820, //9710, 11880. Also 13690 at 0520, 15160 at 0505, 15230 at 2359, and 17795-Shepparton at 0025. (MacKenzie, CA) 15240 at 0341. (Wood, TN) 15515 at 2200. (Jackson,

## A Guide To "GIG-Speak"

Here's a partial list of abbreviations used in the "Global Information Guide."

<p>* — (before or after a time) time the station came on or left the air</p> <p>(l) — (after a frequency) lower sideband</p> <p>(p) — presumed</p> <p>(t) — tentative</p> <p>(u) — (after a frequency) upper sideband</p> <p>v — variable time or frequency</p> <p>// — in parallel</p> <p>AA — Arabic</p> <p>ABC — Australian Broadcasting Corporation</p> <p>AFN — Armed Forces Network</p> <p>AFRTS — Armed Forces Radio TV Service</p> <p>AIR — All India Radio</p> <p>Alt — alternate</p> <p>AM — amplitude modulation, AM band</p> <p>Anmt(s) — announcement(s)</p> <p>Anncr — announcer</p> <p>AWR — Adventist World RadioBC broadcast(er)</p> <p>BSKSA — Broadcasting Service of Kingdom of Saudi Arabia</p> <p>CA — Central America</p> <p>CC — Chinese</p> <p>Co-chan — co-channel (same frequency)</p> <p>comm1(s) — commercial(s)</p> <p>CP — Bolivia, Bolivian</p> <p>CRI — China Radio International</p> <p>DD — Dutch</p> <p>DJ — disc jockey</p> <p>DS — domestic service</p> <p>DW — Deutsche Welle/Voice of Germany</p> <p>EE — English</p> <p>ECNA — East Coast of North America</p> <p>f/by — followed by</p> <p>FEBA — Far East Broadcasting Association</p> <p>FEBC — Far East Broadcasting Company</p> <p>FF — French</p> <p>freq. — frequency</p> <p>GBC — Ghana Broadcasting Corp</p> <p>GG — German</p> <p>GMT — Greenwich Mean Time (UTC)</p> <p>HH — Hebrew, Hungarian, Hindi</p> <p>HOA — Horn of Africa</p> <p>ID — station identification</p> <p>II — Italian, Indonesian</p> <p>Int/Intl — international</p> <p>Irr. — irregular use</p> <p>IRRS — Italian Radio Relay Service</p> <p>IS — interval signal</p> <p>JJ — Japanese</p> <p>KK — Korean</p>	<p>LSB — lower sideband</p> <p>LV — La Voz, La Voix (the voice)</p> <p>MW — mediumwave (AM band)</p> <p>NBC — National Broadcasting Corporation (Papua New Guinea)</p> <p>OA — Peru/ Peruvian</p> <p>OC or O/C — open carrier</p> <p>PBS — People's Broadcasting Station</p> <p>PP — Portuguese</p> <p>PSA — public service announcement</p> <p>QQ — Quechua</p> <p>QRM — man-made interference</p> <p>QRN — noise (static)</p> <p>QSL — verification</p> <p>RCI — Radio Canada International</p> <p>Rdf. — Radiodifusora, Radiodiffusion</p> <p>REE — Radio Exterior de Espana</p> <p>RFA — Radio Free Asia</p> <p>RFE/RL — Radio Free Europe/Radio liberty</p> <p>RNZI — Radio New Zealand International</p> <p>RR — Russian</p> <p>RRI — Radio Republik Indonesia</p> <p>RTBF — RTV Belge de la Communate Françoise</p> <p>Relay — transmitter site owned/operated by the broadcaster or privately operated for that broadcaster</p> <p>relay — transmitter site rented or time exchanged.</p> <p>SA — South America</p> <p>SEA — Southeast Asia</p> <p>SCI — Song of the Coconut Islands (transition melody used by Indonesian stations)</p> <p>s/off — sign off</p> <p>s/on — sign on</p> <p>SIBC — Solomon Is. Broadcasting corp.</p> <p>sked — schedule</p> <p>SLBC — Sri Lanka Broadcasting Corporation</p> <p>SS — Spanish</p> <p>SSB — single sideband</p> <p>SWL — shortwave listener</p> <p>TC — time check</p> <p>TOH — top of the hour</p> <p>TT — Turkish</p> <p>TWR — Trans World Radio</p> <p>Unid — unidentified</p> <p>USB — upper sideband</p> <p>UTC — Coordinated Universal Time (as GMT)</p> <p>UTE, ute — utility station</p> <p>Vern — vernacular (local) language</p> <p>via — same as "relay"</p> <p>VOA — Voice of America</p> <p>VOIRI — Voice of Islamic Republic of Iran</p> <p>WCNA — West Coast of North America</p> <p>ZBC — Zimbabwe Broadcasting Corporation</p>
--	--



We want The Airwaves!



## The Crystal Ship - 2004 Plundering The Airwaves Once Again

FIGHT for FREE RADIO!

*The Crystal Ship pirate (usually 3275 and 6875) wants us to "fight for free radio." Me? I'm too tired. (Thanks Mike Adams. FL)*

PA) 15515 with soccer at 0615. 17715 with rock at 0020 and 17785 heard at 2215. (Maxant, WV)

CVC Intl. 15250-Darwin in Indonesian at 0052. (Charlton, ON)

**AUSTRIA**—Radio Austria Intl, 9870 at 0045. 13675 via Sackville at 1614 and 13775 via Sackville at 1544. (Charlton, ON) 9870 at 0035, 13775 at 1535. (Maxant, WV) 0955. (Fraser, ME) 13775 at 1521. (Wood, TN)

**BELGIUM**—RTBF, 9970 in FF at 0434. (Wood, TN)

**BOLIVIA**—Radio Yura. Yura. 4716.6 at 0035 with man in SS hosting rustic vocals. ID, talk by woman. (D'Angelo, PA)

Radio Mosoj Chaski, Cochabamba, 3310 at 0920 in Quechua to ID at 0931. (D'Angelo, PA)

Radio Santa Cruz, Santa Cruz, 6134.8 in SS with talks, commls. ID at 0313 close. (Alexander, PA)

**BONAIRE**—Radio Nederland Relay, 5975 at 0434. (MacKenzie, CA) 6145 at 0006. (Charlton, ON) 15315 in DD at 2310 with a talk on "football." (Linonis, PA) 17735 in EE at 1942. (Wood, TN)

**BOTSWANA**—VOA Relay, 4930 at 0307 with news and features. (D'Angelo, PA) 9600 closing at 0530. (Wood, TN) 17895 with news at 1936. (Brossell, WI)

**BRAZIL**—(All PP) Radio Bandeirantes, Sao Paulo, 6089.9 at 0020 with Anguilla silent. Possible radio drama, //9645.2, both weak. (Alexander, PA)

Radio Gaucha. Puerto Alegre. 11915.1 at 0244 with two men talking. Off at 0300. (D'Angelo, PA)

Radio Guarujá Paulista, Presidente Prudente, 5045 at 0509 with group vocals. ID, jingles, ad string. (D'Angelo, PA)

Radio Nacional, Macapá, 4915 with music and CODAR QRM at 0637. (Wood, TN)

Radio Aparecida. Aparecida. 5035 at 0910 with talks, promos. ID, Brazilian ballads. Better on //6135. (Alexander, PA) 11855 at 2031. (Charlton, ON)

Radio Clube do Para. Belem. 4885 at 0230. (Brossell, WI) 0646 with slow LA tunes. (Wood, TN)

Radio Nacional Amazonia, 11780 with talks at 1230. (Brossell, WI) 1840 with interview, vocals. (MacKenzie, CA) 2029. (Charlton, ON)

**BULGARIA**—Radio Bulgaria, 6200 in SS at 2238 and 7200 in listed Albanian at 1208. (Brossell, WI) 9600 at 1945 with classical music and intermittent audio problems. (Maxant, WV) 9700 with Bulgarian songs at 0401. (Charlton, ON) 11700 heard at 2356. (MacKenzie, CA)

**BURKINA FASO**—Radio Burkina, 5030 at 0529 sign on with anthem, opening FF anmts. and local tribal music. University Network was not on. (Alexander, PA)

**CANADA**—RCI, 6100 at 1335 and 9515 at 1525. (Maxant, WV) 6100 at 2315 with features, interviews about Canada. (Fraser, ME) 6100 at 0018. 9515 in FF at 1746 and 15235 at 1820. (Charlton, ON) 15455 in SS at 2315. (MacKenzie, CA)

CKZN, St. John's. 6160 at 1930. (Maxant, WV) 2325. (Brossell, WI)

CHU, Ottawa, 14670 with FF/EE time signals at 1620. (Maxant, WV)

**CHILE**—Voz Cristiana, 6070 with SS gospel music at 1935. (Maxant, WV) 6070 in SS at 0306. 9635 in SS at 2236 and 17680 in SS at 2317. (MacKenzie, CA) 17680 in SS at 1744. (Charlton, ON)

**CHINA**—China Radio Intl., 7170 in CC at 2305. (Brossell, WI) 7285 in EE at 2115. (Fraser, ME) 9525 at 1357 going into RR at 1400.

And 11875-Urumqi in RR at 1636. (Strawman, IA) 11695 via Albania in FF at 1923 and 15220 via Sackville in CC at 1414. (Charlton, ON) 13690 in CC at 0315. 13700 via Canada at 2250 and 15130 in CC at 0512. (MacKenzie, CA) 15120 via Cuba in SS at 0045. (Barton, AZ)

CPBS. 7110 in CC at 1201. (Brossell, WI) 11750 in CC at 2305. (MacKenzie, CA) (sites, please!—gld)

Firedrake music jammer 6280 at 2240 and 11590 at 1230, the latter covering RFA via Kuwait. (Brossell, WI) 9540//11700 at 1816. (MacKenzie, CA)

**COLOMBIA**—Marfil Estereo, Puerto Lleras, 5910.4 at 0412 with LA vocals and man host in SS. Off at 0501. (D'Angelo, PA)

La Voz de su Concencia, Puerto Lleras. 6009.5 at 0328 with mix of soft religious vocals, man/woman in SS and long religious talk. (D'Angelo, PA)

La Voz de Guaviare, San Jose de Guaviare. 6035 at 0010 with news and features in SS, phone talks and various remote reports. 5+1 time pips at 0030. (D'Angelo, PA)

**CROATIA**—Voice of Croatia, 9925 via Germany in Croatian at 0052. (Charlton, ON) 0236 in SS. (MacKenzie, CA) 0443 in Croatian. (Wood, TN)

**CUBA**—Radio Havana Cuba, 6000 in SS at 0013 and 11760 in SS at 1435. (Charlton, ON) 11750 heard at 1925. (Maxant, WV)

Radio Rebelde, 5025 in SS at 0415. (MacKenzie, CA)

**CYPRUS**—Cyprus Broadcasting Corp., 5930 in Greek with Greek music, man with closing anmts and more music to carrier cut at 2245. //7210 was fair, //9760 was good. (D'Angelo, PA) (weekends—gld)

**CZECH REPUBLIC**—Radio Prague, 7345//9440 at 0030-0100. (Linonis, PA) 7345 at 0259. (Brossell, WI) 0305. //9870 not heard. (MacKenzie, CA) 9415 at 2218. (Maxant, WV) 9415 at 2230 and 11600 at 2155-2157 close. (Wood, TN) 9440 heard at 0019. (Charlton, ON)

**DJIBOUTI**—RT Djibouti, 4780 at 0300 sign on, opening with national anthem, man in FF with opening ID and anmts. (D'Angelo, PA)

**ECUADOR**—HCJB, 3220 at 2350 with man and woman in SS, children's vocals. (D'Angelo, PA) 11720 in SS at 2350. (Branco, NY) 9745 in Quechua at 2250. 11720 in SS at 2325, 12020 in PP at 2320, 12040 in GG at 2310 and 21455 in SS at 0012, //11720. (MacKenzie, CA) 11960 in SS at 1440. (Charlton, ON)

Radio Quito. Quito. 4919 at 0045 with SS anmts, commls, jingles, SS pops. The audio was a little distorted. (Alexander, PA) 0435 with Latin vocals. SS man host. (D'Angelo, PA)

HD210A, Guayaquil. 3810 heard at 0454 with SS time anmts. (Wood, TN)

**EGYPT**—Radio Cairo/Egyptian Radio, 9460 at 0045-0100 in AA about Gaza and Israel, poor modulation. (Linonis, PA) 9990 at 2230 in EE. (Wood, TN) 2220 with poor audio. (Maxant, WV) 12050 at 1612 in AA. (Charlton, ON)

**ENGLAND**—BBC, 7290 opening in PP at 0429. (Wood, TN) 9410 at 1945. (Fraser, ME) 9465 via French Guiana at 1140 with "World of Football." Also 9740 Singapore Relay at 1254 and 11750 Thailand Relay at 1213. And 11895 Singapore Relay at 1357. (Brossell, WI) 9660 at 1200. (Linonis, PA) 12095 via Meyerton at 1755, 15105 via Ascension in FF at 1815, 15285 Singapore Relay in CC at 1418 and 17830 Ascension Relay at 1945. (Charlton, ON)

**EQUATORIAL GUINEA**—Radio East Africa, Bata. 15190 heard at 1054 with EE religious programming. Slowly overcome by Havana after 1100. (D'Angelo, PA)

**FRANCE**—Radio France Intl, 11705 in FF at 1930 and 11995 in FF at 1937. (Charlton, ON)

**GABON**—Radio Gabon, 4777 at 0456 with open carrier, drums, and man with FF ID and frequency anmt for various local FM outlets, anthem heard at 0459, more anmts and into news. (D'Angelo, PA) 0514 with Afro-pops and anncr who talked over most of the selections. (Wood, TN)

Africa Number One. 15475 in FF at 1837. (Charlton, ON) 17630 at 1452. (Yohnicki, ON)

**GERMANY**—Deutsche Welle, 13820 in SS at 1822, 15275 Rwanda Relay in GG at 1827 and 17850 via Rwanda in AA at 1836. (Charlton, ON) 11865 at 2148. Also 15640 via Vladivostok in GG heard at 2303. (MacKenzie, CA)



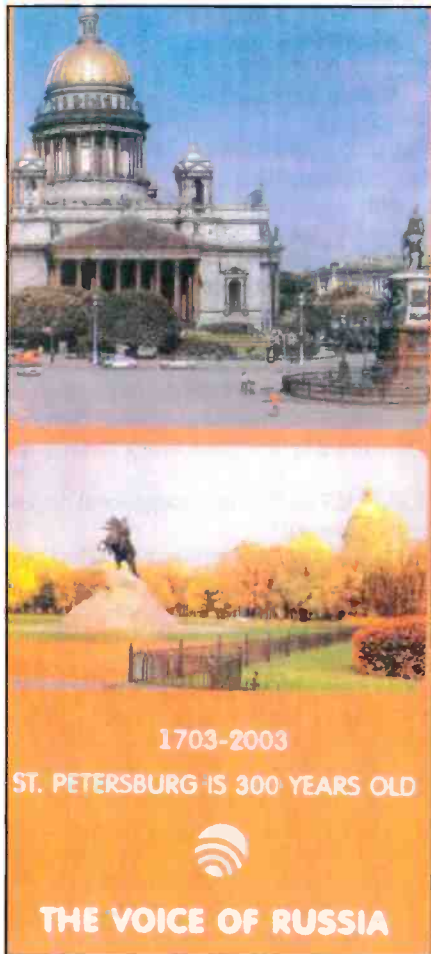

Bob Brossell (WI) got this reply from the Voice of Russia specifying reception of a Russian language transmission from St. Petersburg on 12055.

**GREECE**—Voice of Greece, 7475 in Greek at 0303. (Brossell, WI) 9420 in EE at 2358. (MacKenzie, CA) (EE is not daily—gld) 15630 in Greek at 1924. (Charlton, ON) 2330. (Maxant, WV)

**GUATEMALA**—Radio Verdad, Chiquimula, 4052.5. 0305 with soft religious music in SS. (D'Angelo, PA; Wood, TN) 0326 (Brossell, WI) 0525 in EE with ID for "Radio Truth." (Wood, TN)

**GUINEA**—RTV Guinienne, Conakry, 7125 heard at 2215 with FF talk and variety of local music, Afro-pop and FF ballads. (Alexander, PA)

**HAWAII**—KWHR, 9930 at 1135 with a sermon. (Brossell, WI)

AFN/AFRTS, Pearl Harbor, 6350u with sports talk pgm. (Yohnicki, ON) (What time? 6350 is active 24 hours.—gld)

**HONDURAS**—Radio Luz y Vida, San Luis, 3250.1 at 0324 with soft religious instrumentals. SS religious talk, more music. Closed heard at 0356. (D'Angelo, PA)

**HUNGARY**—Radio Budapest, 9770 in HH at 0115. (Linonis, PA) 11695 in HH at 2024. (Charlton, ON)

**ICELAND**—Ríkisutvarpid, 12115 at 2306 with woman and news/features in



This QSL from Iceland's Ríkisutvarpid highlights radio sets from the start of INBS in 1930. Iceland has now carried out its threat to end its shortwave broadcasts. (Thanks Rich D'Angelo)

Icelandic. Off at 2341. (D'Angelo, PA) (And now off the air for good.—gld)

**INDIA**—All India Radio, 4840-Mumbai at 0026 with music, woman in Hindi, time pips at 0030. (D'Angelo, PA) 9475 in Hindi at 1810. (MacKenzie, CA) 10330-Bangaluru at 0045. (Linonis, PA) 11585 in Hindi at 1352. (Brossell, WI) 15050 in an Asian language at 1339. (Brossell, WI)

**INDONESIA**—Voice of Indonesia, 9525 in Indonesian at 1250. (Brossell, WI) 1340 with II service and pops, EE ID about their website. (Strawman, IA)

**IRAN**—VOIRI, 15085 in FF at 1912. (Brossell, WI)

**ISRAEL**—Kol Israel, 11590 in HH at 0010. (MacKenzie, CA) 0330 sign on. News and music. (Barton, AZ; Wood, TN) 1812. (Charlton, ON) 1920. (Maxant, WV)

Galei Zahal, 6973 at 0100 with US pops and man in presumed HH. (Linonis, PA) 2150 with DJ and pops. Also noted at 2352 on 15777.5. (Alexander, PA)

**ITALY**—RAI Italia, 9760 in EE at 1940. (Brossell, WI) 17780 in II heard at 1430. (Charlton, ON)

**JAPAN**—Radio Japan/NHK, 5960 via Canada in JJ at 0428, 9655 via Ascension in JJ at 2240, 9835 in JJ at 1825, 11970 in RR at 1854 and 13650 in Thai at 2305. Also 15265 via Bonaire at 2352, 17605 via Bonaire in SS at 2322 and 17825 at 2154. (MacKenzie, CA) 6145 via Canada at 0019, 9530 via French Guiana at 1050, 11705 via Canada in JJ at 1434 and 15355 via Gabon in JJ at 1855, (Charlton, ON) 9750 in JJ at 1733. (Brossell, WI) 11730 at 1450. (Wood TN) 11935 at 0130. (Branco, NY)

**JORDAN**—Radio Jordan, 11690 with local FM relay in EE at 1450. (Yohnicki, ON) 11810 in AA at 1931. (Charlton, ON)

**KUWAIT**—Radio Kuwait, 15110 in SS at 2215. (Linonis, PA) 15495 in AA at 0343.

(Wood, TN) 15505 in AA at 1920. (Charlton, ON) 2030. (Maxant, WV)

**LIBERIA**—Star Radio, via Ascension, 9525 at 0723 with messages from Liberians seeking assistance. The entire broadcast was repeated at 0730 instead of airing Cotton Tree News. (D'Angelo, PA)

**LITHUANIA**—Radio Vilnius, 9875 with letters pgm at 2335, folk songs and off at 0000. (Strawman, IA)

**MADAGASCAR**—Radio Nationale Malagasy, 5010 at 0255 sign on with instrumental music, woman anncr in Malagasy at 0300. (D'Angelo, PA)

**MAURITANIA**—Radio Mauritanie, 4845 at 0050 with Koran recitations. (Brossell, WI)

**MEXICO**—Radio Educacion, 6185 in SS at 0258 with two male anncrs. (MacKenzie, CA) 1950 with piano music. (Maxant, WV)

Radio UNAM, 9600 with orchestral music at 0204. (Yohnicki, ON) Tentative at 0935 with classical piano and opera, SS anmts. (Alexander, PA)

**MOROCCO**—RT Marocaine, 7135 in AA at 2300. (Brossell, WI) 11920 with Middle Eastern music at 0345. (Barton, AZ) 15345 in AA at 1826. (Charlton, ON)

Radio Medi Un, 9575 in FF at 0520 and pops in AA, FF and EE. (Wood, TN)

**NETHERLANDS**—Radio Nederland, 11655 via Madagascary Relay at 1852. (Charlton, ON) 1948. (Fraser, ME) 1953. (Brossell, WI) 17810 at 1910. (Maxant, WV)

### In Times Past...

Here's our "Blast from the past" for this month:

**GERMANY**—RIAS (Radio In American Sector), Berlin, 6005 in GG at 0650 on January 21, 1990. 100 kW. (Dexter-WI)





*Radio Zamaneh, based in the Netherlands and beamed to Iran, sent this snazzy QSL card to Rich D'Angelo.*

**NEW ZEALAND**—Radio New Zealand Intl., 6095 with news at 1000. (Fraser, ME) 9615 with news from Fiji at 0540. (Wood, TN) 0620. (Maxant, WV) 9870 at 1224 with Gershwin music. (Brossell, WI) 13730 at 0311 and 15720 at 2337. (MacKenzie, CA)

**NIGER**—La Voix du Sahel, 9705 at 2249 in FF with talk. Koran. Off at 2301. (D'Angelo, PA)

**NIGERIA**—Voice of Nigeria, 9690 at 0814 sign on in Hausa then into listed Fulfulde. Also at 2230 to 2300 close. (Alexander, PA) 15120 at 1915. (Charlton, ON) 2020. (Maxant, WV)

Radio Nigeria, Kaduna, 4770 at 0508 with "News Nation" pgm. (Wood, TN)

**NORTH KOREA**—Voice of Korea. 9325 with plodding instls and KK talks at 1225. (Brossell, WI) 9335 at 1345 with patriotic vocals and propaganda commentaries. (Strawman, IA) 13760 in FF at 0308. (MacKenzie, CA) 15180 at 0300 sign on and into EE. (D'Angelo, PA)

**OPPOSITION**—Radio Free Asia, 9455 via Sri Lanka in an Asian language at 1250. (Brossell, WI) 11550 via Kuwait at 1550 in listed Tibetan. 11795 via Tinian at 1629 in Mandarin, with slight Firedrake QRM underneath. (Strawman, IA) 11975 via Wertachtal in Tibetan at 0246. (D'Angelo, PA) 13760 via Northern Marianas in CC at 0515 and 15585 via Saipan in CC at 2309. (MacKenzie, CA)

Radio Nacional de la RASD (to Morocco), 6300 at 2304 in AA with news items and regional music to 0001 close. (D'Angelo, PA) 2343 in AA. Off at 0000. (Wood, TN)

Radio Farda (to Iran) 7105 in listed Farsi at 0240. (Brossell, WI) 9865 via Morocco at 0445. (Wood, TN)

Sudan Radio Service, 5985 at 0319 to close at 0329. Poor, with co-channel QRM. (D'Angelo, PA)

Radio Solh (Afghanistan) 15265 via Rampisham with Middle East music at 1345. (Brossell, WI) 17770 at 1624 with almost continuous pops. (Strawman, IA)

**PALAU**—T8BZ, 9965 with long religious talk in Mandarin at 1038, EE religious pgm, woman with ID heard at 1100 and another religious program. (D'Angelo, PA)

**PERU**—Radiodifusora La Voz del Rondero, Huancabamba, 6536 at 0210 with OA folk, SS talk, ID, mentions of Huancabamba. Off with anthem at 0224. (D'Angelo, PA)

**PHILIPPINES**—FEBC Intl., 9430 in CC at 1229. (Brossell, WI)

**PIRATES**—WBNY/Radio Bunny, 6925 noted variously at 0004, 0028, 0125, 1443, 2208, 2253, 2300, with Commander Bunny, rock, pop, comedy bits, complaints about FRN, Belfast address. (Zeller, OH) 0045 and 0102, "Voice of the rodent revolution." (Hassig, IL) 1435. (Alexander, PA) 2358. (D'Angelo, PA) 2315. (Wood, TN)

The Crystal Ship, 5386/6875 at 0358 with lots of 80s songs hosted by John Poet, various IDs and audio clips. (Wood, TN) 6875u at 0323 with rock, clips. (D'Angelo, PA)

MAC, 6850.8 at 0120 with "Paul Starr Show," rock oldies and

open/close from 50s "Superman" show. And another date at 0015 with old rock, mention of "Dr. Who." (Hassig, IL)

Grasscutter Radio (t) 6925u at 0015 with weather, spoof of AFN-Vietnam, pop/rock. No ID. Also on 6935 at 0138 on a different date. (Hassig, IL)

Undercover Radio, 6930 at 2335 poor with QRM. Song "Don't Want to be an American Idiot." (Hassig, IL)

WHOT, 6925.2 at 0002 with oldies, jingle IDs, TC and frequency annts. Gave a phone number and took a call from "Bob" in the Marine Park section of Brooklyn. (D'Angelo, PA)

WMPR, 6925u at 0102 open with usual pgm of techno rock and "dance music" Said, "You're invited" between songs. (Zeller, OH) Uncertain on 6945 at 0145 with what sounded like their dance music pgm. (Hassig, IL)

Radio Jammu Intl, 6925u at 2246. Seemed to be the ID for this, and traffic reports and news for Virginia and Maryland. (Zeller, OH)

Radio Pigmeat Intl. 6875.9 heard at 0037 with heavy metal, rock. (Hassig, IL)

WSNR, 6925.9 at 0011 and 2357 with various songs about days of the week. Poorly enunciated. (Zeller, OH)

Random Radio, 6925u at 0222 with various rock selections. (Hassig, IL)

Chicken Radio, 6925u (t) 2215 open with chicken song, sketches about chickens and ad for the movie "Electric Amish Armageddon." No address heard. (Zeller, OH) 0024 with host Super Chicken, "Chickenman" feature, ads for movie *Farmageddon*. (Hassig, IL)

Wolverine Radio, 6925u at 0238 with rock, man anner and IDs between selections. No address. Closed prior to Northwoods Radio open. (D'Angelo, PA)

Northwoods Radio, 6925u at 0100–0234 with possibly a short test and into ballads. Announced as an old genre show "you won't hear on regular radio but will hear on pirates like this one." Occasional loon sounds. (Zeller, OH) 0230 with end of its pgm and mention of broadcasting from the Great Lakes. Off at 0245 but resumed at 0259. (D'Angelo, PA) 0312 with ID and call of the loon. (Wood, TN)

Radio 6X, 6935.5 at 0158 with 50s/60s oldies, DJ sounded like a Wolfman Jack copy. (Hassig, IL)

WTCR, 6925u, MGM fanfare repeated from 0101 sign on, "Twentieth Century Radio with music of the 1900s." Various rock. Off at 0204 with ID and "Have a pleasant tomorrow." Belfast address for this. (Zeller, OH) 0125 with 70s pop/rock. (Hassig, IL) 0136 with nice variety of music, IDs. Requested \$1-\$2 or 3-first class stamps for a QSL. (Wood, TN)

Weekend Music Radio (Scotland) 6400 at 0355 with pops and ID. Poor with RTTY QRM. (Alexander, PA)

**PORTUGAL**—RDP Intl., 9715 at 0115 with PP talk on French-Portuguese relations. (Linonis, PA) 15465 at 1923 in PP with rock. (Brossell, WI) 15560 in PP at 1839. (Charlton, ON)

**ROMANIA**—Radio Romania Intl., 7105 with ID at 2300. (Brossell, WI) 9790 discussing Kosovo. (Maxant, WV) 11735-Tiganes

### This Month's Winner

To show our appreciation for your loggings and support of this column, each month we select one "Global Information Guide" contributor to receive a free book. Readers are invited to send in loggings, photos, copies of QSL cards, and monitoring room photos to me at *Popular Communications*. "Global Information Guide," 25 Newbridge Road, Hicksville, NY 11801, or by e-mail to popularcom@aol.com. The e-mail's subject line should indicate that it's for the "Global Information Guide" column. So come on, send your contribution in today!

This month's book winner is Jack Linonis or Hermitage, PA. Jack receives a 2008 copy of *Passport to World Band Radio* in recognition of his frequent log submissions, not to mention his ongoing efforts to encourage others in his area to get involved in shortwave listening by providing help with equipment, antenna construction, and advice. Hats off, Jack!





*All through the years QSLs from HCJB have been as common as dirt. Replies covering direct reception will be impossible if HCJB broadcasts from Pifo are shut down. (Thanks Jack Linonis, PA)*

at 1749. (Charlton, ON) 11940 at 2210 on ending current school term. 2158 sign on and into news. //9790. (Wood, TN)

**RUSSIA**—Voice of Russia, 7250 at 0100 in presumed RR. (Linonis, PA) 9665 via Moldova in SS at 0039. (Charlton, ON) 0213. And 13635 at 0320. (MacKenzie, CA) 9860 via Vatican at 0451 to 0500 close. (Wood, TN) 11500 via Tajikistan in Hindi heard at 1230. (Brossell, WI)

**SAUDI ARABIA**—BSKSA. 11820-Riyadh in AA at 1936. (Charlton, ON) 17560 with Holy Koran service at 1611. (Strawman, IA) 1645. (MacKenzie, CA; Barton, AZ)

**SEYCHELLES**—BBC Relay, Mahe, on 15420 at 0346 on world food supply and demand. (Wood, TN)

**SLOVAKIA**—Radio Slovakia Intl., 7230 in SS heard at 0250. (Brossell, WI) 9440 with 0100 sign on in EE to NA. (Linonis, PA)

**SOUTH AFRICA**—Channel Africa. 7240 at 0503 with news. (Wood, TN) 7390 at 0300 with ID and time check. (Brossell, WI) 9620 heard at 0625. (Maxant, WV)

**SOUTH KOREA**—KBS World Radio, 9650 via Canada at 1200 with sign on and news. (Fraser, ME) 1410 in KK and 15360 via Latvia in RR at 1831. (Charlton, ON)

**SPAIN**—Radio Exterior de Espana. 6055 in SS at 0308 and 15160 in SS at 0056. (MacKenzie, CA) 9535 in SS at 0100. (Linonis, PA) 9535 in SS at 0035 and 11815 Costa Rica relay in SS at 1934. (Charlton, ON) 9620 in SS at 0115. (Branco, NY) 11625 in EE with what sounded like a music request pgm at 2140. (Wood, TN)

**SWEDEN**—Radio Sweden Intl., 6010 via Canada at 0100 sign on. (Jackson, PA) 15240 at 1344 on working women in the EU. (Brossell, WI) 15240 via Canada in Swedish at 1416. (Charlton, ON)

**SYRIA**—Radio Damascus, 12085 in SS at 2320. (Brossell, WI)

**TAIWAN**—Radio Taiwan Intl., 15600 via Florida at 2217. (Fraser, PA) 15690 via Issoudun at 1702. (Wood, TN) 1701. (Charlton, ON) 17805 via Florida in SS at 2310. (MacKenzie, CA)

**TANZANIA**—Radio Tanzania-Zanzibar, 11735 in Swahili at 2027. (Charlton, ON)

**THAILAND**—Radio Thailand, 5890 via Greenville at 0045 with comml for Bangkok Airways and talk. (Linonis, PA) 0200 in Thai with talks and music. (Branco, NY)

**TURKEY**—Voice of Turkey, 6195 with Turkish music at 2230. (Maxant, WV) 9460 with TT talk, exotic Turkish music at 0100. (Linonis, PA) 9785 in EE at 1905. (Charlton, ON) 15350 in TT with live sports at 1350. (Brossell, WI)

**UKRAINE**—Radio Ukraine Intl., 7440 at 0015 on export commission quotas. (Maxant, WV) Tentative at 0050 in presumed EE. (Linonis, PA) 0300 with ID and news. (Brossell, WI)

**UNITED STATES**—Voice of America. 7555 Kuwait Relay at 2345 with Special English pgm "American Mosaic." 15385 Philippines Relay in CC to 0300 close. (D'Angelo, PA) 9760 via Philippines at 1324 and 13775 Thailand Relay in CC at 2245. (MacKenzie, CA) 9845 via Northern Marianas Relay with news format at 1200. (Strawman,

IA) 12040 via Philippines in CC at 1257. (Brossell, WI) 15410 via Morocco Relay at 1622 and 15580 via Morocco at 1943. (Charlton, ON) Family Radio/WYFR, 9820 via Taiwan in CC at 1222. (Brossell, WI) Trans World Radio, 7485 via Guam in CC at 1325. (Brossell, WI) Adventist World Radio, 11750 via South Africa in listed Hausa at 1955. (Brossell, WI) 11850 via Guam in Indonesian at 2205. (MacKenzie, CA)

WBCQ, 7415 on medical technology at 0045. (Branco, NY)

AFN/AFRTS, 5446.5-Key West, at 0040 with author interviews. ID and AP News at 0500. (D'Angelo, PA) 12133.5-Key West at 1236 with NPR News. (Brossell, WI) 1615 on presidential candidates. (Maxant, WV)

**VATICAN**—7305 at 0250. (MacKenzie, CA) 7335 in SS at 0255 with horrible QRM from CHU. Also 11625 in SS at 1950. (Brossell, WI) 13675 in FF at 1520. (Maxant, WV) 13765 at 1547. (Charlton, ON)

**VENEZUELA**—Radio Nacional, 11675 via Cuba in SS heard at 1803. (Charlton, ON)

Radio Amazonas. Puerto Ayacucho, (t) 4939.6 at 0915 with SS talk. LA music. Strong carrier, but very weak modulation. Also noted at 0105. (Alexander, PA)

And, once again, order is restored! An ocean of thanks to those who held the fort during these months of shaky propagation conditions: William Hassig, Mt. Prospect, IL; Joe Wood, Greenback, TN; Stewart MacKenzie, Huntington Beach, CA; Jerry Strawman, Des Moines, IA; Brian Alexander, Mechanicsburg, PA; Mike Branco, Islip, NY; Charles Maxant, Barboursville, WV; Rick Barton, Phoenix, AZ. George Zeller, Cleveland, OH; Robert Brossell, Pewaukee, WI; Bob Fraser, Belfast, ME; Michael Yohnicki, London, ON; Jack Linonis, Hermitage, PA; Robert Charlton, Windsor, ON; Joe Jackson, Hermitage, PA, and Rich D'Angelo, Wyomissing, PA. My thanks to each one of you!

And until next month—good listening! ■

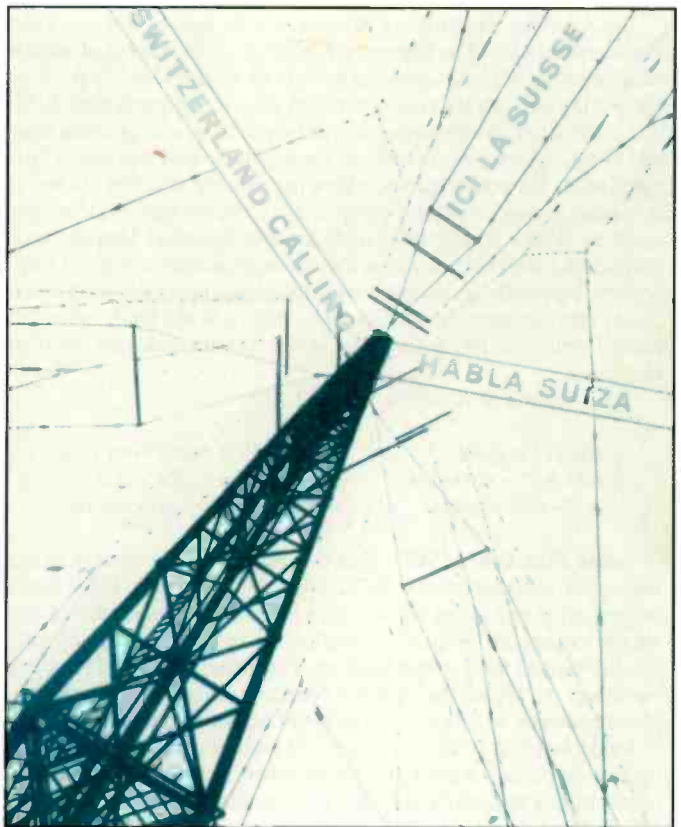

*Swiss Radio International (remember them?) used this card in verifying reception for Mike Adams, Florida, back in 1961!*



## Twenty-five Years Back Into The Future

**P**opular Communications magazine celebrates 25 years of radio hobby support. A lot of space weather history has been made in the last 25 years. In fact, just in the last few years we've seen solar flare and storm intensity records broken. Twenty-five years ago, the level of understanding of space weather was a far cry from what we know today. And the technology employed in monitoring and studying solar phenomenon and space weather has significantly changed through the last two decades. Amazing strides in understanding the dynamics of the sun, and the interaction between our planet and the sun, have been made, and continue to be made.

What's in store for the next 25 years? New satellites are even now being engineered that will probe and explore the space environment through which the Earth moves. A growing sector of the scientific community is arming itself with better computer models, methods, and databases of raw information. All this translates to a better understanding of how the sun affects the Earth and, more specifically, what this means for radio signal propagation.

We've seen two solar cycles in the last 25 years. The last one, Cycle 23, was a weak one, compared with Cycles 21 and 22. Will Cycle 24 be more intense?

In a press release dated April 25, 2007, the National Oceanic and Atmospheric Administration (NOAA) announced a prediction made by their Space Environment Center (SEC) in coordination with an international panel of solar experts. The forecast? The next solar "storm" cycle will start late, but they were not in agreement as to how intense the cycle will be.

### Experts Split Over Intensity

According to NOAA's SEC prediction, the next 11-year cycle of solar storms will most likely start next March and peak in late 2011 or mid-2012. That prediction puts the onset up to a year later than previously expected. The beginning of Solar Cycle 24 was expected to start last fall, and the delay led the international panel of solar experts to disagree on whether a weak or strong period of solar storms lie ahead. Nevertheless, these experts do not predict a record-breaker.

NOAA's press release explained that violent eruptions occur more often on the sun during an active solar period, as is observed during the solar cycle's peak years. Solar flares and coronal mass ejections release energetic photons and highly charged matter toward Earth. The solar plasma and energy that ride the solar wind

### The Ap Index And Understanding Propagation Terminology

The Ap index, or Planetary A index, is a 24-hour averaging of the Planetary K index. The Planetary K index is an averaging of worldwide readings of Earth's geomagnetic field. High indices ( $K_p > 5$  or  $A_p > 20$ ) mean stormy conditions with an active geomagnetic field. The more active, the more unstable propagation is, with possible periods of total propagation fade-out. Especially around the higher latitudes and at the polar regions, where the geomagnetic field is weak, propagation may disappear completely. Extreme high indices may result in aurora propagation, with strongly degraded long-distance propagation at all latitudes. Low indices result in relatively good propagation, especially noticeable around the higher latitudes, when trans-polar paths may open up. Maximum K-index is 9, and the A-index can exceed well over 100 during very severe storm conditions, with no maximum.

Classification of A indices is as follows:

A0-A7 = quiet	A30-A49 = minor storm
A8-A15 = unsettled	A50-A99 = major storm
A16-A29 = active	A100-A400 = severe storm

**Solar Flux Index (SFI):** This flux number is obtained from the amount of radiation on the 10.7-cm band (2800 MHz). It is closely related to the amount of ultraviolet radiation, which is needed to create the ionosphere. Solar Flux readings are more descriptive of daily conditions than the Sunspot Number. The higher the Solar Flux (and, therefore, the higher the Sunspot Number), the stronger the ionosphere becomes, supporting refraction of higher frequencies.

**Ionosphere:** A collection of ionized particles and electrons in the uppermost portion of the Earth's atmosphere, which is formed by the interaction of the solar wind with the very thin air particles that have escaped Earth's gravity. These ions are responsible for the reflection or bending of radio waves occurring between certain critical frequencies, with these critical frequencies varying with the degree of

ionization. As a result, radio waves having frequencies higher than the Lowest Usable Frequency (LUF) but lower than the Maximum Usable Frequency (MUF) are propagated over long distances.

**Smoothed Sunspot Number (SSN):** Sunspots are magnetic regions on the sun with magnetic field strengths thousands of times stronger than the Earth's magnetic field. Sunspots appear as dark spots on the surface of the sun. Temperatures in the dark centers of sunspots drop to about 3700° K (compared to 5700° K for the surrounding photosphere). This difference in temperatures makes the spots appear darker than elsewhere. Sunspots typically last for several days, although very large ones may last for several weeks. They are seen to rotate around the sun, since they are on the surface, and the sun rotates fully every 27.5 days.

Sunspots usually occur in a group, with two sets of spots. One set will have positive, or north, magnetic field while the other set will have negative, or south, magnetic field. The field is strongest in the darker parts of the sunspots (called the "umbra"). The field is weaker and more horizontal in the lighter part (the "penumbra").

Galileo made the first European observations of sunspots in 1610. The Chinese and many other early civilizations have records of sunspots. Daily observations were started at the Zurich Observatory in 1749; continuous observations were begun in 1849.

The Sunspot Number is calculated by first counting the number of sunspot groups and then the number of individual sunspots. The Sunspot Number is then given by the sum of the number of individual sunspots and 10 times the number of groups. Since most sunspot groups have, on average, about 10 spots, this formula for counting sunspots gives reliable numbers even when the observing conditions are less than ideal and small spots are hard to see. Monthly averages (updated monthly) of the Sunspot Numbers show that the number of sunspots visible on the sun wax and wane with an approximate 11-year cycle.

For more information, see <http://prop.hfradio.org>.



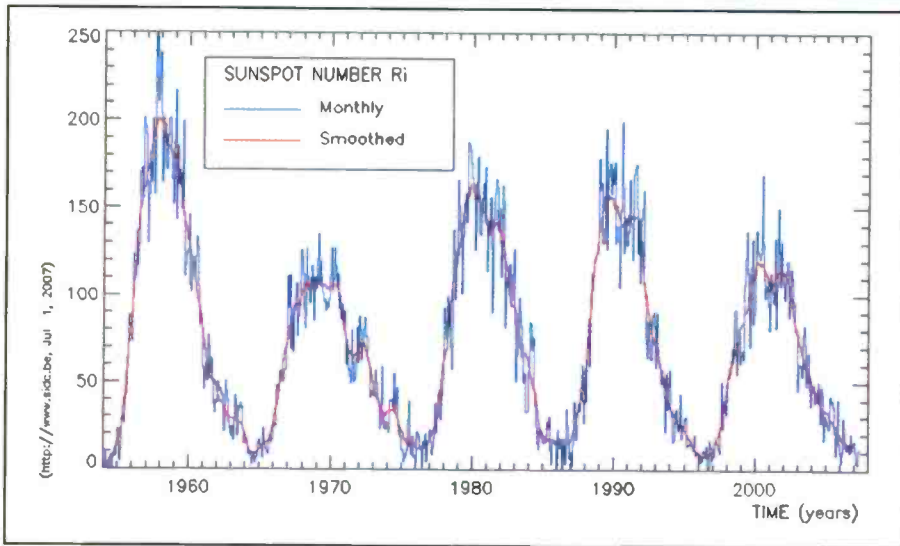

The monthly (blue) and monthly smoothed (red) sunspot numbers for the latest five cycles, as recorded by the keepers of the official sunspot records. Notice that the last cycle was weak when compared to the previous few cycles we've seen during the 25 years Pop'Comm has covered the radio hobby. (Source: Solar Influences Data Center, Belgium)

sunspots there are, the more likely it is that major solar storms will occur.

In the cycle forecast issued by NOAA's SEC, half of the solar expert panelists predict a moderately strong cycle of 140 sunspots, plus or minus 20, expected to peak in October of 2011. The other half predict a moderately weak cycle of 90 sunspots, plus or minus 10, peaking in August of 2012. An average solar cycle ranges from 75 to 155 sunspots. The late decline of Cycle 23 has helped shift the panel away from its earlier leaning toward a strong Cycle 24. Now the group is evenly split between strong and weak.

This author, however, leans toward declaring that the end of Solar Cycle 23 has already occurred. The new cycle, Solar Cycle 24, may already have started during the summer of 2007. We will know for sure by early 2008, because we have to wait for the statistical analysis of monthly smoothed sunspot counts to be considered. Regarding the intensity of Cycle 24, I also lean toward one of the early predictions, which forecasts that the cycle will be one of the best since the 1950s. Is that hopeful thinking?

One disagreement among the current panel members centers on the importance

out away from the sun crash into our planet's ionosphere and geomagnetic field, potentially affecting power grids, radio communications, satellites, GPS signals, even threatening astronauts with harmful radiation. These same storms illuminate night skies with brilliant sheets of red and

green known as auroras, or the northern or southern lights.

As readers of this column know, we measure a solar cycle's intensity by counting the number of sunspots. Sunspots are dark blotches on the sun that mark areas of heightened magnetic activity. The more

## CQ's "Getting Started" series now available on DVDs!

**Our renowned Getting Started videos have been grouped together on DVDs!**

**Ham Radio Welcome Pak 3 in 1 - Three programs on one DVD for only \$24.95**

**Ham Radio Horizons** - An introduction for the prospective ham to what our hobby is all about.

**Getting Started in Ham Radio** - How to select equipment, antennas, bands, use repeater stations, grounding, basic soldering.

**Getting Started in VHF** - Intro to VHF. Repeater usage, VHF-DXing, satellites and more!



**VHF Specialty Pak 3 in 1**

Three programs on one DVD for only \$24.95

**Getting Started in Amateur Satellites** - A newcomer's guide through the equipment, techniques and jargon of satellite communications.

**Getting Started in VHF** - Introduction to VHF. Repeater usage, VHF-DXing, satellites and more!

**Getting Started in Packet Radio** - How to set up the necessary equipment and get on the air on Packet. No theory... just the nuts and bolts of how to do it!



1 Pak \$24.95  
2 Paks \$45.95  
3 Paks \$65.95

**HF Specialty Pak 2 in 1 - Two programs on one DVD for only \$24.95**

**Getting Started in DXing** - Top DXers share their tips and techniques to help you hold your own!

**Getting Started in Contesting** - Learn from the experts. Practical advice, no complicated jargon!

**Purchase 1 Pak for \$24.95 - 2 Paks for \$45.95 - or get any 3 for only \$65.95!**

**Buy any combination in quantity and save!**



**Shipping and Handling:** US and Possessions - Add \$5.00 for the first item, \$2.50 for the second, and \$1 for each additional item. **FREE SHIPPING ON ORDERS OVER \$75.00** (merchandise only). Foreign - Calculated by order weight and destination and added to your credit card charge.

CQ Communications, Inc.

25 Newbridge Road., Hicksville, New York 11801

Order Today! 1-800-853-9797





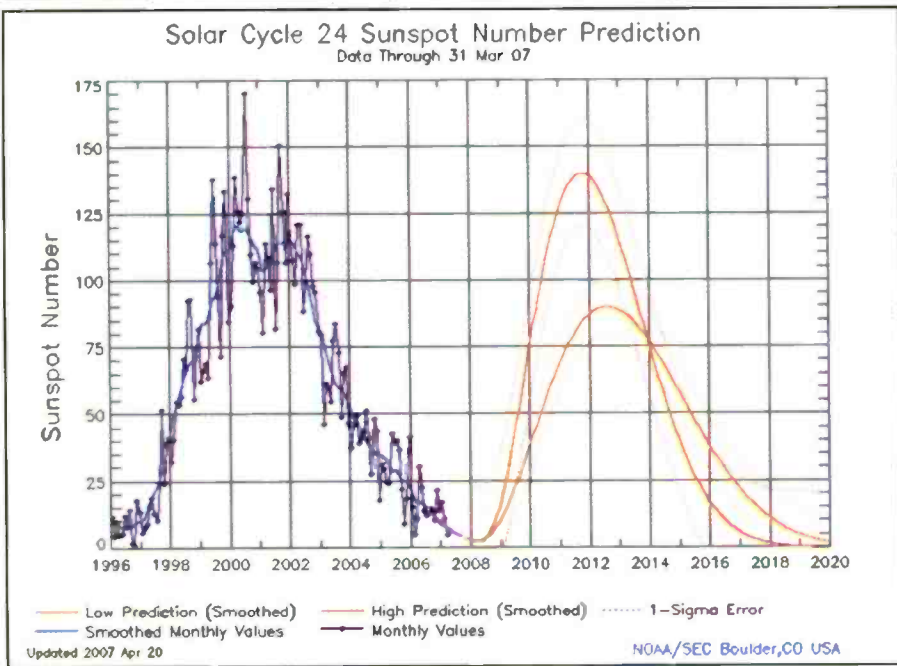

The official NOAA, NASA, and ISES Solar Cycle 24 prediction was released on April 25, 2007, by the Solar Cycle 24 Prediction Panel, comprised of members from NOAA, NASA, ISES, and other U.S. and International representatives. This chart shows the various predictions for Cycle 24. See text for discussion. (Source: NOAA/SEC)

of magnetic fields around the sun's poles as the previous cycle decays. End-cycle polar fields are the bedrock of the approach predicting a weak Cycle 24. The strong-cycle forecasters place more importance on other precursors extending over a several-cycle history. Another clue

will be whether Cycle 24 sunspots appear by mid-2008. If not, the strong-cycle group might change its forecast.

The first year after solar minimum, marking the end of Cycle 23, will provide the information scientists need to arrive at a consensus. NOAA and the panel

decided to issue their best estimate now and update the forecast as the cycle progresses, since SEC customers have been requesting a forecast for over a year.

"The panelists in each camp have clear views on why they believe in their prediction, why they might be wrong, and what it would take to change their minds," said Douglas Biesecker, a scientist with SEC. "We're on the verge of understanding and agreeing on which precursors are most important in predicting future solar activity."

### HF Propagation For October

A change in propagation conditions in the Northern Hemisphere can be observed as we move away from the long sunlit days of summer into the longer hours of winter's darkness. With the shorter period of sunlight each day, the

# Monitoring Times

## ORDER TODAY!

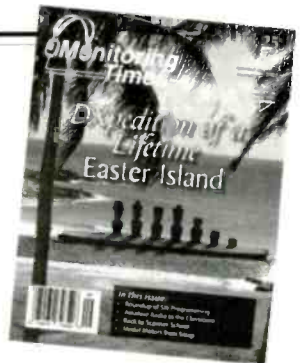

Do you own a radio, a shortwave receiver, a scanning receiver, or a ham radio? Then Monitoring Times® is your magazine! Open a copy of MT, and you will find news, information, and tips on getting more out of your radio listening. In fact, it's the most comprehensive radio hobby magazine in the U.S. MT Express - Not only do we offer a premium monthly printed magazine, but we also offer the popular MT Express digital version of Monitoring Times. This is the best way to get your magazine as soon as it's released, right from the internet! All you have to have is an internet connection with an e-mail address and you're ready for all the excitement of a truly interactive publication. For less than the cost of a printed subscription, you get the full magazine in pdf format with color photos throughout and active links to all web sites mentioned in the text.

Packed with up-to-date information concisely written by the top writers in the field, Monitoring Times® is your foremost guide to profiles of broadcasting and communications installations; home projects; and tips on monitoring everything from air, sea, and space to distant ports of call.

800-438-8155  
828-837-9200 fax: 828-837-2216  
[www.grove-ent.com](http://www.grove-ent.com)

order@grove-ent.com  
7540 Highway 64 West  
Brasstown, NC 28902

Order TODAY and use code MTSPECIAL to get all the great offers!

7540 Hwy. 64 W., Brasstown, NC 28902  
1-800-438-8155 US and Can., 828-837-9200, Fax 878-837-2216  
e-mail: [order@grove-ent.com](mailto:order@grove-ent.com)

	1 month	3 mos	6 mos	1 year
US Rate	<input type="checkbox"/> \$15.00	<input type="checkbox"/> \$28.95	<input type="checkbox"/> \$51.95	<input type="checkbox"/> \$94.95
US 1st Class	<input type="checkbox"/> \$28.00	<input type="checkbox"/> \$57.95	<input type="checkbox"/> \$112.00	<input type="checkbox"/> \$168.00
Canada Surface*	<input type="checkbox"/> \$28.50	<input type="checkbox"/> \$59.50	<input type="checkbox"/> \$115.95	<input type="checkbox"/> \$172.95
Foreign International†	<input type="checkbox"/> \$38.75	<input type="checkbox"/> \$74.50	<input type="checkbox"/> \$141.95	<input type="checkbox"/> \$219.95
Electronic Subscription	<input type="checkbox"/> \$19.95	<input type="checkbox"/> \$38.90	<input type="checkbox"/> \$74.80	<input type="checkbox"/> \$137.65

\*All payments must be in U.S. Funds drawn on a U.S. Bank!

Name \_\_\_\_\_ Address \_\_\_\_\_  
City \_\_\_\_\_ State \_\_\_\_\_ Zip \_\_\_\_\_ Country \_\_\_\_\_  
City \_\_\_\_\_ State \_\_\_\_\_ Zip \_\_\_\_\_  
Country \_\_\_\_\_  
E-mail address \_\_\_\_\_  
MasterCard, Visa, and Discover Card accepted!

Or just go to [www.grove-ent.com](http://www.grove-ent.com) to order NOW!



**Optimum Working Frequencies (MHz) - For October 2007 - Flux = 78, Created by NW7US**

UTC TO/FROM US WEST COAST	00	01	02	03	04	05	06	07	08	09	10	11	12	13	14	15	16	17	18	19	20	21	22	23
CARIBBEAN	20	18	15	12	11	11	10	10	10	9	9	9	9	12	17	19	20	21	22	22	22	22	21	21
NORTHERN SOUTH AMERICA	27	25	22	18	17	16	15	14	14	13	13	12	12	12	20	23	25	26	27	28	29	29	29	28
CENTRAL SOUTH AMERICA	27	24	21	17	16	15	14	14	13	13	12	12	12	15	22	24	25	26	27	28	28	28	28	28
SOUTHERN SOUTH AMERICA	29	27	25	21	19	18	17	16	15	14	13	13	13	12	18	23	26	27	28	29	29	30	30	30
WESTERN EUROPE	9	9	8	8	8	8	8	8	8	8	8	8	8	11	14	15	16	16	16	15	14	11	9	9
EASTERN EUROPE	8	8	8	8	8	9	9	9	8	8	8	8	8	8	12	13	13	12	12	11	9	9	8	8
EASTERN NORTH AMERICA	21	19	15	13	12	11	11	11	10	10	10	10	10	15	19	21	23	23	24	24	24	24	23	23
CENTRAL NORTH AMERICA	12	12	10	7	7	7	6	6	6	6	6	5	5	5	9	11	12	13	13	13	13	13	13	13
WESTERN NORTH AMERICA	7	6	6	5	4	3	3	3	3	3	3	2	2	2	5	6	6	7	7	7	7	7	7	7
SOUTHERN NORTH AMERICA	21	19	17	13	12	11	11	10	10	10	10	9	9	9	15	18	20	21	22	22	23	23	22	22
HAWAII	19	19	18	17	15	12	11	11	10	9	9	9	8	8	8	8	11	15	17	18	19	19	20	20
NORTHERN AFRICA	9	9	9	8	8	8	8	9	8	8	8	8	8	12	15	16	17	18	17	15	11	10	10	9
CENTRAL AFRICA	12	11	11	10	9	9	9	9	8	8	8	8	11	14	16	17	17	18	16	15	14	13	12	12
SOUTH AFRICA	19	17	12	12	11	11	11	10	10	10	10	10	9	16	19	20	22	22	23	23	23	23	22	20
MIDDLE EAST	8	8	8	8	8	9	9	9	8	8	8	8	8	8	13	15	16	14	11	10	10	9	9	9
JAPAN	19	18	18	17	16	14	10	10	9	9	9	9	8	8	8	8	8	8	8	8	13	16	17	18
CENTRAL ASIA	19	18	18	17	16	13	10	10	9	9	9	8	8	8	8	10	11	11	10	10	10	18	19	19
INDIA	12	13	13	13	12	9	9	9	8	8	8	8	8	8	8	8	9	10	11	11	12	12	12	12
THAILAND	18	18	17	17	15	13	10	10	9	9	9	8	8	8	8	8	11	13	12	12	11	11	11	15
AUSTRALIA	24	26	27	26	24	19	16	15	15	14	13	13	13	12	12	12	16	15	14	14	16	19	21	23
CHINA	17	18	17	16	15	13	10	10	9	9	9	8	8	8	8	8	9	8	8	8	8	8	13	16
SOUTH PACIFIC	28	29	28	26	24	20	18	17	16	15	14	14	13	13	12	12	15	14	17	20	22	24	26	27

  

UTC TO/FROM US MIDWEST	00	01	02	03	04	05	06	07	08	09	10	11	12	13	14	15	16	17	18	19	20	21	22	23
CARIBBEAN	22	19	17	15	14	13	13	12	12	11	11	10	12	18	21	23	24	25	25	26	25	25	24	23
NORTHERN SOUTH AMERICA	25	23	20	18	17	16	15	14	13	13	12	12	11	17	20	22	23	25	26	26	27	27	27	26
CENTRAL SOUTH AMERICA	26	23	20	19	17	16	15	14	14	13	13	12	15	21	23	24	26	27	27	28	28	28	28	28
SOUTHERN SOUTH AMERICA	28	26	23	21	20	18	17	16	15	14	14	13	13	18	22	24	26	27	28	29	29	30	30	29
WESTERN EUROPE	9	9	8	8	8	8	8	8	8	8	8	8	13	15	17	17	17	16	16	14	12	10	9	9
EASTERN EUROPE	8	8	8	8	8	8	9	8	8	8	8	8	8	11	14	15	15	14	14	13	11	9	9	9
EASTERN NORTH AMERICA	15	12	9	9	8	8	8	8	7	7	7	7	8	13	15	16	17	18	18	18	17	17	16	16
CENTRAL NORTH AMERICA	7	6	5	4	4	4	3	3	3	3	3	3	3	5	6	7	7	8	8	8	8	8	8	8
WESTERN NORTH AMERICA	13	12	11	7	7	6	6	6	6	6	6	5	5	9	11	12	13	13	13	14	14	13	13	
SOUTHERN NORTH AMERICA	14	13	11	9	9	8	8	7	7	7	7	6	9	12	14	15	15	16	16	16	16	16	16	15
HAWAII	22	21	20	17	13	12	12	11	10	10	10	10	9	9	9	10	14	18	20	21	22	23	23	23
NORTHERN AFRICA	11	10	10	9	9	9	9	8	8	8	8	8	14	16	18	18	19	19	19	19	14	13	12	12
CENTRAL AFRICA	12	10	10	9	9	9	9	8	8	8	8	8	14	16	17	18	19	19	19	17	16	15	14	13
SOUTH AFRICA	19	16	15	14	14	13	13	12	12	12	12	12	21	25	27	28	29	29	29	28	27	25	22	21
MIDDLE EAST	9	8	8	8	8	9	9	8	8	8	8	8	13	15	17	17	17	16	12	10	10	9	9	9
JAPAN	18	17	16	14	10	10	9	9	9	9	8	8	8	8	8	9	8	8	8	8	12	15	17	18
CENTRAL ASIA	18	17	16	14	10	10	9	9	9	9	8	8	8	8	8	12	11	11	11	10	10	10	17	18
INDIA	11	12	12	10	9	9	9	8	8	8	8	8	8	12	13	13	12	10	9	9	8	8	8	8
THAILAND	17	16	15	13	10	9	9	9	8	8	8	8	8	8	12	14	13	13	12	12	11	11	11	13
AUSTRALIA	25	26	25	22	17	16	15	14	14	13	13	12	12	12	12	17	16	15	14	14	17	19	21	23
CHINA	16	16	15	12	10	9	9	9	9	8	8	8	8	8	9	9	9	9	8	8	8	8	11	15
SOUTH PACIFIC	29	28	26	23	20	18	17	16	15	14	14	13	13	12	14	15	15	14	18	21	23	25	27	28

UTC TO/FROM US EAST COAST	00	01	02	03	04	05	06	07	08	09	10	11	12	13	14	15	16	17	18	19	20	21	22	23
CARIBBEAN	17	15	14	13	12	11	11	10	10	9	9	9	13	16	18	19	20	20	21	21	21	20	20	19
NORTHERN SOUTH AMERICA	22	21	19	17	16	15	14	13	12	11	11	11	13	16	19	20	22	23	23	24	24	24	24	23
CENTRAL SOUTH AMERICA	26	23	21	20	18	17	16	15	14	14	13	15	19	21	23	24	26	27	27	28	28	28	28	28
SOUTHERN SOUTH AMERICA	28	25	23	21	20	18	17	16	15	14	14	13	18	21	23	25	26	27	28	29	29	30	30	29
WESTERN EUROPE	9	8	8	8	8	8	8	8	8	8	11	14	16	17	18	18	17	17	16	14	12	9	9	9
EASTERN EUROPE	9	8	8	8	8	8	8	8	8	8	8	14	16	17	17	16	16	15	14	12	9	9	9	9
EASTERN NORTH AMERICA	6	5	5	4	4	4	4	3	3	3	3	3	6	7	8	8	8	9	9	9	9	8	7	7
CENTRAL NORTH AMERICA	15	13	10	9	9	9	8	8	8	8	8	7	9	14	16	17	18	18	19	19	18	18	17	17
WESTERN NORTH AMERICA	21	19	15	13	12	11	11	11	10	10	10	10	10	16	20	22	23	24	24	24	24	24	24	23
SOUTHERN NORTH AMERICA	17	15	12	12	11	10	10	9	9	9	8	8	9	15	17	18	19	20	20	20	20	19	18	18
HAWAII	22	20	16	13	13	12	12	11	11	10	10	10	10	11	11	11	15	19	22	23	25	25	24	23
NORTHERN AFRICA	12	11	11	11	10	10	10	10	10	10	16	20	22	23	24	24	24	23	22	20	16	14	13	12
CENTRAL AFRICA	13	12	12	11	11	10	10	10	10	10	16	20	22	23	24	24	25	24	22	19	17	16	15	14
SOUTH AFRICA	19	18	16	15	15	14	14	13	13	14	21	25	27	28	29	29	29	29	29	28	27	25	23	21
MIDDLE EAST	10	10	9	9	9	8	8	8	8	8	12	16	17	18	19	19	20	20	17	13	12	12	11	11
JAPAN	16	14	10	10	9	9	9	9	8	8	8	8	8	9	9	9	8	8	8	8	10	15	17	17
CENTRAL ASIA	15	13	10	10	9	9	9	8	8	8	8	8	12	12	12	11	11	11	10	10	10	10	15	17
INDIA	8	8	8	9	9	9	8	8	8	8	8	11	13	13	12	12	12	11	11	10	9	8	8	8
THAILAND	14	10	10	9	9	9	9	8	8	8	8	8	8	14	16	16	14	13	12	12	11	11	11	10
AUSTRALIA	25	24	20	17	16	15	14	14	13	13	12	12	12	17	18	17	16	15	14	14	17	20	22	24
CHINA	14	10	10	9	9	9	9	8	8	8	8	8	10	10	9	9	9	9	8	8	8	8	8	13
SOUTH PACIFIC	28	26	23	21	19	18	16	15	15	14	13	13	13	17	16	15	14	16	20	23	25	27	28	29



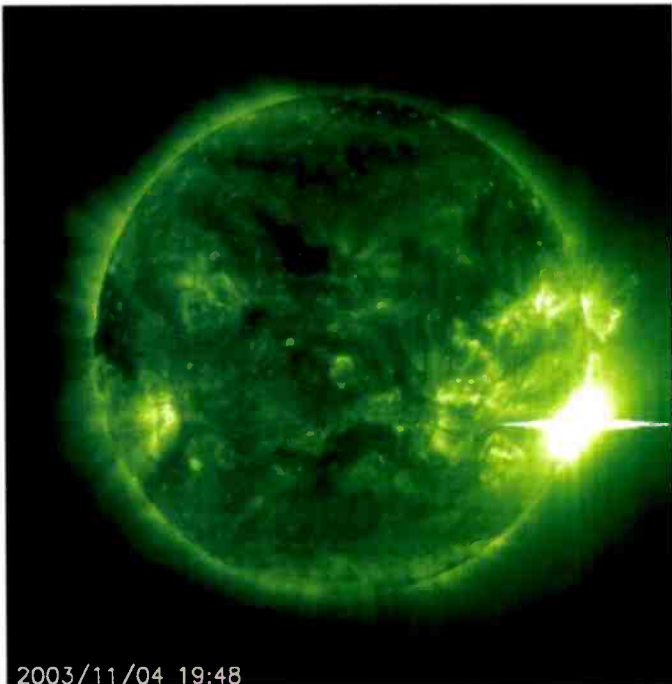

2003/11/04 19:48

*November 4, 2003, saw the most powerful solar flare eruption on record. This one saturated the X-ray detectors on the NOAA's GOES satellites; the jury was, therefore, out for a while on the definitive classification of the flare. Based on the data found on the NOAA SEC's space weather pages (and links therein), speculations ranged from simply well above X20, to X40 or even X50! The final consensus put the flare at a record-breaking X28. (Source: SOHO)*

ionosphere has more time during the dark hours to lose the energy created during daylight hours. This affects the propagation of radio signals by lowering the maximum usable frequency (MUF) over many areas of the Earth. However, the change in the length of daily darkness is not the only influence on the propagation of radio waves through the atmosphere. The amount and strength of radiation arriving and passing through our atmosphere varies from season to season, as well as from the solar cycle minimum to the solar cycle maximum.

During the Northern Hemisphere's winter months, the Earth is closer to the sun than during any other time of its orbit. This makes the daytime ionization more intense than that of summer daytimes. In turn, this higher-level energy during the day causes the average MUF to increase slightly compared to the same time of day during the summer season, over the same radio signal path.

Then, with the longer winter hours of darkness, the ionosphere has more time to lose its electrical charge. This causes the MUF to dip lower at night than during the summer months.

These conditions cause a wide daily variation in the maximum frequency that can be propagated by refraction of the radio waves by the wintertime ionosphere. Many radio enthusiasts celebrate the arrival of the winter shortwave season for these reasons.

Signals below 120 meters are improving, with nighttime paths growing larger in the Northern Hemisphere. Seasonal static, which makes it difficult to hear weak DX signals, is starting to decrease as we move into winter. Expect a few DX openings during the hours of darkness and into the sunrise period. These openings will often be weak due to the rela-

tively high signal absorption during the expected elevated geomagnetic storminess through the rest of this year. Look for openings from Europe and the south if you're listening in the eastern half of the United States, and from the south, the Far East, Australasia, and the South Pacific if you are in the western half of the country.

The best propagation aid is a set of sunrise and sunset curves, since DX signals tend to peak when it is local sunrise at the easterly end of the path in question. A good Internet website featuring a grey line map display is found at [www.fourmilab.to/earthview/](http://www.fourmilab.to/earthview/). Follow the link, "map of the Earth" showing the day and night regions.

Seventy-five through 120 meters is coming alive in late October. Expect long-range DX on the low bands, starting close in right after sunset, and extending farther as the night develops. Signals here should peak from Europe and from a generally easterly direction around midnight. DX paths will move farther west through the night. By morning, openings from Asia should be common. For openings in a generally western direction, expect a peak just after sunrise. The band should remain open from the south throughout most of the night. Propagation in this band is quite similar to that expected on 41 meters, except that signals will be somewhat weaker on the average, noise levels will be a bit higher, and the period for band openings in a particular direction will be a bit shorter.

Forty-one meters should be the hottest DX band during the dark hours as the seasonal static levels are lower than they were during the summer. The band should be open first for European DX in the eastern United States during the late afternoon. Signals should increase in intensity as darkness approaches. During the hours of darkness, expect good DX openings from most areas of the world. Signals should peak from an easterly direction about midnight, and from a westerly direction just after sunrise. Excellent openings toward the south should be possible throughout most of the nighttime period.

Paths on 31 through 19 meters are becoming ever more reliable between North America and Europe in the morning and between North America and Asia during the late afternoon hours. The strongest openings occur for a few hours after sunrise and during the sunset hours.

Thirty-one and 25 meters will often remain open into many areas late into the night and will open early in the morning, especially when part of the propagation path moves through sunlit regions. However, these bands are crowded and signals are usually very strong and steady. Twenty-five meters is expected to be an excellent band for medium distance (500 to 1,500 miles) reception during the daylight hours. Longer distance reception (up to 2,000 to 3,000 miles) should be possible for an hour or two after local sunrise, and again during the late afternoon and early evening. Thirty-one meters will provide medium distance daytime reception ranging between 400 and 1,200 miles.

Twenty-two through 19 meters compete with 16 for the best daytime DX band during October. They will open for DX just before sunrise and should remain open from all directions throughout the day, with a peak in the afternoon. Nighttime conditions will favor openings from the south and tropical areas. Since the Southern Hemisphere has long daylight hours, DX paths on these bands from stations in the south will be common.

Sixteen through 13 meters will occasionally open through October when flux levels reach above 100. Paths from Europe

and the South Pacific as well as from Asia, at least during days of higher solar flux levels, are common, especially on 16 meters. Look for best conditions from Europe and the northeast before noon and from the rest of the world during the afternoon hours. Reception from the South Pacific, Australia, New Zealand, and the Far East should be possible well into the early evening.

## VHF Conditions

Conditions during October should include moderate levels of trans-equatorial propagation (TE) in which stations in the southern states and parts of the Caribbean will be able to work into the northern areas of South America during the late afternoon. During peak years of a solar cycle, October is one of the best months for TE activity, especially later in the month. Since we're in the decline from the current solar cycle's peak, these openings will be rarer than previous years, but some exciting openings might occur.

While sporadic-E activity is sparse during the month of October in the northern temperate zone (where much of the United States is located), there is some possibility of extended tropospheric propagation conditions during October because of the changing weather patterns. Higher VHF is the best frequency range to watch for this.

## Current Cycle 23 Progress

The Royal Observatory of Belgium reports that the monthly mean observed sunspot number for June 2007 is 12. The lowest daily sunspot value recorded was zero (0) on June 14 through June 24. The highest daily sunspot count was 37 on June 7. The 12-month running smoothed sunspot number centered on December 2006 is 12.1. A smoothed sunspot count of 18, give or take 12 points lower to 12 points higher, is expected for October 2007.

The Dominion Radio Astrophysical Observatory at Penticton, BC, Canada, reports a 10.7-centimeter observed monthly mean solar flux of 73.7 for June 2007. The 12-month smoothed 10.7-centimeter flux centered on December 2006 is 77.9. The predicted smoothed 10.7-centimeter solar flux for October 2007 is 78, give or take about 15 points.

The observed monthly mean planetary A-Index (Ap) for June 2007 is 7, while May's adjusted figure is 9 instead of 8.

The 12-month smoothed Ap index centered on December 2006 is 8.5. Expect the overall geomagnetic activity to be varying greatly between quiet to disturbed during most days in October.

## I'd Like To Hear From You

You can join in with others in discussing space weather, propagation, and shortwave or VHF listening, at <http://hfradio.org/forums/>. Be sure to check out the latest conditions, as well as the educational resources about propagation,

which I have put together for you at <http://prop.hfradio.org/>. I also provide a WAP/WML resource for wireless devices. If you want the latest propagation information, like the solar flux, Ap reading, and so forth, check out <http://wap.hfradio.org/>, the wireless version of my propagation site.

Please don't hesitate to write and let me know about any interesting propagation that you have noticed. Do you have questions about propagation? I look forward to hearing from you.

Happy signal hunting! ■

## When Disaster Strikes...



# REACT is Ready!

**REACT** Teams work with local, state, and national disaster response agencies. Often **REACT** plays a unique role in disaster relief because **REACT** is the only volunteer communications organization whose members are trained to use **all types of two-way communications** from CB to packet radio, Amateur radio to GMRS.

Fortunately, disasters don't happen every day. **REACT** Teams maintain their readiness and serve the public by monitoring emergency channels and by providing communications services for a variety of activities and community events.

Find out how you can be part of the **REACT** Team! Visit [www.reactintl.org](http://www.reactintl.org) to find a Team in your area – or information on starting your own Team.



**REACT International, Inc.**

(301)316-2900 or (866)REACT99  
5210 Auth Rd., Ste. 403 \* Suitland, MD 20746



# Software-Defined Radios: The Next Generation

The next generation of software-defined radio (SDR) receivers is here, and anticipation is growing with the development of future generations already well underway. Regardless of what designers might be dreaming about for the future, an SDR receiver could be the last receiver you'll ever need to buy as downloadable software upgrades may keep it fresh for many years to come. All-mode reception (AM, SSB, CW, FM), spectrum analyzer display, and the ability to record RF for later re-reception/playback are all standard features of SDR receivers. Here's a review of SDR broadcast receivers available today and a speculation of what's ahead.

## Direct Sampling Technology

Early attempts at SDR technology typically consisted of an analog front-end that would downconvert to an intermediate frequency (IF) before analog-to-digital (A/D) conversion. The latest generation of SDR receivers is all digital, from the antenna input until its converted back to analog audio for your listening pleasure, thanks to direct digital sampling (DDS) technology that utilizes sampling rates greater than 60 MHz.

The development of the "I and Q" format digital datastream further enhanced the technology by allowing for efficient USB and soundcard interface. I and Q is a data processing technique, a complex modulation scheme used in quadrature sampling that essentially delivers a large amount of information on a carrier signal. DDS eliminates the need for analog circuitry to downconvert to an IF. Any IF downconversion is done



The RFSpace SDR-IQ portable receiver.

digitally. Bottom line, DDS plus I and Q mean that outstanding, reliable SDR receiver performance can be easily achieved while making features previously found only in professional equipment costing tens of thousands of dollars more affordable for consumer applications.

RFSpace ([www.rfspace.com](http://www.rfspace.com))

RFSpace offers two models: the SDR-14 and SDR-IQ. These SDR receivers take advantage of the Analog Devices (a manufacturer of integrated circuits used in analog and digital signal processing applications) direct sampling receiver combination of an AD6620 65 MSPS Digital Receive Signal Processor and AD6644 A/D converter. A sampling rate of 66.667 MHz cov-

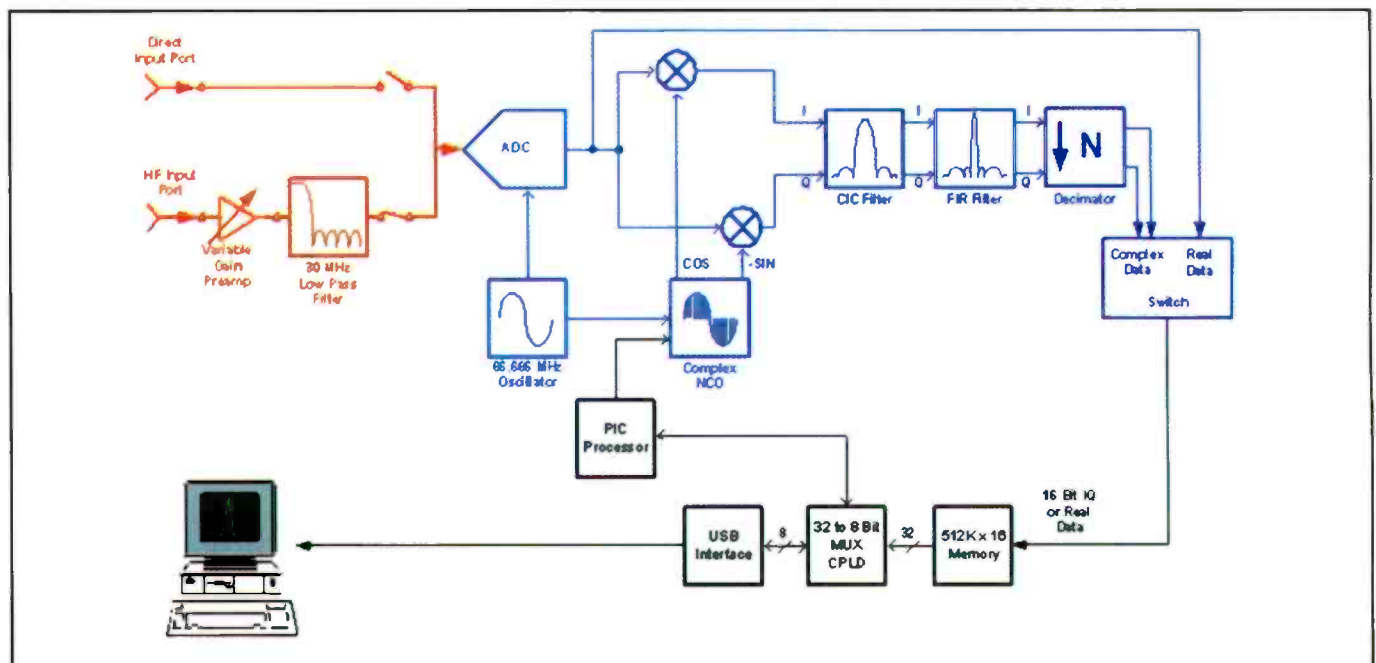

A block diagram of the RFSpace SDR-14 receiver.

ers 0 to 30 MHz. I and Q data is sent to a PC via USB 2.0, which provides a recording capability of up to 190 kHz of bandwidth for later "re-reception" or playback. All receive functions, including tuning, demodulation, and spectral analysis are done by software on the PC side. Third-party SpectraVue software is provided for spectrum display and analysis with RFSpace SDR receivers.

The RFSpace model SDR-14 (\$1,099.95) has a unique direct input port to the D/A converter for potential reception of signals at frequencies over 230 MHz. The SDR-14 receives DRM digital broadcast signals through third-party Dream software, an open source software implementation of a DRM receiver. (DRM is the European standard for in-band on-channel digital AM broadcasting.) The SDR-14 requires a 12-VDC external power supply.

As a receiver, the SDR-14 is not very easily navigated though. Its primary function is spectrum analysis, lacking typical receiver controls. Also, when recording RF bandwidth for later playback, it only stores the spectrum display without any radio receiver functionality. The SDR-14 is still very impressive, comparable to professional-grade spectrum analyzers.

The SDR-IQ (\$399.95 OEM PC board without chassis; \$499.95 complete in a chassis) represents the latest design by RFSpace, unique in that it's powered solely by 5 volts through the USB connection, making it an excellent companion for portable laptop operation, and thus an outstanding tool for DXpeditioning. However, as of this writing, the SDR-IQ was only available OEM without a chassis, pending FCC approval, so some custom mechanical assembly is required. Check with Universal Radio ([www.universal-radio.com](http://www.universal-radio.com)) for the status of shipment with a chassis.

Analog Devices ([www.analog.com](http://www.analog.com)) offers online application notes for anyone interested in learning more about direct digital sampling reception and downconversion. The write-up "Designing a Superheterodyne Receiver Using an IF Sampling Diversity Chipset," for instance, explains in greater detail how it all works. AD6620 and AD6644 evaluation boards and development software are available for engineers and experimenters.

*WiNRADiO* ([www.winradio.com](http://www.winradio.com))

WiNRADiO offers several SDR receiver models for professional and consumer use. Its most highly regarded SDR for broadcast DXing is the WR-G313. It's available as a desktop PC-card plug-in (model 313i for internal, \$949.95) or as a "black box" portable unit that connects to a laptop via USB (model 313e for external, \$1,149.95). Coverage is 9 kHz through 30 MHz with optional extended coverage to 180 MHz. Published specs are impressive, such as 95-dB dynamic range and AM sensitivity of 0.4  $\mu$ V, comparable to high-end conventional communications receivers. The synchronous detection is outstanding and actually useful for DXing, not just program listening. DRM digital radio reception is optional. Several WR-313i receivers, as many as there are free PCI slots, can be controlled by a single PC.

The WR-313e/i is a DDS-based dual-conversion superhet front end with intermediate frequencies of 45 and 16 kHz. A 20-kHz bandwidth "Spectrum Scope" allows you to watch sig-



The WiNRADiO WR-313e/i user interface featuring an integrated spectrum analyzer display.

nals while listening in real time, and the same 20-kHz RF bandwidth can be recorded for later re-reception/playback. While the 20-kHz recording capability is a plus over standard analog receivers, it's the one limitation of the WR-313e/i compared to other SDR receivers that record up to 190 kHz bandwidth. This 20-kHz limit is likely due to how the 45/16-kHz IF is implemented. The WR-313e/i ergonomic design is ideally suited for non-computer geeks and entry-level SDR applications, as it's essentially plug-and-play. The WR-313e version is powered by a provided external linear power supply, or an optional rechargeable battery pack.

*FlexRadio Systems* ([www.flex-radio.com](http://www.flex-radio.com))

FlexRadio has introduced a line of SDR transceivers for amateur radio applications: the SDR-1000 and the Flex-5000 series. What's unique about FlexRadio is its open source "Power SDR" software, which allows experimenters to submit upgrades. The latest software revisions are then posted online on a regular basis for FlexRadio users to download.

The SDR-1000 model (\$875) is available with the transmit capability disabled for unlicensed broadcast DXers. It covers 12 kHz to 60 MHz using the Analog Devices AD9854 300 MSPS Quadrature Complete DDS (operating at 200 MHz) for exceptional performance. Dynamic range of 99 dB can be achieved with a Delta 44 soundcard or Edirol FA-66 FireWire



The FlexRadio SDR-1000 amateur radio transceiver.



soundcard unit, the only soundcards recommended for the SDR-1000. The SDR computer interface is via parallel port or an optional USB/parallel adapter. DRM digital reception is optional through third-party open source Dream software. The SDR-1000 is powered by 13.8 VDC.

As the parallel port interface, soundcard requirements, and open source software development would indicate, the SDR-1000 might be better suited for the technically inclined. A basic understanding of computer and soundcard troubleshooting is recommended, but a background in computer programming or software design certainly isn't necessary to operate the SDR receiver.

The Flex-5000 is the latest SDR transceiver from FlexRadio. It's a complete SDR transceiver, no soundcard required, interfacing to a PC via FireWire. The Flex-5000A (\$2,499) is the basic unit, while the 5000C (\$4,499) comes with its own integrated computer. A receive-only Flex-5000 is not yet available, so an amateur radio license is required.

"We have 11 banks of 11th order filters in the Flex-5000. These are currently aligned respectively with each of the 11 Ham bands from 160m through 6m," reported Gerald Youngblood, K5SDR, president of FlexRadio, on the Flex e-mail group reflector. "A receive only version, when offered, would repurpose some of those filter banks for longwave and MW reception. For example, we would use the 12m slot for lower frequencies and combine 10/12m on one filter. We can do the same with 17/15m, etc."

*Elad (www.elad.it)*

The Elad FDM77 (\$599.95) SDR receiver comes from Italy and was first introduced and made available through U.S. distributors in 2005. Coverage is 50 kHz to 60 MHz. An external 12-VDC power supply is required. Universal Radio includes an MFJ-1316 wall-wart power supply in the standard package. The FDM77 features bandpass tuning, two configurable notch filters, USB interface, and DRM digital reception.

The FDM77 is unique because it was specifically designed with DRM in mind. At the same time it's a relatively basic SDR.



Front and rear views of the Elad FDM77 SDR receiver.



The ICOM IC-PCR2500 user interface featuring simultaneous reception of two frequencies.

The spectrum bandwidth is rather limited for an SDR receiver at only 12 kHz. However a 2005 press release stated, "Elad is studying the possibility to develop also a professional version of DRM receiver (FDM770) conceived for radio monitoring." Later it was announced that the FDM78, a new high-end professional receiver, was scheduled to debut toward the end of 2006.

*ICOM (www.icomamerica.com)*

The ICOM entries into the computer arena, the IC-PCR1500 and IC-PCR2500, aren't really SDR receivers, but are more accurately described as software-controlled receivers. Still, the ICOM receivers are worth mentioning here as they're a departure from standard desktop communications receivers. The ICOM IC-PCR1500 (\$499.95) is the basic model, while the IC-PCR2500 (\$729.95) has incorporated some unique features (see "Tech Showcase" in the June 2007 *Pop'Comm*). Both models cover 10 kHz to 3300 MHz, less cellular, and are computer controlled via USB interface. An optional controller head can be used for operation independent of a computer.

The IC-PCR2500 features "dual watch" ability to receive two signals simultaneously and two antenna inputs can be used for diversity reception. On the downside, although typical of receivers covering such a wide frequency range, sensitivity on the AM broadcast band is rather poor at 25  $\mu$ V.

*HPSDR (http://hpsdr.org)*

Could 1-MHz RF bandwidth be within reach? The High Performance SDR (HPSDR) group is currently developing the next generation SDR receiver. The group consists of engineers, experimenters, and software developers, working on individual modules that together will morph into the ultimate SDR receiver. The group operates under an open source model for both software and hardware development.

Prototype modules include the Mercury direct sampling receiver, Janus ADC/DAC board, and Ozy high-speed USB interface. The Mercury DDS design uses the Linear Technology LTC2208 for 0 to 55 MHz reception. Initial tests of the Mercury DDS have been very promising, generating plenty of excitement among those monitoring the group's progress. Interested parties are more than welcome to join the group by contribut-

ing through email discussions or as part of the design team. They are especially in need of PC board design/layout expertise.

## A Caveat

It's worth noting that none of the SDR receivers is compatible with AM HD digital radio in the United States. This is probably due to the proprietary nature of HD radio, which is licensed through iBiquity, the sole licensee of in-band on-channel digital broadcasting technology in the United States. However, SDR technology is still at a highly specialized level, not yet at a consumer distribution level that would support the investment into an HD radio license. Because everything is done through software in an SDR receiver, the lack of HD radio reception shouldn't be a roadblock when considering SDR for your next receiver purchase. Like the current DRM options for SDR, upgrading to HD radio shouldn't be anything more than a software revision and/or a third party add-on once it becomes available.

That's the beauty of SDR technology. In this fast changing world of high technology, it will be a long time before your investment in an SDR receiver becomes obsolete.

## Broadcast Loggings

The bottom of the solar sunspot cycle continues to provide some nice AM DX reception, as indicated by the following selected logs from our regular reporters. All times are UTC.

**540 2AP SBC Radio One, Apia, Samoa,** at 0722 modern country music, lyrics mentioned "all my rowdy friends," and talk in Samoan. Heard earlier at 0655 with Samoan song done Ray Price/Patsy Cline style while near Ala Moana Center. Fair; 550 KMVI interference. (Park-HI)

**612 RTM A, Sebaa-Aioun, Morocco,** at 0245 a good signal with a flute instrumental parallel 207 kHz. (Conti-ME) At 0305 fair with what sounded like prayers. (Barstow-MA)

**620 XESS ESPN Deportes, Ensenada, Mexico,** at 0725 noted during KIPA moment of dead air; man in Spanish talking fast with probable sports report, mentioning Colombia, Peru. Fair signal. (Park-HI)

**700 RJR Hague, Jamaica,** at 0500 through lightning noise and WLW: R&B vocal. "RJR...Nationwide News Network, we broadcast...Kingston, Jamaica, West Indies... Montego Bay..." (Conti-ME) At 0805 in WLW null; unmistakable Gyptian reggae vocal parallel 720 kHz. (Conti-NH) Listed inactive in 2007 *WRTH*.

**765 RSR Option Musique, Sottens, Switzerland,** at 0120 a French female vocal;

fair. (Connelly-MA) At 0147 good; Option Musique ID and adult contemporary French vocal. (Conti-NH) At 0313 talk; in strong. (Barstow-MA)

**800 PJB TransWorld Radio, Bonaire, Netherlands Antilles,** at 0119 Spanish religion with familiar male announcer; initially evenly mixed with VOWR with some possible CHRC under, then coming up to full dominance. Phaser was set for a thorough aggregate null of the WNNW, CJAD, and CKLW jumble. (Connelly-MA)

**819 RTM A, Rabat-Temara, Morocco,** at 0250 good with lively music and a female vocal parallel 612 kHz. (Conti-ME)

**864 France Bleu, Villebon-sur-Yvette, France,** at 0123 "Jealous Guy" by John Lennon; to good peak. At 0141 a French male pop vocal; good. (Connelly-MA) At 0317 romantic songs; in good. (Barstow-MA)

**950 LR3 La Nueve Cincuenta, Capital Federal, Argentina,** at 0800 ID, "La Nueve Cincuenta en la ciudad de Buenos Aires," folk-type melody with harp, into talk show with two women, numerous mentions of Buenos Aires. Very good, over KJR and KAH1. 1350 LS6 was also good then. (Wood-HI)

**1000 ZYK522 Radio Record, São Paulo, Brazil,** at 0045 Portuguese sports talk; mixed with Venezuela and Colombia. (Connelly-MA) At 0224, good; Web address ending "...punto com punto br," man in Portuguese, 0232 "...Rádio Record" jingle with WMVP fading in. (Conti-ME)

**1040 XECH Toluca, Mexico,** at 1100 with lots of trios norteño music and a few románticas, ID as "La Primera" at 1108. (Barton-AZ)

**1110 YVQT Radio Carúpano, Venezuela,** at 0102 Radio Venezuela slogan used, then typical tropical music; good/dominant. (Connelly-MA) At 0138 good with llanera music, UTC-4 time check with Carúpano ID, then merengue. (Conti-ME)

**1130 KRDU Dinuba, California,** at 0600 ID into religious program, mixing with an unidentified Spanish language station, then fading out. (Barton-AZ)

**1134 Glas Hrvatske, Zadar, Croatia,** at 0100 Slavic rock, then pips, and "Hrvatski Radio" mention going into news; loud. (Connelly-MA) At 0200 signature time signal and ID in English, "This is Croatian Radio, the Voice of Croatia. You're listening to Croatia Today," into news, audio on dxclipjoint.com. (Conti-NH)

**1160 VSB3 Hamilton, Bermuda,** at 0148 caught with a BBC documentary; over/under WSKW with phaser set for full null of WOBM/WVNJ off the "back" of the cardioid array. (Connelly-MA)

**1170 Radio Sawa, Al Dhabiya, United Arab Emirates,** at 0103 a Sawa ID and Arabic talk surfacing over a Latin American pile-up with WWVA phased. (Connelly-MA)

**1230 LT2 Radio Dos, Rosario, Argentina,** at 0910 "Notidós" news program, 0914 promo, "Radio Dos es la radio mejor..." 0920, "La provincia de Santa Fe...los princi-

pales titulares en Radio Dos." 0922 ID, "Radio Dos AM doce-treinta," into "el pronóstico" by woman weathercaster, then back to "Notidós" news. Good to very good, booming at times, new, my most distant graveyarder. (Wood-HI)

**1250 XESJ Saltillo, Mexico,** at 0602 ID, "Una emisora de la red...XESJ, la emisora de Saltillo," into Mexican oldie "Cuando." Good on a remarkable sunset skip pinpoint opening to southern Coahuila. (Wood-HI)

**1431 Radio Sawa, Arta, Djibouti,** at 0013 dance-type Arabic vocal with drums; through WXKS slop. At 0038 pop Arabic music; good; loudest transatlantic signal at the time! (Connelly-MA) At 0017 good; hourly news in Arabic. (Conti-ME)

**1650 KHRO El Paso, Texas,** at 0215 oldies rock-n-roll from '50s to late '60s, mixing with KBJD Denver, Colorado. Heard later alone on the frequency. This one threw me, as they must have only recently dropped the format of Air America talk programs. (Barton-AZ)

Thanks to Roy Barstow, Rick Barton, Mark Connelly, WA1ION, Dale Park, and Richard Wood.

Whether DXing with an SDR or conventional receiver, let us know what you're hearing. November is the annual DXpedition edition of "Broadcast Technology," so look for reports from exotic locations to be featured next month. Until then, 73 and Good DX! ■

## Quattro WiFi Radio



Receive Your Favorite Stations\*  
Over 6,000 Available Worldwide

- Excellent, Clear Audio
- Danish Design, Real Walnut
- Works on Any Broadband Signal
- Real, MP3, WMA Formats
- Audio-In for MP3 Player
- No Subscription Fee
- Easy Set Up

\*Your favorite station must stream audio.  
You must have broadband internet service.

\$349<sup>95</sup> - Incl. FREE U.S. Shipping

**C. CRANE**

Free Catalog

800-522-8863 • [ccrane.com](http://ccrane.com)



## Happy Anniversary!

**B**y the time you've read through enough of this magazine to get to my column, you'll have already become aware that we're celebrating a full 25 years of *Pop'Comm*. Time really does fly when you're having fun, doesn't it? It has for me. I've now been a radio hobbyist for 41 years. I got started when I was about eight years old, listening to distant AM broadcast stations at night. From there, I went on to shortwave broadcast stations, VHF/UHF communications monitoring, CB, amateur radio, and, of course, the HF utility stations that are the subject of this column.

As the years passed, I read countless magazines dealing with one or more of my radio interests. Many of the magazines I read early in my radio "career" no longer exist. Others do, and I continue to read some of them regularly to this very day. As for the ones that vanished from the newsstand, eventually I discovered other publications to replace those that attrition and changing demographics conspired to deprive me of as some of my early favorites went belly-up and disappeared from circulation.

I couldn't begin to tell you when it was that I first discovered an issue of *Pop'Comm* or even where it was that I found it, but undoubtedly it was in the magazine section of a bookstore during the early-to-mid 1980s, and it is equally certain that I followed my customary procedure upon encountering a new radio-related periodical that looks as if it might be interesting. That is to say, I plucked a copy from the display rack, opened it to the table of contents, and scanned the titles to determine if the content was worth the price of the magazine. Then, upon deciding that the publication had sufficient promise to warrant opening my wallet (at risk of allowing all the moths to escape), I summarily purchased my first issue of the magazine.

Again, I do not recall what year or month this was. I do recall that once I got it home, I sat down and started reading, and if memory serves, I hadn't even gotten halfway through it before asking the ceiling where this magazine had been for the previous 15 years or so.

You see, most of the hobby magazines I'd previously read were ham radio magazines, although a few were on CB. The notable exceptions were *Popular Electronics* and RadioShack's relatively short-lived publication, titled, *Radio!*

The latter had been the only attempt at a general-interest radio magazine that I'd seen, and provided many people with a good reason to make a monthly pilgrimage to a nearby RadioShack to pick up each month's issue. For me this was unnecessary since, in those days, RadioShack was still interested in living up to its name and selling radios (instead of PCS phones), and the products that appeared in their free printed catalog were the only reasons I needed to visit one of their stores. Too bad that in recent years, they've chosen not to have a printed catalog any longer. No telling how much of my hard-earned cash they've missed out on because of that decision.

But, I digress. There was nothing else on the local magazine racks that pertained to shortwave listening, or broadcast DXing, or scanner listening...until that day when I discovered *Pop'Comm*, which immediately became my favorite magazine. The monthly pilgrimage to the bookstore to pick up the new



Photo A. The space shuttle Discovery landing at Edwards AFB at the conclusion of STS-92. (NASA photo)

issue of *Pop'Comm* each month became as much of an SOP (standard operating procedure) as hitting the power switches on my radios when sitting down to begin a session of enjoying my favorite hobby, which happens to also be called *Radio!*

I remember noticing that the editor, Tom Kneitel, had a ham ticket, and the number in his K2AES callsign meant a New York or New Jersey location, which caused me to check and see where the magazine's offices were located. I'd hoped to find that they were in Buffalo, but it turned out they were somewhere I'd never heard of, called Hicksville, New York. That sent me off looking for a state map, and upon finding one, I learned that Hicksville was far from Buffalo...too far from Buffalo, in fact. This, as far as I was concerned, was somewhat of a shame. Moving to Long Island was out of the question, and I remember thinking to myself, "Well, so much for my chances of ever getting a job there."

Well, some 20 years later, here I am. I haven't moved to Long Island, either, I'm still living near Buffalo...but if you're reading this, then I still have my job at *Pop'Comm* even though it took me almost all of the intervening 20 years to get it, and when I did, the magazine found me instead of my finding the magazine. This happened largely thanks to the magic of the Internet, which has made the world smaller and allows me to do my work in the comfort of my home, while sipping my favorite sports drink and listening to the various radios whose sounds fill the room (and when I go out into the kitchen, makes it sound like there's a party of 15 or 20 people going on back in my shack).

While I've only been a part of the *Pop'Comm* gang for a little over a year now, I've read the magazine regularly for almost as long as it's been around, and I lament missing the issues I did miss before discovering it on the newsstand. Still, I suppose that I've gotten more than my 15 minutes of fame, to go along with many years that I've enjoyed reading this publication. For this, I am thankful, and I still look forward every month to reading

it...especially that which I didn't write, and which is therefore new to me. So, Happy Anniversary, *Pop Comm*, and best wishes for many more.

## Upcoming Shuttle Mission

The targeted launch date for the STS-120 space shuttle mission to the International Space Station (ISS) is this month, on October 20. Now, bear in mind that due to lead time, this is being written in July, so you'll need to check for updates to NASA's launch schedule if you're planning to monitor this event. If you're in the #monitor IRC channel on IRC-GLOBAL, you can, of course do this by using the !NASA command to query the infobot, RoboEgg. Otherwise, you can point your Web browser to the launch schedule page on NASA's website. You'll find that at [www.nasa.gov/missions/highlights/schedule.html](http://www.nasa.gov/missions/highlights/schedule.html).

Assuming that previous missions haven't gone off as scheduled for whatever reason, STS-120 will be the 23rd shuttle mission to the ISS and will take the Node 2 connecting module (an Italian-built U.S. multi-port module) to the station. Veteran shuttle pilot Col. Pamela Melroy, USAF, will become the second woman to command a shuttle, while Col. George Zamka, USMC, will serve as pilot. The space shuttle *Discovery* (**Photo A**) is the orbiter scheduled for the mission, which will blast off from launch pad 39A at the Kennedy Space Center in Cape Canaveral, Florida, before returning to the KSC 11 days later for landing.

It has been a while since we've published frequencies for monitoring space shuttle launches and landings. That's because the frequencies used vary from one event to the next, and the list of potential frequencies is quite extensive. The key frequency to keep in mind is 10780.0 where CAPE RADIO (or DOD CAPE, in the case of missions involving military payloads) typically comes up 24 hours prior to launch time with the frequencies for the various nets involved. If you miss the transmission, it's pot luck on finding the active frequencies for various functions, such as range control/clearance/safety functions, solid rocket booster (SRB) recovery, contingency support, etc.

In fact, during the last shuttle launch I monitored, CAPE RADIO was heard on a frequency that isn't even listed on the most frequently cited Internet frequency reference for NASA communications. However, short of posting an exhaustive list of frequencies (which would require several pages in the magazine, and which would not necessarily supply you with active frequencies for any particular launch/landing event), in addition to 10780.0, the following have proven to be notably productive for me to search during shuttle launches and landings: 5187.0, 5810.0, 7765.0, and 9043.0.

The SRB recovery vessels *Freedom Star* and *Liberty Star* may also be snagged (propagation conditions permitting) on 2639.0 and 2716.0 (the inter-ship operations and harbor operations channels, respectively). And, of course, if you're within VHF/UHF range there are another few hundred frequencies to listen to for the various ships, aircraft, and ground stations involved in one of these events.

Once the vehicle has been launched, you can try listening for the mission audio rebroadcasts by the Goddard Amateur Radio Club in Greenbelt, Maryland. The club retransmits mission audio on the following amateur frequencies, plus or minus 5 kHz: 3860 LSB, 7185 LSB, 14295 USB, 21395 USB, and 28650



Photo B. A Delta II booster rocket with commercial satellite as its payload is scheduled to launch from Vandenberg AFB this fall. (NASA photo)

USB. There are also quite a few other ham radio clubs in several states which retransmit shuttle audio on local VHF/UHF repeaters, so take a spin through the repeater and simplex frequencies, including ATV frequencies, on the 6-meter, 2-meter, 1.25-meter, 70-centimeter, 900-MHz, and 1.2-GHz bands.

## Amateur Radio And The ISS

Speaking of ham radio, the ISS itself has operational ham radio equipment on board. You may be able to hear the station by listening on 145.80 MHz. This is the crossband FM repeater downlink and also the worldwide downlink for packet. If you're a licensed ham and want to actually work the ISS, the uplink frequencies are 437.80 for the crossband FM repeater, 145.990 for the packet uplink, 145.20 for the FM voice uplink in ITU Region 1, and 144.490 for the FM voice uplink in ITU regions 2 (which includes North and South America, Hawaii, Johnston Island, and Midway island) and 3. These frequencies all are subject to the Doppler shift so you'll need to adjust your frequency accordingly.

The callsigns used by the ISS for amateur operations are distinctive—ARISS for the packet digipeater, RSØISS and NA1SS for voice, with the packet station also using RSØISS-11 for the packet mailbox and RSØISS-3 for the packet station keyboard callsign.

To the best of my knowledge, all of the other communications aboard the ISS are VHF, UHF, S-band, Ku-band, or Ka-band systems. As of right now, there are no HF radios aboard the ISS. It does have an HF antenna located on the Service Module, which is expected to work on 10 meters and might work on 15 meters or 20 meters as well, so there's hope! In the meantime, try 145.80 and cross your fingers and trust that an





Photo C. Vehicles carrier vessel Century Highway No. 5 is prepared for its transit through the Panama Canal (see article text).

HF ham transceiver will someday be activated aboard the station so that you can log the station on HF as well!

## Something Else To Watch For

While I'm on the subject of space shots, the fall launch schedule for Vandenberg Air Force Base in California currently includes plans for the launch of a Delta II rocket (**Photo B**) to insert a commercial Earth imaging satellite into a sun-synchronous orbit. The exact date and time of this launch have yet to be announced, and the current schedule simply shows "Fall" for the launch date. If you're a space program enthusiast, keep your ear to the ground, so to speak.

## Dipping Into The Reader Mailbag

This month, regular "Utility Communications Digest" contributor Steven Jones checks in with a story that illustrates an interesting way that Steven found to combine the radio hobby with the Internet. Let's turn it over to Steven for this one:

I picked up a vehicles carrier, *Century Highway No. 5*, when it sent an AMVER position report via SITOR-A early on the morning of June 17 to NMO, Honolulu on

8389.5 kHz, sailing with a load of vehicles from Japan.

I kept my overnight monitoring setup (video camera focused on the monitor that displays the decoded output from my Universal M-8000 terminal) watching that frequency as the vessel submitted regular position reports each morning, beginning at about 550 miles NNW of Honolulu when I first logged it, and sailing SSE around the islands to several hundred miles off the California coast, then down the Pacific coast of Mexico and Central America to Balboa, the western entrance to the Panama Canal.

The canal authority has three webcams at its website that have images of the Pacific and Atlantic canal locks, as well as the Centennial Bridge midway along the passage.

Since I knew from the AMVER reports the approximate time the vessel would arrive at the Miraflores Locks for entry from the Pacific side, I set up my computer to snap the webcam images overnight, and caught a series of photos of this ship as it was in the process of being raised up from the ocean to transit the canal over to the Atlantic side. The quality isn't that great, but it was an interesting experience combining radio with the Internet.

Along with this report, Steven sent along one of the photos of *Century Highway No. 5* that were taken by the webcam at the Miraflores Locks on June 29, and if you'll direct your attention to **Photo C**, you can see for yourself that Steven found a nifty way to use the Internet to bring his listening target much closer to home.

Incidentally, this illustrates one of the positive developments in the radio hobby that has resulted from the popularity of the Internet. We always bemoan the loss of a listening target when, for example, another shortwave broadcaster succumbs to economic conditions and cuts its over-the-air schedule, replacing that programming with streaming audio over the Internet. That happens a lot these days, and it can be very discouraging for SWLs, but keep in mind that the Internet also provides us with unparalleled access to information.

Yes, those who sat in their shacks 50 years ago and listened to their vacuum tube-driven receivers while copying maritime traffic in CW could log vessels such as the ones Steven regularly snags, just as easily as we do today—but there's no way those SWLs of past years could have come up with a photograph of the vessel while they were listening to it!

## Safety First, Please!

This item comes from the "Word To The Wise" Department.

As we move into autumn in the northern latitudes, many of us will be performing the last-minute (before the onset of winter) antenna work that we put off doing during the summer because of vacations or other activities, or perhaps simply because it was just too hot outside to be climbing around on our rooftops under the full glare of the sun's rays.

While you're up there tightening and securing things, and maybe even putting up a new wire or two or an extra set of aluminum antlers, PLEASE make safety your number one priority. Watch out for overhead power lines, and be careful when lifting things. If it's still hot out where you are, be sure to stay hydrated and to rest when you need to. Don't climb towers unless you have the proper gear and know how to use it.

Much of this is common sense, but too often we get so exuberant looking forward to all the great stuff we're going to hear with that new antenna that we tend to overlook little things, like wearing a hard hat to protect your noggin when you're on the ground as part of a bunch of guys working on a tower. When the guy who has climbed the tower drops something onto your head from 60 feet up a tower, you'll be glad you remembered to wear that hard hat. What's worse is that when this kind of thing happens, someone usually yells something like, "Watch

## Glossary Of Utility Terms And Acronyms

**AFB**—Air Force Base

**ALE**—Automatic Link Establishment, a link control system that includes automatic scanning, selective calling, sounding, and channel selection, without human intervention using processor control.

**AM**—Amplitude Modulation

**ANDVT**—Advanced Narrowband Digital Voice Terminal, a secure voice mode used by the military.

**ATC**—Air Traffic Control

**CAMSLANT**—Communications Area Master Station Atlantic, the U.S. Coast Guard's primary HF radio station for the Atlantic region, located at Portsmouth, Virginia.

**CAMPAC**—Communications Area Master Station Pacific, the U.S. Coast Guard's primary HF radio station for the Pacific region, located at Pt. Reyes, California.

**COMMSTA**—Communications Station, for example: COMMSTA Kodiak, a communications station of the U.S. Coast Guard, located at Kodiak, Alaska.

**CGAS**—Coast Guard Air Station

**Cut Numbers**—The use of letters in place of numbers when sending a long string of numbers, for brevity's sake. This is often done by "numbers" stations, such as sending one long dash instead of five normal dashes to indicate a zero, or the letter N instead of the number nine, etc.

**CW**—Continuous Wave (Morse code)

**DE**—The Morse code operating prosign DE, meaning "from," as in DE NMN, meaning from station NMN

**D-Layer Absorption**—A phenomenon where the sun's rays ionize the D layer of the atmosphere causing it to absorb, rather than propagate (reflect/bounce), radio signals at certain frequencies.

**Duplex**—A means of radio communication where a station can both transmit and receive at the same time.

**EAM**—Emergency Action Message, coded instructions commonly sent by U.S. military stations. Despite the name, they usually aren't emergency traffic at all.

**EHF**—Extremely High Frequency (30-300 GHz)

**FAX**—Facsimile, a transmission mode used to send maps, charts, and other non-textual material.

**FEMA**—Federal Emergency Management Agency, a part of the Department of Homeland Security.

**FM**—Frequency Modulation

**Ham Station**—A licensed station operating in the Amateur Radio Service under the control of an operator who is licensed to operate the station.

**HF**—High Frequency (3–30 MHz)

**LINK-11**—Also called TADIL-A for TACTical DIGital Link, a secure digital data mode used by the military. Utilizes a 16-tone data modem to allow assets to share digital information, such as radar data.

**MV**—Merchant Vessel

**NAS**—Naval Air Station

**Propagation**—The means by which radio signals get from one place to another; some forms are quite simple (such as line of sight) while others are much more complex (such as EME, or earth-moon-earth).

**QRM**—Man-made interference to radio signals

**QRN**—Natural interference to radio signals, such as the static crashes often heard due to thunderstorms

**QSO**—A contact between two or more stations

**QSY**—Change frequency.

**QTH**—Location

**RTTY**—Radio TeleTYpe

**SELCAL**—SElective CALLing, a method for activating a radio or data terminal at one station without disturbing other stations that are monitoring the same frequency.

**Simplex**—A means of radio communication where a station may transmit or receive at any given time, but not do both at the same time.

**SITOR**—Simplex Teletype Over Radio, a transmission mode used to transmit text messages over radio. There are two SITOR modes: SITOR-A (also called AMTOR) uses Automatic Repeat Request (ARQ); SITOR-B uses Forward Error Correction (FEC).

**SWL**—Shortwave Listener, a person who enjoys listening to short-wave radio stations.

**UHF**—Ultra-High Frequency (300–3000 MHz)

**USAF**—United States Air Force

**USB**—Upper Sideband

**USCG**—United State Coast Guard

**USMC**—United States Marine Corps

**USN**—United States Navy

**UTC**—Coordinated Universal Time, formerly known as Greenwich Mean Time, and also commonly referred to as ZULU time and abbreviated as in 1200Z.

**UTE**—Utility Station

**Utility Station**—Stations transmitting material that is not intended for reception by the general public and is not originating from an amateur (ham) station.

**VHF**—Very High Frequency (30–300 MHz)

**VOLMET**—Station that transmits aeronautical weather information. Comes from a French term that literally means, "flying weather."

out!" and the instinctive reaction is to look up to see what the fuss is about—just in time to be hit right in the face by the falling item. Therefore, safety glasses wouldn't be a bad idea, either.

According to conventional wisdom, a word to the wise is sufficient. If you're not wise, we'll be reading about your mishap eventually. That's not a pleasant thought, so we'll assume that you are wise and move on now!

### Multiservice Brevity Codes Revisited

In our July issue, I discussed U.S. Navy carrier strike groups and made several references to multiservice brevity codes that I had heard used during a recently monitored CSG tactical net. The

brevity codes that I used in the article were explained in a glossary that accompanied the article, but because of space considerations, the glossary never appeared in the magazine. Instead, it was supposed to have been posted to our website, along with the standard glossary that has accompanied this column for the past few months.

That's what was *supposed* to have happened.

Unfortunately, what *actually* happened is that Murphy stepped in and apparently thrust a lead pipe into the spokes of our wheels while the glossaries were on their way to the website, and as a result, readers who are not familiar with the multiservice brevity codes used by the military forces of the U.S. and its allies have been left in the dark about the mean-

ing of some of what was written in the July column.

I hereby apologize for this. I can only say that I don't control what does (and doesn't) appear on the *Pop'Comm* website. I do, however, control what appears on my own website, and so I have posted the *entire* manual of multiservice brevity codes at the following URL: [www.kc2hzmz.net/codes.pdf](http://www.kc2hzmz.net/codes.pdf)

The document I posted is in portable document format (.PDF), so it can be read on most any platform, and is a complete copy of the official DoD (Department of Defense) publication which standardizes air-to-air, air-to-surface, and surface-to-air brevity code words used in multiservice operations. Don't worry—the document is approved for public release and distribution is unlimited; it says so right



on the front page. I'm not giving away classified information here.

At any rate, I hope this will make up for last month's snafu, and even go a step further by giving you the entire DoD publication, rather than just selected excerpts from it. This way, should you find a tactical net in the future during which these code words are being used, you'll be able to understand what you're hearing.

In the very near future, I will be adding to my website a page specifically intended to support this column, and while the contents will not duplicate what appears in these pages, it will support this column by presenting additional information that, for whatever reason, doesn't make it into the magazine.

For example, because of the three-month lead time on the production of the magazine, it makes no sense for me to write in July that a space shuttle launch tentatively scheduled for August 7 has been given a launch time of 7:02 p.m. EDT, because the information won't appear in the magazine until the October issue comes out, well after the launch date. Yet this is exactly what's happened with the scheduled STS-118 mission. NASA updated its launch schedule with that launch time on July 11. I'm writing this on July 12. You won't get to read it until October, when we'll be past STS-118 and STS-119, and we will already be listening for the launch of STS-120.

This illustrates precisely why I'm going to create a webpage where this information can be made available before it's too late to do anyone any good. Detailed information about upcoming events, such as NASA missions and military exercises, often does not become available until it's far too late for it to appear in the column in a timely fashion. I'm even considering the idea of starting a weblog (also known as a *blog*) so I can present information related to current monitoring events.

However, that brings with it its own set of complications, so I may elect to go with a webpage for now instead of a blog. Nothing's written in stone yet, though, so stay tuned to this column for future developments...and consider taking the advice I gave last month, and have also given several other times in the past: Install a good IRC client program on your computer, and regularly check in on the #monitor channel, where you can chat in real time with other utility enthusiasts, as well as make use of the infobot (which, incidentally, not only can poll the NASA website for launch schedule information, but also

knows the entire manual of multiservice brevity codes!).

## Reader Logs

Last, but certainly not least, this month we have another batch of great logs from you, our readers. I can't say "Thank You!" nearly enough. The logs that readers submit each month are greatly appreciated.

To join the "Utility Communications Digest" crew, simply email your loggings to me at the address that appears at the beginning of the column, observing the standard format that's been in use for 25 years now: Frequency, Station, Details/Comments, in (Mode) at (Time). (Name/QTH)

For several excellent examples, check out this month's logs from Allan Stern, Satellite Beach, FL (ALS), Mark Cleary, Charleston, SC (MC/SC), Steven Jones, Lexington, KY (SJ/KY), Glenn Valenta, Lakewood, CO (GV/CO), and myself (JK/NY).

**2899.0:** Shanwick Radio working various flights, in SELCAL and USB at 0326Z. (JK/NY)

**4130.0:** Two males in casual simplex QSO in English, discussing fishing lines, numbers and directions, New England accents, USB at 0855Z. (SJ/KY)

**4149.0:** WPE (Crowley Marine, Jacksonville, FL) wkg Tug *Seabreeze* (WBN-3019) and other tugboats providing position reports. WX, sea state, winds, barometric info, etc. in USB at 0510Z. (ALS)

**4703.0:** Link-11 data transmission at 1143Z. (MC/SC)

**5058.5:** NF1 (FBI, Norfolk, VA) clg RH1 (FBI, Richmond, VA) in ALE USB at 0751Z. (MC/SC)

**5598.0:** MWARA New York wkg REACH 5034 (KC-10A #85-0034, McGuire AFB 305AMW), passes posrep 44N, 50W, FL340; next 48N, 20W, SELCAL check for HLKQ; handed off to Gander on 2899, in USB at 0640Z. (ALS)

**5711.0:** Cape Radio, Cape Canaveral, FL, in space shuttle SBR recovery net, in USB at 1952Z. (GV/CO)

**5711.0:** NASA vessel *Freedom Star* working BRD and reporting space shuttle SRB impact, in USB at 2344Z. (MC/SC)

**5732.0:** HAMMER wkg OMAHA 3MR passing frequencies for comms with USCGC CONFIDENCE and helo, in USB at 0113Z. (MC/SC)

**5778.5:** R26611 (UH-60L) clg B1Z171 (1-171st AVN) in ALE USB at 1922Z. (MC/SC)

**5833.5:** G23691 (UH-60A) clg STPOPS (AASF, St. Paul, MN) in ALE USB at 0219Z. (MC/SC)

**6501.0:** NMN USCG Portsmouth, VA w/manually read WX in USB at 0537Z. (GV/CO)

**6688.5:** Two unid. males in simplex QSO in Spanish, frantic-sounding w/distorted audio or some sort of rudimentary speech inversion, repeating phrases including numbers. USB at 0130Z. (SJ/KY)

**6697.0:** RENT A CAR (US MIL) with EAM broadcast at 2240Z. (MC/SC)

**6727.0:** Two unid. males in simplex QSO in Spanish, somewhat frantic, mentioned vehicle and hospital, seemed to be using "COME ON" instead of "CAMBIO," USB at 0125Z. (SJ/KY)

**6910.0:** R23354 (UH-60A) clg T2Z147 (2-147 AVN) in ALE USB at 0259Z; T2Z147 (2-147 AVN) clg R26891 (UH-60L) in ALE USB at 0236Z. (MC/SC)

**6911.5:** R23008 (UH-60A) clg KMUING (Muir AAF) in ALE USB at 0035Z. (MC/SC)

**6945.0:** Two unid. males in casual simplex QSO in English, out of band fishermen w/Rhode Island accents, much profanity about money, albacore, boats, gear, charts, workers and Life in General, USB at 0730Z, here again the next night at 0710Z, very entertaining, but not for children. (SJ/KY)

**6950.0:** ENIGMA M51 w/fast and steady machine-sent groups, full letters, in CW at 0408Z; same here 2 nights later, pauses after groups w/NR55, NR56, NR57 headers and "J 15 06:20:09" for one header among them, apparent date and time, 2 hours ahead of UTC, in CW at 0525Z. (Decent signal strength; I don't think this is the Cubans, daylight time in France is 2 hours ahead of UTC). (SJ/KY)

**6985.0:** R23732 (UH-60A) clg T12 (12th Aviation Bn) in ALE USB at 1130Z. (MC/SC)

**7361.5:** T12 (12th Aviation Bn, Davison AAF) clg R26860 (UH-60A) in ALE USB at 2138Z. (MC/SC)

**7527.0:** PANTHER wkg RESCUE 33 (HH-60J) with new search tasking from District 7 at 1357Z. (MC/SC)

**7703.0:** K2Y (US MIL) with EAMS incl. 4WDZYQ22 chars then out, in USB at 0233Z; related to military exercise activity logged on 11175.0 (JK/NY)

**7895.0:** Link-11 data transmission at 2330Z. (MC/SC)

**7903.5:** AL1 (FBI, Albany, NY) clg IP1 (FBI, Indianapolis, IN) in ALE USB at 1700Z. (MC/SC)

**8004.0:** Two very weak stations in QSO w/machine-sent CW at 0234Z. (SJ/KY)

**8035.1:** XNet Yachting Association email service w/idle frequency marker of PACTOR-like "doodle" and occasional ID as "XNET" in CW at 0248Z, same station heard previously on 9115.1, 10385.1 and 13977.1 kHz. (SJ/KY)

**8066.4:** Intermittent CW with lots of numbers, possibly maritime position report, Unid., in CW at 0541Z. (GV/CO)

**8146.0:** Probable maritime simplex QSO in Spanish, with one callsign being BBE, good levels in USB at 0543Z. (GV/CO)

**8181.5:** R26881 (UH-60L) clg KALBNG (AASF, Albany, NY) in ALE USB at 0124Z. (MC/SC)



**8210.0:** Unid. station calling Olympia Radio in poor EE, no joy, in USB at 0548Z. (GV/CO)

**8264.0:** V7HD3, *DISCOVERER ENTERPRISE*, 69,500-ton Marshall Islands-registered drilling ship w/duplex voice traffic including current position 100 mi SE of Grand Isle, LA to WLO, Shipcom R., Mobile, AL, USB at 2344Z. (SJ/KY)

**8379.0:** 3FCV3, *PROTEO*, 99,392-ton Panama-registered VENFLEET crude oil tanker w/AMVER/SP for departure from "Loop By Out," 30 mi SW of Grand Isle, LA, en route to Puerto La Cruz Pilot Stn, Venezuela, arrive in 5 days, 5-digit SELCAL 42004 and abbreviated ID "PROT" in SITOR-A at 2234Z. (SJ/KY)

**8381.0:** 3DU6, *SAAMIS ADVENTURER*, 30,938-ton Panama-registered chemical/oil products tanker w/Direct Telex for NBDP test plus abbreviated ID "SMAR" in SSITOR-A at 1458Z; C6FX6, *DOLE ECUADOR*, 11,613-ton Bahamas-registered refrigerated container ship w/AMVER/SP for departure from San Diego, CA, en route to Paita, Peru, arrive in 7 days, in SITOR-A at 0250Z; C6QZ5, *DOLE COLOMBIA*, 30,106-ton Bahamas-registered container ship w/AMVER/PR for weekly run to Santa Marta, Colombia, to load fresh fruit, detailed route leg list through the Bahamas, in SITOR-A at 0425Z. (SJ/KY)

**8383.46:** Unid. vessel w/long exchange to WLO, Shipcom R., Mobile, AL on paired frequency 8423.5 kHz, ship station was slightly off-frequency from standard 8383.5 kHz and had problems breaking the link, in SITOR-A at 0510Z. (SJ/KY)

**8388.0:** 3FUG7, *CROWN RUBY*, 10,338-ton Panama-registered refrigerated container ship w/partial AMVER/PR plus INMARSAT ID, in mid-Atlantic en route to Sagunto on Spain's Mediterranean coast, in SITOR-A at 0214Z. (SJ/KY)

**8389.5:** 9VCM8, *IKARUGA*, 24,382-ton Singapore-registered container ship w/AMVER/SP for departure from Honolulu, HI, en route to Yokohama, Japan, to arrive in 8 days, in SITOR-A at 0743Z; A8AZ2, *YM AMERICA* (former *MING AMERICA*), 46,785-ton Liberia-registered container ship w/MMSI and abbreviated ID "MAME" in SITOR-A at 0810Z; S6FZ, *IKAN SELANGAT*, 37,554-ton Singapore-registered bulk carrier w/AMVER/SP for departure from New Orleans, LA, en route to Veracruz, Mexico, arrive in just over 2 days, in SITOR-A at 0930Z; WTH4389, *ALASKA PACKER*, U.S.-registered fish factory ship w/MMSI and callign to NMO, USCG, Honolulu, Hawaii in SITOR-A at 1046Z. 3FVN4, *CENTURY HIGHWAY NO. 5*, 15,380-ton Panama-registered vehicles carrier w/AMVER/PR 550 mi NNW of Honolulu, HI, en route to Balboa, Panama, for canal transit, arrive in 11 days in SITOR-A at 1056Z; same vessel heard at

1105Z next morning 620 mi NE of Honolulu, sailing on course 093 at 13.8 knots; S6EL8, *ESTEEM BRILLIANCE*, newly built 110,802-ton Singapore-registered crude oil tanker w/MMSI, vessel name, abbreviated ID "ESBR" and test msg requesting acknowledgement in SITOR-A at 1237Z. (SJ/KY)

**8391.0:** Unid. vessel w/SELCAL MKCV (4360) for TAH, Istanbul R., Turkey, good signal here, but no contact, in SITOR-A at 0444Z. (SJ/KY)

**8764.0:** NMC, USCG CAMSPAC, San Francisco, CA w/"Perfect Paul" computer-generated voice, eastern Pacific WX forecast, off w/full ID, in USB at 0502Z. (SJ/KY)

**8906.0:** NY Radio handing off unheard AC to Gander Radio, in USB at 0531Z. (GV/CO)

**8912.0:** 33C airborne with 6 SOB requests guard from PANTHER at 1448Z. (MC/SC)

**8953.3:** Two unid. male ship captains out of band on aero frequency in casual simplex QSO, in southern-accented Mandarin Chinese (Jiangsu or Zhejiang Province), laughing, discussing times, reports, how far they traveled yesterday, in USB at 0715Z. (SJ/KY)

**8983.0:** CG 2117 (HU-25, CGAS Miami) airborne from NAS Key West requests guard from CAMSLANT at 1230Z. (MC/SC)

**8992.0:** LK 04 (P-3C, VP-26) radio check with Puerto Rico HF-GCS at 1215Z. (MC/SC)

**9056.7:** Egyptian Embassy, Washington, D.C. w/extended open text traffic in ATU-80 Arabic, including summary of an article in that day's issue of the U.S. publication "The Daily Standard" about the political aspirations of Egyptian President Hosni Mubarak's son Gamal, booming signal strength, in SITOR-A from 0048-0134Z; here again at 0039-0142Z the next night but weaker, signed off both nights w/YKS YKS YKS ("bai bai bai" ["Bye Bye Bye"] when converted); heard again earlier at 0004Z the next night on a Friday, short message and off. Same station on again several days later in QSO w/station on 9067.7 kHz, the t/c alternated SITOR-A and B, including "KDS RKUKGK" ("To Havana") and "0329," requesting other side to use 9231.7 kHz for link (read the number from right to left and add 1.7 kHz). (SJ/KY)

**9063.0:** Cuban ENIGMA M8a w/machine-sent cut numbers in CW, off at 0538Z; here again next night, very strong signal, using one of Fidel's SWBC transmitters at 0522Z. (SJ/KY)

**9063.0:** M8a numbers station just starting, very good levels, in CW at 0503Z. (GV/CO)

**9067.7:** Egyptian Ministry of Foreign Affairs or embassy in brief QSO w/station on 9056.7 kHz, in SITOR-A at 2212Z. (SJ/KY)

**9130.0:** ENIGMA E10 (Israeli Mossad) w/YL slowly reading English phonetics, slight British accent, in AM at 0345Z.

**9157.0:** HEC, Berne R., Switzerland, Globe Wireless coast station w/idle channel marker, into brief traffic, in GW-PACTOR at 0224Z. (SJ/KY)

Listening is only half the fun...

## POPULAR COMMUNICATIONS

is the other half!

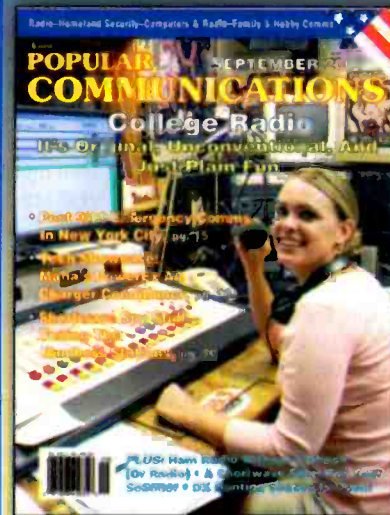

The World's most authoritative monthly magazine for Shortwave Listening and Scanner Monitoring. Read by more active listeners world-wide.

You'll find features on scanner monitoring of police, fire, utility, and aircraft communications; international shortwave listening; CB radio; amateur radio; FRS; GMRS; monitoring radio digital communications including CW, RTTY, SITOR, etc; AM/FM commercial broadcasting; weather and communications satellites; telephone equipment and accessories; radio nostalgia; alternative radio; clandestine radio; and military radio.

	USA	VE/XE	Foreign
1 Year	\$32.95	\$42.95	\$52.95
2 Years	\$58.95	\$78.95	\$98.95
3 Years	\$85.95	\$115.95	\$145.95

### Popular Communications

25 Newbridge Road, Hicksville, NY11801  
Phone: 516-681-2922; Fax 516-681-2926

Visit our web site:

[www.popular-communications.com](http://www.popular-communications.com)



**9231.7:** Egyptian Ministry of Foreign Affairs or embassy in QSO w/station on 9056.7 and 9067.7 kHz, in SITOR-A at 2215Z. (SJ/KY)

**10000.0:** WWVH, U.S. National Institute of Standards and Technology standard time and frequency station in Kauai, HI substantially overriding much closer sister station WWV in Fort Collins, CO, in signal strength, in AM at 0530Z. (SJ/KY)

**10001.0:** 4XZ, Israeli Navy, Haifa, Israel w/CW marker "VVV DE 4XZ 4XZ -," into numerical traffic, in CW at 2159Z. (SJ/KY)

**10051.0:** New York VOLMET with much QSB, in USB at 0118Z; Gander VOLMET, weaker than NY and also with QSB, in USB at 0120Z. (JK/NY)

**10780.0:** Cape Radio, Cape Canaveral, FL, preparing for space shuttle launch, in USB at 2237Z. (GV/CO)

**10780.0:** CAPE RADIO in radio checks with M/V *Liberty Star* in USB monitored at 1332Z. (MC/SC)

**10993.6:** CG 6008 (MH-60J, CGAS Clearwater) w/kg SECTOR KEY WEST and SHARK 23 with TOI report, in USB at 2030Z. (MC/SC)

**11175.0:** HF-GCS Station McClellan w/kg KING 46 (NY-ANG C-130, Gabreski 106RQW) for radio check in USB at 1222Z; HF-GCS "Station Puerto Rico" w/kg LL-76 (P-3C, NAS Jacksonville VP-30 "Pro's Nest" Sqdn) for radio check in USB at 1238Z; HF-GCS Station OFFUTT w/kg NASA 928 (WB-57F High-Altitude Research Acft) for phone patch to a number in Houston, TX, reports they are having a payload problem, but the acft is ok; they are heading to El Paso and plan to press on to Mexico; also passes telephone number in Florida and requests they be contacted; working the space shuttle STS-117 landing, in USB at 1651Z. (ALS)

**11175.0:** CORN SNOW (US MIL) with 2 long EAMs, ending with "standing by for traffic" and called by another station (weak, poss. PORE or CORE 15 or 75) but no contact, in USB at 0148Z; CORN SNOW reading EAM traffic and possibly simulcasting on 8992.0 as well, in USB at 0236Z (these first two were Nightwatch Net exercise activity, related to activity logged on 7703.0); and OFFUTT HF-GCS with multiple EAM transmissions, simulcast on at least 8992.0 and 4724.0, in USB at 0115Z (not related to the exercise activity). (JK/NY)

**11133.0:** Broadcast feeder of La Red, Buenos Aires, Argentina, OM and YL w/talk and advertising, in LSB at 0225Z. (SJ/KY)

**11220.0:** FURY 12 (B-2A, 509 BW) w/kg Offutt HF-GCS with request for secure voice checks, in USB at 1442Z. (MC/SC)

**11232.0:** Canadian Coast Guard 1501 working Trenton Military, Ontario, aircraft position 49.51N, 52.12W, 150 mi N of St. John's, Newfoundland, in USB monitored at 1730Z. (SJ/KY)

**11232.0:** CANFORCE "Trenton Military" working unknown aircraft for p/p to Lajes Metro (no response—they called the wrong DSN number); in USB at 1952Z. (ALS)

**11232.0:** GOLIATH ALPHA (E-3 AWACS) p/p via TRENTON MILITARY to BEST DEAL with line code report, followed by p/p to ALI BABA for freq for radio check, in USB at 1243Z; AKELA 69 (MC-130, 58 SOW) p/p via TRENTON MILITARY to COYOTE OPS at Kirtland AFB, in USB at 1831Z. (MC/SC)

**12206.4:** Two unid vessels in casual simplex QSO, males in Vietnamese, USB at 0300Z. (SJ/KY)

**12274.0:** Two unid vessels in casual simplex QSO, males in Cantonese, USB at 1255Z. (SJ/KY)

**12326.0:** Two males in simplex QSO in English, Australian accents, QSY to 12359.0 kHz, in USB at 2201Z. (SJ/KY)

**12344.9:** Two unid vessels in casual simplex QSO, males in Tagalog, USB monitored at 0306Z. (SJ/KY)

**12359.0:** Two males in simplex QSO in English, Australian accents, discussing engine and alternator repairs, probably yachts, in USB at 2202Z. (SJ/KY)

**12479.0:** P3GK9, *UBC SINGAPORE*, 31,759-ton Cyprus-registered bulk carrier w/MMSI and abbreviated ID "SING" in SITOR-A at 1503Z; 9VHG, *EAGLE BALTIMORE*, 99,405-ton Singapore-registered AET crude oil tanker w/AMVER/PR, MMSI and abbreviated ID "EBAL" 80 mi SE of Nantucket and sailing SW, in SITOR-A at 1615Z; same vessel heard here 6 days later at 1935Z w/AMVER/SP for departure from Ambrose Pilot St. near NYC to return to Cape Breton, Nova Scotia, Canada, arrive in 3 days; S6NK3, *EAGLE TOLEDO*, 107,092-ton Singapore-registered AET crude oil tanker w/AMVER/PR, MMSI and abbreviated "ETOL" ID, 80 mi N of George Town, Cayman Islands, sailing ESE, in SITOR-A at 1617Z; 3FMP3, *TESEO*, 99,477-ton Panama registered VENTFLEET crude oil tanker w/partial AMVER/PR and abbreviated "TESE" ID, en-route to Lake Charles Pilot Stn, LA, arrive in 26 hours, in SITOR-A at 1618Z; C6FR7, *TROPICAL MORN*, 11,979-ton Bahamas-registered refrigerated cargo ship w/AMVER/DR, MMSI and abbreviated ID "MORN" for course change to Great Circle route to Lisbon, Portugal, arrive in 8 days, in SITOR-A at 1648Z; H9RP, *GEORGIA S*, 30,187-ton Panama-registered self-discharging bulk carrier w/MMSI and abbreviated ID "GEOR" in SITOR-A at 1724Z. (SJ/KY)

**12482.0:** 9VKH2, *EAGLE PHOENIX*, 106,127-ton Singapore-registered AET crude oil tanker w/garbled AMVER/PR, MMSI and abbreviated ID "EPHO" in SITOR-A at 1513Z; 3FGZ3, *PARNASO*, 99,471-ton Panama-registered VENTFLEET crude oil tanker w/AMVER/PR en-route to Jose Pilot

St., Venezuela, arrive in 3 days, in SITOR-A at 1615Z; *PARNASO* heard here again 3 days later with AMVER/FR at 1635Z for arrival at Jose PS and again 17 days later, 200 mi NW of Caracas, headed back to Puerto Cruz, Venezuela, arrive in 3 days; V7KH6, *CCNI ANGOL* 46,376-ton Marshall Islands-registered general cargo ship w/AMVER/PR 60 mi N of San Juan, PR en-route to Marin on Spain's NW Atlantic coast, in SITOR-A at 1618Z, S6OE, *EAGLE COLUMBUS* 107,166-ton Singapore-registered AET crude oil tanker w/partial AMVER/PR en-route to Philadelphia, PA, in SITOR-A at 1620Z; V7AL2, *LAKE ERIE*, 35,630-ton Marshall Islands-registered bulk carrier w/AMVER/PR 200 mi N of Panama, en-route for Canal transit, in SITOR-A at 2129Z. (SJ/KY)

**12486.5:** 3FCB8, *EVER DELIGHT*, 55,135-ton Panama-registered container ship in the Pacific 400 mi W of San Salvador, El Salvador, w/BBXX format coded WX OBS, MMSI and abbreviated ID "DLIT" in SITOR-A at 0008Z. (SJ/KY)

**12490.0:** 3FEB7, *KEOYANG NOBLE*, 51,662-ton Panama-registered wood chips carrier w/weak partial AMVER/PR, MMSI and abbreviated ID "KENO" in SITOR-A at 1540Z; MLXK3, *ELISE SCHULTE*, 106,122-ton Isle of Man-registered oil products tanker w/MMSI and abbreviated ID "MLXK" in SITOR-A at 1918Z; LADF6, *CLIPPER POSH*, 46,316-ton Norway-registered LPG tanker w/AMVER/PR 200 mi E of Belize, en-route to Kaarstoe, Norway, arrive in 12 days, noted "VESSEL PROCEEDING AT ECONOMIC SPEED AWAITING FIRM ORDERS," PR gave 16.0 knots on bearing 077, in SITOR-A at 2105Z; 3FUG7, *CROWN RUBY*, 10,338-ton Panama-registered refrigerated container ship w/partial AMVER/PR sailing on course 060 degrees at 19 knots, destination San Juan, Puerto Rico, but lost contact w/NMN, CAMSLANT, USCG Portsmouth, VA on paired freq 12592.5 kHz before full report sent, in SITOR-A at 0345Z. (SJ/KY)

**13152.0:** WLO, Mobile, Alabama, w/msg to write the USCG about dropping WX FAX, then into weather broadcast, in USB at 0502Z; WLO w/WX, also holding traffic for vessels *Whitestar*, *Moonshadow*, and *Triumph*, in USB at 0305Z. (GV/CO)

**13927.0:** TEAL 14 (WC-130J Hurricane Hunter, 53 WRS/403 AW) p/p request via AFA1WP (USAF MARS), in USB at 1957Z; NIGHTSTAR (E-8 JSTARS) p/p via AFA1WP to 18th Airborne Corps to see if they are coming up in Link, in USB monitored at 1313Z. (MC/SC)

**13927.0:** USAF MARS Operator "AFA3HS" (Kansas City) w/kg REACH 271T for phone patch to Cleveland Air Svc: IDs as inbound C-130 half-hour out of Cleveland; rqsts their freq; is passed 131.425; also orders two large pepperoni pizzas in USB at 1528Z;

USAF MARS AFAIEN (Shelbyville, IN) wkg REACH 6212 (MC-130P 66-0212, CA-ANG, Moffett Field) for phone patch to get WX forecast, in USB at 1630Z; USAFMARS wkg HOIST 99 (McGuire AFB KC-10A) for phone patch to Edwards AFB. CA: rqsts PPR for arrival today; is told to call later when Base Ops open, in USB at 1130Z. (ALS)

**13927.0:** USAF MARS AFAIEN (Shelbyville, IN) wkg CHALICE FOXTROT (E-3 AWACS, Tinker AFB 552ACW) for radio check, but barely hears him; CHALICE FOXTROT is hailing Trenton Military on this freq rather than the correct 11232.0, is corrected by AFA2QZ, says he will check his freq; in USB at 1909Z; AFAIEN wkg REACH 383 for M&W phone patch; long chat between pilot and AFAIEN re MARS new freqs dropping .1 and .6 endings; also passes MARS website URL of www.MARS.phonpatch.net, in USB at 1450Z. (ALS)

**13927.0:** USAF MARS AFA6PF (Los Angeles) wkg AWACS Sentry 61 for phone patch to Tinker AFB, Raymond 24, passes several lines of a formatted report in USB at 1845Z; USAF MARS wkg REACH 250 for phone patch to McGuire AFB re inbound message in USB at 0110Z; USAF MARS AFA1WP (Boston, MA) wkg SENTRY 23 (AWACS, Tinker AFB) for M&W phone patch in USB at 1412Z; USAF MARS Operator "AFA2MH" (Waleska, GA) wkg KEYS 81 (KC-135R, MS-ANG, Key Field, Meridian MS) over Okla. for phone patch, in USB at 1424Z; AFA2MH wkg REACH 596 over North Atlantic, for phone patch in USB at 1330Z; USAF MARS Operator AFA2XD (Satellite Beach, FL) wkg EVAC 39 for two phone patches, second patch was to Robert Gray AAF Base Ops, Ft Hood; announced ETA 2045ZZ; rqsts ambulance meet acct; rqsts 25,000 pounds fuel, in USB at 1424Z. (ALS)

**13927.0:** USAF MARS AFA1QW (Greenwood, IN) wkg SAM 1536 (89AW, Andrews AFB), comms not strong enough to permit phone patch (though strong and clear at my QTH), in USB at 1348Z; AFA1QW wkg AWACS SENTRY 40 for M&W phone patch in USB at 1638Z; USAF MARS AFA6PF (Los Angeles) wkg REACH 3037 for radio check in USB at 1704Z; AFA1QW wkg JEST 17 (KC-135R) overhead Altus AFB, OK for phone patch to Barksdale CP; rqsts status of B-52H TUFF 12, is told TUFF 17 is preparing to take off, in USB at 1603Z. (ALS)

**13966.0:** Two OM in casual simplex QSO in Portuguese, whistling, sound of horn blowing, in USB at 2327Z. (SJ/KY)

**13998.0:** KZN508, Sailmail R., Rock Hill, SC w/PACTOR-2 traffic and CW ID at 2300Z. (SJ/KY)

**15016.0:** AFA, USAF, Andrews AFB, MD w/alphanumeric EAM, USB at 1920Z. (SJ/KY)

**16181.7:** Probable Egyptian Ministry of Foreign Affairs or an embassy w/SITOR-A traffic at 1450Z, very weak. (SJ/KY)

**16331.8:** "P" beacon, Baltic Fleet, Kaliningrad, Russia, CW at 1750Z. (SJ/KY)

**16540.0:** Several unid. vessels in simplex QSO in Tagalog, one mentioned Gulf of Mexico, many repeatedly calling "Parekoy" plus someone singing in the background, USB from 1858-1915Z. (SJ/KY)

**16545.0:** Three unid. vessels in casual simplex QSO in Tagalog, laughing, USB at 2022Z. (SJ/KY)

**16550.0:** Two unid. vessels in simplex QSO in Tagalog, USB at 2055Z. Much regular activity related to Philippines vessels around this frequency. (SJ/KY)

**16555.0:** Unid. vessel w/news in English, mostly about the Philippines, piracy off Somalia coast, Philippine hostages in Nigeria, in SITOR-B at 1922Z, s/off w/MARAMING SALAMAT PAREKOY ("Thank you very much, friend") at 1940Z. (SJ/KY)

**16557.0:** Two vessels in simplex QSO in Tagalog, one slowly dictating a message in English to the other, including cargo info and numbers, in USB at 0040Z. (SJ/KY)

**16560.0:** Two unid. vessels in simplex QSO in Tagalog, in USB at 2058Z. (SJ/KY)

**16621.0:** Unid. station w/rapid handsent traffic w/keyer, full numbers, very weak station responding, in CW at 0224Z. (SJ/KY)

**16689.0:** Unid. vessel attempting to contact USCG, Apra Harbor, Guam w/SELCAL XVSC (1096) in SITOR-A at 2010Z. (SJ/KY)

**16696.5:** ZCDJ3, *ROME EXPRESS* (former *CP CHALLENGER*), 40,744-ton Bermuda-registered container ship w/weak partial AMVER report in SITOR-A at 1523Z; 9MGN2, *MARITIME KELLY ANNE*, 44,508-ton Malaysia-registered chemical/oil products tanker w/AMVER/PR, MMSI and abbreviated "MTKA" ID, 160 miles S of Kingston, Jamaica, en-route to Galveston Bay, TX, arrive in 4 days, in SITOR-A at 1730Z, same vessel heard 2 days later at 1750Z on 12490.0 kHz,

just passed through Yucatan Strait; 3EBR, *GEMINI GLORY*, 305,795-ton Panama-registered crude oil tanker w/several attempts to send a belated AMVER/SP 300 mi E of Trinidad & Tobago, en-route to U.S. Gulf coast near Houston, TX, arrive in 8 days, also MMSI and abbreviated "GEMQ" ID, in SITOR-A at 2110Z. (SJ/KY)

**16747.0:** Unid. vessel w/regular rebroadcast of news in English, mostly about Philippines and the maritime industry, some sports, in SITOR-B at 2028Z, better signal than usual, off abruptly w/out ID heard at 2043Z. (SJ/KY)

**16780.5:** Unid. vessel w/SELCAL QVXV (2010) for XSG, Shanghai R. China, good signal here, but no contact, in SITOR-A heard at 1424Z. (SJ/KY)

**16814.5:** CBV, Chilean Navy, Valparaiso Playa Ancha R., Chile w/traffic in English and Spanish re radiotelephone services and charges, in SITOR-B at 2202Z, parallel to much weaker 12583.5 kHz. (SJ/KY)

**16939.0:** 9HD, Valetta R., Malta, Globe Wireless coast station w/idle channel marker, in mode GW-PACTOR monitored at 0102Z. (SJ/KY)

**17260.0:** WLO, Shipcom R., Mobile, AL w/maritime WX forecast, female computer-generated voice in USB at 1710Z; parallel to slightly weaker 17362.0 kHz. (SJ/KY)

**18390.0:** WQAB864, Sailmail, San Diego, CA w/PACTOR-2 traffic and CW ID at 1955Z. (SJ/KY)

**19685.5:** WLO, Shipcom R., Mobile, AL w/CW+SITOR-A marker, good signal at 0520Z. (SJ/KY)

**22291.5:** Unid. vessel attempting to contact WLO, Shipcom R., Mobile, AL w/SELCAL XVSV (1090) and its own 5-digit SELCAL 09783 plus abbreviated ID "BRZX" in SITOR-A at 0116Z, decent signal—sunspots are coming! (SJ/KY) ■

### When does my subscription expire?

Your subscription expiration information is located in the top line of the address label on each issue. Here's a rundown of what each of the numbers stand for:

Year (27)=2007 Month (01)=January

Current Issue

01 002345678 2801 2709  
RICH MOSESON W2VU  
25 NEWBRIDGE ROAD  
HICKSVILLE, NY 11801-2345  
//////// (Bar Code)////////

First two digits are the magazine's ID#: (CQ=01, PC=02, VHF=03).

Next is your 9-digit account number.

Followed by your 4-digit expiration date. First two digits denote the year 28=2008, second two the month 01=January.

The last group of numbers denote the issue the label is affixed to — 2709 in our example above would be September 2007 (27=2007; 09=Sept).

If the code for your expiration date begins with a 3, such as 3008, your subscription extends past 2009. A code of 3001 denotes January 2010 (31=2011, 32=2012, etc.)

CQ Communications, Inc.

516-681-2922; fax 516-681-2926;

or e-mail <circulation@cq-amateur-radio.com>

## Licensed Before 1982?

QCWA invites you to join with those distinguished amateurs licensed 25 or more years ago. Request an application form:

QCWA, Inc., Dept. P  
PO Box 3247  
Framingham, MA 01705-3247  
www.qcwa.org





# The Carrier Current Ghost



**I**t was an odd little smudge on my AM dial that annoyed the heck out of me," described a *Pop Comm* reader's letter. "Just a dead spot coated with a hint of background hum," he remembered, "like when a kid erases somebody's eyes and mouth from a newspaper picture, making it nearly impossible to tell who it is."

Unlike other correspondence received at the "Shannon Headquarters," this note did not request that I solve a broadcast history mystery. The sender, who promised to divulge a really neat radio story in exchange for my simply giving him a phone call and about 10 minutes of my time, had already accomplished that. An Ocean State DXer, he possessed the contact info of someone

he hoped could provide context to the blank carrier glassing over 580 kHz on the 1960s Hallicrafters Model S-119 Sky Buddy II general coverage receiver built from a \$39.95 kit. With most of the investigative work done, the guy simply needed help with one elusive witness who his other contacts predicted could add color to the otherwise black and white account of the ghost at 580.

## Running Wire For Iran

During the final months of the Carter administration, this month's column catalyst and his wife bought a 1000-square-foot home in a Sputnik-era development adjacent to Barrington College in Barrington, Rhode Island. A patch of scrubby, neglected woods, maybe 40 feet wide, separated neighborhood houses from the campus. Only in winter, when the leaves were gone, could one see any evidence of the school. From his vantage point, he saw the backside of a single-story, U-shaped brick dormitory, dubbed Woodward Hall. The fellow first really noticed the structure during the late fall of 1980 while in the backyard at the edge of the woods where he was trying to find a suitable tree from which to string the far end of his Hallicrafters' longwire antenna.

"I was hoping the aerial would pull in a Middle Eastern short-wave signal or two containing insider news about the Iranian hostage situation," he recalled, "so I dug that long dormant Sky Buddy II out of a packing carton and put it back to work. Though the AF Gain control was a bit scratchy from having sat idle since my high school days, the old gal's tubes lit right up. Truth be told, I never got very proficient with Greenwich Mean Time, foreign languages, and SW frequency schedules. Instead, I obtained most of my 'hostage crisis' information via ABC Television's then fledgling program, *Nightline* with Ted Koppel.

"In the process of fooling around with the Hallicrafters, however, I did rediscover the fun of domestic broadcast band DXing—audio that faithfully appeared at 10-kHz intervals, offered (at least in those days) local flavor, and was typically delivered in English! Situated within the coverage area of AMs

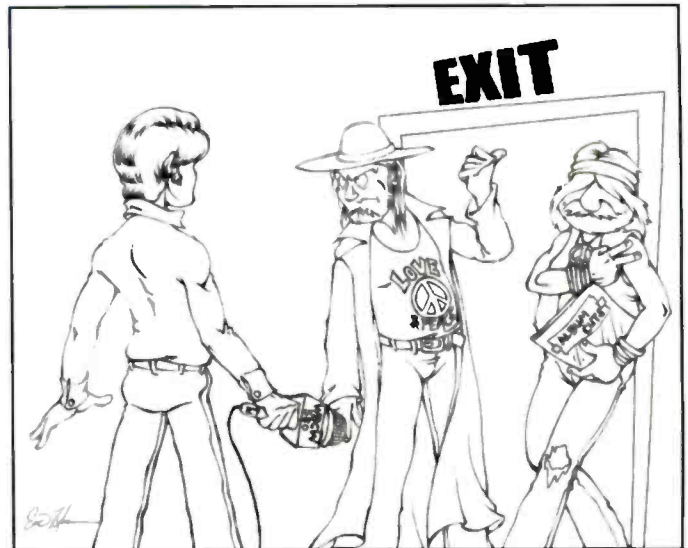

*Not your garden-variety "flower power" people, the hippies who confiscated WBCW sure knew how to turn a full blooming college radio station into a weedy sand lot. At least that's the perspective of one of our story's characters who felt he got run off this radio farm.*

from Boston, Cape Cod, Southern Connecticut, Eastern Long Island, and 99 percent of Rhode Island's broadcast footprints, the reception dial card kept handy next to the Hallicrafters was chock full.

His circa 1981 jottings noted reception from 540 WLIX Islip, New York, albeit squashed under 550 WGNG Pawtucket, Rhode Island, all the way up to 1600 WBOS Brookline, Massachusetts, with a bit of WLNG Sag Harbor in the background. Of course, WHJJ 920 and WPRO 630, a pair of Providence-licensed 5-kilowatters with towers literally down the road from his "shack," sapped the selectivity from either side of their respective operating frequencies, but not even WPRO's influence could explain away the eerie blank at 580 kHz.

## Duh! It's Coming From The Dorm!

One early spring Saturday morning, he explained, the weather was absolutely perfect... or at least it was nice enough to spark his aerobic wife, Susan, into getting him outside to take up jogging with her. "She'd bought me a 'stylish exercise outfit' for Christmas and had recently shamed me into abandoning a tattered pair of favorite old black high top sneakers for some overpriced scientifically designed running shoes that made my feet hurt," he continued. Happily, though, part of the re-outfitting included a generic AM/FM Walkman-type radio that soon made the forced march worthwhile.

They'd nearly trekked his wife's requisite suburban mile when, thankfully, she spotted a friend who was also on a major health kick. After convincing her that he'd be willing to hobble home by myself, Sue joined her compatriot. The two trim ladies waved and sprinted away. Alone, he remembered the radio



*This contemporary shot of what is now a Zion Bible College residence hall shows the former Barrington College Woodward Hall clock tower front entrance way. In the late 1960s, WBCW engineers installed carrier current AM transmitters at each end of the 80-room, U-shaped building. The one in the left-hand wing and hidden away behind a basement partition just kept going like the Energizer Bunny. Those trees behind the building are at the edge of the small woods leading to the neighboring housing development in which our curious Pop'Comm reader lives.*

strategically hooked to his waistband. He carefully pulled the headphones from a jacket pocket, plugged them into the miniature jack, and experimented with the thumbwheels. Eureka! The darn thing worked! And no annoying dead spot between WPRO and WGNG, either. In fact, identifiable shreds of WTAG 580 Worcester, Massachusetts, entered his ears.

"So captivated by the tiny receiver was I that, every few hundred yards, I dialed in another station," he recalled. "It was just me, the great outdoors, and my new-found mini link to music, news, and weather." The experience might have ended there had he not become so euphoric that he decided to actually jog the final few hundred yards towards home. In the process, the tuning wheel got rubbed off frequency.

While trying to remedy that, he was startled by the presence of that silent slice just below the tuner's little "6" indicator. "It's come back to haunt me!" he remembered thinking. Weak at first, the strange signal definitely strengthened as he approached his driveway. Determined to find its source, he set off past his house and down the street. Within the distance of three or four homes, 580 kHz belonged to WTAG's fringe again. The frequency was completely reclaimed by dead air, however, a stone's throw from his

address. That's when he went into serious radio direction finding mode.

"Rick is a neighbor who, circa 1957, was one of the first to build a house in our development," he recounted. "Retired and nose-y in a contagiously friendly sort of way, he seems to know the ins and outs of everything that goes on locally. That's why I didn't mind when I noticed him walking across my yard in an attempt to learn what I was doing holding up a radio and frantically pointing here and there like some haywire compass."

"What ya got there, buddy?" Rick wondered.

"Just hoping to find the source of some weird interference," he explained, and then had Rick don the headphones to hear for himself. Rick said it sounded like "something that was nothing," but concurred that the signal got louder as they ventured into the muddy woods towards Woodward Hall.

About an hour into these investigations, Sue returned from her jaunt and suggested that Rick and her husband share some healthy yogurt with her on the back deck. "Fortunately, my neighbor concocted a plausible excuse about allergic reactions to dairy products," said our sleuth. "And, then, under the auspices of needing me to help him with something important, we both escaped to his kitchen where a pot of coffee and a bulging box of chocolate coconut donuts awaited. This feast provided a tasty backdrop for our eventual consensus that the empty carrier was emanating from the dormitory. But why?"

Recalling a college open house that Barrington held in the early 1970s, Rick recounted touring the school's nicely appointed student union building where he passed by a student-run radio station. "Don't remember much about it," he admitted, "other than noticing two huge record players and chatting with some young gentleman in a suit and tie who told me that they only broadcast on campus with low-power AM, but hoped to go FM soon."

### Station Investigation

True to his outgoing nature, Rick proposed that they grab another donut, cut through the woods, head over to the Student Union, and see if the station was still there. Their query met with little informed response, though a 30-something woman in the office remembered that there used to be a radio studio on the

second floor, but doubted it had been active in the past year.

They ascended a wide, winding staircase to a sort of mezzanine where several college kids were watching TV while a couple of others, sprawled out in vinyl cushioned chairs, were reviewing their class notes. Through an entryway and onto a balcony system that ran down both longitudinal sides of the contemporary Union building, they stopped in front of what appeared to be a classroom door. Rick pointed to four stick-on letters (the kind that hardware stores sell to people who want their name on a mailbox) affixed directly above a small window on that door. *W-B-C-W*, they announced.

A quick look revealed little in the way of broadcast culture other than a nearly empty record shelf against the left hand wall and a homebrew "L" shaped table with sundry wires poking through hastily drilled holes in its surface. It was obvious that WBCW had not been operational recently.

"There are them big record players I told you about," Rick noted, gesturing at a pair of 16-inch RCA turntables, each with ratty black felt covering their platters. Long, silver and black Shure M-232 tone arms were mounted aside each RCA unit. Somebody had removed their stylus cartridge heads, though, causing the weighted arms to salute upwards about 30 degrees off of the tabletop.

"There's your ghost," said Rick, smiling as he nodded towards a faded, drooping, homemade poster. Amid a curled-up collage of rock star pictures, somebody had emblazoned across it in fat purple magic marker, *NO COMMERCIAL SOUNDING HITS AND DJs, JUST ALBUM CUTS. 580 AM—BARRINGTON'S ONLY ALTERNATIVE.*

On their walk back to the neighborhood, the two concluded that there was no other choice but to believe that the dead spot with the faint hum at 580 kHz was WBCW twisting in the wind. Anxious to settle the assumption, Rick, a retired ad salesman with the *Providence Journal* newspaper, consulted an old pal who had engineered for the paper's co-owned radio properties, WEAN 790 and WPJB-FM 105.1.

The erstwhile broadcast tech speculated that WBCW had been a carrier current station, an unlicensed, low-wattage AM arrangement that uses a building's electrical AC wiring to transmit its signal. He said that carrier current signals couldn't pass through the wiring in trans-



formers, typically making it necessary for the station to employ at least one transmitter in each building where reception is desired. Though carrier current transmitters don't need an external antenna because the building wiring grid radiates the RF output, more than a few of these boxes have been equipped with traditional radiators (long wire or vertical whips) by engineers wanting to add some zing.

The FCC's Part 15 rules dictate that carrier current output be confined to within 100 feet of its host building's wiring system. A little "innocent" souping up, however, can move these signals well past dormitory walls. Such was likely the case with that lingering transmitter hidden away in the Woodward Hall basement.

Reportedly, the transmission remained steadily active through approximately 1985, when Barrington merged with a Boston-area college and sold its Rhode Island campus to Zion Bible College. During the transition, the signal disappeared—perhaps because the electricity was shut off—only to resurface for about two years after Zion's takeover. Then, either somebody from the Bible College found and disconnected the neglected unit, or the poor thing finally died on its own.

## Putting A Voice With The Call Letters

Our *Pop'Comm* reader seemed shocked when I phoned him this past March with a rough outline for a WBCW-related column. For decades he'd been fascinated by the obscure carrier current station, but was surprised anyone else might share his interest in such a gnat on the broadcast history screen. He amassed the bulk of his findings from several old Barrington College yearbooks that turned up at a local garage sale. This data was subsequently augmented by queries to the alumni offices at Barrington and then Gordon College of Wenham, Massachusetts.

What amazed me most about this quest was that his WBCW research had been periodically updated to include successive addresses and phone numbers for one Robert C. Huber, the Barrington graduate who apparently had started the station, but that our sleuth made no attempt to contact this fellow. That's what he hoped I would do.

The following evening, I tapped out an Arizona number and found myself chatting with the affable Mr. Huber. He was pleasantly taken aback that his college radio exploits—nearly four decades old—were to be chronicled in a nationally distributed publication, and then he offered the following account of how WBCW materialized. In his words,

Just a few days after my high school graduation in Delaware, I moved to Rhode Island where I lived for the summer with the family of the Director of Admissions of Barrington College, a small private institution with a picturesque campus not far from the ocean. This school had once been the licensee of a pioneer non-commercial FM radio station in Providence. WPTL-FM debuted in 1947 at 91.5 megacycles with 2500 watts.

For reasons unclear to the few who remember this early religious frequency modulation facility, the license was (by the mid-1950s) returned to the FCC for cancellation. Due to this radio heritage and a Sunday morning program, "The Mountaintop Hour," which was still recorded by an emeritus Barrington president for weekly air on a commercial Providence AM, many of the administrators and staff had hoped the college would again own a broadcast outlet to serve as a voice of the college.

Through my college application essay, the admissions person learned of my founding role with 10-watt high school station WMPH-FM in Wilmington, Delaware. He thought I might help start a similar facility



*Noted on eBay this past summer was a vintage 100-mW AM carrier transmitter that has the homebrew look of those RF generating units once powering WBCW. Schools that couldn't afford LPB brand transmitters—for decades, the box of choice among well-heeled, low-power university broadcasters—typically built tube-type transmitters in a bare chassis. Meddlesome student station volunteers with access to such gear touched the sometimes-dubiously grounded box at their own risk! Unfurled and hooked to a flea power AM's antenna output terminal, the neatly wound wire in the foreground would be a more than sufficient radiator to break FCC rules and send a signal flying past the Commission's Part 15 boundaries.*

at Barrington, so he aggressively recruited me to attend the college. As a creative way to mitigate tuition costs, he even secured me a summer factory job, loaned me his small motorcycle, and invited me to stay with his family until classes began in September. As an ulterior motive, he figured the two months prior to school would allow me to get to know the college community, meet the incoming student council president, and extol broadcasting's virtues to the college's administrators.

The plan began yielding fruit. Not far into my freshman year, a group of like-minded college radio proponents and I acquired administrative approvals, were granted funding (albeit less than \$1,000), and secured two meeting rooms in the relatively new Student Union, to be dedicated as our studio and office.

It was decided that an unlicensed carrier current AM operation would be surer and quicker than applying for even a Class "D" 10-watt educational FM construction permit, and then waiting several years for the request's possible FCC approval. A preliminary 1969 frequency search indicated one vacant FM channel might fit at Barrington, but seemed to hinge on whether or not a dormant 10-watter, still licensed to a nearby school, could be coaxed to officially fold.

As the FCC doesn't bother with law-abiding carrier current stations, we were free to pick a fictitious callsign, even if it was technically assigned to a licensed AM, FM, or TV property. The letters, W-B-C-W, some joked stood for Elmer Fudd's pronunciation of Barrington College Wadio, but we registered our formative group's consensus and felt we were ready to go. During my sophomore year, we hit the "air" live 19 hours a day and simulcast a local commercial station over nights.

As de facto general manager, I soon had a staff of about 50, which was just under 10 percent of the little picturesque Christian liberal arts college's entire student body! Our chief engineer, one of several recently discharged Vietnam-era military people on the WBCW staff, literally built the console from scratch using RadioShack and scavenged parts (mostly from a couple of old TV sets). Suffice it to say many of us got "zapped" whenever sticking our hands in the works to try getting audio to flow from the monitor speaker again.

The balcony hallway outside of the studio looked down on a spacious Student Union common area or giant living room with a huge

fireplace and massive speakers suspended from the towering ceiling. With the studio door open and by piping the section throughout the Union's PA system, whoever was "on-the-air" could hear—without headphones—what he or she was saying and get instant response from students lounging down below. They'd laugh at jokes and yell up song requests. When the PA was on, it was doubly fun to be the DJ at the controls.

To reach the two—one female, one male—dormitories, WBCW used several carrier current transmitters. I believe we had three to five of these 5-watt units. Woodward Hall, the men's dorm, was especially challenging to cover, as it was a sprawling and wide U-shaped structure running some 300 feet in each part of the "U." One length of Woodward's basement housed a large number of washers and dryers where some kids, hanging around for their laundry to be done, were prone to fool around with anything interesting in sight. I think that our engineer had to make that section's transmitter more clandestine than the others. When all of the boxes were working, it was routinely possible to pick-up the station on a car radio about a quarter mile away from campus.

It was my experience that, during the station's first few years, it was highly respected among the students. This was especially true with fans of WBCW's excellent sports broadcasters, members of an announcing crew who were much better than many "pros" I've heard over the years.

It was up to me to "get us a telephone line" when we started doing away games. Honestly, this usually included tapping into telephones in phone booths (due to their higher quality lines) and posting convincing "out of order" signs on the phones. Later, we broadcast several tournaments to a network of three schools, which actually paid for the "broadcast loops" and made our sports guys feel legal.

By the way, the Barrington basketball team became the #1 small college team within its East Coast league. Broadcasting that championship game, which was won in the final second, was definitely one of my radio highlights. Another WBCW milestone came during the days and weeks following the tragedy of May 1970's terrible student killings at Kent State University and the intense reaction by students across the nation. Though professional news people might have balked if they discovered WBCW was a tiny public address system and carrier current operation, we assertively contacted ABC News and became a regular ABC story provider "stringer" as well as one of their campus barometers, which we all took very, very seriously.

From the start, I had four former professional broadcasters working on my staff. They were non-traditional students, typically a bit older than the standard 18- to 22-year-old college population, and served as role models for others on the WBCW team. Several other students, including myself at an AM in Salem, New Jersey, joined the commercial broadcasting ranks after having tasted radio at WBCW.

## You Might Want To Try This Guy

When I thanked Bob Huber for his kindness in providing me so much detail, even though my call to him had been out of the blue, he added to the favor by giving me the email address of a WBCW alumnus who went on to broadcast in a major radio market, was named a *Billboard* magazine Air-Personality-of-the-Year, and owned a couple of radio stations. Mr. Huber cautioned me, though, that this fellow probably would not care to be identified, but suggested I see if he'd provide some additional color to the WBCW saga.

After extending an invitation to this person, however, I heard nothing for nearly three months. And then, with my first draft of this column ready for a final edit and submission the *Pop'Comm* literary skipper, Edith Lennon, a familiar subject line appeared on my melodyfm@yahoo.com account. It simply read, "WBCW:"

The message's first sentence sought my pledge that the writer's name NEVER be mentioned in the article. The second

line asked me to reply with a statement to that effect. I immediately did so and, within what was probably 30 seconds, received the narrative, which I've decided to print without any modification. The story certainly delighted our aforementioned *Pop'Comm* WBCW investigator and I thought you'd get a smile, too, from picturing the rise and nearly perpetual fall of this one little New England carrier current station. In the words of our anonymous source,

My parents wanted me to go to college mainly so that I wouldn't end up in Southeast Asia. They didn't care where I went just as long as it kept me from getting drafted for Vietnam. But, they would not allow me to enroll in the quickie broadcasting course often advertised on my local Hartford, Connecticut, Top-40 outlet.

Consequently, in November 1970, I visited and later applied to a grand total of one post secondary school—Barrington College. The only thing that peaked my interest was the fact that the campus owned a radio station. My tour guide neglected to mention that the darn thing had been homemade out of recycled pie plates and generated most of its captive audience by being patched into the Student Union building's public address system.

No matter, after getting deposited at Barrington the following September, the first thing I did was head up to the radio station and see if they'd let me be an announcer. Within this collegiate microcosm of obvious misfits, professional nerds, and relative slackers, the fellow who ran Barrington's WBCW was just anachronistic enough to impress me as being both serious and easy-going.

This guy, Bob Huber, had me read aloud some advertising copy and, after looking pensive for a moment, pronounced that I had a "decent voice and potential for on-air work." I felt like I'd won a million bucks. He assigned me a two-hour air-shift for the following afternoon and authoritatively instructed another student staff member to teach me how to run the control board and follow the programming format.

I fumbled through my first solo session with the mic and turntables, mispronouncing words and inadvertently starting 45-rpm records at 33-1/3. By week's end, my broadcast schedule doubled when the next person slated to do a program didn't show up. As the lion's share of WBCW's fair-weather September team lost interest in being on the radio, that attrition allowed me some 40 hours of weekly airtime by early November.

One night, well past ten, when I questioned my sanity for spending so much time in the studio, a cute girl from my English class appeared at the door. She was studying downstairs and wondered if I'd play her a Neil Diamond ballad. Shyly, I nodded. She was gone, and then reappeared just long enough to say, "You're a good DJ." That made me want to stay on the air all night.

Huber often dropped by the studio with something positive to say about my performance, and offered a pointer or two. On an otherwise nondescript February evening, when the two or three kids down in the lounge had the PA switched to a Boston hard rock FM, he directed me to put WBCW on "simulcast" (with a Providence beautiful music outlet) and then took me to nearby WRLM-FM 93.3 in Taunton, Massachusetts, where we visited with the "actual professional" announcer on duty there. It was the first time I'd ever stepped foot in a "real" radio station and it was just the shot in the arm I needed to commit to pursuing a broadcasting career.

Another time, we gained rare access to the observation deck of the college administration building's massive stone tower (where this



## BROADCAST PRO-FILE

28243 ROYAL ROAD  
CASTAIC, CA 91384-3028

Complete radio station histories at a nominal cost.  
Write for catalog.



"castle's" early 20th Century builders had planned to place a water tank). From that remarkable vantage point, miles of the surrounding terrain could be easily seen—line of sight just begging for an FM transmitter and some antenna bays. We talked enthusiastically of making headway on applying for a broadcast license, but understood that college officials had cooled on the idea. The experience got me looking at all real estate with an eye for the ideal transmitter site, a practice I used when later planning my own stations.

Needless to say, I considered Bob Huber to be a world-class mentor. In a universe of people working angles, he asked for nothing in return other than that I stay focused on using my talents to encourage listeners by keeping them in good company. Huber graduated at the end of my first year at Barrington.

I returned the following September with a whole summer's worth of enthusiasm and ideas about how to sound even more chipper on the air...only to discover that hippies had

somehow taken control of WBCW! These lovely folks had been eyeing the station with the idea of turning it into a 24-hour psychedelic musical haven for people on acid, but in past years, Huber kept such invaders at bay by offering them only a midnight specialty slot.

Within a week, the hippies kicked me off the air because I sounded "too commercial and AM'ish" (as opposed to Amish, the genuine keepers of legitimate peace and love). They also convicted me for playing the Top-40 instead of their suggested drug lyric-laced 12-minute album cuts containing zero melody. For at least two weeks after my unceremonious firing, I sulked around campus as if I'd lost a petite naturally blonde girlfriend. My roommates implored me not to listen to WBCW anymore, but I was too heartbroken to completely walk away at that point.

That all changed when I heard a hippie slowly and deliberately belch over the carrier current. And then this broadcast hijacker laughed uncontrollably about the burp while

he absolutely butchered a weather forecast. "Oh well," the hipster slurred, "Who gives a @#%\$! about the weather anyway? Tricky Dick Nixon and the capitalist corporations probably control it so they can kill more babies in Nam." That pretzel logic accomplished, the guy managed a chasm of dead air and then tracked tuneless LPs for an hour.

This eminent domain theft of my beloved WBCW made me so mad that I started complaining to anyone within earshot. Miraculously, Bob Huber heard of my wintry discontent and briefly returned to campus in order to dare me to "do something about it get a job on a real station." It was the kick in the pants I needed to get me to Boston to take a test for my 3rd class FCC radio operator permit and seek broadcast employment.

Huber arranged for the studio door to be conveniently unlocked one morning so that I could sneak in and cut an audition tape while the hippies were still crashed on their commune mattress in some sloppy off campus flop house. About a month later, on a Sunday at 1 a.m., I actualized Huber's admonition by becoming the part-time all night announcer on WNGG Pawtucket, Rhode Island. Boy, did those hippies make fun of me then! "It's Mr. Bubblegum the teenybopper radio DJ," the hipsters howled when they spied me in the cafeteria line. "Hey AM dude, please play me something by the David Cassidy and the Partridge Family...or maybe a Monkees record! Ha, ha, ha!"

But I was no longer within their target range. They got theirs soon thereafter, anyway, when the college Dean decreed that no dope-related songs or even mildly suggestive sex and drug talk would be allowed on WBCW. With nothing left to communicate, the hippies soon abandoned the studio and WBCW went the way of the wind.

A couple of times, a kid or two would try resurrecting it for a few hours, but by then the PA system had blown and been rewired without a link to the studio. For the remainder of my time at Barrington, I stayed busy with term papers and working my way up to WPRO-AM/FM Providence. Never again did I go upstairs in the Student Union building. So, it's impossible for me to pinpoint when WBCW breathed its last radio wave.

I do know, however, that at least one of its dorm-based transmitters remained active for years. On the day after my 1975 graduation, I remember leaving college for the last time and noticing on the car radio that a blank carrier wave could still be detected on 580 kHz. Admittedly, I drove out of campus slow enough to hold the last strains of that silent signal while recalling how it and Bob Huber had happily influenced my future.

## Until Next Time...

And so ends another day of broadcasting history on *Pop'Comm*. ■

## TUNING IN (from page 4)

into the future with an exciting new editor. That would be Edith Lennon, N2ZRW, who was formerly the magazine's managing editor.

Edith brings to the table the asset of being an active hobbyist, combined with a respect for the magazine's basic premise, along with a number of exciting and fresh new ideas. All of us here look forward to what Edith has to offer. I know that our readers will offer her their enthusiastic support.

As our hobby continues to grow and evolve in the coming years, *Pop'Comm* looks forward to sharing it with each of you.

## ...And While I'm On The Subject

I got to thinking the other day about portions of that ridiculous Electronic Communications Privacy Act (ECPA) those clowns in Washington passed 20 years ago. That was in an era when analog cellular phones were in wide use and everyone in the world could eavesdrop using a scanner. Drug dealers, politicians, and folks cheating on their spouses became very sensitive about their private conversations being overheard by strangers, especially when it all showed up in the newspapers.

The ECPA stipulated that scanners be designed and manufactured with cellular frequencies blocked.

Well, analog cell phones have been replaced by digital phones that can't be monitored with scanners. Not only that, a large number of mobile phones operate on PCS channels that lie outside the basic cellular phone channels.

Don't you think it's time for the FCC to see to it that there is no longer any point or purpose to requiring that cellular frequencies be blocked? It's an outmoded restriction that should be revoked.

That's what I think. What do *you* think? Let us know.

*Popular Communications* invites your comments, questions, criticisms, compliments, article submissions—in a word, your thoughts. Write to me at [editor@popular-communications.com](mailto:editor@popular-communications.com).

# Podcasting: Talk Radio And Educational TV For Hams! Plus The Real Dope On Coax

Unless you're an aging hipster or an Apple, Inc., fanboy, chances are good that your kid—or any kid 12 years or older—knows more about podcasting than you do. But because there's an ever-growing collection of podcasts produced by hams, for hams, that's going to change!

The term itself was created by Apple iPod evangelists a few short years ago when this stuff was getting started, but you don't need an Apple iPod MP3 player to fully enjoy the wonderful world of recurring digital content that is podcasting. You simply need an Internet-connected PC with a sound system and a speaker or two. And if you don't have that, some of the more prominent podcasts can be heard via C-band (big dish) satellite, on a few AM radio stations, or via your local repeater ("Amateur Radio Newline" or "ARRL Audio News," for example).

## What's In A Pod?

So, what is a podcast? It's not much different from a broadcast, really. Podcasts are audio or video "programs," usually episodic, that are available via websites (at least) or are distributed automatically to listeners or viewers through various Internet syndication methods (the most popular being Apple's iTunes service and RSS, which stands for Really Simple Syndication; do a Google search for more on RSS). In the purest sense of the word, podcasts are automatically downloaded to your iPod so you can simply grab the handy little player and listen to your favorite audio shows on the way to work or school. It's nice if you happen to have an iPod, but unnecessary, so don't worry if you don't.

Most podcasts are produced by non-professionals for their own enjoyment, but more and more commercial and organizational podcasts are showing up. The person producing the podcast is called a podcaster (go figure!). These electronic "broadcasters" may work alone, producing and distributing their digital content, or they may work through an online community of podcasters or a company that makes it easy to get started. These "aggregators" provide support to many podcasters and make their recurring content available online (like a network does in broadcasting terms).

Still with me? Still confused? Well, then simply think of podcasting as talk radio and educational television for hams! Think of podcasts as audio and video shows that can be downloaded periodically and enjoyed via a computer instead of television or radio. Most podcasts are updated weekly, some daily, and some only occasionally.

## Getting Started

The easiest way to get started is to point your Web browser to the site that hosts the podcast you're interested in, click on the link required to listen to or download the audio or video file, and enjoy! Once you've mastered that you can move on to hav-

ing the shows automatically delivered to your PC (or your iPod) every week as soon as new episodes are released (via RSS or other syndication methods, mentioned above).

So to jumpstart your podcasting adventure, here are a few listings you might want to check out:

### "This Week in Amateur Radio"

Probably the most slickly produced extravaganza of them all, "TWIAR" is a weekly audio magazine of current amateur radio happenings, tidbits, stories, propagation, DXing, product reviews, celebrities—you name it! The show sounds like commercial radio, but it's sometimes funny to hear the "broadcast-quality" announcers break their conversational stride to s-l-o-w-l-y speak call signs or even phonetic content, as though they were working a rare DX station under difficult conditions instead of working with studio-quality sound! With correspondents reporting from every point of the compass, "TWIAR" tops my short list of ham radio podcasts each week. ([www.twiar.org](http://www.twiar.org))

### "Soldersmoke"

Coming in a close second (for me) is the "Soldersmoke" podcast produced by Bill Meara, MØHBR (CU2JL, N2CQR). In his rambling—yet charming—way, Bill discusses homebrew projects and various ham radio electronics conundrums with other homebrewing hams in the United States and Europe via the Echolink VoIP (Voice over Internet Protocol) system. The weekly shows run an hour or two and are quite interesting for build-it-yourselfers (but may be insanely boring for those who aren't interested in this aspect of our hobby!). ([www.soldersmoke.com](http://www.soldersmoke.com))

### "Amateur Radio Newline"

Now in its 30th year ("ARN" was hip long before the podcasting era!), "Amateur Radio Newline" produces weekly episodes in audio and text formats that are filled with news of interest to hams everywhere. ([www.arnewline.org](http://www.arnewline.org))

### "ARRL Audio News"

News and info of interest to hams everywhere (the same material finds its way into ARRL on-air bulletin broadcasts, the *ARRL Letter*, etc). ([www.arrl.org/arrlletter/audio](http://www.arrl.org/arrlletter/audio))

### Online Ham Radio Classes

If you're looking for some help in getting your ham license, John Martin, KF8KK, and Mike Dell, N7LMJ, produce free online exam classes that are downloadable as podcasts! Multi-part Technician- and General-class programs are now available, with higher-class material to follow. Listen online, subscribe to the podcasts, or order the complete course material on CD. ([www.hamradioclass.org](http://www.hamradioclass.org))

### The "RAIN Report"

Produced by Hap Holly, KC9RP, the "RAIN Report" is a weekly audio show with interviews about ham radio and people in the hobby. ([www.rainreport.com](http://www.rainreport.com))



News and views from the Radio Society of Great Britain (the ARRL's sister society in the International Amateur Radio Union) are available from the new GB2RS podcast. The URL is a bit of a doozy! (<http://homepage.ntlworld.com/g4njh2/rsgb.html>)

*Ham Podcasts via Satellite*

Hosting a wide variety of ham, SWL, satellite, and general

variety audio shows (from tame to strange), the WØKIE Satellite Radio Network has been up and running since 1996. Present satellite broadcasts are on C-band satellites AMC 3 and Galaxy 26, but the network's eclectic programming is streamed on the Internet and can even be heard via dial-up telephone! ([www.w0kie.com](http://www.w0kie.com))

*Other Interesting Podcasts/Blogs*

Although they may not be as slickly produced as some of the

### RG-6 To The Rescue!

Although it's a perennial topic, I've been getting a lot of questions about coaxial cable and coaxial connectors these days—enough to prompt me to write about it and cough up a confession or two. Beginning hams often wonder which cables work best for a variety of applications, which connectors to use, and how to attach the connectors to the cable when everything's in place.

Like anything else, when it comes to coax, you usually get what you pay for, unless you're getting leftovers from your local cable company for free (hint, hint). But I digress! So, who makes the good 50-ohm coax? It's pretty hard to go wrong with RF cables made by Belden, Andrew, or Times Microwave, but there are other high-quality makers that you'll discover if you look around. Which coax should be avoided? Anything priced too good to be true.

Careful readers will notice that I said "50-ohm coax..." Aren't hams supposed to use 50-ohm coax? That's been in the ham literature since WWII, right? Well, yes, but for most ham applications below 50 or 144 MHz, 75-ohm RG-6 "satellite cable" works just as well (or better) and has a lot of potential advantages. For instance,

- Because it's used in cable TV and satellite TV applications, RG-6 has to be relatively low-loss up to 1 GHz (which is really great if you're using it at 3.5 MHz!).
- Because it's produced in huge quantities (compare the number of people who have TV sets with the number of hams), it's inexpensive.

• Unlike traditional RG-8/RG-58, for example, you can find good quality RG-6 just about everywhere, even Wal-Mart and RadioShack.

• Unlike inexpensive RG-8/RG-58 "ham coax," which can have a skimpy 65-percent braided outer shield, RG-6 is *at least* double-shielded, with "quad-shielded" versions readily available.

• Because RG-6, like its little brother RG-59, is designed to use crimp-on "F-style" connectors, putting ends on the stuff won't cause you to collapse in frustration! With a variety of readily available adapters, you can transform an F connector into a PL-259, a BNC, or whatever you need.

### Purists Should Look Away Now!

Correctly soldering PL-259 connectors to the ends of 50-ohm coax can make a grown ham weep. Despite the fact that the procedure is (clearly?) documented in every radio handbook and manual on the shelf, making high-quality cable ends is just

**Table. Coaxial Cable Signal Loss In dB Per 100 Ft (Typical) For Low-SWR Loads**

	RG-58	RG-8X	RG-8U	RG-6
1 MHz	0.4	0.5	0.2	0.2
10 MHz	1.4	1.0	0.6	0.6
50 MHz	3.3	2.5	1.6	1.4



A ham's best friends? Shown here are a pair of RG-6 crimp connectors and an F-to-PL-259 adapter. Other adapters, not shown here, allow the use of RG-6 cable with BNC, Type N, and other RF connectors. (Photo by the author)

more prominent podcasts, there are a lot of interesting tidbits out there in cyberspace! Check out the following offerings as well: Podcasts for San Diego hams ([www.podcastdirectory.com/podcasts/index.php?id=8504](http://www.podcastdirectory.com/podcasts/index.php?id=8504)); News and features from Minnesota's Handiham World (<http://handiham.blogspot.com>); Ham videos from 99 Hobbies (<http://99hobbies.blogspot.com>); and Ham videos from Jeff Davis, KE9V (<http://ke9v.net/category/podcast>).

plain difficult unless you are taught (in the flesh by an expert) a good technique and practice it *regularly*. If you're making only the occasional cable—using connectors made by various manufacturers and bargain basement coax—forget it. Literally!

### My Confession

Here's where I start confessing. I, too, hate soldering PL-259 connectors to coax (and forget about BNC and N connectors!). Although I can do an okay job if I use high-quality components, I still hate it. Like many hams I used to resort to buying manufactured cables! That's fine for in-shack jumpers, but what about antenna installations?

I simply use RG-6 sat cable, attach a high-quality crimp connector with a big, heavy crimping tool (about \$20 at RadioShack and elsewhere) and add adapters as needed (see the photo). It's easy, fast, flexible—and it works like a charm!

Purists may grumble about the connectors adding impedance bumps and about the cable's 75-ohm impedance, as opposed to the traditional 50-ohm specs, but unless you're making phasing harnesses or coaxial impedance-matching lines, it doesn't really matter.

In the real world, 75 ohms is plenty close enough to 50 ohms. Some antennas we commonly think of as having 50-ohm feed-point impedances actually match better to 75-ohm coax. And, sure, your rig is designed to match 50-ohm loads, but what if your specific final amplifier actually specs out to 40 ohms? Or 65 ohms? Your receiver front end, by the way, couldn't care less about the teeny difference.

Remember, coax should only be used to feed antennas that present low SWR values to the antenna system, like feeding an 80-meter dipole an 80-meter signal. That presents an SWR between the transmitter and the antenna of less than 4 to 1, and the line losses due to SWR will be low. If you feed that 80-meter dipole with coax and try to tune up on 160 meters, however, the SWR losses on the line will soar, turning your antenna system into a dummy load!

In situations where the SWR on the feed line will be high (as in many multiband or non-resonant wire antennas), you should use 450-ohm ladder line or 600-ohm open-wire line and a suitably balanced antenna tuner, as we've covered in this column before.

I was reluctant to try RG-6 at first, but a thorough Internet search convinced me that more and more hams are turning to the flexibility afforded by high-quality, low-cost RG-6 sat cable for feeding ham antennas (and scanner/SWL antennas as well). I've been using the stuff for several years and have been impressed with its convenience and performance. You might want to give it a try!

—NTØZ

## Earn Your HAM RADIO LICENSE The Quick and Easy Way! No Morse Code Required!!



**GWTM**  
**\$18.95**  
+ \$6 S&H

Start earning your Technician ham license today! Get on the air and enjoy the fun hobby of amateur radio. Learn from the "Master" – Gordon West, WB6NOA. Study manual includes all possible test Q&A and more – or study at your PC using interactive practice exam software – NCS \$44.95 + \$6 S&H.



**GSTD**  
**\$19.95**  
+ \$6 S&H

*Getting Started in Electronics* is a complete electronics course in 128 pages! Forrest Mims teaches you the basics, takes you on a tour of analog and digital components, explains how they work, and shows how they are combined for various applications. 100 electronic circuits you can build and test!

### The W5YI Group

POB 565101 – Dallas, TX 75356

Order today on the web or call:  
[www.w5yi.org](http://www.w5yi.org) ♦ 800.669.9594

Want to know more about ham radio? Call us!  
Mention this ad to receive a free gift with your order!

## Good News for the VHF/UHF Enthusiast

The all-time favorite magazine for the VHF/UHF enthusiast, *CQ VHF* is better than ever and here to serve you!



By taking advantage of our subscription specials you'll save money and have *CQ VHF* delivered right to your mailbox. Only \$26 for four information-packed quarterly issues. Or better yet, enter a two or three year subscription at these special prices. As always, every subscription comes with our money back guarantee.

**DON'T MISS OUT  
CALL TODAY**

	USA	VE/XE	Foreign Air Post
1 Year	26.00	36.00	39.00
2 Years	52.00	72.00	78.00
3 Years	78.00	108.00	117.00

Please allow 6-8 weeks for delivery of first issue

Mail your order to:

**CQ VHF • 25 Newbridge Road • Hicksville, NY 11801**

Subscribe on line at [www.cq-vhf.com](http://www.cq-vhf.com)

FAX your order to us at 516 681-2926

**Call Toll-Free 800-853-9797**



# Pop'Comm books, calendars, cds, & dvds!



## CQ HF Operator's Survival Guide

Hands-on guide for newcomers to high-frequency (shortwave) Amateur Radio. Discusses the characteristics of each HF ham band and explains which is best and when, basic HF operating practices, choosing your first HF transceiver, antenna basics, HF modes and activities. Includes an HF band chart!

Order No. HFSurv **\$2.00**

## Ham Radio Magazine on CD

Brought to you by CQ & ARRL

Enjoy quick and easy access to every issue of this popular magazine, broken down by years!



Three sets, each containing 4 CDs -

1968-1976 Order No. HRCD1 **\$59.95**

1977-1983 Order No. HRCD2 **\$59.95**

1984-1990 Order No. HRCD3 **\$59.95**

Buy All 3 Sets and Save **\$29.90!**

Order No. HRCD Set **\$149.95**

## W6SAI HF Antenna Handbook



by Bill Orr, W6SAI

Inexpensive, practical antenna projects that work! Guides you through building wire, loop, Yagi and vertical antennas.

Order No. W6SAI **\$19.95**

## The Complete DXer

Third Edition

The joy of the chase, the agony of defeat, the thrill of victory are the stuff of The Complete DXer, a book that is almost as seductive as the DX chase it describes.

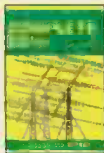

Order: COMPDXer **\$19.95**



## HR Anthologies

**\$19.95 ea.**

Buy all 4 for only **\$75**

Now you can enjoy collections of the best material published in *Ham Radio magazine*, conveniently arranged by subject and original publication date. Choose your interest, your time period and choose your anthology!

Homebrewing Techniques ..... Order # AHOME

Test Eqpt & Repair Techniques...Order # ATEST

Antennas - 1968 - 1972 .....Order # ANTS1

Antennas - 1973 - 1975 .....Order # ANTS2

Get all 4 for **\$75 plus Free shipping** . . . Order # ASET

## Understanding, Building & Using Baluns & Ununs

by Jerry Sevick, W2FMI

Successor to the extremely popular and authoritative Baluns and Ununs. Great deal of new tutorial material, Includes new designs, and explanations of how and why they work.



Order No. 2BU **\$19.95**

## Passport to World Band Radio

Edition 2007

The World's #1 selling shortwave guide! Have the world at your fingertips! Details on what to buy and where to tune.



Order No. PASS **\$22.95**

## 2008/09 calendar

15 month calendar  
January 2008—March 2009

**CQ Ham Radio Operators Calendar**

This year's calendar brings you 15 spectacular color images of some of the biggest, most photogenic shack, antennas, scenics and personalities from across the country. Calendar orders will ship on October 8th. You will not be billed until your order ships.

Order No. HRCAL **Still only \$10.95**

## Heathkit - A Guide to the AR Products

by Chuck Penson, WA7ZZE

This greatly expanded Second Edition is a must for collectors and Ham history buffs! Pick up this 328-page volume and you won't be able to put it down!



Order No. HEATHKIT **\$29.95**

## 2007 World Radio TV Handbook

The Directory of Global Broadcasting

The most up-to-date info on medium-wave, shortwave, and FM broadcasts and broadcasters. Includes articles on topics of great interest to both listeners and DXers, reviews of the latest equipment, updated maps showing SW transmitter sites and more.



Order No. WRTH **\$29.95**

## The Short Vertical Antenna & Ground Radial

by Jerry Sevick, W2FMI

Small but solid guide on the design and installation of inexpensive, yet effective short HF vertical antennas. Antenna restrictions a problem? This book could keep you on the air!



Order No. SVERT **\$10.00**

## The NEW Shortwave Propagation Handbook

by W3ASK, N4XX & K6GKU

A comprehensive source of HF propagation principles, sunspots, ionospheric predictions, with photos, charts and tables galore!



Order No. SWP **\$19.95**

## MIL SPEC Radio Gear



Korean War To Present Day  
by Mark Francis, KI0PF

Detailed write-ups for many familiar sets: PRC-25/-77, RT-68, PRC-1099, GRC-106, GRR-5, R-392 and more. Over 230 pages of operation, modification, and maintenance tips and information, including 200+ illustrations.

Order No. MILSPEC **\$27.95**

## "Getting Started" DVD Paks

Our renowned Getting Started videos have been grouped together on DVDs!

1 - \$24.95  
2 - \$45.95  
3 - \$65.95

### CQ Ham Radio Welcome Pak

1 DVD contains 3 programs:

Ham Radio Horizons

Getting Started in Ham Radio

Getting Started in VHF

Order # HAMDVD \$24.95

### CQ HF Specialty Pak

1 DVD contains 2 programs:

Getting Started in DXing

Getting Started in Contesting

Order # HFDVD \$24.95

### CQ VHF Specialty Pak

1 DVD contains 3 programs:

Getting Started in Satellites

Getting Started in VHF

Getting Started In Packet

Order # VHFVDVD \$24.95

### CQ DVD 3 Pak - one of each

of the DVDs listed above.

Order # 3DVD \$65.95

Buy any combination of DVDs and save!

1 Pak for \$24.95; 2 Paks for \$45.95;  
3 Paks for \$65.95



\*Shipping & Handling: U.S. & Possessions-add \$5 for the first item, \$2.50 for the second and \$1 for each additional item. FREE shipping on orders over \$75.

\*For a single Calendar or CQ HF Survival Guide purchase - U.S. & Possessions add only \$2 Shipping and Handling.

All Foreign Shipping & Handling - calculated by order weight and destination and added to your credit card charge.

CQ Communications, Inc., 25 Newbridge Rd., Hicksville, NY 11801

Call 1-800-853-9797 - FAX your order to 516-681-2926 - www.cq-amateur-radio.com



## Washington Beat *(from page 8)*

October 1, permits antennas up to 90 feet in height in areas regulated solely by municipal—county and city—ordinances, according to a report from the American Radio Relay League.

With the passage of HB1340, half the states in the country have PRB-1 language laws on the books.

## Oklahoma Passes Antenna Support Structure Legislation

Oklahoma Senate Bill 426 was signed into law May 31 by Governor Brad Henry, legislating that antenna support structures can be put up as long as the structure complies with 47 C. F. R., Section 97.15(b). This "allow[s] for the erection of an amateur radio antenna or an amateur radio antenna support structure at a height and dimension sufficient to accommodate Amateur Radio Service communications," the law reads.

The law says an antenna support is a "structure or framework that is designed to elevate an antenna above the ground for the purpose of increasing the effective communications range and reliability of an amateur radio station. Amateur Radio antenna support structures are removable by design and therefore are a removable structure for assessment purposes."

The law is scheduled to take effect on November 1, 2007.

## FCC Commissioner Gets Support From President

President George Bush announced his intention to nominate Deborah Taylor Tate to a full term as a commissioner on the FCC. Tate is serving out the term of former FCC Chairman Michael Powell.

"If confirmed, I look forward to continuing to work closely with Commissioner Tate," said FCC Chairman Kevin Martin. "She has served admirably at the Commission for the past year and a half, and I appreciate her continued dedication to public service. Debi brings important insight to the Commission, including her distinguished career as a leader in state government. Her thoughtfulness, dedication, and leadership have made Debi an invaluable member of the Commission."

Tate serves as chair of both the Federal-State Joint Board on Universal Service (Universal Service Joint Board) and the Federal-State Joint Board on Jurisdictional Separations. ■

## readers' market

**Advertising Rates for Readers' Mart:** Non-commercial ads are 30 cents per word, including abbreviations and addresses; minimum charge \$6.00 per issue. Ads from firms offering commercial products or services are \$1.00 per word; minimum charge \$20.00 per issue. Boldface words are \$1.20 each (specify which words). Leading key words set in all caps at no additional charge. All ads *must be prepaid in full* at time of insertion; a 5% discount is offered for prepaid 6 time insertions. All ads must be typewritten double spaced. **Approval:** All ad copy is subject to Publisher's approval and may be modified to eliminate references to equipment and practices which are either illegal or otherwise not within the spirit or coverage scope of the magazine.

**Closing Date:** The 10<sup>th</sup> day in the third month preceding date of publication. Because the advertisers and equipment contained in Readers' Market have not been investigated, the Publisher of *Popular Communications* cannot vouch for the merchandise listed therein. Direct all correspondence and ad copy to: Attention: Classified Dept., PC Readers' Market, 25 Newbridge Rd., Hicksville, NY 11801.

**COMMUNICATIONS MONITORING ANTENNAS.** HF/VHF/UHF Super Discone \$49.75. AntennaCraft Scantenna \$47.70. 30–1200 MHz. 4–12 dB Log Periodic \$69.50. 806–900 MHz. 13 dB 9 element Yagi \$74.00. MURS/GMRS Dual Band Base \$48.95. All prices **INCLUDE** Priority S&H&I. See these antennas plus many, many more for Amateur, Business, CB, and Monitoring radio, plus cellular phone antennas on the web at: [www.antennawarehouse.com](http://www.antennawarehouse.com) MCV/visa Order line 877-680-7818. To help maintain our low pricing, we do not print catalogs.

**REPEATERS, REPEATERS, REPEATERS!** New complete systems, parts, pieces, lines and antennas. If you need it for a repeater, we have it! [CookTowersInc@aol.com](mailto:CookTowersInc@aol.com) or toll free at 877-992-2665

**FOR SALE - DRAKE TR-7/TR-7A/R-7/R-7A Service kit.** Includes 13 Extender Boards and Digital Jumper Card. \$64.05 includes postage. See <http://pweb.amerion.com/~w7avk> Bob W7AVK, 807 Westshore J28, Moses Lake, WA 98837, [w7avk@arrl.net](mailto:w7avk@arrl.net), 509-766-7277

**IS YOUR RADIO SICK?** We service all types of radios, low band, VHF, 222 and UHF, 900 MHz, Citizens Band radio, GMRS, marine radio, aircraft radio, and shortwave. [CookTowersInc@aol.com](mailto:CookTowersInc@aol.com) or toll free 877-992-2665.

## ADVERTISERS' INDEX

Advertiser	Page #	Website Address
AOR USA, Inc. ....	Cov III .....	<a href="http://www.aorusa.com">www.aorusa.com</a>
Advanced Specialties .....	32 .....	<a href="http://www.advancedspecialties.net">www.advancedspecialties.net</a>
Antique Radio Classified .....	32 .....	<a href="http://www.antiqeradio.com">www.antiqeradio.com</a>
Atomic Time, Inc. ....	21 .....	<a href="http://www.atomictime.com">www.atomictime.com</a>
C. Crane Company .....	65 .....	<a href="http://www.ccrane.com">www.ccrane.com</a>
CQ Bookshop .....	82 .....	<a href="http://www.cq-amateur-radio.com">www.cq-amateur-radio.com</a>
CQ Calendars .....	24 .....	<a href="http://www.cq-amateur-radio.com">www.cq-amateur-radio.com</a>
Communications Electronics .....	7 .....	<a href="http://www.usascan.com">www.usascan.com</a>
Computer Aided Technology .....	47 .....	<a href="http://www.scancat.com">www.scancat.com</a>
Electric Radio Magazine .....	21 .....	<a href="http://www.ermag.com">www.ermag.com</a>
GRE .....	42,43 .....	<a href="http://www.greamerica.com">www.greamerica.com</a>
ICOM America, Inc. ....	Cov. IV .....	<a href="http://www.icomamerica.com">www.icomamerica.com</a>
Kenwood .....	13 .....	<a href="http://www.kenwoodusa.com">http://www.kenwoodusa.com</a>
MFJ Enterprises, Inc. ....	3 .....	<a href="http://www.mfjenterprises.com">www.mfjenterprises.com</a>
Monitoring Times .....	58 .....	<a href="http://www.grove-ent.com">www.grove-ent.com</a>
PowerPort .....	32 .....	<a href="http://www.powerportstore.com">www.powerportstore.com</a>
QCWA .....	73 .....	<a href="http://www.qcwa.org">www.qcwa.org</a>
RSGB .....	23,27 .....	<a href="http://www.cq-amateur-radio.com">www.cq-amateur-radio.com</a>
REACT International, Inc. ....	61 .....	<a href="http://www.reactintl.org">www.reactintl.org</a>
RentScanner .....	21 .....	<a href="http://www.rentscanner.com">www.rentscanner.com</a>
Sangean .....	5 .....	<a href="http://www.sangean.com">www.sangean.com</a>
Swift WX .....	41 .....	<a href="http://www.swiftwx.com">www.swiftwx.com</a>
Universal Radio .....	1 .....	<a href="http://www.universal-radio.com">www.universal-radio.com</a>
W5YI Group, The .....	81 .....	<a href="http://www.w5yi.org">www.w5yi.org</a>
Yaesu .....	Cov II .....	<a href="http://www.vxstdusa.com">www.vxstdusa.com</a>

Reach this dynamic audience with your advertising message, contact Arnie Sposato at 253-853-4080, FAX 253-853-4070, or e-mail: [advertising@popular-communications.com](mailto:advertising@popular-communications.com).



## A Bathroom With A View

**E**ach time we get together, Norm tries desperately to get me to put up some kind of antenna so that I have no excuse (or at least *less* excuse) to get on the air. This last visit was slightly different. This time it was a television antenna.

Taking an old antenna down is usually very easy, because the old antenna does not have to be saved. You just lasso it and pull, but I wanted to “refurbish” the old antenna and put it back up. After all—it’s just tubing and terminals

“All we have to do,” Norm told me, “is get a rope around it, then one of us gets up there and unfastens it from the mount, and the guy on the roof lowers it gently while the guy on the ground keeps tension on his end of the rope. That’ll keep it from banging into the gutters, and into the side of the house. I should tell you that the roof is a steep-pitched metal (tin) roof the peak of which is about two-and-a-half stories off the ground.

Being of not-so-sound mind but a far lighter body, Norm volunteered to be the climber while I would be the ground crew. We figured we’d need about 100 feet of nylon clothesline.

When Norm had climbed to the edge of the roof, he stopped and surveyed the situation for quite some time. About the same length of time it took George Washington to survey the entire commonwealth of Virginia.

“What’s up?” I asked.

“Old man,” he said, “this roof is much steeper than it looks from the ground.” Truly the comment of a person who is getting, as they say in the dog world, “white in the muzzle.”

I asked if he’d be able to climb up the 20 or so feet to the antenna, or if we should just abandon the project.

“Oh, no—we can do this. I just wish I had my climbing belt with me.”

I had my “positioning harness” in my van. I use it at work. Even though I don’t climb any substantial heights, I use it to hold myself in place so that I can use two hands to work on equipment and not have to “hold on” with one hand while trying to start a tiny screw in the side of a waveguide flex-twist connector with the other. It’s worth its weight in gold, and it even supports me.

“I’ve got a harness down here. Come on down and we’ll rig you for the job.”

“Buddy,” he said, “if it fits you, it’s sure not gonna fit me!” I told him to just come down and we’d get him strapped in. We are, after all, the Laurel and Hardy of the amateur radio world.

Of course, you don’t support a human being—not even Norm—with braided nylon clothesline. That’s for clothes. I did have some heavy rigging rope in my truck and some steel towing cable with hooks attached. Together, that gave me enough length.

“Come on, Norm,” I said, “I’ll hook you up and pull you up with the truck, then you climb over the eaves and lay on your belly on the roof and I’ll pull you up till you can reach the antenna. Then you can lower the antenna down to me with the clothesline.” It was pretty surprising that Norm looked forward to being hoisted through the air, but I guess he knew he’d never go hang gliding, so he looked at this as a sporting event rather than a dangerous chore.

---

*“I did not expect my wife to step out of the shower just as Norm passed by the bathroom window. In hindsight, I doubt that Norm did either...”*

---

A neighbor came over to “spot” Norm and tell me his position and relay communications back and forth between us. The rope was thrown across the peak of the roof, the end with the cables was attached to the truck, and I tied Norm off carefully. There was enough of the heavy rope left that I tied off a stationary piece for him to “hand-over-hand” as I pulled him up, in case there was some problem with the lifting rope. Slowly, I let the clutch out and drove forward, and the little Ford began to hoist Norm up the side of the house.

I did not expect my wife to step out of the shower just as Norm passed by the bathroom window. In hindsight, I doubt that Norm did either, nor does this *begin* to take into account what she thought as Norm dangled outside while she fumbled with the blinds. I stopped immediately when I heard him let out a sort-of startled yelp, leaving him in what might have been the most awkward position he’s ever been in to this day.

I called back to my neighbor, who was watching for Norm’s safety, and he shrugged, saying “He’s fine! maybe he came across a nest of bees or something!” So I again let out the clutch and lifted him up toward the eaves. It was much later that I learned what happened that day.

Norm worked his way onto the roof, which was slippery enough that it was easy for me to drag him upward until he could reach the base of the antenna to undo the rusty bolts that held it in place. I took the redness in Norm’s face to be sunburn.

After Norm tied the clothesline onto the antenna, held on to one of the 50-foot pieces and tossed me the other, he lifted the base of the antenna mast out of the bracket that held it. I was just keeping light tension on my piece of clothesline, and I have to say that, looking back, it’s easy for me to understand now why Norm made the mistake of holding the wrong end of his clothesline, allowing the antenna to tumble unceremoniously to the ground, tightening Norm’s rope just after it had become a useless pile of aluminum.

“I guess I should have held it closer to the antenna,” Norm said. I just told him we probably couldn’t have salvaged it anyway, lowered him back down and loosened him from his harness.

“C’mon,” I said, “Lets go inside and see if someone’s making lunch.”

“Uhhh...why don’t we go over to that nice little diner in the shopping center,” Norm said. “I’ll buy.”

Only later did I fully understand this outburst of generosity. Norm never mentioned a thing about the “incident,” probably thinking that to mention it in any way would somehow be a terrible breach of etiquette, so I only got a full understanding of the events of the day after he left that evening. He has never once brought up the subject—and neither have I. ■

# Watch What Happens!

The SR2000A is an ultra-fast spectrum display monitor that lets you SEE received signals in FULL COLOR

## AOR SR2000A Frequency Monitor

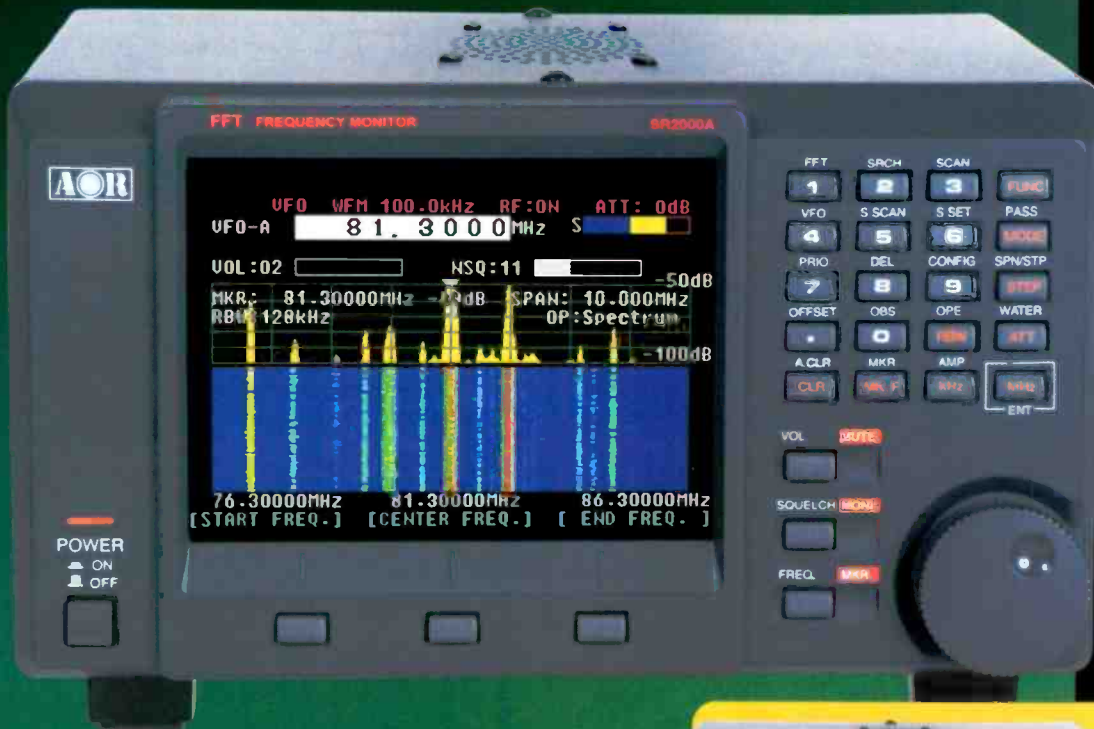

- Frequency coverage: 25MHz ~ 3GHz (nc gaps)\*
- Ultra-stable, high-sensitivity triple-conversion receiver
- External video output (composite video)
- AM/NFM/WFM/SFM/TV receive modes
- Displays up to 40MHz of spectrum bandwidth (20MHz or 40MHz selectable)\*\*
- P25 decoding function available with optional P25-E600
- Waterfall (time) display function
- 1000 memory settings (100ch x 10 memory banks)
- Average or peak value readings

Using the power of FFT (Fast Fourier Transform) algorithms with a powerful receiver covering 25MHz ~ 3GHz\*, the SR2000A features a color monitor that displays up to 40MHz spectrum



- Video display function (NTSC/PAL/SECAM auto select)\*\*\*
- 5 inch TFT color LCD display
- Versatile color display uses state of the art digital signal processing

bandwidth or video display of NTSC, PAL or SECAM signals.

Ultra-sensitive, incredibly fast, yet easy to use, with a high quality internal speaker for crisp, clean audio signals.

Scans 10MHz in as little as 0.2 seconds! Instantly detects, captures and displays transmitted signals.

- High speed FFT search quickly captures new signal transmissions
- Easy menu-driven operation
- PC control through RS232C serial port or USB interface



Authority on Radio  
Communications

AOR U.S.A., Inc.  
20655 S. Western Ave., Suite 112, Torrance, CA 90501, USA  
Tel: 310-787-8615 Fax: 310-787-8619  
info@aorusa.com http://www.aorusa.com

\*Government version. Cellular blocked for US consumer version.

\*\*No audio is available when the frequency span is set to 20MHz or 40MHz.

\*\*\*No audio available while displaying video signal on the LCD. If both video and audio need to be monitored simultaneously, an optional (external) TV2000 is required.



# Bringing the world to your desktop. Your car dash. Kitchen table. Flybridge. Rec room. Office cubicle. Hotel room. Vacation home. Ham shack. Cockpit.

## IC-PCR1500

- 0.01 ~ 3299.99 MHz\*\*\*
- AM, FM, WFM, CW, SSB
- Record and Save Audio as .WAV File
- USB Cable Connection
- Optional DSP



## IC-PCR2500

- 0.01 ~ 3299.99 MHz\*\*\* (Main)  
50 to 1300 MHz\*\*\* (Sub)
- AM, FM, WFM, CW, SSB
- Optional APCO 25 and D-STAR
- Dual Wideband Receivers
- Dual Watch PC window



## Icom black box receivers

It all starts with a little black box. Plug it in to your PC or opt for one of the remote head versions. Whichever way you go, go with Icom wide-band!



## IC-R1500



- 0.01 ~ 3299.99 MHz\*\*\*
- AM, FM, WFM, CW, SSB
- Single Receiver
- Mobile or PC Controlled

## IC-R2500



- 0.01 ~ 3299.99 MHz\*\*\* (Main)  
50 to 1300 MHz\*\*\* (Sub)
- AM, FM, WFM, CW, SSB
- Dual Wideband Receiver
- Mobile or PC Controlled
- Optional APCO 25 and D-STAR
- Dual Receiver Diversity



## Now bundled with RadioCom 4.5

Icom's black box radios now come bundled with Bonito's RadioCom 4.5. With RadioControl, Equalizer-Filter-Analyzer, AudioRecorder, RTTY-, CW-, WFAX-, SatFax, SSTV-, PSK- and Time Signal Decoding, Frequency- and Schedule-Manager, as well as SatTracking...(whew), you have EVERYTHING in one program.



## THE WORLD IN YOUR HAND:



**IC-R20**  
ADVANCED OPS  
0.150 - 3304.0 MHz\*\*\*



**IC-R5**  
SHIRT-POCKET COMPACT  
0.5 - 1300.0 MHz\*\*\*

For free literature:  
425.450.6088 or  
[www.icomamerica.com](http://www.icomamerica.com)



\*Radio cover is actually black. World as seen from space artwork not included.  
\*\*Blocked versions only. Limited time offer. See dealer for details. \*\*\*Refer to owner's manual for exact frequency specs.  
©2007 Icom America Inc. The Icom logo is a registered trademark of Icom Inc. All specifications are subject to change without notice or obligation. 9549