

**Projects you can build!**

GERNSBACK SPECIALTY SERIES 49604

**FALL  
1994**

**Popular  
Electronics**

# **ELECTRONICS HOBBYISTS handbook** <sup>TM</sup>

**SPECIAL SECTION ON....**

**High-Voltage  
Electronics** <sup>TM</sup>

**\$3.95 U.S.  
\$4.50 CANADA**

**HV Capacitors  
Voltage Doublers  
Wimshurst Machine**

**PLUS-**

- **Wireless IR Headphones**
- **9-Band SW Receiver**
- **Telephone Scrambler**
- **SCA Adapter**
- **Test Bench Amp**
- **DVM for Your PC**
- **Portable Barometer**
- **Relative Humidity Gauge**



A  
**GERNSBACK**  
PUBLICATION



# 24 HOUR SHIPPING ELENCO • HITACHI • B&K PRODUCTS GUARANTEED LOWEST PRICES

TO ORDER  
CALL TOLL FREE  
1-800-292-7711  
1-800-445-3201 (Can.)

**AFFORDABLE - HIGH QUALITY  
2 YEAR WARRANTY**

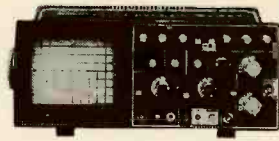


**STANDARD SERIES**  
S-1325 25MHz \$349  
S-1340 40MHz \$495  
S-1365 60MHz \$849

Features:

- High Luminance 6" CRT
- TV Sync
- 1mV Sensitivity
- 2 - x1, x10 Probes
- X-Y Operation
- Complete Schematic
- Voltage, Time, + Frequency differences displayed on CRT thru the use of cursors (S-1365 only)
- Plus much, much more

**ELENCO OSCILLOSCOPES**



**DELUXE SERIES**  
S-1330 25MHz \$449  
S-1345 40MHz \$575  
S-1360 60MHz \$775

Features:

- Delayed Sweep
- Automatic Beam Finder
- Z Axis Modulation
- Built-in Component Test
- Plus all the features of the "affordable" series
- Dual time base
- Illuminated internal gradicule

**Hitachi Compact Series Scopes**

V-212 - 20MHz Dual Trace	\$399
V-525 - 50MHz, Cursors	\$995
V-523 - 50MHz, Delayed Sweep	\$949
V-522 - 50MHz, DC Offset	\$895
V-422 - 40MHz, DC Offset	\$795
V-222 - 20MHz, DC Offset	\$649
V-660 - 80MHz, Dual Trace	\$1,149
V-665A - 60MHz, DT, w/cursor	\$1,325
V-1060 - 100MHz, Dual Trace	\$1,395
V-1065A - 100MHz, DT, w/cursor	\$1,649
V-1085 - 100MHz, QT, w/cursor	\$1,995
V-1100A - 100MHz, Quad Trace	\$2,495
V-1150 - 150MHz, Quad Trace	\$2,895

**B&K OSCILLOSCOPES**

2120 - 20MHz Dual Trace	\$389
2125 - 20MHz Delayed Sweep	\$539
1541B - 40MHz Dual Trace	\$695
2160 - 60MHz Dual Trace, Delayed Sweep, Dual Time Base	\$949
2190 - 100MHz Three Trace Dual Time Base, Delayed Sweep	\$1,395
2522A - 20MHz / 20MS/s Storage	\$875

**Digital Capacitance Meter**



**CM-1550B**  
by Elenco  
**\$58.95**  
9 Ranges  
.1pf-20,000ufd  
5% basic accy.  
Big 1" Display Zero control w/ Case

**Digital LCR Meter**



**LC-1801**  
**\$125**  
Measures:  
Coils 1uH-200H  
Caps .1pf-200uf  
Res .01-20M  
by Elenco  
Big 1" Display

**Digital Multimeter**



**DVM-638**  
**\$39.95**  
11 Functions with Case

**FLUKE MULTIMETERS**

Scopemeters (All Models Available Call)	
Model 93	\$1,225.00
Model 95	\$1,549.00
Model 97	\$1,795.00
10 Series	
Model 10	\$62.95
Model 12	\$79.95
70 Series	
Model 70II	\$65.00
Model 77II	\$149.00
Model 79II	\$169.00
80 Series	
Model 87	\$289.00

**12A DC Power Supply**



**B-K 1686**  
**\$169.95**  
3-14V @ 12A

Fully regulated & protected  
Separate volt & current meters  
with current limiting, low ripple

**Quad Power Supply XP-580**



**\$79.95** 2-20V @ 2A 5V @ 3A  
12V @ 1A -5V @ .5A  
Fully regulated and short circuit protected



**B&K 390**  
**\$139**  
3-3/4 Digit DMM  
Bargraph  
9 Functions including  
Temp, Freq  
Rubber Boot



**Dual-Display LCR Meter**  
w/ Stat Functions  
**B-K 878**  
**\$239.95**  
Auto/Manual Range  
Many Features  
w/ Q Factor  
High Accuracy

**Sweep/Function Generator**



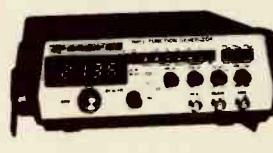
**\$239**  
Elenco  
**GF-8026**  
Int/Ext operation  
Sine, Square, Triangle, Pulse, Ramp  
2 to 2MHz, Freq Counter .1-10MHz

**Audio Generator**



**Elenco GF-800**  
**\$59**  
20Hz-150KHz  
Sine/Square  
Waves  
Handheld

**2MHz Function Generator**



**B-K 3011B** **\$219.95**  
LED Display, Sine, Square, Triangle, Ramp  
& Pulse Waves. TTL & CMOS

**Digital Multimeter Kit**



with Training Course  
**Elenco**  
**M-2665K**  
**\$49.95**  
Fun & Easy  
to Build

**Learn to Build and Program Computers with this Kit**

Includes: All Parts, Assembly and Lesson Manual



**Model**  
**MM-8000**  
**\$129.00**  
by Elenco

Starting from scratch you build a complete system. Our Micro-Master trainer teaches you to write into RAMs, ROMs and run a 8085 microprocessor, which uses similar machine language as IBM PC.

**Elenco Wide Band Signal Generators**



**SG-9000** **\$119**  
RF Freq 100K-450MHz AM Modulation of 1KHz Variable RF output  
**SG-9500 w/ Digital Display & 150MHz built-in counter \$239**

**TELEPHONE PRODUCT TESTER**



**B-K 1045A** **\$499.95**  
Provides basic operation tests for corded & cordless telephones, answering machines and automatic dialers.

**Multi-Function Counter**



**Elenco F-1200**  
1.2GHz  
**\$229**  
Measures Frequency, Period, Totalize  
8 LED digits, Crystal oven oscillator,  
.5ppm accuracy

**WE WILL NOT BE UNDERSOLD**  
UPS SHIPPING: 48 STATES 5% OTHERS CALL  
IL RES add 7.75% TAX  
**PROBES INCL ALL SCOPES & METERS**

**C&S SALES INC.**

1245 ROSEWOOD, DEERFIELD, IL 60015  
FAX: 708-520-0085 • (708) 541-0710



**15 DAY MONEY BACK GUARANTEE**  
**FULL FACTORY WARRANTY**  
**WRITE FOR FREE CATALOG**  
PRICES SUBJECT TO CHANGE



# AMAZING Electronic and Scientific Products

## Mystery Levitating Device!

Remember War of the World? Objects float in air and move to the touch. Defies gravity, amazing gift, conversation piece, magic trick or great science project.

ANT1K Easy to Assemble Kit / Plans ..... \$19.50



## Laser Ray Gun



**DANGER**

IRRADIATE LASER RADIATION  
AVOID EYES OR SKIN EXPOSURE  
DO NOT DIRECT OR SCATTER RADIATION  
CLASS II LASER PRODUCT

Advanced project produces a burst of light energy capable of burning holes in most materials. Hand-held device uses rechargeable batteries. 500 joules of flash energy excite either a neodymium glass, yag or other suitable laser rod. This is a dangerous CLASS IV project (individual parts/assemblies available).

LAGUN1 Plans ..... \$20.00  
LAGUN1K Kit / Plans ..... Price on Request

## Extended Play Telephone Recording System



READY TO USE! Automatically controls and records on our X-4 extended play recorder, taping both sides of a telephone conversation. Intended for order entry verification. Check your local laws as some states may require an alerting beeper.

TAP20X Ready to Use System ..... \$129.50



## Shocker Force Field / Vehicle Electrifier

Neat little device allows you to make hand and shock balls, shock wands and electricity objects, charge capacitors. Great payback for those wise guys who have wronged you!

SHK1KM Easy to Assemble Electronic Kit ..... \$24.50



## Blaster Pulsar

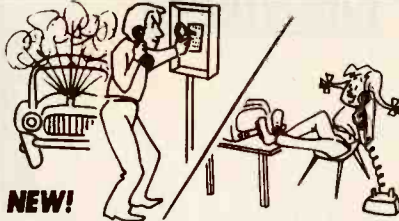
Pocket-sized wand produces 100,000 watts of power for personal defense, field and lab use, etc. BLS3 Plans ..... \$10.00  
BLS3K Kit / Plans ..... \$69.50

## Homing / Tracking Transmitter

Beeper device, 3 mile range.  
HOD1 Plans ..... \$10.00 HOD1K Kit / Plans ..... \$49.50

## Listen Through Walls, Floors

Highly sensitive stethoscope mike.  
STETH1 Plans ..... \$8.00 STETH1K Kit/Plans ..... \$44.50



**NEW!**

## INFINITY TRANSMITTER++

### Room Monitor / Phone Line Grabber

**ALL NEW! The Ultimate In Home or Office Security & Safety!** Simple to Use! Call your home or office phone, push a secret tone on your telephone keypad to access either: A. On premises sounds and voices; or B. Existing telephone conversation with break in capability for emergency messages. **CAUTION:** Before assembly or use, check legalities with your state Attorney General's office as you may require "beepers" or other 3rd party alerts.

TELEGRAB1 Plans Only ..... \$10.00  
TELEGRAB1K Kit / Plans ..... \$99.50

## Ultrasonic Blaster

Laboratory source of acoustical shock waves. Blow holes in metal, produce "cold" steam, atomize liquids. Many cleaning uses for PC boards, jewelry, coins, small parts, etc.

ULB1 Plans ..... \$10.00 ULB1K Kit/Plans ..... \$69.50



## 100,000V Intimidator / Shock Wand Module

Build an electrical device that is effective up to 20 feet. May be enclosed for handheld, portable field or laboratory applications.

ITM2KM Easy-to-Assemble Electronics Kit ..... \$49.50  
ITM2 Plans only, credit-able to kit ..... \$10.00



## Ion Ray Gun

Projects charged ions that induce shocks in people and objects without any connection! Great science project as well as a high tech party prank. IOG3 Plans ..... \$8.00  
IOG3K Kit/Plans ..... \$69.50

## Invisible Pain Field Generator

Shirt pocket size electronic device produces time variant complex shock waves of intense directional acoustic energy, capable of warding off aggressive animals, etc.

IPG7 Plans ..... \$8.00 IPG7K Kit/Plans ..... \$49.50  
IPG70 Assembled ..... \$74.50



**1000 Ft++**

## Potato Cannon

**NOT A TOY.** Uses electronic or piezo ignition. **CAUTION REQUIRED!**  
POT1 Plans .....  
(Dangerous Product) ..... \$10.00

## FireBall Gun

Shoots flaming ball - two shot capacity  
Great for special effects and remote fire starting. **CAUTION REQUIRED!**  
FIREBALL Plans (Dangerous Product) ..... \$10.00



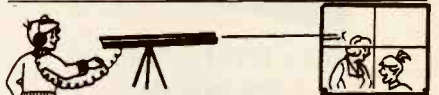
## TV & FM Joker / Jammer

Shirt pocket device allows you to totally control and remotely disrupt TV or radio reception. Great gag to play on family or friends. Discretion required. EJ1KM Easy to Assemble Electronic Kit ..... \$24.50

## Visible Beam Laser

High brightness red HeNe laser visible for miles. Produce your own light show! Projects a visible beam of red line clearly visible in most circumstances. Can be used to intimidate by projection of a red dot on target subject. Also may be used to "listen in" using our laser window bounce method #LLIS1 below. Easy to build module makes A working visible laser!

LAS1KM Kit w/1mw Laser Tube, Class II ..... \$69.50  
LAS3KM Kit w/2.5mw Laser Tube, Class IIA ..... \$99.50



## "Laser Bounce" Listener System

Allows you to hear sounds from an area via a file beam reflected from a window or other similar objects. System uses our ready-to-use LATR1 Laser Terminator gun site as the transmitter. The receiver section is supplied as an easy-to-build kit, including our cushioned HS10 headsets. LLIS2 Plans ..... \$20.00  
LLIS1K Kit of Both Transmitter and Receiver ..... \$199.50  
LLIS20 Assemble with Laser Gun Site ..... \$299.50

## 3mw Visible Red Pocket Laser

Utilizes our touch power control!  
VRL3KM Kit / Plans ..... \$74.50



## Electronic Hypnotism

Puts subjects under control using highly effective electronic stimuli. Intended for parties and entertainment but must be used with caution. Includes valuable text book reference and plans.

EH2 Plans and Text Book ..... \$19.50

## Pocket Sized Night Viewer

Uses Low Level Starlight to See in the Dark!  
• Low Cost  
• Ultra-Hi Lite Amplification!  
• Auto Brightness Control  
• Limited Amount Available  
• Made in USA • Night surveillance • Animal studies, etc.  
Can be used to fly an airplane or drive a car!  
PKV7 Plans ..... \$15.00  
PKV7K Easy to Assemble Kit ..... Price on Request  
PKV70 Ready to Use ..... Price on Request



## 3 Mi FM

## Wireless Microphone

Subminiature! Crystal clear, ultra sensitive pickup transmits voices and sounds to FM radio. Excellent for security, monitoring of children or invalids. Become the neighborhood disk jockey, or go "under cover" using our sunglasses FM radio (see catalog). FMV1 Plans ... \$7.00  
FMV1K Kit and Plans ..... \$39.50  
SUGL10 Sunglasses with built in FM Radio ..... \$29.50



## Telephone Transmitter - 3 Mi

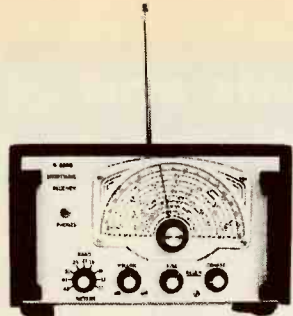
Automatically transmits both sides of a telephone conversation to an FM radio. • Tunable Frequency • Undetectable on Phone • Easy to Build and Use • Up to 3 Mile Range • Only transmits during phone use.  
VWPM7 Plans ..... \$7.00  
VWPM7K Kit/Plans ..... \$39.50

**INFORMATION UNLIMITED**

Dept PEM16, Box 716, Amherst, NH 03031  
Phone: 603-673-4730 FAX 603-672-5406  
MC, VISA, COD, Checks accepted. Please add \$8.00 Shipping & Handling

**CATALOG**  
With many more items!  
Free with Order or send \$1 P&H

Order by Mail or by 24 Hour Orders-Only Phone  
**800-221-1705**



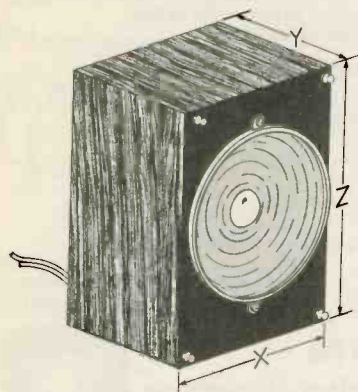
9-Band Shortwave Receiver  
See page 19



Add a DVM to Your PC  
See page 46



Portable Barometer  
See page 51



Design Your Own Loudspeakers  
See page 79



Telephone Scrambler  
See page 75

# Popular Electronics®

# FALL 1994

## Contents

### HIGH-VOLTAGE ELECTRONICS

- The Wimshurst Machine** ..... 57  
*The ultimate static-spark machine and you can build it*
- Voltage Doublers** ..... 61  
*An easy and inexpensive way to experiment with high voltages*
- Make Your Own High-Voltage Capacitors** ..... 65  
*Take on a big charge*

### MEASURING THE WEATHER

- Portable Barometer** ..... 51  
*Sense small changes in barometric pressure*
- Relative Humidity Gauge** ..... 84  
*Keep an eye on the humidity with this build-iy gadget*
- Build an Anemometer** ..... 98  
*Keep up with the wind with this inexpensive device*

### FABULOUS PROJECTS

- Nine-Band Shortwave Receiver** ..... 19  
*Tune in the world with this classic regenerative receiver*
- Microwave Motion Detector** ..... 27  
*A security system for your home or car that works on the same principles as police radar*
- Computer-Controlled A/B Switch** ..... 32  
*Gadget makes it easy to switch any pair of AC or DC signals, including RS-232 signals*
- Test Bench Amplifier** ..... 38  
*Add this handy little amplifier to your test-station arsenal*
- Call Blocker** ..... 40  
*Use this circuit and the 'phone company's "Caller ID" service to spare yourself from unwanted calls*

As a service to readers, *Popular Electronics Fall 1994 Electronics Hobbyists Handbook* publishes available plans or information relating to newsworthy products, techniques and scientific and technological developments. Because of possible variances in the quality and condition of materials and workmanship used by readers, we disclaim any responsibility for the safe and proper functioning of reader-built projects based upon or from plans or information published in this magazine.



# ELECTRONICS HOBBYISTS handbook <sup>TM</sup>

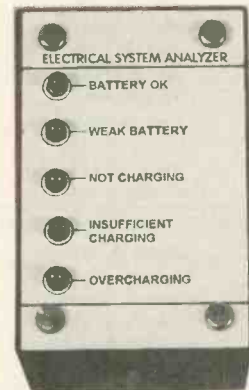
<b>Add a DVM to Your PC</b> .....	<b>46</b>
<i>Turns your PC into a digital voltmeter for automated testing, to record readings over time, and more</i>	
<b>How to Split a Power Supply</b> .....	<b>49</b>
<i>A nifty way to get a dual supply from a single-ended source</i>	
<b>Electrical Analyzer for Your Car</b> .....	<b>72</b>
<i>Avoid inexpensive road-service calls with a monitor that alerts you to any of several problems</i>	
<b>Build a Telephone Scrambler</b> .....	<b>75</b>
<i>Foil the snoopers and keep your conversations private</i>	
<b>Design Your Own Loudspeakers</b> .....	<b>79</b>
<i>Three simple programs that will help you design your own system right away</i>	
<b>Remote Control Relay Station</b> .....	<b>89</b>
<i>Your IR signals will turn corners or overcome extra-long and well lit rooms</i>	
<b>SCA Adapter</b> .....	<b>91</b>
<i>Hear the hidden broadcasts on the FM band</i>	
<b>Wireless IR Headphones</b> .....	<b>94</b>
<i>Cut the tether between you and your hi-fi</i>	
<b>DEPARTMENTS</b>	
<b>Editorial—Discover our secret</b> .....	<b>4</b>
<b>New Products—All that's fit to buy</b> .....	<b>6</b>
<b>Cartoon Page—A couple of laughs</b> .....	<b>10</b>
<b>Electronics Library—Tomes for technicians, etc.</b> .....	<b>12</b>
<b>Free Information Card</b> .....	<b>32A</b>
<b>Classified Advertising</b> .....	<b>111</b>
<b>Advertiser's Index</b> .....	<b>111</b>
<b>Advertising Sales Offices</b> .....	<b>112</b>

Since some of the equipment and circuitry described in *Popular Electronics Fall 1994 Electronics Hobbyists Handbook* may relate to or be covered by U.S. patents, we disclaim any liability for the infringement of such patents by the making, using, or selling of any such equipment or circuitry, and suggests that anyone interested in such projects consult a patent attorney.

*Popular Electronics Fall 1994 Electronics Hobbyists Handbook* is published semi-annually by Gernsback Publications Inc. All rights reserved. Printed in U.S.A. Single copy price \$3.95. Canadian G.S.T. Registration No. 125166280. Canada \$4.50. ©Gernsback Publications Inc., 1994.



Microwave Motion Detector  
See page 27



Electrical Analyzer for Your Car  
See page 72



Computer-Controlled A/B  
Switch  
See page 32



Test Bench Amplifier  
See page 38



# **ELECTRONICS HOBBYISTS handbook**™

---

**Larry Steckler**

*EHF, CET*

*Editor-In-Chief and Publisher*

---

**Julian S. Martin**

*Editor*

---

## **POPULAR ELECTRONICS EDITORIAL DEPARTMENT**

**Carl Laron**

*Editor*

**Robert A. Young**

*Associate Editor*

**John J. Yacono**

*Associate Editor*

**Teri Scaduto**

*Associate Editor*

**Evelyn Rose**

*Editorial Assistant*

**Marc Spiwak**

*Editorial Associate*

---

## **PRODUCTION DEPARTMENT**

**Ruby M. Yee**

*Production Director*

**Karen S. Brown**

*Production Manager*

**Kathy Campbell**

*Production Assistant*

---

## **ART DEPARTMENT**

**Andre Duzant**

*Art Director*

**Russell C. Truelson**

*Illustrator*

---

**Jacqueline P. Cheeseboro**

*Circulation Director*

---

**Michele Torrillo**

*P-E Bookstore*

---

## **BUSINESS AND EDITORIAL OFFICES**

Gernsback Publications, Inc.  
500-B Bi-County Blvd.  
Farmingdale, NY 11735  
1-516-293-3000  
Fax: 1-516-293-3115

President: **Larry Steckler**

---

**Advertising Sales Offices listed on page 112**

---

Cover by  
**Loewy Design**  
Oak Ridge, TN

Illustration by  
**John Edwards**

Composition by  
**Mates Graphics**



Since some of the equipment and circuitry described in **1994 ELECTRONICS HOBBYIST HANDBOOK** may relate to or be covered by U.S. patents, **1994 ELECTRONICS HOBBYIST HANDBOOK** disclaims any liability for the infringement of such patents by the making, using, or selling of any such equipment or circuitry, and suggests that anyone interested in such projects consult a patent attorney.



# **Editorial**

We are getting to be a habit. When *Electronics Hobbyists Handbook* was first published a few years ago, our magazine appeared once a year on the newsstand. Now we publish twice a year, Spring and Fall. Considering the fact that as many as 500 new magazines are published each year, you can imagine that the fatality rate of new magazines is very high. We made it this far because our readers accept the magazine for its contents.

The *Electronics Hobbyists Handbook* is not supported by any society or association, whether they be business, trade or consumer groups. Nor do we look to sell subscriptions to underwrite the magazine. So then, what is the secret of our success?

You are our big secret. You, the builders of countless projects, who are constantly looking for new and better electronic gadgets to build to satisfy your recreation desires. You are hobbyists to the core, and we found you and give you the do-it-yourself projects that make your spare time activities enjoyable. When we fail you, you'll leave us. That is not going to happen because the editorial staff will continue to present to you projects that you want to build. We get feedback from suppliers that tell us which projects are hot! You tell us directly when you write to us, and we find out what you like by building projects ourselves and being just like you.

The editorial staff sends its personal thanks to the many readers who support this magazine and we look forward to as many years of service to our readers as we have fun doing it! Thank you for being out there.

Julian S. Martin,  
Editor



# Don't Despair...REPAIR!

Here's how to troubleshoot and repair your electronics successfully!

## You Can Be Your Own Repair Expert!

For VCRs, camcorders, audio equipment, TV equipment, computer hardware, office equipment, home appliances, automobile electronics, and outdoor equipment.

- Pinpoint and analyze problems quickly.
- Successfully complete repairs with hands-on troubleshooting instructions.
- Become skilled understanding flowcharts and schematic diagrams.
- Confidently use test equipment such as oscilloscopes, frequency counters, and video analyzers.
- Keep your equipment in top condition with effective preventive maintenance techniques.

## Continue to Broaden Your Repair Expertise!

You'll receive quarterly supplements, up to 160 pages, with new step-by-step repair and maintenance instructions, valuable schematics and new repair techniques. Learn how to repair a growing variety of appliances with hands-on repair projects that will keep you up-to-date with later models and technology. You'll be thrilled with your ability to repair a growing list of electronic equipment! Supplements may be returned or cancelled at any time.

**SAVE \$10**

Call our toll-free number, pay by credit card, and mention this ad. We'll deduct \$10! We'll also waive shipping and handling.

Order today for your 30-day, no-risk review of The Electronics Repair Manual.

For Faster Service Call TOLL-FREE  
**1-800-222-WEKA**  
Or Fax To: 1-203-622-4187

CIRCLE 20 ON FREE INFORMATION CARD



## One Source For All Your Repair Needs!

Better organized than a magazine, more current than a book.

- 900-page manual
- easy-to-follow, detailed instructions
- trouble analysis flowcharts
- safety precaution checklists
- comprehensive replacement parts list
- directory of manufacturers



**Order your copy today!**

### MONEYBACK GUARANTEE

There's no risk in trying the ELECTRONICS REPAIR MANUAL to see if it's right for you. If you are not delighted, simply return the manual after the 30-day trial period and receive a prompt refund.



97 Indian Field Rd.  
Greenwich, CT 06830

**YES!** Please rush me a copy of the new Electronics Repair Manual for only \$59.95 + \$5.50 shipping and handling. I understand that if I am not satisfied I may return the manual within 30 days for a complete refund. Supplements are sent quarterly for 25¢ per page (never more than \$30) and may be returned or cancelled at any time.

My payment is enclosed  Bill me later  
 Charge my  Visa  MasterCard

Acct. No. \_\_\_\_\_ Exp. Date \_\_\_\_\_

Signature \_\_\_\_\_

Phone ( ) \_\_\_\_\_ Signature and phone number are required for all orders.

Name \_\_\_\_\_

Address \_\_\_\_\_

City \_\_\_\_\_ State \_\_\_\_\_ Zip \_\_\_\_\_

All payments must be in U.S. funds. Canada add \$10. All other countries add \$15. CT residents add 6% sales tax.

Mail to: WEKA Publishing, 97 Indian Field Rd.,  
Greenwich, CT 06830

400082



# NEW PRODUCTS

## Video Titlemaker



The broadcast-quality *TitleMaker 2000* video titler, an upgraded version of *Videonics'* popular *TitleMaker*, offers a host of new features. Intended to bring an added level of convenience and flexibility to home moviemakers who want to give

their productions professional-looking titles and special effects, the *TitleMaker 2000* features "preview output," an additional video output that allows a second monitor to be used to create new pages or modify the titles. Other new features include more than 90 font and size combinations, including script fonts; rapid page access without scrolling; advanced scrolling, which allows a title to scroll in from one direction and out from another; and a set of independent pages that can be saved for different jobs or users. Like the original unit, the *TitleMaker 2000* offers backgrounds, letters, outlines, and borders that can be created with over a million colors or a wide range of patterns, including animated patterns. The keyboard has accented characters for more than 16 languages and special characters.

The *TitleMaker 2000* has a suggested retail price of \$599. For further information, contact *Videonics*, 1370 Dell Avenue,

Campbell, CA 95008-6604; Tel. 708-866-8300; Fax: 408-866-4859.

**CIRCLE 105 ON FREE INFORMATION CARD**

## SOLDERING IRON/ TORCH KIT

*Philips ECG J-500* soldering iron/torch is now available in a 10-piece kit complete with carrying case, four different tips, and



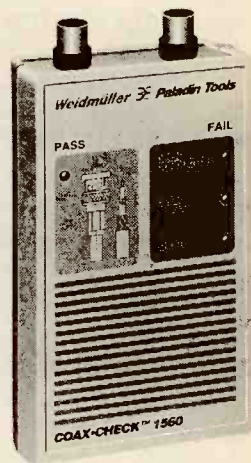
other accessories. The compact, lightweight, handheld tool features a see-through refillable butane tank, a temperature control for accurate adjustment of tip temperature, and a built-in igniter. The *J-500KT* kit includes the *J-500*, a solder tip, a blow-torch tip, a hot-knife tip, a heat-blower tip, a metal safety stand, a cleaning pad, spare flints, and a half-ounce of 60/40 rosin-core solder, all packaged in a heavy-duty, fitted carrying case. Additional tips are available optionally. Applications include electrical/electronic circuit repair, light-gauge welding, jewelry and eyeglass-frame repair, model building, crafts, and thawing frozen locks.

The *J-500KT* soldering iron/torch kit has a suggested retail price of \$35.50 and is available from participating *Philips ECG* distributors in the United States and Canada. For more information, contact *Philips ECG*, 38 State St., Seneca Falls, NY 13148-0730; Tel. 315-568-5875.

**CIRCLE 106 ON FREE INFORMATION CARD**

## COAXIAL-CABLE CHECKER

Designed for testing coaxial cables in common use for network and audio/video applications, *Paladin Tool's Coax-Check 1560* provides a simple pass-or-fail



analysis for RG58, 59, and 62 coaxial BNC-type cables. It tests the continuity of both the conductor and the braided shield, and identifies shorts resulting from contact between the conductor and the shield. A green LED indicates a "pass" diagnosis. One of a group of red LED's lights to indicate the reason for failure. The tester comes in a high-impact case, complete with a 9-volt battery installed.

The *Coax-Check 1560* has a suggested retail price of \$35.67. For additional information, contact *Paladin Tools*, 3543 Old Conejo Road, Suite 101, Newbury Park, CA 91320; Tel. 800-272-8665; Fax: 800-272-5257.

**CIRCLE 107 ON FREE INFORMATION CARD**

## WEATHER WIZARD II

You can monitor indoor and outdoor weather at the touch of a button with *Davis Instruments' Weather Wizard II*. The sophisticated, professional-quality weather station measures inside temperature from 32°F to 140°F, outside temperature from -50°F to 140°F, records high and low temperatures, monitors wind direction and wind speed, records high wind speed, calculates wind chill to -134°, and records low wind chill. All highs and lows are recorded with time and date. Alarms can be set to

Enter A World Of Excitement with a Subscription to

# Popular Electronics®

Get the latest electronic technology and information monthly!

Now you can subscribe to the magazine that plugs you into the exciting world of electronics. With every issue of **Popular Electronics** you'll find a wide variety of electronics projects you can build and enjoy.

**Popular Electronics** brings you informative new product and literature listings, feature articles on test equipment and tools—all designed to keep you tuned in to the latest developments in electronics. So if you love to build fascinating electronics, just fill out the subscription form below to subscribe to **Popular Electronics**... It's a power-house of fun for the electronics enthusiast.

## EXCITING MONTHLY FEATURES LIKE:

- CONSTRUCTION**—Building projects from crystal sets to electronic roulette
- FEATURES**—Educational training on digital electronics, Ohm's Law, Antennas, Communications, Antique Radio, Simplified Theory
- HANDS-ON-REPORTS**—User test comments on new and unusual consumer products
- SPECIAL COLUMNS**—Think Tank, Circuit Circus, Computer Bits, DX Listening, Antique Radio, Scanner Scene, Amateur Radio

## PLUS: ALL OUR GREAT DEPARTMENTS!

You'll get 12 exciting and informative issues of **Popular Electronics** for only \$18.95. That's a savings of \$23.05 off the regular single copy price. Subscribe to **Popular Electronics** today! Just fill out the subscription order form below.

MODEL ROCKET LAUNCHER • CES ROUND-UP • TELEPHONE-CALL ROUTER

MAY 1994

# Popular Electronics

**TIME-DELAYED MODEL-ROCKET LAUNCHER**  
Add a touch of class and safety with this deluxe controller

**CONSUMER ELECTRONICS SHOW ROUND-UP**  
Satellite TV gets small, multimedia gets big, 3D0 gets real, and other news direct from the show floor

**Build A Distinctive Ring Switch**  
It routes your telephone calls to the right person or device

**A Relay Station For Your Remote Control**

Save 55% Off The Regular NEWSSTAND Rate

FOR FASTER SERVICE CALL TODAY

# 1-800-827-0383

(7:30AM-8:30PM) EASTERN STANDARD TIME

## Popular Electronics® SUBSCRIPTION ORDER FORM

AH394

P.O. Box 338, Mt. Morris IL. 61054

**YES!** I want to subscribe to **Popular Electronics** for 1 Full year (12 Issues) for only \$18.95. That's a savings of \$23.05 off the newsstand price.  
(Basic Subscription Rate—1 yr/\$21.95)

Payment Enclosed  Bill me later  
Please charge my:  Visa  Mastercard

Acct. #

Signature

Exp. Date

PLEASE PRINT BELOW:

NAME

ADDRESS

CITY  STATE  ZIP

Allow 6 to 8 weeks for delivery of first issue. U.S. Funds only.  
In Canada add \$6.68 Postage (Includes G.S.T.) All Other Foreign add \$7.50 Postage.



# MORE NEW PRODUCTS

sound when temperature, wind speed, or wind chill fall above or below preset levels.

The Weather Wizard II's functions can be easily expanded with optional add-ons. The Rain Collector allows you to measure daily and accumulated rainfall. Weatherlink allows you to link the Weather Wizard II to an IBM-compatible PC or Macintosh to process, analyze, and store weather data.

The Weather Wizard II, complete with an anemometer with



40 feet of cable, an external temperature sensor with 25 feet of cable, a junction box with eight feet of cable, an AC-power adapter, and detailed instructions, costs \$195. For more information, contact Davis Instruments, 3465 Diablo Avenue, Hayward, CA 94545; Tel: 800-678-3669 or 510-732-9229; Fax: 510-732-9188.

**CIRCLE 100 ON FREE INFORMATION CARD**

## 900-MHZ TELEPHONE

According to *BEL-Tronics*, its *Micro 900* cordless phone system features the industry's lightest handset in a multi-handset 900-MHz model. Operating on the 900-MHz frequency, the system provides exceptional clarity and up to three times the range of traditional cordless phones. It is also virtually free of interference from electric motors, fluorescent lights, and other cordless phones. The 7.4-ounce handset is paired with either the stand-up model *900M*



or the lie-down model *900LX* base. A complete *Micro 900* system consists of three basic elements: a base-and-handset unit, up to three *900MR* remote extension-and-recharger units, and a *900BP* battery pack. Each base-and-handset unit has the capacity for up to three remote extension handsets, and can work independently of the extensions; the extensions require a base unit to operate. The extension rechargers can be plugged into any wall outlet in the home with no need for additional telephone jacks.

The *900M* base/handset costs \$499.95; the *900LX* base/handset costs \$529.95; each *900MR* handset/recharger costs \$349.95; and the *900BP* battery pack costs \$27.95. For further information, contact *BEL-Tronics Limited*, 8100 Sagi Parkway, Covington, GA 30209; Tel: 800-341-1401.

**CIRCLE 103 ON FREE INFORMATION CARD**

## FRONT-AND-REAR LASER DETECTOR

Because police laser-monitoring devices can clock both approaching and receding vehicles, *BEL-Tronics' Super Wideband with Laser Plus* series of integrated radar/laser detectors feature rear laser detection. No added attachments are required for rear detection. Besides *Dual Tracking Laser (DTL)* system, the new detectors also feature a wide field of view for off-axis laser detection and advanced super-wideband Ka radar detection to pick up signals from 33.4 to 36 GHz.

Each model in the series fea-

tures dual-patented *Fundamental Mixer Technology (FMT)*, which uses a fundamental-mixer response to detect each radar frequency and provide maximum sensitivity to all radar bands. Each also features advanced signal-processing techniques that automatically eliminate common sources of falsing for both radar and laser, a combination power/volume control, instant-on audio and visual alerts, single-setting CTY mode, and memory retention for all mode selections. The top-of-the-line *645STi-P*, pictured here, also offers "Shadow Technology" for complete immunity to the *Interceptor VG-2* or any other radar-detector detector.

Prices for the *Super Wide-*



band with *Laser Plus* series of radar/laser detectors range from \$279.95 to \$499.95. For more information, contact *BEL-Tronics Limited*, 8100 Sagi Parkway, Covington, GA 30209; Tel: 404-787-6500 or 800-828-8804; Fax: 404-784-9898.

**CIRCLE 101 ON FREE INFORMATION CARD**

## HOME-STUDY ELECTRONICS ENGINEERING TECHNOLOGY DEGREE

A leading electronics home-study school, the *Cleveland Institute of Electronics (CIE)*, has organized *World College*, which offers a Bachelor's Degree in Electronics Engineering Technology (BEET). The independent-study program concentrates on electronics technology and also includes courses on computer engineering, mathematics, basic science, communications, so-

cial science, and humanities. World College, which is located in Virginia Beach, has been authorized to enroll students in the BEET program by the Virginia Council of Higher Education, and is currently awaiting the Council's approval to grant the BEET degree. World College is also accredited by the Accrediting Commission of the National Home Study Council.

For additional information, contact World College, 1776 East 17th Street, Cleveland, OH 44114; Tel: 800-243-6446.

**CIRCLE 102 ON FREE INFORMATION CARD**

### 32-SWITCH REED-RELAY CARD

A versatile PC-based switching solution from AccuSys, the 32-Switch Reed Relay Card, allows PC's to control real-world applications by smoothly switching any signal. Offering simple-to-use and completely configurable low power management of analog or digital signals, the card can be used in such diverse applications as flight simulators, home automation, irrigation systems, modem switching, and even model-train operation. An expanded options connector allows more switch configurations than other switch cards, including conditional and multi-conditional switching combinations. New circuitry allows status checks of any relay with a simple software inquiry. An optional Windows application,



"Win-Switch," offers simple control and relay scheduling with an easy graphic interface. A broad selection of addressing options allow the user to populate any ISA-slot compatible system with as many cards as there are slots available. That allows a single PC to control hundreds of signals. If an application requires a lot of specially wired cards, mini-daughterboards are available optionally for easy replication of special relay

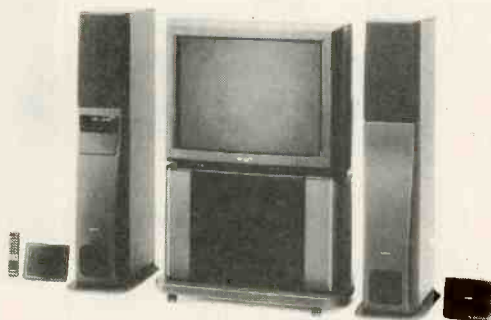
interconnections. An optional B-side connector, which provides discrete access to both sides of all relays, is also available.

The 32-Switch Card, including software primitives in Assembler, BASIC, C, Fortran, Cobol, FoxPro, and dBase, costs \$395. The B-Side connector costs \$29, and "Win-Switch" costs \$89.95. For more information, contact AccuSys, Inc., Information Group, 3695 Kings Row, Reno, NV 89503; Tel: 702-746-1111.

**CIRCLE 104 ON FREE INFORMATION CARD**

### INSTANT HOME-THEATER SOUND

Presenting a unified approach to home entertainment, Sony's SA-VA3 is a complete Dolby Pro



Logic Surround Sound audio system that can be set up in ten minutes. The SA-VA3 includes front and rear speakers, built-in amplifier, and a Dolby surround-sound processor. The system features four amplified A/V speakers—two specifically designed for the front and two optimized for the rear surround-sound channel: an integrated center channel, built-in Dolby Pro Logic, five surround-sound modes; and a super woofer. The complete system adds dramatic impact to any audio track for movies, music videos, or video games.

The SA-VA3 home-entertainment sound system has a suggested retail price of \$950. For additional information, contact Sony, 1 Sony Drive, Park Ridge, NJ 07656.

**CIRCLE 108 ON FREE INFORMATION CARD**

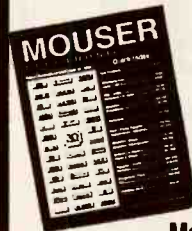
(More New Products on page 10)

# 45,296

## ELECTRONIC COMPONENTS

Whether you order 1 part or all 45,296...MOUSER stocks and...ships same day!!

**CALL...  
(800) 992-9943**



for your  
**FREE  
CATALOG**

2401 Hwy 287 N.  
Mansfield, TX 76063

## MOUSER ELECTRONICS

Sales & Stocking Locations Nationwide

**CIRCLE 16 ON FREE INFORMATION CARD**

FULL- OR PART-TIME JOB/BUSINESS:

### Learn VCR repair!

Professional-level home study course. Master easy-to-learn, high-profit repairs without investing in costly high-tech instruments. For free career literature, send or call 24 hours a day.

**800-223-4542**



Name \_\_\_\_\_ Age \_\_\_\_\_

Address \_\_\_\_\_ Phone ( ) \_\_\_\_\_

City \_\_\_\_\_ State \_\_\_\_\_ Zip \_\_\_\_\_

The School of VCR Repair, Dept. VRH351  
PCDI, 6065 Roswell Rd., Atlanta, GA 30328

### Great careers!

Home study career training. Check only one course below. Then send or call 24 hours a day for your free career literature.

- |  |   |
|--|---|
| <input type="checkbox"/> Paralegal Studies/<br>Legal Assistant | <input type="checkbox"/> Interior Decorating                    |
| <input type="checkbox"/> Computer Training                     | <input type="checkbox"/> Hotel/Restaurant<br>Management         |
| <input type="checkbox"/> Bookkeeping and<br>Accounting         | <input type="checkbox"/> Medical and Dental<br>Office Assistant |
| <input type="checkbox"/> Auto Mechanics                        | <input type="checkbox"/> Real Estate Appraisal                  |
| <input type="checkbox"/> Gunsmithing                           | <input type="checkbox"/> Home Inspection                        |
| <input type="checkbox"/> Veterinary Assistant/<br>Animal Care  | <input type="checkbox"/> Property Management                    |
| <input type="checkbox"/> Computer Repair                       | <input type="checkbox"/> Fitness/Nutrition                      |
| <input type="checkbox"/> Travel Agent                          | <input type="checkbox"/> Conservation                           |
|  | <input type="checkbox"/> Medical Transcription                  |



**Free literature: 800-223-4542**

Name \_\_\_\_\_ Age \_\_\_\_\_

Address \_\_\_\_\_

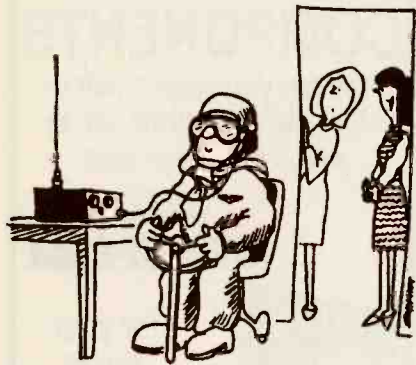
City \_\_\_\_\_ State \_\_\_\_\_ Zip \_\_\_\_\_

Professional Career Development Institute  
6065 Roswell Rd., Dept. XXH351, Atlanta, GA 30328

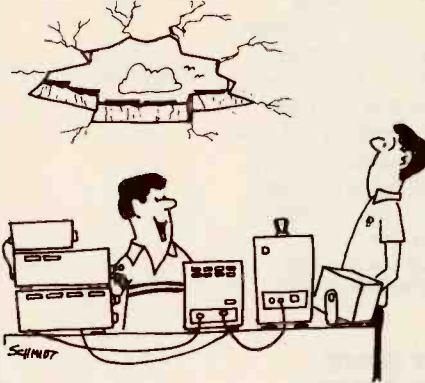
**CIRCLE 19 ON FREE INFORMATION CARD**



# A Couple of Laughs and a Yuk!



"Neil can't tear himself away from that aero-band monitor."



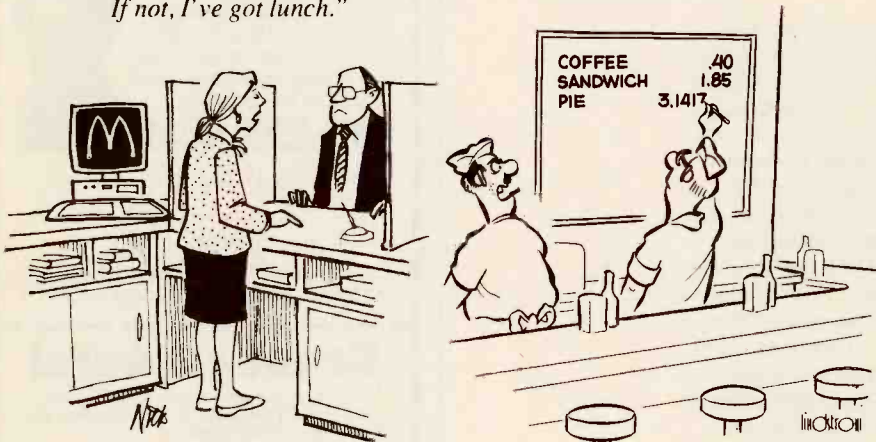
"Larry, I solved the overheating problem!"



"If it works, you have a computer. If not, I've got lunch."

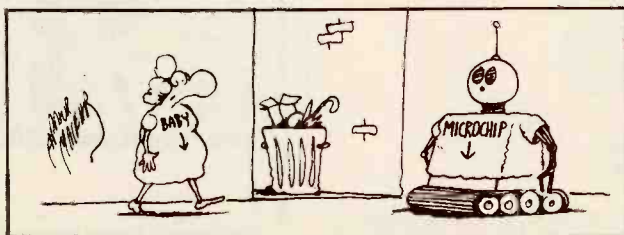


"I'm trying to tell Bob he won our 'Communicator-of-the-Year' award, but I can't raise him."



"Sorry, the computer's gone to lunch."

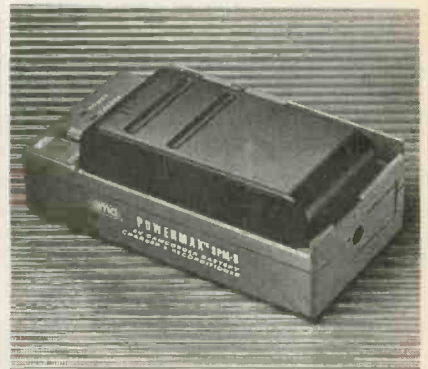
"Kelly!"



## NEW PRODUCTS

### AC-ONLY CHARGERS/ DISCHARGERS

With more and more 8mm and VHS camcorder owners recognizing the importance of eliminating battery memory, chargers and reconditioners are becoming must-have accessories. Sima's PowerMax Models SPM-8 and SPM-9 are specialized charger/dischargers in that they are AC-only. The SPM-8 is for use exclusively with 6-volt batteries, the most commonly used type. The SPM-9 can be used with virtually all 6-, 7.2-, and 9.6-volt batteries. In addition, the



SPM-9 features an auto-select mechanism that automatically senses battery voltage and begins charging/discharging. Users don't have to remember to switch the unit to the proper setting. Both products fully discharge and then charge camcorder batteries in one automatic and continuous cycle.

The PowerMax Models SPM-8 and SPM-9 chargers and reconditioners have suggested retail prices of \$37.45 and \$47.45, respectively. For more information, contact Sima Products Corporation, 8707 North Skokie Blvd., Skokie, IL 60077.

**CIRCLE 109 ON FREE  
INFORMATION CARD**

### CORDLESS PHONE/ ANSWERING SYSTEM

Sanyo's CAS-170 cordless telephone/digital TAD provides noise-free, tape-free convenience. With all-digital recording, an integrated chip stores up to 18 minutes worth of

incoming messages, and two 60-second outgoing messages. The record-memo function allows the user to record a message for a family member or friend without calling in. A two-digit LED call counter lets the user know exactly how many messages have been received. The answering machine also features a time/day stamp, two-way recording from the base or the handset, extension-phone disconnect, rapid message erasing, announce-only mode, and 100 user-selected security codes. The phone features Compander IV noise reduction, which compresses the audio signal at the base and amplifies it at the handset,



which leaves noise outside audible levels. The CAS-170 also offers 10-million digital security codes.

The CAS-170 cordless telephone with digital answering system has a suggested retail price of \$229.99. For more information, contact Sanyo, 21350 Lassen Street, Chatsworth, CA 91311-2329; Tel: 818-998-7322; Fax: 818-701-4149.

**CIRCLE 110 ON FREE INFORMATION CARD**

### CONVERTIBLE HEADPHONES

Jasco's Model 455 super-bass convertible headphones feature a unique design that allows the basic headphones to be transformed to over-ear design with the easy addition of convertible adaptors. The Model 455 also features an adjustable padded headband for a comfortable fit. Other features include a single side cord with a gold-plated 1/4-inch adaptor and 40mm samarium cobalt magnets for super-bass sound.

The Model 455 convertible headphones have a suggested retail price of \$31.99. For additional information, contact Jasco



Products Company, Inc., P. O. Box 466, Oklahoma City, OK 73101; Tel: 405-752-0710.

**CIRCLE 112 ON FREE INFORMATION CARD**

### MONITOR ANTI-GLARE FILTERS

The Secure-View anti-glare filter from Kantek Spectrum combines 99% glare reduction with an innovative design that restricts the peripheral view of material on the screen. That provides a practical means of controlling access to sensitive information in a crowded office environment. The filter is made of high-quality, optically pure glass that contains multiple thin-

film anti-radiation coatings on each side. Anti-Radiation versions of the Secure-View filter have an additional coating and grounding cord that block up to 99.999% of ELF/VLF E-field ra-



diation, and 100% of static. "Universal" models can be adjusted to fit most 12-15-inch VDT's and installs in seconds without tools. "Spectrum-Contour" models give irregular-shaped and curved VDT's a customized look, fitting snugly around the front of the monitor.

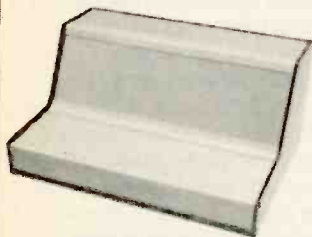
Secure-View filters are priced starting at \$169. For more information, contact Kantek Inc., 15 Main Street, East Rockaway, NY 11518; Tel: 516-593-3212; Fax: 516-593-3295.

**CIRCLE 111 ON FREE INFORMATION CARD**

EASY TO FABRICATE  
DESIGNED FOR SMALL LOY  
PRODUCTION

## SHEET METAL BOXES FOR CONSTRUCTION

ALL ITEMS STOCKED  
FOR QUICK DELIVERY  
SHEET METAL BOXES SHIPPED FLAT



PANELS ARE .063" ALUMINUM

PANELS ARE .063" ALUMINUM

PANELS ARE .063" ALUMINUM AND ARE FIELD REMOVABLE

### DUAL SLOPE METAL CABINETS

MODEL	DESCRIPTION	PRICE
	MAJOR DIM. SECONDARY DIM. W x D x H (inches)	\$
DS-1	4 x 6 x 4 x 1.2 x 1.6 x 2.4 x 1.6	59.00
DS-2	6 x 6 x 4 x 1.2 x 1.6 x 2.4 x 1.6	63.25
DS-3	8 x 6 x 4 x 1.2 x 1.9 x 2.4 x 1.6	67.50
DS-4	10 x 6 x 4 x 1.2 x 1.9 x 2.4 x 1.6	71.50
DS-5	12 x 6 x 4 x 1.2 x 1.9 x 2.4 x 1.6	76.00
DS-6	18 x 6 x 4 x 1.2 x 1.9 x 2.4 x 1.6	81.00
DS-7	4 x 8 x 6 x 2 x 3.1 x 3.5 x 1.9	69.00
DS-8	6 x 8 x 6 x 2 x 3.1 x 3.5 x 1.9	73.00
DS-9	8 x 8 x 6 x 2 x 3.1 x 3.5 x 1.9	76.00
DS-10	10 x 8 x 6 x 2 x 3.1 x 3.5 x 1.9	82.75
DS-11	12 x 8 x 6 x 2 x 3.1 x 3.5 x 1.9	87.75
DS-12	18 x 8 x 6 x 2 x 3.1 x 3.5 x 1.9	100.75

### RACK CHASSIS

MODEL	DESCRIPTION	PRICE
	W x D x H (inches)	\$
1RU5	19 x 5 x 1.75	30.55
1RU7	19 x 7 x 1.75	33.10
1RU10	19 x 10 x 1.75	35.25
2RU5	19 x 5 x 3.5	33.10
2RU7	19 x 7 x 3.5	35.25
2RU10	19 x 10 x 3.5	37.50
3RU5	19 x 5 x 5.25	41.90
3RU7	19 x 7 x 5.25	44.10
3RU10	19 x 10 x 5.25	46.30

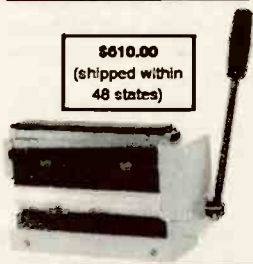
### METAL CABINETS

MODEL	DESCRIPTION	PRICE
	W x D x H (inches)	\$
MC-1A	4 x 3 x 2	16.50
MC-2A	6 x 3 x 2	18.75
MC-3A	8 x 3 x 2	20.95
MC-4A	4 x 4 x 3	18.75
MC-5A	6 x 4 x 3	20.95
MC-6A	8 x 4 x 3	23.15
MC-7A	4 x 7 x 4	20.95
MC-8A	6 x 7 x 4	23.15
MC-9A	8 x 7 x 4	25.75

### SHEET METAL PUNCHES

MODEL	HOLE SIZE & SHAPE	PRICE
PUNCH 1	3/8" ROUND	9.95
PUNCH 2	7/16" ROUND	9.95
PUNCH 3	1/2" ROUND	9.95
PUNCH 4	9/16" ROUND	12.95
PUNCH 5	5/8" ROUND	12.95
PUNCH 6	11/16" ROUND	12.95
PUNCH 7	3/4" ROUND	12.95
PUNCH 8	13/16" ROUND	12.95
PUNCH 9	7/8" ROUND	12.95
PUNCH 10	1" ROUND	13.95
PUNCH 11	1-1/16" ROUND	13.95
PUNCH 12	1-1/8" ROUND	13.95
PUNCH 13	1-3/16" ROUND	13.95
PUNCH 14	1-1/4" ROUND	14.95
PUNCH 15	1-3/8" ROUND	14.95
PUNCH 16	1-1/2" ROUND	16.95
PUNCH 17	1-5/8" ROUND	21.95
PUNCH 18	1-3/4" ROUND	24.95
PUNCH 19	2-5/8" ROUND	31.95
PUNCH 20	1 1/4" SQUARE	32.95
PUNCH 21	3/4" SQUARE	36.95
PUNCH 22	1" SQUARE	40.95
PUNCH 23	2 1/2" x 1 1/2" RECT.	48.95
*PUNCH 24	*THURST RACES	10.95

\$610.00  
(shipped within  
48 states)



### BRAKE & SHEAR

CUTS METALS, PLASTIC, ETC. TO .063" THICK AND 7 7/8" WIDE AND BENDS UP TO 60°. GREAT SHOP TOOL

TECH LINE (702) 565-3993 M - Th 8 am To 4 pm (Pacific Time)

ORDERS (800) 634-3457

FAX ORDERS (800) 551-2749

Line will only be answered by our technician; if no answer, please try at another time

OFFICE (702) 565-3400

FAX (702) 565-4828

### NEW FOR 1994

RACKER 'N' STACKER™ SERIES  
A NEW 1/4 RACK SYSTEM WITH ITS OWN TABLE-TOP RACK  
AVAILABLE IN CLEAR, BLACK AND GOLD FOR A GREAT PRESENTATION

### EXTRUDED SERIES

MODEL	DESCRIPTION	PRICE
	W x D x H (inches)	\$
ET-1	4.52 x 4.35 x 1.37	10.00
ET-1B	4.52 x 4.35 x 1.37	10.00
ET-2	4.52 x 6.00 x 1.37	24.00
ET-2B	4.52 x 6.00 x 1.37	24.00
CCET	PLASTIC CARRYING CASE	18.00

SESCOM, INC.  
2100 WARD DRIVE  
HENDERSON, NV 89015 USA



CALL OR WRITE FOR YOUR FREE 24 PAGE CONSTRUCTOR'S CATALOG!  
PREPAID ORDERS SHIPPED GROUND AT NO CHARGE (48 STATES)



CIRCLE 15 ON FREE INFORMATION CARD



# ELECTRONICS LIBRARY

## A Beginners Guide to TTL Digital ICs

by R. A. Penfold

Logic circuits are now part of everyday life, and TTL logic IC's are widely regarded as standard digital devices, used in a wide variety of applications. Because many fundamental concepts of digital design seem abstract and far removed from practical applications, getting started with logic circuits can be difficult. This book covers the basic theory of digital electronics and the use of TTL IC's, but keeps in mind the real-world applications. Along with the basic

### A Beginners Guide to TTL Digital ICs



concepts of logic circuits, the book covers the functions of gates, inverters, and other logic building blocks; TTL IC characteristics and their use in circuit design; oscillators and monostables; flipflops, binary dividers, and binary counters; and decoders, data latches, and three-state buffers. The emphasis is on the practical side of the subject matter, and all the circuits presented are based on real TTL IC's.

*A Beginners Guide to TTL Digital ICs* (order number BP332) is available for \$6.50 plus \$2.50 shipping and handling from Electronics Technology Today Inc., P.O. Box 240, Massapequa Park, NY 11762-0240.

**CIRCLE 80 ON FREE INFORMATION CARD**

### BECOMING AN ELECTRONICS TECHNICIAN: Securing Your High-Tech Future

by Ronald A. Reis

Aimed at would-be electronics technicians, this book offers a complete picture of what the career is like, what preparation and training is required, and how to secure that first electronics-technician position. In a conversational style, the book thoroughly discusses what it means to be an electronics technician in today's high-tech world. It explores the history

### BECOMING AN ELECTRONICS TECHNICIAN

SECURING YOUR HIGH-TECH FUTURE

and background of the field, and describes the general occupations and people who make up the industry. The specifics of the electronics technician's job are clearly outlined. The book includes discussions of what it takes to make it through the required course work to obtain a certificate, an associates degree, or a four-year degree. Particular attention is paid to the non-technical, non-electronic skills necessary to completing the course work—reading, listening, calculation, and writing skills. The book also suggests a wealth of activities and interests that students can explore on their own time to supplement and expand their knowledge of electronics.

*Becoming an Electronics Technician: Securing Your High-Tech Future* costs \$10 and is published by Macmillan Publish-

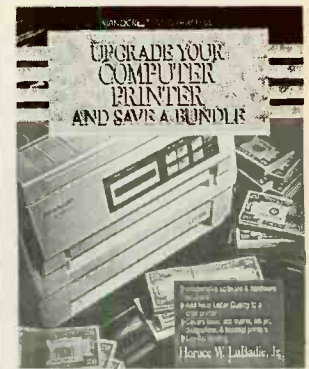
ing Company, 445 Hutchinson Avenue, Columbus, OH 43235.

**CIRCLE 81 ON FREE INFORMATION CARD**

### UPGRADE YOUR COMPUTER PRINTER AND SAVE A BUNDLE

by Horace W. LaBadie, Jr.

This book provides computer users with the practical guidance they need to give their old printers the power and flexibility



of today's best commercial models at the lowest possible price. It describes how to take advantage of inexpensive hardware and software upgrade options for all types of computer printers, including dot matrix, ink jet, daisy wheel, and thermal from all major manufacturers. The step-by-step, illustrated instructions show readers how to get near-letter quality from a draft printer by adding RAM chips to expand the input buffer; ROM chips for font or emulation changes; printer spoolers/buffers; printer-sharing and networking boxes; interface converters; HP PCL, Adobe PostScript, and PostScript emulators; and various software enhancements.

*Upgrade Your Computer Printer and Save a Bundle* costs \$19.95 and is published by Windcrest/McGraw-Hill, Blue Ridge Summit, PA 17294-0850; Tel: 800-233-1128; Fax: 717-794-2103.

**CIRCLE 86 ON FREE INFORMATION CARD**

## WORDPERFECT 6 EXPLAINED

by P.R.M. Oliver and N. Kantaris

Intended to help PC users get a handle on WordPerfect as quickly as possible, this book provides practical, hands-on routines for first-time word-processor users as well as those who are switching from another program. To that end, each chapter is a self-contained tutorial unit that builds upon the information presented in previous chapters. Readers can follow the book from beginning to end, or select only those chapters that they need. An emphasis is placed on the most-often used features of the program.

The book explains the hardware requirements and the installation process before familiarizing the reader with the WordPerfect environment and

## WordPerfect 6 Explained

P. R. M. OLIVER & N. KANTARIS



basic functions. It describes how to enter and edit text, use formatting codes, and setup and use the printer interface. The advanced features covered include document handling, columns, tables, outlines, file management, macros, and the Macro Programming Language. The book also explains how to get up and running with other stand-alone programs—WordPerfect Shell and the Text



From the Lab  
to your  
Living Room!

## Does your VCR have a "Head Cold?"

Probably not! However, through constant playing and using of degrading dry or wet cleaners, the output of your video tapes has slowly diminished to an unacceptable level and the VCR plays as if it has a head cold! The culprit is most likely clogged and dirty video and/or audio heads.

The **3M Black Watch™ Head Cleaner Videocassette** uses a patented magnetic tape-based cleaning formation to remove head clogging debris. No foreign substances such as cloth, plastics or messy liquids and no harsh abrasive materials are present. The cleaner's usable life is 400 cleanings or more! It's easy to use. Place the **3M Black Watch™ Head Cleaner Videocassette** in the VCR and press the Play button. A pre-recorded message appears clearly on your screen and an audible tone is heard, telling you that the cleaning process is now completed. No guess work, you never over clean!

**3M Black Watch™ Head Cleaner Videocassette SVHS VHS.....\$19.95**

Once your VCR's head cold is cured, and the unit plays like new, consider using the finest videocassette you can buy—the **3M Black Watch™ T120 Hi Pro VHS 4410 Videocassette**. The 4410 is the highest performing videocassette available today for use with all standard format VHS recording hardware!

Here's what you hear and see....A sharp, clear picture—brightest colors—freedom from streaks, flashes and snow—outstanding high-fidelity audio reproduction—optimum camcorder performance—maintains recording integrity. **3M Black Watch™** video tape is 100% laser inspected to guarantee surface smoothness and drop-out free performance.

**3M Black Watch™ T120 Hi Pro VHS 4410 Videocassette VHS.....\$8.00**

**CLAGGK INC. — 3M VHS Special Offer**  
P.O. Box 4099, Farmingdale, New York 11735

Yes, I like your offer and here is my order for 3M Black Watch™ products!

___ 3M Black Watch™ Head Cleaner Videocassette	(\$19.95 each)	___ \$
___ 3M Black Watch™ T120 Hi Pro VHS 4410 Videocassette	(\$8.00 each)	\$ ___
Shipping and handling per order		<b>\$ 4.00</b>
Total Amount in U.S. Funds only		\$ ___

New York State residents add local sales tax. Canadians add \$6.00 per order. No foreign orders. Do not send cash.

Bill me  VISA  MasterCard      Expire Date \_\_\_/\_\_\_/\_\_\_  
 Card No. \_\_\_\_\_  
 Signature \_\_\_\_\_  
 Name (Please print) \_\_\_\_\_  
 Address \_\_\_\_\_  
 City \_\_\_\_\_ State \_\_\_\_\_ ZIP \_\_\_\_\_



# ELECTRONICS LIBRARY

CONTINUED

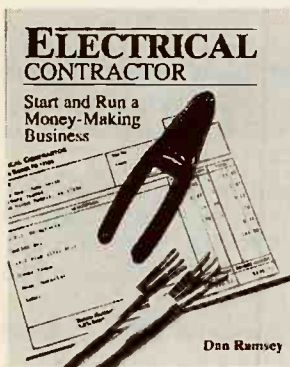
Editor—that are included with the WordPerfect 6 package.

*WordPerfect 6 Explained* (order number BP351) is available for \$6.95 plus \$2.50 shipping and handling from *Electronics Technology Today Inc.*, P.O. Box 240, Massapequa Park, NY 11762-0240.

**CIRCLE 87 ON FREE INFORMATION CARD**

## **ELECTRICAL CONTRACTOR: Start and Run a Money-Making Business** by Dan Ramsey

This book provides apprentice and journeyman electricians with the knowledge they need to make it on their own without a business degree. It offers sound advice on how to start or expand a self-owned electrical-contracting company. The book



begins by describing the latest opportunities for residential, commercial, and industrial electricians, including the newest technologies that make electrical contracting more productive and profitable than in the past. The book goes on to address all the issues that would-be contractors are likely to face. Those include choosing a location and obtaining a license; obtaining financing; reducing overhead; estimating jobs and setting prices; hiring and managing employees; leasing versus buying equipment; finding and keeping customers; minimizing risk; marketing and advertising; and communicating

with clients, employees, partners, and government officials. The book includes practical worksheets that make it easy to estimate jobs and costs, keep track of income and expenses, and bid on jobs.

*Electrical Contractor: Start and Run a Money-Making Business* costs \$17.95 and is published by *Tab Books Inc.*, Blue Ridge Summit, PA 17294-0850; Tel: 1-800-233-1128.

**CIRCLE 88 ON FREE INFORMATION CARD**

## **LOOKING GOOD IN PRINT: A Guide to Basic Design for Desktop Publishing** by Roger C. Parker

There's more to successful desktop publishing than learning to use the software. Good design is a basic element of any effective printed material, be it a newsletter, an ad, a manual, or a letter. Aimed at any computer-literate but "graphically challenged" desktop publisher—regardless of the type of hardware and software being used—this book teaches the elements of good design. As it guides the reader through the maze of boxes, grids, screens, fonts, clip art, and other graphic elements, it offers guidelines, advice, and a wealth of ideas for creating professional materials.

The third edition contains new information on adding impact and accent with color in a new chapter with 24 pages of four-color illustrations. It also explains how to choose, place,



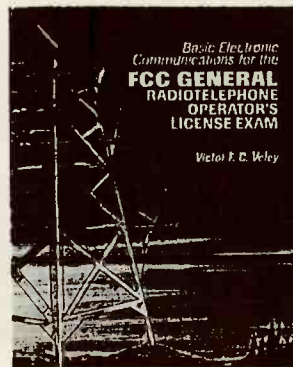
crop, and retouch photos; work with service bureaus; and vast resources of ready-made art that are available to desktop publishers for a minimal cost.

Looking Good in Print, Third Edition costs \$24.95 and is published by *Ventana Press*, P. O. Box 2468, Chapel Hill, NC 27515; Tel: 919-942-0220; Fax: 919-942-1140.

**CIRCLE 99 ON FREE INFORMATION CARD**

## **BASIC ELECTRONIC COMMUNICATIONS FOR THE FCC GENERAL RADIOTELEPHONE OPERATOR'S LICENSE EXAM** by Victor F. C. Veley

This comprehensive study guide and reference work provides all the information necessary to pass the FCC



General Radiotelephone Operator's License (GROL) exam. More than just a sampling of exam questions, the book provides detailed answers and explanations that help aspiring technicians fully understand the principles of electronic communications. Starting with the basics of alternating and direct current, the book progresses logically through the operation and use of diodes and power supplies, transistors and other semiconductor devices, AM and FM transmitters and receivers, transmission lines and antennas, microwaves and radar, numbering systems, and digital concepts. The Ship Radar En-

dorsement (Element 8) is also thoroughly covered.

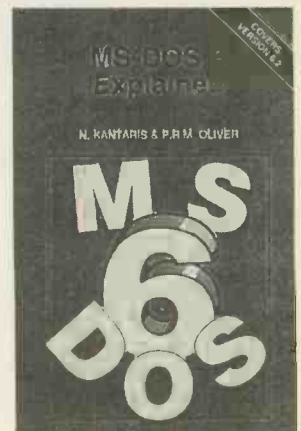
*Basic Electronic Communications for the FCC General Radiotelephone Operator's License Exam* costs \$24.95 and is published by *Tab Books Inc.*, Blue Ridge Summit, PA 17294-0850; Tel: 1-800-233-1128.

**CIRCLE 98 ON FREE INFORMATION CARD**

## **MS-DOS 6 EXPLAINED** by N. Kantaris & P.R.M. Oliver

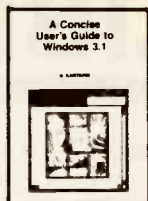
To use a PC effectively, you must have a thorough working knowledge of its operating system. This book helps readers gain such an understanding of MS-DOS 6. For those who are upgrading, the differences between versions 5 and 6 are explained wherever possible. Written for busy, non-expert PC users, each self-contained chapter builds upon what was taught in previous chapters.

The book explains the enhancements over previous versions, how the operating system is structured, how to use directories and subdirectories to effectively structure the hard drive, how to use the DOS Shell graphical interface, how to manage disk files, and how to use the MS-DOS editor to fully configure the system. In addition, it covers how to increase memory using MemMaker, how to increase speed, how to write batch files to automate system operation, and how to write and



# Electronic Paperbacks at Special Prices

**BP325—A CONCISE USER'S GUIDE TO WINDOWS 3.1 . . . \$7.95.** Come to grips with Windows 3.1 in the shortest and most effective way. Learn how to manipulate Windows screens and DOS by Windows graphics interface. Master its word processor, Paintbrush and data base along with Notepad, Macro Recorder, PIF Editor, and Calculator.



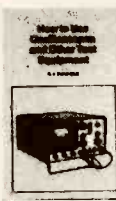
**BP311—AN INTRODUCTION TO SCANNERS AND SCANNING . . . \$7.95.** Radio scanners have opened a realm of exciting radio listening. Understand radio wave propagation, types of transmissions, antennas, band assignments—the straight dope on what to hear and where to hear it! Comes complete with index, glossary of important terminology.



**BP287—A REFERENCE GUIDE TO PRACTICAL ELECTRONICS TERMS . . . \$8.95.** More than just a dictionary of practical electronics terms, the book goes a step further in getting down to fundamentals. A reference volume that can be read casually by a reader seeking knowledge.



**BP248—TEST EQUIPMENT CONSTRUCTION . . . \$5.95.** Details construction of simple, inexpensive, but extremely useful test equipment. AF Gen, Test Bench Ampl, Audio Millivoltmeter, Transistor Tester and six more.



**BP267—HOW TO USE OSCILLOSCOPES AND OTHER TEST EQUIPMENT . . . \$6.95.** Mastering the oscilloscope is not really too difficult. This book explains all the standard controls and functions. Other equipment is also described.



**BP265—MORE ADVANCED USES OF THE MULTIMETER . . . \$5.95.** Use these techniques to test and analyze the performance of a variety of components. Also see how to build add-ons to extend multi-meter capabilities.



**BP256—INTRO TO LOUDSPEAKERS AND ENCLOSURE DESIGN . . . \$5.95.** We explore the variety of enclosure and speaker designs in use today so the reader can understand the principles involved.

**BP298—A CONCISE INTRODUCTION TO THE MACINTOSH SYSTEM AND FINDER. . . \$6.25.** If you have one of the popular Macintosh range of computers, this book is designed to help you get the most from it. Although the Mac's WIMP user interface is designed to be easy to use, much of it only becomes clear when it is explained in simple terms. All Macintosh computers are covered including the new "Classic" range.



**BP299—PRACTICAL ELECTRONIC FILTERS . . . \$6.95.** Presents a dozen filter-based practical projects with applications in and around the home or in the constructor's workshop. Complete construction details are included.



**BP249—MORE ADVANCED TEST EQUIPMENT CONSTRUCTION . . . \$6.95.** Eleven more test equipment construction projects. They include a digital voltmeter, capacitance meter, current tracer, etc.



**BP309—PREAMPLIFIER AND FILTER CIRCUITS . . . \$6.95.** Provides circuits and background info for a range of preamplifiers, plus tone controls, filters, mixers and more. All are high-performance circuits that can be built at a reasonable cost.



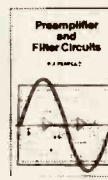
**BP245—DIGITAL AUDIO PROJECTS . . . \$5.95.** Practical circuits to build and experiment with. Includes A/D converter, input amplifier, digital delay line, compander, echo effect and more.



**BP247—MORE ADVANCED MIDI PROJECTS . . . \$5.95.** Circuits included are a MIDI indicator, THRU box, merge unit, code generator, pedal, programmer, channelizer, and analyzer.



**BP257—INTRO TO AMATEUR RADIO . . . \$6.95.** Amateur Radio is a unique and fascinating hobby. This book gives the newcomer a comprehensive and easy to understand guide to the subject.



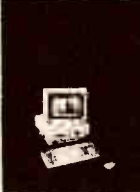
**PCP115—ELECTRONIC PROJECTS FOR HOME SECURITY . . . \$10.00.** 25 projects ranging from a single-door protection circuit that can be completed in an hour or two, to a sophisticated multi-channel security system. Each project is described in detail with circuit diagrams, explanations of how it works, instructions for building and testing, and how to adapt circuits to meet special requirements.



**BP303—UNDERSTANDING PC SOFTWARE . . . \$6.95.** This book will help you understand the basics of various types of business software in common use. Types of software covered include word processors, spelling checkers, graphics programs, desktop publishing, databases, spreadsheets and utilities.



**BP251—COMPUTER HOBBYISTS HANDBOOK . . . \$8.95.** A wrapup of everything the computer hobbyist needs to know in one easy to use volume. Provides a range of useful reference material in a single source.



**BP190—ADVANCED ELECTRONIC SECURITY PROJECTS . . . \$5.95.** Includes a passive infra-red detector, a fiber-optic loop alarm, computer-based alarms and an unusual form of ultrasonic intruder detector.

**BP235—POWER SELECTOR GUIDE . . . \$10.00** Complete guide to semiconductor power devices. More than 1000 power handling devices are included. They are tabulated in alpha-numeric sequence, by technical specs Includes power diodes, Thyristors, Triacs, Power Transistors and FET's.

**BP234—TRANSISTOR SELECTOR GUIDE . . . \$10.00.** Companion volume to BP235. Book covers more than 1400 JEDEC, JIS, and brand-specific devices. Also contains listing by case type, and electronic parameters. Includes Darlingtons transistors, high-voltage devices, high-current devices, high power devices.

**BP117—PRACTICAL ELECTRONIC BUILDING BLOCKS—Book 1 . . . \$5.75.** Oscillators, Timers, Noise Generators, Rectifiers, Comparators, Triggers and more.

**BP196—INTRODUCTION TO SATELLITE TV . . . \$9.96.** A definitive introduction to the subject written for the professional engineer, electronics enthusiast, or others who want to know more before they buy. 8 x 10 in.

**BP179—ELECTRONIC CIRCUITS FOR THE COMPUTER CONTROL OF ROBOTS . . . \$7.50.** Data and circuits for interfacing the computer to the robot's motors and sensors.

**BP238—GETTING THE MOST FROM YOUR MULTIMETER . . . \$5.95.** Covers basics of analog and digital meters. Methods of component testing includes transistors, thyristors, resistors, capacitors and other active and passive devices.

**BP97—IC PROJECTS FOR BEGINNERS . . . \$5.50.** Power supplies, radio and audio circuits, oscillators, timers, switches, and more. If you can use a soldering iron you can build these devices.

**RADIO—100 RADIO HOOKUPS . . . \$3.00.** Reprint of 1924 booklet presents radio circuits of the era including regenerative, neutrodyne, reflex & more.

**BP42—SIMPLE LED CIRCUITS . . . \$5.50.** A large selection of simple applications for this simple electronic component.

**BP122—AUDIO AMPLIFIER CONSTRUCTION . . . \$5.75.** Construction details for preamps and power amplifiers up through a 100-watt DC-coupled FET amplifier.

**BP92—CRYSTAL SET CONSTRUCTION . . . \$5.50.** Everything you need to know about building crystal radio receivers.

**BP255—INTERNATIONAL RADIO STATIONS GUIDE . . . \$7.95.** Provides the casual listener, amateur radio DXer and the professional radio monitor with an essential reference work designed to guide him or her around the more than ever complex radio bands.

## CHECK OFF THE BOOKS YOU WANT

**ELECTRONIC TECHNOLOGY TODAY INC.**  
P.O. Box 240, Massapequa Park, NY 11762-0240

Name \_\_\_\_\_  
Address \_\_\_\_\_  
City \_\_\_\_\_ State \_\_\_\_\_ Zip \_\_\_\_\_

HHF4

### SHIPPING CHARGES IN USA AND CANADA

\$0.01 to \$5.00 . . . . .	\$1.50
\$5.01 to \$10.00 . . . . .	\$2.50
\$10.01 to 20.00 . . . . .	\$3.50
\$20.01 to 30.00 . . . . .	\$4.50
\$30.01 to 40.00 . . . . .	\$5.50
\$40.01 to 50.00 . . . . .	\$6.50
\$50.01 and above . . . . .	\$8.00

**SORRY No orders accepted outside of USA & Canada**

Total price of merchandise . . . . .	\$ _____
Shipping (see chart at left) . . . . .	\$ _____
<b>Subtotal</b> . . . . .	\$ _____
Sales Tax (NY State only) . . . . .	\$ _____
<b>Total Enclosed</b> . . . . .	\$ _____

All payments must be in U.S. funds

Number of books ordered



# ELECTRONICS LIBRARY

## CONTINUED

implement multiple configurations. The book describes the use of Microsoft Utilities such as DoubleSpace, MsBackup, and AntiVirus. A summary of all DOS commands, illustrated with examples, is provided in the last chapter.

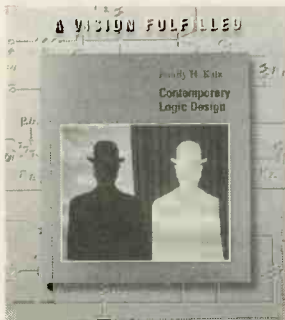
*MS-DOS 6 Explained* (order number BP341) is available for \$7.95 plus \$2.50 shipping and handling from Electronics Technology Today Inc., P.O. Box 240, Massapequa Park, NY 11762-0240.

**CIRCLE 90 ON FREE INFORMATION CARD**

### CONTEMPORARY LOGIC DESIGN

by Randy H. Katz

This textbook offers an innovative approach to logic design that combines a superior introduction to design fundamentals with an in-depth look at today's state-of-the-art design technologies. Recognizing the hardware-design revolution brought about by CAD, rapid prototyping, and PLD's, the book demonstrates how each tool fits



in the design process. Numerous case studies, along with special "Practical Matters" sections, underscore the book's emphasis on the development of practical design knowledge. In addition, an extensive supplements package is available separately. The package includes almost 600 electronic transparencies, a complete instructor's guide, and hardware and software labs.

*Contemporary Logic Design*

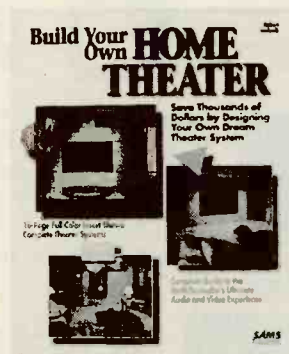
costs \$67.75 and is published by *The Benjamin/Cummings Publishing Company, Inc.*, 390 Bridge Parkway, Redwood City, CA 94065; Tel: 800-950-BOOK.

**CIRCLE 89 ON FREE INFORMATION CARD**

### BUILD YOUR OWN HOME THEATER

by Robert Wolenik

Home theater has changed the way we watch TV. Viewers are turning to large-screen sets, ac-



companied by surround-sound audio systems. If you've been thinking of updating your existing audio/video system or building a complete home theater from the ground up, this book can help you do it without spending a fortune.

The book describes exactly what components go into various home-theater systems—from the simple TV-stereo hook-up to a system complete with Dolby Pro Logic surround sound and even a satellite dish—and then helps you decide what to include in your home theater. It clearly explains the differences between direct-view, rear-projection, and front-projection televisions; Dolby Surround, Dolby Pro Logic, and THX; and other audio and video options.

The book also shows how to fit all the electronics equipment into your home. Beginning with selecting an appropriate room, the book explains how to acoustically insulate it for the best possible performance, how to arrange speakers for true sur-

round sound, how to shop for an entertainment center, how to choose colors and lighting that complement the system, and how to arrange furniture to maximize viewing pleasure. Numerous illustrations as well as photographs of real-life home theaters illustrate the concepts presented in the text.

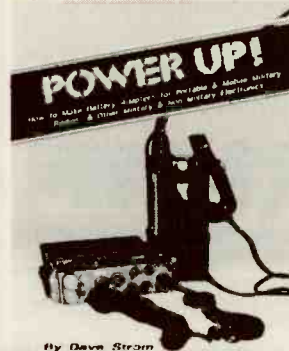
*Build Your Own Home Theater* costs \$16.95 and is published by *Sams Publishing*, 201 West 103rd Street, Indianapolis, IN 46290; Tel: 317-581-3500; Fax: 317-581-3500.

**CIRCLE 95 ON FREE INFORMATION CARD**

### POWER UP! How to Make Battery Adapters for Portable & Military Radios, and other Military & Non-Military Electronics

by Dave Strom

Readily available on the surplus market, military radios are rugged, versatile, well-designed, and easy to operate. It's no wonder that the surplus sets are used by amateurs, National Guard units, experimenters,



federal agencies, and survival groups. The only problem with them is that almost every type of portable and mobile military set requires a different, usually hard-to-find, battery, designed particularly for that piece of equipment.

This book solves the problem

of powering surplus military radios and electronic equipment. It shows how to easily make battery adapters for the many popular units, allowing the use of standard commercially-available batteries. The fully illustrated book contains detailed instructions and clear wiring diagrams that show exactly how to make adapters that can be used to power a wide variety of popular portable and mobile military radios. In addition, the book covers battery adapters for strobes, night scopes, radiac sets, detection/intrusion sets, and field telephones.

*Power Up!* is available for \$13.95 plus \$4 shipping and handling (\$5 to Canada) from *CRB Research Books, Inc.*, P.O. Box 56, Commack, NY 11725; Tel: 800-656-0056 in continental U.S., or 516-543-9169. (New York residents please add \$1.53 state sales tax.)

**CIRCLE 94 ON FREE INFORMATION CARD**

### A CONCISE INTRODUCTION TO MICROSOFT WORKS

by N. Kantaris and P.R.M. Oliver

Written with the busy, non-expert person in mind, this book aims to help the beginner come to grips with Microsoft Works for MS-DOS in the shortest and most effective way. Fully updated to cover the improvements included in version 3.0, the book has an underlying structure that allows the reader to build upon the information presented in each chapter. Experienced Works users need not read the book cover-to-cover, but can start from any of the self-contained sections.

The book explains how to use the word processor to type, edit, print, and save documents. It describes how Works can be used to build up simple spreadsheet examples and then to edit, save, print, and retrieve

## Just like these Fully Trained Electronics Professionals



"Thanks to CIE I have tripled my previous salary, and I am now in a challenging and rewarding new field where only the sky is the limit."

Daniel Wade Reynolds  
Industrial Electrician  
Ore-Ida Foods



"CIE was recommended to me by my boss. It was appealing since I could study at my own pace at home and during business travel."

Dan Parks  
Marketing Manager/Consumer Products  
Analog Devices, Inc.



"I loved the flexibility CIE offered. It was the only way I could continue both school and my demanding job."

Britt A. Hanks  
Director of Engineering  
Petroleum Helicopters, Inc.



"I liked the way the school was set up with laboratory assignments to enforce conceptual learning. The thing which impressed me the most about CIE's curriculum is the way they show application for all the theory that is presented."

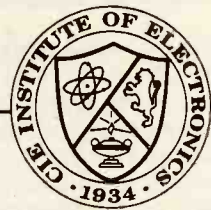
Daniel N. Parkman  
Missile Electro-Mechanical Technician  
U.S. Air Force



"Completing the course gave me the ability to efficiently troubleshoot modern microprocessor based audio and video systems and enjoy a sense of job security."

Tony Reynolds  
Service Manager/Technician  
Threshold Audio & Video

# Graduate with an Associate Degree from CIE!



CIE is the best educational value you can receive if you want to learn about electronics, and earn a good income with that knowledge. CIE's reputation as the world leader in home study electronics is based solely on the success of our graduates. And we've earned our reputation with an unconditional commitment to provide our students with the very best electronics training.

Just ask any of the 150,000-plus graduates of the Cleveland Institute of Electronics who are working in high-paying positions with aerospace, computer, medical, automotive and communications firms throughout the world.

They'll tell you success didn't come easy...but it did come...thanks to their CIE training. And today, a career in electronics offers more rewards than ever before.

### CIE'S COMMITTED TO BEING THE BEST...IN ONE AREA...ELECTRONICS.

CIE isn't another be-everything-to-everyone school. CIE teaches only one subject and we believe we're the best at what we do. Also, CIE is accredited by the National Home Study Council. And with more than 1,000 graduates each year, we're the largest home study school specializing exclusively in electronics. CIE has been training career-minded students for nearly sixty years and we're the best at our subject...  
**ELECTRONICS... IT'S THE ONLY SUBJECT WE TEACH!**

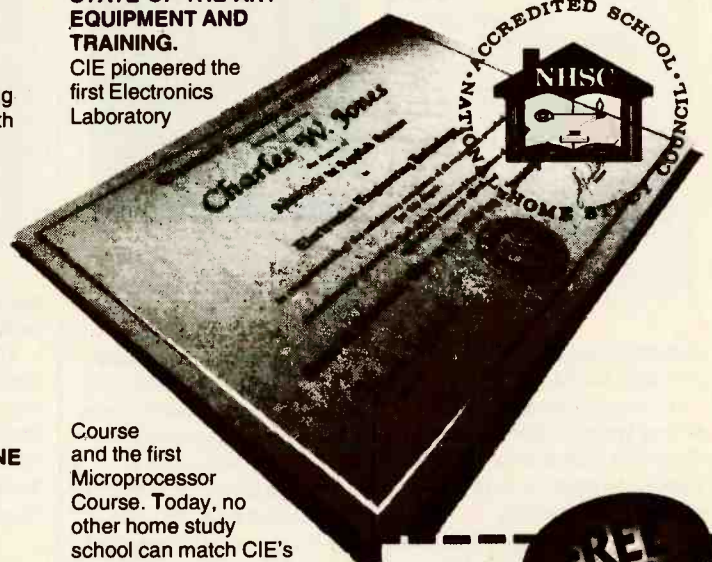
### CIE PROVIDES A LEARNING METHOD SO GOOD IT'S PATENTED.

CIE's AUTO-PROGRAMMED® lessons are a proven learning method for building valuable electronics

career skills. Each lesson is designed to take you step-by-step and principle-by-principle. And while all of CIE's lessons are designed for independent study, CIE's instructors are personally available to assist you with just a toll free call. The result is practical training... the kind of experience you can put to work in today's marketplace.

### LEARN BY DOING...WITH STATE-OF-THE-ART EQUIPMENT AND TRAINING.

CIE pioneered the first Electronics Laboratory



Course and the first Microprocessor Course. Today, no other home study school can match CIE's state-of-the-art equipment and training. And all your laboratory equipment, books and lessons are included in your tuition. It's all yours to use while you study and for on-the-job after you graduate.

### PERSONALIZED TRAINING...TO MATCH YOUR BACKGROUND.

While some of our students have a working knowledge of electronics others are just starting out. That's why CIE has developed twelve career courses and an A.A.S. Degree program to choose from. So, even if you're not sure which electronics career is best for you, CIE can get you started with core lessons applicable to all areas in

electronics. And every CIE Course earns credit towards the completion of your Associate in Applied Science Degree. So you can work toward your degree in stages or as fast as you wish. In fact, CIE is the only school that actually rewards you for fast study, which can save you money.

## YES!

I want to get started. Send me my CIE course catalog including details about the Associate Degree Program. (For your convenience, CIE will have a representative contact you - there is no obligation.)

Please Print Clearly

AHV01

Name \_\_\_\_\_

Address \_\_\_\_\_

City \_\_\_\_\_

State \_\_\_\_\_ Zip \_\_\_\_\_ Age \_\_\_\_\_

Phone No. \_\_\_\_\_

Check box for G.I. Bill Benefits.

Veteran

Active Duty

Cleveland Institute of Electronics, Inc.  
1776 East 17th Street  
Cleveland, OH 44114

A School of Thousands.  
A Class of One. Since 1934.

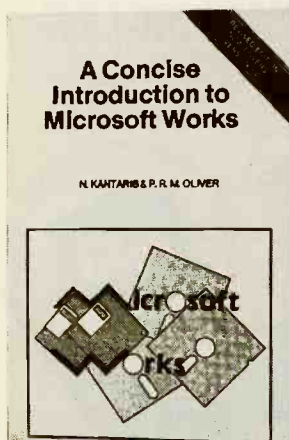
Send for CIE's FREE Course Catalog and See How We Can Help Your Career Too!



# ELECTRONICS LIBRARY

CONTINUED

them. It shows readers how to generate, edit, and print both single and multiple graphs. The book covers setting up, sorting, and searching through a database-management system, and how to use it to create top-quality printed reports. To simplify long, repetitive tasks, the book explains how to create simple macros and how to



customize the program to meet your own needs.

*A Concise Introduction to Microsoft Works* (order number BP294) is available for \$6.95 plus \$2.50 shipping and handling from *Electronics Technology Today Inc.*, P.O. Box 240, Massapequa Park, NY 11762-0240.

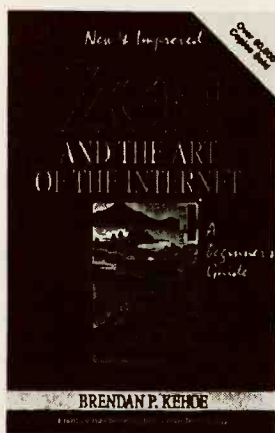
**CIRCLE 97 ON FREE INFORMATION CARD**

**ZEN AND THE ART OF THE INTERNET: A Beginner's Guide, Third Edition**  
by Brendan P. Kehoe

If you are considering joining the more than 15-million people worldwide who are already connected to the Internet, this book can help you get started. In a straightforward, easy-to-read style, the book makes learning about and traveling through the Internet easier for beginners. No previous knowledge of the Internet is assumed, and the book works for any type of

computer operating system.

This third edition of the first user's guide to the Internet has been updated and expanded to reflect the rapidly changing technology and services. New topics covered include Gopher, WAIS; InterNIC; Internet BBS's;



how to connect to CompuServe, Genie, and BIX; the Online Career Center; and Internet Talk Radio. The book also includes network basics, electronic mail, anonymous FTP, Usenet News, TELnet, commercial services, various tools, and country codes. The third edition features a lay-flat binding that makes it easy to read while at your computer.

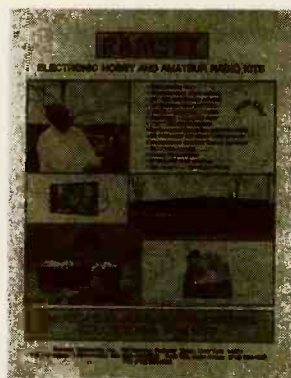
*Zen and the Art of the Internet: A Beginner's Guide, Third Edition* is available for \$23.95 from PTR Prentice Hall/Neodata, P. O. Box 11073, Des Moines, IA 50381-1073; Tel: 515-284-6751; Fax: 515-284-2607.

**CIRCLE 84 ON FREE INFORMATION CARD**

**ELECTRONIC HOBBY AND AMATEUR RADIO KITS CATALOG**  
from Ramsey Electronics

This 20-page catalog contains an assortment of exciting, educational kits for the electronics hobbyist or student. The products range from fast and easy

"Mini-Kits"—including a universal timer, a voice-activated switch, and a light-beam communicator—to VHF/UHF/FM transceiver kits. Other projects include QRP transmitters, active antennas, shortwave gear, a microwave motion detector, a radio direction finder, a TV transmitter, and an FM broadcast-band receiver. The catalog also offers



test equipment, antennas, and radio accessories.

*The Electronic Hobby and Amateur Radio Kits Catalog* is free upon request from Ramsey Electronics, Inc., 793 Canning Parkway, Victor, NY 14564; Tel: 800-446-2295; Fax: 716-924-4555.

**CIRCLE 96 ON FREE INFORMATION CARD**

**SOUTHPAW ELECTRONICS CATALOG 931**  
from Southpaw Electronics

Electronics hobbyists and technicians alike will find a wide



variety of components and parts in this 22-page catalog. Included are LED's, switches, piezo products, capacitors, transistors, replacement semiconductors, resistors, rectifiers, diodes, transformers, and more. Special buys are offered on several products, including quartz crystals, oscillators, shorting jumpers, and a jumper-cable assembly. The company offers a "frequent buyer bonus plan" that awards buyers with a bonus point (worth five cents on future purchases) for each dollar of merchandise ordered. Certain products—including grab-bag specials of assorted parts—earn double or triple bonus points.

*Catalog 931 is free upon request from Southpaw Electronics, P. O. Box 886, New Hyde Park, NY 11040-0311; Tel: 800-851-8870; Fax: 516-775-5091.*

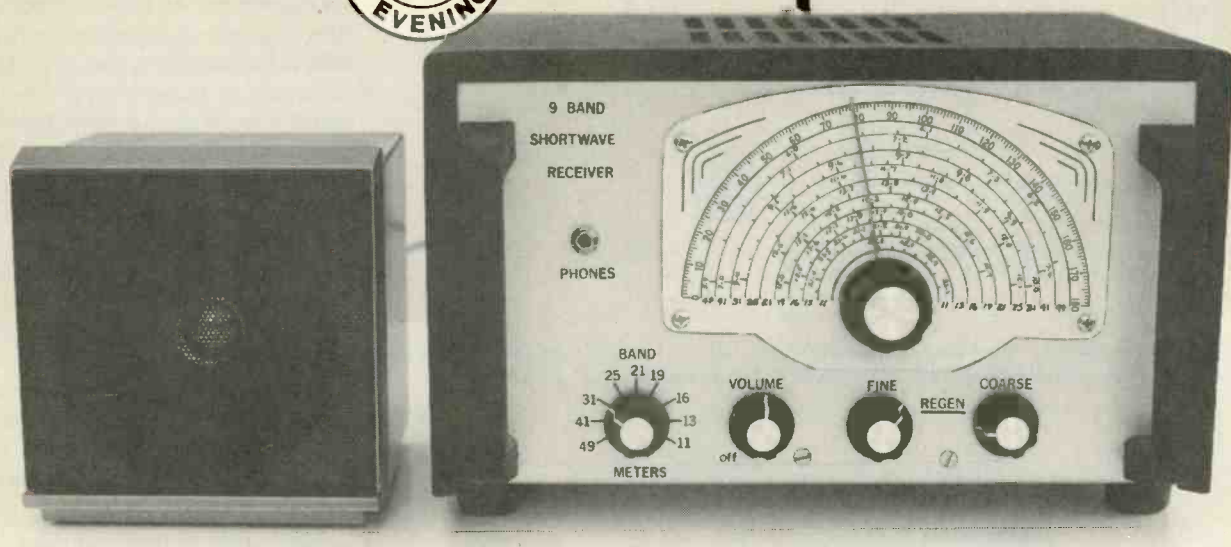
**CIRCLE 93 ON FREE INFORMATION CARD**

**GREAT RADIO READS!**  
from Tiare Publications

Tiare's 1994 catalog is filled with books that will help you get the most from your radio hobby, no matter what form it takes. The catalog features books covering everything from amateur-radio QSL'ing to scanning your local law-enforcement agencies to tuning in radio signals from outer space. Other books can show you how to work more stations, log more stations, get a better response from your QSL'ing efforts, and run your ham station more efficiently. A new division of Tiare, LimeLight Books, offers general non-fiction titles for the radio enthusiast.

*Great Radio Reads! (Catalog #8)* is available for \$1 from Tiare Publications, P. O. Box 493, Lake Geneva, WI 53147; Tel: 800-420-0579 (8AM to 6PM Central Time).

**CIRCLE 92 ON FREE INFORMATION CARD**



# Nine-Band Shortwave Receiver

*Tune in on the world with this nine-band solid-state version of the classic regenerative receiver*

BY LYLE RUSSELL WILLIAMS

**A**lthough once extensively used in military and maritime applications, today the regenerative receiver is generally viewed as a hobby or toy circuit. However, the redesigned regenerative receiver described in this article is much more than a toy or a historical curiosity. The *World Band Regenerative Radio* (which hereafter will be referred to as the WBR) can receive all nine shortwave broadcast bands, allowing you to listen to numerous foreign, English-language stations—such as the BBC, Radio Netherlands, Radio Canada, Radio China, and Japan Radio. If so desired, the number of bands can easily be extended beyond the initial nine provided on the basic receiver. It can also receive single-side band (SSB) and continuous-wave (CW) code signals.

Unlike traditional regenerative receivers, the WBR has a calibrated frequency dial and uses a short whip antenna. The unit also has an output that can be fed to a frequency counter to provide a digital frequency readout. Also, because there are no custom parts (including inductors), the WBR is easy to build.

**Regenerative Radio.** There are three favorable characteristics of regenerative radios: For a one-tube or transistor device, it has extraordinary sensitivity; for a one resonant-circuit device, it has extraordinary selectivity; and unlike a single-conversion superhet, the regenerative radio does not produce unwanted image signals.

A schematic diagram of the traditional tube-based regenerative receiver is shown in Fig. 1. That circuit is essentially an RF oscillator with variable feedback (that is connected to an antenna) with a resonant circuit composed of variable-capacitor C1 (the tuning control) and inductor L1. Feedback is provided through a second coil (L2), called a tickler coil, that is located on the same coil form as L1 and is wired into the tube's plate circuit. The amount of positive or regenerative feedback is controlled by a variable resistor that's connected across the tickler.

The quality (Q) factor of the resonant circuit without feedback is less than 50 when loaded by the antenna and the vacuum tube. When the feedback of the oscillator is adjusted so that it is just below the point of os-

cillation, the Q of the resonant circuit increases to around 1000. That increase in Q greatly amplifies the signal and narrows the bandwidth of the resonant circuit.

The tube is biased so that plate detection of an AM signal can take place. Thus, RF amplification and AM detection are accomplished with a single vacuum tube. The 3–30-pF trimmer capacitor (C2) that is connected in series with the antenna is used to reduce the loading effect of the antenna. In some cases, antenna loading can be large enough to prevent oscillation. The regenerative principle is sometimes used in different parts of superhet radios: The second detector, intermediate-frequency (IF) amplifier, or the radio-frequency (RF) amplifier stage can be regenerative. In the latter case, the stage is called a Q multiplier.

A review of approximately 40 regenerative-receiver designs revealed some interesting characteristics of the traditional circuits. There are over a dozen distinct types of RF oscillators (such as Colpitts, Hartley, Pierce, etc.), any of which could be used as the basis of a regenerative radio. But for



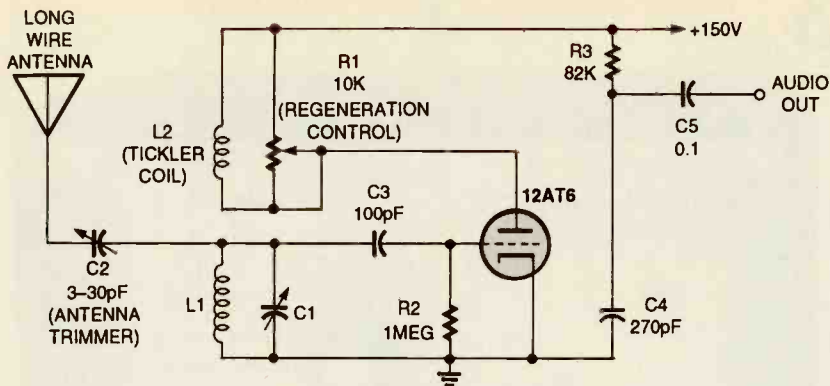


Fig. 1. The traditional tube-based regenerative receiver is essentially an Armstrong RF oscillator with variable feedback that is connected to an antenna and a resonant circuit.

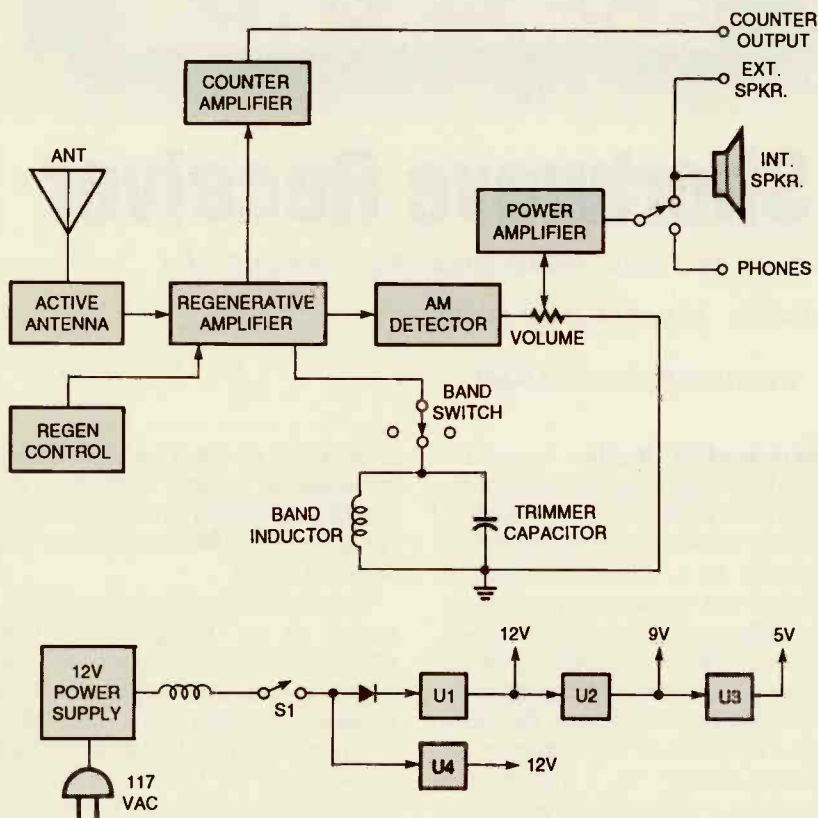


Fig. 2. As shown by this block diagram, the WBR is composed of several subassemblies: An active antenna, an amplifier (with a regeneration control and a band-switching circuitry), an AM detector, a power amplifier, and some form of output device (internal speaker, external speaker, or headphones), plus a multi-voltage power supply.

The receiver is composed of several subassemblies: An active antenna, an amplifier (with a regeneration control and band-switching circuitry), an AM detector, a power amplifier, and some form of output device (internal speaker, external speaker, or phones), plus a multi-voltage power supply.

The schematic diagram of the WBR is shown in Fig. 3. In that solid-state version of the regenerative receiver, a dual-gate MOSFET, Q4 (which is analogous to a pentode vacuum tube), is used as the regenerative amplifier. The dual-gate MOSFET is configured as a Colpitts oscillator, rather than an Armstrong type. The MOSFET's feedback from source to gate is provided via R18 and C33.

The circuit contains several standard fixed-value inductors, each of which is connected in parallel with a small variable capacitor. Those L/C pairs along with a SP12T rotary switch (S2) are used for band selection. Plug-in coils were very popular for band switching in the past, but this rotary-switch arrangement is cheaper and more convenient.

Regenerative amplification and AM detection are performed by two separate transistors, Q4 and Q5. The AM detector (which is called an infinite impedance detector) has the advantage of not loading the RF stage appreciably. Because D3 is operated with a slight forward bias, either a germanium or silicon diode can be used in that position. The DC voltage across R24 (the volume control) should be about 0.1 volts.

Regeneration is controlled by varying the voltage applied to gate 2 of Q4. That changes the transconductance of the transistor. The circuit also contains fine and course regeneration controls that allow delicate adjustments.

The traditional regenerative receiver required at least an indoor long-wire antenna for proper reception. The WBR, on the other hand, uses an active-antenna circuit, consisting of transistors Q1, Q2, and Q3. Thanks to that circuit, under most conditions, a short whip antenna is adequate.

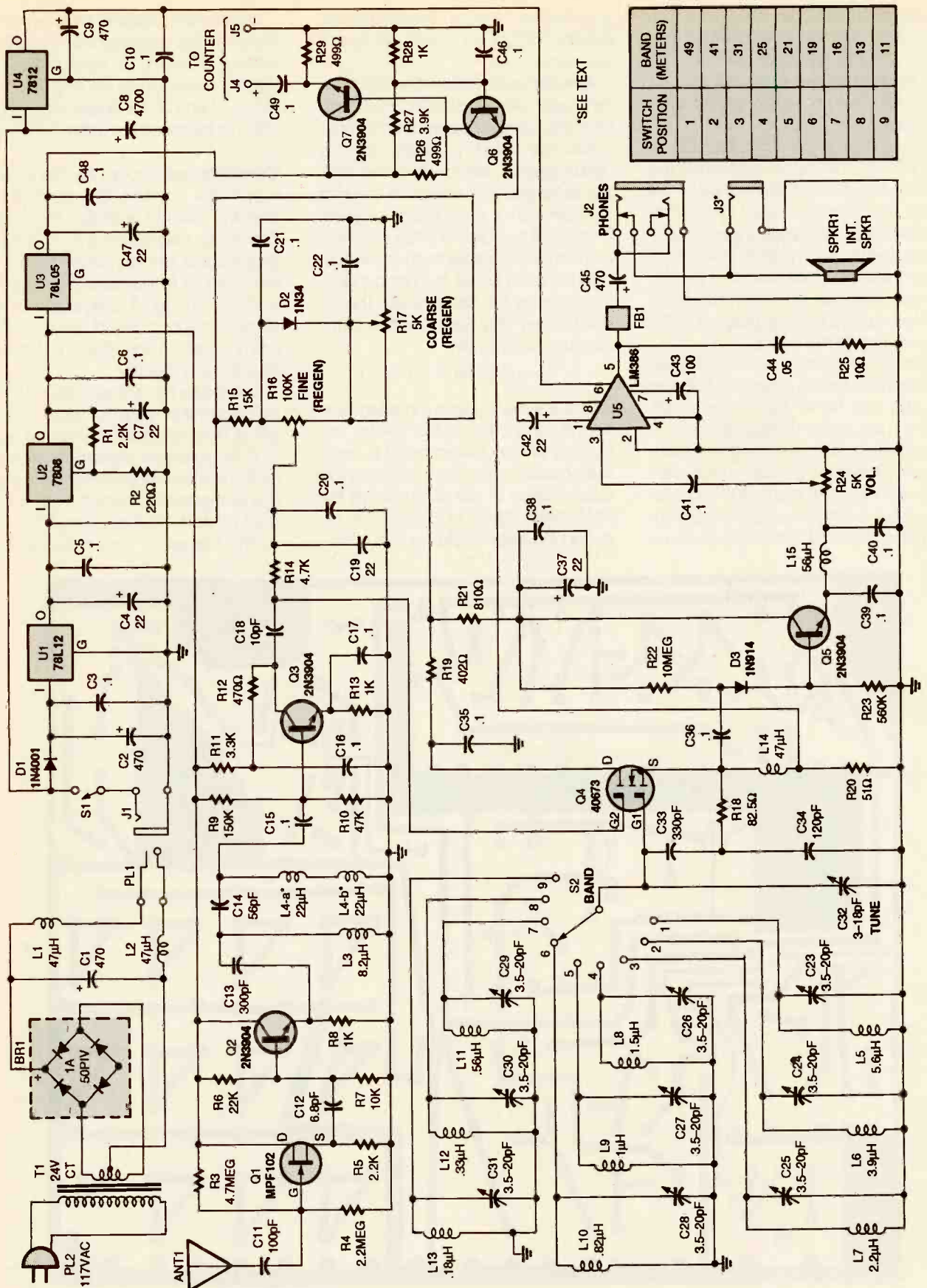
The active-antenna circuit connects to gate 2 of Q4, while the resonant circuit is connected to gate 1. The resonant circuit is isolated from the antenna and tuning is independent of antenna length, allowing a

some reason, nearly all of the old designs used the basic Armstrong circuit shown in Fig. 1.

Tradition must have played a role in the strong preference for the Armstrong circuit. It was well known that using a pentode tube in a regenerative receiver was superior to the triode design. However, nearly all of the old circuits were of the triode type. Almost none of the old circuits had a volume control. The volume of

the receiver had to be reduced by backing off the regeneration control, which had the undesirable effect of widening the bandwidth of the circuit. Fortunately, those and other undesirable characteristics of the traditional regenerative receiver have been overcome in this modern, solid-state design.

**The WBR Receiver.** A block diagram of the WBR is shown in Fig. 2.



\*SEE TEXT

BAND	SWITCH POSITION	(METERS)
49	1	
41	2	
31	3	
25	4	
21	5	
19	6	
16	7	
13	8	
11	9	

Fig. 3. In this solid-state regenerative receiver, a dual-gate MOSFET configured as a Colpitts oscillator takes the place of the vacuum-tube based Armstrong oscillator that was used in the traditional version.



calibrated dial to be used on the tuning capacitor. The level of regeneration as set by R16 and R17 is unaffected by the antenna, and so the WBR does not require an antenna trimmer.

Components C12–C14, C18, L3, L4, R6, R7, and R14 form a high-pass filter (which has a cutoff frequency of 3.4 MHz) that prevents local broadcast stations from overloading the circuit. If operated in a rural area away from strong stations, that filter can be disabled. (The high-pass filter may have to be modified if bands below 3.4 MHz are added to the WBR.)

Many traditional regenerative receivers had tuning ranges as large as 10-MHz per band. But in our circuit, using a low-value tuning capacitor allows the circuit to tune only the short-wave broadcast bands—which vary in width from 350 kHz to 700 kHz. Narrowing the range makes the receiver easier to tune. It is not necessary to use

a reduction drive on the tuning capacitor. A simple knob with a pointer is adequate.

Although a standard 12-position rotary switch was used for S2, only 9 positions are needed. However, the three additional switch positions can be used to extend the range of the WBR. The extra positions could be used for the ham bands, WWV signals at 5 MHz and 20 MHz, or some other segment of the shortwave spectrum. In order to add the extra band, the band inductances must be determined. The inductances required for the extra bands, are given by:

$$L = [1/f(6.96 \times 10^{-5})]^2$$

where L is the desired inductance in henrys, and  $f$  is the center frequency of the desired band in hertz. The equation assumes a mean tuning capacitance of 123 pF. To receive the WWV time signal at 5 MHz, the required inductor would be 8.25  $\mu$ H.

Resistor R20 is used to sample the RF signal in the regenerative amplifier without affecting its operation. The signal is amplified by Q6 and Q7, and fed to J4 and J5 for application to an external frequency counter if desired.

**Construction.** Except for the power supply, the controls, the connectors, and the internal speaker, the entire circuit was assembled a 5- × 6-inch, single-sided, printed-circuit board. A template for the printed-circuit layout is shown in Fig. 4. Once you have etched your board and obtained the parts listed in the Parts List, construction can begin.

Guided by Fig. 5, begin assembly by installing the passive components (resistors and capacitors), making sure that the polarized capacitors are correctly oriented. After installing the passive components, install the semiconductors; start with the diodes, followed by the transistors, and then the IC's.

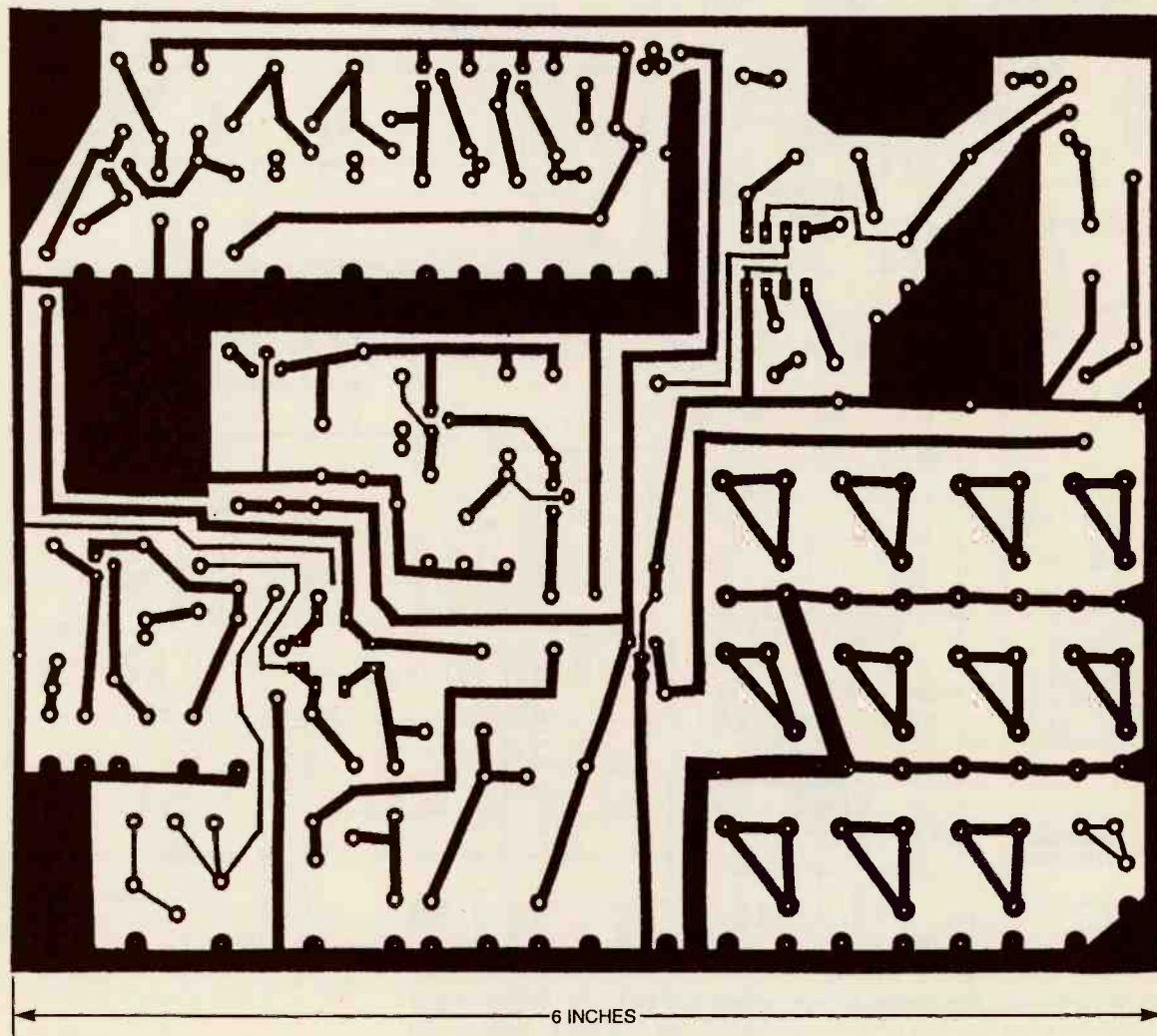


Fig. 4. This full-sized printed-circuit template can be used to etched your own board.

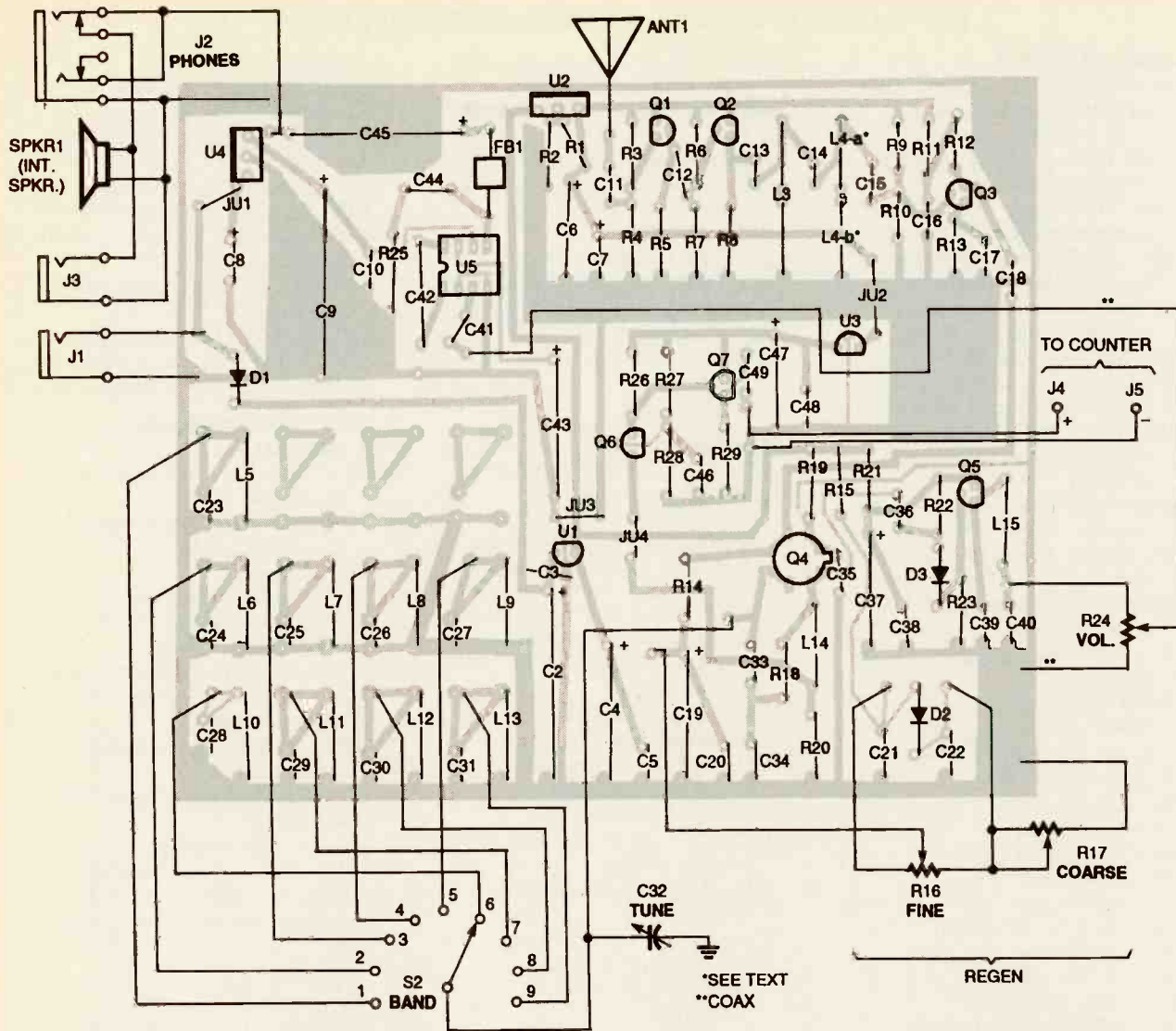


Fig. 5. When assembling the WBR's printed-circuit board, make sure that the polarized capacitors are correctly oriented. Also, when installing the semiconductors, pay particular attention to the orientation of Q4, and be careful that you do not confuse the 2N3904 general-purpose transistors with the low-power (78Lxx series) voltage regulators, both which are housed in the same TO-92 style case.

TABLE 1—FREQUENCY LIMITS OF THE INTERNATIONAL BAND

Band (Meters)	Band Limits (MHz)	Frequency Received (MHz)	L/C Band Trimmers
49	5.95 - 6.20	5.90 - 6.26	L5/C23
41	7.10 - 7.30	7.00 - 7.40	L6/C24
31	9.50 - 9.90	9.40 - 10.0	L6/C25
25	11.65 - 12.05	11.37 - 12.1	L8/C26
21	13.60 - 13.8	13.44 - 14.23	L9/C27
19	15.10 - 15.6	14.96 - 15.88	L10/C28
16	17.55 - 17.9	17.44 - 18.46	L11/C29
13	21.45 - 21.85	21.21 - 22.40	L12/C30
11	25.67 - 26.10	25.10 - 26.32	L13/C31

Pay particular attention to the orientation of Q4 (the dual-gate MOSFET). Be careful when installing the 2N3904 general-purpose transistors and the low-power (78Lxx-series) voltage reg-

ulators; those units are housed in the same TO-92 style case, so don't get them confused.

Note from the parts-placement diagram that there are three unused

pad groupings in the area of the band-determining capacitor/inductor pairs. Those pads (as mentioned earlier) are provided for those who want to extend the band coverage of the WBR.

Once all of the on-board components have been installed, check your work for construction errors—cold solder joints, solder bridges (and other shorts), misoriented or misplaced components, etc. When you are satisfied that there are no errors, put the board to the side momentarily and go on to the next phase of construction.

**Power Supply.** The next thing that you will need is a power source for the WBR. There is, of course, nothing critical about the circuit's power source, and no printed-circuit layout is provided for that portion of the project. Instead, an external power supply,



## PARTS LIST FOR THE WORLD-BAND REGENERATIVE RADIO

### SEMICONDUCTORS

- U1—78L12 12-volt, 100-mA, voltage regulator, integrated circuit  
 U2—7808 8-volt 1-amp or 78L08 8-volt 100-mA, voltage regulator, integrated circuit  
 U3—78L05 5-volt, 100-mA, voltage regulator, integrated circuit  
 U4—7812 12-volt 1-amp, voltage regulator, integrated circuit  
 U5—LM386 low-voltage audio-power amplifier, integrated circuit  
 Q1—MPF102, VHF JFET  
 Q2, Q3, Q5—Q7—2N3904 general-purpose NPN silicon transistor  
 Q4—40673, MPF121, MPF131, or NTE222, or similar dual-gate MOSFET  
 BR1—DB101 1-amp, 50-PIV, bridge rectifier  
 D1—1N4001 1-amp, 50-PIV, rectifier diode  
 D2—1N34 general-purpose germanium diode  
 D3—1N914 general-purpose silicon diode

### RESISTORS

(All fixed resistors are 1/4-watt, 5% carbon units, unless noted.)

- R1, R5—2200-ohm  
 R2—220-ohm  
 R3—4.7-megohm  
 R4—2.2-megohm  
 R6—22,000-ohm  
 R7—10,000-ohm  
 R8, R13, R28—1000-ohm  
 R9—150,000-ohm  
 R10—47,000-ohm  
 R11—3300-ohm  
 R12—470-ohm  
 R14—4700-ohms 1/4-watt, 1%, metal-film  
 R15—15,000-ohm  
 R16—100,000-ohm panel-mount linear potentiometer  
 R17—5000-ohm panel-mount linear potentiometer  
 R18—82.5-ohm, 1/4-watt, 1%, metal-film  
 R19—402-ohm, 1/4-watt, 1%, metal-film  
 R20—51-ohm 1/4-watt, 1%, metal-film  
 R21—810-ohm, 1/4-watt, 1%, metal-film  
 R22—10-megohm  
 R23—560,000-ohm  
 R24—5000-ohm, panel-mount, audio potentiometer with SPST switch  
 R25—10-ohm  
 R26, R29—499-ohm 1/4-watt, 1%, metal-film  
 R27—3900-ohm

### CAPACITORS

- C1, C2, C9, C45—470- $\mu$ F, 16-WVDC, electrolytic  
 C3, C5, C6, C10, C15—C17, C20—C22, C35, C36, C38—C41, C46, C48, C49—0.1 $\mu$ F, ceramic-disc  
 C4, C7, C19, C37, C42, C47—22- $\mu$ F, 16-WVDC, electrolytic  
 C8—4700- $\mu$ F, 16-WVDC, electrolytic  
 C11—100-pF, silver mica  
 C12—6.8-pF, silver mica  
 C13—300-pF, silver mica  
 C14—56-pF, silver mica  
 C18—10-pF, silver mica  
 C23—C31—3.5–20-pF, miniature ceramic trimmer  
 C32—3–18-pF panel-mount air variable  
 C33—330-pF, silver mica  
 C34—120-pF, silver mica  
 C43—100- $\mu$ F, 16-WVDC, electrolytic  
 C44—0.05- $\mu$ F, ceramic-disc

### INDUCTORS

- L1, L2, L14—47- $\mu$ H (J. W. Miller 9250-473)  
 L3—8.2- $\mu$ H (J. W. Miller 9310-34)  
 L4—43- $\mu$ H (J. W. Miller 9210-58) or two 22- $\mu$ H (J. W. Miller 9310-44),

see text

- L5—5.6- $\mu$ H (J. W. Miller 9310-30)  
 L6—3.9- $\mu$ H (J. W. Miller 9310-26)  
 L7—2.2- $\mu$ H (J. W. Miller 9310-20)  
 L8—1.5- $\mu$ H (J. W. Miller 9310-16)  
 L9—1.0- $\mu$ H (J. W. Miller 9310-12)  
 L10—0.82- $\mu$ H (J. W. Miller 9310-10)  
 L11—0.56- $\mu$ H (J. W. Miller 9310-07 or 9230-14)  
 L12—0.33- $\mu$ H (J. W. Miller 9310-04 or 9230-08)  
 L13—0.18- $\mu$ H (J. W. Miller 9230-02)  
 L15—56- $\mu$ H (J. W. Miller 9250-563)  
 FB1—General-purpose ferrite bead

### ADDITIONAL PARTS AND MATERIALS

- J1—2.1-mm DC power jack (Radio Shack 274-1565)  
 J2—1/8-inch panel-mount, closed-circuit stereo jack  
 J3—RCA jack  
 J4, J5—Individual pin-jacks  
 S1—SPST switch (part of R24)  
 S2—SP12T rotary switch  
 SPKR1—4–8-ohm, miniature speaker  
 PL1—2.1-mm power plug (Radio Shack 274-1567)  
 ANT—30-inch whip antenna (Radio Shack 270-1401)  
 T1—24-volt, 300-mA, center-tapped transformer  
 Printed-circuit materials, enclosure, 117-volt AC power plug with line cord, four small control knobs, one large pointer knob, wire, solder, etc.

The following is available from Dan's Small Parts and Kits, 1935 S. 3rd W. #1, Missoula, MT 59801; Phone/Fax 1-406-543-2872. Printed circuit board \$13.00 plus \$2.50 shipping and handling. Circuit board plus complete kit of all components (excluding power supply, cabinet, knobs and hardware) \$59.95 plus \$3.75 shipping and handling.

comprised of two chokes, a filter capacitor, and a bridge rectifier were wired together (see Fig. 3) on a small section of perfboard. The perfboard and a 24-volt transformer were then wire together and mounted to a block of wood. An AC line cord was then connected to the input of the supply and a suitable plug connected to its output. Doing things that way helps to keep power-line noise out of the receiver.

Of course, a standard plug-in 12-volt, 500-mA or so power adaptor can be used as the power source as well; if you decide to go that route, connect

two filter chokes between the supply and the receiver.

**The Enclosure.** The author's prototype was housed in a large aluminum enclosure measuring about 9 1/4 x 5 3/8 x 6 3/4 inches. Prepare the enclosure by drilling holes in suitable locations for the controls, and mounting holes for the printed-circuit board and the unit's internal speaker.

The author's front-panel layout includes the band, volume, the fine and coarse regeneration controls, and a phone jack. The rest of the off-board components—the counter, auxiliary

speaker, and the power and antenna jacks—are mounted to the rear panel of the prototype.

After deburring the holes, dry-transfer lettering can be used to label each control, switch, and connector. Once labeled, mount the off-board components to their respective positions on the enclosure and, using short lengths of insulated wire, connect the off-board components to the appropriate points on the printed-circuit board. The connections to the volume control (R24) and the counter jacks should be made through small-gauge shielded cable.

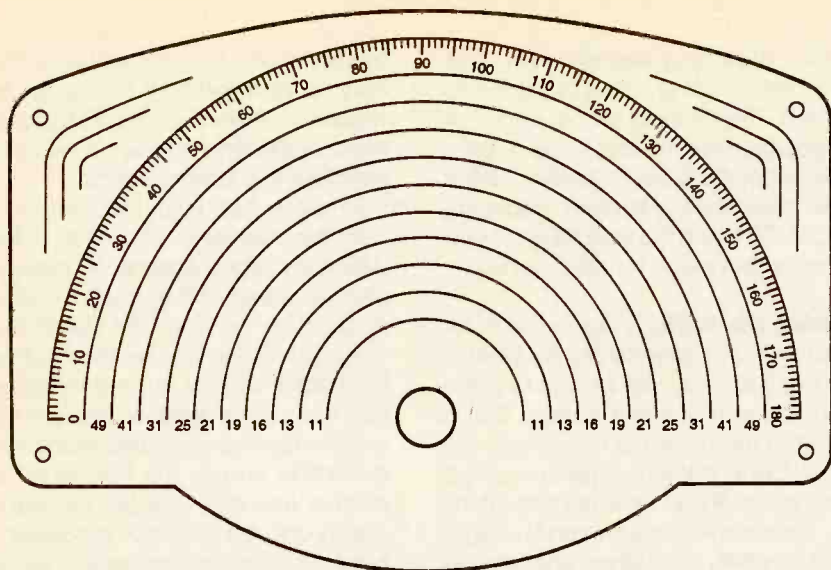


Fig. 6. The author started out with a blank tuning-dial pattern like this one, and added the appropriate frequency markings to the dial during the calibration procedure.

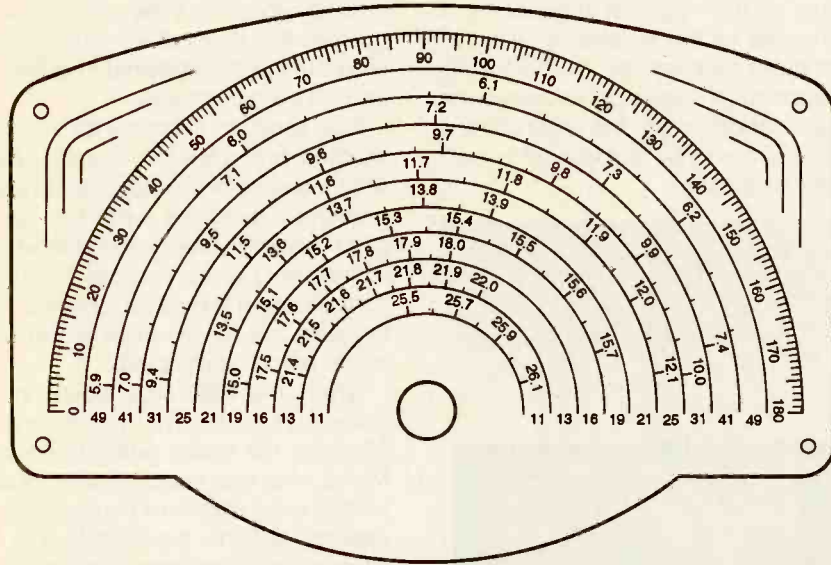


Fig. 7. Using a marker generator, the author first located and marked the 100-kHz points on the tuning dial, then the 50-kHz points, followed by 25-kHz points. This is what his dial looked like when completed. The dial shown here is strictly for reference. Each unit is different and must be calibrated according to the instructions given in the text to compensate for the tolerances of the actual components used in the set.

**Down The Dial.** The tuning-dial pattern for the WBR was made by taking a blank pattern (like that shown in Fig. 6), and gluing it to a piece of cardboard using white paper glue (available from art-supply stores).

Once the glue dries, the excess cardboard can be cut away with a single-edge razor blade or X-acto knife. Cut the screw and the capacitor-shaft holes in the dial face and mount the dial on the aluminum enclosure with four 4-40 screws and nuts. The mounting nut for the variable capacitor goes outside the dial cardboard and helps hold the dial to the enclosure. Frequency markings on

the dial will have to be added after construction is completed.

The dial pointer was made from a large paper clip. The paper clip was straightened out and filed down slightly. A hole was drilled in the side of a large control knob with a #66 drill bit (the size used to drill printed-circuit boards). The filed-down paper clip was then force fitted into the hole in the knob, and the knob was mounted on the shaft of the tuning capacitor.

Once the knob is mounted, set the tuning capacitor to maximum capacitance and place the pointer so that it points to the far left (log scale 0) position on the dial. After that, mount

the unit's internal speaker to the inside surface of the enclosure. The connections between the internal speaker wires and the printed-circuit board should be made with short lengths of twisted-pair wire and kept close to the metal enclosure and away from the antenna.

The antenna was mounted to the back of the cabinet with two plastic brackets that were intended to anchor the bottom of window blinds. The antenna feedthrough was made by drilling holes to mount an SO-239 coax receptacle. Instead of mounting an SO-239, however, a piece of sheet plastic was mounted over the cutout and a hole was drilled in the center of the plastic. A wire from the antenna connection on the printed-circuit board was then passed through the hole in the plastic to the antenna termination on the outside of the enclosure. That type of feedthrough has a lot less capacitance than a coax connector.

**Calibration.** Calibration should be done before the outside cover is placed on the enclosure. The first step is to set the band limits. A frequency counter is helpful for that purpose. If a counter is available, connect it to the counter terminals, J4 and J5. Connect the power supply to the receiver and turn it on. Set R24 for maximum volume and set R16 (FINE REGEN) to its center position. Set S2 to 49 meters. Turn R17 (COARSE REGEN) control until the WBR oscillates (heard as a rushing sound, a hum, or whistle from the speaker) and the counter shows a steady reading. From Table 1, note that the band limits for 49 meters are 5.95 MHz to 6.20 MHz. Adjust C23 until the receiver covers that range as C32 is rotated from maximum to minimum capacitance—a range of 5.9 to 6.26 MHz was obtained in the author's receiver.

Referring to Table 1, switch S2 to a higher frequency band and adjust R17 (COARSE REGEN) for continuous oscillation if necessary. While rotating C32 from minimum to maximum capacitance, adjust the appropriate trimmer capacitor so that the receiver tunes the international band. On some of the bands, the tuning capacitor will tune a wider frequency range than needed.

Trimmer capacitors C23 through C31 should have enough range to allow the proper band limits for each



band to be set. But if the frequency range is too high, a small fixed capacitor can be soldered across the appropriate inductor (L5 through L13). If the frequency range is too low, the inductor for that band will have to be changed to the next lowest value.

The dial should be calibrated when the receiver is completed and no further changes are expected. Each band should be calibrated when the fewest radio stations are on the air. The lower frequency bands are clear during the daytime, and the higher frequency bands are clear at night.

A marker generator capable of generating squarewaves of 100 kHz, 50 kHz, and 25 kHz that was built from plans found in the 1988 *ARRL Handbook* was used to calibrate the dial. Use a frequency counter to find the approximate location of the first multiple of 100 kHz on the dial. Start by turning on the WBR and allowing it warm up for at least 30 minutes. Rotate R17 until the WBR oscillates. Back off R16 until oscillation stops; then advanced it until the set almost oscillates. Set the marker generator to 100 kHz and turn it on.

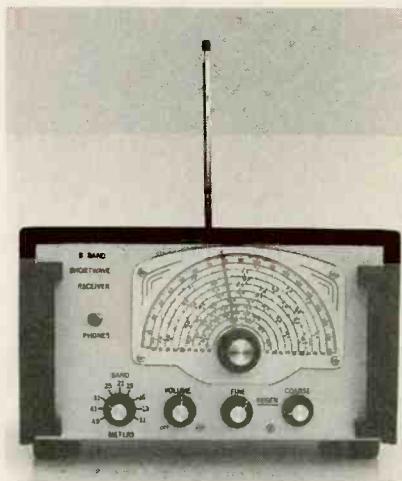
Loosely couple the output of the marker generator to the antenna of the WBR. A wire from the output of the marker generator placed near the WBR's antenna should be adequate. A signal that is strong enough to be received but weak enough that the regeneration control can be set to its most sensitive position is desired. Turn C32 (TUNE) slightly until a weak signal is heard as a rushing sound or a hum. If no signal is heard, increase the coupling to the marker generator and try again. When a signal is heard, turn the marker generator off and on to verify the origin of the signal. Using a pencil, lightly mark the point on the dial. Move the tuning capacitor up the dial and mark the next 100-kHz point.

When all the 100-kHz points are marked, switch the marker generator to 50 kHz and mark points between the 100-kHz points. Make those points distinguishable from the 100-kHz points. Once the 50 kHz points have been marked, switch the marker generator to 25 kHz and add those points. When all the points for all bands are on the dial, remove the dial from the radio, write over the dial markings in ink and add the frequency numbers. Erase any pencil markings left visible.

Spray the completed dial with clear lacquer or cover with a clear plastic sheet. The finished dial should look something like the one in Fig. 7. If the receiver drifts out of calibration, adjust the appropriate trimmer capacitor (C23–C31) until the stations appear in the correct place for each band.

**Using the WBR.** A regenerative radio does not operate like a superhet. It requires more adjustment to properly receive a given station. That is part of the charm of this vintage circuit. Once the technique is learned, the receiver can be easily operated.

The narrowest bandwidth and highest sensitivity is obtained when the regeneration control is set just below the point of oscillation. The optimum setting of the regeneration control changes as the receiver is tuned to different frequencies. As the tuning capacitor is tuned up in frequency (less capacitance), the regeneration control has to be backed off to prevent oscillation.



*Here is the author's attractively laid out prototype of the WBR. Note the professional-looking lettering that adorns the front panel.*

Turn the radio on, select an appropriate band, extend the antenna to its maximum length, turn the volume (R24) all the way up, rotate C32 to the minimum capacitance (highest frequency) position, set R16 to its center position, rotate R17 until the receiver oscillates and back off until the set just stops oscillating.

Rotate C32 to tune down the scale until a station is heard. Adjust R16 for maximum sensitivity; back off R24 if the station is too loud. When a dif-

ferent station is tuned, it will be necessary to readjust R16 for optimum reception. Potentiometer R17 should need readjusting only when the set is switched to a different band.

To use a frequency counter, connect the counter to J4 and J5 of the WBR. Very strong stations will provide enough signal at the counter output to produce an accurate station-frequency reading. To use the counter for weaker stations, tune in a station and turn up the regeneration control until the receiver oscillates. Going into oscillation causes the frequency to drop a few kHz. Tune up the band slightly until the oscillator produces a beat note against the station. Adjust C32 for minimum frequency (pitch) of the beat note. Then read the frequency on the counter. If the band is congested, this procedure cannot be used but the approximate frequency can still be determined.

If the sensitivity is too low for a given situation, add a few feet of wire to the whip. If an indoor or outdoor long-wire antenna is available, wrap two turns of the insulated wire around the whip to create a loose couple. Directly connecting a long-wire antenna to the whip will usually result in the receiver being overloaded.

When the WBR was being developed, I tuned in a ham operator on 40-meter LSB (lower sideband) from Miami who was describing to other hams the conditions as hurricane Andrew moved onto the Florida coast. A few days later, the same hurricane hit near my location in Louisiana.

For receiving LSB, locate the station using the same procedure as used for AM stations. Then turn up the fine regeneration control until the receiver oscillates continuously. Turn the tuning capacitor slightly up in frequency then slowly tune down until the operator's voice is intelligible. Changing the fine regeneration control slightly may be helpful for obtaining a good signal. The required tuning is delicate.

Receiving USB is the same except that the tuning capacitor must be tuned up the band until the speech is intelligible. CW (Morse code) stations will be heard in the vicinity of amateur voice stations. Like SSB they are received with the radio oscillating. Often several code stations will be heard at once, but the audio tone of each will be different. ■

**H**ave you ever wondered how microwave signals are used to detect movement within a defined area? Well, here's your chance to find out! The *Microwave Motion Detector* described in this article can be used to sense speed or any moving body—a person, animal, car, or bicycle!—using the *Doppler effect*.

Doppler theory states that when sound, light, or even radio waves are emitted or reflected by a moving object, the frequency of the waves will be different from those emitted or reflected when the object is stationary.

**Circuit Description.** The Microwave Motion Detector is nothing more than a combination transmitter/receiver circuit that's built around four transistors, and a quad op-amp. A schematic diagram of the Microwave Motion Detector is shown in Fig. 1. In that circuit, Q3 (a 2SC2570 high-frequency NPN silicon transistor) is configured as a free-running (astable) RF oscillator that is designed to operate at the low end of the microwave band (approximately 1.0 GHz).

The microwave signal developed by the oscillator follows two paths. In

ference, which can range from 10 to 40 Hz depending upon the speed of the moving object, is applied to the input of U1-c (¼ of an LM324 quad op-amp) at pin 10. The output of U1-c is fed to sensitivity control R8, which allows you to adjust the Doppler-shift difference signal. The Doppler-shift signal is applied to U1-d (another ¼ of the LM324 quad op-amp), which, in this instance, is configured as a bandpass filter.

The output of the bandpass filter (U1-d) is fed to U1-a (another op-amp; this one configured as a buffer), and

# Build This Microwave Motion Detector

BY FRED BLECHMAN

Essentially what happens is that as the object moves toward you, the frequency emitted by or reflected off of the object increases. The opposite is true as the object moves away from you; the frequency decreases.

A similar effect can be seen in everyday life: Have you ever noticed how a train whistle, racing car engine, or car horn appears to alter in frequency as the vehicle approaches, passes, and moves away? The perceived change in frequency is caused by the waves being either compressed or stretched as they leave the moving object. Compressing the waves increases the perceived frequency, while stretching the waves reduces it.

Doppler-effect based systems are used to clock speeding cars, missile velocity, and even to detect moving air. In fact, Doppler radar systems are used at some of the larger airports to detect dangerous cross winds, called *windshear*, which have been blamed for countless takeoff and landing accidents.

one path, the microwave signal is applied to D1, a 1SS99 Schottky barrier diode, which is designed for operation at low microwave frequencies. At the same time, the microwave signal is applied to ANT1 and is radiated outward in an omni-directional pattern, filling the surrounding area with microwave signals.

The radiated microwave signals, upon contacting an object within the covered area, are reflected back to the antenna. The frequency of the reflected signal depends on the object's direction of movement. (The motion detector doesn't care which direction is taken by the object; it is only interested in the frequency shift that results because of that movement.) The antenna, in turn, picks up the reflected signal, and feeds it to D1, where it is mixed with the originally radiated signal, to produce both a sum and difference signal at D1's cathode.

The sum frequency is bypassed to ground via capacitor C8, leaving only the difference frequency. The dif-

ference signal is applied to the positive half cycle of the input waveform, producing a series of positive-going pulses. The rectified output of D2 charges C17 (to some unspecified value), during the positive alternation of the signal.

At the same time, a voltage equal to the charge on C17 is applied to pin 5 of U1-b, which is wired as a comparator. During the negative half cycle, the charge on C17 is bled to ground through R17 and U1-a. Components C17 and R17 determine the "on" time of U1-b. Larger values of either C17 or R17 result in a longer on time for U1-b.

Each time that the voltage at pin 5 of U1-b exceeds the reference voltage on pin 6, the output of U1-b at pin 7 swings positive. The pin-7 output is applied to the gate terminal of Q4 (a BS170 N-channel T MOS FET) and causes it to turn on and off. Each time that Q4 turns on, a ground path (though Q4) for LED1 is completed, causing it to turn on and off, as the input signal dictates. Transistor Q4 can



*This security-system add-on for your home or car works on the same principles as police radar.*



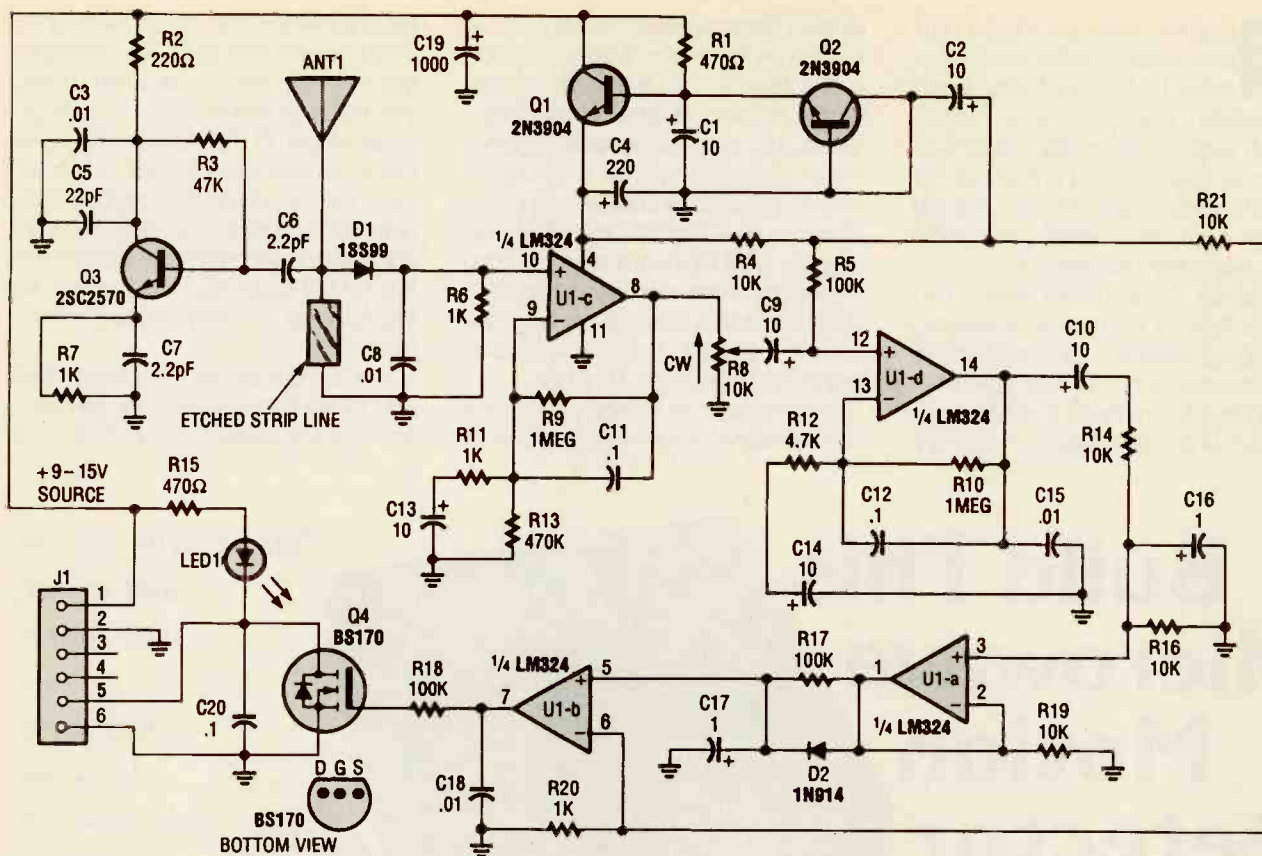


Fig. 1. The Microwave Motion Detector is essentially a combination transmitter/receiver circuit built around four transistors, and a quad op-amp.

## PARTS LIST FOR THE MICROWAVE MOTION DETECTOR

### SEMICONDUCTORS

U1—LM324 quad op-amp, integrated circuit

Q1, Q2—2N3904 general-purpose NPN silicon transistor

Q3—2SC2570 high-frequency, NPN silicon transistor (or NEC NE02132E).

Q4—BS170P-ND N-Channel, enhancement, TMOS FET (Digi-Key)

D1—1SS99 Schottky barrier diode (NEC). See text.

D2—1N914 or 1N4148 general-purpose, small-signal, silicon diode

LED1—Green light-emitting diode

### RESISTORS

(All fixed resistors are 1/2-watt, 5% units.)

R1, R15—470-ohm

R2—220-ohm

R3—47,000-ohm

R4, R14, R16, R19, R21—10,000-ohm

R5, R17, R18—100,000-ohm

R6, R7, R11, R20—1,000-ohm

R8—10,000-ohm PC-mount 1/2-watt potentiometer (see text)

R9, R10—1-megohm

R12—4,700-ohm

R13—470,000-ohm

### CAPACITORS

C1, C2, C9, C10, C13, C14—10- $\mu$ F, 16-WVDC, electrolytic

C3, C8, C15, C18—0.01- $\mu$ F, ceramic-disc

C4—220- $\mu$ F, 16-WVDC, electrolytic

C5—22-pF, ceramic-disc

C6, C7—2.2-pF, ceramic-disc

C11, C12, C20—0.1- $\mu$ F, ceramic-disc

C16, C17—1.0- $\mu$ F, 16-WVDC, electrolytic

C19—1000- $\mu$ F, 16-WVDC, electrolytic

### ADDITIONAL PARTS AND MATERIALS

J1—Molex WM 3303 6-pin female PC board connector (Digi-Key)

Printed-circuit materials, enclosure,

9-15 volt DC power source, solder, hardware, etc.

**Note:** The following items are available from Ramsey Electronics, Inc. (793 Canning Parkway, Victor, NY 14564; Tel. 716-924-4560): A complete kit of parts for the Microwave Motion Detector (MD-3BP), including printed-circuit board (but not the case or control knobs)—\$19.95; an etched and drilled printed-circuit board only (MD-3PCBP)—\$10.00; a Special Parts Kit (MD-3SPKBP) containing all semiconductors, R8, and J1—\$12.50; a custom case and knob set (CMD-BP)—\$14.95, optional Siren Kit (SM-3BP) including printed-circuit board and manual—\$3.95; optional Universal Timer Kit (UT-5BP) including printed-circuit board and manual—\$7.95. Please add \$3 for orders under \$20, plus \$4.95 postage/handling. New York residents, please add appropriate sales tax.

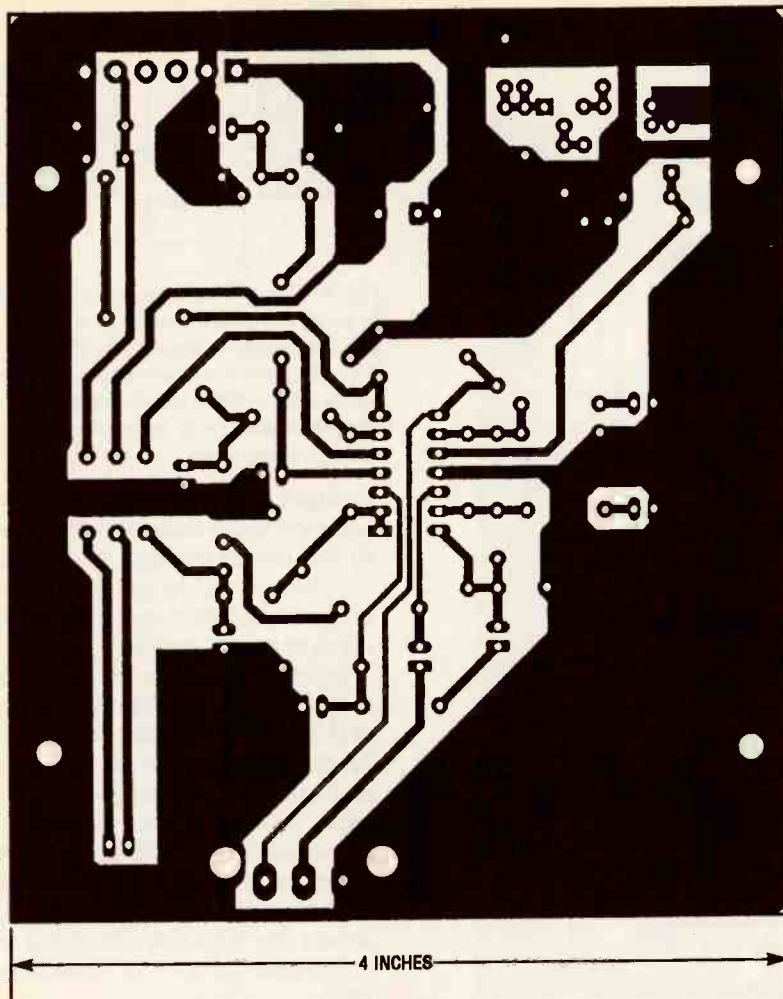


Fig. 2. The project was assembled on a printed-circuit measuring about  $4 \times 4\frac{3}{4}$  inches. A template of that printed-circuit board layout is shown here full-size.

be safely operated at voltage levels as high as 50 volts DC and current levels of 250 mA. Capacitor C20 is included in the circuit to provide transient suppression for stability.

The output of the Microwave Motion Detector (via pins 5 and 6 of J1) can be used to drive any number of signaling devices, timers, counters, etc. More on that later.

Power for the circuit is supplied through J1 (a multi-conductor jack) from an external source of 9–15 volts. The external source voltage is regulated by Q1 and Q2. That transistor regulator circuit also provides the reference voltage used by comparator U1-b. In the regulator portion of the circuit, the reverse-biased base-emitter junction of Q2 behaves like a low-power Zener diode, with a breakdown voltage in the 6- to 8-volt range. Capacitor C19 is used to filter the external power source to assure a clean and smooth source of current.

**Construction.** The Microwave Motion Detector was assembled on a printed-circuit measuring about  $4 \times 4\frac{3}{4}$  inches. Because of the critical nature of microwave-circuit wiring, where lead lengths and ground connections can effect circuit operation, don't try building this project without using the printed-circuit board layout. And don't be alarmed when looking at the printed-circuit board pads that connect the anode of D1 and the antenna to what looks like ground. That short "etched stripline," is carefully designed to function as a small inductor at the selected microwave frequency, forming part of the resonant tank circuit for the microwave oscillator (Q3)!

Figure 2 shows a full-size template of the Microwave Motion Detector's printed-circuit board layout. You can etch your own board from the template provided and gather your own parts, or you can order the board only or a kit (which includes an etched and

pre-drilled, printed circuit board and all the components, but no case) from the supplier listed in the Parts List.

Although most of the parts for this project are commonly available through conventional electronic-component suppliers, some of them may be difficult to find. A source for the more difficult-to-find parts is indicated in the Parts List. The difficult-to-find parts (such as Q3, D1, and R8) are available in a "Special Parts Kit" from the listed source. If you opt to gather your own parts, or you plan to use what you have on hand, keep in mind that the printed-circuit board layout was designed to accommodate the special mounting or specific dimensions of J1 and R8.

In any event, once you have the printed-circuit board and all of the parts, assemble the Microwave Motion Detector according to the parts-placement diagram shown Fig. 3. When assembling the Microwave Motion Detector, take special care that polarity-sensitive components (electrolytic capacitors, diodes, transistors, and the integrated circuit) are installed in the right direction.

Begin construction by installing the passive components (jumper wires, resistors, and capacitors) first; follow that by installing the active components (diodes, transistors, and the IC). Once the active components have been installed, check your work for the usual construction errors: cold solder joints, misplaced or misoriented components, solder bridges (a magnifying glass helps here), etc.

Once you've determined that the circuit has been correctly assembled, it's time to consider the enclosure that will house the Microwave Motion Detector. The circuit can be housed in any enclosure of your own choosing. However, if you prefer, an optional case and knob kit is available from the supplier listed in the Parts List. The sturdy black plastic instrument case is supplied with neatly lettered front and rear panels, knobs, rubber feet and mounting screws.

If you choose a case other than the one available from the listed supplier, it will be necessary to drill holes in the front panel of the enclosure to accommodate the shaft of R8 and LED1's lens. Once that's taken care of, it will be necessary to make a cutout in the rear panel for the output connector,



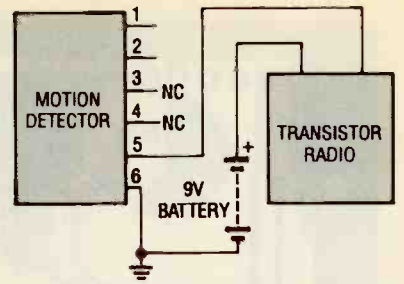
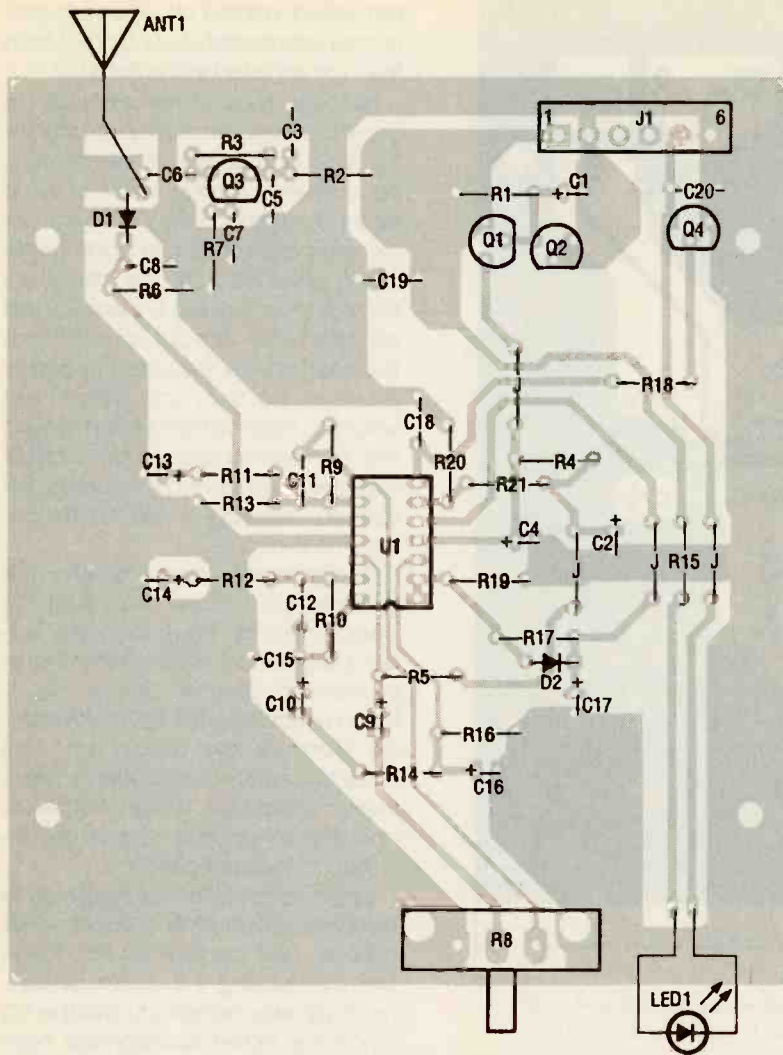


Fig. 4. The detector can easily be tested by using a transistor radio as a signaling device. Simply wire the two devices together as shown here, and turn on the radio. When the detector is triggered, power will be applied to the radio, turning it on.

voltage change. For the same reason, use short leads when feeding power to the circuit through J1. Connect +9-15 volts DC to pin 1 of J1, and connect pin 2 of J1 to the ground terminal of the DC supply.

Rotate R8 fully counter-clockwise to the minimum-sensitivity position—and the LED extinguish. Slowly rotate R8 clockwise until the LED lights. Back off R8 until the LED just goes out. Now move your hand near the antenna; you should see the LED light up. Moving either toward or away from the Detector should trigger it. The LED should stay lit for only about one second. Adjust R8 for the desired sensitivity.

Figure 4 shows how the Motion Detector can be wired to use a transistor radio as a signaling device; other, more practical applications will be discussed later on, but this set-up is useful for testing. The positive terminal

Fig. 3. Once you have the printed-circuit board and all of the parts, assemble the Microwave Motion Detector according to this parts-placement diagram. Note when assembling the circuit, take special care that the polarized components are properly oriented.

J1, and a small hole in the top of the enclosure for the antenna. Once properly prepared, the cabinet's front and rear panels can be labeled using dry-transfer lettering.

**Testing and Tune Up.** Testing the Microwave Motion Detector requires nothing more than a stable source of direct current of from 9 to 15 volts. There should be no tendency for the voltage to drop when under load. While the Detector uses only about 15 mA on standby, it draws about 30 mA when triggered. That difference is enough to affect the operation of the circuit when using a typical small 9-volt transistor radio battery—even an alkaline unit. The effect is that once triggered, the Detector output keeps retriggering itself due to the on-off

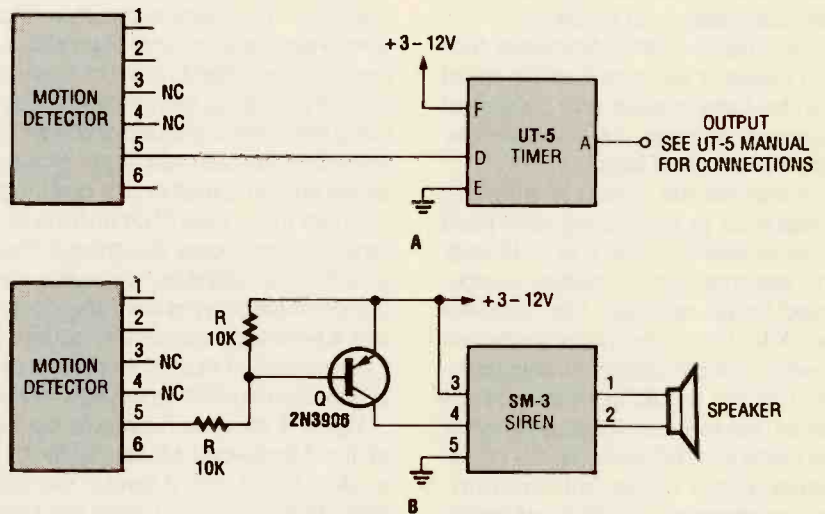


Fig. 5. The output of the detector can be used to trigger a timer (as shown in A), or to drive siren (as shown in B). The timer and siren circuits can be obtained in kit form from the supplier listed in the Parts List.

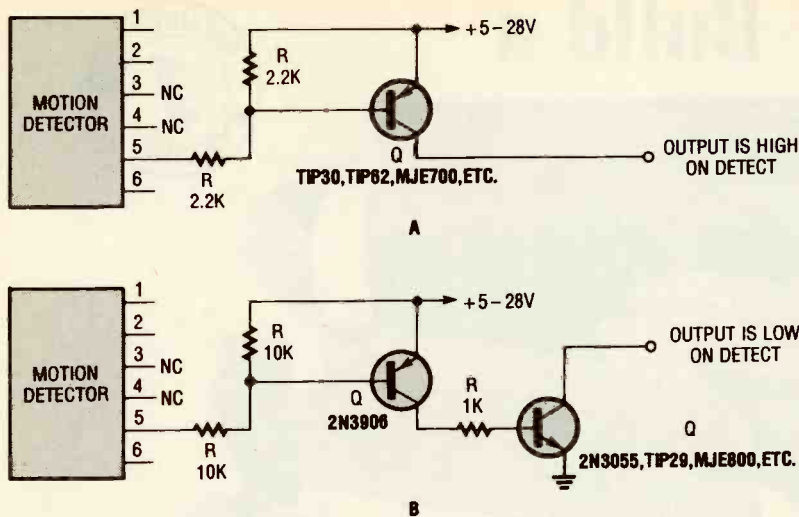


Fig. 6. The output of the motion detector can be used to trigger a transistor driver circuit, like those shown here. The one in A is designed to deliver a positive output voltage to the circuit that follows, while the one in B is designed to complete the ground-return path for that same circuit.

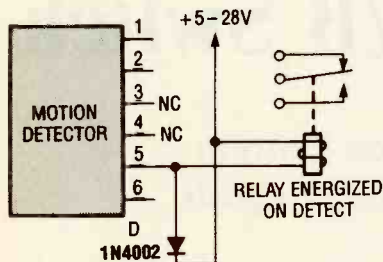


Fig. 7. The Microwave Motion Detector's output can also be used to trigger a relay.

of a separate power source (a 9-volt battery in this case) is connected to the positive supply input of a transistor radio, and the negative terminal of the radio going to pin 5 of J1. Pin 6 of J1 is connected to the negative side of the 9-volt battery.

With the radio switched on, it should play whenever the Motion Detector is triggered. Note that trying to use the Motion Detector power supply to also power your external load will probably result in unwanted retriggering. If you find that your load triggers the detector, try moving it further away. The detector is extremely sensitive to its surroundings.

The control (pin 5 of J1) switches to ground through Q4 when motion is detected. **Do not** apply an AC voltage to the circuit and **do not** attempt to "sink" more than 250 mA at pin 5.

**Modifications.** If you find that the detector seems to constantly retrigger

at the medium- or high-sensitivity settings, try adding a 0.1- $\mu$ F non-polarized capacitor across pins 5 and 6 of J1.

The antenna may be tweaked to maximize the detector's range by simply clipping or adding 1/4-inch lengths of wire to the antenna, while checking for a range improvement. Typically, the detector should have enough sensitivity to pick up an adult walking at a normal pace from 10 to 12 feet away in a clear room. Note that room characteristics can affect range.

You may wish to shape the pickup pattern of the Microwave Motion Detector. That's fairly easy to do. Try placing a 12- x 12-inch metal plate about 4 inches behind the Microwave Motion Detector's antenna. That sharpens the detection beam forward of the plate and reduces it behind the plate. You may wish to experiment with different sizes of plates placed at different distances from the antenna.

**Interface Circuits.** The Microwave Motion Detector's output transistor, Q4, provides only a short switched "on" time when motion is sensed. You have probably asked the question, how do I make it do something other than just make the LED blink?

For instance, you might want to activate an alarm for a period of time after the motion is detected. That's easily accomplished using a solid-state timer, such as the optional UT-5 Universal Timer-Oscillator (based on

the popular 555 oscillator/timer) offered in the Parts List. The UT-5 can be wired as either a timer or an oscillator. Figure 5A shows how the two circuit's are wired together.

When the UT-5 is wired as a timer, a variable resistor and several supplied capacitors allow you to set "on" times of from several seconds to several minutes with a single trigger pulse. The output of the UT-5 can be used to trigger a relay or alarm siren.

If you'd prefer to have the Microwave Motion Detector drive a siren directly, one is offered (the SM-3 Police Siren) in the Parts List. The connections for the siren and the Motion Detector are shown in Fig. 5B. The Siren sounds with an upward wail whenever the PNP transistor turns on, connecting pin 4 to the positive supply voltage.

In that circuit, a 10k pull-up resistor is tied to the base of the transistor, holding it at cutoff. Whenever the Detector is triggered, the base of the PNP transistor is pulled to ground, allowing the transistor to conduct. That places a positive voltage on pin 4, causing the siren to sound. When the Detector turns off, positive voltage is removed from pin 4 of the siren, turning it off. The total sounding time of the siren is roughly twice the detector's on time.

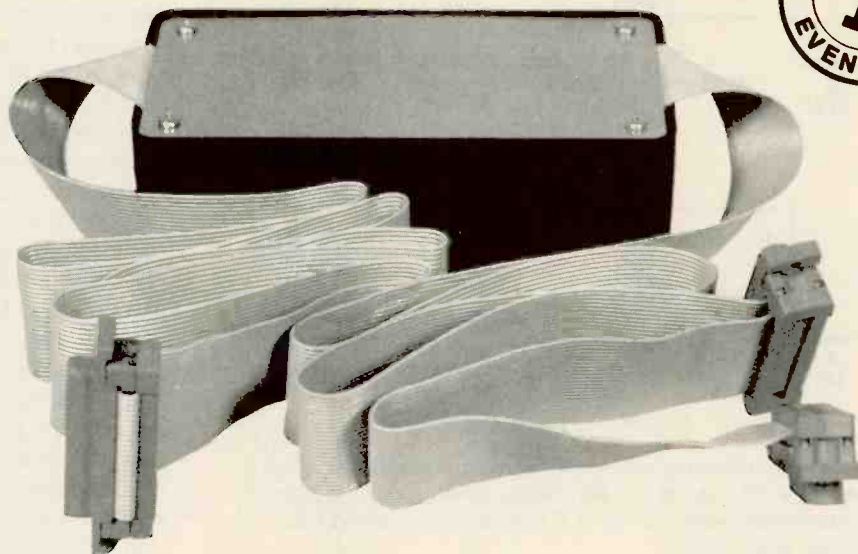
Figures 6A and 6B show typical transistor driver circuits triggered by the Motion Detector in a similar fashion. The circuit in Fig. 6A is designed to deliver a positive output voltage to the circuit that follows. The circuit in Fig. 6B, with the aid of a second transistor (which is used as an inverter), is designed to complete the ground-return path for the circuit that follows.

Figure 7 shows how the Microwave Motion Detector can be used to trigger a relay. If that scheme is used, just be sure to note the limits of 50 volts DC or 250 mA at pin 5 of J1. Of course, if a higher capacity is required, the small relay of the circuit in Fig. 7 can be used to trigger one that's capable of handling the heavier load.

Another application for the motion detector might be to connect a tape recorder with a recorded message (or perhaps the sound of a barking dog) to the circuit using the scheme outlined back in Fig. 4. Then with the recorder turned on and set to the playback mode, when the motion detector senses movement, the recorder will play the message. ■



# Build a



## Computer-Controlled A/B Switch

*Our simple computer-controlled A/B switch makes it easy to switch any pair of AC or DC signals, including RS-232 signals.*

BY JOHN YACONO AND MARC SPIWAK

It would seem that there are two general types of computer owners: power users with up-to-the-minute hardware and those that get by with slightly older equipment. However, both types eventually end up with a stockpile of hardware; advanced users quickly amass hardware because they want to, while modest users accumulate wares because they have to upgrade just to remain moderately current.

Once you end up with enough surplus hardware, old and/or new, it seems pretty natural to want to connect at least some of it (terminals, modems, printers) together, if for no other reason than the versatility that such a mini-network can provide. That usually leads to the purchase of a couple of A/B switches to permit you to configure new set ups on the fly.

Unfortunately, simple A/B switches must be directly operated by the user. That is pretty inconvenient if you're working from a remote terminal. Besides, your computer should "know" what resources you need and auto-

matically provide them for you—shouldn't it? After all, let's say that you have two computers or terminals sharing a modem. It would be nice if the A/B switch between them automatically switched to the computer that's presently running communications software. An A/B switch like that could even be used in a similar way to allow two computers to share a serial printer.

The *Computer-Controlled A/B Switch* presented in this article is such a device. In fact, it's one of the most versatile communication devices that you'll find. It can direct just about any pair of AC and/or DC signals. With it, power users can use one to multiplex input to a data-acquisition board, and more common folks can redirect audio signals between their home-entertainment components. Further still, just about anything possible with a double-pole, double-throw switch rated for 350 volts at 120-mA AC or 200-mA DC can be done with our A/B Switch.

The device was originally designed

to allow a computer to disconnect one device on a three-wire RS-232 communications link and switch to another device on the line. (Specifically, the unit would interrupt a communication between two modems so the computer could communicate with one of them). However, after the prototype was working, we found that by re-wiring the "contacts and poles" of the switch, its operation could be modified for use in many other applications. In this article we'll show you how to build, configure, and (if necessary) write software to "A/B switch" almost any pair of signals.

**Circuit Operation.** The A/B Switch circuit is the electronic equivalent of the double-pole double-throw switch shown in Fig. 1. Refer back to that figure (the labels on the poles and contacts) from time to time as we discuss the actual A/B Switch circuit.

The Switch's schematic diagram is shown in Fig. 2. Note that key points in the schematic bear the same labels (Continued on page 34)

# NRI knows: The best way to learn to service today's computers is to actually build a state-of-the-art computer from the keyboard up.



NRI training is the best way to prepare for a profitable new career, even a high-paying business of your own, as a computer service technician.

Before long, you'll be assembling and using your 486sx IBM-compatible computer system with all these state-of-the-art features ...

- Space-saving mini-tower design
- 80486sx Intel CPU
- Super VGA color monitor
- 200 meg hard drive
- 3 1/2" floppy drive
- CD-ROM drive
- 8-bit sound card
- MS-DOS 6.2
- QBasic
- Microsoft Works
- Ultra-X diagnostic package



## TRAIN WITH THE LEADER - NRI

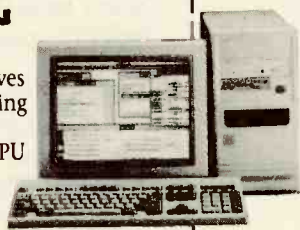
A pioneer in at-home training for 80 years, NRI was the first school of its kind to offer a hands-on course in computer repair ... and the only school today that makes theory come alive with real-world experiments. Those same benefits that set us apart from other schools help our graduates earn respect and financial security.

Regardless of your background in electronics, NRI's step-by-step approach can help you break into the field that's expected to produce over 220,000 jobs by the year 2005. It's true: The Department of Labor forecasts a full 38% increase in jobs for computer service technicians, which means there's big opportunity for the person with the right training — NRI training!

## LEARN BY DOING

NRI's highly acclaimed learn-by-doing approach gives you a complete understanding of the intricate electronics behind the 80486sx Intel CPU included in your course.

Unlike other schools, NRI familiarizes you with the fundamentals of computer operation so that you'll be able to service virtually any kind of computer with virtually any kind of problem.



You perform hands-on experiments with your versatile NRI Discovery Lab and professional digital multimeter, then build and test the powerful 486sx/25 MHz computer system that is yours to keep.

You install the floppy drive and 200 meg hard disk drive for quick, trouble-free storage and retrieval. And you interface the assortment of popular multimedia peripherals included in your course: the Super VGA color monitor, CD-ROM drive, and 8-bit sound card.

Best of all, you learn to identify and service computer problems with Ultra-X's extraordinary R.A.C.E.R. plug-in card and QuickTech diagnostic software.

You even explore operation, programming, and applications software as you work with MS-DOS 6.2, QBasic, and Microsoft Works.



## STUDY AT YOUR OWN PACE

As an NRI student, you enjoy the freedom of studying at home, at your own pace.

Your training begins with newly expanded lessons covering everything from batch file applications to recovering lost data to printer servicing and more — all in easy-to-understand detail.

And throughout your course, you put your new knowledge to work with hands-on projects that are reviewed by your own personal instructor.

Only NRI gives you such an effective combination of theory and practical experience. You won't find a better training value anywhere!

## FIND OUT MORE ABOUT NRI TODAY

Send today for our FREE, full-color catalog that describes every aspect of NRI's innovative computer training, as well as hands-on training in other growing, high-tech fields.

If the coupon is missing, write to: NRI Schools, McGraw-Hill Continuing Education Center, 4401 Connecticut Avenue, NW, Washington, DC 20008.

IBM is a registered trademark of International Business Machines Corp. R.A.C.E.R. and QuickTech are registered trademarks of Ultra-X, Inc. Intel Inside logo is a trademark of the Intel Corp.

### FREE CATALOG! CALL 1-800-321-4634

**NRI Schools** McGraw-Hill Continuing Education Center  
4401 Connecticut Avenue, NW, Washington, DC 20008

Check one FREE catalog only

- MICROCOMPUTER SERVICING
- TV/Video/Audio Servicing
- Telecommunications
- Industrial Electronics & Robotics
- Security Electronics
- Electronic Music Technology
- Basic Electronics

- Computer Programming
- Programming in C++ with Windows
- Desktop Publishing & Design
- Word Processing Home Business
- Bookkeeping & Accounting
- Home Inspection
- Building Construction
- Small Engine Repair
- Automotive Servicing

For career courses approved under GI Bill, check for details.

Name \_\_\_\_\_ (please print) Age \_\_\_\_\_

Address \_\_\_\_\_

City/State/Zip \_\_\_\_\_ Accredited Member, National Home Study Council 32-0894



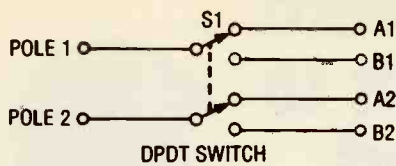


Fig. 1. The A/B switch is very similar to a standard double-pole, double-throw switch, like the one shown here.

as the poles and contacts in Fig. 1. The circuit's active components are nothing more than a pair of diodes that steer current through the inputs of four special optocouplers. The optocouplers are specially designed for telecom (standard slang for "telecommunications") applications and conform to the RS-232C standard.

As you can see, each diode is connected in series with (and in between) the inputs of two optocouplers. Also note that the two series-connected optocoupler-diode-optocoupler legs of the circuit are connected back-to-back (i.e., with opposite polarity) between the control input and ground. In that configuration, U1 and U2 will turn on whenever the control voltage is positive, and U3 and U4 will turn on when the control voltage is negative. When any one of the optocouplers is on, its output pins short to simulate switching action.

The circuit wired as shown in Fig. 2 is fine for AC signals, but it can be modified for enhanced DC performance. The necessary modifications are shown in Fig. 3. The revised circuit operates just like the AC circuit, but wiring the optocoupler outputs as shown permits them to handle more current and yields faster switching action. However, you must obey the polarity indicators to wire the device properly.

If desired, one pole of the circuit can be wired to handle AC with the other pole configured for enhanced DC operation. For example, U1 and U3 can be wired for AC, as shown back in Fig. 2, while U2 and U4 can be wired for DC as in Fig. 3, or vice versa.

One benefit of using optocouplers in an application like this is the isolation provided between the device generating the control signal and the signal lines. The incidental isolation will protect the controlling device from harmful voltages (perhaps due to a nearby lightning strike) on the signal line up to 3750 volts! Since the controlling device will likely be a computer or terminal, that sort of protection is very nice indeed.

**Our Application.** Take a look at the version of the A/B Switch circuit shown in Fig. 4. Note that pins 2 and 3 of J3 (the connector to modem 2) are connected to the poles of the switch. That way, the circuit can switch J3 (the poles) between J1 (which you can think of as position A) and J2 (or position B).

The switch receives its control signal from pin 20 of J1, which supports the data-terminal ready (DTR) line on the computer. (The reason that we used the DTR line will be explained a little later.) The DTR line causes one pair of optocouplers to turn on when

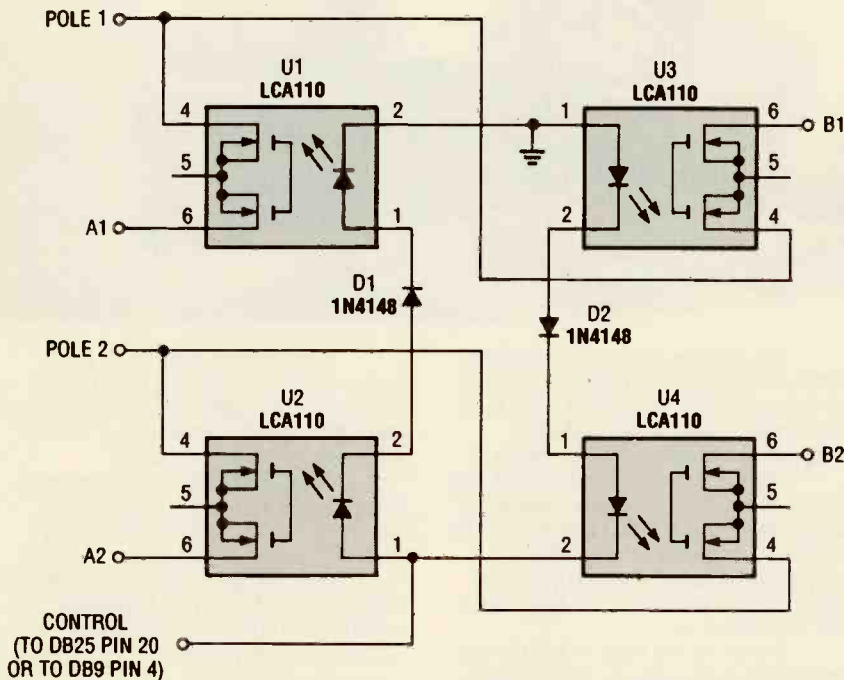


Fig. 2. The A/B switch is very simple, as you can see. Four special telecom switches (U1-U4) are wired together to form a double-pole, double-throw switch.

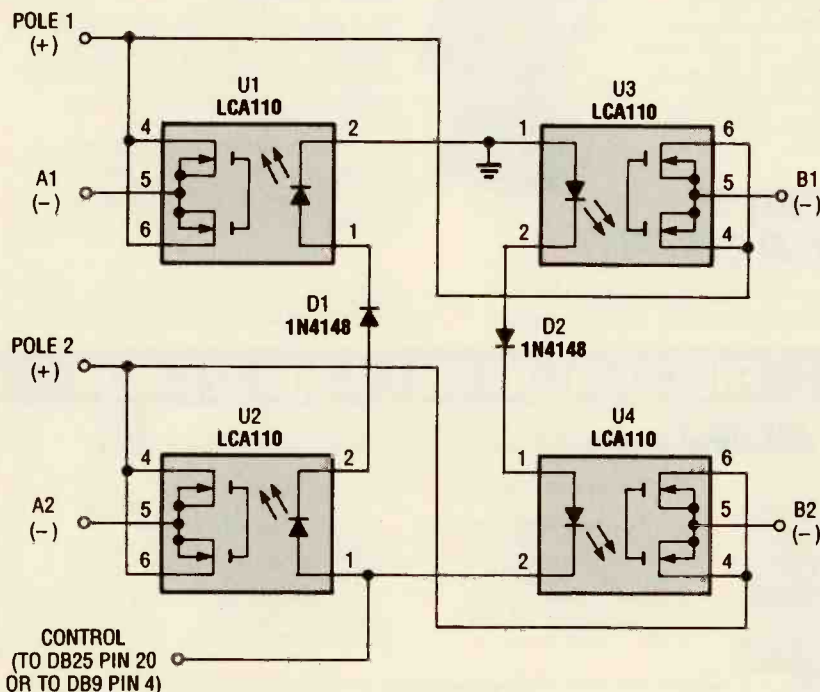


Fig. 3. The version of the A/B switch shown back in Fig. 2 is fine for AC signals, but it can be enhanced for DC operation by rewiring the optocoupler outputs as shown here.

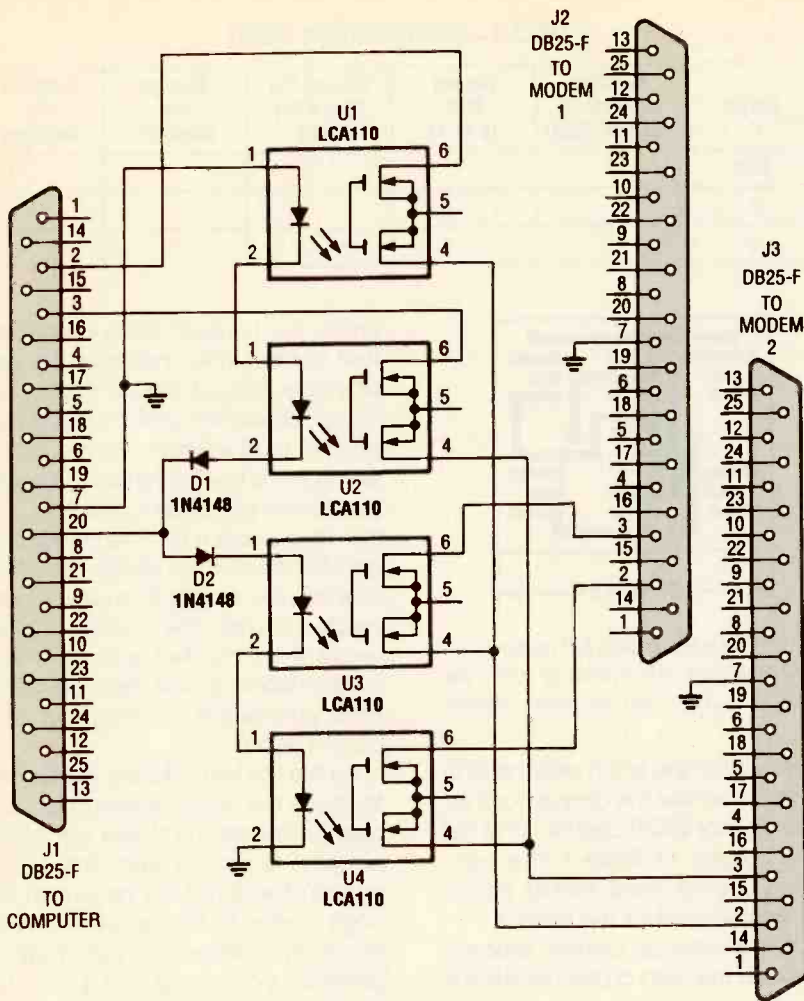


Fig. 4. Our application circuit for the A/B switch (shown here) allows a computer to interrupt one modem to talk with another.

positive, and the other pair to turn on when negative (remember, RS-232 ports use bipolar signals).

If we wanted one of the modems to have control of the switch instead of the computer, we could have used pin 20 of J2 or J3. While that's not what we wanted, you should keep that in mind when sizing up your own needs.

Wired as shown, the state of pin 20 from the computer controls the switch's "position." That allows the computer to disconnect modem 2 from modem 1 and get its full attention.

If you wish to use the circuit for computer communications, please keep in mind that the switch should connect transmit lines to receive lines, and vice versa. In other words, the switch should not attempt to connect two transmit pins together, or two receive pins together. See the documentation for your peripherals to determine their pin functions. By the

way, if you make a wiring mistake, don't worry; RS-232 devices are designed so that they **cannot** be damaged by such mistakes.

If you will be using DB9 connectors in place of the DB25's we used, you should again check the peripheral's manual to determine the identity of the transmit and receive pins. However, we can tell you right off the bat that pin 4 on that connector is for the DTR line, and pin 5 is ground.

**Automatic and Programmed Control.** The DTR line was chosen to control the switch because that line changes states as soon as any standard communications software is ready to run. That makes the action of the switch automatic: if the controlling computer runs communications software, the A/B Switch will change states when the program toggles the DTR line.

For less-automated control of the

### LISTING 1

```

PUSH      AX
PUSH      DX
MOV       DX, 03FC
IN        AL, DX
XOR       AL, 02
OUT       DX, AL
POP       DX
POP       AX
RET

```

A

```

PUSH      AX
PUSH      DX
MOV       DX, 02FC
IN        AL, DX
XOR       AL, 02
OUT       DX, AL
POP       DX
POP       AX
RET

```

B

```

PUSH      AX
PUSH      DX
MOV       DX, 03EC
IN        AL, DX
XOR       AL, 02
OUT       DX, AL
POP       DX
POP       AX
RET

```

C

```

PUSH      AX
PUSH      DX
MOV       DX, 02EC
IN        AL, DX
XOR       AL, 02
OUT       DX, AL
POP       DX
POP       AX
RET

```

D

switch, you could run a program like one of the ones shown in Listing 1, which are available from the authors (see the Parts List for ordering information). The four programs shown are (structurally speaking) identical. They differ only in the communications port they affect. The program shown in A works for COM1, the one in B for COM2, C affects COM3, and D is for COM4. It should go without saying that the program of choice must run on the controlling computer or terminal.

Since the programs are almost identical, we'll just discuss the one in A. (If you are not familiar with accessing ports, see "Programming Serial Ports," in the August, 1993 issue of **Popular Electronics** for more information). The first two instructions simply preserve the contents of the AX and DX regis-



ters (special-purpose memory locations in the CPU) by "pushing them onto the stack" (storing them in another special location). The third instruction places the hexadecimal number "3FC" into the DX register. That number is the address of the byte that controls the DTR line. In the next step, the value stored in the address in DX (to be literal, the value stored at address 3FC in hexadecimal) is placed in the lower half of the AX register (the lower half is denoted "AL").

We now seek to toggle the bit that controls the DTR line. That would be the least-significant bit of the number that was taken from address 3FC, which is now in AL. To toggle that bit,

### PARTS LIST FOR THE COMPUTER-CONTROLLED A/B SWITCH

- U1-U4—LCA110 opto-MOS telecom switch
- D1, D2—1N4148 general-purpose small-signal silicon diode
- Printed-circuit board, DB9 and/or DB25 connectors as needed (see text), ribbon or other suitable cable, IC sockets, case and mounting hardware, solder, etc.

you simply take the exclusive XOR of 1 and the value in AL, which is performed by the next instruction. Now that the value of AL has been appropriately altered, it replaces the old value in 3FC as soon as the OUT instruction is performed. The DX and AX registers are then restored to their initial values by "popping them off the stack" (retrieving them from the special location mentioned before) and the program terminates. The state of the DTR line will change each time this program is run, toggling the A/B Switch.

**Determining Your Needs.** Table 1 has been provided mainly to assist you in configuring your switch for RS-232 applications, although it does have limited use for other applications. In particular, the table will help you configure the connector wiring. Let's discuss how to fill-in the table.

Start by mentally designating the device being switched as the "pole" device, one of the other devices as unit "A," and the remaining one as unit

TABLE 1—CONFIGURATION CHART

Device	Required Connectors (DB9 or DB25)	Ground Pins (5 or 7)	Control Pin (One Entry Only)	Receive Pin Numbers	Transmit Pin Numbers
Pole					
A					
B					

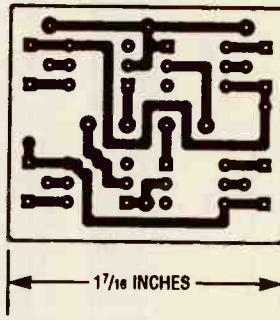


Fig. 5. You can use this foil pattern to build your own A/B switch, or order the board, kits, etc. from the listed supplier.

"B." Now examine each peripheral in turn to determine the connector it requires (DB9 or DB25) and fill-in the first blank column of Table 1. The connectors you list there should be on your shopping list for the project.

In the ground-pin column, place a 5 in each row with a DB9 connector,

and/or a 7 for each DB25 connector. That column now indicates the appropriate ground pin for each connector. Determine which device (the pole, A, or B) will have control of the switch. In the row for that device under the control-pin column, place a 20 if the device uses a DB25 connector, or a 4 if the device uses a DB9 connector. That tells you which pin on which connector carries the control signal. Leave the other two spaces in that column blank or cross them out as the other connectors will not generate a control signal.

For the last two columns, you'll need to check the documentation for your peripherals. You must find out which pin (pin 2 or pin 3) is used for transmission and which is for reception on each device. Fill the last columns with those pin numbers accordingly. In general, computers use pin 2 for

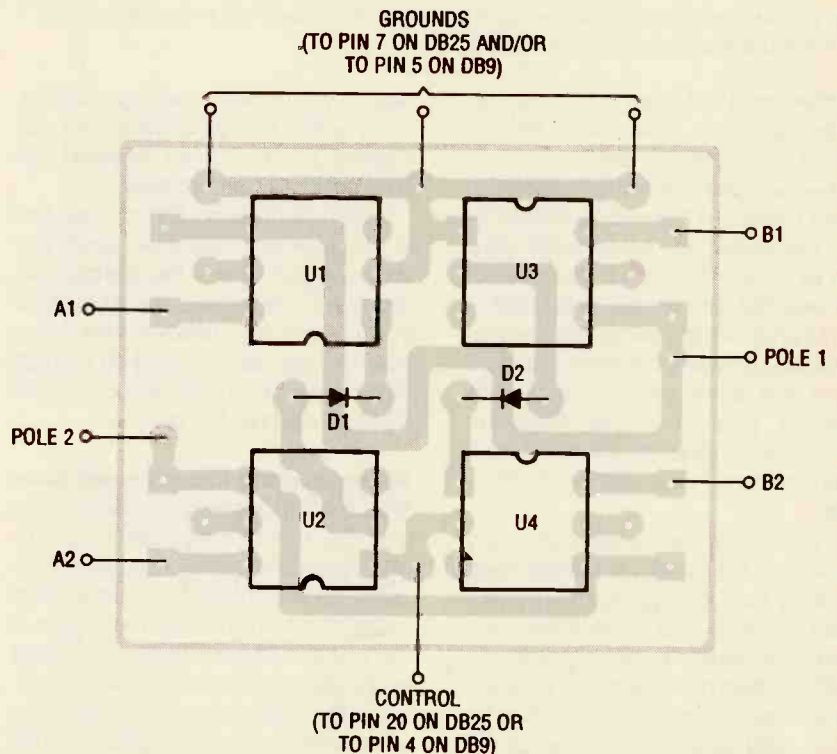


Fig. 6. Follow this parts placement diagram to stuff the board for AC use (such for true RS-232 applications or audio projects).

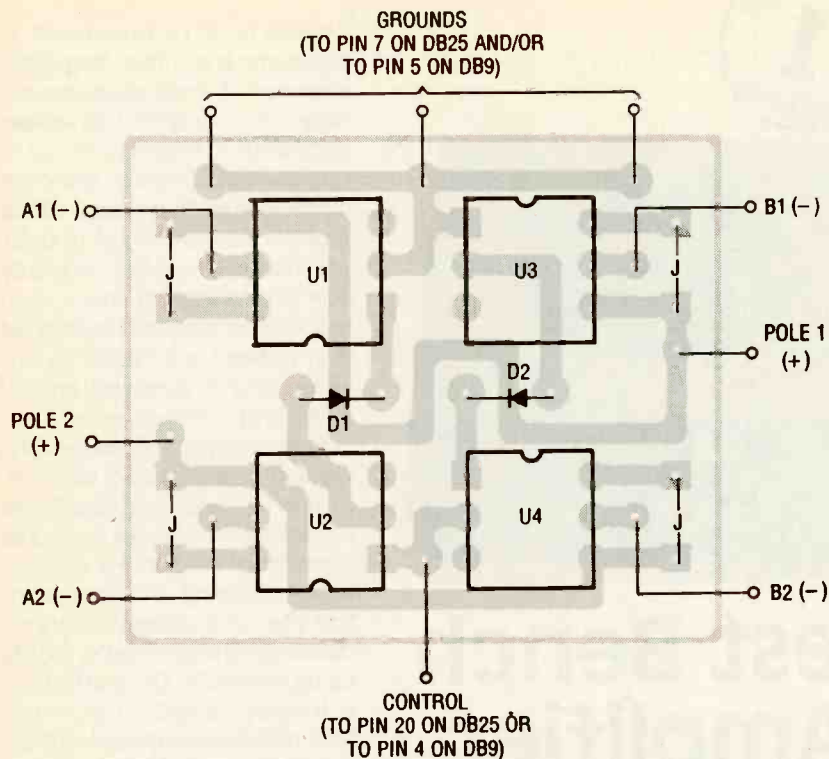
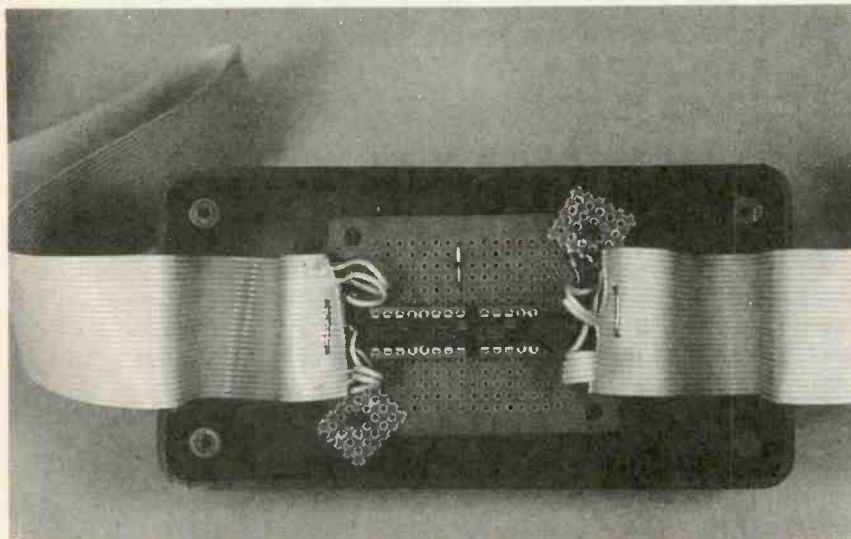


Fig. 7. To use the switch for DC operation, this method of stuffing the board will yield a device that is faster and capable of handling higher current.



Here's what the inside of the A/B switch looks like. Note the compactness of the design.

transmit and pin 3 for receive when they have a DB25 connector, and just the opposite when they have a DB9 connector. Most modems are entirely the opposite: they use pin 3 for transmit and pin 2 for receive over a DB25 connector, and vice versa for a DB9 connector.

**Construction.** Now that we understand how the A/B switch works, it's time to build one. A printed-circuit

board should be used. Not only will using a printed-circuit board save you time and lessen the chance of wiring errors, it will also eliminate the possibility of signals interfering with one another. If you want to make your own printed-circuit board, you can use the foil pattern shown in Fig. 5. Otherwise, printed-circuit boards, kits, and fully assembled units are available from the source mentioned in the Parts List.

If, as we talked about before, you

want to use the A/B switch for AC (like RS-232 and audio applications), follow the parts-placement diagram in Fig. 6, and wire your connectors using Fig. 1 as a guide. However, to use the switch for DC operation, the configuration shown in Fig. 7 will yield a device that is faster and capable of handling higher current. (Please observe the proper polarity of the outputs for DC use.) As mentioned earlier, you can even wire half the unit for AC and the other half for DC signals.

For strict RS-232 applications, you should follow the parts-placement diagram in Fig. 6 to stuff the board (that illustration omits the jumpers of Fig. 7). Connect the grounds and the control line guided by Table 1. Connect the transmit and receive lines from the pole device to poles 1 and 2, respectively. Connect the receive and transmit pins of the A device to A1 and A2, respectively (again guided by the table). Also use the table to help you connect the receive and transmit pins of the B device to B1 and B2, respectively, and the wiring is complete. The finished board can now be installed in any case you like. ■

# FREE

*Electronics & Computer Software  
Education Catalog*

- \*Fast-Track Individual Learning Programs
- \*State-of-the-Art Classroom Courses
- \*The **Best Values** in Electronics Education

## New

**Career-Level Courses**  
*Personal Computer Servicing  
TV and VCR Servicing*

## New

**Computer-Aided Instruction**  
*DC & AC Electronics  
Semiconductors  
Electronic Circuits*

*The stunning animations, hypertext  
glossary, and easy-to-understand text make  
learning electronics a breeze...and fun!*

Learn the easy and affordable way from the  
Masters in Electronics Training - **Heathkit**.  
From Basic Electricity to Advanced Microproces-  
sor Applications and more, Heathkit will provide  
you with an unparalleled learning experience at a  
fraction of the cost of other programs.

# Heathkit<sup>®</sup>

**Educational Systems**

For your FREE Catalog, call  
**Toll-Free 1-800-44-HEATH**  
please mention this code when calling 107-032

CIRCLE 18 ON FREE INFORMATION CARD



If you experiment with audio circuits or are involved with audio-equipment repair, the *Test Bench Amplifier* described in this article may be just what you need. At the heart of the circuit is a high-efficiency, audio power amplifier, coupled with a few support components. The circuit includes options for either or both internal and external power sources.

The Test Bench Amplifier can be used to boost low-level signals enough to drive a speaker, or it can be coupled with an AC voltmeter (with the speaker muted) for adjusting a circuit for peak output. The Test Bench Amplifier can also be used as a high-frequency RF-signal tracer; when used in that capacity, it renders AM signals audible. For experimenters, it can be used as a general-purpose power op-amp with a 300 kHz bandwidth.

**About the Circuit.** Figure 1 shows a schematic diagram of the Test Bench Amplifier (which is designed as a "building block" to allow it to easily be incorporated into a myriad of other projects). The circuit is built around an LM386 low-voltage, audio power amplifier (U1), which is easy to use, stable, and requires very few support components. The LM386 can deliver up to 0.4 watts with harmonic distortion below 1%. It can be powered from a supply voltage of anywhere from 4 to 12 volts, and has a quiescent current drain of 3 mA, making it ideally suited to battery-powered projects.

The minimum voltage gain of the LM386 is internally set at 20 (26 dB); however, by adding C2 (a 10- $\mu$ F capacitor connected across pins 1 and 8 of U1, shunting an internal resistor), the voltage gain is increased to 200 (46 dB).

For some applications needing adjustable gain, a 5k potentiometer added in series with C2 will smoothly set the voltage gain between 20–200. Capacitor C1 is used as an audio-input coupler, which provides DC-voltage isolation from the audio source. Potentiometer R3 serves as a volume control and sets the input impedance of the amplifier at 10k. The LM386 has an input impedance of 50k. If your application requires a higher input



## Test Bench Amplifier

*Add this handy little amplifier to your troubleshooting/ design-station arsenal*

BY LUTHER STROUD

impedance, select a larger value for R3.

A corresponding value resistor should be inserted in the circuit between U1 pin 2 and ground that reflects the resistance in the U1, pin-3 circuit. It isn't needed if R3 is below 25k. The series circuit of R1 and C5

provide a bit of bass boost to overcome the limited frequency response of small speakers. You may want to shift the values somewhat to tailor the sound to your speaker or leave the parts off altogether. Don't leave off the snubber network of C6 and R2, which keeps the LM386 stable by compensating for the inductance of the speaker. Leaving out that network can result in distorted sound, excessive current drain, and RF interference.

Capacitor C3 provides bypassing of the internal bias network in U1's input-amplifier stage. Capacitor C7 couples the audio signal at U1 pin 5 to the speaker, while providing DC-path isolation. The pin-5 voltage without an audio signal is at  $\frac{1}{2}$  the DC supply. Components D1, C8, and R5 form a wideband radio-frequency (RF), amplitude-modulated (AM) detector circuit. Almost any AM signal applied to the project's input when S2 is in the RF (open) position will be converted to an audio signal that can be heard from the speaker. Note that D1 is a germanium diode; a silicon type, such as a 1N914 or similar unit, will not work here.

When S2 is closed, shorting D1, audio signals pass freely. Opening S3 mutes the loudspeaker audio, thus isolating the amplifier so that it can be used alone or with a level-indicating device; SPKR1 can be used as a test speaker since it is isolated from the other circuitry.

**Getting It Together.** To minimize cir-

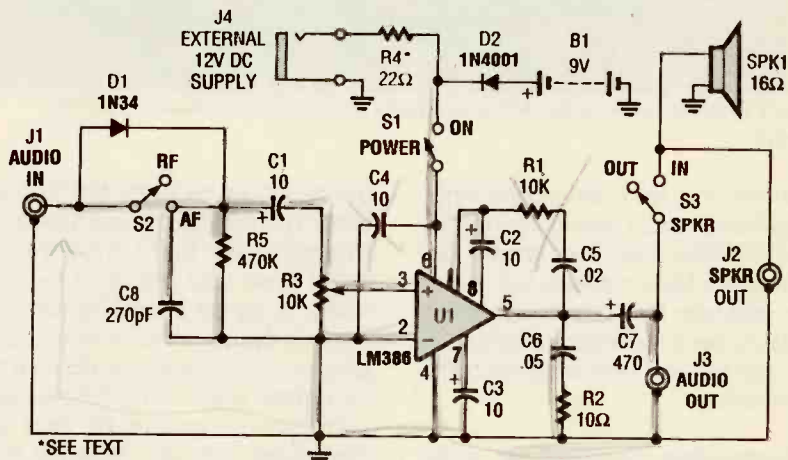


Fig. 1. The Test Bench Amplifier (which is designed as a "building block") is built around an LM386 low-voltage, audio-power amplifier (U1).

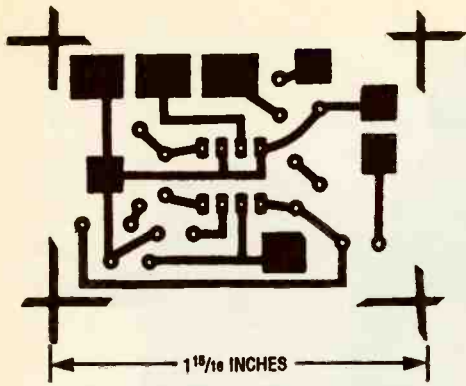


Fig. 2. The author's prototype was assembled on a printed-circuit board, measuring about  $1\frac{3}{8}$  by  $1\frac{15}{16}$  inches. A template of the printed-circuit layout is shown here.

tation of U1. If you follow the board-stuffing sequence of the lowest profile components first (resistors and U1, followed by the capacitors, and finishing with C7 and R3), the assembly will proceed easily.

The terminals of R3 (the large volume-control potentiometer) and the wiring that connects the off-board components to the main chassis are soldered to the oversized pads distributed around the edge of the circuit board. Solder a short wire from ground to the case of R3 to help prevent noise from entering the input circuitry through the body of the control. As you assemble your project, be sure

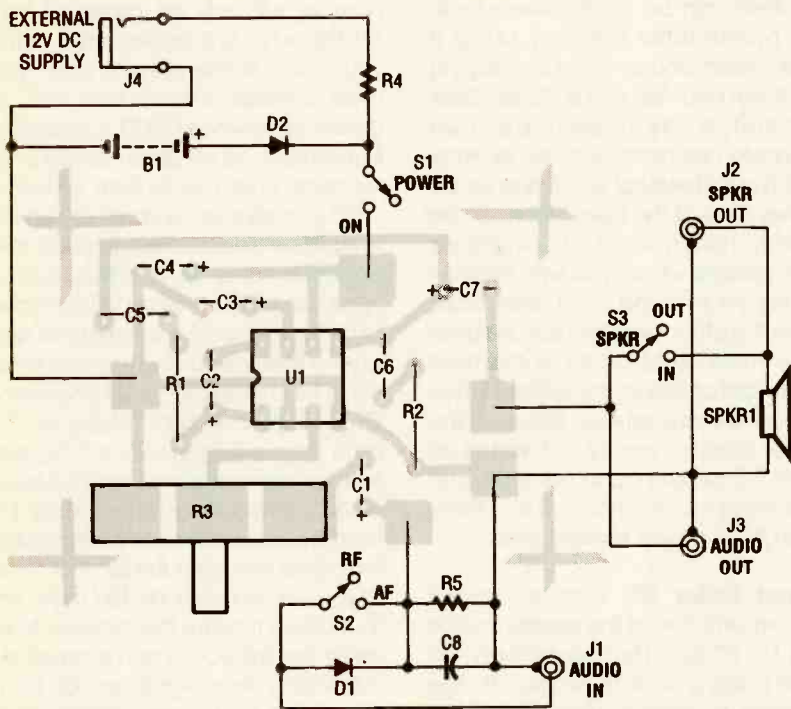


Fig. 3. Assemble your printed circuit board according to this parts-placement diagram. When assembling the board, be mindful of the orientation of the electrolytic capacitors, the diodes, and U1.

circuit size and to cut down on stray input/output coupling, the author's prototype was assembled on a printed-circuit board measuring about  $1\frac{3}{8}$  by  $1\frac{15}{16}$  inches. A template of the printed-circuit layout is shown in Fig. 2. You can etch your own board from the artwork provided or order a board from the vendor listed in the Parts List.

Figure 3 shows a parts-placement diagram for the author's printed-circuit layout. When assembling the board, be careful with the polarity of the electrolytic capacitors and orien-

ting to avoid possible damage from excessive heat.

tion of U1. The front panel of the author's model is metal so only one ground connection was needed for all of the input/output connectors. If your version is plastic, be sure to add the appropriate ground connections. Again, note that D1 is a germanium diode; a heat sink should be placed on the diode's leads, about  $\frac{1}{4}$  inch away from the body of the unit, when sol-

## PARTS LIST FOR THE TEST BENCH AMPLIFIER

### SEMICONDUCTORS

U1—LM386 low-voltage, audio-power amplifier, integrated circuit  
D1—1N34 general-purpose germanium signal diode  
D2—1N4001 1-amp, 50-PIV, rectifier diode

### RESISTORS

(All fixed resistors are  $\frac{1}{4}$ -watt, 5% units.)

R1—10,000-ohm  
R2—10-ohm  
R3—10,000-ohm potentiometer  
R4—22-ohm,  $\frac{1}{2}$ -watt (see text)  
R5—470,000-ohm

### CAPACITORS

C1—C4—10- $\mu$ F, 16-WVDC, radial-lead electrolytic  
C5—0.02- $\mu$ F, ceramic-disc or Mylar  
C6—0.05- $\mu$ F, ceramic-disc or Mylar  
C7—470- $\mu$ F, 16-WVDC, radial-lead electrolytic  
C8—220-pF, ceramic-disc

### ADDITIONAL PARTS AND MATERIALS

S1—SPST—miniature toggle switch  
S2, S3—SPDT miniature toggle switch  
SPKR1—4-inch, 16-ohm, round speaker  
J1—J3—RCA phono jack  
J4—Miniature phone jack  
Printed-circuit materials, enclosure, battery holder and connector or optional AC adaptor (see text), knob, wire, solder, hardware, etc.

**Note:** The following is available from Pershing Technical Services, P.O. Box 1951, Fort Worth, Texas 76101: A partial kit of parts, consisting of the printed-circuit board, all board-mounted components, and the battery connector for \$9.50. Price includes shipping cost. Texas residents, please add appropriate sales tax.

dering to avoid possible damage from excessive heat.

**A Word on Power.** The LM386 consumes very little power at idle, increasing to about 75 mA when driven to full volume. An input signal of about 10 millivolts is sufficient to drive the speaker to full volume. The LM386's low power consumption makes it suitable for battery power.

The internal resistance of the bat-

(Continued on page 110)



# Build The Call Blocker

Use this circuit and the telephone company's "Caller ID" service to spare yourself from unwanted calls.

BY TERRY J. WEEDER



**H**ave you ever been annoyed by a phone that constantly rings off the hook while you were trying to devote your attention elsewhere. To make matters worse, it seems that most of those calls are from people you did not wish to speak with. You can, and at times probably have, broken down and turned off the bell on your phone just to get a little peace and quiet. The only problem with that solution is that you are then completely cut off from the outside world and even important calls from friends or family can't get through.

There are a number of companies that are now offering a device that will display the number of the calling party for you to view prior to picking up the telephone (called "Caller ID"). That is nice, but even if you can determine that you don't want to answer the call, your peace has already been invaded by the ringing of the telephone and the act of getting up to see whose number is displayed on the screen.

There is a better solution. The *Caller Block* described in this article is a device that connects between your telephone and the telephone wall jack and prevents the phone from ringing unless the telephone number of the person calling matches one of the numbers you have entered into its memory. For maximum versatility, an answering machine can be placed on the same line to handle those calls that do not qualify to ring the phone; those can be dealt with later on at your own convenience. The unit can be used in conjunction with a Caller-ID display unit

A list of up to 62 different telephone

numbers can be easily entered into the non-volatile memory using a tone-dialed phone without changing the initial hook-up of the Caller Block unit. The memory is broken up into two separate directories with an external switch used to select which one will be active. One of the directories can be used to hold a large list of numbers from people whom you wish to allow to ring your phone on a daily basis, while the other directory can be used for a more selective list of the most important callers for those times when you want more privacy. Because the Caller Block's memory is stored in an EEPROM, all telephone numbers programmed into memory will stay there even if the power is interrupted.

**About Caller ID.** With the recent implementation of the service known as CND (Calling Number Delivery) on most major phone networks, it is now possible to receive data about the calling party prior to picking up the phone. That data is what is used by the many caller ID units now hitting the market, and it is what makes this circuit possible. CND is a subscriber feature that transmits data (date, time, number) about the calling party during the silent period between the first and second ring. You must subscribe to the service or no data will be received, but once you have subscribed, you will receive the data on all calls regardless of whether the caller subscribes or not. Call your local phone company to get more information about getting CND on your line.

The date and time information is sent on all calls, but the actual calling

number will only be available from parties who are calling from within your area. At the present time "your area" consists of local calls that originate from where CND is available, but will soon be set up to include long-distance calls made from wherever CND is available. As more and more telephone companies upgrade their equipment, the list of callers outside "your area" will continue to decrease.

The actual data sent over the telephone line is a burst of modem tones using 1200 Hz as a logical 1 (mark) and 2200 Hz as a logical 0 (space). The data stream begins with a "Channel-Seizure" signal that consists of a block of 300 alternating mark/space bits used by the receiver as an indication that data will soon follow. That is followed immediately by 180 mark bits; that allows time for the receiver to set up for the first word. Each data word is 8-bits long (least significant bit transmitted first), and is preceded by a start bit (space) and followed by a stop bit (mark). In addition, up to 10 mark bits may be added between words.

The portion of the message that contains the calling number is preceded by a "type code" of 04(hex). The first word to follow is a "length" word that indicates the number of the words in the message. Following the length word, the date, time (in 24-hour format), and the telephone number is sent in ASCII format. Finally, a "checksum" word is sent. For example, 01-15-94 2:30pm 513-555-1212 would be sent as follows:

```
<type><length>  
01159414305135551212  
<checksum>
```

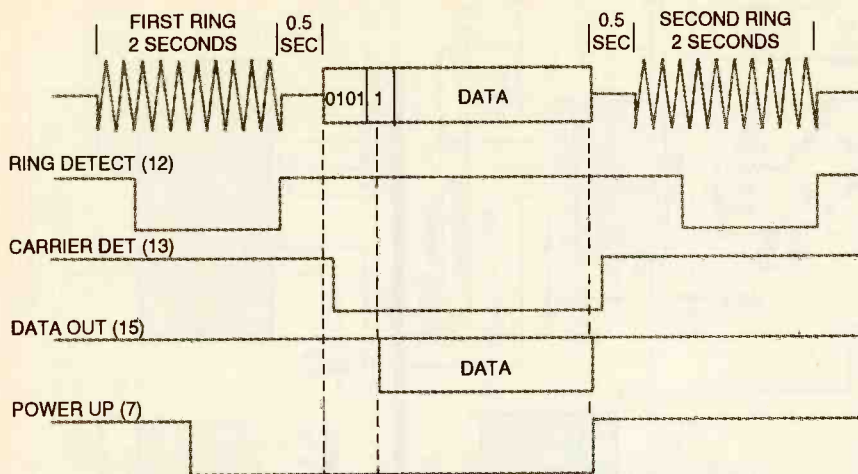


Fig. 1. The timing relationships between the data sent over the phone line (top trace), and the output pins of U2 (Motorola's new calling line identification receiver chip) are shown here.

**Circuit Theory.** The circuit is made possible by U2, Motorola's new Calling-Line Identification Receiver chip (part no. MC145447), which receives the modem-like tones from the telephone line and decodes them. Figure 1 shows the timing relationship between the data on the phone line (top), and the various output pins of that IC.

When a ring pulse is detected on the phone line, the RING DETECT pin (pin 12) goes low. About 1/2 second after the end of the ring, the channel-seizure signal (shown as 0101) causes the CARRIER-DETECT pin (pin 13) to go low. The "1" shown after the "0101" represents the series of marks that are sent to allow the microprocessor to set up to receive data. The DATA-OUT pin (pin 15) goes low when receiving the very first start bit, which is the space following the series of marks, and continues to output the decoded data, serially, at TTL levels. The POWER-UP pin (pin 7) was designed for use in battery-operated circuits to conserve power and is not used here.

The schematic diagram for the Caller Block is shown in Fig. 2. The modem-like tones are coupled through C3, C4, R1, and R2 to pins 1 and 2 of U2. The metal-oxide varistor (MOV1) protects the circuit from high-voltage spikes, such as those produced by lightning strikes. The ring pulses are coupled to the RING-DETECT pins (pins 3 and 4) of U2 via C1, C2, BR1, and R3-R5. The relay (K1) is used to connect/disconnect the telephone from the phone line. The optoisolator (U5) monitors the current flow through

the telephone and pulls the voltage on R10 low when the phone is lifted off hook. Transistor Q2 is used as a switch to turn LED1 on and off, which indicates when the circuit is in the programming mode.

Power is taken from a 9-VDC wall adapter and is regulated by U6, a low-current 5-volt regulator, and filtered by capacitors C13-C15. To allow the telephone's keypad to be used, current is supplied to the telephone through R9 when the circuit is in the programming mode.

The heart of the circuit is U1, a PIC16C55 EPROM-based 8-bit CMOS microcontroller manufactured by Microchip. That microcontroller has one 4-bit and two 8-bit I/O ports, with each I/O pin being configured separately as either an input or output through software commands. The chip has 512 x 12 bits of EPROM memory to hold the operating program and 32 x 8 bits of data RAM used for working registers. A block diagram of U1's operating program is shown in Fig. 3. For those who wish to program their own PIC, the .ASM and .OBJ code files are available in the PE Library on this magazine's BBS (516-293-2283, 8N1, up to 9600 bps), or a pre-programmed PIC16C55 microcontroller can be purchased from the source mentioned in the Parts List. A non-programmed chip along with a PIC programmer can be obtained from Digi-Key (701 Brooks Ave. South, P.O. Box 677, Thief River Falls, MN 56701-0677) and other sources.

The output pins of U2, as referred to in Fig. 1, are connected to U1 through

the upper half of port B. U1 monitors the RING and CARRIER-DETECT pins and when a call is detected, U1 reads the calling party's number from U2, which is output serially through pin 15, and stores it in an internal register. The telephone number is then compared to the group of numbers stored in U4, a 93LC56 2K serial EEPROM also manufactured by Microchip. The 93LC56 uses a 4-line (CHIP SELECT, CLOCK, DATA IN, and DATA OUT) interface, which is connected to port A of U1. After a high is detected on the CHIP-SELECT pin, data is then transferred to and from the 93LC56 on the positive transition of the CLOCK pin. Each read or write function is preceded by a start bit, an opcode (identifying the function to be performed, i.e. read, write, etc.) an 8-bit address, and the 8 bits of data that are being written to, or read from, that address. Immediately preceding and following all write operations, the microcontroller (U1) sends instructions to the 93LC56 that enables/disables the write function, thereby protecting the data afterwards.

When entering the programming mode, the telephone is disconnected from the phone line by the relay (K1) and is connected to the analog input (pin 7) of U3, a DTMF receiver manufactured by Motorola. Integrated-circuit U3 is used to decode the tones emitted by the telephone and place its 4-bit word equivalent on the lower half of U1's port B. As each number is entered by the telephone, U1 reads the 4-bit word on port B and writes it to the EEPROM (U4) using port A. If the jumper (JU1) is installed, the microcontroller is configured to omit all area codes (both in programming and receiving), thereby simplifying the programming operation and allowing more numbers to be entered into memory.

**Construction.** The whole circuit, except for the switches and LED, fits nicely on a double-sided printed circuit board. The artwork is provided in Fig. 4 for those who wish to etch their own board, or you may purchase a pre-etched and drilled PCB from the source mentioned in the Parts List. Once you have obtained your board, identify the component side of the PCB board (which is marked), then refer to the parts-placement diagram shown in Fig. 5 to begin construction.



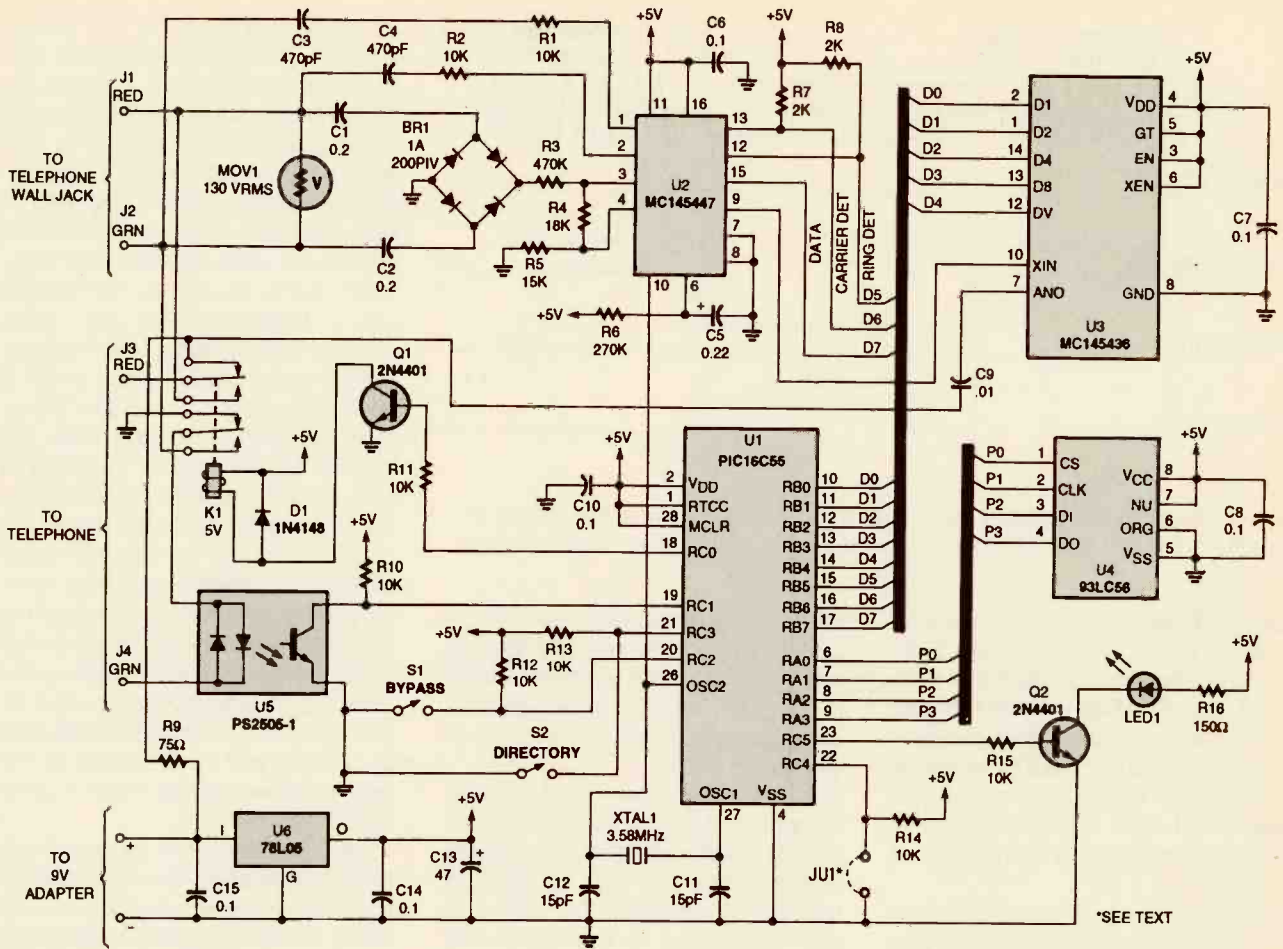


Fig. 2. Microcontroller (U1) reads the calling party's telephone number from U2, compares it to the list of user-entered numbers stored in U4 and closes the relay (K1) if a match is found.

Start by installing and soldering the IC sockets for U1 through U4. Solder U5 and U6 directly to the board, using the component orientations shown in Fig. 5. Mount the rest of the components to the board, paying particular attention to C5, C13, D1, BR1, Q1, and Q2 to prevent installing them backwards. When soldering the crystal (XTAL1), leave a small space between the bottom of the crystal and the PC board. There is a chance that the metal case of the crystal could short the two solder pads together if it is pushed flush against the board when soldering.

At the time of this writing, CND (Calling Number Delivery) was not available on calls originating outside the local area code (at least not in the author's community). As mentioned, with JU1 in place, the microcontroller is configured to ignore the area codes on all incoming calls; only the last seven digits of each number in your list of telephone numbers will

have to be entered into memory. In the future, when the CND link has been extended nationwide, you can simply remove the jumper and re-enter your list of telephone numbers using their area codes.

After all components are soldered to the board, inspect both sides for solder bridges or cold solder joints, which appear as dull blobs of solder, and correct if necessary. Carefully plug U1 through U4 into their sockets, making sure that they are oriented correctly. Make sure that all IC's are seated correctly with no pins bent or misaligned.

Cut four pieces of insulated hook-up wire, about 6-inches long, and twist them into pairs, then solder one end of each pair to the board terminals labeled S1 and S2. Cut two pieces of different-colored wire to the same length, and twist and solder them to the LED terminals on the board (take care to note which color is connected

to the cathode terminal and which is connected to the anode).

The two telephone cords that plug into the telephone and into the wall jack can be made from a single phone cord with a modular plug on each end (such cords are available from Radio Shack and elsewhere) by cutting it in half. Label one cord to WALL JACK and solder its red and green wires to terminals J1 and J2. Label the other cord TO TELEPHONE and solder its red and green wires to the terminals labeled J3 and J4. Note that the yellow and black wires on both cords are not used. Use an AC wall adapter with an output of 9VDC, such as the Radio Shack 273-1455; cut the coaxial plug off the end of the output cord and solder the "+" and "-" wires to the appropriate terminals on the board.

The size of the PC board and the location of the mounting holes are such that it will mount directly into a plastic enclosure available from Digi-

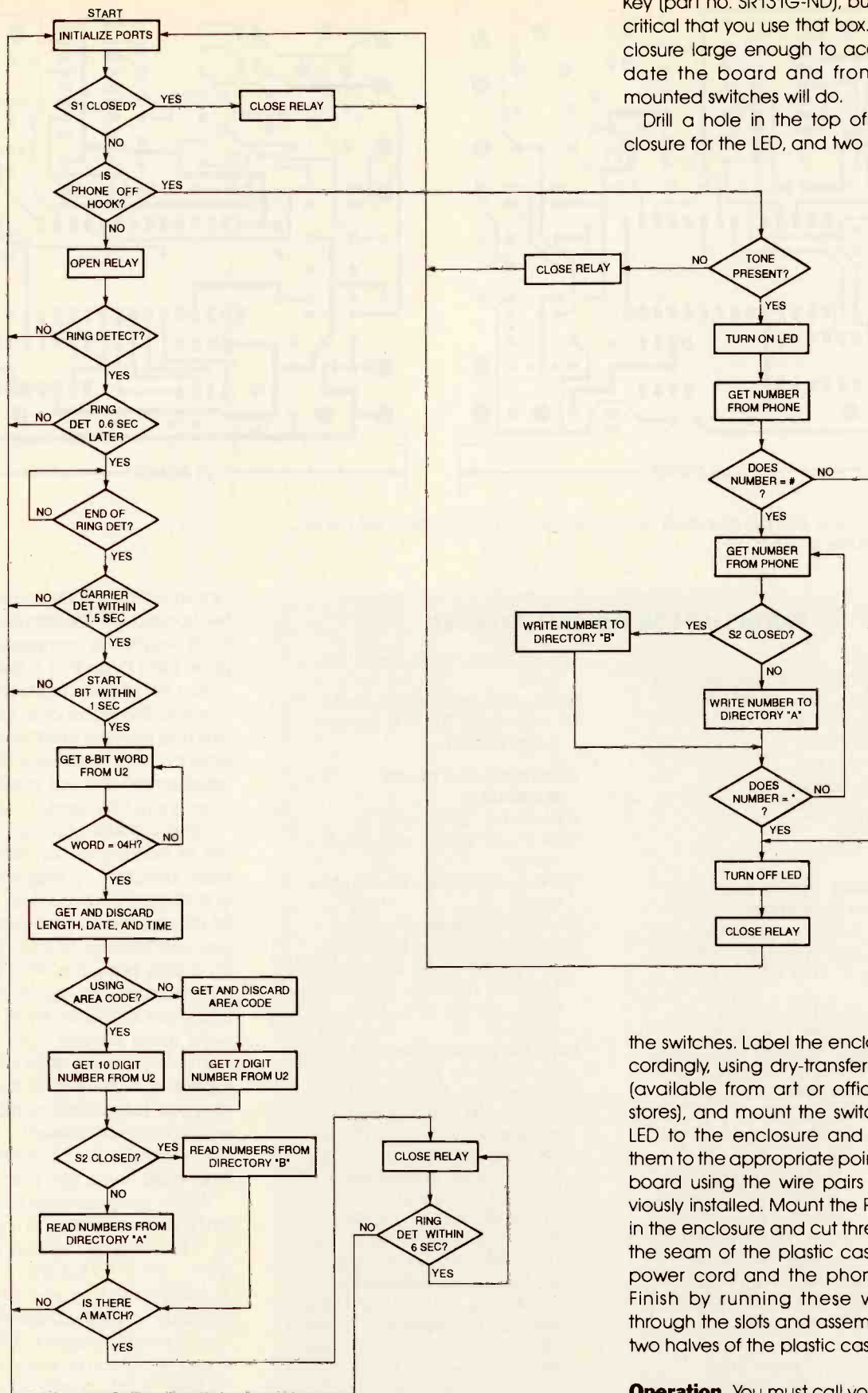


Fig. 3. This flowchart shows how UI's operating program works. A pre-programmed microcontroller is available from the source mentioned in the Parts List.

Key (part no. SR131G-ND), but it is not critical that you use that box. Any enclosure large enough to accommodate the board and front-panel mounted switches will do.

Drill a hole in the top of the enclosure for the LED, and two holes for

the switches. Label the enclosure accordingly, using dry-transfer lettering (available from art or office-supply stores), and mount the switches and LED to the enclosure and connect them to the appropriate points on the board using the wire pairs you previously installed. Mount the PC board in the enclosure and cut three slots in the seam of the plastic case for the power cord and the phone cords. Finish by running these wires out through the slots and assembling the two halves of the plastic case.

**Operation.** You must call your phone company and subscribe to the Caller ID service for your Caller Block unit to



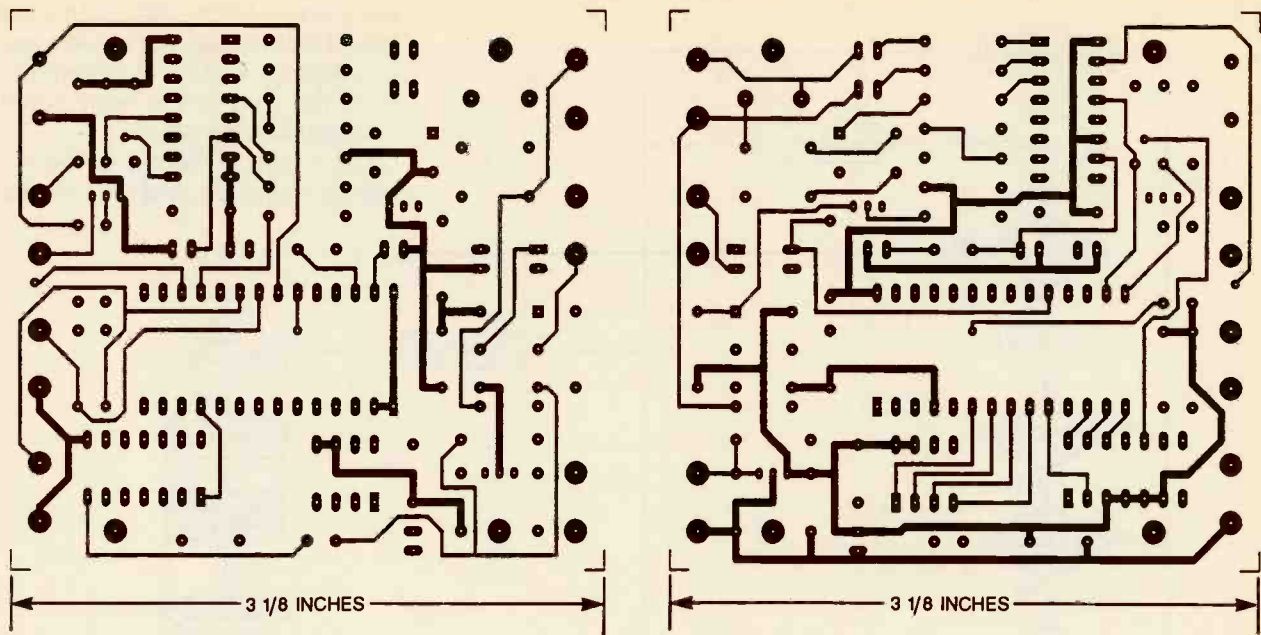


Fig. 4. The Caller Block is assembled on a double-sided PC board. Both sides of the board are shown here full size.

### PARTS LIST FOR THE CALL BLOCKER

#### RESISTORS

(All resistors are 1/4-watt, 5% units)

R1, R2, R10-R15—10,000-ohm

R3—470,000-ohm

R4—18,000-ohm

R5—15,000-ohm

R6—270,000-ohm

R7, R8—2000-ohm

R9—75-ohm

R16—150-ohm

#### CAPACITORS

C1, C2—0.2- $\mu$ F, Mylar

C3, C4—470-pF, ceramic disc

C5—0.22- $\mu$ F, 16-WVDC, tantalum

C6-C8, C10, C14, C15—0.1- $\mu$ F, Mylar

C9—0.1- $\mu$ F, Mylar

C11, C12—15-pF, ceramic disc

C13—47- $\mu$ F, 16-WVDC, electrolytic

#### SEMICONDUCTORS

U1—PIC16C55-XT/P, microcontroller, integrated circuit (Microchip)

U2—MC145447, calling-line identification receiver, integrated circuit (Motorola)

U3—MC145436, DTMF receiver, integrated circuit (Motorola)

U4—93LC56, serial EEPROM, integrated circuit (Microchip)

U5—PS2505-1 optoisolator or equivalent, integrated circuit

U6—78L05 low power 5-volt regulator, integrated circuit

Q1, Q2—2N4401 general-purpose NPN silicon transistor

D1—1N4148 general-purpose silicon diode

LED1—Red light-emitting diode

BRI—1.0-amp, 200-PIV, fullwave-bridge rectifier

#### ADDITIONAL PARTS AND MATERIALS

K1—5-VDC, DPDT relay

MOV1—130 VRMS, metal-oxide varistor

XTAL1—3.58-MHz, TV colorburst crystal

S1, S2—SPST toggle switch

Enclosure, PC board, IC sockets, wall adapter (9-volt DC, see text), telephone cord with modular plugs, hook-up wire, solder, hardware, etc.

**Note:** The following items are available from Weeder Technologies, P.O. Box 421, Batavia, OH 45103: A double-sided etched and drilled PC board (WTCBL-B), \$11.50; a kit of all board-mounted components including a pre-programmed PIC16C55 (WTCBL-C), \$34.50; a pre-programmed PIC16C55 only (PIC-CBL), \$18.00. All orders must include an additional \$3.50 for shipping and handling. U.S. and Canadian orders only, please. Ohio residents must add 6% sales tax. Please call your local telephone company to verify that "Caller ID" is available in your area before ordering.

function. It may take several days to be hooked up, depending on your local telephone company, so it is a good idea to do that in advance.

Plug the phone cord labeled to WALL JACK into the telephone jack on the wall and plug the cord labeled to TELEPHONE into your telephone. Plug the AC adapter into the wall and the Caller Block should be ready to go.

Using a piece of paper, make two lists of telephone numbers, one for each directory. As explained earlier, one directory can contain a large list of all your friends and family whom you wish to allow to ring your phone on a daily basis. The other list can be more selective, listing only those most important callers for times when you want more privacy. Each directory can hold up to 255 characters including the "#" sign, which is used to separate the telephone numbers. That works out to 31 different 7-digit telephone numbers or 23 different 10-digit numbers (those with area codes).

When programming the Caller Block, you may enter just a prefix such as "752", and all numbers beginning with "752" (752-0001 through 752-9999) will ring your phone. That comes in handy if you wish the people in your neighborhood to be included in your list but you do not want to enter all their numbers separately. Also, if the unit is configured to use the area code, entering a three digit prefix will

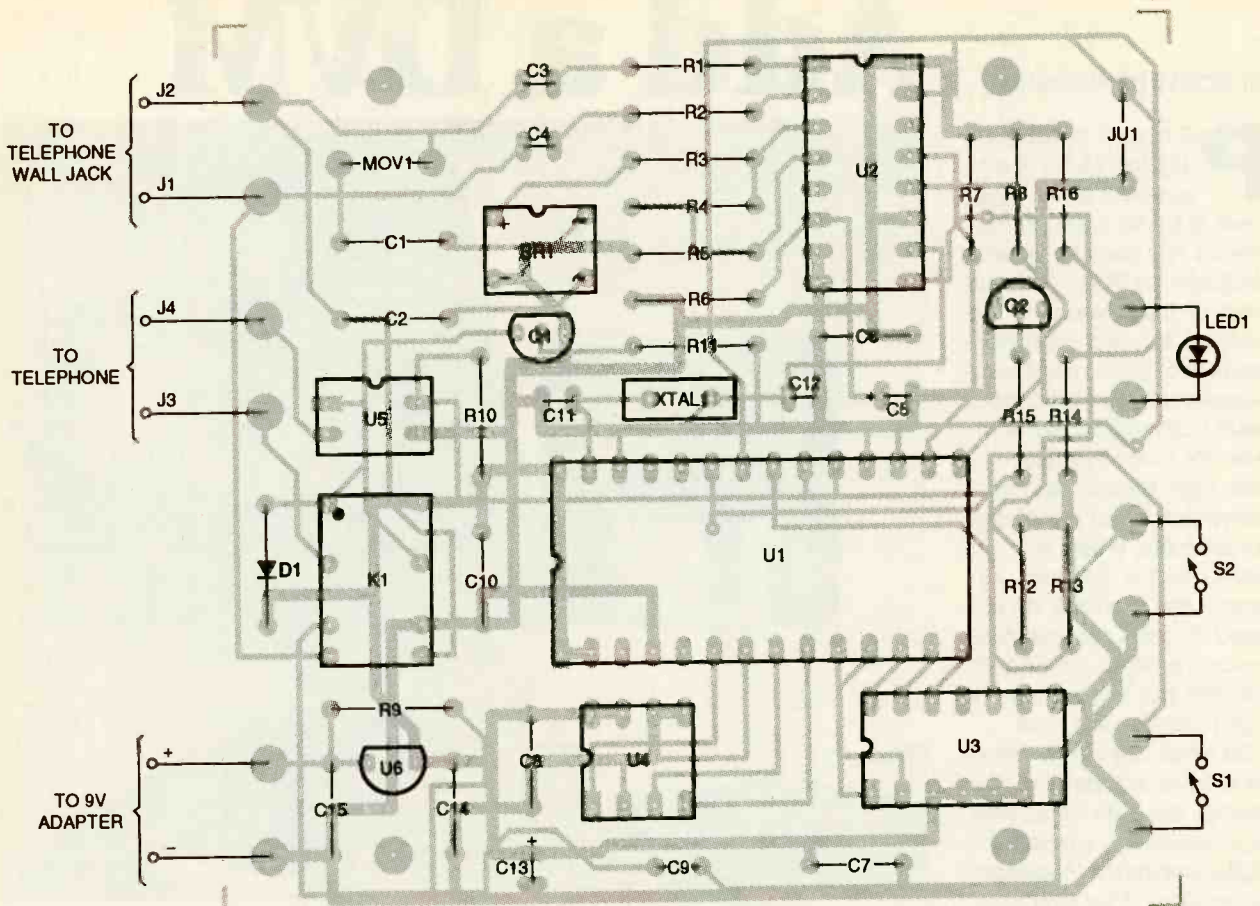


Fig. 5. Use this parts-placement diagram when assembling the PC board. The jumper (JU1) should be installed if you do not want to include area codes with each telephone number stored in memory.

include all callers from that particular area code.

Note: If you configured your Caller Block to use area codes (omitting JU1), all numbers entered into memory must include the area code whether local or long distance. The number "1" is not required at the beginning of long distance numbers and should not be used when entering your numbers.

To enter your list of telephone numbers into memory, first verify that the bypass switch (S1) is inactive (open), then switch S2 to the desired directory and pick up the phone while holding down the "\*" button on its keypad. The LED should light indicating that you are in the programming mode. Release the "\*" button and begin entering your telephone numbers with your phone's keypad. At the end of each telephone number press the "#" button, and after all numbers have been entered press the "\*" button to end programming. An example would be as follows (note that

hyphens have been added for clarity but obviously would not be entered):

555-1212#555-0110#231-0675#  
753-9607#752#444-2276#  
786#225-35#831-097##\*

Note, that a prefix can be any length less than a full number. If you make a mistake, press the "\*" button to end programming then hang up the phone and begin again. If the "#" button is accidentally pressed twice in a row while programming, it is interpreted as being a prefix consisting of no numbers, thereby allowing any telephone number to be accepted and ring the phone. After you have finished entering numbers into the current directory and ending by pressing the "\*" button, simply hang up the phone, switch S2 to the second directory, and repeat the process with your second list of numbers.

If you run out of memory while entering your telephone numbers, the programming mode is automatically

terminated. Count the characters in your list, including the "#" sign between the numbers, and verify that it does not exceed 255 characters.

If you have a problem with certain callers whose numbers you've entered into memory but can still not ring your telephone, call your phone company and ask if their exchange is included in your Caller ID network. Although the people calling you do not have to subscribe to Caller ID as you do, their exchange must be in the Caller ID network in order to ring your phone.

Closing the bypass switch (S1) allows you to bypass the circuit and allow all calls through as normal. When picking up the telephone to make a call, the circuit is also automatically bypassed. Note, that power must be applied to the Caller Block or the telephone will be disconnected from the phone line, even when the unit is switched to bypass or when trying to make a call. If you wish to use an answering machine, place it in the line ahead of the Caller Block.



BY SCOTT HENDERSHOT

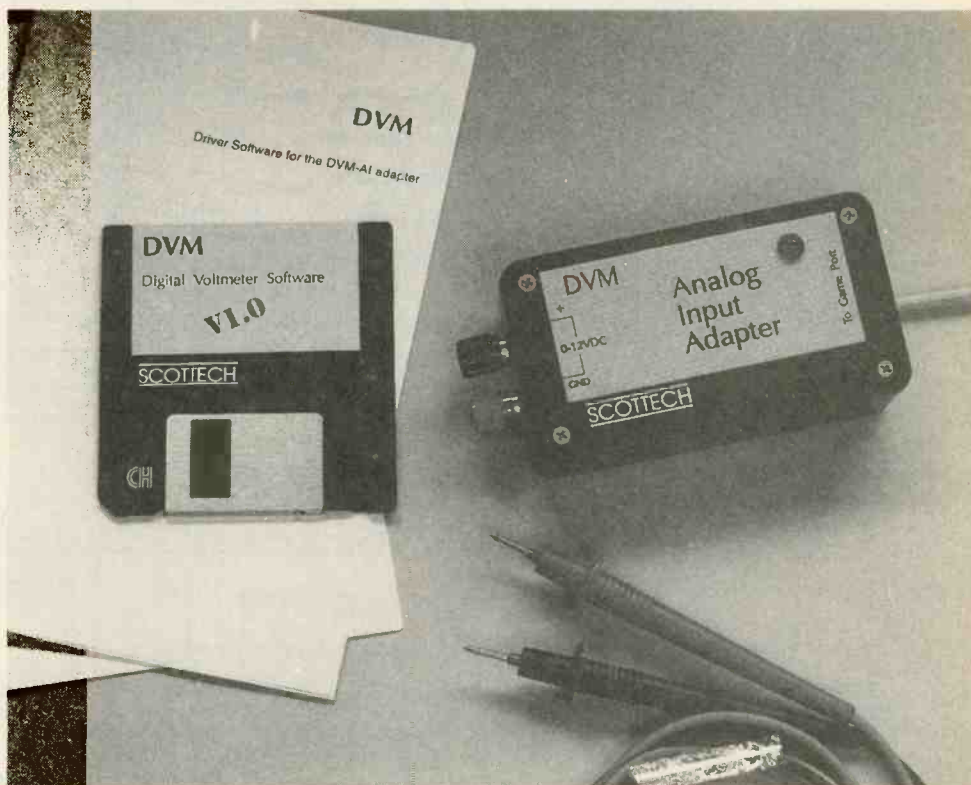
# Add a DVM

**P**C-based analog-to-digital (A/D) conversion is a hot topic these days. So there are numerous A/D adapter boards available for PC's. However, most of them seem to be geared toward digitizing waveforms in the megahertz frequency range and, as a result, cost megabucks. However, for many types of signals, high-speed, high-cost conversion is not necessary. For example, unless you are doing some special, research you probably do not need to take temperature measurements at 50,000 samples per second even if high resolution is a must.

So what data-acquisition technique will yield a cost savings by permitting slow, high-resolution analog-to-digital conversion? Voltage-to-frequency (or V/F) conversion, which is very useful for digitizing steady-state or slowly changing DC signals. Voltage-to-frequency conversion is seldom discussed in texts on analog-to-digital conversion, probably because of its generally slow conversion speed. However,

it offers some important advantages over other techniques. For example, its inherent integration of the input signal makes it more immune to noise. Also, high-resolution is more easily obtainable with this form of conversion. You can take advantage of all that by building the project presented in this article. It is a 0- to 12-volt analog-input adapter that uses the Analog Devices AD654 voltage-to-frequency converter IC. That IC has several features that make it very attractive to the experimenter including extremely low cost, low support-component count, and the ability to be powered by a single 5-volt supply. The circuit uses a PC's game port as the interface, has a resolution of 1 part in 12,000, and can be built for about 15 dollars.

As you read through this article you will probably see opportunities to



## to your PC

*Turn your PC into a digital voltmeter for automated testing, to record readings over time, and more.*

customize this project for your own needs. Fortunately, there are many parameters that can be changed (which we'll explore in moderate detail) once you understand how each affects the overall system. The intent here is not to fully illustrate the AD654, but to present the basics of a complete A/D converter project and allow the experimenter to use it as a starting point for other designs.

**The Circuit.** Looking at the schematic diagram in Fig. 1, you will notice that there are only two active components: U1 and U2. Taking U1 first, it is an Analog Devices AD654, which is the actual analog-to-digital converter. More accurately, it is a voltage-to-frequency converter; it accepts an analog input voltage (the difference between its  $-V_{in}$  and  $+V_{in}$  inputs)

and generates a squarewave. The chip was chosen for its ease of implementation. For example, it can be powered from a single supply such as the 5 volts available from a PC's game port. The full-scale input range can be set by a single resistor, and it has a linearity of 0.1% or better.

Integrated circuit U2 is an LM324 single-supply general-purpose op-amp with an input impedance of 250-megohms set up as a voltage follower. It provides input protection and bias-current compensation for the AD654. Other single-supply op-amps will also work, however the LM324 is readily available while others might be difficult to find.

As mentioned, the output of U1, and therefore the circuit, can be connected to any digital input on the PC. For example, one of the parallel-port

## PARTS LIST FOR THE ANALOG-INPUT ADAPTER

### SEMICONDUCTORS

U1—AD654 voltage-to-frequency converter, integrated circuit  
 U2—LM324 operational amplifier, integrated circuit  
 D1, D2—1N458, or 2N5089 diode  
 LED1—light-emitting diode

### CAPACITORS

C1—not used  
 C2—0.01- $\mu$ F polypropylene  
 C3, C4, C6—0.1- $\mu$ F monolithic bypass  
 C5—10 $\mu$ F, 6-WVDC, Tantalum

### RESISTORS

(All fixed resistors are 1/8-watt, 5% units unless otherwise indicated.)

R1, R3—10-megohm  
 R2—1-megohm  
 R4, R5—10,000-ohm  
 R6—1000-ohm  
 R7, R8—10-ohm, 1/8-watt  
 R9—2200-ohm

### ADDITIONAL PARTS AND MATERIALS

J1—not used  
 J2—Male DB-15 connector

Printed-circuit board or perfboard, 14-pin IC socket, 8-pin IC socket, connector hood, binding posts, hardware, solder, wire, etc.

The following are available from SCOTTECH (485 Old Ridge Road, Webster, NY 14580; Tel. 716-671-8783, FAX 716-787-2788): Software, \$5.00; printed-circuit board, \$12.00; a kit including software, circuit board, U1, C2, and the IC sockets, \$25.00. Add \$3.00 shipping with your order, and NY State residents must add 8 1/2% sales tax.

The AD654 voltage to frequency converter is available from Newark Electronics (N. Ravenswood Ave., Chicago, IL 60640-4496; Tel. 312-784-5100)

mended: polystyrene, NPO ceramic, and polypropylene. Other types are not recommended due to their poor temperature stability.

With the output of the AD654 connected to a TTL-input port and tied to 5 volts, it will generate a 0–5-volt square-wave. The frequency of the square-wave will be linearly proportional to the input voltage. The component values chosen will give us a 10-kHz square-wave at full scale. That

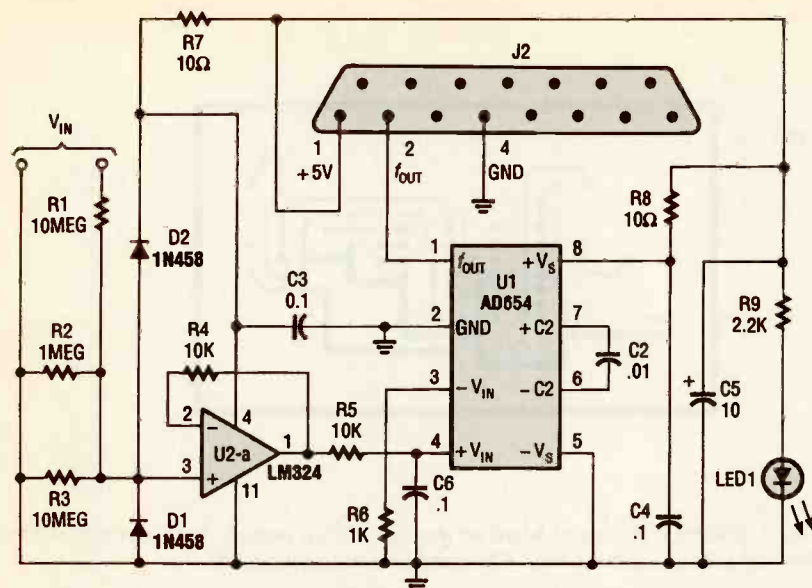


Fig. 1. Effectively, the adapter can be broken down into a voltage-to-frequency adapter with a signal-conditioner/protection-circuit at the front end.

handshaking inputs or one of the button inputs on the game port. We decided to use the game port (via J2) because of its 5-volt outputs. Bear in mind that the AD654 has an open-collector output capable of sinking about 10-mA. So the input of the computer port you use must be tied to 5 volts through a pull-up resistor residing either inside the computer or the adapter circuit. The inputs on the game port are tied high within the computer, so we don't need to worry about this. If you decide to use another input port (such as the parallel port), you will need to deliberately pull the signal line high.

The AD654 can accept input voltages of up to 4 volts less than the power supply. Since we will be using the PC's 5-volt supply, our maximum input voltage will be 1 volt. In order to extend this range to 12 volts, a voltage divider is used ahead of both U1 and U2 to scale the input down to 1 volt. Looking at the schematic you will see the divider is made up of R1, R2, and R3. Resistors R2 and R3 are in parallel and have a total resistance of 909,000 ohms. In series with the 10-megohm resistor that provides a 12:1 attenuation of the input signal. Component values are not critical and 5% types are okay to use. Any accuracy problems will be compensated for in software. Using the attenuator will reduce the input impedance to 10 megohms. This is about the same as most digital volt meters and should not be a prob-

lem for most applications.

Once supplied with appropriate input, the AD654 requires the addition of only two passive components in order to operate. These are a timing capacitor (C2) and a scaling resistor (R6). The scaling resistor sets the overall input-voltage range and the capacitor sets the full-scale frequency.

The scaling resistor converts the IC's input voltage to a current. That resistor must be selected to provide 1 mA of input current at the full-scale input voltage. For example, our full-scale input voltage will be 1 volt, so by Ohms law, the resistor needs to be 1k. You might be tempted to substitute another resistor to achieve some other full-scale voltage. That is fine as long as you observe the design parameters that follow.

The timing capacitor should be selected by using the following formula:

$$C = V/(10Rf)$$

where  $f$  is the full-scale frequency (10 kHz for our design),  $R$  is the scaling resistor, and  $V$  is the full-scale input voltage, which is 1 volt for our circuit. This sets the value of our timing capacitor, C2, at 0.01- $\mu$ F. It is possible to design the circuit to operate at a higher frequency, but most PC's will not be able to keep up with the signal. This frequency is suitable for PC/XT and later machines.

The only other criteria for the capacitor is a stable temperature coefficient. The following types are recom-



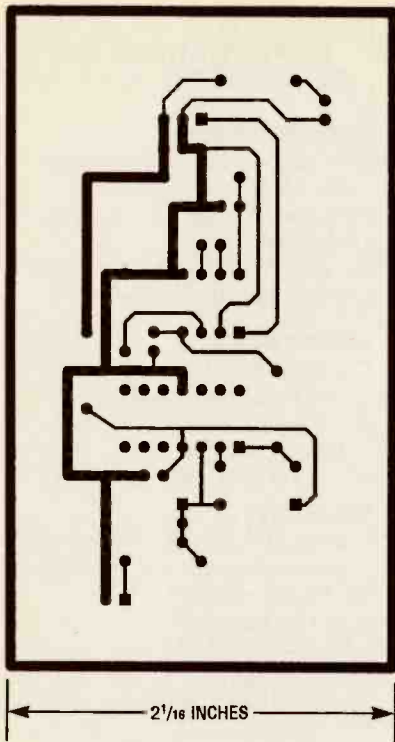


Fig. 2. It is recommended that you use this foil pattern for making your own adapter circuit board.

translates to 10 Hz per millivolt. Actually, because of the voltage divider, our scaling will be 0.833 Hz per millivolt. However, because of the way the software measures the voltage, it is not necessary to have a 1-to-1 correlation of Hz to millivolts.

Diodes D2 and D1 provide input protection in case of polarity reversal or over-voltage. These should be Schottky or low-leakage type diodes.

Resistor R5 provides bias current compensation to the AD654. Together with C6 they form a single-pole filter with a time constant of 1 millisecond. That helps suppress noise at the input to prevent false readings. Remember we are measuring voltage changes of only 100 microvolts.

A 10- $\mu$ F tantalum capacitor (C5) at the point where the supply voltage enters the circuit quiets any power-supply noise to produce a clean square-wave output. The additional resistors and 0.1- $\mu$ F monolithic capacitors shown in the schematic just decouple the IC's.

**Software.** Precise timing software is the key ingredient to using this technique on a PC. Most high-level languages are inadequate for microsecond timing so the software must be

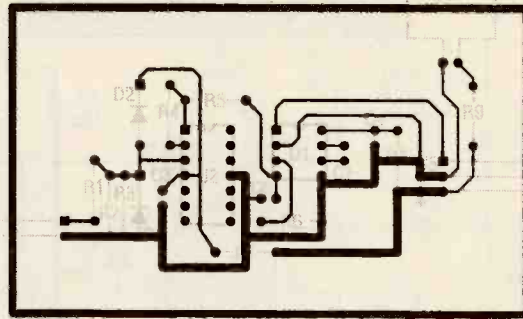


Fig. 3. If using a PC board based on the author's foil pattern, stuff it as shown here. Note the polarity of the diodes, C5, and LED1 as you proceed.

written in machine language. To spare you the agony of assembly-language programming, all of the necessary interface routines complete with manuals have been made available by the author (see Parts List). There are demo programs that show you how to call the data-acquisition routines from C and BASIC, and linkable object modules for both languages. There is also a quick library that can be loaded into the QuickBASIC environment.

A single call is all that is necessary to acquire a sample from the adapter. The functions return a floating point value that is already adjusted for the current calibration. The supplied functions have a conversion time of about 17 ms. That will provide about 60 samples per second. This sample rate was chosen to reduce the effects of 60-cycle noise. Each sample will last exactly as long as one cycle of a 60-Hz sine wave, therefore fully integrating any noise. The functions have been tested with Microsoft BASIC and QuickBASIC, Microsoft C and Quick C. I cannot guarantee their compatibility with other compilers.

Along with the sample programs, there is a program called DVM.EXE. This program is a digital voltmeter application. When run, it expects to find a square-wave signal on the button-0 input of the game port. If the signal is there, the program reads the frequency and displays the calculated voltage. Complete instructions for using DVM are provided with the software.

For convenience, all this software

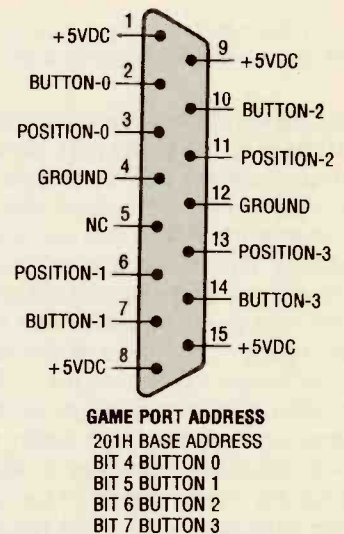


Fig. 4. You can use the additional button inputs on your PC's joystick port to receive data from multiple adapters.

has been posted on this magazine's bulletin board. The telephone number is 516-293-2283 and the protocol is no parity, 8 data bits, and 1 stop bit. However, if you go this route you'll have to do without the manuals. [At the time this was being prepared for publication a Windows version of the software was due to be released. Contact Scottch for further information—*Editor*]

**Construction.** The circuit should be constructed using a printed-circuit board. You can obtain one from the author (see Parts List for ordering information), etch your own using the pattern in Fig. 2, or design your own.

If you design your own PC board consider the following precautions.

(Continued on page 108)



# How to Split a Power Supply

*What can you do if you need a dual supply, but only have a single-supply source? Build our splitter, of course!*

BY MICHAEL A. COVINGTON

**W**hat do you do if you have a single output power supply and you need a dual one? That's a problem that often arises with op-amp circuits. Many op-amp configurations require a split supply, but most lab-type power supplies have only a single output. That means you can't use them to power op-amp circuits... or can you?

You can if you use the supply splitter circuit presented here. It neatly splits its input voltage—anywhere from 8 to 30 volts—in half to give you two equal voltages of opposite polarity.

**How it Works.** The key idea is that in a dual-supply powered circuit,

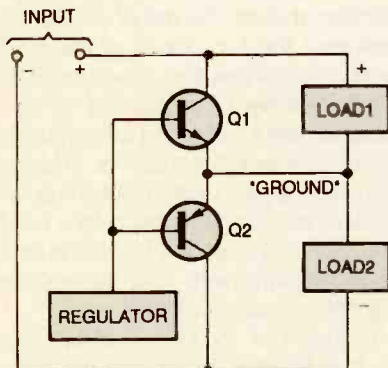
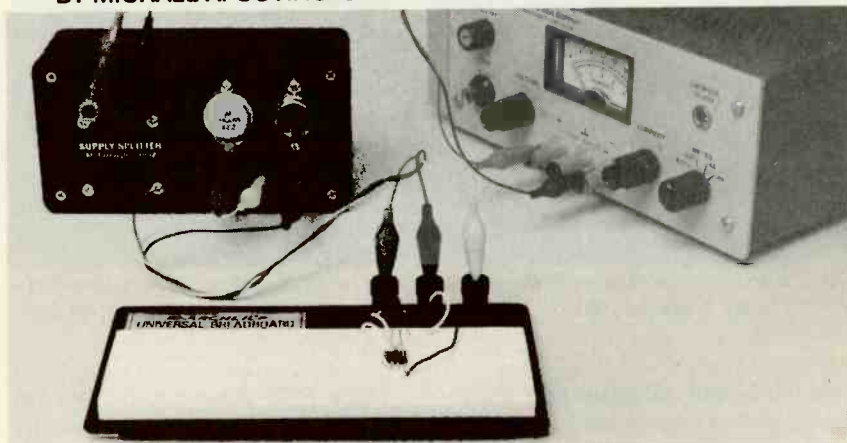


Fig. 1. Transistors Q1 and Q2 regulate the "ground" voltage to hold it midway between the + and - terminal voltages.



The splitter connects between the existing power supply and the circuit to be powered, in this case an op-amp circuit.

"ground" is midway between the positive and negative supply voltages. Accordingly, all we have to do is derive a regulated voltage halfway between  $V+$  and  $V-$ , and we're done.

Unfortunately, ordinary voltage regulators can't do the job. The reason is that they can only source current, not sink it. However, the ground terminal in a dual supply may have to either source or sink current, depending on which half of the load is drawing more current at the time.

Figure 1 shows the idea behind our special two-way voltage regulator that does what's needed. If Load 1

and Load 2 are drawing exactly equal currents, then the voltage between them is already halfway between  $V+$  and  $V-$ , so the regulator need not do anything. If the currents drawn by the two loads are different, then either Q1 or Q2 will conduct extra current to make up the difference. That way the ground voltage stays exactly halfway between the positive and negative rails.

Figure 2 shows the circuit. In it, R1 and R2 divide the input voltage in half. Op-amp U1 reproduces that voltage at the "ground" output terminal by making either Q1 or Q2 conduct as much as necessary. Capacitors C1 and C2



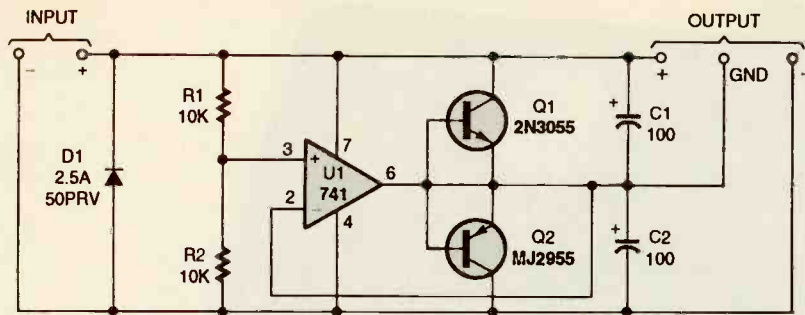
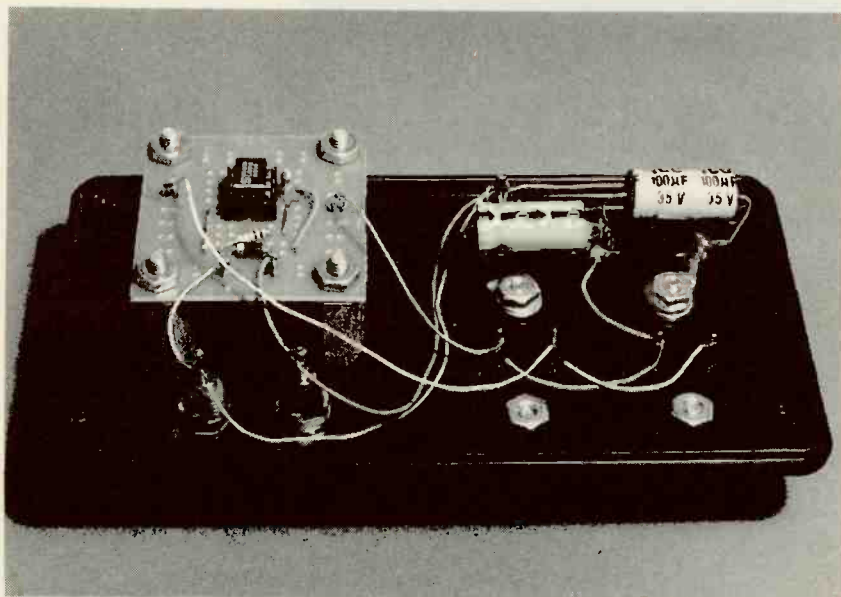


Fig. 2. In the actual circuit, a 741 op-amp (U1) is used as the regulator that controls the action of Q1 and Q2 to maintain a voltage between the input voltages.



The smaller components are mounted on perfboard while the capacitors are mounted directly to the binding posts. They, in turn, are mounted in holes in case just like the transistors.

hold the output voltage steady when the load changes suddenly.

### PARTS LIST FOR THE POWER-SUPPLY SPLITTER

#### SEMICONDUCTORS

- U1—LM741 operational amplifier, integrated circuit
- Q1—2N3055 silicon NPN power transistor
- Q2—MJ2955 silicon PNP power transistor
- D1—2.5-amp, 50-PIV rectifier diode

#### ADDITIONAL PARTS AND MATERIALS

- R1, R2—10,000-ohm, 1/8-watt, 5% resistor
- C1, C2—100-µF, 20-WVDC, electrolytic capacitor
- Enclosure, binding posts, circuit board, solder, wire, optional heat sinks for Q1 and Q2, etc.

Diode D1 is present to protect the circuit's input from reversed polarity by blowing the fuse of the main power supply. If your power supply has no fuse or you might one day use the circuit with an un-fused supply, place D1 in series with the circuit (say, in the positive input line and pointing toward R1) instead. That will afford the same protection with only slightly reduced regulation and voltage output.

Purists may object that the turn-on voltages of Q1 and Q2 are 1.2 volts apart, producing an operational "dead zone" that the output of U1 must cross in order to catch up with an unbalanced load. It is possible to bias Q1 and Q2 to eliminate the dead zone, but that proved unnecessary in practice because U1 can cross the dead zone very rapidly. After all, C1 and C2 guarantee that changes in the load balance won't be in-

stantaneous. In extensive testing, this circuit gave excellent regulation powering not only op-amp circuits, but also "messy" loads such as buzzers and flashing light bulbs.

**Construction.** Note that although this unit has separate input and output terminals for V+ and V-, the inputs and outputs are internally connected together. So, unless D1 was placed in series, you can build the splitter with three terminals instead of five if you wish.

Because there are so few components, a printed-circuit board is not necessary. Instead, the smaller components (D1, R1, R2, and U1) can be mounted on a small piece of perfboard. Capacitors C1 and C2, on the other hand, should be placed close to the output terminals. If you use binding posts, put them exactly 3/4-inch apart so that dual banana plugs can mate with them.

With regard to using a replacement for U1, the best op-amp to use is actually the cheap 741 specified. Higher-performance op-amps such as the TL081 do not improve performance.

**Using it.** As mentioned, you can use the splitter with fixed- or adjustable-voltage power supplies ranging from 8 to 30 volts. Make sure your power supply is isolated. That is, neither V+ nor V- should be connected to the power-supply's cabinet ground or power-line ground.

How much current can the splitter handle? That's a tough question. Remember that as long as Load 1 and Load 2 are equal, the splitter doesn't do any work at all. For most op-amp circuits, that's typically the case.

As a rule of thumb, this splitter can handle at least 250 mA of difference between the two halves of the load while operating with a 30-volt input. To do that, either Q1 or Q2 has to dissipate almost 4 watts and will get quite warm. If, in practical use, you find the transistors getting so hot that you can't touch them comfortably, add a heat sink. With the specified transistors and an adequate heat sink, this splitter can handle several amps.

Remember that Q1 and Q2 are "hot" in another sense, too: the case of Q1 is connected to V+, and Q2's to V-. So don't let anything accidentally come into contact with them. ■

Everyone is interested in the weather. Some of us even have our own temperature and humidity gauges to tell us what's happening day by day. But perhaps the weather forecasting instrument that holds the greatest mystery for most people is the barometer—a device that is used measure absolute air pressure. Weather forecasters rely on the prevailing atmospheric pressure (specifically the direction of the change in pressure) to predict the next weather front. For that reason, it is important that small changes in the barometric reading be detected.

Unfortunately, some home analog barometers may not be sensitive enough to detect minute changes in pressure. But the *Digital Barometer* described in this article is designed to address the deficiencies of such units. The Digital Barometer—an easy-to-build, reliable, portable weather-forecasting instrument that will provide years of accurate barometric readings—uses a 4½-digit LCD readout to display readings from 28.00 to 31.99 inches of mercury.

### Pressure Fundamentals.

Pressure can be expressed in many ways. Barometers are often calibrated in inches of mercury—14.7 PSI is equivalent to 29.92 inches of mercury; that is the typical barometric reading obtained at zero altitude or sea level under average weather conditions.

Most people are accustomed to the concept of gauge pressure, often specified as pounds-per-square-inch gauge (PSIG). That specification refers to differential pressure with sea-level atmospheric pressure (14.7 PSI or 29.92 inches of mercury) as the reference. A barometer, however, displays absolute pressure (PSIA), which is the difference between the current pressure and zero pressure (a perfect vacuum). A barometer, therefore, is a differential pressure gauge that is referenced to zero pressure.

**Pressure Sensor.** Before one can understand the operation of the Digital Barometer, it is important to know

the theory of operation of an absolute pressure sensor. The pressure sensor used in our barometer (developed by Motorola Semiconductor Products, Inc.) contains a monolithic silicon piezoresistor that generates an output voltage that varies with applied stress.

The pressure sensor is a four-terminal device that contains two chambers that are separated by a silicon diaphragm and piezoresistive element. The resistive element is de-

chanical stress placed on the diaphragm (and piezoresistive element) by atmospheric pressure causes the sensor to generate an output voltage that is proportional to the applied pressure as seen by the open port of the sensor.

**About the Circuit.** Refer to Fig. 1. Power to the circuit is provided by a 9-volt transistor-radio battery (B1). The circuit draws about 6 mA of current.

Since battery voltage falls off with use, a fixed 5-volt regulator, U1, is used to maintain a constant voltage to the circuit, thereby ensuring retention of barometer accuracy as the battery is depleted.

The piezoresistor within SENS1 is connected between pins 1 and 3 of the sensor assembly, and is driven by the regulated 5-volt supply. The taps on the piezoresistor (which are internally connected transversely across the element and are brought out to pins 2 and 4) sense the differential voltage developed across the pressure-sensitive element in SENS1 to provide an output voltage that varies linearly with absolute pressure.

Under normal conditions (in which atmospheric pressure places stress on the piezoelectric resistor), the sensor's output voltage is a finite, but very small in value. At sea level that voltage is typically about 20 mV. Over a range of 29 to 31 inches of mercury, the output of the sensor changes by only about 1.3 mV.

A differential analog amplifier, comprised of U2-a and U2-c, boosts the output of the sensor by an amount determined by the values of resistors R1 through R6. The output voltage at pin 8 of U2-c represents the amplified output voltage of the sensor, offset by a DC bias of 1.5 volts that's generated by a 100k Thevenin equivalent, comprised of R1 and R3.

Op-amp U2-b (which is configured as a voltage follower) is fed from the wiper of potentiometer R8. That combination forms an altitude correction/calibration adjustment and is used to compensate for circuit tolerances as well as for any error caused by the altitude of the barometer. It also permits the DC bias generated in the



# Portable Barometer

*Be your own weather forecaster with an easy-to-build circuit that, by sensing small changes in the barometric pressure, lets you predict the next weather front.*

BY ANTHONY J. CARISTI

signed to respond to absolute atmospheric pressure (pressure measured with respect to a perfect vacuum—zero pounds-per-square-inch-absolute or 0 PSIA).

One chamber of the sensor is exposed to atmospheric pressure by means of an external port. The other chamber (evacuated to as perfect a vacuum as possible by modern manufacturing techniques) is sealed. In that way, the diaphragm of the sensor is under constant stress from the difference between atmospheric pressure on one side, and essentially a perfect vacuum on the other. The me-



analog amplifier by R1 and R3 to be nulled out.

The differential output of the analog amplifier (at pins 8 and 7 of U2-c

and U2-b, respectively) is fed to the differential analog input terminals of U3 (an A/D converter that contains all the necessary circuitry to drive a 3½-digit LCD readout), shown in Fig. 2. Analog-input sensitivity for a full-scale display of 1999 is determined by the reference voltage applied between pins 35 and 36 of U3, and is equal to twice the reference input. In this project, only the three full digits of the A/D converter are used. The half digit, 1, is not required. But a leading "2" or "3" is required; let's see how it is generated.

Since the circuit uses a readily available 3½-digit A/D converter and is required to respond only to a limited range of pressure, an unusual readout system was used to produce a display containing four digits. The A/D converter generates the three least-significant digits (LSD's) of the display. A simple logic circuit provides the most significant digit (either a "2" or a "3"). The reference voltage (0.1-volt) applied between pins 35 and 36 of U3 is

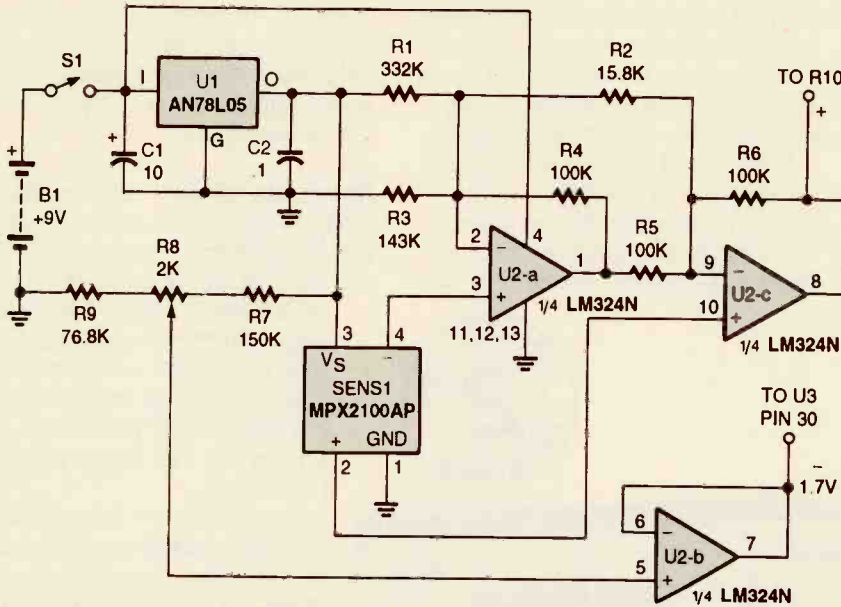


Fig. 1. At the heart of the Digital Barometer is the MPX2100AP 15-PSIA pressure sensor, SENS1, which outputs a differential voltage that is fed to an amplifier arrangement built around U2, an LM324 quad op-amp.

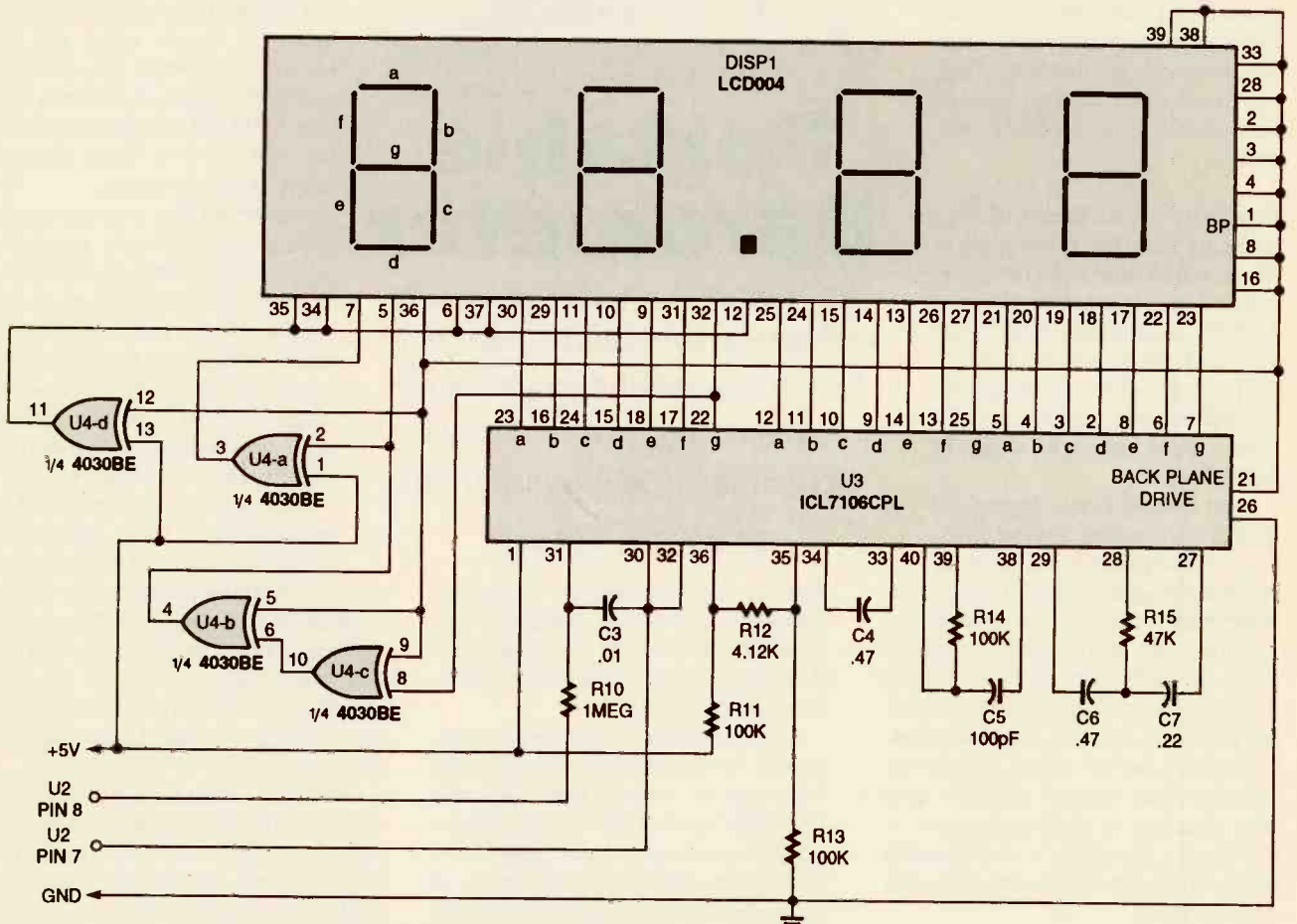


Fig. 2. The output of the op-amp arrangement in Fig. 1 (at pins 8 and 7 of U2-c and U2-b, respectively) is fed to the differential analog-input terminals of A/D converter U3, which processes the input signal and displays that information as a barometric-pressure reading.

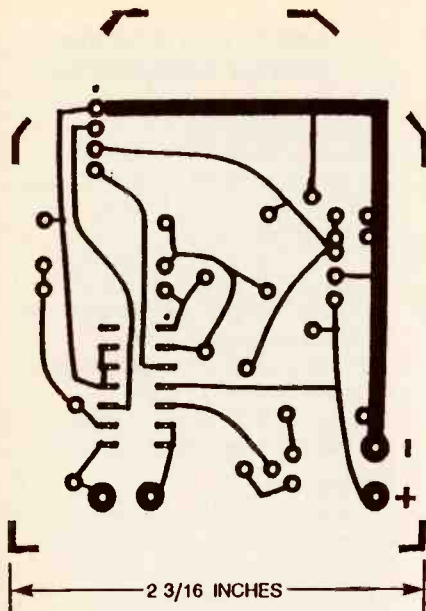


Fig. 3. The Digital Barometer was built on two single-sided, printed-circuit boards—one of which (the one shown here) is referred to as analog board. You can use this full size template (and the one in Fig. 4) to etch your own boards or purchase a set from the supplier listed in the Parts List.

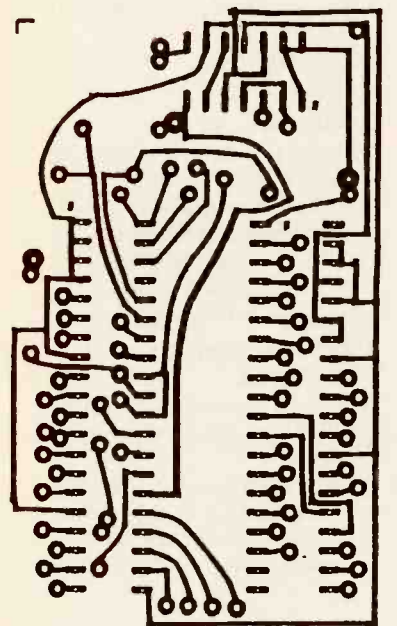


Fig. 4. The template for the other board—called the display board (which contains the A/D converter, digital logic, and LCD readout)—is shown here full scale.

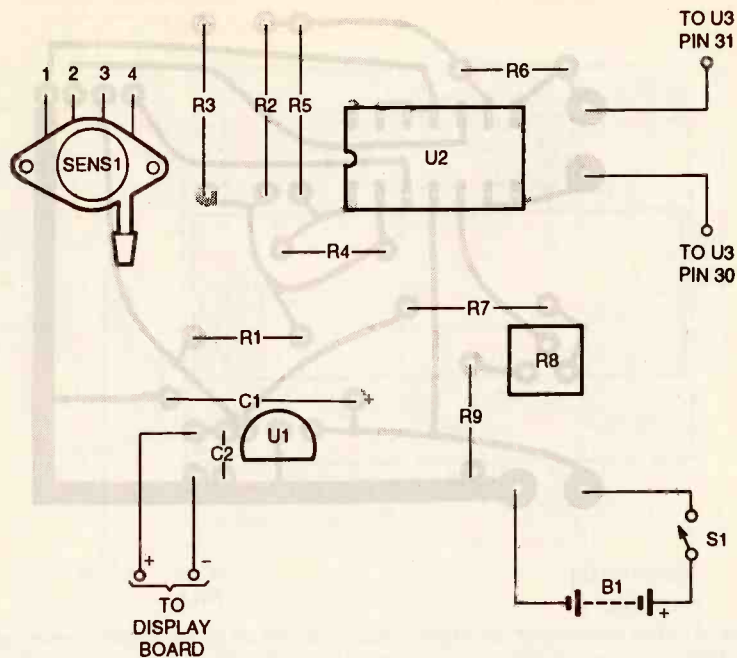


Fig. 5. When assembling the analog board (guided by this parts-placement diagram), it is recommended that sockets be used for the DIP IC's.

determined by voltage divider comprised of R11–R13.

The decimal point of the LCD readout is hard wired for a display resolution of 0.01 inches of mercury. That causes the three least-significant digits of the display to read 8.00 for a differential input voltage of 0.08 volts, 9.00 for 0.09 volts, 0.00 for 0.10 volts, and 1.00 for 0.11 volts.

The gain of the analog amplifier is chosen so that a variation of 1.00 inch of barometric reading as detected by the sensor is translated into a change of 0.01 volts at pin 8 of U2-c. That causes the display's three least-significant-digits to read 8.00 at 28.00 inches, 9.00 at 29.00 inches, 0.00 at 30.00 inches, and 1.00 at 31.00 inches.

Generation of the most-significant digit of the display (2 or 3) is accomplished via U4 (a 4030 quad two-input exclusive-OR gate). The XOR gate produces a logic 1 output only when the signals applied to its two inputs are opposite to each other. The key to generating either a 2 or 3 is determined by examination of the "g" segment of the second most-significant-digit, since the barometer need display only 28 to 31 inches of mercury. If that digit is either an 8 or a 9, its "g" segment is energized and the most-significant digit must then be a 2. If the second most-significant digit is either 0 or 1, the "g" segment is dormant and

the most-significant-digit must then be a 3.

Integrated circuit U4-c simultaneously examines the "g" segment of the second most-significant digit and the back-plane waveform generated by U3. When the "g" segment is active (8 or 9), the output at of U4-c at pin 10 is at a logic 1. Otherwise it is zero for digits 0 and 1. Integrated circuit U4-b is used to conditionally invert the back-plane waveform, so that its output is identical to back-plane when the digit is 0 and 1, and is an inverted back-plane when the digit is 8 or 9.

Integrated circuit U4-b pin 4 feeds segment "e" of the most-significant-digit, which must be displayed as a "2" when the next digit is 8 or 9. Similarly, U4-a is used as a conditional inverter so that the "c" segment of the most-significant-digit is always driven opposite to the "e" segment as required for a "3."

Finally, U4-d is used as an inverter so that the remaining segments, common to display a digit of 2 and 3, are always energized. The logic circuit, comprised of U4, always generates the correct most-significant-digit of the barometric reading, but cannot display any digit other than 2 or 3.

**Construction.** The Digital Barometer was built on two single-sided, printed-circuit boards; one is referred to as



## PARTS LIST FOR THE DIGITAL BAROMETER

### SEMICONDUCTORS

- U1—AN78L05 5-volt, 100-mA, voltage regulator, integrated circuit
- U2—LM324N quad op-amp, integrated circuit
- U3—ICL7106CPL 3½-digit A/D converter, integrated circuit
- U4—CD4030BE quad exclusive-OR gate, integrated circuit
- DISP1—LCD004 4½-digit or similar LCD readout (Digi-key)
- SENS1—MPX2100AP 15-PSIA pressure sensor (Motorola)

### RESISTORS

(All fixed resistors are ¼-watt, 1% metal-film units, unless otherwise noted.)

- R1—332,000-ohm
- R2—15,800-ohm
- R3—143,000-ohm
- R4—R6, R11, R13—100,000-ohm
- R7—150,000-ohm
- R8—2,000-ohm PC mount, cermet potentiometer
- R9—76,800-ohm
- R10—1-megohm ¼-watt, 5%, carbon
- R12—4120-ohm
- R14—100,000-ohm, ¼-watt, 5%, carbon
- R15—47,000-ohm, ¼-watt, 5%, carbon

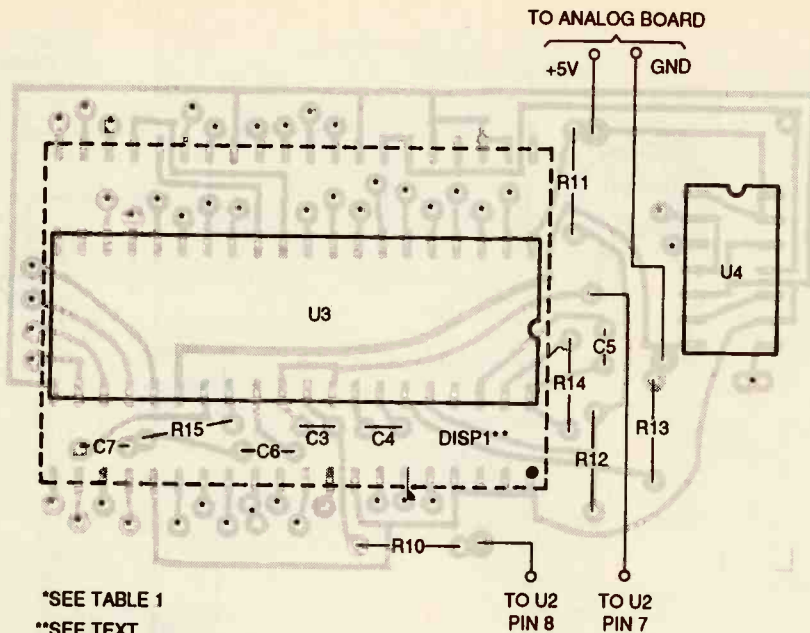
### CAPACITORS

- C1—10-µF, 15-WVDC, axial-lead electrolytic
- C2—0.1-µF, ceramic-disc
- C3—0.01-µF, ceramic-disc
- C4, C6—0.47-µF, ceramic-disc
- C5—100-pF, ceramic-disc
- C7—0.22-µF, ceramic-disc

### ADDITIONAL PARTS AND MATERIALS

- B1—9-volt transistor-radio battery
- S1—SPST miniature toggle or slide switch
- Printed-circuit materials, enclosure (Radio Shack 270-222 or similar), IC sockets, battery holder and connector, wire, solder, hardware, etc.

**Note:** The following items are available from A. Caristi (69 White Pond Road, Waldwick, NJ 07463): Pressure sensor (SENS1), \$42.50; a set of two printed-circuit boards, \$19.75; 78L05 5-volt regulator (U1) 2.00; LM324 op-amp (U2), \$2.00; ICL7106CPL A/D converter (U3), \$16.50; 4030 quad XOR gate (U4), \$2.00; set of eleven 1% metal-film resistors, \$4.95. Please add \$3.00 postage/handling to all orders. New Jersey residents please add appropriate sales tax.



\*SEE TABLE 1

\*\*SEE TEXT

Fig. 6. After assembling the display board, install all of the jumper connections listed in Table 1 on the component sided of the board. The LCD module is then mounted to the copper side of the board.

analog board (which contains the analog circuit and regulated power supply) and the other is called the display board (which contains the A/D converter, digital logic, and LCD readout). Splitting the circuit into two sections allows stacked printed-circuit construction so that the entire project can be assembled into a small enclosure, complete with the battery. The readout was mounted on copper side of the digital board to allow it to protrude through the cover of the housing, for ease of viewing.

If you do not wish to etch your own boards, they are available from the source given in the Parts List. Templates for the two printed-circuit boards are shown in Fig. 3 (the analog board) and Fig. 4 (the display board) full scale. The parts-placement diagrams of the analog and display boards are shown in Fig. 5 and 6, respectively. Also shown in those diagrams are the hard-wire connections between the boards and to the external components.

It is recommended that sockets be used for the DIP IC's. Because of the limited space in the recommended enclosure, only low-profile sockets should be used. The LCD readout can be soldered directly into the digital board. If desired, a socket for the readout can be fabricated by cutting a 40-pin DIP socket in half lengthwise. Do not install the readout or IC's into

TABLE 1—JUMPER CONNECTIONS

From	To
U3 pin 2	DISP1 pin 18
U3 pin 3	DISP1 pin 19
U3 pin 4	DISP1 pin 20
U3 pin 5	DISP1 pin 21
U3 pin 6	DISP1 pin 22
U3 pin 7	DISP1 pin 23
U3 pin 8	DISP1 pin 17
U3 pin 9	DISP1 pin 14
U3 pin 10	DISP1 pin 15
U3 pin 13	DISP1 pin 26
U3 pin 14	DISP1 pin 13
U3 pin 15	DISP1 pin 10
U3 pin 16	DISP1 pin 29
U3 pin 17	DISP1 pin 31
U3 pin 18	DISP1 pin 9
U3 pin 22	U4 pin 8
U4 pin 8	DISP1 pin 32
U3 pin 23	DISP1 pin 30
U3 pin 24	DISP1 pin 11
U3 pin 25	DISP1 pin 27
U4 pin 2	DISP1 pin 5
U4 pin 3	DISP1 pin 7
DISP1 pin 12	DISP1 pin 6
U4 pin 11	DISP1 pin 12

the boards until you are instructed to do so later on during the checkout procedure.

Pay strict attention to the orientation of all polarized components; if any of the polarized components (electrolytic capacitors and IC's) are inadvertently installed backwards, the circuit won't work and there is the possibility of damage to one or more of the components.

The accuracy of the barometer relies on the tolerance and stability of

the amplifier and A/D converter resistor values. For that reason, it is necessary to use only 1% metal-film resistors where specified in the Parts List. Ordinary carbon resistors are not stable enough for the circuit, and should **not** be used in place of the metal-film types.

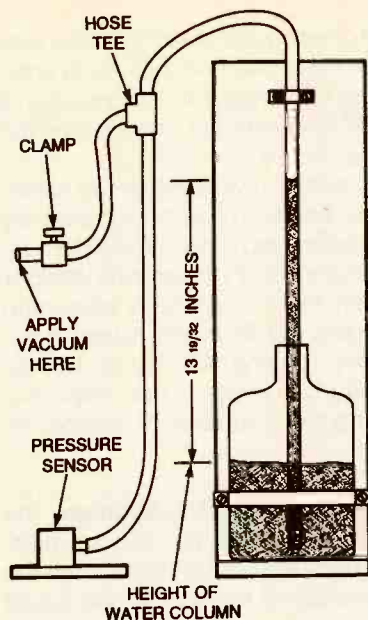
**Analog Board.** The pressure sensor is a reasonably sturdy device, but care must be taken when forming the leads at right angles so that the body lies flat on the board. Use two long-nose pliers when bending the leads—one to prevent stress on the lead where it enters the plastic body and the other to bend the terminals to the proper position.

Before forming the leads, locate pin 1 of SENS1, which is identified by a small indentation cut into the flat terminal of pin 1. Once you have identified pin 1, you'll be able to form the leads in the correct direction so that the sensor can be properly installed in the circuit. The use of mounting hardware for the sensor is optional; if used, place the head of the screws on the bottom side of the board to allow it to rest on the bottom of the enclosure. No pneumatic connection to the pressure port of the sensor is required for the barometer except during an optional calibration procedure (that is discussed later).

After completing the analog board, examine it very carefully for opens, shorts, and cold solder joints. It is much easier to correct a problem at this stage rather than later on should you discover that the barometer does not work.

**Digital Board.** To keep the size of the barometer as small as possible, the LCD readout was mounted on the copper side of the board. That allows you to mount the display board to the cover of the enclosure with the display protruding through a 2 $\frac{1}{16}$  by 1 $\frac{5}{16}$ -inch rectangular opening. Drill four holes in both the display board and cover to accommodate the mounting hardware. Be careful not to drill through any of the copper conductors.

The display board requires a number of jumper wires to complete the circuit; a listing of those connections are given in Table 1. Use #24 or #26 insulated, stranded wire for the



*Fig. 7. For those who wish to obtain the greatest possible accuracy from the circuit, this set up can be used to calibrate the Digital Barometer using a procedure founded in some basic laws of physics.*

jumper connections. All jumper wires must be placed on the component side of the display board to allow room for the readout module on the opposite side.

After all other components have been installed, install the LCD's socket (as described earlier), if one is to be used, on the copper side of the display board. Do not install the LCD at this point; the circuit must be determined to be bug-free first, with no opens, shorts, cold solder joints, or other construction errors.

**Final Assembly.** There are 4 connections that must be made between the analog and display boards; +5 volts, ground, and the two differential outputs from U2-c and U2-b. Use different color insulated stranded wire for those connections and be sure to allow sufficient lead length to permit the boards to be placed as required in the enclosure.

In the author's prototype, two corners of the analog board were cut off at 45° angles to permit the board to be positioned near one end of the specified enclosure, allowing sufficient room for B1 next to the board. It is not necessary to fasten the analog board to the recommended enclosure; it will automatically be held in

place when the cover is screwed down.

The wiring between the two circuit boards must be positioned so that it does not lie across the top of U3 when the cover of the enclosure is put in place; otherwise, there may be insufficient clearance when attempting to seal the enclosure that is specified in the Parts List.

Connect a battery clip to the circuit. When wiring the clip to the circuit, be sure to observe proper polarity as indicated in the parts-placement diagram. Switch S1 can be installed on the side of the enclosure. Because of the limited space within the enclosure, use a miniature toggle or slide switch.

**Checkout.** For the initial checkout of the circuit, do **not** install the IC's (U2, U3, or U4) or the display (DISP1) on the boards. The power supply will be checked first, using any DVM or VOM. Connect a fresh battery to the circuit. Connect the negative lead of the voltmeter to the circuit ground (negative battery terminal) and turn on S1. Measure the output of the regulated 5-volt supply at pin 3 of SENS1. You should get a reading of from 4.8 to 5.2 volts. If that checks out, proceed with the remainder of the test. If you do not obtain the proper reading, troubleshoot the circuit and correct the problem before proceeding.

If the power supply is not delivering the correct voltage, check the terminal voltage of the battery when powering the circuit: The minimum permissible voltage is 7 volts. Check the orientation of U1. With the battery disconnected, measure the resistance between the 5-volt bus and ground to be sure that there is no short circuit in the wiring.

When you are satisfied that the power supply is operating properly, disconnect the battery. Very carefully insert U2-U4 and DISP1 into their respective sockets, with the correct orientation. When installing those components, be sure that none of the IC pins are inadvertently bent underneath the body of the IC.

With all of the components installed, apply power to the circuit, and measure the voltage at pin 8 of U2, with respect to ground. You should get a reading of about 1.8 volts. If your reading does not coincide with that



voltage, carefully check to make sure that R1 through R6 are of the correct values. If in doubt, use an ohmmeter to measure the resistance of any resistor after disconnecting one end from the board. Try a new LM324N. Check the sensor for correct orientation in the circuit. Set R8 to mid-position and measure the voltage at pin 7 of U2. A reading of about 1.7 volts is normal. If you do not get the correct reading, check R7–R9 for the correct values.

The next step involves checking the operating range of R8, and if necessary changing R7 and/or R9 to compensate for normal tolerance variations in the sensor and other circuit components.

Connect the negative lead of the voltmeter to pin 7 of U2, and the positive lead to pin 8 of U2. Set the voltmeter to a sensitive range (such as 200-mV full scale). Apply power to the circuit and record the reading as R8 is adjusted to each end of its range. Ideally, the maximum and minimum readings should be centered around 100 mV (0.1 volt), with an adjustment range of at least  $\pm 10$  mV. It may be necessary to tailor the values of R7 and/or R8 in order to obtain a voltage-adjustment range that covers 90 to 110 mV as R8 is varied from one extreme to the other.

Once R8 has been centered about 100 mV, very slowly adjust R8 over its range and note the reading of the display. You should be able to obtain barometric readings of at least 29.00 to 31.00 inches of mercury. Remember, the circuit is not capable of displaying numbers such as 27 and 32, so ignore such readings, which can occur at either end of the adjustment range.

If you do not obtain a legitimate barometric display, or if the display is totally blank, the problem probably lies with the display board. A totally blank display indicates that the backplane-drive signal generated at U3 pin 21 (a 5-volt peak-to-peak square-wave of about 50 Hz) is absent. Check all of the components associated with U3. Check the orientation of DISP1 to be sure it is installed correctly.

Check the wiring to be sure that there are no solder bridges across the closely spaced conductors. If possible try a new A/D converter (U3) and XOR gate (U4). If the display is energized,

but one or more of the digits has segments that are either incorrectly energized or extinguished, the problem is most likely with the connections between U3, U4, and DISP1.

Carefully review Table 1 to determine whether all of the jumpers are correctly wired. Check the solder connections to DISP1 for opens and shorts. When the barometer is operating properly, set R8 to the current barometric reading, which can be obtained by calling a local airport or tuning into a radio or TV weather report.

**Precision Circuit Calibration.** The Digital Barometer can provide reliable and accurate readings since the tolerance of the sensor and circuit components are reasonably good. For those who wish to obtain the greatest possible accuracy from the circuit, a simple calibration procedure using some basic laws of physics can be used to trim the amplifier gain for the particular sensor used in the circuit.

Calibration involves using a water-column manometer, which can be assembled from easily obtainable materials. The manometer is used to simulate a pressure difference of 1 inch of mercury so that the circuit is checked at two different pressure readings, 30.00 and 29.00 inches. Resistor R2 can then be trimmed to provide a precise circuit gain for a change in pressure of 1 inch of mercury.

Figure 7 illustrates the manometer setup. The materials require include a clean bottle, clear plastic tubing, a hose "tee" to make a 3 way connection, a hose clamp, a short length of wood, and a scale. (A small amount of food coloring can be used to make the water level easier to see.) The accuracy of this procedure is determined by how precisely you can measure and set the height of the water column, which can be marked on the length of wood.

The bottle and plastic hose can be secured to the wood to keep the tubing above the top of the bottle as straight as possible. Keep the assembly vertical during the procedure. With the pressure sensor connected to the manometer as shown in Fig. 7, apply power to the circuit. Open the clamp and be sure that there is no

water or bubbles in the tubing above the water level in the bottle. Set potentiometer R8 so that the display reads 30.00 inches.

Now gently apply suction to the open end of the tubing so that the water level rises in the tube. Carefully raise the level of the water  $13\frac{1}{32}$  inches (34.5 centimeters) above the level in the bottle. Close the clamp so that the water in the tubing remains at the desired level. Note the reading of the barometer, which should be 29.00 inches.

If the reading is greater than 29.00, the amplifier's gain is set too low, and the value of R2 needs to be reduced. If the reading is below 29.00, R2 needs to be increased. The required change in R2 will be extremely small, possibly less than 100 ohms. It's best to use a small carbon resistor connected in series to raise the value, or a large carbon resistor connected in parallel to reduce the value.

Once the optimum value for R2 has been determined and placed in the circuit, the barometer is calibrated. Adjust R8 for the prevailing barometric pressure.

**Using the Barometer.** Once R8 has been adjusted, it needs no further attention unless the altitude of the barometer is changed by moving it to another location. If so, reset R8 by obtaining a current barometric reading from an airport or weather report. When operating the barometer, you may see some fluctuation in the least-significant digit of the display; it should hover between two readings. That's normal for the A/D converter used in the circuit.

Also note that the circuit is far more sensitive than the common analog barometer, and will give a continuously updated pressure reading. Thus, you may see small changes in readings as the ambient air pressure varies. That can be very noticeable on a windy day. To use your barometer for weather forecasting, note the direction of change in readings ~~also~~ taken an hour or more apart. Increasing readings usually indicate fair weather ahead; falling barometric pressure indicate stormy or unstable weather is on its way.

Be sure to turn off the instrument when not in use. That ensures long battery life. ■

*It's a high-voltage apparatus that has earned a place in history. Now it's your turn to get in on the fun!*

**“W**imshurst machine? So that's what it's called!” my neighbor said, his eyes as wide as half dollars. I often heard that comment.

I took the Wimshurst machine off the shelf in my den and placed it on the desk before him. I turned the handcrank, the black plastic plates spun, and sparks jumped between the metal globes. “It will create 75,000 volts,” I commented. He leaned away from the machine. As the plates spun, the machine hummed and sparks snapped between the globes. The smell of ozone soon filled the room.

# THE WIMSHURST MACHINE

BY GREGORY B. PUTZ

The photo on this page is reprinted, with permission, from book #3575 “Homemade Lightning,” by R.A. Ford. Copyright 1990 by TAB Books, a division of McGraw-Hill, Blue Ridge Summit, PA 17294; Tel. 800-233-128 or 717-794-2191.

High-Voltage  
Electronics



I'm sure that you, too, have seen a Wimshurst machine although you may not have known its name. You probably know more about its cousin, the Van de Graaff generator. Both are electrostatic generators, but that is where the similarity ends. The Van de Graaff generator creates static charges by friction, while the Wimshurst device does it by induction. In the early days of electrostatics, the principle of induction was also known as "influence." In fact, the machine is more correctly called a "Wimshurst influence machine."

The Wimshurst machine played an important role in the early years of electrostatics. It provided high-voltages necessary for experiments in X-ray. But before I tell you how the Wimshurst machine works, let's take a quick look at the science of electrostatics.

**Electrostatics.** Electrostatics was first noticed sometime in 600 BC when the Greek philosopher Thales discovered that amber attracted light objects when rubbed. The phenomenon not only demonstrated a fundamental concept of electrostatics, but also gave us the word "elektron," meaning amber in Greek.

When Italian physicist Alessandro Volta invented the "voltaic pile" (or battery) in 1800, the science of electrostatics changed forever. Volta's new invention provided scientists with a stable, dependable source of moving charges (i.e., DC). This invention was a turning point in electricity because now scientists could study *electrodynamics*, whereas before they were limited to studying *electrostatics*.

**Triboelectric Effect.** It's been a while since the days of Thales, but we all know a few modern ways to make electricity by rubbing. Shuffling our shoes across the carpet on a dry day causes a spark between our finger and a metal door-knob. Likewise, rubbing a glass rod with flannel and then pulling them apart causes the flannel to hang unnaturally towards the rod. The rubbing action causes the glass to develop an abundance of positive charges and the flannel an abundance of negative ones. Once pulled apart, the difference in charge of the two materials causes the attraction of the flannel to the glass.

The same happens when you rub paper against a plaster wall or wooden door. It sticks to the vertical surface because the rubbing creates opposite charges on the paper and the wall. Try

it with a balloon and you'll see the same effect. In each of these cases, rubbing creates segregated electric charges and static electricity is the result.

In high school, you probably saw a Van de Graaff generator. It made sparks fly, fluorescent tubes glow, and your hair stand on end when you touched its dome. The Van de Graaff generator works in a way that is similar to rubbing glass with flannel, except

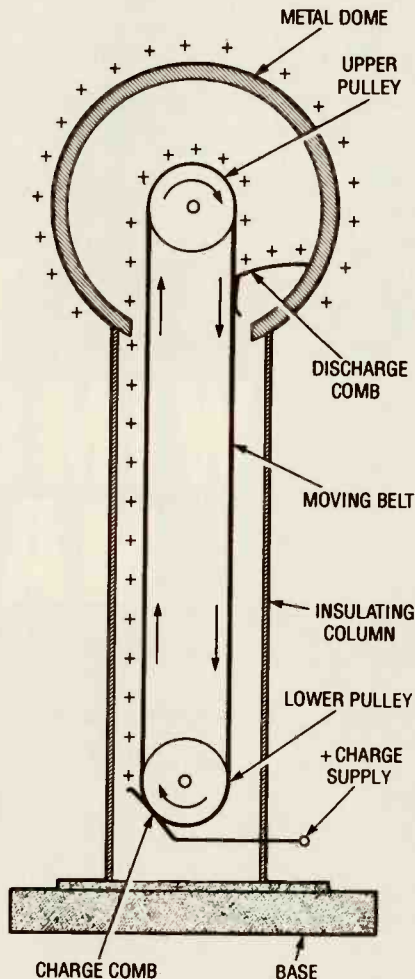


Fig. 1. A Van De Graaff generator places a high-voltage charge on its metal dome by friction, whereas a Wimshurst machine charges via induction.

**WARNING!!!** This article deals with and involves subject matter and the use of materials and substances that may be hazardous to health and life. Do not attempt to implement or use the information contained herein unless you are experienced and skilled with respect to such subject matter, materials and substances. Neither the publisher nor the author make any representations as to the accuracy of the information contained herein and disclaim any liability for damages or injuries, whether caused by inaccuracies of the information, misinterpretations of the directions, misapplication of the information or otherwise.

that the rubbing is made continuous by using a moving belt inside the generator (see Fig. 1). As an electric motor turns the belt, metal combs in the generator's dome and base strip charges from the belt. As a result, the dome and base develop opposite charges. Small, classroom-sized Van de Graaff generators produce 200,000 volts. Larger ones, like those used for sub-atomic particle research, create several-million volts.

Glass rubbed with flannel, and paper, or balloons sticking to a wall, and the Van de Graaff generator are all examples of creating static electricity using friction. That is also known as *triboelectric* charging. As we mentioned, there is another way to create static electricity and that is by induction.

**Induction.** John Canton, in 1753, was the first to put forward the concept of induction of charge. He demonstrated that when a charged body is brought close to a neutral body, the neutral body develops a charge of equal magnitude but opposite polarity. One of the earliest devices to demonstrate induction was the "electrophorus." The electrophorus is the simplest electrostatic generator.

Later in 1787, Abraham Bennet, the inventor of the gold-leaf electroscope, developed the first simple machine to induce electrostatic charges. The device was called a "doubler" because of its ability to progressively accumulate static charges. His doubler did not use friction, but used Canton's induction concept to generate separate positive and negative charges.

New varieties of doublers, or "influence machines" as they were soon called, were developed by Nicholson in 1788, Belli in 1831, and Lord Kelvin in 1860. Also in 1860, Varley built the first successful high-voltage influence machine. Other induction devices were subsequently developed by August Toepler and Wilhelm Holtz. But it wasn't until 1878 that British engineer James Wimshurst invented the first dependable device to inductively generate static electricity. The Wimshurst influence machine was born.

**The Machine Itself.** Before we explain how a Wimshurst machine works, it's a good idea to describe its structure. The Wimshurst machine has three major parts: rotating parallel plates, neutralizing rods, and collecting combs

(see photos). Today's bench-sized demonstration units typically have 12-inch diameter plates. During the heyday of electrostatics, larger Wimshurst machines (used for research or powering early X-ray machines) had multiple pairs of plates several feet in diameter.

Each Wimshurst machine develops a maximum electrostatic potential based on the number of plates used, their diameter, and the spacing between them. Interestingly enough, increasing the rotating speed of the plates does not increase the maximum discharge voltage. Only increasing the number of pairs of plates increases the discharge voltage.

The plates can be any sturdy, non-conducting material, such as glass or plastic (see Fig. 2). The plates are mounted in pairs, separated by a quarter-inch gap, on a horizontal shaft. The closer the plates are mounted to each other, the better the machine will operate. The plates are turned by belts and pulleys from a common crankshaft, but they rotate in opposite directions. A difference in pulley diameters causes the plates to spin several times faster than the handcrank.

Metal-foil strips called "sectors" are

## Resources.

Wimshurst electrostatic generators are available from Edmund Scientific Company (Cat. No. B70,070), 101 E. Gloucester Pike, Barrington, NJ 08007-1380; Tel. 609-573-6250, and from The Chem Shop, 1151 South Redwood Road, Salt Lake City, UT 84104; Tel. 801-973-7966.

Also, contact Dynamic Systems, Inc., 48 Sunlight Drive, Leicester, NC 28748; Tel. 704-683-1280, Fax 704-683-3511.

See the following books:

*The Wimshurst Machine: How to Make and Use It*, by Alfred W. Marshall; Lindsay Publications, Inc., P.O. Box 12, Bradley, IL 60915-0012.

*Electrostatics: Exploring, Controlling and Using Static Electricity*, by A.D. Moore; Anchor Books, 1968.

*Handbook of Electrostatic Discharge Controls*, By Bernard S. Matisoff; Van Nostrand Reinhold Company, 1986.

*Electrostatics: Principles, Problems and Applications*, By Jean Cross; Adam Hilger, 1987.

evenly spaced along the outer surface of each plate. Those help extract excess charges from the non-conductive plates.

The charges that accumulate on the sectors are removed by pairs of collect-

ing combs made of tinsel threads. Each pair of combs is mounted on a U-shaped bracket, with one brush touching the front plate and the other brush touching the rear plate. The two U-shaped brackets are mounted opposite one another. They carry the accumulated charges to the machine's discharge balls.

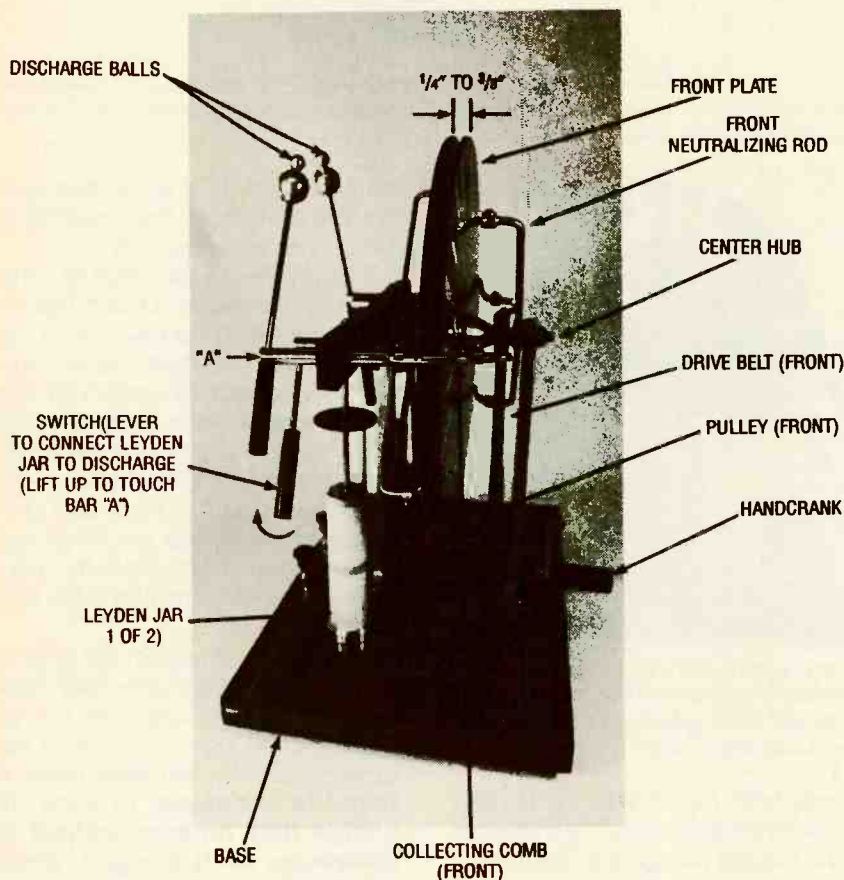
There are two "neutralizing rods" that span the diameter of each plate and also have metal tinsel combs on each end. The front and rear rods are perpendicular to each other and are positioned at an angle of 45° to 60° from the machine's base.

In addition to the three basic parts of a Wimshurst machine, they typically have two built-in Leyden jars, which are very simple glass and foil capacitors. Each Leyden jar can be electrically connected to a collecting comb by means of a hinged rod. If the Leyden jars are not connected to the collecting combs, then a continuous arc jumps between the discharge balls when the handcrank is turned. If the connecting rods are lifted to touch the collecting combs, then a sharp (and intense) snap of electricity jumps between the discharge balls every few seconds.

It is important to notice that all the metal parts of a Wimshurst machine are built with rounded edges. A fundamental rule of electrostatics is that charges find it much easier to "jump" from a pointed surface than from a rounded one. Any sharp points on the machine would allow the charges to dissipate quickly.

**How it Works.** Remember that the Wimshurst machine is an induction device. It doesn't depend on friction to make an electrostatic charge. As you'll see, quadrants of negative and positive charge are created across the plates by induction between the front and rear plates. As the plates rotate, these positive and negative charges are syphoned off through the metal sectors by the collecting combs.

As you may recall, the principle of induction requires that an object be initially charged before you can use it to induce a charge in something else. That holds true for the plates on the Wimshurst machine. Even before you crank the handle the plates have some static charges on their surface. The charge is created from the incidental rubbing and handling of the machine, and the machine actually amplifies this initial imbalance of charge.



The Wimshurst machine is composed of many parts. However, not all Wimshurst machines have Leyden jars although this one does.



Looking at Fig. 2 let's say that quadrant CD of the rear plate had a slight negative charge before the crank was turned. That would induce a small positive charge on the front plate in the same sector. As you turn the crank, electrons on the front plate sector at point C are repelled by the electrons built up on the rear plate. That pushes them up the neutralizing rod to A, which is a more desirable place to be because the rear plate has a positive charge there. That leaves electron-starved quadrant CD with a net positive charge, and electron-rich quadrant AB becomes more negatively charged.

Note that the rear plate—rotating in the opposite direction—works in a reciprocal fashion: Electrons move through the rear neutralizing rod from B to D. So on the rear plate, quadrant AB becomes more positive and quadrant CD becomes more negative. That permits the front neutralizing rod to scoop up more repelled electrons and so on.

In the region of the collecting combs, the front and rear plates have the same charge. The charges on the plates repel each other in those areas. That permits the collecting combs to scoop up the excess charges and send them to the discharge balls. The charges will continue to accumulate until surface leakage or a spark between the discharge balls dissipates them.

You can see the charge leakage by placing the device in the dark, setting the discharge balls a good distance apart, and looking at its corona discharge radiating from the edges of the plates. You'll also see tiny, purple arcs around all combs.

Setting the gap between the discharge balls an inch or two apart, causes a continuous shower of sparks to jump between the spheres. Connecting the Leyden jars to the discharge spheres allows you to separate the balls by a larger distance to produce big crackling sparks.

**Demonstrations.** Here are some demonstrations that you can try with a Wimshurst machine. For instance, with the Leyden jars disconnected, move the discharge balls far enough apart so that there is no spark when you turn the handcrank. Light a candle and hold it close to one ball and then the other. At the positive ball, the flame will be attracted toward it, and at the negative one, the flame will be repelled.

For another experiment, hold a piece of cardboard between the dis-

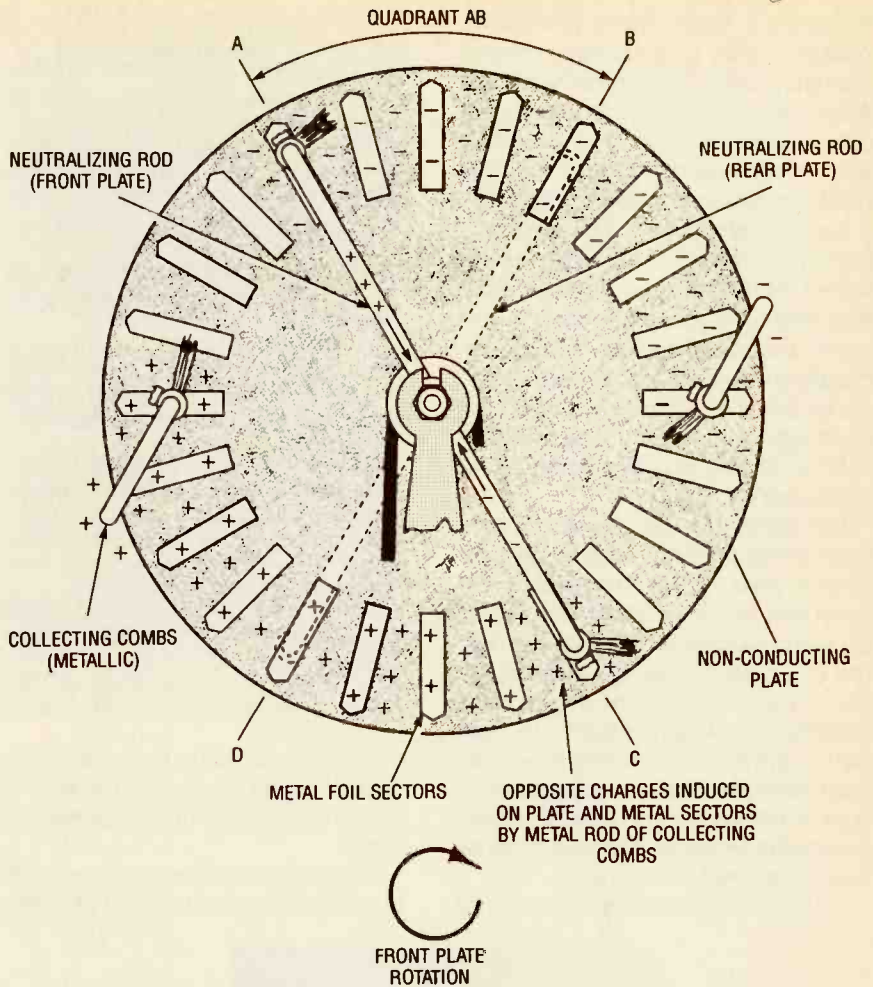
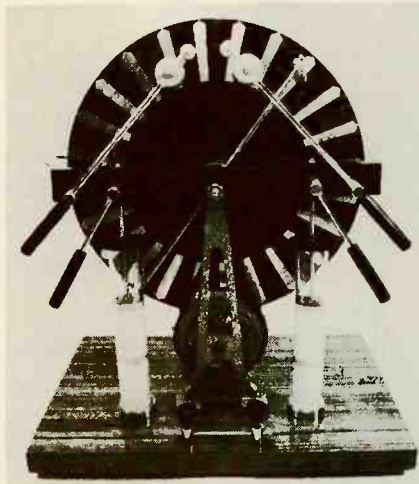


Fig. 2. This is the charge distribution on the front plate. Front and rear neutralizing rods scoop the charges up and move them to more desirable quadrants. The collecting combs can then whisk them away.



Here you can plainly see the Leyden jars and discharge spheres. The jars are connected to the spheres by lifting up the levers attached to them.

charge balls (again with the Leyden jars disconnected). Allow the shower of sparks to jump through the cardboard. Inspect the cardboard and notice that the hole caused by the spark is bulged

on both sides. That shows that sparks act like AC current, they oscillate between the discharge balls.

For a different effect, start by cutting some kind of shape out of a piece of aluminum foil. A good example is a letter, such as T or L. Paste the aluminum design to a piece of cardboard. Using a knife or razor blade, cut the design in several places to create discontinuities in the foil (don't let the cuts exceed  $\frac{1}{32}$  inch wide). Connect each end of the shape to one of the discharge balls. Run the machine and watch the arcs as the charges jump the cuts in the foil.

**Safety.** You must respect the potential of any electrostatic generator. Under normal use, they are safe, but you should not let that lull you into a false sense of security. **You must never attempt to condense, or store, the charge they produce without full knowledge of its dangers. Simply said, avoid connecting any capacitor to any electrostatic generator. ■**



# VOLTAGE DOUBLERS

*Voltage doublers are an easy and inexpensive way to experiment with high voltage.*

RALPH HUBSCHER

IF YOU'VE BEEN LOOKING FOR A WAY to generate high voltage, you've undoubtedly run across the voltage doubler. Voltage doubling using diode-capacitor combinations is a common practice. However, whole banks of doublers, called cascades, can also be used for producing extremely high DC voltages from moderate to high AC voltages. Such high DC voltages may be needed for TV sets, lasers, air purifiers, industrial smoke-stack dust removers, negative-ion generators, and, of course, for experimenting, on which we'll concentrate here.

### Half-wave doubler

Figure 1 shows a half-wave voltage doubler; we'll assume that C1 and C2 are initially discharged. During the first half-cycle shown in a, the upper input terminal is positive and the bottom negative, so D1 conducts and C1 charges to about 170 volts peak. Diode D2 can't conduct, since it's back-biased, so C2 discharges through  $R_L$ . In the second half-cycle (b), the analysis is similar, except that D2 conducts and C2 charges.

The circuit is really a transformerless voltage amplifier. While T1 can provide isolation, as well as increase the AC voltage initially going into the doubler, the amplification due to the doubling action would occur without it. When the polarity reverses, both the input voltage and the charge across C1 are in series like two batteries, producing about 340 volts peak. One problem, though, is that a half-wave doubler can't be used with a load that draws much current.

### Full-wave doubler

Let's see how a full-wave voltage doubler is related to and built from both positive and negative half-wave rectifiers. Figure 2-a shows a half-wave rectifier with a positive output, Fig. 2-b shows the same version with a negative output, and Fig. 2-c shows the two combined into a full-wave voltage rectifier.

The full-wave voltage doubler shown in Fig. 3 has been redrawn for greater clarity; it has better regulation than a half-wave version, and is easier to filter. The circuit produces nearly double the peak AC voltage of 170 volts, or about 340 volts peak across  $R_L$ . For the first half-cycle (a), D2 is cut off and D1 conducts, so that  $V_{C1}$  equals approximately 170 volts DC. On the next half-cycle (b), the positive voltage is replaced by a negative voltage, so D2 conducts and D1 is cut off.  $R_L$  goes across C1 and C2 in series, effectively creating a doubled level of about 340 volts DC.

Warning!! This article deals with and involves subject matter and the use of materials and substances that may be hazardous to health and life. Do not attempt to implement or use the information contained herein, unless you are experienced and skilled with respect to such subject matter, materials, and substances. Neither the publisher nor the author make any representation as for the completeness or accuracy of the information contained herein, and disclaim any liability for damages or injuries, whether caused by or arising from the lack of completeness, inaccuracies of the information, misrepresentations of the directions, misapplication of the information, or otherwise.

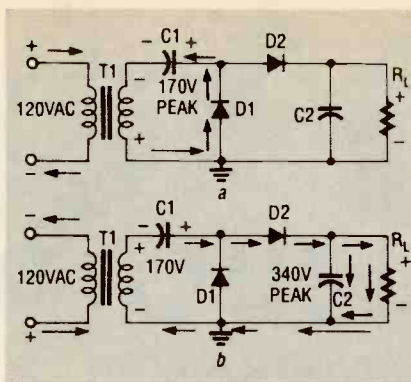
Unlike the half-wave voltage doubler, the full-wave version has two capacitors across  $R_L$  rather than one. Whereas C1 shown in Fig. 1 is cut off and unsupplied for half of every cycle, C1 and C2 in Fig. 3 are supplied on alternate half cycles. When the capacitor corresponding to the diode that's cut off discharges, it can only do so through the capacitor being supplied, slightly decreasing both its current and the maximum voltage it reaches.

### Measuring high-voltage DC

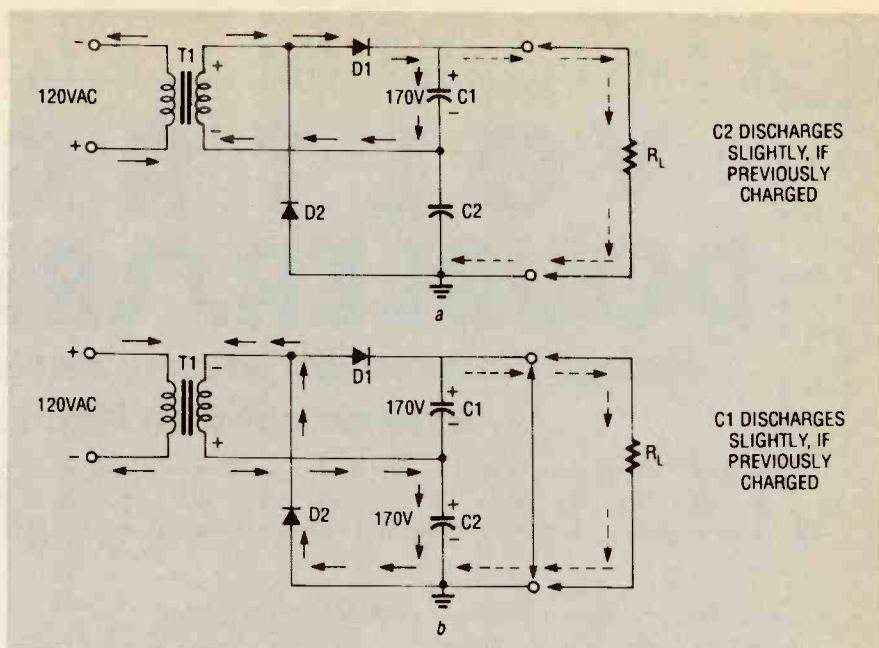
Voltage measurements will be possible only to about the second or third stage of a cascaded voltage doubler with most voltmeters. Beyond that, you'll need to use either a high-voltage DC meter or an external voltage divider for use with a standard high-impedance voltmeter (10 megohms or more).

A good voltage divider that can be used for the purpose of high-voltage measurements is the RCA SK3868/DIV-1, a high-voltage DC divider; it's used in TV's to reduce the final anode voltage going to the CRT to the level required for the focus voltage. It consists of resistors R1 (200 megohms) and R2 (40 megohms) in series, as shown in Fig. 4. There are three leads, one for the free ends of each resistor, and the other at their juncture. If you put both a 10-megohm meter (shown as  $Z_M$  in Fig. 4) and a 2.7-megohm resistor (R3) in parallel with the 40-megohm resistor (R2), you can achieve almost exactly 100:1 range multiplication, for a full-scale deflection of 20 kilovolts DC.

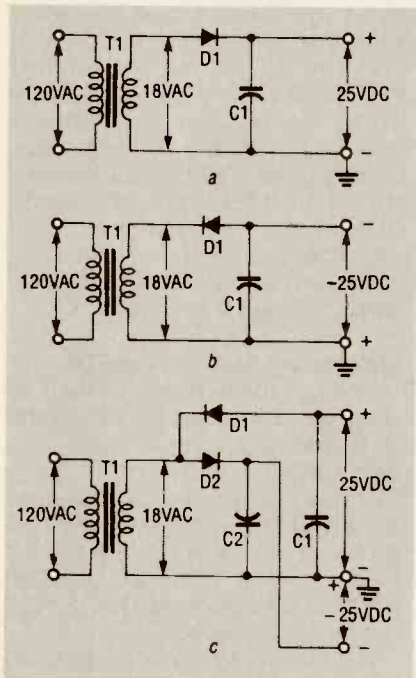




**FIG. 1—HALF-WAVE VOLTAGE DOUBLER.** During the first half-cycle (a), D1 conducts, D2 cuts off, C1 charges to 170 volts peak, and C2 discharges through  $R_L$ . For the second half-cycle (b), the input polarity is reversed, and both the input and C1 are in series, producing 340 volts peak. Now D1 cuts off while D2 conducts, and the current divides between C2 and  $R_L$ ; the cycle then repeats.



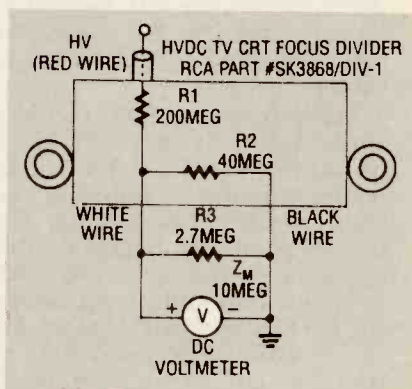
**FIG. 3—FULL-WAVE VOLTAGE DOUBLER, redrawn for greater clarity.** For the first half-cycle (a), D2 is cut off and D1 conducts, producing about 170 volts DC across C1. On the next half-cycle (b), D2 conducts and D1 is cut off. The output voltage is now across C1 and C2 in series, doubling the level to about 340 volts DC.



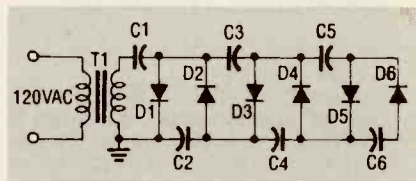
**FIG. 2—TWO HALF-WAVE RECTIFIERS, one with a positive output (a) and one negative (b), combine to make a full-wave voltage doubler (c).**

### Cascaded voltage doublers

Figures 5–8 show four additional voltage doublers. The one shown in Fig. 5 is the most straightforward. If you build it, use 1N4007 diodes with peak inverse voltage (PIV) ratings of 1 kilovolt for D1–D6, and 0.068–0.1  $\mu\text{F}$  capacitors with working voltages of 400 volts DC. Figure 5 is electrically identical to the one in Fig. 6, so keep that in mind if you should come across either format. Figure 7 shows an extended version that's better



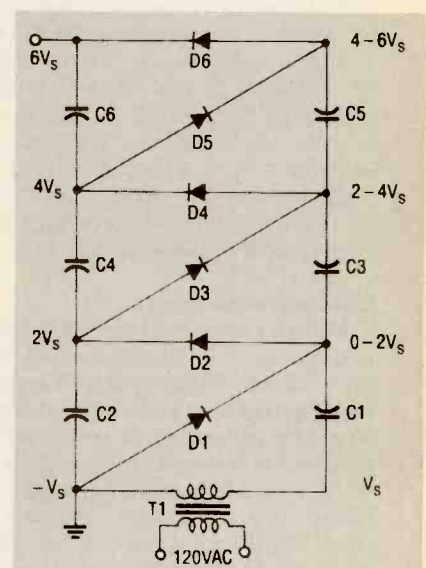
**FIG. 4—TO MEASURE HIGH VOLTAGES** with an ordinary 10-megohm meter, you can use the RCA SK3868/DIV-1 high-voltage divider. The circuit provides a 1:100 voltage division, allowing 20 kilovolts to be measured on a 200-volt scale.



**FIG. 5—THIS CASCADED DOUBLER** uses 1N4007 diodes rated at 1 kilovolt PIV, and capacitors from 0.068–0.1  $\mu\text{F}$  with a 400-volt DC working voltage.

stabilized for moderate-current applications; it's called either a Cockcroft-Walton or Greinacher cascaded voltage doubler.

You can use a sewing needle as an emitter for the doubler shown in Fig. 8 to generate "corona wind." That will sound like a his-



**FIG. 6—THIS VOLTAGE DOUBLER** is the same as the one shown in Fig. 5, although it's drawn differently. You should be able to recognize both versions.

sing noise. (We'll show you how to demonstrate the "wind" later on.) The circuit delivers 3.75 kilovolts DC when powered from 120 volts AC, or 7.5 kilovolts DC when powered from 240 volts AC.

The output of a cascaded voltage doubler should be terminated with no less than 200 megohms, and only then be allowed to extend beyond a protective plastic case, for safety. Voltages as high as 5 megavolts DC have been generated using

cascaded voltage doublers, especially when operating in a pressurized atmosphere. The biggest advantage to using voltage doublers is that they use inexpensive low-voltage parts. Otherwise, if all the parts had to be of the high-voltage variety, you would have to use expensive and rather large capacitors like the one shown in Fig. 9.

If you have problems with the circuit in Fig. 8 (or any other high-voltage circuit), you must discharge every capacitor (we'll tell you how in a minute) before you check for malfunctions. When examining the circuit for problems, closely check the solder connections, and then the diode directions and continuity. The 1N4007's should have a resistance of 1.1K when forward-biased and be open when reverse-biased, while the capacitors

should all have infinite resistance.

To properly discharge capacitors, build a discharging wand like the one shown in Fig. 10. Use a 2-foot wooden (or plastic) dowel, and connect a stiff wire tip

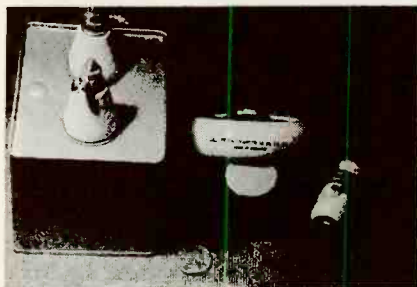


FIG. 9—HIGH-VOLTAGE CAPACITORS. A 0.25  $\mu$ F, 7.5-kilovolt capacitor is on the left; a 100 pF, 15-kilovolt capacitor is in the middle; and 0.0005  $\mu$ F, 5-kilovolt capacitor is on the right.

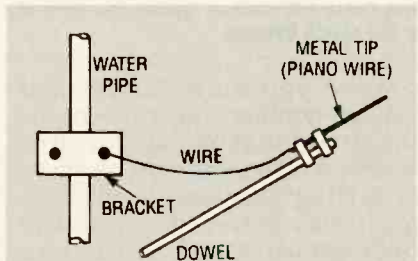


FIG. 10—A HIGH-VOLTAGE GROUNDING wand is used to discharge capacitors. A 2-foot wooden dowel is attached to a stiff wire tip. The metal tip must be connected to an earth ground, such as a cold-water pipe.

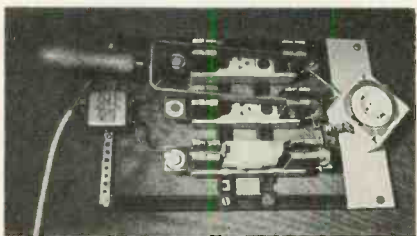


FIG. 11—HOMEMADE SWITCH for high-voltage DC. The line filter at left is a safety measure to keep high-voltage DC out of the house wiring.

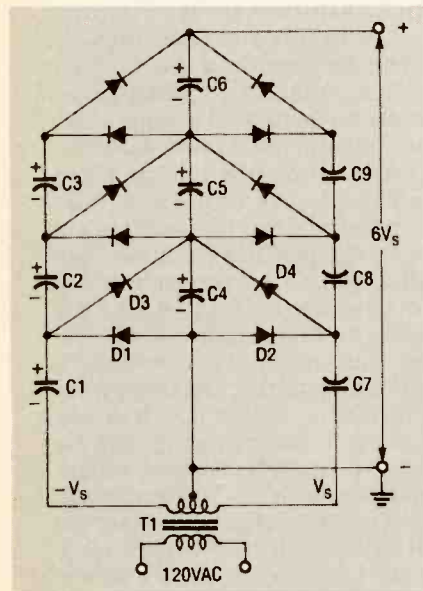


FIG. 7—THE COCKROFT-WALTON, or Greinacher cascaded voltage doubler, has improved performance for moderate-current applications.

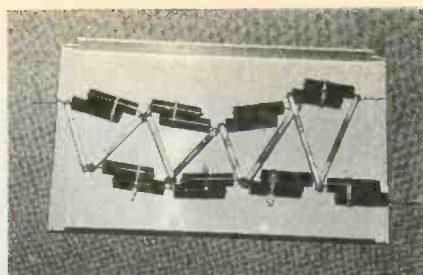


FIG. 12—A TYPICAL CASCADED voltage doubler. Note the wide spacings between the diodes, the long connecting wires, and the smooth solder joints.



FIG. 13—THIS IS THE DOUBLER from Figure 12, after being sealed in candle wax. For better protection, you can immerse it in pure paraffin oil.

(piano wire works well) to a cold water pipe as earth ground with a good electrical connection. Discharge all capacitors twice, since they generally either hold charge, or tend to recharge from other capacitors. Don't use an AC line ground or chassis ground instead of an earth grounded water pipe, or you may blow a fuse or damage parts.

Figure 11 shows a switch for high-voltage DC that you can use with any of the cascaded voltage-doublers shown here; standard switches may present a shock hazard. Also, use an electromagnetic interference (EMI) line filter like the one seen at left in the photo to keep high-voltage DC out of house wiring, and to prevent shock from static charge. The EMI filter is from Corcom Corp. (1600 Winchester Road,

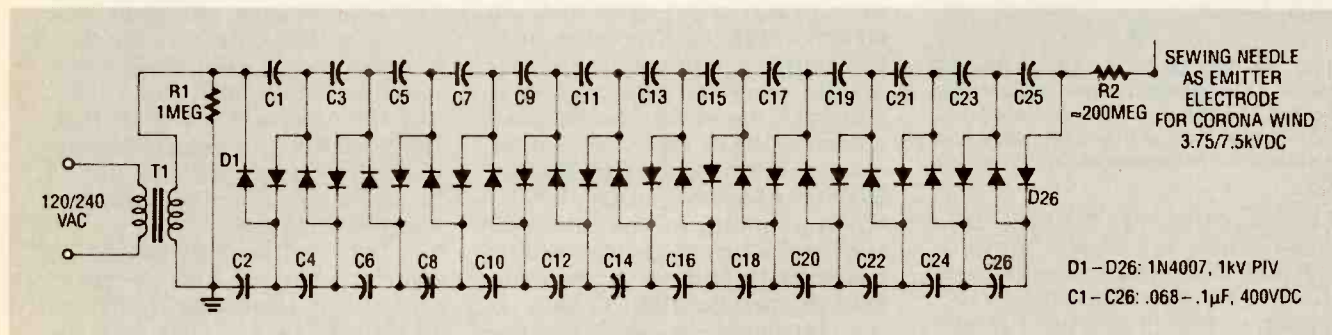


FIG. 8—THIS 25-STAGE VOLTAGE DOUBLER will generate "corona wind." It delivers 3.75 kilovolts DC when powered from 120 volts AC, or 7.5 kilovolts DC when powered from 240 volts AC.

SEWING NEEDLE AS EMITTER ELECTRODE FOR CORONA WIND 3.75/7.5kVDC

D1-D26: 1N4007, 1kV PIV  
C1-C26: .068 - .1 $\mu$ F, 400VDC



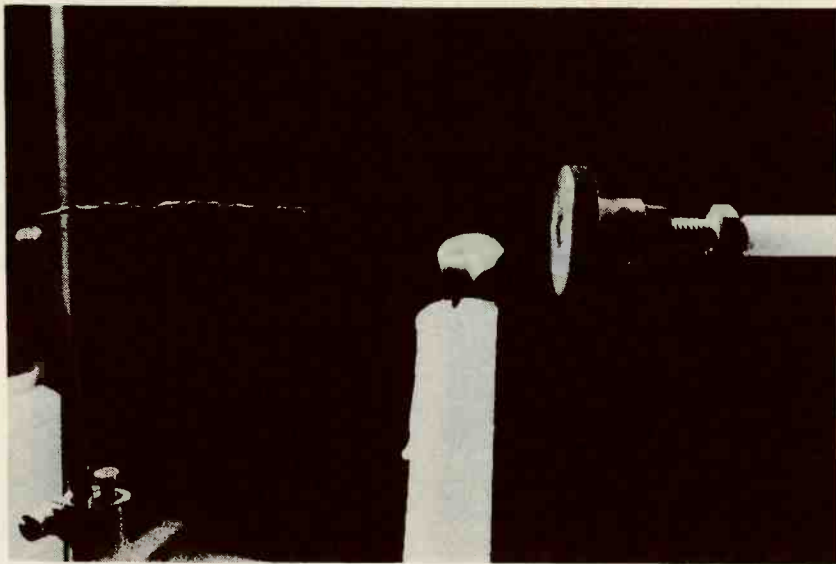


FIG. 14—CORONA WIND DEMONSTRATION. The flame will deflect toward the ground plate. Note the black ground wire attached near the screw threads.

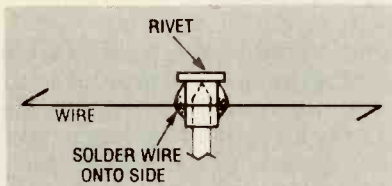


FIG. 15—THIS ION-MOTOR ROTOR, when placed on top of the sewing-needle emitter, will spin in a circle.

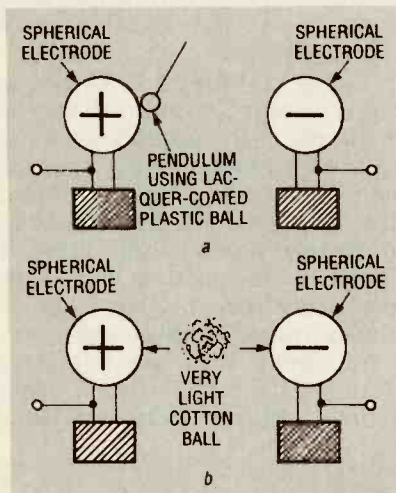


FIG. 16—TWO CHARGED DOOR KNOBS cause a suspended, lacquer-coated plastic ball to behave like a pendulum (a). A light cotton ball will bounce back and forth without being suspended on a string (b).

Libertyville, IL 60048, tel. 312-680-7400). Model 2061 is rated at 20 amps, 250 volts, and 50–400 Hz. The high-voltage DC switch in Fig. 11 also uses an old 100-amp fuse box, shown on the right; it may look like an antique, but it will prevent any shocks.

When you build a cascaded voltage doubler, you can encase the circuit in pure paraffin oil or candle wax to reduce the chances of getting shocked. It will also minimize corona loss, so the high-voltage DC arrives where it's needed. Figures 12 and 13 show a typical ladder-type voltage doubler before and after being sealed in wax.

### Experiments

There are many experiments that can produce observable effects due to the high-voltage DC produced by voltage doublers.

- With a high-voltage emitter pointed at a ground plate (used to attract ions), with a burning candle placed in between them (see Fig. 14), you'll see the candle flame deflect toward the metal plate.

- You can make a rotor for an ion motor, using a light pivot made from a rivet with thin, stiff wire (like piano wire) attached, as shown in Fig. 15. The rotor must be balanced on top of the sewing-needle emitter (much as in a compass) used for the doubler shown in Fig. 8. (We ran a similar construction project in **Radio-Electronics**, February, 1991.) When powered up, the rotor will spin and a hissing sound will be heard. Both ends of the wire are bent at opposite right angles, so the emitted electrons propel the wire in a circle. You should sharpen both ends of the rotor wire to provide a sharp surface

good for corona generation and electron emission. The sharpened ends will have a small radius of curvature (a tight curve or bend), giving rise to a highly distorted electric field at its surface. The high electric field is what tends to ionize air molecules in the vicinity.

- Another experiment you could try involves holding a fluorescent tube near the emitter. The tube will glow, but be careful not to touch the terminals on the ends, or you'll get a shock.

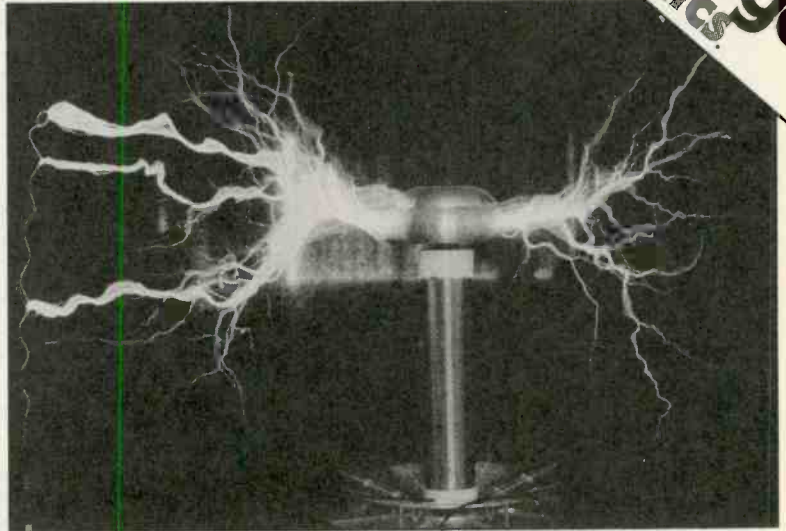
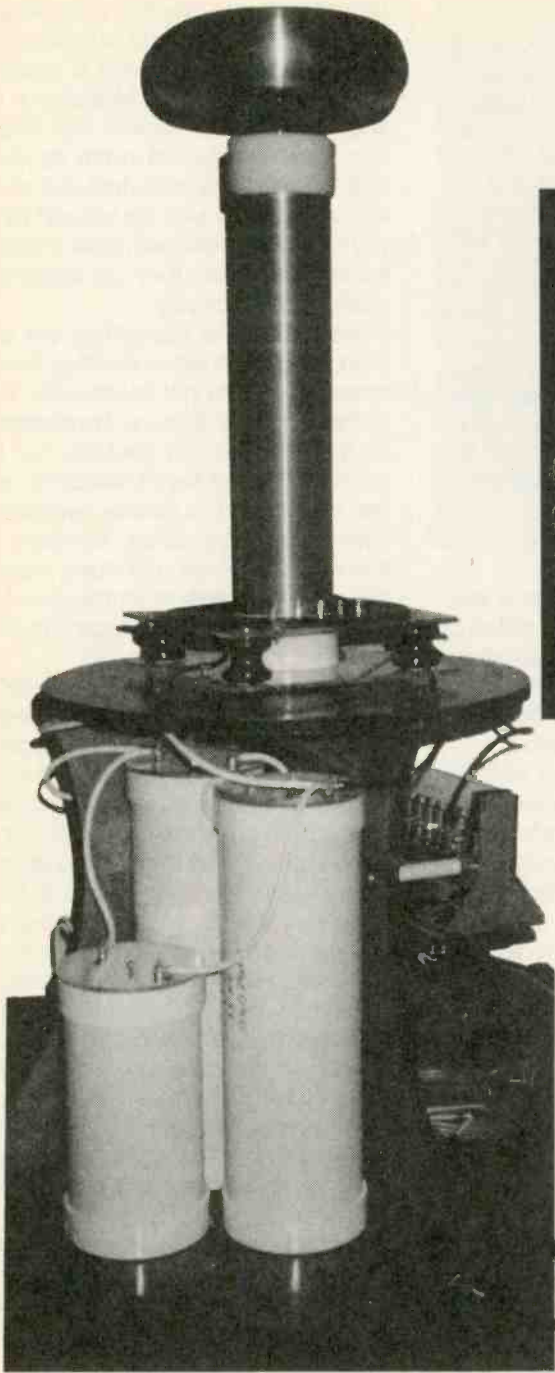
- Lines of force of an electrostatic field can be demonstrated by placing the electrodes (the high-voltage DC output and ground) in a tray covered with castor oil containing some farina. The farina will produce the pattern of the electric field lines; similar to iron filings shaken lightly on a piece of paper in the presence of a bar magnet.

- If you place two round door knobs on insulated stands made from plastic cups filled with candle wax, and then charge them, then a plastic ball suspended from a string will be drawn to and touch the positive electrode, and fall back to center when the spheres are discharged (see Fig. 16-a). A plastic ball coated with conductive lacquer swings toward the positive electrode like a pendulum; when the ball and doorknob touch, the ball becomes positively charged, so they repel one another. It then swings toward the negative side, absorbs electrons, becomes negatively charged, and is repelled back to the positive. The process repeats indefinitely as long as the high-voltage DC is present, and it will continue to operate for some time after it's shut off. The charge exchange is slow, and there'll be arcing at the positive electrode.

- A grounded metal ball alternates between both electrodes, like the conducting plastic ball. However, the arcs are smaller due to its greater weight, and should be observed at both ends, but more on the positive side.

- A light cotton ball should be drawn to the positive electrode and hang there by itself, as shown in Fig. 16-b. It's then repelled 0.5-inch toward the negative electrode, and the process should repeat indefinitely. ■

Build capacitors that  
really pack a punch  
for high voltage fun!



BY ANTHONY CHARLTON

# MAKE YOUR OWN HIGH- VOLTAGE CAPACITORS

**A**s one who supplies parts to those who experiment with high voltage, I get a lot of letters and phone calls from frustrated builders that go like: "Can you supply an inexpensive XXX microfarad capacitor at a working voltage of YYY? My only source wants \$249 for one." Sometimes, a high price is justified; other times, a seller has the only capacitors of a special value available, and will soak you for the maximum dollar.

It is feasible to build your own ca-

pacitors of any voltage and energy storage size for either AC or DC use. The process involves a step-by-step logical approach that we'll present here. We'll explain how to plan and construct a capacitor, where to get materials, safety considerations, tips and hints, and include a few simple projects.

**A Capacitor's Description.** A capacitor consists of two or more plates of a conductive material separated by an insulating substance called a

dielectric. A dielectric may be solid, gel, liquid, or gas. A capacitor's ability to store energy is measured in either microfarads ( $\mu\text{F}$ ), nanofarads (nF), or picofarads (pF). Micro means one millionth, nano stands for one billionth, and pico for one trillionth (farads are also used, but in high voltage work they are impractically large units). Several factors affect capacitance. The formula for determining capacitance is:

$$C = (0.224KA/d)(n-1)$$



where C is the capacitance in picofarads, K is a constant that depends on the insulator (or dielectric) between the plates (called the dielectric constant), A is the area of one conductive plate in square inches, d is the separation between adjacent plates in inches, and n is the number of plates. As you may know, different insulators have different dielectric constants. Table 1 shows the values of K for some common materials and the peak voltage they can withstand per  $\frac{1}{1000}$  inch (called a mil) of thickness. This rating is called the puncture or breakdown voltage.

**Dielectrics.** The better the insulating property of the dielectric, the higher its resistance, and the less dielectric leakage loss present. In low current, high voltage power supplies, minimizing all sources of loss is important to prevent undue power-supply loading. For that reason, plastics are by far the best materials for large capacitors. A serious project should involve one of the plastics.

Lexan, Polystyrene, and Plexiglas in particular are easy to glue, and can be cut with a table saw using a plastics blade, or a carborundum impregnated all-purpose cutting blade like *Zippity-Do* (which is cheaper). A sabre saw with a really coarse wood blade will also work (other blade types clog or chip). Such plastics may be drilled

**WARNING!!** This article deals with and involves subject matter and the use of materials and substances that may be hazardous to health and life. Do not attempt to implement or use the information contained herein unless you are experienced and skilled with respect to such subject matter, materials, and substances. Neither the publisher nor the author make any representations as for the completeness or the accuracy of the information contained herein and disclaim any liability for damages or injuries, whether caused by or arising from the lack of completeness, inaccuracies of the information, misinterpretations of the directions, misapplication of the information or otherwise.

with high quality steel drill bits or special plastic bits. They must be drilled at 300 RPM or slower to prevent chipping and melting, and be sure to leave the protective film or paper on the plastic when working with it.

Mylar, Polyethylene, Nylon, and especially Teflon are difficult to work with as they are very slippery. The best way to attach plates to any of those materials is to use a glue specifically designed for the material. Polyvinyl chloride (or just PVC) is moderately slippery. It can be glued with a PVC cement, or foil plates can be attached using silicone RTV.

Glass is, in principle, an even better

dielectric. It also has the advantage of being easy to glue to with Silicone RTV or *Krazy Glue*, and it is readily available and cheap. However, it is fragile, and may contain impurities that allow conductive paths for destructive arcs. Contradictorily, for your first capacitor or two, we suggest that you try a type made with glass to gain experience, since they go together easily and are cheap.

Many industrial capacitors are oil filled. Oil has an extremely high resistance, so it does not measurably increase leakage. Silicone transformer oil is the best liquid insulator, but is rather hard to obtain. Mineral oil, on the other hand, is readily available from most pharmacies. Although it has a low dielectric constant, it can be used in a variety of simple ways to make very good high voltage capacitors.

For example, a dandy variable DC capacitor can be made by immersing a junked AM-radio tuning capacitor of the movable-plate type in mineral oil so its shaft and connection leads come out of the container's top. If you wish to try this idea, make absolutely certain the "cold" plates of the capacitor (the moving plates) are at ground potential. Use a good, large, non-metal knob for adjustment. A 100- to 365-pF variable capacitor with a 1-kVDC breakdown voltage (*i.e.*, a plate spacing of 1 mm) becomes a 270- to 985-pF unit with 7500-VDC breakdown rating. Try pricing a 7500-volt variable capacitor sometime, and you'll see the advantage to this approach!

You can use mineral oil in designs of your own, too. Immersion of a home-made capacitor in mineral oil will greatly improve its voltage rating and lifetime.

Paper is an excellent dielectric when saturated with mineral oil. Try 20-lb. bond computer paper which has a 4 mil thickness. Prepare this inexpensive capacitor by interleaving layers of dry paper with aluminum foil, and then immerse the capacitor in oil until the paper gets saturated.

One disadvantage to using oil in home-made capacitors is that the tape or glue used to bond the assembly must be oil-resistant. Silicone RTV is the best glue for these purposes.

**Design Considerations.** There are

**TABLE 1—DIELECTRIC CONSTANTS AND BREAKDOWN VOLTAGES**

Insulator	Dielectric Constant	Puncture Voltage per 0.001 Inch	Notes
Air	1.0	30	1
Window glass	7.8	200	
Polyethylene	2.3	450	
Paper (bond)	3.0	200	
Polycarbonate (Lexan)	2.96	400	
Teflon	2.1	1000	
Polystyrene	2.6	500	
Epoxy circuit board	5.2	700	2, 3
Pyrex	4.8	335	
Plexiglas	2.8	450	
PVC (rigid type)	2.95	725	
Silicone RTV	3.6	550	
Polyethylene terphthalate (Mylar)	3.0	7500	
Nylon	3.2	407	4
Mineral Oil, Squibb	2.7	200	2, 5
Shellac	3.3	200	

**NOTES:** All measurements at 1 MHz unless otherwise noted.

<sup>1</sup>Tested with dry air.

<sup>2</sup>Tested at 300 HZ using a Heathkit IM-2320 Multimeter and homemade capacitor.

<sup>3</sup>Estimate, based no experiences.

<sup>4</sup>Lowest value of 3 types.

<sup>5</sup>Estimate. Probably higher. A 0.040" gap withstood over 10,000 volts DC before breakdown in one test.

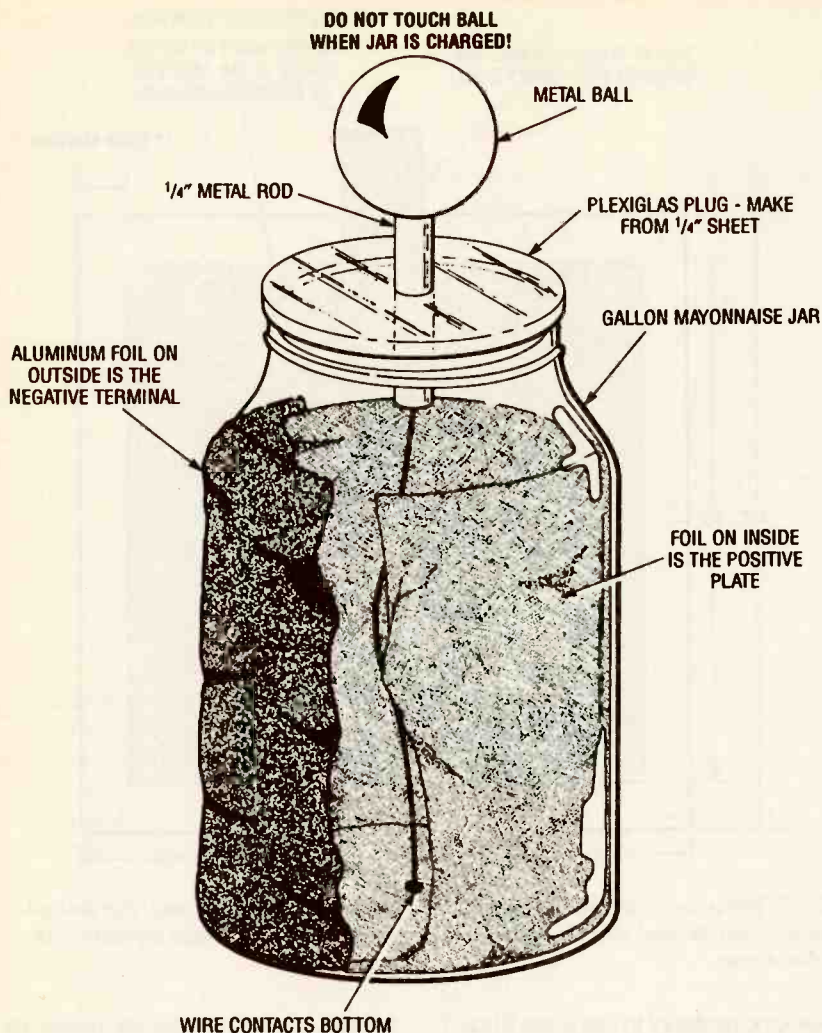


Fig. 1. The classic Leyden jar is the oldest storage capacitor we know of. They are easy to make and the materials only cost around \$2.

several things to consider when designing and constructing your own capacitor. Let's point out each one before moving to the construction details. The first and most important thing to concern yourself with is safety. Despite the romance of high voltage, it is foolish to needlessly risk your life. Since you will probably be working with lethal voltages, observance of all safety practices for high voltage (or HV) is **absolutely essential**. For some guidelines, see the boxed text entitled "High Voltage Safety."

The next aspect to consider is capacity. If you have a specific capacitance in mind, you can design a capacitor using the information provided elsewhere in this article. Try one of the designs described later. Or perhaps you prefer experimenting instead. Either way, when building for the first time, we suggest making small

designs first to get used to techniques and quirks before you invest lots of time and money.

You must also take into consideration the voltage that will be applied to the capacitor. That will affect your choice of a dielectric and thus its required thickness. Should you use an inadequate dielectric or thickness, sparks or arcs can result. A spark is a temporary breakdown that a lot of capacitors will survive, but an arc is serious: it is a path burned into the dielectric or other component. Arcs carbonize materials, producing a highly conductive channel that often renders an apparatus useless and very likely dangerous. Except in special cases where the insulator is a "self-healing" type (like air, oil, and some plastics), a single arc will ruin the capacitor.

To compensate for the impurities

### High Voltage Safety.

High voltage is considered any value over 500 volts AC or DC. When you attach a capacitor to high voltage, you are multiplying its hazard manyfold. Therefore, experimenters must take extra precautions to avoid painful shocks and possible electrocution. Here are a few guidelines to follow when working with high voltage:

- Label your project in several locations with: "Danger, High Voltage" where appropriate. Such a warning label is provided here for you to copy (see Fig. A). Keep children, pets, and curiosity seekers away from the apparatus. Cover all bare leads, wires, connection terminals, and possible points of contact with high voltage putty or a cover fabricated from thick clear plastic.

- Work in a dry location. Working in a damp basement or workshop courts disaster. Wear rubber-soled boots or sneakers. Stand on a thick rubber mat.



Fig. A. Curiosity can hurt more than just felines, so use this warning label on all your high voltage projects to protect the unwary from harm.

- Never put your body in a position to become a conductor. Locate your apparatus away from appliances, metal doors and windows frames, heating ducts, vents, radiators, sinks, or water pipes. All these items can become a deadly ground if your body comes between them and high voltage.

- Always pull the plug when working on a high voltage circuit unless you must test it. When testing a live circuit, use utmost caution. Keep one hand in your pocket. Use clip-on test leads that are rated twice the voltage of the live circuit. Use a high voltage probe whenever possible—its insulating handle will help protect you.

- Use NE-2 neon lamps to indicate live or stored high voltage. Bleed off the charge on capacitors with a power resistor before performing adjustments.

- Adequate ventilation must be provided for circuits that produce large amounts of ozone such as Jacob's ladders or Tesla coils.

that often appear in materials that are not highly refined for capacitor use, we must add a safety margin to the thickness of the dielectric. In the



case of DC, a good rule of thumb is a 50% margin. For example, say you need a 500-volt DC capacitor using polystyrene. Consulting Table 1, note polystyrene's breakdown is 500 volts per mil, thus 1 mil is required. Adding 50% gives you 1.5 mils, which is adequate for pure DC. You can always use a thicker dielectric if it's expedient, providing that you adjust the number of plates or their size to accommodate the wider plate separation. It should be mentioned that when making a paper capacitor, you should use a healthy safety margin since paper is not always uniform in thickness.

In comparison to AC, DC puts relatively little stress on a capacitor. By contrast, AC reverses the dielectrics' polarity every cycle. So the dielectric in an AC capacitor must have twice the thickness required in an equivalent DC capacitor. Further, when considering dielectrics in AC applications, you must deal with the *peak voltage*—not rms (*Root Mean Square*) voltage—that they will be exposed to. If you wish to convert an rms voltage to its equivalent peak sinewave value, multiply it by 1.414.

So, to roughly calculate the proper voltage rating needed for an AC capacitor, you first double its required rms voltage rating then multiply by 1.414. To further simplify this calculation, all one needs to do is multiply the AC (rms) voltage in question by 2.828. Now divide the voltage by the puncture-voltage rating to get a preliminary thickness value. Finally, you must add a safety margin of 50% to 100%. The actual percentage depends on the characteristics of the applied AC voltage. For a pure sinewave AC, we suggest a 50% safety margin whereas high frequency, non-sinusoidal applications such as Tesla coils require a full 100% extra thickness.

If one is available, equip an oscilloscope with a high voltage probe to visually observe exactly what the circuit is doing so you can determine the proper safety margin. An oscilloscope will also enable you to detect destructive voltage spikes and superimposed AC (also called AC ripple) so you can design a capacitor to handle those harmful excursions.

Of course physical size, weight, and fragility are also important characteristics of capacitor design. If you have size limitations, Mylar is the best

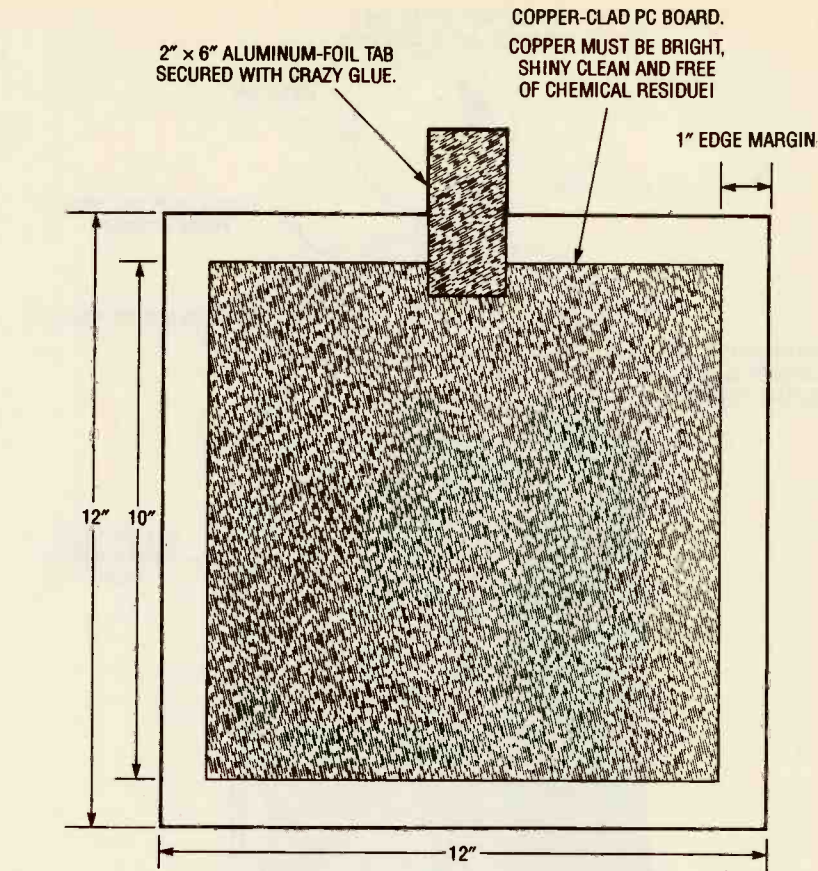


Fig. 2. For a single-section capacitor, use one double-sided PC board. For multiple sections, use several single-sided boards clamped together or bolted together with nylon screws.

dielectric material to use since it has a very high puncture voltage per mil, and thus makes a very compact capacitor. Plastics are light, so most capacitors will weigh less than ten pounds. The toughest plastic is Lexan, which is difficult to crack even with a hammer and is often used for vandal-proof windows. Glass is the worst material for a lightweight, durable capacitor, and can even crack under its own weight when lifted. Take all this into account when selecting your materials.

Of course, the overall cost in labor and materials should also be considered before constructing a capacitor. Calculate beforehand the cost of your materials. Paper and polyethylene are the cheapest. Glass is the next higher price. Labor time is about the same with Plexiglas, Lexan, and glass sheet capacitors. Exotic plastics such as Teflon are not needed unless your application demands extreme chemical and thermal deterioration resistance. Polyethylene has excellent chemical resistance, but

breaks down gradually upon exposure to ozone gas (always present around high voltage) becoming brittle and less resistant to arc puncture.

That brings us to another important consideration: the capacitor's useful life. To enhance a capacitor's life keep the working voltage at or below the rated specification in both DC and AC applications. We discovered that charging at no more than 70% of a capacitor's working voltage resulted in an amazing 10-fold increase in lifetime for one type of commercial capacitor. Also, for DC capacitors, watch out for voltage reversals. If your system has a lot of inductance, reverse voltage swings are always produced. Increase the safety margin if a lot of inductance is in the circuit. Furthermore, the temperature should be kept below 120°F. As mentioned earlier, watch out for superimposed AC, voltage spikes, and ringing. These types of AC waves can drastically shorten lifetime. Tesla coils have notorious ringing. To repeat: if feasible, use an oscilloscope to visually analyze

your circuit. Often a power resistor inserted in the current path to the capacitor quenches ringing. With this criteria under our belts, let's look at some problems your design and construction methods should prevent.

**Signs of Trouble.** Your assembly techniques should seek to minimize the likelihood of a few possible problems. Luckily, all of them can be prevented at least in part by using ample amounts of insulating material such as No-arc or Corona Dope and/or high voltage putty on all exposed areas. A plastic case to enclose the apparatus is also recommended (more on that later).

Still and all, you should know what problems the insulation is preventing. The first problem insulation relieves is the possibility of electrical shock.

Insulation also minimizes the production of ozone—a gas created when high voltage causes three oxygen atoms to join together. Ozone has a tart, sweet “electrical” smell, and is 100 times as poisonous as carbon monoxide. Beware: it quickly causes headache, nausea, vomiting, and respiratory irritation. In addition to insulating all the exposed HV areas, you should also operate your equipment with good ventilation if it produces any ozone.

Closely linked to ozone generation is corona leakage. It is produced by a charge being leached off a highly charged object by the air. That typically produces ozone. However, sometimes a device (such as a Van deGraff generator) is constructed specifically to display corona discharge, and insulating it would defeat that purpose. In such cases, good ventilation is the only practical means of hazard prevention.

Ozone can also be created by arcing, which can occur anywhere. However, ozone production is not the greatest hazard arcing presents. At 50 kV, a spark can arc between an un-insulated contact and your body if you come within 2 inches of the contact. Arcing commonly takes two forms: directly through a capacitor's dielectric (as mentioned earlier), or across the edges of a capacitor's plates to an adjacent plate. A snapping sound indicates the presence of arcing, so keep your ears open.

Arcing from the edges of a capaci-

tor plate, or anywhere the shape of a conductor changes abruptly (such as the tip of a nail) is called point discharge. It can be readily observed in a dark room at very high voltages. Small, bright blue pinpoint(s) are seen leaking electrons into the air, accompanied by a hissing sound and copious ozone production.

Once again, insulation and proper ventilation are the proper solutions to all these problems, and there are some specialized techniques to insulate your capacitors and otherwise improve the safety of your high voltage projects. Let's get to those now.

**Construction Requirements.** A key ingredient in a good assembly is a proper case. Your capacitor's housing must protect it against moisture, dirt, and accidental discharge. Plastic cases for dry capacitors are easy to make with acrylic sheets glued at all corners with Silicone RTV. Oil-proof cases can be made for immersed models, but you will need to rough-up the plastic at the sealing edges with sandpaper and use both a bonding and second fillet glue coating for a liquid-proof seal. Metal cases can be made from PC boards cut on a shear or large paper cutter and soldered at the edges. Copper roof flashing (available at hardware stores) works well too. However when using metal, always beware of contamination by solder rosin, solder bits, and other crud, which can short out plates or otherwise reduce efficiency.

Whether a capacitor is enclosed or exposed, discharge paths must be wide enough to avoid arcs to the case, adjacent plates, terminals, connections, or components. That is especially important in situations where conductors must be left uninsulated. Note that the space from each plate to the edge of the dielectric must be wide enough to stop any spark from “crawling” over the edge of one plate to another.

Power leads must be capable of withstanding the full voltage of the charge plus at least a 50% safety margin. TV anode wire, which comes rated up to 40-kVDC, makes great leads. Vinyl tubing or aquarium air hose may be slipped over leads to increase their voltage rating.

Make sure the plates are securely mounted or they will tend to shift, or make a noisy rattle when used with AC. Glue or compress the assembly to hold it secure. With regard to mounting, keep in mind that glues that dry by evaporation of a volatile chemical might not set properly if “buried” inside an assembly away from air, and could thus become a fire hazard.

Rolled-up capacitors may be held securely by wrapping the interleaving layers of foil and insulator tight around an insulating mandrel and then taping with a clear PVC tape. Where necessary, coat the ends with Silicone RTV. That will eliminate end-arcing flash-over and corona loss. Alternatively, although it is somewhat brittle, paraffin (with a puncture voltage of 250 volts/

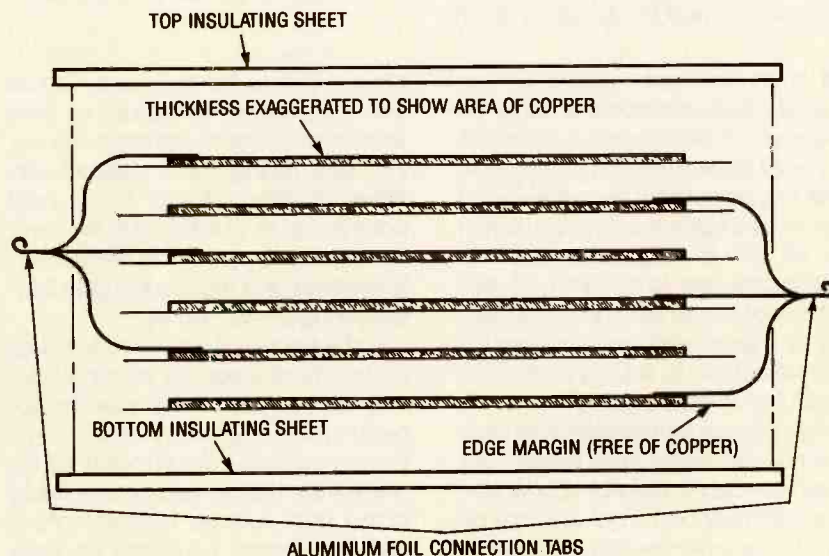


Fig. 3. With this design, you may stack as many plates as you wish, provided there are an equal number of plates attached to each lead.



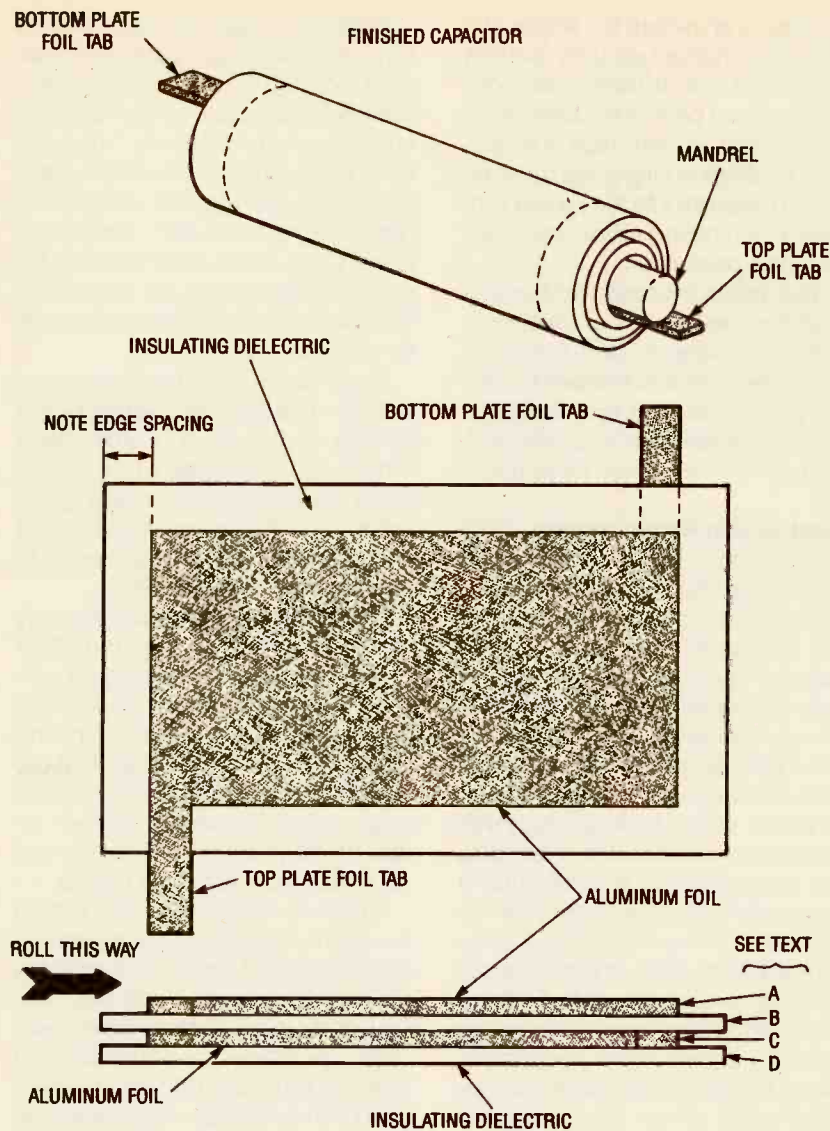


Fig. 4. A rolled-up capacitor, like that shown here, can provide the greatest capacitance in the smallest space. Note that the dimensions in the side view have been greatly exaggerated for the sake of clarity.

mil) is an excellent insulator for the ends of rolled-up capacitors and the edges of flat-plate type capacitors. If you want to use melted paraffin wax, heat the wax only in a double-boiler pan, since if it gets too hot it can catch fire. Be sure to apply several coats, allowing the wax to harden between each coat. Liquid electrical tape also makes a great end seal, however it is somewhat hard to find. Try mail-order distributors for that product.

High voltage terminals for your projects can be made from plastic rods drilled through to accept connection wires. You may add a nut and bolt on top for convenience. However, beyond about 3,000 VDC this method suffers from point discharge. Metal

balls make good terminals. Clean them up with a wire brush or steel wool to eliminate rough spots. The author uses fishing floats covered with either aluminum foil or nickel print paint for up to 10 kVDC. Split the bobbin first with a razor blade, remove the line holder and spring, and glue it together again with epoxy.

Furthermore, as you work, keep all materials as clean as possible. Not only will your work have a better appearance, but arcs and burn-throughs due to contaminants will be prevented. High voltage easily tracks along dust, surface contamination, and even finger oil (which contains salt). Also, we shall refer to a "section" as consisting of two conductive plates

with an insulating dielectric between them.

By now, we hope you have a good understanding of the principles and techniques involved in making your own capacitors. Without forgetting safety, let's talk about how to build some simple capacitors, any of which can be modified for your application.

**A Leyden Jar Capacitor.** Leyden Jars are one of the first types of capacitors made, having been invented nearly two and a half centuries ago. Their development was first recorded in 1745 by Ewald von Kliest. In 1746, Peter van Musschenbroeck of Leyden, Holland experimented further with the invention. We can build our own modernized units with a gallon-size wide-mouthed mayonnaise jar. The project only costs about \$2, and is good to at least 10 kVDC at 2.5 nF. Units we've tested at 15 kVDC did not fail; at that voltage, the capacitors stored just under  $\frac{1}{3}$  joule each.

First select a jar without bubbles, cracks, or blemishes and that has a mouth large enough to comfortably slip your hand through. Next, carefully clean it out. You'll use aluminum foil inside and out as the conductive plates (see Fig. 1). Cut a foil disk 1-inch bigger than the bottom of the jar. Now coat the dull side of the foil and inside jar bottom with a thin, even layer of rubber cement. Let both dry for 10 minutes, and press together. Smooth with firm hand pressure. Avoid excess wrinkles. Do the rest of the inside except the top inch of the bottle using three or four pieces of foil. (It is easiest to do the plate in pieces instead of all at once, since rubber cement "grabs" and it is difficult to reposition the foil once contact has been made.) Now do the outside foil plate in pieces, leaving the top inch bare. Check the foils with a continuity tester to determine if the pieces are in good electrical contact. Areas of foil not in contact can be bridged with strips of foil or nickel-print paint.

For the top cover, cut two disks of clear plastic, one slightly smaller than the rim, the other  $\frac{1}{4}$ -inch larger than the rim. Glue the two pieces together to form a plug. Drill a  $\frac{1}{4}$ -inch hole through the plug's center. Cut and insert a length of  $\frac{1}{4}$ -inch (outer diameter) metal rod or tubing through this hole. Attach a ball to its top, and sol-

der a wire or small-link chain to its bottom. The wire must make good electrical contact with the foil. Let the assembly dry for a day with the cover off, to allow vapors from the rubber cement to dissipate, then cement the cover on with silicone or *Krazy Glue*.

**PC-Board Capacitor.** Some nifty low inductance capacitors can be made from pieces of copper-clad epoxy circuit board (see Fig. 2). For a simple two-plate capacitor, you can use one double-sided sheet. For multiple sections, use single-sided board.

To prepare each board, start by etching away a 1-inch strip from around all its edges. That process can be simplified by first masking off the strip, spraying the bare copper with an etch-resistant paint, removing the masking tape, and then etching.

Clean the board after etching, and rinse with de-ionized or distilled water. Thoroughly air-dry the sections, or use a blow dryer. Attach strips of aluminum foil to each plate.

If you are building a multiple-section capacitor, connect the aluminum foil strips together as shown in Fig. 3 and secure them using glue or nylon bolts at each corner. Spray the finished assembly with several coats of an insulating product, or paraffin.

If you use the dimensions shown in Fig. 2 and a 0.060-inch gap between plates, you can achieve a capacitance of 1.94 nF (1940 pF) per section. When deciding on the gap width to use, keep in mind that the greater the space between successive plates the lower the chance of arcing. For example, a 1-inch spacing gives you a 30% larger gap than a 20-kV spark can jump. Insulation will further improve that margin.

**The Stacked Sheet Design.** This type is virtually identical to our PC board capacitor, but it can be designed to handle considerably more voltage. You simply substitute sheet plastic or glass dielectrics, and glue aluminum foil in place of the copper for each section (refer to the PC board capacitor drawing in Fig. 3 as needed). All in all, it's an easier design to build, as it does not involve the effort of etching copper, and you can continue to add sections to your original prototype to increase its capacity as future demands require.

## Sources

All types of plastics: United States Plastics Corporation, 1390 Neubrecht Lane, Lima, OH, 45801; Tel. 800-537-9724. Company changes for catalog and requires a minimum-amount order. Write or call for details.

High voltage rectifiers and meters: MCM Electronics, 858 E. Congress Park Dr., Centerville, OH 45459-4072; Tel. 513-434-0031. Free catalog.

Sheet and formed metals, plastics, and precision tools: Small Parts, Inc., PO Box 381966, Miami, FL 33238-9980; Tel. 305-751-0856. Free catalog.

Information, technical assistance, high voltage parts, and kits: Allegro Electronic Systems, 3 Mine Mountain Road, Cornwall Bridge, CT 06754; Tel. 203-672-0123 (9 AM-12 noon EST weekdays). Free catalog.

When building a large capacitor of this type, we suggest that you use nylon bolts at the corners to hold it all together. The bolt holes should be pre-drilled before assembly, and all chips cleared away. Make sure the plate-to-edge spacing is adequate for the voltage you will subject the capacitor to. Add extra spacing if you intend to use bolts at the edges.

Glue foil carefully to the top of the first plate using a small amount of spray adhesive, *Krazy Glue* or RTV silicone. Press it smooth and let it dry. A photographic finishing roller is handy for flattening foil. Repeat the procedure for the second sheet, orienting the foil connection tab in the opposite direction. Keep the plates and dielectrics aligned as assembly proceeds. Repeat this procedure for as many sections as you want. Always keep the final number of plus and minus plates equal.

Put an insulating sheet above and below the last plate and secure the assembly with nylon bolts. Do not over tighten or the center of the assembly will "bow." Finally, clean the ends with a very small amount of isopropyl (rubbing) alcohol and wipe dry. Smear a coating of silicone RTV over all the edges.

**Roll-Up Design.** The kind of capacitor depicted in Fig. 4 can provide large capacitance in a small size. They are a little trickier to make than stacked-section type capacitors, so you might want to try a few small pro-

totypes first. The design uses a layered approach (as shown), and we suggest using only one section as it is difficult to align and wrap multiple sections. By contrast, a single section several feet long is not too unwieldy.

Aluminum foil works great in these capacitors. You'll find the oven/broiler type, which is heavy-duty foil, far easier to work with than the plain variety. Polyethylene and Mylar are the most common dielectrics, but you can experiment with other materials.

Looking at the figure, note the orientation and shape of the foil plates (A) and (C). They can be easily secured to the dielectric (B) using double-sided Scotch tape. Note also the edge spacing. An outer covering of dielectric (D) will prevent the finished capacitor from having a "hot" case, which might be a hazard. With those points in mind, lay the foil out on a smooth sheet of paper, which in turn should be laid out on a smooth, hard surface to prevent wrinkling. Carefully assemble the four layers as shown in the drawing. Strive to make them flat and smooth.

Wrap the capacitor "sandwich" around a non-conductive mandrel or spool—ideally made of plastic or glass rod (be careful not to break a glass rod). Try to make the roll straight and free of lumps and wrinkles. When it's all rolled up, secure it with plenty of tape. The author uses clear package-sealing tape for this. Now secure the positive foil tab (assuming it's going to be for DC) to the mandrel using tape. Finally, coat the exposed ends with an insulating product like silicone RTV.

The remaining foil connection tab may be reinforced by rolling it around a small metal dowel. A nail, or a cut-off piece of 1/8-inch uncoated brazing rod is suggested. Apply glue to hold the assembly together.

Foil tabs can be strengthened by adding "ribs" of adhesive from a hot glue gun. Similarly, the tabs can be made tear-resistant by applying hot glue where they enter the capacitor.

Note most problems with this design come from particle contaminants that stretch a dielectric thin in spots where they are trapped by the tightly rolled dielectric. Another trouble is inadequate edge spacing, causing arcing across the ends. Careful planning and assembly will eliminate both headaches. ■



# An Electrical-System Analyzer for your car

In these times of rising costs and diminishing *real* income, every driver knows how very costly vehicle maintenance can be, even for relatively minor repairs. For most problems, a driver has no alternative but to take the vehicle to a service technician. Sooner or later all vehicles require repairs to the battery and charging system, and if the problem is not diagnosed properly, you could spend a fortune replacing perfectly good parts. But there is one area—the vehicle's battery and starting and charging systems—that can be monitored and diagnosed for possible problems using a simple electronic circuit.

Although modern automotive batteries and their charging systems can be somewhat complex, diagnosing them is relatively simple. And diagnosing electrical-system problems is just what the *Automotive Electrical Diagnostic System* described in this article is designed to do.

**Some Background.** The Automotive Electrical Diagnostic System monitors the battery's terminal voltage to determine the condition of the vehicle's electrical system under various operating conditions—including standing idle prior to starting, cranking, idling, and running with various electrical accessories in operation. It keeps tabs on your vehicle's battery, alternator, regulator, and cranking voltage through a set of 5 LED's.

Under normal conditions, a green LED lights and remains lit as long as the battery voltage is normal prior to starting the engine. The other 4 LED's light only when a malfunction occurs. The circuit is powered from the vehicle's electrical system, so it does not require a separate power source. It can be permanently installed in the vehicle (to continuously monitor electrical system status) or assembled as a portable unit and connected to any vehicle with a 12-volt electrical system.

All vehicles that use a 12.6-volt lead-acid battery as the power source will fall within certain voltage constraints as the vehicle is operated. For example, a battery in good condition will

faults when any of the voltages levels falls outside of the acceptable limits.

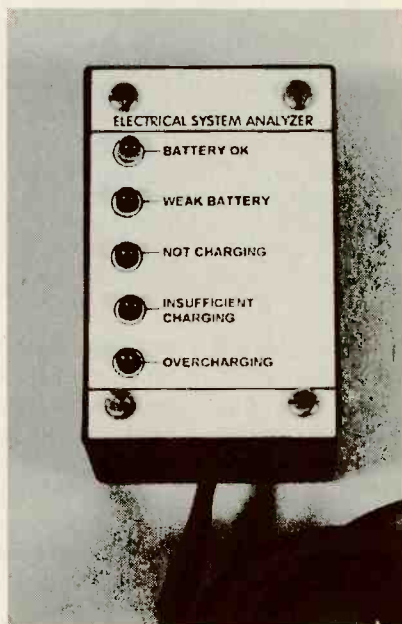
**Circuit Operation.** At the heart of the Automotive Electrical Diagnostic System (see Fig. 1) is the Maxim MAX8214ACPE five-stage voltage comparator, U1, which also contains a built-in 1.25-volt precision reference. The chip also has an on-board logic circuit that allows the outputs of two of the comparators to be inverted by tying the mode-select input (MS, at pin 15) high (more on that later).

In the Automotive Electrical Diagnostic System, the non-inverting inputs of all of the comparators are tied to U2's internal 1.25-volt reference, while the MS input is tied high, causing the outputs of comparators U1-a and U1-b to be inverted. When any comparator output is driven low, its associated LED lights.

Resistors R1-R6 form a voltage-divider network that provides specific voltage levels at five junctions, each of which feeds the positive input of one of U1's five comparators; thus each comparator receives a known percentage of the input (battery) voltage. Since each of the five comparator circuits are similar, an explanation of one such circuit will cover all. Take U1-e (the NOT CHARGING MONITOR), for example.

When the engine is at rest, the battery voltage is 12.8 volts or more, so the voltage at the R3/R4 junction exceeds the 1.25-volt reference, causing the output of U1-e to go high, holding LED3 off and indicating that the charging system is delivering current into the battery at engine idle. Even if the battery voltage rises above 12.8 volts (which is normal during engine operation), the output of U1-e at pin 10 remains high, keeping LED3 off. But should the charging system fail, battery's terminal voltage will dip below 12.8 volts, causing LED3 to light, alerting the driver to the condition.

Comparators U1-c and U1-d operate in a similar manner, lighting their LED's if the battery voltage falls below 9.0 and 13.4 volts, respectively, indicating WEAK BATTERY (insufficient cranking voltage) or INSUFFICIENT CHARGING (defective alternator operation).



*Build an electrical system monitor that can alert you to any one of several problems so that you can avoid the inconvenience and expense of a road-service call.*

BY ANTHONY J. CARISTI

have a terminal voltage of about 12.6 volts when the engine has not been in operation for some time. During cranking, battery voltage should not fall below 9 volts.

When the engine is operating, the voltage regulator should hold the terminal voltage between 13.5 and 15.0 volts. When all accessories are on, the alternator should be able to maintain at least 13.5 volts across the battery at about 1500 or 2000 engine RPM. Table 1 illustrates normal battery-terminal voltages under various operating conditions and specifies possible

**TABLE 1—AUTOMOTIVE ELECTRICAL FAULTS**

Condition	Normal Voltage	Possible Fault
Vehicle at rest	12.6 volts	<12.4 volts: bad cell or severely undercharged battery
Cranking	>9 volts	<9 volts: Weak battery
Idling	>12.8 volts	<12.8 volts: Not charging; bad alternator or wiring
Running minimum load	>13.4 volts	<13.4 volts: defective alternator or voltage regulator
Running minimum load	<15.2 volts	>15.2 volts: Overcharging; defective regulator
Running maximum load	>13.4 volts	<13.4 volts: alternator defective or belt slipping

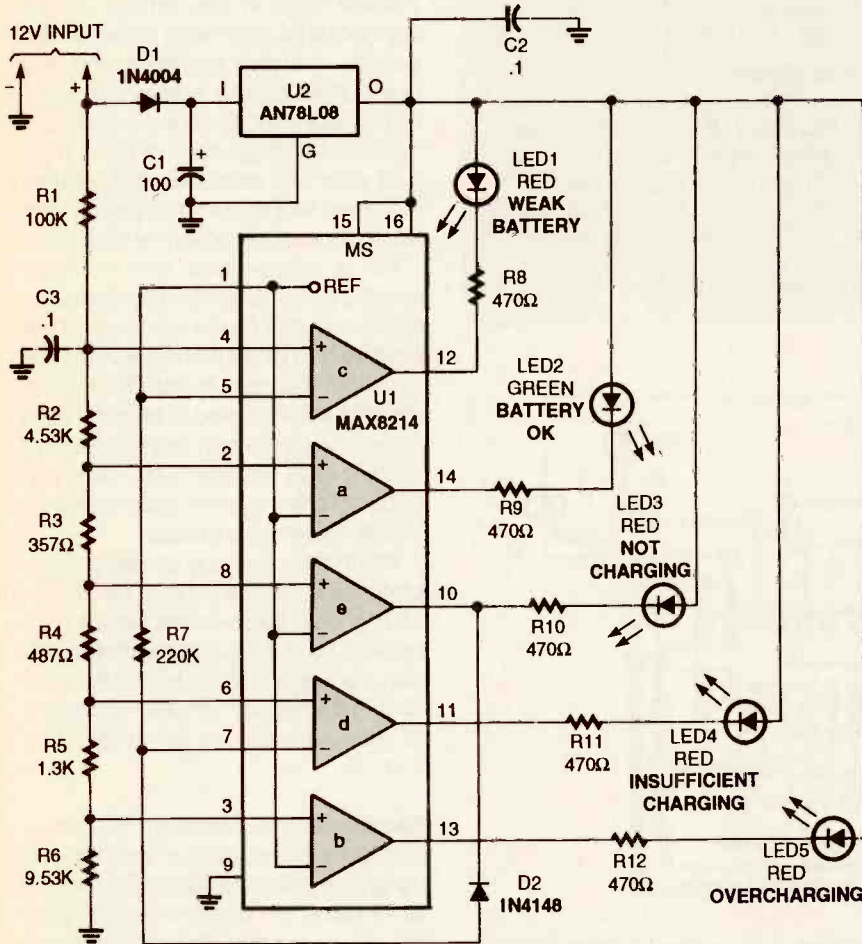


Fig. 1. The Automotive Electrical Diagnostic System is built around a Maxim MAX8214ACPE five-stage voltage comparator, which contains a built-in 1.25-volt precision reference, and on-board logic that allows the outputs of two of the comparators to be inverted.

Comparators U1-a and U1-b have to sense voltage levels higher than 12.4 and 15.2 volts, respectively to light their LED's. To accomplish that, the mode-select input of U1 is connected to  $V_{CC}$ , thereby inverting the outputs of those two comparators, and causing their respective LED's to light when the battery voltage rises above 12.8 volts prior to starting (a normal condition), and above 15.2 volts (OVERCHARGING).

In order to prevent ambiguity between a NOT CHARGING and INSUFFICIENT CHARGING situation, which would cause two normally off LED's to simultaneously light, R7 and D2 are placed into the circuit. A low output from U1-e (NOT CHARGING) pulls down the reference input of U1-d (INSUFFICIENT CHARGING) to prevent LED4 from lighting. Thus, when the vehicle charging system is not working at all, LED3 (NOT CHARGING)

will light and LED4 (INSUFFICIENT CHARGING) will not.

Integrated circuit U2, a fixed 8-volt voltage regulator, maintains a constant supply voltage for U1. Diode D1 has been placed in the circuit to prevent component damage in case the lead polarity is accidentally reversed when connecting the Automotive Electrical Diagnostic System to the vehicle's electrical system.

**Construction.** Although circuit wiring is not critical, and could have been done on perfboard, the author's prototype was assembled on a small printed-circuit board measuring about 2 by 2½ inches. A template of that printed-circuit pattern is shown in Fig. 2. A printed-circuit board is available from the source specified in the Parts List.

A parts-placement diagram for the printed-circuit board is shown in Fig. 3. Regardless of which method of construction you choose, it is strongly recommended that you use a socket for U1. That makes testing and troubleshooting the circuit easier should it ever be necessary.

When installing the parts, be very careful to properly orient the polarized components. Just one component inadvertently installed backwards will prevent the circuit from operating and may cause damage to itself and/or other components. So, as always, double-check the position of the parts before soldering them in place.

When connecting the LED's to the circuit board, use flexible insulated

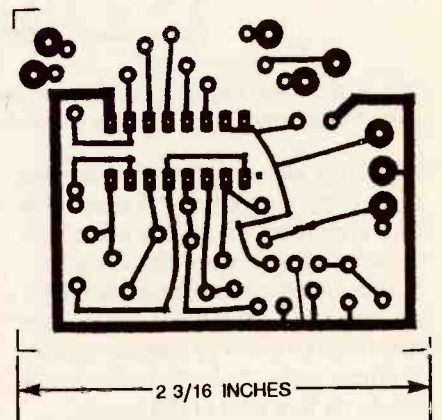


Fig. 2. The project was assembled on a small printed-circuit board measuring about 2 by 2½ inches. A printed-circuit board is available from the source specified in the Parts List.



## PARTS LIST FOR THE AUTOMOTIVE ELECTRICAL DIAGNOSTIC SYSTEM

### SEMICONDUCTORS

- U1—MAX8214ACPE voltage-comparator, integrated circuit (Maxim)  
 U2—AN78L08 8-volt, 100-mA voltage regulator, integrated circuit  
 D1—1N4004 1-amp 400-PIV silicon rectifier diode  
 D2—1N4148 general-purpose silicon diode  
 LED1, LED3—LED5—Red light-emitting diode  
 LED2—Green light-emitting diode

### RESISTORS

- (All resistors are 1/4-watt, 1%, metal-film units, unless otherwise noted.)  
 R1—100,000-ohm  
 R2—4530-ohm  
 R3—357-ohm  
 R4—487-ohm  
 R5—1300-ohm  
 R6—9530-ohm

- R7—220,000-ohm, 1/4-watt, 5%, carbon  
 R8—R12—470-ohm, 1/4-watt, 5%, carbon

### CAPACITORS

- C1—100- $\mu$ F, 25-WVDC, radial-lead electrolytic  
 C2, C3—0.1- $\mu$ F, ceramic-disc

### ADDITIONAL PARTS AND MATERIALS

- Printed-circuit materials, IC socket, enclosure, test leads, alligator clips, solder, hardware, etc.

**Note:** The following parts are available from A. Caristi, 69 White Pond Road, Waldwick, N.J. 07463: printed-circuit board, \$11.95; a set of 6 metal-film resistors, \$4.50; U1, 12.50; U2, \$2.50. Please add \$3.00 postage/handling. New Jersey residents please add appropriate sales tax.

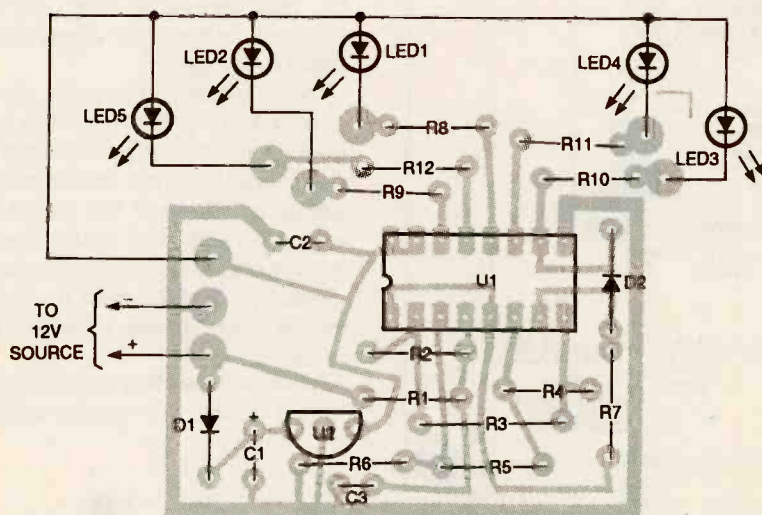


Fig. 3. Assemble your printed-circuit board according to this parts-placement diagram. It is strongly recommended that a socket be provided for U1.

wire; solid wire is not recommended since it has a tendency to break. It is also important to use 1% metal-film resistors where specified. The accuracy of the circuit depends on the 1% tolerance of those resistors. The tolerance of ordinary carbon resistors is simply not sufficiently accurate or stable for that part of the circuit.

The circuit board can be housed in almost any a small plastic or metal enclosure. If you house the circuit in a metal enclosure, be sure that no part of the wiring touches any metal sur-

face, and use a rubber grommet where the input leads of the instrument pass through the enclosure. The LED's should be mounted to the front panel of the enclosure and each should be labeled to indicate its meaning. Use a green LED for LED2 (BATTERY OK) and a red unit for all others.

If you wish to permanently install the project into a vehicle, connect the negative input wire to any metal part of the chassis. It is best to connect the positive input lead directly to one of the wires of the ignition switch, which is

powered only when the ignition is turned on. That avoids unnecessary battery drain when the vehicle is not in use.

**Note:** To maintain the Automotive Electrical Diagnostic System's accuracy, it is not recommended that the positive lead of the circuit be connected to any part of the vehicle's electrical system in which a significant voltage drop from the battery positive terminal occurs, especially with accessories turned on. To measure the voltage drop in the vehicle wiring, connect a DC voltmeter between the positive battery terminal and the point at which the Automotive Electrical Diagnostic System is to be connected. A voltage drop of more than 0.05 volts with accessories operating indicates that some other point in the wiring should be chosen for the circuit.

For a stand-alone unit connect lengths of 18- or 20-gauge flexible or test-lead wire (color-coded red for positive and black for negative) to the circuit for the input leads. Those wires should be terminated in alligator clips large enough to grip the terminals of the vehicle's battery. Such clips are available from most auto-parts or electronics-supply outlets.

When the assembly phase is complete, examine the project very carefully for cold solder joints (which may appear as dull or rough blobs of solder). Also, examine the board for short circuits, especially between adjacent IC pins. Correct any errors that you find.

**Checkout.** It is important to bench test the project before installing or using it on a vehicle. To test the project you'll need an well-filtered variable, DC power supply with an adjustment range of at least 8 to 16 volts, and an accurate DC voltmeter. Connect the voltmeter and project input leads to the output of the power supply, while observing the proper polarity of both sets of wires.

Start with the supply set to its minimum voltage and slowly raise the output until it reaches 8 volts. At that point, both LED1 and LED3 (WEAK BATTERY and NOT CHARGING) should light. The project's display is indicating that the battery voltage is below 9 volts, and also that there is no charging current. Note further that LED2 (BATTERY OK) is ex-

(Continued on page 106)



# Build a Telephone Scrambler

*Keep your privileged conversations completely private with this audio-scrambling circuit.*

BY TERRY J. WEEDER

**H**ow private are your private telephone conversations? If you are like most people, you take for granted that conversations held over the telephone are strictly between you and the person on the other end. It is a very uneasy feeling to find out later that someone has been listening in.

Well worry no more, for the *Telephone Scrambler* described in this article is designed to dispose of that problem. The Telephone Scrambler, which connects between your telephone and wall jack and does not require modifications to your telephone, is designed to scramble your voice before sending it over the telephone line. Anyone picking up an extension or monitoring your conversation with a telephone-line transmitter will hear nothing more than garbled sound. Only the party at the other end of the telephone line, using another Telephone Scrambler, will be able to understand what you are saying.

**Theory.** There are many different ways to scramble audio signals that contain speech so as to render the speech unintelligible. The difficult part of making speech unintelligible lies in doing so in a manner that allows it to be restored to its original form. The Telephone Scrambler accomplishes

that task by shifting all high frequencies to low frequencies, and all low frequencies to high frequencies.

The exact amount of frequency shift is determined by the distance in Hz that the original signal is from the center frequency of 1790 Hz. For example, the parts of your speech pattern that lie at 2290 Hz (500 Hz above the center frequency) will be shifted to 1290 Hz (500 Hz below the center frequency), and vice versa, the parts of your speech that lies, at say, 2790 Hz (1000 Hz above the center frequency) will be shifted to 790 Hz (1000 Hz below the center frequency), and vice versa. The result is a garbled audio signal sounding similar to that of listening to an SSB-modulated carrier with an AM receiver.

The process of restoring the audio to its original form can be accomplished in the same way. Simply perform the task of frequency shifting on the scrambled audio for a second time, and all the products in the speech pattern will be shifted back to their original frequency. (The process is analogous to double-inverting a signal in a digital system.)

**About the Circuit.** Figure 1 shows a functional block diagram of the Telephone Scrambler. The circuit is comprised of two hybrid networks, two low-pass filters, two balanced modulators,

an oscillator, a divide-by-1000 counter, and two buffer stages. The circuit's operation is really quite simple. The oscillator provides a 3.58-MHz signal that is down-converted by the divider to provide a 3.58 kHz signal, which is then fed through the buffer to one of the modulators. While that's going on, speech is applied to the hybrid network, which transfers the signal to the balanced modulator, where the two signals are mixed (to produce scrambled audio), and then output to the telephone line through a low-pass filter.

A schematic diagram of the actual circuit is shown in Fig. 2. The circuit is powered from a 13-volt AC wall transformer, the output of which is converted to DC by a fullwave bridge rectifier (BR1) and regulated by a pair of Zener diodes (D1 and D2) to form a dual ( $\pm$ ) 6.2-volt supply. Power for the relay (K1) is tapped from the output of BR1 (prior to regulation) so as not to put an unnecessary strain on the regulated 6.2-volt source.

Initially, relay K1 is de-energized, so the circuit is bypassed through K1's normally closed contacts, allowing the telephone to operate in the normal manner. A PS2505-1NEC optoisolator/coupler (U6) is used to monitor current flow through the telephone and provides base bias current for Q1 only when the telephone is



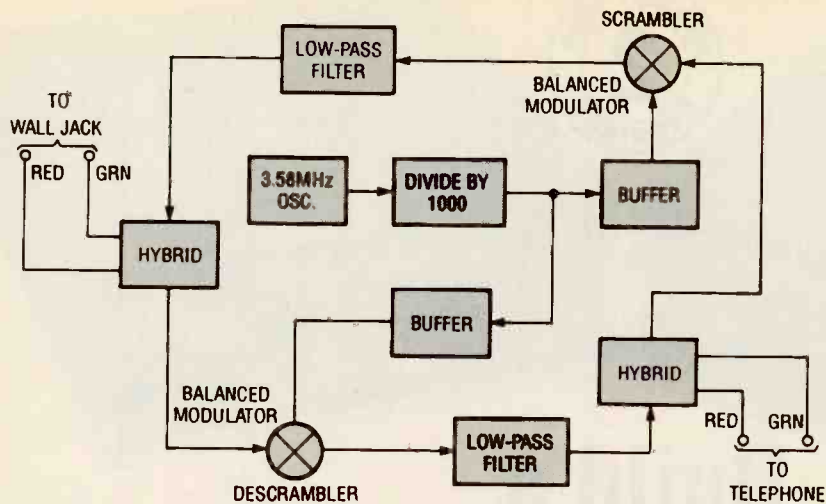


Fig. 1. The Telephone Scrambler scrambles all outgoing dialog from the telephone, while it descrambles all incoming dialog from the telephone line.

off hook. With base bias present, pressing S2 (SCRAMBLE) turns on SCR1 and current flows through Q1, current-limiting resistor R44, and the coil of relay K1, activating it. Current also flows through LED1, indicating that the circuit is in the scrambled mode.

Diode D3 is included in the circuit to

protect Q1 from reverse voltage spikes, resulting from the de-energization of K1. Capacitor C15 provides temporary bias current for Q1 during the break in telephone current when the relay armature is in the process of moving between sets of contacts.

When K1 (a DPDT relay) is energized,

one set of its contacts places the primary winding of transformer T1 across the telephone line, completing the current loop that alerts the central-office switching equipment to an off-hook condition, while coupling audio signals to and from the telephone line. At the same time, -6 volts is applied to the telephone through K1's second set of contacts and transformer T2's primary winding, providing operating power to the telephone (like in the normal off-hook condition), and allowing audio to be coupled to and from the telephone.

The circuit includes two hybrid networks. The first consists of the secondary winding of T1, coupled with U3-d and R22 through R24. The second hybrid network is comprised of the secondary winding of T2, coupled with U3-c and R19 through R21. Those networks allow signals from the secondary windings of the transformers to be applied to the inputs of op-amps U3-c and U3-d. The outputs of op-amps U3-a and U3-b are in turn applied to the secondary windings of

### PARTS LIST FOR THE TELEPHONE SCRAMBLER

#### SEMICONDUCTORS

- U1—4069 hex inverter, integrated circuit
- U2—4040 12-stage ripple-carry binary counter/divider, integrated circuit
- U3—LM348N quad op-amp, integrated circuit
- U4, U5—LM1496N balanced-modulator/demodulator, integrated circuit
- U6—PS2505-INEC optoisolator/coupler, integrated circuit
- SCR1—S401E-ND 1-amp, 400-PIV, non-sensitive gate, silicon controlled rectifier
- Q1—2N4400 general-purpose NPN silicon transistor
- BR1—1-amp, 200-PIV, full-wave-bridge rectifier
- D1, D2—1N4735, 6.2-volt Zener diode
- D3—1N4148 general-purpose silicon switching diode
- LED1, LED2—Light-emitting diode
- MOV1—130-VRMS, metal-oxide varistor

#### RESISTORS

(All fixed resistors are 1/4-watt, 5% units.)

R1—10-megohm

- R2—1200-ohm
- R3, R40—4700-ohm
- R4, R39—47,000-ohm
- R5, R38—20,000-ohm
- R6, R7, R19, R20, R23, R24, R36, R37—10,000-ohm
- R8, R14, R30, R35—3900-ohm
- R9, R10, R28, R29, R42—51-ohm
- R11—R13, R15, R17, R18, R25—R27, R31, R32, R34—1000-ohm
- R16, R33—6800-ohm
- R21, R22—560-ohm
- R41—130-ohm
- R43, R47—220-ohm
- R44—750-ohm
- R45, R46—20-ohm

#### CAPACITORS

- C1, C4, C16, C17, C20—0.1- $\mu$ F, Mylar
- C2, C3—36-pF, ceramic-disc
- C5, C14—220-pF, ceramic-disc
- C6, C13—0.02- $\mu$ F, Mylar
- C7, C12—0.033- $\mu$ F, Mylar
- C8, C11—1- $\mu$ F, 16-WVDC, tantalum
- C9, C10—22- $\mu$ F, 16-WVDC, electrolytic
- C15—2.2- $\mu$ F, 16-WVDC, tantalum
- C18, C19—100- $\mu$ F, 35-WVDC, electrolytic
- C21—1000- $\mu$ F, 35-WVDC, electrolytic

#### ADDITIONAL PARTS AND MATERIALS

- XTAL1—3.58-MHz, TV color-burst crystal
- T1, T2—600-ohm to 600-ohm audio transformer
- K1—12-volt DC, DPDT relay
- S1, S2—SPST momentary pushbutton switch
- Printed-circuit materials, enclosure, 13-volt AC, 800-mA wall transformer (Radio Shack no. 273-1610 or similar), telephone cord, power cord jack, wire, solder, hardware, etc.

**Note:** The following items are available from Weeder Technologies, P.O. Box 421, Batavia, Ohio 45103: An etched and drilled printed-circuit board (WTTS-B), \$14.00; a kit of all board-mounted components (WTTS-C), \$29.00; a pre-assembled circuit board (WTTS-A), \$69.00. All orders must include \$3.50 for shipping and handling. U.S. and Canadian orders only please. Ohio residents must add 6% sales tax. Above prices are for single units only. 2 Telephone Scramblers are required.

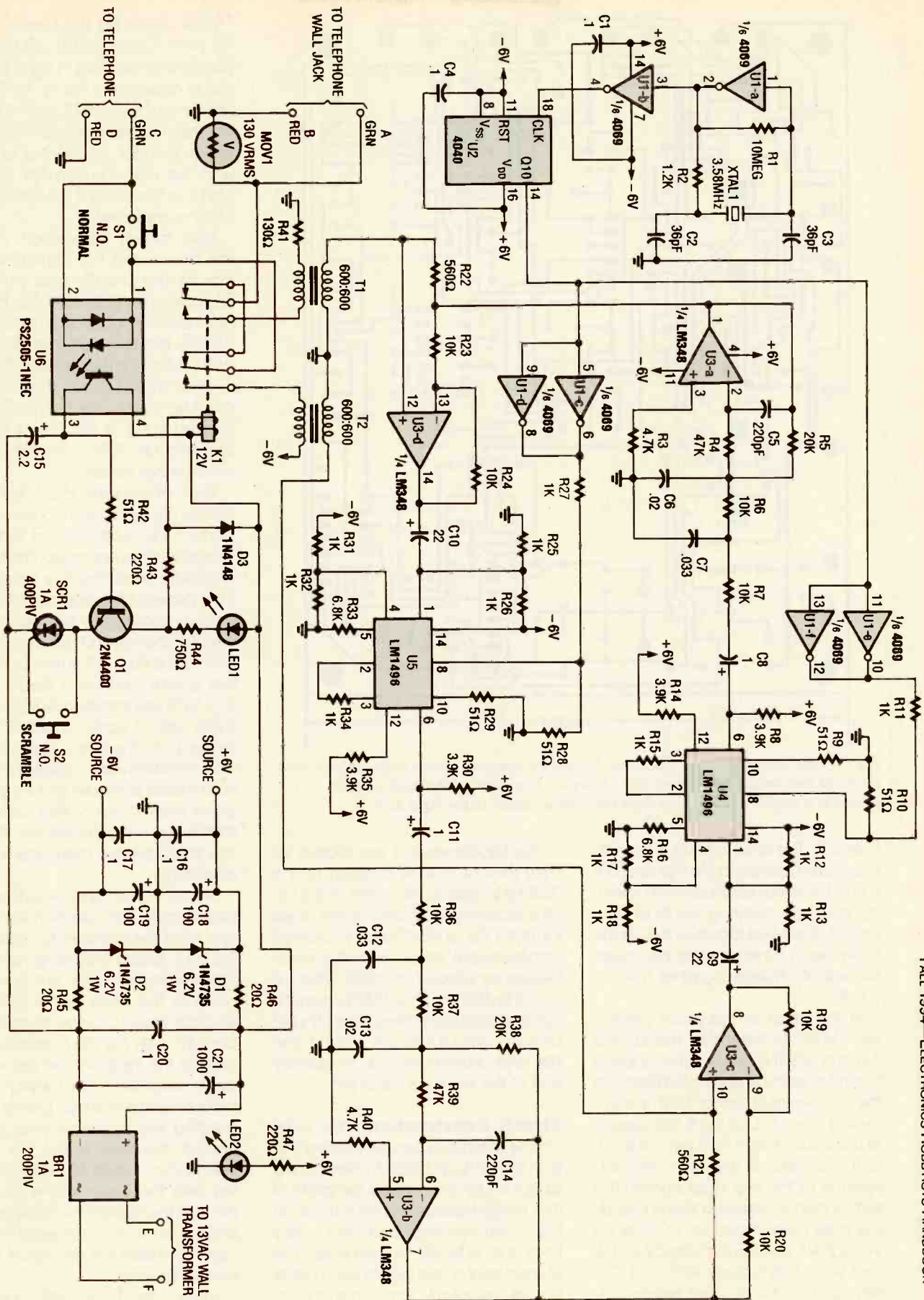


Fig. 2. The heart of the Telephone Scrambler is a pair of balanced modulators (U3 and U5), which are used in both scrambling and descrambling dialog.



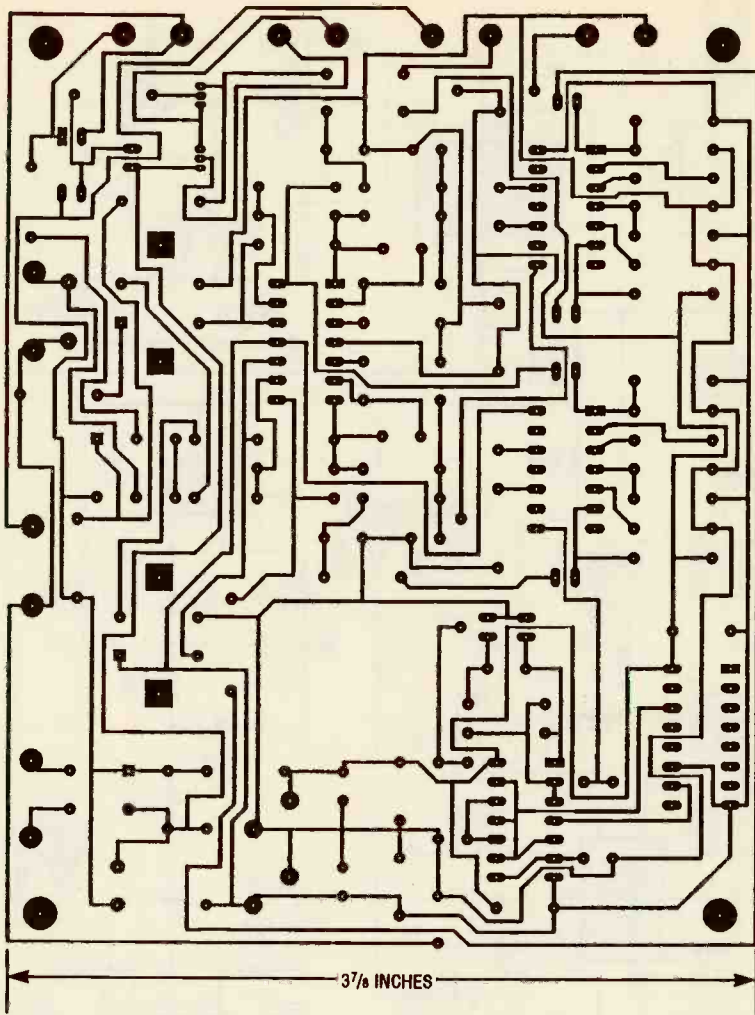


Fig. 3. This template for the Telephone Scrambler's printed-circuit board is presented for those who prefer to roll their own. However, if you are so inclined, you can purchase a prefabricated board from the supplier listed in the Parts List.

T1 and T2. The outputs of U3-a and U3-b are also applied to the inputs of U3-c and U3-d, but because both inverting and non-inverting inputs of U3-c and U3-d are tied together, the signals nullify each other (the signals cause no output change to either U3-c or U3-d).

At the heart of the circuit are the two LM1496N balanced modulators (U4 and U5). The audio signal applied to pin 1 of both U4 and U5 is mixed with the squarewave signal that is introduced to each IC at pin 8. The outputs of U4 and U5, taken from pin 6 of each unit, consists of the sum and difference of the two input signals. The sum of the two signals is filtered out by low-pass filters made up of U3-a, R4 through R7, and C5 through C7 for U4, and U3-b, R36 through R39, and C12 through C14 for U5. That leaves only the difference frequency.

The squarewave is generated by U1-a (1/8th of a 4069 inverter) and a 3.58-MHz color-burst crystal. The 3.58-MHz squarewave is used as the clock input for U2 (a 4040 binary counter) whose output at pin 14 is the clock frequency divided by 1000, which is equal to 3580 Hz. That 3580 Hz signal is applied through buffers, consisting of U1-c through U1-f, to pin 8 of U4 and U5, and determines the frequency shift of the input signals at pin 1.

**Circuit Construction.** The Telephone Scrambler was assembled in a printed-circuit board, measuring about 4 7/8 by 3 7/8 inches. A template of that printed-circuit artwork is shown in Fig. 3. You can etch your own board from the artwork, or purchase the etched and drilled board and a kit of board-mounted components from the supplier listed in the Parts List.

After obtaining the board and all the parts in the Parts List, use the parts-placement diagram in Fig. 3 to guide you in assembling the circuit. Start by mounting U1-U6, T1, T2, and K1. Mounting those larger components first will make it easier to orient your board with the parts-placement diagram and find the correct locations for the other components.

Next, mount the resistors, capacitors, and diodes. Pay particular attention to the diodes and polarized capacitors to make sure that they are not installed backwards. Finish by installing the remaining components and the four jumper connections. Verify that all IC's have their notches pointing in the right direction (according to Fig. 3). Also check to make sure that Q1, SCR1, and BR1 are not installed backwards.

Your enclosure must be large enough to house the board and any part of the switches and jacks that extend into the enclosure. Prepare the enclosure by drilling four holes in the front panel of the appropriate size to accommodate the two switches (S1 and S2) and two LED's (LED1 and LED2). Then drill a hole in the rear panel to fit the power jack. (If a Radio Shack 273-1610 wall transformer is used, it will mate with a Radio Shack 274-1563 power jack. The inside diameter of a wall transformer's connector varies from model to model so it would be a good idea to verify that wall transformer you select mates with the jack you select before mounting it to the enclosure.)

Mount the LED's, switches, and power jack. Then position the board and mark the locations for drilling. Drill the four board-mounting holes and install standoffs. Drill out two more holes in the back panel just, large enough to run a piece of telephone cord through. File the holes smooth to protect the insulation on the wires. A single telephone cord with modular jacks on each end can be cut in half, feeding the cut ends through the holes in the back panel. The author put a 2-inch piece of heat-shrink tubing over the cords where they pass through the holes in the back panel to protect them and a tie wrap on each cord just inside the enclosure to provide strain relief.

Label one of the cords TO WALL JACK  
(Continued on page 104)

# Design your own

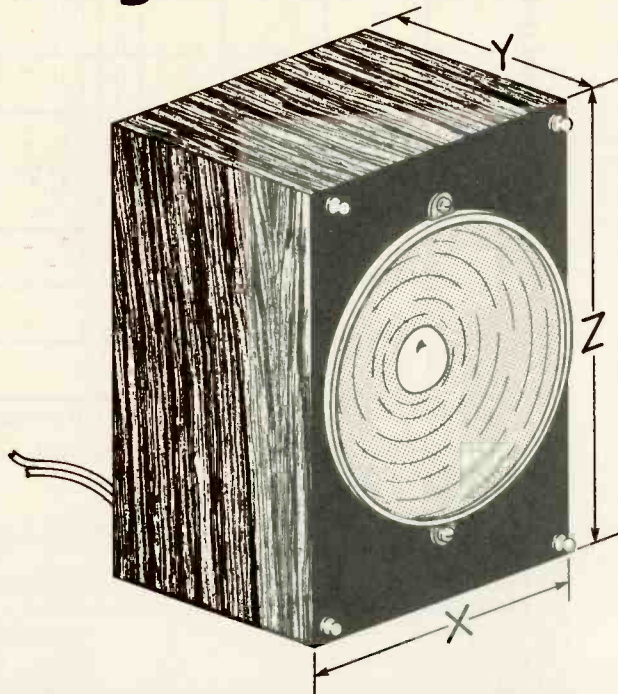
**T**o many Popular Electronics readers, loudspeaker design may seem more than a bit mysterious, what with all the talk of "Thiele/Small parameters," resonance, and various, more arcane terms. Indeed, for many, building a speaker simply means buying some "raw drivers" and putting them in any old cabinet they might have around, and hoping for the best. Too often, such haphazard work is a big disappointment.

In contrast, when a hardy soul goes hunting for some more substantial design theory, all they might find are some very specialized physics texts. All in all, it is a discouraging situation, to say the least.

However, all is not lost. Thanks to the work of two insightful engineers—A. N. Thiele and R. H. Small—the number of parameters you'll need to choose between to produce a good loudspeaker design has been reduced from hundreds to just three. Further, the three programs presented in this article will let your PC do the number crunching for you. Specifically they'll tell you the volume and dimensions of the enclosure, and design a crossover network for you.

To simplify this approach further, most driver manufacturers provide you with some of the necessary parameters to help you decide on a driver. Many even publish them right in their catalogs and brochures. That will allow you to do some useful trial-and-error work with your computer, instead of wasting many hours of hard work and dollars worth of wood and drivers.

**The Cabinet.** First we'll look at cabinet design. At this point you might be wondering if a cabinet is at all necessary. There are two reasons why you need a cabinet (more properly called an "enclosure"). The first is to prevent the sound radiated from the



## Loudspeakers

*Three simple programs that will help you design your own speakers the right way.*

BY WILLIAM R. HOFFMAN

rear of the driver (which is in opposite phase to that from the front) from meeting and canceling the driver's forward output. Second, an enclosure serves to flatten and extend the driver's bass output. (Anyone who has ever propped up a driver without a cabinet and played some music through it knows what happens to the bass.)

Specifically, we'll discuss the design of a sealed acoustic-suspension cabinet. Of course, there are other types of enclosures—bass-reflex, ducted-port, passive-radiator, horn, and more. All of them could serve the same purpose, but are much harder to design and build. So we will only deal with a simple, acoustic-suspension system here.

**The Basics.** There are a couple of

preliminary concepts of speaker design that we must first introduce. Let's start by defining the three parameters that Thiele and Small have given us. They are commonly abbreviated  $f_o$ ,  $Q_{ts}$  (also referred to as  $Q$ , or the "Q"), and  $V_{as}$ . As mentioned earlier, those parameters are commonly supplied by a driver's manufacturer.

Let's start with  $f_o$ , or the frequency of oscillation. That refers to the natural bass-resonance frequency of a loudspeaker driver without a cabinet. It will be used to determine how low in frequency our assembled system will efficiently go, or  $f_{cab}$ .

Second,  $Q$ , is the degree of peaking that occurs in the driver's response, again without a cabinet, at the bass-resonance frequency. That is related to the  $Q$  within a cabinet, which we'll call  $Q_{cab}$ . The parameter  $Q_{cab}$  can be decided more or less by the designer.

Last,  $V_{as}$  is the volume of air contained within a closed space that would have the same compliance or "springiness" as the suspension of the driver's moving part (the cone).

With the three manufacturer-supplied parameters ( $f_o$ ,  $Q_{ts}$ , and  $V_{as}$ ), a carefully chosen cabinet  $Q$  ( $Q_{cab}$ ), and the help of our first design program, we can exactly specify the volume of a sealed acoustic-suspension cabinet. The enclosure will work with the chosen driver to give the best bass response possible.

Now that you know the parameters, there are two things we need to mention about using them to design a loudspeaker. First, there's more than one possible enclosure for any given driver. The difference between the designs is a trade-off between how low we want the frequency response to extend ( $f_{cab}$ ) and how sharply we want the response to fall off below that bass cut-off point determined by ( $Q_{cab}$ ).



Second, we must understand that once we have selected our driver, we can only set one of those two parameters (bass frequency response or bass fall-off). Although it can be either one. Once we decide the value of one parameter, the remaining parameter will be fixed by the laws of physics.

**Realistic Bass Cutoff.** It is important to recognize that a given size driver has a fairly well defined lower frequency limit. That is because the movement of the cone of a driver must quadruple (yes, quadruple) for every halving of frequency to maintain the same acoustic output. There comes a point at which the driver will simply run out of cone excursion (the distance the cone can move) and its sound output will fall off sharply.

There are many advertisements that claim miraculous bass reproduction from tiny speakers, but Table 1 gives us some practical values to shoot for in our design work. Attempting to push a driver much below those recommended frequency limits will usually result in weak or distorted output, or even driver damage.

The table also indirectly gives us a guide to our lower limit for the value of  $f_{cab}$ , your speaker's bass-output capability. That's because the driver in a cabinet can't produce bass response lower than it can in free air—a natural consequence of the loading effect of the volume of air trapped in the sealed cabinet behind the driver. It therefore sets a lower practical limit on one of our "designer-determined" parameters.

**TABLE 1—LOWEST FREQUENCIES**

Driver Size (inches)	Low Limit (Hz)
4	90 - 95
5	85 - 90
6	65 - 70
8	40 - 45
10	30 - 35
12	25 - 30
15	20 - 25

**The Q.** Now, we must consider the "Q" of the system ( $Q_{cab}$ ), the other parameter we can set ourselves. There are some things we need to know about Q. To begin with, the higher the Q, the stronger the bass output will be. You might be tempted to make the Q as high as possible, but

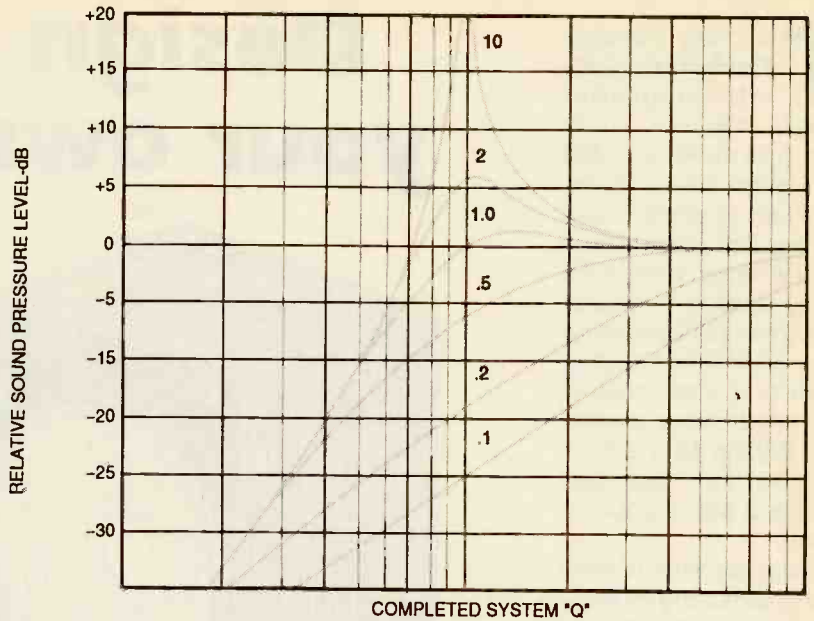


Fig. 1. If the Q is too high, there will be an undesirable peak in the frequency response. Thus the speaker will sound to boomy.

**LISTING 1**

```

9 PRINT:PRINT:PRINT:PRINT
10 PRINT "          LOW FREQUENCY ACOUSTIC SUSPENSION LOUDSPEAKER"
11 PRINT:PRINT
12 PRINT "                                DESIGN PROGRAM"
13 PRINT:PRINT:PRINT
14 PRINT "                                By William R. Hoffman"
15 PRINT:PRINT:PRINT
17 PRINT "                                Copyrite 1993"
18 PRINT:PRINT:PRINT
20 INPUT "                                Proceed? (1=yes 2=no) and Enter ";P
22 PRINT:PRINT:PRINT:PRINT:
25 ON P GOTO 30, 990
30 INPUT "                                Free air resonance of driver (Hz) =";B
35 PRINT
40 PRINT "                                Air volume compliance equivalent of"
45 INPUT "                                driver (Vas) in cu. ft. =";C
46 PRINT
50 PRINT "                                Free air total Q of driver at"
55 INPUT "                                bass resonance (Qts) =";D
60 PRINT
65 PRINT "                                What is desired completed system Q "
70 INPUT "                                at bass resonance (Qcab) =";E
75 PRINT:PRINT:
100 LET Z=(E/D)^2*(1.05)-1
110 LET Y=B*E/D
120 LET X=C/Z
130 PRINT"
135 PRINT
140 PRINT"
145 PRINT
150 PRINT"
155 PRINT"
160 PRINT
165 PRINT"
170 PRINT"
172 PRINT
175 PRINT"
180 INPUT"
182 PRINT
185 ON F GOTO 30, 990
187 PRINT
990 PRINT"
999 END

```

remember, the higher the  $Q$  the faster the speaker output will fall off below  $f_{cab}$ . Also, just as in an electrical circuit, too high a  $Q$  can cause ringing and oscillation, which means highly distorted (typically muddy or boomy) bass.

So then, what would be a good value? Figure 1 shows some  $Q$  curves possible with our completed speaker system. Notice, that for values much over 1, a large peak in the output occurs, growing with increasing  $Q$ . The peak is what you must avoid if you want good sound from the completed system.

For some guidelines, look at Table 2 where a range of  $Q$  values are suggested for various bass-driver sizes. The values are based on many factors, including the size of the driver itself. Notice that very small drivers should have rather high  $Q$  values, while larger ones have lower  $Q$ 's. The reasons for those suggestions are very practical. A tiny 4–5-inch driver has so small a cone, and consequently such weak bass output, that the slight peak due to a high  $Q$  value actually makes the sound fuller and more satisfying. A very large driver, on the other hand, can produce so much bass output that a lower  $Q$  is required to control and smooth-out its response. So now, armed with some knowledge about  $f_{cab}$  and  $Q_{cab}$ , we are ready to begin some practical design work.

TABLE 2—POSSIBLE  $Q$ 's

Driver Size (Inches)	$Q$ Value Range
4–5	0.9–1.2
6	0.8–1.0
8	0.7–0.9
10	0.6–0.9
12–15	0.5–0.8

**Our First Program.** To begin with, you need to enter the speaker-design program (see Listing 1) in a directory along with GWBASIC or BASICA, at least one of which you must have to run the program. We called our program LFSPKR-1.BAS. It's job is to calculate the volume of the enclosure and the bass resonance frequency of the system.

Be sure to carefully enter it as it is shown, including all punctuation and spaces. They are very important to the program. All the blank spaces found in the "input" and "print" statements

bring the displayed lines in the program to a nicely centered place on the working screen, so be sure to include them. If anyone needs help, or has never entered or run a BASIC program, just find a friend or ask someone about how it is done: the process is very easy. Really!

**Running LFSPKR-1.** Once the program has been typed in and entered as LFSPKR-1.BAS, from the DOS prompt we can start it by typing GWBASIC LFSPKR-1.BAS if you are using GWBASIC, or BASICA LFSPKR-1.BAS if you are using BASICA. When the opening screen appears, the title, "Low Frequency Acoustic Suspension Loudspeaker Design Program" appears. The program then asks you, if you wish to proceed. After answering "1" (or yes), you will be asked for the values of  $f_c$ ,  $V_{as}$ , and  $Q_{ts}$ , in that order. Then, you will be prompted for a value for  $Q_{cab}$ , the completed system  $Q$  at bass resonance. That value must always be higher than

the bass resonance,  $Q_{ts}$ .

Since we are only making trial-and-error calculations, we can search for a bass driver/ $f_{cab}/Q_{cab}$  combination that gives you the system a bass cut-off frequency/ $Q$  combination that you want based on the guidelines already given. Once you've entered the driver-based parameters, choose a  $Q$  value ( $Q_{cab}$ ), from Table 2. Once that is entered, the program will automatically calculate the interior volume of a cabinet that will yield the  $Q_{cab}$  we specified.

Typically it's good to line an enclosure with at least a single 1–2-inch thick layer of material. Typically Fiberglas, which usually comes in a roll or in pillow form, is cut into batts that cover the area of each of the interior surfaces, and fastened to the walls using a staple gun. Applying it that way means you can probably expect to gain about 5% of the effective enclosure volume, something you can usually ignore.

## LISTING 2

```

10 PRINT:PRINT:PRINT:PRINT:PRINT
15 PRINT "
16 PRINT:PRINT
17 PRINT "
18 PRINT:PRINT:PRINT
19 PRINT "
20 PRINT:PRINT:PRINT
21 PRINT "
22 PRINT:PRINT:PRINT
23 PRINT "
24 PRINT "
25 PRINT "
26 PRINT:PRINT:PRINT:PRINT
27 INPUT "
28 PRINT:PRINT:PRINT:PRINT
30 ON P GOTO 40, 990
35 PRINT:PRINT:PRINT:PRINT
40 PRINT "
41 INPUT "
43 PRINT:PRINT:PRINT:
45 ON A GOTO 50
50 LET X=A^(1/3)*(12)
55 LET Y=X*.62
60 LET Z=X*1.62
70 PRINT "
71 PRINT "
72 PRINT "
75 PRINT:PRINT:PRINT
80 PRINT "
85 PRINT "
90 PRINT "
95 PRINT:PRINT
100 PRINT"
110 INPUT"
120 ON B GOTO 35, 990
990 PRINT:PRINT:
995 PRINT"
999 END

```

### SPEAKER ENCLOSURE DIMENSIONS"

#### DESIGN PROGRAM"

By William R. Hoffman"

Copyrite 1993"

This is a program designed to calculate optimum" dimensions for a loudspeaker enclosure when only" the desired volume is known."

Proceed? (1=yes 2=no) and Enter";P

The desired enclosure internal" volume is (cu. ft.) =" ;A

The following are the INSIDE dimensions of a box" of "A" cubic feet that are optimized to provide the" least number of standing waves (or resonances)."

HEIGHT = "Z  
WIDTH = "X  
DEPTH = "Y

Do you wish to try another volume?" (1=yes 2=no) and Enter";B

Good listening!"



**Now the Questions.** Looking at our calculated values, we can ask ourselves: is the frequency of  $f_{cab}$  low enough to ensure good bass response, but still within the limits suggested by Table 1? If it is somewhere near the limit shown in the table, then we will be getting all that we probably can from it. Then we can ask: is the size of the suggested enclosure too big or smaller than we want?

If the values are unsatisfactory, then you can simply try again. At the prompt, respond (1=yes), and then enter another value of  $Q_{cab}$  for the particular driver you are working with, or instead try the specifications of another driver that you might want to use. Because this is a computer program, you can easily try as many times as you want until you find the right set of specifications for your needs. If you wish, you can even have a printer (almost any printer will work) print out the entire screen with all the prompts and information contained. Simply use the PRINT SCR key on the keyboard.

**What Volume?** Now, the next logical step is to use the calculated volume and another small program to get the actual internal cabinet dimensions (height, width, and depth,) as indicated in Fig. 2. But before we introduce the next program, let's discuss a few points first.

For one, the enclosure volume calculated in our first program (LFSPKR-1.BAS) was the empty cabinet volume. That is, no allowance was made for the space that would be occupied by the driver (or drivers), any extra bracing you might want to use, or the crossover network.

Alternatively, you can change the volume with acoustic damping material (Fiberglas, wool, or foam). Adding it will make the cabinet seem larger than it really is. (Yes, I said larger!) When the acoustic waves from the rear of the driver pass through these soft, absorptive materials, they are actually slowed down by a small amount—typically by about 20%—and are also partially absorbed. The result is that the enclosure seems "acoustically bigger" than it really is. For a typical material like Fiberglas, up to 40% larger. So, if you were to lightly "fluff" fill a box of 1 cubic foot in volume, it would acoustically look like

about 1.4 cubic feet to the driver.

**The Second Program.** Our second program is a simple one. It asks for the volume of enclosed empty air space we are looking for. In return, it gives us a set of inside (not outside) dimensions that offer the least opportunity for resonances or standing waves to develop within the enclosure. Also, it gives us a nice rectangular shape that is pleasing to the eye.

To use the program, ENCDDES-1.BAS, first enter it as shown in Listing 2. Like the first program, be sure and enter it exactly as shown. Once this is done,

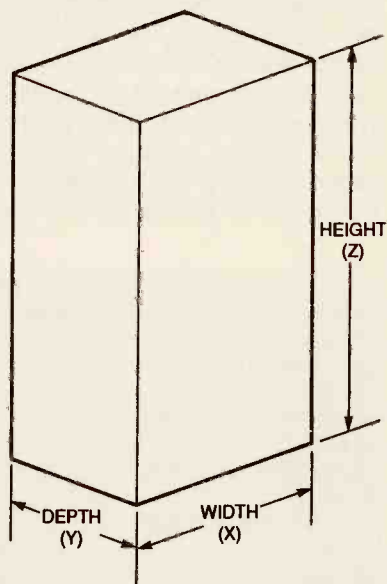


Fig. 2. The second program uses the three variables shown here to indicate the cabinet dimensions.

you may access it along with your copy of BASIC by entering either GWBASIC ENCDDES-1.BAS (if you are using GWBASIC), or BASICA ENCDDES-1.BAS (if you are using BASICA) at the drive prompt.

Once the opening screen appears, respond to the prompt with a "1," and ENTER. Following that, another prompt will ask for the enclosure volume. Enter the value in cubic feet, but remember that the box volume must include an allowance for the driver(s), acoustic material, bracing, and crossover, if any. Once that is done, the program will calculate and display a set of values for the three inside dimensions, in inches. With these, then, we are ready to start building our new speaker system.

Now we need to talk about crossover networks and the last of the three programs to be presented. The program calculates the exact values of inductors and capacitors that you will need to complete your loudspeaker system.

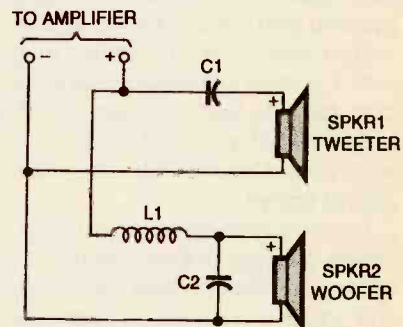


Fig. 3. A crossover network divides the frequency spectrum up so only the necessary sonic components are reproduced by each driver.

**What is a Crossover?** Most speakers have more than one driver. The reason for having multiple drivers is simple: a big driver will reproduce bass frequencies very well, but is very poor on the highs because its cone is too big and heavy to move very quickly. While on the other hand, a little driver can make its light little cone move very rapidly and reproduce the highs very well, but it cannot move enough air to reproduce deep bass in any quantity. Obviously, then, we must have at least two different types of drivers (one large and one small) to really be able to make a good, wide-range speaker with low distortion.

There are also speaker systems made with even more drivers. There are some with three or even four, each one covering only a very narrow and specific range of frequencies (for which it is optimized.) In such a system each driver is physically smaller than the last as we move up from the bass, through the midrange, and on to the highs. However, here we'll limit our scope to a two-driver, or two-way system.

To prevent large drivers (called "woofers") from distorting while trying to reproduce highs, and small drivers (the smallest of which are called "tweeters") from blowing out from lows, a crossover network is used. A crossover separates the sonic frequency spectrum into the ranges

needed by each driver in a multi-way loudspeaker. More specifically, it is a combination of inductors and capacitors that form an electronic filter network.

**The Crossover Components.** Let's look at an example circuit to see just what a crossover does. The simple crossover circuit in Fig. 3 is applied to a speaker system that has a woofer and tweeter. Notice that there is an inductor wired in series with the woofer, and a capacitor wired in series with the tweeter. Those two elements divide the sound spectrum between the drivers.

The inductor when connected as in Fig. 3, forms a low-pass filter. That is, it allows the low frequencies to pass through it, but will block all high frequencies. The result is that only the bass is passed, which is fine since the woofer can only mechanically reproduce bass any way, and therefore it avoids wasting power from the amplifier uselessly. The action of the low-pass filter on frequency is shown graphically in Fig. 4A.

The capacitor, when it is connected to a tweeter as shown back in Fig. 3, performs a function that is the complement to the inductor: It forms a high-pass filter. It will only allow high frequencies to pass, keeping the strong bass power out of the small high-frequency driver. That prevents possible distortion and damage. The effect the high-pass filter has is shown in Fig. 4B.

In addition, another capacitor is connected directly across the terminals of the woofer to perform another necessary function: compensation. The voice coil of the woofer is just that, a coil, so it has a substantial inductance just like the inductor we are using for the low-pass filter. If we didn't use C2, the voice-coil inductance would defeat the crossover inductor, and no crossover action would take place. The compensation capacitor nullifies the effects of the woofer's voice-coil inductance and allows the inductor to create the low-pass function we require.

**The Crossover Program.** Listing 3 shows the BASIC program, called XDES-1.BAS, which we will use to calculate the values of inductance and capacitance we need for our crossover network. As with the previous pro-

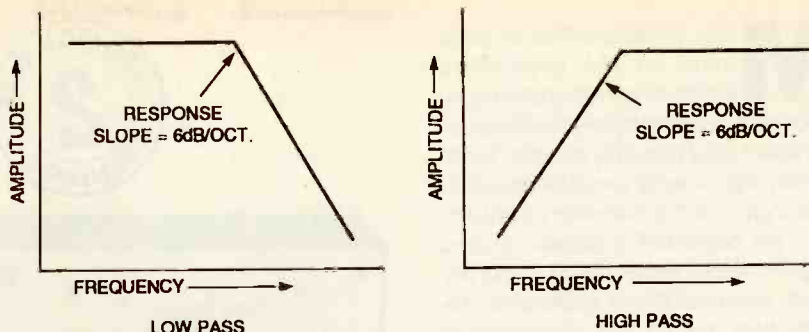


Fig. 4. The action of the woofer and tweeter outputs of the two-way crossover are shown here in A and B respectively.

**LISTING 3**

```

5 PRINT:PRINT:PRINT:PRINT:PRINT
10 PRINT "
11 PRINT:PRINT
12 PRINT "
14 PRINT:PRINT:PRINT
15 PRINT "
16 PRINT:PRINT:PRINT
17 PRINT "
18 PRINT:PRINT:PRINT
20 INPUT "
22 PRINT:PRINT:PRINT
25 ON P GOTO 30, 990
27 PRINT:PRINT:PRINT
30 INPUT "
35 PRINT:PRINT
40 PRINT "
45 INPUT "
46 PRINT:PRINT
50 PRINT "
55 INPUT "
60 LET X=((B)/(6.28*A))*1000
65 LET Y=((1)/(C*6.28*A))*10^6
66 LET Z=((1)/(B*6.28*A))*10^6
70 PRINT:PRINT:PRINT
75 PRINT "
80 PRINT:PRINT
85 PRINT "
86 PRINT:PRINT
87 PRINT "
90 PRINT:PRINT:PRINT
95 PRINT "
96 INPUT "
97 ON Q GOTO 27, 990
990 PRINT:PRINT
995 PRINT"
999 END

```

**DESIGNING A LOUDSPEAKER " Crossover Network "**

By William R. Hoffman"

Copyrite 1993"

Proceed? (1=yes 2=no) and Enter";P

Crossover frequency is (Hz) =";A

Impedance of low frequency driver at the crossover frequency is (ohms) =";B

Impedance of high frequency driver at the crossover frequency is (ohms) =";C

L = "X"mHy"

C1 = "Y"uF"

C2 = "Z"uF"

Would you like to try another set of values ? (1=yes 2=no) and Enter";Q

Good listening!"

grams, carefully enter it in with your copy of GWBASIC or BASICA, being sure to get all spaces and punctuations correct. Once that is done, we can access the program like the others by typing GWBASIC XDES-1.BAS or BASICA XDES-1.BAS.

Once the opening screen appears, answer the prompt, and you will be prompted for the frequency (in Hz) that you want the crossover function to take place at. Then you will be asked for the impedance of the bass driver at the crossover frequency you

have just selected. You can usually find that value from an impedance curve supplied by the driver manufacturer. If not, use an impedance bridge that you or someone you know might have to measure the driver's impedance. If neither of these sources of information are available, then use the nominal impedance of the driver (usually 8 ohms). This should get you fairly close, since our filter slope is quite shallow (as Fig. 4 shows, it's only 6 dB/octave.)

(Continued on page 104)



**M**any of people like to keep track of the prevailing weather conditions using indoor and outdoor thermometers, barometers, and humidity gauges. High-quality instruments provide accurate readings, but the common, consumer-type humidity gauges—called hygrometers—leave much to be desired. Even relatively expensive devices that rely on the absorption of moisture by a human hair or some other organic substance cannot respond accurately to very low or very high relative-humidity levels.

Modern solid-state technology has brought advances in relative-humidity measurements by providing various types of capacitive and resistive sensors that respond to varying amounts of moisture in the air. Many of those, however, are non-linear and may not give reliable readings at humidity levels below 10% or more than 90%.

**It's All Relative.** Relative humidity (RH), a measure of the quantity of moisture contained in the air, is important to our well being and can be a significant factor in forecasting weather conditions. The term "relative" refers to the percentage of water vapor contained in a given volume of air as compared to the maximum amount of moisture that can be accommodated in that volume of air at the same temperature. A condition of 100% RH indicates that the air is saturated with moisture, and that any further increase in moisture content will result in precipitation (rain, snow, or condensation).

Personal comfort is closely related to humidity. In the summer, mild temperatures accompanied by high relative humidity are uncomfortable because the body's natural cooling system (which works by evaporation of perspiration) is slowed. Conversely, the reduction in relative humidity during the winter when indoor air is heated causes one to feel cold unless the temperature is raised to 72 degrees or more.

Adverse reaction to insufficient or excessive relative humidity is not limited to the human body. You may have noticed that wooden drawers and doors tend to expand and stick during the summer, and furniture often shrinks and cracks during the winter. Even electronics, such as VCR's



# Relative-Humidity Gauge

*Keep an eye on the humidity with this easy-to-build digital instrument.*

BY ANTHONY J. CARISTI

and copying machines, can fall prey to moisture unless the relative humidity is kept within certain limits. In extreme cases, where high humidity is coupled with high temperatures, mildew can form everywhere, causing significant damage.

There are many ways to measure relative humidity. One way is by detecting the rate of water evaporation using an instrument, known as a psychrometer, that uses two thermometers. One thermometer has a continuously moistened cloth covering its bulb, which senses a reduction of temperature through moisture evaporation. That reading is compared to the dry-bulb thermometer, which responds to ambient temperature. A chart is then consulted to determine the relative humidity that corresponds to the two temperature readings. But that method, which can be very accurate, is not convenient to use.

Another method of measuring humidity is the one used in many low-cost, consumer-type, relative-humidity gauges that have been around for many years. Such instruments have been designed to respond to the percentage of relative humidity through the action of a strand of hair; the hair changes length in accordance with the amount of water vapor that it absorbs from the air. It is not surprising that such instruments are not very accurate and any reading of relative humidity may not be meaningful, especially at very low or very high humidity levels. There are also several electronic methods by which relative humidity can be gauged; one of which uses passive components that change capacitance or resistance in accordance with the air's moisture content.

However, the *Digital Relative-Humidity Indicator* described in this article takes advantage of a new development in sensor technology to produce a professional-quality instrument that is simple to build, accurate, and easy to use. The sensor—the IH3602L precision humidity sensor, one of several developed by Hy-Cal Engineering (9650 Telstar Ave., El Monte, CA 91731; Tel. 818-444-4000)—is linear over a range of 0 to 100% RH, and with proper calibration can be used to produce an instrument that is accurate to within  $\pm 2\%$ .

Our circuit can measure and display relative humidity with significantly better accuracy and resolution than can be obtained from common, consumer devices, thereby enabling you to determine whether a humidifier or dehumidifier needs to be turned on or off. It can also be used to indicate an improvement in humidity once you have taken corrective action, with the added advantage of being able to give an indication of whether your humidifier, dehumidifier, or air conditioner is doing its job.

**How it Works.** Figure 1 shows a schematic diagram of the Digital Relative-Humidity Gauge. The heart of the humidity-measurement system is SENS1 (the Hy-Cal IH3602L, an 6-pin CMOS device with only 3-active terminals), whose DC output voltage varies linearly with RH levels from 0 to 100%.

The sensor is fed from a regulated 5-volt source provided by U1, an

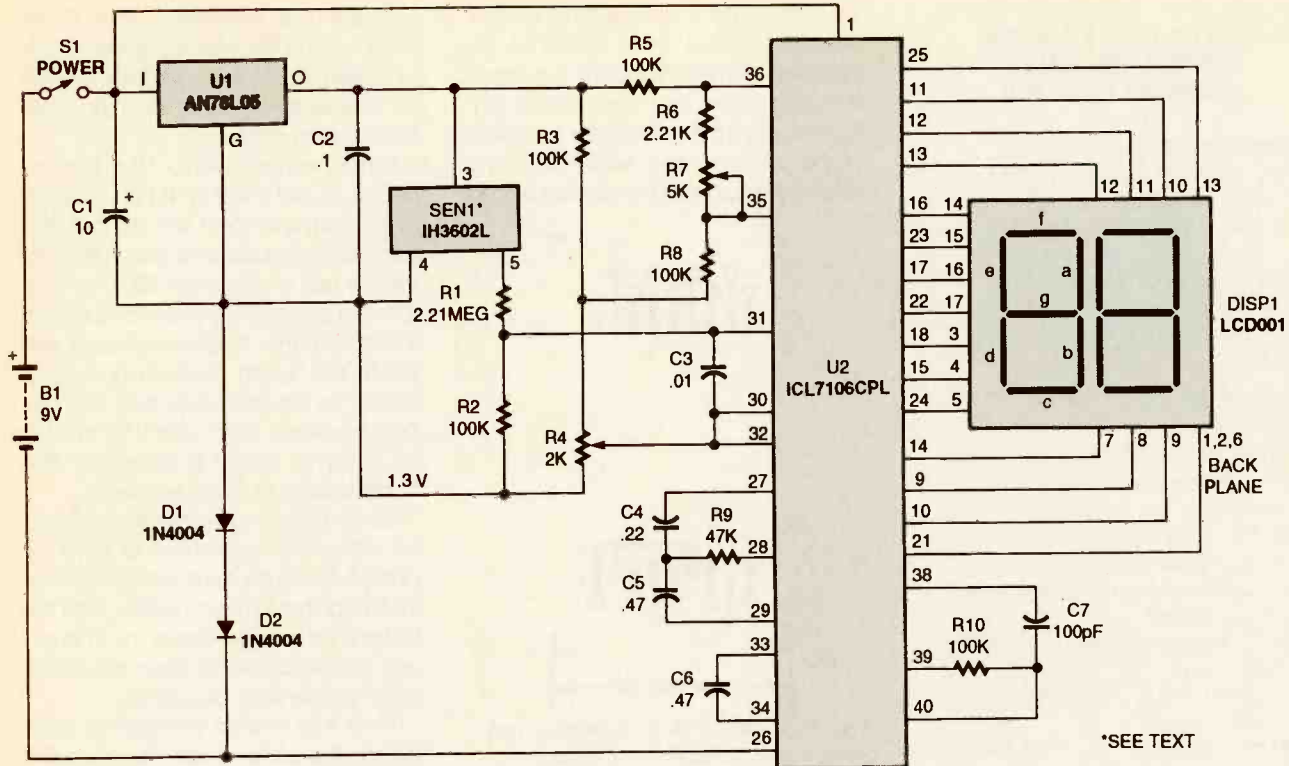


Fig. 1. At the heart of the Digital Relative Humidity Gauge is the Hy-Cal IH3602L SENS1 (a 6-pin CMOS device with active 3-terminals).

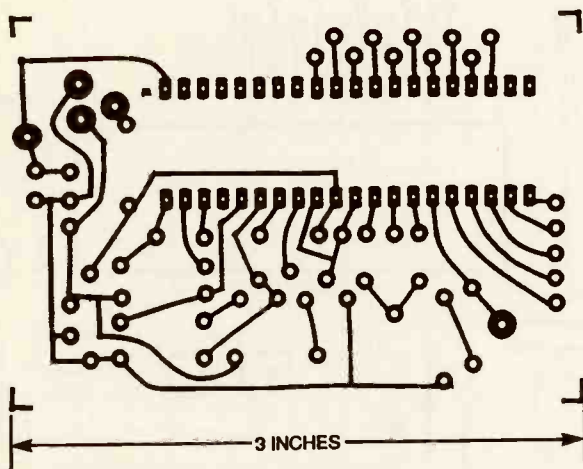


Fig. 2. The Digital Humidity Gauge was assembled on two single-sided, printed-circuit boards; a template for one of them—the sensor board—is shown here full size.

AN78L05 100-mA fixed regulator. The output of the sensor (measured with respect to its negative power input terminal) is ratiometric and varies linearly from 0.8 volts at 0% RH to 3.65 volts at 100% RH when powered by 5-volts. The sensor output is fed through resistors R1 and R2, which form a voltage-divider network that reduces the output voltage of the sensor to a range of about 35 to 158 mV. The change in voltage (28.5 mV/% RH) is used to drive U2 (an ICM7106CPL A/D

converter that also contains an on-board oscillator, output latches, 7-segment decoder/drivers, and a back-plane signal generator).

Potentiometer R4 is used to set pin 30 of U2 at 35 millivolts, while the reference voltage of the chip is set to equal the total change in voltage at pin 31, 123 mV (158 mV - 35 mV). Potentiometer R7 permits full-scale calibration of the instrument for variations in humidity sensors by allowing adjustment of the reference voltage of U2.

Although U2 is capable of driving a full 3½-digit LCD readout, in this application only two sets of U2's digit drivers are used (the most-significant and least-significant digits are not used). A full scale reading, 100% RH, occurs when the analog input voltage is equal to the reference voltage. That would normally give a display of 100.0; but, since the most- and least-significant-digits are not used, 100% RH is represented by a two-digit display of 00.

Components D1, D2, and R4 set the analog-ground terminal of U2 at pin 32 to slightly above ground (at 1.3 volts). Pin 31 of U2 (the positive analog differential-input terminal) is connected to the output voltage of the sensor through a voltage divider composed of R1 and R2. Diodes D1 and D2 are also used to generate a fixed voltage of about 1.3 volts, which is necessary to bias the analog input stages of the A/D converter. Pin 30 (the negative analog differential-input) of U2 is connected to the wiper of R4, allowing calibration at 0% RH. Pins 35 and 36 of U2 are the reference-input terminals and are used to set the full-scale range of U2. A full-scale output occurs when the input voltage applied between pins 31 and 30 is equal to twice the reference voltage.



## PARTS LIST FOR THE DIGITAL RELATIVE-HUMIDITY GAUGE

### SEMICONDUCTORS

- U1—AN78L05 5-volt, 100-mA voltage regulator, integrated circuit  
 U2—ICL7106CPL 3½-digit A/D converter, integrated circuit  
 DISP1—LCD001 2-digit liquid-crystal display (Digi-Key)  
 SENS1—IH3602L P/N sensor (Hy-Cal)

### RESISTORS

- (All fixed resistors are ¼-watt, 5% units, unless otherwise specified.)  
 R1—2.21-megohm, ¼-watt, 1% metal-film  
 R2, R3, R5, R8—100,000-ohm, ¼-watt, 1% metal film  
 R4—2,000-ohm, cermet, PC-mount potentiometer  
 R6—2.210-ohm, ¼-watt, 1% metal film  
 R7—5,000-ohm, cermet PC mount potentiometer  
 R9—47,000-ohm  
 R10—100,000-ohm

### CAPACITORS

- C1—10-μF, 25-WVDC, radial-lead electrolytic  
 C2—0.1-μF, ceramic-disc  
 C3—0.01-μF, ceramic-disc  
 C4—0.22-μF, 50-WVDC, metallized-film  
 C5, C6—0.47-μF, 50-WVDC, metallized-film  
 C7—100-pF, 50—WVDC, ceramic-disc

### ADDITIONAL PARTS AND MATERIALS

- B1—9-volt transistor-radio battery  
 S1—SPST momentary-contact switch  
 Perfboard materials, enclosure, IC sockets, battery holder and connector, wire, solder, hardware, etc.

**Note:** The following parts are available from A. Caristi, 69 White Pond Road, Waldwick, NJ 07463: a set of two printed-circuit boards for \$18.95; U1 for \$2.50; U2 for \$17.75; LCD readout for \$11.00; kit of 5 metal-film resistors for \$3.00; sensor \$65.00. Please add \$4.00 postage/handling to all orders. New Jersey residents, please add appropriate sales tax.

**Construction.** The Digital Relative-Humidity Gauge was assembled on two single-sided, printed-circuit boards, referred to as the sensor and

the display boards. That type of construction allows the boards to be stacked if desired to permit the circuit to be housed in a very small enclosure. Figure 2 is a full-size template of the sensor board, while Fig. 3 is a full-size template of the display board.



Fig. 3. Use this full-size printed-circuit pattern to etch the display board for your Digital Humidity Gauge.

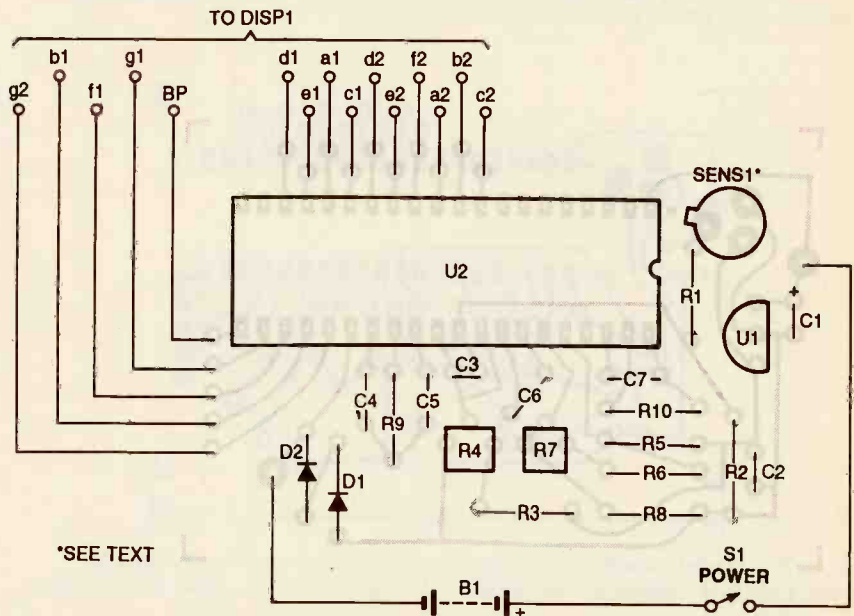


Fig. 4. When assembling the sensor board be sure that all of the polarized components are correctly oriented and installed in their proper locations.

If you choose not to etch your own board, a set of boards can be obtained from the source given in the Parts List.

Figures 4 and 5 are the parts-placement diagrams for the sensor and display boards, respectively. When assembling the boards, be sure that all of the polarized components (the display module, IC's, diodes, and electrolytic capacitors) are properly

oriented. It is mandatory that those components be placed in the circuit as shown. Doing otherwise will result in an inoperative circuit and possible component damage.

When assembling the sensor board, do not install SENS1 (the humidity sensor); that part will be installed later, when the circuit is calibrated. Be sure to use a socket for U2. That permits the project to be serviced should it ever become necessary, and is well worth the slight additional cost. A socket for the display is optional; one can be easily fabricated by cutting an 18-pin IC socket lengthwise in half to produce two 9-pin sections.

When handling the display module, be extremely careful not to exert excessive force; that unit is fragile. When inserting the IC and display into the boards be sure to orient them properly (as indicated in their respective parts-placement diagrams).

Note that most of the resistors specified in the parts list are 1% metal-film types. Those resistors are used in the

circuit to ensure temperature stability, as well as ensure that its calibration does not change with temperature variations or from component aging. Ordinary carbon resistors don't have the necessary stability, and should not be used as a substitute for metal-film resistors.

The sensor and display boards are connected to each other via a set of 15 wires; labeled "a" through "g," and

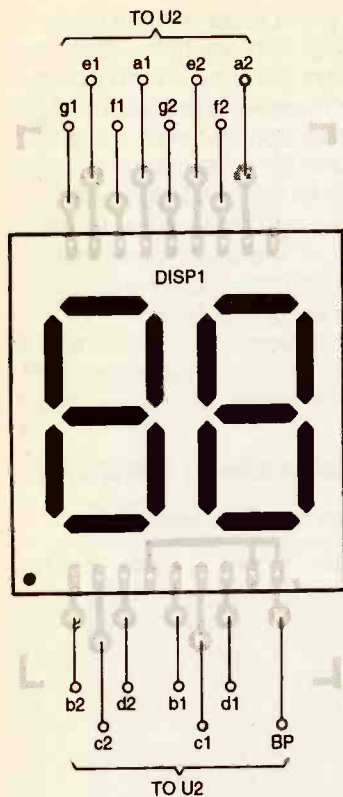


Fig. 5. The display board (as shown by this parts-placement diagram) holds only one component, the LCD readout. Although, from appearances it may seem difficult to assemble this board the wrong way, looks can be very deceiving, so make absolutely sure that the readout is properly oriented on the board.

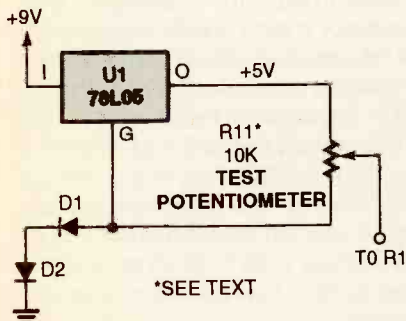


Fig. 6. The Digital Humidity Gauge can be calibrated using two procedures. The first is a two-point method, outlined in this diagram. It requires a potentiometer and digital voltmeter to set R4 and R7. (See the text for more details.)

BP (for back plane) in the parts-placement diagrams. For those connections, use #24 AWG or similar insulated stranded wire. Do not use solid wire; it will break during handling of the boards. Be sure to allow sufficient wire length in accordance with the final position of the assembly in the selected enclosure. The most compact

design is to stack the two boards on top of each other and mount the assembly to the front panel of the enclosure, with a rectangular opening into the front panel to allow the display to be viewed.

Connect a 9-volt battery connector to the circuit, and mount a 9-volt battery holder inside the enclosure to secure the battery in place so that it does not rattle around.

There is just one operating control, S1. It is recommended that a momentary "spring-return" switch (either toggle, slide, or pushbutton) be used for S1 so that there is no possibility of accidentally leaving the unit turned on after taking a humidity reading.

When you have finished assembling and wiring the project (with the exception of installing the humidity sensor), examine the circuit very carefully for shorts, especially between ad-

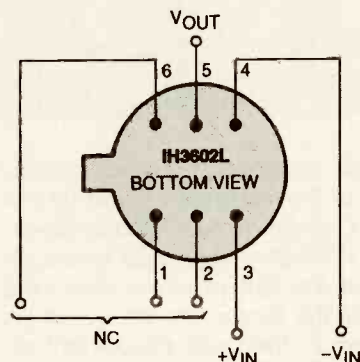


Fig. 7. The Hy-Cal IH3602L sensor, SENS1 (a 6-pin CMOS device with only 3-active terminals), is at the heart of the humidity measurement system. The IH3602L provides a DC output voltage that varies linearly with relative humidity levels from 0 to 100%.

jacent IC terminals, and cold solder joints (which may appear as rough or dull blobs of solder), and correct any deficiencies; it is far easier to fix a problem at this stage than during the checkout procedure when you turn the project on, only to find that the circuit does not work.

**Two-Point Calibration.** Either of two procedures can be used to calibrate the circuit: the two-point method (described here) and the one or two-point precision method (to be discussed a little later on). In the two-point method, see Fig. 6, a potentiometer and a digital voltmeter are used to set R4 and R7. It is recommended

that the two-point calibration be performed first to verify the proper operation of the circuit. Afterward, the second, more accurate, calibration procedure can be performed if desired (more on that later).

In Fig. 6, a 10k potentiometer (R11) is temporarily substituted for the humidity sensor. That unit is connected in parallel with C2, and the voltage at its wiper is then fed through R1 to the following circuitry as if it were the output of SENS1. By setting the voltage at the wiper of R4 to 0.08 volts and the wiper R7 to 3.65 volts, the digital display will show the correct reading.

Connect a fresh 9-volt battery (or a well-filtered 9- to 15-volt DC wall adapter) to the circuit. Turn S1 on and measure the output of U1 across C2. The reading should be 4.75 to 5.25 volts. If the voltage falls within that range, record the actual value on a piece of paper. If you do not obtain the correct voltage, disconnect power and troubleshoot the circuit to locate and correct the fault.

Check the orientation of C1, U1, U2, D1, and D2. Examine the circuit board carefully for any possible shorts, especially between closely spaced copper conductors. Check the output voltage and polarity of the power source to be sure it is delivering at least 8 volts to the regulator. If everything looks good, try a new regulator. When the fault has been corrected, record the actual output voltage of the regulator and proceed with the checkout.

With power applied to the circuit, the display should show a two-digit number that varies as R11 is adjusted. If either or both of the digits have incorrectly illuminated or extinguished segments, the problem lies with one or more of the 14 segment connections between U2 and the display.

Refer to the schematic diagram to determine which wire connections between U2 and DISP1 are at fault. Use an ohmmeter to verify any suspect connections which can be either shorted or open circuits, or miswiring. If the display is totally blank, the problem most likely lies with the back-plane signal that runs between U2 pin 21 and DISP1 pins 1, 2, and 6. Refer to Figs. 4 and 5 to verify that U2 and the display module are properly oriented and correctly wired together.

If an oscilloscope is available, pin



21 of U2 can be checked for the presence of the back-plane signal. A 60-Hz squarewave of about 6 volts peak-to-peak is a normal indication. If that signal absent and the component orientation and wire connections are correct, try a new U2.

At this point, with the display reading properly, the calibration can be performed. First calculate the nominal output voltage of the sensor, for 0% and 100% RH, by using the following two expressions:

$$V_L = (0.8)(V)/5$$

$$V_H = (3.65)(V)/5$$

where  $V_L$  is the nominal output of the sensor at 0% RH,  $V_H$  is the nominal output of the sensor at 100% RH, and  $V$  is the regulated supply voltage as measured and recorded earlier.

Set R7 to mid-position. Connect the negative lead of the digital voltmeter to the anode of D1, and the positive

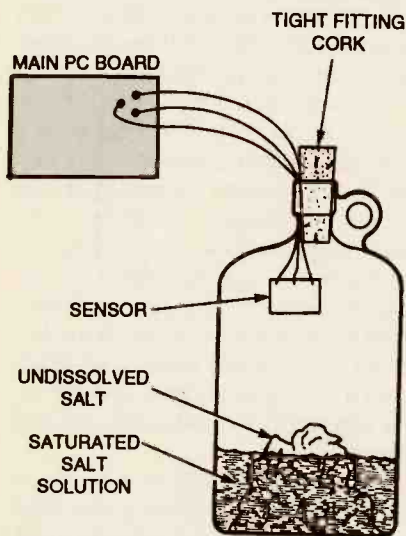


Fig. 8. The second calibration method uses the first procedure, coupled with the one outline in this illustration. (See the text for full details.)

lead to the wiper of R11. Adjust R11 so that the DVM reading is equal to the  $V_L$  value calculated above. Adjust R4 so that the display reads 00. Note: The A/D converter is capable of displaying negative numbers even though no polarity sign is used in this circuit. As a result, the display will vary from both sides of 00 as R4 is adjusted.

Set R11 so that the DVM reads  $V_H$  as calculated earlier. Adjust R7 so that the display reads 00 (representing 100% RH). Perform those steps several times to ensure that neither R4 nor R7 need further adjustment.

TABLE 1—RH OF VARIOUS SATURATED SALT SOLUTIONS

Salts	Percent RH
Lithium Bromide	6.4
Lithium Chloride	11.3
Potassium Acetate	22.7
Magnesium Chloride	32.8
Potassium Carbonate	43.2
Magnesium Nitrate	53.2
Potassium Iodide	69.1
Sodium Chloride	75.3
Ammonium Sulphate	81.1
Potassium Chloride	84.3
Potassium Nitrate	93.8

end of the scale and the other near the high end; select the appropriate solutions using the information in Table 1. However, an easier one-solution method can be used if desired. To perform the one-solution calibration, adjust R4 first for 0% RH (as discussed earlier), and then use a saturated solution of sodium chloride (common table salt and water) and adjust R7 for a display of 75% RH.

To calibrate the circuit, the humidity sensor must be temporarily connected to the sensor board via a

TABLE 2—CORRECTION FACTOR FOR VARIATIONS IN AMBIENT TEMPERATURE

Ambient Temperature In Degrees F	Uncorrected Relative Humidity Reading						
	20%	30%	40%	50%	60%	70%	100%
25	-1.2	-1.7	-2.3	-2.8	-3.4	-4.0	-5.7
35	-1.0	-1.4	-1.8	-2.3	-2.8	-3.2	-4.6
45	-0.8	-1.0	-1.4	-1.7	-2.1	-2.4	-3.5
55	-0.5	-0.7	-0.9	-1.2	-1.4	-1.6	-2.3
65	-0.3	-0.4	-0.5	-0.6	-0.7	-0.8	-1.2
75	0	0	0	0	0	0	0
85	0.2	0.3	0.5	0.6	0.7	0.9	1.2
95	0.4	0.7	1.0	1.2	1.5	1.7	2.5
105	0.7	1.1	1.5	1.9	2.2	2.6	3.7

That completes the initial calibration of the instrument. If you do not elect to perform the more precise circuit calibration described below, remove the test potentiometer and place the sensor into the circuit (as shown in the parts-placement diagram, Fig. 4).

**One or Two-Point Precision Calibration.** The known property of a saturated salt solution having a specified RH level in the enclosed air space above the liquid level provides the means for a simple but accurate calibration of the instrument. In this method, a sealed bottle containing a mixture of a specified salt and water produces a known level of relative humidity in the air above the liquid at a given temperature.

To calibrate the unit, the sensor is placed in the air space of a sealed container that holds the saturated salt solution. When equilibrium is reached (when the liquid and water vapor in the bottle are at the same temperature), the appropriate potentiometer (R4 or R7) adjustments are made as described below.

The most accurate method is a two-point calibration performed by selecting two solutions, one near the low

three flexible wires. To aid in the hook up of the sensor, a pinout diagram of the sensor is shown in Fig. 7. Note (as mentioned earlier) although the unit is a 6-pin device, it has only 3 active terminals.

Refer to Fig 8. The solutions are prepared by mixing a sufficient quantity of the selected salt with water, so that the excess undissolved crystals that remain are saturated with water and at a level slightly above the liquid level. It is very important that the bottle be absolutely air tight. The temperature of the solution and the room should be as close to 75°F (24°C) as possible, and remain constant, to ensure accuracy.

Place the sensor in the air space above the liquid. **Caution:** At no time should any liquid or salt be allowed to touch the sensor. Doing so could damage it. Allow a minimum of ½ hour for stabilization; 1 to 2 hours is better. That time delay is required to allow the air space within the bottle to reach its final level of relative humidity.

Adjust the appropriate potentiometer until the display shows the value specified in Table 1, rounded to the nearest integer, for the selected salt solution. For example, if sodium chlo-

(Continued on page 106)

# Build a Remote-Control Relay Station

*A one-evening project can help your remotes' signals turn corners, or boost their power for well-lit or extra-long rooms.*

BY JOHN YACONO



I really think remotes are great. They give you the freedom to control a battery of entertainment units and other equipment from a single location. To some that's a support for laziness, but to me that freedom makes it easier to switch to more enriching programming if what I'm watching or hearing isn't worth the time.

Sometimes though, that freedom extracts an extra price. For example, you might have to draw a blind to keep sunlight from interfering with a remote (a problem in one unfortunately shaped room in my house). Or perhaps you might have to place a couch or easy chair conspicuously in the middle of a very large media room (a problem for a friend of mine). You are also confined to the room containing the equipment—that's hardly full freedom.

Of course, a remote booster may solve the first two problems, but with three provisos: you must deal with added bulk on the remote, the booster must be strong enough to work from the viewing position, and you must swap the booster between remotes or buy more than one. So a booster may be unsightly, tiring to hold, still inadequate for some rooms, and either a pain or expensive for multi-remote use. It is also unlikely to bounce signals around corners.

An alternative is to use an RF universal remote. However, you must find one that is "universal" enough for all your equipment. Furthermore, they

tend to lack buttons for most equipment's special features (commercial skip, alternate channels, a jog shuttle, etc.) which might have played a part in your original purchase decision. Not to mention they're down-right frightening to non-technical family members (believe me, I know)! Besides, most folks are looking to reduce the amount of RF around the home due to the ELF health scare (see "Electromagnetic Fields and Your Health," **Popular Electronics**, March, 1993).

A third possibility is to use an IR-to-RF relay station. They allow you to use your own remotes from any location, but again, only provided your not concerned about RF radiation. Oh yes, and you must plunk-down around \$100 (almost the cost of a play-only VCR with its own remote).

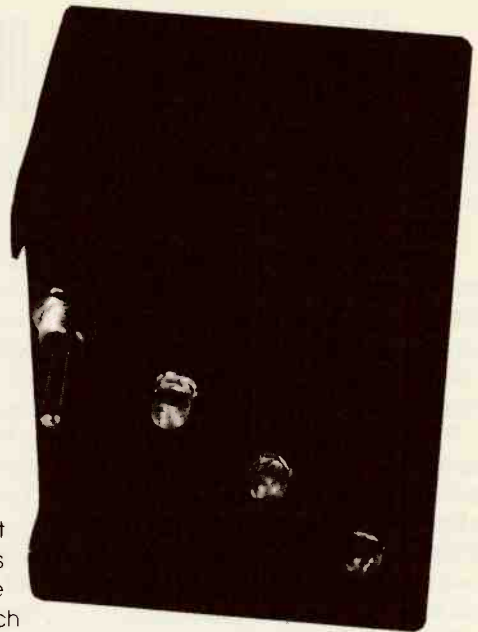
I didn't like any of the mentioned alternatives, so I built the *Remote-Control Relay Station*. It looks for IR signals, demodulates them (to ensure they're from a remote), then re-modulates and broadcasts them at high-power. It can be placed anywhere between the remote user and the equipment (say on a coffee table) to act as an unobtrusive booster, or in a strategic corner to rebroadcast signals from a user down a hallway. Also, the units are so inexpensive to build, it would be more economical to build several to relay signals between rooms than to buy an RF remote or IR-to-RF relay station.

To add to its charm, the circuit is

simple to build, and it's a good project for beginners. Its components are readily available, and no special PC board is required. The unit's simplicity is mainly due to the use of an all-in-one IR-demodulator module. Let's discuss its operation and function first.

**Demodulating IR.** Remote controls basically transmit serial digital information. They encode digital pulses on an IR carrier by turning the carrier on and off. That is known as burst-style data transmission. To see what all that means, take a look at Fig. 1. The top-most waveform represents a series of digital pulses that need to be transmitted by the remote control one at a time. The remote control transmits them by turning on a 40-kHz oscillator for the duration of each pulse. The output of the oscillator (represented by the bottom plot) drives an infrared emitter that pumps those 40-kHz pulses into the room as IR.

As mentioned earlier, the Remote-Control Relay Station uses a special module to detect and convert those 40-kHz IR pulses back into the digital pulses they represent. It is called the GPIU52X infrared-detector module. To help explain its operation, I have broken it down into functional blocks that are shown in Fig. 2. Refer to that figure as I explain further.





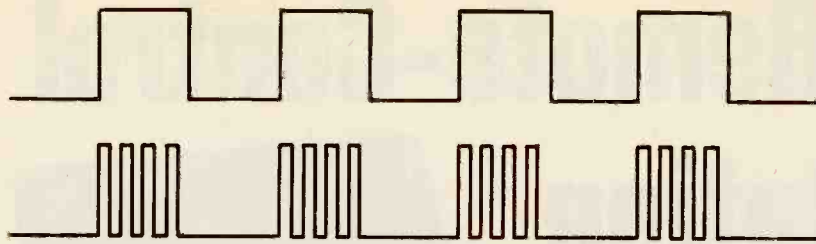


Fig. 1. Some data pulses that must be encoded and transmitted by a remote are shown at the top. The data is transmitted as a series of bursts of infrared as shown in the bottom plot.

All IR is received by the module via an IR photodiode. The diode is operated in its reverse-bias mode. The amount of reverse-bias current it permits depends on the intensity of the received infrared light.

The fluctuations in the reverse-bias current are then amplified by a high-gain stage. The output of the amplifier is then "limited" by the next stage. The limiter chops the extreme highs and lows off the amplified signal and the result is a quasi-digital pulse train.

The simplified wave then passes through a bandwidth filter. It has its center frequency at 40 kHz and a bandwidth of  $\pm 4$  kHz. The filter cuts out more noise and also prevents sources of infrared operating at the wrong frequency (such as the light bulb) from causing false activation. The filtered signal is then rectified for further processing.

At that point, the circuit has effectively retrieved the 40-kHz remote carrier. The reproduced carrier is then integrated. What that means is that it is

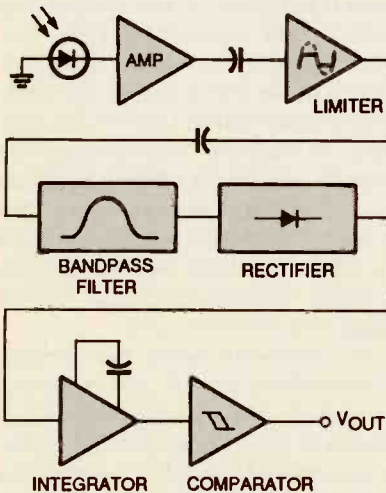


Fig. 2. The module stages look something like this. Together they process infrared light to extract any pertinent waveform and then demodulate it.

sent through a filter that responds slowly to the changing signal—too slowly to follow the 40-kHz carrier pulses, but quick enough to rise and fall significantly with each burst and pause between bursts, respectively.

The next stage takes advantage of those characteristics. It is called an "inverting Schmitt trigger." It will not go low unless the filter's output signal surpasses a certain amplitude, and will not go high again until the signal drops below a certain minimum. Thus the Schmitt trigger only responds to large changes in the filter's output (caused by bursts and pauses) and ignores small changes (caused by the 40-kHz carrier to which the filter can't respond quickly). The Schmitt-trigger's output is thus low when a 40-kHz burst

## PARTS LIST FOR THE RELAY STATION

### SEMICONDUCTORS

- U1—555 oscillator/timer, integrated circuit
- Q1—2N2222 general-purpose NPN silicon transistor
- Q2—2N3906 general-purpose PNP silicon transistor
- LED1—LED3—SY-IR53L IR-light-emitting diode
- MOD1—GPIU52X IR detector/demodulator module (Radio Shack No. 276-137)
- D1—D2—2.4-volt, 500-mW Zener diode
- D3—1N914 general-purpose small-signal silicon diode

### RESISTORS

- (All resistors are 1/4-watt, 5% units unless otherwise indicated.)
- R1, R2—18,200-ohm, 1/4-watt, 1%
- R3—47-ohm
- R4—100,000-ohm
- R5, R6—10,000-ohm

### ADDITIONAL PARTS AND MATERIALS

- C1—0.001- $\mu$ F, NPO ceramic-disc capacitor
- C2—0.1- $\mu$ F bypass capacitor
- B1—9-volt transistor-radio battery
- S1—SPST on/off switch
- Project box, double-sided foam, perf-board, wire, solder, etc.

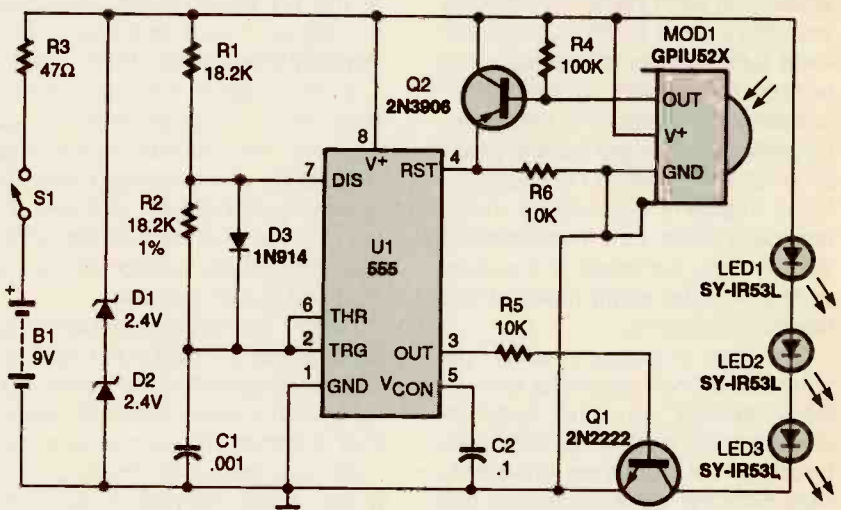


Fig. 3. In the IR-relay circuit, all of the signal processing is performed by the infrared detector/demodulator module, MOD1. The rest of the components regulate power and generate 40-kHz IR pulses.

is received, and high during pauses between bursts. The resulting waveform is an inverted version of the pulses that were modulated and transmitted by the remote. Let's turn our attention to the project to see how those signals are put to use.

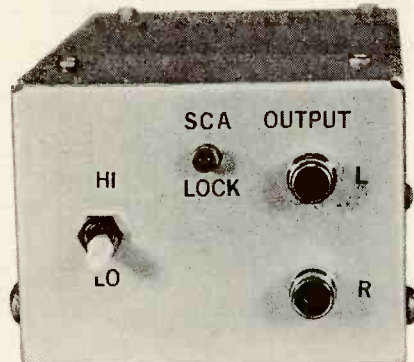
**The Relay Circuit.** A schematic diagram of the Remote-Control Relay Station is shown in Fig. 3. To summarize its pertinent features, it consists of the IR-demodulator module (MOD1) connected to an inverter (made of Q2, (Continued on page 102)

**F**rom time to time, articles on SCA communications have appeared in hobby-electronics periodicals. The articles range in emphasis from circuit experiments and construction projects to rather sensational sounding descriptions of secret or mysterious signals not accessible to the general public. Actually, there is nothing really that mysterious about SCA, which stands for Subsidiary Communications Authorization.

The technical basis for SCA is the FM-on-FM data-transmission technique developed by range-instrumentation engineers back in the 1950's. Shortly afterward, the FCC authorized its use by FM stations to expand their services. FM stations broadcasting SCA programs frequency-modulate their main carrier (88 to 108 MHz) with one or both of the commonly used subcarrier frequencies of 67 and 90 kHz. Those subcarrier frequencies are, in turn, modulated with program material. In order to prevent interference with the main program, both the amplitude and upper-frequency limit of the SCA programs are held to relatively low values.

Since SCA program material is not meant for reception by the general public, the FCC protects it by prohibiting manufacturers from selling SCA-capable receivers on the consumer market. For electronics experimenters, however, it is not hard to build a demodulator that can be connected to any FM tuner to receive these transmissions.

**About the Circuit.** A schematic diagram for the SCA Adapter is shown in Fig. 1. The circuit, for the most part, is comprised of seven active elements: five assorted transistors and two IC's. The 67- or 90-kHz subcarrier signal is picked off the FM tuner (more on that later) as the input to the circuit. After passing through a parallel-T network, the signal is applied to the input of a two-stage amplifier comprised of Q1 and Q2. That amplifier boosts the signal's strength by about 20 dB before it is applied to the input of U1 (an XR2211CP FSK demodulator/tone decoder) at pin 2. That chip contains a phase-locked loop or PLL (which in its most basic form is comprised of a phase comparator, low-pass filter, and a voltage-controlled oscillator or VCO), a quadrature phase detector



# SCA Adapter

*Hear the hidden broadcasts on the FM band with this easy-to-build add-on unit.*

BY DON McCORMICK

(which provides carrier detection), an FSK voltage comparator, and a pre-amp. It is specifically designed for data communications, can operate over a wide supply-voltage range (4.5–20 volts), and can accommodate analog input signals of from 2 mV to 3 volts. Timing capacitor C7 (connected between pins 13 and 14) and the total resistance connected between pin 12 and ground determine the circuit's lock or center frequency. Switch S1 allows the user to select either 67-kHz (LO) or 90-kHz (HI) SCA reception.

The voltage at pin 6 is held at zero when the input signal is either off-frequency or missing. When locked, pull-up resistor R16 causes pin 6 to go high (rising to about 7 volts), causing Q5 to turn on and LED1 to light.

That high also causes squelch transistor Q4 (a 2N3820 P-channel JFET) to turn off. That allows the twice-demodulated signal, which is output at pin 11

of U1, to be fed through R18, C18, and R19 to the base of Q3 (the output amplifier).

Power for the SCA Adapter is derived from the circuit consisting of T1, BR1, U2, and their support components. T1 can either be a standard power transformer as specified in the Parts List or a wall-plug type with an appropriate AC output.

**Assembly.** The SCA Adapter was assembled on a small printed-circuit board measuring about 4 $\frac{3}{16}$  by 2 $\frac{1}{16}$  inches. A full-size template of the circuit-board layout is shown in Fig. 2. Once you have etched your own printed-circuit board and gathered all of the required parts, construction can begin.

Note that all components are readily available and none are critical to proper operation of the circuit with the possible exception of C7. Although a polystyrene capacitor is recommended for C7, a polyester unit can be substituted. Since the P-Channel JFET might be hard to find, three choices for it are listed in the Parts List.

Guided by the parts-placement diagram shown in Fig. 3, install the passive components first—beginning with an IC socket for U1, followed by the resistors and capacitors (making sure that the polarized capacitors are properly oriented). Normally, it would be advisable to install the jumper connections at this time, but because the jumpers will have to be snaked around many of the board-mounted components it is recommended that they be installed just before mounting U1 in its socket. When you reach the jumper phase of construction, leave one end of the squelch jumper (JU1) disconnected; that will deactivate the squelch function, thereby avoiding confusing behavior during the circuit's checkout routine.

In any event, once the passive components have been installed, install the active components, starting with the diodes followed by the transistors and U2. Do not install U1 in its socket yet; it will not be installed until the checkout phase of the construction. If desired, LED1 can be temporarily mounted directly to the board to facilitate the checkout.

**Checkout.** The circuit must be checked out and aligned before it is



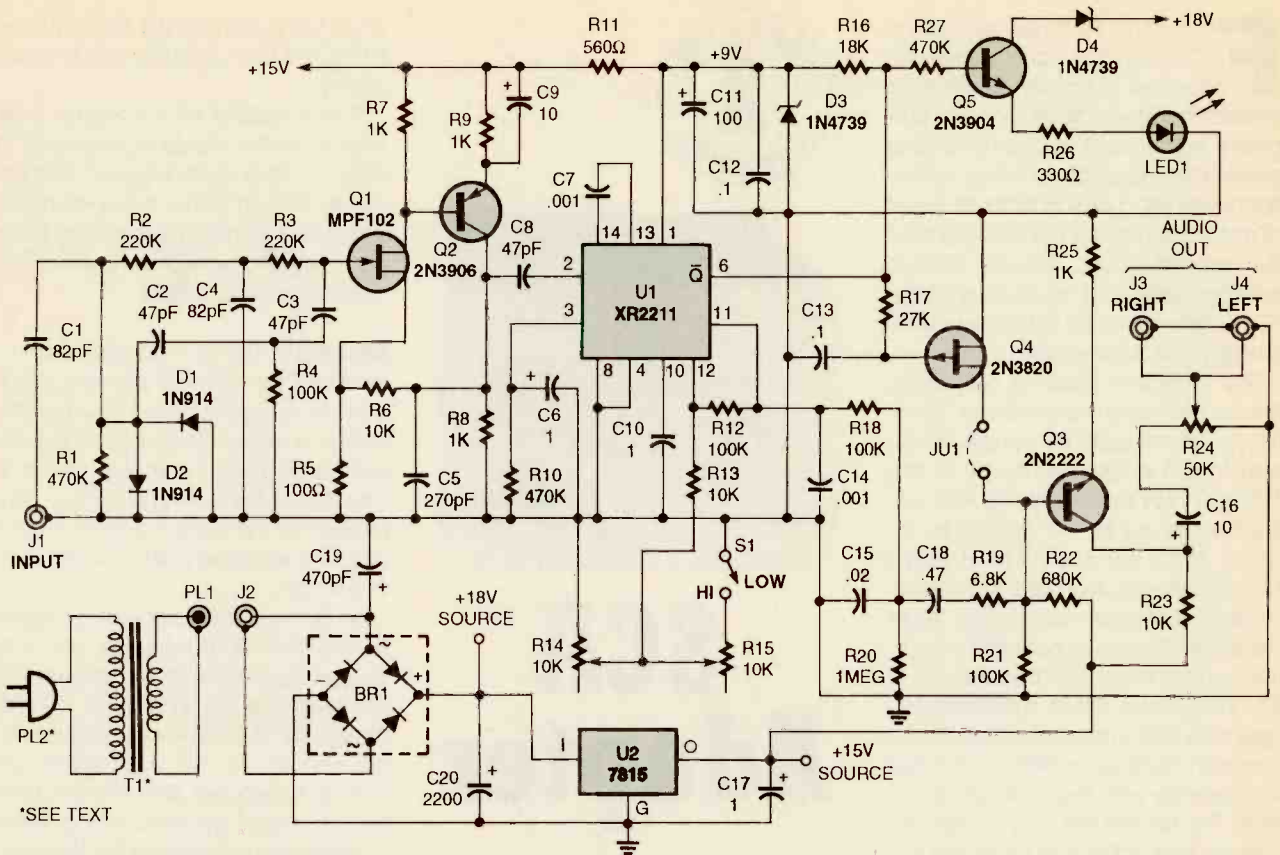


Fig. 1. This SCA adapter is built around an XR2211 FSK demodulator, some transistors, and a handful of support components.

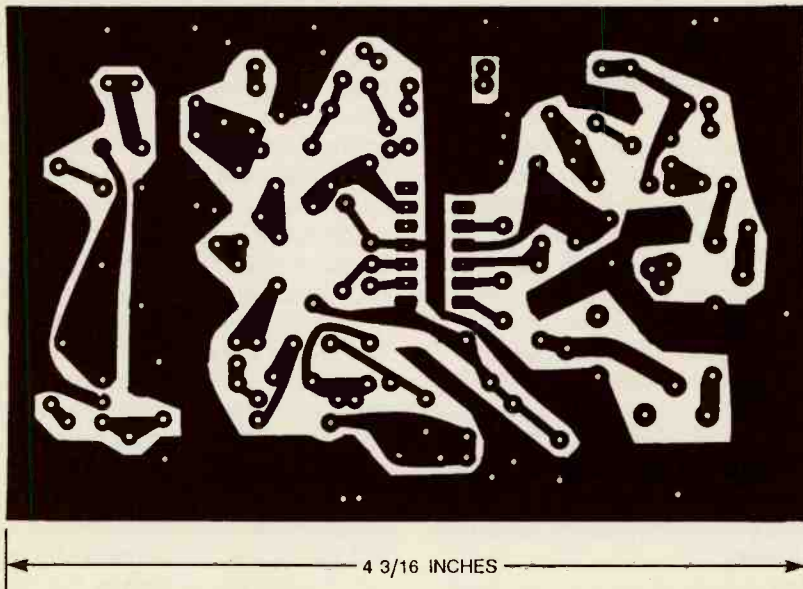


Fig. 2. Although not strictly needed, this foil pattern allows for neat and easy construction. It is shown here full size.

permanently connected to an FM receiver or mounted in an enclosure. Once the circuit has been assembled and you have double-checked your work, set each of the trim potentiometers at the midpoint of its rotation.

Power up the circuit and check the +18- and +15-volt DC voltages. Also, the voltage at pin 1 of the IC socket should measure between +8 and +9 volts DC. If the DC supply voltages are okay, remove power from the cir-

cuit, install the jumpers, and install U1 in its socket.

**Set-Up and Use.** The best way to align the board is with a signal generator that can cover the range from 50 to 100 kHz. With S1 set to the  $\infty$  position, feed a low-level 67-kHz signal into the input and adjust R14 until LED1 lights. Continue adjusting R14 to find the point where the LED goes off and trim the adjustment to midway between the on and off points. Set S1 to the HI position, feed a 90-kHz signal to the input, and repeat the operation, this time adjusting R15.

In selecting a tuner or receiver you have two options. First, you can be brave and resourceful and use your favorite equipment. If that is too much excitement in your life, you can go looking for an old clunker tuner or pull-out car radio at garage sales, etc., keeping in mind that, while it can be either stereo or mono, it must work properly as an FM tuner. It should also have reasonably good RF and IF linearity to avoid cross-talk leakage between the main program and the SCA output. Modern PLL/digitally tuned re-

## PARTS LIST FOR THE SCA ADAPTER

### SEMICONDUCTORS

U1—XR2211CP FSK demodulator, integrated circuit (Exar)  
 U2—7815 15-volt voltage regulator, integrated circuit  
 Q1—MPF102 N-channel JFET transistor  
 Q2—2N3906 PNP transistor  
 Q3—2N222 NPN transistor  
 Q4—J176, 2N3820, or NTE-326 P-channel JFET transistor  
 Q5—2N3904 NPN transistor  
 D1, D2—1N914 silicon diode  
 D3, D4—1N4739 9-volt Zener diode  
 LED1—red light-emitting diode  
 BR1—1.5-amp, 100-PIV bridge rectifier (Radio Shack 276-1152 or equivalent)

### RESISTORS

(All fixed resistors are 1/4-watt, 5% units unless otherwise indicated.)  
 R1, R10, R27—470,000-ohm  
 R2, R3—220,000-ohm

R4, R12, R18, R21—100,000-ohm  
 R5—100-ohm  
 R6, R13, R23—10,000-ohm  
 R7—R9, R25—1000-ohm  
 R11—560-ohm, 1/2-watt  
 R14—10,000-ohm, potentiometer  
 R15—25,000-ohm, potentiometer  
 R16—18,000-ohm  
 R17—27,000-ohm  
 R19—6,800-ohm  
 R20—1-megohm  
 R22—680,000-ohm  
 R24—50,000-ohm, potentiometer  
 R26—330-ohm

### CAPACITORS

C1, C4—82-pF, ceramic-disc  
 C2, C3, C8—47-pF, ceramic-disc  
 C5—270-pF, ceramic-disc  
 C6—1- $\mu$ F, tantalum  
 C7—.001- $\mu$ F, polystyrene  
 C9, C16—10- $\mu$ F, 16-WVDC, electrolytic  
 C10, C12, C13—0.1- $\mu$ F, ceramic-disc

C11—100- $\mu$ F, 16-WVDC, electrolytic  
 C14—.001- $\mu$ F, Mylar  
 C15—.02- $\mu$ F, Mylar  
 C17—1- $\mu$ F, 16-WVDC, electrolytic  
 C18—0.47- $\mu$ F, Mylar  
 C19—470-pF, ceramic-disc  
 C20—2200- $\mu$ F, 25-WVDC, electrolytic

### ADDITIONAL PARTS AND MATERIALS

T1—12-15-volt, 100-300-mA power transformer (Radio Shack 273-1385 or equivalent), see text  
 S1—SPST switch  
 J1, J3, J4—phono jack  
 J2—coaxial power jack  
 PL1—coaxial power plug  
 PL2—AC power plug  
 PC board; enclosure (Radio Shack 270-238 or equivalent), see text; solder, wire, hardware, etc.

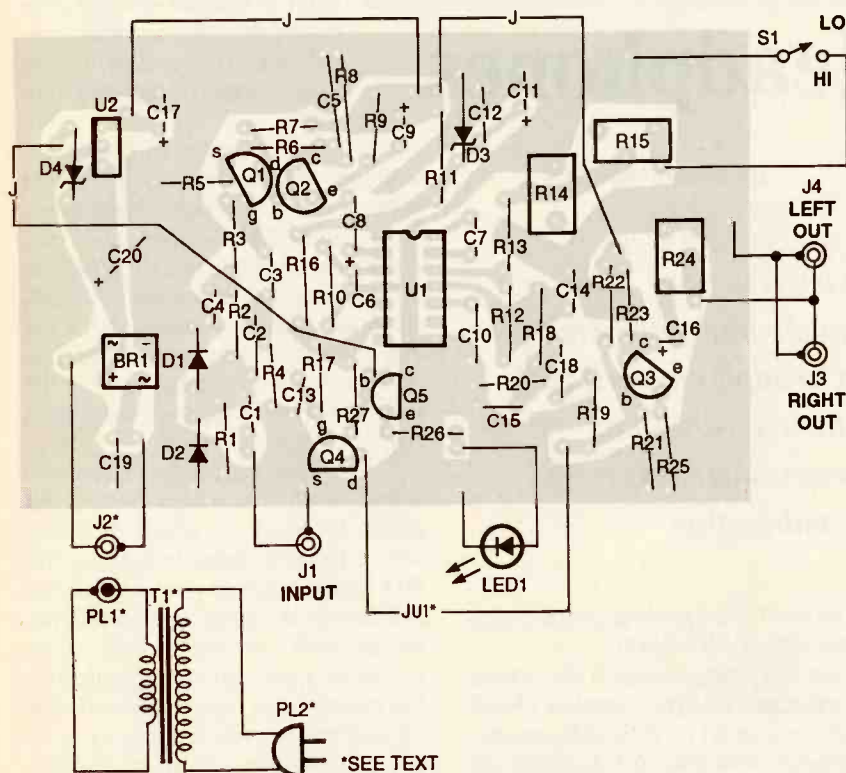


Fig. 3. Use this parts-placement diagram when installing parts on the PC board. Do not install jumper JU1 until the board has been completely checked out.

ceivers seem to be best in this regard.

If you have aligned your SCA board as previously described, you may use it as a probe to find the baseband signal take-off point in the receiver. The proper connection point is at the output of the FM demodulator before

any de-emphasis circuitry. Locate a strong station, one that you know is broadcasting SCA signals. Connect the output of the SCA circuit to another amplifier and speaker and listen while you make trial connections to the receiver. Remember that the

better the reception of the main FM program, the better the SCA reception. Once you've located the correct connection point, touch up the potentiometer settings by ear and enable the squelch circuit by connecting jumper JU1.

If you were unable to pre-align your SCA circuit, the same basic hook-up procedures should be followed, but there is a lot more trial-and-error involved. Set R14 to its midpoint for starters and try various combinations of hookup points and R14 settings until you find an SCA signal.

Now for the finished product. There are two ways to go. The easiest and most obvious is to house the SCA Adapter in a separate enclosure. If you choose to go that route, an appropriate enclosure is listed in the Parts List. You will also want to use a wall-plug type transformer rather than the one mentioned in the Parts List. Just make sure the one you select has an appropriate AC output.

The other approach is to house the adapter in the same enclosure as the radio with which it will be used. You will then need to select the unit so that there is sufficient space for the board and T1. The adapter controls can then be added to the front-panel of the receiver or mounted on a small piece of angle aluminum that is added to the top or side of the enclosure. ■



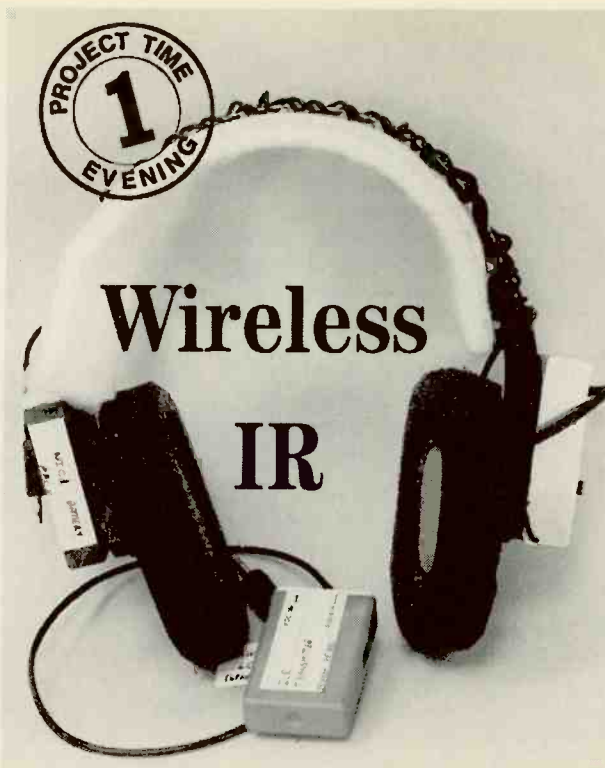
**T**he age of wireless is here. Although the term "wireless" has until recently implied radio that is by no means the only wireless media. The *Wireless Headphone* project described in this article uses a different form of wireless link—infrared. Using a 100-kHz frequency-modulated (FM) carrier, the Wireless Headphone has a 4-kHz bandwidth, making it suitable for general-purpose listening. Its high carrier frequency provides interference-free operation, even around most consumer IR remote controls, which operate with a carrier frequency of 40 kHz. And it requires no special connections to the radio or TV.

The power requirements for the system are modest: The transmitter requires a 7- to 14-volt, 200-mA DC supply, while the receiver draws about 10 mA (at minimum volume) from a 9-volt battery. The receiver has a volume control for convenience, although the audio source's volume control may also be used to that end.

**The Transmitter Circuit.** The transmitter for the Wireless Headphone (see Fig. 1) consists of a pair of infrared LED's and a CD4046 CMOS phase-locked loop (or PLL, which is comprised of two phase comparators, a voltage-controlled oscillator or VCO, a source follower, and a Zener reference)—coupled with a driver transistor. Note that in this application, only the PLL's VCO is used.

The VCO's supply voltage is stabilized by the internal Zener reference. The VCO input at pin 9 is biased near the midpoint of the VCO's linear region. The VCO's programmable sensitivity and high input impedance eliminates the need for signal pre-conditioning.

Components C1 and R2 provide impedance matching for low-impedance speakers; those components should be eliminated if the audio source has a high impedance (600 ohms). The VCO frequency is set by R4, R5, and C4 for a minimum frequency of 85 kHz, a maximum frequency of 115 kHz, and a nominal center fre-



# Headphones

BY BRIAN MCKEAN

*Listen to your favorite music unencumbered from a headphone cord with this easy-to-build transmitter/receiver combination*

quency of 100 kHz, which yields a VCO sensitivity of 7.5 kHz/volt.

The VCO output at pin 5 of U1 drives a saturated common-emitter circuit, built around Q1 (a 2N2222A general-purpose NPN silicon transistor). Although U1's Zener reference decouples the VCO from supply variations, the IR-emitter current is not regulated. Components shown in the schematic should be suitable for most applications. The number of IR emitters (on our circuit, LED1 and LED2) connected to the collector of Q1 can be increased to provide increased room coverage, as long as the supply volt-

age is sufficient to drive the LED string. Allow 1.8 volt per LED, and select R7 so that the peak current through the LED's does not exceed the part specification (typically 100 mA).

The IR transmitter's supply voltage may be an unregulated DC source greater than 7 volts. An internal Zener reference at pin 15 of U1 regulates the supply to 5–6 volts for the VCO. The current through the IR LED's may be adjusted by changing the value of R7 to suit the diode ratings.

**Receiver.** The schematic diagram of the receiver for the Wireless Headphone—essentially a reverse-biased photodiode detector/amplifier—is shown in Fig. 2. That circuit consists of a CA3237 high-gain IR remote-control preamp (U1), a 4046 phase-locked loop (U2), and an LM386 low-voltage audio amplifier (U3).

Integrated circuit U1—which is designed for 40-kHz carrier systems but can provide limiting action to up to 1 MHz—contains two amplifiers whose gain is set by C6/R4, and C7/R5. Together those components provide DC and low-frequency blocking, while setting the combined gain of the amplifiers to about 85 dB at 100 kHz. The Schmitt-trigger section (pins 4 and 6) of U1 is not used.

The IR remote-control preamp's output at pin 7 is AC coupled to the phase-locked loop, which operates with a 100-kHz center frequency. The PLL's 15-kHz capture range allows for considerable center-frequency mismatch with the transmitter while providing proper demodulation bandwidth and noise rejection. The VCO of the PLL has a range of  $\pm 30$  kHz around the center frequency, which also allows for transmitter/receiver mismatch without unduly sacrificing loop performance.

The loop lowpass filter output contains the demodulated audio signal and is internally buffered at pin 10. The audio is filtered and fed through amplitude control R12 to the non-inverting input of U3 (an LM386 low-voltage audio power amplifier), which pro-

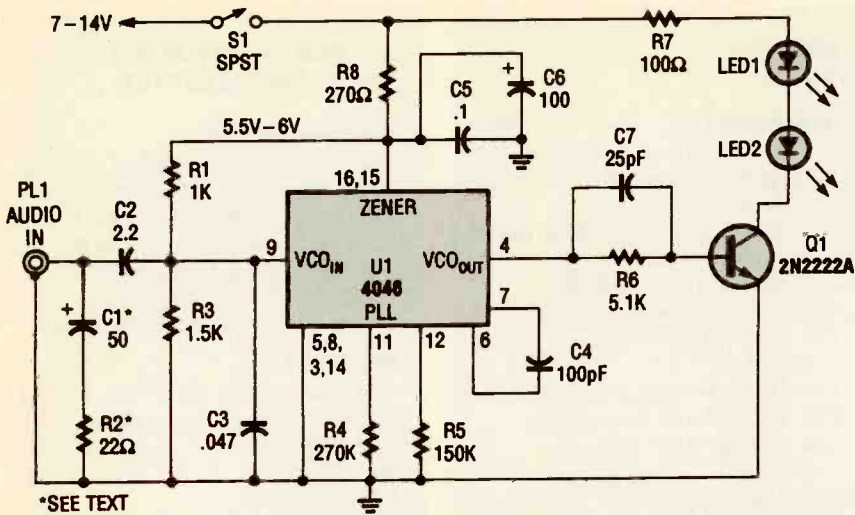


Fig. 1. The transmitter for the Wireless Headphone is built around a CD4046 CMOS phase-locked loop or PLL, coupled with a driver transistor, and a pair of infrared LED's. Although the CD4046 is comprised of two phase comparators, a voltage-controlled oscillator (or VCO), a source follower, and a Zener reference, only its VCO is used in this application.

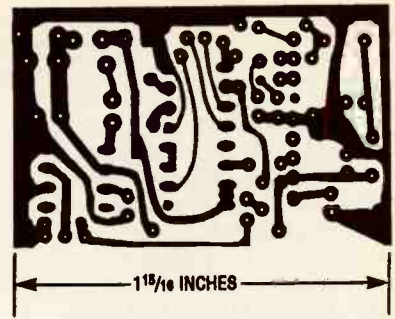


Fig. 4. The receiver's full-size printed-circuit layout is shown here.

require such a circuit to be enclosed in a metal case to provide electrostatic shielding. That may not be necessary, but is recommended for best range.

**Assembly.** Most parts are quite non-critical. Many parts can be replaced with near value(s) without affecting

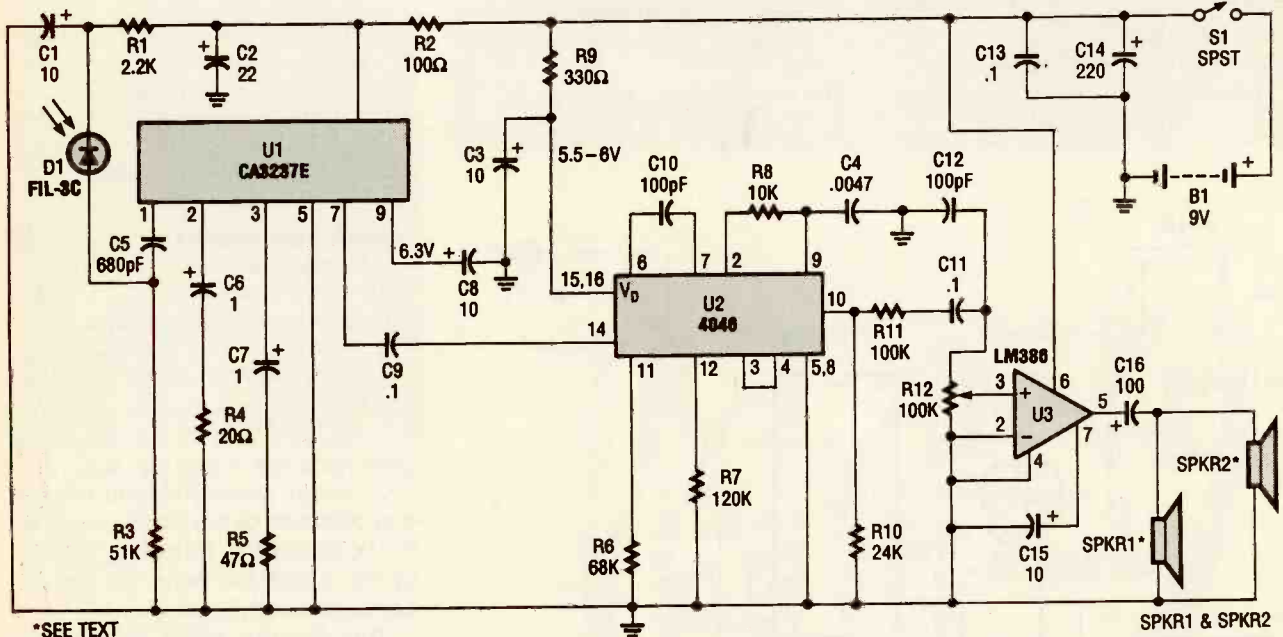


Fig. 2. The receiver for the Wireless Headphone consists of a CA3237 high-gain IR remote-control preamp (U1, which is designed for 40-kHz carrier systems.), a 4046 phase-locked loop (U2), and an LM386 low-voltage audio amplifier (U3).

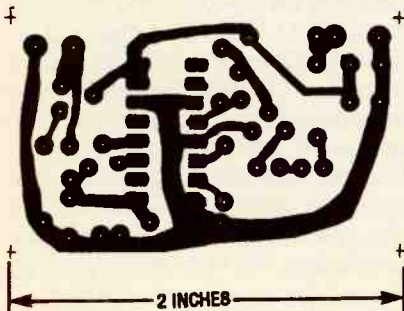


Fig. 3. The transmitter's printed-circuit layout is shown here at full size.

vides 26-dB gain and will easily drive a paralleled pair of AC-coupled, low-impedance earphones.

Voltage regulation in the receiver is provided by U1 and U2, with the assistance of R2 and R9. The receiver will operate from supply voltages as low as 7 volts, making battery operation from a rechargeable 9-volt battery highly practical.

A final note regarding the high-gain receiver: Normal practice would

the circuit. The exceptions are noted on the schematic diagrams by asterisks—those parts should not be replaced with any other value. If you can not find the specified photodiode, one salvaged from a commercial IR receiver should work well. It should have a capacitance of 30 pF or less at -5 volts, and be 0.1-inch diameter or less. The electrolytic capacitors should be miniature radial-lead units.



## PARTS LIST FOR THE RECEIVER

### SEMICONDUCTORS

U1—CA3237E IR preamplifier (NTE1682), integrated circuit  
 U2—CD4046B CMOS phase-locked loop, integrated circuit  
 U3—LM386 low-voltage, audio-power amplifier, integrated circuit  
 D1—FIL-3C, FIL-5C, PIN-3CD, PIN5D, or similar IR-detector diode

### RESISTORS

(All fixed resistors are 1/8-watt, 5% units.)

R1—2200-ohm  
 R2—100-ohm  
 R3—51,000-ohm  
 R4—20-ohm  
 R5—47-ohm  
 R6—68,000-ohm  
 \*R7—120,000-ohm  
 \*R8—10,000-ohm  
 R9—330-ohm  
 R10—24,000-ohm  
 R11—100,000-ohm  
 R12—100,000-ohm PC-mount potentiometer

### CAPACITORS

C1, C3, C8, C15—10- $\mu$ F, 16-WVDC, radial lead electrolytic or tantalum  
 C2—22- $\mu$ F, 16-WVDC, radial lead electrolytic or tantalum  
 \*C4—0.0047- $\mu$ F, ceramic-disc  
 C5—680-pF, ceramic-disc  
 C6, C7—1- $\mu$ F, 16-WVDC, electrolytic  
 C9, C11, C13—0.1- $\mu$ F, ceramic-disc  
 \*C10, C12—100-pF, ceramic disc  
 C14—220- $\mu$ F, 16-WVDC, electrolytic  
 C16—100- $\mu$ F, 16-WVDC, electrolytic

### ADDITIONAL PARTS AND MATERIALS

SPKR1—8-32-ohm speaker  
 S1—SPST toggle switch  
 B1—9-volt alkaline, or rechargeable battery  
 Printed-circuit materials, enclosure, earphone jack, 9-volt battery connector, wire, solder, hardware, etc.

\*Do not substitute

## PARTS LIST FOR THE TRANSMITTER

### SEMICONDUCTORS

U1—CD4046B phase-locked loop (do not use the 74C version)  
 Q1—2N2222A general-purpose NPN silicon transistor (use TO-18 if driving LED at high current)  
 LED1, LED2—RS276-143 infrared, light-emitting diode (Radio Shack)

### RESISTORS

(All fixed resistors are 1/8-watt, 5% units, unless otherwise noted.)

R1—1000-ohm  
 R2—22-ohm  
 R3—1500-ohm  
 R4—270,000-ohm  
 R5—150,000-ohm  
 R6—5100-ohm  
 R7—100-ohm, 1/4-watt  
 R8—270-ohm, 1/4-watt

### CAPACITORS

C1—50- $\mu$ F, 1-WVDC, radial-lead electrolytic or tantalum  
 C2—2.2- $\mu$ F, non-polarized multilayer ceramic  
 C3—0.047- $\mu$ F, ceramic-disc  
 C4—100-pF, ceramic-disc  
 C5—0.1- $\mu$ F, ceramic-disc  
 C6—100- $\mu$ F, 10-WVDC, electrolytic  
 C7—25-pF, ceramic-disc

### ADDITIONAL PARTS AND MATERIALS

S1—SPST switch  
 Printed-circuit board materials, enclosure, 7- to 14-volt DC, 200-mA source, wire, solder, hardware, etc.

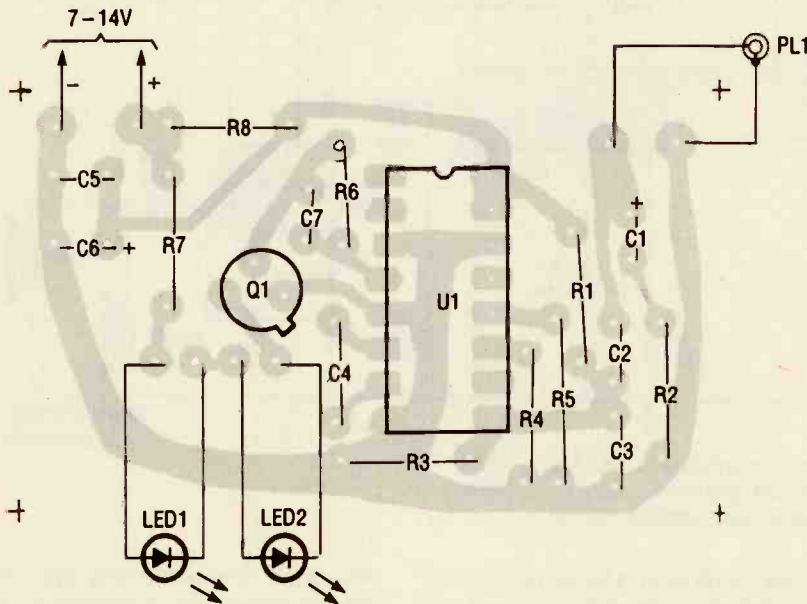


Fig. 5. The size of the parts used to build the transmitter are important due to space constraints, thus, 1/8-watt or smaller resistors are a must and miniature (radial lead electrolytic or otherwise) capacitors are recommended.

Figure 3 shows a full-scale template of the transmitter printed-circuit artwork, and Fig. 4 shows a full-scale template of the receiver's printed-circuit artwork. Printed-circuit assembly is recommended, particularly for the

receiver, which has a very high gain. As can be seen from the size of those foil patterns, the most important factor governing the use of a particular component is its physical size. Due to that factor, the smallest sized compo-

nents available should be used.

Once you have etched your boards and obtained all the parts, assemble the board for the transmitter guided by Fig. 5 and the board for the receiver guided by Fig. 6.

The circuits, once assembled, should operate immediately without adjustment or alignment. The Zener references can be checked at pins 15 and 16 of the CD4046's and at pin 9 of the CA3237. The transmitter and receiver VCO's can be checked at pin 4 of the two CD4046's. The free-running frequency of the transmitter should be 100 kHz  $\pm$  10 kHz; and the transmitter and receiver VCO frequencies should be identical when the two units are optically coupled and properly functioning. The VCO tests should be made without an audio input to ensure a stable frequency reading.

(Continued on page 103)

# SAFETY CIRCUIT

Long ago, when we had just a few simple tools to work with, "Murphy" was close at hand to see that some body part got be-

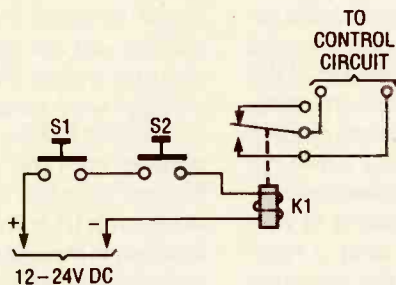


Fig. 1. The simple two-hand safety-control switch shown here is little more than two pushbutton switches connected in series so that both must be depressed in order to energize the relay.

tween the tool and an immovable object. The resulting injury, in most cases, probably was not life threatening and, after a time, things returned to normal. But with today's high-tech metal-crunching machines, there's no place for even the slightest error. Your first mistake could literally be your last. Machines just don't care what, or who, they mangle.

## A SIMPLE SAFETY SWITCH

A good number of the small-parts stamping and

molding machines that are still in use today are electrically controlled by the operator. The operator puts a part in place and then, by operating hand-control switches, sends a signal to the machine to complete the cycle. Since both hands are out of harm's way holding down the hand-control switches, the machine operates safely.

Figure 1 shows a simple two-hand safety-control switch that is still used in some manufacturing facilities. On the surface, the circuit fulfills the basic safety need by requiring that two switches be closed before the machine will operate. That's just fine and dandy. But when an operator does piecework, ingenuity gets in the way of safety.

By placing something heavy on one of the switches, the machine can be operated with one hand, leaving the other hand free to speed up the operation by putting the next part in place a little sooner. Hands, fingers, and other body parts have been lost that way—certainly not good for

the operator, the company, or the insurance company.

## IMPROVED SAFETY CIRCUIT

An improved safety circuit, which eliminates the operator's ability to defeat the safety feature, is shown in Fig. 2. That circuit requires that each hand switch be operated at about the same time to produce a machine control output. The two large electrolytic capacitors (C1 and C2) are charged to 12 volts through two current-limiting resistors (R1 and R2). If both S1 and S2 are closed at the same time, the normally open contacts of relays K1 and K2 close momentarily, causing K3's (the control relay's) open contacts to close.

The control relay's on-time is controlled by C1 and C2, so fine tuning the output time period isn't exactly an easy job. In addition, R1 and R2 must be selected to limit current to less than K1 and K2's holding current, otherwise, the relay will remain active as long as their respective control switches are held down. ■

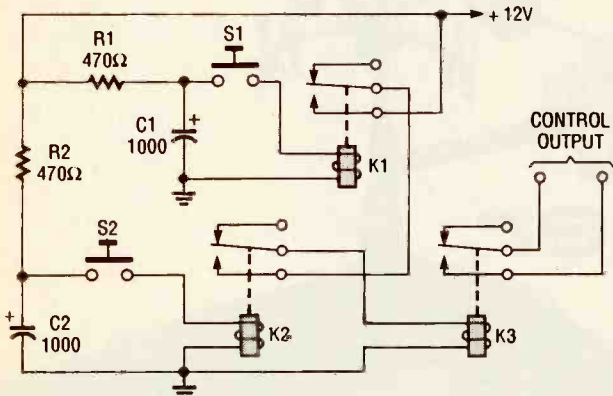


Fig. 2. This safety control switch offers an improvement over the previous one in that S1 and S2 must be depressed at about the same time to power the load circuit.

### PARTS LIST FOR THE SIMPLE SAFETY SWITCH

S1, S2—Normally open pushbutton switch  
K1—SPDT AC or DC relay  
Wire, solder, hardware, etc.

### PARTS LIST FOR THE IMPROVED SAFETY CIRCUIT

C1, C2—1000- $\mu$ F, 16-WVDC, electrolytic capacitor  
K1-K3—12-volt DC relay with 100-150-ohm coil  
R1, R2—470-ohm, 1-watt, 5% resistor  
S1, S2—Normally open pushbutton switch  
Perfboard materials, 12-volt source, wire, solder, hardware, etc.



**S**pinning pinwheel-like devices are frequently seen mounted atop the masts of ships, the masts of weather and air-sampling stations, and atop tall towers located at airports and air fields. Those wind-driven spinning devices are mechanical sensors that are part of an instrument—known as an anemometer—that is used to measure the force of the wind and hence its speed. Hikers, campers, bikers, home owners, drivers, pilots, and sailors are interested in wind speed and force because it allows them to anticipate hazardous weather conditions and plan activities accordingly.

In this article, we'll show you how to build a simple, effective, and inexpensive anemometer. But before we get into details of the circuit, it is wise to review some background material.

**Theory.** Wind consists of air molecules in motion. When those molecules strike an object, they impart a force (pressure) on the object that is proportional to their velocity. The total force on an object is the sum of the pressure per unit area multiplied by the total effective area of the object.

Paddles or cups mounted to a rotor can be used to convert the wind force into torque. That torque can then be used to turn a wire loop or coil that is positioned between two permanent magnets (a DC motor or generator) to produce a voltage that is proportional to the torque or wind speed.

The resulting voltage can then be processed and displayed on a DC ammeter (calibrated to read miles per hour, mph, instead of amps) as wind velocity.

That is the essence of the anemometer described in this article. The author used a simple DC motor as the generator. A rotor was then fabricated from parts obtained locally, and combined with the generator.

To calibrate the generator/rotor assembly, it was mounted on a board that was, in turn placed on top of the author's van. On a windless evening, the van was driven at speeds ranging from 5 to 45 miles per hour (MPH) in 5 MPH increments. The generator's output voltages were measured at various vehicle velocities, using a high-impedance voltmeter. The measurements were recorded, and data was then statistically processed and used to develop the graph shown in Fig. 1. As shown, the generator's output voltage varied linearly from 0 to 300 millivolts (mV) over the vehicle's speed range (0 to 45 mph).

**A Look at the Circuit.** Figure 2 is a schematic diagram of the Anemometer. That circuit, which is shown separated into two parts (the processor and the monitoring circuit) is

comprised of the generator (denoted MOT1 in Fig. 2), an LM324 quad op-amp (U1, whose individual op-amps provide pre-amplification, integration, and buffering), a pair of light-emitting diodes (LED1 and LED2), a 0- to 15-mA meter (M1), and a few support components.

A reed relay (K1) and decoupling capacitors (C1 and C3) were included in the processor portion of the circuit to insure that the generator voltage was not applied to the input op-amp before the  $\pm 9$ -volt supply voltages were present.

The input to the circuit (the voltage derived from the generator) is fed through K1 to the non-inverting input of op-amp U1-a. The output of U1-a is then fed to the inverting input of U1-b, whose output is then fed to the inverting input of U1-c. The output of U1-c is then fed to the final op-amp stage, U1-d, which is configured as a voltage follower. The output of U1-d is fed through a voltage divider network consisting of three fixed resistors (R10-R12) and a potentiometer (R13), to the DC ammeter, M1. That resistor string allows the meter to be set for full-scale deflection at 45 MPH. Switch S1 (a momentary-contact DPDT unit) is used to initiate a measurement.

Power for the circuit is provided by a

*Build this simple and inexpensive wind-speed measuring device and become your own meteorologist*

# Build an Anemometer

BY BOB SIMCOX



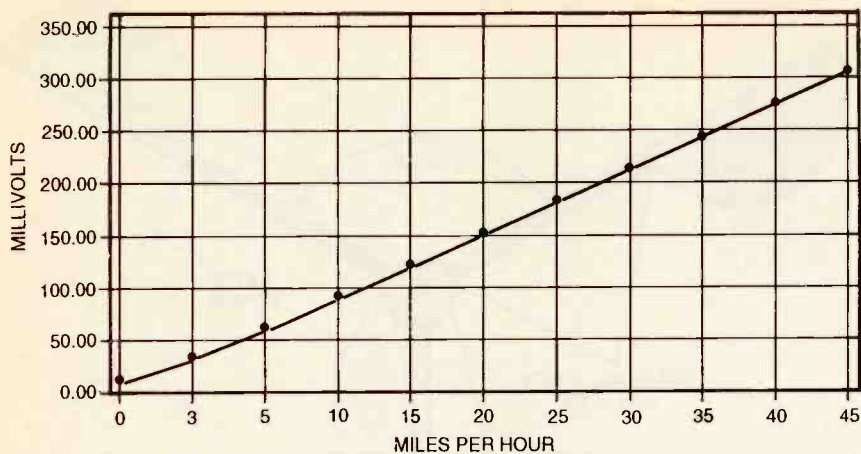


Fig. 1. The generator/rotor assembly was mounted on top of the author's van, which was driven at speeds ranging from 5 to 45 miles per hour (mph) in 5-mph increments on a windless evening. The generator's output voltages—measured at various vehicle velocities, using a high-impedance voltmeter—were recorded, and the data was used to develop this graph.

pair of 9-volt transistor-radio batteries (B1 and B2), to produce a  $\pm 9$  volts DC. That dual-voltage arrangement allows the output of the op-amps to go to zero volts instead of half of the supply rail. Two LED's, LED1 and LED2, are used to monitor the positive and negative supply voltages (LED1 for B1 and LED2 for B2).

**Electronics Construction.** The electronics portion of the project was assembled in two parts called the processor and the monitoring circuit. The processor portion of the circuit was assembled in a small section of perfboard (approximately  $1\frac{1}{2} \times 2\frac{5}{8}$

inches), and enclosed in the generator housing (more on that later). Resistor R3 in the processor board is actually a pair (3.3k and 15k) of series connected resistors. The monitoring circuit was hard wired on a barrier strip that was mounted in a 5- x 7- x 2-inch electrical breaker box. The two portions of the circuit were then connected to each other through a 50-foot length of 4-conductor cable.

**Mechanical Construction.** The rotor hub was fabricated from a  $\frac{3}{4}$ -inch x  $1\frac{1}{2}$ -inch bolt head. The required drilling and cutting is shown in Fig. 3. After all holes were drilled and the set-

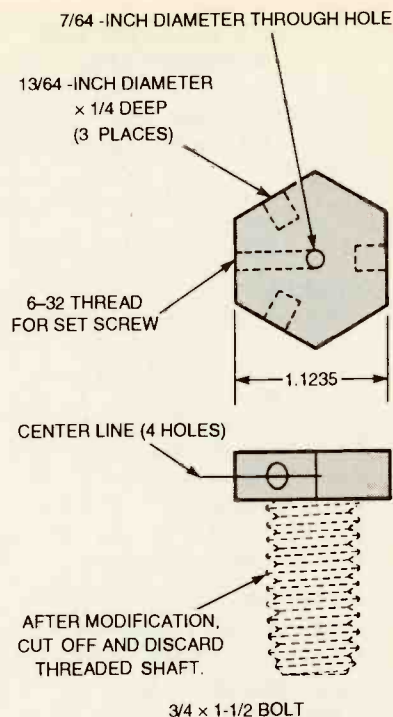


Fig. 3. The rotor hub was fabricated from a  $\frac{3}{4}$ -inch x  $1\frac{1}{2}$ -inch bolt head. The bolt head was drilled (as shown in this diagram) and shaft of the bolt was cut off. The bolt head was retained as the rotor hub and the shaft was discarded.

screw hole threaded, the shaft of the bolt was cut off and discarded. The bolt head was retained as the rotor hub. To assist in locating the holes, the faces and top of the bolt head were coated with a permanent marker

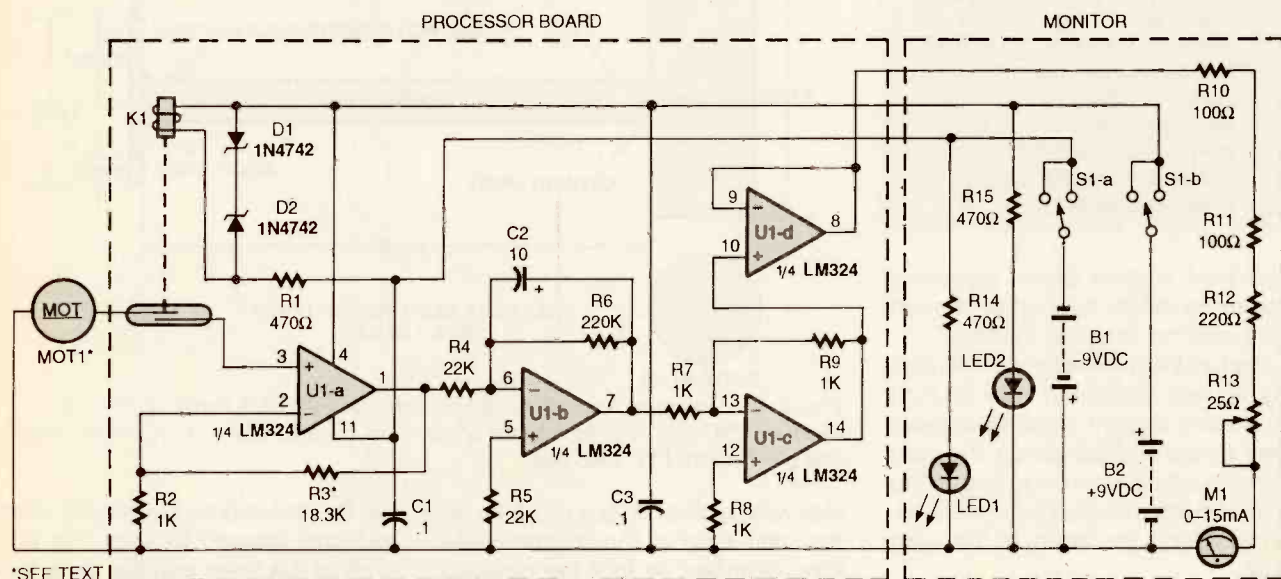


Fig. 2. The anemometer is comprised of the generator (denoted MOT1), an LM324 quad op-amp (U1, whose four op-amps form a preamp, an integrator, and buffer); a pair of light-emitting diodes (LED1 and LED2, which are used to monitor battery voltage), an ammeter (M1), and a few support components.



## PARTS LIST FOR THE ANEMOMETER

### SEMICONDUCTORS

U1—LM324 quad op-amp, integrated circuit  
 D1, D2—1N4742 12-volt, 1-watt, Zener diode  
 LED1, LED2—Light-emitting diode

### RESISTORS

(All fixed resistors are 1/4-watt, 5% units.)  
 R1, R14, R15—470-ohm, 1/2-watt  
 R2, R7—R9—1000-ohm  
 R3—18,300-ohm (see text)  
 R4, R5—22,000-ohm  
 R6—220,000-ohm  
 R10, R11—100-ohm  
 R12—220 ohms  
 R13—25-ohm potentiometer

### CAPACITORS

C1, C3—0.1- $\mu$ F, ceramic-disc  
 C2—10- $\mu$ F, 35-WVDC, electrolytic

### ADDITIONAL PARTS AND MATERIALS

MOT1—9-18-volt DC motor (Radio Shack #273-563), see text  
 M1—0-15 mA DC meter (Simpson SK-525-T2) or 0-15-volt DC meter (Radio Shack #270-1754), see text  
 K1—1-amp, 12-volt reed relay (Radio Shack #275-233)  
 S1—DPDT 6-amp momentary-contact, toggle switch  
 B1, B2—9-volt transistor-radio battery  
 Perfboard materials, enclosure, IC socket, pegboard hangers, electrical box connector, 3/4  $\times$  1/2 inch bolt, soup ladle, set screws, sheet metal screws, 1/2-inch diameter PVC pipe, 1/2-inch PVC end caps, 1/2-inch diameter electrical conduit, 3  $\times$  1  $\times$  1/4-inch mounting plate (see text), epoxy, paint, 4-conductor wire, battery holder and connector, wire, solder, hardware, etc.

and then scribed across opposing corners to locate the center of each face and the center of the top.

Each of the three rotor spindles (see Fig. 4) were fabricated from 3 1/2-inch lengths of straight 1/4-inch diameter peg board hanger. Once the peg board hangers were cut to length, the spindles were beveled (using a grinder) to match the slope of the wind cups.

The three wind cups were fabricated from 2 7/8-inch diameter soup ladles. The ladle handles were cut off and discarded. The cups from the la-

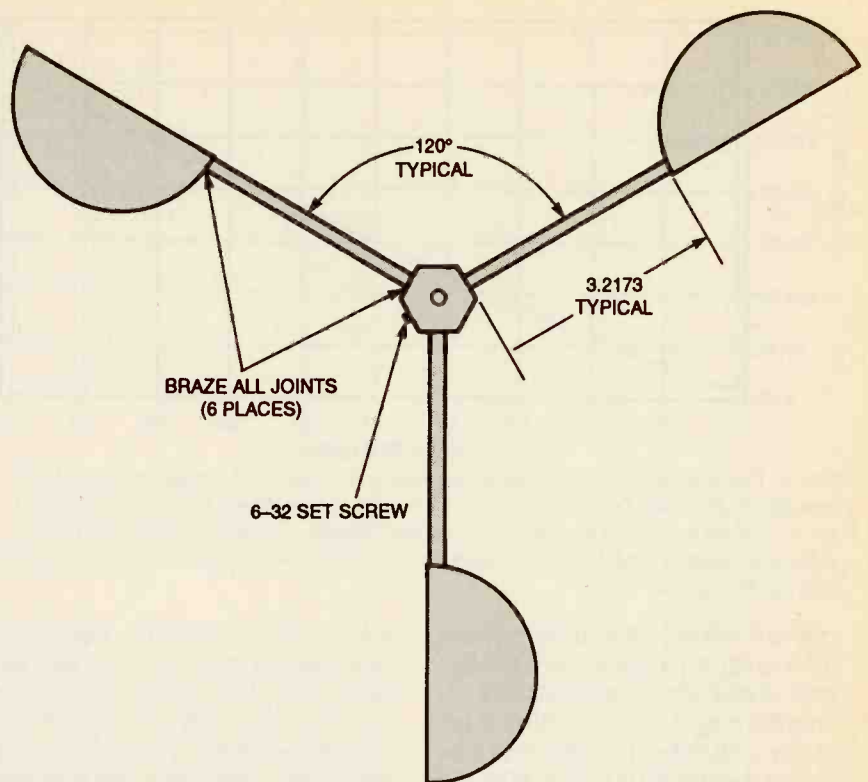


Fig. 4. Three rotor spindles were fabricated from 3 1/2-inch lengths of straight 1/4-inch diameter peg board hanger, and the wind cups were fabricated from 2 7/8-inch diameter soup ladles.

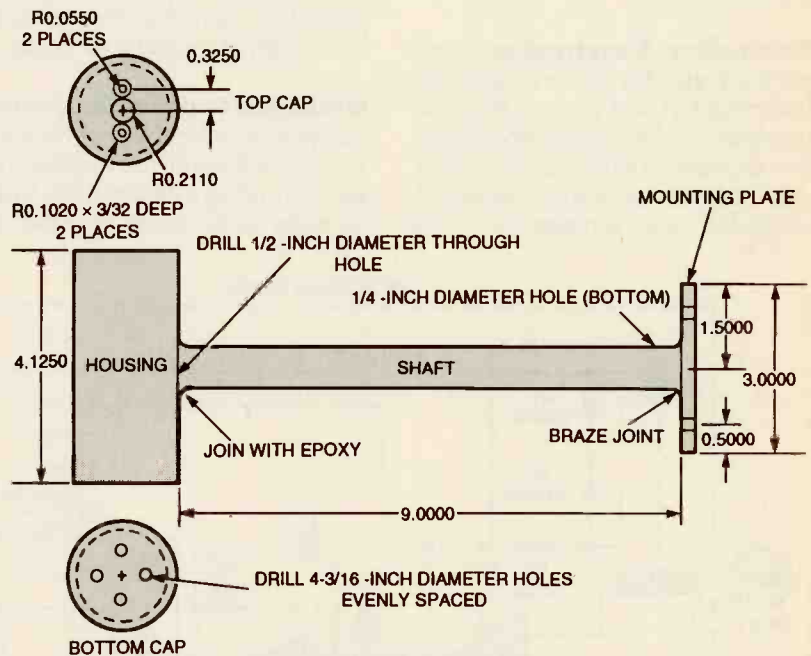


Fig. 5. The generator housing was fabricated from a 4 1/8-inch length of 1/2-inch diameter PVC pipe, a 1/2-inch length of electrical conduit, a 1-  $\times$  3-  $\times$  1/4-inch strap, and two 1/2-inch PVC end caps.

dles were clamped face down on an insulated surface. The spindles were then clamped so that the beveled edges contacted the wind cups—coplanar with the mouth of the cups and centered. A single setup was used for all three spindles. The spin-

dle-to-wind-cup joints were then brazed and allowed to cool. The hub ends of the three spindles were flattened slightly to form a force fit when inserted in the 1/4-inch holes in the hub. The spindles were arranged so that all cups opened to the left when

viewed from the top and were at right angles to the plane of the spindles. The three spindles were then brazed to the hub to complete the fabrication of the rotor assembly.

**Generator Housing.** The generator housing (see Fig. 5) was fabricated from a 4½-inch length of 1½-inch diameter PVC pipe, a ½-inch length of electrical conduit, a 1- × 3- × ¼-inch strap, and two 1½-inch PVC end caps.

First, the 1½-inch PVC pipe was cut to length and a ½-inch hole was drilled through one wall at the center of the pipe (see Fig. 5). Next the ½-inch electrical conduit was brazed to the 1- × 3 × ¼-inch strap (as shown) to form the shaft and mounting plate. The shaft was then clamped to the housing so that the hole in the wall of the housing matched the internal diameter of the conduit. That joint was then coated with epoxy putty so that a smooth ½- to ¾-inch radius fillet was established between the shaft and the housing. Next the top end cap was drilled and then cemented to the housing with PVC cement. The generator was then mounted to the top cap. The mounting screws were coated with Elmers "Stix All" cement before installation. After mounting, the recessed counter bores were filled with "Stix All" for waterproofing.

Once the generator housing was complete, the processor circuit was connected to the generator (MOT1) using a twisted wire pair. Sufficient slack was left in the cable and generator wires so that the processor board could be removed from the housing for maintenance. Next, a 4-conductor cable was routed through the bottom ¼-inch hole in the shaft, through the shaft, through the ½-inch hole in the housing to the processor board. After connecting the 4-conductor cable to the board, the board was placed into the housing behind the generator, and the bottom cap was pressed onto the housing.

Holes for two #6 × ⅜-inch sheet metal screws were drilled through the bottom cap into the PVC housing and the bottom end cap was secured to the PVC housing by the sheet metal screws. The entire assembly was then painted with silver epoxy paint.

**The Control Box.** The control box was fabricated from a 5- × 7- × 2-inch

electrical breaker box (from the author's junk bin). However any metal or plastic enclosure with a minimum size of 4 × 4¾ × 2 inches will do.

The control box was prepared by drilling four mounting holes for the meter using a template provided with the unit. Three additional holes were then drilled along the right side of the enclosure, next to the meter, to accommodate LED1 and LED2, and the momentary contact switch. Grommets were placed in the two LED holes to make a snug fit.

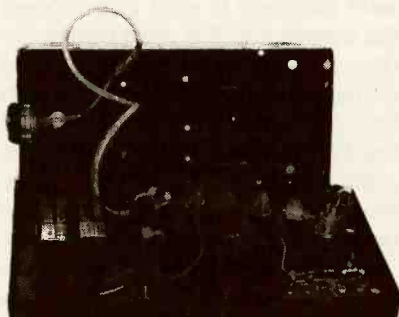
Next the meter has to be recalibrated for wind velocity. The relationship between wind velocity in MPH and current in milliamperes is given by:

$$X \text{ MPH}/45 \text{ MPH} \approx Y \text{ mA}/15 \text{ mA}$$

That equation was used to determine the new indices for the meter.

Once wind velocity conversion was calculated, the cover plate was removed from the meter, the milliamp markings were covered using correction fluid ("White Out"), and wind speed in miles per hour were placed on the meter face with an indelible-ink marker. After that, the meter's cover plate was placed back on the meter, and the meter was then mounted to the enclosure. Note that while a Simpson SK-525-T2 0- to 15-mA meter (also from the author's junkbox) was used in the prototype, a Radio Shack DC voltmeter (#270-1754) can be used if that unit's series resistor is removed. After that, the LED's were pressed into the grommets, and the momentary-contact switch was mounted just below the LED's.

A five-lug tie-point barrier strip was mounted on the upper-right meter-



*Most of the monitor circuit was assembled inside an electrical breaker box on a five-lug tie-point barrier strip, and connected to the meter, the power source, switch and LED's via hook up wire.*

mounting screw, and the resistor chain (R10, R11, and R12) was mounted across the five-lug strip. The variable resistor, R13, was mounted through a ⅝-inch hole in a "Z-bracket." The Z-bracket can be nothing more than a 1-inch-wide strip of scrap metal bent at 90° angles in two places; the bends should be about an inch apart.

The battery clips were mounted on the inside surface of the panel using the two ⅝-inch holes and were fastened with ⅜-inch pop rivets.

One end of a 4-conductor cable was brought into the box through a ½-inch electrical clamp. The metering section of the circuit was then connected to the sensor portion of the circuit via the 4-conductor cable.

**Testing and Calibration.** The processor board and control box were bench tested using a 300-mV source. The 300-mV source was applied to the input of the circuit, producing an output of approximately 5.8 volts DC at U1-a, approximately -7.5 volts at U1-b, approximately 7.1 volts at U1-c, and approximately 6.8-volts DC at the output of U1-d. The generator was connected to the input of the processor board and a test run was made with the sensor mounted on top of the author's van.

Data from the test run was analyzed to determine that the resistor network should have a total resistance 450 ohms; R13 was then adjusted using a digital meter, to bring the network to the required value.

**Variations.** Design of the anemometer can be varied to accommodate variations in the size or type of wind cups, the DC generator used, the meter used, etc. The critical issues are: adjust the gain of the operational amplifiers so that the dynamic range of the generator is within the linear range of the op-amps, adjust the gain of the circuit to drive the combined meter and resistor string, and calibrate your unit using a similar process to the one used by the author.

If you wish, ±9-volt DC supplies could be used in place of the batteries to provide continuous, display of wind speed. Also, the range of the meter could be increased or decreased to customize the anemometer to measure wind speeds that are typical at your location. ■



## BUILD THE RELAY STATION

(Continued from page 90)

R4, and R6), a 40-kHz oscillator (the 555 and its timing components), an IR transmitter (R5, Q1, and LED1-LED3), and a power supply (the rest of the circuitry).

Taking the power supply first, the current source is a 9-volt battery that is switched on by S1. Its output is limited by R3, and voltage regulated down to 4.8 volts by D1 and D2. The regulation is necessary to reduce the voltage to a level that MOD1 can handle. It has the added advantage of allowing us to connect the three IR LED's in series without using a dropping resistor, which would dissipate power but do no useful work.

While the oscillator circuit is based on a 555 timer, that IC is used in a non-standard configuration. Normally, D3 would not be present. Without it, C1 (the oscillator's timing capacitor) would charge through R1 and R2, and discharge through only R2. Therefore, it would discharge faster than it would charge. Since the 555's output goes high as the capacitor charges and low as it discharges, the output would not be high for the same amount of time that it is low. In other words, its duty cycle would not be 50%, which is needed for this application.

With D3 in the circuit, R2 is bypassed (or shorted out) while C1 is charging, but is in the current path during discharge. Therefore, by making R1 and R2 equal, the charge time equals the discharge time, yielding an output with a 50% duty cycle. Components R1, R2, and C1 (all precision, drift-free units) have been chosen to provide a 40-kHz output in this configuration. That output strobes the IR LED's via Q1.

However, the oscillator only functions when pin 4 of the 555 is high. Since that pin is connected to the inverter circuit, the oscillator functions when the inverter's input is low. The inverter's input is connected to MOD1's output, which goes low with each remote burst received. So overall, the circuit produces a 40-kHz IR burst when it receives one.

**Construction.** Building this project is very easy. That's because it uses very few components to do its job, and they can all be purchased from Radio

Shack. My circuit was constructed using point-to-point wiring of three assemblies: the module plus inverter, the IR-LED chain, and the rest of the circuit (which was placed on a "main board").

The assemblies were installed in a metal cabinet to reduce RF interference. If you'll just be using the unit as a repeater for long or well-lit rooms, the IR assembly and the module should face out through opposite surfaces of the cabinet. If you'll use the unit as a repeater to broadcast signals around corners, the IR assembly and the module should be on adjacent surfaces of the cabinet. Keep that in mind when laying out your own unit. One unique way of accommodating both situations would be to make a swivel mount for the module out of an old film canister. It could be attached to a surface adjacent to that of the LED's via a screw in the canister's cap, and rotated to face any desired direction.

The inverter's components (Q2, R4, and R6) were mounted directly onto the module by soldering their leads right to the module's pins. The module's ground pin was also connected to its case. That is a must for reducing RF interference, which would make the unit buggy. Three wires were then attached to pertinent points in the assembly (V+, ground, and the inverter's output) and run to the main board. The module face was then attached to the case with a piece of double sided foam, allowing it to peer through a hole made in the cabinet.

The IR LED's were mounted on a piece of vector board by themselves. They were wired together in series and the two remaining LED leads were attached to wires that connect the assembly to the main board. Another piece of vector board was used as a drilling template to make holes in the case to accommodate the LED's. The LED assembly was pushed into position through the cabinet face. Then a hole was drilled through the board and case to accommodate S1. The switch was passed through the holes and fastened, which holds the LED board in place. The switch was then wired to the battery clip and main board.

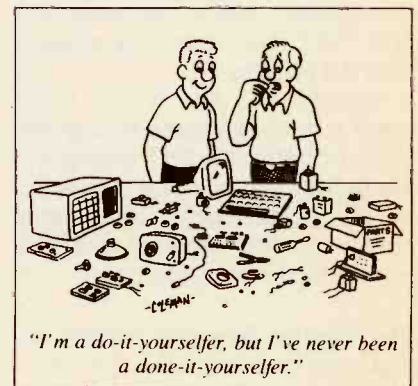
The remaining components and battery-clip lead were connected to the main board (a small piece of ex-

perimeter's board). The board and a fresh battery were mounted in the enclosure with double-sided foam. The battery clip was then snapped on the battery and the case was closed.

Since there's nothing to adjust, if you've wired your unit properly it should be ready to work as soon as you switch S1 on. To test the circuit, try to hide your remote control and the detector side of the Relay under some newspapers. Make sure the Relay is off and check to ensure that the remote cannot operate anything from under the paper. If it still controls anything, shuffle the papers around until the equipment no longer receives responses from the remote. Switch the Relay on and activate the remote. If everything is working as it should, all your components should respond normally to the signals being re-broadcast by the Relay.

If something's amiss, disassemble the unit. Fire a remote at the detector and using a multimeter or oscilloscope look for a digital signal at the detector-module's output. If there is none, you've got a faulty module, or you've incorrectly wired it to the inverter. If MOD1 is fine, check the inverter's output. Its output signals should be the compliment of the signals from MOD1. If not, check your inverter's wiring. If that's fine, check pin 3 of U1 for 40-kHz bursts while operating the remote. A lack of signal there indicates an oscillator problem. If all is well, check for pulsed current flow through the IR-LED chain. A lack of current there could only be the result of a bad Q1, a bad LED, or miswiring.

Hopefully this circuit will add more freedom to your use of remotes. Unlike many of the manufactured alternatives, its low-cost, safety, and ease-of-use should make it a really big hit with the family, too. ■



## WIRELESS HEADPHONES

(Continued from page 96)

**Implementation and Use.** The receiver may be mounted in a number of ways, depending on the user and the availability of parts. Perhaps the most obvious, but most difficult, is in a headset. The small size of the receiver circuitry facilitates proportionally small packaging, but the added mass on a light-weight headset can result in an unstable mount. Use a large-size headset (full ear enclosure) and mount the receiver and battery as low as possible to maintain a low center of gravity.

Placing the receiver and battery on opposite sides of the two speaker elements is ideal or at least more balanced. Use shielded audio cable between the two headset speakers.

An alternative packaging idea is to use a lapel mount, in which the receiver and battery are combined in a single enclosure that is separate from the headphones. The photodiode may be oriented on the printed-circuit board to permit side or front illumination relative to the printed-circuit board.

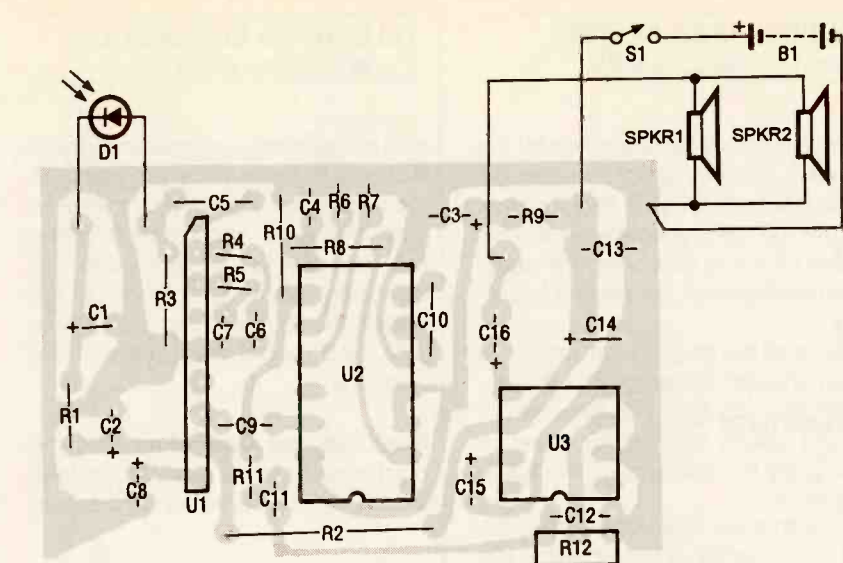
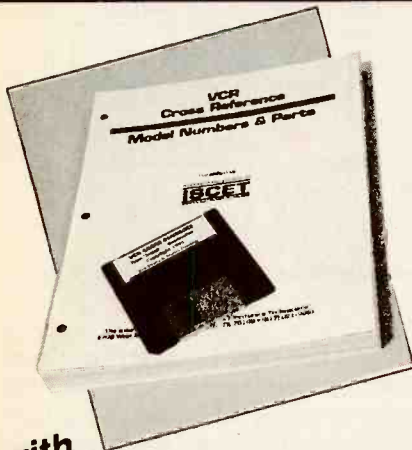


Fig. 6. The receiver's printed-circuit board should be assembled using  $1/8$ -watt or smaller resistors and miniature (radial lead electrolytic and ceramic-disc) capacitors. The volume control (R12) can be a miniature PC-mounted potentiometer or conventional unit, which would have to be mounted off-board.

No external lens is necessary at ei-

ther the receiver or the transmitter—in fact I recommend against it in order to maintain a wide field of view at the receiver end. ■

# NOW Find the Right Part for Your VCR!



## with the ISCET VCR CROSS REFERENCE

**NEW!** The Fourth Edition is contained on a diskette for IBM PC AT/XT compatibles, DOS 2.1 or higher. The disk software allows technicians to search by manufacturer for model numbers and description of part numbers. A parts editing sequence gives an on-screen view of all substitutes for parts entered. With the diskette, the technician can update files by adding model and parts

The 320-page, Fourth Edition of the VCR Cross Reference contains both model and part number cross references. Over 1300 new parts and 360 new models have been added.

VCR's are made in a few factories from which hundreds of different brand names and model numbers identify cosmetically-changed identical and near-identical manufactured units. Interchangeable parts are very common. An exact replacement part may be available only a few minutes away from you even though the original brand-name supplier is out of stock. Also, you may be able to cannibalize scrap units at no cost.

crosses of future models. The Fourth Edition can be printed on pages completely from the diskette.

The ISCET VCR Cross Reference, Fourth Edition, is on  $8\frac{1}{2} \times 11$ -in., pre-punched pages and sells for **\$36.00**. The  $3\frac{1}{2}$  inch diskette sells for **\$69.95** and you can view listings from a monitor or printed page.

Only **\$36.00** for pages  
**\$69.95** diskette

Claggk Inc.  
VCR CROSS REFERENCE OFFER  
P.O. Box 4099  
Farmingdale, New York 11735

Name \_\_\_\_\_  
Business \_\_\_\_\_  
Address \_\_\_\_\_  
City \_\_\_\_\_  
State \_\_\_\_\_ Zip \_\_\_\_\_  
Phone \_\_\_\_\_

Enclosed \$36.00 for the ISCET VCR Cross Reference, Fourth Edition.

Enclosed \$69.95 for the diskette containing the ISCET VCR Cross Reference, Fourth Edition. Please specify:

5¼ Diskettes (2) 3½ Diskette (1)

Include \$3.00 for shipping each Cross Reference (Pages or Diskette)

The total amount of my order is \$ \_\_\_\_\_

Check enclosed—do not send cash.

Visa  MasterCard Exp. Date  / /

Signature \_\_\_\_\_

New York State residents must add applicable local sales tax to total.



## LOUDSPEAKER DESIGN

(Continued from page 83)

Finally, you will be prompted for the tweeter's impedance at the selected crossover frequency. To find that value, use the same strategy mentioned above for the woofer, using the nominal impedance of the driver if necessary.

Once all the above information has been entered, the program will automatically calculate the inductor/capacitor values and display them for you. Copy the values down for future reference.

Now that we have completed this last in our series of loudspeaker design programs, I hope that you all have begun to feel a little more at home with speaker systems, and can start to do a little designing and building for yourselves without undo fear of failure. Admittedly, the speakers you can design using these programs are fairly basic, but they are surprisingly good performers that can give you years of enjoyable listening. ■

**CABLE TV  
DESCRAMBLERS**  
Best Prices in the U.S.A!  
Guaranteed to Work!

**QUANTITY DISCOUNTS**



Jerrod, Scientific Atlanta  
Pioneer, FTB-3, SA3

**The Newest & the Latest**

TVT-3K - Jerrod Impulse &  
Starcom series  
SA3-DFA - Scientific Atlantas  
including 8536, 8536+  
8580, Drop-field  
PN-3A - Pioneer systems

Panasonic TZPC145G 99 Ch Converters  
Zentek XL2100 99 Channel Converters

**30 DAY MONEY BACK GUARANTEE  
FAST SHIPMENTS & FREE CATALOG**

**1-800-772-6244**

M-F 9-6 EST  
U.S. Cable TV, Inc. Dept.: KEH074  
4100 N. Powerline Rd, Bldg. F-4 Pompano Beach FL 33073  
NO FLORIDA SALES!

## TELEPHONE SCRAMBLER

(Continued from page 78)

and solder the green and red wire of that cord to the appropriate points on the board as in Fig. 4. Label the other cord TO TELEPHONE and solder its green and red wires to the appropriate circuit-board pads. Lastly, hook up the wires to the LED's, switches, and power jack, and mount the board to the standoffs.

**Hook Up and Operation.** Plug the cord labeled TO WALL JACK into the telephone jack on the wall. Plug the cord

to the non-scrambled mode (LED1 off) and wait until the dial tone ceases and is replaced by a recording prompting you to hang up and try again (approximately 30 seconds). As soon as you here the recording press S2, switching the unit into the scrambled mode and lighting LED1. The recording should now be unintelligible but still present. Pressing S1 should return the recording to normal.

To use the Telephone Scrambler, each party must have their own unit. Dial the phone and establish contact with the second party before engaging the scrambler. If you engage the scrambler first, the tones from a touch-

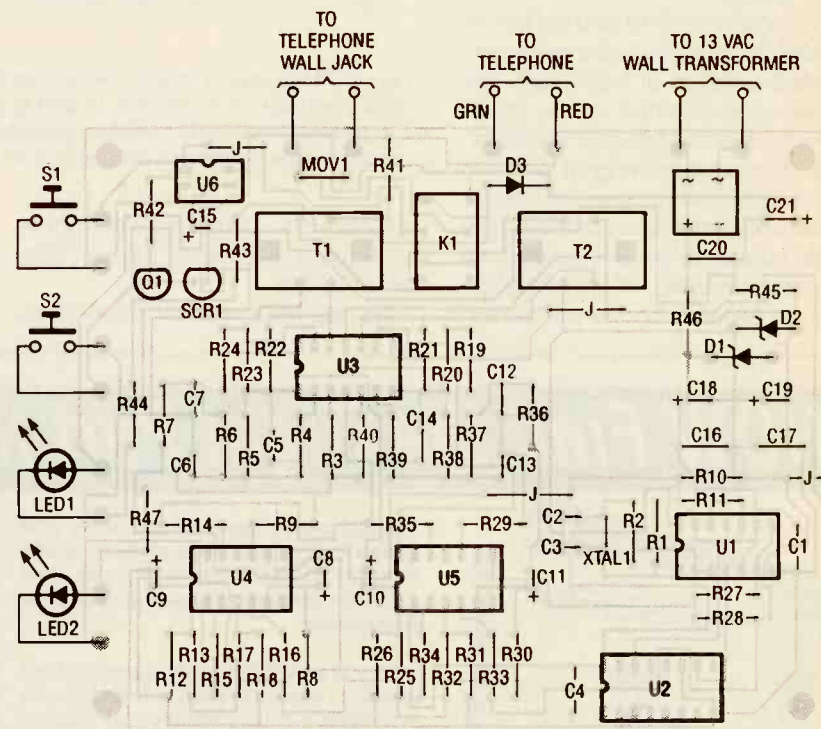


Fig. 4. Use this parts-placement diagram when assembling the printed-circuit board. Don't forget to install the four jumpers.

labeled TO TELEPHONE into the telephone. Hook up the power cable, and plug in the transformer. If LED2 does not light check for 13 volts AC at the points where power enters the board and check for the correct orientation of BR1. Pick up the telephone and check for normal operation. If the phone is not working properly, check the orientation of U6 and the hookup of the telephone cables to the board.

Pressing S2 should light LED1, and pressing S1 should turn off LED1. If that does not happen, check the orientation of Q1 and SCR1, and for solder bridges on those components. Switch

tone phone will be scrambled, rendering them useless in dialing the phone. After establishing contact, both parties can engage their scramblers by pressing S2 and enjoy a completely private and secure conversation.

Note: You'll be able to hear the 3580-Hz tone in the background very faintly. That is normal and can serve as a kind of reminder that your conversation is secure from any third party monitoring. Upon hanging up the telephone, the scrambler will automatically switch back to the non-scrambled mode. ■

# Popular Electronics

The HDTV Revolution

Photoflash Power System

The Exciting World of Ham Radio

Security Systems

Logic Probe

Shaky!

Born with a workbench, it's an electronic alternative for the young amateur paying his dues!

DIY Librarian

Plans for the world's zaniest plaything—  
September 1989

Build a Super-Simple Laser Power Supply

# Popular Electronics

Handy & Mac

The Electronic Druggist

All About Receiver Sensitivity

Build the Rocket Sentinel

What Do Electrical Engineers Do?

Build a Super-Simple Laser Power Supply

Put together your own Macintosh computer—  
September 1991

# Popular Electronics

Square Tesla Coil

Stetic Level Monitor

The E13 Circuit

Winning the Odds

The Amazing Mouse

Circle 31 with a checkmark on this page of an electronic magazine

Build the Tesla Coil that went square!—  
August 1989

# Popular Electronics

Build Your Own Dice-Roulette Game

Lucky Lotto Selector

A Hot Socket

Test Equipment on the Cheap

Cord Buster

Radionics

Your Hobby and the IRS

Build a Radio

Take a chance on our Dice-Roulette project—  
April 1989

# Get the one you missed!

# Popular Electronics®

Popular Electronics back issues are available although quantities of some issues are nearly exhausted. Here's an opportunity to complete your collection, or obtain a selected back issue you cannot find elsewhere. This offer is valid only when using the coupon on this page or a photo copy.

## Special Back Issue Offer!

Please circle the issue(s) ordered!

	Jan.	Feb.	Mar.	Apr.	May	June	July	Aug.	Sep.	Oct.	Nov.	Dec.
1987	1	2	3	4	5	6	7	8	9	10	11	12
1988	1	1987-1988 back issues not available								22	23	24
1989	25	26	27	28	29	30	31	32	33	34	35	36
1990	37	38	39	40	41	42	43	44	45	46	47	48
1991	—	49	—	50	51	52	53	54	55	56	57	58
1992	59	60	61	62	63	64	65	66	67	68	69	70
1993	71	72	73									

Note: Issues prior to November 1988 are "Hands-on Electronics"—the predecessor of Popular Electronics.

## How to determine cost!

Quantity	Price per copy		
	United States	Canada	Foreign*
1-5	\$6.50 US	\$6.50 US	
6-11	5.50	5.75	\$8.00 US
12-23	5.00	5.25	7.50
24 and more	4.50	4.75	7.00

Prices include handling and shipping. Prices subject to change. All orders payable in U.S.A. funds only, via international money order, check drawn on a U.S.A. bank, or acceptable credit card (Visa, MasterCard) in U.S.A. funds. Allow 6-8 weeks delivery. Foreign orders may take longer. \*Minimum foreign order—6 issues.

Visa       MasterCard       USA Bank Check       US or Int. Money Order

[Note: Credit Card minimum order is \$15.00.]

Credit Card Number \_\_\_\_\_ Exp. Date \_\_\_\_/\_\_\_\_/\_\_\_\_

Signature \_\_\_\_\_

Name \_\_\_\_\_

Address \_\_\_\_\_

City \_\_\_\_\_ State \_\_\_\_\_ ZIP \_\_\_\_\_

Send Orders To: CLAGGK, Inc., P.O. Box 4099, Farmingdale, NY 11735. Sorry, no telephone orders.

HHF4



## HUMIDITY GAUGE

(Continued from page 88)

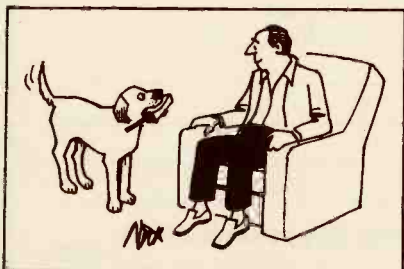
ride (table salt) is chosen for the solution, the calibration is performed by adjusting R7 for a reading of 75% RH.

If a two-point calibration is desired, choose a salt from Table 1 that represents a low value of relative humidity. Then repeat the above procedure, this time adjusting R4 to reflect the correct reading. That completes the calibration procedure.

Once the circuit has been calibrated, remove the temporary wires from the board and install SENS1. Be sure to observe correct orientation. Note: the humidity sensor is somewhat light sensitive, therefore it must be shielded from light while in use. That is automatically taken care of if an enclosure is used to house the instrument. A small opening can be made in the housing to allow the instrument to respond faster to changing humidity levels.

**Use.** Relative-humidity measurements can be made at any time by applying power to the circuit. A reading will be produced in less than a second. The use of a spring-loaded power switch for battery operated units ensures long battery life. Should the battery become exhausted, the display reading will become erratic. For the best results, it is recommended that a fresh alkaline battery be installed once a year.

The Digital Relative-Humidity Gauge is designed primarily for indoor use where the temperature is relatively constant, and assumes an ambient temperature of 75°F. However, it can also be used outdoors, and at lower and higher temperatures. For variations in ambient operating temperatures, refer to Table 2; that table gives correction factors that can be added to the relative-humidity reading. ■



## AUTOMOTIVE TESTER

(Continued from page 74)

tinguished, indicating that the battery voltage is below normal.

Now, slowly raise the supply voltage until LED1 goes out (that should occur at about 9.0 volts). Further increase the supply voltage until LED2 (BATTERY OK) lights, which should occur at 12.4 volts. Slowly increase the power-supply voltage until LED3 (NOT CHARGING) goes out and LED4 (INSUFFICIENT CHARGING) comes on simultaneously. That should occur at 12.8 volts.

Continue to raise the power-supply voltage, and when it reaches 13.4 volts only LED2 should be lit. Finally, raise the voltage until LED5 (OVERCHARGING) comes on, which should occur at 15.2 volts. **CAUTION:** Do not allow the power supply's output voltage to exceed 16 volts.

If you get the responses outlined above, the project is operating properly. The voltage levels at which the LED's change state should be within 0.1 volt of the specified voltages. If your project falls out of that tolerance, you should adjust the value of one or more of the resistors of the voltage divider (R1 through R6) by about 1% to bring the circuit into spec.

If the project does not respond properly at any one of the specified voltage levels, check pin 1 of U2 to be sure the 1.25-volt reference voltage is present. If not, check the orientation of D1, C1, U1, and the LED's. Try another chip if possible. If only one LED malfunctions, troubleshoot the comparator that drives that LED. Then measure that output voltage as the input voltage is varied about the specified triggering level. Check the orientation of the inoperative LED, and replace it with a new one. If the simultaneous switchover between LED3 and LED4 does not occur, check the orientation of D2.

**Using the System.** The following steps should be performed in sequence when checking an automotive electrical system. If the project is intended for stand-alone use, connect the project's input leads directly to the vehicle's battery terminals before starting the engine; be sure to observe the proper polarity. Check the vehicle's alternator belt for proper

tension.

1. Before the engine is started, the BATTERY OK (LED2) should light. The NOT CHARGING indicator (LED3) should also be illuminated since the alternator is not operating at this point. Note: If the engine has just been turned off, LED4 may be illuminated instead of LED3, since the battery may have a higher than normal terminal voltage from being charged by the alternator.

2. Have an assistant start the engine while you observe the project's display. If the WEAK BATTERY indicator (LED1) comes on during cranking, the battery terminal voltage has fallen to less than 9 volts. That indicates that the battery is in a low state of charge or is near the end of its life. Recharge the battery and repeat the test.

3. With the engine idling, only LED2 (BATTERY OK) should be illuminated, indicating that everything is normal. Note that some vehicles will indicate INSUFFICIENT CHARGING (LED4 will be lit) because the battery's terminal voltage has not exceeded 13.4 volts while idling. That will be checked at the next step in the procedure. If the NOT CHARGING indicator (LED3) is lit, the charging system of the vehicle is totally inoperative. That could be caused by a defective regulator circuit, an open alternator field, or a bad connection somewhere in the electrical harness.

4. To check the charging capacity of the alternator, turn on the heater/AC fan (highest setting), rear window defroster, windshield wiper (fastest speed), and high-beam headlights. Race the engine to 1500 or 2000 RPM (moderate speed). Only LED2 should be illuminated. If LED4 (INSUFFICIENT CHARGING) lights, the alternator cannot deliver enough current to handle the accessory load. That may be caused by a shorted or open diode, or a shorted winding in the alternator itself. Since the alternator is a three-phase device that uses a 6-diode bridge circuit, it will be able to deliver some output even though one of the phases is defective.

5. To check the regulator, turn off all accessories and race the engine to about 2000 RPM. If LED 5 (OVERCHARGING) lights, the regulator is defective. That will cause the battery to have excessive water consumption and shorten its life. In many vehicles, the regulator is non-adjustable and must be replaced. ■

# GET THE LATEST ADVANCES IN ELECTRONICS

SUBSCRIBE TO—

# Electronics NOW<sup>®</sup>



## ENJOY THE WORLD OF ELECTRONICS EACH MONTH!

Subscribe to the best informed electronics magazine—the one that brings you the latest high-tech construction projects, feature articles on new technology, practical troubleshooting techniques, circuit design fundamentals, and much more.

**Electronics Now** looks to the future and shows you what new video, audio and computer products are on the horizon. You'll find helpful, monthly departments such as Video News, Equipment Reports, Hardware Hacker, Audio Update, Drawing Board, Computer Connections, New Products, and more. All designed to give you instruction, tips, and fun.

### Electronics Now gives you exciting articles like:

- Buyer's Guide to Digital Oscilloscopes
- Build A Scanner Converter
- Single-Chip Voice Recorder
- Build A MIDI Interface for your PC
- Troubleshoot Microprocessor Circuits
- Build A High-Power Amplifier for your Car
- Add Music On Hold to your Phone
- All About Binaural Recording
- VGA-to-NTSC Converter



FOR FAST SERVICE CALL OUR TOLL-FREE NUMBER!

# 1-800-999-7139

## DON'T DELAY — SUBSCRIBE TODAY!

If you prefer, just fill out the order card in this magazine and mail it in today.

7H34L



# FUN WITH ELECTRONICS



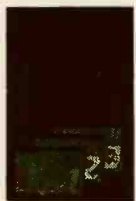
◀ □ **160—COIL DESIGN & CONSTRUCTION MANUAL** .... \$5.95. How to make RF, IF, audio and power coils; chokes and transformers. Practically every possible type is discussed.

□ **PCP113—THE PC MUSIC HANDBOOK** .... \$13.95. Learn the basics of computer music systems. For the professional musician, gifted amateur or just plain curious.



◀ □ **BP297—LOUDSPEAKERS FOR MUSICIANS** .... \$6.25. Loudspeaker design from the musician's point of view! All you need to know, and you should be able to design your own after reading this.

□ **BP277—HIGH POWER AUDIO AMPLIFIER CONSTRUCTION** .... \$6.25. Here's background and practical design information on high power audio amplifiers capable of 300 ± 400 watts r.m.s. You'll find MOSFET and bipolar output transistors in inverting and non-inverting circuits.



◀ □ **BP302—A CONCISE USER'S GUIDE TO LOTUS 1-2-3 RELEASE 3.1** .... \$6.25. If you are a PC user and want to upgrade to Lotus 1-2-3 release 3.1, this book can teach you how to do that in the shortest and most effective way.

□ **BP298—A CONCISE INTRODUCTION TO THE MACINTOSH SYSTEM AND FINDER** .... \$6.25. This introduction for those new to the Mac, this book also serves as a quick refresher for experienced owners that have not used the machine in some time.



MAIL TO: **Electronic Technology Today, Inc.**  
P.O. Box 240  
Massapequa Park, NY 11762-0240

## SHIPPING CHARGES IN USA AND CANADA

\$0.01 to \$5.00	... \$1.50	\$30.01 to \$40.00	.. \$5.50
\$5.01 to \$10.00	.. \$2.50	\$40.01 to \$50.00	.. \$6.50
\$10.01 to \$20.00	.. \$3.50	\$50.01 and above	.. \$8.00
\$20.01 to \$30.00	.. \$4.50		

**SORRY, No orders accepted outside of USA and Canada**

Total price of merchandise	..... \$	_____
Shipping (see chart)	..... \$	_____
Subtotal	..... \$	_____
Sales Tax (NYS only)	..... \$	_____
Total Enclosed	..... \$	_____

Name \_\_\_\_\_  
Address \_\_\_\_\_  
City \_\_\_\_\_ State \_\_\_\_\_ Zip \_\_\_\_\_

## ADD A DMV

(Continued from page 48)

Analog devices recommends a guard ring around the timing capacitor for demanding applications. For this project, careful placement should be enough. Make sure the timing capacitor is placed as close to the AD654 as possible. They also recommend that you do *not* use a ground plane.

To stuff the board of Fig. 2, look at Fig. 3 and begin by installing the passive components. Then add the IC sockets. You may wish to hold off from soldering LED1 to the board until the case is prepared. This way you will be sure to cut the leads to the proper length. While that LED is optional, it indicates that power is present. If power is not present, you should not connect a signal to the inputs. Therefore, LED1 also provides an indication that it is safe to use the adapter.

After you have prepared a circuit board, you should build the interface cable. The cable should be constructed from a length of three-conductor cable. Keep the length to about six feet or less. Strip one inch of jacket from each end of the cable exposing the three wires. Strip one sixteenth inch from the ends of each of the wires. Solder the conductors to pins 1, 2, and 4 of the DB15 connector.

Cut two lengths of wire to about two inches in length. Strip 1/16 inch from each of the ends. These will connect the input terminals to the board. Drill two 1/8-inch holes in one end of the case about one inch apart for mounting the terminals. Drill a 1/4-inch hole in the opposite end for the interface cable. Feed the interface cable through the 1/4-inch hole and solder the conductors to the appropriate pads on the circuit board. I like to drill holes in the board on either side of the cable so I can use a cable tie to secure the cable to the board.

Once everything is in place, I recommend using a flux stripper on the solder side of the board to be sure it is clean and free of contamination. Residual flux can cause shorts and problems that are difficult to debug at a later time.

With the power off, plug the interface cable into the game port. Turn the computer on. Check for the prop-

er voltage and polarity on the board. Remember the button-0 input of the game port has a pull-up resistor on it, so there will be +5 volts present on that signal line. If the voltages check out turn the computer off, unplug the interface cable and insert the AD654 and LM324 into their sockets. Plug the interface cable in and turn on the computer. If you have an oscilloscope, check for a square-wave on pin 1 of the AD654. If you do not have a scope, you can use a logic probe or frequency meter. If there is no signal on pin 1 then there is a problem with the board or perhaps the interface cable. Turn the computer off and double check the circuit against the schematic and then check the wiring of the interface cable to find any errors.

If the circuit checks out then run the DVM program. If the program finds a square-wave on the button-0 input, it will begin to display values on the screen. If the signal is not present, the program will display a message and abort.

Once the circuit is functioning correctly you can secure the circuit board in the case and connect the input wires to the terminals. That's all there is to it; your circuit is now ready for use.

**Going Further.** There are 4 digital inputs on the game port so you can have up to 4 Analog Input Adapters connected at the same time. You can easily construct a circuit board that distributes power and ground to the attached adapters. Remember to connect the signal lines to different button inputs on the port. Refer to the pinouts in Fig. 4 for the proper connections and input addresses for the game sport connector. ■



# FLUID CIRCUITS

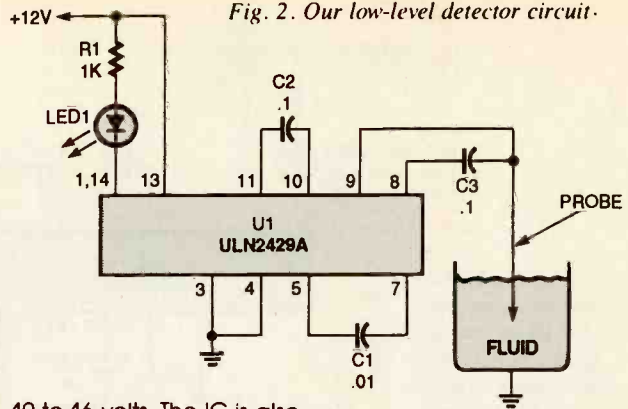
By Charles D. Rakes

The ULN2429A was designed to be used as an automotive coolant-level detector. The IC can also be used to detect the presence or absence of a number of other liquids. It is available for less than \$2 from D.C. Electronics (P.O. Box 3203, Scottsdale, AZ 85271-3203; Tel. 1-800-467-7736).

The IC features a high-current square-wave output that can be used to drive an LED, an incandescent lamp, or a speaker. The output may also be converted into a high-current DC voltage to control relays or solenoids. There's an internal voltage regulator that allows the IC to operate from a power source of

10 to 16 volts. The IC is also protected from reverse supply-voltage damage and is temperature compensated. The IC is also not bothered by high-frequency noise. All-in-all the ULN2429A IC is an excellent candidate for our purpose.

Fig. 2. Our low-level detector circuit.



The IC's block diagram is shown in Fig. 1A and its schematic in Fig. 1B. There are four basic circuits operating within the IC. Transistor Q5 and the 7-volt Zener make up a series voltage-regulator circuit. Devices Q1, Q2, and Q6 operate together as a square-wave oscillator circuit. The oscillator's frequency is determined by the value of capacitor connected between terminals 5 and 7. Transistors Q3 and Q4 operate as a simple detector/amplifier circuit. Units Q7 and Q8 amplify the detected signal as either AC or DC to drive the load connected between Q8's collector and the positive supply.

If the circuit is to be operated in the AC-detection output mode no decoupling capacitor is needed between pins 10 and 11 or between pin 12 and ground. For the circuit to operate in the DC output mode a capacitor is needed at either or both decoupling locations. A relatively small capacitor value may be connected between pins 10 and 11 to remove any AC content from the output. A larger capacitor may be tied to pin 12 and ground to add a slight turn on/off delay to the DC output.

The circuit has two oscillator outputs. Pin 6 offers the maximum output of about 3 volts peak-to-peak

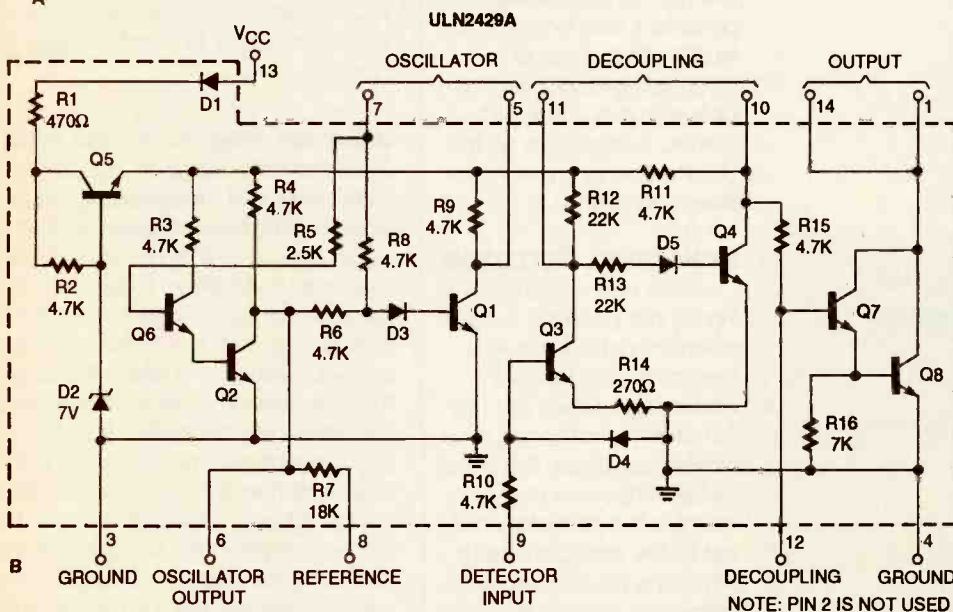
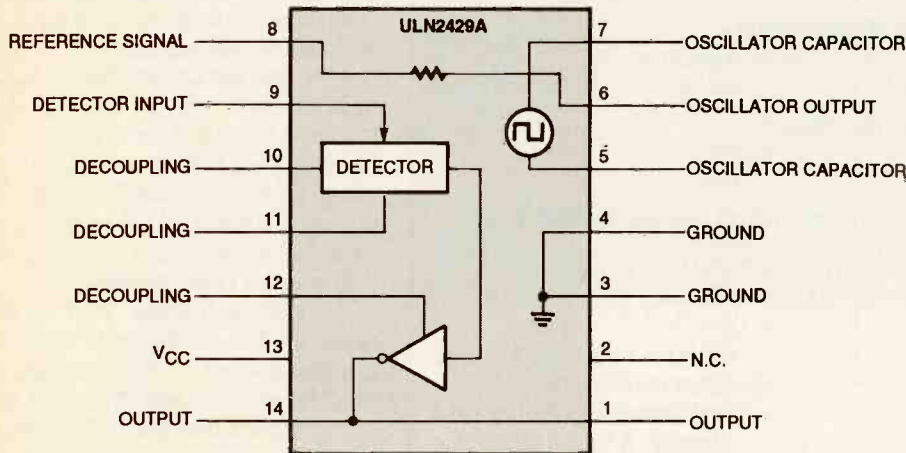
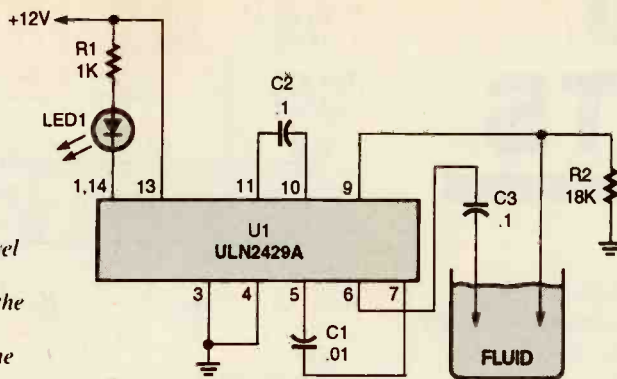


Fig. 1. As shown in A, the ULN2429A contains four basic circuits: a series voltage-regulator, a square-wave oscillator, a detector/amplifier, and a load driver. The components of those circuits are shown in B.



Fig. 3. The high-level detector keeps the LED on as long as the liquid level is above the probes. When the liquid level drops below the probes, the LED turns off.



and pin 8's output is buffered by an internal 18k resistor.

Our first two circuits will show the IC operating as intended in a level-detector circuit. Let's look at them right now.

### LOW-LEVEL DETECTOR

The first level-detector circuit (see Fig. 2) turns on LED1 when the liquid level drops below the probe. Configured as shown, the internal oscillator is running at about 2.4 kHz. That is the IC's recommended operating frequency. With the probe immersed in the liquid, the oscillator's signal from pin 8, which must travel through the internal 18k resistor, is coupled to ground through the liquid. When the level drops below the probe, the oscillator's

### PARTS LIST FOR THE LOW-LEVEL DETECTOR

#### SEMICONDUCTORS

LED1—Light-emitting diode  
U1—ULN2429A fluid detector, integrated circuit

#### CAPACITORS

C1—0.01- $\mu$ F, ceramic-disc  
C2, C3—0.1- $\mu$ F, ceramic-disc

#### ADDITIONAL PARTS AND MATERIALS

R1—1000-ohm,  $\frac{1}{4}$ -watt resistor  
Probe, perfboard, solder, wire, etc.

signal is no longer taken to ground and is coupled to the detector's input at pin 9 through a 0.1- $\mu$ F capacitor, C3. The signal is detected, amplified, and converted to DC with the use of a decoupling capacitor, C2, between pins 10 and 11. The DC output turns on the LED indicating a low liquid-level condition.

### HIGH-LEVEL DETECTOR

In the next circuit (see Fig. 3), the oscillator is again operating at 2.4 kHz. As long as the liquid level is above the probes, the LED remains on, indicating a normal condition. The liquid between the two probes couples the oscillator's output to the detector's input. When the liquid level drops below the probes, the signal is lost and the LED turns off.

### PARTS LIST FOR THE HIGH-LEVEL DETECTOR

#### SEMICONDUCTORS

LED1—Light-emitting diode  
U1—ULN2429A fluid-detector, integrated circuit

#### CAPACITORS

C1—0.01- $\mu$ F, ceramic-disc  
C2, C3—0.1- $\mu$ F, ceramic-disc

#### ADDITIONAL PARTS AND MATERIALS

R1—1000-ohm,  $\frac{1}{4}$ -watt, 5% resistor  
R2—18,000-ohm,  $\frac{1}{4}$ -watt, 5% resistor  
Probes, perfboard, solder, wire, etc.

## BUILD A TEST BENCH

(Continued from page 39)

tery should be considered during operation. The internal resistance of a typical dry-cell battery is between 10 and 100 ohms. Considering the cost of batteries these days, you may want to use an AC wall adaptor as a power source for lengthy operation. If the external power supply is used, a resistor (R4) should be added in series with the source to simulate the internal resistance of a dry-cell.

In the author's unit, a 22-ohm,  $\frac{1}{2}$ -watt resistor was used for resistor R4. To prevent charging B1, a reverse-biased diode is used as an automatic change-over switch. If external power is removed, the battery automatically takes over. If the battery you use for your unit is a rechargeable, you can omit diode D1 and choose a value for R4 to limit charging current.

If the Test Bench Amplifier is incorporated into another project, and made to share the same power supply, such as a high-gain preamplifier, use a 100-ohm resistor for R4 and increase the value of C4 to 100  $\mu$ F to increase isolation from other circuitry and prevent unwanted feedback.

The normal speaker load impedance for the LM386 is 16 ohms or greater. An 8-ohm speaker can be used, however, provided that the supply voltage is clamped at 9 volts or less to prevent overheating U1. If you must use a 4 ohm speaker, further reduce the supply to 6 volts to keep U1 happy.

**Using the Project.** The Test Bench Amplifier can come in handy in a wide variety of applications. For instance, it can be used when checking out a new circuit or repairing audio products. In addition, it can be used around the house with an inductive pickup coil to trace concealed (in-wall) AC wiring or to allow the whole family to listen in when a favorite relative visits by telephone. It makes a great extension amp for boosting the output of headphone-style personal radios. (Stereo sound, of course, requires that you build two such amplifiers, one for each channel.) In any event, once you build it, you are sure to find many applications for this versatile and useful circuit.

# ELECTRONICS MARKET PLACE

## FOR SALE

**THE Case Against the Patents.** Thoroughly tested and proven alternatives that work in the real world. \$28.50. **SYNERGETICS PRESS**, Box 809-C, Thatcher, AZ 85552. (602) 428-4073. Visa/MC.

**300 Experimenters Circuits** — Complete in 6 practical books using diodes, relays, FET's, LED's, IC 555's, and IC CA3130's for building blocks. Only \$33.00 plus \$5.50 for shipping. USA and Canada only. US funds. **ETT, INC.**, PO Box 240, Massapequa Park, NY 11762-0240.

## BUSINESS OPPORTUNITIES

**START** your own technical venture! Don Lancaster's newly updated **Incredible Secret Money Machine II** tells how. We now have autographed copies of the Guru's underground classic for \$18.50. **SYNERGETICS PRESS**, Box 809-C, Thatcher, AZ 85552. (602) 428-4073. Visa/MC.

**LET** the government finance your small business. Grants/loans to \$500,000 yearly. Free recorded message: (707) 449-8600. (KS3)

## PLANS AND KITS

**ALL-in-One catalog.** AM/FM/Ham/Spy, transmitters/amplifiers, voice disguisers, descramblers, audio/TV/science projects. Start your own licensed/unlicensed radio station, books/plans/kits for import and export. 60 mouth-watering pages for \$1.00. **PAN-COM INTERNATIONAL**, PO Box 130-H, Paradise, CA 95967.

**60 SOLDERLESS Breadboard Projects** in two easy-to-read pocket books. Complete with circuit descriptions, schematics, parts layouts, component listings, etc. Both books (BP107 & BP113) only \$11.90 plus \$3.50 for shipping. USA and Canada only. US funds. **ETT, INC.**, PO Box 240, Massapequa Park, NY 11762-0240.

**THE only catalog needed!** Kits, plans, surveillance, test, radios, more! Part locating, best prices! Send \$1.50 (refundable) **NEUTRONICS**, 4 Croydon Ct., Englishtown, NJ 07726.

## SURVEILLANCE

& COUNTERSURVEILLANCE Electronic Devices

Bugging/Phone Tapping Detectors • Caller ID • Covert Video  
• Phone Scramblers • Voice Changers • Shotgun Mics • Vehicle  
Tracking • Transmitter Kits • Locksmithing • AND MORE!

7-Hour Telephone Recording System  
Tapes phone calls automatically. \$125



FOR CATALOG SEND \$5.00 TO...  
P.O. Box 337, Buffalo, NY 14226 (716) 691-3476



## RECEIVING TUBES

**OVER 3000 TYPES IN STOCK!**

Also hard-to-find transformers, capacitors and parts for tube equipment.

Send \$2.00 for our 32 page catalog.

## ANTIQUE ELECTRONIC SUPPLY

6221 S. Maple Ave. • Tempe, AZ 85283 • 602-820-5411

## Prototype it..... FAST!

with ProtoQuick 8051 or 28  
• Complete single board computers  
• Up to 32K EPROM and 8K RAM  
• 12 bit in (dual) through hole drive  
• RS232 C serial port or DB25 serial  
• Op sys. in EPROM or source code  
• Assembly, ready to run - \$1, only  
• MS-DOS cross assembler included!

ProtoQuick 28 and 8051  
**\$99.00** each

Software Release  
2708 Roundwood Road  
Channahon, IL 61414 USA  
(513) 561-2080

Run prototype applications or experimental hardware from the serial port WITHOUT PROGRAMMING!

## BUY BONDS

MAY THE  
SOURCE  
BE WITH  
YOU

Don't let the dark forces of ignorance defeat you. Right in this galaxy, you can tap into the source -- the free Consumer Information Catalog. It lists free and low-cost government publications on cosmic topics such as federal benefits, jobs, health, housing, educating your children, cars, and much, much more. So dispel the darkness and send for the source. Write today to Pueblo, Colorado for the free Consumer Information Catalog. Just send your name and address to:



Consumer Information Center  
Department Source  
Pueblo, Colorado 81009

## ADVERTISING INDEX

POPULAR ELECTRONICS magazine does not assume any responsibility for errors that may appear in the index below.

RS #	Page
—	Antique Electronics Supply . . . 111
17	C&S . . . . . CV2
—	CIE . . . . . 17
—	CLAGGK . . . . . 112
—	CLAGGK VCR . . . . . 13, 103
—	CLAGGK Video . . . . . CV4
—	EDE . . . . . 111
—	EIA . . . . . CV3
—	Electronics Technology Today . . 15
—	Electronics Technology Today . 108
18	Heath . . . . . 37
—	Information Unlimited . . . . . 1
—	ISCET . . . . . 102
16	Mouser . . . . . 9
—	NRI . . . . . 33
—	Popular Elect. Back Issues . . . 105
19	School of VCR Repair . . . . . 9
15	Sescom . . . . . 11
—	Software Science . . . . . 111
20	Weka . . . . . 5
—	Zentek . . . . . 104



# Pass the COMMERCIAL RADIO OPERATOR LICENSE EXAM



## with this CONFIDENCE BUILDER!

As a reader of *Electronics Now* you most likely know many of the answers to the FCC General Radiotelephone Operator License exam questions. All it may take to get your license is a quick review of the *Commercial Radio Operator License Educational Package* and taking one or more sample exams—consisting of the actual questions used in the FCC exams! If not, even a novice can bone up using License Exam Preparation software (on a PC disk) and successfully pass the FCC exam. Don't believe it? Buy it! Try it! It's guaranteed to do the job or your money back!

### Look at these features:

- All exam questions (*guaranteed word-for-word*) and answers contained in this package are the ones used in the FCC exams. There will be no surprises when you take your examination.
- You will be taking *practice* FCC license examinations right at your personal computer or work from printer copies.
- Question selection formula is the one used in the *actual* FCC examination.
- Computer constructs *unique* written theory tests for you to answer on the screen, or on print out! Program *supports* all dot matrix and laser printers.
- All schematic diagrams *appear* on PC screen.
- Computer *bargraph scoring* by individual sub-element highlights topics requiring further study.
- Software tells you when *you are ready* to take the FCC exam and **PASS!**
- Change *screen colors*. . .choose *sound effects*. . .and more! *Windows* not required.
- Thousands sold to *satisfied* operators and technicians.

### CLAGGK INC. — FCC Commercial Exam Special Offer P.O. Box 4099, Farmingdale, New York 11735

Yes, I like your offer and here is my order for the Commercial Radio Operator License Educational Package!

Complete FCC Radiotelephone Exam Special Offer that includes one 3½-in. and two 5¼-in disks, Question and Answer booklet containing Elements 1 and 3 and FCC Part 13 Regulations, and Educational Package booklet.

(\$39.95 each) \_\_\_\_\_ \$ \_\_\_\_\_  
Shipping and handling per order \_\_\_\_\_ \$4.00  
Total Amount in U.S. Funds only \_\_\_\_\_ \$ \_\_\_\_\_

New York residents add local sales tax. Canadians add \$6.00 per order. No foreign orders. Do not send cash.

Bill my  VISA  MasterCard \_\_\_\_\_ Expire Date \_\_\_\_/\_\_\_\_/\_\_\_\_

Card No. \_\_\_\_\_

Signature \_\_\_\_\_

Name (Please print) \_\_\_\_\_

Address \_\_\_\_\_

City \_\_\_\_\_ State \_\_\_\_\_ ZIP \_\_\_\_\_

# ELECTRONICS HOBBYISTS handbook™

## ADVERTISING SALES OFFICE

Gernsback Publications, Inc.  
500-B Bi-County Blvd.  
Farmingdale, NY 11735  
1-(516) 293-3000

Larry Steckler, EHF/CET  
President

Christina Estrada  
Assistant to the President

For Advertising ONLY  
516-293-3000  
Fax 1-516-293-3115

Larry Steckler  
publisher

Arline Fishman  
advertising director

Denise Mullen  
advertising assistant

Kelly Twist  
credit manager

Subscription/  
Customer Service/  
Order Entry  
1-800-827-0383  
7:30 AM - 8:30 PM EST

## ADVERTISING SALES OFFICES EAST/SOUTHEAST

Stanley Levitan  
Eastern Sales  
1 Overlook Ave.  
Great Neck, NY 11021  
1-516-487-9357, 1-516-293-3000  
Fax 1-516-487-8402

## MIDWEST/Texas/Arkansas/ Oklahoma, Colorado, Arizona

Ralph Bergen  
Midwest Sales  
One Northfield Plaza, Suite 300  
Northfield, IL 60093-1214  
1-708-446-1444  
Fax 1-708-559-0562

## PACIFIC COAST/Mountain States

Mike Brooks  
Hutch Looney & Assoc., Inc.  
1800 North Highland Avenue  
Suite 717  
Hollywood, CA 90028  
1-213-462-2700  
Fax 1-213-463-0544

# What Do These Prestigious Companies Have In Common?

## Aerovox®

DC Film and RFI Suppression Capacitors, Aluminum Electrolytic and AC Oil Capacitors, EMI Filters

## AMP

Electrical/Electronic Connectors, IC Sockets, PCB Switches

## AMRAD Engineering, Inc.

Motor Run Capacitors, HID Lighting Capacitors, Power Factor Correction Capacitors



Miniature and Subminiature Coaxial Connectors and Cable Assemblies.

## AVX CORPORATION

MLC, Tantalum and Thin Film Capacitors, Resistors, Networks, Integrated Passive Components, Trimmers, Oscillators, Resonators, Filters, Piezo Devices, and Connectors

## BERG ELECTRONICS

High Density and Industry Standard Connectors/Subsystems

## CAROL

Electronic and Electrical Wire and Cable and Power Supply Cords

## COLE FLEX

Tubing, Conduits, Hose, Sleeveings, Splices, Insulation and Cable Harness Products, Power Cords and Cordsets

## Communications Instruments, Inc.

CII Midtex  
Relays and Solenoids

## COOPER

**Bussmann**  
Fuses, Fuseholders, Fuse Blocks, and Fuse Accessories

## CORNELL DUBILIER

Capacitors-Aluminum Electrolytics, Mica, AC Oil, Film, MICA Paper and Relays



**Dale Electronics, Inc.**

Resistors, Networks, Oscillators, Displays, Inductors, Thermistors, Connectors, & Transformers

## DI DANTONA INDUSTRIES, INC.

Batteries: Computer, Cordless Phone, Laptop, Scanner, Alarm and Medical  
Antennas: Cordless Phone and Scanner

## DEARBORN WIRE AND CABLE L.P.



## EATON

Eaton Corporation, Commercial & Military Controls Operation  
Switches, Relays, Displays and Keyboards



Quartz Crystals, Clock Oscillators, Surface Mount Products, Programmable Devices

## A GERNSBACK PUBLICATION

Electronics Now Magazine

## G GUARDIAN

Relays and Solenoids

## KEMET

Electronics Corporation  
Multilayer Ceramic and Solid Tantalum Capacitors

## KOA SPEER

Resistors, SMT Tantalum Capacitors Inductors, Resistor Networks, SMT Thermistors

## MALLORY

North American Capacitor Company  
Tantalums, Aluminums, Sonalerts®R Ceramics, Films and AC's

## M-tron

Quartz Crystal  
Hybrid Oscillators

## muRata®

Fixed Ceramic Capacitors, Variable Capacitors and Resistors, Crystal Oscillators, Ceramic Filters, Resonators, EMI Filters, Hybrid Circuits and more.

## Panasonic Industrial Company

Resistors, Resistor Networks, Ceramic, Film, Electrolytic, Double Layer Capacitors, Potentiometers, Switches, Inductors, Filters, Resonators, Varistors, Thermistors

## Philips Components

Philips Electronics North America Corporation  
Resistors, Ferrite Components  
Aluminum Electrolytic, Film & Ceramic Capacitors

They sell through distributors.

They belong to the E.I.A.

They belong on your vendor list.

## Quam

Loudspeakers and Commercial Sound Products

## ROHM

Rohm Electronics Division  
Resistors, Ceramic Capacitors, Transistors/Diodes, Opto Components and IC's



Switches, Relays, Terminals, Indicator/Pilot Lights, LED Indicators, Test Clips, Test Leads, Cable Ties and Heat Shrinkable Tubing

## A COMPANY OF SPRAGUE

Tantalum Capacitors, Wet & Foil Capacitors, Resistor Networks, Resistor Capacitor Networks, Filters

## Switchcraft

A Raytheon Company  
Switches, Connectors, Jacks, Plugs, Jackfields & Audio Accessories, Cable Assemblies

Leadership in electronics is not just a matter of designing products better and manufacturing them better, but also of marketing them better. And the sponsors of this message understand that better service to customers requires effectively involving distributors as part of their marketing teams.

Distributor involvement means lower prices, quicker deliveries, better service over-all. The Buyer wins...the Seller wins.

Distributors help achieve marketing leadership. So does the manufacturer's involvement in the Components Group of the Electronic Industries Association. EIA fosters better industry relations, coherent industry standards, and the sharing of ideas, which helps one another and serves customers better.

In choosing your component supplier, look for the marks of leadership--

- availability through distribution
- membership in E.I.A.



Our 70th Anniversary Year

Electronic Industries Association/Components Group  
2001 Pennsylvania Avenue, N.W., 11th Floor  
Washington, D.C. 20006  
Phone: (202) 457-4930  
Fax: (202) 457-4985

Committed to the competitiveness of the American electronics producer.



# Countersurveillance

**Never before has so much professional information on the art of detecting and eliminating electronic snooping devices—and how to defend against experienced information thieves—been placed in one VHS video. If you are a Fortune 500 CEO, an executive in any hi-tech industry, or a novice seeking entry into an honorable, rewarding field of work in countersurveillance, you must view this video presentation again and again.**

*Wake up!* You may be the victim of stolen words—precious ideas that would have made you very wealthy! Yes, professionals, even rank amateurs, may be listening to your most private conversations.

*Wake up!* If you are not the victim, then you are surrounded by countless victims who need your help if you know how to discover telephone taps, locate bugs, or “sweep” a room clean.

There is a thriving professional service steeped in high-tech techniques that you can become a part of! But first, you must know and understand Countersurveillance Technology. Your very first insight into this highly rewarding field is made possible by a video VHS presentation that you cannot view on broadcast television, satellite, or cable. It presents an informative program prepared by professionals in the field who know their industry, its techniques, kinks and loopholes. Men who can tell you more in 45 minutes in a straightforward, exclusive talk than was ever attempted before.

## Foiling Information Thieves

Discover the targets professional snoopers seek out! The prey are stock brokers, arbitrage firms, manufacturers, high-tech companies, any competitive industry, or even small businesses in the same community. The valuable information they filch may be marketing strategies, customer lists, product formulas, manufacturing techniques, even advertising plans. Information thieves eavesdrop on court decisions, bidding information, financial data. The list is unlimited in the mind of man—especially if he is a thief!

You know that the Russians secretly installed countless microphones in the concrete work of the American Embassy building in Moscow. They converted



**1-516-293-3751**

**HAVE YOUR  
VISA or MC CARD  
AVAILABLE**

what was to be an embassy and private residence into the most sophisticated recording studio the world had ever known. The building had to be torn down in order to remove all the bugs.

## Stolen Information

The open taps from where the information pours out may be from FAX's, computer communications, telephone calls, and everyday business meetings and lunchtime encounters. Businessmen need counselling on how to eliminate this information drain. Basic telephone use coupled with the user's understanding that someone may be listening or recording vital data and information greatly reduces the opportunity for others to purloin meaningful information.

**CLAGGK INC. HF4**  
P.O. Box 4099 • Farmingdale, NY 11735

Please rush my copy of the Countersurveillance Techniques Video VHS Cassette for a total cost of \$53.95 each (which includes \$4.00 postage and handling).

No. of Cassettes ordered \_\_\_\_\_  
Amount of payment \$ \_\_\_\_\_  
Sales tax (N.Y.S. only) \_\_\_\_\_  
Total enclosed \_\_\_\_\_  
Bill my  VISA  MasterCard \_\_\_\_\_  
Card No. \_\_\_\_\_  
Expire Date \_\_\_\_\_ / \_\_\_\_\_  
Signature \_\_\_\_\_  
Name \_\_\_\_\_  
Address \_\_\_\_\_  
City \_\_\_\_\_ State \_\_\_\_\_ ZIP \_\_\_\_\_

All payments in U.S.A. funds. Canadians add \$4.00 per VHS cassette. No foreign orders.

The professional discussions seen on the TV screen in your home reveals how to detect and disable wiretaps, midget radio-frequency transmitters, and other bugs, plus when to use disinformation to confuse the unwanted listener, and the technique of voice scrambling telephone communications. In fact, do you know how to look for a bug, where to look for a bug, and what to do when you find it?

Bugs of a very small size are easy to build and they can be placed quickly in a matter of seconds, in any object or room. Today you may have used a telephone handset that was bugged. It probably contained three bugs. One was a phony bug to fool you into believing you found a bug and secured the telephone. The second bug placates the investigator when he finds the real thing! And the third bug is found only by the professional, who continued to search just in case there were more bugs.

The professional is not without his tools. Special equipment has been designed so that the professional can sweep a room so that he can detect voice-activated (VOX) and remote-activated bugs. Some of this equipment can be operated by novices, others require a trained countersurveillance professional.

The professionals viewed on your television screen reveal information on the latest technological advances like laser-beam snoopers that are installed hundreds of feet away from the room they snoop on. The professionals disclose that computers yield information too easily.

This advertisement was not written by a countersurveillance professional, but by a beginner whose only experience came from viewing the video tape in the privacy of his home. After you review the video carefully and understand its contents, you have taken the first important step in either acquiring professional help with your surveillance problems, or you may very well consider a career as a countersurveillance professional.

## The Dollars You Save

To obtain the information contained in the video VHS cassette, you would attend a professional seminar costing \$350-750 and possibly pay hundreds of dollars more if you had to travel to a distant city to attend. Now, for only \$49.95 (plus \$4.00 P&H) you can view *Countersurveillance Techniques* at home and take refresher views often. To obtain your copy, complete the coupon or call.