

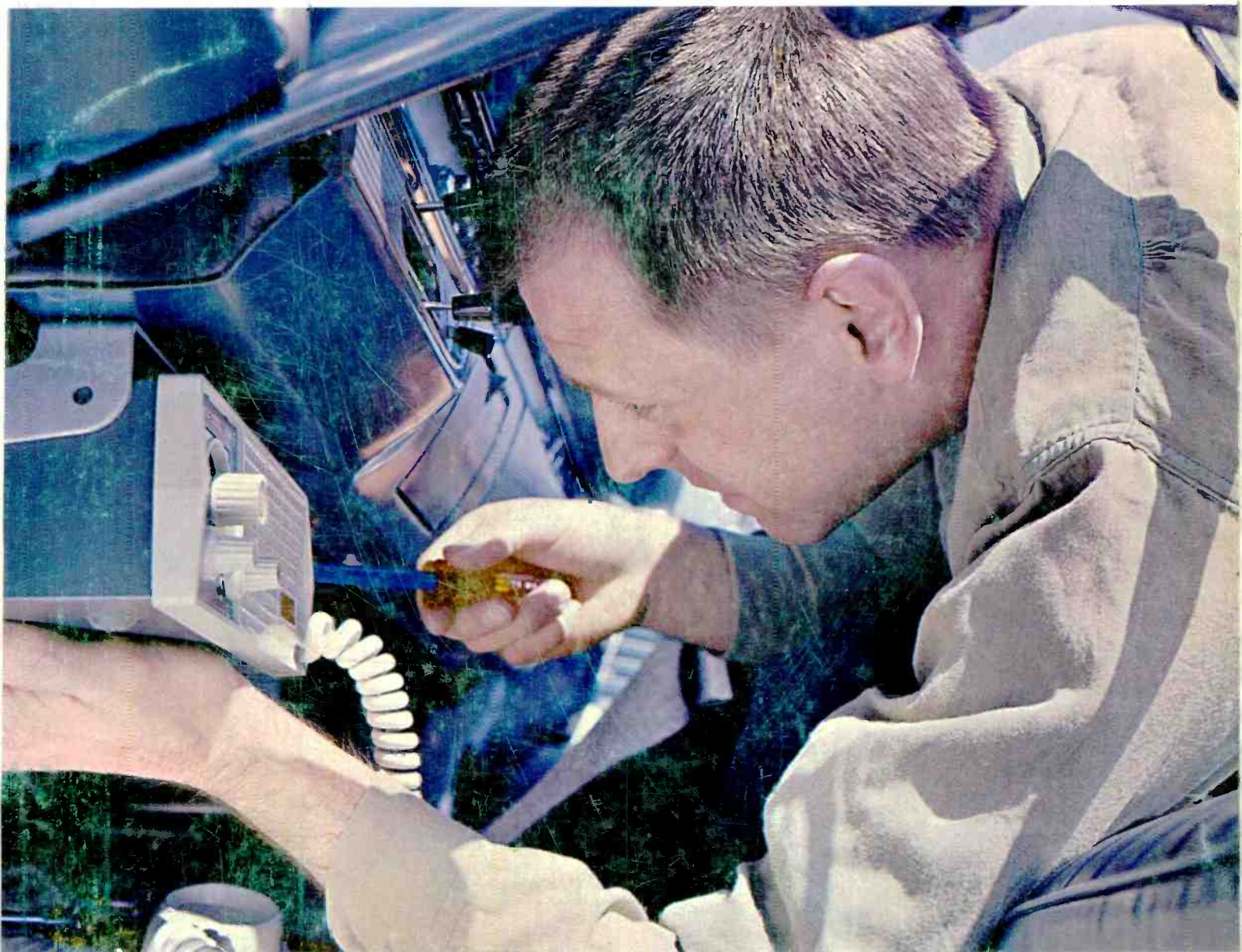

PF Reporter™

PHOTOFACT

the magazine of electronic servicing



IA 2L 1104 1200
WM. M. DAVIS
RAD. & TV SERV.
118 RIVERSIDE AVE.
CANON CITY, COLO.

Special CB-COMMUNICATIONS Issue

- Installing a CB Mobile Unit
- Where Stands CB With FCC?
- Arbitrating Problems of CB-TV
- Unusual CB Alignment Characteristics
- Plus other servicing features

INTRODUCING Jerrold COLORAXIAL™ Program COAX IS A MUST FOR COLOR TV



← THIS
NOT
THIS →



Commercial installations have proved that coaxial downlead is *essential* for predictable, consistently good color TV pictures. Coax loss doesn't increase in wet weather, while twinlead loss goes up as much as six times. Coaxial cable can be run anyplace, even next to metal, without mismatch. Coax doesn't deteriorate with age. It won't pick up ignition noises or other interferences. In a word, for satisfactory color reception, even in "ideal" reception areas, your customers need coax.

And now, new Jerrold COLORAXIAL antennas

and kits give you a perfect home-installation package for every color-reception need. With COLORAXIAL, you can offer the whole system, from coaxial antenna to indoor matching transformer, or adapt an existing 300-ohm antenna for coax operation. Listed below are all the COLORAXIAL components packaged individually and in kits, for easy, low-cost conversion. Ask your Jerrold distributor for COLORAXIAL brochure, or write *Jerrold Electronics, Distributor Sales Division, Philadelphia, Pa. 19132.*

CAX-16 • COLORAXIAL COLORGUARD

COLORAXIAL Antenna for metropolitan and suburban reception areas. Prematched to 75-ohm coaxial cable; complete with fitting. No outdoor matching transformer required—only an indoor Model T378. List \$11.95

K-CAX-16 • COLORAXIAL Antenna Kit. Everything you need for complete installation—a CAX-16 Antenna, antenna tri-mount with 5-ft mast, 50 feet of coax cable with fittings, and T378 indoor matching transformer. List \$29.95



COLORAXIAL PARALOGS

PAX-40 • COLORAXIAL Antenna for difficult suburban areas. Prematched to 75-ohm coaxial cable; complete with fitting. No outdoor matching transformer required—only an indoor Model T378 needed. List \$22.95

PAX-60 • COLORAXIAL Antenna for suburban to semi-fringe areas. Prematched to 75-ohm coaxial cable; complete with fitting. No outdoor matching transformer required—only an indoor Model T378 needed. List \$32.95

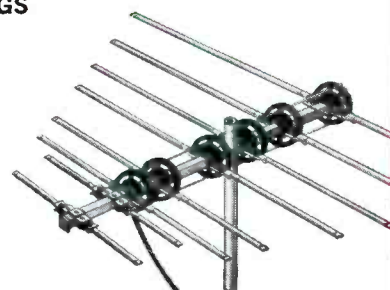

CAT-2 • COLORAXIAL MATCHING TRANSFORMER KIT

One TO-374A mast-mounting matching transformer for any 300-ohm antenna, and one T378 set-mounting matching transformer, complete with bracket and mounting strap. List \$8.20

COLORAXIAL matching transformers are also available individually: TO-374A, list \$4.95; T378, list \$3.25

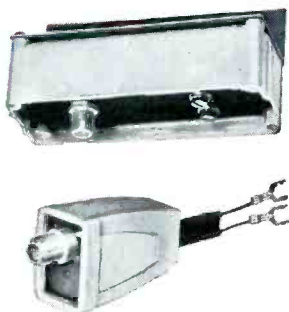

COLORAXIAL CABLE

CAB-50 • 50 feet of sweep-tested RG-59/U 75-ohm coaxial cable complete with F-59A fittings attached, plus weatherboot. List \$9.50

CAB-75 • 75 feet of sweep-tested RG-59/U 75-ohm coaxial cable complete with F-59A fittings attached, plus weatherboot. List \$11.50



**JERROLD
ELECTRONICS**

A subsidiary of The Jerrold Corporation

Circle 1 on literature card

www.americanradiohistory.com

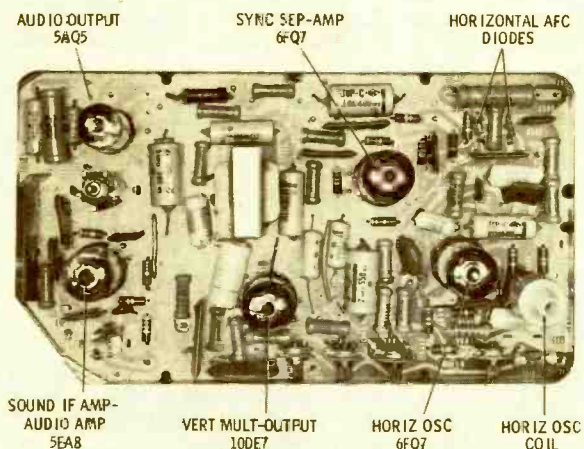
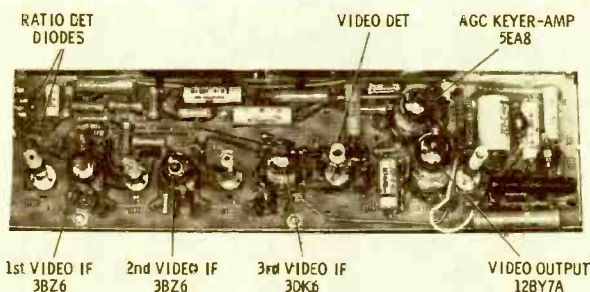
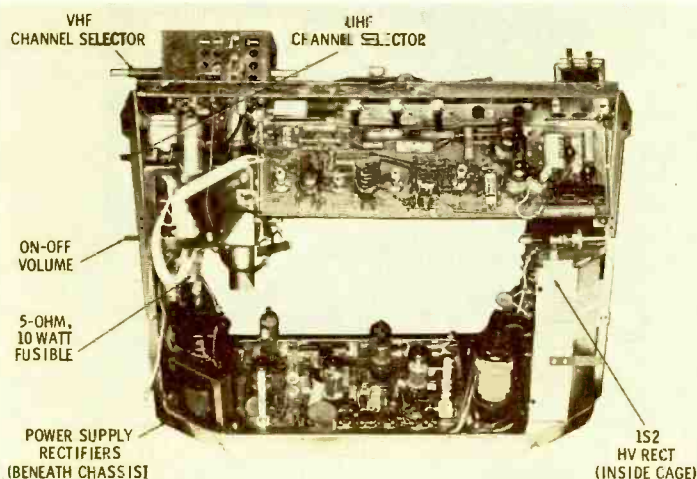
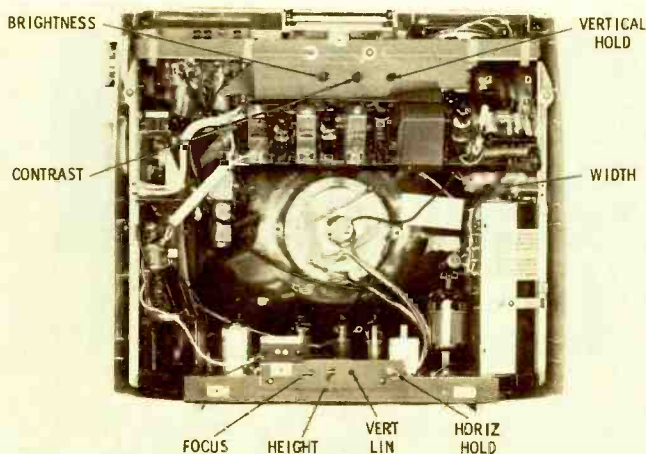

**Magnavox
Model 1U107
Chassis U49-01-00**

Here's one of the portables available in the Magnavox '65 line. This model uses a 16AUP4 picture tube and is equipped with a built-in dipole antenna and earphone jack. This chassis, manufactured in Japan, wraps around the picture tube and utilizes a minimum of space. The video and AGC circuits are on the printed board mounted at the top of the chassis. The audio, sync, and deflection circuits are on the board at the bottom, the left side (viewed from the rear) is the low-voltage power supply and tuners, while the right side consists of the high-voltage cage.

Electrically this receiver is basically the same as Magnavox sets manufactured in this country. The three-stage video IF strip consists of 3BZ6's in the first two stages and a 3DK6 in the third. A 12BY7A serves as video output. Two 5EA8's are used: one as the sound IF amplifier/audio amplifier, the second as AGC keyer/amplifier. A 6FQ7 functions as sync separator/amplifier, and the same tube type functions as the horizontal oscillator. A 10DE7 is used as vertical blocking oscillator/output. (The blocking-oscillator circuit, rather obsolete in American-made sets, is used quite often in imported receivers.)

A number of diodes are used in this receiver (11 in fact). Two of these are used in the power supply as a half-wave voltage doubler (a 5-ohm, 10-watt fusible resistor protects the silicon) and one as a filament rectifier (the fillaments operate on DC). A bias rectifier supplies a negative bias voltage to the grid of the vertical output tube. The ratio detector and video detector account for three of these diodes and the horizontal AFC for two more. The final two are AGC rectifiers, one each for the RF and IF AGC voltages.

A 2DZ4 is used in the UHF tuner as an oscillator, and a 1N82A diode serves as the mixer. The VHF tuner tubes are 2GK5 RF amplifier and 5CG8 mixer/oscillator. Individual oscillator slugs are provided for each channel and are accessible by removing the channel-selector and fine-tuning knobs. Set the fine tuning to midrange and adjust the oscillator slugs for best sound and picture, starting with the highest channel and working downward.



Olympic Model K-985 Chassis NAP

The pictured combination model has 23" television, AM-FM radio, FM multiplex, stereo amplifier, and four-speed automatic record changer. The television chassis is physically divided into three sections. There are two printed-circuit boards; the smaller board consists of the video IF stages, while the larger board is composed of all the additional circuitry except the horizontal output stage and the low- and high-voltage power supplies. These latter sections are hand-wired and mounted on the main chassis.

The picture tube is a 23FXP4; other tubes worth noting are the 3HA5 RF amplifier, 10JT8 video output/sound IF amplifier, 4AV6 sync separator, 13DE7 vertical multivibrator/output, and 8FQ7 horizontal oscillator. The remainder of the tubes are common types and shouldn't cause any replacement problems.

The low-voltage power supply consists of two silicon rectifiers connected in a half-wave voltage-doubler circuit. Rectifier protection is afforded by a 5.5-ohm, 7-watt surge-limiting resistor. The series filament string has a 25-ohm, 10-watt dropping resistor. Additional protection is provided by a circuit breaker in series with one side of the AC line.

The radio, stereo amplifier, and multiplex chassis have a separate power supply. This supply is in the radio chassis and consists of a selenium rectifier and 7.5 ohm, 5-watt surge-limiting resistor. These components are pointed out in the photo of the radio chassis which also contains the stereo amplifier.

An individual printed-circuit board comprises the FM multiplex receiver (its location can be seen in the photo of the cabinet rear).

Channel selector for VHF and UHF, and controls for on-off volume, brightness, contrast, and vertical hold are accessible from within the record-changer compartment. The vertical linearity, height, and horizontal-hold controls are mounted on the rear of the TV chassis. These can be adjusted from the rear of the receiver without removing the cabinet back. Focus may be varied by connecting the jumper on the base of the CRT from pin 6 to pin 1 or 10.

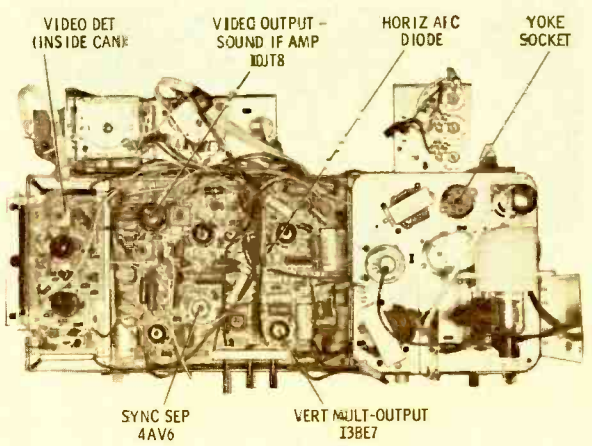
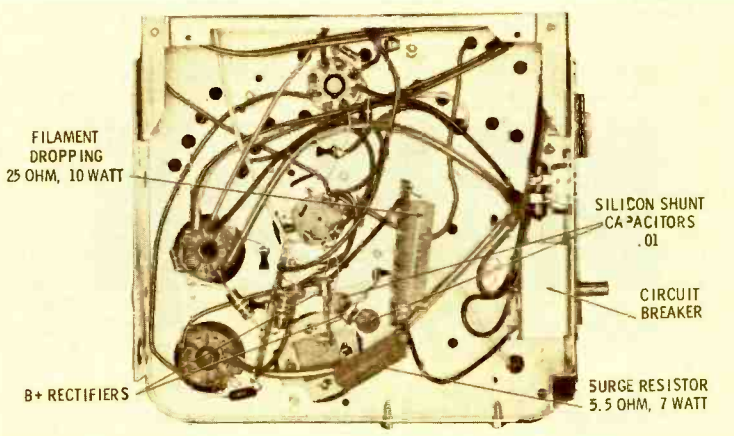
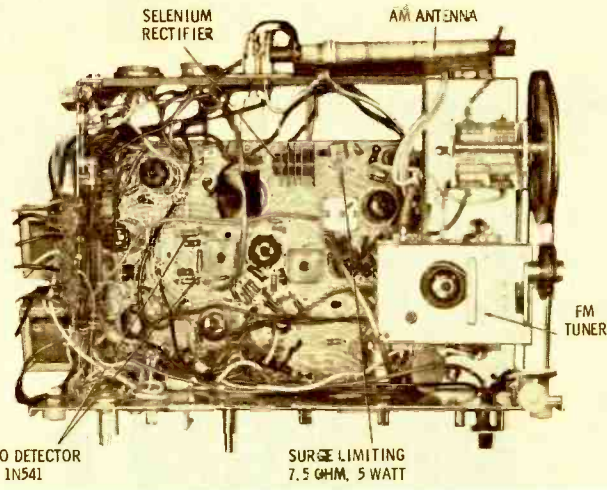
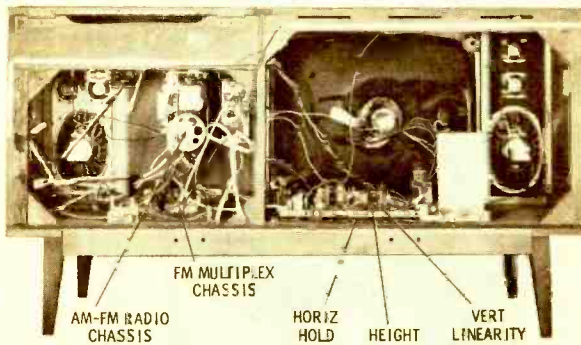

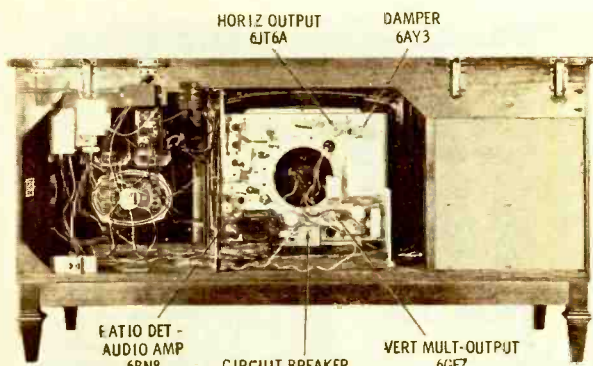

**Packard Bell
Model 23K6
Chassis 88-16C**

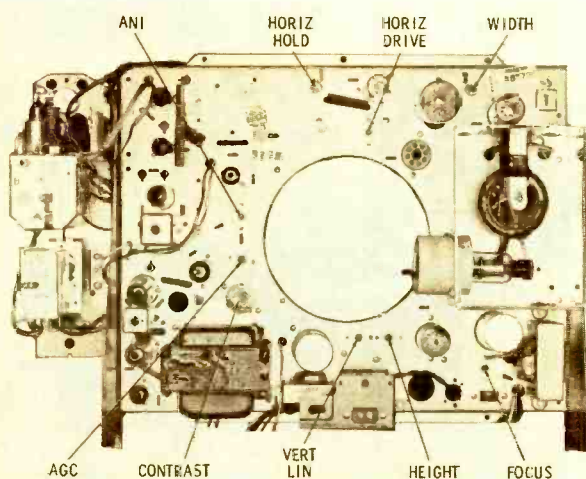

TOP VIEW -AM -FM - FM MPX RADIO CHASSIS

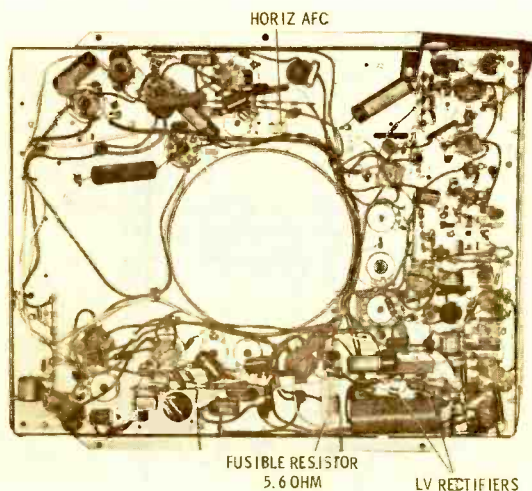
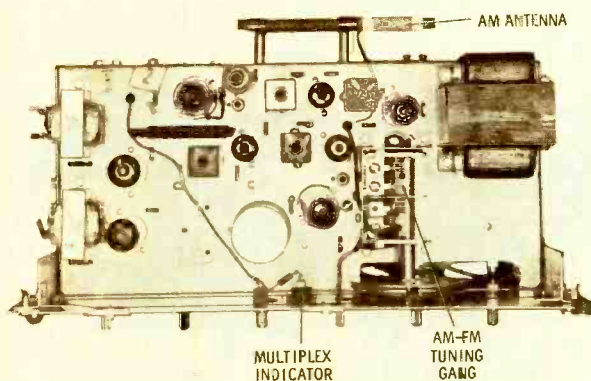

The above photo is of Packard Bell's 23" combination using the vertically-mounted, hand-wired 88-16 chassis. All of the 23" models use the same basic chassis and either a 23EK4 or 23FL P4 picture tube—the EK4 is used here. This year's 19" models use the 88-14 chassis, which is similar to the 14 series of last year.

The same design trends are followed in this receiver as in other sets manufactured by this company. A three-stage video IF strip consists of 6BZ6's in the first two stages and a 6GM6 in the third. A 6GN8 functions as video output/noise inverter and a 6GH8A as sound IF amplifier/sync separator. The dual-diode portion of a 6BN8 serves as the ratio detector, and the triode section is an audio amplifier. Sweep output tubes consist of a 6GF7 in the vertical and a 6JT6 in the horizontal.

An extensive number of controls are provided for obtaining optimum performance and compensation for component tolerances and minor deterioration. Aside from the controls found on nearly all television receivers, this one has adjustments for focus, horizontal drive, AGC, ANI (automatic noise inverter), and width (a width coil is used).

The low-voltage circuit consists of two silicon rectifiers wired in a full-wave voltage-doubler circuit. Overload protection is afforded by a circuit breaker (rated at 3.75 amps) in one side of the AC line and a 5.6-ohm fusible resistor, connected between the junction of the doubler-filter capacitors and one side of the secondary winding of the power transformer.

The VHF tuner uses a 6HQ5 RF amplifier and a 6GX7 as mixer/oscillator. The UHF tuner is transistorized—the UHF oscillator transistor is a 24T002. A crystal diode serves as UHF mixer. Signal diodes are also used as video detector and horizontal AFC (a dual unit).

Chassis removal is rather simple and straightforward. Remove the cabinet rear cover and TV control knobs. Disconnect speaker wires, picture-tube socket, yoke plug, high-voltage anode lead, amplifier plug, and antenna wires from the tuner. Remove the three screws from the tuner-mounting bracket, three screws from the bottom of the cabinet, and one from the top of the chassis. Loosen two screws from top left of chassis and mounting brace will slide down. The tuner and chassis are ready for removal from the cabinet.

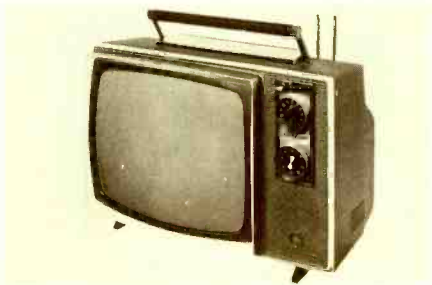

**Westinghouse
Model H-P 8020
Chassis V-2478-2**

A new receiver in the Westinghouse '65 line is the small-screen, lightweight portable pictured above. This 12" receiver uses a 12BDP4 picture tube and incorporates many of the same features commonly found in larger, more expensive receivers. These added features include a built-in dipole antenna, a tube-type UHF tuner, and an "instant-on" circuit (in the 2478-2 chassis only). This set is made in Japan, but Westinghouse parts, made in the United States, are suitable as replacements.

The chassis uses one large printed-circuit board with the majority of the components mounted on the board. The tube lineup is similar to that used in other Westinghouse receivers. The two-stage video IF uses a 4EH7 and 4EJ7; a 10JA8 functions as video output/sync separator; a 6CL8A serves as AGC Keyer/sound IF amplifier. Audio detection is accomplished by a ratio detector circuit utilizing two 1N60 crystal diodes. The triode section of a 4AV6 performs as audio amplifier (the diode section of this tube isn't used). Rounding out the audio stage is a 12FX5 output tube.

A single silicon rectifier provides B+ and is protected a 5-ohm, 7-watt fusible resistor. A second silicon unit supplies the series filament string with partial filament voltage when the receiver is turned off. When the set is turned on, the diode is shorted, and the usual 117 volts AC is applied to the filaments.

Two adjustments are provided for controlling AGC action, an AGC trimmer capacitor varies the keying pulse, derived from the flyback, and an RF AGC delay control varies the RF AGC voltage.

The trimmer should be adjusted with a scope. Connect the vertical input from test point B (video detector output) to ground. Tune the receiver to the strongest station available and adjust the trimmer for 2.75 volts peak-to-peak. The control is adjusted in the normal manner—for best picture and sound with no overload.

The receiver shown here has a range-centering control in series with the horizontal hold control. Some other sets have jumpers to either add or eliminate resistance in series with the hold control. The service data gives the proper adjustment procedure for both versions. Width is adjustable by moving a jumper in the screen of the horizontal-output tube, thus varying the resistance from screen to B+.

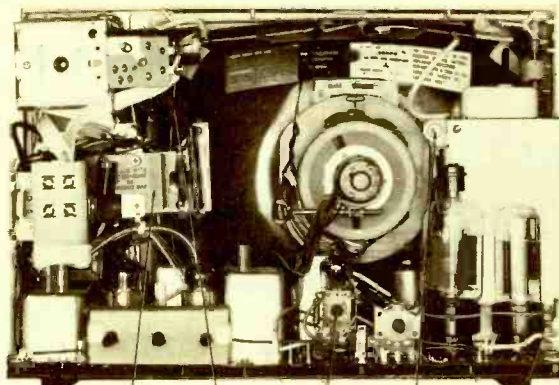

FUSIBLE RESISTOR 5-OHM, 7 WATT RF AGC DELAY HORIZONTAL RANGE AGC TRIMMER WIDTH CONNECTIONS

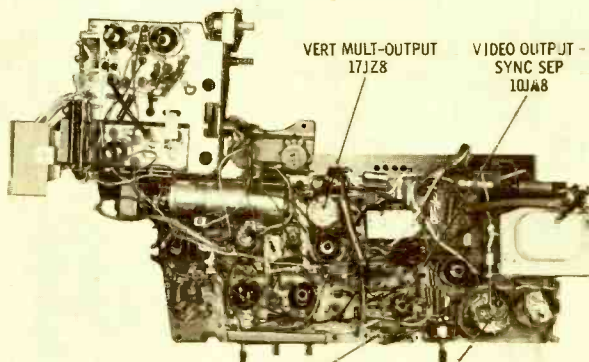

VERT MULTI-OUTPUT 17J28 VIDEO OUTPUT - SYNC SEP 10JA8
TEST POINT B HORIZ OUTPUT 17DQ4B DAMPER 17DM4

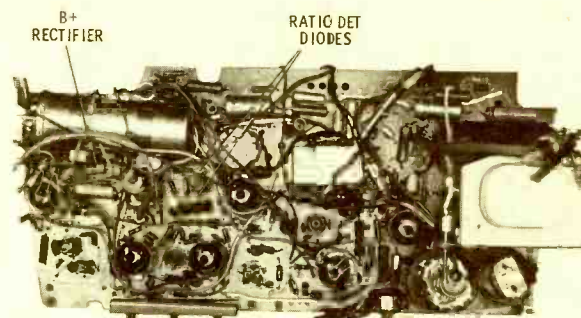

B+ RECTIFIER RATIO DET DIODES
VERT HOLD VERT LIN HEIGHT HORIZ HOLD

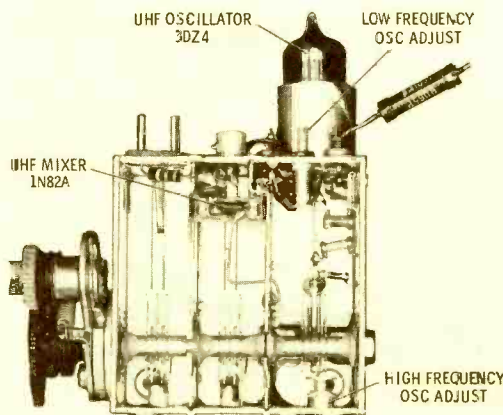

INTERNAL VIEW OF UHF TUNER

See PHOTOFACT Set 649, Folder 3

Mfr: RCA **Chassis No.** KCS 136YA

Card No: RCA KCS136YA-1

Section Affected: Pix and sound.

Symptom: Video and sound weak; voltages at pins 5 and 6 of V3 are low.

Cause: Leaky screen bypass capacitor in 3rd video IF; causes plate supply resistor to overheat.

What To Do: Replace C24 (470 pf) and R27 (470 ohms).

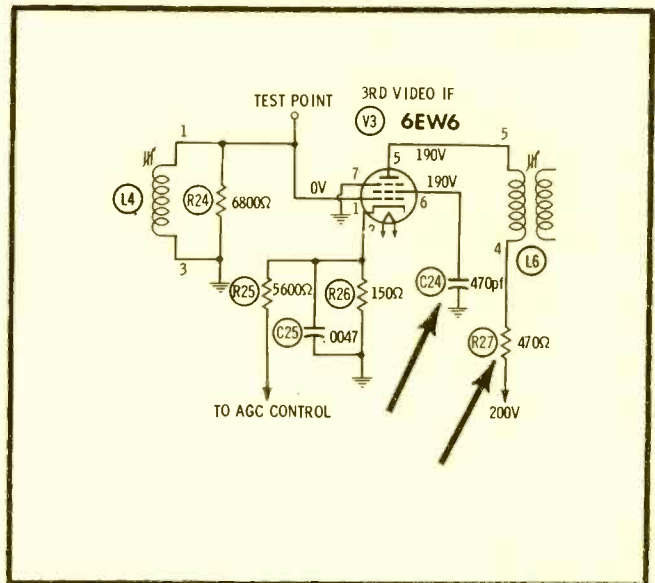

Mfr: RCA **Chassis No.** KCS 136YA

Card No: RCA KCS136YA-2

Section Affected: Pix and sound.

Symptom: No pix; no sound; raster normal.

Cause: Shorted video detector, which disrupts AGC and cuts off video IF's.

What To Do: Replace M7 (1N295).

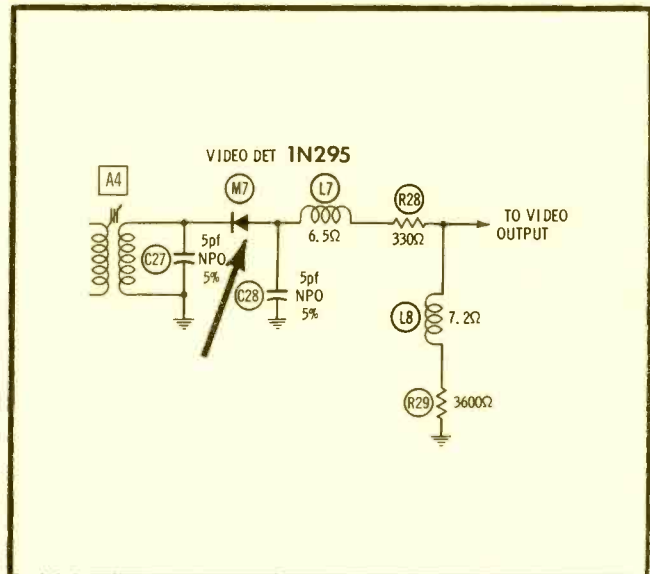

Mfr: RCA **Chassis No.** KCS 136YA

Card No: RCA KCS136YA-3

Section Affected: Vertical sweep.

Symptom: Vertical linearity cannot be adjusted properly.

Cause: Vertical output cathode bypass capacitor open.

What To Do: Replace C2D (100 mfd).

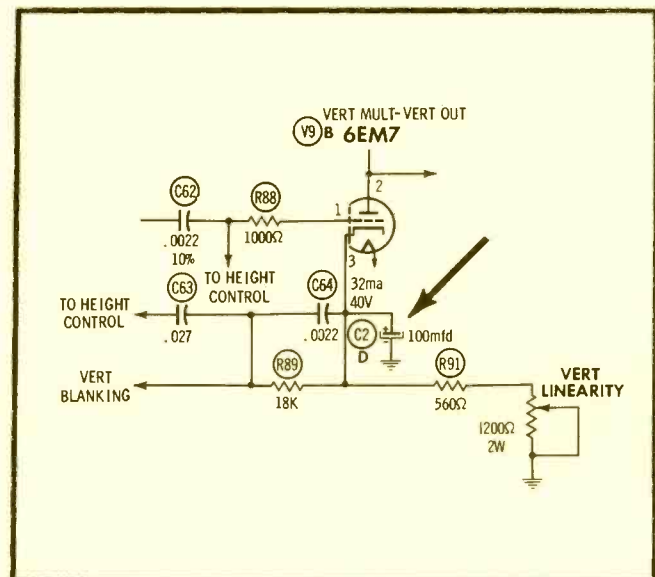

See PHOTOFACT Set 649, Folder 3

See PHOTOFACT Set 649, Folder 3

See PHOTOFACT Set 649, Folder 3

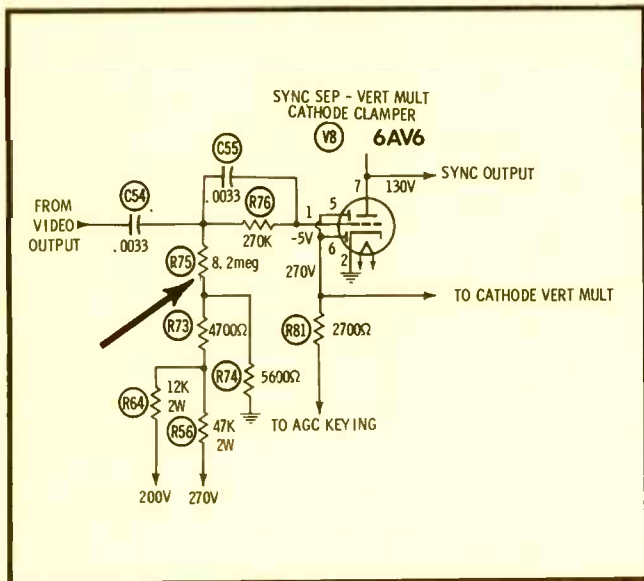

Mfr: RCA Chassis No. KCS 136YA

Card No: RCA KCS136YA-4

Section Affected: Sync.

Symptom: Loss of vertical and horizontal sync; pin 1 of V8 excessively negative.

Cause: Sync-separator grid resistor open.

What To Do: Replace R75 (8.2 meg).

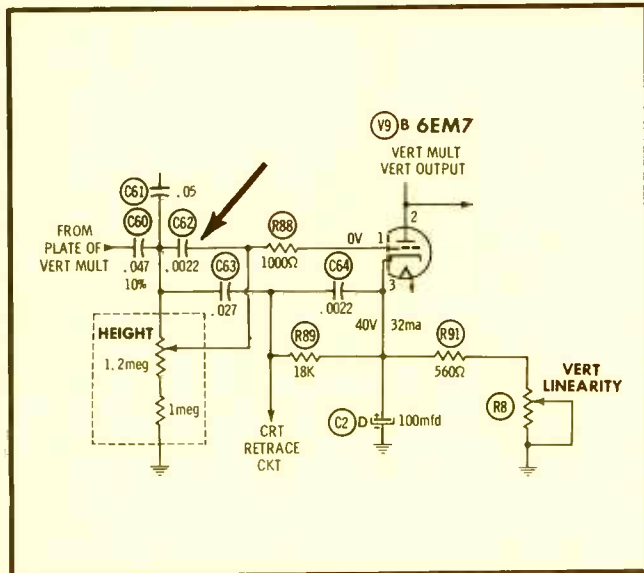

Mfr: RCA Chassis No. KCS 136YA

Card No: RCA KCS136YA-5

Section Affected: Vertical sweep.

Symptom: Poor vertical linearity and insufficient height.

Cause: Vertical output coupling capacitor shorted.

What To Do: Replace C62 (.0022 mfd).

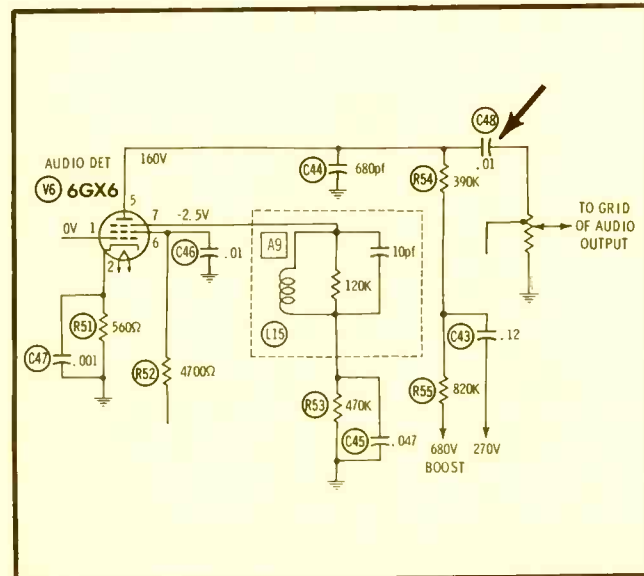

Mfr: RCA Chassis No. KCS 136YA

Card No: RCA KCS136YA-6

Section Affected: Sound.

Symptom: Intermittent sound.

Cause: Audio coupling capacitor opens intermittently.

What To Do: Replace C48 (.01 mfd).

See PHOTOFACT Set 682, Folder 3

Mfr: Zenith Chassis No. 14L30

Card No: ZE14L30-1

Section Affected: Sound.

Symptom: Weak sound; low voltage on plate of audio detector.

Cause: Detector plate supply resistor increased in value.

What To Do: Replace R52 (390K).

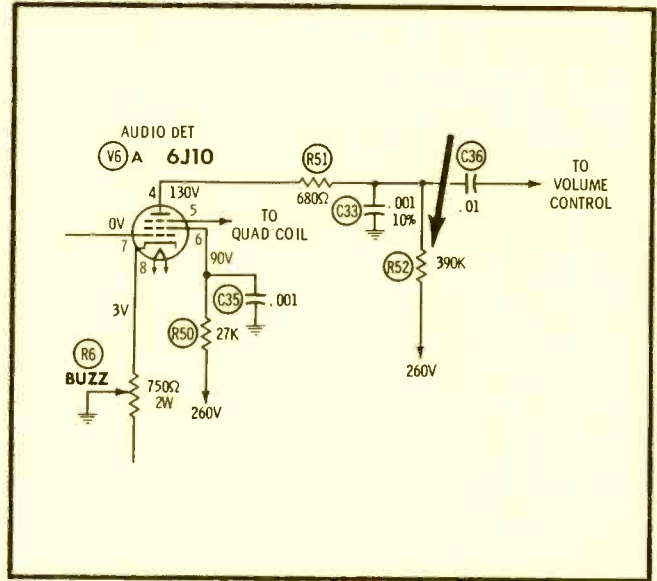

See PHOTOFACT Set 682, Folder 3

Mfr: Zenith Chassis No. 14L30

Card No: ZE14L30-2

Section Affected: Pix and sync.

Symptom: Video overload and loss of sync.

Cause: Open AGC winding on horizontal-output transformer.

What To Do: Replace T4.

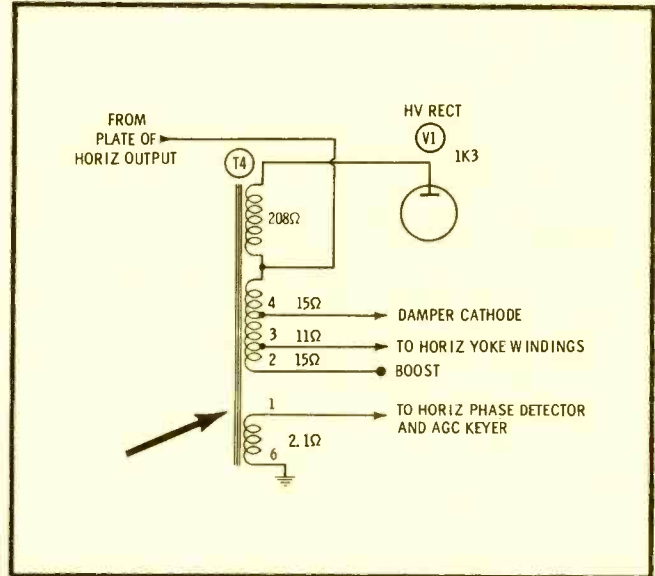

Mfr: Zenith Chassis No. 14L30

Card No: ZE14L30-3

Section Affected: Vertical sweep.

Symptom: Vertical sweep collapses after set is on for about an hour.

Cause: Vertical feedback resistor opens.

What To Do: Replace R60 (82K).

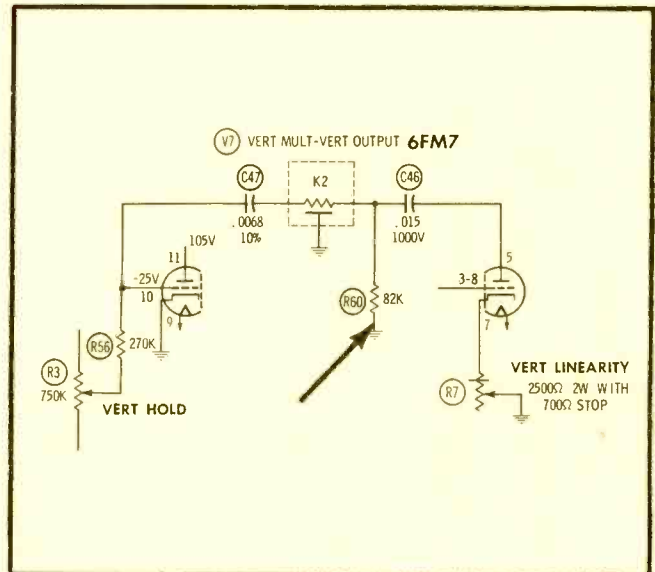

See PHOTOFACT Set 682, Folder 3

See PHOTOFACT Set 682, Folder 3

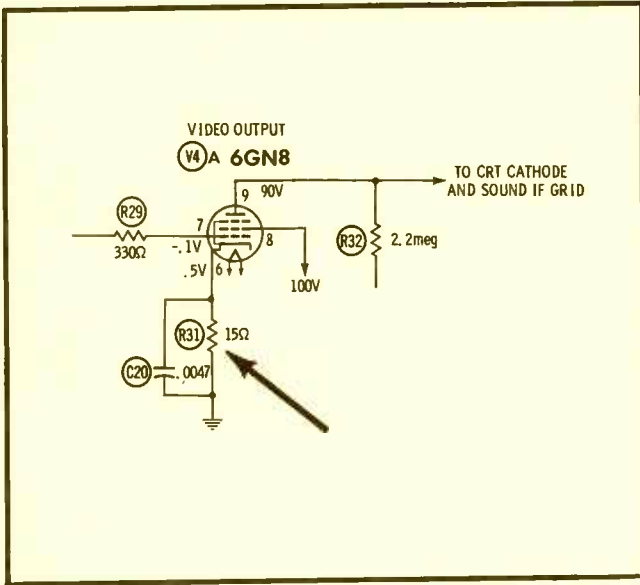

Mfr: Zenith Chassis No. 14L30

Card No: ZE14L30-4

Section Affected: Pix and sound.

Symptom: Picture and sound disappear intermittently; voltage on pin 6 of V4 rises.

Cause: Cathode resistor overheats and opens, probably due to defective video output tube.

What To Do: Replace R31 (15 ohms) and check V4 (6GN8).

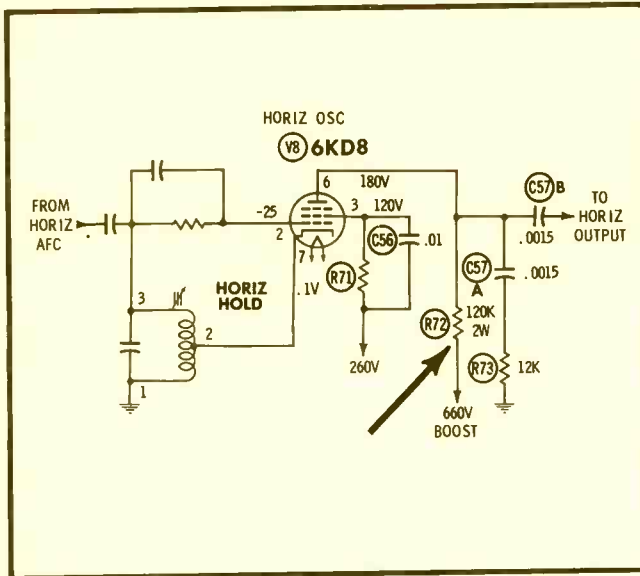

Mfr: Zenith Chassis No. 14L30

Card No: ZE14L30-5

Section Affected: Raster.

Symptom: Insufficient width; low voltage on plate of horizontal oscillator.

Cause: Horizontal oscillator plate supply resistor increased in value.

What To Do: Replace R72 (120K, 2 W.).

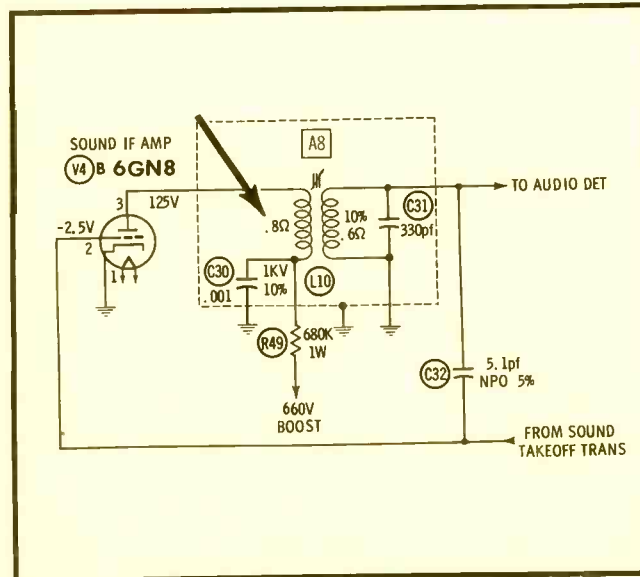

Mfr: Zenith Chassis No. 14L30

Card No: ZE14L30-6

Section Affected: Sound.

Symptom: Intermittent volume.

Cause: Defective sound-IF transformer.

What To Do: Replace L10.

who else but **TARZIAN**



\$9.50

fixes **TUNERS** for only

■ And, who else but the world's largest manufacturer of TV and FM tuners is as well-equipped, well-qualified and has available ALL necessary specifications required to provide unexcelled service on all makes and models?

Sarkes Tarzian, Inc. maintains Tuner Service Centers—completely-equipped and conveniently-located—to offer fast, dependable tuner repair service to any part of the country.

Cost, including ALL labor and parts (except tubes) is only \$9.50 and \$15 for UV combinations . . . with a 12-month warranty against defective workmanship and parts failure due to normal usage. No additional charges. No hidden costs. You do pay shipping.

Tarzian Service Centers are staffed by well-trained technicians and are assisted by engineering

personnel to assure you of FAST, DEPENDABLE repair service. Every channel—not just the channels existing in any given area—is checked and re-aligned per manufacturer's specifications. Tarzian's exclusive cleaning method makes the tuner look—as well as operate—like new. In most instances, tuners received one day will be completely overhauled and shipped out the next.

Replacements on tuners beyond practical repair are available at low factory cost.

When inquiring about service on other than Tarzian-made tuners, always send TV make, chassis and Model number. Check with your local distributor for Sarkes Tarzian replacement tuners, parts, or repair service. Or, use the address nearest you for fast, factory repair service.

S A R K E S

TUNER SERVICE DIVISION



T A R Z I A N

BLOOMINGTON, INDIANA

537 South Walnut Street
Bloomington, Indiana
Tel: 332-6055

10654 Magnolia Blvd.
North Hollywood, Calif.
Tel: 769-2720

Manufacturers of Tuners • Semiconductors • Air Trimmers • FM Radios • AM-FM Radios • Audio Tape • Broadcast Equipment

Circle 2 on literature card

SUPPRESS RFI IN YOUR CUSTOMERS' MOBILE RADIO GEAR!



NEW!
SPRAGUE SUPPRESSIKITS
FOR VEHICLES WITH
ALTERNATOR SYSTEMS

**Easily and profitably installed
on cars or trucks with citizens' band, amateur,
industrial, or public service mobile radio equipment**

AVAILABLE AFTER JUNE 1 FROM YOUR SPRAGUE DISTRIBUTOR

- ★ Three different Suppressikits to choose from—Type SK-10 for Chrysler Corp. cars and trucks, Type SK-20 for Ford Motor Co. vehicles, and Type SK-30 for General Motors Corp. equipment.
- ★ Designed to fit most newer vehicles through the 1965 model year. (for older vehicles, see the SK-1 Suppressikit, below.)
- ★ Well-engineered L-C Networks and/or heavy-duty Thru-pass Capacitors handle the hash and eliminate the siren-like whine caused by the alternator output.
- ★ Extremely easy to install—no cutting, no soldering, no wiring harnesses. All components are neatly marked and packaged, and come complete with comprehensive step-by-step installation instructions.
- ★ Provide really *effective* interference suppression through 400 mc, at moderate cost.
- ★ Will stand up under continuous operation in hot engine compartments.
- ★ Permit faster, more readable, less tiring communication at greater ranges.

TYPE SK-1 SUPPRESSIKIT FOR VEHICLES WITH D-C GENERATORS



Designed for simple but effective installation. The generator capacitor is built for continuous heavy duty 257°F (125°C) operation. A full 60 ampere current rating plus the high rated operating temperature provide an extra factor of safety against expensive generator burnouts, unlike many suppression assemblies containing general-purpose capacitors. Effectively suppresses RFI through 400 mc. Includes easy-to-follow installation instructions. Order the Type SK-1 Suppressikit from your nearest Sprague Distributor today!



WORLD'S LARGEST MANUFACTURER OF CAPACITORS
Circle 3 on literature card

PF Reporter™

PHOTOFACT

the magazine of electronic servicing

VOLUME 15, No. 5

MAY, 1965

CONTENTS

SPECIAL CB-COMMUNICATIONS SECTION

Stock Guide of Communications Tubes		18
Unusual CB Alignment Characteristics	Edward M. Noll	30
<small>Practical hints for obtaining maximum performance from CB units.</small>		
Installing A CB Mobile Unit		32
<small>The camera gives a close look at automobile CB installations.</small>		
Where Stands CB With FCC?	Thomas R. Haskett	44
<small>The attitude of the FCC toward CB can affect your business; here's what that attitude is.</small>		
Arbitrating Problems of CB-TV	Paul Norman	68
<small>Here are some hints to help you keep peace between the viewer and the CB'er.</small>		

Previews of New Sets

Magnavox Model 1U107, Chassis U49-01-00		1
Olympic Model K-985, Chassis NAP		
Packard Bell Model 23K6, Chassis 88-16C		
Westinghouse Model H-P 8020, Chassis V-2478-2		

Video Speed Servicing

Service hints on RCA Chassis KCS 136YA and Zenith Chassis 14L30.		5
--	--	----------

Letters to the Editor

The Electronic Scanner		12
-------------------------------	--	-----------

Symfact: Vertical Output		21
---------------------------------	--	-----------

(Half of Multivibrator)

See what happens to voltages and waveforms when troubles occur.		25
---	--	-----------

Tracing B+ Feed Paths

Quicker Servicing—Don't be misled when checking supply voltages in a set.	Larry Allen	34
---	-------------	-----------

Square-Wave Testing in Resistive Circuits

Advanced Service Techniques—Your scope and square-wave generator can tell you more about these circuits than an ohmmeter can.	Robert G. Middleton	37
---	---------------------	-----------

Book Review

A review of the products that can solve your mending problems.		51
--	--	-----------

Adhesives for Service Jobs

Norman D. Tanner	52
------------------	-----------

Troubleshooting High-Voltage Regulators

Servicing these circuits is much easier if you know how they work and what to look for.	Carl H. Babcock	62
---	-----------------	-----------

Notes on Test Equipment

Lab reports on Jackson Model 825 CRT Tester, SENCORE Model PS127 Wideband Oscilloscope, and Sprague Model TO-6 Capacitor Analyzer.	Allen B. Smith	71
--	----------------	-----------

The Troubleshooter

Color Countermeasures	76
------------------------------	-----------

PFR Bench Report

Product Report	79
-----------------------	-----------

Product Report

Free Catalog and Literature Service	80
--	-----------

Free Catalog and Literature Service

Monthly index on free literature card

ABOUT THE COVER

This month's cover portrays a scene that is becoming more and more common in the electronic servicing business. Installing and maintaining CB and other communications equipment already represents a significant source of potential income for the service technician, and the demand for such services continues to increase. For the technician who is—or wants to be—engaged in communications work, we present the features on pages 18, 30, 32, 44, and 68.



publisher

Howard W. Sams

editor

Forest H. Belt

managing editor

James M. Moore

ass't to the editor

Norman D. Tanner

associate editors

Major Henricks

Allen B. Smith

consulting editors

William E. Burke

Joe A. Groves

C. P. Ollphant

research librarian

M. D. Bishop

production manager

Esther M. Rainey

Robert W. Paal, Asst.

circulation manager

Pat Tidd

Katherine Krise, Ass't.

Cora La Von Willard, Ass't.

art directors

Louis J. Bos, Jr.

Robert W. Reed

advertising & editorial assistants

Hazel Boyer

Rebecca Clingerman

photography

Paul Cornelius, Jr.

advertising sales offices

Hugh Wallace, advertising sales manager

midwestern

Robert N. Rippy

PF REPORTER, 4300 West 62nd Street,

Indianapolis, Ind., AXminster 1-3100

eastern

Gregory C. Masefield

Howard W. Sams & Co., Inc., 3 West 57th Street,

New York, N. Y., MUrray Hill 8-6350

southwestern

C. H. (Jake) Stockwell

C. H. Stockwell Co., 4916 West 64th St,

Mission, Kansas, RAndolph 2-4417

western

G R. Holtz

The Maurice A. Kimball Co., Inc.

Los Angeles area: 2008 West Carson Street,

Suites 203-204, Torrance, Calif. 90501,

320-2204; and 580 Market Street,

Room 400, San Francisco 4, Calif. EXbrook 2-3365

Address all correspondence to

PF REPORTER, 4300 W. 62nd Street

Indianapolis, Indiana 46206



Copyright© 1965 by Howard W. Sams & Co., Inc. PF REPORTER is a trademark of Howard W. Sams & Co., Inc. No part of PF REPORTER may be reproduced without written permission. No patent liability is assumed with respect to use of information herein. Acceptance of advertising does not in any manner signify the products, policies and services so advertised have been approved, endorsed or recommended by this magazine. Subscription Prices: 1 year—\$5.00, 2 years—\$8.00, 3 years—\$10.00, in the U. S. A., its possessions and Canada. All other foreign countries: 1 year—\$6.00, 2 years—\$10.00, 3 years—\$13.00. Single copy 50¢; back copies 65¢.

Indexed in Lectrodex.

Printed by the Waldemar Press Div.

of Howard W. Sams & Co., Inc.

ATR PRODUCTS FOR MODERN LIVING

NEW ATR Golden Line



FREQUENCY-STABLE INVERTER*

This ATR 12T-RME-1 INVERTER with "Frequency-Stability" and "Automatically Controlled," will deliver 110-volt A.C. 60 cycle power for all popular make 11" to 13" portable TV Sets.

12T-RME-1 (12 v.d.c.) rated—140 watts max. Shipping wgt.—14 lbs.

A.C. HOUSEHOLD ELECTRICITY Anywhere . . . in your own car, boat or plane!

Operates Standard A.C.

- Portable TV Sets
- Record Players
- Small Tape Recorders
- Dictating Machines
- Small Radios
- Electric Shavers
- Heating Pads, etc.

*Additional Models Available

Special Dealer Net Price **\$29.16**

Also NOW...

HAND WIRED—NO PRINTED CIRCUITRY

ATR ALL-TRANSISTOR ULTRA COMPACT UNIVERSAL MODEL 707



Karadio
IN DASH...
UNDER DASH...

Complete with variable tone control . . . R. F. stage . . . Built-in speaker . . . and External speaker jack.

ATR MODEL 707N **\$25.97** Dealer Net



ATR ALL-TRANSISTOR ROOF-MOUNT and IN-DASH MODELS

TRUCK

Karadio

MODEL TR-720

FITS ALL TRUCKS • BOATS • STATION WAGONS
INSTANT PLAY . . . POWERFUL

Complete with patented antenna-yoke assembly.
(U.S. Patent No. 3,087,118. Canadian Reg. 575,567)

ATR MODEL TR-720N **\$36.97** Dealer Net



ATR "A" Battery ELIMINATOR

For Demonstrating and Testing Auto Radios—TRANSISTOR or VIBRATOR OPERATED!
Designed for testing D.C. Electrical Apparatus on Regular A.C. Lines.

MAY ALSO BE USED AS A BATTERY CHARGER
MODEL 610C-ELIF. . . 6 volts at 10 amps. or 12 volts at 6 amps. Shipping weight 22 lbs.

DEALER NET PRICE **\$55.00**

ATR AUTO RADIO and COMMUNICATION LONGER-LIFE VIBRATORS



"The Best by Test!"

SEE YOUR ELECTRONIC PARTS DISTRIBUTOR OR WRITE FACTORY FOR LITERATURE & DEALER PRICES

ATR ELECTRONICS, INC.

Quality Products Since 1931

St. Paul, Minnesota 55101—U.S.A.

Circle 4 on literature card

Letters to the Editor

Dear Editor:

After finishing reading your article on CATV, I think you should certainly be commended for your stand. I have read many different stories, biased and un-biased, and feel I can speak with some authority. I am, at this time, the manager of a cable system and also a service technician for a TV-sales store. I was a technician before the cable system came to town, so I am familiar with the problems then and now. Before the cable system was installed, we were served by two UHF stations. They were the only TV we could receive, and then only in certain good locations. The cable system brings us four TV channels, one weather channel with FM background music, and five FM stations. Servicemen here now have TV to service as well as FM and Stereo. Some of the things I have found: (1) People won't stand for a snowy picture any more; they want it to be like the neighbor's. This means service work and, believe me, cable systems aren't anxious for service. (2) With a bigger selection of channels for Mom, Dad, and the kids to fight over, this means buying a second set. It may be a used one, but it is still a sale and means future service work. (3) Most cable systems carry FM, and there are several old FM-AM sets around that could use service. Also, if you sell radios, this means more FM sales. Most cable systems frown on doing service work themselves. At the store where I work, we try to repair only the TV's we sell. Whenever we have a cable call, we always tell them to call their favorite repairman. I would like to pass along a tip to the TV serviceman. CATV is a good field to get into. Most cable-equipment manufacturers hold schools, and they are anxious to get men into the field. I would like also to say that our system was started in 1960 and, out of a potential of 1700, we are now servicing 1400 homes. This proves that people are willing to pay for better TV.

LEO. J. GRIMONE, JR.

Manager, BBC CATV Emporium, Pa.

Thanks, Leo, for your professional viewpoint on CATV and the effect it has on servicemen—from both a sales and a service viewpoint. If any of our readers have similar or different experiences, drop me a letter about them.—Ed.
Dear Editor:

In reading page 36 of "Royal Road to Transistor Servicing" in the December 1964 issue, I can't follow your mathematics for finding a 2-volt drop across R5 in Fig. 1B. You state 2 volts/2700 ohms = .37 ma. Isn't this a misprint? Actually 1 volt/2700 ohms = .37 ma.

ERIC E. STERN

Flushing, N. Y.

You are correct, Eric; it should read 1 volt/2700 ohms = .37 ma.—Ed. ▲

3 WAYS TO BIGGER



NEEDLE



CARTRIDGE PROFITS!

1. More "look-alike" exact replacement models than any other brand. Over 350 needles, 225 cartridges.
2. Easy-to-use reference material. E-V computer-printed catalogs make proper needle/cartridge selection easy, fast and accurate.
3. Highest standards. Rigid quality control and inspection cuts call-backs, gives full value to every customer.

Stock and sell E-V needles and cartridges for more profits. Pick up your FREE replacement guide at your nearby Electro-Voice distributor today!

ELECTRO-VOICE, INC.

Dept. 557R, Buchanan, Michigan 49107

Electro-Voice
SETTING NEW STANDARDS IN SOUND

Circle 5 on literature card

BETTER RECEPTION

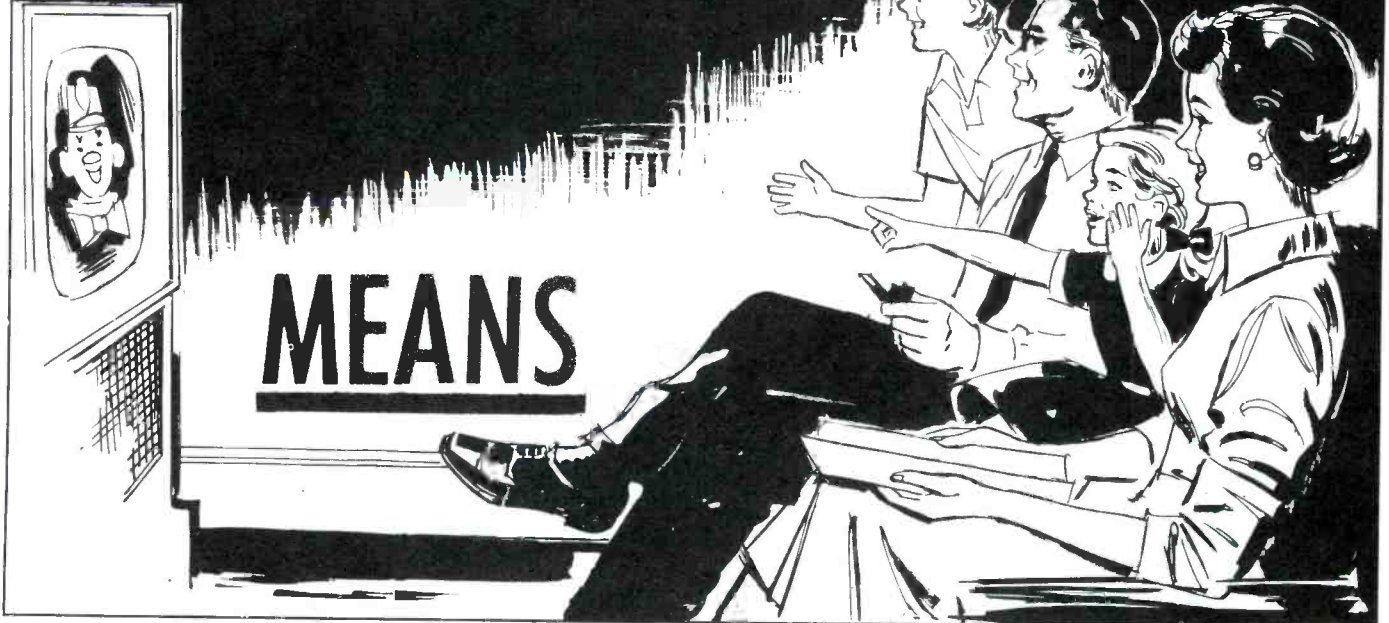

MORE SALES!

IT'S AS SIMPLE AS THAT! And with ANTENNACRAFT Antennas Reception is at it's very BEST!

Just a little extra care and a little extra effort goes into Antennacraft—and it shows—in the appearance of the product and in the sharp, clear pictures on your customer's television set.

The new UHF-VHF TV sets need a combination UHF-VHF antenna to take advantage of the total programming available. Antennacraft's Channel-Spanners are all channel antennas, VHF 2 to 13 and UHF 14 to 83 and are designed to be used with these new sets with only one lead-in.

Antennacraft's Channel-Spanners produce snow-free, ghost-free pictures to the far edge of the UHF class B signal area. Maximum signal response is obtained from VHF and FM stations together with good picture quality at the class B distance and throughout the medium fringe areas.

If you are not already using Antennacraft products, contact your distributor for full information on all fine Antennacraft products. Find out for yourself how that "little extra" pays off in bigger profits for you.

**FOR CHANNELS 2 TO 83
UHF - VHF - FM**

ONLY \$24.95

**ANTENNACRAFT
CHANNEL-SPANNER**

ONLY \$17.95

BETTER BUILT FOR BETTER PERFORMANCE

ANTENNACRAFT

Automatic Channel Selector
TV ANTENNAS
Burlington, Iowa

Circle 6 on literature card

May, 1965/PF REPORTER 13



Feather your nest this spring

With valuable premiums from General Electric Receiving Tubes

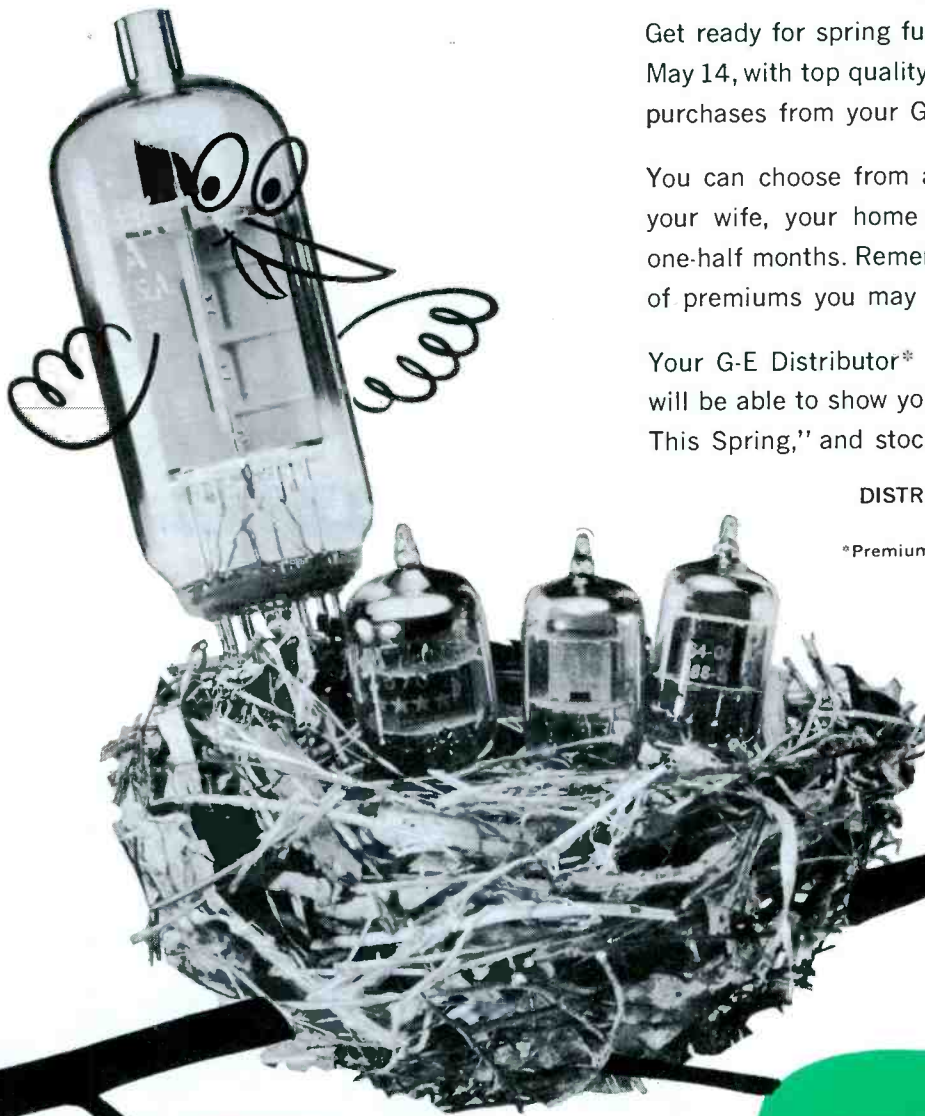

Get ready for spring fun and projects from March 1 through May 14, with top quality merchandise available only with tube purchases from your General Electric Tube Distributor.

You can choose from a wide selection of gifts for yourself, your wife, your home or your shop during these two and one-half months. Remember, there's no limit on the number of premiums you may earn.

Your G-E Distributor* is the man to contact for details. He will be able to show you how easy it is to "Feather Your Nest This Spring," and stock up on G-E Tubes at the same time.

DISTRIBUTOR SALES, OWENSBORO, KENTUCKY

*Premiums available at the option of your G-E Distributor.

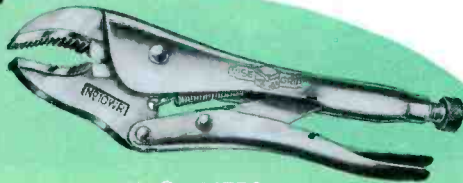

WISE-GRIP® PLIERS

for home or business offer tremendous gripping power and easy adjustment. Forged steel claws lock into position for the strength of a wrench. Fast release lever enables quick readjustment. Order: ETR 4212



SEAMLESS HOSIERY

in the beautiful sun-tan shade for the woman in your life. Three pairs of sheer stretch nylons will complement the latest spring and summer fashions. One size fits all. Order: ETR 4207

**24"
COOKING
CENTER**



makes outdoor summertime meals remembered throughout the year. The beautiful metallic red and gray baked-on enamel covers a bonderized steel construction for added years of service. Five-position elevation control allows the backyard chef full opportunity for cooking perfection. Order: ETR 4211

**SABER
SAW**



does the work of eight saws . . . rip, crosscut, jig, hack, band, coping, keyhole, and scroll. Offers built-in cooling, adjustable base, rip guide, and mitre gauge. Bevel cuts from 0° to 45°. Includes wood, scroll, and metal blades. Order: ETR 4217

19" PATIO TABLE



is ideal for year 'round use indoors or out. Stain-resistant top doubles as a beautiful serving tray. Brass legs collapse for easy storage. Order: ETR 4210

**GARCIA SPINNING ROD
AND REEL**



featuring the Mitchell 304 reel with anti-reverse control and full bail line pick-up. The 6½' two-piece medium-taper rod offers medium light action. Order: ETR 4208

**MELAMINE
DINNERWARE**



24 pieces — will add beauty to your table. This break and stain resistant set is dishwasher safe and includes four: tumblers, decorated dinner plates, cups, saucers, bread and butter plates and fruit dishes. Order: ETR 4206

**SANFORIZED
SHIRT**



for dress or play in assorted colors. Smart looking collar and permanent stays assure the fresh look even after many washings. The little or no ironing required makes it even more popular on wash day. Order: ETR 4213

**SKOTCH
KOOLER®**



two quart capacity — is completely unbreakable. The leather textured handle and surface in white and copper-tone make it a handsome accessory for summer outings or patio use. It is light-weight and stain resistant for added convenience. Order: ETR 4209

LAWN SPRINKLER



covers an area from 20-80 feet with a full circle throw or any part of a circle. Features sturdy metal construction, sled-type runners, and rotating coupling nut. Order: ETR 4218

**LIBBY
GLASSES
AND CARRIER**



make serving beverages outdoors easy and stylish. Each glass has a lovely gold leaf design and holds 12½ ounces. Order: ETR 4216

GENERAL  ELECTRIC

Circle 7 on literature card

www.americanradiohistory.com

A major breakthrough in

FINCO ALL-BAND

UHF • VHF • FM

"COLOR VE-LOG"

For the
best reception
in the world

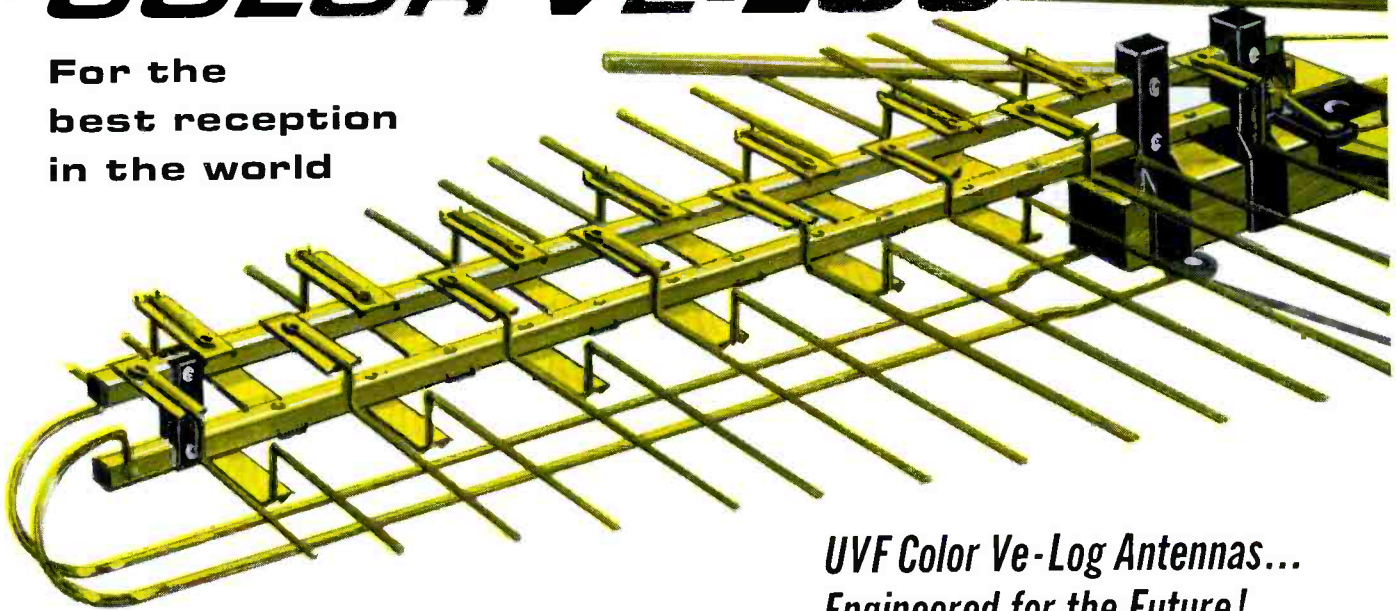

UHF Color Ve-Log Antennas... Engineered for the Future!

Finco's new All-Band Color Ve-Log Antenna does the work of three—gives startlingly clear black and white pictures and beautiful color on **both** UHF and VHF television channels. Its superlative design also assures the finest in stereophonic and monophonic FM sound reproduction. Comparison tests have proved the superiority of the All-Band UVF Series—superiority backed by Finco's guarantee of supremacy and unquestioned warranty.

- Revolutionary new UHF Section
- Heavy Aluminum reinforced insulator insert cup and heavy duty rivet
- Back-up bracket and square boom
- Finco's exclusive triple thick sleeved elements
- Lock-tite no-tilt saddle bracket
- Finco's exclusive double contact to drive line
- Continuous one-piece drive line and exclusive air insulated polystyrene cross-over spacer

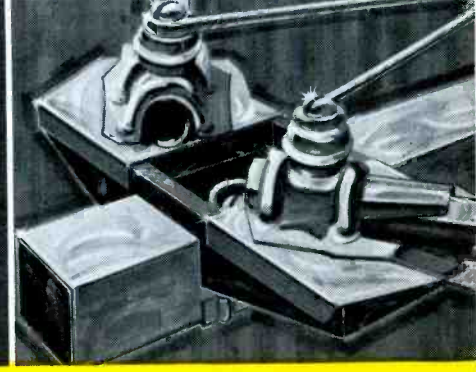
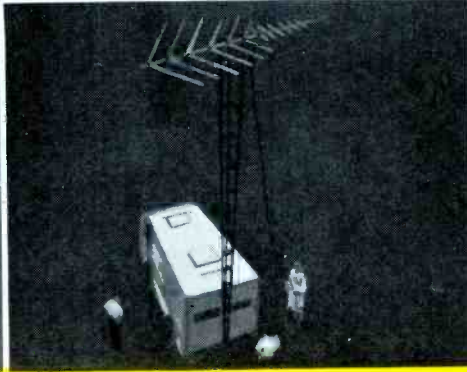

Write for beautiful color brochure Number 20-322 and Coupler-Splitter Specification sheet Number 17-2308G

Antenna design!

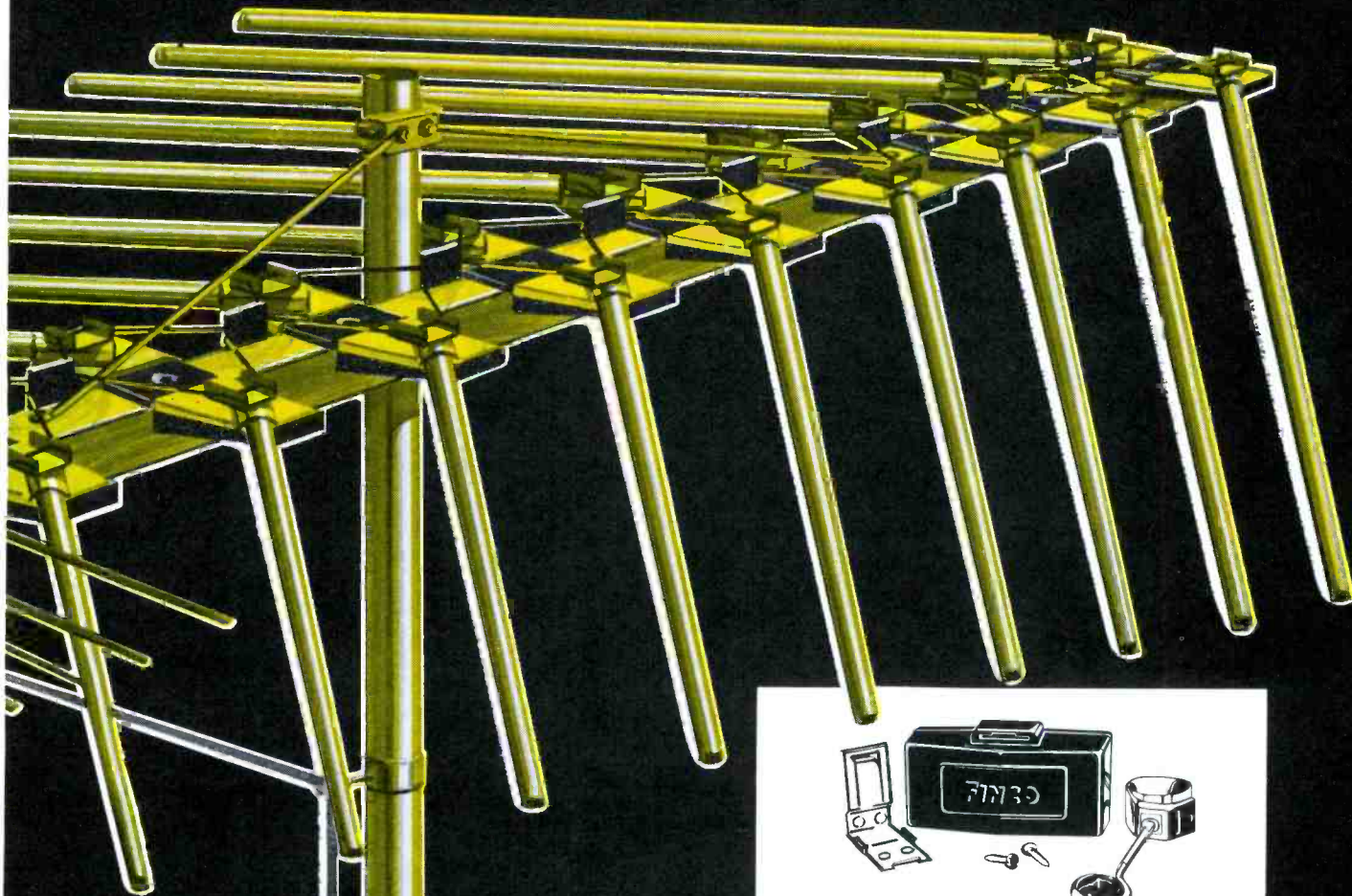

Finco Model
UVF-24

For Near Fringe and
Deep Fringe Areas

- 15 UHF Elements
Channels 14 thru 83
 - 9 VHF Elements
Channels 2 thru 13
 - FM Monaural and
Stereophonic
- List \$59.95



For maximum performance use these
FINCO VHF - UHF - FM Coupler-Splitters

Model 3014	
UHF-VHF Coupler-Splitter	\$4.25
Model 3017	
UHF-VHF 2 Set Coupler-Splitter	6.95
Model 3018	
UHF-VHF-FM Coupler-Splitter—Low Loss	8.95
Model 3019	
UHF-VHF-FM Coupler-Splitter—Strong FM Signal	5.50

Featuring Finco's Exclusive Gold Coating

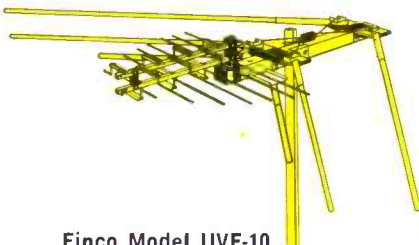

Finco Model UVF-10
For Metropolitan Areas
List \$18.50

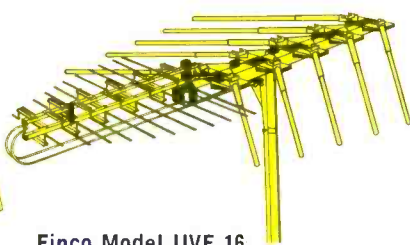

Finco Model UVF 16
For Local and Suburban Areas
List \$30.50

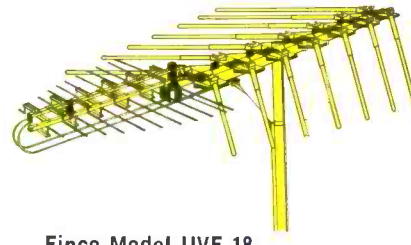

Finco Model UVF 18
For Suburban and Near Fringe Areas
List \$42.50

Prices and specifications subject to change without notice

The FINNEY Company • 34 Interstate Street • Bedford, Ohio

GUIDE to CB-Communications Tube Usage

The increased use of radio communications equipment, especially mobile radio and Citizens band transceivers, has provided opportunities for many servicemen in expanding their business. If you, too, are planning to branch out into this fast-growing phase of the electronics service business, the list on this page will give you an idea of the tube stock you may need to maintain.

The chart does not include all types that will ever

be needed, but it does give a good basic stock for servicing all makes and types of two-way equipment. Naturally, if you plan to specialize only in certain brands you will be governed accordingly.

The major use or uses for each type are given, to help in familiarizing you with typical applications. The designation "CB" next to a type indicates that it is found in Citizens band transceivers but is not necessarily used exclusively in such equipment.

Type	Application	Type	Application	Type	Application
0A2	CB voltage regulator	6BL8	CB IF amplifier	7A8	converter or modulator
0B2	CB voltage regulator	6BM8	CB output/modulator/speech amplifier	7AG7	VHF amplifier
1AD4	submin. RF, AF amplifier	6BN8	CB ANL/squelch/IF amplifier	7C5	beam-power output
1AG5	submin. detector/amplifier	6BQ5	CB AF, RF beam-power output	7C7	amplifier or oscillator
1AH4	submin. RF amplifier	6BQ7A	VHF amplifier	7F7	AF amplifier
1AJ5	submin. detector/amplifier	6BS8	CB RF amplifier	8BN8	CB noise limiter/squelch/AF amplifier
2C39A	UHF lighthouse	6BW4	CB full-wave rectifier	12AB5	CB output/modulator
2E24	RF beam-power output	6BW8	CB IF amplifier/detector	12AL5	CB detector
2E26	RF beam-power output	6BY6	CB converter	12AQ5	CB beam-power output
3A4	CB transmit oscillator	6BZ6	CB RF amplifier	12AT7	CB oscillator/mixer
3B4	CB final amplifier	6BZ8	CB RF amplifier	12AU6	CB RF amplifier
3V4	CB final amplifier	6C4	CB RF oscillator	12AU7	CB AF amplifier
4-125A	RF power output	6CB6	CB RF amplifier	12AV7	CB noise amplifier/oscillator
4CX250B	RF power output	6CL6	RF, AF amplifier	12AX7	CB AF amplifier
5R4GY	full-wave rectifier	6CL8	CB detector/AVC/speech amplifier	12AZ7	CB AF amplifier/speech amplifier
5U4GB	full-wave rectifier	6CM8	CB noise amplifier/squelch	12BA6	CB RF amplifier
5V4GA	full-wave rectifier	6CS7	CB AF amplifier	12BE6	CB converter
5W4GT	full-wave rectifier	6CW4	CB mixer	12BH7	CB output/modulator
5Y3GT	full-wave rectifier	6CW5	CB output/modulator	12BR7	CB squelch/noise limiter
5Z3	full-wave rectifier	6CX8	CB RF oscillator/output	12BW4	CB full-wave rectifier
6AB4	CB receiver oscillator	6CZ5	CB final amplifier	12BY7	CB RF, AF power amplifier
6AH6	RF amplifier	6DC6	CB RF amplifier	12BZ6	CB RF, IF amplifier
6AJ8	CB oscillator/IF amplifier	6DS4	CB RF amplifier	12CR6	CB detector/AF amplifier
6AK5	CB RF amplifier	6DS5	CB final amplifier	12X4	CB full-wave rectifier
6AK6	CB AF power output	6E5	CB modulator indicator	100TH	VHF power amplifier
6AL5	CB detector	6EA8	CB RF amplifier	807	beam-power output
6AM8	CB ANL/oscillator	6EM5	CB final amplifier	813	modulator/output
6AN5	RF beam-power amplifier	6ES8	CB RF amplifier/mixer	816	mercury-vapor rectifier
6AN8	CB RF, AF amplifier	6EZ8	CB converter	829B	VHF twin beam-power
6AQ5	CB RF, AF beam-power output	6FM8	CB detector/squelch/ANL	832A	VHF twin beam-power
6AR5	CB final amplifier	6FY5	CB oscillator	866A	mercury-vapor rectifier
6AS5	CB modulator/output	6GF5	CB final amplifier	1635	AF output (R.R. radio)
6AT6	CB detector/AVC/AF amplifier	6GH8	CB RF, IF amplifier	5651	voltage regulator
6AU6	CB RF amplifier	6GK5	CB oscillator	5670	VHF amplifier
6AU8	CB RF oscillator/output	6GK6	CB final amplifier	5672	submin. power amplifier
6AV6	CB detector/AF amplifier	6GV8	CB oscillator/final amplifier	5678	submin. RF amplifier
6AW8	CB RF oscillator/output	6GW8	CB AF amplifier/output/modulator	5763	CB final amplifier
6AY11	CB detector/AVC/speech amplifier/squelch	6HZ8	CB oscillator/final amplifier	5829	submin. rectifier
6AZ8	CB IF/Speech Amplifier	6J4	UHF amplifier	5894	RF power output
6BA5	CB output/modulator	6J5	amplifier or oscillator	6029	submin. VHF oscillator
6BA6	CB RF amplifier	6J6	CB mixer	6146	modulator/RF output
6BA7	CB converter	6K6GT	CB beam-power output	6883	VHF beam-power output
6BE6	CB converter	6KE8	CB converter	6907	RF power output
6BF6	detector/AF amplifier	6SC7	CB AF amplifier/speech amplifier	7054	CB final amplifier
6BF7	submin. VHF	6T8A	CB detector/AF amplifier	7056	RF amplifier
6BH6	CB RF amplifier/oscillator	6U8A	CB converter	7058	AF amplifier
6BH8	CB RF oscillator/output	6V6GT	CB beam-power output	7059	converter
6BJ6	CB RF amplifier	6X4	CB full-wave rectifier	7060	RF oscillator/output
6BJ7	CB detector/AVC/squelch	7A6	detector or rectifier	7061	CB final amplifier
6BJ8	CB detector/AVC/squelch			7167	RF amplifier
				7687	CB AF amplifier
				8327	CB final amplifier

ALL NEW FROM *HICKOK*

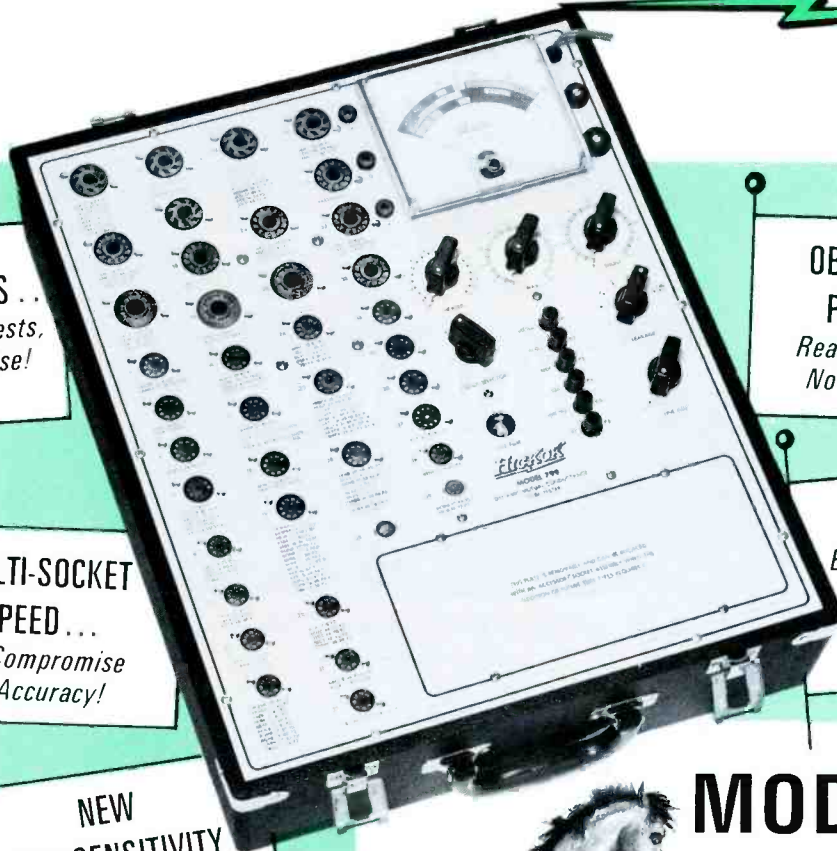

100% G_m TESTS . . .
*No Emission Tests,
 No Compromise!*

**OBSOLESCENCE
 PROTECTION**
*Realistic, Practical
 No Compromise!*

**MULTI-SOCKET
 SPEED . . .**
*No Compromise
 In Accuracy!*

MORE PROFIT
*Because You'll Sell
 More Tubes . . .
 Sell Them
 Honestly!*

**NEW
 HIGH-SENSITIVITY
 LEAKAGE AND
 GAS TESTS!**

MODEL 799



Mustang
\$199⁹⁵

From the laboratories of the world's leading tube tester manufacturer comes the model 799 "Mustang" — a completely new tube tester.

Multi-socket tube testers used to have two serious drawbacks: circuit limitations made them obsolete overnight and, at best, no more than 10% of their tests were actually mutual conductance. But the Hickok "Mustang" doesn't compromise; it delivers *honest* mutual conductance tests. And a unique circuit approach, together with an easily replaceable accessory socket panel, makes it "circuit ready" for

any possible new tube types.

A solid-state power supply gives increased accuracy and dependability. An all-transistorized gas and leakage test circuit sets a new standard of reliability for spotting "tricky" tube defects that can "chew up" your profit. You can actually read interelement leakage to 50 megohms; gas/grid leakage effects to 0.1 μ a!

We call it the "Mustang" because it uses fresh, new engineering ideas and because it gives you a real opportunity to break into new profits.

See it at your Hickok distributor or write for circular TT799.

HICKOK

**THE HICKOK ELECTRICAL
 INSTRUMENT CO.**

10566 Dupont Avenue, Cleveland, Ohio 44108

Represented in Canada by Stark Electronics, Ajax, Ontario

Internationally by Hughes International, Culver City, California

you get **PRODUCT PLUS** *from your Sylvania Distributor*

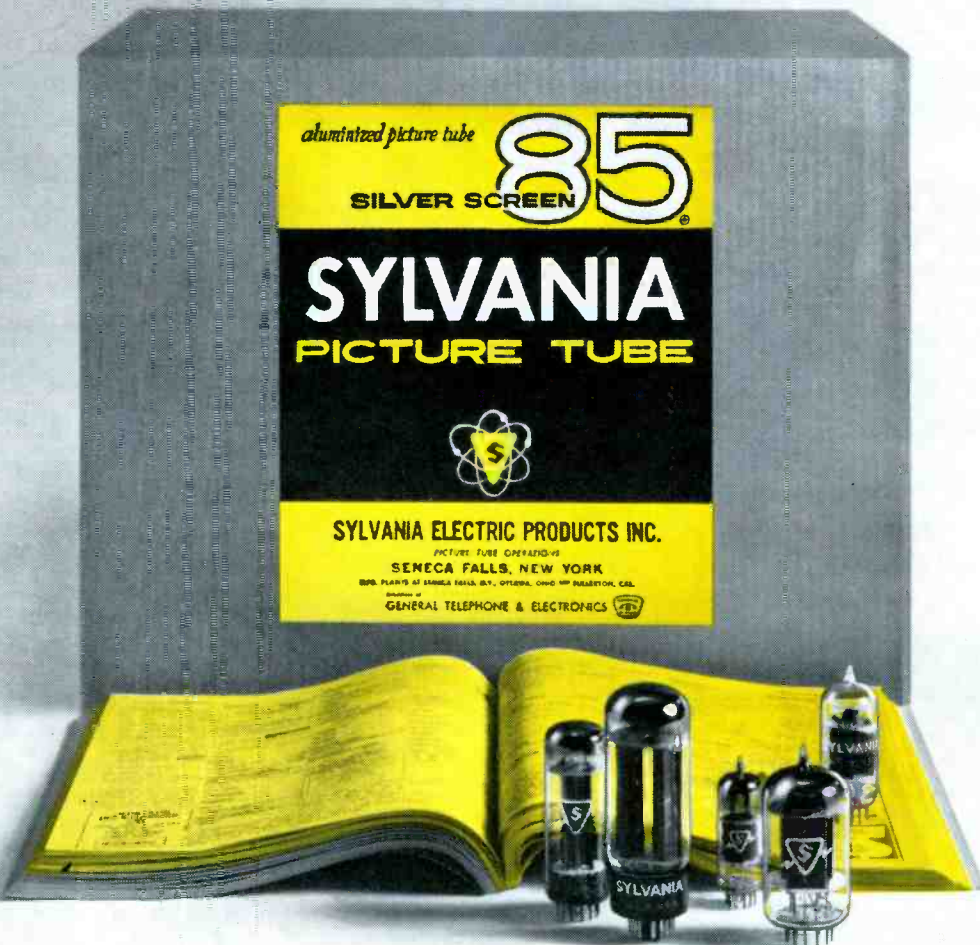

Now your Sylvania Distributor can put you in The Yellow Pages

The Yellow Pages are the first place people look *when they want to buy*. Studies show that 90% of all telephone subscribers consult their Yellow Pages when they want to find a local source for products and services. It's a fact: your potential customers let their fingers do the walking when a TV set needs professional servicing.

Here's a special program that means more customers and extra profits for you. *Our ads appear in your local Yellow Pages*, directing customers to you. Your Sylvania distributor can show you how your own listing may be part of the Sylvania ad.

The new Sylvania Trade Mark Heading will be seen—it's big, attractive, and descriptive. It tells

customers that you sell the dependable line of radio and TV tubes, including famous SILVER SCREEN 85® and *color bright 85®* picture tubes.

Your Sylvania distributor has full particulars on how you can share in this program designed especially for you. Check with him today.

Electronic Tube Div., Sylvania Electronic Components Group.

SYLVANIA

SUBSIDIARY OF
GENERAL TELEPHONE & ELECTRONICS **GTE**

NEW CAPABILITIES IN: ELECTRONIC TUBES • SEMICONDUCTORS • MICROWAVE DEVICES • SPECIAL COMPONENTS • DISPLAY DEVICES

Circle 10 on literature card



The Electronic Scanner

news of the servicing industry

What Is Your Future?

In a recent article in *NEDA Journal*, J. A. (Shine) Milling, president of the Sams Division of **Howard W. Sams & Co., Inc.**, made these observations about the future of electronic distributors and technicians:

For several years now, I have listened to parts manufacturers and distributors debate the merits of the replacement parts business versus the industrial parts business. Some have said that the replacement service parts and tube business will soon become as dead as the proverbial dodo bird.

The reasoning behind all of this is that, for the past few years, component parts, tubes, and semiconductors going into radio and television sets are of greatly improved quality resulting in fewer service calls and reduced parts, tube, and semiconductor sales.

It has been pointed out that, during 1964, 36 parts distributors with liabilities of \$7,575,000 went bankrupt, and 186 branches have closed their doors or have been absorbed or merged with others. Some of the reasons advanced for these failures are that the service parts business is decreasing and these distributors can no longer operate on a profitable basis.

If this is true and some other factors are not considered, then the obvious and erroneous conclusion is that the service parts and tube business will soon be greatly reduced, and the service business as we know it today will just fade away. More distributors will close their doors, and we will all have service-free end products in our homes.

If for one don't believe this will ever happen, and here's why—

It's a generally known fact that my company has, since 1946, produced a Sams PHOTOFAC service folder, complete with schematic and replacement parts list for practically every piece of consumer equipment, both domestic and imported, sold in the U.S.

In 1960 we produced PHOTOFAC folders for a total of 88 different television chassis. In 1964, or just four years later, we produced PHOTOFAC folders for 225 television chassis, and now in 1965 we are currently producing at a rate of 20 television PHOTOFAC folders per month, or 240 annually. This is almost three times as many annually as we produced just five years ago.

Last year approximately 1.3 million color television sets were sold. Practically all of these incorporated the 21" round picture tube. It is estimated that in 1965 about 2 million color sets will be sold, but there will be four tube sizes—19", 21", 23", and 25". Some of these will be rectangular. Most of these various sizes will require different or considerably modified chassis.

It is also estimated that about 8 million black-and-white television sets will be produced in 1965 with 12 different tube sizes ranging from 9" to 27" in both round and rectangular sizes. This does not include the smaller Japanese 4", 5", 6", 7", or 8" sets which will be sold and require replacement parts, semiconductors, tubes, and service.

As long as these numbers continue to increase, and as long as new chassis with new features are designed, produced, sold, and operated under conditions which expose them to heat, humidity, dirt, friction, and the human element, there will continue to be an increasing need for replacement parts, tubes, and service.

Where we have standardization and quality improvement of components and end products on one hand, we have a multiplicity of new models, chassis, and sets in use on the other. All of these must have replacement parts and tubes as well as service information and test equipment to keep them operating. **THIS IS THE MARKET!**

The greatest need now is for qualified service technicians to keep this consumer electronics market operating so that the needed parts and tubes can be replaced.

COMPLETE TUNER OVERHAUL

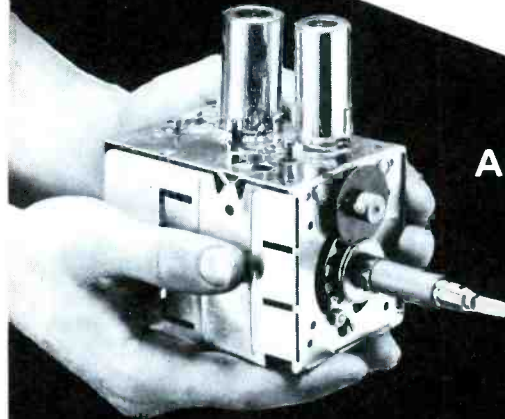

ALL MAKES —
ONE PRICE

995

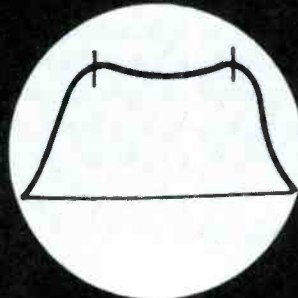

3.58

ALL LABOR
AND PARTS
(EXCEPT TUBES
& TRANSISTORS)*

COLOR TUNERS

GUARANTEED COLOR
ALIGNMENT — NO
ADDITIONAL CHARGE



Simply send us the defective tuner complete; include tubes, shield cover and any damaged parts with model number and complaint. Your tuner will be expertly overhauled and returned promptly, performance restored, aligned to original standards and warranted for 90 days.

UV combination tuner must be single chassis type; dismantle tandem UHF and VHF tuners and send in the defective unit only.

Exact Replacements are available for tuners unfit for overhaul. As low as \$12.95 exchange. (Replacements are new or rebuilt.)

And remember—for over a decade Castle has been the leader in this specialized field . . . your assurance of the best in TV tuner overhauling.

Pioneers of TV



Tuner Overhauling

CASTLE TV TUNER SERVICE, INC.

MAIN PLANT: 5701 N. Western Ave., Chicago 45, Illinois

EAST: 41-90 Vernon Blvd., Long Island City 1, N.Y.

CANADA: 136 Main Street, Toronto 13, Ontario

*Major Parts are additional in Canada

Circle 11 on literature card



**SIGNAL
ACTIVATING**

•
**LAMP
INDICATING**

•
**SERIES
HKA**

BUSS FUSEHOLDERS

FOR 1/4 x 1/4 INCH BUSS GLD FUSES, 1/4 TO 5 AMPS.

When fuse opens, indicating pin completes a circuit that lights indicating lamp in holder and makes contact on external signal circuit. External signal can be an audible alarm or another lamp mounted at a distance, or it can operate a relay.

BUSS

Write for BUSS
Bulletin SFB

BUSSMANN MFG. DIVISION, McGraw-Edison Co., St. Louis, Mo. 63107

Mr. Lowe said that "eventually diffusion and drift will destroy every semiconductor device, even at room temperature, be it tens or hundreds of years from now. Within our lifetime, we probably won't see much of this increasing failure rate, but we should think about the chance failures." He cited a situation in which six short-term failures are at work—each affecting a small percentage of the total microcircuit package—but where universal failure is operating in the 10- to 100-year period. Cumulative distribution in this case would show a decreasing failure rate through about two years, a "golden age" of constant-background failure through about 11 years, followed by rapidly increasing failure rates.

Excise Repeal Asked

The Electronic Industries Association has formally asked the Treasury Department to urge legislative repeal of the manufacturers' excise tax on radio and television receivers, phonographs, and their components.

The views of the association's Consumer Products Division were set forth in a conference including officials of the Treasury Department, staff members of the Joint Congressional Committee on Internal Revenue Taxation, and members of the division's Executive Committee. Besides seeking complete repeal of the excise tax at the earliest possible date, EIA urged the Treasury Department to recommend that Congress enact legislation providing for floor-stock refunds of excise levies paid on radio and TV sets and phonographs already off the production line to prevent any lull in sales while the proposal is being considered by Congress. Similarly, EIA asked in a separate suggestion that the Treasury Department urge Congress to authorize income-tax credits to consumers who have purchased taxable sets and components retailing for the substantial price of \$100 or more. EIA said a principal justification for tax repeal is the unique position the industry was placed in by the All-Channel TV Act, which required a UHF

BUSS: The Complete Line of Fuses...

Who said the replacement parts, tube, and service business is dead! I didn't!

If we critically analyze our operations, we will find that the real reason for the 36 distributor bankruptcies and 186 branch closings or mergers in 1964 was not really a lack of replacement component business, but poor business practices such as over-expansion, duplicate inventories, lack of adequate capital, price cutting, extended credits, and poor management.

The service technicians who have not survived are those who have not only failed to keep up with the technical advances and training required to cope with today's service problems, but also those who have ignored good business practices and merchandising opportunities in the operation of their business.

It's not the replacement service parts, tube, and semiconductor business that's dying. Instead, it's a lack of imagination to recognize and capitalize on the opportunities that already exist in this comparatively young, dynamic, constantly changing, and ever increasing business in which we have chosen to make our livelihood.

AND YOU CAN QUOTE ME ON THAT!

Microelectronics Questioned

Claims made by the electronic industry on the reliability of its microcircuits were sharply challenged before the Los Angeles District Computer Symposium of the Institute of Electrical and Electronics Engineers (IEEE) by a computer scientist who described them as containing "fancy as well as fact." Rodger R. Lowe, vice president of Mesa Scientific Corp. and an authority on computer-system design, said that at least three major statements now being made by the industry on microcircuit reliability "sound more like hard-sell than accurate statistics." These are: "all microcircuits are very good—except for the bad ones"; "complexity doesn't affect reliability"; and "a reliability factor of .001% per 1000 hours is just around the corner."

**GMW FUSE
and HWA
FUSEHOLDER**

**FUSE SIZE
ONLY .270 x .250
INCHES**



**BUSS
VISUAL
INDICATING**

Sub-Miniature FUSE-HOLDER COMBINATION

For space-tight applications. Fuse has window for inspection of element. Fuse may be used with or without holder.

Fuse held tight in holder by beryllium copper contacts assuring low resistance.

Holder can be used with or without knob. Knob makes holder water-proof from front of panel.

Military type fuse FM01 meets all requirements of MIL-F-23419. Military type holder FHN42W meets all military requirements of MIL-F-19207A.

BUSS

Write for BUSS
Bulletin SFB

BUSSMANN MFG. DIVISION, McGraw-Edison Co., St. Louis, Mo. 63107

BLOCKS for BUSS FUSES

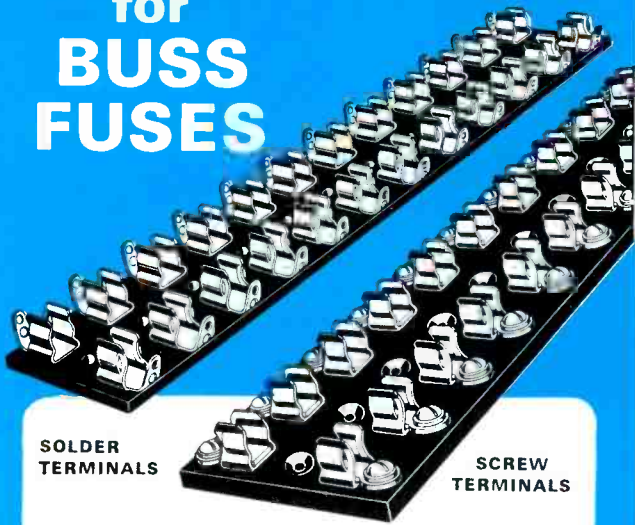

Above standard types available in any number of poles —
From 1 to 12... plus other types for every application.....

BUSS

Write for BUSS
Bulletin SFB

BUSSMANN MFG. DIV., McGraw-Edison Co., ST. LOUIS, MO. 63107

and black-and-white television sets and stereophonic high-fidelity phonographs, through the company's independent distributor organization. The agreement will provide dealers with adequate display and back-up inventory to assist them in developing maximum sales potential. In addition, the new agreement will enable dealers to simplify their inventory control through the use of GAC's streamlined inventory-control system.

One-Year Carry-In Service Warranty

The Chicago division of **Admiral Corp.** has announced that the former 90-day free carry-in service warranty on Admiral portable television receivers has been extended to one full year. Victor Croft, general manager, said that, effective immediately, Chicago-area purchasers of new 1965 Admiral 13", 19", or 21" portable TV sets will receive the 12-month service and parts warranty covering all repairs, including labor, on sets brought to an authorized Admiral service agency.

The new extended-service policy on portable TV was offered, Croft said, because of the success of the free one-year labor warranty, announced on November 15, 1964, on all Admiral color television receivers bought in Chicagoland.

Electronics and Astronomy

Electronic image intensifiers have been added to photographic telescopes to triple the observable brightness of an image and open new frontiers in space for astronomers. A new image-intensifier tube makes it possible for smaller telescopes to rival the unaided capability of the largest instruments, giving astronomers the world over markedly greater power to explore the universe from several vantage points. For example, the new image intensifier tube will enable a 60" reflector telescope to photograph faint star images of objects now obtainable only with 180" diameter instruments. The tube, which measures 3" in diameter and 5" in length, was developed by **RCA** in collaboration with the Carnegie Institution. ▲

of Unquestioned High Quality...

tuner on all TV sets with a corresponding higher price for the set. This not only has inhibited sales of TV sets, but also means that consumers are paying a higher price, even though most of them are outside the service area of a UHF TV station. The association further noted that three government agencies—the Federal Communications Commission, the Department of Commerce, and the Department of Health, Education and Welfare—support EIA's plea for excise tax relief.

Prize Winners

A drawing for door prizes was held during the recent National Electronics Week Convention in New York City by the Magazine and Industrial Divisions of **Howard W. Sams & Co., Inc.** First prize, a bumper pool table, went to Mr. Dallas Photopoulos of Standard Kollsman, Melrose Park, Illinois. Second prize, a lady's wristwatch, went to Mr. Tom Gray of RCA Parts and Accessories, Deptford, New Jersey. Third prize, a man's wristwatch, went to Mr. Vern Rawn, Rawn Company, Spooner, Wisconsin. The drawing was held in the Magazine Division hospitality suite at the New York Hilton.

Three Color-Tube Sizes

With the addition of 23" and 25" rectangular color TV to its 21" models, **Admiral Corp.** now offers a complete choice of color-TV screen sizes. Topping the Admiral color-TV line are three receivers with the new 25" rectangular picture tube providing 296 square inches of viewing area—23% more than that on round-tube sets.

Financing Arrangement

A distributor-financing arrangement has been agreed upon by the Home & Commercial Electronics Division of **Sylvania Electric Products, Inc.** and General Acceptance Corporation. A line of credit will be provided for dealers of Sylvania color

Screw type knob
designed for easy
gripping, even
with gloves. Has
a "break-away"
test prod hole
in knob.



Screw type slotted
knob that is
recessed in holder
body and requires
use of screwdriver
to remove or insert it.

BUSS Space Saver Panel Mounted Fuseholders

- Fuseholder only 1 3/8 inches long, extends just 2 3/8 inch behind front of panel. Takes 1/4 x 1 1/4 inch fuses. Holder rated at 15 ampere for any voltage up to 250.
- Military type available to meet all requirements of MIL-F-19207A.

BUSS

Write for BUSS
Bulletin SFH-10

BUSSMANN MFG. DIV., McGraw-Edison Co., ST. LOUIS, MO. 63107

Circle 12 on literature card



You can lose 99% of your color TV signal with the wrong transmission line!

By Roland Miracle
 Engineer, Electronics Division
 Belden Manufacturing Company
 Richmond, Indiana

Many color TV sets are receiving less than 1% of the signal picked up by the antenna! Why? . . . because the wrong type of transmission line is used. It is easy to forget that the *best* color TV receiver gives an image only as good as the signal it receives.

Because of the increasing volume of UHF and color TV installations, Roland Miracle, electronics engineer at Belden Manufacturing Company's Richmond, Indiana plant, answers questions on the various transmission lines available today.

Q. Will most of the lead-in types now available perform adequately at UHF channels or in critical color TV applications?

A. No! There are three basic types of lead-in on the market . . . flat ribbon . . . tubular . . . and encapsulated lead-in. Flat

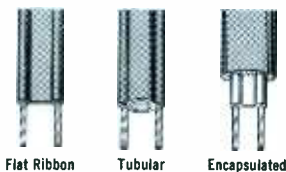

Flat Ribbon Tubular Encapsulated

and tubular . . . perform well at UHF frequencies *only* when they are free from all traces of surface deposits. The minute these lines encounter dirt, rain, snow, salt, smog, fog or industrial deposits, problems arise. These deposits interfere with the critical signal area. Impedance drops abruptly. Attenuation losses soar. Ghost pictures result.

Q. What about the encapsulated lead-in?

A. This type of lead-in is made by Belden Manufacturing Company under the name, "Belden All-Weather Permohm* Lead-in" and is highly recommended for UHF and

color TV installations. The encapsulated lead-in features a low loss cellular polyethylene protective jacket which surrounds the precisely spaced conductors, keeping all surface deposits out of the critical signal area . . . regardless of weather conditions.

The illustrations show how the signals are *unprotected* by the flat and tubular lines, but *protected* by the Belden All-Weather lead-in.

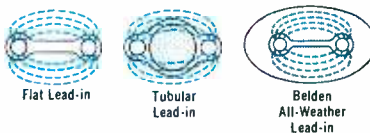

Q. Is there really much difference in the three types?

A. Let's look at the charts below which show how *all* types of lead-in operate at VHF and UHF frequencies when *weather conditions are good*.

At VHF frequencies, from 70% to 87% of the signal remains . . . at UHF frequencies, 52% to 70% remains. Under good weather conditions, there isn't much difference between the three lead-in types.

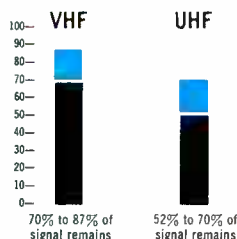

Now look at the relative performance when *weather conditions are bad*. The chart to the left shows that with *VHF frequencies*, the flat lead-in does poorly . . . delivering

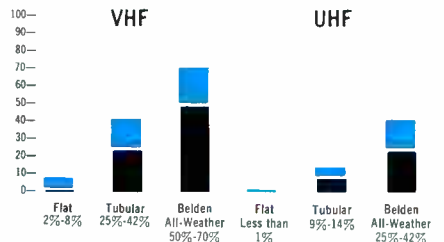

from 2% to 8% of the signal. The tubular lead-in delivers from 25% to 42%. However, the Belden Permohm All-Weather Cable delivers from 50% to 70% of the signal.

The chart to the right shows performance at *UHF frequencies* . . . less than 1% for the flat lead-in . . . only 9% to 14% for the tubular lead-in . . . but from 25% to 42% for the Belden All-Weather Permohm lead-in. Obviously, a color TV receiver gives a better image with a stronger signal.

Q. Does Belden Permohm lead-in cost more?

A. Yes . . . but it's well worth it. Permohm helps you make sure the picture is right the first time around. You cut way down on those costly call-backs. Ask your distributor about Belden Permohm.

BETTER BUILT
 BETTER BUY



BELDEN MANUFACTURING COMPANY
 P. O. Box 5070-A • Chicago, Illinois 60680

8-2-5

*Belden Trademark Reg. U. S. Pat. Off.

Second Half of Multivibrator

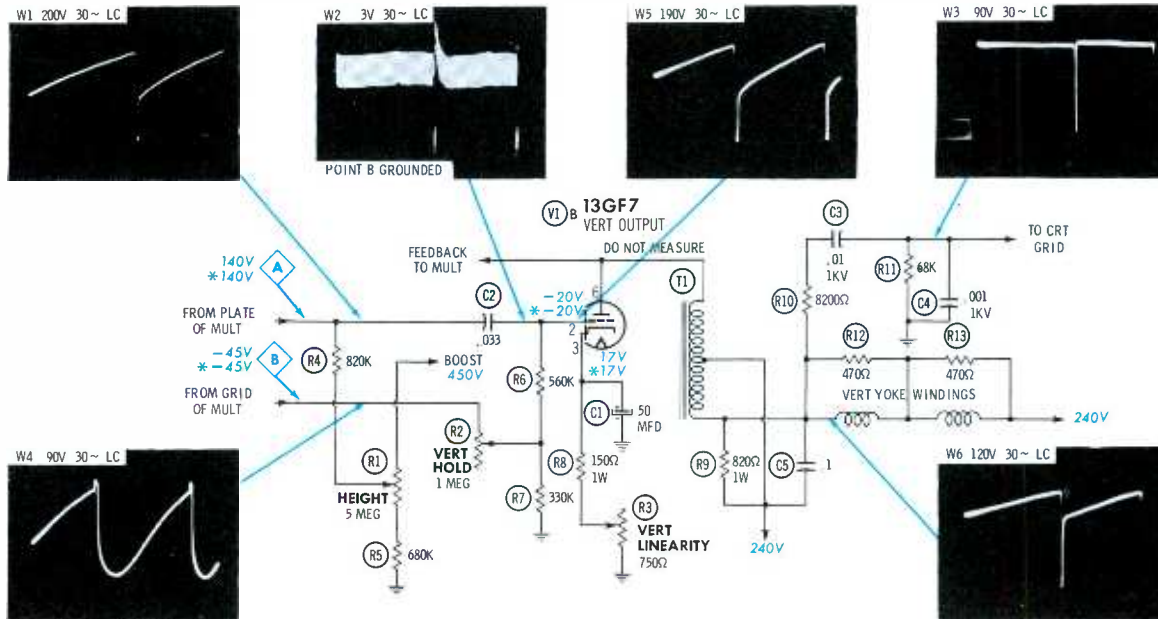

DC VOLTAGES taken with VTVM, on inactive channel; antenna terminals shorted. *Indicates voltage taken with signal present — see "Operating Variations."

WAVEFORMS taken with wideband scope; TV controls set to produce normal picture and sound. Direct (D) and low-cap (LC) probes used where indicated.

Normal Operation

Circuit shown (from Silvertone .61496 chassis series) is that of right, or output, half of vertical-deflection multivibrator in which output tube is also used as deflection amplifier. Feedback network, which connects from plate of V1B to grid of V1A, is not shown since output section (V1B) is our main consideration. Control R2 provides vertical frequency adjustment by varying discharge time of coupling capacitance from plate of V1B to grid of V1A. R1 is height adjustment; it varies amount of boost voltage applied to V1A. Cathode bias for V1B is developed by R3 and R8. C1 bypasses R3 and R8 to prevent degeneration. R3 controls linearity by setting total resistance at cathode of V1B; the resultant bias of V1B places trapezoid waveform coupled from V1A at particular position on Eg-Ip curve of V1B. Coupling of signal from plate of V1A to grid of V1B is by C2. Autoformer T1 matches impedance between V1B and deflection yoke. R9 aids in proper damping during retrace, while C5 helps maintain correct phase between input and output of T1. The voltage waveform from output of T1 is coupled through R10 and C3 to shaping network R11 and C4; it is then applied to CRT grid for blanking during vertical retrace. Since output tube (V1A) is part of multivibrator, troubles there may affect vertical frequency as well as vertical size and linearity. V1A is not shown, but points of connection are. Note caution at plate of V1B; many scope inputs don't have insulation rating to withstand high peak voltage (1000 volts or more).

Operating Variations

A

Rotation of controls from CCW to CW causes following DC voltage changes: R1, 250 to 22 volts; R2, 100 to 160 volts; R3, 148 to 124 volts.

B

Rotation of controls from CCW to CW causes following DC voltage changes: R1, -62 to -15 volts; R2, -110 to -175 volts; R3, -35 to -58 volts. Adjust R2 by setting it to roll picture down, then up until picture locks; turn control slightly to make scanning lines equidistant.

Pin 2

Rotation of controls from CCW to CW causes following DC voltage changes: R1, -15 to -25 volts; R2, -22 to -15 volts; R3, -5 to -32 volts. R3 has greater effect on top of raster, while R1 affects mostly bottom.

Pin 3

Rotation of controls from extreme CCW to extreme CW causes following DC voltage changes: R1, 14 to 24 volts; R2, 13 to 19 volts; R3, 24 to 8 volts.

WAVEFORMS

Waveform amplitudes will vary in ratio proportionate to DC voltage changes. Since multivibrator cannot run with point B grounded, W2 shows only incoming vertical sync pulse. This test will show if sync is present when you're checking out symptom such as vertical rolling.

Height Insufficient

Vertical Rolling

SYMPTOM 1

C1 Open

(Cathode Bypass Capacitor—50 mfd)

Symptom Analysis

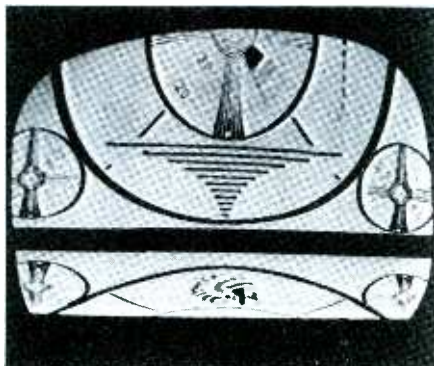

Nonlinear deflection at bottom of screen results in extreme compression of bottom portion of raster; top of raster is normal, so result is bad linearity. Frequency of multivibrator is also upset, resulting in fast rolling. No foldover is present at bottom.

Waveform Analysis

Deflection waveform at output of T1 shows rise rate of W6 decreasing and finally leveling off. Amplitude has decreased to 110 volts p-p. Waveform W5 has increased in amplitude to 220 volts p-p without much change in shape. This indicates V1A circuit is operating well enough. Check at pin 3 of V1B reveals highly distorted waveform; inverted parabola is correct shape—sharp trailing edge of sawtooth could not appear across good C1.

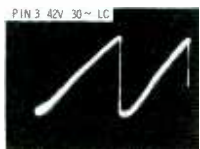
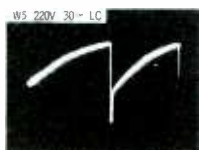
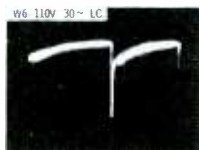

Voltage and Component Analysis

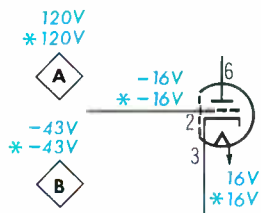

Voltage measurements are some help. Reduced negative voltage on pin 2 indicates bias is upset, but this is not significant. Voltage at point A is reduced by 20 volts, but that amount doesn't indicate anything specific. Voltage at point B is very close to normal. Resistance measurement of R3, R6, R7, and R8 shows no change; however, when ohmmeter is touched across R3 and R8, lack of needle "kick" indicates high-value capacitor is not in circuit. If C1 were shorted, raster would show poor overall linearity and foldover at bottom.

Best Bet: Waveform analysis with scope.

No Vertical Deflection

Bright Horizontal Line

SYMPTOM 2

T1 Open

(Vertical Output Autoformer)

Symptom Analysis

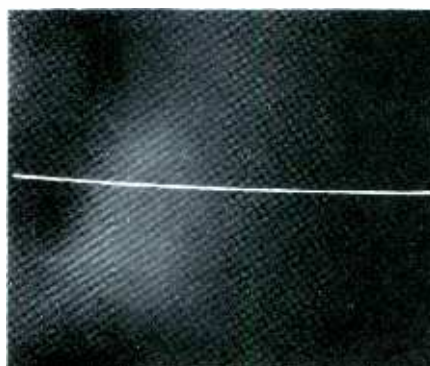

No vertical deflection. Normal horizontal deflection indicates trouble isn't in circuit shared by both vertical and horizontal sweep systems (such as B+ or boost). Troubles that cause total loss of vertical sweep are usually located in output stage.

Waveform Analysis

Absence of W6 indicates no drive to vertical deflection coils; waveform shown is caused by hum and horizontal pickup. Check at grid of V1B (W5) shows normal pulse is missing; only signal present is sync drive to multivibrator—indicates multivibrator is not running. Absence of any waveform at pin 3 indicates V1B is not conducting or that cathode-to-ground short exists. In any case, trouble in plate or cathode circuit is indicated.

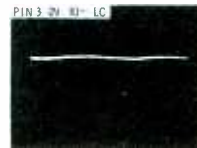
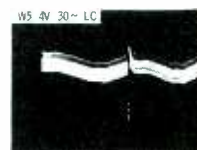
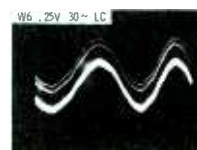

Voltage and Component Analysis

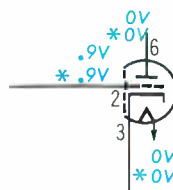

No cathode or plate voltage on V1B; grid voltage is very low (.9 volt). Zero voltage on cathode indicates output tube is not conducting. Ohmmeter check from cathode to ground shows correct resistance there. Voltage check at plate and B+ indicates open circuit; trouble is pinpointed to open output transformer by normal voltage reading at center tap of T1. Check of T1 continuity with ohmmeter eliminates short at pin 6 as cause of no plate voltage. Also check condition of R9 and C9; damping is controlled by R9 and C5.

Best Bet: Voltage checks.

No Vertical Deflection

Horizontal Line Visible

SYMPTOM 3

R3 Open

(Linearity Control—750 ohms)

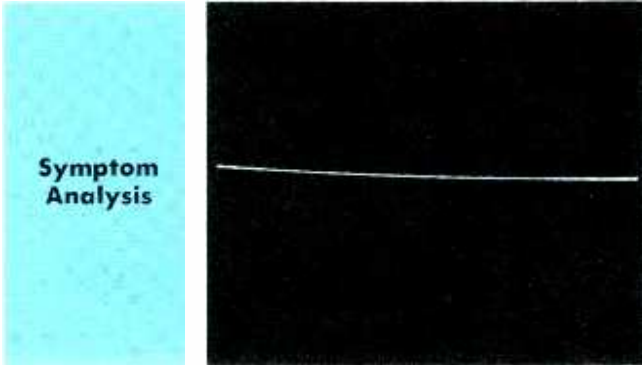

Screen shows complete loss of vertical deflection. Since no change in width is noticeable, any trouble related to horizontal section—such as defect in B+ or boost—is eliminated. Symptom definitely points to trouble in vertical oscillator and/or output.

Waveform Analysis

Absence of waveform at W6 shows no drive at all is being applied to yoke. W4 contains mostly pickup from horizontal circuitry, indicating no output from V1B. Waveform W5 shows sync pulse is present. Even though multivibrator is not running, W5 would be amplified and reappear at W4 if V1B were conducting. Waveform check could have been made at pin 3 but would have shown lack of signal at that point, only slight pickup.

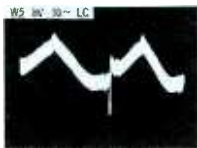
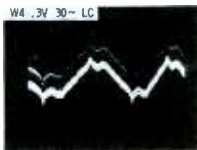
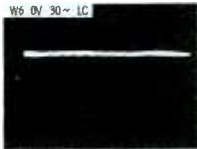

Voltage and Component Analysis

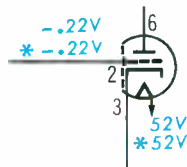

Voltage measurements show only small negative voltage present at pin 2, indicating little grid-leak bias. Abnormally high voltage is present at pin 3. At first, this might seem to indicate that tube is conducting very heavily; however, if that were the case, increased negative voltage should appear at grid. Resistance measurements in grid and cathode circuit of V1B will locate open R3. Then what about the high cathode voltage? C1 was charging via electron stream of V1B, same as if tube were just simple resistor, connected to B+.

Best Bet: Voltage and resistance checks are adequate.

Poor Linearity

Slight Rolling

SYMPTOM 4

C2 Leaky

(Grid Coupling Capacitor—.033 mfd)

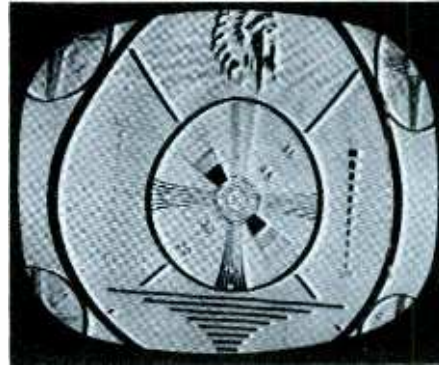

Increased height, poor linearity most noticeable at top of raster. Free-run frequency of multivibrator has changed enough to allow it to go out of sync. Range of vertical hold control is sufficient to bring multivibrator back into sync.

Waveform Analysis

Check of voltage waveform applied to yoke shows W6 is slightly clipped at top of rise. Most likely cause of clipping is V1. Normal appearance of W5 indicates no trouble in V1A, but W4 suggests fault in output stage. Remember—grid circuit is part of V1B plate circuit. Cause of distorted W4 is not actually V1B; tube is being biased above normal level due to DC leakage through C2. Same check could have been made at V1B pin 3.

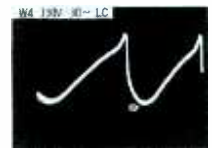
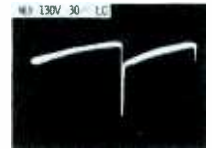

Voltage and Component Analysis

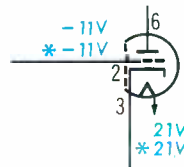

High cathode voltage indicates increased cathode current. Lower negative grid voltage indicates less drive or that positive leakage from C2 is offsetting negative potential. Voltage measurements at other points are not indicative of trouble. Since suspected component is now C2, check capacitor by unsoldering lead connected to pin 2 and connecting voltmeter to that lead. Any positive voltage shows that C2 is leaky. Good practice is to replace any tube that has been overdriven for any length of time. Check resistors that have overheated.

Best Bet: Voltage measurements and component checks.

Height Insufficient

Short at Top and Bottom

SYMPTOM 5

R8 Increased in Value

(Cathode Resistor—150 ohms)

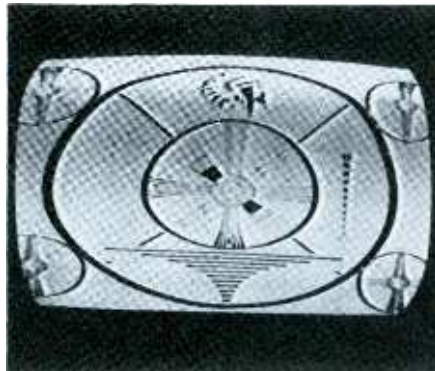
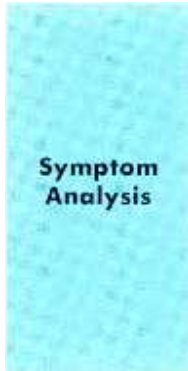

Raster is reduced in amplitude at top and bottom. Change in linearity is also noticeable. Vertical rolling may occur but can usually be stopped with hold control. Raster has normal brightness and width, indicating no B+ or boost trouble.

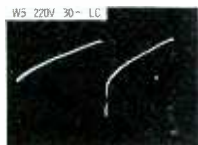
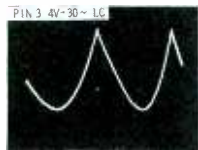
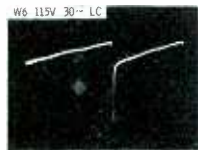

Waveform Analysis

W6 shows poor linearity in rise of sawtooth; also, amplitude of sawtooth portion is slightly reduced. Check at pin 3 reveals no clue to source of trouble. W5 gives first clue to trouble: Close inspection of waveform indicates bias of multivibrator may be upset—notice slow-rising portion of sawtooth. This is case where waveform analysis does nothing more than give clue to type of trouble. Indicated trouble is apparent change in bias of V1B.

Voltage and Component Analysis

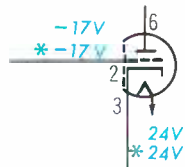

Voltages on V1B show that grid voltage is slightly low—result of reduced conduction or drive. Cathode voltage is somewhat high—result of increased cathode current or increased cathode resistance. Resistance checks of resistors that affect V1B bias show R8 has increased in value. This indicates tube has been drawing excessive current. Also, check condition of R3 and V1. Other components that should be checked are: C2, T1 (check for signs of overheating), and any resistance in B+ feed line.

Best Bet: Voltage and resistance checks.

Height Insufficient

Shortest at Bottom

SYMPTOM 6

R4 Increased in Value

(V1A Plate Supply Resistor—820K)

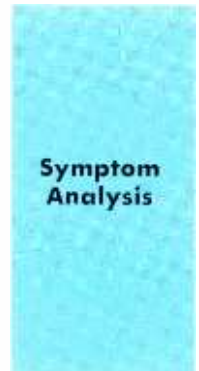
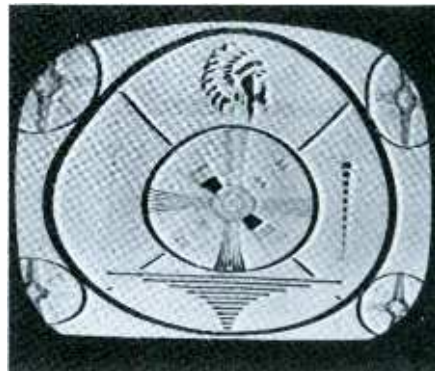

Decreased height, mostly at bottom. Multivibrator frequency is affected somewhat, but hold control has enough range to maintain proper sync. Linearity is also poor. Greater compression at bottom of raster is clue that trouble may be in V1A circuit.

Waveform Analysis

Waveform W6 is slightly low in amplitude; doesn't necessarily indicate trouble in that immediate area, but does show that amplitude of waveform applied to yoke windings is reduced. No change is apparent in waveform W4, indicating conduction of V1B is normal. First real clue is at plate of multivibrator—W1 amplitude is reduced, indicating reduced amplification in V1A. W5 could have been checked, but would have reflected same information.

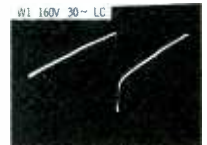
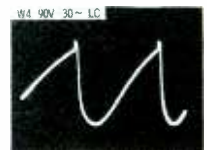
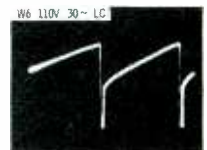

Voltage and Component Analysis

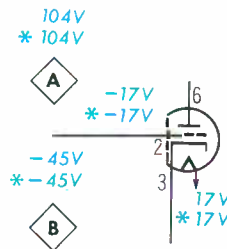

Reduced negative voltage at pin 2 is result of lower drive from V1A. Amount of negative voltage developed at grid is directly proportional to amount of drive, since bias is grid-leak. Strong clue is reduced voltage at point A, although boost is normal. Villain (increased value of R4) is quickly discovered by resistance measurements in boost-supply chain of V1A. Make measurements quickly, or resistors may return to normal upon cooling. Other components that may be suspected are: R1 and V1A with associated components.

Best Bet: Voltage and resistance checks.

A New Electronic Slide Rule with Instruction Course

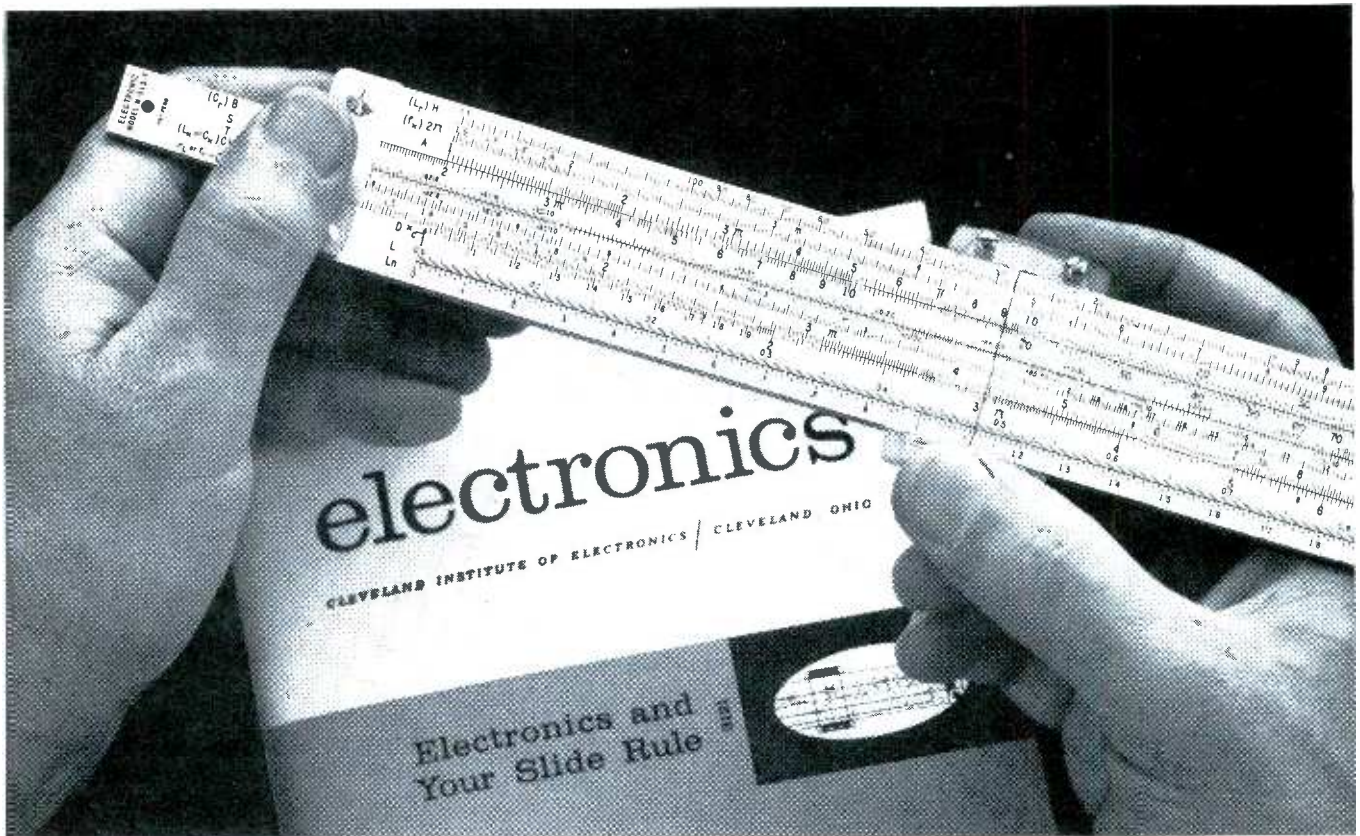

Why didn't someone think of this before?

Here's a great *new* way to solve electronic problems accurately . . . easily. The Cleveland Institute Electronics Slide Rule* is the only rule designed specifically for the exacting requirements of electronics computation. It comes complete with an illustrated Instruction Course consisting of four AUTO-PROGRAMMED lessons . . . each with a short quiz you can send in for grading and consultation by CIE's expert instructors. With this personal guidance, you'll soon be solving complex electronics problems in seconds while others still struggle along with pad and pencil.

Here's what Mr. Joseph J. DeFrance, Head of the Electrical Technology Dept., New York City Community College, has to say about it:

"I was very intrigued by the 'quicke' electronics problem solutions. It is an ingenious technique. The special scales should be of decided value to any technician, engineer, or student. The CIE slide rule is a natural."

See for yourself. You will learn how to use special scales to solve problems dealing with reactance, resonance, inductance, AC and DC circuitry, etc. And, as an added bonus, you can use this high-quality rule for conventional computation, too.

This all-metal Slide Rule is a full 10" long and is made to our rigid specifications by Pickett, Inc. Slide Rule, Instruction Course and handsome top-grain leather carrying case . . . all yours for just \$14.95. Cleveland Institute of Electronics, 1776 East 17th St., Department PF-102, Cleveland, Ohio 44114.

SATISFACTION Warranty

The Electronics Slide Rule with Instruction Course is available only from Cleveland Institute of Electronics, and is covered by CIE's exclusive "Satisfaction Warranty." Order it now . . . use it for ten full days. Then, *if you're not completely satisfied*, CIE will refund full payment. *U.S. Patent Number 3,120,342.

SEND COUPON TODAY

to: **Cleveland Institute of Electronics**

1776 East 17th St., Dept. PF-102 • Cleveland, Ohio 44114

- Please send FREE brochure only . . . without obligation.
 Please send me your Electronics Slide Rule with Instruction Course and leather carrying case. I am enclosing \$14.95.

Name _____ (Please Print)

Address _____ County _____

City _____ State _____ Zip _____

A leader in Electronics Training . . . since 1934

UNUSUAL

CB ALIGNMENT CHARACTERISTICS

Touchup suggestions to maximize performance.

by Edward M. Noll

The alignment of a CB unit involves both a receiver and a transmitter. Peak performance from each is important to system performance in terms of range, reliability, intelligibility, and noninterference.

Receiver alignment is not just a matter of peak sensitivity and gain. Proper alignment insures maximum adjacent-channel rejection up to the capability of the basic design. In fixed-tuned sets, improper oscillator alignment can reduce intelligibility and range because incoming signals aren't placed within the IF band-pass. In fact, in some transceivers, this adjustment is readily accessible to permit easy touchup. . .

Correct transmitter alignment insures on-frequency operation, maximum power output from the rated power input, and clean modulation. Transmitter adjustments may be undertaken only by the holder of a First- or Second-Class Radiotelephone Operator's License, issued by the FCC. Even plug-in replacement of a transmit crystal comes under the heading of transmitter maintenance because, when such a change is made, the frequency should be checked immediately with test equipment that can measure frequency within the tolerance allowed by the FCC for CB transmitters. In fact, any CB-unit adjustment or repair that can influence compliance with any FCC technical standard must be made by or under the immediate supervision of a licensed technician.



Fig. 1. Checking frequency in mobile.

FCC Technical Standards

Relative to transmitter operation, the FCC is concerned with frequency of operation, power output, and proper modulation. These three operating characteristics thus are the major considerations of any transmitter repair or alignment. As a matter of fact, the FCC advises frequency checks on a six-months basis. If a transmitter shows any tendency to drift, frequency checks had better be made more often.

For class-D Citizens-band operation, the frequency tolerance is .005%. What does this figure mean for Class-D operation? The assigned frequency of channel 1 is 26.965 mc; channel 23 is 27.255 mc. Therefore, the maximum permissible off-frequency operation for these two channels is 1348.25 and 1362.75 cps respectively (.00005 times the channel frequency). Maximum permissible frequency drift for class-D channels is thus approximately 1350 cps.; more specifically, channel 1 can drift no lower than 26.96366 mc, and channel 23 no higher than 27.25636 mc.

An accurate frequency meter (Fig. 1) is required to measure within this tolerance. The FCC recommends a frequency meter with a tolerance of .0025% for CB tests. This is a rather liberal requirement by commercial standards, and it is recommended that your frequency meter have an even higher accuracy; units are available with accuracies of .001% and better. Inasmuch as you must spend a considerable amount of money for any good frequency meter, investment in high accuracy is advisable.

FCC power requirements are specified as the DC power input to the final modulated circuit—the product of the DC supply voltage to the stage times the average DC plate current. Although it is very true that the product of these two components is limited to 5 watts in CB

transmitters, the actual measurement may be misleading in terms of maximum RF-power output. On occasion, CB transmitters have been *mistuned* at exactly 5 watts input (or even higher), but with far less than maximum RF-power output—less than if the unit were tuned correctly and the DC input power were perhaps even less than 5 watts.

At any rate, best tuning procedure is to adjust the transceiver for maximum RF-power output and then doublecheck the DC power input to be certain the 5-watt limit has not been exceeded. If it reads somewhat less, do not be concerned; the cause may be only the light loading of the antenna system or perhaps a slightly lower-than-normal supply voltage. Also remember that no two output transistors draw exactly the same DC current.

Modulation control is more or less automatic in modern CB transceivers. Clipping circuits are employed in the CB audio-modulator circuits to prevent overmodulation. However, close-talk shouting may push the modulation limiting system to excessive clipping, causing your signal to spill over into adjacent channels; under this condition, you are, in effect, transmitting an illegal signal.

Oppositely, a feeble voice or a microphone held too far from your mouth will result in a low modulation percentage. Although this is not illegal, it considerably reduces range. Between the two extremes



Fig. 2. Small test set for mobile use.

there is quite a wide latitude of voice level and microphone placement that will give you a strong, cleanly modulated output.

Inexpensive meters to measure RF-power output and amplitude modulation are available. Modulation checks should be a routine when you're going through frequency measurement and adjustment. It is no particular problem to observe the RF modulation percentage on your oscilloscope.

RF Signal Sources

Adjustments that influence transmitter frequency should be made only when an accurate frequency meter is available. Expensive types employ frequency counters and often provide direct readout of the transmitter frequency. Some include facilities for calibration checks with a WWV signal. Heterodyne types can be used as signal sources as well as frequency meters. A means of AM- or FM-modulating the RF test signal may or may not be included.

Some more expensive two-way-radio frequency meters employ FM demodulation so the instrument can be used as a monitor in the VHF-FM radio services. Quite often, no facilities are included in these for measuring AM modulation.

A CB transceiver can itself serve as an accurate signal generator, supplying signals on whatever channels are desired. A well shielded unit operated into a dummy load will radiate enough signal for RF alignment of another nearby unit. A transistor tone oscillator can supply a constant audio signal to the microphone input of the test transmitter. The radiated test signal can be picked up with a short loaded-type CB antenna. RF and IF alignment can then be performed using an audio output meter. The CB transmitter that is used as a signal source should be checked carefully with the frequency meter.

Another accurate signal source can be one of the test sets (Fig. 2) that include an RF oscillator for checking crystal activity. With appropriate CB transmitter crystals, they can be used as an RF signal source that can be calibrated against the frequency standard. Some of these units include an audio oscillator so the RF output can be am-

plitude-modulated with tone signal.

Some less costly frequency meters are crystal controlled instead of employing continuous tuning. Crystals are purchased for measuring each specific channel. Such a frequency meter can also be used as a signal source for receiver alignment. Usually such alignment is done using a center-band channel. For maximum accuracy, a crystal oven is often included with this type of frequency meter, and a high order of accuracy is possible.

Frequency Checking

In frequency measurement, a direct connection can be made between the transceiver output and the frequency meter via a suitable isolating and attenuator pad. In most cases, radiated pickup can be employed using the small antenna that is part of many frequency meters. In a bench setup, a small loaded-base antenna can be used on the transceiver.

If frequency adjustment proves to be necessary, the oscillator can sometimes be adjusted with the mobile transmitter in the vehicle, depending on the mounting. The frequency meter usually has facilities for a headset so an exact aural zero-beat can be heard.

Transmitter Alignment

Most transmitter alignment involves a simple peaking process. Once the oscillator is exactly on frequency, it is only necessary to peak the remainder of the RF adjustments. This should be done with the output of the transmitter terminated in a 50-ohm resistive impedance. Low-cost RF output meters are now available that provide simultaneously the proper 50-ohm termination and a means of measuring modulation percentage. Some versions include facilities for checking the weaker outputs of hand-held and unlicensed CB units—usually 100 mw or less.

One or two of the transmitter output adjustments may be accessible through the case, to allow for the influence of the case capacitance on adjustments. Furthermore, the antenna itself seldom presents a pure 50-ohm resistive impedance. The accessible output adjustments can be touched up for ideal matching and maximum power output

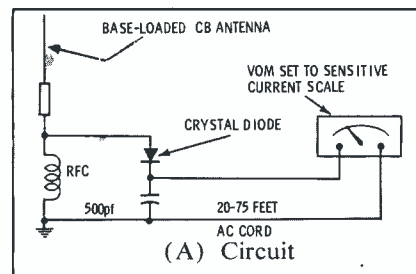

(A) Circuit
(B) In use
Fig. 3. Remote-indicating field meter.

with the operating antenna connected.

The arrangement of Fig. 3 can be quite helpful in the final touchup of the output stage in a mobile-installed unit. A short CB antenna is mounted on a small box, and the choke-diode-capacitor combination mounted inside. The detector develops a DC output current corresponding to the magnitude of the signal picked up by the antenna. This DC can be transferred over a long length of ordinary AC cord to a DC meter at the transceiver mounting position. The remote field-strength meter can be placed a considerable distance away from any influence the metallic car body might have on its pickup, and it serves as a pretty good indicator of how well the CB car antenna is actually radiating. The transmitter output stage can be peaked conveniently for maximum.

In all-transistor models, final peaking of the RF output stage should be done with modulation applied. This takes care of the influence modulation often has on collector current in the transistor output stage. The operating point of a transistor stage is influenced by DC current. Optimum loading conditions are often more closely duplicated if the final adjustments are made with modulation near 100%. By so doing, maximum positive modulation of the transistor output stage can be obtained during subsequent operation.

• Please turn to page 81



Here we see the equipment that must be installed: power and lead-in cables, antenna, and receiver. The most logical procedure is to install antenna, cables, and set, in that order.



The installation doesn't require any special tools. You'll need a 1/2" box-end wrench, a couple of "spintites," 3/8" and 11/32", and possibly the few others that are shown here.



Installing a Mobile CB Unit

There is no cut-and-dried procedure for installing a mobile CB radio. The antenna can be positioned in various places on the automobile. Depending on customer preference and the type of vehicle, the unit may also be mounted in several different locations. The sequence of photos shown here gives a thorough and detailed explanation for one installation.

One good reason for mounting the antenna first is to let the hot engine cool off. The antenna may be a bumper mount, needed for the full 108" whips; a rear-deck mount; or a top mount. The latter is a base-loaded whip, electrically equivalent to a quarter-wave but physically shorter. Follow instructions packed with each antenna, and be sure to tighten bumper mounts snugly.

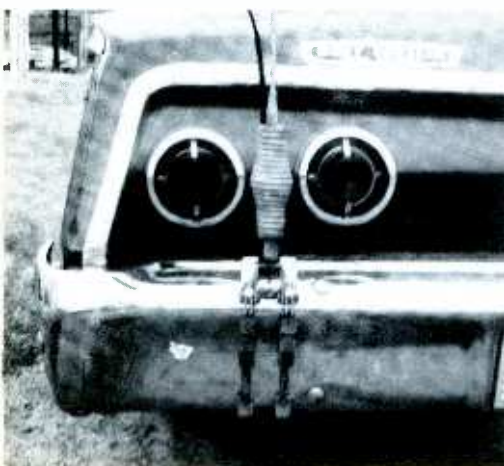



The lead-in cable goes under the floor mats. Push the plug end forward and the other end under the rear mat and seat.



Now, under the hood, remove the battery ground cable while you fasten the hot wire of the receiver to the starter switch.



For best reception, install bypass capacitors on the generator armature and voltage regulator; coaxial types are best.

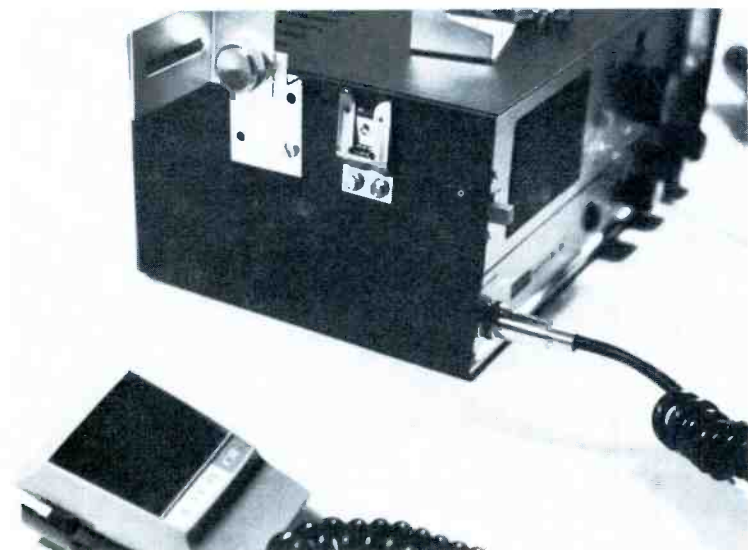

You are now ready to mount the receiver. This usually requires two small brackets fastened to the set and to the underside of the automobile dash. Most cars already have one hole in the dash; if so, measure the distance and drill a second hole.

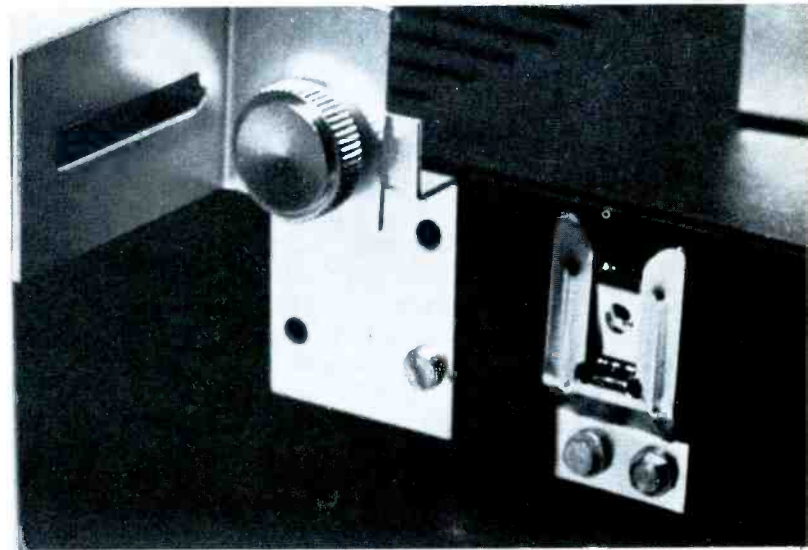

This closeup photo shows how the receiver hooks on these mounting brackets. Notice the unit is held tightly in place by the knurled knob. The mounting hardware can be taken off the radio by removing one screw and two bolts from each side.

The receiver may be mounted under the center of the dash, or on the right side, or even on top—a handy position for pickup trucks. The top mount is accomplished by using two pieces of aluminum "angle" bolted to the sides of the case, with a third piece between them. Place a rubber pad over this third bracket. Lastly, follow instructions and tune up the transmitter.

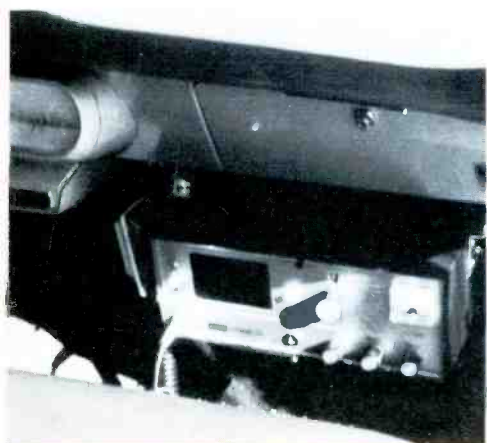



TRACING

FEED PATHS

by Larry Allen

Of all the servicing techniques and skills you can develop, the one you'll use most is the ability to trace and analyze voltages. Indeed, unless you can use your voltmeter to probe the mysteries of electronic circuits, all the signal-tracing and scope-analyzing procedures you can absorb are not likely to bring you to the final goal of your searching—pinpointing faulty components.

Electronic amplifiers, oscillators, detectors, power supplies—be they tube-operated or transistor—depend on or produce DC voltages of one sort or another. Functional tubes need plate, screen, and bias voltages, all of which are mainly DC; passive tubes such as rectifiers and diodes produce a DC component either as the prime goal or as a by-product; transistors require DC

potentials for their emitters, bases, and collectors. We're going to examine how these voltages are carried from one point (their source) to another (their point of use).

General Considerations

For purposes of explanation simplicity, no distinction will be made among the various uses of DC voltages, because the principles of handling them are universal. We'll discuss only the distribution of operating voltages for tubes and transistors.

One point we will consider and then dismiss, for it has no direct bearing on our discussion. In an operating electronic circuit, there is seldom such a thing as pure DC voltage—there are nearly always signals of one sort or another superimposed, either wanted or unwanted. The DC voltages we measure with our VTVM or VOM are the average currents in the tube or transistor. When we talk of DC voltages, we completely ignore the instantaneous variations that take place thousands (and millions) of times per second as the result of signals in the circuit; we are concerned with the DC voltages around which these signals form. Forget about signal voltages; we will refer to them no more in this article.

We're discussing operating voltages and currents. In tube circuits, they are referred to as B+ voltages; for transistors, they may be referred to as A voltages. In this article, we're going to call them all B+ voltages, because the principles apply no matter what nomenclature is pinned on the voltage and they work with every circuit in every form of electronic instrument you'll ever encounter.

DC Principles

Item One: DC flows most easily through the path that offers the least resistance to the movement of electrons. Look at the seven circuits in Fig. 1; each of them shows electrical paths between points X, Y, and Z.

In A, the jumpers between the points present no resistance to the flow of electrons—their resistance is zero ohms—they are the shortest "distance" between two electrical points. In B, resistor R1 makes it more difficult for electrons to move through the path from X to Z; in

other words, there is more resistance (1000 ohms) in the path, and the distance is "longer." In C, there is even more resistance due to the presence of R2.

In circuit D, resistor R3 has been added to provide an alternate path bypassing, or shunting, R1. Since there are now two paths, it is easier for a flow of electrons (current) to pass from X to Y. In fact, the 10-ohm resistor offers a path so much better than the 1000-ohm resistor that R1 could be removed from the circuit without a noticeable change in the resistance between X and Y. This is the same as saying that the resistance between X and Y has been reduced to 10 ohms. The resistance between Y and Z has not changed, but the resistance between X and Z (the total path) is noticeably less—barely over 5000 ohms, now—than in circuit C.

In circuit E, there are two paths from X to Z. One of these, R3, has a resistance of only 10 ohms. It is easy to see that it is now extremely easy for electrons to flow between X and Z. This idea is carried a step further in circuits F and G. The jumpers offer no resistance to the flow of electrons. If resistance is thought of as electrical distance, the jumpers in A, F, and G provide the shortest path between X and Z. For this reason, jumpers can be called *short circuits* or just *shorts*.

Now let's examine the paths from X to Y. The resistances are zero in A, 1000 ohms in B, 1000 ohms in C, and 10 ohms in D (remember the effect of putting a 10-ohm resistor in shunt with a 1000-ohm resistor).

Circuits E, F, and G may pre-

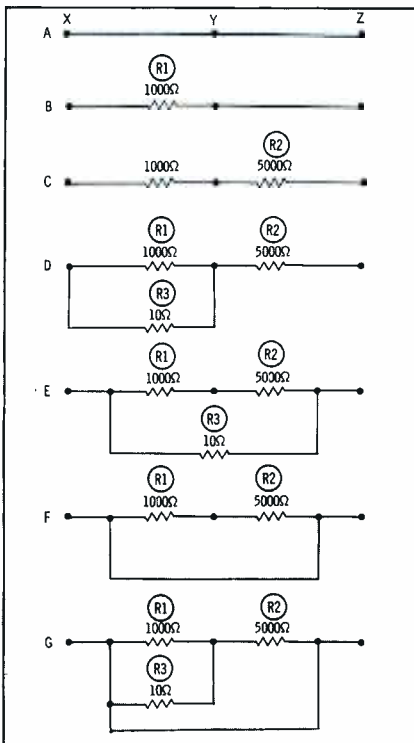

Fig. 1. Resistive paths are chiefly the DC distance between electronic points.

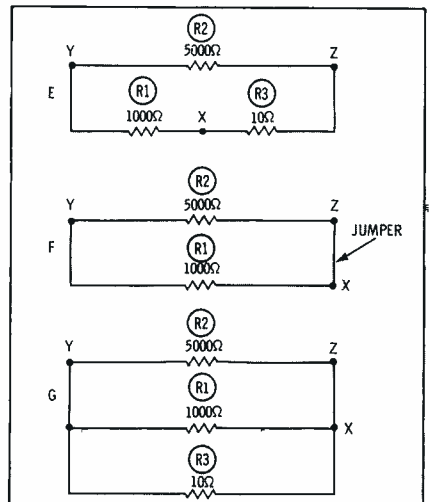

Fig. 2. Redrawn to show parallel paths.

sent a few surprises if you are not careful. These have been redrawn for clarity in Fig. 2. Notice in E, for example, that there are two paths from X to Y: the obvious one through R1, and another path through R3 and R2. If R3 were removed, the circuit would be the same as C, and the resistance between X and Y would be 1000 ohms. Since another path has been added in E, it is now easier for current to flow from X to Y, and the resistance between these points must be *less than* 1000 ohms.

In circuit F, there are also two paths from X to Y (through R1 and through the jumper and R2). The resistance is again less than 1000 ohms.

In circuit G, there are three paths: through R1, through R3, and through the jumper and R2. The 10-ohm resistor provides a path so much shorter than the others that the other two paths could be removed without any noticeable change in the resistance. The resistance between X and Y can therefore be considered to be 10 ohms.

When you examine the Y-Z paths, you'll find the resistances to be: A-zero ohms, B-zero ohms, C-5000 ohms, D-5000 ohms, E-less than 1010 ohms (note the two paths, through R2 and through R1 and R3), F-less than 1000 ohms (two paths—through R2 and through R1 and the jumper), and G-less than 10 ohms (*three* paths, as shown in Fig. 2). As you can see, when more than one current path exists between two points, the resistance between the points is less than that of the lowest-resistance path between them—the electrical distance is somewhat shorter than the shortest

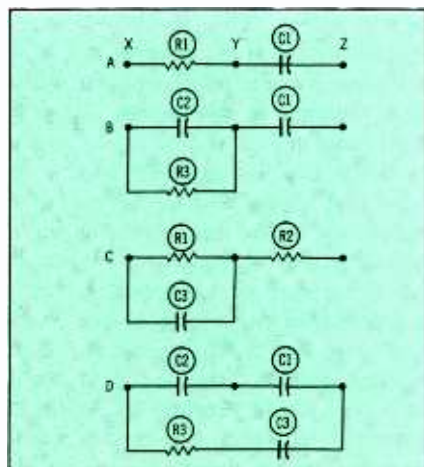

Fig. 3. Capacitors prevent DC passage.

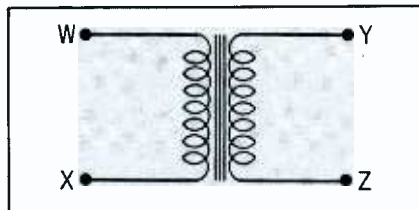

Fig. 4. Transformers conduct and block.

parallel path.

Remember well the facts demonstrated by these simple little examples. They form the basis of all DC voltage-distribution circuits.

Item Two: While resistances of various values conduct DC voltages from one point to another with greater or lesser ease depending on their values, other components are used to keep DC from reaching certain points. Chief among these are capacitors; used in this manner, they are called *blocking* capacitors.

Fig. 3 shows how blocking capacitors keep DC potentials or currents from reaching certain points. In A, DC can flow from X to Y, but not from Y to Z; effectively, then, DC at X is blocked from Z. In B, R3 offers a resistive path for DC around C2, and therefore the X-Y path is okay for DC; C1 blocks DC between Y and Z, so the overall X-Z path is still incapable of transferring DC. The circuit in C, on the other hand, shows DC continuity from X all the way to Z; capacitor C3 is shunted by R1, so it has no blocking effect at all. In the D schematic, C1 and C2 exclude DC from the X-Y and Y-Z paths, so the X-Z path is apparently blocked; resistor R3 can conduct DC, but only as far as C3, so what starts out as a possible path around C1 and C2 comes to a dead end at C3. It is interesting that the blocking action of C3 would be equally effective if it were on the X side of R3 instead of the Z side.

Item Three: Transformers offer a combination of conductivity and blocking for DC voltages and currents; Fig. 4 shows how. It is easy to see DC continuity between points W and X and between Y and Z. It is equally obvious that DC cannot travel from W or X to Y or Z. Thus the transformer can transfer other types of energy while keeping DC energy in the precise paths desired.

To summarize, then: Resistances and coil windings can transfer DC voltages and carry DC currents to

any point desired, while capacitors and the winding separation of transformers prevent DC from entering any point of circuit where its presence isn't wanted. With these simple principles in mind, it is easy to trace B+ path anywhere in the most complicated electronic gear.

Hand-Wired Paths

Tracing paths followed by DC voltages includes both following feedlines on the schematic and tracking them through the maze of wiring in the chassis. Generally, tracing paths on the schematic is easier, but a few special techniques can simplify even that.

On some schematics, all the B+ connections and feedlines are shown by a maze of solid lines; colored pencils can be used to help identify lines that run closely parallel. In others, the source points are labeled and the supply points are then identified with each source voltage. Fig. 5 shows an example, somewhat simplified, of how these supply points are identified with the supply sources. In a complex unit such as a TV receiver, which has perhaps 20 or more different stages, there will be many supply-point references for each of the supply sources. Again, colored pencils are helpful; lines can be drawn between all common points to help visualize the several branches of a particular B+ supply.

It may not always be easy to visualize the common connections when you see them in the wiring of a chassis. For example, it may seem strange to see a resistor connected from the plate of V1 to the cathode of V3 (Fig. 5); one may be a sync tube and the other an audio output stage. If you look a bit further, how-

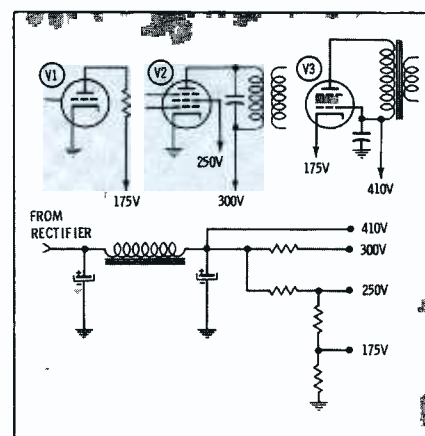

Fig. 5. Showing sources, supply points.

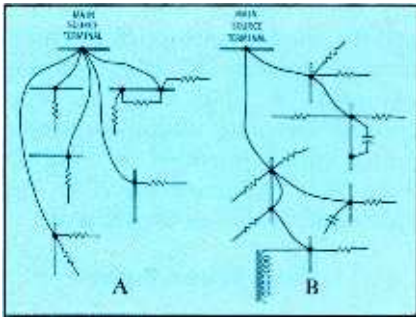

Fig. 6. Examples of B+ branching.

ever, you'll find that feeder lines (or a common one) connect both points to the 175-volt source. The line may even pick up some more "riders" along the way. Important to remember is that the supply source is common to *all* these supply points; no matter how lengthy is the buss that connects them, or no matter how many of them are connected to one terminal, they are all wired together in one way or another—all 175-volt points are common, all 300-volt points are common, etc.

Circuits such as these are *branches*, and must be identified physically in the chassis if you are to trace them. They may branch simply as shown in Fig. 6A, or they may be arranged in any one of the ways in Fig. 6B. Sometimes they are color coded, but more often they are not.

To help you understand and learn to trace the form of supply paths shown in Fig. 5, we've drawn a little more elaborate system both schematically and pictorially in Fig. 7. Practice tracing a B+ system such as this in an actual chassis. Remember that capacitors block DC, so

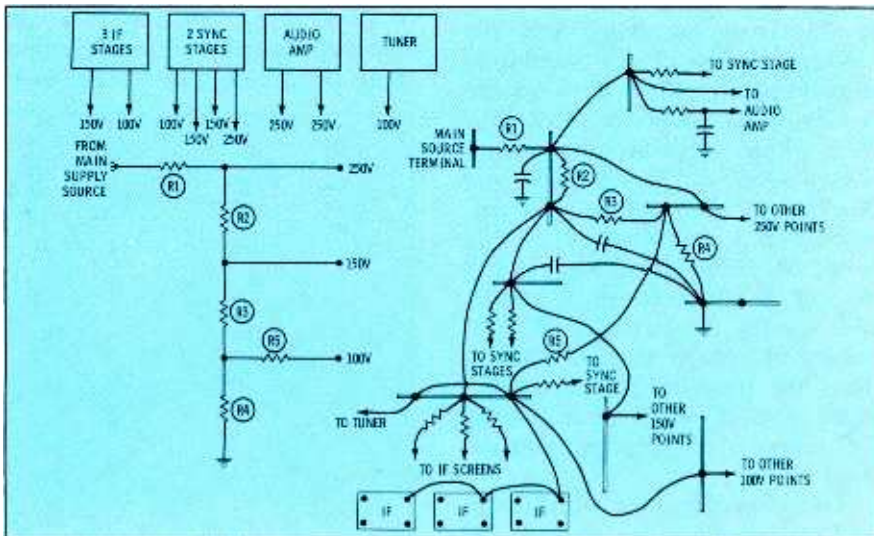

Fig. 7. Complex array of B+ circuits and supply sources in a typical TV set.

you can ignore them. When you're tracing through a complex system of B+ paths such as shown in Fig. 7 and you come to a capacitor, just ignore it and trace off in some other direction, following the conductive path through resistors, coil windings, wire jumpers, or busses.

Printed Boards

Some technicians look on printed boards with a distaste that is often blamed on "their undependability" but actually stems from not understanding how to troubleshoot or trace circuit paths on them. With the printed board, a study of the schematic is important, for the easiest way to trace B+ paths on printed boards is by the point-to-point system.

To see an example, look at Fig. 8; this board is part of a transistor radio, but the principles involved in tracing B+ on it are the same as in TV sets or any other equipment with printed circuits. The schematic that corresponds to the board is shown in Fig. 9. On both, various points in the circuit are identified by numbers (a copyrighted system known as CircuiTrace and used only on PHOTOFACT schematics).

You can see several points on the schematic that are numbered 26, and at the bottom a 4.8-volt source symbol is tagged 26; every point 26 on the schematic is connected directly with all others and to the 4.8-volt source. Touching a voltmeter probe to the single point 26 on the board (Fig. 8) is therefore equivalent to checking any or all of the schematic points numbered 26.

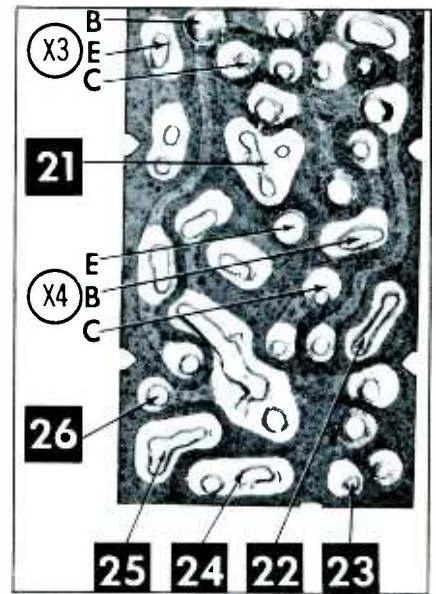

Fig. 8. Printed board of transistor set.

The path of B+ from its source to the base of transistor X4 can be traced from point 26 through R14 to point 19 (the same as E of X3). From this point, a capacitor blocks the supply voltage in one direction, and the other path is through R15 to point 21. Capacitor C25 blocks DC; therefore the path is up through the winding of L6 to B of X4 (C27 blocks it from reaching point 22). Using Fig. 8, you can see how easy it is to check this same feed path with your DC voltmeter. Touching the probe successively to point 26, X3E, 21, and X4B traces the entire path from source to X4 base.

Another supply path on the schematic is 45, 27, 20, and X3B. Photos of the other boards would have locations marked for these points. Keep in mind that the board may actually have many points corresponding to each numbered schematic point, or that one board point may represent several schematic points. This is of no consequence to tracing, because a probe touched to any one point measures the voltage at all points bearing that number.

What do you do with boards in sets that don't have a CircuiTrace schematic? You can establish identifying points of your own by noting the junctions of components. Pretending that the numbers are omitted from Fig. 9, the path from B+ source to the base of X4 could still be traced: From the B+ input terminal of the board (or B+ source in the set) the path is

• Please turn to page 83

by Robert G. Middleton



SQUARE-WAVE TESTING

In Resistive Circuits

Introduction to Square-Wave Testing

Last month, we introduced a new department in PF REPORTER, called "Advanced Service Techniques." The kickoff article ("Advanced Techniques for Future Servicing") was an introduction to the square wave, in preparation for teaching you how to use square waves to test multifunction components of the future. The article starting on this page is the first of a series in this department on the actual testing of components. This one begins with the testing of resistors of various types.

The techniques outlined can be carried out properly only with a triggered scope of the variety described in the March 1965 PF REPORTER article "Learning About Triggered-Sweep Scopes." Few service shops have such an instrument available; they are found mostly in television broadcast stations, electronic and research labs, and of course a few truly forward-thinking shops. If you can find any way to gain the use of such a scope, for even a few hours each month, take advantage of the opportunity to familiarize yourself with its operation and to practice the testing techniques we're outlining in this series. The time will come when much of your servicing work will require a scope like this; a lot of your present troubleshooting could be greatly simplified by a high-quality triggered scope on a rollabout cart in your shop. Future articles, in addition to showing you how to test component combinations of the ordinary and microcircuit variety, will teach you to use a triggered-sweep scope for regular troubleshooting in television and stereo receivers, the ability of a fast-rise triggered scope to reproduce faithfully every "squiggle" in a waveform can speed your circuit analysis tremendously.—*The Editor.*

Square-wave testing is used by factory technicians for inspection and quality control; the scope patterns show whether a component is out of tolerance or defective. In the development lab, the square-wave generator is second only to the signal generator as the workhorse of test-voltage sources. On the other hand, square-wave testing is practically ignored by the service technician. Thus, the square-wave generator is either a "hero" or a "bum," depending on who's calling. Service technicians often believe square-wave testing is "for the birds" simply because they do not understand how to test components and circuits with square-wave voltages and that is because they have not been taught. The pertinent information has been published in papers, articles, and books over the years, but it has been locked in a prison of longhair mathematics and obscure terminology. In this series, we hope to lift some of these shrouds of uncertainty and explain and illustrate in practical terms the uses of square

waves for testing electronic circuits.

Elementary Testing Principles

A simple component such as a resistor, coil, or capacitor is basically a two-terminal device. In a test setup, however, since a ground return is required we are concerned with a three terminal configuration. Fig. 1 makes this clear. Although a resistor is a two-terminal device (Fig. 1A), three terminals—both resistor terminals and a ground—are in Fig. 1B. If you change to a shunt test as in Fig. 1C, three terminals are still used—input, output and common ground.

A Simple Test

Since a resistor is the simplest electronic device, let us start with the square-wave testing of resistors. Suppose you have two 300-ohm resistors. They look exactly the same, and each measures 300 ohms on an ohmmeter, but one is a composition resistor and the other is wirewound. How can you tell quick-

ly which is the composition resistor? Simply use the test setup shown in Fig. 1B, with the square-wave generator set for approximately 1 mc. The composition resistor gives the waveform illustrated in Fig. 2A, while the wirewound resistor produces the waveform in Fig. 2B. What we are actually doing is making a *ringing test* of each resistor to find out whether it is composition or wirewound.

Keep in mind that if you make this test with inadequate equipment, you cannot tell the difference between the two resistors. In the first place, the wirewound resistor in this example is ringing at approximately 5 mc; your scope must therefore have at least a 5-mc bandwidth, or the ringing waveform will be "wiped out" in the vertical amplifier. In the second place, the square-wave voltage must have a fairly strong 5-mc harmonic or the ringing waveform cannot be produced.

The inductance in the wirewound unit causes it to ring when excited by the fast-rise square wave. Whether or not, the square wave will ring

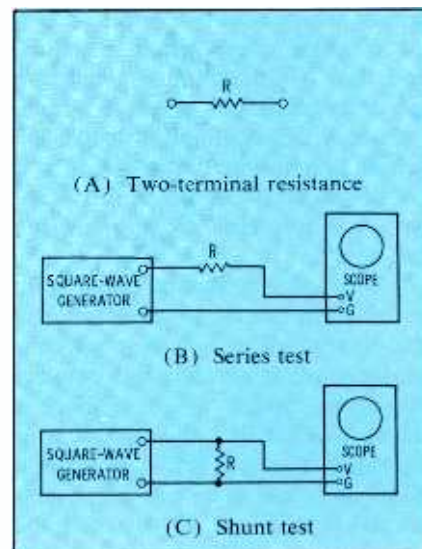
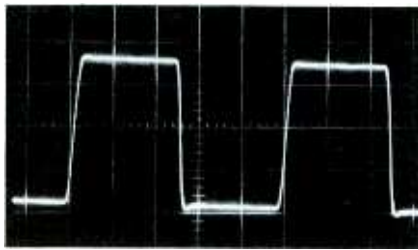
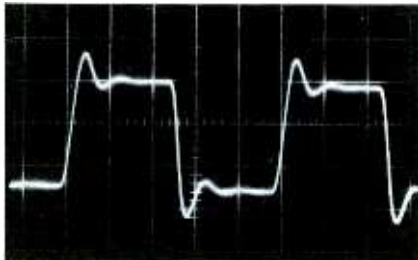

Fig. 1. Simplest of square-wave tests.



(A) Composition



(B) Wirewound

Fig. 2. Identifying a resistor's makeup.

the wirewound resistor depends on the *rise time* of the square wave more than on the generator frequency. If your scope has adequate bandwidth, but you cannot ring the resistor, the rise time is too slow. A rise time of .02 uses was used for the waveform in Fig. 2B—one cycle of a 5-mc sine wave occupies .2 usec ($T=1/f$), and the rise portion of the square wave in this example is about .1 of that period. It would be possible to use a square wave with slower rise time, but the ringing waveform would be weakened accordingly.

Another Practical Example

The wirewound resistor developed a ringing waveform because it had substantial *inductance*. Other types of resistors exhibit substantial *capacitance*. For example, ordinary potentiometers have more capacitance than composition resistors, and thus a potentiometer might be unsuitable for replacement in a high-frequency circuit. Suppose you have a 15K potentiometer and wonder if it will pass a 5-mc waveform without distortion. How could you make this test?

You'd use a square wave with a .02-usec rise time, and connect the potentiometer in shunt with the square-wave generator and connect the scope probe to the slider as shown in Fig. 3A. This circuit configuration is usual for a potentiometer, and the test will be under normal conditions. As you vary the setting of the 15K pot, the square wave on the scope shows different

distortions. At midsetting, you will see the serious overshoot illustrated in Fig. 3B. Obviously, the pot has failed the test—it is not suitable to pass waveforms with a rise time of .02 usec.

Notice especially the difference between the rounded ringing waveform (Fig. 2B) and the spiked appearance of the overshoot in Fig. 3B. The ringing overshoot of 2B was caused by inductance, while the differentiated overshoot of 3B is the result of capacitance. Keep this difference of appearance in mind.

Equipment Settings

These elementary examples have shown the type of information to watch for during square-wave tests of basically resistive components. Now that you are familiar with what to look for, we shall, in keeping with our promise to supply the practical information connected with square-wave testing, show you

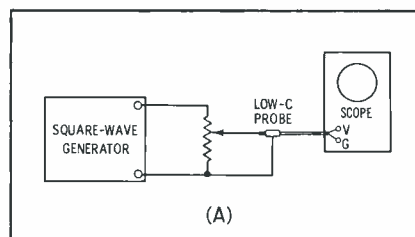

(A)

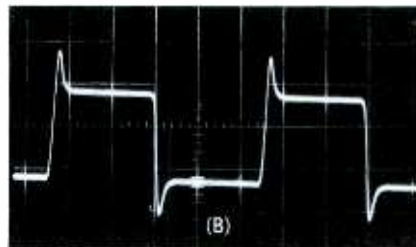

(B)

Fig. 3. Testing a carbon potentiometer.

how to set up and adjust the equipment. It isn't complicated, but you will want the answers to a few questions.

Square-Wave Frequency

You are probably wondering what square-wave frequency should be used to test resistors and potentiometers. The answer is that it really doesn't make much difference. What does matter is the rise time of the square wave. A high-quality square-wave generator has practically the same rise time over its entire range. Therefore, as you change frequency, the overshoot or ringing amplitude in a component remains the same. (It may be necessary to advance

the intensity control of the scope as the square-wave frequency is reduced, because the pattern becomes dimmer). If the damped ringing waveform covers most of the flat top, lower the square-wave frequency; if it is too narrow for easy viewing, raise the frequency.

In other words, in a high-Q resistor, you might use any square-wave frequency from 25 kc to 1 mc, and the overshoot seen in Fig. 3B remains unchanged because the rise time of the square wave remains unchanged. On the other hand, you must use a triggered-sweep scope to display square-wave-test waveforms. If you try to use a scope with free-running (recurrent) sweep, you will have only a choice of evils—either the overshoot part of the waveform is so dim you can't see it or the waveform is so badly overlapped that the pattern is hopelessly confused.

Sweep Speed

We have stated that the scope must have triggered sweep. Next question: "What sweep speed should be used?" Again, this is not really critical consideration. For example, the overshoot illustrated in Fig. 3B is displayed using a sweep speed of .2 usec/cm. The square-wave frequency happens to be 1 mc. Next, the square-wave frequency is reduced to 25 kc, and the intensity control turned up. Now the scope's sweep speed is increased to .04 usec/cm, which has the effect of expanding the overshoot interval and the result is seen in Fig. 4.

In other words, we've shown that it actually makes no basic difference whether we use a fast sweep speed or a slow sweep speed, whether we use a high square-wave frequency or a low square-wave frequency, except as it affects how much of the flat top is occupied by the ringing waveform. The amount

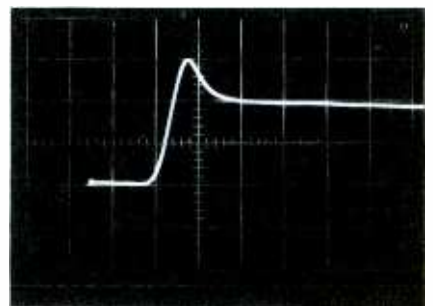

Fig. 4. Expanded display of Fig. 3 trace.

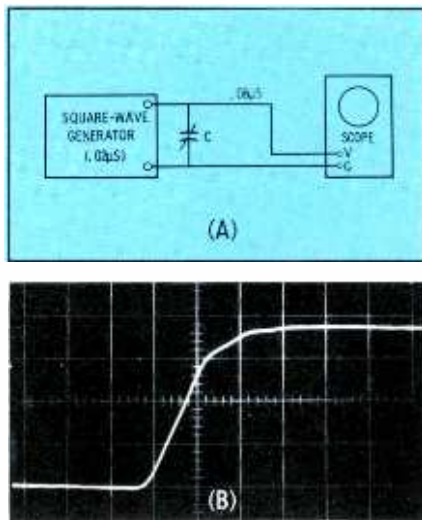

Fig. 5. Altering rise time of generator.

and duration of overshoot depends only on the rise time of the square wave. We do have to avoid extremes; if we use a very low square-wave frequency, we will not be able to advance the intensity control enough to get a clearly visible overshoot display. Or, if we use too slow a sweep speed, the overshoot display will be so cramped that it will be difficult to see. Fig 3B represents a good average for both sweep speed and square-wave frequency.

Control of Rise Time

Suppose your square-wave generator has a rise time of .02 usec but you want to check a potentiometer for replacement in a circuit that has a 4-mc bandwidth. How do we handle this requirement? In the first place, we must determine the rise time of a 4-mc circuit. To answer this question quickly, we can call upon a valuable rule of thumb which states that the rise time of an amplifier or circuit is equal to one-third of the period at its high-frequency limit.

Here's a practical example: The 4-mc circuit has a period of $1/f$, or .25 usec. One-third of .25 usec is about .08 usec. Hence, this potentiometer must pass without distortion a square-wave which has a rise time of .09 usec.

Your square-wave generator has a rise time of .02 usec, so you obviously must slow down its rise time to .08 usec. This is very easy—just shunt a small capacitor across the generator output as shown in Fig. 5(A). A suitable value will slow the rise time to .08 usec—300 pf was required for the generator used in this series of demonstrations.

How do we measure rise time? (This was explained in detail in the March and April articles mentioned in the box on the first page, and is briefly reviewed here—Ed.) The rise time of a square wave is the time required for the voltage to climb from 10% to 90% of its maximum value. Suppose the sweep speed of the scope is .04 usec/cm (microseconds per centimeter); it would take .08 usec for the spot to travel 2 cm horizontally on the graticule. Now, observe Fig. 5B. The rise of this waveform occupies two spaces (cm), so the rise time of the square wave is .08 usec.

After you have slowed down the rise of the square wave to accommodate the test requirements which were determined previously, you are ready to go ahead and test the potentiometer. If it shows no overshoot at any slider setting, it is satisfactory for use at a rise time of .08 usec; stated in terms of frequency, it is suitable for use at a frequency of 4 mc.

Generator Termination

Typical square-wave generators have coaxial output cables which

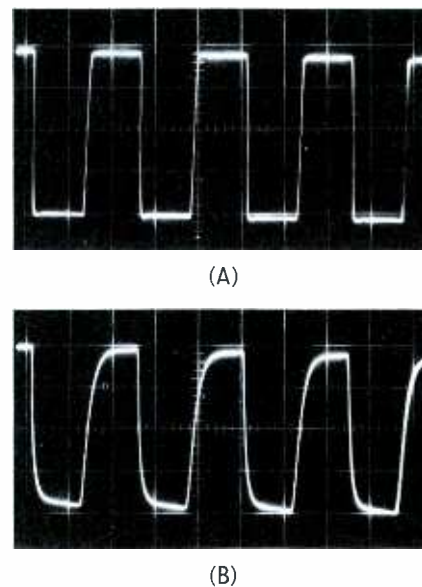

Fig. 6. Distortion—unterminated cable.

must be properly terminated to obtain a clean, square waveform. For example, consider a generator which has an output cable with 93 ohms characteristic impedance. When the cable is terminated with a 93-ohm composition resistor, the waveform appears as shown Fig. 6A. On the other hand, when the cable is left unterminated, the waveform is badly

distorted, as seen in Fig. 6B. The square-wave frequency in these photos is 1 mc.

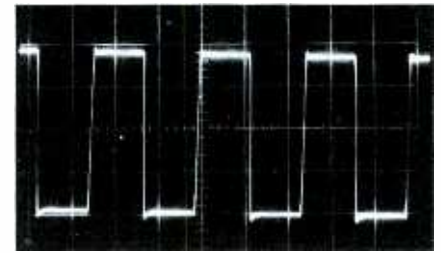

Fig. 7. Wrong termination, overshoot.

Fig. 7 shows the result of terminating the cable in 37 ohms instead of 93 ohms—a small amount of overshoot and ringing appears in the 1-mc square wave. When the terminated cable is applied across a resistor which is to be tested, the terminating resistance becomes equal to the resistance of the parallel combination. This becomes significant when you are testing resistors having comparatively low values, so a 93-ohm terminating resistor is used only when the resistor under test has a comparatively high value. When the resistor under test has value in the order of 100 ohms or less, the value of terminating resistor should be increased to make the resistance of the parallel combination about 93 ohms.

Use Low-Level Test Voltage

Triggered-sweep scopes are sensitive, and you can make tests with only a fraction of a volt of square-wave output. There is no point in using a 5- or 10-volt square wave, for sensitive resistors or diodes could be damaged.

Testing Resistors

Let's go back to wirewound resistors and discuss why they ring when tested with a square wave. They act as a tuned circuit because the inductance of the resistor is also shunted by distributed capacitance. Hence, the resistor rings at a frequency derived by the resonant-frequency formula:

$$f = \frac{1}{2\pi\sqrt{LC}}$$

The shunt capacitance is a combination of distributed capacitance in the resistor and the capacitance of the test circuit which is connected to the resistor. If you omit the low-capacitance probe when you

test a wirewound resistor, the ringing waveform will have a somewhat lower frequency. Of course, we are not primarily concerned with the ringing frequency when we check a wirewound resistor. What we really want to know is whether the resistor does or does not ring when it is used with waveforms (of any shape) that have a certain rise time.

Now, here is another important fact: If a wirewound resistor has a high resistance value, it will not ring. This is because high resistance causes a high I²R loss or, in other

words, a low Q. We know that very-low-Q coils will not ring; similarly, very-low-Q wirewound resistors will not ring.

If you intend to terminate the output cable from a signal generator, it is essential to use a composition resistor. Resistors used in RF front ends should have composition construction. Even in 4-mc video amplifier circuits, composition resistors are generally used because a wirewound resistor is the equivalent of a resistor plus a peaking coil; unfortunately, the inductance of a

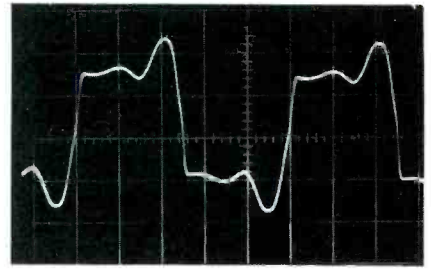

Fig. 8. Scope trace from wirewound pot.

peaking coil is somewhat critical, and the inductance of an arbitrarily selected wirewound resistor is not likely to be correct for the stage. If you are uncertain of the structure of a particular resistor, a square-wave test will identify it.

Wirewound Potentiometers

Another form of resistor is the wirewound potentiometer. It has distributed capacitance, just as a carbon-type potentiometer, but it also has inductance. Therefore, it is not surprising to find that wirewound potentiometers ring when tested with a square-wave generator. Tested as shown in Fig. 3, a potentiometer might produce a square-wave display like that in Fig. 8. As you slow down the rise time of the square-wave generator, you will eventually arrive at a value where the wirewound potentiometer does not overshoot and ring. The pot can be used satisfactorily with any waveforms that have rise times

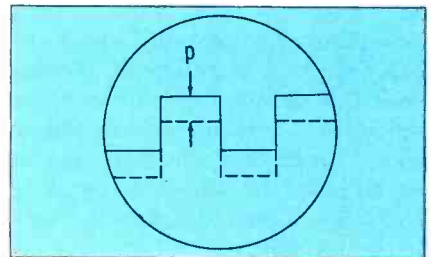

Fig. 9. Vertical shift from nonlinearity.

longer than this value; to find the highest frequency at which the pot can be used, multiply the rise time (at which there is no distortion) by 3, and convert it to frequency ($f = 1/T$).

Nonlinear Resistance

All of the resistor types discussed thus far are classified as linear resistances; *i.e.* current flow is directly proportional to applied voltage: $I = E/R$. However, we must now consider another large class of resistors—these which have nonlinear

NOT JUST ONE—BUT 2 FREE GIFTS FOR YOU

When you buy this special package of SARKES TARZIAN Rectifiers at a special reduced price!



1 Electronic Service Wrench Kit—FREE



With every size you need for radio-TV service work, including hard-to-find 1/2" and 9/16" sizes. These 8 tools are all American-made, of cadmium-plated steel, in a durable plastic holder. A \$1.49 value.

2 Re-usable Hinged Plastic Box—FREE



Clear sturdy plastic—ideal for spare parts, odds and ends—dozens of uses in shop or home. You've bought boxes like this for 49¢—but it's free with Sarkes Tarzian Rectifiers.

These Rectifiers are the Units you Regularly Need

This special, double bonus package contains 14 rectifiers of the types you most frequently need in radio-TV service:

- 3 type F-6; 420 VAC RMS, 1 amp DC, plastic case
- 3 type 60H; 420 VAC RMS, 1 amp DC, top hat
- 4 type F-4; 280 VAC RMS, 1 amp DC, plastic case
- 4 type 40H; 280 VAC RMS, 1 amp DC, top hat

Rectifiers	\$10.41 net
Tool Kit	1.49
Plastic Box	.49
	\$12.39

You Pay Only \$9.95

YOU SAVE \$2.44



SARKES TARZIAN, Inc.

SEMICONDUCTOR DIVISION • BLOOMINGTON, INDIANA
World's leading Manufacturers of TV and FM Tuners • Closed Circuit TV systems • Broadcast Equipment • Air Trimmers • FM Radios • Magnetic Recording Tape • Semiconductor Devices
Canadian Licensee: Marsland Engineering Limited, Waterloo, Ontario

Circle 15 on literature card

Get The GENERATOR That Has EVERYTHING!

3. EXCLUSIVE 5:4 CROSSHATCH

Faster convergence, easier linearity checks

4. SINGLE COLOR BAR

3.58MC color reference signal, gives *positive*, simple color performance check

5. 500-DOT PATTERN

0.1 μ sec dot—smallest anywhere! Complete screen coverage, more accurate convergence

2. GUN KILLERS

Check all three color guns, speed purity checks

1. READY FOR THE FUTURE

Broad-Coverage signal for VHF and UHF. Interchangeable CRT assemblies handle *all* color tubes

6. SEPARATE HORIZONTAL & VERTICAL BARS

Spot vertical and horizontal misconvergence faster, speeds over-all job

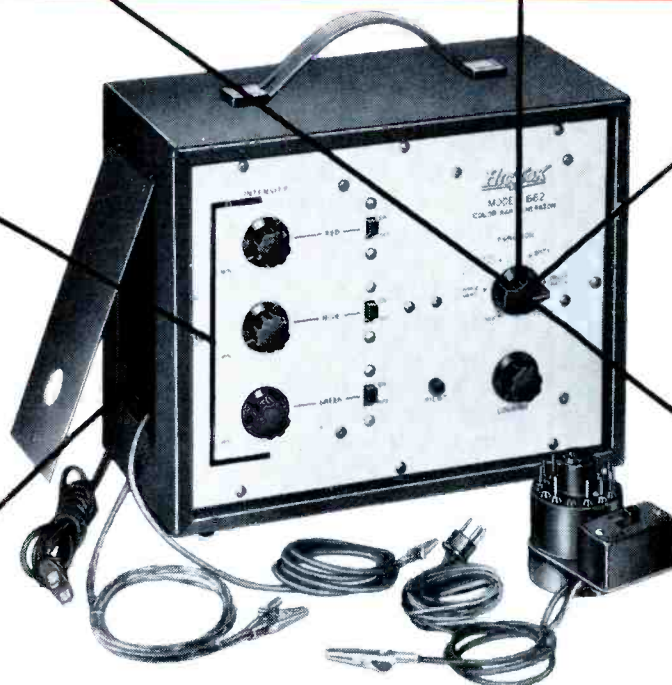

Model 662
\$159.⁹⁵

HICKOK

- 1. Ready For The Future**—Untuned, broad-coverage RF signal injects signal directly into antenna terminals, covers both VHF and UHF. Interchangeable CRT assemblies assure coverage of all present and anticipated color tubes, including new 25" tubes.
- 2. Gun Killers**—Individual pots and switches control each of the CRT guns separately. You can check the picture for emission, gas, shorts, in addition to individually checking the R-Y, B-Y and G-Y signals.
- 3. 5:4 Crosshatch**—Means more vertical lines, more horizontal lines and complete screen coverage including hard-to-converge areas at the edges.

- 4. Single Color Bar**—Simplified color reference bar at 3.58MC color burst frequency for definite color performance checks, impossible with gated rainbow generators.
- 5. 500-Dot Pattern**—Superior to 150-dot system because dot size is smaller (actual size, 1 line or 0.1 μ sec) for accurate convergence and complete screen coverage—no *blank* spots.
- 6. Separate Horizontal and Vertical Bars**—Quickly determines major areas of misconvergence, saves time by showing you where to start first.

HICKOK

THE HICKOK ELECTRICAL INSTRUMENT CO.

10566 Dupont Avenue · Cleveland, Ohio 44108
Represented in Canada by Stark Electronics, Ajax, Ontario
Internationally by Hughes International, Cuiver City, Cal.

Circle 16 on literature card



THE **MAGIC**
OF
COLORMAGIC
TV ANTENNAS
ADVANCED
ENGINEERING
DESIGN

BEST FOR COLOR AND BLACK AND WHITE

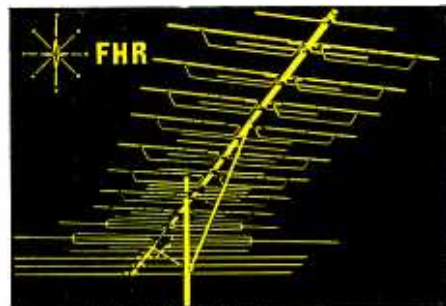

Only Colormagic...

has been top-rated in independent consumer publications for broadband performance, gain, front/back ratio, beam width, impedance match, construction and ease of assembly, etc.

Only Colormagic...

has FHR which is the exclusive development of GC Electronics for process applied to all Colormagic series of antennas, to provide a resonating action within the elements of the fundamental harmonics of both the high and low bands.

Only Colormagic...

has the outstanding Award Winning Carton in which all Colormagic series antennas are carefully packed.



Only Colormagic...

has the endorsement from Philco, one of the leading manufacturers of TV receiving equipment. Colormagic antennas are recommended and approved for all Philco TV Color and black and white installations.



Write now for free four page color brochure which describes the entire Colormagic series of antennas.



Dept.: BMW

GC ELECTRONICS
400 South Wyman Street Rockford, Illinois

Circle 17 on literature card

resistance. Ohm's law does not apply to nonlinear resistance in the same way it does to linear resistance; in nonlinear resistances, R is not a constant, but changes in a definite manner from one voltage value to another. Examples of nonlinear resistors are detector diodes, selenium rectifiers, horizontal-AFC diodes, and other semiconductors; transistors are three-terminal nonlinear resistances.

To test a simple nonlinear resistance, use the test setup shown in Fig. 1B, note the display, and then switch the scope from AC to DC. When you switch in this manner, the waveform is displaced vertically on the screen by distance D , as shown in Fig. 9. The amount of shift is a measure of the nonlinearity in the resistance's E/I characteristic.

Suppose a diode produces no shift in the pattern. This proves the diode has no rectifying action and is defective. You could be misled if the square-wave-generator has a DC voltage in its output; if you should encounter this difficulty, simply connect a large-value capacitor in series with the generator output lead—it will block any DC coming from the generator.

General Conclusions

With the foregoing experimental data in mind, the basis approach to square-wave testing becomes clear. It is a *shortcut* method of comprehensive measurement and analysis.

A wirewound resistor is essentially an LCR component. You can use a signal generator to analyze the resistor, plotting a frequency-response curve one step at a time. The shape and bandwidth of the curve defines the Q of the resistor. If Q is sufficiently high, the resistor will ring; if the impedance is appreciable, the resistor will at least overshoot, in any case. But, this is the hard way to get an analysis. To speed things a bit more you can use a sweep generator and scope, but you still have to make laborious calculations. The shortcut method is to apply a suitable square wave and analyze the result on the scope screen.

The basic difference between a sweep generator and a square-wave generator is that the sweep genera-

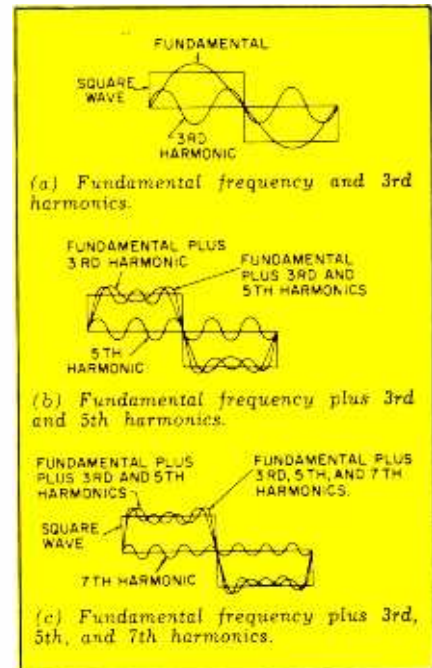

Fig. 10. Formation of the square wave.

tor applies a range of frequencies *sequentially*, while the square-wave generator applies them all *simultaneously*. This fact is seen in Fig. 10, which shows the manner in which a square wave is built. Because the sine waves are applied simultaneously, a complex waveform is obtained; if you know how to analyze the test waveforms, you get quick answers.

The answer to whether a potentiometer has excessive capacitance for a given application could be determined by using a signal generator and VTVM. You could make point-by-point measurements to determine the highest frequency which is passed without substantial attenuation. But how much faster it is to use the shortcut method and simply apply a square wave of suitable rise time to the potentiometer.

To fix these basic principles clearly in mind, repeat the foregoing tests with a square-wave generator and triggered-sweep scope the first chance you get. With a little practical experience, you will appreciate the value and convenience of square-wave testing. The next article will explain and illustrate square-wave tests of coils and transformers, and in the following one you will learn how to check capacitors. With this basic understanding of components tests, square-wave testing of three-terminal circuitry, to localize defective components, will be easy for you to comprehend. ▲

Now you can quickly locate defective capacitors affecting the performance of electronic circuits —and prevent costly call-backs!

CAPACITOR TESTING IN-CIRCUIT/OUT-OF-CIRCUIT IS QUICK AND EASY



NEW B&K CAPACITOR ANALYST

for TV, Radio, Transistor Radio, Auto Radio, Hi-Fi, and other electronic equipment

Unique new B & K development puts the measurement of capacitors and electrolytics on a practical basis—picks up all defects that will affect performance—turns lost time into profit dollars.

Servicemen are aware that capacitors and electrolytics are second only to receiving tubes in creating the most servicing problems.

The new B & K Capacitor Analyst enables you more easily to measure capacitance and leakage resistance—detect both opens and shorts—both in-circuit and out-of-circuit. In-circuit leakage resistance test can be made on low-voltage circuits such as transistor radios, or on higher voltage circuits. Checks capacitor value from 25 pfd to 100 mfd.

Tests electrolytic capacitors by unique circuit (Pat. Pend.) which determines how well the electrolytic does the job of storing electrical energy and returning it back to the circuit. Detects marginal electrolytics that should be replaced. Also predicts life expectancy of any electrolytic capacitor rated 3 volts or more.

Model 801 Capacitor Analyst is attractive, rugged, and easy to use.

NET, \$99⁹⁵

*Ask Your B & K Distributor for Details,
or Write for Bulletin No. 108-R*



B & K MANUFACTURING CO.
DIVISION OF DYNASCAN CORPORATION
1801 W. BELLE PLAINE AVE. • CHICAGO, ILL. 60613
Canada: Atlas Radio Corp., 50 Wingold, Toronto 19, Ont.
Export: Empire Exporters, 123 Grand St., New York 13, U.S.A.

Circle 18 on literature card

where stands



CB
with
FCC

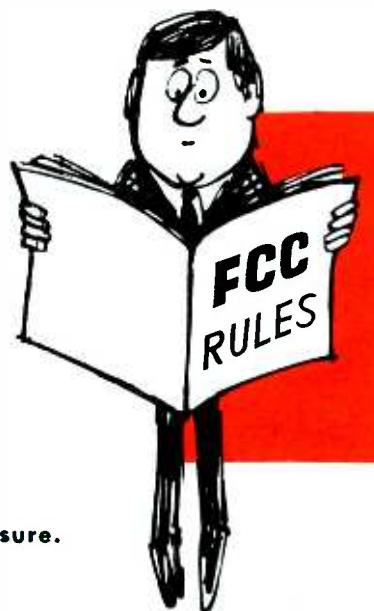

Your CB customer may not be sure.

by Thomas R. Haskett

One of the hottest controversies in recent years has been over the uses and misuses of the Citizens band. Much of the heat has been generated by CB users who feel that the Federal Communications Commission does not treat them fairly. There is, in fact, much confusion about what CB is, how it should be used, and for whose benefit it was established. To find the answers to these and similar questions, we asked the present six commissioners (one chair is vacant) for their comments. We'll examine their replies later.

What CB Has Been

Before World War II, only businesses, services, public agencies, and similar organizations could legally operate a radio station in this country. At the war's end, the Citizens Radio Service was established which allowed any U.S. citizen (18 or older) to legally operate a certain restricted type of radio station for his personal and private affairs. Personal affairs were interpreted by the Commission to include personal businesses. Assigned frequencies were in the band 462-466 mc, with power up to 60 watts.

Because the range at 466 mc was extremely limited by line-of-sight transmission, relatively few citizens

took advantage of the service in the early postwar years. In 1959, the FCC allotted a band of frequencies around 26-27 mc for CB use, with voice stations designated as class D. Power was limited to 5 watts, but due to the comparatively low frequency, workable distance was much greater than at 466 mc. Inasmuch as 27-mc circuits are much easier and cheaper to build than 466-mc circuits, equipment manufacturers could produce relatively inexpensive transceivers. Hundreds of models were put on the market; for the first time in U.S. history, economical, reliable, two-way radio communication with reasonable range was thus available.

The result was staggering; approximately a million licenses have been issued in the Citizens Radio Service (most of them for class D stations), and the FCC has installed a computer and data-processing equipment for the sole purpose of processing CB applications. It seems no one guessed the tremendous popularity the Citizens band would achieve. As uses increased, however, so did misuses—particularly the use of CB for hobby-type communications, which is not permitted under FCC rules. In 1960 the Commission, cognizant of this misuse, issued a ban (Docket 12987)

against hobby use of CB. This rule had little effect, for the misuse of the band continued.

Major Change in CB Rules

On July 22, 1964, the Commission adopted an extensive set of amendments (in Docket 14843) to Part 95 of their rules, the Part which governs the Citizens Radio Service. In general, these amendments tightened existing rules and spelled out in exact language the permitted and prohibited uses of CB, leaving no loopholes. Here is a brief summary of the amendments:

1. Hobby activity—operating a CB station in and of itself—is definitely prohibited.
2. The primary use of CB is for communication between units of the same licensee. Other uses are secondary.
3. Communication between two separate licensees, or CB stations, is restricted to seven channels—9, 10, 11, 12, 13, 14, and 23—and even then only under certain conditions.
4. There is no restriction of on-air time for communications between units of the same licensee.

There is such a restriction, however, for communications between stations—five minutes on followed by a five-minute silent period.

5. Station identification must be used on each frequency and must include both the originating and called station. All users of CB gear must operate under their own calls only. It is prohibited to make use of another's call sign.
6. An individual whose license has been revoked or canceled may not operate any station of the same class until he is again issued a license by the FCC.
7. Prohibited users of CB are: Any illegal activity; messages for hire; obscene, indecent, or profane words, language, or meaning; and general communication not addressed to a specific person; malicious interference; music or sound effects; "ham" talk (How does this rig sound? How many "S" units do I read? etc.); advertisements or solicitations of goods or services; any communication with a station over a distance greater than 150 miles.
8. Volunteer organizations — fire, police, civil defense, and the like — must obtain group licenses, and the members of these groups must cease operating under their individual licenses while engaged in group activity. They must use group licenses and call signs.

Reasons for Rule Changes

Let's examine the comments made by the Commissioners at the time they adopted the above rule changes. These were published in the Federal Register on July 31, 1964.

"These rules are designed to provide a useful radio-communication service to meet the business and personal needs of a large segment of the public. No provision was made

in the rules to permit hobby-type operations . . . We have reviewed this matter in light of operational experience over several years . . . and reaffirm our determination that the public interest would not be served by permitting hobby-type operations in the Citizens Radio Service."

Why doesn't the FCC view hobby activity as proper for CB?

"There are many reasons why the public interest would not be served by opening the Citizens Radio Service to hobby-type use. The principal reason is that, because of the limited number of frequencies available, the most effective and productive uses for public purposes must be made. Hobbying is not consistent with such purposes. There is a need, however, by a sizeable segment of the public to have radiocommunication for business and personal needs within the purview of the rules as adopted herein. Further, the very nature of hobby-type communications generates greater use of the frequencies and is substantially detrimental to more purposeful uses."

But doesn't hobby activity foster youthful interest in radio, thereby developing valuable future radio operators? Yes, says the FCC, but those interested in radio as a hobby should get amateur licenses—that's what the ham bands are for.

The ruling against certain types of communications on CB—doesn't this violate the free-speech provisions of the Communications Act of 1934, which created and governs the FCC? No, says the FCC, for that same Communications Act, in Sections 303 (a) and (b), "authorizes the Commission, as the public convenience, interest, or necessity requires, to classify radio stations and prescribe the nature of service to be rendered by each class of licensed station."

What about communication between different stations?

"Even though the primary use of a Citizens Radio station is for a communication between units of the same station, it is recognized that there is a need for interstation communications for business and personal activities as specified in the various rules. However, it is in the area of interstation communication that most abuses of station operating privileges have occurred. Con-

fining communications between units of different stations to specific frequencies will best serve the primary purpose of the service and will facilitate the enforcement of the limitations on permissible communications for both inter- and intra-station operation."

Why were power-output ratings changed?

Instead of the old 5-watt plate input rating (for class D), we now have, in addition, a 4-watt power output maximum. Nothing has been changed, says the FCC; the DC-power limit is still the same. But it is now easier to measure direct RF power with a wattmeter in the feedline. 5 watts in and 4 watts out is 80% efficiency—well above existing transmitter capabilities.

Is single-sideband operation permitted, and why?

" . . . class D stations may employ single-sideband emission and/or reduced or suppressed carrier . . . Thus we have concluded that single-sideband operation should be permitted because of the possible spectrum economy to be obtained by its use."

Section 95.53 of Part 95 says in effect that, when a CB licensee receives a notice of violation from the FCC resulting from technical misoperation, he must turn off the transmitter and have it checked out by a technician holding either a First or Second Class FCC license in radiotelephone or telegraph. Why?

"Our information indicates that many technical violations are the result of modifications or repairs to transmitters made by station licensees, without the requisite knowledge and skill. Thus, the tests and adjustments required . . . must be made or supervised by the holder of a First or Second Class Commercial Operator License. The notification from the Commission will indicate the time allotted before a report must be filed containing the results of tests and adjustments. The report must be signed by the responsible licensed operator as well as by the station licensee."

What about communication between CB stations and 100-mw hand-held transceivers?

"Licensees are again cautioned that Citizens Radio stations may not communicate with low power com-

brand new
... and very important ...

QUAM COLOR TV REPLACEMENT SPEAKERS PREVENT COLOR PICTURE DISTORTION

OFTEN CAUSED BY STRAY
MAGNETIC FIELDS FROM
ORDINARY LOUDSPEAKERS



When you use an ordinary loudspeaker in a color TV set, you're looking for trouble . . . picture trouble. The external magnetic fields from standard loudspeakers will deflect the primary color beams, causing poor registration and distorted pictures.



QUAM RESEARCH SOLVES THIS PROBLEM

An entirely new construction technique, developed in the Quam laboratories, encases the magnet in steel, eliminating the possibility of stray magnetic fields and the problems they cause! These new Quam speakers have been eagerly adopted by leading color TV set manufacturers. Quam now takes pride in making them available for your replacement use. Five sizes (3" x 5", 4", 4" x 6", 5 1/4", 8") . . . in stock at your distributor.

QUAM

QUAM-NICHOLS COMPANY

234 E. Marquette Rd. • Chicago, Ill. 60637

Circle 19 on literature card

munication devices operated under Part 15 of the Commission's rules . . . if communication with such transmitters is necessary they must be licensed as Citizens Radio stations and conform with all the requirements of Part 95."

If you can't discuss S-units, modulation, and similar technical items on the air, what about service shops that use CB for radio, TV, and antenna work?

"A licensee in the electronics business may continue to use his own Citizens Radio station for communications to other units of his station that are necessary to his installation and servicing of radio equipment."

How can a CB'er protect himself from possible rule violations?

"Section 95.105 requires that each licensee must retain a current copy of Part 95 of the Rules. It is expected that the licensee will read such Rules and comply with the requirements therein."

The Amendments Postponed

Following the above rule changes, and before they could become effective, many CB licensees and a number of interested organizations filed petitions for reconsideration and/or rehearing with the FCC. Requests were made that the Commission either stay the effective date of the rule amendments or set aside the Report and Order and hold hearings on the matter. As a result, on September 23, 1964, the Commission issued an order postponing the effective date of the amendments until 30 days after the disposition of the petitions for reconsideration. The effect is that anyone may now comment on the pro-

posed rule changes; the FCC will consider all comments and will finally rule on the various proposals.

There have been many comments and proposals. To get around the code requirements of the Amateur Radio Service, a codeless ham band has been proposed. Code is required for hams by international treaty to which the U.S. is a party, but this same treaty makes an exception for frequencies above 144 mc. It has been proposed that a few channels be set aside in the Citizens band for strictly hobby-type activities, with the remaining frequencies reserved for business use. There have also been suggestion that all communication between separate stations be forbidden.

The Commissioners' Views

The six incumbent FCC Commissioners, asked their views on CB, replied as follows:

E. William Henry, Chairman: "Petitions, for reconsideration here of the FCC's announced position, and of the action taken in adopting the new regulations, are now pending and will be passed on shortly. Since we must await the outcome of formal consideration of the points raised by the petitioners and a formal decision regarding their disposition before any other position can be announced, it would not be appropriate for me individually to comment on the petitions at this time.

"I can advise you, however, that I subscribe fully to the action of Docket 14843 and to the principles enunciated and implied in the Report and Order. Basically, I do not favor abolition of the Citizens Radio Service. I think it can and does serve an important communi-

950

ALL PARTS
(except tubes)
Plus Shipping Charge

QUALITY TV TUNER SERVICE

24 hrs.

Service
Most Makes

UHF - VHF - COLOR - (COMBOS. - 14.50)
15 YEARS OF TUNER EXPERIENCE

- 1 Year Warranty
- Tuners completely cleaned and checked
- Open Account on approved credit
- Dist. write for price structure



- Pack Tuner Carefully
- Insure Package —
- Include all parts (Broken or not)

QUALITY TUNER SERV.
5142 W. 25th St.
CHICAGO, ILL. 60650

Circle 20 on literature card

MIRACLE WORKER

in professional TV service shops

PINPOINTS ANY TV TROUBLE FAST! UPS YOUR PROFIT!



DELUXE B&K

MODEL 1076 B&W and COLOR TELEVISION ANALYST

*with Crystal-Controlled Keyed Rainbow Color Display
and Highly-Stable Horizontal Oscillator Sync*

FLYING SPOT SCANNER

*transmits B&K patterns or your own
pictures onto TV screen*

It's like having your own TV station! You can inject your own TV signals at any time, at any point—and quickly solve tough dogs, intermittents, any TV trouble, as you watch the generated test pattern on the raster. Checks any and all circuits in any stage throughout the video, audio, r.f., i.f., sync and sweep sections of the TV set. No external scope or waveform interpretation is needed. And if you wish, you can transmit your own slide-pictures.

Makes Color TV Servicing Easy, Too.

Generates white dot, crosshatch and color bar patterns for convergence. Generates crystal-controlled keyed rainbow color display to check color sync circuits, check range of hue control, align color demodulators. Demonstrates correct color values.

Saves time and work for the "pro." Makes servicing easier and faster for the beginner technician.

Most valuable instrument in TV servicing.

Net, \$329.95



*Profit with a B&K Service Shop
See your B&K Distributor
or Write for Catalog AP21-R*

B & K MANUFACTURING CO.

DIVISION OF DYNASCAN CORPORATION

1801 W. BELLE PLAINE AVE. • CHICAGO, ILL. 60613

Canada: Atlas Radio Corp., 50 Wingold, Toronto 19, Ont.
Export: Empire Exporters, 123 Grand St., New York 13, U.S.A.

Circle 21 on literature card

May, 1965/PF REPORTER 47

REPLACEMENT
GUIDE

No. 165

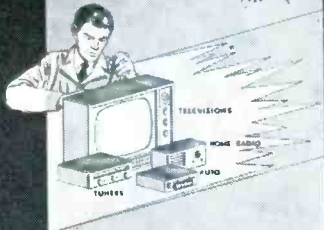

J. W. Miller Company

Los Angeles, Calif. 90003

Area Code 213
Phone 232-4239

NEW COIL CATALOG AND REPLACEMENT DIRECTORY No. 165

New 160-page catalog gives specifications and prices for the world's most complete line of RF and IF coils . . . comprehensive directory cross references exact replacements for all known TV sets, radios, car radios.

For your free copy, see your local distributor or write directly to:



J. W. MILLER COMPANY

5917 South Main Street • Los Angeles, California 90003

Circle 22 on literature card

PROFESSIONAL Plastic Repairs with Plas-T-Pair

Missing Parts

can be poured on as liquid plastic or molded on as a plastic dough.

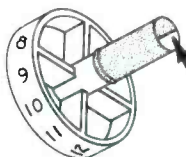
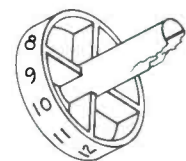

NEW—knob repairs using plastic tubes

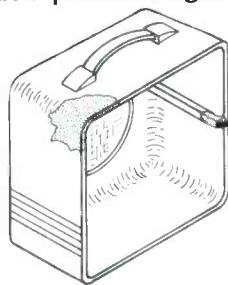

New Screw Post in one minute New Plastic Tube

Professional quality repairs can now be made in minutes. PLAS-T-PAIR repairs can also be made to match any color . . . applies putty-smooth, hardens like rock—yet can be trimmed with grinder, sandpaper or drilled.

See Plas-T-Pair at your dealer.

Can be made any color with Plas-T-Pair Color Kits

No Tool Box or Fish Box should be without it!

Write for free detailed instruction sheets for the above repairs.

Rawn Company, Inc. Box 23, Spooner, Wisconsin



**REPAIRS
Ready for use
in 15 min.**

repair

**APPLIANCES
OPTICAL FRAMES
DENTURES
TYPEWRITERS
TOOLS
AUTOMOTIVE
PLASTIC PARTS
BOATS
PLEXIGLAS
AIRCRAFT
INSTRUMENTS
LEATHER
WOOD
FISHING TACKLE
SOLDER GUNS
V.O.M. CASES
REPAIR CLOCKS
REFRIG. TRAYS**

cations need. Its ability to serve that need has been impaired by a number of licenseholders who use it to serve purposes completely foreign to those which can be fully justified and for which the Citizens Radio Service was initially intended. I don't have too much sympathy with the view that these purposes and the permitted uses are so vague and indefinite as to be incomprehensible. In a nutshell, the Amateur Radio Service is a hobby service. Operation comparable to that universally carried on in the Amateur Service was not intended and, in my view, should not be permitted in the Citizens Radio Service.

"For the official position of the Commission, you must await their action on the petitions, which I believe will be soon."

Robert E. Lee: "Since the Chairman's response also covers my position in the matter, a separate detailing of my views seems to be unnecessary."

Kenneth A. Cox: "In the first place, I think the Citizens Radio Service was needed at the time it was founded. Those acquainted with the history surrounding its establishment realize that the development of conventional land mobile radio services — with consequent spectrum congestion in metropolitan areas, with changes due to advances in the state of the art, and with ever-increasing costs—left persons whose activities, though not of a priority nature, were certainly important enough to justify the use of radio as a tool. It was just too expensive prior to the CB service to use radio and in many cases impossible to qualify for eligibility in one of the established services. With the later development of the Business Service, with its practically unlimited eligibilities for licensing, I am dubious as to whether the original justification for CB radio still exists.

"The radio spectrum is a natural resource belonging to all the people. I want to emphasize that we now have a tremendous congestion problem in the land mobile service spectrum in many areas. The problem is so severe that a special Land Mobile Advisory Committee has been established to look at the situation and, if possible, make recommendations to the Commission. This fact

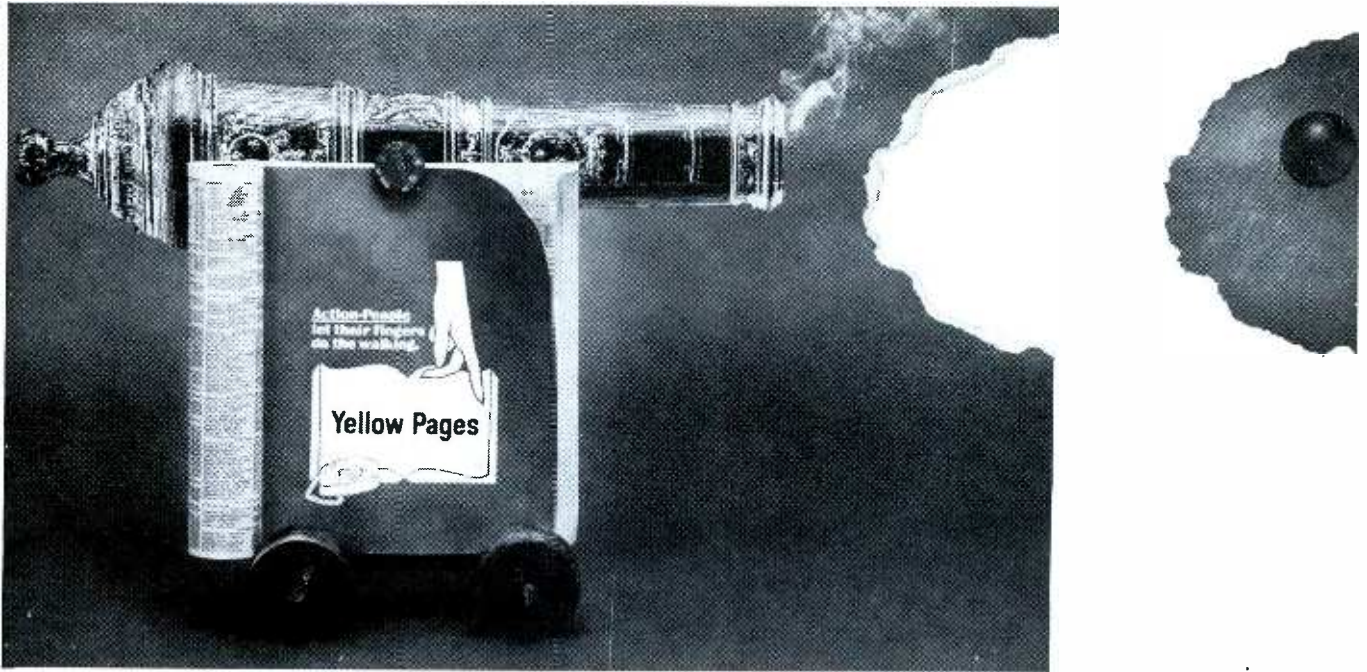

Sales boom

We've got a powerful, proved way to expand your sales.

We can tell you how many people use the Yellow Pages to find most products or services.

We can tell you how many took Action ...a visit, a call, or a letter...after looking in the Yellow Pages.

So, if you want to start a sales boom for your business...take a long look at the Yellow Pages National Usage Study.

Call your Yellow Pages man, today...for the details. You'll find him listed in the Yellow Pages, naturally, under Advertising — Directory & Guide.

Circle 24 on literature card

May, 1965/PF REPORTER 49

Devant "1"

The All NEW
DEVANT-1
From MOSLEY

The result of
continuous research
and development to bring you
Superior Quality at a

NEWEST ADVANCE IN CB COMMUNICATIONS

A field tested base station antenna that will equal or outperform anything available on the CB market today. Many of the features of the DEVANT "1" are built into the base section. The vertical element terminates in a phenolic sleeve which has greater strength than the aluminum element. Radials terminate into a high strength "Cyclac" base, which again, has more strength than the aluminum element. The Coax female connector is part of the (weather-proof) radial support assembly. Antenna mounting is simplified, just mount the antenno on your mast, tighten two screws and lock nuts.

Tapering the ends of the aluminum tubing (called swaging) is designed to reduce wind load, and any possibility of vibrations which would cause metal fatigue. Loading and impedance matching of the DEVANT "1" is accomplished with loops of one eight inch aluminum rods.

Available Nov. 1st.

New Low Price
\$22.76

\$14.50

The Traveling Companion of
the Base Station DEVANT "1"
is the New Mosley DEVANT "2"

This stainless steel mobile antenna has
the world famqus Mosley performance.
A slim line beauty with built-in durability.

Cash in on these outstanding engineering efforts
wherever Mosley antennas are sold.

For detailed specifications and performance data on
the DEVANT "1" and / or DEVANT "2"
clip coupon below and mail.



27 Mcs.
CB Mobile Ant.

Please send me (FREE of charge & obligation) literature on the following
antennas. DEVANT "1" DEVANT "2"

Name

Address

City/State

Mosley Electronics Inc.

4610 N. Lindbergh Blvd.,
Bridgeton, Mo. 63044

alone signifies that it may not be in the public interest to restrict the use of radio by public safety agencies or by businesses important to the public and at the same time permit the use of valuable spectrum space solely for hobby activities.

"I don't think the problems associated with the 27-mc Citizens band can be boiled down to the simple question of whether the Commission should or shouldn't permit hobby use. Instead, the problem involves a much more fundamental question of frequency allocation policy. I think the Commission should permit mobile uses of the spectrum only in those portions technically suited for such purposes. In the present state of the art, this means bands from about 25 mc to 1000 mc. With few exceptions, I think it is fundamentally wrong to use valuable mobile spectrum for point-to-point communications. Between fixed points, you have many alternatives to VHF or UHF radio.

"I do not advocate the discontinuance of the Citizens Radio Service; I think it can be used for purposes that are very much in the overall public interest. In my opinion there should be a minimum of regulation as to the kind of traffic permitted over CB radio. I have no problem with family stations where the wife asks her husband, who is out in the family car, what time he expects to be home; or with organizations of CB'ers whose purpose is to promote the public safety or public convenience through activities in connection with civil defense or public emergencies. I do have trouble justifying the use of this natural resource for any kind of CB point-to-point use between homes or business establishments already equipped with land-line telephone service. I see no justification whatsoever for a CB base or mobile station getting on the air just to see how many of the operator's friends can be contacted by radio or to see just how good skywave propagation conditions are at the moment.

"As to increased power, I feel that one of the advantages of the CB concept is the ability to accommodate a large number of stations within a rather small area by repeating channel usage over and over from town to town. If power is in-

creased, the distance over which interference occurs will increase; the 27-mc band will become even more crowded than it now is. If a user has an important requirement for increased range, I think it might be better for him to go into another service where the power limitations are not so severe.

"... I can't speak for the Commission as a whole, though I am glad to give you my personal comments on these matters."

Lee Loevinger: "Since this seems to be a highly controversial subject and since it is now pending and will be pending before the Commission for determination of policy, it seems wholly inappropriate for me to indicate a viewpoint in a casual

statement having no official function. I think the appropriate procedure for all members of the Commission is to keep an open mind, to study the record and the presentations made to the Commission, to consider all viewpoints, and to engage in discussions within the Commission and with the staff. When a policy determination has been made, it should be set forth fully and explicitly in a statement that is available to the entire public."

Rosel H. Hyde: "As you are aware, the future course of the Citi-

zens Radio Service is presently before the Commission... In view of the pendency of this matter, I do not believe it appropriate to make comments at this time."

Robert T. Bartley: "I voted for the Report and Order (Docket 14843) which sets forth in detail our reasons for its adoption."

These, then, are the present positions of the FCC on the Citizens band. Draw your own conclusions as to their future disposition of the new amendments and how they will affect your customers. ▲

BOOK REVIEW

Basic Theory and Application of Transistors; Department of the Army, Dover Publications, Inc., New York, New York; 263 pages, 6½ x 9¼, paperback, \$1.25. This book is a republication of Department of the Army Technical Manual TM 11-690. Following a brief introductory chapter are 12 chapters that progress from the fundamental theory of transistors to pulse and switching circuits and modulation, mixing, and demodulation applications. Other chapters are devoted to amplifier fundamentals; bias stabilization; transistor analysis and comparison using characteristic curves and charts; audio, tuned, and wideband amplifiers; and special semiconductor devices. Two appendixes (listing letter symbols and a number of references), a glossary, and an index complete the volume.

Numbered headings throughout the text identify the major topics. Each main section within the chapters begins with a general introduction to what follows. A brief summary concludes each chapter. The book is thoroughly illustrated with line drawings, schematic diagrams, charts, and graphs. In the second chapter, a number of "three-dimensional" drawings aid comprehension of crystal structure and the action of PN junctions.

To fully understand some portions of the text, a knowledge of simple algebra is required. The book is written on the assumption that the reader has good familiarity with vacuum-tube principles and circuits.

The word "basic" should not be construed to mean "superficial;" this is a book that must be studied if the reader is to acquire the knowledge contained within its pages. An understanding of the fundamental principles of transistors and their related circuits should result from this study. ▲

ARTIFICIAL RESPIRATION FOR CRT'S

CREATES MORE PROFIT FOR YOU



Easy, professional way to check and correct B&W and Color Picture Tubes

TESTS AND REJUVENATES

- all picture tubes at correct filament voltage from 1 to 12 volts.
- all Hi G-2 and Lo G-2 picture tubes, including tubes that require as low a G-2 voltage as 30 volts.
- 110° tubes and the new 19" and 23" tubes.
- color picture tubes, including the new 90° 23" 23EGP22. Checks and corrects each gun of color tube separately.



ALL-IN-ONE **B&K CRT 445**

THE INDUSTRY'S STANDARD
Most Widely Used Today
by Professional Servicemen

SAVES CUSTOMERS—ADDS SERVICE INCOME—MAKES NEW TUBE SALES EASIER

Does the job in a few minutes right in the home without removing tube from TV set.

Gives new life to weak or inoperative tubes. Checks for leakage, shorts, open circuits and emission. Removes inter-element shorts and leakage. Repairs open circuits and low emission. Restores emission and brightness. Life Test checks gas content and predicts remaining useful life of picture tube.

Quickly pays for itself.

Net, \$74.95

See Your B&K Distributor for Demonstration, or Write for Catalog AP21-R

Subscribe to
New
Picture Tube
Information
Service



B & K MANUFACTURING CO.
DIVISION OF DYNASCAN CORPORATION
1801 W. BELLE PLAIN AVE. • CHICAGO, ILL. 60613
Canada: Atlas Radio Corp., 50 Wingold, Toronto 19, Ont.
Export: Empire Exporters, 123 Grand St., New York 13, U.S.A.

Circle 26 on literature card



Chemicals for sticky bench repairs.

by Norman D. Tanner

There are many types of adhesives on the market for use in electronic servicing. Many of these chemicals are designated for specific uses, while still others are called "all-purpose" cement or glue. The technician is faced with the problem of deciding which is most suitable for the particular repair job he has to perform. This article will describe some of the important characteristics of many adhesives now on the market.

Speaker Repair

First of all, it should be mentioned that repairing a speaker cone is possible, but in many cases it isn't advisable. For instance, if the speaker in an elaborate hi-fi set needs mending, it would be better *not* to perform a "home remedy." A speaker that has been repaired in the service shop is not likely to maintain exactly the same frequency response as when it was new; the customer may therefore be disap-

pointed when he listens to his favorite stereo record. There are companies that specialize in reconing speakers, and patronage of such companies is many times the best practice.

Let's look, however, at another type of speaker—the one used in a relatively inexpensive phonograph or a cheap AM table radio. For this type of instrument, a speaker repair job in the shop, performed correctly, will normally be quite satisfactory and considerably less expensive to the customer.

Most of the cements used for speaker repair come in a 2-oz bottle and have an applicator brush as part of the lid. Some of these require a thinner, while others can be applied directly. Adhesives used on speakers should be resistant to vibration and shouldn't warp or shrink the paper cone. Normally, these solutions are fast-drying and form a flexible bond.

When using any of these speaker-repair cements, be sure both surfaces to be joined are free from dirt or grime. After the surfaces have been cleaned, apply the cement to both sides, then press firmly together and hold for a few seconds.

When the speaker cone is torn badly, a patch is usually required. The best material for patching is a piece of another cone. However, if you don't have a junked speaker from which to cut a patch, a piece of tissue paper folded two or three

Manufacturers	Speakers	Coils	Dial Cords	Plastics	Fabrics	Woods	Drive Belts
Chemtronics	TV-Radio Cement 2B — \$.55			All-Purpose Glue 2B — \$.55		All-Purpose Glue 2B — \$.55	
Colman Electronic Products	Radio-TV Service Cement 2B — \$.55			Plasti-Patch 1.5 oz bottle of powder & liquid \$1.95		Plyobond Cement 2B — \$.55	
G-C Electronics	Radio-TV Service Cement 2B — \$.55	Polystyrene Q-Dope 2B — \$.55	Liquid Non-Slip 2B — \$.55	Plastic Cement 2B — \$.55	Fabric & Grille Cloth Cement 2B — \$.53	Wood Glue 2B — \$.48	Phono Non-Slip 2B — \$.96
Injectorall	Speaker Cement 2B — \$.48		Grip-Well 2B — \$.48	Stik-It Glue 2SB — \$.24		Stik-It 2SB — \$.24	Grip-Well 2B — \$.48
Rawn				Plas-T-Pair Complete kit \$2.85			
Techni-Parts Corp.							Mak-A-Belt Kit
Walsco	Radio Cement 2B — \$.55	Polystyrene Q-Dope 2B — \$.55	Dial Cord Dressing Stick — \$.25	Plastic Cement 2B — \$.55	Fabric Cement 2B — \$.53	Wood Glue 2B — \$.48	Phono Non-Slip 2B — \$.48
Workman	Speaker Cement 2B — \$.57			Plastic Mender 2SB — \$.42	Fabric Mender 2SB — \$.42	Match-Wood 2SB — \$.60	

2B = 2 oz bottle

2SB = 2 oz squeeze bottle

TRIPLET

EXTRA QUALITY IS HIDDEN*

MODEL 630 V-O-M PRICE † \$49.50

Standard Of The Industry



USES UNLIMITED:

- Field Engineers
- Application Engineers
- Electrical, Radio, TV, and Appliance Servicemen
- Electrical Contractors
- Factory Maintenance Men
- Industrial Electronic Maintenance Technicians
- Home Owners, Hobbyists

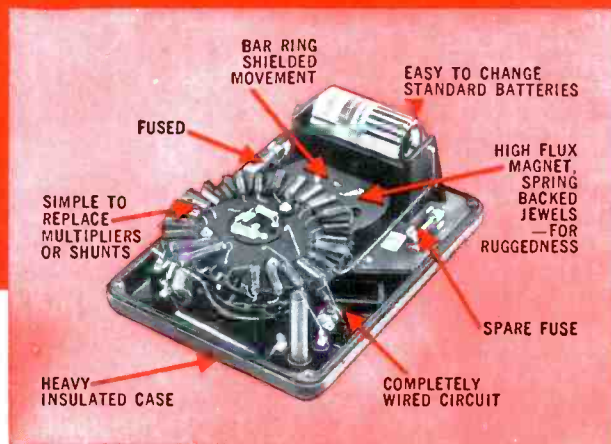

FACTS MAKE FEATURES:

- 1** Popular streamlined tester with long meter scales arranged for easy reading. Fuse protected.
- 2** Single control knob selects any of 32 ranges—less chance of incorrect settings and burnouts.
- 3** Four resistance ranges—from .1 ohm reads direct; 4½ ohm center scale; high 100 megohms.

Attention to detail makes the Triplet Model 630 V-O-M a lifetime investment. It has an outstanding ohm scale; four ranges—low readings .1 ohm, high 100 megs. Fuse affords extra protection to the resistors in the ohmmeter circuit, especially the XI setting, should too high a voltage be applied. Accuracy 3% DC to 1200V. Heavy molded case for high impact, fully insulated.

†630A same as 630 plus 1½% accuracy and mirror scale only \$59.50

TRIPLET ELECTRICAL INSTRUMENT COMPANY, BLUFFTON, OHIO

RANGES

DC VOLTS	0-3-12-60-300-1,200-6,000 at 20,000 ohms per volt.
AC VOLTS	0-3-12-60-300-1,200-6,000 at 5,000 ohms per volt.
OHMS	0-1,000-10,000.
MEG OHMS	0-1-100.
DC MICRO-AMPERES	0-60 at 250 millivolts.
DC MILLI-AMPERES	0-1.2-12-120 at 250 millivolts.
DC AMPERES	0-12.

DB: -20 to +77 (600 ohm line at 1 MW).

OUTPUT VOLTS: 0-3-12-60-300-1,200; jack with condenser in series with AC ranges.

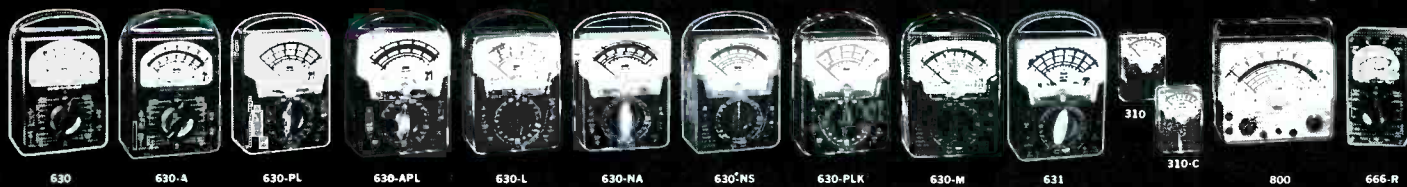

THE WORLD'S MOST COMPLETE LINE OF V-O-M'S. AVAILABLE FROM YOUR TRIPLET DISTRIBUTOR'S STOCK.

Circle 27 on literature card

New BERNS Perfect Pin Crimper

Picture-Tube Repair Tool

Also for—5U4, 65N7, 6BQ6, etc

Eliminates that hard soldering job
only \$1.25 each

Also for color pic tubes



Fix loose pin connections in seconds. Pays for itself in time saved on first job. 3" long

U.S. Pat. 2,878,698 Can. Pat. 592,702

Intermittent operation of color, black and white picture tubes and other tubes due to defective solder connections easily corrected. Provides solid electrical connections, can also be used as channel-selector wrench and screwdriver. Pin keeps its original form. A 3-in-1 tool.

3 MODELS ELIMINATE SOLDERING

Makes Solid Electrical Connections Phono Pin-Plug Crimper

Slip wire in "pin plug," insert in tool, and squeeze job is done

Crings 1c ea.

Use end of tool to push on Cring for ground connection.



Ant. plugs, hi-fi, multiple plugs, public address, radio and TV tubes, radar, speakers, and loop connections. Many, many more uses.

Model LC-3 for 5/32" pin diameter

The most wanted tool sold to and used by thousands of professional TV Service Technicians and School Trainees from coast to coast and foreign countries, also sold to U.S. Government. Nothing like it anywhere.

At your parts distributor. If not available have them order from us.

BERNS Mfg. Co. P.O. Box 7968
14500 Kercheval
Detroit, Mich. 48215

Circle 28 on literature card

NEW PRICES from QUIETROLE

the oldest, most widely proved and sold radio and TV lubricant



2 oz. bottle with dropper	LIST \$1.49
4 oz. bottle	LIST 2.54
4 oz. bottle (brush-n-cap)	LIST 2.64
8 oz. bottle	LIST 5.07
6 oz. spray can — with extender	LIST 2.79
3 oz. spray can — with extender	LIST 1.79

Quietrole is your guarantee of the most effective, quick silencer of noisy radio and TV controls — the quality product that is a top value. Get Quietrole at quality jobbers. Some territories available for Experienced Representation.

manufactured by **QUIETROLE Company**
Spartanburg, South Carolina

Circle 29 on literature card



times and glued together should prove satisfactory.

In cases where the two edges of the torn area are close together, a rubber-base cement will often bond the torn edges and a patch won't be necessary.

Plastic Repair

The last few years has seen an enormous expansion in the use of plastics for electronics gear. Practically all knobs are made from plastic. Many radio and TV cabinets are also made of plastic, especially in portables. The wider use of plastics naturally means the radio-TV service shop will have more need for an adhesive that is suitable for repairing meter cases, knobs, cabinets, etc.

Actually, the repair of plastics is divided into two categories. These areas are related but require different procedures and solutions for repairing.

Missing Sections

If a plastic part has been broken and a portion of the original is completely missing, the missing area can sometimes be completely rebuilt using a plastic-powder-and-liquid mender of the fiberglass family. A good example would be a broken channel-selector knob. If these materials are used correctly, the patched knob will be as strong as when it was new.

When making a repair, mix the desired amount of the powder and liquid together and allow it to set for a few minutes until it forms a dough. Moisten the area being repaired with a little of the liquid before molding the dough into the desired shape. (For a neat, clean-looking repair job, be sure your hands are clean.)

In the case of a knob, pushing it onto its shaft before the plastic sets will produce an exact fit; to prevent the knob from sticking to the shaft,

Make \$4.00 Extra Profit For Each Color TV Service Call!



USE, DEMONSTRATE AND SELL

COLOR TV DEGAUSSER

NO. 2592

LIST PRICE 9.95
NET PRICE 5.95
Your Profit \$4.00

BUTTON SWITCH

SAFE MOLDED CASING 7" DIA.

★ HIGH QUALITY

★ LOW COST

Hanging Clip included for back of TV set



WALSCO ELECTRONICS

DIV. OF GC-TEXTRON ELECTRONICS, INC.

Main Plant: Rockford, Ill., U.S.A. • Hicksville, L.I., N.Y. • Los Angeles, Calif.

Only \$5.95

NET

Circle 53 on literature card

RCA Solid Copper Circuits



**replace old-fashioned
"hand wiring"...give TV
space age
dependability.**

RCA Solid Copper Circuits are made by methods as modern as tomorrow. They give greater dependability . . . better TV performance. It's typical of the advanced design you'll find throughout every RCA Victor home instrument. It all adds up to sets that are easier to service so that owners are more satisfied with results.

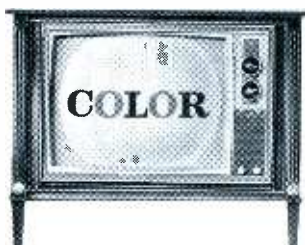

The Most Trusted Name
in Electronics Tmk(s)®



More TV servicemen own RCA Victor Color TV than all other leading makes combined



USE YOUR AC POWER TOOLS



or anywhere with
TÉRADO

PACKAGED ELECTRIC POWER
Provides 117 Volts, 60 Cycle AC
... just like any wall outlet!

COMPLETE,
SELF-CONTAINED
POWER SUPPLY
inverter, battery and
automatic charger;
not dependent on
car battery.



\$69.50

OPERATES:

Electric Drills,
Soldering Irons,
Other Hand Tools, Model 50-160 "Trav-Electric"
Test Equipment,
Lights, Tape Recorders, Record Players,
Portable TV, and much more! Unexcelled
source of emergency power!
60 cycle frequency stable
within 1/2 cycle, regardless of
load. Recharges from car cig-
arette lighter or A.C. recepta-
cle. Wt. 30 lbs., including bat-
tery. Copper clad steel case,
12" x 5 1/2" x 8".

Other models to 600 watts capacity.
FOR FURTHER INFORMATION, WRITE:



terado
CORPORATION
1073 Raymond Ave., St. Paul, Minn. 55108

Circle 43 on literature card



TYPE CTC . . . cardboard
tube electrolytics especially de-
signed for exact placement in
television sets . . . one end closed
. . . long insulated leads out the
other end . . . sealed with high
melting point wax . . . guaran-
teed for one year . . . individually
packaged.

PLANET SALES CORP.

225 Belleville Ave.
Bloomfield, New Jersey

Circle 42 on literature card

coat the shaft with vaseline. To prevent the solution from sticking to any surrounding areas, they should also be coated with vaseline.

An alternative method can also be employed for a repair such as the one just mentioned. For example, when rebuilding a missing corner of a radio cabinet, form a piece of tinfoil around a corner that is undamaged. Then transfer the tinfoil to the broken corner and secure it in place with a piece of tape. Pour the form full of the mixed plastic dough, just as before. When the repaired area has hardened, remove the tinfoil and the tape. The repair area may be sanded, polished, or painted as desired.

Joining Two Areas

When repair of a cracked cabinet is required, a much less detailed procedure is acceptable. For example, some plastics can be softened by applying a solvent liquid to them. If this is the case, simply use the liquid as you would a glue; apply a small amount to each of the broken surfaces and press the surfaces firmly together for a few minutes. The repair should be made from the inside so it will be invisible from the outside. Also, the solution will soften any area it comes in contact with; therefore, any that is accidentally dropped on an adjoining area should be quickly wiped off—another good reason for making the repair from the inside.

For mending of miniature cracks in cabinets or other plastic items, an epoxy glue or cement can be easily applied and should prove acceptable if the joined parts are not exposed to excessive stress or strain. Here again, coating with vaseline is recommended to avoid deterioration of surrounding areas.

There are glues, cements, or so-



Precise Scope Spectacular!

(now going on at leading electronic distributors)



Four top quality scopes (kits or wired) including a low cost color scope, Model 3151, K. \$89.95, W. \$137.95 • a top value in a 5" general radio and TV scope, Model 315, K. \$79.95, W. \$113.95 • two professional performance scopes the 7" Model 300C, K. \$169.95, W. \$222.95, and the 8 1/2" Model 308, K. \$179.95, W. \$249.50. Prices slightly higher in West. Save now at your Precise distributor. For free 1965 catalog write:



PRECISE ELECTRONICS & DEVELOPMENT DIV. OF DESIGNATRONICS, INC
76 EAST SECOND STREET, MINEOLA, NEW YORK 11501

Circle 30 on literature card

Where to use audio attenuators

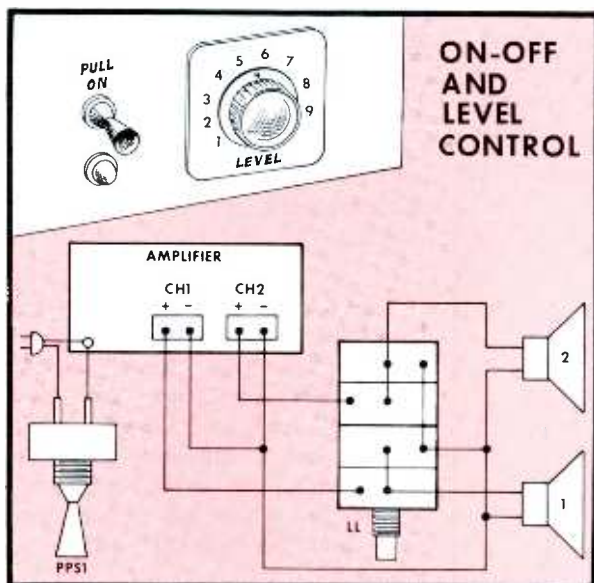

Are volume control "twidgers" upsetting the careful balance of your hi-fi rig? After you spend an hour or better setting "levels", "contour", "bass", and "treble" does your dear wife come along and goof the whole deal up because everything is too *LOUD*?

Why not maintain your balance, your temper, and your domestic tranquility by installing a simple on-off switch and an audio attenuator. In this way the dear girl can simply turn the music on at one place and control the sound with one knob. The drawing to the left shows a Mallory PPS1 push-pull switch and an LL pad controlling the whole works. It works great and looks fine. If you want to add a "Hands Off" sign on your amplifier, that's up to you.

Balance Control. We have a brand new control you'll be interested in (BAL8 and BAL16). It's a true stereo balance control. Consists of two L pads connected back to back so that when one level goes up the other goes down. Dead center loss is a tiny 5 db which you'll never miss. Saves a lot of time and gives marvelous flexibility to your stereo sound system.

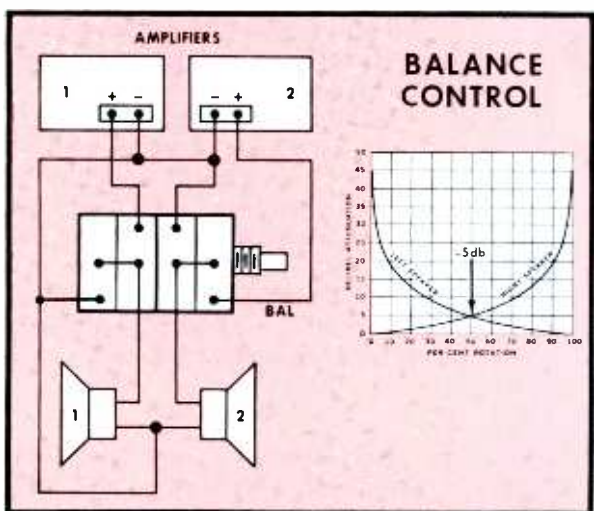

Remote Speaker Control. Why not install a set of stereo speakers in your family room or other remote location? Use an LL dual pad to control the level here, too. You can install the LL in one speaker enclosure and eliminate all those extra steps back to the main controls. Or you might want to check out the RR50 control (a dual rheostat) which is the perfect low-cost way to control inexpensive speakers in the basement or on the porch.

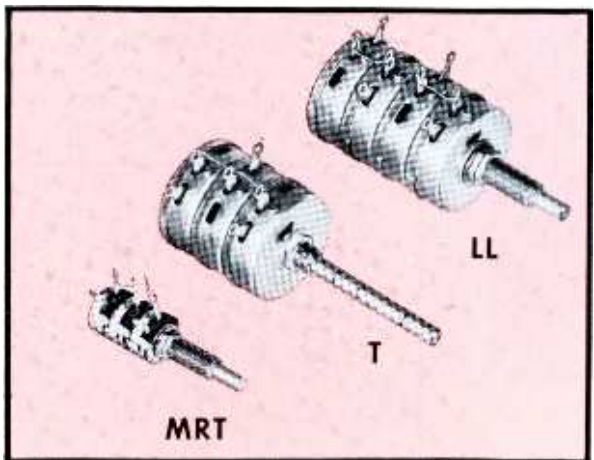

Your Mallory Distributor can help you select an audio attenuator exactly right for the job. Choose from the new miniature MRL, MRT and MRL pads . . . rugged Mallory RL, RT and RR . . . the 15-watt T, L, LL, and BAL pads, or the powerful 50-watt MGL and MGT series. You name it, he has it.

In case you'd like a complete list of Mallory audio controls and other precision electronic components, drop us a line. We'll send you the new 1965 Mallory Catalog. Write to MALLORY DISTRIBUTOR PRODUCTS COMPANY, a division of P. R. Mallory & Co. Inc., P.O. Box 1558, Indianapolis, Indiana 46206.

lutions that you mix yourself, which will repair virtually any plastic material used today. A few kept handy in your caddy or on the service bench can lead to many profitable repairs and satisfied customers.

Drive Belts

If you have been plagued with drive-belt slippage in phonographs or tape recorders, a bottle of non-slip compound can solve your problems. Use the applicator that is included and apply the solution to the

wheel or drive surfaces. Some adhesives for this purpose must be applied to the cables or belts. Directions on the bottle should be followed for specific applications.

In addition to preventing slippage in drive belts, many of these materials are recommended for coating dial cords and their drive shafts for smoother, more even movement and better gripping.

We should also mention the availability of a complete kit consisting of several feet of rubber material, a special merging fluid, and a razor blade. This kit enables you to make



a complete belt, or the merging fluid may be used for shortening a stretched belt.

Other Uses

The service technician will find literally hundreds of uses for numerous types of these "sticky" materials. A broken coil form may need to be repaired or resealed. In this case, choose a cement or glue that will not alter the inductive characteristics but which will at the same time hold the windings firmly in place.

Wood glues are useful for minor cabinet touchup or for affixing loose labels such as model numbers, tube-layout diagrams, etc.

Many times a couple of minutes spent refastening a loose cloth to the grille, or a piece of felt to a turntable, will result in customer satisfaction and avoid a free return call. Also, this person will voice his satisfaction to another, who in turn will remember your shop when his equipment goes bad.

Conclusion

Next time you visit your local distributor, take a few extra minutes and look at his supply of adhesives. You will notice most of them are priced below \$1.00, and there is an adhesive available for patching, mending, or repairing virtually any type of material. ▲

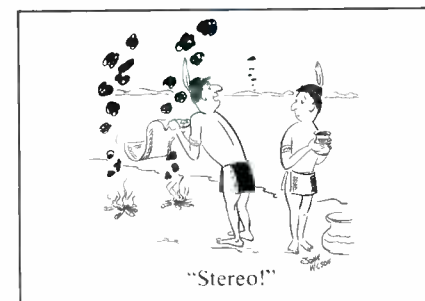

The difference in screwdrivers is spelled

CHANNEL LOCK®

You'll do the job easier and faster, year after year with CHANNELLOCK drivers. Blades are forged from tough, chrome vanadium steel... won't twist or snap. Tips are ground lengthwise to assure greater "end" strength and snug fit in screw slot. Opaque blue plastic (UL) handles are shockproof, breakproof and locked to the blade. Specify CHANNELLOCK drivers... you'll be glad you did

Tips are ground lengthwise for greater end strength

SHOCKPROOF... BREAKPROOF

FREE Catalog showing complete line of hand tools yours for the asking.

CHANNEL LOCK, INC. Meadville, Pennsylvania
Formerly Chicago Drill and Tool Co.

Circle 32 on literature card



The quality goes in before the name goes on

FOR THE FINEST COLOR AND UHF RECEPTION INSTALL ZENITH QUALITY ANTENNAS

... to assure finer performance in difficult reception areas!
More color TV sets and new UHF stations mean new antenna installation jobs for you. Proper installation with antennas of Zenith quality is *most* important because of the sensitivity of color and UHF signals.

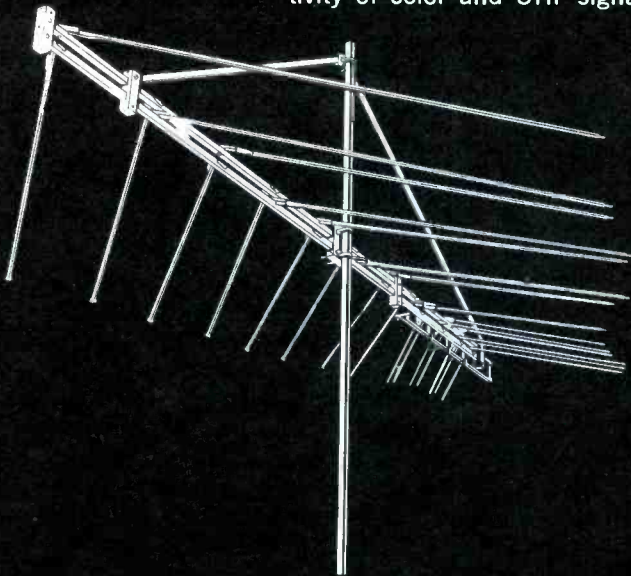

ZENITH ALL-CHANNEL VHF/UHF/FM AND FM-STEREO LOG-PERIODIC ANTENNAS

The unusually broad bandwidth of the new Zenith VHF/UHF/FM and FM-Stereolog-periodic resonant V-dipole arrays pulls in all frequencies from 50 to 900 mc—television channels 2 to 83 plus FM radio. The multi-mode operation provides high gain and good rejection of ghosts.

These frequency independent antennas, developed by the research laboratories at the University of Illinois, are designed according to a geometrically derived logarithmic-periodic formula used in satellite telemetry

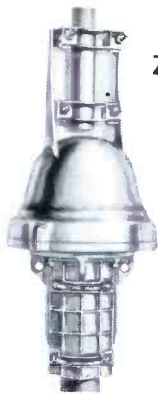

ZENITH QUALITY HEAVY-DUTY ANTENNA ROTORS

Zenith quality antenna rotors are heavy-duty throughout—with rugged motor and die-cast aluminum housing. Turns a 150-lb. antenna 360 degrees in 45 seconds. The weather-proof bell casting protects the unit from the elements. Each rotor mounts easily to either a mast or tower without an adapter.



ZENITH QUALITY WIRE AND CABLE

Zenith features a full line of quality packaged wire and cable. Also especially designed UHF transmission wires, sold only by Zenith. Zenith wire and cable is engineered for greater reception and longer life, and is available in various lengths to suit every serviceman's needs.

Check the Yellow Pages for the Zenith Distributor nearest you.
Or write to Zenith Sales Corporation, Parts and Accessories Division,
5801 West Dickens Avenue, Chicago, Illinois 60639,
for Distributor name plus complete catalogue and technical
information on Zenith Quality antenna installations.

Specifications subject to change without notice.

Circle 33 on literature card

*before you buy any
color generator...
get all the facts*



only one has all
these features and
it's only 99⁵⁰*

LECTROTECH V6

Any comparison will prove that the Lectrotech V6 truly stands alone. Provides all of the time-tested standard features plus many Lectrotech exclusives for the fastest, most reliable color installation and servicing. The V6 gives you: Crystal-controlled keyed rainbow color display • All cross hatch, dots, vertical lines only, horizontal lines only • Red-blue-green gun killer (usually extra or not available on other color bar generators) • Exclusive Dial-A-Line feature (Horizontal adjustable 1 to 4 lines wide) • Exclusive solid state reliability • Exclusive voltage-regulated transistor and timer circuits • Exclusive simplified rapid calibration • Off-On Standby Switch • Adjustable dot size • Color level control • Connects to antenna terminals (no connections needed inside of set) • Power transformer-line isolated, to prevent shock hazard • Lightweight and portable, only 4½" H. x 7⅝" W. x 10⅜" D. Weight, 7½ lbs.

*Except our own V7

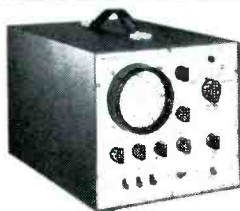

V7 Sensational new Lectrotech V7 — the only complete Color TV Test Instrument.

Has all the features and performance of the V6 PLUS Lectrotech's exclusive built-in Color Vectorscope for simplified visual color servicing.

Complete.....only **189⁵⁰**



See your distributor or write for details before you buy any color generator.

LECTROTECH, INC.
1737 Devon Avenue • Chicago, Illinois 60626

Circle 34 on literature card



SECTION Quick CB Tests



Much can be learned about the performance of an all-transistor transceiver by observing the current drawn from the battery. A typical set-up is shown in the photo. A current meter is inserted between the hot-shot battery and the transceiver. (A hot-shot is handy for checking low-drain CB units almost anywhere.) A combination RF-output meter and modulation-percentage indicator is connected to the antenna connector, providing the proper 50-ohm termination for the transmitter output. This method of testing transmitters is recommended because of on-the-air test restrictions.

Current drain of a set like that shown falls between 50-350 ma. When no signal is being received, current drain is of course very low (approximately 50 ma). When a signal is received and the class-B audio amplifiers go into operation, input current rises, reaching a peak of 350 ma with strong voice components. These current changes, observed on the current meter connected to the battery, give a rather good picture of the receiver operation.

In a similar manner transmitter-current drain of 650-850 ma is normal. When the transmitter is keyed on, there will be a substantial increase in current drawn from the supply source; with strong modulation, the peak current will swing up to 850 ma. These current fluctuations can be observed as you speak into the microphone.

In addition, with a proper termination, the output meter will read RF power as well as modulation percentage. You can compare the modulation-percentage variations with the fluctuations in current drawn from the supply. This gives a rather positive indication of how the transmitter is performing. Of course, an improper reading will indicate that some adjusting or troubleshooting of the transceiver is in order. ▲



Next time you need one, get it fast.

Mail this coupon.



YES, Philco, I want faster, complete parts service! Tell the nearest Philco Parts Distributor to send me information about special Philco parts offers, prices and facts. And tell him to hurry!

I particularly would like information about _____

Name _____

Address _____

City _____ Zone _____

State _____

Mail to: Philco Parts & Service Department
 P. O. Box No. 3635
 Philadelphia, Pennsylvania 19125

Cathode ray tubes, receiving tubes and genuine Philco parts — your Philco Parts Distributor has them. In one quick stop you can also get universal replacements for nearly every TV and radio ever made, a tremendous range of national brand components and many profit-making accessories and extras.

The rare time a Philco part isn't in stock, Philco's Lifeline Emergency Service jumps into action. Your order is instantly transmitted to Philco's national parts depot in Bedford, Indiana — and the part you need is on its way to you, *by air*, in 24 hours or less.

Extra services from your Philco Parts Distributor include valuable knowhow and data on just about every TV, radio or phono ever made. When you're stuck on something, he's the man who can help you.

If you're not getting this kind of fast, one-stop parts service, you should. Mail the coupon and start doing business with your Philco Distributor.

PARTS & SERVICE DEPARTMENT
PHILCO[®]
 A SUBSIDIARY OF *Ford Motor Company*

Circle 35 on literature card

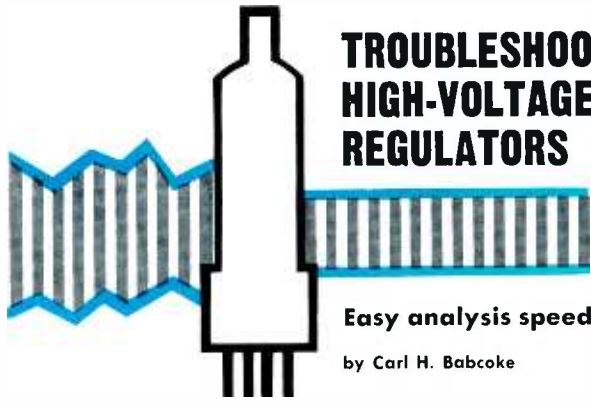

TROUBLESHOOTING HIGH-VOLTAGE REGULATORS

Easy analysis speeds your servicing.

by Carl H. Babcock

How many high-voltage (HV) regulators have you adjusted in the past year? If your answer is "none," you have lots of company! Veteran color TV technicians agree this circuit is often neglected.

Did you know a defective HV regulator can cause vertical roll? Focus and width problems? If these symptoms seem fantastic, please read on. In many cases, the effect of improper operation is more noticeable than the effects of total lack of regulation.

Before we can intelligently repair

or adjust this circuit, we should have an idea of the purpose and general operation of the HV regulator in a typical color receiver. The purpose is simple: to prevent changes in height, width, focus, and convergence when the raster brightness is changed.

How It Works

Just how a simple triode regulator does that requires a little explanation. If horizontal sweep width is kept constant, a reduction in high voltage will make the raster larger

because the beam is easier to deflect. If this is carried to an extreme, the picture gets taller, wider, and dimmer. This is called *blooming* and might be caused by a weak HV rectifier (low current).

Consider what happens if the blooming is caused by *excessive* HV current. The picture will get taller because of lowered HV and narrower because of reduced horizontal sweep. Why is sweep reduced? A three-gun picture tube may draw up to 35 watts of DC power, which must be supplied by the horizontal output stage; the effect of any great change in horizontal loading, such as by drawing too much HV current from the flyback HV rectifier circuit, is to reduce width.

Circuit Development

Fig. 1 shows a block diagram of the two basic types of regulators—series and shunt. Both regulate the voltage across the load, but only the shunt keeps a constant load on the source; it actually regulates the voltage by maintaining constant current through the rectifier. The regulator is supposed to draw any HV current that is not being used by the picture tube, so the *total* of current in the CRT and the regulator is always the same. Regulation of the high voltage alleviates any changes in height or focus, and keeping the HV current constant prevents changes in width, linearity, or convergence.

If picture-tube current increases, the regulator draws less, and the total of the two remains constant in the HV rectifier. If the brightness control is advanced too far, the picture tube draws more current than the designed total; the regulator draws none, and blooming starts. Blooming can occur very rapidly when brightness is too high, even if it is only instantaneous, such as in a portion of a scene; this is quite normal, and the regulator should handle it.

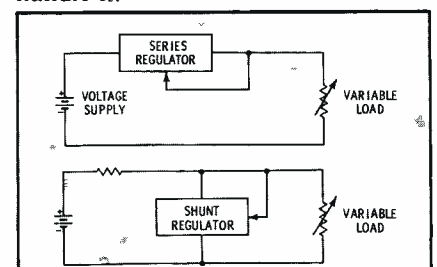

Fig. 1. Basic forms of HV regulators.

Regulator Case Histories

Symptom: Noise streaks in picture; worst at low brightness.

Test: Removed regulator tube; noise stopped.

Repair: Replaced regulator cap and lead; bad weld inside cap.

Symptom: Intermittent arc inside picture tube.

Test: HV 32 kv. regulation poor, line voltage 127 volts AC.

Repair: Changed primary of power transformer to 128-volt tap; HV still some too high. HV control apparently misadjusted by previous technician. Reset control; no arcs.

Symptom: Picture 2" narrow on each side, poor focus, bloomed easily.

Test: New tube did not help. HV control could not be adjusted.

Repair: Replaced .0033 capacitor from grid to cathode, reset control.

Symptom: Slight change in width with brightness variations.

Test: Had jumpered regulator grid to chassis as quick test—checked CRT screen for change. Tip of screwdriver almost melted by resulting short circuit. Grid-to-cathode capacitor shorted in-

ternally with this surge in voltage (grid end grounded, cathode end at 400 volts) but checked okay on meter.

Repair: Replaced capacitor as insurance, and reset regulator with a meter this time. No more shortcuts!

Symptom: Horizontal output and regulator tubes lasted only about three weeks. Frequent HV arcs inside picture tube.

Test: High voltage measured 30 kv, but was regulated normally. Line voltage normal, boost voltage too high. Removed chassis and found extra resistor in parallel with original horizontal output screen resistor; also a resistor from grid to ground on the regulator tube. It seems the customer had wanted more brightness and a previous technician had modified the circuit to obtain more high voltage, but forgot about tube dissipation.

Repair: Removed extra resistors and adjusted regulator current with meter; HV then normal with no arcs. Set screen controls for slightly higher brightness level.

A **HOWARD W. SAMS** SPECIAL PUBLICATION

Color TV Guidebook

NEW
THE ONLY
PUBLICATION
OF ITS KIND!

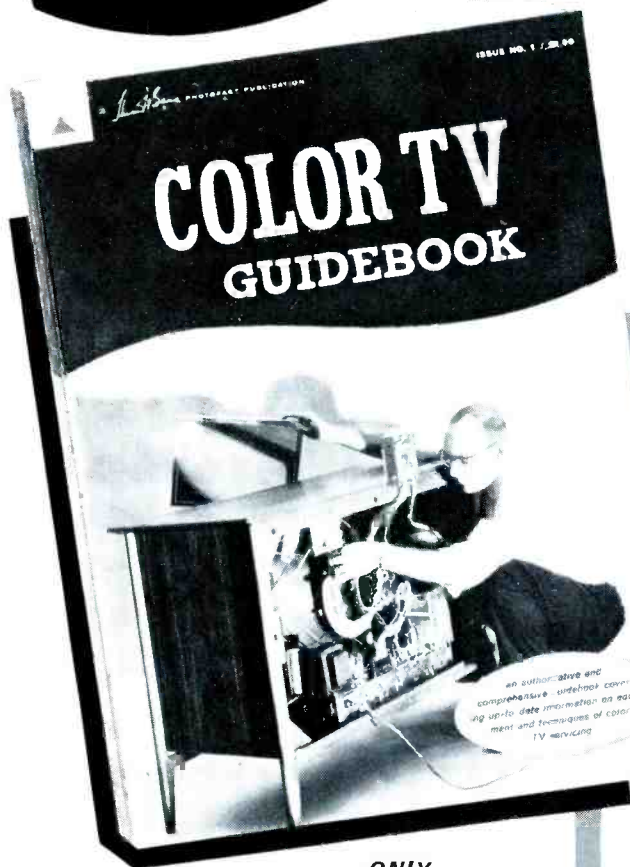

MOST COMPLETE AND AUTHORITATIVE GUIDE TO COLOR TV, SERVICING TECHNIQUES, EQUIPMENT REQUIRED, AND RELATED SUBJECTS

Nothing else like it! A completely **NEW** and **DIFFERENT** publication, bringing you all the general information you want on color TV, *plus* the specific facts you need for profitable color TV servicing. A 100% practical guide, written in down-to-earth style and profusely illustrated. A "MUST" BOOK FOR EVERYONE INTERESTED IN COLOR TV!

FACT-PACKED CONTENTS:

- **The Manufacturers View Color TV**—The facts about the "ins" and "outs" of chroma set-making.
- **The Networks View Color TV**—What the plans are and what the future holds for color TV programming.
- **A Look Inside a Color TV Station**—An informative description of how the color TV signal originates in the broadcasting station.
- **A Color Broadcasting Center**—An interesting tour of the new CBS color broadcasting complex in New York.
- **Starting a Color TV Service Business**—What it takes and what you should know to realize the big profit potential in this field.
- **Using Your Head in Color Servicing**—Tells the technician how to think through the problems of color servicing—important for newcomers to the field.
- **Selling Color TV**—An informative discussion of how to turn those three basic colors into the "long green."
- **Are You Equipped for Color?**—A complete run-down on the instruments and tools required for successful color TV servicing.
- **Color Tube Stock Chart**—Invaluable information on the types and quantities of tubes required for practical stocking.
- **Color-Picture Symptoms**—A four-color picture story showing you how to make use of troubleshooting clues revealed by the screen of a malfunctioning color set.
- **The Facts About Color TV Antennas**—Full analysis of antennas and how to choose the right one for the job.
- **Color Waveform Analysis**—A picture story of waveforms encountered in color sets, providing basic information for making a true analysis of waveforms.
- **Quicker Checks with Color-Bar Patterns**—4-color picture story showing fast ways to test color sets by observing the effects of color-bar patterns on the TV set screen.
- **How to Replace Rectangular Color CRT's**—A picture story on how to replace the new 23" and 25" rectangular color CRT's.

THE BIGGEST DOLLAR'S WORTH OF USEFUL, PRACTICAL COLOR TV DATA AVAILABLE TODAY!

ONLY
AN INSTANT
BEST SELLER! **\$1.00**

Plus

Invaluable new information on many significant aspects of color TV . . . information everyone interested in the subject will want to have for permanent reference.

- **Basic Chroma Circuits for 1965**—Major circuit innovations in the latest sets, typified by Zenith and Motorola.
- **How to Get Better Color Reception**—Brand-new ideas, including the use of coaxial downlead for better color pictures.
- **Transistorized Color TV**—A detailed analysis giving you an understanding of the circuits peculiar to these types of sets—exclusive new information.
- **Small-Town Color TV**—Provides an understanding of color TV servicing problems in fringe areas.
- **New Developments—Color CCTV**—How industry is finding natural color a distinct help in its operations.
- **Building a Color TV Kit**—Provides a better knowledge of color TV circuitry, theory and construction through the building of a kit-form color set.

THE INDISPENSABLE REFERENCE FOR EVERYONE INTERESTED IN COLOR TV

AVAILABLE NOW FROM YOUR SAMS DISTRIBUTOR

LIMITED QUANTITY—ORDER TODAY!

ONLY
\$1.00

HOWARD W. SAMS & CO., INC.

4300 W. 62nd St., Indianapolis, Indiana 46206

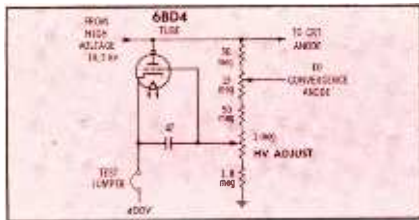

Fig. 2. Early model of shunt regulator.

Fig. 2 shows the HV regulator in the old RCA CT100. A sample of the high voltage is brought to the regulator grid through a variable voltage divider. When the HV rises for any reason, grid bias is reduced,

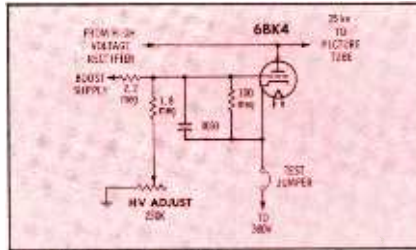

Fig. 3. Improved version in later set.

and the 6BK4 draws more current to reduce the HV and vice-versa. It is obvious that the regulator tube must have high Eg-Ep amplification, since a 500-volt change in the HV

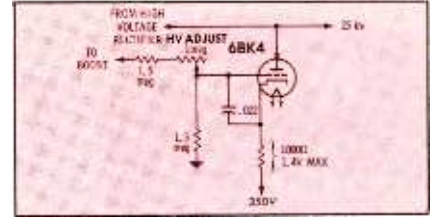

Fig. 4. One modern set uses this one.

produces only a 10-volt change at the grid.

The next evolutionary step (Fig. 3) came in the 1956 RCA CTC4 chassis, after someone found that the boost also varied with changes in HV load current. The regulator tube could thus be controlled by shifts in boost voltage instead of directly by HV changes. This circuit revision helped reduce the failures that had proved inevitable with high-value resistors in HV circuits, and also simplified insulation and arcing problems. In this regulator, a change in boost of about 25 volts produces a 10-volt bias change at the 6BK4 grid.

(This change in boost with a change in HV explains why some sets, when the regulator is not working right, roll vertically every time the brightness is varied: The vertical oscillator receives B+ from the boost line.)

The RCA CTC5 chassis uses a similar circuit; the variable control is omitted, and the grid resistors were hand-picked at the time of manufacture. If adjustment is needed, these resistors must be replaced and their values juggled until the regulator draws the right amount of current.

The Zenith 25MC36 regulator circuit shown in Fig. 4 is typical of modern regulator design. Several small but clever variations are used in other brands. Fig. 5 shows that the Motorola TS 908 has a voltage-sensitive resistor (VDR or varistor) between boost and the regulator grid circuit. Since a varistor will reduce its resistance when the voltage

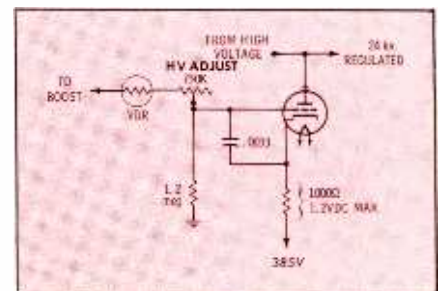

Fig. 5. A varistor improves regulation.

hallicrafters quality
is the **BIG NEWS** in
TEST INSTRUMENT KITS
... and hallicrafters engineered quality means outstanding specifications and performance ... plus simplified construction!



NEW "Fail-Proof" soldering terminal strips simplify making of positive connections.

NEW assembly ease. Mechanical parts are riveted to the chassis at the factory.



CAPACITANCE DECADE Kit HD-1

Ideal for experimental and service work requiring precision capacitors. Sixteen commercial slide switches give total variability in 100 pf steps. Uses silv. mica capacitors and long lasting stable defilm capacitors. Range .0001 to 1.0 mfd in four decades. Price \$14.95



RESISTOR DECADE Kit HD-2
Use to substitute known-value precision resistors in a circuit. Resistors are one-watt, 10%. Twenty-eight commercial slide switches give total variability in 1-ohm steps. Range: 1 ohm to 10 megohms in seven decades. Price \$14.95

R.F. GENERATOR Kit HG-1

Generates frequencies from 50 kc. to 55 Mc. in six steps. Calibrated harmonics in two steps from 55 Mc. to 220 Mc. Low frequency range exceptionally stable. Accuracy 1 1/2% of the reading. R.F. output .1-volt. Bandswitch assembly pre-wired and calibrated. Price \$29.95



VACUUM TUBE VOLT MILLIAMETER Kit HM-1

Has an exclusive built-in milliammeter circuit, available at the turn of a switch. Illuminated meter and separate front panel On-Off switch. Has seven AC, DC voltage ranges, from 1.5 to 1500; seven ohmmeter ranges, 0 to 1,000 megohms; and six milliammeter ranges, 1.5 to 500. Price \$29.95



CONDENSER TESTER Kit HC-1

Handy service bench instrument for checking unknown condenser and resistor values under operating conditions. Has precision tuning eye for easy operation. Four capacitance ranges: 10 mmf to 2,000 mfd. Three resistance ranges: 0.5 ohm to 5 megohms. Price \$29.95



5-INCH OSCILLOSCOPE Kit HO-1

A perfect scope for servicing color TV sets. Has full 5 Mc. bandwidth. Tube is 5 UPl. One-volt peak-to-peak source attenuator permits voltage measurements over range of 10,000 to 1. Retrace blanking amplifier provided. Phasing is continuously variable from 0 to 140°. Has two axis (beam) modulation. Price \$84.95



BATTERY ELIMINATOR Kit HP-1

Reliable source of 6- or 12-volt DC power for servicing car radios, including transistor and "hybrid." AC ripple less than .25%; exceptionally low. Voltage ranges 0-8 volts and 0-16 volts. Also use as battery charger. Has voltage and current panel meters. Price \$49.95



Look for this display



at your Authorized Hallicrafters Kit Headquarters!



hallicrafters
Master Kits

For FREE Catalog write Dept. 30-E, 5th & Kostner Aves., Chicago 24, Ill.
Circle 36 on literature card

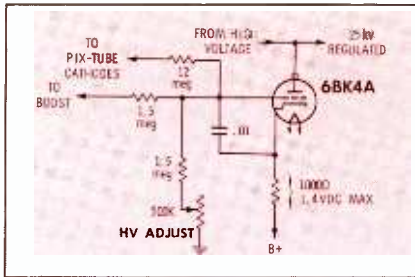

Fig. 6. Video level affects regulation.

across it increases, this makes the change in regulator grid bias larger for any given change in boost, thus improving HV regulation.

Another variation, which may escape you if you don't trace the entire circuit, is in the RCA CTC15 and CTC16 chassis—Fig. 6. Notice the 12-meg resistor that returns to the picture-tube cathode. When the brightness control is turned up or the video level increases, the CRT cathodes become less positive. A part of this change in voltage goes through the 12-meg resistor to the regulator grid; as a result, the regulator tube draws less HV current. This adaptation improves overall HV regulation and ties it more closely to instantaneous video levels.

Regulator Adjustments

Adjustment of any of these HV regulators is very easy, if you have the right meters and can reach the test points. Some manufacturers recommend setting the HV control for a certain voltage at the anode of the picture tube when the brightness control is turned completely down; others recommend adjusting for a certain regulator current. I use the regulator current method, with measurement of the HV as an important secondary test. For one reason, current meters retain accuracy better than do high-voltage probes, so current readings are likely to be more dependable. Also, the correct picture-tube brightness range happens to be exactly the range of the regulator current: if the regulator draws .3 ma with the picture dark, then the picture tube can draw only .3 ma before regulation is lost. For this reason, it is desirable that the regulator be set for as much current as is allowed by the design of any particular model.

The exact amount of high voltage is not quite so critical. There is, however, a limit to the safe amount of high voltage. X-rays may be

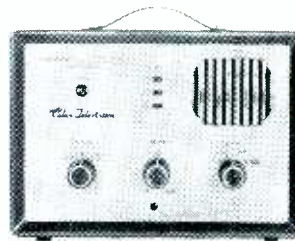

New RCA WR-64B Color Bar / Dot / Crosshatch Generator



THE ESSENTIAL COLOR-TV TEST INSTRUMENT

Now in a new model with more features for greater stability and versatility

- Crystal-controlled RF oscillator for stable picture carrier.
 - Three additional crystal oscillators are used to produce the sound carrier, color sub-carrier signal and the three patterns.
 - Convenient front-panel gun killing switches to aid individual gun testing as well as convergence and purity adjustments.
 - Sound-carrier signal unmodulated for accurate adjustment of fine tuning control of TV receiver. . . accurate setting of the fine-tuning control is essential for checking the performance of the receiver.
 - Generates all necessary test patterns: COLOR BARS for checking and aligning color circuits; CROSSHATCH for adjusting vertical and horizontal linearity and raster size; and DOTS for accurate convergence.
 - Color-phasing adjustments may be made with this instrument in the home without a scope.
 - The standard of the Color-TV servicing industry: much of the practical information available for trouble-shooting color circuits is based on the RCA Color Bar Generator.
- Only \$189.50*

ASK TO SEE IT AT YOUR AUTHORIZED RCA TEST EQUIPMENT DISTRIBUTOR

*Optional distributor resale price. All prices subject to change without notice. Prices may be slightly higher in Alaska, Hawaii and the West.

RCA Electronic Components and Devices, Harrison, N. J.



The Most Trusted Name in Electronics

created if the DC voltage exceeds 27 kv. It is unlikely that any receiver will exceed this limit if the regulator tube draws the right amount of current, but it is possible if the line voltage is high or if the receiver has been modified. Even though receivers have shielding against X-ray radiation, it is best not to take chances—measure the HV and be sure. If the abnormal high voltage is reduced by increasing regulator current above the normal rating of the regulator tube, the life of the tube will be greatly shortened; don't eliminate one trouble by causing another.

The best place to measure regulator current is in the cathode circuit. Older models have a test jumper (see Figs. 2 and 3) to make this easier. The jumper can be unsoldered from one of its tie-lugs and a current meter inserted. Newer sets usually have a 1000-ohm resistor in the cathode circuit so that soldering is unnecessary: connect 2 voltmeters in parallel, calculate current by Ohm's law: e.g., 1 volt across 1000 ohms equals 1 ma; if the voltmeter says 1.2 volts the current is



Fig. 7. Construction of regulator tube.

1.2 ma. CAUTION: Both meter leads are connected to B+, so watch out for shorts or shock hazard.

Turn the brightness completely down so no raster is visible; then adjust the HV control for correct regulator current. If the exact value is not known, a useful approximation is: 1957 sets should be about .8 ma, 1965 sets about 1.4 ma. By interpolating from this rule of thumb, a 1959 set should be set for 1 ma. In general, the newer the model, the more regulator current.

Attach a voltmeter with a HV probe and monitor both the high voltage and the regulator current as you vary the receiver brightness

from zero to maximum. The high voltage should remain within 500 volts of the no-brightness value, until blooming becomes visible at high brightness (if the brightness control reaches that far). The regulator current should at the same time decrease smoothly to zero; any slight increase in brightness beyond that point must cause blooming. Picture brightness when regulator current reaches zero is the true maximum for that particular set—an important yardstick.

Without Instruments

What can you do if you do not have these meters handy, or if you are on a home call and don't want to pull the chassis to get at the regulator cathode? There are other methods of checking and setting regulation, but their accuracy is not very great: You can watch the width of the picture carefully as you increase brightness up to the blooming point. There should be a very pronounced change in width at the blooming point and none before then.

Or, you can watch the orange

SAVES
your back...
SAVES
your time...



YEATS SHORTY DOLLY for RADIO and TV

just 47 inches high for STATION WAGONS and PANEL PICK-UPS



FOLDING PLATFORM
15 1/4" x 24 1/2" top.
Snaps on or off.
(Platform only)
\$11.95

Designed for TV, radio and appliance men who make deliveries by station wagon or panel truck... the short 47 inch length saves detaching the set for loading into the "wagon" or pick up. Tough, yet featherlight aluminum alloy frame has padded felt front, fast (30 second) web strap ratchet fastener and two endless rubber belt step glides. New folding platform attachment, at left, saves your back handling large TV chassis or table models. Call your YEATS dealer or write direct today!

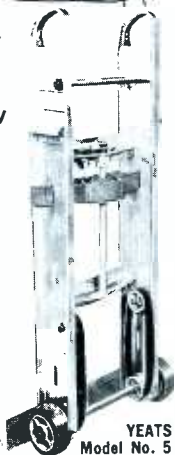

YEATS Model No. 5
Height 47"
Weight 32 lbs.



FURNITURE PAD

"Everlast" COVER AND PADS

YEATS semi fitted covers are made of tough water repellent fabric with adjustable web straps and soft, scratchless white flannel liners. All shapes and sizes — Write



TV COVER



APPLIANCE DOLLY SALES COMPANY

1307 W. Fond du Lac Ave. • Milwaukee, Wisconsin
Circle 37 on literature card

END TV TUNER CALLBACKS

with **CHEMTRONICS**

IMPROVED
TUN-O-LUBE



Cleans Faster, Lubricates Longer!

- Will not harm plastics
- More powerful spray
- Will not detune TV tuner

SERVICEMEN: For all your chemical needs, see the Chemtronics Display at your Distributor!

CHEMTRONICS INC.

1260 Ralph Avenue, Brooklyn, N.Y. 11236

Circle 38 on literature card

glow in the bottom of the regulator tube as you vary the brightness. It should glow noticeably when the raster is dark and be nearly invisible when the set blooms. The regulator current causes the plate to glow slightly; you can see the glow reflected from the corona shield which surrounds the cathode and grid assembly at the bottom of the tube. The open view of Fig. 7 will clarify this; the plate is midway up in the hollow tubular heat radiator and cannot be seen from the top of the tube. When current is near maximum, heat from the plate causes a dull red glow on the heat radiator. With a little practice in comparing these shortcuts with the meter readings, you can make a good approximate adjustment.

Since we can control maximum screen brightness with the CRT screen adjustments, the question may be asked: "Should we adjust the set so the customer cannot raise the brightness enough to bloom?" Before we answer the question, we must keep in mind that moderate or occasional blooming does not damage the picture tube, but it gives a poor picture. Severe or prolonged blooming can warp the internal shadow mask and do permanent damage. Optimum adjustment seems to be so the set just barely blooms at the top of the brightness control. Normal aging of the final video amplifier also reduces maximum brightness, so the brightness capability should be slightly more than what is barely needed; this setting will help avoid useless callbacks.

Shooting Trouble

We might logically assume the only symptom that would be caused by a regulator which draws no current is a slight change in width with brightness variations. But the high voltage goes up, however, as brightness goes down; if the station were to broadcast no video for a time, the voltage might climb to 30 or 32 kv. The increase may trigger minor corona arcs between metal parts around the picture tube, and a crackling sound will be heard from the change in electrostatic attraction. The boost also changes, which may cause roll if the vertical oscillator receives plate voltage from boost.

Loss of width, poor focus, and

excessive blooming can be caused by high regulator current. The quickest test for this is to temporarily remove the regulator tube plate cap and insulate it so it doesn't arc. If the picture is better with the tube removed, the regulator was drawing too much current.

After the tube, the next suspect is the capacitor from grid to cathode. You might wonder how any capacitor could develop leakage with only 20 volts DC across it, for this is the normal maximum in this circuit. But what voltage would be across this capacitor if a quick arc occurred inside the 6BK4? The leads of this capacitor are held close together in some sets by a small piece of plastic; this forms a spark gap, but any voltage large enough to arc could also puncture the capacitor.

Table 1. HV Regulator Faults

Low Regulator Current	
1.	Weak or dead regulator tube.
2.	HV control set wrong.
3.	Resistor from B boost to grid raised in value.
4.	Weak horizontal output tube. (low HV and boost)
5.	Weak damper tube. (low HV and boost) (This can also effect width.)
Excessive Regulator Current	
1.	Gassy or shorted regulator tube.
2.	HV control set too high
3.	Resistor from grid to ground raised in value.
4.	Capacitor from grid to cathode leaky or shorted.
5.	B boost voltage too high. (not likely unless modified)

High-voltage regulator systems aren't at all difficult to troubleshoot, provided logical techniques are used. The charts in Table 1 offer clues to high or low regulator current, so you've probably guessed that monitoring cathode current is a good clue to whatever trouble may exist in the regulator circuit. From these tests, you can also learn much about how the horizontal output section of the receiver is operating.

The box at the beginning of the article also suggests cures for some common troubles from the experience of seasoned color-TV experts. Use them to help you take care of any faults you encounter in HV regulator systems. ▲

new SAMS BOOKS

Color TV Training Manual, New Second Edition



by C. P. Oliphant & Verne M. Ray. This newly revised comprehensive manual is the most up-to-date guide available for technicians preparing to service color-TV receivers. Describes the science of color, requirements and make-up of the composite color signal, latest color circuits, and servicing procedures. Full-color picture tube photos are invaluable for setup and alignment procedures, as well as trouble-shooting. Chapters: Colorimetry; Requirements of the Composite Color Signal; Make-up of the Color Signal; R-F and I-F Circuits; Video, Sync & Voltage-Supply Circuits; Band pass-Amplifier, Color-Sync and Color-Killer Circuits; Color Demodulation; Matrix Section; Color Picture Tube & Associated Circuits; Setup Procedure; Aligning the Color Receiver; Troubleshooting. 224 pages; 8 1/2 x 11". Order TVC-2, only \$5.95

Industrial Transistor Circuits

by Allan Lytel. Semiconductor characteristics—extremely long life and reliability, plus low power and small space requirements—make them ideal for many industrial applications. This valuable reference book describes dozens of solid-state circuits designed for reliable industrial service. Schematics and explanatory text fully outline principles and operation of each circuit. Covers solid-state circuitry controls, amplifiers, regulators, alarms, counters, timers, meter controls, etc. An important book for technicians, designers, and experimenters. 112 pages; 5 1/2 x 8 1/2". Order ITL-1, only \$2.50

Basic Electricity/Electronics Lab Workbook

by Training & Retraining, Inc. This comprehensive programmed-type workbook is the project-teaching supplement for the popular Sams Basic Electricity/Electronics series. The workbook includes dozens of lab projects keyed to the 5-volume series. Each project is accompanied by text explaining the principles of electricity and electronics under demonstration. Pictorial and schematic diagrams, parts lists, and step-by-step wiring instructions guide the reader through the actual construction of each practice project. Questions (and answers) help to gain understanding of the project and its principles. Workbook leads finally to construction of a superhet receiver. 256 pages; 8 1/2" x 11". Order ECY-W, only \$4.95

Basic Electricity/Electronics Series

Vol. 1 Basic Principles & Applications
Vol. 2 How AC and DC Circuits Work
Vol. 3 Understanding Tube & Transistor Circuits
Vol. 4 Understanding & Using Test Instruments
Vol. 5 Motors & Generators—How They Work (Each Volume, softbound \$4.50; hardbound, \$5.50)
5-Vol. Softbound Edition, order ECS-50, only \$19.95
5-Vol. Hardbound Edition, order ECS-50, only \$24.95

Electronic Systems for Convenience, Safety and Enjoyment

by Edward A. Altshuler. In this new book, the author carefully points out to TV-radio technicians, distributors and manufacturers the need for a new marketing approach in the electronics industry. He shows convincingly that electronics markets will expand rapidly—requiring growing services from technicians, distributors and manufacturers—as totally integrated electronic systems are developed and adopted for entertainment, communications, control, and special services. He cites striking examples of how today's electronics technology can be applied and sold in home, plant, office, school, and hospital. Must reading for everyone with a stake in electronics. 256 pages; 5 1/2 x 8 1/2". Order SAS-1, (softbound), only \$4.95
Order SAH-1, (hardbound), only \$5.95

HOWARD W. SAMS & CO., INC.

Order from your Sams Distributor today, or mail to Howard W. Sams & Co., Inc., Dept. PF-5, 4300 W. 62nd Street, Indianapolis, Ind. 46206

Send me the following books:
 TVC-2 ECY-W ECS-50 SAH-1
 ITL-1 ECY-50 SAS-1
 Send FREE Sams Booklist. \$_____enclosed

Name _____

Address _____

City _____ State _____ Zip _____

My Distributor is _____

IN CANADA: A. C. Simmonds & Sons, Ltd., Toronto 7

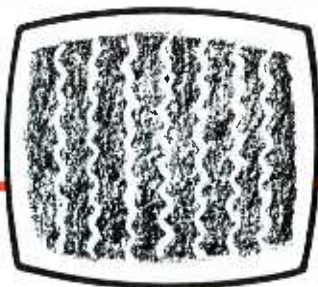

Arbitrating Problems of **CB-TVI**

Keeping CB'ers and TV'ers both happy

by Paul Norman

There are hundreds of thousands of Citizen's band transmitters in use in the U.S. today, and it's inevitable that in some cases their transmissions interfere with TV reception. The interfering signals are usually picked up by the TV set, where they cause a beat with TV-station signals, causing interference patterns similar to those shown in the photos. (Of course, any transmitter could cause similar patterns.) The main reason for the CB-TVI problem is simply that there are a lot of TV's



Fig. 1. Clean pix without interference.

and a lot of CB's.

As a serviceman, you'll be concerned with CB-TVI in one of two ways, depending on whether you service CB's or TV's. In some cases, the television owner knows who the offending CB'er is and gets in touch with him. The CB'er may then call a CB serviceman. In some cases, the CB serviceman will contact a TV serviceman.



Fig. 2. Herringbone from RF signal.

What Does CB-TVI Look Like?

However you enter the case, it's important for you to recognize the symptoms and be able to track the interference to its source. In Fig. 1 you'll see a strong, clean signal from a local TV station. In Fig. 2 you can see the familiar RF herringbone produced by a nearby transmitter. In Fig. 3 the transmitter is on a slightly different frequency, and the pattern is more of a checkered one. The preceding examples were caused by unmodulated RF carriers—now look at Fig. 4 to see what a modulated signal, as from a CB rig, does to the picture.

A key point to remember: Fringe areas have more TVI trouble than large metropolitan areas, simply because the TV signal is weak and more susceptible to interference. Take for instance the signal of Fig. 5—weak and snowy. Fig. 6 shows how the RF herringbone really tears up the video when a nearby transmitter goes on the air; compare with Fig. 2—the strong TV signal. Fig. 7 shows the effect of modulated RF on a weak TV signal.

Don't mistake other problems for RF interference. Fig. 8 illustrates what happens when the TV lead-in breaks or the antenna terminals open and close intermittently. The proof here is an ohmmeter check for continuity of the antenna and lead-in; the remedy is replacement. Fig. 9 illustrates electric-motor noise, which is almost always picked up via the AC line and can be eliminated by replacing a defective motor, cleaning it, readjusting its brushes, or by placing an AC line filter at the TV receiver (although it works better at the offending motor).

Another key point to remember: Whatever your location, big city or fringe area, most CB-TVI problems involve TV sets with 20-mc

IF's—and this means they are old. (Nearly all new TV's use 40-mc IF's.) The CB frequencies are smack in the middle of these old IF's, so they are prone to create all sorts of trouble. Even in metropolitan areas, if the CB rig is close by, you can count on some interference.

What Can You Do?

In almost every case, the TV set's at fault. Most late-model CB rigs have TVI traps and are properly adjusted when they leave the factory. (FCC rule 95.49 limits harmonic radiation from CB transmitters.) Therefore, the usual



Fig. 3. Another pattern from RF signal.

remedy is to install a TV lead-in filter between the set's antenna terminals and the 300-ohm lead-in. Representative filter models are: Ameco HP-45; Drake TV-300-HP; Regency HP-45; Superex CPC "Clear-Pix". These are high-pass filters—they pass signals above 54 mc and block those below.

In rare cases, a CB transmitter

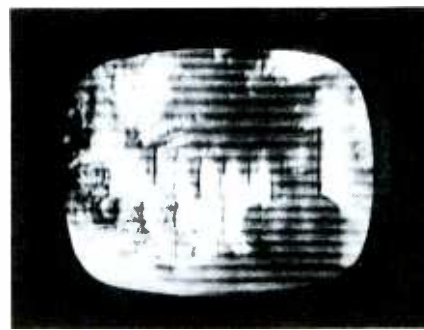

Fig. 4. Modulation interference bars.

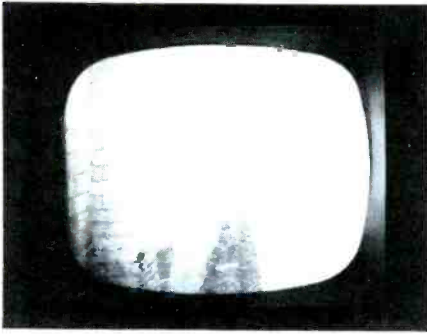

Fig. 5. Ordinary weak signal; snow.

does emit harmonics; the remedy is the same as above—a line filter between the transmitter and the antenna. Available models include Ameco LN-2 and Drake TV-100-LP. These are low-pass filters, passing the 20-mc band of CB frequencies and blocking those above.

How Can You Prevent Bloodshed?

Be diplomatic. Sometimes the day after a CB ground-plane or quad

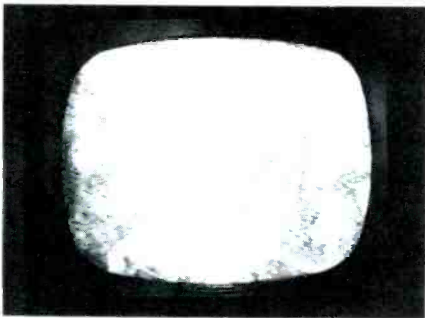

Fig. 6. RF interference on weak signal.

goes up, neighborhood TV viewers imagine interference—even before the transmitter has been plugged in the AC line! Don't laugh—the man has money invested in that TV set and he wants to enjoy it. Besides, he's paying you money to advise him, so give him the benefit of your specialized technical knowledge. Investigate the suspected CB installation—perhaps taking along a portable TV. If the CB's not clean, perhaps you and the owner can kill the harmonics. If it's a case of imagi-

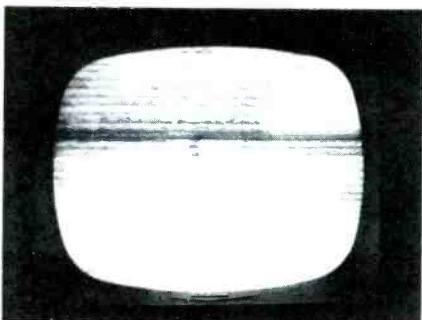

Fig. 7. Weak video, from modulated RF.

Use it to
Cut Snow on
Weak Channels



As 2-Set
Coupler, Gives
Each Set Min.
of 7db Gain



Extends
Rabbit Ear
Range
In Medium
Signal
Areas





REPLACES EC-230

Boosts
Signals
to a
4 or 6 Set
Coupler



THIS IS THE ALL NEW WINEGARD BC-107... MOST VERSATILE BOOSTER- COUPLER IN ITS PRICE CLASS

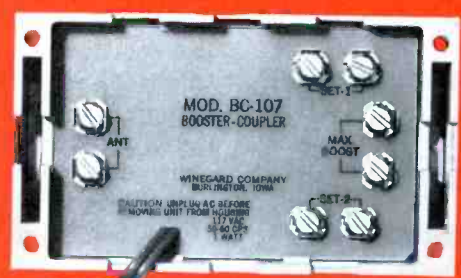

Extra Terminals
let you boost
Signal to Single
TV or FM Set
With Minimum
12db Gain

What makes the BC-107 such a special booster-coupler? Well, for one thing, the BC-107 eliminates the 3 to 4db loss inherent in 2 set couplers. In fact, it actually gives a 7db boost to both sets connected to it. Now you can easily connect 2 sets to one antenna in fringe areas and get perfect reception on both sets—in color or black and white. An extra set of terminals lets you use the BC-107 as a booster for 1 set with a minimum of 12 db gain.

This powerful, transistorized unit also has linear frequency response across both TV and FM bands and an exact match into 300 ohms. This means No

Smear, No Ghosts, No Picture Degradation, No Interference Between Sets.

Works with TV and FM signals from 25 to 45,000 microvolts. Has one 300 ohm input, three 300 ohm outputs, no-strip terminals, 110V-AC cord, and a brand new casing of high impact polystyrene, specially designed for the neatest, simplest indoor installation possible.

Write today for complete details or ask your distributor about the BC-107 from Winegard . . . Hottest new number in the Red Hot Booster-Coupler Market.

\$18⁹⁵
list

 **Winegard Co.**

3009-F KIRKWOOD BOULEVARD • BURLINGTON, IOWA

Circle 39 on literature card

nary interference, make the investigation anyway, asking the CB'er to try out his rig to assure yourself it's not a troublemaker. Fig. 10 shows the best way to prove or disprove the CB-TV problem. If the TV set's at fault, show the owner another set getting a clean picture while a CB transmitter operates in front of it. If the CB's at fault, this test will show it.

If you're a CB serviceman called by the CB'er on the complaint of the TV'er, you may find the TV

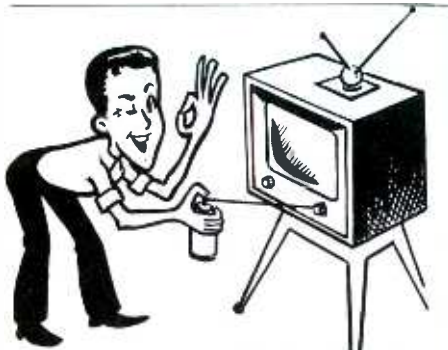

INJECTORALL

THE NEEDLE DOES THE JOB!

NEW!
INJECTORALL
TUNER CLEANER
AND LUBRICANT
with...
INJECTOR NEEDLE

The leak-proof steel Injectorall Needle lubricates where you need it... you can reach hard-to-get at Wafers without pulling Tuners apart, or even removing Chassis.

INJECTORALL CO.
Great Neck, N.Y. 11024

Circle 40 on literature card

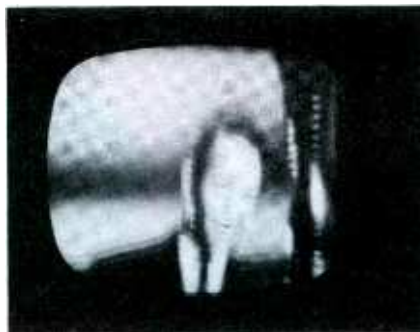

Fig. 8. Effect on pix of broken lead-in.

owner resents you slightly, due to your connection with CB. It may be worthwhile to refer the TV'er to his own serviceman, who will almost always back you up. On the other hand, if you're a TV serviceman called into such a problem, it may be your ticklish task to explain to the TV owner why and how his set's at fault. Tell him that CB manufacturers, servicemen, and owners have done their best to insure that they don't interfere with anybody's reception, but that a great many older TV sets just weren't built with CB in mind. Class-D Citizens band didn't exist before 1959, and nobody had any idea how popular the 27-mc Citizens Radio would become, nor how many of these transmitters would be in use. Be polite and honest, and assure the TV'er that the CB'er is quite legal (be certain he is) and there is nothing you can do but install an inexpensive filter that will prevent interference from *any* CB transmitter.

Do People Cooperate?

A majority do. Most CB'ers have a sense of responsibility and, if you explain honestly and politely, will let you check their transmitters. The same goes for TV owners and



Fig. 9. Motor noise causes pix streaks.

for other servicemen. Just remember that you are the catalyst—you must sweet-talk both sides, soothe ruffled tempers, mollify sourpusses, and be an ambassador of goodwill. You were called into the case because you're an expert, so be one. Be sure to talk to both sides because in your case, talk is *not* cheap—you are getting paid for it.

Is There CBI from TV?

Rarely, signals originating from horizontal-sweep oscillators occasionally get into CB receivers—the horizontal output transformer is



Fig. 10. Proof that a CB unit is "clean."

rich in harmonics, you know, and the high-voltage rectifier doesn't help matters much. The fortunate thing about this problem is that installing a high-pass filter between the TV and the lead-in not only keeps CB signals *out* of the TV, it also helps keep sweep interference from leaving the TV and getting into the CB receiver. Neat trick, huh? Well, in extremely rare cases, you may have to staple some aluminum foil inside the TV cabinet and ground it to the chassis, or even connect the TV chassis to earth, before you can get rid of the sweep hash. If the TV and the CB are in the same building and using the same AC service, an AC line filter at either or both locations may help.

Whatever you do, be confident—your customer is counting on you.

NEW!

ESCO DYNAMIC TRANSISTOR TESTER

NO CHARTS—INSTANT TEST IN OR OUT OF CIRCUIT!

Quickly tests ALL transistors: RF, Audio, Power, Switching, PNP, NPN, Unijunction types, etc.—under ACTUAL OPERATING CONDITIONS! Easy to use, accurate, rugged and compact. The perfect instrument for portable or bench use!

SEE it, TRY it, at your LOCAL DISTRIBUTOR

Dealer Net
MODEL XT-1 **\$18⁹⁵**

DISTRIBUTOR INQUIRIES WELCOMED

Manufactured by
ESCO, 400 Hempstead Turnpike, West Hempstead, N. Y. — 516 IV 5-6068

Circle 41 on literature card



Notes on Test Equipment

analysis of test instruments . . . operation . . . applications

by Allen B. Smith

Roll-Chart Reference

Tube and CRT testers of any type are little more than a source of AC and DC voltages with several switchable outputs. Whatever their specific uses, they are designed to simulate conditions approximating those under which the tube will normally be used. In almost all cases, the test conditions are a compromise between all of the various uses to which a tube might be put and those which are most easily combined with those of other tubes. So, in the final analysis, most testers are pretty much the same, electrically. In the area of special tests and checks, however, differences are more apparent.

The Jackson Model 825 CRT Tester shown in Fig. 1 has several test circuits that will aid technicians in performing a straight-forward and rapid analysis of CRT's. The instrument is mounted in a small, compartmented case which has space for the line cord, test cable and the required adapter sockets. The roll chart which provides the information for each CRT is mounted directly into the case as are the meter and the control panel with its ten push buttons. A comprehensive list of operating instructions is stapled to the inside of the cover.

Before testing any CRT, it is advisable to read thoroughly the instructions for the use of each of the many panel controls. With this instrument, as with most other CRT testers, it is possible to damage a tube while testing its various parameters if certain



Fig. 1. CRT tester has compartment for cables and the adapter sockets.

Jackson Model 825 Specifications

Function:

Tests most color and black-and-white CRT's, using a single cable with multiple plug-in sockets.

Tests Performed:

Continuity and interelectrode leakage, G2 emission, life test, short (G-K) removal, rejuvenation, and cathode welding. Setup information shown on panel-mounted roll chart.

Features:

G1 voltage variable 0-150VDC for cutoff tests, tapped transformer for line-voltage adjustments, 11-step G2 voltage switch, RGB switch for color CRT's, pushbutton test operation.

Size (HWD):

5½" x 14½" x 12½"

Weight:

12 lbs

Power Requirements:

105-125 volts AC, 60 cps

Price:

Dealer Net, \$119.95

precautions are not observed. These precautions are noted fully in the instruction sheet. The function of each of the 19 panel controls and interpretation of the meter scales are covered in detail, as well.

Testing a CRT is divided into four separate areas: evaluation; boost, if required; weld, if required; and short removal, if required. Color tubes are tested as three separate tubes; the RGB switch selects the gun under test. Normal procedure for evaluation begins with reference to the roll-chart information and requires setting heater, continuity-leakage, grid-1, grid-2, and meter-calibration switches as indicated on the chart. After a warm-up time of about five minutes, the tube is checked for continuity and leakage paths. Indication is by means of an EM84/6FG6 electronic-eye tube—a closed eye indicates continuity in four CONT positions, and an open eye indicates no leakage in four LEAK positions. Grid-2 emission and grid-1 cut-

off are then checked by noting proper meter indications. A life test (with filament voltage reduced by 10%) gives an approximation of the reserve life remaining in the cathode.

If the CRT requires boosting, two options are available: In the first case (BOOST 1), a high-voltage charge is applied to the cathode at normal filament voltage; in the second case (BOOST 2), the charge is applied as before, and the filament voltage is increased by 35%. This is accomplished by applying the full line voltage across a smaller portion of the heater-transformer primary winding.

In the case of an open cathode circuit, welding may be attempted in a manner similar to that described for boosting. During this repair function, the filament voltage is increased by 85%, after which the high-voltage charge is applied. Obviously, for both BOOST 2 and WELD tests, damage may result to the tube, and these tests should not be attempted unless the tube is otherwise unusable.

The final function is to remove grid-cathode shorts. For this repair, the filament voltage is removed completely, and the high-voltage charge is applied to the cathode. Once again, this procedure should be regarded only as a last-ditch effort to repair an otherwise discarded tube.

The meter can be read directly in microamperes during emission-current tests by using control S to set the meter needle to 100% when pressing pushbutton TEST.

Every technician, whether he specializes in black-and-white or color, knows the value of determining the condition of the CRT early in the repair effort. The Model 825 can measurably aid in such an evaluation.

For further information, circle 128 on literature card.

Wideband Oscilloscope

Use of a wideband oscilloscope with acceptably flat response to 4.5 or 5



Fig. 2. Operating controls and terminals are conveniently arranged on panel.

EVERYONE'S A WINNER!

in Winegard's Gala Gift Parade

And Here Are the Lucky Winners of the 10 Big Grand Prize Awards

1st PRIZE

A 1965 FORD
MUSTANG
FASTBACK



John Winegard (center) talks things over with first prize winner, Orville Schroeder (left) as Darwin Olson, Schroeder's jobber salesman, looks on.

Mr. Orville Schroeder of Nelson TV & Appliances, 231 14th Avenue, Rochester, Minn. Jobber salesman, Darwin Olson, of the SM Supply Co., Rochester, Minn.

2nd PRIZES

TWO HONDA
SPORTS
CYCLES



Bonded TV
1145 South Fourth Street, Fort Pierce, Florida
Mr. Gene Beechman
Harwick Appliances, 575 Chestnut Street, Emmaus, Pa.

3rd PRIZES

SEVEN
BICYCLES-
BUILT-FOR-
TWO



Rodney Van De Hey, Eugene, Oregon
Plaza TV & Appliance, Tustin, California
Vernon Whitaker, Chehalis, Washington
Norman Paul, North Providence, Rhode Island
Lin Baker, El Cerrito, California
Raymond Sosinski, Pittsburgh, Pennsylvania
Donald Bailey, Danville, Illinois

We would like to congratulate all the winners and encourage those who have yet to participate in one of Winegard's Gift Parade promotions to be sure to enter next time. It could be your turn to win the next Ford Mustang or another gift-of-a-lifetime from Winegard.

Winegard Co.

3009-E Kirkwood • Burlington, Iowa
Circle 44 on literature card

mc has gained considerable favor in many active repair shops. The rapid growth of consumer interest in color television has provided the initial impetus, but wise shop owners know that the increased fidelity provided by such an oscilloscope also aids in viewing pulse waveforms, having rapid rise time, in other applications as well.

The SENCORE Model PS127 shown in Fig. 2 is useful for all general TV service work (black-and-white and color) as well as for servicing communications, medical, and industrial equipment. The Model PS-

SENCORE Model PS127 Specifications

Vertical Channel:

Sensitivity—Direct terminal, .015 volt rms per inch $\pm 5\%$; *response*— ± 3 db, 10 cps to 4.7 mc; *rise time*—.07 uses; *input impedance*—2.7 megohms with 22-pf shunt at jack, 2.7 megohms with 90-pf shunt using direct probe, and 27 megohms with 9-pf shunt using low-capacity probe.

Horizontal Channel:

Sensitivity—Direct terminal, .9 volt rms per inch; *response*—10 cps to more than 400 kc; *input impedance*—cathode-follower input, 4.5 megohms with 10-pf shunt.

Sweep Generator:

Range—5 cps to 500 kc in five overlapping decades, continuously adjustable. TV horizontal (7875 cps) and vertical (30 cps) test frequencies for fast checks on TV sets. *Synchronization*—three positions: internal, external, and 60 cps Adjustable sync-phase control.

Features:

Vertical-amplifier gain controls calibrated directly in peak-to-peak volts, retrace blanking, direct connection to deflection plates, Z-axis input.

Size (HWD):

11" x 9" x 15½"

Weight:

22 lbs

Power Requirements:

105-125 volts AC, 50-60 cps @ 110 watts operating, 54 watts standby.

Price:

\$169.50

127 is what might be called a straightforward, no-nonsense wideband scope. Its design incorporates well-proved circuits and techniques which take the direct approach (shunt peaking for high-frequency response, grid-injected retrace blanking, and a phantatron

sweep circuit, for example). Standardized design, with no frills, characterizes the Model PS127. This design approach should provide good life in servicing use as well as simple troubleshooting and maintenance procedures.

In actual use, we found that the controls and external connectors and terminals were conveniently arranged for quick setup and connection to the equipment being checked. All CRT controls (INTENSITY, FOCUS, VERT. POS, HORIZ. POS, and HORIZ. GAIN) are clustered vertically alongside the CRT itself. The input and sweep-frequency controls are located in a horizontal row across the panel, below the CRT and its controls. Connectors and terminals for vertical, sync, and horizontal inputs are lined up across the bottom of the front panel. Another terminal-board strip (for direct CRT plate and cathode connection) is located at the rear of the main chassis and is accessible through a cutout in the cabinet.

Overall circuit organization of the Model PS127 is shown in the block diagram of Fig. 3. As is general oscilloscope practice, there are three primary circuit divisions: the vertical amplifier/deflection channel, the horizontal-sweep oscillator, and the horizontal-deflection channel.

The vertical channel in this scope

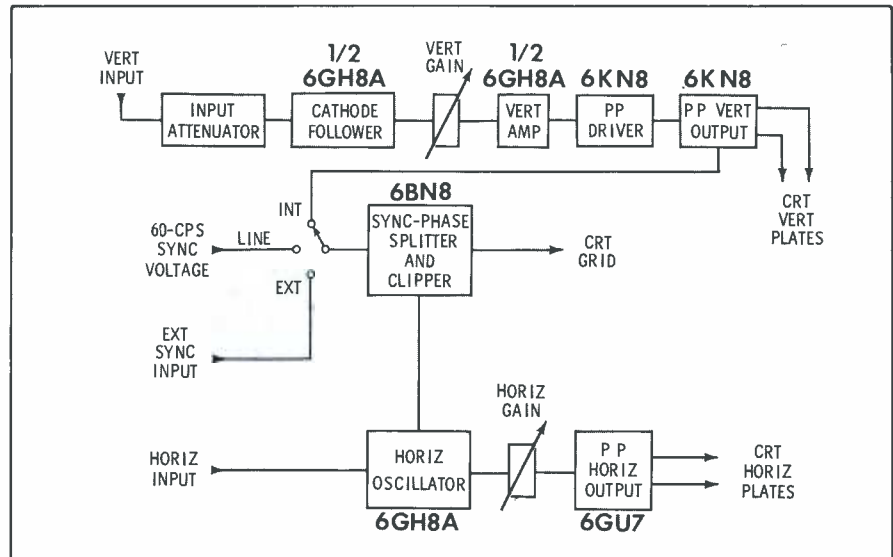

Fig. 3. Block diagram shows straightforward circuits used in wideband scope.

consists of an input attenuator, a 6GH8A (the triode section used as a cathode follower, the pentode section as an amplifier), a push-pull driver using a 6KN8, and a second push-pull 6KN8 in the output. The attenuator incorporates a small "gimmick" to handle high-frequency components in the X1, X10, and X100 attenuator position. Vertical-gain variation is accomplished in the grid circuit of the pentode section of the 6GH8A. A 5000-ohm VERTICAL CAL control,

paralleled by a 33-pf capacitor, is connected between the two cathode elements of the output 6KN8 to control the degeneration between sections. This action varies the relative gains of the two sections to assure equal deflection by each of the CRT vertical-deflection plates. Shunt-peaking coils are used in both plate circuits of the push-pull driver and output stages to provide acceptably flat response in excess of 4 mc.

A synchronizing pulse is taken from

great profits



that's about the size of it

Microminiaturization has come to cartridge design in the new Sonotone Micro-Ceramic[®] Cartridge—a king-sized profit-maker in a tiny case. This remarkable new cartridge updates to 1965 performance almost any phonograph using a ceramic cartridge produced within the past 20 years.

The Sonotone Micro-Ceramic Cartridge embodies all the advantages of miniaturization and light weight. Designed for low mass, lightweight tonearms—it weighs less than 1 gram (without bracket). Superb stereo performance is assured by—high compliance; ability to track at the low forces required by today's modern record changers; excel-

lent separation and a smooth, clean response over the full audio range. To top it off, all Micro-Ceramic cartridges are equipped with the virtually indestructible Sono-Flex[®] stylus. For ease of installation, three different standard mounts are available.

Four Micro-Ceramic cartridges cover all of your replacement needs; the "27T," a high capacitance model for transistorized phonographs; the high compliance "25T" for deluxe stereo units; the "26T" and "28T" for replacement in a wide range of popularly priced phonographs.

For comprehensive Cartridge Replacement Guide, write:



Sonotone Corp., Electronic Applications Div., Elmsford, N. Y.

Circle 45 on literature card

May, 1965/PF REPORTER 73

the plate circuit of one section of the vertical-output stage and coupled through the INT position of the SYNC switch to the horizontal oscillator. The oscillator employs a phantastron circuit to provide a linear sawtooth waveform. The HORIZ. FREQ switch selects capacitors of various values to determine the output frequency. A potentiometer in the cathode circuit of the sweep oscillator serves as the HORIZ. GAIN control. The sweep sawtooth is fed to the grid of one triode section of the 6GU7 horizontal amplifier, and the output of that section is coupled to one CRT horizontal-deflection plate.

It is also capacitively coupled to the grid of the second section of the 6GU7, and a sawtooth of opposite polarity to that at the plate of the first section is coupled from the second section to the second CRT horizontal-deflection plate. The output amplifier uses low-value (18K) plate-load resistors to improve high-frequency response.

Low-voltage and high-voltage power supplies are of familiar design, using full-wave rectification for the 400-volt supply and half-wave circuitry for the 1300-volt supply. A standby switch applies power to only the filaments in

STBY position. A 200K potentiometer across the filament supply provides a variable-phase voltage for use as a synchronizing signal in the LINE position of the SYNC switch.

Use of the Model PS127 in various troubleshooting situations in our labs and in the field showed good results in both black-and-white and color sets. The color-burst signal held good sync for examining the burst waveform, and in square-wave checks the scope gave good response with little tilt at the higher frequencies. Under continuous use, the power transformer in our unit seemed to heat excessively, but placing the standby switch in STBY position allowed the scope to cool during inactive periods.

For further information, circle 129 on literature card.

Capacitance Bridge/Analyzer

The average serviceman probably repairs more equipment through capacitor replacement than by any other method. Capacitors short, open, or alter value. The time-tested procedure for troubleshooting capacitor problems is through resistance checks and by direct substitution—valid techniques in



AMPLI-VOX SOUND CRUISER

COMPLETE MOBILE SOUND SYSTEM

- Equip any car, truck, bus, or boat for clear powerful soundcasting in just 45 seconds
- 32 watt solid state amplifier plugs into auto cigarette lighter socket
- Noise cancelling hand-held microphone has 5' coil cord, push-to-talk switch
- Two weatherproof horn speakers swivel and lock in any direction, are pre-mounted on car-top carrier ready to clamp to car
- Ideal for voice or music; inputs for tape recorder, turntable, etc.

Model S-310, Complete system, including F.E.T. **\$169.95**
Model S-300, Amplifier only, including F.E.T. \$79.95

Write for literature and detailed specifications.

AMPLI-VOX AUDIO PRODUCTS are manufactured in U.S.A. by

PERMA-POWER COMPANY 5740 N. Tripp Ave., Chicago, Ill. 60646

Phone (312) 539-7171

Circle 46 on literature card

Sprague Model TO-6 Specifications

Function:

Analysis of capacitors to determine capacitance value, power factor, insulation resistance, and leakage current.

Capacitance Range:

1 pf to 2000 mfd in five overlapping ranges selected by a series of push buttons.

Leakage Current:

Measured at rated voltage using continuously variable DC supply. Leakage current read directly on meter.

Power Factor:

Indicated directly on meter during test of electrolytics.

Insulation Resistance:

Measured with 150-volt or 30-volt potential applied. Range for 150-volt test—500 megohms to 50K megohms. Range for 30-volt test—100 megohms to 10K megohms.

Size (HWD):

8 $\frac{3}{8}$ " x 14 $\frac{1}{8}$ " x 6 $\frac{1}{8}$ "

Weight:

13 lbs.

Power Requirements:

115 volts AC, 50-60 cps, 35 watts

Price:

\$99.50



Fig. 4. Definitive capacitor analysis is possible with Wien-bridge circuitry.

many cases, but time consuming. The Model TO-6 Capacitor Analyzer shown in Fig. 4 offers a means for direct analysis of capacitors suspected of being faulty. This method can be useful and time-saving and, at the same time, can provide qualitative answers instead of a mere "yes-or-no" evaluation. The Model TO-6 will provide capacitance, leakage-current, insulation-resistance, and power-factor data on all types of capacitors ranging from 1 pf to 2000 mfd, as applicable.

The instrument is housed in a gray hammertone-finished steel case and has a leather carrying handle. It is also available in a case configuration intended for mounting in a standard 19" relay rack. Both styles may be obtained for use with 115/230-volt, 50-cps power sources.

Heart and soul of the Model TO-6 is the Wien-type bridge used as a comparator for capacitors of unknown value and for determining the power factor of electrolytics. The capacitor under test forms part of the bridge itself, the bridge is balanced by a continuously variable ratio-arm element. The variable resistance used in the ratio arm is a close-tolerance, linear-taper, wirewound unit. The rotary motion of this variable resistor's shaft is calibrated to correspond to the capacitance of the unit under test; thus the resistive correction required to balance the bridge is directly related to the unknown capacitance. The reference voltage (60 cps) applied to the bridge is obtained from a separate winding on the power transformer, and a 6E5 "eye" tube indicates bridge balance or "null."

Fig. 5 shows the equivalent circuit used to determine the insulation re-

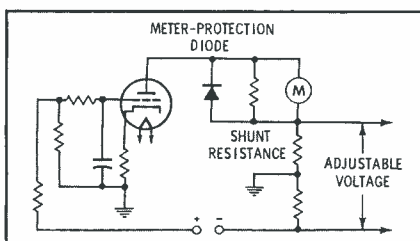

Fig. 5. Equivalent circuit used to determine insulation-resistance values.

sistance of mica, paper, ceramic, etc., capacitors. (Electrolytics are checked for leakage current.) Any current which flows through the capacitor, when voltage is applied as indicated, increases the bias on the triode, thus lowering the plate current flow. Meter M is calibrated directly in megohms.

Electrolytics are checked for leakage current by direct application of full rated voltage to the capacitor, which is connected for test in series with the meter. A network of switched resistances controls the level of the applied voltage and the meter sensitivity. Leakage current is read directly on the meter after division by the fac-

tor indicated on the panel behind the appropriate pushbutton.

The manual for the Model TO-6 gives precise instructions for performing the required evaluation and also provides a good understanding of tolerances and test limits. ▲

For further information circle 130 on literature card

ERRATUM

In the February "Notes on Test Equipment" item describing the Hickock Model 727 Stereo Generator (page 76), the price was listed incorrectly. The correct price for the Model 727 is \$199.95.

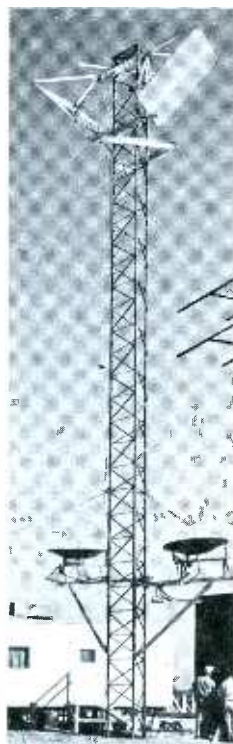

The most Famous Name in
TOWERS of ALL KINDS!

Here are the advantages you get
when you insist on **ROHN TOWERS**

LARGEST FULL RANGE OF TOWERS—you can get anything from home TV and amateur radio towers to heavy-duty communication and micro-wave towers. Included are 500 foot self-supporting towers, 1,000 foot guyed towers, "fold-over" and crank-up towers. Regardless of your needs, ROHN can supply it.

UNQUESTIONED LEADERSHIP IN DESIGN AND MANUFACTURE—you get the latest in advanced tower engineering. All communication towers are engineered to EIA specifications, and are proved by thousands of installations. No other manufacturer can surpass the quality and fine reputation of ROHN.

QUALITY MATERIALS AND WORKMANSHIP—Only highest quality steel is used which fully meets the specifications for the job. ROHN towers are hot-dipped galvanized **after fabrication**—a feature ROHN pioneered!

SERVICE WHEREVER YOU WANT IT—ROHN representatives are world-wide. Complete erection service for communication systems, broadcasting, micro-wave, and other needs is available; also competent engineering service to help you.

Settle for the BEST in TOWERS—ROHN—today the world's largest, exclusive manufacturer of towers of all kinds!

Also available: Rohn Lighting Kits, Microwave Passive Reflectors, Tower Installation Service and Engineering Assistance. Representatives World-Wide to Serve You.

For your needs, contact your local ROHN salesman, distributor or dealer; or write direct for information.

SEND THE HANDY COUPON INDICATING YOUR NEEDS

ROHN
Manufacturing
Co.

BOX 2000
PEORIA, ILLINOIS

Send me complete literature on the following ROHN Products:

- | | |
|---|--|
| <input type="checkbox"/> Home TV Towers | <input type="checkbox"/> Amateur Towers |
| <input type="checkbox"/> Communication Towers | <input type="checkbox"/> AM-FM Broadcasting Towers |
| <input type="checkbox"/> Micro-Wave Towers | <input type="checkbox"/> Government |

Name _____

Firm _____

Address _____

City _____ State _____

"World's Largest EXCLUSIVE Manufacturer of Towers; designers, engineers, and installers of complete communication tower systems."

a new money-making,
traffic-building tube tester

for you or your customer!



THE ALL NEW SENCORE TC131 SEMI-AUTOMATIC TUBE CHECKER

After thousands of requests here is the "counter/bench" version of the famous Sencore Mighty Mite Tester; designed for the ultimate in tube checking thoroughness and operational simplicity! Designed for two-way use — as a professional shop tester and customer self-service unit. Tests over 2500 tubes — including Nuvistors, Compactrons, 10-pins, Novars, Magnovals and foreign tubes with a big 6-inch meter for easy reading. Semi-automatic; simply turn function control to any test and watch lighted arrow on meter automatically stop on right scale. User can't go wrong — no guess work — everything is read right on the meter (no tricky neon lights to misread); only 3 set-up controls. Easy to read, speed-indexed set-up cards make every test fast and sure. Like the famous Mighty Mite, the TC131 uses 100-megohm grid leakage sensitivity to spot those "tricky" tubes other testers miss; tests inter-element shorts and makes cathode emission tests under full operating levels. A real profit maker as a counter checker or self service tube seller in your shop . . . and it's only

\$129⁹⁵

See your distributor about the big TC131 trade-in deal.

professional quality — that's the difference!

SENCORE

426 SOUTH WESTGATE DRIVE • ADDISON, ILLINOIS

Circle 47 on literature card

76 PF REPORTER/May, 1965



The Troubleshooter

answers your servicing problems

Cold Trouble

I have an Admiral portable Chassis 19G3-D (covered in PHOTOFACT Folder 681-1) that won't work when it is cold. During the first five minutes of warm-up, the set develops a split picture and then shifts into a horizontal flutter. After the set is completely warm, the trouble disappears and doesn't appear again until the receiver is completely cooled off.

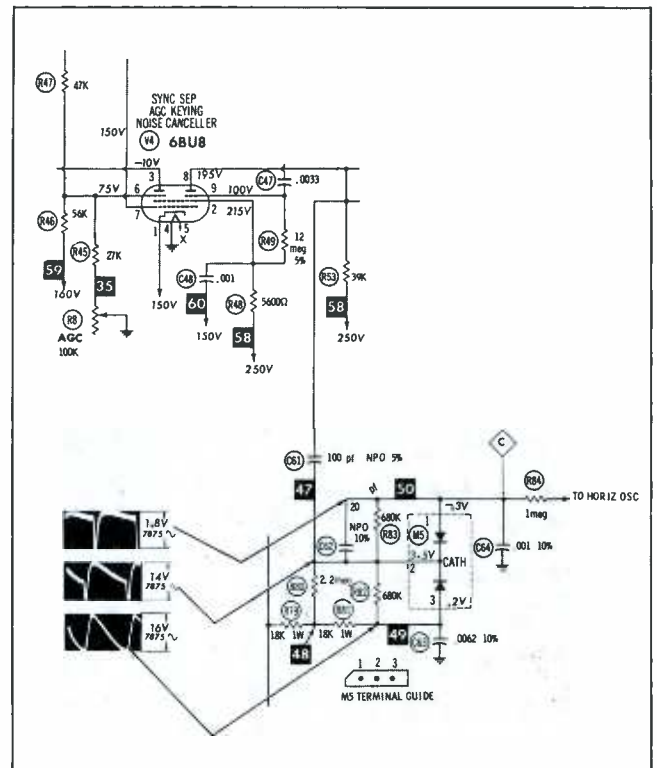

I have changed practically every component in the horizontal AFC and sync-separator circuit—but no help. The only abnormalities I have been able to find are the voltages and waveforms on M5. The waveforms on pin 1 and pin 5 both are contaminated with video information. The voltage on pin 1 is .2 volt and the voltage on pin 2 is 11 volts. Any assistance you can offer in helping me locate this trouble will be deeply appreciated. I am at my wits end.

HERMAN DAVIS

Chicago, Ill.

It seems you have fairly well eliminated the horizontal AFC as the cause of this trouble. The video contamination of the waveform on the horizontal AFC diode seems to indicate you have trouble in the sync-separator circuit. The sync-separator section of the 6BU8 evidently isn't doing its job—separating the composite video signal from the sync pulse. Be sure to measure the voltages on the 6BU8 when the set is first turned on—when the symptom is present. Since the condition develops when the set is cool, you might try spraying components around the separator circuit with circuit coolant. Also, try pressing around on the printed circuit board in the area of the sync

separator to see if you can make the condition come and go on the screen. There's a strong possibility that there is a poor solder joint someplace on the printed circuit board.

Hi-Fi Hum

I would like to pass on for the benefit of other servicemen some experiences I have had with earlier models of Symphonic hi-fi phonographs (similar to the one shown here.) These sets came in with excessive hum, and the trouble was suspected to be in the two 50C5 push-pull output tubes. Replacing the tubes seemed to cure the trouble; however, in a few weeks the sets were back in the shop with the same problem. The exact source of trouble was isolated to leakage in the 50C5 tube sockets. Replacing these sockets with phenolic or any high-temperature socket will nearly always clear up the hum.

H. M. PORTER

Griffin, Ga.

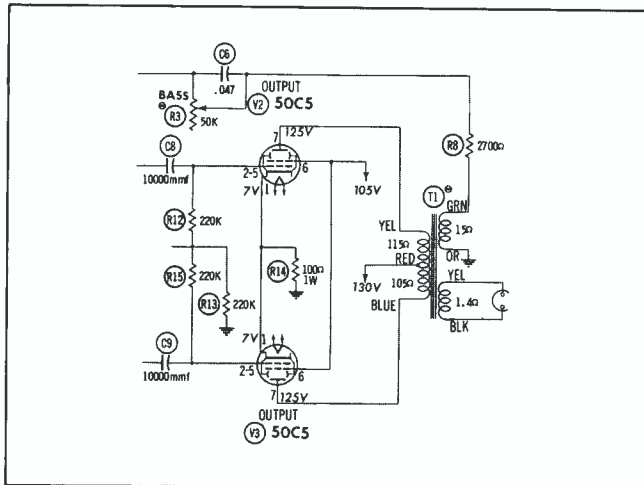

Thanks, Mr. Porter, for this helpful tip. If any of you fellows encounter a hi-fi with a hum problem, this bit of information should save you a lot of time and money.

Reduced Brightness

I have an RCA color set, Chassis CTC5 (covered in PHOTOFACT Folder 353-11) with the following trouble. The B+ voltage is 370 volts instead of 400, and high voltage is only 18 kv instead of the 22.5 kv shown in PHOTOFACT. The symptom is low brightness level, but otherwise the set has an acceptable black-and-white or color picture.

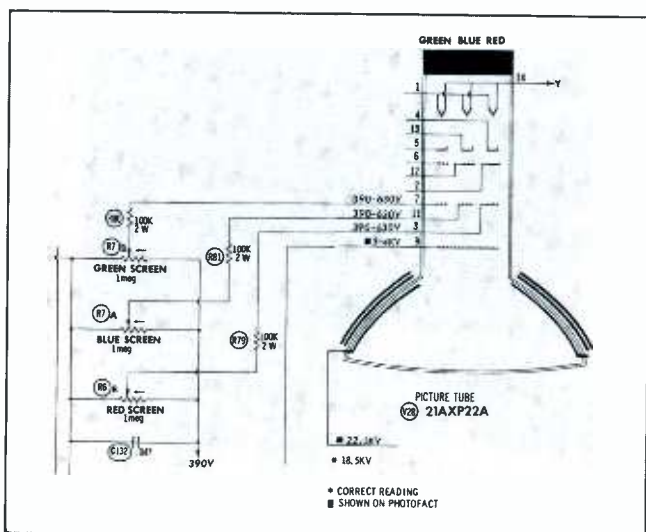

at last...
instant color patterns
at your finger tips...
zero warm-up time



THE ALL NEW SENCORE CG135 DELUXE TRANSISTORIZED COLOR GENERATOR

The big push is on in Color TV. Equip yourself now with the new, solid state Sencore CG135 and cash in on the zooming volume of new service business as Color-TV booms! Instant, service-ready RCA standard color bars, cross-hatch, white dots and individual vertical and horizontal bars enable you to set up or trouble-shoot more Color TV sets per day; earn top money in this fast growing service field. It's an analyzer too: Color gun interruptors, unmodulated video for chroma circuit trouble isolation and unmodulated sync pulses to keep Zenith receivers in sync for this test, make color trouble shooting a snap. Sturdy all-steel construction for rugged, heavy duty in the field or shop. Another Best Buy in profit-building service instruments from Sencore at **\$149⁹⁵**

COMPARE THESE FEATURES: SEE WHY THE CG135 IS IN A CLASS BY ITSELF

- Solid state construction employs high priced GE "Unijunctions" to develop six "jump out proof counters" that guarantee stable patterns at all times with no warm-up
- Standard RCA licensed patterns as shown on schematics throughout the industry
- Handy universal color gun interruptors on front panel
- Lead piercing clips insure non-obsolence
- CRT adaptors optional
- Crystal-Controlled 4.5mc Sound Carrier Analyzing Signal to insure correct setting of fine tuning control
- RF output on Channel 4 adjustable to Channel 3 or 5 from front of generator when Channel 4 is being used
- No batteries to run down; uses 115 V AC
- Less than one foot square, weighs only 8 lbs.

professional quality — that's the difference!

SENCORE

426 SOUTH WESTGATE DRIVE • ADDISON, ILLINOIS

Circle 48 on literature card

**top money maker in
the service business**



**NEW IMPROVED SENCORE CR133
CRT CHECKER & REJUVENATOR**

The new, improved CR133 CRT Checker is designed to test all present picture tubes — and it's ready for future tubes too! Two plug-in replaceable cables contain all sockets required. The compact, 10 lb., CR133 checks CRT emission, inter-element shorts, control grid cut-off capabilities, gas and expected life. Checks all tubes: conventional B&W, new low drive B&W, round color tubes and new rectangular color picture tubes. Exclusive variable G2 Volts from 25 to 325 Volts insures non-obsolence when testing newly announced "semi-low" G2 CRT tubes. New Line Voltage Adjustment insures the most accurate tests possible. Uses well-filtered DC for all checks to avoid tube damage and reading errors. Color guns are individually tested as recommended by manufacturers. Exclusive automatically controlled rejuvenator applies rejuvenation (ACR) voltage as required by individual tube condition; precisely timed to prevent over-rejuvenation or tube damage. The ACR feature is most useful for color tube current equalization to insure proper tracking. Hand-wired and steel-encased for protection of meter and panel in truck or shop, the new improved CR133 is only . . . **\$89⁹⁵**

The famous CR128 CRT Checker and Rejuvenator is similar to above, but with a three position G2 slide switch and without Line Voltage Adjustment at \$69.95

professional quality — that's the difference!

SENCORE

426 SOUTH WESTGATE DRIVE • ADDISON, ILLINOIS

Circle 49 on literature card

I have substituted the 5U4 low-voltage rectifier tubes and all electrolytic capacitors in the power supply, but no improvements were noted. I checked the horizontal-output tube current and found it to be normal—200 ma. I checked the yoke and flyback transformer with a VTVM and TV Analyst, but found no indication of shorted turns. Can you give me an idea as to what I am overlooking?

NORMAN PICHETTE

Auburn, Maine

You probably are aware that the information contained in PHOTOFACT is compiled from the actual chassis, voltage readings, component values, etc. Our information reveals that 18.5 kv is maximum for this receiver, but through an error (which will be corrected next printing) 22.5 kv was shown as maximum on PHOTOFACT Folder 353-11. Your high voltage, B+, and horizontal output current are all correct.

A characteristic of the CTC5 chassis is the relatively high settings required for the screen controls (red R6B, blue R7A, and green R7B). If readjustment of these controls doesn't help the picture brightness level, I suggest you check the quality of the 21AXP22A CRT.

Filament Trouble

I have an RCA color chassis CTC9 with the filaments burned out on V3, third video IF amplifier/sync separator. In PHOTOFACT Folder 459-1, page 17, the arrow pointing to L7 indicates nothing to me. The schematic has X connections leading from pins 4 and 5 of V3 to M4. This confuses me because this is a parallel filament string. I attempted to bridge from M4 to pin 4 and 5 of V3, but this wasn't of any help. There is a shield covering the back of the IF strip making it difficult to check that side. Will certainly appreciate any help you can extend me.

HARRY BORENSTEIN

Baltimore, Md.

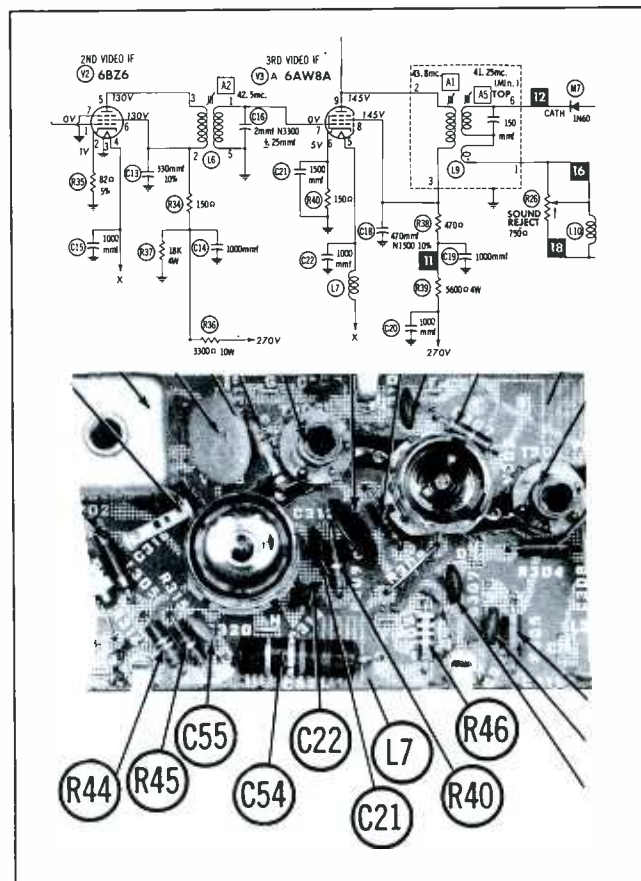

The line pointing to L7 signifies the coil is located on the other side of the board (this is a printed coil). In a PHOTOFAC component callout photograph, when a line points to a printed board but does not have an arrowhead, it indicates the component is located on the reverse side of the board.

The X on the schematic indicates that L7 is connected to the filament fuse wire, M4. The X on pin 4 of V3 (sync separator) is an error—pin 4 is actually connected to ground. Evidently, your trouble is that either capacitor C22 is shorted or filament choke L7 is open. ▲

COLOR COUNTERMEASURES

Symptoms and service tips from actual shop experience

Chassis: Magnavox 45 series.

Symptoms: Insufficient brightness.

Tips: The procedure for adjusting black-and-white tracking is changed. The brightness circuit is still active, even when the normal-service switch is in the service position. The original service manual gives the normal procedure for adjusting each screen control for a barely visible line on the face of the CRT with the brightness and contrast at mid-range. However, using this method the receiver will appear to have insufficient brightness. A revision of the original manual gives the following procedure:

1. Place the normal-service switch in service position.
2. Turn the brightness to minimum (fully counterclockwise).
3. Set the contrast control to midrange.
4. Turn each screen control and the CRT bias control to minimum (fully counterclockwise).
5. Adjust the screen controls (one at a time) until each just produces a visible line on the screen. If any control fails to produce a line, leave that control at maximum (fully clockwise), and adjust the CRT bias control until a line is just visible. Adjust the remaining screen controls for a barely visible line.
6. Return the normal-service switch to normal position.

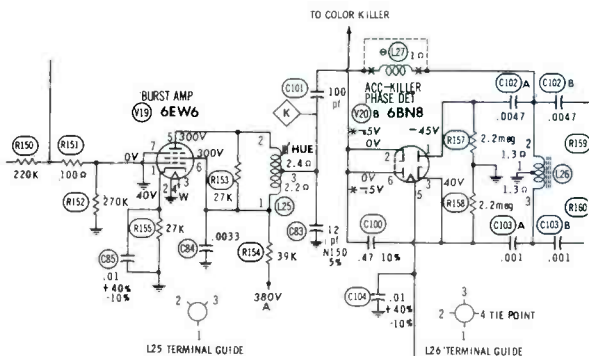

Chassis: Zenith 29JC20 (early run).

Symptom: Fine tuning range not broad enough on color program. Color drifts in and out and is difficult to tune.

- Tips:**
- A. Replace the 6GH8 (first color amplifier) tube with a 6HL8. The latter tube has greater sensitivity and will provide approximately 4 db gain—resulting in more color gain and easier “fine” tuning.
 - B. Remove the 27K damping resistor (R153) across the hue control. This will increase the burst level approximately 10%, insuring cutoff of the color-killer tube with weak incoming color bursts.

PINPOINT COLOR TV TROUBLES IN SECONDS...



WITH THE NEW IMPROVED SENCORE CA122(A) COLOR CIRCUIT ANALYZER

It's a standard ten color bar generator; produces vertical lines, horizontal lines, crosshatch, and adjustable dots, PLUS a complete TV analyzer for color and B&W—at less money than color generators only. Here is what the CA122(A) will do for you by tried and proven signal injection into these stages.

UNIVERSAL TUNER SUBSTITUTE for Color (or B&W). A must to check tuner restriction of RF color signal.

BANDPASS AND CHROMA AMPS signal injection for color trouble isolation.

EACH IF STAGE to quickly isolate a stage with low gain.

CHECKOUT COLOR DEMODULATORS for troubles or phase adjustments.

VIDEO AMPS from detector to the CRT tube, up to ± 30 VPP.

SYNC CIRCUITS; vertical and horizontal pulses to quickly isolate sync faults.

4.5 MC IF for signal injection up to the audio discriminator.

AUDIO AMPS; 900 cycles for injection right up to the speaker.

PLUS:

The CA122(A) is not only a color generator and analyzer, but provides color gun interruptors for purity adjustments and a shading bar pattern for color temperature control settings. You get all this for only. \$18750

39G12 Rectangular color tube adaptor. \$495

See your distributor today. He has the CA122(A) in stock now.

SENCORE

426 SOUTH WESTGATE DRIVE • ADDISON, ILLINOIS
Circle 50 on literature card

May, 1965/PF REPORTER 79

add an fm-stereo service center
with this one new
sencore unit!



THE SENCORE MX129 FM STEREO MULTIPLEX GENERATOR & ANALYZER

FM-Stereo growth continues to mount and is fast becoming as big a field as Color TV. This means more FM-Stereo service business for you, now and in the future. Is your shop equipped? It can be — completely and economically — with the MX129, the FM-Stereo "Service Center in a Case." The instantly stable, 19-Transistor, crystal controlled MX129 is the most versatile, most portable (only 7½ pounds), most trouble free and efficient multiplex unit on the market — just like having your own FM-Stereo transmitter on your bench or in your truck. Powered by 115 volts AC, it produces all signals for trouble shooting and aligning the stereo section of the FM receiver . . . can be used to demonstrate stereo FM when no programs are being broadcast. Self-contained meter, calibrated in peak to peak volts and DB, is used to accurately set all MX129 controls and as an external meter to measure channel separator at the FM-Stereo speakers. **NO OTHER EQUIPMENT IS REQUIRED.** **\$169⁵⁰**
only

SIGNALS AVAILABLE FOR ALIGNMENT, TROUBLE SHOOTING AND ANALYZING:

FM-RF carrier with composite multiplex audio signal with 38kc suppressed carrier, 19kc pilot and 67kc SCA signals • Multiplex signal formed by 60 or 1000 cycle internal tones or any external signal • Full control over left and right channel amplitude (modulation) • External 67kc SCA signal available for trap adjustment • Composite signals available for signal injection FM detector •

professional quality — that's the difference!

SENCORE

426 SOUTH WESTGATE DRIVE • ADDISON, ILLINOIS

Circle 51 on literature card

PFR Bench Report



Card-Style Tube Manual

A new-style tube manual called *Fast Fax* is actually a file of 3" x 5" cards, each of which lists a separate tube type. The file places tube data for 600 types within easy reach. Each card is slot punched for easy removal or insertion.



The tubes are listed in alphabetical order instead of by voltages. For example The characteristics for the 13GF7 are filed under "G" rather than under "13." The same card lists the 6-, 10-, and 13-volt tubes in the 'GF7 family. This method of listing avoids situations in which a technician looks up a tube type in the standard tube manual only to be referred to another page where the characteristics are listed. Tube data is condensed; information not pertinent to the job of the service technician is omitted.

The cards also indicate available improved (A) versions. The substitutions that are available are listed as "replacements for" at the bottom of each card. These are cross-indexed in the last few cards as a substitution guide. A form is provided on the back of each card for inventory control—a handy way to estimate future requirements for each tube type.

The *Fast Fax* receiving-tube characteristics file is supplied complete with index separators and steel holder. The file may be placed on the bench or mounted on a wall by the use of two pre-punched holes in the holder. The file is available from **Raytheon Company** distributors at \$3.95. A subscription service is available at no extra cost to keep the file up to date. ▲

For further information, circle 131 on literature card.

CB Alignment Techniques

(Continued from page 31)

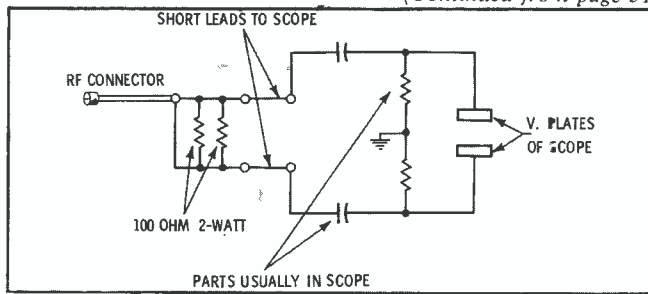

(A) Circuit

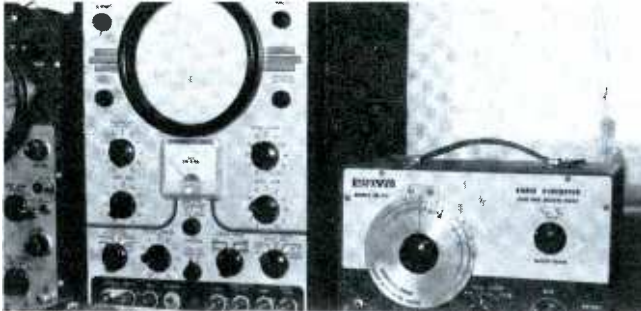

(B) Equipment

Fig. 4. Modulation check can be made easily with a scope.

Modulation Checks

An AM modulation meter can tell much about the modulation characteristics of the transmitter. It should be no problem to maintain 100% modulation on peaks with the microphone several inches from the mouth and the voice at normal level. If considerable voice power is needed to swing negative modulation in excess of 100%, this indicates modulation limiting is taking place and the RF carrier of the transmitter is not over-modulating in a manner that will produce splatter on adjacent channels.

The simple arrangement of Fig. 4A can be used to display CB modulation on an oscilloscope. A regular service-type scope can be used if there is provision for application of RF voltage directly to the vertical deflection plates. An audio oscillator is used to supply signal to the microphone input stage of the transmitter.

A short length of transmission line is attached to the output of the transmitter and is terminated in a 50-ohm resistance (two 2-watt 100-ohm resistors in parallel), for which two short leads connect directly to the vertical deflection plates of the oscilloscope. (Make certain your scope includes two high-voltage isolation capacitors between the deflection plates and the direct-input terminal board so the hazardous high-voltage DC potential is not brought out to the terminal strip. If such capacitors are not used, two of them should be inserted in the leads that connect from the terminal strip to the 100-ohm load resistors.)

It is now possible to observe on the scope the modulation characteristics of the transmitter, by setting the scope frequency to 1/2 or 1/3 the frequency of the modulating tone. The RF carrier with no modulation will provide some vertical deflection on the scope CRT—1" is rather typical. With 100% modulation, the envelope should not distort, the peak-to-peak amplitude should be double (2") the unmodulated value, and the negative excursion should swing close to the

america's most popular tube tester

... because it
finds the
"tough dogs"
others miss!

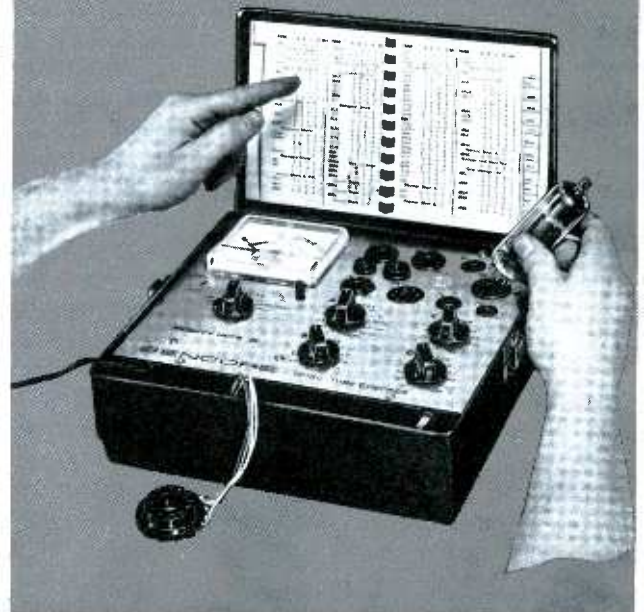

THE NEW SENCORE TC130 MIGHTY MITE III TUBE TESTER

New in looks and compactness, updated with many exclusive features. The MIGHTY MITE tester, long America's most popular tube checker because it has the versatility and reliability professional servicemen demand! The MIGHTY MITE III checks them all — more than 2,500 tubes plus picture tubes, including the new frame grid tubes (has four extra sockets for latest tubes). It's fast and thorough, checks for control grid leakage, then, with the flick of a switch, tests for interelement shorts and cathode emission at full operating levels. Uses costly moving coil meter for high sensitivity (100 megohms) to find those "tough dog" tubes other low-sensitivity testers miss. In versatility, reliability, portability and operating simplicity, the TC130 is **\$74⁵⁰** your best buy in tube checkers at

COMPARE THESE MIGHTY MITE III FEATURES:

Lower voltage for Nuvistors and all frame grid tubes • Unique circuit tests for inter-element shorts, each and every element • Checks cathode emission at full operating levels • Checks control grid leakage at 100 megohms sensitivity, like "eye tube" testers.

Speed-indexed set-up cards greatly reduce look-up time • Simplified panel layout speeds checks, prevents errors • Burn-out proof, stick-proof meter • Sturdy, all-steel case, rubber feet • Styled for modern, professional look

professional quality — that's the difference!

SENCORE

426 SOUTH WESTGATE DRIVE • ADDISON, ILLINOIS

Circle 52 on literature card

May, 1965/PF REPORTER 81



Fig. 5. Setup for bench-testing CB's.

zero base line (center) of the scope display. Even with modulation input to the transmitter increased well above normal, the negative modulation should not swing to the point at which there is carrier cutoff. Clipping action is indicated by a rounding off of the modulation envelope at its crest and a flattening in the trough.

Receiver Alignment

In most superheterodyne alignment, there are three basic steps: the IF, local oscillator, and RF adjustments, in that order. In some CB models, however, a single accurate RF setup can be used to align both the RF and IF sections in one procedure, because of the

fixed nature of the crystal oscillator. An amplitude-modulated RF signal is applied to the antenna input, and an audio voltmeter is connected across the loudspeaker as an output indicator. In other models, of the tunable-front-end variety, the application of an IF signal to the mixer stage is recommended for IF alignment.

A separate step is advisable for setting the local oscillator correctly, particularly in a double superheterodyne arrangement. The local oscillator coils can be adjusted using an incoming signal on one of the center-band channels. Alignment procedures for tunable local oscillators usually include separate adjustments for precise tracking at both the high and low ends of the class-D frequency spectrum.

The system of using another CB unit as an alignment-signal source is attractive because of the narrow-band IF systems now employed for adjacent-channel rejection. Alignment can be for peak sensitivity with the audio quality kept under scrutiny at the same time. This system also ensures that the sharp selectivity of the receiver will not distort voices in normal operation.

When separate RF, local oscillator, and IF signal sources are employed in the alignment process, it is particularly important that the signal sources be exactly at the recommended frequencies. If inexpensive signal sources are employed, they should be crystal controlled or checked against some accurate standard. Accurate RF signal sources for the CB spectrum and 455 kc can be obtained at low cost. Difficulties may arise with double-superheterodyne receivers because of the high IF, usually in the range of 1.5 to 3 mc. As yet there has been no standardization of high-IF frequencies or of the mixing arrangements used in a frequency-synthesis local-oscillator systems. One or more crystals cut for specific high-IF specifications can be purchased and used in the crystal circuit of your crystal-activity tester or in a two-way-radio test set that includes an RF oscillator. Fig. 5 shows a bench setup for overall checks and alignment.

CB transceivers with power-input ratings greater than 100 mw, the .005% FCC frequency tolerance applies. It does not apply to the 100-mw transceivers used in the Part 15 Radio Service. However, when these latter units are employed in conjunction with class-D Citizens-band stations, they must be licensed and maintained on frequency the same as ordinary CB units. Fewer stages are usually involved, and alignment procedures are simple and straightforward.

In one simple unit, the three transmitter adjustments are oscillator, input to the output stage, and the output pi network. For the final transmitter tuning step, the crystal-oscillator frequency is adjusted precisely within the FCC tolerance for the specific channel. Receiver alignment of this unit uses a tone-modulated RF signal. Alignment can be on either of the two receive channels.

Most hand-held units are crystal-controlled on both receive and transmit. Separate oscillator adjustments provide a fine setting for both transmit and receive crystals. Since the transmit oscillator must be operated within FCC frequency tolerance, it should be set first. Next, set the receive oscillator for maximum sensitivity and minimum distortion of the incoming signal. Whenever possible, check out the performance of the hand-held unit with the associated base or mobile station.

If just two hand-held units are to be used without relation to any other CB base or mobile station, they should be aligned carefully to each other. One transmit oscillator should first be aligned very carefully with a precise frequency meter. Then the other transmit oscillator is set to the same precise frequency by zero-beating the signals from both units together in some receiver. It is now possible to use the one hand-held unit to set the receiver oscillator of the second unit, and vice versa. The two hand-held units are thus matched to each other, and communications between the two is optimized.

Many hand-held units include a jack for an earphone. This jack is convenient for inserting an AC voltmeter as an output indicator for alignment and peaking adjustments.



3 PLANTS TO SERVE YOU BETTER HERMETICALLY SEALED PRECISION GROUND CUSTOM-MADE NON-OVEN CRYSTALS

Gold or silver plated, spring mounted, vacuum sealed or inert gas, high freq. stability, 10 milliwatt max. current cap. Meet mil. specs.
1000KC to 1600KC (Fund. Freq.)
Prices on Request
1601KC to 2000KC (Fund. Freq.)\$5.00 ea.
2001KC to 2500KC (Fund. Freq.) 4.00 ea.
2501KC to 5000KC (Fund. Freq.) 3.50 ea.
5001KC to 7000KC (Fund. Freq.) 3.90 ea.
7001KC to 10,000KC (Fund. Freq.) 3.25 ea.
10,001KC to 15,000KC (Fund. Freq.) 3.75 ea.
15MC to 20MC (Fund. Freq.) 5.00 ea.

OVERTONE CRYSTALS

15MC to 30MC Third Overtone\$3.85 ea.
30MC to 40MC Third Overtone 4.10 ea.
40MC to 65MC Third or Fifth Overtone 4.50 ea.
65MC to 100MC Fifth Overtone 6.00 ea.

DRAKE 2-B Receiver Crystals\$4.00
(All Channels—Order by Freq.)

OVEN-TYPE CRYSTALS

For Motorola, GE, Gonset, Bendix, etc.
Add \$2.00 per crystal to above prices
SUB-MINIATURE PRICES slightly higher

ORDER FROM CLOSER PLANT TEXAS CRYSTALS

DEPT. PF
1000 Crystal Drive
FORT MYERS, FLORIDA
Phone 813 WE 6-2109

Division of



AND
4117 W. Jefferson Blvd.
LOS ANGELES, CALIF.
Phone 213-731-2258

Hand-Held Transceivers

For those hand-held and portable

Circle 54 on literature card

B+ Feed Paths

(Continued from page 36)

through a 180-ohm resistor to the base connection of X3 (also easily identified as the junction of a 180-ohm resistor, a 1000-ohm resistor, and a capacitor), through a 1000-ohm resistor to terminal 1 of IF coil L6 (also the junction of a 1000-ohm resistor, a 15K resistor, and a .01-mfd capacitor), out of terminal 4 of the IF coil to the base connection of transistor X4 (where a 6-pf capacitor is also connected). Thus you see that tracing B+ paths, even without the numbering system, is not really difficult on printed boards—even when you can't see the printed wiring to trace visually.

Troubleshooting B+ Paths

The most common fault in B+ feed paths is low voltage; less often will the voltage be too high. Furthermore, low voltage can be from two causes—a short on the B+ line or a faulty supply source. There is one easy way to chase down the root of either symptom, once you know how to find your way through the maze of B+ paths: disconnecting various sections or branches and noting how the voltage is affected.

Low Voltage (Short)

B+ can be pulled down by an overload at any point on the feed line. The overload can be a dead short, or it could be merely leakage. This type of overload is always characterized by an increase in current drawn by the line, and it is often accompanied by overheating of certain parts (severely, if the trouble is a direct short).

If resistors along the B+ path are overheated and discolored, they can be a clue to the location of the short. Check the schematic and identify the path through the discolored components. At the point farthest from the source, at the end of the path of discolored resistors, you'll probably find a shorted or leaky part—capacitor, tube (or transistor), or a winding-to-core breakdown in a transformer.

Another system, useful mostly with direct shorts, involves tracing the path with a voltmeter; at the point of the short, the voltage will have diminished to zero. In a transistor set similar to the one in Fig. 9, excess current suggested a short somewhere on one B+ feed path.

a handful is all
it takes...
for many tests



Simpson MICRO-TESTERS...18 Types...Get Several

If you run tests on communication systems, motors, wiring, appliances, tubes, components, batteries, or coolers, these nifty little testers are just what you're looking for. Micro-Testers measure only 3" x 5 7/8" x 2 1/2". They give you Simpson quality in a tester that is compact in both size and price. All 18 are in stock for immediate delivery. Call your Electronics Distributor or the factory for Bulletin 2066.

AC/DC VOLT-OHM-MILLIAMMETER: 12 ranges	Model 230	\$33.95
AC/DC VOLT-OHM-MILLIAMMETER: 14 ranges	Model 240	34.95
OHMMETER: 6 ranges, 0 ohms to 50 meg.	Model 372	29.95
LOW-OHMMETER: 0-5, 0-25 ohms	Model 362	26.95
AC AMMETER: 0-1, 2.5, 5, 10, 25 amp. ±5% FS	Model 370	24.95
DC AMMETER: 0-1, 2.5, 5, 10, 25 amp. ±3% FS	Model 375	23.95
AC MILLIAMMETER: 0-5, 25, 100, 250, 1000 ma, ±5% FS	Model 378	26.95
DC MILLIAMMETER: 0-1, 5, 10, 25, 50, 100, 250, 1000 ma, ±3% FS	Model 373	23.95
DC MICROAMMETER: 0-50, 100, 250, 500, 1000, ua ±3% FS	Model 374	26.95
AC VOLTMETER: 0-5, 10, 25, 50, 100, 250, 500, 1000 v, ±5% FS	Model 376	23.95
AC VOLTMETER: 0-150, 300, 600 v, ±3% FS	Model 371	24.95
DC VOLTMETER: 10 ranges, 0 to 1000 v, ±3% FS	Model 377	24.95
DC MILLIVOLTMETER: 0-10, 30, 100, 300, 1000 mv, ±3% FS	Model 387	29.95
AC VOLT-AMP-WATTMETER: 8 ranges (300 v, 15 a, 3000 w. max) ±5% FS	Model 390	54.95
AC/DC VOLT-WATTMETER: 4 ranges (260 v, 3000 w, max) ±5% FS	Model 391	47.95
AC/DC VOLT-WATTMETER: 4 ranges (260 v, 5000 w, max) ±5% FS	Model 392	49.95
BATTERY TESTER: for radios, flashlights, hearing aids	Model 379	29.95
TEMPERATURE METER: -50° to +70°F (up to 3 temp. one time)	Model 385-3L	35.95



Simpson
INSTRUMENTS THAT STAY ACCURATE

SIMPSON ELECTRIC COMPANY
5209 W. Kinzie Street, Chicago, Ill. 60644
Phone: (312) ESTebrook 9-1121
In Canada:
Bach-Simpson Ltd., London, Ontario

Circle 55 on literature card

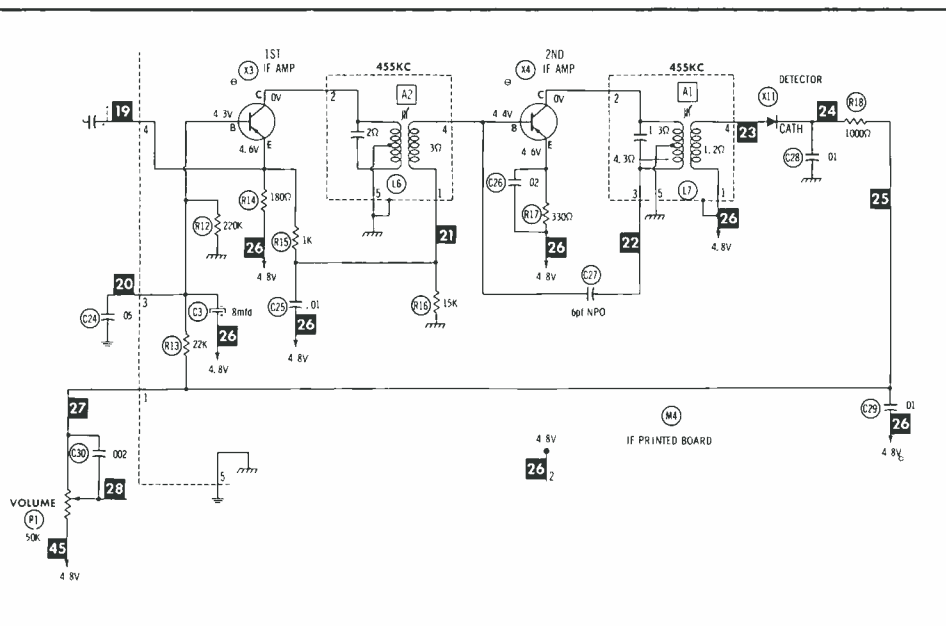

Fig. 9. Schematic diagram of the printed circuit board illustrated in Fig. 8.

Checking in the several branches, we finally were tracing along the R14-R15-L6 path. At 26, source voltage was loaded down to 4.2 volts; at X3E, we measured 3 volts; at 21, virtually nothing—indicating the short was that point. Examining the schematic, we decided that either C27 was shorted or X4 had a base-collector short. We opened the collector connection at X4C (it goes to ground through L7) and measured over 4.5 volts; at the same time, we found the X3E voltage was back to normal, as was the source. Our diagnosis of a base-collector short was thus verified, and a new transistor corrected the trouble.

The fact that the X3E and point-26 voltages returned to near normal leads us to one of the surest ways of locating a short or leakage. When the shorted branch of a B+ feed path is disconnected, voltage on the remainder of the circuit returns to normal or slightly above, and ex-

cessive current drops off to normal or slightly less.

In the set shown in Fig. 9, for example, opening the circuit at either end of R14 would have relieved the short, but the suspects would still have included X3, C27, X4, or a winding-to-case short in L6. If opening R15 cleared the short, X3 was eliminated as a suspect. Disconnecting terminal 4 left L6 clear. If opening the connection to C27 failed to relieve the short, X4 was the only possibility left. If removing X4 from the circuit had failed to relieve the short, we'd have started looking for shorts between socket contacts or between foil strips on the circuit board (or, in a hand-wired set, for wires that were touching).

Low Voltage (Source)

Troubleshooting in the B+ feed paths may prove the trouble isn't a B+ short. If the B+ is low, simply unload every branch from the

source, rechecking source voltage after each branch is disconnected. If removing any branch allows the voltage to rise again to normal, that branch is shorted and is loading down the source. If B+ remains low after all branches are disconnected, the fault is at the power supply itself—bad rectifier, poor filter capacitor, defective power transformer, or other fault.

There is another way to tell whether low B+ voltage is caused by a faulty source or an overload. If the current is easy to monitor (and it often is), measure it at the output of the power supply. Low current indicates the fault is at the source; high current signifies an overloaded B+ system.

High B+

If B+ at some point is higher than normal, chances are good the circuits beyond that point are inoperative in some manner and aren't drawing enough current to keep the voltage loaded down to its normal value. A current check will reveal the defect, or you can open the path and notice if the voltage becomes any higher—it will if the circuits beyond have been drawing current. Every B+ branch can be checked out in this way.

If all the B+ paths are drawing normal current and the overall B+ voltage is still too high, the fault has to lie in the supply. Line voltage could be high; the transformer primary could have a partial short that raises the secondary voltage; the wrong transformer may have been installed or the wrong connections made; or a capacitor may incorrectly have been added to the input of a choke-input filter.

Conclusion

There is no royal road to servicing B+ systems. Although the principles involved are rather elementary; you still have to dig in. Learn first to trace circuits on the schematic and in the chassis. Then learn how to make tests by the point-to-point testing method, analyzing your results as we've outlined. Shortly you'll feel at home in any type of B+ system, whether it's hand-wired or printed. After that, you'll realize you're saving a lot of troubleshooting time by working your way through B+ feed paths confidently and quickly. ▲

PRECISION TUNER SERVICE

P. O. BOX 272 1210 S. WALNUT ST.
BLOOMINGTON, IND. EDISON 99653

7.95

V or U

COMBO PLUS

9.95 POSTAGE

6 MONTH WARRANTY



All Types T.V. Tuners Cleaned, Repaired and Aligned to Factory Specifications. Same day in shop service on most Tuners. Price Includes Minor Parts, Major Parts at Cost Price. We use Original Parts if possible. State Make Model and Enclose all Parts and Tubes. Pack Well and Insure.

ALSO HAVE LARGE STOCK OF EXCHANGE TUNERS, WRITE FOR TYPES AND PRICES.

Circle 56 on literature card

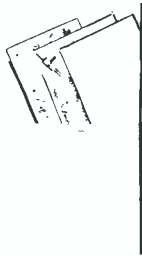

Product Report

For further information on any of the following items, circle the associated number on the Catalog & Literature Card.

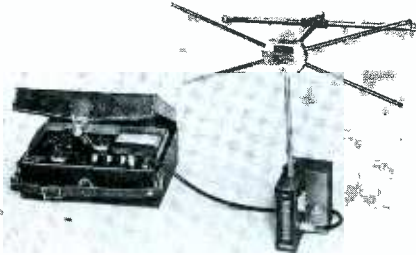

UHF FSM Adapter (132)

An adapter designed to allow any VHF field-strength meter to be used for UHF measurements is now available from Sadelco, Inc. The accessory unit has been designed to assure compatibility with existing meters; a universal mounting bracket allows the UA-1 to become an integral part of any present mounting bracket. Compatibility is also stressed in the unit's output frequency of 64 mc (about midchannel 3). A built-in battery supply also permits the unit to be operated at a distance from the field-strength meter. The adapter then becomes a hand-held VHF-signal probe and a plug-

in antenna is supplied for this purpose. Each unit includes: a solid-state voltage regulator enabling batteries to be used down to 40% below their rated voltage; a level meter to indicate when batteries are exhausted; a backward-diode mixer and a mesa-transistor IF stage for low noise and wide dynamic range from below 5 microvolts to .1 volt. The unit is priced at \$120.

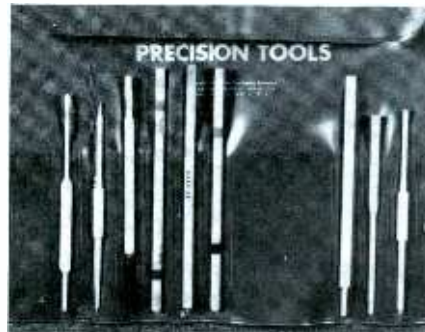

New Citizens Band Alignment Tool Kit (133)

A handy tool kit for use by FCC-licensed CB technicians is available from

GC Electronics. The CB Alignment Tool Kit No. 9210 contains nine adjustment tools designed for tuning IF transformers, RF coils, antenna and oscillator coils, and for making other adjustments that may be required in CB units. The kit is sold in a plastic carrying case for compact storage, at a suggested net price of \$4.89.

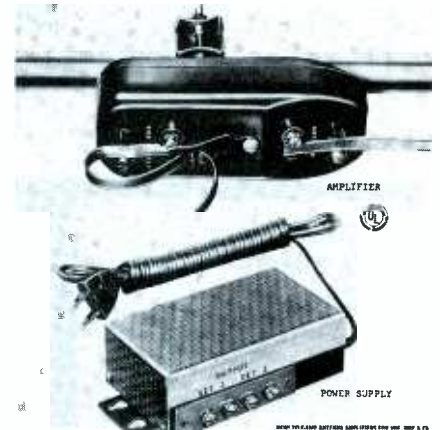

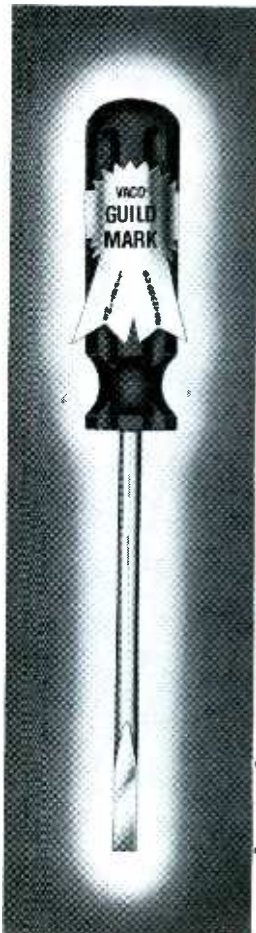

Solid-State Antenna Amplifiers (134)

Increased reliability for installations exposed to weather is claimed for a new line of antenna amplifiers from JFD Electronics Corp. Featuring transistor and nuvistor design and printed-circuit construction, each amplifier is mounted in a case sealed with "Poly-U" sealant to provide protection from adverse atmospheric conditions.



VACO[®] announces a major break-thru in screw driver construction **VACO GUILD/MARK**

The Solid Neoprene Handle Driver
with the Lifetime Guarantee
with These Ultimate Selling Features

-  **Exclusive Neoprene Rubber Handle** featuring famous VACO Comfordome design—impervious to oil, grease, acids . . . you can't ruin it!
 -  **Extra Comfort, Improved Grip-Power** assured thru new Dual Dyrrometer Process . . . most comfortable screw driver you ever used.
 -  **Chrome Vanadium Steel Blade** locked in construction, beautifully polished, nickel chrome finish . . . best looking screw driver you've ever seen.
- Backed by a Lifetime Guarantee, this Symbol permanently embossed in the handle . . . your protection for now and years to come.



LOOK FOR THIS BADGE OF QUALITY FOUND ONLY ON VACO GUILD/MARK SCREW DRIVERS . . . DO YOUR HAND A FAVOR . . . SEE THEM . . . TRY THEM.

Sold through better stores everywhere.
VACO PRODUCTS COMPANY
317 East Ontario Street Chicago, Ill. 60610

Circle 59 on literature card

The Year's
**BIGGEST
BREAK THROUGH!!!**

KLEEN-IT

**A 99¢ CLEANER . . .
SAFE FOR PLASTICS**

For use on tuners, switches and controls

- For All Tuners
- Powerful Cleaner
- Non-Flammable
- Lasting Protection
- Shock-Proof Extension
- Contains Silicones

No. 1628-6S Contents 6 oz.

KLEEN-IT . . . SAFELY . . . for just 99¢

Look for the Bright Orange Can
COLMAN ELECTRONICS Amarillo, Texas

Circle 58 on literature card

3 Reasons Why It Pays to Use General Electric Renewal Parts

INCREASED CUSTOMER SATISFACTION

The best customer is a satisfied one—satisfied with your service and with the quality of the parts you use. Satisfy your customers with G-E quality.



REDUCED INVENTORY AND SERVICE COST

With G.E.'s continuing parts standardization program you can stock fewer parts. Save time and money in everyday service operations.



FAST PARTS SERVICE

Need a part? Count on General Electric for quick service—your distributor will ship your order promptly.

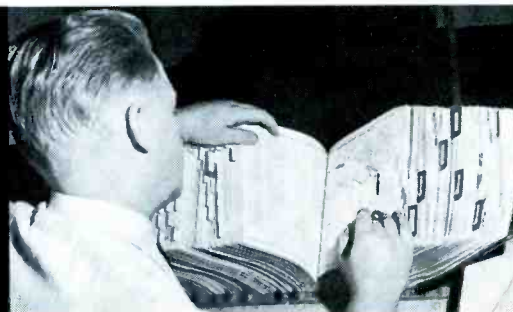

BUILD PROFITS WITH THESE FAST MOVING TV AND PHONOGRAPH PARTS



Transistor EA15X25



Spindle EA97X174



Knob ET43X299



Polarized Extension Cord
ET90X32

These are four samples of G-E renewal parts, parts that are factory engineered, precision-fitted, and designed for long-lasting performance. Call your nearby General Electric distributor and ask him for Genuine G-E Renewal Parts.

830-38

GENERAL  ELECTRIC

Circle 57 on literature card

The circuits employed in the amplifiers use high-frequency matching transformers at both input and output to minimize losses due to mismatches. A transformer-powered, solid-state power supply eliminates any possibility of dangerous electrical shocks. Six models are available with prices ranging from \$34.95 to \$49.95.

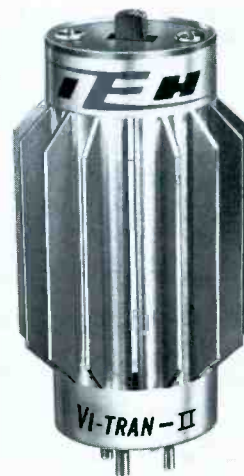

Vibrator Replacement (135)

A new solid-state vibrator eliminator for heavy-duty communication equipment is offered by IEH Mfg. Co. The Vi-Tran II will replace the standard 4-pin vibrator in communications equipment which draws from 5 watts to 25 watts of power, at either 6 or 12 volts. Two models are available: VE 196 with pin 1 positive, and VE 197 with pin 1 negative. Vi-Tran II will operate at temperatures ranging from -50°F to 180°F ; the case is a finned aluminum extrusion for maximum heat dissipation. User net price is \$9.95.



Elliptical-Stylus Cartridge (136)

A new stereo cartridge that incorporates an elliptical stylus is specifically designed

by **Audio Dynamics Corp.**, for the high tracking pressures required by automatic record changers. The ADC 660/E, as this cartridge is called, is free of the damaging effects on records that are ascribed to elliptical styli when they are used at any but minimum tracking pressures. ADC research established that the design of the cartridge suspension, rather than tracking force, was the underlying cause of excess wear. The solution is a design which, while capable of perfect tracking at pressures as low as 1 gram, will still support the necessary weight of up to 3 grams required by many record changers.

INDEX TO ADVERTISERS

MAY 1965

ATR Electronics, Inc.	12
A. T. & T.	49
Antennacraft Co.	13
B & K Mfg. Co.	43, 47, 51
Div. of Dynascan Corp.	
Belden Mfg. Co.	24
Berns Mfg. Co., Inc., The	54
Bussmann Mfg. Div.	22, 23
Castle TV Tuner Service	21
Chanellock Inc.	58
Chemtronics, Inc.	66
Cleveland Institute of Electronics	29
Colman Electronic Products	85
ESCO Mfg. Co.	70
Electro-Voice, Inc.	12
Finney Co.	16, 17
GC Electronics Co.	42
General Electric	14, 15, 86
Hallcrafters Co.	64
Hickok Electrical Instrument Co.	41, 19
Injectorall Co.	70
Jerrold Electronics	Cover 2
Lectrotech, Inc.	60
Littelfuse, Inc.	Cover 4
Mallory, P. R. & Co., Inc.	57
Miller, J. W., Co.	48
Mosley Electronics, Inc.	50
Perma-Power Co.	74
Philco Corp.	61
Planet Sales Co.	56
Precise Electronics	56
Precision Tuner Service	84
Quality Tuner Service	46
Quam-Nichols Co.	46
Quietrole Co.	54
RCA Electronic Components and Devices	65, Cover 3
RCA Sales Corp.	55
Rawn Co.	48
Rohn Mfg. Co.	75
Sams, Howard W. & Co., Inc.	63, 67
Sarkes Tarzian, Inc., Semiconductor Div.	40
Tuner Service	9
SENCORE Inc.	76, 77, 78, 79, 80, 71
Simpson Electric Co.	83
Sonotone Corp.	73
Sprague Products Co.	10
Sylvania Electric Products, Inc.	20
Terado Corp.	56
Texas Crystals	82
Triplett Electrical Instrument Co.	53
VACO Products Co.	85
Walsco Electronics Co.	54
Winegard Co.	69, 72, 87
Yeats Appliance Dolly Sales Co., Inc.	66
Zenith Radio Corp.	59



Unusual UHF Antenna (137)

A new antenna with adjustable bandwidth, the "Bandsaw," has been developed by **Channel Master Corp.** Available in two models, 13-element suburban Bandsaw (Model 4311G) and 22-element fringe Super Bandsaw (Model 4310 G) this antenna provides broadband UHF reception that can be adjusted for 12 db and 15½ db peak gain in that section of the band in which the customer is most interested. When they are stacked, there is an increase in peak gain of 3 db. Adjustments are made using a calibrated scale with six printed channel numbers. An unusual design, called a "sawtooth" flatplane folded dipole, gives the Bandsaw a distinctive appearance. A large reflecting screen minimizes rear pickup. Suggested list price is \$15.95 for the Bandsaw, \$19.95 for the Super Bandsaw.



Low-Priced Tube Tester (138)

Tubes, decals, magnavols, and 7-pin nu-vistors can be checked on the **Mercury Electronics Corp.** Model 1101. In addition, it will test most older and presently used tubes, novars, compactrons, and most industrial types, for emission, shorts, leakage, and gas content. The checker also tests many TV picture tubes, including standard 12-pin duo-decal and 110° RCA 8-pin types. The 3½" meter is protected against accidental burn-out. The instrument is priced at \$49.95. ▲

Winegard Dealer of the month

No. 36 of a series

Bailey Baumgardner says: "The salt spray in our area is a definite problem, that's why we recommend Gold Anodized Winegard Colortrons."



Winegard salutes Authorized T.V. and Appliances, Oxnard, California, and their distributor, Hurley Electronics, Oxnard California.

There are a lot of reasons why Bailey Baumgardner has become a top Winegard booster. One is that Winegard has solved the problem of Salt Spray corrosion which is so prevalent in his area. But also, says Bailey, "Colortrons give us the best overall reception by far for the area we serve... and that includes some rugged deep fringe areas, too."

In addition to its quality construction and outstanding performance, Bailey says, "Many people ask for Winegard Colortrons due to their substantial nationwide consumer advertising program in Life and Parade. This makes them easier to sell."

The confidence Bailey Baumgardner has shown in Winegard comes from installing Winegard antennas and seeing them in action. He is one more important service man who knows Winegard's standards of excellence first hand.

Winegard Co.

Antenna Systems

D3009E Kirkwood • Burlington, Iowa
Circle 60 on literature card

May, 1965/PF REPORTER 87



FREE Catalog and Literature Service

*Check "Index to Advertisers" for further information from these companies.

Please allow 60 to 90 days for delivery.

ANTENNAS & ACCESSORIES

62. **ALLIANCE**—Flyer describing Model 300 broad-band VHF booster; suitable for black-and-white or color.
63. **ANTENNA-CRAFT**—Latest literature on *Channel-Spanner*, a new broad-band high-gain VHF-UHF TV antenna.*
64. **CLEAR BEAM**—Catalog sheets on line of VHF-UHF indoor antennas and outside FM-stereo antennas.
65. **FINNEY**—Catalog UVF describes new swept-element log-periodic VHF-FM antennas.*
66. **JFD**—Literature on complete line of log-periodic antennas for VHF, UHF, FM, and FM stereo. Brochure showing converters, amplifiers, and accessories; also complete '64-65 dealer catalog plus dealer wall chart of antenna selection by area.
67. **MOSLEY ELECTRONICS**—Illustrated catalog giving specifications and features on large line of antennas for Citizens band, amateur, and TV applications.*
68. **MULTITRON**—Illustrated literature on FM-stereo antenna No. M-A-44, Multituner Model M-11, and Minienna No. MIN-4T.
69. **STANDARD KOLLSMAN**—Catalog sheet on UTC-051 transistor UHF converter kit with IF amplifier.
70. **TRIO**—Brochure on installation and materials for improving UHF translator reception.
71. **G. F. WRIGHT**—Catalog sheets on guy wire for use with outside antenna installations.
72. **ZENITH**—Informative bulletins on antennas, rotors, batteries, tubes, loudspeakers, record changers, and wire and cable.*

AUDIO & HI-FI

73. **ADMIRAL**—Folders describing line of '65 equipment; includes black-and-white TV, color TV, radio, and stereo hi-fi.
74. **CINE SONIC**—Data sheet describing rental service which supplies background music prerecorded on 7", 10½", and 14" reels of tape or in cartridges.
75. **GIBBS SPECIAL PRODUCTS**—Folders describing principles of sound reverberation and *Stereo-Carb* reverberation units for automobiles.
76. **JENSEN**—24-page catalog, No. 165-K, illustrates and describes speakers and speaker system kits.
77. **NUTONE**—Two full-color booklets illustrating built-in stereo music systems and intercom-radio systems. Includes specifications, installation ideas, and prizes.
78. **OAKTRON**—"The Blueprint to Better Sound," an 8-page catalog of loudspeakers and baffles giving detailed specifications and list prices.
79. **OXFORD TRANSDUCER**—Product information bulletin describing complete line of loudspeakers for all types of sound applications including replacements for public address and intercom systems.
80. **QUALITONE**—Information on selling diamond needles and earning free gifts.
81. **QUAM-NICHOLS**—General catalog listing replacement speakers for public address, hi-fi, and radio-TV applications.*
82. **SHURE BROTHERS**—Folder on newly introduced hi-fi magnetic cartridge.
83. **SONOTONE**—Catalog sheet on *Sonomaster* Model RM-0.5 speaker system.*
84. **TURNER**—New four-page full-color catalog No. 1040 describing microphones designed for church applications.

COMMUNICATIONS

85. **E-Z WAY PRODUCTS**—Information on crank-up, tilt-over towers for amateur radio, Citizens band, and industrial communications.

86. **PEARCE-SIMPSON**—Specification brochure on IBC 301 business-band two-way radio, *Companion II*, *Escort*, and *Guardian* 23. Citizens-band transceivers.
87. **SONAR RADIO**—Specification sheet on Model FM-40 business radio.

COMPONENTS

88. **BUSSMAN**—Bulletin SFH-10 on new compact fuseholders only 1½" long, extending just 29/32" behind front of panel, and requiring only ½" mounting hole. Holders take ¼" x 1¼" fuse and are available either with screw-type knob that is easily removed by hand or with screw-driver slot.*
89. **CBC INDUSTRIES**—Catalog of picture-tube brighteners; featuring new all-voltage types.
90. **E-Z-HOOK**—Catalog sheets showing complete line of test connectors, harness-cable board binding posts, and test leads and clips.
91. **GC ELECTRONICS**—80-page industrial catalog FR-66-1 showing newly introduced products.*
92. **J-B-T-INSTRUMENTS**—General catalog 565; bulletins on reed relays, oscillator controls, toggle switches, and subminiature rotary-lever switches.
93. **PERMACEL**—Product specifications on plastic tapes listing types, technical data, uses, and product features.
94. **PERMA-POWER**—New catalog sheet on complete line of CRT brighteners and TV service accessories.*
95. **RAVN**—New professional ideas for knob and plastic repair.*
96. **RCA BATTERIES**—Manual BDG-111 includes battery theory and applications, electrical and mechanical characteristics, and terminal connections for all types in the RCA line.*
97. **SPRAGUE**—Latest catalog C-616 with complete listing of all stock parts for TV and radio replacement use, as well as *Transfarad* and *Tel-Ohmike* capacitor analyzers.*
98. **SWITCHCRAFT**—Phone-plug and patch-cord catalog P-202 listing current product line as well as 6-conductor twin-plugs.
99. **WALDOM**—Latest catalog No. 6F5 covering solderless terminals and connectors, hardware, tube sockets, terminal strips, knobs, dials, and service replacement parts. Includes index and prices.
100. **WORKMAN**—Coil catalog No. 109 and cross reference for replacement of antenna coils, IF transformers, RF chokes, linearity coils, and others for FM radios, tape recorders, and color TV receivers.

SERVICE AIDS

101. **CASTLE**—How to get fast overhaul service on all makes and models of television tuners is described in leaflets. Shipping instructions, labels, and tags are also included.*
102. **PRECISION TUNER**—Literature supplying information on complete, low-cost repair and alignment services for any TV tuner.*
103. **YEATS**—The new "back-saving" appliance dolly Model 7 is featured in a four-page booklet describing feather-weight aluminum construction.*

SPECIAL EQUIPMENT

104. **ATR**—Descriptive literature on selling new, all-transistor *Karadio* Model 707, having retail price of \$29.95. Other literature on complete line of DC-AC inverters for operating 117-volt P.A. systems and other electronics gear.*
105. **ENTRON**—Information on Model B-1 transistorized bridging amplifier, designed for outdoor use in CATV systems.

106. **EQUIPTO**—Catalog No. 484-52 describes steel assembly bins; catalog 332 gives information on shelving, drawers, bins, utility trucks, benches, and cabinets.
107. **GREYHOUND**—The complete story of the speed, convenience, and special service provided by the Greyhound Package Express method of shipping, with rates and routes.
108. **TERADO**—Latest information on *Taper Rite* battery charger.*
109. **VOLKSWAGEN**—Large, 60-page illustrated booklet, "The Owner's Viewpoint," describes how various VW trucks can be used to save time and money in business enterprises, including complete specifications on line of trucks.

TECHNICAL PUBLICATIONS

110. **CLEVELAND INSTITUTE OF ELECTRONICS**—Free illustrated brochure describes electronic slide rule with four-lesson Instruction Course and grading service.*
111. **RCA INSTITUTES**—64-page book, "Your Career in Electronics," detailing home study courses in TV servicing, communications, automation, drafting, and computer programming; for beginners and experienced technicians.*
112. **HOWARD W. SAMS**—Literature describing popular and informative publications on radio and TV servicing, communications, audio, hi-fi and industrial electronics, including special new 1965 catalog of technical books on every phase of electronics.*

TEST EQUIPMENT

113. **B & K**—Bulletin 108-R on Model 801 Capacitor Analyst. Bulletin No. 124-R on Model 1240 color generator. Catalog AP-21R describing uses for and specifications of Model 1076 Television Analyst, Model 1074 TV Analyst and Color Generator, Model 700 and 600 *Dyna-Quik* Tube testers, Model 445 CRT Tester-Rejuvenator, Model 960 Transistor Radio Analyst, Model 360 *V-O-Matic* VOM, Model 375 *Dynaonic* VTVM and other test instruments.*
114. **EICO**—New 1965 catalog listing over 200 products including color-bar generator, oscilloscopes, and others; all available in kit form.
115. **HICKOK**—Specification sheets on Model 662 installer's color generator, Model 677 wideband scope, Model 470A uni-scale VTVM, and Model 799 *Mustang* tube tester.*
116. **JACKSON**—Complete catalog describing all types of electronic test equipment for servicing and other applications.
117. **LECTROTECH**—Bulletins on new color TV test instruments, horizontal deflection circuit meter, meter protective devices, and substitute for VTVM battery.*
118. **MERCURY**—Literature covering Model 1100A 1101 and 202E tube testers; Model 1500 signal generator; and entire line of test equipment.
119. **PRECISE**—New 1965 catalog on complete line of test equipment in kit or wired form.
120. **SECO**—Catalog sheet describing Models 980 and 990 color-bar generators and 88, 98, and 107B tube testers. Also, line folder describing all portable test equipment.
121. **SENCORE**—Information on all solid-state color generator Model CG 135.*
122. **SIMPSON**—Complete 16-page brochure on entire line of electronic test equipment; also, catalog on line of panel meters.*
123. **TRIPLETT**—All new test-equipment catalog No. 46-T showing complete line of VOM's, tube testers, transistor analyzers, and signal generators.*

TOOLS

124. **BERNS**—Data on unique 3-in-1 picture-tube repair tools, on *Audio Pin-Plug Crimper* that enables technician to make solderless plug and ground connections, also for color and other picture tubes. Model AV-2 for RCA type phono plugs, along with C rings for shielded braided wire ground connections and LC-3 for 5/32" pin diameter.*
125. **ENTERPRISE DEVELOPMENT**—Time-saving techniques in brochure from Endeco demonstrate improved desoldering and resoldering techniques for speeding up and simplifying operations on PC boards.
126. **UNGAR**—Catalog No. 763 giving information on series of soldering irons and accessories.
127. **VACO**—Latest literature on *Guild/Mark* and *Iron Man* screwdrivers.*

DANGER
HIGH VOLTAGE

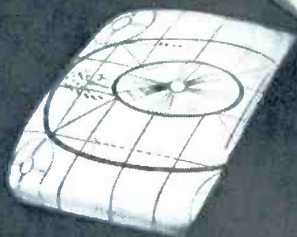
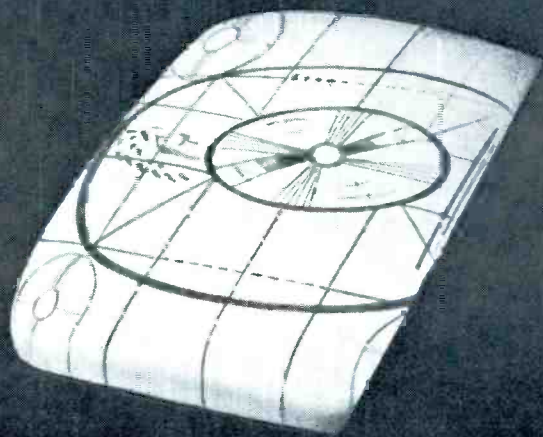

TRAP FOR FAULTY PICTURE TUBES

RCA Guards Against Callbacks 26 Ways

Under the watchful eyes of trained inspectors, RCA Silverama® Picture Tubes are carefully scrutinized for screen quality and focus.

All Silverama replacement picture tubes as well as those destined for original equipment undergo a battery of 26 automated tests. These include: warm-up, emission, gas, leakage, electron-gun performance, and other critical factors that can spell the difference between long-term performance or costly callback. Tubes failing a single test are automatically tagged and rejected. In addition to automatic testing, every tube lot leaving the RCA plant has been sampled by Quality Control.

Nothing is left to chance; part by part, inside and out, from base to faceplate the quality of each tube has been carefully controlled and assured prior to assembly. Even the Silverama envelope is carefully inspected prior to re-use, and is internally scrubbed, buffed, and restored to the peak of its optical capabilities. Result: a superior picture tube, an RCA Silverama. Make it your next installation choice.

RCA ELECTRONIC COMPONENTS AND DEVICES, HARRISON, N. J.



The Most Trusted Name in Electronics

www.americanradiohistory.com



CARRY EACH SILVERAMA FACTORY-FRESH INTO YOUR CUSTOMER'S HOME. New Foam-Lined RCA Picture Tube Tote Bag makes scratched, marked, or scuffed faceplates a thing of the past. Makes carrying both easier and safer. Two sizes: one for 16" to 19" tubes, one for 20" to 24" tubes.

SEE YOUR AUTHORIZED RCA PICTURE TUBE DISTRIBUTOR FOR DETAILS

Introducing a Complete Line of Littelfuse Quality Circuit Breakers



Actual Size
1 3/4" x 1 7/16" x 1/2"

Exact replacement from factory to you

Designed for the protection of television receiver circuits, the Littelfuse Manual Reset Circuit Breaker is also ideally suited as a current overload protector for model railroads and power operated toy transformers, hair dryers, small household appliances, home workshop power tools, office machines, small fractional horsepower motors and all types of electronic or electrical control wiring.

LITTELFUSE

DES PLAINES, ILLINOIS

Circle 61 on literature card