

AUGUST 1963

50 CENTS



PHOTOFACT REPORTER

Including **Electronic Servicing**

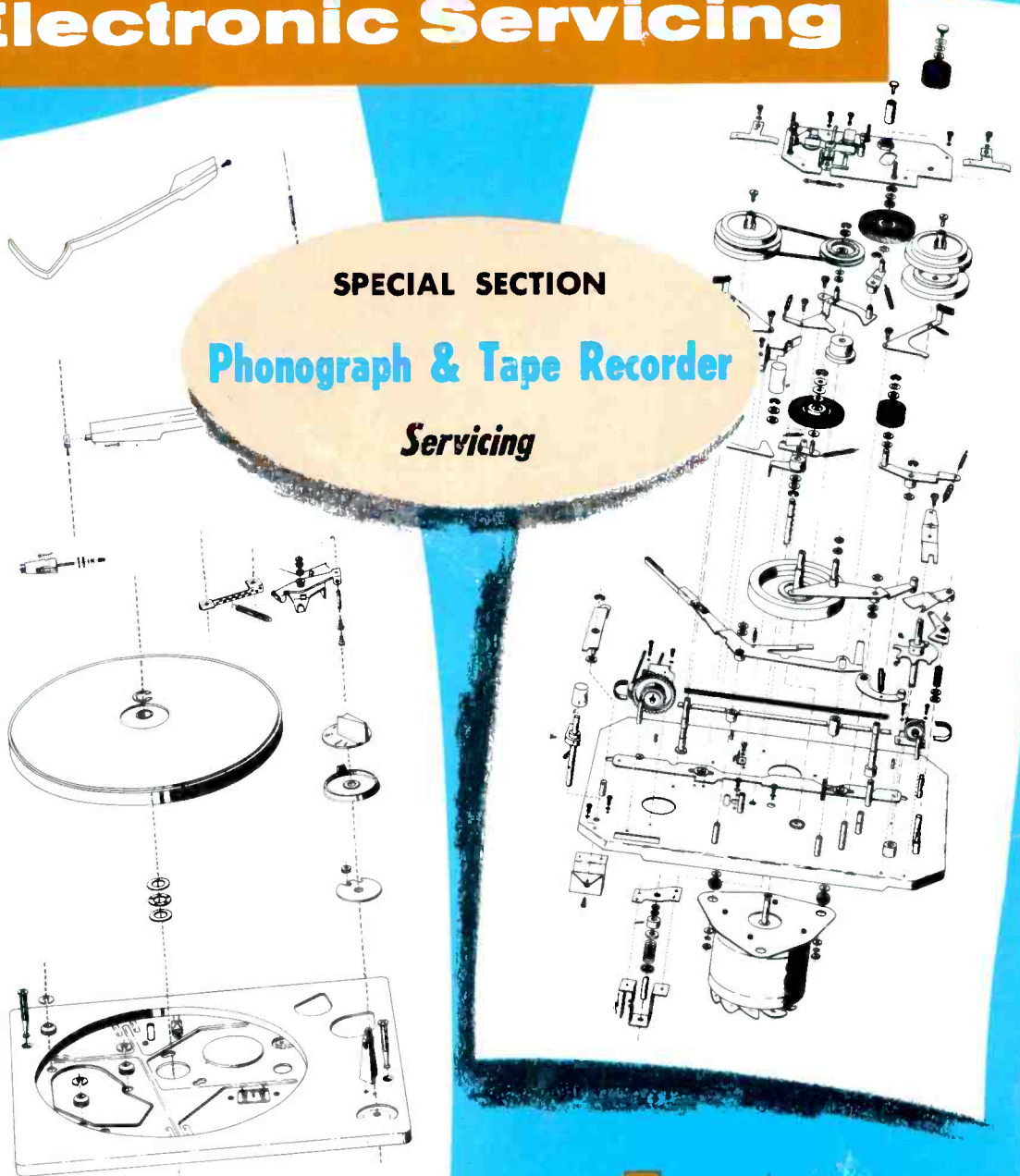

SPECIAL SECTION
Phonograph & Tape Recorder
Servicing

8-page book section

Analyzing Automatic Changer Mechanisms

Is the Cartridge Shot?

Tape Recorders Yield to a Direct Approach

Replacing the Phono Needle

Guide to Phono-Tape Charges

Monitoring Helps Spot Intermittents

IA 2L 1104 1266
WM. M. DAVIS
RAD. & TV SERV.
118 RIVERSIDE AVE.
CANNON CITY, COLO.



STANDARD KOLLSMAN BRINGS

Beauty TO UHF CONVERTERS

The Model "A", the only UHF converter you can show and sell with pride. Designer styled in beige and tan to blend with today's decor . . . to harmonize with modern TV cabinet design. Standard waited . . . and tested, analyzed, and re-tested until they could bring you the quality instrument you and your customers have a right to expect from the leading manufacturer of tuners. As a result, you now have a converter which is beautiful, *profitable*, and *dependable*.

Contact your Standard representative . . . or write

standard kollsman INDUSTRIES, INC.

Formerly Standard Coil Products Co., Inc., Metrose Park, Illinois / WORLD'S LARGEST MANUFACTURER OF TELEVISION TUNERS

PERFORMANCE YOU CAN SEE

New low-noise, shielded tuner permits fine tuning for all 70 UHF channels. Functions perfectly with color or black and white sets. Two simple controls: one for VHF, UHF, and "off" . . . the other for channel selection and fine tuning. The "SK" installs in about a minute with just a screwdriver.

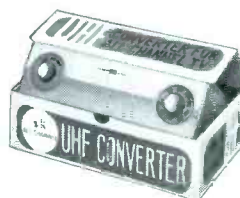

Feature this exciting counter-top display carton

POWER IN PROMOTIONAL SUPPORT

With a first order of 12 units or more, Standard supplies 3 newspaper ad mats . . . 3 radio spot scripts . . . materials for a powerful TV spot . . . 2-color catalog sheets . . . a giant (3' x 6') 2-color window banner . . . a counter card . . . as many pre-printed jumbo post cards as you can use PLUS hard hitting ads in TV Guide.

ANALYZING AUTOMATIC CHANGER MECHANISMS

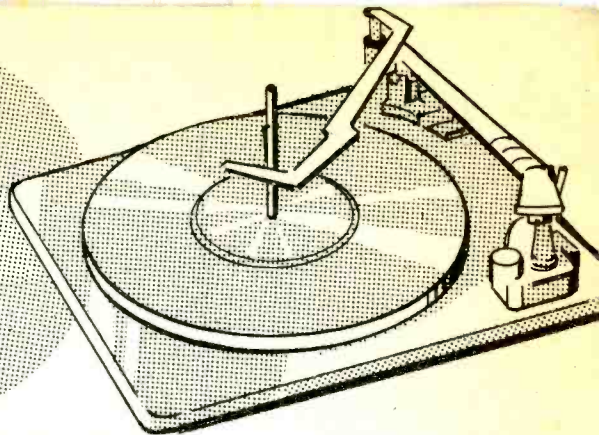

How to trace the sequence of action in various models.

by Forest H. Belt

Record-changer servicing is a segment of the electronics business that seems to grow with each passing year. Record changers just keep on increasing in numbers, and are seemingly destined to be around for years to come. Too, they have seen countless improvements through the past several decades, and have enjoyed steadily increasing popularity through all these years of development. By its very numbers, the record changer is an important part of the electronics business. And servicing these units can be a very rewarding undertaking for any service technician.

Basically Simple

There are some servicemen who don't want to bother with record changers. They offer various excuses, and find countless reasons for turning down changer jobs; the *true* reason is generally that they don't thoroughly understand the mechanical operation. If this is why you don't service changers, or accept them only grudgingly, you're missing a good bet. Changers are not really that complicated. They can be analyzed as a chain of operations, exactly as you analyze an electronic circuit that performs certain definite functions. If you can analyze *one*, you can learn to apply the same sort of reasoning to any other. Thus, with a little familiarization, you can become expert in a very short time.

All record changers have one thing in common: their purpose. They must drive a turntable at a predetermined speed to "spin" the records, provide a support for holding unplayed records, and drop the records one at a time as each is played. In the latter process, the tone arm must be raised clear of those records on the turntable and moved out of the way of dropping records, placed back in the starting groove no matter what the record diameter, and returned to a resting position when the last record is played. No matter what brand or style of changer you encounter, you'll find all these functions are provided. The only real difference lies in the means used to perform each function.

More elaborate changers include accessories that make them seem more complicated. Vacuum cleaners on the tone arm endeavor to keep the record clean. Stylus brushes either "sweep" the record or brush across the stylus during the change cycle. Leveling devices show the operator when his turntable is precisely level. The important point for you to remember is that none of these accessories should confuse the basic issue—servicing the changer mechanism. Just as you ignore many of the circuits in a television receiver, and

look for a fault in only the stages where trouble is suspected, you can learn to analyze a record changer in the light of only that section which is malfunctioning. Let's look at some of the "stages" of a changer mechanism, and see just how *mechanical troubleshooting* is done.

The Primary Functions

The "stages" of a changer mechanism are divided into certain primary functions, just as there are sections of a television set for various purposes. Fig. 1 shows a block diagram of the interdependence between various sections of a record-changer mechanism. Remember these "stages," and understand the need for each; they are the building blocks for a thorough knowledge of changers.

The turntable-driving device is probably the most important, for all other functions usually depend upon rotation of the turntable. As it goes around, it actuates and drives various slides, gears, wheels, and cams to initiate each of the record-changing functions. Thus, the very first step in servicing a troublesome changer is to make sure the turntable is being driven firmly, freely, and smoothly. Many seemingly unrelated complaints can be traced to turntable drive faults, as you will see presently.

Next in sequence is the trip mechanism. The trip can be actuated manually by a "reject" switch or automatically at the end of each record by the tone arm. In Fig. 1, note the "feedback" loop from the tone arm to the trip device. The automatic-manual switch is pro-

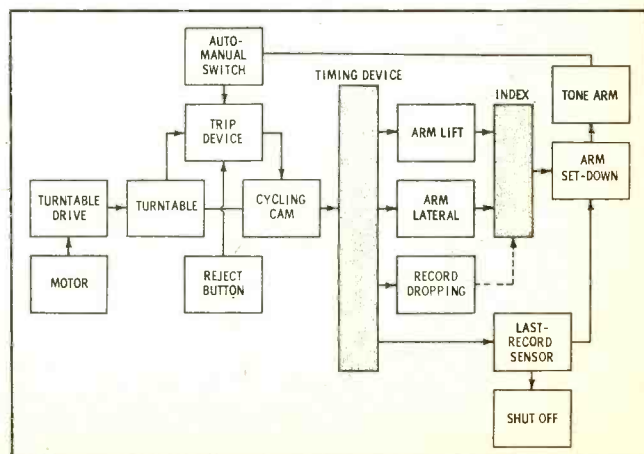

Fig. 1. Block diagram of changer mechanism shows sequence of functions, same as a similar diagram for electronic circuit.

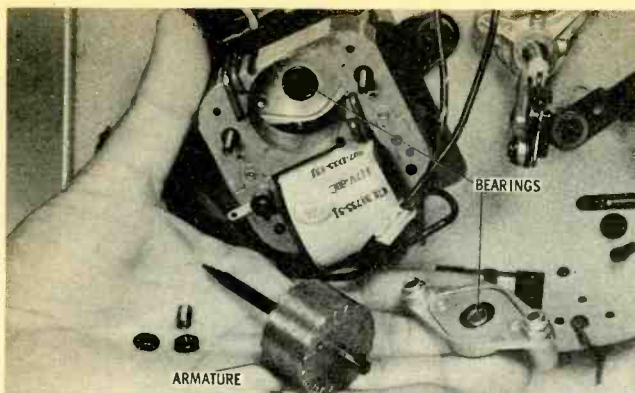

Fig. 2. Changer motors of two-pole variety are easily disassembled for repairs or cleaning. Note bearing for each end.

vided in some changers to disable the "feedback" loop (which is a mechanical linkage), bypassing the automatic action of the changer mechanism.

The trip device is merely a means for starting the cycling cam into operation. It is the cycling cam that actually drives each of the various cycling functions, usually through a timing device of some sort that determines the exact sequence of operations.

In most machines, a sensing device determines when the last record is dropped. When no more records remain on the support, the end of the change cycle is altered—the arm sets down on its rest instead of on a record, and usually the machine shuts off.

The chart in Fig. 1 can be an excellent troubleshooting aid. Suppose you want to do a thorough job on a record changer, carefully checking all operations. Start at the left and work your way to the right across the chart, checking each operation in the changer you're servicing. So you'll know what to expect in each "stage," let's go over each one in detail. Different models use different mechanisms to perform each function, and you will want to understand all the basic types. At the same time, we'll discuss typical trouble symptoms and cures.

Turtable Drive Systems

For discussion purposes, and for troubleshooting, we prefer to subdivide the drive system into its major parts: the motor, the speed-changing device, and the actual drive components. Each part has its own characteristics and troubles, and each varies from model to model.

Changer Motors

Expensive changers frequently use the costly *hysteresis synchronous* motor. These motors seldom cause hum in the changer pickup circuits, because of their construction. Since they are sealed, repairs are impractical. Should one of these motors become noisy, or vibrate too much, it is wise to replace it without hesitation. The changer that uses one of them is undoubtedly a high-quality unit, and the owner is not so likely to quibble over cost if it means perfect operation.

In many of the medium-priced changers, the *shaded four-pole* motor is quite popular. This unit is relatively free from stray hum fields, at least compared with its less expensive two-pole counterpart. It normally runs quite smoothly, with little "chatter" of either the laminations or the armature. Trouble usually occurs when a bearing becomes defective, or a winding opens. If excessive vibration occurs, simply replace the unit, for



Fig. 3. Stepped motor shaft for changing speeds. Note idler plate raised and lowered by moving over stepped grooves.

repairs are seldom worthwhile. Some of these motors use shielding that makes access difficult.

The simple *two-pole* motor has been found satisfactory for most changers, and is popular because of its price. Modern designs and shielding have produced units that are far more hum-free than older units of this type. Also, with the advent of ceramic and similar types of high-fidelity cartridges, hum pickup has been reduced; hum trouble was most noticeable when a two-pole motor was used in a changer with a magnetic or moving-coil type of cartridge.

Two-pole (and some four-pole) motors use an open type of construction, making them prone to accumulate dust in the armature over a period of months or years. Too much accumulation causes sluggish operation and loss of power; a few will become so dirty as to stall during the change cycle or refuse to start the turntable without a "push." The motors can be easily disassembled, as shown in Fig. 2, and cleaned thoroughly with alcohol. During reassembly, a very small amount of solid (wheel-bearing) grease can be added to each end bearing; beware of oil, for it will simply run down into the motor, hastening the dust accumulation.

Speed Control

This device is easily found in most changers, as it is connected to the speed-change switch—which is readily visible. In some systems, the switch is connected via a mechanical linkage to a small plate that carries three (four, in a four-speed unit) idler wheels or pulleys of differing sizes. Shifting the switch moves the proper idler into contact with the other turntable-driving components, providing a drive ratio that produces exactly the speed desired.

Another speed-control system uses a stepped idler wheel. When the speed lever is moved, the speed-idler mounting plate moves over a stepped section of the main deck plate; this moves the idler wheel up or down, and places the proper step in contact with the driving wheel.

The most popular modern system is similar, except that the motor shaft is stepped instead of the drive idler—see Fig. 3. The speed-change lever merely moves the idler plate over stepped grooves on the main deck, raising or lowering the idler to the proper step on the motor shaft.

A few elaborate changers provide means for varying the speed smoothly instead of in steps, or for "fine-tuning" the speed to precise accuracy. This is done by means of a tapered idler, over the surface of which

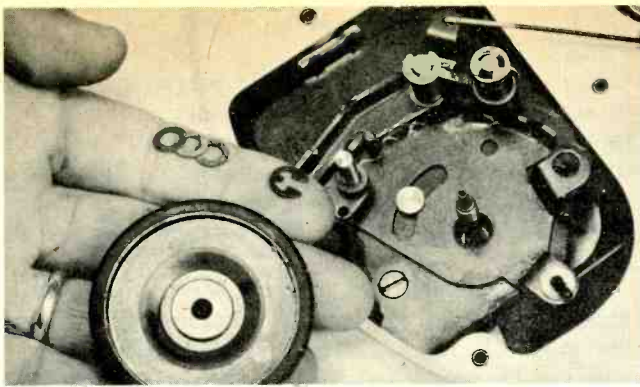

Fig. 4. Removing idler wheel from its shaft (near index finger) is simple matter of pulling clip. Note the washers.

the drive wheel can be moved to change the drive ratio and vary the speed.

From a troubleshooting standpoint, about the only things that normally happen to the stepped type of speed control are slippage or misalignment. Alcohol cleaning will take care of the former. Misalignment can be caused by a bent speed-idler mounting plate, a bent stepping plate, a bent or broken stepped idler, or a bent motor shaft. In many cases, careful straightening can effect a cure; in others, replacing the warped component is the quickest and most dependable repair.

In the continuously variable speed control, slippage is the most troublesome fault. Since they are usually made of rubber, hardened or deteriorated tapered idlers might cause the trouble, in which case a replacement is necessary. In most, however, a thorough alcohol cleaning will stop any slippage.

Turntable Drives

There are only two basic drive mechanisms used in modern changers—idler-wheel and belt drives. The simplest of these is the idler wheel that is held against the motor drive shaft and in contact with the inner rim of the turntable. As the motor turns, the idler turns, and drives the turntable.

Other, more elaborate idler drives use one or two intermediate idler wheels, particularly where several speeds are involved. One of the idlers between the motor shaft and the turntable may be the speed idler mentioned earlier. No matter how many idlers are used, the sequence is easy to trace, and troubleshooting steps that apply to one idler apply to all.

You'll encounter a few idler drive systems in which the idler contacts the turntable on the underside of its flat surface, instead of on the rim. Actually, this makes no difference whatsoever in analyzing or servicing the system, for the same principle applies to these as to other drive mechanisms.

Somewhat different from the idler-wheel arrangement is a system that is popular in more expensive changers—the drive belt. Using a belt drive seems to eliminate the effects of age on the speed of a machine, for the drive pulleys are metal and cannot shrink or develop flat spots; thus, the drive ratios are kept constant.

The motor shaft drives, through a rubber belt, another pulley which supports a second belt. The second belt usually drives the speed idlers, or a stepped speed

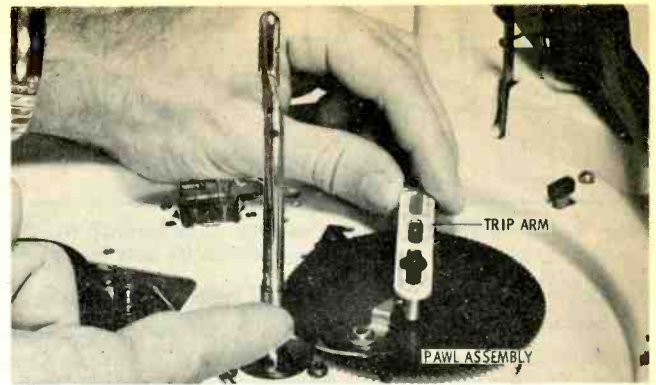

Fig. 5. Velocity trip system, with arm and pawl. Below the changer deck, motion of tone arm is transmitted to trip arm.

idler. The speed idler transmits energy to the turntable through a drive idler. Thus, you see, even the belt arrangement is something of a hybrid system. In very rare cases, a belt drives the turntable directly from the speed pulley.

In a few older sets, you may find a turntable that is gear-driven. This is rarely seen nowadays, and is barely worth mentioning. If you encounter one, it should be little problem to trace the gear train.

Drive systems are early victims of age, as a rule. Oil seeps onto the drive surfaces, causing slippage. Rubber surfaces become hard, cracked, and brittle, causing variations in turntable speed (wow) and frequent stalling in cycle. Dirt can build up inside the center holes of idler wheels, causing sluggish action and resultant stalling.

A common occurrence in some models is the "bumpy" idler wheel, which causes "wow" in the sound. A flat spot may be pressed into a rubber idler wheel when it is left in contact with another idler wheel or shaft for extended periods. When the idler revolves, the bump causes a rise and fall in the speed of the turntable. Many changers disengage the idlers when the unit is "off," eliminating this problem.

"Bumpy," cracked, or brittle idler or drive wheels must be replaced, whether they are on the speed-change plate or driving the turntable. Each good idler should be removed from its shaft and cleaned thoroughly with alcohol, and the mounting shaft cleaned. (Most idlers can be removed easily by pulling a clip—as in Fig. 4.) A small piece of sandpaper rolled up and inserted a few times in the hole of the idler wheel will remove any metal filings that might cause binding.

Remember, at least 90% of the troubles that affect turntable speed, or cause stalling of the changer during its cycle, can be traced to slipping or binding in the drive mechanism. So, whenever you are servicing a changer for any reason, be sure to clean all the drive parts thoroughly—including the turntable drive surface. And if any of the parts are warped or bent, or if any of the rubber surfaces are brittle or cracked (even a little), replace them. You'll be adding callback insurance that you can't buy as cheaply in any other type of electronics servicing. The cost is low in time and material, and the dividends are enormous.

Trip Mechanisms

The trip mechanism used in most modern changers

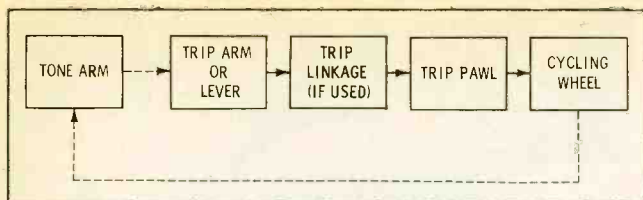

Fig. 6. Action diagram indicates how each part of tripping assembly actuates next operation, begun by arm movement.

is the velocity type. This arrangement has been used in one form or another for quite a few years, but some manufacturers have incorporated other types in their changers. Even in models that used a form of electrical tripping, the velocity trip was used to initiate the electrical action.

Velocity trip action draws its name from the sudden increase in tone-arm tracking velocity when the needle enters the eccentric leadout groove in the center of a record. As the tone arm follows the *modulated* grooves of a record, a trip arm (see Fig. 5) follows the movement of the tone arm. As the tone arm nears the center of the record, the trip arm (sometimes connected to a trip linkage) nudges a trip pawl. This nudge is very slight, and a slight projection on the turntable hub pushes the pawl back with each revolution of the turntable.

As the tone arm enters the leadout groove, the trip arm and link push the pawl quickly, since the leadout groove moves the arm rapidly toward the center post. The quick movement of the pawl places it against the turntable hub before one revolution has a chance to push it back. The hub projection catches the trip pawl firmly this time, pushing the change cycle wheel (or cam) into mesh (or center) with the turntable. The turntable then proceeds, by gear or friction, to drive the cycling wheel through its cycle and back to the rest position—where it waits to be tripped at the end of the next record. The tone arm, meanwhile, moves the trip arm back to the starting point where it starts over.

All parts of a velocity trip mechanism must be completely free of oil, dirt, or grease—anything that could even slightly hamper free movement. A common complaint is constant tripping, where a changer just continues to cycle without pausing to play any of the records; a sticky or bent trip link or pawl is the most likely cause. A thorough cleaning with alcohol (disassembling if necessary to reach all parts) is the solution to sticky parts. Replacement is the only practical cure

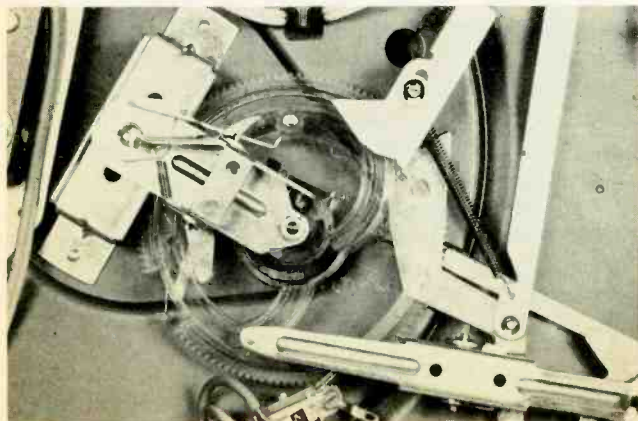

Fig. 7. Grooved timing (cycling) wheel actuates number of levers, arms. Many units use metal wheel instead of plastic.

if a part is bent—straightening is both time- and patience-consuming.

If a changer fails to trip, there are several possible causes. The best troubleshooting procedure is a step-by-step check of the tripping mechanism—see the troubleshooting block diagram in Fig. 6. First, make sure the trip arm (and linkage if used) is moving toward the trip pawl as the tone arm moves across the record.

Next, see if the trip pawl works correctly, being nudged backward with each revolution until the lead-out groove is reached. Then it should swing quickly with the tone arm and trip linkage, being pushed all the way in to the hub. If it fails in this quick swing, the trip arm may be too loose; some changers have an adjustable collar that sets the friction for the trip arm, while others depend on the friction caused by a bent spring washer. In the latter systems, replacing the washer may be necessary to get just the right amount of friction—neither too tight nor too loose.

If the trip pawl works, make sure the projection at the hub of the turntable engages it the next time around. If not, perhaps the pawl is bent so it still fails to engage the projection. If you try straightening it, be sure you don't cause other trouble by going too far. Replacement is always more sure to effect a permanent cure.

Lastly, be sure the cycling wheel is positioned—at its resting point—so the pawl can push it into mesh with the gears (or into contact with the turntable hub, if a cam is used). Make sure its stop point is "timed" properly so it comes to rest at the proper point during the change cycle.

Careful analysis of the action of each step outlined in the chart will reveal any deviation from normal operation. And if you'll follow that hard-and-fast rule—*keep oil and grease off all changer drive and trip parts, cleaning with alcohol when necessary*—you'll have little trouble keeping changer trip systems operating.

Change Cycle and Timing

All the actions that occur during the automatic record-changing cycle are powered by the turntable, through a drive wheel or cam (not to be confused with the turntable drive idlers) called either the cycling wheel or cycling cam. A gear wheel is used most frequently nowadays, but some changers still use the rubber-tired cycling cam. The cycling cam very often

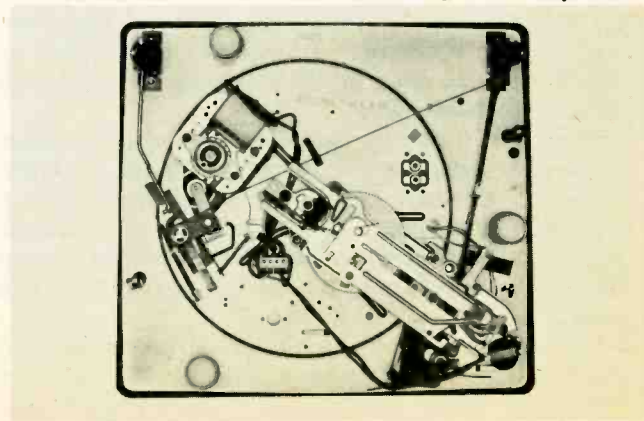

Fig. 8. Timing slide is used in a number of changers in place of cycling wheel. Slide is driven by a cycling cam.

drives a timing slide mechanism, which we'll discuss presently.

Whatever the form taken by the drive wheel, it is engaged with the turntable by the trip mechanism, and its job is to furnish drive energy for the various actions that take place during the change cycle.

The change cycle itself is probably the least understood part of record-changer operation. This is because it consists of a large number of almost simultaneous actions: the arm is raised, moved laterally in two directions, and set down; records are dropped; the arm is indexed to the proper setdown point; the trip mechanism is reset; a sensor indicates whether there are any more records to be played, and if not, a shutoff mechanism turns the machine off. Each of these operations must all occur at precisely the correct instant, or one action will "get in the way" of another. Keeping these actions happening at exactly the proper point in the change cycle is the function of the timing wheel or slide. Sometimes timing is a function of the cycling wheel, with special grooves initiating the various actions (see Fig. 7). In several modern changers, timing is handled by a timing slide—often called the cycling slide—shown in Fig. 8. In some, timing is taken care of by sequential operation of various parts, with one action initiating operation in another section; Fig. 9 shows a changer of this type, with part of the cycling mechanism above the deck and part below.

Instead of trying to analyze an entire change cycle at once, look at one specific function at a time, tracing only the actions of that particular phase. Fig. 10 shows how the change cycle is organized. Remember that each operation is initiated by some function of the timing mechanism; if an operation depends on a prior action, it is necessary to follow the entire sequence. But in most cases, you can analyze one phase at a time. Let's examine each phase, and see how it is accomplished.

Arm Lifting

Since this is the first step in the change cycle, we'll consider it first. The idea of this action is to lift the tone arm clear of the record so the stylus will not drag when the arm moves sideways or laterally.

One of the most common methods uses a push rod that slides up and down inside the hub or spindle of the tone arm. Underneath the changer deck, a raised portion (riser) of the timing wheel or slide slips under the tip of the push rod, shoving it upward through the

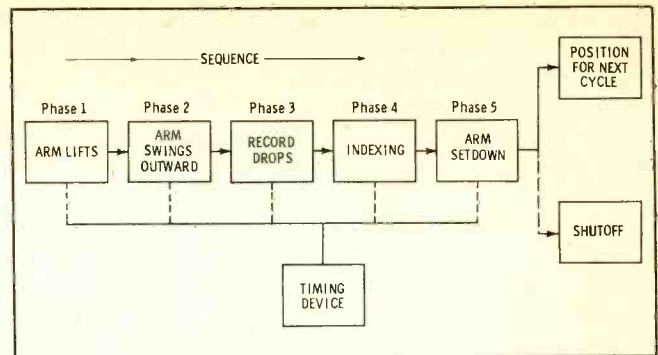

Fig. 10. Functional sequence of change cycle, as initiated by the timing device. Each function can be analyzed separately.

tone-arm hub. It strikes a plate in the base of the tone arm, raising the entire arm on its vertical pivots. If it fails to work, the cause may be a bent or improperly positioned plate (an adjustable screw is sometimes used as the striker plate); the push rod could be missing the striker; the raised portion of the timing slide could be missing the push rod; in some changers, a linkage or lever connecting the timing wheel and the push rod could be at fault.

Arm-lifting troubles would be indicated by the tone arm striking or rubbing the records still waiting to be played (arm too high), or by the stylus dragging across the records on the turntable (arm too low)—especially when the stack contains several records. Most changers have an adjustment of some sort, usually at the base of the tone arm; if adjusting can't cure the fault, check to see if the push rod is free, and that the riser plate or striker plate isn't bent. The push rod can be cleaned, if necessary, with the old standby—alcohol. No oil or grease should be used.

Arm Lateral Movement

This operation includes swinging the tone arm from the center, where it has just finished playing a record, outward to the edge of the changer to make room for the next record to drop. Usually, the arm will move outward and hover over the rest post, but will not be set down on the rest unless the last record has been played. Lateral movement also includes the return to a position over the lead-in grooves of the record, but we will consider this portion later when we discuss indexing. Both movements are generally actuated by the same portion of the change-cycle wheel or slide, but the action is different.

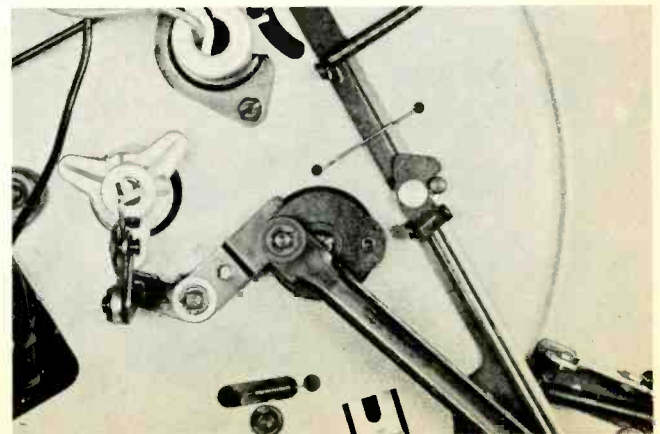
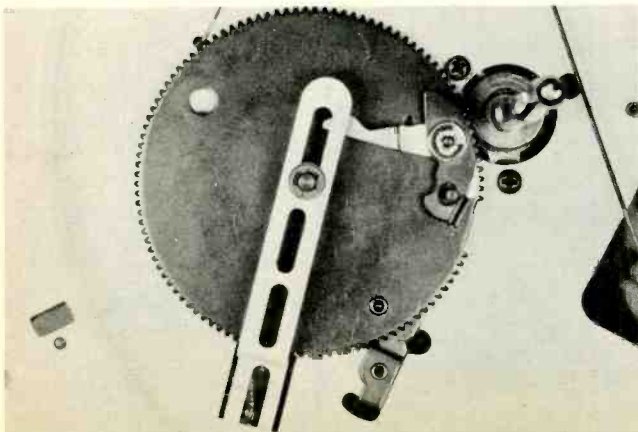

Fig. 9. In these two photos, the above-deck mechanism (left) drives sequential changing operations below decks (right).

To the bottom of each tone-arm spindle is attached a bar. It is fixed firmly to the spindle shaft, usually by a setscrew. Thus, wherever this bar is pushed, the tone arm must follow.

The cycling slide or wheel contacts a linkage or lever (one example is shown in Fig. 11) that in turn applies motion to the lateral-movement bar on the bottom of the tone-arm spindle. As the cycle enters the second phase (moving the arm out of the way), the lateral-movement linkage starts swinging the tone arm outward until its limit is reached, over the arm rest.

Remember that these two movements have taken place during the first few degrees of rotation by the cycling cam.

The most common trouble with this particular portion of the change cycle shows up as the tone arm reaches its outer limit—it doesn't go far enough to clear the record that is about to drop. This can—as often as not—be traced to abuse by the user; the changer has been operated with the tone arm held stationary by hand or by the transporting clamp. In many changers this will cause the arm to be twisted from its normal position on the spindle. Before taking steps to rectify this problem, confirm the cause by checking the setdown position. If it is also wrong, chances are the tone arm has slipped on the spindle. (This may also show up as an inability of the machine to trip automatically. The tone arm reaches the center, but the trip arm below the deck doesn't.) The cure is to loosen the tone-arm setscrew (usually below deck, but not always), run the changer through the first part of its cycle by hand, note where the lateral-motion linkage and bar reach the outer limit, position the tone arm over the arm rest, and tighten the setscrew. This is only an approximate setting, but can usually be refined with the indexing adjustment described later.

Carefully inspect each portion of the linkage and bar; bent parts can usually be spotted quite readily. Straightening may be the only practical cure for some, for they may be riveted in place. Be sure all sections work freely; and keep grease away from these, too.

Record Dropping

The third phase of the change cycle involves dropping the record to the turntable. All modern changers use the center spindle to support the stack of records to be played. Some push the records off the

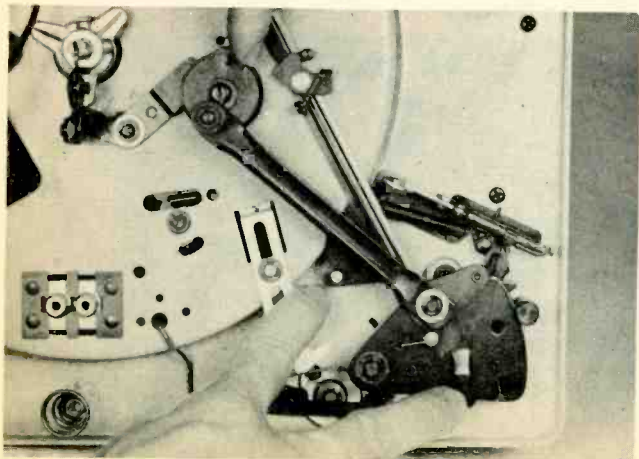

Fig. 11. Cycling wheel (top) actuates lateral movement linkage (under plate at bottom), bar (indicated by index finger).

spindle, one at a time, with a tab in the spindle that engages the center hole of the bottom record, while others push them off by a sliding mechanism that contacts the record's edge. In the latter units, the pushoff platform serves also as partial support for the record stack.

Since most changers now use the spindle-dropping method, we will analyze the dropping action of this type first (Fig. 12). There are several different designs, but all operate similarly from the standpoint of practical servicing. The cycling wheel or slide operates a lever that contacts the bottom tip of a push rod which extends up inside the spindle post. As the cycle progresses, the push rod is lifted farther into the post, actuating a small projection, or tab, that extends above the record platform by just about the thickness of a record. Engaging the bottom record, the pushoff tab moves the bottom record sideways until it is no longer supported by the platform; then the record slides down the spindle to the turntable.

Troubles in this dropping system are not at all uncommon. Complaints range from dropping no record through dropping two at a time. Troubleshooting is best accomplished by simply following the sequence of action. The lever which contacts the push rod should be checked to make sure it hasn't become bent. (A few models may incorporate more than one linkage, but the action shouldn't be difficult to trace since you know what to look for.) At the bottom tip of the spindle push rod, you'll sometimes find an adjustment. Make sure this is adjusted so the full action of the lever is transmitted to the push rod, but not so tight that the pushoff tab pushes off two records or can't return to normal. (It must, to engage the next record after one has been dropped.)

Lastly, in the spindle post itself, make sure the push-off tab isn't binding, and the push rod within the post is free. On some, there is a guide tab that keeps all records except the bottom one centered over the platform portion of the post; make sure this is completely free, and doesn't extend so far down as to interfere with the bottom record.

If any oil or grease has gotten into the post, remove it from the changer deck and flush it out with alcohol. If any of the parts are bent or binding, simply replace the entire spindle post; that's cheaper than trying to repair it, in almost every instance.

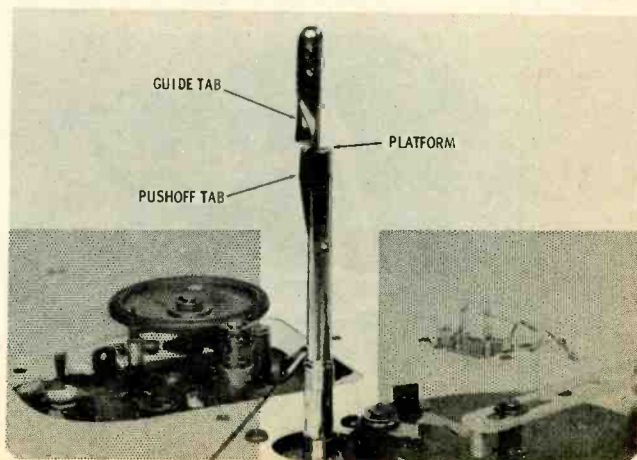

Fig. 12. Spindlepost supports records waiting to be played, and contains mechanism for dropping records one at a time.

The other method of record dropping involves a pushoff platform. In a few older changers, the entire platform moves toward the turntable spindle, pushing the bottom record off the post platform. Modern machines have a flat knife that slides out and pushes the bottom record off the pushoff and spindle platforms. The spindle of these is a fixed post, with no moving parts.

From the standpoint of troubleshooting, this type of system is little different from any other. Trace the motion from the cycling wheel through the linkages to the base of the pushoff platform. Check for free action (with no bends or binds) of the linkage, and of the lever that operates the sliding knife. Occasionally, a knife will become warped or worn and miss a record; recheck the alignment, and replace the knife if you have to. This is one of the few spots that a little lubrication sometimes is needed—but *not grease or oil*. Use a fine grade of powdered graphite, such as you can buy from a locksmith. And use it sparingly; it doesn't take much to do a good job. Just squirt it into the track in which the knife slides, wipe off the excess with a cloth dampened in alcohol, and work the knife back and forth a few times.

Record Size (Indexing)

Since most record-changer users collect more than one record size, changers are usually equipped to "sense" automatically the size of record being played. Some can intermix sizes, but most operate best with one size record at a time. The sensing process, or indexing, is the fourth phase of the change cycle.

Basically, the principle behind most indexing systems lies in designing the machine to operate for 7" records without any sensing. Indexing for 10" records is accomplished by placing a sensing tab near the rim of the turntable, projecting through the deck — as in Fig. 13. A 10" record, extending past the rim of the usual 9" turntable, blocks any attempted upward movement of the tab. The lack of upward movement is passed on to the indexing mechanism and controls the setdown point for the tone arm.

The 12" sensing tab most commonly used is also shown in Fig. 13. This tab is struck by the edge of any 12" record dropping past (on its way to the turntable). It is pivoted within the covering, and when it is struck by the dropping record, it releases a small cam (un-



Fig. 13. Indexing sensors for both 10" and 12" record sizes.

derneath the deck) that controls the setdown point.

Now let's look at the underside of the deck, and analyze the actual workings of the indexing mechanism. While the arm is pausing over the arm rest, waiting for the record to drop, an indexing plate with three notches (Fig. 14) moves into position around an indexing finger that is part of the lateral-movement bar mentioned in phase two. As the cycling wheel continues its revolution, the lateral movement toward center commences. If neither of the indexing tabs sense a record, the indexing finger enters the deepest of the three notches, and the tone-arm travel is stopped at a position directly over the leadin grooves of a 7" record.

However, if the tab adjacent to the turntable can't rise (because a 10" record has dropped), the indexing plate is held in such a position that the finger engages the middle slot; the tone arm then moves only as far as the 10" setdown position. If a 12" record trips the 12"-sensing tab, the small cam moves into position and blocks the arm movement at a point over the 12" leadin grooves.

Another system, used in some more elaborate changers, uses a feeler arm that swings out and contacts the edge of the records still on the center post. Underneath, the second phase of the cycling action also swings a serrated or notched plate past the below-deck portion of this feeler arm; wherever the feeler is stopped by striking the record edge, the appropriate notch is engaged. Then the record drops (phase three), and the cycling action swings on into the indexing phase. The notched plate stops the inward lateral movement of the tone arm at the correct setdown point.

Troubleshooting the indexing system of any changer is simply a matter of tracing the sequence of actions, making sure that each operation has the desired effect on limiting the return travel of the tone arm. If the normal speed is too fast to permit convenient observation, spin the turntable by hand, and trip the appropriate indexing sensor at the point in the cycle when the record would normally drop (watch the pushoff tab or knife).

The most common complaint is that the tone arm misses the record or is set down too far into the record. All except the most inexpensive changers have an adjustment at the base of the tone arm that will make compensation for any slight indexing error. If the error is beyond the range of adjustment, it may be neces-



Fig. 14. Plate with notches controls setdown position of arm.

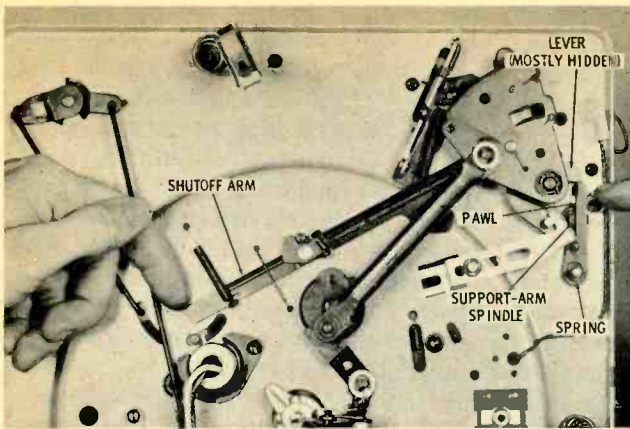

Fig. 15. Component parts of automatic shutoff mechanism.

sary to loosen the tone-arm setscrew (described earlier) and slightly change the position of the tone arm on its spindle.

In case this latter step is necessary, be sure to check the lateral travel as described under the paragraphs on "lateral movement"; if the arm gets in the way of dropping records, or doesn't trip correctly, the indexing system is at fault and must be repaired. The only part likely to bend is the indexing finger, and this is ordinarily not difficult to replace. Other parts should be kept clean and free of oil and dirt, as with most other sections of the changer mechanism.

Arm Setdown

When the arm is indexed into position, it is then lowered vertically to the record—phase five of the change cycle. This action is accomplished by the same parts that lift the arm. If the push rod (and levers, if used) are free, little trouble should be encountered.

Occasionally, the arm will be sluggish about lowering to the record. If so, check the pivot screws on the tone arm; sometimes they are too tight, or become gummy, and cause the arm to remain above the record. Make sure the arm can raise and lower freely, needing only its own weight to pull it downward.

Resetting

The five phases of the change cycle are accomplished in one revolution of the cycling wheel or cam. The wheel then returns to a resting position, awaiting the next tripping impulse. In some changers, a positive detent prevents movement beyond this resting point unless the tripping mechanism functions. In most, this step is accomplished by merely disengaging the drive, usually by a few missing teeth on the drive gear or an indentation in a rubber cycling cam. The next trip action again engages the drive.

In some machines, the trip pawls are on the cycling cam. In others, they are mounted on the deck. In either case, at some point in the cycle they are pushed back to their initial position in readiness for the next velocity tripping action. Make sure the trip pawl is repositioned; otherwise, constant tripping (recycling) will occur.

Loose and sloppy drive gears or cycling cams will also cause recycling. Any parts with defective teeth (or rubber tire) should be replaced without question, as should any that become worn and loose on the mount-

ing shaft. And the ever-constant warning—keep oil, grease, and dirt out.

Automatic Shutoff

Automatic shutoff indicates one of two common operations—either complete shutoff (removing power from the motor) or merely bringing the tone arm to rest on the armrest. In the latter case, the motor continues to operate until shut off manually. A few that completely shut off also remove the drive idler from contact with the driving shaft, to prevent the "bumps" described earlier.

The sensing device that indicates when no more records are waiting to be played is usually the record-support arm that keeps the records flat on top of the spindle post. When resting on records, the support arm is partially up out of its pivot post; after the last record is dropped, the support arm drops back all the way and contacts the shutoff linkage. Actuating the shutoff linkage alters the last two phases of the change cycle—the indexing and setdown—and sets in motion the switch-shutoff device, if one is used.

In changers that use the feeler arm for indexing, shutoff is usually initiated by the feeler when it fails to detect any more records on the centerpost. A few older changers sensed the shutoff with the center spindle; the weight of records unplayed kept the shutoff disabled until the last record had dropped.

The last two phases of the change cycle are altered very slightly. The indexing step merely changes so the tone arm is blocked completely from moving laterally toward the centerpost; instead the arm hovers over its rest until the fifth phase sets it down on the rest. Remember that this change in indexing is brought about by the shutoff *sensor*.

The support arm, while resting on top of one or more records, has no effect on the shutoff pawl—see Fig. 15. The spring holds it in the position shown, where it blocks the shutoff lever and prevents any movement of the shutoff arm. When the final record drops, the support arm sinks to its lowest position; its pivot shaft projects from the bottom of the deck and pushes the pawl out of the way of the shutoff lever. Then, when the record is finished, as the tone arm moves outward (phase two of the change cycle), a portion of the positioning bar on the bottom of the tone-arm shaft moves the shutoff lever and bar into position beside the switch lever, because the pawl is not in the way to interfere. The final set-down movement (phase five) pushes the lever and bar, which in turn pushes the switch to the off position.

Other shutoff mechanisms can be traced in the same manner, merely by observing the effects of the sensor on the levers and bars that actually shut the switch off.

Conclusion

Fixing record changers by guess-and-try is a difficult, complicated task; it's no wonder servicemen shy away from such a job. But with a planned, ordered approach such as outlined here, a mechanical problem can be solved as easily as an electronic one. The key is in the logical, step-by-step analysis of the several separate actions—and now that key is yours. ▲

Prices effective January 1, 1963

**Tarzian offers
FAST, DEPENDABLE
TUNER REPAIR
SERVICE (ALL
MAKES)**

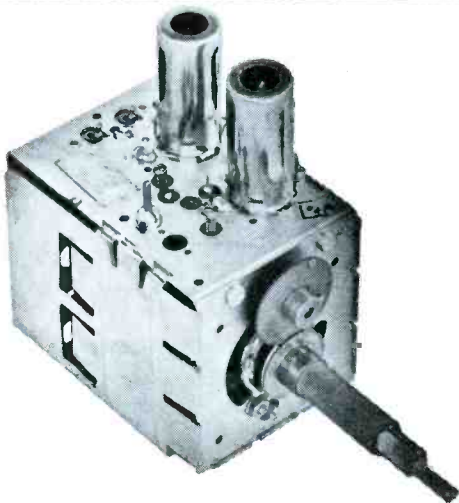

It just makes sense that a manufacturer of tuners should be better-qualified, better-equipped to offer the most dependable tuner repair and overhaul service.

Sarkes Tarzian, Inc. pioneer in the tuner business, maintains two complete, well-equipped Factory Service Centers—assisted by Engineering personnel—and staffed by specialized technicians who handle ONLY tuner repairs on ALL makes and models.

Tarzian-made tuners received one day will be repaired and shipped out the next. Allow a little more time for service on other than Tarzian-made tuners.

Tarzian offers a 12-month guarantee against defective workmanship and parts failure due to normal usage. And, compare our cost of \$9.50 and \$15 for UV combinations. There is absolutely no additional, hidden charge, for ANY parts except tubes. You pay shipping costs. Replacements on tuners beyond practical repair are available at low cost.

Ⓢ Tarzian-made tuners are identified by this stamping.

When inquiring about service on other tuners, always give TV make, chassis and Model number. All tuners repaired on approved, open accounts. Check with your local distributor for Sarkes Tarzian replacement tuners, replacement parts, or repair service.



SARKES TARZIAN, INC.

Bloomington, Indiana

MANUFACTURERS OF TUNERS . . . SEMICONDUCTORS . . . AIR TRIMMERS . . . FM RADIOS . . . AM/FM RADIOS . . . AUDIO TAPE . . . BROADCAST EQUIPMENT

**ONLY
\$9.50
INCLUDING**

**ALL PARTS
(except tubes)
and LABOR**

**24-HOUR SERVICE
1-YEAR WARRANTY**

**TWO SERVICE CENTERS
TO SERVE YOU BETTER**

**See your distributor, or use the
address nearest you for fast fac-
tory repair service**

537 South Walnut St.
Bloomington, Indiana
Tel: 332-6055

10654 Magnolia Blvd.
North Hollywood, Calif.
Tel: 769-2720

the HIDDEN 600*

PRESENT 
5 WORLD FAMOUS PERFORMERS **5**

*The "Hidden 600" are Sprague's behind-the-scenes staff of 600 experienced researchers who man the largest research organization in the electronic component industry and who back up the efforts of some 8,500 Sprague employees in 26 plants.

DIFILM® BLACK BEAUTY® MOLDED TUBULAR CAPACITORS



The world's most humidity-resistant molded capacitors. Dual dielectric—polyester film and special capacitor tissue—combines best features of both. Exclusive HCX® solid impregnant produces rock-hard section—nothing to leak, or drip. Tough case of non-flammable phenolic—cannot be damaged in handling.

DIFILM ORANGE DROP® DIPPED TUBULAR CAPACITORS

Especially made for exact, original replacement of radial-lead tubulars. Ideally suited for printed wiring boards. Dual dielectric combines the best features of both polyester film and special capacitor tissue. Exclusive HCX® solid impregnant—no oil to leak, no wax to drip. Double dipped in bright orange epoxy resin to beat heat and humidity.



TWIST-LOK®

ELECTROLYTIC CAPACITORS

The most dependable capacitors of their type. Built to "take it" under torrid 185°F (85°C) temperatures—in crowded TV chassis, sizzling auto radios, portable and ac-dc table radios, radio-phono combinations, etc. Hermetically sealed in aluminum cases for exceptionally long life. Withstand high surge voltages. Ideal for high ripple selenium rectifier circuits.

ATOM®

ELECTROLYTIC CAPACITORS



The smallest dependable electrolytics designed for 85°C operation in voltages to 450 WVDC. Small enough to fit anywhere, work anywhere. Low leakage and long shelf life. Will withstand high temperatures, high ripple currents, high surge voltages. Metal case construction with Kraftboard insulating sleeve.

CERA-MITE® CERAMIC CAPACITORS

Tiny, tough, dependable in practically every application. Low self-inductance of silvered flat-plate design gives improved by-pass action in TV r-f circuits. Higher self-resonant frequency than tubular ceramics or micas. Tough moisture-proof coating. Designed for 85°C operation.



NOW APPEARING DAILY AT YOUR FAVORITE SPRAGUE DISTRIBUTOR!

For a permanent reference to this world-renowned galaxy of star performers, ask your Distributor for a copy of Sprague's handy Hanging Wall Catalog C-457, or write Sprague Products Company, 105 Marshall Street, North Adams, Massachusetts.

publisher
Howard W. Sams

general manager
Mal Parks, Jr.

executive editor
Verne M. Ray

editor
Forest H. Belt

assistant editor
Thomas A. Lesh

associate editors
George F. Corne, Jr.
Patrick M. Craney

consulting editors
William E. Burke
Joe A. Groves
C. P. Oliphant

production manager
Robert N. Rippy

circulation fulfillment
Pat Tidd, Mgr.
Katherine Krise, Ass't.
Cora La Von Willard, Ass't.

art directors
Dick Lovell
Robert W. Reed

advertising & editorial assistants
Gladys Bauer
Georgeanna Caldwell
Clare Hult
Ellie Rother

photography
Paul Cornelius, Jr.

advertising sales offices
D. L. Milling, advertising sales manager

midwestern
Hugh Wallace
PF REPORTER
4300 West 62nd Street,
Indianapolis 6, Ind.
AXminster 1-3100

eastern
Charles Horner
Howard W. Sams & Co., Inc.
3 West 57th Street,
New York, N. Y.
MUrray Hill 8-6350

western
The Maurice A. Kimball Co., Inc.
2550 Beverly Blvd., Los Angeles 57, Calif.
DUnkirk 8-6178; and 580 Market Street,
Room 400, San Francisco 4, Calif. EXbrook 2-3365

Address all correspondence to
PF REPORTER, 4300 W. 62nd Street,
Indianapolis 6, Indiana



Copyright © 1963 by Howard W. Sams & Co., Inc.
PF REPORTER is a trademark of Howard W. Sams
& Co., Inc. No part of PF REPORTER may be
reproduced without written permission. No patent
liability is assumed with respect to use of
information herein. Acceptance of advertising does
not in any manner signify the products, policies
and services so advertised have been approved,
endorsed or recommended by this magazine.
Subscription Prices: 1 year—\$5.00, 2 years—\$8.00,
3 years—\$10.00, in the U.S.A., its possessions and Canada.
All other foreign countries: 1 year—\$6.00, 2 years—
\$10.00, 3 years—\$13.00. Single copy 50¢; back copies 75¢

Indexed in *Lectrodex*.
Printed by the Waldemar Press Div.
of Howard W. Sams & Co., Inc.



PF REPORTER

including **Electronic Servicing**

VOLUME 13, No. 8 **CONTENTS** AUGUST, 1963

Analyzing Automatic Changer Mechanisms	Forest H. Belt	1
Investigate what goes on underneath the turntable.		
Letters to the Editor		12
The Electronic Scanner		18
Is the Cartridge Shot?	George F. Corne, Jr.	22
A phono pickup in good condition is essential for clear sound.		
Symfact: Grid-Coupled CRT Circuits (With Horizontal Retrace Blanking)		25
See what happens to voltages and waveforms when troubles occur.		
Monitoring Helps Spot Intermittents	E. D. Ladyman	30
Quicker Servicing—Save time by seeing which test readings change when the symptom shows up.		
Replacing the Phono Needle		32
Modern types need no special tools; just "snap it loose."		
Intercoms With All the Extras	Edward M. Noll	34
Servicing Industrial Electronics—Versatile systems adapt well to custom installations.		
Scoping Common-Cathode Horizontal AFC	Allan F. Kinckiner	36
Shop Talk—See how this circuit differs from the balanced dual-diode type.		
Tape Recorders Yield to a Direct Approach		38
Start looking for the trouble—you'll find it.		
Common Blunders in Handling Credit	K. V. White	48
Dollar and Sense Servicing—Crude collection methods are a losing proposition.		
Guide to Phono-Tape Charges		54
Notes on Test Equipment		56
Lab reports on the GC Model 36-568 Transistor-Radio Tester and Hickok Model 752A Tube Tester.		
The Troubleshooter		62
Product Report		78
Free Catalog & Literature Service		80
Monthly Index	on free literature card	

ABOUT THE COVER

Here's the rub for many servicemen when they attempt to repair phono-graphs and tape recorders: they have trouble figuring out how these units should normally function. This special issue addresses itself to the task of making phono and tape devices more understandable, hence easier to service.



ATR PRODUCTS FOR MODERN LIVING

ATR PLUG-IN TYPE PORTABLE INVERTERS*

A. C. HOUSEHOLD ELECTRICITY Anywhere in your own car, boat or plane

Operates Standard A.C.
 ● Record Players
 ● Dictating Machines
 ● Small Radios
 ● Electric Shavers
 ● Heating Pads, etc.
 In your own car or boat!

MODELS
 6-RMF (6 volts) 60 to 80 watts. Shipping weight 12 lbs. DEALER NET PRICE \$33.00
 12T-RME (12 volts) 90 to 125 watts. Shipping weight 12 lbs. DEALER NET PRICE \$33.00
 *Additional Models Available

ATR "A" Battery ELIMINATOR

For Demonstrating and Testing Auto Radios—TRANSISTOR or VIBRATOR OPERATED!

Designed for testing D.C. Electrical Apparatus on Regular A.C. Lines—Equipped with Full-Wave Dry Disc-Type Rectifier, assuring noiseless, interference-free operation and extreme long life and reliability.

MAY ALSO BE USED AS A BATTERY CHARGER
 MODEL 610C-ELIF . . . 6 volts at 10 amps. or 12 volts at 6 amps. Shipping weight 22 lbs. DEALER NET PRICE \$49.95
 MODEL 620C-ELIT . . . 6 volts at 20 amps. or 12 volts at 10 amps. Shipping weight 33 lbs. DEALER NET PRICE \$66.95

AUTO-RADIO VIBRATORS

By every test ATR Auto-Radio Vibrators are best! and feature Ceramic Stack Spacers, Instant Starting, Large Oversized Tungsten Contacts, Perforated Reed, plus Highest Precision Construction and Workmanship and Quiet Operation!

There is an ATR VIBRATOR for every make of car!

Ask your distributor for ATR's Low Priced type 1400, 6 volt 4-prong Vibrator; and 1843, 12 volt 3-prong; or 1840, 12 volt 4-prong Vibrator. **THE WORLD'S FINEST!**

ATR UNIVERSAL KARADIO MODEL 600 SERIES

Easily installed in-dash or under-dash. Amplifier power-supply chassis may be separated from tuner chassis for easy servicing. Utilizes 6-tube superheterodyne circuit (2 dual-purpose tubes). Supplied with separate 5" x 7" speaker. Neutral gray-tan baked enamel finish. Overall size 4" deep x 6 1/2" wide x 2" high. Tuner Chassis; with Amplifier Chassis, 2 3/4" deep x 6 1/2" wide x 3 7/8" high. Shipping weight 7 lbs. **WILL OUT-PERFORM MOST SETS!**

Model 612—12 Volt, Dealers Net Price \$31.96
 Model 606—6 Volt, Dealers Net Price 31.96

Airplane Style Overhead Mounting under Cab Roof **NO PRINTED CIRCUITRY**

ATR TRUCK KARADIO

Excellent Tone, Volume, and Sensitivity!
 Compact, yet powerful. Fits all trucks, station wagons, most cars and boats. Just drill a 3/8 inch hole in roof and suspend the one-piece unit (aerial, chassis and speaker) in minutes. Watertight mounting assembly holds antenna upright. Yoke-type bracket lets you tilt radio to any angle.

Extra-sensitive radio has 6 tubes (2 double-purpose), over-size Alnico 5 PM speaker for full, rich tone. Big, easy-to-read illuminated dial. Fingertip tuning control. Volume and tone controls. 33-in. stainless steel antenna. Neutral gray-tan enameled metal cabinet, 7 x 6 1/2 x 4 in. high over-all. Shipping weight 10 1/2 lbs.

Model TR-1279—12A for 12V Dealer Net Price \$41.96
 Model TR-1279—6A for 6V Dealer Net Price \$41.96

See Your Electronic Parts Distributor Write Factory For Free Literature

ATR ELECTRONICS, INC.
 Formerly: American Television & Radio Co.
 Quality Products Since 1931
 ST. PAUL 1, MINNESOTA—U.S.A.



Dear Editor:

I had practically forgotten about the PF REPORTER Ten-Year Subject Index January, 1961 issue). Recently, however, I had need to locate a Troubleshooter item concerning picture pulling in a certain TV chassis. I remembered the item was published several years ago, but couldn't recall just which issue. As I started to thumb through past issues, I came across the Ten-Year Index. Needless to say, in a couple of minutes I had located the information I wanted—in the April, 1958 issue. Just had to say "thanks" for the Index; I think I'll frame it.

HAROLD S. VANDEMAN
 San Bernardino, Calif.

Never thought I'd be so willing to agree to an obvious "frame-up." Incidentally, reprints of the "Ten-Year Cumulative Subject Index 1951-1960" are still available at no charge.—Ed.

Dear Editor:

In the article "Molecular Electronics Explained" in your May issue, reference was made to our product *Nichrome* without mention of the fact that its name is a registered trademark of the Driver-Harris Company. *Nichrome* is a very old trademark, having been registered by us in 1908 and used continuously ever since that time to denote our famous alloy.

R. B. ALLARDICE, JR.
 Secretary-Treasurer
 Driver-Harris Co.
 Harrison, N. J.

We certainly had no intention of breaking a precedent of over 50 years' standing!—Ed.

Dear Editor:

Enclosed is a sample of a splice for 300-ohm twin lead. We think this is a better method than the one shown on page 41 of your April, 1963 issue.

STUART WELWOOD
 The Village Radio & TV Shop
 New Milford, Conn.



Dear Editor:

We are using a twin-lead splice that we believe to be better than the one illustrated in "How to Strip and Solder Cables" (April issue) If you stagger the cuts in the two leads, and overlap the stubs of plastic insulation between the spliced lead ends, you will find you have a pretty sturdy connection after it is secured with a good plastic tape. Wind the tape from bottom to top on a vertically mounted outdoor lead, to make it more weatherproof.

HENRY TYSSIE
 Holland Radio & Appliance Co.
 Holland, Mich.

Dear Editor:

I was really surprised to see the illustration for splicing 300-ohm twin lead in your April issue. No wonder you say this lead should not be spliced if it can be avoided. I'm sending you a splice of a type I use all the time, and think you will agree with me that it is far superior to the one you illustrate. You'll note I do not cut away the center of the insulation, but overlap the ends and use them as reinforcements.

R. J. STONER
 Aurora, Colo.

Dear Editor:

We formerly used the splicing procedure shown in your April issue, but found it had a tendency to break and cause a lot of trouble. Enclosed is a sample of a splice that works ten times better.

GABRIEL BOURDON
 Lachute, P. Q.
 Canada

Dear Editor:

Why didn't you show the boys a splice that is a splice? I am enclosing a sample of one that is stronger than the rest of the line, once it has been taped.

M. W. THOMPSON
 Toronto, S. Dak.

Dear Editor:

On splicing 300-ohm lead-in, I always leave about a 1" tab of plastic insulation on each piece; this makes a better strain joint.

ARNOLD J. BURT
 Grand Rapids, Minn.

Dear Editor:

The splice shown is okay for an "inside job," but outdoors it is a weak sister. Instead of cutting off the stub ends of insulation, you can overlap them and tape them together to reinforce the splice. I have used this method for many years, and have yet to see one fail. Personally, I prefer to leave the soldered wire ends untaped, and coat them with plastic spray to weatherproof the joint. Tape over the rough surface of the wires tends to form a moisture trap that invites trouble.

WALTER G. DUNBAR
 Normal, Ill.

We connected all your sample splices end to end (using the suggested method, of course) and used them to hang the author of the article.—Ed.



WHAT ELSE DOES PHILCO PUT IN THE CARTON?

When you pick up the box, you expect to find a receiving or CR tube in it. Naturally.

But when the name PHILCO is on the carton, you get something more . . . at no extra cost to you. In every Philco carton there is an important extra . . . a bonus that you can't see but is even more valuable to you!

What is it? . . . it's *A SATISFIED CUSTOMER!*

The name "Philco" has enjoyed prestige and respect in parts and accessories for over 33 years. Now, it has added resources and stability with another famous name . . . "Ford". Together they stand for products that assure your confidence and dependability . . . now, even more than ever before.

When you use Philco tubes, your customer knows you are delivering the best.

Use the tubes that mean "satisfied customers" . . . Philco Star Bright 20/20 picture tubes and Philco receiving tubes. A complete line of all types for all makes and models of television and radio receivers, manufactured under exacting quality standards, thoroughly tested and inspected.

Notice: All material and parts used in the manufacture of this tube are new except for the envelope, which prior to reuse, has been inspected and tested to the same standards as new envelopes.

DEPEND ON YOUR PHILCO DISTRIBUTOR . . . your one-stop-shopping center for quality picture tubes and receiving tubes for Philco or ANY OTHER MAKE.

PHILCO MODERN COPPER
ENGRAVED CIRCUITS

— for Simplified Service



PARTS AND SERVICE OPERATIONS

PHILCO

A SUBSIDIARY OF *Ford Motor Company*

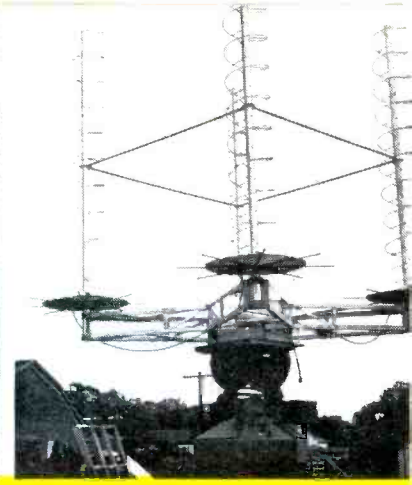

**THE SAME ENGINEERING, SAME PLANT THAT
PRODUCES AMERICA'S GREATEST SATELLITE-
TRACKING AND TELEMETRY STATIONS, HAS CREATED**

the revolutionary new

PARALOG

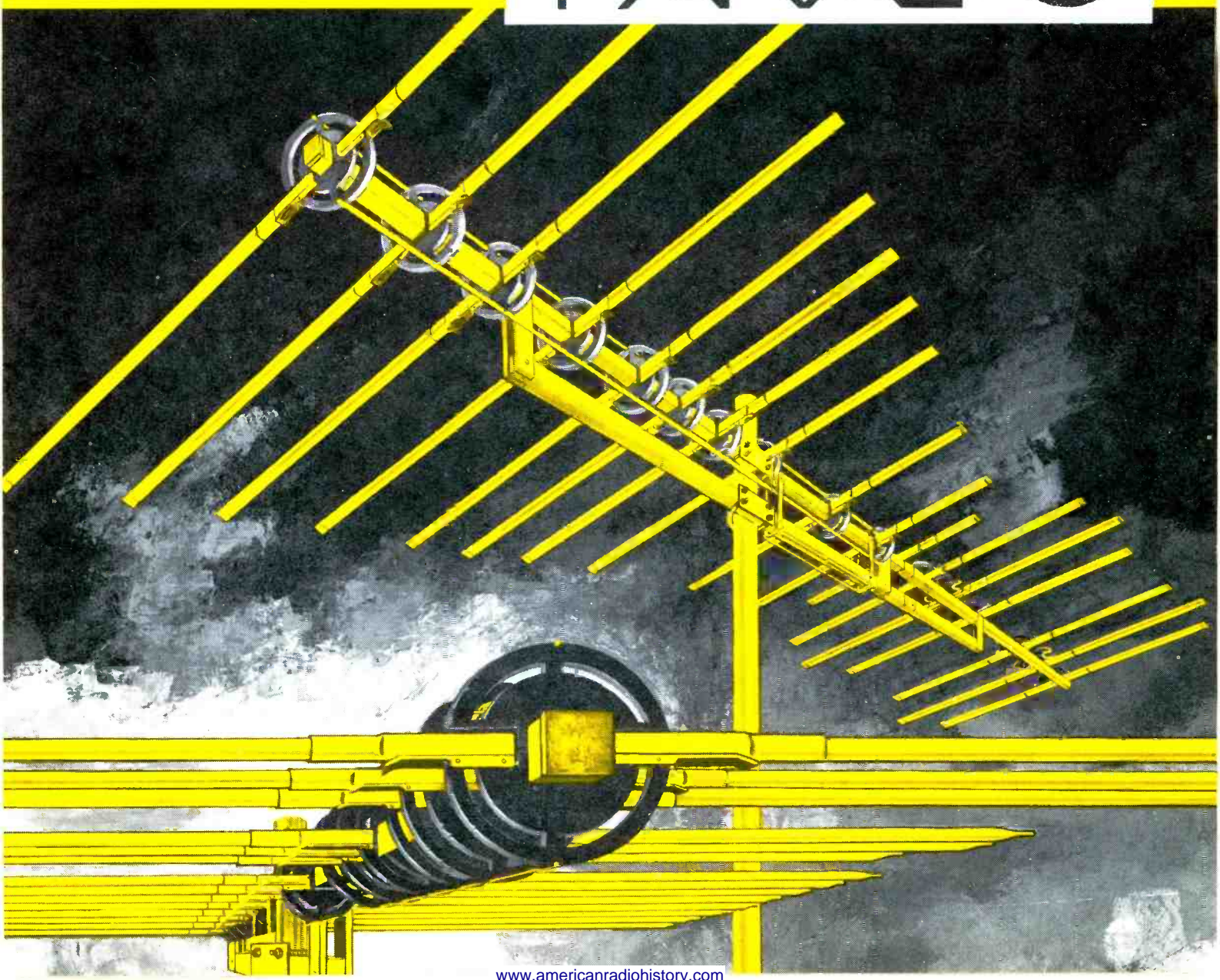



PARALOG

TV/FM ANTENNA

... Unparalleled performance because it has **ALL 4**:

- **HIGH GAIN**
- **EXTREMELY LOW VSWR**
- **HIGH FRONT-TO-BACK RATIO**
- **RUGGED CONSTRUCTION**

HERE IT IS—the space-age TV/FM antenna from the only manufacturer with actual space-age experience!

From the laboratories of Jerrold-TACO, designers of powerful satellite-tracking and space-telemetry antenna arrays for the U. S. Government, comes the all-new PARALOG, first home TV/FM antenna truly based on the log-periodic principle with a unique parasitic-element system for maximum all-channel gain.

Exclusive Cyclocac insulating mounts on PARALOG antennas assure constant impedance under all weather conditions, and eliminate the troublesome and unsatisfactory cross-feed systems of other antennas. Cyclocac, tough enough to be used for timber-splitting wedges and golf-club heads, makes each insulating mount a *strong point* on the PARALOG. Look at all these features:

PARALOG FEED SYSTEM

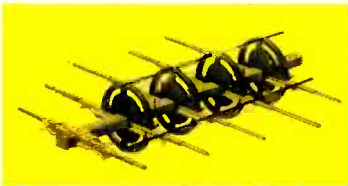

OTHER FEED SYSTEMS

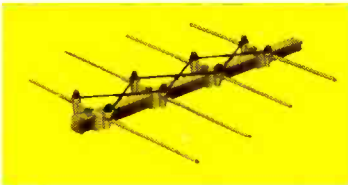

SELF-CLEANING WEDGE-SNAP LOCKS

eliminate dipole-junction noise, can't loosen to cause vibration snow. Wind vibration merely serves to tighten wedge further into dipole.

CYCLOCAC INSULATORS

and radically-new impedance-stabilizing phase correctors eliminate the poor criss-cross transmission-line characteristics of other antennas.

UNIFORM STRONG FORWARD LOBE

is maintained throughout high and low bands. Left: 69 mc (mid-channel 4); right: 195 mc (mid-channel 10). Lobe patterns for each channel equal or surpass these.

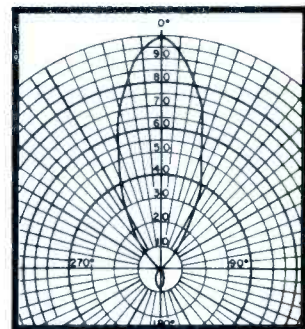
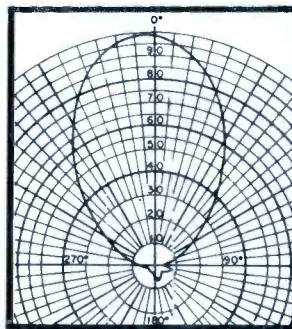

4 Electronic Models feature NEW TWIN-TRANSISTOR SUPER POWERMATE

Best gain/overload capability in the industry—brings in distant stations without overloading from nearby signals.



14 MODELS, UNSURPASSED FOR EVERY RECEPTION NEED

Seven non-amplified and four electronic PARALOGs for TV and FM, plus three special FM-stereo models, give you a line prepared to meet any reception condition at distances up to 200 miles.

ELECTRONIC MODELS

JTP-130S—List \$94.95 JTP-190S—List \$114.95
JTP-160S—List \$104.95 JTP-220S—List \$124.95

FM STEREO MODELS

FMJTP-8—List \$29.95 FMJTP-10—List \$39.95
FMJTP-16—List \$59.95

See your Jerrold-TACO distributor now, or write Jerrold Electronics, Philadelphia 32, Pa.

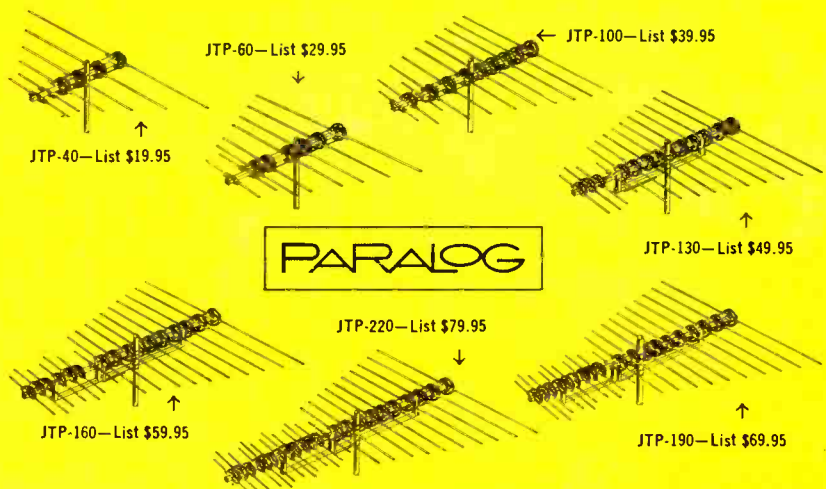

JTP-40—List \$19.95

JTP-60—List \$29.95

JTP-100—List \$39.95

JTP-130—List \$49.95

JTP-220—List \$79.95

JTP-160—List \$59.95

JTP-190—List \$69.95

SENCORE

SIMPLIFIES COLOR SERVICING

NEW! CA122

COLOR CIRCUIT ANALYZER

A simple approach to a complex problem

Here is an instrument that is designed to eliminate the guesswork in color TV servicing. A complete analyzer that provides all required test patterns and signals for testing from the tuner to the tri-color tube. Additional analyzing signals for injection at each stage including audio, video and sync, brings to life a truly portable and practical TV analyzer for on the spot service; virtually obsoleting other analyzers with the advent of color. Sencore's simplified approach requires no knowledge of I, Q, R-Y, B-Y, G-Y or other hard to remember formulas. The CA122 generates every signal normally received from the TV station plus convergence and color test patterns.

The CA122 offers more for less money:

TEN STANDARD COLOR BARS: The type and phase that is fast becoming the standard of the industry. Crystal controlled keyed bars, (RCA type) as explained in most service literature, offer a complete gamut of colors for every color circuit test.

WHITE DOTS: New stabilized dots, a must for convergence, are created by new Sencore counting circuits.

CROSS HATCH PATTERN: A basic requirement for fast CRT convergence.

VERTICAL AND HORIZONTAL BARS: An added feature to speed up convergence, not found on many other color generators.

SHADING BARS: Determines the ability of the video amplifier to produce shades (Y Signal) and to make color temperature adjustments. An important feature missing on other generators.

COLOR GUN INTERRUPTOR: For fast purity and convergence checks without upsetting color controls. Insures proper operation of tri-color guns, preventing wasted time in trouble shooting circuits when CRT is at fault.



A must for color . . .
a money maker for black and white TV servicing

ANALYZING SIGNALS: RF and IF signals modulated with any of the above patterns for injection into grid circuits from antenna to detector. IF attenuator is pre-set for minimum signal for each IF stage to produce pattern on CRT thus providing a check on individual stage gain. Sync and video, plus or minus from 0 to 30 volts peak to peak, have separate peak to peak calibrated controls for quick checks on all video and sync circuits. Crystal controlled 4.5 mc and 900 cycles audio simplify trouble shooting of audio circuits.

NEW ILLUMINATED PATTERN INDICATOR: A Sencore first, offering a rotating color film that exhibits the actual color patterns as they appear on color TV receivers. Locks in with pattern selector control.

You'll pay more for other color generators only.

Dealer Net 187.50

NEW! PS120 PROFESSIONAL WIDE BAND OSCILLOSCOPE

A portable wide band 3 inch oscilloscope for fast, on-the-spot testing. An all new simplified design brings new meaning to the word portability . . . it's as easy to operate and carry as a VTVM. Though compact in size, the PS120 is powerful in performance: Vertical amplifier frequency response of 4 MC flat, only 3 DB down at 7.5 MC and usable to 12 MC, equips the technician for every color servicing job and the engineer with a scope for field and production line testing. AC coupled, with a low frequency response of 20 cycles insure accurate low frequency measurements without vertical bounce. Sensitive single band vertical amplifier; sensitivity of .035 volts RMS for one inch deflection saves band switching and guessing. Horizontal sweep frequency range of 15 cycles to 150 KC and sync range from 15 cycles to 8 MC (usable to 12 MC) results in positive "locking" on all signals. New exclusive Sencore features are direct reading peak-to-peak volts — no interpretation; dual controls to simplify tuning; lead compartment to conceal test leads, jacks and seldom used switches. Rear tilt adjustment angles scope "just right" for easy viewing on bench or production line.

Size: 7" w x 9" h x 11 1/4" d. Weight: 12 lbs.

Dealer Net 124.50
(with low cap. probe)

Kit 74.50



A must for servicing color TV in the home . . . lowest priced broad band scope. All hand wired — all American made

SENCORE

SIMPLIFIES SWEEP CIRCUIT TROUBLE SHOOTING

SS117 SWEEP CIRCUIT ANALYZER

For Color and Monochrome Testing

A professional trouble shooter that helps you methodically walk the trouble out of "tough-dog" sweep circuits in monochrome and color receivers. The SS117 provides a positive but simple push button test on all circuits indicated in the block diagrams. These time-consuming circuits are checked step-by-step with tried and proven signal injection and substitution methods. All checks can be made from the top of the chassis or from under the chassis when it is removed from the cabinet.

TV horizontal oscillator check is made by substituting a universal oscillator known to be good. Horizontal output check consists of a cathode current and screen voltage test. The TV horizontal yoke is checked by substituting a universal yoke from the SS117 and viewing brightness or restoration of 2nd anode voltage. Horizontal flyback is checked dynamically in circuit by measuring the power transfer to the yoke when TV is turned on. TV horizontal sync can be used to control the SS117 horizontal oscillator, providing a positive check on sync from the video amplifier to the TV oscillator. Vertical circuits are tested by simple signal injection from vertical yoke to oscillator for full height on CRT. The SS117 with the CA122 Color Analyzer provides a complete TV analyzer for virtually every stage in monochrome or color receivers.

External checks for AC, DC, peak to peak voltage readings and DC current in the upper right hand corner save using a separate VTVM. Accurate 2nd anode measurements up to 30,000 volts are made with a sensitive 300 microamp meter and the attached high voltage probe. AC outlets, all steel construction and mirror in the cover makes every servicing job easier.

Size: 10 1/4" x 9 1/4" x 3 1/2". Wt. 10 lbs.

Dealer Net. 89.50



The SS117 checks them all



FREE—A 33 RPM half hour permanent record packed with every unit explains each test.

FOR FASTER MORE ACCURATE TUBE TESTING

TC114 MIGHTY MITE TUBE CHECKER

This is the famous Mighty Mite, acclaimed by over 25,000 servicemen, maintenance men and engineers as "the best they've ever used." A complete tube tester that is smaller than a portable typewriter yet finds tubes that testers costing hundreds of dollars miss, thus selling more tubes and reducing call backs. A real money maker for the serviceman and a trusty companion for engineers, maintenance men and experimenters. The Mighty Mite has been acclaimed from coast to coast as the real answer for the man on the go. Even though the Mighty Mite weighs less than 8 pounds, new circuitry by Sencore enables you to use a meter to check grid leakage as high as 100 megohms and gas conditions that cause as little as one half microamp of grid current to flow. Thus, too, it checks for cathode current at operating levels and shorts or leakage up to 120,000 ohms between all elements. And it does all this by merely setting four controls labeled A, B, C, & D with new type easy grip knobs. Check these plus Sencore features... Meter glows in dark for easy reading behind TV set... The new Mighty Mite has large size Speedy-Setup Tube Chart inside of cover—cuts setup time for even faster servicing. New stick proof D' Arsonval meter will not burn out even with shorted tube... Rugged, all steel carrying case and easy grip handle.

The improved Mighty Mite will test virtually every radio and TV tube that you encounter, nearly 2000 in all, including foreign, five star, auto radio tubes plus the new Compactrons, Novars, Nuvisitors and 10 pin tubes. Has larger, easy-to-read type set-up booklet for faster testing.

Size: 10 1/4" x 9 1/4" x 3 1/2". Weight: 8 lbs.

Dealer Net. 74.50

TM116 TUBE TESTER MODERNIZING PANEL

New tube adapter for testing Compactrons, Novars, Nuvisitors and 10 pin tubes in any tube tester except cardomatic types. Plugs into octal socket of your tube tester enabling you to test these new tubes in the same manner

Fast, Accurate... never lets you down

A must for color



that your tester checks conventional tubes. Tube set-up chart included with each adapter.
Dealer Net. 24.95



NOW! CASTLE OFFERS YOU THE BIGGEST BARGAIN IN TV TUNER OVERHAULING!

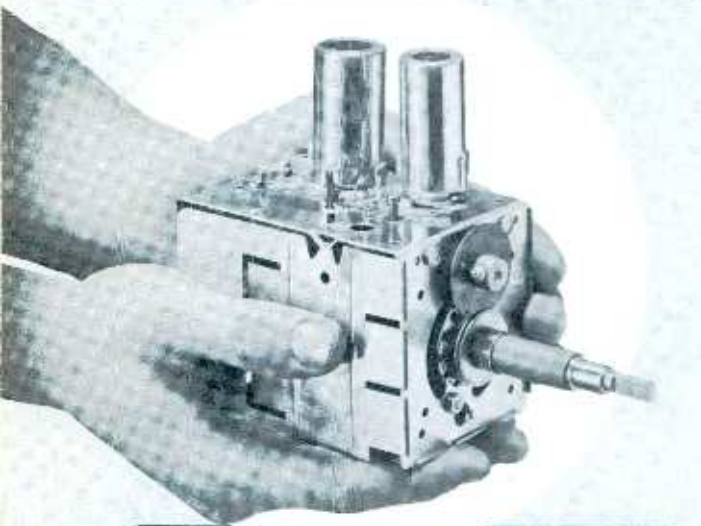

**ALL MAKES
ALL LABOR
AND PARTS
(EXCEPT TUBES)***

9.95

ONE PRICE

THIS ONE LOW PRICE INCLUDES ALL UHF, VHF
AND UV COMBINATION* TUNERS

In a decade of experience overhauling TV Tuners of ALL MAKES, Castle has developed new handling and overhauling techniques which give you . . .

Fast Service

A recent study at our Chicago Plant revealed that of all tuners accepted for overhauling, over 30% were completed and shipped within . . . **Seven Hours** . . . all others within 24 Hours.

Simply send us your defective tuner complete; include tubes, shield cover and any damaged parts with model number and complaint. 90 Day Warranty.

Exact Replacements are available for tuners unfit for overhaul. As low as \$12.95 exchange. (Replacements are new or rebuilt.)

*UV combination tuner must be of one piece construction. Separate UHF and VHF tuners must be dismantled and the defective unit only sent in.



CASTLE

TV TUNER SERVICE, INC.

5701 N. Western Ave., Chicago 45, Illinois
653 S. Palisade Ave., Cliffside Park, New Jersey
Canada: 136 Main St., Toronto 13, Ontario

*Major Parts are additional in Canada

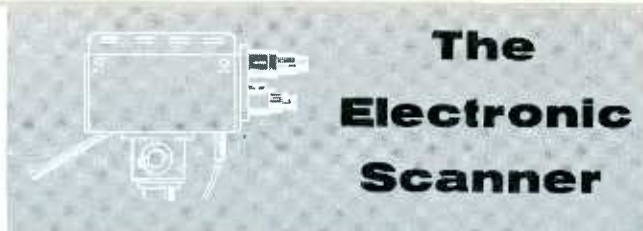

The Electronic Scanner

Fuse News



Littelfuse, Inc. has developed a new transparent plastic top for the standard metal boxes used for packaging its line of electronic, electrical, and automotive fuses. Like the metal lid formerly used, the new top slides open. Walter Clements, Littelfuse vice president, states that not only will this new way of merchandising stimulate fuse sales through visible exposure of the product, but it will cut down inventory time considerably.

Littelfuse conceived their "see-through" container some time ago, and instituted a marketing survey in the field. Since the prime reason for a "see-through" plastic box is to allow a user to see the fuses instantly, Littelfuse customers unanimously suggested a transparent lid. "The natural tendency is to place the box on the table with the right side up," commented one of the firm's leading customers.

Sweepstakes Off and Running!

The first of the 1963 series of **Amperex** Sweepstakes contests for service technicians wound up with an announcement of 10 grand-prize winners—each receiving a Motorola console TV. 100 consolation-prize winners each received a Sessions electric clock.

The contest calls upon the entrant to identify — from a photograph — a widely used TV chassis, supplying the manufacturer's name and the chassis number. A different chassis is represented in each of the four 1963 contests. Entry cards, rules, and full-color illustrations are on display at Amperex distributors.

Two-Way Contract Awarded

Mr. G. E. Smith, president of **Communications Co., Inc.**, announced a contract with DuMont Laboratories of Clifton, New Jersey, by which Comco will provide DuMont's Communications Dept. with a complete line of VHF and UHF land-mobile FM communications equipment. The new contract will provide for mobile, base, and remote-control units to operate in the 25-50 mc, 150 mc, and 450 mc bands. Transistorized equipment in the 150 mc range, presently in production at Comco, is included in the contract. Delivery time to Comco dealers will not be affected by the new contract, because of a factory expansion program completed last year.

Planning Technirama '64

Philco Corp. is planning two new Technirama programs in 1964, covering both appliances and electronics. R. E. Nugent, manager of the Parts and Service department, said the success of Technirama '63, which attracted more than 20,000 service personnel to a series of 123 scheduled meetings, prompted Philco to plan the new series.

Technirama '63 covered the servicing of Philco's "Perma-Circuit" panels and "Cool Chassis" television receivers, color television, and multiplex FM.

Philco International Corp. will sponsor a Technirama this summer for Latin-American technicians in Kingston, Jamaica. These meetings will cover the servicing of "Perma-Circuits," transistor theory, and some basic FM and multiplex circuits.

New Plant Site

A new ten-acre plant site located in the Chatsworth, Calif. industrial area has been purchased by **Clear Beam Antenna Corp.**, according to Bob Raynor, President of the firm. Clear Beam's expansion plans are necessitated by increased sales and continued growth of its product line in the United States and overseas markets, plus the addition of new products developed by its newly formed Chatsworth Industries Division.

Currently occupying a space of 64,000 square feet at a plant in Canoga Park, California, the company produces over 8,000 antennas per day, utilizing the most automated production equipment in the industry. On the new site, Clear Beam plans to build larger production quarters of more than 100,000 square feet to accommodate increased product research and development.



*SUGGESTED RETAIL PRICE © 1963 VOLKSWAGEN OF AMERICA, INC.

What's extra?

Extras on the VW Truck that you don't pay extra for:

1. Bumper guards.
2. Bumper overrides.
3. Outside rearview mirror.
4. Fresh air heater/defroster.
5. Fresh air ventilating system.
6. Passenger seat.
7. Cabin partition.
8. Cabin-width parcel shelf.

9. Synchromesh 4-speed transmission.
10. Directional lights.
11. I.C.C. safety lights.
12. Dome light.
13. Tool kit.

Extras on the VW Truck that you pay for:

1. Swivel driver's seat \$70.90.*
2. Additional set of side doors for the left side \$80.00.*

3. Outside right-hand mirror \$6.95.*
4. Windshield washer \$12.15.*
5. Walk-through front seat with split partition \$59.80.*

The point is this: If you want custom extras on your truck, we have them. (At reasonable prices.)

But why pay extra for stuff that's standard equipment on a Volkswagen?





Dick Nyholm, Radio & TV, 108 N. Lower Ave., Centralia, Washington

"Television antennas represent an important part of my business. Since handling Winegard Colortrons, my business has increased greatly. Seems that one person tells another and your advertising also pays off."



Edwin L. Fisher, Fisher Appliances, Inc., 107 N. E. Front Street, Milford, Delaware

"During the thirty-one years I have been in the Radio and Appliance business few new items have been so immediately successful as your Colortron antenna."

"Our sales of color television testify that your new Colortron antenna has been the answer. In fact we will not sell a customer if they are not willing to install a proper type antenna to operate the new color set."

"Hoping this letter will encourage you to further efforts in developing more new products."



Ken Kesler, Electromatic, Inc., 237 N. E. Broadway, Portland 12, Oregon

"We have used the Winegard assortment of antennas for over three years and find that whatever situation we encounter, Winegard has the answer."

"We have been especially pleased with the WINEGARD COLORTRON which we have used extensively since Color TV has come into its own."



Ray Summers, Ray Summers, Inc., Louisville, Illinois

"We live in an area which has the poorest television reception in the State of Illinois. There are no stations closer than 100 miles. Our TV and antenna sales have more than doubled since using the Winegard Colortron as it has improved reception to the point where we can get good reception from several channels."



George W. Terry, Terry's Electric, McLean, Texas

"I am so pleased with the new Winegard Colortron antennas that I would like to tell you about the reception we have here in McLean, Texas."

"We have these antennas as far as 100 miles from our local stations in Amarillo, Texas and the customers are overjoyed with the reception."

"We have installed over 200 Winegard Powertrons and Colortrons on a money back guarantee. As yet we haven't had the return of even one antenna!"



Twin City Radio & TV, Inc., 97 National Avenue, Chehalis, Washington

"We are especially pleased with Winegard Colortrons and the Nuvisor amplifier is the best by far. Keep up the great engineering and your fine advertising-both help us sell more antennas and boosters."

THEY SAY IT BETTER THAN

Some of America's leading dealers tell why they think Winegard Colortrons are



Dave Tucker, Avon Television Co., 189 Bway, Amityville, New York

"We here at Avon T.V. have used many different antennas for our color installations and have found that for best all around results in color as well as black and white reception the Winegard Colortron is superior in every respect."

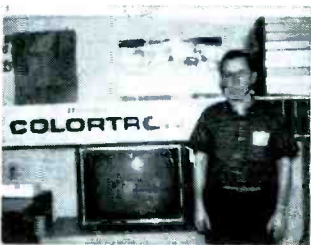

William D. Miles, Miles Electronic Co., Baxley, Georgia

"We are over one hundred miles from the nearest commercial station. We have tried most of the so-called color antennas. Thanks to Winegard's high signal-to-noise ratio and high directivity Winegard is the only acceptable antenna-booster combination which was found to meet our 'customer's satisfaction' requirements. Beautiful color is being received now with the Colortron."



Roy Sahlin, Central Television & Appliance, 911 Chehalis Ave., Chehalis, Washington

"Finest piece of equipment we have worked with in electronic field. The Winegard Colortron and all Winegard products have no competition."



Walter Finkbeiner, 107 New Jersey Ave., Absecon, New Jersey

"I have found the Winegard Colortron and Electronic Power Pack to be the most powerful antenna in our fringe area. Colortron antennas make a perfect combination with our Admiral Color television installations."

"I install Colortrons on trial and have not lost a sale to date."



Charles Dumaine, Dumaine Antenna Service, 735 Woodtick Road, Waterbury, Conn.

"Among the top three antennas I have found it to be the best for any reception. The AP220N Nuvisor Amplifier is tremendous in controlling both high and low channels; eliminating all types of interference. Being an exclusive Winegard dealer, I make between 30 to 40 installations per week of the Winegard Colortron and Amplifier. The people for whom the installations were made are all well satisfied with the performance; bringing more business my way than I can handle."

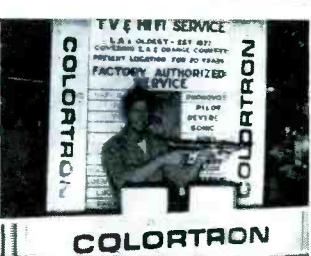

Leonard P. Hellenthal, Nielsen & Neilson, Inc., 1462 Glendale Blvd., Los Angeles 26, California

"I am extremely happy to inform you that we have been a constant user of the Winegard line of antennas and related products for six or seven years."

"We are now moving into the Colortron series which we find to be another added improvement in new type hardware and improved over-all performance."

"As you know, our clients in this area consist of many television and movie stars as well as prominent city officials. We are, therefore, of necessity, quite concerned about the equipment we use and its performance. We are looking forward to future success with this newer series of antennas and amplifiers."



J. C. McNiven, The Gester-McNiven Co., 305 N. Tower, Centralia, Washington

"We feature Winegard Colortrons because they have helped us immeasurably to sell more color sets. They really bring in a magnificent color picture and black and white is also the best. Finest antenna on the market, and we've tried them all."



G. Borders, Borders Radio & TV Service, Flora, Illinois

"In my opinion, the Winegard Electronic Antenna is perhaps the finest piece of equipment I have worked with in the last thirty years."



J. A. Etchison, Etchison Brothers Appliances, Flora, Illinois

"The new Winegard Colortron with the twin nuvistor amplifier permits us to give our customers the best television reception ever!"

Berkeley M. Phelps, TV & Radio Repair, Washington Depot, Conn.

"The high gain of Winegard antennas and boosters give the customer excellent pictures on channels that were not usable before. Winegard equipment does not require sales pressure—seeing is believing!"



WE DO!

the world's finest TV antennas...



Jack Ross, Smith's Home Furnishings, Portland 2, Oregon

"This is hilly country, with lots of tall trees. We install and service thousands of sets a year. We've found many real problem areas—where only a Winegard Colortron antenna with Nuvistor amplifier will pull in the kind of picture a set owner has the right to expect. We recommend Colortron to our customers—especially to the many people now buying Color TV."

David B. Newman, Radio Service Co., 262 Ninth St., Astoria, Oregon

"With the new Colortron TV antenna and Stereotron FM antenna and matching Nuvistor boosters we have obtained excellent reception of the Portland, Oregon TV and FM stations. We are 100 miles from Portland with the coast range of hills between us. We also obtain good results from Seattle, 150 miles away. These are the finest antennas on the market today!"



If you haven't tried Winegard Colortron antennas or Colortron Nuvistor amplifiers, we hope you will try a few soon.

We feel confident there is nothing on the market that can match them for performance and quality. Write for technical bulletins or ask your Winegard distributor.

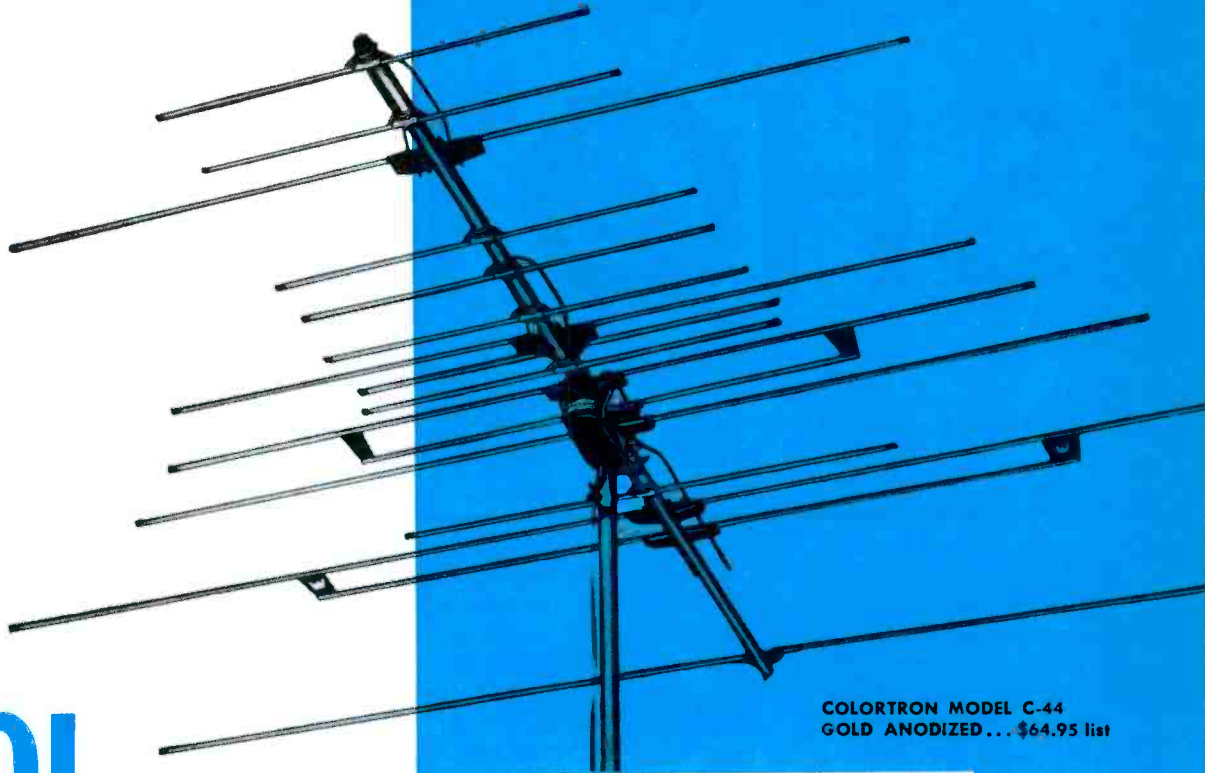

COLORTRON MODEL C-44
GOLD ANODIZED...\$64.95 list

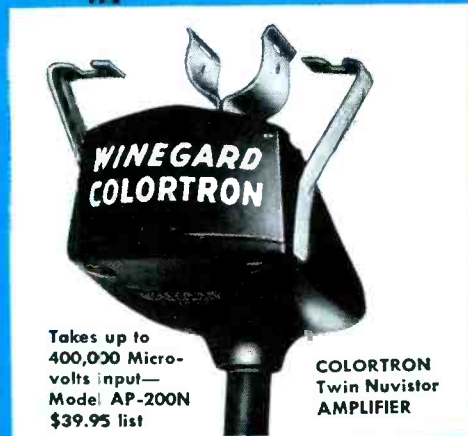

Takes up to
400,000 Micro-
volts input—
Model AP-200N
\$39.95 list

COLORTRON
Twin Nuvistor
AMPLIFIER



MODEL C-43 \$51.90 list

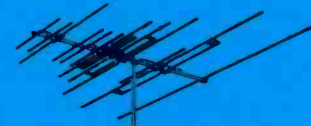

MODEL C-42 \$34.95 list



MODEL C-41 \$24.95 list



Winegard

ANTENNA SYSTEMS

3009-8 KIRKWOOD • BURLINGTON, IOWA

IS THE CARTRIDGE

SHOT?



by
George F. Corne, Jr.

What to do about
"front-end" troubles
in phonos.

Although small in size, the phono pickup cartridge has a crucially important function in an audio reproducing system. No matter how elaborate the amplifier and speaker system may be, the net result and quality of the output can be only as good as the information transferred from the pickup.

Let's take a closer look at the ceramic and crystal cartridges being used in most home entertainment equipment (excluding the more elaborate and expensive types of high-fidelity components). We'll focus on the physical construction of these pickups; then we'll discuss their most vital part, the needle.

Physical Structure

A few slabs of ceramic material, an elastic torque coupler, three or

four connecting terminals, and two different-sized needle tips: Combine these inside a mounting assembly, and you have a basic phono cartridge. Fig. 1 shows the internal construction of a typical stereo unit. Two ceramic slabs (of barium titanate) are used for each channel. The slabs in each pair are clamped together, with an insulating strip between them, and both pairs are mounted to a rigid support at the rear of the assembly. At the front, all of the slabs are attached to a flexible torque coupler that has a V-shaped slot in which the stylus rests. As the needle moves through the grooves of the record, its movement is passed through the stylus to the coupler—which in turn warps or bends the ceramic slabs, generating a corresponding audio voltage.

The rubber damper marked in the photo is placed between the

ceramic elements to prevent excessive bending or shaking of the ceramic slabs. This feature helps to smooth out the frequency response of the cartridge.

Fig. 2 is a rear view of this same cartridge. The four terminals protruding from the rear provide connections from the cartridge to the amplifier input circuit. Slip-on connectors are generally used at this point instead of soldered terminals, since heat is very damaging to a cartridge. If a wire or terminal connector happens to break, disconnect the lead *before* repairing it.

Cartridge Failure

Despite the small size of cartridges, they are still fairly rugged components. Usually, the cause of failure is simply physical deterioration of the different materials in the cartridge. Take the torque coupler, for instance: The consistency of its elastic material must be rigid enough to transmit the stylus motion to the ceramic slabs; however, it must still be flexible enough to prevent jarring of the stylus assembly. With age, this material may become hardened, and lose some of its ability to reproduce the vibrations recorded in the grooves of the record. For a similar reason, the sound output can become distorted due to a hardening of the rubber damping device in the cartridge. The length of time a cartridge can be used before failures of this type occur will depend, of course, on the operating conditions and the unit's construction.

Physical shock, more than any other cause, shortens the life of cartridges. The average customer, usually because he doesn't realize the harm he's doing, fails to treat the unit with *tender care*. He accidentally drops the tone arm, or jars the cartridge in some other manner . . . kids are especially good at this! Some newly introduced cartridges have a "floating" mechanism to prevent possible damage to both the cartridge and the needle. Anytime pressure is applied to the cartridge, it retracts safely into the tone arm, and a "bumper" (located on the tone arm) absorbs the shock. There are several different versions of this type of design—floating cartridge or flexible needle—presently available; the future will probably bring other similar designs.

How can a serviceman spot a

• Please turn to page 75

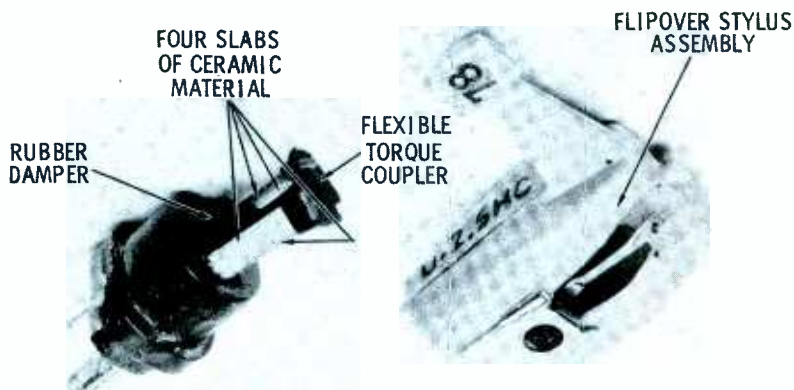

Fig. 1. The torque coupler transfers force from stylus to ceramic slabs.



Tips for Technicians

Mallory Distributor Products Company
P.O. Box 1558, Indianapolis 6, Indiana
a division of P. R. Mallory & Co. Inc.

When you need a lot of microfarads...



You may be occasionally confronted with the problem of finding a lot of capacitance. Maybe for a sound system where you want to squeeze the last bit of ripple out of a power supply. Or for brute-force filtering of low voltage, as in a DC supply for filament circuits.

If your first inclination is to round up a bunch of duals, triples and quads until they add up to the microfarads you need, then hook them in parallel—for the sake of your budget, resist the temptation and read the rest of our tip. For you can get a lot of capacitance in a single unit, at considerably lower cost, by using a Mallory Type CG Computer Grade Capacitor.

These are called computer grade because they were designed specifically for use in computer power supplies. But you don't need to own a computer to use them. What's special about them is the way they're made. Since they are expected to last practically forever, they are made of extra-pure materials and assembled with tender, loving care. All of which seems to pay off, for they turn out to be just about the purest microfarads you can find—very low in equivalent series resistance and d-c leakage. And life is almost unbelievable! We've tested them for the equivalent of 20 years service at room temperature!

What *isn't* special about them is their price. In many instances, a single Type CG will cost less than half as much as the three or four conventional capacitors you would need to get the same rating. In standard stock case sizes, you can get as much as 75,000 mfd at 3 volts and 1300 mfd at 350 volts.

And best of all, you can get 'em when you need 'em at your Mallory Distributor. He's your best source for all electronic components.

ELECTROLYTIC CAPACITORS
FOR HIGH RELIABILITY APPLICATIONS

MALLORY

COMPUTER GRADE

Mallory manufactures the most complete line of aluminum electrolytic capacitors specifically designed for the computer industry. Computer-grade capacitors meet the high quality and extreme reliability requirements of filter and energy storage capacitors used in the power supplies of military and commercial computers.

Mallory Computer Grade Capacitors Feature

- PRESSURE SENSITIVE SAFETY VENT CONSTRUCTION
- TEMPERATURE RANGES 0°C AND 80°C
- WIDE VARIETY OF CONTAINER SIZES
- TWO TYPES OF INSULATING SLEEVES
- TWO TERMINAL INSERT SIZES
- LONG LIFE—see pages 2 and 7

Ask your Mallory Distributor for Bulletin 9-282 on Computer Grade Capacitors. It lists all ratings which he carries in stock.

Another BUSS First

New BUSS VISUAL-PAK

*With the clear plastic box,
there's no need to open
to see how many fuses are in it.*



The new BUSS fuse 'Visual-Pak' originated by BUSS holds five fuses and is an outstanding development in fuse packaging.

The box doesn't have to be opened to see the number of fuses in it. This is a real help when taking inventory—and it also guards against running short on fuses.

Slide cover top securely grips bottom of box to prevent accidental spilling of fuses.

For quick identification, size and type of fuses are printed in large clear type on a flat apron on the lid of box.

The new BUSS 'Visual-Pak' fits display stands and channels—it has the same dimensions as the BUSS metal box.

Many sizes of BUSS fuses are now being shipped in the 'Visual-Pak', and shortly all sizes will be shipped in this modern package.

BUSS continues to be your profit line in fuses because—it's the complete line—it's the quality line—and it's the line with outstanding merchandising aids, such as the new 'Visual-Pak'.

BUSS

BUSSMANN MFG. DIVISION

**MAKERS OF THE COMPLETE LINE OF
FUSES OF UNQUESTIONED HIGH QUALITY**

McGraw-Edison Co. • St. Louis 7, Mo.

With Horizontal Retrace Blanking

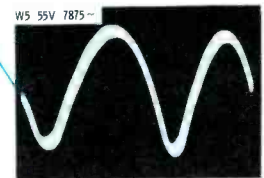
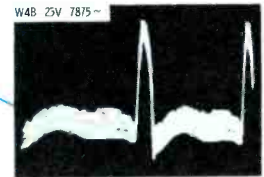
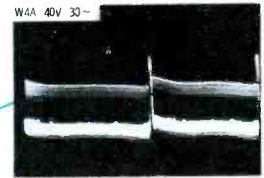
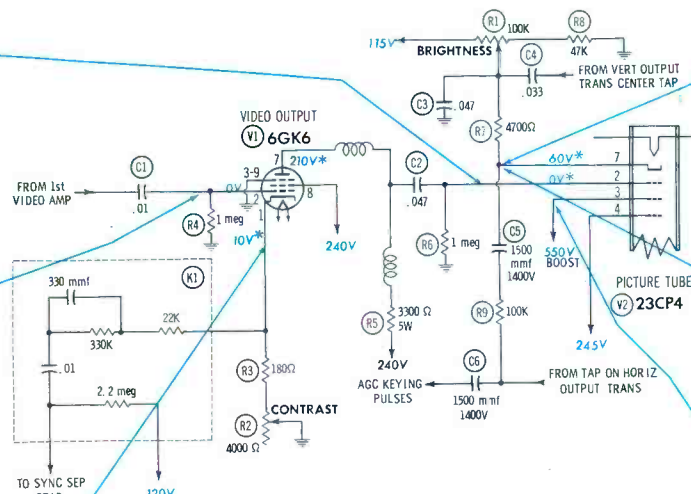
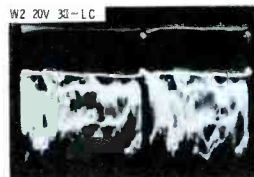
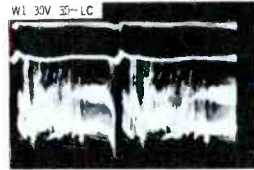
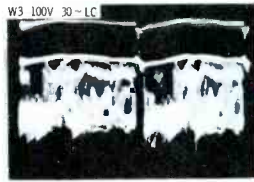

DC VOLTAGES taken with VTVM, on inactive channel; antenna disconnected from set. *Means voltage varies with conditions — see "Variations."

WAVEFORMS taken with wide-band scope; controls set for 100-volt p-p video to CRT. Low-cap probe (LC) used where direct probe distorts signals.

Normal Operation

Although most TV sets now have single video amplifier stage that feeds output to cathode of picture tube, a few new models—and many older ones—use two-stage circuit that drives CRT grid. First video stage (not shown here) inverts and amplifies signal coming from video detector; second stage (V1 in this schematic) gives some additional voltage gain, and again inverts signal so it will have correct polarity (W3) for grid of picture tube V2. Ordinarily, signal at plate of first video stage is utilized as input to sync separator and keyed AGC, but this particular receiver—Setchell-Carlson Chassis UX163—has unusual hookup wherein second stage acts as cathode follower for sync input signal W2. Sole output from plate of V1 is to V2, via simple RC coupling circuit C2-R6. As in most other TV sets, picture-tube bias is adjusted by varying positive cathode voltage with brightness control. W4 at cathode is mixture of both vertical and horizontal retrace-blanking pulses. Vertical-yoke input waveform (110 volts peak to peak) is impressed across C4 and C3 in series, and 40-volt portion developed across C3 is fed to V2. Horizontal pulses are derived from 500-volt sample of flyback pulse, attenuated by R9, and coupled to V2 via C5. Both types of pulses are positive, to accomplish objective of cutting off CRT during sweep retrace time. Voltage and signal ratings of V2, a 110° 23CP4, are similar to those of most other picture tubes. Accelerating anode (pin 3) is connected directly to boost source; W5 is normal boost ripple.

Operating Variations

- V1** Cathode voltage ranges from 12 to 6 volts as contrast control is advanced, and plate voltage changes from 230 to 120 volts. Readings are practically same with or without signal.
- V2 PIN 7** Limits of DC voltage range, at minimum and maximum brightness settings, are 115 and 45 volts (few volts higher with station signal present). Video seen in W4 is developed across R7 by fluctuations in CRT cathode current; amount of video ranges from 5 to 20 volts, depending on how brightness and contrast are adjusted.
- V2 PIN 2** DC voltage remains at zero except when brightness is high and contrast is at or near maximum; then positive peaks of W3 draw grid current and generate grid-leak bias (as much as -20 volts, varying with picture content). Amplitude of W3 is 20 volts at minimum contrast; 200 volts at maximum. Since grid drive is less efficient than cathode drive, and receiver has nearly 20-kv high voltage, video requirement for normal viewing is 100 volts peak to peak, instead of usual 50 volts.
- V2 PIN 3** As in most TV sets, boost voltage will vary to some degree according to load on high-voltage supply. However, this particular receiver has relatively good regulation, and boost ordinarily stays within ±25 volts of stated value.

Brightness Too High

SYMPTOM 1

Raster Width
May Decrease

C2 Leaky

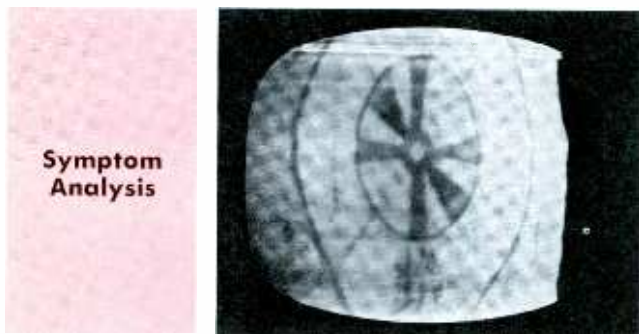

Contrast is normal. R1 has visible effect, but does not extinguish raster. Toward upper end of control range, sides of raster pull in; flyback circuit is evidently overloaded by excessive drain on HV supply. Vertical retrace lines appear at both ends of R1 range.

Waveform Analysis

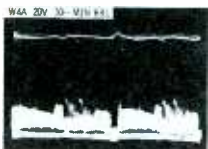
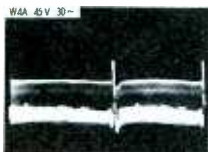

Scope traces give only incidental clues. W3 is normal; so is W4, except for slightly low amplitude of retrace-blanking pulses. This is an odd reflection of trouble, not much help in isolating fault. With R1 at minimum, vertical blanking pulses disappear. This effect is normal, since pulses are bypassed to ground through filters on 120-volt line.

Voltage and Component Analysis

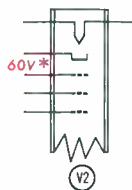

High positive voltage is found on grid of V2; it rises from 50 to 90 volts as contrast is reduced. Likely source of this voltage is leakage through C2, easily checked by unsoldering grid end of capacitor and testing for DC voltage on free lead. In-circuit ohmmeter check also gives valid clue—upscale movement of pointer (due to charging B+ filters via R5) instead of constant 1-meg reading normally expected at grid. Cathode voltage of V2 is normal at low settings of R1, but comes to rest within few volts of grid voltage as R1 is advanced. CRT then passes enough beam current to overload HV circuit and thus reduce horizontal sweep.

Best Bet: Analysis of voltages on CRT elements.

Brightness Too Low

Contrast Normal

C5 Leaky

SYMPTOM 2



Symptom Analysis

Raster is present, but dim, on vacant channels. When a station is tuned in, brightness increases to usable level if contrast is turned up high. Some set owners would put up with this harsh-toned picture; others would recognize trouble and call for service.

Waveform Analysis

As in symptom 1, waveforms are of slight importance. W3, if viewed while contrast control is at or near maximum setting, will show some sync compression; but this is a normal condition due to overdriving of V1. Only unusual condition in W4 is slight decrease in video content, merely a result of abnormally low current through cathode circuit of picture tube.

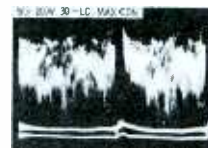

Voltage and Component Analysis

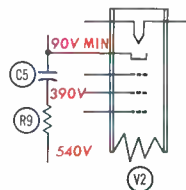

At cathode of V2, DC voltage cannot be reduced below 90 volts by advancing R1. Grid voltage is zero, as usual; so V2 is biased at or near cutoff, except on positive swings of strong video signal at grid. Source of excess positive voltage can be spotted by checking voltage drop across cathode-circuit resistors. Arm of R1 is less positive than cathode, so trouble obviously isn't in brightness-control or vertical-retrace circuit. But CRT end of R9 is 150 volts less positive than other end, so DC must be passing through R9 and C5. Leaky C4 will cause similar symptom, but no appreciable voltage drop will be noted across either R9 or R7.

Best Bet: Thorough voltage analysis at CRT cathode.

SYMPTOM 3

Raster Dim or Absent

Brightness Control Has No Effect

R7 Open

Symptom Analysis

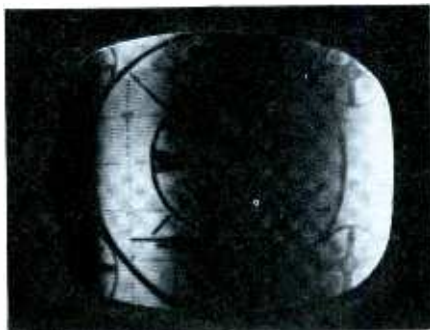

With no signal, set's own CRT has raster blanked out; 8" check tube displays this peculiar, shadowed raster. Strong station viewed at high contrast shows fairly bright highlights, but deep black shadow areas predominate, and picture is not fit to watch.

Waveform Analysis



Surprise clue is 300-volt horizontal-pulse signal at V2 cathode. Identical pulses are found at junction of C5-R9, and normal 500-volt waveform is found on other side of R9. Some cathode-circuit defect is preventing normal shaping of horizontal blanking pulses. Waveform at arm of R1 contains correct vertical-blanking signal, clearing C3 and C4 of suspicion.

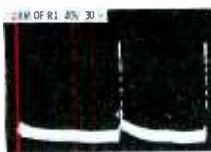

Voltage and Component Analysis

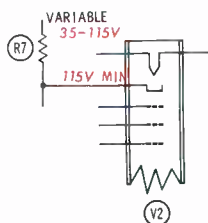

Touching VTVM probe to V2 cathode causes slight increase in brightness. On vacant channel, reading is 115 volts—unchanged by turning R1. Applying signal and increasing contrast causes rise to 150 volts. At arm of R1, voltage varies from 35 to 115 as R1 is rotated. These observations suggest that R7 is open, and high cathode-voltage reading is being produced by small cathode current through high resistance of VTVM circuit. Almost same visual symptom could be caused by open circuit between R1 arm and ground; but W4 would look normal, and DC voltage at V2 cathode would measure steady 120 volts.

Best Bet: Scope to localize; VTVM to pinpoint.

Low Contrast

Brightness Normal

SYMPTOM 4

R3 Increased in Value

Symptom Analysis

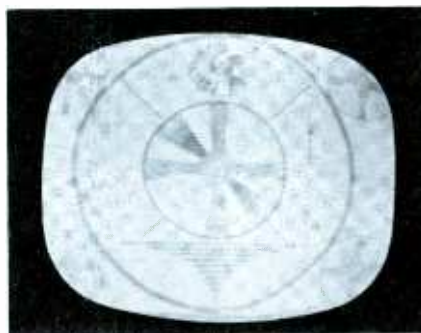

Picture looks rather washed out and contains no signal; however, some snow (and audible noise) is noted on unoccupied channels. Contrast control is operative, but makes very little visible difference in picture. Good brightness and focus discount possibility of bad CRT.

Waveform Analysis

W3 has only 20-volt amplitude at maximum contrast setting, and 10 volts at minimum contrast. Tracing back through video circuitry reveals that plate waveform of V1 is weak (same as W3), but grid waveform W1 has normal shape and amplitude. W2 is slightly stronger than normal, and does not materially change in amplitude as it should when R2 is rotated.

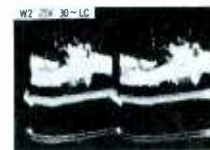
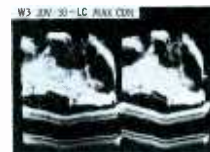

Voltage and Component Analysis

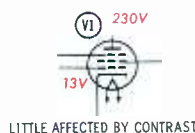

Plate voltage of V1 is nearly 230 volts, and varies by only a few volts when R2 is adjusted; so V1 is apparently operating near cutoff. Grid voltage is zero, as usual. Reading at cathode is 13 volts—close to normal value for minimum contrast—but decreases by only 1 volt as R2 is turned fully clockwise. Resistance to ground from cathode should be only 180 ohms at highest R2 setting, but actual reading is nearly 3000 ohms. Direct measurement across R3 pinpoints fault. Strong W2 developed across high resistance in unby-passed cathode circuit causes enough degeneration to reduce voltage gain of output stage to less than 1.

Best Bet: Signal-trace with scope; follow with ohmmeter.

Narrow Raster

SYMPTOM 5

Brightness Control
Inoperative

C3 Shorted

Symptom
Analysis

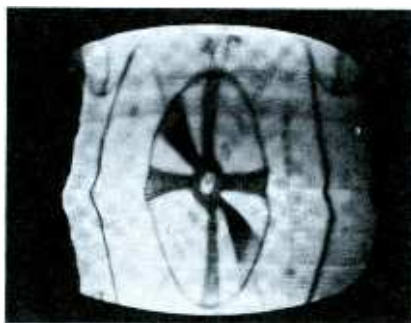

Raster fills out to nearly normal width when strong signal is applied to set and contrast advanced to maximum, but it shrinks during station breaks. Picture looks rather blurry and smeary. As in symptom 1, loss of width looks like case of high-voltage overload.

Waveform Analysis

W3 is normal except for mild increase in sync compression, which is probably related to trouble, but provides no direct clue to its location. W4A apparently contains no vertical blanking pulses, and horizontal pulses are weak; on the other hand, its video content is normal. Waveform on other side of R7 contains only vertical pulses, of 10-volt amplitude. This wave-shape is normal, but amplitude should be 40 volts.

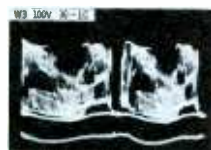

Voltage and Component Analysis

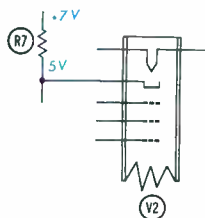

CRT cathode is only 5 volts above ground. Grid voltage is zero unless video signal is fed in; then grid-leak bias is developed in proportion to signal strength (maximum -50 volts). Arm of R1 has less than 1 volt at all control settings. Ohmmeter connected to this point reads only 200 ohms until C3 is cut loose. (Capacitor is almost, but not quite, dead short.) With bad C3 in circuit, turning R1 fully counterclockwise can damage this control by heavy surge of B+ current, so R1 should also be replaced to prevent callback.

Best Bet: Shrewd analysis of voltages is quickest way.

Negative Picture

Complete Sync Loss
at Maximum Contrast

SYMPTOM 6

C1 Leaky

Symptom
Analysis



Picture is basically normal (but too weak to watch) with R2 near minimum; dark and light tones are reversed at medium contrast; normal tones return, but severe video-overload symptoms (such as sync disturbances) are noted as contrast approaches maximum.

Waveform Analysis

W3 has distortion corresponding to visual symptoms. When picture is negative, waveform polarity is inverted; when overloading is present, W3 is very distorted, with flattened sync pulses. In latter case, W1 is also seriously defective; but it shows merely a slight reduction in sync-pulse height while picture is negative. Apparently, trouble prevents V1 from inverting signal in normal manner. W2 duplicates waveshape of W1.

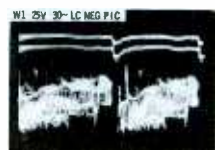
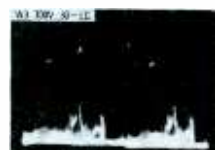
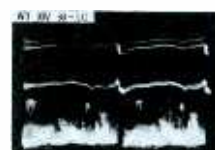

Voltage and Component Analysis

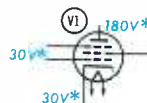

DC voltages on V1 are severely upset. Grid is highly positive, ranging from 15 volts at maximum contrast to 50 volts at minimum contrast. As a result, cathode current of V1 is extremely heavy, and cathode voltage rises to level of grid voltage (except when R2 is close to clockwise end of its rotation). Plate voltage is well below normal, indicating substantial plate current. Only obvious source of positive grid voltage is leakage in C1; this component can be given in-circuit ohmmeter check, or disconnected for voltage test, as in symptom 1.

Best Bet: Preliminary scope tests; follow with VTVM.

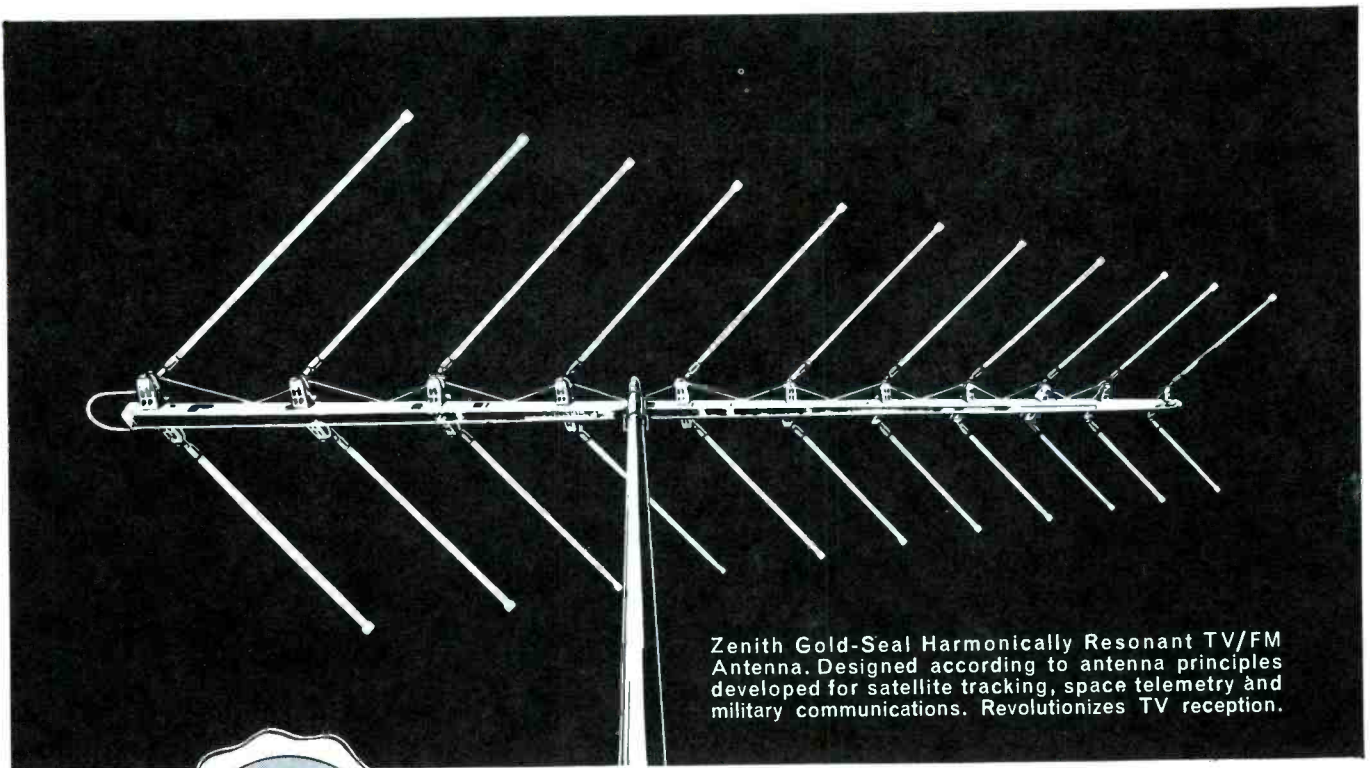

Zenith Gold-Seal Harmonically Resonant TV/FM Antenna. Designed according to antenna principles developed for satellite tracking, space telemetry and military communications. Revolutionizes TV reception.



ZENITH QUALITY COMES TO INDOOR AND OUTDOOR TV & FM ANTENNAS!

Now Zenith brings you a complete line of **Stereo FM, Color TV, UHF and VHF** quality antennas—easy to sell, easy to install, packed with profits! Zenith Gold-Seal Antennas cover every installation requirement, from super fringe to metropolitan areas. And you can offer your customers a wide selection of indoor and outdoor antennas,

plus a complete line of exact replacements for Zenith instruments. Best for Color TV! Best for black-and-white TV! Best for FM and Stereo FM! Best for UHF! Zenith Gold-Seal Antennas are built to the highest Zenith quality standards to give you extra sales and profit opportunities!

ZENITH QUALITY ANTENNAS FOR B&W OR COLOR TV • FM AND STEREO FM • REPLACEMENTS



Zenith Gold-Seal
Broadband Yagi VHF
Antenna
(Channels 2 to 13)



Zenith Gold-Seal
VHF Folded Inline
Antenna
(Channels 2 to 13)



Zenith Gold-Seal
UHF Stacked Bow-tie
Antenna
(Channels 14 to 83)



Zenith Twin Driven
FM Stereo Yagi An-
tenna (For FM fre-
quencies 88-108 MC)

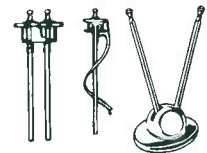

Zenith indoor TV
antennas and exact
replacements for
Zenith instruments

BUILT TO HIGHEST ZENITH QUALITY STANDARDS!

Contact your Zenith Distributor for further information or write: Zenith Sales Corp., Parts Sales Division, 5801 W. Dickens, Chicago 39, Illinois
Specifications subject to change without notice.



MONITORING . . .

helps spot INTERMITTENTS

The revenue of an electronics service shop depends mostly on the operator's ability to use his time productively, so any step taken to reduce the amount of wasted time is bound to improve the profit situation.

Servicemen know, all too well, that one of the greatest causes of lost time is intermittent troubles. Customers naturally aren't agreeable to paying a serviceman just to sit around and wait for an intermittent to "act up." To recover the cost of his time, he must make a direct attack on the problem. The time-honored method of beating on the chassis with a screwdriver, although it may make the serviceman feel better, has only limited use-

fulness; a more scientific approach will get quicker and surer results.

Radio-TV servicemen can learn a lesson from commercial broadcasting stations, which strive to protect their revenues by staying "on the air" every second of every broadcast day. To aid in holding "down time" to a minimum, the transmitting equipment has built-in meters for use in monitoring key check points. Potential troubles can be detected, isolated, and corrected before they cause failure of the equipment. Such a complex system of built-in monitoring devices is obviously impractical for home entertainment equipment, but the service technician can still adapt certain basic monitoring techniques

to his own bench work—especially for dealing with intermittents. A methodical, pre-planned monitoring procedure will result in happier customers, greater profits, and more cheerful technicians.

Why Monitor?

The word "intermittent" suggests that something abnormal is happening to a particular component as a result of changes in operating conditions or temperature. Some reaction to applied voltage or heat is to be expected, and manufacturers allow for this in the design of their sets. But if components change more than the tolerances permit, you've got trouble.

The very nature of these changes makes them difficult to detect by ordinary methods. Heat causes expansion of the materials in components, and unequal movement of different materials may cause an open or short circuit (or a change in value) that will correct itself as soon as the temperature is reduced. In addition, DC or signal voltages applied to a component can produce leakage or shorts that appear to heal when the voltage is removed. Probing the circuit with a test prod is likely to "cure" an intermittent defect, either by mechanically forcing a connection into normal contact, or by creating an electrical pulse that temporarily "welds" the faulty connection. Troubles of this type can be exasperating enough to drive a man to drink—which can be either a blessing or a curse, depending on your outlook!

The beauty of monitoring is that it eliminates the problem of shocking the receiver into normal operation. You choose the most impor-

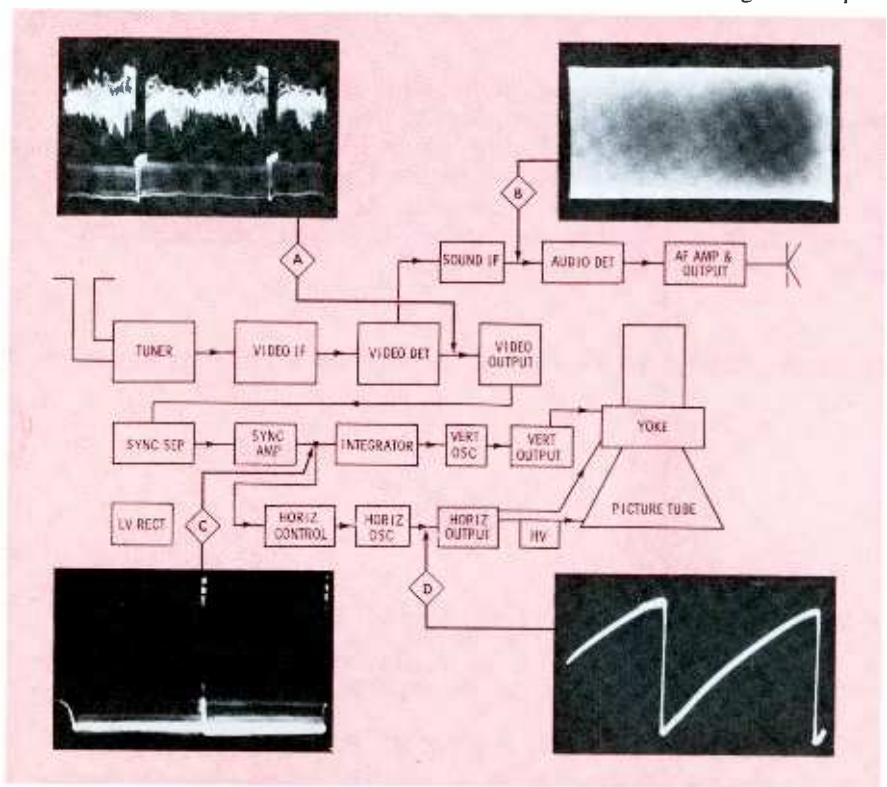

Fig. 1. Four major check points help isolate trouble to some area of set.

tant test points in the suspected circuits, and hook your instrument probes to these points *before* turning the receiver on. Then you can let the equipment operate until the intermittent fault shows up, and check to see if any test indications have become abnormal. While you're waiting, you are free to work on other jobs.

Where to Monitor

The check points used in monitoring are no different from those used in ordinary servicing, but since you can make only a few tests during each monitoring period, you must pick your check points with extra care.

The first step is to try isolating a defect to some definite section of the equipment; once you've ascertained that a certain group of stages is not operating normally, you can monitor various secondary check points in the area to close in on the trouble. In TV work, this initial phase of trouble isolation depends on a shrewd analysis of the picture and sound symptoms—the same method routinely used by all TV men to decide where to begin troubleshooting. However, intermittents cause special complications, because you may have to depend on the customer's description of the symptom (not so much *what it is* as *when it appears*). It's important to get a thorough understanding of his complaint. Sometimes it helps to ask leading questions, such as, "Does the trouble appear only about suppertime?" or "Do you have to reset this control every time you turn the set on?"

The choice of a primary test point may be easy if the set has a symptom such as "creeping" vertical nonlinearity, which plainly indicates a defect in some small area of the set. But quite a few symptoms, like intermittent loss of sync, aren't so easily pinpointed to a stage—or even within several stages. If there is any doubt about the general location of the fault, or if you're not sure of the customer's complaint, you'll find it helpful to begin monitoring at one or more of the four major check points marked on the block diagram in Fig. 1:

- A—Output of video detector
- B—Input to audio detector
- C—Output of last sync stage

D—Drive to horizontal output

Using these points, you can break up the circuits into manageable sections, and greatly reduce the number of tests needed.

How to Make It "Intermit"

Unfortunately, you can't even make that first test until you can coax the trouble to show up. You have several possible ways of doing this, but before doing anything, stop and think. Is the *trouble* really intermittent, or only the *symptom*? Even if the set seems to be acting normally, go ahead and make a few key checks with the scope and VTVM. You may spot some borderline fault such as compressed sync in the video signal, low or poorly filtered B+ voltage, or a misadjusted horizontal oscillator, which may explain why the set's operation is rather erratic.

If the "normal" readings seem correct, you'll have to duplicate the conditions that cause the breakdown, to eliminate the possibility of the set operating normally on your service bench for endless hours. Most customers are unhappy when told the trouble could not be found, and are prone to take such reports as personal affronts to their intelligence. Thus, we repeat: listen very carefully to their accounts of the trouble. Frequently, the complaint will contain a statement such as, "If I want to watch an 8 o'clock program, I turn the set on at 7," or "It runs about an hour, then off it goes." These are clear signs of *thermal* intermittents caused by changes in temperature. The first

type of complaint indicates trouble during warmup, which can be made to appear with comparative ease. The chassis will stay much cooler on the service bench than in the cabinet, thus prolonging the warm-up time. If necessary, a strategically-placed fan or two can forestall normal heating. When the trouble does go away, a shot of "freeze spray" chemical will often bring it back; by carefully aiming the spray, you can pinpoint the offending component.

The other type of complaint, a "hot" intermittent, is much more difficult to bring forth, because the chassis may never run hot enough on the bench to induce the trouble. Heat lamps directed at the suspected area have been used effectively for years, but this method has certain disadvantages. The intense heat radiated by the lamp can melt wax and other insulation from components in the area, possibly causing other troubles or even producing a temporary cure of the original fault. A preferred method is to cover the chassis with a material that will hold heat in much the same manner as a cabinet. Ideal for this purpose is a large cardboard box. If you're using a monitoring technique, you've already made the test connections, so you don't need to reach under the box.

Intermittent troubles that can't be tied to temperature variations may be due to component breakdowns that occur under certain line or signal voltage conditions. Such cases demand more observation and experimenting than simple heat problems; again, the important thing is to come as close as possible to the conditions under which the owner operates his set.

Down to Business

Once you've decided which check points to monitor, and how to induce the symptom, you're "halfway home" on conquering the intermittent. To go the rest of the way, let's consider what to look for at particular test points.

A—Video Detector

This point is useful for isolating the cause of weak video with no snow, or touchy sync. (This test isn't necessary to troubleshoot the

• Please turn to page 71



(A) Typically caused by loss of AGC



(B) Possible result of misaligned IF
Fig. 2. Distortion of detected video.

replacing the phono NEEDLE

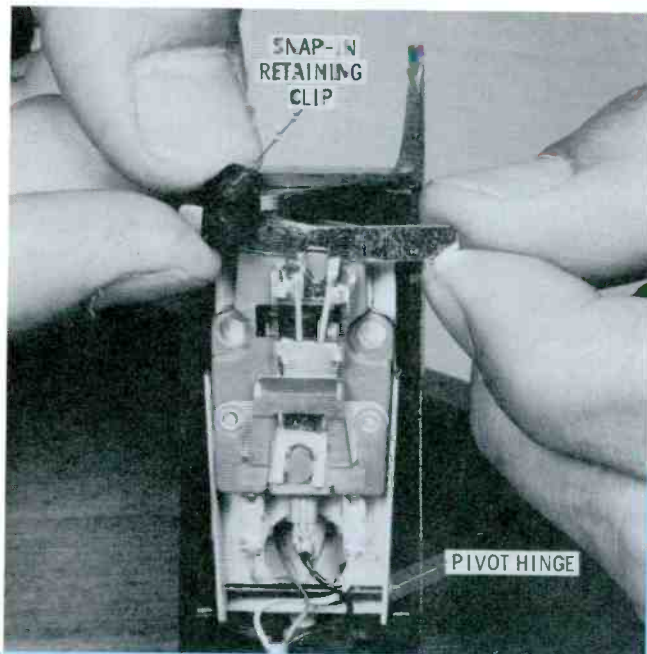

This is one of the new "floating-type" cartridges on the market this year. The snap-in clip marked in the first photo holds the front of the cartridge in place, and blocks the extraction of the dual needle assembly. After this clip has been taken out of the way, the needle assembly can be

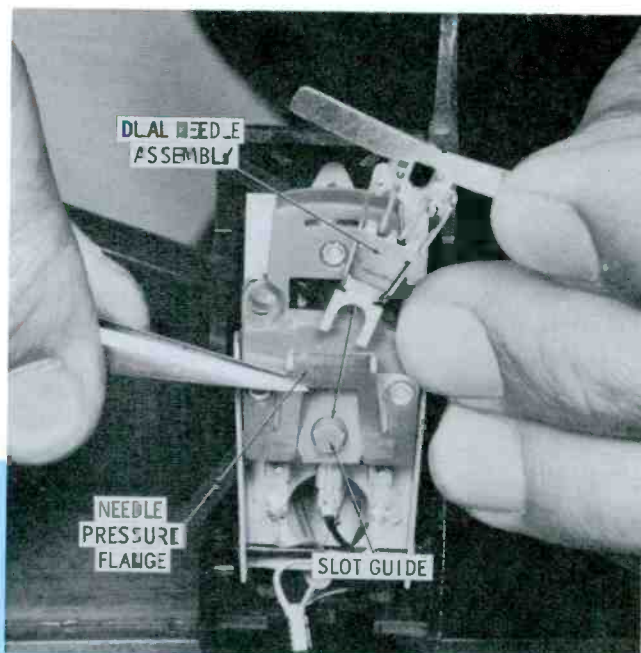

replaced as shown in the second photo. Using a pointed-nosed tool to apply pressure to the rear retaining flange, slip the needle assembly slightly sideways, out, and away from the cartridge. Just reverse the above procedure to snap in the new unit.

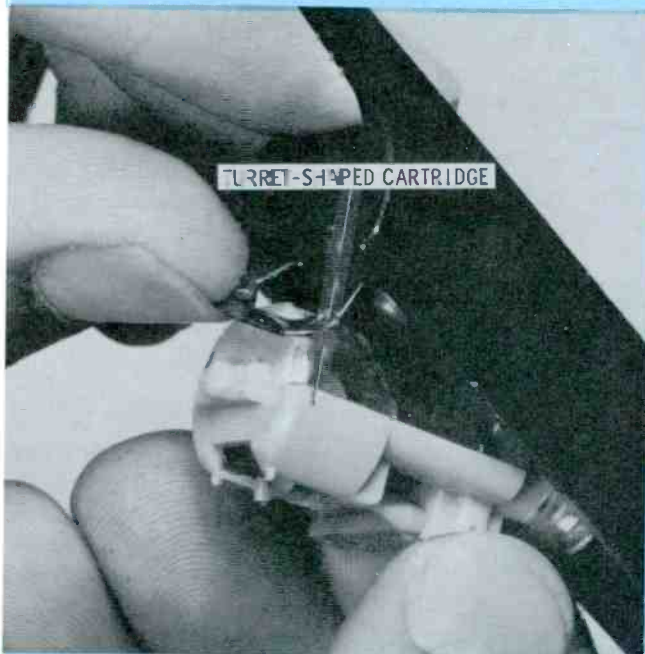

Depicted in these photos is one of the new turret-shaped cartridges. As the trend towards snap-out cartridge mountings increases, replacing the stylus becomes an easier task. Being able to remove the cartridge lets you see exactly how the stylus is mounted, making it easier to remove and replace. The photo of the stylus separated from the cart-

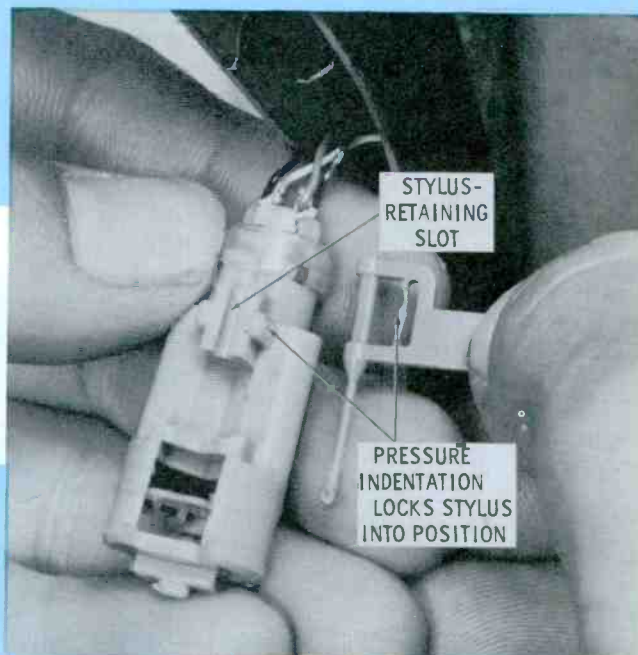

ridge will give you a better idea of how the stylus is held in place. This cartridge and the stylus lever are made mostly of a plastic material, and it's a simple job to un-snap the stylus from the cartridge. However, you'll find it takes a good firm pull to release the stylus from the retaining slot, in this type of assembly.

Replacing a phonograph needle usually presents no problem to the technician active in the servicing of high-fidelity equipment. However, for those not too familiar with some of the newer phono cartridges on the market, installing a new needle can be quite a trick. Many different types of cartridges are appearing in today's home entertainment equipment, and most of these are dual-needle

types for playing both microgroove and 78-rpm records. Needle changeover is sometimes accomplished by means of a flip-over cartridge, while in other cases, only the stylus rotates—the rest of the assembly remains stationary. Shown in these photographs are four of the most common types of new cartridges, illustrating the correct procedures for changing a stylus without damaging cartridge or needle.



When a clip-held cartridge is used, the stylus will be easier to remove if you first release the cartridge-retaining spring, and drop the cartridge away from the tone arm. This may be the only way to reach the stylus, if tone-arm travel in the upward direction is limited. In the cartridge shown, the

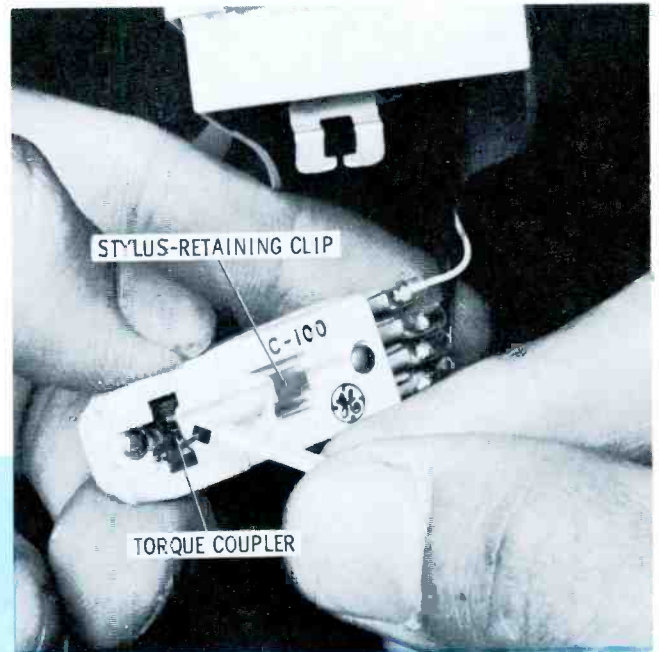

turnover stylus is held in place by a metal retaining clip. After lowering the cartridge away from the tone arm, move the stylus to the center position, and pull it forward and away from this clip. When a new stylus is installed, make sure its shank fits into the V-shaped torque coupler.



This type of cartridge is another that can be released quickly and dropped down from the tone arm. Sometimes, though, it's unnecessary to remove the cartridge, again depending on the tone-arm clearance—whether it can be raised high enough to remove the stylus conveniently. The stylus in this cartridge can be extracted in much the same



manner as the similar type shown in one of the other photos. Move the turnover stylus to the halfway point, and pull up and out to remove it from the metal retaining clip. When replacing the stylus, make sure the shank is properly seated in the coupling saddle, to insure accurate transmission of audio information from needle to cartridge.

I N T E R C O M S

with all the



EXTRAS

Intercommunications is rapidly emerging as an entirely separate branch of electronics. From simple carrier-current arrangements to the most elaborate multiunit systems, intercoms are commonplace in large factories and offices, smaller businesses (such as grocers and garages), and even private homes. Except for the largest industrial and commercial companies — who may have their own electronics service personnel — most intercom users need to call in a qualified inde-

pendent technician to lay out, install, and service their particular systems.

Although there are many types of installations involving many different models of intercoms, the differences among systems are concerned mostly with the number of stations and the variety of extra features included. In reality, all intercoms are *basically* the same. An intercom station comprises a speaker (which generally also serves as the microphone), a tube-type or

transistorized audio amplifier, and anything from a simple *Talk-Listen* switch to an elaborate control panel equipped with all the "extra" features. The fundamental requirements of the audio amplifier and speaker remain fairly consistent throughout the range of different models—although, of course, the units may vary somewhat in design and output power. On the other hand, the amount and type of switching circuitry is dependent upon the features of the system and the overall number of units. The more features, generally, the more switch or relay contacts involved; thus, the more interconnecting wires employed.

Basic System Design

Fig. 1 shows three fundamental intercom arrangements. In each case, (the designation *master station* means a control point for an entire intercom system. Slave stations are simpler units with few or no control features.

Master with Unswitched Slave

In the simple arrangement of Fig. 1A, the only component in the slave station is speaker-microphone M2. Selector switch S2 chooses the desired station by number. Then, when the operator at the master station moves talk-listen switch S1 to the "talk" position, he is able to call a particular slave station. Notice that master speaker M1 connects to the input of the amplifier, and speaker M2 connects to the output. When S1 is transferred to the listen position, M2 is connected to the input of the amplifier and M1 to the output, so the slave station can be monitored. In this type of system, no calls can be initiated from any slave station unless that station is switched into the circuit

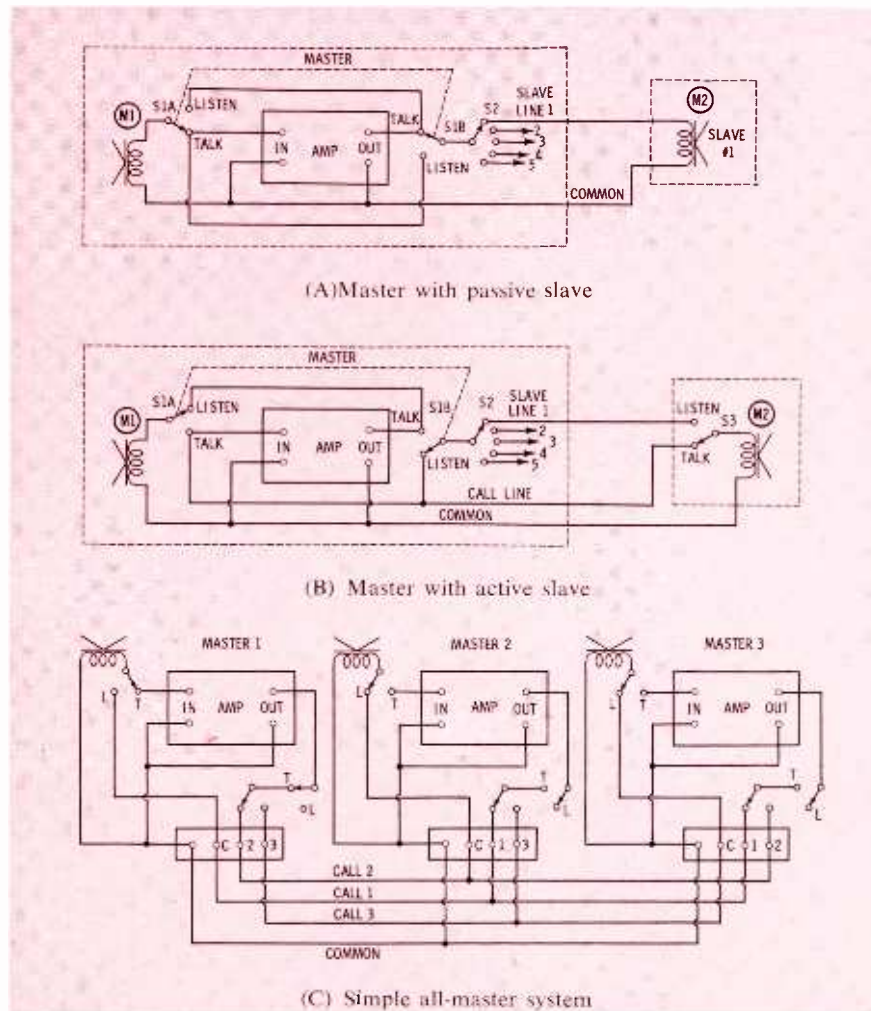

Fig. 1. Basic intercom systems showing wiring layouts between stations.

by selector switch S2 at the master station.

Master with Switched Slave

Fig. 1B also illustrates a master and slave combination. Here, however, it is possible for any slave to initiate a call to the master station. Otherwise, the circuit operates the same as that in Fig. 1A.

To call the master from a slave station—assuming the master station is on—switch S3 is set to the talk position. M2 is thus connected to the input of the amplifier and M1 to the output. To reply, the operator at the master station sets selector switch S2 for the correct slave station. From here on, the system operates as in Fig. 1A, spring-return switch S3 having returned to its normal position.

Some slave-station units are available with an additional switch position that prevents the master unit from eavesdropping.

Note that in Fig. 1B it is necessary to run three wires between the master station and each of the slave units. In Fig. 1A, only two wires link the master station with each slave.

All-Master System

The third basic intercom arrangement is the all-master plan of Fig. 1C. In this system, all stations have an amplifier plus controls and switching arrangements. Hence, any station is able to initiate and establish contact with any other station or stations. Although this arrangement does provide complete versatility in an intercom system, a multi-conductor cable must be used to join the various master stations together in a parallel arrangement. It is well to keep in mind that the cable for a given all-master installation must contain one conductor more than the number of interconnected master stations (i.e., six stations require seven wires).

A modified version of the all-master system, consisting of a number of master stations plus a number of slave units, reduces both the cost of the system and the number of conductors needed.

Selling Versatility

Modern intercom units and associated items permit the installation of versatile systems that can accommodate the needs of prac-

tically all commercial and business enterprises. For instance, slave units can be wired to initiate calls selectively to any one or several master stations. Thus, in a multiple master arrangement, a number of conversations can be going on privately. Indicator lights can be included to show what circuits are in operation, or to inform the person initiating a call that his signal is going through. Some master stations even include lights that indicate which station is calling.

Many other convenient features and accessories are available for specialized applications. For example, in certain industrial and business locations where the noise level is so high that ordinary intercom operation is impossible, the telephone handset is the answer. Some telephone sets have a bell or buzzer which signals the operator to the handset intercom. Others feature coded bell or light signals to attract the attention of specific individuals. These annunciator facilities are also becoming increasingly popular as "extras" in speaker-equipped intercom systems.

Large industrial and business establishments often use paging systems to call an individual to the nearest intercom or telephone. This is particularly effective in attracting the attention of those persons who normally move about into various areas. Many establishments already

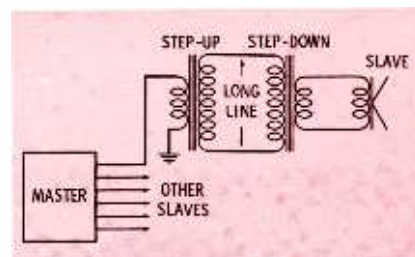

Fig. 3. Line transformers help reduce the line losses between stations.

have wired music-PA installations which are used also for intercom paging.

In large installations, intercom, paging, and wired-music systems are frequently integrated; either combined program and intercom amplifiers, or separate amplifiers (as in Fig. 2) may be used. Normally, the program material is sent over the wires to each of the slave units. The master operator, however, can cut in and call any slave unit by depressing the appropriate switch. In so doing, the intercom path is established to that particular slave, and the program material is turned off. The program is interrupted only at the slave station being contacted—not at any others.

All-station paging can be accomplished by setting the master station selector to the all-call position. In this case the output of the intercom amplifier is fed to the input of the program amplifier. Since the output of the program amplifier

• Please turn to page 67

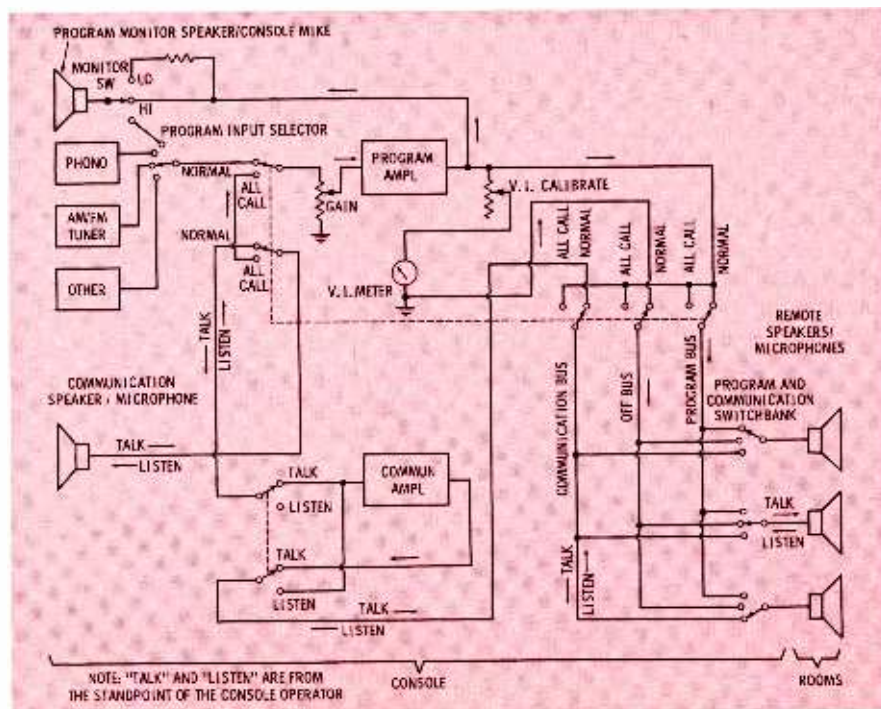

Fig. 2. Block diagram of music-intercom system using separate amplifiers.

SCOPING COMMON-CATHODE HORIZONTAL AFC

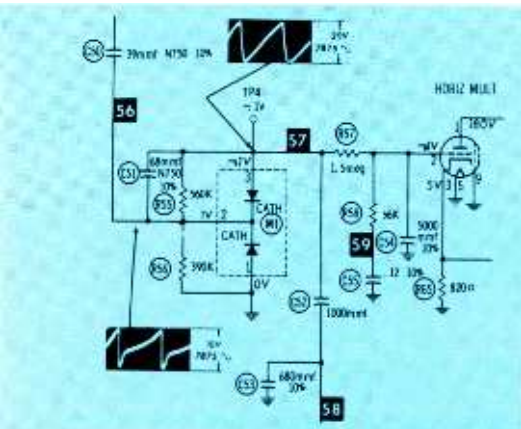
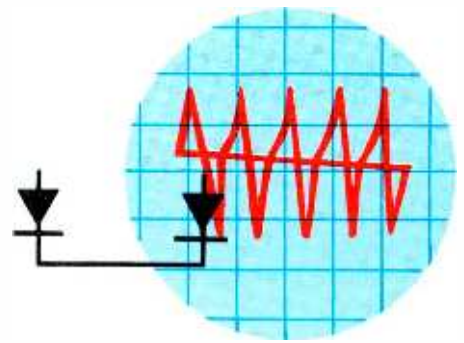

Fig. 1. Common-cathode AFC circuit requires only one sync-pulse input.

Most TV sets of recent design, and even some of the old-timers, use a type of dual-diode horizontal AFC circuit that differs somewhat from the "balanced" circuit I described in the June *Shop Talk* column. This alternate circuit, which uses selenium or vacuum-tube diodes with a common cathode connection, might conveniently be called "unbalanced" diode AFC without implying inferiority to the balanced circuit. Both arrangements are equally capable of supplying efficient, stable, and quick-acting horizontal synchronization.

The unbalanced circuit has some advantages and also some disadvantages when compared with the balanced type. In its favor is the fact that it requires only one sync pulse, of negative polarity—making it usable in receivers having a

single-stage sync circuit. Also, because it can accept a sample sawtooth signal with the steep slope running in a negative direction, it is possible to obtain a usable sample signal from the negative spike of the horizontal drive waveform—thus eliminating the output tube and flyback from the AFC feedback loop. Dual diodes with a common cathode are available in many different types of multisection tubes, and this factor greatly simplifies receiver design. All of these advantages add up to a welcome reduction in cost when the unbalanced type of diode AFC is used.

On the debit side of the comparison ledger, the unbalanced diode AFC develops a more negative than positive correction voltage, instead of being zero centered. Therefore, it makes frequency or phasing corrections more effectively when the oscillator is running slow (or is lagging the sync signal) than when the oscillator is fast. This disadvantage is not serious; it is usually counteracted by using a different shunt resistance across each diode, applying slight positive bias to the AFC, or designing the horizontal multivibrator so it will operate properly with a slight negative voltage on the AFC-controlled grid. When the unbalanced AFC circuit is used with horizontal oscillators other than multivibrators—for example, the sine-wave oscillator and reactance tube—this disadvantage actually becomes an advantage.

Circuit Action

Fig. 1 shows a modern version of the common-cathode circuit, using selenium diodes. Its operation is fundamentally the same as that of the balanced circuit: When the oscillator runs fast, or leads the sync, the combined action of the

sync and sample waveforms develop a positive correction voltage which is fed through a filter to the controlled grid of the oscillator or multivibrator. Conversely, when the oscillator runs slow, or lags the sync pulses, a negative voltage is developed.

Generally, the unbalanced circuit can operate with a smaller sync pulse than the balanced circuits; in some cases, 5 to 10 volts is an adequate peak-to-peak amplitude. The sample signal may have from two to five times as much amplitude as the sync-pulse signal.

The circuit's greater ability to correct a below-frequency or lagging-phase condition can be demonstrated by turning the hold control off frequency in either direction and slowly turning back toward synchronization. With the unbalanced circuit, five bars—slanting to the right—are seen just before the picture pulls into sync, but the pull-in point in the other direction is not reached until only three bars are seen slanting to the left. This obser-

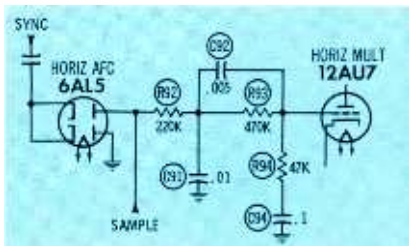

Fig. 2. Some sets, like Westinghouse V-2216, have elaborate AFC filter.

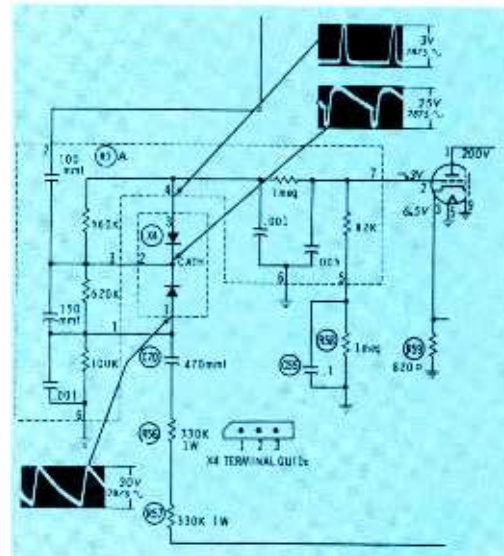

Fig. 3. Different method of applying sawtooth to common-cathode circuit.

vation is mentioned to emphasize the fact that unequal pull-in does not indicate an AFC defect except in a balanced circuit, which should pull in equally from either direction.

Some unbalanced circuits use a relatively large number of components in the correction-voltage filter circuit. Let's analyze one example of a complex filter, as used in a Westinghouse V-2216 chassis (Fig. 2): The combination of C91-R92 is primarily a short-time-constant, low-pass filter; C92-R93 is a noise-immunity network; and C94-R94 is a long-time-constant, low-pass filter. The low-pass filters prevent fluctuations of the correction voltage, and the noise-immunity circuit does just what its name implies—it makes the oscillator less sensitive to noise.

Another variation of the unbalanced circuit is shown in Fig. 3. The same negative-going sync signal is used, but the sawtooth signal is reversed in polarity (with a short positive-going slope). This sample signal is fed to the diode terminal farthest from the multivibrator—just the opposite of the arrangement used in Fig. 1. A resistor is inserted between this diode terminal and ground, to complete the DC ground path without shorting out the sawtooth signal. The correction-voltage output is almost the same as in Fig. 1.

The sawtooth signal for the circuit of Fig. 3 is shaped from a large positive pulse taken from the flyback circuit, just as in a balanced AFC system. (The shaping networks were discussed in the June issue.) I'm inclined to consider this feature a disadvantage, since I have seen too many troubles develop in sample-signal networks which derive a signal from a large pulse.

Troubles and Troubleshooting

The same troubles that afflict the balanced AFC circuit—leaky diodes or coupling capacitors, distorted input signals, etc.—are also found in the unbalanced AFC, but the latter type is more critically affected by tolerance errors or minor defects in components. The unbalanced type is also not so easy to troubleshoot as the balanced type. For one thing, the horizontal oscillator is not likely to have exactly zero voltage on its controlled grid for normal operation, as is usually the case with the balanced circuit. Consequently, the

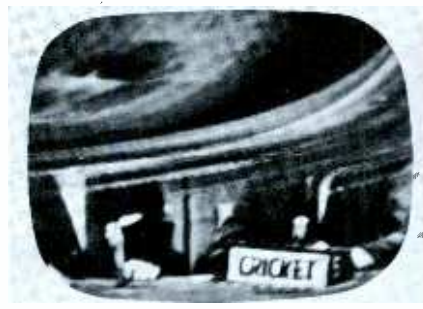

Fig. 4. AFC-circuit trouble allowed top half of picture to "tear loose."

free-running operation of the oscillator is not so easily checked by simply grounding the controlled grid. To bring the oscillator to 15.750 cps, it may be necessary to reset the horizontal frequency adjustment or else substitute an external bias voltage for the AFC voltage.

Nor is the unbalanced circuit as easy to check with a scope, because the shunt resistors and capacitors cause a certain amount of interaction between the sync and sample signals even when the diode unit is removed. In spite of this, scope examination of these signals still turns up most causes of poor AFC action. One case where scope tracing proved its worth involved a Philco 9L35 which presented the partial tearout shown in Fig. 4. Since the lower half of the picture was normal, I knew the oscillator was running on frequency, and "guesstimated" that the AFC was at fault. After inserting a test adapter in the 9BR7 socket, I scoped pins 7 and 8, where the sample signal and sync are respectively fed to the AFC. The signals I found at these points are shown in Figs. 5A and 5B. From the absence of a sawtooth wave, I deduced that K6 in Fig. 6 (Philco part number 30-6512-6) was defective. Installing a new unit restored normal AFC and sync action. I again scoped pins 7 and 8, and this time the traces appeared

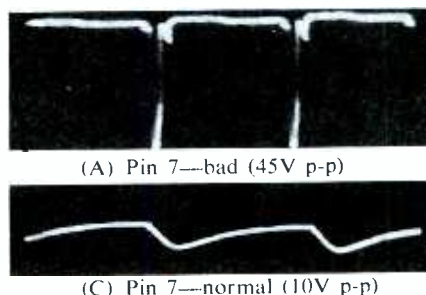

Fig. 5. Normal and abnormal waveforms from AFC tube of Philco 9L35.

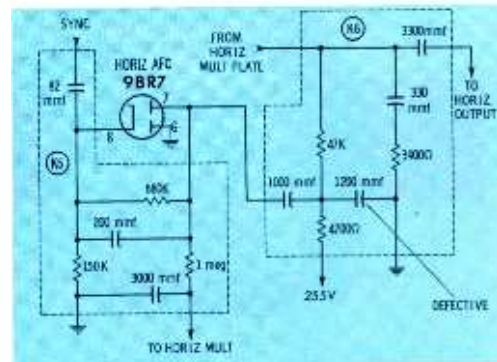

Fig. 6. Loss of sample sawtooth was traced to open capacitor inside K6.

as in Figs. 5C and 5D.

To obtain an illustration of my previous statement about the interaction between the AFC sync and sample signal even with the diode removed, I took an old 12AU7, snipped off pins 6, 7, and 8, and installed it in the 9BR7 socket. Pin 7 still scoped the same as in Fig. 5C, as expected, but pin 8—where a pure sync pulse might be anticipated—was just barely different from Fig. 5D.

A Tough Old Bird

Sometimes even the scope can't directly pinpoint the cause of AFC trouble. A fellow serviceman confronted me with a Westinghouse V-2216, using the circuit of Fig. 2, which he said was too critical in locking. "Look," he challenged, "I know these sets are normally critical, but this one is worse than it should be." I checked it and found he wasn't just "whistlin' Dixie"; the set was really touchy. Using up every troubleshooting trick I could think of left me exactly where I was when I started. Scope traces were perfect, and voltages were right on the ball, but AFC action was still lousy. Finally I examined every part in the circuit and came up with a .001 capacitor in the noise-immunity network of the correction-voltage filter, where a .005

• Please turn to page 68

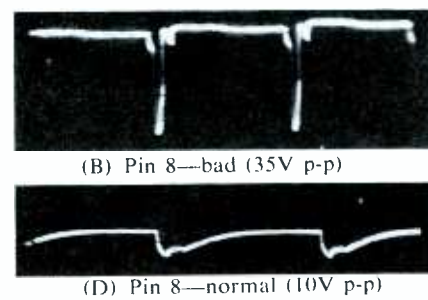

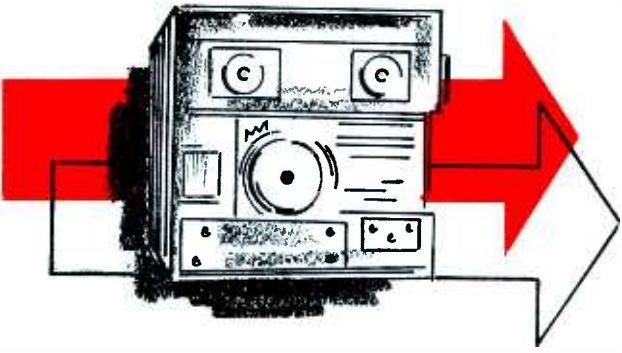

TAPE RECORDERS

*Yield to a **DIRECT** approach*

by Larry B. Allen

But it's well to keep these special troubleshooting pointers in mind.

One afternoon not so long ago, a serviceman friend dropped in for a "casual" visit. We made small talk, and bragged about business; then, somehow, the conversation turned to tape recorders.

"You know, I dread to see a tape recorder brought into the shop!" he complained. "They always seem like so much work for the little dab of money you get for servicing them."

"Oh, I don't know," I replied, "I always charge enough to cover my time when I service one. In fact, I sort of enjoy whipping a troublesome machine into shape."

"I'll be right back . . .". He was out the door and back in less time than it takes to tell, lugging a tape recorder of rather recent design. "Here's one you might enjoy whipping into shape. Electronic faults I can find easily, but these mechanical defects keep me snowed!"

Wishing I'd known when to keep quiet, I countered by asking him what sort of trouble he was having with it and hinting that he should be able to fix it himself.

"I know it," he admitted, "But it seems the only way to service one of these monsters is by the guess-and-try method. And I usually end up spending a whole day at it. Then I'm ashamed to charge for so much time."

I could see what he meant, because no customer would want to pay the cost of a day of *my* time just for getting one tape recorder fixed. So I figured here was my chance to do a good turn and pass along my method of attacking tape-recorder service. My friend acted pleased at the chance to learn a better approach to his problem (although I'm sure he came by with no other purpose in mind) . . . and I must admit the prospect of show-

ing off my ability didn't strike me as a bad idea, either.

Now let me hasten to add, I'm no expert—and there's a lot about tape recorders I hope to learn by continuing to service them. But I've developed a "philosophy" of servicing that I felt my friend should know about, and I think you'd like to hear about it, too.

I believe in the direct approach. I used to waste a lot of time trying to "analyze" the problem before I even took the top off the recorder. If the trouble is mechanical, you're going to take the top off anyway, so why not do it to start with? If you consider the logic of this approach, it makes sense. The time to analyze mechanical symptoms is *after* you expose the parts involved. Also, you can't possibly repair the mechanism until it's visible, so why hesitate? The toughest part of any job is getting started, and disassembling the machine gives you something to do while you're thinking about the trouble.

Before going to work on the problem, I clamp the transport deck into a dolly of the sort used for record changers; this places the unit clear of the bench where I can observe its operation without upending it. As I demonstrated to my friend, a small pocket flashlight helps me see into shadowed corners.

Classifying Faults

With my friend's recorder all set up for bench analysis, I was ready to explain how to diagnose the problem. Mechanical defects in a tape recorder fall into a very limited group of categories, as far as their effect on operation is concerned. Most of them affect *tape drive* (the action of transporting the tape from one reel, across the magnetic head,

and winding it up on the other reel). The various possible drive troubles can be grouped as affecting the capstan drive (fairly common), take-up-reel drive (also common), unwind-reel drive, or rewind (running the tape back onto the unwind reel).

Capstan Drive Troubles

These are faults that affect the drive mechanism for either playback or recording. In most machines, anything that affects one mode of operation will affect the other, but occasionally this isn't so. Drive troubles may occur in several ways.

"Wow" may be heard when a tape is played on the machine, indicating slippage in the mechanism that drives the capstan. A below-deck inspection will usually reveal a drive wheel with hardened (or oily) rubber, a loose or weak pull-in spring (the one that holds the drive wheel against the capstan), or a slipping drive belt. In any case, the remedy is obvious.

In belt-driven machines, slippage may mean the drive belt has accumulated a deposit of oil from the mechanism and lost traction; on the other hand, it may simply have become stretched. In a few machines, the belt drive can be kept tight by an adjustable "idler" roller that makes it possible to take up the slack as the belt stretches through continued use. In this way, a longer period of service can be obtained from a rubber drive belt. When the idler adjustment nears its end, be sure to replace the belt; it's about finished.

Sometimes capstan-drive systems will fail to work because the pressure roller, which holds the tape in contact with the capstan, will become hardened or oily. This can be seen without even peering under the deck, but the top must be off:

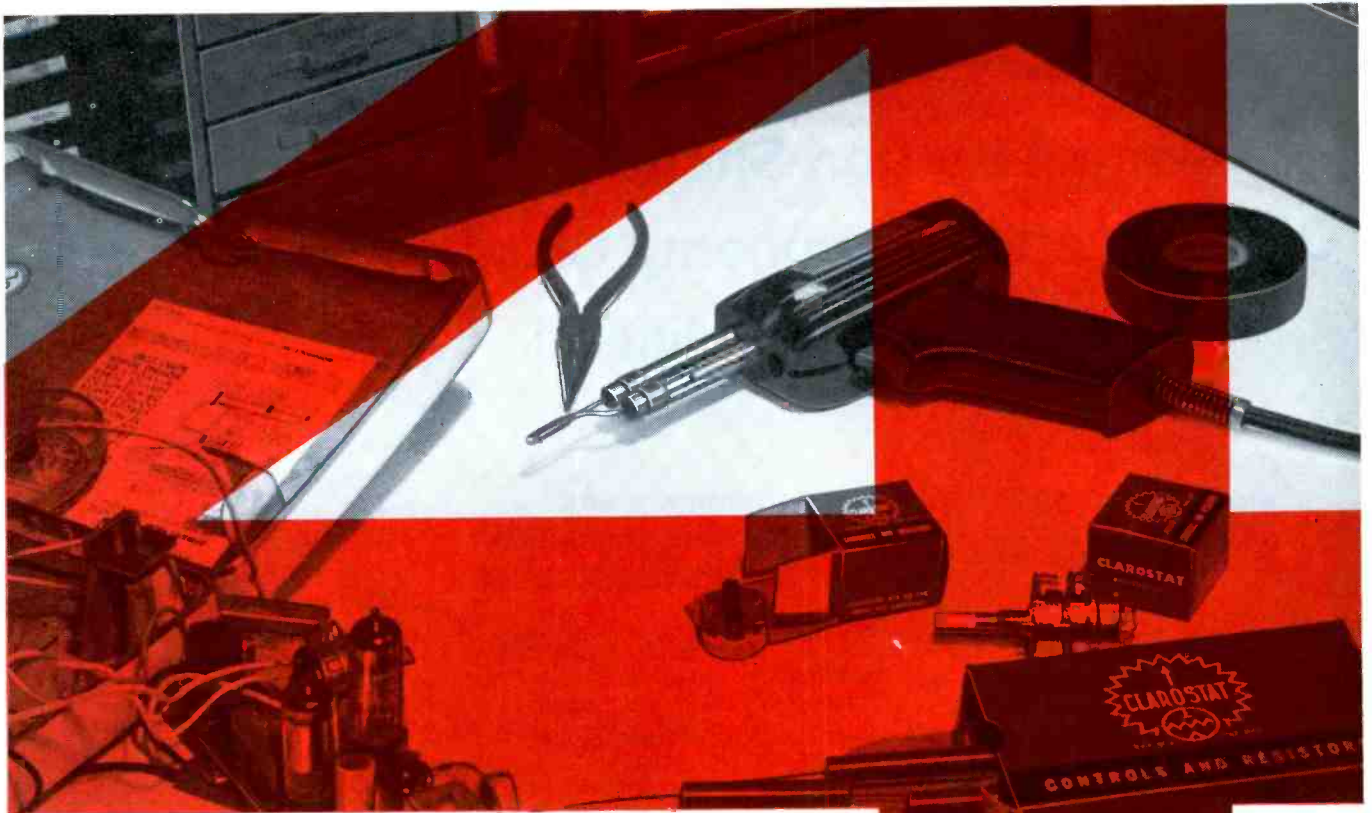

**for
service**

**CLAROSTAT POTENTIOMETERS
ARE RIGHT
FOR EVERY SERVICING NEED**



For all your television, radio, Hi-Fi, stereo, and sound system control needs, Clarostat has the appropriate potentiometer. Clarostat replacement potentiometers are the same fine quality that has made them first choice with the most critical equipment manufacturers.

RTV exact replacement controls ready for installation right from the carton.

Standard wire-wound and composition controls for all popular requirements.

Series DA field assembled duals for balanced functions in audio and stereo.

Uni-Tite field assembled dual concentrics go together quickly and easily.

Get complete details from your Clarostat Distributor, or write . . .

DISTRIBUTOR SALES DIVISION



CLAROSTAT

CLAROSTAT MFG. CO., INC. DOVER, NEW HAMPSHIRE

Harman-Kardon Shatters Old Concepts of Economy-Class Public Address Amplifiers!



COMMANDER CA-12

New performance and versatility standards with the "CA" SERIES COMMANDER

Unprecedented! 5 New Commanders . . . every one with CERTIFIED POWER RATING! Now you can plan a job accurately, get the results you expect!



COMMANDER CA-23

Versatile! Inputs for High and Low Impedance Mics—with on-chassis socket for plug-in mic matching transformer! Every quality or cable length requirement is now satisfied!



COMMANDER CA-35

Expandable! Add Mic Channels as Needed! Space provided on medium and high power models for two additional mic channels. Up to four mic inputs now possible.

Fidelity! Socket for an optional plug-in mag phono-tape head preamp with genuine built-in RIAA and NARTB equalization. Works in aux channel; avoids loss of a mic input.



COMMANDER CA-65
with extra mic pre-amp installed

Adaptability! Every Commander can be set up for precedence operation, essential for background music systems, special and emergency announcements, etc. CA-12 has MIX-MUSIC-PAGE switch; all others function automatically.

Flexible! Optional area speaker selector assembly installs in CA-35/65/100 to provide selective paging and musicasting to any or all of 8 areas.

It's impossible . . . to add here the numerous other MAJOR features of this remarkable new economy class public address line. But, a big new free catalog tells you the whole story about Commander and provides valuable, revealing information about public address amplifiers generally . . . Send for it.



COMMANDER CA-100
with extra mic channels and
area selector switch assembly

Harman-Kardon, Inc. Desk **H-8**
Commercial Sound Div.
55 Ames Court, Plainview, L.I., N.Y.

Rush me the new p/a catalog that tells me the things I ought to know about public address amplifiers.

Name _____

Address _____

City _____ State _____

harman kardon

A subsidiary of THE JERROLD CORPORATION

thus you see why I remove the top, very first thing. The cure for a bad pressure roller, as with most faulty drive parts, is a replacement. I've "livened up" a few by placing them in contact with the wire buffing wheel on my grinder, but this is only a last resort if a replacement is unavailable. A thorough cleaning with alcohol is acceptable if oil or grease is the only problem; but the deterioration has already started, and a replacement is best.

Takeup-Reel Drive

Defects which affect takeup action usually show up by frequently broken tapes, by tape pileups in the mechanism or on the deck, or—in a few machines—by "wow" in the playback.

Takeup drives can become either too loose or too tight. The normal drive ratio is such that the takeup reel tries to turn a little faster than the capstan; thus, the normally acting takeup reel pulls gently on the tape after it leaves the capstan, keeping all the slack out. Notice I said a *normal* reel pulls gently, and the takeup reel *tries* to turn faster than the tape is fed. A clutch arrangement, either between two flat rubber surfaces or between a rubber belt and its metal track, allows the small amount of slippage necessary to prevent snapping the tape apart.

If the slippage becomes too easy, the reel turns too slowly and the tape piles up. If the clutch is too tight, it either pulls the tape through the capstan in an irregular manner (causing "wow") or breaks the tape. A common form of takeup-reel trouble is a fluctuating tension that alternately loosens and tightens the tape between the reel and capstan, frequently resulting in breakage.

A third type of takeup drive—not seen too often—is the pressure-roller drive. The pressure roller is generally driven by a rubber belt; therefore, the same forms of trouble that affect capstan drives can be expected with this type of takeup mechanism. The important difference is that the takeup drive *must* slip a little, while the capstan drive *must not* slip at all.

Unwind (Followup) Reel

During either playback or recording, the reel of tape that's full at the start can't run as fast as the tape-

Half of all TV lead-in cable needs replacement...now!

TV lead-in cable should be replaced at least once every two years. Hot summers, cold winters, and salty air do the dirty work... and the picture suffers.

This means that you have a made-to-order replacement market. Automotive garages make extra profits by selling replacement spark plugs and fan belts. You can make extra profits simply by telling your customer how his old deteriorated cable keeps him from getting the best possible picture.

Tell him about the best... Belden. It is an insurance policy against weak signals and reception failure. And there is a Belden lead-in cable for every requirement, including Permohm* for areas of salt or industrial contamination, Weldohm† with 2½ times the flexing strength of ordinary lead-in, Celluline* for resistance to sun and wind, RG59/U for multi-set operation and areas of extreme interference, neutral color Decorator lead-in, plus regular 300-ohm line, 150-ohm line, and 75-ohm line. Call your Belden jobber.

power supply cords • cord sets and portable cordage
electrical household cords • magnet wire • lead wire



*Belden Trademarks and Patents—U.S. Patent No. 2782251 and 2814666

†Belden Trademark—Reg. U.S. Pat. Off.

8-3-3



Be a Cartoon
Gag Writer!

Win a \$25.00
Savings Bond

Send us your gag ideas for future cartoons. For each of your gag ideas used, we'll send you a \$25 Savings Bond. Write Belden Manufacturing Company, Attention: Mrs. Madelsa Allison, P.O. Box 5070-A, Chicago 80, Illinois.

*This month's winner: Charles W. Forster,
3744 Charles Street, San Diego 6, California

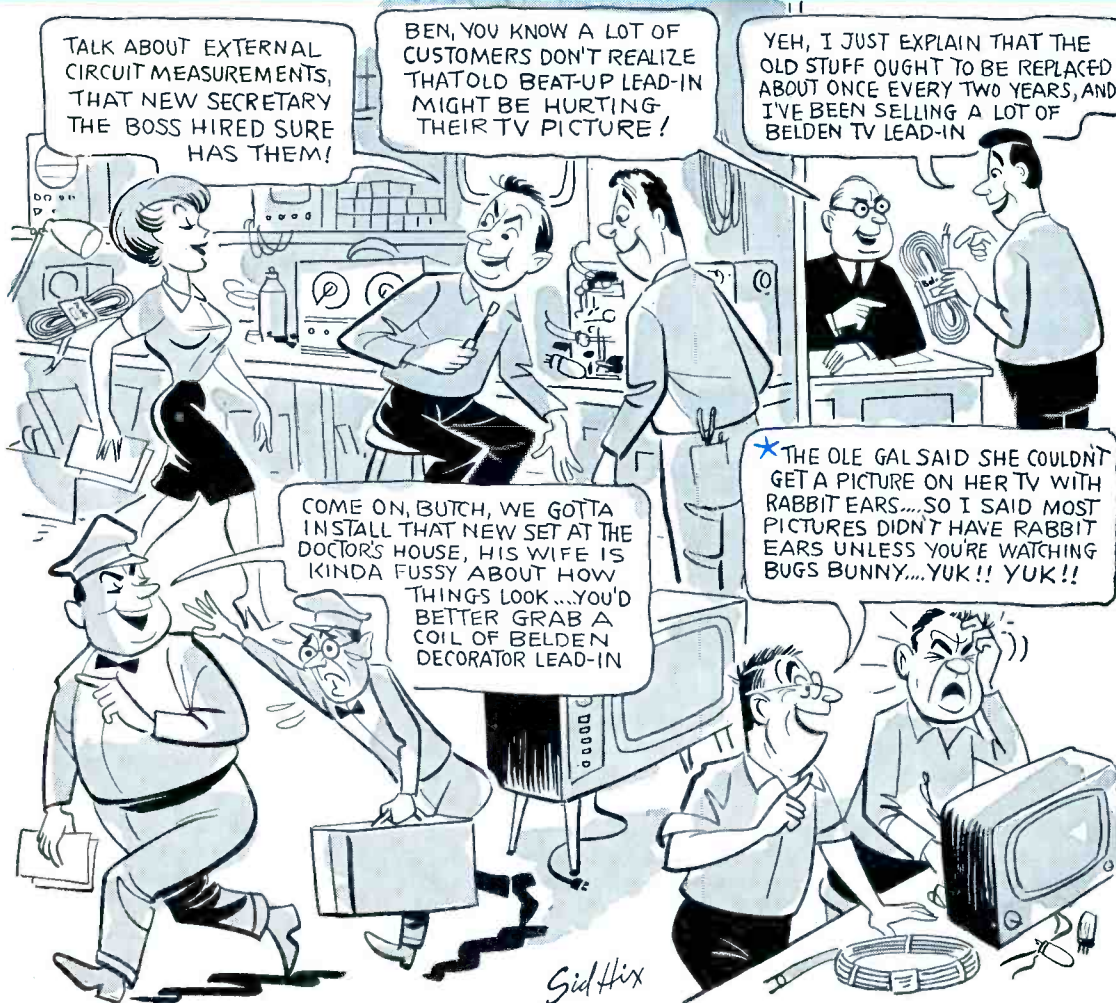

You'd expect an FM booster designed by Blonder-Tongue to be something special...

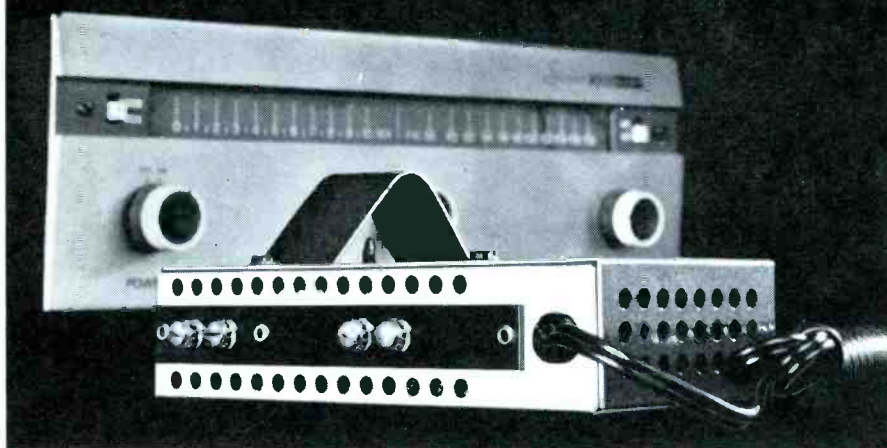

this one is

The Blonder-Tongue FMB STEREOBOOSTER is special because it increases signal strength 8 times (18 db gain), while keeping noise down to the bare minimum (noise figure 3.8 db) . . . because it eliminates distortion caused by phase and amplitude variation and by impedance mismatch (low VSWR) . . . because it doesn't overload when there are strong local stations present . . . and because it does all these things steadily and reliably. But since Blonder-Tongue is the company with the *most* experience in TV and FM signal amplification, how could you expect any less? A must for multiplex stereo, and for mono in weak signal areas . . . installed quickly & easily anywhere indoors. Improves reception with an FM antenna, your TV antenna, or a homemade twinlead dipole. List \$21

engineered and manufactured by
BLONDER-TONGUE | CANADIAN DIVISION:
8 Alling St., Newark, N. J. | BENCO TELEVISION ASSOC., LTD., TORONTO, ONT.

drive speed; otherwise, it would "push" tape toward the magnetic head and the capstan, resulting in a pile of tape on or in the deck. Therefore, this unwind reel (often termed the "followup" reel) must apply a gentle holdback action to the tape, so it will be fed smoothly across the tape head and to the capstan.

In some machines, this is done by setting up the drive ratio so that the unwind reel tries to turn more slowly than the tape drive. As with the takeup reel, a certain amount of slippage allows the tape to pull on the reel and make it rotate at a speed different from its "natural" tendency, thus keeping the tape tight. At the unwind reel, too much slippage will allow the tape to pull the reel too fast, resulting in erratic "bouncing," and ultimately causing a tape pileup. If the slippage is insufficient, and the tape is kept too tight, "wow" is likely and breakage is pretty apt to occur soon.

Rewind Problems

The "Rewind" position of the recorder switch causes the unwind reel to turn backwards at a high speed—to rewind the tape rapidly. This necessitates a change in drive ratios, because in forward speeds the reels turn more slowly.

In some recorders, the unwind reel is simply held by a sort of brake during recording or playback (so tape doesn't pile up); thus the drive mechanism can be "thrown into gear" by the "Rewind" button, and the high-speed rewind can proceed. In others, a mechanical change in the drive system—say, from pressure roller to drive belt—accomplishes the change in drive ratios. In most machines, switching to "Rewind" also releases the tape from close contact with the magnetic head. As pointed out earlier: With the top off, and the machine in a position for easy inspection, figuring out the drive system is greatly simplified. Go directly to the section indicated by the symptoms, and your job is half over. Often a simple adjustment is the answer; other times a simple replacement or cleaning job is sufficient.

Replacing Drive Parts

As I pointed out to my fellow serviceman, probably the single most difficult item to replace—at

New TRANSISTOR RADIO ANALYST

makes it Easy and Profitable to Service all Transistor Radios



B&K Model 960

TRANSISTOR RADIO ANALYST

with Exclusive *DYNA-TRACE*
Single-Point Probe—and Built-in
Metered Power Supply and VTVM

Complete Transistor Radio
Service Shop in One Instrument

Signal-Generator, Power Supply, Milliammeter, VTVM, Battery Tester, Ohmmeter, and Both In-Circuit and Out-of-Circuit Transistor Tester—All in One

Also Speeds Servicing of Tube-Type Radios

Check all circuits - Pinpoint any trouble ... in minutes

Now you can profit from transistor radio servicing! This amazing new B&K "960" ANALYST gives you *everything* in one complete easy-to-use instrument. Makes transistor radio servicing *quick and easy*. Nothing else is needed except the transistor radios themselves waiting to be serviced. Brings you new customers for service, parts, and batteries. Makes this new business *yours*.

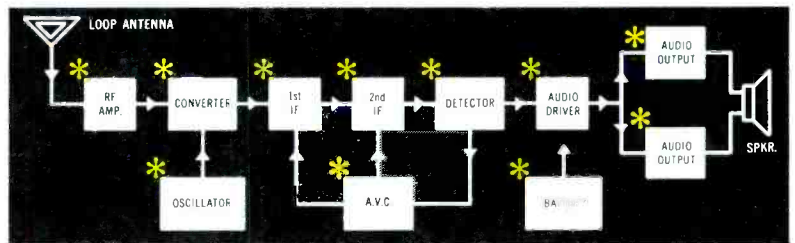

EASILY TROUBLE-SHOOT ANY STAGE BY UNIQUE POINT-TO-POINT SIGNAL INJECTION

The ANALYST gives you a complete signal-generating source for point-to-point signal injection. Easily enables you to trouble-shoot any transistor radio—check all circuits stage-by-stage—isolate and pinpoint the exact trouble in minutes.

Supplies modulated signals, with adjustable control, to check r.f., i.f., converter, and detector. Supplies audio signal to check audio driver and audio output. Provides unmodulated signal to test local oscillator. Provides separate audio low-impedance output for signal injection into loudspeaker voice coils to check speaker performance.

BUILT-IN METERED POWER SUPPLY FOR EASY SERVICING

Makes it easy to operate radio under test, while you inject your own signals. Provides from 1 to 12 volts in 1½ volt steps. Supplies all bias taps that may be required.

SIMPLIFIES IN-CIRCUIT TRANSISTOR TEST WITH NEW DYNA-TRACE SINGLE-POINT PROBE

Unique single-point probe needs only the one contact to transistor under test. No longer are three wires required to connect to emitter, base, and collector. Gives fast, positive meter indication. Saves time. Makes trouble-shooting simple and easy.

BUILT-IN VTVM

Includes high-input-impedance vacuum-tube voltmeter, which is so necessary for transistor radio servicing.

TESTS ALL TRANSISTORS OUT-OF-CIRCUIT

Meter has "Good-Bad" scale for *both* leakage and beta. Also has direct-reading Beta scale, calibrated 0-150. Assures quick, accurate test. Also automatically determines whether transistor is NPN or PNP. Meter is protected against accidental overload and burn-out.

Model 960. Net, \$99⁹⁵

Solve Every Service Problem and Profit with a Modern B&K Service Shop. See Your B&K Distributor or Write for Catalog AP21-R



B & K MANUFACTURING CO.

Division of DYNASCAN CORPORATION

1801 W. BELLE PLAINE AVE. • CHICAGO 13, ILL.
Canada: Atlas Radio Corp., 50 Wingold, Toronto 19, Ont.
Export: Empire Exporters, 253 Broadway, New York 7, U.S.A.

SARKES TARZIAN Silicon Rectifiers

are first choice among service technicians (according to a nation-wide poll) for the third year in a row



Tarzian 400V and 600V "F" Series units in handy Ten-Paks, Doubler Replacement Kits, and in bulk

Tarzian 400V and 600V "H" Series units in handy Ten-Paks, Doubler Replacement Kits, and in bulk



Preference high! Here's why:

- ★ They are immediately available from distributors throughout the nation
- ★ They are "handy-packed" in the quantities and sizes you need most
- ★ Their proven quality and dependability eliminates callbacks that waste your time and profits

A free Tarzian "Replacement Line" catalog is yours for the asking. It's your guide to replacement rectifiers with competitive prices, unsurpassed performance.

Write or call your nearest Tarzian distributor, or:



Tarzian's nine standard tube replacement rectifiers replace over 95% of all vacuum tube rectifiers

Tarzian M-500 and M-150 units in Conversion Kits and in bulk



Tarzian's four "condensed stack" selenium rectifiers fit small-size, high-efficiency applications



least, in a comparison with its cost—is the drive belt. Pressure rollers are usually held by a clip or bolt, but drive belts have a mysterious way of being "threaded" through some of the most intricate mechanical mazes. So I showed him a few little tricks I have learned over the years.

By removing the belt from its associated drive wheels or pulleys, you can pull it up against whatever levers, bars, or wheels prevent it from just slipping off. Frequently, you can see how it can be worked around these and removed without disassembling the machine. If not, at least you have identified the very smallest amount of disassembly which will free the belt and allow a new one to be installed.

There's another way to change defective belts, too. You can buy rubber belt material (such as shown on page 100 of the October, 1962 issue) and make the drive belt yourself. The secret to saving time with this method is to thread the belt into position before bonding the ends together. Be sure to make the belt slightly shorter than the actual distance around the pulleys; then, when you snap it into place, it will be firm and tight.

Miscellaneous Defects

There is little that needs explaining about top-of-deck servicing. With the covers off, everything is plainly visible. I showed my friend how to clean the heads (I had the feeling he was merely humoring me during that portion of the demonstration), check the tracking of the tape, and check head alignment.

I use prerecorded tapes for the last two tests. If the tapes are only slightly out of tracking (especially noticeable on four-track stereo tapes), the head can be raised or lowered by an adjustment provided; in a couple of extreme cases, I've had to alter the guide bars to each side of the head. Head alignment is saved till last; then a head-alignment tape is used to adjust for maximum output. Sometimes tracking and head alignment will interact, so always recheck each adjustment a couple of times whenever you have to make either one.

An occasional complaint will mention excessive clatter in the machine. Instead of wasting a lot of time looking for the noisy part, iso-



SARKES TARZIAN, Inc.

World's Leading Manufacturers of TV and FM Tuners • Closed Circuit TV Systems • Broadcast Equipment • Air Trimmers • FM Radios • Magnetic Recording Tape • Semiconductor Devices
SEMICONDUCTOR DIVISION • BLOOMINGTON, INDIANA
Canadian Licensee: Marsland Engineering Limited • 350 Weber Street North, Waterloo, Ontario

Find it and Fix it in 1/2 the time!

EASILY SOLVES "TOUGH DOGS"... INTERMITTENTS... ANY TV TROUBLE



**MODEL
1076**

TELEVISION ANALYST
BLACK & WHITE AND COLOR

ANALYST

By Easy Point-to-Point Signal Injection, You see the Trouble on the TV Screen and Correct it—Twice as Fast and Easy!

Simplified technique stops lost hours never recovered on "tough dogs", intermittents, and general TV troubleshooting. This one instrument, with its complete, accurate diagnosis, enables any serviceman to cut servicing time in half... service more TV sets in less time... satisfy more customers... and make more money.

With the Analyst, you inject your own TV signals at any time, at any point, while you watch the generated test pattern on the picture tube of the television set itself. This makes it quick and easy to isolate, pinpoint, and correct TV trouble in any stage throughout the video, audio, r.f., i.f., sync and sweep sections of black & white and color television sets—including intermittents. No external scope or waveform interpretation is needed. Checks any and all circuits—solves any performance problem. Gives you today's most valuable instrument in TV servicing—proved by thousands of professional servicemen everywhere.

Available on Budget Terms. As low as \$30.00 down.

Net, \$32995

SIMPLIFIES COLOR TV SERVICING, TOO

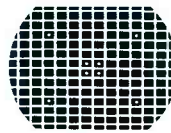

Enables you to troubleshoot and signal trace color circuits in color TV sets, or facilitate installation.



Generates white dot, crosshatch and color bar patterns on the TV screen for color TV convergence adjustments.

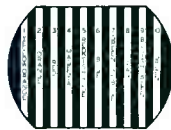

Generates full color rainbow display and color bar pattern to test color sync circuits, check range of hue control, align color demodulators. Demonstrates to customers correct color values.

Time-Saving, Money-Making Instruments Used by Professional Servicemen Everywhere



Model 960 Transistor Radio Analyst



Model 360 V O Matic Automatic VOM



Model 375 Dynamatic Automatic VTVM



Model 700 Dyna-Quik Tube Tester



Model 440 CRT Rejuvenator Tester

See Your B&K Distributor
or Write for Catalog AP21-R



B & K MANUFACTURING CO.

Division of DYNASCAN CORPORATION

1801 W. BELLE PLAINE AVE. • CHICAGO 13, ILL.

Canada: Atlas Radio Corp., 50 Wingold, Toronto 19, Ont.

Export: Empire Exporters, 253 Broadway, New York 7, U.S.A.

New Sonotone Sono-Flex[®] Stylus

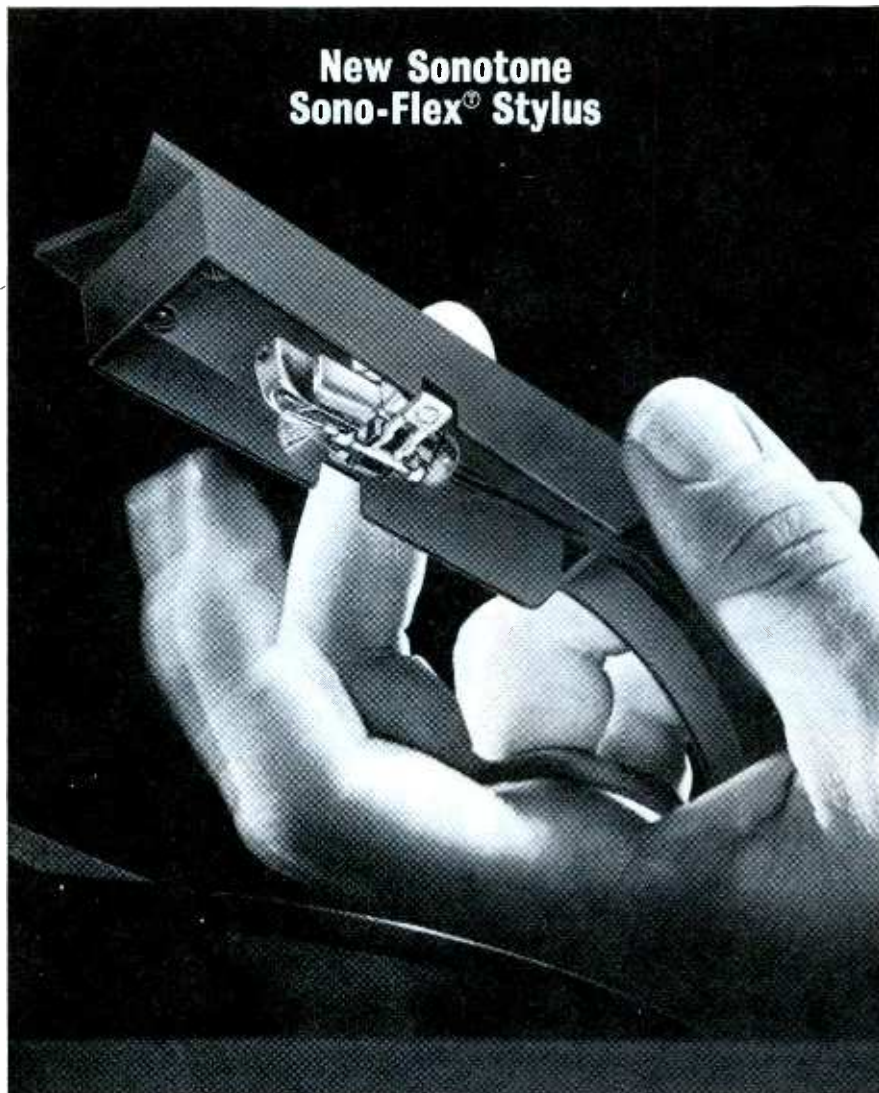

try this with any other cartridge
(at your own risk)

No way to treat a cartridge, for sure—That is, any cartridge except the Sonotone models featuring the new Sono-Flex[®] needle. No more bent or broken needle shanks caused by flicking off some lint, dropping the arm, or scraping it across the record.

The newly developed Sonotone Sono-Flex[®] needle to the rescue! Gripped in a resilient butyl rubber mount, you can flex this needle shank in a 360-degree orbit without breaking. Pluck it—flick it—bend it—bump it—it will continue to perform as good as new.

Moreover, the Sono-Flex brings advantages in performance never before offered by any replacement cartridge: Higher compliance, wider and flatter frequency response, lower IM distortion, and longer needle and record life.

Sonotone Sono-Flex[®] increases your profits two ways

Sonotone cartridges are better than ever, easier to sell, because they're better performers. Further, you eliminate callbacks because of broken needle shanks. Sono-Flex needles are standard right now in these Sonotone cartridges models: 9TAF, 16TAF, 916TAF and the Velocitone Mark III.

Sono-Flex opens up lucrative needle replacement business for upgrading these Sonotone cartridges models: 9T, 9TA, 9TV, 9TAV, 16T, 16TA, 16TAF and 916TA, original equipment in over a million phonographs. Replacement is fast, simple—requires no tools—assembly snaps into position easily, and gives immediate proof of better performance plus abuse-proof, longer needle life.

See your distributor today and ask for Sonotone cartridges with the Sono-Flex[®] needle.

SONOTONE CORPORATION Electronic Applications Division Elmsford, New York
In Canada: Atlas Radio Corp., Ltd., Toronto • cartridges • speakers • batteries
• microphones • electron tubes • tape heads • hearing aids • headphones

late the cause of excessive vibration — that's the likely culprit. Smooth out the operation, and clatter will disappear.

The most common cause of vibration is a bent fan on the motor or motors. Unless you're an expert at balancing fans, don't waste time—replace it. To balance a fan is time-consuming at best, and seldom satisfactory.

A worn bearing in a motor can cause an unusual amount of vibration to the machine. Holding the motor tightly will usually damp out the shaking, and identify the fault more conclusively. Again, the best answer is a replacement. Motors usually cost less than the time involved in trying to disassemble the defective one, and some are sealed, anyway.

Vibrations that occur only during recording, playback, or rewinding can be traced to some part associated with driving that particular function. Especially noticeable are worn reel spindles (some of which can be replaced), warped reel carriers, and drive wheels that have been worn eccentric (oval-shaped). A pencil held next to the edge of a suspected part will usually transmit the vibration or wobble to your fingers.

Some hard-to-spot vibrations can be located by rolling a paper into a long, thin cone, holding the large end near your ear, and probing around the mechanism with the tapered end. The cone makes an acoustic amplifier, and the small end forms an isolated pickup device for noise. Beware, however, that you don't locate the *result* of a vibration this way, and overlook the *cause*.

A Friend Indeed

Naturally, this entire demonstration used the recorder my pal had dragged onto my service bench. In the process, we found the cause of his trouble—a defective drive belt. So he got his recorder fixed, at the expense of an hour or so of my time.

But I'm not sorry; after all, he is a good friend of mine, and I myself benefited from a review of just why I do things the way I do. And, if he hadn't dropped by, I'd not have bothered telling *you* about my direct approach to tape-recorder servicing; so I guess we all benefited. ▲

Service Technicians ahoy!

RCA to the rescue!

In electronic servicing, it's the little things that count . . . the minor problems that add up to a major loss of time. Now RCA answers the S-O-S of busy servicemen with 5 new service aids:

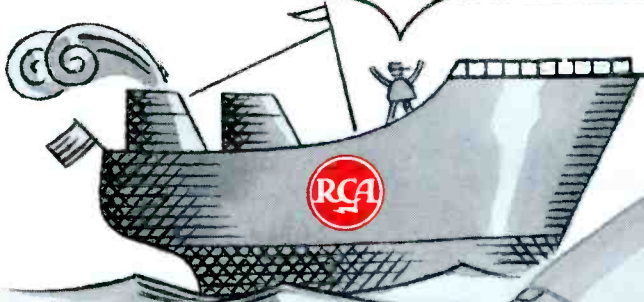

NUVISTOR PULLER:

Saves time. Grips nuvistors tightly to ease them from sockets quickly and effortlessly. 1A1347

NUVISTOR SOCKETS:

Saves time-wasting socket-seeking. The two most wanted nuvistor sockets: For conventional mounting and stand-off printed circuits.

1A1382—conventional mounting.
1A1383—stand-off printed circuits.

RCA 6-WAY PIN STRAIGHTENER:

Saves time and trouble with bent pins on novars, nuvistors, 12-pin tubes and 7-, 9- and 10-pin miniatures. Trim, free-form design, complete with screws for attaching to work-bench or tube caddy. 1A1369

NEW RCA DROP CLOTH:

Saves customers' carpets, floors. 3' square with cushioned lining—fully skid and scratch-resistant. Packs easily, resists wrinkles. 1A1044A

NEW RCA FOAM-RUBBER FLOOR MAT:

Saves tired feet when you stand all day at your service bench. Put one at your primary work area, another behind your counter. Bright red RCA monogram dresses up your entire shop. 1A1381

And for quicker, more efficient servicing, two popular basic service aids:

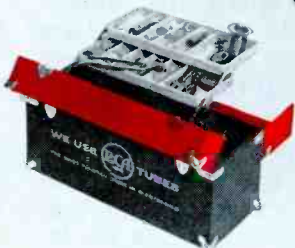

RCA SERVICE-SPECIAL TOOL CHEST:

1A1280—Saves missing tool problems. Ample room for all tools with special compartment for RCA WV-38A V-O-M or RCA power line monitor. Keep everything right where you want it.

RCA LITEWEIGHT TUBE CADDY:

1A1241—Saves carrying a full-size caddy when not needed. Made of sturdy, stain-resistant lightweight molded plastic. And it can hold up to 210 receiving tubes at one time.



RCA Electronic Components and Devices



The Most Trusted Name in Electronics

SEE YOUR PARTICIPATING RCA TUBE DISTRIBUTOR FOR ALL THESE RCA SERVICE AIDS.

www.americanradiohistory.com

Common Blunders in Handling Credit

Owners of electronics service shops are frequently faced with credit and collection problems forced on them by competitive pressure. A previous article ("Handling Credit On Your Own" in the June 1962 issue) covered these problems in a general way, and made some suggestions specifically designed to aid the service-shop owner in handling these problems more effectively and less expensively. Now, let's look at some actual case histories—credit and collection situations with which television servicemen were actually faced—and see how these problems were handled by the serviceman in question. In each instance, we shall suggest a solution which may well have proved to be more effective, under the existing circumstances.

Missed Payments

The Situation: A television serviceman decided to handle his own financing of a relatively large account for extensive repairs, and arranged with the customer for monthly payments of \$17.00 to be made. The customer made several payments as agreed, but then missed one payment. The serviceman was aware of the missed remittance, but was not too concerned, considering the debtor's past credit performance. Payments were resumed the following month, although the missing payment was not made up.

A short time later, two more consecutive payments were missed, and the serviceman became alarmed. He called the debtor, who told him of unexpected financial reverses which would undoubtedly result in several more missed payments.

The Serviceman's Solution: Upset at the gloomy results of his telephone call to the debtor, the serviceman immediately called in a collection agency, who contracted to collect the account at a rate of 33 $\frac{1}{3}$ % of the gross amount brought in.

The collection agency then called the debtor and

threatened him with garnishment of his wages if the account was not paid in full within five days. The debtor became frantic at this threatened loss of his income, and borrowed sufficient money to pay the account in full.

The television serviceman was very pleased when he received this remittance, less the amount of the collection-agency fee.

In the meantime, the debtor, embittered by his treatment in the hands of the agency and the serviceman, was busy getting revenge in his own way—by loudly criticizing the serviceman's professional capabilities in front of anyone who would listen. These attacks quickly grew into rumors that could not help but draw attention in the serviceman's small community. Some old customers were lost, and the serviceman's income was reduced more than enough to outweigh the gain achieved by forcible collection.

An Alternate Solution: The serviceman, of course, had adequate reasons to be concerned about the account; but he called in the collection agency much too quickly. Actually, he might have averted the need to do so, if he had started questioning the debtor at the time the first payment was missed. This past-due bill, in itself, was a good indication that the customer was in financial difficulty of some kind.

Certainly, after the second missed payment, the serviceman should have been prepared to discuss the situation with the debtor. The outcome of this conversation would have depended, of course, on the individual circumstances involved. However, if collection problems are discussed in a temperate manner, a solution can usually be worked out.

If the financial pinch had appeared to be temporary, reduced payments might have been arranged; or, in case of long-term difficulties, the serviceman could have suggested the possibility of refinancing the account. It is never a good idea to suggest suspending payments

From RCA Victor—another big advance in

Space-Age Sealed Circuitry

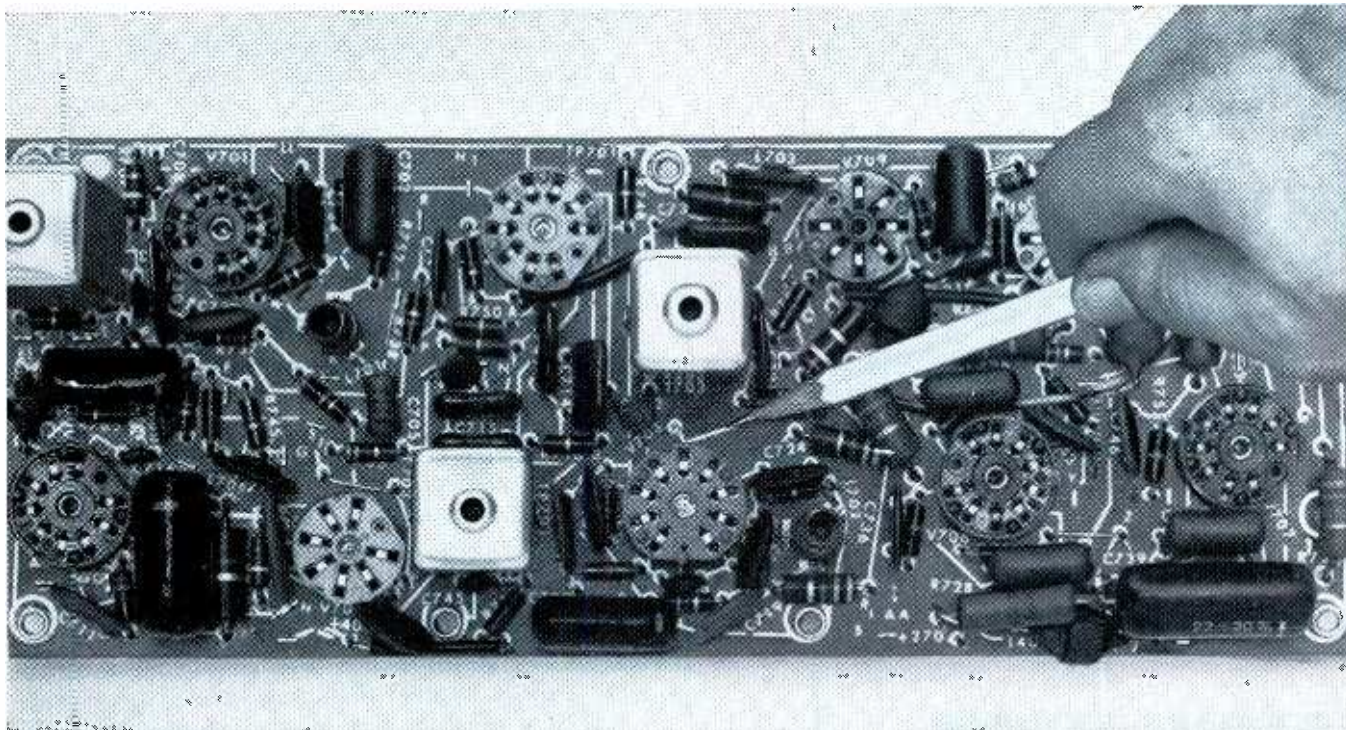

RCA Victor Color TV Chroma Circuitry

You can see at a glance how new streamlined “road-mapping” makes servicing faster, easier, surer than ever before

Pictured above is the “new look” in RCA Space Age Sealed Circuitry . . . the new precision-crafted boards that you’ll see in *all* 1964 New Vista Color and in most RCA Victor black-and-white television sets for 1964.

This new schematic diagram “road-mapping” consists of *straight white lines* that run *directly* from *point-to-point*. No confusion, no difficult paths. And the extra space gained has been used

to make the label markings larger. You can see and trace the circuits at a glance.

Here again RCA Victor has made a vitally important contribution to easier, faster and more accurate servicing. It is part of our continuing research program to offer the utmost in reliability with Space Age Sealed Circuitry.

See Walt Disney’s “Wonderful World of Color,”
Sundays, NBC-TV Network



The Most Trusted Name in Electronics

Tmk(s)®

**NEW
AND MOST
VERSATILE**

TRIPLETT



MODEL
850
\$79.50

**MODEL 850
ELECTRONIC VOLT-OHMMETER
IS BEST FOR YOU**

FACTS MAKE FEATURES:

- 1** Long 7" easy-to-read scale.
- 2** .5 D.C. volt range for transistor circuits.
- 3** HIGH STABILITY. Meter connected in cathode circuit of 12AU7.

High Input Impedance (11 MEGOHMS) and wide Frequency Ranges give this extremely versatile Electronic Volt-Ohmmeter considerable advantage in the measurement of DC voltages, AC RMS and Peak-to-Peak voltages. It measures directly the Peak-to-Peak values of high-frequency complex wave forms and RMS values of sine waves on separate scales.

ADDED PROTECTION. Meter is shorted out in OFF position for greater damping, meter safety during transit, electrically protected against accidental overload. ZERO CENTER mark for FM discriminator alignment, plus other galvanometer measurements.

New pencil thin test probe used for all functions: DC, AC, and ohms. No need to change cables. Beautifully styled case for professional appearance and functional utility, 7 $\frac{5}{8}$ " x 6 $\frac{7}{16}$ " x 3 $\frac{3}{4}$ ".

Carrying handle can be used as a tester stand to place the tester at 25° angle for ease in reading.

Frequencies to 250 MC may be measured with auxiliary Diode Probe, \$7.50 extra. DC voltages to 50 KV may be measured with auxiliary High Voltage Probe. \$20.50 extra.

TRIPLETT ELECTRICAL INSTRUMENT COMPANY, BLUFFTON, OHIO

entirely on an account for a period of time. Even if only token payments can be made, they should be accepted, so the debtor is constantly reminded that the account is not yet paid up.

Refinancing is a sensitive subject, and any suggestion along these lines should be made with care. The television serviceman should not put himself in a position of forcing his customer to seek outside financial help. This will only arouse a feeling of resentment in the debtor, since any new loan is bound to create an additional repayment problem. Such resentment will be directed toward the serviceman if he has aggressively insisted on full payment of an account at a faster rate than the debtor can manage.

In any credit situation, *premature* use of an outside agent for collections will only lead to trouble. It should be remembered that a collection agency is likely to threaten a debtor with legal action of some kind, in order to effect a quick turnover of the account. This type of threat frightens most debtors, and may lead to some very undesirable side effects from the standpoint of the television serviceman.

Poor Credit Risk

The Situation: A service dealer had ordered and received an advance credit report on a prospective new-set buyer. The report indicated that the person was "slow" in making utility payments, and "very slow" in paying the majority of his other credit obligations. After carefully considering this information, the dealer did not care to carry the account himself, and he knew his financing organization wouldn't accept it.

When the dealer hesitated to extend credit, the customer offered to buy a large console TV, rather than the 19" model he had been considering.

The Service Dealer's Solution: The television dealer could not resist the lure of extra profit, and closed the transaction. However, the account went bad after the first payment was made.

An Alternate Solution: Once an adverse decision has been made on the acceptance of an account, there should be no backing down from that decision if it was based on sound background information.

A poor risk will rarely become a good risk overnight. In this particular case, the serviceman should not have let himself be persuaded to change his mind.

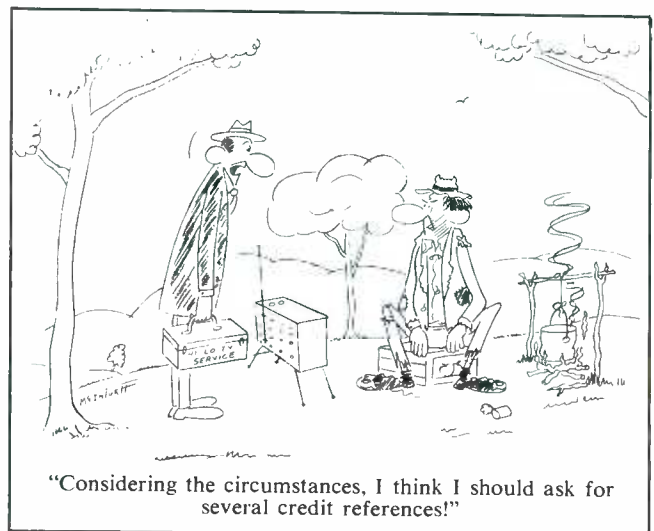

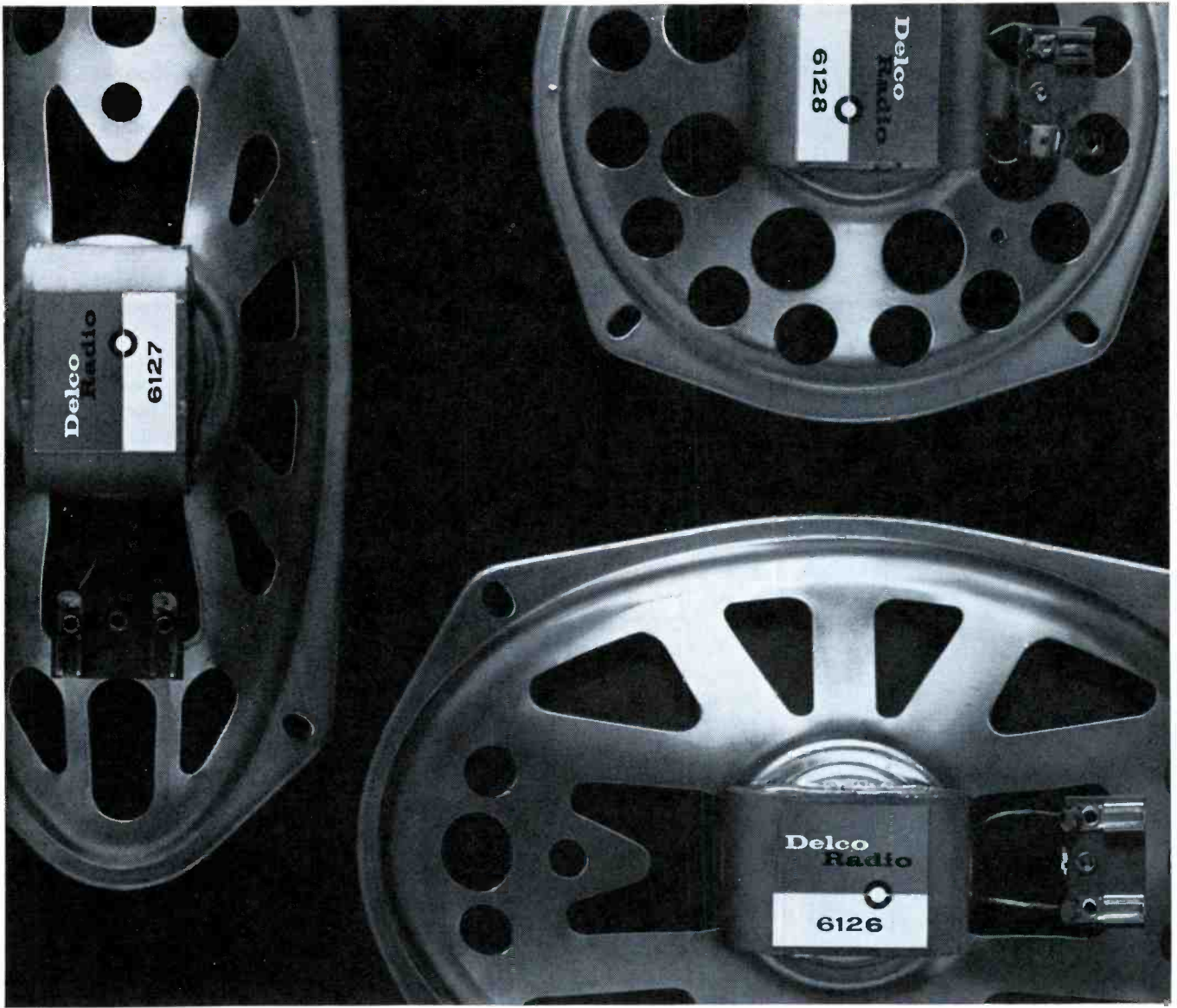

3 SPEAKERS CAN NOW REPLACE 16

simply say **Delco**

These three new Delco Radio 8-10-ohm replacement speakers permit you to cut 16 numbers from your inventory. They can replace all units in current General Motors cars and many competitive makes. They

install easily and quickly, take a "tip jack," "blade," or solder connection. Excellent for home hi-fi and TV sets, too! Speak up for the latest in replacement speakers. Call your United Delco supplier today.

THREE NEW SPEAKERS, ALL WITH SLOTTED MOUNTING HOLES

Number	Size	Magnet Wt.	Mounting
6126	6 x 9"	1.6 oz.	front/rear
6127	4 x 10"	1.6 oz.	front/rear
6128	6" round	2.5 oz.	rear-seat

SPECIAL

**UNIVERSAL 8-10-OHM
6 x 9" REAR SPEAKER PACKAGE**
Contains all materials necessary for rear-seat speaker installation: Speaker, Grill, Wiring, Switch. Part No. 6122.

Delco Radio Automotive Radio Service Parts and Electro-Mechanical Devices are distributed nationally through **United Delco**

DELCO RADIO, Division of General Motors, Kokomo, Indiana



1



Genuine, fresh Little Devil® resistors (on "Tally Tape" or in Cabinet Assortments)

2



Quality 2-watt pots, Type AB



Gold-bonded germanium diodes at "entertainment diode" prices.

3 WAYS TO MAKE SURE IT STAYS FIXED

You're always safe, always sure with any of these three quality replacements. Why be otherwise? Repair jobs that boomerang cost you hard-earned profit. Little Devil® resistors come in 1/10, 1/4, 1/2, 1, and 2 watts from 2.7 ohms to 22 Megs . . . AB Pots from 50 ohms to 5 Megs in several shaft lengths and styles . . . gold-bonded diodes in ninety 1N types off the shelf.

Call your distributor for the latest Ohmite Stock Catalog 30.

Be right with



"Skip Tracing"

The Situation: A serviceman extended \$157.32 in credit to a customer who subsequently disappeared without a trace. While there was no guarantee that the account could be collected in full even if the customer were found, the entire amount was obviously a dead loss as things stood.

The Serviceman's Solution: Faced with a loss of such proportions, the serviceman panicked. He called in a local collection agency, and was advised they would undertake collection of the account for a fee of 50% of the gross amount collected. Although this fee would obviously wipe out any hope of a profit on the account, the serviceman agreed to the action, on the theory that half a loaf was better than none.

After several months, the debtor was located by the collection agency. By this time, however, several other accounts were involved, and when the debtor was confronted by the agency, he advised them that he had filed a bankruptcy petition. The serviceman eventually received a settlement of \$15.73, half of which he owed to the agency.

An Alternate Solution: The serviceman still had the debtor's credit application on file. It contained various items of information that could be used in tracing the debtor—including the name and address of his brother, who lived in a nearby town.

An inexpensive telephone call or telegram to this relative might very well have produced the current address of the debtor. If this lead had been unproductive, the credit application would still have provided other possible contacts—for instance, former employers or neighbors, school or church officials, banks, or loan companies. If the serviceman had taken the initiative in this manner, he might have reached the debtor before the combined pressure of his obligations made him decide to go into bankruptcy. There would then have been at least, a chance of recovering a larger amount.

"Special Deals"

The Situation: A serviceman was approached by the sales representative of an unknown collection agency about the agency's "special

plan," which promised to settle difficult accounts at a much lower rate than normal. In due course, the serviceman signed a contract with the agency on the assumption that his past-due accounts would be collected for an agency charge of 5%.

The Serviceman's Solution: Accepting the "special" plan without further investigation, the serviceman turned over to the salesman a number of past-due accounts that had accumulated.

A few weeks later, the serviceman noticed that payments were coming in on these accounts, but in much smaller amounts than he had expected. A further investigation revealed that 33 1/3% to 50% of each account was going to the agency, in accordance with the regular rates charged by that organization.

On close reading of the agreement he had signed, the serviceman discovered that only the accounts collected in a three-week period following the date of the contract were subject to the 5% service charge. All others were automatically put into the regular collection channels of the agency, and were then subject to the higher fee.

An Alternate Solution: Since there are unscrupulous firms in the collection-agency business, as well as in any other field, service-shop owners are well advised to check the background of any agency that solicits collections of their delinquent accounts. They might also consider utilizing the services of an attorney; the fee charged is normally comparable to that of an agency. The average debtor will react in the same way to an attorney's efforts as to legal action initiated by a collection agency.

Conclusions

In each of the cases described, the serviceman would have lost a great deal less money if he had taken prompt and aggressive action on his own, rather than letting a credit situation drift from bad to worse. Each shop owner should formulate a collection and credit policy that is effective for his particular situation and area of operation. By thus assuming the major responsibility in these activities, the serviceman will eventually find that he can minimize his loss of income from problem accounts. ▲



Compactrons take the heat off service dealers



More and more of today's newest TV sets are featuring compactrons . . . G.E.'s multifunction electronic devices. This means, eventually, you'll be seeing more compactron circuits in your shop. Therefore, to anticipate some of your questions about compactrons, let's take a look at how compactrons can help take the heat off you and your business:

1. Long waits for repair will be a thing of the past. Simple compactron circuits mean you can locate trouble faster, repair it easier, get sets back to your customers quicker. Fast, effi-

cient service builds repeat business and gets you free word-of-mouth advertising.

Repairs are consistently better because compactrons combine functions having similar life spans. Thus if one section fails, the entire compactron must be replaced—automatically restoring top performance through replacement of the other weakened sections. You save time by not having to check extra tubes and you eliminate the possibility of "weakened ordinary-tubes" not showing up on the tester.

2. No more call backs! When you fix a compactron set, *it stays fixed*. Call backs are virtually eliminated by service-designed compactrons which have a 40% lower operating temperature than ordinary tubes. Cooler operation means greater reliability and gets rid of a difficult trouble spot—peeling and cracking of printed circuits.

3. You make more profit on compactrons because the unit price is higher. Replacing a compactron is like replacing 2 or 3 ordinary tubes. Simpler compactron circuits, plug-in replacement, and fewer tubes to check, let you service more sets in any given time. Employees become more efficient, and need less training.

Multifunction design means that eventually you can substantially reduce your tube inventory. This gives you more "free" operating capital, more shelf space, plus less capital investment . . . hence a greater profit per dollar invested.

Remember, you'll be seeing more compactrons in the future . . . They'll mean easier servicing and happier customers for you.

Progress Is Our Most Important Product

GENERAL  ELECTRIC

DISTRIBUTOR SALES

August, 1963/PF REPORTER 53



Guide to PHONO-TAPE Charges

This chart is meant to be used only as a general guide for determining the proper fees to charge for phonograph and tape recorder servicing. Prices shown here are the average of those charged by a number of different shops.

The exact figures set by a specific shop, or for a given piece of equipment, are affected by several variables. For example, shops that specialize in servicing phono and tape equipment are often able to do profitable work at lower rates than shops having only occasional activity in this field. In both types of businesses, the service charge for a foreign-made unit (especially a tape recorder) is frequently quoted two

or three dollars higher than for a domestic model, because the imported sets are considered harder to service. Besides having unfamiliar mechanical and circuit features, they sometimes take twice as long just to disassemble.

Tape recorders of the "toy" type, and record players listed in the "phono with amplifier" category of the chart, command a lower service charge for at least three reasons: low original cost, simple design, and noncritical performance standards. Quite a few shops do not accept toy tape recorders for servicing, because they have found no way to do so at a profit. On the other end of the price scale among tape recorders,

the professional-type machines costing several hundred dollars are serviced mainly by specialists who do a meticulous job and charge accordingly.

Some shops charge a flat rate for each phono or tape job, while others favor an hourly rate subject to a minimum charge. Nearly all those we have contacted do not exceed a certain maximum fee, even when they encounter a time-consuming "dog"; but the maximum charge is on a sliding scale, based on the complexity of the equipment. Note the prevalence of higher charges for tape recorders than for record changers. ▲

	CHANGER MECHANISM	CHANGER WITH AMPLIFIER	PHONO WITH AMPLIFIER	TAPE RECORDER		
				Toy	Home	Pro
HOME SERVICE CALL	SAME AS USUAL TV SERVICE CHARGE					
BENCH SERVICE — MIN.	\$5.00	\$5.00	\$4.00	\$4.00	\$8.50	\$12.50
BENCH SERVICE — MAX.	\$10.00	\$12.50	\$7.50	\$7.50	\$16.00	——
FLAT RATE FOR OVERHAUL (LUB, ADJ, ETC.)	\$7.50	\$7.50	\$4.00	\$4.00	\$8.50	\$12.50
BENCH SERVICE—HOURLY RATE	\$7.50 FOR ALL TYPES OF EQUIPMENT					

Centralab



BRAND NEW CENTRALAB FASTATCH II® FRK-200 KIT WITH EXACT REPLACEMENT SHAFTS

Makes Control Replacement A SNAP!

- Centralab's new FRK-200 kit gives you the most convenient, most versatile, and simplest system for control replacement.
- Since it includes 13 sizes of exact replacement shafts, shaft cutting is eliminated on *all* the popular dual concentric controls and on almost 60% of all dual controls.
- The Fastatch II® Control System is a snap to use. Single and dual concentrics snap together without tools! Shafts plug in and are permanently locked. Assembled units can't loosen—shafts can't pull out.

JUST CHECK THESE EXCLUSIVE FEATURES:

1. Just one control system for dual concentric or single controls.
2. Universal terminals.
3. Plug-in, permanently locking shafts.
4. Rotary or push-pull (snap-on) line switches attach to both front and rear controls.

The FRK-200 kit is contained in two stacking Equipto steel cabinets with plenty of extra space for expansion. *All* your control needs, including push-pull, are at your finger tips.

THE FRK-200 KIT CONTAINS:

- | | |
|--|---|
| 35 Exact Front Shafts (7 sizes) | 9 Assorted Rear Controls |
| 30 Exact Rear Shafts (6 sizes) | 40 Assorted Universal Shafts for
Single and Dual Concentrics |
| 5 Universal Push-Pull Shafts
(1 size) | 5 SPST on/off Switches |
| 5 Push-Pull Line Switches | 2 DPST on/off Switches |
| 5 Twist-Tab Adapter Plates | 1 DP on/off Switch |
| 2 3-Drawer Equipto Cabinets | Complete with current
cross-reference guides. |
| 27 Assorted Front Controls | |

Dealer Net \$72.50

Less Credit for your old controls!



THE ELECTRONICS DIVISION OF GLOBE-UNION INC.
942H East Keefe Avenue • Milwaukee 1, Wisconsin
TWX: 414-731-8731
In Canada: Centralab Canada Ltd., P. O. Box 400, Ajax, Ontario



NEW CADRE C-75 CB TRANSCEIVER

The new Cadre C-75 1.5-watt, 2-channel transceiver is 15 times too powerful for youngsters (under 18 years of age) to operate, according to FCC regulations. Clearly, it's not a toy. It's designed for serious CBers who need 'big set' performance that can be used anywhere.

The new C-75, weighing less than 2 lbs; provides clear, reliable 2-way communications up to 5 miles and more. All solid state design creates an extremely rugged transceiver to absorb rough handling, stays on frequency. Two crystal-controlled channels spell perfect communications contact everytime. Sensitive superhet receiver (1 μ v for 10 db S/N ratio) brings in signals in poor reception areas. Powerful transmitter has one watt output to the antenna. Adjustable squelch silences receiver during standby. AGC assures proper listening level. In a word, the C-75 has all the features you'd look for in a quality full size CB unit.

The C-75 has all the portable conveniences you'd want, too: operates on alkaline or mercury penlite cells (8-hour rechargeable nickel-cadmium battery available); earphone and antenna jacks; built-in retractable antenna; jack for base operation while recharging.

Use the Cadre C-75 anywhere in the field, for vehicle, office, boat or plane. Use it constantly too, because its all-transistor modular circuit (11 transistors and 2 diodes) is virtually maintenance free. \$109.95. Recharger and 2 nickel-cadmium batteries \$31.85.

Cadre also offers a complete line of 5-watt all transistor transceivers and accessories.

See your Cadre distributor or write

CADRE INDUSTRIES CORP.
COMMERCIAL PRODUCT DIVISION □ ENDICOTT, NEW YORK □ AREA CODE 607, 748-3373. Canada: Tri-Tel Assoc., Ltd., 81 Sheppard Ave. W., Willowdale, Ont. Export: Morhan Exporting, 458 B'way, N. Y. 13, N. Y.

NOTES ON TEST EQUIPMENT

by Forest H. Belt

Down With Transistor Troubles

To help in the never-ending battle of serviceman versus transistor radio, here is another compact troubleshooting aid—the Model 36-568 Transistor Radio Troubleshooter (Fig. 1) by GC Electronics. This multi-purpose instrument is housed in a metal carrying case for portability.

Specifications are:

1. *Power Required*—117 volts AC; 60 cps.
2. *Tests* — Checks transistor I_{ceo} and gain; checks rectifier leakage; measures current and voltage, up to 100 ma and 24 volts, respectively; tests radios by signal injection.
3. *Outputs*—Power supply can furnish maximum of 24 volts DC at current levels up to 50 ma, or maximum of 18 volts at 100 ma, metered by panel meter; 1.5-volt DC tap; signal generator tunable from approximately 450 cps to 1200 cps, with output (an essentially square waveform with shape variable by VOLUME control) about 1 volt peak to peak, although rms value varies with waveshape.
4. *Panel Meter*—Face size 2 $\frac{1}{2}$ " ; sensitivity 1 ma, 1000-ohm movement; 0 to 24 voltage scale, 0 to 100 ma current scale, 0 to 100 gain scale, and three "good-bad" leakage scales.
5. *Controls and Terminals* — Rotary function-selector switch; VOLTS ADJ and VOLUME potentiometers; POWER and LO-HI (gain) slide switches; GAIN push button; transistor socket and three test terminals; three voltage-output terminals.
6. *Size, Weight, Price*—3" x 9 $\frac{1}{4}$ " x 9" overall, with cover in place; approximately 4 lbs; \$49.50.

The Model 36-568 contains most of the instruments needed to trace the majority of transistor-radio troubles. Included are the means for isolating the defective stage in a faulty set, testing the transistor or diode involved, measuring voltages and currents in and around the circuit, and powering the receiver during all these tests.

Of course, the instrument itself is transistorized, incorporating two transistors in the multivibrator circuit (Fig. 2) that serves as the signal generator. The VOLUME control affects both the fre-

quency and the waveshape of the multivibrator signal. The frequency is lowest at minimum feedback (slider near the 100K resistor), since the resistance of the control is in the feedback circuit and the time constant is longest. Minimum frequency of the unit we tested is in the neighborhood of 450 cps, but this would probably vary with different transistor characteristics. In addition, the 1-volt peak-to-peak waveform is more nearly a sine wave at minimum feedback, and has the least rms (effective) value.

As feedback is increased, the feedback capacitor is nearer to the base of X1, and the frequency rises — reaching 1200 cps in the unit we checked. In addition, the waveshape takes on the sharp-cornered characteristic of square-wave pulses. The consequent increase in rms value (even though the peak-to-peak value remains the same) results in more signal strength for troubleshooting. The increase in effective signal appears in the transistor receiver as greater volume—thus the label "VOLUME" on the Model 36-568 output control.

A pair of 1N536 silicon diodes supply



Fig. 1. Compact transistor-testing instrument is contained in metal case.

PHOTOFACT[®]

GIVES YOU MAXIMUM TV COVERAGE

to keep you up-to-the-minute!

NOW—PHOTOFACT gives you quicker-than-ever service data coverage for TV and for more of the kind of equipment you most frequently repair!

It's the same famous PHOTOFACT time-saving, troubleshooting help—*everything* you need to earn more daily. You get: Exclusive Standard Notation Schematics, packed with all the service details you need; full photo coverage of all chassis views; *complete* replacement parts lists; tube placement diagrams; actual waveform photos; CircuiTrace[®] for printed boards; alternate tuner data; terminal identification and connections; disassembly instructions; field servicing notes—plus dozens of other great time-saving features.

Take the *right* step to fast, profit-building servicing—see your Sams Distributor for details on a money-saving PHOTOFACT Standing Order Subscription and Easy-Buy Library—or send coupon today!

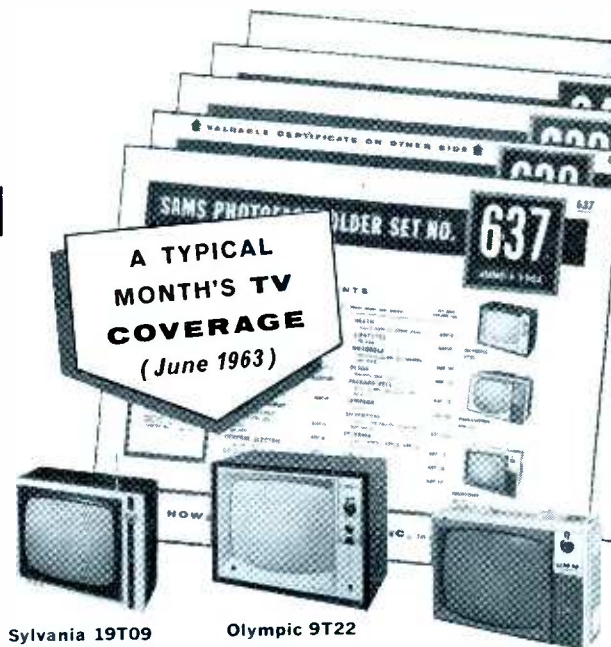

Sylvania 19T09

Olympic 9T22

Truetone 2DC3360



Coronado TV2-9650A



Westinghouse H-K3911U



Panasonic AN-14



Coronado TV2-9442A



Olympic 9TV19-B



RCA Victor 213G235RV



Emerson C-2001A



AMC D1863A



Electrohome Cameo



Capehart 19PT25



J. C. Penney 19P362A



Clairtone ST-801

SAVE 30¢ PER SET!

SIGN UP TODAY FOR A MONEY-SAVING PHOTOFACT STANDING ORDER SUBSCRIPTION!

With a Standing Order Subscription to receive PHOTOFACT regularly each month as issued, you pay only \$1.95 per Set instead of the regular \$2.25 price. You save 30¢ per Set—and you keep right up with the rapidly-increasing current model output! You enjoy the same 30¢ per Set savings when you purchase an Easy-Buy PHOTOFACT Library. Take advantage of substantial savings—sign up for a Standing Order Subscription or Easy-Buy Library with your Sams Distributor, or send coupon now for full details.

SAVE WITH A STANDING ORDER SUBSCRIPTION!

HOWARD W. SAMS & CO., INC.

Howard W. Sams & Co., Inc., Dept. 7-H3
4300 W. 62nd St., Indianapolis 6, Indiana

- Enter my Photofact Standing Order Subscription
- Send full information on money-saving Easy-Buy Plan

My Distributor is: _____

Shop Name _____

Attn. _____

Address _____

City _____ Zone _____ State _____

DC power for the instrument. A small power transformer with center-tapped secondary forms the voltage source for a full-wave rectifier circuit, which develops an output voltage of nearly 30 volts DC. Filtered by a 100-mfd electrolytic capacitor, the DC voltage is utilized for the internal signal generator as well as for powering the transistor receiver to be tested.

In using the Model 36-568 for troubleshooting transistor radios in our lab, we found that several sets required more filtering and decoupling than provided by the instrument. Motorboating is not an uncommon occurrence when these receivers are being serviced, because they depend on the low internal impedance of their power supply (fresh batteries) to prevent interstage coupling. We found

that by adding a 1000-mfd electrolytic capacitor across the output terminals of the Model 36-568 we could reduce the "apparent" internal impedance of the instrument sufficiently to eliminate most of this tendency to regeneration.

In some sets (again those which contained little filtering of their own), a distinct hum was heard. To be sure, the hum was not enough to seriously hamper servicing, but in troubleshooting certain types of audio faults it was necessary to take this noise into consideration. For example, we've developed scope techniques to speed transistor servicing in some circuits; while applying these, we found noticeable hum on scope traces and had to consider it when interpreting scope patterns. Connecting the 1000-mfd capacitor across the output leads again

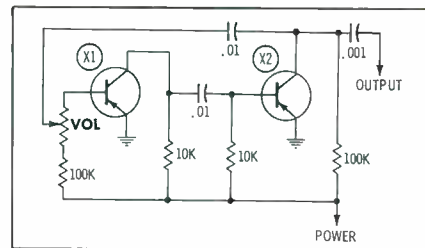

Fig. 2. Multivibrator is used to form audio square-wave pulses for injection.

proved a workable solution.

One of the most useful capabilities of the instrument proved to be the testing of transistors (Fig. 3). Qualitative tests of individual transistors are simple and informative. The quick test for shorts or I_{ceo} leakage is a time-saving way to find faulty transistors, since this particular defect is one of the most common in transistors. If I_{ceo} leakage becomes very significant, a transistor cannot operate normally; therefore, the I_{ceo} test is most useful for determining whether a transistor will function at all.

The gain test goes a step further. If the I_{ceo} test shows the leakage is not too great, the gain test then tells how efficiently the transistor will amplify. For this test, a fixed bias voltage is applied to the base, and the resultant collector current is measured by the panel meter. An important point to remember with this type of tester is that gain tests should be correlated with the I_{ceo} leakage test. That is, if a transistor indicates a high collector-emitter leakage, the gain reading will be correspondingly higher than for a transistor with little or no I_{ceo} leakage. Thus, a transistor with an I_{ceo} of 5 ma and a gain reading of 60 on the panel meter might be better than one with an I_{ceo} reading of 10 and a gain of 70. It is well to keep this in mind when you're matching transistors for output stages and similar uses where comparative gain is important.

Since the test bias applied to every transistor is the same (except for power transistors, which are tested with a



Fig. 3. Setting one switch and pressing pushbutton make up testing procedure.

For



BRIGHTER TV PICTURES
and brighter
customer smiles...

the **TU·BRITE** sparkles with
a **NEW LOOK!**



Handsomely packaged for instant acceptance, and color-coded by base type for instant selection, the TU-BRITE gives new life to fading picture tubes in an instant.

No worries about wrong voltages, either. With Tu-Brite, *if the base is right, the boost is right.* Model C-202 brightens duodecal base picture tubes; Model C-212 brightens 110° button base CRT's; and Model C-222 handles 110° shell bases. Make sure you have them all in stock! Write for Perma-Power's free Britener Selector Chart, your guide to the base type of every picture tube now in the field.

Perma-Power COMPANY

5740 North Tripp Avenue • Chicago 46, Illinois
Phone 539-7171 (Area 312)



Compact colorful display rack attracts attention, stimulates sales.

slightly higher bias), all gain readings of the Model 36-568 are relative rather than actual. To make these readings more meaningful for individual transistors, a booklet included with the tester contains relative readings for a large number of the more popular transistors. With this chart, you can determine quickly and easily if the gain of any particular transistor is normal for its type, or if its I_{ceo} is greater than it should be.

For further information, circle 102 on the literature card.

Tube Testing—Deluxe Style

The tube tester shown in Fig. 4—the Hickok Model 752A—is one of the more complete tube-testing instruments presently available. It is designed to fulfill the testing needs of the diversified servicing shop—the service business that engages in industrial and communications servicing as well as radio and television repair.

Specifications are:

1. Power Required—105-125 volts AC; 60 cps; 40 to 70 watts, depending on tests being performed.
2. Tubes Tested—All receiving, transmitting, and industrial types, including voltage regulators, 5-pin nuvistors, and subminiature types; special adapters available for CRT's, lighthouse tubes, pencil types, and a few other uncommon types; roll chart lists more than 1200 types, and instrument design permits setting up to test all others; each section of dual-purpose tubes tested separately.
3. Tests Performed — Mutual conductance in ranges from 0 to 1500, 3000, 6000, 15,000 and 30,000 micromhos; interelement leakage, sensitive to 10 megs; life test, a check of cathode activity under reduced filament temperature; emission test for rectifiers and diodes; gas test.
4. Panel Meter—Face size 4½"; lighted; sensitivity 280 ua, 645-ohm movement; leakage scale, 0 to 10 megs; 0 to 1500 micromhos; voltage-regulator scales, 0 to 200 volts and 0 to 100 ma.
5. Controls and Terminals—Ten test push buttons; rotary selector switches labeled FILAMENT (voltage), FILAMENT (heater pin), FILAMENT (grounded pin), GRID A, GRID B, PLATE,

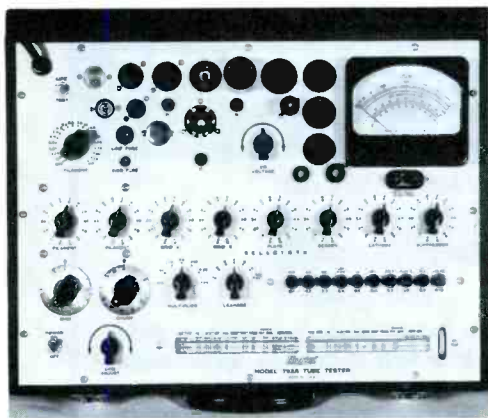
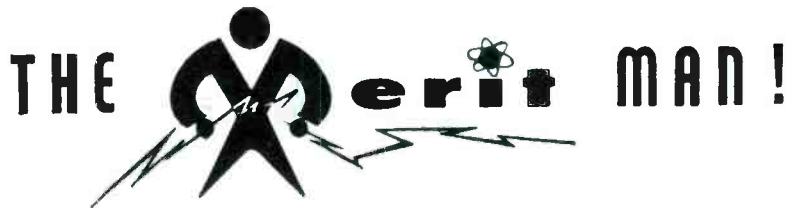

Fig. 4. Elaborate tube tester can check communications and industrial tubes.



ELECTRONICS' FAMOUS TRADEMARK

means . . .

THE PRESTIGE LINE
THE PROFIT LINE
THE ACCEPTED LINE

transformers
flybacks
yokes
coils

Merit Plaza
Hollywood, Florida

MERIT
COIL and TRANSFORMER CORPORATION



For best results squeeze bulb from sides rather than up against handle

ENDECO DESOLDERING IRON

removes soldered connections quickly . . . easily . . . profitably

No need to send your printed circuit boards out to a specialist when you have an Endeco Desoldering Iron. You'll find it easy to remove resistors, transformers, condensers, resistors, diodes and even those difficult multiple pin or button type sockets with center posts. Endeco puts the profit margin back into your printed circuit work.

Any iron will melt solder; Endeco with its vacuum pickup completely removes melted solder . . . collects it in a non-breakable, stainless steel tube. The exclusive compact design lets you see the connection while you're desoldering. One hand operation.

No need to reach for another tool. Without even changing tips, you can resolder a clean, new connection. Worn tips are easily replaced, when it is necessary, even while iron is hot.

Endeco Desoldering Iron is not an attachment, but a complete desoldering/resoldering tool. The desoldering principle (pat. pending) is incorporated into the rugged Weller soldering iron with the exclusive Weller Magnastat sensing device in tip body which maintains constant temperature.

The new Model 100A Endeco Desoldering Iron is available at your electronic distributor or write direct.



ENTERPRISE
DEVELOPMENT
CORPORATION

1102 East 52nd Street
Indianapolis 3, Indiana

SCREEN, CATHODE, SUPPRESSOR, MULTIPLIER, and LEAKAGE; LINE ADJUST, VR VOLTAGE, BIAS, and SHUNT potentiometers; POWER toggle switch; LINE push button; SELF-BIAS RESISTOR terminals; 4-pin, 5-pin, 6-pin, 7-pin, octal, loktal, compactron, novar, noval and 10-pin miniature (combined), 7-pin miniature, 7-pin in-line subminiature, 8-pin subminiature, acorn, and nuvistor tube sockets; three pin jacks for plate, grid, and cathode caps; 7-pin and 9-pin straighteners; lighted roll chart.

6. Size, Weight, Price—7 $\frac{1}{2}$ " x 18 $\frac{3}{8}$ " x 16 $\frac{3}{4}$ "; 25 lbs; \$355.00.

An important consideration in any tube tester is the completeness of its tests. Tubes operate under so many different conditions that tests are sometimes inconclusive unless they are made under conditions similar to those of actual use. The Model 752A closely duplicates operating conditions, to give very accurate tests. Its settings are arranged so tests can be completed quickly. True, more time is required than with quick-check testers, but in industrial and communications work (and often in radio-TV receiver servicing) the extra time taken in precisely evaluating tubes for critical circuits is well spent. The Model 752A has been designed with complete testing in mind—thus the extra provisions for separate and distinctive tests.

Another feature of the 752A that deserves consideration is the convenience of setting up your own test data for tubes that don't have tester settings listed. (See "Develop Your Own Tube-Test Data" in the April, 1962 issue.) Once characteristics have been published for a new tube type, you can easily set up the Model 752A to evaluate the tube accurately.

The instruction manual with the instrument indicates what voltages are connected to which elements of a particular tube socket during each test. For example, you can choose either of two plate voltages—75 or 150 volts DC; you can select either 56 or 130 volts DC for the screen; grid bias can be set at any value from zero to -40 volts DC, or a resistor can be connected (at terminals on the panel) to operate the tube with self-bias; you can select any one of 18 filament voltages from .6 volts through 117 volts AC; and you can choose a signal voltage that best fits the tube being



Fig. 5. Typical VHF communications RF amplifier shows excellent gain in test.

tested—.25, .5, 1.25, or 4.5 volts AC. These selections permit a wide latitude of test conditions, to suit almost any operating situation.

Fig. 5 shows a typical communications tube being tested in the Model 752A. Following each step as we check this 6146 VHF amplifier will give you some idea of the thoroughness with which a tube can be evaluated. Locating the 6146 on the roll chart, we set the selector switches according to the listing: Filament selector set for 6.3 volts; pin-selector switches set at pins 7 and 2 for filament, 5 for grid A, 0 for grid B (there is none in the 6146), 0 for the plate (a plate-cap connection must be used), 3 for screen, 1 for cathode, and 8 for suppressor; bias control at 12; multiplier switch set for X10 to obtain the correct Gm range on the panel meter; and plate-cap lead connected.

With the tube in the socket, our first step was to check for leakage by rotating the LEAKAGE test switch. Finding nearly 600K at positions 1 and 2 of the switch, we consulted a chart in the instruction manual and identified the fault as cathode-heater leakage. Since the transmitter circuit from which this tube was taken operates with the cathode grounded, we decided this fault would not adversely affect operation, so we proceeded with further tests.

Next, with the LEAKAGE switch at the "Tube Test" position, we depressed test switch S5 (as directed by the roll chart) and read the mutual conductance (Gm) on the 1500-micromho scale of the panel meter. The reading was 750; since we were using the X10 setting, the actual

PRECISION TUNER SERVICE

P. O. BOX 272

1200 S. WALNUT ST.

BLOOMINGTON, IND.

EDISON 99653

7.50
V or U

COMBO PLUS
9.95 POSTAGE

6 MONTH WARRANTY



All Types T.V. Tuners Cleaned, Repaired and Aligned to Factory Specifications. Same day in shop service on most Tuners. Price Includes Minor Parts, Major Parts at Cost Price. We use Original Parts if possible. State Make Model and Enclose all Parts and Tubes. Pack Well and Insure.

ALSO HAVE LARGE STOCK OF EXCHANGE TUNERS, WRITE FOR TYPES AND PRICES.

Gm reading was 7500 micromhos.

The life test was next. This evaluation consists primarily of comparing an arbitrary Gm reading with a second reading taken with the heater voltage significantly reduced. The multiplier switch was set to the "Shunt" position, S5 was depressed, and the SHUNT potentiometer was adjusted for a reading of exactly 1000 on the panel meter (two-thirds of full scale). Then, with S5 held down, the LIFE TEST push button was depressed. If the meter reading had dropped to less than half scale, this would have indicated a limited life expectancy for the tube (because of cathode deterioration). In the 6146 we tested, the reduction was only a couple of scale divisions—an insignificant amount. Thus, the life expectancy of the tube (as far as cathode emission is concerned) was proven quite satisfactory.

Lastly, we checked for gas content. Setting the scale MULTIPLIER switch for X2, we depressed GAS-1 push button S6, and adjusted the BIAS control for a reading of 100 on the Gm scale. Holding S6 down, we depressed GAS-2 push button S7 and watched the meter pointer. Excessive gas is shown by an upward deflection of the pointer—two or more scale divisions. The 6146 showed hardly a flicker of the pointer, indicating it was completely free of gas.

Later, we ran the Model 752A through our "gamut" of known defective tube types, noting how the instrument reacted to the various faults represented in this collection of bad tubes. Mutual conductance readings were similar to those indicated by our lab tester, and leakage indications were dependable. A few borderline gas cases slipped by, although in every one the amount of gas was less than will usually cause trouble except in very critical circuits. For example, one of our prize "gassers" is a tube that draws only about 5 ua of grid current, but in certain IF stages causes unusual picture-pulling symptoms. This one has been missed by most service-type testers we've had in our lab, except for those with extremely sensitive grid-emission tests. With this one exception, the Model 752A went through our series of "curve-balls" without an error.

For further information, circle 103 on the literature card. ▲

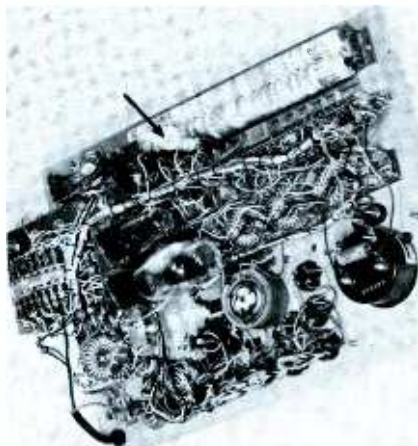

Fig. 6. Large lamp illuminates the roll chart. Note 5Y3 and 83 rectifier tubes.

TELEVISION

F. M.

RADIO

CROSSWAY TELEVISION - RADIO
SALES - SERVICE

ANBURY ROAD

ILTON, CONN.

Customer's Order No. _____ Date _____ 196__

M Cash

Address _____

SOLD BY	CASH	C. O. D.	CHARGE	ON ACCT.	MOSE. RETD.	PAID OUT
QUAN.	DESCRIPTION				PRICE	AMOUNT
2	5045B					4 20
1	6CD66A					5 75
1	6AF4A					4 -
	Labor					5 -
Rec'd by _____					Tax	49
No. 002062					ALL claims and returned goods MUST be accompanied by this bill	
					1944	

Now, put more profit in this

with this!



NEW SONOTONE VALUE LINE

How much of that figure called "total" is profit? Depends on the cost of the tubes. That's why the new Sonotone Value Line puts more profit into that bill: they cost much less! They're top quality, first-line tubes, too. Every one is thoroughly tested to meet Sonotone's rigid quality standards—no more extra callbacks. And Sonotone makes sure you can enjoy these

extra profits on all calls. The Value Line includes all the popular home entertainment types—the ones you're most likely to need. So ask your distributor for the Sonotone Value Line. Start making bigger profits tomorrow. Now your distributor has two great Sonotone lines—the new Value Line and the well-regarded Premium Line.

SONOTONE CORPORATION • ELECTRONIC APPLICATIONS DIVISION • ELMSFORD, N. Y.
Cartridges • Speakers • Tape Heads • Microphones • Electron Tubes • Batteries • Hearing Aids • Headphones

3 WAYS TO BIGGER

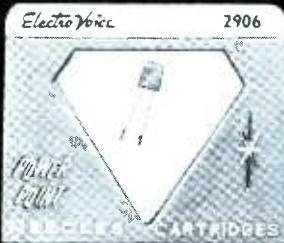

NEEDLE



CARTRIDGE PROFITS!

1. More "look-alike" exact replacement models than any other brand. Over 350 needles, 225 cartridges.
2. Easy-to-use reference material. E-V computer-printed catalogs make proper needle/cartridge selection easy, fast and accurate.
3. Highest standards. Rigid quality control and inspection cuts call-backs, gives full value to every customer.

Stock and sell E-V needles and cartridges for more profits, today! Write for FREE replacement guides!

ELECTRO-VOICE, INC.
Buchanan, Michigan, Dept. 837R,

Electro-Voice
SETTING NEW STANDARDS IN SOUND



THE TROUBLESHOOTER

answers your service problems

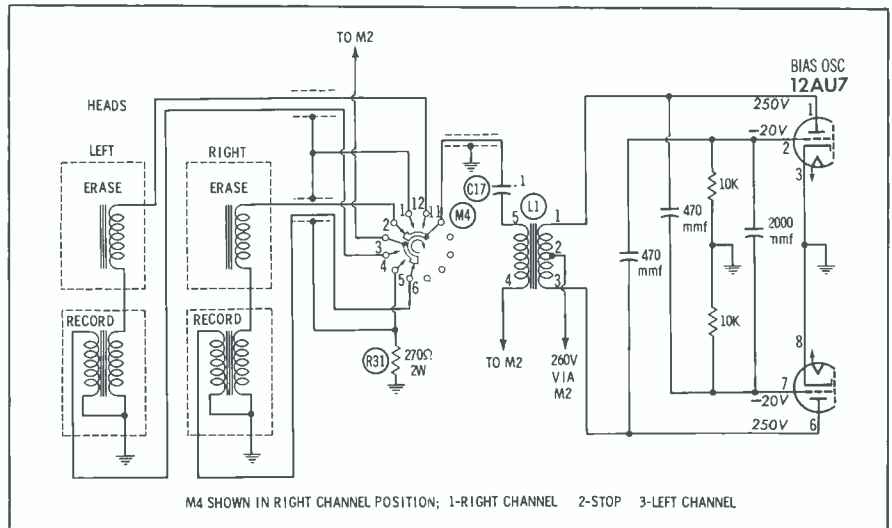

If I Could Erase . . .

After replacing a worn head in a Webcor Model 2812 tape recorder (PHOTOFACT Folder 393-12), I noticed the machine's inability to erase previously recorded material. A new signal is simply recorded on top of anything that is already on the tape. This trouble is present when the tape is traveling either to the left or to the right, even though separate record and erase direction heads are provided for each direction of tape movement.

I've carefully checked all voltages and resistances, replaced all the tubes, and checked all the wiring around the erase and record heads; but I can find nothing amiss. A test signal from a generator can be fed through either set of heads to the amplifier, and comes out loud and clear. Going by this evidence, and considering that both tape tracks are affected, I suspect trouble in the bias-and-erase oscillator; however, I need help in getting on the right track toward a solution to the problem.

ED DURKIN

New York, N.Y.

I agree with your diagnosis: now let's see what might be wrong with the oscillator. This circuit is a cross-coupled multivibrator that feeds a 60-kc signal via L1 and head switch M4 to the erase heads. To troubleshoot this section, record-playback switch M2 must be in the "record" position; otherwise, no B+ will be applied to the multivibrator plates. Failure of M2 to make proper contact could disable the multivibrator. Various other troubles within this circuit could also cause it to stop oscillating. To make a quick check of its operation, use your

scope to look for a fairly strong 60-kc waveform at terminal 5 of L1. If there is no signal here, voltage and resistance readings in the multivibrator should pinpoint the cause.

Should you find a waveform at L1, trace toward the heads with the scope to find where the signal is being lost. An open C17, or poor contact in M4, would be the most probable troubles. I doubt that you'll find a defective head, because this fault would affect recording and playback as well as erasure, and it would be a rare occurrence for both sets of heads to give trouble at once.

Distorted Recordings

I'm having trouble with severe distortion in a Recordio Model 804 tape recorder (PHOTOFACT Folder 548-12). The difficulty seems to be in making the recordings, since there is no distortion when I play back tapes that were made before the set became defective. Voltages all check okay except for a few slight discrepancies in the area of cathode follower V2. I've changed V2, C8, C9, B+ filter capacitor C1, R8, R9, R19.

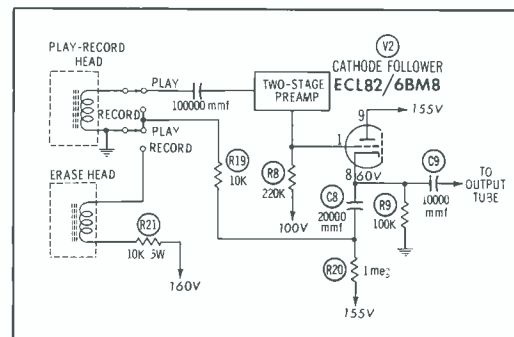

R20, and R21 with no effect. If I reduce the value of R20 from 1 meg to 220K, most of the distortion is eliminated, but the volume becomes too weak to be satisfactory. I've tried using a different microphone, and monitoring the output from the amplifier while recording—still no clues.

JIM KEY

Farmington, Mo.

A recording problem that doesn't impair the playback function is most likely due to trouble in the erase-head circuit—either a defective head or an external fault that causes incorrect current through the head. This recorder uses a simple DC input to magnetize the head for erasing and biasing the tape; therefore, checking the erase circuit is a simple matter of tracing voltages or resistances through R21, the head, and M2 with the machine in "record" mode—also substituting for the head, if necessary.

If the erase circuit is in good shape, consider the possibility of the play-record head being overloaded by strong signals fed to it in the "record" position. To follow up on this idea, check the condition of the play-record head, and carefully examine the circuit of V1.

Hum on Playback

A Wollensak Model T-1515 tape recorder (PHOTOFACT Folder 400-13) has me at bay. In the playback position only, it has a 60-cycle hum that appears to be originating in the first section of preamp tube V1. To eliminate possible hum pickup from the heads and motor, I've disconnected these components so the unit can operate as a straight amplifier.

When pin 7 of V1 is grounded, the hum disappears; when I ground pin 2, it's still present at low volume. The scope shows a hum waveform at the plate (pin 1). I've changed C4B, and have scoped the B+ line to make sure it is free of abnormal ripple. Shorting the cathode of V1A (pin 3) to ground only increases the hum level.

When the unit was brought in, the preamp was acting as a multivibrator whose output frequency increased as the volume was turned up. On the bench, I can't induce this condition now. Wires and components have been rerouted, and connections resoldered, without making any difference. I went over the play-record switch and found no open contacts.

The hum increases as I bring my hand close to the chassis, but decreases when

An oscilloscope gives a visual picture of what is happening in a circuit, something no other test instrument can do. This very feature makes a good scope a money maker for your shop. It saves you time, analyzes those intermittent faults, and makes routine servicing easier than ever. Once you start using a scope regularly you'll never be without one.

You've pulled a set with a buzz in the sound. Is it 60-cycle hum or 60-cycle buzz? A quick look with the scope and you'll know. You'll either see a 60-cycle sinewave caused by heater-cathode leakage or there'll be a vertical deflection sawtooth probably resulting from a defective bypass capacitor.

I.f. alignment required? A scope is a must. Set it up along with your EICO post injection sweep generator, and you have only to adjust transformer and sound trap slugs to finish the job. Same thing for setting up the 4.5-mc sound takeoff network.

Losing the signal somewhere in the video circuits? Hook up the scope and see where it's going astray. There's a good chance you'll spot the bad component at the same time.

But when you go to buy a scope, what do you look for? Large screen, high sensitivity, frequency response, attenuators, synchronization, calibrator? All of these are important and are included in the design of any professional scope intended for the service technician.

Large screen: You can get by with 3 inches, but take the 5-inch screen of the EICO 460. Get a close look at what's happening. It's got an edge lit calibrated bezel too. **High sensitivity:** The 460's vertical amplifier delivers 25 mv per cm. All you'll ever need and more. **Frequency response:** EICO makes it flat from dc to 4.5 mc

in the 460. Ideal for color and black and white as well as industrial production and research, audio testing and experimenting. **Attenuators:** The vertical attenuator in the EICO 460 is a 4-step frequency compensated network. Can't beat this kind of design. **Sync:** Any signal reaching the screen is fully synced—automatically. And for special purposes you can inject your own external sync signal. **Calibration:** Accurate peak-to-peak voltage calibrator is built right into the 460.

All this adds up to the top scope for TV service. You can get it as a kit for \$89.95 or completely wired for \$129.50.

If you don't need so elaborate an instrument, take a careful look at the 427 dc to 1 mc scope or the new 3" General Purpose scope, the EICO 430 (kit, \$65.95; wired, \$99.95). The new 430 does everything bigger and more expensive scopes do. Vert amp/flat from 2 c to 500 kc, -6 db at 1mc. Sensitivity 25 mv/cm. Horiz amp. flat from 2 c to 300 kc. Sensitivity .25 V/cm. Flat face 3" tube; mu-metal shield eliminates effects of external fields.

There are plenty of accessories for EICO scopes too. An Electronic Switch to put two different signals on the scope screen at the same time (EICO 488: kit, \$23.95; wired, \$39.95). Voltage Calibrator for the less expensive 427 and 430 (EICO 495: kit, \$12.95; wired, \$17.95). Three accessory probes—demodulator, direct and low capacitance types.

Whether it's scopes, tube testers or VTVM's you get the best for less with EICO. Save money by building your instruments from kits, or buy them factory-wired at a substantial savings. See your distributor. Write for complete 28 page catalog. **Dept. PF-8** Add 5% in west

make extra dollars with your scope



EICO

EICO ELECTRONIC INSTRUMENT CO. INC., 3300 Northern Blvd, L. I. C. 1, N. Y.

EXPORT: ROBURN AGENCIES INC., 431 GREENWICH ST., N. Y. 13, N. Y.

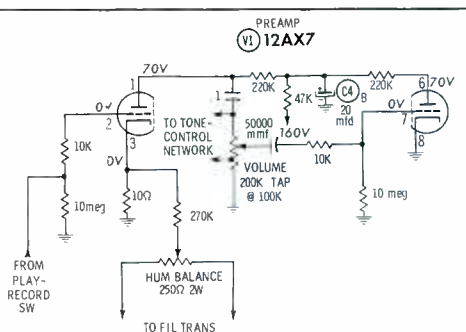

NEW SAMS BOOKS

BROADCAST ENGINEERING NOTEBOOKS,
Vol. 3 • AM-FM Broadcast Maintenance

by Harold E. Ennes. The third volume in this popular series for broadcast communications personnel provides vital information on the care, use, and repair of major broadcast equipment for AM and FM stations. Combines valuable explanations of theory and principles with practical discussions of broadcast procedures, emphasizing maintenance. Authoritative sections cover: Decibels, Volume Units, Levels & Pads; AM-FM Propagation; Testing & Maintenance at the Studio; Testing & Maintenance at the Transmitter; The Chief Engineer's Reference Section. An essential reference for everyone connected with Broadcasting. 256 pages, 5 1/2 x 8 1/2"; \$5.95 comb-bound. Order BEN-3, only.

Marine Electronics Handbook (Revised)

by Leo G. Sands. Completely updated edition of the leading book on marine electronics. Tells how to select, install, operate, and maintain the various types of electronic equipment used on both large and small marine craft. Covers equipment from radiotelephone and CB gear to sonar and radar. Includes operating procedures and regulations. Special foldout maps show shore-based marine transmitting facilities. Contains numerous schematics and service tips for equipment maintenance. Invaluable for boat owners and technicians. 264 pages; 5 1/2 x 8 1/2". Order MES-2, only. \$3.95

Essentials of Vector and Phase Analysis

by Alan Andrews. This basic theory text explains the fundamental principles so essential for understanding AC circuit operation. Starts with a comprehensive discussion of vectors, and progresses through both vector and phase analysis, emphasizing practical approaches to solving actual problems. Chapters cover: Alternating Current & Phase; Angular Measurements; Vectors; Complex Numbers; AC Network Calculations; Miscellaneous Vector Applications. Includes review questions and answers, reference appendices and index. An essential reference for engineers, technicians, and students. 128 pages; 5 1/2 x 8 1/2". Order VEC-1, only. \$2.95

Color TV Servicing Made Easy

by Wayne Lemons. Written by an expert practicing service technician in his famous "make easy" style. Takes the mystery out of color TV servicing. Introduces you to color principles and setup adjustments; thoroughly covers color circuitry, adjustments, and servicing of all color TV sets produced to date; includes trouble-shooting procedures, alignment, antennas and antenna distribution systems for color TV, and methods for reducing external and internal interference. Covers test equipment for color TV servicing, and troubles in black-and-white circuitry peculiar to color sets. This book will help to put you into this fast-growing, profitable service work. 128 pages, 5 1/2 x 8 1/2". Order CSL-1, only. \$2.95

Basic Electronic Series: Radio Circuits

by Capt. T. M. Adams, U.S.N. Fifth volume in a series using unique 4-color diagrams to show visually the voltage and current actions and signal paths in basic electronic circuits, during each and every moment of operation. This volume explains how oscillator, amplifier, detector and rectifier circuits are combined to form all the basic types of radio receiver circuits. Superior to any previous texts. 160 pages; 5 1/2 x 8 1/2". Order BER-1, only. \$2.95 Previous 4 vols. in slipcase—Save \$1.85! Order BEL-40, only. \$9.95

ABC's of Electronic Test Equipment

by Donald A. Smith. A comprehensive, easy-to-understand introduction to each major instrument type. Describes uses for each instrument, how it works, how to use it properly to make tests for which it is intended. Chapters cover: The Meter; The Volt-Ohm-Milliammeter (VOM); The Vacuum-Tube Voltmeter (VTVM); Battery, Diode & Transistor Testers; Tube Testers; The Signal Tracer; The Oscilloscope; Battery Eliminators; The Signal Generator. Clear text and supporting illustrations make this book an ideal guide to understanding test equipment. 96 pages, 5 1/2 x 8 1/2". Order STE-1, only. \$1.95

HOWARD W. SAMS & CO., INC.

Order from your Sams Distributor today, or mail to Howard W. Sams & Co., Inc., Dept. H-33, 4300 W. 62nd Street, Indianapolis 6, Ind.

Send me the following books:

- BEN-3 VEC-1 BER-1 STE-1
 MES-2 CSL-1 BEL-40

\$ enclosed. Send FREE Booklist

Name _____

Address _____

City _____ Zone _____ State _____

IN CANADA: A. C. Simmonds & Sons, Ltd., Toronto 7

any metal part is touched; can you explain this?

RAYMOND BARNETT

Hazleton, Pa.

I think you'll find a poor ground connection somewhere in the preamp stage, or at the play-record switch; this trouble has occurred a number of times in these particular recorders.

Double-check to make sure the hum-balance control is operative. Also, to eliminate stray pickup of radiated hum, be sure the shield cover is in place over the input jack underneath the amplifier chassis.

Heat Prostration

An Elizabethan Model LZ49 tape recorder, made in England, operates normally for about 45 minutes; then a loud grinding sound comes from inside the machine, and the takeup reel stops turning. In addition, the "start" and "fast forward" keys do not function. Since I noticed that the unit runs quite hot, I checked the temperature by placing a thermometer on the deck; the reading is 100° F when the trouble appears. If I turn off the machine and let it cool down for an hour or so, it plays normally again until the heat reaches the critical point.

AL RAMO

Long Island City, N.Y.

An operating temperature of 100° is not the least bit abnormal for a continuously operating tape recorder, but this unit is apparently suffering from a mechanical fault that is aggravated by the heat. Expansion of poorly fitted parts in the drive mechanism may bring on the condition, or the drive surfaces may be contaminated by grease or oil that gets slippery enough to destroy traction at high temperatures. Carefully inspect the mechanism to see if you can find any points where binding or slippage is likely to occur; while you're at it, clean the drive surfaces with alcohol.

Loads of Speakers

I have a 50-watt audio power amplifier, and want to connect six 8-ohm speakers to it in such a manner that the volume can be individually controlled at each speaker. (Six 8-ohm level controls are on hand for this purpose.) Three of the speakers will be 50' away from the amplifier, and the remaining three will be approximately 30' away. I can use No. 12 or No. 14 wire if necessary.

DUDLEY S. WEAVER

Kent, Ohio

The feedback used in this amplifier should be sufficient to let you make the

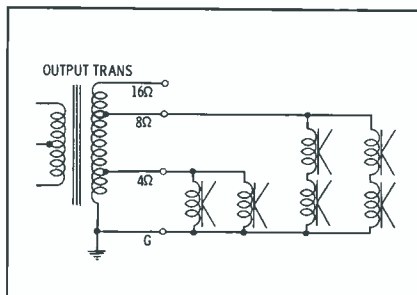

BUZIT

TRANSISTORIZED SIGNAL TRACER

FOR ONLY \$8.10 DEALER NET WITH BATTERIES



USED FOR TROUBLE SHOOTING

- A.F. CIRCUITS • I.F. CIRCUITS
- R.F. CIRCUITS • CONTINUITY CHECKS • SPEAKERS, ETC.

EXCELLENT FOR TRANSISTOR RADIOS BECAUSE BUZIT USES ONLY A 3 VOLT POWER SUPPLY

ASK YOUR ELECTRONIC PARTS DISTRIBUTOR FOR MODEL NO. BZ-1

Manufactured by **WORKMAN Electronic PRODUCTS, INC.**
SARASOTA, FLORIDA

5 CORES
WETS FASTER
MELTS FASTER
Solders Better

ERSIN
Multicore
5-CORE SOLDER
WORLD'S FINEST

BIC INDORSO QUALITY

Multicore Sales Corp. Port Washington, N.Y.

For information, write Department MK943

hookup shown in the schematic without unduly affecting amplifier response. Connect two of the speakers in series, and two others in series; then parallel the two strings and connect them to the 8-ohm tap. Wire the remaining two speakers in parallel, and connect them to the 4-ohm tap. Assuming the level controls are of the pad type, simply hook them at each speaker so a constant impedance is presented to the amplifier—not to the speaker. (If they are of the type that present constant impedance in both directions, there is no problem.)

As you are probably aware, the amplifier will furnish only about 8 watts to each speaker, even if you have a good impedance match. However, 8 watts may be sufficient for the purpose you have in mind.

Recorder Out of Order

In my shop I have a Tapemaster Model PT-121 tape recorder (PHOTOFACT Folder 186-14) that will not operate. I have tried a new head, replaced all tubes, checked all electrolytics, and made sure the B+ voltage is normal. Other voltages agree with those on the schematic except for the following: Plate of preamp stage reads 200 volts—should be 140 volts in record mode and 170 volts in playback. Both grids of bias-erase oscillator (a multivibrator) read -10 volts—should be -60.

My prerecorded tapes will not work on this machine, possibly because the tape moves in the opposite direction from that of most other recorders. I checked the unit with a mike and an external amplifier, and it passed the signal, but its performance was only fair.

EMORY A. FERGUSON

Snohomish, Wash.

The high plate voltage on the preamp may mean the tube is not conducting hard enough; the reason could be a bad socket connection, an open or high-value cathode resistor, or low filament voltage. Such a fault would readily explain the poor performance of the recorder.

The low grid voltages on the multivibrator might mean trouble, but I rather doubt this. Did you, by any chance, use a VOM instead of a VTVM? It would load either multivibrator-grid circuit and falsify the readings.

You should be able to use a prerecorded tape for testing, even though the tracks would be run backwards on the Tapemaster machine. However, it would be easier at first to use a signal-injection technique for isolating the defective stage or section, just as in any other audio amplifier.

Unchanging Volume

One of my customers dropped his Westinghouse Chassis V-2397A transistor radio (PHOTOFACT Folder 477-14), breaking several connections. After repairing the breaks, I found the volume control had no effect: the output remains at maximum. I've checked the ground connection of the control, and have removed and disassembled it—finding no trouble

NEW

SECO TUBE TESTER Model 98

GUARANTEED TO GIVE ALL MODERN TV TUBES, RADIO TUBES AND FILAMENT RECTIFIERS A COMPREHENSIVE ANALYSIS . . .

checks heater current on series string tubes



NEW SECO MODEL 98

ONLY \$99.50 NET

This new test instrument is a complete tube tester that locates all tube faults quickly and accurately. It has a two-stage DC amplifier which isolates the rugged 1 ma meter from the tube under test, protecting the meter and permitting a wide range of load currents and test conditions. The new Model 98 tests more than 2500 different tubes. The entire unit is contained in a compact case with removable cover. The cover holds speed-indexed tube data cards, pin straighteners and condensed operating instructions. For complete information see your electronic supply dealer or write to Seco.



SECO ELECTRONICS, INC.

1221 S. Clover Drive, Minneapolis 20, Minn.

A DIVISION OF DI-ACRO CORPORATION

transistorized electronic ignition system

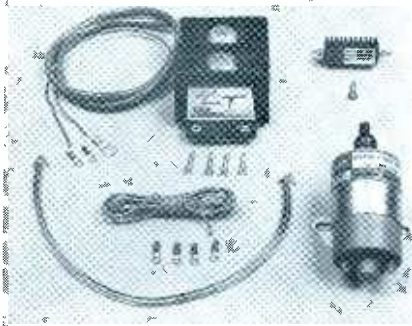

Banshee TS-30

Up-date your old fashioned system with our new and completely different ignition . . . the biggest engine improvement in over 50 years.

ADVANCE STYLING AND DESIGN

- Universal installation on all makes of cars, trucks and boat distributors.
- Advanced styling, two heavy-duty transistors assure dependability.
- Die cast finned heatsink facilitates rapid cooling.
- Waterproof and shockproof for all environments.
- 30 Amp Heavy-Duty circuit for maintenance-free service.
- High-temperature resistant racing-type coils are of latest design for faster saturation. High voltage and primary terminals at opposite ends of coil to prevent high voltage leakage from primary to secondary and assure highest efficiency and safety.
- Open plugs 5 to 10 thousandths which eliminates plug fouling.
- Coil output 30 to 55KV . . . Point current 1/4 Amp . . . rids pitting and burning.
- Faster and Smoother acceleration with no misfiring.
- Increase in speed 10% to 30%.
- No ignition overheat problems in slow city driving.
- Complete engine combustion from hotter spark.
- Increases gas mileage to 10%.
- Reduces battery drain with no hard starting.
- Eliminates distributor-condenser breakdown.
- Tune-ups stay adjusted for peak performance.

Complete Banshee Systems are available in the following models:

- 30 KV Output with F-250T Coil, 250:1 turns ratio, neg. ground . . . \$39.95
- 45 KV Output with F-400T Coil, 400:1 turns ratio, neg. ground . . . 44.95
- 55 KV Output with F-500T Coil, 500:1 turns ratio, neg. ground . . . 49.95
- Banshee TS-30 with F-500T, pos. ground . . 59.95
- Free Color Brochure

PARTS FOR EXPERIMENTERS

- Special F-250T Coil 250:1 turns ratio \$ 9.95
- New F-400T Coil, 400:1 turns ratio . . . 14.95
- New F-500T Coil, 500:1 turns ratio . . . 19.95
- Die-cast aluminum heatsink ballast resistor, .517 OHM designed for all above coils . . 3.25

TESTED • APPROVED
FULLY GUARANTEED ONE YEAR

SLEP ELECTRONIC COMPANY, Automotive Division
P.O. BOX 178-PF Ellenton, Florida
Ph. (813) 722-1843

Name _____
Address _____
City _____ State _____
YEAR _____ MAKE _____ MODEL _____

COLOR COUNTERMEASURES

Symptoms and tips from actual shop experience

Chassis: Zenith 27KC20, 29JC20

Symptoms: Wrong colors; hue control inoperative.

Tip: This trouble with reception of color programs is usually the result of misadjustment by the customer. The reproduced hues on the face of the picture tube will appear predominantly blue and green—with very little red. When this defect appears, connect the color-bar generator to the antenna terminals, and tune in the generator signal. Then try rotating the hue slug (with the knob removed), while watching the screen for the correct color display from the generator. In some cases, you'll find the slug to be jammed because the customer has turned it too far into the coil form. If this has happened, it will be necessary to gain access to the coil slug itself, before you can loosen it to a point of turning freely. In either case, position the slug to obtain the proper color pattern on the CRT. As a final step, replace the operating knob (a stop-tab type, depicted in the photo) and be sure to show your customer how to prevent a recurrence.

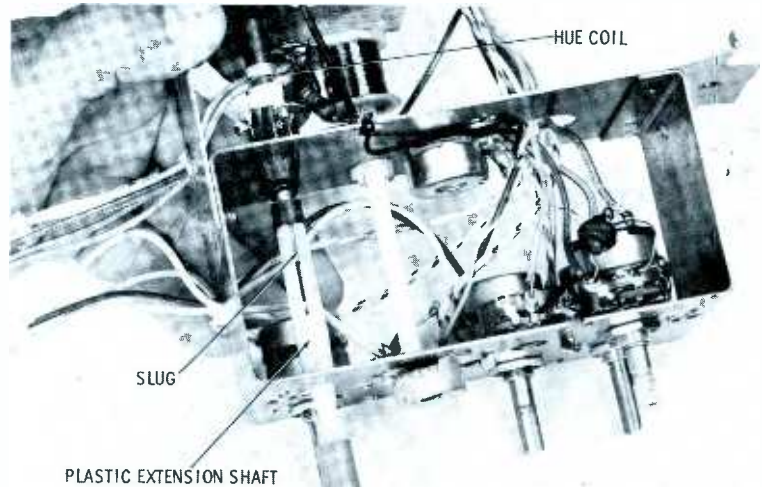

there. Checking components and voltages in the related circuits has not led me any closer to a solution.

EDWARD E. THORNLEY

Georgetown, S. C.

Closely inspect the printed wiring and see if you have a solder bridge or other leakage path between the conductors identified by CIRCUIT numbers 23 and 24. These conductors, which respectively go to the top side and the arm of the volume control, run very close to each other for a fair distance—and this particular area of the board is quite vulnerable to damage.

Of course, there is also a possibility of an incorrectly connected component such as C10 or R8. If no obvious faults can be found, try replacing transistor X3, which operates as a reflex amplifier for both the IF and audio signals.

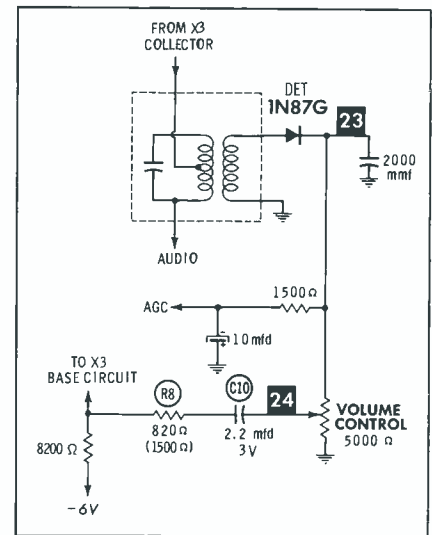

Latest Jackson Tube Test Data

Model 648					Model 658						
Tube Type	Fil.	D.	E.	Plate Test	Sec.	Heater	Circuit H-K	P-G	Plate	Grid Test	Heater Current
2DZ4	2.5	A235	A17	3BX1	T	2.5L	125	a37	125	15WY	AB.5M Z600
2GW5	2.5	A235	A17	16XZ	T	2.5J	125	a37	16R	7WY	AB.5L Z600
3DZ4	3.0	A235	A17	38XY	T	3.0P	125	a37	125	15WY	AB.5F Z450
6HA5	6.3	A234	AC15	30Y	T	6.4J	124	ac35	18R	7WY	
6JB6	6.3	1237	AB459	17W	P	6.4N	1237	ab450	22R	80VY	

Nor. -S switch in S position

SUPPLEMENT TO LATEST ROLL CHART 648-27
658-6

Intercoms

(Continued from page 35)

supplies signals to all of the slave stations, the paging announcement will be heard at each station. (Of course, the switch that closes the microphone circuit also opens the program circuit so they won't both be on at the same time.)

Locating the Stations

To derive the most benefit from today's versatile intercom systems, initial planning by the technician is the key to customer satisfaction. It is first necessary to evaluate the user's needs and also to inspect each one of the proposed station locations to determine maximum accessibility and minimum background noise. (A high noise level can seriously deteriorate communications, even when handsets are used.)

Although it is best to position the intercom near the operator and in a quiet location, it is sometimes difficult to do so. In his normal activity, the operator may at times be a considerable distance from the intercom. Also, if the station serves several people, it must be adequate to cover the area of activity concerned.

Even if the area served is noisy, it may be possible to use a conventional speaker-style intercom station. Simply employing a highly efficient type of speaker will often make incoming calls audible over a sufficient distance. If additional power input to a speaker is needed, booster amplifiers are available.

System Wiring

Proper wiring is a very important consideration in maintaining good intercom sound levels. Overall line resistances of several ohms can attenuate sound levels seriously in low-impedance systems; therefore, the longer the line length, the greater the minimum permissible conductor size. Typical recommended values are:

- 20- 200 feet #24 wire
- 200- 400 feet #22 wire
- 400- 700 feet #20 wire
- 700-1000 feet #18 wire

After you have decided upon the placement of the various stations, it is necessary to estimate conductor lengths, particularly between the master station and the farthest slave station, or between the two master stations that are separated the greatest distance. From this information, you can determine the type of cable that should be used in the installation.

For very long line runs, the most economical way to minimize audio power losses may be to increase the line impedance. As shown in Fig. 3, step-up and step-down line transformers are used to match the various intercom components to the medium-impedance (usually 500 ohms) line.

Follow Up the Installation

After determining the customer's needs and completing the installation, don't let him drop. From time to time, stop in and reevaluate the system with him. In many cases you'll be able to sell another unit or two, or a different type of system, to meet his changing needs. You'll also be able to arrest any loss of performance due to deterioration of components, or to tampering with the system.

Intercoms, unlike radio or TV sets, are fairly permanent. To modify them generally requires changes in wire routing and length, and other services of a qualified technician—you! ▲



Replacement SPEAKERS for all makes, models

All sizes, oval, round, 4", 5", 8", 5 x 7", 4 x 6", 6 x 9", 2 x 10". PM speakers, 3.2 ohms, 1.47 oz., 3.16 oz., 2.15 oz. magnets. Special prices for quantity lots

PRIVATE LISTENING RECEIVERS

... 15 and 500 ohm
Magnetic-type hearing aid. Quality manufactured, all with receiver and metal ear piece plus 39" cord. Also 15 ohm, 500 ohm and 2000 ohm deluxe models.

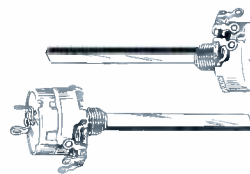
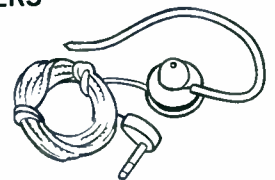

TELEVISION CONTROLS

Standard taper, 3" shaft, 1/2 flat to fit Philco and other makes. Complete selection, 1 Meg; 2 Meg; 500 K types with on-off switch or without.

OUTPUT TRANSISTORS For Philco or other makes

Special Philco type, replaces twenty numbers formerly needed. Packed two to a package. Also 60 watt output transistor for GM radios, also exact replacement for 2N173, 174, 277, 278, 442, 443.

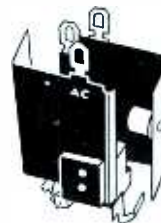
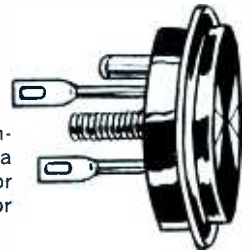

DUAL GERMANIUM RECTIFIERS

Snap in mountings. 2-300 MIL rectifiers at 130 volts. Replacements for GE (1N584). Also 500 MIL cartridge rectifiers, Hi-density 500 MIL rectifiers and guaranteed 750 MIL molded rectifiers in stock.

YOUR PHILCO DISTRIBUTOR Features These Famous Brand Parts and Accessories

- PHILCO
- EVEREADY Batteries
- FLASHLIGHTS
- CAROL CABLES
- GOODRICH V-Belts
- GC Products
- AUDIOTEX
- WALSCO Products
- TELCO Antennas
- PRECISION Test Equipment
- PACO Kits

PHILCO MODERN COPPER ENGRAVED CIRCUITS — for Simplified Service

stalled, traces A, B, and C of Fig. 9 changed to their counterparts in Fig. 10. The amplitude was reduced to a normal 40 volts in Fig. 10A, with other traces in proportion. Incidentally, all the scoping was done with the 6AL5 out of its socket. With the tube installed, Fig. 10B borrows a greater sawtooth slope from the sample signal.

The other Zenith 20J21 did not have the same side effect of critical vertical hold. For this reason, I went directly to the AFC stage to begin troubleshooting. Removing the 6AL5, I scoped the AFC signals.

At both pins 1 and 7, identical traces like Fig. 10C were found. Asking myself, "What could cause a direct connection between these pins?" I soon found a shorted C61.

These cases very aptly demonstrate that scope traces should be critically examined for minor irregularities as well as for major distortions.

Triode AFC

There are two types of AFC cir-

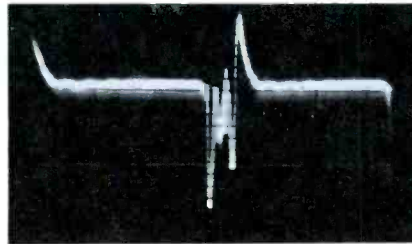

(A) Sync-separator plate (85V p-p)

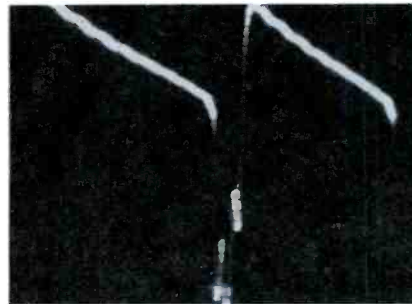

(B) AFC pin 1 (150V p-p)



(C) AFC pin 7 (over 200V p-p)
Fig. 9. Abnormal traces in first set.

Beware
OF
CHEAP
IMITATIONS

INSIST ON

"No NOISE"

- **VOLUME CONTROL** and Contact Restorer
- **TUNER-TONIC** for ALL tuners including wafer type
- **FORMULA EC-44** for ALL electrical contacts

FREE with ALL No-Noise Products
5" Plastic Extender Push-button Assembly for pin-point applications. Does not cause shorts!

14 Years of Recognized Leadership

ELECTRONIC CHEMICAL CORP.
813 Communipaw Ave., Jersey City 4, N. J.

DON'T REPLACE CRYSTALLIZED RUBBER
PHONOGRAPH DRIVE WHEELS UNNECESSARILY

brush on **NEW FONO-MAGIC***

eliminate slipping... dragging
SAVES DRIVE WHEEL INVENTORY COSTS TOO!

*FONO-MAGIC is a NEW compound of special rubber and carbide particles. When FONO-MAGIC is brushed on metal drive surfaces, it forms a coat of live, pliable non-slipping rubber .000065 inches thick. Carbide particles imbedded in the rubber coating will scratch slipping rubber idler wheels, exposing live rubber and prolonging the life of the idler wheel. Just one bottle of FONO-MAGIC is equivalent to the replacement of 100 drive wheels. Only \$1.95 dealer net. Sold at Better Jobbers everywhere.

manufactured by R-COLUMBIA PRODUCTS CO., INC. Highland Park, Illinois



PHILCO®
FALL
FIESTA

SEE THE
PARTS
MANAGER
AT YOUR

PHILCO
DISTRIBUTOR

circuits in which a single triode takes the place of dual diodes. One type operates similarly to the balanced diode system; two sync pulses of equal amplitude but opposite polarity are applied to the grid and cathode, with a sawtooth sample signal being applied to the plate. AFC correction voltage is developed between the grid and cathode and is taken off from between two resistors connected to these elements. This circuit might be considered as a balanced triode AFC, inasmuch as the amount of phasing and frequency correction is equal for either

fast or slow operation of the oscillator. The pull-in frequency range is somewhat less than for dual-diode AFC.

A second type of triode AFC approximates the unbalanced diode AFC circuit. A negative-going sync pulse is applied to the cathode, and a sample signal to the plate. Correction voltage is developed between plate and ground in some circuits; between grid and ground in others. This is probably the least common AFC system, and it is also probably the least efficient. It has less pull-in range, less noise immun-

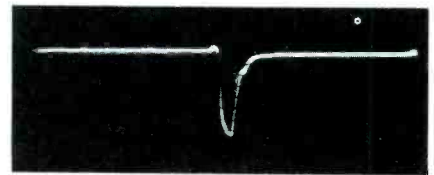

(A) Sync-separator plate (40V p-p)

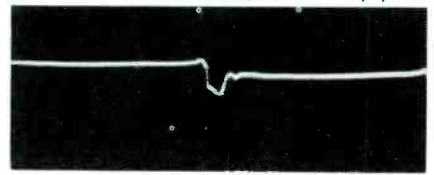

(B) AFC pin 1 (15V p-p)

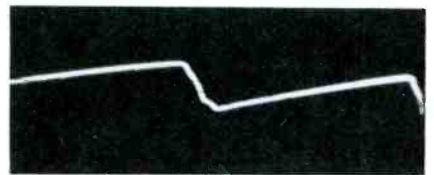

(C) AFC pin 7 (20V p-p)

Fig. 10. Normal traces for comparison.

ity, and less tolerance to component-value shifts.

Triode AFC systems have all the troubles that can arise in the diode systems, plus one more—namely, squegging. Of all the sets I've serviced, I don't remember a single instance where a defect in a diode AFC circuit produced squegging (although defects in a diode-controlled horizontal oscillator have done so). I have, however, seen several triode AFC systems—and I'm not talking about pulse-width systems—where defects in the AFC itself caused squegging. Fig. 11, photographed from a Motorola chassis TS-292, is a case in point. The cause of this wild symptom was an open integrating capacitor in the sample-signal network.

In servicing any type of AFC system, you'll benefit from using the scope early and often, and you should keep a sharp eye out for troubles in the sample-signal feedback network. Adhering to this advice will wrap up most AFC troubles for you. ▲



Fig. 11. Squegging caused by fault in operation of a triode-type AFC stage.



- Tests TV and Radio Tubes —both old and new
- Tests all Novars
- Tests Nuvistors, 10-pin Tubes, and 12-pin Compactrons
- Tests Voltage Regulators, Thyratrons, Auto Radio Hybrid Tubes, European Hi-Fi Tubes, and Many Industrial Types

B&K PROFESSIONAL QUALITY AT LOW COST

Model 600 Compact Portable Dyna-Quik Makes Tube Testing Quick, Accurate, Profitable!

It's amazing how quickly you can accurately check out tubes on every call—sell more replacements, and make more money—with this up-to-date, low-cost professional quality tube tester.

Checks for all shorts, grid emission, leakage, and gas. Checks each section of multi-section tubes separately. Checks tube capability under simulated load conditions. Rejects bad tubes, not good tubes. Quickly reveals tube condition, saves customers, stops call backs, increases servicing profit.

Exclusive adjustable grid emission test. Sensitivity to over 100 megohms. Phosphor-bronze socket contacts.

Complete tube listing in handy reference index. Handsome, sturdy leatherette-covered carry-case.

Size 8½" x 11" x 4½". Net, \$74.95



**QUICK, DIRECT, ERROR-FREE
READINGS WITHOUT MULTIPLYING**

Model 375
VTVM
Net, \$89.95



Model 360
V O Matic
Net, \$59.95

See Your B&K
Distributor
or Write for
Catalog
AP21-R



B & K MANUFACTURING CO.

Division of DYNASCAN CORPORATION
1801 W. BELLE PLAINE • CHICAGO 13, ILL.
Canada: Atlas Radio Corp., 50 Wingold, Toronto 19, Ont.
Export: Empire Exporters, 253 Broadway, New York 7, U.S.A.

TV TIPS FROM TRIAD

NO. 22 IN A SERIES

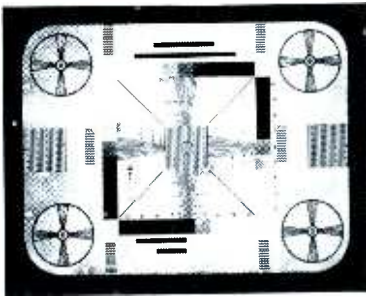

Bill, the Senior PTM, pushed his chair away from the bench with finality. He had just finished wiring a new Triad hi-fi output transformer into a vintage audio amplifier. "Well, that's that," he informed his assistant, Joe.

Apprising the new, grey Triad S-156A gleaming in the durable period piece, Joe remarked, "What is this? Give the people more for their money week?"

Bill deftly grabbed the cue. "Old stuff with us. As you know, the frequency-limiting factor in most audio amplifiers is the output transformer. Too often the small, original part does not have enough iron and copper to prevent saturation. Also, the primary current capability is insufficient. Result—overheating and failure. Unfortunately, the customer never enjoys the full frequency range the rest of the amplifier and equipment can produce because of the output transformer bottleneck!"

Bill warmed into the second part of his oratory. "New materials such as grain-oriented steel, improved processing, and latest construction techniques in winding and stacking add up to greatly improved products nowadays. They enhance listening quality so much the customer immediately notices the improvement!"

"And there are other advantages," said Bill, reaching his finale. "The primary impedance can be matched closely to the new output tubes. Tapped secondary impedances of 4, 8, or 16 ohms are available to drive the newer high-impedance voice coils if the customer wishes to upgrade his speaker system. And the circuitry can be easily changed to screen-tap operation. Naturally, since you are saving the customer lots of money by making his old amplifier perform as well as many new models for only a modest investment, he will be happy to compensate you fairly."

"You've convinced me!" concurred Joe, "No one ever loses by giving a customer more for his money!"

MORAL: Overwhelm your customers with value beyond the call of duty. See your nearest Triad Distributor, or write for our latest Replacement Catalog TV 63/64. It lists a complete range of audio outputs from 2 to 100 watts for every purpose. Triad Distributor Division, 305 North Briant Street, Huntington, Indiana.

A DIVISION OF LITTON INDUSTRIES 

Intermittents

(Continued from page 31)

symptom of a snowy picture, which pretty well isolates itself to the tuner or antenna.) A normal video waveform, like that in Fig. 1—with constant amplitude and no distortion—proves the entire RF-IF section is free of intermittents. The next step, in this case, is to signal-trace (monitor style) through the video circuits.

If the detector-signal amplitude changes when the trouble appears, follow-up checks should be made of the AGC bias voltage, IF-amplifier plate voltages, and other factors that could alter gain. Signal-tracing through the IF's with a scope and demodulator probe can often be helpful, too.

Intermittent distortion of the detected video, as in Fig. 2A, is often a hint to make a complete check of the AGC circuit. Certain faults, like the "punched-in" vertical pulses in Fig. 2B, could indicate drifting of some RF or IF tuned circuit; defects of this sort can be further isolated by using a visual alignment setup for later monitoring tests.

B—Audio Detector

This point is helpful in troubleshooting complaints that the sound "cuts out" or erratically changes in volume. We're not overlooking the volume control as a convenient point for dividing the sound section into two blocks for trouble isolation, but the sound IF and detector are such common offenders that we recommend a prompt attempt to divide one from the other.

An ordinary wideband scope will display the 4.5-mc detector-input signal well enough to let you check



It has a hysteria motor. I think.

now there are 3 time & tool-saving double duty sets

New PS88 all-screwdriver set rounds out Xcelite's popular, compact convertible tool set line. Handy midgets do double duty when slipped into remarkable hollow "piggyback" torque amplifier handle which provides the grip, reach and power of standard drivers. Each set in a slim, trim, see-thru plastic pocket case, also usable as bench stand.



PS88

5 slot tip,
3 Phillips screwdrivers



PS120

10 color
coded nutdrivers



PS7

2 slot tip,
2 Phillips screwdrivers,
2 nutdrivers

WRITE FOR CATALOG SHEET N563

XCELITE

XCELITE, INC., 18 Bank St., Orchard Park, N.Y., U.S.A.
Canada: Charles W. Pointon, Ltd., Toronto, Ont.

NEW! FROM CHEMTRONICS
NEW! NON-FLAMMABLE TUNER CLEANER
TUN O LUBE

for a limited time ONLY...

16 oz. TUN O LUBE 2.98
 3 oz. TROL AID .98
 REGULAR PRICE ~~3.96~~

NOW \$2.98
 DEALER NET

CHEMTRONICS INC.
NEW! NON-FLAMMABLE TUNER CLEANER
TUN O LUBE
special offer
 only \$2.98

TROL AID FREE!

SPECIALLY FORMULATED TO CLEAN AND LUBRICATE ALL TYPES OF TUNERS.

FREE FLEXIBLE STAINLESS STEEL NEEDLE, FOR PIN POINT APPLICATION

CHEMTRONICS INC. 870 East 52nd Street • Brooklyn 3, N. Y.
 MANUFACTURERS OF CHEMICAL PRODUCTS FOR THE ELECTRONIC INDUSTRY . . . EXCLUSIVELY

In Canada: Active Radio and TV Ltd. 431 King St. West • Toronto 2B, Ontario



See Around Corners

... with this handy, chrome-plated Beau-Tech inspection mirror.

The Beau-Tech inspection mirror lets you see into the most hard-to-reach places. This high quality mirror has polished aluminum handle and a special non-slip grip for easy handling. Available with plain or magnifying mirror. Two mirror sizes: 3/4" or 1". Buy now from your electronics distributor. He has a Beau-Tech Tool for most every soldering job.

69¢ Each



BEAUCHAINE
 Laconia, New Hampshire **Sales CORP.**

its amplitude; see Fig. 1 for the characteristic pattern. If a normal signal is reaching the detector, you can continue to signal-trace with the scope until you find the erratic stage.

C—Sync Output

Scoping this point is essential for analyzing the cause of bending, rolling, jitter, and related troubles. The output pulses at the last sync stage should be strong, steady in amplitude, and free from all but the slightest trace of video. In a two-stage sync circuit, positive pulses like those in Fig. 1 are normal; but negative pulses can be expected if the sync separator is the only sync stage.

If any distortion or fluctuation of the trace is seen when the trouble appears, try to "box in" the fault by monitoring other points as far back as the video detector.

In cases of unstable vertical sync, you need a true picture of the signal actually reaching the vertical oscillator; thus, the output of the integrator is a better spot than point C for initial monitoring. Follow instructions in service data for disabling the vertical oscillator to get a clearer view of the sync pulse. Sometimes you'll find nothing wrong with the sync input; this is a clue to drifting of the oscillator. Monitoring voltages, as well as waveforms, in this stage should help you determine which part of the oscillator circuit is defective.

D—Horizontal Drive

A steady flow of letters across the editor's desk indicates that servicemen have more difficulty with

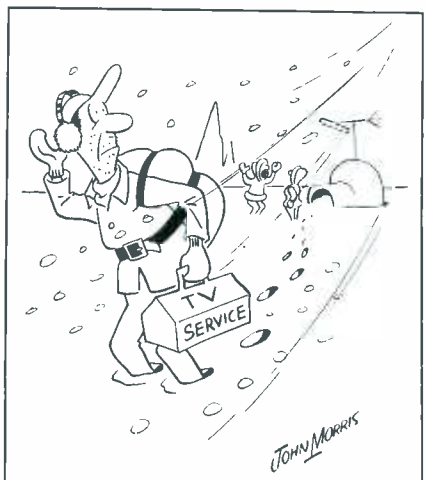

"How about that: Four dollars for one home service call!"

the horizontal sweep section than any other part of a TV receiver. The problem is multiplied by interaction between the horizontal oscillator and output stages, especially when an intermittent trouble is present. Thus, the most important check point associated with the horizontal section—and perhaps in the entire receiver—is the grid of the horizontal output tube. It's a waste of time to do much work on the flyback, boost, and high-voltage circuits without first making sure the grid is receiving a constant drive waveform of normal shape and amplitude.

If the drive signal is unstable, a "vicious circle" involving all the horizontal stages may have to be broken before you can go on. Grounding or disabling the AFC input to the oscillator will let you see if the oscillator can run steadily enough to develop a constant drive signal.

In receivers that use boost voltage as a plate supply for the oscillator, trouble almost anywhere in the horizontal circuit can complicate matters by varying the plate voltage. A positive method of isolating the defect is to connect the proper DC voltage to the oscillator plate from an outside source. Should this eliminate the intermittent problem, the output circuit can be assumed to be at fault and you can choose the next point to be monitored—perhaps the screen of the output tube, or the boost line.

Wrap It Up

All later steps in monitoring should have the object of picking out individual components or networks that might be defective. As far as possible, these suspected parts should be checked by substitution for a conclusive test—followed by a long enough period of "cooking" to verify the results.

Test Recordings

Here's a group of test records, made by CBS Laboratories, that are now available to hi-fi and stereo service technicians. Originally designed for use by broadcasting and recording studios, they offer a comprehensive group of test signals for

RCA BRINGS YOU TWO IMPORTANT NEW TEST INSTRUMENTS

TO GENERATE
RF SIGNALS

TO PROVIDE STEREO
FM SIGNALS



RCA WR-51A FM
STEREO SIGNAL SIMULATOR

RCA WR-50A RF SIGNAL GENERATOR

Generates continuous wave or amplitude-modulated rf signals of sinusoidal waveform from 85 Kc to 40 Mc. Particularly useful for aligning and signal tracing in AM and FM radio receivers and Citizens' Band transceivers—and for aligning if amplifiers, and for signal tracing in TV receivers.

- Wide frequency range—continuous coverage 85 Kc to 40 Mc in 6 overlapping ranges
- Built-in crystal-calibrating oscillator circuit with front panel crystal socket
- Permanently attached, shielded output cables prevent errors, minimize time loss and inconvenience. Built-in DC blocking capacitors
- Internal 400 cycle audio oscillator
- Individual inductance and capacitance adjustments for each range
- Two-step rf attenuator switch plus a continuously variable attenuator control
- Easy-to-read dial scale—vernier tuning
- Readily portable—weighs only 5 pounds

\$59⁹⁵*

Generates signals necessary to service and maintain stereo multiplex FM receivers and adapters.

GENERATES:

- Four FM signals: Left stereo, right stereo, special phase test, monophonic FM
- Eight sine-wave frequencies: 400 cps, 1 Kc, 5 Kc, 19 Kc, 28 Kc, 38 Kc, 48 Kc, 67 Kc—available separately or for modulating FM signals.
- 100 Mc carrier signal tuneable ± 0.8 Mc to permit selection of a quiet point in the FM band
- 19 Kc subcarrier signal crystal-controlled within ± 2 cps
- 100 Mc sweep signal adjustable from 0-750 Kc at 60 cps sweep rate
- Choice of three composite stereo output signals: left stereo, right stereo, and special phase test

ALSO features crystal-controlled markers for receiver rf and if alignment. Zero-center meter for checking the balance of stereo amplifier output. Portable and compact: weighs only 14 pounds.

\$249⁵⁰*

*User price (optional)

See them at your Authorized RCA Test Equipment Distributor
RCA ELECTRONIC COMPONENTS AND DEVICES, HARRISON, N. J.



The Most Trusted Name in Electronics

PERMALINE 300 OHM TELEVISION Transmission Line

The **only** television wire available today with a 15 year and 25 year written guarantee against:

- DETERIORATION
- CRACKING
- THE EFFECTS OF WEATHERING



Since introducing Permaline over 9 years ago, Columbia has yet to replace one single foot for reasons of deterioration, cracking or brittleness, or due to weather or salt-air conditions. This is the finest television wire available, with insulation unequalled for long life, under the most severe atmospheric conditions.

Why put up with inferior wire, dissatisfied customers, and nuisance calls, insist on Permaline from your distributor.



No antenna is better than the television line that brings the signal to the set. Yet the cost is surprisingly low.

SEND FOR FREE SAMPLES AND LITERATURE

All Columbia Wire and Cable Products are available at distributors everywhere.



checking any recording or playback system.

The specially prepared tracks on the four recordings contain waveforms for testing almost every conceivable factor in an audio system. Technical bulletins included with each record explain the various tests, and indicate which grooves contain the signals for each test.

One recording (STR 130) furnishes all the signals to perform sweep-frequency and spot-frequency tests in RIAA systems. The waveforms can be used to calibrate the recording equipment and for testing the entire playback system. Special bands check both channels of stereo systems, both separately and simultaneously.

Another (STR 111) furnishes square waves and combined-frequency signals for intermodulation and transient-response tests. A third record (STR 120) provides signals at 10 cps through 50,000 cps for testing wide-range pickups.

The fourth (STR 100) is a stereophonic test record for checking sweep and spot-frequency responses, channel separation, compliance, wavelength loss, stylus wear, and tone-arm resonance. Using this recording as the signal source, the stereo serviceman can check an entire system, from stylus to output transformer, for exact balance of channels and performance of the system as a unit.

For further information, circle 101 on the literature card. ▲



make MORE MONEY in P.A. SOUND



Get into the all-year-round commercial sound trade and do away with seasonal repair work slumps! This steady-profit business — sales, installation and service — is available right in your own neighborhood! Factories, auditoriums, restaurants, offices, schools, bowling alleys... for outdoors — athletic fields, airports, stadiums, swimming pools, etc.... all are prospects for you.

Atlas Sound products, built to quality standards and backed by over 25 years of "know-how," are insurance for your reputation. Your Atlas Sound Distributor can supply you with a complete line of performance-proven, job-rated equipment: speakers, mike stands and related accessories for a professional sound installation.

Breakthrough In Design, Materials, Performance



ATLAS SOUND EC-10 ALL-NEW PAGING SPEAKER

\$1425 net

Every way you look at it, this compact, weather-proof, American-made speaker is 100% NEW. It's a powerhouse of crisp, articulate sound for a wide variety of uses. Precision-molded Implex* horn assures vibration-free, resonance-free output. Improved magnetic circuit features new ceramic blend with any decor. Adjustable, versatile bracket.

Specs: 6 watts; 8 ohms (also 45 ohms); Length 6 3/8"; Bell Diameter 6 1/4"; Weight 2 lbs. Special Model T-4 line matching transformer available.

*t.m. Rohm & Haas — new, tough, all-weather plastic.



Write for full details and latest catalog ATLAS SOUND

Division of American Trading and Production Corporation
1419-51 39th Street, Brooklyn 18, N. Y.
In Canada: Atlas Radio Corp. Ltd., Toronto

Cartridge

(Continued from page 22)



Fig. 2. Most cartridges use slip-on terminals instead of solder connections.

defective cartridge? The answer to this question is sometimes very simple. If the sound output is quite low in volume, only one test may be needed—merely touching your finger to the “hot” terminal on the rear of the pickup assembly, and listening to the hum introduced into the amplifier. A loud sound from the speaker indicates the amplifier stages are functioning; therefore, the pickup must be bad. When distortion is the complaint, an easy (and logical) move is to install a new needle or cartridge, and recheck the output; if the sound is cleared up to the customer’s satisfaction, the job is completed. The ease of replacement featured in most new cartridge designs makes it a simple matter to try a new unit.

Sometimes a quick substitution check is unworkable because the correct replacement isn’t at hand, the trouble is too complex, or the customer is critical. In such cases, it’s best to run a more detailed signal-tracing check, aided by audio test equipment, with a test record as a signal source. This “lab test”

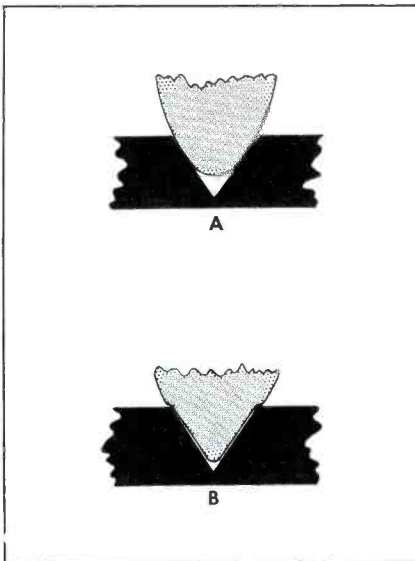

Fig. 3. A worn needle, with flattened sides, increases the wear on records.

method is more time-consuming, but phonograph owners can be convinced it’s well worth a higher service charge than for simply replacing a part.

Needle Tips

Long before the entire cartridge needs replacing, new needles will probably have to be installed. The stylus assembly for the cartridge shown in Fig. 1, as in most stereo and monophonic units now in use, contains two separate needles: one for microgroove recordings (33 and

45 rpm), and the other for 78-rpm recordings. The great majority of present cartridges have a .7-mil needle tip (stereo) or a 1-mil tip (monophonic) for microgroove, and from 2 to 3 mils for 78-rpm records.

Modern needle tips, except for a few low-priced types made of osmium (a precious metal), are either sapphire or diamond. The latter is fast becoming the most popular tip, mainly because it gives a longer playing time without developing worn spots that damage records.

Model 501 COMPONENT SUBSTITUTOR

...places a complete range of components at your fingertips

NEW



for fast substitution

only
\$3750

Slightly higher in the West

All hand wired . . .
All American made

Will substitute up to 4 different components at the same time

A surge protector switch prevents arcing, sparking, or heating of electrolytics

Electrolytics are discharged automatically

The Model 501 provides all the substitutes for electronic components you want and need in your every day work . . . more than any other instrument of its type. No longer do you have to handle hard-to-manipulate crumpled parts . . . solder and unsolder components as you trouble shoot a set. With a twist of a knob and a flip of a switch you can set the 501 to any one of over 80 component values . . . substituting as many as four different components simultaneously. Smart, sturdy grey hammertone steel housing . . . handy storage compartment accommodates the insulated test leads provided with the instrument. Size: 10" wide x 6¼" high x 4½" deep.

SUBSTITUTES FOR:

CARBON RESISTORS

12 VALUES 1 watt: 10/18/33/56/100/180/330/560/1000/1800/3300/5600 ohms

12 VALUES ½ watt: 10,000/18,000/33,000/56,000/100,000/180,000/330,000/560,000/1,000,000/1,800,000/3,300,000/5,600,000 ohms

POWER RESISTORS (20 watt Wire Wound)

20 VALUES: 2.5/5/7.5/10/15/25/50/75/100/150/250/500/750/1,000/1,500/2,500/5,000/7,500/10,000/15,000 ohms

CAPACITORS (600 volts)

12 VALUES: .0001/.0005/.001/.0025/.005/.01/.015/.02/.05/.1/.22/.5 mfd.

ELECTROLYTICS (450 volts)

17 VALUES: 4/8/10/12/14/18/20/28/30/40/50/70/80/130/150/200/230 mfd.

RECTIFIERS (Universal)

CRYSTAL DIODES—all general purpose low voltage types
SELENIUM POWER RECTIFIERS—up to 500 ma., 800 PIV
SILICON POWER RECTIFIERS—up to 750 ma., 800 PIV

See your electronics parts distributor or write for complete literature

Mercury ELECTRONICS CORPORATION
manufacturers of quality electronic products

111 Roosevelt Avenue, Mineola, New York



SAFE!

FOR NYLON SHAFTS AND PLASTICS IN TUNERS!

SUPER 100 . . . is a fast drying cleaner and lubricant that is excellent for TV tuners. It cleans contacts sparkling clean and evaporates quickly leaving a lubricated coating.

Dealer Net . . . \$2.25
Introductory Offer . . . \$1.75
 Cat. No. 100-8

INJECTORALL COMPANY
 BROOKLYN 14, NEW YORK



Fig. 4. Playing 15 LP records caused this much wear on different needles.

The safe playing time for a diamond needle averages from 750 to 1500 hours. Compare this with 60 to 100 hours for a sapphire, and only 20 or 30 hours for an osmium type. Fig. 3A shows how a new needle fits into the groove of a record; B shows how a worn needle fits the groove. When the needle is new, the point is round and smooth, and contacts only a small area on the upper walls of the record grooves. Now, look at what happens when the needle becomes worn! The point is no longer round; it has flattened, notched edges that gouge deeper into the record groove. When a needle is in this condition, sound distortion usually occurs, and worse, the wavy impressions in the record grooves will tend to be "bulldozed" away. The record, if played repeatedly, will be permanently damaged.

Fig. 4 compares the tips of diamond, sapphire, and osmium needles after 15 plays at 8 grams pressure. Notice how worn the sapphire and osmium types are, and how well the diamond tip has held up. Actually, the cost per hour of playing time is a whopping one-fourth cheaper for a typical diamond than for a sapphire with a much lower initial cost. These facts should be pointed out to a customer when he needs a new needle or cartridge assembly.

Maybe he's already aware that a worn needle has adverse effects on

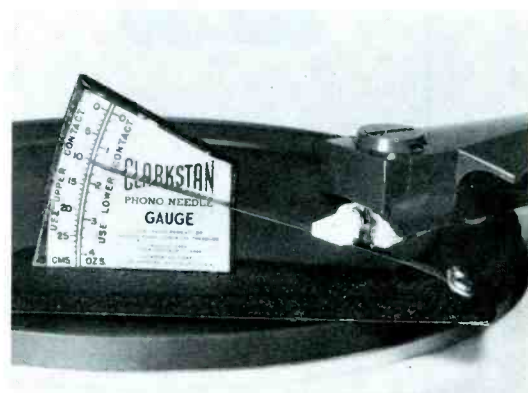

Fig. 5. Pressure of tone arm bends the spring, which acts as scale pointer.

SERVICEMEN

EXTRA \$\$ in your pockets

BERNS all new **ION** shielded beam bender



Thousands in use **Net 89c**
List \$2.95

Replace old ion traps which lose their strength and cause dull, poorly focused, dim, distorted pictures. Replace every two years with **BERNS ALL-NEW ION BEAM BENDER** for **BETTER BRIGHTER CLEARER PICTURES**.

Old ion traps may burn brown ugly spots on front of picture tube.

Formed nonmagnetic metal sleeve protects neck of tube; also helps hold heat around gun of pic tube. Very helpful on weak picture tubes.

BERNS ALL-NEW ION adjusts easily on sleeve; removes all worries about scratching neck of pic tube, making it easy to break.

BERNS ALL-NEW ION's come boxed separately in a beautiful, attractive box, wrapped with tissue paper. List price marked on box.

At your parts distributor or write us

BERNS

Mfg. Co.
 9853 Chalmers,
 Detroit 13, Mich.

COLOR CODED PHONO PLUGS

PREVENT...



STEREO-CONNECTION MIX-UPS

To avoid wiring errors when interconnecting two pieces of stereo equipment . . . use new Switchcraft phone plugs with "SNAP-ON" Color Coded Handles, in **RED, BLACK and WHITE**.



Just solder wire and "SNAP-ON" plastic handle. Handle "locks-on" plug to give you a permanent finger grip when disconnecting equipment.

For positive Stereo channel identification order Switchcraft Series 3508 Color Coded Phono Plugs in Red, Black or White,—only **\$0.25 LIST PRICE**.

Contact your dealer or write us for name of dealer nearest you.

SWITCHCRAFT

5573 N. Elston Ave. • Chicago 30, Ill.

the grooves of a record, and has been keeping track of playing time. But he may have overlooked another cause of excessive record wear: improper pressure applied by the tone arm to the record. An explanation of this point, and an offer to check his tone-arm pressure, is part of a thorough service job.

This test can be made in a matter of minutes, using one of the commercially available pressure gauges. Depicted in Fig. 5 is an inexpensive gauge (it costs a couple of dollars) being used to measure tone-arm pressure on a turntable. This foreign-made type requires a pressure of from 10 to 12 grams, and our gauge pointer is sitting on the lower limit of this range. The pointer is actually a metal spring with two separate slots to hold the needle and keep it from slipping. The upper slot is used to obtain a readings in grams; the lower one gives an indication in ounces.

You'll need to check the service information on the particular piece of equipment you're servicing for the correct tone arm pressure. Usually, the pressure on domestic changers is much lower than on the unit shown here—somewhere around 6 grams, plus or minus one or two. The adjustment for resetting tone-arm pressure is usually a metal screw located on the rear of the arm; its operation is fairly simple.

In Fig. 6, we've shown a more elaborate type of pressure gauge that sells for around \$10. The changer pictured here is the same as in Fig. 5; however, we reset the pressure-adjustment screw, making the meter read close to 13 grams. This type of gauge is a little more accurate than the other type shown, and will allow setting the pressure within closer tolerances.

A simple check on tone-arm pressure is important from the customer's viewpoint, once he understands its purpose; so it should also be important from your *business* viewpoint!

To Locate a Replacement

Finding a correct replacement for a defective cartridge usually presents no problem, since a wide variety of direct replacements are available from many different manufacturers. Most replacement catalogs and brochures have two or three cross-reference listings, such as the original cartridge manufacturer's part number, and replacement cartridge numbers. Usually, these catalogs include electrical specifications and physical dimensions of different cartridges, in addition to other valuable information. With so many replacements available, when a cartridge is "finished," the choice of replacements is yours! ▲

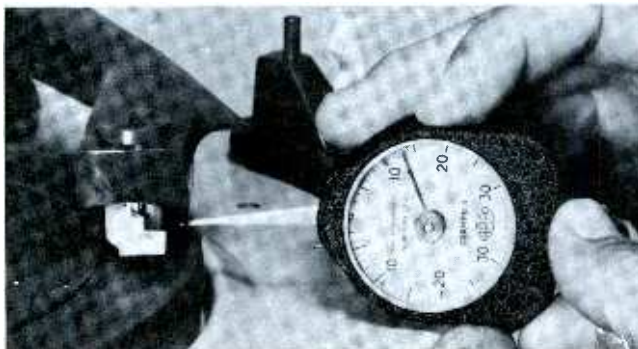

Fig. 6. More elaborate pressure gauge gives readings from rotating pointer.

PRODUCT
NEWS from EPL

Only 37¢ per watt output DC Power Supply

Unbeatable Performance and Price



► Look at these exclusive features . . .

- Lowest price per watt output.
- Full 10 ampere rating on 0-12 volt range.
- Surplus power on 0-16 volt range.
- Full year warranty.
- Superior filtering over entire output.
- Large, easy-to-read plastic meters.
- Heavy overload capacity.

► Compare with others . . .

Brand	Voltage Output	Ampere Cont.	Output Interm.	Meters	Price/Watt Output**	Warranty	Terminals
EPL	0-8	10	20*	Large, clear plastic	\$.37	1 Year	Insulated binding posts
	0-16	10	20*				
A	6	10		Metal	.69	90 Days	Stud and wing nuts
	12	6					
C	0-8	10	20	Metal	.62	90 Days	Stud and wing nuts
	0-16	6	12				
E	0-8	10	20	Metal	.50	90 Days	Insulated binding posts
	0-16	6	10				
M	0-8	10	20	Metal	.62	1 Year	Stud and wing nuts
	0-16	6	14				
P	0-8	10	20	Metal	.68	90 Days	Metal binding posts
	0-16	6	12				

*Best of all for operating signal seekers! **Based on maximum continuous ratings.

17 Others from 6 to 125 VDC from \$19.95 up

Stocked at Your Electronic Distributor

FREE NEW CATALOG PS-562 on complete line



**ELECTRO PRODUCTS
LABORATORIES**

6125-T Howard, Chicago 48 (Niles), Ill.
Phone: 647-6125

2217

Canada: Atlas Radio Ltd., Toronto

Since 1936 . . . Pioneers in Low Voltage DC Power Supplies

PRODUCT report

For further information on any of the following items, circle the associated number on the Catalog & Literature Card.

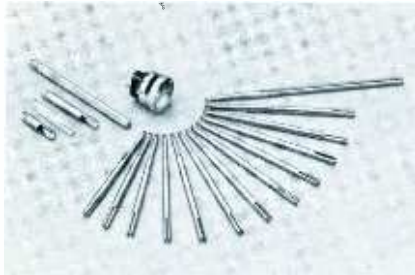

Control Accessories (67C)

Centralab has announced the addition of 14 new items to the "Fastatch II" replacement control system for fabricating TV controls with push-pull switches.

Among the accessories are a KR-8 push-pull line switch which snaps onto the rear of any dual concentric "Fastatch II" control; a snap-in universal shaft and twelve exact-replacement shafts in various sizes round out the group. These accessories combine with any Fastatch II control to exactly duplicate push-pull control-and-switch combinations in many TV models.



UHF Converters (68C)

A new line of **General Instrument Corp.** one- and two-tube UHF converters, styled to complement most TV sets, provides simple adaptation of any VHF television receiver to all-channel reception.

Models TC-10 (one tube) and TC-20 (two tubes) both meet FCC requirements for oscillator radiation; they employ the F. W. Sickles (a G-I division) UHF tuner Model 204. Each unit weighs about 6 lbs., measures 9½" × 4" × 5", and is available in a wide variety of both painted and vinyl-clad cabinets with matching knob combinations.

Both converters cover channels 14 through 83 continuously, with approximately 9 mc overtravel at each end of the band. Channels are equally spaced over the entire tuning dial for simplified tuning without station crowding.

In the Model TC-20, a jewel light indicates UHF operation. The output of the mixer is amplified by a 6CW4 nuvistor to provide high gain over the entire UHF band.

AM-Shortwave Transistor (69C)

Designated the 2N2672, this new **Amperex** transistor is for use in RF or IF stages from standard broadcast frequencies up to 6 mc. It is especially suitable for use in battery-operated car and portable radios, since it operates at supply voltages as low as 3.0 volts. The 2N2672 features low internal feedback capacitance, low collector leakage, high signal-current gain, and high collector-base breakdown voltage (greater than 25



volts). The unit also has a low collector capacitance and low output conductance to facilitate use in highly selective circuits. Housed in the standard TO-39 case, it has a low conversion-noise figure and good AGC performance at high temperatures.

Gun Tacker Attachments (70C)

Three brand-new accessories for the widely-used **Arrow T-50 Gun Tacker** are: A screen attachment for use on all types of screening, such as window and porch screens; a wire attachment for electrical wiring, wire fencing, netting, plant stems, etc.; and a window-shade attachment for fastening window shades to poles, or cloth or material to any round object or doweling. These interchangeable acces-

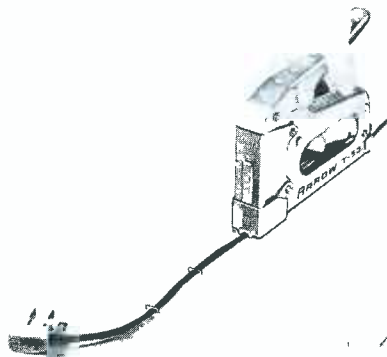

sories snap on over the front of the staple gun. The attachments, and also the SL-50 Staple Lifter, have been individually pre-packaged on skin-packed, pilfer-proof display cards for self-service buying. The attachments, which retail for \$1.00 each, are packed six to the box and three dozen to the carton.

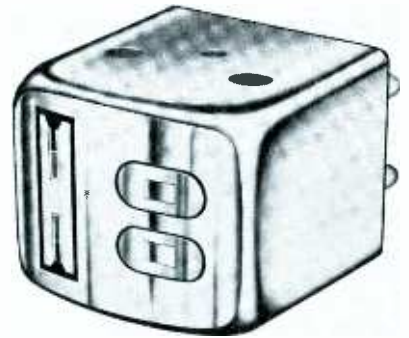

Compact Tape Heads (71C)

Nortronics Co., Inc., has developed a new series of magnetic-tape heads which will allow more compact construction in the above-deck design of tape recorders. Each head, combining record, play, and erase functions, measures only .490" high, .575" wide, and .580" deep. The complete line includes four-track and two-track stereo heads; four-track, two-track, and full-track monophonic heads; and heads with custom configurations for specialized applications. Each head features laminated construction with quartz gaps, precision-polished all-metal face, and either hyperbolic or cylindrical face contour. Phenolic connector plugs are available for all models.

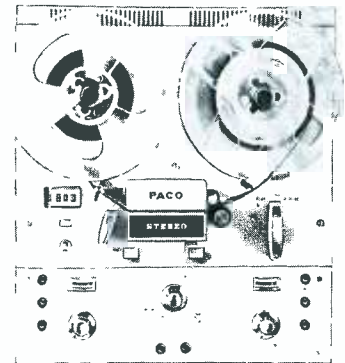

Tape Deck and Preamp Combination (72C)

Featuring a completely integrated dual preamplifier, the **PACO** three-speed stereo tape deck permits four-track and two-track stereo or mono recording and playback, and has facilities for "sound with sound" recording. This versatile unit is suitable for either rack mounting or custom installation. Other features include: two separate VU meters, individual volume controls for each channel, digital tape index counter, automatic tape shutoff, and fast forward and rewind controls. The unit has a frequency response of 30-15,000 cps ± 3 db at 7½ ips; flutter and wow are less than 0.4% at 7½ ips.

Multi-Impedance Speaker (73C)

A new line of multi-impedance replacement speakers from **Oaktron Industries** promises to cut unnecessary stocking by one-third. By utilizing multi-

INDEX TO ADVERTISERS

Atlas Sound Corp.	74
ATR Electronics, Inc.	12
B & K Mfg. Co.	
Div. of Dynascan Corp.	43, 45, 70
Beauchaine & Sons, Inc.	72
Belden Mfg. Co.	41
Berns Mfg. Co., Inc., The	76
Blonder-Tongue Labs	42
Bussmann Mfg. Div.	24
Cadre Industries	56
Castle TV Tuner Service	18
Centralab, Div. of Globe-Union, Inc.	55
Chemtronics, Inc.	72
Clarostat Mfg. Co., Inc.	39
Columbia Wire & Supply Co.	74
Delco Radio Div. (GMC)	51
EICO Electronic Instrument Co., Inc.	63
Electronic Chemical Corp.	69
Electro Products Labs	77
Electro-Voice, Inc.	62
Enterprise Development Corp.	60
GC Electronics Co.	68
General Electric Co.	
Receiving Tube Dept.	53
Harman-Kardon, Inc.	40
Injectorall Co.	76
Jackson Electrical Instrument Co.	66
Jerrold Electronics	14-15
Littelfuse, Inc.	4th Cover
Mallory, P. R. & Co., Inc.	23
Mercury Electronics Corp.	75
Merit Coil & Transformer Corp.	59
Multicore Sales Corp.	64
Ohmite Mfg. Co.	52
Perma-Power Co.	58
Philco Corp.	
Parts and Service Operations	13, 67, 69
Precision Tuner Service	60
RCA Electronic Components and	
Devices	47, 3rd Cover
Commercial Engineering Dept.	79
Electronic Instrument Section	73
RCA Sales Corp.	49
R-Columbia Products Co.	69
Sams, Howard W. & Co., Inc.	57, 64
Sarkes Tarzian, Inc.	
Semiconductor Div.	44
Tuner Service	9
Seco Electronics, Inc.	65
SENCORE, Inc.	16-17
Slep Electronics Co.	66
Sonotone Corp.	46, 61
Sprague Products Co.	10
Standard Kollsman	
Industries, Inc.	2nd Cover
Switchcraft, Inc.	76
Triad Distributor Div.	71
Triplett Electrical Instrument Co.	50
Volkswagen of America, Inc.	19
Winegard Co.	20-21
Workman Electronic Products, Inc.	64
Xcelite, Inc.	71
Zenith Sales Corp.	29



ple-winding voice coils, a single speaker is able to match any of three commonly used audio-output impedances—10, 20, or 40 ohms. Each speaker has a clearly detailed wiring diagram conveniently located near the voice-coil terminals. These speakers are available in standard 4" x 10" and 5" x 7" sizes, and in 6" x 9" with shallow profile. All types utilize an aluminum voice coil plus extra-heavy windings to handle maximum power without overheating or loss of efficiency. Their rugged construction allows them to withstand ambient temperatures up to 105° C encountered in some automotive applications.



Precision Pocket Microscope (74C)

This pocket microscope, a product of Jonard International Corp., features optically ground and polished lenses for precision inspection of microminiature components. The pocket microscope fills the gap between a pocket magnifier and a vertical microscope with magnification of 40X, 50X, and 60X.

The instrument also has a built-in mirror that condenses and reflects light. This feature comes in handy for inspecting in small, dark areas. The unit comes in satin black and chrome finish, with a pocket clip and protective leatherette case. Designated the Model M-1, it is priced at \$12.50.

FOR SHARP, CLEAR 2-WAY COMMUNICATION

Fixed or mobile, business or pleasure
Get the new, low-cost

RCA MARK VIII

27-Mc Citizens Band Radio-Phone

Here's the LOW-COST C-B radio-phone for car, boat, home, office, or shop. High sensitivity receiver pulls in weak signals. 2½ watt speaker output delivers ample volume to overcome engine noise. Automatic noise suppressor minimizes ignition interference. Light and compact—only 3½ inches high, weight only 9 pounds; fits easily under the dashboard of even compact cars.

PLUS THESE PREMIUM FEATURES—RCA MARK VIII RADIO-PHONE

- 9 crystal-controlled transmit and receive channels
- Tunable receiver permits reception of all 23 C-B channels; dial marked in both channel numbers and frequency
- Exceptionally good voice reproduction—high intelligibility
- Excellent modulation characteristics
- Operates from standard 117-volt AC; separate 6- and 12-volt DC power supplies (optional) for mobile installations
- Electronic switching—no relay noise or chatter
- Illuminated "working channel" feature plus many more features to increase usefulness and efficiency.

AC Unit only \$149.50*

DC Power Supplies, Where Needed, \$19.95*
*Optional list price



The Most Trusted Name in Electronics

MAIL COUPON FOR MORE INFORMATION

RCA Electronic Components & Devices
Commercial Engineering Dept. H-33-R
415 South Fifth Street, Harrison, N. J.
Please send more information on the RCA Mark VIII 27-Mc 2-Way Radio-Phone.

Name _____
Address _____
City _____ Zone _____ State _____

CATALOG AND LITERATURE SERVICE

ANTENNAS & ACCESSORIES

- 1C. **ANTENNACRAFT**—Catalog sheet, illustrated in color, with complete performance and pricing information on new *Gold UHF* antennas—single, stacked, or in kits.
- 2C. **ANTENNA SPECIALISTS**—Complete set of catalog pages listing outstanding features of both amateur and Citizens-band beam antennas.
- 3C. **BLONDER-TONGUE**—Quick-reference index for all types of home antenna products: signal amplifiers, UHF converters, matching transformers, traps, etc. Also 16-page reference manual for master TV systems.*
- 4C. **CHANNEL MASTER**—Brochure describing *Super-Crossfire* high-gain antenna, designed for both stereo-FM and TV reception.
- 5C. **CUSH CRAFT**—Illustrated brochure on complete line of Citizens-band antennas and accessories, including *Blitz Bug* coaxial lightning arrester.
- 6C. **GALLO**—Descriptive brochure on FMS-101, an FM antenna system with transistorized preamplifier, entirely contained within decorative 6½" x 3¼" x 1-3/15" case.
- 7C. **JERROLD ELECTRONICS**—6-page, color-illustrated catalog on *Paralog*, new line of log-periodic antennas with modular parasitic elements, for VHF TV and FM installations.*
- 8C. **JFD**—Specifications and operating information on *Transis-tenna* and newly-designed, long-range *LPV* log-periodic TV antennas. Illustrated brochure showing entire line of indoor antennas and accessories for TV and FM.
- 9C. **WINEGARD**—New *Fact-Finder* booklets on line taps, "K" series antennas, FM antennas, and multiset couplers.*
- 10C. **ZENITH**—Informative bulletin on new line of log-periodic vee-type antennas for FM, and for monochrome and color TV.*

AUDIO & HI-FI

- 11C. **ADMIRAL, National Service Div.**—Recently published catalog listing replacement parts and accessories, with special cross-reference guide to phonograph needles and cartridges.
- 12C. **ATLAS SOUND, Div. of American Trading and Production Corp.**—New illustrated catalog number 563, containing specifications of microphone stands and loudspeakers for use in public address, commercial, or industrial installations.*
- 13C. **DUOTONE**—Supplemental 1963 catalog and needle-replacement Wall Chart.
- 14C. **ELECTRO-VOICE**—Three informative catalogs: General catalog No. 157, High-Fidelity catalog No. 159, and Commercial Sound catalog No. 158.*
- 15C. **EUPHONICS**—Four informative brochures illustrating ceramic phono cartridges and microphones; cartridge cross-reference index is included.
- 16C. **OAKTRON**—"The Blueprint to Better Sound," an 8-page catalog of loudspeakers and baffles giving detailed specifications and list prices.
- 17C. **PERMA-POWER**—Descriptive literature on battery-operated, portable sound systems: *Roving Rostrum* and *Diplomat*.*
- 18C. **PRECISION ELECTRONICS**—Bulletin 101 describing popular Model 502M stereo tuner-amplifier, now offered at new lower price.
- 19C. **QUALITONE**—Wall chart, with needles pictured, for cross-reference of all popular needle replacement needs.
- 20C. **QUAM-NICHOLS**—*Speaker Replacement Guide* listing the speakers used in all automobiles from 1955 through 1962.
- 21C. **ROBINS**—Special Reference Guide for phonograph and recorder drive belts and wheels; lists all popular units and specifies Pobins replacement.
- 22C. **SARKES TARZIAN**—"Lower the Cost of Fun With Tape Recording," a large 32-page booklet containing information about tape recorders. Ways of using recorder as a notebook, for tricks, for recording unusual sound sources, are all explained in this informative booklet.*
- 23C. **SONOTONE**—Special cross-reference catalog for cartridges, listing many popular brands of phonographs; descriptive literature on *Sono-Flex* needle.*
- 24C. **SWITCHCRAFT**—New Product Bulletin No. 129 describing color-coded phone plugs with cable clamp and plastic snap-on handles in red, black, and white.*

COMMUNICATIONS

- 25C. **CADRE INDUSTRIES**—Detailed information on 5-watt Citizens-band units, and on new 1.5-watt hand-held transmitter.*
- 26C. **ELECTRONIC COMMUNICATIONS, INC.**—Illustrated leaflets describing line of communications gear, including CB transceiver and 30-watt linear amplifier.
- 27C. **RAYTHEON**—Descriptive sheet on Ray-Tel CB communications system, using solid-state frequency synthesizer.

COMPONENTS

- 28C. **BUSSMANN**—24-page bulletin SFB detailing information on the complete line of *BUSS* and *FUSETRON* small-dimension fuses and fuseholders used in protecting electronic equipment.*
- 29C. **COLUMBIA WIRE**—Comprehensive catalog 110 describing many service-dealer wire needs plus an array of multicolor coax cables.*
- 30C. **LITTELFUSE**—Form L-562 showing prices and specifications on complete line of fuses, fuse holders, and merchandising aids.*
- 31C. **SPRAGUE**—Latest catalog C-615 with complete listings of all stock parts for TV and radio replacement use, as well as *Transfarad* and *Tel-Ohmike* capacitor analyzers.*
- 32C. **STANCOR ELECTRONICS**—Durable wall-card tabulating proper output transformer to use with each of 260 different audio output tubes; includes specifications for each transformer recommended.
- 33C. **TRIAD**—New catalog TV-63/64 lists many replacement items for radio, TV, and hi-fi.*

SERVICE AIDS

- 34C. **CASTLE**—How to get fast overhaul service on all makes and models of television tuners is described in leaflet, which also contains a comprehensive list of universal and original-equipment tuners.*
- 35C. **CHEMTRONICS**—Brochures illustrating dozens of chemical products for TV and radio use. Includes information on new *Jet Spare* aerosol-spray compound that seals tire punctures and re-inflates tire in one operation.*
- 36C. **COLMAN**—New 1963-64 catalog of radio-TV replacement components and service aids.*
- 37C. **ELECTRONIC CHEMICAL CORP.**—Catalog listing chemical sprays for cleaning and lubrication in all types of electronic equipment.*
- 38C. **INJECTORALL**—New 1963 catalog showing complete line of chemicals used in electronics.*
- 39C. **PRECISION TUNER**—Literature supplying information on complete, low-cost repair and alignment services for any TV tuner.*
- 40C. **STANDARD KOLLSMAN**—Tuner replacement guide, covering all TV sets from 1947 through 1962, with replacement parts listings.*
- 41C. **WORKMAN**—General catalog CAF-102, fusible resistor and circuit breaker cross-reference guides, information on transistorized auto ignition system, and power converter sheet 25C.*
- 42C. **YEATS**—The new "back-saving" appliance dolly Model 7 is featured in a four-page booklet describing feather-weight aluminum construction.

SPECIAL EQUIPMENT

- 43C. **ATR**—Descriptive literature on selling DC-AC inverters for operating 117-volt PA systems, tape recorders, and other electronic gear in vehicles such as automobiles, boats, aircraft, etc.*
- 44C. **GC ELECTRONICS**—Giant-sized catalog FR-65 contains 330 pages, forming the most complete listing yet published of new products and equipment offered by all company divisions.*
- 45C. **GREYHOUND**—The complete story of the speed, convenience, and special service provided by the Greyhound Package Express method of shipping, with rates and routes.
- 46C. **SIMPSON**—Latest series of VOM's are described in test-equipment bulletin; also information on line of automotive test equipment.*
- 47C. **SWITCHCRAFT**—Bulletin No. 129 describing new series 3508 color-coded phono plugs, with snap-on colored handles and positive-grip cable clamp; simplified stereo, hi-fi, and test equipment hookups.*
- 48C. **TERADO**—Sheet depicting wide line

of 60-cps mobile power inverters and several types of battery chargers.

49C. **VOLKSWAGEN**—Large, 60-page illustrated booklet "The Owner's Viewpoint" describes how various VW trucks can be used to save time and money in business enterprises; includes complete specifications on line of trucks.*

TECHNICAL PUBLICATIONS

- 50C. **CLEVELAND INSTITUTE OF ELECTRONICS**—"Pocket Electronics Data Guides" with handy conversion factors, formulas, tables, and color codes. Additional folder, "Choose Your Career in Electronics," describes home-study electronics training programs, including preparation for FCC-license exam.
- 51C. **HOWARD W. SAMS**—Literature describing popular and informative publications on radio and TV servicing, communications, audio, hi-fi, and industrial electronics; including special new 1963 catalog of technical books on every phase of electronics.*

TEST EQUIPMENT

- 52C. **ANTRONICS**—General catalog describing Anchor Model T-475 *Reacto-Tester*, which repairs, analyzes, and tests every type of picture tube.
- 53C. **B & K**—Catalog AP-21R describing uses for and specifications of new Model 1074 Television Analyst, Model 1076 Television Analyst, Model 850 Color Generator, Model 960 Transistor Radio Analyst, new Model 445 CRT Tester-Rejuvenator, new Model 230 Substitution Master, Model 375 *Dynamic* VTVM, Model 360 *V-O-Matic* VOM, Models 700 and 600 *Dyna-Quik* Tube Testers, and Model 1070 *Dyna-Sweep* Circuit Analyzer.*
- 54C. **EICO**—Catalog sheet on new Model 430 small general-purpose oscilloscope, with 3" screen.*
- 55C. **ELECTRO**—Illustrated folder gives all the lowdown on low-cost power supplies for transistor or auto-radio servicing; lists 18 different units for various applications.*
- 56C. **HICKOK**—Complete descriptive and operating information on Model 661 *Chrom-Aligner* standard NTSC color-bar generator.
- 57C. **MERCURY**—Catalog giving full information on Models 1000, 1100, and 1200 Tube Testers, Models 202 and 203 Self-Service Tube Testers, new Model 301 Combination Tester, new Model 501 Component Substitutor, and Model 800 CRT Tester-Reactivator.*
- 58C. **SECO**—New four-page catalog describes *Vari-Volt* units for controlling lighting, heating elements, or AC-DC motors up to 15 amps.*
- 59C. **SENCORE**—Special, newly released data on color test equipment, including the entirely new, low cost CG126 Color Generator, CA122 *Color Circuit Analyzer*, and PS120 *Wide-Band Scope*.*
- 60C. **TRIPLETT**—Catalogs displaying complete line of test equipment for servicing, and industrial meters for all purposes.*

TOOLS

- 61C. **BURNS**—Data on unique 3-in-1 picture-tube repair tools, on *Audio Pin-Plug Crimper* that enables technician to make solderless plug and ground connections, and on *ION* adjustable "beam bender" for CRT's.*
- 62C. **ENTERPRISE DEVELOPMENT**—Time-saving techniques in brochure from Endeco demonstrate improved desoldering and resoldering techniques for speeding up and simplifying operations on PC boards.*
- 63C. **EVERSOLE**—Sheets describing and listing prices of *DeSod* desoldering tools for removing and replacing parts on printed circuit boards, including new tip for miniature IF transformers.
- 64C. **XCELITE**—Bulletin N563 describing three compact tool sets (PS88, PS120, and PS7) containing pocket-sized nut-drivers and/or screwdrivers with "piggy-back" torque-amplifier handles.*

TUBES AND TRANSISTORS

- 65C. **AMPEREX**—Catalog specifically devoted to extensive line of silicon planar epitaxial transistors. Describes applications for different types, with their basic specifications.
- 66C. **SEMISTRONICS**—New updated 16" x 20" wall chart CH7 lists replacements, with substitution data, for 2000 U.S. and foreign transistors.

*Check "Index to Advertisers" for further information from this company.

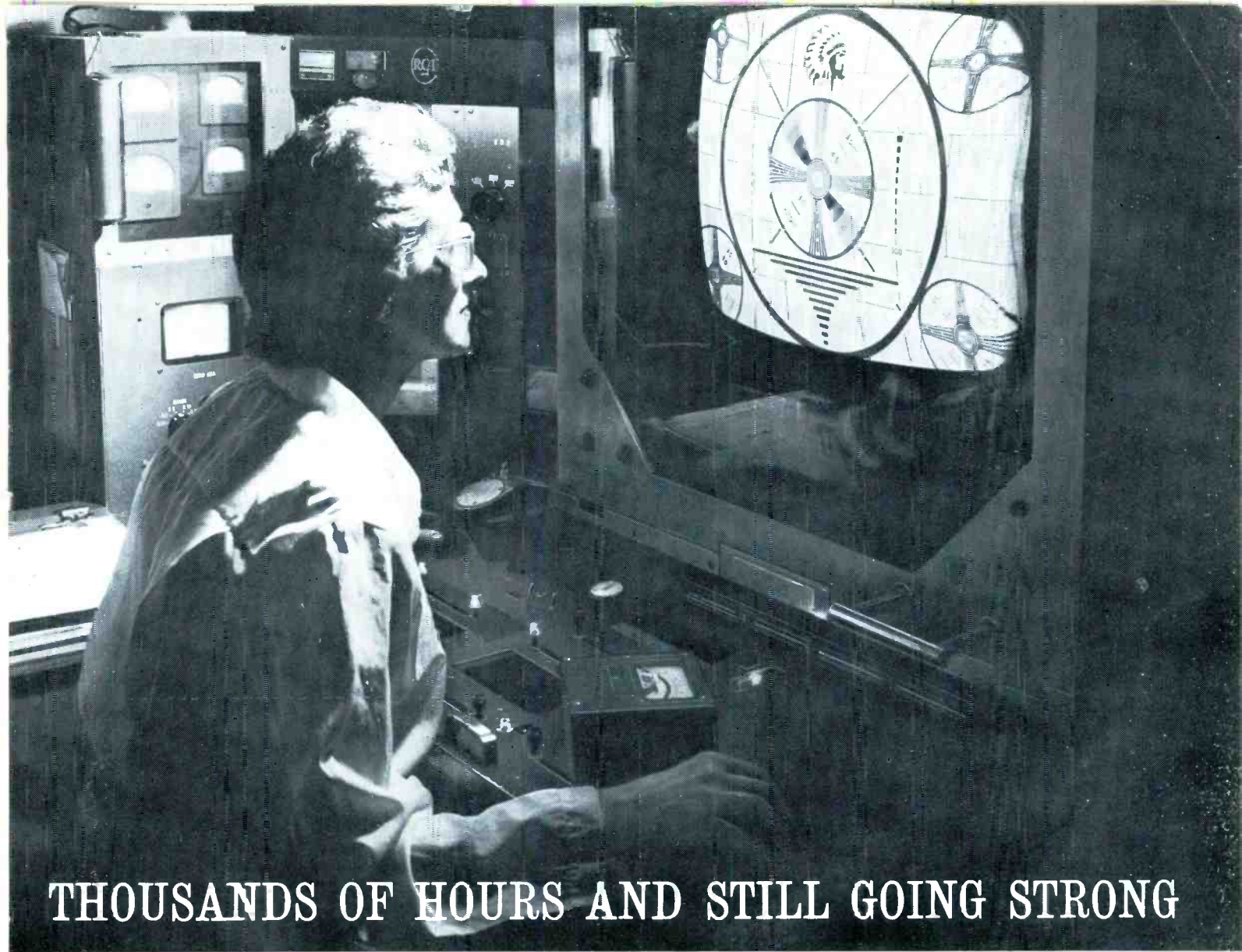

THOUSANDS OF HOURS AND STILL GOING STRONG

How RCA Assures Long Life in Silverama® Picture Tubes

In the darkness of the Life Test Rating Lab at our Marion, Indiana picture tube plant, a skilled operator studies the performance of an RCA Silverama picture tube that has been in operation thousands of hours.

Life testing takes place in banks of actual TV receivers. After this gruelling life test, tubes are rated in a precision test unit for focus, brightness, resolution, emission, amount of leakage to all elements—every factor that affects performance—to determine the exact degree of deterioration produced during life testing. And this is but one of many different quality control checks to which

every run of Silverama picture tubes is subjected.

What does this mean to your business? It means long-term customer satisfaction with every Silverama you install. The wide consumer acceptance of Silverama picture tubes is your assurance that your customer will call you again when he needs to replace his picture tube.

Today's Silverama is made with an all-new electron gun, finest parts and materials, and a used envelope that has been completely scrubbed internally, polished, and rescreened to restore it to the peak of its optical capabilities.

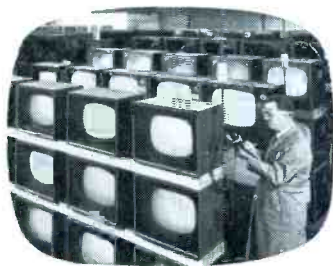

Picture Tube Life-Test Banks. Here RCA determines how Silverama picture tubes perform in actual TV receivers of all makes, under actual operating conditions, for thousands of hours of continuous service.

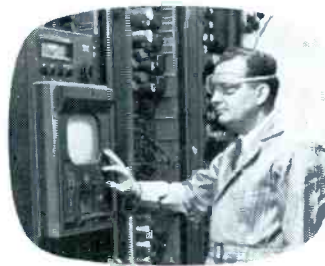

Precision Signal Generator sends out the test pattern shown on the screen above. Fidelity of reproduction of this virtually perfect signal (resolution: up to 2,000 lines!) is an accurate index of the picture tube's performance after life testing.

RCA ELECTRONIC COMPONENTS AND DEVICES, HARRISON, N. J.



The Most Trusted Name in Television

See the caddy

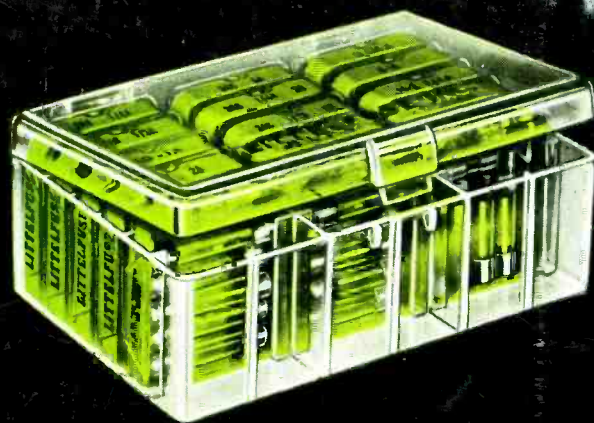

See the fuse box
through the caddy



See the fuses
through the
fuse box
through the caddy

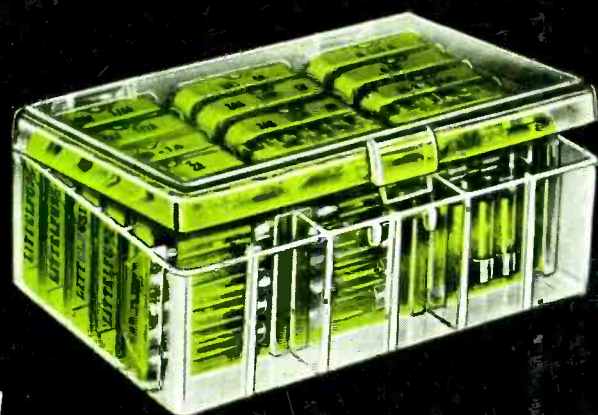

See more profits through

LITTELFUSE

DES PLAINES, ILLINOIS