

MARCH, 1961

35 CENTS



PHOTOFACT REPORTER

including **Electronic Servicing**



ROBERT O. WALTRAVEN
803 HEUSS AVE.
SCHOFIELD, WISCONSIN
IA 9X 1623 163

overcoming **COLORITIS**
Servicing Tape Recorders
Transistor-Tailored Techniques
Troubleshooting Synchro Systems

MAKE ANY TV-FM ANTENNA AN ELECTRONIC ANTENNA!

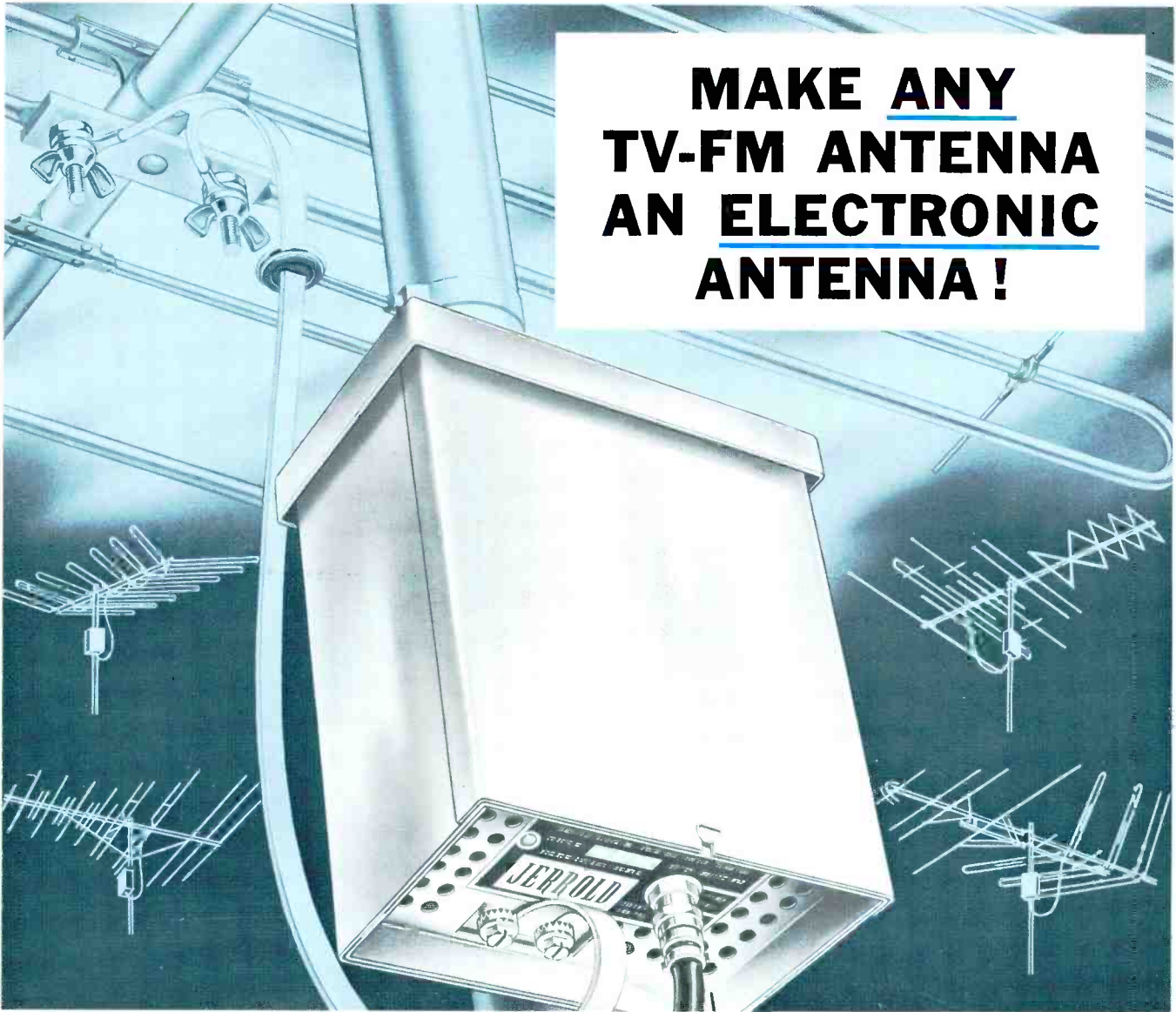

New Jerrold DE-SNOWER[®] Model 202 Increases Gain of Any Antenna **10 TIMES!**

Out of the Jerrold laboratories, where the famous DSA-132 was born, comes the ultimate in signal preamplifiers for all channel TV (VHF) and FM reception. By combining *two* frame grid 6DJ8 dual triodes in a special low noise circuit, Jerrold's new DSA-202 develops *minimum* 20 db gain (10 times) on all TV channels and 8db (min.) on FM . . . *triple* the gain developed when using one 6DJ8. Also featured is a new lightweight iridite-aluminum weather-proof housing; no-strip twin lead terminals; and sliding access panel. All new high output remote power supply reduces a 117v AC to a safe 22 volts which goes up same cable that amplified signal comes down.

Only Jerrold assures you of proven reliability and unequalled performance based on more than a decade of designing and producing mast mounted preamplifiers . . . more Jerrold De-Snowers are in use today than all other makes combined.

See your Jerrold distributor or write for eight page booklet No. 435-286



ELECTRONICS CORPORATION • Distributor Sales Division

Dept. IDS-128, Philadelphia 32, Pa.

Jerrold Electronics (Canada) Ltd., Toronto
Export Representative: CBS International, New York 22, N.Y.



Includes new power supply model 407-P. Has "on-off" switch and handy cable compensating control.



Output uses shielded coax. to eliminate antenna feed-back and interference pick-up on down-lead.

Two 6DJ8 tubes develop 20 db gain (minimum) on all TV (VHF) and FM channels.

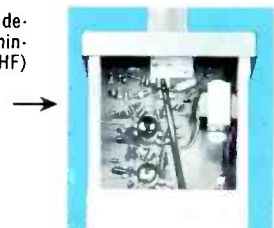

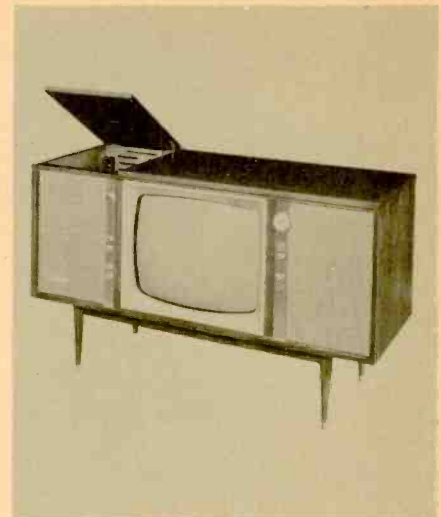
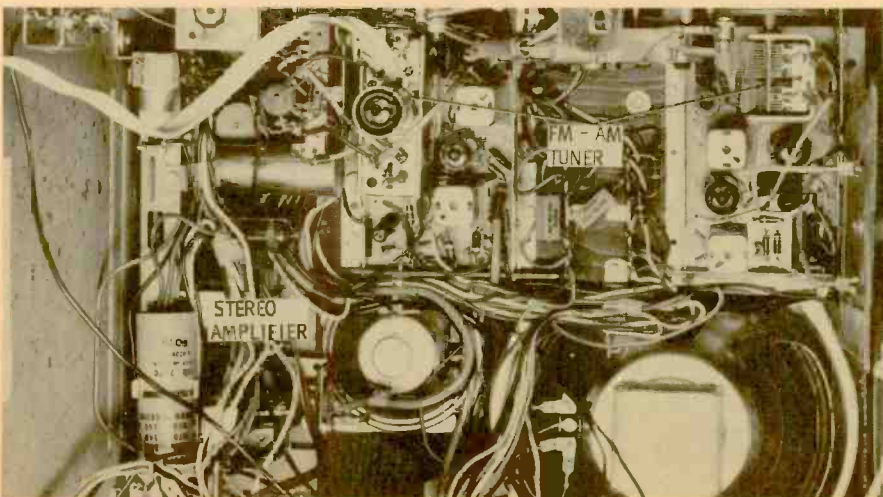
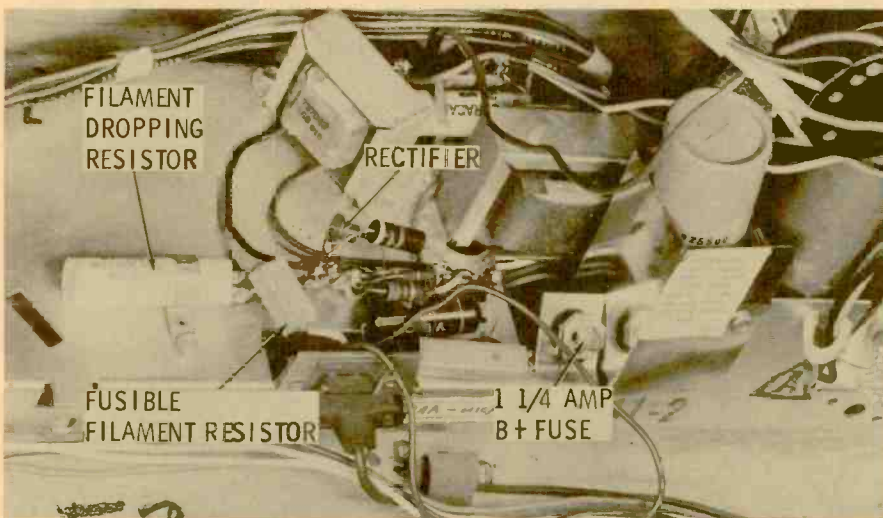
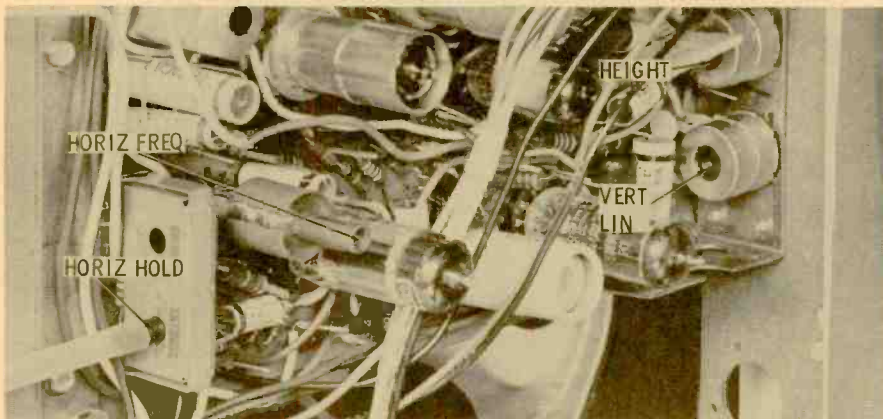
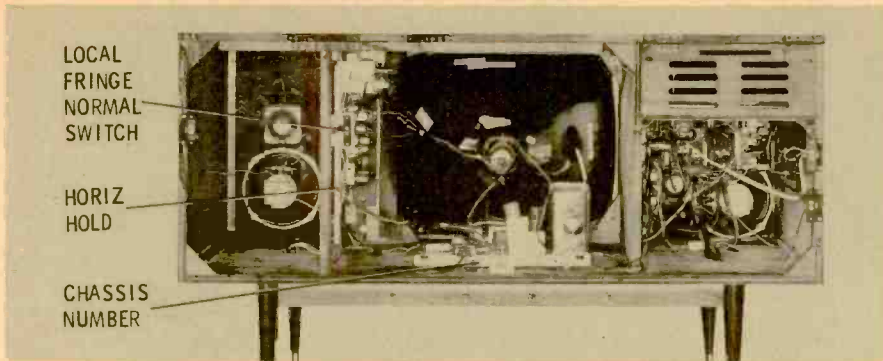

Emerson Model 1534 Chassis 120541C

First introduced as a late-1960 receiver, this model is one of 12 carried over into Emerson's '61 line. Four chassis variations are used in the series. This one is an AM-FM/stereo phono/TV combination—some are TV only. This model has a 23XP4 CRT with a bonded safety shield; others use a 21CBP4. All operational controls are front-mounted except the horizontal hold control, which has a phenolic tube protruding through the back.

The two-section TV chassis consists of a vertically-mounted printed board and a conventionally-wired unit fastened to the bottom of the cabinet. An unusual local-fringe-normal circuit, incorporating two side-by-side slide switches, controls the input signal to the tuner and the RF-AGC bias.

Horizontal-multivibrator and vertical-deflection circuits dominate the lower part of the printed board. A hex-head alignment tool is required when making the horizontal frequency adjustment. The height and vertical linearity controls are rear sections of the brightness and vertical hold controls; they can be adjusted from the back or through the hollow shafts of the front sections.

The conventionally-wired portion of the chassis houses the simple half-wave power supply and the horizontal deflection circuit. B+ (135 volts) is obtained from a silicon rectifier supply protected by a 1 1/4-amp, type-N fuse. The 16-tube series-filament circuit uses a 1-ohm fusible resistor and 28-ohm dropping resistor between the AC line and the first tube (a 12DQ6A).

A separate compartment contains the left-channel speakers and the three printed boards comprising the 5-tube AM-FM tuner and 3-tube stereo amplifier. The TV sound system is coupled to all speakers when the radio-phono switch is in the off position. The function-selector switch provides for AM, FM, AM-FM simulcast, and stereo phono operation (TV is selected by the radio-phono switch). Tubes you may not ordinarily stock in your caddy are the 25EH5 audio output, 5AS8 third video IF-video detector, and 8EB8 video output-vertical multivibrator.

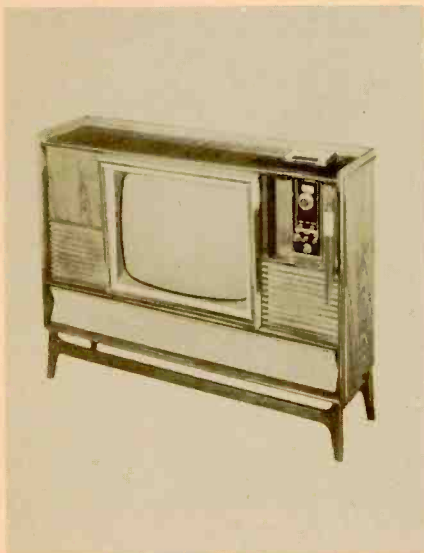

**General Electric
Model R870 VWD
Chassis U5**

GE's deluxe U5 chassis is used in this 1961 model. A 114°, 23KP4A picture tube, with separate safety glass, goes with all models using this chassis. You can remove the glass for cleaning after taking off a trim strip. This model uses a four-button remote control unit (modulated-RF type, carried over from '60), which provides bidirectional channel selection, up and down volume control, and on-off operation. Some models have manual tuning.

The "U" shaped chassis is a refined version of last year's U4 and follows the same basic layout. All setup controls are mounted so the adjustments can be made from the back. Focus can be varied by connecting pin 4 of the CRT socket through a 1-meg resistor to 260V, 135V, boost, or ground points.

A width switch, in conjunction with a tapped width coil, determines the amount of inductance connected in parallel with a winding on the flyback transformer. The terminal board holding the width coil is attached to a perforated heat shield which surrounds the horizontal output circuits and serves to dissipate the heat generated in these circuits.

In this year's chassis, the area immediately to the left of the video and sound printed board (mounted on the left side) has been cleared of all components except the fuses protecting the AC line and horizontal sweep circuit. This simplifies the job of replacing tubes used in the video IF, output, and sound stages.

Although the chassis is transformer-powered, a pair of germanium rectifiers are connected in a full-wave voltage doubler circuit that provides 275 volts B+. In the rear-center area of the bottom printed board, you'll find a white ceramic device connected to the same point as the pin-3 lead of the picture tube. This component is simply a spark gap to prevent excessive boost or pulse voltages from reaching the accelerating anode of the CRT. The horizontal frequency coil, which requires a hex-head alignment tool for adjustment, is mounted at the right side of the same board.

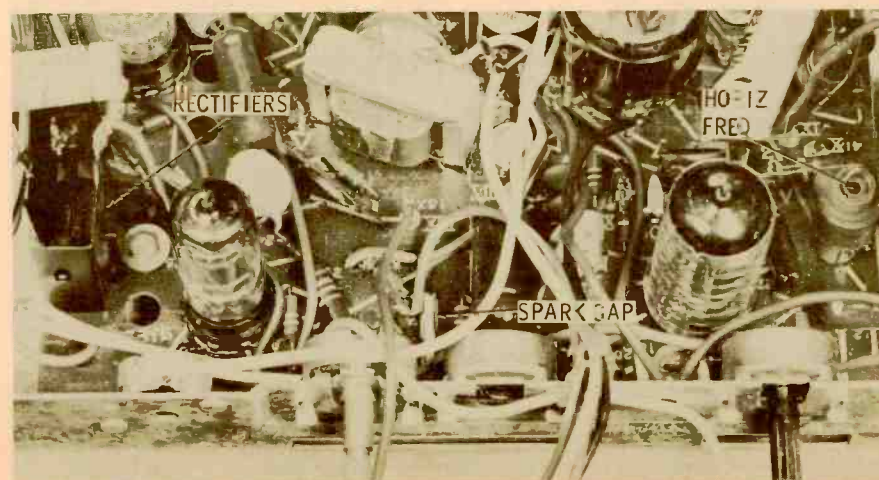
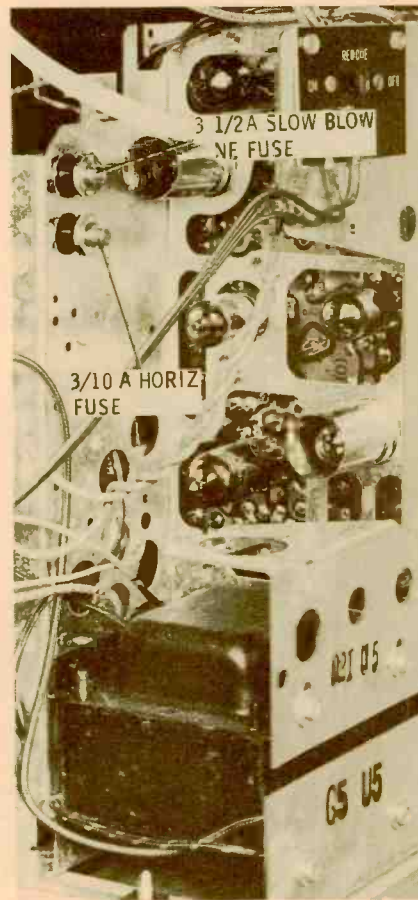
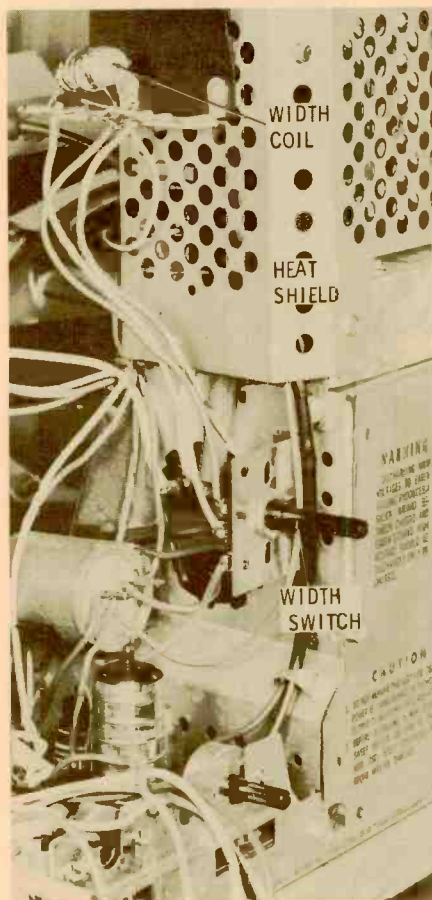
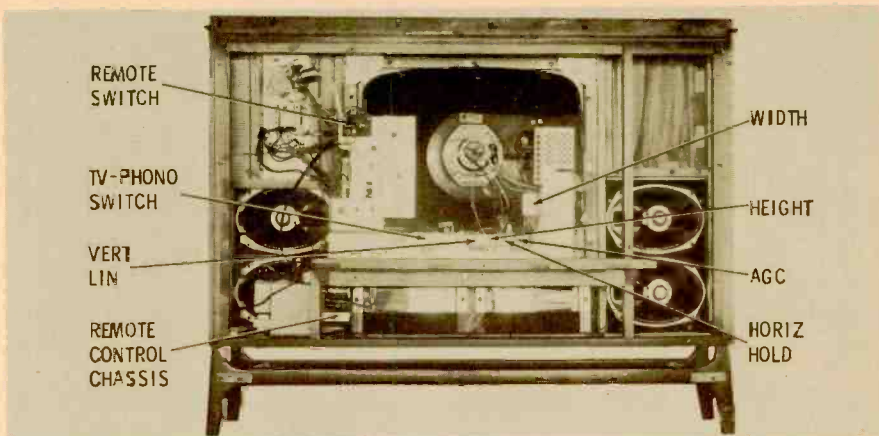

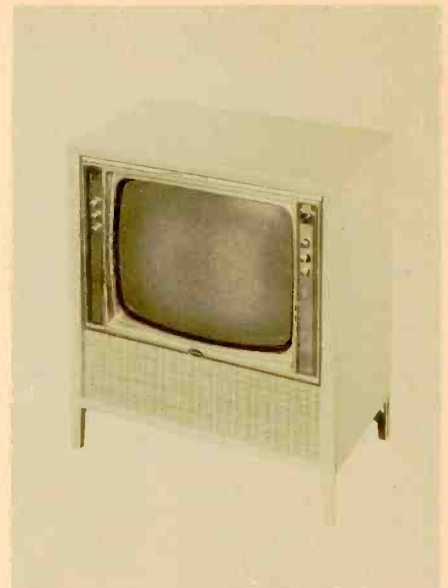
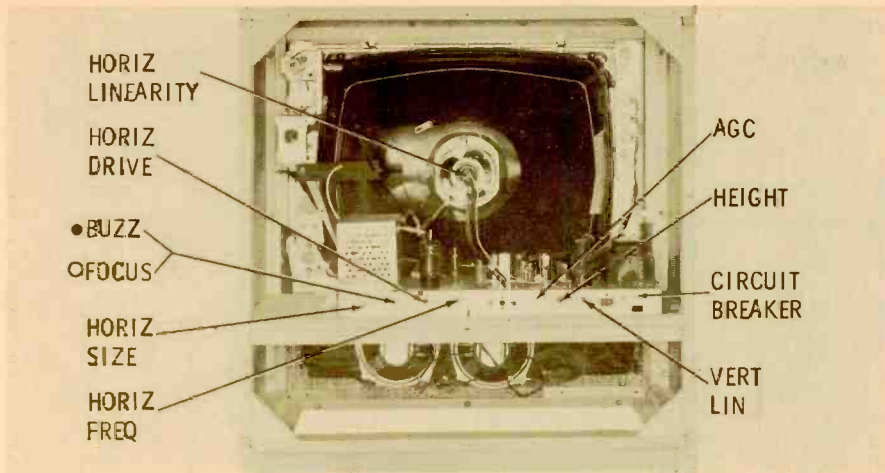

**Hoffman Model B3823
Chassis 326**

Hoffman's 1961 *Continental* line is represented by this basic 23", 110° model. The series also includes more elaborate chassis with provisions for remote control, a *Zoom* feature to increase picture size, and automatic brightness regulation. All sets use a 23CP4 picture tube with bonded safety shield. Operational controls are front-mounted and well marked for easy identification.

The 18-tube, hand-wired chassis is spaciouly arranged on a horizontal base. All setup controls are mounted on the rear apron for easy access. The sound detector is unique among 6DT6 types in that the cathode circuit includes a buzz control. Horizontal linearity is adjustable by changing the position of a plastic-encased metal-foil strip inserted between the yoke and the bottom side of the CRT neck.

Both the picture tube and chassis are attached to the front mask to form a single assembly. Three bolts secure the base chassis, and four lip clamps hold the front of the cabinet. When these have been removed, the entire chassis can be slipped out from the front.

A single protective device (a 3.5-amp circuit breaker) is connected in series with the AC line to the power transformer. A separate 6.3-volt secondary, supplying filament voltage only to the 6AW8A video output-AGC keyer, is connected to a 100-volt B+ point to reduce the potential between the tube's cathode and heater. The above-chassis components just to the left of the 5U4GB comprise the video output circuit; their location provides a convenient test point for checking the composite video signal.

Above-chassis troubleshooting is also made easier by the three test points at the right end of the video IF strip. Point "A" goes to the AGC line, point "B" goes to the video detector output through a 10K-ohm isolating resistor, and point "C" goes to the 6DT6 cathode through a 10K-ohm isolating resistor. Notice that all of the IF stages are equipped with captive tube shields. These should always be left in the raised position for maximum protection against interference pickup.

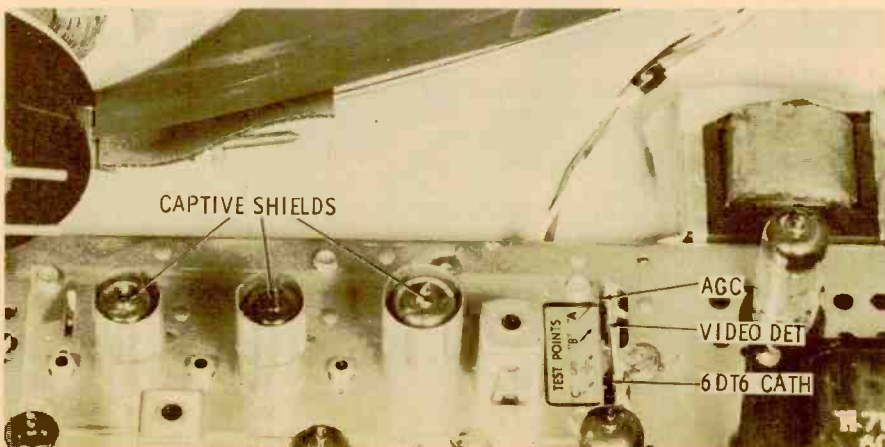
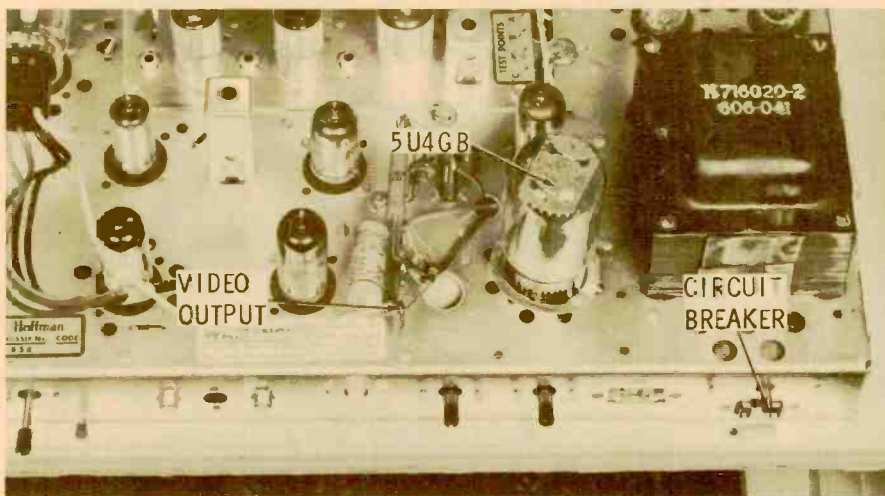
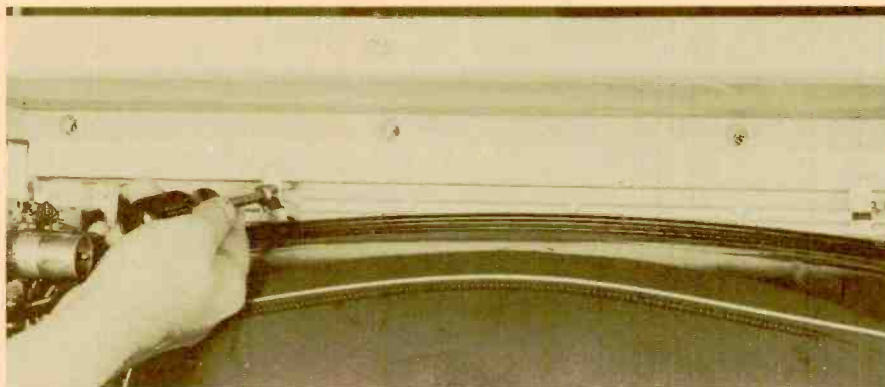

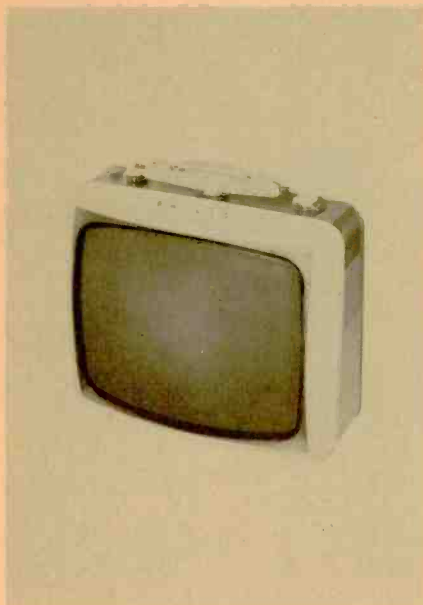

**Philco Model J-3210PL
Chassis 11J27**

Briefcase 19 identifies Philco's '61 series of 19", 114° portables. The picture tube is protected by a plastic "safety glass," so be sure to use only mild soap and water for cleaning.

A 15-tube, 450-ma series filament string is used in the "hot" chassis. The 19ABP4 CRT has a 2.68-volt filament rating, a point to remember if you have occasion to test it. All circuits, except those for the power supply, are on three printed boards. To the left of the yoke, a horizontal-linearity magnet compensates for any horizontal compression.

All operational controls and service adjustments are accessible from the top. Thumbwheel knobs for the brightness, horizontal hold, and vertical hold have holes in the top to permit adjustment of vertical linearity, coarse horizontal hold, and height. A width control is mounted at an angle so it can be adjusted when the on-off-volume and contrast knobs are removed. Silicon rectifiers for the half-wave doubler power supply are mounted on the top control panel. A 5.6-ohm fusible resistor is connected in series with the AC line supplying the rectifiers to protect the B+ supply. A temperature-compensating resistor, rated at 400 ohms cold, is used in series with the filament supply to provide controlled tube warm-up.

Two new tube types make their appearance on the two printed boards in the lower left corner. A 6HJ8 tube serves as the third video IF and detector, while a 12ED5 is used in the audio circuit. The screw-head adjustments at the left end of the top board are for the traps and IF coil forming the input to the first IF stage.

All of the deflection circuits occupy the board above the high-voltage cage. Adjustment of the horizontal frequency coil, next to the output tube, requires use of a hex-head alignment tool. Immediately to the left of the coil is one of the new component combination units with individual snap-in sections; when one of the sections becomes defective, it can be pried from its mounting clips and replaced with a standard part.

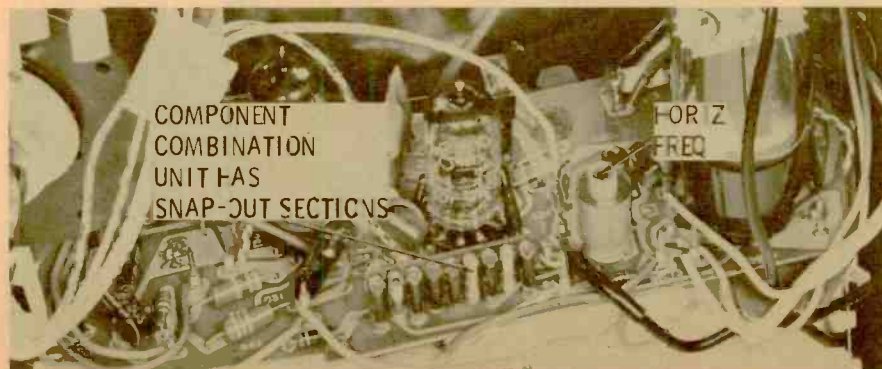
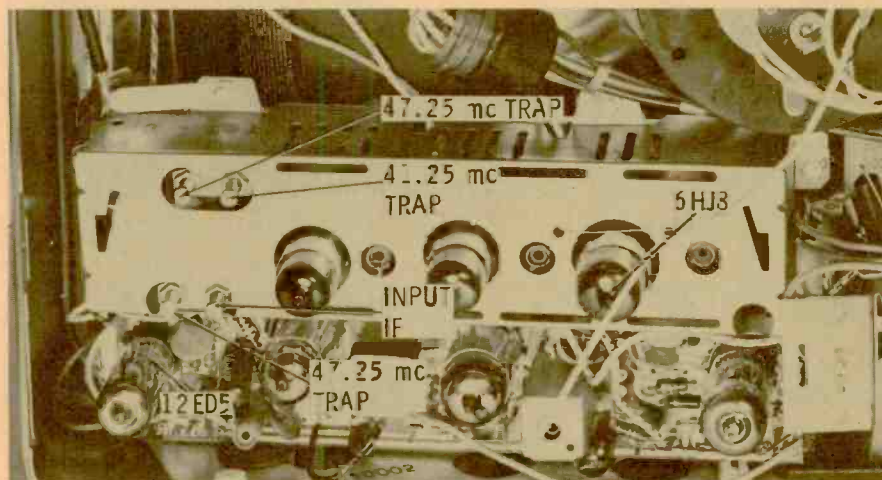
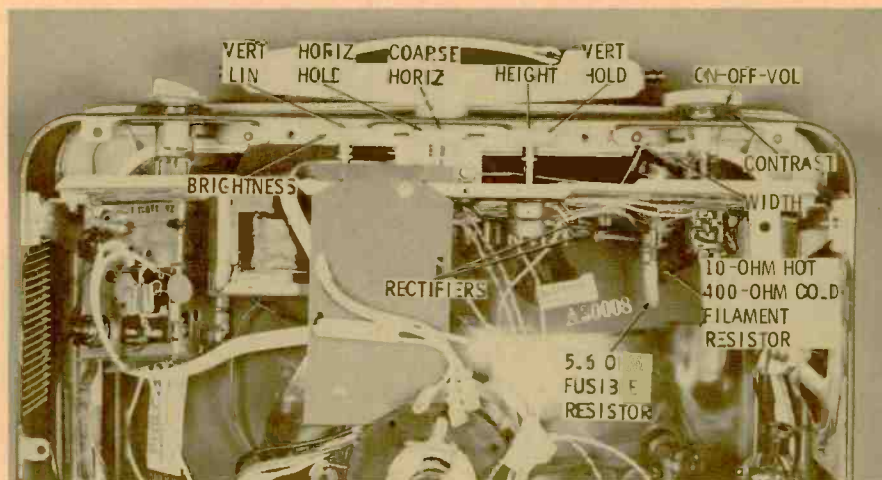
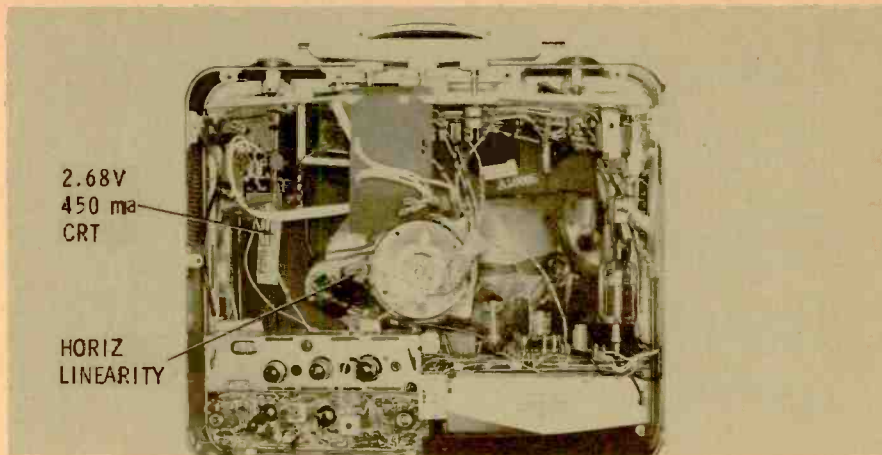

See PHOTOFACT Set 489, Folder 1

Mfr: RCA Chassis No. KCS127AE

Card No: RCA 127AE-1

Section Affected: Raster.

Symptoms: Raster disappears intermittently. When it is absent, there is no boost voltage.

Cause: Intermittently open RF choke in plate circuit of damper.

What To Do: Replace L19.

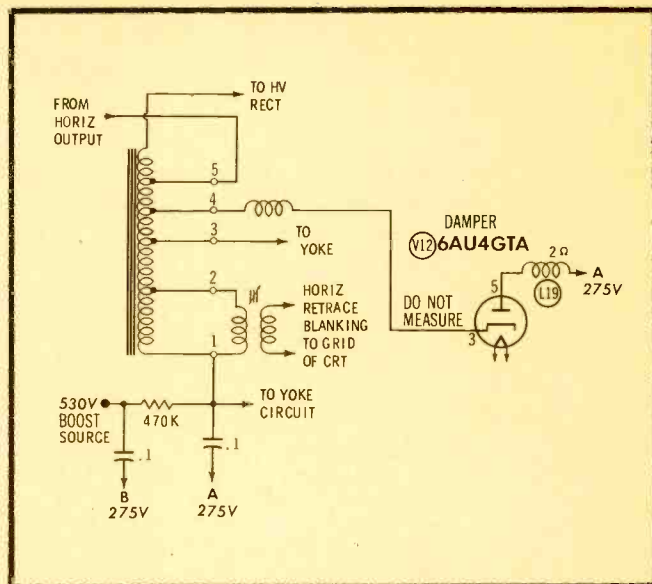

Mfr: RCA Chassis No. KCS127AE

Card No: RCA 127AE-2

Section Affected: Sync.

Symptoms: Unstable horizontal and vertical hold. High positive voltage on grid (pin 2) of sync amplifier (V8A).

Cause: Leaky coupling capacitor between sync separator and amplifier.

What To Do: Replace C42 (.033 mfd).

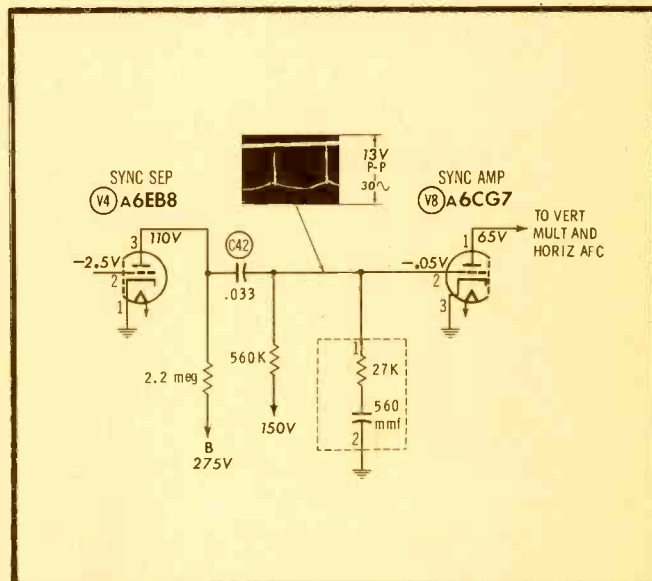

Mfr: RCA Chassis No. KCS127AE

Card No: RCA 127AE-3

Section Affected: Sync.

Symptoms: Picture rolls vertically. Low voltage on plate (pin 3) of sync separator (V4A).

Cause: Plate-load resistor of sync separator has increased in value.

What To Do: Replace R49 (2.2 meg).

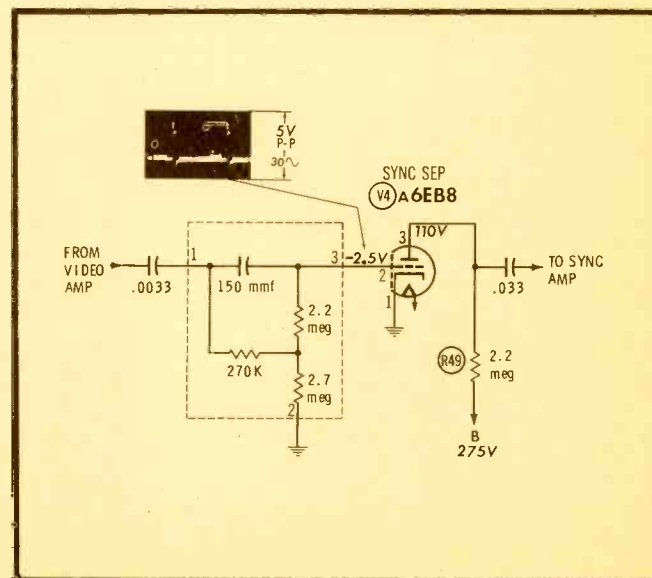

See PHOTOFACT Set 489, Folder 1

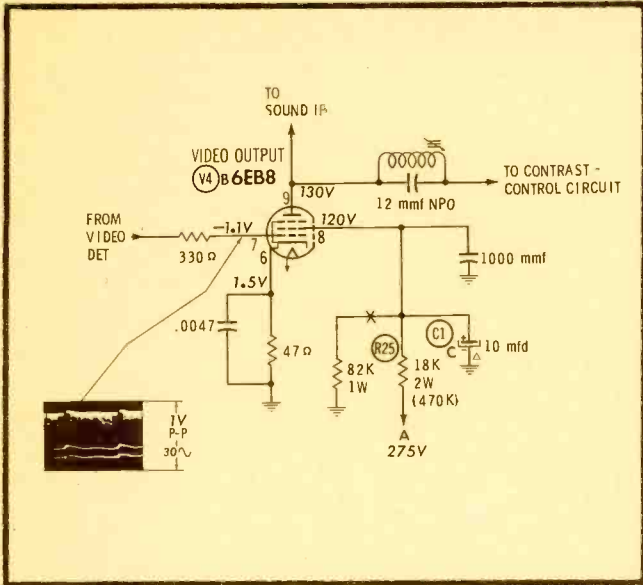

See PHOTOFACT Set 489, Folder 1

Mfr: RCA Chassis No. KCS127AE

Card No: RCA 127AE-4

Section Affected: Pix.

Symptoms: No picture; no voltage at pin 8 (screen grid) of video output tube (V4B); screen resistor usually burned.

Cause: Shorted screen-bypass capacitor in video output circuit.

What To Do: Replace C1C (10 mfd) or preferably entire C1 (100-20-10 mfd, 400-400-350V). Check R25 (18K—2W in some sets, 470K in others).

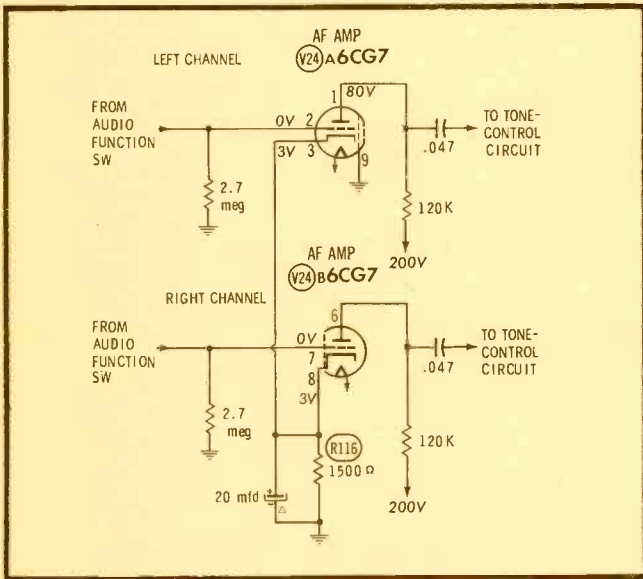

Mfr: RCA Chassis No. KCS127AE

Card No: RCA 127AE-5

Section Affected: Sound.

Symptoms: Sound disappears after short period of operation. Cathode voltage of right-channel preamp tube in stereo amplifier chassis (pin 8 of V24B) increases beyond normal value.

Cause: Open cathode resistor in circuit of V24B.

What To Do: Replace R116 (1500 ohms).

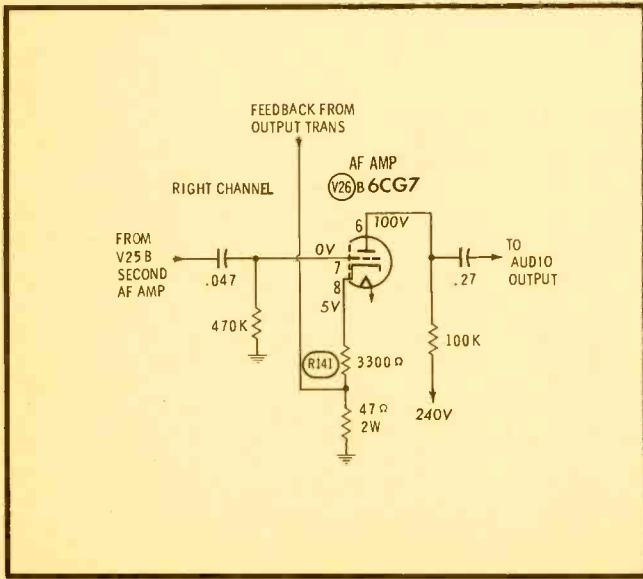

Mfr: RCA Chassis No. KCS127AE

Card No: RCA 127AE-6

Section Affected: Sound.

Symptoms: Sound becomes distorted after receiver has played awhile. Cathode voltage of third stage in right channel of stereo amplifier (pin 8 of V26B) is lower than normal.

Cause: Cathode resistor in circuit of V26B has decreased in value.

What To Do: Replace R141 (3300 ohms).

See PHOTOFACT Set 492, Folder 2

Mfr: Zenith Chassis No. 16E27

Card No: ZE 16E27-1

Section Affected: Raster.

Symptoms: Flashes and streaks; insufficient width; abnormally low voltage at screen grid (pin 4) of horizontal output tube (V10).

Cause: Screen-grid resistor burned and increased in value.

What To Do: Replace R95 (8200 ohms—3W) and check V10 (6DQ6B).

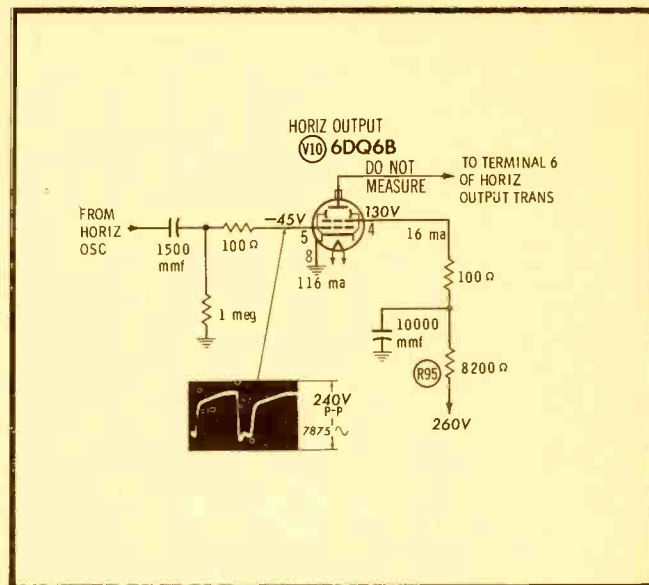

See PHOTOFACT Set 492, Folder 2

Mfr: Zenith Chassis No. 16E27

Card No: ZE 16E27-2

Section Affected: Raster.

Symptoms: Streaks in raster; incorrect voltage at plate (pin 5) of vertical multivibrator (V8A).

Cause: Internal arcing in vertical size control.

What To Do: Replace R5 (5 meg) and R73 (2.2 meg).

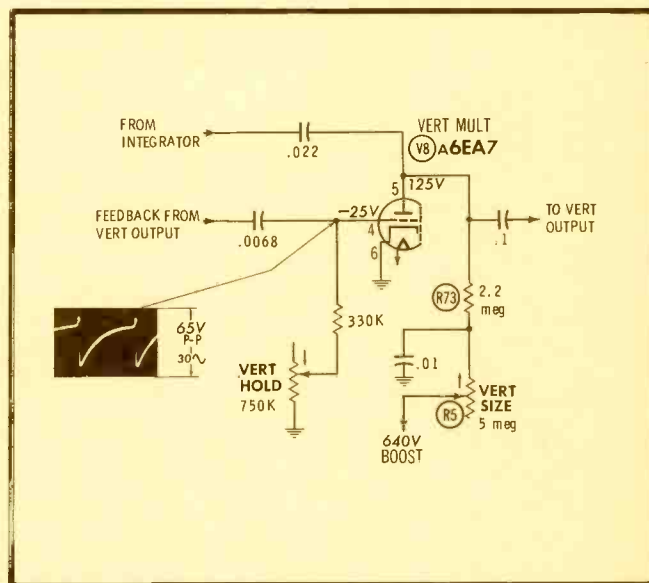

Mfr: Zenith Chassis No. 16E27

Card No: ZE 16E27-3

Section Affected: Pix.

Symptoms: No picture; zero volts on plate (pin 9) of video output tube (V4A).

Cause: Open plate-load resistor in video output stage.

What To Do: Replace R33 (7500 ohms — 4W).

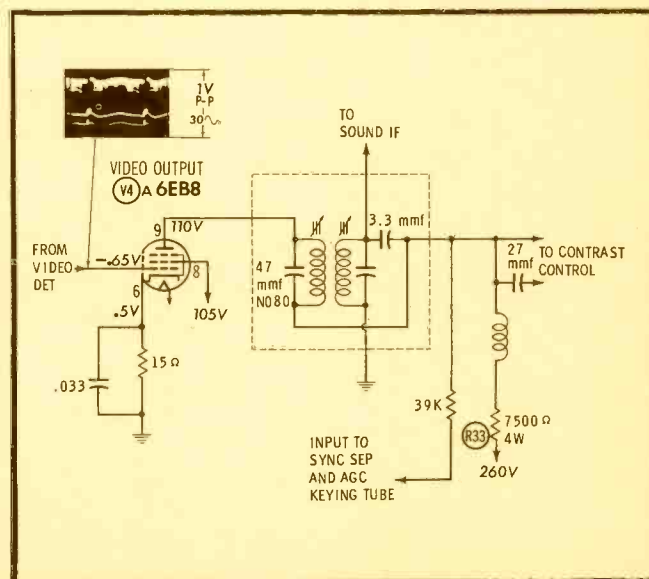

See PHOTOFACT Set 492, Folder 2

See PHOTOFACT Set 492, Folder 2

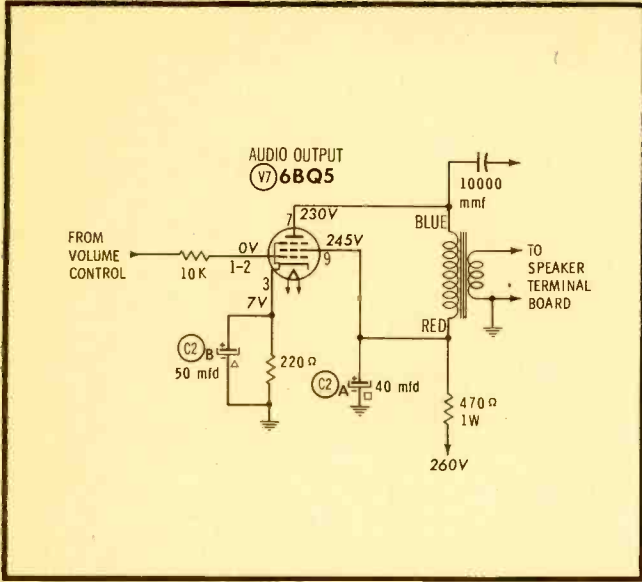

Mfr: Zenith

Chassis No. 16E27

Card No: ZE 16E27-4

Section Affected: Pix.

Symptoms: Sound bars in picture.

Cause: Open cathode-bypass capacitor in audio output stage.

What To Do: Replace C2B (50 mfd) or preferably entire C2 (40-50 mfd, 450-25V).

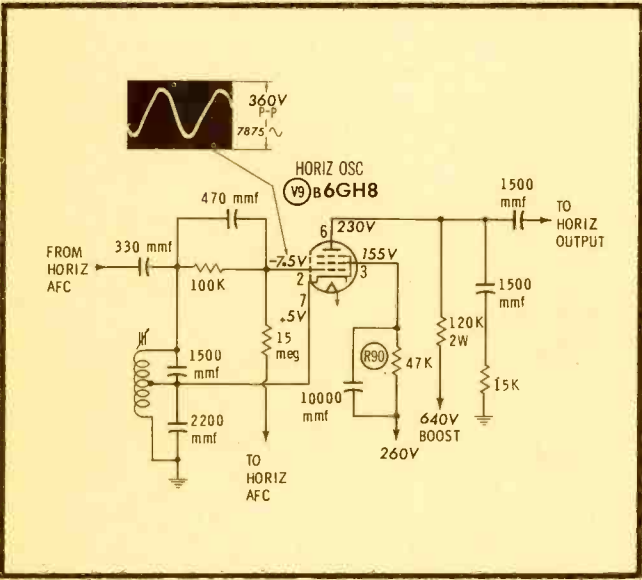

Mfr: Zenith

Chassis No. 16E27

Card No: ZE 16E27-5

Section Affected: Raster.

Symptoms: No raster; zero volts on screen grid (pin 3) of horizontal oscillator (V9B).

Cause: Open screen resistor in horizontal oscillator stage.

What To Do: Replace R90 (47K).

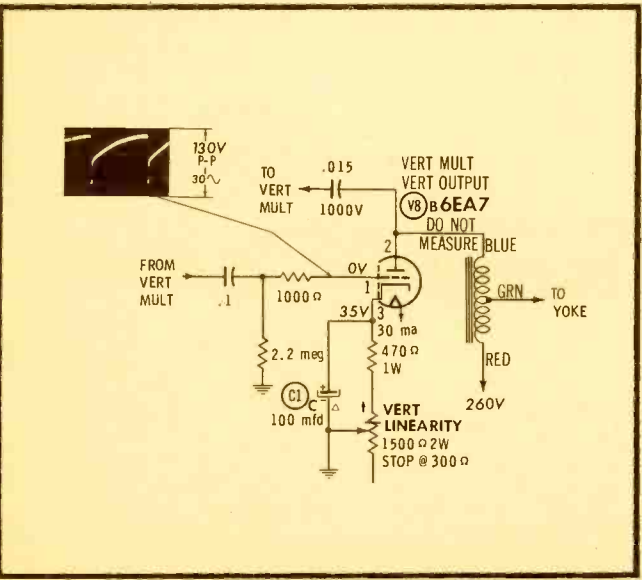

Mfr: Zenith

Chassis No. 16E27

Card No: ZE 16E27-6

Section Affected: Raster.

Symptoms: Poor vertical linearity and insufficient vertical sweep.

Cause: Open cathode-bypass capacitor in vertical output circuit.

What To Do: Replace C1C (100 mfd) or preferably entire C1 (40-80-100 mfd, 400-400-50V).

every
soldering iron
ever
invented



is now
old-fashioned as
high button shoes

Introducing **IMPERIAL** 



Think of every feature, every benefit, you would design into a soldering iron if you could... and you have IMPERIAL! *Only* UNGAR experience and research could have developed this cool, light-weight, easy-handling iron. From tip to cord... the ultimate in interchangeability. There are so many revolutionary new ideas in IMPERIAL we had to put them all in an 8-page brochure. Send for your free copy now!

UNGAR ELECTRIC TOOLS PF-U61-2C-3
Electronic Division of Eldon Industries, Inc.
1475 E. El Segundo Blvd., Hawthorne, Calif.

Please send me free full-color IMPERIAL brochure!

NAME _____

TITLE _____

COMPANY _____

ADDRESS _____

CITY _____ STATE _____

IMPERIAL 

*designed to keep pace
with the space age*

Another outstanding product by the HIDDEN 500* who plan for your future:



TYPE TE LITTL-LYTIC® CAPACITORS



Transistors revolutionized the industry. And to make the most of their inherent advantages, they called for an entirely new group of components. Here, Sprague Research was the first to answer the call with the smallest truly reliable dry electrolytic made for transistor circuits—the Littl-Lytic. This reasonably priced capacitor is the most reliable subminiature you can buy for transistorized radios, hearing aids, wireless microphones, pocket wire recorders, and other miniature electronic equipment.

The remarkable reliability of Littl-Lytic is the result of a new manufacturing technique in which *all the terminal connections are welded*. Units are hermetically sealed and metal encased . . . *with no pressure joints . . . there are no "open circuits" with the passage of time*. Leakage current is extremely low as the result of the use of high purity foil and ultra-stable formation techniques. Sprague's catalog replacement ratings are the most comprehensive in the industry. They assure you of exact replacements to meet your day-to-day service requirements.

Littl-Lytic is a typical example of how Sprague Research keeps its products up-to-the-minute. Reliable components mean reliable service work—your business keeps pace with the electronic industry when you use Sprague.

*The "Hidden 500" are Sprague's 500 experienced researchers who staff the **largest research organization in the electronic component industry** and who back up the efforts of some 6,000 Sprague employees working in 14 manufacturing operations—four at North Adams, Mass.; Bennington and Barre, Vt.; Concord and Nashua, N.H.; Lansing, N.C.; Grafton, Wis.; Visalia, Calif.; two at Ponce, Puerto Rico; and Milan, Italy.

WORLD'S LARGEST CAPACITOR MANUFACTURER

SPRAGUE®
THE MARK OF RELIABILITY

publisher
Howard W. Sams

general manager
Mal Parks, Jr.

editor
Verne M. Ray

managing editor
Joe A. Groves

associate editors
Leslie D. Deane
Thomas A. Lesh

consulting editors
William E. Burke
Robert B. Dunham
George B. Mann
C. P. Oliphant
Paul C. Smith

art director
Don W. Bradley

advertising & editorial assistants
Georgeanna Caldwell
Paula Haffner
Jean Sekulski

production manager
Robert N. Rippy

circulation fulfillment
Pat Tidd, Mgr.
Constance McCawley, Ass't.
Katherine Smith, Ass't.

photography
Robert W. Reed

advertising sales offices
midwestern

John Groce, PF REPORTER
2201 East 46th Street, Indianapolis 6, Ind.
Clifford 3-6441

eastern

Howard W. Sams & Co., Inc.
Corning Glass Building
717 Fifth Ave., New York 22, N. Y.
MUrray Hill 8-6350

western

The Maurice A. Kimball Co., Inc.
2550 Beverly Blvd., Los Angeles 57, Calif.
Dunkirk 8-6178; and 681 Market Street,
San Francisco 5, Calif. Exbrook 2-3365

Address all correspondence to
PF REPORTER, 2201 East 46th Street,
Indianapolis 6, Indiana



Copyright © 1961 by Howard W. Sams & Co., Inc. PF REPORTER is a trademark of Howard W. Sams & Co., Inc. No part of PF REPORTER may be reproduced without written permission. No patent liability is assumed with respect to use of information herein. Acceptance of advertising does not in any manner signify the products, policies and services so advertised have been approved, endorsed or recommended by this magazine.

Indexed in *Electronic Guide and Lctrodex*.
Printed by the Waldemar Press Div.
of Howard W. Sams & Co., Inc.



PF REPORTER

including **Electronic Servicing**

VOLUME 11, No. 3

MARCH, 1961

CONTENTS

Previews of New Sets	1
Emerson Model 1534 (Chassis 120541C), General Electric Model R870VWD (Chassis U5), Hoffman Model B3823 (Chassis 356), Philco Model J-3210PL (Chassis 11J27).	
Video Speed Servicing	5
Service hints on RCA Chassis KCS127AE and Zenith Chassis 16Z27.	
Letters to the Editor	12
The Electronic Scanner	14
Recovering From the Bends	18
Across the Bench—When the top of the raster won't straighten up, a scope can take you "off the hook." <i>Stan Prentiss</i>	
Simplified Inventory-Control Systems That Work	20
Dollar and Sense Servicing—How to keep a good stock of fast-moving items and rid your shelves of dust-catchers.	
Overcoming "Coloritis"	22
How your present knowledge of black-and-white TV will give you a good start on servicing color. <i>Joe A. Groves</i>	
Transistor-Tailored Techniques	24
New ideas are taking the place of conventional methods to put profit into transistor-radio work.	
Troubleshooting Synchro Systems	26
Most mechanical and electrical problems can be identified from visual symptoms. <i>Alan Andrews</i>	
The Secret Source of Low B+	28
Quicker Servicing—Why troubles in the audio output stage can affect picture as well as sound.	
Notes on Test Equipment	38
Lab reports on the Electro Products Model PS-3 regulated DC power supply, Jackson Model 605 sine-square wave audio generator and 606 "Square-Waver," and Seco Model GCT-9W tube-element tester. <i>Les Deane</i>	
Servicing Tape Recorders	46
"Customer problems" often predominate over electronic and mechanical problems. <i>Allan F. Kinckiner</i>	
The Troubleshooter	56
Product Report	70
Free Catalog and Literature Service	72
Monthly Index	on free literature card

ABOUT THE COVER

No, it's not a new style TV chassis—just an artist's conception of "coloritis," an ailment that clouds the minds of electronic technicians faced with a color TV service job. Symptoms of this not uncommon infection include delusions such as seeing "rainbows" which don't exist, talking to oneself, a generally irritable nature, and habitual nightmares in which everything appears in crazy mixed-up colors. "Coloritis" sufferers seeking a quick cure are referred to page 22 of this issue.

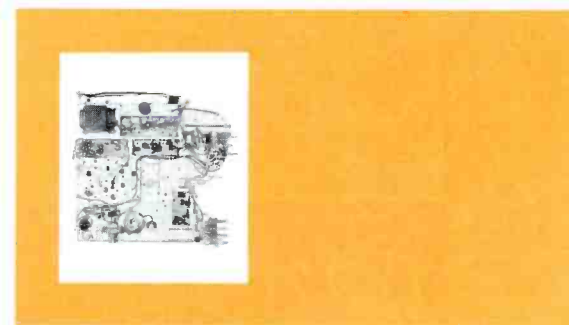



PRODUCTS FOR MODERN LIVING



ATR PLUG-IN TYPE PORTABLE INVERTERS*

A.C. HOUSEHOLD ELECTRICITY Anywhere... in your own car!

Operates Standard A.C.

- Record Players
- Dictating Machines
- Small Radios
- Electric Shavers
- Heating Pads, etc.

In your own car or boat!

MODELS

6-RMF (6 volts) 60 to 80 watts. Shipping weight 12 lbs. DEALER NET PRICE: \$33.00

12T-RME (12 volts) 90 to 125 watts. Shipping weight 12 lbs. DEALER NET PRICE: \$33.00

*Additional Models Available



ATR "A" Battery ELIMINATOR

For Demonstrating and Testing Auto Radios—TRANSISTOR or VIBRATOR OPERATED!

Designed for testing D.C. Electrical Apparatus on Regular A.C. Lines—Equipped with Full-Wave Dry Disc-Type Rectifier, assuring noiseless, interference-free operation and extreme long life and reliability.

MAY ALSO BE USED AS A BATTERY CHARGER

MODEL 610C-ELIF... 6 volts at 10 amps. or 12 volts at 6 amps. Shipping weight 22 lbs.

DEALER NET PRICE: \$49.95

MODEL 620C-ELIT... 6 volts at 20 amps. or 12 volts at 10 amps. Shipping weight 33 lbs.

DEALER NET PRICE: \$66.95

MODELS

6-RMF (6 volts) 60 to 80 watts. Shipping weight 12 lbs. DEALER NET PRICE: \$33.00

12T-RME (12 volts) 90 to 125 watts. Shipping weight 12 lbs. DEALER NET PRICE: \$33.00

*Additional Models Available

AUTO-RADIO VIBRATORS



By every test ATR Auto-Radio Vibrators are best! and feature Ceramic Stack Spacers, Instant Starting, Large Oversized Tungsten Contacts, Perforated Reed, plus Highest Precision Construction and Workmanship and Quiet Operation!

There is an ATR VIBRATOR for every make of car!

Ask your distributor for ATR's Low Priced type 1400, 6 volt 4-prong Vibrator; and 1843, 12 volt 3-prong; or 1840, 12 volt 4-prong Vibrator. **THE WORLD'S FINEST!**

ATR CUSTOMIZED KARADIO



Vibrator-Operated with Tone Control

ATR KARADIO... is ideal for small import cars or compact American cars! Unit is completely self-contained—extremely compact! Powerful 8-tube performance provides remarkable freedom from engine, static, and road noises. The ATR Customized Karadio comes complete with speaker and ready to install. Can be mounted in-dash or under-dash—wherever space permits! No polarity problem. Neutral Gray-Tan, baked enamel finish. Overall size, 7" deep, 4" high, and 6 1/2" wide. Shipping weight, radio set, 7 lbs.

Model K-1279—12 A for 12V Dealer Net Price: \$33.57

Model K-1279—6 for 6V Dealer Net Price: \$33.57

ATR TRUCK KARADIO



Excellent Tone, Volume, and Sensitivity!

Compact, yet powerful. Fits all trucks, station wagons, most cars and boats. Just drill a 3/8 inch hole in roof and suspend the one-piece unit (aerial, chassis and speaker) in minutes. Watertight mounting assembly holds antenna upright. Yoke-type bracket lets you tilt radio to any angle.

Extra-sensitive radio has 6 tubes (2 double-purpose), over-size Alnico 5 PM speaker for full, rich tone. Big, easy-to-read illuminated dial. Fingertip tuning control. Volume and tone controls. 33-in. stainless steel antenna. Neutral gray-tan enameled metal cabinet, 7 x 6 1/2 x 4 in. high over-all. Shipping weight 10 1/2 lbs.

Model TR-1279—12 A for 12V Dealer Net Price \$41.96

Model TR-1279—6A for 6V Dealer Net Price \$41.96

NO PRINTED CIRCUITRY

SEE YOUR ELECTRONIC PARTS DISTRIBUTOR WRITE FACTORY FOR FREE LITERATURE...



AMERICAN TELEVISION & RADIO Co.
Quality Products Since 1931
SAINT PAUL 1, MINNESOTA—U.S.A.

LETTERS TO THE EDITOR

Dear Editor:

Thanks to Alan Andrews for his wonderful article, "Synchros and Servo Systems," on page 36 of the January issue.

Just this past month, we obtained a pair of *Selsyns* with brass fittings, *not wired*, from a surplus house now dismantling ships in this city. (They weigh 18 pounds!) We have them wired now, and are wondering what to do with them. By any chance, do you know of a clever window display in which the synchros might be put to use? We'd like to construct a real traffic-stopper.

C. J. GUST

Genie Studio
Portland, Ore.

18 pounds of Selsyns in the middle of the street might do the trick! Anyone else have a better idea?—Ed.

Dear Editor:

Many thanks to The Troubleshooter for his courtesy in answering my letter about a negative picture on a Hoffman TV.

While there are few programs I enjoy watching on the "idiot box," I do enjoy troubleshooting. Of all the technical magazines I subscribe to, I find yours by far the most interesting.

BILL NEILSON

San Jose, Calif.

Thanks, Bill, for letting us know The Troubleshooter is still accurate in "calling his shots." Incidentally, he's a little "snowed under" with pleas for help, so please be patient.—Ed.

Dear Editor:

What a way to celebrate a birthday—you giving to us instead of us giving to you! I mean the 10-Year Cumulative Subject Index in the January issue of the best magazine that has ever been written for radio and TV servicemen. Many, many thanks, and many more happy birthdays.

JOHN W. AUTEN

Columbus, Ga.

You just gave us the best present we could ask for, John—evidence that what we publish is what you want.—Ed.

Dear Editor:

I've been wondering about the effect observed when a 150-watt electric light bulb is held so that the center contact of

its socket touches the plate of a 1B3 high-voltage rectifier. An RF arc shoots through the bulb toward the hand holding it, with no apparent effect on the hand.

Is this in any way comparable to arcing inside a picture tube? Also, is there any danger to the hand from this stunt?

MORRIS GORDON

Philadelphia, Pa.

This is the same effect demonstrated on our November, 1956 cover. There were no ill effects, although the glass did get a little warm. Yes, this type of RF arcing can appear within a CRT, but damage is much less likely than for a DC flashover between elements.—Ed.

Dear Editor:

Why not have someone read proof on your Contents page? Even a vault full of jewels is worthless without the combination.

HENRY G. ZUK

Madison, Ill.

For the benefit of those who don't get the meaning of Hank's suggestion, he's caught us in a big goof. Our February Contents page failed to reflect some last-minute changes in make-up, resulting in wrong page numbers for five of the articles. Consecutive features shown as beginning on pages 18, 21, 26, 28, and 30 really start on pages 28, 30, 24, 26, and 32, respectively.

We'll agree with you on the "jewels," Hank, but even though we gave you the wrong "combination," you'll have to agree we left the "door" ajar!—Ed.

Dear Editor:

Walter A. Koehler's idea for getting customers to pick up their sets (Feb. *Letters to the Editor*) was very good. But what do you do when you get no response? What is the best way to legally dispose of merchandise when it becomes evident no one is going to claim it? We are especially troubled by this problem where small radios are concerned.

B & R T.V.

Pomona, Calif.

Most states have laws governing the disposition of unclaimed merchandise, but they usually require the business proprietor to advise customers—in writing—of intentions to dispose of unclaimed property. Signs with a message like "Not responsible for goods left over 30 days" are also part of a merchant's responsibility in some locales.

We plan to develop an article covering this subject in the near future. Meanwhile, check with a lawyer and follow his suggestions for legal action.—Ed.

Dear Editor:

With reference to your answer to W. G. Edwards (Feb. *Letters to the Editor*), I agree with you wholeheartedly. But, bananas—oh, brother! Have you priced them lately? Money is cheaper!

R. B. CHAMBERS

Chambers Radio & TV Service
Dallas, Texas

We weren't thinking of "Texas-sized" bananas.—Ed.

Immediate Delivery from all authorized ARCO distributors

not 940
not 1000
but 1401*

EXACT REPLACEMENT ELECTROLYTICS



99.99% high purity
aluminum foil
electrolytics
at no extra cost!

Arcolytic

* The largest selection of exact replacement
Twist Mount and Tubular electrolytics in
the industry . . . 1401 values.

- Choose from stock any single, dual, triple or quadruple capacitance — voltage combination for replacement in television, radio, and other electronic equipment.
- Made to withstand high ripple and high surge voltages.
- Designed for 85°C high temperature operation.
- Greater shelf and operating life because only premium grade ingredients are used.
- Built and tested to meet EIA Specification RS-154.
- Individually packaged with mounting plates for your convenience.
- Unconditionally Guaranteed.

Write today for our new Catalog 1060



Manufactured by
ARCO electronics inc. ELECTROLYTIC DIVISION

Community Drive
Great Neck, New York
Branches: Dallas 7 • Los Angeles 35

from **EICO**... a completely new
CITIZENS BAND TRANSCEIVER

that meets
FCC regulations*



Model 760: 117 VAC
Kit \$59.95 Wired \$89.95
Model 761: 117 VAC & 6 VDC { Kit \$69.95
Model 762: 117 VAC & 12 VDC { Wired \$99.95
incl. mtg. bracket (Pat. Pend.)

*EICO premounts, prewires, pretunes, and seals the ENTIRE transmitter oscillator circuit to conform with FCC regulations (Section 19.71 subdivision d). EICO thus gives you the transceiver in kit form that you can build and put on the air without the supervision of a Commercial Radio-Telephone Licensee!

Highly sensitive, selective SUPERHET (not regenerative) receiver with 5½ dual function tubes and RF stage. Continuous tuning over all 23 bands. Exclusive Super-Hush® noise limiter. AVC. 3" x 5" PM speaker. Detachable ceramic mike. 5-Watt crystal-controlled transmitter. Variable "pi" network matches most popular antennas. 12-position Posi-Lock® mounting bracket. 7 tubes and 1 crystal (extra xtals \$3.95 each). Covers up to 20 miles. License available to any citizen over 18—no exams or special skills required, application form supplied free. Antennas optional.

YOU PROFIT WITH EICO

Everything in top-quality
TEST EQUIPMENT for Shop
and Field—at savings of 50%.



COLOR & Mono DC-5MC
Lab & TV 5" Oscilloscope #460
Kit \$79.95, Wired \$129.50
5" Push-Pull Oscilloscope #425
Kit \$44.95, Wired \$79.95



Peak-to-Peak VTVM #232 & *UNI-PROBE®
Kit \$29.95, Wired \$49.95
*U. S. Pat. No. 2,790,051
Vacuum Tube Voltmeter #221
Kit \$25.95, Wired \$39.95

More typical EICO values: Signal Generators from \$19.95, Tube Testers from \$34.95, Sweep Generators from \$34.95, Power Supplies from \$19.95, VOMs from \$12.90.

Everything in CUSTOM HI-FI:
finest quality at 1/3 the cost.



FM Tuner HFT90
Kit \$39.95, Wired \$65.95
Cover \$3.95. Includes FET.

AM Tuner HFT94
Kit \$39.95, Wired \$65.95
Includes Metal Cover and FET.

FM/AM Tuner HFT92
Kit \$59.95, Wired \$94.95
Includes Metal Cover and FET.



Stereo Dual Amplifier-Preamp HF81
Kit \$69.95, Wired \$109.95
Includes Metal Cover.

Stereo Dual Amplifier AF4
Kit \$38.95, Wired \$64.95
Includes Metal Cover.

Write for free catalog PF-3 and
name of nearest distributor.
Most EICO distributors offer budget terms.

EICO

3300 N. Blvd., L.I.C. 1, N. Y.
Add 5% in the West

"See EICO at IRE BOOTH 3509"

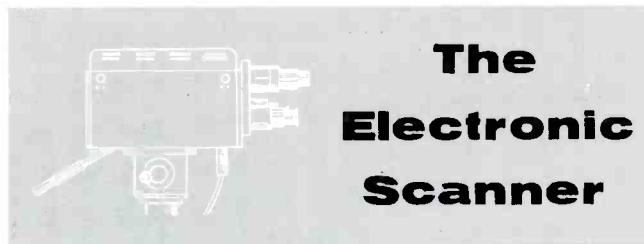

The Electronic Scanner

Seminar on Modern Servicing Techniques



Over 400 servicemen attended a recent TV servicing seminar sponsored jointly by B & K Mfg. Co. and their distributor, Nationwide W-J. The program, conducted at Chicago's Graemere Hotel, included discussions of modern troubleshooting techniques to simplify and speed TV servicing, improve customer satisfaction, and increase profits.

Highlight of the meeting was a working demonstration of how to use the "Television Analyst" to pinpoint troubles in any stage of a TV receiver.

No Haystack for These Needles



A 3-step program, aimed at helping service dealers merchandise phono needles more effectively, has been instituted by Walco Electronics Co., Inc. Concentrating heavily on the promotion of diamond needles, the program includes a "Gillette-type" counter-top mer-

chandiser (pictured), a new hard, clear-plastic diamond-needle container, and a 1961 needle catalog. The counter display tray, which has an unbreakable glass top and holds 160 diamond needles, may be obtained from Walco distributors at no charge with the purchase of a small selection of needles.

Longer Warranty Period for Tuners

Standard Kollsman Industries has extended the warranty period on their television and FM tuners from 90 days to one year. The new warranty policy, effective on all units produced since the first of this year, is offered at no increase in selling prices because of improvements which have increased the reliability of these products.

Association Elects New Officers

Newly-elected officers of C.E.T.A., Certified Electronic Technicians Association, New York City are as follows: Al Shaw, President; Frank Joseph, Vice-President; Sol Fields, Corresponding Secretary; Hy Brandeis, Recording Secretary; John McManmon, Treasurer; and Graham Holzhausen, Sergeant at Arms. This new group has already formulated an upgrading program, consisting of a series of lectures by various manufacturers, to keep organization members up to date on servicing techniques and electronic industry developments. We'll be looking forward to hearing how the meetings turn out, fellas.

One Stop for Tubes and Wearing Apparel

As a special incentive to encourage dealers and servicemen to stock their premium-rated tubes, the Motorola Parts and Accessory department is conducting a special "dress-up for profits" campaign. Through the purchase of picture or receiving tubes, you can have your choice of dress and sport shirts, sweaters, jackets, and other items from a "famous make" line of men's wear. There's no limit on the number of premiums you can earn.

Tax Consultant Is Answer Man to Thousands of Small Businesses

Many Are The Questions

Small Firms Depend On Tax Consultant

7 OF 10 SMALL BUSINESSES OVERPAY TAXES

Many Small Business Failures Due To Poor Record Keeping

DANGER
AHEAD FOR SMALL BUSINESS

THOUSANDS OF SMALL BUSINESSES FAIL EACH MONTH

Thousands Rely On Tax Experts

STEER CLEAR
Raytheon now makes available its new personalized Business Management Program*

FINDING ANSWERS IS A BIG BUSINESS

Will The Small Businessman Be "Choked" Out Of Business?
Experts Stresses Need To Keep Abreast Of Newest Ideas And Latest Methods To Meet Problems Of Changing Times

... you get personalized on-the-spot service
TAX RETURNS are prepared for you—You get RECORD-KEEPING help on your own premises — plus LOW-COST LIFE, HEALTH and ACCIDENT INSURANCE for you and your family.

From now on, no more tax tangles because of 'months-old' Record-Keeping. The new Business Management Program made available by Raytheon helps you get your tax and business records straight, keep them straight, *taking no more than a few minutes a day!* Come tax time, your tax returns will be prepared by expert tax accountants.

The Raytheon Program provides a representative — right on-the-spot in your territory — who will come to *your* premises, explain this simplified 3-steps-a-day Record Keeping method; year-round advice is available any time at no extra charge. These services are *completely confidential*. Supplementary insurance plans bring you huge benefits for family and business. All this additional to the business building features of the Raytheon Program — technical service, decals, 90-day repair bond and many more. No other business program offers so much, so liberally.

Sure it pays to be a Raytheon Bonded Dealer! Thousands of get-ahead independent radio/TV dealers, coast-to-coast, can prove it. Join them in success. Call your local Raytheon distributor — today.

*Services rendered by Simplified Tax Records, Inc.
Raytheon Distributor Products Division • 411 Providence Turnpike • Westwood, Massachusetts

RAYTHEON COMPANY



"Never a call-back with Mallory"

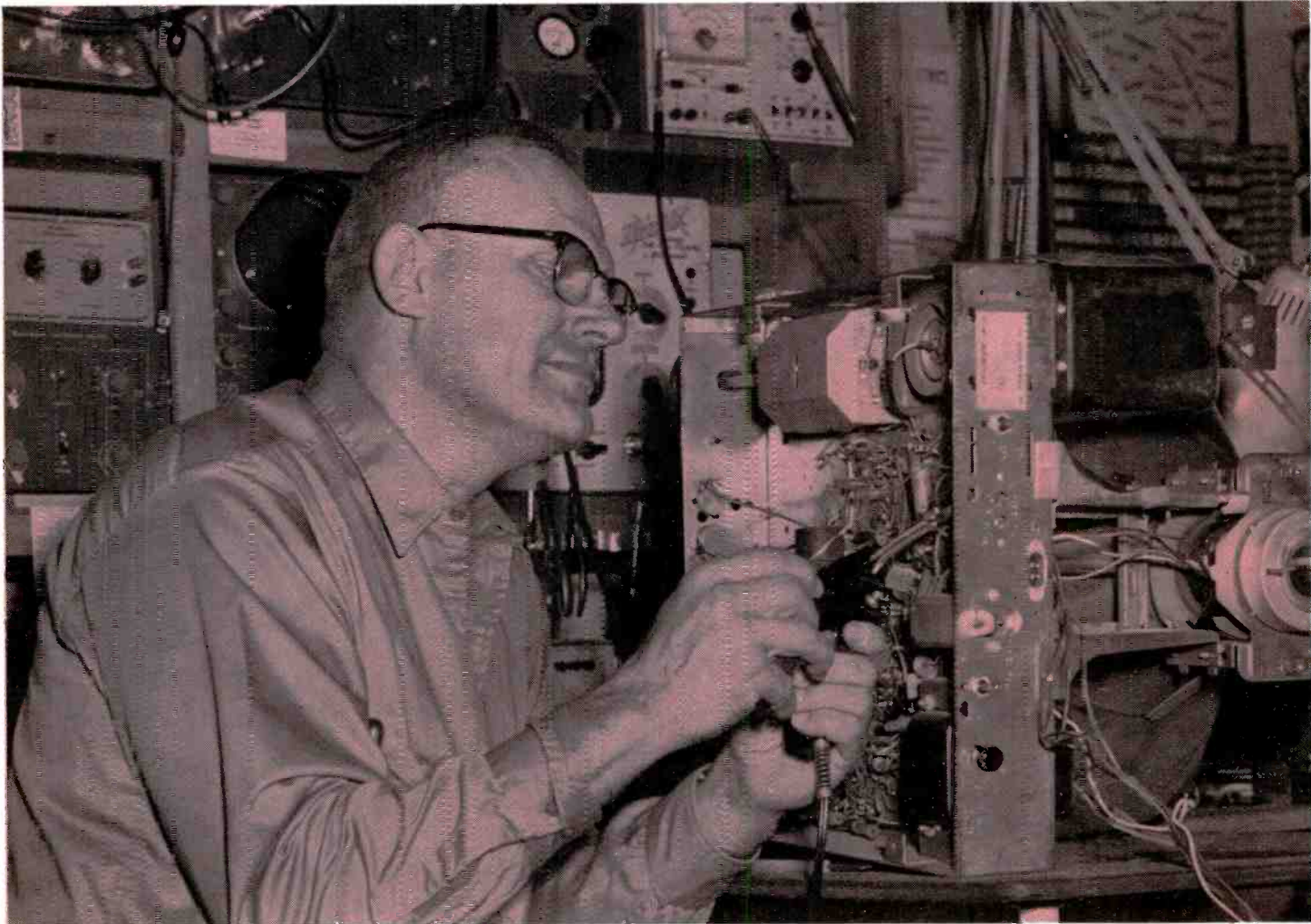

Your Mallory distributor stocks these quality components



TC TUBULAR ELECTROLYTICS

Economical filter capacitors. Hermetically sealed. Also special TCX type for -55°C . Twin-pack keeps leads free from kinks.



FP ELECTROLYTICS

Original 85°C capacitor, now better than ever. Etched cathode gives hum-free performance. Chassis or printed circuit mounting.



STA-LOC® CONTROLS*

Your distributor can custom build in just 30 seconds, any of over 38,000 single or dual controls.

*U. S. Patent 2,958,838.



GOLD LABEL® VIBRATORS

Quietest ever made... for the best in auto radio servicing. Buttonless contact design gives longest trouble-free service, sure starts.

says Vern Maxwell, owner of Maxwell Radio & TV, Cantrall, Illinois

"I check every capacitor used in my work, for value tolerance and insulation leakage. I have never rejected a Mallory capacitor, and have never had a call-back due to premature failure of a Mallory capacitor in my thirty years of servicing electronic equipment."

That's reliability for you. It's the kind of reliability that saves you money, builds your reputation, keeps customers satisfied. It's the kind of reliability that you can expect from the complete line of Mallory service-engineered replacement parts . . . the broadest line in the industry. On every job, make it sure by making it Mallory . . . famous for top quality at sensible prices.

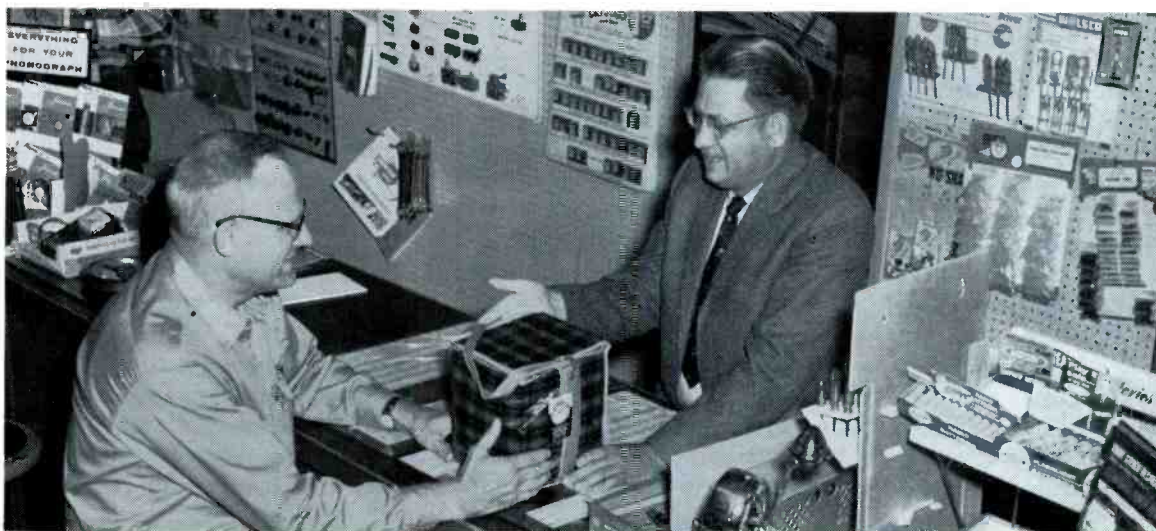

Vern W. Maxwell in his shop, and (above) buying his "Voodoo cooler" Mallory kit from Woodbur D. Ryan of Bruce Electronics, Springfield, Illinois. Vern's entry in the Mallory "Cool Deal" contest won first prize for him and for Ryan.

Distributor Division, Indianapolis 6, Indiana

P. R. MALLORY & CO. Inc.
MALLORY



MALLORY PVC CAPACITORS

New, blue Mylar** capacitors. Withstand moisture, heat, bending of leads and overloads.

**Reg. T. M., E. I. du Pont de Nemours & Co., Inc.



MALLORY MERCURY BATTERIES

Tops for transistor radios. Up to 7 times more *sound power*† . . . guaranteed against leakage . . . stay "live" for years when idle . . . won't fade. †T.M.



GEMS

Rugged, moisture-proof tubular capacitors, great for filter, buffer, by-pass and coupling service. Handy five-pack keeps stock clean, leads kink-free.



RMC DISCAPS®

Quality standard for original equipment. In handy 3" x 5" file card package.

®Trademark Radio Materials Company, a Mallory division.

Recovering From The



It was a beautiful winter afternoon—sunny and not too cold. Everything would have been fine if I hadn't just been thrown a curve. Perhaps "hook" would be a better word to use, for I'd just fired up a split-chassis Philco (No. 35 RF unit and F2 deflection chassis) with the neatest hook you ever saw. The set had one of those exasperating bends at the top of the raster, accompanied by an occasional severe horizontal jitter, which you'll find every now and then in receivers both young and old.

I knew this particular type of bending is caused by vertical sync or sweep signals affecting the horizontal circuit. The trouble theoretically might lie in the differentiating com-

ponents between the sync and horizontal AFC stages—or vertical horizontal AFC stages—or vertical filtered power supply, could momentarily be detuning the horizontal oscillator by modulating its plate voltage. However, as I got ready to tackle the Philco job, it occurred to me that most of the bend problems I had experienced over the years had been traceable to three other causes.

In sets such as this one, with pulse-width horizontal AFC (Fig. 1), trouble often occurs in the *anti-hunt network*—a resistor-capacitor timing circuit (R108, C90, and C91) intended to prevent overcorrection of the horizontal oscillator by the AFC circuit. As the AFC tube conducts, it places a charge on

C90 and C91 proportional to the width of the positive peaks in the combined sync-and-feedback signal at the grid. The voltage across the capacitors is then applied to the grid of the horizontal oscillator, in order to modify its grid-leak bias and thus regulate its frequency. As you might suppose, the quality and value of the anti-hunt capacitors are both critical.

In all types of receivers, certain faults in the sync circuits will occasionally produce a bend in the top of the raster. The cause is generally a leaky or off-value coupling capacitor, although an increase in the value of a plate or screen resistor sometimes produces the same symptom.

A less direct, but equally common, cause of a "hook" is insufficient AGC bias voltage. This fault produces overloading of the video IF's, which can be recognized by an excessively dark and contrasty picture with poor sync stability. Overloading causes compression of the sync pulses in the composite video signal, with a corresponding distortion of the sync signal fed to the horizontal AFC. The worst distortion usually follows the vertical sync pulse, which is why raster bending is generally most severe at the top of the screen. A suspicion of AGC-related trouble can be verified by adjusting the AGC control (if there is one), disconnecting the antenna, or clamping the AGC line with a variable bias voltage. From there on, troubleshooting in this area is a matter of checking the IF's for grid current or leakage across transformers, or checking the AGC network for leaky and open capacitors. Resistors are seldom offenders in this low-current, low-voltage network, but

• Please turn to page 61

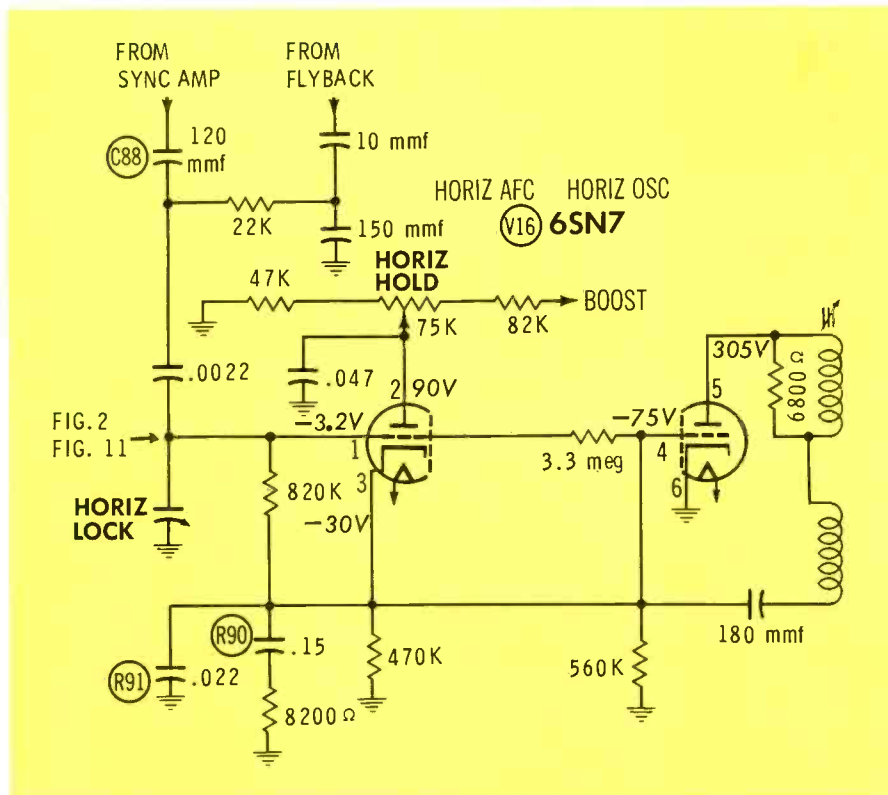

Fig. 1. Pulse-width horizontal AFC circuit used in Philco sweep chassis F2.

DOUBLES YOUR EFFECTIVE MANPOWER



Fix "Tough Dogs" Fast!

Save Half Your Time!

Step Up Your Profit!

B&K NEW
MODEL 1076

TELEVISION ANALYST

for Black & White and Color



Check all circuits—Pinpoint any TV trouble...in minutes

**By Easy Point-to-Point Signal Injection,
You See the Trouble on the TV Screen and
Correct it—Twice as Fast and Easy!**

There's no longer any need to "lose your shirt" (and customers)—and worry about the lost hours you never recover—on "tough dogs" or even intermittents. The remarkable B&K Analyst enables you to inject your own TV signal at any point and watch the resulting test pattern on the picture tube itself. Makes it quick and easy to isolate, pinpoint, and correct TV trouble in any stage throughout the video, audio, r.f., i.f., sync, and sweep sections of black & white and color television sets—including intermittents. Makes external scope or wave-form interpretation unnecessary. Most useful instrument in TV servicing! Its basic technique has been proved by thousands of successful servicemen the world over.

The Analyst enables any serviceman to cut servicing time in half, service more TV sets in less time, really satisfy more customers, and make more money.

Model 1076. Net, \$29995

Available on Budget Terms. As low as \$30.00 down.

Combines all the features of both
the Model 1075 and Model A107

- | | |
|--|--------------------------------------|
| COMPLETE R.F. and I.F. | HI-VOLT INDICATOR |
| VIDEO TEST PATTERN | YOKE and HI-VOLTAGE TRANSFORMER TEST |
| COMPOSITE SYNC | Also Now Provides: |
| FM MODULATED AUDIO | SWITCH-TYPE TUNER |
| COLOR PATTERNS | NEGATIVE BIAS SUPPLY |
| HORIZONTAL and VERTICAL PLATE and GRID DRIVE | AGC KEYING PULSE |
| B+ BOOST INDICATOR | PICTURE TUBE MODULATION |

B&K

B & K MANUFACTURING CO.
1801 W. BELLE PLAINE AVE • CHICAGO 13, ILL.
Canada: Atlas Radio Corp., 50 Wingold, Toronto 19, Ont.
Export: Empire Exporters, 277 Broadway, New York 7, U.S.A.

See Your B&K Distributor or Write for Bulletin AP17-R

SIMPLIFIED INVENTORY CONTROL SYSTEMS

THAT WORK!

RESISTORS 1/2 W

	1/16	1/8	1/4	1/2	1/10	1/20	1/40	1/80
220K	5	-	2	3	10	12	2	10
330K	8	-	1	7				1
390K	3	-			1	2		10
470K	11	1	10	4	6	2	24	5
560K	8	-	1	7				1
680K	7	-			1	6		
820K	4	-						
1 meg	9	1	0					

Almost anyone who is responsible for making a profit from a service shop will agree that an accurate inventory-control system very often makes the difference between showing a profit or a loss. A properly handled system not only minimizes the number of parts that disappear from stock without being billed to a job, but also shows which tubes, parts, and accessories are fast-movers and can be purchased in larger quantities. In addition, perpetual inventory records indicate what's being sold and what isn't, making it possible to reduce stocks of slow-moving parts and invest your money in items that sell faster.

In a recent check of several service operations, we found that few actually made use of any worthwhile inventory-control system—apparently because the owners did not know how to develop a plan that would supply the right answers with a minimum amount of work. Those shops with workable systems tailored them specifically to their personnel, their volume of work, and the size of their stock.

Every one of these systems we analyzed had a fundamental similarity—they all provided a running inventory of every item stocked. Normally, the initial count was obtained either from the tax-reporting records, or from copies of invoices. Once the original list was made, the methods of keeping it current varied greatly.

One of the simplest systems we found was used in a shop employing a bench man, an outside technician, and a girl who answered the telephone and waited on counter customers. One copy of this shop's itemized repair bills is turned over to the girl when each job is completed. She then posts the total usage figures for each type of component at the end of every day. For example: Three 1X2A tubes, two .01/600-volt capacitors, two 470K resistors, etc.

The record is kept in a ledger that lists everything kept in inventory. A new list is made at the start of each year, when the physical count is taken. Items are listed in categories (tubes, capacitors, speakers, etc.) thus making it relatively simple for new items to be added. At the end of every week, the total usage figures are recorded in the ledger, and a new total is posted. Wednesday is the last day of the weekly recording period, since the distributor salesman normally calls on Thursday. As new items are received, the figures posted in the ledger are preceded by a plus sign to distinguish them

from those indicating usage.

The shop manager (who is also the owner and bench man) is able to tell at a glance how his stock is moving—just by leafing through the ledger. Since the system has been in use, he has been able to rid his stock of items called for only once or twice a year. Another advantage is that he now orders parts only once a week—except for picture tubes and certain other specialized parts. This has cut his costs and helped him to make better use of his working capital by increasing his turnover. Emergency trips to the distributor have also been reduced to a bare minimum, saving a considerable amount of time (and time is money!).

We found a one-man shop employing a minor variation of this same system. The owner uses a loose-leaf ledger to record usage figures at the end of each day. At the end of the week, he uses the daily figures to compute weekly balances—which tell him what quantities of what parts to order. On the average, it takes him between 5 and 10 minutes a day for the book work, and about 30 minutes to determine weekly balances and new stock requirements.

These two systems work because they are based on one important principle—keeping track of parts used and purchased. Even the most elaborate systems contain the same basic ingredients; they've just been expanded to accommodate larger stocks and increased volume . . . or to provide more refined information.

STOCK REQUISITION

Part	No.	Description	Job No.
470K	2	1/2 W resistor	10305
Antenna	1	rabbit ear	10298
6AV6	2	tube	10304
6AV6	1	"	10309
6DQ6	1	"	"
N-14	1	1/4 amp fuse	"

1/26/61
Date

John Doe
Technician's Signature

For example, suppose a shop handles enough business to employ several technicians—perhaps a half dozen or more. Each man is supplied with an initial tube and component stock for which he is responsible. All job tickets are assigned numbers, and replacements for parts used on each job are requisitioned by the technician. For this purpose, he uses a stock requisition form, filling in the job number for each item. Parts used are also shown on the job ticket for billing purposes, but this record is not used in the

inventory system, except when a double check is necessary. This plan also makes it easy for a technician to draw parts before they are used. If he thinks he may need an antenna, or a special tube or component for one of his scheduled jobs,

470K - gw	Resistors	airman - 20
1/16	5	114
1/8	4	111
1/4	2	114
1/2	3	111
1/10	7	111
1/20	2	111
1/40	2	111
1/80	4	111
1/16	4	111
1/8	2	111
1/4	2	111
1/2	1	111

he merely enters the item and the job number on his daily requisition form. Bench men also draw needed parts against the job tickets, which accompany receivers brought in for shop service.

The stockroom record itself can be kept by one of the girls, a bench technician, or the shop manager. Daily entries can be kept in a ledger, although 3" by 5" file cards are more appropriate for larger inventories. After the system is in use for a short time, a minimum allowable stock can be established for each item. As the minimum is approached, the item is placed on order. The same stock-evaluation program discussed earlier can be used to determine when, and in what quantities, to buy required parts. When ordered parts are delivered, they are added to inventory and recorded on the cards.

In all of these perpetual inventory systems, we found a provision for listing parts needed, but not on hand. Generally, if the same item was required more than once a month, it was added to the stock inventory, assigned a quantity of one, and periodically checked for increased or decreased demand. As a result, the most-needed parts are always on hand, and very little capital is invested in seldom-needed items.

Of course, no system will work unless everyone follows the rules to the letter. This means whoever is responsible for posting the figures must be reliable and accurate. Even, then, it may be necessary to follow up occasionally, as a check against human error, pilferage, etc. In this day and age, slipshod methods just won't do—success or failure depends on making every penny count. As you can see, an accurate perpetual inventory system will help immeasurably. Why not start yours today?

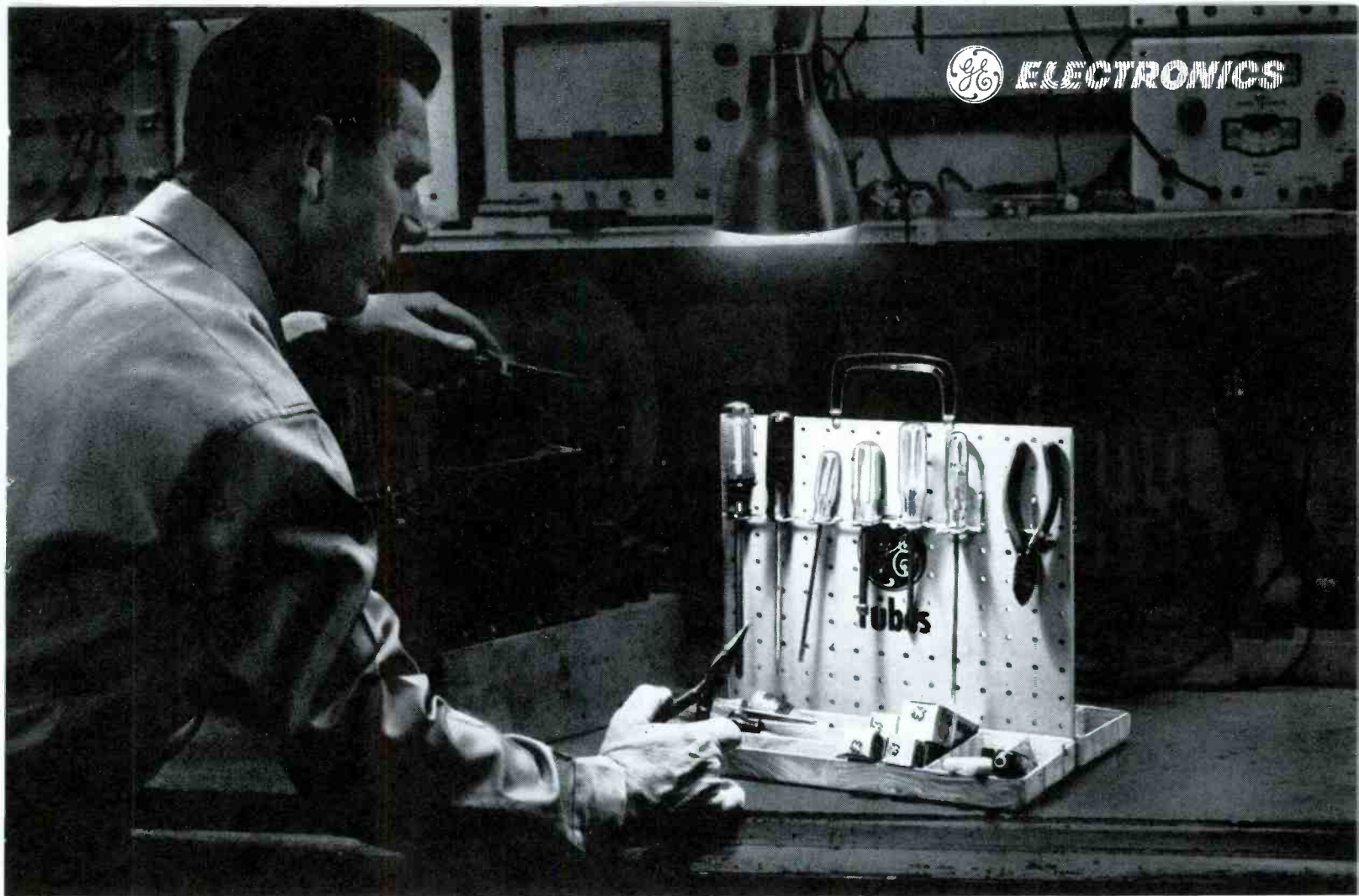

New G-E Tool Toter puts tools and parts at your fingertips

No more digging for the right tool—not with this handy new G-E Service Aid. The Tool Toter. Measures just 11" x 14", 12" high. It's especially designed to go along wherever tools are needed: on the bench, on the counter, on the job or for general maintenance. Pegboard with tool holders keeps screw drivers, pliers, nut drivers, etc., clearly visible and easily removed or replaced. High-impact plastic trays hold screws, nuts, lockwashers, fuses, and other small tools or parts that are needed on-the-spot. Order your Tool Toter today—helps make service calls more profitable. Saves your time and your temper. ETR-2338 Tool Toter.

These are the three newest in the series of G-E Service Aids which can make your work more pleasant and more profitable. Useful tools especially designed by service technicians for service technicians. Get them from your General Electric tube distributor, or mail coupon to Chicago warehouse address given. Distributor Sales, Electronic Components Division, General Electric Company, Owensboro, Kentucky.



Two More in the Series of G-E Service Aids

Four-Edged Wire Stripper Saves Time—Handles All Wire Sizes
Here's the easy way to strip off insulation, without nicking the wire: Press insulated wire into cutting channel—rotate wire stripper around wire and pull. Easy! 4" plastic handle. ETR-2376 Wire Stripper.

New Forked Soldering Tool Easy to Use in Tight Spots
Plastic handle makes it easy to hold and use • 6" long • Rod sealed in plastic—will not pull out • Forked tool best for removing soldered wires • ETR-2377 Soldering Tool.



Progress Is Our Most Important Product

GENERAL  ELECTRIC

GENERAL ELECTRIC COMPANY, DEPT. B
3800 N. Milwaukee Ave., Chicago 41, Illinois

Please ship, prepaid:

..... ETR-2338 Tool Toter, \$3.00 ea. or \$2.50 plus
10 G-E 6 volt series tube carton tops.

..... ETR-2377 Soldering Tool, 60¢ each.

..... ETR-2376 Wire Stripper, 50¢ each.

My check or money order is enclosed for the required amount plus any sales or use tax applicable in my area.

Name

Address

City Zone State

overcoming

COLORITIS

Never mind the fancy terminology — Color-TV circuits work basically the same as black and white . . . Joe A. Groves

One of the bright spots in the field of radio-television service is the way the "old pros" have swung onto the color TV bandwagon. Daily, more and more competent technicians, well skilled in the art of black-and-white TV service, are adding color TV to the list of services they offer.

However, many competent men are holding back — mostly because they are afflicted with a good case of *coloritis*. This is a negative disease that affects the thinking patterns of servicemen; it can be compared to another disease known as *transistoritis*, which filled many with doubt before they found the proper antidote. In the paragraphs to follow, you'll learn how to apply your knowledge of black-and-white TV circuitry to overcome coloritis.

All too often we "can't see the trees for the forest." Confounded by colorimetry, subcarriers, and vector relationships, we overlook the obvious fact that color receivers employ ordinary circuits — with tubes, resistors, capacitors, and

coils — not unlike those used in monochrome sets. Furthermore, about two-thirds of the circuitry of a color receiver is practically the same as for an ordinary black-and-white set. No wonder, then, that most of the troubles encountered when servicing color sets have to do with black-and-white operation!

When you stop to think about it, the burst amplifier, chroma-sync phase detector, chroma-oscillator control, and chroma-oscillator circuits (Fig. 1) can be compared with the familiar sync-separator, horizontal-AFC, and horizontal-oscillator circuits. Take the long-handled names off, change the operating frequency from 15,750 cps to 3.58 mc, and lo and behold — the circuits look familiar! About the only big difference is that a horizontal oscillator feeds a power output stage, while a chroma oscillator simply provides enough output to key a couple of demodulators into conduction.

The color-killer circuit of Fig. 1 is very similar to a conventional

keyed AGC circuit. The tube is keyed into conduction by a pulse from the flyback transformer, and a negative voltage is developed at the plate. This voltage can be adjusted with the killer threshold control to cut off the chroma band-pass amplifier when no color signal is present, thus preventing the color circuits from operating. With a color signal present, the burst signal (3.58-mc sync input) increases the bias on the killer, reduces the negative voltage on its plate, and permits the chroma bandpass amplifier to conduct.

Fig. 2 shows the chroma band-pass amplifier, the take-off from the chroma oscillator, and the demodulator circuits of a typical color set. Stripping away the names of these circuits and applying more familiar terms like "3.58-mc IF amplifier" and "color detectors" makes them easier to understand. The detector circuits are different from an ordinary video detector in that they have a controllable input, are keyed into conduction by pulses from the 3.58-mc oscillator, and provide signal amplification. The take-off circuit from the 3.58-mc oscillator includes components to provide the required keying-signal phases for the two detectors to recover the signals for the B-Y and R-Y amplifiers. Ignoring the -Y, which is handled by the video output stage, we can justifiably call these the blue and red output stages. The cathodes of these stages share a common resistor, which also serves to provide an input signal for the green output stage. The signals at the plates of the three color-signal output stages are fed to the control grids of the respective CRT guns.

Convergence circuitry has no direct comparison in conventional black-and-white television. However, systematic tests with an ohmmeter, and waveform analyses of the signals fed to the circuits, make

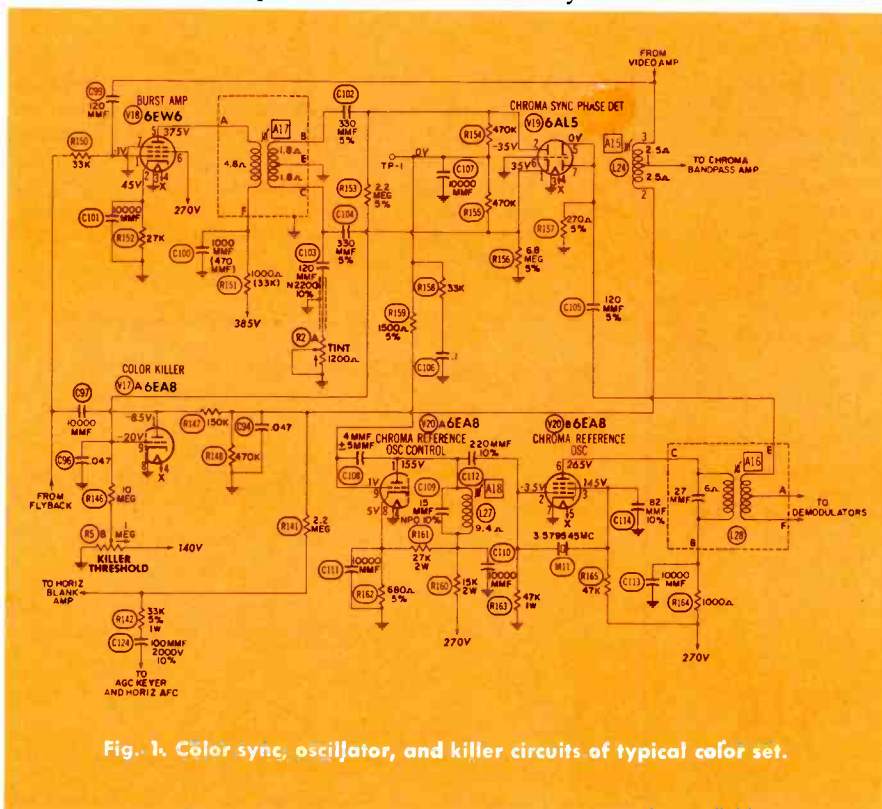

Fig. 1. Color sync, oscillator, and killer circuits of typical color set.

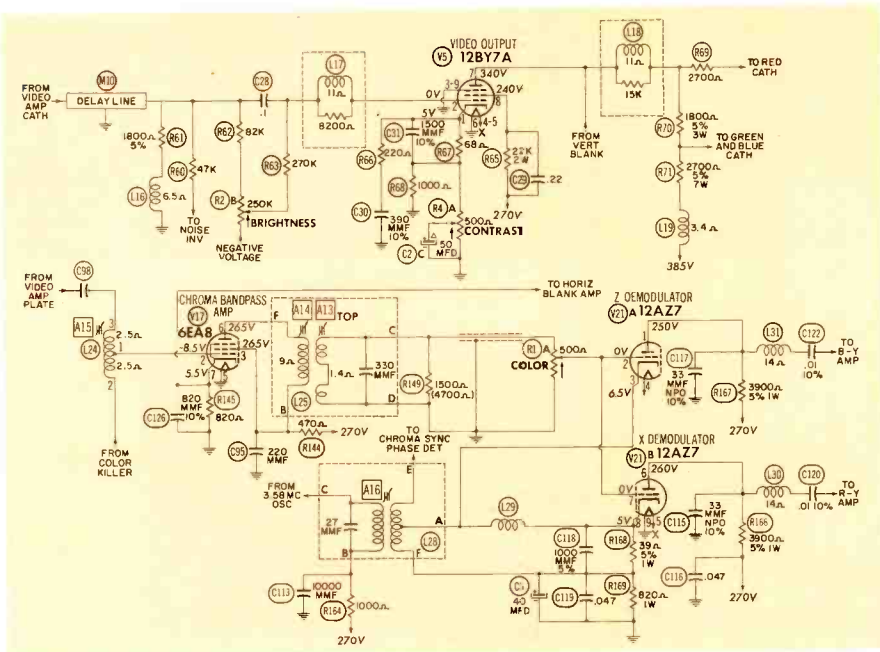

Fig. 2. Color IF (bandpass) and demodulator circuits of typical color set.

them relatively easy to check.

Localizing the Trouble

While the manner in which you approach color TV service will depend on your normal troubleshooting procedures, you may have to adopt more refined techniques. If you're a "scope man," you'll have little trouble telling if the stages are operating as they should. If you're a "VTVM man," you'll be confronted with situations where the voltages won't change by more than 10% with trouble present.

Another factor which must be considered is the problem of not having a color signal to trace when troubleshooting color circuits. While you may find that you can do most of your color servicing during color-programming periods, the signal from your own color-bar generator will serve your needs better. For one thing, you'll soon learn what signals to expect at different points in the color circuits because the input signal is the same at all times. For making convergence adjustments, you'll also need a dot and cross-hatch generator — a unit that will prove a worthwhile addition to your black-and-white equipment if you don't already have one. Fortunately, there is an ample supply of moderately-priced test equipment to choose from.

As noted earlier, most of the troubles that develop in color receivers affect monochrome reception as well. For locating these troubles, the familiar techniques

used in conventional sets will serve quite well. For strictly color trouble, however, you may have to refine your techniques to quickly determine what general area is harboring the trouble.

To simplify things, color circuits can be classified as groups of circuits which perform certain functions. Take, for example, the color-synchronizing circuits previously compared to horizontal circuits. The entire color sync, AFC, and oscillator chain can be checked for over-all operation first. If trouble is indicated, the individual stages can then come under scrutiny. By the same token, color IF (bandpass), detector, and output circuits (the "color video" group), can be given an over-all check prior to individual circuit consideration.

Getting Down to Business

To pinpoint the general trouble area as fast as possible, make your initial tests at the demodulators (Fig. 2). If you're using a VTVM, critical cathode-voltage measurements will tell you if the oscillator signal is present. Without it, the cathode voltage will drop roughly 25%. Plate voltage, on the other hand, may not change even 10%. It's almost impossible to use voltage measurements to determine if color information is reaching the demodulators.

Using a low-capacitance probe and a wide-band scope, the wave-

• Please turn to page 58

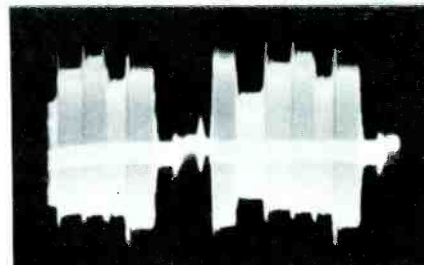

(A) Demodulator grid signal.

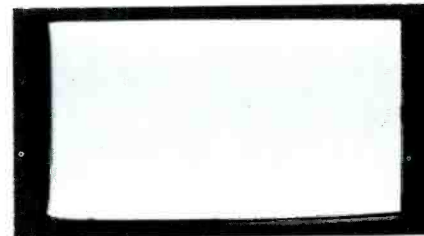

(B) 3.58 signal at cathodes.

Fig. 3. Demodulator input signals hold important clues for troubleshooting.

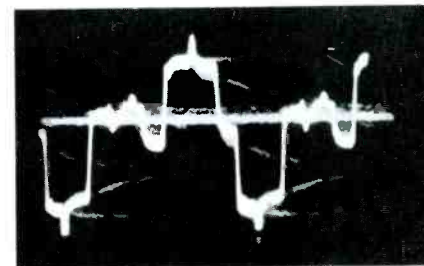

(A) X output feeds R-Y amplifier.

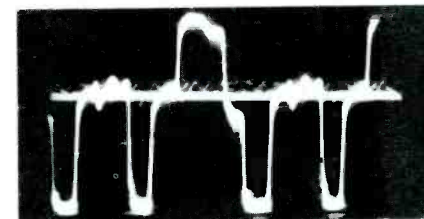

(B) Z output feeds B-Y amplifier.

Fig. 4. X and Z demodulator signals to the red and blue output stages.



(A) Chroma shows in plate waveform.

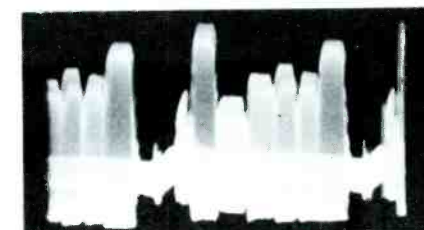

(B) Input chroma signal at the grid.

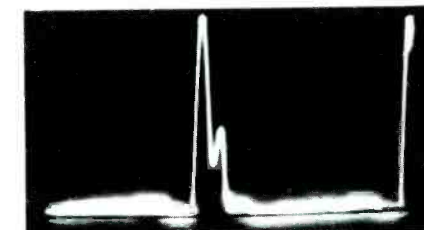

(C) 20V p-p waveform at the cathode.

Fig. 5. Normal chroma bandpass-amplifier waveforms when color is present.

With spring almost upon us, and summer just under the next couple of calendar pages, it's time to get ready for the portable-radio rush. Here are some bench-tested techniques to expedite servicing of these midget transistorized sets.

TRANSISTOR-

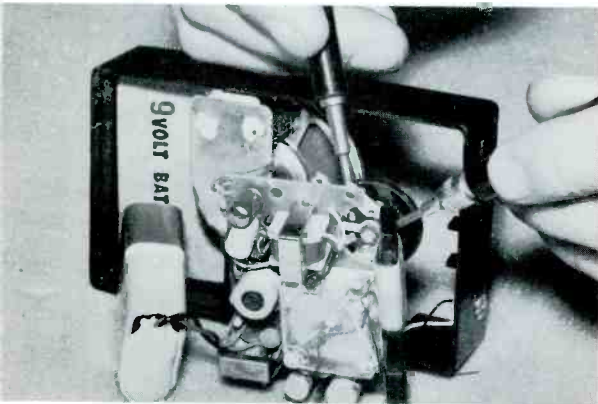

Current Clues

Measure the total current drain. If you don't use a bench supply with built-in meter, simply bridge a milliammeter across the power switch as shown. Typical portables will draw from about 5 to 20 ma (less without signal). Zero current often points to a poor solder joint, open switch, or broken conductor. Excessive current indicates a shorted conductor, a defective transistor, or a leaky electrolytic. Low current may mean an inoperative output circuit; but remember, a transistorized push-pull stage draws little current with no drive signal.

Check Each Stage

Purposely short between the base and emitter of the transistors, one at a time, and check for a slight decrease in current drain. It may be easier to work on the foil side of the board, as pictured here. If the current is too high to begin with, and shorting one transistor causes a considerable drop, this stage is incorrectly biased or else the transistor itself is faulty. If a current change cannot be detected, the stage is not drawing sufficient current to function properly; this, too, may mean a bad transistor.

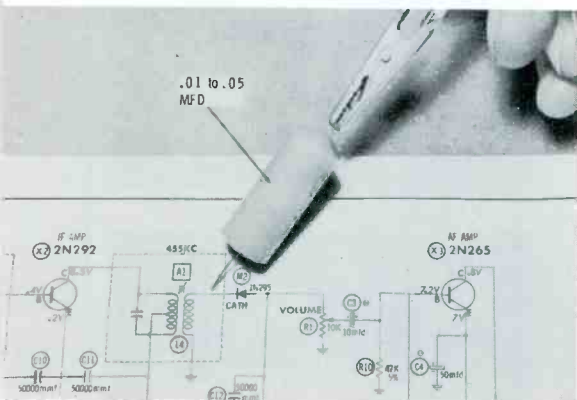
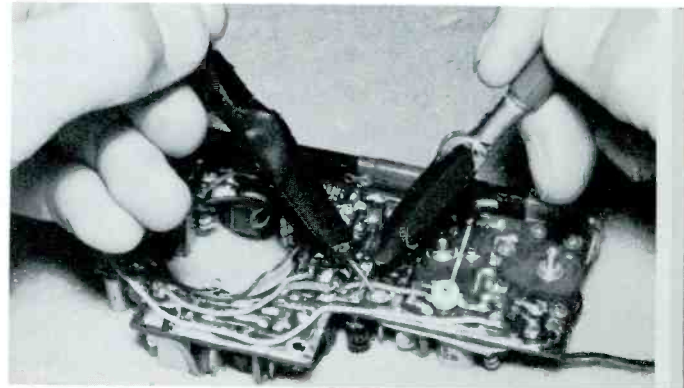

Signal Tracing

When injecting a test signal, place a capacitor in series with the generator lead. Direct feed into a low-impedance transistor circuit may provide insufficient signal, or the generator output may swamp or detune the stage. In this case, you may also find yourself advancing the generator output to obtain a tone. This procedure is not really testing the signal path, since the tone can be driven through by brute force. A different solution is to use a small probe-type noise generator that requires no grounding to chassis.

Oscillator Check

A simple and safe method of testing an oscillator is to set the tuning gang in the fully-closed position and place another normally-operating superhet radio (tube or transistorized) close by. If the oscillator in the defective receiver is working, you'll detect a whistle or squeal in the speaker of the good receiver when it is tuned near the middle of the dial, and possibly also near both ends.

An alternate technique is to monitor current through the converter stage while shorting out the oscillator coil.

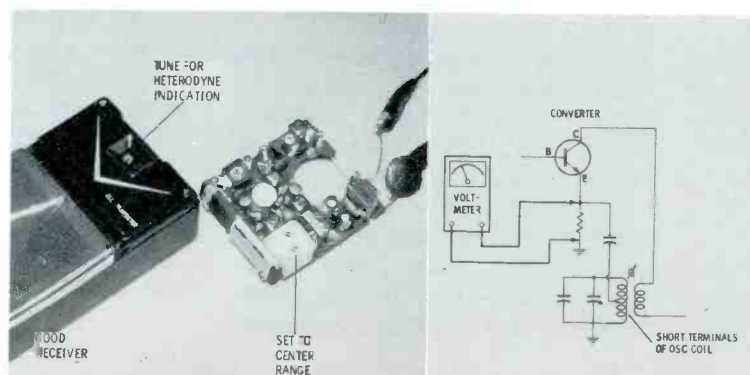

TAILORED TECHNIQUES

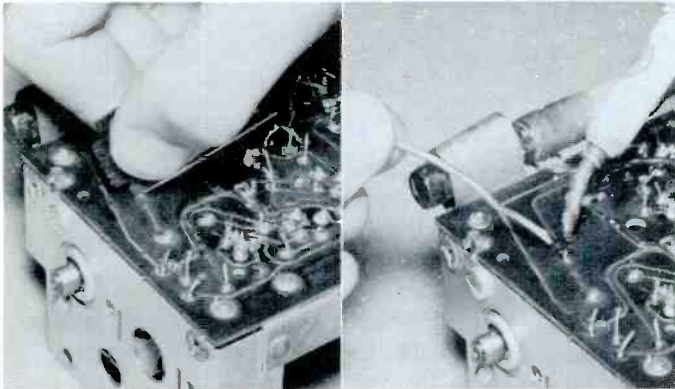

Foil-Cutting Trick

Cutting the printed foil is not as destructive as you might think. A worse enemy of these miniature printed circuits is a hot soldering tip. By unsoldering parts for testing, you're apt to create troubles such as shorts, sweating the foil from the board, or overheating a transistor. Foil-cutting is a more expedient and far-safer way to isolate shorts and check resistances. To restore circuit continuity, simply bridge the cut with solder; but wield the hot iron as though you were heating something on the back of your hand.

Check Your Ohmmeter

Many transistors have maximum voltage ratings of 10 to 20 volts, and maximum current capabilities of 10 to 15 ma. Miniature electrolytic capacitors also have low voltage ratings from about 3 to 12 volts. When using either a VTVM or VOM to measure resistance, you can very easily exceed these values and thereby damage vulnerable components. Test your meter as shown, and use only those resistance ranges that involve both low current and low voltage.

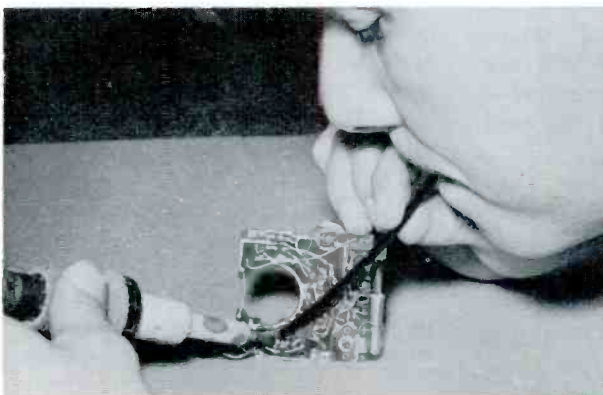
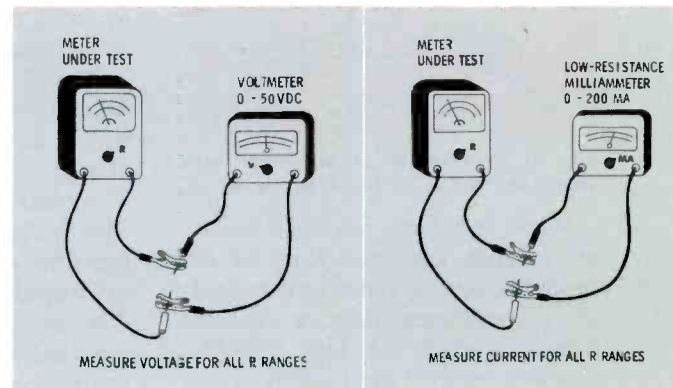

Blow Solder Away

Instead of holding the hot tip of an iron on a connection while you wiggle or pry a lead free, apply the heat quickly and blow the solder off the contact, using an ordinary soda straw or piece of spaghetti insulation. With all solder removed from around the lead, it may be withdrawn easily. Watch out for flying solder, however, which could cause a short at another point on the board.

Small Tools a Must

Aside from the items pointed out in the first picture, you should have a pair of tweezers, a set of very small screwdrivers, a miniature-tipped iron, a magnifier, and all test leads and probes modified for close, tedious work. You might also stock some extra-small components such as 1/6-watt resistors. By the way, to save trouble in reading values of capacitors like those in the second photo, here are some equivalents: 103P = .01 mfd; 203M = .02 mfd; and 502M = .005 mfd.

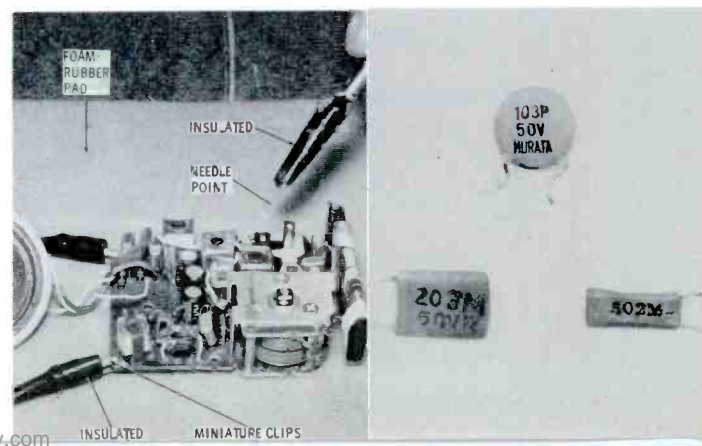

By Alan Andrews

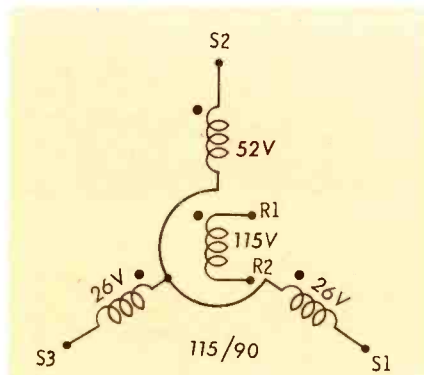

Fig. 1. Synchro is at electrical zero when the rotor is lined up with S2.

While synchros are high-quality units which can give years of dependable service under proper operating conditions, they do develop troubles from time to time. Troubleshooting involves mechanical as well as electrical considerations. In addition, the main operating advantage of synchros—the wide separation between transmitting and receiving units — becomes a complicating factor from the standpoint of service. Careful analysis of trouble

symptoms is the most effective way to overcome this problem.

General Troubles

The most common troubles in a newly-installed synchro system are improper zeroing of the synchro units, wrong connections, or failure to use a common power source for all the rotors.

The above faults can usually be disregarded in dealing with failures which have occurred in a system after a period of normal operation. Troubles often encountered in this case are opens, shorts, or grounds in synchros or connecting wires; loose or frayed connections; water, oil, dirt, or corrosion in the system; or mechanical troubles with shafts, bearings, gears, or couplings. Since the synchro generator has a mechanically-positioned rotor which is not free to rotate "on its own," symptoms of electrical trouble will not often be noticed at the generator—even when the fault is in this unit itself.

ship, it may be the heading or bow. For industrial use, almost any arbitrarily-chosen direction can be used, depending on what is being controlled.

Probably the easiest and most reliable method of electrical zeroing is the use of an AC meter and a source of voltage. For synchro generators and motors, electrical zero is defined as the angular rotation at which the R1 end of the rotor coil is in line with stator coil S2, as shown in Fig. 1. This is a 115/90 unit, so the maximum single-coil stator voltage is 52 and the S1 and S3 voltages are both 26. The phasing dots indicate that the S2 voltage is in phase with R1, the reference end of the rotor. S1 and S3 voltages are opposite in phase, compared to S2.

At electrical zero, a voltmeter connected from S1 to S3 would show zero, so it might seem that this test would be usable for zeroing. However, if the rotor is rotated 180°, all of the stator phases change, but the S1-S3 voltage is still zero; therefore, any zeroing procedure must include a test to find out if the rotor is at 0° or at 180°.

To zero a synchro generator or motor, first connect it as shown in Fig. 2A to determine a coarse set-

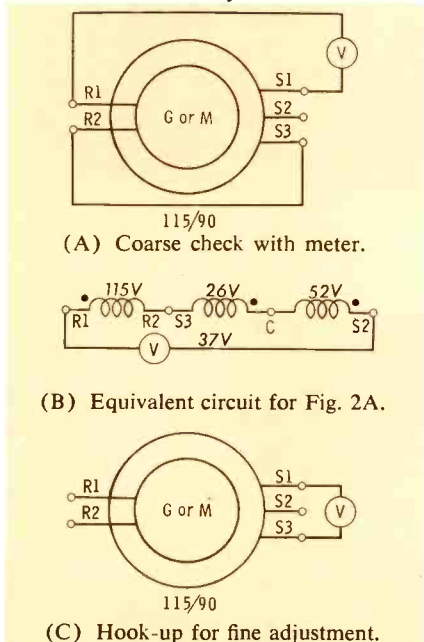

Fig. 2. Zeroing a generator or motor.

Zeroing Synchros

For proper operation, all synchros in a system should be zeroed with respect to each other. This is a must before a newly-installed system is put into operation, or after completion of repairs on an existing system. The easiest method of alignment is to line up all the units to electrical zero, and then set the mechanical references as desired. The latter procedure consists of turning the housings of the units so that all the rotor indicators point to the correct angle of rotation, and rigidly securing the housings to maintain the proper angle.

The mechanical reference depends on the system application. For compasses or antennas, the reference point may be north; on a

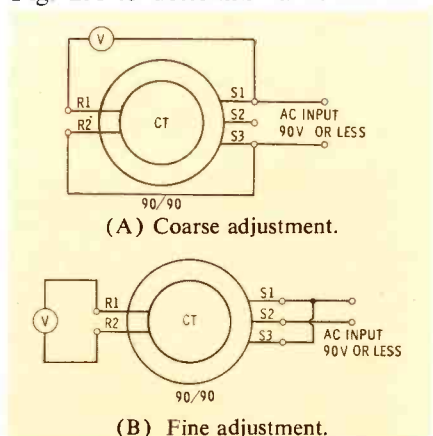

Fig. 3. Zeroing control transformer.

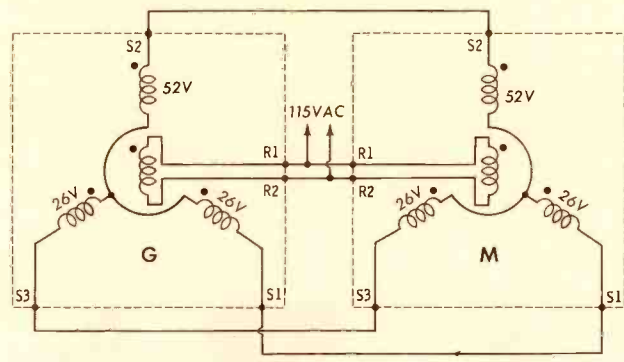

Fig. 4. Standard synchro generator and motor connections.

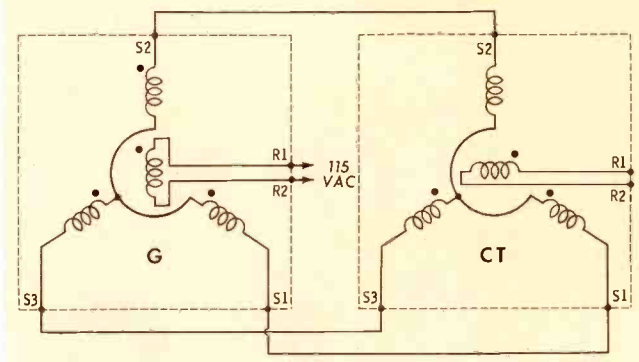

Fig. 5. Interconnections for generator and control transformer.

ting. With R2 connected to S3, a meter reading of about 37 volts should be obtained between terminals R1 and S2 when the rotor is at zero. In this test, the rotor is connected in series with coils S2 and S3 as shown in Fig. 2B, and the two stator voltages (78 volts total) oppose the rotor voltage (115 volts) to give a difference reading of 37 volts.

If the rotor is set at 180°, its voltage will be in phase with the S2 and S3 voltages, and all three will add to give a reading of about 193 volts. The voltages will be different if differently-rated synchros are used. In all cases, however, the reading from R1 to S2 should be considerably less at 0° than at 180°.

This test gives a coarse setting of electrical zero. To finish the job, the synchro should be connected as shown in Fig. 2C. Starting at the point where minimum voltage was obtained before, the rotor is turned very slightly until the voltmeter reads zero across S1 and S3.

The connections indicated in Fig. 2A are not the only ones which can be used for the coarse-zeroing test. For example, R1 could be connected from S1 to R2, and a minimum voltage reading would still occur at the zero position. Very often the stator and rotor of a synchro have

marks which can be lined up to give the approximate zero position.

Control transformers can be zeroed somewhat similarly, but since AC is not normally applied to the CT rotor, it is necessary to feed an AC input voltage to the stator coils. The circuit of Fig. 3A can be used first as a coarse adjustment. R2 is connected to S3, and an AC input is applied across S1 and S3. A voltmeter is connected between R1 and S1. In order to prevent damage to the units, the applied voltage should not exceed the rating (90 volts across any two stator terminals in the unit of Fig. 3A). Actually, some synchros can be zeroed by using only about 6 volts AC.

With connections as shown in Fig. 3A, the rotor or stator is turned to produce a dip in the meter indication. The minimum reading obtained is usually very close to half the applied voltage, or 45 volts in the case shown. After this step, the supply voltage and meter should be reconnected as in Fig. 3B, and a finer adjustment made to the rotor or stator in order to obtain minimum voltage across the rotor coil.

In a conventional hook-up of a synchro generator and control transformer, the CT rotor output is zero volts when both units are properly zeroed. Turning the CT rotor counterclockwise produces an output voltage in phase with the generator-rotor voltage, while clockwise rotation results in an out-of-phase output voltage.

relative direction of rotation or introducing a constant angle of lead or lag.

Three general types of changes can be made without resulting in overheating or altering the torque characteristics. Reversing the rotor leads on one of the units introduces a constant error of 180° without changing the direction of motor rotation; reversing two stator leads on one unit causes the motor to turn in the opposite direction from the generator, as well as introducing an error angle; and changing all three stator connections on either synchro creates an error angle other than 180° without reversing the motor rotation. The exact results are summarized in Table I for a synchro generator-motor hook-up (not applicable to control transformers or other units). All angles in this and succeeding tables refer to positive rotation in the counterclockwise direction.

In a control-transformer hook-up (Fig. 5), reversing the rotor connections of either unit simply reverses the phase of the output voltage obtained from the CT rotor. Reversal of any of the stator leads causes an angular error in the input to the CT stator coils, thus creating an incorrect output from the rotor.

Table I — Reversed Connections

STATOR CONNECTION CHANGES	MOTOR DIRECTION COMPARED TO DIRECTION OF GENERATOR	WHEN GENERATOR IS SET AT ZERO, THE MOTOR POINTS TO:	
		WITH NORMAL ROTOR CONNECTIONS	REVERSED ROTOR CONNECTIONS
S1 and S2 REVERSED	OPPOSITE	240°	60°
S2 and S3 REVERSED	OPPOSITE	120°	300°
S3 and S1 REVERSED	OPPOSITE	0°	180°
S1 to S2, S2 to S3, S3 to S1	SAME	120°	300°
S1 to S3, S2 to S1, S3 to S2	SAME	240°	60°

Reversed Connections

Most synchro generator-motor systems use the standard connection pattern in which all like-numbered terminals are connected together (Fig. 4). In some cases, however, certain of these connections can be reversed to produce a specific desired result—either changing the

Shorts and Opens

Table II lists the symptoms

• Please turn to page 66

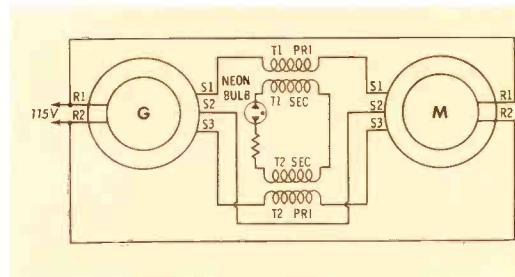

Fig. 6. Bulb lights to indicate excessive stator current due to motor lag.

THE SECRET SOURCE OF ...



Ever fix a TV troubled with no picture or sound by just changing the audio-output tube? Or, how about fixing one displaying weak video and critical sync by replacing a leaky grid-coupling capacitor in the audio-output circuit? The symptoms may seem a bit peculiar for the components involved, but these situations can and do happen in receivers which use the audio-output cathode as a source of low B+.

Don't be misled, however; the output tube does not generate B+ voltage—it merely functions as a voltage divider. Certain TV stages require positive potentials much lower than the output of the B+ supply; therefore, a distribution system capable of considerable wattage dissipation is often used to obtain this reduced voltage. Since output tubes are generally capable of handling the extra power, the final audio stage is very often selected for the job.

Fig. 1 shows a conventional circuit using a beam-power tube as both audio output and B+ divider. High B+ (270 volts) from the power supply is applied to the decoupling or dropping resistor R4. Its value may range from 220 to 680 ohms, and since it carries both plate and screen currents, its power rating is usually 2 to 5 watts. This resistor drops in the neighborhood

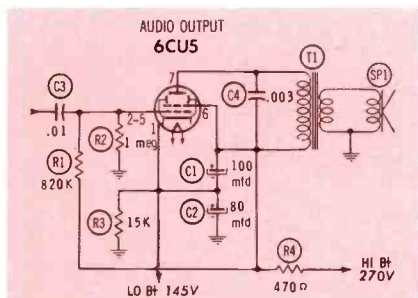

Fig. 1. An audio output stage that can disrupt picture, sound, and technician.

of 20 volts, thus placing the output screen at about 250 volts. The audio output transformer drops an additional 10 volts or so, which leaves about 240 volts for the plate. The drop across the tube itself, during normal operation, is on the order of 95 volts. Thus, the potential at the cathode ends up at approximately 145 volts.

This reduced B+ source generally supplies a number of stages, including the sound IF, video IF, video amplifier, and sync; sometimes it also biases the cathode of the CRT or AGC keyer. The 15K-ohm resistor R3 is by no means a cathode return for the output stage. Ground return is actually through the many other conducting tubes. Resistor R3 is effectively a regulating bleeder; if it opens or increases in value, you may detect a slight step-up in voltage, but little or no change in over-all set operation. Should this component decrease in value, however, voltage will drop and trouble symptoms will affect both picture and sound. (See Fig. 2.)

Electrolytics C1 and C2 serve as bypass filters and decoupling capacitors. If either capacitor shorts, you've got trouble—usually no picture and no sound. The raster may remain, especially if the set is not fused; at any rate, you'll undoubtedly find R4 wide open. If either capacitor opens, voltage and resistance checks may not give you a clue, but the symptoms will; the sound will buzz or have a hum in the background, and the picture will have a tendency to overload.

With proper filtering in the main power supply, you'll encounter little ripple on the low B+ line. The normal peak-level should be less than 1 volt. If it becomes greater

• Please turn to page 32

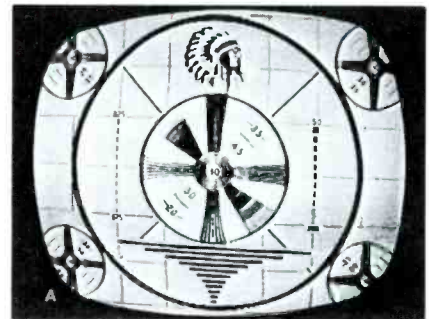

(A) Overload

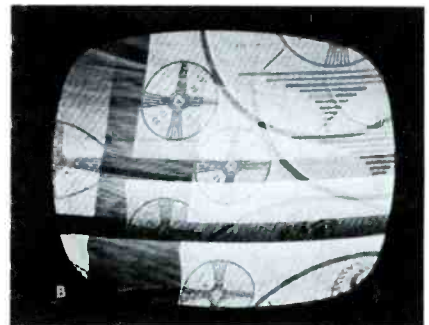

(B) Loss of sync

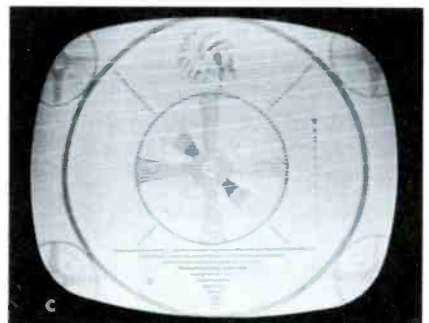

(C) Weak video

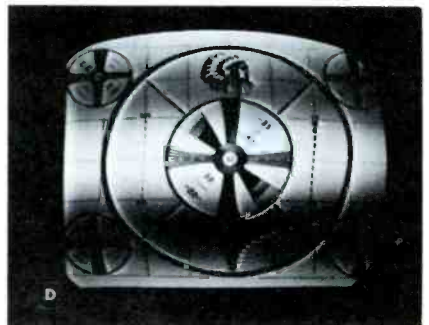

(D) Hum modulation

Fig. 2. Troubles originating from the audio output voltage-divider circuit.

NEW SENCORE Transi Master

**Analyze Every Transistor Circuit
Trouble in Minutes!**

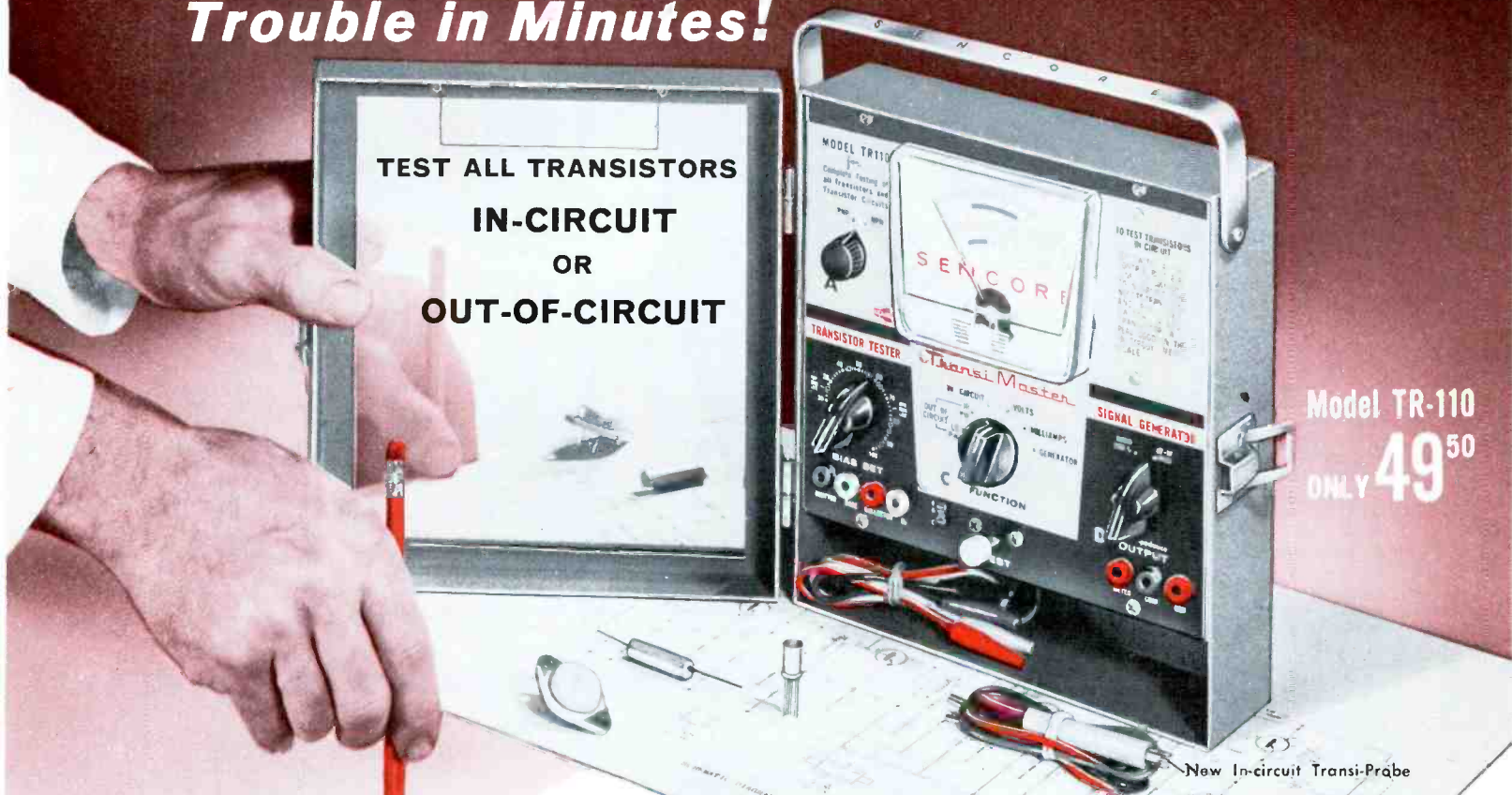

**TEST ALL TRANSISTORS
IN-CIRCUIT
OR
OUT-OF-CIRCUIT**

Model TR-110
ONLY **49⁵⁰**

New In-circuit Transi-Probe

Now you can...

**It's a... COMPLETE TRANSISTOR TESTER • SIGNAL TRACER
VOLTMETER • BATTERY TESTER • MILLIAMETER**

Transistors are tested in-circuit with a new unique AC GAIN check and out of circuit with an accurate DC GAIN and LEAKAGE check. Set-up chart included for reference only.

- Test all transistors in-circuit with a new unique AC GAIN check. It works every time and without the use of the set-up booklet.
- Test all transistors out of circuit with the AC GAIN check or with a more accurate DC current gain and leakage check.
- Read current gain (beta) direct for experimental, engineering work or for matching transistors.
- Check diodes simply and accurately with a forward to backward ratio check.
- Signal trace from speaker to antenna with a special low impedance generator. No tuning, adjustments, or indicating device needed for transistor radio trouble shooting. Just touch output leads to transistor inputs and outputs until 2000 cycle note is no longer heard from speaker. (Generator output monitored by meter.) It's a harmonic generator for RF-IF trouble shooting and a sine wave generator for audio amplifier trouble shooting.
- Check batteries under operating conditions as well as the voltage dividers with a special 12 volt scale.
- Monitor current drawn by the entire transistor circuit or by individual stages with a 0 to 50 Ma current scale. A must for alignment and trouble shooting cracked boards.

Benefit from these Sencore extras

- Lists Japanese equivalents.
- Automatically determines NPN or PNP.
- Mirror in detachable cover to reflect opposite side of printed board.
- Special clip to fit between batteries for current check.
- Transi-probe for making in-circuit transistor checks.

Color.....modern two tone gray
Size.....8" x 7⁵/₈" x 3"
Weight.....only 5 lbs.
Meter.....0 to 3 Ma, 3¹/₂", 5% tolerance,
modera plastic
Batteries.....two size "C" cells

ALL PARTS ARE **SENCORE** MADE IN AMERICA

SENCORE
ADDISON, ILLINOIS

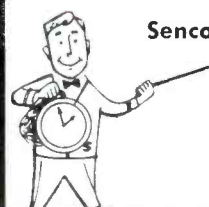

Sencore Sam says, "You'll save hours servicing transistor circuits. Only 49.50, see it at your distributor."

SENCORE

Most Popular Time Savers for Servicemen, Technicians, Engineers, Maintenance Men, Hobbyists!



"MIGHTY MITE" TUBE CHECKER

Smaller than a portable typewriter . . . yet will outperform testers costing hundreds of dollars.



\$5950

A new dynamic approach to tube testing. Check over 1,300 tubes for cathode emission, grid emission, leakage, shorts and gas. A "mite" to carry but a whale of a performer that outperforms testers costing much more. New unique "stethoscope" approach tests for grid emission and leakage as high as 100 megohms yet checks cathode current at operating levels. Special short test checks for shorts between all elements. The Mighty Mite will test every radio and TV tube that you encounter (over 1,300!) plus picture tubes. Set up controls as easy as "ABC" from easy to follow tube chart. New features: • Meter glows in dark for easy reading behind TV set. • Stainless steel mirror in cover for TV adjustments. • Rugged, all steel carrying case and easy grip handle. • Smallest complete tester made. Measures only 9" x 8" x 2½" and weighs just seven pounds.

It's a real money-maker

LC3 LEAKAGE CHECKER

Provides grid emission and leakage checks with the same sensitivity as the famous Mighty Mite but checks critical tubes only; 172 types

\$2895



Ask any serviceman who owns one . . . or try one for just one day of servicing. You'll see for yourself how much time the LC3 can save you. Checks for leakage between all elements, whether caused by gas, grid emission or foreign particles. Also checks leakage on all capacitors with voltage applied — including electrolytics. Provides instant filament checks in "Fil-Check" position—no need for a second filament checker. One spare pre-heating socket and new roll chart prevent obsolescence. New charts provided free. For 110-120 volts, 60 cycle AC.

SENCORE SS105 SWEEP CIRCUIT TROUBLE SHOOTER

The Missing Link in TV Service . . .

IT'S A . . . UNIVERSAL HORIZONTAL OSCILLATOR.

For direct substitution. No wires to disconnect in most cases. Traces trouble right down to the defective component. Variable output from 0-200 volts, peak-to-peak. Oscillator will sync to TV sync signal giving check on sync circuits.

HORIZONTAL OUTPUT CATHODE CURRENT CHECKER. A proven method that quickly checks the condition of the horizontal output tube and associated components. Adaptor socket prevents breaking wires. Easily replaceable Roll Chart gives all necessary pin, current and voltage data. New Roll Charts are Free.

UNIVERSAL DEFLECTION YOKE. A new, simple way to determine yoke failure accurately—without removing yoke from picture tube. Merely disconnect one yoke lead and substitute. If high voltage (also bright vertical line) is restored, TV yoke is defective.

DYNAMIC FLYBACK TRANSFORMER CHECKER. Merely flip switch to "Flyback Check" and meter will indicate condition of flyback transformer, in degrees of horizontal deflection. Extremely sensitive and accurate; even shows up one shorted turn on flyback.

VOLTMETER. For testing bootstrap, screen and other voltages. Direct-reading voltmeter, 0-1000 volts.



\$4295



HORIZ. OSC.	VERT. OSC.
HORIZ. O.P. STAGE	VERT. O.P. STAGE
HORIZ. FLYBACK XFORMER	VERT. O.P. XFORMER
HORIZ. DEFLEC. YOKE	VERT. DEFLEC. YOKE

UNIVERSAL VERTICAL OSCILLATOR. Checks oscillator, output transformer and yoke. Merely touch lead to component and check picture on screen. **SS105 is completely self-contained, nothing else is needed.** New, improved Circuit.

FC4 FILAMENT CHECKER

The ideal tool for servicing series string filaments.

\$275



Purposely works off your cheater cord to give you a positive check on line voltage. Prevents checking all tubes to find that your trouble was no line voltage. Only checker that checks all tubes automatically and has no batteries to replace. Cost half that of battery operated testers. Patented.

FC4 with test leads for checking continuity or AC or DC Voltage . . . \$295

VB2 "VIBRA-DAPTOR"

Checks 3 and 4 prong Vibrators Faster and Easier . . .

Plugs into any tube checker; ideal for use with LC3 or the Mighty Mite. To check 6v. vibrators, set for 6AX4 or 6SN7; for 12 v. vibrators, set for 12AX4 or 12SN7. Two No. 51 lamps indicate whether vibrator needs replacing. Instructions on front panel. Steel case.

\$275



"FUSE-SAFE" CIRCUIT TESTER FS3

Instantly tells you whether or not it is safe to replace fuse resistors, fuses, or circuit breakers. Separate red and green scale for each commercially available fuse resistor used in radio and TV. Eliminates guesswork, wasted time. Also handy for wattage checks up to 1100 watts at 115v.

\$895



Time Savers for America's
ALL PARTS



Radio, TV and Electronic Minit-Men
MADE IN AMERICA

SENCORE

You can own all these popular Time Savers for less than some Mutual Conductance Tube Testers!



For TRANSISTOR RADIO SERVICING

Everything you need for less than \$50.00

SENCORE TRC4

TRANSISTOR-RECTIFIER CHECKER

\$1995



Now lists Japanese equivalents

Checks Transistors, Diodes, Rectifiers . . . A transistor tester that is used by over 50,000 servicemen, engineers and experimenters from Coast to Coast. Recommended by TV and Radio manufacturers; used by such leading companies as Sears Roebuck, Bell Telephone and Commonwealth Edison. Tests indicate that the TRC4 will outperform testers costing many times more. The TRC4 tests all transistors for gain, leakage, and open or shorts. Simple to operate without set-up chart for service work and with set-up chart for more accurate checks. With batteries.

SENCORE PS103

BATTERY ELIMINATOR & TROUBLE SHOOTER

\$1995



Replaces Batteries During Repair . . . Replaces batteries during repair time of transistor radios and helps trouble shoot, too. For transistor radio servicing, experimenting and to charge nickel cadmium batteries. Dial output voltage from 0 to 24 volts DC and read on meter. Low ripple insures no hum or feedback problem. Meter reads from 0 to 100 MA. Shorted stage will cause current to read high as indicated on PF schematics; open stage will cause current to read low. To align transistor radio, tune in station signal and adjust IF slugs for maximum current. The PS103 is the only supply that will operate radios with tapped battery supplies; such as Philco, Sylvania, Motorola, etc.

SENCORE HG104

HARMONIC GENERATOR

\$995



Finds Defective Stage in a Minute . . . Believe it or not. Just touch the output leads of the HG104 to inputs and outputs of transistors and a clear 1000 cycle note from speakers will tell you whether or not the stage is defective. Here is an unexcelled time saver, not a "pencil" gimmick. It actually works every time from speaker to antenna. Two leads and calibrated output (not found on pencils) are a must for speaker connection, grounding to prevent RF spray and front end checks. Also saves time when servicing HiFi, TV and radios. With life-time batteries.

Get all 3



COMPLETE TRANSISTOR RADIO SERVICE LAB
All 3 Time Savers shown above in handsome display carton carrying case

MODEL TL107
\$4985



For SUBSTITUTION SERVICING

Goodbye to messy parts . . . the mess of soldering and unsoldering in testing.

SENCORE H36

"HANDY 36"

\$1275



Substitute for Capacitors, Resistors . . . Provides the 36 most often needed resistors and capacitors for experimenting, substituting or testing. Eliminates searching for replacement components, unnecessary soldering and unsoldering and the mess it creates. Says goodbye to crumpled parts. Flick of a switch instantly selects any of: 24 Resistors from 10 ohms to 5.6 megohms, 10 Capacitors from 100 mfd to .5 mfd, 2 Electrolytics, 10 mfd and 40 mfd at 450 Volts. All components are standard American brand.

SENCORE ES102

ELECTRO-SUB

\$1595



Substitute for Electrolytic Capacitors . . . Complete, safe substitution . . . from the smallest electrolytics used in transistor radios to the largest used in costly Hi-Fi amplifiers. Contains 10 electrolytics from 4 to 350 mfd. Select correct value with the flick of a switch. Features automatic discharge, surge protector circuit. Prevents accidental "healing" of capacitor being bridged. Completely safe—no arc or spark when connecting or disconnecting. Usable from 2 to 450 volts, DC.

SENCORE RS106

RECTIFIER TROUBLE-SHOOTER

\$1275



Locate faulty Rectifiers, Diodes . . . This unique substitution unit simplifies trouble shooting rectifiers and diodes, gives you a positive check every time. Substitute for suspected rectifier or diode, watch picture or listen to sound and you'll know in seconds whether or not the rectifier or diode should be replaced. No guess work, soldering mess or time lost. The RS106 costs less than having loose rectifiers and diodes in the shop for testing and is worth many times more. A must for servicing voltage doubler circuits. Protected by a 1/2 amp. Slow Blow Fuse.

All 3 Time Savers shown above in handsome display carton carrying case

MODEL SL108
\$4145

SENCORE BE3 "ALIGN-Q-PAK"

Eliminates messy batteries in TV service work. Handy for alignment, AGC troubleshooting or checking gated sync circuits. Dial the voltage you need, 0-18 volts, positive or negative. Completely isolated DC supply, less than 0.1% ripple. Covers all voltages recommended by TV set manufacturers and in Photo Fact schematics. For 110-120V, 60 cycle AC.



\$785

NEW! POWER RESISTOR SUBSTITUTION SENCORE BIG 20 MODEL PR111

For all resistors up to 20 watts from 2.5 to 15,000 ohms. Covers all power resistors encountered in Radio, Hi-Fi and TV circuitry.

Substitute for all questionable power resistors; determine values of burned out 2 and 4 watt carbon resistors, wire wound potentiometers, fuse resistors and resistor value in a hundred and one places in servicing and engineering. A great time saver in restoring circuit to normal fast so that you find the actual defective component. Each resistor stands up to 20 watts normal testing time. The Big 20 pays for itself the first month in time saved.



\$1275

See your Parts Distributor

Caught in the Act...

at MERIT PLAZA

by Flashgun Sam, the Candid Camera Man



Merit operator photographed building MAXIMUM PERFORMANCE into Merit Electronic Components!

WHAT SHE'S DOING: Testing each Component individually. Merit does not employ the prevalent "spot check" system. Every unit is subjected to rigorous tests far beyond ordinary usage. Just one of many ways Merit builds maximum performance into its line. Just one more reason why...

MERIT QUALITY BUILDS CONFIDENCE



Low B+

(Continued from page 28)

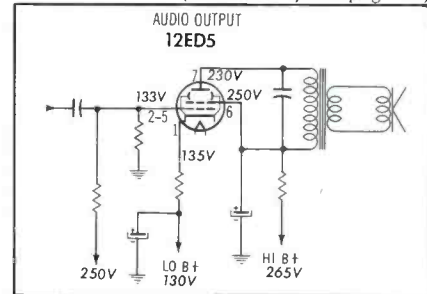
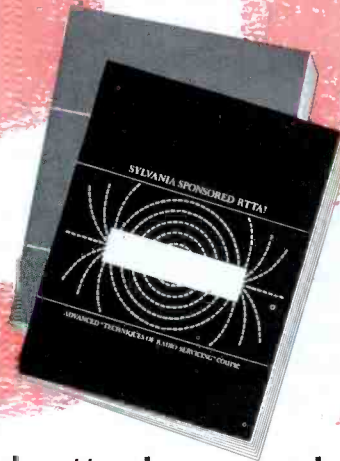

Fig. 3. Typical audio-output voltage-divider stage used in a modern portable: than 3 or 4 volts, suspect the output tube before capacitors C1 and C2. Heater-to-cathode leakage often results in garbled sound and a dim picture. If the leakage is severe, you may get only hum bars on the screen. Just a slight amount of leakage, on the other hand, may cause only a decrease in volume and weak video.

One component that can really make a "dog" out of a repair job is the audio coupling capacitor C3. If this unit opens, sound will cut out and no other symptoms will be apparent. However, should it develop even a little leakage, the picture will lose contrast and sync will be touchy, but the sound may decrease only slightly in volume. On a symptom like this, you don't normally go poking around in the audio output circuit—but you might take a quick check on low B+. If it's down about 25 volts and high B+ is OK, you might suspect leakage in the coupling cap. Normally, the positive potential on the grid of the output tube will be about 10 or 15 volts below the cathode. Another cause for these same symptoms is an increase in the value of resistor R4 (Fig. 1).

Fig. 3 shows another audio stage found in one of the modern series-string portables. The circuit functions basically the same as the one in Fig. 1, but since a low-voltage supply line may feed different stages in different receivers, the trouble symptoms associated with each circuit will vary. In addition to those sections of the receiver previously mentioned, such a source may also supply B+ to the tuner, a focusing potential for the picture tube, or cathode bias to a sync stage. When this supply voltage is affected, the trouble symptoms will depend on which stage or section is most severely affected.

"Score" more profits



“**THE NEW SYLVANIA RTTA!**”

“**TECHNIQUES OF RADIO SERVICING**” COURSE

“**STUDY AT HOME!**”
12 LESSON COURSE FROM RTTA

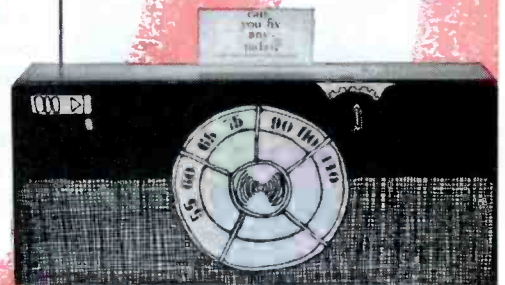

Enroll in the Sylvania “advanced radio repair course”

Radio is “booming.” Sales hit a ten-year high in 1960 . . . over 10 million! You can “zero in” on extra servicing profits by signing up for the Sylvania sponsored RTTA “Advanced Techniques of Radio Servicing Course.”

This new Sylvania 12-lesson *home study* course covers all the latest servicing techniques on the tremendous variety of radios your present customers own and expect you to service. Shows you how to complete repairs quickly, efficiently, profitably. Gives you the latest dope on everything from transistor circuits to citizen band radio. Look at the subjects covered:

- working with transistors
- transistor circuits
- repairing auto radios
- servicing AM receivers
- servicing AM & FM tuners
- servicing foreign radios
- servicing mobile receivers
- testing transistors
- servicing transistor radios
- installing auto radios
- servicing FM receivers
- servicing communications receivers
- marine radio repair
- servicing citizen band radio

It's easy to enroll. Your Sylvania tube distributor has all the details. Call him today. And when you order tubes be sure to specify Sylvania Silver Screen 85 picture tubes and Sylvania quality receiving tubes.

Electronic Tubes Division, Sylvania Electric Products Inc., 1740 Broadway, New York 19, New York.

SYLVANIA

SUBSIDIARY OF

GENERAL TELEPHONE & ELECTRONICS



Ride the
**• hi-fi • stereo
 • recorder**
**ACCESSORY
 SALES BOOM**



with
SWITCHCRAFT

"MINI-MIX"
 MINIATURE

2-INPUT AUDIO MIXER



A practical, fun-producing accessory. Ideal for mixing voice with music or two sound sources when recording on tape, wire or disc. There is a model for every connection.

**"STEREO-
 MONAURAL
 TRANSISTORIZED
 MIXER"**
 NO. 306TR



Handy switch: In Stereo position mixes sound sources for Stereo Tape Recording or for Stereo Amplifiers; In Monaural position permits mixing up to four microphones or combination of sound sources for recording on tape, wire, or disc. No loss—provides 6 db. gain.

"MIX-AMP"
 MINIATURE
 TRANSISTORIZED
 AMPLIFIER



Designed for use with Switchcraft non-transistorized mixers. Overcomes loss and actually provides a 3 db. gain.

"MOLDED CABLE ASSEMBLIES"
 (Interconnecting Cords)

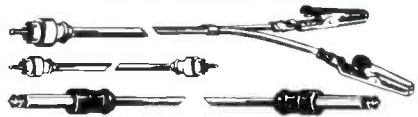

Over 200 different combinations of connectors molded to cable. Various lengths.

Write for Bulletin S-590
SWITCHCRAFT®

5573 N. ELSTON AVE.
 CHICAGO 30, ILL.

Canadian Rep.: Atlas Radio Corp., Ltd., 50 Wingold Ave., Toronto

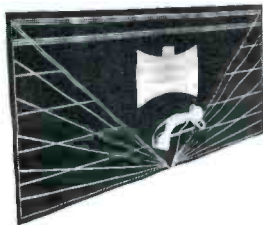

Antenna Check

Not long ago I had an opportunity to field-test Jerrold's new *Magic Carpet* antenna.

Back in the days when I had my own shop, I sold and installed hundreds of single and double-stacked conical antennas. Most of these were put up in an area which can be classed as gently rolling, with no hills or large buildings to cause ghost problems. All the available channels (4, 6, 8, and 13) are in the same general direction, 25 to 50 miles away; thus, conicals and yagis are used predominantly. Rabbit-ears are strictly no go; so I considered the area perfect for testing an indoor antenna advertised as "comparable to a standard conical."

I unrolled the *Magic Carpet* on the living room floor, and proceeded to connect it to the receiver. When I fired up the set, on came a picture . . . which sure beat a set of rabbit ears.

I then rolled up the antenna and headed for the attic. As I laid it on the ceiling joists and orientated it, a voice from the living room cried, "There it is."

I went down for a look. Frankly, the picture looked as good as it ever did. Using my family as "guinea pigs," we made several comparisons between the pictures obtained with the *Carpet* and our regular conical. My conclusion was that they couldn't tell which was which. ▲

The Modern
"PUSH BUTTON"
 way to protect
ELECTRONIC PARTS!



- Prevents corona in high voltage section
- Keeps lead-in connections tight
- Prevents rusting and pitting of antenna
- Goes on in seconds—DRIES IN MINUTES



**CRYSTAL CLEAR
 ACRYLIC SPRAY**

Protect radio, TV and hi-fi equipment indefinitely against humidity and dust with Krylon Crystal-Clear, the modern "push button" acrylic spray. High dielectric strength, excellent weatherproof qualities. Available at your favorite radio-TV repair shop.

KRYLON, INC., Norristown, Pa.

Paint touch-up work easily, expertly, with Krylon Spray Paints—choice of 24 colors

IF YOU PRIZE IT...KRYLON-IZE IT!

TV TUNERS * **REBUILT OR EXCHANGED**
 ALL TYPES

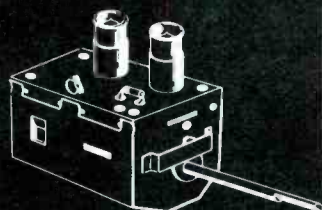

\$9.95 Including all parts and labor (except broken wafers—billed at cost)

- Normally shipped same day received
- 90 day full guarantee
- U/V combinations \$17.95

FREE—!! Mailing carton sent to you on request

Phone Republic 3-9189

L. A. TUNER EXCHANGE

4611 West Jefferson Blvd.
 Los Angeles 16, California



“Our servicemen make over half of our color sales!”

Says RCA VICTOR Color TV Dealer

EVAN CAMPBELL, JR.

Campbell TV and Radio, Shreveport, La.

“Here at Campbell TV and Radio, our nine servicemen know—and believe in—RCA Victor Color TV. Whenever they’re out on service calls, they talk Color TV to the customer, and we pay them a commission on every sale they bring in.

“The result? *Better than half of our Color TV sales are made by our own service personnel!* In particular, they are almost singlehandedly responsible for the big replacement market (Color for black-and-white) we have built up.

“Altogether, Color TV sales and service are adding \$50,000 annually to our billing. Best of all, *Color TV sales have stimulated other business* as well! Many related sales, especially in stereo, are a direct result of the interest in Color TV that brings customers *into* our store, and the satisfaction with Color that brings them *back!*”—*Evan Campbell, Jr., Campbell TV and Radio, Shreveport, La.*

*Put RCA VICTOR Color
in your TV profit picture!*



The Most Trusted Name in Television

RADIO CORPORATION OF AMERICA

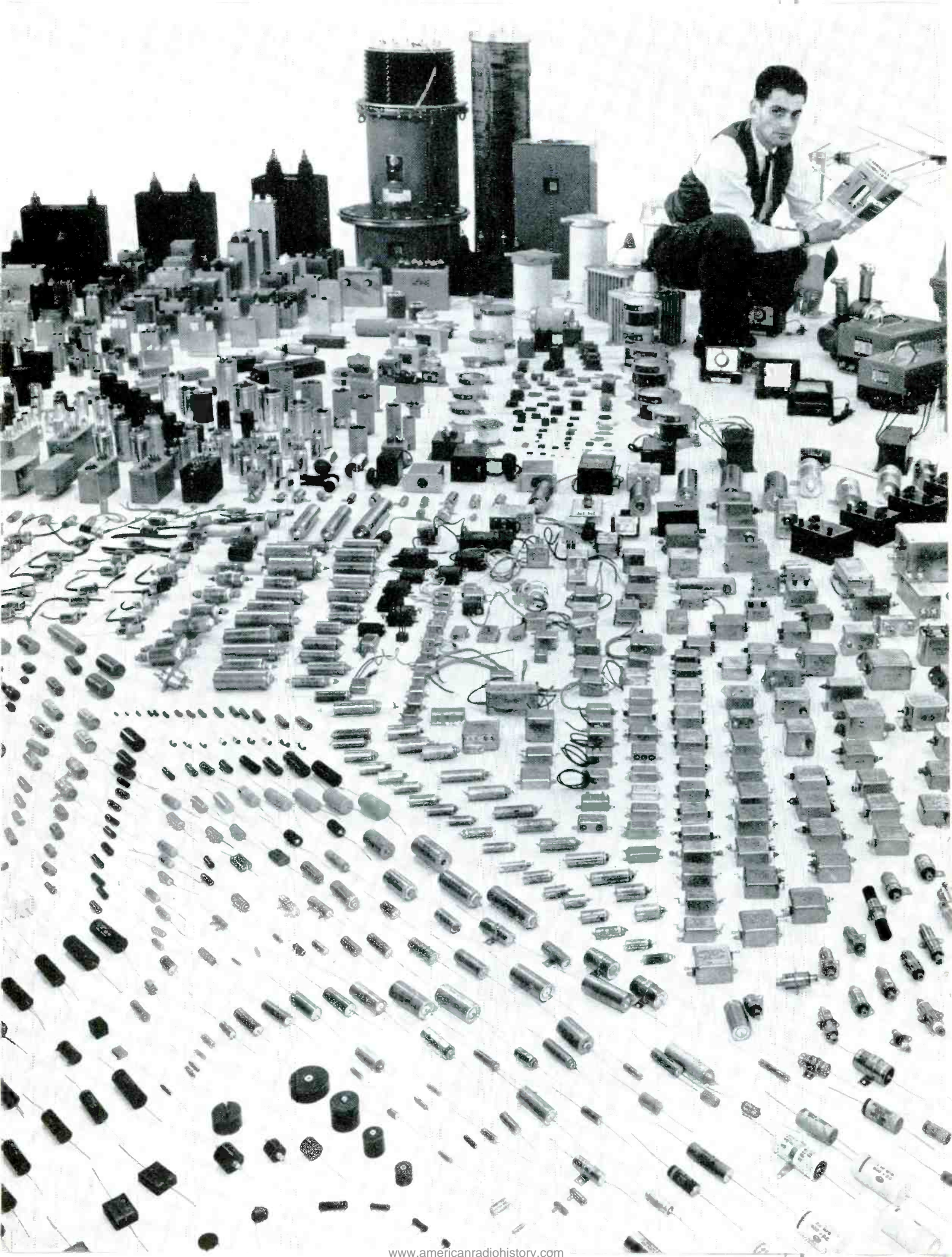

*in
50 years...
over
3,500,000,000
capacitors*

For over fifty years, Cornell-Dubilier has specialized in the design, production and distribution of capacitors. William Dubilier is regarded throughout the world as the "Father of the Capacitor Industry." From a modest beginning in 1910, CDE has continued as the leader in this important phase of electronic components pioneering.

Today the many vast and widespread facilities of CDE provide a single source of unmatched capacitor technology. There are more CDE capacitors in use today than any other make—every conceivable known type, style and class—fabricated and sold by CDE in every part of the world.

Designs still unborn are being conceived and developed in CDE's Research Center . . . particularly "High Reliability" components for the most advanced applications of the Electronics Age.

Be it ceramics, mica, electrolytics, tantalum, film, paper, metalized or types yet unknown, CDE can be depended upon to meet the needs of the Electronics Industry . . . today and in the future.

CDE also produces relays, semiconductors, filters, delay lines, pulse networks, packaged circuits and systems, test instruments, vibrators and converters, and antenna rotors . . . all allied electronic devices frequently associated with capacitor technology.

When you have been around for 50 years there are reasons . . . uncompromising quality of materials, meticulous care in production, exhaustive testing and a compelling "Urge to Serve."

Look to CDE every time you look for Capacitors. Cornell-Dubilier Electronics Division, Federal Pacific Electric Company, 50 Paris Street, Newark 1, N. J.

SEE YOU AT THE IRE SHOW! BOOTHS 2721-25



highly reliable electronic components and systems

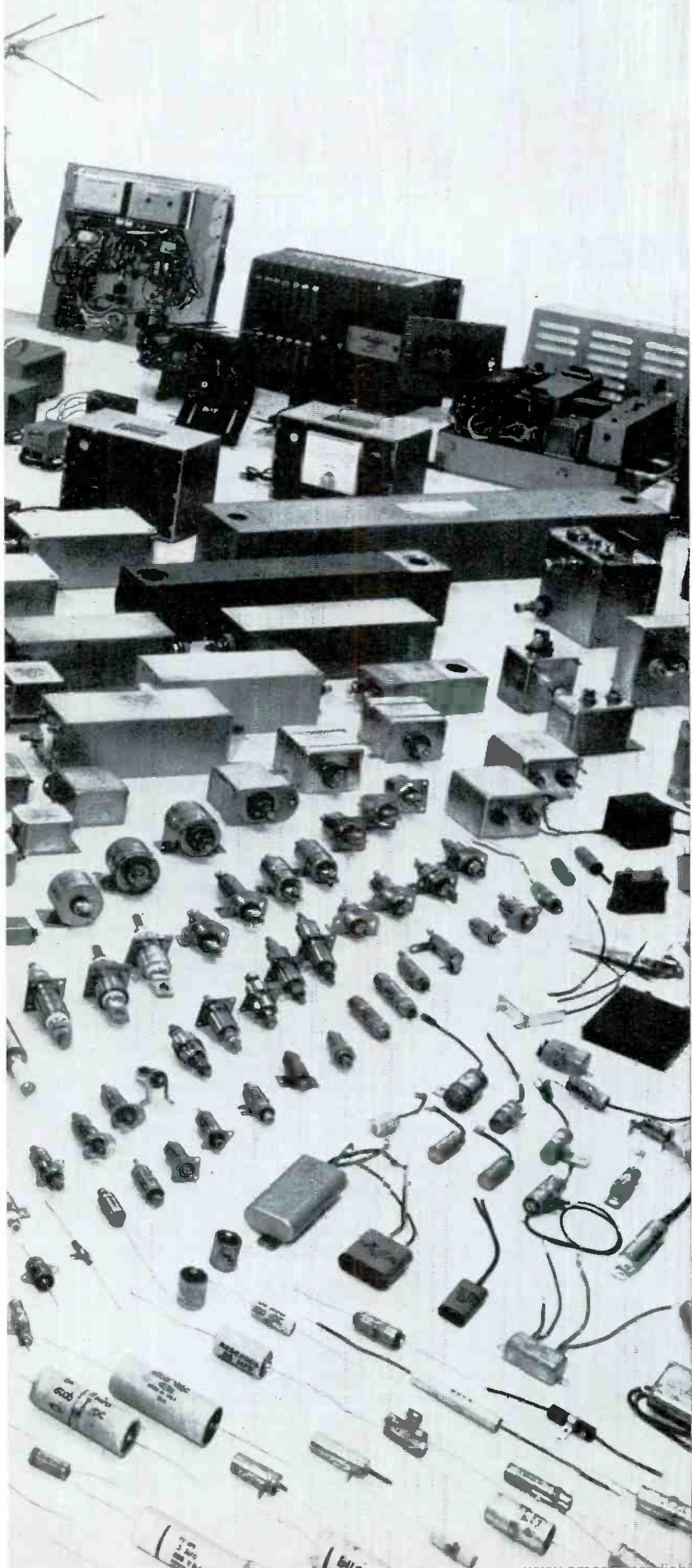

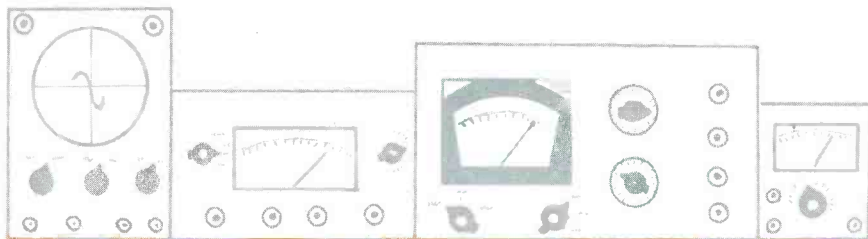

NOTES

ON TEST EQUIPMENT

by Les Deane

Power Pack With Governor

A new regulated DC power supply with a "set it and forget it" feature has recently been introduced by Electro Products Labs. of Chicago. Pictured in operation in Fig. 1, the Model PS-3 has built-in regulation components that govern the output voltage regardless of input-line or output-load fluctuations. The instrument comes complete with operating instructions and universal binding posts suitable for use with any type of test lead.

Specifications are:

1. *Power Requirements* — 110/130 volts, 60 cps; power consumption variable with load; transformer-isolated; line fuse and pilot light provided on panel.
2. *DC Output* — regulated to within 500 mv for currents up to 100 ma at 25 volts, and up to 200 ma at 15 volts; output control includes on-off switch.
3. *AC Ripple* — output rms voltage less than 1 mv at rated loads (.004% with 25 VDC output.)
4. *Panel Meter* — combination DC voltmeter and milliammeter; output ranges of 0-25 VDC, 0-100 ma, and 0-200 ma; function and range switches provided on panel; accuracy within 2% of full-scale value.

5. *Size and Weight* — 6¼" x 5" x 6", 3½ lbs.

The Model PS-3 is designed to serve as a battery substitute for powering any low-current device. It uses no tubes, but depends on three transistors, four silicon rectifiers, and a Zener diode for AC-to-DC conversion and control. It's obvious from the low ripple figures given in the specifications that the supply is well filtered—meaning that it will introduce no hum or feedback into the equipment it powers.

The front-panel photo in Fig. 2 shows the meter used to monitor both output voltage and current. Directly below the meter are two slide-type switches; the one labeled VOLTS-MA enables the operator to select the meter function, while the other (100 MA-200 MA) is used to change the meter's DC current range. Three separate output terminals are provided on the panel—positive, negative, and chassis ground. Both + and - terminals are "floating," thus permitting the chassis-ground terminal to be used as either a positive or negative reference point.

Good regulation in a DC supply of this type is obviously desirable, so I performed a number of tests to prove whether the Model PS-3 had it or not. I employed our service lab's 60-cycle AC line as a

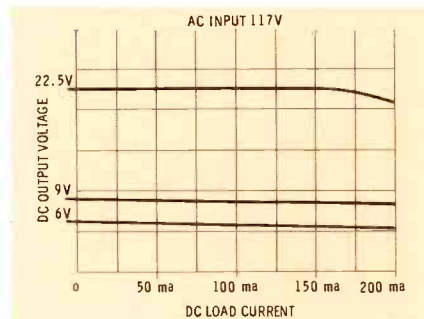

Fig. 3. Output voltage is virtually constant for normal load currents.

source, but controlled the input by running it through a variable transformer unit, and monitored its output with an accurate AC voltmeter. For a load on the PS-3, I used a resistive decade with incremental step adjustments; thus, I could simulate any load within the total current range of the Electro unit. I also checked DC voltage and current on laboratory instruments, to determine the accuracy of the dual-purpose meter incorporated in the supply itself.

With an input of 117 volts and a DC output of 25 volts at 25 ma, I found that I could vary the AC input potential from 90 to 140 volts without causing the DC output voltage to change by more than 100 millivolts. I did find, of course, that load currents above 150 ma caused the DC output voltage to drop slightly when the line voltage fell below 110 volts; however, I compensated for this by simply advancing the output control. With 117 volts input, I was able to obtain a maximum DC output of 30 volts for loads requiring up to 100 ma. Under these conditions, however, AC ripple voltage jumps way up, which is understandable, since the voltage is entirely out of the specified range. With a load of 100 ma, I found that a DC output in excess of 28 volts will cause an abrupt increase in the ripple content. Below this level, ripple remains extremely low.

My findings on "output voltage vs. load current" are summarized in the graph of Fig. 3. For loads equivalent to the average portable transistor radio (9 volts at 5 to 25 ma), the output voltage remained virtually constant; actually, according to my over-all findings, the regulation specifications are conservative.

Since the instrument is equipped with a panel meter, it is very convenient for measuring total current drain—a meaningful factor when troubleshooting transistor portables. Not only can you tell when one or more stages are inoperative, but removing or disconnecting the transistors one at a time will help you pinpoint causes for excessive current drain.

Push-Button Audio

The Jackson Electrical Instrument Co. of Dayton, Ohio is now producing a combination sine- and square-wave signal generator that features push-button selection of output-frequency ranges. The Model 605 Audio Oscillator (Fig. 4) has a total range of 20 cps to 200 kc and is suitable for use in a wide variety of applications.



Fig. 1. PS-3 low-current DC supply offers automatic voltage regulation.



Fig. 2. Meter on front panel of PS-3 reads its output voltage and current.

FOIL this
SKULKIN'
VARMINT

THE
OLD TUBE
RUSTLER



PHILCO announces a sensational
**OLD TUBE
ROUND-UP**

Here's your chance to get a big bounty for your old, burned out receiving tubes. Yes, turn them into cash by trading them in on new Philco tubes you use every day. We'll smash all old tubes you trade in.

PHILCO—the brand mark of **QUALITY** in receiving tubes

You can
rope in a husky

7¢ FOR
EVERY
OLD TUBE
YOU TRADE IN!

LIMITED TIME ONLY!
(MARCH 1961)

SEE YOUR PHILCO DISTRIBUTOR!

now for the first time

a comprehensive
compilation of 4500
direct transistor
substitutions

INTERNATIONAL TRANSISTOR SUBSTITUTION GUIDEBOOK

(Direct Substitutions Only)
by Keats A. Pullen, Jr., Eng. D.

Only an engineer with the experience of the author—Keats A. Pullen, Jr. (member of the Scientific Staff, Ballistics Research Laboratories, Aberdeen Proving Grounds) could possibly have compiled the transistor substitution data contained in this Guidebook. Everyone who works with transistors in repairing, maintaining or designing—must have this time-saving tool. Here's why:

● COMPLETE AND COMPREHENSIVE

—International in coverage, it lists 4500 direct substitutions comprised of American, Japanese, British, French, German, Dutch and Italian transistor types. Includes both triodes and tetrodes.

● PROVIDES DIRECT SUBSTITUTIONS—ELECTRICAL AND PHYSICAL—Not only are the direct electrical substitutions shown, but case styles and dimensions also are given for maximum substitution flexibility.

● COVERS TRANSISTORS USED IN ALL TYPES OF ELECTRONIC EQUIPMENT—The guidebook is universal in its application. It covers transistor substitutions for radio and television receivers, all types of military, industrial, communication and computer equipment.

Nothing like the International Transistor Substitution Guidebook has ever been published. It will be available in April. Be sure to act now to reserve your copy at your electronic parts distributor. #276—64 pages, \$1.50.



JOHN F. RIDER PUBLISHER, INC.
116 West 14th St., New York 11, N. Y.

Specifications are:

1. *Power Requirements* — 110/120 volts, 50/60 cps; power consumption approximately 50 watts; line-isolation transformer and pilot light provided.
2. *Output Signals* — sine wave variable from 0 to 5 volts rms, harmonic distortion less than 1%; square wave variable from 20 mv to 5 volts peak-to-peak, low-frequency response less than 5% tilt at 60 cps, less than 1% above 200 cps; output control and cable provided.
3. *Frequency Range* — 4 continuous bands from 20 cps to 200 kc; output within 1 db on all ranges; square-wave rise time less than .2 microsecond; 6" frequency-indicating scale provided.
4. *Accuracy* — over-all calibration within 1 cycle or 3% (whichever is larger); maximum hum -50 db at all output levels.
5. *Other Features*—waveform-selector switch and square-wave symmetry control provided.
6. *Size and Weight* — 11" x 7 $\frac{5}{8}$ " x 13", 17 lbs.

Working with the generator in the lab, I was impressed with the ease of its set-up procedure. After power is applied, the output cable is connected to the jack in the lower right corner of the front panel.

The type of output signal (sine or square) is selected by a small two-position knob located just above this jack. The frequency range is chosen by depressing one of the four push buttons in the center of the panel. From left to right, these button switches select ranges of 20-200 cps, 200-2000 cps, 2000 cps-20 kc, and 20-200 kc. The tuning dial and frequency scale, taking up the entire top portion of the panel, is used to select a precise frequency within the chosen range.

An interesting feature of the Model 605 is the method it uses to generate steep-sided square waves. The heart of this system is a Schmitt trigger stage employing a pair of pentodes. This relaxation oscillator produces a constant flat-topped output pulse as long as the input signal exceeds a specific grid-bias level. The controlling input signal, of course, is derived from the sine-wave oscillator section of the instrument.

Symmetry of the square-wave signal is not fixed; by removing a small plug from

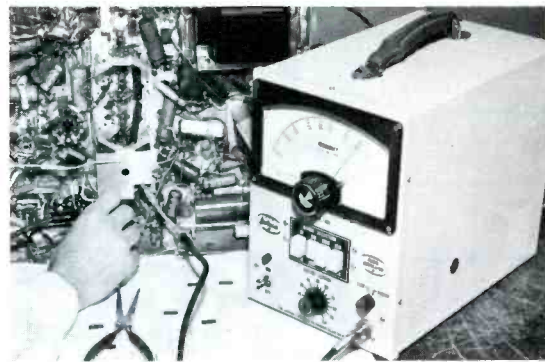

Fig. 4. Output of Jackson's new generator is within 1 db, 20 cps-200 kc.

the right side of the instrument's case, you can vary the positive and negative durations of the wave by making a simple screwdriver adjustment.

Aside from the many uses of a "sine-square" generator in audio work, I'm constantly on the alert for practical troubleshooting applications in other equipment. One, for example, is checking amplification and frequency response of video amplifiers. The waveform presentations of Fig. 5 show both the input and output signals of a normally operating stage. Since the response of the scope used may alter the shape of the waveform, it's best to first apply the generator signal directly to the scope and observe the square-wave reproduction. Any resulting distortion can therefore be taken into consideration.

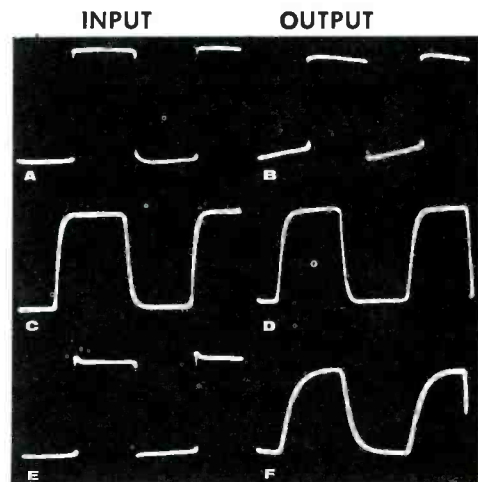

Fig. 5. Square-wave test of video amp. (A-B) 60 cps; (C-D) 100 kc; (E) low-C probe effect; (F) load distortion.

PHONE
ED 9-9653

\$7.50

plus parts,
C.O.D. and postage charges



90 DAY
WARRANTY

Precision Tuner Service

ALL TYPES T.V. TUNERS REPAIRED AND ALIGNED TO FACTORY SPECIFICATIONS ON CRYSTAL-CONTROLLED SWEEP GENERATORS

24-HOUR SERVICE ON MOST TUNERS

UHF - VHF COMBINATIONS — \$13.50

See your local distributor or send to:

P.O. Box 272, 601 N. College
BLOOMINGTON, INDIANA

State make and model. Send
all parts, tubes and shields

BEST FOR SOUND CONTROL

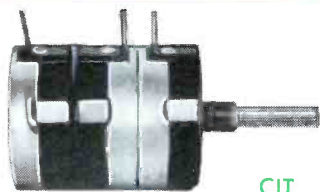

CIT



CIL

CONSTANT IMPEDANCE CONTROLS

L-pads and T-pads rated at 2½ watts DC and 10 watts audio. Continuous range from 0.5 to 30 db attenuation in 90% rotation. Last 10% provides infinite attenuation. These units maintain a constant input and/or output impedance throughout the associated circuitry, regardless of settings.



CIB

CONSTANT IMPEDANCE ATTENUATOR

Handles up to 30 watts audio. Linear attenuation in 3 db steps up to 34 db, then 30 db, followed by infinity. Ideal for output level control for power amplifiers, or input attenuator for speakers in a PA system.

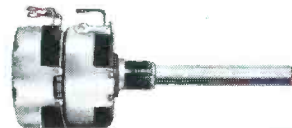

CIL43



CIT43

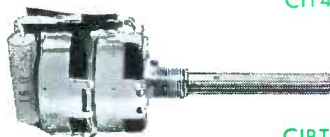

CIBT43

SERIES 43 CONSTANT IMPEDANCE ATTENUATORS

Space savers for requirements up to 4 watts audio. Provide up to 30 db attenuation over 90% rotation and additional 60 db in remaining 10%. Available with constant input and output impedances, or constant input impedance only. Ideal for use in home systems. Diameter only 1½".

WRITE
FOR COMPLETE
CATALOG



CM

THEATRE SPEAKER CONTROLS

8-ohm L-pad, 50-ohm linear rheostat, 35-ohm tapered rheostat. Popular replacements for all makes of drive-in theatre speaker controls.



CLAROSTAT

CLAROSTAT MFG. CO., INC.

DOVER, NEW HAMPSHIRE

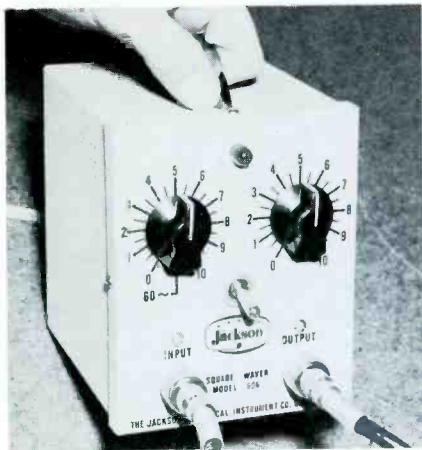

Fig. 6. The Square-Waver turns externally-applied sine waves into squares.

Waveforms in Fig. 5 are normal; however, when a video stage is not functioning properly, the output square wave may exhibit tilt on its flat horizontal portions, rounding of its leading edges, or overshoots (accompanied by damped oscillations) following each steep leading edge.

The instruction manual gives complete information on other applications—such as checking audio systems for frequency response, phase shift, and distortion—as well as testing audio transformers, audio filters, the over-all fidelity of radio receivers, and the modulation percentage of an AM transmitter. In this last operation, a sine wave is applied to a microphone feeding the transmitter; then, using an oscilloscope with a simple voltage take-off network, the final tank signal is coupled to the vertical plates of the scope,

while a signal from the modulation transformer is applied to the horizontal plates. Normal scope displays representing no modulation, 100% modulation, less than 100%, and more than 100% are pictured in the manual for comparison purposes.

Jackson is also producing the Model 606 Square Waver pictured in Fig. 6, which is a "chip off the 605 block" inasmuch as it, too, generates square waves through the use of a Schmitt trigger circuit. However, the 606 does not encompass a built-in sine-wave oscillator and therefore requires an external driving signal. Any sine, clipped-sine, sawtooth, or symmetrical square-wave signal of 5 volts rms or more may be used for this purpose. Output and range are the same as specified for the Model 605; accuracy, of course, depends on the driving signal used.

NEXT MONTH

Now, for the 1st Time, An Entire Issue

Devoted Entirely to Electronic
Test Instruments and Their Uses

Here's just a sample of the titles:

How to Select Test Equipment
Test Instruments for Audio
Servicing

Picking the Probe for the Job
Using Communications Test
Equipment

Old Faithfuls of the Bench

The Professional Touch in Kit
Building
Industrial Electronic Test
Equipment

Getting the Most from Your VTVM
Pitfalls in Meter Readings
Special Analyzers for TV
Troubleshooting

Plus . . . a special 8-page BONUS Feature —
Getting the Most from Your Scope

Send in your new or renewal subscription today, and receive your choice of these helpful and informative premium books.



SERVICING TV
FROM TUNER
TO PICTURE TUBE



SERVICING
INDUSTRIAL
ELECTRONICS



THE
TROUBLESHOOTER'S
HANDBOOK

Tube-Element Fault Finder

Seco Electronics Inc. of Minneapolis has recently come out with a vacuum-tube grid-circuit tester that supersedes all previous GCT models. Shown in Fig. 7, the new Model GCT-9W is designed to check tubes for gas or grid emission, leakage, and shorts in one operation. The unit is housed in a compact portable case; the same instrument is also available in an all-metal case without the panel lid (Model GCT-9S).

Specifications are:

1. Power Requirements — 105/125 volts, 60 cps; power consumption less than 5 watts standby; ON-OFF switch on front panel.
2. Tube Tests — static DC measurements for gas or grid emission, leakage, and shorts indicated on tuning-eye tube; tube setup data including foreign and industrial types furnished.
3. Special Tests — filament- and cathode-continuity checks plus shorted-elements identification test.
4. Other Features — 4 panel test sockets; 7-position selector provides heater potentials for 2- to 13-volt tubes; "W" models include pin straighteners for 7- and 9-pin miniatures, operating instructions, and setup data in lid.
5. Size and Weight — Model GCT-9W, 3 13/16" x 7 7/8" x 7 1/8", 4 1/2

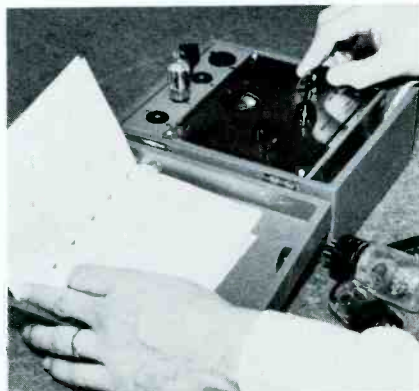

Fig. 7. Seco GCT-9W tests tubes for gas, grid emission, leakage, shorts.

Enter my subscription to PF REPORTER
and send me free book(s) checked.

3 Years \$9.00 2 Years \$7.00 1 Year \$4.00

The Troubleshooter's Handbook
 Servicing Industrial Electronics
 Servicing TV from Tuner to Picture Tube

Check one for
each year you
subscribe

Bill Me Remittance Enclosed Extend Present Subscription

Take this coupon to your distributor, or mail to:
Howard W. Sams & Co., Inc.
2201 E. 46th St., Indianapolis 6, Ind.

Please Check Your
Business Classification

- Independent Radio, TV Owner, Mgr.
Serviceman
- Retailer with Service Service Mgr.
Department
- Industrial Electronics Employee
Service
- Other (Specify occupation, and title)

Name _____

Firm _____

Address _____

City _____ Zone _____ State _____

361

11 DOES IT

Radio Transistor Replacements Are Quicker, Easier...

**WHEN YOU STOCK THESE
11 TUNG-SOL TRANSISTORS!**

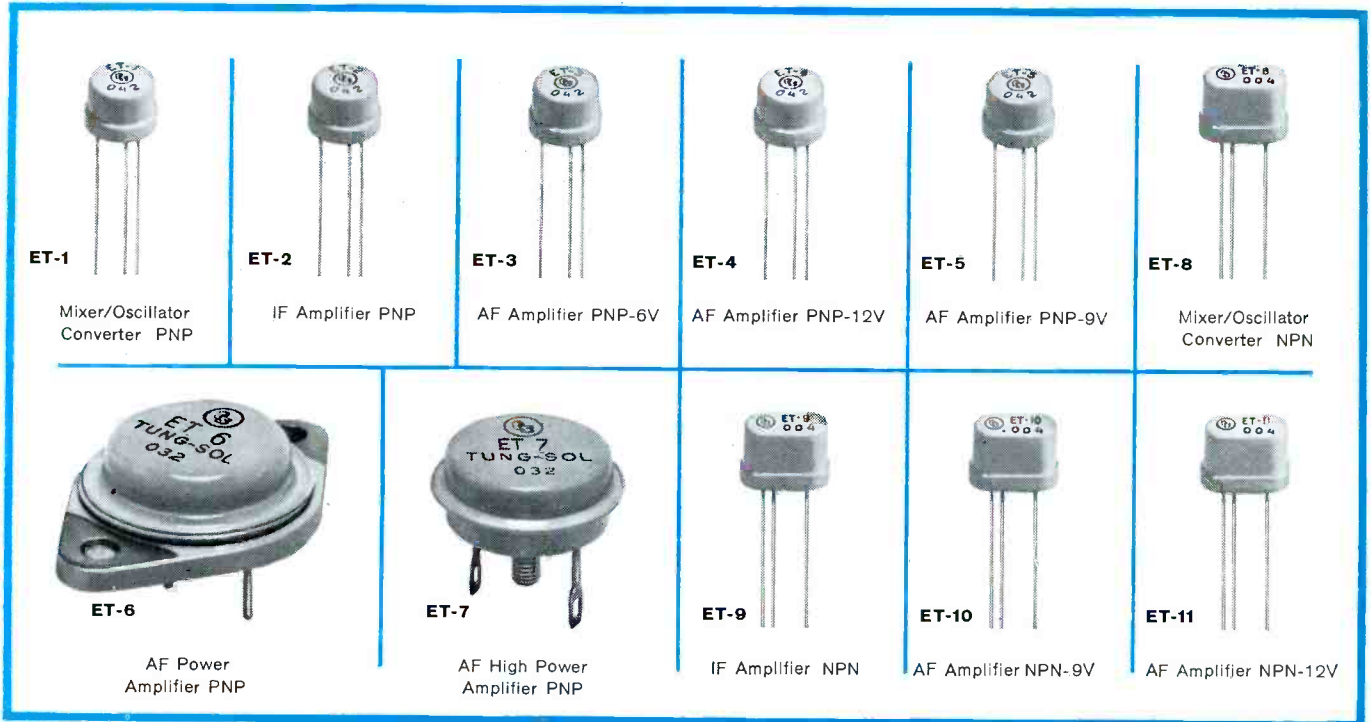

The compact new Tung-Sol "11" transistor line meets virtually every common radio service requirement . . . obsoletes costly duplication of inventory. Just these eleven Tung-Sol transistor types provide you with the replacements needed for almost all of your radio repair work.

● The Tung-Sol "11" eliminates dead shelf space . . . cuts your inventory problems.

● The Tung-Sol "11" lowers your costs . . . reduces your inventory investment in slow-moving items.

● The Tung-Sol "11" saves labor . . . cuts service time lost by searching for the right replacement part.

● The Tung-Sol "11" builds profits . . . assures faster turnover on smaller investment . . . with fewer call-backs.



Packaged for Fast Selection

Each Tung-Sol transistor is packed in a carton which is clearly marked with both type number and application. Just pick the one marked for the right kind of service and you have the right transistor."



Priced for Profitable Service

The Tung-Sol "11" transistor line enables you to handle most radio service work with a minimum of stock. Type selection is quicker—easier. You make more profit per service hour.

Warranted for Superior Performance

Famous Tung-Sol quality-control assures optimum specified performance. Your best choice is always a Tung-Sol product.

For complete information on the Tung-Sol "11" transistor line — and full details on Tung-Sol's profit-building sales support program — contact your Tung-Sol Distributor, or write to:

TUNG-SOL ELECTRIC INC., NEWARK 4, N. J.

 **TUNG-SOL**[®]
TRANSISTORS

lbs.; Model GCT-9S, 2½" x 6½" x 6½", 4 lbs.

Basically, the GCT-9W is similar to earlier models, although there are added provisions to permit testing for cathode continuity and shorts identification. The new Seco tester has only three control knobs and four test sockets on its front panel. The eye tube, a 6AF6, has a hooded shield with the eye's shadow-deflection area marked BAD - ? - OK. After the eye-tube circuitry has been calibrated by a simple screwdriver adjustment, the width of the eye opening automatically indicates the condition of the tube under test. The data booklet supplied with the instrument lists all necessary set-up data.

Since the unit does not check cathode emission or mutual conductance, it is in a

category of its own. Instead of a tube tester, it's more of a tube-element checker. As such, it provides an interelement leakage test more sensitive than incorporated in many tube testers, a factor I found useful when trying to catch those stubborn tube defects that so often cause borderline trouble symptoms.

Analyzing the Seco test, I found that a short, leakage, grid emission, or gas within a tube will cause the test circuit to develop a certain bias for a built-in DC amplifier stage; this, in turn, controls the shadow movement of the eye tube.

Through the use of prewired sockets and multiple switch positions, the instrument effectively recognizes trouble between tube elements as illustrated in Fig. 8. With the tube connected in the test cir-

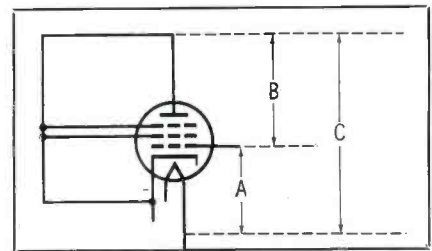

Fig. 8. Element connections for testing a typical pentode in the GCT-9.

cuit as shown, leakage between the heater and all other elements, and between the control grid and all other elements, is automatically detected.

The sensitivity of this measurement is determined by the interelement resistance that will produce an eye-shadow deflection into the area labeled BAD. When the eye-tube circuit is properly calibrated, the leakage value is approximately 20 megohms between heater and control grid, 75 megohms between control grid and other elements, and 1 megohm between heater and other elements. Incidentally, by following a set procedure in the Seco manual, you can also determine what tube pins are producing the defect, and thus identify the elements involved.

After testing a number of known faulty tubes on this piece of equipment, I was reminded that substitution methods in the customer's home won't always work. For instance, if you run up against a trouble caused by a slight amount of leakage or gas in two or more tubes of the same type, and you only carry a single replacement, you'll undoubtedly pull a chassis needlessly. This, of course, is only one example of where a tester like the Model GCT-9 comes in handy.

Incidentally, a special accessory called a piggy-back adapter is also supplied with the instrument. With this bracket attached to the tester's case, the instrument can be conveniently carried "piggy-back" on a tube caddy (see Fig. 9). ▲

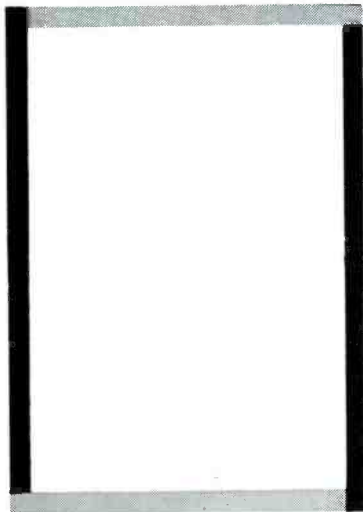

◀ *this*

is a picture of the technician who had a call-back on a Quam Speaker installation.

(You'll notice the space is blank. Servicemen who install Quam speakers can "sell 'em and forget 'em." You just don't get called back.)

this ▶

is a picture of a Quam speaker which was defective when received from the factory.

(This space is blank, too. Every Quam speaker is individually checked and tested before it leaves the factory.)

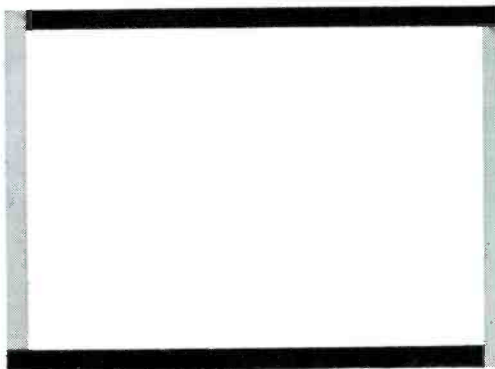

◀ *this*

is a picture of your bank book.

You'll notice how your deposits grow when you rely on Quam Adjust-a-Cone Speakers for every installation.



QUAM-NICHOLS COMPANY
234 E. MARQUETTE ROAD • CHICAGO 37, ILLINOIS

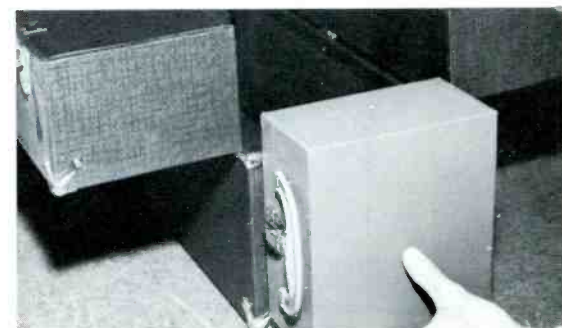
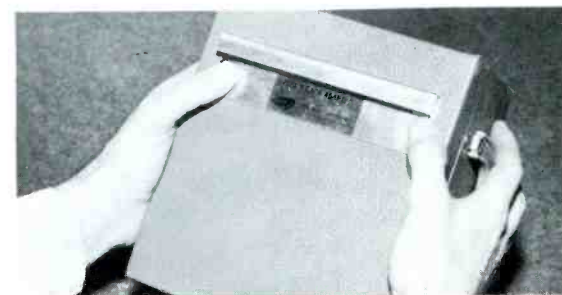

Fig. 9. "Piggy-back" adapter bolts to Seco unit and mounts it on caddy.

NOW IN KIT FORM!

The RCA Senior VoltOhmyst®

WV-933(K)

ONLY \$62.50*

With probe, cable, clips and instruction booklet.

Featuring Pre-Assembled Etched-Circuit Board and Pre-Assembled DC/AC-OHMS Probe (VPG-299D)

- Easy-to-read meter—6½" wide
- 200-microampere meter movement with less than 1% tracking error
- Precision multiplier resistors accurate to ± 1%
- Meter electronically protected against burnout
- Separate color-coded peak-to-peak and rms-voltage scales
- Die-cast aluminum case with leather carrying handle

MEASURES:

DC voltages: 0 to 1500 volts
AC voltages: 0 to 1500 volt rms or 0 to 4200 volts peak-to-peak
Resistances from 0.2 ohm to 1,000 megohms.

RCA WV-933 available factory-wired and calibrated: \$79.50*

Real dollar-savings! Assembly time is cut to the bone!

This extra-heavy etched-circuit board comes with all components completely mounted and soldered. The input probe and cable, likewise, comes to you already assembled and wired.

OTHER OUTSTANDING RCA KIT VALUES...



RCA VOLTOHMYST® KIT WV-77E(K) Only \$29.95*

Famous VoltOhmyst® quality and performance at a low price! Special test features include: separate 1.5-volt rms and 4-volt peak-to-peak scales for accurate low AC measurements. Measures AC and DC voltages to 1500 volts, resistances from 0.2 ohm to 1,000 megohms. Complete with ultra-slim probes, long flexible leads, special holder on handle to store leads.

RCA WV-77E available factory-wired and calibrated: \$43.95*



RCA WV-38A(K) VOLT-OHM-MILLIAMMETER KIT Only \$29.95*

The V-O-M with the extras! • 0.25-volt and 1.0-volt DC ranges • Big easy-to-read 5¼" meter • Non-breakable sealed plastic case—no glass to crack or shatter • Jacks located below switches to keep leads out of the way • Spring clips on handle to hold leads • Attractive, scuff resistant, rugged carrying case, only \$4.95* extra.

RCA WV-38A available factory-wired and calibrated: \$43.95*

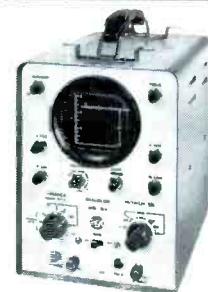

RCA SUPER-PORTABLE OSCILLOSCOPE KIT WO-33A(K) Only \$79.95*

Now in kit form. A scope you can carry anywhere! Rugged and compact, yet weighs only 14 pounds. Just right for in-the-home and shop troubleshooting and servicing of black and white and color TV, radio, hi-fi components, tape recorders, etc. Ample gain and bandwidth for the toughest jobs. Scaled graph screen and internal calibrating voltage source for direct reading of peak-to-peak voltage.

RCA WO-33A available factory-wired and calibrated: \$129.95*

See them all at your Authorized RCA Test Equipment Distributor



The Most Trusted Name in Electronics
RADIO CORPORATION OF AMERICA

*User Price Optional

Audio Facts—by Allan F. Kinckiner
Teaching the customer how to
use the recorder cures many
“service” problems.

SERVICING TAPE RECORDERS

Tape-recorder owners frequently report having difficulty in finding a service shop willing to undertake repair of these units, so it appears that many servicemen, by hesitating to venture into the tape-recorder field, are missing out on a profitable source of income . . . and one that is growing by leaps and bounds. There's really no valid reason for this attitude; operating techniques are easily mastered, and once past this hurdle, tape recorders are not too different from more familiar types of equipment. Mechanical maintenance is not difficult, and the electronic circuitry in tape recorders is practically the same as that used in radios and audio equipment.

Probably the most misunderstood point about tape recorders is how they respond to various control settings. For example, when a control on a radio is adjusted, some effect is immediately noticed—either the tone, volume, or station tuning changes audibly. This is not so with tape recorders; the result of any adjustment made during recording is not immediately evident, but is delayed until the tape is played back. This condition results in a large number of service calls to take care of “customer problem” cases—where the users cannot obtain good recordings even with properly-operating recorders.

Customers' Woes

To assist the customer in properly setting the controls while recording, each tape recorder has some type of indicating device—eye tube, meter, or neon lamp—to show whether the recording is being made at the correct level. All too often, this level indicator is completely ignored. In one recent instance, a new recorder

was delivered to the customer with instructions printed in large letters on a heavy paper form attached to the recorder face. Furthermore, the indicator was of the meter type with its scale divided into three different colors; in addition, the three scale sectors contained printed instructions. Yet, the customer paid not the slightest attention to all this information, and he soon brought the unit in because he could not get good recordings.

Even when the customer understands the recording-level indicator, some other feature of the recorder may trip him up. The level indicator only shows whether the recording is being made at the right volume, without registering the effect of the tone controls. To indicate tone, some recorders contain a monitor speaker which reproduces (at a reduced level) the material fed to the recording head. This monitor-speak-

er system works fine when material such as a radio program is being recorded, but it cannot be used when recording through the microphone. Some customers have to learn this the hard way.

One of these unfortunates recently brought in a late-model Webcor and placed it on my bench. In the compartment with the tape reels were several glass-encased color slides; exuding great pride, he insisted I look at these. (They *were* pretty good.) Finally getting down to business, he explained that he had taken the slide pictures on his recent vacation, and now he was intending to have a slide-projector show with a running commentary presented simultaneously on tape—but his recorder was noisy. I threaded his tape into the machine and started to play it back. At first his voice came through fairly clear; then there was a loud snap, followed by horrendous howling. It seemed obvious that the trouble was in his recording technique, so I invited him to show me how he recorded. Speaking into the microphone, he properly set the recording-level control; next he got the tape moving, and *then* he turned on the monitor speaker.

To the servicemen reading this, the causes for the snap and howling should be obvious—the one was due to switching on the speaker, and the other was due to feedback from the monitor to the mike. To the customer, however, this explanation went for naught. I got nowhere even when I reminded him of the feedback howling which used to occur in an old-fashioned telephone when the earpiece and mouthpiece were brought together. Finally, I had to draw an analogy between the tape

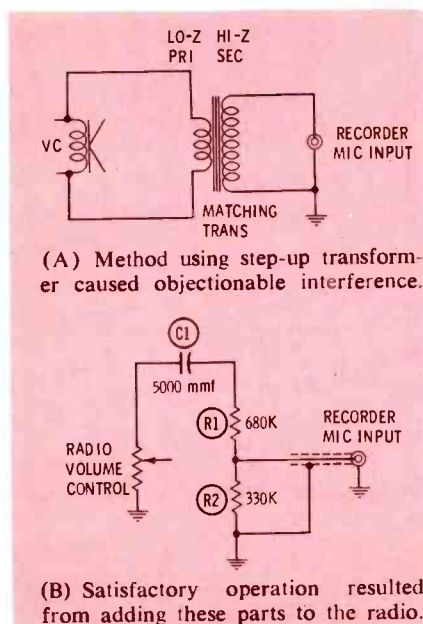
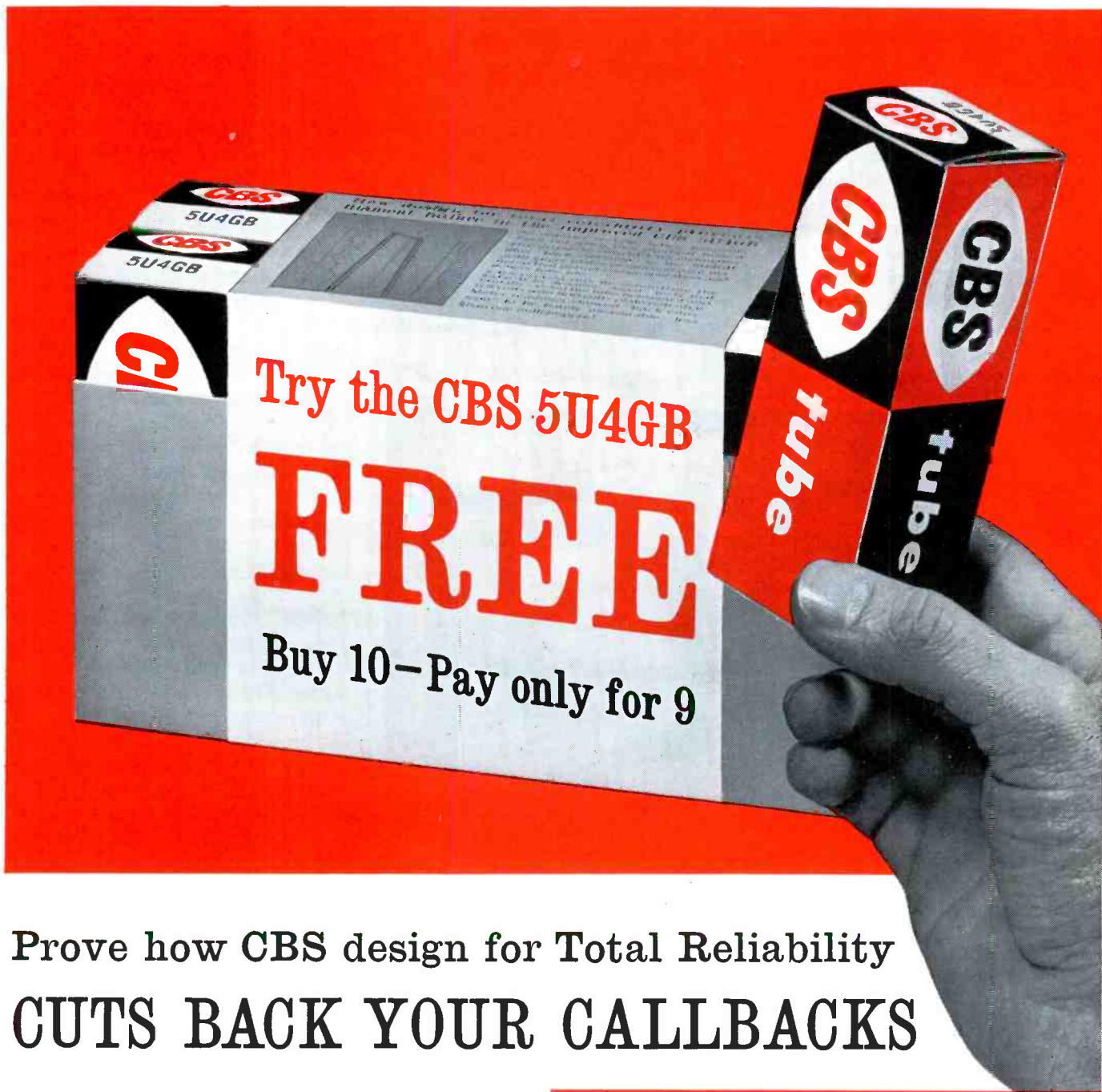

Fig. 1. Connections from recorder to radio permitting low speaker volume.



Prove how CBS design for Total Reliability CUTS BACK YOUR CALLBACKS

Are callbacks stealing away your profits? CBS Total Reliability tubes can keep them in your pocket. Take the CBS 5U4GB, for example.

This improved CBS tube has been specifically engineered with advanced features for utmost dependability. And its extra quality and longer life will build customer confidence—important for your continued success.

Now you can prove this to yourself right on the job—at CBS Electronics' expense. For a limited time only, you get a free trial CBS 5U4GB when you buy nine. You get a full "10-pack" *but you pay for only 9 tubes*. Order now from your CBS Electronics distributor. Offer expires March 15.

CBS ELECTRONICS

Danvers, Massachusetts

A Division of Columbia Broadcasting System, Inc.

Receiving, industrial and picture tubes • transistors and diodes • audio components • and phonographs

How design for Total Reliability prevents filament failure in the improved CBS 5U4GB

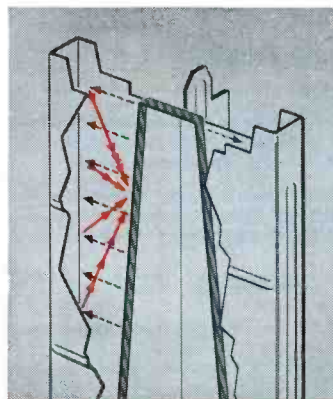

In ordinary rectifier tubes, filaments burn out when they overheat from a rise in reverse current. CBS eliminates this "back emission" in the 5U4GB with larger plates of non-emissive material that permit cooler operation and longer tube life.

CBS proved this by submitting the 5U4GB to dynamic "blast" tests that brutally cycled the tube between 4 and 6.8 volts with 800 volts plate potential. Meter readings showed "back emission" to be barely measurable—less than one ma.

recorder and his camera to convince him he could make good recordings by relying on the recording-level indicator. In photography, his camera should capture good pictures if his various settings are correct; but there is no way to be sure until the film is developed. Likewise, in recording, the controls should be set as accurately as possible according to instructions; playing back the tape will show if there is any need for a change in recording technique.

When the customer related that some of his better pictures were the result of experimentation with cam-

era exposure settings, I advised him to try experimenting with the tape recorder. His eyes lit up in anticipation. Funny thing about this customer—the last time we met, he seemed prouder of his recordings than he had been of his photography.

A simple change in recording procedure remedied a hum trouble in a V-M recorder owned by an executive who took considerable dictation work home with him. He brought the unit in with the complaint that his recordings contained a background hum. Listening for amplifier

hum in the speaker, I found none, but there was some motor rumble which I felt when touching the recorder case. I checked the motor-mounting grommets and tried tightening up the motor-casing screws, all to no avail. When I ran our pre-recorded tape through the machine, it played as well as desired, without any trace of hum. Making a recording through the mike from a small radio, I found I was able to record clearly as long as the mike was not in contact with the recorder case. After the condition was explained to the customer, he admitted that he generally recorded with the mike on top of the recorder. On learning the cost of replacing the motor, the owner decided against doing so. Now he props the recorder in an overstuffed chair, sets the mike on the desk where he is working, and dictates his letters—"without a trace of hum," he claims.

Tape recorders are becoming more popular among youngsters learning to play musical instruments. Oddly enough, youngsters seem to have less trouble in recording properly than their parents do, though occasionally they will gum up the works.

For example a parent brought in a Wilcox-Gay recorder with the complaint that speed was changing and recordings were not clear. Both faults were immediately obvious to my ear. On examination, the tape and drive components were found to be sticky. After cleaning the drive capstan, pressure roller, and tape head with a commercial recorder cleaner, I could play back our test tape with no trace of speed changing or poor tone. Since it was impossible to clean the customer's tape thoroughly, he purchased several new reels. I subsequently learned that the stickiness was caused by Junior dropping his grape-jellied bread on the recorder during his violin lesson.

Misconnections

One special category of customer problems arises from the various and sundry means used to connect tape recorders to other equipment from which recordings are taken. Sometimes it requires great skill and ingenuity to satisfy customers' particular needs in this line.

I recall a Webcor owner who wanted to record music from his

Now Completely SELF-CONTAINED

For Testing & Rejuvenating

BLACK AND WHITE and COLOR including 110° TUBES

NEW CRT 440

CATHODE REJUVENATOR TESTER

B&K

TESTS AND REJUVENATES

all black & white and color picture tubes at correct filament voltage from 1 to 12 V.

TESTS AND REJUVENATES

110° tubes with 2.34, 2.68, 6.3 and 8.4 volt filaments.

TESTS AND REJUVENATES

color picture tubes. Checks each color gun separately same as black & white tubes.

Used by Thousands of Professional Servicemen
MAKES NEW PICTURE TUBE SALES EASIER

Gives you more value than ever—all-in-one. Quickly checks and corrects most TV picture tube troubles in a few minutes right in the home without removing tube from set. Gives new useful life to weak or inoperative tubes. Checks leakage. Restores emission and brightness. Repairs inter-element shorts and open circuits. Life test checks gas content and predicts remaining useful life of picture tube. Completely self-contained in leatherette-covered carrying case. Net, **\$7495**

ACCESSORIES for USE ONLY with FORMER B&K Models 400 and 350 CRT



Model C40 Adapter. For use only with all previous B&K Model 400 and 350 CRT's. Tests and rejuvenates TV color picture tubes and 6.3 volt 110° picture tubes. Net, **\$9.95**

Model CR48 Adapter. For use only with all previous B&K Model 400 and 350 CRT's. Tests and rejuvenates 110° picture tubes with 2.34, 2.68, and 8.4 volt filaments. Net, **\$4.95**



See your B&K Distributor
or Send now for Bulletin AP17-R



B & K MANUFACTURING CO.
1801 W. BELLE PLAINE AVE • CHICAGO 13, ILL.
Canada: Atlas Radio Corp., 50 Wingold, Toronto 10, Ont.
Export: Empire Exporters, 277 Broadway, New York 7, U.S.A.

DIPPED AND MOLDED MYLAR* CAPACITORS AND SUBMINIATURE ELECTROLYTICS

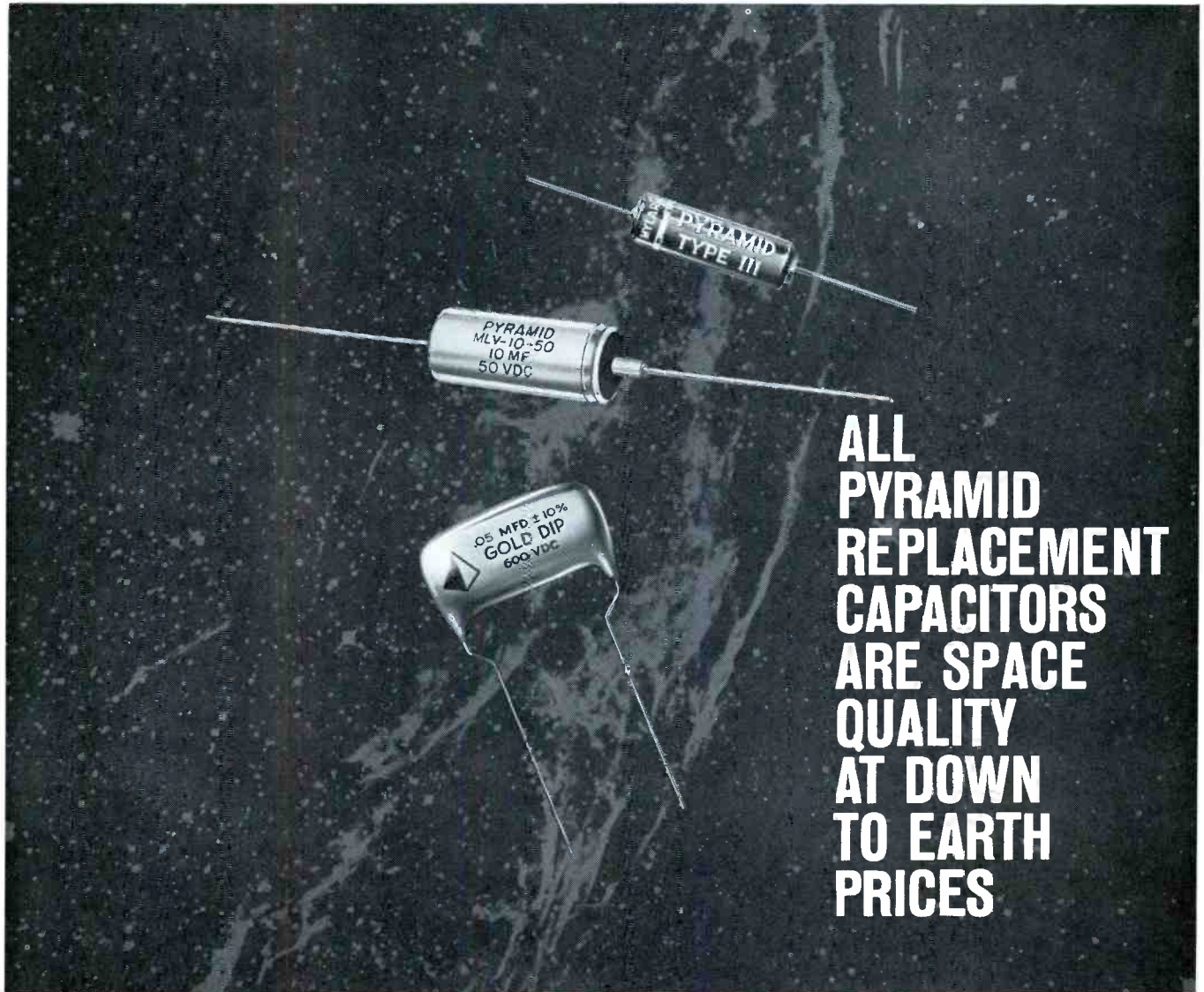

Pyramid makes the capacitors you want for replacement. Every type of Pyramid capacitor is manufactured under the most rigid standards to insure their high reliability and long life. You can depend on them.

MOLDED MYLAR

Type 111 "Gold Standard" Molded Mylar Capacitors are now available in greatly reduced sizes. They have a noninductive polyester film extended foil section, and are molded in a noninflammable thermosetting plastic case. These capacitors have very high insulation resistance, are impervious to moisture and are extremely rugged.

Operating temperature range: -55°C to $+100^{\circ}\text{C}$.

SUBMINIATURE ELECTROLYTICS

MLV Miniature Electrolytic Capacitors are ideally suited for transistorized radio receivers, hearing aids, portable TV sets, and miniaturized circuit requirements. These capacitors are noted for low leakage and a long shelf and operating life. They are designed for 85°C operation.

DIPPED MYLAR

Type 151 Gold-Dip Mylar capacitors are designed to be used for printed board circuitry as well as conventional applications. They are engineered for the highest reliability, are moisture resistant and have high insulation resistance.

Operating temperature range: -55°C to $+110^{\circ}\text{C}$. Look for them on Pyramid's new Whirl-o-mat, five to a package, in Clear-Vu paks.

*DUL PONT TM

PYRAMID ELECTRIC COMPANY
DARLINGTON, SOUTH CAROLINA

Canada: Wm. Cohen, Limited, 8900 Tanguay Street, Montreal
Export: Morhan Exporting Co., 485 Broadway, New York 13, N.Y.



IRE: Booth 1212

JUST RIGHT

for Profit-Minded Service Technicians



\$335.00

JACKSON 600

for wide band or high sensitivity operation

Your profit potential goes up when you're equipped with a new Jackson 600 Oscilloscope. You can do all these jobs:

- Peak to peak voltage measurements
- Square Wave Testing from 10 cycles to 200 KC
- Modulation Checks
- Transformer Ringing
- Low Frequency Measurements
- Checking Audio and Video Distortion low frequency and high frequency response... phase shift.

This is a fine quality instrument "service-engineered" by Jackson to best suit the needs of the really active radio and TV Service Technician.

SPECIFICATIONS:

Linear Sweep:
10 cycles to 100 KC

Sensitivity:
20 mv/inch

Wide Band
Vertical Amplifier:
Flat within 1 db from
less than 10 cycles
to 4.9 MC.

Ask your electronic distributor to demonstrate a Jackson 600 or write for Bulletin 106.



ELECTRICAL INSTRUMENT COMPANY

124 McDonough St., Dayton, Ohio

In Canada: The Canadian Marconi Co.

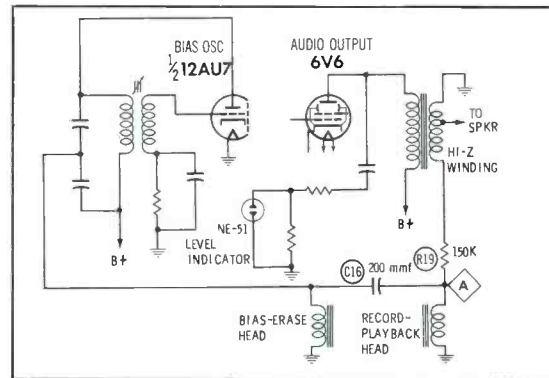

Fig. 2. Tape-head circuits of Bell Sound Model RT-65B in Record position.

FM radio. The dealer from whom he purchased the recorder supplied him with clip leads for attachment to the radio voice coil, but he didn't like this arrangement because he had to play the radio louder than wanted. Another serviceman then obtained a special matching transformer and hooked up the circuit shown in Fig. 1A. With this setup, he received cross-modulation from a nearby AM station. From there, the job fell in our laps.

After some experimentation, we came up with the circuit of Fig. 1B. The parts were all mounted inside the radio, with a jack to accept a shielded cable from the tape recorder.

Dealing With Customers

Contrary to the implications that might be garnered from the customer-problem cases just discussed, tape-recorder owners generally impress us as being slightly more intelligent than customers bringing in other types of service jobs. Many of the mistakes I have noted are only to be expected, considering the public's relative unfamiliarity with tape recorder operation.

Because of the prevalence of customer problems, we try, if possible, to examine the recorder in the customer's presence. At this time, if the trouble is due only to incorrect techniques on the part of the owner, this is gently explained—and he is instructed in proper recording technique. We charge for this instruction, just as a lawyer, doctor, or engineer bills his clients for consultation. Our rate is the same as for bench servicing. If the serviceman keeps his conversation on a strictly technical level, this charge is much easier to collect.

For the tone-conscious tape-recorder owner who records through a

BUSS FUSES

PLUS
CLIPS—
BLOCKS—
& HOLDERS

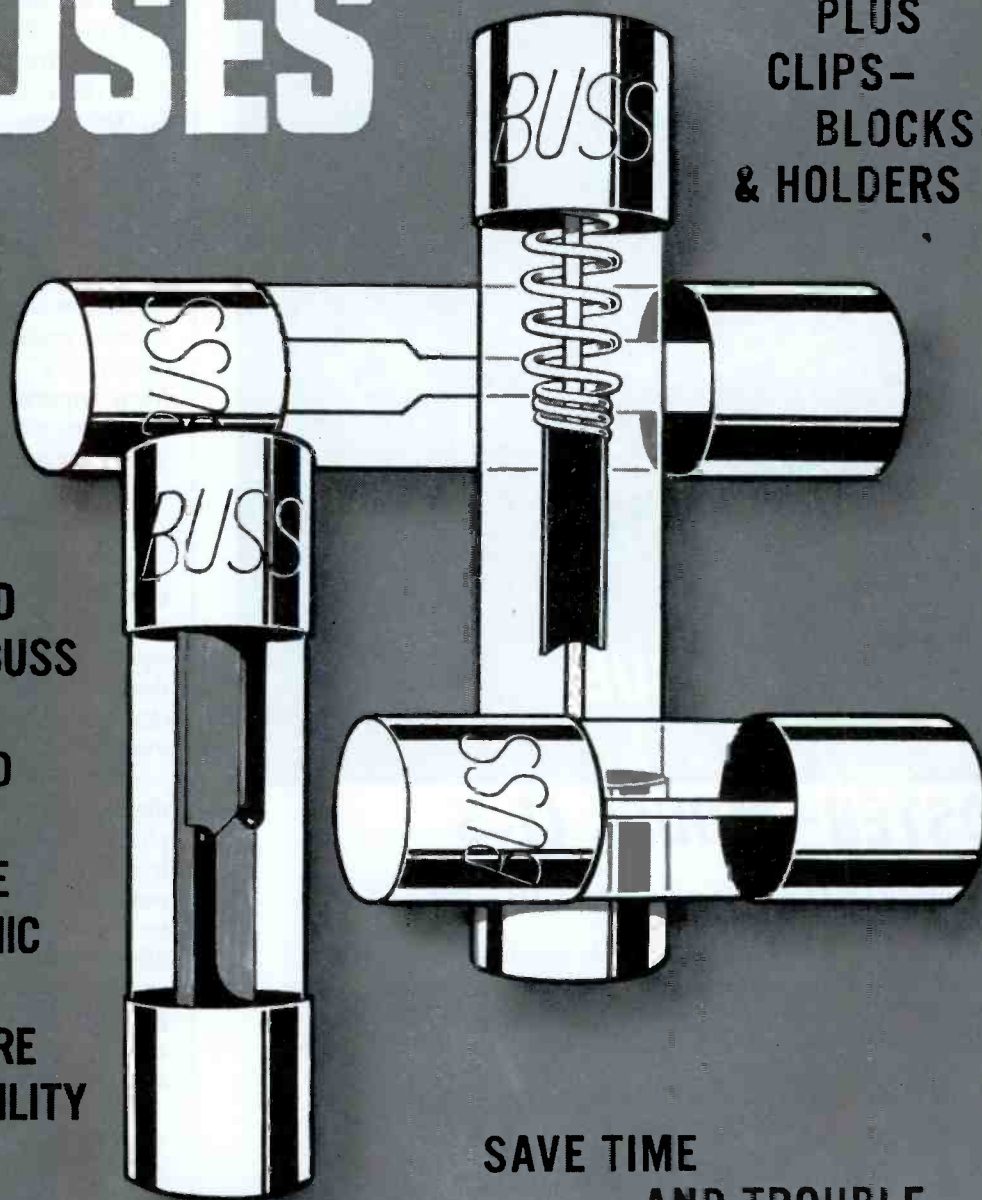

EACH AND
EVERY BUSS
FUSE IS
TESTED
IN A
SENSITIVE
ELECTRONIC
DEVICE
TO ASSURE
DEPENDABILITY

SAVE TIME
AND TROUBLE...

by standardizing on BUSS fuses. There's a right fuse for every need in the complete line. Write for the BUSS bulletin on small dimension fuses (Form SFB) to get full data for your files.

Bussmann Mfg. Division McGraw-Edison Co.
University at Jefferson, St. Louis 7, Mo.



lowest cost
master antenna system
ever developed

**NEW
BLONDER-TONGUE
TRANSISTOR 4-SET
BOOSTER—MODEL IT-3**

All the gain you need from one antenna for 4 TV or FM sets!

This new transistor-operated 4-set booster provides higher gain and lower noise than any comparable vacuum tube unit. There are no tubes to replace, lower power drain and negligible heat — all contributing to lower cost, longer maintenance-free operation than any unit on the market. List price of model IT-3, \$32.50.

SUPERB 1, 2, 3 or 4 SET PERFORMANCE

- **1 SET**—B-T 'straight thru' circuit provides full gain without isolation losses (Gain: 9 to 14 db, TV; 8 to 12 db, FM).
- **2, 3 OR 4 SETS**—splitting circuit provides gain and inter-set isolation necessary to provide top performance on 2, 3 or 4 sets. Gain two sets—each set 4 to 8 db; Gain three sets—each set 3 to 4 db; Gain four sets—each set 2 to 3 db.

*Sold through distributors. For details write: Dept. PF-3
engineered and manufactured by*

BLONDER-TONGUE
9 Alling St., Newark, N. J.

Canadian Div.: Benco Television Assoc. Ltd., Toronto, Ont. • Export: Morhan Export Corp., N. Y. 13
home TV accessories • UHF converters • master TV systems • industrial TV systems • FM/AM radios

mike, the serviceman should demonstrate the superiority of higher-priced mikes over the inexpensive types generally supplied by the recorder manufacturer. Such demonstrations can frequently lead to microphone sales.

By the way, as the foregoing items have implied, the most helpful item in tape-recorder checking is a pre-recorded reel. These are commercially available, or you can make your own. Such a tape might contain test frequencies such as 100, 400, 1000, 2000, 5000, 7000, and 10,000 cycles, each played for one minute and identified orally. Following the frequency recordings, the tape should contain music recorded from a high-fidelity disc or possibly an FM radio. The test recording should be made in the various tape speeds encountered or expected, chiefly 7½" and 3¾" per second. Most important of all, the recording must be made on an instrument known to be in first-class condition!

Equipment Troubles

Not all tape-recorder troubles can be explained away by blaming the customer. Like other audio equipment, recorders occasionally develop actual electronic or mechanical malfunctions.

Distortion

One of the most common complaints is distorted sound. The amplifier channel of a tape recorder, from the preamp to the power-output stage, is subject to the same distortion-causing conditions as any other audio amplifier. Types of distortion peculiar to tape recorders can also arise from such faults as slippage in the drive mechanism or misaligned tape heads.

The best check for distortion is the use of a test recording having good fidelity. Nearly all conditions creating distortion during playback can also be assumed to cause distortion during recording, since the same amplifier is used in both operations. Furthermore, the playing back of tape recorded with slight distortion will result in increased distortion, due to the double passage through the defective amplifier.

Like all electronic devices, tape recorders have their quota of elusive and rare troubles. For instance, one V-M Model 710 had distortion

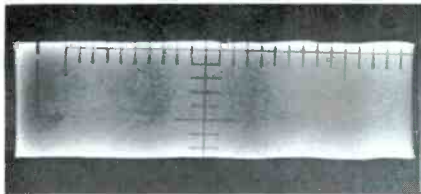

(A) 400-cps modulation is barely visible in 500-volt, 60-kc bias signal.



(B) Vertical expansion of scope trace brings peaks of audio into view.

Fig. 3. Modulated bias signal across record/playback head (100-cps sweep).

when its gain control was advanced about 60 per cent of maximum in either the record or playback position. With the PLAY button depressed, even with no tape in place, a sound that was neither a hum nor motorboating emanated from the speaker. The scope showed it to be a low-frequency square wave. Grounding the grid of the second amplifier killed the sound, while grounding the grid of the first amplifier had no effect. The tube (a 12AX7) was changed, and all circuit parts were double-checked without finding any discrepancy. Finally it was found possible to cure the trouble by better grounding of the major filter capacitor, even though the scope at maximum sensitivity (better than .05v/in) failed to show any signal on the can. The electrolytic capacitor was originally grounded by twisting the mounting tabs in slots in the aluminum chassis; we improved this ground return by adding a soldered connection. Later editions of these recorders used a ground bus, so apparently this trouble might have been somewhat common.

The precise cause of the trouble was never actually determined, but we guessed that a feedback loop was established between the plates of the first and second amplifiers—both of which returned to a filter section in the can.

Won't Record

In another recent case, a Bell Sound Model RT-65-B would not record at all, even when the level indicator was fully lit. Since it was



It's the new Sonotone Ceramic "Velocitone"

No stereo cartridge—not even the finest magnetic in the world—outperforms it!

Listen!...with any magnetic you sell today—at *any* price. Then replace it *directly* in any component system with Sonotone's new "VELOCITONE" STEREO CERAMIC CARTRIDGE ASSEMBLY. Listen again! We challenge you to tell the difference. Experts have tried...in dozens of A-B listening tests. And, in every single one, Sonotone's "VELOCITONE" performed as well as or better than the world's best magnetic.

Listen!...perfectly flat response in the extreme highs and lows (better than many of the largest-selling magnetics).

Listen!...excellent channel separation—sharp, crisp definition.

Listen!...highest compliance—considerably superior tracking ability.

Listen!...absolutely no magnetic hum—quick, easy, *direct* attachment to any magnetic inputs.

Listen!...remarkable performance characteristics unexcelled anywhere. (Write Sonotone Corporation for specifications.)

Now listen to the price. Only \$23.50...about one-half the price of a good stereo magnetic cartridge. Stock and sell Sonotone's "VELOCITONE"...the stereo ceramic cartridge system that cannot be outperformed by any magnetic—regardless of price.

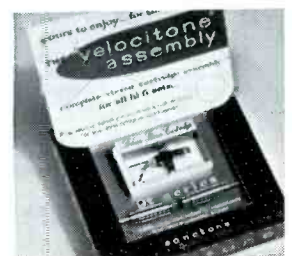

Sonotone[®] CORP.

ELECTRONIC APPLICATIONS DIVISION, ELMSFORD, N. Y., DEPT. C10-31
IN CANADA, CONTACT ATLAS RADIO CORP., LTD., TORONTO

LEADING MAKERS OF CARTRIDGES • SPEAKERS • TAPE HEADS • MIKES • ELECTRONIC TUBES • BATTERIES

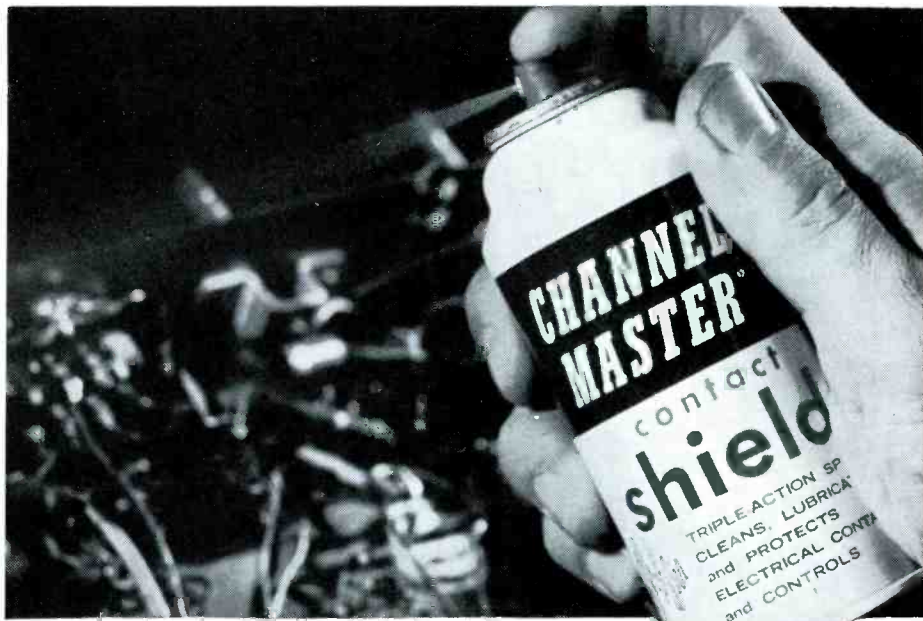

BEST OF ALL CONTACT SPRAYS

As reported by independent product-testing laboratory

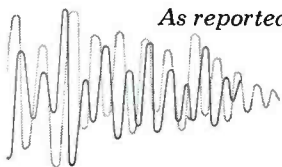

Triple-action Contact Shield cleans, lubricates, and protects electrical controls and switches in seconds. Most effective, safest product of its kind as proved by laboratory tests.

CHANNEL MASTER works wonders in sight and sound

Ellenville, New York



SIGNAL TRACER

Checks all stages from Antenna to Speaker or Picture Tube. Tests microphones, appliances, pickups, transformers, speakers, resistors, condensers, etc.

- Model 202 (with AF Probe) .Net \$61.95
- Model A Probe (RF Demodulator) .Net 4.50
- Model B Probe (RF Demodulator, Amplifier) .Net 7.50



VTVM KIT

Easily assembled! Solves numerous problems. Sensitive voltage measurements with negligible circuit loading. Accurate AC voltage ranges for checking line voltages, amplifier power output, frequency response. Positive and negative DC voltage ranges. Checks resistance. Radio, TV servicing; maintenance of electronic equipment; many other uses. Net \$27.95.

PRECISION ELECTRONICS, INC.
9101-0 King Ave., Franklin Park, Illinois

SAMS PHOTOFAC INDEX



sent direct to your shop

FREE

SEND FOR IT!

Yes, now you can have the valuable SAMS MASTER INDEX TO PHOTOFAC FOLDERS and Index Supplements sent direct to your shop at no cost to you! Just mail coupon below and you'll be sure to receive regularly your handy guide to the world's finest service data covering over 33,000 TV, Radio, Amplifier, Tuner Tape Recorder and Changer models. Send for it—it's FREE!

MAIL COUPON Howard W. Sams & Co., Inc.
1720 E. 38th St., Indianapolis 6, Ind.

Put me on your mailing list to receive the Sams Photofact Master Index and Supplements

I'm a Service Technician: _____ full time; _____ part time

My Distributor is:

Shop Name: _____

Attn: _____

Address: _____

City _____ Zone _____ State _____

capable of playing back our test tape in a normal manner, we knew that the record/playback head and amplifier were functioning. This evidence made us suspect the bias oscillator (Fig. 2), which must supply a high-amplitude supersonic signal to the record/playback head during recording to minimize distortion due to hysteresis in the head. Scoping point A in the circuit of Fig. 2, we found a normal bias signal—a sine wave at approximately 60 kc and 500 volts peak to peak. However, when this signal is viewed at a low scope-sweep frequency, it should show at least slight evidence of amplitude modulation by audio, as demonstrated in Fig. 3. We saw no trace of audio, so we had to conclude that the signal was not getting through from the amplifier to the tape. A little further probing disclosed that R19 was open. Simple as the trouble was, the owner seemed actually surprised that we were able to get the machine operating; he had taken it to several other shops without being able to get it serviced.

When checking for audio modulation on the bias signal, you can see it more clearly by vertically expanding the scope trace, as in Fig. 3B. The audio in this photo is a 400-cps sine wave, somewhat greater in amplitude than the normal amount applied during recording. Incidentally, in cases such as this, where the audio level control has been turned up abnormally high during a fairly long interval of recording or troubleshooting, the head is likely to need demagnetizing when you are through.

In closing, I'd like to bring out two particular points regarding mechanical servicing of tape recorders. First, the bearings used in most tape recorders are of the type which supposedly never require oiling, but I have encountered quite a number of these "oil-less" bearings which eventually drag or squeal and can be cured only by judicious lubricating.

Also, cleaning and demagnetizing the record/playback and bias heads should be normal procedure on every tape recorder brought in for servicing. This operation might be likened to the cleaning of the picture tube and safety glass in TV service work—a professional job is not complete without it. ▲

**FROM GULFPORT
MISSISSIPPI:**

"Color reception is amazing. For the first time we will really be able to sell color television."

**FROM GREAT BEND
KANSAS:**

"I've tested and used about every fringe antenna. Your Powertron gives the sharpest reception I have ever seen here."

**FROM FARGO
NORTH DAKOTA:**

"It's fantastic! We're getting several stations with Powertron we've never seen before."

FIRST DEALER REPORTS ON THE WINEGARD POWERTRON

World's First Electronic TV Antenna

The Powertron antenna has caused more letters to flow into Winegard's offices than any thing we have ever made. TV service-technicians who have tried one are amazed at the tremendous reception and advantages of this new antenna.

The Powertron is an all channel yagi antenna with a built-in high gain RF amplifier in one integral unit. It comes equipped with a power supply that lowers 117 V. AC to a safe 24 volts which is fed up the lead-in to the antenna. It is 5 to 9 times more powerful than any other antenna made.

With the Powertron, you can get your customers many channels they couldn't even see before. For example, in Burlington, Iowa, we easily pull in 9 channels where we used to pull in only 5 with a Color'Ceptor—our finest antenna before we developed the Powertron.

You can run 10 TV sets with a Powertron and all of them will have a better picture than you now get on one set with your present antenna.

You can make your installations 30 to 40% lower in height with a Powertron without affecting reception, in most cases.

You can remote the Powertron antenna 1/4 mile away from the TV set and get a better picture than with an ordinary antenna mounted next to the set.

You can deliver the clearest, sharpest, truest, color TV you've ever seen because the Powertron's extremely linear response makes it the *only* antenna that should be installed with a color receiver.

In short, this antenna is amazing. But don't take our word for it—test one and see for yourself. Ask your distributor or write today for *free* technical bulletin.

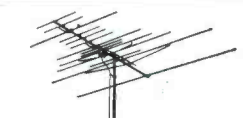
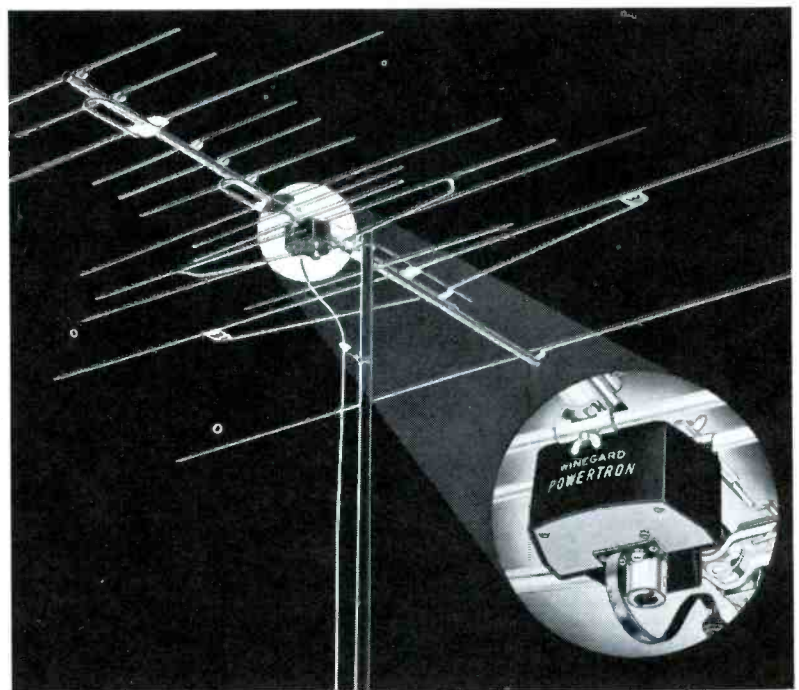

Model P-44 Powertron — \$74.95 list, 14 elements. 5 times more voltage gain than Color'Ceptor.



Model P-44X Powertron with Pack — \$91.90 list, 21 elements. Up to 54% more gain, higher front to back ratio than Model P-44.



Model SP-44X Super Powertron — \$104.95 list, 30 elements. Twice the gain of Model P-44.



Winegard

3009-3 Scotten Boulevard • Burlington, Iowa

IMPORTANT NEW SAMS BOOKS

BECOME A COMMUNICATIONS EXPERT!

Second-Class Radiotelephone License Handbook

by Edward M. Noll



You must have a second-class radiotelephone license to repair (and in some cases to operate) various communications equipment, including two-way mobile radio. Here's all the information you need to pass the 2nd class exam, and to successfully maintain and operate 2-way and other communications units on the job. 6 chapters contain questions and answers based on the FCC exam. 6 more chapters of text give you the thorough background and full knowledge of communications theory and practices you will need. Gives vital data on fundamental systems, rules and regulations, operating practices and procedures, communications test equipment, transmitter tuning and adjustment, etc. Elements I, II, and III of the 2nd class exam are explored in detail. Extensive Appendix provides much useful reference data. 240 pages; 5½" x 8½". Only **\$395**

HELPS YOU SOLVE THE "TOUGH DOGS"!

Radio and TV Trouble Clues



A collection of unusual "tough dog" troubles, based on actual field experiences with specific radio and TV receivers. Compiled by the Sams engineering staff from material featured in the "Quicker Servicing" column of PF REPORTER magazine, the book shows you in detail how to avoid time-consuming errors. Three sections cover troubles in TV and radio receivers, plus "oddball" problems; illustrated with dozens of photographs and schematics of the set or circuits being analyzed. Here's a guide that will help you get those "tough dogs" off your bench faster and easier. 96 pages; 5½" x 8½". Only **\$750**

NEW

Tube Substitution Handbook

NEW VOL. 2. Revised to include over 4,450 direct substitutions. Lists 1,644 receiving tubes with over 2,500 substitutions; shows 186 Industrial and 494 European substitutes for American receiving tubes; 453 American receiving tube substitutes for European types, with 725 direct substitutions. 17% more substitutions than in previous volume! Handy **\$750**
5½" x 8½" size. Only.....



1960-1961 TV Circuit Handbook



Shows you what's new in TV circuits for 1960-61. Describes circuits of all major manufacturers, from remote tuner controls to picture tubes, including color TV. The best "briefing" you can get on the new, unfamiliar TV circuits. 136 pages; 8½" x 11". Only **\$395**

HOWARD W. SAMS & CO., INC.

Order from your Sams Distributor today, or mail to Howard W. Sams & Co., Inc., Dept. C-31 1720 E. 38th St., Indianapolis 6, Ind.

Send me the following books:

- Second-Class Radiotel. License Hdbk. (QAN-1)
- Radio and TV Trouble Clues (RTQ-1)
- Tube Substitution Handbook, Vol. 2 (TUB-2)
- 1960-1961 TV Circuit Handbook (CHM-1)

\$.....enclosed. Send Free Book List

Name _____

Address _____

City _____ Zone _____ State _____

(Outside U.S.A. priced slightly higher)

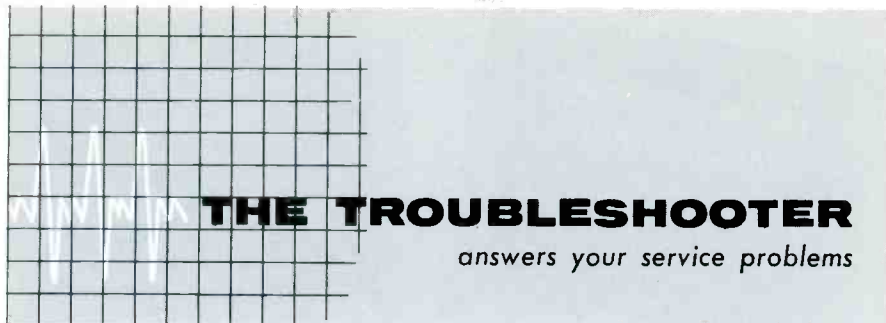

THE TROUBLESHOOTER

answers your service problems

Plus and Minus Supplies

I'm having trouble servicing an Emerson Chassis 120124 with a power supply that provides both positive and negative voltages. The service data says to measure voltages "from common negative unless otherwise stated." How can I determine where common negative is? I've been told to use the negative lead of the filter, but this doesn't seem to work.

DENNIS T. FLYNN

Chicago, Ill.

Ordinarily, the "low side" of nearly every circuit in a receiver is connected to a "common negative" point in the power supply. This isn't necessarily the most negative point, as we'll see in a moment. Some of the older transformerless TV sets avoid a "hot" chassis by having all B+ return points wired together. This return circuit is often referred to as B- or "common negative."

Many of the older TV sets have power supplies with minus-voltage taps to furnish potentials which are negative with respect to B-. The Emerson set is somewhat unusual in that the lowest tap (a -155-volt source) is used as a common return for some circuits, while the chassis is the common return for other circuits. The voltage and resistance charts for this set include notes to indicate whether the -155-volt source or chassis should be used as the reference point. If in doubt, see which point is connected to the cathode of the particular circuit you are checking. Beware of using the negative side of

filter capacitors as a common reference point. While this may be the most negative point in the power supply, it is not necessarily the common ground return.

50,000-Watt Feedback

I ran into a "tough dog" while working on a stereo hi-fi system using two Cal-Best amplifiers. Since the problem could happen in almost any system, I thought it might be of interest to your "Troubleshooter" readers.

The signal from our local 50,000-watt radio station could always be heard when the system was turned on. No matter what function the amplifier served (AM, FM, phono or tape), an undistorted, low-volume radio signal was always present in the output.

My first suspicion was insufficient shielding in the amplifier. This was proved wrong when I took it to the shop—it worked perfectly! Back in the home, the signal was still present. Hours of fruitless attempts to overcome the problem followed.

Just as I was about to give up, I hit on the idea it might be due to pickup in the speaker leads. They ran up one wall, across the ceiling, and down another wall to the speakers — and they weren't shielded leads. Another check of the service data showed a negative feedback circuit connected from the secondary windings of the output transformers back into the preamplifiers. The speaker leads

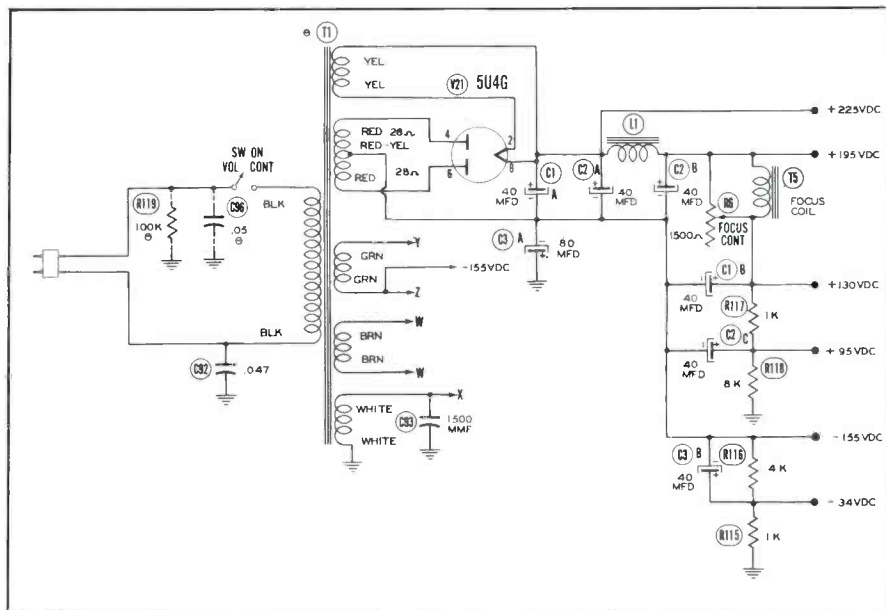

were picking up the strong signal, and the feedback network provided the input path to the amplifier. Placing .01-mfd capacitors across the output terminals of the amplifier bypassed the RF signal and solved the problem.

THOMAS H. LYNCH

Compton, Calif.

Thanks for the "feedback," Tom. Perhaps I should refer our readers' sound-system troubles to you!

Convert German TV?

We have a Grundig-Majestic TV in the shop. Made for use in Germany, it was brought over by an ex-GI who wants to know if it can be converted so he can use it here. The set has a turret tuner, but apparently the German channels are different from ours, because it doesn't pick up our stations. Can you offer any suggestions?

CHARLES B. WAGNER

Rolla, Mo.

You're so right in thinking that the German channels are different from ours. They have a 7-mc channel width, and the sound carrier is 5.5 mc above the video carrier. Also, their sweep frequencies are different — 50 cps for the vertical and 15,625 cps for horizontal — providing 625 lines per frame.

The video carrier frequencies for the German channels are:

1— 41.25 mc	6—182.25 mc
2— 48.25 mc	7—189.25 mc
3— 55.25 mc	8—196.25 mc
4— 62.25 mc	9—203.25 mc
5—175.25 mc	10—210.25 mc
	11—217.25 mc

The problem of conversion hinges mostly on how to get the signals through the RF, IF, and sound circuits. The range of the sweep circuits will probably be sufficient to operate at our scanning rates; if not, the resistance of the respective RC time circuits can be altered slightly to achieve the desired results.

Probably the best approach is to replace the tuner with one of the readily-available American designs. The IF frequency of the set is probably in the 30-mc range, so you can choose a tuner with either a 21-mc or 41-mc output. If the IF strip cannot be realigned to provide satisfactory operation at the chosen IF range, you can replace the IF coils with readily-available standard types. You'll get best results if you'll sweep align the IF strip to obtain maximum gain and acceptable response. The input IF coil should tune to the same frequency as the tuner IF. (You'll undoubtedly have to do the same for the tuned circuits of the sound stages in order to have them tune at 4.5 mc.)

The above information isn't meant to make the conversion sound insurmountable. However, it will be a fairly lengthy shop job, and may be economically feasible only if the set is in good condition and is expected to provide several more years of service.

"My Photofact Library is the most important tool in my daily servicing. With my Photofacts I am able to complete a job in just half the time it would take without them . . . Membership in the PEET program is the best thing that could happen to any Electronic Technician. I believe I speak from experience as this is my 19th year of full-time servicing."

—A. Kish, Jr.
Al's Radio & Television
Carteret, N. J.



Service Technicians! YOU EARN MORE... YOU RATE with the public when you own the PHOTOFACT® service data library!

You enjoy maximum earnings as the owner of a complete PHOTOFACT Service Data Library! It's inevitable, because no matter how expert you are, you can always *save more time on any job, get more jobs done daily—EARN MORE, DAY IN AND DAY OUT...*

What's more—as the owner of a complete PHOTOFACT Library, you know your customers' sets *best*. You can actually show each customer you have the PHOTOFACT Folder covering his very own set. Result: You command public respect and acceptance which paves the way to more business and earnings for you.

HOW TO STAY AHEAD...

Yes, the truly successful Service Technicians are those who own the complete PHOTOFACT Library, who can meet and solve any repair problem—faster and more profitably. And these men *keep ahead* because they're on a Standing Order Subscription with their Distributors to receive all new PHOTOFACTS as they are released monthly. (They're eligible for the benefits of membership in PEET, too—see below!)

ONLY \$10 DOWN puts the complete PHOTOFACT Library in your shop—and you have up to 30 months to pay. See your Sams Distributor today, or write to Howard W. Sams

NOW IS THE TIME TO JOIN

"PEET"

THE POWERFUL NEW PROGRAM FOR QUALIFIED TECHNICIANS

If you now own a PHOTOFACT Library or plan to own one, you can apply for membership in "PEET." It's the first industry program really designed to build powerful public acceptance for the Service Technician who qualifies. Builds enviable prestige and business for its members. Benefits cost you absolutely nothing if you qualify. Ask your Sams Distributor for the "PEET" details, or mail coupon today.

HOWARD W. SAMS & CO., INC.
1728 E. 38th St., Indianapolis 6, Ind.

- Send me full details on the new "PEET" Program.
- Send full information on the Easy-Buy Plan and Free File Cabinet deal.
- I'm interested in a Standing Order Subscription.
 - I'm a Service Technician full-time; part-time

My distributor is _____

Shop Name _____

Attn: _____

Address _____

City _____ Zone _____ State _____

NEW

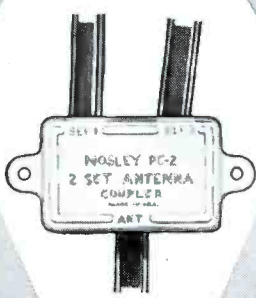

Mosley PC-2
TWO SET COUPLER

FOR TWO SET TV-FM OPERATION

You'll enjoy using the PC-2 two set coupler because your work and time will command a better price. The more efficient installations result in satisfied customers . . . fewer callbacks!

FEATURES INCLUDE:

- * Printed Circuit Design!
- * Low Forward Loss!
- * High Inter-set Isolation!
- * Call-Back Proof Connections!
- * Compact - Neat!
- * May be installed outdoors in semi-protected area!

Profit Wise TV Servicemen Choose Mosley.

PC-2, Dealer Net, \$1.36
(Suggested List \$2.26)

Another "Premium Quality"
Mosley TV Accessory.

Order from your Authorized Mosley
Distributor or write.

Mosley Electronics, Inc.

4610 N. Lindbergh Blvd. - Bridgeton, Missouri

Coloritis

(Continued from page 23)



Fig. 6. The "grassy" color signal at the grid of the killer increases bias.

form at the grid of either demodulator should be as shown in Fig. 3A, when a standard NTSC colorbar signal is being received. The oscillator signal present at the cathodes of the demodulators (Fig. 3B) keys them into conduction when the chroma signal is present at the grids. This provides signals to the B-Y amplifier as shown in Fig. 4A, and to the R-Y amplifier as in Fig. 4B.

The initial tests at the demodulators should give you clues about where to look next. If the chroma signal of Fig. 3A is reduced in amplitude, is distorted or absent, your search is directed to the video amplifier, chroma band pass amplifier, and color killer. If the grid signal is OK, but the cathode signal is weak or absent, the trouble centers in the chroma-reference oscillator, AFC, phase detector, or burst amplifier circuits.

Chroma Troubles

A weak chroma signal at the grid of the demodulator, or no signal, should lead you to the bandpass amplifier. Don't overlook the possibility of finding the trouble visually. You'll be surprised how many troubles can be pinned down to burned resistors.

The best way to check the bandpass amplifier is with a scope. A highly practical test can be made by connecting a low-capacitance scope probe directly to the plate. Sure, it'll detune the circuit, and cause loss of color in the picture tube display (even if the set is working perfectly); but the important thing is that a waveform similar to Fig. 5A will be obtained if the stage is functioning properly. Grid waveform 5B and cathode waveform 5C can also provide helpful information.

Voltages on the plate and screen grid of the bandpass amplifier are relatively unaffected by the presence

Service Dealer Program No. 3 in a Series

All 5 ads only

\$1.00 for glossy proofs

\$1.75 for ad mats

TV-RADIO TUBES CHECKED FREE!

CALL ME 8 0000

YOUR NAME

jittery TV

Does your TV jump around? Do you have a picture that is all over the place? Do you have a picture that is all over the place?

CALL ME 8 0000

YOUR NAME

WE SERVICE COLOR TV

CALL ME 8 0000

YOUR NAME

IT'S TIME TO CALL ME 8 0000 FOR FAST DEFENSIBLE TV REPAIR

YOUR NAME

USE THIS COUPON TO ORDER ADS DESCRIBED ON PAGE 69

PF REPORTER 361
2201 E. 46th Street
Indianapolis 6, Indiana

Please send me:

- ad mats @ \$1.75
- glossy prints @ \$1.00
- both for \$2.50

Enclosed is \$_____ to cover cost.

Name _____
Address _____
City _____ Zone _____ State _____

Picture-Tube Repair Tool

Eliminates that hard soldering job

only \$1.25 each

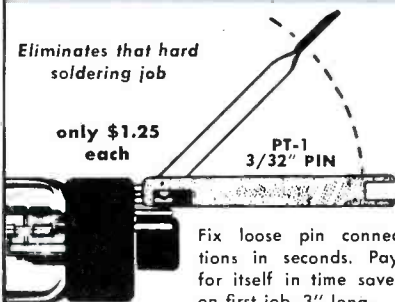

Fix loose pin connections in seconds. Pays for itself in time saved on first job. 3" long.

Patented
Intermittent operation of picture tubes due to defective solder connections easily corrected. Provides solid electrical connections, can also be used as channel-selector wrench and screwdriver. Pin keeps its original form. A 3-in-1 tool.

**3 MODELS
ELIMINATE SOLDERING
Makes Solid Electrical Connections
Pin-Plug Crimper**

Slip wire in "pin plug," insert in tool, and squeeze . . . job is done.

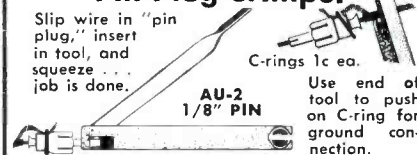

Use end of tool to push on C-ring for ground connection.

Ant. plugs, hi-fi, multiple plugs, public address, radio and TV tubes, radar, speakers, and loop connections. Many, many more uses.

Model LC-3 for 5/32" pin diameter
At your parts distributor or write us

BERNS Mfg. Co.
9853 Chalmers,
Detroit 13, Mich

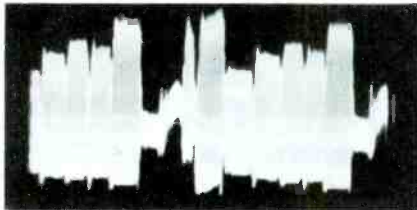

(A) 1.25V p-p color-sync signal.

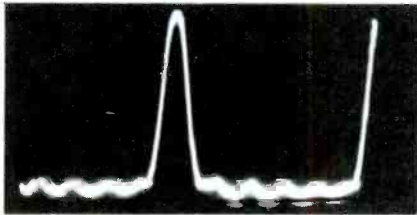

(B) 70V p-p horizontal keying pulse.

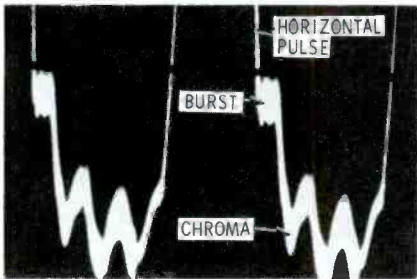

(C) "Grass" is the chroma signal.

Fig. 7. Burst amplifier input has both 3.58 color sync and keying signals.

or absence of a color signal. The control-grid and cathode voltages, on the other hand, may vary by 75% to 300%! This variation, of course, is due primarily to the action of the color killer.

The killer (Fig. 1) depends on a signal from the burst amplifier to reduce the negative voltage developed on its plate during the keyed conduction period. (Remember, the killer tube is keyed into conduction by a positive pulse derived from the flyback circuit.) Adjustment of the threshold control varies the negative voltage considerably; therefore, you'll need to check for a burst-produced signal at the control grid of the killer and a horizontal pulse signal at the plate to be sure the killer has the right signals for normal operation. Fig. 6 shows the grid waveform present in a properly-operating set when a color signal is being received. Obtained by using a direct scope probe, it measures .02 volt peak to peak. Its amplitude will vary with the setting of the threshold control; however, the fuzzy grass is the important thing to observe in this signal, because it indicates that chroma information is present.

Oscillator Troubles

The burst amplifier depends on

*A new "Caddy-Pak"...
designed specifically for the service dealer...*

Mullard

QUALITY ELECTRON TUBES

Mullard 8-Pak (type A)
for replacement in
stereo and monaural high
fidelity amplifiers, pre-
amplifiers, tuners.

ECC81/12AT7
ECC82/12AU7
ECC83/12AX7
ECL82/6BM8
EL84/6BQ5
EZ81/6CA4
7025
7189

**Dealer Pak Price
\$10.**

Mullard 8-Pak (type B)
for replacement in
foreign auto radios, hi-fi
equipment, tape recorders.

EABC80/6AK8
ECC82/12AU7
ECC83/12AX7
ECC85/6AQ8
ECF80/6BL8
ECL82/6BM8
EL84/6BQ5
EZ81/6CA4

**Dealer Pak Price
\$10.**

Mullard 8-Pak (type C)
for replacement in
television and FM tuners.

EC95/6ER5
EC97/6FY5
ECC189/6ES8
ECC91/6J6
EF183/6EH7
EF184/6EJ7
ECC85/6AQ8
XC95/2ER5

**Dealer Pak Price
\$10.**

Now in convenient "Caddy-8-Paks"

... include the most popular
replacement tube types for

- HIGH FIDELITY • TELEVISION
- AM-FM • FOREIGN EQUIPMENT



Three 8-Paks
specially selected
and grouped to satisfy
your everyday service requirements,
are now available at all leading
electronic parts distributors
... at the Dealer Pak Price
of \$10.

Get the Paks You Need Today!



TRADE MARK OF
MULLARD LTD., LONDON

INTERNATIONAL ELECTRON CS CORP.
81 SPRING STREET • NEW YORK 12, N. Y.

A Profitable New Field!

INDUSTRIAL ELECTRONIC SERVICING

with
OHMITE®
QUALITY
Components

Industrial electronic servicing is profitable new business for you. Especially when you stock and replace with dependable Ohmite components . . . the line your industrial customers know and prefer. Service such industrial equipment as mobile radio, aircraft and marine radar and radio, electronic controls for factory processes and automation, industrial P.A. and intercom systems, and—medical and dental electronics.

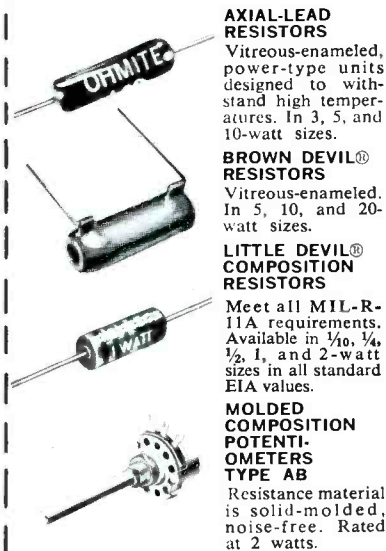

Write for Stock Catalog

OHMITE®
DEPENDABLE
RESISTANCE
UNITS

OHMITE MANUFACTURING COMPANY
3644 Howard Street, Skokie, Illinois

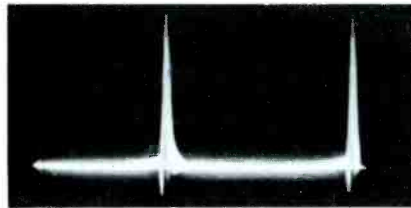

Fig. 8. Normal 3.58 color-sync signal as it appears at plate of burst amp.

two signals at its control grid to supply the burst (3.58-mc sync) signal to the phase detector. The chroma signal, containing the burst information, has a low amplitude as it comes from the video amplifier (see Fig. 7A). To obtain this waveform, the 70-volt horizontal keying signal (Fig. 7B) was removed from the grid by disconnecting R150. It's possible to check for the presence of both signals by increasing scope gain 10 times and looking for the chroma signal — the grassy trace between the horizontal pulses in Fig. 7C. You can tell whether the stage is functioning or not by checking for a burst signal at the plate of the amplifier (Fig. 8). This test detunes the circuit sufficiently to kill color reproduction of a normally-operating set, but it serves to check the operation of the stage.

The tuned plate circuit of the burst amplifier couples the 3.58-mc sync pulse to the phase detector. This regulates the conduction of both diodes to produce the bias voltage for the chroma-oscillator control stage — a variable-reactance circuit that keeps the 3.58-mc oscillator in tune. Adjustment A18 in the plate circuit of V20A acts just like the hold control used in the more familiar horizontal oscillator circuit, while A16 and A17 are simply tuned for maximum transfer of energy.

To Summarize

1. Most TV men already have sufficient understanding of circuit operation to service color TV.

2. A VTVM, low-capacitance scope probe, and wide-band scope are the basic test instruments required for color TV service. Color-bar and dot-pattern generators are readily available to complete equipment requirements.

3. Comparing color circuits to the more familiar configurations found in black-and-white receivers helps in understanding how a circuit operates and what it does. ▲

VALUABLE SAMS BOOKS ON TEST EQUIPMENT

available from your local
SAMS DISTRIBUTOR



Famous "101 Ways" Series

BY BOB MIDDLETON

These wonderfully practical books will help you put your test equipment to work more frequently and profitably. Bob Middleton shows you simply and clearly how to apply each instrument, how to make proper connections, what added equipment is needed, proper test procedure and evaluation of results. Each book is handy 5½" x 8½" size and fully illustrated.

101 Ways To Use Your Sweep Generator.	
144 pages. No. TEM-1. Only	\$2.00
101 Ways To Use Your Oscilloscope.	
180 pages. No. TEM-2. Only	\$2.50
101 Ways To Use Your VOM & VTVM.	
116 pages. No. TEM-3. Only	\$2.00
101 Ways To Use Your Signal Generator.	
128 pages. No. TEM-4. Only	\$2.00
101 Ways To Use Your Audio Test Equipment.	
136 pages. No. TEM-5. Only	\$2.00
101 Ways To Use Your Ham Test Equipment.	
168 pages. No. TEM-6. Only	\$2.50
101 More Ways To Use Your Scope in TV.	
160 pages. No. TEM-7. Only	\$2.50

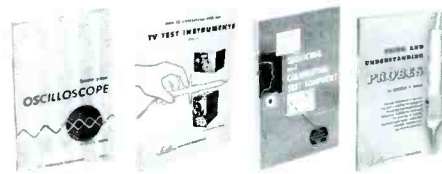

Know Your Oscilloscope. Covers circuitry, operation, adjustments, servicing and applications of oscilloscopes. Chapters include: Power Supplies; Sweep Systems; Synchronization; Amplifiers; Special Features; Accessories; Adjusting and Servicing; Frequency and Phase Measurements; Radio and TV Alignment; Practical Applications and Servicing Procedures. 160 pages, 5½" x 8½". No. KOS-1. Only **\$2.00**

How To Understand and Use TV Test Instruments. Revised and enlarged to include latest data on instruments for servicing Color TV. Tells how each instrument operates, how to use and get the most from it. Covers: VTVM's, Signal Generators, Sweep Generators, Scopes, Video Signal Generators, Field Intensity Meters and Voltage Calibrators. 176 pages, 8½" x 11". No. TN-1. (Revised). Only **\$3.50**

Servicing and Calibrating Test Equipment. Shows you how to keep your test instruments in reliable working order. Explains proper operation of instruments, calibration procedures, simple ways to check instrument accuracy, how to service test equipment. 190 pages, 5½" x 8½", illustrated. **\$2.75** No. TEK-1. Only

Using and Understanding Probes. Analyzes and describes uses of various probes: direct, isolation, high-voltage, low-capacitance, rectifying, demodulator, signal-tracing, signal-injection and special purpose. Includes industrial as well as TV and radio applications. 192 pages; 5½" x 8½". No. PRG-1. **\$3.95** Only

FREE SAMS BOOKLIST AVAILABLE—
ask your Distributor or write us direct

HOWARD W. SAMS & CO., INC.

1720 E. 38th St., Indianapolis 6, Ind.
In Canada: A. C. Simmonds & Sons, Ltd., Toronto 7

Recovering From the Bends

(Continued from page 18)

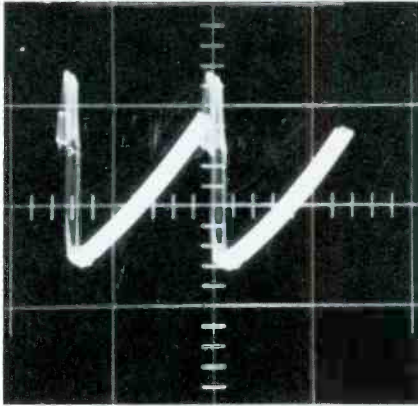

Fig. 2. Excessive jitter in grid waveform shows what's producing the hook.

capacitors anywhere are subject to eventual breakdown. Generally, the large-value units such as AGC filters seem more likely to develop leakage, shorts, or internal resistance than smaller-value capacitors.

Facing the Problem

A quick "clamp test" on the Philco did not affect the symptom, so I dismissed the thought of AGC trouble and decided to go directly to the horizontal AFC stage. To find out whether the fault was in the sync or in the AFC, I disconnected coupling capacitor C88 (Fig. 1) and momentarily synchronized the horizontal oscillator with the hold control. The sync bends were gone. With this bit of information at hand, I connected a low-capacitance probe to the vertical input terminals of my oscilloscope and switched to AC input. Reconnecting C88 and looking at the grid signal of the AFC tube, I saw a jittery sync signal (Fig. 2) that would upset much harder



Easy Adjustment of Hidden Controls

With Centralab Twist-Tab Radiohms



You'll get a big bang out of CENTRALAB tab-mounted Radiohm Controls—because they're easy to install and easy to adjust. These Twist-Tabs are tailored to the *minimum* shaft length needed for TV hidden controls. When a *longer* shaft is needed, it's simple to use the 2" polyethylene extension packed with each unit. Nothing to saw—a snip of the scissors gives the needed length, and the adjustment slot is still there, and still easy to get at.

CENTRALAB Twist-Tabs are available in 25 values from 200 ohms to 7.5 megohms... rated at $\frac{1}{2}$ watt, $\frac{15}{16}$ " diameter, $\frac{7}{16}$ " deep. Shoot over to your CENTRALAB distributor for full details.

Centralab

THE ELECTRONICS DIVISION OF GLOBE-UNION INC.
942C EAST KEEFE AVENUE • MILWAUKEE 1, WISCONSIN
CENTRALAB CANADA LIMITED—AJAX, ONTARIO

B-6115 S

**ELECTRONIC SWITCHES • VARIABLE RESISTORS • CERAMIC CAPACITORS
PACKAGED ELECTRONIC CIRCUITS • ENGINEERED CERAMICS**

TOP PERFORMER

...and profitmaker!

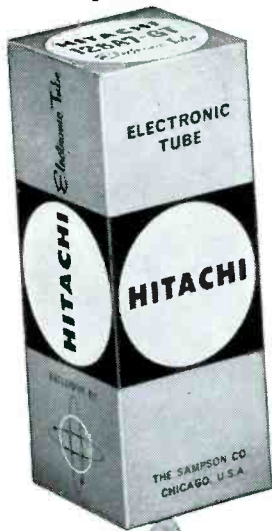

SELL—SERVICE—SATISFY

RECEIVING TUBES

MADE BY
GRAND PRIX AWARD-WINNING

HITACHI



Choice as original equipment by
manufacturers in the U.S. & abroad

From all points come good words about Hitachi tubes—on all points, tubes that can't be beat for performance and reliability. Most popular types are available . . . each made with strict quality-control to fully meet top American standards. Yet important cost savings guarantee you extra profits. And distribution's on a localized prompt-delivery basis.

THE SAMPSON COMPANY

ELECTRONICS DIVISION, 2244 S. Western Ave., Chicago 8, ILL

See your HITACHI Distributor
Or Write for Catalog
CT400-A

A COMPLETE LINE
OF QUALITY ELECTRONIC
COMPONENTS

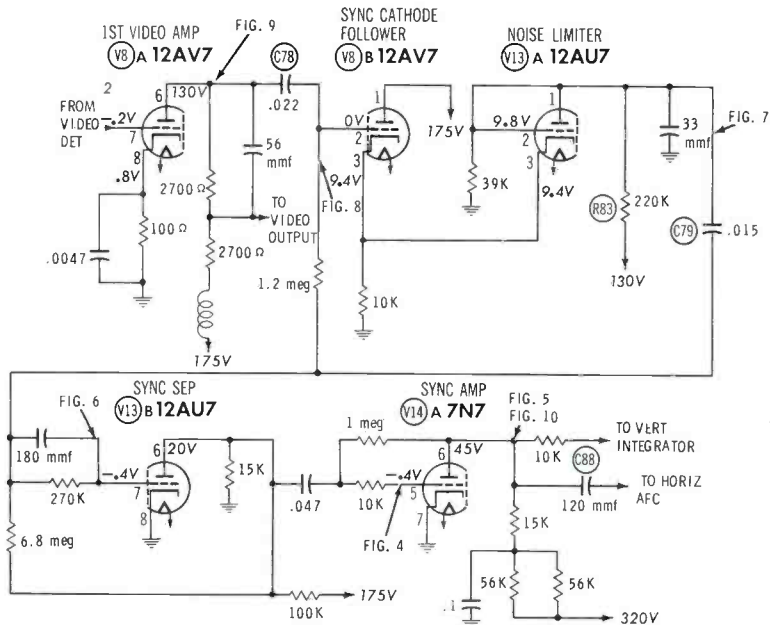

Fig. 3. Search for the source of trouble led back through the sync circuits.

circuits than this sensitive horizontal oscillator.

The most logical place for the next check was at the input of the sync amplifier V14A (Fig. 3). The waveform here had plenty of amplitude—18 volts peak to peak—but all was not well. A scope-sweep rate of 30 cps revealed compression of the horizontal pulses for a short time following each vertical pulse, as shown in Fig. 4A, while an inspection of the same waveform at 7875 cps (Fig. 4B) disclosed a pronounced jittering of the horizontal pulses.

Although the vertical pulses were somewhat compressed, they were steady enough to account for the lack of disturbance to the vertical oscillator. However, the instability of the horizontal pulses showed me that I'd have to search back through the preceding sync stages to find the reason for the bends.

Tubes had already been checked

before I'd brought the receiver to the shop—something I consider a must for even the most routine troubleshooting procedure. Thus, I stayed with the scope through the next several steps. However, I decided to switch over to a DC input, since this would permit a simultaneous check of both DC operating levels and AC peak-to-peak signal amplitudes at various points in the circuit.

A look at the output of V14A (Fig. 5) was convincing proof that the defects in the grid waveforms weren't just imagination; the compression following the vertical sync pulses was very real. The base line at the bottom of this positive-pulse waveform was riding at almost exactly 50 volts DC, confirming that both the tube and the associated B+ voltages were OK.

If the grid and plate waveforms of an amplifier are both bad, it's obvious the trouble lies ahead of that

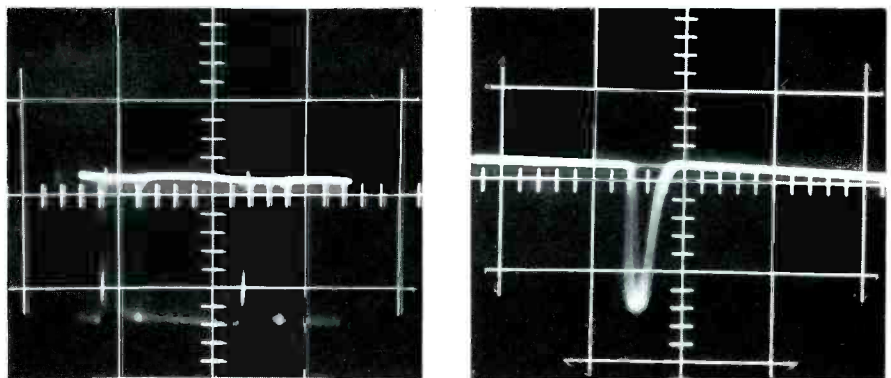
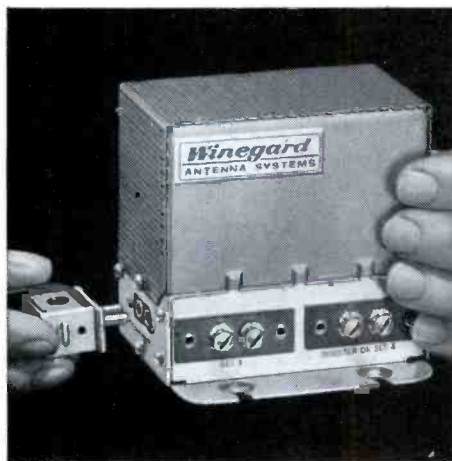

Fig. 4. Horizontal and vertical waveforms viewed at sync-amplifier grid.

WEAK TV signals get STRONG with new all-AC Winegard WBC-4X signal booster



Here's a sure, easy way to deliver better TV reception to your customers—sell them a Winegard WBC-4X Signal Booster. Get new distance, cut snow, get more picture contrast. Winegard WBC-4X has one tube, 4 sets of no-strip lead-in terminals, on-off switch, antenna disconnect plug. Runs 1—4 sets. It's all AC—no "hot" chassis. Only \$27.50 list. Ask your distributor or write for technical bulletin.



Everything from
antenna to set

Winegard

ANTENNA SYSTEMS
3009-3 Scotten, Burlington, Iowa

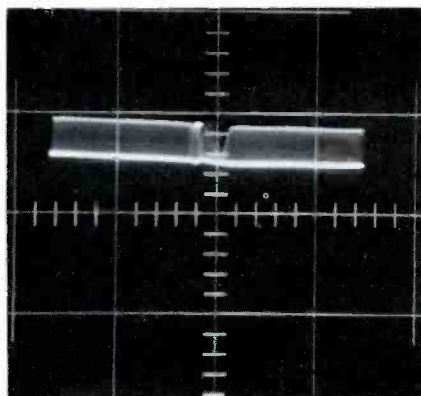

Fig. 5. Sync-amp waveform showed proper voltages and compressed sync.

stage. Consequently, my search led back to the plate of sync separator V13B. Here was the same signal I'd seen at the grid of the sync amplifier, with its base line riding at a normal 20 volts DC—so there was no trouble in the plate or coupling circuits. This called for a look at the input to the sync separator. At first glance (Fig. 6), it appeared normal, but a closer inspection made me change my mind. The sync pulses were compressed to less than 25% of the total signal amplitude, and I knew that even a 25% figure is insufficient for sets (like this Philco) with extra stages or peaking networks between the video amplifier and sync separator. Obviously, something was wrong ahead of V13B.

A quick check at the plate of noise limiter V13A showed that the no-signal DC voltage had risen to +15. On further testing, I found that R83 had decreased in value and C79 was leaky. With this resistor and capacitor changed, the plate waveform of V13A (which had looked similar to Fig. 6) was altered into the shape shown in Fig. 7. The sync pulses had greatly increased in amplitude, but now the video was compressed—and the bend was still

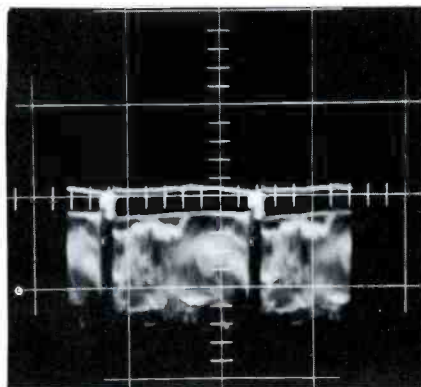

Fig. 6. Excessive video at grid of sync separator held an important clue.

Introducing

**Dry Battery
Point-of-Purchase
PROFIT
PAK**

Plus Quality
Profit

Eye-Catching New Self-Displayer Carton features 8 of the fastest-moving, performance-proved transistor battery types—needed for

- ✓ Radios ✓ Toys ✓ Flashlights
- ✓ Small Tools and Appliances, etc.

PLUS—Colorful Window Streamer

PLUS—Cross Reference Retail Price Guide

SAMCO

DRY BATTERIES BY FUJI ELECTRIC

Contact your Sameco Distributor Today or Write:

THE SAMPSON COMPANY

ELECTRONICS DIVISION
2244 S. Western Avenue
Chicago 8, Illinois

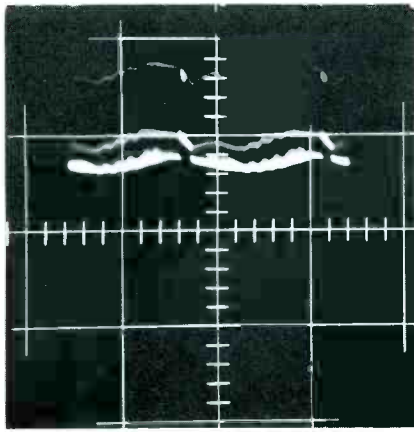

Fig. 7. Peaked sync and hum modulation after changing C79 and R83.

present in the raster.

The waveform included some 60-cycle ripple which might or might not be due to hum from an external source finding its way into the scope's vertical amplifier. The best way to settle this question was to touch the scope-input cable near the front-panel binding posts. In this instance, the ripple increased, so radiation of hum from a nearby instrument was obviously at fault. If touching the cable had not affected the ripple, I could have presumed that the hum was present in the sync signal itself.

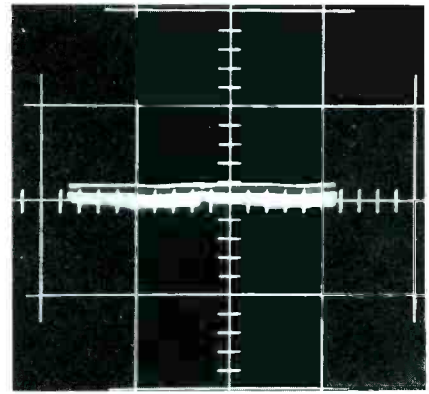

Fig. 8. The input to sync circuit was correct except for its low amplitude.

The next waveform of interest was the input to sync cathode follower V8B. As shown in Fig. 8, the positive sync-pulse tips and the video information seemed to be reasonably regular, and the average value of the signal was near the expected zero-volt level. On the other hand, the peak-to-peak amplitude was only about 25 volts, instead of 40 as it should have been.

Therefore, I moved the scope probe back to the plate of the first video amplifier. Everything was normal here—a 40-volt signal with an average DC value of about 150 volts.

Where's the Attenuator?

Surely I was close to the root of the problem by now. The plate of the first video amplifier and the grid of the sync cathode follower were separated only by C78. The scope checks of these two points revealed no significant leakage in the capacitor, and yet they did indicate a definite loss of waveform amplitude. Well, as I've mentioned from time to time, capacitors (particularly paper tubular units) may reduce in value sufficiently to cause noticeable

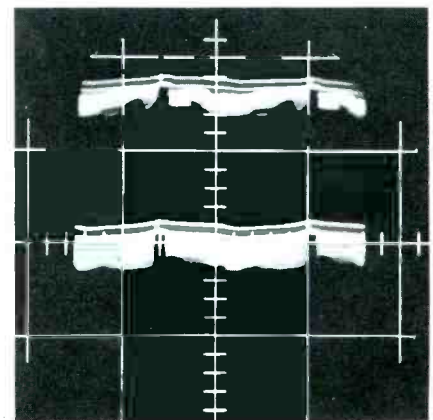

Fig. 9. Equal signal amplitude on both sides of new C78 confirmed results.

Neatest Tool Trick In Years!

It's

VACO'S®

"PIGGY-BACK" SCREW DRIVER OFFER

Look What You Get!

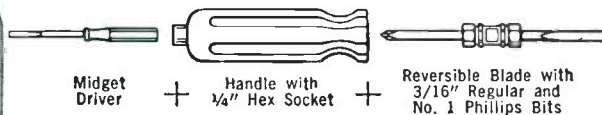

Only \$1.28 complete (Dealer Net)

A regular Vaco instrument-type screw driver is included FREE in this deal with the purchase of a quality VACO DU-11 Reversible with dual purpose regular and Phillips bits and 1/4" hex socket on dome of handle.

Midget Driver FREE!

The midget driver handle, as illustrated, fits "piggy-back" into the hex socket of the DU-11 handle dome. This gives extra length and precision control when working in hard-to-get-at places.

Look for this display or ask your Parts Distributor for the VACO DU-11 "Piggy-Back" offer.

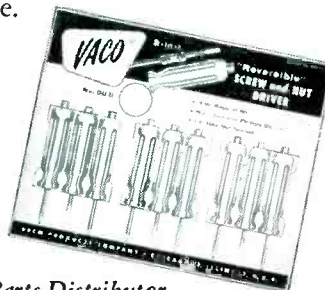

VACO PRODUCTS COMPANY

317 East Ontario Street, Chicago 11, Illinois

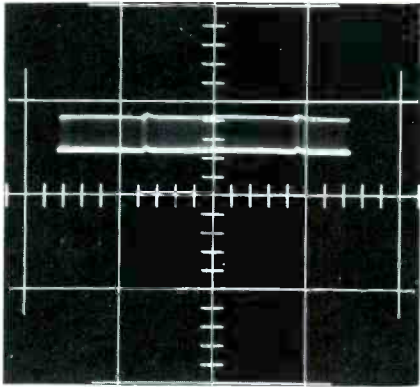

Fig. 10. Rechecking the output of the sync amplifier showed it was normal.

attenuation of the signals they are supposed to pass. Obviously, C78 was a "bad actor" of this sort and needed replacing.

Dilemma

I would have been most happy to install a new capacitor right then and there, but I ran into one snag—the unit I pulled out of the receiver was a .01, but the schematic called for a value of .022 mfd. What now? Just as I was about to mutter something unprintable and stomp off to a greener pasture, the light dawned. Perhaps this was an early version of the chassis, and maybe there had been a production change.

A double check of the service data proved I was right; this particular chassis was an early version that had used a .01-mfd unit for C78. Evidently, there had been some trouble in the field leading to a change in value for later production runs. This was all the reassurance I needed. In went a brand-new .022, and on went the Philco!

Happy Ending

I wasn't particularly surprised, but I was certainly relieved and pleased, to find that the horizontal

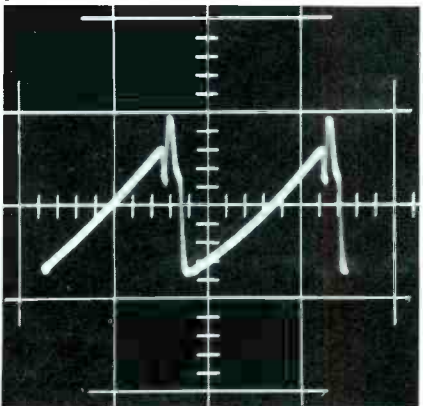

Fig. 11. Reward—a stable waveform at the grid of the horizontal AFC stage.

jitter and bending were now gone. Nothing more remained except to verify my waveforms and readjust the horizontal circuit for best stability.

Making a DC scope check of the waveforms on either side of the new C78, I got the results shown in Fig. 9. The grid signal of the sync cathode follower (lower waveform) now had just as much amplitude as the plate signal of the video amplifier (upper waveform), and they both maintained their normal DC levels.

The input waveform to the sync separator was now 50% sync and

50% video, a most desirable condition for this circuit. The signal at the plate of the sync amplifier was also encouraging; as Fig. 10 demonstrates, the irregularity in the horizontal sync pulses was gone. Here was a good, solid sync waveform, ready to do its duty in both the horizontal and vertical circuits.

The most gladdening waveform of all was the combined sync and feedback signal at the grid of the horizontal AFC tube (Fig. 11), now steady and true. Perseverance and logic had paid off in the satisfaction of a job done right. ▲

Professional Technicians Use CASTLE'S

Complete TV TUNER OVERHAUL

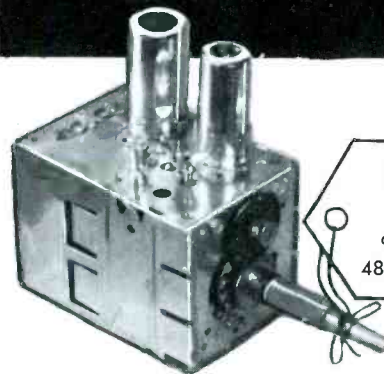

**SAME DAY
SERVICE!**

on Popular Types
48 Hours most Others

Castle overhaul charge includes all labor and minor parts and written 90 day warranty. Tubes and major parts are extra at net prices. Tuner to be overhauled should be shipped complete; include tubes, shield cover and any damaged parts. Write down model number and state complaint. Pack well and insure.

Write for Special Quantity Rates and Discounts

CASTLE
TV TUNER SERVICE, INC.

5710 N. Western Ave. • Chicago 45, Ill.

INCANADA

136 Main Street • Toronto 13, Ontario

**ALL MAKES
ONE PRICE
\$9⁹⁵**

**VHF TUNERS
UHF TUNERS
UV Combinations***

*UV combination tuner must be of one piece construction. Separate UHF and VHF tuners with cord or gear drives must be dismantled and the defective unit only sent in.



Overhauling TV tuners is our only business. We do not manufacture and sell you a so called "universal" replacement tuner. When the original equipment tuner is overhauled by Castle you are assured that it will fit properly and the electrical specifications, set by the receiver manufacturer, will be met exactly.

Castle



TV TUNERS

Synchro Systems

(Continued from page 27)

typically produced by various opens and shorts in individual units of a synchro system. An open in the like-numbered stator windings of both motor and generator (or in the connecting leads) would have the same effect as an open stator in one unit only. On the other hand, an open

in both rotors would cause a total loss of system operation, because the primary excitation would be missing.

In a complex system including several motors operated by the same generator, an open stator winding can be localized to a specific unit by keeping in mind that a fault in the generator will cause all the

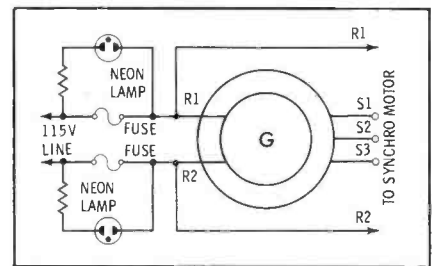

Fig. 7. If fuse burns out, neon lamp on central control panel becomes lit.

motors to oscillate, while an open in a motor will affect only that particular motor. Fast changes in operating speed, or quick reversals, will produce various other types of erratic behavior besides those listed in Table II. It should also be noted that two open stator coils in the same synchro will prevent that unit from operating at all.

Resistance or voltage measurements can often be a real help in troubleshooting synchro systems, especially if the correct readings are known. Usually, all of the units in a synchro system are identical, so all of the stator windings will have very close to the same resistance and voltage readings under comparable conditions. Rotor resistance will also be the same. Knowing the correct readings in advance of a breakdown is thus helpful in locating troubles in minimum time.

Mechanical Troubles

Any troubleshooting or maintenance procedure for synchro systems must include a consideration of mechanical faults, which are just as likely to occur as electrical failures.



NEW TRANSISTORIZED



MODEL PS-3 \$69⁵⁰ net
0-25v. DC variable output voltage

REGULATED DC POWER SUPPLY

NOW service technicians and industrial users can afford the performance of a regulated variable-voltage power supply.

Set It and Forget It—Voltage remains essentially constant at any output voltage setting regardless of load (within ratings) and AC supply voltage fluctuations.

Extremely Low Ripple—Less than 1 MV (.001 V) RMS for all conditions of rated operation . . . less than ½ MV (.0005 V) for AC line voltage between 115 and 120 volts.

Output—0-200 MA, 0-15 volts. 0-100 MA, 0-25 volts.

Input Voltage—110 to 130 volts, 60 cycles.

Regulation—500 MV maximum, for above mentioned ratings.

Sold by Leading Electronic Distributors. Send for Catalog Sheet PS-3

ELECTRO PRODUCTS LABORATORIES

4501-T Ravenswood, Chicago 40 / Canada: Atlas Radio Corp., Ltd., Toronto, Ont.

AT ONE-HALF THE COST!

BOGEN SOUND SYSTEMS

exclusive Bogen Flex-Pak offers:

- wall-mount bracket



- rack panel mount



- carrying case, with or without speakers

plus: tamper-proof locking plate • E-Z Service removable cover • easily-mounted turntables... and many other optional features.

Bogen Flex-Pak® Series

Bogen-Presto, world's leading manufacturer of packaged P.A. and sound products, serves all sound needs . . . "across the board." All 13 exclusive Bogen Flex-Pak models offer the very finest sound equipment available . . . featuring award-winning styling* and many special features designed to meet all requirements.



MX60 Deluxe 60-watt Amplifier.
• master gain control • built-in remote gain control circuit • 4 mike channels (one converts to phono).



MO100 100-watt Booster Amplifier.
Exceptional wide-range frequency response. Ideal wherever undistorted high power is required.

*Styling plus! MX60 is the winner of the Milan Triennial Gold Medal for design excellence.

For information on the complete line, write for FREE Sound Systems file TODAY.

BOGEN-

Table III lists a number of mechanical troubles and the symptoms which they produce. This list is by no means exhaustive, but it does include the troubles which most often occur. The same rules which apply to other types of rotating machinery also apply to synchro systems; however, more emphasis is placed on accuracy than in the case of power generators, motors, etc.

Aids in Troubleshooting

Overload and blown-fuse indicators, located on a central control board or panel, save time for the serviceman by providing a quick means of checking widely-separated parts of the system.

Overload Indicators

In a synchro system consisting of a generator and motors, there is rotor current in all the units at all times, but stator currents exist only when the generator and motor are out of correspondence (not at the same angle). The amplitude of these stator currents depends on the angle between the rotors. Normally, the motor follows the generator with only a few degrees of lag, thus setting up only small stator currents.

However, if the system is overloaded in any way, the additional drag on the motor makes it more sluggish in following the generator. As a result, larger stator currents are set up. These currents may not be enough to blow a fuse, but they could damage the units over a period of time. An overload indica-

tor will detect this condition.

Fig. 6 shows an overload indicator connected into a simple synchro system consisting of a generator and a motor. The device must be connected into at least two stator leads because, even with an overload in two windings, the current in the third could still be zero. The two transformers, T1 and T2, have a

few turns of large wire for primaries, and a large number of turns of fine wire for secondaries. The secondary voltages depend on the currents in the primaries (S1 and S3 leads). The voltage applied to the neon bulb is determined by the difference between the two stator currents, and this difference increases with the angular difference between



Type "CTC" . . . cardboard tube electrolytics especially designed for exact replacement in television sets . . . one end closed . . . long insulated leads out other end . . . sealed with high melting point wax . . . guaranteed for one year . . . individually packaged.

Write today for complete information.

PLANET SALES CORPORATION
225 Belleville Avenue Bloomfield, New Jersey

ACROSS THE BOARD !!!

Bogen Challenger Series

Engineering precision and peak performance make the famous Bogen CHALLENGER series the sound choice of many organizations and institutions. Designed and assembled with all the care and quality of the exclusive Flex-Pak line, the CHALLENGER series offers performance, versatility and value in all nine models.



CHA75A 75-watt Amplifier features a modern high-gain circuit with specifications equal to amplifiers that cost far more.



CHA620Y 20-watt Mobile Amplifier . . . with 3-speed phono top. Designed to operate on 110v AC, 6v DC, or 12v DC.

a sound product for ANY application

- P.A. Systems
- Office and Home Intercoms
- Internal Telephones
- School Consoles
- Portable Transcription Players
- Hi-Fi & Stereo Components
- Professional Studio Equipment

PRESTO  **SIEGLER**

DESK 611, PARAMUS, N. J.

A DIVISION OF THE SIEGLER CORPORATION

POWER TRANSISTORS

FOR GENERAL REPLACEMENT PURPOSES IN AUTO RADIOS, POWER AMPLIFIERS, FARM RADIOS, MARINE RADIOS, ETC.

Individually packaged in a plastic see-thru box with instructions and cross-reference information.



4 TYPES OF POWER TRANSISTORS THAT WILL REPLACE A LARGE MAJORITY OF TRANSISTORS IN USE TODAY



- V176 LOW WATTAGE TYPE
- V155 MEDIUM WATTAGE
- V40 HIGH WATTAGE TYPE
- V50 *Gold Bond* HIGH WATTAGE-HIGH GAIN (Finished in gold)

SILICON RECTIFIERS

FOR GENERAL REPLACEMENT PURPOSES

For use in radios, television sets, amplifiers or any electronic equipment presently using a tube, selenium or silicon rectifier

INDIVIDUALLY PACKAGED IN A PLASTIC SEE-THRU BOX

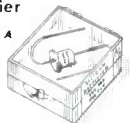

Adapter included for Fuse type mounting

500 MA 200 P.I.V. TYPE PART No. SR-52

For use in all radios, phono amplifiers and electronic equipment where an RMS voltage of 140 volts or less is applied.

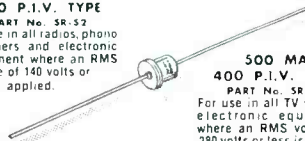

500 MA 400 P.I.V. TYPE PART No. SR-54

For use in all TV sets and electronic equipment where an RMS voltage of 280 volts or less is applied.

Vidair ELECTRONICS MFG. CORP.
365 BABYLON TPKE. — ROOSEVELT, N. Y.

the business-like approach

to SERVICE CHARGES and RECORD KEEPING

For customer's prices on every replacement part, plus flat rate and hourly service charge data, regional and national. Dave Rice's OFFICIAL PRICING DIGEST, listing over 63,000 items. \$2.50.



▲ AVAILABLE FROM YOUR DISTRIBUTOR ▼

If you want to operate on a professional level, Dave Rice's OFFICIAL ORDER BOOKS give you triplicate forms for order, invoice, and office records... spaces for tubes, parts, serial numbers, labor and tax charges, signatures, etc. 75c per book, \$6.50 for dust-proof box of 10.



Dave Rice's

ELECTRONIC PUBLISHING COMPANY, INC.
180 N. WACKER DRIVE • CHICAGO 6, ILL.

Table II — Opens and Shorts

FAULT	SYMPTOM
R1 or R2 open	Motor follows with sluggish action. May align correctly or 180° off. Other synchro may get hot.
S1 open	As the generator is rotated through 360° the motor oscillates back and forth between 0° and 120°, or between 180° and 300°.
S2 open	As the generator is rotated through 360° the motor oscillates back and forth between 120° and 240°, or between 300° and 60°.
S3 open	As the generator is rotated through 360° the motor oscillates back and forth between 60° and 180°, or between 240° and 360°.
open generator open motor	All motors oscillate. Only the affected motor oscillates.
R1 or R2 shorted	Line fuse blows because of the short across the power line.
S1 and S3 shorted	Synchros lock at 0° or 180°. Zero voltage from S1 to S3. Rotor voltages normal. Excessive heat and hum.
S2 and S3 shorted	Synchros lock at 60° or 240°. Zero voltage from S2 to S3. Rotor voltages normal. Excessive heat and hum.
S1 and S2 shorted	Synchros lock at 120° or 300°. Zero voltage from S1 to S2. Rotor voltages normal. Excessive heat and hum.

the two units. If there is overloading, with subsequent lag, the neon bulb lights to indicate the overload.

Blown-Fuse Indicator

Synchros are most often protected by fuses or circuit breakers in the leads which supply line voltage to the rotors. A blown-fuse indicator (Fig. 7) is connected so that a neon lamp will light whenever a fuse blows. This arrangement is especially desirable when the rotors are fused separately.

A number of different types of circuits are used to indicate overloads or blown fuses, but the two hook-ups just described show the basic ideas involved in the operation of such protective devices. Other servicing aids are also available, such as special synchros which can be quickly substituted in place of a defective unit. However, observation is probably the single most important point in servicing synchro systems. ▲

Table III — Mechanical Troubles

FAULT	SYMPTOM
Tight bearings	Motor rotation lags generator angle, often with large error. Excessive heating and hum.
Worn bearings or shaft	Excessive heating, hum, and inaccurate operation, especially with fast rotation.
Improper damping	Excessive oscillations of motor around the command position. In some cases, spinning occurs.
Defective slip rings or brushes	Intermittent operation.
Loose couplings of shafts, gears, or other mechanical linkages	Motor fails to follow rotation of generator, especially on fast changes.
Improper gear mesh	Noisy and somewhat inaccurate operation.
Units not zeroed properly	Constant angle of error between generator and motor.
Excessive load	Slow response and overheating.

Save TIME and DOLLARS with "INSTANT 2-WAY RADIO CONTACT"



Talk and Listen Instantly to Your Men "On the Job"
New 2-way radio actually fits into your pocket. Exclusive, rechargeable battery lasts year or more. Range—1/2 to 1 mile. No license required.

GLOBE ELECTRONICS Pocketphone

THE FINEST 2-WAY RADIO AVAILABLE TODAY

Ideal for office, factory, stores, surveying, construction, sports, recreation, home. Finest quality available. Makes handy paging system. Use with Globe Electronics CB-100A or CB-200 for longer range systems.
• Actual size—1 1/4" x 2 3/4" x 6 1/4" • Weight—13 oz. • High impact cyclac case • All Transistorized. \$125.00 each

FOR LONGER RANGE COMMUNICATION



CITIZENS BROADCASTER CB-100A... Complete 3-channel, 2 way station. Fixed or mobile installation. Easy to install, operate. Range 5-15 miles. \$139.95 each

BROADCASTER DELUXE CB-200... A rugged transceiver for commercial use. Transmits on 5 channels. Receives on all 22. Adapts to selective calling system. \$189.95 each

CLIP AND MAIL COUPON TODAY FOR INFORMATION

GLOBE ELECTRONICS
A Division of Textron Electronics, Inc.
22-30 So. 34th St., Council Bluffs, Iowa
Please send me complete information on the new Globe Electronics Pocketphone CB-100A CB-200



PF-3

NAME _____
ADDRESS _____
CITY _____ STATE _____

A Service-Keyed Advertising Program

Response to the unique PF REPORTER advertising program has proved beyond any doubt that such a service is needed. This response is a healthy sign that the radio-TV electronics service industry is aware of the necessity for *good* advertising copy.

The PF REPORTER program has been planned and executed by men intimately aware of your needs. Some of the messages are seasonal; others emphasize specialized services on hi-fi, color TV, auto radios, antenna systems, etc., while several are designed for special offers.

To make sure these ads will get results, the program has been carefully developed and field-tested. As a service to our readers, each month's selection of 5 ads is available *at cost* in two forms—durable newspaper mats at \$1.75 per set, or high-quality reproduction proofs at only \$1.00 per set. The latter will serve as finished artwork for offset printing if handbills, postcards, doorknob hangers, direct-mail pieces, etc. To obtain your set of this month's ads, use the convenient order form on page 58. Your ads will be sent to your postpaid.

ES-16: 1 7/8" x 4 3/4"

Ads which concentrate on typical TV troubles always get results. For a case of TV shakes, potential customers find you have a tranquilizer for their twitching eyeballs.



ES-35: 3 3/4" x 3 3/4"

For potential customers whose pictures bend like this one, here's an eyestopper that says you'll provide dependable service in a hurry. It also gets in a plug for your radio and hi-fi service.



ES-38: 1 7/8" x 3 3/8"

Capitalizing on the popularity of western TV shows, and the viewing public's demand for fast service, this ad tells potential customers you are ready to serve them.



ES-50: 1 7/8" x 5"

Troubled by "drug-storeitis?" Here's a solution. Tell your customers it takes professional know-how to make a tube tester tick.



ES-58: 1 7/8" x 3 3/8"

Here's an ad that's suitable for use anywhere. If you're good enough to service color TV, you're good enough to service any set.

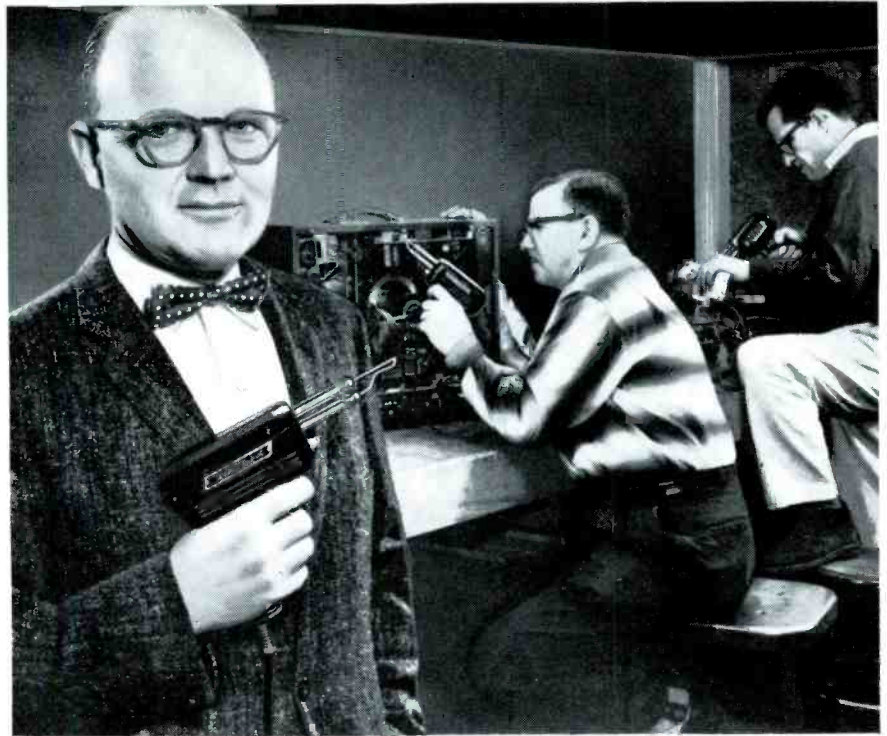

MR. RAY ROUGHTON, TECHNICAL SUPERVISOR OF UNIVERSAL TELEVISION CO., SAYS:

"Universal TV does 200 service jobs a day . . . faster and more efficiently with

Weller® DUAL HEAT SOLDERING GUNS"

Universal Television Company of Los Angeles is one of the nation's largest contract service organizations. They have 25 servicemen—each with his own Weller Dual Heat Soldering Gun. Why *Weller Dual Heat*? For *speed and flexibility!* Although fast heat is the most important benefit, Dual Heat runs a close second, according to Mr. Roughton. The 2 trigger positions permit their servicemen to switch instantly to the low heat required for printed circuit soldering—and the high heat needed for conventional soldering. Result? Faster servicing and more reliable soldered connections. Don't settle for less! Buy Weller—the original Soldering Gun.



Available at Electronic Parts Distributors

WELLER ELECTRIC CORP. EASTON, PA.

**A.C. to D.C.
POWER SUPPLY**

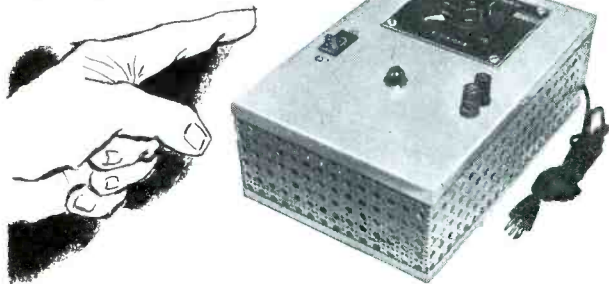

**... just what you need
FOR TESTING TRANSISTORS**

Plug this instrument into any 60 cps, 95/130 volt circuit and get a stabilized source of direct current, adjustable over a range from 0 to 45 volts DC, with current output 0/2.5 amperes. Filtered direct current output range 0/45 volts 0/2.5 amperes is continuously adjustable and stabilized $\pm 1\%$ at any setting regardless of alternating current fluctuation. Voltage regulation is approximately 5% between full load and no load at full voltage setting.

This DC Power Supply instrument is ideal for use in transistor testing, circuit testing, to provide regulated voltage for light testing, eliminates the need of batteries by supplying exact DC voltage required.

Write for Bulletin 17-BL01 which gives full details and models available. SAA 3402-1850

ACME ELECTRIC CORPORATION

943 WATER STREET

CUBA, N. Y.



A GRANCO FIRST!



**GO WITH
EXCLUSIVE
GRANCO FM
CAR RADIO
CONVERTER!**

ONLY \$49.95

Add the beauty in sound of Granco FM to AM car radio in a marvel of minutes. Superb quality . . . compact design — only 1 1/4" thick . . . and ease of installation make this Granco innovation a "must" for every car.

Get in on this big new profit maker . . . write for details today!

GRANCO America's Leading Specialist in FM
DIVISION • DUMONT EMERSON CORP., 680 FIFTH AVE., N.Y.C.

**PRODUCT
REPORT**

For further information on any of the following items, circle the associated number on the Catalog & Literature Card.

VOM With Automatic Features (41Z)

The B & K "V O Matic 360" displays only one scale at a time, automatically changing scales when the range switch is turned. For zeroing the meter on the ohms scale, the test leads can be conveniently shorted together by a switch on the ohms-adjust control. The unit checks capacitance in three ranges, in addition to audio power output, DBM, peak-to-peak AC (of sine waves), DC and AC voltage, and resistance. Sensitivity is 20K ohms per volt on DC, and 5K on AC. Price is \$59.95, including batteries and leads.



Auto-Radio Controls (42Z)

Original controls in 1959 Delco auto radios can be replaced with new Centralab parts as follows: 7273993 (Buick) with BD-59; 7273302-1221260 and 7273367-1221268 (Chevrolet) with CD-59-A and CD-59-B; 7272855 (Oldsmobile) with OD-59; and 7273623 (Pontiac) with POD-59. Also, controls M/U-2 and M/U-6 through -9 are available to replace original parts in 1957-9 Chevrolet and 1959 Pontiac radios built by Motorola.

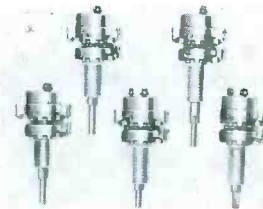

Transistor Kit (43Z)

The 12 transistors and one crystal diode in the Motorola Model HK46 "Transistor Troubleshooting and Replacement Kit" form a basic stock of "universal" types for replacement or temporary substitution testing of practically all semiconductor employed in portable radios. A "Replacement Guide" booklet gives information on substitutions, and a 6-drawer, 9 3/4" x 3 1/2" x 6 3/8" polystyrene cabinet is furnished for storage of transistors and other miniature-radio parts.

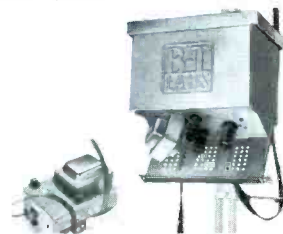

Miniature Electrolytics (44Z)

The Aerovox AK-510 kit consists of a compartmented plastic box holding 18 Type PTT-PWE "Polycap" plastic-cased miniature electrolytic capacitors. This assortment is claimed to cover 90% of the serviceman's replacement needs for portable transistor radios and other limited-space uses.



Antenna-Signal Amplifier (45Z)

Signals can be carried over a mile of open-wire line (or 1500' of 300-ohm lead) between a TV/FM antenna and receiver, if a Blonder-Tongue Model AB-3 "Mast-Mounted Broad-band TV/FM Amplifier" is installed at the antenna site. A 6DJ8 frame-grid twin triode and two 6EW6 pentodes provide an average of 22 db gain over the VHF band. The power supply is located at the receiver, has adjustable voltage output, and draws 340 ma at 117 volts. List price is \$104.50.

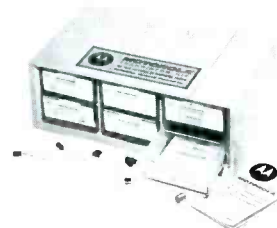

Dipped Tubular Capacitors (46Z)

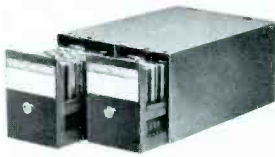

TK-24 (\$24.90) holds 124 capacitors of 13 ratings. Capacitors in both kits are packed in clear plastic boxes; end labels permit easy selection.

Two "Service-Selected" assortments of Sprague "Orange-Drop" dipped, radial-lead tubular capacitors (with dual "Mylar"-paper dielectric) are now being furnished in metal file drawers. One-drawer kit TK-23 (\$11.70) contains 60 capacitors of 10 different ratings, while two-drawer kit

Fringe-Area Antennas (47Z)

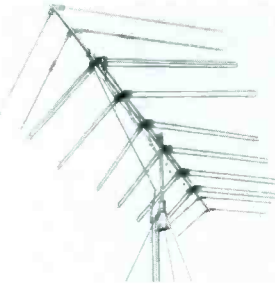

driven dipoles.

Two new versions of the Channel Master "Traveling Wave" antenna have higher gain than previous models, due to an improved system of four parasitic elements— independent reflectors and directors for the low and high VHF bands. The Super 10 T-W (Model 358, \$59.95), for deep-fringe use, employs six interconnected hairpin-type driven dipoles, while the smaller Super 8 T-W (Model 359, \$44.95) has four

Reverberation Device (48Z)

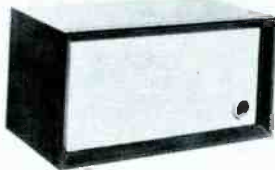

component hi-fi systems. The available in mahogany, walnut, or blond finish. Price, including cables, is \$109.90.

All necessary elements for adding the reverberation effect to an audio system—delay line, amplifier, "reverb" control, and speaker—are contained in the Utah Model RVB-1. This unit, effective on both monophonic and stereo material, can be used with either packaged or 20" x 10" x 10 1/4" cabinet is

Pocket Citizens Band Unit (49Z)

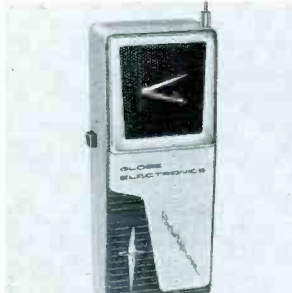

The nine-transistor, 13-oz. Globe Electronics "Pocket-phone" can be carried about as a local "radio-paging" receiver with antenna retracted, or the built-in whip antenna can be extended to permit two-way communications on the Class D Citizens band for a distance of 1/2 to 1 mile. RF power is low enough to exempt the user from FCC licensing. Power comes from a rechargeable nickel-cadmium battery.

Fuse Holders (50Z)

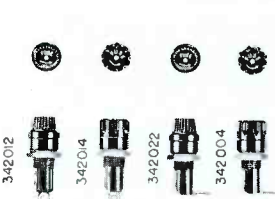

Designed for panel mounting, Littelfuse 3AG miniature fuse posts are available with two different types of terminals—one requiring 1 11/32" of space behind the panel, and the other only 1 1/64". A choice of two knob styles is also offered. Maximum electrical ratings are: Current, 15 amps; voltage, 250V.

Silvered Mica Capacitors (51Z)

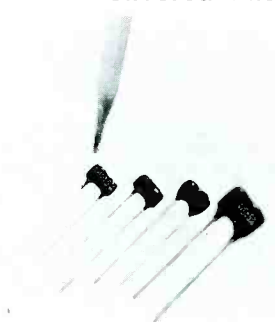

Dip-coated with blue phenolic insulation, Cornell-Dubilier "Royal Blue" silvered mica capacitors are smaller and more economical than molded types; however, they have equally stable temperature characteristics. The basic line covers a range of values from 1 to 40,000 mmf in three ratings of 500, 300, and 100 WVDC, with tolerances of ±1/2, 1, 2, 5, and 10%. Many values are also obtainable at 1000, 2000, and 2500 WVDC.

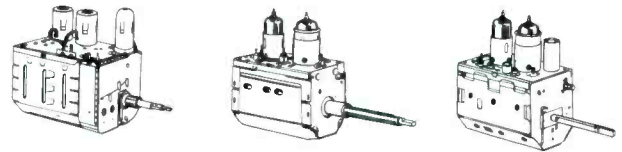

TUNERS REPAIRED \$8.50

24-Hour Service 6-Month Warranty

Repair Charge includes ALL Replacement Parts

SARKES TARZIAN, INC., pioneer in the Tuner Manufacturing business, offers fast, dependable, factory repair service on all makes and models. Cost—\$8.50 per unit. \$15 for UV combinations. Now offering 6-month warranty against defective workmanship and parts failure due to normal usage. Tuners repaired on approved, open accounts. Replacements available at low cost on tuners beyond practical repair.



Tarzian-made tuners easily identified by this stamping. When inquiring about service or replacements for other than Tarzian-made tuners, always give tube complement . . . shaft length . . . filament voltage . . . series or shunt heater . . . IF frequency, chassis identification. And, allow a little more time for service on these tuners. See your distributor, or use this address for fast, factory repair service:

SERVICE MANAGER • TUNER DIVISION
DEPT. A



SARKES TARZIAN INC

east hillside drive • bloomington, indiana
edison 2-7251

Mfgs. of Tuners, Semiconductors, Air Trimmers, FM Radios, Audio Tape, and Broadcast Equipment

NEW! x-acto[®] PENknife

The world famous X-acto knife in a brand new "carry-about" case!

• **Famous X-acto Knife Features!** All the features of the famous Interchangeable Blade X-acto Knife. Takes 3 styles of surgically sharp blades—specially designed for precise cutting and slitting operations.

• **So Safe!** Crystal clear "See-Thru" Plastic Cap reveals the blade. No mistaking it for anything but a knife when carried with other capped instruments.

• **Always Convenient!** Just clip it to your pocket and carry it with you everywhere.

For immediate improvement in efficiency, accuracy and safety switch to X-acto!

(Here's an idea! The X-acto PenKnife can be imprinted. It makes an excellent business gift. Complete details, with quantity prices, sent upon request.)

No. 3-ST
Actual Size

Open and ready for action! When not in use, replace the cap (like a pen) and clip it to your pocket . . . always handy.

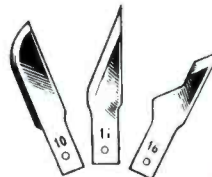

- No. 10 — for small, fine general cutting.
- No. 11 — for fine angle cutting, deep cuts, narrow spots.
- No. 16 — for small holes, notches, slits — in thin materials.

— Sample Offer —

HANDICRAFT TOOLS, Inc.
Div. of X-ACTO, INC.
48-422 Van Dam Street,
Long Island City 1, N. Y.

Enclosed is \$1.00. Please send me a PenKnife with the number _____ (specify #10, 11 or 16 blade) blade and free illustrated catalog of X-acto precision knives, blades, and tools.

Name _____
Company _____
Address _____
City _____ Zone _____ State _____

March, 1961

Acme Electric Corp. 70
American Television & Radio Co. (ATR) 12
Arco Electronics 13
B & K Mfg. Co. 19, 48
Berns Mfg. Co. 58
Blonder-Tongue Labs 52
Bogen-Presto 66, 67
Bussmann Mfg. Div. 51
CBS Electronics 47
Castle TV Tuner Service 65
Centralab, A Div. of Globe-Union, Inc. 61
Channel Master Corp. 54
Clarostat Mfg. Co., Inc. 41
Cornell-Dubilier Electric Corp. 36-37
EICO 14
Electro Products Laboratories, Inc. 66
Electronic Publishing Co., Inc. 68
General Electric Co. Receiving Tube Dept. 21
Globe Electronics Corp. 68
Granco Div. 70
Handicraft Tools, Inc. 71
International Electronics Corp. 59
Jackson Electrical Instrument Co. 50, 72
Jerrold Electronics Corp. 2nd cover
Krylon, Inc. 34
Littelfuse, Inc. 4th cover
Los Angeles Tuner Exchange 34
Mallory & Co. Inc., P. R. 16-17
Merit Coil & Transformer Corp. 32
Mosley Electronics, Inc. 58
Ohmite Mfg. Co. 60
Philco Corp. - Accessories Div. 39
Planet Sales Corp. 67
Precision Electronics, Inc. 54
Precision Tuner Service 40
Pyramid Electric Co. 49
Quam-Nichols Co. 44
RCA Electron Tube Div. 45, 3rd cover
RCA Sales Corp. 35
Raytheon Co. 15
Rider Publisher, Inc., John F. 40
Sampson Co., The (Electronic Div.) 62, 63
Sams & Co., Inc., Howard W. 54, 56, 57, 60
Sarkes Tarzian, Inc. Tuner Div. 71
SENCORE 29, 30-31
Sonotone Corp. 53
Sprague Products Co. 10
Switchcraft, Inc. 34
Sylvania Electric Products, Inc. Electron Tube Div. 33
Tung-Sol Electric, Inc. 43
Ungar Electric Tools, Inc. 9
Vaco Products Co. 64
Vidaire Electronics Mfg. Corp. 68
Weller Electric Corp. 69
Winegard Co. 55, 63

Latest Jackson Tube Test Data

Table with columns: MODEL 648, MODEL 598, Plate Type, Filament, etc. It lists various tube types and their characteristics.

ANTENNAS AND ACCESSORIES

- 12. BLONDER-TONGUE—New literature on Model AB-3 Mast-Mounted TV/FM Amplifier...
22. CHANNEL MASTER—4-page brochure with description and specifications for the TENNA-LINER...
32. JFD — New 1961 Exact-Replacement Antenna Guide...
42. MOSLEY — Catalog of TV antenna and audio accessories...
52. WINEGARD — Full-color dealer brochure giving complete details on world's first electronic TV antenna...

AUDIO AND HI-FI

- 62. CBS ELECTRONICS—Bulletin E-412, with description and technical specifications for Mark III ceramic-microphone assembly kit...
72. EICO — New 28-page catalog of kits and wired equipment for stereo and monophonic hi-fi...
82. SONOTONE—8-page 1961 catalog of audio and electronic products...
92. SWITCHCRAFT — New Product Bulletin 106 on two-conductor, screw-terminal Littell Plugs...
102. UNIVERSITY — 16-page booklet entitled University Speakers and Speaker Systems...

BUSINESS AIDS

- 112. SYLVANIA—Ad mats for selling professional TV service. One warns the TV owner against "do-it-yourself" repairs, another tells owners why it pays to call a reliable repairman...

COMPONENTS

- 122. ARCO — Circular on Elmenco Disc Ceramic Kit No. C120...
132. BUSSMANN — Bulletin EFA on two new handy fuse assortments designed to give the dealer-serviceman practically all types he needs...
142. CLAROSTAT — Information on ABC Handi-Bin assortment of A47, B47, and C47 controls...
152. LITTELFUSE — Information on fuse caddy for serviceman's tube caddy...
162. PYRAMID — No. J-10 "hang-on-wall" capacitor-replacement catalog...
172. SAMPSON — Transistor Battery Data and Reference Guide...
182. SARKES TARZIAN — Flyer on new tuner subchassis for FM radios...
192. SPRAGUE — New 48-page catalog C-614, showing all standard replacement parts including capacitors, resistors, and printed circuits...

RADIO3

- 202. ATR — Complete descriptive literature

- on Customized Karadios to fit imported and compact American cars, featuring 8-tube performance with excellent sensitivity, tone, and volume. See ad page 12.
212. GRANCO—Information on ARC-60 FM car radio converter, which utilizes existing auto antenna and AM radio circuits...
SERVICE AIDS

SERVICE AIDS

- 222. ACME ELECTRIC—Catalog 091-BL01 giving detailed information on automatic voltage stabilizers and manual voltage adjusters for TV receivers...
232. CASTLE—Leaflet describing fast overhauling service on television tuners of all makes and models...
242. ELECTRONIC CHEMICAL CORP.—Data on new pressurized No-Noise rubber coat insulating spray...
252. PRECISION TUNER—Information on repair and alignment service available for any type of TV tuner...
262. VIDAIRE — Flyer on Model LR-10 Line Voltage Regulator...

TECHNICAL PUBLICATIONS

- 272. CBS ELECTRONICS—Tech Tips bulletin PA-504, "Of Mikes and Men," by Bud Tomer...
282. RIDER—Latest book list. See ad page 40.
292. HOWARD W. SAMS — Literature describing all current publications on radio, TV, communications, audio and hi-fi...
302. SYLVANIA (Home Electronics)—Information on availability of service literature on television, radio, and high fidelity, and monthly Service Digest.

TEST EQUIPMENT

- 312. B & K — Bulletin AP16-R gives information on new Model 1076 Television Analyst, Models 1070 and A107 Dyna-Sweep Circuit Analyzers...
322. ELECTRO PRODUCTS—Information on Model EFB and NFB DC power supplies for use in design and servicing of all types of electronic equipment...
332. JACKSON — Catalog sheet describing Model 600 wide-band, high-sensitivity laboratory-type oscilloscope...
342. RCA (Electron Tube Div.) — Folder 1Q1016, with complete specifications for the Senior VoltOhmyst...
352. SENCORE—New booklet, How to Use the SS105 Sweep Circuit Troubleshooter...

TOOLS

- 362. BERNs—Data on 3-in-1 picture-tube repair tool, on Audio Pin-Plug Crimper that lets you make pin-plug and ground connections for shielded cable without soldering...
372. HANDICRAFT TOOLS — Pocket-sized 12-page catalog illustrating X-acto precision hand tools for industry...
382. VACO—New 8-page catalog on specialty tools, entitled "Choose Your Cards," illustrating 34 different carded displays of tools...

TUBES

- 392. INTERNATIONAL ELECTRONICS—4-page folder with specifications, basing diagrams, and cross-reference listings for Mullard preferred type receiving tubes...
402. SAMPSON — Hitachi receiving-tube manual, giving extensive specifications, basing diagrams, and outlines for complete tube line...

TUBE QUALITY BY DESIGN



YOUR CUSTOMERS' CONFIDENCE BEGINS HERE

From a tube design conference like this at RCA comes a stream of innovations that continually improve the quality of RCA receiving tubes you install... which in turn helps build your customers' confidence.

A typical design conference includes design and development engineers, applications engineers, production supervisors, quality-control specialists, chemists and physicists. It takes many skills to make a basic tube improvement.

This group may be discussing a more effective pattern of anti-leakage slots in tube micas; or a sturdier cage structure to minimize microphonics; or a new metal alloy to improve heat dissipation; or new shielding and basing arrangements to minimize shorts and leakage; or a new heater wire coating to improve heater performance and assure longer life.

Whatever the problem, it's attacked with a single goal in mind: to provide you with a tube you can depend on. *Another reason why every RCA tube you install is an investment in customer confidence.* Give yourself the extra advantage of RCA tube dependability. Check with your Authorized RCA Distributor this week. *Electron Tube Division, Harrison, N. J.*



The Most Trusted Name in Electronics
RADIO CORPORATION OF AMERICA

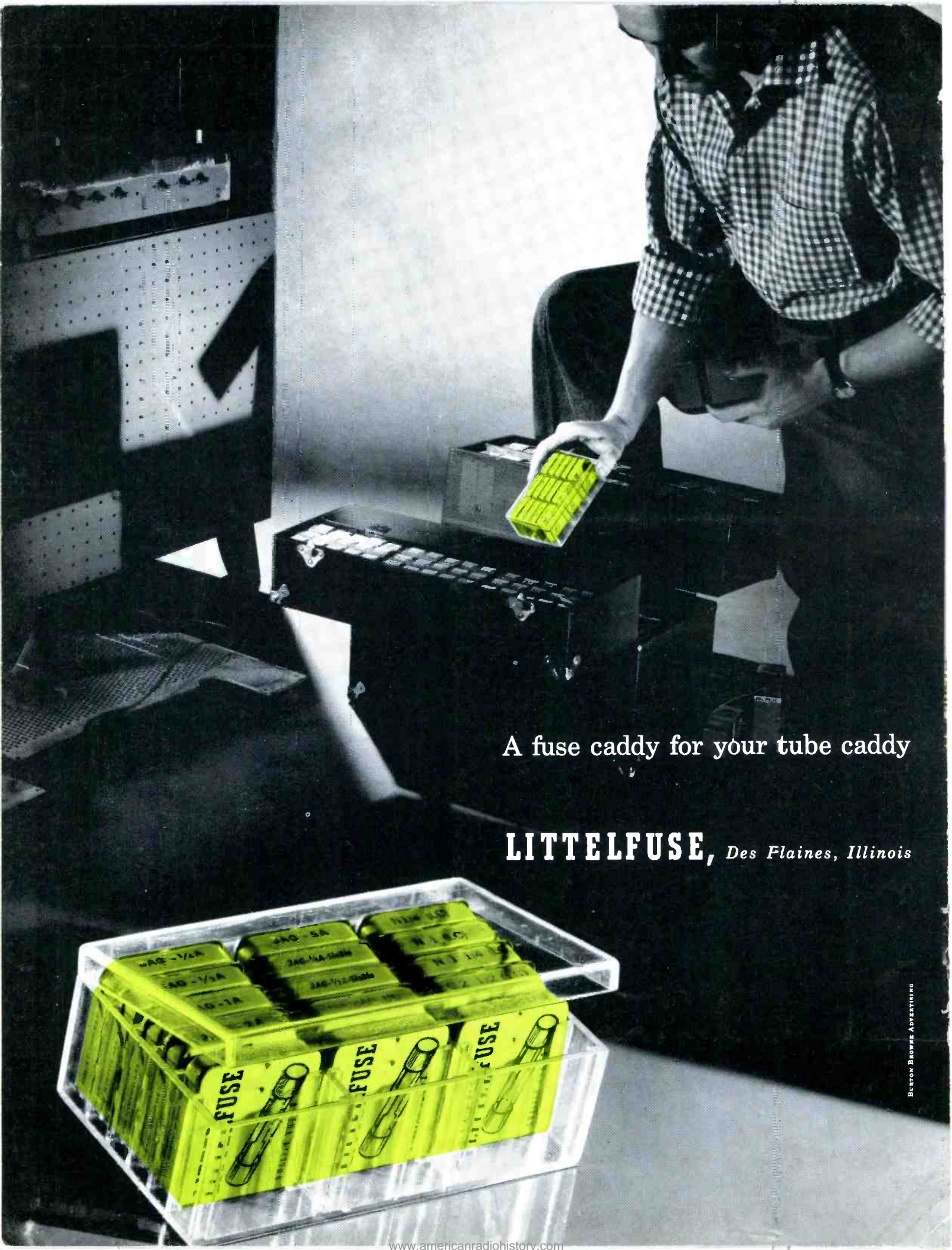

A fuse caddy for your tube caddy

LITTELFUSE, *Des Plaines, Illinois*

