

JUNE • 1958 25 CENTS

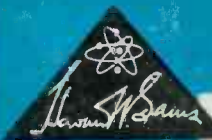

RF
PHOTO-FACT

REPORTER

FOR THE ELECTRONIC SERVICE INDUSTRY



Across the Bench—page 10

PHONO-CARTRIDGE REPLACEMENT—page 38

Walk-In Sales Items—page 18

ANALYZING THE VERTICAL CIRCUIT—page 50

PLUS JUNE SUPPLEMENT TO SAMS MASTER INDEX

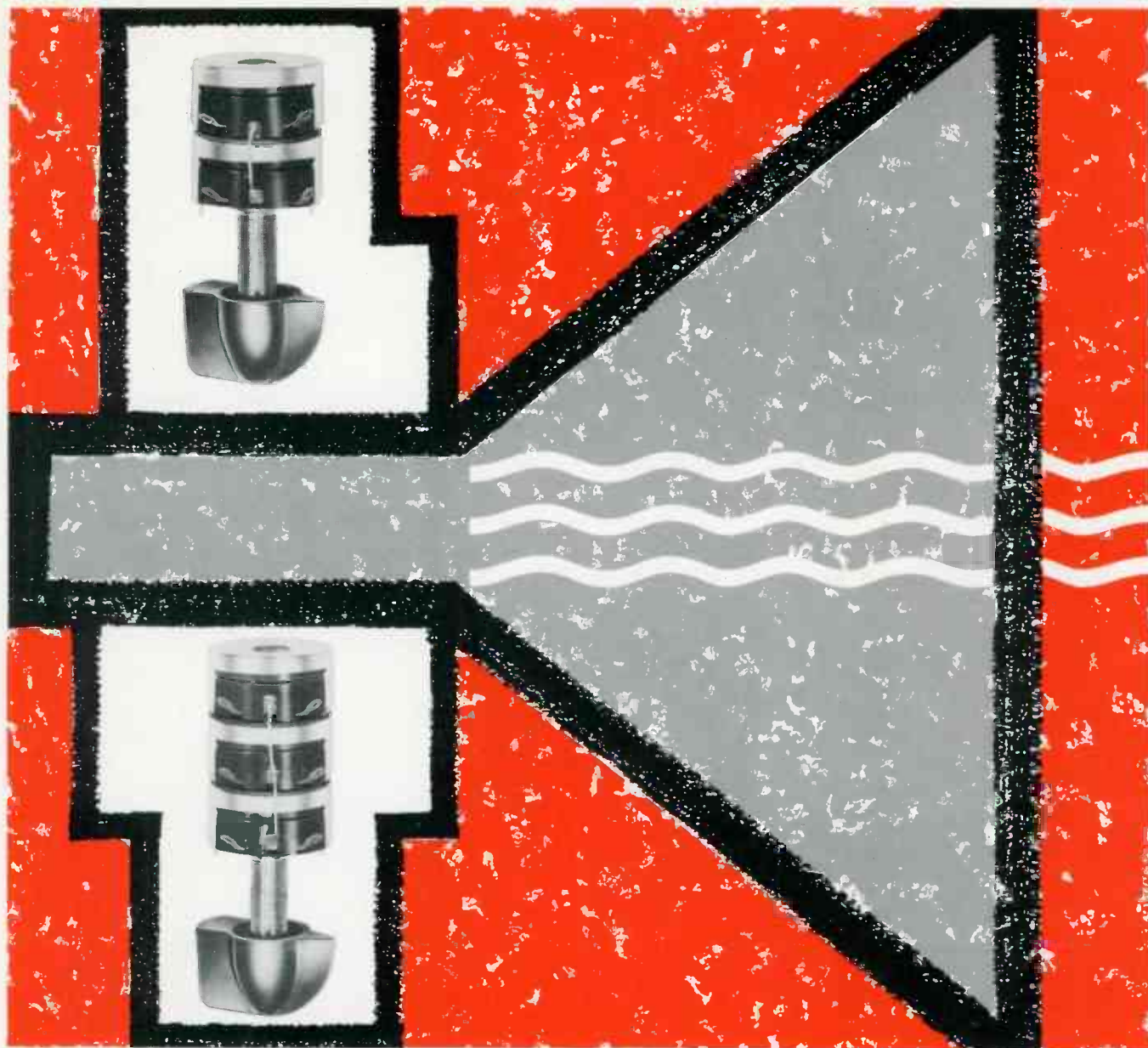

New L and T Pads for Speaker Controls

Here's something new from IRC that you'll want to put to work right away—a new line of L and T Pads for sound systems and speaker controls. Compact—about the diameter of a half-dollar—and constructed with characteristic IRC thoroughness.

TYPES

L (Constant input impedance)
T (Constant input and output impedance)

SPECIFICATIONS L & T

Resistances: 4, 8, 15 and 500 ohms.

Rating: 10 watts Audio, 3 watts, D.C.

Mounting: 3/8" x 32-7/8" long bushing (with 2 mounting nuts) for panels up to 3/4". A 1-1/4" long interchangeable bushing is also available for mounting in shallow depth.

Diameter: 1-1/4"

Depth Behind Panel: 1-9/32" for L Pad; 1-27/32" for T Pad.

Price, including knob and dial plate L Pad—\$4.65 list;
T Pad—\$5.25 list.



INTERNATIONAL RESISTANCE COMPANY • Dept. 365, 401 N. Broad St., Phila. 8, Penna. • In Canada: International Resistance Co., Ltd., Toronto, Licensee

**NEW
COMPLETE**

**DIRECT
VIEWING**

TELEVISION ANALYST

test each stage
SEPARATELY

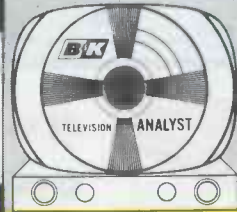
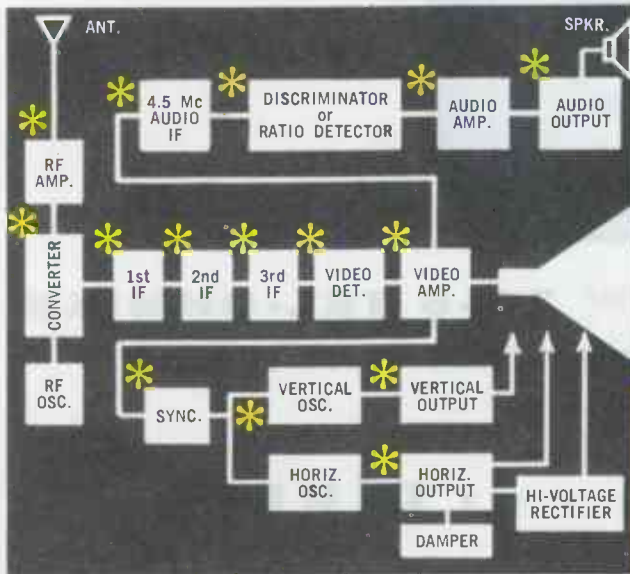

← and watch the
result on the
TV set itself

UNIQUE NEW SIGNAL-INJECTION TECHNIQUE
Saves TV Trouble-Shooting Time and Work

- R.F.** Supplies complete r.f. and i.f. signals with video and audio modulation to quickly trouble-shoot each stage in each of the sections of the TV receiver. Enables you to check the r.f. sensitivity and AGC settings of TV receivers.
- I.F.** Reproduces a complete test pattern on the screen of the TV picture tube and injects signals into each video stage of the TV receiver for fast, visual trouble-shooting and correction—anywhere, anytime. Makes it easy to check bandwidth, resolution, shading and contrast capabilities of the TV set.
- VIDEO** Provides composite signal, sync positive and negative.
- SYNC** Provides separate vertical and horizontal driving pulses for trouble-shooting deflection circuits.
- SWEEP CIRCUIT DRIVING PULSES** Provides separate vertical and horizontal driving pulses for trouble-shooting deflection circuits.
- INTERMITTENTS** Test signal injection also aids in locating intermittent troubles.
- AUDIO** Provides a 4.5 mc sound channel, FM modulated with approximately 25 kc deviation. (This audio carrier is modulated either from a built-in 400 cycle tone generator, or from your own external audio source.) Injection of the 400 cycle tone signal simplifies trouble-shooting of the audio section.
- COLOR** Enables you to trouble-shoot and signal trace color circuits in color TV sets.
Generates white dot and crosshatch patterns on the TV screen for color TV convergence adjustments.
Generates full color rainbow pattern of orange, red, magenta, blue, cyan, green to test color sync circuits, check range of hue control, align color demodulators, etc.
- SET ADJUSTMENT** Enables you to check and adjust the vertical and horizontal linearity, size and aspect ratio of television receivers.



NEW
B&K
MODEL 1075



QUICK, DIRECT, COMPLETE TV TROUBLE-SHOOTING

Now, by point-to-point signal injection and test pattern reproduction, you can easily trouble-shoot and signal trace *any stage throughout the video, audio and sweep sections* of black & white and color TV receivers. With the remarkable new Model 1075 B&K TELEVISION ANALYST, you can quickly isolate and diagnose TV troubles (including intermittents). By use of the generated test pattern, you can *actually see* the condition directly on the picture tube of the television set itself. No external scope is needed. The TELEVISION ANALYST is practically a *complete TV service shop in one instrument!* Net, \$259⁹⁵



See your B&K Distributor or write for Bulletin AP12
B & K MANUFACTURING CO.
3726 N. Southport Ave. • Chicago 13, Illinois

Canada: Atlas Radio Corp., 50 Wingold, Toronto 10, Ont. Export: Empire Exporters, 458 Broadway, New York 13, U.S.A.

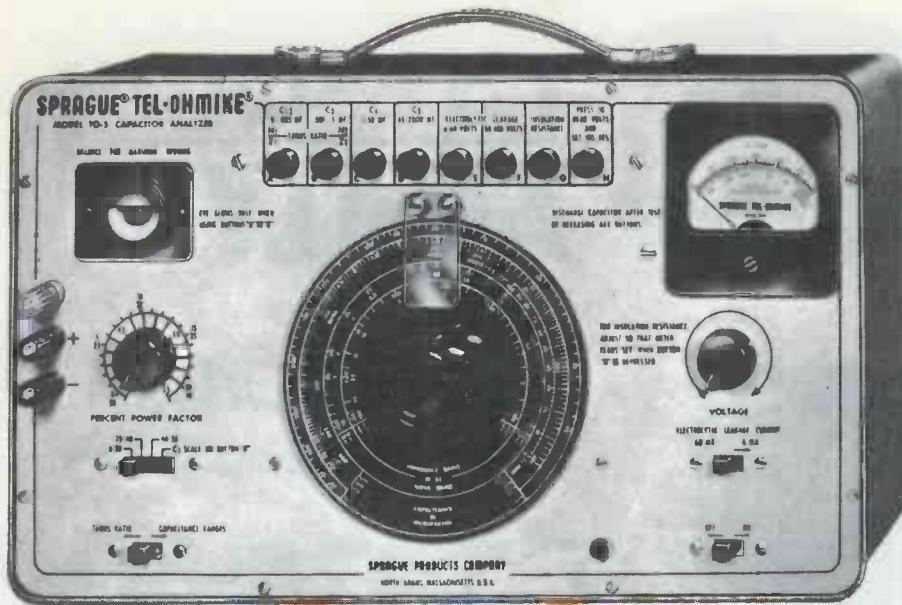

**NEW TO-5 TEL-OHMIKE®
capacitor analyzer**

measures all 4 . . . plus

1 CAPACITANCE	2 POWER FACTOR	3 LEAKAGE CURRENT	4 INSULATION RESISTANCE	extra® feature TURNS RATIO
Measures up to 2000 μf in five overlapping ranges . . . including an accurate 1 to 100 μmf range, exclusive with Sprague.	Power factor of electrolytic capacitors is measured by the highly accurate bridge method. Reads up to 55% in three ranges for convenience in measurement.	Leakage current of electrolytics is measured directly on the meter, with exact rated voltage up to 600 v. applied from continuously adjustable power supply. Two ranges — 0-6-60 ma.	Insulation resistance of paper, ceramic, and mica capacitors is read directly on meter . . . up to 20,000 megohms.	In addition to its function as a complete capacitor analyzer, the TO-5 also measures the turns ratio of power and audio transformers.

The NEW TO-5 TEL-OHMIKE Capacitor Analyzer is one of the fastest and surest ways of measuring . . . capacitance, power factor, leakage current, insulation resistance, and turns ratio. This compact, easy-to-use instrument has the highest accuracy of any instrument of its type available to the service trade.

New jumbo dial makes meter reading easy. Special color-keyed pushbuttons permit instant range selection . . . and allow automatic safety discharge of capacitors after testing. Magic-eye tube simplifies bridge balancing for capacitance and power factor measurements.

SEE THE NEW TO-5 TEL-OHMIKE IN ACTION . . . AT YOUR DISTRIBUTOR!

This 4-in-1 test instrument is only 8 $\frac{7}{8}$ " high, 14 $\frac{5}{8}$ " wide, and 6 $\frac{1}{8}$ " deep . . . weighs a mere 12 $\frac{1}{2}$ pounds. The complete price for . . .

MODEL TO-5 (115 VAC/50-60 cy) .. Only **\$83⁹⁰** net

Also available: Model TO-5X for 115-230 V/25-60 cy. . . . \$89.90 net
Model TP-5RM for rack mounting \$93.90 net



SPRAGUE PRODUCTS COMPANY, DISTRIBUTORS' DIVISION OF SPRAGUE ELECTRIC COMPANY, NORTH ADAMS, MASS.

PUBLISHER
Howard W. Sams
GENERAL MANAGER
Mal Parks, Jr.

EDITOR
Verne M. Ray

ASSOCIATE EDITORS
Leslie D. Deane
Thomas A. Lesh
Calvin C. Young, Jr.

CONSULTING EDITORS
William E. Burke C. P. Oliphant
Robert B. Dunham George B. Mann
Paul C. Smith

ART DIRECTOR EDITORIAL ASSISTANT
Don W. Bradley Pat Moriarity

PHOTOGRAPHY CIRCULATION
Robert W. Reed Pat Tidd

ADVG. PRODUCTION
Carol B. Gadbury

ADVERTISING SALES OFFICES

MIDWESTERN
PF REPORTER,
2201 East 46th Street, Indianapolis 5, Ind.
Clifford 1-4531

EASTERN
Paul S. Weil and Donald C. Wejl,
39-01 Main Street, Flushing 54, New York.
Independence 3-9098.

WESTERN
The Maurice A. Kimball Co., Inc.
2550 Beverly Blvd., Los Angeles 57, Calif.
Dunkirk 8-6178; and 681 Market Street,
San Francisco 5, Calif. EXbrook 2-3365.

Published monthly by Howard W. Sams & Co.,
Inc., at Indianapolis 5, Indiana.
Entered as second class matter October 11,
1954, at the Post Office at Indianapolis, Indiana,
under the Act of March 3, 1879.

Copyright 1958 by Howard W. Sams & Co., Inc.
No part of the PF REPORTER may be repro-
duced without written permission. No patent
liability is assumed with respect to the use of
information contained herein.

Subscription prices in U.S.A. and possessions:
1 yr., \$3.00; 2 yrs., \$5.00; 3 yrs., \$7.00. In
Canada and Pan America: 1 yr., \$3.60; 2 yrs.,
\$6.00; 3 yrs., \$8.50. Foreign subscriptions:
1 yr., \$6.00; 2 yrs., \$11.00; 3 yrs., \$15.00.
A limited quantity of back issues are available
at 35c per copy.

next month

CONVERTING TO STEREO

In the hi-fi field today, stereo-disc reproduction is all the rage. How does it work? What about phono cartridges? Can existing hi-fi rigs be converted for stereo operations? All these questions and more will be answered in July.

TRANSISTORIZED PORTABLE DESIGN

With the vacation season coming on, public interest in "pocket-sized" radios will be at its peak. Since their compact (and unfamiliar) designs may present you with some servicing problems, however, this article reviews the latest models—even to the extent of showing you how to "open 'em up" without using a can-opener.

INSTALLING AND SERVICING GARAGE-DOOR OPENERS

Here's an electronically-operated device that is becoming increasingly more popular in today's push-button world. If you'd like a share in the sales and servicing profits, be sure to see this picture story in next month's issue.

VOLUME 8, No. 6



JUNE, 1958

PF REPORTER

FOR THE ELECTRONIC SERVICE INDUSTRY

CONTENTS

This Month's Cover	65
Letters to the Editor	4
Across the Bench	10
We all like to know why certain symptoms develop. Here are the "whys" of two case histories.	
Dollar & Sense Servicing	12
AGC Circuits for '58	16
Part 2—Descriptions of latest designs and how they work.	
Walk-In Sales Items for the Service Shop	18
Audio Facts	20
Variations in speaker design; checking amplifier response; new audio products.	
Quicker Servicing	22
Tube-substitution guide; foreign-made component replacement; fused-circuit tester.	
Let's Talk Business	28
There are times when the customer is right!	
The Troubleshooter	34
Phono-Cartridge Replacement	38
Notes on Test Equipment	40
TV circuit analyzer; sweep-marker generator; capacitor-resistor checker; color-bar generator.	
Analyzing the Vertical Circuit	50
Troubles pin-pointed to stages and components.	
Product Report	61
Free Catalog & Literature Service	68
Supplement to SAMS Master Index	69

SUBJECT REFERENCE INDEX

AUDIO

Amplifier, EICO Model HF-32 ..	66
Phono cartridges, replacing	38
testing output of	38
Speaker design	20
Square-wave tests for amplifiers ..	65
Stereo preamp control amplifier ..	66
Stylus balance scale	67

BUSINESS

Customer complaints	28
Evening calls	12
Sales sidelines	18

CIRCUITS AND DESIGNS

Packard-Bell Chassis V8-2, AGC control in	59
Philco Chassis 8L35, contrast control in	60
6BU8 AGC circuit, in DuMont Chassis RA-400	16
in Motorola Chassis TS-542	17

COMPONENTS AND MATERIALS

Newly introduced	61
------------------------	----

SERVICING

German AM-FM auto radio	22
High voltage, loss of	36
Horizontal bending	34
Horizontal output stage	10
Pie-crust effect	34
Retrace blanking network	57
"Snivets"	37
Tape-recorder reel squeak	36
Tuner, cold-solder joint in	58
Vertical sweep circuits	50

TEST EQUIPMENT

AC current-drain checker, Sencore Model FS-3	24
Capacitor-resistor analyzer, Pyramid Model CRA-2	46
Color-bar generator, Simpson Model 430	48
Sweep-marker generator, Hickok Model 615	44
Television "Analyst," B & K Model 1075	40
VOM, using on hot chassis	36
VTVM, RCA Model WV-74A	67

TUBES

Substitution chart	22
--------------------------	----

USE HANDY CARD AT BACK TO ENTER YOUR SUBSCRIPTION

MORE PROFITABLE SERVICING...

with the
KINGSTON
ABSORPTION ANALYZER

All purpose wave-form analyzer provides complete antenna to CRT and speaker testing without any physical connection and from top-side.

See how it works.

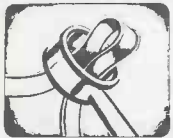

Picks up signal directly from antenna and shows wave-form. Aids antenna orientation. Indicates rapid voltage change.



Checks signals from RF amplifier. Detects cathode to filament leakage. Checks oscillator-mixer stage to determine if o.k.



Locates hum injected at video IF stages. Detects overloading. Checks progressive gain. Often shows man-made noise.



Checks sound IF and audio amp. Phones allow audible check. Follows signal right to speaker. Checks progressive gain.



Checks progressive gain of video amp. stages. Takes signal from input of CRT by holding crescent probe to leads.



Checks horiz. osc. and output. Detects output loss in either stage. Electrostatic probe simplifies locating intermittents.

TWO MODELS

Model VS-5



TV servicing model comes complete with small & large ring and crescent probe.

All Purpose Model EA-1

Has continuous sweep, jacks for external sync and horiz. sweep. Tuner clips for frequencies from 3 to 240mc.

ANOTHER KINGSTON PRODUCT...

KINGSTON PROBE-MASTER



Built-in capacitive network, two clips and neon bulb, most versatile testing probe on the market.

KINGSTON
ELECTRONIC CORPORATION
39 NORTH ST., MEDFIELD, MASS.

Letters to the EDITOR

Dear Editor:

A local contractor has asked me to draw up plans for and submit an estimate of the cost for the installation of a television signal distribution system for a ten-apartment building. I have never worked on anything like this, and would like to know if there is any past issue of PF REPORTER from which I can get some help. He wants an outlet in each apartment with one master antenna on the roof.

H. K. BROWN

Brown Radio & TV Service
Wheaton, Ill.

We ran a series of "Shop Talk" articles by Milton S. Kiver which dealt with the subject of master antenna systems, and these should be of considerable help to you. Descriptions of various systems were given in January and February, 1957, and servicing pointers appeared in March, 1957. The distributors in your area for antenna system manufacturers such as Jerrold and Blonder-Tongue should be able to aid you in making cost estimates.—Ed.

Dear Editor:

Here is a suggestion to pass on to your readers. After you have found the correct Sams Photofact Folder for a TV set which you are repairing, stamp or mark the chassis and back cover of the receiver with the Sams Set and Folder number. This takes only a minute, but it expedites future servicing of the set.

EVARD E. VON FELTNER, PH.D.

Pompano Beach, Fla.

A very good idea. Why not use small gummed labels on which appropriate markings can be made?—Ed.

Dear Editor:

I would like a Subject Reference Index covering January through December, 1957. PF REPORTER is a helpful guide in solving many problems in our work, and I always find the time to read the articles in each month's issue.

MRS. ORA A. MORGAN

Baldwin Park, Calif.

We did a "double-take" when we saw the "Mrs." in the signature. Had we found a bona-fide lady technician among our readers, or was Mrs. Morgan helping her husband as described in "Your Wife Can Run Your Business" in the February issue? We were especially intrigued because we were right in the midst of the anticipated male reaction to that article. (See the letter from Bill Hendrix in the May issue.) Being curious, we asked Mrs. Morgan to tell

us more about herself. Here is her reply:

"I'm an independent radio and television technician, a 1955 graduate of a Los Angeles radio-TV school. Since that date I have completed four subjects from a nearby college pertaining to electronics. My husband has also completed the above subjects; he became interested shortly after I enrolled in school. Many discouraging problems arise, but they eventually are solved. Thank you for your interest in my being in electronics."

Well, you male critics, what do you have to say now?—Ed.

Dear Editor:

My son is stationed in France with the U. S. Air Force. He would like to use his American-made TV set and clock-radio over there, but he is uncertain as to whether or not they would operate properly on the French 110-volt, 50-cycle current. If they won't, is there some adapter or "gadget" which he could use to make them work?

A. M. STRAKA

Radio-TV & Appliance Service
Vandergrift, Pa.

If your son's Air Force base has an Armed Forces Radio Service TV station operating on U. S. transmission standards, he should be able to view this station on his set—even if he plugs into a 50-cps power line. However, he will be unable to receive local French stations because their transmission standards are widely different from ours. (Examples: Horizontal lines per picture, 819 instead of 525; channel bandwidth, 14 mc instead of 6 mc.)

Clock-radios will not keep correct time because of the difference in power-line frequency, but the radio portion of these units should operate satisfactorily and pick up any broadcasts available in the area. The B+ filter of a radio or TV set might not operate quite as efficiently at 50 cps as it would at the frequency for which it was designed, but the difference in performance should be slight.—Ed.

Dear Editor:

I noticed in the February issue that you still have about two dozen of your Tube Substitution Guides on hand. I would very much like to have one if other readers haven't beaten me to them.

GEORGE R. KINWORTHY

St. Louis, Mo.

After the February item appeared, the two dozen Guides vanished like a handful of corn in a crowded chicken yard. In order not to disappoint George and the many other readers who wrote in for copies of the chart, we ordered 1000 more reprints and mailed them out as soon as we could.

We have completed the revision which we promised, and the up-to-date chart appears this month in the "Quicker Servicing" column. Reprints of the new Substitution Guide are available upon request.—Ed.

How to make more money as an independent RAYTHEON BONDED ELECTRONIC TECHNICIAN

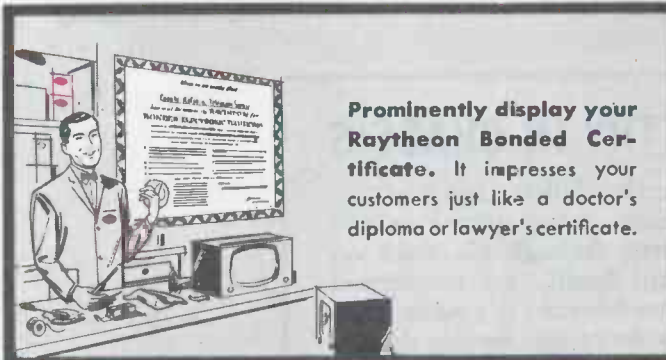

Prominently display your Raytheon Bonded Certificate. It impresses your customers just like a doctor's diploma or lawyer's certificate.



Feature the Raytheon Creed Display and the Bonded Dealer Decal in your windows. The Creed Display shows potential customers your Code of Business Ethics. The Decal identifies you as a nationally advertised Bonded Dealer.



Carry "ID" Cards. You and your technicians should always carry your Raytheon Identification Cards. Presenting the card puts your customers at ease when you must remove a set from the home.



Advertise your Bonded Dealer standing. Use the newspaper mats Raytheon makes available to you for local newspaper advertising. Rates are low, results high. Scripts for radio and TV spots are also available to you at no cost.



Use the Yellow Pages. List your shop as a Bonded Dealer shop in the Classified Telephone Directory — many customers select service dealers from this source.



Make Mailings to Potential Customers. Raytheon has available to you many attractive Post Card mailers and a special Bonded Dealer self-mailer. Regular mailings stimulate service business.



Identify your shop. This traffic stopping metal sign will tell all passersby that you are the Bonded Dealer in your community — the Bonded Dealer that Raytheon is presenting to America as the top TV-Radio technician in the country.

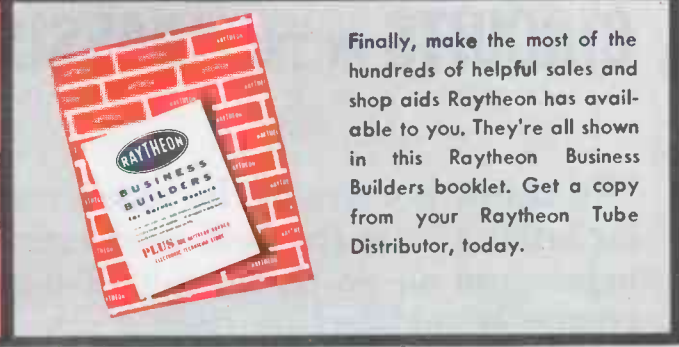

Finally, make the most of the hundreds of helpful sales and shop aids Raytheon has available to you. They're all shown in this Raytheon Business Builders booklet. Get a copy from your Raytheon Tube Distributor, today.

P.S.

If you're not a Raytheon Bonded Dealer call the Raytheon Tube Distributor who sponsors the Bonded Program in your neighborhood. He'll tell you if you can qualify.



RAYTHEON MANUFACTURING COMPANY

Receiving Tube and Semiconductor Operations

NEWTON 58, MASS. 55 Chapel Street
CHICAGO, ILL. 9501 Grand Ave. (Franklin Park)
ATLANTA 6, GA. 1150 Zonolite Rd. N.E.
LOS ANGELES 7, CALIF. 2419 So. Grand Ave.

Raytheon makes all these } Receiving and Picture Tubes, Reliable Subminiature and Miniature Tubes, Semiconductor Diodes and Transistors, Nucleonic Tubes, Microwave Tubes.



YES! WE HAVE

STILL NO PRINTED CIRCUITRY IN CHASSIS



Even though Dr. Alexander Ellett, head of Zenith's research department, is recognized as the daddy of printed circuitry through his work on radio proximity fuses, still Zenith uses no printed circuitry in its TV chassis because it means more service headaches and often causes service delays.

LESS SERVICE HEADACHES FOR SERVICEMEN

Easier to service...more accessible

ZENITH'S **HANDCRAFTED**
SERVICE-SAVER **HORIZONTAL**
CHASSIS WITH **NO PRINTED**
CIRCUITS IN THE CHASSIS

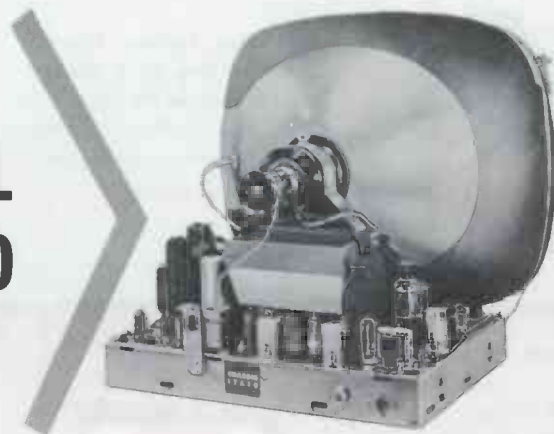

We think it's worth the extra cost of HANDcrafted standard circuitry to get the best performance and fewer service headaches and so do thousands of dealers who would sooner sell customer satisfaction than a price tag.



ZENITH RADIO CORPORATION, Chicago 39, Illinois

The quality goes in before the Zenith name goes on.

Backed by 39 years of leadership in radionics exclusively.

Also makers of Radio, High-Fidelity Instruments and fine Hearing Aids.

NO PRINTED CIRCUITS IN ZENITH TV CHASSIS

**ZENITH HANDCRAFTED
STANDARD CIRCUITRY
COSTS MORE BUT IT MEANS MORE
SATISFIED CUSTOMERS FOR
ZENITH DEALERS AND SERVICEMEN**

QUALITY BY

ZENITH®

THE ROYALTY OF TELEVISION

Sylvania comparisons point out—

The big difference

Here's the inside story on why local "off-brands" don't measure up to Silver Screen 85® standards

If you're like most dealers, you know off-brand tubes don't have the same quality standards as first-line tubes. To help you see how big the difference is, Sylvania purchased a nationwide sample of sixty 21YP4A made by 19 different local tube makers. These tubes were put through the same production tests that all Sylvania tubes must pass.

Not a single local off-brand passed all 54 mechanical and electrical tests! Many of these were minor defects making little or no difference in whether or not the tube "lit up." But look how loose manufacturing controls can affect the important features of light output, focus, and life!

LIGHT OUTPUT

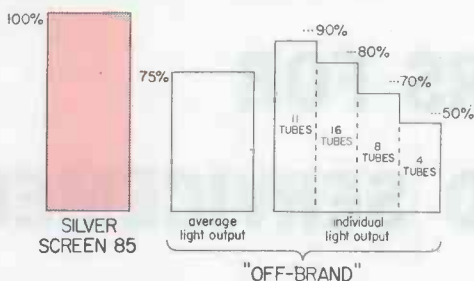

So far, 39 off-brand tubes have been compared with the *minimum* light output of Silver Screen 85. Five additional tubes couldn't even be tested. Eleven tubes were less than 90% as bright as the *minimum* for Silver Screen 85; 16 were less than 80%; 8 were less than 70%; and 4 were *less than 50%* as bright. Since most Silver Screen 85 tubes average as much as 125% of minimum standards, the difference becomes even greater. Small wonder that Silver Screen 85 is the easy way to more satisfied customers.

FOCUS

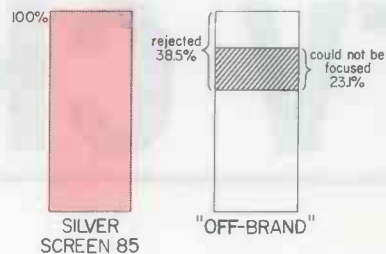
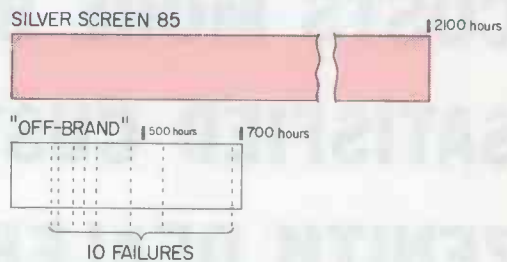

Chart 2 shows how these same 39 tubes stacked up to registered limits on focus voltage. 38.5% were rejected under these limits. Over half of all those rejected could not be focused in a TV receiver. Small wonder then that "Silver Screen 85" pictures are sharper, brighter, clearer.

LIFE TEST



Nineteen off-brand tubes were placed on Sylvania's standard 2000-hour life test. Chart 3 tells you how fast these tubes developed slow-heating cathodes. Over half, or ten units, failed to go beyond the 700-hour mark. Small wonder then that Silver Screen 85 gives you less troublesome callbacks.

Of all the off-brand tubes tested, Sylvania engineers estimate that 43% probably would not have operated properly in a TV set. Why gamble your reputation, customer satisfaction, and success. It's just *good business* to sell up to "first line" picture tubes; Silver Screen 85 picture tubes.

in Picture Tubes!



Take it from Bill Shipley: "Silver Screen 85" consumer advertising makes it easy to *sell-up* to 'first line' picture tubes."

New TV Campaign dramatizes test results . . . sells consumers up to "first line" picture tubes . . . builds more profitable sales and satisfied customers for dealers everywhere.

Sylvania's fabulous new family, "The Real McCoys," is one of the top new television shows of the season and has been named the "Sleeper of the Year." Week after week, on the "Real McCoys" Sylvania is making millions of set owners aware of the big difference in picture tubes.

New commercials like the "Brightness Test" are pre-selling consumers on the "first line" performance of Silver Screen 85.

For dealers everywhere it means more and more customers asking for "Silver Screen 85"—Pre-sold customers make satisfied customers—strengthening your business reputation and building long-range profitable growth.

Sylvania has designed this powerful new selling tool for you. Get behind it and *sell-up* to "first line" Silver Screen 85 picture tubes.

Highlights of Sylvania's TV "Brightness Test."



"Don't be fooled by picture tubes that look alike — they don't act alike."



Sylvania's Silver Screen 85 is over twice as bright as this "off-brand" tube.



"Insist on a nationally known 'Silver Screen 85'—there's one to fit every make TV."



SYLVANIA

SYLVANIA ELECTRIC PRODUCTS INC.
1740 Broadway, New York 19, N. Y.
In Canada: Sylvania Electric (Canada) Ltd.
University Tower Bldg., Montreal

across the BENCH

CURRENT CAPERS by Stan Prentiss

EDITOR'S NOTE: This, the first in a series of bimonthly columns, will introduce you to Stanton Rust Prentiss, who will be sharing this space with Milt Kiver's "Shop Talk." We are sure you'll be looking forward to Mr. Prentiss' future visits in this column, which is written from many years of practical experience and firsthand servicing knowledge.

Recently, I came across a Magnavox receiver with a relatively common fault that seemed well worth reporting. It occurred in a Model 108B series—the one with the nice control knobs on the front, the pretty grille and big speaker at the bottom.

According to the owner, the picture had gone out about a month ago, and when he replaced the 6BQ6 horizontal output tube, the picture temporarily came back. Thereafter, he said, the receiver only ran for a short while before "the screen turned black and the 1/4-amp fuse blew."

Recognizing that this ailment

was probably the fault of a capacitor or resistor, I turned the receiver on its side and did a bit of high voltage exploring. While it wasn't surprising to discover that 15K, 2-watt R100 was thoroughly scorched (Fig. 1), I was surprised to note that its 1-watt brother (R101, a 22K-ohm unit in parallel) had not been damaged. Certainly this phenomenon required some investigating.

Let's Turn It On

The blown fuse was replaced with another of equal value, the receiver was turned on and the temperature of the scorched resistor was tested by the "touch" system. Sure enough, in less than a minute it became quite warm. Meanwhile, R101 remained cool, as though all the current were passing through R100. To eliminate any possibility that the high voltage transformer T2 was at fault, I turned the receiver off and disconnected the plate cap of the horizontal output tube. Upon restoring power to the receiver, R100 began to heat considerably more quickly and, within two minutes, started to smoke. Shutting off the AC immediately, I studied the schematic and developed a plan of action.

Open or Short

First, it was necessary to find if the screen voltage of the horizontal output tube was high or low, indicating the presence of an *open* or *short*. Second, it was necessary to know the general value of the receiver's B+ voltage to discover if this was the only stage actually affected. Third, I was obliged to determine if the appro-

appropriate AC signals were present in the AFC and multivibrator circuits so that the output stage could be brought into satisfactory operation once repairs were made.

Naturally, I had already checked tubes in the stages under discussion and had actually replaced the horizontal output tube, noting that its plates were glowing red when R100 heated up. The receiver was then turned on and the B+ voltage on the fuse side of R100 and R101 was measured. It was a trifle low but not enough to be indicative of trouble. Checking further, I found that the screen voltage at pin 4 of the horizontal output tube wasn't 150 volts as it should have been, but a very high 220 volts. This eliminated the possibility of a short, cleared C76 (the .047 bypass capacitor) and, for all practical purposes, substantiated correct operation of electrolytic filter C1. Satisfied that the primary fault had been isolated to the original premise (that of a capacitor and/or resistor), I quickly investigated the remainder of the horizontal sweep section.

Supporting Circuits

Selected resistors were spot-checked for their proper value and boost capacitors C77 and C78 were disconnected and tested with a capacitance checker for value and voltage-handling ability. C78 was found leaky and replaced (Fig. 2). Electrolytic C5 was also checked with the capacitance checker and found to measure 15 mfd. but capable of carrying the voltage load. Therefore, even though it was 5 mfd. over its rated value, its filtering capabilities were adequate (perhaps increased), and it was left in the circuit. Finally, DC blocking capacitor C79 was checked and found leaky after application of only 200 volts. It was replaced with a unit having a 600-volt rating.

• Please turn to page 56

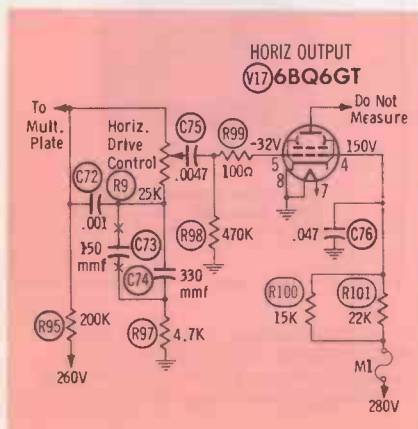
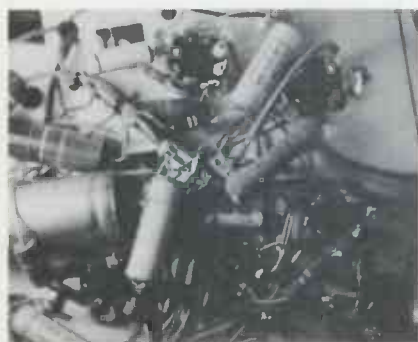

Fig. 1. Circuit of the burned 2-watt resistor and its unscathed 1-watt brother.

now from *Electro-Voice*, compatible stereo power point cartridges for general replacement!

Mass-market stereo is here . . . *now!* Stereo tape gave the public a taste of the market. Dramatic—enormously stimulating—but limited to the esoteric few by cost and complexity. Overnight, the simultaneous perfection of stereo records and E-V Compatible Stereo Cartridges, made MASS stereo sales a practical reality . . . providing years of vast new profit potential for the service industry. New radio-phonograph lines will feature stereo. National sales campaigns by virtually every phonograph manufacturer will give the impact of millions of advertising impressions every month.

Capitalize on this demand now with E-V's new popular-priced compatible stereo Power Point. With the exception of "kiddie type" high-voltage cartridges, E-V's 60 Stereo Power Point Series can be your universal replacement . . . priced to guarantee you a profit . . . engineered to outperform existing monaural cartridges.

Here are some of the answers to your questions concerning stereo:

Q How does the compatible E-V Stereo Power Point Cartridge differ from conventional cartridges?

A It plays both the new type stereophonic discs and conventional records. Inherent in its design is an improved monaural performance.

Q Are stereo discs compatible with conventional cartridges?

A Most monaural cartridges damage the stereo record. Modifying an existing phonograph with a compatible Stereo Power Point Cartridge makes it possible to play monaural or stereo discs monaurally. Adding a second speaker and amplifier will give your customer stereophonic sound.

Q What about the modification problems?

A Using an E-V Model 66, which is constructed so that its output is corrected to the RIAA curve, you match the equalization of virtually all modern radio-phonographs. Inserting the cartridge and mount is simple. It will fit any standard tone arm. Wiring the stereo-leads to a jack at the back of the set modifies it for *monaural operation*, makes it compatible with all types of records and ready for the additional amplifier-speaker.

Q What if the customer does not want to invest in the equipment for the second channel at this time?

A By installing the E-V Stereo Power Point Cartridge, his unit is completely modernized. He can use a television receiver or small AC-DC radio as the second channel. This gives acceptable stereo performance that can be improved later.

Q What about cost?

A The Electro-Voice Compatible Stereo Power Point Cartridge carries a list price of \$5.95 to the consumer. With a .7-mil diamond and 3-mil sapphire, the list price is \$19.50. Realistically priced to permit you to charge fair rates for your labor and still not present the consumer with prohibitive charges for the installation.

Q What if my customers are not ready for stereo? Can I prepare now to take advantage of the interest that will be whetted later by national advertising?

A The Electro-Voice Stereo Power Point is completely compatible physically with the monaural Power Point. *You can install the universal Power Point mount and wire it to the rear of the set. You can supply the customer with a monaural Power Point now and sell them a Stereo Power Point at a later date, along with the second speaker and amplifier.*

Q What about performance in comparison to existing monaural cartridges?

A The Model 66 delivers monaural performance comparable to present-day, high quality production cartridges. It reproduces stereophonic records with equal fidelity, providing average channel separation of 15 db.

Q What about record availability?

A Recordings by major record manufacturers are being introduced almost weekly. By mid-1958 thousands of selections will be available.

Q What if your customer is not a hi-fi enthusiast? Will stereo be of interest?

A The effect of stereo is just as dramatic to those who have no interest in high fidelity reproduction. It is the most potent selling tool you will ever have in your possession. Install it for one family in the neighborhood and you will automatically line up other enthusiastic customers.

Q How do you go about getting your Electro-Voice compatible Stereo Cartridge?

A Visit your distributor. Ask for E-V Stereo Power Point Model 66 with .7-mil stereo tip and 3-mil sapphire tip for monaural, or E-V Model 66DS with .7-mil diamond. All Electro-Voice Power Points work in turn-under mount Model PT3, \$1.00 list or the fixed-type mount PFT3, 50¢ list. If you don't know the name of your nearest distributor, please write.



SPECIFICATIONS

Response:	20 to 15,000 cps
Element:	Ceramic (composite element*)
Output:	.5 volts
Compliance:	2
Tracking force:	4 to 6 grams
Weight:	2.5 grams
Stylus:	Diamond and sapphire—.7 mil
Mount:	EIA (RETMA) standard 1/2" and 7/16" centers
Size:	1/4" diameter, 3/4" long

* Patent Pending

MODEL	STYLUS SIZE	LIST
61	.7 mil sapphire (stereo) .7 mil sapphire (stereo) Compatible	5.95
61D	.7 mil diamond (stereo) .7 mil sapphire (stereo) Compatible	19.50
66	.7 mil sapphire (stereo) 3 mil sapphire (monaural) Compatible	5.95
66DS	.7 mil diamond (stereo) 3 mil sapphire (monaural) Compatible	19.50
PT3	Turn-under stereo mount	1.00
PFT3	Fixed type stereo mount	.50

Minimum distributor pack:

61 and 66-6
61D and 66DS-1
PT3 mounts-6
PFT3 mounts-6



Electro-Voice®
ELECTRO-VOICE, INC.
BUCHANAN, MICHIGAN

CANADA: E-V of Canada Ltd., 73 Crockford Blvd., Scarborough, Ontario

FOREMOST IN ELECTRO-ACOUSTICS . . .

Microphones, Phono-Cartridges, High-Fidelity Loudspeakers and Enclosures,
Public Address Speakers, Marine Instruments,
EVI Professional Electronic Instruments and Military Material.





Sell Radios. There's a lot of money-making potential these days in portable, table, and clock radios. EIA reports that total sales of all these items added up to over 9.7 million units in 1957—well over a million more than were sold in 1956. Even if your main business is service, you might sell a surprising number of radios by putting a few of them on prominent display in your shop to encourage impulse buying. The public seems to find new radios with their colorful cabinet designs as hard to resist as those Cornish game hens and other delicacies they see in modern supermarkets.

\$ & ¢

Test Your Tact—IV. Field experience with new models of TV sets turns up occasional minor flaws in design or manufacture which were not discovered before the receivers reached the market. As a rule, production changes are promptly put into effect in order to correct these defects. You can probably remember having encountered several troubles of this nature in your own work. Perhaps an inadequately rated capacitor broke down, or a vertical oscillator that was too critical in design gave you a rough time with intermittent vertical rolling.

It's a normal reaction to be quite pleased with yourself when you cure a stubborn trouble with the aid of production-change information. But does your pride tempt you to make a special point of telling the customer that most other sets similar to his have developed the same defect, and that you had to modify the design of the receiver in order to repair it? Or do you simply state that you have fixed the set?

We're inclined to be close-mouthed in situations like this. The customer, not being technically-minded, doesn't usually

share your interest in the reasons why his trouble developed. The words "modify the design" may even backfire on you by stirring up some of the following vague suspicions in his mind:

"Doesn't the factory know what it is doing? Why did it bring out this model if the design wasn't right in the first place?"

"So the TV man thinks my set was a poor design! Somebody's putting something over on me—either the serviceman or that salesman who sold me the set."

"So he monkeyed around with the design of the set! If it breaks down again, he'd better come back and straighten it out." (Free, of course.)

That's why we prefer to say that we replaced such-and-such parts to cure the trouble, and usually let it go at that.

*"In the adder, my lunch box just fits"
Said a computer technician named Fritz,
But when the program was started,
Flip-flops were retarded,
And his lunch was blown to bits.*

*A radio repairman named Peters,
While working without any meters,
Used a screwdriver to see
If the voltage was B,
It was A and he blew all the heaters.*

Evening Calls. The average householder whose set conks out during the evening feels a compelling urge to take some action right away, so it's a good bet that he will immediately try to call a TV shop. When you hear his voice over the phone, it's easy to picture him pacing around and chewing his fingernails until the service truck arrives. Many shops keep men on the go until late in the evening in order to catch this business while it's hot. Other service outfits, including a lot of one- and two-man shops, would much rather stick as close as possible to a normal business day. When they survey the situation, though, they are likely to con-

clude that they are missing out on many calls—so they reluctantly stay open until a late hour.

An intriguing point on this subject was recently brought up by the "Parts Peddler," a Phoenix, Ariz. distributor newsletter, which claims that the mere act of making a definite appointment for a service call will temporarily satisfy the customer's urge for action. As long as he has done something concrete toward getting his set fixed, he will probably be willing to settle down and wait for the call—no matter whether the technician arrives the same night or the next day.

According to this point of view, technicians should think twice before wearing themselves out on night calls. However, they should make sure that an order-taker or answering service is on hand to "nail down" any calls that come in during the evening.

\$ & ¢

Remote Possibilities. When the 1959 TV sets are introduced this summer, several more manufacturers are expected to bring out models that feature remote control. Unusually heavy interest in remote tuning has been created by the success of remote-control devices on some of the 1958 models.

Some new systems of the wired type will be offered, but you can also expect to see a few additions to the roster of wireless control units. If you haven't been paying much attention to remote controls, it's time to sit up and take notice.

\$ & ¢

Calling All Boats. The current boom in pleasure craft is creating new markets for marine electronic equipment such as two-way radio-telephones. A recent survey disclosed that more new radio equipment is now going into pleasure boats than into the commercial fleets which are usually considered the mainstay of the marine electronics business.

Of course, activity in this field is concentrated on the coastlines and along the Great Lakes, but there are a surprising large number of opportunities to install such items as built-in radios for the gadget-happy speedboaters who are now pursuing their hobby almost anywhere where there is water.

mounts in seconds!

completely waterproof! highest "Q"!

NOW...

LOK-MATIC by **WARD!**

It's today's most revolutionary antenna!

Truly a "fingertip" installation—done in seconds—by one man—entirely from the outside!

So advanced, it will fit all cars—even '59 and '60 models.

Positive . . . easy . . . fool-proof. New exclusive triple interlocking parts fall into place *automatically*—provide tighter, easier installation. The *only* completely waterproof mount—highest "Q" ever. The Lok-matic antenna extends to 55" from 19½" collapsed. Has 3 sections. Adjusts to 43°. 54" low-loss Elektran lead cable. Fits any hole from ⅜" to 1⅛". Popularly priced. Put the easiest mount of all at *your* fingertips—order the Lok-matic antenna (Model L-1000) from your distributor today! Pre-assembled—no loose parts. *Only* Ward has it!

Self-locating rocker locks automatically, can't spread. Positive ground. Self-aligning pad. Completely waterproof. Interlocking features of insulator and cap prevent twisting. Dome-shaped nut.

Pat. App. For

watch **w a r d** WARD
PRODUCTS
CORP.

1148 Euclid Ave., Cleveland 15, Ohio • Division of The Gabriel Company
In Canada: Atlas Radio Corp., Ltd., 50 Wingold Avenue, Toronto, Canada



This new dual-concentric control by Mallory enables a distributor to custom-build an exact replacement from selected units, rigidly locked together, in just 30 seconds. You can stop "touring the town" looking for hard-to-find "factory-built" replacements when you start using the new Mallory "Sta-Loc" controls.



Tops in capacitors for every service need . . . the Mallory FP line. Now, the new and improved design gives you even greater dependability, lighter weight, and longer life, thanks to the exclusive new internal structure that eliminates "potting". Still retains the exclusive etched cathode construction . . . hum-free performance.

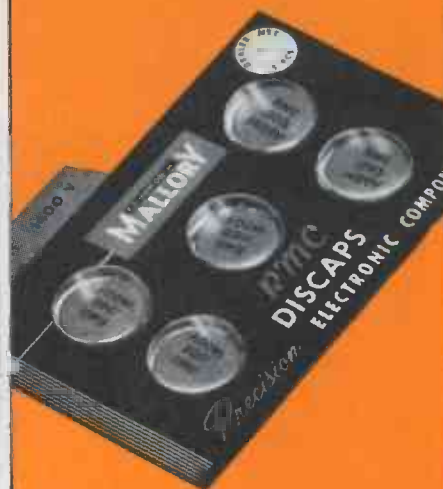

Long the original equipment standard, now available for service . . . it's the Mallory-RMC Discap, a product of the world's largest maker of ceramic disc capacitors. Look for the handy 3" x 5" file-card package. It's easy to stock, and easy to use. Hangs over your bench, tells you at a glance what capacitors you have.

Look to Mallory...



The new portable car radio depends on Mallory mercury battery power, as do thousands of personal portables. Cash in on this profitable replacement market with a ready stock. Mercury batteries, pioneered by Mallory, have long shelf life, and a long, dependable service life. Mallory also offers a broad line of zinc-carbon batteries.

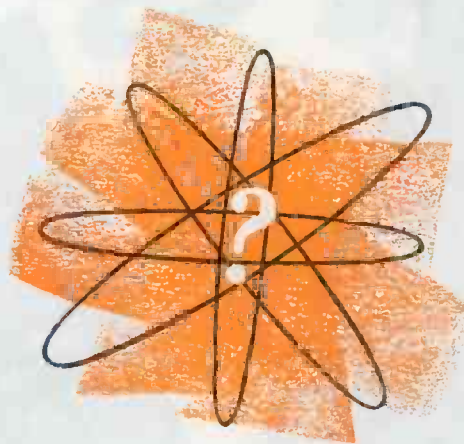

And in your future . . . who knows what electronic marvels will become reality, and thus become new service business for you. Mallory will continue to develop components for new circuits, and replacement parts to service these new needs. You can continue to depend on Mallory leadership, ingenuity, and your Mallory Distributor.



It's a "Gem" of a package—5 Mallory "Gem" tubular capacitors in a trim, easy-to-use dispenser. Keeps your stock clean and fresh—keeps kinks out of lead wires. Look for it on your distributor's self-service display—you can't find a better capacitor than these rugged, moisture-proofed Mallory "Gems".



You can add a modern touch to service jobs by replacing with the new Mallory "push-pull" line switch. The receiver can be turned on or off without rotating the control... warms up to the volume level in use when the set was turned off. Mallory offers a complete line of replacement controls featuring this modern touch.



For longer, more trouble-free auto radio servicing, especially on critical jobs, replace with the new Mallory Gold Label vibrator. For economy jobs, use the new Mallory Highlander in the handy ten-pack carton. Both lines feature Mallory's exclusive buttonless contact design for longer, quieter, more efficient service.

... for Leadership ... and Profits

for Innovations to Meet Your Needs...

Dependable Components of Precision Quality

There is evidence aplenty on these pages of dynamic growth in the Mallory line. All of these are developments of the past 12 months—continuation of years of progressive pioneering by Mallory to meet the needs of the service industry.

As you face the problems of repairing increasingly complex equipment, you can depend on Mallory for the proven quality that prevents "come-backs"—

makes your service jobs right the first time! Depend on Mallory, too, for new designs that keep pace.

Perhaps you have associated the Mallory name only with vibrators... or electrolytics... or volume controls. If so, you should meet the rest of the big Mallory family of service-engineered components. Your local Mallory distributor is prepared to introduce you.

P. R. MALLORY & CO. Inc.
MALLORY

P. R. MALLORY & CO. Inc., INDIANAPOLIS 6, INDIANA

- Capacitors
- Vibrators
- Resistors
- Power Supplies
- Mercury and Zinc-Carbon Batteries
- Controls
- Switches
- Rectifiers
- Filters

A G C CIRCUITS

In the April issue, we described the 6BU8 "dual pentode" tube now being used in AGC circuits of Zenith and Admiral TV sets, and mentioned that DuMont and Motorola had also developed new circuits utilizing this tube. This month's article starts off with a full description of these additional -BU8-type AGC systems.

DuMont Chassis RA-400

The 1958 DuMont circuit shown in Fig. 1 is a non-keyed type, similar in basic design to the circuit employed in Zenith 15A Series sets but considerably different in many details.

In Fig. 1, the AGC voltage applied to the RF and IF stages is obtained by mixing a constant negative voltage with a variable positive voltage. The power supply includes a special B- rectifier, and its output of -78 volts is used as the source of fixed negative potential. The positive source is the plate voltage of the AGC sec-

tion of the 6BU8, which has an average value of about 30 volts and varies according to video signal amplitude.

When a signal is being applied to the receiver, the voltage on the IF branch of the AGC line is normally a few volts negative with respect to ground. If it attempts to go positive at any time, the line is shorted to ground by conduction of a clamper diode.

AGC circuit operation is controlled by no fewer than three potentiometers. One, the *RF AGC Delay*, taps off a voltage from the AGC line for application to the tuner. In the maximum clockwise position of this control, the tuner and IF strip both receive the same value of AGC voltage. In other words, maximum bias is furnished to the RF amplifier in order to prevent overloading of the stage in strong signal areas. As the control setting is reduced, the RF voltage is made progressively less negative than the IF in order to

permit as much tuner gain as possible in weak signal areas.

The "Dumonitor" control regulates the DC bias on the outer control grid (pin 9) of the 6BU8. This adjustment serves to vary the average amount of plate current passed by the AGC section of the tube, and thus determines the degree of effectiveness of the AGC system.

Another control, the *Fringe Lock*, is in the noise-cancelling circuit connected to pin 7 of the 6BU8. Like the control of the same name in Zenith 17A Series chassis, it is adjusted so that any strong noise pulse in the video signal will drive the grid voltage at pin 7 below cutoff, thus removing the noise pulse from both the sync and AGC outputs.

In installations where noise is not a problem, it is advisable to turn the *Fringe Lock* control to the maximum counterclockwise position. The grid leak circuit connected to pin 7 (composed of a

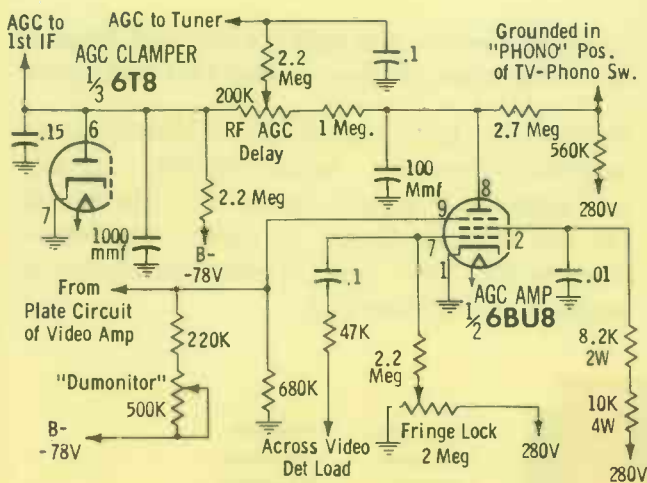

Fig. 1. 6BU8 AGC circuit used in DuMont Chassis RA-400 includes three service adjustment controls and a clamper diode.

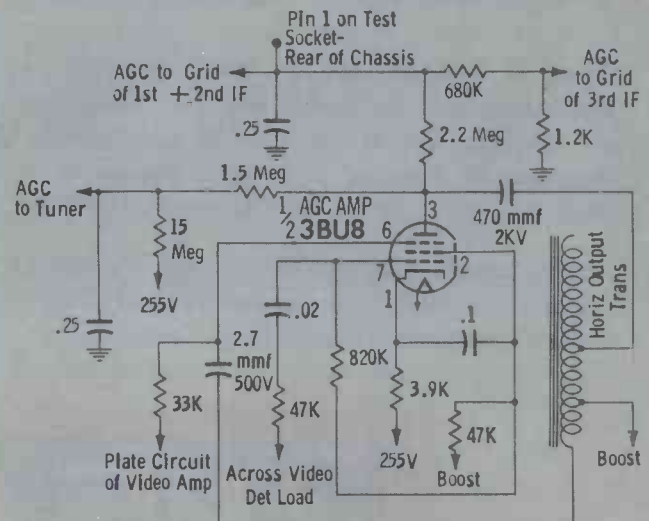

Fig. 2. 3BU8 circuit in Motorola Chassis TS-542 is keyed by 600-volt pulses, has negative feedback cancellation feature.

FOR 1958 More -BU8 Circuits and Other New Designs

by Thomas A. Lesh

.1-mfd capacitor and a 2.2-megohm resistor) is then returned directly to B+, and this high positive potential prevents an appreciable charge from building up on the capacitor. As a result, minimum bias is established at pin 7, and the noise-cancelling signal applied to this point has a minimum degenerative effect on the plate current of the 6BU8. If the control is advanced clockwise, the positive potential at the arm of the potentiometer is reduced and grid-leak bias is allowed to build up at pin 7. The correct value of bias is that which will allow noise spikes to drive the grid voltage below cutoff. If the control is turned farther than necessary, the bias will become excessive and the negative-going sync pulses in the signal will also cut off the tube. This explains why the control is adjusted by advancing it until sync becomes unstable and then backing it off until good sync is restored.

Motorola Chassis TS-542

Motorola's new -BU8 circuit is patterned after the keyed AGC system they previously used. Fig. 2 is a schematic of the circuit found in transformerless 21" sets (Chassis TS-542). Cathode voltage is only slightly below the 255-volt B+ level. Screen grid voltage, which is obtained from the boost B+ line, is about 70 volts higher than the cathode voltage.

The grid-leak circuit of the noise-canceller grid (pin 7) is also returned to boost B+ to provide a positive voltage source for the "bleeding off" of excessive bias from the grid. This grid tends to run positive when no noise is present in the input signal, but strong noise pulses arriving at the grid have sufficient amplitude to cause a momentary negative shift in grid voltage and thus produce the desired cancelling action. No control is provided in this circuit.

The correct bias voltage and input signal for the outer control

grid (pin 6) are obtained simply by connecting this grid through an isolating resistor to the plate circuit of the video amplifier.

Positive keying pulses of high amplitude (over 600 volts peak-to-peak) are required for proper operation of this AGC circuit, and these are obtained from the fly-back transformer. Since the outer control grid is close to the plate, there is sufficient interelectrode capacitance between these two elements to couple considerable pulse energy back into the grid circuit. This undesirable feedback is cancelled by feeding a negative pulse to the grid through a small (2.7 mmf) capacitor from another tap on the flyback transformer.

The AGC line in Fig. 2 is generally similar to those in other Motorola keyed AGC circuits. Note the voltage divider, from which a small portion of the AGC voltage is applied to the third IF.

The new -BU8 circuit is also

• Please turn to page 59

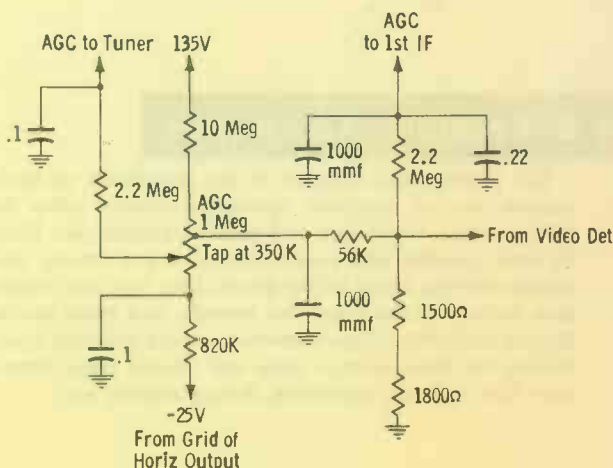

Fig. 3. Packard-Bell Chassis V8-2 has unusual tuner AGC control circuit involving plus-to-minus voltage divider hookup.

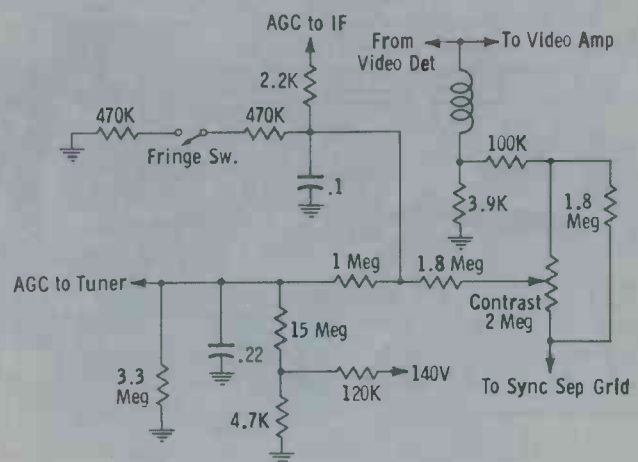

Fig. 4. In Philco Chassis 8L35, the contrast control is included in the AGC circuit and adjusts the gain of RF and IF stages.

walk-in SALES ITEMS

for the service shop

Introduction

Your shop can be more than just a place where repairs are made. Smart shop-owners find that sideline sales account for a good part of their gross income and a substantial percentage of their net profits. Many, in fact, expect sales of walk-in items to completely cover rent, utilities, etc. These businessmen realize that the public is subject to impulse buying, and that accessory-item displays will compel passersby to come in and shop around. In turn, this stimulates service business.

Use the illustrations and ideas in this article to guide your own thinking—you'll probably think of many more saleable items than we've shown. And remember—"fancy" displays aren't absolutely necessary; ingenuity, giving the customer a reason to buy (a new antenna will give you better reception; a new phono needle will protect your investment in records, etc.), and having the right items on display are more important.

Radio-TV Tubes

Like it or not, self-service tube testers are responsible for a good percentage of tube sales. You can beat this competition and snag the trade of local residents and sidewalk traffic by offering expert technical advice in addition to free tube testing. For instance: why should a customer buy a new damper tube when his present one is only 70% efficient and the trouble is really no vertical sync? And look at the business you pick up when the customer finds he can't cure the trouble. Either way, you win—either you sell him the tubes or you get the service call.

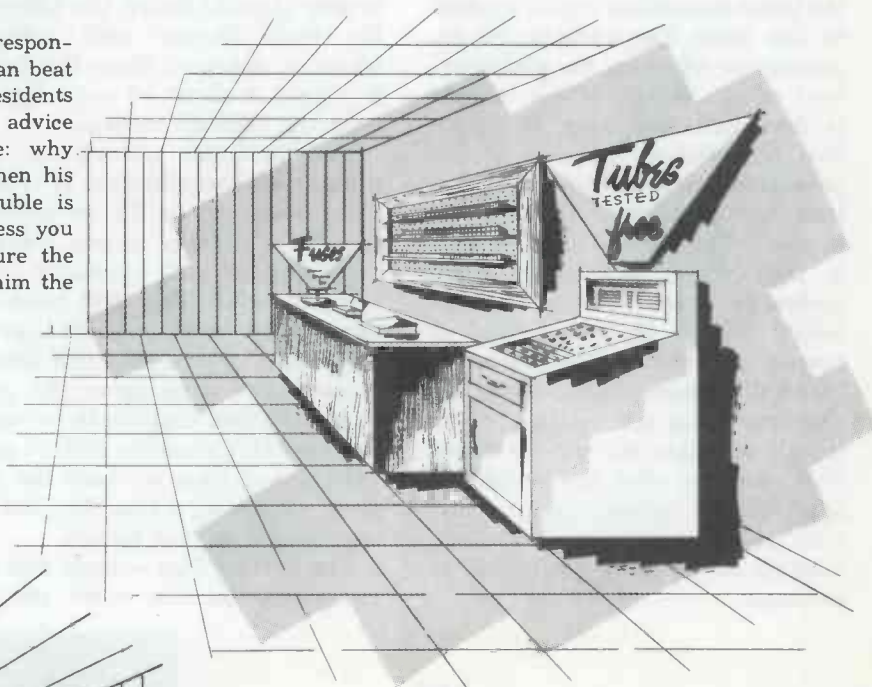

Phono & Recorder Accessories

The phenomenal increase in the popularity of hi-fi assures you of excellent across-the-counter sales in this category. Cartridges and needles, record care kits, 45 rpm spindles and record adapters are among the fastest-moving items in the phono line, but you might also include strobe discs, test records, and gram scales for the audiophile. Tape-recorder owners are good customers for tape, storage cans and chests, reels, tape-care kits, splicers, threaders, demagnetizers, etc.

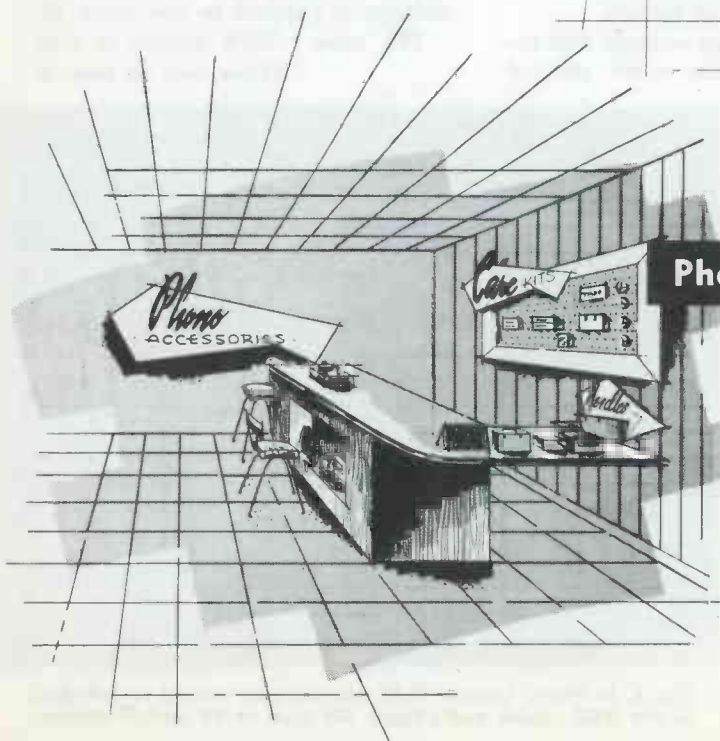

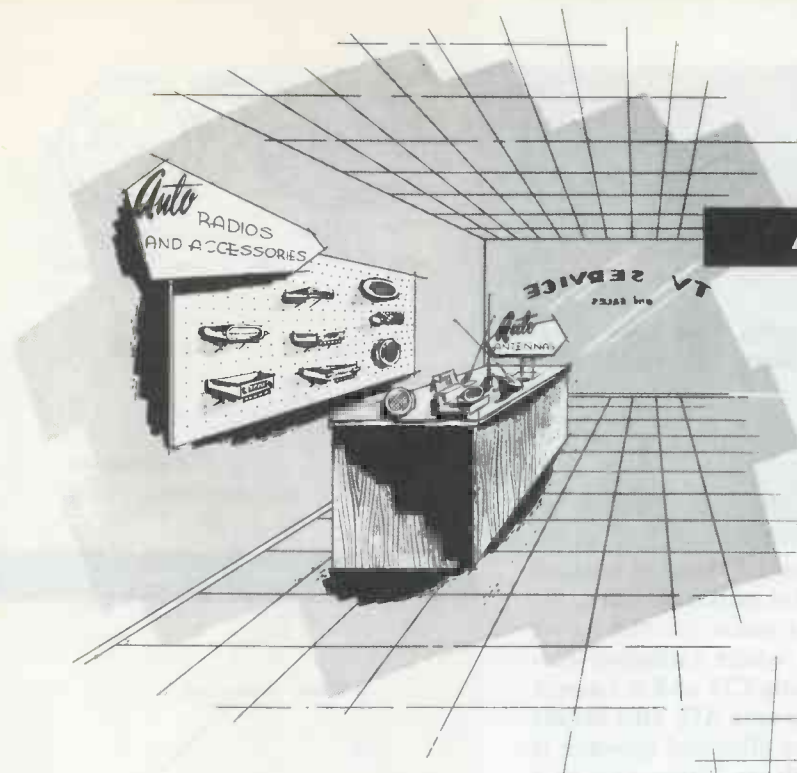

Auto Radio Accessories

Rear-seat speaker kits, auto antennas, noise suppressor kits, power inverters, vibrators, antenna leads, and connectors can be combined into a very attractive self-selling display. This type of merchandise is especially profitable when your location is suitable for attracting trade from passing motorists. Added thought—you might even include at least one model of a universal-mounting radio for the “Big Three” autos.

Batteries

Here's an item *everybody* needs. If you can tempt passersby to come in and browse around (perhaps to watch a Dodger-Yankee 9th inning), you should have no trouble in moving your battery supply. Most-needed types are for flashlights, portable radios, toys, and flash guns. Remember, however, that these items have a limited shelf life, and are to some extent seasonal in demand, so adjust your stock purchases accordingly.

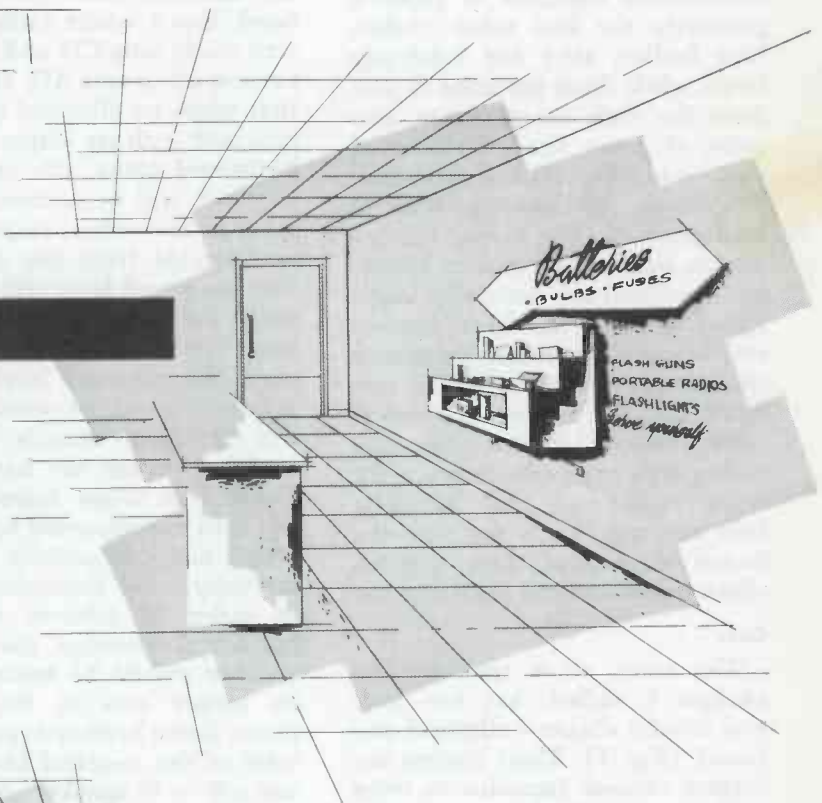

Antennas

Indoor antennas are always good sellers, particularly when they're on display to provoke impulse buying or to remind the customer of the need for a new one. Outdoor “do-it-yourself” kits will also move well, particularly during pleasant-weather months when Father (or son) gets the urge to tackle such a project. Be sure to keep extra miscellaneous stock (lead-in, chimney mounts, masts, multiple-set couplers, and hardware) on hand so you can sell him everything he needs. Offer advice free! He'll be back.

AUDIO

Speaker Design
Checking Amplifier Response
Products for Profit

FACTS

by Calvin C. Young, Jr.

Speaker Design

In music, we know that those instruments designed to produce primarily the low tones (tubas, bass fiddles, etc.) are relatively large, while those designed to produce the high tones (flutes, piccolos, etc.) are small. Because of various mechanical and acoustical limitations, the same is true of loudspeakers. We know, for instance, that low-frequency speakers (woofers) are generally large, high-frequency speakers (tweeters) are small, and mid-frequency speakers (squawkers) are of medium size. The factors that determine, affect and limit the response and operation of speakers are the cone, voice coil, and magnetic field and gap. Let's see how the design of each of these sections affects operation and performance.

Cone

The cone, as a speaker diaphragm is called, has two general frontal shapes—elliptical and round (Fig. 1). Their shapes are further classed (annulus to voice coil) as conical, flared or exponential, and conical with corrugations. Any of the three annulus-to-voice coil shapes may be used on either the elliptical or round speaker.

The elliptical cone was developed because in certain cabinets, where the vertical distance is limited, the elliptical shape permits a larger cone area for the available space, thereby extending the obtainable low-frequency response. In addition, there is a change in the radiation pattern. Referring again to Fig. 1, notice that distance AB is equal to distance CD for the round cone, but is larger for the elliptical cone.

The round cone has equal vertical and horizontal radiation patterns; the elliptical cone, on the other hand, has a wider radiation pattern along axis CD and a narrow pattern along axis AB. This means that when an elliptical speaker is mounted with its longer axis in a horizontal plane, the side-to-side response will be narrow with respect to the vertical response. This is desirable from the standpoint that the sound level will be essentially the same whether the listener is sitting or standing; however, the coverage angle of any given room will be restricted (see Fig. 2). Areas outside the horizontal coverage arc have appreciably less sound intensity than the area encompassed by the arc, which has substantially the same intensity level throughout. Thus, in order to achieve maximum horizontal coverage, the elliptical speaker should be mounted with its longer axis in the vertical plane. Some lowboy-type TV consoles use a 6" x 9" speaker mounted in this manner. Some of the newer table model TV receivers employ a form of elliptical speaker (3" x 14") with the longer axis mounted horizontally, the thinking apparently being that any speaker at the front of the cabinet, whatever its response pattern, is better than a small speaker on the side.

The three annulus-to-voice coil cone styles illustrated in Fig. 1 can be formed through the use of a *felting* process. In this process, a mixture of pulp and water is forced through a porous form of the desired shape. When properly dried, the material can be easily removed from the form. This produces a cone having the dia-

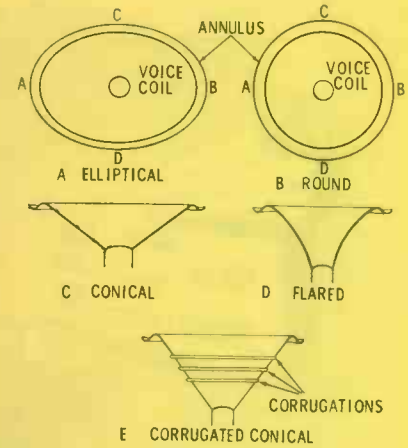

Fig. 1. Speaker cone configurations.

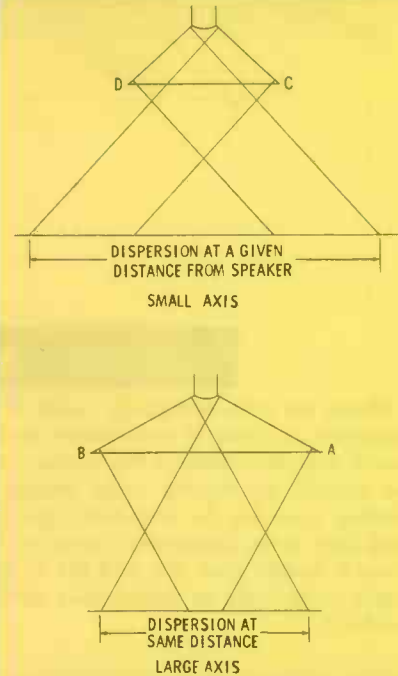

Fig. 2. Elliptical speaker dispersion.

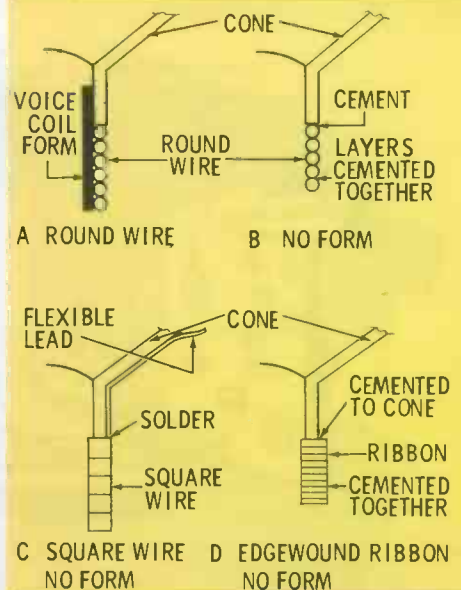

Fig. 3. Common voice coil construction.

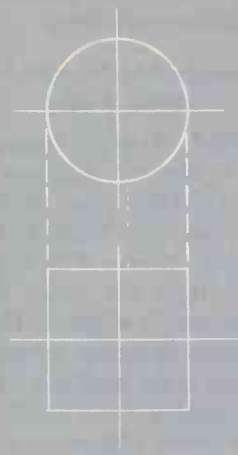

Fig. 4. Use of square wire instead of round decreases voice coil space required.

phragm, annulus suspension and center section all in a single, seamless piece—a most desirable form.

The simple conical and conical with corrugations might also be constructed of hard paper (stamped while moist to produce the corrugations), then formed into a cone and glued along the seam. This method cannot be used to produce the flared cone. For general usage such as radio and TV, most speakers are made of glued, hard paper for reasons of economy. Fidelity is a secondary, although still important, consideration in these applications.

In comparing the simple conical design with flared and corrugated-conical configurations, the flared design produces a sharper directional pattern on high frequencies because of its exponential curvature and added rigidity. The corrugated conical, having considerable radial rigidity, has a wider directional response pattern.

Other facets of cone design that materially affect the operation of a speaker are its size and weight. To reproduce the "popular" or mid-range audio frequencies without regard for the extremely low or high frequencies, a 5" to 10" unit having a hard paper cone is most often used. This type of speaker is very efficient in the mid-audio range; however, at the low end of the audio spectrum, its radiation resistance is too small and the cone tends to break-up or wrinkle, producing very poor low-frequency output. At the high end of the spectrum, cones of the larger 8" to 10" units, even though

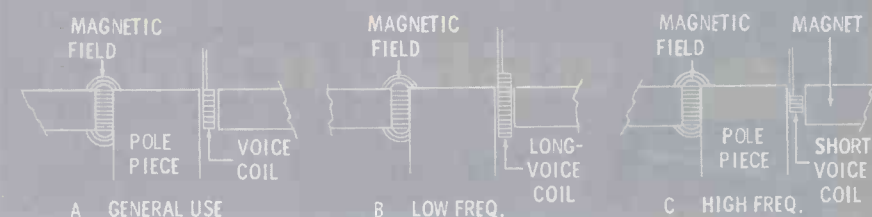

Fig. 5. Relationship of voice coil and magnet gap for different type speakers.

they are fairly light, cannot move rapidly enough to produce the desired high-frequency output. To overcome these difficulties, low-frequency speakers or woofers are designed with rather thick and heavy cones. Their large size increases radiation resistance and therefore low-frequency output. The thick, heavy construction prevents "break-up" when subjected to long, low-frequency movements necessary to produce loud, low tones. High-frequency speakers or tweeters are small and have very light, rigid cones which are capable of rapid vibration.

From what has been said, it follows that woofer cones must travel a considerable distance, while tweeter cones are very limited in their travel. For a 10" speaker to produce an output of .02 acoustic watts at 1,000 cps, the cone must travel .0005", while to produce the same .02 acoustic watts at 100 cps, it must move .050". Thus, you will find that woofer cones travel a half inch or more, while the movement of a tweeter is very minute and cannot be seen with the naked eye.

Voice Coil

Voice coils of modern speakers generally follow one of four styles. See Fig. 3. Paper voice-coil forms are used to facilitate mass production. Voice coils and cones are assembled separately and then combined in a machine operation. Use of a paper form, while it simplifies construction, creates an additional problem in that it adds bulk and weight, neither of which helps

speaker operation. The voice-coil style shown in Fig. 3B eliminates the form because the voice coil is assembled as a self-supporting unit with thermo-setting cement between layers. The gap in the speaker magnet may thus be made smaller, effectively increasing the usable magnetic strength. A more efficient voice coil (Fig. 3C) can be made using square wire and thermo-setting cement. Again, the paper form is eliminated and more voice-coil mass is provided for a given area (Fig. 4). As you can see, both the square and the circle have the same outer dimensions, but the square has the larger area. This means that smaller diameter square wire can be used, further reducing the size of the necessary magnet gap. Edge-wound ribbon voice coils are even more efficient, for the reasons just cited. Made of aluminum and copper, they are used in a great many of the large high-quality speakers designed to reproduce low- and mid-range tones.

We previously mentioned that, in woofers, the cone was required to move a considerable distance, while in tweeters it moved hardly at all. This creates certain problems in speaker design. To obtain the maximum magnetic field with a given magnet size, the gap must be as small as possible. If the voice coil is the same length as the magnet gap (Fig. 5A), then the voice coil will cut magnetic lines of various forces as it moves, and result in distortion. Therefore, the practice is to make the voice coils of

• Please turn to page 64



QUICKER SERVICING

by Calvin C. Young, Jr.

Tube Substitution Guide

Since publication of the tube substitution guide in our August, 1956 issue, a great many new tubes have been developed and included in TV and radio receivers. The guide presented this month is a revised version of the original, and includes all of the tubes that have reasonable substitutes and are currently being used in volume. We again want to state, however, that this guide is primarily intended for use on home service calls where a tube of the original

type is not available. By consulting the guide, a substitute tube can be selected for testing purposes. Substitute tubes should not be left in a circuit permanently. Only the particular tube designed for the circuit should be the permanent "resident."

The basing of tubes in each division is identical; however, the electrical characteristics are somewhat different for each tube and the substitute tube will not, therefore, work in all cases. Pay special attention to the notes included

with the chart to obtain maximum benefit of its usefulness.

Foreign-Made AM-FM Auto Radio

A friend of ours recently obtained a Becker Europa Model MUK AM-FM auto radio that didn't work very well on FM. Investigation of the FM alignment revealed that the ratio detector was improperly aligned. The cores in the ratio detector transformers were very tight and hard to turn. The secondary core finally broke before correct alignment could be achieved. A replacement unit could not be obtained without a long wait, so it was decided to try and adapt a miniature transformer recommended for use in this type circuit (Fig. 1). Transformers suited for this application were found to be Thordarson-Meissner 17-3498, Merit FM-253, and J. W. Miller 1465.

The original transformer was mounted through the aluminum chassis in such a way that the

TUBE SUBSTITUTION GUIDE

1. 1X2A, 1X2B
2. 1B3GT, 1G3, 1J3, 1K3
3. 2AF4, 2AF4A, 2T4, (Note A)
4. 3BY6, 3CS6
5. 3CB6, 3CF6, 3DK6, 3BZ6
6. 4BC5, 4CE5
7. 4CB6, 4DK6, 4BZ6
8. 4BQ7, 4BZ7, 4BC8, 4BZ8 (Note B)
9. 4BS8, 4BX8
10. 5DH8, 5BE8
11. 5U4G, 5U4GA, 5U4GB, 5A54A
12. 5Y3GT, 5Y3GA, 5Y4GA, 5AZ4
13. 6AX4GT, 6DA4
14. 6BQ6GT, 6BQ6GTA, 6BQ6GTB, 6BQ6GA, 6CU6, 6DQ6, 6DQ6A
15. 6AU5GT, 6AV5GT, 6AV5GA
16. 6AG5, 6BC5
17. 6AF4, 6T4 (Note A)
18. 6AT6, 6AV6
19. 6BD6, 6BA6
20. 6BK7A, 6BQ7A, 6BZ7, 6BZ8/X155, 6BC8 (Note B)
21. 6BH8, 6AU8, 6AU8A
22. 6BL7GT, 6BX7GT
23. 6BY6, 6CS6
24. 6CB5A, 6CL5
25. 6CB6, 6CB6A, 6CF6, 6DE6, 6DK6, 6BZ6
26. 8AU8, 8AU8A, 8BH8, 8BH8A
27. 12AC6, 12AF6 △
28. 12AD6, 12AG6, 12EG6 △
29. 12AT6, 12AV6
30. 12AV7, 12AZ7, 12AT7
31. 12AX4GT, 12D4

32. 12AX7, 12AX7/ECC83, 12DF7
33. 12BD6, 12BA6
34. 12BQ6GT, 12BQ6GTA, 12BQ6GTB, 12CU6, 12DQ6, 12DQ6A
35. 12BY7, 12BV7
36. 12CA5, 12R5, 12C5
37. 17AX4GTA, 17D4
38. 17CA5, 17R5, 17C5
39. 25BQ6GTA, 25BQ6GTB, 25CU6
40. 25CA5, 25C5

The following tubes are listed from left to right in ascending order. No tube can be used to replace one listed to the right of it.

41. 5BS8, 5BQ7
42. 6CA5, 6CU5
43. 6CD6G, 6DN6, 6CD6GA
44. 6K6GT, 6V6GT, 6EF6, 6W6GT
45. 6U4GT, 6W4GT, 6AX4GT, 6AU4GT, 6AU4GTA, 6DA4
46. 6X5, 6X5GT, 6AX5GT
47. 12L6GT, 12W6GT, 12EN6
48. 17CA5, 17CU5
49. 25EC6, 25DN6, 25CD6GB
50. 25L6GT, 25W6GT
51. 25W4GT, 25AX4GT

Substitution may not work because of different cutoff characteristics.

52. 3AU6 (Sharp), 3BA6 (Remote)
53. 4AU6 (Sharp), 4BA6 (Remote)
54. 6AU6 (Sharp), 6BA6 (Remote)
55. 6BH6 (Sharp), 6BJ6 (Remote)

△ Used in 12V hybrid auto radios.

(Note A) These tubes are used in UHF applications and may not work when substituted.

(Note B) These tubes are used as cascode RF amplifiers in VHF tuners and may be interchanged for testing purposes if carefully selected.



BUSS FUSES can help you maintain customer good-will!

Your customers stay satisfied with BUSS fuses because . . . BUSS fuses provide, dependable, 'trouble-free' electrical protection under all service conditions.

Every BUSS fuse you sell or install is tested in a sensitive electronic device. Any fuse not correctly calibrated, properly constructed and right in all physical dimensions is automatically rejected.

BUSS fuse dependability helps you gain satisfied customers — and BUSS fuses help you avoid adjustments or call-backs that cut into your profits.

BUSS fuses can further help you maintain your reputation for quality and service because BUSS is the KNOWN brand of fuses. The universal acceptance of BUSS fuses as the finest available is built on the millions upon millions of BUSS

fuses used in home, on farm and in industry over the past 43 years.

For more information on the complete line of BUSS and FUSETRON Small Dimension Fuses and Fuseholders, write for bulletin SFB.

Bussmann Mfg. Division McGraw-Edison Co. University at Jefferson, St. Louis 7, Mo.

BUSS fuses are made to protect — not to blow, needlessly



A COMPLETE LINE OF FUSES FOR HOME, FARM, COMMERCIAL, ELECTRONIC, AUTOMOTIVE AND INDUSTRIAL USE.

SENCORE
Another Sencore Time-Saver
Handy "36"
R-C Substitution Unit



"36"
Most Often Needed Components At YOUR Fingertips!

3 pole, 12 position switch individually selects one of the "36" components for direct substitution.

Contains:

- ★ 12-1 watt 10% resistors from 10 ohms to 3600 ohms
- ★ 12-1/2 watt 10% resistors from 10K ohms to 5.6 megohms
- ★ 10-600 volt capacitors from 100-mmf. to .5mf.
- ★ 1-10mf., 450V Electrolytic
- ★ 1-40mf., 450V Electrolytic
- ★ For Shop, Lab, or outside service

Completely isolated from 100-mmf. to .5mf.

ONLY **\$1275** DEALER NET

POPULAR SENCORE PRODUCTS

- Transistor Tester
- Leakage Checker
- Filament Tester
- Voltage Regulator
- Bias Supply

AVAILABLE AT ALL PARTS DISTRIBUTORS!
SENCORE SERVICE
INSTRUMENTS CORP.
 177 OFFICIAL RD., ADDISON, ILL.

Cut out this ad now for further information.

all new edition
 VOL. III, NO. 1

up-to-date component prices

PLUS

the quick easy way to figure service charges

Dave Rice's

OFFICIAL PRICING DIGEST



Flat rate and hourly service charges, based on and showing regional and national averages, plus up-to-date list or resale prices on over 63,000 components. Arranged alphabetically by manufacturers and products, numerically by part number. Compact, convenient size fits in tube caddy, toolbox or pocket. \$2.50 per copy from your distributor.

ELECTRONIC PUBLISHING COMPANY, INC.
 180 N. WACKER DRIVE, CHICAGO 6, ILL.

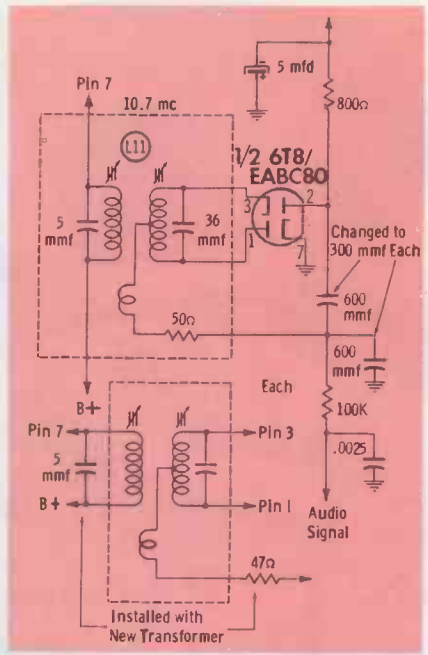

Fig. 1. Changes made in ratio-detector circuit when transformer was replaced.

replacement couldn't be mounted without some metal work. As you know, a metal adapter plate is supplied with all 3/4" transformers; however, this plate couldn't be bolted in place because there wasn't enough room for the tabs with the bolt-down holes. The tabs were therefore cut off as shown in Fig. 2, and the modified mounting plates were soldered to the aluminum chassis using a recently-developed soldering flux called "Sal-Met" (available from most hardware stores).

In making the circuit connections, a 47-ohm resistor was added in series with the tertiary winding since the replacement unit did not contain the 50-ohm resistor used in the original. Connecting the sweep generator and scope and checking the alignment of the detector revealed the pattern shown in Fig. 3. Adjustment of both the primary and secondary cores of the transformer resulted in no improvement. Consulting the schematic, it was noticed that a 5-mmf capacitor had been used to tune the primary winding. Since this component was not a part of the replacement unit, one was temporarily connected into the circuit. The detector "S" pattern became larger, indicating an increase in gain, but still the pattern wasn't shaped as it should be.

The sample circuit supplied with the transformer called for 300-mmf capacitors instead of the 600-



Fig. 2. Modified mounting plate required for installation of the new transformer.

mmf values used in the original Becker configuration. When 300-mmf units were installed, a normal "S" pattern was obtained. As a final check, the 5-mmf capacitor temporarily connected across the primary was removed. As a result, the pattern reduced to about one-third of its former size, so the 5-mmf was installed permanently. The listening test on local FM stations proved this replacement to be a satisfactory one.

If you are ever confronted with obtaining an identical replacement unit for a foreign-made receiver, remember this little anecdote. It should be of some help.

Circuit Tester

The "Sencore" Model FS-3 shown in Fig. 4 is designed for testing AC-line current or wattage and the combination of AC and DC currents through fusible resistors or fuses in power supply circuits. When the FS-3 is inserted between the AC line and the receiver, AC current is automatically indicated.

The two ranges provided are 2 and 10 amps. Power consumption is normally checked with the switch in the 10-amp position and read directly from the wattage scale. On the 2-amp range, power consumption may be determined by dividing the indicated wattage by 5. Fusible resistors and fuses are checked by connecting the permanently-attached test leads and positioning the switch in the test-leads position.

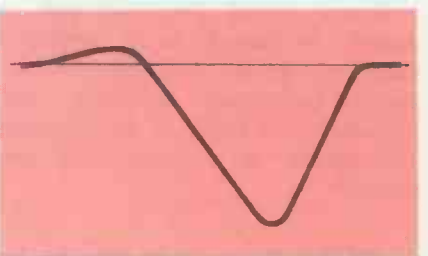

Fig. 3. How detector "S" pattern looked before circuit modifications were made.

FREE from HOWARD W. SAMS!...valuable all-steel file cabinets with your purchase of **PHOTOFACT**—
the world's finest TV-Radio Service Data



FREE! FOR REGULAR PHOTOFACT SUBSCRIBERS

You get your File Cabinets FREE if you are a regular subscriber to PHOTOFACT Folders and buy all new Sets as issued each month. Your Folders come to you in special envelopes, each including a "Bonus Certificate." Sixty (60) of these entitle you to a single-drawer File Cabinet ABSOLUTELY FREE...



FREE! FOR PHOTOFACT LIBRARY PURCHASERS

Get FREE File Cabinets as you complete your profit-building PHOTOFACT Library... here's how:



FREE!
Single-Drawer File Cabinet with your purchase of 60 Sets of PHOTOFACT Folders.
Cabinet Worth... \$895



FREE!
Two single-drawer File Cabinets with your purchase of 120 Sets of PHOTOFACT Folders.
Cabinets Worth... \$1790



FREE!
Three single-drawer File Cabinets with your purchase of 180 Sets of PHOTOFACT Folders.
Cabinets Worth... \$2685



FREE!
Four single-drawer File Cabinets with your purchase of 240 Sets of PHOTOFACT Folders.
Cabinets Worth... \$3580

NEW EASY-BUY PLAN

It's easy to complete your present PHOTOFACT Library or start a PHOTOFACT Library. Use the EASY-BUY PURCHASE PLAN:

- NO INTEREST
- NO CARRYING CHARGE
- AS LITTLE AS \$10 DOWN
- UP TO 24 MONTHS TO PAY

Get the world's finest TV-Radio Service Data... get FREE File Cabinets with your PHOTOFACT purchases...take advantage of the Easy-Buy Plan. See your Sams Distributor today, or write to Howard W. Sams for full details.

HOWARD W. SAMS & CO., INC.
2201 E. 46th St., Indianapolis 5, Indiana



get the full details of the HOWARD W. SAMS money-saving way to build your complete profit-making PHOTOFACT Library!

Send details on your FREE File Cabinet offer and EASY-BUY Plan.

I'm a Service Technician: full time; part time

My Distributor is: _____

Shop Name: _____

Attn.: _____

Address: _____

City _____ Zone _____ State _____

USE ASTRON CAPACITORS

and

DON'T INSTALL A CALLBACK

How much is your time worth? The capacitor you just installed or the one you are about to install holds the answer. Your guarantee of quality workmanship to your customers includes the components you use.

How much is your time worth?

With Astron's "Safety Margin" * capacitors you get the reliability that turns your time into profit —

- 99.99% Pure Aluminum Foil — *Low Leakage*
- Premium Quality Paper — *High Dielectric Strength*
- Hermetic Sealing — *Reliability in all Climates*
- Heat Aging — *Long Life*
- Contamination Free Assembly — *Eliminates Corrosion*

Ask your distributor for Astron Capacitors . . . designed to give service to the serviceman.



ASTRON

C O R P O R A T I O N

255 GRANT AVENUE, E. NEWARK, N. J.

WEST COAST WAREHOUSE: I. R. STERN AND COMPANY
4109 BURBANK BLVD., BURBANK, CALIF.

*Trademark



Fig. 4. "Sencore" Model FS-3 circuit tester is excellent for use on home calls.

A schematic of this unit (Fig. 5) shows that a 5-ohm, 10-watt resistor is included in the test-lead circuit. Its surge-limiting action, normally provided by the fusible resistor, protects the B+ circuit under test. Separate *green-red* scales for fusible-resistor ratings of 4.7, 5.5 to 6.6, 7.5, 9 to 10, 22, 47, and 100 ohms give an instantaneous indication of normal or abnormal circuit operation. If the needle rests in the green area for the circuit under test, current drain is normal and a new fusible resistor may be safely installed. In addition, the 2-amp scale is calibrated for standard fuse ratings of $\frac{1}{4}$, $\frac{3}{8}$, $\frac{1}{2}$, $\frac{3}{4}$, 1, $1\frac{1}{2}$, and 2 amps.

The small size, $3\frac{1}{2}'' \times 4\frac{1}{2}'' \times 1\frac{5}{8}''$, and the low cost of \$8.95 make this an excellent unit for the home service technician. ▲

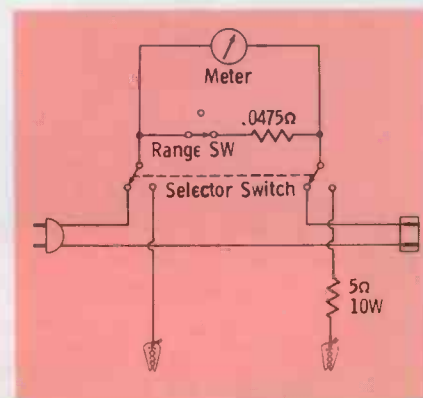

Fig. 5. Schematic of the FS-3 shows connections of selector and range switches.



If it's worth Engineers' time . . .



. . . It's worth Engineered Cable



Belden

**INTERCOMMUNICATING
AND
SOUND SYSTEM CABLES**

Indoor-outdoor, phones
or speakers—there is a
Belden engineered cable
to meet your needs for
a permanent, trouble-
free installation.

"Items from the
Complete Belden Line"

*The TV station, the systems for
music, paging, and intercom-
munication in the new
Prudential Insurance Company
of America's Building in Chicago
have been—wired by Belden.*



Belden

**WIREMAKER FOR INDUSTRY
SINCE 1902
CHICAGO**

8-8

Magnet Wire • Lead and Fixture Wire • Power Supply Cords, Cord Sets and Portable Cord • Aircraft Wires
Welding Cable • Electrical Household Cords • Electronic Wires • Automotive Wire and Cable



Let's Talk Business

the customer is **NOT** always right, but..

by H. M. Layden

The customer is *not* always right, but right or wrong, he is the gent who pays the freight. Since, among service technicians, he has no voice, he can only register his displeasure in one way—by shopping around.

A year ago we were experiencing a sharp decline in the demand for our services. The top brass decided that this state of affairs called for drastic measures—like dumping all callbacks into the lap of the service manager. After four weeks in the field tying up loose ends and placating irate customers, we came to the conclusion that their “beefs” are not altogether unjustified. They abhor the “rush act,” despise the “high-pressure artist,” resent the “brush-off,” and can’t stomach the “messy mechanic.” We have chosen four typical case histories which vividly illustrate this pronounced distaste.

Haste Makes Waste

The first episode in this chronicle took place in an old house—a three-story walk-up. By the time I reached the third landing I was arm weary. The caddy felt like it was loaded with lead, and that three-flight hike not only dampened my ardor, but my countenance, and disposition as well.

It was dark in that hallway, but with the aid of my flashlight I managed to find the apartment. According to the information on the service ticket, the set, a General Electric, had been serviced two days previously for sound but no raster. The technician had changed the damper tube.

The door was opened by a middle-aged gentleman who eyed me suspiciously. I grinned and said, “Good morning, sir. I’m your television service technician. I understand you are having some trouble with the set. May I come in?”

He seemed undecided, and continued to scrutinize me for a moment longer; then, without uttering a word, he ushered me into the living room. The set stood at the far end of the room between two windows. As I moved slowly towards it, I inquired if he would mind showing me the trouble. He obliged by turning on the set, which was what I wanted him to do, as it spared me the embarrassment of fumbling with the front-panel controls to find the off-on switch.

Picture and sound came on together, and a faint, eerie noise emanated from within the cabinet. With the back off, it seemed to be coming from within the high voltage cage, which has a sliding cover.

When this cover was slid back, I could see the glow of a corona discharge in the vicinity of the flyback transformer. This set uses a 6V3 damper with its cathode connection at the top cap. With the chassis withdrawn from the cabinet, close inspection of the cathode lead revealed a few broken strands at the flyback terminal. The only explanation for this was *rough handling!* In the high humidity, the sharp points were perfect jump-off points for the high pulse voltage. I fashioned a new lead on the spot, and with the set perking OK, gathered up my equipment and prepared to leave.

“What’s the damage?” the gentleman inquired. I told him it was on the house and that I hoped he would not hold this “accident” against us. At these words, the tension eased somewhat and loosened the lock he had kept on his tongue. He now began to unburden himself in a torrent of terse phrases. He said he was an easy man to get along with, that he didn’t expect to get something for nothing, but that he didn’t relish the “rush act,” either. He claimed our boy hadn’t spent more than ten minutes fixing the set, and was gone with the wind before he could complain about the weird sound.

He shook his head as he went on, “The only way I can figure it, he must have used one hand to remove the back, changed the tube with the other, and written out the bill with his toes!”

I mumbled something about our boys being well trained to spot trouble quickly, and took off in high gear, promising myself an interesting session with the joker whose hurry-up tactics laid a three-flight walk-up in my lap. That boy was just too hot not to cool down, and I knew just the refrigerant that would do the trick! But that’s another story.

A Bit of Highbandedness

In marked contrast, the second episode took place clear across town in one of those swanky duplex apartment dwellings which house the elite of the human and canine worlds. The lobby is guarded day and night by what looks like an Admiral of the Swiss

NOW, "SNOW-WHITE" TUBE MANUFACTURE . . . PLUS VITAL DESIGN IMPROVEMENTS!

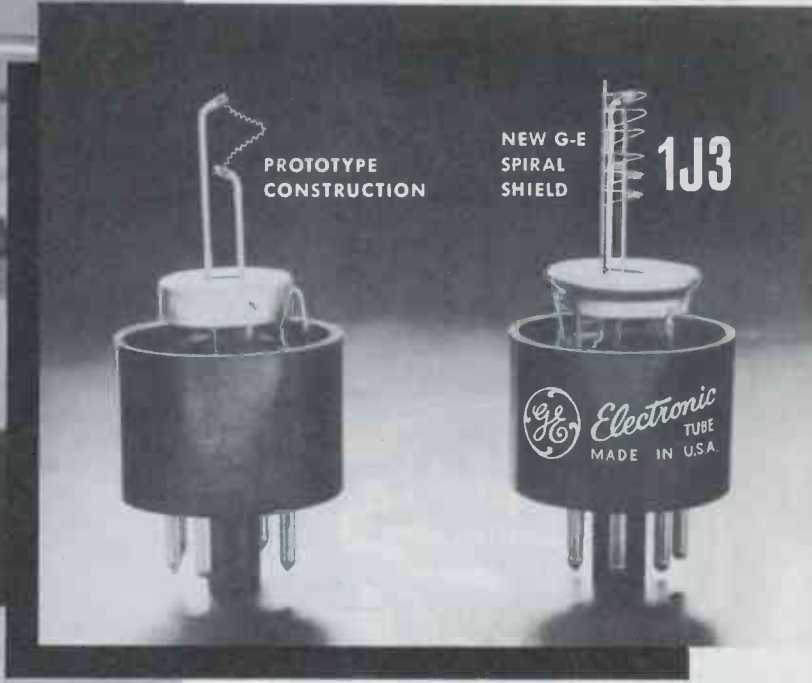

IMMACULATE CLEANLINESS marks the assembly of all General Electric Tubes. Lint and dust—common causes of tube shorts—are banned by the use of lint-free white garments by all workers . . . by cleaning floors frequently and with special care . . . by filtering and conditioning the air.

YOU CAN SEE WHY the Service-Designed 1J3 out-performs its prototypes! The new spiral-wound filament shield (right) won't bend from electrostatic pull. Filament distortion, and the shorts it causes, are cut 'way down. The 1J3 takes high peak anode voltages in stride!

CUT CALLBACKS WITH NEW G-E SERVICE-DESIGNED 1J3 HV RECTIFIER TUBES!

Customer complaints from rectifier-tube failures will drop sharply once you install new General Electric Service-Designed 1J3's. These tubes will stand up under the severe peaks common both with high line voltages, and where TV sets employ exceptionally high picture-tube voltages.

Every Service-Designed 1J3 is tested at 23,000 volts DC, 28,000 volts inverse. The tube is interchangeable with the 1B3-GT, and priced the same.

Two other new Service-Designed Tubes will cut your callbacks, build owner goodwill, increase your business—the 6AF4 and 6AF4-A. They're two bulb sizes of General Electric's sensational new UHF triode that once installed, *remains efficient* . . . no excess snow, no sudden loss of picture!

Now, 25 Service-Designed Tubes—all with su-

perior performance. And Service-Designed Tubes cost no more! Order from your G-E tube distributor! *Distributor Sales, Electronic Components Division, General Electric Company, Owensboro, Kentucky.*

G-E HIGH-QUALITY, LOW-CALLBACK SERVICE-DESIGNED TUBES INCLUDE:

1B3-GT	6AF4	6BG6-GA	6BX7-GT	6SN7-GTB
1J3	6AF4-A	6BK7-B	6BZ7	12SN7-GTA
1X2-A/B	6AL5	6BQ6-GA/6CU6	6CB6/A	25BQ6-GA/25CU6
5U4-GB	6AV5-GA	6BQ6-GTB	6CD6-GA	25BQ6-GTB
5Y3-GT	6AX4-GT	6BQ7-A	6J6	25CD6-GB

Progress Is Our Most Important Product

GENERAL  ELECTRIC

CDR ROTORS

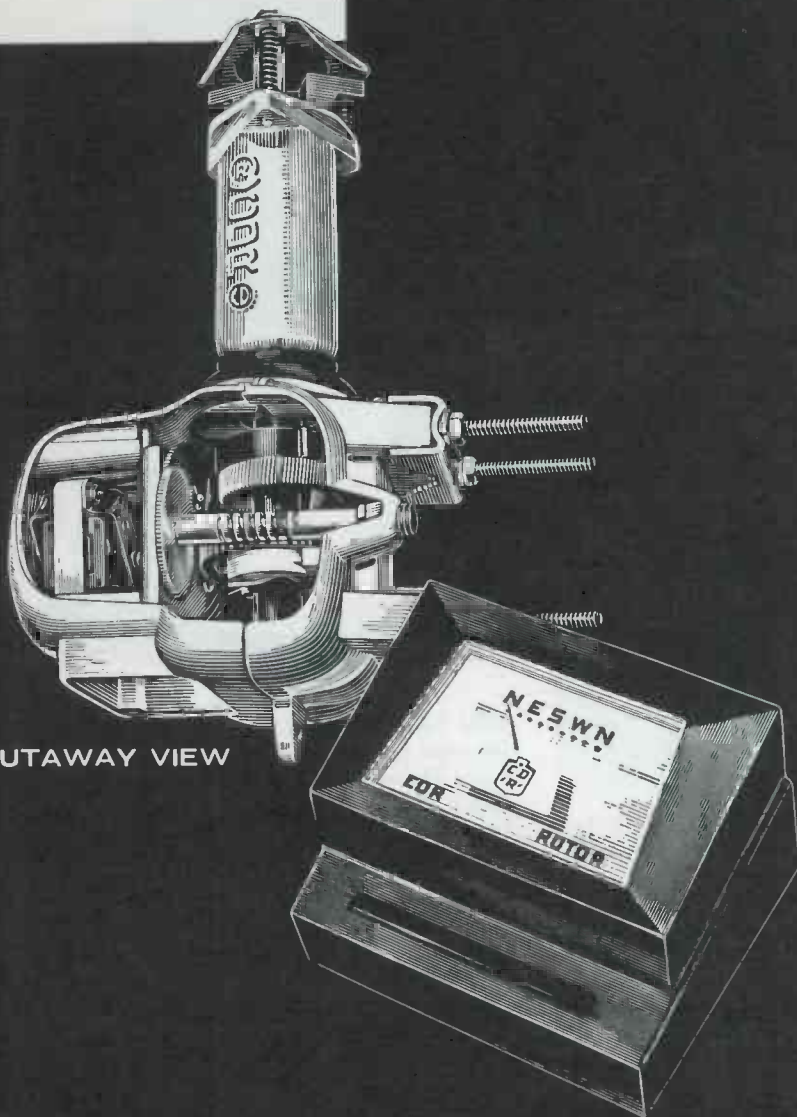

CUTAWAY VIEW

All new features

Completely designed from the ground up, CDR Model TR-15 and TR-16 Rotors have features never before available in the popular price range. Check these refinements and you'll see why: Quick mounting mast collet... speedy installation (no loose parts to assemble)... self-centering sawtooth clamps take masts up to 1½" O.D.... instant locking prevents drift... mechanical brake releases magnetically... instantly reversible... makes complete revolution in 45 seconds... meets JAN salt water test... great strength thrust bearing support... low weight... completely weather-sealed... fits standard towers... streamlined to reduce wind resistance... mahogany or blonde finish control box. Get full details today from your local CDR distributor.

CORNELL-DUBILIER ELECTRIC CORP.
South Plainfield, New Jersey

THE RADIART CORPORATION
Indianapolis, Indiana



CDR

Antenna Rotors

Old Hands at Dependability

Navy, and woe be it to any plebeian who dares to cross its portals! Pekinese and dachshunds have free access, but TV men must enter through the cellar—and what cellars they are! I was wandering around down there in the bowels of the earth for ten minutes before a fellow in dress blues took me in tow and deposited me in front of the right elevator.

The car was at the landing; I entered and gave the indoor jockey my destination. "Oh! 10A, is it? He's one of the richest men in the country. Matter of fact, he just bought four uranium mines. But watch your step with his English butler! That gink runs the whole show." I stowed away this bit of incidental intelligence, disembarked at the tenth floor, and pressed the buzzer of Apt. 10A.

The service ticket read, "Could not help this party. Master antenna trouble." But over the phone, the customer had complained of "rudeness and high-handed treatment." The antenna system was maintained exclusively by contract between the real estate operators and another company. Provisions of this contract precluded any other agency from servicing the system.

The door was opened by an immaculately-attired individual who, from his faultlessly-gathered black bowtie to his creased, striped trousers and well-tailored morning jacket, had all the earmarks of a maitre de. I pegged him at once for the "gink who runs the whole show."

I introduced myself, and his eyebrows snapped to attention as he said, "Oh, you're from the television people! My word, I am glad it's not that other fellow. Beastly chap, you know, quite rude and all that sort of thing. This way, if you please, the machine is in the Master's bedroom."

I followed him into a large room, tastefully decorated in the modern trend. The set, a Philco 21" table model equipped with remote tuning, was located against a wall, about ten feet from, and facing, the bed. The remote cable ran in back of a molding, completely concealed, to a side table within easy reach of the bed's occupant. There, it terminated in

a tuning box having a remote speaker assembly in addition to the usual controls for off-on, volume, brightness, and fine tuning.

The antenna outlet was directly in back of the set about a foot from the floor. Coaxial cable and fittings were used between it and the set. The cable lay on the floor, unconnected at the outlet. The butler, hovering at my shoulder, explained that the antenna maintenance company had disconnected it, having tested the outlet the day before and given it a clean bill of health. Their man had left the cable unconnected to indicate, he said, that the trouble must be in the set. (The connecting cables are not part of the antenna system, per se; they are considered part of the set.)

The set was afflicted with "snow" on all channels. I disconnected the cable and matching transformer from the set and touched the antenna post with a finger. There was a considerable reduction in the amount of "snow." I took the cable over to the window to inspect it in a better light. The inspection revealed nothing. I dug out the ohmmeter and checked for continuity of the inner conductor, and for a possible short between it and the shield. That did it—the needle swung to zero. I began stressing the cable at the male end, and as I applied pressure at the tip the needle swung back to infinity, only to return to zero when the pressure was removed. With a soldering gun I removed the male connector (quite a feat, in itself!) and shortened the cable about two inches before reconnecting it. The short was gone and the set came to life without "snow." In soldering the inner conductor to the male tip, it is most important not to apply too much heat. The polystyrene insulation begins to melt and a short ensues if too much heat is applied.

When our man was there, a couple of days previous to my visit, the complaint had been, "erratic behavior," to use the description of the butler. Our man had noticed a lack of solder at the tip of the male connector, and had set about supplying that lack with his trusty soldering iron. The results you already know. The

CORNELL-DUBILIER CAPACITORS

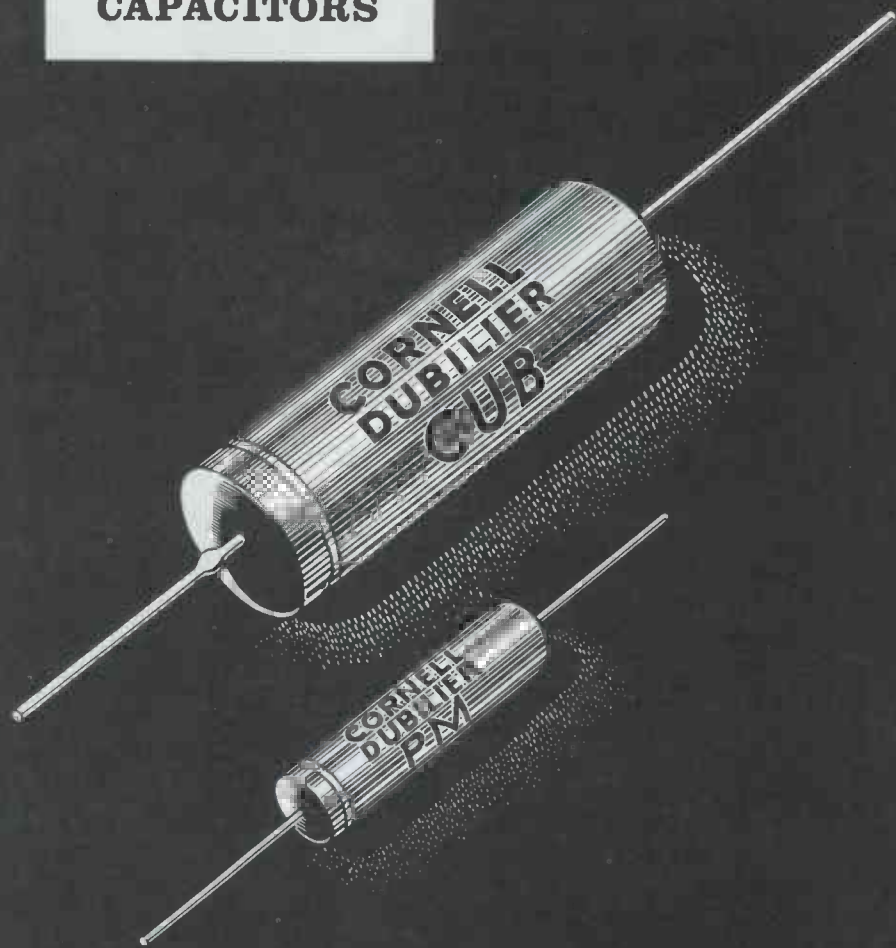

Thoroughbreds when the heat's on

Here are two types of C-D tubulars so thoroughly entombed in high-grade plastic that they're virtually unaffected by heat, cold and humidity. And, because they employ superior dielectrics, these capacitors have a 15%-25% greater voltage breakdown margin. That makes them the ideal replacement capacitors on all servicing jobs.

The C-D CUB, shown, is available with HT COMPOUND or DYKANOL "C" dielectric. The C-D PM utilizes the superior dielectric qualities of DUPONT "MYLAR." Both types maintain excellent electrical characteristics at high temperatures.

For a lasting service job, use C-D CUBS or PM'S. Your local C-D distributor carries complete stocks. For full data, ask for catalog 200D-3, or write Cornell-Dubilier Electric Corporation, South Plainfield, New Jersey, Dept. PR-68



CORNELL-DUBILIER CAPACITORS

Old Hands at Dependability

RADIART VIBRATORS



Consistently dependable power

Next time an auto-radio vibrator replacement is called for, try Radiart. There's a complete line for all 6-volt and 12-volt applications. And no waiting for the type you want, because your local Radiart Distributor maintains a full stock for your convenience. Ask him for your free copy of the Radiart Vibrator Replacement Guide, or write to Dept. S-1, The Radiart Corporation, Indianapolis 5, Indiana.



RADIART TOBE Vibrators

Old Hands at Dependability

butler had complained to him that the set was worse now than when he had arrived, and he had flip-pantly retorted, "Look Bud, you have a bad antenna situation. I can't give you a complete electronics course in ten minutes. You do the butling and leave things you don't understand to those who do!"

The butler had got his back up at this "brush off," and apparently still had it up. I passed it off with, "He really is a fine technician—one of our best—but he has been having more than his share of domestic troubles lately. His wife just won a neighborhood beauty contest, and won't let him forget how lucky he was when he got her to say yes."

"Oh, I say, I do pity the blighter. I didn't know! Women can be such shrews, you know. My third wife almost drove me to a hermitage, but I keep hoping that some day I'll meet the right girl. The only trouble is, I don't see how I shall be able to afford her, what with paying alimony to her three predecessors and all!" And we think we have troubles!

Technical Doubletalk

Everyone is probably familiar with the "high pressure" sales pitch, and most of us thoroughly despise the technique. We don't like to have our intelligence insulted! When carried over into TV servicing, "high pressure" tactics can disenchant and lose more customers faster than halitosis ever did. Take, for instance, "The Case of the Missing Channel." The set, a 630 custom job, had been serviced for "weak sound on channel 9."

In adjusting the oscillator slug in the Standard Coil tuner, the serviceman lost it in the coil, having turned it past the point where



the guide spring meshed with the slug's thread. This meant removing the chassis from the cabinet, and then the channel-9 oscillator strip from the tuner to recapture the slug. In this custom assembly, that's quite a job. Instead, he reverted to a trick he had learned elsewhere, adjusting the channel-10 oscillator coil so that it would be used instead of channel 9! He explained the discrepancy of the numbers with, "The new building activity of the neighborhood has changed the antenna pattern for this street."

The customer's wife bought this line, but her husband raised the roof with her that evening, and with our office the next morning. We had to get over there, fast, to rectify matters.

Watch Out for Mr. Messy

If a "messy mechanic" inveigles his way into your employ, there isn't much you can do to repair the bad reputation he engenders. We paid \$50.00 for a rug which was ruined by a hot soldering iron, but still we lost the customer—and some of her friends.

In another case, the customer left things just as they were when our "messy mechanic" left her home. She came over to the shop and insisted that someone accompany her to see the "mess." The back was on the floor, the high voltage cage was off and stuck into the speaker compartment, and slivers of solder were imbedded in the flooring.

We find that prevention is the only remedy for handling situations like this. For the first week all new men are accompanied by the service manager. Thus, we find out how they operate, and the "messy" ones either mend their ways pronto, or they are politely dropped! ▲

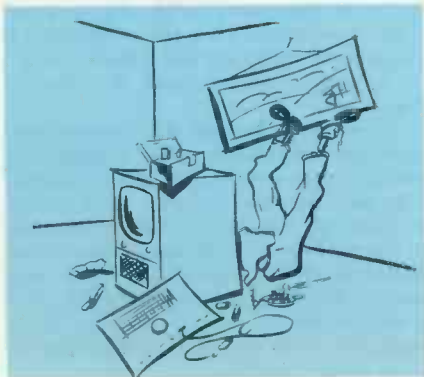

TOBE SERVICE CAPACITORS

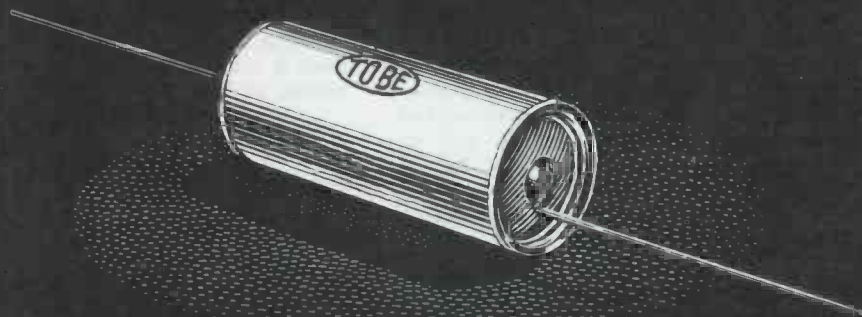

Designed exclusively for service

Tobe Service Capacitors are the only capacitors literally "designed from the ground up" to meet the exacting requirements of modern radio and TV servicing. Before a capacitor was ever produced, Tobe engineers determined the ideal characteristics—then borrowed from their 36 years experience in the design and manufacture of high-quality commercial and industrial types. Result: capacitors like the plastic-sleeved streamlined "Jets" that stand up in the toughest circuits.

You owe it to yourself to try Tobe Service Capacitors on your next job. The line is complete—and they cost no more! See your Tobe Distributor today for full details or write Tobe Deutschmann Corporation, Distributor Division, 2900 Columbia Ave., Indianapolis 5, Ind.



TOBE
RADIART
CAPACITORS

Old Hands at Dependability

the troubleshooter

answers your service problems

Picture Bends

I am servicing a General Electric Model 17C103 with a bend in the picture. On one station (Channel 2) it weaves slowly, beginning at the bottom and slowly working up through the picture. The hints given in your "Suffering From the Bends" article in the January, 1958 issue have been carefully followed, but the trouble has not been completely cured. I have checked all filters and have replaced two of them, and all tubes have been checked by substitution.

LOREN TIMBERMAN

Springfield, Ohio

It sounds as though hum interference is getting into the horizontal AFC and oscillator circuits, so the tests you have made thus far have been on the right track.

Have you tried substituting more than one tube at a time? This is sometimes necessary because two or more tubes in the same set will occasionally develop heater-to-cathode leakage. The symptoms are the same as if the leakage were present in only one tube.

Try to save some time on this stubborn problem by isolating the trouble to either the RF-IF-video or the sync-sweep portions of the set. This is done by disconnecting the input to the sync circuits (at the point marked with an X on the diagram), and seeing whether or not you can momentarily bring in a bend-free picture by careful adjustment of the controls. If you can make the bends disappear, the trouble is probably ahead of the sync amplifier.

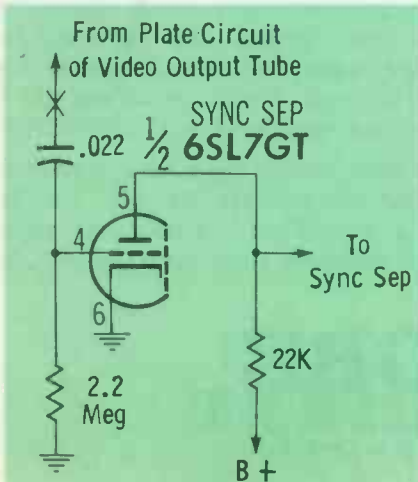

Unusual Instructions

While working on an Emerson Model 686F, I found a notation on the "Photo-fact" schematic that said, "Picture tube removed for measuring voltage and resistance." This is the first time I have run across any instructions of this kind. What is the reason for this note, and does it mean physical or electrical removal, or both?

PAUL J. TATE

Wattsburg, Pa.

The note means that the tube was removed both physically and electrically from the chassis. This was done to eliminate the shock hazard presented by the metal picture tubes used in many Model 686F sets. Voltage readings should be about the same whether the picture tube is left in place or removed.

Ion Trap Placement

I have just put a new RCA 24VP4A picture tube in a Philco Model 24B6104. When I reinstalled the original ion trap, I had to move it up against the picture tube base to get maximum brightness. What causes this unusual situation? Is it all right to leave the ion trap in this position, or should I get a magnet of less strength as a replacement?

STEVE GRESKEVITCH

Elm Grove, W. Va.

This condition is not too unusual, especially when there is some slight difference between the original and replacement picture tubes. The new one which you installed may be a "compromise" type designed to work satisfactorily in place of a 24CP4A, 24VP4A, 24TP4 or 24ADP4; in this case, the ion trap magnet might well have to be placed in an unusual position even though no defect is present in either the tube or the magnet.

You might try using an adjustable magnet (such as J. W. Miller 6295) to see if you can get an improvement in performance; however, the old ion trap, adjusted to produce maximum brilliance, should give satisfactory results.

Low B+

I am having considerable difficulty getting sufficient width in a Motorola TS-52 chassis. The flyback is an auto-former with no width control. The voltage from the B+ power supply, meas-

ured at the speaker field input terminal, is supposed to be 275 volts; but I read only 150 volts at this point, with all other B+ voltages proportionately low. Would that cause the condition I have described?

I have checked many capacitors and resistors, and have tried new filter capacitors with no effect. I also checked the two selenium rectifiers in the B+ supply and even retested them with no increase in voltage.

C. BERNARD SMITH

Paradise, Calif.

Correcting the B+ trouble should definitely take care of your width problem. Instead of transposing the selenium rectifiers, try substituting a new pair; both units may be bad even though they might have checked OK. If new rectifiers don't restore B+ to the normal value, you probably have a short somewhere in the B+ system. Disconnect first one branch of the B+ circuit and then another until the voltage comes up to normal. The last branch disconnected will be the one to check for shorted components or leakage to ground.

Pie-Crust Effect

I am having trouble with an Emerson Chassis 120144-B which employs a metal picture tube. The symptom is a displacement of horizontal lines or pie-crust effect, and the trouble persists even though I have made extensive checks in the horizontal oscillator and AFC stages.

On the top of the picture-tube rim are two metal clamps which are part of the hardware used to fasten the picture tube to the chassis. Scraping a metal screwdriver blade across these clamps seems to aggravate the trouble. I cleaned all the insulators on the bell of the picture tube, but this did not clear up the condition; nevertheless, I still suspect that the distortion of the horizontal lines in the picture could be due to high-voltage arcing around the face of the picture tube. If this is occurring, how can I eliminate it?

R. W. GREGWARE

Troy, N. Y.

If possible, try substituting a 5AXP4 or 8XP4 check tube for the metal picture tube. Your suspicions will be borne out if the pie-crust symptoms do not appear on the check tube, and then you can keep on checking for trouble in parts associated with the original CRT. You might cure the symptom by completely replacing the plastic "boot" or mounting ring around the face of the tube.

Arcing in or around the high-voltage cage can sometimes cause a symptom similar to pie-crust effect in the picture. You may be able to locate such arcing visually by making a close inspection of the receiver in a darkened room. The 500-mmf, 20-kv high-voltage filter capacitor could be arcing internally, and it should be replaced if it heats up in operation or if you are not sure that it is in good condition.

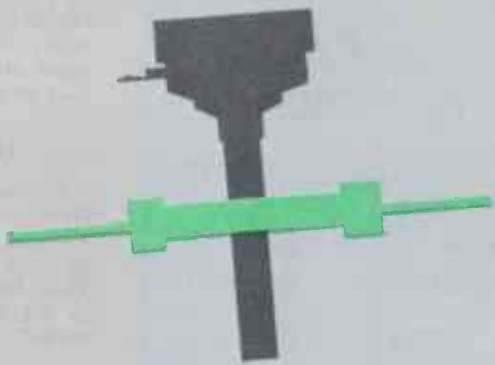

CLAROSTAT

RESISTORS
CONTROLS
POTENTIOMETERS
SWITCHES

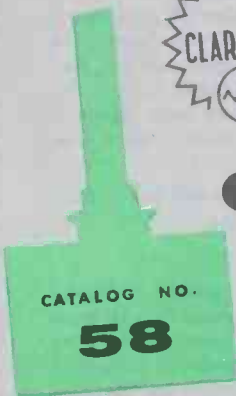

BRAND NEW

32 pages of Clarostat potentiometers, rheostats, switches, resistors, and resistance devices. Many new items. Everything shown and described in detail. If you work in electronics, radio or television, you can't afford to be without the new Clarostat catalog. Ask your Clarostat distributor for your free copy . . .



Controls and Resistors

CLAROSTAT MFG. CO., INC., DOVER, NEW HAMPSHIRE

In Canada: **CANADIAN MARCONI CO., LTD., TORONTO 17, ONT.**

TRANSISTOR RADIO REPAIRS NOW EASY!



with this

NEW *Howard W. Sams* BOOK

"SERVICING TRANSISTOR RADIOS"

COMPLETE ANALYSIS OF 70 POPULAR TRANSISTOR RADIO MODELS

includes new General Motors (Delco) Transistorized Auto-Portable Radio

Also Valuable Section— "BASIC POINTERS ON SERVICING TRANSISTORIZED RADIOS"...

COVERS LATEST MAKES AND MODELS

This book helps you earn big profits on Transistor Radio repairs—gives you complete, time-saving information—helps you become an expert on transistorized radios! Complete data on 70 latest models is based on actual lab analysis of each set. You get the famous Sams Standard Notation schematics—accurate, big, legible; full photo views of each chassis, with all components identified; complete alignment instructions; complete parts lists with full replacement data—everything you need to be successful in fast-growing transistorized radio servicing. Here's a "must" book for your bench. Order it now!

152 pages; 8 1/2 x 11" \$2.95
PRICE ONLY.....

SEE THIS BOOK AT YOUR SAMS DISTRIBUTOR OR MAIL COUPON

FREE TRIAL COUPON

Howard W. Sams & Co., Inc., Dept. 3-FFB
2201 E. 46th St., Indianapolis 5, Ind.

Send me Sams "Servicing Transistor Radios" for 10 days FREE examination. In 10 days I will pay for the book, plus few cents delivery cost, or return postpaid.

We pay delivery costs if you remit with this coupon; same return privilege.

Name _____

Address _____

City _____ Zone _____ State _____

(Outside U.S.A. priced slightly higher)

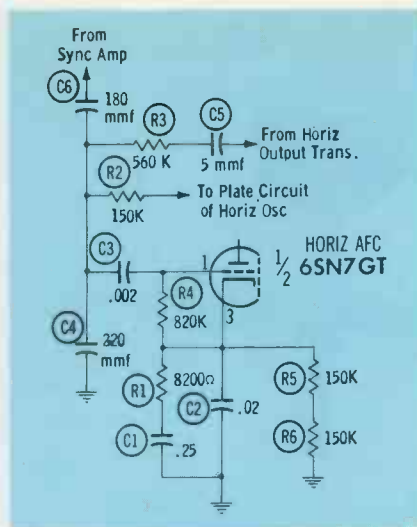

Another?

Our shop has taken in a Hallicrafters Model 680 in which parts of the picture take on a jagged appearance. The same effect appears in the edges of the raster. We've replaced a number of capacitors, including all those in the horizontal AFC and oscillator stages, but get nowhere. With the brightness control retarded, the effect is not bad; when it is advanced, the trouble is worse. Can you suggest a cure?

JAMES I. MILLER

Chetek Sales and Service
Chetek, Wis.

Your trouble may be due to high-voltage arcing, as discussed in the previous item. It is also possible that the AFC stage is not working properly, even though all capacitors in the circuit seem to be in good condition. Referring to the diagram, double-check R1 and C1. Malfunction of this RC combination (the anti-hunt circuit) is one of the most common causes of the jaggedness in the picture which we know as pie-crust effect.

It is a good idea to use a scope to check the signal being delivered to the AFC tube by the sync amplifier. If appreciable amounts of video, hum or noise are present in this signal, they will tend to interfere with AFC operation. Disconnect R2 and R3 from the AFC grid circuit and attach a low-capacitance probe from the scope to the junction of C3 and C4. The signal at this point should be composed mainly of clean sync pulses.

Tape Squeak

On my tape recorder, a squeaking noise comes from the supply reel during playback, especially toward the end of the recording. What can be done to cure this?

KASMIER J. KULESHA

Teaneck, N. J.

One edge of the tape is probably rubbing against the outer edge of the supply reel as the tape unwinds. You may be able to eliminate the noise by changing the height of the supply reel relative to the tape guides. (Do this by adding or removing shims underneath

the supply spindle.) Also be sure that this spindle is perfectly parallel with the tape guides and is not wobbling on its axis. In addition, any warped reels should be replaced with good ones. You might benefit from trying different types of reels to see which ones work best on your machine.

Hot-Chassis Servicing

Although an isolation transformer is recommended for servicing "hot-chassis" TV sets, it is too much of an extra load to carry on home service calls. Can a VOM be used on a transformerless set in the home without damage to the meter?

JAMES KOLOCOTRONIS

No Picture No Sound
TV-Radio Service
University City, Mo.

Yes, you can use a VOM on a transformerless receiver without injuring the meter—as long as you don't permit contact between earth ground and metal parts of your instrument. But beware of "tickles" from the TV chassis and from exposed metal parts on the meter.

The VOM is relatively safe for use with an unprotected chassis because this type of meter is self-contained and affords no return to the AC line. But AC-powered test equipment (with line cord) is dangerous to use on a "hot" set because there is a risk of causing a direct short across the power line. Many people have been getting by with using a VTVM or scope on a non-isolated radio or TV chassis, since most test instruments are transformer-powered and thus provide their own isolation. But suppose that some defect should develop in the test equipment, allowing severe leakage between the power line and the chassis? If you happen to insert the AC plug a certain way and then connect the instrument chassis to a "hot" TV chassis—POW!

No High Voltage

A Silvertone Model 106 has no high voltage. The cathode resistor of the horizontal output tube overheats, and the cathode and grid voltages are both approximately 100 volts DC. Screen voltage is correct, and a normal arc is present at the plate cap. Turning the horizontal drive trimmer has no effect on the grid voltage, and the signal at the grid measures only 8 volts p-p. The flyback checks OK, and the horizontal output and damper tubes have been substituted without success.

HARRY L. MERCER

Mercer TV Service
Greensboro, N. C.

The horizontal output tube is over-conducting, probably because of a lack of proper drive signal. The waveform at the grid should have an amplitude of over 50 volts p-p instead of the 8 volts you measured. Remove the output tube from its socket and recheck the drive waveform; if it is still low in amplitude, look for trouble in the oscillator circuit or in the coupling circuit between oscillator and output stages.

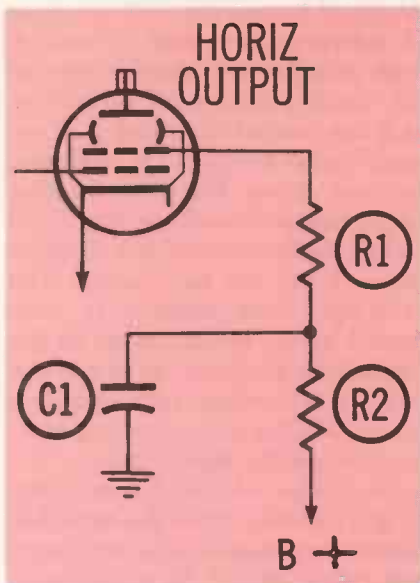

Snivets!

On a 17" Crosley Model F-17TOLU, reception on UHF Channel 17 is always accompanied by what appears to be Barkhausen oscillation, except that the interfering line is about 4 inches from the right side of the picture. This line is present whether or not I use an antenna. I have tried different 6AF4 and 6T4 tubes, have checked shields and shielded leads, and have tried placing an ion trap on the 6BQ6 horizontal output tube, but have accomplished nothing toward solving the trouble.

DON THOMPSON

Buffalo, N. Y.

Your problem sounds like a rousing case of snivets. This effect results when some oscillation within the receiver is picked up by the tuner. In your case, it is probably riding in on the antenna lead to the UHF tuner. One approach to the problem is to prevent pickup of the spurious signal on this lead. Try various combinations of the following: Shorten the lead, dress it away from the chassis and picture tube, or shield it.

The alternative remedy is to remove the snivets at their source. They may disappear if you replace the horizontal output tube with one in which the "knee" in the plate-current characteristic curve occurs at a less critical point. (Since this "knee" varies among individual tubes of a given type, you might try several different tubes of the same type as the original.)

In some cases, you can kill snivets by slightly rewiring the screen circuit of the horizontal output tube as shown in the diagram. Replace the dropping resistor with two separate units, R1 and R2, and connect the screen bypass capacitor C1 to their junction. At first, make R1 equal to 1000 ohms and use whatever value of R2 is necessary to make the sum of R1 and R2 equal to the value of the original resistor. This arrangement introduces some degeneration at the screen grid. Better results may be obtained at times by raising the value of R1 and lowering that of R2 accordingly. ▲

Because You Demand Jerrold Quality In UHF Converters

... we proudly introduce

ULTRACON

Your Choice of 2 Models Featuring:

- **PRESELECTION**—a "must" in 2-channel areas, UHF or VHF.
- **COAXIAL TUNING**—for no drift-stability, low noise operation, no wiping contacts.
- **LONG LIFE OPERATION**—newly developed 6AF4A oscillator tubes, low noise mixer-diodes.
- **VERNIER TUNING**—coupled to slide rule dials for easy station selection.

ULTRACON

MODEL TCU

for quality reception in normal signal areas. Lowest noise figure over entire UHF band of any similarly priced converter! Handsomely styled cabinet.

\$22.95 list

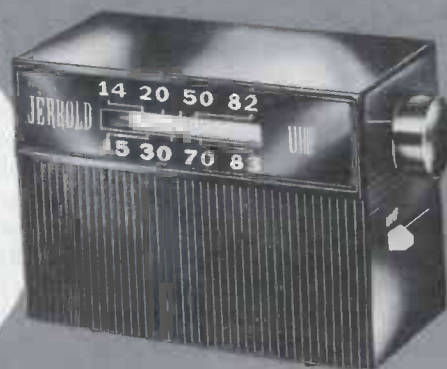

ULTRACON DE LUXE MODEL FTC

for excellent reception in areas where other units don't work. Combines high-gain amplification with low loss circuitry. Built-in UHF antenna. Matched Impedance. Handsome mahogany or blonde cabinet.

\$39.95 list



"Radar Designed" dual cavity tuner is the heart of DE LUXE ULTRACON. Completely sealed unit contains nothing to cause noise!

For full information, see your Jerrold distributor, or write:

JERROLD

ELECTRONICS CORPORATION

Dept. PD 57 • 15th & Lehigh, Philadelphia 32, Pa.

Jerrold Electronics Corp., Ltd., Toronto, Canada
Export Representative, CBS International, New York 22, New York

LOOK TO JERROLD FOR AIDS TO BETTER TELEVIEWING

June, 1958 • PF REPORTER 37

PHONO - CARTRIDGE REPLACEMENT

by Calvin C. Young, Jr.

what you should know to do the job right

Testing the Cartridge

The first step in *any* replacement procedure should always be a critical evaluation of the suspected component—the phono cartridge is no exception. Just how do you “go about” testing a cartridge? Well, it depends on the type of cartridge and the instruments you have available. Needed items are a stylus inspection microscope (50 power or more), an audio test record which has bands of pure audio tones at various sound intensity levels, and a sensitive AC-VTVM.

Since your audio test record must be dependable to the *nth* degree, never use it with a needle which is not known to be perfect. The first step, therefore, is to check the customer's stylus and replace it with a new one if it shows *any* wear at all. This eliminates the possibility of damaging the test record (or further damaging those owned by the customer) and at the same time corrects for reduced output caused by a defective stylus.

The next step is to check the cartridge output voltage. With the cartridge supported in the tone

arm, place the test record on the changer and check the voltage output across a load resistor as shown in Fig. 1. A sensitive scope (10 millivolts/in.) can be used in lieu of the AC-VTVM. With the scope gain at maximum, a variable-reluctance cartridge should produce a trace from 1" to 3" high at the test frequency of 1,000 cps. This corresponds to the equivalent .01 to .03 volts which will be registered on the AC-VTVM. The output voltage of ceramic cartridges is generally between .5 volts and 1.2 volts, while the output of crystal units will vary from about .5 volts to 5 volts. Generally speaking, the cartridge used in systems having push-pull audio output stages will have outputs of 1 volt or less, and the cartridge used in the 2- or 3-tube, 3-speed player will have between 2 and 5 volts output.

In case you don't have either a high gain scope or a sensitive AC-VTVM, the cartridge output can be tested using the setup shown in Fig. 2. The amplifier may be either the one in the customer's system, or a test unit of your own. The important thing is that it be

designed to operate with the type of cartridge you wish to test. A high gain preamp stage is needed for testing magnetic cartridges, and the correct cartridge load resistor must be used. In addition, be sure to set the tone controls to the flat or zero-db positions and switch in the correct equalization network for the test record. The cartridge load resistor is connected across the cartridge in the customer's amplifier, so if you are using a laboratory test amplifier, make sure the corresponding component has the same value.

The value of the dummy load (Fig. 2) should equal the amplifier output impedance, and the wattage rating should be equal to or better than the power output rating of the amplifier. The output of the cartridge should be enough to drive the amplifier to its full output level. If you are using the customer's amplifier for the test, or if you have the correct equalization for the cartridge, test the output voltage at several other frequencies between the lowest and highest handled by the cartridge. The frequency response of the better ceramic and crystal units will extend from 50 cps to 10,000, 12,000 or even 15,000 cps, while the response of the high output cartridges used in the small 3-speed players will be limited to the range of 50 or 75 cps to 7,000 or 8,000 cps. The range of magnetic or variable-reluctance units will extend to 20,000 cps in some cases, and will usually respond to at least 15,000 cps.

Selecting the New Cartridge

Naturally, one of the first considerations in choosing a replacement is whether or not the cartridge will fit into the pickup arm. In the “will-fit, won't-fit” category are mounting centers, cartridge length, cartridge width, clearance for front turnover knob, hole in top of arm for needle turn-around knob, and weight.

If the existing cartridge employs a front turnover knob, the same style should be used for replacement purposes to avoid the unsightly hole which would be visible in the end of the tone arm. The same thing goes for cartridges with the top knob. Some tone arms, designed for miniature cartridges, are very narrow through

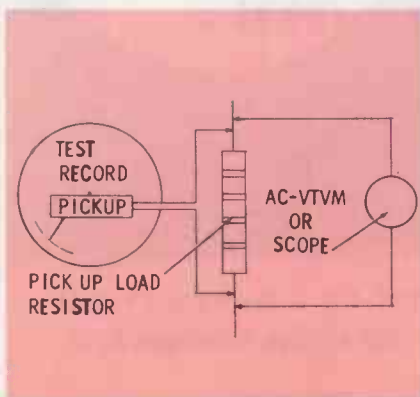

Fig. 1. Test setup for checking cartridge output with a VTVM and test record.

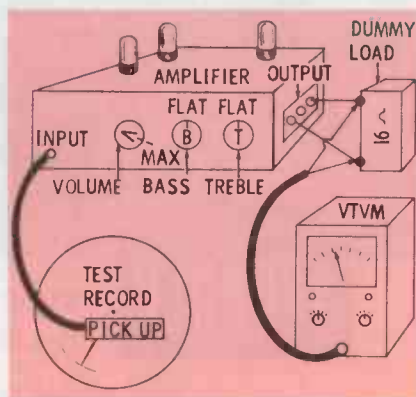

Fig. 2. Alternate test setup involves use of test record, amplifier, and VTVM.



Fig. 3. Use of 2½" screwholding screw-driver speeds installation of cartridges.

the cartridge mounting area and naturally will not accommodate the larger cartridges. Even when there is enough room for the cartridge, its mounting centers usually won't match the tone arm facilities. The two most common mounting centers for phono cartridges are ½" and ⅝", and some are designed to be used with either.

The needle size is another physical consideration, there being four styles in current use; the .7 mil, 1 mil, 2.5 mil and 3 mil. The .7-mil size is being used in all of the new stereo 45/45 cartridges, the 1-mil sizes for LP (33 or 45 rpm), the 3 mil for 78 rpm and the 2.5 mil is used in non-turnover type cartridges for 3-speed players. The 1-mil and 3-mil combination is employed in 3-speed turnover cartridges. The needle material (osmium, sapphire, and diamond) affects only the life expectancy of the needle.

In addition to the physical aspects just mentioned, the frequency response and output voltage of the cartridge must be considered. You can't replace a 5-volt output cartridge having a 75-to 7,000-cps range with one having a .5-volt output and 50-to 15,000-cps range without introducing severe troubles. The power output will be greatly decreased,

and distortions (hum pickup) will be introduced. By the same token, replacing a .5-volt output, wide-range unit with a 5-volt, narrow-range unit will result in overloading and reduced frequency response.

What About Stereo?

Since stereo records are now on the market (more than a dozen record manufacturers have obtained cutters based on the Westrex 45/45 system), question your customers regarding their future intentions toward stereo-disc operation. Anyone intending to convert to stereo within 3 to 6 months should be sold one of the new stereo cartridges. These are offered by most cartridge manufacturers and are fully compatible with monaural systems. As a matter of fact, monaural performance will even be improved in many instances.

Installing the New Cartridge

Once the replacement cartridge has been selected, the hard part is over, and only the physical installation of the new unit is necessary to complete the job. In this respect, there are a couple of hints that will help you to avoid trouble.

Heat is the enemy of all cartridges, and temperatures above 45°C (113°F) will ruin a crystal; therefore, make it a rule never to solder anything on a cartridge. If the wire breaks, remove the terminal connector before attempting to resolder the junction.

Some tone arms don't raise high enough to permit a standard ⅛" × 6" screwdriver to be used in installing the new cartridge. Even if it does, you may have trouble getting the screws started because they are so short. Use of the 2½" screwholding screwdriver shown in Fig. 3 is an answer to both problems. The tool is useful on all screws from No. 00 to No. 3.

The last point we want to cover is tracking force. Regardless of whether an exact replacement is used or not, always check to make sure that the proper tracking force for the new cartridge is being applied. If it isn't, the cartridge won't work right and distortion, low output, excessive needle wear and damage to the records will be the result. ▲

the **ALL NEW**
SENCORE
Align-O-Pak
TV
BIAS SUPPLY

Another Sencore Time-Saver

For **BLACK and WHITE**
and **COLOR**

Just Dial any DC Voltage from 0 to 18 volts positive or negative—For AGC trouble shooting and alignment—Do away with messy bias batteries.

Completely isolated. Recommended by TV manufacturers. Wire wound control for calibration accuracy. For AGC trouble shooting, connect to AGC buss and vary voltage from 0 to 18 volts negative. If picture stabilizes at any voltage, AGC is defective. Complete with test leads. **MODEL BE3**

SENCORE

Dealer Net
Leather Carrying Case...\$2.95

Mfg by

SERVICE
INSTRUMENTS CORP.
171 OFFICIAL RD. ADDISON, ILL.

POPULAR SENCORE PRODUCTS

- Transistor Tester
- Leakage Checker
- Filament Tester
- Handy "36"
- Vibra-Dapter

\$785

Seeing Double?

SURE... THEY LOOK ALIKE
BECAUSE
THEY ARE EXACTLY ALIKE

Each Merit product of the same type is exactly the same as another—both in construction and appearance.

COMPARE IT WITH
MERIT

Take a Merit product off the shelf. Compare it with any other similar product on the market. You'll find Merit is superior!

COMPARE IT WITH
MERIT

MERIT COIL AND TRANSFORMER CORP
MERIT PLAZA . HOLLYWOOD, FLORIDA

notes on TEST EQUIPMENT

Informative reports from the lab

by Les Deane

Troubleshooting Generator

The piece of equipment shown operating in Fig. 1 is a product of B & K Mfg. Co. of Chicago. Referred to as the Model 1075 "Television Analyst," the instrument is capable of generating RF, IF, or video signals which will reproduce pictures or patterns on the screen of any TV receiver. In addition to being a portable TV transmitter (by means of a flying-spot scanner mechanism), the generator also develops all the necessary test signals for use in a complete signal substitution technique to isolate trouble in a defective receiver.

Specifications and features are:

1. **Power Requirements**—117 volts AC, single-phase, 60 cps; line fuse and "Off-Standby-On" switch with panel indicator pro-

vided.

2. **RF Output**—video-, sound-, and sync-modulated carriers for all VHF channels (2 through 6 on fundamentals and 7 through 13 on harmonics); RF attenuator and horizontal frequency controls provided.

3. **IF Output**—video-, sound-, and sync modulated carriers for IF ranges of 25 and 45 mc; continuous tuning provided on front panel.

4. **Video Output**—video-sync signal of either polarity available at separate output jack, terminal-voltage limitation 350 volts; polarity switch and video control provided.

5. **Sound Output**—Internal 400-cycle modulation of FM carriers, 400-cycle tone signal also available at separate jack; in-

put jack for external audio modulation on front panel; additional output jack for 4.5-mc signal with internal or external modulation; gain control for external audio source provided.

6. **TV-Sweep Output**—vertical and horizontal driving pulses available at separate output jacks; horizontal frequency control on front panel and vertical amplitude control on side panel.

7. **Color Output**—RF, IF, or video frequencies modulated by crystal-controlled offset color sub-carrier; rainbow signal also available at separate jack labeled "3.58-mc Color—4.5-mc Sound;" on-off switch for color rainbow display on front panel.

8. **Other features**—complete set of pattern slides, test leads, RF-IF cable, and special self-gripping probe tip are supplied with instrument.

I put the Model 1075 "Analyst" through its paces on some TV test chassis and found it to be a very different and interesting piece of equipment. In general, the unit is designed to be used in troubleshooting a receiver by signal substitution. The instrument generates all the necessary signals, including RF, IF, video, sound, sync, and vertical and horizontal drive.

To supplement the list of specifications and familiarize you with the instrument's operation, the front panel is shown in Fig. 2. On the left side of the case, there are

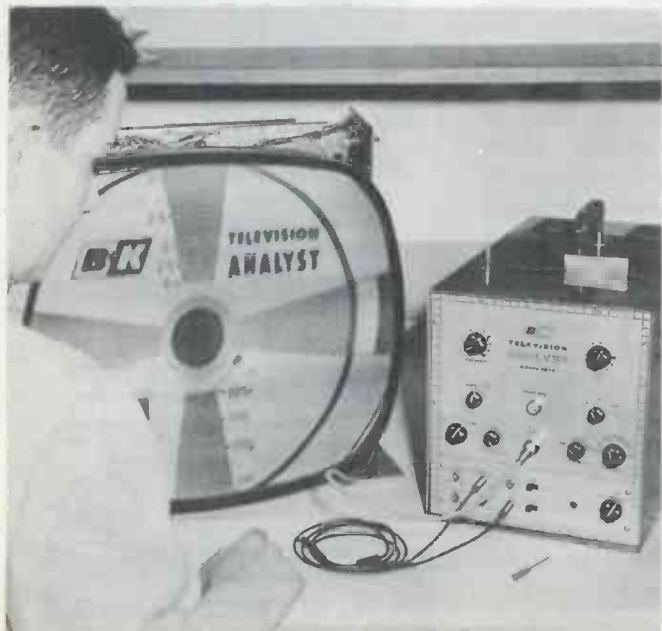
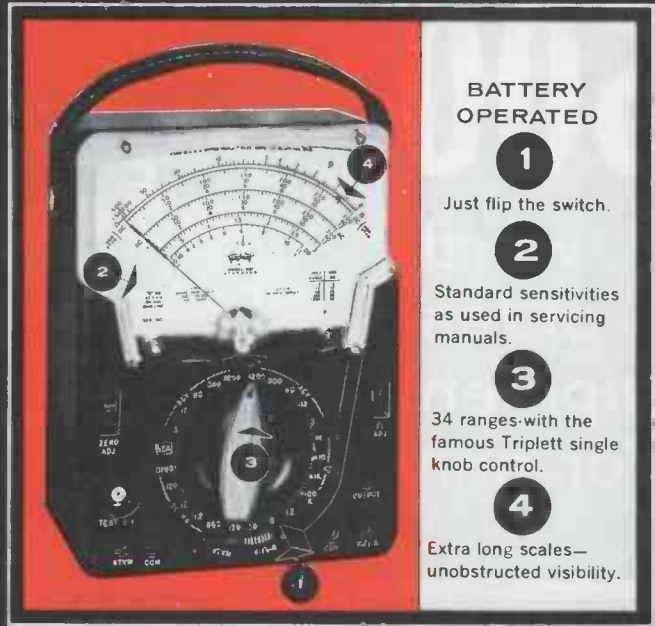

Fig. 1. B & K "Television Analyst" introduces new signal substitution technique.



Fig. 2. Front panel of Model 1075 indicates its versatility in test applications.



BATTERY OPERATED

- 1**
Just flip the switch.
- 2**
Standard sensitivities as used in servicing manuals.
- 3**
34 ranges-with the famous Triplet single knob control.
- 4**
Extra long scales—unobstructed visibility.

double use...half the price

Triplet Model 631 the standard Combination VOM and VTVM \$64.50. Here's the *one* instrument which will do practically *all* the measuring in your electronic projects.

A VOM is essential equipment in electronics for measuring current, resistance and voltage. A VTVM is important for voltage measurements where it is desirable that the measuring instrument cause little or no current drain.

By using the Volt-Ohm-Milliammeter for all general testing (90% of your testing) and the Vacuum Tube Voltmeter only when you need it, you have the advantage of a VTVM with extremely long battery life. Batteries are used only about one-tenth as much as in the ordinary battery-operated VTVM.

Features: Ohms, 0-1500- 15,000 (6.8-68 center scale. First division is 0.1 ohm.)

Megohms: 0-1.5 (6,800-680,000 ohms center scale.)

Galvanometer center mark "-0+" for discriminator alignment.

RF Probe permits measurements up to 250 MC. \$7.00 net extra.

Featured by leading electronic parts distributors everywhere.



53 years of experience

THE MIGHTY NINE

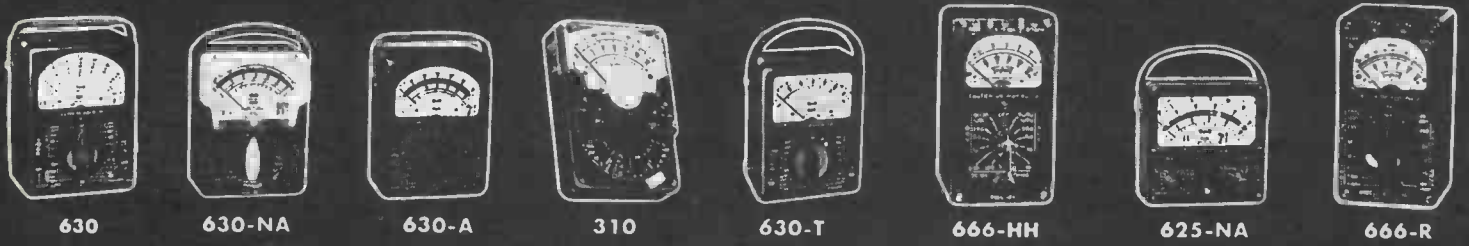

\$500

worth
of test
equipment
for only

\$69⁹⁵



the versatile Model 97

AEROVOX LC-CHECKER

Truly the ONE piece of service equipment that is most capable of answering all your needs. The all-new Model 97 LC-Checker represents the ultimate in versatility and adaptability in a test instrument. Redesigned and engineered according to the very latest in design theories, the LC-Checker incorporates the newest techniques in printed-circuitry for the most effective instrumentation available to service technicians today.

Use the Model 97 LC-Checker as . . .
RF Signal Generator . . . FM-TV Signal Generator . . . UHF Calibrator . . .
Frequency Meter . . . Capacitance Tester.

Just imagine, the LC-Checker can do the work of all these instruments which if purchased individually would cost approximately \$500.00. Yet, the all-new LC-Checker costs you just . . . **\$69.95**

Write for free illustrated literature.

AEROVOX CORPORATION

DISTRIBUTOR DIVISION

NEW BEDFORD, MASS.

also six screwdriver adjustments which include *Beam Current*, *Horizontal Size*, *Vertical Size*, and *Vertical Linearity* for forming and controlling the scanning tube raster. The two remaining controls are identified as *Vertical Driving Pulse Amplitude* and *Sync Level*. Most of these auxiliary controls and the centering magnets for the scanning tube are preset at the factory and should require little or no adjustment in the field.

Following instructions outlined in the manual, I calibrated the "Analyst" by using a normally-operating receiver and a test pattern from a local station. Setting the controls of the receiver for proper synchronization, tuning, pattern size, linearity, and centering, I made the necessary adjustments to obtain a like pattern from the instrument without moving any of the receiver controls. This procedure thus matches the instrument's output with local signal and power-line conditions.

In order to check the RF-IF output of the unit, I placed a test pattern slide in front of the scanning tube, connected the output cable to the antenna terminals of a receiver, and adjusted the necessary operating controls until I obtained the pattern seen in Fig. 1. Switching from RF to IF, I found that I could easily signal-trace the receiver by injecting appropriate test signals at any stage input up to and including the video detector. When troubleshooting the tuner, I noted that either an RF or an IF signal could be applied to the mixer grid and, provided the mixer-oscillator was operating properly, the pattern would appear on the picture tube screen. If the local oscillator was at fault, however, only the application of an IF signal at this point

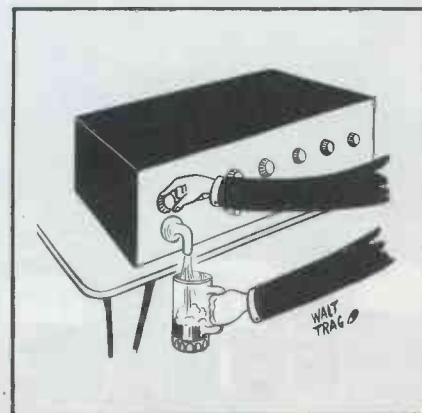

would produce a pattern.

Setting the unit up for a video output, I found I could check the video amplifier and output circuits by using a signal of the proper polarity. Switching the test lead from *Video Output* to *4.5-mc Sound* jack and applying the test signal to the video amplifier, sound-IF amplifier, and FM detector circuits in succession, I was able to check the capabilities of these stages in handling the sound signal. Use of the 400-cps tone signal from another front-panel jack also permitted me to make a check of the audio section.

To make use of the test signals available at both vertical and horizontal driving-pulse jacks, I disabled the vertical and horizontal oscillators in one of the test chassis and fed the driving voltages from the "Analyst" to the grids of the sweep output tubes. Since the output circuits were operating normally in this case, I obtained a complete raster on the picture tube screen. It occurred to me that this form of signal substitution would be extremely helpful to TV technicians, especially when loss of horizontal sweep is encountered and the oscillator plate voltage is supplied from boost B+. In this situation, the technician often has difficulty isolating the fault to either the oscillator or output section.

The rainbow color signal generated by the "Analyst" will modulate either the RF or IF output signal and can be used to localize troubles in a color set. In addition, a 3.58-mc offset subcarrier is available for direct application to the video detector, video amplifier, bandpass amplifier, or the grids of low-level demodulators. The instruction manual gives a complete discussion of various ap-

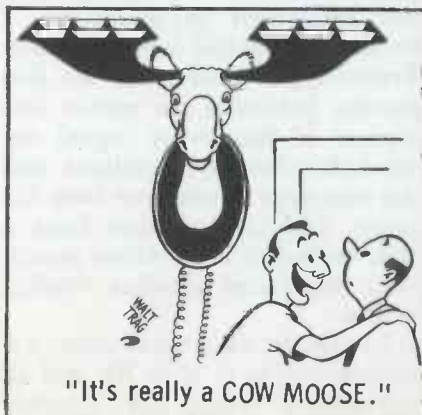

CONTROL REPLACEMENT RECOMMENDATIONS FOR 18,000 TV MODELS!

a **must**
if you
service
TV!

\$
Only **1⁰⁰**

Howard W. Sams

REPLACEMENT GUIDE FOR TV CONTROLS

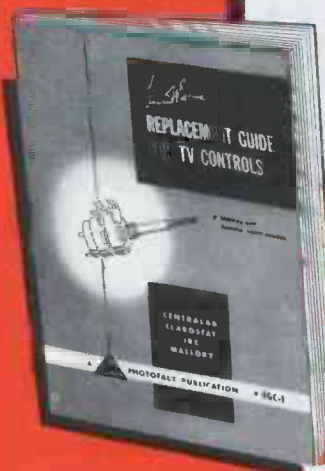

A SAMS FIRST! Lists the recommended replacement TV controls of these manufacturers:

**CENTRALAB
CLAROSTAT
IRC
MALLORY**

nothing
else
like
it!

**IT'S EASY TO FIND THE
PROPER REPLACEMENT BY
EXCLUSIVE NEW "INDUSTRY
PART NUMBER" SYSTEM**



QUICK-ACTION REFERENCE:

You'll find the original control part number (or drawing number) in the special Index Section, listed either alphabetically or numerically under the TV set manufacturer's name. Opposite this listing is the exclusive *Industry Part Number* . . . such as X-400.

Simply look up the *Industry Part Number* (in this case, X-400), and you'll find the recommended replacement controls of four manufacturers (Centralab, Clarostat, IRC and Mallory) listed in the columns beside it . . . takes only seconds—it's that simple!

- The most complete replacement guide for TV Controls ever published—replacements for 18,000 TV models—covers virtually every TV set produced from 1947 to 1958!
- Every replacement control is *currently available* and recommended by the manufacturer to meet "Industry Part Number" specifications!
- Exclusive "Industry Part Number" system gives you quick, easy selection of all four manufacturers' recommended replacements!
- "Industry Part Number" listing helps you maintain inventory of most-needed controls for your service work—avoids needless duplication!
- Saves you time in selecting proper replacement controls—saves ordering time too. Guide actually pays for itself the first time you use it on a control repair job!

8½ x 11"

IT BELONGS
ON YOUR
BENCH!

\$
Only **1⁰⁰**

HOWARD W. SAMS & CO., INC.

Indianapolis 5, Indiana

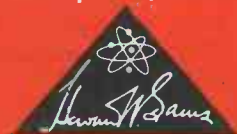

ORDER THIS BOOK FROM YOUR SAMS DISTRIBUTOR TODAY, OR MAIL COUPON BELOW

HOWARD W. SAMS & CO., INC.

Order from your Sams Distributor today, or mail to Howard W. Sams & Co., Inc., Dept. 3-F8 2201 E. 46th St., Indianapolis 5, Indiana

Send copy(ies) of "Replacement Guide for TV Controls." My (check) (money order) for \$ is enclosed.

Name

Address

City Zone State

(Outside U.S.A. priced slightly higher)

REAR SEAT SPEAKER KITS

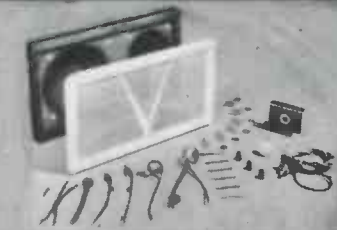

G-C HI-FI SPEAKER KIT
Twin speakers give wide range frequency response. Complete with all parts and instructions.
No. 9502.....List \$19.95



G-C STATION WAGON KIT
Full range tone reproduction for every station wagon. Completely wired for easy installation.
No. 9501.....List \$15.95

GENERAL CEMENT MFG. CO.
Division of Textron Inc., Los Angeles—Rockford, Illinois

ASK YOUR G-C JOBBER
FREE CATALOG . . . send postcard today!

ANCHOR

SANDY SAYS:
"it's the DELUXE britener with the BIG PLUS!"

\$525 LIST

DELUXE UNIVERSAL TV PICTURE TUBE britener MODEL UB 175

USE 8 WAYS . . .

- Parallel Boost
- Series Boost
- Electromagnetic
- Electrostatic
- Parallel Isolation Normal
- Parallel Isolation Boost
- Series Isolation Normal
- Series Isolation Boost

PLUS CORRECT . . .

- Control Grid Short
- Open Control Grid
- Combination of ALL Above.

anchor products co.
ELECTRONIC COMPONENTS
2712 W. Montrose • Chicago 18, Ill.

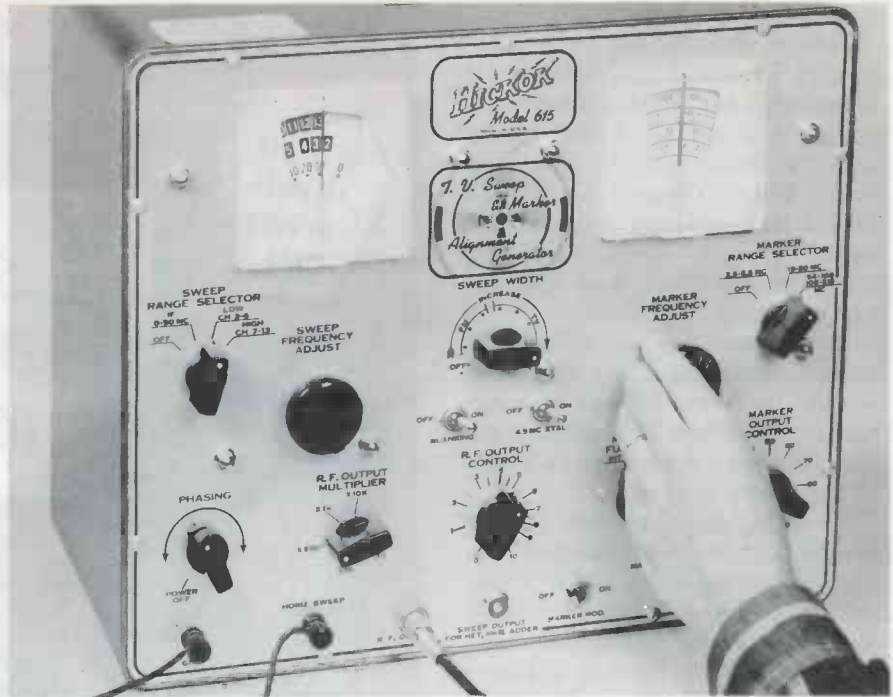

Fig. 3. Hickok Model 615 TV sweep and marker alignment generator.

plications for the instrument, including static and dynamic convergence adjustments for color, adjusting picture linearity and size, checking picture resolution, and displaying patterns or messages on the screen of any TV set.

Of further interest is the fact that B & K will modify existing Model 1000 "Dyna-Scan" units to incorporate all the features of the Model 1075.

Sweep-Marker Generator Speeds Alignment

Hickok Electrical Instrument Co. of Cleveland has recently introduced a new sweep and marker alignment generator to the electronic service field. Pictured in Fig. 3, the Model 615 is specifically engineered for VHF and IF alignment work.

Specifications and features are:

1. **Power Requirements**—105/125 volts AC, 50/60 cps, power consumption 25 watts at 115 volts.
2. **Sweep Output**—.07 volts rms for IF band of 0 to 50 mc and TV channels 2 through 6; .12 volt rms for channels 7 through 13; flat within 0.1 db per mc.
3. **Sweep Width**—variable from zero to 15 mc in 9 steps for all FM and TV alignment requirements.
4. **Output Impedance**—90 ohms at terminals of output cable, 300 ohms obtained by using type 75

Adapter accessory.

5. **Marker Output**—.2 volt rms from 2.5 to 5.5 mc, .2 volt rms from 19 to 50 mc, .5 volt rms from 54 to 108 mc on fundamentals, and 108 to 216 mc on harmonics; 4.5-mc crystal oscillator provides simultaneous sound and picture markers; 900-cycle amplitude modulation and separate output control provided; marker accuracy within 0.5% at any frequency.
6. **Other Features**—internal blanking provides base reference line; separate control for phasing of horizontal sweep signal applied to scope.

When investigating the Model 615, I checked the RF and IF response of one of our TV test receivers by setting up the generator and a scope according to procedures outlined in the operating instructions. After making the proper connections and permitting the equipment to warm up, I turned the control labeled *Sweep Frequency Adjust* until the dial pointer indicated the center frequency of the sweep signal desired. Incidentally, I noticed that the new-type pointers on both the sweep and marker dials have a thin knife-like edge which practically eliminates parallax reading errors.

I obtained very satisfactory response curves in both RF and IF operations. Using the variable

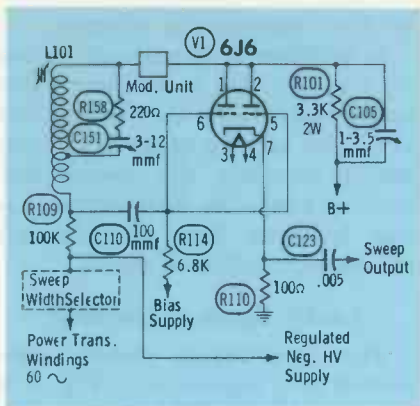

Fig. 4. All-electronic sweep-frequency circuit found in the Hickok Model 615.

marker and the 4.5-mc crystal oscillator, I found it easy to identify picture and sound RF carriers on the scope curve. The instruction manual presents detailed procedures on stage-by-stage, stagger-tuned, and over-all IF alignments as well as sound-IF, discriminator, and tuner alignments.

In looking over the 615's schematic (Fig. 4), the first design feature that caught my eye was the manner in which the FM, 60-cycle sweep is developed. The system is strictly electronic—with no moving parts.

The FM oscillator V1 operates over the range of 175 to 225 mc and is continuously tunable by means of L101's variable core, which is activated by the sweep frequency adjustment on the front panel. To obtain sweep modulation of this oscillator, a 60-cycle voltage is applied through R109 to the tank circuit formed by L101, R158, and C151. The modulation unit shown in the plate circuit is effectively across this tuned tank, and since it is a special reactor, it causes the frequency of the oscillator to vary above and below the tuned frequency. The frequency swing depends on the amplitude of the AC signal chosen



it takes two to **stereo**



NEW WEBSTER

STEREO-CERAMIC CARTRIDGE AND YOU

Everyday, everywhere, more and more people are talking stereo discs. Now the cartridge to play 'em is here—the new Webster Stereo-Ceramic. Now is the time to tell 'em . . . sell 'em . . . install 'em!

Webster design makes it a cinch because the new Stereo-Ceramic is *completely compatible* with present monaural records. It's lighter tracking, too, and that means longer record life. More, the Stereo-Ceramic has an exclusive plug-in design—either cartridge or stylus can be replaced without tools. Staggered terminals mean easier spot soldering.

Be ready for the big switch to stereo—ask your jobber for the money-making facts.

REPLACE WITH WEBSTER . . . IT PAYS!

STEREO-CERAMIC

SC-1D Complete with cartridge, bracket, diamond stylus \$24.50*



MC-1 78 rpm insert with sapphire stylus, \$7.50*



ELECTRONICS DIVISION
WEBSTER ELECTRIC
RACINE · WIS



*List prices—standard discounts apply.

Franklin adv. Y-123



... Superbly made and designed for Radio, T.V. and Electronic Technicians. See your Distributor ... only one quality ... the finest — whether you choose individual items or the handy kits ...

Use the Tools the Professionals use!



XCELITE, INCORPORATED
ORCHARD PARK, NEW YORK
Canada: Charles W. Pointon, Ltd., Toronto

XCELITE
Quality Hand Tools
PREFERRED BY THE EXPERTS

**YOU CAN
"BET
YOUR LIFE"**



ON
**WRIGHT
WIRE STRAND**

Wright TV Guy Wire Strand is your guard against irritating snarls. Each concentric coil measures two feet. You save money in guying antennas. Greater flexibility, heavily galvanized continuous connected coils. Prompt delivery from stocks in Worcester, Chicago, New Orleans, Houston, Dallas and Los Angeles.

Non-Snarling Pre-Measured Wire Strand
Sold only through Wholesale Distributors.

G. F. WRIGHT STEEL & WIRE CO.
235 Stafford St. • Worcester, Mass.

by the sweep-width selector.

In addition to the circuit shown in Fig. 4, the instrument also houses two fixed oscillators, one at 225 mc and the other at 275 mc, which complete the sweep frequency range by heterodyne action between their outputs and the sweep oscillator signal.

Leaky, Open, or Shorted?

The instrument shown connected to a capacitor in Fig. 5 is the new Model CRA-2, a capacitor-resistor analyzer now being offered by Pyramid Electric Co., North Bergen, N. J. This piece of equipment is especially designed for use in checking capacitor values and quality as well as for taking very high resistance measurements.

Specifications and features are:

1. Power Requirements — 117 volts, 60 cps; power "on" indicator on front panel.
2. Capacitance Measurement — 4 ranges covering from approximately 10 mmf to 2,000 mfd; combined Wien and Wheatstone bridge-circuit operation; capacitor discharge button on front panel.
3. "Quick Check" — a speedy test for open, shorted, and intermittent capacitors of all types in or out of circuit; special test leads supplied.
4. Electrolytic Leakage — panel control provides for variation of applied voltage up to 600 volts DC; leakage current monitored on either 5- or 50-ma meter scale; typical leakage readings given in manual.
5. Power Factor — determined by setting of separate 0 to 65% panel control; typical power-factor percentages given in manual.
6. Resistance Measurement — insulation resistance and capacitor-leakage resistance up to

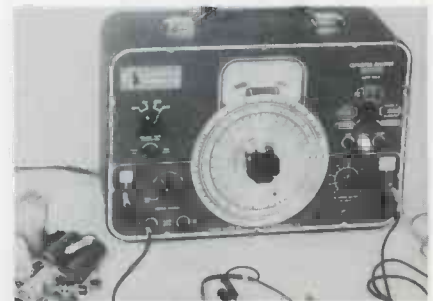

Fig. 5. Pyramid Model CRA-2 is engineered for testing all types of capacitors.



Fig. 6. Close-up view of the Model CRA-2 meter and resistance-capacitance scales.

20,000 megohms indicated on meter scale; vacuum-tube ohm-meter circuit employed.

7. Size and Weight—16½" × 12" × 9", 15 lbs. shipping weight.

I had the opportunity to check out a Model CRA-2 recently, and you can see from the stack of capacitors I used (Fig. 5) that it certainly received a good workout. The capacitors selected were typical units found in radio and TV applications and, although most of them were of known good quality, a few were decidedly defective.

One test afforded by the CRA-2 is the "Quick Check." To perform this operation, I first placed the function selector in the *Quick Check* position and plugged the appropriate test leads in the two *Quick Check* pin jacks. Turning the instrument on and letting it warm up for a minute, I then adjusted the voltage control on the front panel until the meter pointer read near maximum on the right end of the scale. This meant that the pointer was now resting in the region marked *BAD* (see Fig. 6).

My next step was to connect the test clips across the capacitor to be checked. After doing so, I then observed the reading on the meter. In this case, the pointer swung to the left and registered in the *GOOD* region of the lower scale—indicating that the capacitor was not open. Fluctuation of the pointer would have indicated that the unit under test probably had an intermittent condition. If the capacitor had been completely open, the pointer would have remained in the *BAD* portion of the scale.

After the *open* test, I made a check for shorts. Since the value



Carefully
Balanced
Packaged Circuit
Inventory
with the

NEW **Centralab**®

PCK-40

Kit

With almost eighty million Centralab packaged circuits (identified by PEC*) already incorporated in TV chassis, packaged circuit replacement is getting to be bigger business for you all the time. Make it extra profitable by avoiding special trips and phone calls to your distributor.

The carefully balanced inventory of the new Centralab PCK-40 Kit covers 80% of your PEC* needs. You'll have the circuit you need, on hand, *when you need it*. The Kit contains 40 PEC*, divided among 14 of the most frequently used types, each in its individual rigid plastic package. They are conveniently arranged, for instant identification, in a rugged metal cabinet.

Ask your distributor to show you the new Centralab PCK-40 Kit now, with the FREE cabinet and handy guide. Price \$26.93 dealer net.

Centralab products are listed in *PHOTOFACTS*, *COUNTERFACTS*, and *THE RADIO-ELECTRONIC MASTER: PEC* Guide No. 4* available on request from your local distributor or direct from Centralab.

Centralab®
*Trademark

A DIVISION OF GLOBE-UNION, INC.
942 F. KEEFE AVE. • MILWAUKEE 1, WIS.
In Canada: Mt. Pleasant Rd. • Toronto, Ontario

SWITCHES • PACKAGED ELECTRONIC CIRCUITS • CERAMIC CAPACITORS
CONTROLS • ENGINEERED CERAMICS • SEMI-CONDUCTOR PRODUCTS

June, 1958 • PF REPORTER 47

NEW! IMPROVED!

SENCORE
TRC4
TRANSISTOR CHECKER

Another Sencore Time-Saver

America's newest, most popular test instruments

NOW CHECKS:

- ★ **Transistors** for opens, shorts, leakage and current gain. Includes new gain test on power transistors.
- ★ **Crystal Diodes** checks forward to reverse current ratio on all diodes.
- ★ **Selenium Rectifiers** checks forward and reverse currents.

Controls are accurately set for each transistor by referring to replaceable set-up chart on rear. Test leads or socket provides for fast hook-up. See your parts distributor.

SENCORE Mfg. by **SERVICE INSTRUMENTS CORP.**
171 OFFICIAL RD., ADDISON, ILL.

Cut out this ad now for further information



ONLY \$17.95
Dealer Net

SIMPLE TO OPERATE
Cannot become obsolete. Approved by leading manufacturers.

of the capacitor was supposed to be between 100 and 2,000 mmf, I merely depressed the panel push-button labeled *L* and observed the *GOOD-BAD* scale once again. For tests of capacitors between the values of 2,000 mmf and 50 mfd, the button marked *H* should be depressed. Units with a larger value than 50 mfd will usually indicate a short, though perfectly good, due to their low resistance at the test frequency. These units, however, are generally electrolytics, and the leakage and power factor measurements performed by this instrument are the most important factors in determining their worth.

The Analyzer's meter face and a portion of the capacitance-resistance dial are clearly shown in Fig. 6. Note the meter ranges—including the megohm scale, two current and voltage ranges, and the *Quick-Check*, *GOOD-BAD* indications.

Wide Range Color-Bar Generator

An instrument designed specifically for color TV servicing is pictured in operation in Fig. 7. The unit, shown perched on top of a color receiver, is the Model 430 color bar generator manufactured by Simpson Electric Co. of Chicago.

Specifications and features are:

1. **Power Requirements**—100/125 volts constant, 50/60 cps, spe-

cial line-voltage switch provided; power consumption approximately 100 watts.

2. **RF Output**—modulated carriers for channels 2 through 6 on fundamentals and 7 through 13 on harmonics; maximum output greater than 10,000 microvolts; attenuator control of 15 db for channels 2 through 6; output cable provided.
3. **Modulation or Video Output**—luminance (*Y*), chrominance, color signal (NTSC standard), *I, Q, I/Q, R-Y, B-Y, R-Y/B-Y, G-Y /90°*, or burst/sync; chrominance phase accuracy $\pm 5^\circ$ (demodulator $\pm 3^\circ$ from absolute); chrominance and luminance amplitude accuracy $\pm 10\%$; video attenuator range 0 to 3.5 volts p-p.
4. **Types of Output**—positive or negative video, RF with or without 4.5-mc marker, 15,750-cycle sync pulse, and 3.58-mc sine wave.
5. **Color Bar Sequence**—red, yellow, green, cyan, white, magenta, blue, and black.
6. **Size and Weight**—11" \times 14½" \times 16¼", 30½ lbs. approx.

The first two physical features which impressed me about this instrument were the colorful signal-selector dial occupying the whole upper half of the front panel, and the hinged side-door section shown in Fig. 8. The vivid colors circling the large function switch are not

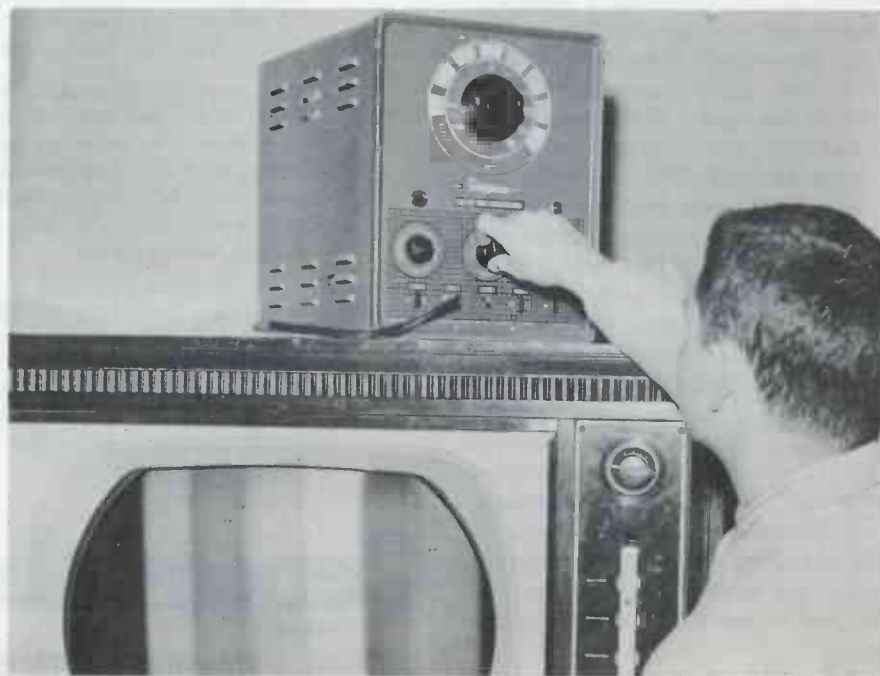

Fig. 7. Simpson Model 430 is characterized by variety of NTSC output signals.

Channel King[®]
INDOOR TV ANTENNA

Extends to 42"
Retracts to 0"

THE TRULY UNIQUE AND
ADVANCED
INDOOR ANTENNA

**HIGH
PROFIT
SALES**

- Ⓚ Hands NEVER touch Antenna arms
- Ⓚ SINGLE DIAL adjusts arms and signal
- Ⓚ FAST, positive wider range tuning
- Ⓚ UNBREAKABLE, flexible stainless steel arms
- Ⓚ COMPACT, attractive appearance
- Ⓚ 6 Rich Color Choices

See your Distributor . . . Or write for Literature and Specification Sheets

MARJO TECHNICAL PRODUCTS COMPANY
1152 E. Henry Street, Linden, N. J.



Fig. 8. Added feature of the Model 430 is easy access to tubes and adjustments.

merely for decoration. Nine of the eleven switch positions represent generated signals which reproduce some form of color pattern on the picture tube. Each color symbol on the panel therefore indicates the color or color combination to be expected when the set is operating properly. Too, these color frames are large enough to be easily compared with screen patterns in making checks for hue and saturation.

As can be seen from Fig. 8, all tubes in the Simpson generator are available through the large access door, which hinges at the bottom and has two snap locks at the top. There are only three adjustments other than the function switch on the front panel of the instrument: the output attenuator, channel tuning knob, and the off-on signal output selector. Across the bottom of the panel are four output connectors for Video, RF, 15,750 cps, and 3.58-mc. A two-position slide switch is also located on the panel to permit turning off or on a 4.5-mc marker for synchronizing tuning between generator and receiver.

As I made use of this precision-built instrument, I found that its color signals were ideal for checking over-all response and matrixing. In addition, it can be used to check chroma levels at the picture tube and test delay line operation, as well as for many other color tests and adjustments. The NTSC signals generated by the Model 430 make the unit quite suitable for shop-bench or laboratory use, and its moderate weight and sturdy carrying handle serve to make it portable for use on home service calls. ▲

Popular and Fast Moving . . .

"ILLINI ELECTROMITE CONDENSERS"

Time Tested Quality

Earn greater profits with this quality line of capacitors which are priced to sell. Available in variety of sizes with flexible leads or tinned pigtail leads. Attractively packed 10 to colorful display box. One full year unconditional guarantee. Write for catalog. SOLD THROUGH RECOGNIZED DISTRIBUTORS EVERYWHERE

PACKED 10 IN A BOX

Telephone: Everglade 4-1300

ILLINOIS CONDENSER COMPANY
1616 N. Throop Street • Chicago 22, Illinois

MAKE SURE IT FITS!

OXFORD SPEAKERS

You obtain the finest sound reproduction when you select the proper speaker for the specific application. Each OXFORD SPEAKER is "tailor-designed" to actually "fit the need."

Specify OXFORD when you next require quality speakers. Remember: Oxford quality has consistently been superior for over thirty years.

Our new catalog is available . . . write for yours NOW!

<p>RADIO & TV SPEAKERS</p> <p>OXFORD Speakers are used by more original set manufacturers — find out why!</p>	<p>OUTDOOR SPEAKERS</p> <p>For rugged, steady performance under any conditions, OXFORD Weather-proof speakers will meet the need.</p>
<p>DUAL CONE HI-FI SPEAKERS</p> <p>Oxford's newest development to provide maximum performance. For Hi-Fi and rear deck applications.</p>	<p>PORTABLE RADIO SPEAKERS</p> <p>More Oxford speakers are used in portable sets than ever before . . . there must be reasons!</p>

OXFORD Components, Inc.
Subsidiary of Oxford Electric Corp.
556 West Monroe Chicago 6, Ill
Export: Roburn Agencies, New York City
In Canada: Atlas Radio Corp., Ltd., Toronto

ANALYZING THE VERTICAL CIRCUIT

a point by point check

It is often difficult to pinpoint a fault in the vertical circuit to a component part, or even a stage. One good reason for this is that several stages (or sections of the circuit) can cause the same (or similar) abnormal picture symptoms. Here's an analysis of the symptoms that result from the breakdown (or change in value) of every single component in a typical vertical circuit. For the most part, the information is applicable to comparable components in other vertical circuits.

Examining the Circuit

Fig. 1 shows a typical vertical circuit including waveforms and pertinent DC voltages. For purposes of analysis, the circuit is

divided into four main sections; the integrator, oscillator, output, and deflection yoke. The integrator integrates (or forms a sawtooth from) the vertical sync pulses supplied by the sync amplifier. The integrator output is a 60-cps sawtooth voltage which is used to pulse the vertical oscillator. The vertical oscillator generates a "peaked" voltage, and, under free-running conditions, inherently oscillates at a frequency slightly lower than the vertical sweep rate of 60 cps in order that it may be triggered by the 60-cps integrator output voltage.

The oscillator output is transformed into a sawtooth-type voltage by the C190-R191 combination (the sawtooth-forming network) before being fed to the

vertical output tube. The output circuit shapes this voltage, "peaks" and amplifies it before applying it to the vertical yoke windings. Here, the essentially trapezoidal voltage produces sawtooth current, from which a magnetic deflection force is derived to produce vertical beam scan.

General Trouble Analysis

Sometimes, it is easy to pinpoint a trouble to a section (and even to a component part) of the vertical circuit; nevertheless, you should at least obtain an idea of which parts of the vertical circuit are responsible for the various abnormal picture symptoms. Table I is keyed to the accompanying picture symptoms to help you isolate the trouble to specific sec-

Fig. 1. Vertical circuit used in Stewart-Warner Model 24C-9370A.

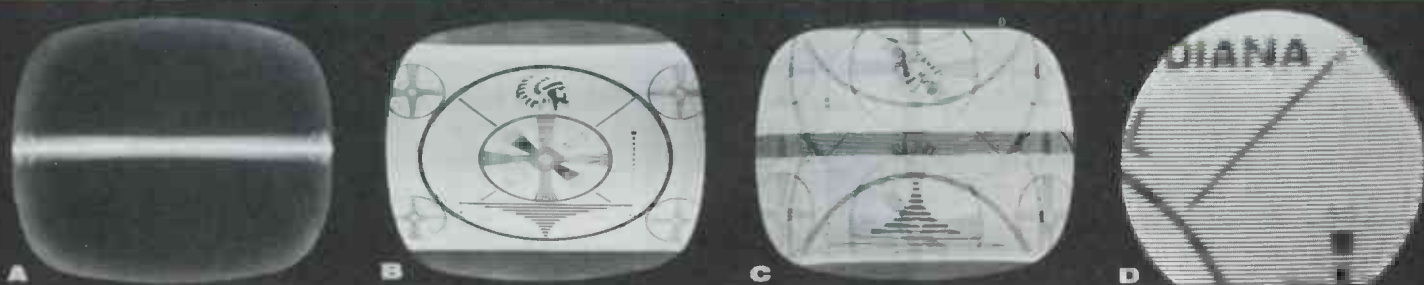
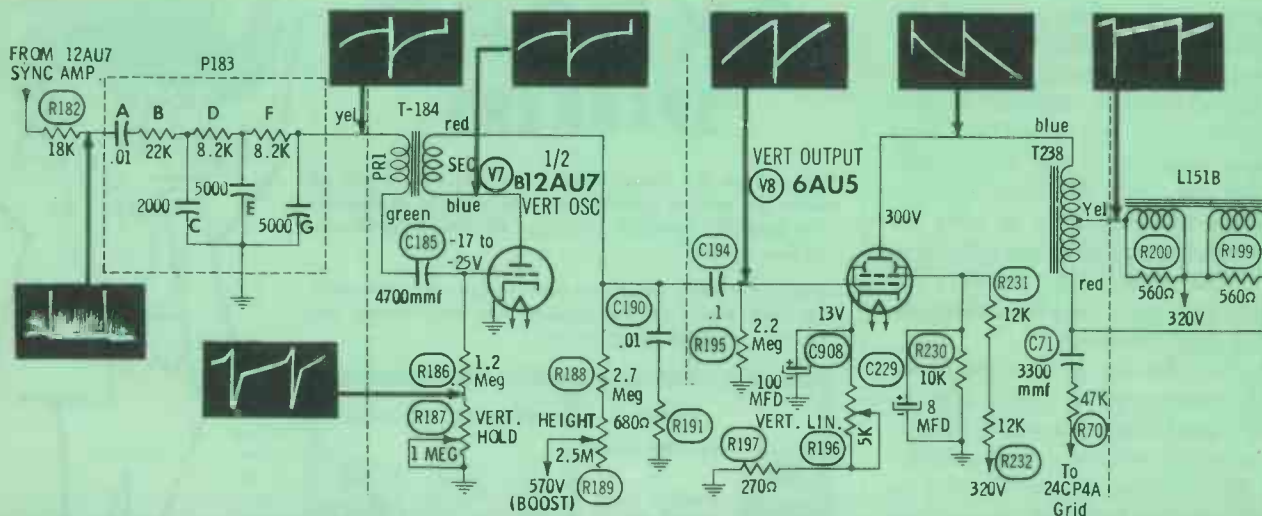

of troubles and symptoms by Jesse Dines

tions of the vertical circuit.

The "Video or Sync Separator" column in Table I indicates that these circuits also can be responsible for the abnormal picture symptoms shown. Why should they cause troubles such as loss of vertical sync, whereas they do not cause loss of horizontal sync (by itself), even though the video and sync separator circuits feed both vertical and horizontal sync circuits? The answer is simply that the horizontal sync system employs AFC, whereas the vertical sync circuit does not. Thus, a sync separator tube, for example, can be just weak enough to affect vertical sync adversely, but not horizontal sync.

Table I indicates that picture symptoms involving vertical height

are likely to be caused by the vertical output or vertical yoke circuits; nevertheless, it is possible for the vertical oscillator (and even the vertical integrator) to cause such troubles. To determine whether the oscillator (or circuits preceding it) or the output stage (or the yoke circuit following it) is causing the trouble, use the following test procedure.

Inject a 60-cps signal into the vertical output tube grid. If there is little or no vertical deflection, the output or yoke circuit is likely to be defective. On the other hand, if a noticeable change in deflection results, look for trouble in the oscillator or preceding circuits. The 60-cps signal can be obtained from any signal generator. In fact,

it can be obtained directly from the filament supply of the receiver itself. In the latter case, however, use caution in series-string sets since the voltage will range up to 110 volts or more, depending on the point you use as a supply. Also, use a .1-mfd blocking capacitor to protect the filament circuit. The amount of deflection obtained by using this method will vary from an inch or so to several inches, depending on the amount of voltage applied to the output grid.

Waveform and Voltage Checks

The waveforms and voltages indicated in Fig. 1 are typical of those found in many vertical circuits. Whenever possible, use the manufacturer's service notes (or

TABLE I—Vertical troubles keyed to picture symptoms and suspected circuits.

PICTURE SYMPTOM	SEE PHOTO	VIDEO OR SYNC SEP.	INTEGRATOR	VERT. OSC.	OUTPUT	VERT. YOKE
Loss of Vert. Sweep	(A)	no	no	possible	most likely	likely
Reduction in Height	(B)	no	possible	possible*	most likely	likely
Loss of Vert. Sync.	(C)	likely	likely	likely	possible	no
Poor Interlace	(D)	possible	most likely	possible	no	no
Improper Height & Lin.	(E)	no	no	likely**	most likely	likely
Vertical Trapezoid	(F)	no	no	no	possible	most likely
Vertical "Jitter"	(G)	likely	likely	likely	possible	no
Vertical Retrace Lines	(H)	most likely	no	possible***	possible***	possible***

* Only if feedback from output stage to oscillator is used.

** Especially sawtooth-forming network.

*** Only if vertical retrace blanking circuit is used.

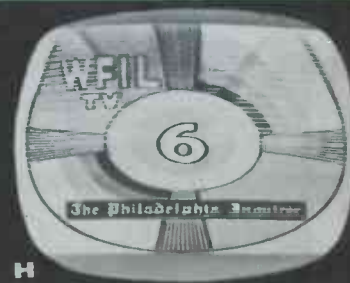
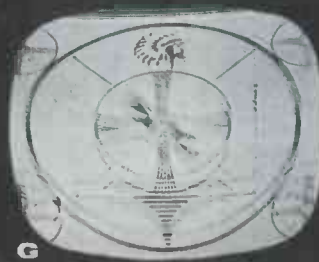
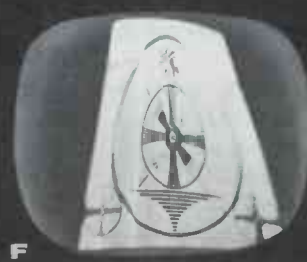
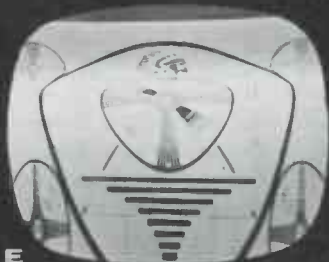

Cut Down Call Backs...

INSTALL A **G-C** WUERTH

SURGISTOR

ON EVERY SERVICE CALL



G-C Wuerth No. 5301
... For Black & White
TV List \$1.65

G-C Wuerth No. 5302
... For Color TV Sets
..... List \$1.95

Stops harmful voltage surges to picture and radio tubes. Sell your customers tripled tube life and you'll profit on each installation.

Simply connect directly into power line.

Functions like a combination resistor-relay to preserve electrolytic capacitors, dry disc rectifiers, transformers, pilot bulbs and other components as well as tubes.

Available right now from your local electronics parts distributor or write direct to:

G-C ELECTRONICS MFG. CO.

division of G-C TEXTRON INC.
Western Plant: Los Angeles 18, Calif.
Main Plant: ROCKFORD, ILLINOIS, U.S.A.

for servicing transistorized equipment

EICO®

LOW RIPPLE

battery eliminator & charger

#1060

Kit \$38.95

Wired \$47.95

- Percent ripple (proportional to current drawn) down to 0.3% @ 2 amps, only 1.5% @ 10 amps (12v range) for operating transistor, "hybrid", or any battery-powered equipment.
- Continuous voltage adjustment with Variac-type transformer.
- 2 ranges: 0-8V: 10 A cont., 20 A int.; 0-16V: 6 A cont., 10 A int.
- 6 exclusives: simultaneous monitoring by separate voltmeter & dual-range ammeter, automatic switching of ammeter to appropriate current range, tilted meter panel, all-steel rugged cabinet, optional wall-mounting feature, industry's lowest price.
- Pi-type heavy-duty filter circuit employing an oversized choke & a dual 5000 mf-20 V electrolytic capacitor (10,000 mfd total) takes full continuous and intermittent current output. Heavy-duty selenium rectifiers.
- Fused primary; automatic reset overload relay for secondary.

See the 50 EICO models IN STOCK at your neighborhood distributor. Write for FREE Catalog. **PF-6**



Prices 5% higher in West.
EICO, 33-00 Northern Blvd.,
L.I.C. 1, N. Y.

similar literature) to obtain precise waveshapes and p-p or DC voltages.

On the subject of voltages, little attention is paid to the measurement of boost voltage when it feeds the vertical oscillator and/or vertical output plate circuits. In some cases, a boost voltage loss of only 5 to 10% can cause improper vertical operation and yet not affect horizontal circuit operation noticeably. This is especially true when the design constants of the vertical circuit are critical. A drop in boost voltage is most likely to be caused by a fault in the fly-back circuit, even though a vertical picture trouble exists. Don't be fooled!

Component Breakdown Analysis

Now let's analyze the functions of the various components in Fig. 1 and see what happens when each becomes faulty.

C185—Frequency-Determining Capacitor

If C185 shorts, the total capacity of the integrator circuit will determine the oscillator frequency (along with the grid circuit resistance). Since this capacity is greater than C185, the discharge time will increase, which will, in turn, decrease the oscillator frequency. Adjustment of R187, the vertical hold control, will not increase the oscillator frequency enough to make it operate properly. Multiple vertical images can result from such a trouble.

This trouble will not appreciably affect V7B DC grid voltage, which will remain at 17 to 25 volts negative, depending on the setting of R187. However, the p-p voltage of the signal at V7B plate will increase by about 20%.

It is not likely that slight leakage in C185 will cause any picture defects, since a minor change in frequency can be compensated for by the setting of R187; it is possible that R187 will compensate even for severe leakage in C185, although it may have to be set in an extreme position.

If C185 opens, there will be complete loss of vertical sweep. Although the oscillator may still function, its frequency will be very high, on the order of 500 cps. V7B plate signal will drop to less than 10 volts p-p, and the DC

voltage will increase about 50%. If the capacitance of C185 decreases, the oscillator frequency will increase, resulting in a loss of vertical sync and an apparent reduction in vertical deflection.

Integrator Components

If integrator capacitor C, E, or G shorts, capacitor A or resistor B, D, or F opens, the vertical sync pulses will not trigger the oscillator and there will be loss of vertical sync. The oscillator will operate at its inherent frequency (less than 60 cps). If capacitor C, E, or G opens, the oscillator frequency will increase, resulting in a loss of vertical sync, since these capacitors, in conjunction with C185, help to determine the oscillator frequency.

If capacitor C, E, or G drops in value, the hold control setting will be more critical and the oscillator will be more easily triggered by random noise pulses. Also, since the over-all time constant of the integrator will be reduced, horizontal sync pulses will charge the integrator capacitors and result in a loss of picture interlace. If resistor B, D, or F increases in value (or capacitor C, E, or G becomes leaky), the integrator time constant will increase and the integrator sync amplitude output will decrease, resulting in poor or touchy vertical sync.

R186 & R187—Grid-Leak, Frequency-Determining Resistors

If either resistor decreases in value, the oscillator frequency will increase and the result will be a loss of vertical sync. For example, if R186 (or R187) decreases to only a few ohms, the frequency may become as high as 120 cps. V7B DC grid voltage will be a very low negative value, and the plate signal voltage will be about 50% lower in amplitude. If the resistance of R186 decreases only slightly (about 10-20%), resetting R187 should restore vertical sync to normal.

T184—Blocking Oscillator Transformer

If a T184 winding opens or shorts, V7B will no longer function as an oscillator. Grid voltage will be zero or some small negative value. The picture symptom will probably be no vertical deflection, although it is possible

that certain faults in T184 (such as a shorted grid winding) may result in some deflection with a loss of vertical sync. In this case, V7B behaves as an amplifier which amplifies the vertical sync pulses to produce the deflection.

R188 or R189—Oscillator Plate Load Resistors

If either resistor decreases in value, sawtooth-forming capacitor C190 will charge to a higher-than-normal value during vertical trace time. Thus, the picture symptom will be increased picture height and vertical nonlinearity. If R188 or R189 decreases to only a few ohms, severe vertical nonlinearity will result (compression at picture top and expansion at picture bottom and center). If R188 decreases by 10 to 20%, the change may be compensated for by readjusting R189 (the size control), although it may have to be set in an extreme position. The more R188 or R189 decreases in value, the greater V7B DC plate voltage will be. If either resistor opens, there will be no DC plate voltage and no vertical deflection.

C190-R191—Sawtooth-Forming Network

If C190 shorts, there will be very little or no vertical deflection and V7B plate voltage will be very low. If C190 is leaky, some vertical sweep will exist, but with foldover at the bottom. Oscillator frequency is likely to be higher than normal, resulting in a loss of vertical sync. If C190 opens or if R191 opens or increases appreciably in value, very little vertical deflection will result along with a loss of vertical sync; the deflection which is seen may also expand and contract in rapid succession. In this case, the oscillator frequency increases, possibly as high as 1 kc. A fluctuating V7B DC plate voltage will exist.

If C190 decreases in value, an elongated picture (scanning lines spread apart), together with vertical foldover, will result. Since C190 will charge to a higher value, the V7B plate signal amplitude will be greater than normal.

C194—Coupling Capacitor

If C194 shorts, reduced picture height, vertical foldover and nonlinearity will result. The reduced

The Tube-Tester that's always up-to- date!

- fast...
- fully automatic...
- pays for itself

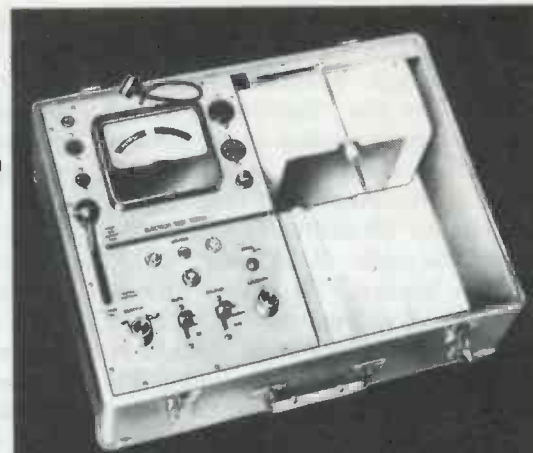

**RCA WT-110A
Automatic Electron
Tube Tester**

\$199⁵⁰* includes 239 punched cards locked in sequence—covers 95% of active TV types...
USER PRICE (Optional) *Prices higher in Hawaii and Alaska

Plus—at no extra cost...



These bonus accessories... 24 additional punched cards, 24 unpunched cards, and sturdy new card punch!

With RCA's exclusive accessory punch and card kit, your WT-110A tester is always up-to-date as fast as new tube type punching information is announced. When you use the RCA WT-110A—the ultra-modern way to test tubes—you gain speed and accuracy for extra service income, and improved efficiency which pays for the tester in a very short time!

Remember, when you choose RCA's WT-110A Automatic Electron-Tube Tester, you also choose a brighter profit picture—now and in the future.

- Fully automatic! Sets up all socket connections and all operating voltages for heater, control grid, plate, screen grid, and bias.
- Checks for shorts and leakage between each element and all others consecutively—plate, screen, control grid, cathode. Multiunit tube sections checked individually.
- Checks amplifier tubes for transconductance—green scale indicates normal range of tube's transconductance.
- File capacity for 700 cards.
- High- and low-sensitivity ranges for gas and leakage tests.
- Automatically selects correct test conditions from 220 different heater voltages (from 0.1 volt to 120 volts) at currents up to 4 amps., 10 bias voltage, and 11 values of cathode resistance.
- Rectifier-type tubes tested for emission under heavy load currents (up to 140 ma per plate).
- 12-volt plate-and-screen supply for testing new auto-radio tubes.

See Your Authorized RCA Test Equipment Distributor!



RADIO CORPORATION OF AMERICA
 Electron Tube Division
 Harrison, N. J.

height is caused by the grid limiting of V8 and the decrease in V7B plate voltage. Vertical foldover is caused by the "flattening" off of the sawtooth portion of the sweep signal as shown in A and B of Fig. 2. Nonlinearity is caused primarily by V8 cathode-to-grid current through R188 and R189, which lowers V7B plate voltage. Abnormal voltage conditions exist as follows: V8 cathode voltage is much higher than 13 volts; V8 grid voltage is approximately the same as V7B plate voltage instead of zero.

If C194 becomes leaky, the picture will probably lock in at 60 cps or 120 cps. If it locks in at 60 cps, it is likely that the bottom portion of the picture will be cramped and the top of the picture will be expanded. If the picture locks in at 120 cps, reduced picture height and extreme vertical foldover will occur.

If C194 opens, no signal will be fed to V8 and there will be no vertical deflection. If C194 decreases in value, V8 grid signal will be less and there will be some vertical deflection.

R195—Grid-Leak Resistor

If this resistor opens or increases appreciably in value, there will be no vertical deflection. Normal deflection may occur (where the picture gradually increases in height) when connecting a VTVM between V8 grid to ground, since the VTVM provides a DC grid return.

C908—Cathode Bypass Capacitor

If C908 shorts, the sweep portion of the V8 plate waveform will become nonlinear (especially at the end of the sweep), causing foldover at the bottom of the picture. See Fig. 2C. R196, the vertical linearity control, will not have any effect on the picture. There will be no V8 grid-to-cathode voltage, and V8 plate voltage will be above normal.

If C908 decreases in value only slightly, reduced picture height will occur; however, normal height can be obtained by resetting R189 and R196. If C908 decreases in value appreciably, proper height and linearity will not be obtained by adjustment of these controls. If C908 opens, there will be about 25% loss in picture height.

R196 or R197—Cathode Bias Resistors

The presence of R197 insures that there will still be V8 cathode bias when R196 is set for minimum resistance. If R197 changes value, resetting R196 will compensate for the change; however, if R197 decreases appreciably

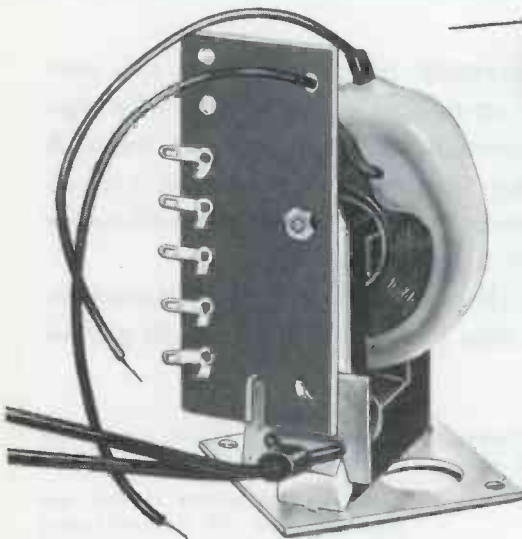

here is PROOF!

This table of STANCOR'S exact replacement flyback coverage is based on an actual count of the models listed in the latest STANCOR TV Replacement Guide. *Only exact replacement flybacks are listed.* These percentages *do not* include flybacks that require chassis or circuit alteration. Actually, true coverage is even higher than these figures indicate since STANCOR covers *all* of the most heavily produced models.

Manufacturer	Stancor EXACT Repl. Flybacks	COVERAGE
Admiral	9	83%
Airline	11	81%
General Electric	14	95%
Olympic	4	83%
Philco	12	90%
RCA	11	91%
Silvertone	11	74%
Zenith	14	97%



Write now for your free copy of the latest TV Transformer Replacement Guide, listing over 17,000 TV models and chassis.

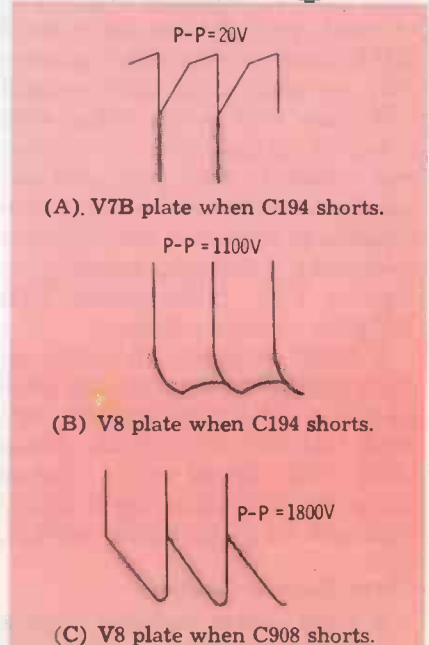

Fig. 2. Waveforms at V7B and V8 plates under specific trouble conditions.

CHICAGO STANDARD TRANSFORMER CORPORATION

3503 ADDISON STREET • CHICAGO 18, ILLINOIS

in value, the excessive current through R196 may cause it to burn out.

C229 & R230—Screen Bypass Capacitor and Voltage-Dividing Resistor

If C229 is leaky, or if R230 decreases substantially in value, V8 screen voltage will decrease and picture height will be reduced. If C229 shorts, picture height will decrease to only a few inches, and the screen voltage will be zero; R231 and R232 will be burned. If C229 decreases in value, degeneration in V8 will occur, reducing picture height. Resetting R189 and R196 may restore the height if the decrease in value is not too great. If C229 opens, about 10 to 50% loss in height will occur, depending on the setting of R189 and R196. Normally, the screen signal voltage is about 1 volt p-p; with this trouble, it will be substantially greater.

R231 & R232—Screen-Dropping Resistors

If either resistor decreases substantially in value, the screen voltage will increase, the screen current will increase, the cathode (and bias) voltage will increase, and V8 will operate along the non-linear portion of its E_g-i_p curve. The result will be a decrease in picture height accompanied by picture expansion at the top (scanning lines spread apart), and compression at the bottom. If the loss in resistance is too great, there will be no vertical sweep.

C71-R70—Vertical Blanking Network

C71 functions to shape and attenuate V8 plate signal voltage into a retrace blanking pulse. If C71 loses capacitance, the blanking pulse amplitude will be reduced, resulting in visible retrace lines at higher brightness control settings. If C71 shorts, considerable current will flow through the brightness control circuit (CRT grid). Brightness will increase, retrace lines will show, and the picture may appear washed out. There may be a slight reduction in picture height, but only temporarily. Before you see it, one of the resistors in the CRT grid circuit will have burned out and CRT cathode voltage will bias it into cutoff (no raster). Subse-

quent failure or trouble with vertical sweep will be due to a faulty R199, since it may be damaged by the excessive current but is not likely to be the first to burn open. If C71 or R70 opens, vertical blanking will not take place, and retrace lines will be seen in the picture.

L151B & R119-R120—Yoke and Damping Resistors

If a winding of L151B (or R199 or R120) shorts, a trapezoidal raster (difference in height at right and left) will be produced.

If L151B opens, a single, wavy horizontal line pattern will result. If R199 or R120 opens or increases in value, probably no noticeable effect will result.

T238—Vertical Output Transformer

If winding opens, there will be no V8 plate voltage and no vertical sweep. If T238 shorts, it will overheat and burn out. Picture height will decrease to a few inches or a single line as soon as the short develops, and no deflection will be observed once it burns open. ▲

**Our
Guarantee
is printed
on our
product**



On every packaged PLANET electrolytic capacitor sold through distributors you will find this statement:

GUARANTEED FOR ONE YEAR

Because PLANET CAPACITORS ARE "ENGINEERED FOR QUALITY", because they are carefully controlled through all stages of production and because the finished product is given a 100% electrical and mechanical check—our one-year guarantee is not only made possible, but is conservative.

Actually thousands and thousands of Planet capacitors five, six and even seven years old are performing excellently, every day, in TV and radio sets all around the world. When you solder a Planet capacitor into a circuit your guarantee of satisfactory performance is right there in front of you—and will be in the circuit for a long, long time. So when you order capacitors—order PLANET.

PLANET SALES CORPORATION

227 BELLEVILLE AVE.

BLOOMFIELD, NEW JERSEY

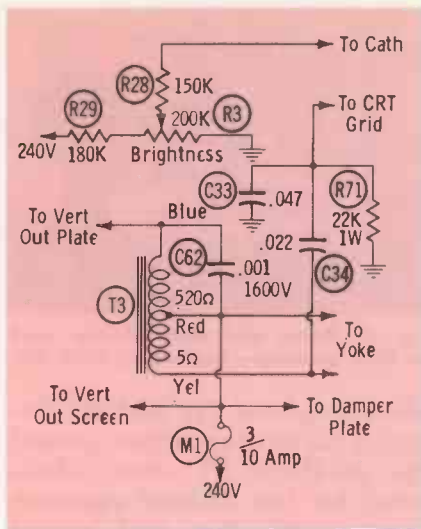

Fig. 3. Circuit containing retrace blanking network used in an RCA portable.

of the time an educated sniff will readily detect the trouble and a good braille reader can do the rest.

However, since the fine old days of wooden sailing ships, things have changed. *Discovery* was an excellent name—then. But in modern electronics, the simple term has given way to the complex, and that noun amounts to little more than another means toward an end. For after *Discovery* we have *recovery*, and then the *hows* and *whys* that collectively complete the solutions.

Let's tackle a 1957 RCA portable model 14S7071G with a KCS102F chassis and a KRK 22R tuner. There are two problems: first, 22K-ohm R71 is burned to a crisp; second, the customer complains of a very faint picture on channel 5. (In the particular locale, this is the weakest of the four allocated stations.)

The "Photofact" schematic in Fig. 3 shows that R71, C33, and C34 are all a part of the vertical retrace blanking network. A nega-

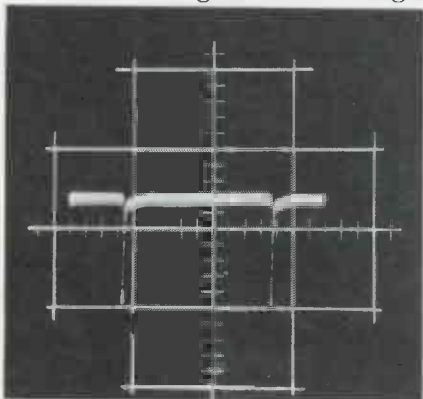

Fig. 4. Waveform of the vertical retrace blanking signal applied to the CRT grid.

tive pulse (Fig. 4) is derived from the vertical output transformer T3 and applied to the CRT grid. Note also that the plate of damper tube V12 is connected directly to the center tap of T3 and to one side of the deflection yoke.

As you may have guessed, M1 was blown. A replacement unit wasn't much help—that blew also. But fundamentally, the extent of the trouble began to shape up.

Thinking Things Over

If you went searching along the 240-volt line through the entire receiver, you'd have an endless task and wind up with literally nothing accomplished. Continuity checks wouldn't help either. For the sake of a starting point, let's go back to burned Mr. R71. He has been so charred by the excess current flow that only the first red identification band is still visible. Tug on him and he breaks apart.

Another look at the schematic reveals a .022-mfd blocking capacitor (C34) between output transformer T3 and the CRT control grid. If C34 were good, you would have a perfect DC block between T3 and the 14RP4A picture tube V15. If you didn't, the woods could be full of strange things.

Well, let's crank up a good VTVM, bridge C34 and see what happens. Only .2 of an ohm—a rather shorted capacitor, wouldn't you say? OK—so you replaced R71, C34, C33 (to be sure) and M1—but don't forget the lesson we learned from the Magnavox. A dead short across C34 will cause the CRT grid to be positive with respect to cathode. Could the picture tube have been damaged before the fuse blew? Wouldn't hurt to use a good tube tester to check it out. And what about the lower portion of T3 and the vertical windings of the deflection yoke? The current that burned R71 also passed through them. Fortunately, the 3/10-amp fuse was adequate protection for them, and as it turned out, the picture tube also; but, as good technicians, it behooves us to think of these things and make sure we correct all the damage before returning the set.

Remember What the Customer Said

Speaking of correcting all the

FREE Information About This

BUSINESS OPPORTUNITY



key to car radio service market

How many car radios have you serviced lately? Most service operators are missing this tremendous market because they have no regular contact with car owners!

This VIS-U-ALL Auto-Radio Service Merchandiser literally moves your shop into the gas stations and garages where car owners must go. It multiplies your sales of parts—booms your repair volume, too. And without increasing your overhead!

Let us tell you how easy it is to increase your net profit by \$50 a week. See distributor or write us.

VIS-U-ALL products company
303 Fuller N.E., Grand Rapids 3, Mich.

repairing P. A.? for the right replacement



you'll find it
faster in the

MASTER

new 1958 edition—world's largest electronic catalog only \$3.50 at your local parts distributor—now Free! Write for Panel Lamp Chart.

THE RADIO-ELECTRONIC MASTER
60 MADISON AVE., HEMPSTEAD, N. Y.

Castle Television Tuner Service

Dealer Net
EACH TUNER
COMBINATION
UHF/VHF
UNITS \$19.90
90 DAYS WARRANTY

Prepaid remittances must include return postage and insurance.

Forward defective tuner complete with GOOD tubes and ALL parts. Quote make and model.

1723 W. LUNT AVE.,
CHICAGO 26, ILL.,
U.S.A.
Ambassador 2-7505

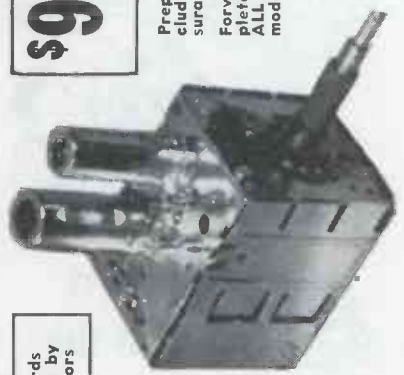

Aligned to Original Standards
Oscillator Tracking Assured by
Crystal Controlled Generators

IMPORTANT
Price includes WORN parts only.
F.O.B. CHICAGO or TORONTO.

DOES NOT include tubes needed; nor parts missing or damaged by abuse and negligent handling.

152 MAIN ST.,
TORONTO 13, ONT.,
CANADA
OXford 4-5637

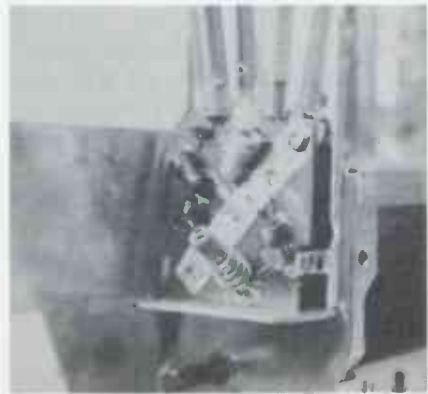

Fig. 6. Bad channel-5 reception was isolated to poor solder joint at balun coil.

SENCORE
FILAMENT
CHECKER

MODEL FC-4

★ COMPLETELY NEW
★ MORE VERSATILE
★ LOWER COST

Quickly finds any open filament. Especially handy for servicing series filament TV sets and radios; only checker that checks all octals, loctals, 7 and 9 pin miniatures automatically.

Continuity and voltage tester — no switches, merely plug in test leads.

Only \$295

DEALER NET WITHOUT LEADS \$2.75

POPULAR SENCORE PRODUCTS

- Transistor Tester
- Leakage Checker
- Filament Tester
- Voltage Regulator
- Bias Supply

AT LEADING DISTRIBUTORS EVERYWHERE
Mfg by

SENCORE SERVICE

INSTRUMENTS CORP.
171 OFFICIAL RD., ADDISON, ILL.

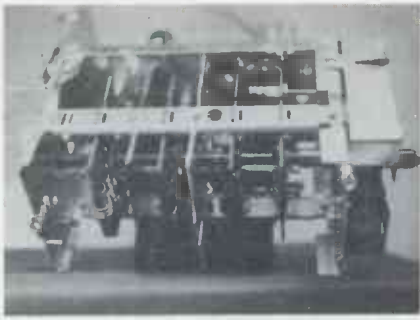

Fig. 5. Location of .68 mmf and injection voltage test point on KRK 22R tuner.

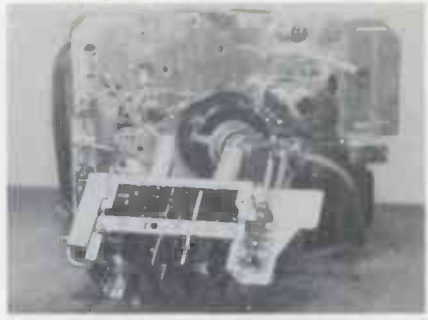

Fig. 7. Tuner and main chassis used in RCA portable—big tuner, little set.

troubles, we now recall that the customer complained about channel 5. Connecting the receiver to an outside antenna and an oscilloscope to the plate of the 2nd IF through a demodulator probe, I checked stage gain and found it to be uniform for all channels except 5. Checks at the plate and grid of the 1st IF revealed the same thing. The difficulty was at once relegated to the tuner.

Some servicemen would throw in the towel at this point, willing to do almost anything to avoid tearing into a tuner. Actually, unless some monkey and a screwdriver got together on the oscillator and RF trimmers, troubleshooting the average tuner is no more of a problem than for any other TV circuit. The first step usually involves removing the protective radiation shield. In many cases, DC voltage for both V1 and V2 can then be checked. For this particular unit, we also had to be sure that the oscillator injection voltage read approximately -3 volts at the black-rimmed test point (see Fig. 5). You may have to use a bias supply at the AGC terminal of the tuner to get a reliable check.

If the voltages are within tolerance, the next step is to reconnect the antenna and tune in the trou-

blesome channel. Try bridging several of the fixed capacitors around the oscillator. (I even substituted for the .68-mmf capacitor between the first and second switch decks.) If these checks produce no obvious results, the difficulty is likely to be confined to the antenna input matching unit ahead of the tuner.

Usually, the search doesn't have to be carried this far. Whether it's going to be something to watch for, particularly in portables, is problematical. As I said before, this was a year-old receiver and it had been in moderate use most of the time. Anyhow, maintaining the receiver on channel 5, I explored the coils following the baluns (Fig. 6) and discovered a bad solder joint at the bottom end of the right balun. Repairs constituted no more than applying the shiny blob of solder evident in the photo of Fig. 6.

As a closing note, you'll probably be interested in Fig. 7, which shows the comparative sizes between the tuner and the main chassis used in the RCA set. Frankly, the tuner work was easier than that performed on the chassis, what with the compact circuitry and printed-board design involved. Oh Well—'nuff said. ▲



AGC Circuits

(Continued from page 17)
included in the Motorola TS-427 and TS-544 chassis. In the latter, an AGC control is provided for regulation of the bias on the outer control grid.

Miscellaneous Circuit Features

Practically all present-day AGC circuits, except the -BU8 designs, fall into one of two basic categories. One of these is the non-amplified type in which the AGC voltage is obtained by filtering the output of the video detector, and

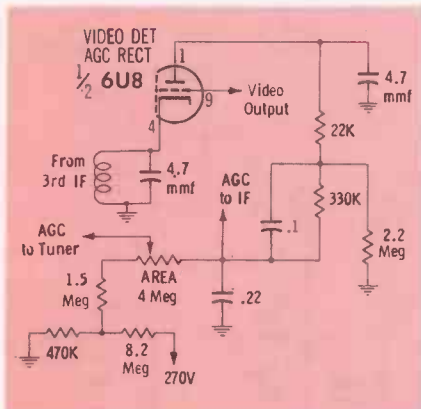

Fig. 5. Triode video detector and AGC rectifier used in Hoffman Chassis 332.

the other is the keyed AGC system. Although these two basic circuit designs are fairly standardized, interesting minor variations of the fundamental circuits are often seen.

The purpose of many design modifications is to increase the effective control range of the AGC system so that the tuner and IF strip can handle the extremely strong signals which are now present in many locations as a result of boosts in transmitter power. One practice which has been widely adopted in recent years is the use of special semiremote-cutoff pentodes (6BZ6, 6DC6) and extended-range, sharp-cutoff pentodes (6DE6) in place of 6CB6's in AGC-controlled IF stages. These newer tube types are able to operate on the linear portion of their characteristic curves over a wider range of AGC voltage values.

An RF delay circuit is also frequently included in AGC systems to increase the set's ability to handle a wide range of signal strengths. The main objective is to reduce the amount of AGC voltage applied to the tuner during reception of weak signals. For

this purpose, a typical delay circuit (such as the one in Fig. 2) includes a connection from the RF branch of the AGC line through a high resistance to B+.

A more elaborate RF-AGC control circuit is used in the Packard-Bell Chassis V8-2. AGC voltage for the tuner is taken from the arm of a potentiometer that is a part of a voltage divider connected between sources of both negative and positive potential. (See Fig. 3.) The voltage present at the RF take-off point depends on two factors: (1) The position

of the potentiometer arm; (2) The value of the AGC voltage fed from the video detector to a fixed tap on the potentiometer.

When the arm is near the top of the control (the end nearer the fixed tap), the voltage obtained from the voltage divider is slightly positive and tends to cancel out some of the AGC voltage for better reception of weak signals. At the bottom end of the control range, the voltage from the divider is slightly negative and adds to the AGC voltage. This supplementary increase of bias on the

GIANT PERFORMANCE IN A SMALL PACKAGE



Tarzian SERIES Silicon Rectifiers



The Handy Five-Pak (Shirt Pocket Size)

- COMPACT—no special holder required . . . supported by pigtail leads
- VERSATILE—will fit into the smallest pocket . . . yet enough power for the biggest color television receiver
- ECONOMICAL—Tarzian's mass production means lower cost to you
- PROVED-PERFORMANCE—in all electronic applications

Send for data sheets.

SPECIFICATIONS

	40K	K-200		40K	K-200
MAX. AC INPUT VOLTAGE	130	130	APPROX. RECTIFIER VOLTAGE DROP	.2	.2
MAX. PEAK INVERSE VOLTAGE	400	360	MAX. OPERATING TEMP.	100°C	100°C
MAX. PEAK CURRENT (MA)	7500	2000	MAX. SURGE CURRENT (AMPS)	.30	.20
MAX. DC CURRENT (MA)	750	200	MIN. SURGE LIMITING RESIS. (OHMS)	7.5	10

DIMENSIONS

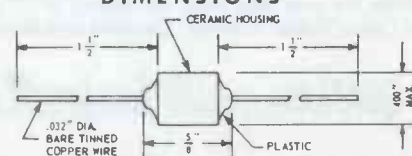

Sarkes
Tarzian, INC.

DEPT. PF2, RECTIFIER DIVISION, 415 N. COLLEGE AVE.
BLOOMINGTON, INDIANA

IN CANADA: 700 WESTON RD., TORONTO 9, TEL. ROGERS 2-7535 EXPORT: AD AURIEMA, INC., NEW YORK CITY

RF amplifier helps to prevent overloading when a strong signal is being received.

Another means of making the AGC system better able to cope with different ranges of signal strength is to place the contrast control in the AGC line instead of in its usual location in the video amplifier circuit. This arrangement, which is well known to "old timers" in the TV field, but which seldom has been employed in the last several years, has made a reappearance in this year's 110° Philco receivers. As shown in Fig.

4, the control adjusts the gain of the RF and IF stages by varying the time constant of the AGC filter.

When the *Fringe* switch is closed, a resistance of about one megohm is shunted across the AGC filter capacitor, lowering its discharge time, thus increasing IF gain in fringe areas.

The unfamiliar-looking resistive network in the RF branch of the AGC line in Fig. 4 is actually very similar in operation to the more conventional delay circuit shown in Fig. 2. Another modified type

of delay circuit, which includes an *Area* control so that the delay can be varied, appears in Fig. 5.

A feature of much greater interest in the latter circuit concerns the method of developing the AGC voltage. In most non-amplified AGC systems now in use, the output of the video detector is simply rectified and filtered, and the control voltage thus obtained is proportional to the average value of the video signal. Somewhat better performance can be obtained by using a separate AGC rectifier designed to produce

**For protection against heat, humidity or dust—
wherever operating conditions are severe—**

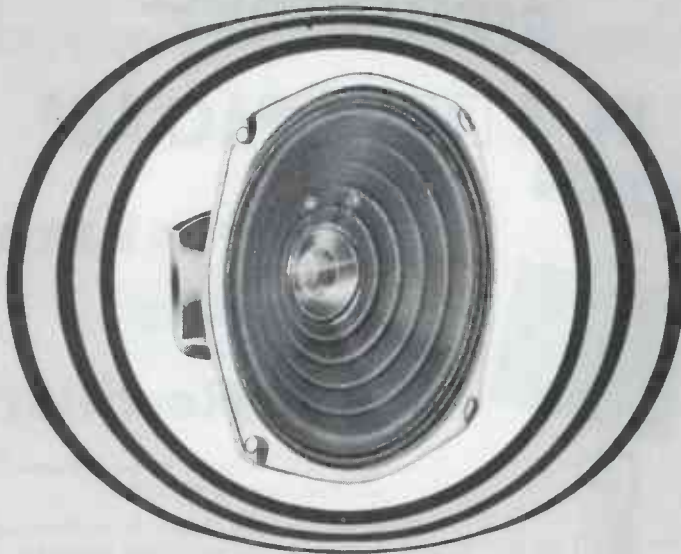

**the installation is safe with QUAM SPEAKERS
featuring the exclusive HUMI-GARD CONE**

This new Quam exclusive, the Humi-Gard Cone, is a plastic-impregnated synthetic fiber fabric cone that has the response characteristics of an untreated paper cone—yet will outlast treated paper cones at least three to one! Not only is it weather-resistant but abrasion-resistant as well! Whenever a TV set or communications system is subject to extreme conditions of humidity, dust or similar situations harmful to speakers, a Quam speaker with a Humi-Gard Cone is the perfect solution. The Humi-Gard Cone is available in speakers up to 6½".

Only in Quam speakers do you get the famous patented Adjust-a-Cone Suspension and U-Shaped Pot, and the new exclusive Humi-Gard Cone.

Write for your free copy of Catalog S-757, describing the complete line of Quam Public Address, Outdoor and Intercom speakers.

QUAM, the quality line for all your speaker needs

QUAM-NICHOLS COMPANY

234 EAST MARQUETTE AVENUE • CHICAGO 37, ILLINOIS

In Canada: A. T. R. Armstrong, Ltd., 700 Weston Road, Toronto 9, Ontario
D. Eldon McLennan, Ltd., 1624 W. Third Avenue, Vancouver 9, B.C.

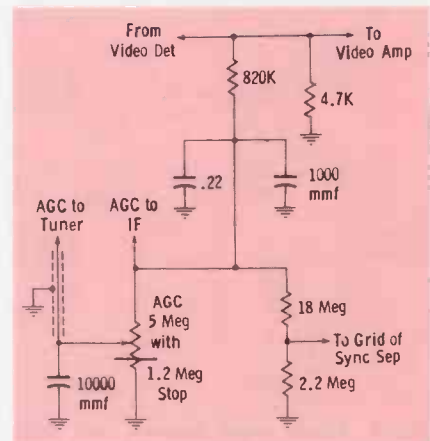

Fig. 6. In Silvertone Chassis 528.51100 tuner AGC voltage is varied with control.

an output proportional to the peak value of the video signal, because peak voltage is a more accurate indication of true signal strength.

In the circuit of Fig. 5, the triode section of a 6U8 is used as though it were a dual diode. The cathode-grid circuit operates as a video detector, and the cathode-plate circuit is connected as a separate AGC rectifier with a high-resistance load circuit to provide peak detection. A very similar circuit is found in the Emerson Chassis 120343-E. Other Emerson receivers of recent design have two separate crystal diode detectors for video and AGC.

Some other 1958 TV receivers have special features such as various kinds of switches or controls. In addition, a connection is sometimes made from the AGC line to the grid of the sync separator to help establish the bias on the latter. The circuit in Fig. 6 contains a couple of examples of these minor modifications. Most AGC circuits containing features of this type are not complicated and should not be too difficult to trace out. ▲

PRODUCT REPORT

Fringe-Area Antenna

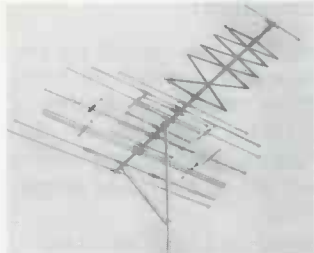

A new fringe antenna, the "Satellite-Helix," has been announced by JFD Electronics Corp., Brooklyn, N. Y. The following electrical features are claimed: Front-to-back ratios up to 15 to 1 on channels 2-6 and up to 18 to 1 on channels 7-13; more gain than previous designs because of new "balanced-sleeve" dipoles with increased capture area; narrower horizontal directivity but wider vertical directivity; and flat frequency response over the VHF television bands. Mechanical features include boom bracing and reinforcement of all elements over 30" long with 15" aluminum dowels.

For further information, check 41S on Literature Card.

Silicon Diodes

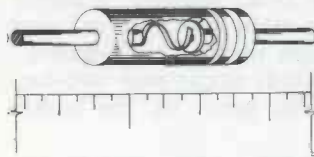

Radio Receptor Co., Inc., Brooklyn, N. Y., has introduced a new line of silicon junction diodes encased in glass. Included in this series is one all-purpose type, the 1N658, which has the following characteristics at 25° C. Average forward DC current 200 ma; maximum inverse voltage, 100 volts; forward voltage drop (at 100 ma), less than 1 volt; operating temperature range, -65° to 175° C. Also available is a series of general-purpose diodes, 1N456 through 1N464, with average forward DC currents ranging from 30 to 90 ma and maximum inverse voltage ratings from 25 to 175 volts.

For further information, check 42S on Literature Card.

Antenna Tower

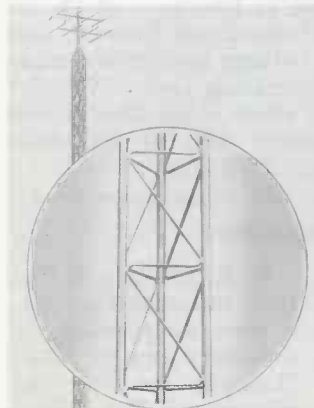

Rohn Mfg. Co., Peoria, Ill., has added a new heavy-duty TV and communications antenna tower to its line. Designated No. 25, the new-type tower is self-supporting in heights up to 50', and can be erected as tall as 150' if guyed. Three main vertical members of 1¼" extra-heavy-gauge steel tubing are joined by steel cross braces into a triangular structure 12½" on a side. Towers are available in either hot-dipped galvanized or enamel finish.

For further information, check 50S on Literature Card.

Special Introductory Offer!

VACO

Red Cap

"At Your Service"

Screw Drivers



Here's your chance to get a beautiful 5-piece screw driver set at a true bargain price! All the most popular sizes (including No. 2 genuine Phillips) plus—a FREE tool hanger board complete with patented, adjustable hanger hooks for holding your most frequently used tools.

A \$5.50 VALUE!

Introductory Special...
Regular price \$3.69
\$2.98
net

FREE Tool Hanger Board and Patented Hanger Hooks

Just mail in the coupon enclosed in the RC 15 Boxed Set and VACO will send you this 12" x 24" perforated masonite panel and set of hanger hooks at no charge.

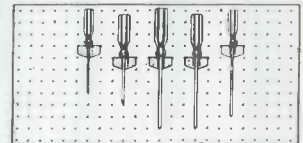

See Your Parts Jobber, Today!

VACO PRODUCTS CO., 317 E. Ontario St., Chicago 11, Ill.
In Canada: Atlas Radio Corp., Toronto 19, Ont.

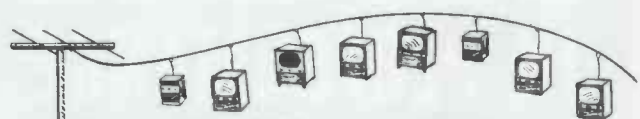

NEW COUPLER

Operates 2 to 20 sets from 1 ANTENNA

WIZARD 300*

CONDUCTIVE CAPACITANCE Set Coupler

HAS NO COILS or RESISTORS

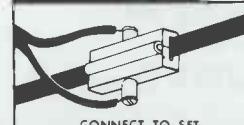
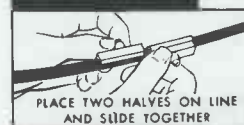

*Pat. Pend.

1. FAST, SIMPLE INSTALLATION

No cutting, splicing, puncturing or soldering... no direct contact with the antenna line.

2. DESIGNED for 300 OHM FLAT LINE

Developed and proved during the past two years, Wizard Couplers are now used in thousands of residential and apartment installations to operate black and white TV, Color TV and FM.

3. PERFORMANCE FACTORS

No impedance mismatch. Insertion loss so slight that systems operating 20 or more sets from 1 antenna require no amplification in normal signal areas. Excellent isolation.

LISTS FOR \$1.95 — Write Dept. PF 8 for additional information and name of your nearest representative.

CHARLES ENGINEERING, INC.
6053 MELROSE AVENUE • LOS ANGELES, CALIFORNIA

LEADING
SET
MAKERS
SPECIFY
TUNG-SOL

HIGH
IN PERFORMANCE



TUNG-SOL®
Magic Mirror Aluminized
PICTURE TUBES

ELECTRON TUBE DIVISION  TUNG-SOL ELECTRIC INC.
NEWARK 4, NEW JERSEY

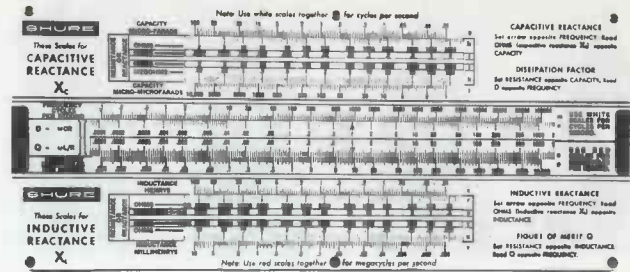

Reactance Calculator

Shure Bros., Inc., Evanston, Ill., has issued an improved type of reactance slide rule for use in computing capacitive and inductive reactance, figure of merit (Q), and dissipation factor. The device includes two separate sets of scales, permitting calculations to be made in terms of either cycles or megacycles per second. Price is 75¢.

For further information, check 48S on Literature Card.

High-Gain Antenna

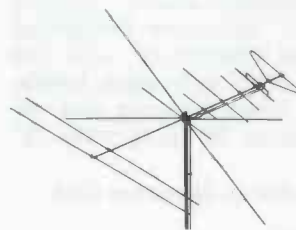

The "Winged" 88 antenna made by Trio Mfg. Co., Griggsville, Ill., is a new, higher-gain version of the "Sharpshooter" 88 conical-yagi antenna. The new design is not a replacement for the original "Sharpshooter," but is an addition to the Trio line. Its most novel feature is a "winged" director element resembling the one used in "Zephyr" and "Color Series" antennas; also new is a "T-match" dipole behind the director. Both single and two-bay models are available, and list price on the single unit is \$13.15.

For further information, check 43S on Literature Card.

DC Power Supply Kit

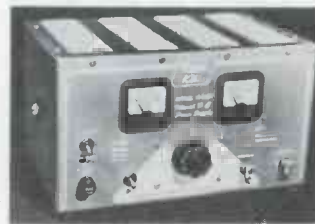

Electro Products Labs., Chicago, Ill., has made available a DC power supply kit, Model K-612T, with two continuously variable output ranges of 0-8 and 0-16 volts DC. Ripple in the output voltage is as low as 1/10 of 1% for very light loads such as transistor portable radios, or as low as 1/2 of 1% for loads up to 5 amps. The choke-input filter is said to provide unusually good voltage regulation, making the K-612T capable of operating Delco "Wonder Bar" auto radio tuners and other solenoid-operated devices that draw very heavy current for short periods. Net price of the kit is \$44.95.

For further information, check 44S on Literature Card.

Ceramic Capacitors



P. R. Mallory & Co., Inc., Indianapolis, Ind., is now distributing an extensive line of RMC "Discaps" (ceramic disc capacitors). The following types rated at 1,000 WVDC are available:

NPO units ranging in value from 1 to 150 mmf, N750's from 2.2 to 300 mmf, and bypass types from

150 to 20,000 mmf. In addition, high-voltage types for either deflection-yoke or general-purpose applications are supplied in ratings of 2, 3, and 6KV. Many popular values of AC line filter capacitors, rated at 1,400 WVDC, are also in stock. For transistor applications, types rated at either 50 or 100 WVDC in values from 5,000 mmf to 1.0 mfd are furnished. "Discaps" are stocked on 3 x 5 file cards, with 5 identical capacitors mounted on each card.

For further information, check 45S on Literature Card.

Merchandising Aids

Mylar Capacitors

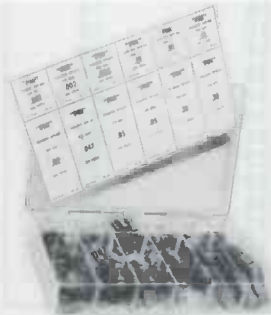

Cornell-Dubilier Electric Corp., South Plainfield, N. J., has announced a kit consisting of 80 assorted Mylar dielectric "PM" tubular capacitors packed in a clear plastic box. Values ranging from .0001 to 1 mfd in ratings of 200, 400, and 600 volts are supplied.

For further information, check 51S on Literature Card.

Phono Needle Stock



Jensen Industries, Forest Park, Ill., is packing a display of 100 phonograph needles and a supply of sales literature into a leather attache case, which is offered free to dealers or distributor salesmen who buy the complete stock of needles.

For further information, check 52S on Literature Card.

Screw-Holding Screwdrivers



Kedman Co., Salt Lake City, Utah offers a gift package (\$3.98 retail) containing 3 "Quick Wedge" screwdrivers.

For further information, check 46S on Literature Card.

Tubular Capacitors



Arco Electronics, Inc., New York, N. Y., has announced a "TV-600" package of 200 assorted "Elmenco" 600-volt tubular capacitors and a free 16-drawer cabinet.

For further information, check 47S on Literature Card.

Service Cases



General Electric Co., Receiving Tube Dept., Owensboro, Ky., has introduced a tool case and two tube caddies with capacities of 160 and 240 tubes, respectively.

For further information, check 49S on Literature Card.

LEADING INDEPENDENT SERVICE DEALERS CHOOSE TUNG-SOL

LOW IN CALLBACKS

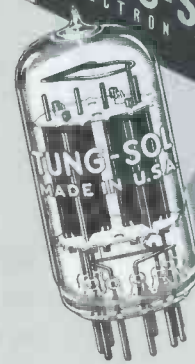

BLUE CHIP
QUALITY

TUNG-SOL® RECEIVING TUBES

ELECTRON TUBE DIVISION  TUNG-SOL ELECTRIC INC.
NEWARK 4, NEW JERSEY

Audio Facts

(Continued from page 21)

low-frequency speakers (Fig. 5B) longer than the magnet gap so that the percentage of the voice coil affected by the concentrated field will remain the same regardless of movement. Voice coils of high-frequency speakers are made shorter than the magnet gap so that the coil never gets out of the concentrated field (Fig. 5C).

Magnetic Field

Cone movement is caused by reaction between the magnetic fields of the voice coil and the permanent magnet assembly of the speaker. Obviously, stronger fields will result in greater cone movement. In order to decrease the maximum voice-coil field and still obtain the same cone movement, therefore, the strength of the permanent field must be increased. There are two ways to increase the effective strength of the permanent field in a speaker— increase the size of the magnet or reduce the magnet gap. The gap can be decreased only to a certain point because the voice coil must

Table I—Power Output in Terms of Voltage Across Fixed Resistor.

DUMMY LOAD— —4 OHMS		DUMMY LOAD— —8 OHMS		DUMMY LOAD— —16 OHMS	
VOLTAGE	WATTS	VOLTAGE	WATTS	VOLTAGE	WATTS
2	1	4	2.0	8	4
2.3	1.3	5	3.125	9	5
2.6	1.71	6	4.5	10	6.25
3	2.25	7	6.125	11	7.5
3.5	3	8	8	12	8
4	4	9	10.1	13	10.6
5	6.25	10	12.5	14	12.25
6	9	11	15	15	14
7	12.5	12	18	16	16
8	16	13	21	17	18
		14	24.5	18	20
		15	28	19	22.5
		16	32	20	25
				21	27.5
				22	30
				23	33
				24	36
				25	39
				30	56
				35	75.6
				40	100

have suitable clearance. It is the practice to design the cone- and voice-coil assembly, and then tailor the magnet assembly to meet the requirements of the speaker. Thus, with a predetermined gap size, the permanent magnet requirements can readily be determined.

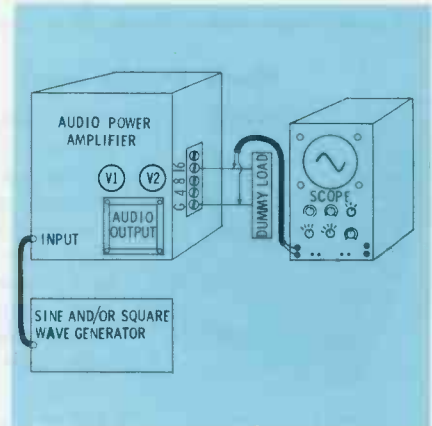
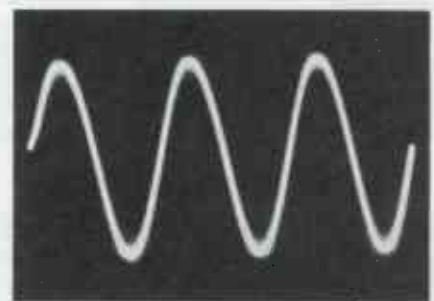
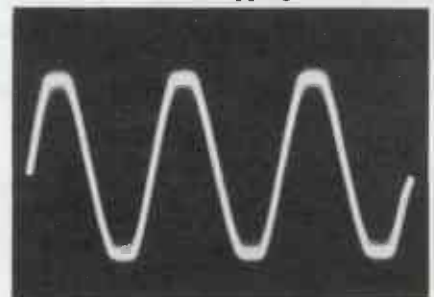

Fig. 6. Test setup for checking amplifier gain over the audio frequency range.



(A) No clipping.



(B) Mild clipping.

Fig. 7. Comparison of scope patterns observed when setting generator gain level.



MODEL 616



MODEL 622A

Hycon 5" OSCILLOSCOPE

Triggered or recurrent sweep, and wide-band response.

A high-precision 'scope, built for pulse work and TV service.

At your distributor **\$426.00**

Hycon COLOR BAR / DOT GENERATOR

—the complete
color signal
test instrument

All operating controls are on the front panel—and a single switch selects all functions. Electronically regulated power supply for stable, reliable operation. NTSC pattern.

At your distributor.....**\$485.00**



Hycon ELECTRONICS, INC.
A SUBSIDIARY OF HYCON MFG. CO.
370 So. Fair Oaks, Pasadena, Calif.

There is also the further consideration of damping. This has to do with how fast the voice coil is brought to rest after it has been pulse-excited. A strong magnetic field is required to obtain adequate damping. Speakers with large voice coils, heavy cones and relatively free suspension systems require that a very strong permanent magnet be used. While a

heavy magnet isn't necessarily the mark of a good quality speaker, it is necessary for good quality reproduction. For general replacement purposes, it is safe to say that the speaker with the heavier magnet and felted cone is better and should be used if space and cost limitations permit.

Using the Square Wave Generator to Test Amplifier Response

Testing a high-quality amplifier without using specialized equipment has always been a problem. However, it is possible to check an amplifier for power output and frequency response with an audio signal generator, AC voltmeter, and scope. If the scope has a wide bandpass response, flat from 0 to 1,000,000 cps or greater, a square-wave audio signal can be used to check both high- and low-frequency responses of the amplifier. If, however, your scope is of the general-service type (response to 500kc), then a sine-wave signal is more suitable for your tests. The limited response of a narrow-band scope will distort the square wave slightly and affect the accuracy of the test.

In making the test setup, the audio signal is applied to the input of the amplifier and the speaker output terminals are terminated with a suitable resistor (8 or 16 ohms of a wattage equal to or greater than the power rating of the amplifier). The scope is connected across this resistor as shown in Fig. 6. We have found that a 25-ohm, 100-watt potentiometer makes a good, universal dummy load.

After allowing about 15 minutes for warmup, the signal generator frequency is set at 1000 cps and the signal level adjusted to the point just below clipping as illustrated in Fig. 7. The AC output voltage can now be measured across the dummy resistor. A sensitive AC-VTVM is best for this measurement; however, a conventional 5000 ohm-per-volt VOM will give satisfactory performance. Compare your readings with those given in Table I to obtain the power output capability of the amplifier under test. If you used a conventional VOM, your amplifier is producing a power output

ABOUT THE COVER

No—it's not a "kiddie car." "Brick" Brikmanis, 6' 7" basketball star, just makes it look that way. It's the new Berkeley sports car, 130" long and 30" high, equipped with 2-cylinder, 2-cycle, air-cooled power plant.

While model Mary Hirsch looks on, lanky "Brick" is doing his darndest to install a radio no bigger than his hand—a problem you may someday face.

Which reminds us—with the traditional slump in TV service at hand, many dealers and service shops will be supplementing their business with auto-radio repairs. Why not you, too?



Dynamic Picture Tube Tester Makes Skeptical Set-Owners Satisfied Customers!

Pix-Chex gives proof positive of picture tube failure to skeptical set-owners . . . and you! You prove your point when you point to your Pix-Chex indicator. Answers all questions for you and your customers yet easily fits your pocket . . . and your pocketbook!

- CHECKS EMISSION
- Checks picture tube in set, in the box or on the bench.
- Transformer powered.
- Checks grid-cathode short.
- Checks heater-cathode short.
- Detects shorts up to 50,000 ohms.
- Checks filament.
- No gimmick rejuvenators.

POCKET SIZE
\$4.95
ONLY NET

Available at your jobbers



HALLMARK ELECTRONICS CORP.
3104 Spring Garden St.
Philadelphia 4, Pennsylvania
BA 2-4333

(Advertisement)

latest JACKSON tube test data

MODEL 648		PLATE		CIRCUIT		MODEL 115/715/561	
TUBE TYPE	FIL. D.	FIL.	E. TEST	X.	PLATE	Y.Z.	
4DE5	4.2	AC1234	567* 15W	4.2	28	2LMS	
5E8	5.0	A125	C388* 20W	5.0	34	5RS	
		127	A46 35Z		10	2PS	
6DW5	6.3	A129	B346 30W	6.3	4	8	7JKS
		AC1234	567* 26W		25	2LMS	
7036	6.3	237	AC14	17YZ	6.3	24	35
							51Q
7137	6.3	3	X	15E7	2	28	
							32
5E8	P	5.0	4	X	236	7	32
	T	5.0	4	X	19	8	
6DW5	P	6.3	4	6	139	7	4
	P	6.3	3	-	1567	2	7
7036	T	6.3	3	56X	17	2	30

Latest Chart Form 648-19, 115/715/561-10, 49-4

This is the 2-Set TV COUPLER Rated No. 1

• • • by a nationally known independent product quality rating group as the result of tests made on 10 leading two-set couplers for:

- IMPEDANCE MATCH
- SIGNAL TRANSFER
- TWO-SET ISOLATION

MOSLEY 902



List Price \$3.10

Rated **FIRST** in overall quality for weak signal reception means; the MOSLEY 902 Dual Match 2-Set TV Coupler can be sold and installed in practically any TV area with full confidence that your customers will be completely satisfied!

Available at Radio and Television Parts Distributors — coast-to-coast.

Mosley Electronics, Inc.
8622 ST. CHARLES ROCK ROAD
ST. LOUIS 14, MISSOURI

GC SERVICE CHEMICALS

G-C DE-OX-ID
Cleans and prevents oxidation on TV, radio, other electronic circuit contacts. No harmful solvents or acids.
No. 19-2 2 oz. . . . List \$1.60

G-C RADIO-TV SERVICE CEMENT
High grade cement for making speaker repairs and other services. Fast-drying, waterproof, permanent.
No. 30-2 2 oz. . . . List \$0.75

G-C TV CORONA DOPE
Use to prevent corona shorts in high voltage circuits in TV sets, electronic circuits. Fast-drying.
No. 50-2 2 oz. . . . List \$1.20

GENERAL CEMENT MFG. CO.
Division of Textron Inc., Los Angeles—Rockford, Illinois

ASK YOUR G-C JOBBER
FREE CATALOG . . . send postcard today!

MAKE YOUR STANDARD TEST PRODS
TEN TIMES
MORE EFFECTIVE IN SECONDS
WITH THE NEW
E-Z-HOOK TIP
CONVERTS YOUR STANDARD TEST PROD TO A SELF-HOLDING CONNECTOR



Here are the TEN added advantages you get with the E-Z-Hook Tip:

1. Frees your hands
2. Won't slip off
3. Insures positive connection
4. Makes difficult connections
5. Easy to connect or disconnect
6. Fits irregular shaped conductors
7. Fully insulated
8. Small and compact
9. Hands clear of wiring
10. Easy to use

No. 56-1 E-Z-HOOK Tip Only 89¢ ea.

ORDER THROUGH YOUR PARTS DISTRIBUTOR



E-Z-HOOK TEST PRODUCTS
Dept. H-1 1536 Woodburn Ave.
Covington, Ky.

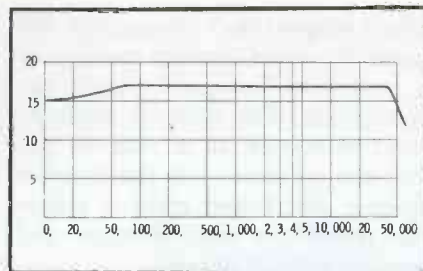

Fig. 8. Amplifier response graph obtained by plotting of output voltage readings.

equal to or slightly higher (10 to 15%) than the figure given in the table.

To check frequency response, adjust the signal generator frequency to the lowest frequency the amplifier is designed to pass, and adjust the output of the generator to produce a signal level above which clipping will take place. Repeat this operation at 500- to 1000-cps increments across the audio spectrum, noting the voltage reading obtained. Plotting the readings on a graph as shown in Fig. 8 will provide you with a gain curve of the amplifier. You won't know about harmonic or intermodulation distortion, but if the gain curve is fairly flat across the band (similar to Fig. 8), the amplifier is doing a reasonably good job. If you need a more accurate check, use a harmonic distortion analyzer and intermodulation analyzer in the prescribed manner.

Products for Profit

Integrated Amplifier

The Model HF-32 integrated-type high-fidelity amplifier produced by EICO of Long Island City, features the new "low-silhouette" look, and is both compact and attractive. Four EL84 tubes used in a push-pull parallel configuration provide up to 30 watts of audio power continuously, 47 watts peak. Other specifications given by the manufacturer are:

IM Distortion (60 cps and 7kc mixed 4:1): 2% at 30 watts, 1% at 20 watts, .5% at 10 watts.

Harmonic Distortion: Less than 1% (20 cps-20kc) within 1 db of 30 watts.

Frequency Response: ± 5 db from 10 cps to 50 kc and ± 1.5 db from 10 cps to 100 kc at 1 watt; $\pm .5$ db from 15 cps to 50 kc and ± 1.5 db from 15 cps

to 100 kc at 30 watts; ± 1 db from 15 cps to 30 kc at any level between 1 mw and 30 watts.

Square Wave Response: 20 cps to 20 kc essentially undistorted.

Inverse Feedback: 20 db.

Damping Factor: Above 10, 20 cps-20 kc.

Output Impedance: 4, 8, and 16 ohms.

Tone Control Range: Treble at 10 kc-13 db boost, 15 db cut; bass at 50 cps—14 db boost, 15 db cut.

Equalization: Mag phono input—RIAA, Columbia (original LP), London, American 78; tape head input—NARTB.

Sensitivity: Mag phono, 5 millivolts; tape input, 2 millivolts; microphone, 4 millivolts; high level inputs (TV, tuner, Aux) .4 volts.

Five rotary controls and two slide switches constitute the front panel controls which are, left to right, the function selector switch,

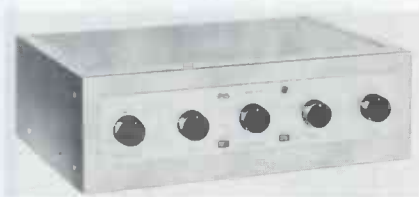

EICO Model HF-32 Amplifier

level or gain control, rumble filter, loudness control, scratch filter, bass control, and treble control on-off switch. A pilot light, upper center, is also provided to signify when the equipment is in operation. The function selector is a 9-position rotary switch that doubles as an equalization selector on phono input. Inputs that may be selected by the function switch are: Aux, TV, Tuner, MIC, Tape Head, and 4 equalized phono positions—same input with either 78, RIAA, COL or LON equalization. Tape equalization is automatically provided in the Tape Head position. The HF-32 is supplied in either wired-form at \$89.95, or kit-form at \$57.95.

Stereo Hi-Fi Preamp-Control Amplifier

Pilot Radio Corp. has recently added a new stereo preamp-control amplifier, Model SM-244, to its line of hi-fi equipment. Among its salient features are two self-contained power amplifiers, each



Pilot Model SM-244 Stereo Preamp

of which is rated at 14 watts (28 watts peak) with less than 1% distortion. Inputs are provided for stereo phono, stereo tape, stereo microphones, stereo FM-AM broadcasts, and auxiliary operation. A *Mode* switch on the front panel permits the operator to select stereophonic normal or reverse operation or monaural channel A or B as desired. The *Balance* control adjusts the relative level of each stereo channel so that balanced operation for true stereo performance, or unbalanced operation for special effects, can be obtained as desired. Continuous equalization using the calibrated tone controls is another outstanding feature. *Volume, Loudness, Bass* and *Treble* controls affect both channels simultaneously, making the operation of this stereo unit almost as simple as the conventional single channel unit.

The SM-244 is housed in a brushed brass and burgundy metal enclosure, which is 4¾" high, 14¾" wide and 12¼" deep, and will retail at \$189.50 (slightly higher in the 11 Western States).

Stylus Balance

Audax, Inc., a division of Rek-O-Kut Co., Inc., is now marketing a new stylus balance scale. This is a redesigned version of the older Audax balance, and consists of balance arm, knife-edged fulcrum, and 3 precision weights. The weights may be used singly or in combinations to achieve proper balance of commonly-used cartridges for both turntables and changers. All hi-fi customers, especially those with expensive record collections, are potential users



Audax Stylus Balance

of such a scale because of the necessity for correct stylus pressure in maintaining proper tracking and in preventing excessive stylus and record wear. By simply advising your audiophile customers of these facts, you are almost assured of a sale.

The Audax balance retails for \$3.95 and is supplied in a compartmented, foam-filled, clear plastic case.

Audio Test Equipment

The Model WV-74A vacuum-tube-AC voltmeter just added to RCA's line of test instruments is very useful in servicing high-quality audio equipment. One application is given in the servicing section of this article—the measurement of AC voltage across a dummy load to determine amplifier power output. Another application entails measurement of sig-



RCA Model WV-74A VTVM

nal output from a phono cartridge excited from a test record.

The meter features 9 overlapping ranges and will measure voltages from .01 volts to 100 volts full scale and decibels from -40 to +40. In addition, the WV-74A can be used as a wide-range audio preamplifier having about 38-db maximum gain. Frequency range on all measurements and amplifier functions is 20 cps to 500 kc. The amplifier function also makes this unit useful as a narrow-band scope preamplifier for signals within its bandpass range.

The power supply is designed to operate over a range of power line frequencies from 50 to 400 cps. Power consumption is 35 watts.

The unit uses a 6½" meter contained in a die-cast aluminum case measuring 7" wide, 6½" high and 3¾" deep and weighs 6 pounds. ▲

WILL YOUR REPLACEMENT Fuse Resistor BURN OUT AGAIN?
Not if you use—
The NEW SENCORE "FUSE-SAFE" CIRCUIT TESTER

Another Sencore Time-Saver

Save costly call backs by testing the circuit before replacing fuse, fuse resistor or circuit breaker.



Individual scale for each value fuse resistor — no interpretation, just read in red or green area.

★ Measures line current and up to 1100 watts of power at 115 volts using line cord and socket.
★ Two convenient current ranges — 0 to 2 amps and 0 to 10 amps. Test leads clip in place of fuse or fuse resistor.

★ 5 ohm, 10 watt resistor prevents TV circuit damage and simulates operating conditions.

As Recommended by Leading Manufacturers

SENCORE Mfg. by SERVICE INSTRUMENTS CORP. 171 OFFICIAL RD., ADDISON, ILL.

Cut out this ad now for further information

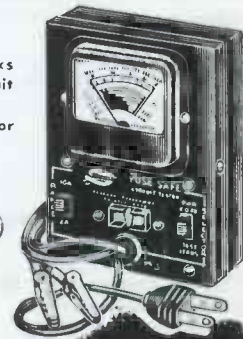

\$8.95 DEALER NET
MODEL FS-3
AC-DC or both as
needed for Fuse
Resistor Circuits

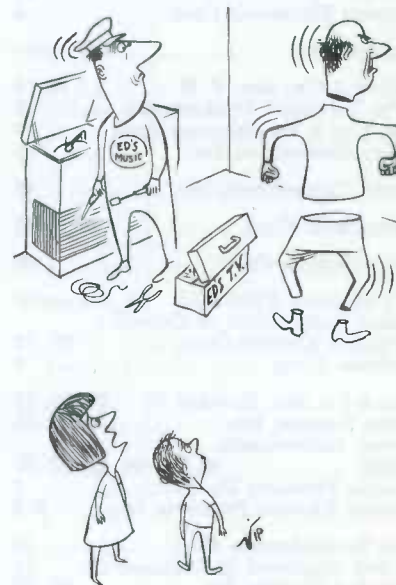

"Papa really goes to pieces when they forget to bring **JENSEN NEEDLES.**"



PF REPORTER

INDEX TO ADVERTISERS

June, 1958

Advertisers	Page No.
Aerovox Corp.	42
Anchor Products Co.	44
Astron Corp.	26
B & K Mfg. Co.	1
Belden Mfg. Co.	27
Bussmann Mfg. Co.	23
Castle TV Tuner Service	58
Centralab, A Div. of Globe-Union, Inc.	47
Charles Engineering, Inc.	61
Chicago Standard Transformer Corp.	54
Clarostat Mfg. Co., Inc.	35
Cornell-Dubilier Electric Corp.	30, 31
EICO	52
E-Z Hook Test Products	66
Electro-Voice, Inc.	11
Electronic Publishing Co.	24
General Cement Mfg. Co.	44, 52, 66
General Electric Co.	29
Hallmark Electronic Corp.	65
Hycon Electronics, Inc.	64
Illinois Condenser Co.	49
International Resistance Co. (IRC)	2nd cover
Jackson Electrical Instrument Co.	65
Jensen Industries, Inc.	67
Jerrold Electronics Corp.	37
Kedman Co.	56
Kingston Electronic Corp.	4
Littelfuse, Inc.	4th cover
Mallory & Co., Inc., P. R.	14-15
Marjo Technical Products Co.	48
Merit Coil & Transformer Corp.	39
Mosley Electronics, Inc.	65
Oxford Components, Inc.	49
Planet Sales Corp.	55
Quam-Nichols Co.	60
RCA Electron Tube Div.	53, 3rd cover
Radiart Corp.—Div. of Cornell- Dubilier Electric Corp.	30, 32
Raytheon Corp.	5
Sams & Co., Inc., Howard W.	25, 36, 43
Sarkes Tarzian, Inc.	59
Service Instruments Corp.	24, 39, 48, 56, 58, 67
Sprague Products Co.	2
Sylvania Electric Products, Inc.	8-9
Tobe Deutschmann Corp.	33
Triplett Electrical Instrument Co.	41
Tung-Sol Electric, Inc.	62, 63
United Catalog Pubs., Inc.	57
Vaco Products Co.	61
Vis-U-All Products Co.	57
Ward Products Corp.	13
Webster Electric Co.	45
Wright Steel & Wire Co., G. F.	46
Xcelite, Inc.	46
Zenith Radio Corp.	6-7

CATALOG and LITERATURE SERVICE

ACCESSORIES

- 1S. *E-Z-HOOK*—A convenient reference sheet titled, "How to Build the Five Most Useful Scope Probes," with schematic, mechanical component layout, etc. *See ad page 66.*

ANTENNA DISTRIBUTION

- 2S. *CHARLES ENGR.*—Complete description of new conductive-capacitance TV set coupler and how it's used for coupling 2, 5, 10, 20 or more sets to one antenna without amplification. *See ad page 61.*
- 3S. *JERROLD*—New 8-page illustrated catalog on equipment for improving home TV reception, simplifying TV distribution systems, and improving TV servicing. *See ad page 37.*

AUDIO ACCESSORIES

- 4S. *TELEX*—4-page catalog on headsets, listening devices and accessories, plus sub-miniature components. Also data sheets on underwater and boom-type headsets.

AUTO ANTENNAS

- 5S. *WARD*—Catalog on new auto antenna featuring "Lok-Matic" fingertip installation. *See ad page 13.*

BUYING GUIDES

- 6S. *UCP*—Complete descriptive literature on Radio-Electronic Master, 1584-page buying guide for the industry. *See ad page 57.*

CAPACITORS

- 7S. *CORNELL-DUBILIER*—Motor start-run capacitors. Bulletin XTR-MOT. *See ads pages 30, 31.*
- 8S. *SPRAGUE*—"ABC's of Ceramic Capacitors," comprehensive brochure on theory and applications. *See ad page 2.*
- 9S. *TOBE DEUTSCHMANN*—Catalog No. 5701. *See ad page 33.*

CONTROLS

- 10S. *IRC*—DLR-58 replacement parts catalog. *See ad 2nd cover.*

FUSES

- 11S. *BUSSMANN*—Complete TV Fuse Guide shows types and ampere ratings of fuses used in various TV sets. *See ad page 23.*

INDOOR ANTENNAS

- 12S. *MARJO*—Specification Sheet #14A on "Channel King" indoor TV antenna. *See ad page 48.*

MICROPHONES

- 13S. *ELECTRO-VOICE*—Catalog #126 on public-address and general-purpose microphones. *See ad page 11.*

PHONO NEEDLES

- 14S. *JENSEN IND.*—New handbook for Jensen Needle dealers. *See ad page 67.*

POWER SUPPLIES

- 15S. *PERMA-POWER*—New catalog of entire line including the new "Magneformer" and Model A410 power supply.

RECTIFIERS

- 16S. *SARKES TARZIAN*—Completely revised Silicon Rectifier Handbook No. 67—40 pages of technical data on complete line of silicon units. *See ad page 59.*
- 17S. *WESTINGHOUSE*—Folder on new silicon TV rectifier, part no. IN-1169.

SALES PROMOTION

- 18S. *VIS-U-ALL*—Auto-radio service merchandising manual. *See ad page 57.*

SERVICE AIDS

- 19S. *ANCHOR*—Colorful catalog sheet on complete "Britener" line, plus several new TV service aids. *See ad page 44.*
- 20S. *HALLMARK*—Catalog sheet and price list on CRT tester. *See ad page 65.*

SPEAKERS

- 21S. *QUAM-NICHOLS CO.*—1958 speaker catalog listing 111 replacement speakers for outdoor and high-fidelity applications. *See ad page 60.*

SWITCHES

- 22S. *GENERAL CEMENT*—Switch chart—Form 3670. *See ads pages 44, 52, 66.*

TECHNICAL PUBLICATIONS

- 23S. *CBS-HYTRON*—New complete descriptive folder for Transistor Home-Study Course, PA-176.
- 24S. *HOWARD W. SAMS*—Complete details on free file cabinet program. *See ads pages 25, 36, 43.*

TEST EQUIPMENT

- 25S. *B&K*—Bulletin AP12 gives helpful information on new point-to-point signal-injection techniques with Model 1075 TV "Analyst"; other bulletins describe "Dyna-Quick" Models 500B, 650, and automatic 675 portable dynamic mutual conductance tube and transistor testers plus Model 400 CRT cathode rejuvenator tester. *See ad page 1.*
- 26S. *CLAROSTAT*—Power resistor decade box—225 watts, 1 ohm to 999,999 ohms in 1-ohm steps. Form #755259. *See ad page 35.*
- 27S. *EICO*—New 1958 16-page catalog shows you how to save 50% on test instruments and hi-fi equipment in both kit and factory-wired form. *See ad page 52.*
- 28S. *JACKSON*—Folder covering entire line of "Service Engineered" test equipment. *See ad page 65.*
- 29S. *KINGSTON*—4-page folders give details on "Probe-Master" and transistor radio probe. Illustrated 8-page accordion folder shows the unique top-side troubleshooting operation of "Absorption Analyzer." *See ad page 4.*
- 30S. *SERVICE INSTRUMENTS*—Stuffer on ten most popular Sencore time-savers. *See ads pages 24, 39, 48, 56, 58, 67.*
- 31S. *TELETEST*—6-page booklet presents details on testers for flybacks, capacitors, and tubes, including a CRT rejuvenator and hundred-card tube tester. Uses for each are given.
- 32S. *TRIPLETT*—Transistor tester circular. *See ad page 41.*
- TOOLS**
- 33S. *KEDMAN*—Catalog sheet describing 4 screwdriver displays and specifications of 14 kinds of screwdrivers in the company's line. *See ad page 56.*
- 34S. *VACO*—Catalog on new "Red Cap" screwdriver deal featuring free tool hanger board. *See ad page 61.*
- 35S. *XCELITE*—Illustrated catalog on full line plus literature on new products. *See ad page 46.*
- TRANSFORMERS & COILS**
- 36S. *CHICAGO STANDARD*—100-page TV Transformer Replacement Guide, cross-referenced for over 7,000 chassis of 98 manufacturers. *See ad page 54.*
- 37S. *MERIT*—Catalog No. 5811 listing more than 900 coils and transformers. *See ad page 39.*
- TUBES**
- 38S. *RCA*—Form No. 1275-H, receiving and picture tubes for AM, FM, and television broadcasting. *See ad 3rd cover.*
- 39S. *RAYTHEON*—Revised 14-page Television Picture Tube Characteristics booklet includes data on aluminized black and white and color tubes, face plate deflection angle, bulb dimension, ion trap information, and basing diagrams. *See ad page 5.*

VIBRATORS

- 40S. *RADIART*—1958 Vibrator Supplement Guide. *See ad page 32.*



SUPPLEMENT TO SAMS FEBRUARY 1958 MASTER INDEX

Covers PHOTOFACT Set Numbers 390 through 404 Released

MARCH through JUNE

This Supplement is your index to new models covered by PHOTOFACT since March 1958. For model coverage prior to this date see the Sams Master Index dated February 1958. Use this Supplement with the Sams Master Index—together they are your complete Index to PHOTOFACT coverage of over 30,000 receiver models.

Table with columns for Set No., Folder No., and model names/numbers. Sections include ADMIRAL, AIRLINE, BLAUPUNKT, BUICK, CADILLAC, CHALLENGER, CHEVROLET, COLUMBIA RECORDS, DUMONT, EMERSON, and FIRESTONE. Each section lists various radio receiver models and their corresponding set and folder numbers.

THIS IS YOUR LATEST INDEX SUPPLEMENT!
FOR COMPLETE PHOTOFACT LISTINGS
USE IT WITH THE FEBRUARY 1958 MASTER INDEX!
THROW AWAY
ALL OTHER SUPPLEMENTS

NOTE: PCB Denotes Production Change Bulletin. • Denotes Television Receiver. S Denotes Schematic Coverage Only.

Set No.	Folder No.
ZENITH—Cont.	
Ch. 17A20, Q, U, 17A21Q	393—4
Ch. 17A30, Q, 17A31Q	390—13-5
Ch. 17Y23, U (See Photofact Servicer)	402
Ch. 17Z33, Q	357—14-5
Ch. 19A20, Q, U	394—4
Ch. 20J23 (See Photofact Servicer)	403

AUTO RADIOS

AIRLINE	
FJB-6571 (See Photofact Servicer)	401

AMERICAN MOTORS	
84MA (8990494)	394—6
8990494	394—6

AUTOMATIC	
CRT-97	403—12-5
CTR-77, CTR-77A	403—12-5
DET-27	403—12-5
FTP-37A	403—12-5

BECKER	
"Europa" MU, MUK	397—5

BLAUPUNKT	
"Frankfurt"	393—7
"Hamburg"	394—8
"Köln"	392—7

BUICK	
981902	404—5
981903	395—18-5

CADILLAC	
7266565 (See Photofact Servicer)	396
7270405	395—18-5
7270555	395—18-5
7270625 (See Photofact Servicer)	397
7268065 (See Photofact Servicer)	397

CHEVROLET	
987724, 987727, 987730	393—13-5
3748611	393—13-5

EDSEL	
85SE	402—8
87SE	403—7

FORD	
B7A-18805-A1	401—8
B8A-18805-B	399—6, 401—8
FEG-18805	399—6
74BF (FEG-18805)	399—6
74MF (B7A-18805-A1)	401—8
84BF (B8A-18805-B)	399—6
84MF (B8A-18805-B)	401—8

LINCOLN	
85BH (FFC-18805-C, -D)	394—17-5
85BHP (FFC-18805-C, -D) (Above Serial No. 50,000)	401—16-5
88BH (FFC-15491-B)	394—17-5
FFC-15491-B	394—17-5
FFC-18805-C, -D	394—17-5
FFC-18805-C, -D (Above Serial No. 50,000)	401—16-5

MERCURY	
84BM (FEW-18805-U)	394—17-5
85BM (FEW-18805-T)	394—17-5
FEW-18805-T	394—17-5
FEW-18805-U	394—17-5
FFC-18805-C, -D (Above Serial No. 50,000)	401—16-5

MOPAR	
845, 846	390—6
848 (P-5801)	398—17-5
923	398—17-5
924 (C-5809)	398—17-5
925 (P-5803)	398—17-5

MOTOROLA	
BMX	401—16-5

OLDSMOBILE	
989127	395—18-5
989131	396—16-5

PACKARD	
AC-2906, AC-2907	396—16-5

PONTIAC	
988822	396—16-5
988823	397—19-5
988837	400—8

STUDEBAKER	
AC-2905	397—19-5
AC-2906, AC-2907	396—16-5

TRUETONE	
DC46238	350—16

RECORD CHANGERS

ADMIRAL	
RC-550A, GA [See Model RC-500—Set 132-2 (CM-4) and Model RC-550—Set 185-2 (CM-5)]	
RC607-1, -1A, -1B, -4, -4A, -6A, RC637-1, -1B, -1E, -2, -2A, -2B, RC647-2D, 3B, -3C, -3F.	398—7

Set No.	Folder No.
COLLARO	
"Conquest"	390—5
GLASER-STEERS	
GS-77, GE, GED	399—7
RCA VICTOR	
RP-208-2, -3, -4, -5	391—11
SYLVANIA	
1-318-1, -2, -3	401—13
V-M	
959	396—13

Set No.	Folder No.
ZENITH	
S-14067	402—15
S-14078, S-14079, S-14082, S-14083, S-14084, S-14085	392—14
S-14086	402—15
RECORDERS	
AIRLINE	
WG-3740A, WG-3741A, B	349—13

Set No.	Folder No.
BELL & HOWELL	
730-G (Steretone), (CM-6)	256—13
770, 775G-1, 775G-10	403—6
RCA VICTOR	
TR-2A-1, -2	397—10
8TR2, 8TR3 (Ch. RS-156F, H)	397—10
Ch. RS-156F, H	397—10
REVERE	
T-700D, TR-800D	395—13
SYLVANIA	
4901 (Ch. 1-400-1, -2, 1-628-1)	404—10

Set No.	Folder No.
SYLVANIA—Cont.	
Ch. 1-400-1, -2	404—10
Ch. 1-628-1	404—10
VIKING	
PB60	(CM-9) 344—15
RP61	(CM-9) 344—15
WEBCOR	
2812, 2816	393—12
2822	393—12
2892, 2896	393—12
WOLLENSAK	
T-1500	400—13

NOTE: PCB Denotes Production Change Bulletin. • Denotes Television Receiver. S Denotes Schematic Coverage Only.

TRANSISTOR RADIO REPAIRS NOW EASY!



with this
NEW *Howard W. Sams* BOOK
"SERVICING
TRANSISTOR RADIOS"

COMPLETE ANALYSIS OF 70 POPULAR
TRANSISTOR RADIO MODELS



includes new
General Motors
(Delco)
Transistorized
Auto-Portable
Radio

Also Valuable Section—
"BASIC POINTERS ON SERVICING
TRANSISTORIZED RADIOS"...

COVERS LATEST MAKES AND MODELS

This book helps you earn big profits on Transistor Radio repairs—gives you complete, time-saving information—helps you become an expert on transistorized radios! Complete data on 70 latest models is based on actual lab analysis of each set. You get the famous Sams Standard Notation schematics—accurate, big, legible; full photo views of each chassis, with all components identified; complete alignment instructions; complete parts lists with full replacement data—everything you need to be successful in fast-growing transistorized radio servicing. Here's a "must" book for your bench. Order it now!

152 pages; 8½ x 11" \$2.95
PRICE ONLY

SEE THIS BOOK AT YOUR SAMS
DISTRIBUTOR OR MAIL COUPON

EARN MORE! MAKE FASTER, EASIER AUTO RADIO REPAIRS

These Howard W. Sams
"AUTO RADIO" MANUALS
SHOW YOU HOW!

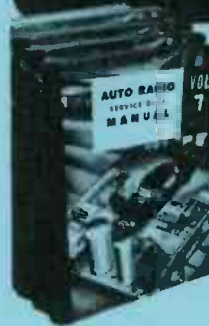

Most complete auto radio service data available: Schematics, voltages, resistance readings, alignment, chassis photo views keyed to components, replacement parts recommendations—everything you need to know for quicker, easier servicing. Each volume, 8½ x 11".

- AR-7. Covers 56 auto radio models produced in 1957. Only \$3.75
- AR-6. Covers 77 models produced during 1955-56. Only \$3.95
- AR-5. Covers 96 models produced during 1954-55. Only \$3.50
- AR-4. Covers 61 models produced during 1953. Only \$3.00
- AR-3. Covers 83 models produced during 1950-52. Only \$3.00
- AR-2. Covers 73 models produced in 1949-50. Only \$3.00

GET EXTRA HELP WITH SAMS "AUTO RADIO REMOVAL" MANUALS



Solves the toughest problem in auto radio servicing—shows fastest ways to remove radio, power supply and speaker units. Covers all standard and sports model cars. 5½ x 8½".

- ARR-57. Covers all 1957 cars.
- ARR-56. Covers all 1956 cars.
- ARR-55. Covers all 1955 cars.
- Each Volume, only \$2.95

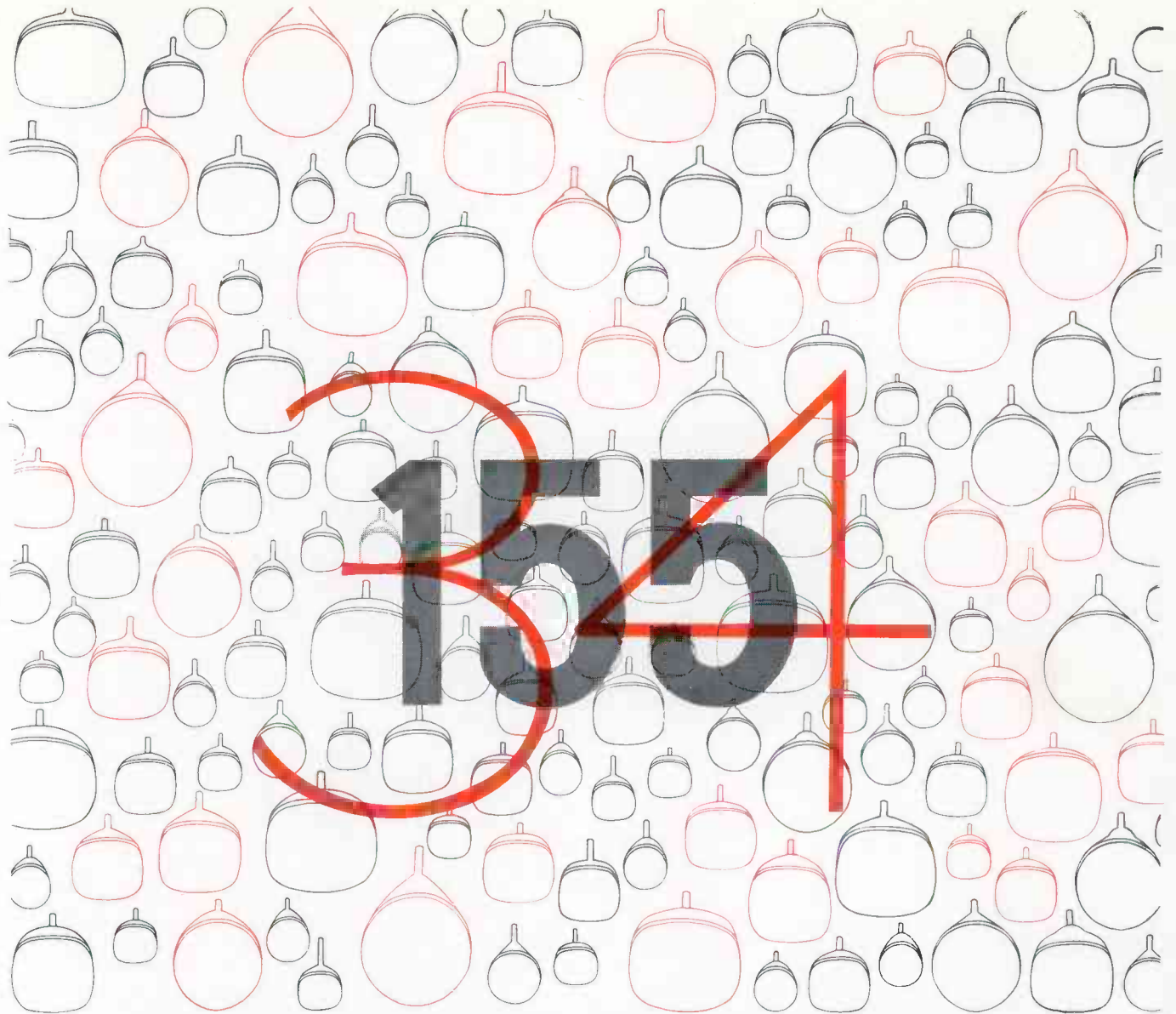

Just 34 RCA Silverama Picture Tubes now replace 155 types!

RCA cuts Picture Tube inventory and complex replacement problems, by nearly 80%. Simplification—that's like money in the bank—as every TV service technician knows.

Best of all, your customer is satisfied, too. He gets a brand name he knows and trusts... that gives his old set a picture that's often clearer and brighter than when the set was new... and that carries a full year's warranty, backed by RCA.



RADIO CORPORATION OF AMERICA

Electron Tube Division

Harrison, N. J.

Silverama®

See your local Authorized
RCA Distributor for your
copy of the Silverama
Replacement Chart

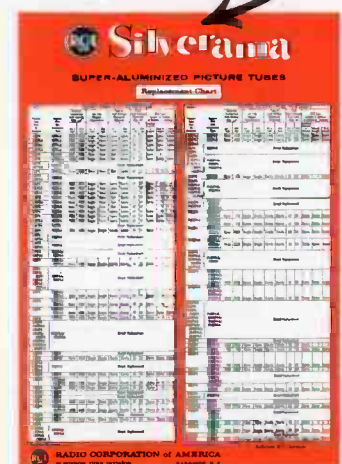



A fuse caddy for your tube caddy

LITTELFUSE, Des Plaines, Illinois



BURTON BROWN ADVERTISING