



PHOTOFACT

# REPORTER

FOR THE ELECTRONIC SERVICE INDUSTRY



## This Month's Highlights

Checking Outdoor  
Antenna Installations  
(see page 16)

Curing Turntable Rumble  
(see page 30)

Tracing Through Wafer-Switch  
Circuits (see page 38)

Know Your VTVM  
(see page 46)

Making CRT Setups  
(see page 14)

**PLUS SUPPLEMENT  
No. 102-C  
TO SAMS MASTER INDEX**



# SAVE MANY WAYS

You pay nothing extra for cabinet

Cabinets stack neatly with others

28 clearly identified compartments

Spend much less time ordering



## with **IRC**<sup>®</sup> Resist-O-Cabinets

### Four "Savingest" Assortments

IRC Resist-O-Cabinets come complete with a colorful all-metal cabinet and any one of four resistor assortments. All resistors are guaranteed fresh and packed in the cabinet at the factory. Cabinets are yours at no extra charge. They have 4 "non-spill" drawers with 28 clearly identified compartments. Design permits neat stacking.

Assortment	No. 3 2 Watt	No. 4 ½ Watt	No. 5 1 Watt	No. 6 Combination
Contents	80 BTB2 Fixed Composition and BW-2 Insulated Wire Wound Resistors. 33 different values from 4.7 ohms to 1 megohm.	100 BTS Fixed Composition and BW-½ Insulated Wire Wound Resistors. 28 different values from 47 ohms to 10.0 megohms.	83 BTA Fixed Composition and BW-1 Insulated Wire Wound Resistors. 28 different values from 47 ohms to 4.7 megohms.	91 resistors including 5 DCF 1 Watt Precisors and 86 ½ Watt, 1 Watt, and 2 Watt Insulated Resistors. Values from 47 ohms to 5 megohms.
List Price	\$26.40	\$17.00	\$20.75	\$23.54
Your Price	<b>\$16.00</b>	<b>\$10.00</b>	<b>\$12.45</b>	<b>\$14.05</b>

ORDER FROM YOUR IRC DISTRIBUTOR

Radio and TV technicians who use IRC Resist-O-Cabinets call them the "savingest" resistor deal they know of. Here's why. You save time and trouble in ordering—all of the resistors most used in TV repair work are pre-selected for you. You save money—you not only get resistors at regular dealer price, but also a handsome all-metal cabinet at no extra charge. And you save time on the job—you know what you have—and you have what you want when you want it. To trim costs and fatten profits, buy resistors in IRC Resist-O-Cabinet assortments.

Wherever the Circuit Says



INTERNATIONAL RESISTANCE CO. Dept. 363 401 N. Broad St., Phila. 8, Pa. In Canada: International Resistance Co., Ltd., Toronto, Licensee

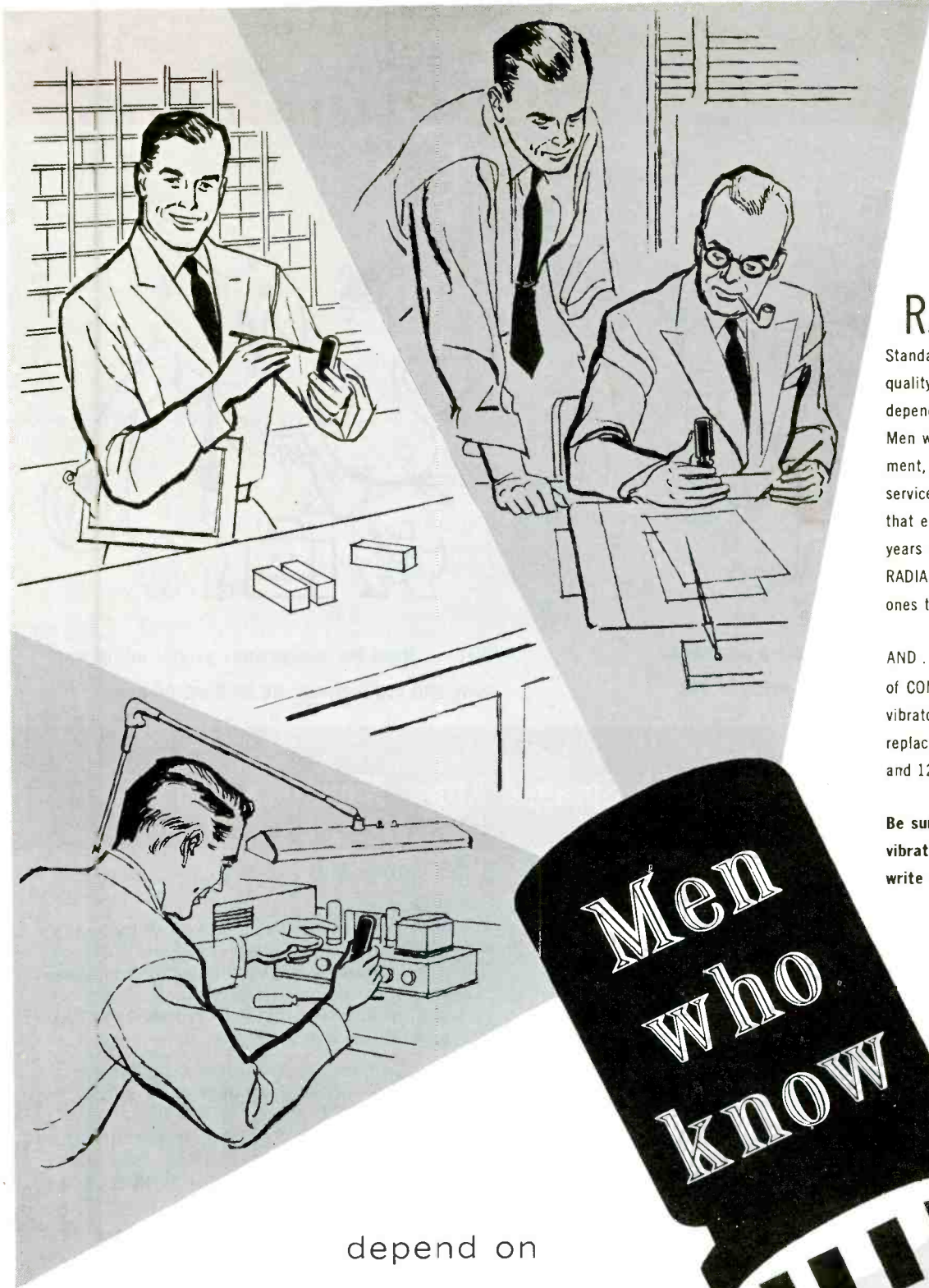

**R**adiart vibrators are the Standard of Comparison for quality, performance and dependability in the industry! Men who know... management, jobbers... and servicemen... ALL agree that experience over the years has dictated that RADIART vibrators are the ones to buy and use.

AND... the complete line of COMMUNICATION vibrators offers the correct replacement for 6 volt and 12 volt applications.

Be sure you have the new vibrator replacement guide... write for your FREE copy...

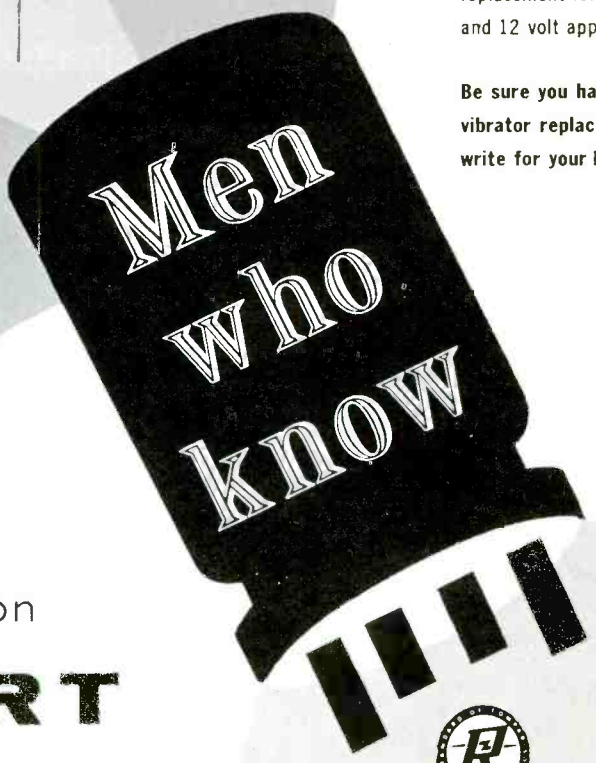

depend on

# RADIART VIBRATORS

... the COMPLETE replacement line



THE **RADIART** CORP.  
CLEVELAND 13, OHIO

A Subsidiary of  Cornell-Dubilier

## Reputation Builder #3: it pays to be neat



- Treat a set-owner's home like a dog house and you're likely soon to be living in one



- BUT . . . treat his possessions as you would your own, and you'll always be an honored guest

## it pays to replace with Sprague Atom<sup>®</sup> Miniature 'Lytics



don't be vague...insist on

- Another way to build and hold a reputation is to insist on top quality replacement parts. Callbacks due to replacement failures not only cost you *money* . . . they also cost you customers! Replace with less than the best and you place your reputation at stake. In capacitors, the best is *Sprague*.
- Take Atom Tubular Electrolytics, for example. The smallest TV 'lytics made, they're the only small ones for 85°C (185°F) up to 450 VDC. Guaranteed for low leakage and long shelf life, they withstand high temperatures, high ripple currents, high surge voltages. From crowded TV chassis to jam-packed portables, Sprague Atoms fit them all.
- Get your copy of Sprague's latest radio and TV service catalog, C-455. Write Sprague Products Co.\*, \*Distributors' Division of Sprague Electric Company 105 Marshall Street, North Adams, Mass.

# SPRAGUE<sup>®</sup>

*world's largest capacitor manufacturer*

SPRAGUE RESEARCH IS CONSTANTLY PRODUCING NEW AND BETTER CAPACITORS FOR YOU



PUBLISHER  
Howard W. Sams

GENERAL MANAGER  
Mal Parks, Jr.

EDITOR TECHNICAL EDITOR  
Glen E. Stutz Verne M. Ray

ASSOCIATE EDITORS

Leslie D. Deane Thomas A. Lesh  
Calvin C. Young, Jr.

CONSULTING EDITORS

William E. Eurke C. P. Oliphant  
Robert B. Dusham George B. Mann  
Paul C. Smith

ART DIRECTOR EDITORIAL ASSISTANT  
Glenn R. Smith Gwen Bigham

PHOTOGRAPHY CIRCULATION  
Robert W. Reed Pat Tidd

ADVERTISING SALES OFFICES

MIDWESTERN  
PF REPORTER,

2201 East 45th Street, Indianapolis 5, Ind.  
Clifford 1-4531

EASTERN

Paul S. Weil and Donald C. Weil,  
39-01 Main Street, Flushing 54, New York.  
Incependence 3-9098.

WESTERN

The Maurice A. Kimball Co., Inc.,  
2550 Beverly Blvd., Los Angeles 57, Calif.  
Dunkirk 8-6178; and 681 Market Street,  
San Francisco 5, Calif. EXbrook 2-3365.

Published monthly by Howard W. Sams & Co.,  
Inc., at Indianapolis 5, Indiana.

Entered as second class matter October 11,  
1954, at the Post Office at Indianapolis, Indiana,  
under the Act of March 3, 1879.

Copyright 1957 by Howard W. Sams & Co., Inc.  
No part of the PF REPORTER may be reproduced  
without written permission. No patent liability is  
assumed with respect to the use of information  
contained herein.

A limited quantity of back issues are available  
at 35c per copy.

## next month

### WORKING IN THE CAGE

A study with photographs of the most likely trouble spots in TV high-voltage circuits. The recommended service technique is illustrated for each case.

### AUDIO FACTS

Proven practices in installing speaker cables, achieving proper speaker phasing, and matching impedances in the system.

### ADJACENT- AND CO-CHANNEL INTERFERENCE PROBLEMS

How to go about finding the proper cures for the various reception troubles due to adjacent- or-co-channel interference.

### THEORY OF CRYSTAL DIODES

Useful facts about the composition, operation, and applications of germanium and selenium diodes.

VOL. 7 · No. 4



APRIL · 1957

# PF REPORTER

FOR THE ELECTRONIC SERVICE INDUSTRY

## CONTENTS

Letters to the Editor .....	8
Shop Talk .....	Milton S. Kiver 11
Analysis of common transistor circuits.	
Coffee Break .....	Verne M. Ray 13
Bud nearly loses a good customer.	
Making CRT Setups .....	14
Checking Outdoor Antenna Installations .....	Calvin C. Young, Jr. 16
What to look for and how to sell the customer your services.	
Servicing New Designs .....	Thomas A. Lesh 19
Facts about the new Sylvania 110° set and the novel Westinghouse video circuit.	
Dollar & Sense Servicing .....	John Markus 21
Resonant Circuits (Part 3) .....	Calvin C. Young, Jr. 23
Impedance, Q and coupling of parallel tuned circuits.	
Quicker Servicing .....	Calvin C. Young, Jr. 25
Trouble Shooting with George .....	Leslie D. Deane 27
The case of the missing symptom.	
Curing Turntable Rumble .....	Leslie D. Deane 30
Tracing Through Wafer-Switch Circuits .....	Thomas A. Lesh 38
Know Your VTVM .....	Thomas A. Lesh 46
Product Report .....	78
Free Catalog & Literature Service .....	80
Supplement to SAMS Master Index .....	81

## SUBJECT INDEX

ANTENNAS AND ACCESSORIES	Setup adjustments on picture tube. 14	
Outdoor antennas, checking and servicing of .....	16	
Rotator service .....	17	
AUDIO	Rumble in phonograph output.... 30	
SERVICING	Alignment tools that count .....	74
Case of the missing symptom .....	27	
Combinations, a service hint for..	74	
Deciding whether or not to repair a TV set .....	75	
Hot-chassis servicing .....	25	
Rotator repair, hints on .....	17	
Rumble in phonograph, finding cause and curing .....	30	
Series filament string, tube failure in .....	25	
TELEVISION	Sylvania 110°-deflection TV Chassis 1-537 .....	19
Westinghouse 14" and 17" portable sets, video amplifier circuit in..	68	
TEST EQUIPMENT	VTVM's, circuits and functions of.	46
THEORY	Coupled tuned circuits .....	71
Parallel tuned circuits, impedance of .....	23	
TRANSISTORS	Circuits, basic types of .....	57
Symbols .....	11	

USE HANDY CARD AT BACK TO ENTER YOUR SUBSCRIPTION

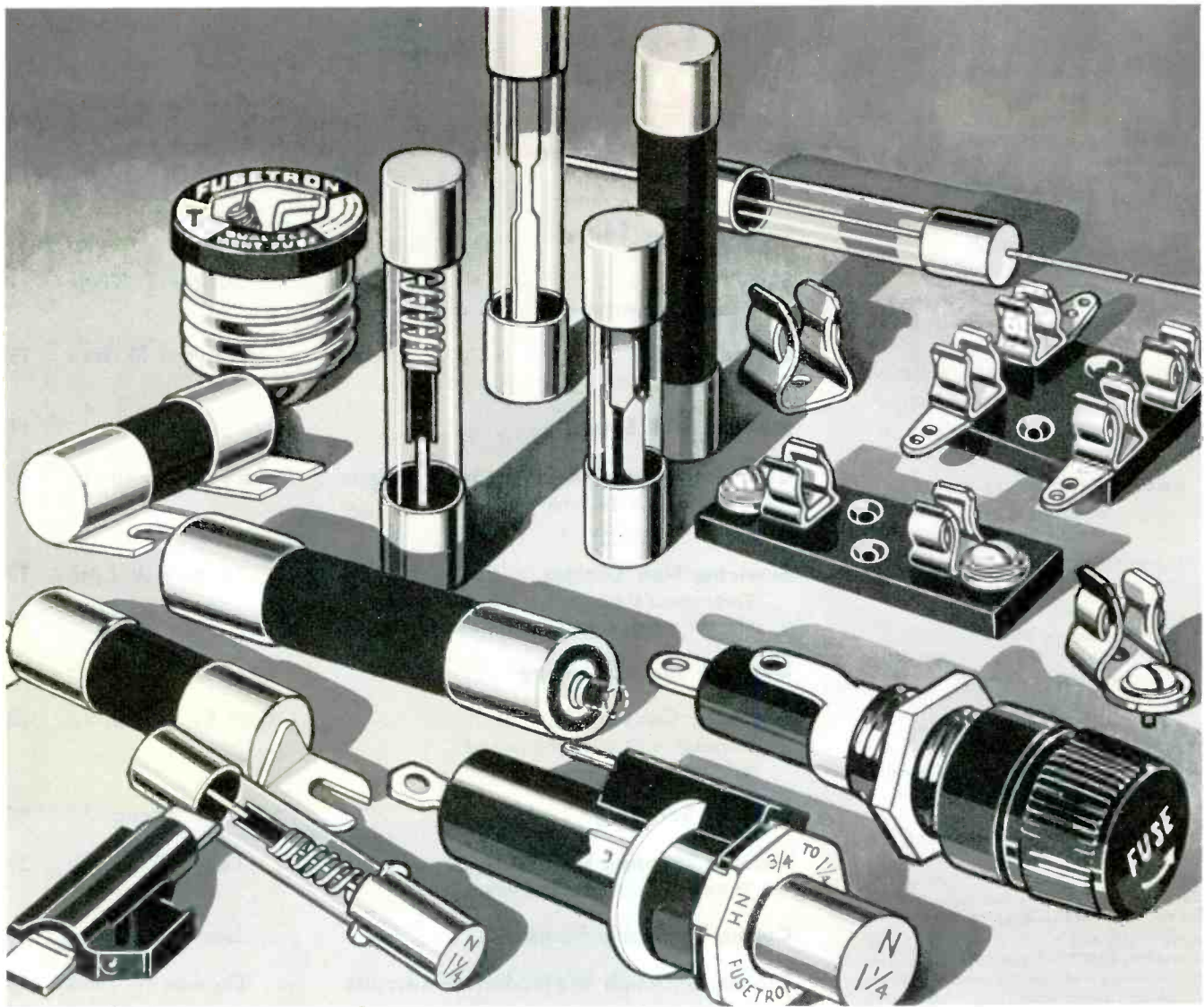

## You can rely on BUSS FUSES to operate as intended.

**Here's why**—With BUSS fuses, dependable electrical protection isn't left to chance. BUSS fuses are tested in a sensitive electronic device. Any fuse not correctly calibrated, properly constructed and right in all physical dimensions is automatically rejected.

The result,—BUSS fuses provide maximum protection against damage due to electrical faults. And just as important, they eliminate useless shut-downs caused by faulty fuses blowing needlessly.

With a complete line of fuses available, it is just good business to standardize on BUSS. Their "trouble-free" performance helps to safeguard your reputation for quality and service and . . . BUSS fuses help servicemen avoid costly, unnecessary call-backs.

### **BUSS fuses have ready customer acceptance . . .**

Over the past 42 years, millions upon millions of BUSS fuses have been used in homes, industries and on farms. As a result, BUSS is the known brand of

fuses—accepted by the trade and consumer as the finest available. This means sales are easier to make because BUSS quality is never questioned.

For more information on BUSS and Fusetron small dimension fuses and fuseholders . . . Write for Bulletin SFB, Bussmann Mfg. Co. (Div. of McGraw Electric Co.), University at Jefferson, St. Louis 7, Mo.

*BUSS fuses are made to protect—not to blow, needlessly*



Makers of a complete line of fuses for home, farm, commercial, electronic, automotive and industrial use.

357



# SHOW ANY PICTURE or PATTERN

at any time — ON ANY TV SET

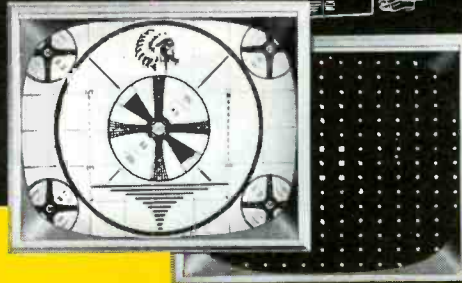

### For Both Black & White and Color TV

Provides standard Indian Head Test Pattern for proper TV set alignment, and stable White Dot and White Line Patterns for color convergence adjustments.

### For Merchandising & Industrial Uses

Provides closed circuit TV system. Transmits pictures or messages for advertising, educational and commercial visual communication.

MODEL 1000



# DYNA-SCAN

## PICTURE AND PATTERN VIDEO GENERATOR

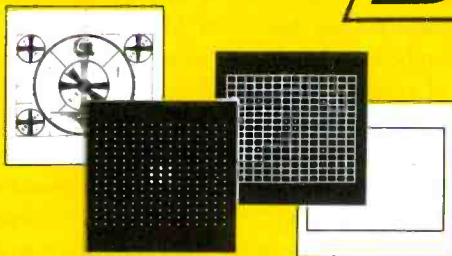

### 3 TEST PATTERN TRANSPARENCIES AND ONE CLEAR ACETATE SUPPLIED

- 1 Indian Head Test Pattern
- 2 White Dot Pattern
- 3 White Line Crosshatch Pattern

These are broadcast-quality transparencies, and assure accurate, high-definition TV images. You can also transmit your own transparencies of any subject you wish. The clear acetate can be used for special messages. Extra transparencies and acetate available.

Make the most of this *Complete Flying Spot Scanner*. It produces a composite video and sync signal that operates any standard black & white or color TV receiver. Can be used with one or more TV sets or fed into a master antenna system or community antenna system. Maximum resolution capability is well in excess of 450 lines; band width in excess of 5 mc. Projects and reproduces pattern or picture with high definition from any slide transparency. Transmits messages typed or written on clear acetate. Makes convenient stand-by and break-in for community distribution operation. Rugged, compact, portable, and ready to operate.

NET \$199<sup>95</sup>

See your B & K Distributor, or Write for Bulletin No. 1000-R

Available on Easy Time Payment Plan

**B & K MANUFACTURING CO.**

3726 N. SOUTHPORT AVENUE · CHICAGO 13, ILL.

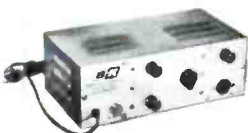

Model 950 Dyna-Scan Pickup and RF Generator only. Enables you to make your own picture and pattern video generator, at a saving. Supplied with three test pattern transparencies and one clear acetate. Net, \$69.95



Model 500 DYNA-QUIK  
Dynamic mutual conductance tube tester. Accurately tests tubes faster. Net, \$109.95



Model 400 CRT  
Cathode Rejuvenator Tester. Tests and repairs TV picture tubes. Net, \$54.95



Model 750 CALIBRATOR  
Designed to check and adjust test instruments with laboratory accuracy. Net, \$54.95

# How far can you go in Electronics without a Degree?



Bernie Roth examines ribbon from printer during Field Engineering Laboratory period.

Without a formal degree, 24-year-old Bernie Roth is already established as a Computer Units Field Engineer—handling a key responsibility with IBM. At the McGuire Air Force Base, a directional control site for Project SAGE, Bernie is part of a team maintaining an entire electronic digital computer system. In this assignment, he must stay abreast of all the most advanced electronic concepts—developing his professional know-how every day. “That’s what’s different about IBM,” Bernie says. “The graduate engineer has an advantage anywhere—but here at IBM the technician also can grow into managerial positions. IBM is one of the few organizations I know of that is willing to invest time and money in training the technical man—and then gauges his future ability strictly on performance.”

IBM instituted its program for specialized technical training many years ago. The theory behind this built-in educational system asked the question: Why should the capable man be denied the opportunity simply because he lacks a formal degree? The wisdom and foresight of IBM’s decision are reflected in the story of Bernie Roth—in the misgivings of his past—in the certainty of his future.



### The Navy steers Bernie on the right course

When Bernie graduated from Croton, N. J. High School in 1950, he received a general diploma—mathematics and science made up a small part of his curriculum. Enlisting in the Navy in 1951, Bernie proved his aptitude for technical work and was assigned to the electronics preparatory school in Jacksonville, Fla. Later, he attended the Class A Aviation Electronics School in Memphis, Tenn. . . . probably the most important phase of his naval training because it was in



Here, he scans the schematic of computer circuits.

Memphis that he became convinced that a technical career was "Right up my alley." But an event that occurred during a furlough in the spring of 1955 put a brand-new light on Bernie's future.

### Reports for training

Bernie smiled when he mentioned that his mother had a tendency to clip want ads. "It was just pot-luck that one of the ads she spotted was for IBM Kingston and Project SAGE." Soon afterwards, Bernie hopped a bus to Newark for an interview with the IBM representative. He took the required number of tests—talked over his hopes and ambitions, and "That's about all there was to it." In July, Bernie notified IBM that he was definitely available, and supplied the necessary references. Meanwhile, he made a study of IBM's history, its policies, its growth, and its future—all of which impressed him favorably. One day in September, Bernie received instructions to report to Kingston to begin training in the applications of electronic computers.

### The material he studied at Kingston

"The Kingston program is a real experience, and quite an eye-opener in

electronic techniques. First of all, I studied basic circuitry. Then, I actually learned a new way to think—the ability to comprehend the whole from the assorted parts. The student must know how to form logic blocks, and in time, he should be able to design his own circuits. All of this proved especially helpful once I got out into the field. Later on, I studied the various input-output devices which are used as auxiliary units to the central computer. Finally, I analyzed the methods that supply the power for this electronic giant. Millions of



Bernie checks a unit in one of the operating consoles.

watts are needed—a phenomenal amount. In general, I'd say that you couldn't find a better training ground for understanding the uses of electronic as well as electro-mechanical equipment."

### How does Bernie feel about his current assignment?

"I'm responsible for the performance of the input-output devices—the auxiliaries that supply information to the central computer. The many Project SAGE outposts—picket ships, reconnaissance planes, Texas towers—flash their signals to the input devices which, in turn, correlate and compile the data. You might say the input devices prepare the food for digestion by the main electronic computer. This, incidentally, is one of the world's largest computers, which is built and tested at Kingston, then disassembled and shipped to a directional control site such as McGuire. Sometimes, I have the chance to assist in systems and displays. Now displays really fascinate me. There's a kind of television screen on which you can detect a plane, determine whether it's friendly or hostile, and where it's headed. My work is always different, never routine, and that's very important to me."

### How does the future look to Bernie?

A happy and prosperous future is in the offing for Bernie Roth. And, based on the records of his older associates, he's confident that in five years' time he will qualify as a Systems Engineer, at the very least. The next steps going up the ladder are Group Supervisor and then Group Manager. "The real satisfaction in working with IBM is the opportunity to understand more and more about electronic techniques. And IBM is quick to recognize and reward improved ability through greater knowledge."



An outdoor man, Bernie takes full advantage of the New Jersey game preserve.

### What about you?

Since Bernie Roth joined IBM Military Products and the Project SAGE program, opportunities are more promising than ever. This long-range program is destined for increasing national importance, and IBM will invest thousands of dollars in the right men to insure its success.

If you have 2 years' technical schooling—or equivalent experience—IBM will train you for 6 months as a *Computer Units Field Engineer*.

If IBM considers your experience equivalent to an E.E., M.E., or Physics degree, you'll receive 8 months' training as a *Computer Systems Engineer*.

After training, you will be assigned to an area of your choice. You receive *salary*, not wages, plus overtime pay. In addition, every channel of advancement in the entire company is open, and IBM is a leader in a field that is sky-rocketing in growth. And, of course, you receive the famous IBM company-paid benefits that set standards for industry today.

WHY NOT WRITE—today—to Nelson O. Heyer, Room 9604, IBM Corp., Kingston, N. Y. You'll receive a prompt reply.

CUSTOMER ENGINEERS: Opportunities are also available, locally, for servicing IBM machines, after training with pay.



DATA PROCESSING • ELECTRIC TYPEWRITERS  
TIME EQUIPMENT • MILITARY PRODUCTS



Startlingly  
**NEW!**

**AMPHENOL**

**polyfoam**  
CABLES

Low Cost, Low Weight, Great Strength—these are the startling new advantages of AMPHENOL's pioneering Polyfoam cable! By means of a revolutionary method of extruding polyethylene foam, new Polyfoam cable features a cellular dielectric made of millions of tiny, sealed air bubbles. Polyfoam 621-715 (RG-59/U type), because of this new process, weighs 50% less, has 50% greater tensile strength and costs 16% less, than standard 59/U! Additional savings result in reduced installation costs through greater tensile strength.

A non-contaminating jacket of specially compounded black polyethylene provides improved weathering properties and extended cable life. Standard RF connectors (such as AMPHENOL BNC Series and UHF Series) may be used for cable/connector assembly.

Capitalize on the advantages of foamed polyethylene—with new AMPHENOL Polyfoam cable!

*This new polyfoam 59/U type cable is also available in Type I and II vinyl jackets. A Polyfoam version of RG-11/U is also available. It has tremendous advantages for Community TV. Send for data sheet describing both of these new cables—today!*



AMPHENOL ELECTRONICS CORPORATION  
chicago 50, illinois

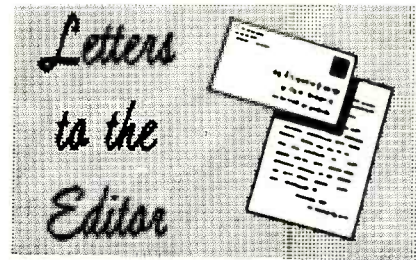

Dear Editor:

I cannot find the proper words of praise for the front cover of the February issue . . . the young man appears to have found something that he has never seen before. Perhaps he is wondering if he has a tube to replace the "old timer" in the set, and the lady in the chair is just divine.

ROY C. BEALE

Newton Junction, N. H.

Dear Editor:

As a subscriber to PF REPORTER, I liked the picture on the cover of the February issue. It takes me back to the "old days" of radio. Could you identify the people pictured?

Also, I would like to know if I can obtain a copy of that picture without the printing on it to frame and hang in my shop.

GERALD G. BIRGE

Temple City, Calif.

*The February cover seemed to strike a responsive chord in a great many of our readers—both old-timers and neophytes alike. The young technician was modeled by Steve Cline, one of our employees. The lady is Mrs. Betty Clamen, a professional model—and the almost-extinct radio is a Day-Fan. The cover was dreamed up by Associate Editor Tom Lesh, and the photograph was taken by Bob Reed, our staff photographer. Unfortunately, we have no covers available without the printing, but are sending Reader Birge the original photo with our compliments. Incidentally, ideas for future covers are welcome.—Editor*

Dear Editor:

After reading about a trouble with picture jitter in this column in the December issue, I find that I have a similar trouble with a Muntz TV-16A2. The bottom of the picture jitters, and at the top it is crowded and tears. I have installed a new vertical output transformer and checked the circuit thoroughly.

I also have a Motorola Model 19F1 with picture flashing. It flashes with no signal present, but with a signal it is okay. I need help on both of these.

I just live for the PF REPORTER. I think it is the most for the least of any magazine on the market, and I sub-

PF REPORTER • April, 1957



scribe to three others. Thanks for a good book.

BERT I. NANCE

Carson Tee Vee  
Torrance, Calif.

The Muntz receiver (Photofact set 108-Folder 8) is somewhat unique in that one-half of a multivibrator circuit also serves as the vertical output stage. It seems logical to assume that the trouble is in the multivibrator and such circuits have given many good men a hectic time. To eliminate the possibility of erratic operation of tube V7, the sync limiter-DC restorer, use a scope to monitor the sync signal at its plate. Any change in the waveform accompanied by the appearance of jitter in the picture would indicate trouble in this stage or ahead of it. If this signal looks okay, substitute for all of the capacitors in the oscillator circuit, specifically C45, C46, C47, C48, C49 and section C of C1, since capacitors are more prone to give trouble in this circuit than other components. From your description of the trouble in the Motorola receiver (Photofact Set 111-Folder 9), it sounds very much as though the horizontal oscillator is running wild when sync signals are not present. The natural free-running frequency of the oscillator may be too far from 15,750 cps, a condition which could be caused by value changes in C99, C100, R94, R2B, or shorted turns in transformer T9.—Editor

Dear Editor:

Why is it that printed circuit components cannot be assembled on simply a snap-in basis? This would ease the complicated methods now confronting the serviceman when he is trouble shooting these circuits.

FORTUNATO P. INSERRA

Randy's TV Service  
Jacksonville, Florida

Manufacturers still agree for the most part that the soldered connection is the best insurance for a good electrical bond between terminals. Of course, we concur with Reader Inserra that if the serviceman did not have to solder and unsolder, particularly on these small printed wiring boards, his job would be a great deal easier.—Editor

Dear Editor:

Please do not give us any more schematic diagrams on red backgrounds as on page 28 of the January issue. The circuits with black backgrounds are hard enough to read as it is.

Arlington, Va.

V. V. GUNSOLLEY

We appreciate Reader Gunsolley's excellent and well-founded criticism. Further use of white diagrams on colored backgrounds for complicated circuits will be avoided as much as possible.—Editor

April, 1957 · PF REPORTER

**NO  
MATTER  
WHAT  
THE  
WEATHER...**

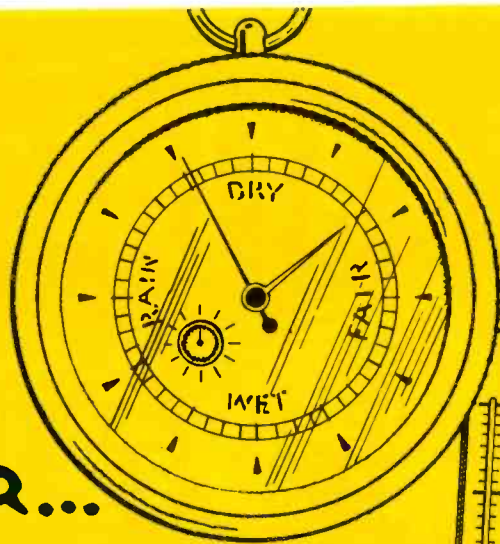

Hot-and-humid or cold-and-damp... Aerovox "DURAMIC" Capacitors give you "trouble-free" operation even under the most adverse weather conditions. You avoid costly call-backs when you specify-and-buy "DURAMIC" capacitors because the severe-service characteristics are built into each capacitor.

#### AEROVOX "DURAMICS"

...utilize a dense steatite case to provide exceptional protection against humidity. All terminal lead wires are firmly imbedded into the end seals so that they will not pull out or work loose even under the most severe operating conditions.

#### AEROVOX "DURAMICS"

...have that exclusive Aerovox end-fill which will not soften or flow nor separate from the case at any rated temperature.

#### AEROVOX "DURAMICS"

...have excellent power-factor, insulation resistance and temperature characteristics. Operating temperatures from  $-55^{\circ}\text{C}$ . to  $+85^{\circ}\text{C}$ . Available in 10 standard voltage ratings from 200 to 15,000 VDC.

Your local Aerovox Distributor always carries a stock of Aerovox "DURAMIC" Capacitors in a wide range of capacitance values and voltage ratings. While you're there ask for your free copy of the latest Aerovox Catalog with complete listings of all Aerovox components.



**AEROVOX CORPORATION**

DISTRIBUTOR SALES DIVISION,  
NEW BEDFORD, MASS.

In Canada: AEROVOX CANADA LTD., Hamilton, Ont.  
Export: Ad Auriema, 89 Broad St., New York, N. Y., Cable: Auriema, N. Y.

# RAYTHEON

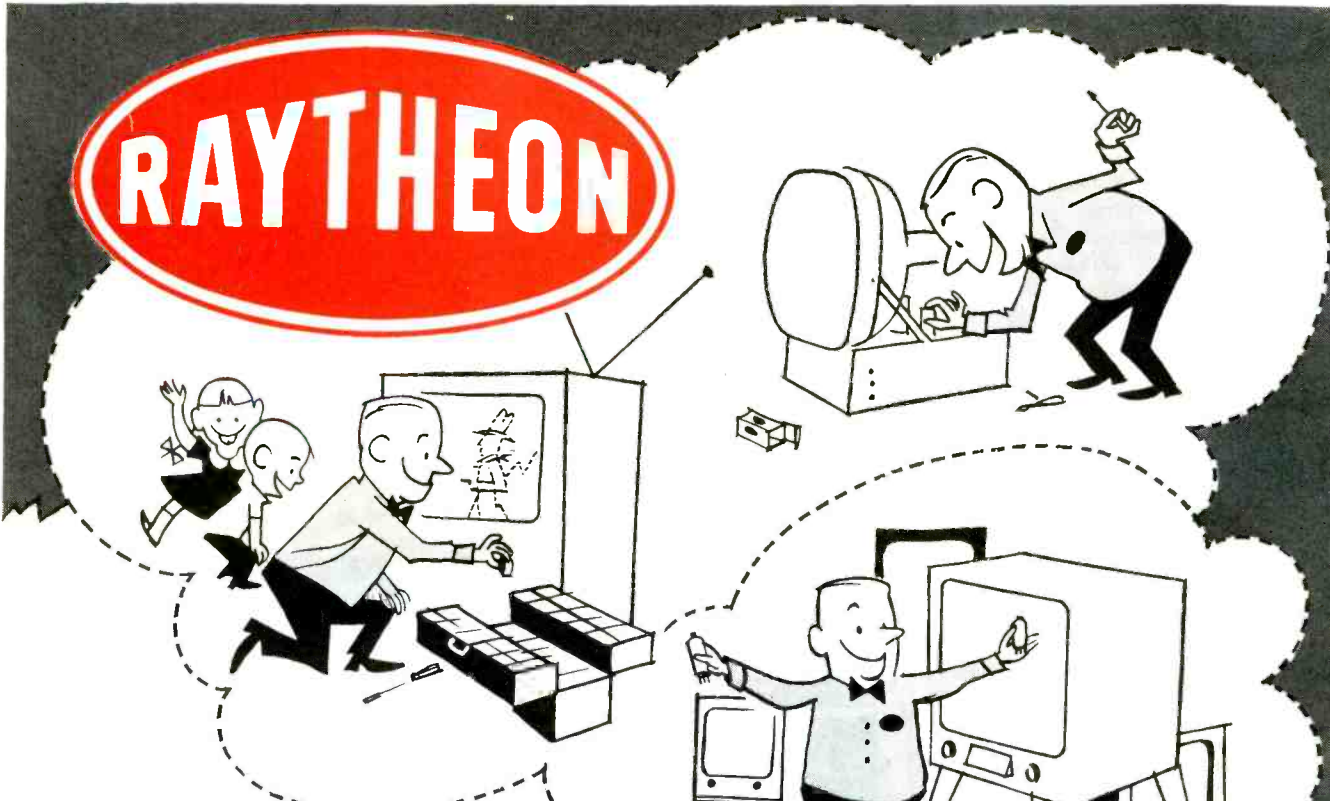

## RAYTHEON "ALL-SET" TUBES

designed with Independent  
Service Dealers in mind

When Raytheon engineers design tubes, they are not restricted to engineering the tubes to the limited specifications of a specific TV or radio receiver. On the contrary, Raytheon engineers must design tubes that combine top quality with all-around performance in all makes and models of receivers. Proof of their success lies in the fact that Raytheon tubes are sold to virtually all TV and radio set manufacturers on a competitive technical basis.

This ability to perform in many circuits makes Raytheon "All-Set" Tubes ideal for service dealer replacement work. Fill your Tube Carrying Cases and tube shelves with Raytheon "All-Set" TV and Radio Tubes and you'll be able to meet tube replacement needs of all sets.

*TV-Radio service is your business . . . serving you is ours*



### RAYTHEON MANUFACTURING COMPANY

Receiving and Cathode Ray Tube Operations

Newton, Mass. • Chicago, Ill. • Atlanta, Ga. • Los Angeles, Calif.

Raytheon makes all these { Receiving and Picture Tubes, Reliable Subminiature and Miniature Tubes, Semiconductor Diodes and Transistors, Nucleonic Tubes, Microwave Tubes.



*Excellence in Electronics*



# ShopTalk

MILTON S. KIVER

Author of . . .  
*How to Understand and Use TV Test Instruments  
 and Analyzing and Tracing TV Circuits*

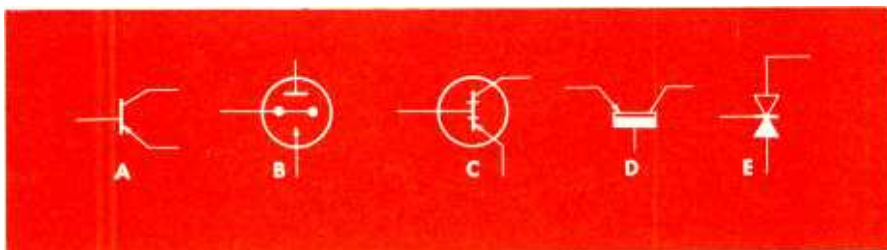

Fig. 1. Varying symbols that have been used to represent transistors.

## Transistor Symbols and Basic Circuits

One could say that the introductory phase of transistors is now ended and we are entering (actually have entered) into the second phase where commercial application is proceeding on a fairly extensive scale. From now on we should see less written material explaining what transistors are and how they function and more information on how they are applied. In short, we will encounter transistor articles (and service manuals) where the writer will presume that the reader is already familiar with transistors and their characteristics and will proceed directly with a discussion of the circuit and what it can do.

In order for the technician to be able to follow these discussions readily and to trace through transistor circuits, certain basic facts must be known. These facts will be presented here, together with the analysis of a number of common transistor circuits, both simple and complex. When the reader has thoroughly digested this information, he will be in a position to analyze any of the transistor circuitry that he may ordinarily encounter.

### Symbols

The first step in analyzing any transistor circuit is to be able to identify the transistor itself. This may seem to be the easiest step to take, and yet it is surprising how many different symbols for transistors are currently in use. All those that this writer has been able to gather are shown in Fig. 1. Note that while some are closely similar, several are sufficiently different to stump anyone not fully conversant with transistor circuits.

The symbol shown in Fig. 2 is the one most widely used, and it will be the one employed here. Do not, however, forget the others.

The next step is to be able to identify each element of a transistor. This is done in Fig. 2, and for the beginner, the element containing the arrowhead is perhaps the one most readily identified. This is the emitter. The other electrode, which is shaped similarly but does not have an arrowhead, is the collector. The remaining element, represented by the line which is drawn perpendicular to the line terminating the emitter and the collector, is the base.

The emitter can be drawn with the arrowhead pointing in toward

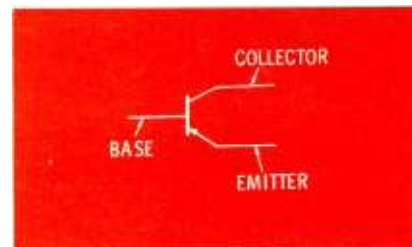
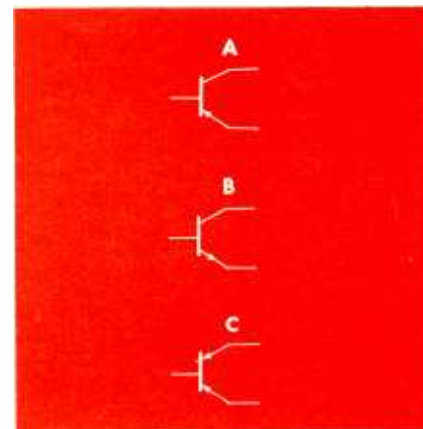

Fig. 2. The most frequently used transistor symbol with elements identified.

the center of the symbol, as Fig. 3A, or away from the center, as in Fig. 3B. The direction of this arrowhead is not at the discretion of the drawer; rather it is prescribed by the nature of the transistor which the symbol represents. If the unit is a p-n-p transistor, the arrowhead points inward; if the symbol is for an n-p-n transistor, the arrowhead is drawn pointing outward. This is the established procedure and should be followed as faithfully as one follows the standard sym-



(A) p-n-p transistor.  
 (B) n-p-n transistor.  
 (C) Symmetrical transistor.

Fig. 3. Differences in the symbols for various transistor types.

bols for vacuum tubes.

Sometimes you will find a transistor symbol which possesses two arrowheads, as shown in Fig. 3C. This is a special symbol representing a symmetrical transistor; i.e., one in which the current can flow in both directions, either from emitter to collector, or from collector to emitter, depending on the polarity of the externally applied voltages. One place where symmetrical transistors are usable is in a phase detector such as we find in the horizontal AFC network of a television receiver.

• Please turn to page 57

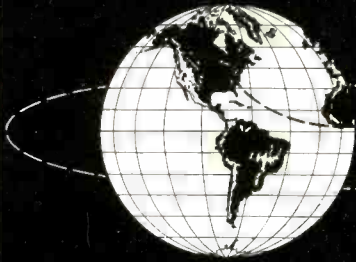

# TENNA

the World's Largest Maker  
of Automobile Antennas

presents . . .

## THE WORLD'S FINEST AND MOST COMPLETE LINE FOR '57

Giving You Super-Quality Features, Super-Quality Materials  
and Super-Quality Construction in Every Antenna

### TENNA BASES

are the Easiest  
of all to Install!



Take your choice of Screw-Ball with split-washer or unique Ball and Rocker mounting bases. Both mount easily, quickly from the top. Only one man needed. Saves time and money!

### TENNA MASTS

are the  
Finest Made!



Masts are of heavy brass tubing with lustrous triple chrome plating. Sealed gaskets prevent water leakage. Special lubricants eliminate rattle.

### TENNA CABLES

are Tops  
in Quality!



Every Tenna Antenna is equipped with a Radar type high "Q" coaxial cable with polyethylene insulation, fully shielded and covered with waterproof Vinylite.

TENNA MATERIALS  
AND WORKMANSHIP  
ARE GUARANTEED  
FOR THE FULL LIFE  
OF THE CAR!



### TENNA Nautilus With TEAR-DROP MOUNTING BASE

For front fenders, rear fenders or rear deck installation.

Famous "Screw-Ball" mounting base.

20° Sweep Back.

Model	Sec.	Len.	Cable
NT-3	3	23"-57"	48"
NT3-1.5	3	23"-57"	180"



### TENNA Snorkle FOR DUAL OR SINGLE REAR MOUNT INSTALLATION

Available in  
"DRESS-UP" AND  
ACTIVE MODELS

Packed in  
Lovely  
Display  
Carton



Model	Description
TRMD	Single "Dress-Up" (no cable)
TRM-27	Single Rear "Active" 15' cable
TRMT-A	Dual Rear "Active" 22' cable
TRMT	Dual Rear, One "Active" 15' cable

3 section, rear fin antenna, beautifully chrome plated from base to tip. Equipped with 15 ft. cable with built-in 75MMF condenser. 33° angle harmonizes with speed lines of modern cars. Len. 10"-27".

### TENNA Screw-Ball Tops 'em all for Mounting Ease!

The "ball" assures angular adjustment for every cowl or fender contour. 30° Sweep Back.

The "Split-Washer" provides economical top-mounting by one man.

Model	Sec.	Len.	Cable
EZ-2	2	25"-49"	36"
EZ-3	3	23"-57"	36"



### TENNA Monarch with "BALL & ROCKER" MOUNTING BASE

Mounts entirely from outside. Holds angular adjustment permanently. 40° Sweep Back.

Model	Sec.	Len.	Cable
MH3B-36	3	23"-57"	36"
MH3B-48	3	23"-57"	48"
MH3B-54	3	23"-57"	54"
MH-3C	3	25"-70"	36"



### TENNA Concealed COLLAPSES to 1" WHEN LOWERED!

Ball & Rocker Mounting Base. Seamless shield tube reduces capacity losses.

Detachable radar type cable. 40° Sweep Back.

Model	Sec.	Len.	Cable
FD-3	3	1"-55"	48"
FD-3A	3	9"-68"	48"



### TENNA De Luxe SIDE COWLS

All metal construction with Tenite insulators.

Detachable cable with speedy screw fittings.

Model	Sec.	Len.	Cable
RAD-3	3	29"-70"	36"
RAD-4	4	29"-92"	36"
RAD-5	5	29"-112"	36"



### TENNA Universal REPLACEMENT MAST

Fits over broken portion of old masts.

Allen wrench furnished to tighten set screws for easy installation.

Model	Sec.	Len.
RA-3	3	23"-57"



The **TENNA** Manufacturing Co.

7580 GARFIELD BLVD.  
CLEVELAND 25, OHIO



Bud no sooner walked into the shop early one afternoon when Tony called to him. "Say, Bud, I'd like to talk to you for a minute." Bud had a few pangs of conscience as he walked toward the back where his boss was working at the bench, for he was almost sure of what was coming.

"What's up, Tony?" he asked, with guilt written all over his face.

Tony finished making a solder connection and laid the gun carefully to one side. Turning around to face his protege, he replied soberly, "Mrs. Johnson called a little while ago." Both men were silent for a short moment. Then when Tony saw Bud's ears turning red, he continued. "She said you walked out on her without even trying to fix the set."

"I might have known she'd complain," Bud spouted angrily. "What does she expect—miracles?"

For a brief moment, Tony's eyes flashed and his face hardened. "Now, just a minute, Bud!" he said sharply. "Mrs. Johnson has always been a good customer, and I've never known her to be unreasonable. But even if she was, the fact that she seems to feel her complaint is legitimate warrants a little more respect. Besides—we sold her that set just last week, and you should know by now that our policy is to bend over backwards for new-set customers."

Bud knew when he was licked. "Okay, okay," he said, "I'll admit I was wrong to get huffy with her—but she started the whole thing! I tried to tell her there was nothing wrong with the set, and she as much as called me a liar."

Tony, however, wasn't very sympathetic. "To hear Mrs. Johnson tell it, everything's wrong with her set," he said soberly. "Now suppose you tell me what the complaint is. I couldn't make head or tail out of what she said over the phone."

Bud shrugged, "Aw, she's griping about 'ghosts' in the picture! I tried to explain that the cause wasn't in the set—even drew a picture showing how secondary signals arrive at the antenna over different paths. Still she insisted that something was wrong and

said the other set didn't have that trouble."

Tony became thoughtful for a moment. "Did you look at the antenna to see if the wind might have turned it?" he inquired.

"Yeah, I looked," Bud replied. "It's pointed just the way it should be. Heck, Tony—a lot of people in that area have ghost problems."

"Well, maybe so," said Tony, unconvinced. "I just hope you don't get fooled on this one."

"Huh—what do you mean by that?" asked Bud, quite puzzled. "Do you know something that I don't?"

"No, no," Tony replied hastily, turning back to his work. "Just making a statement, that's all."

Bud pondered a while, and then he said, "Say, you don't suppose . . . Nah, it couldn't be—or could

I talked to her. Said she never wanted you out there again."

This really sapped Bud's spirit. Eyes downcast, he remarked, "Gosh, I didn't know it was that bad." He started to walk away, and then his face lit up like a beacon. "Listen!" he said, "It couldn't hurt anything if I went back now. Let me take another set over—one just like hers! We'll check it out here first to make sure it's okay. I'll apologize for my behavior and offer to try the second set to see if it does any better. That ought to straighten everything out!"

Tony was pleased and showed it. "You're getting smarter every day, Bud," he said as he clapped his fellow worker on the shoulder. "Take that demonstrator we just put on the floor this morning. It's

## COFFEE BREAK

by Verne M. Ray

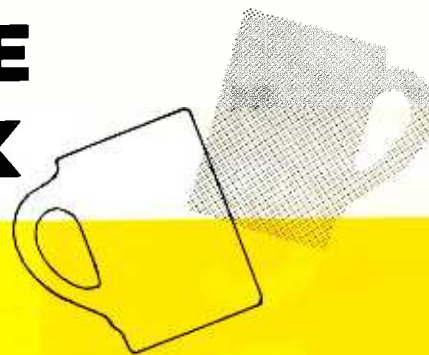

it?" Tony went right on working without saying a word. He knew Bud was a little worried about the situation, and that was good. It showed that he was conscientious. Suddenly, an idea popped into Bud's head. "Hey Tony, I just thought of a way to keep Mrs. Johnson as a customer."

Tony was waiting for this. He knew that the seeds he had sown had sprouted and were ready to blossom. "What have you got in mind, Bud?"

"Well, now that I've thought it over," said Bud rather sheepishly, "I'm not so sure that the trouble isn't in the set. Why don't I go back there and bring it in for a shop check?"

Tony raised his eyebrows, giving accent to the surprise he was really feigning. "You mean you're willing to face Mrs. Johnson again? She was pretty mad when

all checked out and ready to go!"

An hour later, Bud was back. "I've got Mrs. Johnson's set in the truck," he said sheepishly.

Tony grinned, "Yeah, I know. She called while you were on your way back. Said you were really a nice young man and apologized for getting so angry."

"She's really a nice old lady," Bud reflected. "And I learned something, too! The trailing distance of the ghost changes when the fine tuning is rotated. Seems like I read somewhere that this indicates the need for alignment."

"That's not all you learned, my friend," Tony pointed out. "It'll be a long time before you forget that the customer is *always* right—even when he's wrong! You've also learned how to admit your mistakes. I think you've earned a cup of coffee. C'mon—I'll buy." ▲

The trend over the past several years to produce low-cost TV receivers of satisfactory quality has brought about changes both in overall design and in some of the setup adjustments required for picture tubes. The photographs on these pages depict steps in a typical procedure, with the more recent types of adjustments explained, and both newer and older components pointed out.

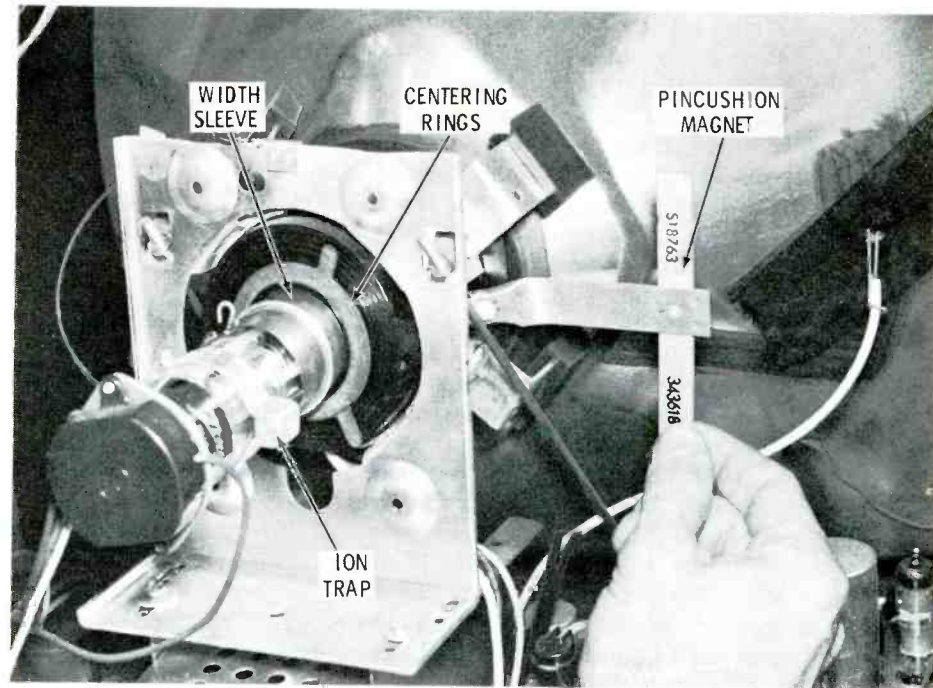

**making**  
**CRT**  
**setups**

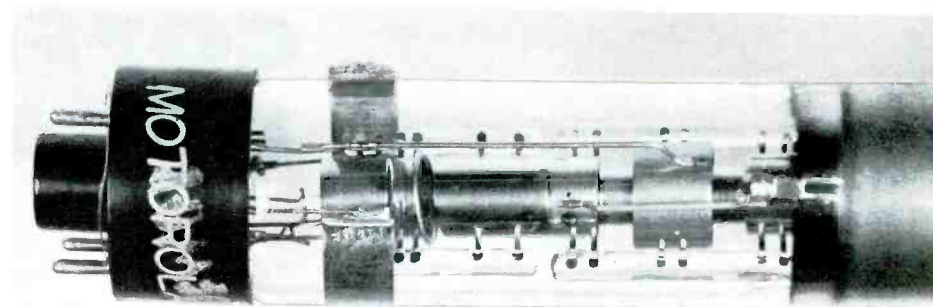

1. The **ION TRAP** should be adjusted first. Prolonged operation of a TV receiver with the ion trap misadjusted can result in damage to the phosphor coating or the electron-gun assembly. To correctly position the ion trap in the shortest possible time, preset it to the position shown in this side view of a picture-tube neck. The band of the ion trap should be over the cathode element, with the magnet on the right or left side of the neck. If a raster doesn't appear within a few seconds, rotate the magnet to the other side of the neck, and a fairly bright raster should appear. Final adjustment for maximum brightness is done by rotating the ion trap from side to side and at the same time slipping it slightly forward or rearward on the neck. **CAUTION:** The ion trap should never be adjusted to compensate for neck shadow.

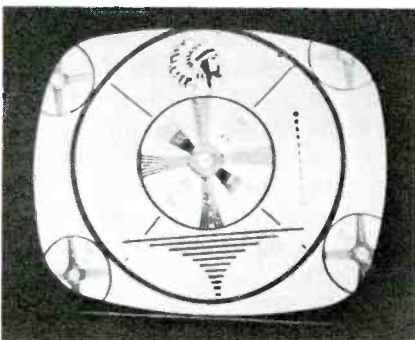

2. This picture indicates that the **YOKE** is positioned incorrectly. With the yoke in its most forward position, rotate it from side to side slightly until the scan lines are horizontal and then secure it by means of its locking screw.

If **CENTERING RINGS** are provided, adjust them for correct picture centering. To make this adjustment in the shortest possible time, bring the tabs on the centering rings close together and then rotate both rings around the neck of the tube until the picture is most nearly centered. Finally, spread the tabs slightly in each direction to complete the adjustment.



3. If a coil or magnet is used for **MAGNETIC FOCUSING**, it should be positioned about 1/4" behind the rear cover of the yoke, and the picture-tube neck should be centered in the clearance hole. A PM focus magnet can be adjusted for best over-all screen focus by turning the adjustment screw, and an EM focus coil, by adjusting the focus potentiometer.

When a PM focus magnet is employed, a mechanical centering device is built into it, and shifting the lever provided will give correct centering. With an EM focus coil, centering is accomplished by moving the coil itself. It is then necessary to adjust alternately the centering and the focus control several times for an optimum setting of both.

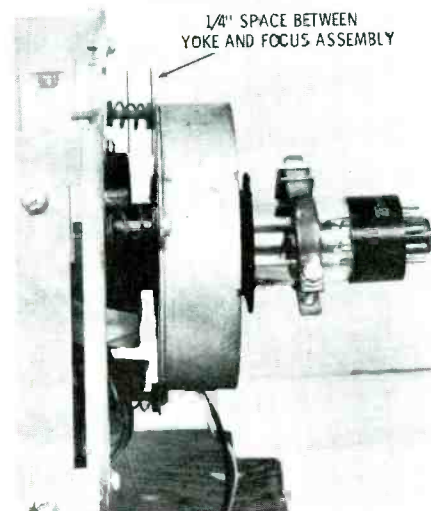

4. Many of the currently produced TV receivers use a system of **ELECTROSTATIC FOCUSING** in which a DC potential is applied to pin 6 of the picture tube. This potential may range from plus 1000 to minus 500 volts but is generally either 0 volts or the value of boost B plus. A metal strap at the base of the picture tube is sometimes used to connect pin 6 to either pin 1 (0 volts) or pin 10 (boost B plus). It is preferred to have the strap between pins 6 and 1 if satisfactory focus can be obtained in this position. In some instances, focus adjustment is made by selecting different DC potentials at the chassis itself; in other cases, a focus control governs the potential applied to pin 6.

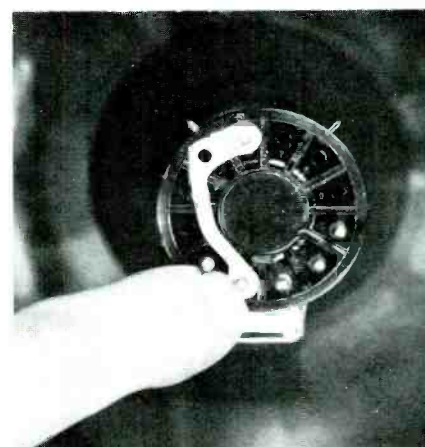

5. The **WIDTH SLEEVE** is made of brass and is held in place with a grounding clamp. Moving the sleeve into the yoke causes the picture to become narrower, and moving it out widens the picture. This photograph shows the sleeve being clamped on a new tube, with the ion trap moved back out of the way.

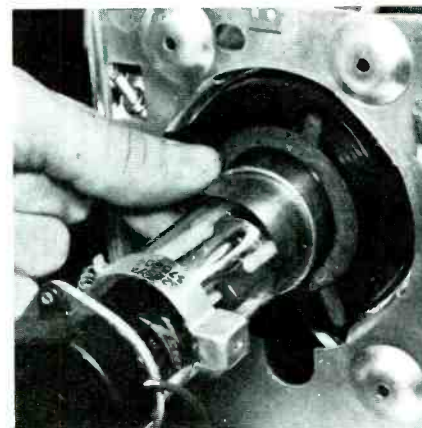

6. **PINCUSHION MAGNETS** are provided on some TV receivers to counteract bowing at the sides or top and bottom of the raster. Such bowing is caused by nonlinearities in the magnetic field of the yoke. During other setup adjustments, the pincushion magnets should be placed for minimum effect as far away from the bell of the picture tube as possible. After the other adjustments have been made, the magnets should be moved toward the picture tube until bowing is minimized. A test pattern or cross-hatch pattern is generally required for this adjustment; but in an emergency, the picture centering can be shifted to reveal first one raster edge and then the other as shown in the photograph.

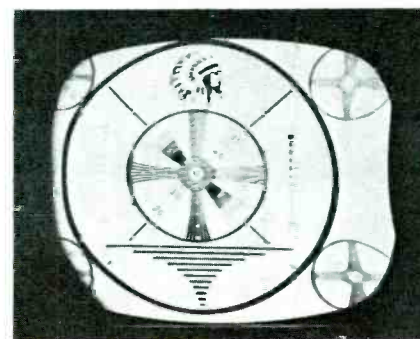

## Spring Inspection and Service Are Needed After a Hard Winter

### Checking Outdoor Antenna Installations



It's that time of year again!

Time for all good men to make preparations for the repair of antennas and rotators which, weakened by the extremes of winter weather, frequently break down or fail as the weather warms up and the winds begin to blow.

Antenna and rotator servicing can—and should be—an important part of any TV service business. There are two reasons for this: (1) It is profitable and (2) the quality of reception which your customer wants can be obtained only when his antenna system is functioning properly. Antenna and rotator servicing is profitable not only because of the services sold to the customer but also because of the supplementary parts sales which can be made. If your initial inspection reveals that the antenna, lead-in, stand-off insulators, mast, mounting hardware, rotator or any part of the antenna is defective, you should so inform the customer and sell him replacements for the defective parts.

#### What to Look for During the Preliminary Check

The first step in assessing the condition of the antenna system is to check the receiver operation with the antenna in its pre-service condition. Be sure the customer is shown the reception defects such as flashing, ghosts, interference patterns, etc. This is also the proper time to sell him a rotator, a new antenna or any other equipment necessary to eliminate his particular problems.

This examination should be as thorough as possible so that no trouble in the system will be overlooked. It takes two men to really check out an antenna system—one to monitor the TV screen and operate the rotator, and one to check the outside operation. The outside man should shake the lead-in wire at several points to check for broken conductors. He should visually check the operation of the rotator and also get near enough to the rotor assembly to hear the unit operate. Grinding noises or jerky operation indicates a need for lubrication or repair. The outside man should also note clearance between the antenna system and all trees and power lines. A thorough check should be made of the mounting base and other hardware such as stand-off insulators, lightning arrester, ground rod, ground wires, guy wires and bent or missing antenna elements.

#### Selling Antenna Service

Using the information obtained in the preliminary check, an estimate of the cost of the necessary repairs can easily be made. List the parts required in one column, their cost in another column, and the time required to install each part in another column.



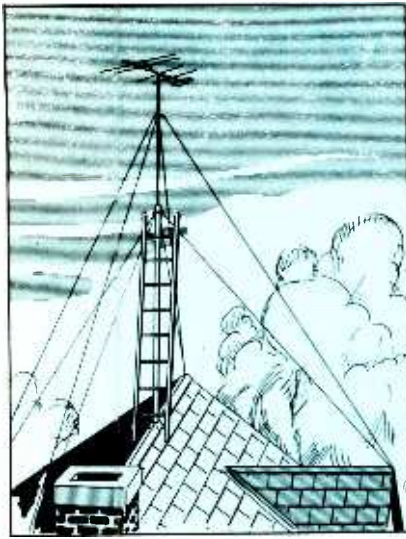

**Fig. 1.** Lowering a tall, telescoping mast to service the antenna involves climbing part way up the mast on a ladder to release the upper mast section.

Add up the labor time and combine it with the time spent on the preliminary check. (The latter is trouble-shooting time and should be charged.) Multiply the time required to do the job by your hourly rate for antenna work (\$6 to \$8 per man-hour in many shops). Once the total labor charge has been determined, it can be added to the parts cost (list price) to arrive at an accurate estimate for the customer.

We would like to emphasize that the antenna system is a very important link in the TV reception chain, and as such it should

### Want to Boost Your Antenna Business?

A booklet entitled "Your Television Antenna System," prepared jointly by RETMA and the Association of Better Business Bureaus, is especially written to explain in layman's terms the answers to many of the questions asked by TV set owners. If you are looking for ways to boost your antenna business this spring, distribution of this 12-page booklet to your customers will get them thinking in the right direction.

Copies can be ordered through Mr. Kenneth Wilson, President, National Better Business Bureau, Inc., Chrysler Bldg., New York 17. Price per copy is 3¢ f.o.b. New York.

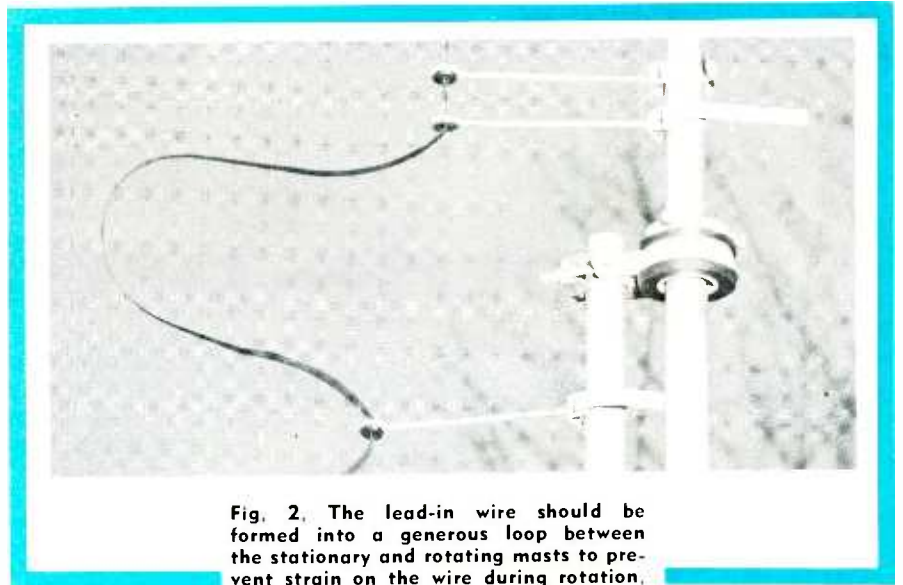

**Fig. 2.** The lead-in wire should be formed into a generous loop between the stationary and rotating masts to prevent strain on the wire during rotation.

never be mentioned in the presence of a customer as anything but a very necessary item. We realize that in some locations fairly good reception can be obtained on an indoor antenna; however, most dependable reception is usually possible only with a suitable outdoor antenna system. The customer should be advised, however, that letting his outdoor antenna system degenerate from lack of maintenance will cause the quality of his TV reception to fall off proportionately.

### Doing the Work

#### Start with the Rotator

If initial inspection reveals defective or poor operation of the rotator, the first step should be to remove it and give it a thorough cleaning and lubrication. In this operation, the rotator is com-

pletely disassembled and all of the old grease and grime removed with a solvent (mineral spirits). Be careful not to splash the motor with this solvent. If the motor requires cleaning, use only pure carbon tetrachloride which does not damage electrical devices.

Clean all electrical contacts in the rotator—use a small ignition file if required. The spacing of the contacts is not critical, but they should make and break cleanly.

When lubricating the rotator mechanism, use Lubriplate or grease of the same type used originally. The motor bearings should be lubricated with one or two drops of SAE 10W oil.

In reassembling the rotator, replace the gaskets and weather seals if there is any doubt that

• Please turn to page 62

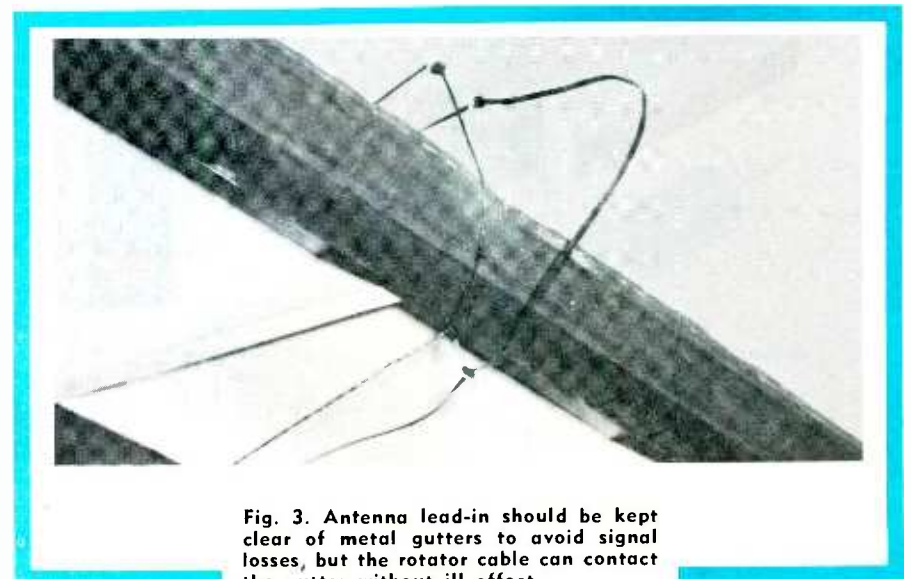

**Fig. 3.** Antenna lead-in should be kept clear of metal gutters to avoid signal losses, but the rotator cable can contact the gutter without ill effect.

# ASTRON *"Staminized"* CAPACITORS ARE

## born -- protected

### TO INSURE REAL STAYING-POWER AFTER INSTALLATION

From the first conception of design, Astron's protection insures highest capacitor quality and reliability.

Only the very finest of raw materials pass Astron's "Selected Purchasing System." Time-proven production techniques assure "surgically clean" assembly. Meticulous quality controls are strictly enforced . . . over 10 separate production line tests are performed, **plus a 100% final inspection of every unit before shipment!**

Astron's climatic protection processes are many . . . each designed to guard the quality of Astron capacitors against moisture and temperature long after installation.

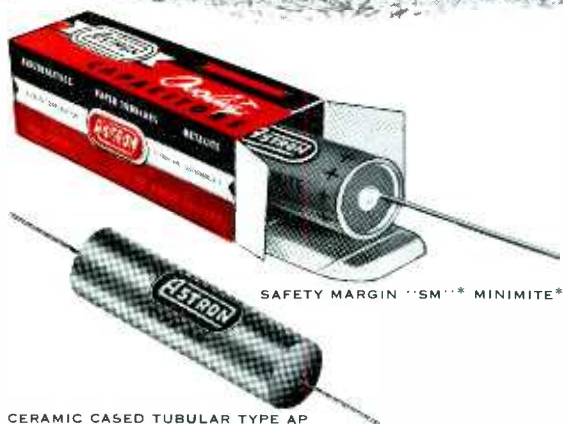
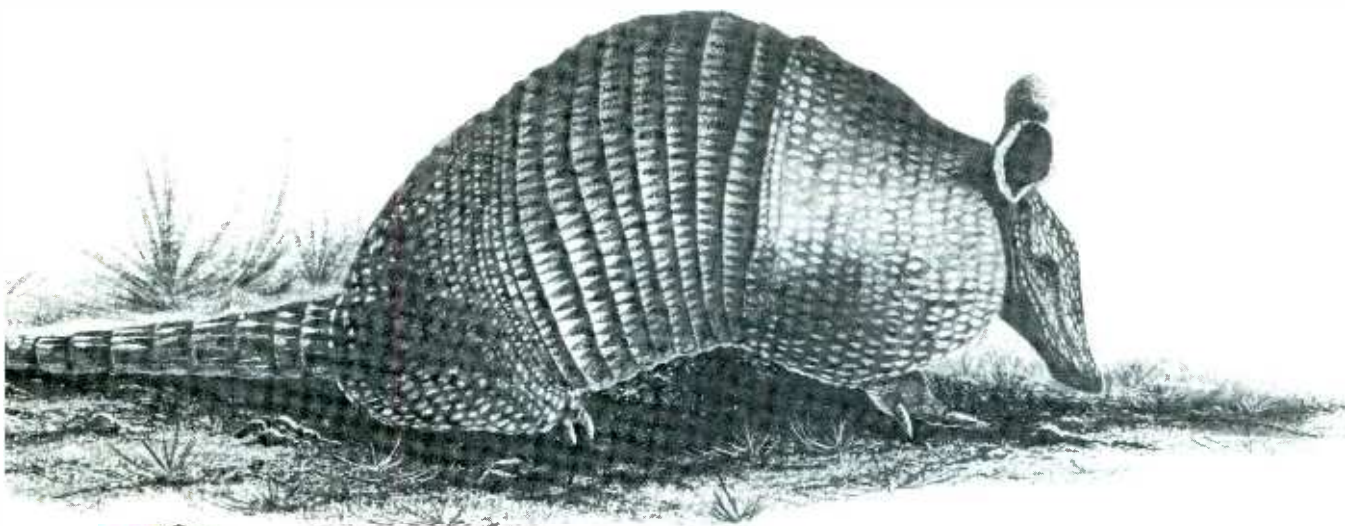

The Astron "Staminizing" method of manufacture guarantees you a "no-call-back" capacitor **with real staying power!**

Remember, your reputation is **our** business. Build it, guard it, protect it . . . Buy Astron Capacitors . . . they're born-protected.

#### FREE Servicing Aid

Save time, use handy Astron Pocket-sized Replacement Catalog and Pricing Guide (AC-4D) . . . Write today!



\*Trade-mark



Export Division: Rocke International Corp., 13 East 40th St., N. Y., N. Y.

**ASTRON**  
CORPORATION  
255 GRANT AVENUE EAST NEWARK, N. J.

In Canada: Charles W. Pointon, 6 Alcina Ave., Toronto 10, Ontario



### First 110° Set

Picture tubes with 110° deflection are out of the development stage and making their appearance in the field. The first 110° tube to hit the market is the 17BVP4, used in a Sylvania portable TV set which was introduced this January. This new 17" tube is shown in Fig. 1, placed side by side with a 90° tube in the 14" size (14XP4) for comparison. Notice that the over-all length of the 17" tube is about the same as that of the 14" type. With its slimmer, more flattened bell shape made possible by the wider deflection angle, the new 17BVP4 is 3" shorter and 3 lbs. lighter than 90° types in the 17" size—and the total weight of Sylvania's new 110° set itself is only 34 lbs.

The new tube is aluminized and uses a single-magnet ion trap. Two important design features which make possible its 110° deflection angle are the unusually small neck diameter and a flare or "secondary bell" where the neck is joined to the main bell. Since the slender neck will not accommodate a standard CRT socket, a new 7-pin type is used. Connections to the pins are as follows:

- 1—blank
- 2—cathode
- 3, 4—filaments
- 5—control grid
- 6—accelerating anode
- 7—focus anode

In Fig. 2, compare the 110° yoke at the left with the 90° unit at the right. The purpose of the severely flared windings on the new unit is twofold. The ends of the windings are not useful in providing deflection, yet the fields generated around them could interfere with normal operation. A greater deflection angle, therefore, requires a greater flare of the yoke ends. This also permits the useful part of the windings to be positioned farther forward, minimizing the possibilities of neck shadow.

The small neck size makes it possible to bring the yoke windings relatively close together and thus provide high deflection sensitivity—that is, the yoke can produce a magnetic field of adequate strength for 110° service without requiring much greater power than that required in a 90° sys-

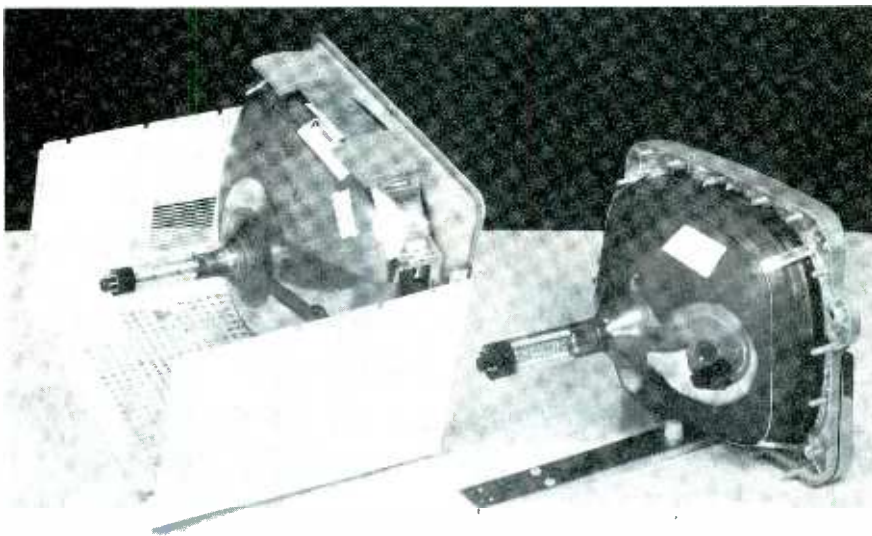

Fig. 1. Screen size of 110° tube (left) is larger than that of the 90° tube even though lengths of both are about equal.

## servicing new designs

by Thomas A. Lesh



Fig. 2. Smaller center hole and severe flaring is shown by this comparison of the new 110°-deflection yoke (left) and a 90° yoke.

tem. Fixed cosine magnets, riveted onto the 110° yoke at the factory, are used to counteract pincushion effect.

The sweep circuits of the 1-537 (S-110) chassis used in the new Sylvania 110° receiver are generally similar to their counterparts in modern 90° designs, with a few distinctive features to take care of the slightly higher power requirements of wider-angle deflection. The vertical circuit is of

a type employed in the majority of new TV sets—a multivibrator in which the second section serves also as the output stage. A new dissimilar dual triode (10DE7) was custom-designed for use in the 110° version of this circuit.

The horizontal sweep circuit includes a 12DQ6A output tube, a revised version of the 12DQ6 which was recently introduced.

• Please turn to page 65



**RCA-WV-98A . . . ALL-NEW SENIOR VOLTOHMYST** . . . incorporates all the important time-proved performance features of earlier VoltOhmysts including direct peak-to-peak readings of complex waveforms. The new Senior VoltOhmyst includes an improved circuit providing greater accuracy, and a BIG full-vision meter face with the easiest-to-read scales ever designed into a VTVM! Complete with WG-299B DC/AC-Ohms probe and cable, instruction booklet . . . . . **79.50\***



**RCA-WV-77C . . . ALL-NEW JUNIOR VOLTOHMYST** . . . one of the greatest values in vacuum-tube volt-ohmmeters. Embodies several new design features in addition to operational characteristics which have made earlier versions of the instrument the choice of thousands in radio and TV servicing, industry, electronics, communications, broadcasting, and in the armed forces. Complete with WG-299B DC/AC-Ohms probe and cable, instruction booklet . . . . . **59.50\***



**RCA-WV-87B...MASTER VOLTOHMYST** . . . features a 27 sq. in. meter with mirror scale. Its easy-to-read peak-to-peak scales are particularly useful for TV, radar, and other types of pulse work. Has accuracy and stability necessary for many laboratory applications. Current ranges from 0.01 ma. to 15 amperes. Complete with probes and cables, including: WG-299C DC/AC-Ohms probe and cable, alligator clip, clip insulator and instruction booklet . . . **137.50\***

\*User Price (optional)

Accurate • Stable • Reliable • Portable • Easy-to-set-up • Easy-to-read

# RCA VOLTOHMYSTS®

superior quality test instruments for SERVICING . . .  
LABORATORY . . . PRODUCTION TESTING

Modern engineering, testing, and production techniques demand test instruments with *practical* operating features. RCA VoltOhmysts are "packed" with practical features which make them especially suited for operation over extended periods under rigorous production-line conditions. Features include: electronically protected meters; accuracy unaffected by normal line voltage fluctuations; easy-to-read expanded scales; one zero setting holds for all voltage and resistance ranges; accessory probes extend dc ranges to 50 KV, and extend frequency response to 250 Mc.

Factory-built, factory-tested, and calibrated to laboratory standards, RCA VoltOhmysts are the finest VTVM's for the money. For the VoltOhmyst to fit your needs, see the chart at the right.

CHOOSE THE VOLTOHMYST THAT SUITS YOUR NEEDS			
Features	Master VoltOhmyst WV-87B	Senior VoltOhmyst WV-98A	Junior VoltOhmyst WV-77C
Measurements			
DC Voltage	0.02-1500v	0.02-1500v	0.05-1200v
AC (rms) Voltage	0.1-1500v	0.1-1500v	0.1-1200v
AC (peak-to-peak) Voltage	0.2-4200v	0.2-4200v	—
Resistance	0.2-1000 meg.	0.2-1000 meg.	0.2-1000 meg.
Current	10 uamp.-15 amp	—	—
Accuracy:**			
DC Current	± 3%	—	—
DC Voltage	± 3%	± 3%	± 3%
AC Voltage	± 3%	± 3%	± 5%

\*\*At full-scale points  
†For positive voltages, ±3% for negative voltages



**RCA Ultra-Sensitive DC Microammeter, WV-84A, For Reading Extremely "Feeble" Currents.**

WV-84A measures minute currents from 0.002 to 1000 ua—in six ranges! It can be used as a very high-resistance voltmeter—up to 1005 megohms on 100-volt range. And, the WV-84A can be used as a megohmmeter for measuring resistance up to 90,000 megohms. \$110.00\* less batteries.

Well-suited for applications in such fields as biology, nucleonics, chemistry, and electro-mechanics—as well as electronics—the WV-84A is completely portable, with a self-contained battery power supply.



**RADIO CORPORATION of AMERICA**  
COMPONENTS DIVISION CAMDEN, N. J.

For technical details on these precision built RCA VoltOhmysts, call your RCA Distributor!



**Portables.** While many dealers are screaming about the money they lose handling portables, others are quietly making money. According to a California dealer, Harold Witham, the trick lies in making every penny count and building up a large volume of sales. Advertising and aggressive selling can bring the volume needed. Volume purchases then result in that all-important extra discount.

This dealer recommends carrying at least three brands to get the choice of colors and styles needed to meet any customer's demand. He makes a 90-day service policy compulsory with each sale, at a price of \$7.50 that seems like a real bargain to most customers. The secret of making money on this contract lies in burning in the sets for three days before selling them, to force early failures so they can be repaired immediately, then requiring that the set be brought into the shop for any service during the 90-day period. Sale of an outdoor antenna installation provides another avenue of profit for some sales.

In contrast, RCA Service Co. offers a one-year contract for \$15.00 on their 14" portable. Here, also, the set must be brought to the shop. The company states that this type of contract has proved profitable partly because of the elimination of home calls and partly because of the large volume of identical sets being serviced.



**Recognition.** If you have men working for you, give them proper recognition for work well done. This can be nothing more than a pat on the back and a few words of praise, if done in the presence of fellow workers. On the other hand, if you are unhappy with a fellow's work, criticize him privately if you want to get best results. These two management techniques can go far toward giving you an enthusiastic working team with a minimum of labor turnover.



**Window Dressing.** Despite the importance and value of putting on a good front, few service shops take full advantage of their window display space. Here are some suggestions for simplifying the job, so that even a weekly change in the window arrangement does not require too much work.



**BY JOHN MARKUS**

*Editor-in-Chief, McGraw-Hill Radio Servicing Library*

First of all, keep the display simple. Too many items just confuse the prospective customer, yet take more time to arrange than does a simple display.

Start out by providing a good permanent base and background for your display. Give consideration to a sheet of Formica that is cut to drop into place without gluing. Formica is available in many attractive and colorful new patterns and can be cleaned or dusted with a few sweeps of a cloth. Other possibilities for the window floor are linoleum, vinyl tile or even asphalt tile in some of the attractive new designs. Measure your space and get prices from a local firm. Chances are that even the most expensive material won't involve more than a ten-dollar bill.

For the side walls, give consideration to pre-waxed plywood panelling with your choice of hardwood veneers, now available from most lumber companies in a variety of sheet sizes. You can put these up yourself with a few small finishing nails and a small nail set. These materials will withstand even direct sunlight for years, to give your window a bright, fresh and modern appearance with just an occasional dusting needed.

With such an attractive permanent background, even a single item on display will look good, provided you change that item each week. Try a new VHF antenna one week, with a neatly lettered card that gets just one idea across, such as "A New Antenna Can Bring New Lift to Your TV Pictures."

Another week, you might simply unreel a few hundred feet of twin-lead and let it sprawl where it will in the window area. A possible card for this might be, "TV Transmission Lines Rarely Last Over Five Years. How Long Has Yours Been Up?"

Another week, perhaps a TV set, with the bottom facing the street, will serve your purpose. The card here could be worded, "One of These Tiny Parts Is Bad. It Takes Skill And Experience To Find It."

Neat lettering is essential for good promotional signs. If you are not good at it, make a deal with a local sign shop to have a lot of signs made up at once, and keep them wrapped and safely stored for re-use every six months or so.



**Definition.** *Television Set* — a family watching machine.



**Taxi TV.** A recent try-out by Admiral engineers showed that portable TV sets work out well in taxicabs. The set was inserted in a hole cut right through the center of the back of the front seat, with the screen facing the passengers in the rear. An inverter operating from the car battery provided AC power for the set. The pop-up antenna normally on the set was mounted outside on the side of the cab near the roof.

The technical problems of taxi TV are thus rather simple to solve. The economic problem of making it pay is still the unknown. Will tips be enough extra to pay for the set and its maintenance? Will coin-in-the-slot operation pay off better? Only experience will tell. Now that radios are so common, an extra tip for radio is practically unheard of, even though a car radio today costs about as much as a portable TV set. In any event, the initial installations in each locality will get the publicity, so give a thought to being first in your town to install portable TV successfully in a taxicab.

# Have you seen your Independent Service advertising campaign?



**PICTURE TUBES DO  
GET DIRTY! SO CALL YOUR  
INDEPENDENT SERVICE-  
DEALER AND...**

**Have your  
Picture Tube  
cleaned today!**



Just like windows and mirrors, the inside of the glass front on your TV set gets dirty. And the face of your picture tube — the TV screen — gets even more fogged up with dust and dirt, smoke and fumes. See for yourself. Have your picture tube cleaned today. You can't imagine how much clearer . . . brighter . . . and more enjoyable your TV picture will be!

**CALL YOUR INDEPENDENT SERVICE-DEALER  
FOR HIS SPECIAL "PICTURE TUBE CLEAN-UP."**

He is *your* neighbor. He pays taxes in *your* community. His children go to the same schools and churches as *yours*. And he knows his standing and reputation depend upon the care and thoroughness with which he services your community's radio and television sets. What is more, he is trained to service any make of set. So patronize your neighborhood independent radio and television service-dealer.

© CBS-HYTRON, Danvers, Mass.  
A Division of Columbia Broadcasting System, Inc.



This emblem is one way to identify your independent radio and television service-dealer. Look for it.



Ask him for CBS tubes. There are no better tubes made . . . and CBS tubes have this seal.

Advertisements like this are appearing every month in all local editions of *TV Guide* . . . telling millions of TV set owners why they should call their neighborhood independent service-dealers.

Ask your CBS Tube distributor how you can have *your* name, address and telephone number listed on adjacent pages in your local edition.

**Join** with other independent service-dealers . . . independent parts distributors . . . and CBS Tubes. Working together, let's build a strong independent service industry.

Identify yourself as an *Independent Service-Dealer*. Arrange for your *TV Guide* listing. Get the tie-in material *and use it*: Independent Service-Dealer decalcomania . . . window display . . . newspaper mats . . . postal cards . . . door knob hanger . . . and consumer booklet.

**Tie In Today!** Ask your distributor for your *TV Guide* listing . . . your display . . . and other supporting material. And for free, 4-page PA-131 flyer giving complete details on how you can profit by your independent service program.

**Remember:** Your continuous purchases of CBS tubes make this independent service-dealer campaign possible. So help keep it going. Say, "I want CBS tubes!"



**CBS-HYTRON, Danvers, Massachusetts**  
A Division of  
Columbia Broadcasting System, Inc.

PF REPORTER · April, 1957



# RESONANT CIRCUITS

## PART 3

## RESONANCE, IMPEDANCE and Q in PARALLEL CIRCUITS

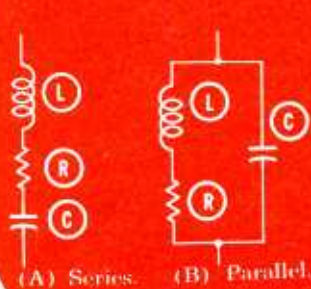

Fig. 1. Basic types of tuned circuits encountered in radio and TV servicing.

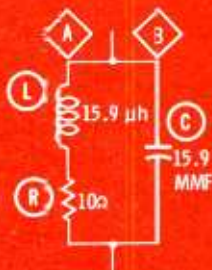

Fig. 2. Resonant circuit with branches labeled. Resonant frequency is 10 mc.

by

Calvin C. Young, Jr.

$$Q = \frac{X_L}{R} \quad (7)$$

Hence,

$$Z_r = \frac{X_L}{R} \times X_C$$

$$Z_r = \frac{X_L^2}{R} \quad (11)$$

If we assign values to the circuit components as in Fig. 2, the value of Z for the parallel circuit at resonance (10 mc) can be determined.  $X_L$  at 10 mc is 1,000 ohms.

$$Z_r = \frac{1,000^2}{10} = 100,000 \text{ ohms.}$$

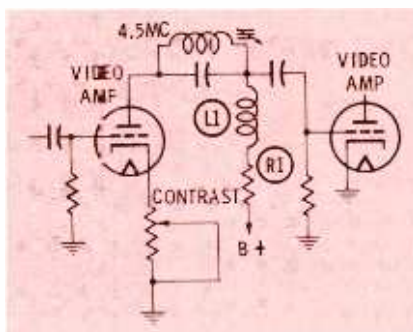

Fig. 3. Parallel tuned circuit used as 4.5-mc trap in a video circuit.

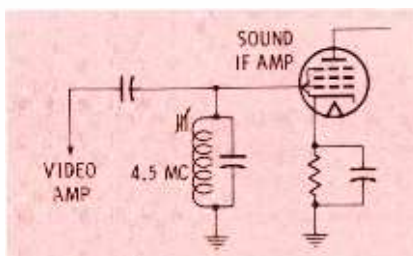

Fig. 4. Parallel tuned circuit used as the grid load for a sound IF amplifier.

In Parts 1 and 2 of this series, we presented the various characteristics of a series tuned circuit and the components in it. This article will follow along much the same lines with parallel tuned circuits.

First of all, let's examine the similarities between the two types of circuits. Both, as shown in Fig. 1, contain an inductor (which has some resistance) and a capacitor. The characteristics of these components are the same when they are used in either circuit; i.e.,  $X_L$ ,  $X_C$ ,  $f_r$ , and Q may be calculated using the same formulas for both series and parallel circuits. If any of these characteristics should be hazy or not fully understood, it is suggested that you review the portions of Parts 1 and 2 of this series that deal with them.

### Impedance of Parallel Tuned Circuit

The effective impedance of a series tuned circuit at resonance is equal to just the resistance of the circuit, a comparatively low value. In a parallel tuned circuit, however, the impedance at resonance is high. It may be determined by using either of the following formulas:

$$Z_r = QX_L \quad (9)$$

$$Z_r = QX_C \quad (10)$$

Equation (9) may be expressed in still another form by using the relationship:

If the impedance of a parallel tuned circuit must be determined at any frequency other than resonance, a different approach must be used. Then we must consider the impedance of each branch and compute as for resistors in parallel. The two separate branches are labeled A and B in Fig. 2 and the combined or total impedance may be found by the formula:

$$Z = \frac{Z_A Z_B}{Z_A + Z_B} \quad (12)$$

When dealing with frequencies at or near resonance, the resistance R can be ignored in the numerator of this expression, but it cannot be ignored in the denominator. Note that the denominator is really the equivalent series impedance of the tuned circuit, and we know that to be:

$$Z_A + Z_B = \sqrt{R^2 + (X_L - X_C)^2}$$

Let's calculate the impedance of the parallel tuned circuit in Fig. 2 at 10 mc, 11 mc and 9 mc to familiarize ourselves with the change in impedance at frequencies away from resonance. At 10 mc,  $X_L$  and  $X_C$  are 1,000 ohms each, so from equation (12) we have:

$$Z_{10} = \frac{1,000 \times 1,000}{\sqrt{10^2 + (1,000 - 1,000)^2}}$$

$$Z_{10} = \frac{1,000,000}{10}$$

$$Z_{10} = 100,000 \text{ ohms.}$$

This agrees with what we had found by using equation (11).

To calculate the impedance of this same parallel circuit at 11 mc, it is necessary to determine the values of  $X_L$  and  $X_C$  at this new frequency.

$$X_L = 2 \times 3.14 \times 11 \times 10^6 \times 15.9 \times 10^{-6}$$

$$X_L = 1,100 \text{ ohms.}$$

$$X_C = \frac{1}{2 \times 3.14 \times 11 \times 10^6 \times 15.9 \times 10^{-12}}$$

$$X_C = 910 \text{ ohms.}$$

• Please turn to page 70

# WIN-TRONIX

## ANALYZE YOUR WAY to Bigger Profits!

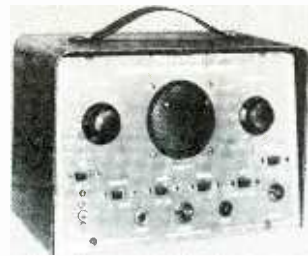
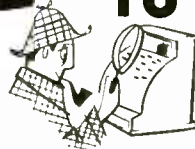

**\$89.95 Net**

Unique principle locates intermittents, detects borderline components **Fast**—

- No bells,
- No buzzers,
- NO WAITING!

### NEW! INTERMITTENT CONDITION ANALYZER Model 828

Locate intermittent capacitors, resistors, coils, chokes, tubes, and other component and hidden wiring failures in minutes—without waiting. Exclusive Wintronix circuit using modulated special r-f test signal, immediately makes any radio or TV receiver super-sensitive to intermittents—gives both audible and visible indication so you can pin-point trouble right away. Reduces callbacks by detecting borderline components *before* they fail.

### Dynamic SWEEP CIRCUIT ANALYZER

Model 820

A complete sweep circuit tester. Simplifies sweep circuit troubleshooting by signal substitution and component testing. Supplies 60 cps sawtooth and 15,734 cps sawtooth or square wave signals to TV deflection circuits. Restores raster to normal by substituting for defective stage. Tests all flybacks and yokes right in the set for continuity and shorts . . . Even tests 1-turn shorts. Completely self-calibrating—no chance for error.

### SYNC PULSE ADAPTER



Model 915/960 Troubleshoot sync circuits by signal substitution. This unit with Model-820 injects (+) or (-) pulse voltages into vertical and horizontal sync stages. Locates defective sync separators, sync amplifiers, AFC, and vertical integrator circuits.

**\$14.95 Net**



**\$69.95 Net**



**\$79.95 Net**

**NEW!**

Takes the guesswork out of AGC troubleshooting for faster, far more profitable color and black-and-white TV servicing.

### Dynamic AGC CIRCUIT ANALYZER Model 825

Here's all you need to test, analyze, service any television AGC circuit . . . all in one compact instrument. Saves you hours by quickly detecting obscure AGC faults before you look further. Requires only two test connections and a flick of a switch to: 1) Furnish standard, adjustable r-f test signal to antenna terminals; 2) Monitor AGC action; 3) Check for shorts and opens in AGC buss; 4) Measure action of gated pulse systems; 5) Clamp and supply AGC bias to correct AGC action and restore operation by substitution.

## HERE'S ALL YOU NEED FOR COLOR SERVICING

### COLOR CONVERGENCE DOT GENERATOR

Model 250

**NEW!**

Here's a complete ultra-stable signal source for color convergence. Contains complete standard sync chain with AFC. Produces optimum white dots, cross hatch, vertical or horizontal bars for color or black-and-white servicing. Absolutely "jitter-free" regardless of picture tube size. Preset r-f frequency, variable 30 db. Highly portable, only 10 1/2" x 7" x 6".

### RAINBOW GENERATOR Model 150



**\$49.95 Net**

Align, adjust, troubleshoot complicated color TV circuits this easy way. Produces vertical color bars of all possible hues representing 360 degrees of phase sweep. Furnished with detailed instructions and illustrations to simplify color TV servicing in the home and in the shop.

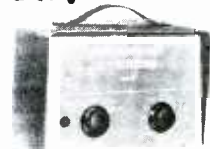

**\$129.95 Net**



**\$29.95 Net**

**FLYBACK and YOKE TESTER**  
Model 810  
Makes foolproof GO/NO-GO tests of all color and black and white flybacks and yokes right in the circuit. Checks 1-turn shorts — self-calibrating.



**\$22.95 Net**

**Dynamic SELENIUM RECTIFIER TESTER**  
Model 610  
New dynamic pulsing principle tests rectifiers under actual surge loads for quality, opens, shorts, leakage.



**\$129.95 Net**

**Wide-Band FIELD STRENGTH METER**  
Model 330  
Reads true microvolts . . . Tests antennas and community systems . . . Checks color reception in absence of color transmission.

See your local parts distributor or write for free literature

**WINSTON ELECTRONICS, INC., 4312 Main Street, Phila. 27, Pa.**



## Tube Failure in Series Filament String

A steady customer with an old TV set recently called and said that his long-ailing picture tube had finally reached the point of no return. Since the customer lived on the other side of town and the set had been serviced only a short time ago, it was decided that the new picture tube should be installed in the home. In addition, a pair of worn-out selenium rectifiers were replaced with silicon units. As far as the technician could tell, the receiver operated perfectly after the call, but three days later the customer telephoned and said the set had failed.

He related the following succession of symptoms: (1) A black bar appeared across the picture and there was a loud hum in the sound, (2) seconds later, the picture collapsed into a single horizontal white line across the screen, (3) the white line and the audio faded away and then (4) an acrid smell was noticed.

At the customer's home, preliminary investigation of the set, a GE Model 14T2, revealed that one of the filament strings did not light. Since the customer had mentioned a burning odor, the technician suspected that a filament dropping resistor had burned open, possibly due to a short circuit. Access to this unit could be gained with the chassis in the cabinet, and a quick check for the presence of voltage at each end of the resistor proved that it had continuity. However, a test of the tube filaments with an instrument designed for that purpose revealed that the 12AU7 vertical output tube had an open heater.

Realizing from the customer's



# QUICKER SERVICING

by Calvin C. Young, Jr.

description of the trouble that this condition might well be the result of a short circuit, the technician pulled the chassis to examine the underside for a burned component. None being obvious, he began to have serious doubts as to the accuracy of the customer's description of the symptoms and decided to risk putting in a new 12AU7 to see if the string would light. This was done, but to no avail. Feeling a little bewildered, and knowing full well he had wasted enough time, the technician took the chassis back to the shop.

On the bench, a meter was used to check filament voltages on the inoperative string. It was found that about 100 VAC was present on pin 2 of the 25L6 audio-output tube, but no voltage reading was obtained at pin 7. A closer examination of this circuit disclosed a well-charred resistor hidden under a capacitor and a heavy film of dust. It was noted that one end of this resistor connected to cathode pin 8. Although the filament check of this tube in the home had shown continuity, the voltage check on the bench indicated that the heater must be open. A few resistance measurements solved the whole problem. (Fig. 1.)

The technician, recapping the

trouble and symptoms in his mind, came to these conclusions: Some amount of heater-to-cathode leakage must have been present in the 25L6, even before the new picture tube was installed. Heater burnout in the 12AU7 caused an increase of at least 20 VAC at the 25L6 heater, and the leakage current through the cathode circuit became great enough to burn the resistor and cause the heater to open, allowing it to sag against the cathode. Tying these facts to the sequence of symptoms, it was obvious that the vertical sweep did not collapse the very instant that the 12AU7 heater opened, but 60-cycle hum appeared immediately. When the 12AU7 cathode ceased to emit electrons due to the lack of heat, this stage ceased to function. The 150-ohm

• Please turn to page 73

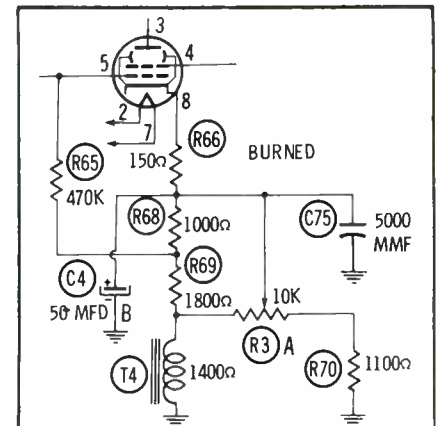
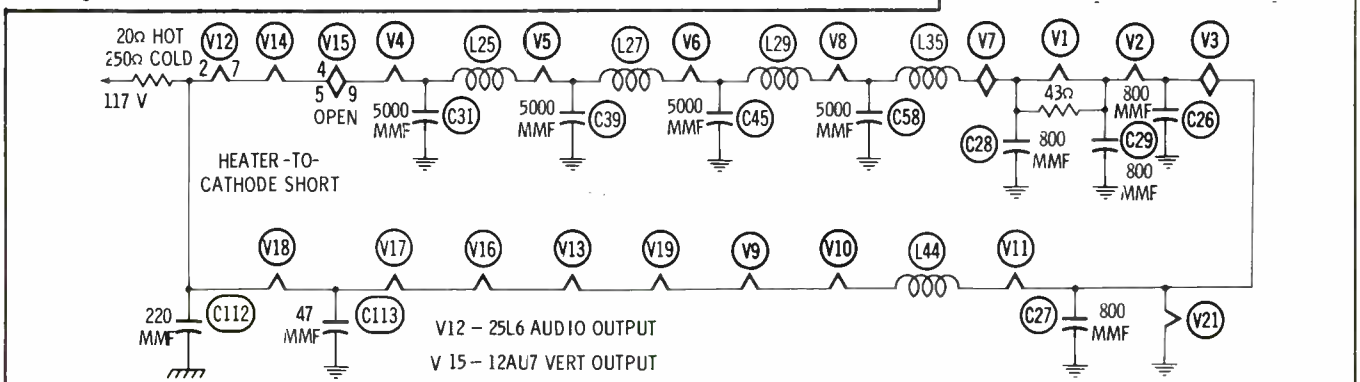
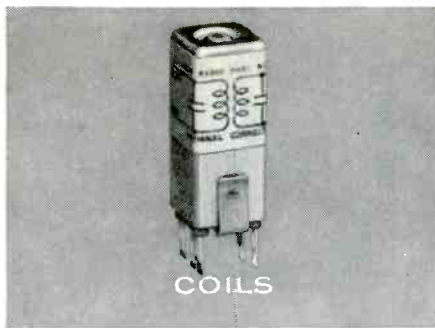

Fig. 1. Partial schematic of General Electric Model 14T2 television receiver.





**SPEAKERS**



**COILS**



**TRANSFORMERS**

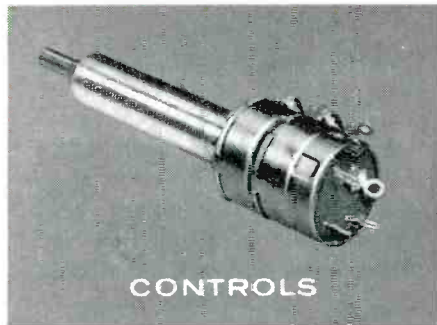

**CONTROLS**



**TRANSISTORS**



**VIBRATORS**

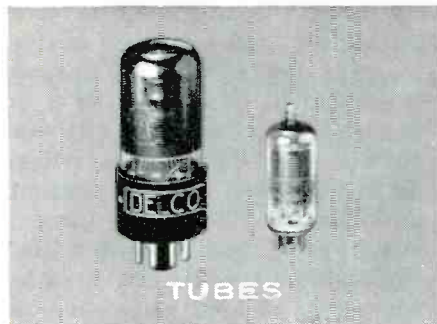

**TUBES**

**From  
DELCO  
RADIO:**



**IRON CORES**

*a complete line of replacement parts*



**CAPACITORS**



**RESISTORS**

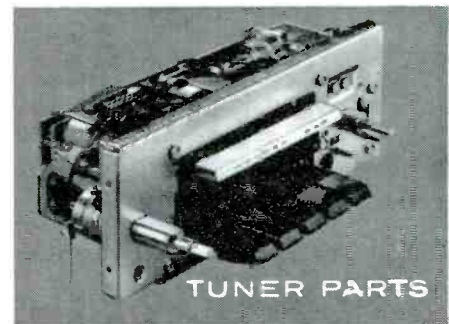

**TUNER PARTS**

*for your Delco Radio service work!*

It's one-stop service from the world leader in auto radio! Your Delco Electronic Parts Distributor gives you fast delivery on all items, *plus* a truly profitable Delco Radio independent dealer program that includes:

1. A technical training program conducted by factory engineers.
2. An attractive warranty policy.
3. Plenty of attractive dealer identification.

Delco Radio also offers a wide selection of Special Application Parts for your convenience and profit. Get the facts today.

**DELCO**



**RADIO**

DIVISION OF GENERAL MOTORS, KOKOMO, INDIANA



A GENERAL MOTORS PRODUCT — A UNITED MOTORS LINE  
Distributed by Electronics Distributors Everywhere



# trouble shooting with **GEORGE**

## THE CASE OF THE ABSENT

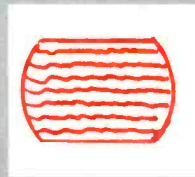
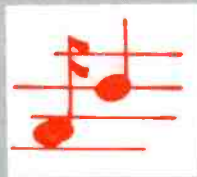
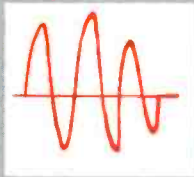

SYMPTOM



by Leslie D. Deane

In his small shop directly off Main St., we find George Fleiback perched on a stool beside his service bench. Although he seems to have plenty of work on hand, our visit catches him just sitting there daydreaming. This is, perhaps, understandable, for ever since the weather started warming up George has been fighting off a severe case of spring fever.

In spite of his lethargy, George had forced himself to make several service calls the day before, and now one of the TV chassis requiring shop work was on the bench in front of him.

The set, a 21" vertical chassis, had displayed extreme picture distortion (Fig. 1) in the customer's home. At that time, George had tried replacing the video-output, video-IF, and RF-amplifier tubes. The mixer and oscillator sections of the tuner employed a 5X8 which George had neglected to stock in his tube caddy, so he substituted this and a few other tubes after he got the set into the shop. Still, the trouble symptom remained. The video information appeared very dark and distorted, but the sound seemed to be normal except for a slight buzz which George thought insignificant. Since the set employed an intercarrier sound system, these symptoms would seem to indicate trouble in either the video-output or picture-tube circuits. Assuming this to be true, George visually inspected components in this section of the receiver. He could detect no visible defects, so he decided to make a

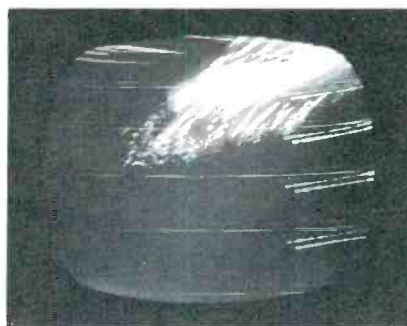

Fig. 1. Picture symptom which confronted George on his problem set.

waveform analysis of the signals in the circuits involved.

Spreading out the service literature in front of him, he first noted the normal waveform (Fig. 2) given for the plate circuit of the video output stage. Turning on his scope, George set the internal sweep frequency at 30 cycles and made the other adjustments necessary to view the waveform of the signal at the plate of the video output tube. This bit of detective work uncovered the evidence shown in waveform W4 of Fig. 3.

George compared the normal waveform with that obtained on

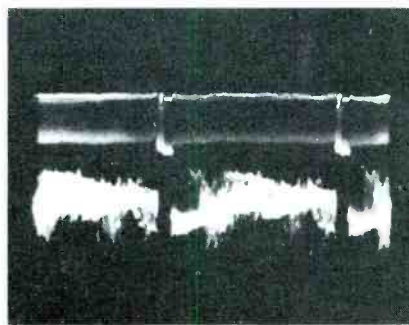

Fig. 2. Normal video output waveform given in the service literature.

the face of the scope. It was evident that the top portion of the signal was being clipped, a clue which led George to believe that possibly the video amplifier was being driven into cutoff.

His next step was to check the signal across the video detector load. George's theory of trouble in the video output stage quickly vanished as he viewed waveform W3 in Fig. 3. He saw that it also showed the effects of clipping. "Now wait a minute," he thought. "Why would there be any trouble ahead of the detector stage with no distortion in the sound?" This confused him, but he proceeded to check the signal outputs of the 1st and 2nd video IF amplifiers. Without a detector probe, George knew that waveforms W1 and W2 in Fig. 3 provided no conclusive evidence. He had worked with weak RF signals in this section of a receiver before and had experienced difficulty in obtaining positive indications even with a detector probe.

Shying away from the waveform approach, George decided to take a few voltage measurements. Positioning his meter close to the chassis, he checked several key points in both IF stages. "I might have known it," said George to himself. "All voltages are within tolerance of those given in the service data."

Feeling that the case was no closer to a solution than when he began, George straightened up from his work for a moment. He recalled that the last set he serviced with video trouble turned

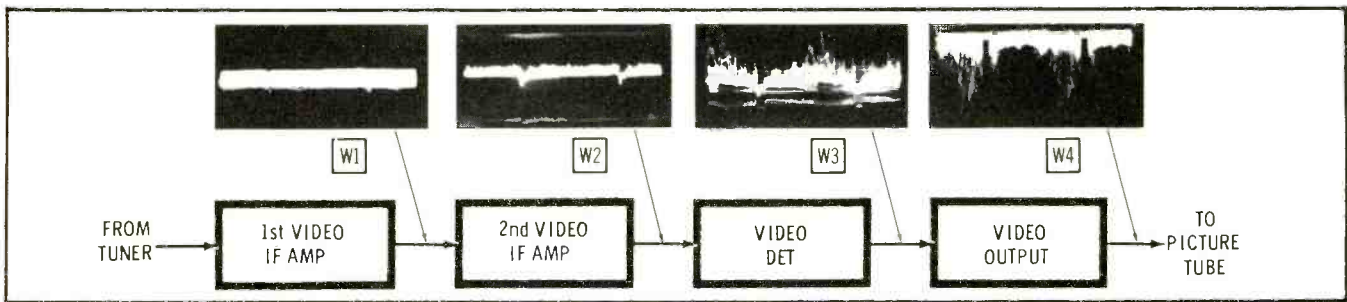

Fig. 3. Block diagram showing waveforms found during analysis.

out to be a faulty crystal in the detector stage. He tried not to let this influence his diagnosis, but this set *did* have a 1N60 in the

video detector circuit and the waveform at its output *was* abnormal.

Disconnecting one end of the

crystal, George placed the leads of his ohmmeter across the unit and measured its resistance, first in one direction and then the other. The diode's reverse resistance measured slightly over 200K ohms while its forward resistance was found to be approximately 200 ohms. Because he had read somewhere that a resistance check of a crystal is not always conclusive proof of its worth, our detective was still not convinced that the component was good. When measuring the resistance of a crystal diode, a great deal depends upon the applied voltage. Resistance readings may vary considerably due to the different battery potentials used on various resistance ranges, even in the same meter. To remove the doubt in his mind, George replaced the 1N60 crystal with a new one from his parts stock.

Completing the solder connections, he turned the set back on and awaited results. The picture returned to the screen but with the same symptoms as before. At this point, George realized that he could no longer attempt to repair the set on merely a hunch.

After mulling over all the clues in his mind once again, he decided to switch to another operating channel. Closely examining the picture on this new channel, he noted that the conditions were somewhat improved. "With good sound, it couldn't be . . . or could it?" thought George. He snatched up his meter leads and made a few quick measurements. "That's it!" he said as he clipped the faulty part out of the circuit.

What component was it? Where was it? Perhaps you've guessed from the beginning which circuit George would eventually find the trouble in. Compare your solution of the case to that given on page 65. ▲

# ADDS INCOME 2 WAYS

1. Tests and Repairs Picture Tubes
2. Makes New Tube Sales Easier

## CATHODE REJUVENATOR TESTER

**CRT 400 PROVES REAL MONEY-MAKER**

*Here's what Joe Driscoll of TV Trouble Shooters, St. Paul, Minnesota says: "It has made more money for us than any other instruments, with the possible exception of tube checkers. We make an additional charge each time we use the instrument in the home to check or correct picture tube conditions. We have been able to convince customers much easier that their old tubes need replacing and have enjoyed a nice profitable business from the sale of new picture tubes without leaving any doubt whatever in the customer's mind that he needed a new tube."*

This is typical of the experience of thousands of servicemen using the CRT 400. It cuts service-operating costs...brings new profits... builds customer good-will...*quickly pays for itself*. Also saves money on TV set trade-in reconditioning. Has 4½-inch plastic meter. Easily portable. **NET \$54<sup>95</sup>**

See Your Distributor today or Write for Bulletin No. 400-R

Makers of CRT, DYNA-QUIK, DYNA-SCAN and CALIBRATOR

## B & K MANUFACTURING CO.

3726 N. Southport Ave. • Chicago 13, Illinois





65 ma -- #205G1



75 ma -- #200G1



100 ma -- #206G1



150 ma -- #201G1



200 ma -- #207G1



250 ma -- #208G1

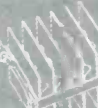

300 ma -- #202G1



350 ma -- #209G1



400 ma (compact) -- #210G1



400 ma -- #203G1



500 ma (compact) -- #211G1



500 ma -- #204G1

# For dependable replacement

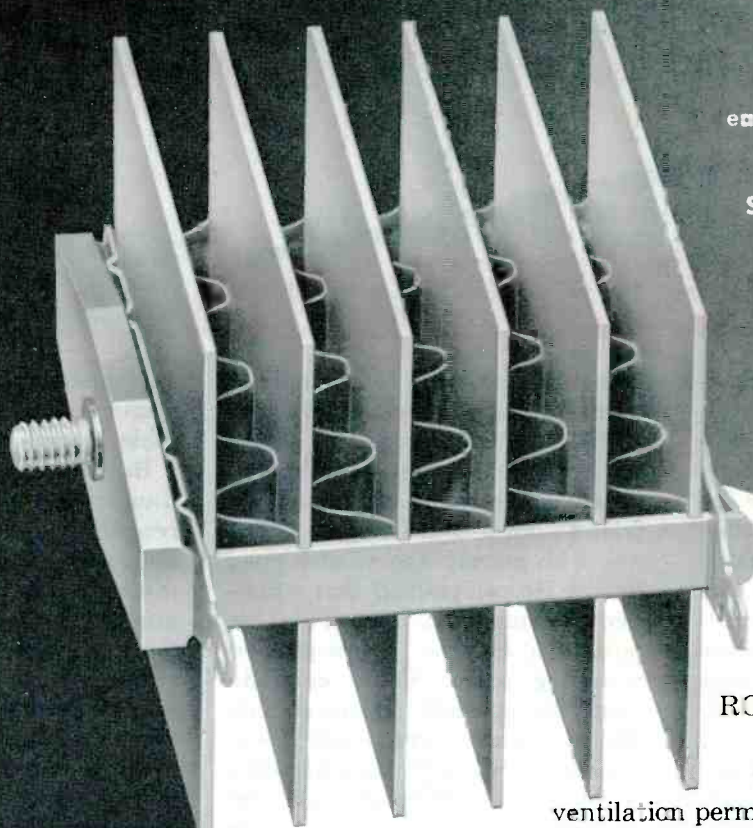

easy to install, efficient in operation, RCA Selenium Rectifiers . . . popular choice of servicemen on the go!

Service technicians appreciate easy-to-install RCA Selenium Rectifiers with modern open design features. RCA's full surface ventilation permits greater heat dissipation, reduces chance of center-core hot spots. One-piece assembly-yoke with molded mounting stud prevents twisting or squeezing stack during installation. They go in faster, operate cooler, more efficiently. Customers appreciate that kind of service!

On your very next selenium rectifier replacement, choose from RCA's comprehensive line, including the smaller sizes for any given current. In 12 types, ratings from 65 Ma to 500 Ma.

Now available through your RCA Distributor!

# RCA SELENIUM RECTIFIERS



**SELENIUM RECTIFIERS**  
RADIO CORPORATION OF AMERICA  
COMPONENTS DIVISION CAMDEN, N. J.



Fig. 1. A typical automatic record changer held in operating position by a handy support rack, a must in phono servicing.

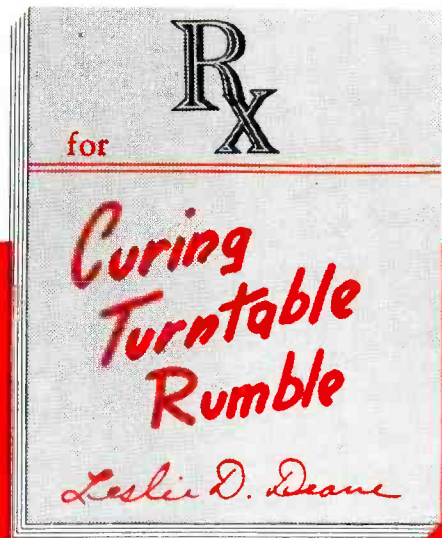

The average radio and television serviceman may direct his efforts toward numerous money-making activities. Although television servicing appears to be the most popular of these today, many servicemen are also realizing profitable incomes from the repair of phonographs incorporating both manual and automatic changers. Not only can this type of work be of direct monetary value, but new customers for other services can often be gained through the personal contacts made when servicing such equipment.

More than ever before, the public's interest is going hi-fi. Many wish to improve their home audio systems so as to fully appreciate the finer quality of modern high-fidelity recordings. With these facts in mind, it is easy to see why enterprising servicemen are now cashing in on general phono repairs.

The technician planning to service any number of phonographs will usually have at his disposal adequate service literature pertaining to various individual instruments. This literature often takes the form of a service manual covering all popular automatic record changers in the field today. Realizing that the technician can thus easily obtain all necessary information regarding operation, maintenance and common troubles associated with such equipment, we have chosen a practical subject for discussion, and one which has received but limited consideration in the past.

The subject of phono rumble—

sometimes referred to as motor or turntable rumble—is a common trouble encountered in many modern phonographs. This was recently called to my attention by a friend—not a hi-fi enthusiast, but one who merely appreciates good music. He complained that whenever he played a record on his automatic changer, a low-pitched rumbling sound would emanate from the speaker. These sounds had become increasingly pronounced and very objectionable, so he asked me what could be done about it. Investigating the problem more thoroughly, I came up with a few servicing hints which I felt would be of interest to our readers.

#### What is Rumble?

The dictionary may define rumble as a low, heavy, rolling sound. The audio engineer, on the other hand, has a much more complex definition—taking into consideration many factors the average technician is unaware of. To simplify our treatment of the subject, however, let us define rumble as

an undesirable low-frequency sound produced by motor or turntable vibrations in a phonograph.

Rumble resembles the sound of thunder in the background of any recording. It is usually more noticeable when the needle tracks through the lead-in or silent grooves of a record and when bass tones are accentuated in the amplifier. "Wow" and "flutter" can only be detected through information or sounds produced by a recording, while rumble becomes more evident when no record information is being reproduced. In other words, during operation, rumble can result whenever the pickup contacts the record disc or any part of the turntable.

Due to the mechanical motion of the motor and drive system, all turntables necessarily have a certain amount of vibration. If these vibrations are not properly absorbed or damped at their source, they can be mechanically transmitted to the tone arm. Vibrations picked up by the phono cartridge produce extraneous signal voltages which are increased by the

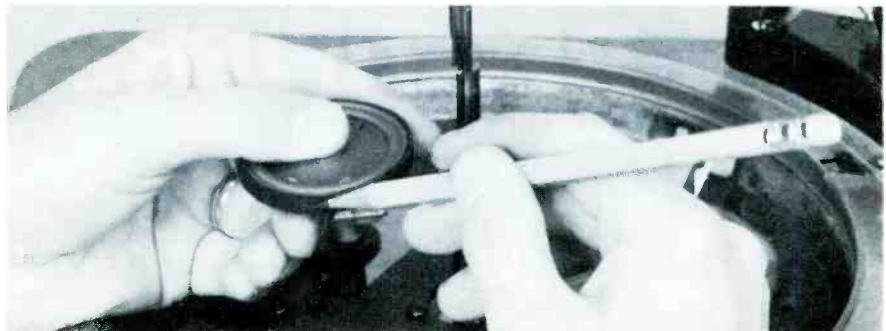

Fig. 2. Rumbling or thumping often results from the rough or flat surfaces of worn drive or idler wheels.



amplifier system. The rumbling sounds resulting from these low-frequency vibrations should never exceed the surface noise of standard recordings or the slight amount of hum present in typical phono amplifiers. If they do, it's time to do something about it!

### Trouble Shooting for Rumble

To properly service record players and automatic changers, the well-equipped service bench should include a turntable support rack as pictured in Fig. 1. This apparatus will secure the instrument in an elevated position and permit the technician to observe the movements of individual parts while the unit is operating. It is also recommended that the service bench have at least one good audio test record. This may either be an orchestral recording or one especially designed for test purposes. When checking for rumble, however, it is desirable to use a record having several silent or unmodulated grooves.

Many individuals may have difficulty in distinguishing between hum and rumble. Both sounds represent relatively low frequencies; however, AC hum usually originates from a 60-cycle source while motor rumble will normally peak at 100 to 200 cycles. Rumble produces somewhat of a rolling sound in contrast to the more steady low-pitched sound of AC hum. To determine whether the background noise is amplifier hum or turntable rumble, remove the phono input to the amplifier. If the objectionable sounds disappear, then the fault is probably originating in the turntable mechanism. An alternate procedure would be to place a short across the phono input jack. This will also reduce the possibility of stray pickup.

When making this test, the technician should keep in mind that hum can also result from a poor ground connection to the amplifier or to the shielded-lead (if one is used) from the phono cartridge. When trouble is isolated to the amplifier, check for an open filter capacitor, heater-to-cathode leakage within one of the tubes, inadequate shielding, or poor ground connections. If the bass boost is excessive in the amplifier

system, hum and rumble will naturally be more pronounced. Should this be the case, check the bass control and its associated circuitry and correct for a more natural reproduction.

Another possible cause of rumble is acoustical feedback. Turntable assemblies are usually shock-mounted with rubber or some type of spring-suspension system. In addition to protecting the mechanism from shock, this feature also minimizes the transmission of turntable vibrations to other objects. This is particularly important when the speaker is mounted in the same cabinet. Under this condition a mechanical feedback between the pickup and the speaker may result, and the vibrations can enter the amplifying system where they will be reproduced as rumble.

Although a stroboscope can be used to detect wow and flutter, it is of little value when trouble shooting for rumble. With an oscilloscope connected directly to the phono plug of the turntable, however, signal voltages produced by undesired vibrations can be monitored and their relative amplitudes evaluated. Probing various mechanical parts while making this test may help to isolate the major cause of any excessive vibration.

If turntable vibrations seem to be abnormally great, always check to see that all packing bolts, strips,



Fig. 3. Inner driving surface of a typical rim-drive turntable.

and lock washers have been removed. This should be done even if the instrument is several years old. Vertical pressure of the tone arm will also have some effect on vibration pickup. If this pressure (or weight) is adjustable, the accuracy of this adjustment should be checked. Also, one should make sure that the needle and cartridge are both firmly mounted, since vibration can originate at these components.

To determine whether the drive mechanism or the phono motor itself is responsible for rumble, uncouple the motor from the turntable drive and let it run without

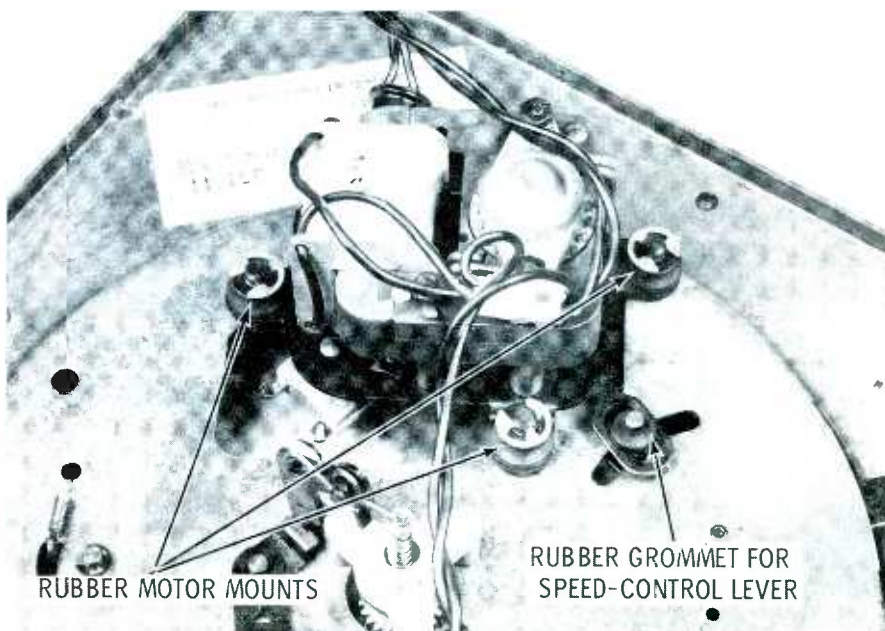

Fig. 4. Motor mounting of a typical rim-drive phono graph showing how it is cushioned to absorb natural motor vibrations.

# Introducing...

## the NEW **PRECISION** CATHODE CONDUCTANCE TUBE TESTER

MODEL  
**640**

The Finest Instrument of its Type — and only \$79<sup>50</sup>

**THE ALL-NEW MODEL 640** gives you the ultimate degree of value in a tube-checking instrument designed according to time-proven emission-testing principles, as have been recommended by tube manufacturers and RETMA.

**THE ALL-NEW MODEL 640** gives you the highest degree of insurance against obsolescence PLUS the utmost simplicity and speed of operation.

**THE ALL-NEW MODEL 640** gives you all this, at such low price, without the slightest sacrifice in the long established **PRECISION** standards of workmanship, quality and reliability.

- Free-point 10-lever element selector system for merit, leakage and short tests.
- Tests all modern TV, FM and AM tube types, including series-string types, tuning eyes, gas rectifiers, etc.
- Filament voltages from 3/4 to 117 volts on 24-position rotary selector switch.
- Dual short-check sensitivity.
- Individual tests for each section of multi-section tubes and ballast tubes.
- Built-in pin straighteners for 7 & 9-pin tubes.
- Extra-large, 5 1/4", rugged PACE meter, ±2% accuracy.
- High-speed, 3-window roll chart with time-saving **PRECISION** "Tube Finder feature."

**Model 640:** with etched, satin-brushed aluminum panel. Leatherette-covered, solidly constructed carrying case with tool compartment and hinged, removable cover. Case dimensions: 18 x 10 1/2 x 6 1/4 inches. Shipping Wt. 16 lbs.  
Code: Baker Net Price \$79.50

**ALSO AVAILABLE—Model PTA Picture Tube Adapter Cable** Net Price \$7.75

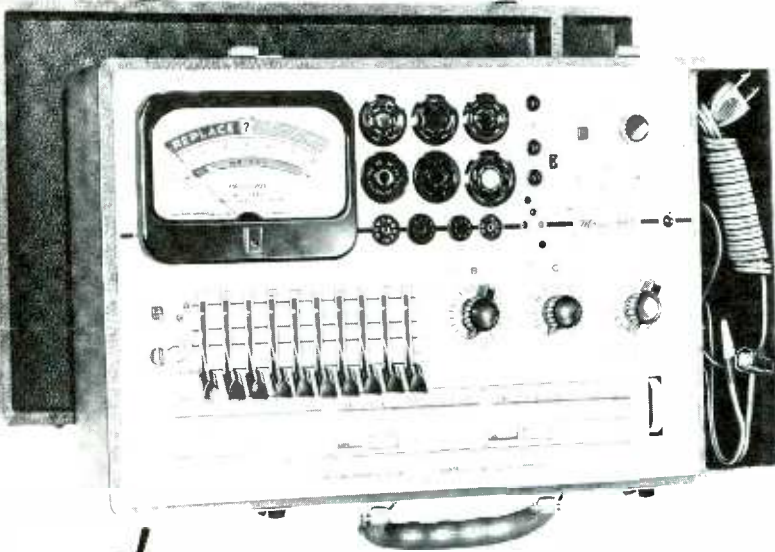

and...

## the NEW **PRECISION** TUBE AND TRANSISTOR TESTER with Picture Tube Beam Current Test

MODEL  
**660**

- The only moderately priced instrument which gives you comprehensive Icbo, gain, leakage, etc. tests of all RF, audio, power and tetrode transistors.
- Also incorporates all tube testing features of the new Model 640 described above, plus special circuitry for beam-current testing all popular picture tubes. (Requires accessory PTA picture tube cable adapter).

**MODEL 660:** same styling, case dimensions and weight as Model 640 described above.  
Code: Baron Net Price \$99.50

See these new instruments at all leading electronic parts distributors.



**PACE**  
THE METER OF PRECISION

**PRECISION Apparatus Company, Inc.**

70-31 84th Street, Glendale 27, L. I., N. Y.

EXPORT 458 BROADWAY, NEW YORK 13, NEW YORK • CANADA ATLAS RADIO CORP., LTD., 50 WINGOLD AVENUE, TORONTO, ONTARIO

load. If the rumble vibrations are being transferred or even amplified by the drive mechanism, then the trouble should stop when the motor is run by itself. If a defective motor is causing the rumble, the pitch or frequency of vibration should not change when different turntable speeds are used. This, of course, is only true for conventional constant-speed phono motors.

When trouble-shooting symptoms point to a defective motor, check the drive shaft to see if its physical relationship with the rubber surface of the drive or idler wheel is geometrically correct. Check motor mounts and examine the motor shaft for excessive play. If the motor shaft or rotor tends to wobble at right angles to its axis, it may be scraping the stator laminations and setting up extreme vibrations during rotation. Worn motor bearings or a warped drive shaft will also produce this effect. A rhythmical thumping sound rather than a rumble often indicates a faulty drive or idler wheel. If the rubber rim of the wheel, as pointed out in Fig. 2, becomes worn or notched, the turntable will receive additional vibrations from the uneven surface. In many cases, a flat spot on the rubber rim will result from prolonged pressure against one portion of the motor drive assembly. Dirt or flaws on the inner drive surface of the turntable can also produce these thumping sounds. See Fig. 3.

### Cures for Rumble

To eliminate or minimize the effects of rumble, as much motor vibration as possible must be shunted from the turntable and tone arm. If the trouble is caused from acoustical feedback, the entire turntable should be float-mounted, and broken or missing spring supports should be replaced. Sometimes a turntable will act as a sounding board and actually amplify certain vibrations. Shock-mounting the speaker will often cure acoustical feedback troubles.

The rubber shock-mounts or grommets used in supporting the motor assembly lessen vibration considerably—see Fig. 4. If these cushions are compressed too



SOUNDLY ENGINEERED BY

# CLAROSTAT

These new controls handle up to 4-watts audio and are small enough to fit standard electrical wall boxes. Ideal for remote control of speakers, in the home, office, stock-room, sound truck, or studio monitor speakers. All units have attenuation range of 0 to 30 db over 90% rotation and 60 db in remaining 10%. Insertion loss less than 0.5 db. **Miniaturized Sound System Controls.**

CIL43

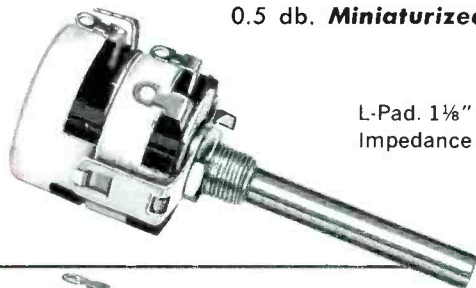

L-Pad. 1½" Diameter. 1½" depth from mounting surface. Impedance values from 4 ohm to 500 ohm.

CIT43

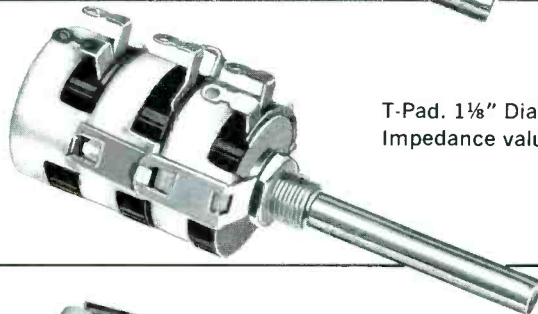

T-Pad. 1½" Diameter. 1¾" depth from mounting surface. Impedance values from 4 ohm to 500 ohm.

CIBT43

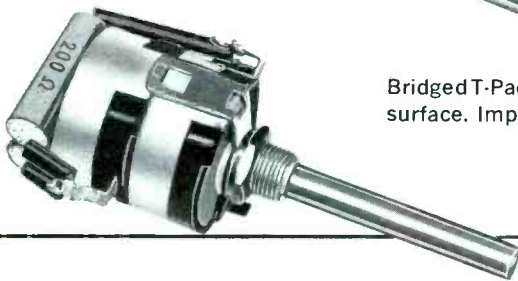

Bridged T-Pad. 1½" Diameter. 1½" depth from mounting surface. Impedance values from 4 ohm to 500 ohm.

**Hardware Note:** All shafts and bushings insulated from circuit elements. ⅝-32 x ⅝" long bushing. ¼" dia. shaft, round, 1½" long. Complete with bar knob and dial plates.

ASK YOUR CLAROSTAT DISTRIBUTOR FOR DETAILS



## Controls and Resistors

CLAROSTAT MFG. CO., INC., DOVER, NEW HAMPSHIRE  
In Canada: Canadian Marconi Co., Ltd., Toronto, Ontario

## MOST COMPACT LOWEST PRICE

of any  
completely packaged  
variable transformer  
on the market!



*Adjust-A-Volt*

# PA-1

## VARIABLE AUTO-TRANSFORMER

This low cost, deluxe auto-transformer is small and compact, measuring only  $3\frac{3}{8} \times 3\frac{3}{8} \times 3\frac{1}{2}$ . It has a wide range of uses in industrial laboratories, schools, homes, and institutions.

The PA-1 can be used as the variable AC voltage control for mixers, agitators, centrifuges; for small motors; model railroading; hobbies; light dimming; and many similar applications.

**SPECIFICATIONS FOR THE PA-1:**  
Input, 120V; load rating max., 165VA; max. output current, 1.25A; output voltage, 0-132V. For PA-1L output voltage, 0-120V.

Designed for long service life, the PA-1 is supplied in an attractive, well ventilated, grey wrinkle finish case with easy to read dial, pilot light, push type switch, fuse, cord, plug and receptacle. The transformer is toroidally wound and features the LoRes brush track for extra long service life.

Write for the catalog describing the PA-1 and complete line of Adjust-A-Volt variable transformers.

**STANDARD**  
ELECTRICAL PRODUCTS CO.  
2240 E. THIRD ST., DAYTON, OHIO

much, however, they will be unable to serve the purpose. There should always be a small space between the rubber and the metal washers. A speed-control lever in multispeed phonographs is usually attached to the motor assembly. This lever can also transmit vibrations; therefore, always check to see that its coupling is also properly shock-mounted. Check all such grommets for free suspension and those which have become hardened, oily, or compressed should definitely be replaced. Also check the motor power leads to see that they have plenty of slack, thus permitting the motor assembly to float.

If the motor has a bent or wobbly drive shaft, bad bearings, or any broken parts, the entire motor unit should be replaced. Tighten all screws and nuts supporting the motor and the turntable-drive mechanism and replace any of those missing. The idler wheel of a rim-drive unit must be freely suspended in such a way that little or no vibration is transmitted to the turntable. It must also be able to absorb as much speed fluctuation as possible from the motor drive. If the wheel is out-of-round or the rubber rim is damaged or shows signs of deterioration, it should be replaced.

Rumble can also occur if the motor or turntable bearings become dry or if any foreign matter causes their surfaces to become rough. In such cases, the bearings

should be thoroughly cleaned and lubricated. Lubricate all items according to the manufacturer's instructions when available. Motor and drive-wheel bearings rarely need lubrication, but if it becomes necessary, use a good grade of light machine or mineral oil. The lubricant should always contain an oxidation inhibitor. Apply only one or two drops on each bearing surface and carefully remove every trace of excess oil before operating the instrument. Oil or grease on the motor shaft, idler-wheel rim or turntable drive surface will usually cause "wow" or "flutter." Remove all lubricant from these surfaces with a suitable solvent.

In some instances, merely the addition of a rubber turntable pad will reduce rumble to a tolerable level. These pads or cushions are commercially available and fit snugly on top of the turntable as pictured in Fig. 5.

If the preceding suggestions fail to cure the rumble, there are certain electrical modifications which can be made to compensate for the difficulty. Since rumble is relatively low in frequency, it is possible to reduce the low-frequency response of the amplifier and lessen rumble without losing too much of the normal bass range. For ordinary crystal pickups, it's better to reduce the lows at the input equalization circuit instead of at the tone-control circuits. To attenuate the lows at this point, place a .3 to .5 megohm resistor



Fig. 5. A foam-rubber pad can be used to dampen vibrations. This will reduce rumble and also help prevent record damage.



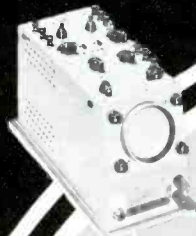

MODEL 385

# HICKOK



MODEL 685

## OSCILLOSCOPES

*for Your every Requirement*



MODEL 387R



MODEL 770



MODEL 675A

**Model 770:** Wide Band DC Amplifiers (0 to 5 MC). 10 MV RMS per inch sensitivity. New flat-face 5" tube permits a more linear reading as well as facilitates photography for permanent records of any pattern or series of patterns. An illuminated calibrated screen is backed with a green filter which reduces reflections. Excellent pulse response, built-in voltage calibrator and unusual stability are features every engineer will appreciate.

**Model 387R:** Industrial's 3" scope in a rack mount style with identical horizontal and vertical amplifiers. DC to 500 KC response and a 10 MV RMS per inch sensitivity. Recurrent and driven sweep, internal or external locking, non-frequency discriminating ten-to-one gain control, full screen deflection without low or high frequency distortion are ideal features designed to permit versatile use of this equipment in all phases of electronic work.

**Model 675A:** Features a vertical wide band frequency response from 1 cycle to 4.5 megacycles, at a 20 MV RMS per inch sensitivity. A new type circuit technique has replaced the need for dual sensitivity. The vertical attenuator is frequency compensated in decade steps. The recurrent sweep has a frequency coverage from 10 to 100,000 cycles with vernier control. Illuminated calibrated screen, DC amplifiers and other features qualify the 675A as high-quality.

Your inquiry is invited. Technical details are available at your request.

### THE HICKOK ELECTRICAL INSTRUMENT COMPANY

10566 Dupont Avenue • Cleveland 8, Ohio

THE NEW WRENCH  
WITH THE "INNER GRIP"

WALDEN

# in-a-grip<sup>®</sup>

TRADE MARK WRENCHES PATENTS PENDING

... GRIP and DRIVE ALL  
HEX HOLLOW-HEAD  
SET SCREWS AND  
CAP SCREWS!

NO FUMBLING  
NO DROPPING



OVER 200 TYPES AND SIZES IN STOCK

WRITE FOR CATALOGUE

MANUFACTURED EXCLUSIVELY BY

MAKERS OF SPINTITES, GRIP  
SPINTITES, — FORCE-FORMED  
SOCKET WRENCHES — AND ALL  
TYPES OF MECHANICS' HAND TOOLS

FOR OVER  
**50** YEARS

**STEVENS WALDEN Inc.**  
500 SHREWSBURY STREET  
WORCESTER, MASSACHUSETTS

## NOW! NO HEAVY, BULKY TRANSFORMER

WEIGHS ONLY 8 OUNCES  
*but —*  
POWER-PACKED AT 150 WATTS  
*and —*  
SOLDERS IN SECONDS

You'll  
like the way  
it handles!

**HEXAACON**  
FEATHERWEIGHT  
INSTANT  
SOLDER GUN

Combines all the advantages of the Solder  
Gun and Conventional Soldering Iron

**NO TIPS TO REPLACE** — Saves time and money because new special alloy Lifetime Tip never wears, corrodes or bends. Solder in a normal manner with a conventionally-shaped, trouble-free soldering tip instead of an awkward piece of wire.  
**NO HEAT LOSS** — Always operates at peak efficiency because heating element is right in the soldering end of the tip. Tip does not scale and there are no wire tip and transformer connections to corrode — therefore there is no heat loss.

**FITS TUBE CADDY** — Takes half the space of transformer guns.  
**LONGER, THINNER REACH** • **EFFECTIVE SPOTLITE**

Order from your distributor today!

**HEXAACON ELECTRIC COMPANY**

589 W. CLAY AVENUE, ROSELLE PARK, NEW JERSEY

HEXAACON  
GUARANTEED



MODEL G14  
\$7.95

**NOW AVAILABLE!**

Solder Gun with smallest tip made — 1/8" tip for tight places. Model G14B. 150 Watts. Price \$7.95



**SOLDER KIT**

Includes G14 Solder Gun, cutting and smoothing tips, sandpaper. Model G14K. Price \$8.95

All models 150 Watts, 120 Volts, AC-DC, any cycle

SERVING INDUSTRY AND CRAFTSMEN FOR A QUARTER OF A CENTURY

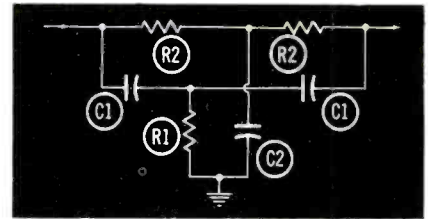

Fig. 6. A simple parallel-T filter which can be used to minimize rumble in amplifier circuits.

across the crystal input. Rumble will be less noticeable due to the de-emphasis placed on the lower frequencies.

Another means of reducing rumble is to design a rumble filter for the phono amplifier. Filters comprised of coils and capacitors are usually difficult to design and have a tendency to pick up hum modulation. Resistor-capacitor networks, however, can be used to reduce rumble and at the same time have less chance of picking up hum. A typical example of such a filter is schematically illustrated in Fig. 6. This network can be inserted between the pre-amplifier and main amplifier or between the first and second audio stages of any conventional system. The value of R2 should equal approximately twice the value of R1 and C2 twice the value of C1. When the peak rumble frequency is known, the technician can use the formula:

$$f = \frac{159,000}{R1 \times C2}$$

Where "f" equals the null frequency of the filter in cycles per second, the value of R1 is in ohms, and the value of C2 in microfarads. Typical values for R1 and C2 are 500K ohms and .003 mfd. respectively. Substituting these values in the above formula, the null frequency works out to 106 cps. When selecting components for the filter, it may be necessary to experiment with various capacitor values to obtain maximum rumble attenuation.

"An ounce of prevention is worth a pound of cure." Eliminating motor or turntable rumble at its source is, therefore, preferred to compensations in the amplifier. The technician should exhaust every effort to reduce vibration in the turntable mechanism before changing the low-frequency response of the pickup or amplifier system. ▲



MR. SERVICE-DEALER:

# YOU CAN MAKE \$6<sup>40</sup> EXTRA on 7 OUT of 10 TV SERVICE CALLS in INDOOR ANTENNA AREAS

with the  *Magic Genie*<sup>®</sup>

**Here's How:**



**1 TAKE** the JFD Magic Genie with you in your tube caddy on your next service call. It's conveniently small and compact.



**2 USE** the Magic Genie to check the picture after you have serviced the set.



**3 YOUR** customer is sure to ask about it. This is your invitation to tell the fabulous Magic Genie story.



**4 SHOW** your customer how much more beautiful the Magic Genie looks than the old ugly indoor antenna sitting on top of her TV set.

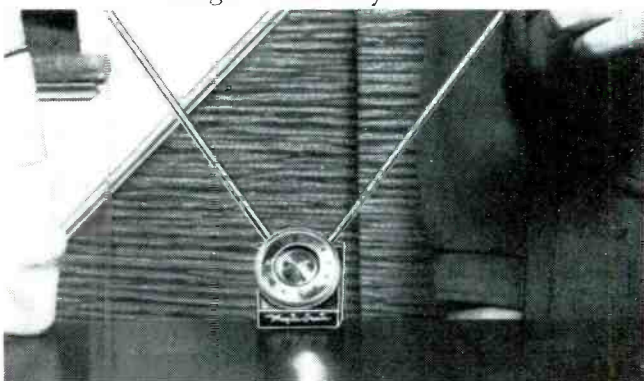

**5 DEMONSTRATE** the way dipoles rotate and adjust in any direction for powerful black and white and color reception.



**6 CLINCH** the sale by pointing out the Magic Genie unconditional money-back guarantee backed by JFD's 28 years of electronic know-how.



**ELECTRONICS, INC.**

PIONEERS IN ELECTRONICS SINCE 1929

NATIONALLY ADVERTISED AT \$17.95 promotionally priced at **\$14.95**

Call your JFD distributor for your Magic Genies and start earning that extra money now. It's so easy.

# Tracing Through Wafer-Switch CIRCUITS

by Thomas A. Lesh

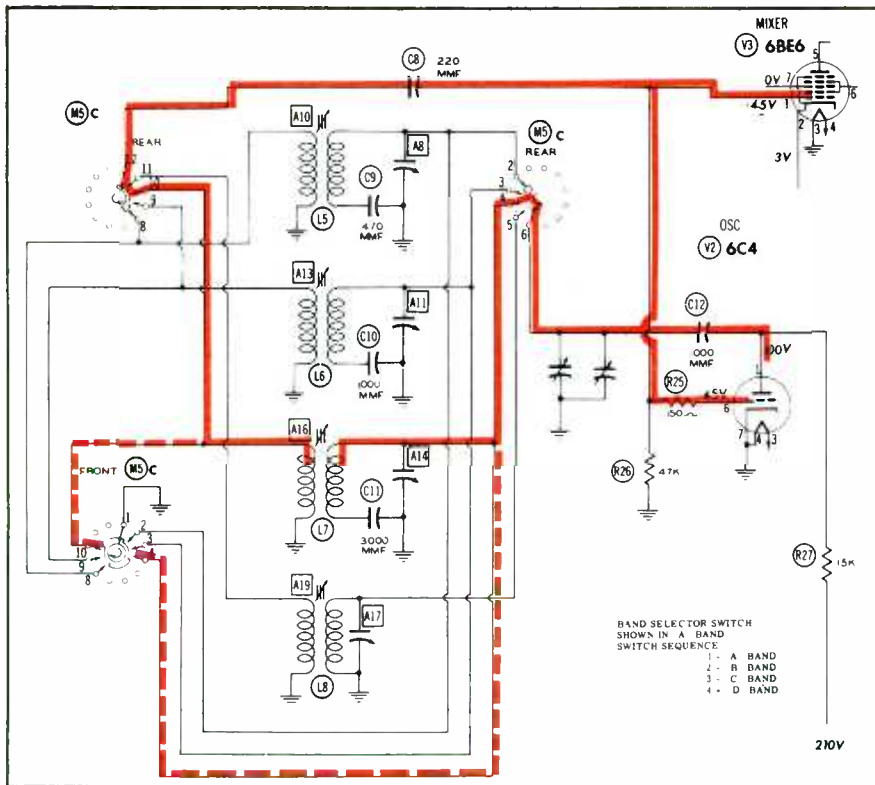

Fig. 1. Schematic of oscillator-mixer circuitry of National Model NC-88 communications receiver. Solid colored line traces active circuit on "C" band.

I guess I'm no different from anyone else when it comes to studying a schematic full of wafer switches. I search all over the diagram, hoping that I'll be able to piece enough of it together without going to the trouble of tracing through all the different switch positions. Failing in this,

I might even hunt through one or two reference books for a simplified schematic which could give some clues. Only as a last resort do I dig into the task of tracing the zigzag lines through the switches in order to find out what happens to the grid return of V3, or the detector output lead, or

some other wire, after it disappears into the jungle.

For some time I've been wondering if there might not be some short cut to this process of switch tracing. Well, after investigation, I've concluded that I was indulging in wishful thinking. There are evidently no "snap" systems; in the long run, the most time is saved by going about the work methodically and making every effort to avoid taking wrong turns. Since the eye is easily sidetracked by careless reading of switch contacts, I always take extra care to make sure a switch is oriented correctly before attempting to trace through it.

To help organize my thinking on this subject, I jotted down a number of facts about schematic diagrams of wafer switches. Some of these points may sound like old stuff to a few of you, but if you're anything like me, a little concentration on this subject will undoubtedly provide you with some new slants that will save your time.

## Contacts in a Circle

To analyze a typical wafer switch, let's refer to Fig. 1, which is a partial schematic of the local oscillator and mixer circuits in a communications receiver. The frequency-band switch in this circuit is relatively easy to trace because its main purpose is to make contact with one tuning coil out of a bank of four compactly grouped on the schematic. Other types of wafer switches, such as function selectors, are a little trickier, since adjacent contacts on the same switch are often connected to circuits which are more or less unrelated and scattered widely over the diagram.

The commonly-used schematic symbol for a wafer switch is somewhat similar to its physical appearance. When you compare the drawing with the equipment, you can readily recognize the movable contact in the middle of the wafer as well as the fixed contacts represented by the dots and arrows around the edge. Only one point is likely to be confusing, and this concerns the fact that a typical wafer has two separate sets of contacts—one on the front and another on the back. These are

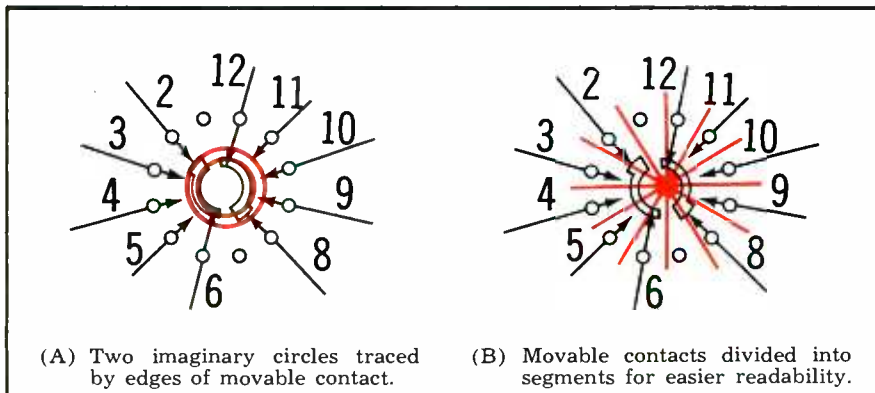

Fig. 2. Rear side of wafer switch M5 in circuit of Fig. 1.



how long would it take you to solve this service problem?

**PHOTOFACT**

helps you lick problems like this in just minutes for only \*2½¢ per model!

**SYMPTOM:**

Raster, No Sound,  
No Picture,  
and No Snow . . .

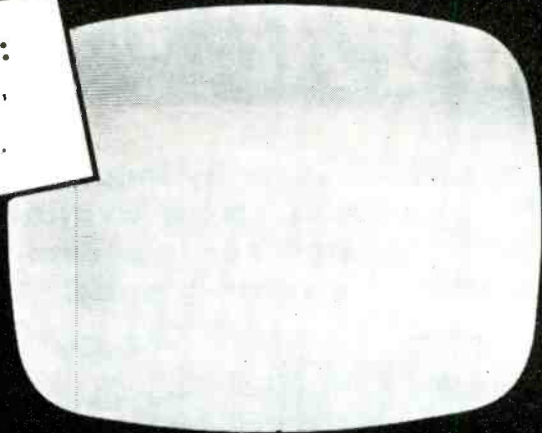

Let's take a look at this problem: A condition such as this can exist only when there is no signal reaching the picture tube or the audio output stage. Using the Tuner Service data (found in every PHOTOFACT TV Folder), first isolate the trouble by connecting an amplitude-modulated signal to the mixer-grid test point "D." The appearance of one or more black bars on the face of the tube would indicate that the trouble is probably in the tuner. So look for the following possible causes:

1. Defective oscillator-mixer tube
2. Defective RF amplifier tube
3. Open plate-load resistor in the oscillator stage
4. Failure of the feedback capacitor in the oscillator stage
5. Open decoupling resistor
6. Dirty or faulty contacts
7. Cold solder joint

Using the applicable PHOTOFACT Folder you can troubleshoot and solve this problem in minutes. Here's how:

Check the oscillator-mixer and RF amplifier tubes. Tubes okay?—then: Check voltages on the tube pins (they're right on the schematic) for open oscillator plate-load

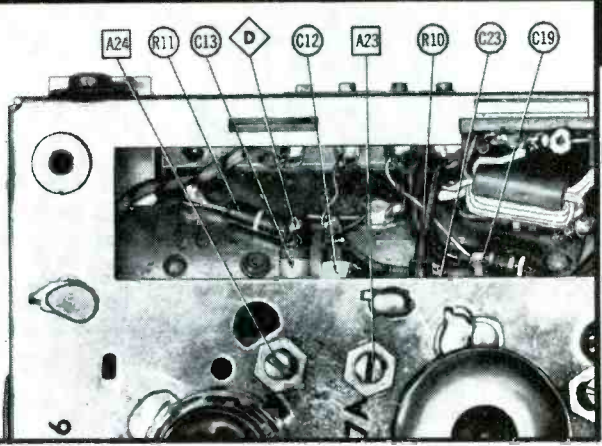

(Based on an actual case history taken from the Howard W. Sams book "TV Servicing Guide")

resistor, open RF decoupling resistor, faulty feedback capacitor, dirty switch contacts or cold solder joints.

Every PHOTOFACT Television Folder contains complete detailed information on Tuners, including separate Schematics, separate Keyed Chassis Photographs, Parts Lists, Alignment Points, Test Points, and Field Service Adjustments that will help you quickly locate the proper parts to replace and tell you how to do a touchup or thorough alignment job after making the necessary repairs. These features are a *plus* exclusive in PHOTOFACT.

Whatever your problem or favorite servicing procedure may be—you will always find all of the information you need at your fingertips in PHOTOFACT. For only \*2½¢ per model, PHOTOFACT helps you solve your service problems in just minutes—helps you service more sets and earn more daily!

\*Based on the average number of models covered in a single set of PHOTOFACT Folders.



**MONEY BACK GUARANTEE!**

Got a tough repair? Try this—at Howard W. Sams' own risk: see your Parts Distributor and buy the proper PHOTOFACT Folder Set covering the receiver. Then use it on the actual repair. If PHOTOFACT doesn't save you time, doesn't make the job easier and more profitable for you, Howard W. Sams wants you to return the complete Folder Set direct to him and he'll refund your purchase price promptly. GET THE PROOF FOR YOURSELF—TRY PHOTOFACT NOW!

**FREE**



**FOR SERVICE TECHNICIANS ONLY**

Fill out and mail coupon today for Free subscription to the Sams Photofact Index — your up-to-date guide to virtually any receiver model ever to come into your shop. Send coupon now.

**HOWARD W. SAMS & CO., INC.**

Howard W. Sams & Co., Inc.  
2201 E. 46th St. Indianapolis 5, Ind.

Put me on your mailing list to receive the Sams Photofact Index and Supplements. My (letterhead) (business card) is attached.

I'm a Service Technician:  full time;  part time

My Distributor is: \_\_\_\_\_

Shop Name \_\_\_\_\_

Attn: \_\_\_\_\_

Address: \_\_\_\_\_

City \_\_\_\_\_ Zone \_\_\_\_\_ State \_\_\_\_\_

# CARBOMITE 5-PAC RESISTORS

Used Extensively by Industrials . . . Meet Military Specs. Now available to the Servicing Engineer in a compact, self-contained-inventory pack.

*Handy Package...*

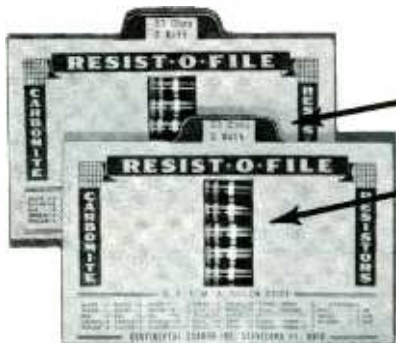

Easy-to-Read Staggered-Tab Identification

Available in All Standard Values. Each Resistor is Coded Per RETMA Standards

Code Table Printed on Each Card

**POPULARLY PRICED**

Quality 10% Tolerance

5-Pac	1/2 Watt	50c List.
5-Pac	1 Watt	75c List.
5-Pac	2 Watt	\$1.00 List.

In All RETMA Standard Values

## Special Offer

Attractive, deluxe, metal cabinet "5-PAC" file is available to you on your very first purchase . . . at manufacturer's cost . . . no coupons necessary. This Resist-O-File is designed as a professional housing for your "5-PAC" cards with staggered-tab file system. Cabinet is large enough to accommodate up to 40 resistor values.



**LOOK FOR THIS SELF-SERVE DISPLAY ON YOUR PARTS DISTRIBUTOR'S COUNTER**

All standard values in 1/2, 1 or 2 watt ratings. Specify Carbomite Resistors for High Quality at a Popular Price.

*Phone your Parts Distributor today and order out a trial set.*

**CARBOMITE 5-PACS**

**"Try them and you'll swear by them."**

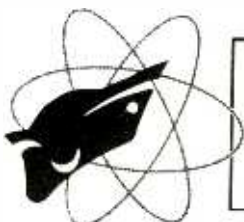

**CONTINENTAL CARBON**

DIVISION OF WIRT COMPANY  
PHONE: Germantown 8-9334  
5225 GREENE STREET \* PHILADELPHIA 44, PA.  
*Quality Resistors for Half-a-Century*

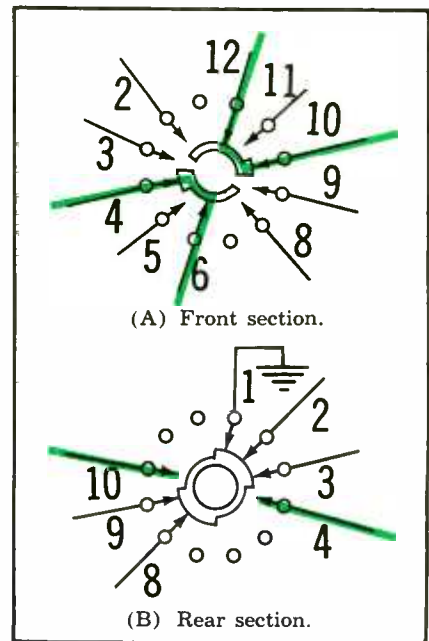

Fig. 3. Wafer switch of Fig. 1 with movable contacts in "C" band position.

frequently used in two entirely different circuits.

The problem, therefore, is simply this: how is the back side of the wafer represented? In PHOTOFAC schematics and many others, all wafer sections are shown as they appear when you look directly at them—both front and rear views. But in some schematics, all wafer contacts may be shown as they appear from the front of the switch. Thus the schematic drawing of the rear half is a "mirror image" of what you actually see when you view the physical counterpart.

Several clues enable you to discover which method of presentation is used. It is conventional to show all switches in the maximum counterclockwise position as seen from the front of the assembly, and then to indicate which way the contacts will move when the switch is turned clockwise. Usually a curved arrow is placed in the drawing to indicate this direction of rotation. If all arrows point clockwise regardless of whether the wafer section shown is a front or rear half, you can assume that all wafers are presented as viewed from the front of the switch. On the other hand, rear views of rear sections will contain a counterclockwise-pointing arrow. If no arrows are shown, look for written instructions somewhere on the schematic. Also see if the contacts are numbered. On many



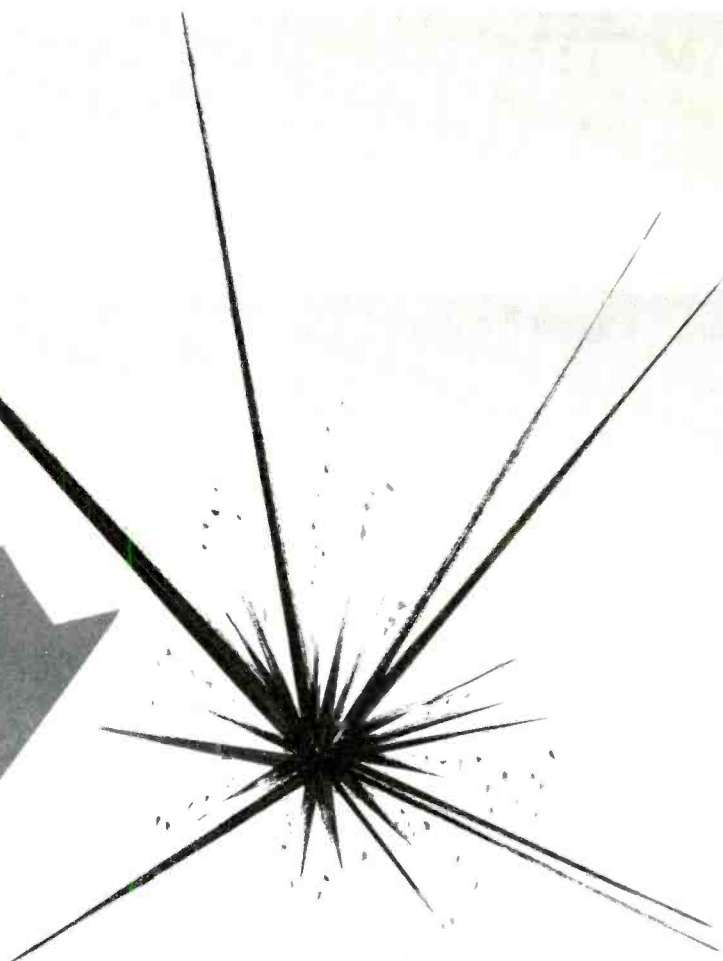

**FOR ALL YOUR TRANSFORMER NEEDS...**

# **STANCOR**

One line will satisfy the huge majority of your transformer needs . . . STANCOR. Why waste time shopping around? You can depend on your STANCOR distributor to have the transformer you want, always.

Do you have our latest catalog and replacement guides? Write for them today. (Free, of course.)

**CHICAGO STANDARD  
TRANSFORMER CORPORATION**

**3503 ADDISON STREET • CHICAGO 18, ILLINOIS**

Export Sales: Roburn Agencies, Inc., 431 Greenwich St., New York 13, N.Y.

... another  
**P. R. MALLORY & CO. INC.**  
**MALLORY**  
service-engineered  
product

watch out for  
shrinking  
capacitance

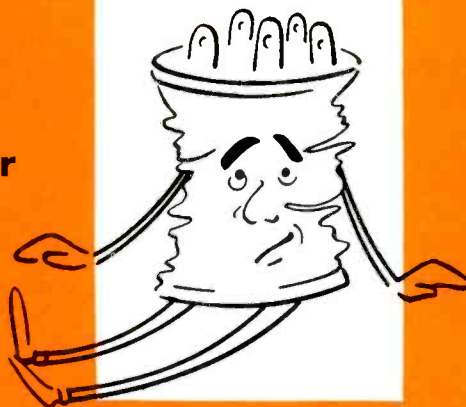

—insist on

# Etched Cathode

Ever notice how some capacitors fail before their time? In just a few weeks, especially in a high ripple circuit, they begin to develop hum.

This is due to loss of capacitance, and it's a common ailment of capacitors with plain foil cathodes.

You'll never have this trouble with Mallory FP's and popular Mallory tubular electrolytics . . . because they have *etched cathode* construction. It's a standard feature of Mallory electrolytics that insures against "missing microfarads."

See your local Mallory distributor for full facts on why etched cathode is important to you—and to your customers!

P. R. MALLORY & CO. Inc.  
**MALLORY**

P. R. MALLORY & CO. Inc., INDIANAPOLIS 6, INDIANA

- Capacitors
- Controls
- Vibrators
- Switches
- Resistors
- Filters
- Power Supplies
- Rectifiers
- Mercury and Zinc-Carbon Batteries

schematics, the contacts on the front face are numbered in a clockwise direction and the rear contacts are numbered counterclockwise.

A schematic normally includes a legend that specifies all the possible switch positions and their order of arrangement. The information for the switch in Fig. 1 states that switch M5 has four positions (A, B, C, and D) corresponding to the four frequency bands of the receiver. It is also stated that the switch is in the "A" position, which is the farthest one counterclockwise as viewed from the front.

As an example of tracing a switch circuit in some position other than the one shown on the schematic, we will describe the effective circuit for the "C" band. According to the information, two clicks of switch M5 will put its movable contacts where we want them. But before we touch the switch, let's examine the diagram closely. The 12 fixed contacts on each face of the switch are represented as small dots or circles arranged in a ring. Numbered leads are connected to all the dots in active use, and these dots also have arrows which are symbols for the fixed contact fingers. The rear side of the wafer has been divided into two portions and shown in separate drawings to facilitate layout of the schematic. Mentally overlap these two partial wafers to get a true picture of all the connections on the rear side of the wafer.

Look closely at the arrows and note that some are longer than others. To see how these two different lengths of arrows fit in with the movable contacts, it is helpful to imagine that the outer edges of the movable contacts describe two concentric circles as the switch is turned. These imaginary circles are drawn in color in Fig. 2A, which is an enlarged view of the rear side of the switch in Fig. 1. Much of the contact surface is entirely within the inner circle and can only be reached by the long arrows. Projecting tabs or wide portions of the movable contact extend into the outer circle, and these are touched only by the short arrows.

The long arrows generally cor-



respond to "basic" contacts which are active in several different positions of the switch. In Fig. 2A, these are Nos. 12 which is tied to the mixer grid, and 6 which goes to the oscillator circuit. Short arrows usually indicate contacts through which a circuit is completed in only one or two switch positions. The short arrows in Fig. 2A connect with the various tuning coils.

When reorienting a switch schematic, I find it helpful to cut it up (mentally) into 12 sections, like a pie, each one containing a contact. This is demonstrated in Fig. 2B, using the same switch as was shown in Fig. 2A. To change the switch from the "A" to the "C" position, the portion of the movable contact within each segment of the "pie" is moved counterclockwise a distance of two segments. The tabs touching contacts 8 and 2, for instance, are moved so that they touch 10 and 4 respectively; and the movable contacts in segments 12 and 6 move over into segments 2 and 8. Each of the latter two segments contains an active contact, but it is a short-arrow type and cannot reach the narrow part of the movable contact. When the switch is in position "C," the net effect is to complete the circuit between the oscillator plate and the mixer and oscillator grids through contacts 4 and 10. The reoriented contacts appear as in Fig. 3A.

The entire circuit just named is shown by the solid line in color in Fig. 1. Notice that coil L7 is connected across the tuning capacitor to provide the correct tuning range for the "C" band of frequencies.

Two extra leads go from the top of L7 to contacts 4 and 10 on the front side of the switch wafer. This auxiliary circuit is open when the switch is in the "C" position (see Fig. 3B); thus there is no effect upon L7. But coils L5 and L6 are shorted through contacts 1, 2, 3, 8, and 9 in order to prevent spurious radiations from these lower-band coils when they are not in use.

#### Contacts in Straight Rows

Although the type of diagram just described is a very realistic picture of a wafer switch, it is so

... another  
**MALLORY**  
service-engineered  
product

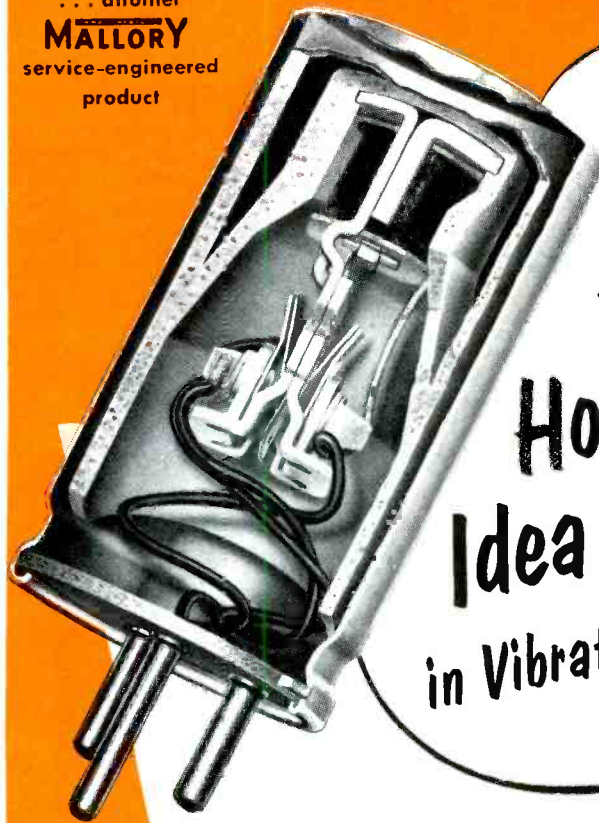

the  
**Hottest  
Idea Ever**  
in Vibrator design!

Look inside the brand new Mallory 1600 series vibrator. There are no contact buttons!

This completely new approach to vibrator design means a big advance in performance. The extra-large spring-leaf contact area gives you up to 100% longer life than ever before... reduces arc erosion.

Sticking of contacts is eliminated, to assure you positive starts. The simpler design makes possible absolute uniformity of every vibrator. And thanks to lighter vibrating mass and noise-stopping design, they're the quietest vibrators you've ever installed.

Be sure to get your stock of the new Mallory 1600 vibrators from your distributor. He carries them in ratings for all auto radios... at the *same price* you would pay for an ordinary vibrator.

P. R. MALLORY & CO. Inc.  
**MALLORY**

P. R. MALLORY & CO. Inc., INDIANAPOLIS 6, INDIANA

- Capacitors
- Vibrators
- Resistors
- Power Supplies
- Mercury and Zinc-Carbon Batteries
- Controls
- Switches
- Rectifiers
- Filters

FOR SOUND SATISFACTION



... use

RCA GOLD LABEL SPEAKERS!



Replace dead speakers with *live* RCA Gold Label Speakers. They're *short* on installation time . . . *long* on customer satisfaction. All types built to RETMA size standards REC 148 . . . mounting hardware is included on most smaller sizes . . . For *all* your speaker requirements . . . play it smart and safe! Be sure you ask for RCA Gold Label Speakers . . . at your local distributor.



**RADIO CORPORATION of AMERICA**

COMPONENTS DIVISION CAMDEN, N. J.

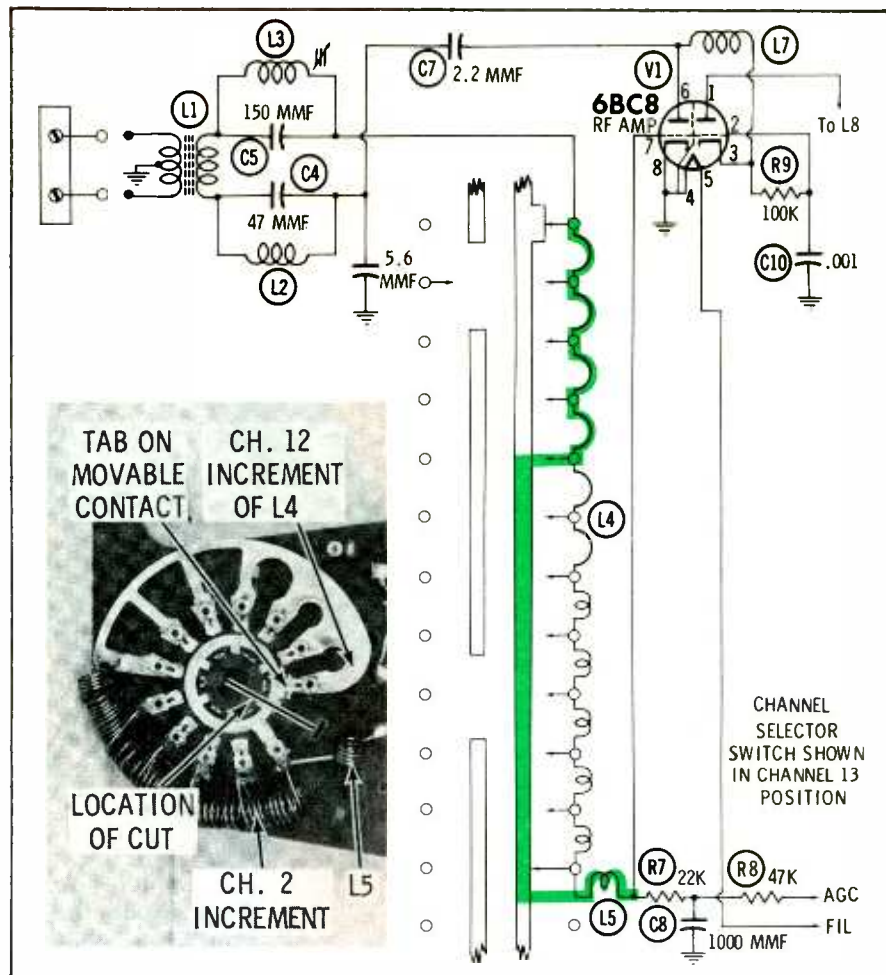

Fig. 4. RF amplifier circuit in Motorola VTT-83 tuner. Colored line traces active portions on channel 9. Inset is photograph of plug-in wafer involved.

compact that it poses difficult problems in schematic layout. Too many leads converge within one small area! In some diagrams, the wafer contacts are rearranged into a straight line in order to make the over-all layout neater and more easily readable. The schematic in Fig. 4 of a switch-type TV tuner is an example of a layout style in which the contacts have been stretched out in a straight line for better visibility, but in which a great deal of the "pictorial" effect of the rotary-style diagram has been retained.

Fig. 4 is a partial schematic diagram of a Motorola VTT-83 tuner—one of the new models with plug-in switch wafers. A photograph of the switch in the RF input circuit is included for easy comparison with the switch in the schematic. To get a better understanding of the diagram, imagine that you could make a radial cut through the wafer at the place shown, and then pull outward at both sides of the cut until all the contacts are lined up in a straight

row. You would then have an arrangement very similar to the schematic shown on the schematic.

The input circuit of the RF amplifier V1 is tuned by means of the coils connected to the switch. On channel 13 (position shown) all of L4 is bypassed through the movable contact of the switch, and L5 serves as the entire tuning coil. Small portions of L4 are added one by one as the tuner shaft is rotated to lower channel positions. The colored line in Fig. 4 indicates the coil sections that would be in the tuned circuit if the movable contact of the switch were positioned for channel 9. The switch on the opposite side of the wafer, shown with blank contacts on the schematic, is utilized in UHF-VHF tuners only.

Any schematic of a wafer switch, whether of the rotary or straight-line type, is a concentrated mass of important information, and interpreting the schematic correctly is essential for fast, efficient servicing. ▲



# NOW...

## a completely new subminiature paper tubular capacitor

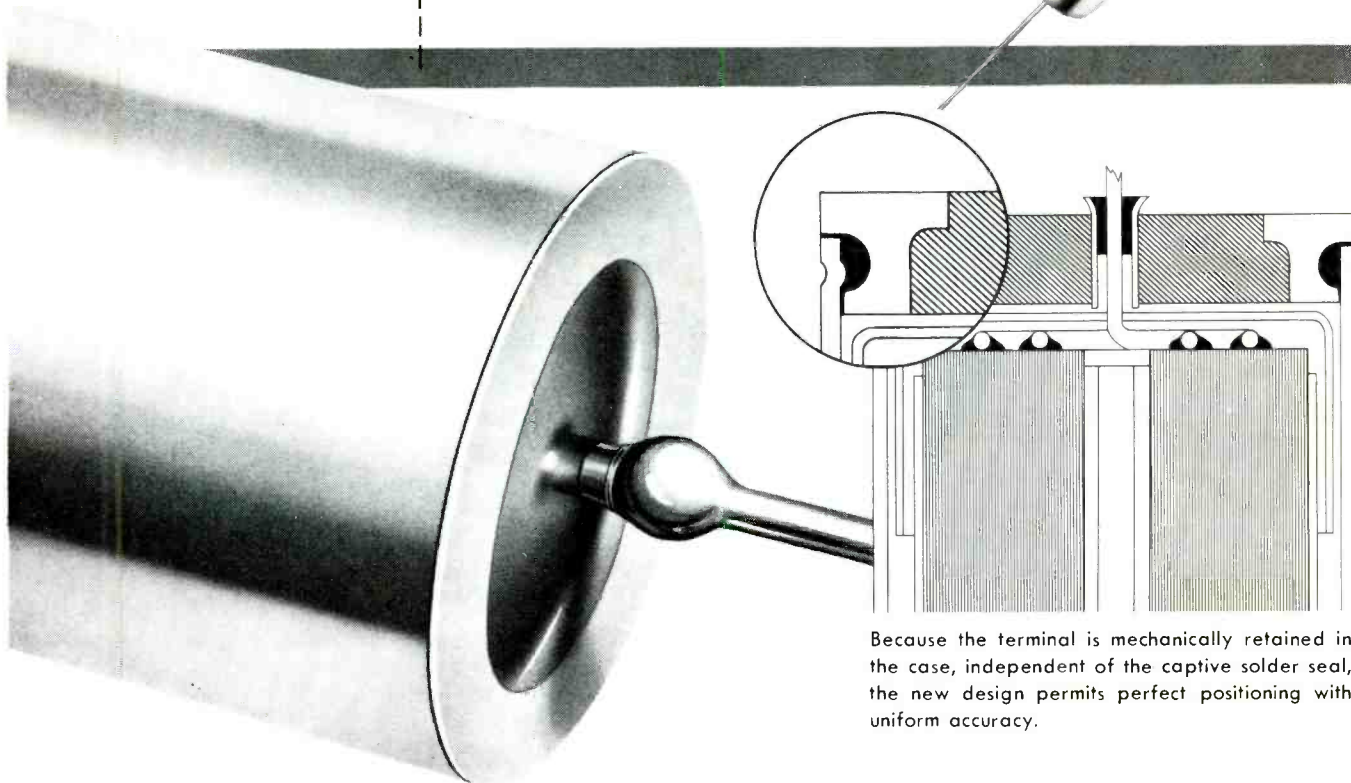

Because the terminal is mechanically retained in the case, independent of the captive solder seal, the new design permits perfect positioning with uniform accuracy.

### Hermetically sealed with Sangamo's new "Innerseal" terminal...for higher reliability...for longer service life

Here is today's latest development in miniaturized military type capacitors—a newly designed terminal for Sangamo subminiatures. This Sangamo engineering development offers many advantages over conventional seals.

The "Innerseal" structure seats and locates itself exactly on the case. Terminals cannot be cocked at angle, extend out of case, or be pushed too deeply into case and cause cupped

ends or section damage. It permits optimum performance and reliability through greater flexibility of internal design.

The solder is confined and automatically sealed. Solder or flux cannot run down inside case to cause life failures due to contamination. There are no cracked terminals due to solder time variation.

Write for Bulletin TSC-117.

**SANGAMO ELECTRIC COMPANY**  
*Electronic Components Division — Springfield, Illinois*

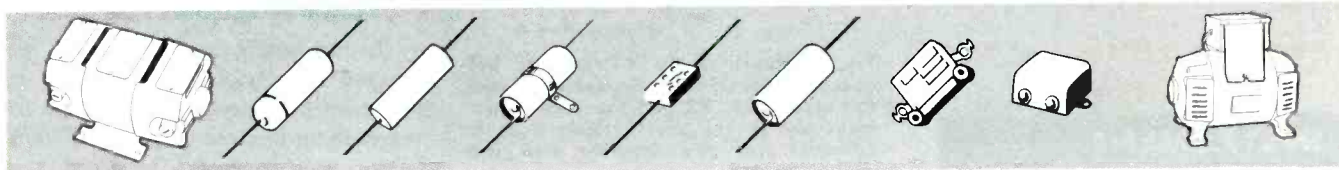

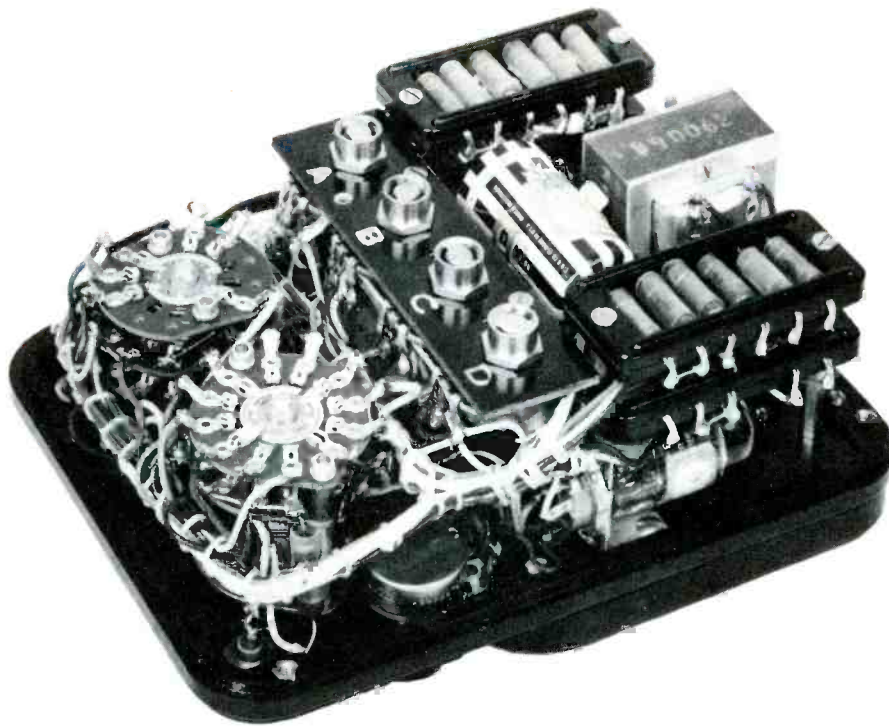

## KNOW YOUR

# VTVM

by Thomas A. Lesh

**FAMILIARIZING**

**YOURSELF WITH**

**YOUR MOST USEFUL**

**INSTRUMENT**

Most users of vacuum-tube voltmeters know that these instruments have a well-deserved reputation for versatility and accuracy, but some technicians may not realize the extent to which a good VTVM can be depended upon to solve trouble-shooting problems. In order to have full confidence in your VTVM's capabilities, you need to know exactly what the instrument can do and be sure that it is in perfect working order. Let's look inside a typical present-

day VTVM and study the circuitry to see how adjustments should be made for peak efficiency.

A complete schematic diagram of a VTVM necessarily includes a maze of switches and the associated wiring. Instead of confusing the issue by trying to untangle this network, we will merely present the various important sections of the circuit with the aid of simplified schematics. Then we will briefly describe how the various circuits are interconnected, without actually showing all the possible switching arrangements. A special coverage on the subject of tracing paths through wafer switches is presented in another article in this issue.

### Meter Bridge and Test Leads

In an ordinary voltmeter, the meter movement is activated by current supplied directly from the circuit under test; but in a VTVM, the meter current is derived from

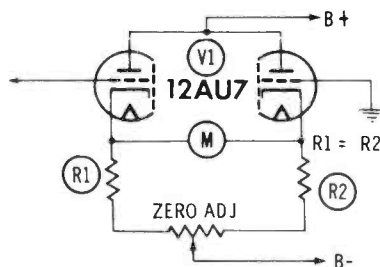

Fig. 1. Heart of the VTVM—the balanced bridge circuit. In some designs, the meter, R1, R2 and the zero adjustment are in the plate circuit and the cathodes are tied together and connected to B-.



# ***LOCKED TV*** ***"TORTURE TEST"***

first to demonstrate  
tube brand  
superiority!

Locked TV comes to your town . . . with the most impressive, most compelling sales story in the tube industry today. Be sure to make the most of it . . . your Westinghouse Tube Distributor will tell you how.

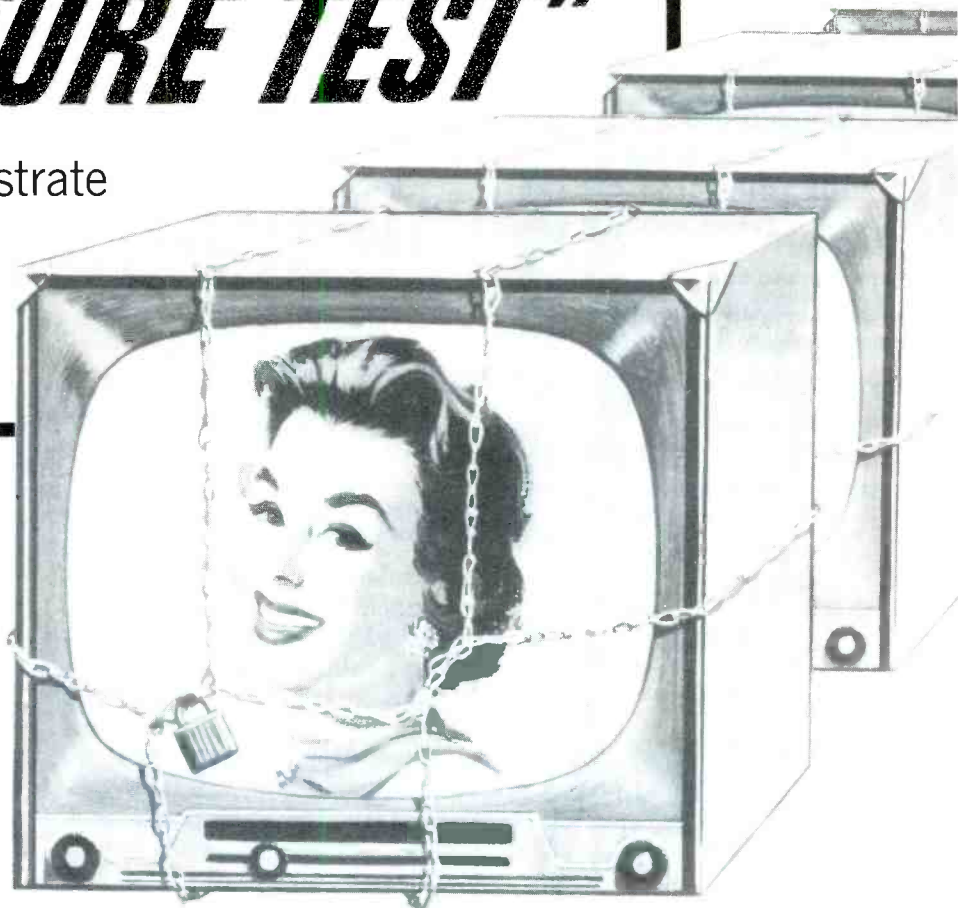

## **WESTINGHOUSE PROVES tube quality to make extra sales for you!**

**IT'S A STANDARD MODEL TV** — like your customers and prospects own. But, there's an important difference. It's 100% equipped with Westinghouse RELIATRON® Tubes. And, it's locked tight—can't be serviced, adjusted or repaired. Once it's on, you're off on a performance "Marathon"—a grueling "Torture Test" to prove that Westinghouse Tubes work better; last longer—in any make and model TV. Build your profits by reducing call-backs!

See the famous Locked TV at your Westinghouse

Tube Distributor now . . . watch it pile up the hours—perform for years of average family viewing time.\* Yet, the picture will stay bright, clear and steady.

Learn exactly how this means more profit for you. Ask about all the FREE tie-ins you can have: FREE MAILING PIECES—FREE WINDOW BANNERS AND POSTERS—ASK YOUR WESTINGHOUSE DISTRIBUTOR TODAY.

\*One Westinghouse "Locked TV" has been running 15,500 hours . . . more than 10 years' average viewing time.

7ET-1106

**YOU CAN BE SURE...IF IT'S Westinghouse**

# NEW

As featured in January 1957  
issue of PF REPORTER

## E-Z-HOOK Custom PROBE

The Test Prod  
Designed For You  
For Your Convenience

### CHECK THESE OUTSTANDING FEATURES

#### E-Z-HOOK CONNECTOR

- won't slip off
- fast, easy and safe
- even fits irregular shaped conductors
- fully insulated
- small and compact
- easy to connect or disconnect



Place Foot Against Wire    Push and Slide    Release

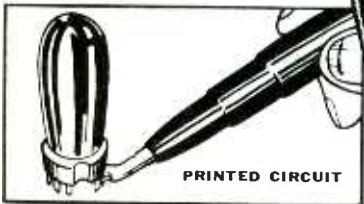

PRINTED CIRCUIT

E-Z-HOOK CONNECTING IN HARD  
TO-GET-TO PLACE UNDER TUBE BASE

#### VERSATILE TERMINAL BOARD

- specialized probe circuits are easily mounted
- strain relief for lead
- mechanical protection for circuit components
- lead easy to attach



Terminal Board With Shielded  
Lead and Isolating Resistor



STREAMLINED  
LIGHTWEIGHT  
Available in Colors

GET THEM AT  
YOUR  
PARTS DISTRIBUTOR **TODAY**

the input signal via a vacuum-tube circuit. In modern instruments, this circuit is a balanced bridge. Almost invariably, two arms of the bridge are halves of a 12AU7 dual triode. The other two arms are identical resistors which may be connected in either the plate or cathode circuits of

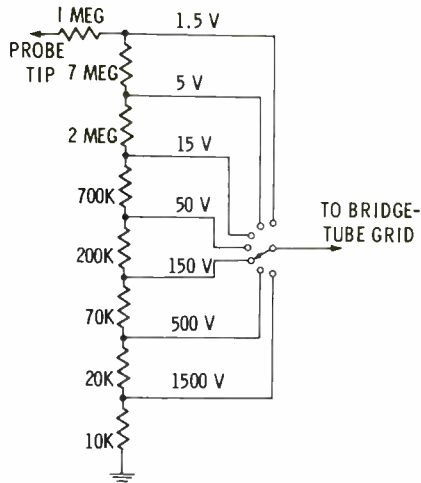

Fig. 2. Range switch and voltage divider for a DC VOLTS circuit.

the tube sections. The meter movement is connected across the center of the bridge. (A schematic of a cathode-connected bridge is given in Fig. 1.) As long as no input signal is applied, the circuit is balanced and equal currents pass through the two tube sections. Thus, the same potential is present on both sides of the meter,

and there is no current through it. The zero-adjustment control shown in Fig. 1 compensates for slight inequalities between the halves of the bridge and brings the circuit into perfect balance.

The voltage to be measured is applied to the control grid of one tube section, changing its potential with respect to the other grid and causing it to conduct more—or less—than before. The voltage at one end of the meter then changes, current passes through the meter, and the pointer is deflected in proportion to the amount of potential difference between the two grids. It is possible to place the zero-adjust control in the circuit of the second grid to vary its potential and thereby balance the bridge.

A VTVM needs two kinds of test leads in addition to the one used for common ground. One lead, used for measuring resistance and AC voltage, is basically just a wire. The other lead contains a series resistor (usually 1 megohm) to isolate the meter from the circuit under test during DC voltage measurements. Some meters have separate AC and DC leads, while others utilize one "universal" probe in which the AC and DC functions are combined. In the combination unit, the isolating resistor can be switched in or out of the circuit

### World's Smallest TV Camera

If you think the receiving end of television is becoming miniaturized, take a look at this camera developed by Grundig in West Germany. The tiny spring-mounted wheels enable the unit to reach remote, cramped locations such as the inside of small

tubes or boilers. The lighting problem in such small areas is solved by a built-in light source. Other uses are: (1) close-ups of reactions and experiments can be viewed from safe distances, (2) areas not accessible to the human eye can be examined, and (3) progress beneath the surface can be seen when drilling for oil or water.





# Electro-Voice™ POWER-POINT

**HELP YOURSELF TO  
PROFITS BY  
HELPING YOUR CUSTOMERS!**

## HERE'S YOUR PROFITABLE OPPORTUNITY

to do your customers—and yourself—a favor!  
Stock and sell E-V POWER-POINT, the unique phonograph  
cartridge-and-needle combination that ends  
service and inventory headaches, insures customer  
satisfaction, assures repeat business!

## ONE SERVICE CALL DOES THE JOB!

You install the mount and cartridge—there's a type for  
almost any phonograph. From there on it's repeat,  
repeat business for you! Because . . . come replace-  
ment time, your customer slips out the old, returns it  
to you for replacement, slips in the new faster than  
you can read this sentence!

## POWER-POINT

is a nylon-encased FRESH ceramic cartridge  
PLUS two Jeweled (Superior synthetic sap-  
phire or natural diamond) playing tips—  
ALL IN A SINGLE UNIT! There's a POWER-  
POINT for every record speed. List prices,  
\$3.95 (for two sapphire tips) to \$21.50  
(for two diamond tips).

Plenty of sales-stimulating merchandising aids  
are available, backed up by national ads. Millions of  
POWER-POINTS are in use as original equipment,  
guaranteeing volume replacement sales.

HERE'S  
POWER-POINT  
ACTUAL SIZE

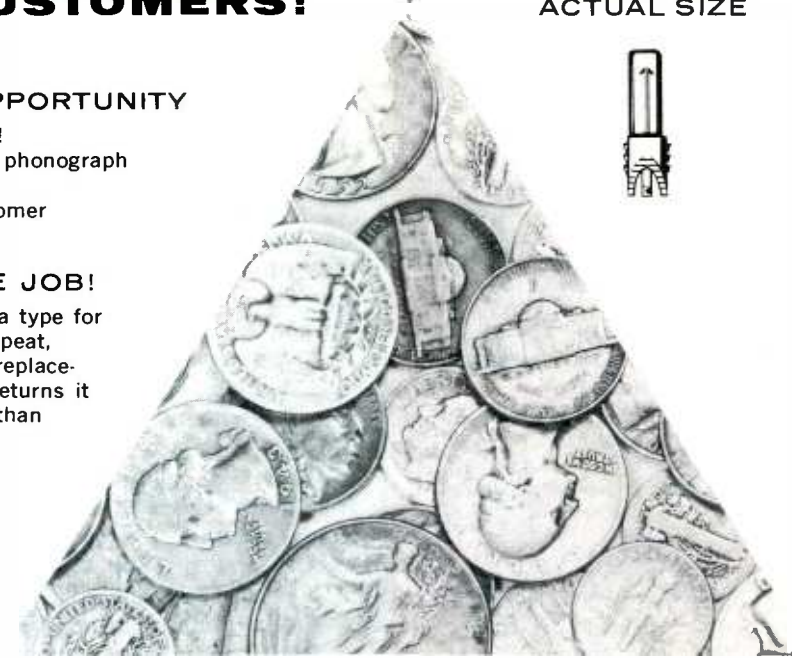

## E-V POWER-POINTS

Model 51-1 (red) Two 1-mil sapphire tips . . . . . List	\$ 3.95	Model 56DS (orange) One 1-mil diamond, one 3-mil sapphire tip . . . . . List	\$21.50
Model 52-2 (green) Two 2-mil sapphire tips . . . . . List	3.95	Model 76S (white) One 1-mil, one 3-mil sapphire tip . . . . . List	4.25
Model 53-3 (black) Two 3-mil sapphire tips . . . . . List	3.95	Model 76DS (pink) One 1-mil diamond, one 3-mil sapphire tip . . . . . List	21.50
Model 56 (blue) One 1-mil, one 3-mil sapphire tip . . . . . List	3.95		

## 3 MOUNTING MECHANISMS



Model PFT-1, fixed mount, 50¢ List.

Model PT-1, turnover mount, \$1 List.

Model PT-2, turnunder mount, \$1 List.



*write* FOR COMPLETE POWER-POINT  
INFORMATION AND SPECIFICATION  
SHEET R-74

# Electro-Voice™

ELECTRO-VOICE, INC. • BUCHANAN, MICHIGAN

Canada: E-V of Canada, Ltd., 73 Crockford Boulevard  
Scarborough, Ontario

Export: 13 East 40th Street, New York 16, U. S. A.  
Cables: ARLAB

**nulife**

**kinecure**

PAT. PENDING

## CORRECTS ALL THESE CR TUBE DEFECTS\*

- Open Cathode
- Shorted Control Grid to Cathode
- Shorted Cathode to Filament
- Open Control Grid
- Open Cathode Combined with a Shorted Control Grid to Cathode
- Open Cathode Combined with an Open Control Grid
- Open Cathode Combined with Both a Shorted Control Grid to Cathode and an Open Control Grid
- Open Cathode Combined with Both a Shorted Cathode to Filament and an Open Control Grid
- Open Cathode Combined with the Triple Defects of a Shorted Control Grid to Cathode, a Shorted Cathode to Filament, and Open Control Grid
- Superior Boost for Low Emission or Slow Heating
- Any Combination of Defects Combined with Extremely Low Emission
- Any Combination of Defects Combined with Slow Heating
- Open Cathode Combined with Shorted Control Grid to Cathode
- Open Cathode Combined with Shorted Cathode to Filament

\* Wiring diagrams are included with each unit. Proper diagnosis is not an immediate problem, because the 'Nu Life' Kinecure cannot harm either the picture tube or the receiver even if the jumpers are placed incorrectly.

Your jabber has 'Nu Life' Kinecure now. Ask him.

by means of a rotary or sliding switch on the head of the probe.

### From Probe to Bridge

If a VTVM were designed to measure only a narrow range of DC voltages, its probe lead could be soldered directly to the input grid of the bridge tube. Such a meter would have very limited usefulness, however. To give commercial VTVM's the versatility demanded by the TV service business, range and function switches and their related circuits are made a part of the connection between the probe and the bridge.

### Range Switches

Most of the voltages which the technician desires to measure are far too high to be applied directly to the bridge circuit, since only a very small change in the grid potential on the bridge tube will result in full-scale deflection. A range switch and several series resistors are therefore employed to scale down the high input voltages to a low level so that they can be handled by the bridge. The range circuit is merely a voltage divider with several taps corresponding to the various ranges.

A network that provides seven DC voltage ranges is shown in Fig. 2. In the VTVM from which this circuit is taken, a change in potential of slightly more than 1.35 volts between the bridge-tube grids causes full-scale deflection of the meter. (The meter movements used in most VTVM's have a 200- or 400-microampere sensitivity.) The values of the resistors in the divider circuit are proportioned so that the voltage required for a full-scale reading will be present at the tap corresponding to a given range at any time when the maximum voltage for that range is applied between the probe tip and ground.

To see how the divider works, let's use the 150-volt range as an example. The applied voltage appears across the 11-megohm resistance of the divider, but only a portion of this voltage—that which is developed across the 0.1-megohm resistance of the bottom three resistors—is fed to the bridge. With 150 volts at the probe tip, the following ratio equation can be used to compute

the value of the bridge input voltage:

$$\frac{E_b}{150V} = \frac{0.1 \text{ meg}}{11 \text{ meg}}$$

$$E_b = 1.363 \text{ volts.}$$

Thus, it is seen that the voltage fed to the bridge from this particular circuit will always be 1/110 of the applied voltage. For example, if only 50 volts were present at the probe tip while the function switch was in the 150-volt position, approximately 0.46 volts would be developed. Assuming that the bridge tube is operating on the linear portion of its  $E_g I_p$  curve (as it should be), the voltage change across the meter circuit should be only 1/3 of that produced with 150 volts input. The current through the meter movement would be proportionately reduced, and the reading would be 1/3 of full scale or 50 volts.

A single-knob range switch with several wafers is usually found in a VTVM. In addition, three or more resistance networks are generally needed to satisfy the range-switching requirements of the DC-, AC- and resistance-measuring circuits.

### Function Switches

The single-knob function selector of a typical VTVM also has several wafers and makes all necessary connections for measuring AC volts, ohms, plus or minus DC volts, and (in some cases) milliamperes or zero-center DC volts.

**+DC VOLTS**—This is the simplest circuit in the meter. The main element in addition to the probe and bridge is a voltage-divider network like the one in Fig. 2. Notice that the input circuit (between the probe tip and ground) at all times includes the entire resistance of the voltage divider plus that of the 1-megohm isolating resistor. Thus, the VTVM has a constant and very high input resistance—usually 11 megohms, and even more in some cases. As a result, the shunting effect of the instrument is held to the practical minimum. In low-voltage high-impedance circuits, the accuracy of voltage readings is affected to some degree, but the effect is negligible. In the same circuits, a reading taken with a 20,000-ohm-per-volt VOM might



be completely misleading.

**—DC VOLTS—**A separate function-switch position is normally included for measurement of minus DC voltages. If this feature were not included, the polarity produced across the meter by a negative bridge-input voltage would be the reverse of that produced by a positive voltage. The pointer would then be deflected to the left, and no usable reading would be obtained. With a VOM, the user would take care of this problem simply by interchanging the lead connections. This procedure, however, would be unsuitable with a VTVM because a negative potential would be placed on the chassis of the meter, and a safety hazard plus possible erroneous readings would ensue.

Ranges for plus and minus voltages are selected from the same voltage divider; the only difference between the +DC and -DC circuits is a reversal in the connections to the meter movement. In the majority of VTVM's this is accomplished by an extra set of contacts on the function switch.

A few meters have a different approach to polarity switching. Positive DC voltages are switched into the grid of the #1 section of the bridge tube, and negative voltages are switched into the grid of the #2 section. The bridge is unbalanced in the same direction in either case, and the meter connections do not have to be reversed.

**AC VOLTS—**The AC voltage to be measured is rectified and then applied to a voltage divider to develop a DC input voltage for the bridge. Modern VTVM's are capable of indicating peak-to-peak values of almost any waveform—even most sync-circuit waveforms having sharp pulses. Fig. 3 is a schematic of a peak-to-peak rectifier circuit, drawn so that you can immediately identify it as a half-wave voltage doubler similar to those frequently used in the power supplies of TV receivers. During the negative portion of the cycle, V1A conducts and charges C1 to the negative peak value in the polarity shown. Then, during the positive excursion, the charge on C1 and the peak positive voltage add in series and charge C2 through V1B to

# DON'T REMOVE THAT PICTURE TUBE!



Save time and effort pulling defective picture tubes. With the 'Nu Life' Kinecure, you can correct INSTANTLY open cathode, shorted control grid to cathode, open control grid, and shorted cathode to filament.

Use the 'Nu Life' Kinecure to save time and money where the customer will not permit the set to leave the house. Follow the wiring diagrams furnished with each unit to snap the picture tube back to normal brilliance — FAST. You can't go wrong with 'Nu Life' Kinecure — can't harm set or tube if erroneously wired. And your customer will thank you for a brighter, better picture than he had before.

Try it. It works like a charm. Your jobber has 'Nu Life' Kinecure now. Or send coupon below for full explanation.

**FREE  
WRITE  
FOR FULL  
DETAILS**

CIRCUIT MANUFACTURING CO., INC.  
26 Rittenhouse Place, Ardmore, Pa.

Gentlemen: Please send me full illustrated details about the 'Nu Life' Kinecure.

YOUR NAME \_\_\_\_\_

COMPANY NAME \_\_\_\_\_

ADDRESS \_\_\_\_\_

CITY \_\_\_\_\_ ZONE \_\_\_\_\_ STATE \_\_\_\_\_

the specs are the proof . . .  
the BEST BUYS are **EICO**<sup>®</sup>  
for COLOR & Monochrome TV servicing



**NEW COLOR**  
and Monochrome  
DC to 5 MC LAB & TV  
5" OSCILLOSCOPE

= 460  
Factory-wired  
and tested \$129<sup>50</sup>  
Also available as kit \$79<sup>95</sup>

• Features DC Amplifiers!

Flat from DC-4.5 mc, usable to 10 mc. VERT. AMPL.: sens. 25 rms mv/in; input Z 3 megs; direct-coupled & push-pull thruout; K-follower coupling bet. stages; 4-step freq-compensated attenuator up to 1000:1. SWEEP: perfectly linear 10 cps-100 kc (ext. cap. for range to 1 cps); pre-set TV V & H positions (30 & 7875 cps); auto. sync. ampl. & lim. PLUS: direct or cap. coupling; bal. or unbal. inputs; edge-lit engraved lucite graph screen; dimmer; filter; bezel fits std photo equipt. High intensity trace CRT. 0.06 usec rise time. Push-pull hor. ampl., flat to 400 kc, sens. 0.6 rms mv/in. Built-in volt. calib. Z-axis mode. Sawtooth & 60 cps outputs. Astig. control. Retrace blanking. Phasing control.



**NEW TV-FM SWEEP GENERATOR & MARKER**

= 368  
Factory-wired  
and tested \$119<sup>95</sup>  
Also available as kit \$69<sup>95</sup>

Entirely electronic sweep circuit (no mechanical devices) with accurately-biased inductor for excellent linearity. Extremely flat RF output: new AGC circuit automatically adjusts osc. for max. output on each band with min. ampl. variations. Exceptional tuning accuracy: edge-lit hairlines, 6:1 vernier. Swept Osc. Range 3-216 mc in 5 fund. bands. Variable Marker Range 2-75 mc in 3 fund. bands; 60-225 mc on harmonic band. 4.5 mc Xtal Marker Osc., xtal supplied. Ext. Marker provision. Sweep Width 0-3 mc lowest max. deviation to 0-30 mc highest max. dev. 2-way blanking. Narrow range phasing. Attenuators: Marker Size, RF Fine, RF Coarse (4-step decade). Cables: output, 'scope horiz., 'scope vertical.

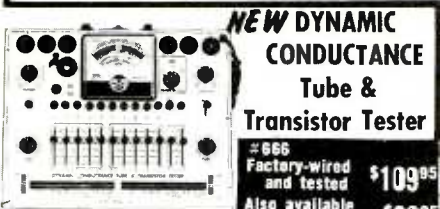

**NEW DYNAMIC CONDUCTANCE Tube & Transistor Tester**

= 666  
Factory-wired  
and tested \$109<sup>95</sup>  
Also available as kit \$69<sup>95</sup>

COMPLETE with steel cover and handle. SPEED, ease, unexcelled accuracy and thoroughness. Tests all receiving tubes (and picture tubes with adapter). Composite indication of Gm, Gp & peak emission. Simultaneous sel of any 1 of 4 combinations of 3 plate voltages, 3 screen voltages, 3 ranges of continuously variable grid voltage (with 5% accurate pot). New series-string voltages: for 600, 450, 300 ma types. Sensitive 200 ua meter. 5 ranges meter sensitivity (1% shunts & 5% pot). 10 SIX-position lever switches: free-point connection of each tube pin. 10 pushbuttons: rapid insert of any tube element in leakage test circuit & speedy sel. of individual sections of multi-section tubes in merit tests. Direct-reading of inter-element leakage in ohms. New gear-driven rollchart. Checks n-p-n & p-n-p transistors: separate meter readings of collector leakage current & Beta using internal dc power supply.

See the 50 EICO models IN STOCK at your neighborhood distributor. Write for FREE Catalog PF-4

Prices 5% higher on West Coast

**EICO**<sup>®</sup> BROOKLYN 11, N. Y.

the full peak-to-peak voltage. Practically all of this charge is retained because of the long time constant of C2 and R1 in conjunction with the resistance of the voltage-divider input. (By the way, this long discharging time explains why the pointer returns rather slowly to zero after an AC measurement is taken.)

In some VTVM's, the switch connections are such that the DC VOLTS range circuit is also utilized on AC. Others have separate voltage dividers for DC and AC ranges.

Separate scales for peak-to-peak and RMS voltages are generally provided on the face of the meter, although the range switch is marked with RMS values only. A word of warning: The RMS calibrations on most meters were arrived at mathematically by dividing the measured peak-to-peak readings by a factor of 2.828, and this ratio holds true only in the case of sine waves. Some meters of pre-TV days had only a single diode rectifier and directly read the RMS values of sine waves. A third type of meter has separate "normal" and "peak-to-peak" positions on the function switch. One of the rectifier diodes is cut out of the circuit in the former position, and is functioning in the latter.

The rectifier input circuit includes a series DC-blocking capacitor. For this reason, the amplitude of an AC signal can be measured without concern for any DC voltage level which may exist in the circuit being checked. The input impedance of a VTVM on AC ranges includes a resistance of about 1 megohm. The input shunt capacitance is also specified because of its attenuating and detuning effects in high-frequency circuits. Usually the value of this capacitance is about 60 or 70 mmf. Specifications often include the statement that RF response on the AC ranges is flat within  $\pm 10\%$  at frequencies up to about 3 mc, if the circuit under test has quite a low impedance (no more than a few hundred ohms). Frequency response falls off drastically as load impedance goes up—one manufacturer states that the response of his meter is down 10% at 270 kc if the external im-

pedance across the meter is 5,000 ohms. An RF probe, available as an accessory for nearly all meters, contains a crystal diode rectifier which permits fairly accurate measurement of signals at frequencies up to 200 or 300 mc.

The AC input of many VTVM's passes through an extra section of the range switch. On the two high-

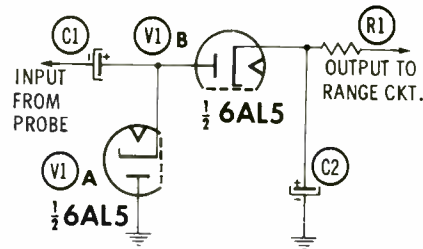

Fig. 3. Dual-diode rectifier used in the measurement of peak-to-peak values. Range circuit following this rectifier is similar to the one in Fig. 2.

est AC scales, a voltage divider (Fig. 4) is added to the circuit in order to reduce the amplitude of the input signal and thus protect the rectifiers.

OHMS—The ohmmeter circuit includes several known resistance standards arranged to provide six or seven different ranges. In the circuit shown in Fig. 5A, one of a group of resistor values is chosen as the standard for a par-

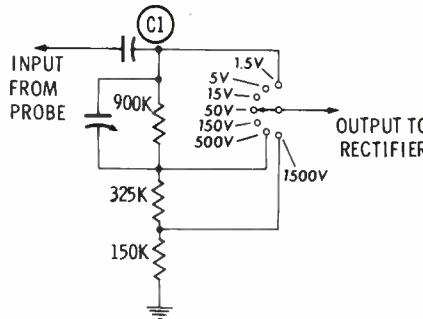
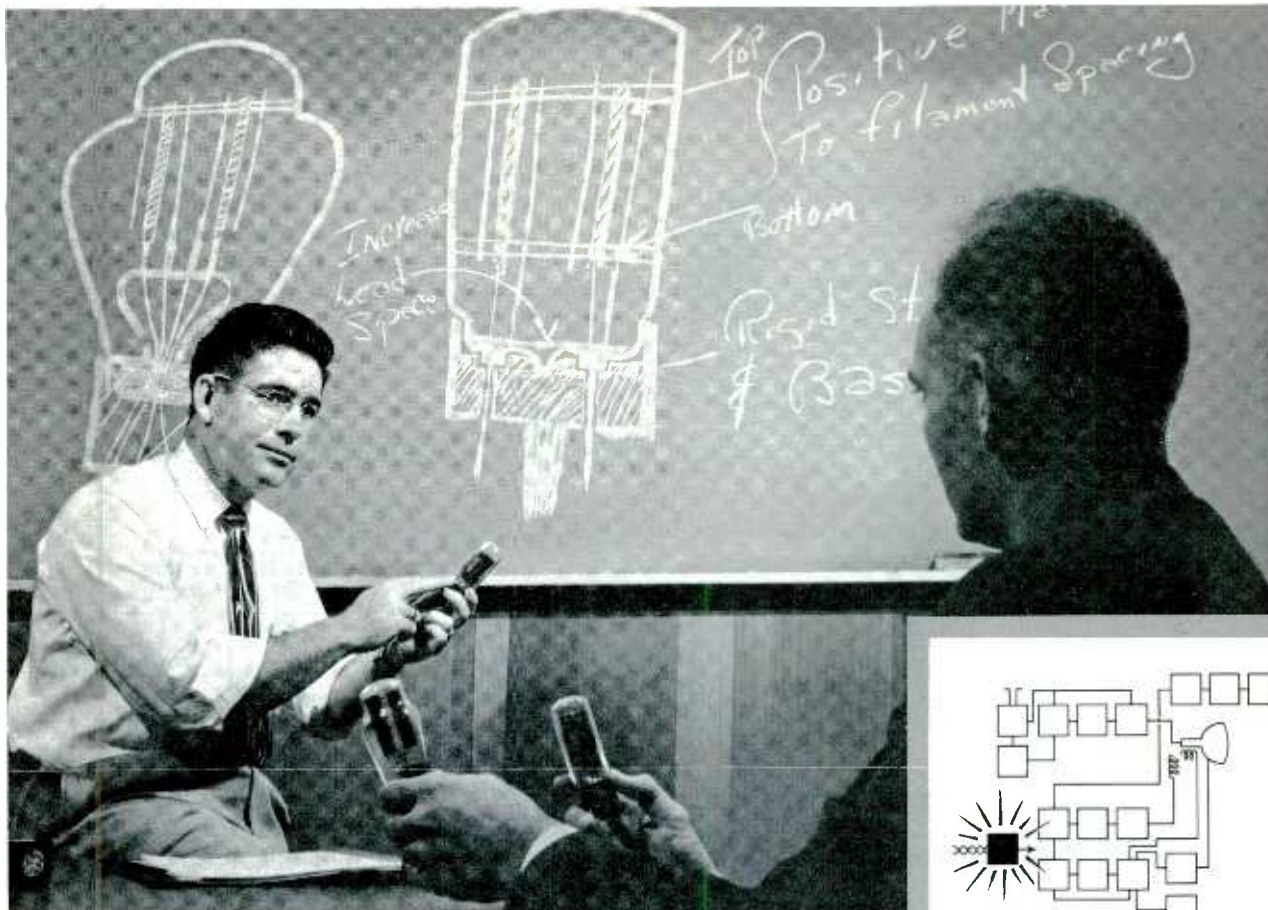

Fig. 4. Voltage divider in the AC input circuit. Full amplitude of input voltage is fed directly to rectifiers on all except the two highest scales.

ticular range. An alternate method of changing standards (shown in Fig. 5B) is to add increments of resistance in series.

The unknown resistance to be measured is placed in series with part of the known resistance, and DC voltage from an internal battery—usually a 1.5V cell—is impressed across both. (Battery polarity depends upon the meter connections in the bridge circuit.) The voltage is divided between the known and unknown resistances, and the portion appearing





How the 5U4-GA/B's improved base design and double-mica construction lengthen tube life, is explained in detail by J. F. Stephens, General Electric tube design engineer.

## Five design improvements give G-E low-voltage rectifier tubes increased performance life!

General Electric's 5U4-GA/B low-voltage rectifier tube features five long-life design improvements that enable you to install full-value performance in customers' sets.

1. Button-stem base! Improved heat conduction reduces electrolysis and consequent air leakage. Widely spaced, rigid leads cut shorts and support base firmly. Notched leakage barriers guard against tube base shorts.
2. Micas top and bottom strengthen tube structure. Filament is centered within plate, lessening the possibility of filament-to-plate arcs.
3. High adherence from improved cataphoretic filament-coating technique helps prevent flaking and filament-to-plate shorts.
4. Getter is at side of tube envelope. As a result, getter flash film won't form on micas to create harmful arc paths between filament and plate.

5. Increased plate area gives greater heat dissipation . . . cuts gas and reduces back emission . . . extends tube life for increased customer satisfaction.

When testing 5U4-GA/B's, General Electric goes beyond standard life testing. In addition, tubes are checked at absolute maximum ratings in a typical rectifier circuit—further assurance of premium performance under the peak current and voltage conditions of big-screen TV.

There are General Electric tubes of the same high quality for every socket in sets you service. Phone your G-E tube distributor! *Electronic Components Division, General Electric Company, Schenectady 5, New York.*

*Progress Is Our Most Important Product*

**GENERAL  ELECTRIC**

161-1A3

**New items  
to save time,  
make money**



**...literally hundreds of them,  
in Centralab's  
new Catalog 30**

Tells you what's new at your Centralab distributor. Keeps you up to date on the latest developments that make servicing of radio, TV, and electronic equipment faster and more profitable.

Shows hundreds of new, exciting items it pays you to know about — new values in Packaged Electronic Circuits — new volume controls — new ceramic capacitors — new switches — new transistor amplifiers.

Everything is arranged so that it's easy to find just what you're looking for. Ask your Centralab distributor for your free copy. Or write us today.

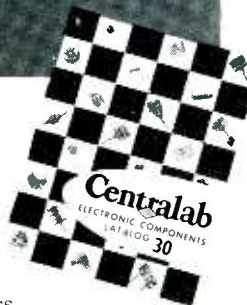

**Centralab** A DIVISION OF GLOBE-UNION INC.  
942D EAST KEEFE AVENUE • MILWAUKEE 1, WISCONSIN  
G-958

across the external unknown quantity is applied to the bridge tube. This portion becomes larger as the external resistance is increased, and when an open circuit exists between the ohmmeter probe and ground, the full battery potential is applied to the bridge. A reading of infinity is therefore indicated by full deflection of the meter pointer.

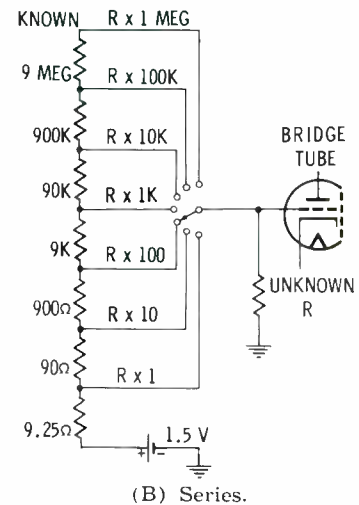
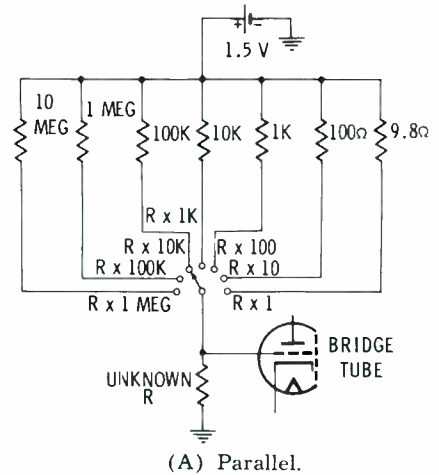

**Fig. 5. Ohmmeter circuits showing two ways of arranging known-value resistors.**

The maximum finite reading on the highest range is commonly 1,000 megohms. With an external multiplier resistor, the highest measurable resistance can be extended even beyond this figure for checking extremely high leakage resistances. However, breakdown under high voltage—an important consideration in cases of high-resistance leakage—cannot be detected with an ohmmeter.

**Controls and Adjustments**

**MECHANICAL ZERO**—With the VTVM turned off, this adjustment screw in the middle of the



front panel is used to bring the meter pointer to a resting position exactly over the left end of the scale.

**ZERO ADJUST**— Sometimes the balance of the bridge circuit is slightly altered by switching from one function to another, and it is necessary to restore balance by adjusting the zero potentiometer on the front panel. The control is turned until the pointer is precisely over the left end of the scale. An open circuit should exist across the test leads while this adjustment is being made on DC and AC voltage scales, but the leads should be shorted together in order to zero the ohmmeter scales.

**ZERO CENTER DC**— A few instruments have a special zero-center position on the function switch. Its purpose is to unbalance the bridge and move the pointer to midscale so that it can indicate both plus and minus voltage deviations. This feature is mainly useful during FM detector alignment. In meters not having a zero-center switch, the zero-adjust control usually has sufficient range to bring the pointer to center scale. You can expect to find a special mark at this spot to help you in locating true center. Sometimes, one or more scales are calibrated to read in both directions from zero. In instruments not having this convenience, you can use any of the regular DC voltage scales with the aid of a little mental arithmetic. Actually, a relative indication is sufficient for discriminator or ratio detector alignment.

**AC BALANCE or AC ZERO**— The pointer may drift slightly upscale when the VTVM is switched from DC to AC. This drift is the result of a slight output voltage (contact potential) from the AC rectifier under no-signal conditions. An AC balance adjustment inside the meter case can be set to provide a bucking voltage which exactly cancels out the contact potential and eliminates the nuisance of resetting the zero control.

Two different sources of bucking voltages are used in the various makes of VTVM's. In units which employ one half of a 6AL5 diode as a B+ rectifier, the other



**Looking  
for  
new  
numbers?**

**All the hot ones are in  
Centralab's  
new, free  
PEC\* Guide**

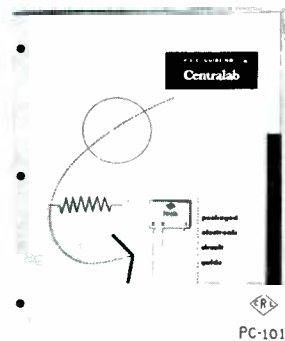

Twenty-five fresh new beauties to choose from. Currently keeping company with the entertainment industry's most popular chassis.

Brand-new edition of the Discriminating Serviceman's Guide — loaded with vital statistics, on both the old favorites and the new models. Gives practical techniques for testing — how to tell good ones from bad.

Get the lowdown on what models have been engaged, and where, by 130 radio and TV manufacturers.

These are facts it pays to have — you encounter more and more of these slim, trim PEC's every day. Over 75,000,000 now in circulation.

These beauties are waiting to be picked up at your Centralab distributor. Write us for your copy of PEC Guide No. 4.

**New—Free  
PEC Guide  
No. 4**

3	2	1

**Centralab** A DIVISION OF GLOBE-UNION INC.  
942D EAST KEEFE AVENUE • MILWAUKEE 1, WISCONSIN

\*Trademark



**\*LISTEN...**

*University  
sounds better*

**"CROSS OVER" AT ANY POINT**



The right note, delivered where needed at the right impedance—thanks to University's complete line of networks.

Crossover selections? From 350 to 10,000 c.p.s. at various impedances.

Versatile? Take our N-2A and N-2B for instance. They can be used singly at 6db per active rate of roll-off 2-way dividing networks, as 12db low or high pass filters, as 12db networks when used in pairs, or together as a 3-way.

The N-1 is a quality high-pass filter and the N-3 ACOUSTIC BATON with presence and brilliance controls is the finest 3-way network obtainable.

To solve your crossover problems, and guard against system obsolescence, look to University! For complete details, send for brochures 78A32 and 78N31.

University Loudspeakers, Inc.  
80 So. Kenston Ave., White Plains, N.Y.

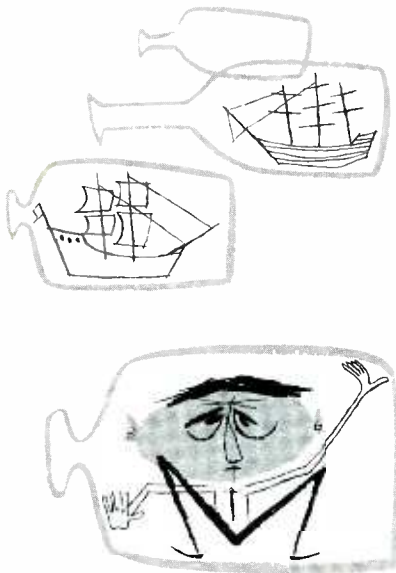

### IN A JAM?

Merit exact replacements will get you out in a hurry  
... no circuit changes,  
no chassis changes ...  
and they're better  
than the original!



# MERIT

MERIT COIL AND TRANSFORMER CORP.

4427 N. CLARK ST., CHICAGO 40, ILLINOIS

half of this tube is available for the balance circuit. Its contact potential is placed in opposition to that of the AC-signal rectifier. Another way to obtain a small bucking voltage is to place a voltage divider across B+. Whatever its source, the voltage at the arm of the AC balance control is mixed with the signal rectifier output to achieve cancellation if these two voltages are of opposite polarity. Or, if they are of the same polarity, one voltage may be fed to each control grid of the bridge tube.

**DC BALANCE**—Several VTVM designs include an internal DC balance adjustment. Its main function is to adjust the range over which the zero-adjust control is effective, and it is placed in parallel with that control. The DC balance control does not ordinarily need adjustment unless the pointer cannot be brought to both the far-left and center-scale positions by use of the zero-adjust control.

**CALIBRATION**—Separate calibration adjustments are provided for DC volts, AC volts, and ohms. In some instruments, plus and minus DC volts are calibrated separately. Each adjustment is a variable resistor placed in series with the meter movement to affect its sensitivity in one position of the function switch. The OHMS ADJUST is one calibration control which is brought out to the front panel and which requires frequent adjustment. With the test leads open, the control should be turned until the pointer rests at "infinity" on the ohmmeter scale which you desire to use. The other calibration controls are seldom touched. Although it is unwise to adjust them unless an accurate voltage standard is available, periodic calibration checks against such a standard are good for the technician's peace of mind.

What standards are available? If you have access to another VTVM which you know is accurate, you can measure the voltage between any two convenient test points and use that voltage as a temporary standard. If you are unable to use this comparison method, look around for sources of accurate voltages. Probably the best such source is a test-equip-

ment calibrator (such as the B & K Model 750). Batteries and the power lines are fairly standardized sources, but they may not be precisely correct because of such factors as battery aging and power-line voltage variations.

Various calibrating voltages such as the ones just named are recommended by the different manufacturers of VTVM's, who also state that a calibration made on any one range should be valid for all other ranges.

A correctly calibrated VTVM should be accurate within  $\pm 3\%$  of the full-scale reading on any DC VOLTS or OHMS scale, and the accuracy should be within  $\pm 5\%$  on AC VOLTS. Accuracy is less on AC because any deviations in the rectifier are added to those in the bridge circuit and meter.

### Repairs

A resistor that changes value or becomes otherwise defective should be replaced with an identical unit—usually a 1% precision wire-wound or deposited-carbon unit. Manufacturers sometimes use selected and matched resistors of a standard tolerance. If one unit of a matched pair becomes defective, both should be replaced with 1% precision units to obtain the desired accuracy.

Tubes also require some special consideration so that you can balance the bridge properly. When selecting a new 12AU7, test it for mutual conductance and use it only if the two halves check fairly equal. Insert the tube into the VTVM, and check it as soon as it is warmed up to see if the operation of the zero control is normal. If so, leave the tube in place with the instrument in operation for an aging period of 24 to 100 hours before making the final calibration. Aging stabilizes the characteristics of the tube and reveals any defects which may develop during the break-in period. If the VTVM cannot be properly calibrated at the end of the aging period, reject the tube and start again with a new one.

With proper care and adjustment, the VTVM is a handy instrument which can give you trustworthy information about almost every circuit you encounter. ▲



## Shop Talk

(Continued from page 11)

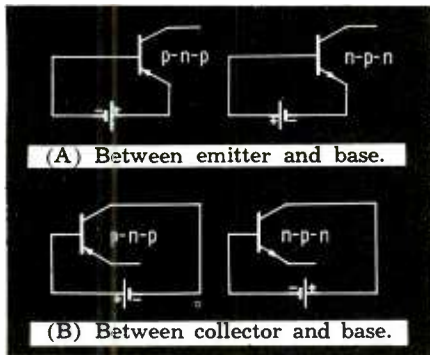

Fig. 4. Polarities of biasing voltages.

Such a circuit will be analyzed in a subsequent article; for the moment, it is simply necessary to know that the double-arranged symbol of Fig. 3C is permissible and will be found occasionally.

Perhaps the next fact about transistors which the reader should know is the polarity of each of the DC operating voltages which are applied to the three elements. In this respect, two facts should be known.

1. The emitter is always biased (with respect to the base) so that current will flow through the emitter-base circuit. Another way of stating this is to say that the emitter is biased in the forward, or low-resistance, direction. This is shown in Fig. 4A.
2. The collector is always biased (with respect to the base) so that no current will flow between collector and base.\* That

\*That a small current, labeled  $I_{co}$ , does flow does not negate this statement. We will indicate the reason for this flow at a later point.

is, the collector is biased in the reverse, or high-resistance, direction. The polarity of the voltage required to do this is shown in Fig. 4B.

Because there are two kinds of transistors, p-n-p and n-p-n, and because these possess opposing internal constructions, it is not surprising to find that the external voltages are applied with opposite polarities. In spite of this, however, both types of transistors perform the same functions (amplification, oscillation, or detection) in essentially identical fashion.

(For those readers who wish to obtain more information concerning the internal differences be-



**"YOU'LL FIND OUR SERVICE CHARGE  
QUITE MODEST — HOWEVER THERE'S A  
5 BUCK CHARGE FOR BREATHING DOWN  
MY NECK!"**

You can stop neck breather downers by using Webster cartridges and arms. Customers will know you know your job because everyone recognizes Webster quality. That means more money for you, too, because there's no call-backs . . . no dissatisfaction.

**BUY WISELY...BUY WEBSTER!**



Model AX — two needle,  
3 speed replacement cartridge

ELECTRONICS DIVISION

WEBSTER  ELECTRIC  
RACINE · WIS

Made by  
**Plasti-Kote**  
 PLASTIC SPRAY  
 ADVERTISED IN LIFE  
 \$1.27  
 Dealer Net  
 16 oz. can  
 The finest acrylic spray you can buy—  
 made by the greatest name in spray  
 paints... Plasti-Kote.  
 Now sold to the radio technician by  
 the makers of the famous "Tube Caddy."  
 Ask your distributor. \*Reg. TM  
**Argos**  
 PRODUCTS COMPANY  
 310 MAIN STREET • GENOA, ILLINOIS

**NOW** a tube caddy\*  
 for every purpose  
 the JUNIOR \$9.50 Dir. Net. Ideal for quick  
 trips. 15¼ x 12½ x 8 in. Model  
 TC-2A  
 the CARRY-ALL \$14.50 Dir. Net.  
 Takes tubes, tools, meter. 21 x 15  
 x 8 in. Model TC-4  
 the ORIGINAL \$14.50 Dir. Net.  
 Favorite of thousands. Upright de-  
 sign. 21 x 15 x 8 in. Model TC-1C  
 \*Reg. TM of Argos Products Co.,  
 originators and leading manufacturers of  
 tube cases for the electronic technician.  
**Argos**  
 PRODUCTS COMPANY  
 310 MAIN STREET • GENOA, ILLINOIS  
*Craftsmanship in Cabinets*

tween n-p-n and p-n-p transistors, reference should be made to the Sept.-Oct. 1953, February 1954 and March 1954 issues of PF REPORTER.)

#### Common-Emitter Amplifiers

Now that we can recognize a transistor symbol and know how the DC operational voltages are connected to it, let us examine the circuits in which transistors are used. The most common, of course, is the amplifier, and a typical circuit is shown in Fig. 5A. The input signal is applied between the base and the emitter; the output signal is taken from between the collector and emitter. The emitter, then, is common to both the input and output circuits and so that is rightfully referred to as a common-emitter amplifier.

If we wish, we can compare this circuit to the vacuum-tube amplifier shown in Fig. 5B. Here, the cathode (which emits electrons) is common also to the input circuit (i.e., grid and cathode) and to the output circuit (i.e., plate and cathode). Hence, this vacuum-tube amplifier could be called a common-cathode amplifier and, as a matter of fact, this designation is coming more and more in use among engineers. Of course, most technicians have always referred to the circuit of Fig. 5B simply as an amplifier and so it remains, whether we call it a common-cathode amplifier or not. Nevertheless, the latter designation does indicate its true nature a little more clearly.

(In place of common-cathode, or common-emitter amplifier, the words grounded-cathode or grounded-emitter are used. Both mean essentially the same thing. In nearly all its applications in electronics, the word "ground" should be considered in its general sense of being a reference point common to one or more circuits. The neophyte in electronics is sometimes led to believe that ground possesses special properties not found in other portions of the circuitry. Ground should be regarded as just another conductor which derives any special qualities it may have only by virtue of the fact that it is common to several circuits.)

Let us examine Fig. 5A closely

to see what the various components do. The DC power source is a small battery connected with its positive terminal to ground and its negative terminal to both base and collector. Because of this arrangement, the base is negative with respect to the emitter. Since the base-emitter circuit is to be biased in the forward or low-resistance direction, the base must consist of an n-type semiconductor and the emitter of a p-type germanium. This means that we have a p-n-p transistor, and this can be verified by noting further that the collector is biased negatively. By connecting a negative potential to p-type germanium, we tend to discourage conduction between the collector and base and thereby bias the collec-

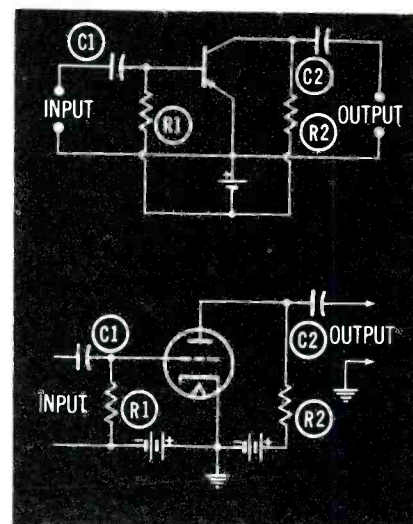

Fig. 5. (A) Typical transistor amplifier, and (B) its equivalent tube circuit.

tor in the reverse or high-resistance direction.

R1 in Fig. 5A limits the current through the base-emitter circuit to the desired value. This is governed by the operating point of the transistor. It can, to a large degree, be compared to the choosing of the grid bias for a vacuum-tube amplifier.

R2 serves a double purpose. First, it serves to bring the negative battery voltage to the collector. Second, it acts as the load resistor for the transistor. The signal developed across R2 is the voltage for the next stage.

C1 and C2 are coupling capacitors, bringing the signal into the base and removing it from the collector. They are also DC block-



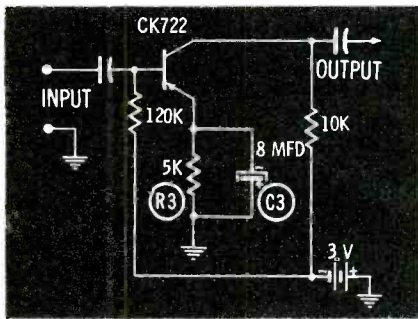

Fig. 6. Common-emitter amplifier with stabilizing resistor in the emitter lead. C3 is used to avoid degeneration.

ing capacitors, keeping the DC biasing voltages within the desired paths. In RC-coupled stages, these capacitors would keep the collector voltage of one stage from the input circuit of the following stage. When transformer coupling is used, the input capacitor (such as C1) would prevent the low DC resistance of the transformer from short-circuiting the voltage.

A form of common-emitter amplifier that is frequently seen is shown in Fig. 6. The chief difference between this circuit and that of Fig. 5A is the 5,000-ohm resistor R3 and filter bypass capacitor C3 which have been inserted in the emitter lead. R3 serves to stabilize the circuit by compensating for differences between transistors and by reducing the effects caused by temperature drift. Capacitor C3 is shunted across the resistor to prevent degeneration and a reduction in gain. In some instances, the added stability provided by degeneration may be desired, in which cases C3 would be omitted.

The similarity of this circuit to a cathode resistor and capacitor in a vacuum-tube amplifier is so obvious it need hardly be elaborated upon. It is helpful to keep these little similarities in mind, although

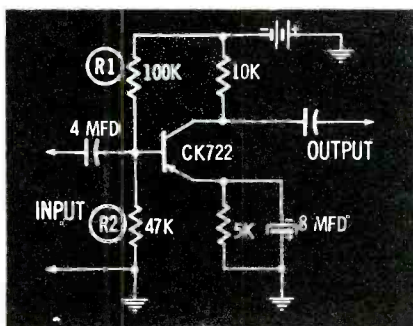

Fig. 7. Variation of the common-emitter amplifier shown in Fig. 6.

April, 1957 · PF REPORTER



UNI-DIRECTIONAL

MODEL 737A



SEMI-DIRECTIONAL

MODEL 51

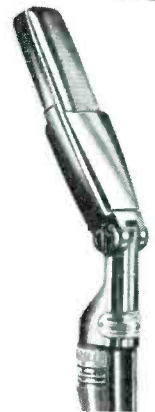

BI-DIRECTIONAL

MODEL 315

You  
have  
your choice  
of three

SHURE

moderately  
priced  
general-purpose  
microphones

Where quality is essential, yet cost is a factor—  
you can rely on these SHURE Microphones

FOR PUBLIC ADDRESS • HOME RECORDING •  
COMMUNICATIONS • PAGING AND INTERCOM  
SYSTEMS

MODEL 737A "MONOPLEX": Uni-directional, moisture-proofed crystal microphone—reduces feedback by 67%! Can be used under adverse conditions of background noise where conventional microphones would be practically useless. "Humi-seal" Crystal for trouble-free operation even in humid climates. High impedance unit with excellent response to 10,000 cps. Output -54.0 db.  
LIST PRICE \$46.00

MODEL 51 "SONODYNE": Semi-directional, dynamic microphone. Switch for low, medium, or high impedance makes it three microphones in one! Ideal for recording and "close-talking" applications. Frequency response is 60-10,000 cps, Output -52.5 db. Unusually rugged microphone; can be used in any climate, indoors or outdoors.  
LIST PRICE \$49.50

MODEL 315 "GRADIENT": Bi-directional high fidelity microphone with multi-impedance switch. Picks up sound equally from front and rear; is "dead" at sides. Ideal for interview broadcasting or group recording. Frequency response 50-12,000 cps. Provides exceptional voice and music reproduction. Particularly useful in installations where feedback is a problem. Output -57 db.  
LIST PRICE \$85.00

All three units have rugged, die-cast metal cases and are finished in a rich satin chrome.

SHURE BROTHERS, INC.

Microphones ~ Electronic Components

202 HARTREY AVENUE • EVANSTON, ILLINOIS

"In Electronics Since 1925"

# Free

## TRIAD SERVICE AID NO. 1



PTM Service Aid No. 1 is a convenient, easy-to-read wall chart listing the logical steps which the Professional Television Man should use to pinpoint the defective sweep component when faced with a "lost raster." Get your free copy from your distributor, or write to us. Supply is limited.

4055 REDWOOD AVENUE  
VENICE, CALIFORNIA

812 EAST STATE STREET  
HUNTINGTON, INDIANA



A SUBSIDIARY OF LITTON INDUSTRIES

they should not be carried too far because of the considerable difference between vacuum tubes and transistors. This word of caution can be likened to that which is given to anyone learning a foreign language. Start off by using the language you know to gain familiarity with the new tongue. But, for proficiency, get to think in the new language as quickly as possible.

Still another variation of the common-emitter amplifier is shown in Fig. 7. Here the base receives its biasing voltage from a voltage divider, R1 and R2. Circuit operation still remains the same.

### Common-Base Amplifiers

The transistor can also be employed to amplify when the base, rather than the emitter, is common to both input and output circuits. See Fig. 8A. The arriving signal is applied between emitter and base and the output signal is taken from the collector-base circuit. As we might expect, the name of common-base amplifier has been given to this arrangement.

An equivalent vacuum-tube amplifier is shown in Fig. 8B. The grid, being equivalent to the base, is grounded. The signal is then fed to the cathode, and the plate is the output circuit.

You will not meet very many common-base amplifiers (at least with junction transistors) because better results can be obtained using the aforementioned common-emitter amplifier. However, common-base amplifiers are entirely usable and will provide a fair amount of gain.

It is interesting to note that in a grounded-grid amplifier, the input and output signals possess the same polarity. That is, in going through the tube the phase of the signal does not change. In a common-base transistor amplifier, the same behavior is found. To illustrate this, assume that a signal is applied to Fig. 8A and, further, that the incoming signal is positive at a certain instant. This positive voltage will counteract some of the normal negative bias between emitter and base and serve to reduce the current flowing through the transistor. A re-

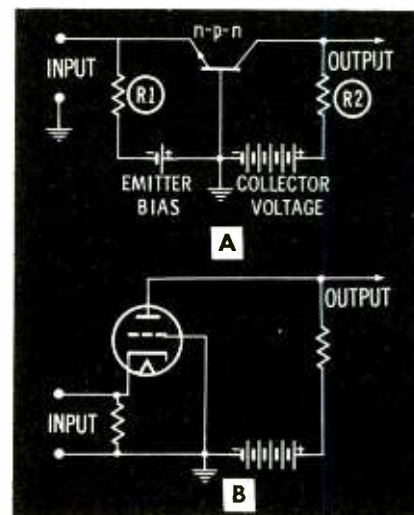

Fig. 8. (A) Grounded-base amplifier, and (B) its equivalent tube circuit.

duction in the voltage drop across R2 will occur and make the collector potential more positive. Thus, a positive-going input signal produces a positive-going output signal.

During the negative half cycle of the input signal, the emitter will be driven more negative than it normally is with respect to the base. This will increase the flow of electrons from emitter to collector and cause the negative voltage drop across R2 to increase so that the collector will become more negative. Again we see that the polarity of the output signal is similar to that of the input signal.

The same type of reasoning, using an applied AC signal, will show that in a common-emitter amplifier, the output signal is 180° out-of-phase with the input signal. The ability to perform this kind of analysis will go a long way in helping you understand many of the finer points in transistor circuits. We can still follow electrons around the circuit here just as we have been doing in vacuum-tube circuits. Do not let the change from tube to transistor throw you off.

### Grounded-Collector Amplifiers

The final circuit arrangement is the grounded collector, shown schematically in Fig. 9 together with its vacuum-tube counterpart. Of course, the plate of the vacuum tube is not DC grounded since this element still requires a positive potential (relative to the cathode) in order to attract electrons. The plate is at AC ground,



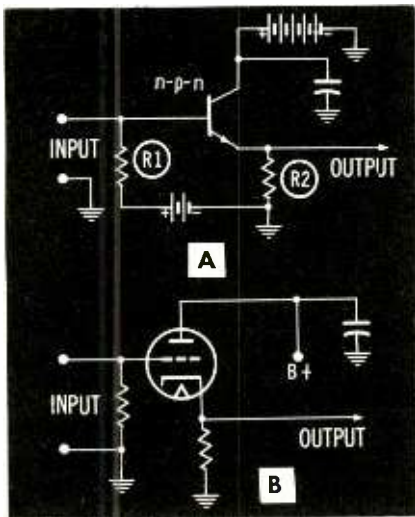

Fig. 9. (A) Grounded-collector amplifier, and (B) its equivalent tube circuit.

however, by virtue of the large bypass capacitor.

The grounded-plate vacuum-tube amplifier will be recognized as the familiar cathode follower which possesses a high input impedance between cathode and grid and a low output impedance. Voltage gain of this arrangement is always less than 1. Similarly, the input impedance of the grounded-collector transistor amplifier is very high because of the reverse biasing of the collector. Typical values range between 300,000 and 600,000 ohms. The output impedance on the other hand is low, frequently less than 100 ohms. And to complete the analogy, the voltage gain of a grounded collector is always less than 1. Thus, this circuit is the transistor equivalent of the vacuum-tube cathode follower.

Phase reversal of the signal does not occur in a grounded-collector amplifier. Any signal applied to the input will appear at the output with the same phase. An interesting feature of the grounded-collector circuit is its ability to pass signals in either direction, enabling it to function as a two-way amplifier. This proves very useful under some conditions, particularly when a symmetrical transistor is used.

Remember that no matter how a transistor is connected, the method of DC biasing remains unaltered. The emitter is always biased in the forward direction, while the collector is always biased in the reverse, or high-resistance, direction. ▲

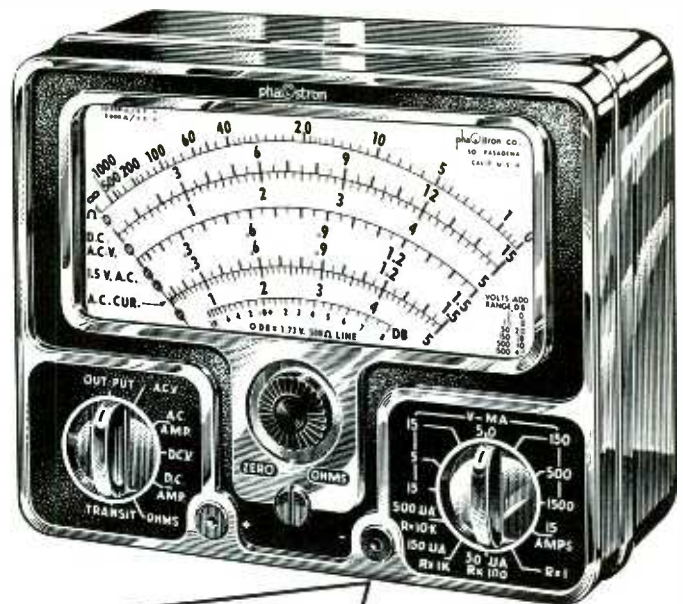

## 555A VOM

### YOU NEED THESE FEATURES:

Meter Movement Protection up to 500 times overload is provided by a rectifier network.

The 555A Measures: AC Current, DC Current, AC Voltage, DC Voltage, Output, Resistance

43 Unduplicated Ranges

Separate Range and Function Switches

Double Magnetic Shielding

3% DC, 4% AC Permanent Accuracy

Easy to Read, Four Color Scales 4 7/8" long

Metal Case with Die Cast Bezel 6 1/8" x 4 5/8" x 2 1/8"

Sensitivity: 20,000 Ohms/Volt DC, 2000 Ohms/Volt AC

Complete with Probes and Batteries at your Parts Distributor **\$49.50**

**PHAOSTRON INSTRUMENT AND ELECTRONIC COMPANY**

151 Pasadena Avenue, South Pasadena, California

# NEW

at Ward...

## REAR FIN ANTENNA

Newest, smartest, pace-setting rear fin on the market. Heavy chrome plated—3 sections extend to 27". 15-ft. lead with built-in signal booster.



### MODEL NO. TFL-1

Also available as dummy mount. —Model TFD-1

### ... AND HERE'S MORE!

#### NEW FENDER PADS ... for 1957 Fords

**Fender Pads—**  
For mounting 8-Ball mount antennas on front fenders of 1957 Ford. C-61



**Fender Pads—**  
For mounting Tear Drop mounts on front fenders of 1957 Ford. C-62

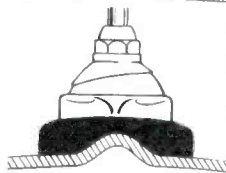

#### Fast-Selling Ward TEAR DROP MOUNT

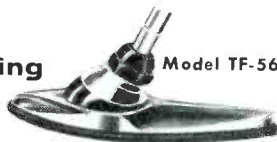

The fastest selling style leader of them all ... the replacement antenna with original equipment styling. Mounts completely outside the car ... easily ... quickly. Heavy chrome plate ... 3 sections extend from 22" to 56".

These are just a few of Ward's new quality leaders that have joined the famous Ward family which includes the 8-Ball, Majorette, Silveramic® and many others. Order *TODAY*. For complete information, write: Dept. PFR-4.

## Ward PRODUCTS CORPORATION

DIVISION OF THE GABRIEL COMPANY

1148 EUCLID AVE. • CLEVELAND 15, OHIO

IN CANADA, ATLAS RADIO CORPORATION • 50 WINGOLD AVE. • TORONTO, ONTARIO

### Antenna Installations

(Continued from page 17)

the old ones will keep the unit sealed properly from the weather. If any water enters the rotator mechanism, it may cause corrosion of the gears, bearings, etc., or shorts in the electrical circuits. In either event, the unit might not operate satisfactorily.

#### The Antenna Next

The antenna and all of its associated mounting hardware should be checked thoroughly, and all defective parts replaced before the rotator is reinstalled. The first step is to replace any faulty items of mounting hardware (chimney straps, mast sections, mounting brackets, base plate, etc.). Once these parts have been taken care of, the rotator mechanism can be put back in place.

Guy wires, if used, present a special problem, since they are used to hold up antenna masts or towers that are not self-supporting. If the guy wires are being used on a tower, new ones should be installed before the old ones are removed. If the wires are in very poor condition, very carefully climb the tower and tie a rope around the side of the tower opposite you. Your assistant can pull on this rope to counterbalance your weight until the new guy wires can be run. In the case of a 10-, 20- or even 30-foot guyed-mast assembly on the top of a house, the replacement of guy wires is somewhat of a problem, since it is no easier to replace guy wires on this type of system than it was to install the system originally.

The general practice is to place a ladder against the mast as shown in Fig. 1 and climb just high enough so you can lower the topmost section with the guys still secured. Install a new top set of guys and service the antenna. Check all elements, tighten all connections, and replace lead-in and insulators, if required. Remove the old set of top guys and install a new set of lower guy wires. Remove the old set of lower guy wires and push the top section back into place. After the ladder has been removed, the guy wires should be rechecked for

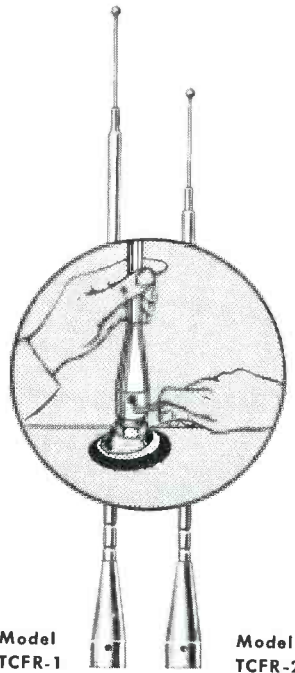

#### Smart NEW Replacement Masts

No need to disturb the mast. Just slip on and tighten. Easiest, quickest replacement ever developed. Bell-shaped collar on mast fastens to stub of original antenna mast with set screws.



proper tension. Long guy wires will have a slight amount of sag, as will any long wire suspended in the air

When the mounting assembly has been restored to proper condition, the antenna may be reinstalled in the rotator. An antenna mounted in a rotator and thrust bearing is shown in the head photograph of this article. The weight of the antenna should be placed on the thrust bearing and not on the rotator mechanism. This may be done by holding the antenna up slightly from its lowest possible position and tightening the set screws in the thrust bearing. If the rotator is of the type that has a heavy-duty thrust bearing below the rotator unit, let the mast rest on this thrust bearing, secure it to the supporting mast, and then tighten the rotator connections.

The next problem is the construction of the turning loop for the rotator. One sure way to get this loop correct the first time is to operate the rotator until it indicates due south, point the antenna south, and make the loop as shown in Fig. 2. The stand-off insulator on the movable mast should be located directly above the insulator on the stationary mast. When the loop between these insulators is made in this fashion, the antenna may be rotated 180° in either direction and the lead-in wire will not loop around the mast when the rotator is operated to the extremes of its rotation.

The lead-in is routed across the roof, around the gutter, down the side of the house, and into the basement. Fig. 3 shows how the lead-in should be dressed away from the gutter as far as possible through the use of long stand-off insulators in order that proximity to metal will not interfere with signal transmission. On the other hand, the rotator control wire may be routed across the gutter without clearance. Notice in Fig. 4 how a ground wire is run from the antenna mount down each side of the house to a ground rod. Moreover, a bonding strap connects the gutters to these ground wires, which are securely fastened to the house with staples. It is not necessary to use insula-

# AT LAST AN IN-CIRCUIT CONDENSER TESTER THAT DOES THE WHOLE JOB!

## The Model CT-1 IN-CIRCUIT CONDENSER TESTER

The CT-1 actually steps in and takes over where all other in-circuit condensers fail. The ingenious application of a *Double Parallel Balance* principle gives the CT-1 a tremendous range of operation . . . and makes it an absolute 'must' for every serviceman.

JUST A FEW FEATURES OF THE CT-1

- Ultra-sensitive 2 tube circuit
- Multi-color direct scale reading for both quality and value in our out of circuit
- Simultaneous independent reading of circuit capacitive reactance and resistance
- Sensitive hi-resistance leakage indicator
- Cannot damage circuits. . . . Simple to operate
- Each instrument bears RETMA guarantee

only \$34.95

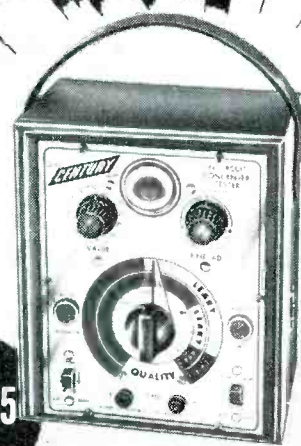

NO LIMITS TO THE JOBS CT-1 DOES FOR YOU checks in-circuit:

- ✓ quality of all condensers . . . leakage-shorts — opens — intermittents in all size condensers
- ✓ Value of condensers 200 mmfd. to 0.5 mfd.
- ✓ electrolytics for quality — any size
- ✓ wiring and socket leakage, transformer leakage, distributed and leakage capacity

checks out of circuit:

- ✓ quality of all condensers . . . leakage-shorts — opens — intermittents in all size condensers
- ✓ Value of condensers 50 mmfd. to 0.5 mfd.
- ✓ electrolytics for quality — any size
- ✓ new or unknown condensers — component leakage — etc.
- ✓ hi-resistance leakage up to 300 megohms

No other instrument approaches the CT-1 — AT ANY PRICE

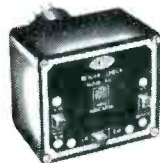

REJUVA-CHECK Model RJC-1 only \$7.95



TV DYNATRACER Model TVD-3 only \$4.95

### OTHER CENTURY TEST INSTRUMENTS AVAILABLE



CRT TESTER-REJUVENATOR Model CRT-1 only \$19.95



ANTENNA LINE TESTER Model ALT-1 only \$19.95



SPEAKER SUBSTITUTER Model SS-1 only \$22.50

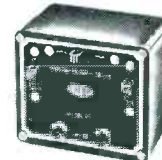

TRANSISTOR-CHECK Model TC-1 only \$6.95

## Century Electronics Co., Inc.

111 ROOSEVELT AVENUE, MINEOLA, N. Y. Dept. PF-4

Yes, I am interested in seeing the Century line at my favorite distributor. I understand this coupon does not obligate me to buy. . . . But I will receive a Bonus Certificate that will entitle me to the PIN STRAIGHTENER and TUBE PULLER absolutely FREE with any Century instrument I may decide to purchase.

My Distributor Is: .....

Name .....

Address .....

City .....

Zone .....

State .....

FREE GIFT FOR YOU

Just return coupon to us to indicate your interest in seeing how the CENTURY test equipment line will help you in your every day work.

You will receive a Bonus Certificate that will entitle you to pick up at your parts jobber—ABSOLUTELY FREE—a unique PIN STRAIGHTENER and TUBE PULLER (actual value \$1.00) with the purchase of any CENTURY instrument. Send coupon today . . . OFFER IS LIMITED to existing supply. BE SURE TO GIVE YOUR DISTRIBUTOR'S NAME.

*Dave Rice's*  
**OFFICIAL**  
**ORDER BOOK**  
 for every TV-Radio  
 service call

Triplicate forms serve as order form, invoice and office record with spaces for complete information on every job. Separate listings for receiving tubes, pix tube, parts, serial numbers, labor and tax charges, signatures, etc. 75c a book, \$6.50 for dust-proof box of 10.



... and for customer's prices on every replacement part, *Dave Rice's*

**OFFICIAL PRICING DIGEST**

listing over 60,000 items. \$2.50

In stock at your distributor, or write

**ELECTRONIC PUBLISHING CO. INC.**

180 North Wacker Drive Chicago 6, Illinois

**Grips**  
**the screw!**  
 Drives it too!

**Quick-Wedge**  
**SCREW-HOLDING**  
**SCREWDRIVER**

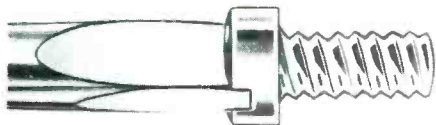

2" to 14" blades, 4 bit sizes  
 Available with shockproof  
 plastic covered tubing  
 Unconditionally guaranteed



**ASK FOR IT AT YOUR DEALER**

Kedman Co., 233 So. 5th W., Salt Lake City



Fig. 4. This end view of a house shows the system of wires and ground rods necessary for secure grounding of an antenna system.

tors for the ground wires; in fact, it is better if they are not used.

A lightning arrester (Fig. 5) is fastened to the house above the lead-in entry, and the ground wire of the arrester is connected to a ground rod. Also visible in Fig. 5 are the feed-through units employed for the lead-in wire and the rotator-control wire.

From this point, the lead-in and rotator-control wires are routed to the set location. Stand-off insulators are employed for the lead-in, even in the basement or crawl space, and the rotator-con-



Fig. 5. The lead-in and rotator cable entering the house through suitable feed-through insulators. Before entering, the lead-in is fastened to a lightning arrester which is grounded to a rod.

trol wire is taped to the shafts of these stand-offs.

As a finishing touch, signal and rotator control jacks are mounted in the floor behind the TV receiver as shown in Fig. 6. The four-terminal outlet is for the rotator. The combination signal and rotator-control panel shown



Fig. 6. In professional-looking antenna installations, the lead-in wire and rotator cable are terminated in wall or floor outlets behind the TV set.

in Fig. 6 gives the system the professional touch which always impresses the customer. Never leave a long hank of lead-in dangling behind the receiver—always provide some sort of outlet plug secured to the woodwork or floor. This will not only make it easier to get behind the receiver for service but will also prevent poor reception which might result from less careful installation. It also permits the customer to unplug the antenna and rotator leads so that the receiver may be moved during housecleaning. ▲



## TROUBLE SHOOTING WITH GEORGE

### The Solution

George found the trouble in the AGC circuit. After measuring the AGC voltage, he took a resistance reading which revealed a 1,200-ohm leakage path between the AGC line and chassis ground. Following up these new clues, he quickly traced the fault to an AGC filter capacitor. Replacement of this component restored the set to normal operation.

Although George Fleiback blamed his poor trouble-shooting approach on inexperience and the weather, he was actually "April Fooled" by the absence of sound distortion. George had been working under the delusion that any severe trouble in the AGC system of an intercarrier receiver would seriously affect the sound. This little experience, however, proved the contrary.

The essential reason for the absent symptom lies in the characteristics of the video and sound signals themselves. The video carrier is amplitude modulated, while the sound carrier is frequency modulated. As both carriers pass through the same stages, the AM or video signal must receive relatively linear amplification. Otherwise, noticeable lack of detail or picture distortion will result. The FM or sound signal, on the other hand, is represented by frequency or phase variations and can therefore withstand greater amplitude changes without seriously affecting the fidelity of the sound from the set.

(Advertisement)

## latest JACKSON tube test data

TUBE TEST	MODEL 648 CIRCUIT		PLATE E. TEST		MODEL 115/715/561 FIL. X. PLATE YZ	
	FIL. D.				FIL.	YZ
5CM6	5.0	129	B346	35W	5.0	4 14 7JKS
6BN8	6.3	A126 125 123	ACT9	28XZ 4 60X 8 60X	6.3	- 30 50Q 2Q 4Q
6CQ8	6.3	A129 A127	AB358	48V A46 80Z	6.3	- 34 5RS 2PR
TUBE TYPE	SEC.	A.	B.	C.	D.	CATH. SHORTS E.
5CM6	P	5.0	4	6X	139	7 34
6BN8	T	6.3	4	X	78	9 32
	D	6.3	4	-	1X	2 41
	D	6.3	4	-	6X.	3 41
6CQ8	P	6.3	4	X	236	7 30
	T	6.3	4	X	119	8 30

Latest Chart Form 648-17, 115/715/561-9, 49-3

## Servicing New Designs

(Continued from page 19)

The latest 12DQ6A design is also being used more and more in the newest 90° sets.

The flyback of the new Sylvania set (shown in simplified schematic form in Fig. 3) has a patented "flux-canceller" feature that is very simple in principle. A secondary winding, connected to the main winding through the damper, carries sweep current 180° out of phase with that in the main winding. The magnetic flux induced in the core of the transformer by this out-of-phase current neutralizes part of the flux generated by the current in the main winding, and this cancellation prevents overheating which would otherwise tend to occur unless a larger core were employed. Notice that the width coil is connected across the secondary winding.

### Receiver Circuitry

The rest of the circuits in the new Sylvania chassis are like those usually found in 17" and 21" receivers. A cascade tuner is used in all except the lowest-priced model, which has a pentode tuner. Tubes are in a 600-ma series string in present models. The following types are used in the various stages: Three 3BZ6 IF stages; a 12BY7A video output tube; a 5BR8 doing double duty as an AGC keying tube and sound IF; a 5T8 ratio detector and audio amplifier; a 5AQ5 audio output tube; twin silicon diodes used for horizontal AFC; a 6CG7 horizontal multivibrator; and a 3CS6 pentagrid tube used as a noise-gated



## SUCCESSFUL SERVICEMAN DOES BETTER JOB AT BENCH, IN FIELD

Direct-from-the-factory product information is the key...

he finds it faster in The MASTER!

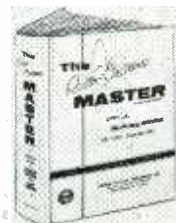

1546 pages  
World's Largest  
Electronic Parts  
Catalog

The MASTER describes, illustrates, lists specifications of over 125,000 items necessary to radio-TV servicing. What's more—it offers thousands of other products that can lead to extra income in Hi-Fi, sound and industrial servicing. You can buy, sell and bill direct from The MASTER. It shows list prices! 1546 pages of current, direct-from-the-factory product information, systematically arranged for quick, easy reference.

Today... Get the NEW  
1957 Radio-Electronic MASTER  
(21st Edition)  
at your parts distributor  
ONLY \$295

The Radio-Electronic MASTER  
60 Madison Avenue • Hempstead, N. Y.

sync separator.

The operation of this type of sync circuit was described in detail in "Signal Tracing in Sync Separators" in the February, 1956 PF REPORTER. The circuit (shown in Fig. 4) requires two composite video signal inputs—a large signal of one polarity at the #3 grid and a small signal of the opposite polarity at the #1 grid. The only function of the latter signal is to cut off the tube during reception of strong noise pulses so that the output signal of the stage will be

kept free of such pulses.

The bias on the #1 grid is fairly critical. If it is insufficient, noise pulses will not be clipped; if excessive, the tube will be cut off by the tips of the sync pulses, and sync will be lost. Many pentagrid-type sync separators include a potentiometer in the #1-grid circuit for use as a bias setter, but the new Sylvania circuit has a form of automatic bias control in place of the manual adjustment.

Notice in Fig. 4 that the screen of the 3CS6 is tied to the #1 grid

through a 1.5-megohm resistor and to the screen of the video output tube through 4.7K ohms. If the incoming video signal increases in amplitude, the video output tube becomes more heavily biased, and this causes an increase in screen voltage. The increase is passed along to the 3CS6, causing the screen and #1-grid voltages to shift in a positive direction. When that happens, the 3CS6 is more difficult to cut off; in other words, it can handle a larger signal amplitude on the #1 grid without

NO SPEAKER  
INSTALLATION  
PROBLEMS  
with  
**QUAM**  
*Adjust-a-Cone*  
SPEAKERS

QUAM speakers have transformer mounting brackets welded to the baskets.

There is a universal mounting bracket packed with every QUAM 3½", 4", 5", 5¼", 6½", 4" x 6" and 5" x 7" Adjust-a-Cone speaker, AT NO EXTRA COST. In addition there are four threaded mounting holes in the pot besides the usual mounting holes in the speaker basket.



QUAM  
HI-FI  
SPEAKERS  
for fine audio  
reproduction  
at low cost

ask for QUAM, the quality line, for all your speaker needs

QUAM-NICHOLS COMPANY

234 EAST MARQUETTE ROAD • CHICAGO 37, ILLINOIS

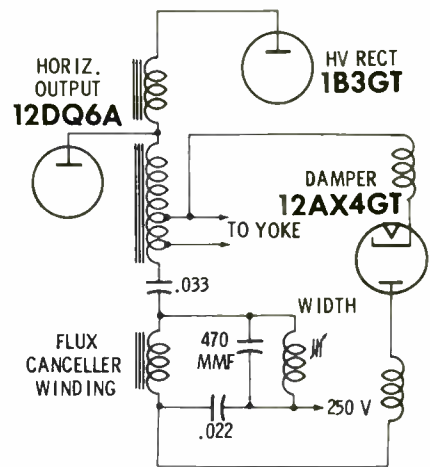

Fig. 3. Simplified schematic of flyback transformer in Sylvania Chassis 1-537, showing "flux-canceller" winding.

being driven into cutoff by the sync tips. The reverse action happens during reception of weak signals. Screen voltage of the video output tube decreases, and the voltages on the 3CS6 are automatically adjusted to permit easier cutoff so that the tube can accomplish its noise-clipping function while a relatively low-amplitude signal is being fed to the #1 grid.

If you ever have trouble servicing any pentagrid sync separator which appears not to have a bias adjustment in the circuit of the #1 grid, check through this circuit and see if there is a feedback path through which some kind of bias control might be supplied to the grid. There are several possible ways of doing this; for instance, the #1 grid return in some Philco receivers is brought through a section of the local-distant switch.

#### Chassis Construction

The use of 110° picture tubes may bring on a new trend in



chassis layout. As a sample of what might be in store, look at the Sylvania 1-537 chassis in Fig. 5. A double-deck horizontal chassis fits neatly in the space around the neck of the picture tube. Sweep, power supply and tuner circuits are on the lower deck, and all other components are mounted on an etched-copper type of wiring board on the upper deck.

For ease in servicing top-deck components, the top of the cabinet is removable after the back has been taken off. This "hood" is re-

leased by taking out three screws on each side and pulling loose all tuning knobs on top of the cabinet. The channel selector and fine tuning knobs are completely removable, but the others are of a captive type and remain attached to the cabinet. Each one is fastened to its related control shaft by a length of rigid plastic tubing, and this connection can be disengaged by a gentle upward pull on the knob.

Removal of the chassis from the cabinet is extremely simple. Four keyhole-shaped slots with their narrow ends pointed forward are cut into the floor of the cabinet to receive the four plastic feet which support the chassis. Two screws, driven into the back of the cabinet along the bottom edge, press forward on the chassis so that the feet are locked into the narrow ends of the slots. When these screws have been loosened, the technician can slide the chassis

back slightly and lift it free of the cabinet. The audio output transformer is attached to the speaker; therefore, the set should be operated with the speaker connected in order to prevent damage to the audio output tube. Connections between the chassis and the speaker are soldered. The two mounting screws for the speaker are driven into clips attached to the speaker frame, and the speaker can be removed and reinstalled more easily than if it

were mounted with nuts and bolts. The leads to the yoke and picture tube socket are long enough so that the set can be operated while the chassis is separated from the picture tube, as shown in Fig. 5. The only accessory needed is an anode extension.

The 5A95 audio-output tube is fastened in place with a spring clip that keeps it from falling out of its socket during shipment. Since the new Sylvania set is a portable type and might receive some rough handling from its

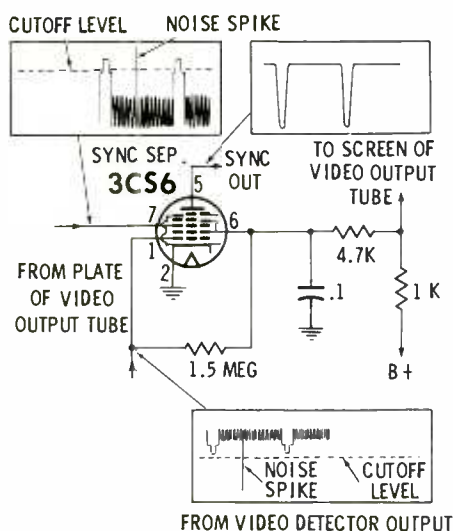

Fig. 4. Simplified schematic of pentagrid sync separator circuit in Sylvania Chassis 1-537. Automatic bias action occurs when noise pulse appears.

leased by taking out three screws on each side and pulling loose all tuning knobs on top of the cabinet. The channel selector and fine tuning knobs are completely removable, but the others are of a captive type and remain attached to the cabinet. Each one is fastened to its related control shaft by a length of rigid plastic tubing, and this connection can be disengaged by a gentle upward pull on the knob.







Removal of the chassis from the cabinet is extremely simple. Four keyhole-shaped slots with their narrow ends pointed forward are cut into the floor of the cabinet to receive the four plastic feet which support the chassis. Two screws, driven into the back of the cabinet along the bottom edge, press forward on the chassis so that the feet are locked into the narrow ends of the slots. When these screws have been loosened, the technician can slide the chassis



# TV HARDWARE

with Di-Chromate Finish

**EVERYTHING YOU NEED... QUALITY MADE FOR PROFITABLE INSTALLATIONS!**

 <b>ROOF MOUNTS</b>	 <b>STANDOFFS</b>	 <b>ARRESTORS</b>	
 <b>TOWERS</b>	 <b>CHIMNEY MOUNTS</b>	 <b>LINE CLIPS</b>	 <b>WALL MOUNTS</b>
 <b>ALL ACCESSORIES</b>		<p><b>Di-Chromate Finish Prevents Roof Streaks</b></p> <p>All Telco TV Hardware is built and finished to last regardless of the rigors of weather, climate or usage. Quality features at a price that makes your TV installations profitable. Insist on TELCO for all your hardware needs.</p>	

**YOUR JOBBER HAS COMPLETE TELCO HARDWARE STOCKS... SEE HIM AND SAVE!**

## TELEVISION HARDWARE MFG. CO.

Division of G-C • Tectron Inc.

400 South Wyman Street

• Rockford, Illinois

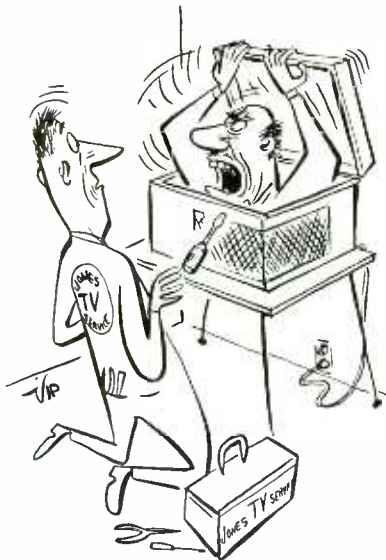

*"Before you start fiddling with this phonograph—did you bring JENSEN NEEDLES?"*

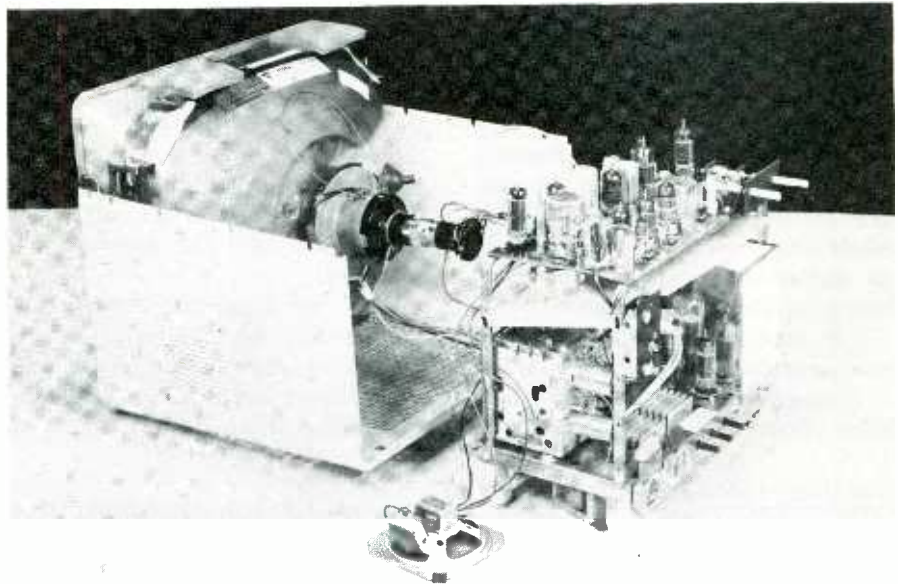

Fig. 5. Sylvania TV set with 110° deflection can be operated in above position.

users, it would be wise to put the clip back on this tube after servicing. The IF tube shields are soldered to the wiring board, but they are low in height and do not have to be removed to extract the tubes.

A sheet of fiber material, mounted slantwise in the space between the two chassis decks, deflects heat from the lower-deck components out through the perforated back cover of the set, thereby keeping the upper deck as cool as possible. Heat generated by the upper-deck circuits escapes through louvers at the back of the cabinet top. Cool air is

drawn in through the perforated bottom and upward in front of the chassis.

The receiver just described is only a beginning; other 110° sets are on their way. RCA is another manufacturer now producing the wide-angle tubes, with types 17BZP4 and 21CEP4 available at present.

#### Video Amplifier With Helper

The latest Westinghouse 14" and 17" TV sets have an unorthodox video amplifier circuit that utilizes both sections of a 6BH8 triode-pentode. (Refer to Fig. 6.) The pentode section of the tube

Sandy Says!  
It's a **WHALE** of  
a **britener**  
Model SP 43

**Anchor**  
Picture Tube  
**Britener**

- Series
- Parallel
- Electrostatic
- Electromagnetic

**4**  
WAY

Offers **BEST VALUE** in a quality unit for restoring Picture Tube Brightness

AT YOUR DISTRIBUTOR OR WRITE:

**anchor products co.**  
ELECTRONIC COMPONENTS  
2712 W. Mantrose • Chicago 18, Ill.

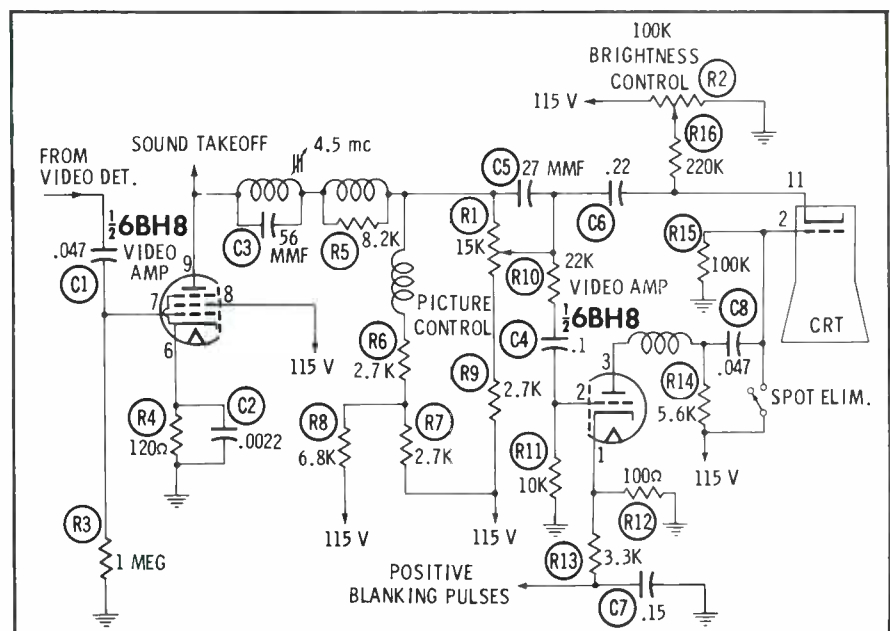

Fig. 6. Two-stage video amplifier circuit used in Westinghouse 14" and 17" portable TV sets. Driving signal for the triode is a sample of the pentode output.



**OHMITE**  
3 WATT SIZE  
9/16" x 15/64"

**OHMITE**  
5 WATT SIZE  
1-1/32" x 11/32"

**AXIAL-LEAD RESISTORS**  
Vitreous-enameled, power-type units designed to withstand high temperatures.

**LITTLE DEVIL® COMPOSITION RESISTORS**  
Meet all MIL-R-11A requirements. Rated at 70C rather than 40C. Available in 1/2, 1, and 2-watt sizes in all standard RETMA values.

**BROWN DEVIL® RESISTORS**  
Vitreous-enameled. In 5, 10, and 20-watt sizes.

**TYPE AB POTENTIOMETERS**  
Resistance material is solid-molded, noise-free. Rated at 2 watts.

**FR-7.5 FUSE RESISTOR**  
For easy replacement in many television receivers. 1 1/2" Tinned wire leads.

write for stock catalog

eliminate call backs . . .  
use dependable,  
industry-preferred . . .

**OHMITE®**  
**COMPONENTS**

OHMITE MANUFACTURING COMPANY  
3644 Howard Street, Skokie, Illinois

**BE RIGHT WITH**

**OHMITE®**

**DEPENDABLE RESISTANCE UNITS**

operates in a conventional video output stage, and delivers a signal with a maximum peak-to-peak amplitude of 50 volts to the cathode of the picture tube. A portion of the pentode output is applied to the triode grid through a voltage divider network comprised of R1, R10, and R11. The triode takes this sample of the video signal, amplifies and inverts it, and delivers the resulting signal to the picture-tube grid at an amplitude of up to 55 volts peak-to-peak.

The 50 volts (sync positive) on the cathode of the CRT and 55 volts (sync negative) on the grid provide relatively the same signal drive as one signal of 105 volts peak-to-peak applied to a single element. This Westinghouse design therefore gives the same results as a push-pull circuit, even though it does not provide true class B push-pull operation. A real push-pull circuit might be compared to a team of loggers using a two-handed saw to cut down a tree, but the circuit of Fig. 6 more nearly resembles a pair of men carrying a heavy piece of furniture—one is just a strong-backed helper who moves in response to directions from the lead man. This "video helper" is added to the circuit in order to increase the amount of picture contrast obtainable in a receiver that has no voltage doubler in the B+ supply.

Like most present-day receivers, the Westinghouse sets have a retrace blanking circuit associated with the CRT control grid. Positive pulses from the vertical sweep system are applied to the cathode of the triode section of the 6BH8. These are inverted by the tube, and negative pulses appear at the picture-tube grid and cut off the electron beam during vertical retrace time.

The "spot eliminator" switch is not a new feature, having been described in this column some time ago (December, 1955). It is ganged with the on-off switch. When the receiver is turned off, a highly positive potential is placed on the picture-tube grid. Then the electrons emitted from the still-hot cathode are drawn into the grid circuit and are prevented from forming a bright spot in the center of the phosphor screen. ▲

New! Revolutionary!

**SECO TUBE TESTER**

offers most complete  
tube checking available!



New! Faster!  
Tube set-up  
chart for all  
current tubes.



Contained in  
handsome  
portable  
carrying case!

1. Grid-Circuit Test—all tubes
2. Dynamic Mutual Conductance Test on pre-wired panel
3. Cathode Emission Test by free point selector system

Outstanding performance and accuracy . . . wide range . . . saves you valuable time by eliminating call-backs due to obsolete or incomplete testing. Justifiably culls and sells more tubes for you.

Dynamic Mutual Conductance Test of all popular radio and TV amplifier tubes made on pre-wired chassis. Designed for speed—tube set-up data printed on panel. Master unit provides Cathode Emission Test for all tubes. Both units incorporate nationally accepted grid-circuit test developed by Seco. Handy new "flip-chart" lists complete tube set-up data. Fast . . . easy to use . . . operates like telephone index. Completely self-contained—mounted in handsome light green carrying case. Easily portable—only 13 1/2" x 9" x 6"—weight 11 1/2 pounds.  
Model 107 Tube Tester . . . . . \$139.50 Net



Dependable! Accurate!  
Quickly spots grid errors  
and leakage in critical  
amplifier tubes!

**Model GCT-5 Grid-Circuit  
TUBE TESTER**

(U. S. Patent No. 2,784,372)

Checks over 95% of all tubes subject to "control grid error." Saves valuable service time . . . electron ray tube indicates faults at a glance! Just 6 1/2" x 6 1/2" x 2 1/2" . . . weight: 4 pounds.

Wired and tested . . . . . \$29.95 Net  
Complete, easy to assemble kit . . . . . \$19.95 Net

**ATTENTION GCT-5 OWNERS; New 1957 replaceable etched aluminum panel is now available. Lists all of the newest and most popular transconductance tubes. Mounts in place in seconds . . . brings your GCT-5 up to date with the newest tube types. Order from your distributor.**



No disconnecting! No charting! Checks complete horizontal coil circuit—not just individual components!

**Model FB-4 FLYBACK CIRCUIT  
and INDUCTANCE ANALYZER**

Nothing faster . . . 100% accuracy. Checks complete horizontal coil circuit . . . not subject to obsolescence due to variables in engineering design.

Model FB-4 . . . . . \$38.95 Net

WRITE TODAY—for complete information and descriptive literature on all Seco test instruments.



**MANUFACTURING CO.**  
5015 Penn Ave. So., Minneapolis, Minn.

## Resonant Circuits

(Continued from page 23)

Then using equation (12), we find:

$$Z_{11} = \frac{1,100 \times 910}{\sqrt{10^2 + (1,100-910)^2}}$$

$$Z_{11} = \frac{1,000,000}{190}$$

$$Z_{11} = 5,260 \text{ ohms.}$$

At 9 mc,  $X_L = 900$  ohms and  $X_C = 1,110$  ohms. Using equation (12) again, we find:

$$Z_o = \frac{900 \times 1,100}{\sqrt{10^2 + (900-1,110)^2}}$$

$$Z_o = \frac{1,000,000}{210}$$

$$Z_o = 4,760 \text{ ohms.}$$

From the preceding calculations, it can be seen that the impedance of a parallel tuned circuit is very high at resonance and falls off very rapidly at frequencies away from resonance. The higher the circuit Q, the higher the impedance at resonance and the sharper the decrease in impedance at frequencies away from resonance.

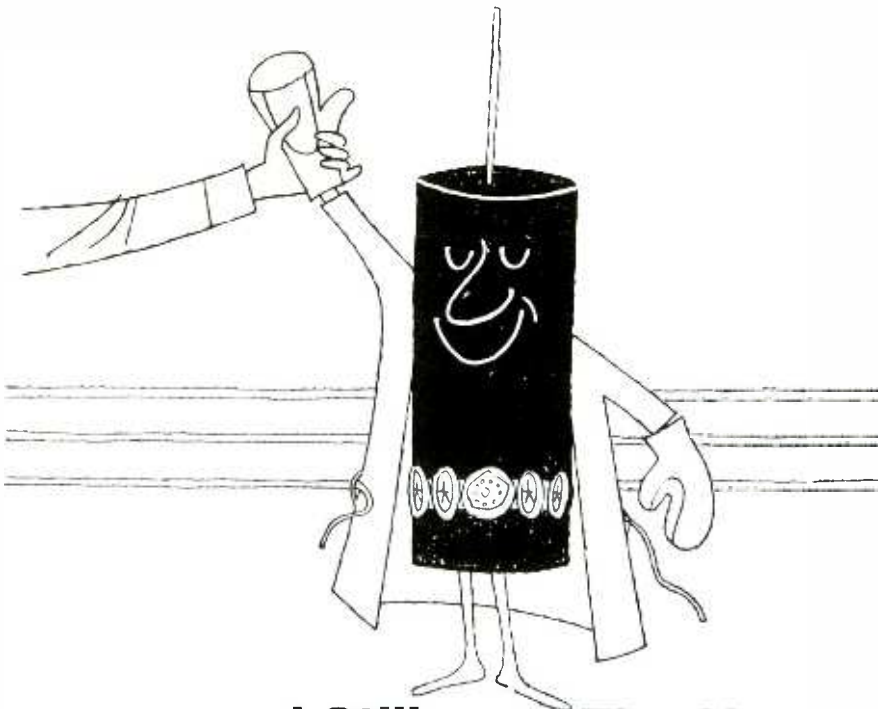

## ...and Still The Champ! Cornell-Dubilier "CUBS"®

YES, THE "CUB" has come through like a real champ in its battle with—high humidity—sizzling temperatures—shattering vibration—and punishing endurance. In the molded tubular class, THE "CUB" rates second to none. THE "CUB" like the "Blue Beaver" is made exclusively for the service trade—for full profit and customer satisfaction. You can bet your reputation on the C-D "CUB" when it comes to tubulars. Ask your nearby C-D Distributor for catalog or write Cornell-Dubilier Electric Corporation, South Plainfield, N. J.



## Cornell-Dubilier capacitors

South Plainfield, N. J.; New Bedford, Worcester & Cambridge, Mass.; Providence & Hope Valley, R. I.; Indianapolis, Ind., Sanford, Fuquay Springs & Varina, N. C.; Venice, Calif., & subsidiary, The Radiant Corporation, Cleveland, Ohio.

## Applications

The parallel resonant circuit is used in two different ways in a television circuit. The 4.5-mc trap (Fig. 3) which is used in the video amplifier circuit represents one of these ways. In this application, the

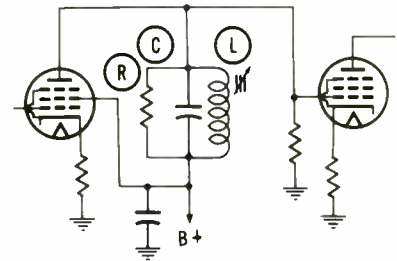

Fig. 5. The shunt resistor loads the circuit, lowering the Q and increasing the passband of the tuned circuit.

high impedance offered by the trap to 4.5-mc signals prevents any 4.5-mc current from flowing through the plate load comprised of L1 and R1 and thus prevents 4.5-mc signals from reaching the next stage.

The simple parallel tuned circuit may also be used as a grid load impedance for the sound IF stage as illustrated in Fig. 4. In this application, the 4.5-mc signal is developed across the high impedance of the tuned circuit and is thus amplified by the stage. Signals at frequencies other than 4.5 mc are not amplified since the impedance of the tuned circuit is low at frequencies away from resonance. In both of the previously mentioned applications, high-Q tuned circuits are used since only a very narrow band of frequencies must be affected.

Parallel tuned circuits are also

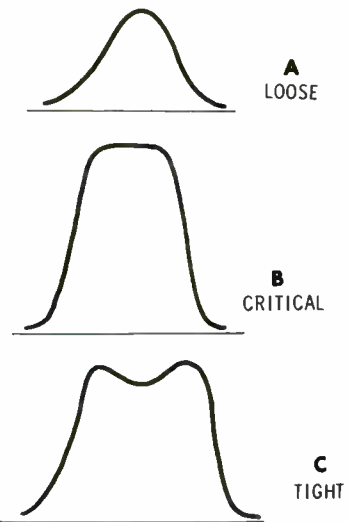

Fig. 6. Bandpass curves showing the effect of changing the amount of coupling.



used in the video IF circuits where a wide band of frequencies must be amplified; therefore, a variation of the simple parallel tuned circuit is employed. In the stagger-tuned type, the circuit is designed to have a low Q (9 or 10) by using a parallel resistance as shown in Fig. 5. The lower the value of the shunt resistor, the lower the Q will be.

Parallel tuned circuits are not always used in their simplest form; in fact, they are seldom used that way. The IF stages in AM and FM radios and in TV sound circuits usually employ two tuned circuits which are coupled together through the mutual inductance between the two coils.

### Coupled Tuned Circuits

Two circuits are said to be coupled when energy can be transferred from one to the other. There are several different types of coupling used between stages—common resistance, common inductance, common capacitance, and mutual inductance are a few. However, this discussion will deal only with mutual inductance coupling.

Mutual inductance coupling is the principle upon which all transformers operate. That is, energy in the primary circuit generates an alternating magnetic field which induces into the secondary a voltage that has essentially the same characteristics as the voltage in the primary. The amplitude of the secondary voltage is determined by the coefficient of coupling and the turns-ratio between the primary and secondary coils. If the coefficient of coupling is unity or very nearly so (all of the magnetic lines generated by the primary circuit cut through or link the secondary circuit), the ampli-

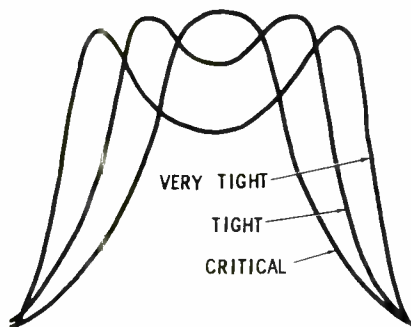

Fig. 7. Effect of increasing the coefficient of coupling toward unity.

tude of the induced voltage depends solely on the turns-ratio.

Unity coupling is used for power transformers, audio transformers and bifilar wound IF transformers. Less than unity coupling is generally used in RF transformers and in double-tuned IF transformers. The degree of coupling used in the latter depends on the desired bandpass characteristic and is usually expressed as tight, loose or critical. The amount of coupling between the two windings of an RF or IF transformer is governed by the

distance between the two coils and the relationship between their axes.

The coefficient of coupling has a pronounced effect on the bandpass characteristics (Fig. 6) of transformers. With loose coupling (coils far apart), only a small amount of energy is transferred from the primary to the secondary, but the bandpass is narrow. With critical coupling, the coils are spaced so that maximum transfer of energy is obtained; with tight coupling, the average energy coupled is somewhat less

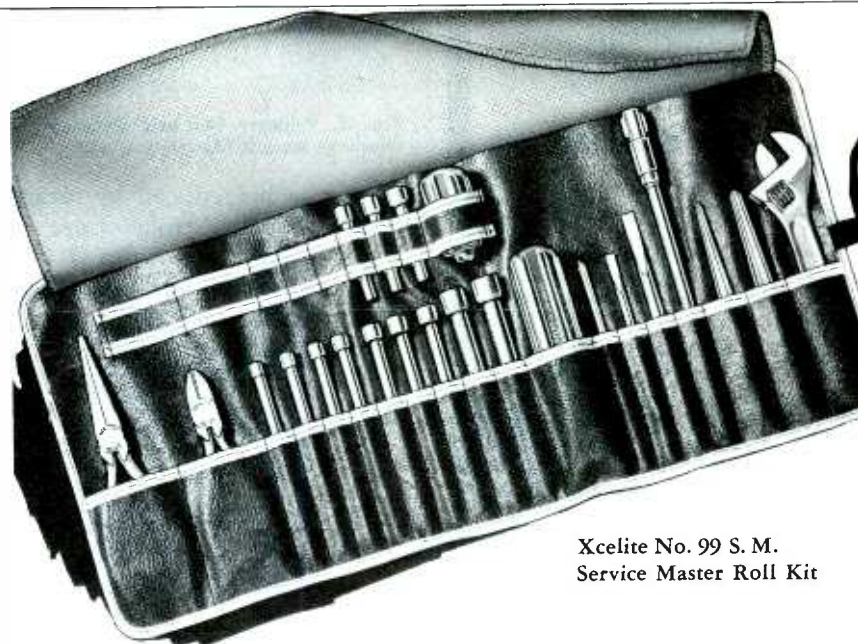

Xcelite No. 99 S. M.  
Service Master Roll Kit

## NOW IT CAN BE SOLD . . .

### THE SUPER-KIT THAT GIVES YOU THE FINEST — AND THE MOST!

At last — a roll plastic kit with "everything" for the Radio-TV serviceman who wants the best on the job. Years in the planning, the "99 S. M." is now ready for you at your distributor's with these quality XCELITE tools:

1. No. 52 Long Nose
2. No. 55 Side Cutter
3. Stubby Combination Handle with  $\frac{1}{4}$ ",  $\frac{5}{16}$ " and  $\frac{3}{8}$ " nut drivers
4. 6" chrome-plated adjustable wrench
5. Regular Combination Handle with
  - a. 9 nut drivers
  - b. 1 Phillips and 2 regular screwdrivers
  - c. 99-X10 Extension shaft (adds 6")
  - d.  $\frac{3}{8}$ " and  $\frac{1}{2}$ " chrome plated SUPREAMERS

## XCELITE, INCORPORATED

Dept. Q, Orchard Park, N. Y.

IN CANADA: Charles W. Pointon, Ltd.

6 Alcina Ave., Toronto, Ontario



ENGINEERED ACCESSORIES BY



FOR BETTER TV & HI-FI

To efficiently couple any combination of 2 or 3 TV sets or FM receivers from antenna . . . of any type.

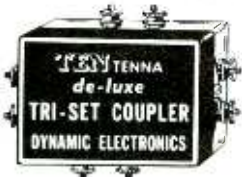

ABSOLUTELY NO INTERACTION

- Less than 6 db insertion loss.
- 40 to 50 db rejection ratio.

Model T130 . . . Sale Price \$5.45

There is a Dynamic precision engineered Accessory or Service Aid for practically every problem!

INSIST ON DYNAMIC . . . THE BEST!  
Full Line Catalog on request.

Manufactured By . . .  
DYNAMIC ELECTRONICS-NEW YORK, INC.  
Forest Hills, Long Island, N. Y.

ENGINEERED ACCESSORIES BY



FOR BETTER TV & HI-FI

Eliminates overload in strong signal areas . . . will improve and remedy faulty AGC circuits . . . REGARDLESS OF CAUSE.



FADES OUT GHOSTS

- Reduces audio-video distortion.
- Eliminates picture tearing.

Model T115 . . . Sale Price \$4.95

There is a Dynamic precision engineered Accessory or Service Aid for practically every problem!

INSIST ON DYNAMIC . . . THE BEST!  
Full Line Catalog on request.

Manufactured By . . .  
DYNAMIC ELECTRONICS-NEW YORK, INC.  
Forest Hills, Long Island, N. Y.

than maximum but there can be a broad dipped response curve. In fact, as the coupling is increased toward unity, the curve becomes broader and the dip between peaks more pronounced, as shown in Fig. 7.

The dip between the resonant peaks obtained with tight cou-

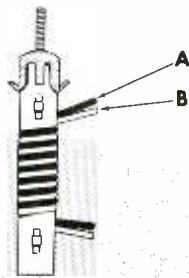

Fig. 8. Primary (A) and secondary (B) windings on a bifilar wound coil.

pling can be reduced by resistive loading of the transformer secondary. This lowers the Q of the circuit and reduces the amplitude ratio between the peaks and the valley. Resistive loading is common practice in television circuits where the required bandpass is such that without the resistance

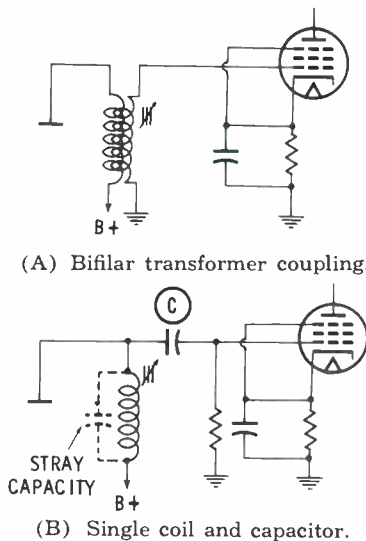

Fig. 9. Comparison between bifilar-wound and single-tuned coils used in interstage coupling applications.

the dip would be excessive and the over-all response severely affected.

It was mentioned earlier that unity coupling was used in bifilar wound IF transformers. This type of transformer (Fig. 8) has a primary and secondary which are wound simultaneously so that, with the exception of the first turn, any turn of winding A lies between two turns of winding B

A very heavy Formvar insulation is used on the individual windings, and they are usually wound at a 1-to-1 ratio in a single layer. When assembled in this manner, the bifilar wound transformer acts as a single coil would and has a similar bandpass characteristic. Adjustment of the slug tunes both primary and secondary, and a single rather than a double humped response curve is produced. Comparison of the video IF circuits in Fig. 9 shows that the use of the bifilar wound transformer eliminates the need for a coupling capacitor, and a considerable saving in the cost of the IF strip can be achieved.

In circuits that employ bifilar wound transformers, as in other stagger tuned IF systems, the capacity required to resonate with the coils consists of a combination of the input and output capacities of tubes, stray wiring capacity and distributed capacity in the transformer. Bifilar wound transformers are constructed to have a Q of 70 or more and may be resistively loaded to achieve a desired bandwidth. ▲



Universal design takes all transmission lines.

Patented strain-relief retaining lips prevent tearing or ripping of wire.

Installs in less time with less effort.

NO. AT105 LIST \$1.25  
(wall mounting)

AT105S LIST 1.50  
(stainless steel strap)

"World's largest manufacturer of TV Lightning Arresters"



MANUFACTURING CO., Inc.  
BROOKLYN 4, NEW YORK



## Quicker Servicing

(Continued from page 25)

resistor was cooked during this time, which was probably 5 to 10 seconds.

If a thorough check of the tubes for leakage or shorts had been made at the time of picture-tube installation, the 25L6 would probably have shown signs of leakage and could have been replaced. This would have prevented the resistor burnout, and the set could have been repaired in the home by simply replacing the 12AU7. Undoubtedly, the customer's mind would have been more at ease, knowing that the trouble was caused by "just a small tube." Then too, the shop would have saved considerable time and money.

In case you are wondering why only the 150-ohm resistor was burned, the 50-mfd capacitor provided a low-impedance bypass to ground for the 60-cycle filament voltage, protecting the other components in the cathode network from damage. Also, checking the 25L6 heater in the home did not provide a positive indication because the design of filament checkers is necessarily such that continuity between either pins 2 and 7 or 7 and 8 of an octal-base tube will cause heater continuity to be indicated.

## Hot-Chassis Servicing

Servicing procedures always specify that an isolation transformer should be used when servicing a hot chassis. Some technicians ignore this step, feeling that they can get by without the transformer. This is dangerous to both man and equipment—a fact which was forcefully brought home to the author when, being in a hurry and not finding the isolation transformer handy, he connected a transformerless receiver to the antenna distribution system and plugged the set directly into the 110 VAC line. The cabinet had been removed from the receiver, and the antenna terminal was hanging loosely.

In the course of looking for the source of a particularly annoying intermittent, the antenna terminals accidentally fell against the chassis, causing an immediate failure of the 10-amp line fuse. The

## SAMS BOOKS keep you ahead in ELECTRONICS

SAMS books cover every phase of Electronics for the service technician, engineer, student or experimenter. Listed below are a few of the many valuable SAMS books available at electronic parts distributors and leading book stores.

the only book of its kind available!



only \$2.95

## "AUTO RADIO REMOVAL"

This time-saving new book gives you step-by-step instructions for the easy removal of radio, power supply and speaker units from all 1955 standard and sports model automobiles. The following information is provided for each car covered: tools required for removal; phantom view of dash panel with radio in place (quickly locates chassis mounting nuts, bolts, cables, antenna and speaker leads); photo showing actual removal of radio. Rear-deck speaker data is given for each model; shows if cutout is provided, speaker size required, and whether speaker control is included or must be added. Includes brief summary of preliminary servicing procedures which should be performed to determine whether radio removal is required to effect repair. An invaluable book. 104 pages; 5 1/2 x 8 1/2"; illustrated. Order today, postpaid only \$2.95

## USE THIS ORDER FORM

### AUTO RADIO REMOVAL ..... \$2.95

**Transistor Circuit Handbook.** This authoritative book completely covers all phases of transistor circuits, types, construction, characteristics, applications, techniques for wiring and testing. 430 pages, 6 x 9"; illustrated. .... \$4.95

**Metallic Rectifiers.** Covers theory, principles and applications of copper-oxide, magnesium-copper sulfide, selenium and new silicon type rectifiers. Includes interesting circuits, applications, terminology, etc. Authoritative complete. 286 pages; 5 1/2 x 8 1/2"; illustrated. .... \$3.00

**Color TV Training Manual.** Prepares the Technician for Color TV service work. Covers principles of the Color TV system; Color receiver circuits; installation and servicing sets. Includes color blocks outlining the use of color test equipment. 260 pages; 8 1/2 x 11"; 300 illustrations. .... \$6.95

**Hi-Fi Handbook.** Invaluable data on Hi-Fi design, selection and installation, including fidelity, sound theory and distortion; loudspeakers; baffles and enclosures; amplifiers, preamps and controls, program source equipment; systems design, selection and installation. 240 pages; 5 1/2 x 8 1/2"; illustrated. .... \$3.00

**Servicing TV Sweep Systems.** Describes the operation, circuit function and circuit variations of vertical and horizontal sweep systems common to most TV receivers. Tells how to analyze circuits; trouble-shoots for you. 212 pages; 5 1/2 x 8 1/2"; illustrated. .... \$2.75

**Electronic Metal Locators.** Explains operation, describes basic types available, shows how to construct home-built units, describes applications. Covers interesting uses in industry as well as applications in prospecting and mine location. Complete and authoritative. 124 pages; 5 1/2 x 8 1/2"; illustrated. .... \$2.50

**Key Checkpoints in TV Receivers.** Prepared by the Howard W. Sams engineering staff. Provides many applications for general TV service work, including time-saving information on how to make quick tests at key points to determine where trouble lies, and how to check overall performance of the receiver after repair, to insure against callbacks. 182 pages; 5 1/2 x 8 1/2"; illustrated. .... \$2.00

**Tape Recorders—How They Work.** Explains recording theory, tape characteristics, motorboard mechanisms, drive motors, amplifiers, magnetic heads, volume indicators, equalization circuits—covers everything you want to know about recorders. 176 pages; 5 1/2 x 8 1/2". .... \$2.75

**Servicing AGC Systems.** Describes the operation and circuit variations of the various types of AGC systems and explains the servicing techniques that can be applied. Illustrated by actual case histories and photographs of symptoms. 132 pages; 5 1/2 x 8 1/2"; illustrated. .... \$1.75

**Servicing & Calibrating Test Equipment.** Shows you how to keep your test instruments in reliable working order, how to determine proper operation and avoid erroneous indications. Explains calibration procedures; gives method for performance record-keeping; shows simple ways to check instrument accuracy; describes proper maintenance and servicing of instruments. 192 pages, 5 1/2 x 8 1/2".... \$2.75

There is an authoritative Sams book on virtually any Electronic subject in which you're interested. Check below for FREE Book List describing all Sams books.

Send Book List



Look for  
**SAMS BOOKS**  
on  
the "Book Tree"  
at your  
Parts Distributor

## ....HOWARD W. SAMS & CO., INC.....

Order from your Parts Jobber today, or mail to Howard W. Sams & Co., Inc., Dept. 3-D7 2201 East 46th St., Indianapolis 5, Indiana.

Send books checked above. My (check) (money order) for \$..... is enclosed.

Name.....

Address.....

City..... Zone..... State.....

(outside U.S.A. priced slightly higher)

diagram in Fig. 2 will show that since the antenna was connected into the distribution system (AC powered type) and the TV receiver had no isolation transformer, this made a direct short across the AC line and blew the fuse. After installing a new fuse, an isolation transformer was located and used for the remainder of the test.

Thinking about the blown fuse a short time later, the author realized that he might have been badly or even fatally injured if, instead of shorting the antenna

terminal to the chassis, he had touched the antenna terminal and the chassis at the same time. Let this example serve as a warning—don't be careless and get hurt!

#### A Service Hint for Combinations

On a recent Monday evening, a technician friend of ours made a call to service an Admiral combination radio-phono-TV receiver that used the 19M2 chassis. The customer's complaint was that the picture flopped and was otherwise unstable. Tube substitution failed to cure the trouble, so the chassis

was removed and taken to the shop for analysis and repair. The customer, an avid Wednesday-night fight fan, let it be known that he wanted his set back in time to see the fights if at all possible (the implication being that he would be mighty unhappy otherwise).

The defects, a shorted sync-coupling capacitor and a weak sync-amplifier tube, were located and repaired too late on Tuesday to permit the return of the set, so it was marked for delivery on Wednesday. The service load for Wednesday was very heavy and it was quite late when the chassis was finally delivered. The technician installed the chassis, checked the TV operation and found it to be perfect. Being late for supper, he hurriedly collected his fee and left—happy that the set was returned in time for the customer to watch the fights.

Now comes the sad part of this tale. Two days later, as luck would have it, the customer called and in a very indignant manner wanted to know what had been done to the radio in his Admiral combination set. It would work fine at 800 kc or higher but was completely dead at frequencies below that point.

There was nothing for the technician to do but make another call. When he arrived at the customer's home, he removed the TV chassis and placed it on its side to expose the radio section. Sure enough, a plate on the rotor of the oscillator tuning capacitor was bent so that it was shorting to the stator. A small nick in the edge of the bent plate gave a clue to what had probably happened. Evidently, it had struck against something either in the shop or when being reinstalled in the cabinet; therefore, the recall was "on the house." The moral of this story is, "Always check all units of a combination before and after shop service is performed." In this way you will have added insurance against a recall due to some action of yours.

#### Alignment Tools That Count

The three tools shown in Fig. 3B all have a unique turn-counting feature. This permits any alignment slug or screw to be ad-

**A** *Always dependable...*

**B** *Better quality and design...*

**C-D**

**VIBRATORS**

*the complete line...*

*There is a CORRECT replacement C-D vibrator for every original installation... no guessing... no problems! And every C-D vibrator delivers longer service that is dependable... and quieter in operation! AND... the complete line of COMMUNICATION VIBRATORS answers every replacement problem in this important field!*

It's as basic as knowing your A B C D's... that C-D vibrators are your best buys year 'round... day in and day out! Look for the famous C-D seal... it is your guarantee of quality combined with skilled engineering and controlled manufacture!

**CORNELL-DUBILIER**

Plants in South Plainfield, N. J.; New Bedford, Worcester and Cambridge, Mass.; Providence and Hope Valley, R. I.; Indianapolis, Ind.; Sanford, Varina and Fuquay Springs, N. C.; and Venice, California.  
Subsidiary: The Radiart Corporation, Cleveland, Ohio.



**SENCORE**  
*Another Sencore Time-Saver*  
**Handy "36"**  
**R-C Substitution Unit**



**"36"**  
**Most Often Needed Components At YOUR Fingertips!**

3 pole, 12 position switch individually selects one of the "36" components for direct substitution.

Contains:

- ★ 12—1 watt 10% resistor from 10 ohms to 5600 ohms
- ★ 12—½ watt 10% resistors from 10K ohms to 3.6 megohms
- ★ 10—600 volt capacitors from 100-mmf. to .5mf.
- ★ 1—10mf., 450V Electrolytic
- ★ 1—40mf., 450V Electrolytic
- ★ For Shop, Lab, or outside service

AVAILABLE AT ALL PARTS DISTRIBUTORS!

**ONLY \$12.75 DEALER NET**

Completely isolated

**POPULAR SENCORE PRODUCTS**

- Transistor Tester
- Leakage Checker
- Filament Tester
- Voltage Regulator
- Bias Supply

**SENCORE SERVICE**  
**INSTRUMENTS CORP.**  
 171 OFFICIAL RD., ADDISON, ILL.

Cut out this ad now for further information.

**Perma-Power**  
**GARAGE DOOR OPENER**

**Opens Garage Doors AUTO-matically**



**At All Distributors**

manufactured by  
**Perma-Power COMPANY**  
 4727 N. Damen Ave., Chicago 25, Ill.  
 manufacturers of electronic equipment since 1929

justed to a new setting and then returned exactly to its original setting at a later time.

Each of the three tools will adjust two different types of slugs. The tool shown in use in Fig. 3A, Walsco 2588, has both a small and a large hexagonal end to permit adjustment of transformers with adjustable cores and hexagonal slots. The tool with the black end, Walsco 2586, will adjust both large and small slotted, brass screws. The other tool, Walsco 2587, has both wide and narrow metal blades to permit adjustment of trimmer capacitors with various types of slots.

### Junk TV Sets?

A customer will sometimes ask a service technician whether a particular set is worth fixing. Several things must be considered in such a situation. First, how old is the set? The average useful life of a TV receiver is 6 to 8 years. The set in question should have 3 or 4 years of life expectancy to warrant major repairs. That is to say, a small 10" or 12" receiver that is 6 years old is not really worth (in potential service and enjoyment to the customer) an expensive repair. By the same token, a 17" or 21" receiver which is only 3 years old is worthy of repairs, even to the extent of a picture tube or other major components.

Second, what use will the customer make of the set after it is repaired? Will the set be used in a basement recreation room or child's play room? Is it a part of an expensive AM-FM, phono, TV combination? Is it the customer's only TV set? The answer to these questions can be very important in deciding whether to repair the set; therefore let us consider them one by one.

If the set is to be used in a basement recreation room or child's playroom as a second set, the customer may want it fixed regardless of screen size, provided the cost is reasonable. This means that the customer doesn't want a picture tube, flyback transformer, yoke, power transformer, or a large number of tubes replaced. It has been our experience that repairs up to about \$35 may be acceptable in these cases.

**MORE INCOME**  
**IN 1957**  
**FOR INDEPENDENT**  
**TV TECHNICIANS!**



**Receiver . . .**  
**precision-engineered**  
**"for those who want the**  
**finest" . . . is a non-**  
**competitive line.**

**GENEROUS COMMISSIONS**  
**THRU EXCLUSIVE**  
**PROFITABLE TV**  
**TECHNICIAN FRANCHISES**  
**NOW AVAILABLE**

You can recommend ATR with the pride and assurance of your own know-how and the reputation and craftsmanship of AMERICAN TELEVISION & RADIO

- ✓ . . . as original sets
- ✓ . . . as replacement sets
- ✓ . . . as the No. 1 set in two-set homes
- ✓ . . . and for special chassis installations (without cabinet)

**UNEQUALLED**  
**IN**  
**PERFORMANCE**

**UNMATCHED**  
**IN QUALITY**  
**CONSTRUCTION**

**UNSURPASSED**  
**IN**  
**BEAUTY**



**FOR FULL INFORMATION —**  
**WRITE TODAY FOR COLORFUL**  
**BROCHURE SHOWING THE**  
**NEW LINE OF ATR TV SETS**

ALSO MANUFACTURERS OF DC-AC INVERTERS,  
 "A" BATTERY ELIMINATORS, AUTO RADIO VIBRATORS

**ATR** **AMERICAN TELEVISION & RADIO CO.**  
*Quality Products Since 1931*  
 SAINT PAUL 1, MINNESOTA-U.S.A.

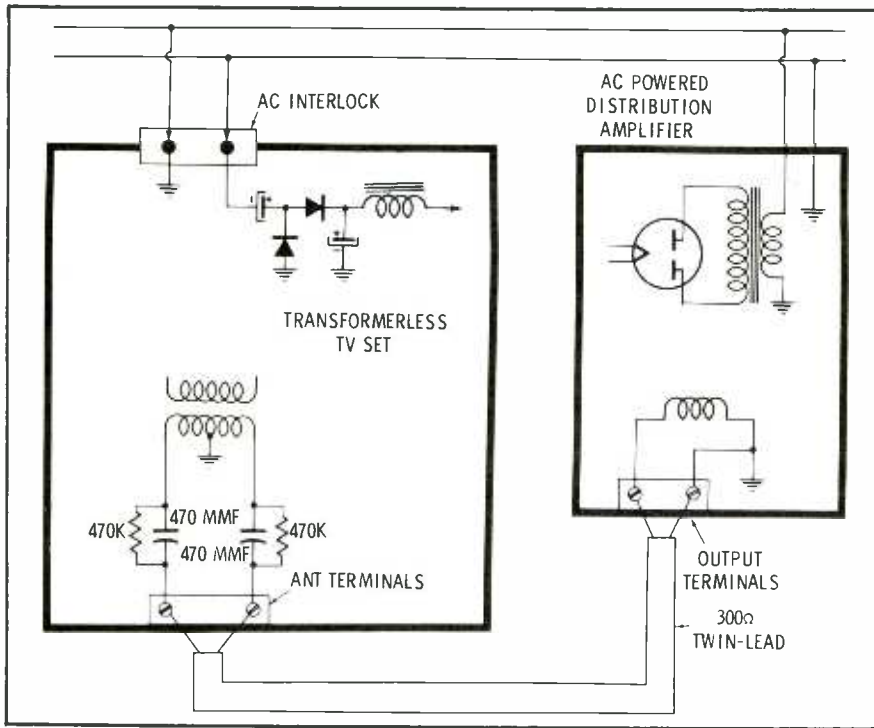

Fig. 2. Path of short circuit when antenna terminals touched TV chassis.

If the TV set is a part of an expensive combination unit (AM-FM, phono, TV), the customer may want the set repaired regardless of cost—with possibly one exception, and that would be

if the screen size were under 16 inches. The cabinet work in some of the early 16" through 21" combination units was very outstanding. The customer who purchased this type of unit probably did so

because the cabinet matched exactly with his living room furniture and decor. This customer's one concern is that the TV set will give new-set performance after it has been repaired, and he won't balk at a repair bill which is large (\$100 or more) if the set is performing right. If the set has a small screen, the customer may be considering the purchase of a large screen receiver. He should be, and you should encourage him to buy it. If you sell sets, this would be a good place to make a sale.

Now to the last point—should the receiver in question be the customer's only TV set, he will naturally be concerned about the amount of time necessary to repair it. He might even prefer to buy a new set rather than wait an appreciable time to have his old one repaired, especially if it is quite old, has a small screen, and needs extensive work. Again, here is a fine opportunity to sell a new set and at the same time make a friend of the customer.

Back to the question of repairs. During the interview with the



## WE MAKE CONDENSERS . . . . . . NOT SCREW DRIVERS!

But for a limited time you can get from your PLANET DISTRIBUTOR—FREE—this handy three-blade Versatool with the purchase of the thirty-five popular PLANET Condensers contained in the PLANET SD-35 Assortment.

See your Planet jobber now.

**PLANET SALES CORPORATION**  
225 BELLVILLE AVENUE, BLOOMFIELD, N. J.

IT'S NEW! IT'S A BARGAIN! IT'S "IN THE BAG"!

**VACO**<sup>®</sup>  
5-PIECE  
ALL HOLLOW SHAFT  
**Nut Driver  
Kit**  
No. K 505

Only  
**\$3.68**  
NET

### Convenient! Compact!

Here's a practical, quality built nut driver kit . . . economically priced, too! 5 popular sizes . . . 3/16", 1/4", 5/16", 11/32", 3/8" ideal for every service need . . . in one convenient plastic bag with button-down flap to keep drivers in place! Made to VACO professional quality standards throughout backed by our famous unconditional guarantee.

See Your Parts Distributor, Today!

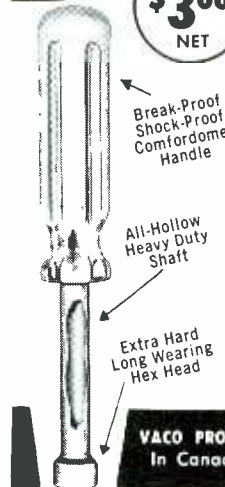

VACO PRODUCTS CO., 317 E. Ontario St., Chicago 11, Ill.  
In Canada: ATLAS RADIO CORP., Toronto 10, Ontario





(A) Adjusting IF transformer.

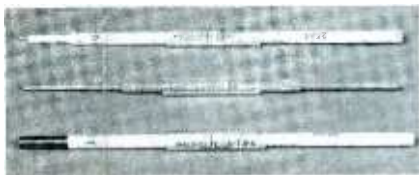

(B) Complete set.

Fig. 3. Three new "Tel-A-Turn" alignment tools made by Walsco Electronics.

customer you will find out his needs and attitudes and will therefore learn whether he expects an inexpensive repair or a complete overhaul job. Since an hour or more may be required to completely check a TV receiver, such a check should be made only if the customer has indicated he is willing to have any reasonable repair made. If only minor repairs are requested, a quick check of the receiver's operation without removing the chassis should reveal if such repairs can be made profitably. In either type of preliminary check, remember that time is money and charge accordingly—even if the customer should decide not to have the set fixed.

One last thing—remember that a TV set is useful to a customer only as long as it will give good steady service. If you honestly feel that a TV set is not worth extensive repairs, explain the facts to your customer. He will appreciate it. ▲



## SPECIALLY DESIGNED to service today's and tomorrow's auto radios

DC Power for TRANSISTOR and Tube Sets  
Modern...Self-Contained...  
and you get these

### 4 big advantages

- 1 **2 Ranges...**0-8 and 0-16 volts, continuously variable.  
10 amperes continuous duty up to 12 volts. 20 amperes intermittent service.
- 2 **Less than 2% ripple output...**a must for TRANSISTOR radio operation — perfect for tube sets. Prevents transistor damage, reduces audio hum.
- 3 **Conduction-cooled selenium rectifiers...** the entire steel cabinet acts as heat sink —gives over 450 sq. in. of cooling surface. Rectifier life is lengthened...normal rating is doubled. Patented—an exclusive Electro feature!
- 4 **Rugged choke input filter...**gives smooth filter action, better regulation, stable output.



More DC Power  
Per Dollar

### ELECTRO PRODUCTS LABORATORIES

4501-F North Ravenswood Ave.  
Chicago 40, Ill.

Send today for detailed Bulletin

Electro Products Laboratories  
4501-F Ravenswood Ave., Chicago 40, Ill.

Rush descriptive and technical data on  
MODEL D-612T Power Supply.

FIRM NAME \_\_\_\_\_

ADDRESS \_\_\_\_\_

CITY \_\_\_\_\_ ZONE \_\_\_\_\_ STATE \_\_\_\_\_

7077

Canada: Atlas Radio Ltd., Toronto



# IT'S Blue Chip



# Quality

Tung-Sol Magic Mirror Aluminized Picture Tubes mirror twice the light to create a picture twice as bright. They bring out the best in every set. Install these superior tubes and see the difference . . . the difference that pays off in smooth, callback-free service and satisfied customers. Tell your supplier you'd rather have Tung-Sol Tubes.

*Blue Chip Quality*



Magic Mirror Aluminized  
**PICTURE TUBES**

TUNG-SOL ELECTRIC INC., Newark 4, N. J. Sales Offices: Atlanta, Ga.; Columbus, Ohio; Culver City, Calif.; Dallas, Tex.; Denver, Colo.; Detroit, Mich.; Irvington, N. J.; Melrose Park, Ill.; Newark, N. J.; Seattle, Wash.



## Metal CRT Conversions

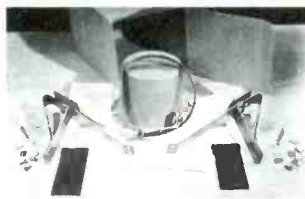

Addition of four new kits which simplify mounting requirements when replacing metal picture tubes with all-glass types in older-model TV sets has been announced by Colman

Tool & Machine Co., Amarillo, Texas.

The new kits are designed specifically for the following makes with 21" screens: No. C-6 (pictured) fits Wells-Gardner, Airline, Truetone, Firestone, Coronado, and Arlington sets. No. C-7 fits Arvin and Silvertone models, while No. C-9 fits Crosley models and No. C-8 fits RCA 27" sets.

## Tunable Indoor Antenna



JFD Electronics, Inc., 6101-16th Ave., Brooklyn, N. Y., has introduced a new indoor antenna, the "Magic Genie," which can be adjusted for best reception on any VHF channel through the use of a 12-position switch connected to a printed-circuit "Clarifier." The two dipole elements of the antenna are adjustable to all angles, and they telescope into a housing on the back of the TV set

when not in use. "Magic Genie" antennas are made in four colors to blend with mahogany, blond, black, or cherry cabinets. Packed five to a carton, they retail at \$14.95 each.

## Fuse Resistor



International Resistance Co., 401 N. Broad St., Philadelphia, Pa., is manufacturing a new Type FR fuse resistor for use as a surge-limiting resistor in voltage-doubler power supply circuits of TV receivers. The unit functions

as a resistor under normal conditions and as a fuse to protect more valuable components under abnormal conditions.

The Type FR is small, completely insulated, and designed to be plugged into a receptacle.



### CRT Restorer

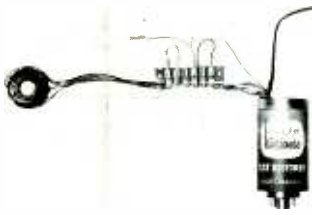

The "Nu-Life" Kinecure marketed by Circuit Mfg. Co., Inc., 6211 Market St., Philadelphia, Pa., provides an inexpensive means of restoring many faulty TV picture tubes to operation. The unit plugs

in between the CRT socket and the CRT base. Filament connections are made through an isolation transformer which provides a voltage set-up, if desired, to compensate for low cathode emission. Jumpers on a terminal board can be rearranged to transfer the cathode input to the filament or the grid input to the accelerating anode (with high resistance inserted in the anode return circuit), enabling a CRT with a shorted or open cathode or grid to produce a picture.

### Translator Reception

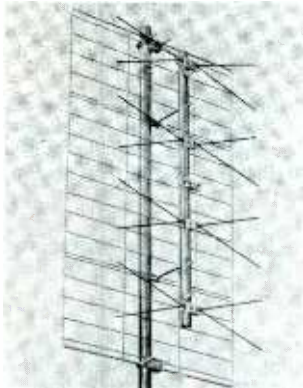

A new UHF antenna especially cut for peak performance on translator channels 70 to 83 has been announced by Clear Beam Antenna Corp., Canoga Park, Calif. Its vertically stacked four-bay construction not only provides high gain (up to 18 db over a tuned dipole) but also serves as "insurance" against loss of picture when atmospheric changes cause slight shifting of the areas of maximum signal strength.

pheric changes cause slight shifting of the areas of maximum signal strength.

### Exact Type Replacements



A new flyback transformer and deflection yoke have been added to the line of exact replacement units made by Chicago Standard Transformer Corp.,

3501 W. Addison St., Chicago, Ill. Flyback A-8285 replaces Capehart part number 850285E-/D-1 used in 38 different models. Yoke DY-21A replaces original part numbers 76653, 78278, 971387-3, and 971744-1 used in RCA Victor chassis KCS68 and KCS81.

### Carbon Film Resistors

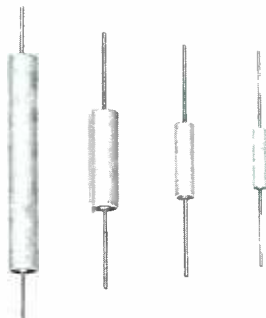

New precision resistors, recommended for use in test equipment and high-frequency circuits, are being manufactured by Continental Carbon, Division of Wirt Co., 13900 Lorain Ave., Cleveland, Ohio. They are made by depositing a layer of carbon on a ceramic rod

and hermetically sealing this combination inside a ceramic tube. 1/4, 1/2, 1 and 2 watt sizes.

# IT'S Tung-Sol



# Quality

Tung-Sol receiving tubes for TV, radio and Hi-Fi replacement are exactly the same as those supplied to leading independent set makers. This one quality—Blue Chip Quality—is your assurance of long, trouble-free service that keeps customers with you year after year. Tell your supplier you'd rather have Tung-Sol Tubes.

*Blue Chip Quality*

**ts TUNG-SOL®**  
**RECEIVING TUBES**

TUNG-SOL makes All-Glass Sealed Beam Lamps, Miniature Lamps, Signal Flashers, Picture Tubes, Radio, TV and Special Purpose Electron Tubes and Semiconductor Products.



# PF REPORTER

## INDEX TO ADVERTISERS

April 1957

Advertisers	Page No.
Aerovox Corp. ....	9
American Television & Radio Co....	75
Amphenol Electronics Corp. ....	8
Anchor Products Co. ....	68
Argos Products Co. ....	58
Astron Corp. ....	18
B & K Mfg. Co. ....	5, 28
Bussmann Mfg. Co. ....	4
CBS-Hytron ....	22
Centralab, A Div. of Globe-Union, Inc. ....	54, 55
Century Electronics Co., Inc. ....	63
Chicago Standard Transformer Co....	41
Circuit Mfg. Co., Inc. ....	50, 51
Clarostat Mfg. Co., Inc. ....	33
Continental Carbon, Inc. ....	40
Cornell-Dubilier Electric Corp. .	70, 74
Delco Radio Div., General Motors Corp. ....	26
Dynamic Electronics- New York, Inc. ....	72
Duotone Co., Inc. ....	65
Electro Products Labs ....	77
Electro-Voice, Inc. ....	49
Electronic Instrument Co., Inc. (EICO) ....	52
Electronic Pub. Co. ....	64
E-Z Hook Test Products ....	48
General Electric Co. ....	53
Hexacon Electric Co. ....	36
Hickok Electrical Instrument Co....	35
International Business Machines Corp. ....	6-7
International Resistance Co...2nd cover	
Jackson Electrical Instrument Co....	65
Jensen Industries, Inc. ....	68
JFD Mfg. Co. ....	37, 72
Kedman Co. ....	64
Littelfuse, Inc. ....	4th cover
Mallory & Co., Inc., P. R. ....	42, 43
Merit Coil & Trans. Corp. ....	56
Ohmite Mfg. Co. ....	69
Perma-Power Co. ....	75
Phaotron Co. ....	61
Planet Sales Corp. ....	76
Precision Apparatus Co., Inc.....	32
Quam-Nichols Co. ....	66
Radiart Corp.—Cornell- Dubilier Electric Corp. ....	1
Radio Corp. of America ....	20, 29, 44, 3rd cover
Raytheon Mfg. Co. ....	10
Sams & Co., Inc., Howard W....	39, 73
Sangamo Electric Co. ....	45
Seco Mfg. Co. ....	69
Service Instrument Corp. ....	75
Shure Bros., Inc. ....	59
Sprague Products Co. ....	2
Standard Electrical Products Co. ...	34
Stevens Walden, Inc. ....	36
Television Hardware Mfg. Co.—Div. General Cement—Texton, Inc....	67
Tenna Mfg. Co. ....	12
Triad Transformer Corp. ....	60
Tung-Sol Electric, Inc. ....	78, 79
United Catalog Pubs., Inc. ....	65
University Loudspeakers, Inc. ....	56
Vaco Products Co. ....	76
Ward Products Corp. ....	62
Webster Electric Co. ....	57
Westinghouse Electric Co. ....	47
Winston Electronics, Inc. ....	24
Xcelite, Inc. ....	71

## CATALOG and LITERATURE SERVICE

APRIL 1957

- 1D. ATR**  
Literature on ATR portable plug-in battery charges and ATR portable plug-in inverters. See ad page 75.
- 2D. ARGOS**  
Complete new catalog on tube caddies, baffles and hi-fi speaker enclosures. See ad page 58.
- 3D. B & K**  
Bulletin 1000 describes new "Dyna-Scan" picture and pattern video generator. Bulletin 750 on new lab-type test equipment calibrator Model 750 that checks instrument accuracy. Also Bulletin 500 on "Dyna-Quik" dynamic mutual conductance tube tester and Bulletin 400 on CRT cathode rejuvenator tester. See ads pages 5, 28.
- 5D. BUSSMAN**  
New and very comprehensive book on fuses and fuse mountings used by the electronics industries. See ad page 4.
- 6D. CENTRALAB**  
Completely new Centralab 48-page, 2-color Catalog #30 listing hundreds of new items. See ads pages 54, 55.
- 7D. CENTURY**  
Free 1957 catalog describing complete line of test equipment for radio and TV servicing. See ad page 63.
- 8D. CHICAGO STANDARD**  
New 1957 STANCOR TV transformer replacement library. See ad page 41.
- 9D. CLAROSTAT**  
Form No. 751773 listing sound-system controls and T & L pads for audio applications. See ad page 33.
- 10D. CORNELL-DUBILIER**  
Extract 200D-3-F on RF interference suppression filters. See ads pages 70, 74.
- 11D. DYNAMIC**  
1957 Catalog of service aids and accessories for better TV and hi-fi. See ad page 72.
- 12D. EICO**  
12-page catalog shows how to save 50% on electronic test instruments and hi-fi equipment in both kit and factory-wired form. See ad page 52.
- 13D. ELECTRO PRODUCTS**  
Catalog sheet describing Model D-612T DC power supply for transistor auto radio servicing. Also Model NFA universal power supply. See ad page 77.
- 14D. ELECTRO-VOICE**  
Pocket-size, "Power-Point" phono-cartridge "Interchangeability Guide" indexes in easy-to-use chart form over 400 conventional cartridges replaced by 7 "Power-Point" models and 3 mounts. See ad page 49.
- 15D. HICKOK**  
New 8-page condensed catalog on latest test equipment, including the new automation-type tube tester. See ad page 35.
- 16D. JFD**  
"Magic Genie" Kit containing assortment of sales promotional displays and helps showing how to make extra profits. Includes name of local JFD "Magic Genie" Distributor. See ads pages 37, 72.
- 17D. KEDMAN**  
Catalog sheet describing 4 screw-driver displays and specifications of 14 kinds of screwdrivers in the company's line. See ad page 64.
- 18D. MERIT**  
Replacement Guide No. 409. See ad page 56.
- 19D. MOSLEY**  
New Mosley Catalog #H57 describing entire line of Mosley amateur rotary-beam antennas.
- 20D. PHAOSTRON**  
Illustrated catalog lists complete line of custom panel meters. Includes comparison chart of Phaotron instruments vs. other brands plus information on dimensions and features. See ad page 61.
- 21D. QUAM**  
Catalog 56, listing the full line of Quam "Adjust-a-Cone" replacement speakers for hi-fi and PA systems-plus others. See ad page 66.
- 22D. SECO**  
Information on Seco complete tube tester Model 107. See ad page 69.
- 23D. SHURE**  
New General Catalog #57 featuring microphones, phono cartridges, magnetic recording heads, acoustic components and accessories. See ad page 59.
- 24D. STANDARD ELECTRICAL**  
22-page catalog describing complete line of "Adjust-A-Volt" variable transformers. Also catalog page on PA-1 "Adjust-A-Volt." See ad page 34.
- 25D. TELEVISION HARDWARE**  
Catalog page entitled "Getting What You Pay For." See ad page 67.
- 26D. TENNA**  
6-page auto-antenna catalog. See ad page 12.
- 27D. VACO**  
Catalog on screwdrivers, nut drivers, pliers, and solderless terminals. See ad page 76.
- 28D. WARD**  
Literature entitled "New 1957 Antenna Models and Accessories." See ad page 62.
- 29D. WEBSTER ELECTRIC**  
Replacement cartridge catalog sheet Bulletin YF-7 lists all Webster cartridges and units they replace. See ad page 57.
- 30D. WINSTON**  
Additional information on use of Win-Tronix Analyzers for more profitable servicing. See ad page 24.
- 31D. XCELITE**  
Folder on new 99 S. M. Service-Master Roll Kit with stubby- and regular-size nut drivers, screwdrivers, pliers and wrenches. See ad page 71.



APRIL 1957
SUPPLEMENT to
SAMS MASTER INDEX No. 102

File this Supplement with your 36-page SAMS MASTER INDEX. Together, they give you complete PHOTOFACT coverage.

This Supplement is your handy index to new models covered in the latest PHOTOFACT Sets 346 through 355. It's your guide to the world's finest service data coverage of the current output of the new TV and Radio receivers, as well as models not previously covered in PHOTOFACT. It keeps you right up to date.

ALWAYS USE YOUR LATEST ISSUE OF THIS SUPPLEMENT WITH THE SAMS MASTER INDEX . . . TOGETHER, THEY ARE YOUR COMPLETE INDEX TO OVER 30,000 MODELS.

For models and chassis not listed in this Supplement, refer to SAMS MASTER INDEX No. 102. If you haven't a copy, send for it today. It's FREE . . . just write to HOWARD W. SAMS & CO., INC., 2201 East 46th Street, Indianapolis 5, Indiana.



IMPORTANT: THIS SUPPLEMENT REPLACES MARCH SUPPLEMENT No. 102-B

Discard prior supplement, since this issue includes all previous listings plus latest models

FILE WITH YOUR SAMS MASTER INDEX No. 102, DATED FEBRUARY, 1957

Table listing models and chassis for ADMIRAL, AIRLINE, ALLSTATE, AMBASSADOR, AMERICAN TELEVISION, ANDREA, ARVIN, AUTOMATIC, BENDIX, CBS-COLUMBIA, CHEVROLET, CROSLLEY, DEWALD, DUMONT, EMERSON, ELECTRO-VOICE, FIRESTONE, FORD, GRANCO, HALLICRAFTERS, HARMAN-KARDON, HOFFMAN, HOTPOINT, INTERNATIONAL TRUCK, KNIGHT, LECTROLAB, MAGNAVOX, MOPAR, MOTOROLA, MUNTZ, OLDSMOBILE, OLYMPIC.

Table listing models and chassis for BENDIX-Cont., BROCCINER, BUICK, CAVALIER, CBS-COLUMBIA, CHEVROLET, COLUMBIA RECORDS, CORONADO, CRESCENT, CROSLLEY, DEWALD, DUMONT, EMERSON, ELECTRO-VOICE, FIRESTONE, FORD, GRANCO, HALLICRAFTERS, HARMAN-KARDON, HOFFMAN, HOTPOINT, INTERNATIONAL TRUCK, KNIGHT, LECTROLAB, MAGNAVOX, MOPAR, MOTOROLA, MUNTZ, OLDSMOBILE, OLYMPIC.

Table listing models and chassis for BENDIX-Cont., BROCCINER, BUICK, CAVALIER, CBS-COLUMBIA, CHEVROLET, COLUMBIA RECORDS, CORONADO, CRESCENT, CROSLLEY, DEWALD, DUMONT, EMERSON, ELECTRO-VOICE, FIRESTONE, FORD, GRANCO, HALLICRAFTERS, HARMAN-KARDON, HOFFMAN, HOTPOINT, INTERNATIONAL TRUCK, KNIGHT, LECTROLAB, MAGNAVOX, MOPAR, MOTOROLA, MUNTZ, OLDSMOBILE, OLYMPIC.

Table listing models and chassis for BENDIX-Cont., BROCCINER, BUICK, CAVALIER, CBS-COLUMBIA, CHEVROLET, COLUMBIA RECORDS, CORONADO, CRESCENT, CROSLLEY, DEWALD, DUMONT, EMERSON, ELECTRO-VOICE, FIRESTONE, FORD, GRANCO, HALLICRAFTERS, HARMAN-KARDON, HOFFMAN, HOTPOINT, INTERNATIONAL TRUCK, KNIGHT, LECTROLAB, MAGNAVOX, MOPAR, MOTOROLA, MUNTZ, OLDSMOBILE, OLYMPIC.

Table listing models and chassis for BENDIX-Cont., BROCCINER, BUICK, CAVALIER, CBS-COLUMBIA, CHEVROLET, COLUMBIA RECORDS, CORONADO, CRESCENT, CROSLLEY, DEWALD, DUMONT, EMERSON, ELECTRO-VOICE, FIRESTONE, FORD, GRANCO, HALLICRAFTERS, HARMAN-KARDON, HOFFMAN, HOTPOINT, INTERNATIONAL TRUCK, KNIGHT, LECTROLAB, MAGNAVOX, MOPAR, MOTOROLA, MUNTZ, OLDSMOBILE, OLYMPIC.

NOTE: PCB Denotes Production Change Bulletin. \* Denotes Television Receiver. S Denotes Schematic Coverage Only.



Set No.	Folder No.	Model No.
<b>OLYMPIC—Cont.</b>		
•14TW50 (Ch. CW)	(See Model 14TW50—Set 337-13)	
•17TX51 (Ch. CX)	(See Model 14TW50—Set 337-13)	
447		349-7
Ch. CW (See Model 14TW50)		354-13
Ch. CX (See Model 17TX51)		354-13
Ch. DA, DAA (See Model 1CA70)		354-13
Ch. DB, DBU (See Model 1CB71)		354-13
Ch. DD, DDU (See Model 1CD73)		354-13
Ch. DF, DDU (See Model 1CF75)		354-13
Ch. DH, DHU (See Model 4KH85)		354-13

Set No.	Folder No.	Model No.
<b>PACKARD-BELL</b>		
•21DC3, -U, 21DC4, -U (Ch. 98D2, -U)		354-13
•21DT2, -U (Ch. 98D2, -U)		354-13
•21ST2 (Ch. 88S2)		349-8
•24CC2, -U (Ch. 98D2, -U)		354-13
•24DD2, -U (Ch. 98D2, -U)		354-13
•24DK2, -U (Ch. 98D2, -U)		354-13
•24DT2, -U (Ch. 98D2, -U)		354-13
Ch. 88S2 (See Model 21ST2)		354-13
Ch. 98D2, -U (See Model 21DC3)		354-13

Set No.	Folder No.	Model No.
<b>PHILCO</b>		
D-1345		347-10
E-670, E-672, E-675, E-676		346-8
E-740, E-742		351-14
E-808, E-810, E-812, E-814, E-816		351-14
E-1351, E-1353		350-12
•E2002C, E2004F, G, SP (Ch. 7E10, 7E11)		348-10
T-7		347-11
•UE2002C, UE2004F, G, SP (Ch. 7E10, 7E11-U)		348-10
•22DS100, 22DS102, L, M (Ch. TV-123)		349-9
Ch. TV-123 (See Model 22DS100)		349-9
Ch. 7E10, -U, 7E11, -U (See Model E2002C)		349-9

Set No.	Folder No.	Model No.
<b>PHONOLA</b>		
155		354-14
255		354-14
355		354-14
455		354-14
555		354-14
655, 855		347-12

Set No.	Folder No.	Model No.
<b>PONTIAC</b>		
988569		346-9

Set No.	Folder No.	Model No.
<b>RCA VICTOR</b>		
6E55 (Ch. RS-157, A)		351-15
78X9H (Ch. RC-1163)		349-10
7EMP1J, 7EMP1K (Ch. RS-152C)		353-10
7EP2 (Ch. RS-152) (See Model 6EMP2A—Set 338-9)		353-10
7EP45 (Ch. RS-152D)		353-10
6EY3A—Set 332-12		354-16
7E56H, 7E56J (Ch. RS-157, A)		351-15
7EY2HH, 7EY2J (Ch. RS-155A)		355-8
7HF4 (Ch. RS-146F)		347-13
7HF5 (Ch. RS-158)		346-10
7HF45 (Ch. RS-159)		354-15
8BT10K (Ch. RC-1156A)		350-13
•1457052, U (Ch. KCS1028, D)		354-16
•1457070, U, 1457071, U (Ch. KCS1028, D)		354-16
•1457074, U (Ch. KCS1028, D)		354-16
•1756032, U (Ch. KCS94, A) (See Model 17PT692—Set 315-9)		355-9
•1756042, U (Ch. KCS94, A) (See Model 17PT692—Set 315-9)		355-9
•1756044, U (Ch. KCS94, A) (See Model 17PT692—Set 315-9)		355-9
•21CS7815, U, 21CS7817, U (Ch. CTC5, A)		353-11
•21CT7835, U, 21CT7837, U (Ch. CTC5B, C)		353-11
•21CT7855, U, 21CT7857, U (Ch. CTC5D, E)		353-11
•21CT7865, U, 21CT7866, U, 21CT7867, U (Ch. CTC5D, E)		353-11
•21D7425, U, 21D7427, U (Ch. KCS104E, F)		346-11
•21D7445, U, 21D7446, U, 21D7447, U (Ch. KCS104H, J)		346-11
•21D7479, U (Ch. KCS104H, J)		346-11
•21D7485, U, 21D7487, U, 21D7488, U (Ch. KCS104H, J)		346-11
•21D7505, U, 21D7506, U, 21D7507, U (Ch. KCS104H, J)		346-11

Set No.	Folder No.	Model No.
<b>RCA VICTOR—Cont.</b>		
•21T7112, U, 21T7113, U (Ch. KCS98A, C)		347-14
•21T7117, U (Ch. KCS98A, C)		347-14
•21T7152, U, 21T7153, U (Ch. KCS98A, C)		347-14
•21T7157, U (Ch. KCS98A, C)		347-14
•21T7352, U, 21T7355, U, 21T7357, U (Ch. KCS98E, F)		347-14
•21T7385, U, 21T7386, U, 21T7387, U (Ch. KCS104A, B)		346-11
•21T7388, U (Ch. KCS104A, B) (See Model 21T7385—Set 346-11)		346-11
•21T7415, U, 21T7416, U, 21T7417, U (Ch. KCS104C, D)		346-11
•24D7545, U, 24D7547, U (Ch. KCS104AA, AB)		346-11
•24D7566, U, 24D7568, U (Ch. KCS104AA, AB)		346-11
•24D7587, U (Ch. KCS104AC, AD)		346-11
•24D7705, U, 24D7706, U, 24D7708, U (Ch. KCS104AE, AF)		346-11
•24D7726, U, 24D7728, U (Ch. KCS104AE, AF)		346-11
Ch. CTC5 (See Model 21CS7815)		353-11
Ch. CTC5A (See Model 21CS7815U)		353-11
Ch. CTC5B (See Model 21CT7835)		353-11
Ch. CTC5C (See Model 21CT7835U)		353-11
Ch. CTC5D (See Model 21CT7855)		353-11
Ch. CTC5E (See Model 21CT7855U)		353-11
Ch. KCS98A, C (See Model 21T7112)		347-14
Ch. KCS98E, F (See Model 21T7352)		347-14
Ch. KCS1028, D (See Model 1457052)		354-16
Ch. KCS104A (See Model 21T7385)		346-11
Ch. KCS104AA (See Model 24D7545)		346-11
Ch. KCS104AB (See Model 24D7545U)		346-11
Ch. KCS104AC (See Model 24D7587)		346-11
Ch. KCS104AD (See Model 24D7587U)		346-11
Ch. KCS104AE (See Model 24D7705)		346-11
Ch. KCS104AF (See Model 24D7705U)		346-11
Ch. KCS104B (See Model 21T7385U)		353-11
Ch. KCS104C (See Model 21T7415)		353-11
Ch. KCS104D (See Model 21T7415U)		353-11
Ch. KCS104E (See Model 21D7425)		346-11
Ch. KCS104F (See Model 21D7425U)		346-11
Ch. KCS104H (See Model 21D7487)		346-11
Ch. KCS104I (See Model 21D7505)		346-11
Ch. RC-1156A (See Model 8BT10K)		350-13
Ch. RS-146F (See Model 7HF4)		347-13
Ch. RS-152C (See Model 7EMP1J)		353-10
Ch. RS-152D (See Model 7EP45)		353-10
Ch. RS-155A (See Model 7EY2HH)		351-15
Ch. RS-157, A (See Model 6E55)		351-15
Ch. RS-158 (See Model 7HF5)		346-10
Ch. RS-159 (See Model 7HF45)		354-15

Set No.	Folder No.	Model No.
<b>REGENCY</b>		
TR-6		346-12

Set No.	Folder No.	Model No.
<b>ROLAND</b>		
4C2		353-12
4PL, 4P2-1, 4P2-2		346-13
5PL, 5P5-1, 5P5U-1		348-11
6TR		347-15

Set No.	Folder No.	Model No.
<b>SCOTT (H. H.)</b>		
223		349-11
330		348-12
331		346-14

Set No.	Folder No.	Model No.
<b>SETCHELL-CARLSON</b>		
•P-62 (Ch. C-101)		346-15
•71 (Ch. C-201)		355-9
•711 (Ch. C-201)		355-9
Ch. C-101 (See Model P-62)		346-15
Ch. C-201 (See Model 71)		355-9

Set No.	Folder No.	Model No.
<b>SILVERTONE</b>		
•PC-7100, Y, Z (Ch. 456.50001, 456.50003) (See Model 7100—Set 339-13)		353-11
•PC-7110, PC-7112 (Ch. 456.50001, 456.50003) (See Model 7100—Set 339-13)		353-11
3250 (Ch. 137.917)		348-13
•6102, 6103 (Ch. 549.20040, 549.20050)		351-22-5
7010, 7011, 7012 (Ch. 132.40000)		352-13
7013, 7014 (Ch. 132.40100)		347-16
7018 (Ch. 528.46500)		352-14
7025, 7026, 7027 (Ch. 528.46700)		352-14
528.46701		355-10

Set No.	Folder No.	Model No.
<b>SILVERTONE—Cont.</b>		
7045, 7046 (Ch. 528.47200)		351-16
7200, 7202 (Ch. 132.40200)		346-16
7222 (Ch. 528.48000)		350-14
7250, 7251 (Ch. 567.33010)		355-11
7299 (Ch. 567.33010)		355-11
Ch. 132.40000 (See Model 7010)		352-13
Ch. 132.40100 (See Model 7013)		352-13
Ch. 132.40200 (See Model 7200)		352-13
Ch. 137.917 (See Model 3250)		347-17
Ch. 456.50001, 456.50003 (See Model PC-7100)		353-11
Ch. 528.46500 (See Model 7018)		352-14
Ch. 528.46700, 528.46701 (See Model 7025)		352-14
Ch. 528.47200 (See Model 7045)		352-14
Ch. 528.48000 (See Model 7222)		350-14
Ch. 549.20040, 549.20050 (See Model 6102)		351-22-5
Ch. 567.33010 (See Model 7250)		355-11

Set No.	Folder No.	Model No.
<b>SONORA</b>		
•518		355-12
•523, 529, 530, 533		355-12
548		354-17
548A (See Model 548—Set 354-17)		354-17
552, 553		354-17
•558		355-12
561		354-17
•565		353-13
571		352-15
•576		353-13
581		354-17
•587, 588		355-12
•605		353-13
607, 608		350-15
•613		353-13
633, 634, 635 (See Model 548—Set 354-17)		354-17

Set No.	Folder No.	Model No.
<b>STEELMAN</b>		
355, 356		348-14

Set No.	Folder No.	Model No.
<b>STUDEBAKER</b>		
AC2786 (Similar to chassis)		336-11

Set No.	Folder No.	Model No.
<b>SYLVANIA</b>		
•21C405 (Ch. 1-532-9, -0) (See Model 21C401—Set 341-15)		352-16
•21C501 Series, 21C502 Series (Ch. 1-533-3, -4)		352-16
•21C605 Series, 21C607 Series (Ch. 1-533-7, -8, -9)		352-16
•21T110 (Ch. 1-532-9, -0) (See Model 21C401—Set 341-14)		352-16
•21T201 Series (Ch. 1-533-3, -4)		352-16
•21T206 Series (Ch. 1-533-3, -4)		352-16
•21T301 Series (Ch. 1-533-3, -4)		352-16
•21T303 Series (Ch. 1-533-7, -8, -9)		352-16
•24C603 Series (Ch. 1-533-7, -8, -9)		352-16
•24T301 Series (Ch. 1-533-3, -4)		352-16
Ch. 1-532-9, -0 (See Model 21C405)		352-16
Ch. 1-533-3, -4 (See Model 21C501 Series)		352-16
Ch. 1-533-7, -8, -9 (See Model 21C605 Series)		352-16

Set No.	Folder No.	Model No.
<b>TRAV-LER</b>		
55C46, 56C46		351-18
•517-106, 517-107 (Ch. 520A5) (Also see PCB 180—Set 349-1)		330-11
•521-111, 521-112 (Ch. 520A5) (Also see PCB 180—Set 349-1)		330-11
•621-740, U (Ch. 631-26, 632-26)		347-18-5
•621-750, U (Ch. 631-26, 632-26)		347-18-5
•721-R400, U (Ch. 631-26, 632-26)		347-18-5
Ch. 520A5 (See Model 517-106)		351-18
Ch. 631-26, 632-26 (See Model 621-740)		347-18-5

Set No.	Folder No.	Model No.
<b>TRUETONE</b>		
D2786A, D2787A		355-13
D3600A		353-14
D4623A, D4624A		350-16
D4625A, D4626A		348-15
•2D1713A, 2D1714A		346-17
•2D1715A, 2D1716A		349-12

Set No.	Folder No.	Model No.
<b>TRUETONE—Cont.</b>		
•2D1734A, B, C, 2D1735A, B, C, 2D1736A, B		355-14
•2D2734A, B, C		355-14
•2D3775A, B		354-18
<b>V-M</b>		
156		353-15
556-A		354-19
625		351-19
1275		347-17

Set No.	Folder No.	Model No.
<b>WEBCOR</b>		
GT1651		348-16
1653 (See Model GT1651—Set 348-16)		348-16
1654, 1657, 1661		346-18
1753 (See Model GT1651—Set 348-16)		348-16
1791, 1792 (See Model 1691—Set 329-16)		329-16



# RCA BATTERIES

... your nest egg

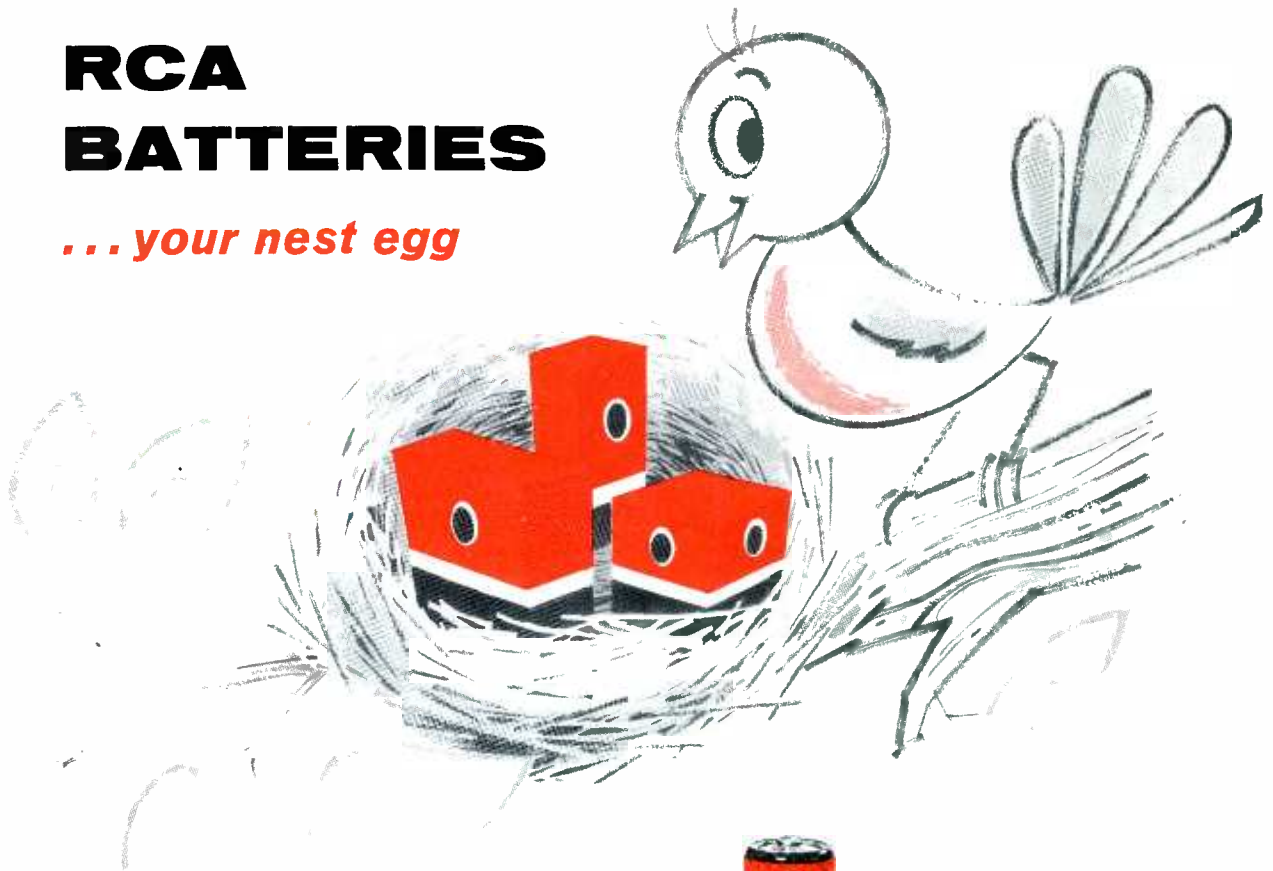

## ... for profits all year long !

Customer acceptance of RCA quality assures you of profit making battery sales all year long. And, there's an RCA Battery to serve virtually every customer's need. This includes batteries for the new transistor-powered portables as well as for industrial and general use. Order your nest egg of RCA batteries *TODAY* for profit making sales all year long!



**RADIO CORPORATION of AMERICA**

COMPONENTS DIVISION

CAMDEN, N. J.

CONSUMER • INDUSTRIAL • GENERAL • RCA IS YOUR BEST BATTERY BUY !

another

# LITTELFUSE



ACTUAL SIZE

# FIRST in service

The new Limited Current (LC) fuses are being used by more and more TV set manufacturers. The LC fuses are designed to protect the TV set manufacturer, the serviceman and the set owner by making it mechanically impossible to replace a fuse with anything but another fuse of the proper amperage range.

LC fuses demand exact replacement.

The table printed below is a quick check list to speed stock planning and replacement identification by TV set brands. The cross reference table is designed to fit the top of the LITTELFUSE fuse caddy. For additional copies see your Littelfuse jobber.

Tear on dotted line

NAME	FUSE DESCRIPTION	LF PART NO.
Admiral	*3/10 amp Type C	332.300
Admiral	*3/4 amp Type C	332.750
Admiral	*2 amp Type C	332002
Airline (Montgomery Ward)	4/10 amp Type N	333.400
Bendix	2 amp Type N	333002
Capehart Farnsworth	1/2 amp Type N	333.500
CBS Columbia	1-6/10 amp Type N	33301.6
Coronado	4/10 amp Type N	333.400
Crosley (Eldorado)	2-8/10 amp Type N	33302.8
DuMont	3/4 amp Type N	333.750
Emerson	6/10 amp Type N	333.600
Emerson	1 amp Type N	333001
Emerson	1-1/4 amp Type N	3331.25
Firestone	4/10 amp Type N	333.400
General Electric	1-1/4 amp Type N	3331.25
Motorola	2 amp Type C	332002
Olympic	3/8 amp Type C	332.375
Packard-Bell	2/10 amp Type N	333.200
Packard-Bell	*3/10 amp Type C	332.300
Packard-Bell	1/2 amp Type N	333.500
Packard-Bell	*3/4 amp Type C	332.750
Philco	7/10 amp Type N	330001
Raytheon	*1/4 amp Type N	333.250
Raytheon	1/2 amp Type N	333.500
RCA	3/10 amp Type C	332.300
RCA	*3/4 amp Type C	332.750
Setchel Carlson	2-1/2 amp Type C	33202.5
Silvertone	*3/10 amp Type N	333.300
Silvertone	*3-1/2 amp Type N	33303.5
Stromberg Carlson	1/4 amp Type N	333.250
Sylvania	2-1/2 amp Type C	33202.5
Truetime	4/10 amp Type N	333.400
Westinghouse	1/2 amp Type C	332.500
Westinghouse	*3/4 amp Type C	332.750
Westinghouse	*7 amp Type C	332007
Zenith	1/4 amp Type N	333.250
Zenith	3/10 amp Type N	333.300

\*Color TV

# LITTELFUSE

Des Plaines, Ill.

LITTELFUSE, INC.