

Howard W. Sams

PHOTOFACT
PF®

REPORTER

JUNE • 1956

25 CENTS

for the Electronic Service Industry

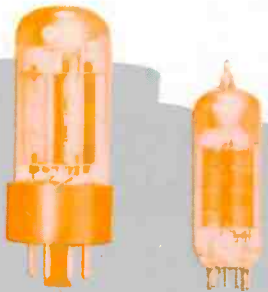

TROUBLES in **VERTICAL SWEEP SYSTEMS**

- **REPLACING RIVET-MOUNTED COMPONENTS**
- **WINDOW DISPLAYS**

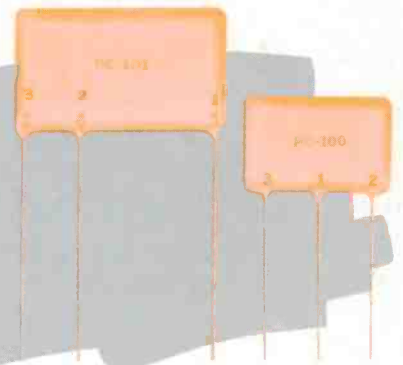
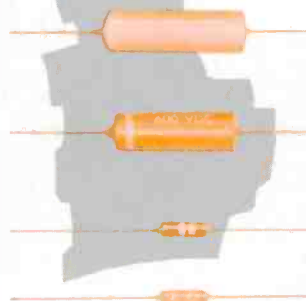

Preferred for modern set servicing

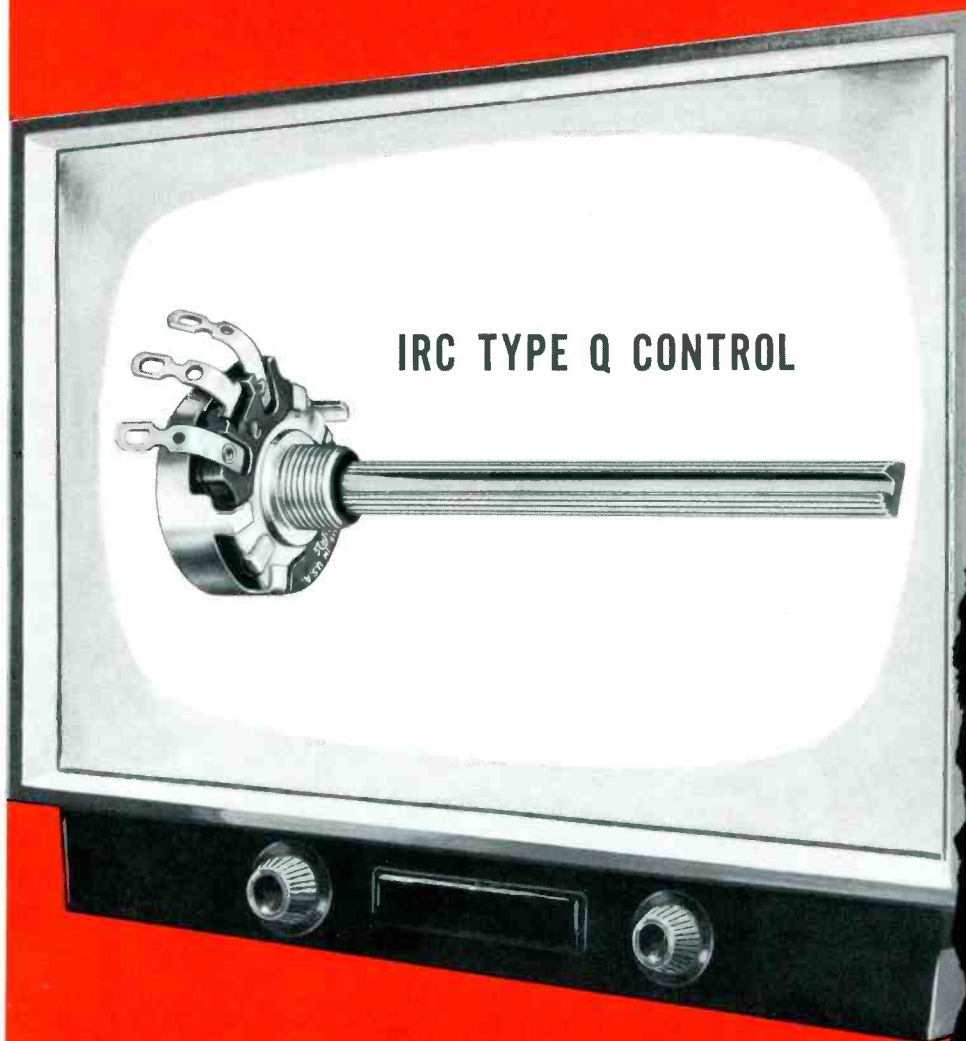

IRC TYPE Q CONTROL

Service technicians get greater coverage with less investment; more practical service features; and easier, faster installation with the IRC Type Q Control. Here's a dependable, basic control that is directly designed for modern set servicing. For appearance, performance and price . . . there's none better. So why settle for less? Tell your Distributor you want Q Controls . . . most servicemen do.

INTERNATIONAL RESISTANCE CO.

Dept. 363, 401 N. Broad St., Phila. 8, Pa.

In Canada: International Resistance Co., Ltd., Toronto, Licensee

Send me Catalog listing IRC Type Q Controls.

Name _____

Company _____

Address _____

City _____ State _____

**KNOBMASTER FIXED SHAFT**
Q Control standard shaft is knurled, flatted and slotted —fits most knobs without alteration.

**INTERCHANGEABLE FIXED SHAFTS**
Exclusive IRC convenience feature—provides fast conversion to "specials", with FIXED shaft security. 15 types available.

**1/4" LONG BUSHING**
Accommodates all small sets, yet handles large set needs perfectly.

**7 STANDARD TAPERS**
Full coverage of all taper requirements is provided in the Q Control.

**94 RESISTANCE VALUES**
For TV, AM and FM coverage, 94 values of plain and tapped controls are furnished.

**QUALITY APPEARANCE**
The handsome professional appearance of IRC Q Controls lets you point to your work with pride.

**CUSHIONED TURN**
The smooth, quality of "feel" of a Q Control contributes to customer confidence.

**TYPE 76 SWITCHES**
Either of two type IRC switches attached as quickly and easily as a control cover—meets all your requirements.



Wherever the Circuit Says 

setting new selling records everywhere

C·D·R TV antenna ROTORS the COMPLETE line A Model for Every Need

AR-1

The completely AUTO-MATIC rotor, powerful and dependable, with a modern design cabinet. Uses 4 wire cable.



AR-2

Completely AUTOMATIC rotor with thrust bearing. Handsome cabinet, uses 4 wire cable.



TR-4

The heavy-duty rotor complete with modern cabinet with METER control dial. Uses 4 wire cable.



AR-22

Here is the completely AUTOMATIC version of the famous TR-2 with all the powerful features that made it so famous.



TR-11

The ideal budget all-purpose rotor with new, modern cabinet featuring meter control dial. Uses 4 wire cable.

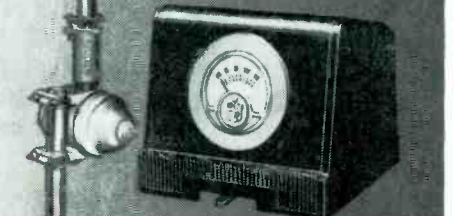

TR-2

The heavy-duty rotor with plastic cabinet featuring "compass control" illuminated perfect pattern dial. Uses 8 wire cable.



TR-12

A special combination value consisting of complete rotor with thrust bearing. Handsome modern cabinet with meter control dial, uses 4 wire cable.

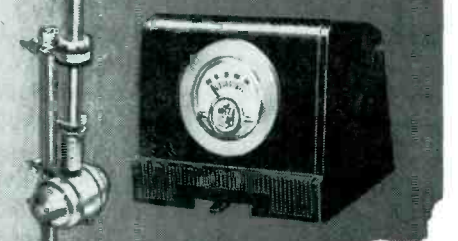

CORNELL-DUBILIER
SOUTH PLAINFIELD, N. J.



THE RADIART CORP.
CLEVELAND 13, OHIO

the capacitor you DREAMED about is HERE!



this **ONE** new ceramic capacitor does the work of **FIFTEEN**

NOW . . . you can handle a big percentage of special value and standard value ceramic replacements with a few Sprague "Universals". Just four of these remarkable new capacitors take the place of forty-two regular capacitors, with capacitance values from 400 μF to .015 μF . You can also use them to replace molded mica, ceramic tubular, and paper tubular capacitors in many bypass and coupling applications.

Sprague "Universals" are easy to use! No complex arithmetic involved. One look at the handy reference card packed with each capacitor tells the complete story . . . which "Universal" to use . . . how to wire the leads for the capacitance required.

Type UHK-1, with seven needed values from .001 to .004 μF , is a High-K capacitor for use where rated capacitance is the lowest value permissible. Type UGA-1, with twelve values from .0004 to .0013 μF , is a general application unit with a capacitance tolerance of $\pm 20\%$. UHK-2, covering eight values from .0025 to .015 μF , is a High-K capacitor like UHK-1. Type UGA-2 covers fifteen values from .0006 to .0027 μF , and is a general application unit with a $\pm 20\%$ capacitance tolerance.

Put Sprague "Universal" ceramic capacitors on your "want" list now. Your customers won't ever have to spend another night without television for lack of a simple ceramic replacement.

don't be vague . . . insist on

Sprague Products Company • Distributors' Division of the Sprague Electric Company • North Adams, Massachusetts.

A FEW EXAMPLES OF HOW FOUR "UNIVERSAL" CAPACITORS MEET 90% OF ALL CERAMIC REPLACEMENT NEEDS

For .0004 μF

Cut leads 2 and 3 from a UGA-1 "Universal". Use leads 1 and 4 as terminals.



For .005 μF

Cut leads 2 and 4 from a UGA-1 "Universal". Use leads 1 and 3 as terminals.



For .001 μF

Cut lead 2 from a UGA-2 "Universal". Solder lead 3 to lead 4. Use leads 1 and 4 as terminals.



For .002 μF

Cut lead 4 from a UGA-2 "Universal". Solder lead 2 to lead 1. Use leads 1 and 3 as terminals.



For .0033 μF

Cut lead 4 from a UHK-1 "Universal". Solder lead 3 to lead 1. Use leads 1 and 2 as terminals.



For .01 μF

Cut lead 1 from a UHK-2 "Universal". Solder lead 4 to lead 2. Use leads 2 and 3 as terminals.



For .015 μF

Solder lead 3 to lead 1 on a UHK-2 "Universal". Solder lead 4 to lead 2. Use leads 1 and 2 as terminals.





PUBLISHER
Howard W. Sams

EDITOR
Lester H. Nelson

MANAGING EDITOR
Glen E. Slutz

TECHNICAL EDITOR
William E. Burke

EDITORIAL STAFF
Leslie D. Deane C. P. Cliphant
Robert B. Dunham Verne M. Ray
Thomas A. Lesh Paul C. Smith
George B. Mann Calvin C. Young, Jr.

EDITORIAL ASSISTANTS
Gwen Bigham Evelyn S. Mouser

ART DIRECTORS
Anthony M. Andreone Glenn R. Smith

PHOTOGRAPHY
Robert W. Reed

PRODUCTION
Douglas G. Bolt Charles A. Ferguson

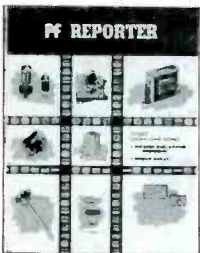

ABOUT THE COVER
Cover photographs illustrate symptoms explained in the article, "Troubles in Vertical Sweep Systems," by Leslie D. Deane and Calvin C. Young, Jr., on page 17. Photographs by Robert W. Reed. Cover design by Glenn R. Smith.

BUSINESS DEPARTMENT
Donald B. Shaw, V. P.
F. T. Dobbs, Secretary
Joe H. Morin, Sales Mgr.
Ann W. Jones, Advertising

ADVERTISING SALES OFFICES
Midwestern: Joe H. Morin, Sales Manager,
2201 East 46th Street, Indianapolis 5, Ind.
Glendale 4531
Eastern: Paul S. Weil and Donald C. Weil,
39-01 Main Street, Flushing 54, New York.
Independence 3-9098.
Western: The Maurice A. Kimball Co., Inc.,
2550 Beverly Blvd., Los Angeles 57, Calif.
Dunkirk 8-6178; and 681 Market Street,
San Francisco 5, Calif. EXbrook 2-3365.

PUBLICATION INFORMATION
Published monthly by Howard W. Sams & Co., Inc., at Indianapolis, Indiana.
Entered as second class matter October 11, 1954, at the Post Office at Indianapolis, Indiana, under the Act of March 3, 1879.
Copyright 1956 by Howard W. Sams & Co., Inc. No part of the PF REPORTER may be reproduced without written permission. No patent liability is assumed with respect to the use of information contained herein.

A limited quantity of back issues are available at 35c per copy.

CONTENTS

Letters to the Editor 6

Shop Talk Milton S. Kiver 9
Transistor testers

Replacing Rivet-Mounted Components Verne M. Ray 10
A photographic coverage

Know Your Oscilloscope (Part V) Paul C. Smith 12
Amplifiers

In the Interest of Quicker Servicing Calvin C. Young, Jr. 15
A service record; home service bench; customer "fixes" set; replacing a picture-tube base; picture-tube face with X-mark

Troubles in Vertical Sweep Systems Leslie D. Deane and Calvin C. Young, Jr. 17
A servicing guide arranged by symptoms

Audio Facts Robert B. Dunham 21
Constructing coils for divider networks

An 8-Inch Check Tube Thomas A. Lesh 23
The new 8XP4

Window Displays Leslie D. Deane 25
Hints on lighting, showroom, and seasonal displays

A Stock Guide for TV Tubes 27

Examining Design Features Thomas A. Lesh 29
The 6B8 tube; tube shields; shorting bar used as interlock

Dollar and Sense Servicing John Markus 31

Coffee Break Verne M. Ray 33

Product Report 66

Please enter my subscription to PF REPORTER for:

- 1 Year \$3.00 2 Years \$5.00 3 Years \$7.00
- In Canada: One Year \$3.60 Two Years \$6.20 Three Years \$8.80
- Remittance Enclosed* Bill Me

*Two extra issues if remittance accompanies order.

Name _____

Firm _____

Address _____

City _____ Zone _____ State _____

- 01 Independent Service Man 12 Service Manager
02 Dealer with Service Shop 37 Student
38 Other _____

Give to your Electronic Parts Distributor or mail, with remittance, to PF REPORTER, 2201 East 46th Street, Indianapolis 5, Indiana.

BUSS FUSES

*A complete line to meet
all your fuse requirements . . .*

You'll find the type and size fuse you need, quickly and easily, by turning to BUSS. The complete BUSS fuse line includes: standard, dual-element (slow blowing), renewable and one-time types — in sizes from 1/500 amp. up . . . plus a companion line of fuse clips, blocks and holders.

BUSS fuses are dependable and "trouble-free"

To assure you of top quality and proper operation under all service conditions — BUSS fuses are electronically tested. A sensitive device automatically rejects any fuse not correctly calibrated, properly constructed and right in all physical dimensions.

That's why BUSS fuses give you protection against costly trouble. They help reduce unnecessary repairs and replacements by safeguarding users' equipment when there is trouble on the circuit. And BUSS fuses help you avoid costly and time wasting callbacks by eliminating needless blows.

But most important, by helping you avoid "kicks" and complaints — BUSS fuses are helping guard you against loss of your most valuable business asset — customer good will.

*For more information on BUSS and
FUSETRON small dimension fuses
and fuseholders, write for bulletin SFB.*

Makers of a complete line of fuses for home, farm, commercial, electronic, automotive and industrial use.

BUSSMANN MFG. CO.

UNIVERSITY AT JEFFERSON,



(Div. of McGraw Electric Co.)

ST. LOUIS 7, MO.

556

ANOTHER **FIRST** FOR **RAYTHEON**

BONDED ELECTRONIC TECHNICIANS



CUSTOMER

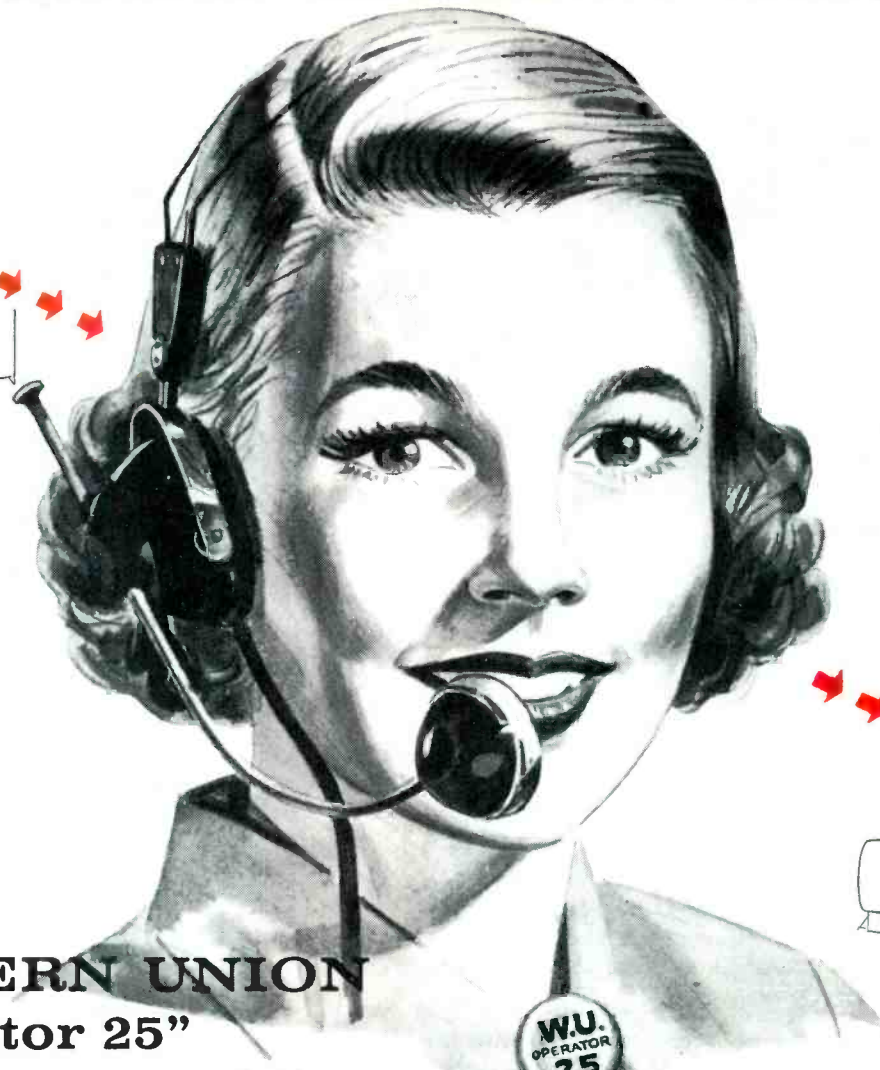

RAYTHEON BONDED SERVICE DEALER

WESTERN UNION
"Operator 25"
 will recommend them to more customers

Something new — and very important — has been added to the sales force of Raytheon Bonded Electronic Technicians. It's "Operator 25". Customers seeking Radio-TV Service simply call Western Union by number and ask for "Operator 25". In answer to their request for a reliable source of bonded service, "Operator 25" gives them the name and phone number of the nearest Raytheon Bonded Dealer. That means more business — exclusive business — for Raytheon Bonded Electronic Technicians.

This customer producing new sales advantage, plus the cash-protection of the Raytheon Bond,

the Raytheon Bonded Certificate, ID Cards, Decals, Raytheon Creed Displays, the Raytheon Code of Ethics, Classified Telephone Directory listings, all backed by sound, hard-hitting national advertising in LIFE, TIME, NEWSWEEK and TV GUIDE — make the Raytheon Bonded Electronic Technician Program the most powerful sales force a service dealer can have.

Call your sponsoring Raytheon Tube Distributor and ask him if you can qualify as a Raytheon Bonded Dealer.

If you can, you're well on your way to more volume and profit.



RAYTHEON MANUFACTURING COMPANY

Receiving and Cathode Ray Tube Operations

Newton, Mass. • Chicago, Ill. • Atlanta, Ga. • Los Angeles, Calif.

Raytheon makes all these	Receiving and Picture Tubes, Reliable Subminiature and Miniature Tubes, Semiconductor Diodes and Transistors, Nucleonic Tubes, Microwave Tubes
-----------------------------	---

Excellence in Electronics

... another
MALLORY
service-engineered
product



New Mallory "Gems" pace setters in paper capacitors

Next time you replace paper tubulars, make sure you use these new Mallory capacitors. They give you a lot of extra value features—without extra cost.

Soldering iron heat can't loosen leads. Wires are permanently attached in the plastic end seal... can't work loose from heating or vibration.

Moistureproof construction, using a protective case of high grade mica-filled bakelite, ends worries about premature shorts due to high humidity.

True center construction protects the foil element from deformation during assembly... assures uniform quality in each capacitor.

Get your stock now, from your local Mallory distributor. Ask for Mallory "Gems"—you'll agree they're a gem of a capacitor!

P. R. MALLORY & CO. Inc.
MALLORY

P. R. MALLORY & CO. Inc., INDIANAPOLIS 6, INDIANA

- Capacitors
- Controls
- Vibrators
- Switches
- Resistors
- Rectifiers
- Power Supplies
- Filters
- Mercury Batteries

JOHN DOE
MAIN STREET
ANYWHERE, U.S.A.



LETTERS to the EDITOR

Dear Editor:

I have noted recently two innovations in American nonelectronic multimeters: (1) frequency-compensated readings usually over the AF ranges and (2) most recently (in a Hickock product review) an automatic overload cutout in some form of pushout button.

Both of these features are long-standing design practices in English nonelectronic multimeters and probably have attained their most refined development in the Universal AvoMeter Model 8 distributed by the British Industries Corporation in Port Washington, L. I., N. Y. Over the past month or so, we have been most satisfied with our own unit.

Possibly, if you discuss the circuits of these American units in the future, it might be interesting for *PF REPORTER's* class of reader (the servicing engineer) to compare the different solutions to these problems.

Cazaly and Roddam, *AC/DC TEST METERS*, Isaac Pitman, 1951, contains general information on English multimeters.

Frank York
St. Albans 12, N. Y.

Dear Editor:

If I may, I would like to bore you with a few questions and a few comments on your "long and painful tale" in the article, "In the Interest of Quicker Servicing," in the February issue of the *PF REPORTER*.

Your articles are always very interesting and constructive, but this one in particular struck home with a bang because I had a very parallel case with a Capehart Model 3002, Chassis CX30. After a very thorough and systematic check of the set, I came up with the same trouble; so you can imagine my feelings as I read of the experiences of your technician.

We differed in a couple of instances. First, he had yoke, flyback, and tuner replacements which he could try and which I don't stock; and second, he had more intestinal fortitude (guts) than I have in that he stuck with the problem 'til he licked it, whereas I returned the set (no charge) to the owner so that he

could run it until the part that was breaking down really breaks down. I understand he is bravely putting up with the tearing conditions until, as I said, some part really breaks down and the pix goes out completely.

After reading your technician's experience with his ringing coil, I'm anxious for my "Cape" to come back so I can work on the ringing coil which they refer to as the horizontal frequency coil, or horizontal blocking-oscillator coil. Thanks for the tip!

In the middle of the first column on page 39, your technician stated how long he worked to accomplish the deed; but he did not say how he made out financially—that's usually a tough "nut."

May I also comment favorably on your servicing-guide series of articles written by Leslie D. Deane and Calvin C. Young, Jr. I enjoy them immensely.

So, in closing, let me say thanks for your down-to-earth servicing problems and solutions.

Howard Z. Dehlinger
Buffalo 11, N. Y.

Good luck, technically and financially, to reader Dehlinger when his "Cape" returns.—Editor

CORRECTION NOTE

Because of a printing error in the April 1956 issue of the *PF REPORTER*, Figs. 4 and 7 in the article "The Horizontal Flyback System" were shown incorrectly.

Corrected illustrations are given here.

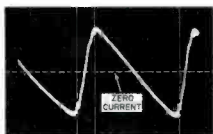

(A) Current Through the Deflection Coils.

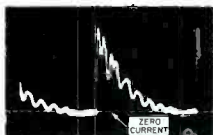

(B) Current Through the Damper Tube.



(C) Current Through the Transformer Winding.
Fig. 4. Waveforms in the Circuit of Fig. 1.

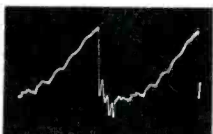
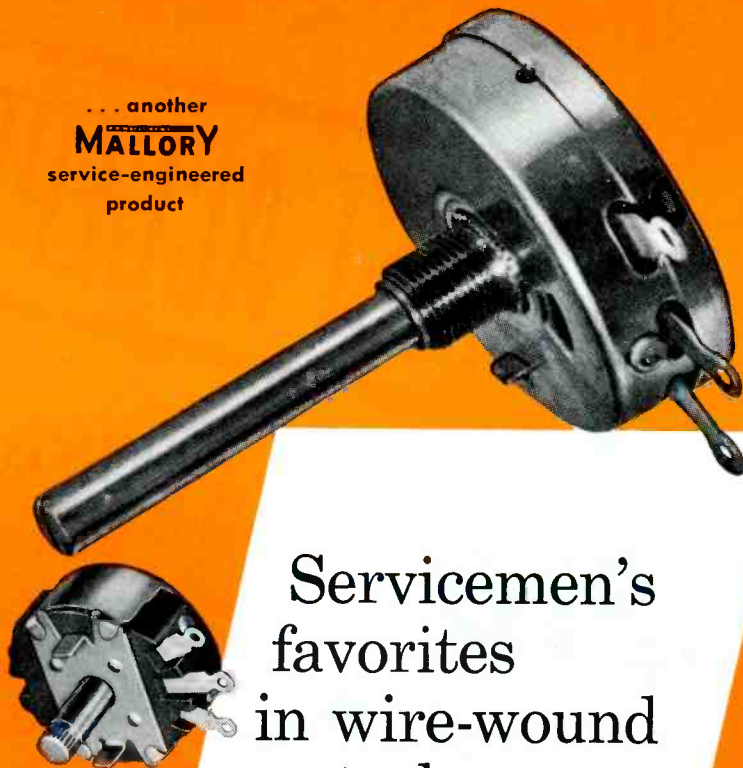

Fig. 7. Waveform of the Current Returned to the Power Supply in the Circuit of Fig. 1.

... another
MALLORY
service-engineered
product



Servicemen's favorites in wire-wound controls

You're sure of giving your customers the best when you use Mallory wire-wound controls. The choice of servicemen and manufacturers everywhere, they have set the standards of the industry for value and performance.

They're conservatively rated—to assure you of cool operation without need for using over-sized units.

They're compact—fit readily into crowded chassis locations.

They're long lasting—give years of stable, dependable service.

They're uniform—made to strict specifications to meet or exceed original equipment requirements.

Mallory 2-watt and 4-watt controls are available in resistance values and tapers to match every replacement need. Your local Mallory distributor has a complete stock—see him today!

P. R. MALLORY & CO. Inc.
MALLORY

P. R. MALLORY & CO. Inc., INDIANAPOLIS 6, INDIANA

- Capacitors
- Controls
- Vibrators
- Switches
- Resistors
- Rectifiers
- Power Supplies
- Filters
- Mercury Batteries

MOST ACCEPTABLE



FROM DELCO RADIO

come the **transformers** with high acceptability.

You trust them...

so do your customers!



Universal vibrator transformers, produced through the combined electronic skills of Delco Radio and General Motors, meet the requirements of nearly every model of auto radio. Each is designed for easy installation and complete customer satisfaction. Laminated core inserts are stamped out of low-loss silicon steel and heat treated to maintain correct magnetic properties. Coils are precision-wound on special machines. All models have ample leads. Your UMS-Delco Electronic Parts Distributor can supply you with all models. Call him today. Remember, the Delco Wonder Bar Radio is being nationally advertised in leading consumer publications . . . so you are tuned in on a constantly increasing service.

Uncased Models 6055, 6065, 6067
do not include filter network

Cased Models 6060, 6064 and 6066 are made with "A" line filter network consisting of an "A" choke and .5 mfd. capacitor. Easy-mount drilling template, plus three self-tapping screws are included for your convenience.

DELCO



RADIO

DIVISION OF GENERAL MOTORS, KOKOMO, INDIANA



A GENERAL MOTORS PRODUCT — A UNITED MOTORS LINE
Distributed by Delco Electronics Parts Distributors

A complete line of original equipment service parts from the
WORLD LEADER IN AUTO RADIO

ShopTalk

MILTON S. KIVER

Author of . . .
*How to Understand and Use TV Test Instruments
 and Analyzing and Tracing TV Circuits*

We have discussed many aspects of transistor operation, including the information which is found on a transistor data sheet; however, from the service technician's standpoint, the most important question of all still remains to be answered. This is, "How can I tell when a transistor is good or bad?" In this month's column, we will discuss several suitable and convenient solutions to this problem.

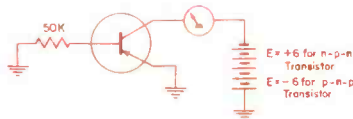

Fig. 1. A Simple Test Circuit for a Transistor.

From the experience which has been garnered to date on transistors, it has been found that a very revealing indicator of the state of a transistor's "health" is the collector current that flows when the emitter is grounded and no signal is applied to the base. This current is a function of the temperature and the resistivity of the germanium, and it will become fairly high when the transistor structure is impaired because of a short circuit or a crystal-lattice defect or when there is any contamination on the surface of the germanium. If we therefore measure this collector current, we will obtain a fairly accurate indication of the general usefulness of the transistor.

A simple circuit with which to check this current was suggested by General Electric, and it is shown in Fig. 1. The polarity of the battery voltage will depend on

the type of transistor being checked. For n-p-n transistors, the positive end of the 6-volt battery is applied to the collector; for p-n-p transistors, the negative end is connected to the collector. This is because the collector of a transistor is always reverse biased. With this test, General Electric states that the transistor should be replaced if the collector current is greater than 0.75 milliamperes at room temperature for a 2N135, 2N136, 2N44, 2N45, or a 2N78 transistor and if it is greater than 2 milliamperes for a 2N137 or a 2N43 transistor. For other transistor types, the limit of collector current revealed by this test is arrived at as follows. From the manufacturer's data sheet for the transistor, obtain the maximum value of I_{co} and the maximum value of β (which is also referred to frequently as the base-current amplification factor). If only one value of β is listed, use it. If β is not given, but α is, then β may be computed from the relationship:

$$\beta = \frac{\alpha}{1 - \alpha}$$

Once β is found, it is multiplied by the maximum value of I_{co} , and the product is multiplied by a factor of 3. The answer represents the limit of collector current which can be tolerated in the foregoing test. The 3 is a "leeway" factor to take into account manufacturing variations in β and I_{co} for a transistor. Generally, a bad transistor will greatly exceed the collector-current limit established by the computation. If the current reading is near the borderline, the results of the next test

to be described may help the service technician reach a definite conclusion. Borderline transistors should be treated in the same way you treat borderline tubes.

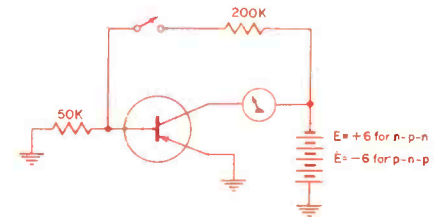

Fig. 2. The Simple Test Circuit Used to Check the β Value of a Transistor.

Another good way to test a transistor is to inject a small current change into the base and to check the current amplification, that is, the change in collector current caused by this change in base current. This current gain, which is our old friend β , can be checked by the circuit shown in Fig. 2. When the switch is closed, the base current increases by 0.03 milliamperes. This is because we are applying 6 volts through a 200,000-ohm resistor. For a good transistor, the collector current indicated by the current meter should increase by at least 0.3 milliamperes for a β value of 10. With a transistor of high β value, the current increase may go as high as 3 milliamperes when β is equal to 100.

In any event, check the value of β you obtain with that specified by the manufacturer. If the measured value is appreciably lower than the specified value, change the transistor.

• Please turn to page 50

REPLACING RIVET-MOUNTED Components

Occasionally, a technician is faced with the problem of replacing a component that is fastened to the chassis with rivets. Small transformers, filter chokes, tube sockets, interlocks, and antenna terminal boards are examples of components which may be rivet mounted. Anyone who has dealt with the problem of replacing such a component knows that the job can be difficult if proper methods are not employed.

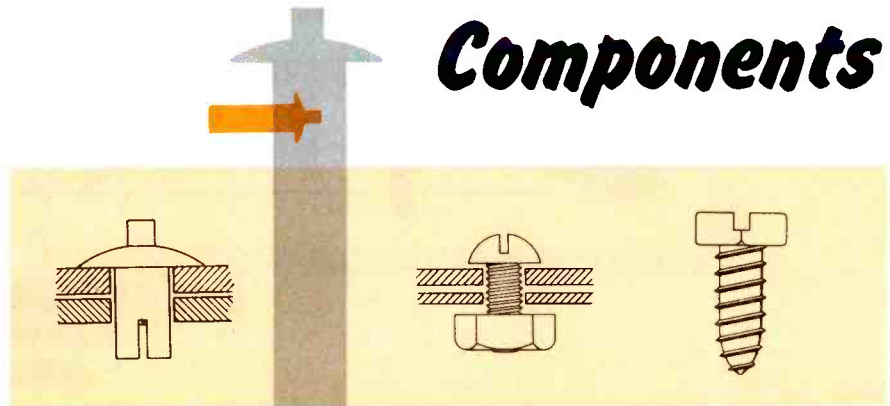

by Verne M. Ray

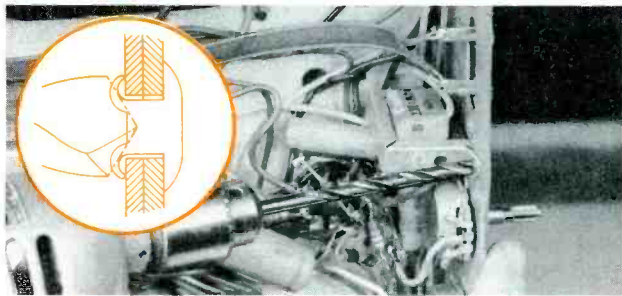

1. Drilling the Peened End of the Rivet.

To remove a rivet, select a bit that is large enough to cut the rolled edge of the peened or spread end. It is not necessary to cut through this edge completely. Cutting away most of the lip will weaken the rivet. The head and shaft can then be separated from the lip by a light blow with a hammer and punch at the weakened end of the rivet.

2. Using a Center Punch on the Rivet Head.

Sometimes the peened end of a rivet will not be accessible, and the technician will be faced with the slightly more difficult task of removing the rivet from the head side. A center punch should be used to make a small indentation in the center of the head.

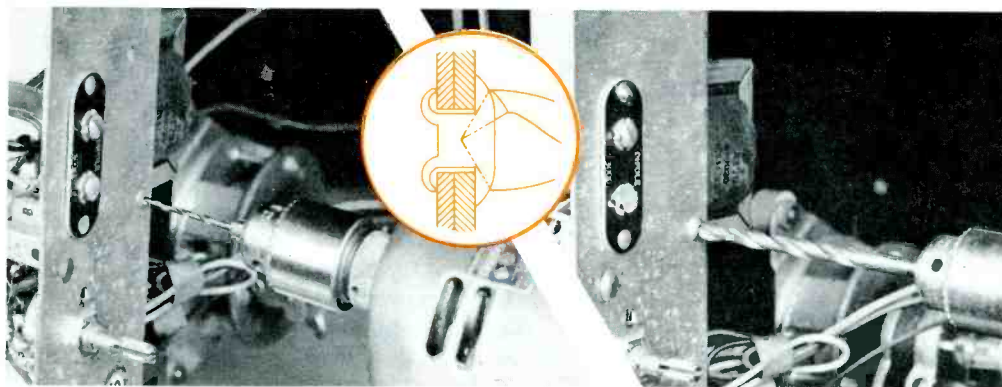
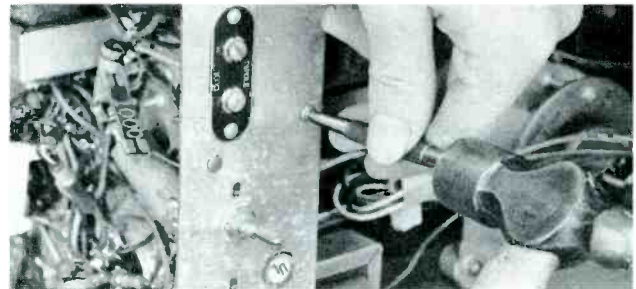

3. Drilling the Rivet Head.

It is best to start with a bit that is smaller than the shank of the rivet and finish with one that is larger. Care should be taken not to drill deep enough to cut into the chassis or the mounting flange of the component being removed. If the head is drilled as shown in the inset, the rivet will be weakened at the base of the head. The shank can then be separated from the head if a small punch is driven into the drilled hole and against the shank.

4. Rivet Replaced by Bolt and Nut.

One of the most common fasteners for securing a replacement component to a chassis consists of a bolt and nut. Their use is most convenient when there is sufficient clearance on each side of the chassis to permit the nut to be threaded and tightened on the bolt. The bolt should have a shaft of sufficient length and its threads should have a diameter slightly smaller than the diameter of the mounting hole.

Photographs: Robert W. Reed

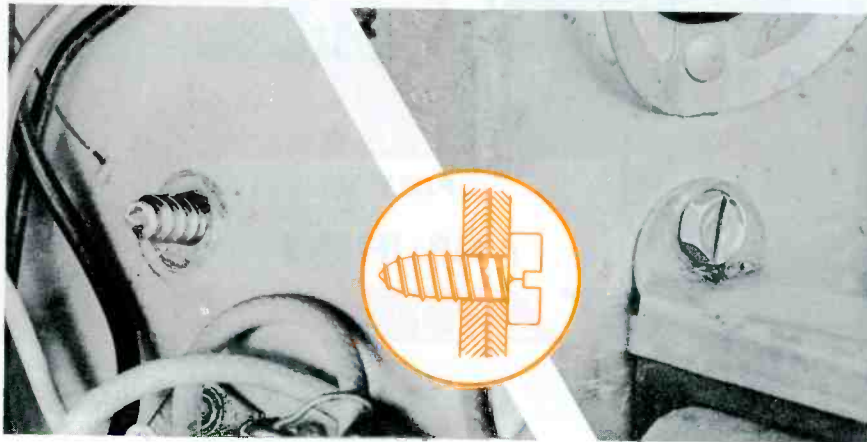
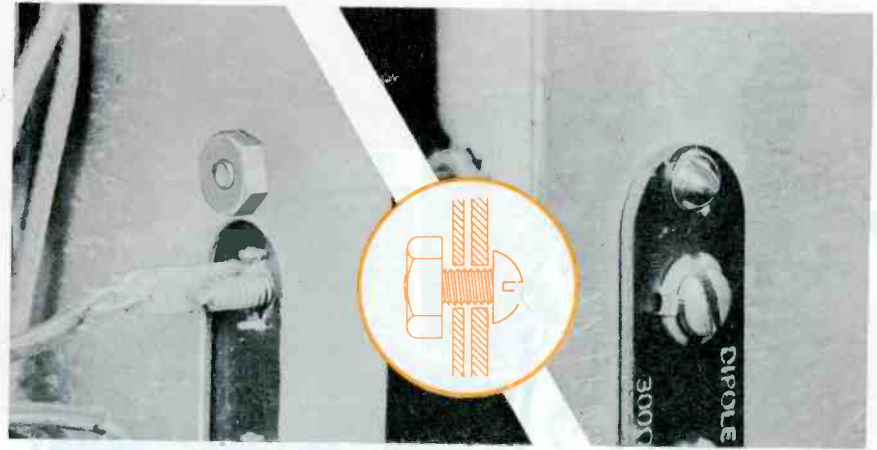

5. Rivet Replaced by Self-Tapping Screw.

It is often convenient to attach a replacement component securely to the chassis with a self-tapping machine screw. This type of fastener should always be inserted so that the mounting flange of the replacement component will be held between the screw head and the chassis. The screw should not be used, however, if doing so causes the tip of the screw to protrude to the outside of a rear, front, or side panel of the chassis.

6. Rivet Replaced by Blind Rivet.

A blind rivet is particularly useful when only one side of the mounting hole is accessible or when a self-tapping screw is unsuitable. There are several types of blind rivets. The one shown here is the Southco drive rivet made by the South Chester Corporation of Lester, Pennsylvania.

The rivet is inserted into the mounting hole, and the head is seated firmly against the mounting surface. Driving the steel pin causes the rivet prongs to expand and form a flowerlike head on the blind side of the work. The expansion of the prongs draws the chassis and the mounting flange of the component tightly together.

It is important that the drive rivet be the proper size for the application in which it is used. Sizes are classified according to shank diameter and grip length. The rivet used on a particular job should have a shank diameter which equals the diameter of the mounting hole and a grip length equal to the thickness of the two materials to be fastened. The rivets which would be most often used in TV work would have diameters of 1/8, 5/32, and 3/16 inch and grip lengths of 3/32 and 1/8 inch.

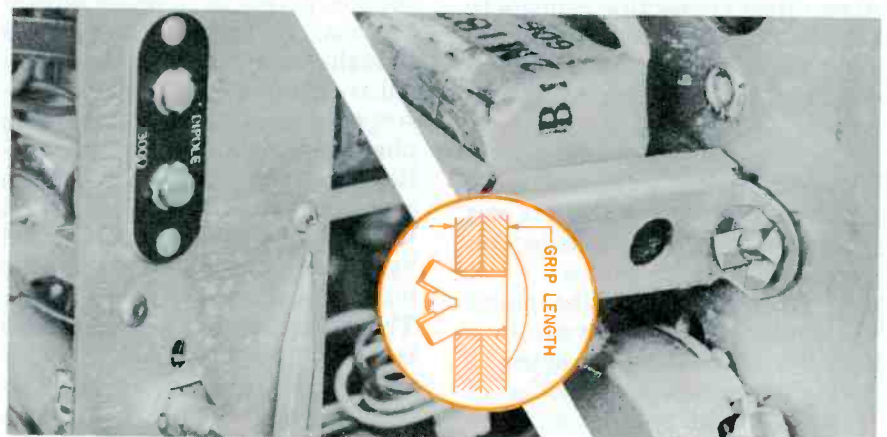
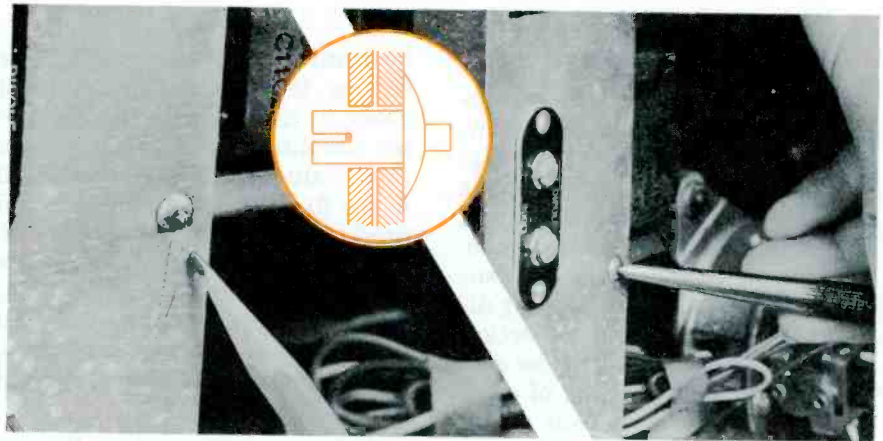

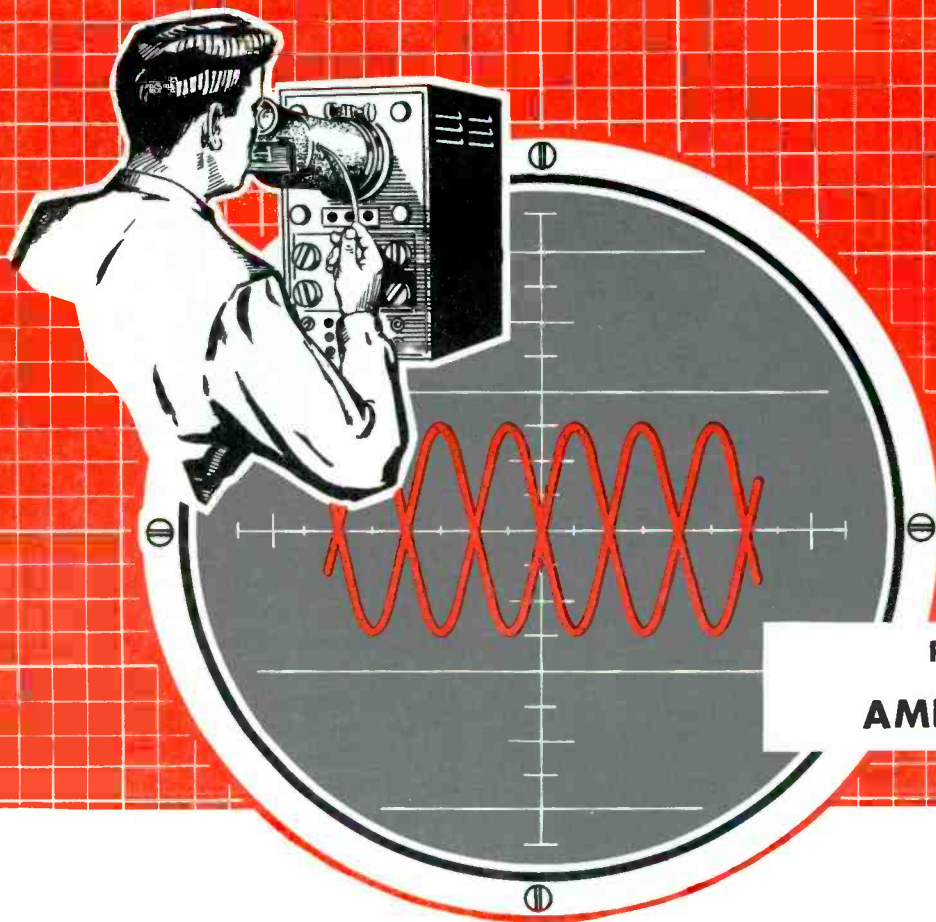

Know Your Oscilloscope

PART V AMPLIFIERS

BY PAUL C. SMITH

AMPLIFIERS

Practically all modern oscilloscopes contain amplifiers to increase the amplitudes of the signals before they are applied to the vertical or horizontal deflection plates of the cathode-ray tube. These same oscilloscopes will usually have provisions for making direct connection to the deflection plates, without benefit of the amplifiers; however, a signal of comparatively high amplitude is required to obtain a useful deflection when direct connection is made to the deflection plates. Amplifiers must therefore be used if signals of low amplitudes are to be observed.

For example, one model of oscilloscope is quoted as having a deflection sensitivity of 15 volts rms per inch at the vertical deflection plates. This means that a 15-volt rms signal applied to the plates will produce a waveform one inch high. Another model is quoted as having deflection sensitivities of 13 and 17 volts rms per inch, respectively, for the vertical and

horizontal deflection plates. The service technician will, in most cases, be dealing with signals having amplitudes much lower than these values. A 15-millivolt signal in the first example quoted would produce a deflection of 1/1,000 inch, which is certainly of no use to the technician. An amplifier with a voltage gain of 1,000 will bring the deflection up to 1 inch—a deflection that is usable, though perhaps not ideal.

A direct connection to the deflection plates may prove advantageous in certain cases, even though a comparatively large signal is required. When the oscilloscope is used to make exacting phase comparisons, direct connection to both sets of deflection plates will avoid phase distortion which might otherwise be caused by phase differences between the horizontal and vertical amplifiers. The frequency response will also be improved by direct connections if the response of the amplifiers of the oscilloscope extends only to a few hundred kilocycles.

The foregoing paragraphs lead naturally to a consideration of two very important characteristics of an oscilloscope, the sensitivity and the frequency response of its amplifiers. The service technician is concerned with these two characteristics because they define to a great extent the limits of the usefulness of an oscilloscope. The sensitivity determines the minimum amount of signal which can be viewed on the oscilloscope, and the frequency response determines the range of frequencies that can be viewed. The use of a detector probe will extend the useful range of the oscilloscope to higher frequencies, but in an indirect manner.

At present, there are on the market general-purpose oscilloscopes having vertical sensitivities of 10, 15, or 20 millivolts rms per inch. A number of such oscilloscopes also have a frequency response which is usable up to 4.5 megacycles and beyond. The sensitivity of an amplifier can be increased by addition of a number

of stages; but when this increase in sensitivity must also be accompanied by a wide-band response, the design of such an amplifier becomes more difficult. Most oscilloscopes at present incorporate wide-band, push-pull amplifiers.

The wide-band response for these amplifiers is accomplished in much the same manner as that of the video amplifier in a TV receiver—by means of series and shunt peaking circuits. In many cases, portions of these circuits are placed under the control of a switch on the front or rear panel so that the operator can choose between operation at narrow bandwidth with high sensitivity and operation at wide bandwidth with medium sensitivity.

High-Frequency Response

Fig. 1 shows an example of the use of series and shunt peaking circuits to extend the high-frequency response of the vertical amplifier of an oscilloscope. A small portion of the circuit diagram for the Jackson Model CRO-2 oscilloscope is shown. V2 and V3 with their associated components form two push-pull stages of the vertical amplifier. L2 through L9 are peaking coils. L3 and L4 are shunted by resistors R10 and R11 in order that their Q factor will be lowered and their response characteristics will be broadened. The switch sections labeled S1-B and S1-C are parts of the vertical input control of the oscilloscope. With the switch set in any of the first three positions, starting at the extreme counterclockwise position, the amplifier is set for wide-band operation. The other three positions are for narrow-band operation.

A different method of extending the high-frequency response is shown in Fig. 2 which is a partial schematic of the Hickock Model 770 oscilloscope. A portion of the vertical amplifier is shown. Trimmers C149, C150, C151, and C152 are used as neutralizers. They reduce the effective input capacitances of V110 and V112; and since these input capacitances shunt the higher frequencies to ground, any reduction in their

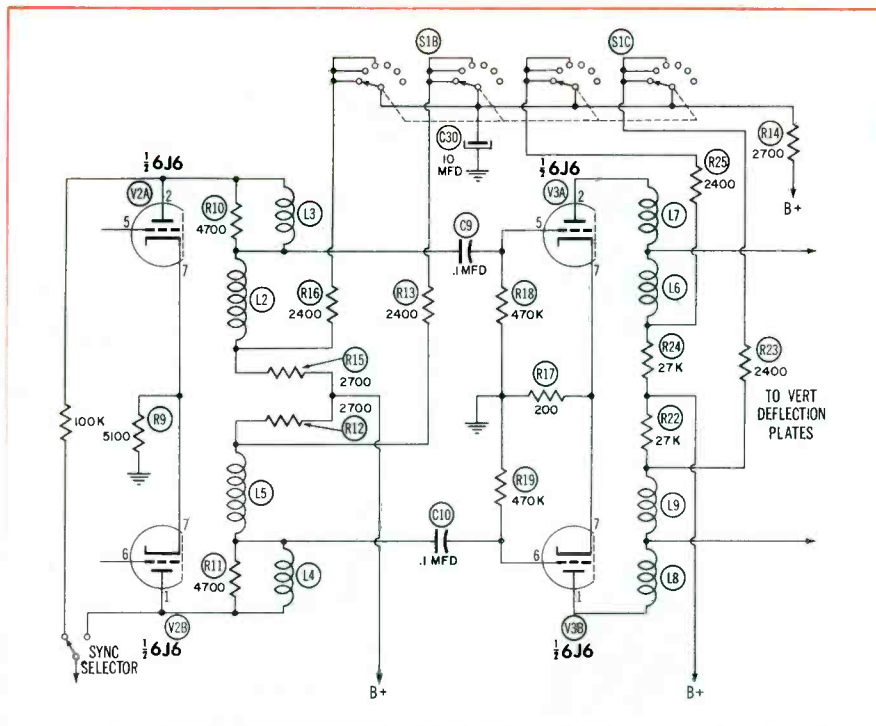

Fig. 1. Partial Schematic Diagram of the Vertical Amplifier of the Jackson Model CRO-2 Oscilloscope.

value helps to increase the amplification at higher frequencies.

Further emphasis of the higher frequencies is achieved in the cathode circuits of V110 and V112. With the vertical bandwidth switch in the position shown in Fig. 2, C153 and C155 are each shorted and a degenerative signal is developed across the cathode resistors at all frequencies. With the switch open, higher frequencies are bypassed more than the lower frequencies; therefore less degeneration takes place at the higher frequencies. The result is an extension of the amplifier response at the high end.

Low-Frequency Response

Good response to low frequencies is equally important if accurate representation of waveforms is to be obtained. The low-frequency response of an amplifier is dependent to a large extent on the size of the filter, bypass, and coupling capacitors. Generally, the larger the value of these capacitors, the better the response to low frequencies. The response can be extended to zero frequency (DC) by the use of direct-coupled amplifiers like that shown in Fig. 2.

The usual practice is to design

• Please turn to page 48

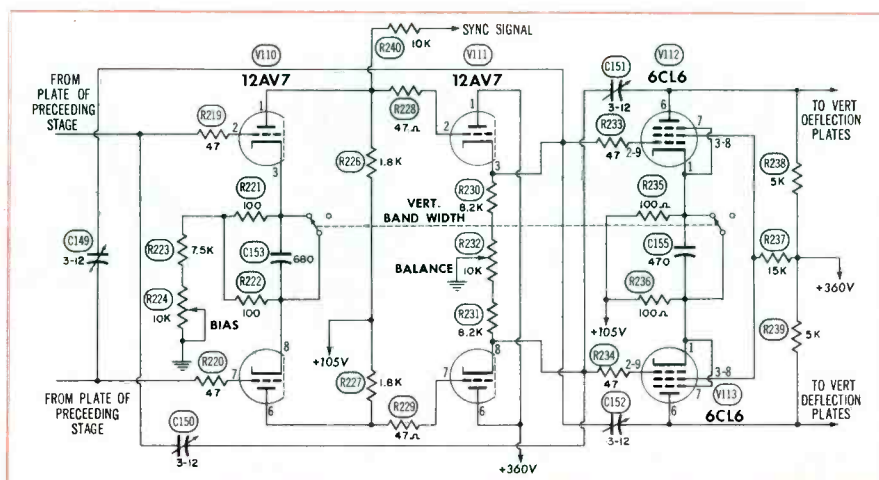
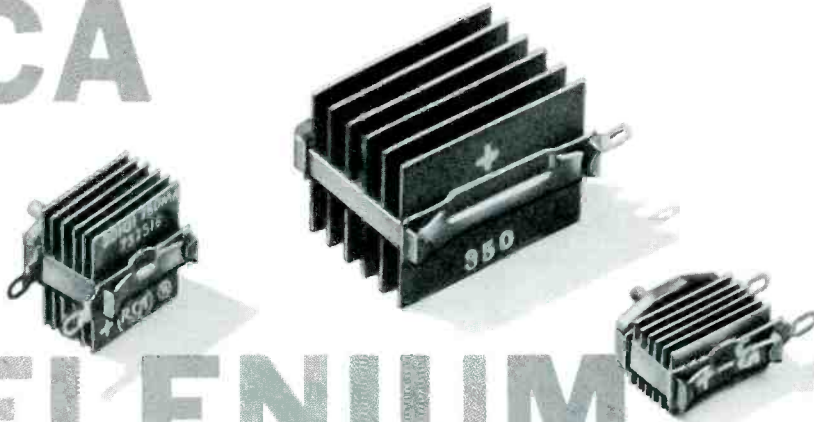

Fig. 2. Partial Schematic Diagram of the Vertical Amplifier of the Hickock Model 770 Oscilloscope.

RCA



Now, RCA offers you a top-grade line of selenium rectifiers for general replacement use in TV, radio receivers, and phonographs. Advanced design, select raw materials, and superior workmanship give you a *dependable* line of selenium rectifiers for *virtually all* service jobs.

Advanced Design for Dependable Performance and Long Life

Note the wide-open plate spacing for elimination of solid center "hot spot." Design utilizes corrugated spacers for *excellent heat dissipation and rigid construction for rugged service.*



NEW—smaller size . . . for any given current, they are smaller than other types.

NEW—quicker installation . . . integral mounting stud.

NEW—wide-open design . . . insures maximum heat dissipation, cooler operation . . . no center "hot spots."

NEW—rigid construction . . . for rugged service.

RCA SELENIUM RECTIFIERS—a *comprehensive line*—for consistently good performance, easier installation, longer life and customer satisfaction. **ORDER FROM YOUR RCA DISTRIBUTOR TODAY!**

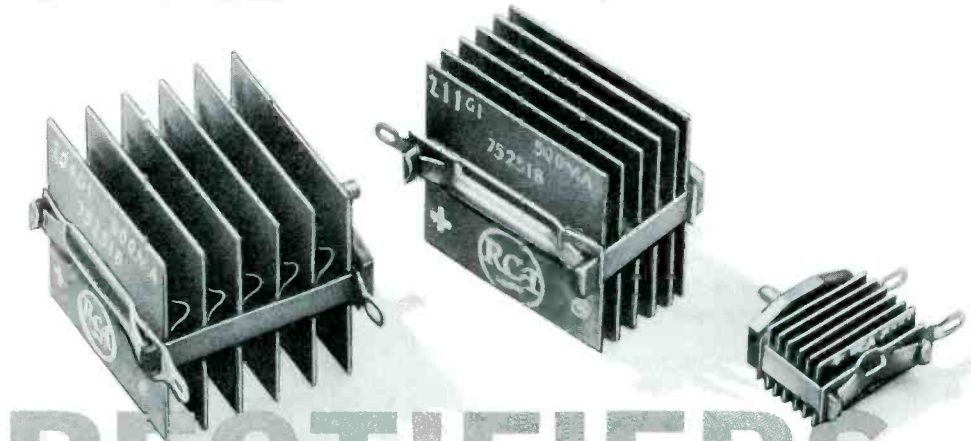

RECTIFIERS

-one comprehensive line for virtually all replacement requirements!

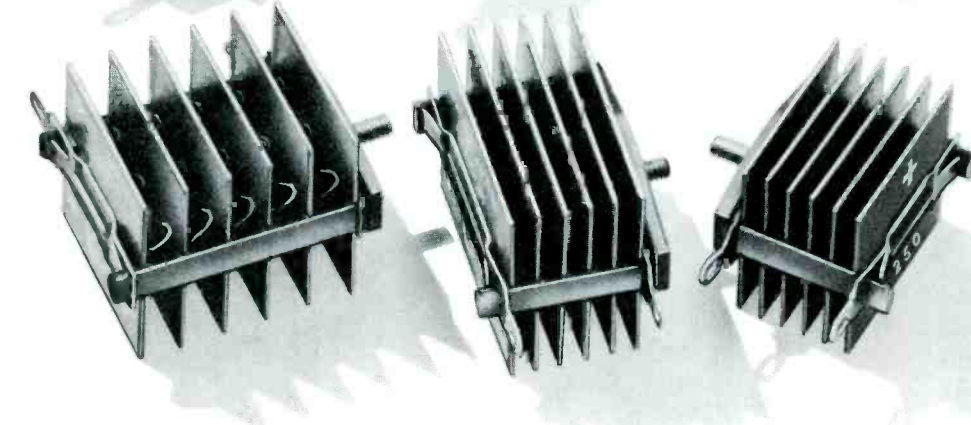

WIDE SELECTION OF 12 TYPES		
Max. Output ma	Max. Input volts	RCA Type
65	130	205G1
75	130	200G1
100	130	206G1
150	130	201G1
200	130	207G1
250	130	208G1
300	130	202G1
350	130	209G1
400	130	203G1
500	130	204G1
400*	130	210G1
500*	130	211G1

*Special thin types for use where available space will not permit the use of type 203G1 or 204G1.



RADIO CORPORATION of AMERICA
ELECTRONIC COMPONENTS HARRISON, N. J.

In the Interest of . . .

Quicker Servicing

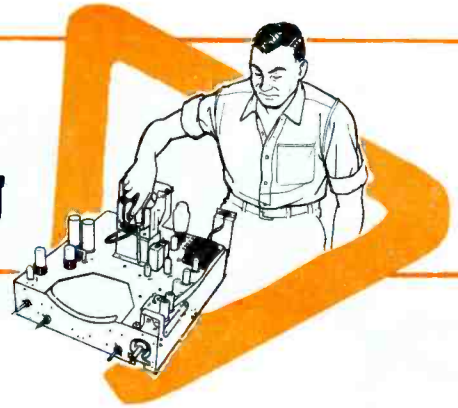

by Calvin C. Young, Jr.

A Record of Service Work Performed

A large reputable company that services radio and television receivers has recently conducted a survey of the service calls made over the period of one week. During this period, 300 requests for service were received. Thirty-two of these calls were either cancelled by the customer or were not made for other reasons. This left a total of 268 calls completed for the week. Table I shows the relationship between the number of times the various servicing operations were performed and the total number of calls.

The total number of operations performed during the week was

289, as shown by the tabulation. This figure is larger than the 268 calls made because more than one operation was sometimes required on a call. In fact, this table shows that out of each 100 calls made, the technician performed an average of approximately 108 operations. Notice that the various operations are listed in order from those performed the most frequently down to those performed the least frequently. This brings to attention the fact that the replacement of tubes was needed in by far the largest number of operations—in 60.8 per cent of them. Adjustments were needed on 11.5 per cent, and shop work had to be done on 10.4 per cent of the

calls. From these figures, it can be seen that 89.6 per cent of the work was completed in the home.

This survey was conducted by a large service company. A small one or a two-man service company might receive only 10 to 15 calls a day, and 300 calls could represent a month's work. With this in mind, the fact that the calls were received over a one-week period does not detract from the accuracy of the survey.

How do the results of this survey, as shown in Table I, compare with the types of operation in your area? If there are differences in your case, we would like to hear of them.*

*Address any remarks concerning your experience to the Technical Editor of the *PF REPORTER*.

TABLE I
TABULATION OF WEEK'S WORK RECORD

KIND OF WORK PERFORMED (on 268 calls)	NO. OF TIMES PERFORMED (out of 268)	PERCENTAGE OF TIMES PERFORMED (out of 268)
Replaced tubes	163	60.8
Adjustments	31	11.5
Shop work	28	10.4
Replaced fuse	12	4.4
New picture tube	9	3.4
Nothing wrong	6	2.2
Sold antenna	4	1.5
New knobs	4	1.5
Instructed customer	3	1.1
Not home, left card	3	1.1
Repaired antenna	2	.8
Repaired dial cord	1	.4
New yoke	1	.4
New vertical oscillator transformer	1	.4
New horizontal linearity coil	1	.4
Miscellaneous	20	7.5
TOTALS	289	107.8

Home Service Bench

For the technician who is interested in making certain types of in-the-home repairs such as replacements of resistors, capacitors, selenium rectifiers, controls,

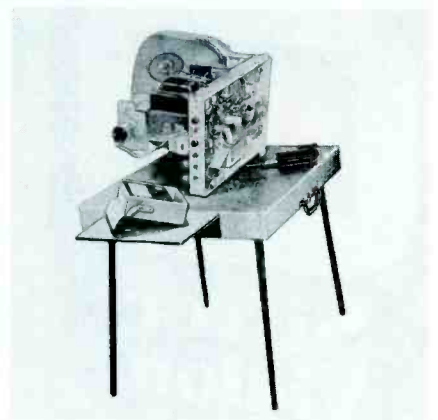

Fig. 1. A Service Bench for Home Calls. (Photograph Courtesy of Argos Products Company.)

• Please turn to page 74

It's easier to sell CBS

Silver Vision

the
"High-Fidelity"

Aluminized Tube

Your customer is aware that Hi-Fi does sound better . . . that it faithfully reproduces the original sound. And you can prove by demonstration that advanced-engineered CBS Silver Vision tubes can do for video what Hi-Fi does for audio.

You know Silver Vision's aluminization . . . silver-activated phosphors . . . and small-spot gun can accomplish this. But technical details do not interest the lady. She does appreciate Silver Vision's sparkling whites . . . deep blacks . . . and wide range of middle gray tones. She likes the way they can be blended to give her truly high-fidelity reproduction of the telecast picture.

Here's a tube whose performance sells it. And Garry Moore makes it still easier by convincing your women customers over the CBS Television Network: "There are no better tubes made than CBS tubes, the tubes with the Good Housekeeping Guaranty Seal." Sell the easy way, follow Garry's lead. Sell CBS Silver Vision . . . the "high-fidelity" aluminized picture tube.

Always show her the CBS carton with the Good Housekeeping Guaranty Seal.



CBS-HYTRON, Danvers, Massachusetts
A Division of
Columbia Broadcasting System, Inc.

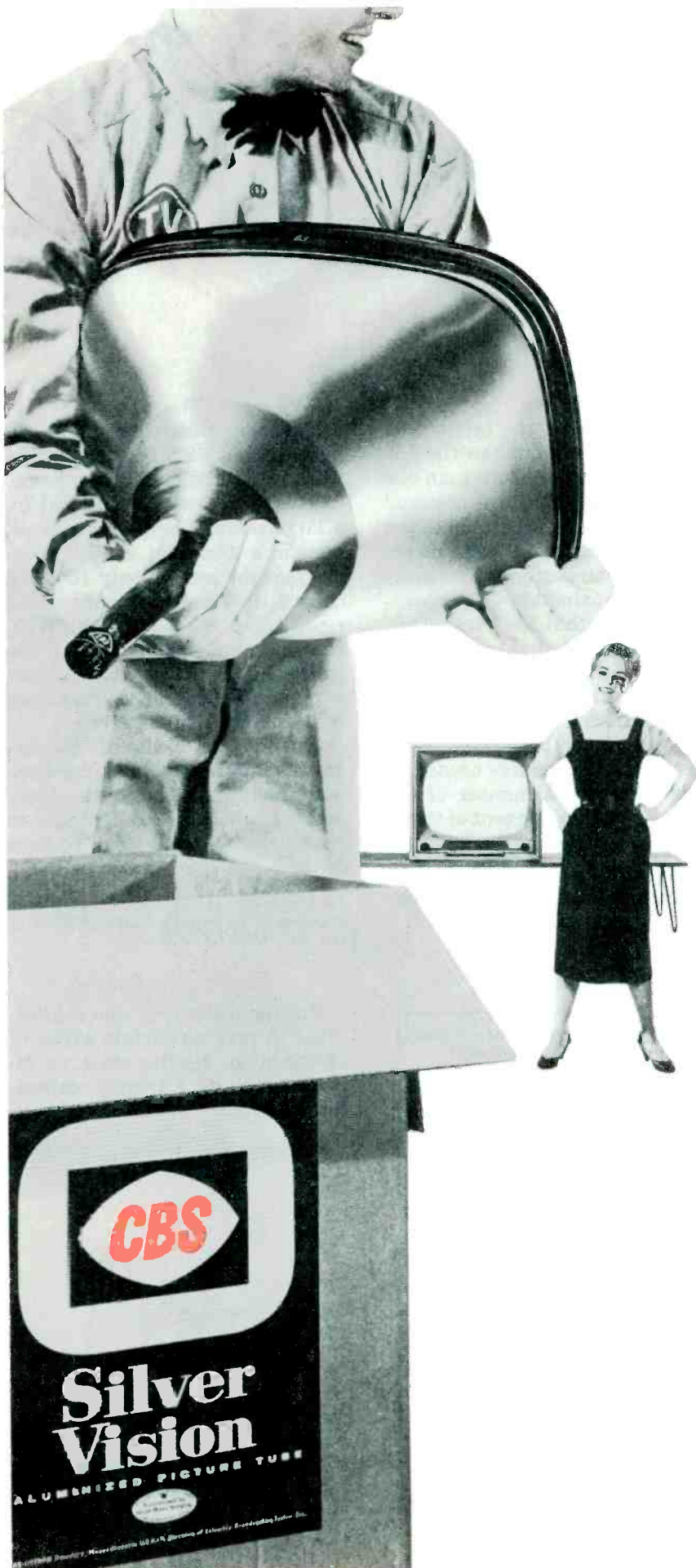

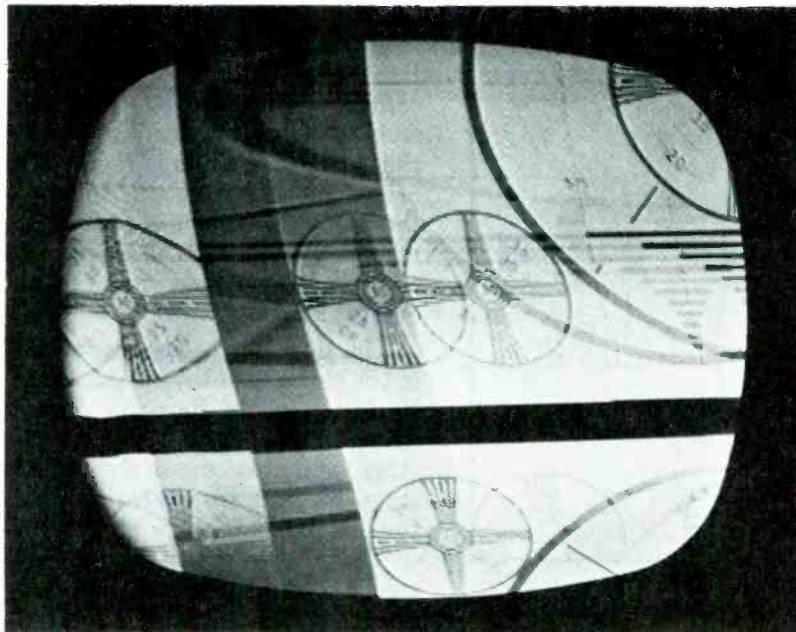

TROUBLES in Vertical Sweep Systems

**A Servicing Guide
Arranged by Symptoms**

**BY LESLIE D. DEANE
and CALVIN C. YOUNG, JR.**

The vertical sweep section of a TV receiver consists of an oscillator stage, an output stage, the vertical deflection coils, and the various associated components. It is the function of this section to sweep the electron beam from top to bottom and back to the top of the picture tube screen at the rate of 60 cycles per second. This rate is required because the picture is transmitted at the rate of 30 frames per second and each frame contains two interlaced fields for a total of 60 fields per second.

Since the frequency of the voltage on the AC power lines cannot be maintained at exactly 60 cps in all parts of the country simultaneously, a TV receiver must have an oscillator to generate a signal which can control the vertical sweep. All oscillators, however, have a tendency to drift; therefore, a synchronizing signal is included in the composite signal that is transmitted by the TV station. The sync circuits in the receiver separate the synchronizing signal from the composite signal. The sync signal is then applied to the vertical oscillator to keep it exactly in synchronism with the vertical scanning rate of the transmitted signal. The vertical output stage of the receiver accepts the signal from the oscillator and produces a linear sweep on the picture tube.

Trouble within the vertical sweep section can usually be de-

tected because of the effect of the trouble on the test pattern or picture on the screen. A thorough understanding of the visible symptoms which are usually associated with this section of the receiver is very helpful in locating and correcting any troubles that develop. Some of the more common of these symptoms are listed as follows:

1. Loss of sweep.
2. Insufficient sweep.
3. Poor linearity.
4. Loss of synchronization.
5. One-way sync or critical synchronization.
6. Poor interlacing.
7. Keystone effect.

Each of the foregoing common symptoms will be dealt with individually; and wherever possible, a photograph of the picture tube displaying the trouble will be

shown. As a basis for reference, a normal test pattern is shown in Fig. 1.

General Discussion

As a preliminary to the discussion of the individual trouble symptoms, let us first review the basic types of vertical oscillator and output circuits in general use.

A blocking oscillator coupled to a triode output stage is shown in Fig. 2. You will notice that the output transformer is of the auto-transformer type and that plate voltage is supplied from the boosted B+ supply rather than from the 60-cycle power supply. The retrace-blanking signal is obtained from the wave-shaping network that is made up of C71, R82, and R83.

The height control is located in the plate circuit of the oscillator

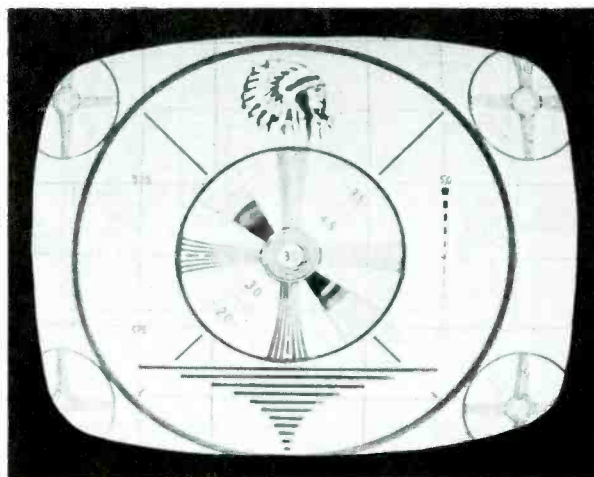

Fig. 1. A Normal Test Pattern.

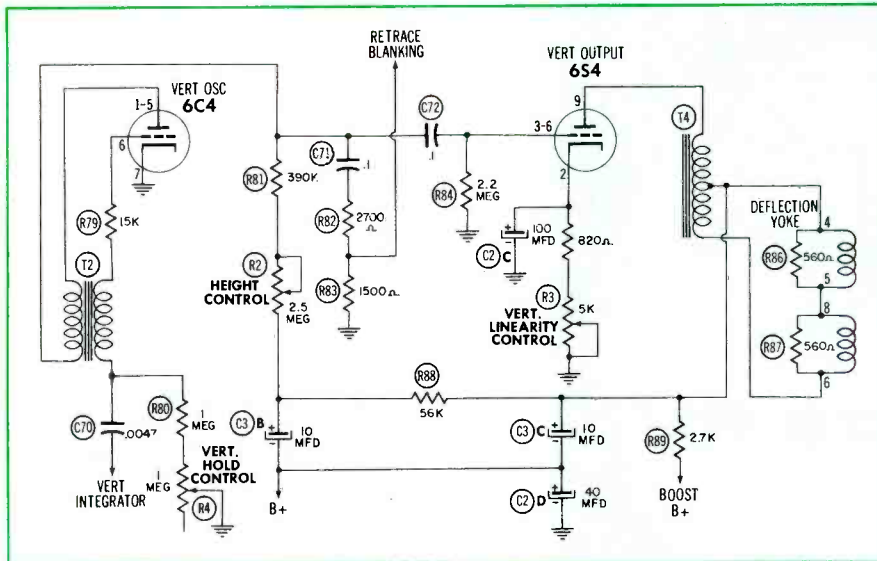

Fig. 2. A Blocking Oscillator and a Triode Output Stage.

tube and is a part of the network which consists of R83, R82, R81, R2, and C71. Varying the height control changes the RC time constant of the network and causes the capacitor to charge to a higher or lower level during the time that the oscillator tube is cut off. This, in effect, changes the amplitude of the output signal from the oscillator stage.

The linearity control is located in the cathode of the output stage. Variation of the linearity control changes the bias on the output stage, and this causes the output stage to shift its operating position on the $E_p I_p$ curve of the tube so that nonlinearity of the grid signal is counteracted by the nonlinearity contributed by the tube.

A 560-ohm resistor is connected across each half of the vertical deflection coils to damp oscillations that would occur during retrace time. The cathode of the output tube is bypassed with a 100-mfd capacitor so that degeneration of the signal will not occur.

A multivibrator oscillator coupled to a conventional output stage of the type previously described is shown in Fig. 3. Additional damping for the vertical output stage is obtained from the 150K-ohm resistor R58 which is connected across the upper half of the output transformer. The height control is the grid resistor for the output stage, and the height is controlled by variation of the amplitude of the driving signal applied to the vertical output grid. Feedback necessary to sustain oscillation is obtained by connection of both cathodes of the multivibrator to a common resistor R52. The plate circuit of the section labeled B (in Fig. 3) of the multivibrator acts as a discharge circuit to develop the vertical sawtooth signal across the RC combination of R56 and C73. The frequency of the vertical oscillator is adjusted by means of control R2. Adjustment of this control changes the RC time constant of the grid circuit of section B of the multivibrator.

The circuit in Fig. 4 consists of a modified multivibrator which drives a beam-power output stage. This circuit uses only a minimum number of tubes and does not re-

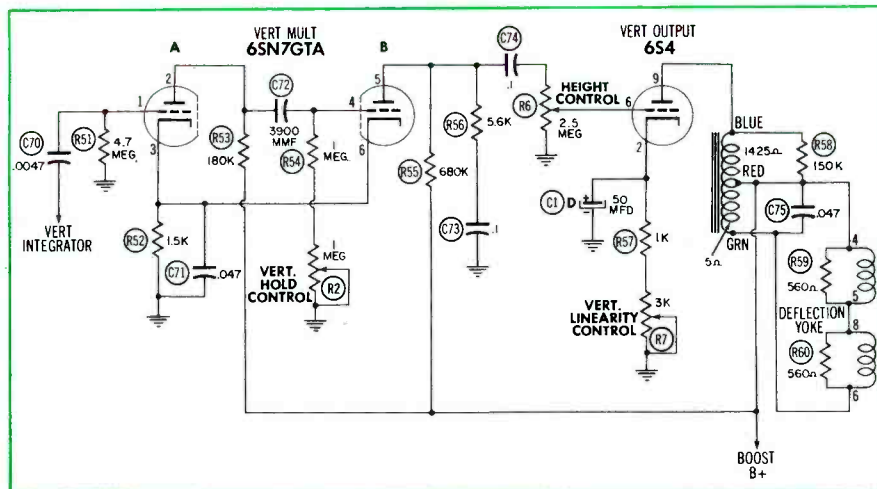

Fig. 3. A Multivibrator and a Triode Output Stage.

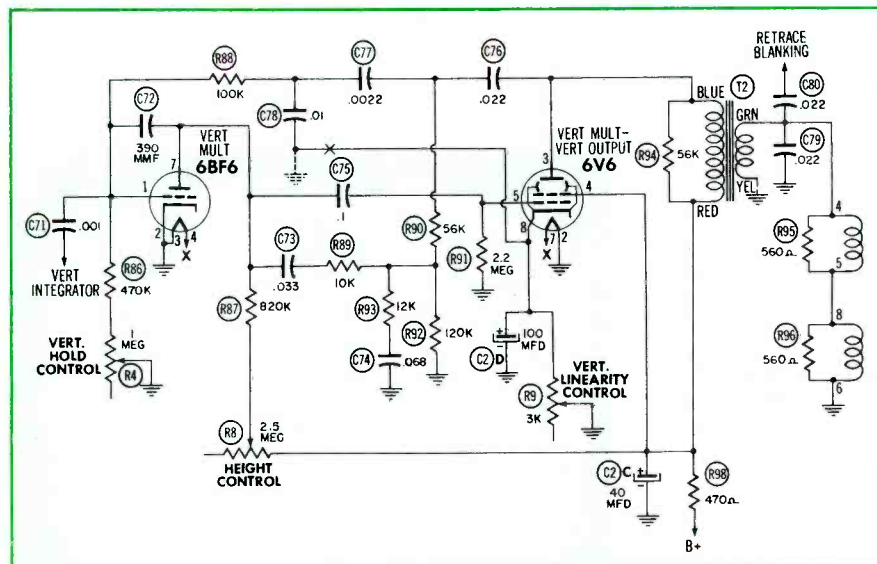
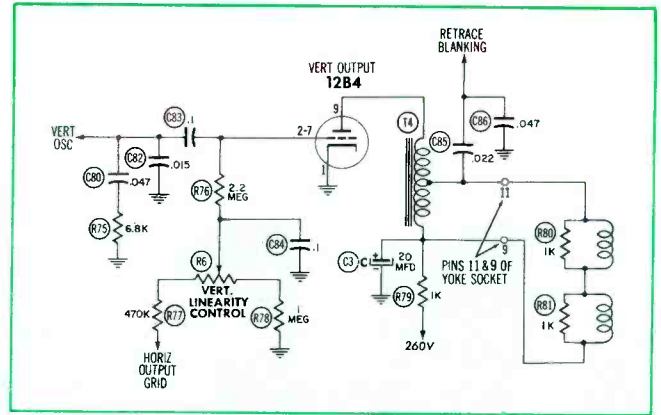

Fig. 4. A Vertical Sweep Circuit in Which the Output Tube Is Part of the Multivibrator.

quire a transformer in the oscillator stage. These factors are important for cost reasons. Feedback to sustain oscillation is obtained from the plate circuit of the output stage. The feedback network is made up of C72, R88, C78, C77, C76, R90, and R92. These components are used to reduce the amplitude of the feedback signal to the proper level and to shape the signal before it is applied to the grid of the oscillator. C73, R89, R93, and C74 form the discharge network which develops and shapes the oscillator signal that is applied to the output grid.

In the circuit shown in Fig. 5, the cathode of the vertical output tube is grounded. The linearity control is located in the grid circuit, and adjustment of this control shifts the operating point of the output tube to provide good linearity. The resistors R77, R6, and R78 are connected in series and are in parallel with the grid resistor of the horizontal output stage. This means that the voltage that is present at the horizontal output grid, because of the signal from the horizontal oscillator, also appears across R77, R6, and R78. Adjustment of R6 places more or less of this voltage on the grid of the vertical output stage

Fig. 5. One Arrangement by Which Provision is Made for Adjustment of Vertical Linearity.



so that the tube will operate on the proper point of its $E_p I_p$ curve and a linear sweep will be obtained. C84 is a bypass capacitor and places the lower end of R76 at ground potential for 15,750 and 60 cps.

A single dual-triode 12BH7 tube is used as a multivibrator and output tube in the circuit shown in Fig. 6. This vertical sweep system is being used in some of the newer models of TV receivers. The feedback network consists of C77, R77, and R78 and uses the integrator network to accomplish the remainder of the wave shaping necessary to provide the proper signal that will cause the stage to function as an oscillator.

General Isolating and Trouble-Shooting Procedure

It is almost essential to have either a transmitted test pattern or a pattern from a linearity or crosshatch generator available when defects in the vertical section are being investigated because linearity and size troubles are the ones that will occur most often in the vertical section.

Naturally, it is assumed that the first step of any trouble-shooting procedure is a thorough test of all tubes within the suspected section. The operation of the height, linearity, and hold controls should next be checked. The actions of the controls can often give clues to the trouble. If the height control would cause the bottom of the

• Please turn to page 34

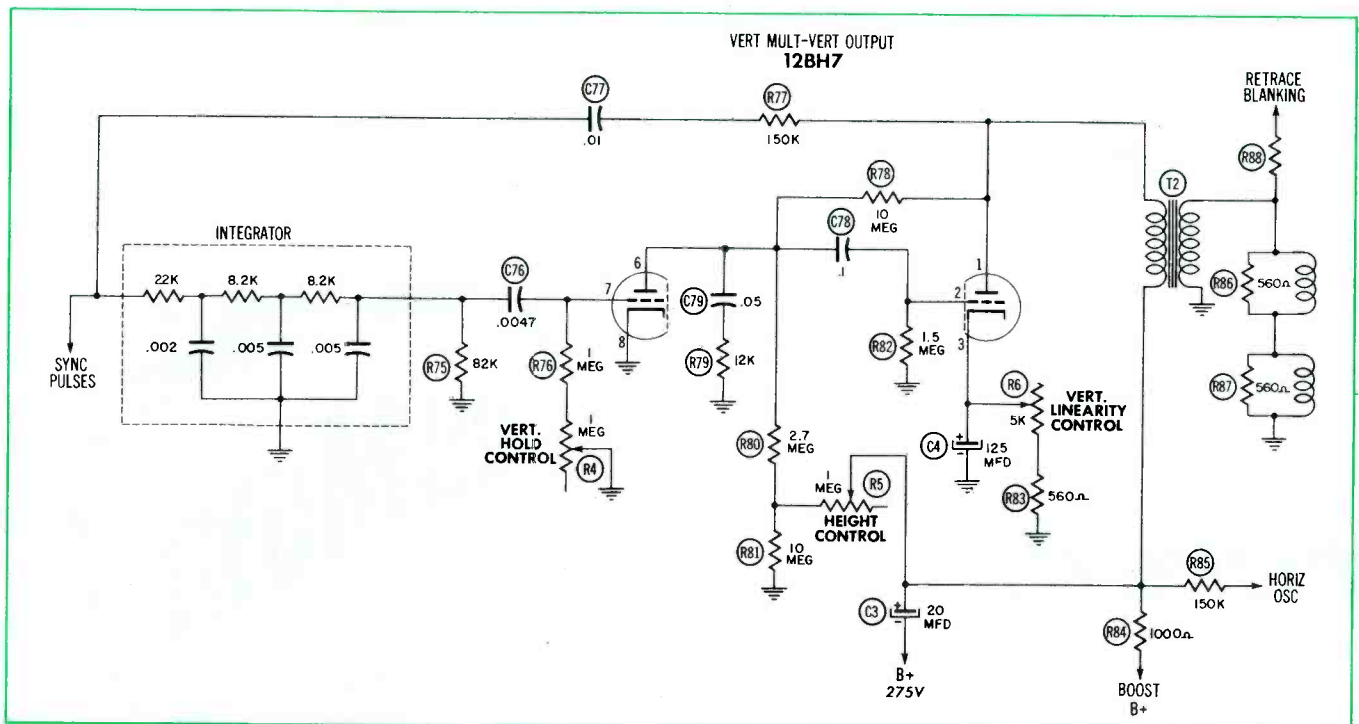

Fig. 6. A Vertical Sweep Circuit Requiring Only One Tube.

YOU PUT THIS TUBE IN AND...
 YAP... YAP... YAP... BLAH... BLAH... BLAH
 ...AND I MISSED MY FAVORITE PROGRAM



...IT'S **YOUR** REPUTATION!

Serviceman, at this point you are on your own! Your customer holds only **you** responsible if the picture tube goes bad because it was **your** selection. If your selection for replacement was a high quality brand, chances are your reputation for quality work wouldn't be under the gun like this.

When you use Du Mont picture tubes your reputation is backed by the pioneer commercial cathode-ray tube manufacturer of the country. The Twin-Screen Hi-Lite* alumi-

nized picture tube is a product of the finest engineering, design, and production features assembled in 25 years of commercial manufacturing. Your confidence is definitely assured because you **know** that the guarantee on Du Mont picture tubes is good—as it has always been.

Your reputation for high quality work is established when you use high quality products. You have a reliable **partner** when you use Du Mont picture tubes.

*The ultimate in aluminized picture tubes

**IT'S
 DEALERS
 CHOICE**

make it...



Cathode-Ray Tube Division

ALLEN B. DU MONT LABORATORIES, Inc., 750 Bloomfield Avenue, Clifton, N. J.

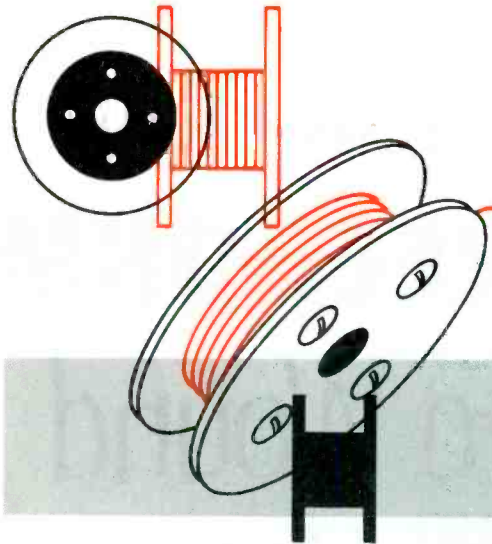

Audio-Facts

CONSTRUCTING COILS FOR DIVIDER NETWORKS

by Robert B. Dunham

Most of those who have had much experience with high quality audio systems are convinced that some type of multiple loudspeaker system must be used in a home music system in order to obtain the best sound reproduction. In most cases this means that a combination of one or more woofers, midrange units, and tweeters will be used in conjunction with some form of frequency-dividing network. The purpose of the divider network is to channel each portion of the signal that falls within a certain frequency range to the loudspeaker unit which can reproduce it best.

Most loudspeaker manufacturers supply complete networks designed for use with their loudspeakers. In addition, they usually supply most of the pertinent data that can be used in assembling a suitable divider network. This would include information about the circuit and the values of capacitors and coils.

Much has been said and written concerning the divider networks in loudspeaker systems. Designs have been discussed and circuits (complete with values of the component parts) have been published, but certain vital things about the actual construction of a practical unit are usually neglected. So we want to talk about the construction of networks and in particular give some practical information on the winding of suitable coils.

When a loudspeaker system supplied by one manufacturer is installed, it is logical to use the

divider network designed and supplied by that manufacturer. On the other hand, many loudspeaker systems are often assembled with units made by two or more different manufacturers; and a special divider network must be used.

Many audio enthusiasts like to experiment and construct such things as networks. In our own case, we have experimented with enough loudspeakers over a period of years that we have had to make use of a variety of divider networks—including the electronic divider unit described in the "Audio Facts" column in the August 1954 issue of the *PF REPORTER*.

Suitable capacitors for a divider network can be obtained from many sources. Most any type of paper or oil capacitor is satisfactory for this application. Low-voltage capacitors can be used because the signal voltage seldom exceeds 50 volts in an amplifier output circuit which has an impedance of 16 ohms or lower. Electrolytic capacitors are often used in networks requiring very large values of capacity. AC non-polarized electrolytic capacitors should be used, or two polarized capacitors of the same value (the value specified for the network) should be connected back to back and used as one capacitor. We have used polarized electrolytic capacitors having high-voltage ratings in divider networks with no apparent undesirable effects on the reproduction or on the capacitors, but we have always pre-

ferred oil or paper capacitors for this purpose.

Suitable coils are more difficult to obtain because coils are supplied only in certain values by the few companies that make them.

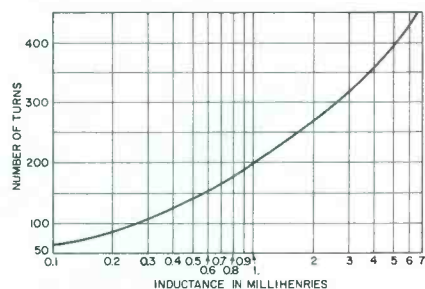

(A) For a Small Coil Form.

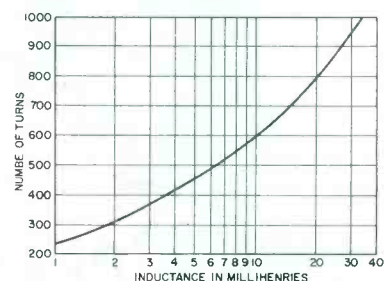

(B) For a Large Coil Form.

Fig. 1. Graphs Showing Inductance Versus the Number of Turns of No. 16 Enameled Copper Wire.

When we made our first divider network, practically no suitable ready-made coils were available; therefore, we wound our own and have been winding them ever since. The design of these coils and the method of making them should be interesting to anyone who would like to construct a divider network for a loudspeaker system.

• Please turn to page 68

shift into high gear...

with **CLAROSTAT GREENOHM**[®]

Wire Wound Resistors

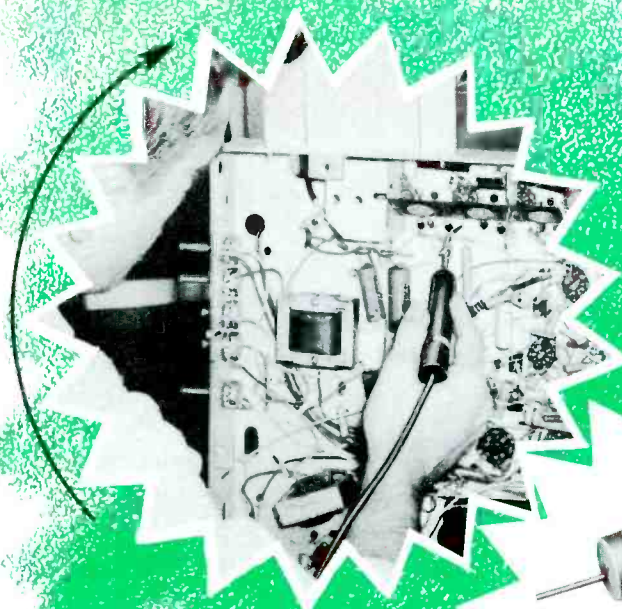

Jobs are done quicker, better, more profitably, with the right components. With **CLAROSTAT GREENOHM** wire-wound resistors you get the complete range of resistances and wattages in both fixed and adjustable. Ideal for radio and television service work when replacing original equipment such as strip-type voltage dividers or regular power resistors. Best of all, **GREENOHM** resistors won't let you down after the job is completed. So, **shift into high gear**. Do your servicing quickly and surely with **GREENOHM** resistors. Ask your distributor for complete details on these **GREENOHM** resistors and other service-designed **CLAROSTAT** products.

CLAROSTAT MFG. CO., Inc. • DOVER, NEW HAMPSHIRE
In Canada: Canadian Marconi Co., Ltd., Toronto 4, Ont.

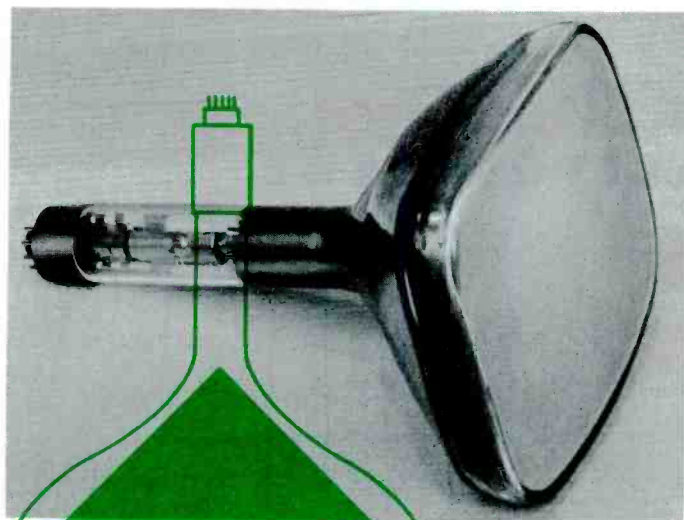

**SYLVANIA'S NEW
8XP4 HAS 90-DEGREE
DEFLECTION**

an **8-inch** **CHECK TUBE**

by *Thomas A. Lesh*

The 8XP4 is a new type of picture tube which has an 8-inch rectangular screen and 90-degree deflection. Its designers, Sylvania Electric Products, Inc., describe it as a TV-receiver check tube. The characteristics of the 8XP4 are such that it is able to reproduce a good picture under a wide variety of operating conditions, and it can therefore be used as a temporary substitute for almost any other picture tube. As a result of this adaptability, the 8XP4 has value as an aid to servicing.

The small size and light weight of the tube are only two of the features which make it easy to handle on the service bench. Other features which are intended mainly for simplification of the electrical requirements of the tube also contribute to the convenience of handling. Since electrostatic self-focusing is employed, no external focusing device is required. In addition, the need for an ion trap is eliminated because the electron gun is mounted parallel to the neck of the tube.

The voltages which are normally applied to large picture tubes are also suitable for the operation of the 8-inch tube. The potential on the second anode may be as high as 22 kilovolts.

When a picture tube is suspected of being defective, an 8XP4

may be tried in its place. This substitution is a convenient and conclusive test of the condition of the picture tube. A normal picture will be developed on the check tube if the circuits in the receiver chassis are operating properly, and the suspicion that a bad picture tube is the cause of trouble will then be confirmed. Some receivers may have defects in the circuits as well as in the picture tube. In many such cases, the defects interact with each other and produce confusing symptoms. When the 8XP4 is connected to a receiver which is in this condition, it will produce a picture which is better than that on the old picture tube but still not satisfactory. Any faults which are seen in the picture on the check tube are relatively clear-cut symptoms of defects in the chassis. The use of the check tube enables the technician to treat chassis and picture-tube defects as separate problems, and the result is that trouble shooting can be done more efficiently.

Even if the picture tube of a receiver might appear to be in good condition, the technician may wish to replace it with an 8XP4 during servicing for the simple reason that the check tube is much less bulky than the picture tube. This use of the check tube for the sake of convenience in handling is especially impor-

tant in view of the current trend toward the cabinet mounting of picture tubes. This style of tube mounting is being featured in many of the new receivers that have vertical chassis and also in an increasing percentage of the receivers that have horizontal chassis.

When a receiver must be taken to the shop for servicing, the chances are that the chassis will have to be removed from the cabinet sooner or later. In the case of a receiver that has a cabinet-mounted picture tube, it is a sensible practice to remove the chassis in the customer's home. The chassis should then be taken to the shop where it can be serviced with the aid of the check tube, and the cabinet and picture tube should be left behind. This practice saves the technician the effort of hauling the entire receiver to the shop, and it minimizes the risk that the picture tube might be broken or that the cabinet might be scratched. The picture tube should be taken to the shop only if it is suspected of being defective.

The yoke should also be left behind if it can be detached easily from the chassis and if a substitute yoke is available at the shop. When the yoke leads of a receiver are connected to the chassis through a plug, separation of the yoke from the chassis is no problem. Some receivers in which the yoke leads are soldered directly to various terminals on the chassis cannot be disassembled so easily. In the latter case, the technician may save time by taking

• Please turn to page 57

ASTRON "Staminized" CAPACITORS ARE rugged

ASTRON CAPACITORS HAVE THAT BUILT-IN "NO-CALL-BACK" CONSTRUCTION!

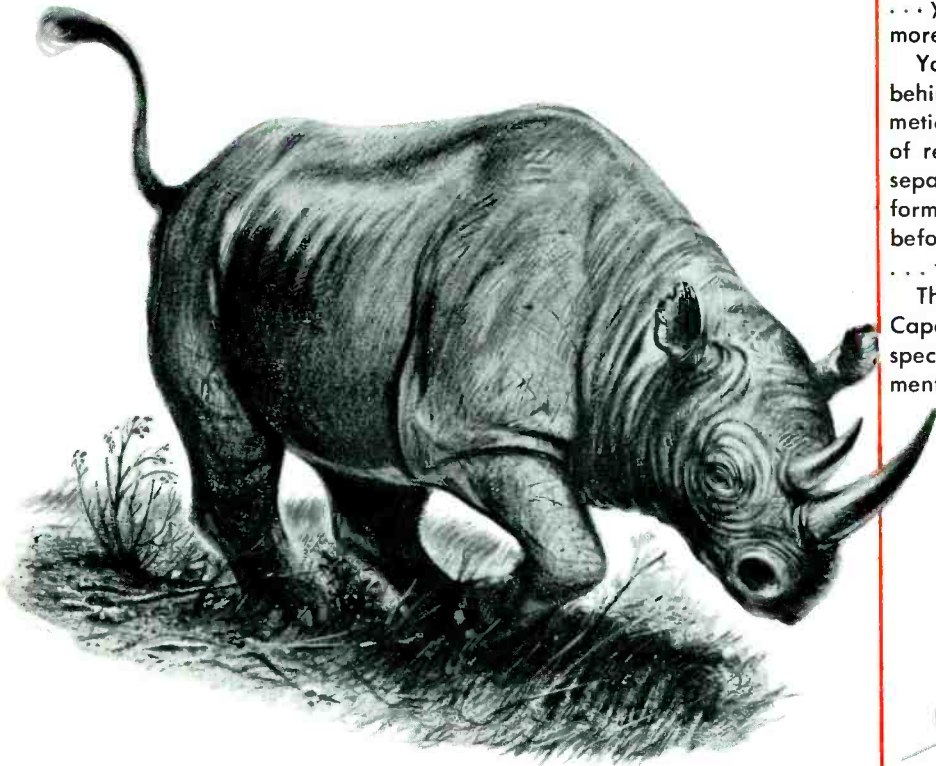

Only the very finest of raw materials pass Astron's "Selected Purchasing System". Astron's special production techniques build extra rugged capacitors that create complete customer satisfaction . . . your key to repeat business and more profit.

You can put your trust in Astron, for behind each Astron capacitor is the meticulous quality control that insures you of real staying power . . . over 10 separate production line tests are performed, plus a 100% final inspection before any capacitor is sent out by Astron . . . your guarantee of top performance.

There is an Astron "Staminized" Capacitor built especially to fill the specific, exacting replacement requirements of any job you tackle.



Safety Margin
"SM" Minimate*



Safety Margin
"SM" Twist Prong



Safety Margin
"SM" Cardboard Tubular



Blue-Point (R) Molded
Plastic Paper Tubular

FREE Servicing Aid



Save time, use handy Astron pocket-sized Replacement Catalogue and Pricing Guide (AC-4D) — Write Today!

ASTRON

C O R P O R A T I O N

255 GRANT AVENUE EAST NEWARK, N. J.



WEST COAST WAREHOUSE: 9041 WEST PICO BLVD., LOS ANGELES - EXPORT DIVISION: ROCKE INTERNATIONAL CORP., 13 EAST 40TH ST., N. Y., N. Y. - IN CANADA: CHARLES W. POINTON, 6 ALCINA AVE., TORONTO, ONTARIO

The majority of service shops, regardless of whether or not they are active in the sale of new merchandise, have a store window of some sort. This article is primarily designed to acquaint the shop owner with some of the possibilities for improving his windows so that he can show the public the quality and extent of the services which he offers.

A few shop owners may recall the initial enthusiasm they experienced when they first set up shop and opened for business. Each one spent time and effort to impress the public and to build up a reliable reputation in his neighborhood. The clean new shop with an attractive window display was a definite part of good advertising, and the shop owner was undoubtedly proud when customers commented on the neat appearance of his shop.

Perhaps some of us have slipped a little since then and have not stopped to realize how the store front may appear to the passer-by. We should remember that the outward appearance of a business establishment usually plays an important part in the success of the organization. Let us renew our enthusiasm along these lines and examine some of the techniques involved in making a good window display.

A window display is often referred to either as point-of-sale advertising or as visual merchandising, and many of the large department stores rely heavily on this medium for advertising their merchandise. A good window display can be as important for a person dealing only in radio and television service as for one dealing in both sales and services.

The store front, including the window display, will reflect the personality of the owner and will also give the public an insight into what to expect in the way of service and general customer-owner relationships. Keeping the display window neat and clean is one of the best advertisements a shop can have.

The value of a window display is partially determined by the number of people that pass by, and this in turn is dependent upon the location of the shop. A shop

WINDOW DISPLAYS

**AN ATTRACTIVE WINDOW
ADVERTISES QUALITY SERVICE**

by Leslie D. Deane

located in a residential neighborhood will not have the number of passers-by that a shop which is operating in the main part of town will have. One organization found that the number of people on the main street in a town of about 25,000 population was 4,000 to 5,000 per day. In larger cities of about 250,000 or more, the downtown circulation may be as much as 42,000 per day. The time and expense devoted to a window display should be governed both by the number of passers-by and by the class of people to which the shop caters. When a shop owner plans to design a window display, he should also consider whether the merchandise will sell through display and whether the margin of profit warrants a showing on a large or small scale. If the display is for the purpose of selling services only, then the margin of profit may be difficult to determine. A window display need not be an expensive one. More important are the originality and individuality that go into an effort of this kind.

It is more difficult to convey a service message to the public through a window display than to convey a merchandise message. Articles for sale can be attractively displayed and thus will sell themselves; but when services are being sold, the display must pre-

sent an idea or thought involving the actual quality and type of service rendered by the organization. The advertising of radio and television repair through a window display may be accomplished by using a suggestive theme.

New design trends toward lightweight portable television receivers have made it more convenient for the customer to bring his set to the shop location for repair. The shop owner may therefore find it necessary to set up a TV counter service as he did for radio in the "old days." This situation may also give rise to new advertising slogans and ideas for window displays.

Window or Showroom

Display windows in many of the service shops are without built-up platforms on which objects can be supported for display. Other windows do have permanent platforms which are part of the window units and which were put in during the original construction.

A more modern building may be designed with glass windows across the entire front. These windows usually extend down to the sidewalk level and are constructed without platforms or backdrops. This new look in window design

• Please turn to page 60



don't rebuild the
set to fit the
transformer

like this

use a transformer
that fits the set... a
STANCOR
verified
exact replacement
TRANSFORMER

When you install a STANCOR exact replacement TV transformer, all you'll need is a soldering iron and a screwdriver, and perhaps a wire cutter . . . because STANCOR transformers are **VERIFIED** exact replacements . . . designed from the original manufacturers specifications and tested by actual installation and operation in the recommended chassis.

FREE STANCOR TV Transformer Catalog and Replacement Guide listing replacement data on virtually all TV sets in use today, with hundreds of **VERIFIED** exact replacement applications.

EXPORT SALES:
Roburn Agencies, Inc.
431 Greenwich Street
New York 13, N. Y.



**CHICAGO STANDARD
TRANSFORMER CORPORATION**

3503 Elston Avenue • Chicago 18, Illinois

A STOCK GUIDE for TV TUBES

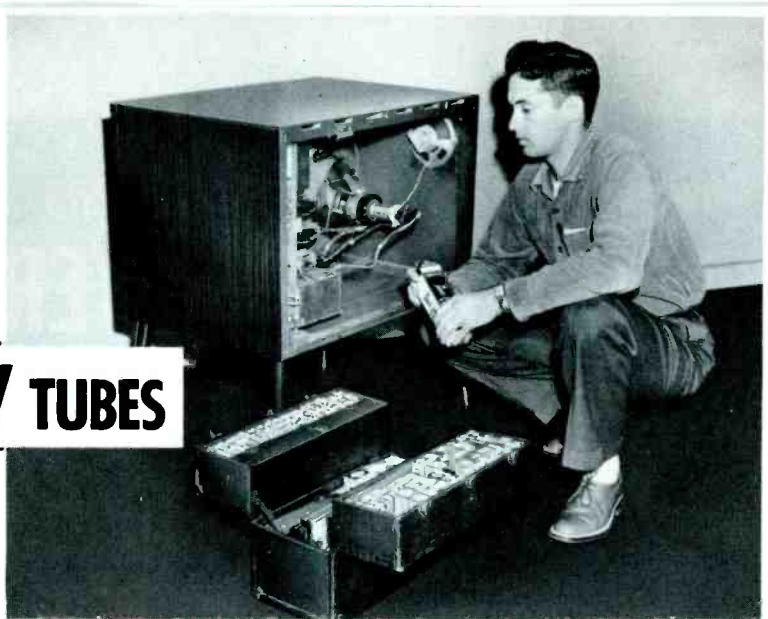

The following chart has been compiled to serve as a guide in the establishment of proper tube stocks for servicing TV receivers. The figures have been derived by combining: (1) a production factor based upon the number of models and upon an estimate of the total number of receivers produced by all manufacturers, and (2) a depreciation factor based upon an average life of six years for each receiver and with the figures reduced accordingly every two months.

The figures shown are based upon a total of 1,000 units. This was done in order to eliminate percentages and decimals. A listed figure of 100 would therefore imply that that particular tube type constitutes 10 per cent of all tube applications in TV receivers.

Some consideration should be given to the frequency of failure of a particular type of tube. A tube used in the horizontal output stage will fail much more frequently than one used as a video detector. As a result, even though the same figure may be given

for both tubes, more of the horizontal output tubes should be stocked.

The column headed '46-'56 is intended for use in those areas where television broadcasting was initiated prior to the frequency-allocation freeze. Entries in this column include all tubes used since 1946 except those having a figure of less than one per thousand—the minimum entry in this chart. The '52-'56 column applies to the TV areas which have been opened since the freeze. Because the majority of receivers in these areas will be of the later models, only the tubes used in these newer sets are considered in this column. The minimum figure of one per thousand also applies to this column.

The listing of a large figure for a particular type of tube is not necessarily a recommendation for stocking that number of tubes. It does indicate that this tube is used in many circuits and emphasizes the necessity for maintaining a stock sufficient to fill requirements between regular tube orders.

TUBE TYPES	46-56 Models	52-56 Models	TUBE TYPES	46-56 Models	52-56 Models	TUBE TYPES	46-56 Models	52-56 Models	TUBE TYPES	46-56 Models	52-56 Models
c0A2	8	7	6AG7	2	2	c68G6G	10	5	c6SN7GT	61	67
c1AX2	—	—	c6AH4GT	3	4	6BH6	5	—	c6SN7GTA	8	8
c1B3GT	41	44	c6AH6	8	7	c6BJ7	—	—	6SN7GTB	2	2
1X2	4	1	6AK5	3	3	c6BK4	—	—	6SQ7	2	2
1X2A	3	4	c6AL5	70	70	c6BK5	3	3	6SQ7GT	2	2
c1X2B	3	2	6AL7GT	4	—	6BK7	2	4	c#6T4	—	1
#2AF4	—	—	c6AM8	2	1	c6BK7A	2	2	c6T8	13	13
*#2AF4A	—	—	#6AN4	—	—	c6BL4	—	—	c6U8	12	14
c3A2	—	—	c6AN8	4	4	c6BL7GT	4	7	6V3	2	3
c3A3GT	—	—	c6AQ5	14	14	c6BN6	8	6	c6V6GT	18	17
3AL5	1	1	6AQ7GT	2	2	6BQ6GA	1	1	6W4GT	23	24
3BC5	1	1	6AS5	3	3	6BQ6GT	17	23	6W6GT	7	11
3BN6	1	1	c6AS6	—	—	6BQ7	5	10	c6X8	6	8
*3BY6	—	—	6AT6	4	3	c6BQ7A	7	9	6Y6G	2	1
3CB6	4	4	c6AU4GT	1	1	c6BY6	—	—	7N7	2	—
*4BZ7	—	—	6AU5GT	3	3	c6BZ7	8	4	c12AT7	12	12
*5AS4	—	—	c6AU6	114	107	c6C4	9	8	c12AU7	42	32
*5AU4	—	—	6AU8	1	1	c6CB5	—	—	c12AV7	2	3
*5BE8	—	—	6AV5GT	2	3	c6CB6	110	143	12AX4GT	2	4
c5U4G	43	45	c6AV6	16	17	c6CD6G	9	10	12AX4GTA	2	2
5U4AG	2	2	6AW8	1	1	6CF6	1	1	12AX7	5	5
5U8	2	2	c6AX4GT	14	13	c6CL6	1	2	12AZ7	—	1
5V4G	5	—	6AX5GT	7	2	*6CN7	—	—	c12BH7	11	13
5Y3GT	3	2	c6BA6	11	8	c6CS6	3	3	*12BR7	—	—
6AB4	2	2	6BC5	9	7	c6CU6	2	2	c12BY7	8	9
6AC7	6	6	c6BC7	—	—	*c6DC6	—	—	12BZ7	2	—
c#6AF4	3	4	*6BC8	—	—	6J5	3	3	12CU6	1	1
#6AF4A	—	—	c6BD4A	—	—	6J5GT	1	—	12L6GT	1	1
6AG5	24	7	6BE6	6	7	c6J6	29	27	12SN7GT	5	4
						6K6GT	13	8	25BQ6GT	3	4
						6S4	8	9	25L6GT	5	5
						c6S4A	—	—	25W4GT	1	1
						6SH7GT	1	—	5642	1	1
						6SL7GT	2	2	c6505	—	—

*New tubes recently introduced.
 #A stock of these tubes should be maintained in UHF areas.
 cThese tubes have been used in color television receivers.

THOUSANDS OF SERVICE DEALERS

SATISFY CUSTOMERS
SAVE REPEAT CALLS

MAKE MONEY EVERY DAY with B&K



DYNA-QUIK MODEL 500 DYNAMIC MUTUAL CONDUCTANCE TUBE TESTER

Tests over 95%

OF ALL POPULAR TV TUBES*— IN SECONDS

It's easy and profitable to check all the tubes in a TV set with DYNA-QUIK—on every service call. Cuts servicing time. Creates more on-the-spot tube sales. Saves repeat calls, protects service guarantee.

DYNA-QUIK 500 measures true dynamic mutual conductance, completely checks tubes with laboratory accuracy under actual operating conditions right in the home.

Tests each tube for shorts, grid emission, gas content, leakage, dynamic mutual conductance and life expectancy. One switch tests everything. No roll charts. No multiple switching. Makes complete tube test in as little as 12 seconds. Large 4½-inch plastic meter shows tube condition on "Good-Bad" scale or in micromhos on scales calibrated 0-6,000 and 0-18,000. Used in home or shop, DYNA-QUIK is a proved money-maker!

*Including new 600 mil series tubes.

NET **\$109⁹⁵**

Dyna-Quik 500. Easily portable in luggage-style carrying case. Size: 15¼ x 14¼ x 5½ in. Weighs only 12 lbs. Has 7-pin and 9-pin straighteners on panel.

DELUXE—PORTABLE

CRT MODEL 400

Tests and repairs
TV Picture Tubes

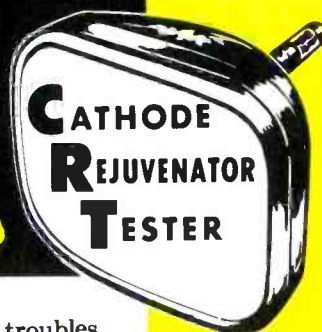

**CATHODE
REJUVENATOR
TESTER**



NET **\$54⁹⁵**

Deluxe CRT 400. With 4½-in. plastic meter. Weighs only 5 lbs. Luggage style carrying case. Size: 11 x 7¼ x 5".

Also available in economy model CRT 200 with 3-in. meter at \$39.95 net.

Quickly spots and corrects picture tube troubles right in the home, without removing tube from set. Restores emission, stops leakage, repairs interelement shorts and open circuits. Life test checks gas content and predicts remaining useful life. Grid cut-off reading indicates picture quality customer can expect. Eliminates tube transportation, cuts service-operating costs. Also saves money on TV set trade-in reconditioning. Earns dollars in minutes—pays for itself over and over again.

Proved in Use by Servicemen Everywhere.

See your B & K Distributor or send for facts on "Profitable TV Servicing in the Home" and Informative Bulletins 500-104-R



B & K MANUFACTURING CO.
3726 N. Southport Ave. • Chicago 13, Illinois

Examining DESIGN Features

by Thomas A. Lesh

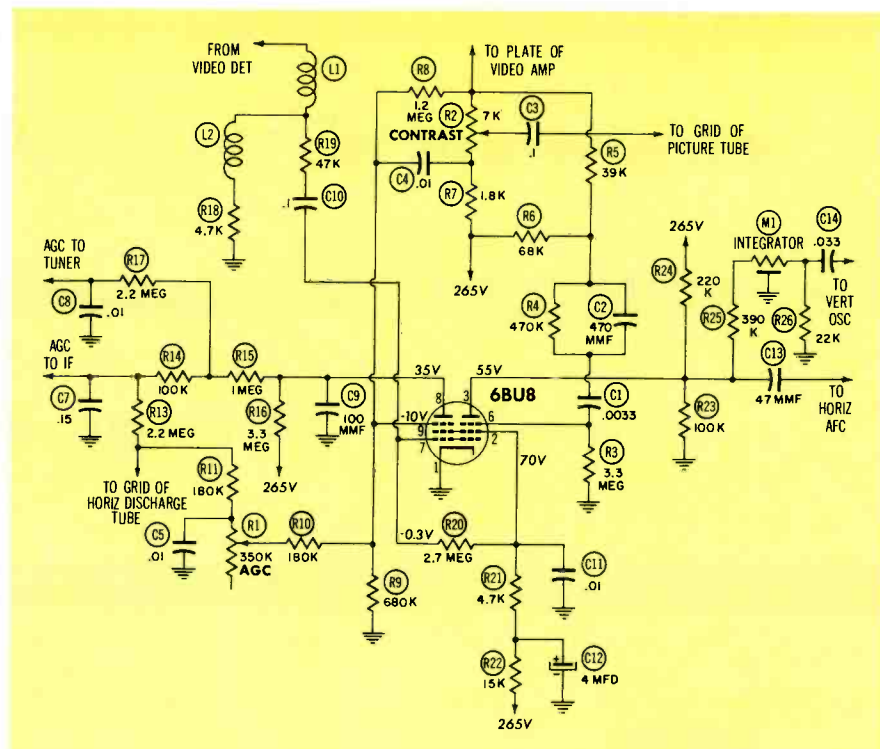

Fig. 1. Schematic Diagram of the 6BU8 Circuit in the Zenith Chassis 17Y20.

The 6BU8 Tube

A new and different circuit is included in some of the latest models of Zenith television receivers. It is built around one tube which does triple duty as a sync clipper, AGC amplifier, and noise inverter. The most unusual feature of this circuit is that the inverter removes noise pulses from the AGC signal as well as from the sync signal. Even though the new Zenith AGC circuit is not keyed, its noise immunity is comparable to that of a keyed AGC system.

A unique tube, the 6BU8, has been used in this circuit. It might be called a "Siamese-twin" pentode. The cathode, the first control grid, and the screen grid are common to both sections of the tube. Outside the screen grid, there is a second control grid which is split into two distinct sections; and there are two separate plates which are in line with these two control grids. The currents in the two plate circuits can be controlled simultaneously by the first control grid or separately by the pair of second control grids.

The 6BU8 tube is used in receivers which have tube heaters in parallel. The 3BU8 is a similar tube found in receivers in which

the tube heaters are connected in series. These tubes have 9-pin miniature bases and are approximately the same size as the 12BY7 or the 12BH7 tube.

Fig. 1 is a schematic diagram of the 6BU8 circuit which is incorporated in a Zenith vertical chassis of the 17Y series. The cathode is grounded so that variations in the plate current of one section of the tube will not be coupled to the other section. The output of the sync clipper is taken from the plate that is connected to pin No. 3, and the AGC output is obtained from the other plate. The first control grid is employed as a noise inverter.

The combined action of the sync clipper and the noise inverter is very similar to the operation of the 3CS6 gated sync separator which was described in "Examining Design Features" in the December 1955 issue of the *PF REPORTER*. A composite video signal containing positive-going sync pulses is coupled from the plate of the video amplifier through C1 to one of the second control grids (pin No. 6) of the 6BU8 tube. Grid-leak bias is developed by C1 and R3, and plate current in the right-hand section of the 6BU8 is

cut off unless a sync pulse is present on the grid. The waveform of plate voltage measured at pin No. 3 of the 6BU8 is typical of the output of a sync clipper. Negative-going sync pulses are developed at this plate, and they are applied to the horizontal AFC tube and to the vertical oscillator without further amplification.

The first control grid of the 6BU8 tube receives a composite video signal from the output of the video detector. This signal is identical in waveform to the sync input signal but is opposite in polarity. It might be assumed from this fact that the two signals would tend to cancel each other. Actually, the signal on the first grid has such a small amplitude that it has only a slight degenerative effect upon the output of the tube. The action of the first grid becomes important only when noise is present in the input signals.

The first control grid is biased so that the tips of the negative-going sync pulses in the signal will almost drive the grid into cut-off. Noise pulses which occur in the composite video signal sometimes have a greater amplitude

* Please turn to page 72

Belden 8411

If it's worth an Engineer's time . . .

Belden 8422

. . . it's worth an Engineered Cable

Belden 8412

**Belden
microphone
cables**

Whatever the installation,
whatever the requirements,
there is an accurately
rated Belden Microphone
Cable built for the job.



4-8

1001 WIRES FOR EVERY ELECTRONIC NEED



Dollar and Sense Servicing

by | *John Markus*

Editor-in-Chief, McGraw-Hill Radio Servicing Library

VANISHING ACT. We moved our color TV set up against a picture window one evening and reran the antenna through the basement to make connections. It worked fine in the new spot; but next morning while shaving, I got an urgent call from my wife. She said that there was sound from the set, but she couldn't see any picture when she stood back away from it. I stood in front of the set to check the tuning, and back came the picture. The morning sun, coming right at the screen through the window, threw so much light on the screen that it wiped out the picture completely.

Women just don't think of such things; therefore, suggest rotating a color set 45 degrees or so if a customer phones in with these symptoms. The manufacturers really mean it when they say that a color set should be in a dimly lit corner of the room.



RIGHT-NOW SERVICE. If normal shop business doesn't quite justify a full-time girl up front, give consideration to a technique used by Werry Electric in Palo Alto, California, and described in *Electrical Merchandising*. This shop offers right-now service for lamps and small appliances that are brought in. The women clerks are trained to replace plugs, line cords, sockets, and switches; to tighten loose connections; and to fix broken connections. This they do while the customer waits and watches, charging only for the cost of the materials used. Strategically grouped around this up-front bench are radios, TV sets, and new appliances for the customer to look over if he's just not interested in seeing how a line cord is threaded through a lamp.

If the trouble can't be readily located or if it calls for a trained serv-

ice technician, the clerk makes out a job ticket and puts the appliance through normal repair-department routine. By this time, the customer is convinced that the trouble is serious and not just some little thing; and he doesn't mind having to leave the appliance there.

Although this quick-fix department apparently operates at a loss since no labor charge is made, it is considered to be a strong factor in building traffic for the store's \$84,000 annual volume in TV and white goods, as well as the \$18,000-a-year gross of the one-man small-appliance service department.

With the increasing use of small appliances in the home, people are becoming more and more dependent on these conveniences and deeply feel the inconvenience of being without one of them for a week or two. This is a real opportunity for profitable expansion of a radio-TV business to the point where an up-front, full-time girl to answer the phone and wait on customers becomes justified.

If you go into something like this, pick your girl carefully. Advertise for one, and carefully interview and test each applicant. You want someone who will stick around for a few years once you've got her trained, so stay away from the cute young things that will leave you to get married at the first opportunity.

A widow or an older woman with a pleasant telephone voice and a good appearance will make a much better impression on customers. Check on their ability to follow simple instructions. Check on manual dexterity by asking them to replace the wires on a line plug. A smart grandmother who's had to fix things herself all her life may be just the one for your job. These grandmothers are doing a beautiful job of building TV sets on assembly lines in practically every factory, so they certainly can do simple appliance repairs once you show them how.

TV TABLE. When homes have both hi-fi equipment and table-model TV, a good place for the TV set is right on top of the loudspeaker cabinet. Saves the cost of a special TV table, and there's no effect on performance since the two pieces of equipment are never used at the same time.



KIDS. In most hospitals, children under 14 are unwelcome visitors. At Morristown Memorial Hospital in New Jersey, however, sick parents can get a look at their kids via ITV. The camera and transmitter are in the visitors' room, operating on an otherwise unused channel to which a patient can tune the TV set in his room. Cost of the installation is reported to be \$2,500 per hospital.



TRAIN ITV. In the club car of the Rock Island's Jet Rocket running between Chicago and Peoria, you can sip your drink comfortably while back-seat driving the train. There's a Capehart industrial TV camera right alongside the engineer in the locomotive, and it is connected to the monitor receiver in the club car.

Here's one idea for which we see a big future, particularly if an economical microwave link can be set up on the train to eliminate running wires through cars and hooking them together between cars each time the train is made up. To maintain cab-to-club car reception on curves, though, some sort of fan antenna would have to be used in place of the customary microwave dishpans.

• Please turn to page 50

Always insist on

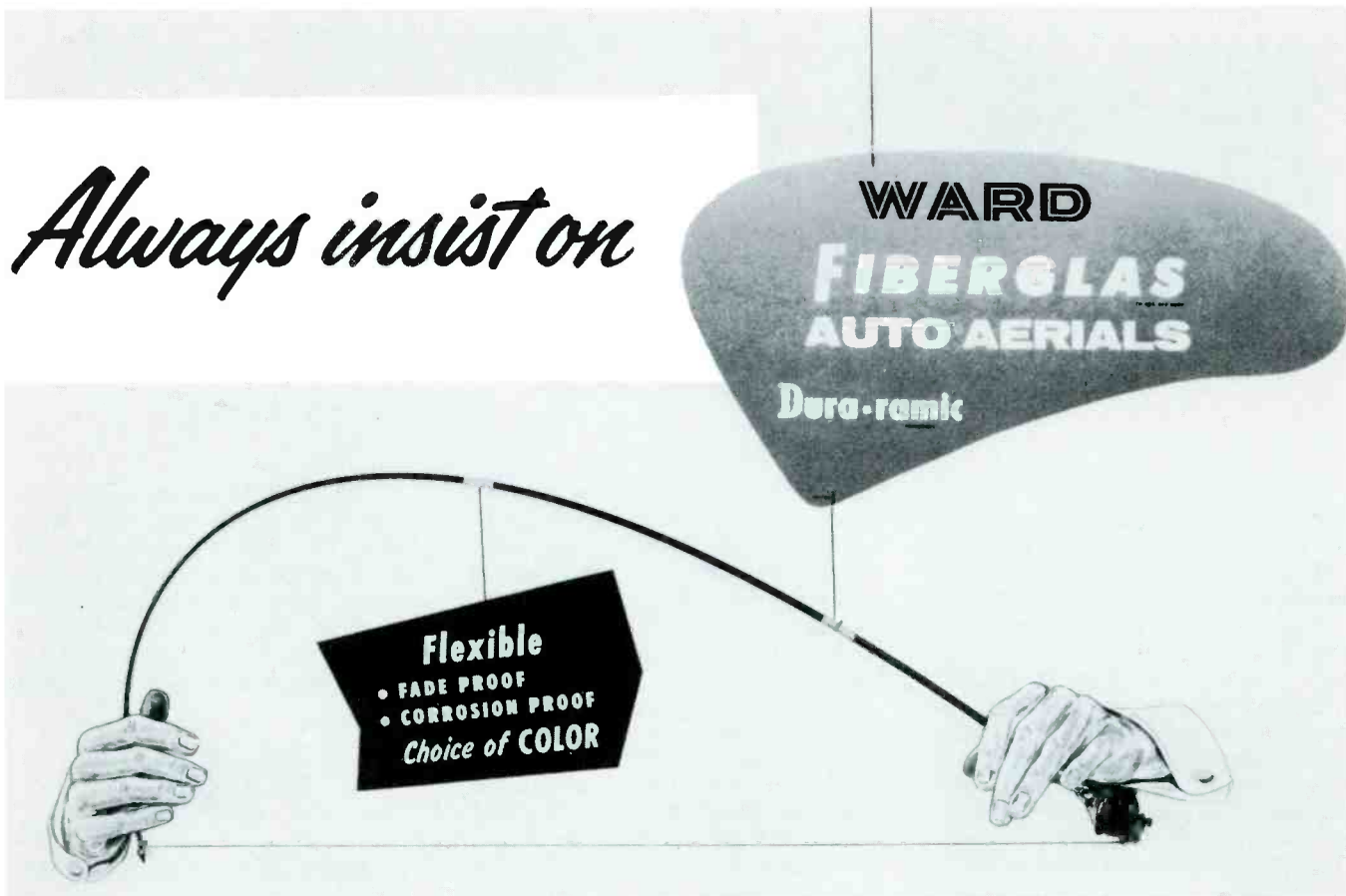

WARD AUTO AERIALS...

for:

- ★ Top quality
- ★ Customer acceptance for over 20 years
- ★ Reliable performance
- ★ Easiest installation

For every radio installation you make, a WARD AERIAL tops it off with the most dependable, acceptable and popular antenna you can buy . . . yet it costs no more than an ordinary aerial.

Here's the *complete* top-quality line for every requirement:

- EIGHT BALL—ever-popular favorite
- MAJORETTE—the economy model
- PHANTOM—disappearing antenna
- TWIN REAR MOUNT—midget 8-ball twins
- MIDGET PHANTOM—twin rear mounts
- SKY QUEEN—smartly styled side mount
- LONG RANGER—longer, for extra signal
- CONTINENTAL—flex-angle side mount for all foreign cars
- DURA-RAMIC®—the original Fiberglas aerial in full colors to complement the car.
Can't fade, rust, warp, break or corrode.

Order your WARD AERIALS now. Keep a few on hand all the time. Keep your customers satisfied with the . . . *World's Finest!*

WARD

PRODUCTS CORPORATION
DIVISION OF THE GABRIEL CO.
1148 EUCLID AVE. • CLEVELAND 15, OHIO

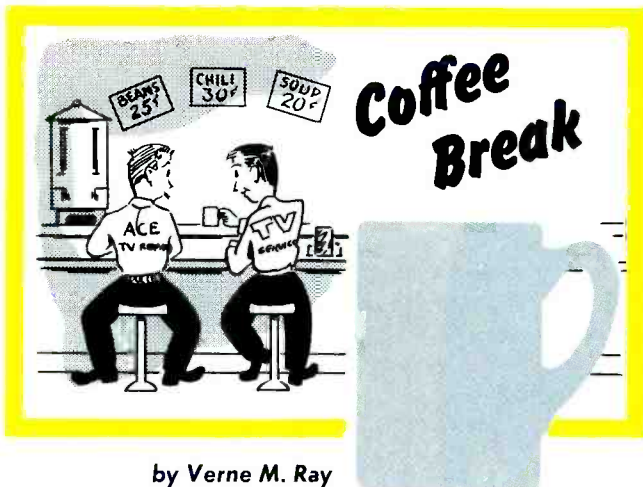

by Verne M. Ray

Bud was quite preoccupied as he walked into the coffee shop one Friday morning. A mind reader would have known that Bud was concerned about a customer whose set he had serviced that very morning. As if in a trance, he started to walk right past his friend Tony.

Tony reached out and tugged at Bud's sleeve. "Hey Bud, don't you know your friends anymore?"

Bud turned around and then in sudden recognition said, "Oh, hi, Tony! I didn't see you sitting there." He pulled back a chair, settled down on it wearily, and managed a wry grin. "Boy, I've had a rough morning! Why is it that every TV set in town seems to have trouble at the same time? I wouldn't mind so much except that I can't be in a half-dozen places at once. Why can't people do without a TV set for just one day?"

"Whoa boy,—take it easy!" Tony chimed in. "I've never seen you get worked up because business was too good! Remember, pal, if people weren't concerned about keeping their TV's in good working order, you and I and a bunch of other guys would be looking around for some other way of making a living. You must have something else on your mind. What's the matter? Did your wife give you a hard time this morning?"

Bud grinned sheepishly. "No, that's not it. I was just feeling sorry for myself—that's all. You remember Mrs. Smith over on Elm Street, don't you?"

"She's been giving you trouble again, hasn't she?" queried Tony with a knowing twinkle in his eye. "The trouble with you, Bud, is that you don't use psychology. I suppose you went over there again this morning and couldn't find a thing wrong with her set."

Bud's gaze transferred sharply from his coffee cup to Tony's face. "How did you guess?" he asked in amazement. "I just came from there. To be truthful about it, I've been there three times in the past two weeks and haven't found that first bit of trouble. I don't know whether I'm dealing with an intermittent receiver or a customer with a mania."

Tony chuckled softly. "And I'll bet each time you went back there you told Mrs. Smith there wasn't anything wrong with the set, didn't you?"

"Sure, what else could I tell her?" Bud fired back in a defiant tone. Then with less spirit he added, "I

told her that the trouble was probably due to transmission difficulties, but she didn't seem to be sold on that idea. I'm firmly convinced that the set is OK, but I haven't been able to convince Mrs. Smith. I don't know what I'll do if she calls again. The last two calls were gratis, and we can't keep going on that basis."

"It is a tough situation," said Tony sympathetically, "but you should know by now that there is more to this business than just repairing sets. Every customer is concerned about two things—good service and low cost for that service. Now take the case of Mrs. Smith. When she called to have her TV repaired, she expected to get the best possible service for the lowest possible price. As I understand it, the chassis was completely overhauled in the shop and a new picture tube was installed."

"Yes, that's right," Bud substantiated, "and we charged her a fair price for the job! She quibbled a little; but when I told her that the price for the picture tube alone was almost \$50, she paid the bill—but with some reluctance, I'll admit."

"Aha!" Tony exclaimed jubilantly, "I figured as much. Mrs. Smith spent a considerable amount of money on her TV set, so it's only natural that she would be critical of the performance. She probably doesn't remember all of the minor troubles that had been piling up before the set went out completely, so she has reached the conclusion that the set isn't working much better than it was before the final trouble developed. In other words, she feels that she didn't get her money's worth."

"I'm beginning to understand," said Bud with a pained expression, "but what can I do about it now?"

Tony mused in silence for a moment before answering his friend. Then he said, "As I see it, there are three lines of reasoning to follow in an attempt to solve Mrs. Smith's problem. First of all, we have to consider that the set might have an intermittent trouble which you have been unable to locate. From what I know of the case, Mrs. Smith has not indicated that the performance is any different from that which you have seen. If that is true, we can assume that there is no intermittent trouble."

"Tony, as far as I can determine, her only complaint seems to be that the quality of the picture isn't what she thinks it should be," said Bud with a shrug of his shoulders.

Tony continued, "All right then, for our second line of reasoning we might assume that she has never been happy with the set and that she expects better performance than the set is capable of giving."

Bud paused momentarily before he replied, "No, I'm pretty sure she was satisfied with the set up until now. She even mentioned that service was only required once during the first year, and that was only to make a minor adjustment. As a matter of fact, her son and a couple of neighbors bought similar sets on her recommendation."

"Then you have no problem," said Tony in a cheerful voice. "Mrs. Smith wanted to be sure that she was getting the kind of performance she paid

• Please turn to page 67



"SOUP-UP" TV RECEPTION with a "DE-SNOWER" pre-amplifier



IN FRINGE AREAS

the Jerrold De-Snower gives beautifully clear TV pictures where conventional boosters fail. Sensitive, noise-free, cascode front end mounts at the antenna . . . amplifies weak signals before line losses set in. Lets you run noise-reducing coax to indoor power supply where it converts back to 300 ohms for receiver.



IN METROPOLITAN AREAS

the De-Snower brings in that "extra" channel that was just out of range before. Coax lead-in cuts troublesome noise and interference pick-up on *all* channels.

- Single-channel models for any VHF channel—30 db gain.
- Broadband models for channels 2 thru 6 or 2 thru 13—25 db gain.
- Noise level approaches theoretical minimum—6 db.
- Flat response for color.

GAIN more satisfied customers and a big new source of income. Send today for full details on the Jerrold De-Snower—the preamp that's used in hundreds of community antenno systems. See your nearest Electronic Parts Distributor, or write directly to Jerrold.

JERROLD

JERROLD ELECTRONICS CORP.
2218 Chestnut Street • Philadelphia 3, Pa.
In Canada: Jerrold Electronics (Canada) Ltd., Toronto 17, Ont.

Troubles In Vertical Sync Systems

(Continued from page 19)

picture to spread but the linearity control would not cause the top of the picture to spread properly, it would then be known that the output stage was not operating on the portion of the $E_p I_p$ curve that should produce a linear picture. The trouble would probably be either improper bias on the stage or a faulty cathode-bypass capacitor.

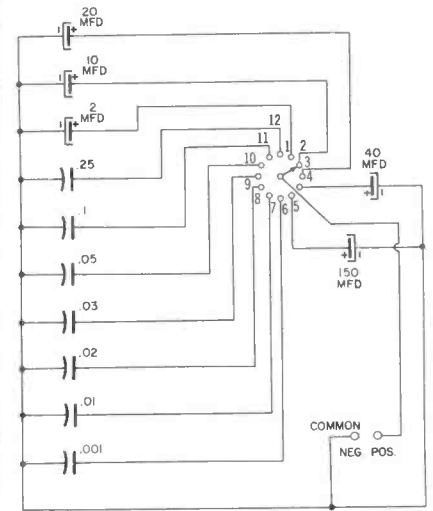
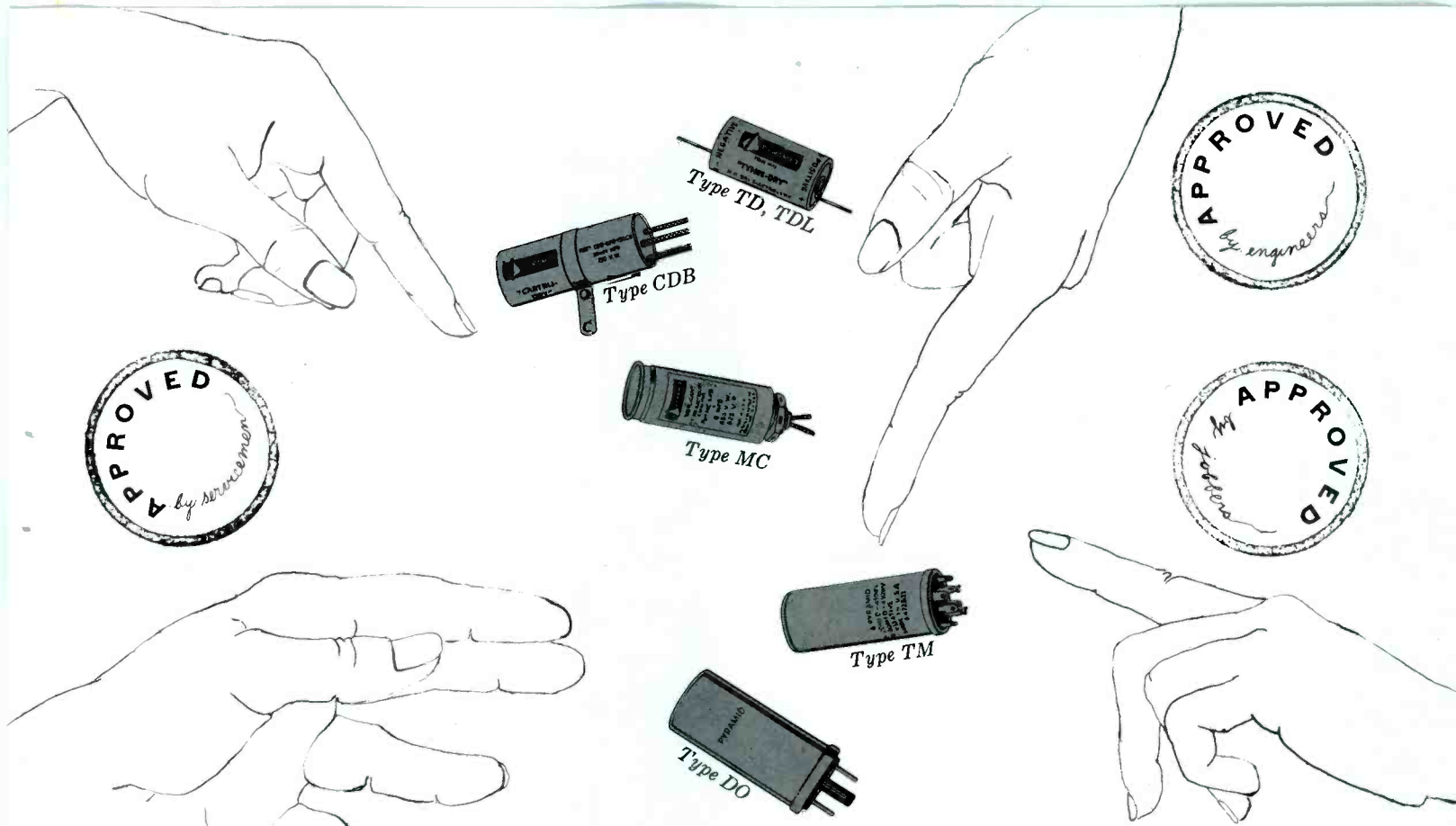

Fig. 7. Schematic Diagram of Capacitor-Substitution Unit.

(The fastest method of checking capacitors that are used for bypasses is to parallel a new capacitor across the suspected unit. It is also very desirable to be able to test coupling and other capacitors by substitution. A substitution unit that will provide various values of capacity for testing purposes can be made of a 12-position rotary switch, a small metal box, two banana jacks, and an assortment of capacitors. Such a unit is illustrated in schematic form in Fig. 7. The electrolytic capacitors should all be 450-volt units. The 2-mfd unit was included so that stabilizing capacitors in ratio-detector circuits might be replaced. All of the paper capacitors should preferably be rated at 1,000 volts because it may be desirable to use the substitution unit in damper and other circuits that have 600 or more volts present.)

If checking the operation of the controls should fail to reveal the



**YOU CAN'T ARGUE
WITH ACCEPTANCE**

The most complete line of twist mount
dry electrolytic capacitors

Proven quality, 100% inspected, accurate
replacement, prompt delivery

Better than any claims we could make is the unqualified and enthusiastic acceptance by engineers and servicemen alike. These are some of the features on which this acceptance is based:

Aluminum containers provide maximum protection against moisture.

Low leakage, long shelf life.

Designed for 85° C. operation.

Complete with metal and bakelite mounting plates.

Easy to mount.

Extremely compact—yet highly dependable. Pyramid capacitors are listed in Sams' Photofacts and Counterfacts.



PYRAMID ELECTRIC COMPANY

1445 Hudson Blvd., North Bergen, N. J.

TENNA

PROUDLY PRESENTS THE WORLD'S FINEST AND MOST COMPLETE LINE OF DUAL ANTENNA SETS

MATCHES THE STREAMLINED BEAUTY OF MODERN CARS

EASILY, QUICKLY INSTALLED. ALL OUTSIDE MOUNTING

HANDSOMELY CHROME PLATED FROM BASE TO TIP

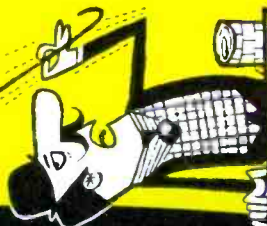

TENNA

DUAL ANTENNA SET

Aera FIREBALL

Sweeps back at 50° angle to match speed lines of modern cars

Model FBD-35A
List \$12.50

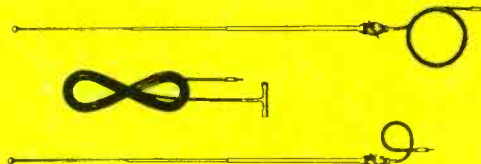

TENNA

DUAL ANTENNA SET

"NAUTILUS"

Tear Drop Mounting Base with 25° Sweep Back Antennas.

Model NTD-14
List \$14.95

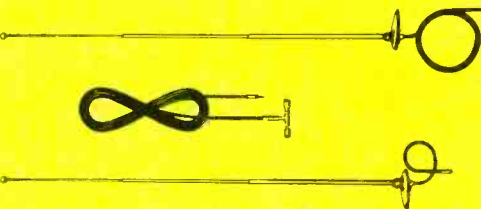

TENNA

DUAL ANTENNA SET

"MONARCH"

Disappears into Seamless Shield Tube. Adjustable flat to 30°. Collapses to 3".

Model RD-35
List \$13.50

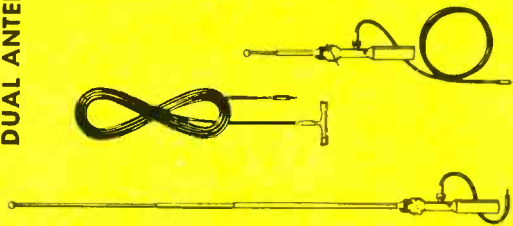

IMPORTANT: TENNA "DUAL" Antenna Sets are handsomely chrome plated from base to tip. Each set has 2 antennas, one with 1' cable and other with 6' cable, plus 15' cable with built-in 75MMF condenser. T-Connector and cable clips also furnished. Each set is individually boxed and packed 10 boxes to a master carton.

TENNA Manufacturing Co.
CLEVELAND 25, OHIO

source of the trouble, the next step would be to check the voltages applied to the oscillator and output plates (and to the screen grid, if there is one). These checks are relevant if trouble is experienced with either the height or linearity of the picture. If these voltages are found to be satisfactory, the signal at the output grid should be checked with an oscilloscope. If the grid signal has the proper shape and amplitude, then it is known that the trouble is located in the cathode or plate circuit of the output tube or in the deflection yoke. A check at the cathode for the proper voltage and waveform should help to isolate the trouble. The next step is to check the waveform across the yoke. If this waveform is defective, disconnect the vertical windings of the yoke and check the waveform across the secondary winding of the output transformer. (The brightness control should be turned to minimum during a check of this type in order to prevent burning of the phosphor in the picture tube.)

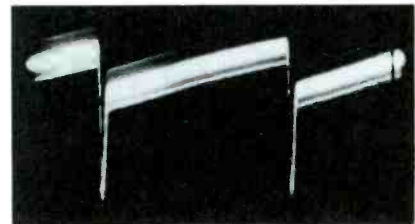

(A) Normal.

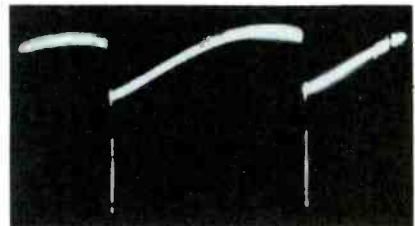

(B) With the Deflection Yoke Disconnected.

Fig. 8. Waveforms Across the Secondary of the Vertical Output Transformer.

Waveform A in Fig. 8 is the one normally present across the yoke when the vertical sweep system is operating satisfactorily. Waveform B of the same figure is the one across the secondary winding of the vertical output transformer when the yoke is disconnected.

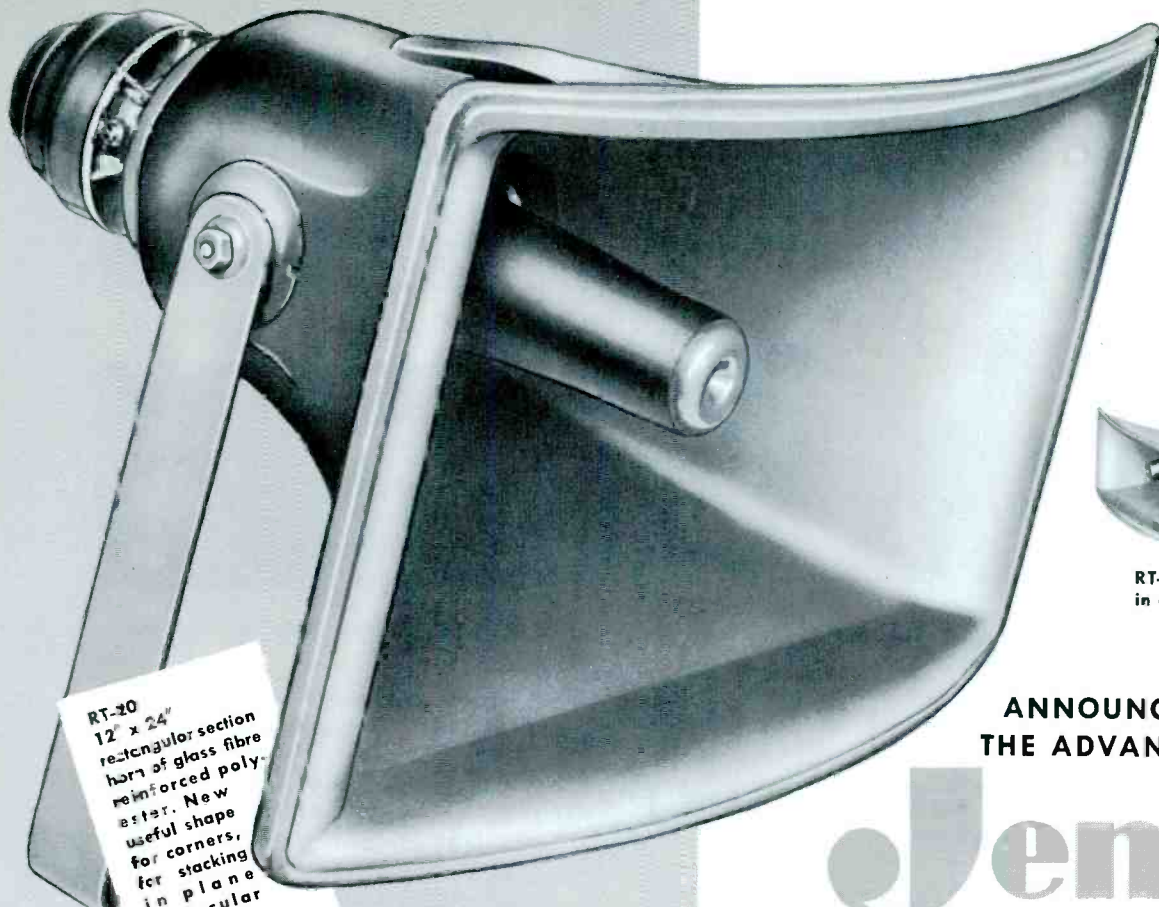

RT-20's
in plane array



RT-20's
in circular array

RT-20
12" x 24"
rectangular section
horn of glass fibre
reinforced poly-
ester. New
useful shape
for corners,
for stacking,
in plane
or circular
arrays.



DD-100
100 watt
driver



15", 20" and
24" horns



HF-100
weatherproof
2-way HI-FI
Projector



D-30 and D-40
30 and 40 watt
drivers

Four 12" and 15"
2-way and 3-way
speakers

ANNOUNCING THE ADVANCED **NEW**

Jensen

PROFESSIONAL SERIES LOUDSPEAKERS

FOR INDUSTRIAL, COMMERCIAL, INSTITUTIONAL, CIVIL DEFENSE, AND MILITARY SOUND SYSTEMS

If sound is your business, here is big news for you . . . a complete new line of loudspeakers to meet for the first time every sound system need for both entertainment and efficient, effective communication. From a fraction of a watt to 1600 watts or even more . . . for high fidelity or high efficiency coverage . . . for distributed or concentrated source projection . . . indoors or out—there is a Jensen Professional Series loudspeaker that will do the job *better, more dependably, and more economically* than ever before. Just as an example, the new Hypex Lifetime Driver Units are *guaranteed indefinitely against failure under normal use!*

Three years of product design and a background of nearly 30 years of field experience and manufacturing know-how come to you in Jensen Professional Series loudspeakers. We can't begin to illustrate or describe all the items here—nor tell you about all the new features for convenience and performance which we've built into them. Catalog 1070 tells the whole story, including valuable information on sound system design. Send for your free copy today.

Jensen MANUFACTURING COMPANY
6601 S. Laramie, Chicago 38, Illinois

Division of The Muter Co. • In Canada, Copper Wire Products, Ltd. Licensee

COMPLETELY SOLDERLESS



NO SOLDER—
braid or contact

NO CRIMP—
braid or contact

AMPHENOL

NEW COAXIAL CABLE CONNECTORS

Two new time-saving, reusable, field-workable coaxial connectors are now available. The 83-850 is a *completely solderless* connector that can be assembled to RG-11/U or RG-59/U cable with a screwdriver and a pair of pliers! The 83-851 is *semi-solderless*, may be used wherever an 83-1SP has been used. Only the contact is soldered—the braid is locked mechanically by a positive-action cable clamp as in the 83-850. Both plugs are plated with corrosion-resistant cadmium.

features

COMPLETELY SOLDERLESS
83-850—no solder, no crimp
83-851—semi-solderless

FULLY RE-USABLE
attach and detach, use again and again

EASY ASSEMBLY
even in field use

applications

MASTER TV INSTALLATIONS
hotels, motels, apartment houses

LABORATORY & SERVICE
TECHNICIAN USE
speeds work, saves money

COMMUNITY TV INSTALLATIONS
for every field application



special
Watch for this solderless
connector dispenser at your Distributors!

AMPHENOL

AMPHENOL ELECTRONICS CORPORATION
chicago 50, illinois

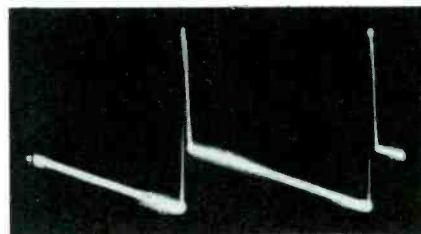

(A) Normal.

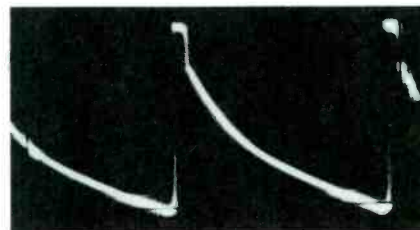

(B) With the Deflection Yoke Disconnected.

Fig. 9. Waveforms Across the Primary of the Vertical Output Transformer.

Waveform A of Fig. 9 is the one across the primary of the vertical output transformer when the vertical sweep section is operating normally. Waveform B of the same figure is the signal across the primary of the output transformer when the yoke is disconnected. Notice the difference in the shape of the A and B signals in Figs. 8 and 9.

Shorted turns in the yoke could cause height or linearity troubles. Familiarity with the waveforms associated with the output transformer under the conditions mentioned would make it possible for

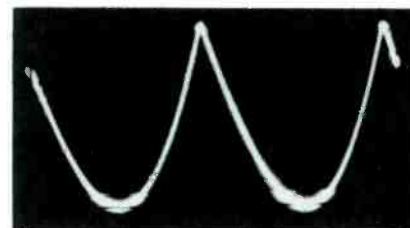

(A) Normal.

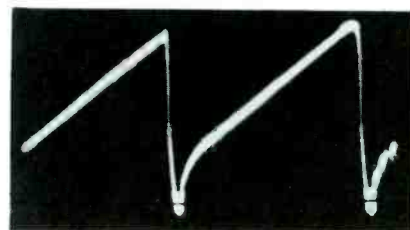

(B) With the Bypass Capacitor Disconnected.

Fig. 10. Waveforms at the Cathode of the Output Tube.

troubles in the yoke or output transformer to be located. A few quick tests on several normally operating receivers can give you a basis for making quick and accurate analyses of troubles in vertical output transformers and deflection coils.

Waveform A of Fig. 10 is the normal waveform found on the cathode of the vertical output stage. Waveform B of this figure was taken with the bypass capacitor disconnected. Notice that waveform B corresponds to the grid signal.

Common Symptoms

1. Loss of Sweep.

Loss of vertical sweep is indicated in Fig. 11. This trouble symptom is present when there is no driving signal to the vertical deflection coils and when the horizontal scanning is normal.



Fig. 11. Appearance of the Screen When the Vertical Sweep Has Failed.

Possible causes of a loss of sweep are:

- a. Defective oscillator or output tubes.
- b. Open coupling capacitor. (See C72 in Fig. 2; C72 and C74 in Fig. 3; C75, C76, and C77 in Fig. 4; C83 in Fig. 5; or C77 and C78 in Fig. 6.)
- c. Open linearity control.
- d. Open height control.
- e. Open output transformer.
- f. Defective blocking-oscillator transformer.

If substitution of tubes has failed to indicate the source of trouble, then the plate, screen, cathode, and control-grid voltages should be checked to make sure that the trouble is not caused by a loss of B+ voltage due to a faulty decoupling network or height control. The next step is to check the waveform on the output grid. If it is defective, a check of the oscillator is the next step. If



TOPS IN ACCURACY ...TOP ECONOMY, TOO!

Full view... full value. The special flat 3" CRT in Hycon's 617 Scope gives a full 3" off-sharp, undistorted trace. High deflection sensitivity (0.1 v/in. rms), 4.5 MC bandpass (flat ± 1 db), internal calibrating voltages, lightweight, rugged, construction... all make the 617 today's best buy for your scope dollar.

Another Hycon test help...



MODEL 614 VTVM

combines top convenience and versatility, maximum accuracy... and lowest cost. Perfect for the radio-TV serviceman.

"Where Accuracy Counts"
Hycon ELECTRONICS, INC.

A Subsidiary of Hycon Mfg. Company
321 SOUTH ARROYO PARKWAY
PASADENA, CALIFORNIA

Send TODAY for latest catalogs

HYCON ELECTRONICS, INC., Dept. P.—
P. O. Box 749
Pasadena, California

Send the latest catalogs on Model 617 and Model 614.

Name _____

Address _____

City _____ State _____

A report on Sylvania's **6-Million-Hour Field Test** in receiving tubes

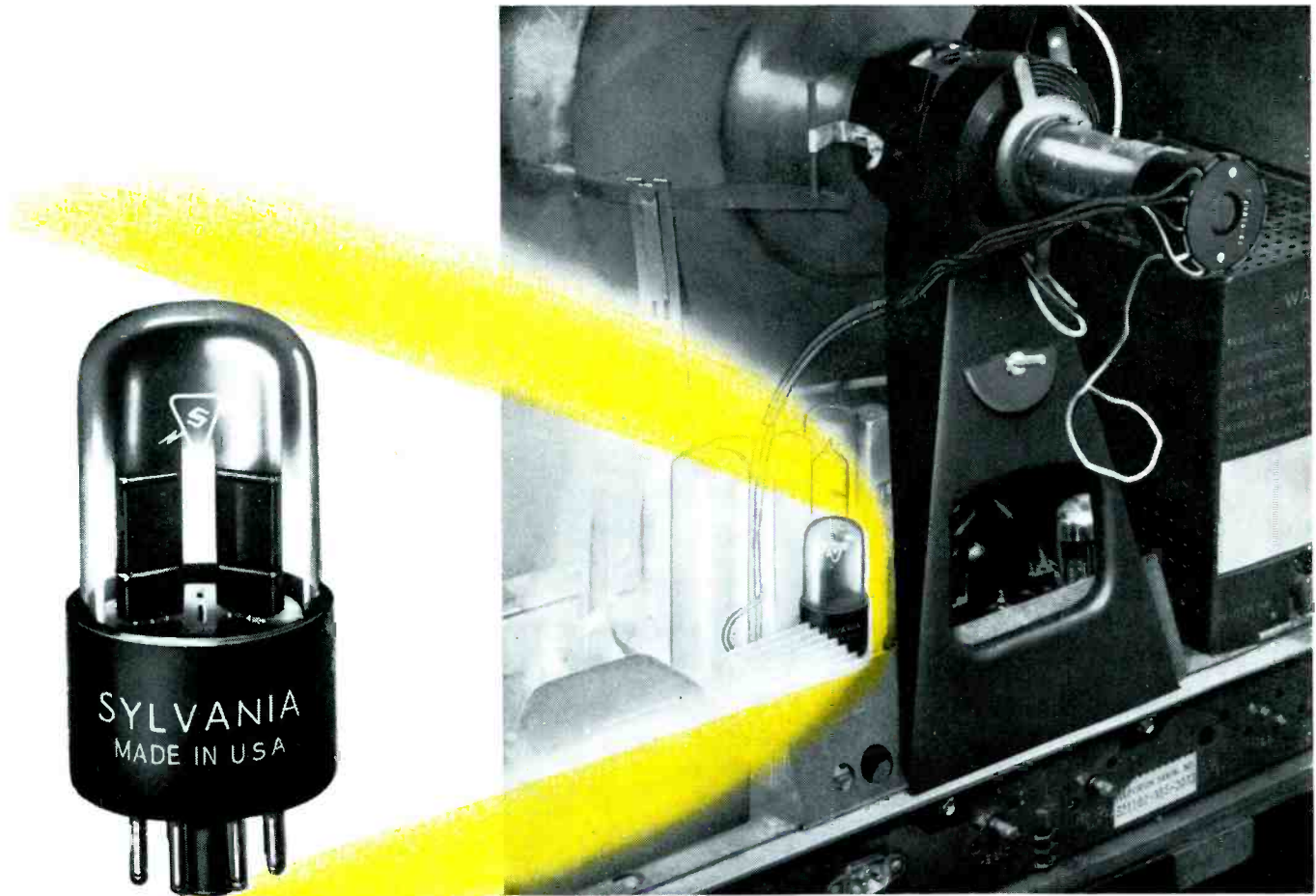

“Circuit tested” in 139 stock TV sets for universal protection against callbacks

FOR UNIVERSAL PROTECTION against callbacks, use the tube that's tested for top performance under actual operating conditions in the sets you service. Sylvania tubes in the familiar yellow and black carton are backed by more than 6 million hours of field testing in TV sets of leading manufacturers.

The 139 stock models selected for the *6-million-hour field test* represent a cross section of the industry and their tube complements include every important replacement tube type. The 6-million-hour field test stacks up as the most extensive program ever under-

taken on the servicemen's behalf to insure universally dependable tubes.

Every set-testing cycle is based on one year of set use, assuring you maximum dependability during the period of your responsibility. That's why we say Sylvania tubes are “time-tested” for trouble-free service and the maximum profits which go along with it.

Look for the yellow and black carton—it represents a new kind of dependability backed by the 6-million-hour field test.



 **SYLVANIA**[®]

SYLVANIA ELECTRIC PRODUCTS INC.
1740 Broadway, New York 19, N. Y.
In Canada: Sylvania Electric (Canada) Ltd.,
University Tower Bldg., Montreal

LIGHTING • RADIO • ELECTRONICS • TELEVISION • ATOMIC ENERGY

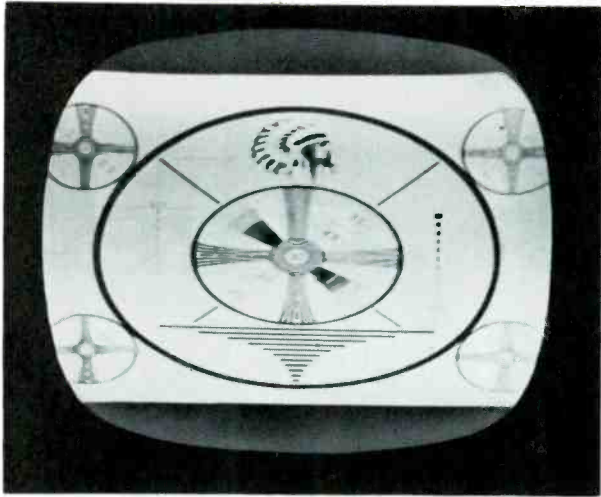

Fig. 12. Test Pattern Showing a Reduction in Height.

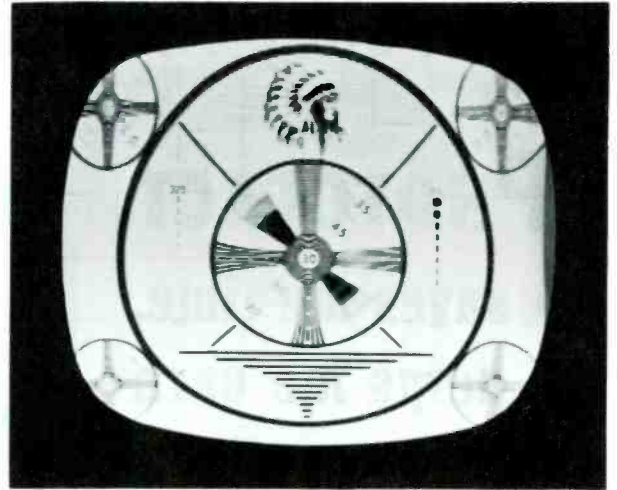

Fig. 13. Test Pattern Showing Compression at the Bottom.

the grid waveform is satisfactory, a check of the output stage should reveal the trouble.

2. Insufficient Sweep.

Insufficient vertical sweep is the condition that exists when a linear picture cannot be made to fill the screen. The picture may not be compressed at the bottom or top. The illustration in Fig. 12 shows a picture that fails to fill the screen at the top or bottom because of misadjustment of the height and linearity controls. You will notice that the picture is linear even though it is lacking in height.

Possible causes of insufficient vertical sweep are:

- a. Improper adjustment of the height and linearity controls.
- b. Weak oscillator or output tube.
- c. Low B+ voltage.

d. Defective decoupling network in a plate circuit.

e. Low boosted B+ voltage.

Weak damper tubes have been known to cause insufficient sweep because they do not generate sufficient boost voltage. In most cases of this type, the high voltage will also be low; and as a result, the picture will be dim. Insufficient sweep also appears on receivers that employ selenium rectifiers if these rectifiers are defective. In these receivers, the B+ voltage may only be 25 or 30 volts low and still cause insufficient sweep.

3. Poor Linearity.

Poor linearity is the condition that exists when the picture tube screen cannot be covered vertically with a normal linear picture. Under some conditions, it may not be possible to cover the screen

completely even with a nonlinear picture.

There are various degrees and types of nonlinearity that may occur in vertical sweep systems. The types of nonlinearity are: compression at the bottom, compression at the top, and foldover.

The illustration in Fig. 13 shows a picture compressed at the bottom. During the servicing of this receiver, the cathode of the output tube was checked with an oscilloscope. A waveform like that in Fig. 10B was found. A check of the bypass capacitor revealed that it was open. After the capacitor was replaced, a normal waveform like that in Fig. 10A was observed at the cathode.

Possible causes of compression at the bottom of the picture are:

- a. Improperly adjusted controls.

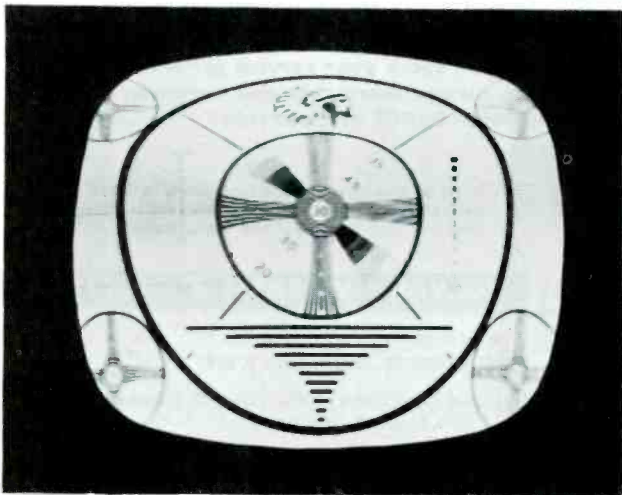

Fig. 14. Test Pattern Showing Compression at the Top.

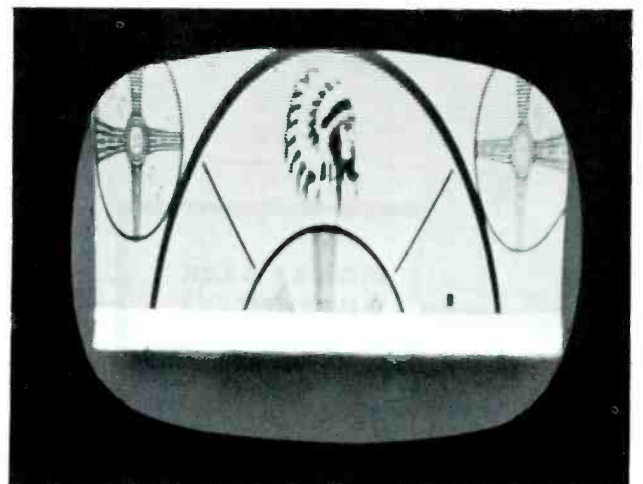

Fig. 15. Test Pattern Showing Foldover Caused by Capacitor Leakage.

"best shop investment I've ever made..."

PHOTOFACT

saves me time,
helps me earn
extra profits
every day..."

SAYS Charles Tanner
of Lindenhurst, L. I., N.Y.

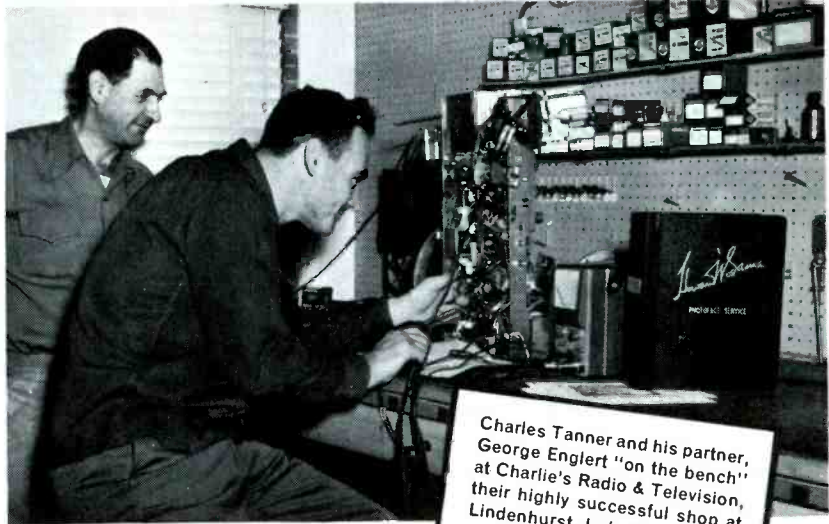

Charles Tanner and his partner, George Englert "on the bench" at Charlie's Radio & Television, their highly successful shop at Lindenhurst, L. I., New York.

Writes Mr. Tanner: "The use of Sams' PHOTOFACT data saves me time on bench jobs, and that means *extra* profits every day, profits I can really measure. The big time-savers I especially like are the convenient Voltage Data* and Waveforms* shown directly on every PHOTOFACT TV schematic diagram. Because of PHOTOFACT's size, too, it's possible to work on a set with that very fine Standard Notation Schematic* lying easily accessible in front of the technician. In my opinion, PHOTOFACT is the best shop investment I've ever made."



George Englert stands near the shop's complete PHOTOFACT Library. Charles Tanner refers to his handy Sams PHOTOFACT Index for the time-saving Folder covering his next bench job.

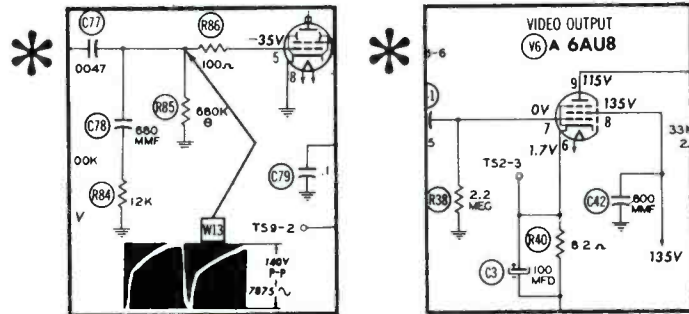

From start to finish, you solve your service problems in just minutes... you service more sets and earn more daily with PHOTOFACT by your side!

*One of 32 features found exclusively in Sams' PHOTOFACT—the world's finest service data covering over 20,000 TV and radio models



MONEY BACK GUARANTEE!

Got a tough repair? Try this—at Howard W. Sams' own risk: see your Parts Distributor and buy the proper PHOTOFACT Folder Set covering the receiver. Then use it on the actual repair. If PHOTOFACT doesn't save you time, doesn't make the job easier and more profitable for you, Howard W. Sams wants you to return the complete Folder Set direct to him and he'll refund your purchase price promptly. **GET THE PROOF FOR YOURSELF—TRY PHOTOFACT NOW!**

free



Send for Sams' INDEX TO PHOTOFACT FOLDERS—your guide to virtually any receiver model ever to come into your shop; helps you locate the proper PHOTOFACT Folder you need to solve any service problem on any model. You'll want this valuable reference guide. Send coupon now.

HOWARD W. SAMS & CO., INC.

Howard W. Sams & Co., Inc.
2201 E. 46th St., Indianapolis 5, Ind.

Send FREE Index to PHOTOFACT Folders
 I am a Service Technician

Name _____
Address _____
City _____ Zone _____ State _____

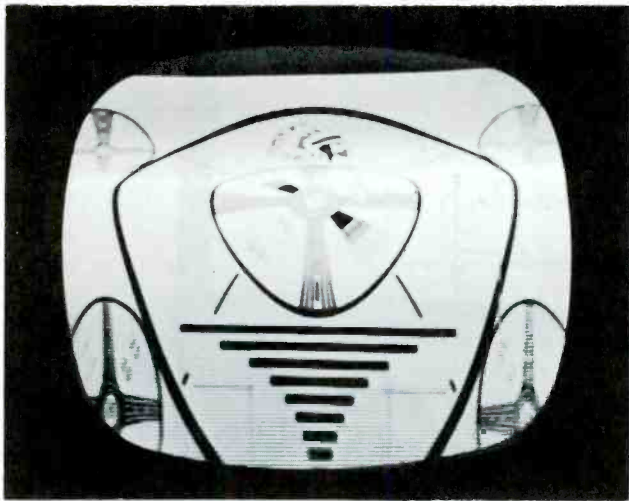

Fig. 16. Test Pattern Showing Foldover Caused by Heater-to-Cathode Leakage.

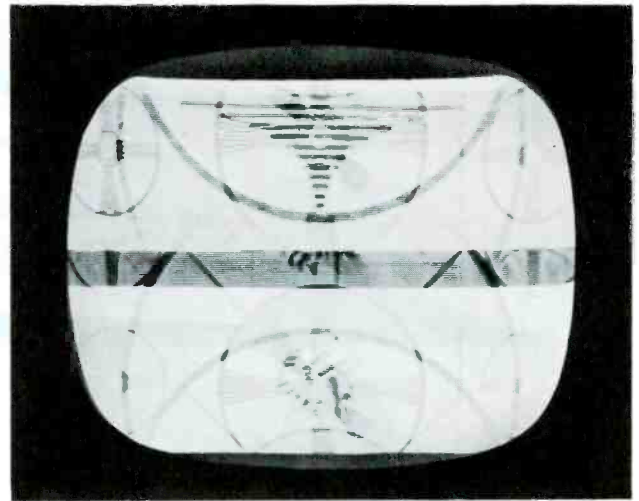

Fig. 17. Test Pattern Showing Loss of Vertical Synchronization.

- b. Open cathode bypass capacitor.
- c. Defective output tube.

The illustration in Fig. 14 shows a picture compressed at the top. This trouble symptom resulted when the grid resistor of an output stage opened.

Possible causes for compression at the top of the picture are:

- a. Improperly adjusted controls.
- b. Insufficient bias voltage in those circuits in which a fixed voltage biases the output stage. (See Fig. 5.)
- c. Defective output tube.
- d. Open grid resistor in output stage.
- e. Changed value of resistors in the cathode of the output stage.

The illustrations in Figs. 15 and

16 are two examples of picture foldover caused by troubles in the vertical sweep section. The picture in Fig. 15 is the result of leakage in the coupling capacitor between the oscillator and output stages. The degree of foldover will be a function of the amount of leakage in the capacitor. The picture in Fig. 16 was caused by heater-to-cathode leakage in the output tube. The degree of foldover will be a function of the amount of leakage in the tube.

Possible causes of foldover are:

- a. Defective output tube.
- b. Leakage in coupling capacitor to output stage.
- c. Defective output transformer.
- d. Leakage in discharge capacitor. (See C71 in Fig. 2, C73 in Fig. 3, C73 and

C74 in Fig. 4, C80 and C82 in Fig. 5, or C79 in Fig. 6.)

4. Loss of Synchronization.

Complete loss of vertical synchronization is indicated in Fig. 17. There are two basic causes of loss of vertical synchronization: (1) lack of a sufficient sync signal and (2) change in the natural frequency of the vertical oscillator. It is the function of the vertical sync pulses to trigger the vertical oscillator into conduction in step with the sweep oscillator of the transmitter. This can be accomplished only if the natural or free-running frequency of the oscillator in the receiver is a little lower than 60 cycles per second.

Possible causes of a loss of synchronization are:

- a. Defective oscillator tube.

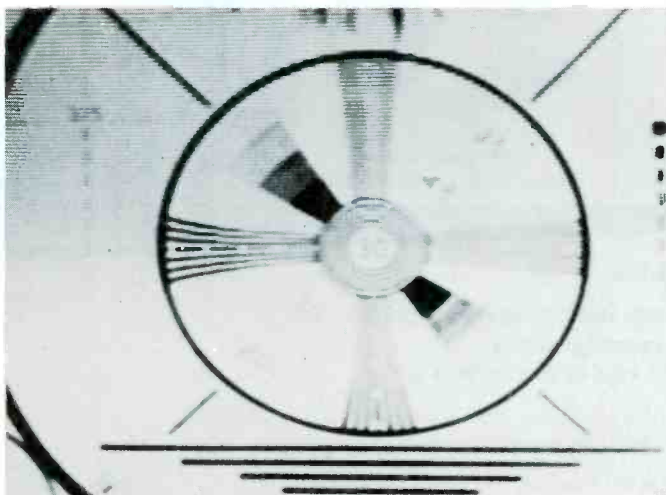

(A) With Proper Interlacing.

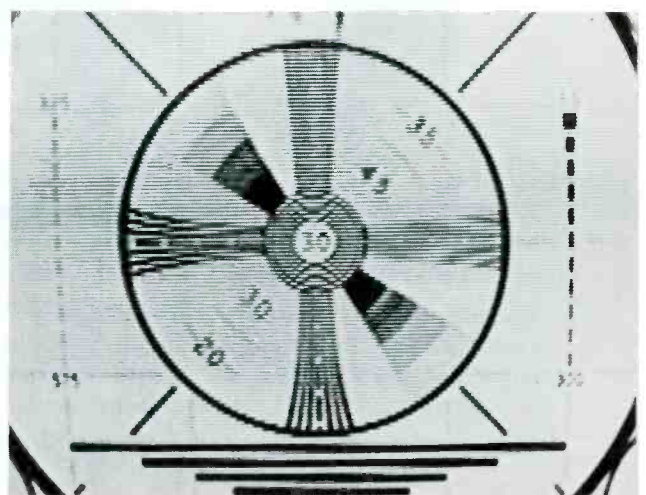

(B) With Poor Interlacing.

Fig. 18. Portions of Two Test Patterns.

In one profitable package University offers everything in loudspeakers for sound reinforcement... and public address—

 <p>REFLEX TRUMPETS</p>	 <p>RADIAL PROJECTORS</p>	 <p>WIDE-ANGLE HORNS</p>
 <p>HIGH EFFICIENCY DRIVER UNITS</p>	 <p>PAGING, TALK-BACK SPEAKERS</p>	 <p>OUTDOOR MUSICASTING</p>
 <p>EXPLOSION-PROOF SPEAKERS</p>	 <p>HIGH POWER SPEAKERS UP TO 720 WATTS</p>	 <p>SUBMERGENCE-PROOF SPEAKERS</p>
 <p>WIRED MUSIC SYSTEMS</p>	 <p>WEATHERPROOF LINE-MATCHING TRANSFORMERS</p>	 <p>ADAPTORS FOR DIVERSIFIED APPLICATIONS</p>

People have come to expect the highest standard of quality in a product bearing the University label.

This kind of public acceptance is something that University has consistently worked to achieve. *First*—by backing you up with an advertising campaign that's making University a "buy-word." *Second*—by building the kind of quality into all our products that ensures your customers' satisfaction.

Yes, everyone is finding out, to his profit, that "University sells on sound!"

For information regarding products or technical data, write to Desk C-7.

University LOUDSPEAKERS, INC. 80 South Kensico Avenue, White Plains., N. Y.



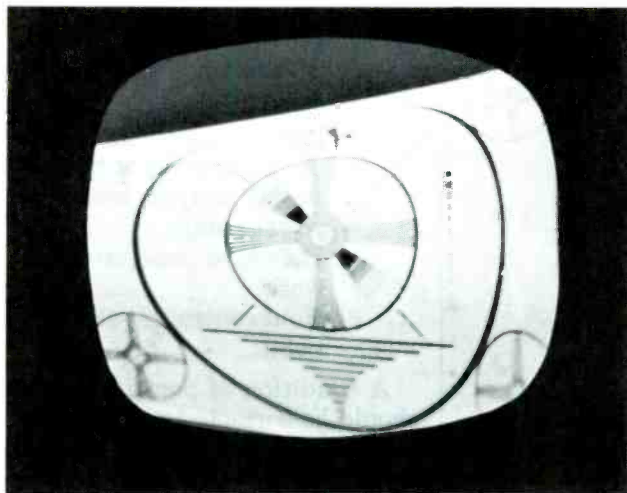

Fig. 19. An Example of Keystone Effect.

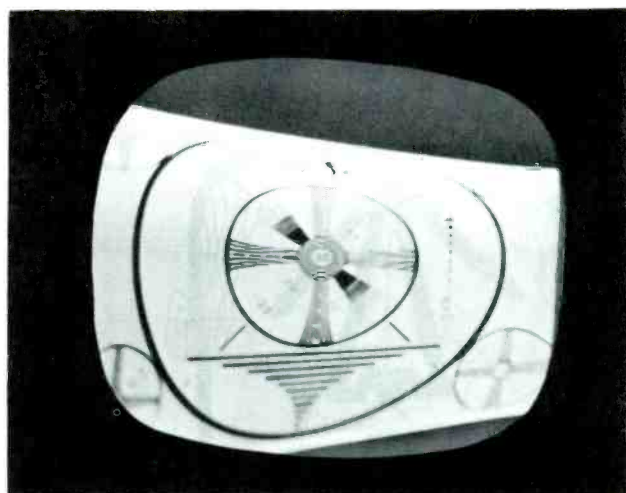

Fig. 20. Another Example of Keystone Effect.

- b. Defective hold control or series resistor. (See R4 and R80 in Fig. 2, R2 and R54 in Fig. 3, R4 and R86 in Fig. 4, or R4 and R76 in Fig. 6.)
- c. Defective oscillator-grid capacitor. (See C70 in Fig. 2, C70 in Fig. 3, C71 in Fig. 4, or C76 in Fig. 6.)
- d. Defective oscillator transformer.
- e. Defective resistor in feedback loop. (See R88, R90, and R92 in Fig. 4 or R77 and R78 in Fig. 6.)
- f. Defective capacitor in feedback loop. (See C72 in Fig. 3; C72, C76, C77, and C78 in Fig. 4; or C76 and C77 in Fig. 6.)
- g. Insufficient or distorted sync signal from integrator network.

A check of the natural frequency of the vertical oscillator can be a great help in isolation of the source of trouble. To make this

check, either remove the sync separator tube or disconnect one end of the integrator network and check the signal on the grid or plate of the vertical oscillator. The signal should have a frequency of slightly less than 60 cycles. A check with an oscilloscope of the line voltage will give a basis for comparison.

5. One-Way Sync or Critical Synchronization.

One-way sync is the condition that exists when it is necessary to turn the vertical hold control to one extreme of its rotation in order to synchronize the picture. The picture will roll in only one direction when the hold control is rotated from one end of its rotation to the other.

Possible causes of critical or one-way synchronization are:

- a. Defective oscillator-grid capacitor. (See C70 in Fig. 2, C70 in Fig. 3, C71 in Fig. 4, or C76 in Fig. 6.)

- b. Changed value of hold control or grid resistor. (See R4 and R80 in Fig. 2, R2 and R54 in Fig. 3, R4 and R86 in Fig. 4, or R4 and R76 in Fig. 6.)
- c. Defective oscillator transformer.
- d. Defective resistor in feedback loop. (See R88, R90, and R92 in Fig. 4 or R77 and R78 in Fig. 6.)
- e. Defective capacitor in feedback loop. (See C72 in Fig. 3; C72, C76, C77, and C78 in Fig. 4; or C76 and C77 in Fig. 6.)
- f. Defective oscillator tube.

If critical synchronization exists in a receiver and the oscillator stage cannot be definitely identified as the source of the trouble, then it is probable that the trouble is due to some defect in the sync stages.

6. Poor Interlacing.

Portions of two test patterns, with each portion showing the left horizontal wedge, are shown in Fig. 18. Fig. 18A shows a wedge that indicates normal interlacing; Fig. 18B shows poor interlacing. Notice that, in the normal wedge, the units of the wedge are straight and easily seen; whereas, in the other pattern, a moire effect is present in the wedge and the lines are not easily seen. In most cases, poor interlacing is caused by trouble in the transmitter. To check on this possibility, switch to a different channel. Good interlacing on this channel would indicate trouble at the transmitter of the first channel.

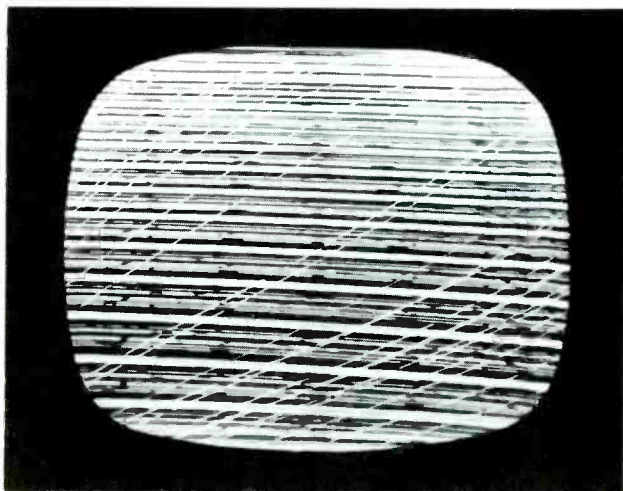
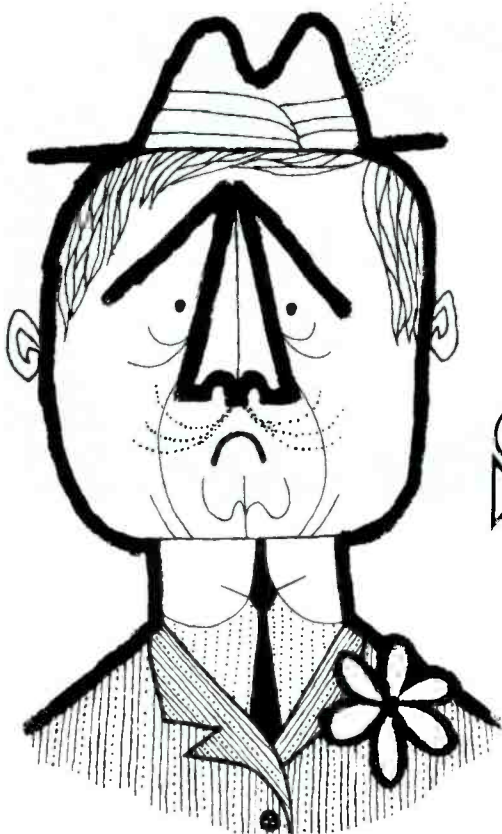

Fig. 21. A Trouble Symptom Which Resembles the Christmas-Tree Effect.



SAD?

because you
weren't able
to get your

1956 *Radio Electronic* MASTER

Sorry you were disappointed. In many areas, there just weren't enough MASTERS to meet the demand.

But — cheer up. If you act fast, we can help you get your industry-wide buying guide. We've located several distributors with extras on hand.

And what's more . . . you'll only pay the \$2.95 distributor price instead of the regular \$7.50.

- 100,000 items
- Complete descriptions
- Specifications—Prices
- 11,000 illustrations
- 8 x 11", 6 lbs.
- 350 mfrs.

So send your coupon now . . . first-come — first-served.

1450-Page Buying Guide . . . helps you shop before you buy. The supermarket pages of The MASTER enable you to compare specs and prices first — then buy and save.

Right in Your Customer's Home . . . you can sell direct from The MASTER's pages. Watch it pay off in extra sales!

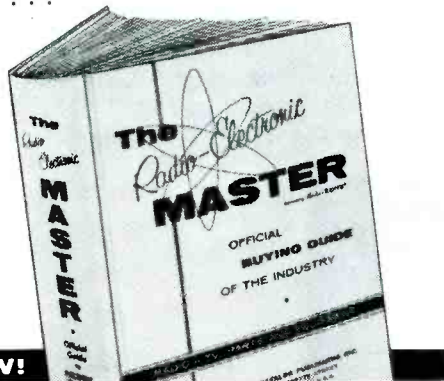

MAIL COUPON NOW!

UNITED CATALOG PUBLISHERS, INC., 110 LAFAYETTE ST., NEW YORK 13, N. Y.
Here's my \$2.95. Please rush me the 1956 MASTER, Official Buying Guide of the Electronic Parts and Equipment Industry.

Name.....

Address.....

City..... Zone..... State.....

PF-6

Possible causes of poor interlacing are:

- a. Pickup by the vertical oscillator of 15,750-cps pulses from the horizontal oscillator stage or the horizontal output and high-voltage stage.
- b. Defective integrator network.
- c. Hold control set at critical point.

A condition of poor interlacing should be corrected whenever it is encountered because it indicates that the vertical oscillator is operating under critical conditions. It can also cause the loss of about 50 per cent of the picture detail, even though the poor interlacing itself is seldom noticeable.

7. Keystone Effect.

This trouble is illustrated in Figs. 19 and 20. Keystone effect is caused by trouble in the deflection coils. The examples shown were caused by a short across first one coil and then across the other. An open vertical deflection coil will produce a keystone effect, and there will be very little deflection; there will be deflection only as long as the damping resistor connected across the open coil is good. If this resistor should open, no current would flow through the other half of the coil and vertical sweep would disappear. If one deflection coil and both damping resistors should open, then a single bright horizontal line with damped oscillations would be produced.

The example in the photograph shown in Fig. 21 was caused by an open discharge capacitor. This illustration has many of the characteristics of Christmas-tree effect caused by the horizontal section. A check of the grid waveform at the horizontal output grid will reveal that the trouble is not in that section, and the technician familiar with this indication will know at once that the discharge capacitor is open. This capacitor corresponds to C71 in Fig. 2, C73 in Fig. 3, C73 and C74 in Fig. 4, C80 and C82 in Fig. 5, or C79 in Fig. 6.

LESLIE D. DEANE AND
CALVIN C. YOUNG, JR.

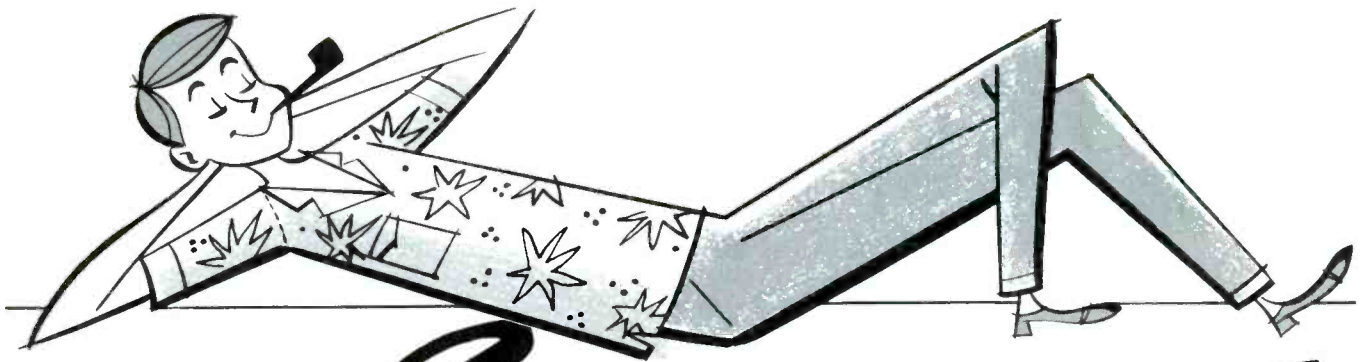

Now with *Siesta-matic*



M 'Super-Fidelis' Model 1200 Changer

Here's the big news you've been expecting! V-M ALONE has a popular-priced record changer with "automatic neutral." Retracts and protects the precision drive idler after last record plays! Turns off power and amplifier, too.

**Slightly higher in the West.*

V-M CORPORATION BENTON HARBOR 7, MICHIGAN

Because it's a V-M changer, it plays all *four* record speeds, all record sizes, any combination of ten 12" or twelve 10" records of the same speed.

NEW white rubber turntable mat for beauty and utility (protects precious records). Restyled in striking charcoal gray and antique white.

You sell the new look at the same popular price—\$46.50* list.

Also available with the new look: V-M Models 1225 (1200 changer on matching metal pan), \$49.95*; 1200GE, \$51.50* and 1225GE, \$54.95* (with GE cartridge).

See your V-M Rep. Stock and Sell V-M 'Super-Fidelis' Model 1200.



WORLD'S LARGEST MANUFACTURER OF PHONOGRAPHS AND RECORD CHANGERS

PHAOSTRON

666 VOM

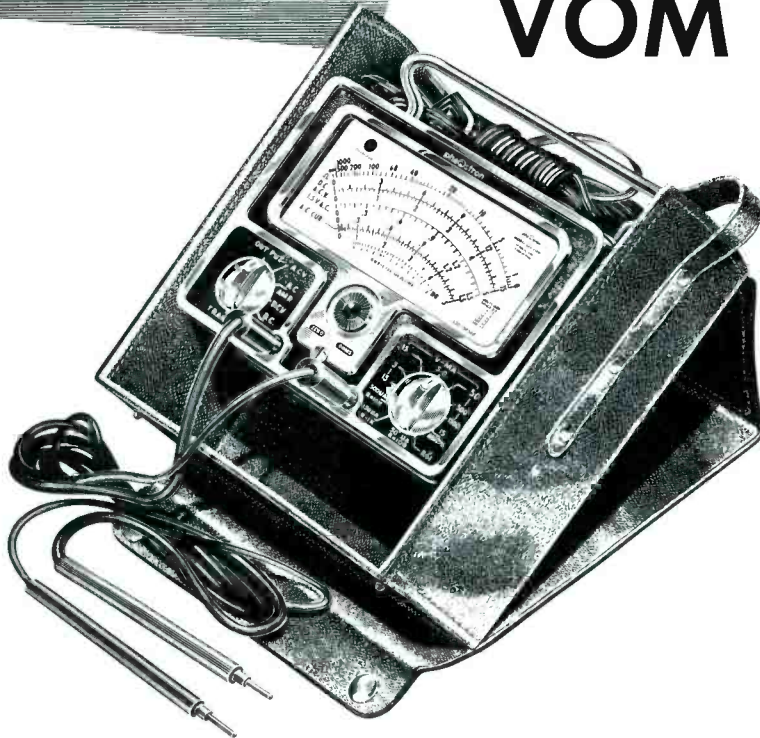

METER OVERLOAD PROTECTION AND OVERLOAD SIGNAL

LIGHT. It is fused to prevent most common burn-outs and instrument damage. The 666 has complete meter movement overload protection. An overload signal light warns the operator of overloads, or incorrect polarity.

RAPID, RELIABLE AND ACCURATE MEASUREMENTS

43 Unduplicated Ranges.
Long (4 $\frac{7}{8}$ ") Scales are Color-Coded for clarity.
Illuminated Dial for easier reading.

AC CURRENT RANGES (from 1.5 MA to 15 Amps) MEAN FEWER INSTRUMENTS TO CARRY

RELIABLE PERFORMANCE

Doubly Shielded 45 UA movement assures continuous accuracy.
Permanent Accuracy 3% DC, 4% AC.
Sensitivity: 20,000 Ohms/Volt DC, 2,000 Ohms/Volt AC.

CONVENIENT TO CARRY

This instrument, with its unbreakable steel case, fits into the provided handsome leather carrying case which has space for all accessories.
Lightweight: 4 lbs. 4 oz.
Compact: 3 $\frac{3}{4}$ " x 6 $\frac{5}{8}$ " x 7 $\frac{1}{2}$ ".

Complete with Probes, Power Cord, Batteries and
Leather Carrying Case at your Parts Distributor. **\$59.50**

PHAOSTRON INSTRUMENT AND ELECTRONIC COMPANY

151 Pasadena Avenue, South Pasadena, California

EXPORT: Ad. Borrero, Inc., 89 Broad St., New York 4, N. Y.

Know Your Oscilloscope

(Continued from page 13)

the vertical amplifier to have as wide a frequency range and as great a sensitivity as economic factors will permit; however, most of the time, the horizontal amplifier will be used to amplify the sawtooth signal from the sweep generator of the oscilloscope. This signal is normally larger than the signal applied to the vertical amplifier, and its frequency range is usually less; therefore, the horizontal amplifier of an oscilloscope will commonly be designed to have less sensitivity and a narrower frequency response than the vertical amplifier although in some models they may be identical in these respects.

Push-Pull Amplifiers

It was mentioned that most present-day oscilloscopes incorporate push-pull amplifiers. If the amplifiers do not have push-pull operation for all stages, at least the stages driving the deflection plates will have such operation. The advantages of this type of operation in oscilloscopes are similar to those obtained from push-pull operation in other applications; they are: better hum cancellation, reduction of second harmonic distortion, and greater signal drive for the same supply voltage. In addition, there is a reduction in the number of defocusing and trapezoidal effects which result when one plate of each pair of deflection plates is at ground potential as it is in the case of single-ended operation.

Attenuators

With voltage amplifications of as much as 1,000 times applied to the weakest signal being viewed, some means must be provided to prevent overloading when stronger signals are being viewed. In most cases, two attenuators will be used for this purpose—one a continuously variable control and the other a switching arrangement which attenuates the signal in units of ten. The switch is placed at the input to the amplifier, and the variable control is usually separated from it by at least one stage of the amplifier. The operator

should keep in mind that, with this type of arrangement, it is possible to overload the first stage of the amplifier and thus to get a distorted response curve even though the vernier control is set for minimum response; consequently, a strong signal should be reduced by the attenuator at the input of the amplifier, and then minor adjustments should be made with the control.

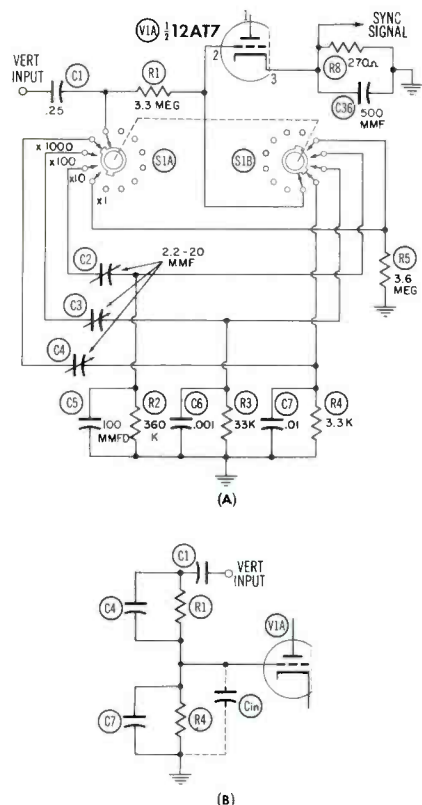

Fig. 3. The Frequency-Compensated Vertical Attenuator of the Simpson Model 458 Colorscope. (A) Schematic Diagram. (B) Simplified Diagram.

The step attenuator for the vertical amplifier of the Simpson Model 458 Colorscope is shown in schematic form in Fig. 3A. In Fig. 3B, the switch has been eliminated and only the active components are shown. R1 and R4 in series form a voltage divider, and only about 1/1,000 of the vertical input signal is applied to the grid of V1A. C4 is a trimmer which provides frequency compensation for the applied signals. If a simple divider consisting only of R1 and R4 were used, the input capacitance C_{in} of V1A would bypass the higher frequencies more than it would the lower frequencies; and conse-

quently, the amplification of the signal applied to the vertical input would be reduced at the higher frequencies. To compensate for this effect, C4 is added. When the product of $R1 \times C4$ equals the product of $R4 \times C_{in}$, the voltage division is independent of frequency. C5, C6, and C7 have been added to C_{in} at three different switch positions so that the design of the attenuator will be simplified. If these capacitors were omitted, the values for the three trimmers would be so small that they would be impractical. For example, for a 1,000-to-1 division, R1 must be approximately 1,000 times as large as R4. Then if $R1 \times C4$ is to equal $R4 \times C_{in}$, C4 must be 1/1,000 as large as C_{in} . For a 12AT7 tube, C_{in} is listed as being 2.2 micromicrofarads; and 1/1,000 of this amount is a very small capacity, even if a generous allowance is made for stray wiring capacities (which should be added to the value 2.2 before the division is performed). By adding C7 in parallel with C_{in} in Fig. 3B, a much more practical value for C4 can be obtained.

Other Features of Amplifiers

We should give some attention to the take-off point for the sync signal. If this signal is to be obtained from within the vertical amplifier circuit, several points could be used. The one shown in Fig. 3A will give a minimum amount of loading on the vertical amplifiers because it is a point of low impedance. This point is also ahead of the vernier control, and adjustment of the vernier control to obtain a larger or smaller response will not upset the synchronization. Since the take-off point is at the front end of the amplifier, no amplification is obtained. Some oscilloscopes might require amplification of the sync signal before it is applied to the sweep generator.

When a choice of polarity of the sync signal is offered, the desired polarity is sometimes obtained by means of a double-throw switch. A potentiometer of a suitable value is sometimes bridged across two points having opposite polarities, and the position of the slider will control both the polarity and the amplitude of the sync signal.

Some oscilloscopes have provision for an inversion of the response curve on the screen. This is useful to those operators who like to compare a response curve directly with that pictured in a manual or service chart. Such inversion can be easily accomplished in the case of push-pull amplifiers if double-pole, double-throw switches are used in the output to the vertical deflection plates. In case the operator is interested in whether a positive signal will give an upward or a downward deflection of the trace, this can be checked by touching the input cable first to a ground point and then to a point of known polarity. If the oscilloscope has DC amplifiers, the trace will move in one direction and will stay there. If an AC amplifier is being used, the trace will jump momentarily in the direction of deflection for that polarity and will then return to its original position.

Expanded Sweeps

The gain of the horizontal amplifier and the amplitude of the sawtooth signal in most modern oscilloscopes are such that the horizontal sweep can be expanded considerably. By merely adjusting the horizontal gain control, the operator can obtain a sweep that is 10 times or more the width of the oscilloscope screen. In this manner, small portions of a response curve can be examined in detail.

Some oscilloscopes incorporate a special circuit for obtaining a greater expansion than the horizontal amplifier affords in normal operation. The Jackson Model CRO-2 is an example. If this model is operated in the expanded sweep position, a greater portion of the sawtooth signal developed by the sweep oscillator is fed to the horizontal amplifier. The horizontal amplifier is overdriven by this signal, but the middle portion of the sweep is linear and is greatly expanded. The linear portion of the sweep can be shifted by means of a control which varies the bias on the horizontal amplifier stage to which the sawtooth signal is applied.

PAUL C. SMITH

Dollar & Sense Servicing

(Continued from page 31)

TAG. An ordinary shipping tag sent out in hand-addressed plain envelopes brought in the phenomenally high figure of 37-per-cent return for a service business in a Philadelphia suburb. Printed in dark green on coral stock, one side of the card was worded as follows:

ANNOUNCEMENT OFFERING

A new service organization in the TV-Radio-Electronics field is now available to you. Simply call AA-0-0000 for service, and present this tag for a

20% DISCOUNT

on your total bill. This offer is made because we are confident that if you try our service once, you will become our future customer. There is **NO TIME LIMIT** on this offer, so if you do not need service now—ATTACH THIS CARD TO YOUR TV SET FOR FUTURE USE.

(over)

The reverse side gives the name and address of the shop, the phone number again in letters half an inch high, and this price schedule:

SERVICE CALL RATES

TV — \$3.50

Radio — \$2.00

Hi-Fi & other electronic equipment—
\$3.50

Color TV — \$5.00

All Materials Used Are Warranted for
90 days

(over)

Part of the success of this card apparently can be credited to the fact that it could easily be tied to or slipped into the back of the set because over half of the replies came from 3 to 6 months after the 500-card mailing went out. It's a low-cost promotion idea that's well worth trying on carefully selected names in the area you want to serve. The easiest way to obtain these names is directly from local tax records where they are arranged by street and number, so here's a good reason for making friends with your local tax collector.



TANTALYTICS. Voltage ratings still mean something in transistor circuits even if they are as low as 6 volts. In one transistor radio, the additional signal from a strong local station boosted the voltage on a 6-

volt tantalitic capacitor just enough over battery voltage to make it break down. You'll just have to learn a whole new set of precautions and tricks once you start working on these tiny transistor radios in appreciable quantities.



TRANSISTORS. In at least one electronics plant, the chief engineer has sent out to his men the following message: "Any engineer who designs an electron tube into a new computer will have to tell me why." Thousands of tube filaments heated to incandescence when a big brain goes to work are no longer attractive, now that transistors can do the same job in much less space and with practically no heating of the room.

So far, however, no big boss has issued this edict to TV receiver design engineers. It'll come some day, though, and perhaps weight of the receiver will be cut down to the point where all customers can take their ailing sets to the shop for fixing. That will definitely help the servicing business because, with city traffic conditions as they are today, your best servicing hours are wasted bucking traffic or looking for parking places.



RECRUITERS. One midwestern university reported that their 75 graduating seniors in electrical and electronics engineering were sought by just about five times that many recruiters from manufacturing plants. Want ads in the *New York Times* and other newspapers confirm this large demand for engineers. On blizzard days in the East, the California ads in eastern papers offer sunshine and bathing pools for engineers; and on smog-clogged days in Los Angeles, the ads in that city's papers extoll the virtues of smog-free air in the Midwest and East.

The demand may be high, but salaries have not gone up in proportion. Carpenters, bricklayers, and many other unionized tradesmen still make more money than engineers in far too many instances.

JOHN MARKUS

Shop Talk

(Continued from page 9)

It is possible to combine the two foregoing circuits to make a transistor checker good for testing either n-p-n or p-n-p transistors. The complete circuit is shown in Fig. 3, and this is essentially

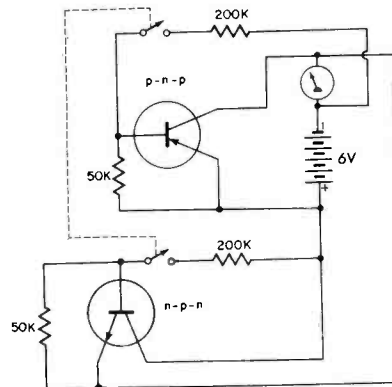

Fig. 3. A Combination Tester Incorporating the Circuits of Figs. 1 and 2.



Fig. 4. The General Electric Transistor Tester. Its Circuit Is Essentially the Same As That Shown in Fig. 3.

the circuit used by General Electric in the transistor checker which they are currently marketing. See Fig. 4. The procedure for testing a transistor would be as follows:

1. Insert the transistor in the proper socket, or attach it to the proper terminals if a socket is not used.
2. Check to make certain that the leakage current is no greater than the limits computed for that unit.
3. Depress the push button, and check to see that the current increases at least 0.3 milliamperes.
4. Check the battery voltage periodically by inserting a 2,000-ohm resistor in either socket

between the emitter and collector. With good batteries, the meter should read close to 3 milliamperes.

In the commercial form of this transistor checker (Fig. 4), the meter scale is marked off in sections labeled GOOD, FAIR, and POOR; and the relative leakage would be judged by the resting point of the needle. A short-circuited transistor will cause the needle to deflect off the scale to the right. An open transistor will be indicated if there is no meter deflection during either the leakage or the gain test.

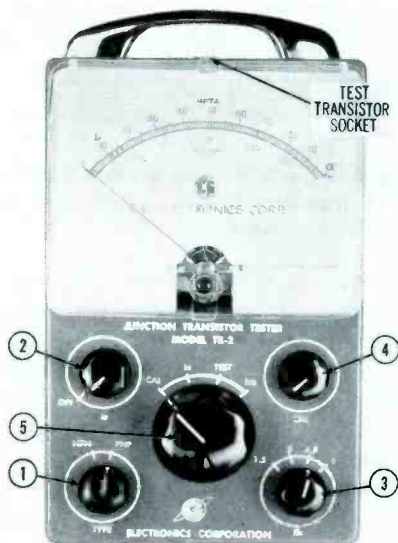
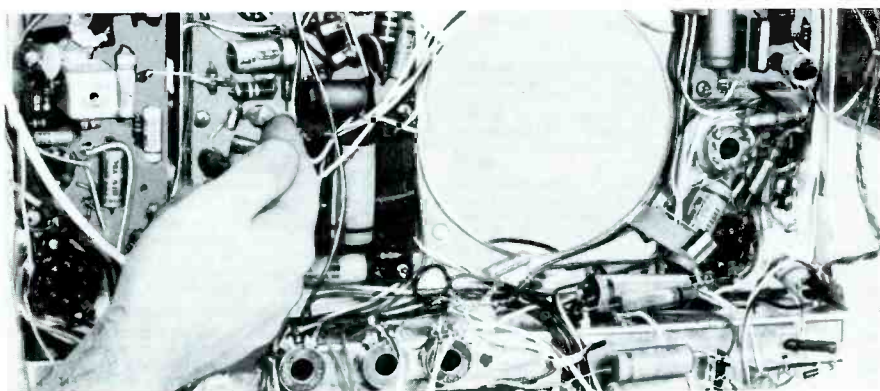

Fig. 5. The Model TR-2 Junction Transistor Tester Manufactured by the CG Electronics Corporation.

Note that the foregoing tests will not tell you anything about the frequency characteristics of a transistor. It may be that a high-frequency transistor will provide excellent gain at low frequencies but poor gain at its normal operating frequencies. The only way to make this check is to test the transistor in a suitable high-frequency amplifier; however, as manufacturing techniques improve, failures from this source should decrease. For most transistor checking, a circuit like the one shown in Fig. 3 will prove to be entirely suitable.

You will sometimes encounter transistors which possess good gain but which also possess a fairly large amount of leakage. The temptation to use such a transistor is very strong, but remember

keep your servicing on-the-go profitably with **RCA SERVICE PARTS**



This is a peaking coil. It is an exact electrical replacement for the high-Q original used in RCA Victor TV receivers. Replacement peaking coils with improper inductance values can cause "trailing reversals" and "smearing." But, with this RCA peaking coil—as with all RCA Service Parts—you get maximum assurance that original performance will be restored—in quick bench-time. This is why successful servicemen everywhere depend on RCA Service Parts to keep their servicing on-the-go, profitably. RCA Service Parts for RCA Victor radios, TV receivers, record-changers, and "Victrola" phonographs are factory-tailored to fit right, install fast, and do their job precisely. So, when it's an RCA Victor home instrument you're repairing, insist upon an RCA Service Part—available from your local RCA distributor.



SERVICE PARTS

RADIO CORPORATION OF AMERICA, HARRISON, N. J.

RCA VICTOR PRODUCTS • RCA SERVICE PARTS—made for each other!

"COLOR TV TRAINING MANUAL"

THE NEW BOOK THAT PREPARES YOU FOR SUCCESSFUL COLOR TV SERVICING

Written by C. P. Oliphant and Verne M. Ray, of the Howard W. Sams editorial staff, in practical, down-to-earth language you can understand. Presented in 3 comprehensive sections. SECTION I: Principles of the Color TV System (includes chapters on Colorimetry; Requirements of the Composite Signal; Make-Up of the Color Picture Signal). SECTION II: Color Receiver Circuits (chapters on RF and IF Circuits; Video, Sync and Voltage Supply Circuits; Bandpass-Amplifier, Color-Sync and Color-Killer Circuits; Color Demodulation; Matrix and Output Circuits). SECTION III: Servicing the Color Receiver (chapters on Setting Up the Color Picture Tube; Aligning the Color Receiver; Trouble-Shooting; Test Equipment Required). Appendices include Equations, Vectors, Color-blocks, Colorplates, Glossary. A comprehensive training course that helps you qualify for Color TV servicing. 260 pages, 8½ x 11"; profusely illustrated.

Postpaid, only \$695

HELPS YOU MASTER
COLOR TV PRINCIPLES
AND PRACTICES

only \$695

ORDER BELOW

SAMS BOOKS
keep you ahead in
ELECTRONICS

Sams books cover every phase of Electronics for the service technician, engineer, student or experimenter. Listed below are a few of the many valuable Sams books available at electronic parts distributors and leading book stores.

USE THIS ORDER FORM

COLOR TELEVISION TRAINING MANUAL \$695

- Analyzing and Tracing TV Circuits. Presents a new approach to TV servicing. 168 pages, 8½ x 11". \$3.00
- TV Service Data Handbook. Most frequently needed charts, tables and formulas required in TV servicing and installation. 112 pages, 5½ x 8½". \$1.50
- Principles & Practices of Telecasting Operations. Discusses equipment and techniques. Covers such subjects as: TV Cameras; Control Rooms; Fundamentals of Studio Lighting; Relay Systems; Maintenance Practices; Technical Production; etc. 600 pages; 6 x 9"; illustrated. \$7.95
- Radio Receiver Servicing. Covers the basic receiver types—gives time-saving hints for solving basic troubles, such as dead set, weak set, noisy set, etc. 192 pages; 5½ x 8½". \$2.50
- So You Want to Be a Ham. Tells you what you need to know about getting your license and acquiring equipment. Covers such subjects as: Conquering the Code; Getting Your Ticket; Going on the Air; Electronics as a Career; etc. 196 pages; 5½ x 8½"; illustrated. \$2.50
- Servicing TV Sweep Systems. Describes the operation, circuit function and circuit variations of vertical and horizontal sweep systems common to most TV receivers. Tells how to analyze circuits; trouble-shoots for you. 212 pages; 5½ x 8½"; illustrated. \$2.75
- The Recording and Reproduction of Sound. Widely used by Audio engineers, Hi-Fi enthusiasts, broadcasting stations and recording studios. Authoritative chapters cover: behavior of sound waves; basic recording methods; lateral disc recording; micro-groove recording; phono reproducers; microphones; home music systems; P.A. systems; amplifiers; tuners; etc. 810 pages; 6 x 9"; illustrated. \$7.95

HOW TO UNDERSTAND AND USE TV TEST INSTRUMENTS

- Completely revised and enlarged to include latest data on instruments used for Color TV Servicing. Covers use of VTVM's Signal Generators, Sweep Signal Generators, Scopes, Video Signal Generators, Field Intensity Meters and Voltage Calibrators. 208 pages, 8½ x 11". \$3.50
- Photofact Television Course. Gives a clear complete understanding of TV principles, operation, practice. Used by thousands of students. 208 pages, 8½ x 11". \$3.00
- Atomic Radiation, Detection and Measurement. Provides basic understanding of nuclear science and its applications. Thoroughly covers and illustrates circuitry and operation of the many types of detection devices. 200 pages; 5½ x 8½". \$3.00
- Basic Radio Manual. Provides all the basic facts on theory, definitions, components. Includes section devoted to actual projects that translate theory into practice. 248 pages; 8½ x 11"; illustrated. \$5.00
- Auto Radio Service Manuals**
 - Vol. 5. Presents complete, accurate service data, schematics, parts lists and photos based on actual laboratory analysis of 87 auto radio models produced during 1954-55. 288 pages; 8½ x 11". \$3.50
 - Vol. 4. 48 models; 1953; 288 pages. \$3.00
 - Vol. 3. 80 models; 1950-52; 288 pages. \$3.00
 - Vol. 2. 90 models; 1948-50; 288 pages. \$3.00
 - Vol. 1. 100 models; 1946-49; 396 p. \$4.95

There is an authoritative Sams book on virtually any Electronic subject in which you're interested. Check below for FREE Book List describing all Sams books.

Send Book List

HOWARD W. SAMS & CO., INC.

Order from your Parts Jobber today, or mail to Howard W. Sams & Co., Inc., Dept. 3-F6, 2201 East 46th St., Indianapolis 5, Indiana.

Send books checked above. My (check) (money order) for \$..... is enclosed.

Name.....

Address.....

City..... Zone..... State.....

(outside U.S.A. priced slightly higher)

Look for
SAMS BOOKS
on the
"Book Tree"
at your Parts
Distributor

that (1) it will consume more than its normal share of battery power and (2) the leakage may very well increase later. If any doubt exists, it is best to change transistors. Note that there is nothing absolutely rigid about the limits established in the foregoing tests. Some differences will be permissible, although high-gain low-leakage transistors are obviously to be preferred. The foregoing checker not only helps you to determine which transistors are good or bad and which give low or high gain, but it also aids you in evaluating transistors for proper applications.

A second transistor checker which is currently available* is

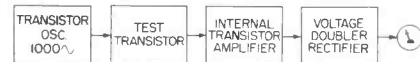

Fig. 6. A Block Diagram of the CG Model TR-2 Transistor Checker When It Is Set To Measure Gain.

shown in Fig. 5. Its principal function is to measure transistor current gain, but it will also reveal the I_{co} value. The latter is indicated in milliamperes so that it may be compared with the value specified by the manufacturer.

A block diagram of this tester is shown in Fig. 6. A 1,000-cycle transistorized oscillator develops a test signal which is applied to the base of the transistor to be tested. The output is taken from the collector of this transistor, is amplified by another transistor amplifier, and is then fed to a voltage-doubling rectifier where it is converted to DC and applied to a 50-microampere meter.

The testing procedure for a transistor is as follows: Set the function-selector switch (item No. 5 in Fig. 5) in the CAL (calibrate) position. No power is applied to the test socket; consequently, the switch should be in this position when transistors are being inserted or removed from

* There are several makes of tube testers in which the manufacturers have incorporated facilities for testing transistors. There are also a number of complex transistor testers available, but these are very high in price and were designed for engineering use. We are concerned here with testers designed specifically for transistor checks and suitable for every-day service work.

the tester. Next, turn the I_e control (item No. 2 in Fig. 5) until the switch clicks on. Do not advance the control past the point necessary to operate the switch. Using the control labeled CAL (item No. 4 in Fig. 5), set the meter to the full-scale reading.

This sets up the meter so that it is ready to indicate α or β values directly from the scale. We will return to the significance of this action after the rest of the operations of the instrument have been examined.

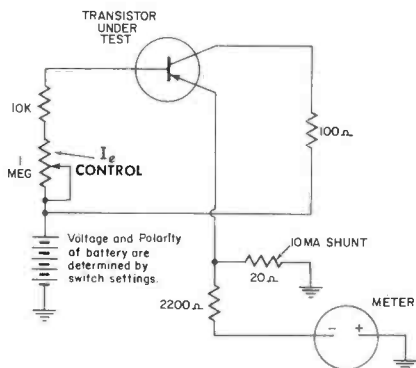

Fig. 7. Effective Circuit of the CG Model TR-2 Transistor Tester When the I_e Control Is Being Set.

Next, the TYPE switch (item No. 1 in Fig. 5) is turned to either the n-p-n or p-n-p position—whichever one is required by the transistor being tested. With the function-selector switch still in the CAL position, insert the transistor into the test socket located on top of the instrument case in front of the handle. Turn the function-selector switch to the I_e position. Then rotate the I_e control (item No. 2 in Fig. 5) until the meter indicates the proper value of I_e for this transistor. Usually this is 1 milliampere. (The proper value for I_e is given under "Average Characteristics" on the data sheet for the transistor being tested.)

For those readers who may be interested, the effective circuit of the tester when the switch is in the I_e position is shown in Fig. 7. The test transistor is connected as a grounded-emitter amplifier. The 20-ohm resistor in the emitter circuit is a shunt which makes the meter read 10 milliamperes at full scale. In the base circuit, there is a 10,000-ohm fixed resistor in series



BA Kit
\$19.40 complete
BB Kit
\$21.48 complete
Suggested net prices

NO QUESTION
about which control it pays to stock

The ones you need most often are in these two

Centralab Blue Shaft® Radiohm® Kits

Convenient, low-cost bench stocks of the radio and TV replacements which sales records show you use most often.

BA Kit — 22 volume controls, plain and switch types, in ½-meg. and 1-meg. audio tapers only.

BB Kit — 22 controls, plain and switch types, 1,000 ohms to 5 megs. — plus 4 extra switches — covering front-panel and "hidden" controls.

Both kits come in metal cabinets. You pay only the regular cost for the contents — get the cabinet free!

You pay less — get Centralab's extra quality. All controls have double-wiping action — take Fastatch® line switches — are 100% factory-tested and guaranteed.

Ask your Centralab distributor about these kits. Or send coupon for Catalog 29 that describes them.

Centralab

A DIVISION OF GLOBE-UNION INC.
922E East Keefe Avenue, Milwaukee 1, Wisconsin

B-5616

Send me Centralab Catalog 29.

Name.....

Company.....

Address.....

City..... Zone..... State.....

CRL

THE BOOK YOU NEED TO PRICE WITH SPEED... for profit

quick check for 60,000 prices
Profit-making time-money-phone
call-saver. 200 pocket-sized pages.
Replacement parts listed by manu-
facturer, product and part number.
up-to-date charging information
Completely revised 4 times a year.



"Very useful to me" - Conway, Penna.

"Nice to have all prices" - Kincaid, Fla.



"It's a perfect book" - Townsend, Ont.

and the perfect partner... DAVE RICE'S OFFICIAL TV-RADIO SERVICE ORDER BOOK

For TV, Radio, Phono or Hi-Fi service,
provides separate listings for:

Picture tubes, receiving tubes, parts and
components, serial numbers, labor and
state and local taxes. 5 1/2" X 8 1/2" - 50 sets
of triplicate orders - carbons bound in.
at parts distributors or send check to

ELECTRONIC PUBLISHING CO., INC.
180 NORTH WACKER DRIVE • CHICAGO 6, ILLINOIS
DIGEST: \$2.50 per copy.
ORDER BOOK: \$.75 each or \$6.50 per
dustproof box of 10.

with the 1-megohm emitter control. It is the latter component which is varied to establish the 1 milliampere of current in the emitter leg.

The transistor is then ready for the gain check. Accordingly, the function-selector switch is rotated to the TEST position, and the meter will indicate α and β directly on their respective scales. It is possible to obtain both readings at the same time because both quantities bear a definite relationship to each other. The readings obtained are accurate to within 10 per cent.

mately 5 to 10 microamperes. Any appreciable flow beyond this level indicates a defective unit and one that should be replaced.

In the CG transistor tester shown in Fig. 5, the I_{co} measurement is achieved through the use of the circuit shown in Fig. 9. The emitter element of the transistor under test is left open. The base is grounded, and a normal voltage is applied to the collector. Any current that flows in the collector circuit must travel through the 1,600-ohm resistor. The voltage produced across this resistor is then fed to the meter. Basically,

Fig. 8. Schematic Diagram of the GAIN Test Circuit of the CG Model TR-2 Checker.

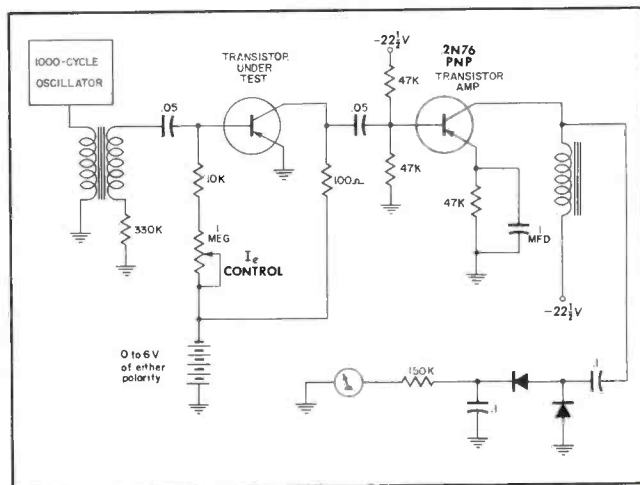

The instrument circuit when the function-selector switch is in the TEST position is shown in Fig. 8. The 1,000-cycle oscillator feeds its signal to the base of the test transistor, and the output from the transistor is fed to the subsequent amplifier. Beyond this is the rectifier where the received signal is converted to DC. Then it is fed to the meter for measurement.

The final position of the function-selector switch is labeled I_{co} . This is the current which flows between the base and collector when the collector is reverse biased and the emitter is open. From the comments made in this column in the March 1956 issue, the reader will recall that this I_{co} current is a result of the liberation from their structural bonds of electrons (and their counterparts, holes) by light or heat energy. Once released, these charges are attracted by the applied battery potential; and a current results. In a good transistor, the flow will be approxi-

the 1,600-ohm resistor is a shunt and is equal in value to the meter resistance; consequently, the full-range current reading of the meter is raised from 50 to 100 microamperes.

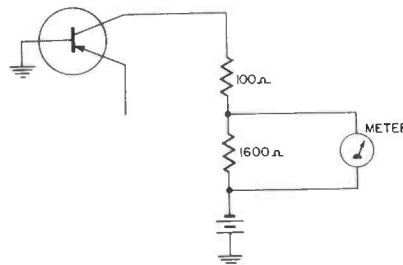

Fig. 9. I_{co} Measurement Circuit of the CG Model TR-2 Transistor Tester.

Now that the over-all operation of the tester is understood, let us see what method is used initially to calibrate the circuit so that the meter will indicate the α and β values directly. For this explanation, we will need Fig. 10. A 10,000-ohm potentiometer labeled ADJ is located in the output of the 1,000-cycle oscillator. The center arm of this control con-

nects to the base element of the transistor used in the amplifier. To find the correct setting for this arm, set up the tester as you would to check an unknown transistor; but insert a transistor of measured known values that will fall approximately midrange on the meter scale. Since this transistor will be your standard, its characteristics must be accurately known. You cannot depend on the manufacturer's published values because these are merely representative of a large group and do not specifically refer to any one transistor in that group.

Adjust the I_e control (item No. 2 in Fig. 5) to the correct value for the calibration transistor, and turn the function-selector switch to the TEST position. Adjust the CAL control until the meter reads the correct value for the calibrating transistor. This places the CAL control at the proper position.

The instrument is then removed from its case, and the function-selector switch is rotated to the CAL position. This operation removes the calibrated transistor from the circuit and feeds the oscillator signal from the movable arm of the ADJ control directly to the base of the internal amplifier. The arm is rotated until the meter reads full scale. This completes the adjustment of the ADJ control.

Let us see what we have done. We have used the CAL control and the ADJ potentiometer to set the meter scale at 100. Since there are two variables, one had to be set accurately; and in this instance, it was the CAL control that was set while a transistor of known characteristics was being measured. Then the transistor was removed from the circuit when the function-selector switch was turned to the CAL position, and the ADJ control was rotated until the meter registered 100.

In all subsequent transistor testing, the ADJ control is not touched.* Then, with the func-

* The ADJ control is set at the factory and need not ordinarily be adjusted in the field; however, if such adjustment becomes necessary because of component changes or replacement, the forgoing procedure should be followed.

Fig. 10. The Circuit of the CG Model TR-2 When the ADJ Control Is To Be Calibrated.

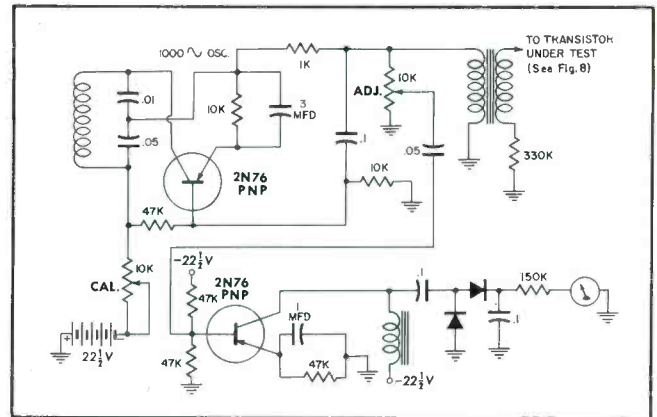

There are many reasons why you should use

QUAM

Adjust-a-Cone®

SPEAKERS

- Adjust-a-Cone® Suspension
- U-Shaped Pot
- Heavier Magnetic Structures
- Factory packaged
- Universal Mounting Brackets
- Baked Aluminum Finish
- Listed in Counterfacts and Photofacts

but it all comes down to this...

ask for QUAM, the quality line,
for all your speaker needs

Your customer can hear the Quality that is built into every Quam Speaker

QUAM - NICHOLS CO.

234 East Marquette Road

Chicago 37, Illinois

NOW! STACKPOLE RESISTORS

(fixed composition types)

are as near
to you as these
jobbers' shelves!

✓ Conservatively rated at 70° ambient—no de-rating required at high temperatures.

✓ Meet or surpass today's critical performance requirements, including MIL-R11 specifications.

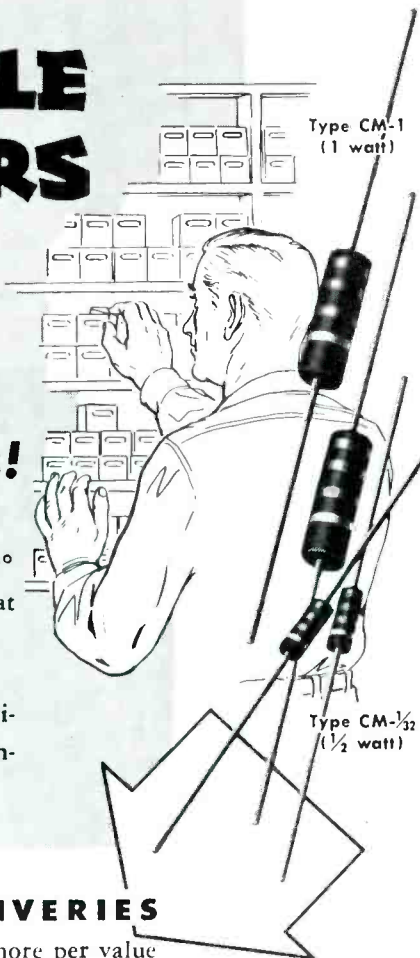

FOR PROMPT DELIVERIES

in quantities of from 1 to 1,000 more per value

ALBANY, N. Y. E. E. Taylor Co.	HARTFORD, CONN. R. G. Sceli & Co., Inc.	PASADENA, CAL. Electronic Supply Corp.
ALLENTOWN, PA. Federated Purchaser	HAZLETON, PA. Moyer Electronic Sup. Co., Inc.	PHILADELPHIA, PA. Almo Radio Co.
BALTIMORE, MD. Konn-Ellert Electronics Inc.	JAMAICA, N. Y. Norman Radio Dist. Inc.	RICHMOND, VA. Meridian Electronic Eqpt. Co.
BINGHAMTON, N. Y. Morris Distributing Co., Inc.	KANSAS CITY, MO. Burstein Applebee Co.	SAGINAW, MICH. Saginaw Distributors Inc.
BOSTON, MASS. DeMambo Radio Supply	LAFAYETTE, LA. Rolphs Radio Electronic Supply	ST. LOUIS, MO. Van Sickle Radio Corp.
BUFFALO, N. Y. Radio Equipment Corp.	LANSING, MICH. Offenhauer Co.	SCRANTON, PA. Fred P. Pursell
CANTON, O. Video Wholesalers Inc.	MANSFIELD, O. Wholesaling Inc.	SPRINGFIELD, ILL. Suter TV Supply Inc.
CEDAR RAPIDS, IOWA Gifford-Brown Inc.	McKEESPORT, PA. Borno Radio Co.	SPRINGFIELD, MASS. Soundco Electronic Supply Co.
CLEVELAND, O. Pioneer Electronic Supply Co.	MILWAUKEE, WISC. Radio Parts Co., Inc.	SYRACUSE, N. Y. Morris Distributing Co., Inc.
COLUMBUS, O. Hughes-Peters Inc.	MOUNTAINSIDE, N. J. Federated Purchaser	TAMPA, FLA. Thurow Distributors Inc.
DALLAS, TEXAS Wholesale Electronic Supply	NEWTON, MASS. Leonard Greene Shaw Co.	TRENTON, N. J. The Dragon Co.
DAYTON, O. Srepcu Inc.	NEW YORK, N. Y. Arrow Electronics Inc.	TUCSON, ARIZ. Elliot Electronics Inc.
DES MOINES, IOWA Radio Trade Supply Co.	NEW YORK, N. Y. Electronics Center	WASHINGTON, D. C. Electronic Wholesalers Inc.
HAGERSTOWN, MD. Zimmerman Wholesalers	NORFOLK, VA. Radio Equipment Co.	WATERBURY, CONN. Bond Radio Supply
	OAK PARK, ILL. Melvin Electronics Inc.	WICHITA, KAN. Interstate Electronic Sup. Corp.

Distributors' Division

STACKPOLE CARBON COMPANY
26 Rittenhouse Place, Ardmore, Pa.

tion-selector switch in the CAL position, the proper position for the CAL control is the one at which the meter reads 100. Next, to test an unknown transistor, rotate the function-selector switch to the TEST position. The oscillator signal goes to the base of the unknown transistor. If you check the secondary circuit of the coupling transformer that brings the signal from the oscillator to the transistor under test, you will see that it contains a 330,000-ohm resistor. This high impedance takes most of the applied signal, and the transistor under test receives only about 1/100 of the voltage. The transistor under test then amplifies the signal, and the amount is recorded on the meter.

The situation is the same as though we had taken the output of an audio generator and applied it directly to a VTVM and as though 100 volts had been indicated. The output of the oscillator was then divided by 100, and this one volt was fed to a test amplifier. As measured by the VTVM, the output of the amplifier would be equivalent to the gain of that amplifier.

We have taken the time to analyze each of these testers in detail so that the service technician will have a clear understanding of the importance of the characteristics of a transistor and so that he will know how to measure their values. With this information, he will be in a far better position to evaluate the worth of an unknown transistor than if he had merely learned how to use a transistor checker without understanding what was being measured.

MILTON S. KIVER



If so, please notify us by the 15th of the preceding month. This will assure uninterrupted delivery of each of your copies of PF REPORTER.

Also, please include your present address. If possible, simply send the address label from one of your back issues. Mail both to:

PF REPORTER

2201 E. 46th Street • Indianapolis 5, Indiana

PF REPORTER • June, 1956

An 8 Inch Check Tube

(Continued from page 23)

the yoke along with the chassis instead of attempting to unsolder the yoke leads.

Receivers in which the picture tube is mounted on the chassis can usually be serviced conveniently with the picture tube in place. There would be some advantage in using a check tube in place of the picture tube if a chassis were undergoing extensive repairs. The implosion hazard would be greatly reduced, and the chassis would be much lighter. The chassis could therefore be moved around on the bench with considerable freedom during a long series of servicing operations.

A picture tube which is mounted together with a vertical chassis on a common base may sometimes be replaced with an 8XP4 during servicing. The chief advantage of this substitution would be that the parts on the front side of the chassis would become much more accessible.

When the 8XP4 is connected to any vertical chassis, it may be propped up in the same position in which the regular picture tube is normally mounted. See Fig. 1. The U-shaped support which is shown in the figure is a very handy prop. It should be placed under the front of the tube because the weight of the tube is concentrated

near the face. Since the tube is supported at two points, it is held steady and does not tend to rock from side to side as it might if it were set upon a flat surface.

The neck of the check tube may be supported by the yoke if the latter is fastened to the chassis by a more or less rigid mounting bracket. More often than not, a yoke is attached to a vertical chassis only by its leads. The tube must support the yoke in this case, and the neck of the tube should be propped up on some object such as a block of wood.

An important advantage of the arrangement shown in Fig. 1 is that all connections to the 8XP4 can be made without the use of extension cables in spite of the fact that the yoke and second-anode leads of most vertical chassis are very short. Notice also that the check tube does not interfere with the accessibility of parts on the wiring side of the vertical chassis. Nearly all servicing operations can be carried on while the tube is in the position shown in the figure.

The check tube will be held in place most firmly and the best possible picture will be obtained if the yoke is pressed tightly against the bell of the tube. A clamp which will accomplish this can be made from a discarded ion trap or a centering-magnet assembly. The magnets should be removed from whichever is used.

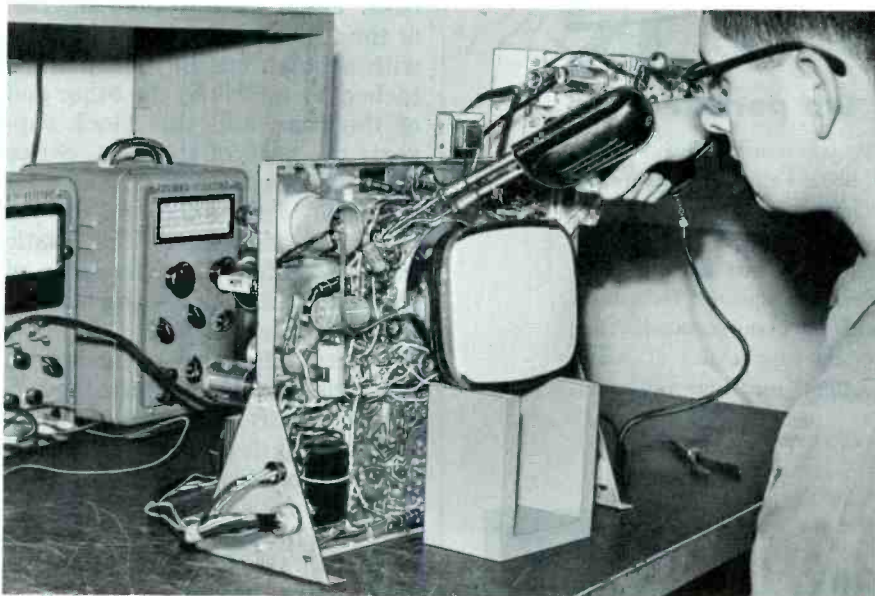

Fig. 1. Technician Repairing a Vertical Chassis to Which an 8XP4 Check Tube Is Connected.

now!

GE

STACKPOLE

Packaged

CARBON

RESISTORS

at your

G-C Stackpole

Distributor



The same genuine Stackpole Carbon Resistors used everywhere are now packaged for greater convenience and protection. You'll find them in their handy plastic boxes at your G-C Stackpole distributor. Look for . . . insist on . . . exact replacement G-C Stackpole Carbon Resistors.

G-C ELECTRONICS MFG. CO.
Division of General Cement Mfg. Co.
919 Taylor Avenue • Rockford, Illinois

Go To The Distributor Displaying
The G-C Stackpole Sign

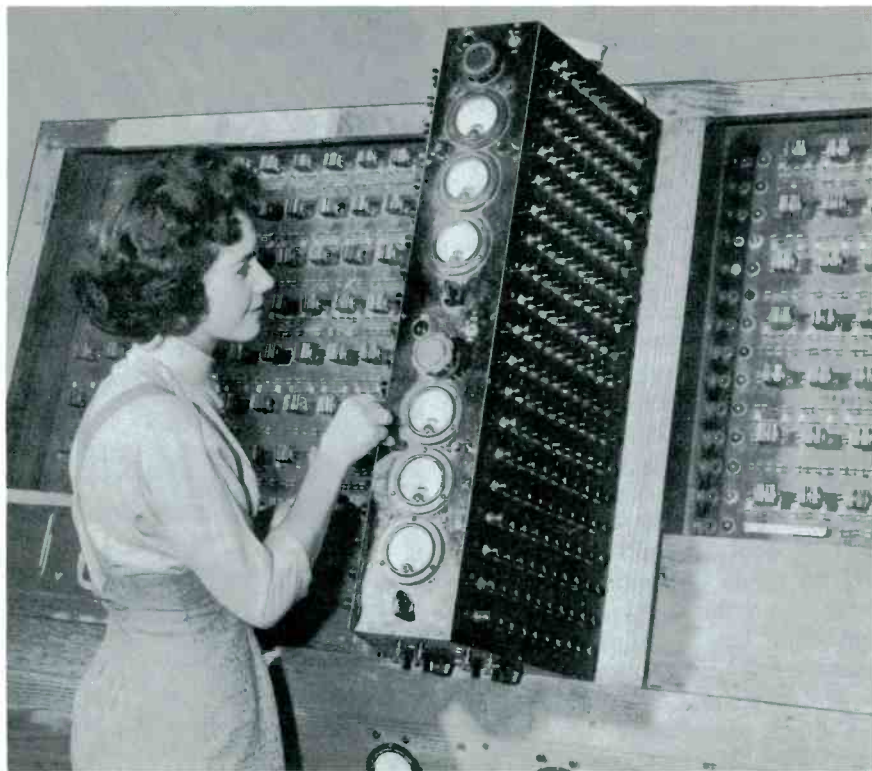

Every RADIO RECEPTOR

Safe Center

selenium rectifier

*passes this "final exam"
before going to work for you!*



100% inspection means top performance

Our special test panel which simulates actual circuits, measures performance of each rectifier for a full half hour. Failures hit the reject bin—*You* get only the units that graduate with full honors.

100% factory testing is one more reason so many servicemen prefer Radio Receptor rectifiers. They're dependable, last longer... And there's a standard replacement for sets of every radio and TV manufacturer. Your parts distributor can supply you... Demand RRco. "Safe Centers" next time you order.

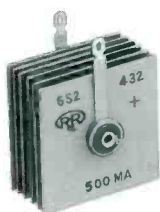

Semiconductor Division

Radio Receptor Company, Inc.

Radio and Electronic Products Since 1922

240 Wythe Ave., Brooklyn 11, N. Y. • EVergreen 8-6000



The clamp is slid forward on the neck of the tube until it presses against the yoke. The friction of the clamp against the neck prevents the tube from sliding out of place. The positioning of this clamp is shown in Fig. 2.

A special rack in which the 8XP4 can be rested is a useful accessory for the service bench. Fig. 3 shows a device of this kind being used during the servicing of a horizontal chassis. Some receivers, like the one shown in Fig. 3, are already equipped with connecting leads that are long enough to reach the check tube without difficulty. The picture-tube leads of some other receivers are so short that a direct connection is awkward or impossible to make. In the latter case, extension cables must be employed. The rack can be used with any kind of chassis. The check tube is protected against rough handling when it is mounted in this manner, and it can be easily moved around on the bench. The rack is also useful as a storage place for the tube.

A simple mounting rack can be built rapidly out of materials which are easily obtainable. The one in Fig. 3 was made from several small pieces of wood, a strip of sponge rubber salvaged from the rim of an old picture tube, and an elastic band obtained at the dime store. A strip of wood and two small triangular blocks are fastened to one end of a wood base. These serve to hold the bell of the tube. A large block of wood with a notch cut in its top is attached by screws to the other end of the base, and this block supports the neck of the tube. Strips of rubber are used as cushions for the neck of the tube and for the rim of the faceplate. The elastic band is fastened to the sides of the triangular blocks; and when it is slipped over the bell of the tube, it exerts a forward pressure and seats the tube firmly in the mounting. As a consequence of the moderate strength and forward direction of the tension exerted by the elastic, the base of the tube can easily be lifted so that a yoke can be placed around the neck.

The 8XP4 might be permanently enclosed in a more elaborate mounting such as a box which

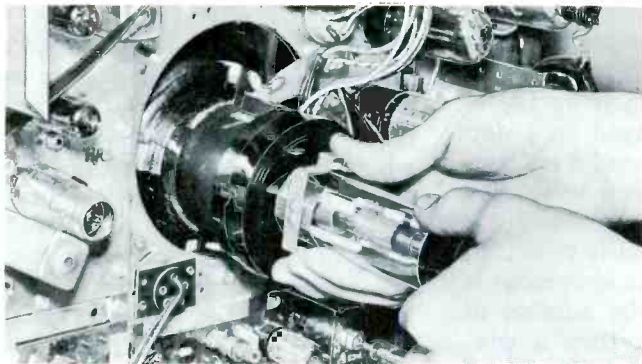

Fig. 2. A Clamp Being Placed on the Neck of a Check Tube.

could be used in the shop or carried in the service truck. Why would a technician wish to carry an 8XP4 in the service truck? The answer is that a suitably mounted check tube would be useful on home calls for the testing of picture tubes by substitution. If the technician specializes in servicing receivers which have approximately the same yoke inductance, he may build a self-contained unit that includes a yoke and a set of extension cables as well as a check tube. He should keep in mind the fact that no single yoke will work properly with all receivers. For general use, such a box should be designed so that various yokes can be temporarily slipped over the neck of the tube. The mounting brackets should be kept clear of the neck. This could be done if the bell of the tube were held in place by straps fastened to the front of the box.

The 8XP4 is one of the smallest picture tubes which has ever been designed for use with 90-degree deflection systems. This feature of wide-angle deflection is very

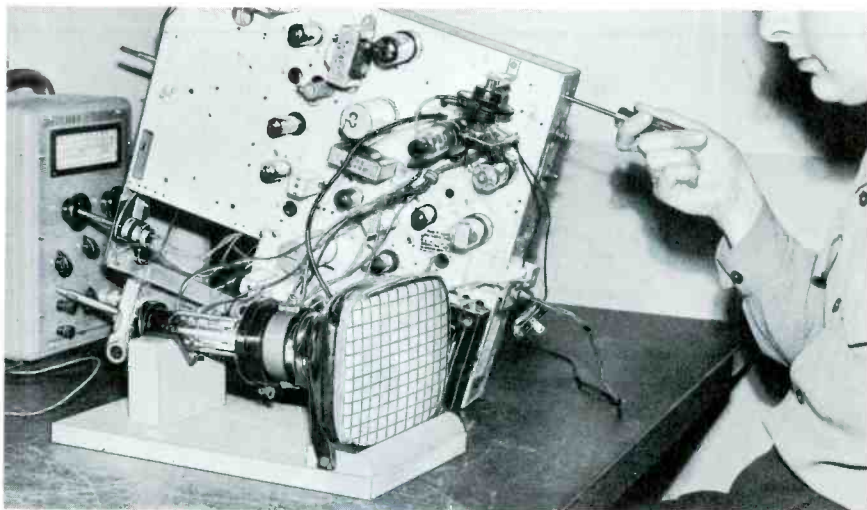

Fig. 3. Technician Servicing a Chassis with the Aid of an 8XP4 Tube Mounted in a Rack.

desirable because it enables the check tube to display almost the entire raster produced by a 90-degree sweep system. The technician therefore can detect troubles that affect the edges of the picture, and he can also make adjustments of size and linearity while the check tube is being used. A typical test pattern which was pro-

duced on the 8XP4 by a receiver having 90-degree deflection is shown in Fig. 4A.

Compare this picture with the test pattern in Fig. 4B. The latter was produced by a receiver with a 70-degree deflection system. The picture does not completely fill the screen, and some pincushion effect is visible at the edges of the picture. Imperfections of this sort may be expected when the 8XP4

is used in a 70- or 53-degree deflection system, but they will detract only slightly from the usefulness of the tube.

Broad tolerances in operating voltages are permissible when the 8XP4 is used. The adaptability of the check tube makes it valuable as a substitute for nearly any picture tube. THOMAS A. LESH

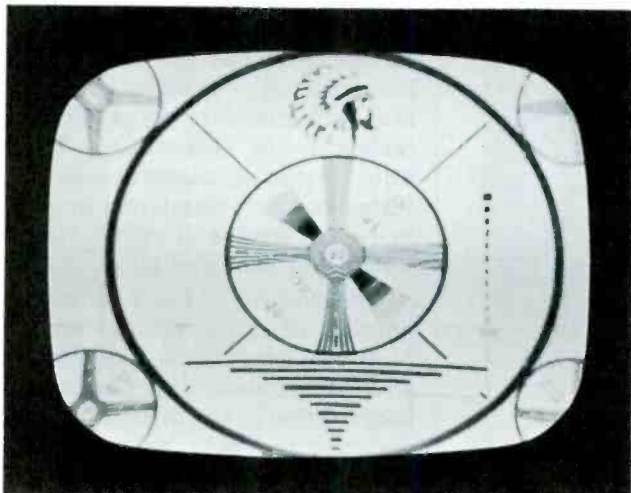

(A) By a Receiver with 90-Degree Deflection.

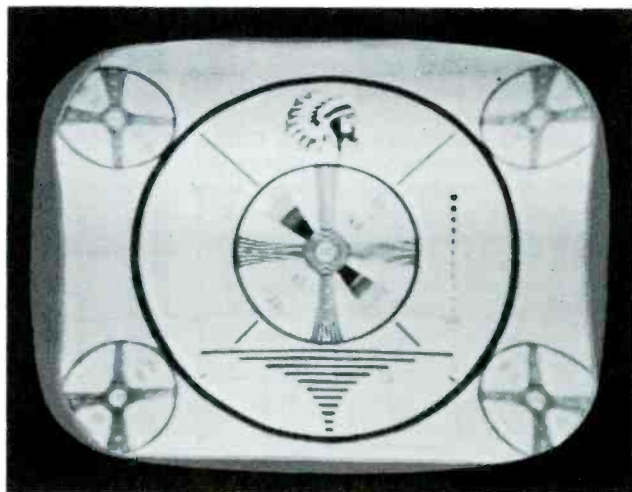

(B) By a Receiver with 70-Degree Deflection.

Fig. 4. Test Patterns Produced on the 8XP4 Tube.

Window Displays

(Continued from page 25)

has permitted the dealer in electrical and electronic appliances to display his products in a different manner. Objects are no longer placed in the window. Instead, many appliances are arranged in a showroom at the front of the shop for the passing public to view from the street.

The interior of this type of showroom should be well lighted and neatly kept. A number of small appliances, such as table-model radios, displayed on a step type of rack and placed a few feet back from the window will make an attractive display and will not completely obstruct the view into the showroom. If the storeroom is rather shallow or the number of sales items limited, then a window display with a platform and backdrop is much more desirable.



The Ceramic Capacitor with the "Million Dollar" Body

Over a million dollars was spent to make C-D the only plant in the world in which a ceramic capacitor is completely made from raw powder to finished unit. Scrupulous supervision and control of quality is paramount in the production of a C-D Ceramic. "Quality"—had top priority. The "Million Dollar Body" is proof of the rugged stability, the consistent uniformity and dependable long life of C-D Ceramics. Ask your nearby C-D Distributor for a catalog or write direct to Cornell-Dubilier Electric Corporation, South Plainfield, N. J.

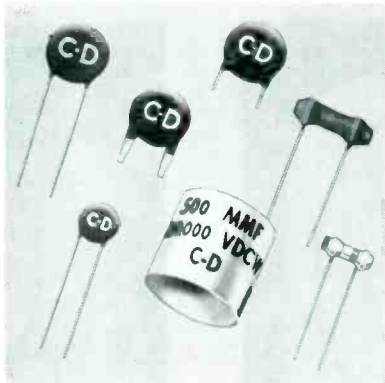

Cornell-Dubilier capacitors

South Plainfield, N. J.; New Bedford, Worcester & Cambridge, Mass.; Providence & Hope Valley, R. I.; Indianapolis, Ind., Sanford, Fuquay Springs & Varina, N. C.; Venice, Calif., & subsidiary, The Radiart Corporation, Cleveland, Ohio.

Platform and Backdrop

A temporary type of platform can be easily built and may be decorated in keeping with the type of the shop and with the objects which will make up the display. An attractive window platform and backdrop can be made from some of the most simple and inexpensive materials. For instance, heavy corrugated or wood boxes when covered with decorative materials can be put together to form an attractive platform that is sturdy enough for small objects that are to be displayed.

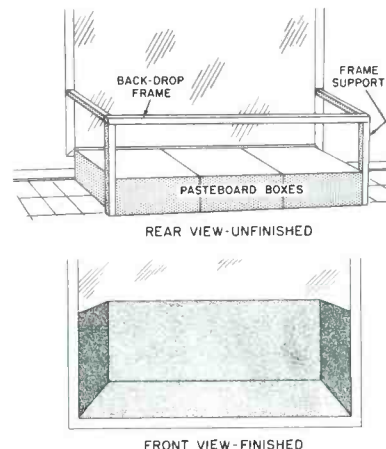

Fig. 1. Corrugated Boxes Used to Form a Platform for a Window Display.

The line drawing of Fig. 1 illustrates how boxes can be used in this way. The backdrop frame shown in this figure may be constructed of wood, metal rods, or heavy wire. When wiring is employed, additional supports are usually required. The frame may be covered with drapery material, seamless paper, oilcloth, plastic, or a similar material. Other materials that may be used in the construction of window platforms and backdrops are plywood, plasterboard, or Masonite. These solid types of construction materials can be attractively finished in pastel shades of either water-base or oil-base paints.

The drawing of Fig. 2 illustrates another design suggested for the platform and background of a window display. The platform is constructed in the form of a table, and the top may be painted or neatly covered with a suitable material. All the space under the platform may be enclosed and made into cabinets for storage.

The frame for the backdrop can be positioned as shown in the drawing, or it may be placed at the ceiling level. The latter position has one disadvantage in that the high backdrop would block light from entering the shop through the front window.

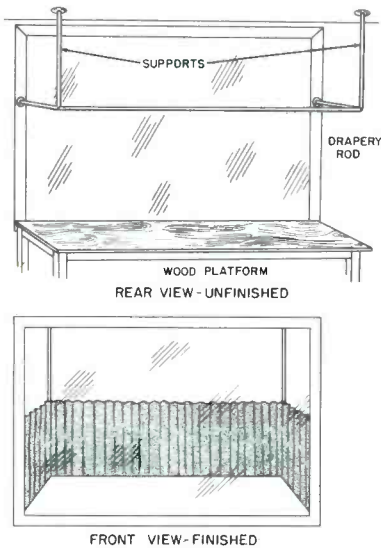

Fig. 2. A Table and Draperies in a Window Display.

Window backgrounds are not limited to drapery or fiberboard materials. The shop owner may use other materials such as paneled screens, blinds, wallpaper, or sections of frosted glass. Keep in mind that the basic illustrations and ideas presented in this article can be improved upon and modernized by the individual when he designs his own display window.

In general, the background for any display should be light in color to avoid street reflections on the glass. When light-colored objects are displayed, a dark background is usually necessary for contrast. If the window of a service shop is high and narrow, horizontal lines in the background will help produce an appearance of added width. An excessively wide window will tend to have improved proportions when vertical lines are used in the background. Another trick is to use diagonal lines which will often lend depth to a shallow window.

Lighting

A good window display should be designed so that it will attract attention from the street as well as from the sidewalk and so that it

It's All NEW!



Model **UX**

WEBSTER ELECTRIC
Featheride[®]

REPLACEMENT CRYSTAL CARTRIDGE

You've never seen a handier, more versatile crystal cartridge than the new Featheride Model UX—ideal as a replacement for WEBSTER's Models CX, C8, C10, C14, C15, etc., Astatic 407, Shure W70 and many, many others.

- NEW**... small, lightweight aluminum construction for broader and better applications
- NEW**... pin terminal connectors for fast, trouble-free installation
- NEW**... direct mounting to all standard 1/2" and the special RCA 5/8" mounting centers
- NEW**... single stud mounting of WEBSTER ELECTRIC Model C10 provided for by standard 1/2" mounting
- NEW**... the only lightweight crystal cartridge furnished complete with needle

See our latest Replacement Chart for cross-reference on the new Model UX. *Write for free copy.*

List \$4⁹⁵ complete with WE-122 Push-in Needle • ORDER TODAY

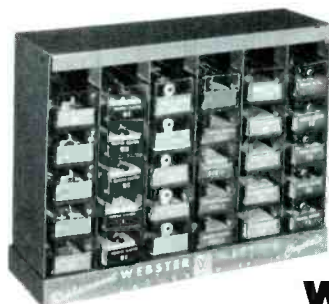

NEW Shelf-size Dispenser

(with self-stacking interlock feature)

Include this Replacement Crystal Cartridge Dispenser (No. 17928-1) with your next cartridge order. Holds five each of six Featheride cartridges. **FREE** with order for 30 or more cartridges—any assortment you choose. Get yours now!

WEBSTER
RACINE



ELECTRIC
WISCONSIN

PROFIT COMES BACK!

to phono cartridge and needle market with...

Electro-Voice®

POWER-POINT

Power-Point replaces over 90% of all popular phono cartridges. Power-Point cuts inventory costs! Power-Point is easy to change! Power-Point sells on sight!

What Power-Point is: Power-Point is a ceramic phono-graph cartridge with jeweled* playing tips in a SINGLE unit—replaceable in seconds without tools! Provides fresh cartridge and two needle-tips at less cost than comparable needles alone.

Four basic types provide Power-Points for any record speed. Just \$3.95 list.

Mail the coupon for complete information.

*Superior synthetic sapphire or natural diamond.

Electro-Voice

Electro-Voice, Inc. • Buchanan, Michigan
Please send me details and specifications of the NEW Electro-Voice Power-Point.

company _____

address _____

city _____ state _____

signed _____

will have appeal both day and night to the passing public. This is often accomplished by installation of lighting fixtures in the display window. It is a known fact that properly controlled lighting can do more for a window than any other single element. When constructing a window platform and background, it is a good idea to install electrical outlets in several locations around the window. Lights are necessary for night advertising, but they are also desirable during the daytime to offset any strong reflections on the outside of the window. Care should always be taken when lights are being positioned in a window so that they will not glare directly into the eyes of passers-by.



Fig. 3. A Neon Sign and Flood Lamps in a Window Display.

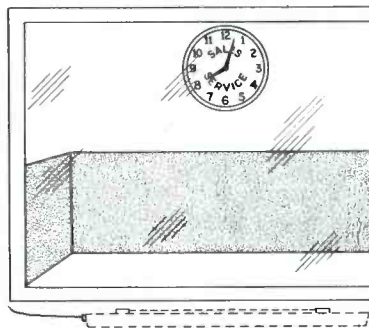

Fig. 4. Simple Window Display Featuring an Electric Clock.

Many attractive displays can be derived from novel lighting effects. The use of colored lights or a revolving color wheel and one white light can produce very eye-catching displays. The drawing of Fig. 3 illustrates a shop window with a neon sign and two flood lamps. The fixtures for the flood lamps should be portable so that they can be placed in different positions, and in this way a wide variety of lighting effects can be produced.

Fig. 4 shows another display having one large fluorescent fixture mounted on the inside base of the window. As an added attraction, an electric clock may be

placed near the top of the window because a clock displayed to the public can become very valuable in the way of advertising. People in the neighborhood begin to rely on your clock for the correct time, and thus the name and services of your organization are more frequently brought to mind. The illustration in Fig. 5 shows an inside view of a display window with three fluorescent lighting fixtures.

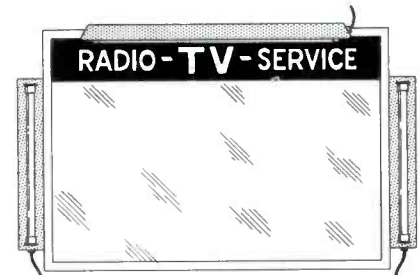

Fig. 5. A Window Display With Three Fluorescent Lights. One Illuminates a Service Sign.

The top portion of the window may be devoted to a sales or service sign. If the glass is painted black with white lettering, this type of sign becomes very effective at night.

Many attractive night displays can be achieved through the use of other lighting techniques. The drawing of Fig. 6 shows the result obtained from directional lighting. In this example, each light fixture is enclosed in a long cylinder that beams the light to one area. This lighting effect can also be produced by use of spotlights which are capable of being focused on individual display items.

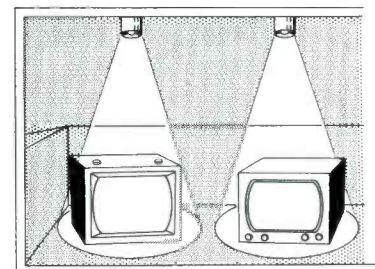

Fig. 6. Directional Lighting in a Window Display.

The name, address, and telephone number of the service organization should be clearly displayed to the public. Other signs describing the types of sales or services performed should also be

placed at the front of the shop. If there are too many signs, however, the passers-by may become confused, and the advertising message may be completely lost.

Novel Displays

The design and composition of a window display should have balance and show imaginative ingenuity. All the available window space should be used to the best advantage, but a pleasing pattern must be followed. There are many "props" and "gimmicks" which are designed to attract attention to window displays. Moving objects or signs are very effective for this purpose.

Other items such as objects that appear to pierce the glass of the window or mechanical devices that tap on the glass periodically are attention getting. Some stores employ electric fans to keep their windows from steaming up during the winter. These fans can also inject motion into a display if paper streamers or plastic bubbles are placed in the air currents. Other ingenious moving displays may be created with old phonograph turntables or antenna rotators.

A volume display of a small accessory item is often impressive. The duplicate units may be arranged in a number of novel ways with an attractive background. These small accessory items are those usually stocked in the shop to accommodate the customer rather than for the profit involved. Anyone passing your window is subjected to impulse buying; therefore, if a person glances at a window display of batteries for portable radios, he may recall that he needs one for his own radio and he may enter the shop immediately. If this new customer is satisfied and impressed, he constitutes a potential customer for other merchandise and services rendered by your organization. To reduce the amount of money invested in a volume display, you can use dummy boxes or cartons. The error most frequently committed in window planning is that of a cluttered display. Remember that it is not necessary to represent the complete sales line of the organization in one window.

BOTH BEAUTY AND TOP PERFORMANCE TELCO GOLDEN *Switch-O-Matic*

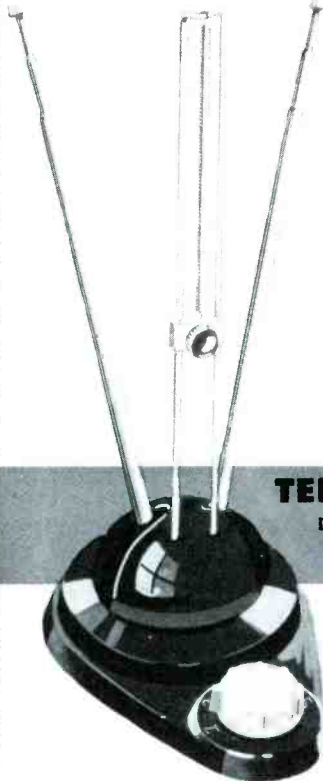

The very latest in indoor TV antennas. Superior in both performance and beauty. With 6 phase switch, you tune to the sharpest, most brilliant picture possible. Tip-proof, felt padded base. Engineered for color TV, as well as UHF-VHF. Telescoping elements. Packaged in attractive, eye catching, carry-out box.

No. A-8140 Golden Switch-O-Matic Indoor Antenna

SEE YOUR DISTRIBUTOR

He can show you the complete line of Telco Antennas.

TELCO ELECTRONICS MFG. CO.

Division of General Cement—Textron American, Inc.

ROCKFORD, ILLINOIS

AN ANTENNA FOR ANY TELEVISION INSTALLATION

The Telco antenna line is complete! Over 100 different models for UHF or VHF, or both, in indoor and outdoor types.



FREE CATALOG
Send a postcard requesting free antenna catalog NOW.

ATTRACTIVELY PACKAGED

SAVE with SECURITY



Because Wright Wire Strand comes to you pre-measured and uncoils without snarling, it gives to you unique economy. Quality wire, perfectly stranded and heavily galvanized, the bright Wright way. **SAVE with Wright.**



Prompt deliveries from stocks in Worcester, Chicago, Atlanta, New Orleans, Houston, Dallas and Los Angeles.

G. F. WRIGHT STEEL & WIRE CO.

249 Stafford St. • Worcester, Mass.

Merit

FIRST IN EXACT REPLACEMENT.

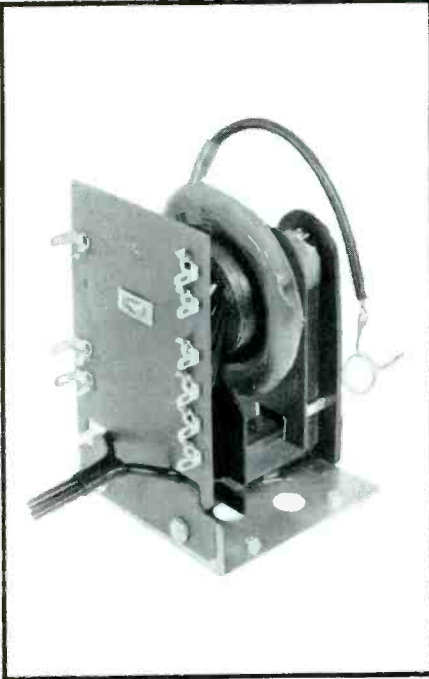

HVO-36 FOR EXACT REPLACEMENT IN ARVIN, CBS-COLUMBIA, DOUGLAS, DUMONT, EMERSON, FIRESTONE, FLEETWOOD, HOFFMAN, KAYE-HALBERT, PACKARD BELL, PACIFIC MERCURY, RADIO CRAFTSMAN, SILVERTONE, STEWART-WARNER, STROMBERG-CARLSON, TRUETONE, WESTINGHOUSE . . . another in the complete Merit line of exact and universal transformers, yokes and coils. Merit is the only manufacturer of transformers, yokes and coils who has complete production facilities for all parts sold under their brand name.

Merit

MERIT COIL & TRANSFORMER COMPANY
4427 N. CLARK ST., CHICAGO 40, ILL.

When displaying any merchandise, it is a good idea to suggest the use of the article to the public. For instance, a flashlight, flash camera, or portable radio should be part of a battery display. Phonographs may be accompanied by popular hit records, and television sets usually become more desirable if a TV program is placed nearby with the outstanding events of the week underlined.

Many promotional items that can help make a window display a success may be obtained from manufacturers within the industry. Some of these articles are free, and others may be purchased at reasonable cost. Such items as neon signs, banners, authorized dealer or service decals, plastic price signs, de luxe background displays, turntable displays, light-flashing devices, racks, stands, billboards, fluorescent signs, electric clocks, and many others that are attractive and novel are available.

Objects in and backgrounds for a window display should never be permitted to become unattractive because of soiling or fading, or for any other reason. Frequent changes in displays will keep up public interest in your neighborhood and will lend an air of modernity to your business. Basic win-

dow displays should be changed with the different seasons of the year at least. Some suggestions for changing seasonal displays are presented in Table I.

The owners of many radio and television service shops prefer displays that suggest the ideas of dependable service, fair prices, and guaranteed work. This type of display can take numerous forms. One may be to display two television chassis, one representing the set before repair and one after repair. Another may show a difference in the picture quality with emphasis on the cleaning of every set repaired. Another display may illustrate the operational differences between two receivers when one has a proper antenna installation and the other does not.

A large picture tube reproducing a clear picture without the aid of any visible chassis can make an interesting window display. A picture tube employing electrostatic focus may be placed in the window and the chassis hidden from view under the window platform. All the leads required for the tube and yoke may be concealed by a hollow pasteboard cylinder that also serves as a support. One basic design for this idea is illustrated in the drawing of Fig. 7.

The advertising of popular

TABLE I
IDEAS FOR SEASONAL DISPLAYS

SEASON	FEATURED SALES ITEMS	FEATURED SERVICES	FEATURED HOLIDAYS	FEATURED SPORTS
Spring	Auto Radios Aerials for autos Rear-seat speakers Light bulbs Fuses	Radio repair Cleaning TV screens Installation of PA and hi-fi systems	Easter Mother's Day Father's Day Flag Day	Baseball Fishing Boating Auto racing
Summer	Portable radios Batteries Tubes Clock radios	Repair of auto radios and portable radios	July 4 Labor Day	Baseball Swimming Travel Golf
Fall	Antennas Boosters Converters Antenna rotators Phonographs	Antenna installation Phonograph repair	Hallowe'en Thanksgiving	Football Hunting Bowling
Winter	TV sets TV tables TV lamps Radios	Repair of TV sets and small appliances	Christmas New Year's Valentine's Day	Basketball Ice skating Boxing Skiing

brands of replacement parts used in repairing radio and TV receivers is another means of expressing quality service to the public. This setup may take the form of a volume display with signs that give the idea of guaranteed service work. A TV set with a large screen

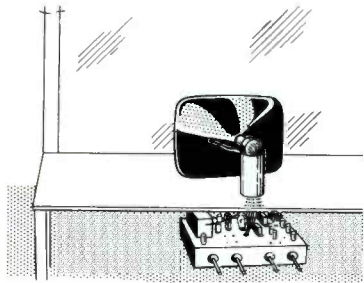

Fig. 7. Window Display Featuring a Picture Tube Powered by a Hidden Chassis.

is very common and receives little attention from the passing public, but one or more small 7-inch sets operating in a display window often stimulate the curiosity of the passer-by. Another novel display like that in Fig. 8 may represent a sick or injured television set. The idea of a hospital room could be indicated in the background, and the advertising message might follow the theme by describing the professional attention given each service job.

In many areas, television sales have reached a high degree of saturation and the public has again become conscious of radio entertainment. This change of buying interest seems to stem from the fact that radios can be

used in a number of places and for a number of purposes for which television is limited. Promotional advertising in these areas should include such sales "pitches" as the need for a battery-operated portable radio for use either in case of a national defense emergency, to carry to a football game, or for listening to outstanding sports events that may not be covered by television.

A window display featuring auto-radio repairs and accessories will have added interest if a few toy automobiles become part of the display. A small effort of this nature will usually make the window more attractive than the general run-of-the-mill displays. Certain items of test equipment used

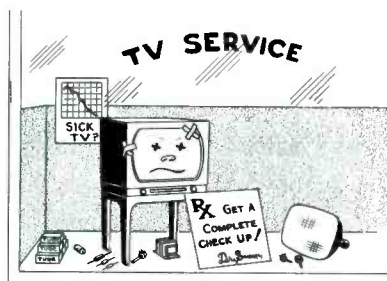

Fig. 8. A Novel Window Display.

in the service shop can often form impressive displays. For instance, an extra oscilloscope placed in the window may be connected to a microphone which is mounted outside the store front. The impulses will produce an indication on the screen of the oscilloscope. A small speaker may be used in place of the microphone if the oscilloscope is connected across the voice coil.

The question of whether merchandise in a window display should be clearly labeled as to price depends a great deal upon the class of the customers. In most cases, the customer will prefer to know in advance the price of any item he is interested in buying. Many of the shops located in the average neighborhoods place more of an emphasis on prices, time-payment plans, and large trade-in values offered by their organization. It is common for this type of shop to have its windows covered with printed sales messages relating the current bargains. This style of advertising is effective

in certain areas if it is controlled properly, but the general public seems to favor variety. If the windows are continually plastered with large signs, they soon become insignificant to those who pass by often.

Sales and service shops in other localities where quality is of the utmost importance may find it more appropriate to display only a small amount of printed advertising. When a price tag or card is to be used in a window display of such an organization, it should be small with a fairly wide border and should be neatly lettered. This arrangement will usually be in keeping with the character of the shop and the surrounding neighborhood.

Remember that a window display must be modern and above all neat and clean if it is to be appealing. The shop owner should keep a constant check on his window display for dust, fallen objects, or burned-out light fixtures. Another simple operation which should never be overlooked is the cleaning of the window glass.

It is sincerely hoped that the suggestions put forth in this article will inspire the service shop owner to improve his store front and window displays and that the improvement will gain for him additional business.

LESLIE D. DEANE

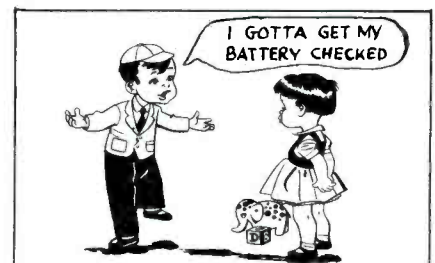

BONE BATTERY. At Children's Memorial Hospital in Chicago, miniature batteries are being built into children's legs to stimulate bone growth when legs are of unequal length. In one case, a leg bone grew $\frac{3}{4}$ inch in 9 months under irritation from 0.03 volt generated by aluminum in contact with stainless steel.

Theoretically, two legs could be stimulated just as well as one to add height and stature without resorting to elevator shoes. We doubt if this technique will become a popular fad, chiefly because of the expense and pain associated with the operations. We presume it requires growing bone and hence works only for children.

MARKUS ••• Dollar and Sense Servicing

(Advertisement)

MODEL 648		MODEL 715/115/561	
TUBE TYPE	CIRCUIT	PLATE TEST	PLATE
5B15	5.0	AL27 AC689*	35
	1.23	4	4 KNS
	5	65X	2 Q
		65X	3 Q
6BE8	6.3	AL27 AC689*	20
		AL23 AC45	2 JNFS
			3 KR
6BL4	6.3	234	6
		12W	4 S

MODEL 49		MODEL 49	
TUBE TYPE	SRC.	A. P. C.	D. GATH. SHORTS
5B15	P	5.0	4
	D	5.0	4
	D	5.0	4
6BE8	P	6.3	4
	T	6.3	4
6BL4	D	6.3	7
		1246	5
			3
			3

Latest Chart Forms 648-18 - 715/115-8 - 49-3

Product Report



Editor's Note:

The material appearing in this column has been taken from literature supplied by the manufacturers of the various products. The *PF REPORTER* cannot assume responsibility for claims of originality or application.

NEW ALIGNMENT TOOLS

Seven new alignment tools intended for use during the servicing of both color and black-and-white receivers are now being introduced by Walsco Electronics Corporation.

These new tools, Nos. 2541 through 2547, have various shapes and sizes; and all are double-ended.



DISC RECORDER

The Rek-O-Kut Company has announced the availability of the Imperial, a new portable disc recorder and playback reproducer. The Imperial features a newly designed, overhead cutting lathe with interchangeable lead screws and with provisions for making run-in and run-off grooves.

The unit weighs 80 pounds and is contained in a single carrying case which measures 25 by 22 by 12 inches.



NEW PUBLICATION

The Howard W. Sams & Co., Inc., announces the publication of their newest book, *Key Check Points in TV Receivers*.

This book (KCP-1) presents voltage measurements and waveforms which are present at key points in receivers that are operating normally. This information is useful both when receiver troubles are being isolated and when the performance of a repaired receiver is being checked.

The list price of KCP-1 is \$2.00.

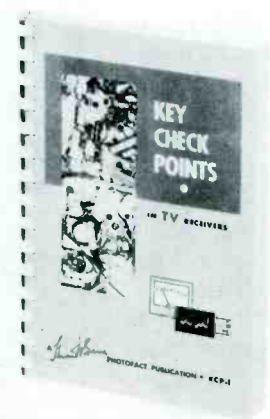

FERRITE-CORE ANTENNA



Vidaire Electronics Mfg. Corp., is producing a new ferrite-core antenna intended for replacement use in radio receivers.

The Ferri-Loop Model FL-6 is small but has high sensitivity. It may be used as a replacement for the older type of round loops. It is designed to track over the broadcast band with most of the standard variable capacitors in use. The Ferri-Loop is packaged with mounting hardware and an instruction sheet.

HIGH-VOLTAGE PROBE

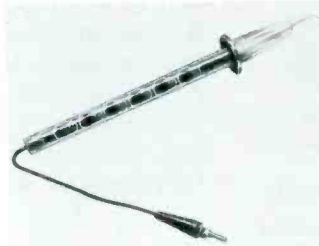

A new high-voltage probe with built-in voltage indicators has been announced by Winston Electronics, Inc., Philadelphia, Pa.

The Model 900 probe is completely self-contained and requires no external meter. A series

of neon indicators in the probe give readings from 2.5 to 25 kilivolts in six steps.

The dealers' net price for the Model 900 high-voltage probe is \$8.95.

SYNC-PULSE ADAPTER

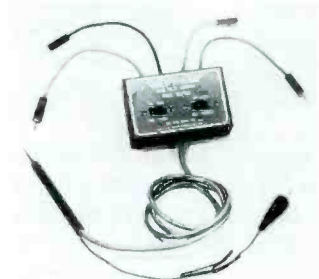

The Model 915/960 sync-pulse adapter has been announced by the Winston Electronics, Inc., Philadelphia, Pa. This adapter is intended to be used with the Model 820 sweep-circuit analyzer to generate vertical and horizontal sync pulses of either polarity.

These pulses can then be injected into the receiver in place of the conventional pulses, and a check can be made for proper synchronization action.

The dealers' net price for the Model 915/960 adapter is \$14.95.

MOISTUREPROOF MICROPHONE



A new carbon microphone, the Model C504C built for use in mobile communications equipment, has been developed by the American Microphone Company, Pasadena, California, the electronics division of the Elgin National Watch Company.

Although it was designed primarily for two-way motorcycle equipment, the microphone has a variety of possible outdoor applications and can be shielded with a special rubber boot which makes it completely moistureproof. The Model C504C weighs just 9 ounces, has an impedance of 40 ohms, and has a frequency response in the 200 to 5,000 cycle-per-second range.

Coffee Break

(Continued from page 33)

for. Her critical eye may have noted a momentary trouble that was caused by transmission difficulties or by local interference. Thinking that maybe the set wasn't quite right, she called you back. You insisted that the set operation was perfectly normal. This attitude left Mrs. Smith with one of two choices. Either she had to admit there was no trouble, in which case she would have no excuse for her complaint, or she had to insist that there was a trouble and leave it up to you to prove her right."

"Do you mean that I should have actually found something wrong with the set?" exclaimed Bud.

"Well, let's look at it this way," Tony said smugly. "There is almost always some slight adjustment which can be made to improve the performance of a set. For instance, the height and vertical linearity controls usually require slight readjustments on practically every service call. Centering and focus are examples of other controls which may require touch-up adjustments. One of the best ways I know to convince a set owner that his set is functioning properly is to misadjust several of the front and rear panel controls and then readjust them while the customer is watching the picture. Almost invariably, the customer will react favorably when the adjustments have been made to suit his or her taste."

"Yeah, but you still won't find any trouble," Bud said doubtfully.

"That all depends," said Tony, "on whether or not there is a trouble to find. The main thing is to take some positive action. This makes the customer feel that you are accomplishing something. It also gives you an opportunity to question the customer further about the complaint. If there is a trouble, your chances of causing it to occur are as good or better than they are when you just sit around and wait for something to happen."

"You may have something there, Tony. I'll bet if I had put on a real show for Mrs. Smith, she wouldn't have any reason to complain. All I did was tap a few tubes."

"There's another thing to watch out for, Bud. Most technicians do employ the tube-tapping system in order to unveil an intermittent condition. I do myself, but many people do not understand this procedure and disapprove of someone banging around on their TV set. If the set owner insists on looking over my shoulder, I usually ask if they would like to help by holding a mirror in front of the set."

This seemed to convince Bud. "I guess I'll have to change my ways," he said sorrowfully, "but it seems a shame that we can't do a job without worrying about what the customer is thinking. Anyway, if Mrs. Smith complains again, I'm going to follow your suggestions, Tony!"

"Just be convincing in your methods and your manners," Tony pointed out, "and your customers will be convinced of your ability. The end result will be happier and better-satisfied customers and fewer callbacks. Well, I've got some sets to look at, so I'd better get going. See you later, Bud."

VERNE M. RAY

June, 1956 • PF REPORTER

Mr. Electronic Service Technician



You have seen and will continue to see, in the chassis of TOP-NAME Radio and TV sets, an increasing number of Planet electrolytic capacitors — conspicuous because of their shiny red cardboard jackets. They are in those quality sets because components engineers have proven for themselves that PLANET condensers are "ENGINEERED FOR QUALITY".

You can take advantage of their findings by purchasing from your distributor Planet universal replacement types of the same high standard of quality. Ask for PLANET by name.

Write now for "ENGINEERED FOR QUALITY"
latest FREE catalog. GUARANTEED FOR ONE YEAR

PLANET PLANET MANUFACTURING CORPORATION
225 BELLEVILLE AVENUE
BLOOMFIELD, N. J.

XCELITE Hand Tools PREFERRED BY THE EXPERTS

No. 137
Nut
Driver
Bench
Set

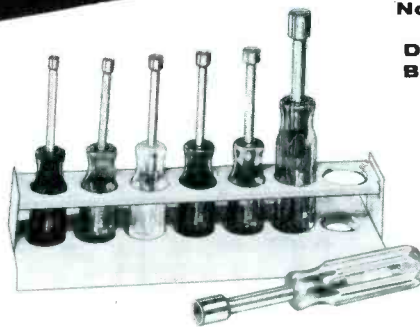

Handles colored to show size!
Precision-formed sockets!
5 regular, 2 hollow-shaft sizes!

In this non-tipping "137" bench set, you get the famous precision Xcelite nut drivers with the big, snug-grip handles — choice of chrome-plated or highly polished shafts — 3/16", 1/4", 5/16", 11/32" and 3/8" regular plus 1/2" and 9/16" hollow shaft. You'll want this set working for *you* — ask your supplier!

XCELITE INCORPORATED

Dept. G.,
Orchard Park, N. Y.

In Canada — Charles W.
Pointon Ltd., 6 Alcina Ave.,
Toronto, Ont.

For Originality
LOOK TO **XCELITE**

ATLAS SOUND CORP.
1451 - 39 St., Brooklyn 18, N. Y.

Send **FREE** Buyer's Guide to save me money on public address Loudspeakers, Microphone Stands and accessories.

Name _____ Title _____
 Firm _____
 Type of Business _____
 Address _____
 City _____ Zone _____ State _____

HOW to SAVE MONEY on LOUDSPEAKERS and MIKE STANDS



Fill in coupon and find out how ATLAS proves that better know-how can produce better products at lower cost to you. Depend on world-famous ATLAS—the complete quality line with specialist know-how since 1930.



ATLAS SOUND CORP.
1451-39th Street, Brooklyn 18, New York
In Canada: Atlas Radio Corp., Ltd., Toronto, Ont.

Audio Facts

(Continued from page 21)

If an audio worker wants to build a divider network and finds that he needs to wind a coil that has an inductance of 1.8 millihenries, he then wants to know how many turns of what size wire must be wound on what kind of form to make a 1.8-mh coil. We will describe how we have handled the problem.

used in low-impedance output circuits in which the signal current can be very high although the signal voltage is low, and resistance must be kept to a minimum amount to prevent loss of signal.

Coil Forms

No iron or steel is used in the construction of the coil forms. Air-core coils are used in divider networks because an iron-core coil can become saturated and over-

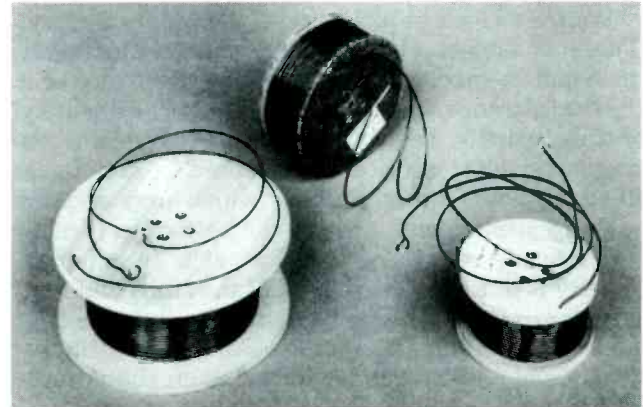

Fig. 2. Finished Coils for a Divider Network.

We have set our own standards with regard to the size of wire used, dimensions of the winding form, and method of winding so that we could calculate the number of turns required for a certain amount of inductance. Because of this standardization, the graphs shown in Fig. 1 can be used to find the number of turns of wire that must be wound on the required form to make a coil with a desired inductance. No. 16 enameled copper wire is used because its large size keeps the resistance of the windings down to satisfactorily low values. Divider networks are

loaded by a powerful signal. Inductance is independent of signal level in an air-core coil, and therefore reactance increases linearly with an increase in the frequency of the signal.

The amount of inductance required in divider networks varies over a wide range; therefore, two sizes of coil forms have been adopted in order that the finished coils (Fig. 2) will have practical shapes. In this way, a small coil is kept from being long and narrow and a large coil from being short and wide. The dimensions of the forms are shown in Fig. 3.

Fig. 3. Drawings of Coil Forms with Dimensions Shown. (A) A Small Coil Form. (B) A Large Coil Form.

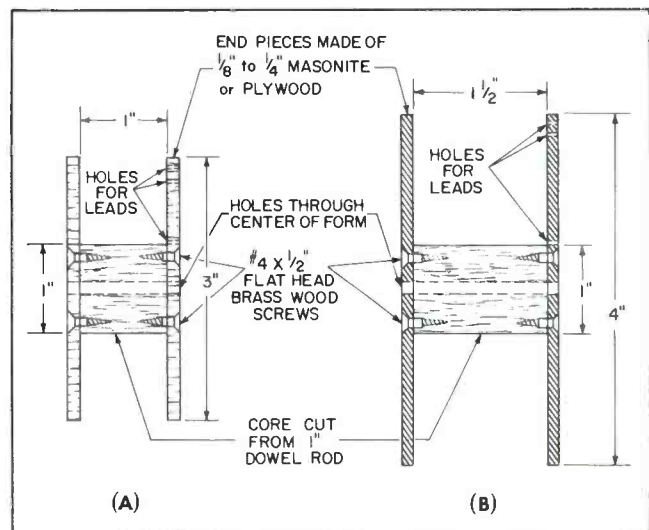

In addition to being of the correct size to hold the required number of turns of wire, a suitable form must be strong and rigid enough to withstand the pressure exerted on it by the wire both during and after the winding process. The cores and pieces must therefore be made from substantial and rigid materials and must be firmly assembled.

A wood dowel rod of one-inch diameter can be purchased at most hardware stores. It is cut in 1- or 1½-inch sections which serve as cores. These pieces must be cut carefully and accurately so that the ends will be square and flat to ensure that the two endpieces of the form will be parallel to each other when they are fastened to the core. A hole to accommodate a 10-32 machine screw is drilled through the center of the core with a No. 10 (0.193-inch) drill.

The endpieces of the coil forms are 3- or 4-inch discs of plywood or Masonite. We have usually cut these from ¼-inch material, but ⅛-inch or ⅜-inch Masonite can be used for the smaller coils.

These discs can be cut in several ways, but we have always used a hole cutter in a hand brace or in a drill press which was turned by hand. When a hole cutter (circle cutter or fly cutter) is used for this purpose, the cutting tool should be reversed so that the edge of the disc will be flat and not tapered.

If a hole was not made in the center of the endpieces when they were cut out, one should be made with a No. 10 drill as was done with the core pieces.

You can begin the assembly of two endpieces and a core by passing a 10-32 machine screw through them, by placing a washer over the end of the screw, and then by clamping the assembly together with a nut. The form is then ready to be fastened together permanently with wood screws. Appropriate locations for the form screws are marked ⅜ inch from the center on both endpieces. A pilot hole is drilled at each location with a No. 50 (0.07-inch) drill and is countersunk for a ½-inch No. 4 flathead brass wood screw. After the eight (four in

each endpiece) wood screws are screwed solidly into the form, the 10-32 machine screw can be removed.

Some method must be provided to secure the ends of the winding and make them available for use as leads; therefore, holes are drilled with the No. 50 drill in one end of the form for that purpose. The hole for the starting end of the winding is drilled in one endpiece at a point that is even with the surface of the 1-inch core. The hole for the finishing end of the coil is drilled through the same endpiece at a point even with the outside layer of the winding. Since the location of the outside layer is usually unknown if an identical coil has not been wound previously, a series of holes can be drilled to ensure that at least one hole will be in the proper position so that the finishing end of the winding can be made secure.

Winding the Coil

The winding of the coil can be done in a number of different ways. The procedure used is not so



"He does have a nose for good records, but you must try a JENSEN NEEDLE."

TELCO SELF-SUPPORTING
tripod MAST TOWERS

FOR FAST, EASY INSTALLATION
ALL ASSEMBLED—NO GUY WIRES

Real profits on any antenna installation—Bolt the tower to the roof and that's it! No bothersome, time consuming screw eyes, guy wires and rings or turnbuckles. Get sturdy, dependable, weatherproof installations. Telco Tripod Towers are a whole roof installation in one! All assembled—ready to install. Get them at your Telco distributor now.

AVAILABLE IN 3 MODELS FOR ANY SIZE INSTALLATION

- Model No. 9063
2 foot heavy steel gauge, plated tower
- Model No. 9144
3 foot electro-galvanized tubing tower
- Model No. 9145
5 foot electro-galvanized tubing tower

REMEMBER THE NAME

3 Ft. Model No. 9144

5 Ft. Model No. 9145

2 Ft. Model No. 9063

TELEVISION HARDWARE MFG. CO.
 Division of General Cement-Textron American, Inc.
ROCKFORD, ILLINOIS

SEE YOUR TELCO DISTRIBUTOR NOW!
 Stand-offs, mounts, arrestors . . . everything you need for every kind of TV installation . . . all at your Telco distributor.

FREE CATALOG
 Send a postcard for your big free Television Hardware catalog

**YOU
BUILD
EICO
KITS
IN ONE EVENING
BUT THEY ...
LAST
A
LIFETIME
AND YOU
SAVE 50%**



New #460 Color & Black-&-White Wide Band 5" Scope Kit \$79.95 Wired \$129.50



425K 5" Scope Kit \$44.95 Wired \$79.95

470K 7" Push-Pull Scope Kit \$79.95 Wired \$129.50



221K VTVM Kit \$25.95 Wired \$39.95



New 324K RF Signal Gen. Kit \$26.95 Wired \$39.95



565K Multimeter Kit \$29.95 Wired \$49.95 20,000 ohms/volt

150 kc-435 mc; 6 fund. bands.

46 MODELS TO CHOOSE FROM! — THE INDUSTRY'S MOST COMPLETE LINE OF

MATCHED TEST INSTRUMENTS

1/2-million EICO Instruments are now in use the world over! That's the proof of EICO's leadership in Value.

For latest precision engineering, finest components, smart professional appearance, lifetime performance and rock-bottom economy—see and compare the EICO line at your Jobber before you buy any higher-priced equipment! You'll agree with over 100,000 others that only EICO Kits and Instruments give you the industry's greatest values at lowest cost.

Write NOW for FREE latest Catalog PF-6

Prices 5% higher on West Coast



377K Sine & Square Wave Audio Gen. Kit \$31.95 Wired \$49.95



1050K Battery Elim. Kit \$29.95 Wired \$38.95



625K Tube Tester Kit \$34.95 Wired \$49.95

• Tests new 600 ma series string type tubes



©56

84 Withers Street, Brooklyn 11, N. Y.

important as long as the required number of turns are wound smoothly and tightly on the form without damage to the insulation on the wire or to the wire itself. The coils can be wound by hand; but winding a large number of turns can become difficult because of the effort, time, and care involved in handling the stiff wire and the form. Some kind of mechanical setup can be very helpful for holding and turning the form, for maintaining tension on the wire, and for counting the number of turns of wire as they are wound on the form. Most anyone with some mechanical skill should be able to improvise an arrangement which would at least do some of these things.

When we wound our first coils for a divider network, we made use of an arrangement which we are still using with very little change. As can be seen in Fig. 4, it is not elaborate; but it has proved to be very satisfactory for our purpose.

A long 10-32 round-headed machine screw is used as a shaft on which the form is mounted. A small hole is drilled crosswise through the head of the machine screw. (The purpose of this hole will be explained later.) The screw is pushed through the center hole of the coil form and is tightened securely with a nut and washers. The 10-32 screw must be 2 inches or more in length for use with the smaller winding form and at least 2 1/2 inches long for use with the larger form.

The end of the 10-32 screw which extends through the form is clamped in the chuck of a hand drill. The drill is then clamped in a vise in such a way that the crank can be turned with one hand while the other hand is left free to guide the wire. The end of the No. 16 copper wire can be threaded through the hole provided in the endpiece of the form for that purpose; and the actual winding of the coil can be performed with this setup.

This arrangement could be made even more convenient. Since counting turns can be a chore, especially if the winding process is interrupted for some reason or if the turns have to be unwound



Converts Battery Radio to Electric Operation!



At All Distributors



ask the "Man-on-the-Roof" why he prefers South River

COMBINATION PEAK & FLAT ROOF MOUNT

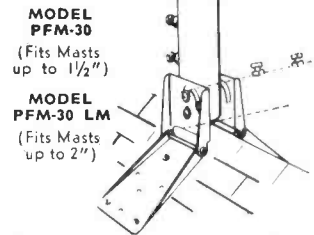

MODEL PFM-30 (Fits Masts up to 1 1/2")
MODEL PFM-30 LM (Fits Masts up to 2")
Features the patented South River "Walk-Up" — "Drop-Lock" mast socket for easy installation on either Peak, Flat or Pitched roofs. Heavy gauge pipe mast socket has two heavy duty screws and locknuts to secure mast. Factory assembled and supplied in a heavily plated rust resistant finish. U.S. PAT. #2734708
WRITE FOR NEW 1956 CATALOG

SOUTH RIVER pioneer & outstanding producer of finest line of antenna mounts
METAL PRODUCTS CO., INC.
South River, New Jersey

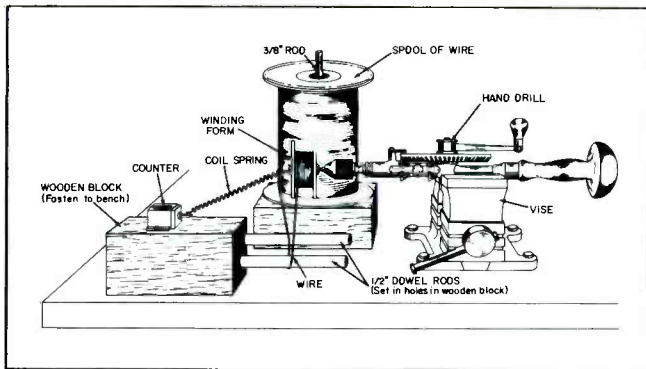

Fig. 4. Arrangement Used When Coils Are Being Wound.

and rewind, we have always made use of the counter shown in Fig. 4. This counter registers one turn for each revolution of its shaft and therefore can be coupled directly to the shaft in the coil form. We have found that a length of coil spring makes a convenient flexible coupling when one end is hooked through a hole in the end of the shaft of the counter and the

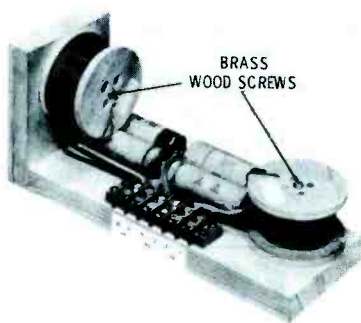

Fig. 5. Coils Mounted in Completed Network.

other end is hooked through the hole drilled in the head of the 10-32 machine screw. The counter is fastened to the workbench at a distance far enough from the coil form so that there will be no slack in the coupling spring. In this way, an accurate count of the turns will be maintained as the wire is wound on the form or is unwound for any reason.

Tension must be applied to the wire at all times during the winding of the coil; otherwise, it will have the troublesome tendency to loosen on the form because No. 16 copper wire is stiff and springy. The wire can be held under tension by the hand if only a small number of turns have to be wound, but this can become very tiresome if a large coil is made. We usually set the spool or reel of wire over an upright rod and pass the wire

over and under a pair of wood dowel rods to maintain the necessary tension. (See Fig. 4.)

We have found that a 1/4-inch wood or fiber rod about 6 or 7 inches long can be very useful as a tool to straighten and push the wire into correct position on the form during the winding process. Any irregularities in the winding can be straightened out and the turns at the ends of the form can be jockeyed into position with the wood or fiber rod without damage to the insulation on the wire.

When the proper number of turns are wound on the coil, the wire is cut at a point which leaves enough to be used as a lead after the end of the wire is pushed through the hole drilled for it near the outside edge of the endpiece of the form.

The completed coils can be mounted with a long brass screw through the center hole, as shown in Fig. 5. Remember that iron or steel screws should not be used to mount the coils and that the coils should not be located too near iron or steel parts because of the effect the latter can have on the inductance of the coils.

The values of inductance as shown in the graphs are correct only for No. 16 enameled copper wire which is wound as closely and tightly as possible on the specified forms. Any nonuniform winding, a wire of another size, a different type of insulation, or a different coil form will result in a different value of inductance. Such deviation from specifications would require the use of instruments to determine the inductance, and it would require an adjustment in the number of turns by the trial and error method.

ROBERT B. DUNHAM



**sells
9 out of 10
CRYSTAL
PHONOGRAPH
REPLACEMENT
CARTRIDGE
CUSTOMERS!**

Here's everything you need . . . in one convenient package!

American's high quality "Clear as Crystal" replacement cartridges are packed in this reusable plastic box . . . ideal as a small parts container. The box contains five of the most popular types of replacement cartridges . . . meets 90% of your customers' requirements.

In addition, you get an authorized repair service decal . . . five identification cartridge labels for your name . . . and a handy crystal cartridge replacement chart.

The whole package costs less, because you get more. And, you give your customers more, too. Why not call your nearby American distributor today and order the new "5-PAK" for yourself.

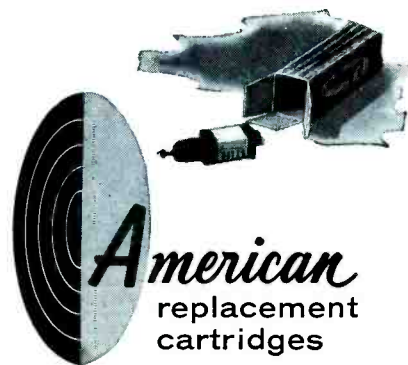

ELECTRONICS DIVISION
ELGIN NATIONAL WATCH CO.
370 South Fair Oaks, Pasadena, California

Design Features

(Continued from page 29)

than the sync pulses. When one of these bursts of noise reaches the first control grid, the grid voltage is driven below cutoff and all conduction within the 6BU8 tube ceases momentarily. A positive noise pulse appears in the signal at the second control grid at the same instant, but the temporary interruption of plate current prevents the development of a corresponding pulse at the plate.

If the noise inverter were not included in the circuit, strong noise pulses would get into the output signal of the sync clipper. They would tend to cause random triggering of the sweep oscillators, and unstable synchronization would result.

The input signal for the AGC section of the 6BU8 tube is a composite video signal with positive-going sync pulses. It is taken from the plate of the video amplifier and is applied to one of the second control grids (pin No. 9) of the 6BU8. This signal is direct-cou-

pled because the DC level of the sync tips is important to the operation of the AGC tube. If the composite video signal is strong, the sync tip level at pin No. 9 of the 6BU8 is less negative than it would be if the video signal were weak. In other words, a strong input signal places a relatively low bias upon the left-hand section of the 6BU8. That section of the tube then conducts heavily, and the voltage on the left-hand plate goes down. The lower the plate voltage becomes, the more AGC voltage is produced.

Since the plate is maintained at a positive potential of approximately 35 volts so that the tube will conduct, the AGC voltage cannot be obtained directly from the plate. Instead, it is derived in the following manner. The plate of the 6BU8 is connected to the grid of the horizontal discharge tube through a voltage divider made up of the resistors R13, R14, and R15. The average DC potential at the grid is -75 volts. Variations which occur in this grid voltage are leveled out by the AGC

filters. The voltages which are present at the intermediate points on the divider are suitable for direct application to the AGC line. Note that the AGC bias voltages for the tuner and for the IF strip are taken from separate points. When no input signal is being applied to the AGC section of the 6BU8, there is a slightly positive voltage at the junction of R14 and R15 and a slightly negative voltage at the junction of R14 and R13. These voltages are fed to the tuner and IF stages respectively. The AGC voltages are both driven in a negative direction when an input signal is applied to the 6BU8, but the IF voltage always remains more negative than the tuner voltage. This arrangement amounts to a simple delay circuit for the AGC line to the tuner.

The negative potential at the grid of the discharge tube is also utilized by a voltage divider which is in the grid circuit of the AGC section of the 6BU8 and which is composed of R9, R10, the AGC control R1, and R11. A negative DC voltage is fed from the junc-



SOLID ALUMINUM—RUST PROOF

CONTROL GUN



FITS OVER CONTROL SHAFT

No. 9280 G-C Control Gun

CLEANS AND LUBRICATES

NOISY VOLUME CONTROLS IN ONE SURE, FAST, EASY OPERATION

Cleans single or dual controls. Constructed of long lasting, durable aluminum, will not rust from use with any chemical normally used in the electronic industry. Simply load gun with G-C Contact Kleener and inject into control—dirt and noises disappear immediately. It's that easy. Positive, leak proof action, plunger can not pull out of gun.

GENERAL CEMENT MFG. CO.

Division of Textron American, Inc.

ROCKFORD, ILLINOIS



G-C Control Kleener
16 oz. and gallons
For use with G-C No. 9280 Control Guns—Will not harm cabinet finishes.
No. 63-16—16 oz.
No. 63-G—gallon



Control Gun Adapter
Special long shank adapter—order now.
No. 9282
Long Shank Adapter



Control Gun Adapter
Designed to adapt G-C Control Gun to auto radio controls—make your Control Kleener complete—get a set of adapters.
No. 9281 Auto Radio Control Adapter



FREE

Send a postcard to G-C for your free copy of the big, new, giant catalog.

YOUR G-C DISTRIBUTOR HAS THEM . . .

The Control Gun, Kleener and Adapters, as well as anything else you may need in your electronic technician work—many new products, stop in and see him today!



HOLDING CUSTOMERS.

When planning promotion, never forget that a satisfied old customer is worth a lot more than a new one. If you spend all your promotion time and money trying to get new customers, there'll be none left to hold the old ones against promotional raids by competitors.

If you offer a special discount or a bit of free service to a new customer, let the old customers in on a special deal now and then, too. If you don't, someone else will.

Help the old customers to remember your name and phone number. Cards get lost, and in many towns the names of service shops are confusingly alike. Use repeated mailings to remind them that they are considered old customers of yours, and their sets will receive special personal attention because of this. Emphasize the reliability of your work—that they won't have to worry when their sets are in your hands. Don't knock competitive claims, but make sure each customer knows you can do consistently good work on his particular set because of your familiarity with it.

MARKUS ••• Dollar and Sense Servicing

tion of R9 and R10 to the grid of the 6BU8, and the input signal from the video amplifier is superimposed upon this DC voltage. The AGC control furnishes a means by which the range of bias on the tube can be adjusted.

If noise pulses in the AGC input signal were uncontrolled, they would cause the AGC section of the 6BU8 to conduct excessively. The voltages in the AGC system would then become too negative. The noise inverter keeps these unwanted pulses from increasing the conduction of the 6BU8, and the AGC voltages are maintained at normal values even when considerable noise is present in the video signal.

The values of many of the components in the 6BU8 circuit are critical. This fact applies especially to the noise inverter. The bias on the inverter grid must be maintained at such a value that the sync tips will almost reach the cutoff voltage of the grid. If the bias is too low, the noise inverter will not accomplish its purpose; but if the bias is too high, the 6BU8 will be driven into cutoff by each sync pulse. The latter condition would cause low AGC voltage and unstable synchronization.

No provision is made for adjustment of the inverter circuit. That is actually an advantage inasmuch as the operation of the inverter cannot be upset by misadjustment of some control.

Tube Shields

Are you tired of struggling with tube shields that cling to the tubes with a bulldog grip? Some relief is in sight. A few recently built receivers are equipped with unusual tube shields which are so constructed that the tubes may easily be removed without risk of breakage.

Some of the new Silvertone and Raytheon receivers have shields like the ones shown in Fig. 2A. This type of shield is made up of two sections which are comparable to the halves of a clamshell. The sections can be pulled apart and swung out of the way so that the tube will be fully exposed. They remain attached to the chassis by means of tabs. The shield is reassembled simply by pressing the

two sections together until they snap into place.

Telescoping shields mounted on the tuner of a different model of a Silvertone receiver are shown in Fig. 2B. These shields are not removable but are riveted to the chassis. When the top half of the shield is given a slight counterclockwise twist, the top section is free to slide down over the fixed bottom section. This arrangement allows the top half of the tube to be exposed so that the technician can grasp the tube and pull it out.

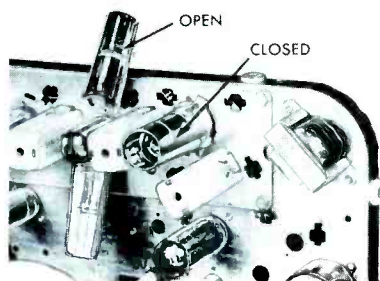

(A) Clamshell Type.

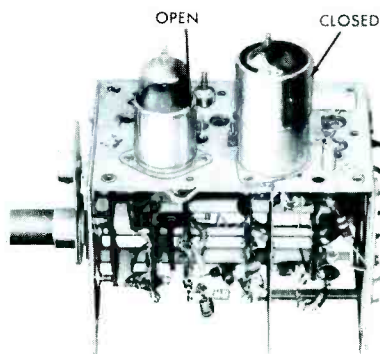

(B) Telescoping Type.

Fig. 2. Unusual Tube Shields.

The tube shields which have been described are an improvement over conventional shields in several respects. Their most important selling point is that tube removal is simplified. In addition, the shields cannot be mislaid since they are attached to the chassis. For the same reason, they cannot accidentally be left ungrounded.

Shorting Bar Used as Interlock

When the back cover is removed from a new Sylvania receiver, a shorting bar automatically drops down onto the socket of the 1B3GT high-voltage rectifier and grounds the rectifier filament. This safety device removes the charge from the high-voltage ca-

pacitor. The shorting bar serves as an interlock and protects unwary persons from the shock hazard that would be present if a residual charge were allowed to remain on the capacitor.

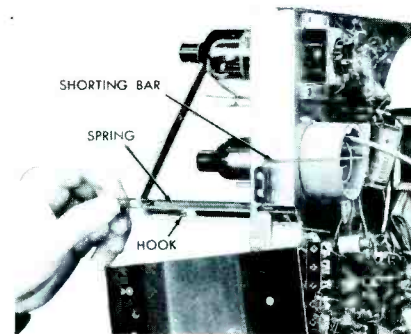

Fig. 3. Technician Disabling Interlock in Sylvania High-Voltage Circuit.

The shorting bar and its mounting arrangement are shown in Fig. 3. The receiver has a vertical chassis. The technician is grasping the trigger which normally presses against the back cover. A long spring is compressed by the trigger when the cover is in place. When the cover is taken off, the spring is released and the shorting bar swings into contact with the tube socket.

This high-voltage interlock must be disabled before the receiver can be operated with the back removed from the cabinet. The method of disabling the interlock is very simple. The trigger is equipped with a hook which can be slipped into a slot in the mounting bracket. When the hook is in place, the spring is compressed and the shorting bar is held in the open position. The technician in Fig. 3 is in the act of engaging this hook. The hook must be released after servicing has been completed.

THOMAS A. LESH

DOORS. Full-door consoles are vanishing from TV lines this year. Reasons are high cost, the nuisance of opening doors to get at the set, the general unattractiveness of sets with opened doors, and the fact that the full-door jobs are the first to be dumped when sales slow up. Can't see why these sets were ever built in the first place; in the average home, the TV set is on so much of the time that doors would just be in the way.

MARKUS ... Dollar and Sense Servicing

KENCO KATE SAYS

"NO INSTALLATION PROBLEMS
when you use
KENCO MOUNTS"



KENCO EAVE MOUNTS

Easily mounted on hanging rafters or trim boards of eave. Eliminates need for drilling into brick or masonry walls. Ideal for buildings with extended roofs. Hot dip galvanized.

AVAILABLE IN 3 SIZES:
Model #122 ... 22" Eave Mount
Model #128 ... 28" Eave Mount
Model #148 ... 48" Eave Mount

OTHER KENCO PRODUCTS:
All-Position Mounts; Parapet Mounts; Sky Struts; "Snap-In" Wall Brackets; "Snap-In" Chimney Mounts; Z-Type Chimney Mounts; Lag Screws and Hardware.

For information on the complete Kenco line write Dept. D.

KENWOOD ENGINEERING CO., INC.
Kenilworth, New Jersey

Quicker Servicing

(Continued from page 15)

and other small parts, the Argos Products Company has made available a portable service bench. One of these service benches is shown in the open position in Fig. 1. This unit is designed so that the legs fold up, and then the table folds to enclose the legs. The folded unit can be as easily carried as a piece of luggage or a tube caddy.

Customer "Fixes" Set

A certain technician was recently called to repair an Arvin Chassis TE-321-3. The customer stated that he had been having trouble with the receiver for several weeks and that the picture had finally gone out completely.

This customer happened to be a devotee of the fix-it-yourself fad. When the original trouble (loss of horizontal sync) occurred, the customer found quite by accident that by removing the noise-inverter tube the picture would synchronize. The picture was distorted slightly; but since the customer was not too eager to spend his money, he used the set and tolerated the distortion. When the picture failed completely, the customer again tried to fix the set himself. He removed all of the tubes from the chassis and took them to the drug store where he tested them in a self-service tester. Several of the tubes tested bad, but installation of the new tubes failed to correct the trouble.

Having failed in his attempt to repair the trouble, the customer called in a technician. After the technician had carefully listened to the customer's tale of woe, he proceeded to substitute new tubes in the video IF, tuner, AGC, and video output stages. This failed to reveal the trouble, so the receiver chassis was removed and taken into the shop. In the shop, a visual inspection of the underside of the chassis revealed that several resistors were badly burned and discolored. These were the plate-load and decoupling resistors associated with the video output stage. (See R55, R56, and R57 in Fig. 2.) Since a defective tube could have caused the resistors to become overheated and thus dam-

aged, the 6AQ5 tube was checked in a tube tester. It was bad, and the defective tube and the resistors were replaced.

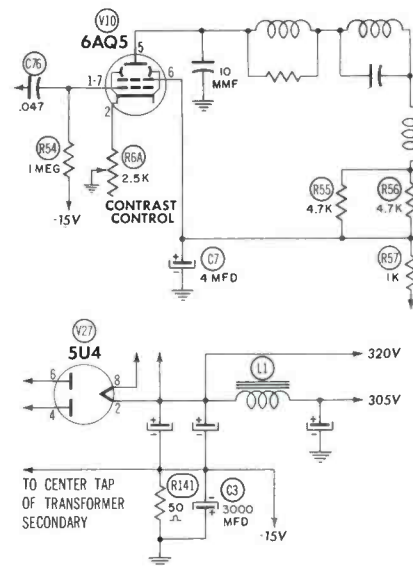



Fig. 2. Partial Schematic Diagram of the Negative Supply and Video Output Circuits in the Arvin Chassis TE-321-3.

The voltages at the socket pins of the 6AQ5 tube were then checked, and the negative 15-volt bias that should have been found on the grid of the 6AQ5 was missing. A check of the B+ and B- supply revealed, after an intensive search, that the 3,000-mfd capacitor C3 was shorted. This capacitor was replaced, and the negative 15-volt supply returned to normal. The technician decided to check the other tubes because he felt that there might be other troubles present in other sections as a result of the customer's attempts to work on the receiver. After the noise inverter tube had been replaced and the AGC controls had been adjusted, the receiver operated normally.

The moral of this story is this: Even though a receiver will operate with certain defects or troubles, it should not be left to do so. In this particular receiver, the failure of a 3,000-mfd capacitor and the continued operation under abnormal conditions had caused a tube and 3 resistors to fail. Not only did the customer have a large repair bill, but he also had had a very poor picture during the time he was operating the receiver with the noise-inverter tube removed. It is never a good

"Did You Say 10¢?"

*Famous headline courtesy Model Tobacco Co.



"Yes I said 10¢ for this **VITAL** test equipment!"

VITAL is right!

Mueller clips close test circuits faster, better, — in tighter spots. They cost only pennies.

LOAD UP!

At jobbers everywhere

SEND FOR FREE SAMPLES AND CATALOG.

Mueller Electric Co.
1561 Y EAST 31st STREET • CLEVELAND 14, OHIO

policy to operate a receiver with parts disconnected or removed over any period of time because this can start a chain of other failures.

Replacing a Picture-Tube Base

When removing a yoke, did you ever have a picture-tube base come off? If you have ever tried to line up the five wires of a picture-tube neck with their respective pins in the base, you know this can be a very difficult trick, especially if the wires are slightly short or badly bent out of position.

To reinsert the element wires of the picture tube into the correct base pins, solder a strand of fine wire to each element wire, as shown in Fig. 3. These extension wires can then be passed through the correct base pins. The extension wires act as guide lines, and the base may be slipped up to the picture tube.

Apply a liberal amount of cement around the neck of the picture tube where the base makes contact, and allow the cement to dry. The cemented area should be between the base and neck surfaces. When the cement has dried, carefully solder each lead wire into its respective pin and remove the extension wire. After the yoke, focus assembly, centering mechanism, and ion trap have been replaced on the neck of the tube, carefully wrap one layer of masking tape around the joint between

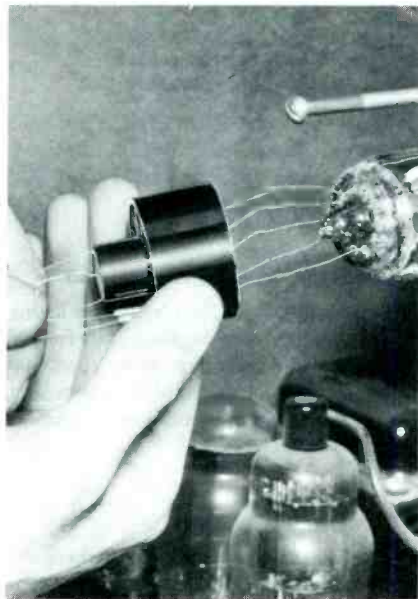

Fig. 3. An Easy Method of Replacing the Base of a Picture Tube.

the base and the neck of the tube. This completes the repair; and if the soldering has been carefully and correctly done, the picture tube should function as well as it did before.

Picture-Tube Face with X-Mark

The illustration in Fig. 4 is a photograph of a picture tube that has very little coating left on the screen and has an X-mark. This screen has much the same appearance as one that has been damaged by ion bombardment except that there is no burn on the screen coating. The coating has flaked off and is lying in the form of dust on the inside of the tube.



Fig. 4. Damaged Coating on the Picture-Tube Screen.

This condition was not caused by a defective or improperly adjusted ion trap but was apparently caused by a defect in the electron gun of the picture tube. The customer had previously complained that the picture was very dim when the set was first turned on; and then in 5 or 6 minutes, the picture would be bright and normal. A check of the receiver during this 5- or 6-minute period revealed that the brightness control did not vary the brightness even though the voltage at the picture-tube socket varied over the normal range. The ion trap was also checked and found to be properly positioned. The customer did not want the tube replaced; therefore, the technician could not cure the trouble.

The continued operation of the receiver with the defective electron gun resulted in the condition which is shown in Fig. 4. With the picture tube in this advanced state of deterioration, the customer decided to have it replaced.

CALVIN C. YOUNG, JR.



leads the way to

NEW Source of Profits



introduces the

FIRST DC POWER SUPPLY

to service the new

TRANSISTOR AUTO RADIOS

Services 6/12 v.
tube radios also



BE THE FIRST

TO PROFIT with this special D-612T power supply that solves a new servicing problem!

Other models for every commercial and industrial servicing need!

ELECTRO PRODUCTS LABORATORIES
4501-PF Ravenswood Ave.,
Chicago 40, Illinois

FOR PRICES AND DATA SEND COUPON TODAY!

Electro Products Laboratories
4501-PF Ravenswood Ave., Chicago 40, Ill.
Rush descriptive and technical data on MODEL D-612T Power Supply for Transistor Auto Radios.
Firm name _____
Address _____
City _____ Zone _____ State _____
612 Canada: ATLAS RADIO LTD., Toronto

INDEX TO ADVERTISERS

June, 1956

Advertisers	Page No.
American Microphone Co.	71
American Phenolic Corp.	38
Astron Corp.	24
Atlas Sound Corp.	68
B & K Mfg. Co.	28
Belden Mfg. Co.	30
Bussmann Mfg. Co.	4
CBS-Hytron	16
Centralab, A Div. of Globe-Union, Inc.	53
Chicago Standard Transformer Corp.	26
Clarostat Mfg. Co., Inc.	22
Cornell-Dubilier Electric Corp.	60
Delco Radio Div., General Motors Corp.	8
DuMont Labs., Inc., Allen B.	20
Electro Products Labs.	75
Electro-Voice, Inc.	62
Electronic Instrument Co., Inc. (EICO)	70
Electronic Pub. Co.	54
General Cement Mfg. Co.	57, 63, 69, 72
Hycon Mfg. Co.	39
International Resistance Co.	2nd Cover
Jackson Electrical Instrument Co.	65
Jensen Industries, Inc.	69
Jensen Mfg. Co.	37
Jerrold Electronics Corp.	34
Kenwood Eng. Co., Inc.	74
Littelfuse, Inc.	4th Cover
Mallory & Co., Inc., P. R.	6, 7
Merit Coil & Trans. Co.	64
Mueller Electric Co.	74
Perma-Power Co.	70
Phaostron Co.	48
Planet Mfg. Corp.	67
Pyramid Electric Co.	35
Quam-Nichols Co.	55
Radiart Corp.—Cornell-Dubilier Electric Corp.	1
Radio Corp. of America	14, 51, 3rd Cover
Radio Receptor Co., Inc.	58
Raytheon Mfg. Co.	5
Sams & Co., Inc., Howard W.	42, 52
South River Metal Products Co.	70
Sprague Products Co.	2
Stackpole Carbon Co.	56
Sylvania Electric Products Inc.	40
Tenna Mfg. Co.	36
United Catalog Pubs., Inc.	46
University Loudspeakers, Inc.	44
V-M Corp.	47
Ward Products Corp.	32
Webster Electric Co.	61
Wright Steel & Wire Co., G. F.	63
Xcelite, Inc.	67

While every precaution is taken to insure accuracy, we cannot guarantee against the possibility of an occasional change or omission in the preparation of the REPORTER.

PF
REPORTER

CATALOG and LITERATURE SERVICE

valuable manufacturers' data available to our readers

- 15. AMERICAN MICROPHONE (Electronics Div., Elgin National Watch Co.)**
504 series of waterproof microphones, designed particularly for mobile communications, especially motorcycle. *See advertisement page 71.*
- 25. B & K (B & K Manufacturing Co.)**
Informative article titled: "Profitable TV Servicing in the Home," by Henry Gronski, General Manager of Central Television Service, Chicago. Also Bulletin No. 500 on newest B&K Dynamic Mutual Conductance Tube Tester, and Bulletin No. 104 on CRT Cathode Rejuvenator Tester. *See advertisement page 28.*
- 35. BUSSMANN (Bussmann Mfg. Co.)**
Bulletin showing fuses and fuse-holders adapted to protection of TV and other electronic equipment (Form SFB). *See advertisement page 4.*
- 45. STANCOR (Chicago Standard Transformer Corp.)**
Stancor General Catalog S-102. Stancor Transformer Replacement Guide, No. 500. Stancor Television Transformer Replacement Guide. *See advertisement page 26.*
- 55. CLAROSTAT (Clarostat Mfg. Co., Inc.)**
Power Rheostats, 25 watt and 50 watt, Form No. 754668. *See advertisement page 22.*
- 65. CORNELL-DUBILIER (Cornell-Dubilier Electric Corp.)**
Catalog No. 163, "Universal Replacement Capacitors for Motor-Starting." *See advertisement page 60.*
- 75. ELECTRO-VOICE (Electro-Voice, Inc.)**
Power Point Cartridge. Completely new way to change both cartridge and needle in seconds. Brings profit back to the Phono-Cartridge business. Write for Bulletin No. 223. *See advertisement page 62.*
- 85. IRC (International Resistance Co.)**
Replacement Parts for TV, Auto, & Radio Controls Catalog DLR-56.
- 95. JENSEN (Jensen Industries, Inc.)**
WALL CHART—new 1956—completely illustrated; contains all up-to-date replacement needle information including point size, point material, cartridge numbers; list price. *See advertisement page 69.*
- 105. KENWOOD (Kenwood Engineering Co., Inc.)**
A new 16-page catalog listing television mounts and accessories that are available through distributors. Four pages devoted to new products. *See advertisement page 74.*
- 115. LITTELFUSE (Littelfuse, Inc.)**
Illustrated price sheet showing pictures of our products and giving description and list price of each. *See advertisement 4th Cover.*
- 125. MALLORY (P. R. Mallory & Co., Inc.)**
New complete line parts catalog for 1956-1957. *See advertisement pages 6 and 7.*
- 135. QUAM (Quam-Nichols Co.)**
New 1956 Catalog listing over 100 replacement and high fidelity speakers, with detailed specifications on each unit. *See advertisement page 55.*
- 145. RADIART (Radiart Corporation)**
Vibrator Supplement 1956. *See advertisement page 1.*
- 155. RCA (Radio Corporation of America)**
RCA Renewal Products Catalog Form No. 4F3—including latest information RCA Tubes, Parts, Batteries, Test Equipment, Technical Literature. *See advertisement page 14, 53, 3rd Cover.*
- 165. RADIO-ELECTRONIC MASTER (United Catalog Publishing Co.)**
Industry-wide Panel and Flashlight Lamp Chart. Includes illustrations, base, volts, amps and bead color. *See advertisement page 46.*
- 175. SPRAGUE (Sprague Products Co.)**
Catalog C-611. Completely new listing of Standard Replacement Parts for TV and Radio including more than 700 new twist-lok electrolytic types not shown in previous catalog. *See advertisement page 2.*
- 185. XCELITE (Xcelite, Inc.)**
Folder on new transverse cutters for flush cutoff on miniature circuits; general catalog on screw drivers, nut drivers, pliers, *See advertisement page 66.*

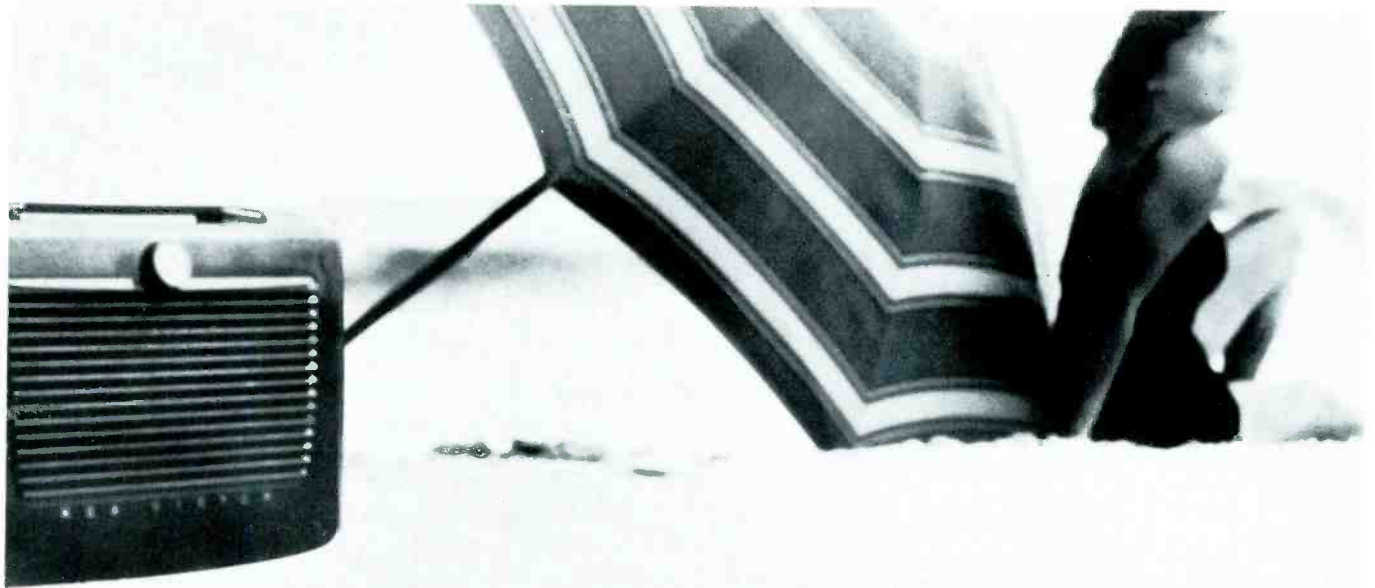

Get in the swim for bigger profits...

STOCK AND SELL RCA RADIO BATTERIES

Your customers are going "on vacation" every day now—and wherever they go, along go their portables! Catch this rising tide of portable battery business—stock, promote, and sell RCA Radio Batteries. RCA offers you the brand-name customers go out of their way to buy—a famous emblem that pre-sells *for you*. RCA backs you up with the most extensive sales promotion program in the radio-battery industry, featuring the powerful theme: "PORTABLES COME TO LIFE WITH RCA BATTERIES... *radio engineered for extra listening hours.*" Your RCA Distributor is ready now to help you make this your biggest battery season ever. See him soon. He'll get you right in the swim for bigger profits—with RCA Batteries.



RADIO BATTERIES

RADIO CORPORATION OF AMERICA • HARRISON, N. J.



A fuse caddy for your tube caddy

LITTELFUSE, *Des Plaines, Illinois*

BURTON BROWN ADVERTISING