

Western Electric

OSCILLATOR

NUMBER 12

NOVEMBER 1948

Program Control, 10 KW FM in One Room • Sound Gives Lift to Store Sales

Ed. Brown



Western Electric

O S C I L L A T O R

A quarterly publication devoted to developments in communications and electronics and published by Western Electric Company, Inc., 195 Broadway, New York, N. Y.

S. BRACKENPresident
F. R. LACKVice President
Editorial Advisers.....W. M. REYNOLDS, J. V. HILLIARD
N. R. FRAMESecretary
H. H. REDDALLTreasurer
Editor.....R. S. LANIER

CONTENTS

"Manufactured By Machlett Laboratories"	Page 3
Program Dispatching Unit and FM Transmitter at WIP	Page 8
Carillon and "Celestron"	Page 11
Program Quality Depends on Turntable Precision	Page 14
Transmitter Building Ahoy!	Page 20
New Aid to Merchandising . . . Store-Wide Sound Distribution	Page 22
Sound Distribution System Pays Off	Page 26
Broadcasters Report on the 10 kw FM Transmitter:	
KCMC-FM, Texarkana, Texas	Page 30
WJR-FM, Detroit, Michigan	Page 31
WIBA-FM, Madison, Wisconsin	Page 33
WJDX-FM, Jackson, Mississippi	Page 34
KJBS-FM, San Francisco, California	Page 34
KWK-FM, St. Louis, Missouri	Page 36

ON THE COVER



Engineer Bengate of WIP is shown in the cover Kodachrome at one of the station's most important operating posts. As described in detail beginning on page 8 of this issue, the new master control room at WIP combines two functions—program dispatching, and operation of the FM transmitter. The center of the console in the cover picture holds the Western Electric RD100 unit recently installed by WIP to provide automatic program dispatching from the various studios to the outgoing lines. The Western Electric 506B-2, 10 kw FM transmitter can be seen in the wall at the rear. With the automatic and presetting features of the RD100 unit, the operator can also supervise the operation of the FM transmitter.

When caught by the camera Mr. Bengate was preparing his switching connections for the next station break, with the aid of the order wire panel in the left wing of the console.

The "Oscillator" does not accept responsibility for quoted statements appearing in the magazine. Such statements reflect only the opinions of the person quoted. Copyright, 1948, by Western Electric Company, Incorporated. Printed in U. S. A.

Western Electric commercial products distributors: In the United States — Graybar Electric Company, 420 Lexington Avenue, New York 17, N. Y. In Canada and Newfoundland — Northern Electric Company, 1620 Notre Dame Street W., Montreal, Quebec.

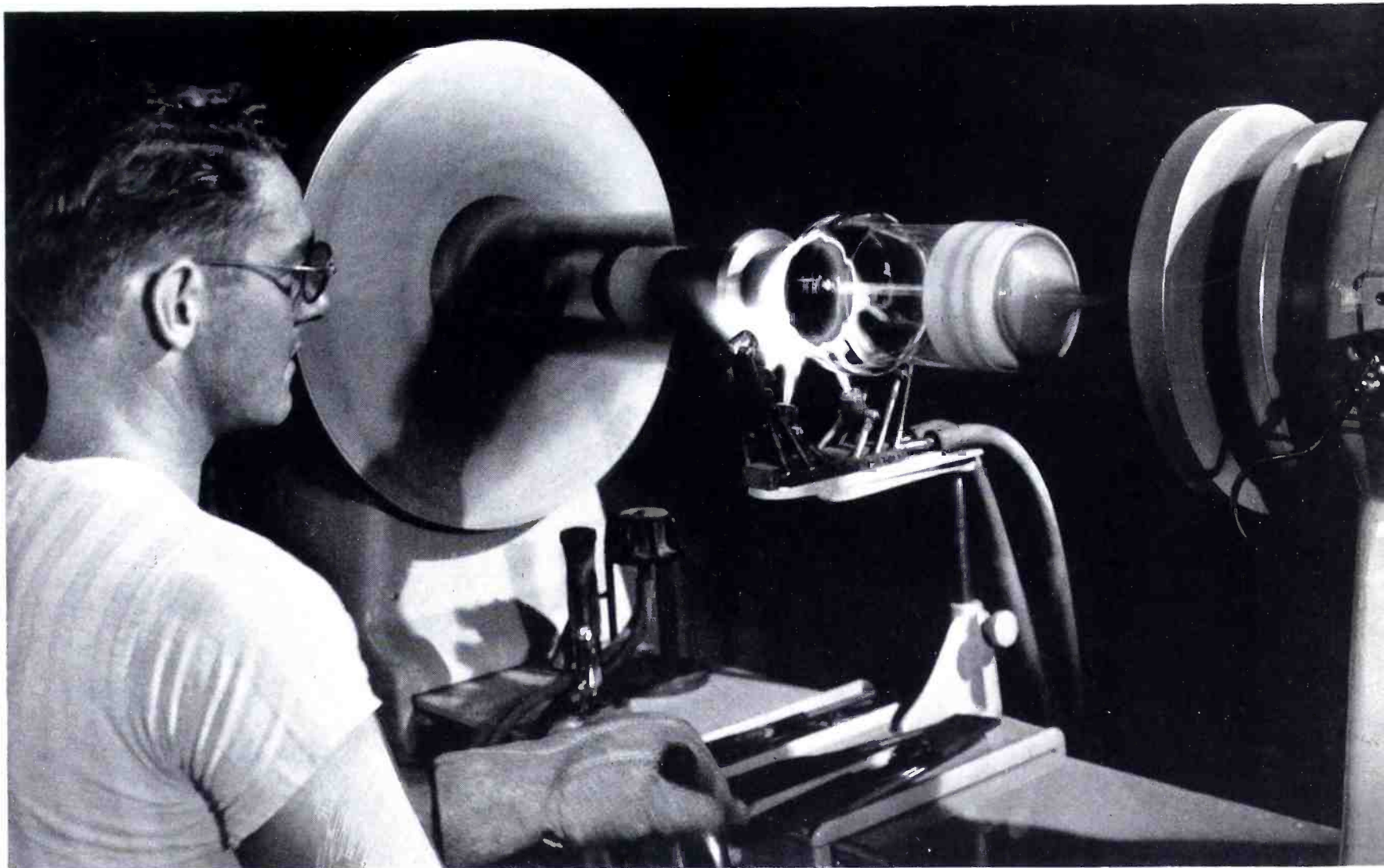

**“Manufactured by MACHLETT LABORATORIES
for the WESTERN ELECTRIC COMPANY”**

**New designation on Western Electric high power vacuum tubes signals
manufacturing collaboration between two pioneers in electron tube development**

by H. D. Wilson

Manager, Electronic Products Sales, Radio Division, Western Electric Company

AN EVENT of marked interest to the broadcasting industry and to industrial users of high power electron tubes occurred as Machlett Laboratories, Incorporated took over the manufacture of Western Electric's long established line of high power tubes for broadcast transmitters and allied applications.

The designation to be borne by these tubes is “Manufactured by Machlett Laboratories for the Western Electric

Company.” This is an accurate description of the relation of these two companies in the production of the tubes. With manufacture in the hands of Machlett Laboratories, the tubes will be the same Western Electric tubes, built to the same high standards, that are so familiar to broadcast engineers. They will be manufactured according to Bell Telephone Laboratories designs, with full use of the production techniques developed by the Western Electric Com-

pany. They will be distributed for Western Electric through the more than 100 nation-wide offices of the Graybar Electric Company along with other Western Electric products. As Western Electric tubes they will carry the full Western Electric responsibility for service and guarantees of performance that users of the Company's tubes have always enjoyed.

F. R. Lack, vice-president of the Western Electric Company, comments as follows on production of Western Electric tubes by Machlett:

"The Western Electric Company is proud that the outstanding production skill, the engineering ingenuity, and the high integrity of Machlett Laboratories will be utilized in the manufacture of Western Electric high power electron tubes. The collaboration of the two firms will be applied to the continuance of the advance position Western Electric tubes have always held in the art of broadcasting."

A representative group of the Western Electric tubes to be manufactured by Machlett Laboratories is illustrated on page 38, with a complete list in the upper left of the same page, including a brief description of each type.

When radically expanded demand on the production facilities of Western Electric for electron tubes made it imperative to find new manufacturing capacity quickly, it was decided that continuity of production of these high

power electron tubes and the strictest maintenance of quality standards could best be obtained by making use of the highly specialized skills of Machlett Laboratories. Rapid installation of certain additional manufacturing facilities in the Machlett plant in Springdale, Conn., allowed production to begin during the fall of this year. Close liaison of engineering and quality control between the two companies will be maintained so that the experience and skills of both will be effectively used in the manufacture of the tubes.

In providing for the closest possible collaboration between Bell Telephone Laboratories, Western Electric Company and Machlett Laboratories, it is the purpose to assure to the broadcasting and related industries the continuous availability of the Western Electric line of modern, high quality, long life electron tubes—and the type of service which Western Electric tube users have always enjoyed.

The combination of experience, skills and "know-how" which this relationship now provides will effectively implement Western Electric's constant effort to give the communications industries the very best in tube product, performance and service.

The experience of Machlett Laboratories in electron tube

(Continued on page 7)

Quality of power tubes made by Machlett Laboratories benefits from vacuum casting of anodes, one of outstanding techniques developed by firm. Below left, rods of copper can be seen inside evacuated chamber, being heated by r-f energy from induction coil. As copper melts down around graphite mold, continuous pumping removes liberated gases, minimizing contamination of finished tube by gases from hot anode. Below right, a group of anodes, with graphite molds to the rear.

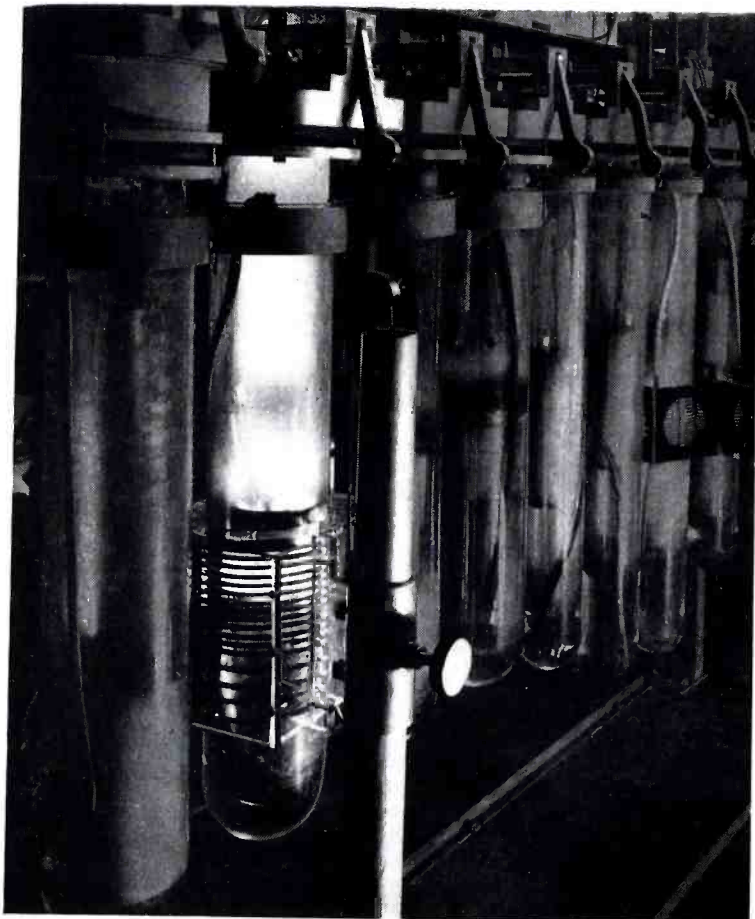



Grid structure is added to high power r-f tube by Machlett workers who maintain strict cleanliness of tube parts. Assembly shop in which girls work has close control of temperature, humidity, all dirt removed from air.



Above: Another view of assembly shows white-gloved worker inserting silvered ball bearings in the rotor of rotating anode X-ray tube, one of the most ingenious and precisely designed electron tubes developed by Machlett.



Below: Milling of cathode heads is done to tolerances as close as one ten-thousandth of an inch, to provide the sharply focussed electron beam necessary in certain X-ray tubes.

Manufactured by MACHLETT LABORATORIES

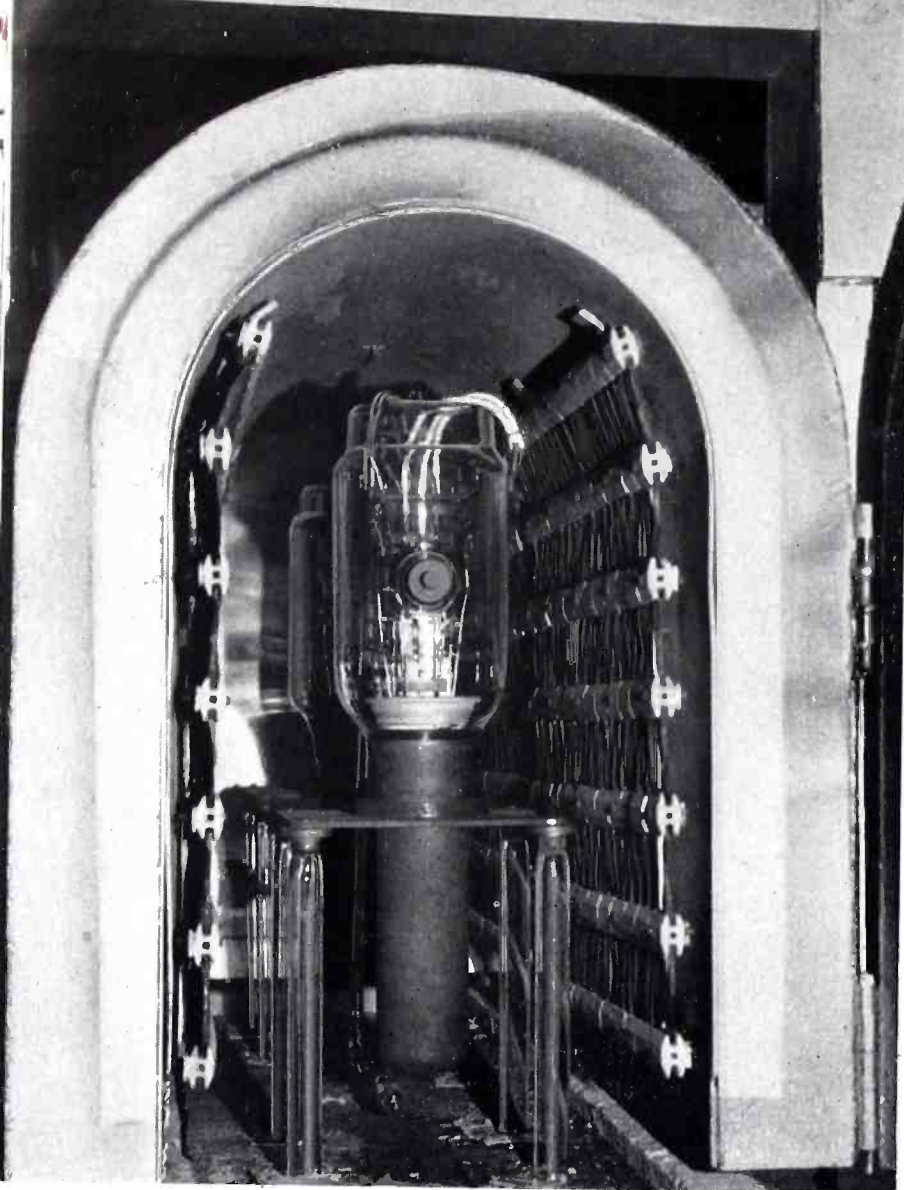

Outgassing procedure originated by Machlett uses dolly-mounted pumping units, on which tubes can be continuously pumped while moving through three stages of procedure. At left, high power transmitting tubes on pumping dolly are in baking oven, first step of process. Picture below shows one entire line, with oven at left, r-f bombarder in center for heating internal structure, and the enclosed high voltage station at right end, with operator at console. Lower parts of dollies and pumps are visible in the first and second stations.

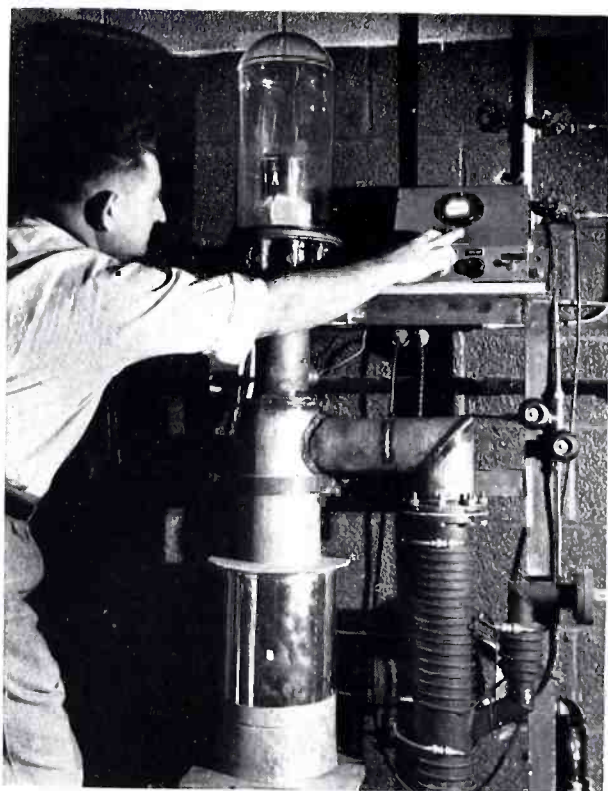
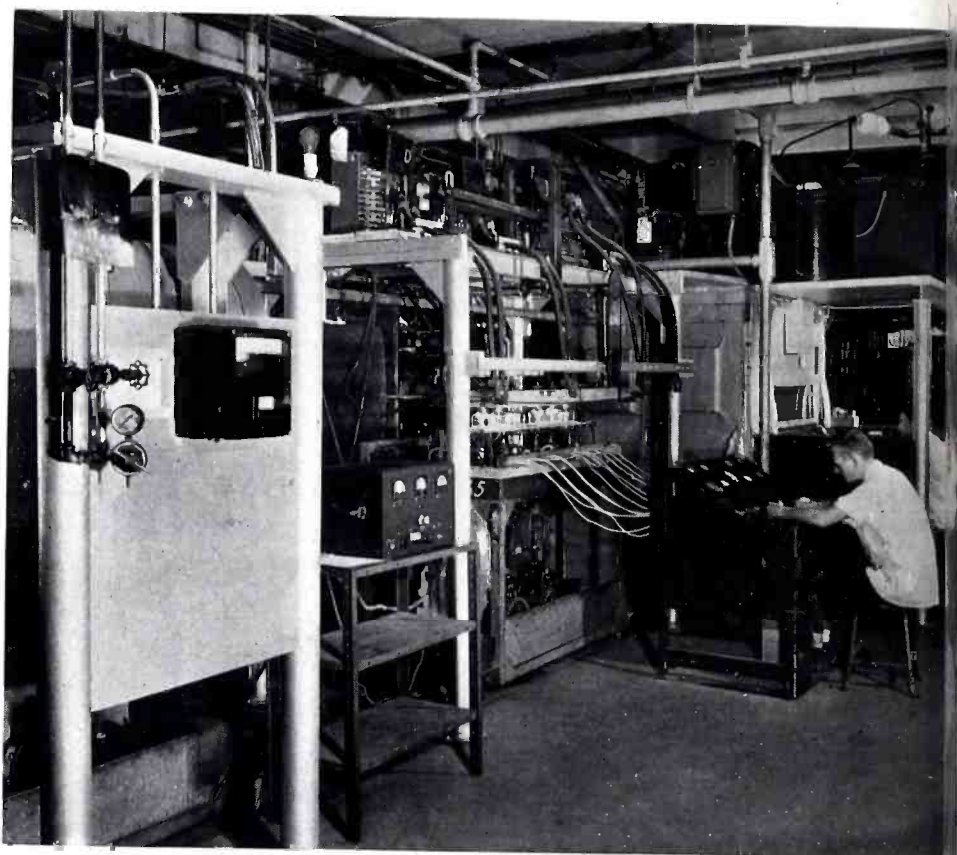

At left is shown another specialized production technique developed by Machlett, the brazing of metal to ceramics in a high vacuum, used in construction of planar electrode tubes for uhf.

manufacture results from its position as the world's largest producer of X-ray tubes, and from the extensive development of tubes for r-f heating and other industrial applications—fields requiring the highest standards of ruggedness, performance and quality. Under the direction of its founder, Robert Machlett, the firm made one of the first, if not the very first, X-ray tube for commercial distribution in this country, in the 1890's. In reaching its present leading position Machlett Laboratories made numerous pioneering contributions both as to design and manufacturing methods for X-ray tubes and industrial heating tubes.

X-ray tube production is basically like that of electron tubes for communications use, in that a metal and glass assembly is made which will maintain a very high vacuum, and in which electron beams are produced and controlled under precise conditions. An X-ray tube is essentially a diode. However, it differs from tubes made for communications purposes in that it employs very much higher anode voltages, ranging from 25,000 to 2,000,000 volts and higher; in the necessity for sharp focusing of electron beams; and in the provision for control of the energy leaving the tube structure, i.e., the X-rays which the tube is built to produce. These and other related differences make the manufacture and testing techniques for X-ray tubes, and the control of quality for long life and proper performance, in general more difficult than corresponding techniques for communications tubes.

From X-ray tubes, Machlett Laboratories has been led within recent years to the production of high power tubes

for r-f heating and for high power transmitters. Thus there has been established a flow of techniques and skill from the long background accumulated in X-ray tube production into the related but somewhat different field of tubes for communications uses.

At the Machlett plant one finds an organization which is uniquely adapted to meet the requirements of high power, high voltage electron tube development and manufacture. Development and design engineering groups are organized and function in a manner which assures the closest coordination with the quality control and production activities. Due to the demanding requirements of X-ray and high power electron tube manufacture, the Quality Control division is more extensive in size and scope than is customary in the tube industry. The practice of 100 percent inspection on components as well as finished products is rigidly adhered to. Throughout the plant one finds many unique manufacturing processes, such as vacuum casting, powder metallurgy, intricate arc welding in hydrogen and argon, vacuum firing, mobile exhaust systems, beryllium casting and fabrication, plus almost endless examples of ingenious mechanical devices for the assembly of vacuum tubes.

Western Electric tubes—present types and new ones to come—manufactured by Machlett Laboratories will have a secure place in the Western Electric family of products, and in the service of the broadcast industry.

(For a complete list of Western Electric Tubes to be made by Machlett, see page 38.)

Static characteristics of large power tubes are determined rapidly and accurately at this test console constructed to Machlett specifications. Visible in closed compartment at left end of console, a Western Electric 279A, 1200-watt air cooled transmitting triode is going through test procedure.

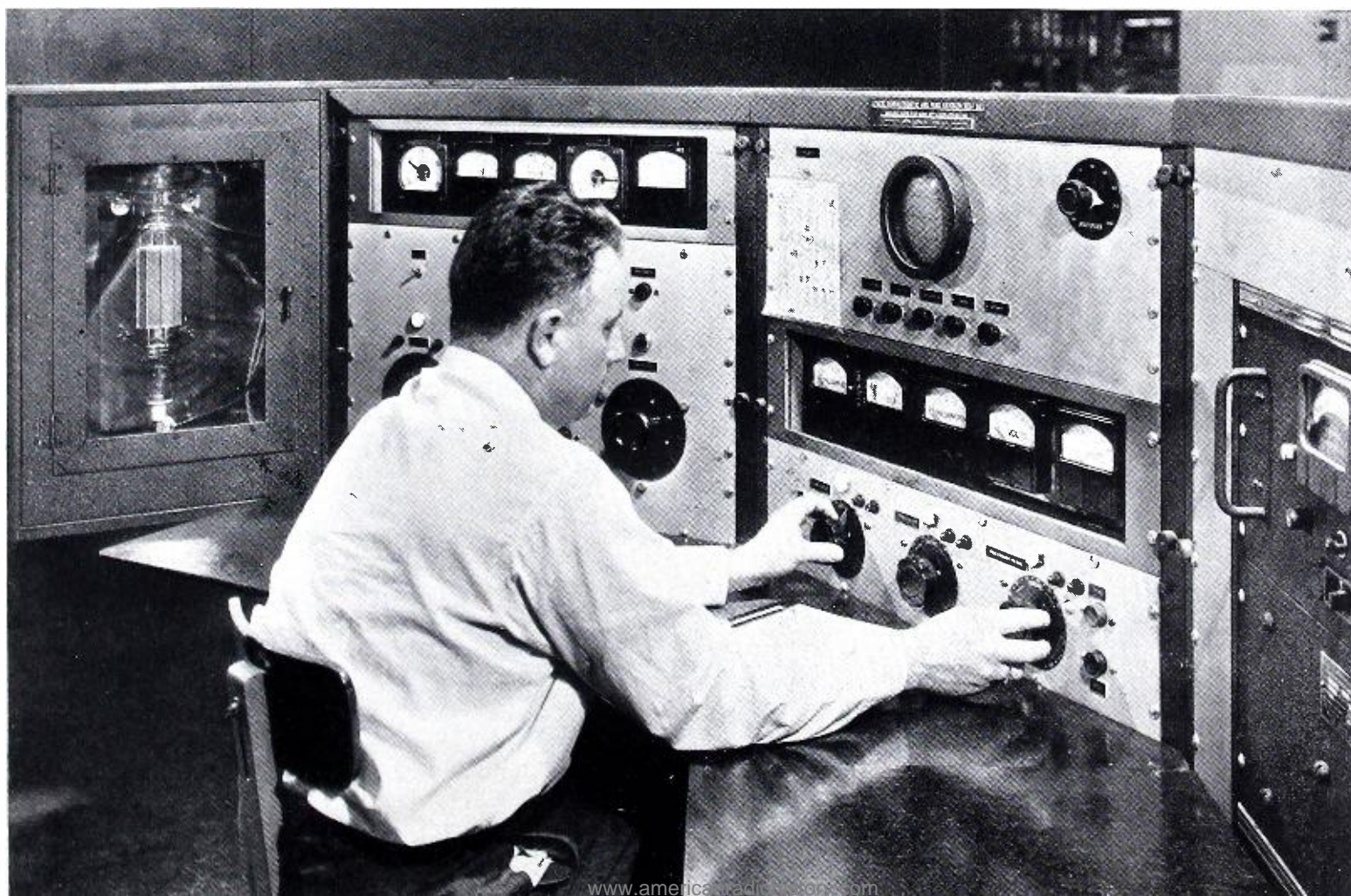

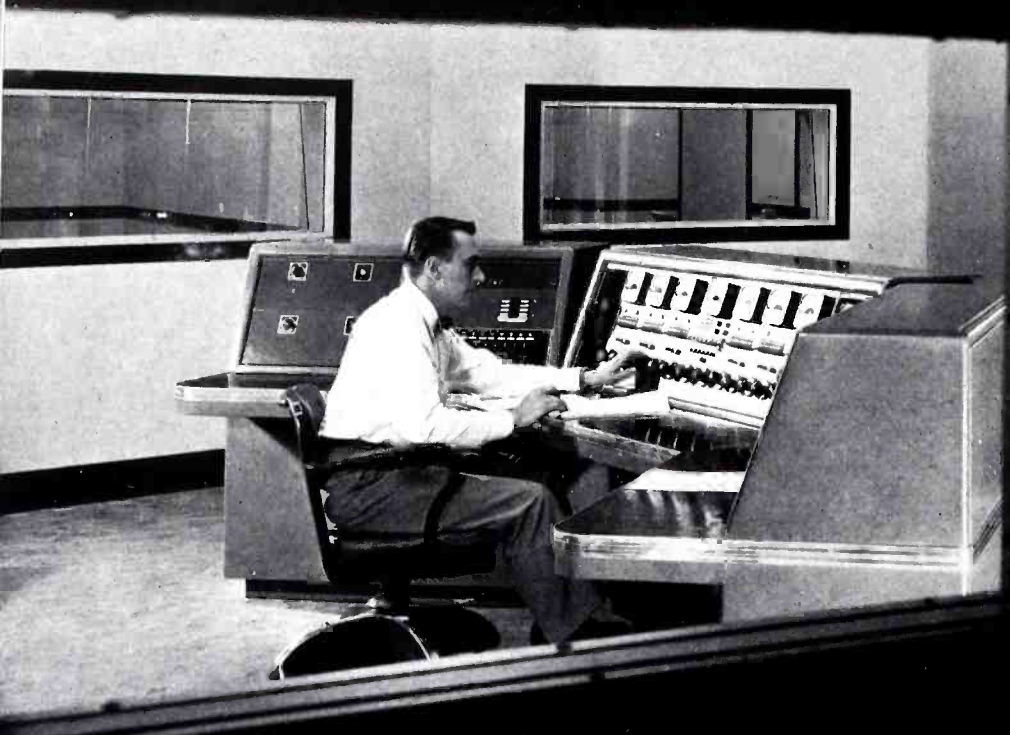

Program Dispatching Unit Make a Show Place at WIP

Benedict Gimbel jr, President and General Manager of WIP and WIP-FM



Philadelphia station
under a single operator, with

AT WIP, the Gimbels' broadcast station on the twelfth floor of their old and respected Philadelphia store, visitors coming into the studios go past a long window opening on a major equipment room, as shown in the above picture. To the uninitiated, the effect inside the window is one of neatness, light, space and impressive, gleaming equipment, with a technician efficiently and unhurriedly at work in the center of it. To the technically minded, however, the room means a lot more. It is a beautiful solution to an important part of the station's technical operating problem. In this room are combined two major func-

Western Electric OSCILLATOR

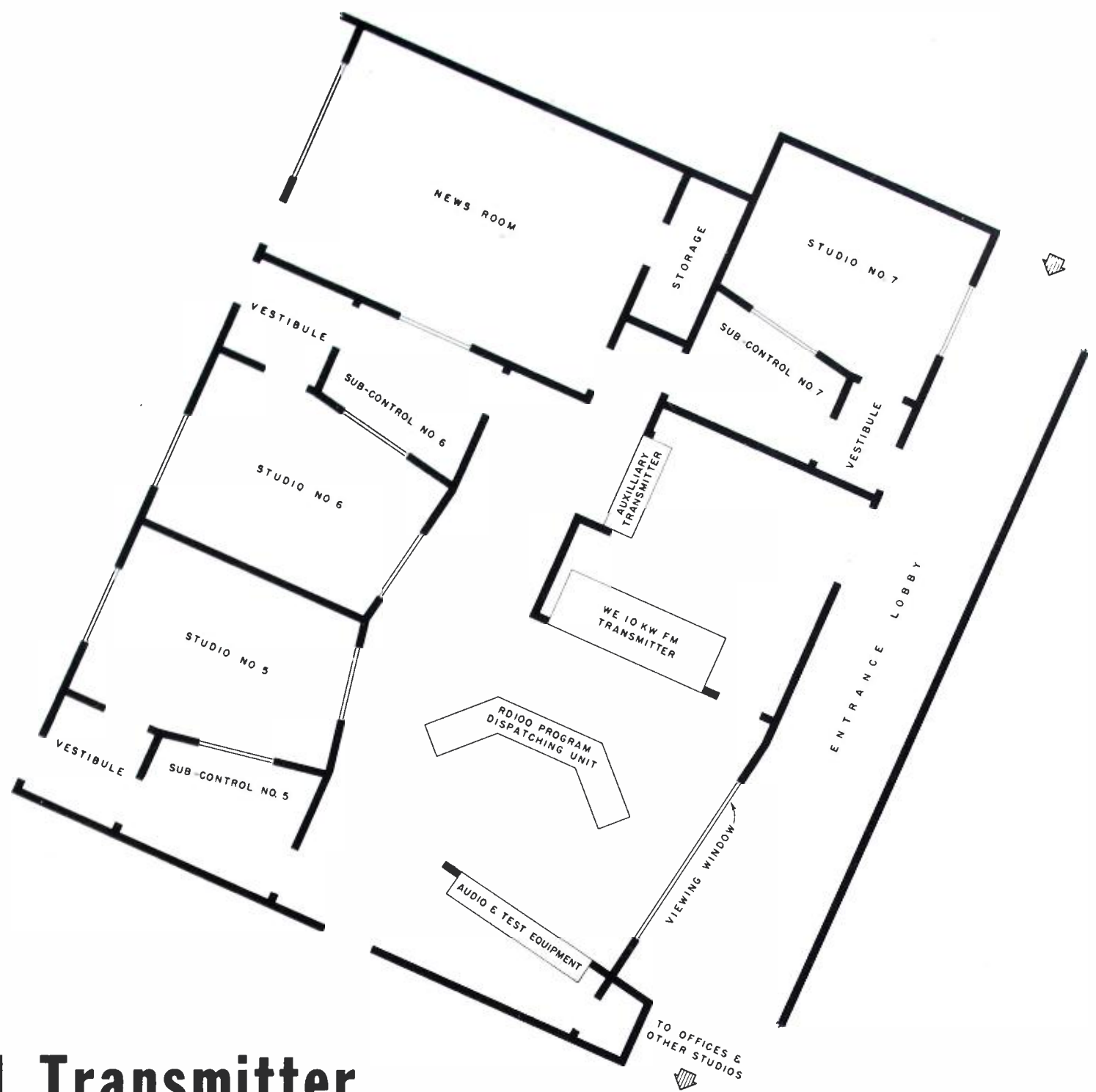

and FM Transmitter

**puts 10 kw FM transmitter and master control console
viewing window to show "the works" to the public**

tions . . . program dispatching, and operation of the 10 kw FM transmitter. As can be seen in the photographs reproduced on these pages, and in the Kodachrome on the front cover, the program dispatching is accomplished with a Western Electric RD100 unit, set in the center of the room. In the wall facing the operator of the program dispatching desk is the Western Electric 506B-2 10 kw FM transmitter. In the wall in back of the operator are the racks for audio, test and monitoring equipment.

The RD100 unit provides group or individual switching of preset program connections between the six . . .

eventually seven . . . studio program sources and the three output trunks at WIP: AM transmitter, FM transmitter, and at intervals to the Mutual Network. Equipment is complete in the unit for three additional inputs and three additional outputs, whenever they are needed . . . a total of 10 input and six output channels which can be connected in any combination. The sure-fire simplicity of setting up the program routing in advance of the station break, and accomplishing the change-over at the proper time with the push of a button, enables a single operator to perform efficiently both the program routing and the routine operation of the



All program routing is done at RD100 console. Left wing holds order wire panel. FM transmitter is supervised from console position.



Racks in rear wall of combined master control-FM transmitter room put audio, test, monitoring equipment in easy reach of operator.

FM transmitter.

The floor plan on page 9 shows the arrangement of this master control-FM transmitter room and the immediately surrounding areas at WIP. Installation of the program dispatching unit is part of a studio rebuilding plan designed to handle in the most efficient manner the enlarging activities of the pioneer Philadelphia station. WIP, under the Gimbels' continuous ownership since its inception in 1922, now is a 5 kw AM—10 kw FM—network originating operation. The AM transmitter is a Western Electric 405B-2 equipment, installed in a modern building 6.7 miles from the studios. The station has been on FM with a 1 kw Western Electric transmitter since April, 1942. When the conversion of the 1 kw FM equipment to a driver and addition of the 10 kw amplifier were being planned, it was decided to combine the operation of the 10 kw FM transmitter with the program dispatching in one room. The conversion to 10 kw was completed August 10, 1948, and the new operation plan has given completely satisfactory service.

As shown on the floor plan, two of the smaller studios adjoin the master control room, and have viewing windows

which enable the master control operator to coordinate his switching directly with the studio operation, whenever this is desired. The news room opens into the new studios so that news reports and commentator programs are efficiently produced. The space to the rear of the FM transmitter is used as a power distribution room. The entrance lobby will carry visitors past the viewing window, as shown, and on into WIP's new auditorium studio, not yet completed.

Proved Itself During Conventions

The program dispatching system got its first serious test during the political conventions in July. The RD100 unit was put into operation just in time to give WIP a lift in handling its night-and-day load as the Mutual Network's originating station at the conventions. In addition to the all-network pooled pickups, WIP operated independently no less than 13 remotes through the convention period. Each of them used a Western Electric 22D equipment for on-the-spot control. Three of the locations were studios in the Bellevue-Stratford, three were studios at Convention Hall, etc.

At Convention Hall, a Western Electric 25B Console coordinated the various pickup points in the Hall. All programs came into the just-installed RD100 unit in the WIP studios, for routing to the WIP transmitters and to the various groupings of Mutual Network stations which had contracted for different portions of the convention coverage.

Chief Engineer Cliff Harris comments as follows on the performance of his new program dispatching system during the hectic convention period:

"There was not a single hitch. Aided by the most complete and accurate installation data I ever saw, we simply put the equipment in and it worked perfectly. It gave us the needed solid support during one of the busiest periods in our history."

Close-up of racks shows Engineer Bengate reading plate current in 106A line amplifier. Limiting amplifiers are at top of rack at right.

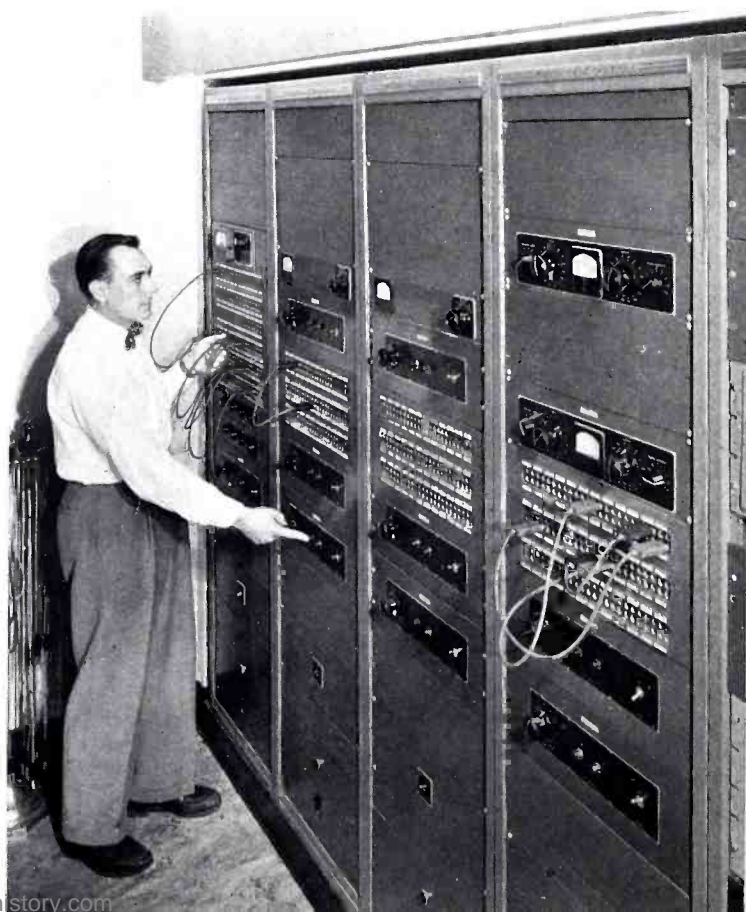

Carillon and 'Celestron'

give Daytonians a Musical Park

Carillon tower has high power Western Electric sound reproduction system in addition to complete set of Carillon bells.

A 151-FOOT TOWER of striking modern design is today playing an important and unusual role in the musical life of the people of Dayton, Ohio. The tower is the Deeds Carillon, a gift to the city from Mrs. E. A. Deeds as an expression of her interest in and aspirations for the community.

The Deeds Carillon incorporates a number of unusual features. It is the only Carillon in which the bells are suspended in the open and without enclosure of any kind. It is also the only one which combines a complete set of carillon bells and a high-power sound distribution system as a second source for its musical programs.

The two musical systems . . . the sound system, called the "Celestron," and the Carillon with its bells, . . . are used to produce regular musical programs for the enjoyment of visitors at Carillon Park, located at Patterson Blvd. and Miller's Ford Road.

Filling a Park With Music

The Celestron is essentially a straightforward high quality sound reinforcement system on a greatly magnified scale. Engineered by the Western Electric Radio Division it was installed by the Modern Sound System Company, Graybar Electric's Pittsburgh sound dealer. It consists of three turntables, microphone and telephone line inputs, special high-power amplifiers, and 16 dual loudspeakers arranged in groups of four each for complete 360 degree coverage. The design objective was to provide equipment that would faithfully reproduce high quality transcriptions and make them audible within a radius of 1000 feet from the tower; and for voice reinforcement for community activities such as the annual Easter Dawn Service. The design requirement for this application was that speech be intelligible throughout the same 1000 foot radius. Regular weekly programs of recorded music every Thursday evening were begun in June with the equipment measuring up to all expectations.

The photograph at the right is a view looking up at the beautiful tower, which rises above a terrace in the center of the Park. Some of the interesting data on the bells and the tower are given in the table on page 13. The cross sectional view of the tower on page 13 shows the location of the control room and other equipment.

Galeria for "Celestron" loudspeakers is seen in lower part of this view of Carillon tower.

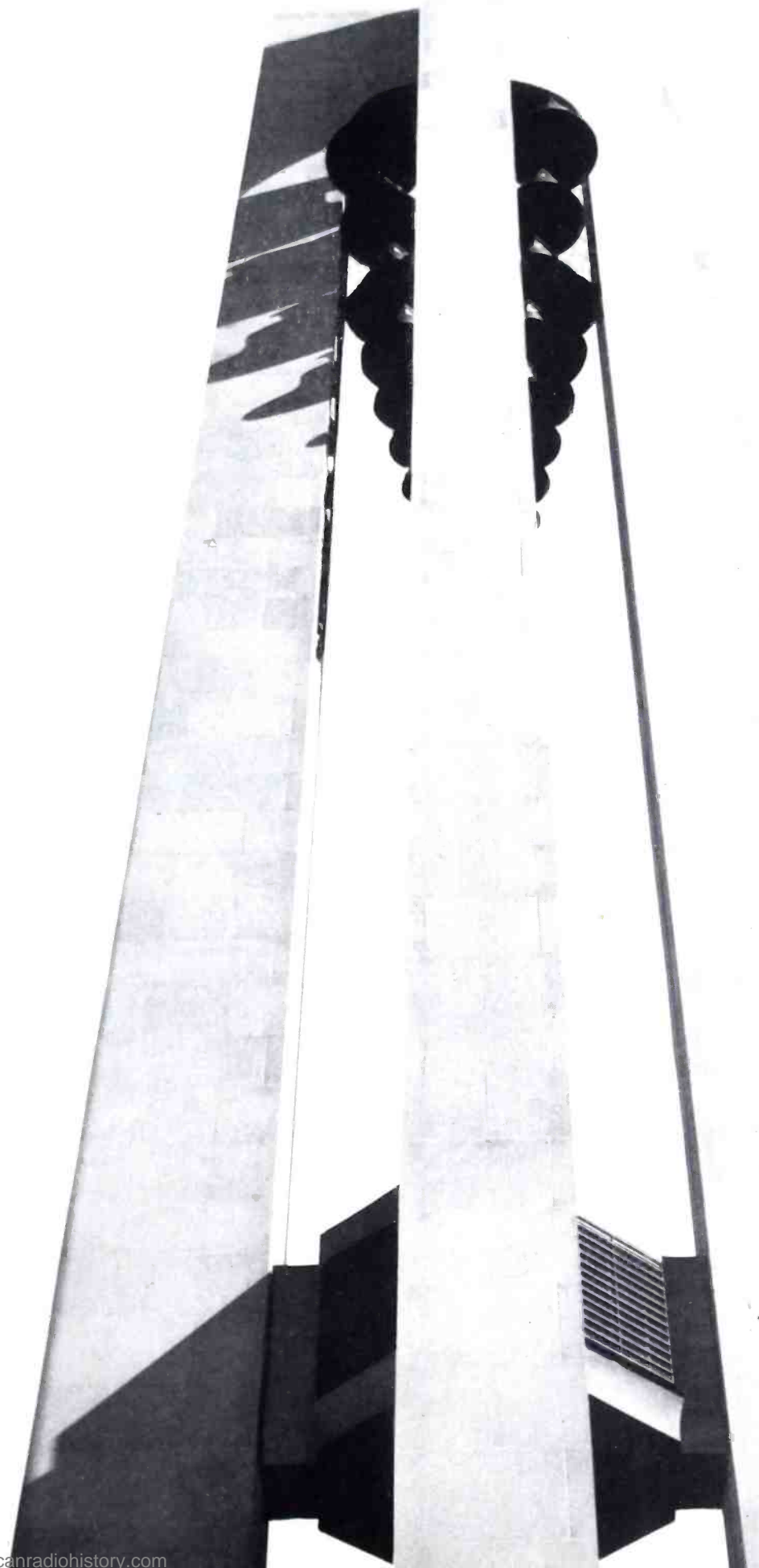



Programs on Carillon bells are performed at this electrically operated keyboard, located in Carillon Console room at the ground level.



Celestron programs originate at this transcription turntable in main room, or at two additional tables in power room below ground level. Input controls are above turntable.

At the bottom of this page is a simplified block schematic of the Celestron. This shows the general arrangement of the audio amplifying equipment. The inputs are arranged in four channels, one for transcription reproduction and three for microphone and telephone line inputs. The reproducers play both lateral and vertical cut recordings, at turntable speeds of $33\frac{1}{3}$ or 78 rpm. The output is fed through an equalizer and booster amplifier to a volume control, which is used mainly to adjust for the different recording levels which occur on different types of records.

System Uses Level-Governing Amplifier

Four microphone input circuits are provided, for an announcing microphone on a table stand in the console room and for microphones on floor stands. The Western Electric 633A microphone is used for the floor stand applications as these will usually be outdoors. The signal from the microphones is fed through booster amplifiers to the main microphone volume controls and equalizers which may be used to reduce the low speech frequencies, if desired.

The input channels are combined, and the program is fed through a Western Electric 120B amplifier to the master volume control. This control is arranged on a switch so that it may be cut out of circuit and a remote volume control substituted.

The program is then fed into a Western Electric 1126 Type amplifier, which terminates in a line-level bus across which power amplifiers are bridged. This amplifier acts as a volume limiter, preventing overloads on the power amplifiers and loudspeakers in case of accidental noises or too high a program level.

1000 Watts of Power for Quality Coverage

Four output channels are bridged on the line-level bus, one for each group of four loudspeakers. Each of these output channels includes a 118 Type amplifier and a special 250-watt amplifier, for a total of 1000 watts of audio output. Each 118 Type amplifier contains a volume control so that the volume of each loudspeaker group may be controlled separately. An output switch and substitute load is provided for each loudspeaker group so that all necessary system tests and adjustments may be made without any sound coming from the loudspeakers.

A volume indicator is provided to permit proper adjust-

Left—Some of the open-hung Carillon bells can be seen, in vertical rows with larger bells near the top of tower.

Right—Simplified block schematic shows arrangement of four input channels feeding 120B as booster amplifier, followed by master volume control, program limiter, monitor, and power amplifiers furnishing 1,000 watts of power to loudspeaker groups.

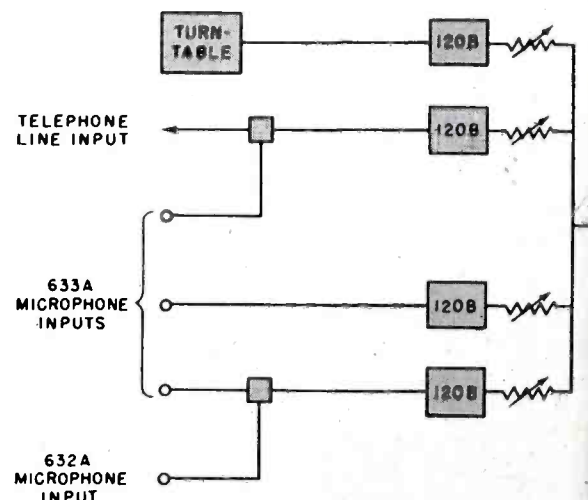

ment of the program level. This is normally connected to the line-level bus. A rotary switch is provided, however, so that this meter may be switched to the output of any 250-watt amplifier in testing the system. Normally a 1000-cycle, single-frequency recording is used for system tests and alignment.

The photo on opposite page shows the control panel, on a shelf above the transcription turntable in the main room of the tower. There are two additional turntables in the power room on the level just below the console room. These are used during the normal Celestron programs and the use of two eliminates any delay between numbers. The single turntable in the console room is used during programs combining both Carillon and Celestron music. At right are shown the racks of amplifiers and other equipment.

Loudspeakers Cover Park from Tower

The loudspeaker groups are located approximately 38 feet up the tower in the galeria shown in the tower views, and pointed 90 degrees apart for complete circular coverage. Each group includes four special Western Electric low-frequency units in wooden horns, and four Western Electric 713B high-frequency units with small metal horns, coupled by dividing networks . . . a total of 32 individual loudspeaker units. These speakers were assembled by the Modern Sound System Company.

The Deeds Carillon and Celestron were originally conceived by Mrs. Deeds because of her love of music and desire to add to the musical resources of the city. The music for the Celestron is being carefully selected from best-liked favorites recorded by the world's most famous instrumentalists, singers, and orchestras. The programs will be varied to meet all tastes and will range from symphonic to light classics and popular ballads.

For those visitors to the park who like to sit in their cars while listening to the music, ample parking space is available in the south end of the park, well within range of the high quality sound coverage provided by the system. Printed programs are provided for each Carillon and Celestron program during the year. Driving to Carillon Park for music in a serene, beautiful setting is a growing habit with Daytonians. Sound reproduction proves, in a new way, its power to aid the cultural life of a community.

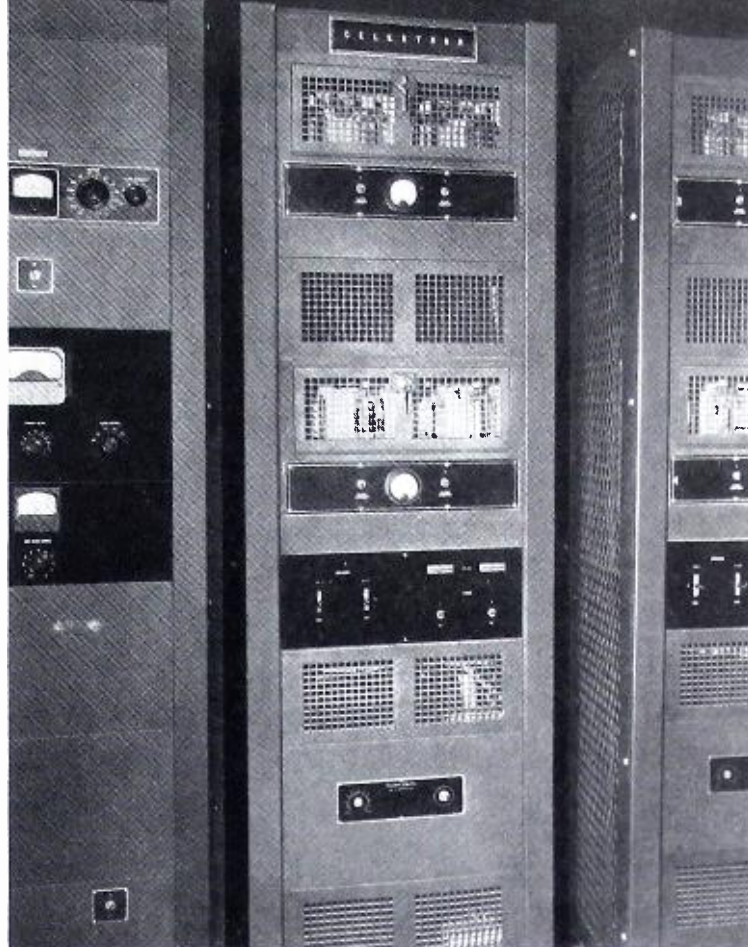

In this view of equipment in the power room two of the 250-watt amplifiers can be seen in the center rack, the other two in the rack to the right, and the program limiting amplifier in top of left rack.

DEEDS CARILLON

Number of bells.....	32
Total weight of bell chandelier.....	32 tons
Diameter of largest bell...	6 ft.
Diameter of smallest bell	1 ft. 6 in.
Height of tower above terrace	151 ft. 6 in.
Height of tower from bottom of foundation...	183 ft. 7 in.

Construction: Indiana Limestone with granite Base.

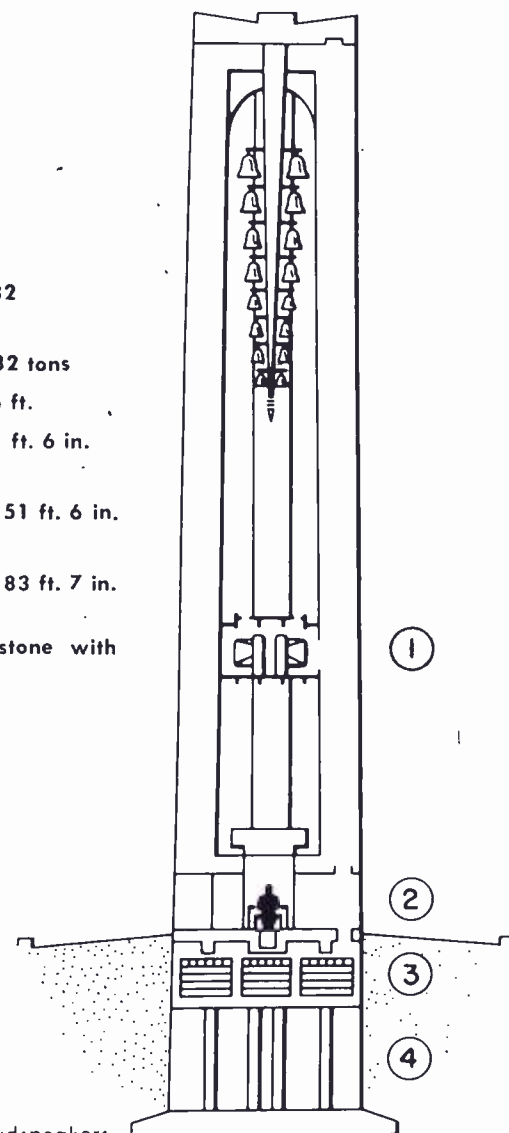

- KEY
- (1) Galeria for Celestron Loudspeakers
 - (2) Carillon Console Room and Celestron Transcription Table
 - (3) Power Room
 - (4) Basement

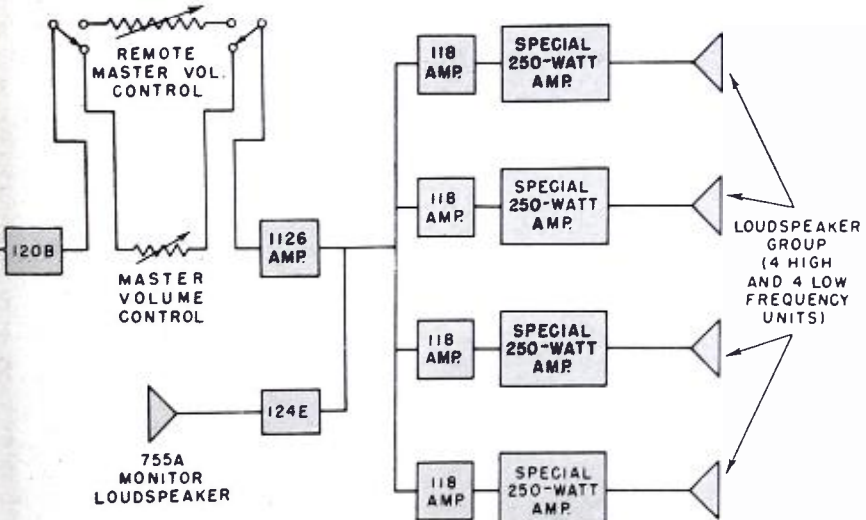

THE GOOD WILL of a broadcaster's audience rides on many factors. Not least among them is a transcription turntable which starts recorded program material on its way to the listener without imposing annoying distortion on the signal. Every audio engineer responsible for installing and operating such equipment in broadcast stations knows that flutter, rumble and change in playing time can create havoc in the quality of the reproduced sound. Sound reproduction from discs shares with every other method . . . tape, wire, film or whatever . . . the highly distasteful distortion that is produced by irregularities in the motion of the record.

The turntable driving mechanism in Western Electric's 1304 Reproducer Set is a fresh approach to this familiar problem, based on a thorough re-study of all the mechanical design factors affecting quality of reproduction. This new precision equipment for 78 rpm and 33 $\frac{1}{3}$ rpm disc playback in broadcast stations, high quality sound distribution systems, and re-recording dubbing applications, is designed from the ground up for distortionless reproduction and for convenience, ease of use and flexibility of installation.

A precision turntable drive is, of course, only a part of the problem of producing a distortion-free signal from disc recordings. The pickup is of equal importance. In Western Electric's 1304 Reproducer Set, the famed 9A and 9B mov-



Program Quality

**Low-flutter, low-rumble drive is essential to satisfactory playback
 ... Features of new Western Electric 1304 Reproducer Set**

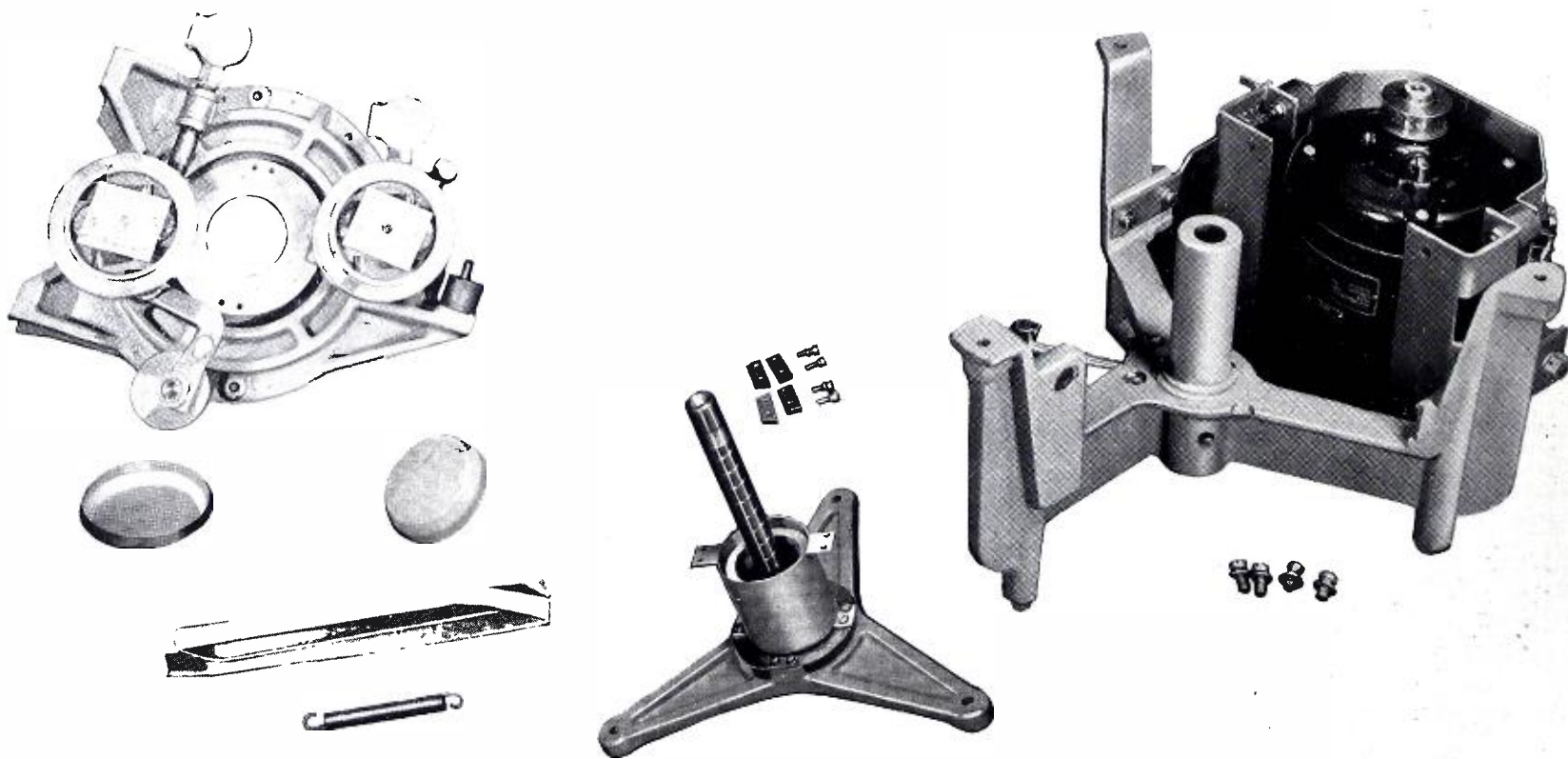

ing coil reproducers provide a "clean" transformation from mechanical to electrical signal. Recent tests have shown the 9 Type Reproducer to have the lowest intermodulation distortion of any pickup commercially available. The design features that have made the 9 Type Reproducers standard for high quality transcription service are known throughout the industry. Thus the present article will be devoted to a discussion of the characteristics of the new turntable drive mechanism... in general, the features of a turntable which affect the quality of reproduction; and specifically, how the design of the new turntable meets the various requirements of quality.

The three characteristics of a turntable drive mechanism which must be rigidly controlled for high quality reproduction are flutter, rumble and playing time variation. It should be of interest to describe each of these in general terms, defining what it is and how it is measured. They will be taken up in the order given above, following which the methods used to control them in the 1304 Reproducer Set will be explained.

Flutter, one of the most serious faults of a turntable drive, can be broadly defined as any periodic change in the angular velocity of the turntable. Since signal frequency depends on turntable speed, regular variation in the speed naturally produces frequency modulation of the signal. Low frequency

flutter, which most often has a once-per-revolution period, is the all too familiar "wow" with its sliding pitch effect. This variable pitch effect of low frequency flutter is easily understood and is familiar to all workers in the field... and to most owners of home phonographs as well.

However, if the flutter frequency is above some frequency in the lower part of the audible range, the effect on the ear is quite different. It was demonstrated in a series of exhaustive experiments on flutter, reported by Messrs. Shea, MacNair, and Subrizi of the Bell Laboratories in 1935, that with a "center" frequency of 1000 cycles, the sliding pitch effect is not heard when the modulating frequency is above 40 cycles or so. What is heard instead is a roughness of tone somewhat similar to the effect of non-linearity in a reproducing system.

How Flutter Produces Distortion

This characteristic audible distortion of high-frequency flutter, as contrasted to the low frequency "wow" which is audible as a wavering tone, finds its explanation in the nature of a frequency modulated signal. It is well known that such a signal can be analyzed as a set of distinct signals, with frequencies spaced on both sides of the "carrier," or center frequency, at regular intervals which are equal to the modulating frequency. The relative amplitudes of the center fre-

Depends on Turntable Precision

of transcriptions...

assure distortion-free reproduction

by J. G. Lawrence

Radio Division, Western Electric Company

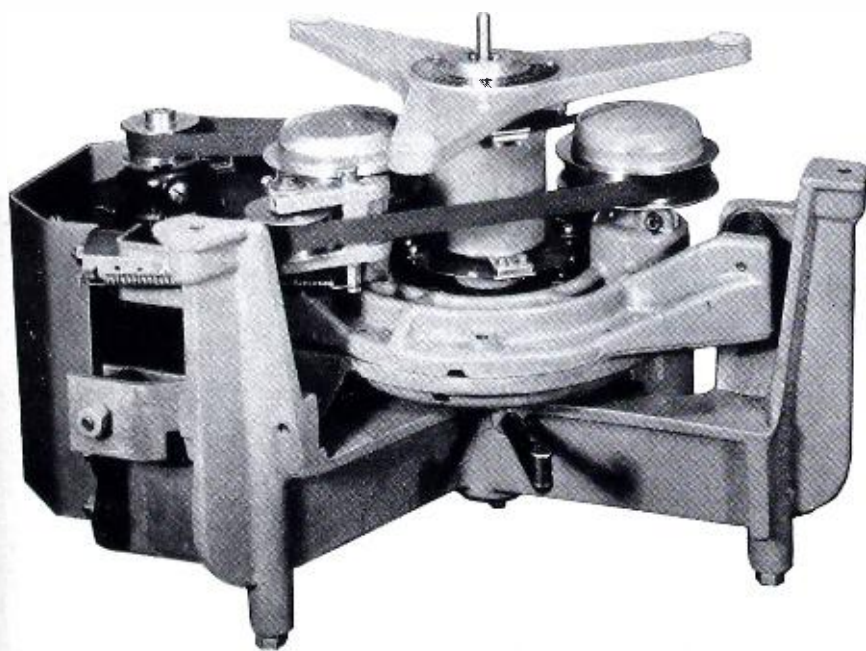

November 1948

15

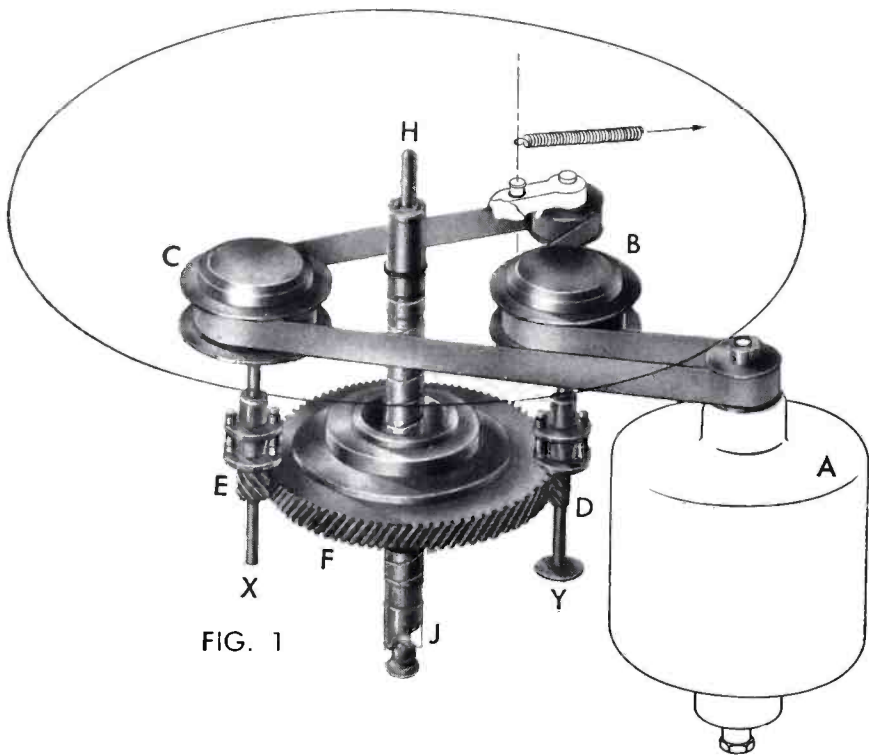

FIG. 1

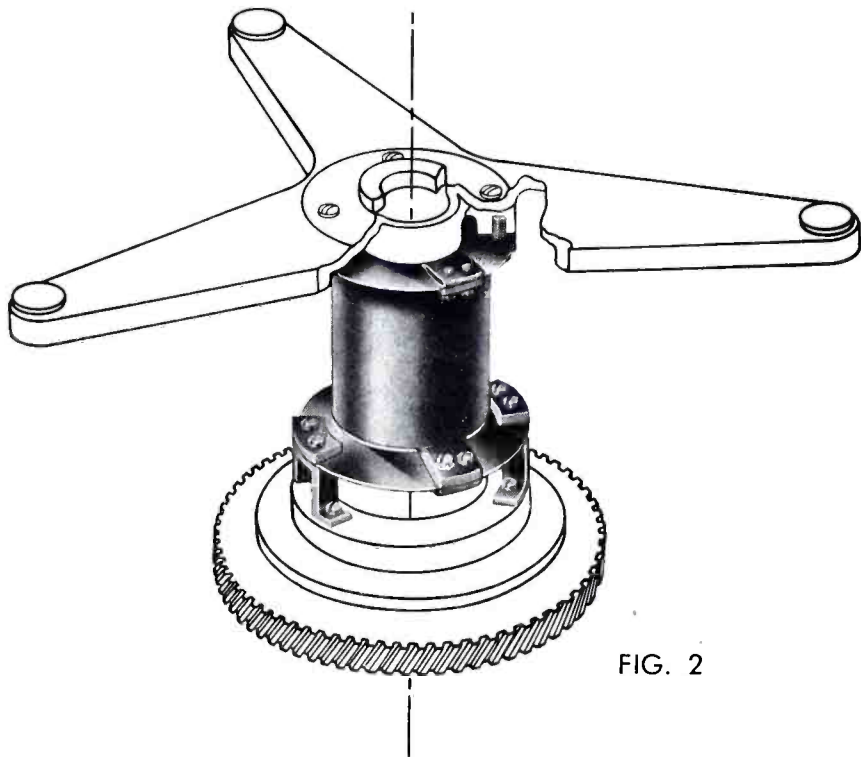

FIG. 2

HOW IT WORKS

Figure 1: Power is carried by belt from motor to clutches at B and C, which transmit rotation to pinion D or E, depending on direction of rotation of motor. Reversal of motor effects change from $33\frac{1}{3}$ to 78 rpm or vice versa. Spring-loaded idler in back of clutch B maintains proper belt tension. Connection between driving gear F and platter shaft H is not shown. — Figure 2: Only coupling between driving mechanism and platter is this cylinder, flexible in every plane except rotational, isolating rumble. — Figure 3: Exploded view of clutch shows simple, positive grip, release mechanism. — Figure 4: Each pinion and shaft forms mechanical filter to reduce residual flutter. Section shows oil chamber at end of shaft which damps flutter motion.— Figure 5: Entire driving mechanism, shaded portion of drawing, is isolated from frame by rubber mountings.



FIG. 3

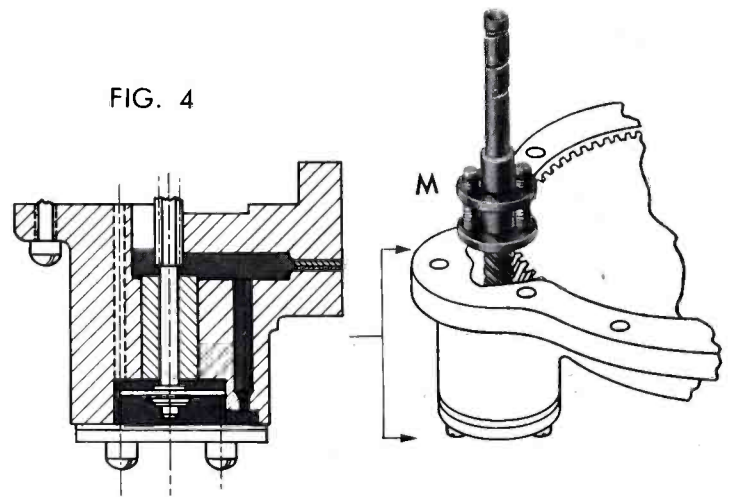

FIG. 4

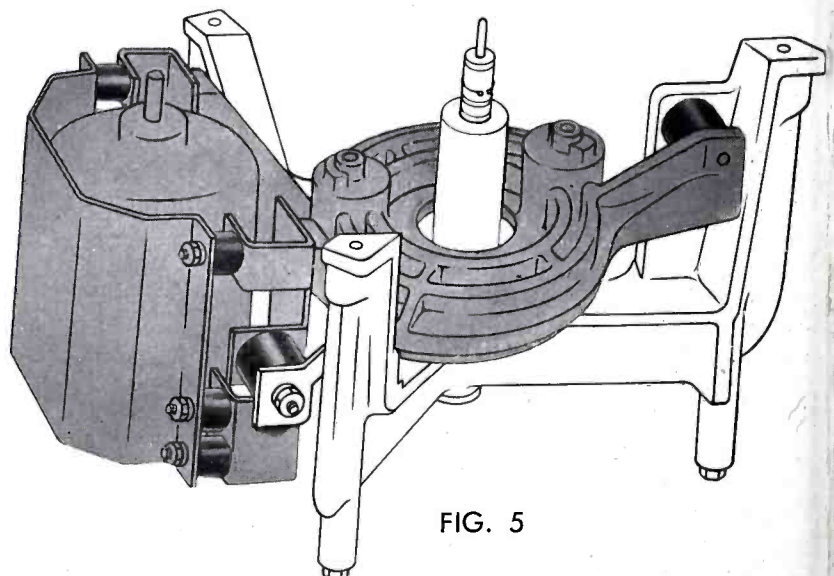

FIG. 5

quency and the sidebands vary with the modulation index; under certain conditions of modulation, the center frequency is equal to zero. As the signal picked up from a transcription turntable which is subject to flutter is frequency modulated by the flutter frequency, it displays all the characteristics of such a signal, including the sideband series. This means that a whole series of extraneous frequencies are introduced. It is this combination of signal and sideband series which the ear perceives when the flutter frequency is above a certain critical value. Since the added sidebands are not in general harmonically related, the total effect is one of roughness.

Thus, whenever a transcription reproducing system displays a roughness of tone, turntable flutter should be considered as a possible cause, along with the familiar imperfections of stylus, pickup, amplifier, etc., . . . assuming of course, that the distortion is not on the transcription itself. Because the ear is extremely sensitive to the effects of frequency modulation, flutter of very low amplitude can dull the fine edge of clarity in an otherwise excellent reproducing system.

The causes of flutter in a turntable mechanism include imperfections in gear drives; unbalance in any rotating member in the mechanism; slippage of friction drive; flats on rim drive wheels, or on the balls used in planetary drives. Each gear in a mechanism can introduce a separate flutter of a definite frequency and complex gear trains and planetary drives often have many flutter components, some of them at low frequencies which are difficult to eliminate.

Flutter Turns Away the Listener

With some experience in interpreting "ear results," a constant frequency record or a piano recording with long sustained notes can be used to test a turntable for flutter. The effect of flutter is apparent to the trained ear: low frequency flutter or "wow" with its varying pitch, and high frequency flutter with its characteristic fuzziness or roughness. It should be emphasized that although some training may be required for the actual identification of flutter in a recording system, the effects of flutter on quality are apparent and very distasteful to the completely untrained ear. Small amounts of flutter can be effective in creating acute dissatisfaction with reproduced music even though the listener is unable to analyze the cause of his strong antipathy.

Rumble, the noise voltage produced by any motion or vibration of the turntable with respect to the pickup outside of regular rotation, can be just as annoying to the listener as flutter. Anything which shakes or moves the turntable, whether it comes from within the mechanism, or is transmitted through the cabinet from the building, can produce a noise voltage in the pickup. One method of test is to hold the record motionless with the stylus in the groove and the turntable revolving under it. A rough idea of the rumble level can be obtained by ear, or the output of the system under the conditions stated can be measured on a vacuum tube voltmeter or oscilloscope.

It is important in such a test that the measuring system respond only to rumble frequencies in the range which will be reproduced by the system as a whole, and that due regard be given to the characteristics of the ear, in order that the measurement correlate with the actual ear effect of the rumble. The proper criterion of low rumble in a playback instrument takes into account the position of the residual rumble in the frequency spectrum. Rumble of so many db below signal level at 80 cycles may be a serious matter; rumble of several times this value at 10 or 15 cycles may cause no trouble whatever. Thus a wide open measurement of the rumble voltage will not indicate the merit of a turntable as far as rumble level is concerned; the frequency spectrum of the rumble must be determined.

Playing time variation has obvious disadvantages for broadcasters on their closely timed programs. The effect is to cut into, or to unduly lengthen, the period of a minute or less which is available at the end of a transcribed program for the "program break." Commercial and station announcements, etc., must be fitted into this period. Test for playing time variation can most conveniently be made with a timed record and a stop watch.

Precision is Lasting in the 1304

Each of these factors . . . flutter, rumble, and playing time variation . . . has been positively controlled in the new Western Electric 1304 Reproducer Set to such an extent that all three are lower than the corresponding characteristics of many recording equipments now standard. In addition the mechanism has been so designed that the rumble, flutter and playing time variation will *not increase with time*. Wear is one of the worst enemies of precision in a turntable mechanism: the design of the 1304 driving system is such that it will maintain its original characteristics over long periods of use.

Figure 1 shows the essentials of the mechanism. The reversible synchronous motor at A is belt-connected to two pulleys at the tops of vertical shafts X and Y. These pulleys drive the shafts through over-riding clutches B and C. Each shaft has near its lower end a helical pinion gear, D and E. The pinion gears engage a large driving gear, F. The driving gear is connected through a drive isolation coupling, (not shown in Figure 1, see Figure 2) to the turntable shaft, H. Except for this coupling, there is no connection between gear F and shaft H. The platter and shaft turn on the single-ball thrust bearing at J. With the use of the belt drive and all vertical shafts, a configuration is provided which allows the entire mechanism to be attached to the top mounting panel . . . an important advantage as will be pointed out.

Operation of the turntable is as follows: with the motor turning in the clockwise direction, the clutch on shaft Y engages, and pinion D drives the large gear and platter at the $33\frac{1}{3}$ rpm speed. With this direction of drive, clutch C is disengaged so that pinion E is idling. The throw of the speed change switch reverses the direction of rotation of the motor

to counter-clockwise and then pinion E will drive while D idles. The difference in the number of teeth in the two pinions furnishes the speed change from 78 to $33\frac{1}{3}$ rpm. Thus the speed change is effected by the simple throw of a switch, and does not involve disengaging of gear trains or planetary ball devices.

Other features of the mechanism are shown in Figures 2, 3, 4 and 5. The drive isolation coupling between driving gear and turntable platter is shown in Figure 2. As will be described, this is an important element in the system for reducing the rumble level. In Figure 5 the whole unit has been shown, without the platter and the drive isolation coupling, but with the "floating drive" arrangement made clear by shading the portion of the mechanism that rides on rubber mountings, free of a direct connection to the frame. This is also a necessary feature of the rumble control system to be described.

Flutter control is accomplished in part by the mechanism shown in Figure 4. This is a detail and vertical section of one of the pinion gears and the lower part of its shaft. The dark shaded portion on the sectional drawing is an oil-filled chamber, the function of which will be described. The clutch mechanism is shown in exploded form in Figure 3. The photographs on pages 14 and 15 give additional views of the various parts and of the assembled mechanism.

Keeping Flutter at 1/10 of 1%

Consider first how flutter is closely controlled to a level of 1/10 of 1% or better, or well below the troublesome range, at either 78 or $33\frac{1}{3}$ rpm. A single helical gear drives at either speed, with the gears permanently engaged at all times to eliminate wear caused by engaging and disengaging the drive. The residual high-frequency flutter resulting from the gear action is reduced by a novel filter system. This filter, as shown in Figure 4, consists of the oil chamber at the bottom of each shaft, into which the shaft projects; a coupling at M; and the lower part of the shaft. The couplings, M, allow the lower parts of the shafts to move a short distance along their axes, and because of the use of helical gearing any flutter tends to be taken up in axial motion of the shafts, rather than being transmitted to the main drive gear. Each coupling with associated shafts and springs forms a mechanical filter proportioned to reduce the specific frequency of the flutter. The oil chambers furnish damping.

The level of "wow" is reduced by the high inertia turntable platter with its rim-concentrated weight; and by precision manufacture of all rotating members. The flutter level of 1/10 of 1% includes "wow," which puts the sliding pitch effect at an inaudible level. Thus both effects of flutter, roughness of quality and varying pitch, with their attendant unfavorable audience reactions, are effectively eliminated.

Reduction of rumble in the 1304 turntable has been given very careful attention. By concentrating on those sources and frequencies of vibration and rumble which can actually

Here are the various combinations in which Western Electric Transcription Playback Equipment is available.

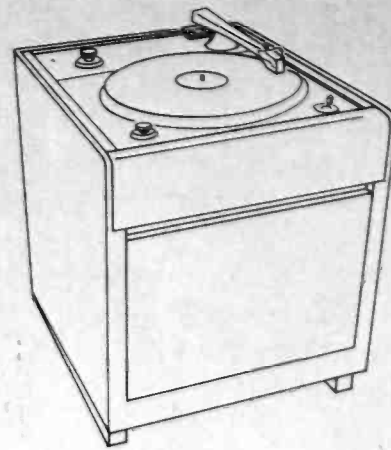

Complete floor type unit. 1304A & B Reproducer Sets include 22A cabinet, 109AA or 109B Reproducer Group, 706A guard, platter, drive, motor, speed change, on-off switches.

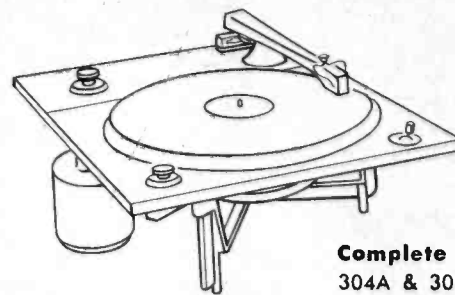

Complete Single - Panel Units. 304A & 304B Reproducer Panels include all items except 22A cabinet, will operate on any suitable cabinet or shelf.

Turntable and Drive Unit. 305A Reproducer Panel has platter, drive, motor, and rear panel drilled for 109-type Reproducer Group. 305B is the same, less the panel for 109 Group, so purchaser can use drive mechanism with any type of reproducer equipment.

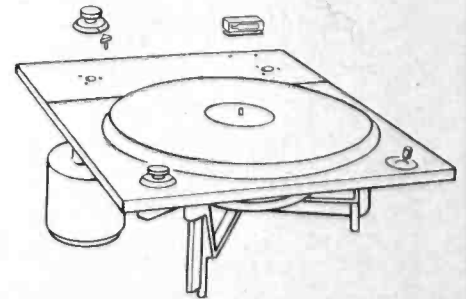

Pickup and Equalizer Assembly. Below are elements of 109 type Reproducer Group: 9A or 9B Reproducer, 5A arm, KS 13386 variable equalizer, 171A repeat coil.

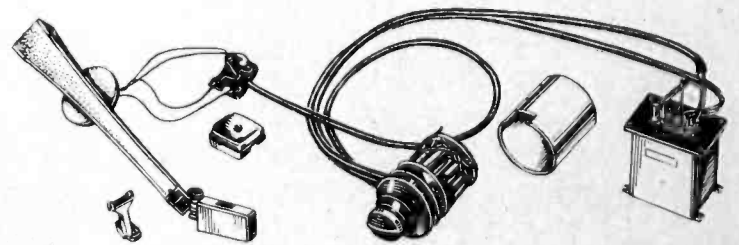

Equipment For Cabinet Space. Below are two arrangements for use of space in 22A cabinet. Left, rack mounted amplifying or power equipment. Right, 701A shelf for transcription storage.

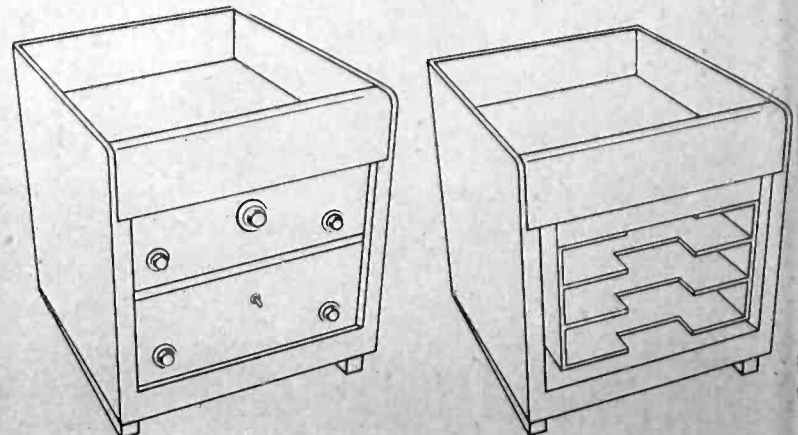

produce a distressing ear effect, the design provides a practical and positive solution to the rumble problem, and one which is long-lived and foolproof. As already described, Figures 2 and 5 show the method of isolating vibration in the driving mechanism, so that it does not reach the platter. The entire drive mechanism including the motor, floats separately from the frame and platter shaft, riding on three large rubber isolators, two of which are visible in Figure 5. The motor in turn is isolated from the gear system with six smaller rubber mountings between it and the drive mechanism, four of which can be seen in the drawing; and by the use of a belt drive.

Rotation Without Vibration

Finally, the drive isolation coupling of Figure 2 completes the separation of the entire drive mechanism and motor from the platter, by providing the only connection between driving gear and platter shaft. As shown in Figure 2, the coupling consists of a thin-walled cylindrical member concentric with the platter shaft, connected to the platter at the top and the driving gear at the bottom by two thin discs. The cylinder is tied to each disc at two points only, at the ends of a diameter of the disc. Each disc in turn is tied to the platter or to the driving gear at the ends of a second diameter, at right angles to the first diameter. This combines great flexibility in every plane except the rotational, in which plane the coupling is quite rigid. Thus the driving motion is transmitted efficiently to the platter, while motion in any other plane is effectively isolated.

The design features described above isolate rumble originating in the drive mechanism itself. To protect the turntable from rumble originating exterior to the mechanism, the panel to which the entire mechanism is attached is floated in the cabinet on vibration mounts at the corners. Thus building vibration, blows against the cabinet, etc., are prevented from interfering with the action of the turntable. The single-panel construction makes this straightforward method of exterior rumble control practical.

Playing time variation in the 1304 is eliminated as a factor in operation. With a playing time variation of ± 1.8 seconds in 15 minutes, a mere 0.2%, there is no perceptible variation in the period assigned at the end of a transcribed program to cueing, commercial announcements, cutover to other program conditions, station and network announcements, etc.

To make the mechanism long-wearing and trouble free, large, properly lubricated bearing surfaces have been included throughout. The main shaft bearing is of the ball-thrust type as shown in Figure 1 because this is the smoothest type of thrust bearing, while the bearings for the pulleys and pinion shafts are of phosphor bronze. The vertical main shaft has a spiral groove which pumps oil to the top during rotation for its lubrication, allowing the excess oil to return to the bottom by gravity through a hole in the center of the shaft. Wick type oilers furnish lubrication for

both the upper pinion shafts and also for the idler pulley. In addition, a spiral groove is cut into each pinion shaft to move oil from the oilers to the pulley bearings.

The overriding clutches that transmit the belt drive from pulleys to pinion shafts are of a simple, positive brakeshoe type, as can be seen in the exploded view of Figure 3. On life tests these clutches have operated more than 25,000 times, without a failure. Since the belt is used for approximately a 2 to 1 speed reduction only, large diameter pulleys can be used, with a large wrap-around of the belt to aid in maintaining speed precision and low wear. The spring-loaded idler pulley with a wide positive movement further guarantees against any possibility of belt slippage.

The design features of the drive mechanism described make the 1304 a precision instrument, adapted to every high-quality transcription playback application, including dubbing, with its most severe performance requirements. But a broadcaster's transcription turntable must be more than a precision playback mechanism... it must provide reliable, error-free operation under the conditions of day-to-day broadcast programming, or its design is at fault. Every feature of the 1304 was thought out for regular, long lasting, trouble-free operation under the strenuous usage of the broadcast studio or the music distribution installation.

Consider the following operating conveniences which have been incorporated:

Speed Change

The unique speed change method already described allows rapid change of speed at any time, with motor running or still. The change of speed occurs so quickly and with so little disturbance of the platter motion that when a disc has been started at the wrong speed, for instance, the speed change switch can be thrown to the correct speed, without serious or prolonged disturbance of the sound quality.

Rapid Acceleration

The platter comes to full speed in $1 \frac{9}{10}$ revolution at 33 $\frac{1}{3}$ rpm and $\frac{1}{2}$ revolution at 78 rpm. Because of the very low overshoot completely stable speed is reached a small fraction of a second later. This means that a transcription started on a stationary platter comes up to a full steady speed so quickly that very short cueing distances can be used. Even if the table is started from a stopped position with the stylus in a recorded portion of the track, the starting "wow" is so short as to be unnoticeable to most listeners.

Transcriptions can be started, of course, by the method used in many broadcast stations... releasing the disc on the revolving turntable.

Interchangeable Switches

The "On-Off" and "Speed Change" switches on the panel can be readily interchanged in order to put them in the most convenient position for any given control arrangement.

(Continued on page 37)

"Transmitter building

Or how two Western Electric broadcast transmitters rode safely over

KPQ, Wenatchee, Washington, stayed on the air with its transmitter building afloat for six weeks

There's a mark 13 feet high on a power pole near KPQ's transmitter at the junction of the Wenatchee and Columbia Rivers. That mark was placed there by a KPQ operator at the height of the flood which swept through the Pacific Northwest early this summer.

The last week in May the water of the Columbia river rose an inch an hour, day after day. To get KPQ ready for the flood, a crew of house movers and radio engineers placed half a dozen huge rubber assault pontoons . . . sixty-man life rafts . . . under the transmitter building. When the water came up above the foundation, the building floated on the air-filled pontoons, and KPQ was really "on the air". For two weeks, while the rampaging Columbia did damage estimated at a hundred million dollars, the water was 13 feet deep under KPQ's floating station. The 30-ton building was above its foundation for six weeks.

Coaxial cables from the transmitter to towers went out early in the game. To keep the station in operation, Chief Engineer George Frese climbed up one of the towers in the middle of the night, in a howling gale, to hang a shunt feed wire. He literally swam around the transmitter building with a pair of pliers in his teeth. Power leads were moved, with no break in service, phone wires were shifted, and operators traveled to and from work every day for the six weeks in row boats.

With uninterrupted operation possible, the 1000 watt

Western Electric 304B transmitter stayed on the air day and night to serve the community during the flood emergency. KPQ is credited with saving at least one Wenatchee Valley town. Late one night a frantic telephone call came from Cashmere, 12 miles from Wenatchee. A dike was being washed away, and more men were needed at once. The plea was broadcast, and within 20 minutes 400 volunteers were on the job.

Within another 20 minutes the city's stocks of sandbags were gone. Another KPQ call brought an immediate response. More than 8,000 bags were available at the Centennial flour mill in Wenatchee, but there were no trucks to haul them. Another radio plea and in five minutes, 25 trucks of all sizes choked the streets around the flour mill. Calls for relief workers throughout the next two days and nights were always answered, and not a drop of river water got into the city of Cashmere.

How much the water in the main stream would rise each day was vital information. The exact statistics . . . and they were right most of the time . . . were compiled by the KPQ news department after daily phone calls up and down the 1000 mile length of the river, after calls to key points on the main tributaries, and after a great deal of head scratching and slide rule manipulating. The United States Weather Bureau used KPQ's river level figures and forecasts for its own predictions for points farther downstream.

When it was all over, KPQ's staff faced a big clean up job, but they had the satisfaction of having completed a most unusual and dangerous stint that was at the same time a valuable service to the community.

On the way to KPQ's offshore transmitter building, Sales Manager Pat O'Halloran, Chief Engineer George Frese, and Manager Jim Wallace use rubber boat to cross rising Columbia River. At height of flood building floated in 13 feet of water.



AHOY!"

The spring floods



WKYW, Louisville, put its transmitter building on pontoons, just in case the Ohio River came

And come it did. For six days during April 1948, WKYW's 1 kw Western Electric transmitter operated in a waterborne transmitter house . . . riding high above more than 20 feet of the Ohio's spring flood.

In the September 1947 *Oscillator*, WKYW's pontoon-mounted structure was pictured and described as an interesting example of the solution of a special problem in transmitter building architecture. In order to make use of a desirable transmitter location on low ground next to the Ohio River, WKYW made provision for the worst that the rampaging river might do. This included not only the pontoons permanently attached to the transmitter building, and supported on concrete piers, but also arrangements for rapid installation of flexible power and signal cables, etc.

Early in April when Weather Bureau predictions indicated enough water on the way down the river to lift the building off its concrete piers, preparations were made to cast off from moorings and at the same time anchor so that when the pontoons became waterborne the transmitter building would float directly above the permanent concrete foundation.

All ground conduit, telephone cables and transmitter ground straps were disconnected from the transmitter shack, to permit floating of the pontoons. The transmission line and conduit leading to the tower are above ground and were loosened from their mountings for a distance of 30 feet from the transmitter.

November 1948

As the waters continued to rise use of the permanent coaxial transmission line, although under several feet of water, was possible by maintaining an air pressure of 25 lbs. Operations continued satisfactorily until water rose above the tower insulator which is 12 feet above ground. This grounded the antenna and submerged the tuning unit making that operation impossible.

Prior to this, however, and permitting continued operation without loss of air time other than occasional instantaneous breaks, an emergency antenna was installed as follows: Number A8 copper wire, 250 feet long was suspended from about 200 feet up on the tower to the transmitter house and insulated from each. A lead in from this "flat top" was connected in series with a capacitor-inductive network consisting of an Army Surplus BC 939A antenna loading unit, a large variable condenser, and two fixed .002 mfd. condensers, making up the emergency antenna array. Tuning of the Doherty-final transmitter and loading network were done simultaneously with the use of an oscilloscope in the usual manner, without any particular difficulties.

While results from this emergency arrangement were naturally not perfect, WKYW was able to put out a strong signal. With the building waterborne and moored in its flood position, listeners' reports kept coming in from all directions in the service area . . . WKYW was reaching its audience and continued to "get out" all during the flood.

During the six days that the Ohio River poured under the transmitter building, engineering personnel covered the half mile to shore in power boats. Then, when the river started to fall these boats were used to guide the pontoons back to their normal position on the permanent foundation. All went off according to plan—the "voyage" ended with no damage to any equipment in the building, and WKYW's personnel thoroughly satisfied that they knew how to live with their river.

At top, Engineer Karl Haberman arrives by motor boat at WKYW's transmitter building, to be greeted "on deck" by WKYW President F. Eugene Sandford and Engineer Arnold Haun. Below, Engineers Pontrich and Haberman phone back to transmitter latest water level at tuning box.

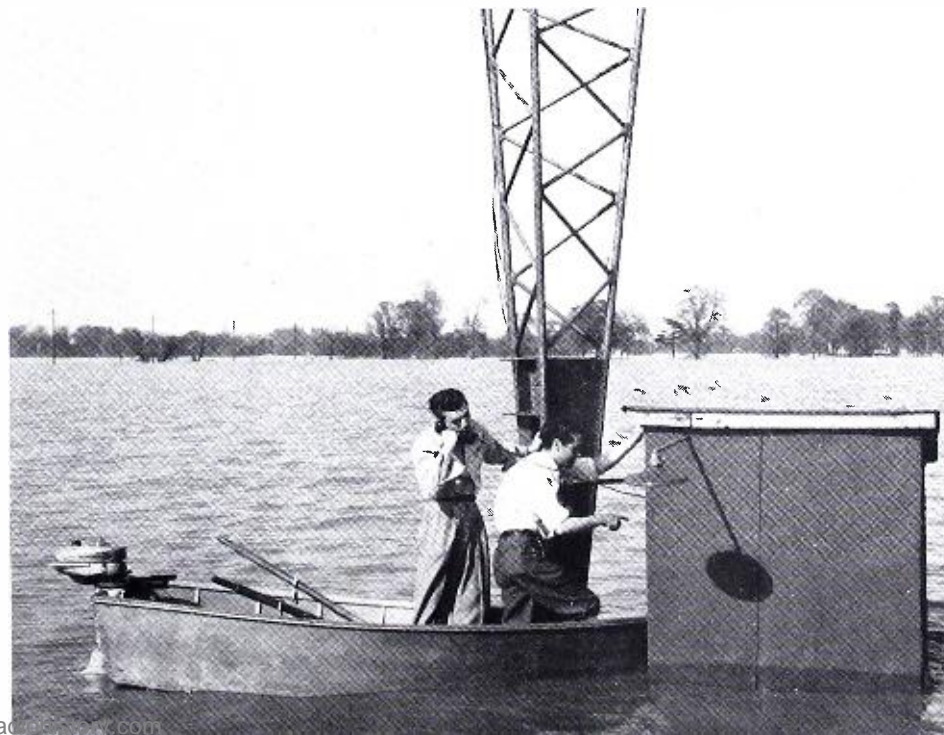

NEW AID TO MERCHANDISING...



Square grilles in ceiling, over aisle in center of above picture, show location of a few of the loudspeakers that aid in the operation of Hess Brothers' modern department store, by distributing entertainment and promotional programs in shopping and work areas. Another row of speakers is visible at right near the escalators. Inset shows one of the 755A speakers with covering grille removed.



...STORE-WIDE SOUND DISTRIBUTION

Hess Brothers' department store at Allentown finds many uses

for Western Electric sound system with more than 850 loudspeakers in store

THE CROWD moving through the wide aisles on the first floor of the large department store suddenly hears a clear, pleasant voice, at a moderate conversational level that seems nevertheless to fill the whole floor with ease:

"Good Afternoon Friends. Ladies! Scoop! Misses' Dresses, sizes 12 to 20, regularly priced at \$9.95 are being offered at \$7.95 in the Dress Department of our Basement Store. See these washable and crease resistant dresses at only \$7.95 in our Basement Store Dress Department."

Women all over the floor pause to listen to the announcement. There is a definite movement toward the escalator in the center of the floor. As they move, soft music fills the floor with the same pleasant, even quality . . . a short, lively orchestral number that brings a lift to the movements of the shoppers and brightens the faces of the salesgirls behind the counters.

The voice speaks again: "Mrs. John Doe. Your party is waiting for you at the Service Desk on the Main Floor."

This sequence of events is a small sampling of the operation of the new all-Western Electric sound system which has been installed in the Hess Brothers' Department Store of Allentown, Pennsylvania. With more than 850 high-quality Western Electric loudspeakers distributed throughout the shopping and work areas, the system is one of the largest ever put in an American department store. The arrangement of the system, its programming provisions and technical characteristics all illustrate the many important functions that a modern, high-quality, sound system can perform in department store operation.

The store was founded 51 years ago by Charles and Max Hess. It has grown and prospered so that now it occupies six shopping floors with about 42,000 square feet each, and has introduced into Allentown the most up-to-date, metropolitan department store features . . . including a complete set of escalators, which are something of a rarity in Pennsylvania stores outside of Philadelphia and Pittsburgh.

When the progressive management planned a post-war program of modernization, they decided on a flexible, store-wide sound distribution system to go along with their redecoration, air conditioning, fluorescent lighting, escalators, and many other new features. This large sound system was *not* to be just another "added attraction". In the minds of the Hess Brothers' management, it had a number of definite

and important applications which would aid in the operation of the store.

During the war, the store put in a "public address" system of the usual type, with single loudspeakers covering large areas from the ends of the shopping floors. This was to be used for air raid drills . . . and actual warnings if the dread event had ever materialized. But this temporary system turned out to have many other uses of real dollars-and-cents importance. The store management decided on a more elaborate permanent system for post-war installation, to be put in at the same time as the air-conditioning and other changes, thus making for the most economical improvement program.

Purchased through the Graybar Electric Company, and installed by R. S. Collmus, Baltimore's Western Electric Sound System Dealer, the permanent system uses 850 Western Electric loudspeakers, 16 Western Electric pre- and power amplifiers, Western Electric transcription turntable and reproducer, and Western Electric Type 633A and 639A microphones.

Each of the six shopping areas of the store . . . five floors and basement . . . has complete "sound coverage", with

Enclosures for loudspeakers were placed above new plaster ceiling which was installed in modernization of the store's shopping areas.





Two views of control center for sound system: left, Publicity Director Wessner adjusting fixed-tuned AM radio, installed next to FM tuner; right, making a store-wide announcement, with switching unit that controls the whole system at his left elbow. Transcription turntable is readily operated from same position.

Western Electric 755A eight-inch loudspeakers installed in each ceiling on approximately 16 foot centers each way. This system allows for the "even" distribution of sound already described, and eliminates one of the main objections to the old "public address" system . . . the blasting high volume necessary in the vicinity of the loudspeakers, in order to cover the whole floor.

In addition, the adjoining nine-floor annex for the storage and service departments has a total of 50 speakers which are spotted not for the complete coverage of the shopping floors, but wherever paging or calling is needed. The co-workers recreation center, which includes an auditorium and a cafeteria, has a separate local sound system, which in addition to local use can be connected either to receive from, or to transmit programs to, the main system.

Program sources are:

- (a) AM and FM radio receivers;
- (b) transcription turntable with Western Electric 9A Reproducer for $33\frac{1}{3}$ rpm and 78 rpm disc recordings;
- (c) announce microphones in control center;
- (d) plug-in microphones at various points in the store;
- (e) telephone line bringing in radio programs from local broadcast station, or wired music programs;
- (f) programs originating in co-workers' recreation center, as described above.

In addition, the telephone operator has an announce microphone, a monitor speaker and a keying and relay system which allows her to cut into the program lines for paging.

Flexibility is assured by having a separate power amplifier driving the loudspeakers on each shopping floor, and an

amplifier for the speakers in the annex, for a total of seven main loudspeaker groups, with channels provided for up to three separate programs at one time. The transcription table, radio tuners, all amplifiers, control switches, announce mike input and monitor speaker, are all installed in a control center on the third floor. The microphone and relay equipment for the telephone operator are installed next to the main switchboard. Only two of the three program lines are available to the telephone operator: the third is reserved for programs which are not to be interrupted.

Seven Ways the Sound System Aids Store Operation

With this highly adaptable, store-wide arrangement, the management is prepared to engage in a variety of program distribution activities on a greatly expanded scale. A partial listing of these activities, which have proved the functional value of the sound system in the store's operations, is as follows:

(1) In-the-store advertising, consisting of "commercials" announcing special items, sales, clearances, etc. It has been found that these give a tremendous shot in the arm to the movement of specific merchandise or sales in progress, if attractively presented and timed properly to catch the crowd.

(2) Messages of immediate or of long-range interest from the store management directed either to customers, or to co-workers of the store.

(3) Material of recreational interest to co-workers, or forming a part of the "co-worker relations" program of the store, as for instance the regular announcements of co-workers' birthdays, which are a tradition in the store; recre-

ational events or programs planned for co-workers; or the dramatic, musical or other spare-time activities of the co-workers in the recreation center.

(4) Musical or other entertainment programs. With the variety of sources available, the programs can consist of general background music; popular radio programs, either national or local, including in particular radio programs sponsored locally by the store itself; seasonal music; public interest features; local or national events, etc., etc. The use of music to lift the emotional tone of both customer and co-worker, is of course, a most important function in itself and in the experience of many large stores justifies on its own merits the installation of a high-quality sound system.

(5) Aid in reaching the public with the many promotional programs of the store. For instance, at Christmas time, by prearrangement with Hess Brothers', Santa Claus arrives in Allentown in a helicopter; at Easter time, the Easter bunny emerges from a mammoth egg. The sound system is made an integral part of these events, drawing attention to them as they approach, and carrying a blow-by-blow description as they occur. Other activities in this general classification are interviews with customers in various parts of the store, the "inquiring microphone"; the programs of special outside personalities imported for short periods, like authors in the book department, sports champions in the sports department, radio and screen celebrities, etc.

(6) Calling persons in the store urgently wanted at home, or elsewhere, and restoring lost children, are useful functions of the system. All the other varieties of "paging" are, of course, made convenient by the arrangement of the system.

(7) In the annex the system operates primarily as a "calling" device for reaching co-workers there, but the entertainment and other programs can be distributed as desired.

Provision for Flexible Program Control

A technical examination of the system shows careful planning to obtain maximum flexibility in operation. Each of the seven main loudspeaker groups is treated as a programming unit, and is driven by a Western Electric 143 Type amplifier. The 75 watts of high-quality output provided by each amplifier assures that there will be ample undistorted volume available to cover each floor.

Each program source feeds into a preamplifier, and the output of any preamplifier can be switched on to any one of the three program channels. The inputs to the main amplifiers, in turn, can also be connected to any one of the three channels. A spare amplifier is available which can be switched into any one of the speaker circuits in-

In furniture department of store, where installation of speakers inside the ceiling was impractical, a simple and attractive solution was attachment of speaker enclosures directly to surface of ceiling.

November 1948

stantaneously. All switching is done on a compact console installed in the control center. The equipment at the telephone operator's position includes a microphone input, volume indicator meter, monitor speaker and two control keys which operate a relay connecting the telephone operator to either one of the two program lines available to her.

The 755A loudspeakers which are the backbone of the system are installed in the ceiling, each one in an enclosed baffle consisting of a box 24" x 24" x 6". The photograph on page 23 shows one of the loudspeaker boxes in process of installation and illustrates the method employed to make the loudspeakers an integral part of the ceiling. The change from a metal ceiling to the smooth plaster type which was a part of the modernization program, gave the store a perfect opportunity for efficient installation of the loudspeakers in the ceiling of the store. The small space requirements of the 755A loudspeaker with its unusually small 3 1/8" depth make possible this shallow, easily installed loudspeaker box, with complete preservation of the high quality characteristics of the loudspeaker. Such shallow boxes are adaptable, of course, not only to "in the ceiling" flush mounting, but can be attached to the outer surface of the ceiling, and still maintain the architectural effect of an interior, as shown in the photograph below.

With their new sound system in operation for a short period the store management is thoroughly convinced that it will have great value in many aspects of store operation which up to the present time have not been fully explored. Already it has proven itself along the lines outlined in this article and as one of the officials puts it, "it is hard to see how we ever got along without our complete sound distribution system."





Sound Distribution

from New York City to

AS THE American Steamship *Panama* plies its pleasant way between New York and the Canal Zone, 200 passengers "have a lot of pleasure thanks to the new sound distribution and music system," according to a ship's officer.

The installation of Western Electric speakers and microphone locations is boat-wide and covers all public areas. It was installed last spring by the Smith-Meeker Engineering Company of New York as a part of a complete redecorating and reconditioning program designed to make the *Panama* as attractive and enjoyable a vessel as sails the seas.

The system's nerve center is a small control room on "A" deck. The space is compact, as is traditional aboard ship. In one corner stands a specially designed two-channel master control rack with Western Electric 117A and 118A Amplifiers in each channel. Four feet away is a Western Electric turntable with a 9A pickup.

Here originates an hour of recorded music three times a day . . . during lunch, the cocktail hour and dinner. On Sunday afternoons a special concert is pre-

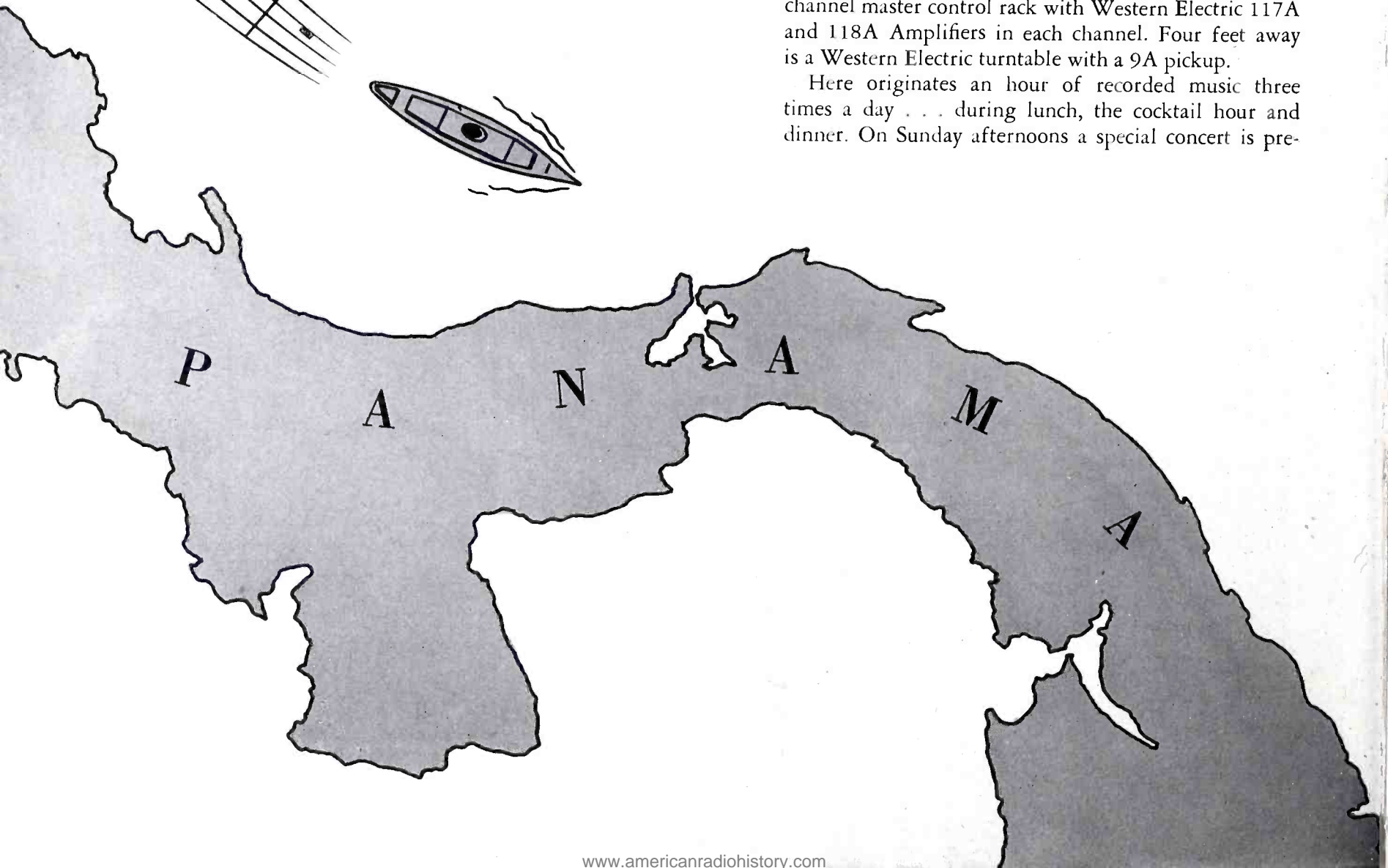

System Pays Off in music, entertainment, fun the Canal Zone and Panama

sented. Occasionally, for variety, radio programs picked up from long and short-wave stations are "piped in."

Well-concealed Western Electric 755A speakers are used in all interior areas . . . six in the main dining room, two in the lounge, and one in the club room. Outside locations are served by Type 754B speakers which are built to withstand the rigors of weather at sea. Four of these are in the deck cafe, one on the sun deck and another at the swimming pool.

Remote microphone locations are used for special purposes and entertainment . . . for instance, in the deck cafe for bingo and horse races and in the main lounge for church services. Spots where a microphone and volume control may be plugged into the system are in the Purser's Office, the deck cafe, and main dining room at the captain's table. Western Electric 633A microphones are used.

Unique in the system is the location in the smokestack of a new crystal-controlled, 17-channel radio receiver which covers shortwave as well as standard bands. The pretuned channels are electrically operated from the main rack in the central control room.



Purser A. H. Jennings in his office finds his remote location microphone indispensable when in port and passengers are going ashore. Mr. Jennings is responsible for the operation of the ship's sound system.



In the central control room, Robert J. McGrath, 1st Asst. Purser, handles music programs and makes all necessary announcements. The Panama has a library of 1500 records for use during entertainment periods.

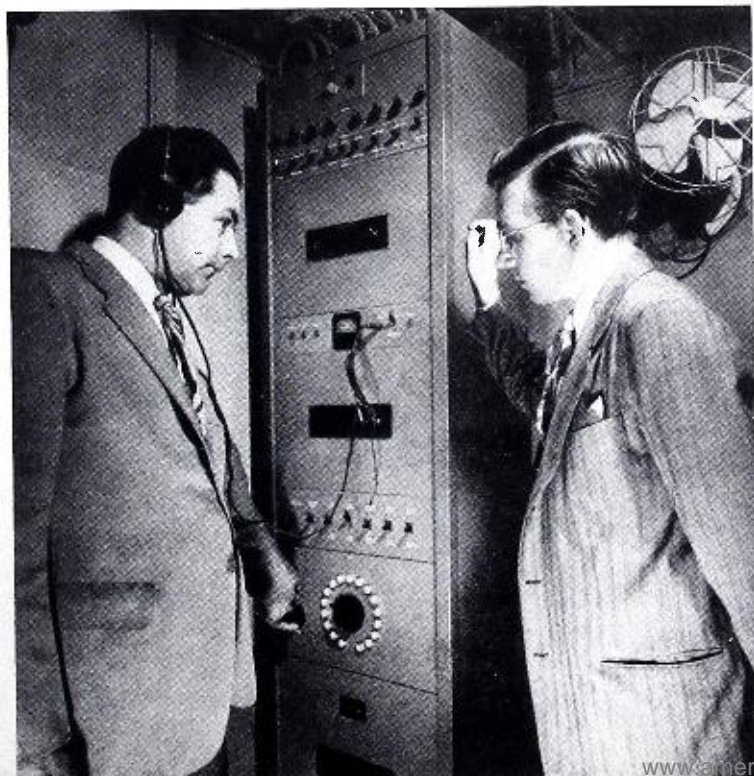

P. V. Stratford (left) and Donald Giebel, Smith-Meeker engineers, at the master rack in the control room. Mr. Stratford supervised the sound system installation and Mr. Giebel did much of the design work.

(See next page for additional photographs)

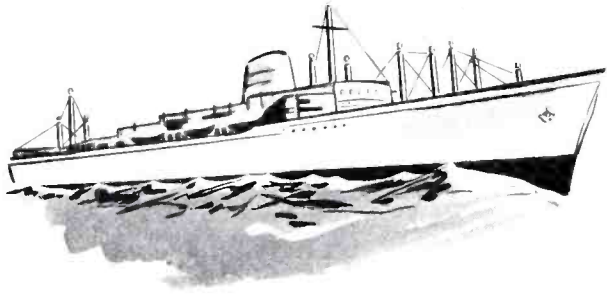

Sound Distribution System Pays Off

Absolute control of speakers in all locations is provided by this panel on the master control rack. Two channels make it possible to provide two programs simultaneously, recorded music, for instance, in the main

lounge, and a radio program in the club room. Note individual volume control for each location, and locking keys for choice of channel to feed each of the loudspeaker locations in various parts of ship.

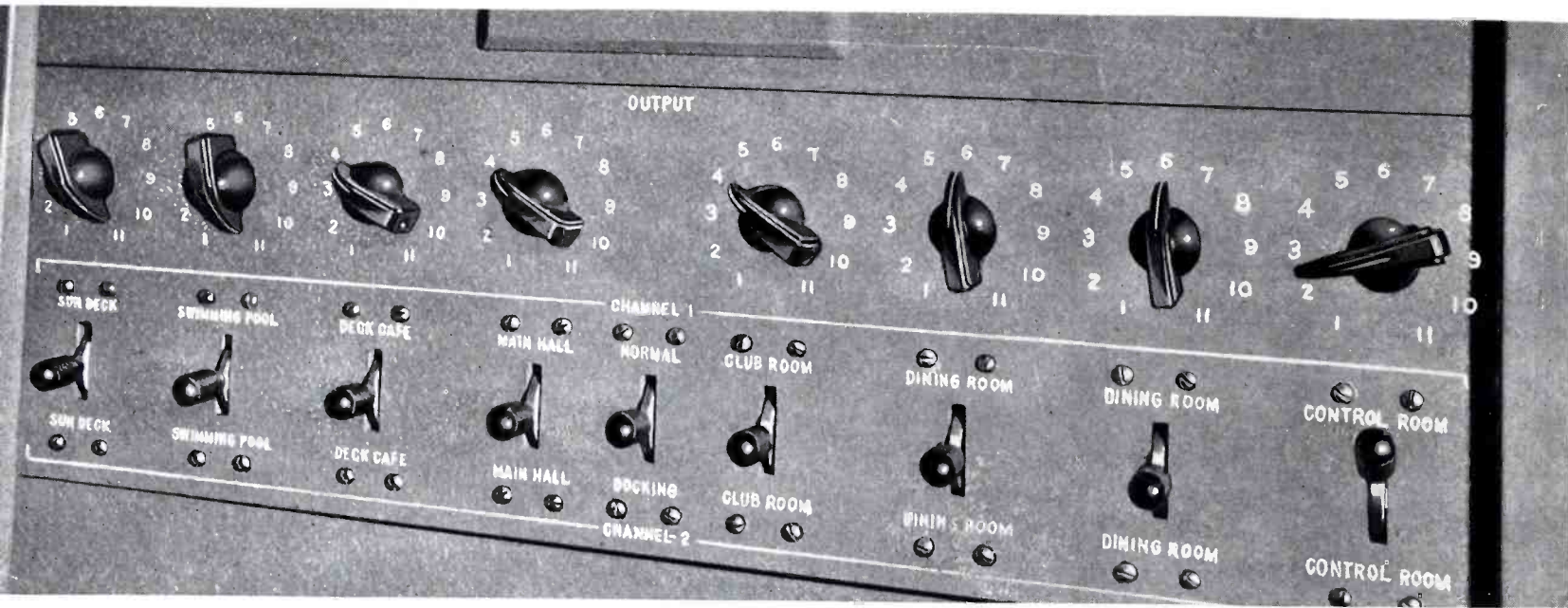

The Panama — showing locations of speakers, remote microphone spots, etc., in relation to one another and the central control room. All public areas on three decks inside and out are covered.

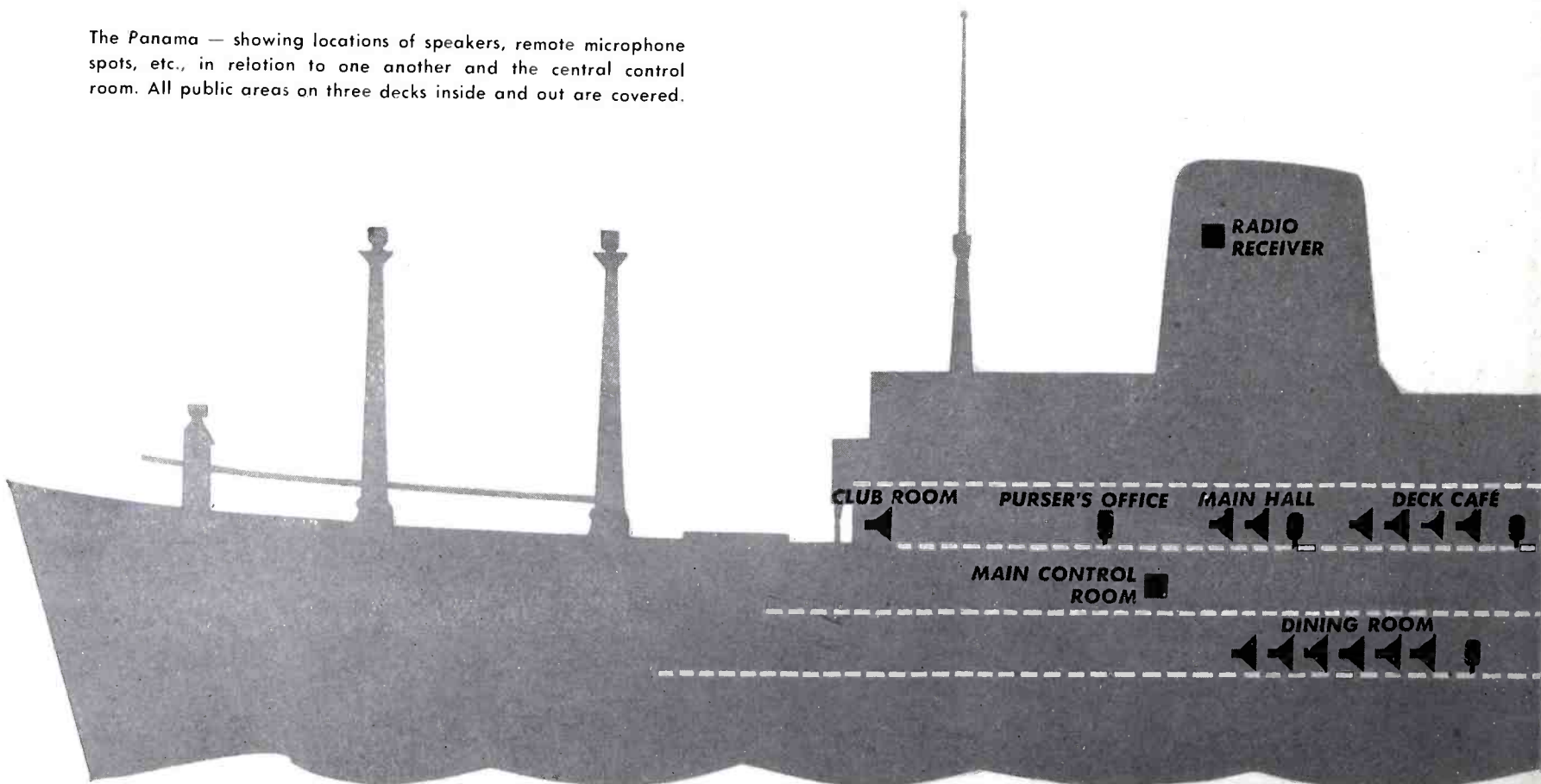



Here is a corner of the main dining room. Arrow points to one of six well-concealed loudspeakers which provide diners with music.



Here is a Western Electric 633A portable microphone and volume control unit which may be plugged into outlets in remote locations.

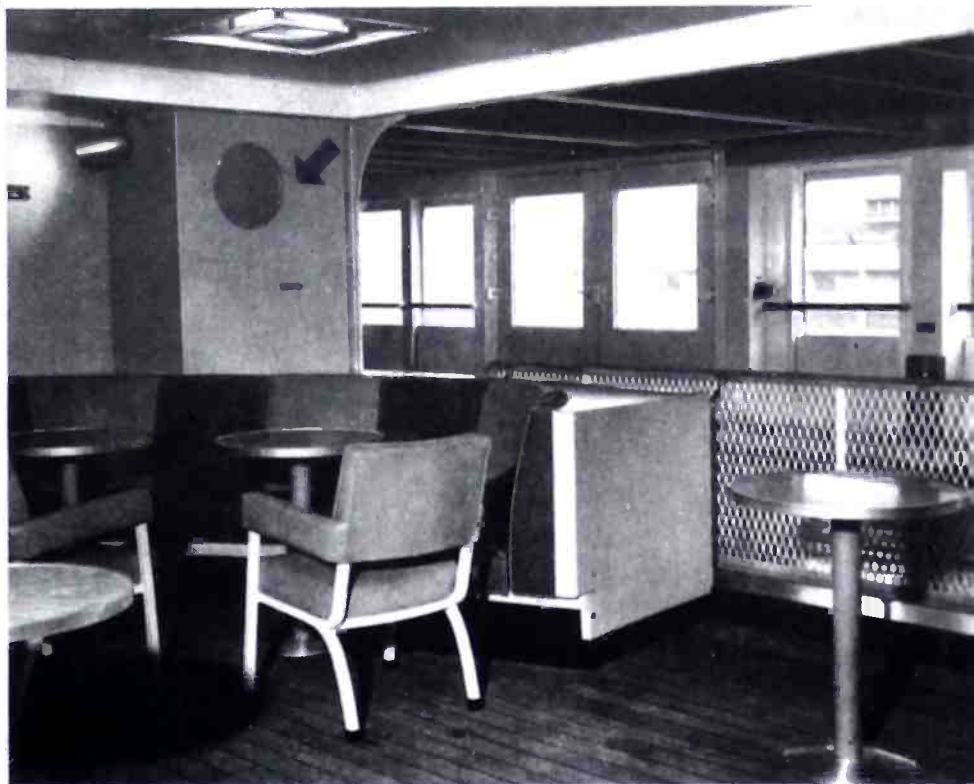

The four 754B speakers in outside deck cafe are completely weather-proofed. Arrow in above picture of cafe shows location of speaker.



The station selector dial on the control rack for automatic radio tuning. Note shortwave stations on right beginning with "Panama."

KEY

- CENTRAL EQUIPMENT
- 🔊 SPEAKER
- 🎤 MICROPHONE

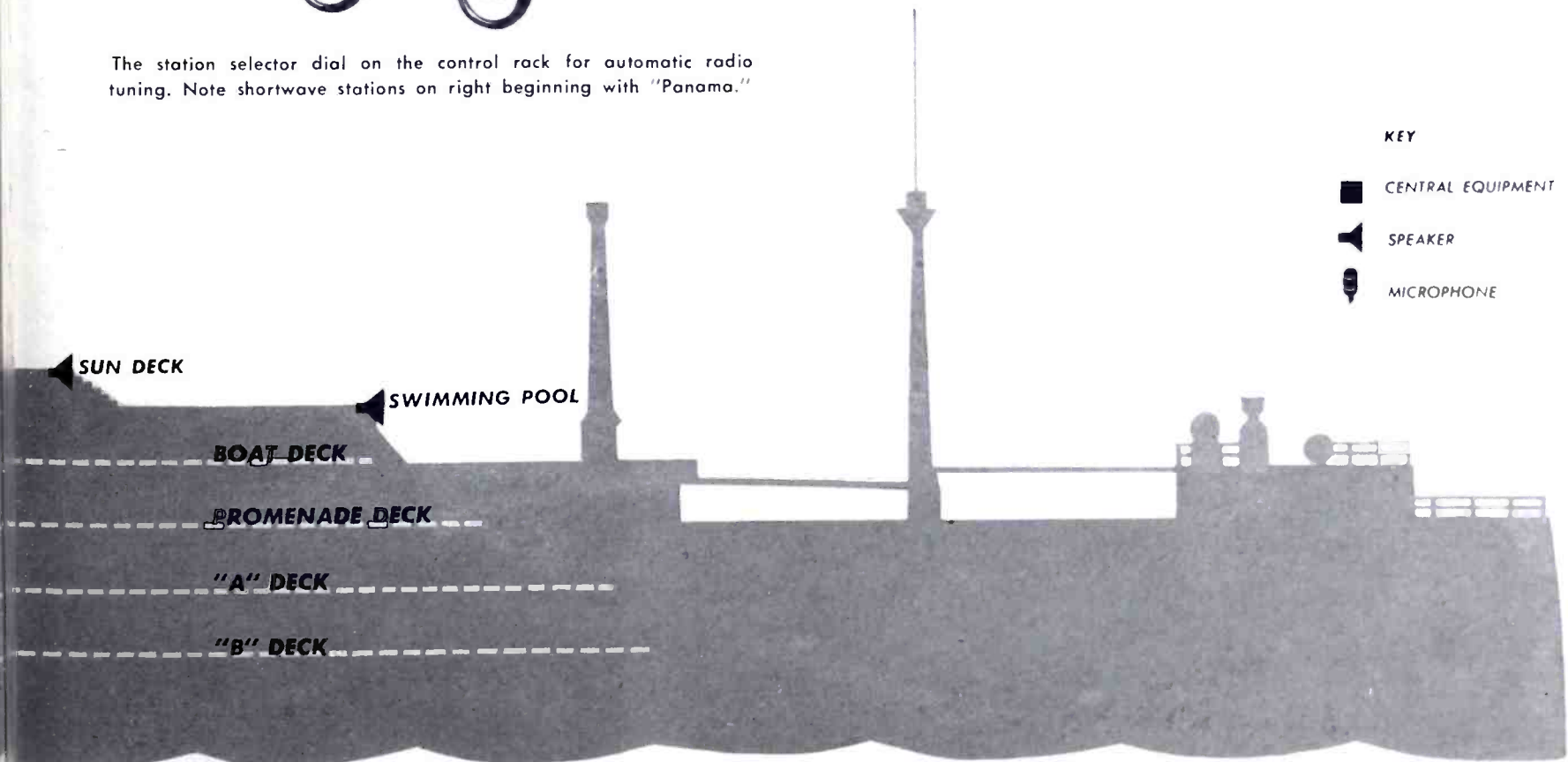

The more than 650 stations now operating on FM are spread across the United States, in every section and every kind of operation . . . small city with surrounding rural audience, large metropolitan center, network outlet, local community station. Reports on a few of the recent installations of Western Electric 506B-2 10 kw FM transmitters show that FM is doing a job for the industry efficiently and well in every variety of broadcast operation.

Broadcasters Report on the

KCMC-FM Texarkana, Texas-Arkansas



Above, Frank O. Myers, general manager of KCMC and KCMC-FM. At left, Clover-Leaf starts toward top of KCMC-FM's 415-foot tower.

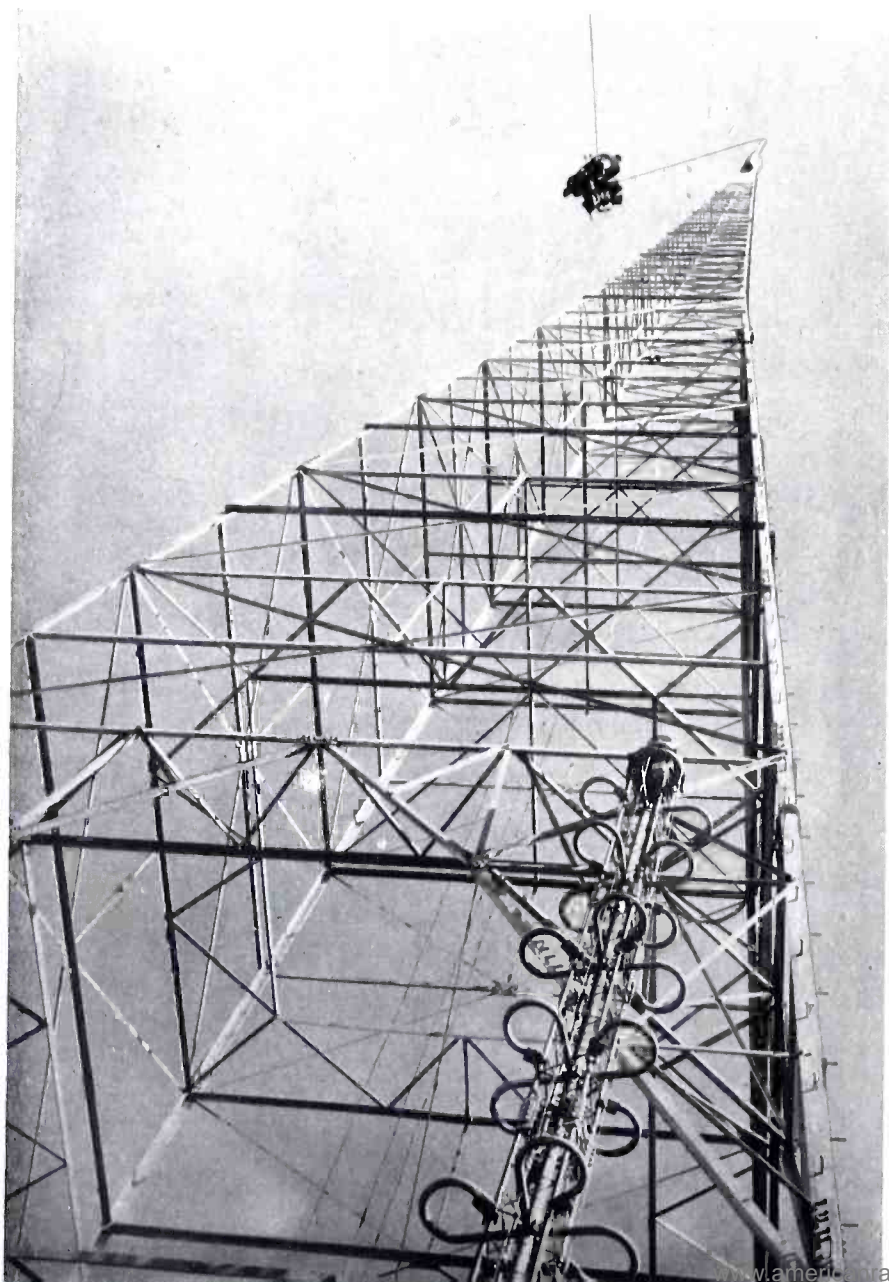

Up in the rolling country of Texas' northeast corner, KCMC-FM, the *Texarkana Gazette and News* station, sits squarely on the state line between Texas and Arkansas. Its day-and-night signal spreads not only into the two adjoining states, but reaches many thousands of listeners in nearby areas of Louisiana and Oklahoma as well. KCMC, the AM sister station, has been on the air in Texarkana since 1932, and now uses a Western Electric 451A-1, 250-watt, AM transmitter. KCMC-FM was inaugurated with 250 watts of power in February, 1947. The station came to "full-size" on FM in May 1948, with the installation of the Western Electric 506B-2 10 kw FM transmitter in a new transmitter building on the edge of the city, and an eight-bay Clover-Leaf antenna on top of a 415-foot tower to bring the effective radiated power to 40,000 watts. The AM and FM operations share the four modern, poly-cylindrical-walled studios in the *Gazette-News* building.

KCMC and KCMC-FM are full-time affiliates of the American Broadcasting Company and of the Texas State Network and the Arkansas Network. The network programs are balanced with local and national news; sports;

Western Electric OSCILLATOR

10 kw FM Transmitter

a full measure of music, from hill-billy to highbrow, from a massive library of recordings; and many local-talent and community public service programs which effect a close integration of the station with the people of the community.

The new FM transmitter has greatly enlarged the station's opportunities by providing better service throughout the listening area. Twenty-three percent of the persons covered in a survey, made early in 1948 in fourteen cities and towns within a 60 mile radius of the station, were FM listeners. Not only this audience, but regular listeners from as far as 250 miles away, have responded to the new service with satisfying enthusiasm. Veteran broadcaster Frank O. Myers, general manager of KCMC and KCMC-FM, says: "The service we are able to give with our 10 kw FM transmitter has exceeded all our expectations. This new equipment is certainly carrying the ball for us."



In modern studios shared by KCMC and KCMC-FM, audience watches program production through windows installed opposite control room.

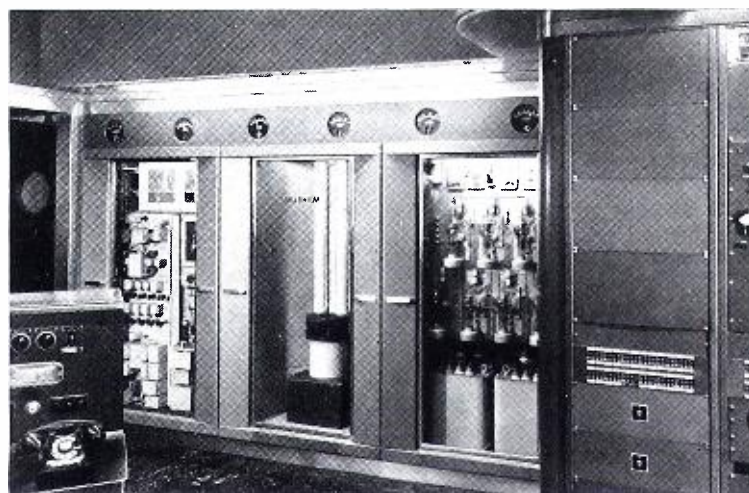

New FM transmitter at WJR is installed in master control room for ease of operation.

WJR-FM Detroit, Michigan

Up above the hustle and bustle of Detroit, on the 21st floor of the Fisher Building, WJR-FM serves the millions in the metropolitan area of the automobile city, as well as the rich farming region of rural Michigan surrounding the city—and a substantial area across the border in Canada. The antenna is on top of the building, 479 feet above average elevation in the service area. The Western Electric 506B-2 transmitter is installed between the Master Control Room and the workshop, adjoining the elaborate studios shared by WJR and WJR-FM. Here is a fine example of the big-city-office-building installation of 10 kw FM, with its convenience in operation and its solid coverage of a great center of population.

WJR, the "Goodwill Station", one of the leading stations in the Middle West since its founding in 1925, brings the programs of the Columbia Broadcasting System to the Detroit area, as well as a full complement of programs originated in its own studios. One important "studio" is a mobile unit, mounted in a bus, which is used to cover the rural areas for such events as the state sheep-shearing contest, or an important auction at the annual State Farmers' Week. The station went to 50,000 watts on AM in 1935, with a Western Electric 306B transmitter.

The 10 kw FM transmitter went on the air with regular programs May 30, 1948. Prior to the installation of the FM transmitter, the executive offices of the station were moved to the 28th floor to make room for the new polycylindrically treated studios and control rooms on the 21st floor. Putting the FM transmitter with front in

the Master Control Room and rear in the workshop, as shown in the photographs on these pages has proved highly satisfactory and most convenient in operation, with no trouble of any kind from r-f energy being picked up by the speech input equipment.

Program routing at WJR, with the Master Control unit designed by Technical Supervisor Friedenthal and built of Western Electric components, is a story in itself. Engineer Friedenthal described an earlier installation in the September, 1938 issue of *Pickups*. The Master Control Unit now in use has many additional features, reflecting the growing complexity of the control problem at WJR.

WJR-FM has proved itself a reliable day-and-night performer throughout the 50-mile radius of its primary service area. Enthusiastic listeners' reports testify to the establishment of an effective new voice for the "Goodwill Station".



View of Studio "A" at WJR and WJR-FM, looking toward the control room, shows efficient arrangement and attractive decoration.



At left, G. A. Richards, Chairman of the Board of WJR and WJR-FM, and at right, G. F. Leydorf, Vice President in charge of engineering.

Rear of Western Electric 10 kw FM transmitter at WJR-FM, with a corner of the well-equipped workshop visible at left.

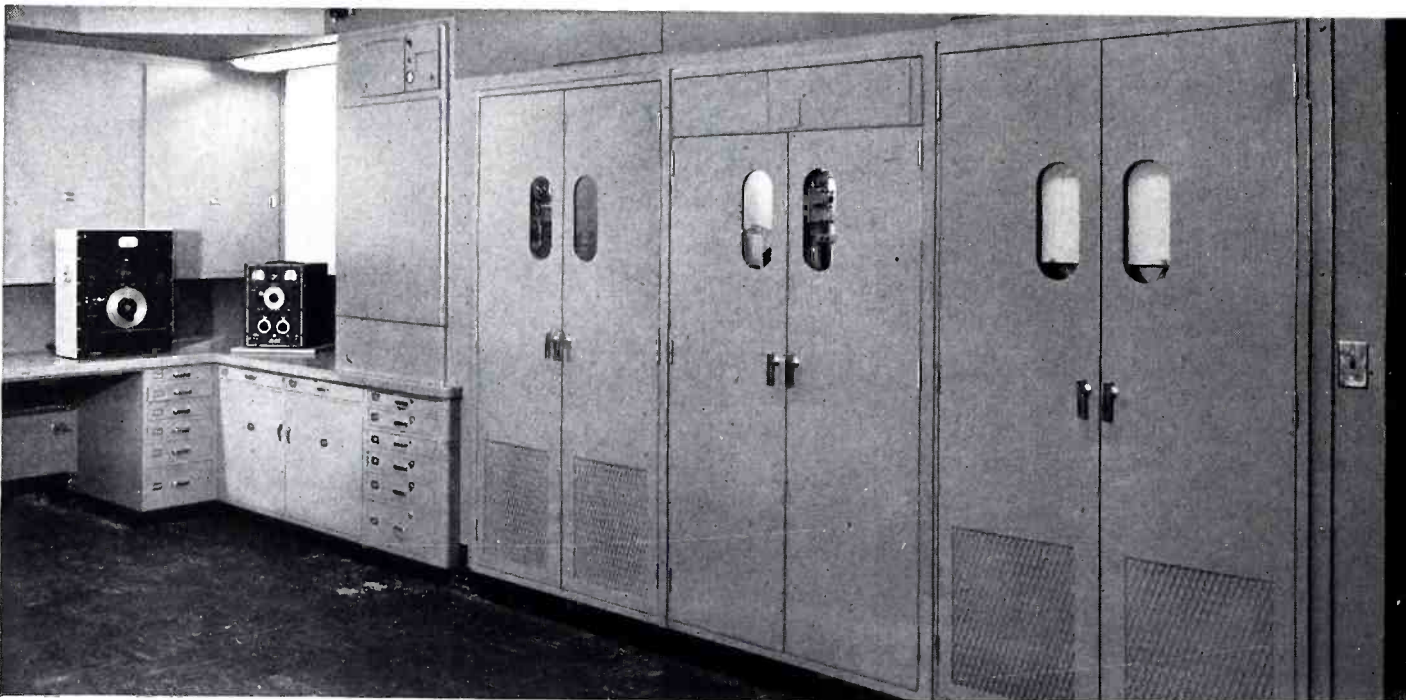

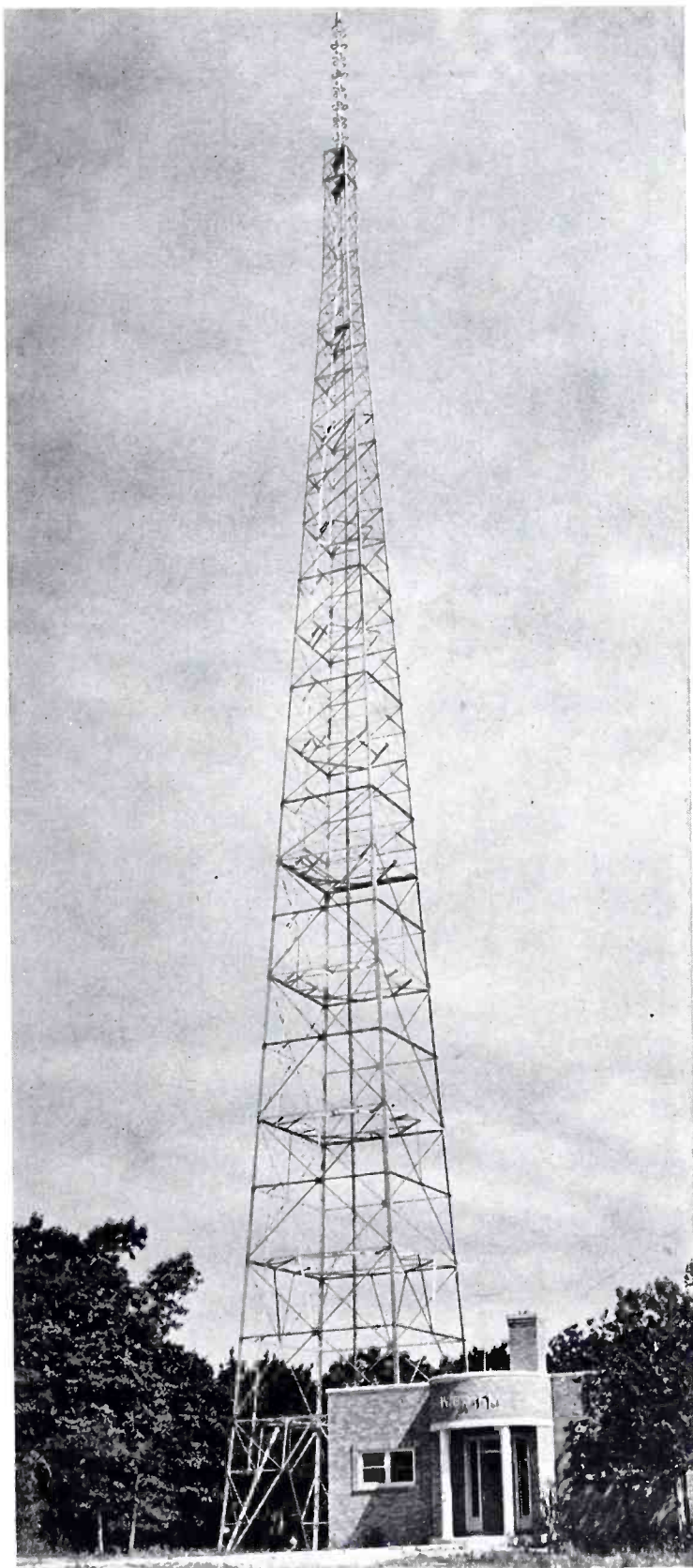

Above, new transmitter building and antenna tower for WIBA-FM at Blue Mounds, 1716 feet above sea level in southern Wisconsin. At right, Chief Engineer Norman Hahn adjusts new 10 kw FM transmitter.

WIBA-FM Madison, Wisconsin

The setting for WIBA-FM is the famed capital city of Wisconsin, with its University, beautiful lakes, pleasant living and rich, rolling countryside dotted with dairy farms. The Badger Broadcasting Company, which operates WIBA (5 kw AM) and WIBA-FM, is principally owned by *The Capital Times* and *Wisconsin State Journal*, Madison daily papers. The FM operation began March 7, 1948, with a temporary antenna fed by the Western Electric 506B-2 transmitter, installed in the handsome new transmitter building shown in the accompanying photograph. The new building is at Blue Mounds, Wisconsin, 26 airline miles from Madison, with an elevation of 1,716 feet above sea level, and 750 feet above average terrain, second highest point in the state. Because of the remote location on a high hill, three miles from the nearest village, complete living quarters for the engineering staff are included. The building is an excellent example of modern architecture in brick, stone and concrete.

On July 14, 1948, the 300-foot tower, eight-bay Clover-Leaf and six-inch transmission line were complete and tested, and WIBA-FM began to cover a large segment of southern Wisconsin's dairy farms and prosperous towns with its 45,000 watts effective radiated power. To alert the listening audience to the new service, ads in Madison newspapers and in the country weeklies, and a 30-minute broadcast entitled "The FM Story", described the way FM works and its technical advantages in layman's language, and the service that WIBA-FM would bring to the community.

General Manager Kenneth F. Schmidt and Chief Engineer Norman Hahn find that their FM transmitter is the strong performer they had hoped for. Says Manager Schmidt: "The response to our FM operation has been wonderfully enthusiastic. Our FM signal has proved itself a reliable delivery agent throughout our wide-spread service area."

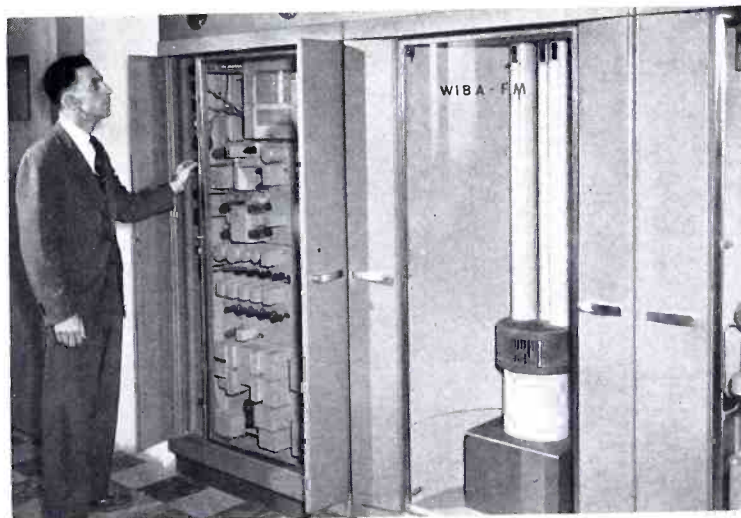

WJDX-FM

Jackson, Mississippi

The existence of WJDX-FM is testimony to the happy relationship between broadcasting and the Lamar Life Insurance Company, one of the largest enterprises in the State of Mississippi. In 1929, Lamar Life went on the air with WJDX, determined to devote the station's activities to public service and to good will for the Company. No advertising or soliciting for the Company has ever been done through its broadcasting outlet. The station prospered and became one of the first network outlets in the state, with a National Broadcasting Company affiliation.

Keeping pace with the growth of broadcasting, Lamar Life dedicated WJDX-FM on April 15, 1948, in a two-hour program with the help of many dignitaries including Governor Wright of Mississippi, Mayor Speed of Jackson,

etc. The Western Electric 506B-2 FM transmitter is housed in a new transmitter building 5 miles from the city. Two miles of road were constructed to reach the transmitter location, which puts the 459-foot antenna at a height of 590 feet above average terrain. Effective radiated power is 60 kilowatts. Since going on the air, WJDX-FM has duplicated network programs, and concurrently developed separate and distinct programs both sustaining and in public interest. Chain breaks and sustaining periods are used to explain FM and to promote the sale of FM-AM combination sets or FM tuners so more people can hear the newest in radio reception.

Wiley P. Harris, Director of both WJDX and WJDX-FM, writes about the results to date of WJDX-FM's operation: "Reports of dependable reception have been received from listeners up to 190 miles. The Western Electric transmitter has given superb performance, and its quality has been commended by listeners throughout the service area."

KJBS-FM San Francisco, California



The Top of the Mark, famed vantage point overlooking San Francisco, gives view of KJBS-FM's antenna with background of Bay, Pacific Ocean, Golden Gate Bridge.

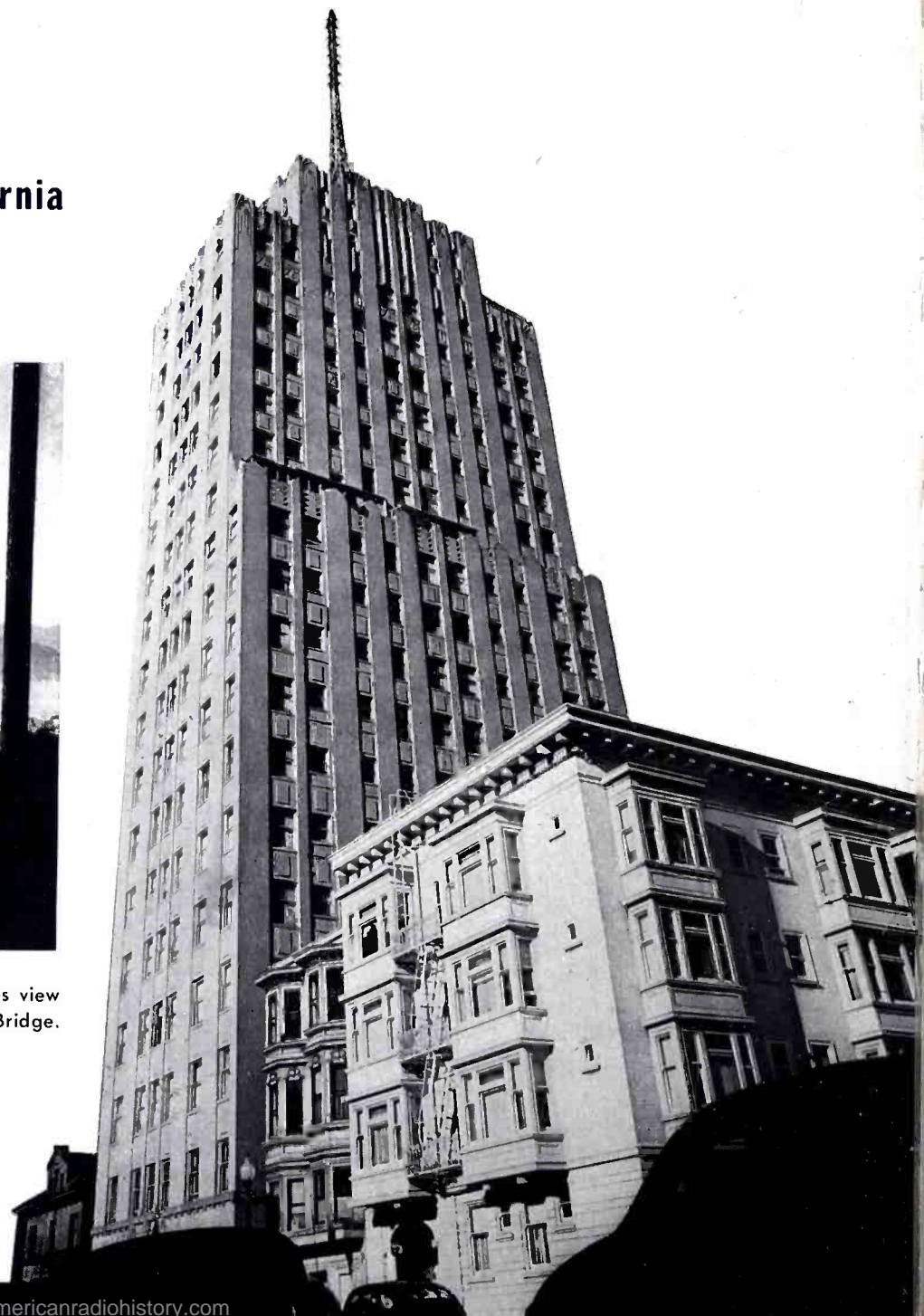



New transmitter building five miles from city houses 10 kw FM transmitter for WJDX-FM, with base of antenna tower visible at right.



Wiley P. Harris, Director of WJDX and WJDX-FM.



Howard Langfitt, Program Director, WJDX and WJDX-FM.



R. R. Smathers, Chief Engineer of WJDX-FM.

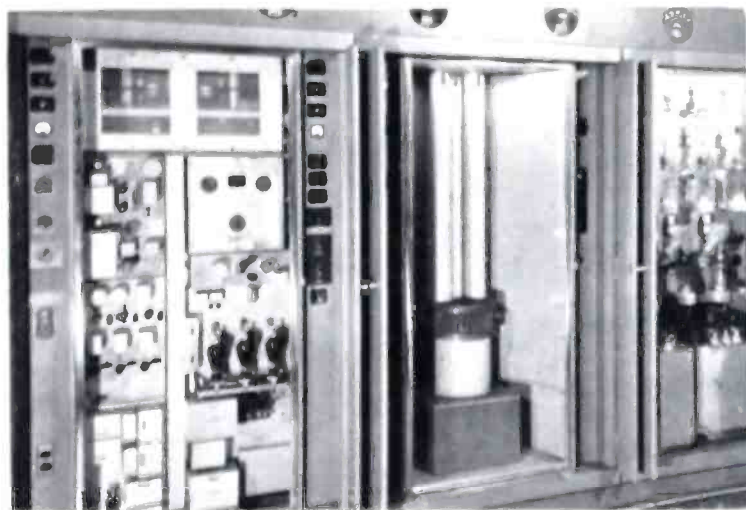

From the tops of the tall buildings set on the hills of downtown San Francisco, the visitor is shown the famous panoramic views of city, bay, great bridges, and prosperous satellite communities across the bay. Here are ideal locations for metropolitan FM with its concentrated coverage. In the Clay-Jones Apartment, one of the highest spots in San Francisco, KJBS-FM has installed its Western Electric 506B-2 transmitter. The eight-bay Clover-Leaf, lifted by its tower above the roof of the building, reaches a point 728 feet above sea level. On June 16, 1948, the 10 kw transmitter was put into service and KJBS-FM began to serve the millions in the San Francisco Bay region with its full effective power of 35

kilowatts, one of the first FM stations on the Pacific Coast to reach full authorized power.

This FM sister of KJBS, 1,000 watt AM station, first went on the air at 1 kw in December, 1946. Based on experience during the first year of operation, and on surveys of FM listeners throughout the Bay Area's nine counties, Program Manager C. F. Pendleton decided to devote 100 percent of his FM time to classical music. This policy has met with the strong approval of KJBS-FM's listeners. They keep writing their praise—including the man who needed more classical music than he had in his own record collection to lull his son to sleep every night.

President and General Manager E. F. Franklin has assembled an all-veteran staff to man his FM station, including Chief Engineer Wayne Berthold, Engineers William Nielsen and Roger Roberts, and announcers Ross Snyder and Lloyd Sutherland. The engineering staff had the ticklish task of supervising the hoisting of the transmitter up the outside of the Clay-Jones building, a distance of 232 feet from street to roof. Now that the station's 10-kilowatt equipment is fully installed, the man in charge can look out at the wonderful city-and-harbor view below him, and see scattered throughout the panorama many thousands of the homes that KJBS-FM is reaching with its high quality service.

New operating room at KWK-FM for W.E. 10 kw FM transmitter.



N. J. Zehr, Chief Engineer of KWK and KWK-FM.

KWK-FM, St. Louis, Missouri

KWK, now at 5,000 watts on AM, has been serving the industrial area of St. Louis since 1927. The Thomas Patrick station, a Mutual Broadcasting System affiliate, is a thoroughly established enterprise in the shoe making, beer brewing, manufacturing city on the west bank of the Mississippi.

On April 1, 1948, a Western Electric 506B-2 transmitter was put into service for KWK-FM, to enlarge the "voice" of KWK throughout the St. Louis area. So far, KWK-FM has been duplicating programs of KWK. Results have been up to all expectations. Ray E. Dady, Vice President and Station Director, says: "No special ceremony was held to signify the opening of improved service from KWK-FM, but it was definitely another day in the development of the broadcast art and an extension of KWK's effort to provide a better service to the listening public in this area. KWK-FM offers service to areas which heretofore have not been able to hear the KWK-AM signal, and also offers better reception to our primary area AM audience."

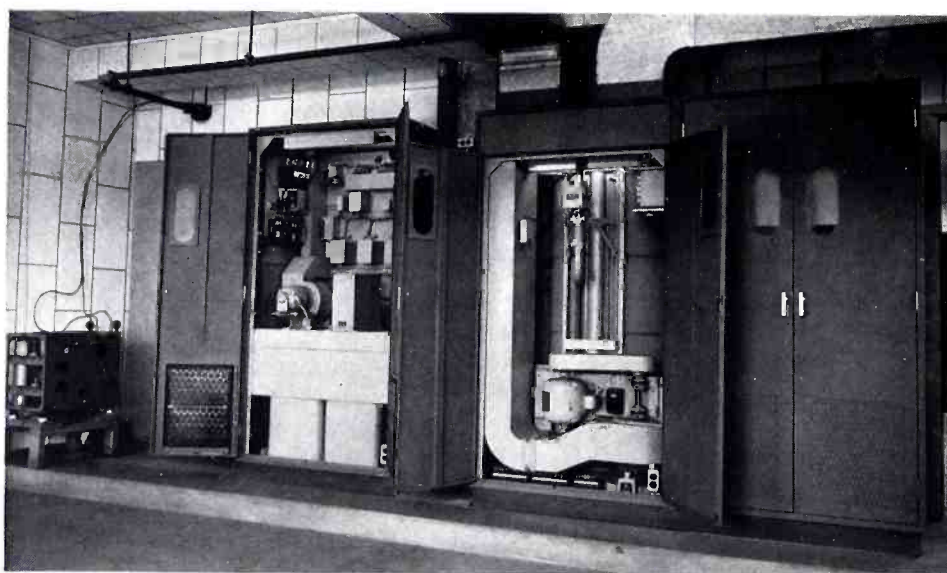

Rear view of FM transmitter shows arrangement of air ducts for cooling, and routing of transmission line from top of 10 kw amplifier.

Western Electric OSCILLATOR

Precision Turntable

(Continued from page 19)

Removable Center Pin

The record pin supplied may be removed and replaced with pins of other diameters. The turntable comes equipped with a standard NAB center pin (.284 inch), and a small-sized pin, (.281 inch) is supplied as an extra part. A small pin with a removable tapered sleeve which, in effect, makes the diameter of the pin somewhat adjustable, can also be supplied to order.

Stainless Steel Platter

The stainless steel turntable platter, which will not darken with age or stain the fingers, has a concentric depression so that the edge of a 10- or 12-inch disc can be easily grasped for removal.

Rapid Slowdown

The 1304 comes to a very rapid stop since there is no overdrive which would leave the turntable free to spin. Every broadcast studio technician will appreciate the convenience of this rapid slowdown, as it permits fast record changing without the annoyance of having to stop the platter by hand.

Accessibility of Mechanism

Removal of the platter exposes the mechanism from the top of the cabinet for normal servicing operations. The whole mechanism can be lifted out with its panel by removing a few screws, and placed on the work bench in an *operable condition* . . . another point where the single panel construction pays off.

Pickup Guard

The 706A Pickup Guard which is furnished with the complete 1304 Reproducer Set and with the other assemblies which include the 109 Type Reproducer Group (see panel on page 18) provides the most convenient arm support yet available. It completely eliminates the following dangers to the pickup: 1) dropping the reproducer on the turntable panel: the guard automatically latches and holds the arm when it is moved to the rest position; 2) striking the stylus on the rim of the turntable platter or on the edge of a 16" transcription; 3) dropping the stylus on and catching it in the felt surface of the turntable platter . . . a major cause of reproducer damage; 4) stylus travel into the drive holes or pins.

Convenient Adjustment to Changes in Supply Frequency

The mechanism is easily adaptable to 50 cycle operation using the identical synchronous motor normally supplied for 60 cycle operation, by a replacement of the motor pulley

with a larger one to bring the belt up to the proper speed. Any reasonable speed change can be accomplished by changing the motor pulley. In addition, motors of other types as required for specific applications, if of the proper size, may be readily mounted in place of the motor with which the turntable is supplied. This adaptability is another advantage accruing from the use of a belt drive.

Leveling Screws

The turntable cabinet is supplied with leveling screws which permit convenient leveling of the platter.

Convenient Placement

The turntable platter and pickup have been placed close to the front edge of the cabinet thus making for ease in operation. The recessed supports at the floor and the sloping front reduce the danger of program interruption from accidental kicks against the cabinet.

It's Day-to-Day Reliability That Counts

All of the features described are aimed directly at the convenient, trouble-free, day-to-day operation which pays off in a broadcast station. In addition, because of the single panel construction of the drive mechanism it has been possible to make the playback components available in various forms and combinations, to fit any installation requirements. The panel on page 18 shows the various combinations that can be supplied.

The 22A cabinet incorporates a number of other conveniences. Standard 19" rack panels 10 $\frac{3}{4}$ " high, can be mounted one above the other in the back of the cabinet. By adding rack mounting equipment, rack panels can also be installed in the front of the cabinet. Alternatively, the cabinet space can be taken up by use of the 701A shelf which provides for storage of transcriptions. The cabinet height is adjustable and may be leveled between 29" and 32" above the floor, permitting the turntable height to be adjusted to agree with that of associated control desks or other equipment.

It should be clear that the precision, the operating convenience, and the ease of installation and maintenance of the 1304 Reproducer Set, as described in this article, can be translated directly into "greatest economy for the broadcaster." *Precision in performance* means that "wow," distortion, flutter, do not turn away the listener. *Complete operating convenience* means that the technician likes to use the unit, makes fewer errors. A hard-to-operate turntable will eventually be retired as a bad investment.

Installation flexibility, as shown on page 18, means that the unit can be fitted in to utilize the purchaser's own equipment and studio arrangement. And finally, *dependability and ease of maintenance* eliminate costly servicing. The 1304 Reproducer Set is a permanently good performer—in the user's cost record, and on the air.

(Continued from page 7)

The familiar Western Electric High Power Transmitting Tubes to be made by Machlett Laboratories include the following types:

- 212E Air cooled triode, 275 watts
- 220C Water cooled triode, 10 kilowatts
- 220CA Forced-air cooled triode, 5 kilowatts
- 222A Water cooled high vacuum rectifier, 25 kv. inverse voltage
- 232B Water cooled triode, 25 kilowatts
- 232BA Forced-air cooled triode
- 233A Water cooled high vacuum rectifier, 50 kv. inverse voltage
- 236A Water cooled triode, 20 kilowatts
- 240B Water cooled triode, 10 kilowatts
- 241B Air cooled triode, 275 watts
- 251A Air cooled triode, 1000 watts
- 255B Mercury vapor rectifier, 20 kv. inverse voltage
- 266B Mercury vapor rectifier, 22 kv. inverse voltage
- 266C Mercury vapor rectifier, 22 kv. inverse voltage
- 270A Air cooled triode, 350 watts
- 279A Air cooled triode, 1200 watts
- 298A and B Water cooled triode, 100 kilowatts
- 308B Air cooled triode, 250 watts
- 340A Water cooled triode, 25 kilowatts
- 341AA Forced-air cooled triode, 5 kilowatts
- 342A Water Cooled triode, 25 kilowatts
- 343A Water cooled triode, 10 kilowatts
- 343AA Forced-air cooled triode, 5 kilowatts
- 357B Air cooled triode, vhf, 400 watts
- 363A Air cooled pentode, vhf, 350 watts
- 379A Air cooled triode, 1200 watts
- 5530 Forced-air cooled triode, uhf, 3 kilowatts
- 5541 Forced-air cooled triode, uhf, 10 kilowatts

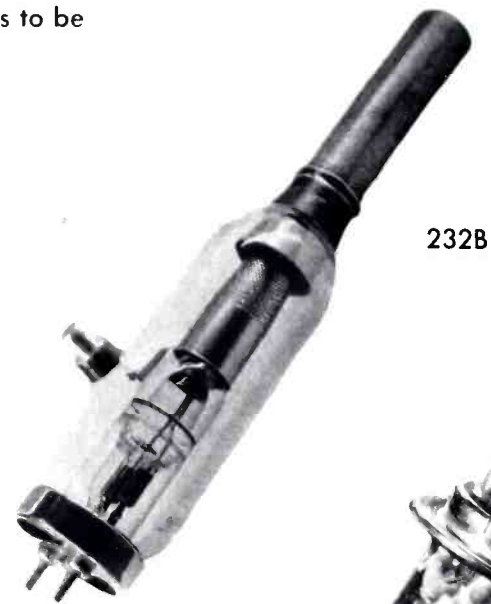

232B

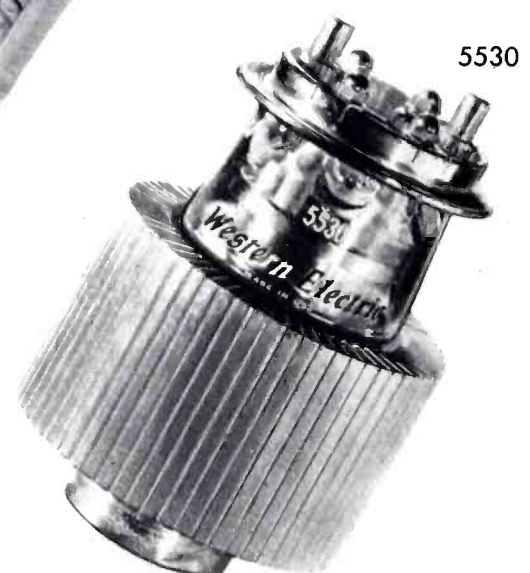

5530

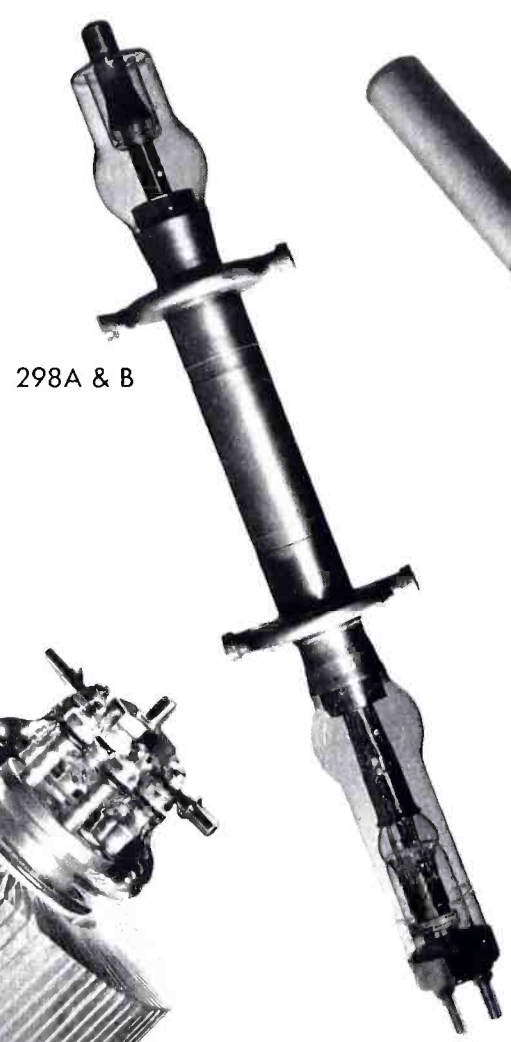

298A & B

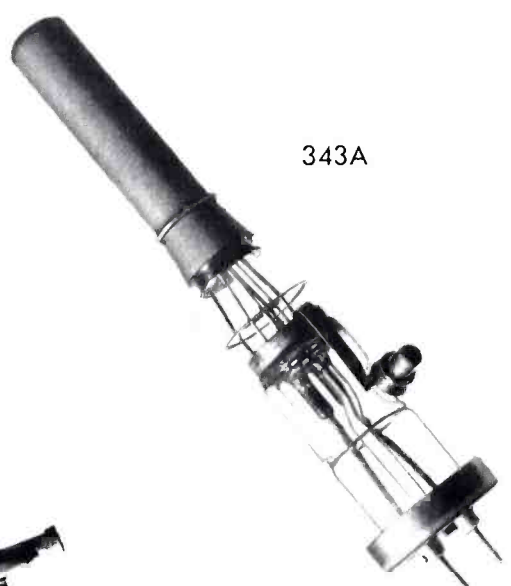

343A

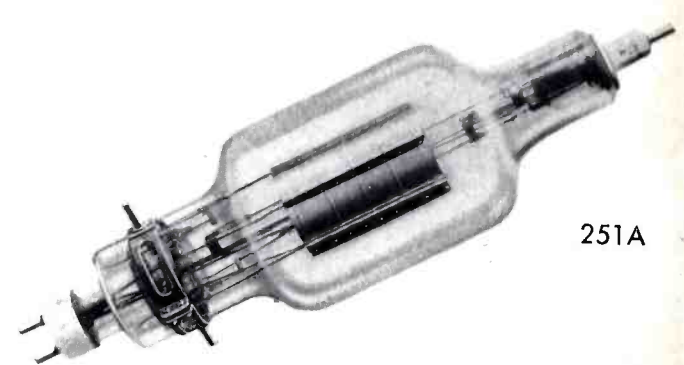

251A



5541



343AA

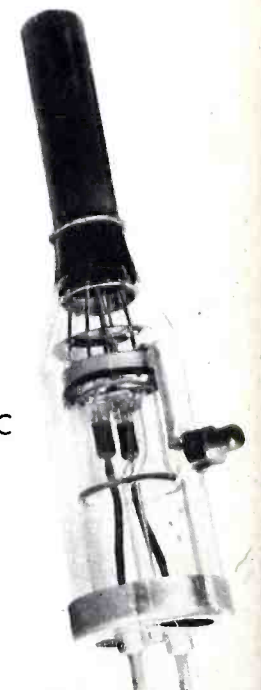

220C



H. D. WILSON

Contributors to This Issue

H. D. Wilson, author of "*Manufactured by Machlett Laboratories for the Western Electric Company*" (page 3), was graduated from Brown University with a B.S. in Civil Engineering in 1929. He joined the Bell Telephone Laboratories in July of that year, and became a member of the technical staff in May 1930. In June 1942 he transferred to Radio Division, Western Electric Company to head Vacuum Tube Procurement in the Government Contract Service. In 1945 he became Manager of Vacuum Tube Sales, Government and Commercial, and in 1947 he assumed responsibility for sales of the specialty products of Radio Division, as well as vacuum tubes, with his present title of Manager, Electronic Tube and Products Sales.



J. G. LAWRENCE

J. G. Lawrence, author of *Program Quality Depends on Turntable Precision* (page 14), worked for Bell Laboratories from 1927 to 1932, on audio and sound motion picture equipment. From 1932 to 1937, he worked for various firms, designing audio devices and large sound installations, including those at Jones Beach and Randalls Island. He was consultant on sound and lighting installations for the New York World's Fair in 1939, and served as Superintendent of Displays for the duration of the Fair. In 1942 he joined the Field Engineering Force of Western Electric, working on Navy radar in this country and in the Pacific. He came to the Broadcast Sales group of Radio Division in August, 1946, and presently serves as Sales Engineer, Audio Facilities.



357B

212E

233A

342A

For the finest sound,
just pick from
this line...



755A—8" direct radiator,
8 watts, 70-13,000 cycles.



756A—10" direct radiator,
20 watts, 65-10,000 cycles.



757A—dual unit system,
30 watts, 60-15,000 cycles.



728B—12" direct radiator,
30 watts, 60-10,000 cycles.



754A—12" direct radiator, extra high
efficiency, 15 watts, 60-10,000 cycles.

754B—12" direct radiator, for out-
door use; 50 watts, 60-10,000 cycles.

★ NO MATTER what your loudspeaker needs may be, one of these five Western Electric types will fit like a glove!

If you're looking for *superlative* reproduction, you can't beat the dual unit 757A, with its unequalled combination of efficiency, frequency response and power capacity.

If you want the finest in direct radiators, you'll get just that in any one of the four Western Electric types—simply pick the *power* you need.

All types are available for immediate delivery. Call your nearest Graybar Representative or write to Graybar Electric Company, 420 Lexington Ave., New York 17, N. Y.

Western Electric
— QUALITY COUNTS —

DISTRIBUTORS: IN THE U. S. A. — Graybar Electric Company. IN CANADA AND NEWFOUNDLAND— Northern Electric Company, Ltd.

