

# The Radio Collector

May-June, 1995

## The Receiving Tube Story Part 5 - The Power of the Pentode!

Last month's installment in *The Receiving tube Story* dealt with the development of the screen-grid tube. As you'll recall, this four-element (tetrode) design permitted a much higher degree of radio frequency amplification than did the triode (3-element) tube. Its extra grid, placed between the control grid and the plate and maintained at a positive potential, helped isolate the grid and plate circuits of the tube from each other, minimizing feedback and instability.

The screen-grid design was a remarkable breakthrough in vacuum tube technology, significantly improving the performance of the TRF receivers then in common use. However, there was a catch. The negatively-charged electron stream emitted by the cathode, accelerated to even higher velocity by the attraction of the positively-charged screen grid, impacted strongly on the plate. This knocked loose additional electrons from the surface of the plate (a phenomenon known as "secondary emission"). Many of these electrons were attracted to the screen-grid, which reduced the current (electron flow) in the plate circuit, limiting the amplification that could be achieved.

Secondary emission is also responsible for introducing non-linearity into the plate voltage vs plate current curve of the tube (see graph). In fact, the plate current actually begins to decrease with

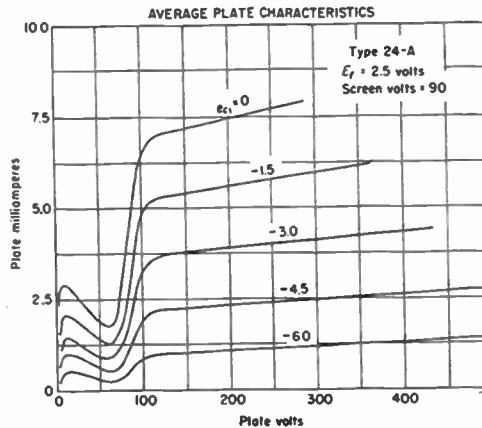

*Dip in tetrode's plate current vs plate voltage curves (shown here for type 24-A) made the tube unsatisfactory as an audio power amplifier.*

increasing plate voltage in the region where the plate and screen voltages are similar--causing a pronounced dip in the curve. That phenomenon

introduced distortion that made the tetrode unsuitable for use as a power amplifier (audio output) tube.

The pentode (five-element) tube was developed to overcome this deficiency. Born in the research laboratories of the Holland-based Phillips Company, the concept behind the pentode tube is elegant in its simplicity.

An additional grid, known as the *suppressor grid*, is located between the screen grid and the plate and connected (usually internally) to the cathode or filament. Since the suppressor grid is at the same potential as the cathode, it has no effect on the electrons emitted by the cathode, neither impeding nor accelerating them on their journey to the plate.

However, by virtue of being connected to the cathode, the suppressor grid is negative with respect to the plate. Because of that, it repels the electrons knocked out of the plate--sending them back towards that element, where they are reattracted and become part of the plate current. The result: improvement in linearity and significant gains in efficiency and power-handling capability.

The first power pentode type generally available in this country was the type 33, which like the pioneering type 22 tetrode (see last month's installment of this story) was a battery tube released at the dawn of the



• A •

### POWER AMPLIFIER PENTODE NOW AVAILABLE

The RCA-247 has been designed for use in the audio power output stage of newly-designed AC receivers.

*Detail from 1931 RCA ad introducing the type 47.*

## The Radio Collector<sup>®</sup> Volume 2, Number 4

*The Radio Collector* is published bi-monthly by Marc F. Ellis. Editorial content copyright 1995 by Marc F. Ellis, except as noted. The Publisher is not responsible for transactions resulting from advertising published herein or for any applications of editorial content. Subscription and advertising rates, as well as magazine format, may be revised at any time.

### How to Subscribe:

Annual subscription rates are as follows: via surface mail \$20.00 (U.S.), \$21.50 (Canada--U.S.funds); via air to other countries, \$35.00 (U.S. Funds). Make out checks or money orders to *The Radio Collector* and mail to our post office box (see "How to Reach Us" below).

Back issues, when available, are \$3.50 each, postpaid to U.S. locations.

### Classified Advertising

Subscribers may place classified ads in *The Radio Collector* at no cost. See classified section for instructions and limitations.

### Display Advertising

Rates and size requirements for display advertising are posted elsewhere in this issue.

### Contributions

*The Radio Collector* welcomes the submission of articles, tips, and/or photos covering any phase of radio collecting. We are particularly interested in contributions that will assist newcomers to our hobby. Submissions will be printed at our discretion and may be edited. Unless special arrangements are made, submissions will not be returned and, if printed, become our property.

### How to Reach Us

To order a subscription, or place an advertisement, write *The Radio Collector*, P.O. Box 1306, Evanston, IL 60204-1306. Please include full payment for financial transactions, including any fee for extra words. Classified ads should be submitted on a separate sheet from other correspondence.

Our voice line is (708) 869-5016; for 24-hour fax, dial (708) 869-5054. Answering machine picks up voice calls after 5th ring.

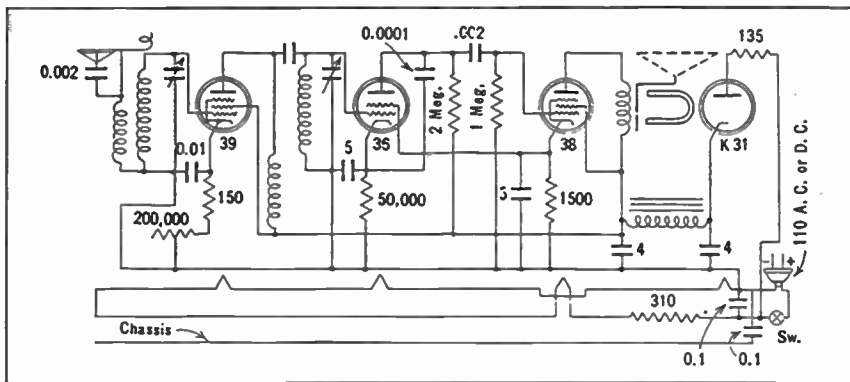

*International Kadette Universal schematic, reprinted from July, 1994 Information Exchange, shows type 38 as power amplifier, type 39 as r.f. amplifier.*

a.c. tube revolution. Like the 22, this tube saw very little use and is on the rare side. If you have any in your collection, don't let them go!

Following the 22 was the type 47 (released in 1931), which *did* see wide usage. The 47 was a directly heated (no cathode) tube with the 2.5-volt filament that had become standard for tubes operating on a.c. power. Like the 71-A (see February installment), which was actually a battery tube, its lack of a cathode did not prevent it from operating as a hum-free power amplifier when lit from an a.c. source.

In his *Radio Physics Course* (second edition, 1933), Alfred Ghirardi provides an insight into the quantum performance leap made possible by the introduction of the pentode as a power amplifier. He reports that the type 45 triode then in wide use as a power amplifier consumed 8 watts of power in its plate circuit while delivering 1.6 watts to a speaker with a 50-volt signal applied to its grid. The type 47 power pentode drew about 10 watts in its plate circuit, but delivered 2.5-watts of undistorted power to a speaker with a signal voltage of only 16.5 volts applied to its grid.

The net result: the type 47 provided almost as much power as two push-pull 45's (a common configuration). And since the 47 required only about one-third of the signal input voltage as the 45, the "first audio" stage required in front of the 45's could be eliminated along with its contribution to hum and distortion.

In 1931, soon after the release of the 47, the first indirectly-heated power pentode appeared. The type 38 was designed for auto radios; its

filament operated from the 6.3 volts d.c. supplied by the vehicular electrical systems of the day. However, being equipped with a cathode, it could also be a.c. powered. And the 38's .3 ampere heater current rating matched the standard being developed for the series string a.c.-d.c. sets that were beginning to appear on the depression-era market.

The 38, and its companion the type 39, (a pentode r.f. amplifier released a year later) were perfect for the low-cost a.c.-d.c.'s because they could deliver high performance with a low tube count. The International Kadette Universal, one of the first of these minimal radios (See June, 1994 *Information Exchange*), used a 38 and a 39, in addition to a type 35 screen grid tetrode.

The year 1932 also saw the release of other indirectly heated power pentodes, including the first 2.5-volt a.c. filament design (type 59) and the first 6.3 volt filament design intended specifically for a.c. sets (type 42).

Additional pentode r.f. amplifiers appeared about the same time, including the 2.5-volt, indirectly heated types 57 and 58. These were the first tubes to depart from the old pear-shaped envelope design, being equipped with the new type ST ("double dome") bulb.

The pentode r.f. amplifier tube, with its more efficient performance and superior inter-electrode shielding, would soon supplant tetrodes such as the 24-A, just as the pentode power amplifier had outclassed the earlier triode designs.

Just one quick disclaimer before the

(continued on p. 4.)

# PLAY IT AGAIN!

*A No-Nonsense Course in Radio History, Evolution and Repair*

## SIGNAL TRACING A BATTERY SET

In the last two issues of this column, we took you through a methodical protocol for checking over a simple battery set (in our case, an Atwater Kent Model 20C) prior to first applying power. We concluded by suggesting procedures for safely connecting the set to a power source, turning it on and tuning in a station.

If you carefully followed the suggested procedures, there's a good chance that you now have a working radio. But there's also a chance that the set will be dead. This month, we'll talk about how to bring such a radio back to life.

There are three main reasons for a dead radio: bad tubes, missing or incorrect voltages and interruptions in the signal path. The first two are easily detected, but signal interruptions are more difficult to find. A lot of things (such as open secondaries in the RF coils or AF transformers) can cause a dead set without upsetting voltages.

### Building an Audio Source

You need a source of RF and AF signals to troubleshoot a dead set. Commercial signal generators and tracers are nice, but you can repair sets without them. RF signals are all around us - all you need is an antenna to get them. A simple source of audio signals can be built for a few dollars with parts from Radio Shack as shown in Fig. 1.

T is a small (300 mA) 12V transformer. Diodes, D, are 1N914 or 1N4148. R1 is 470Ω, ½W and R2 is a 100KΩ potentiometer. The on-off switch may be separate or on the 100KΩ pot. C is a 0.01μF/500V ceramic capacitor. *Its rating must be 500V or higher.* Defects in old radios can cause high voltages to appear where they shouldn't, and this capacitor may have to withstand several hundred volts.

The diodes are arranged as a full-wave bridge rectifier, but that is not their prim-

ary function here. The circuit serves as a frequency doubler to give a distinctive 3V, 120 Hz AC signal with a strong harmonic content. C isolates the source from the radio under test. R2 controls the output. The whole thing can be built into a small minibox. Use banana jacks for the common and output terminals so you can use a set of standard test prods to inject the signal into the radio.

### Checking the Audio Section

Getting back to our dead AK 20C, we will use our AF source to test the audio section. You should already have checked the tubes and measured tube voltages to assure that they are present and correct. Connect the COMMON jack to B- and insert a test lead in the OUTPUT jack. Set the output of the audio source near maximum and touch the test prod to the grid of the second AF tube (V5 in the diagram shown in the Feb. 1995 issue). If you hear a loud, raw hum, the tube and speaker are OK. If you hear no sound, there is a fault in this stage. Measure voltages again and recheck the tube and each component in the stage to locate the fault. Don't forget to remove the power when making resistance checks with your ohmmeter!

After repairing the fault, repeat the test to make sure there is sound. Next, reduce the output of the source and touch the prod to the grid of the first AF tube (V4). The indications and procedure are the same as before. Locate and repair any faults, then check for sound with your AF source. Often there are multiple faults in an old radio. This procedure locates and repairs them one at a time. Complete the testing of the audio section by reducing the source output nearly to minimum and touching the prod to the grid of the detector tube (V3). If there is no sound, repeat the troubleshooting and repair routine. The grid leak and capacitor (R3, C2) are not included in this test. We are testing

V3 as an amplifier - not a detector.

You could have tested the entire detector-audio section at once by applying signal to the grid of the detector tube at the start of your test session. If you had heard sound, fine. But if not, how would you know where the fault lay? By working backwards, we locate and fix the faults one at a time in a logical sequence.

### Checking the Detector

Now that the audio section is working, we can connect an antenna and see if the set plays. If not, we will have to continue stage testing into the detector and RF amplifiers using an antenna as a source of RF signals. Connect a 250pF/500V capacitor to your antenna or to a long piece of wire strung around the room. Connect the other end of the capacitor to the stator (fixed section) of the detector variable capacitor (right-hand dial). Tune the capacitor and you should hear some stations if the detector is working. The sound will be weak and the tuning broad. Absence of sound indicates a fault in the coil, grid leak or capacitors.

### Checking the R.F. Amplifiers

If all is well, connect the 500pF capacitor to the stator of the center capacitor (which feeds V2). Tune this capacitor and the right hand capacitor for maximum volume and leave the right hand capacitor alone from now on. The volume should be louder than before because there is a stage of RF amplification in the circuit. No sound indicates a fault in V2 or its associated parts.

The last step is to connect the antenna to the antenna terminal of the set and tune the left and center capacitors to the same settings as the right hand capacitor. If V1 and its components are good, you will hear the set performing as it should, though you may have to "tweak" the adjustment of all three capacitors for maximum volume. See you next month, when we will begin studying AC-powered sets.

Conducted by Ken Owens  
478 Sycamore Dr.  
Circleville, OH 43113

*Ken will be happy to correspond directly with readers who have questions about radio theory or repair. Please include a long SASE with your query. The correspondence will be also be printed in R.C.'s "Information Exchange" column so that all readers can benefit from it.*

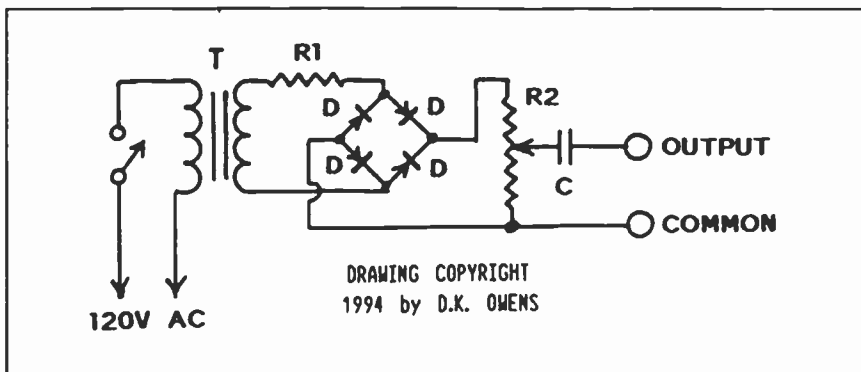

Fig. 1. Simple audio signal source can be built for a few dollars.

# HOW RADIO CAME TO OUR HOUSE

## Installing A New Battery Set in 1927

By Anthony P. Jacobi

*Tony Jacobi is well-known to our readers as author of the two-part "Audio Output Transformers" story that appeared in the January and February issues. He is also the first reader to collect our coffee-mug reward (see January, 1995 editorial) for sending in an interesting short article. Thanks, Tony, for sharing your vivid childhood memories of what it took to install a battery set, and learn to live with it, back in 1927. We hope you enjoy your handsome new Radio Collector mug!*

If you bring home a new radio today, you would probably insert a battery, or plug it into a wall socket, and it is ready to use. Back in the 1920's, it was not quite that simple. I can still remember my parents getting our first radio in 1927.

In preparation for this event, the first thing needed was to erect an antenna. Since our property bordered on a creek, we had an ample supply of tall willow trees. My dad cut down one of suitable length and, after digging a suitable hole and peeling off the bark, erected the pole. Of course, he remembered to attach the antenna wire and insulator beforehand.

Peeling the bark off not only made the pole look nicer, but prevented it from starting to grow again—a bad habit with willows. My twin brother and I were about seven years old at this time, and we got the job of helping peel bark to keep us occupied.

This pole was set about 75 feet from the house. The other end of the wire was attached to an insulator in a tree next to the house. Then, a ground rod was driven into the ground next to the basement wall. The wires from it, and the antenna, were run into the house through a hole by the window. These were connected to a SPDT knife switch inside, wired so that the antenna could be switched to ground in case of a thunderstorm.

Finally, a few days later, the radio arrived: a Thorola 57, a fancy curved horn speaker, three big 45-volt "B" batteries, a "C" battery and a 6-volt car battery. I was a little disappointed; who had ever heard of a Thorola radio? All the others I'd known of in town had names like Atwater-Kent, RCA or Crosley. But, the Thorola was a nice-looking set and proved to work as well as any neighbor's set did. One thing that intrigued me was the three "doughnut" coils in there. All other sets

I'd seen had flat-wound coils, but these were entirely different.

The radio and speaker were set on a table in the living room. But my mother said she definitely was not going to have all those batteries sitting there on the floor, especially that messy car battery. So, my dad calmly solved that problem by drilling a hole in the floor by the baseboard, then running heavy wires from the radio to the basement. Down there we had an old table, so the batteries were set on it and connected up. This turned out to be a nice, neat arrangement.

That fancy curved horn didn't survive very long. During one of my mother's dusting sessions, it was knocked off the table and shattered. My dad wisely got another speaker made of some sort of pressed paper product. It was straight and ugly, but worked well and didn't break.

Since we did not have an automobile, it became my duty every couple of weeks to haul the car battery in my coaster wagon to the charging place in town. The battery, and 50 cents, would then be exchanged for a recharged battery, and we were all set for another couple weeks reception. This arrangement went on for quite some time; then one day my dad brought home an "A" and "B" eliminator (power supplies to you young fellers). This, as it says, "eliminated" the need for batteries, so now we had a strictly AC set. Since the eliminators were fairly neat-appearing green boxes, my mother permitted them to sit on a shelf under the radio.

The Thorola gave us several years of enjoyment. I do not remember it ever having to be repaired, or even needing new tubes. But then, it was only used at noon to get the local news, and a few hours in the evenings, especially to listen to the Amos and Andy show. Its demise came one cloudy afternoon when lightning struck the power line outside our house. Although the radio was turned off, it made some squawking noises as though it was going to start playing—then smoke started pouring out of it.

Thus ended the Thorola's career, but the same event started mine in electronics. About half of the radio was burned up, but there was still a bunch of good parts and tubes to experiment with. The "A" eliminator was also burned up, but the "B" was still good. A few days later, my dad brought home a Clarion tombstone, all

electric. Now, who the heck ever heard of a Clarion. . .

---

### THE POWER OF THE PENTODE

(continued from p. 2)

triode-loving hi-fi aficionados climb all over me! Even in those days, triodes were noted for their purer tone and were still frequently preferred over pentodes in high-end sets.

Though the plate voltage vs plate current curve of a pentode was quite a bit more linear than that of a tetrode, there was still room for improvement—especially in the critical power amplifier spot. That was achieved with the release, in 1936, of the first *beam power* output tube—dubbed the 6L6.

In a sense, the 6L6 is a cross between a tetrode and a pentode. It has control and screen grids, but no suppressor grid as such. Instead of the latter it is equipped with a pair of deflector plates (or "beam forming electrodes") that are connected internally to the cathode. These are positioned in such a manner that they concentrate the stream of electrons into an intense beam. It is difficult or impossible for secondary emission electrons to penetrate the beam and reach the screen grid.

Another feature of the beam power tube is the alignment of the control and screen wires so that the former "shade" the latter from the electron stream. This minimizes the number of electrons that would be attracted to the screen and therefore lost to the plate.

To get an idea of the improvement in efficiency made possible by the 6L6, Marcus, Marcus and Horton tell us (*Elements of Radio*, 1943) that the 6L6 delivers 6.5 watts of power with only 14 volts on its grid. Compare this with Ghirardi's numbers for the type 47 quoted earlier.

As it happens, the 6L6 was almost *too* potent, delivering more power than most receivers required. Accordingly, the beam power tube didn't really threaten the conventional power pentode for use in home receivers until the 6V6, a scaled-down version of the 6L6, was introduced in the following year.

Come on back next month, when we'll continue our receiving tube saga!

MFE

## INFORMATION EXCHANGE

This is an open forum for interaction among our readers. Here you can ask questions about some aspect of our hobby, answer a question that's been posed or pass along other information of general interest. Send your questions, answers and information to **The Radio Collector**, P.O. Box 1306, Evanston, IL 60204-1306. Submissions may be edited or paraphrased.

### Safe Radio Startup

Along with his letter about sightseeing at the RCI and CBC studios in Montreal (see "Correspondence From Our Readers"), Allan Brown included the schematic at the bottom of this page. He either forgot to include a write-up or figured that the device would be self-explanatory (which, in fact, it is). However, I'll presume to add the following words of explanation, anyway.--Ed.

The circuit is a safety device used to power-up radios whose condition is unknown. If the radio has a short somewhere in the power supply, the set will be prevented from being damaged further by excessive current, or even fire, when turned on for testing. The circuit could be put together in a small utility box, with an a.c. cord and plug attached at "line in" and a standard electrical outlet connected at "to radio."

Plug the circuit protector into the wall and plug the radio (making sure it is shut off) into the circuit protector. Switch the circuit protector to the "test" position and turn the radio on. If the set has a short, most or all of the line voltage will appear across the lamp rather than at some vulnerable circuit point within the set. The lamp will then glow brightly but harmlessly.

If there is appreciable glow, disconnect the radio and look for the short. Do not switch to the "operate" position; you may well cause a fire in the radio and/or burn out the ammeter in the circuit protector. If there is little or no glow, remove the lamp from the circuit by switching to "operate" and proceed with testing the radio.

Keep your eye on the a.c. ammeter if you have one. If it shows a reading inconsistent with the rated current drain of the set, there is a problem. Shut off the set immediately and investigate. The built-in 5-amp fuse provides another safety factor. It will "blow" a lot faster than the 15- or 20-ampere fuse or circuit breaker in the house circuit, shutting off the power in the event of an unexpected overload.

### Pitfalls of Water-Pipe Grounding

The uncritically accepted practice of grounding a home's electrical system to the plumbing may result in a ground that is unsafe and high in resistance.

If the home has plumbing with soldered joints, grounding currents resulting from the operation of electrical devices will accelerate the decomposition of the lead in the solder, thereby contaminating the water. Expensive pipe-joint leaks may also result.

Water-pipe grounded systems also provide an alternate return path to the electrical distribution network, resulting in the generation of mag-

netic fields in the house each time neighbors switch an appliance on or off. Grounding radio sets to the plumbing will accelerate these problems, and, in any case it is good practice to install an independent earth ground for radio work.

All these effects can be avoided by connecting the electrical system to the soil, as close to the service entrance as practical, with the required heavy-gauge copper wire attached to a regulation 8-10 foot copper-clad rod. Locating the rod where the soil can be kept wet will reduce the soil's resistance. Mixing salt and charcoal with the soil in the area around the rod will further reduce the resistance.

If any reader knows of a way to actually measure soil resistance, I hope he will inform us. Ten ohms is considered the upper limit of acceptability by the military. Residential codes allow 25 ohms.--P.V. Petrosino, Oceanside, CA.

*This is a little out of my line, but I do know that most people living in urban areas don't have much choice about where their electrical systems are grounded. Strictly-enforced local codes govern that and, quite often, the plumbing ground is what is specified. As always, reader comments are solicited.--Ed.*

### Book Review:

#### New Revision of an Old Classic

THE RADIO COLLECTOR'S DIRECTORY And Price Guide Second Edition by Robert E. Grinder. Sonoran Publishing Co., Chandler, AZ, 1995. 530 pages. Softbound.

This second edition of *The Radio Collector's Directory and Price Guide* is a welcome addition to the radio collector's library--not that it will spend much time on the shelf. The "Directory" will find frequent use whenever the age or value of a collectible radio is in question.

The original 1986 Directory listed 8,500 radios, with about 600 trade names, manufactured between 1921 and 1941. This new revised and expanded edition covers radios from 1921 to 1965, and includes data on over 20,000 models

representing some 1,400 trade names.

The value of a directory such as this does not lie in its mere bulk, however, but in the organization of the material it contains. The challenge is to strike a balance between touching all of the possible bases and providing enough "meat" to create a true reference work. Grinder has met the challenge nicely.

*The Radio Collector's Directory* is divided into two three broad categories: "Radio in America, 1921-1965" is a six-chapter overview of technical developments, regulations affecting radio, and the effects of broadcasting on people's lives. "The Radio Directory and Price Guide," which comprises most of the book, provides basic data on all listed models. "The Trade Directory" is a very useful index listing manufacturers by trade name and trade names by manufacturer.

The "Directory" section is the reason that the collector will want to carry this book to swap meets, flea markets and auctions. The information provided falls into five columns. The first is a list of models by manufacturer; the second gives the year of introduction of each model; the third lists the power source for the radio--AC, DC, or AC/DC line; batteries; or "3-way" (AC/DC and batteries).

Column four identifies the set's cabinetry (table, console, portable, breadboard, mantle, etc.). "Midget," radio-phono combination, and clock radios are specifically identified in this list, as is the cabinet material of table model and portable sets (plastic, wood, leatherette, etc.).

The final column provides the all-important price range. Pricing antique radios is not an exact science. Too many factors are involved, including perceived condition of the radio, rarity (again perceived), the prospective buyer's urge to own that particular set and the would-be seller's desire (or need) to get rid of it. Under such conditions, the best attempt at valuation can only be an approximation.

The "Directory" approaches the problem by offering a six-step set of "value ranges" on which to base a judgement. All other things being equal, the price of a proposed purchase should fall within the range assigned to the set in question.

In all, *The Radio Collector's Directory and Price Guide* an essential for the serious collector. It also valuable to beginning collectors because of the orientation it provides to the antique radio hobby. This is a book that will settle many questions -- and arguments -- for those who respond to the lure of those fascinating old-time sets.--Julian Jablin, Skokie, IL

(continued on page 8)

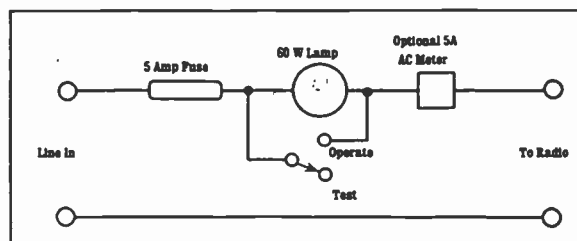

Allan Brown's "Series Illumination Circuit Protector."

## CORRESPONDENCE FROM OUR READERS

*Letters may be paraphrased, shortened, or otherwise edited so that everyone gets a chance at the floor!*

### Sparton Maverick

The advent of the TRF, regenerative and Neutrodyne radios was followed by a most interesting circuit. It was the Sparton model 930 Equasonne. This radio was not any of the above; it was a maverick.

Signal selection was handled by two RF coils and four coupled tuning capacitors. They fed a broad band amplifier using 485 tubes (although my set had 27's installed) coupled by coils that were unique.

The coils were bifilar (which most might think were a much later innovation). They were wound on small wooden forms and untuned. If you bypassed the front-end tuning circuit by applying the antenna to the first tube, you heard all the local stations at one time.--Alton A. DuBois, Jr., Queensbury, NY

### PC Predecessors

These days, most electronic circuits are built on PC boards. Many people are credited with the origin of the printed circuit, but my first contact with the idea was in 1950, when I read about an English development in electronics construction. The idea was to produce a plastic plate molded with grooves comprising the layout of the circuit. The grooved side would be plated with copper, covering all of the valleys and ridges. Then the ridges would be milled off, leaving the copper only in the valleys. The copper-plated valleys became the leads connecting the various components.

The idea was considered quite new at that time. However, I own a 5-tube "3-dialer" that, instead of being wired with the usual square-drawn bus bar, has brass strips that were pre-stamped to connect the various parts.--Alton A. DuBois, Jr., Queensbury, NY.

### Fessenden Facts

This month's "Mini Quiz" answer is Reginald Aubrey Fessenden per *His Master's Voice in America* published by General Electric Co., 1991: "The first transmission and receipt of a human voice by wireless was demonstrated by Dr. Reginald Fessenden in Pittsburgh, PA on December 23, 1900. . . The first broadcast of a phonograph record was made by Fessenden in 1906."

*The New Encyclopaedia Britannica* (1982, Vol 4) indicates that from Brant Rock, Massachusetts "On December 24, 1906, wireless operators were startled to hear speech and music coming in over their receivers."

However, maybe there's some doubt about the date because in his 1918 book *Radio Telephony* (reviewed by Paul Bourbin in the last issue), Alfred Goldsmith indicates that on December 11, 1906 both speech and music transmission were demonstrated. Also wire line (telephone) signals were transmitted.--Charles F. Brett, Colorado Springs, CO.

*If there's any doubt that Fessenden's famous broadcast took place on Christmas Eve, 1906, it should be dispelled by this shot, sent in by radio historian Alan Douglas, of the commemorative plaque that used to be mounted at the base of the Brant Rock tower.*



*Alan understands that the plaque is no longer in place, having been removed for safe keeping. He tells us that the site is now a trailer park/campground, and is still owned by the same family that originally leased it to Fessenden.*

*The December 11 "demonstration" referred to by Goldsmith probably was just that, and not a full-fledged broadcast.--Ed.*

### When in Montreal. . .

Although not quite a vintage radio topic, here are a couple of related travel items that might be of interest. Some of your readers may have heard broadcasts by Radio Canada International (RCI), or the Quebec Northern Service of the CBC, on the shortwave band of their old radios. RCI is transmitted worldwide and should be available to most parts of the US. The Quebec Northern Service, however, is beamed way up north (even by Canadian standards) and therefore may not be available. I sometimes receive it in Ottawa, Ontario.

RCI and the CBC are based in Montreal. While visiting Montreal for the day last week, I decided to check them out. My first stop was RCI. Although I dropped in unannounced, I was welcomed and given a tour of the facility. Due to cut backs in funding, RCI is now basically a news broadcaster although they do retransmit some domestic programming. I happened to be in the studio just as the Russian

News and current affairs programming was starting.

There are actually four studios at the facility, but only one is regularly used due to the reduced programming schedule. There is also a studio for the military, who transmit programmes on the military network (different frequencies). I also saw the recording and tape duplicating rooms, the "technical room" and the news room. RCI also retransmits material from several foreign networks such as the BBC. The Programmes are sent via satellite to the transmitter located at Sackville, New Brunswick.

A Gallup Institute survey shows that in the US, one and a quarter million people tune into RCI at least once a week. For a free copy of RCI's programme schedule—published twice yearly—write to Radio Canada International, P.O. Box 6000 Montreal, Canada H3C 3A8.

Just down the road from RCI is the CBC complex. They have guided tours on Tuesdays and Fridays. As I was there on a Monday, I was not able to go on the tour.

However, there is a display area on the main concourse and the lower level. Starting on the main concourse is a photographic history of broadcasting in Canada. It begins with the Marconi experiments and proceeds, through the twenties, thirties and WWII, to the present. This exhibit leads you to the lower level where on display, is a collection of radios and TV's from the twenties through to the seventies. The display is arranged by decade. I don't know if any of the radios work.

Also, there is a collection of equipment used in transmitters, studios and in the field. Adjacent to this is a display of tubes, again arranged by decade, from the twenties to the fifties. Placards tell the stories of broadcasting firsts.

After finishing with the exhibit in the lower level, one can view the TV control rooms located there. Each has large windows so you can watch the action. When I was there, a kids programme was being taped on a stage area made to look like an old house.

RCI is located at 1055 Rene Levesque Blvd E. Their phone number is 514 597 7555. CBC is located at 1400 Rene Levesque Blvd. E. The nearest main cross road is Papineau Ave.

While in Montreal, also be sure to check out Ben's Deli!--Allan Brown, Woodlawn, Ontario, Canada.

## VINTAGE BOOK REVIEWS

*Books from the era when vintage radios were new! Look for them at swap meets, flea markets and used book stores.*

*A TOWER IN BABEL A History of Broadcasting in the United States Volume I to 1933* by Eric Barnouw. Published by Oxford University Press. New York, 1966. 344 pages. Hardbound.

Sometimes, we radio collectors forget that those grand old sets were not invented to be put on display. Home radios were made to give pleasure to their owners via broadcasted information and entertainment. *A Tower in Babel* discusses the history of the broadcast industry through 1933. Unlike many broadcast history books, which start with the pioneering KDKA broadcasts, this one begins with the invention of radio, tracing its evolution from the first dots and dashes, through the early attempts to send voice and music over the air, to the golden age of broadcasting.

Barnouw points out that while many were happy with radio's original role as a wireless replacement for the telegraph, others wanted more from the medium. Some people with vision realized that, if radio could transmit voices, it could serve as a "wireless telephone" that would provide many benefits, including making it possible for lay persons to talk between ship and shore. Some were fascinated by radio's capacity to entertain, sending out experimental "broadcasts" of live and recorded music just to see if anyone would hear and respond.

While World War One hastened the development of wireless telephony, it also shut down non-military uses of radio. The experiments were over for the duration. But when the war was over, the air was cleared for further development of this new form of communication. Many veterans had returned home with a working knowledge of radio; the technology existed; and the public was ready.

Broadcasting began on a single frequency with unpaid talent and no commercials! Record companies did not want their records played on the air. Everyone wanted to get into radio and stations were started in barns, attics and garages.

Eventually, order came out of chaos. The AM broadcast band was created. Paid performers replaced the volunteers, commercials punctuated the entertainment and the broadcast industry was born.

*A tower in Babel* is quite well-written: scholarly, but in a narrative everyone will enjoy. There are details about the obscure people and stations that make the history of broadcasting so very interesting. The early experimental television broadcasts are also well-documented.

There are many pages of photographs throughout the book. In addition to the main text, Barnouw includes a chronology of broadcasting, the text of the Radio Acts of 1912 and 1927, and an extensive bibliography and index.

This book makes a fine addition to the library of the radio scholar/historian or the collector who wants to know why people bought the things he has on his shelf.

---

*RADIO ENGINEERING* by Frederick E. Terman. Published by McGraw-Hill Book Company. Second Edition, 1937. 813 pages. Hardbound.

Frederick Terman should have the title: "The Father of Silicon Valley." From his famous electrical engineering classes at Stanford

University came: the Varian brothers, Hewlett, Packard, Lawrence and many other notable contributors to the fields of electronics and physics. *Radio Engineering* is one of the textbooks he wrote for his classes.

The first four chapters cover the basics of radio electronics: the elements of a system of radio communication, circuit constants, and properties of resonant circuits and vacuum tubes. These chapters cover quite thoroughly the basis for all of what follows.

The next three chapters deal with vacuum tube amplifiers, including power amplifiers. All facets of amplification as they were known at the time are covered and, interestingly, the majority of pages are devoted to audio amplification. The preoccupation with high fidelity reproduction was just beginning, and one can see the basis for many of the early hi-fi designs.

Next, a group of three chapters deals the "other" major uses for vacuum tubes: oscillation, modulation and detection. There are discussions of virtually every then-current (and obsolescent) circuit. This is followed by a four-chapter discussion of transmitters, receivers, wave propagation and antennas, stressing the medium to ultra-high frequencies. Though all major types of receivers and transmitters are mentioned, little design information is given. The antenna chapter, however, goes into greater theoretical detail.

The last three chapters discuss some applications that were just coming out of the development stages and into public use: television; radio aids to navigation; sound and sound equipment. An appendix includes useful formulas and the book is indexed both by name and by subject.

This book was designed as a text for a two-semester engineering course, and is not good bedtime reading. While Terman states in the preface that the book uses as little math as possible (especially in the first few chapters), the math is actually quite extensive. Though one can gain quite a lot of information without it, a knowledge of algebra and trigonometry are required to understand the formulas.

In any case, to get the most out of this volume, you'll have to spend quite a bit of time studying it. As with many textbooks, there are questions at the end of each chapter but, alas, there are no answers. The book has some interesting pictures and is quite filled with drawings and diagrams. Most of the equipment shown is not identified.

Terman's approach was overview-oriented and did not stress practical circuit design. But, if you want a very thorough understanding of the field of electronics as it was in the thirties--by one of the most important teachers in the field--this is an excellent book. There are other books better suited to the needs of the neophyte who wants a layman's understanding of radio or a person who does not want complex formulae staring at him from (what seems to be) almost every page.

*Please feel free to correspond with me at any time about old radio books.*

Conducted by Paul Joseph Bourbin  
25 Greenview ct.

San Francisco, CA 94131

Copyright 1995 by Paul Joseph Bourbin

## COMPANY CHRONICLES

*Brief biographies of Classic Radio Manufacturers*

# FADA Radio

Radio company histories abound with "rags to riches" tales of enterprising young men from impoverished backgrounds who made it big in the booming 1920's radio market. And the story of Fada Radio is no exception. Frank Angelo D'Andrea, the son of a junk dealer, had a driving ambition to get rich. At age eleven, he stopped helping his dad collect scrap and struck off on his own. Beginning as a newsboy, he later tried his hand at prizefighting and working in an electroplating plant.

Frank eventually became a tool-and-die maker at a firm specializing in experimental work for inventors. World War I was in progress, and the young man became involved in adapting a German-designed receiver for wartime production. After the prototype was completed, the De Forest Company received the production contract and D'Andrea went along to supervise.

Not long after the Armistice, D'Andrea went into business for himself. In June, 1920, adapting the Fada brand name from his initials, he set up a store front firm in the Bronx, (New York City) to manufacture crystal detectors. With beginning of the radio boom in late 1921, Frank expanded into three more stores and was soon turning out 1800 detectors per day. By early 1922, the company was taking in as much as \$50,000 per month.

Fada began to manufacture some vacuum tube gear, but continued to specialize in crystal detectors until D'Andrea learned of Hazeltine's newly-invented Neutrodyne circuit. The Fada firm was the first to put the circuit into production and, in 1923, began to market a line that eventually included both completed sets and kits.

The firm did very well in 1923 and an additional plant was opened. However, the cyclical nature of the radio business being what it was, the original plant was closed down in the following year. Nevertheless, Fada's 1924 gross was well over a million dollars.

1925 was a slow year, and D'Andrea responded with several strategies. A low-priced receiver (the Model 192A) was developed to draw on the inventory of overproduced parts; the Fada dealers were required to purchase a quota of older models in order to obtain new stock; a top-notch engineer was brought on board to develop a new state-of-the-art set; and a Canadian company was formed.

Fada's 1926 profits approached a million dollars, with the firm paying record royalties to Hazeltine. Sales for the first half of 1927 were also strong, but bad times were approaching. The new a.c.-operated sets were cutting into the company's business, and Fada shut down, near the end of the year, to retool for a competitive radio. During this period, Fada also lost its new engineer and its top marketing executive.

The new sets didn't work well and the company was forced to shut down again for redesign. Though Fada kept going, this was the beginning of the end. In 1932, the firm was purchased by a group of Boston businessmen and that year posted a loss of over a quarter of a million dollars. It was in bankruptcy by 1934 but, revived by other interests, continued into the 1940's.

D'Andrea himself formed a new company, Andrea Radio, in 1934. He operated Andrea until his death in 1965.

*The information for this company biography was obtained from Alan Douglas' three-volume encyclopedia "Radio Manufacturers of the 1920's," published by Sonoran Publishing, 116 N. Roosevelt, Suite 121, Chandler, AZ 85226, and copyrighted 1988, 1989 and 1991 by Alan Douglas.*

### INFORMATION EXCHANGE

*(continued from p. 5)*

#### Rectifier Roundup

The other day, I was going through a box of rectifier tubes, and found I had representatives of most of the types produced from the earliest days of plug-in radios through the inception of World War II. Some were widely used and others had very limited popularity.

I thought it might be interesting to arrange the types in (roughly) chronological order of introduction and jot down some of the things I remember about them. Comments on the list and additions to it will be welcome! Years given are approximate. All are full-wave rectifiers except as noted.

**80 (1927)** - Most widely used of all rectifiers. Powered millions of radios right up through the 1950's. Some Philco's used the 80 to power a lineup of 9-pin miniature tubes.

**81 (1928)** - Half-wave, high-voltage rectifier. Fell into disuse around 1929, after the introduction of the type 45 audio tube (which ran at about 300 volts) made the 450-volt B+ less common.

**82, 83 (1932)** - Mercury-vapor rectifiers, little used in home sets.

**83V (1934)** - Similar ratings to 83, but is vacuum type rather than mercury vapor and is indirectly heated (has cathode).

**84/6Z4 (1932)** - First rectifier with cathode separated from filament. This feature made it possible to develop simple, cheap vibrator power supplies for auto radios.

**0Z4 (1933)** - Mercury vapor rectifier with no filament. Used in auto radios. Very temperamental when battery ran low.

**1V (1932)** - Half-wave. The first rectifier with both separate cathode and a 300-ma heater suitable for use in a.c.-d.c. series strings. Disappeared with the introduction of the 25Z5.

**2X2 (1938)** - First high-voltage, low-current rectifier for scope circuits. Before this, the type 80 had to be used (requiring 10 watts of heater power to supply 1 watt of B-). Available by the millions as WWII surplus. A similar tube handling higher voltage, the 1B3, was later introduced to suit the needs of TV sets.

**5Z3 (1935)** - Heavy-duty version of the type 80.

**5U4 (1937)** - Like 5Z3, but with octal rather than 4-pin base.

**5V4 (1937)** - Among the best rectifiers I've come across. Indirectly heated design gave a slow warm-up, protecting power supply capacitors. Close electrode spacing gave low voltage drops, even at 175 ma! Heater drew only 2 amps, like an 80 or 5Y3.

**5Y3 (1936)** - Similar to 5U4 but lower voltage and current ratings.

**5Y4 (1936)** - Identical to 5Y3, but different pinout. Set manufacturer's proprietary tube (Zenith?).

**5W4 (1936)** - Metal tube for use in sets having low current requirements.

**5Z4 (1935)** - First indirectly-heated, octal-based rectifier.

**5T4 (1937)** - Similar to 5U4, but metal and with lower-current heater.

**6X5 (1936)** - Like 84, but with octal base instead of 5-pin, higher current rating.

**12Z3 (1933?)** - Similar to 1V, but has 12-volt filament instead of 6-volt and somewhat reduced d.c. voltage rating. Higher heater voltage was an advantage in series filament string. Short-lived type.

*(continued on p. 9)*



## DICK'S CORNER

*Tips and Tidbits from the World of Antique Radio Collecting and Restoring*

### Rosette Replacement

Many early wood radio knobs were made with decorative faces; you may hear them referred to as "rosette knobs." At first glance, such knobs appear to be made in two pieces: the metal insert that fits over the shaft and the wood body of the knob itself. However these are usually *three-piece* knobs. The rosette was generally fabricated separately and then glued into a recess in the front of the knob.

The rosette was often made from sawdust salvaged from the manufacture of the main part of the knob and mixed with glue or other form of bonding agent. This mixture was then molded (often under pressure) into a rosette wafer and heat-cured. Being composed of the same wood as the knob proper, the wafer could be stained to a similar appearance prior to being glued to the knob body.

It's also possible that some of these rosettes were stamped out of thin sheets of wood (the wood may have been moisture-impregnated to prevent cracking or splitting during the process). Does anyone out there have additional information on the subject?

However the rosette was manufactured, the glue holding it in place dries out with age. The wafer then tends to fall out of the knob and become lost. This leaves the collector with a set of wood knobs having no front decoration except the all-too-visible end of the control shaft.

You may not be able to locate similar replacement knobs, but there is a solution! You'll find it in the catalogue of S. LaRose Inc., P.O. Box 21208, Greensboro, NC 27429. Phone 910-621-1936. LaRose is mainly a dealer in parts and supplies for the repair and restoration of clocks, but many of the items they carry are also quite useful in radio restoration. Their catalogue will cost you \$2.50, but it is fun to browse through and definitely worth having on hand!

LaRose has replacement rosettes just right for gluing into those ugly spaces. I've even purchased a plain wood knob (available from Antique Electronic Supply, 6221 S. Maple Ave., Tempe, AZ 85283; phone 602-820-5411; write or call for free catalogue), turned an appropriate depression into the face, and glued in a LaRose rosette. The result is a very attractive and authentic-looking knob.

### Ready-Made Vintage Case

Starting in the 1930's and continuing right through to the late 1950's, VOM's and other small pieces of test equipment were commonly packaged in small "suitcase-type" enclosures with tops about twelve inches square. Some were covered in black leatherette; others had a natural wood finish. Such instruments have limited use. Modern ones are smaller, more accurate, and

much easier to equip with the necessary batteries.

You may want to hang onto one or of these vintage instruments if you are furnishing a vintage radio repair shop. Otherwise, I'd like to suggest an alternate use.

Many of the old instruments had two compartments; a large one to hold the meter movement and a smaller one to hold test leads and other accessories. That large compartment (minus the meter movement) makes an excellent housing for a crystal set, or a one-tube radio and its batteries. The accompanying headphones should slip nicely into the smaller compartment. Several radios of the 1920's were originally sold in similar enclosures.

Old test instruments of this kind are common at radio meets and hamfests, usually selling for well under \$15.00 in good condition. Try to build your own replica vintage case for that amount!

### More Bakelite Lore

One additional note on Bakelite. A few years ago I discovered I had a 1925 one-tube set, commercially-made but with no labels on the front panel. Another member of my radio club had the same set with a labeled front panel but missing the main tuning components (a spiderweb coil and compression-type capacitor).

We decided to set up a mutual borrowing arrangement. He borrowed my set in order to duplicate his missing components. I borrowed his set and took it to an engraver to have the lettering copied onto my blank panel.

On examining the pieces, the engraver told me that the original panel had been stamped, rather than engraved. It seems that newly-manufactured Bakelite is soft enough to be stamped, but the material becomes brittle with age and then can't be processed that way. Caution: the older the Bakelite, the easier it will crack!

### Doll House Radios

For more than a century, doll houses have been popular playthings for young girls. And over the years, almost every item that might be used to furnish a home has been produced in miniature for furnishing a doll house. Keep your eyes open at flea markets and swap meets, and you might be able to uncover doll-house receivers from radio's golden age.

I have a number of these "sets" in my collection, including a brown bakelite 1940's console, a red plastic radio-phono combination from the early 50's, a small wood cathedral and, perhaps the most impressive, a 3 1/2"-tall battery console circa 1924. A wide door at the top opens to reveal "3-dialer"; doors at the bottom conceal a battery compartment. The built-in speaker at the top actually has a piece of grill cloth over the opening.

Conducted by Dick Mackiewicz

### INFORMATION EXCHANGE

*(continued from page 0)*

*12Z5 (?) - Short-lived 6/12-volt tube offered by Arcturus. Presumably could be used to replace 1V or 12Z3.*

*25Z5 (1933) - Long-lived successor to 1V and 12Z3 for AC/DC-series-string service. Still higher (25-volt) heater rating made it*

*even more desirable than the former tubes.*

*25Z6 (1936) - Like 25Z5 but with octal, instead of 6-pin, base.*

*35Z4 (1939) - Predecessor to 35Z5 and similar electrically, except for lacking the pilot-light tap on the heater.*

*35Z5 (1939) - 35-volt heater with the 150-*

*ma. current rating that became standard for the "All-American 5" series string. Made in the millions.*

*45Z5, 50Y6, 117Z3, 117Z6 (later 30's) - Higher-voltage heater types found use mostly in portables, I think, and remained until solid-state rectifiers arrived.—Ray Larson, W. Los Angeles, CA*

## CLASSIFIED ADVERTISING

Subscribers may place one free classified ad, up to 30 words long, in each issue. Count your name, ham call (if desired), complete address and one phone number as six words. Do not count the words in the boldface heading. Additional words are 15 cents each per issue. Non-subscribers pay 30 cents each per issue for all words. Free ads will be automatically run in two issues, but expire after their second insertion unless renewed by mail or phone. Those wishing to run the same ad for extended periods of time may want to use a "business card" space (see Display Advertising Dimensions and Prices table elsewhere in this issue). This is a boxed area in which we can print your business card or any advertising message that will reasonably fit (no charge for setting type). We reserve the right to make editorial adjustments in classified ads without advance notification and to refuse advertising at our discretion. We will reprint, without charge, any ad containing typographic errors, but assume no other financial responsibility.

**Wanted Radio Servicing Made Easy** by Leonard C. Lane, Volume 2. Claude Jordan, 3010 Acorn Rd., Augusta, GA 30906.

**Wanted Old headphones, headphone parts, plugs, adapters, junction boxes, paper.** I will purchase any amount, or trade for phones not in my collection. Dick Mackiewicz 1549 N. River Rd., Coventry, CT 06238. (203) 742-8552.

**Wanted Cable to connect Drake RV3 remote VFO to TR4C.** Also schematic for ERLA Model S51 radio. James C. McColl, KA4PVT, 2627 Whitestone Dr., Florence, SC 29505. (803) 669-4906.

**Wanted General Electric consoles models LFC 1118 and H-87.** If you don't want to sell, I would appreciate pictures. Bill Miedma, 101 Devonshire Rd., Tower Lakes, IL 60010-1209. (708) 526-6131.

**For Sale Sencore tube tester TC 136 \$35.00.** RCA Sound Products catalogue (1948) copies. 83 pages of amps, mics, speakers. \$15.00. Kevin L. Moe, 616 Lockrem St., Ottawa, IL 61350. (815) 433-4598.

**For Sale Pioneer 1970's solid state AM-FM stereo amps VG condition SX-780 \$40.00 and SX-980 \$45.00. PA amplifier 2 - 6L6's #12155 \$70.00. Fanon commercial AM-FM amplifier with mic and aux inputs. Solid state vlg \$25.00.** Kevin L. Moe, 616 Lockrem St., Ottawa, IL 61350. (815) 433-4598.

**For Sale You need our 80-page set of flyers listing surface mount parts to old time radio parts: tube sockets, knobs, terminal strips, etc.** All priced right, easy to order-we pay shipping. 3 flyers are free, all 80 pages sent priority mail for \$3.00. Star-Tronics, Box 98102, Las Vegas, NV 89193. Phone (702) 795-7151.

**For Sale Reproduction crystal detectors, replacement Philmore domes, new loop antenna wire, grille cloth - more! SASE for details.** Do you need some oddball part or information? Drop me a note. I'll try! Dick Mackiewicz, 1549 N. River Rd., Coventry, CT 06238. (203) 742-8552.

**For Sale 40-year accumulation of old radios, parts, tubes, service data. Cash and carry only.** Phone, write. No lists. Krantz, 100 Osage Ave., Somerdale, NJ 08083-1136. (609) 783-0400.

**For Sale Crystal radio kits complete with face panel, base board, variable capacitor, prewound coil and the many parts for old style radio.** Remit \$22.50. Carl and Grace Enterprises, 5636 Romeyn, Detroit, MI 48209.

### SERVICE DATA & REPAIR PARTS

FREE CATALOGUE  
A.G. TANNENBAUM  
P.O. Box 110  
EAST ROCKAWAY, NY 11518.  
(516) 887-0057  
24 HOUR FAX (516) 599-6523.



1936 Zenith 16A63 "STRATOSPHERE"

### ★ WANTED ★

#### Classic Radios & TV's

- Pre-1940 Console radios by Zenith, Lincoln, E. H. Scott, McMurdo Silver
- Class of Mirror radios by Spinton, Troy, Itako Glo, others
- TV's - Spinning Disk Type by Jenlans, Baird, Westam, others
- Pre 1941 CRT TV's by RCA, Andrea, GE, etc. (all have 1 to 5 channels)

DON HAUFF (612) 374-9759 24 hrs.  
P.O. Box 16351, Minneapolis, MN 55416

#### PROCLAIM YOUR INTEREST

to the world! Wear our distinctive logo printed in deep blue on a Hanes Heavyweight 50-50 T-shirt (XL only). \$12.50 postpaid. **The Radio Collector**, P.O. Box 1306, Evanston, IL 60204-1306.

### THE RADIO COLLECTOR Display Advertising Dimensions and Prices

TYPE	H" x W"	1 MONTH	3 MONTHS	6 MONTHS	1 YEAR
1 page	9 0/0 x 6 3/4	\$65.50	\$177.00	\$319.00	\$574.50
1/2 page	9 0/0 x 3 1/4	33.00	88.50	160.00	288.00
1/2 page	4 3/8 x 6 3/4	33.00	88.50	160.00	288.00
1/4 page	4 3/8 x 3 1/4	16.50	45.00	81.00	145.50
1/8 page	2 0/0 x 3 1/4	8.50	23.00	42.00	75.00
Bus Card	1 1/8 x 2 1/8	-----	12.00	21.50	38.50

### MONTHLY MINI QUIZ

Match wits with our quiz editor! See next month's issue for the answer, as well as the names of all readers who responded correctly.

The "singing arc" was an advanced high-frequency transmitting device invented by this British engineer.

Answer to last month's Quiz -- Reginald Fessenden. Correct answers sent in by Charles F. Brett and Alan Douglass.

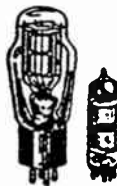

### TUBES — 3000 TYPES DISCOUNT PRICES!

Early, hard-to-find, and modern tubes. Also transformers, capacitors and parts for tube equipment. Write or call for our 36 page catalog.

### ANTIQUE ELECTRONIC SUPPLY

6221 S. Maple Ave. • Tempe, AZ 85283 • 602-820-5411  
/ Fax 602-820-4643 • Toll free Fax 800-706-6789