

The
Indiana
Historical
Radio Society

BULLETIN

Volume 45

July 2016

Number 2



*"Mary Pickford - - - speaking by radiophone
with her studio at Hollywood,
thirty miles distant."*

The Indiana Historical Radio Society Bulletin

July 2016

Mary Pickford, Pickford-Fairbanks Studios, Hollywood.



On the cover: The cover of this issue was cropped from a post card of Mary Pickford on a movie set. The top of the card is titled "Mary Pickford, Pickford—Fairbanks Studios, Hollywood" The reverse of the card offers "*Mary Pickford- -speaking by radiophone with her studio at Hollywood, thirty miles distant.*" The "radiophone" receiver is a file box size crystal radio - taking liberty with "speaking", "listening" is more correct—unless there is a boom mike connected to a close by transmitter.

In this issue:

- Take note of the request for candidates for IHRS office during 2017 on the facing page.
- Despite a bumpy start the 2016 IHRS Spring Meet was well attended. Our apologies for the inconvenience some may have experienced with the loss of our advertised venue. Pages 4 and 5 provide a sample of the events offered during the Spring meet.
- Page 6! It is time to focus on Cool Creek. The next IHRS Swap Meet!
- Fred Prohl reminisces about his radio search while traveling, page 7.
- The Spring Meet Old Equipment Contest did not fail to show rare and unusual radio equipment. See pages 11, 12, 13, and 24.
- Ed Dupart writes of his experience in constructing a transistor radio using vintage Raytheon transistors, pages 14-19.

See you at Cool Creek! *Fred Prohl, Editor for the IHRS Bulletin*

**“Request for candidates for office in the
Indiana Historical Radio Society.”**

To: All members of the Indiana Historical Radio Society

From: Officers of the Indiana Historical Radio Society

The IHRS will have an election of officers at the Fall Meet at Riley Park, Greenfield, October 1. All positions are open for nominations.

Dave Mantor has decided to not to run for the President’s position in 2017. So as of this date we have one declared opening, that is the position of President.

We ask that you consider your involvement in the IHRS and encourage you to take a leadership role.

Contact any one of us to convey your interest or to ask questions regarding the responsibilities of an officer in the IHRS. Officer contact information is on page 23 of this Bulletin.

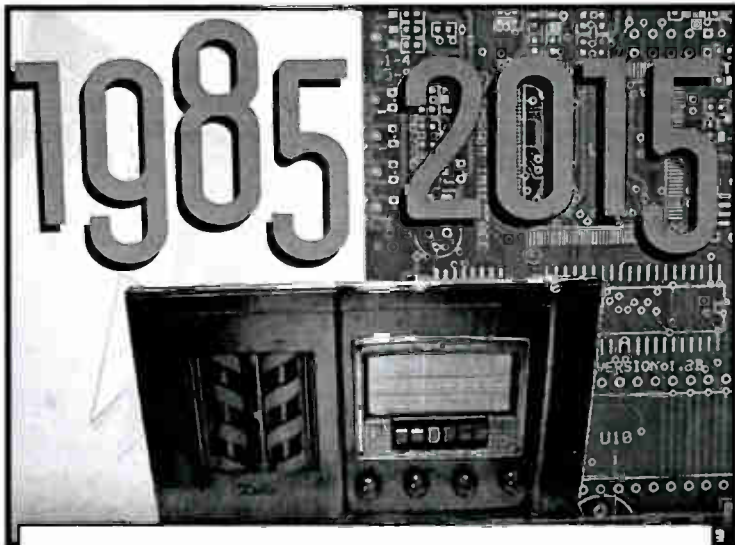

Now on YouTube!

***“A Thirty Year Restoration”
Of a 1940 Delco R-1177***

A Bill Morris video of his 1985 to 2015 radio experience.

Ed Dupart leads the Spring Meet Friday night "Tech Talk".

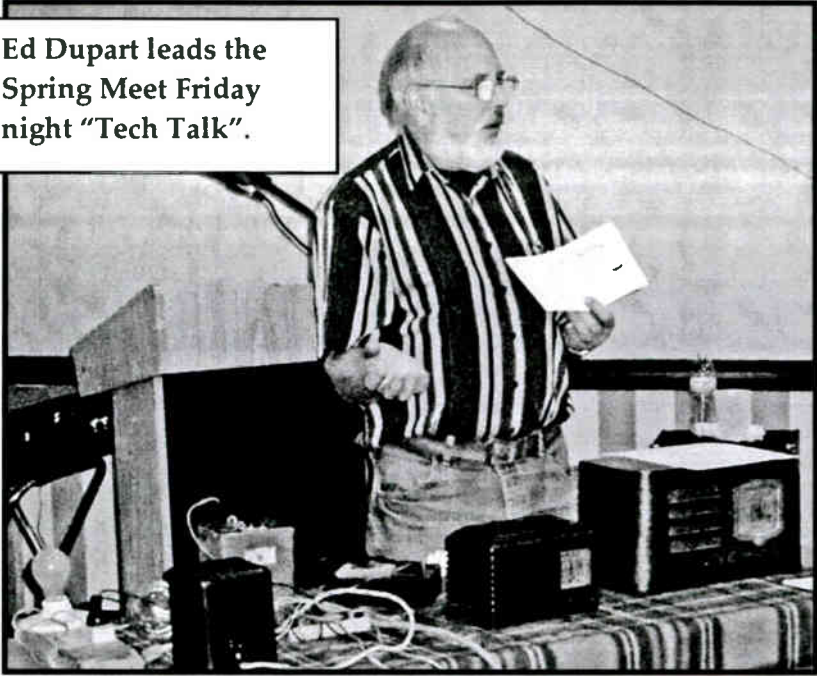

Prepared with two AC/DC radios, isolation transformers, meters, a series lamp load, and considerable experience, Ed Dupart talks about working with "Hot Chassis" radios.

The Bulletin editor's notes on Ed's talk include the following:

- Many radios built in the 1940's, 50' and into the 1960's were designed to operate without a power transformer.
- A power transformer isolates the AC input from the radio's chassis. Without the transformer, the chassis is connected directly to one of the AC input lines, creating a shock hazard.
- Frequently the ground side of the AC line was switched on or off for radio operation—leaving the radio chassis "hot" even when the radio is off.
- An isolation transformer is a must for the workbench when troubleshooting AC/DC radios with grounded test equipment. Even with the isolation transformer the shock hazard is still there.
- Some AC/DC circuits use a floating ground. Floating ground circuits use a capacitor/resistor combination from the floating ground to the chassis to complete the tuning circuit. A floating ground does not remove the possible shock hazard.
- When troubleshooting a plugged in radio, switched on or off, work with only one hand. (Sit on the other.) Electron flow from one hand to the other is deadly!

Rusty McClure, grandson of Lewis Crosley , and author of the book "Crosley" talks with IHRS members at the recent IHRS Spring Meet in Kokomo.

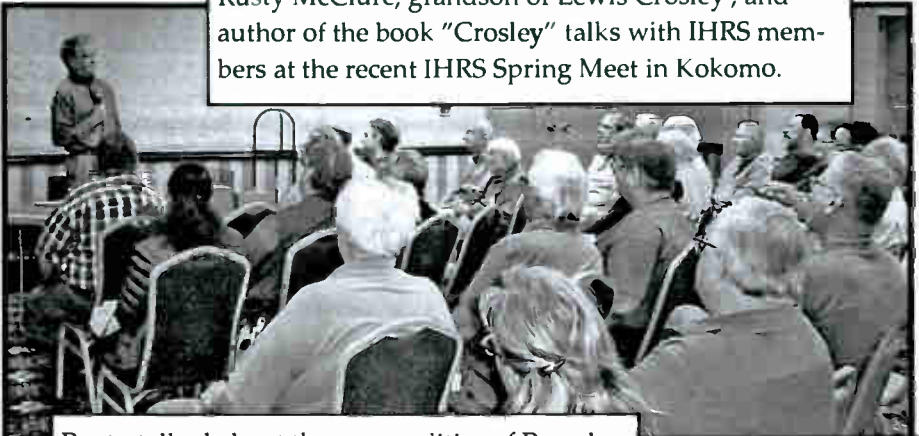

Rusty talked about the personalities of Powel and Lewis Crosley, their individual roles in the development and production of automobiles, radios and radio stations, appliances, military equipment, and yes, airplanes. Following his talk he signed his books for the audience. In addition to the book "Crosley" Rusty McClure co-authored "Coral Castle" and "Cincinnati". All three books were available for those attending the presentation.

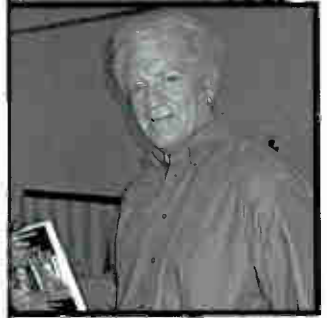

Donation Auctions are an event at a radio meet that many members look forward to. Projects and treasures can be purchased at a reasonable price, with the proceeds going to the IHRS. Usually not seen is all the effort that goes in to setting up the auction. The loading, hauling, storing, loading and hauling again with a final setup on site was done by Dave Mantor and Don Yost, with the assistance of Ed Dupart and J. D. Leach .

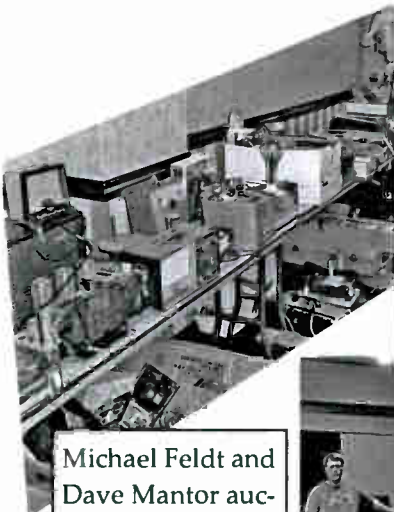

Michael Feldt and Dave Mantor auctioning donated equipment.

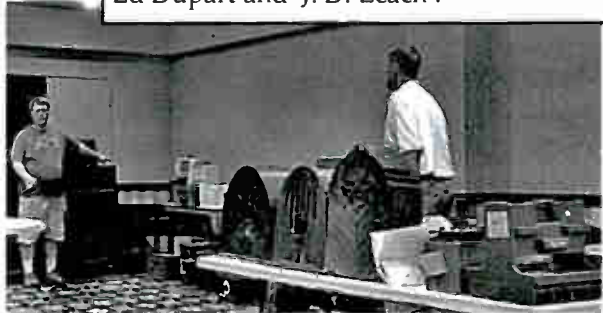

Saturday, August 13 - the Indiana Historical Radio Society 2016 Summer Meet. Cool Creek Park, 2000 East 151st Street, Carmel, Indiana

There is space for indoor and outdoor Swap N Sell setup. Tables are available indoors. General admission is free. Swap N Sell set-up in the building and parking lot is \$10 for IHRS members, \$15 for non-members.

Complimentary doughnuts and Danish, coffee and soda will be provided.

- Schedule of activity:
- 7:00 AM—set up for Swap N Sell
 - 8:00 AM the IHRS Summer meet begins. Set up entries for the contest.
 - 10:00 AM Vote for your favorite radio in each of the contest categories.
 - 10:15 AM contest results and announcements.

Cool Creek Park, Carmel, is located east of US31 and north of 151st Street. From US31 go east on 151st Street to a round-about. The Cool Creek Park entrance is the street north out of the round-about.

The 2016 Summer Meet Popular Vote Contest categories:

category 1 – A 6" X 10" Tube radio (maximum radio base is 6 inches by 10 inches)

category 2 – Open to all radio and radio related equipment

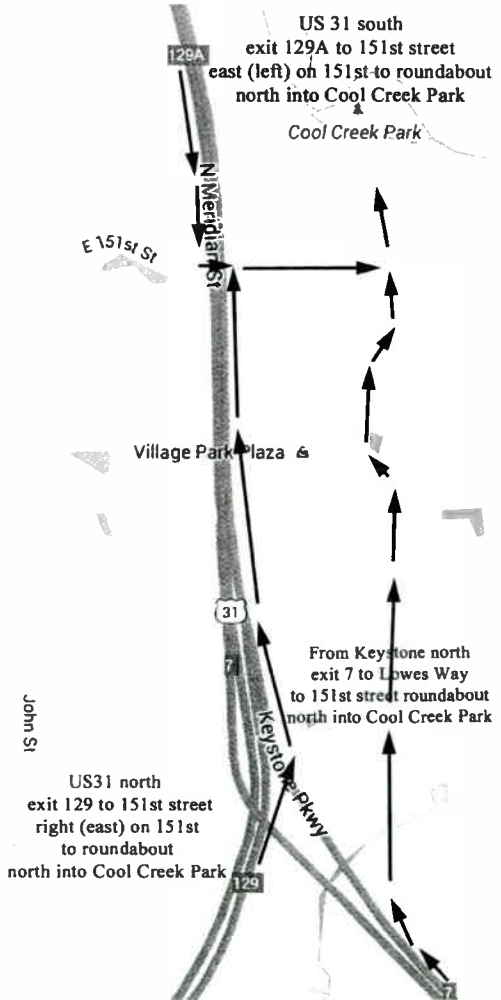

Contact information: Michael Feldt
feldtm@msn.com 317-844-0635

LEMCO and Mary Pickford by Fred Prohl

For a number of years my job required travel to Northern California. The trips frequently included a weekend stay. This was a time when air travel was very different from now. On one occasion I purchased a horn speaker at an antique show in the Oakland area the same day I was to fly home. No problem, I packed the base in my book bag and carried the horn on board. The flight attendants had fun teasing me about my hearing aid and suggested I store it on the floor by my feet. Try that today!

I did have some schedule flexibility, so planning the trip when there was a radio swap meet suited me,

The LEMCO crystal radio came from a weekend California Historical Radio Society swap meet. This was in the late 1970's, shortly after CHRS was formed. I remember it as a pleasant day, a



Mary Pickford (1892–1979) was a Canadian motion picture actress, producer, and writer. During the silent film era she became one of the first great celebrities of the cinema and a popular icon known to the public as "America's Sweetheart".

parking lot swap meet, and friendly CHRS members.

The post card pictured on the cover of this issue was purchased at an antique shop in Pleasanton.



LEMCO model 340
Lee Electric and Manufacturing Co.
San Francisco
The Phones are "Pennsylvania"
Hambutg & Hambutg
Pittsburg

So what's the Pickford/LEMCO connection? Very little—the post-card pictures Mary Pickford listening to a radio that looks very much like the California manufactured LEMCO. The 3x5 card file style box crystal radio can also be found with the name "Excello" (Sterling Radio) and "U. C." (UC Battery MFG). (*"Crystal Clear" M. L. Sievers*)

The LEMCO is nicely made with triangle hinges and ports for antenna, ground and head phones. However, standard headphone tips will not fit through the port.

The instructions in the LEMCO lid include how to connect the crystal radio headphones, antenna and ground.

Below is the portion of the instructions that describe how to tune a station using the two multi-contact switches and cat-whisker.

Fred—June 2016

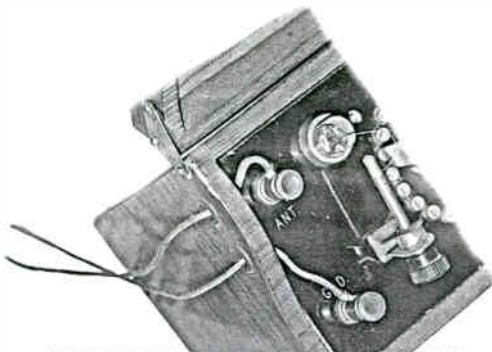

The LEMCO model 340 Crystal Receiver has antenna, ground, and phone ports on the sides of the box.

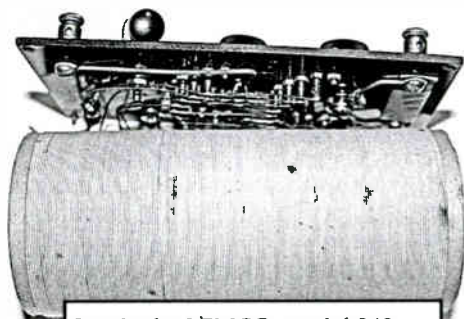

Inside the LEMCO model 340 showing the tapped coil circuit.

LEMCO
RADIO TELEPHONE CRYSTAL SET NO. 340
INSTRUCTIONS FOR OPERATING THIS RECEIVING SET

~~~~~

The set is equipped with two switches. On the left is the front circuit switch, which should be adjusted to the wave length if the incoming signals. On the right is the detector circuit switch which should be adjusted until signals are heard loudest, or may be used to advantage in tuning out undesirable interference. Turning the switch knobs to the right increases the wave length. To hear radio signals or music, place receivers on ears and set the ground circuit switch about mid-way on the contacts, set the detector switch a few points to the right, then adjust the crystal detector by sliding the "cat-whisker" over the crystal in detector cup until a sensitive point is located and signals are heard. Adjust the switches again and continue to explore crystal with the "cat-whisker" until signals are heard loudest.

With the average size antenna (100 feet in length) this set will respond to wave lengths up to 900 meters.



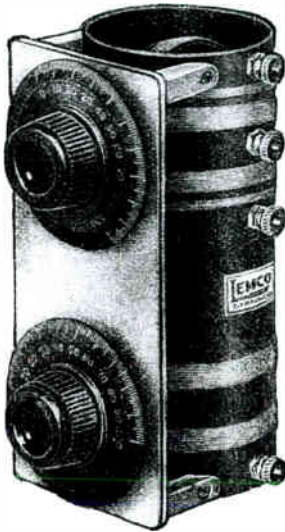

## SIMPLIFY YOUR SET!

Increase Your Range—Improve Your Control—Hook Up a

**LEMCO**  
EQUIPMENT

### TRIPLE DUTY TUNER

Insist on Lemco Products from your supply dealer; if he hasn't them, we'll forward prepaid on receipt of purchase price.

No. 100. Broadcast Tuner list (less dials) .....\$7.50  
With Bakelite dials (as illustrated).\$8.70  
No. 340. Crystal Set (as illustrated).\$7.50

*Circulars with diagrams for simple regenerative, Flewelling, radio frequency and other circuits sent on request.*



DEALERS and JOBBERS  
Write for Attractive Proposition

LEE ELECTRIC & MFG. CO.  
220 Eighth St. San Francisco, Cal.

Radio News (June 1924), p. 1863

# YOU CAN GET EVERYTHING YOU WANT WITH THIS SET

**LEMCO**  
EQUIPMENT

No. 340 Crystal Receiver

\$6<sup>00</sup> Delivered

provides clear, distinct, loud reception of both voice and music within 50 mile radius. Thousands in use attest their popularity.

### LEMCO RADIO PARTS

offer more real value for the money than any made. Note the low prices.

|                                                           |                                                        |
|-----------------------------------------------------------|--------------------------------------------------------|
| No. 250 Reflex Coils .....\$2.00                          | No. 100 Broadcast Tuner ..\$5.00                       |
| No. 275 Reflex Units, with 17-plate condensers ..... 8.00 | No. 340-B Crystal Receiver .... 6.00                   |
| No. 300 Fixed Crystal ..... .60                           | No. 55 Knock-down kit (2-tube Harkness reflex ..\$5.00 |
| No. 401 Audio Transformer.. 3.50                          | No. 50 Neutroflex Receiver ....\$5.00                  |

If your dealer can't supply you—send direct. We'll deliver C. O. D. anywhere.

LEE ELECTRIC & MFG. CO.

220 EIGHTH STREET

SAN FRANCISCO, CALIF.



Write for Booklet R-81

Radio News (Nov. 1924), p. 766

## - 2016 Regional Vintage Radio -

### **Indiana Historical Radio Society (IHRS)**

August 13—Summer Meet, Cool Creek Park, Carmel

October 1—Fall Foliage Meet Greenfield Riley Park

[indianahistoricalradio.org](http://indianahistoricalradio.org)

### **Mid-South Antique Radio Club (MSARC)**

Meet information contact: [layvinrad@twc.com](mailto:layvinrad@twc.com)

### **Antique Radio Club of Illinois (ARCI)**

[www.antique-radios.org](http://www.antique-radios.org)

July 29—July 31 RADIOFEST

Medinah Shriners, 550 Shriners Drive, Addison, IL

### **Michigan Antique Radio Club (MARC)**

[www.michiganantiqueradio.org](http://www.michiganantiqueradio.org)

### **Cincinnati Antique Radio Society (CARS)**

Info. at [oltubes@roadrunner.com](mailto:oltubes@roadrunner.com) or Bob Sands 513-858-1755

### **Dayton Antique Radio Club (SPARK)**

Contact - Ed App 937-865-0982

### **Central Ohio Antique Radio Association (COARA)**

Info. at <http://coara.org> for event schedule.

### **Pittsburg Antique Radio Society (PARS)**

information at [pittantiqueradios.org](http://pittantiqueradios.org)

### **AWA-Antique Wireless Association**

August 17—August 20 2016 Annual Convention

RIT Inn & Conference Center, Henrietta, NY

[www.antiquewireless.org](http://www.antiquewireless.org)

### **Renew your membership now!**

If the date on your mailing envelope for this issue of the Indiana Historical Radio Society Bulletin is 12/15 or earlier, it is time to renew your membership. Send your check payable to the **Indiana Historical Radio Society**

in the amount of \$15.00 per year. Send your payment to:

**Don Yost, IHRS, 3814 E 400 N, Windfall, IN 46076.**

Include your current mailing address, if not on your check, and your email address, if you have one. Membership questions? Contact

Don at [dირsir@netscape.com](mailto:dირsir@netscape.com) or call him at (765) 945-7014.

# IHRS 2016 Spring Meet Contest

## NORDEN-HAUCK Super 10

A 1927 10 tube TRF receiver.

5 RF stages,

1 detector stage

4 audio stages

submitted by Michael Feldt

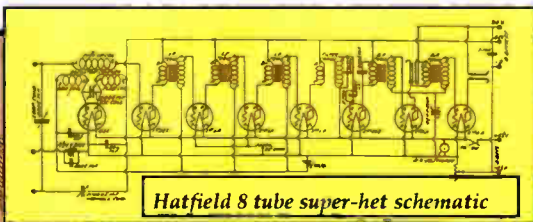

*Hatfield 8 tube super-het schematic*

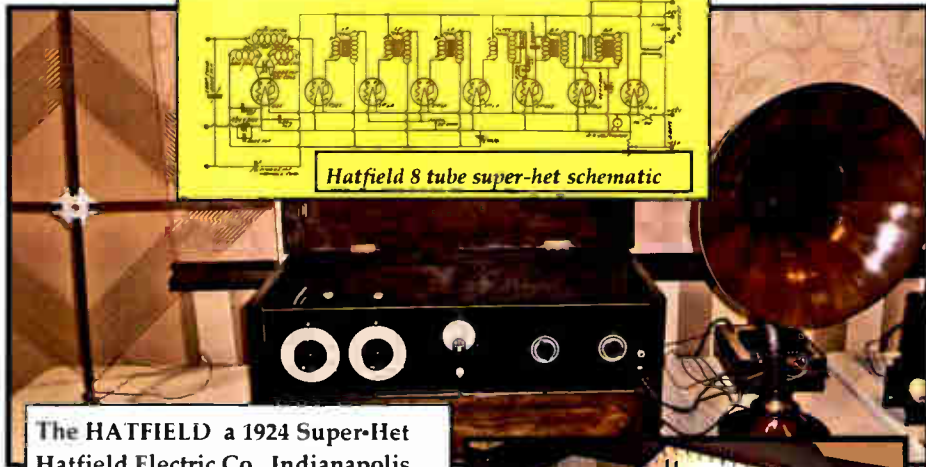

**The HATFIELD** a 1924 Super-Het

Hatfield Electric Co., Indianapolis

Entered by Michael Feldt

Responding to the "Crosley" theme. Dr Ed Taylor entered a "Time for Crosley" clock with Crosley memorabilia—including a picture record of the Vernon Indiana IHRS meet featuring former Crosley employees.



# Old Equipment Contest IHRS Spring Meet

A De Forest D-10 4 tube reflex receiver submitted by Bob Sands.

Bob's entry included the D-10 receiver with loop antenna, a carry case, and promo material.



Left—A rare "MOON" horn speaker, submitted by Ed Dupart.

Right—Horn speakers entered by Tom Adelsperger. The collection included two Rola speakers and a hard to find Indiana made Starr, Richmond.



On the left, in the Open category, Tom Williams entered a GE "Coffee Pot" clock radio.

On the right Tom Williams presented a Crosley 2 band receiver.

Fred Prohl submitted a Crosley 58TC.





## Raytheon 3 Transistor Radio, Ed Dupart



Responding to the IHRS challenge to build a vintage transistor radio, Ed Dupart constructed multiple versions of transistorized receivers. Two versions were on display at the IHRS Spring meet. Featured in this issue of the "Bulletin" is a three transistor circuit using the CK722, a very early Raytheon transistor. Pictured on this and the following page is the "3 Vintage Raytheon Transistors Radio" or "The Chinaberry Project". (The Article begins on page 13.)

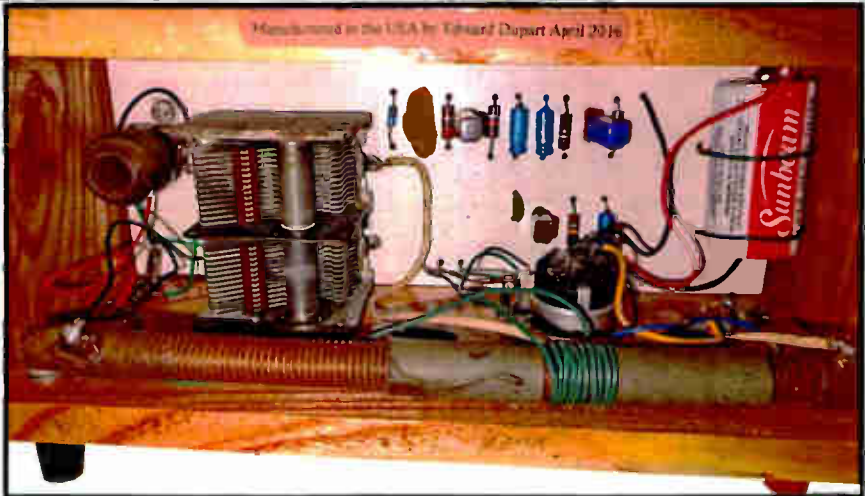

# Raytheon 3 Transistor Radio, Ed Dupart



Operating on a single "C" cell battery, this version of a vintage transistor receiver drives vintage headphones with considerable volume.



## The Raytheon 3 Transistor Radio by Edward Dupart

For many of us the Popular Electronics magazines were a source of entertainment and education and we couldn't wait for the next month's issue. The local drug-store down the street in Detroit, complete with a soda fountain, was my source for magazines and I knew when to check for the latest issue of Popular Electronics.

The January 1960 issue had a one transistor radio that used a 2N217 transistor, a 1N54A diode and a long, 7 1/4", ferrite rod loop antenna and I wanted to build it. The 2N217 is the same as the 2N109, which I had. The 1N54A was a special high back resistance diode that I couldn't obtain at that time so I had to use the time tested 1N34A. Forget the long ferrite bar, I had to use an adjustable Miller high Q coil that a lot of us would like to have now. I put the little radio together in a plastic box. I adjusted the coil to tune in my stations. It worked good and I could run it along a wall and find the electrical wiring because it would act as an antenna and the station would get loud when near the electrical wiring. While it worked quite well in Detroit and it was neat to have and I could sneak it into school, it just didn't have that long ferrite bar I wanted to experiment with.

In the late 1960's I had to make room, so I gave a neighbor, who was into electronics, all my Popular

Electronics, but I always wished I had kept that January 1960 issue. Not that I needed it for the circuit, because I had it memorized and made several radios after that with basically the same circuit, I just wanted it, because I wanted it. So since the 1980's the search was on and it wasn't until 2015 I found that January 1960 issue along with almost a complete set of Popular Electronics from about 1956 to about 1964 at an estate sale in Michigan. Now I'm happy.

Now that I have my January 1960 Popular Electronics magazine next to me, I decided to build that one transistor radio. My junk box contained several loopsticks and lo and behold there was one with a 7 1/4" ferrite bar from a tube radio that pretty much matched the hand wound coil in the January 1960 Pop Electronics' article. As far as transistors go, I have lots of them, so I decided to try several vintage transistors and the first one I picked is a high quality GE transistor that looks just like a 2N107 with the pinched top but is actually a high speed GE PNP germanium transistor. Luckily, I have a 1N54A diode and all the rest of the parts. So I put it together and it worked quite well. It picked up the local station without an external antenna and with that loop antenna it was quite directional. I decided to compare the 1N54A with other diodes and it

## The Raytheon 3 Transistor Radio —continued

didn't work any better than a 1N34A. So I tried a 1N110 diode from a 1950's computer circuit board that used tubes. I have found this diode to work very well in crystal radios and I think it worked better than the 1N34A and the 1N54A so I left the 1N110 in the circuit. My one transistor radio is now complete and works very well on 1½ volts and is still on a breadboard.

Surely I can improve on this circuit so why not add an additional transistor for audio amplification and I did. That really increased the volume and would drive a speaker in a quiet room

antenna and a variometer for antenna matching I was able to pick up at night, Nashville, Chicago, Louisville, Cleveland and a few others. Not bad for a simple circuit, but I'm not through.

Most people reading this will remember the first hobbyist transistor introduced by Raytheon, the CK722 in 1952 and were hearing aid transistor CK718 rejects. They didn't meet the specs for the hearing aid but were good enough for a lot of simple circuits and they became an overnight success. I had several of them and I really liked the pretty blue ones. I built a lot of circuits with them, but they were-

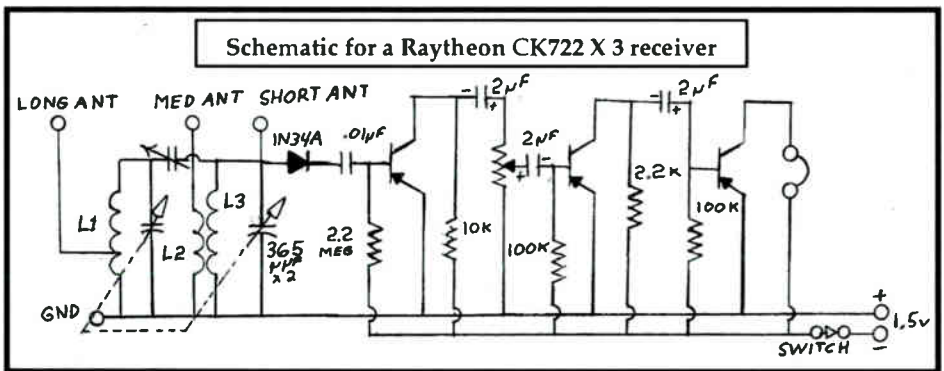

and on 1½ volts! I wondered what would happen if I added a third transistor. So I added a third transistor and now it's really loud and I needed to add a volume control, which I did and a 100K pot worked well. All three transistors were the same late 50's GE computer transistors. With an outside

n't as good as the RCA 2N109. The CK722 came in three colors. The black one was used from 1952 to 1955 and the pretty blue one was introduced in 1955 and the silver one was introduced in the late 1950's. Most of the date codes I see for the silver one is 1960. 1964 was maybe the last year of production



for the CK722.<sup>1--</sup> (*Jack Ward* [www.ck722museum.com](http://www.ck722museum.com)) I always wanted to put these three variations of the CK722 in a circuit and I now have the ideal circuit to do it with.

I replaced the high quality GE transistors with the Raytheon units and what I discovered was that the CK722 is very noisy compared to the high quality GE units I used previously and the gain was very poor for the earliest black CK722. The newest 1960 silver CK722 was the noisiest one but had the highest gain and so it worked best as the first transistor. The blue 1956 CK722 was middle of the road on gain and so it became the middle transistor and the 1955 black CK722 became the last transistor and was the one to drive the headphones. After switching around the transistors getting the radio to work the best as possible, it still wasn't comparable to the GE transistors, so I did some engineering. I changed the biasing and load resistors and worked on it one stage at a time. Increasing the 220K bias resistor for the noisy silver CK722 to 2.2 Meg and increasing the load resistor to 10 K quieted the transistor down quite a bit. Decreasing the bias resistor on the older blue and black CK722's to 100K increased the gain tremendously and the 2.2K load resistor gave the blue CK722 a clear sound. It now plays as well as the

high quality GE transistors, but is still noisy compared to the GE transistors, but is now acceptable. I initially used a 100K volume control, which worked nicely, but a 5K to 500K will work as well. I used a 500K control because it had an on/off switch on it, but the control doesn't have a nice even feel when adjusting the volume. There is a lot of control at the bottom and the top ends of the control, so a lower value would be better, but I didn't have a lower value with a switch in a vintage style. I stayed with 1½ volts so as not to put any undue stress on the old transistors, especially the 1955 black CK722. Even with only 1½ volts and only drawing 3mA it has amazing volume.

At this point the radio has been breadboarded so it is now time to construct a cabinet and mount the parts on some kind of chassis. My brother in Texas gave me some Chinaberry wood that he has been using to make rocking chairs and other furniture pieces out of and it has an awesome grain and color to it, so I decided to make a simple cabinet from the Chinaberry wood. Out came the table saw, router and the drill press. The Chinaberry is a unique wood to work with, easy to drill and also easy to chip on the corners when hand sanding, but it cuts easy with little burring/chipping with the table saw. The grain is very open and difficult to

## The Raytheon 3 Transistor Radio — continued

sand really smooth so finishing it requires a wood filler or lots of coats of what ever one uses and in my case it was lacquer. My brother uses thick polyurethane as a filler and saves Chinaberry sawdust that he mixes with wood glue and uses that as a wood filler. After a couple of hours I had the cabinet cut out and I used brass screws that were recessed to hold it together.

I took the front panel back in to the radio shop. Now to plan out where the variable capacitor, volume control and the circuit board will all go. I used the Hobby Lobby 1/8 " basswood for the circuit board and I painted it white after I sanded it. On a piece of paper I laid out where all the parts will go in pencil and I taped it to the circuit board and then I used a drill press to drill all the holes. The paper was removed and I inserted all the parts and soldered it. I mounted the board to the bottom of the variable capacitor and the variable was mounted to the front panel with screws attached to the front of the variable capacitor. I recessed all the mounting holes for the variable capacitor so the screws wouldn't interfere with the knobs. I put 4 binding posts on the left side of the cabinet for the ground and the three antenna connections and two binding posts were put on the right side of the

cabinet for the headphones. This gave the radio an older appearance and the two antique knobs I used enhanced that older appearance. All the parts I used were vintage parts and so the circuit board definitely has that 1950's to early 1960's look.

Not much was said about the Chinaberry wood, but it is a tree that was introduced into the US around 1830 from the Himalayas and was an ornamental tree. The tree is now considered a junk tree in Texas because its fruit is poisonous and its leaves give off a musky smell, but the wood is gorgeous and they do make pesticides from it.

Now a little bit about the front-end circuitry of this radio. I didn't have a single gang 365- pf capacitor, but I did have a dual 365-pf capacitor and that's what I used. So now I added a second coil and created a bandpass tuner, which greatly increases the selectivity, but also decreases the sensitivity. If this radio were to be used in a big city with lots of close by stations this would be the antenna connection to use because it would separate the stations better, so this would be a long antenna connection. I added 10 turns of #22 wire on the ferrite loopstick antenna to make another possible antenna connection, what I call a medium

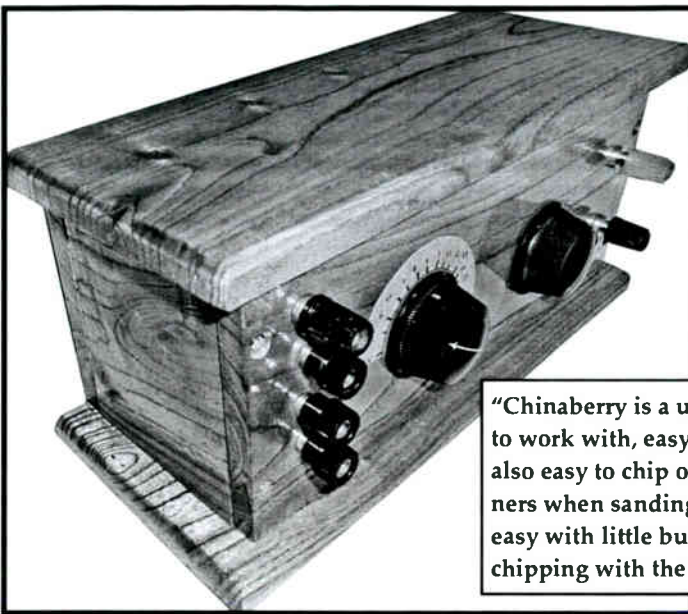

“Chinaberry is a unique wood to work with, easy to drill and also easy to chip on the corners when sanding, but it cuts easy with little burring/chipping with the table saw.”

length antenna. There is a direct connection to the junction of the diode and variable capacitor for a short antenna. Attaching a ground to this radio also helps in its reception.

Should someone want to build this radio, you will find the audio coupling capacitors are not critical. The .01mfd capacitor between the diode and the first transistor can vary from a .01mfd to a 10mfd capacitor. The 2mfd electrolytics can vary from 1 to 10mfd. The larger values will give better bass response, but is barely noticeable especially with a small speaker. I used the 2mfd capacitors because I have several of them, they are vintage and in a pretty blue package. The base bias resistors are typically around 220K and it is a good starting point if one is experimenting

with biasing. A word of caution here; If the base bias resistor is too low in value it can cause too much collector current to flow and can burn up your transistor. Using a current meter would be helpful. Notice that I didn't go any lower than 100K. The bias circuit used in this radio is called "Simple base bias" and is prone to thermal runaway, but is a high gain circuit that uses a minimum of parts. At 1½ volts thermal runaway is not a problem and so it is widely seen in circuits with a low voltage.

What started out as a simple one transistor radio wound up being a bit more complicated, but also performs a whole lot better. The Chinaberry cabinet makes it a showpiece. *Ed, April 2016*

**Radio Activity – Spring Meet 2016**



**A busy room  
at Kokomo**



**The doughnut brings a  
smile from Peter Konshak**

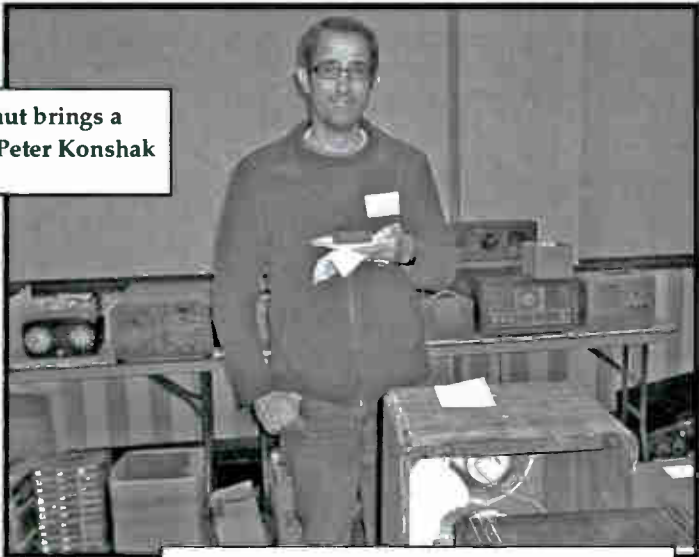

**Picture credits for this issue of the Bulletin:  
Ed Dupart, Michael Feldt and Fred Prohl**



# Golden age of radio gone, but collecting is going strong

By Doug Graves

At one time there were 300 radio manufacturers in the U.S. According to members of The Radio Attic antique radio club in Alabama, there are an estimated 4,500 collectors of those vintage radios in 50 radio collector clubs nationwide. An estimated 600 reside in Ohio.

One of those collectors, Bob Sands of Fairfield, Ohio, has been at this fun yet expensive hobby the past 30 years. Radios in his home, some nearly 95 years old, range in price from \$1,000 and up.

A stroll through any

Kent radio I talked him into buying it. I was into the modern gadgets, but was schooled in old vacuum tubes so I knew an old radio when I spotted one. Eventually started going to antique mall looking for more of this old equipment."

In the past 30 years, Sands has been buying an swapping antique radio. Only thing is, he's accumulated more radios than he's given away. And, with the blessing of his wife, Sue, he has many those pristine pieces (most from the 1930s) in the living and family room.

"I had 300 at one time, but got rid of a lot of them," he says. "It's tough finding them in good condition. Too many people put them in the attic, not knowing that this just drives out the wood."



Above: Montgomery Ward got into the radio business and held

The June 20, 2016 issue of the Antique Week has a feature article on collecting vintage radio. Interviewed for the article was IHRS member Bob Sands. The article, written by Doug Graves, includes a brief history of radio, collecting radio, and frequent reference with pictures to Bob's large collection of vintage radio. Most libraries will have back copies of the Antique Week.

## EMAIL?

**Is your email address current on the IHRS contact list?**

**Periodically the Society officers communicate with IHRS members by way of email—meeting notices and area vintage radio sales are the most frequent messages.**

**For member privacy emails from IHRS are sent as a blind copy. Your address should be the only address you see on the email.**

**If you have recently changed your email address or would like to add your email to the IHRS contact list, send it to [inhistradio@gmail.com](mailto:inhistradio@gmail.com)**

# RADIOADS

Submit your "FREE TO CURRENT MEMBER" RadioAd by the 15th of February, May, August, or November in time for the Bulletin issue that follows.



"A Fiction Story", a feature article in the October 1924 issue of Wireless World, is a better stated article title than "Radio In Politics" for 2016 politics!

## Features in this Issue

Radio in Politics

A Fiction Story You'll  
Remember



## 2016 Officers

### David Mantor, President

P. O. Box 1  
Fairmount, Indiana 46928  
(765) 618-8342 before 7pm Indiana time  
email dmjmantor@gmail.com

### Michael Feldt, Vice President

12035 Somerset Way, East  
Carmel, Indiana 46033  
(317) 844-0635 email: feldtm@msn.com

### Don Yost, Treasurer

3814 E 400 N  
Windfall, Indiana 46076  
(765) 945-7014  
email: dearsir@netscape.com

### Alex Whitaker, Secretary

2927 South East Street  
Indianapolis, IN 46225  
317-787-2854 ehscott@sbcglobal.net

### Fred Prohl, Editor

615 Wren Drive  
Franklin, IN 46131  
(317) 736-1228 email inihstradio@gmail.com

### Dr. Ed Taylor, Historian

245 North Oakland Avenue  
Indianapolis, Indiana 46201-3360  
(317) 638-1641

## Responsibilities

Activities, business,  
administration, & publicity

Sites and dates of meets

Dues, financial, and address  
change. Please notify  
immediately of change of address.

Record and publish IHRS business  
meeting minutes.

News articles, radio ads, photos  
for Bulletin publication  
Maintain indianahistoricalradio.org

Donations & scrapbook material

**Bulletin Deadlines:** News, Articles & Radio Ads, 2/15, 5/15, 8/15, 11/15

**IHRS Web site address:** [www.indianahistoricalradio.org](http://www.indianahistoricalradio.org)

The INDIANA HISTORICAL RADIO SOCIETY is a non-profit organization founded in 1971. Annual membership dues of \$15.00 includes the quarterly IHRS "BULLETIN." Radio-Ads are free to all members. Please include an S.A.S.E.



*Open  
Crosley!*

**Bob Pote set up this display of early Crosley battery radios at the IHRS 2016 Spring Meet. His collection received first place in the open category.**