

National RADIO-TV NEWS

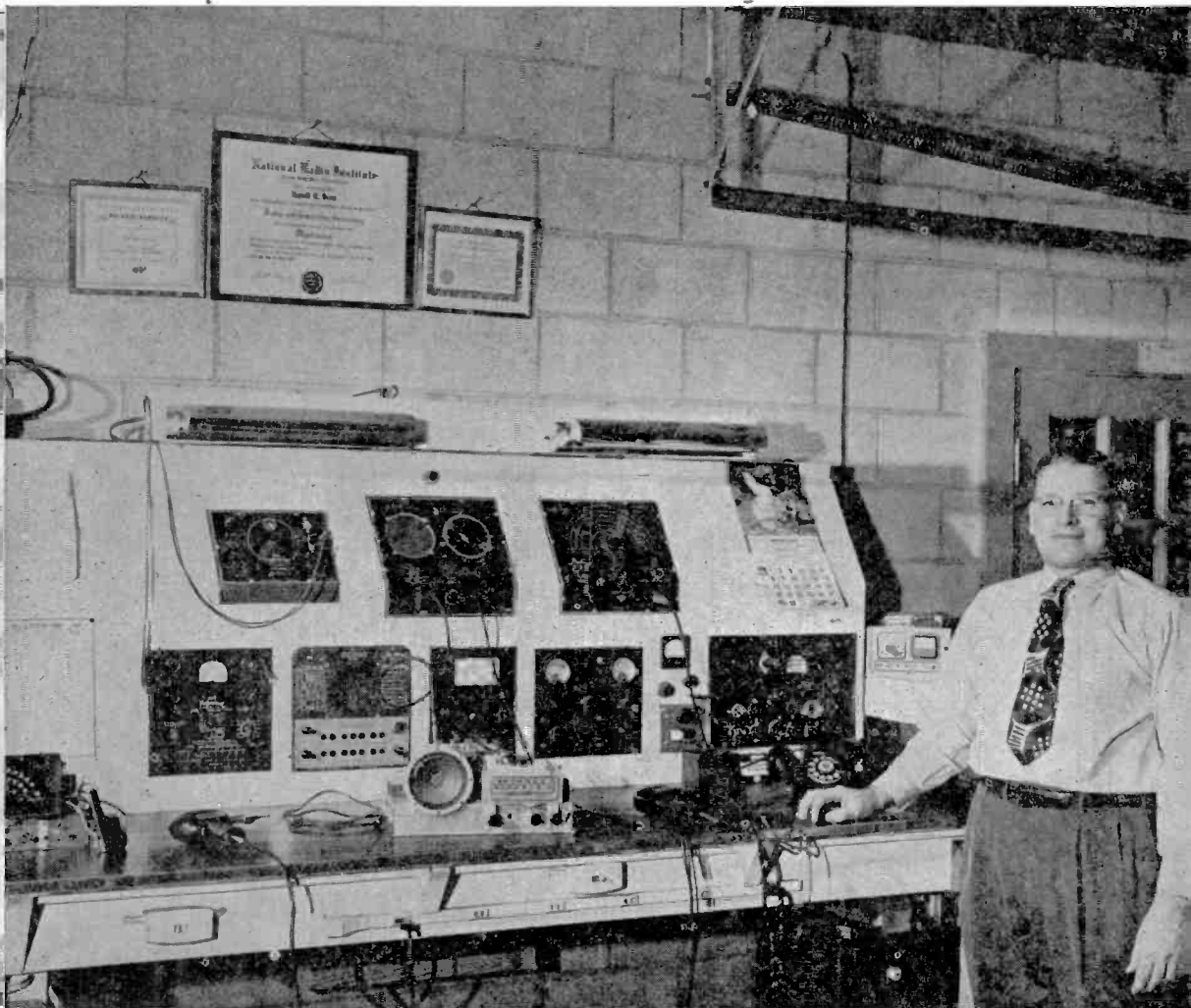

IN THIS ISSUE

NRI Practical Training Plan for Television
Television Servicing Methods
Alumni Association News

Feb.-Mar.
1951

VOL. 14
No. 7



COMPETITION

When a competitor opens a shop in your neighborhood, your first reactions are probably the same as those of most people—you feel that he is “cutting in” on your trade and that, by fair or foul means, he may run you out of business. However, there is another view to take of this problem.

First, forget your fears! A mind frozen by mistrust and hate is incapable of reasoning; it will lead you to the very downfall you fear. Face the facts: someone else is in the same business, so you must make your services so much *better* than his that you get your share of the work.

Welcome the competitor as a spur—something to force you to your best efforts—something to make you become more careful, more efficient, more alert. You will find that honest competition adds enjoyment to your work.

And, another thing, force your competitor to rise to *your* level to survive—don’t stoop to his. Do your best work and you’ll find that your fears were not justified—there is plenty of business for the man who can deliver the goods!

J. E. SMITH, *President.*



Louis E. Garner, Jr.

The NRI Practical Training Plan For Television

By LOUIS E. GARNER, JR.

NRI Consultant

THE NRI Practical Training Plan for Radio, introduced many years ago, has proved extremely popular with students. The practical training plan was designed to give a student practical experience on receivers, and to learn to recognize defects that cause specific complaints without having to use the long, drawn out method of apprenticeship. In the NRI Practical Training Plan the student learns by experience to recognize defects that he may not encounter in years of apprenticeship. By learning to recognize specific complaints, and to know where to look in the receiver for the defects, the student soon acquires the important "knack" of servicing many receivers in a limited time.

The NRI Practical Training Plan is so versatile that it may be applied, with little modification, to television receivers. In the early years of TV such a plan could not be recommended since television receivers were fairly expensive, and, once purchased, were used almost continuously for entertainment as long as stations were broadcasting programs. However, as the 16-inch and larger receivers become available, the once popular seven-inch and ten-inch receivers have been accepted as "trade-ins" by dealers. These 7-inch receivers can now be purchased at comparatively low prices, and are ideally suited for carrying out the practical training plan.

Your first step in the NRI Training Plan for TV is to obtain a suitable television receiver, preferably one that is AC-operated, that is, one using a power transformer and in which the filaments of the various tubes are connected in parallel rather than in series. Where such a circuit is used, individual tubes may be removed from their

sockets without appreciably affecting the operation of other stages. However, if such a receiver is not available, you can still obtain worthwhile and valuable experience on receivers where "filament strings" are employed.

Since there is a fundamental difference between electrostatic and electromagnetic television receivers, maximum experience can be obtained by carrying out the training plan on both types of receivers. Electromagnetic receivers are the more popular at the present time, but you may find it somewhat easier to obtain an electrostatic set first.

To locate a suitable set, contact your local radio and television dealers, and watch the ads in the classified sections of local newspapers. It is not necessary to obtain a cabinet with the receiver, and it may be possible to obtain a receiver at lower cost if the cabinet is not included.

However, it is quite important that you obtain a receiver that is in good operating condition. Otherwise you cannot be sure whether the complaints that you later simulate are due to troubles that you have introduced, or if they are defects that are already in the receiver. It is also important to be sure that the receiver is properly aligned.

Once you have secured a suitable experimental chassis in good operating condition, write to NRI for service data on your receiver. NRI has available the schematic diagram and service data for most TV receivers. The price of this information including the diagram is \$1.00 for each set. When you write, be sure to enclose

your remittance and to give the set manufacturer's *name* and *model number*. It is also a good idea to include the number and the types of tubes used.

Once you have received the service data for your receiver, first familiarize yourself with the circuit diagram, and note the various stages of the receiver. Identify the various important circuits in the receiver such as the "front-end," "video i.f. amplifiers," "audio i.f. amplifiers," "video second detector," "video amplifier," "audio FM detector," "audio amplifier," "sync separation stages," "vertical deflection oscillator and amplifier circuits," "horizontal deflection oscillator and amplifier circuit," "high-voltage circuits," and "low-voltage power supply circuits."

Trace the signal in the receiver using the schematic, and try to identify the stage where changes in the signal take place—where it is converted to an i.f. value, where the modulation is removed, and where the signal is finally applied either to "sync-sweep" oscillators to modulate the picture tube, or to operate a loudspeaker. Note that there are several signals to consider in the television receiver, and you should make sure that you know the path of each one.

Now follow the path of the video signal through the receiver up to the point where it is applied to the cathode-ray picture tube. The sync pulses will be removed from the video signal at some point along the way, and these sync pulses will be passed through circuits and applied to the vertical and horizontal oscillators. Be sure you are able to follow the path of the sync pulses. Besides the video and sync signals, you should also consider the path of the audio signal. In some receivers, you will find that the audio i.f. signal is taken directly from the mixer tube in the front-end. In other receivers, the sound take-off point will be located in one of the video i.f. amplifier stages, and in still other receivers the sound take-off point will be located after the video second detector.

If any special circuits are used, such as automatic frequency control or a.g.c. circuits, trace through these circuits and re-draw them if necessary for better understanding.

Next, trace the power supply circuits on your diagram. Follow the path over which the voltage is applied to the plate and screens of each tube. Trace the grid and the cathode circuits. Make sure that you can find the DC path between the grid and the cathode of each stage, and between the plate and the cathode of each stage.

To become even more familiar with your receiver, imagine now that various parts are defective, and determine how you would check them with an ohmmeter or voltmeter. For ex-

ample, select a part on your diagram such as a plate load resistor. Suppose that the plate load resistor were open. Determine how a check with a voltmeter would indicate this defect, and how you would use an ohmmeter to check the part.

Trace through the circuit to see if other parts are in parallel with the part you imagine to be defective, and see if these parts might cause erroneous ohmmeter measurements. In this way, determine whether it would be necessary to disconnect one lead from the part to make an ohmmeter test. For typical defects, imagine that resistors have changed values or are open. Imagine that condensers have either become leaky, shorted, or open and that the coils are shorted or open. Imagine that the tubes have internal shorts or are open. Where "filament strings" are used in the receiver, determine which tubes would fail to light if a particular filament were open.

Repeat this process of reasoning with parts in all stages of the receiver.

The next step is to use your schematic diagram and to refer to your chassis. Identify the various stages of your television receiver on the chassis itself. Probably one of the quickest ways of doing this is to identify the tubes that are used in the various circuits, and their location in the receiver. Also identify the major parts in the receiver which will help you to locate the stages.

Figure 1 shows a typical TV chassis with the major parts identified. This should help you to identify the major parts in your own receiver.

After having identified the various stages in your receiver, make continuity tests with your ohmmeter, following your schematic diagram. Previously, you may recall, you traced the tube supply circuits on the schematic diagram. Now, use your ohmmeter to check the DC resistance path of the various tubes from the plate and screen back to the appropriate B+ terminal, and from the cathode back to the appropriate B- terminals. Again refer to the schematic diagram and estimate what resistance measurements you should obtain, and compare your estimate with the measured value. Where a difference exists, remember that there is a tolerance on resistor values that may be sufficient to cause a considerable variation from the measured reading and the estimated reading. Remember also that wherever parts are in parallel the resistance reading obtained will be less.

Select a stage at random in your receiver and check the parts in that stage with your ohmmeter. Check the resistors for correct value, the coils for continuity and possible shorts, and the condensers for leakage. When checking a

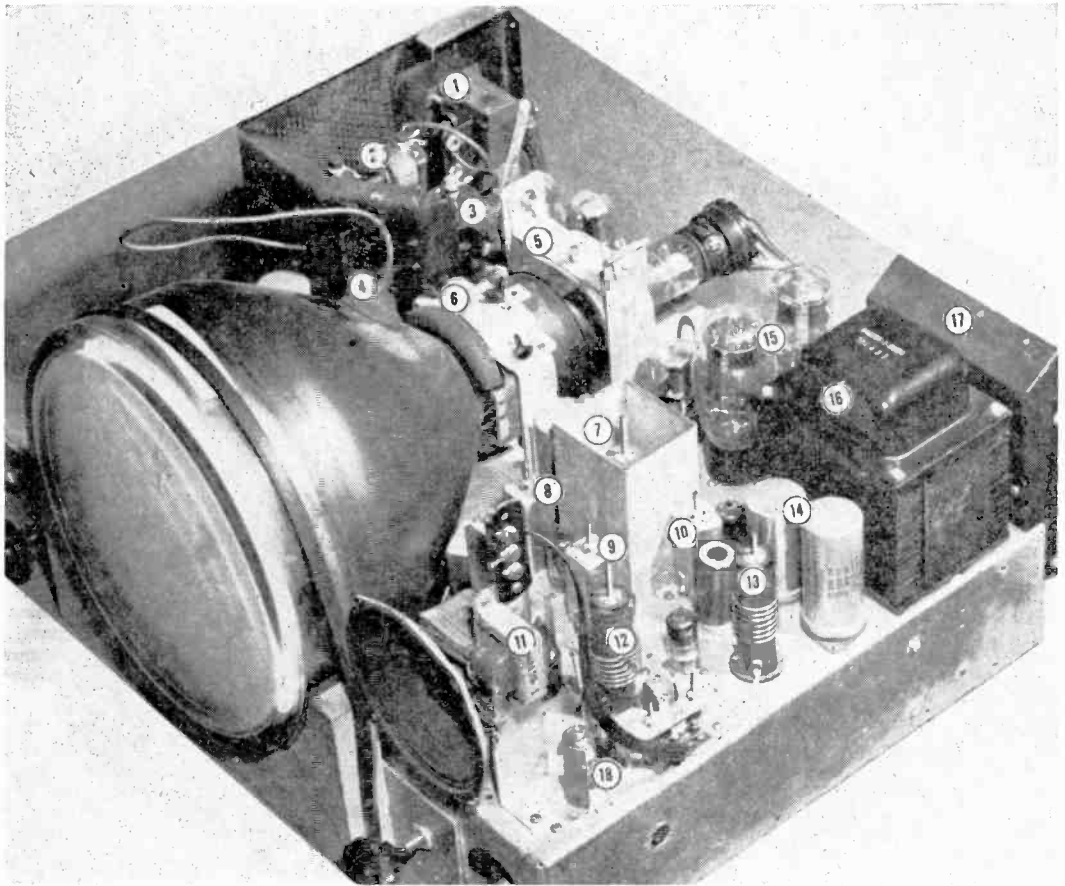

Fig. 1. RCA Model 630-TS Television Receiver chassis. Major parts are as follows: (1) Horizontal output transformer; (2) High voltage filter condenser (3) 6BG6 horizontal output tube; (4) High voltage lead; (5) Focus coil and mounting bracket; (6) Deflection yoke and mounting bracket; (7) Cathode sound trap in 4th video i.f. stage; (8) 2nd sound i.f. transformer; (9) 1st sound i.f. transformer; (10) 2nd video i.f. transformer and adjacent channel video trap; (11) Audio output transformer; (12) Converter transformer; (13) 1st video i.f. transformer and adjacent channel sound trap; (14) Low voltage power supply filter condensers; (15) 2-5U4 low voltage rectifier tubes; (16) Low voltage power supply transformer; (17) Cover for low voltage power supply voltage divider resistors.

condenser with an ohmmeter, it is generally best to disconnect one lead of the condenser and then connect your ohmmeter directly across the condenser, using the highest ohmmeter range. With reasonably large capacities, the needle will probably "flick" toward the zero end of the scale, and then return to a high-resistance reading.

When checking electrolytic condensers, take one reading, reverse your ohmmeter probes and take another reading. The highest resistance reading obtained will be the true indication of the

condition of the condenser. Remember that an electrolytic condenser is polarized, and that your ohmmeter actually applies a small DC voltage to the condenser. If you know which polarity of your ohmmeter will give the highest test, only one reading is necessary.

After completing your checks on the receiver with an ohmmeter, plug in the receiver and make DC voltage tests. Check the plate-cathode, screen-cathode, and grid-cathode voltages on each stage. Also check the DC voltage readings with respect to chassis, and see if you can

identify the reasons for any differences between cathode-plate and chassis-plate readings.

Measure the total rectifier DC output voltage from the power supply and note the polarity. This is particularly important in sets in which a power transformer is not used. In many of these sets, there will be voltage doubler circuits which supply both negative and positive voltages with respect to chassis, or with respect to the set "ground." In such cases, the negative voltage supply may be connected to the cathode of a particular tube, whereas the positive voltage supply is connected to the plate of the same tube. This places a voltage on the particular tube which is almost twice the voltage available from either supply, and which makes the plate-cathode voltage much higher than either electrode voltage with respect to chassis or "ground."

If there are any operating controls that may affect the DC operating voltages, check these voltages in that particular stage or circuit with the control in both minimum and maximum positions. Note how the voltage changes when the control is adjusted.

There are several precautions that should be observed when making DC voltage tests. Do not attempt to measure the high DC voltage applied to the second anode of the cathode-ray picture tube unless you have a high-voltage probe available for your Multitester and know how to use it. Also, do not attempt to measure the plate voltage on the plate cap of the horizontal output tube used in electromagnetic receivers. Although the average DC voltage here may be low, a high voltage pulse exists at periodic intervals which may damage your meter, or may cause severe shock.

If you have a voltage chart for your receiver along with the schematic diagram and other service data, compare your measured voltage readings with those given by the manufacturer. Try to account for any large differences observed. Consider the type of Multitester you are using and the type used by the manufacturer in making his tests. Also consider that your line voltage may be higher or lower than that used on the receiver when the original tests were made.

Remember that a low-resistance DC voltmeter may cause certain voltage readings to be much lower than those obtained with a high-resistance or a vacuum-tube voltmeter.

Check the Performance of Your Receiver

After you have made voltmeter and ohmmeter tests in your receiver, and have become familiar with the location of major parts and stages in your receiver, connect an antenna to the receiver and tune in your local TV channels. For

the preliminary tests, it is best to tune in a local station that is broadcasting a test pattern (see Figure 2), because on a test pattern, small changes in linearity and picture quality that may go unnoticed on a program show up readily and can be identified easily.

Next, with a station tuned in, try varying every control and adjustment on the receiver throughout its range, noting the effect on the picture. After having seen how every control and adjustment in the receiver affects the picture, haphazardly turn all controls and adjustments to an abnormal position.

Now carefully follow through a standard "setting up" procedure for your receiver. In this way, become familiar with how the picture varies when two or more of the "fixed" adjustments or controls are misadjusted, and with the exact procedure necessary for properly "setting up" the receiver to obtain clear, normal test pictures.

In Table I, page 9, is a list of the various controls generally encountered in TV receivers, however, some of these controls may be found only in certain sets. As an example, controls 13, 14, 15, 17, 18 and 20 will generally not be found in sets employing electrostatic picture tubes. In some sets, certain other controls may be considered "fixed," and will be located on the back of the chassis or on the side rather than on the front-panel of the receiver. As an example, in some receivers the "focus" control (No. 11 in the Table) will be found on the front panel of the receiver, to be adjusted by the customer whenever necessary. In other receivers, this is a fixed adjustment on the back of the receiver, and is adjusted only when the receiver is "set up."

If there is a "fine tuning" adjustment on your receiver, or if channel selection is obtained by means of a continuous tuning arrangement, try tuning carefully throughout the range at which each channel is received. Note how the sound and the picture varies as the fine tuning of the front-end is changed. There should be only one position in which good sound and good picture are both obtained.

However, there may be as many as three positions in which sound is obtained, and you should be able to obtain a picture of some type over quite a wide range of the tuning. Also note that in some positions that the "video buzz" can be heard through the loudspeaker. In other positions of the fine tuning, the sound will appear on the picture as horizontal "bars" whose number and intensity vary with the sound.

If the television signal is low in your particular locality, you may find that the best sound signal is not obtained at the same time that the

brightest picture is obtained. This is because the normal i.f. alignment curve is such that the video carrier falls along the slope of the video i.f. response at about the 50% point. If the fine tuning is changed so that the video i.f. carrier is nearer the top of the video response curve, then the picture brightness increases. However, when the set is tuned in this manner, the audio i.f. carrier will fall at some other point in the overall response curve, and poor sound or no sound is obtained. This accounts for the peculiar condition often noted in fringe areas where it is possible to tune the receiver so that either picture or sound, but not both, can be obtained.

Review Service Techniques

There are a number of servicing techniques with which you are familiar from your work in radio circuits that may be applied directly to television servicing such as the "circuit disturbance tests," "stage blocking tests," "signal injection," "voltage analysis tests," etc. However, some of the tests will not work satisfactorily in certain TV receivers. Try each service technique with which you are familiar and see if it is effective in your receiver.

For an example, the circuit disturbance test is generally used to isolate trouble where the complaint is "dead receiver." In a television receiver, there can be several conditions of "dead receiver." In one case, the receiver can be completely dead with the complaint of "no picture, no raster, no sound." In another case, the picture section alone may be "dead," with the complaint of "sound normal, no picture, raster normal." As previously shown in your regular NRI lessons and in earlier NRI News articles, each general complaint permits a preliminary isolation of the trouble, and so the service technique is applied to the section of the receiver where the defect is suspected.

In a radio receiver, the circuit disturbance test may be carried out by pulling out and replacing each tube in turn, or by touching the control grids of the tubes. In a television receiver a similar technique may be carried out. When a set uses a power transformer and the filaments are in parallel, the tubes may actually be removed temporarily from the sockets and replaced as above. In the sound section, the dis-

turbance will show up as a click or noises in the speaker, and in the picture section the disturbance will show up as flashes on the screen of the picture tube. In a receiver using a "filament string," the circuit disturbance is introduced by actually touching the grids of individual stages.

In many cases, the circuit disturbance test will fail to indicate when a particular stage is defective. This is due to the interaction between the many different stages in the television receiver. A "dead" stage may actually be by-passed by the disturbing signal either through the a.g.c. system, low-voltage power supply, or through some other circuit. Thus, in many instances, the circuit disturbance test will fail to work, or can only be used when the circuit

conditions in the television receiver are remembered.

Therefore, try each service technique with which you are familiar on your particular receiver, and see how effective it is for isolating trouble, or for identifying a defective stage.

Simulating Receiver Defects

Precautions: In order to simulate typical complaints when introducing defects in a receiver, be careful that you do not

anything that will damage the receiver, or that will damage any major parts. As an example, do not attempt to short filter condensers in the power supply. In general, do not attempt to short any high B+ points to ground or to B-, unless there is a high resistance in series. Do not short any transformer windings that are likely to cause damage, particularly power transformer windings. In receivers that have a series "filament string," do not introduce any defects that will cause unusually high currents to flow through any of the filaments of the tubes.

Also, in such receivers, do not open the filament circuit. If you wish to simulate the effect of a "dead" tube, simply disconnect the leads to the cathode terminal of the tube.

Do not introduce any defects that will remove the load completely from the B+ supply. To do so may cause the voltage across the input filter condenser to rise to an excessively high value, causing the condenser to break down.

Under no circumstances permit the grid of the



Fig. 2. Typical TV station test pattern.

picture tube to become positive with respect to its cathode.

When working on the receiver, do not place the receiver so that there is any danger of the picture tube falling out of position or being struck or scratched. If necessary, improvise a "harness" of some sort to hold the picture tube in position. In most of the more modern receivers, the picture tube will be held firmly in position by a strap and by clamps. In some of the older receivers, such as the ones you may use in carrying out the practical training plan, the picture tube is held in place by clamps or brackets in the cabinet. In this case it will be necessary to improvise a bracket or strap for holding the picture tube in place.

General Defects

Turn off the receiver and introduce a defect in one of the resistors (open one lead, or connect a resistor across it or in series with it to change the value). Try to figure out what effect this defect will have on receiver performance. Then turn on the receiver and see exactly what happens. Suppose you are servicing a receiver which had exactly the same complaint; figure a service technique which would enable you to locate the defect in the quickest possible time and then proceed to carry out this technique until you come logically to the defective resistor. If you can think up two or more servicing techniques that may enable you to locate the defect, try them both and see which one permits you to isolate the trouble more quickly.

Repeat this procedure for a number of the resistors in the receiver, making sure you correct any defect you introduce before introducing another. You should try opening a resistor because an open resistor is the most common resistor defect.

Use a similar procedure for introducing defects in various condensers in the receiver. Disconnect one lead to create an open, short the condenser terminals to create a short, or shunt the condenser with a resistor (about 50,000 ohms) to create a leaky condition. Do not introduce condenser defects that are likely to injure other parts, however.

In each case, after you introduce the defect, but before turning on the power, study the schematic diagram and see if you can figure out exactly what complaint the particular defect you introduced should cause. Also, in each case, after turning on the receiver and observing the condition obtained, figure out a service technique that will enable you to isolate the trouble quickly and then try this method.

This same procedure may be repeated on the various r.f. and i.f. coils in the receiver. Defects

in coils may be simulated by either opening or shorting the coils. As mentioned previously, do not short power transformer windings or other transformer windings that may cause the part to be damaged.

Defective tubes can be simulated by removing the tube from a socket or opening its filament connection in the case of parallel filament connections, or by opening the cathode connections in the case of series filament connections. Low emission may be simulated in a receiver with a parallel filament hook-up by inserting a 10-ohm, 25-watt rheostat in series with one filament lead to the tube, and adjusting the rheostat until the filament voltage for the tube is about 60% of its original value. (For rectifier tubes, a 2-ohm adjustable resistor should be used.)

Cathode-to-heater leakage may be simulated in a receiver by connecting a 1000-ohm resistor between the cathode and one heater terminal.

Defective controls may be simulated by opening one or more leads to the control, by substituting a control of a different value, or by connecting a resistor in series with one lead to the control.

Create Specific Complaints

Referring to your schematic diagram, make a list of defects that will cause common receiver complaints. Try to do this by reasoning alone, without looking at any notes you have made from the previous defects you have introduced. Then introduce each defect in the receiver in turn, to prove that it does cause the particular complaint. Apply any service technique necessary for isolating the trouble with each complaint you cause.

Some of the defects that you should try to introduce are: "no sound, no picture, no raster"; "sound normal, no picture, no raster"; "sound normal, raster normal, no picture"; "picture normal, no sound"; "picture normal, hum in sound"; "picture normal, sound distorted"; "picture normal, sound weak"; "sound normal, picture out of sync vertically"; "sound normal, picture out of sync horizontally"; "sound normal, picture out of sync both horizontally and vertically"; "sound normal, picture distorted horizontally"; "sound normal, picture distorted vertically"; "sound normal, picture faint, lacking in contrast"; "sound normal, picture too small (horizontally, vertically, and both)"; "sound normal, picture brilliancy low"; "sound normal, hum bars in picture"; "sound normal, oscillation in picture"; etc. In addition to these common complaints, try to introduce specific defects that will cause complaints of poor picture quality—smear, poor high-frequency response and loss of definition, improper focus, etc.

Poor low-frequency response and resulting

Table I

CONTROL	USE
1. Station Selector, Channel Selector, TV Tuning	Selects desired TV station.
2. Volume, Volume Control, Sound Volume	Adjusts sound volume.
3. Brightness, Brilliance, Background	Adjusts average light intensity.
4. Contrast, Picture, Picture Control	Adjusts video signal amplitude.
5. Width, Horizontal Size, Horizontal Amplitude, Picture Width Control	Adjusts picture size in horizontal direction.
6. Height, Vertical Size, Vertical Amplitude, Picture Height Control	Adjusts picture size in vertical direction.
7. Horizontal Hold, Horizontal Speed, Framing	Adjusts free-running frequency of horizontal oscillator.
8. Vertical Hold, Vertical Speed	Adjusts free-running frequency of vertical oscillator.
9. Horizontal Centering, Horizontal Position Control	Adjusts picture position in horizontal direction.
10. Vertical Centering, Vertical Position Control	Adjusts picture position in vertical direction.
11. Focus, Focusing Control	Adjusts C.R. tube spot definition.
12. Fine Tuning, Sharp Tuning, Vernier	Tunes accurately to sound channel.
13. Vertical Linearity	Adjusts shape of vertical scanning wave.
14. Horizontal Linearity	Adjusts shape of horizontal scanning wave.
15. Horizontal Oscillator Frequency Adjustment, Horizontal Lock	Adjusts frequency of sine-wave oscillator (a.f.c. control).
16. Tone, Tone Control	Varies audio frequency response.
17. Horizontal Drive, Horizontal Peaking	Adjusts amplitude of peak portion of horizontal scanning wave.
18. Horizontal Oscillator Phase Adjustment	Adjusts phase of horizontal oscillator to pulse rate (a.f.c. discriminator).
19. Picture Cut-off or C.R.T. Bias Adjustment	Adjusts "black" level of picture tube (grid 2 voltage).
20. Ion Trap Adjustment, Beam Bender	Adjusts current through the ion trap magnet coils.
21. Service Control, Screen Voltage Horizontal Output Tube	Adjusts output of horizontal amplifier (auxiliary width control).
22. Coarse Focus	Sets range of main focus control.
23. Phase Detector Balance	Adjusts balance of a.f.c. discriminator.
24. Excitation, Anode Voltage Control of Projection Tube	Adjusts operating point for projection picture tube.
25. High-Low Bandswitch	Selects input system for high or low channel group.

"smear" may generally be simulated by partially opening coupling condensers in the video amplifier stages. Poor high-frequency response can generally be simulated by shorting out peaking coils, or by increasing the size of plate load resistors in the video amplifier.

In each case, after you figure out a defect that will cause a specific complaint, introduce the defect and turn on the receiver to see if the complaint is actually introduced by your defect, be sure to isolate the defect using a standard service technique which you have figured out. In each case, after isolating the defect, correct it just as you would if servicing an ordinary receiver. Be sure you correct any defect you introduce before introducing another defect.

Try introducing an interfering r.f. signal by connecting an ordinary AM signal generator to the antenna terminals of your receiver along with the antenna transmission line. Tune the signal generator through the video i.f. value for your receiver, noting the effect, if any, on the picture. See if you can simulate common interference conditions, and can obtain common interference patterns such as are illustrated in the regular NRI lesson texts.

With the receiver tuned to a test pattern, carefully observe the quality of the picture. See "how far down" the lines in the vertical wedges can be distinguished. Try adjusting various i.f. transformers in the receiver, one at a time, and see if you can notice any difference in the quality of the picture. In each case, make a careful note of how far you turn each trimmer or slug adjustment, and in which direction. Then readjust the i.f. transformers for normal reception.

Using the proper test equipment (signal generator or sweep generator and oscilloscope), check the alignment of the receiver and realign it following the instructions in the manufacturer's service manual for your receiver. Repeat the alignment procedure several times until you know exactly which adjustment should be made, and what order should be followed.

Next, when you are sure you are skilled in aligning your receiver, throw the receiver completely out of alignment and then realign it. Before attempting to realign the receiver, however, look at the picture and listen to the sound obtained to see how misalignment affects the operation of the receiver.

After completing these steps, "overhaul" the receiver. Be sure that it is properly aligned, replace any parts or wiring you have damaged, resolder joints if necessary, and in general "clean up" the receiver as if you were going to return it to a customer.

Page Ten

After following through the general procedure outlined above, you should feel reasonably confident when you encounter a TV receiver for repair. However, for maximum training benefit, you should carry out the procedure on both an electrostatic receiver and an electromagnetic receiver. As you experiment with the two receivers, you will undoubtedly discover other unusual defects you can introduce and will learn the value of having several service techniques at your command.

It is through a training plan such as the one described above that you can acquire real experience working with TV receivers that will enable you to best apply the training which you have received in your NRI course.

— n r i —

Our Cover Photo

The smiling face and outstanding Radio service bench on the front of our magazine belong to Graduate Harold R. Scott, of Anderson, Ind., who says: "At the time of my enrollment with your school, in 1948, I was employed by Stokely Tools, Inc., as a field supervisor, and Radio was my hobby. I am proud to say that since starting full time servicing this year I have erected a building for the purpose of servicing all makes of home and auto radios, with heated drive-in for auto radio service. The firm name is 'Scott Radio Service.' Thanks to NRI."

— n r i —

NRI Graduate Assigned to Radar Maintenance

"May I take this opportunity to tell you of my induction into the Armed Forces. I joined the Signal Radar Maintenance Unit. It is our job to maintain and repair Radar units which locate and track airplanes. I am very well pleased, as this is a small unit of three enlisted men and a Warrant Officer in charge.

"Needless to say, my understanding of Radio theory obtained in your Servicing course qualified me for this job. As I am now taking NRI's Communications course, my chief says that I can do my experiments in my spare time in our portable shop, and that I may keep my NRI material there. Rest assured that my best efforts are being put forth to complete this new course, as I believe it will be extremely useful in my video work."

PAUL E. F. MOREY, Laconia, N. H.

— n r i —

Hay is something we must make between the time we get out of it and the time we hit it.

OUR DEMOCRACY by Mat

"PUT YOUR SHOULDER TO THE WHEEL"

IF HIS WAGON BOGS DOWN OR HIS CAR IS MIRED, THE SELF-RELIANT MAN PUTS HIS OWN SHOULDER TO THE WHEEL

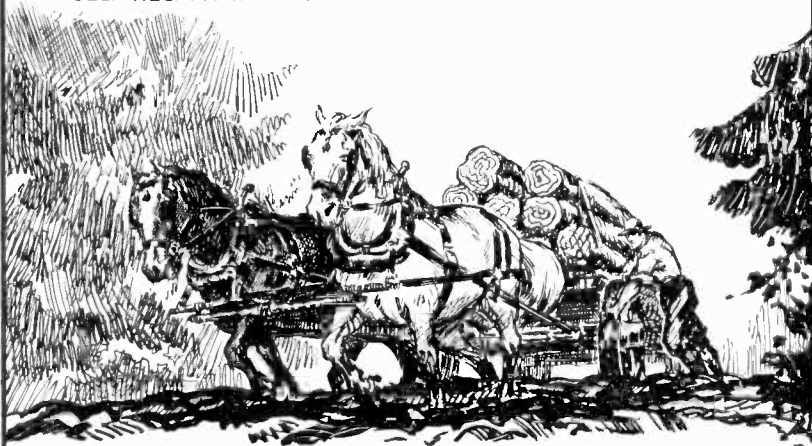

-AND AS WE WORK TOGETHER, EACH OF US DOING HIS SHARE, IT IS THIS SHOULDER-TO-THE-WHEEL PHILOSOPHY, THIS DOCTRINE OF PERSONAL INITIATIVE AND RESPONSIBILITY THAT GIVES AMERICAN DEMOCRACY ITS RESILIENT STRENGTH.



NOW, AS IN THE PAST, WHEN OUR DEMOCRACY IS ALERTED AGAINST AGGRESSION, THE NATION'S SLOGAN FOR ALL OF US, IS —
" SHOULDERS TO THE WHEEL! "

Read How NRI Graduates Are Forging Ahead in Radio and Television



Radio Has Been the Means of His Livelihood for Years and Now, Television too

"I finished your radio service course in 1937. I have been in radio repair ever since. I have made a living out of servicing radios, airborne, radar, sonar, etc., and now television, along with home sets.

"I am now employed in Sacramento by one of the largest home furnishers in California. I like the job of servicing the latest in radio."

FOREST G. SEALY
Box 317
Broderick, Calif.

— n r i —



Enrolled While in High School. Already Has Many Satisfied Customers

"I completed my NRI course during my senior year at high school at the age of seventeen. When I first thought of enrolling in your course, my parents were afraid it might interfere with my school work, but due to your kindness and consideration I have completed my course. Neither I nor my parents regret for one moment my taking the course.

"The knowledge that I have obtained about electricity alone through the course was well worth the cost plus the benefits I derived about radio and television. I am only working on radios part-time at the present due to my school work but I already have many satisfied customers. I can sincerely recommend this course to any one who is interested."

EARLWOOD SMITH
RFD 4, Box 36
Hartsville 3, S. C.

— n r i —

Earned Approximately \$500 While Studying the Course

"I have purchased about \$400 worth of test equipment, which gives me everything necessary to do complete service work on home and auto radios. My part-time shop at home gives me all the work I can handle.

"Have earned approximately \$500 while studying the course which I converted into test equipment and started a stock of parts. I now am averaging around \$20 to \$25 net in my spare time each week."

A. R. SHAEFFER
412 E. Franklin St.
Russellville, Ala.



Receiving NRI Diploma Was Great Thrill

"When I received my diploma from NRI, I think I experienced the greatest thrill of my life. I was unable to graduate from high school because the death of my father necessitated my leaving school.

"At first I was hesitant to enroll in a correspondence course. After studying and receiving grades on only a few lessons I decided that here, indeed, was the answer I had been searching for. I have proved to myself that even those who have no knowledge whatsoever of the workings of radio can master the job of servicing radios through this splendid course. I have serviced over 150 radios, in my spare time, with satisfaction to both customers and myself."

WILLIAM L. LANAHAN
RFD 1, Box 62
Afton, Va.

— n r i —



Full-Time Radio and Television Business



"I am owner of my own business. I have a full time sales and service business with my wife selling. I also do part time servicing after my regular day at another job. I am doing very well.

"I am now starting in TV; having sold some sets. I am going into TV servicing. I am an authorized Philco man in my town. I am now earning about \$1,800 to \$2,200 for my part time servicing."

ANTHONY MILLS
313 Mathew St.
Rome, N. Y.

— n r i —

Started Earning After 12th Lesson. Now Has Full Time Radio Business

"Since taking your course I have my own radio repair business and also do radio repairing for two other firms. I also service P.A. systems and do other electrical work. When I enrolled for your course, I knew nothing about radio.

"When I completed my twelfth lesson I started repairing neighbors' radios and made between \$10 and \$15 per week. I consider the NRI course as the best that can be had at any price. Many thanks for the consultation help you have given me during my course and in the years since graduation."

ALVA C. BUFFINGTON
1809 Jackson Ave.
Portsmouth, Ohio

— n r i —

As space permits, from time to time, we plan to devote a page or two in NR-TV News to short success stories such as above. They are taken from testimonial letters we have on file. Photographs and letters of this kind are always greatly appreciated by us. We feel we should pass them on to our readers for the inspiration to be gained from a reading of them.

TELEVISION SERVICING METHODS

By WILLIAM F. DUNN

NRI Consultant



William F. Dunn

"NO picture" is probably one of the most misleading complaints that the TV serviceman will receive. To the customer this term covers practically everything from "no raster" to a defect in the sync circuits that causes the picture to break up. When the serviceman is called on to service a receiver with this complaint, he should first listen to the customer's description of the trouble and then check the performance of the receiver to verify the complaint.

In this article we'll discuss the common defects that usually result in this complaint, excluding defects in the sync circuit.

No Raster

When the electron beam is swept over the face of the picture tube by the horizontal and vertical sweep circuits an illuminated rectangle is produced on the face of the picture tube. This rectangle will have a 3 to 4 aspect ratio. The illuminated rectangle is called a raster. When the face of the picture tube fails to light, the defect is referred to as "no raster."

Where there is no raster present the set owner will frequently jump to the conclusion that the picture tube is defective. Servicemen who are just getting started in TV service work may also jump to the same conclusion. However, the experienced serviceman knows that the failure to obtain a raster does not necessarily mean that the picture tube is defective, as a matter of fact, in the majority of cases the trouble is due to improper operating voltages on the picture tube rather than to a defect in the tube itself. Therefore when this defect is encountered, the first step should be to check the operating voltages

on the picture tube. (*CAUTION:* Do not attempt to measure the second anode voltage on the picture tube unless you have a suitable high-voltage multiplier probe for your voltmeter.)

When checking the operating voltages on the picture tube you should check the cathode and the grid voltages, also the first and second anode voltages. In addition to this, make sure that the operating voltages are being applied to the heater.

When the trouble is caused by improper operating voltages, it's usually because there is a defect in the high-voltage supply that provides the voltage for the second anode of the picture tube. Several types of power supplies are in use. Fig. 1 shows a comparatively simple r.f. type of power supply. A supply of this type is found in most of the smaller sets that use a 7-inch picture tube.

In checking a supply of this type, the first thing to do is to try new tubes. The 6C4 high-voltage oscillator tube may test good in a tube tester and still fail to give satisfactory performance in this circuit. Therefore, it is essential that a new tube is tried rather than rely on a tube tester. In the case of the 1B3, a tube tester will usually indicate whether or not the tube is good.

If the tubes prove to be good, the two .001-mfd, 6000-volt condensers used as the high-voltage filter condensers should be checked. It is usually possible to check these condensers simply by disconnecting them, and then checking the operating voltage to see if it increases.

If it increases when one of the condensers is

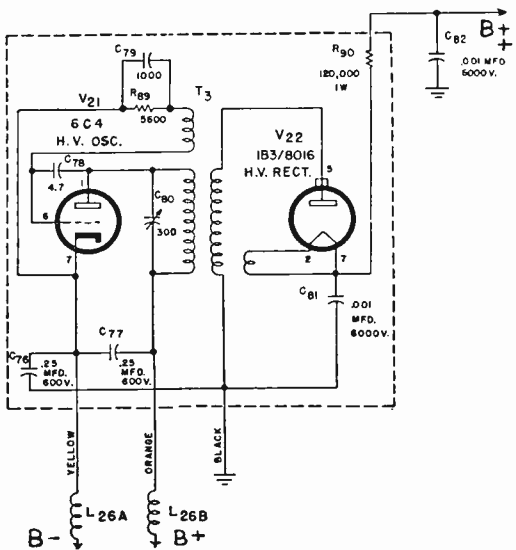

Fig. 1. High voltage power supply used in Hallicrafters T-54 TV receiver.

disconnected, that condenser should be replaced. Do not rely on an ohmmeter to test these condensers, because even though they may show a leakage resistance as high as 30 or 40 megohms, they may break down when the high operating voltages are applied to them.

If the two high-voltage filter condensers are good, the trouble could be caused by any of the other condensers or resistors used in the oscillator circuit, and, of course, they should be checked. However, it is seldom that these parts cause trouble. Usually when the tubes and the high-voltage filter condensers are good the trouble is due to a defect in the high voltage oscillator coil.

If a winding of the coil opens, it is comparatively easy to locate this trouble, since an ohmmeter test will show it up. However, the trouble is not usually caused by an open winding, but rather by a low Q as the result of moisture absorption. The average serviceman does not have equipment available to check a coil of this type, and therefore when the tubes and all components are in good condition, and yet the high voltage output is low, a new coil should be tried.

The "Kick-Back" Supply

While the circuit shown in Fig. 1 is a comparatively simple circuit, it is not found in the latest TV receivers. The "kick-back" type of supply shown in Fig. 2, or some variation of this circuit, is used by most manufacturers.

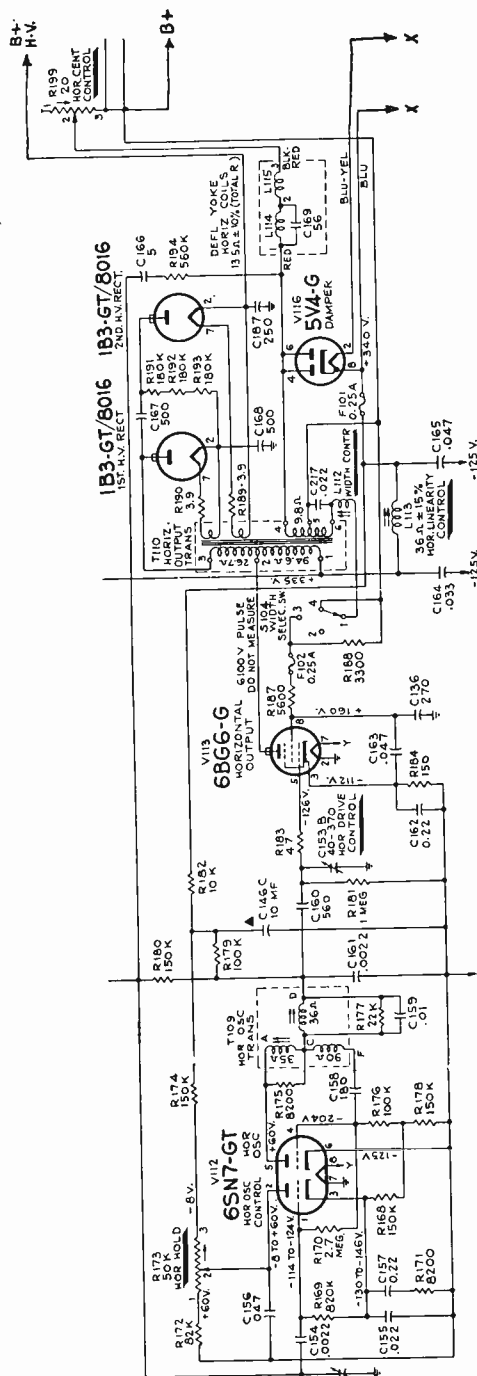

Fig. 2. Horizontal sweep circuit and kick-back high voltage power supply, including voltage doubler circuit, as used in RCA 9T270.

The high voltage is generated by the inductive kick-back produced by the rapid collapse of the field in the horizontal deflection coils and in the horizontal output transformer. This inductive kick-back is produced when the electron beam is moved rapidly from the right side of the picture tube back to the left side to start the next horizontal line. The operation of the high voltage supply is tied to the horizontal sweep circuit, so if there is no high voltage present, it may be caused by a defect anywhere in the horizontal sweep circuit, or in the high voltage supply.

At first, it might appear that it would be difficult to locate the defect in a circuit such as that shown in Fig. 2. However, actually the trouble can be pinned down very rapidly to one stage, and once the defective stage has been located it is not very difficult to find the part that is causing the trouble.

In servicing receivers using this circuit when the complaint is "no raster," the first step would be to check the high voltage. If you find that there is no high voltage present, the next step is to pin the trouble down to one stage, and then to the troublesome part.

With the receiver turned on, touch the metal blade of an insulated screwdriver to the top cap of one of the 1B3 tubes. You should be able to draw an arc about $\frac{1}{2}$ inch long off the top cap of the tube. Then check to see if you can draw an arc off the top cap of the other 1B3 tube. If you can, the chances are that the trouble is being caused by defective 1B3 tubes, since ample high voltage is reaching the plates of the tubes, even though there is no high voltage output.

If you do not obtain an arc on the top cap of the 1B3 tubes, or if you obtain only a small spark, it indicates a defect somewhere ahead of the 1B3 tubes. Try checking the drive on the grid of the 6BG6. You can do this by checking the voltage across the grid resistor used in the grid circuit of the 6BG6. In Fig. 2, the grid resistor is the 1-megohm resistor marked R181. The end of this resistor that connects to C160 and R183 should be negative. There should be a voltage of from 10 to 15 volts across this resistor. If this voltage is not present, check R183 to be sure that it is not open. If this voltage is present, the signal from the horizontal oscillator is reaching the grid of the 6BG6, and the trouble is somewhere between the grid of this tube and the plate of the high-voltage rectifier tubes.

The first step, when this difficulty is encountered, is to try a new 6BG6 tube in the receiver. Also check the fuse marked F101 and the fuse F102.

If these fuses are good, check the screen voltage and the cathode voltage on the 6BG6. Do not try to measure the plate voltage on this tube, because there is a high-voltage pulse pres-

ent. You can, however, check to see if there is a defect in the plate circuit by turning the receiver off and then using an ohmmeter to check through the horizontal output transformer, the horizontal linearity coil, and the other components in the plate circuit of the 6BG6.

When checking one winding of the horizontal output transformer it would be worth while to check the remaining windings. The resistance of each winding is given in this particular case.

The winding between terminals 2 and 3 should be checked very carefully. If the resistance of this winding is somewhat lower than normal, it indicates that there may be some shorted turns on this winding, this would cause the high voltage to drop to a very low value. If the resistance of this winding has gone up to a high value, it indicates that the winding is open.

In addition to trying a new 6BG6 horizontal output tube you should also try a new 5V4 damper. If the emission of this tube is low, the plate current of the 6BG6 will drop to a low value.

Sometimes the horizontal output transformer will check good when actually it is defective. If you have normal drive in the grid of the 6BG6, if all the tubes in the horizontal output, high voltage rectifier, and damper circuits are good, and all the components used in these circuits appear to be in good condition, then it is usually worth while to try a new horizontal output transformer in the receiver.

So far we have discussed defects that may exist somewhere between the grid of the horizontal output tube and the output of the high voltage supply. However, a defect in the horizontal oscillator in a circuit of this type may also result in no high voltage.

Using the same service procedure that has been outlined, you would check at the top caps of the 1B3 tubes to see whether or not you could draw off a reasonably good arc. Next, check across the grid resistor for the 6BG6 using a d.c. voltmeter. If the defect is in the horizontal oscillator it will show up when you check across the grid resistor. You'll find that there is little or no d.c. voltage across this resistor indicating that there is no drive reaching the grid of the 6BG6 tube. In a circuit of this type the plate and/or screen current of the 6BG6 tube may go up so high that the two fuses in the high voltage supply will blow. When the serviceman discovers the defective fuse, he may be misled and assume that the defect is somewhere in the 6BG6 horizontal output stage. However, if the drive is checked across the 1-megohm grid resistor he'll find that there is no drive across this resistor, and, therefore, the basic trouble is caused by a defect in the horizontal oscillator.

The horizontal oscillator in a TV receiver is, in many respects, like the local oscillator in a superheterodyne receiver. You can find out whether or not it is operating by checking the voltage across the oscillator grid resistor. If the oscillator is operating there will be a voltage across this resistor having a polarity such that the grid end is negative. If you check across this resistor and find no voltage present, you immediately know that the horizontal oscillator is not operating. If you check across the resistor and find a voltage present, but still no drive on the grid of the horizontal output tube, in a circuit of this type, the trouble would probably be caused by an open coupling condenser; C160 could be causing the trouble.

If the horizontal oscillator is not operating, the first step is to try a new tube, even though the one in the set may test good in a tube tester.

If a new tube fails to clear up the trouble, a check on the operating voltages on the tube may reveal the defect. If the operating voltages are close to normal, check each winding on the horizontal oscillator transformer carefully. If there is a defect in the transformer, the resistance of one of the windings may have changed. In addition to the oscillator transformer, the miscellaneous small components should be checked one at a time.

Before leaving the circuit shown in Fig. 2, it would be well to point out that resistors R191, R192 and R193 will frequently open. When one of these resistors opens, the high voltage output from the supply will drop to a low value. When you use a screwdriver to check the arc on the top cap of the 1B3 tubes, you will probably obtain a normal indication on the top cap of the first high-voltage rectifier tube, but usually you'll obtain only a small spark on the top cap of the second high-voltage rectifier tube. This is an indication that one of these resistors is open. The receiver should be turned off, and then as a precaution each of the condensers used in the high-voltage supply should be carefully shorted out. After you have shorted each of the condensers, you can safely use an ohmmeter to check the resistors one at a time.

The circuit shown in Fig. 3 is somewhat similar to Fig. 2. The same type of high-voltage supply is used. However, notice in this supply that a single half-wave, high-voltage rectifier is used, whereas in the circuit shown in Fig. 2 a voltage doubler circuit is employed.

The circuit is shown simply to point out the plate circuit of the 6BG6 horizontal output tube. Notice that the plate of this tube connects to the horizontal output transformer as in Fig. 2, but also connected to the plate of the tube in the circuit shown in Fig. 3 is a lead going back to the horizontal a.f.c. tube. This circuit goes

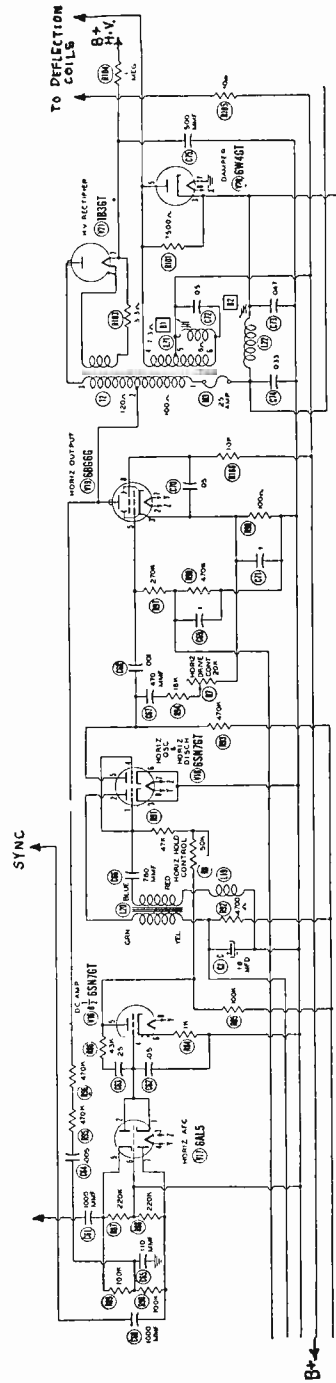

Fig. 3. Horizontal sweep circuit and kick-back high voltage power supply as used in Emerson 614.

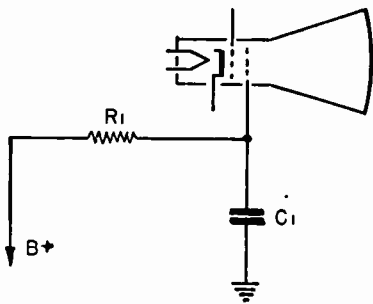

Fig. 4. Kinescope 1st anode voltage circuit.

through two 470K resistors, and then there is a .005-mfd. condenser. Frequently you will find that low output from the high-voltage supply is caused by leakage in this condenser. When the condenser breaks down, the two 470K resistors usually will change value, and also the two 100K resistors R89 and R90 will frequently be damaged.

If you run into low output from the high-voltage supply in a receiver using this circuit be sure to check the .005-mfd. condenser C64, and also the four resistors.

No First Anode Voltage

Usually the first anode of the picture tube connects directly to the B supply, and in this case you'll have voltage on the first anode as long as the B supply is operating. If the B supply fails, of course the receiver will be completely dead, and this in itself would indicate a power supply defect.

However, in some receivers a circuit such as shown in Fig. 4 will be encountered. In these receivers a defect either in R₁ or C₁ may remove

the voltage from the first anode of the picture tube, and no raster will be obtained even though the high voltage on the picture tube may be of the correct value.

In this type of circuit, if there is no voltage present on the first anode, C₁ should be checked for a short. If C₁ is shorted it probably will be necessary to replace R₁ also, as the chances are that the value of the resistor would change, because of the overload. In some cases C₁ may be good, and R₁ may simply have gone up in value.

In receivers that use an electrostatic type of picture tube, the first anode voltage is varied

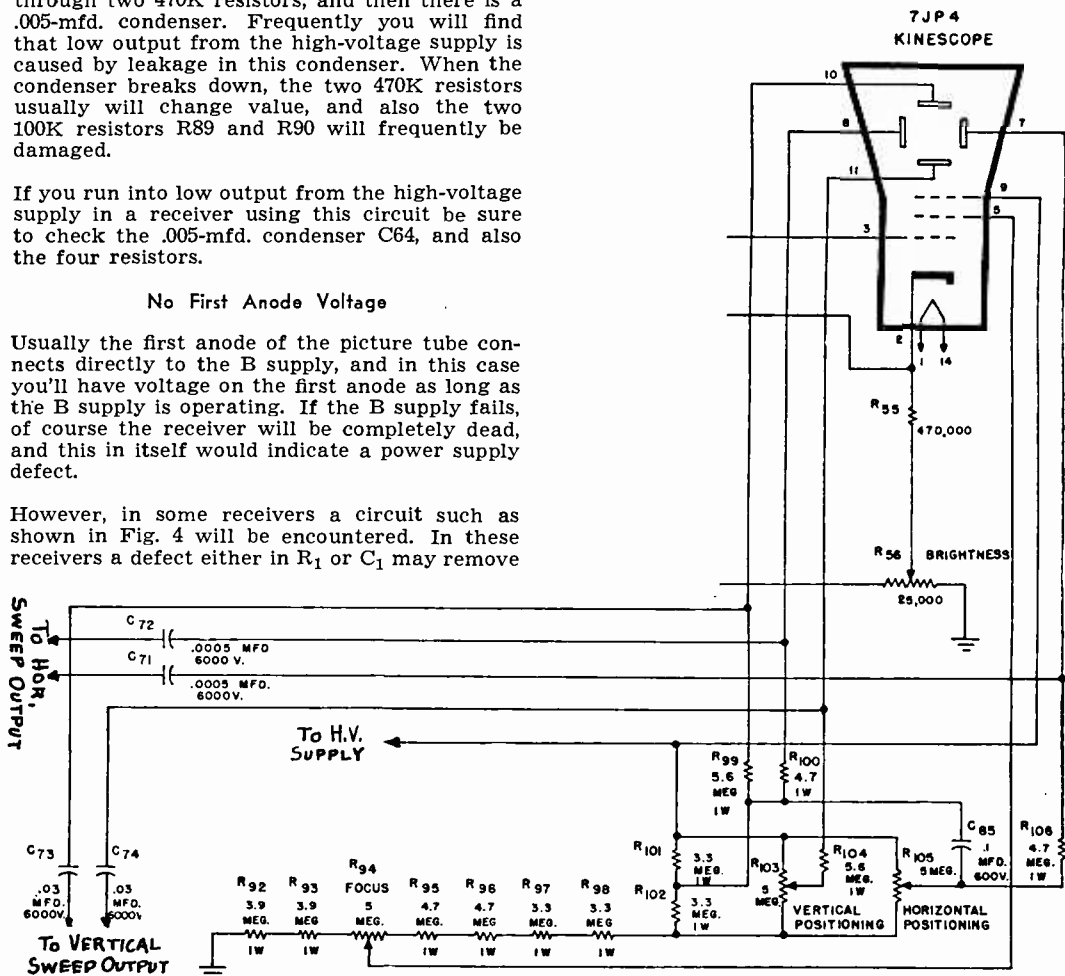

Fig. 5. D.C. voltage circuit as used with electrostatic deflection in Hallicrafters T-54.

to focus the tube. Usually the voltage is obtained from the high voltage supply by using a series of resistors across the supply.

Fig. 5 shows a 7JP4 picture tube and the operating voltages applied to the deflection plates, the first anode, and the second anode. Notice that the first anode connects to the center tap of the focus control. If you have normal voltage on the second anode, but no voltage on the first anode, it may be caused by a defective focus control, or an open in R95, R96, R97, or R98. If the voltage on the first anode should be somewhat higher than normal, either R92 or R93 may be open.

While we're looking at this circuit it might be well to mention the effect that condensers C71, C72, C73, and C74 may have on the raster if these condensers develop leakage. Leakage in these condensers will reduce the high voltage by loading down the high-voltage supply. Usually if one of the condensers develops leakage, the high voltage will drop so low that no raster will be obtained. The defective condenser can be located easily by disconnecting each one in turn and trying the set. For example, if you have no raster and everything in the high-voltage circuit is in good condition, try disconnecting C71. Then try the set. If a raster is obtained with this condenser disconnected, and the raster disappears when the condenser is connected up, then the condenser is defective and should be replaced.

A small amount of leakage in these condensers will not load the high-voltage supply enough to cause the raster to disappear. However, this leakage can result in another undesirable defect. If either C73 or C74 develops a small amount of leakage it will cause the picture to drift up or down depending upon which condenser is defective. It is sometimes very difficult to tell which one is causing the trouble, and the best way to clear it up is to replace both of the condensers. This type of trouble frequently occurs after the set has been on for ten or fifteen minutes. It can be corrected by adjusting the vertical positioning control, but after the set has been on for a while longer the picture will have drifted further, and eventually it will have drifted so much that it can't be corrected by the centering control. Similarly horizontal movement, either to the left or to the right, indicates leakage in either C71 or C72.

Excessive Bias

In some cases where the complaint is "no raster" you'll find that the voltages on the first and second anodes of the picture tube are normal. In this case it would be worth while to proceed further and check the bias on the picture tube. This may involve checking the cathode or the grid voltage, or in some cases both the cathode and the grid voltages must be checked.

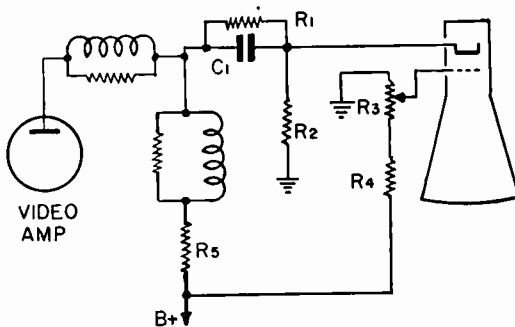

Fig. 6. Kinescope video input circuit.

In the circuit shown in Fig. 6 the resistance of R5 is comparatively low, and therefore practically the whole B supply voltage is available at the junction of R1, C1, and the peaking coils.

The values of R1 and R2 are chosen to apply a positive voltage on the cathode of the tube which will be high enough to cut off current flow. The values of R4 and R3 are also selected so that the positive voltage on the grid may be brought up until it is slightly less than the voltage on the cathode. With R3, the brightness control turned all the way up, maximum illumination will be obtained on the picture tube, and the grid will have almost the same positive potential as the cathode.

In this circuit, if C1 were to short, the full B supply voltage would be applied to the cathode of the picture tube. This would place a high positive voltage on the cathode of the tube, and when R3 is adjusted to increase the positive voltage on the grid of the tube you would not be able to increase it far enough positive, because of R4, to overcome the high positive voltage on the cathode of the tube. In other words, the cathode would always remain so far positive with respect to the grid (the grid negative with respect to the cathode) that current flow would be cut off, and no raster could be produced.

Of course, after checking the first and second anode voltages, once you have checked the voltage on the cathode and grid you would find that the cathode voltage is somewhat higher than normal, and this would immediately indicate a defect in C1.

Miscellaneous Defects

If the heater of the picture tube fails to light there will be no raster produced even though all the d.c. operating voltages applied to the tube may be normal. In TV receivers using a power transformer where the heaters of the various tubes are connected in parallel, the failure of

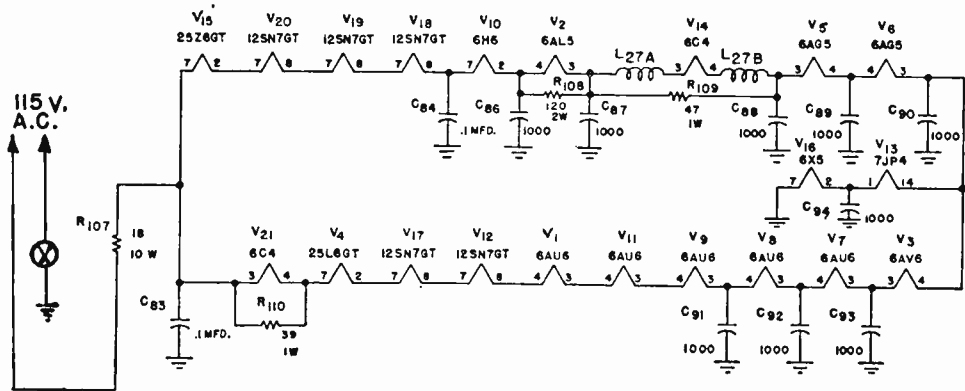

Fig. 7. Tube filament string used in Hallicrafter T-54.

the picture tube heater to light may be caused by a defective heater, a bad socket, or one of the heater leads going to the socket might have broken or pulled loose. In this type of set it is not very difficult to find the defect. The first thing to do is to check the heater for continuity, and then if the heater is good check the leads and the socket.

However, some TV receivers employ a heater string. Fig. 7 shows a typical heater string in a TV receiver. Notice that there are two separate strings, and that the current from both of these strings flows through the picture tube and through one of the rectifier tubes. Therefore if a defect develops in either one of the heater strings the picture tube will not light.

If the heater of one of the tubes in either one of the strings is open, then none of the tubes in that string will light; this is not difficult to locate. However, sometimes one of the tubes will develop cathode-to-heater leakage. If this tube happens to be one of the tubes near the end of the string, for example V5 or V6 in the upper string, practically all of the tubes in the set will light except the picture tube and the one rectifier tube.

This type of defect can usually be located by checking the tubes for cathode-to-heater leakage in a tube tester, or by pulling the tubes out of the set one at a time. For example, in the lower string you would start with V3 first, then V7, then V8, etc. If V3 is the tube with the cathode-to-heater short, all the tubes in this string will go out when it is removed. If the short is not in V3, you should put the tube back and try removing V7. If V7 is causing the trouble, all the tubes in this string will go out when it is removed.

In a circuit of this type, if none of the tubes light it's probably an indication that either the

6X5 or 7JP4 tube has an open heater. Of course, you could have an open heater in both strings, but this would be a coincidence.

The failure to obtain a raster on the picture tube is frequently caused by loose socket connections or broken leads. On many picture tubes the base of the socket can be removed, and the voltages can be checked right on the tube pins. If all operating voltages appear to be normal, it is frequently worth while to try checking the voltage right at the tube pins.

If all the operating voltages on the picture tube are normal and the tube fails to light, the indications are that the picture tube is defective. About the only way you can test the tube is to try a new one in the receiver, or try the old tube in another receiver that is known to be operating satisfactorily. If the old tube fails to light in the other receiver, or if a new tube lights in the original receiver, the old picture tube is defective.

Sometimes you'll find that the voltage on one of the elements in the picture tube is low or possibly drops to zero. For example, when you check the high voltage on the second anode you may find that there is no high voltage present. This may lead you to suspect a high-voltage power supply defect. Usually it is a good idea to shut the receiver off, and remove the second anode connection from the picture tube. Then turn the set on again and check the voltage between the second anode lead and the chassis.

If you have voltage when the lead is disconnected from the picture tube, it indicates a short inside of the picture tube. It is worth while to make this test before going to work on a high-voltage supply; it only takes a minute, and it will avoid spending time on the high-voltage supply when the defect is actually caused by a short inside of the picture tube.

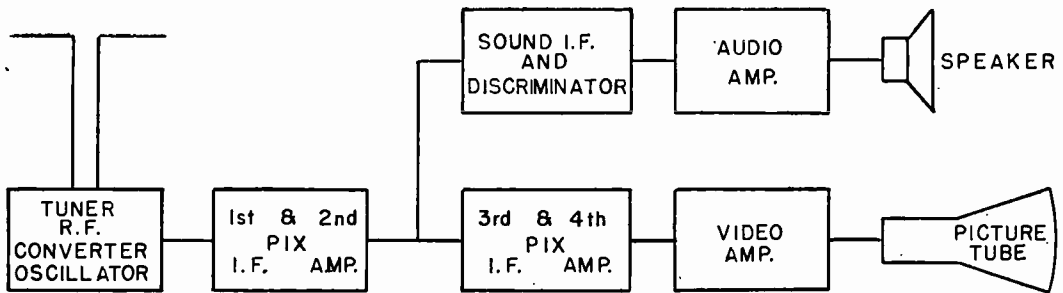

Fig. 8. Block diagram of TV receiver using separate sound i.f. channel.

Of course, when this situation is encountered, some of the components in the high-voltage supply may be damaged by the load placed on them. If a filter resistor is used between the filament of the high-voltage rectifier tube and the second anode of the picture tube the resistor may have changed value. In addition to this, the high-voltage rectifier tube may have been damaged.

There are other defects that may result in "no raster," but the defects mentioned above cover the majority of cases. If the servicing procedures outlined here are used, you should be able to locate any trouble causing this defect without too much difficulty.

Raster But No Picture

When a raster is obtained on the face of the picture tube it indicates that the tube is good, and also that normal operating voltages are applied to it. When no picture is obtained it means that there is a defect somewhere between the antenna and the grid of the picture tube that is interrupting the signal path.

Two situations may be encountered which will help to isolate the trouble to one section of the receiver. In one case, both the picture and the sound will be missing; in the other the sound will be present. When the complaint is "raster, but no picture," it is very important that the serviceman check the set to find out whether or not sound is obtained, since this will be a definite indication as to where the trouble is in the receiver, and it will simplify the job of locating the defective component.

Fig. 8 shows a block diagram of the video and sound signal circuits of a modern TV receiver.

Notice that both the sound and the picture signals pass through the tuner and also through the first and second video i.f. amplifiers. At the output of the second video i.f. amplifier the sound is taken off and fed to the sound i.f. amplifier, and from there on through the audio system to the speaker. The video signals are taken from

the output of the second video i.f. amplifier and fed on to the remaining stages in the video i.f. amplifier, and from there to the video detector, through the video amplifier, and to the picture tube.

In servicing a receiver of this type, if both the sound and the picture were missing, but there was a raster on the face of the picture tube, the trouble is probably in the tuner or in the first or second video i.f. amplifier. In other words, some defect has developed that has interrupted both the picture and the sound signals, and therefore it is likely that it is in one of the circuits common to these two signals. Of course, there could be two separate defects, but this is unlikely.

If you have sound and a raster, but no picture then the defect must be somewhere between the sound take-off point and the picture tube. This isolates the trouble to the third and fourth video i.f. stages, the video detector, or the video amplifier. The trouble could be further isolated by a circuit disturbance test, by signal injection, or by checking operating voltages and components. The procedure would be exactly the same as that used on a defective broadcast band radio receiver.

In the block diagram shown in Fig. 9 a somewhat different arrangement is employed. In this receiver the sound is taken off after the video amplifier. This type of sound system is called "inter-carrier" sound. Both the sound and the picture signals are fed together into the video detector where they beat together and produce a 4.5-megacycle beat frequency. This 4.5-megacycle signal is fed through the video amplifier, and then taken off and fed to the sound i.f.

In a receiver of this type, if both the sound and the picture are lost, but a raster is present on the picture tube, the trouble could be anywhere between the antenna and the sound take-off point. In other words, the trouble could be in the tuner, the video i.f. amplifier, the video detector, or the video amplifier. Because of the large number of stages involved, it would be ad-

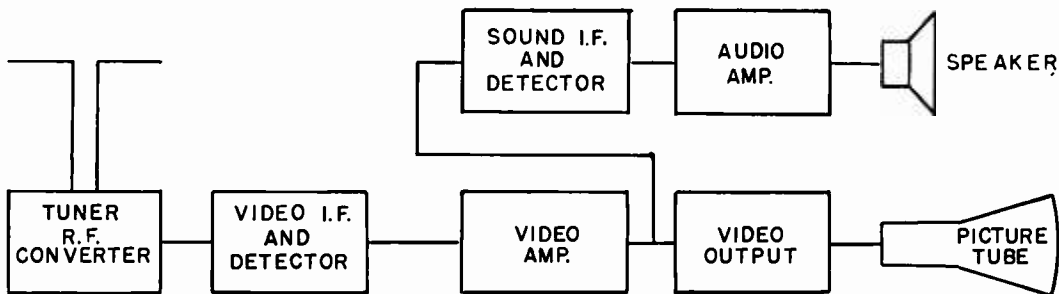

Fig. 9. Block diagram of TV receiver using inter-carrier modulation.

visible to employ some sort of circuit disturbance test to try to further isolate the trouble.

However, if you have both sound and raster, but no picture, the trouble is pretty well isolated to one stage. The trouble would have to be between the sound take-off and the picture tube, and this leaves only the video output stage and its associated parts to be checked. You can try a new tube, check the operating voltages, and even if you had to check each of the components individually there wouldn't be too many to check and you should be able to find the defective part without very much trouble.

Sometimes you may encounter a situation where the picture disappears intermittently. The picture may disappear for only a few seconds, or in other cases it may disappear for several minutes. Again, in isolating the trouble, you should check the set carefully to find out whether or not the sound disappears when the picture disappears. This information will immediately tell you what part of the receiver is causing the trouble, and rather than have to check the entire picture circuit, starting with the tuner and working toward the picture tube, you can eliminate those sections of the circuit that are common to the sound system if the sound remains when the picture disappears, or concentrate on those sections that are common to the sound if both the sound and the picture disappear at the same time.

Picture Brightness Cannot Be Reduced

A fairly common defect in some TV receivers is that the brightness control does not have the proper control of the picture brilliancy. With the brightness control in the maximum brilliancy position the picture will be extremely bright, usually it is out of focus and the retrace lines will be visible. Reducing the setting of the brightness control may have some effect on the brightness, but with the control turned all the way back in the position that would normally black out the picture completely it will still be very bright.

In the circuit shown in Fig. 10, this trouble may be encountered when a defect develops that will upset the bias on the picture tube.

The most common defect that causes this trouble is leakage in the .01-mfd. coupling condenser marked C₃₄. This condenser is used between the grid of the picture tube and the plate of the second video amplifier. When the coupling condenser develops leakage, a positive voltage will be applied to the grid of the picture tube.

When you encounter a situation where the brightness control fails to control the brightness of the picture, check for a positive voltage on the grid of the picture tube by placing the positive probe of a d.c. voltmeter on the end of the grid resistor that connects to the grid of the tube and the negative probe on the other end of the grid resistor. In this particular circuit you can simply connect the meter between the grid of the tube and ground, but in some sets the grid resistor will not go directly to ground, and therefore the voltmeter should be connected directly across the resistor in the method described.

If you obtain an upscale reading with the meter connected across the grid resistor, it indicates that there is either a gassy picture tube or a leaky coupling condenser. By disconnecting the coupling condenser from the grid of the tube you can check again to see if the voltage is still present across the grid resistor. If it is, the picture tube is gassy, whereas if the voltage disappears when you disconnect the coupling condenser, the coupling condenser is leaky and should be replaced.

If you do not obtain a positive voltage on the grid of the picture tube, there is some defect in the brightness control circuit. You can check for this by checking the voltage between the center tap of the brightness control and ground. See if the voltage varies as you rotate the brightness control, and also check the actual voltage present with the brightness control set at both extremes, and compare your results with those listed by the manufacturer.

No Vertical Sweep

When this defect is encountered the customer will usually describe the defect by stating that there is a thin horizontal line on the face of the picture tube. The fact that there is a horizontal line immediately indicates that there is high voltage and also that there is horizontal sweep available. However, since there is no height there must be some defect in the vertical sweep circuit. This trouble may be caused by a defect in the vertical deflection yoke, the vertical output transformer, the vertical output stage, or in the vertical sweep generator. The serviceman must isolate the trouble to one stage so that he can then isolate the trouble to the defective part.

Usually the best thing to do first is to find out whether or not the vertical sweep generator is operating. You can do this simply by checking for a voltage across the oscillator grid resistor. If the oscillator is oscillating there will be a voltage across the resistor having a polarity such that the grid end is negative. Refer to Fig. 11, and then check for a voltage across R₂₈ to see whether or not the oscillator is operating.

If you find that the oscillator is not operating,

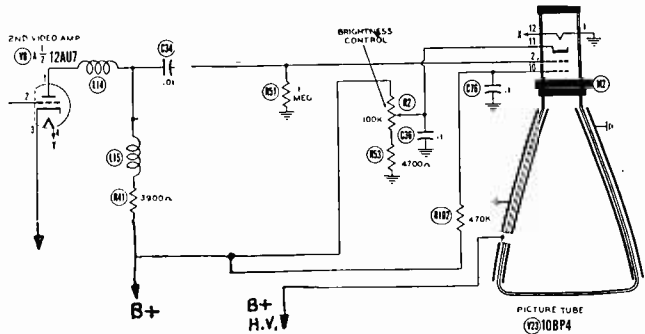

Fig. 10. Video input circuit to Kinescope, Emerson 614.

the first thing to do is to try a new tube even though the old one may test good in a tube tester. If the oscillator still fails to operate, you should check the operating voltages; this may give you a clue as to where the defect exists. For example, you may find that one section of the oscillator has no plate voltage.

If normal operating voltages are obtained, you can check the individual components used in this circuit one at a time. There aren't very many components, so it shouldn't be difficult to find the defective part.

Many TV receivers use a blocking oscillator type

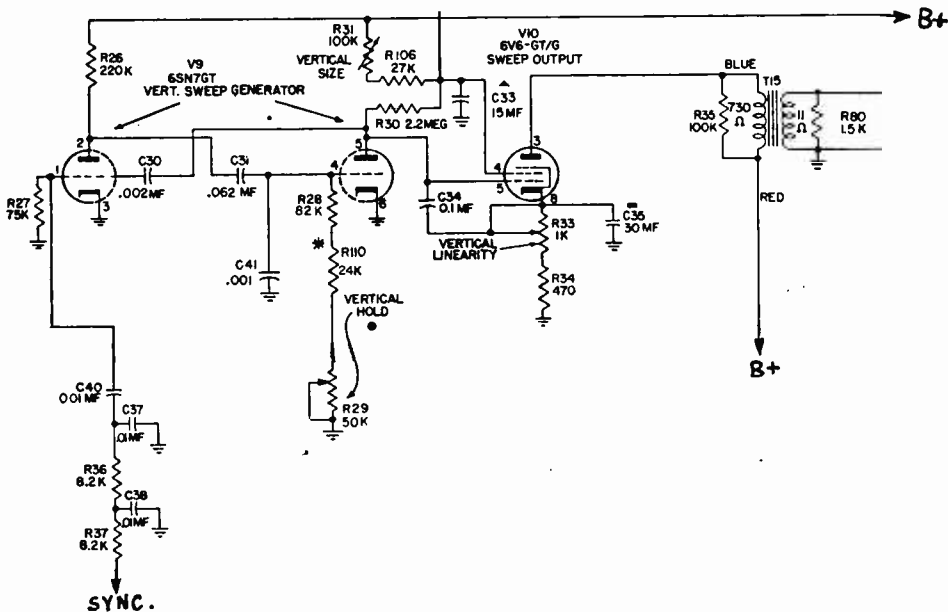

Fig. 11. Vertical sweep generator circuit used in General Electric 810.

of circuit. In sets of this type where the operating voltages are approximately normal and a new tube fails to clear up the trouble, the difficulty is frequently caused by a defect in the blocking oscillator transformer. In many cases, one of the windings will be open, but in other cases the transformer will appear to be good. If the new tube fails to clear up the trouble and the parts all check good, it is usually worth while to try a new transformer.

If you discover that the vertical sweep oscillator is operating, the next step is to check the vertical output stage. If a cathode-ray oscilloscope is available, use it to check the drive on the grid of the tube, and also to check the wave form at the plate. If drive is available on the grid, but there is no output at the plate it indicates a defect in this stage. On the other hand, if a sweep is available at the plate of the tube, the trouble must be in the vertical output transformer or in the vertical yoke.

Actually, when the vertical sweep fails completely it is not difficult to find the trouble. However, sometimes you'll encounter a receiver in which there is some sweep available, but the sweep may be non-linear, or there may not be sufficient sweep available to properly sweep the tube.

These difficulties are more troublesome and harder to locate than a defect that results in complete failure of the sweep circuit.

A short or leakage in either C_{37} or C_{38} in the circuit shown in Fig. 11 will result in insufficient vertical sweep. These components should be checked, and if there is any doubt about their quality they should be replaced when this trouble is present.

If the vertical sweep generator itself appears to be operating properly there may be some defect in the vertical output transformer. You should check the resistance of each winding carefully, if the resistance of one of the windings is somewhat less than that indicated on the diagram it may indicate that some of the turns on that winding have shorted out. A new vertical output transformer should be tried.

Sometimes turns will short out on the vertical deflection yoke. Again, the resistance of the yoke should be checked and carefully compared with the resistance listed by the manufacturer. A low reading indicates shorted turns, whereas a high reading indicates an open yoke.

Each half of the vertical deflection yoke is shunted by a resistor. When the reading obtained when checking the resistance of the yoke is equal to the value of the shunting resistor it indicates that that section of the yoke is open.

When the deflection yoke opens, the lead may

simply break off where it is joined to the terminal. It is usually possible to repair a defect of this type simply by resoldering the lead to the terminal. However, where the open occurs toward the center of the winding the only thing you can do is replace the yoke.

No Horizontal Sweep

When this defect is encountered the customer's complaint will be, "a thin vertical line." The line is caused by the presence of high voltage, and the fact that the line is swept vertically means it must have vertical sweep.

Fig. 2 shows the complete horizontal sweep circuit and high voltage supply for a typical television receiver. Since failure of the horizontal oscillator results in no horizontal sweep and no high voltage, we know when there is a thin vertical line on a receiver using a power supply of this type that the horizontal oscillator must be operating, otherwise there wouldn't be any high voltage.

However, some defect has occurred which has removed the horizontal sweep. About the only thing that can do this without upsetting the high voltage also is a defect in the horizontal deflection coils. One of the coils has probably opened.

However, all TV receivers do not use the kick-back type of power supply. Some receivers use an r.f. type of power supply, and in sets of this type a thin vertical line indicates a defect in the horizontal sweep circuit. This could be in either the horizontal oscillator, or the horizontal output stage. The trouble can be isolated to one stage by using the methods described previously. Defects that result in complete failure of the horizontal sweep are not too difficult to locate. The difficulty usually is in locating the defect that results in poor linearity or insufficient sweep.

Probably the most common cause of poor linearity is a defect in the horizontal output tube. When the picture has a tendency to fold over on the right, it indicates low emission in the horizontal output tube. If the picture folds over on the left, it is caused by a defective damper tube. In either case a new tube should be tried.

Non-linearity may also be caused by a change in value of some of the components used in the horizontal output or horizontal oscillator stages. Individual components may be checked one at a time. It is also helpful to check the operating voltages.

Of course, you must remember that a certain amount of non-linearity may be tolerated. On a test pattern, non-linearity might show up, but usually when a picture is being received a small amount of non-linearity cannot be noticed.

That Other Flag

At the American National Red Cross building in Washington, a block from the White House, two flags fly side by side—the Stars and Stripes, and the Red Cross flag of mercy. These two flags are as inseparable in national emergencies as on the battlefield.

A Washington newspaper recently called the Red Cross “Old Reliable,” going on to say, “When war erupts . . . or when nature goes on a rampage, Americans turn instinctively to their Red Cross . . . but people’s memories fade in . . . days of peace, and the organization has a tough time collecting its funds.”

In adopting the slogan “Mobilize for Mercy” for its March 1951 fund campaign, the Red Cross asks the help of every American not only in supplying badly needed funds for its expanded work for the armed forces and civil defense, but in recruiting volunteers to make this work possible.

In addition to continuing its regular work, the American Red Cross has been asked to expand its activities as follows:

1. The Blood Program. The Secretary of Defense last summer asked the American Red Cross to be the official blood procurement agency for the needs of the armed forces. The National Security Resources Board also has requested that the Red Cross coordinate a nationwide blood program for civil defense. Therefore, including its regular peacetime program, the Red Cross will be responsible for procuring large quantities of blood by the end of this fiscal year.

2. First Aid. The NSRB has asked the Red Cross to undertake the training of as many as 20 million persons in first aid, including all civil defense workers. This is no short-time job, and in accepting it, the Red Cross looks to the public both to fill classes and to help instruct those classes.

3. Nurses Aides and Home Nursing. In an emergency, hundreds of thousands of women will have to give nursing care to their families and their neighbors. More hundreds of thousands will be needed to serve as nurse’s aides in hospitals, at blood centers, and emergency shelters. The Red Cross has accepted from the NSRB the responsibility for recruiting and training these women in home nursing courses and as nurse’s aides.

To do its regular job as well as an emergency one, the Red Cross will need millions of volunteers—as blood donors, as non-professional workers in hospitals, as drivers for Motor Service, and as other workers in connection with all local chapter needs. The Red Cross has a long

history of trained volunteer service. How much can you give to help make Red Cross know-how count in 1951? How much will you give to keep that other flag flying?



Membership. American Red Cross membership has averaged 37,614,000 annually for last 10 years.

— n r i —

Job Opportunity for Graduates

Two positions are open in Washington, D. C. area which may be of interest to NRI graduates.

They are in private industry—(non-Government) no traveling.

Both are permanent; many employment advantages.

Both require thorough knowledge of theory and practical experience.

One requires background of Radio and Television receiver servicing.

The other requires a Communications background. A first or second class radio telephone or telegraph license is necessary.

Application should be by letter. Longhand letters will be given same consideration as typed letters. However, they should give a complete outline of education, experience, personal circumstances, salary requirements, and other helpful information including age, draft status, health, and so on.

We cannot give out more information about these positions or the company than has been authorized and is outlined above, except to say the organization has a good reputation and a good record. Write direct to: *Employer, Post Office Box 3046, Washington 9, D. C.*

Canadian Import Controls Removed

Import Permits No Longer Required

As of January 2, 1951, Canada's Emergency Import Controls are ended, according to information we have received from the Department of Trade and Commerce at Ottawa, Canada.

This is good news for NRI's Canadian students and graduates. It means they will no longer have to obtain import permits to receive their experimental kits. They can freely order from us such items of student supplies as Lesson Paper and Envelopes, Lesson Binders, Batteries, etc.

Students and graduates can buy Testing Instruments, Tool Kits, etc., from our Supply Division.

There is still some restriction on the amount of money which may be sent by a resident of Canada to the United States without special permit, being limited to \$50 in any calendar month. Residents of Canada who want to send more than \$50 at a time should apply to their nearest branch bank.

Of course Canada's customs regulations are still in effect, which means that any merchandise imported into Canada must be cleared through the customs offices and the regular duty charges paid.

— n r i —

New TACO 5-Element Yagi For Weak Signal Areas

A new 5-element Yagi Antenna tuned for any one of the low-band (2-6) or high-band (7-13) channels is announced by Technical Appliance Corporation, Sherburne, N. Y., manufacturers of antenna systems.

Three directors, antenna element and reflector designed and manufactured to most efficient dimensions electrically, assure fine performance in fringe and sub-fringe areas. Extremely high front-to-back ratio and pinpoint directivity inherent in the Yagi design minimize ghost effects caused by reflected signals. Delivers 11 db gain by actual field measurement.

The Taco 5-element Yagi for low-band channels is assembled by means of the exclusive Taco Jiffy-Rig type of construction saving the installation man time and costly call-backs due to mechanical failures.

The 5-element Yagi for the high-band channels comes pre-assembled in the new Taco spring-loaded Click-Rig form. No assembly time is needed as all elements flip into position and lock. Antenna may be carried to point of installation

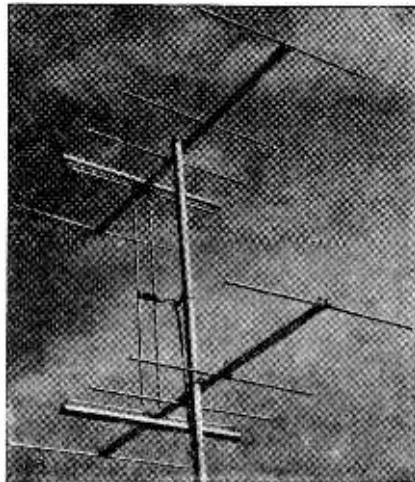

in folded form and then opened, as there are no nuts, screws or thumb-screws to tighten.

Both models are of all-aluminum construction for extra long life. Physical shape offers low wind resistance, thus cutting need for guys. Both are available in several types for varying needs, stacked or single, depending upon signal strength available. Stacking lines are supplied with stacked assemblies, or may be obtained for addition of antenna to existing array.

— n r i —

New British Speaker

A new British-made speaker is now being distributed by Sun Radio & Electronics Co., 122-124 Duane Street, New York City, distributors of industrial and high-fidelity sound components.

The new British Wharfedale W10/CSB is a 10" speaker especially designed for medium to small rooms. Response is comparable to most 12 to 15 inch speakers, without the booming effect caused by the larger speakers when used in smaller rooms.

Center diaphragm reacts to highs, while larger paper cone handles the lows. Cone is suspended by cloth in order to eliminate carry-overs. Real-presence effect is achieved with up to 5 watts power input. Impedance is 12/15 ohms.

The speaker was designed by G. A. Briggs, renowned speaker authority and author and is used by the BBC for monitoring purposes.

Sun Radio has designed and produced a cabinet for this speaker providing proper baffle and at the same time with overall dimensions proper

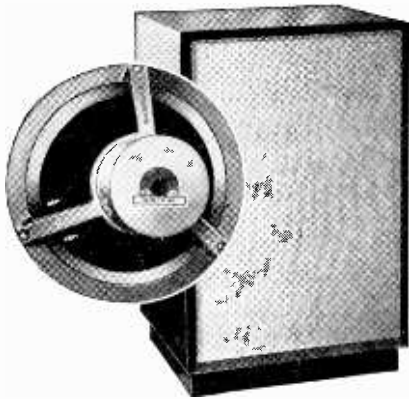

for smaller rooms. It is available in either blonde or mahogany finish.

— n r i —

Automatic Line-Voltage Regulator For Steadier TV Pictures

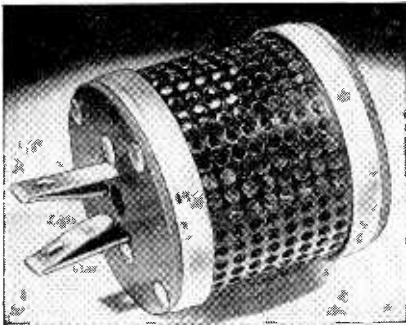

For steadier TV pictures regardless of line-voltage fluctuations, Clarostat Mfg. Co., Inc., Dover, N. H., now offers its Automatic Line-Voltage Regulator to and through its distributors. This aid to still better TV entertainment, particularly in rural districts or areas experiencing line-voltage fluctuations, is really a handy accessory. With male and female Edison connections at either end it plugs in between the TV set's attachment plug and the outlet. Two models are available: TV-A rated at 300 watts, for sets consuming 200 to 300 watts, and TV-B rated at 375 watts, for sets consuming 300 to 375 watts.

— n r i —

Twin-Driven Corner Antenna For All-Channel Coverage

A new all-driven-element antenna is announced by Technical Appliance Corporation, Sherburne,

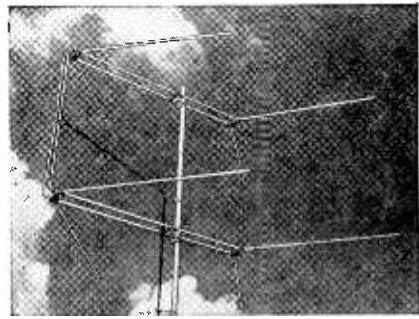

N. Y., manufacturers of Taco antenna systems for TV, FM, and AM. This new antenna type has been designated as the 1700 Series and is called the Twin-Driven Corner Antenna.

Electrically and mechanically this all-channel antenna offers advantages over the popular X-Type antennas. With all elements driven the directivity of reception has been narrowed, thus minimizing ghosts caused by reflected signals.

The front-to-back ratio is extremely high adding to its fine performance. Both high- and low-band lobes coincide due to the phase relationship controlled through feeding.

Mechanically, the new Taco Twin-Driven Corner Antenna offers low-wind resistance and proves very rigid when assembled. Assembly is accomplished by means of the famous Taco Jiffy-Rig type of construction. The antenna elements are merely swung into place and wing nuts tightened to complete the antenna ready for installation.

These new antennas are available in single or stacked models, depending upon the requirements of the installation.

— n r i —

New Automatic TV Tube Machines Used by Sylvania to Process 24 Inch Picture Tubes

Huge automatic machines designed and built by Sylvania Electric Products, Inc., are used in daily production of larger sizes of TV picture tubes. These new machines are used to exhaust as many as twenty-four 24" tubes in a step-by-step process. Each machine is said to cost upwards to \$200,000. According to H. D. Broker, manager of Sylvania's large picture tube plant in Seneca Falls, N. Y., current demand is now at the rate of about 7,000,000 tubes annually, most of them in the sixteen inch and larger sizes. Sylvania also has a large picture tube plant in Ottawa, Ohio.

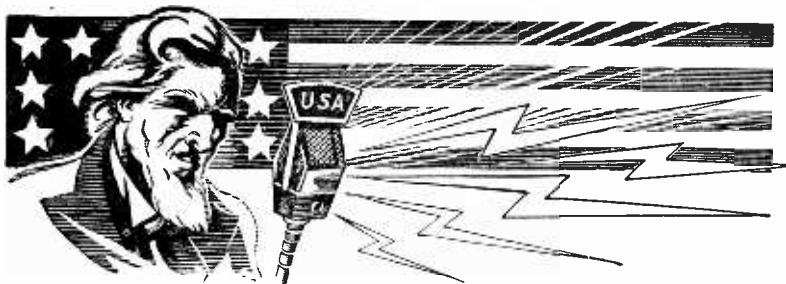

THE VETERAN'S PAGE

Devoted to news items and information of special interest to veterans taking NRI courses under the GI Bill of Rights.

Veterans: Play Safe!

AS we go into the New Year—1951—veteran students need to be particularly thoughtful in their actions related to GI training.

First: The time within which new courses may be started is becoming quite limited.

Second: Changing from one course to another is becoming more difficult.

Third: Stopping courses for trivial reasons or by mere neglect may prove costly.

A recent instruction of the VA based on PL-610—better known as Taft-Teague Bill—makes resumption of courses more difficult than before if the course was interrupted because of failure to make progress. You may be interested in an abbreviated quotation from the Instruction:

"Where evidence . . . establishes that a veteran by reason of his unsatisfactory progress will no longer be retained as a student . . . there will be no further entitlement to education or training . . . unless:

- "1. The veteran . . . is able to establish . . . that his failure to progress was not due to his own misconduct, negligence or lack of application, *and*
- "2. It is shown that the veteran has need of the desired course to complete his . . . objective, and that his aptitudes . . . assure that he can successfully complete the requested course."

"No further consideration will be given to a veteran's request for an additional course or training . . . if . . . there has been discontinuance of more than one course . . . because of unsatisfactory progress."

You will notice that if the course was discontinued for lack of progress, the veteran must establish that the interruption was not due to

negligence *and* must show need for the course *and* ability to complete it. This is very important because it makes resumption of training, under some circumstances, more difficult than enrolling originally. It is important that *your* training be not interrupted for failure to make progress; if you can't study, by all means tell us. It makes a difference—whether you "withdraw" or "fail to make progress."

* * *

Form 7-1905e

The title of VA Form 7-1905e explains its uses: *Request for Change of Course, Additional Education, or Transfer From Place of Training.*

As regards NRI courses this form would be required in these situations: (1) To change from one NRI course to the other without finishing the first; (2) To take the second NRI course after completing the first; (3) To take training elsewhere after enrolling at NRI or to train at NRI after enrolling somewhere else.

In each of these cases the regional office requires the veteran to complete the *front* of the form and the *previous* institution to complete the *back*. If the application for a change is approved, a "Supplemental" certificate is issued for the authorized training.

Supplying the completed form to the VA is the veteran's job. He must take the initiative. Most schools will cooperate by completing the *back*, but you'll get better service when requesting it by supplying a stamped, addressed envelope and particularly by using your student number so your record can be located.



N.R.I. ALUMNI NEWS

H. J. Rathbun	President
F. Earl Oliver	Vice Pres.
Claude W. Longstreet	Vice Pres.
Norman Kraft	Vice Pres.
Louis J. Kunert	Vice Pres.
Louis L. Menne	Executive Secretary

CHAPTER CHATTER

Detroit Chapter is off to a great start in 1951 with the new slate of officers planning and putting into operation a varied program of educational lectures and demonstrations, plus a liberal sprinkling of entertainment. The new officers are Chairman, Harry R. Stephens; Vice-Chairman, E. L. Slater; Secretary, Kenneth L. Kacel; Treasurer, F. Earl Oliver; Financial Committeemen, Clarence McMaster, Emmett Haag; and Librarian, Prince Bray.

The Service Forum is, of course, always a popular part of our programs. Members are requested to bring in sets for servicing. Some lively discussions take place in which all members are permitted to take part. . . . Earl Oliver is often in charge of the Service Forum and doing a bang-up job. Floyd Buehler was in charge of one meeting and through his courtesy we were shown a film on the Hallcrafters two-way communications apparatus.

At a recent meeting, members of Detroit Chapter, as guests of the Institute of Radio Engineers, heard Mr. James B. Tharpe, Sales Manager, Trans. Division of Allan B. Dumont Laboratories, on the subject, "Industrial Color Television." . . . Meetings on the second and fourth Friday of each month at Electronics Institute, 21 Henry Street, at Woodward.

Philadelphia-Camden Chapter had the pleasure of another visit by Mr. John F. Hirst, Field Service Engineer, Zenith Television, whose headquarters are the Stuart F. Lauchheim Company of Philadelphia. Mr. Hirst gave a two hour demonstration in aligning a television receiver, using a Sweep Generator and Oscilloscope. Mr. Hirst injected irregularities into the set and then proceeded to show our members how to correct them with the use of the Sweep Generator and Oscilloscope.

Mr. L. L. Menne, our Executive Secretary, paid us a visit on this occasion. After the meeting refreshments were served.

Harvey Morris, at another meeting, gave us a similar demonstration, using a Capehart Television receiver which he aligned, step by step, using a Sweep Generator, Scope, and Meter.

We have been averaging about thirty members at our meetings, but attendance is now picking up, which is encouraging to our officers who have arranged excellent programs for the immediate future. . . . Remember, we now meet in the K of C Hall, Tulip and Tyson Streets, in Philadelphia, on the second and fourth Monday of each month.

Chicago Chapter comes through with exciting news regarding pepped up activity in the Windy City. The new chairman, Mr. Charles C. Mead, ably assisted by an enthusiastic staff of officers, is working very hard for the benefit of our members. . . . Louis J. Brodhage took over at one meeting and explained in detail and by demonstration the problems that may be encountered in servicing an automobile radio where vibrator replacement may be contemplated. At this meeting Anthony Maday and Urban J. Volte joined our Chapter.

At another meeting, Brodhage gave an interesting demonstration of the effect of introducing defects in an AC-DC set and the trouble shooting solution to the problem.

The Service Forum is the old reliable meeting in Chicago, as in other chapters. Word has been received that Chairman Mead has purchased an Oscilloscope kit and a VTVM kit. The boys are starting to go to work with this material. . . . Meetings on the second and fourth Wednesday



Going It Alone?

Let's face it. Maybe the trouble with my work isn't the boss, or the folks I work with, or the way the stuff is coming through . . . Maybe it's me!

And maybe the trouble with you started around the time you decided to skip church for some extra sleep, for fishing, or just fooling around.

For nothing can take the place of church in your life—in anyone's life. It fills a deep-seated human hunger for peace of mind and all the satisfactions that spring from it.

New thousands every day are finding this is so. By going to church, by reaffirming their faith, they're gathering new strength, new hope, new courage.

Families, finding themselves through faith, are being brought closer . . . becoming real families, strong against the world, happier, more tolerant among themselves.

Men and women everywhere are gaining a new sense of "the balance of things" . . . the inner security that brings success to work as well as to life . . . by finding themselves through faith.

Can you honestly say that things have been better for you, going it alone? Or wouldn't you rather join your neighbors . . . and find a happier, more successful life—through faith!

—*International Harvester*

— n r i —

Names and Addresses of NRI Alumni Association Officers

- President H. J. Rathbun
506 E. 26th St., Baltimore, Md.
- Vice President F. Earl Oliver
3999 Bedford, Detroit 24, Mich.
- Vice President Claude W. Longstreet
533 Rahway Ave., Westfield, N. J.
- Vice President Norman Kraft
6 S. 8th Street, Perkasio, Penna.
- Vice President Louis J. Kunert
539 Seaford Ave., Massapequa, N. Y.
- Executive Secretary Louis L. Menne
c/o National Radio Institute Alumni Ass'n.,
16th & U Sts., N.W., Washington 9, D. C.

— n r i —

One must think to learn; and to learn, one must learn to think. . . .

of each month at 8 P.M., at 666 Lake Shore Drive, in the Tower Space. This is in the American Furniture Mart. Enter building through the West door.

New York Chapter is rolling along in great style, as usual. Never less than fifty members in attendance at a meeting, and usually seventy-five or more. . . . Same aggressive officers in the chairs and keeping things moving at all times. . . . Nothing like enthusiastic officers, and man, they have them in New York!

Ralph Georg is the latest big name as a lecturer. Mr. Georg has talked to the Chapter on a number of occasions on television. He fits in very well with Hull, Remer, Williams, Newbeck, Clayton, Guzy, and others who do so much to assist Chairman Wappler and Secretary Kunert in keeping things moving at all times. Remer and Zimmer, two members of the Executive Committee, also always on the job. That is why there are never any dull spots in meetings of New York Chapter.

Visitors are cordially invited. L. L. Menne was a recent visitor. . . . Met with the Executive Committee and expressed great satisfaction in the type of meetings held by our Chapter. Meetings are held on the first and third Thursday of each month, at St. Mark's Community Center, 12 St. Mark's Place, between Second and Third Avenues, in New York City.

Baltimore Chapter, jubilant over the election of H. J. Rathbun to President of the NRI Alumni Association, is planning a big year in 1951. Incidentally, Mr. Rathbun was recently installed in office by the Executive Secretary from Washington. . . . Election of officers was held and the following will serve during the current year: Chairman, Elmer Shue; Vice Chairman, Clifford Whitt; Treasurer, Frank Orban; Secretary, Thomas P. Kelly; Sergeant-at-Arms, Thomas Clark; Librarian, H. C. Voelkel; Audit Committee, H. J. Rathbun and Clifford Whitt.

A most interesting talk on "Converting a TV Receiver to a Larger Screen Tube" was given by Clifford Whitt.

Meetings are held on each Tuesday night of the month (except the first Tuesday of the month) at Redmen's Hall, 745 West Baltimore Street.



Here And There Among Alumni Members

Graduate Walter J. Rhoades, of Woodside, Long Island, New York, now has his own store, specializing in Radio

and Television Servicing.

Congratulations to Graduate Henry L. Mueller, Jr., of Two Rivers, Wisconsin. Mueller has just received his First Class Radiotelephone license and is ready for a position in Radio Communications.

Alumnus Jose B. Valerio, of Taos, New Mexico, is doing fine with Radio and electrical appliance work. Has more work than he can do.

Graduate L. J. Howard, of Chattanooga, Tennessee is successfully operating his own business known as "Howard's Radio Service." He is in business, full time, and plans to move soon to a better location—needs more room.

John L. Zimmerman, of Coral Gables, Florida, reports that he is employed, full time, as a technician with Television Installation Company, Inc., Miami, Florida. Says "Effect-to-cause reasoning" is the key to successful repairs.

A recent visitor at NRI was Alumnus H. Wittenstein, of the Bronx, New York. Wittenstein is a full time motion picture projectionist, Radio and Television being his hobby.

Al Bimstein is employed by one of the leading Radio and Television servicing establishments in Brooklyn, New York. He has worked his way up from an Installation Helper to the TV Service Department, where he is now employed. In addition, Bimstein has his own spare time Radio and TV Servicing business.

Russell A. Ferris, of Dundas, Ontario, Canada, reports that he is now employed by the Canadian Westinghouse Company, Hamilton, Ontario, in their Radio Department, doing test and inspection work. Ferris says this is the best position he has ever filled and gives due credit to proper Radio training.

Graduate George W. Jackson, Franklin Square, L. I., New York, who is an Aeronautical Engineer, says that before taking NRI training, Radio equipment in aircraft was a complete mystery to him. Now he reports a working knowledge of this equipment, which is helping him greatly in his work.

Recent visitors to NRI were Mr. and Mrs. Harold Hazzard, of Binghamton, New York. Graduate

Hazzard has had his own full time Radio and Television Servicing business for the past six years. He is doing very well. His wife is now also active in the business.

We have received word from Alumnus Floryan J. Sendora, of Slovan, Pennsylvania, happily informing us that he has accepted a position with the RCA Service Company, doing installation and service work in his area. His work is in Television. Sendora also holds a First Class Radiotelephone license.

Graduate Manuel Flores, of Laredo, Texas writes that he has moved up from the Radio Repair business to enter the Wholesale Radio Distributing business. This is quite a venture. However, he indicates that he is already well on the way to success.

One of our older alumni, now located in Columbia, South Carolina, writes that he is contemplating a new Radio Service Shop there. He is Edwin A. Melville, who graduated from NRI in 1923. Melville says he has had contact with many NRI graduates down through the years, and is now personally coaching four students who are taking NRI courses.

Graduate Arley Studyvin, of DeSoto, Missouri, owner of two very large Radio and Television Sales and Service stores, writes that his business has been one of steady growth. Business during 1949 was far more than double any previous year, and business during 1950 was over one-third more than during 1949. Television sales and service have been responsible for much of this growth.

William V. Yocum, of Florence, Alabama, reports amateur call letters W4RUG. Yocum is a Staff Sergeant in charge of communications for his Battery with the Alabama National Guard. He also has a spare time home and auto radio service business.

Congratulations to Graduate Ernest D. Puckett, who is now with Station WAGC, Chattanooga, Tenn., as a transmitter engineer. He is well pleased with his work and future opportunities.

Chester Cromwell, of Nunda, New York, reports a growing part time Radio and Television Service business. He says that Television is taking up a very big share of his spare time.

Graduate Blueford W. Stanley, of Johnson City, Tennessee, writes that NRI training has greatly improved his knowledge of reading and arithmetic, as well as his ability to service radios. Reports a profit of \$532.50 servicing radios during the time he was taking NRI training.

NATIONAL RADIO-TV NEWS

16th & U Sts., N.W.

Washington 9, D. C.

Sec. 36.44, P. L. & R.
U. S. POSTAGE
1c PAID
Washington, D. C.
Permit No. 7052

For:

Mr. Francis H. Fingado
611 17th St.
Denver 2, Colo.

25236

4



Vol. 14 February-March, 1951 No. 7

Published every other month in the interest of the students
and Alumni Association of the

NATIONAL RADIO INSTITUTE
Washington 9, D. C.

The Official Organ of the N R I Alumni Association.
Editorial and Business Office, 16th & You Sts., N. W.,
Washington 9, D. C.

L. L. MENNE, EDITOR
J. B. STRAUGHN, TECHNICAL EDITOR

NATIONAL RADIO-TV NEWS accepts no paid advertising. Articles referring to products of manufacturers, wholesalers, etc., are included for readers' information only, and we assume no responsibility for these companies or their products.

Index

Article	Page
Editorial	2
The NRI Practical Training Plan for Television	3
Our Cover Photo	10
Television Servicing Methods	14
Canadian Import Controls Removed	26
The Veteran's Page	28
NRI Alumni Association News	29
Here and There Among Alumni Members	31

Printed in U.S.A.