

NATIONAL RADIO NEWS



FEB-MAR.
1946

IN THIS ISSUE
How to Repair Dial Drives
Developing the Ability to Diagnose Receiver Troubles
Alumni Association News

VOL. 12
NO. 1



Repeat Business

Have you ever seen two stores in similar businesses—one obviously succeeding and the other rapidly failing? Both may attract customers with similar merchandise and similar advertising, but the operators of the successful store know how to *keep* their customers.

The first requirement is to do the best job possible—to sell reliable merchandise and give honest service. But there is more. Your customers are human and expect courteous, respectful treatment. If you treat them as if you never expected to see them again (and didn't care either!) then you can expect them to go somewhere else next time.

A little politeness and a willing eagerness to be of service will do wonders in your relationships with customers. Treat each one as if you expected to do business with him forever. Of course, you won't be able to keep them all but continue your efforts nonetheless. Customers are "gold mines" of future business—bringing not only their own trade but also that of their friends, relatives and neighbors. Can you afford to throw away this business by being careless or thoughtless?

E. R. HAAS, Executive Vice President.



How to Repair Dial Drives

By J. B. STRAUGHN

Supervisor of Training

THE ticklish job of repairing dial drives recurs regularly in receiver servicing. Since there is little published information about the subject servicemen dread these jobs. However, with patience and the instructions I am about to give, you should be able to repair dial drives with the best.

When you turn a knob to tune a radio, your action changes the settings of condensers or coils within the set, and also operates a mechanism that indicates the frequency to which the radio is tuned (usually by moving a pointer over a dial or a dial past a pointer). When we speak of the dial-drive mechanism, we mean the mechanical system that causes these actions when you turn the tuning knob.

Belt and cord drives are the two types in most common use today. Other kinds of drives have been used—particularly direct drives, in which the tuning knob is attached to the tuning condenser shaft, and friction drives, in which a rubber roller, secured to the tuning knob, bears against a dial secured to the tuning condenser shaft—but these systems are so simple that you can repair them without instructions.

Belt Drives. A typical belt drive is shown in Fig. 1. As you can see, there are two pulleys, one mounted on the tuning shaft, the other on the condenser shaft, over which an endless belt passes. Usually there is some way of controlling the belt tension; in the illustration, this is done by the idler pulley P, which is held against the belt by the spring S with enough force to create the desired belt tension.

Although the dial has been shown as transparent

here so you could see how the system works, it is actually made of metal. The condenser shaft projects through a hole in the middle of the dial,

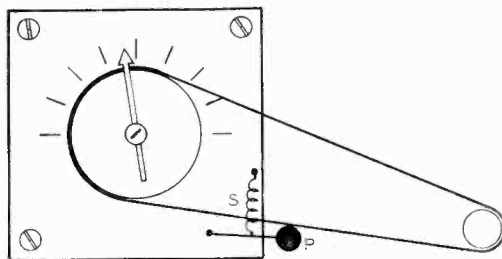

Fig. 1. A belt drive consists of two pulleys over which an endless belt passes. Optimum belt tension is maintained by idler pulley P and spring S.

and the pointer is fastened to the end of the shaft by a machine screw. The condenser pulley is mounted behind the dial.

Cord Drives. Cord drives are usually considerably more complicated than belt drives. Fig. 2 shows one of the simpler forms. Notice that the basic difference between this and the belt-drive system is that the dial cord (usually strong fish-line or similar material) is securely fastened to the condenser pulley, or drum, instead of merely running around it as a belt does. In fact, the dial cord is brought down inside the condenser drum (through a slit in the drum rim) and is hooked to a spring that keeps it taut.

Besides connecting the tuning shaft and the condenser drum, the cord also passes over two small pulleys. A pointer is clamped to the cord in the length between these pulleys, and, as the arrows show, this pointer slides along a supporting edge from left to right when the tuning shaft is rotated clockwise. Thus, this system gives us a horizontal movement of the pointer instead of the rotating movement produced by a belt drive, and so permits use of the rectangular "sliderule" type of dial that has become so popular.

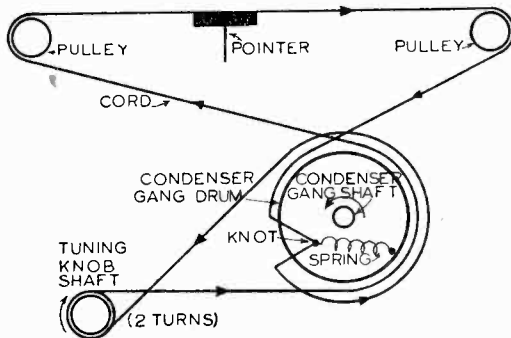

Fig. 2. A simple cord drive. The two ends of the cord are held firmly inside the drum by means of the spring. Turning the condenser gang shaft moves the cord and the pointer slides along the metal edge of the dial.

Now let's see how to repair belt and cord drives when they become defective.

Repairing Belt Drives

The usual defect of a belt drive is that the belt slips, either because it has stretched or frayed or because the idler pulley does not hold it under tension. There is usually some way to increase the tension on the belt. In the system shown in Fig. 1, for example, the belt can be made tighter by shortening the spring that holds the idler pulley against the belt. Sometimes the tuning shaft is in a slot, in which case the belt can be tightened by sliding the shaft in the slot. If the belt is stretched or frayed, however, it must be replaced.

The important thing to watch in replacing a belt is that you have a belt of the right size. There are more than a hundred different sizes in use, and generally the wrong size will not work; either it will be too tight, in which case it will break very soon and make the set hard to tune in the meantime, or it will be too loose, and the tuning system will not work at all. The best way to get the right size is to order an exact duplicate belt for that particular receiver from either your

supply house or the set distributor or manufacturer. The make and model number of the set are all you need to know to get the right belt from one of these sources.

If an exact duplicate belt is not available, you will have to know the precise size of belt you want. One way to find this out is to cut the old belt and measure it carefully. Sometimes, though, the old belt will be missing, or will have stretched so much that a measurement won't give you accurate information. In this case, the best thing you can do is to run a silk cord (which will not stretch) over the pulleys to find the right length.

Installation of endless belts is easy. Usually you will have to remove the dial to put one on, and sometimes you must unscrew the bracket holding the tuning shaft so that its pulley can be moved closer to the condenser pulley; then the belt can readily be slipped over the pulleys.

Repairing Cord-Drive Systems

There are so many variations of cord-drive systems that a much longer article than this could not cover them all. However, each manufacturer usually issues diagrams showing how to repair and restring his sets; these diagrams, and your own mechanical ability, will let you repair almost any system. We've included a number of samples of manufacturers' diagrams to show you what they're like. It would be a good idea for you to build up a file of such information; you can al-

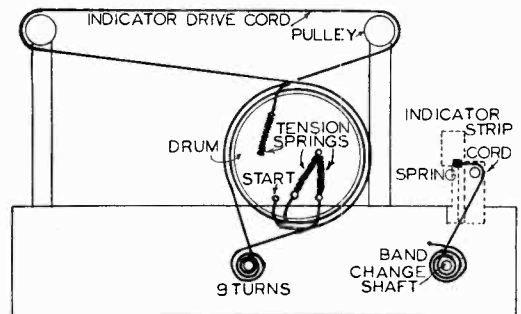

Drive of RCA K-130 receiver. In this system there is a separate band indicator drive besides the station indicator drive.

ways get the instruction leaflets from the manufacturer, and usually from his distributor.

We're not going to attempt to cover specific drive systems here. Instead, we are going to give you a series of service hints that apply to any system.

The first is—be sure you know what the drive is supposed to do. If you have the manufacturer's diagram, or the old cord is still on the set, trace what happens when you turn the tuning knob. Before you remove the cord, if you don't have the manufacturer's diagram, make a sketch to show where the cord is supposed to go, with arrows to show the direction the cord and the pointer move when the tuning knob is turned. (Generally, but not always, the pointer moves across the dial from left to right, and the con-

used. Any fishline you use should have a breaking strength of at least 18 pounds.

Phosphor-bronze wire cords are also available. These are particularly useful in sets where the cord must move a heavy mechanical system. Heavy linen cords are also used in such installations.

Cords usually come in 10- and 25-foot lengths, wound on spools. You can get them from any radio supply house.

Common Defects. Several things may happen to cord-drive systems. The cord may lose tension, either because it stretches or because the tension spring does; the cord may slip; the pointer may stick; or the cord may jump off its pulleys, or fray, or break. Let's see what to do in each case.

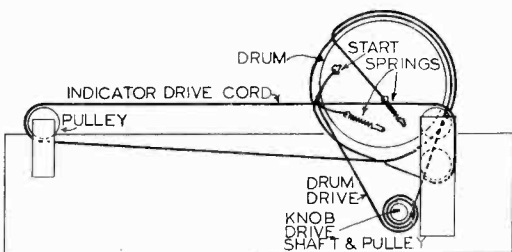

Drive of RCA U-125 receiver. Here two dial cords are used.

denser gang opens when the knob is turned clockwise.)

If the cord is not on the set, or has broken and been pulled off the pulleys, you may have to study the set carefully to figure out just what the system is supposed to do. Once you have decided how to make the repair, draw a diagram to show just what you intend doing. This will serve a double purpose: it will keep you reminded of how you are going to make the repair, and, if you find you are wrong, it will show you what not to do the next time.

The cord is usually wound around the tuning shaft at least twice, often more, and you must be careful to wind the correct number of turns on the shaft when you install a new cord. If you put on too few turns, the cord will probably slip; too many turns, on the other hand, will tend to bunch up and may jam the system. If the cord is gone, so you can't tell how many turns there should be, try using two or three.

What Cord to Use. Ordinary string or thin cotton fishline is not satisfactory, because it will stretch. If a thin cord is needed, silk or nylon fish cord is best. A cord with a Fibreglass core and a synthetic braid cover will also work well. Medium thickness cords (diameter approximately .04 inch) are made of nylon, linen, or cotton; cotton cords of this diameter are satisfactory because they will not stretch at the tensions normally

Loss of Tension. If the cord is too loose, it will simply slip around the tuning shaft instead of turning with it. Usually this defect can be remedied by shortening the cord. One way is to knot it again at the point where it is attached to the tension spring inside the condenser shaft pulley. Always use a square knot which will not slip. You can put a drop of speaker cement, fingernail polish, or shellac on the knot as an added precaution against slipping.

Sometimes the cord is loose because the tension spring has stretched too much. If the spring al-

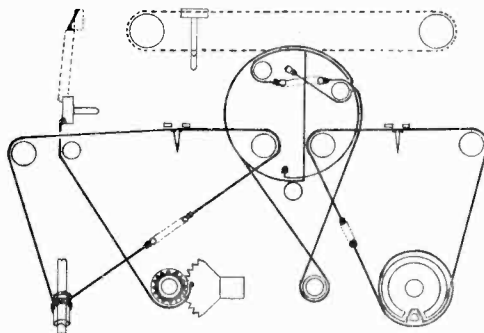

Drive of GE 73 receiver. Notice the use of multiple cords and pointers to indicate wave band, volume, etc.

lows the knot in the cord to come almost out of the slit in the condenser shaft drum, tighten the spring rather than shorten the cord. Inspect the end of the spring that is not hooked onto the cord. This end is anchored inside the drum, usually either to a bent-up metal ear or in a hole. There may be other ears or holes, farther from

the slit, in which the spring can be anchored; if so, try one of them and see if the cord tension is sufficiently increased.

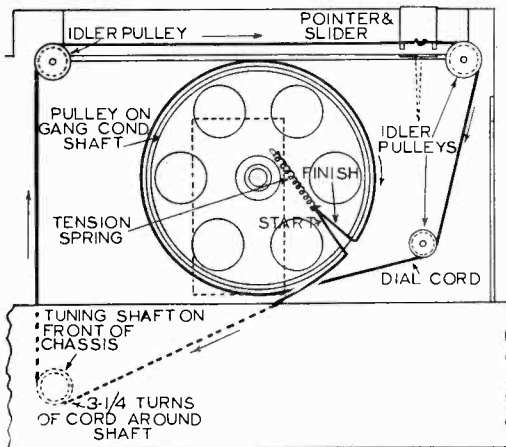

Drive of Motorola 51F12 receiver. An extra idler pulley is used.

If not, or if no other anchor points are provided, you can either shorten the spring or install a new one. To shorten the spring cut off a few turns

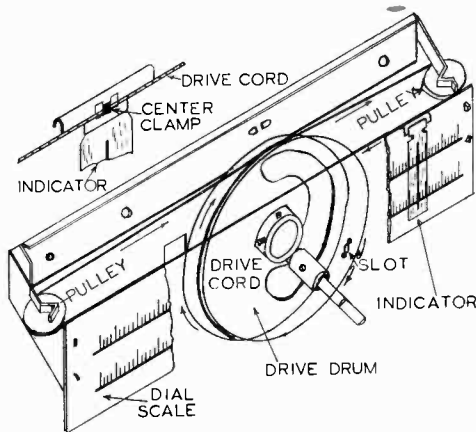

Drive of GE-U51 receiver. A flat spring is used to hold the pulleys.

from the anchor end with a pair of cutting pliers and bend the cut end to form a new hook.

If a shortened spring is still too weak, install a Page Six

new one. The exact size is not important, but be sure it is strong enough so that it will not be stretched out of shape when it is installed—otherwise it will quickly lose its tension. When you install a new spring, or shorten an old one, be careful not to let the cord slip off the pulley system—if it does, you may have to restring the whole drive. You can hold the cord in place by pressing your thumb firmly over the slit where the two parts of the cord emerge from the condenser shaft drum. If you need both hands for the spring, put a piece of scotch tape over the slit instead.

Be sure you seat the end of the spring firmly in its anchor hole or around its anchor post. Usually it's easiest to do this by grasping the end of the spring with a pair of needle-nose pliers, stretching it slightly past the anchor point, then allowing it to relax and guiding it into or around its anchor as it does so.

Slipping Cord. If the cord seems tight, but slips on the tuning shaft, probably grease or oil has gotten on it. You can remedy this condition by working powdered rosin into the cord. A commercial non-slip compound, having a rosin base, is available in stick and liquid form. This compound has the advantage that it shrinks the cord slightly in drying, thus giving increased tension as well as eliminating the effects of oil or grease.

Sticking Pointer. As we said earlier, cord drives are always used with slide-rule dials, in which a pointer moves horizontally over a long, rectangular dial that resembles a slide rule. If the pointer sticks or binds, the cord will get taut on one side of the pointer and loose on the other, and may jump off its pulleys; if the cord does not jump off, the tuning knob will at least be difficult to turn.

The pointer of such a dial usually slides along a metal track on the edge of the dial, or on the dial plate edge itself. If the pointer sticks, inspect the track for burrs that may cause increased friction. Remove them with fine sandpaper, and spread a light film of vaseline over the track. (Don't get oil or grease on the cord.) Make sure the dial lights do not interfere with the pointer movement; if they do, bend their brackets slightly.

Cord Jumps Off Pulleys. Provided the cord is tight enough so that it should normally stay on its pulleys, the usual reason it jumps off is that it is caught somewhere in the system. Turning the tuning knob then tightens part of the cord and loosens part of it until the loose part finally slips off its pulleys altogether. The usual cause is a sticking pointer, as we just said. Whatever the cause, remedy it, then put the cord on again. Make sure that it is tight enough to stay.

Frayed or Broken Cord. Either of these must be replaced. The broken cord is usually harder to replace, because the drive system will probably be completely unstrung and you will have to figure out how the system works. Replacement is not difficult if you have the manufacturer's sketch of the stringing arrangement. If you do not, be sure to make a diagram of the system. If the cord is frayed but still in place, make the diagram before you remove it.

Turn the condenser gang either fully closed or fully open (maximum or minimum capacity) before you start restringing, then string the drive in a direction such that any tension you put on the cord will tend to keep the condenser in position. This will let you pull the cord taut during the operation without fear of its slipping. Manufacturer's instructions usually specify whether the gang is in or out for the direction of string-

denser gang is full out, and goes toward the low-frequency end when the gang is turned in. You may have the system strung backwards, in which

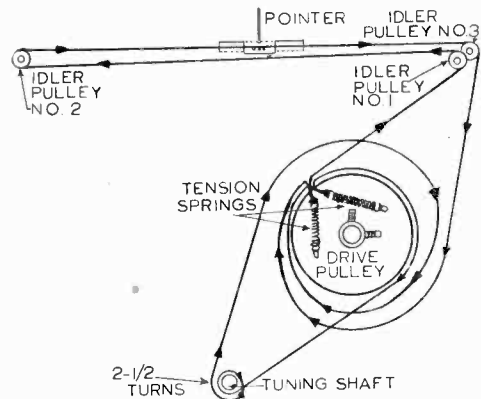

Drive of Motorola 61T23 receiver. Notice that the two drive cords are completely separate.

case all you can do is try to smile and do the job over.

Turn on the set and check the accuracy of the pointer setting. If necessary, adjust the pointer position until both the frequency of the station being received and the frequency indicated by the pointer are exactly the same. Then, place a drop of speaker cement or collodion on the pointer clip to bind it to the cord. It's worth while

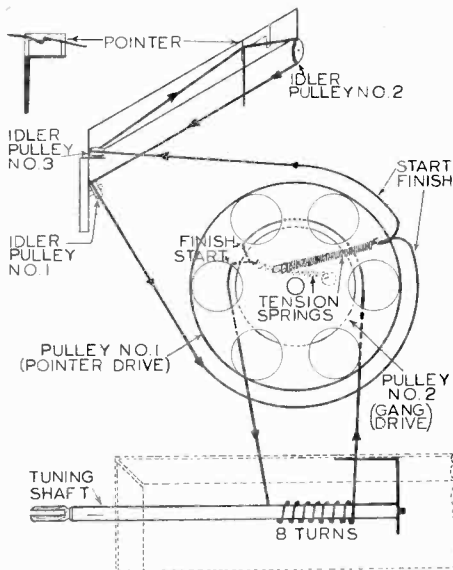

Drive of Motorola 101R21 receiver. In this drive two drums secured together are used.

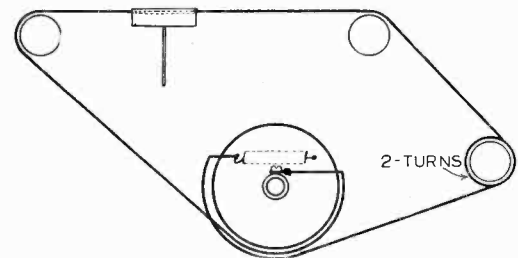

Drive of GE-J64 receiver. The cord ends are anchored separately.

ing shown. (Be sure you cut enough cord off the spool to do the job. It's better to waste a few inches than to have to waste the whole piece because it is short by half an inch.)

Finally, connect the pointer to the cord in a temporary manner. (Most pointers clip on the cord, but in some systems the cord is wrapped around a stud on the pointer slider.) See that it is at the high-frequency end of the dial when the con-

to take a little trouble with this, because your customer may find it irritating to have the pointer indication even a little off what it should be. In fact, you can demonstrate to him how accurately the pointer is set when you're finished.

These instructions have been quite general. With care and patience you should be able to handle all the dial drive troubles brought to you. Don't forget to make a sketch of the arrangement before tearing down a complex drive for which you do not have the manufacturer's data and file for future reference your notes about the trickier cases.

— n r i —

Gets Radio Business from Five Counties in Rural Community

Mr. J. E. Smith, President
National Radio Institute
Washington, D. C.

Dear Mr. Smith:

"I have recently received my diploma as a graduate of NRI and am mighty proud of it. The diploma represents many hours of hard work, but I wouldn't trade what the diploma means in knowledge for a great deal.

"It is befitting at this time to thank you and your organization for all the wonderful help and cooperation you have given me during my studies and preparation for a most interesting work. I

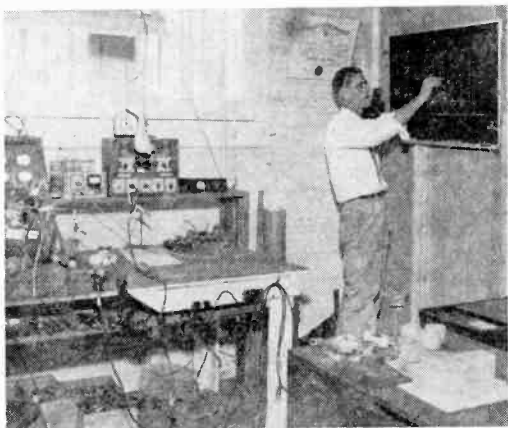

find it very difficult to select words to express my very deep appreciation for your kindness in various respects during the past year.

"Your system and methods of assisting the uninitiated mind from the very beginning of the NRI Course are unsurpassed in my opinion.

Page Eight

"To prove to you that you do really have 'something' in the NRI Course, I submit the following information:

"I live in a small rural county having a population of about 6,000 and being situated on the Gulf of Mexico. The largest town in the county (Sopchoppy) has a population of 1,000. We have several small towns in Wakulla County, one of which is Crawfordville and the County Seat. I am bor-



dered by several cities, such as Tallahassee, Florida which is the capital of the State. Tallahassee is about 40 miles from my location (Sopchoppy) to the north. I have other cities to the south. I receive radio service work from four additional counties other than my home county absolutely without solicitation whatsoever. This work comes in from the result of 'word of mouth' advertising. I have restored many sets to good operating conditions which others in cities had failed on.

"My ability to perform good service is attributed directly to the NRI Course. I could not have done it without your help. With all my good fortune with respect to the subject, I still realize that I have only begun to learn. I have prepared myself to be in a position to read and learn.

"I have a service shop in the back of my store. The shop is 12x16 feet with plenty of light and fresh air. I have a ten foot service bench which is portable and all equipment, power supplies and AC outlets are mounted and installed right in the bench. I have one master power AC cord which plugs into the main AC power line and supplies all equipment, power packs, instruments, etc. In case of emergency I can unplug this master power cord and no power can be supplied the entire work bench. This is convenient also if I choose to relocate my work bench. In addi-

tion to plenty of window lights in the shop, I have the shop equipped with fluorescent lighting. I have my book case and desk located at



the left end of the work bench. At the right end of the work bench I have a row of all metal cabinets each having 30 small metal drawers. These carry all small radio parts—all arranged so as to be quickly accessible. I have a regular office chair which has cushions at back and seat. The chair is mounted on rollers. Thus you see I can reach parts from cabinets, materials from desk, and any diagrams, service manuals or reference books from book case without having to get out of the chair. This saves a lot of time and of course my time is money and therefore my living.

“All work is strictly cash. Work by the hour is done at \$1.50 per. All services are as honest as ‘The days are long.’ We make no attempt to take advantage of the other fellows’ lack of knowledge about electronics.”

Very truly yours,

A. B. CARRAWAY.

A sailor attending an auction was doing some spirited bidding for a parrot. He bid \$5. Someone bid \$10. He bid \$15. Someone bid \$20. Finally he got the bird for \$40.

Feeling a little foolish, he said to the auctioneer, “That’s a lot to pay for a parrot, can he talk?” Whereupon the parrot replied, “And who do you think was bidding against you?”

Amateur Transmissions

Some 60,000 amateur operators may now resume operations in new frequency bands allocated by the FCC, it was recently announced by the Federal Communications Commission.

The following frequency bands are assigned for amateur use:

28.0-29.7 mc using type A1 emission (code), 28.1-29.5 mc using type A3 emission (voice), 28.5-29.7 mc using special emission for radiotelephony (FM), 56-60 mc using A1, A2, A3 and FM transmission emissions. 144-148 mc. using A1, A2, A3 and FM emissions and special emissions for radiotelephony and radio-telegraphy (FM). That portion of the band between 146.5-148 mc shall not be used by stations located within a 50 mile area of Washington, D. C., or Seattle, Washington, because these facilities for the time being are used by other services.

The frequencies of 2300-2450 mc, 5250-5650 mc, 10000-10500 mc and 21000-22000 mc using A1, A2, A3, A4 and A5 (television) emissions and special emission for radiotelephony and radiotelegraphy (FM). None of these frequencies may be used by amateur stations in Central, South and West Pacific Ocean areas for the present time.

Station and operator licensing is handled on FCC form 610, at some 30 FCC local offices throughout the country.

— n r i —

Television as an Advertising Medium

Television in sponsored advertising will have great importance in coming years. There is a large amount of money—\$3,000,000,000 per year—spent on services with which television will be competitive. This money is now put up about 50% by the public, 50% by sponsors. Although radio and sound broadcasting is a less expensive and faster growing advertising medium than any other, television can cost considerably more and still not exceed the cost to sponsors for the same effect obtained by magazines and newspapers, since television combines sight, as they do, with the added attention value of sound and action. Some advertising experts estimate television has 3 to 10 times the selling value of sound radio.

— n r i —

A Rude Awakening

A preacher at the close of his sermon discovered one of his deacons asleep. He said: “We will now have a few minutes of prayer. Deacon Brown will lead.”

“Lead” said Deacon Brown, suddenly awakening. “I just dealt.”

GET A LETTERHEAD

Mr. Hugo Gernsback, in his magazine, Radio-Craft, has an interesting article which he addresses to "GI Radio Servicemen." We asked for and received permission from Mr. Gernsback to repeat his article because the point he makes is a very important one, especially during these days of reconversion. Not only the returning war veteran but every radio serviceman who is not yet fully established can profit from what Mr. Gernsback says. Following is a reproduction of the article for which we owe thanks to Mr. Gernsback. Remember it is Mr. Gernsback who is speaking.

A FEW weeks ago a radio serviceman who lives in the suburbs of a large city called upon us. Previous to his call he had written announcing that he would pay us a visit on a certain day. This is a routine occurrence and we see many radio servicemen and engineers during the course of a week, as can be readily surmised.

This particular caller, an old reader of the magazine, was recently discharged from the Army. He had set up shop again to reestablish himself once more in his community as a radio serviceman, as have countless other returned war veterans.

All this is prosaic and normally would not rate valuable space in any magazine. But this case was different because our caller, whom we may call Mr. X, had made the trip for one purpose only. That was to unburden himself of a "gripe." We use the GI term in this instance because Mr. X seemed on the surface to be justified in his wrath. Indeed, he was on the warpath. He cursed the radio industry from one end to the other in no uncertain terms. Said he, and we quote verbatim:

"Since my discharge and return home from abroad I have tried desperately to get back into the radio servicing game. I sent out no less than 35 letters to radio manufacturers, which includes set manufacturers as well as parts people, so I could get an agency for my town. So far I have received four answers out of 35 letters and these four answers were vague and hold out little promise. Yes, I did receive a few leaflets and circulars, and some advertising matter, but that is all. The few letters that came in referred me to the nearest distributor.

"Is that what we boys have fought the war for? Is that all the consideration war veterans are getting from the radio industry, when we are **rarin'** to go in order to do a job?

"Perhaps there is an answer, and if there is, I

would like to have it. That's why I called on you because if anyone can tell me, you can."

After Mr. X had cooled down, and had lit the fresh cigarette which we offered him, we looked over the letter in which he had announced his coming.

The letter was written on a plain sheet of white paper, not too clean. It was handwritten by Mr. X, and the writing was none too intelligible.

We asked him if he would answer a few questions before we went to the core of the problem. He said he would be happy to answer all of them if he could.

We then asked him if he was married. He said not yet, but he intended to be, "real soon." We continued:

"When you are going out with your best girl in your community just how do you proceed? Do you wear your working clothes? Do you take her to a nice eating place, unshaven, without collar and tie, or just how do you proceed in that particular case?"

Mr. X looked puzzled and annoyed: "What has all this got to do with my problem? Nevertheless the answer is, of course I do spruce up. I put on my best blue suit and I certainly do tidy up, the same as we had to do in the Army. Any self-respecting man would do the same. My girl would not think much of me if I wanted to take her out in fatigue dress."

"Precisely. That is exactly what we thought," we answered.

"Now Mr. X, we find it necessary to give it to you straight, right between the eyes. We have before us your letter which you sent us. It is just a plain handwritten letter as you will observe. Few men realize the importance of a letter to a business concern. You would not think of taking out your best girl unless you were presentable, but you did send to big firms letters which land in the waste paper basket or are relegated to a clerk who has hundreds, if not thousands almost alike and which under the pressure of today's tremendous business will never be answered.

"As your girl judges you by your appearance and the care you take in dressing, so the business house judges you by your letter. Every executive has acquired a sort of sixth sense whereby he can tell by merely glancing at a letter the type of man the sender is. To put it another way, you would not call upon the manager of a big radio company in your fatigue dress if you want-

ed to get a radio set agency for your community. Yet, if you sent out letters like the sample which we have before us to the 35 radio concerns which you mention, we are not at all surprised that you got nowhere. It is surprising that you got any replies at all.

“You should remember first of all that you are in a seller’s market today. Every radio manufacturing company, with a few exceptions, is over-worked and understaffed. They have a tremendous amount of requests such as yours and can afford to be choosy. When handwritten communications such as yours and others come into the office they are not taken seriously because the immediate impression is that it does not come from a business man. Today successful firms want to deal with business men only—men whom they think can do justice to their line. Even a neat typewritten letter composed faultlessly will meet with no attention whatsoever if it is not on a printed letter head.

“Now Mr. X, suppose you put yourself in the shoes of the radio manufacturers. Of course they want business. Of course they wish to sell as many sets as they can. But how are they to judge the radio servicing fraternity? If the radio manufacturing firm is old and long established they probably have their own representatives who visit the different localities to find out for themselves who in the community is best equipped to handle their line. If the serviceman has a well-run shop, if he is known in his community, there will be little difficulty. It is then a simple matter to choose a representative for the line.

“But take new concerns, of whom many are springing up now, who are looking for live servicemen to represent their product. They have nothing to go by except perhaps mailing lists, which are not always helpful, particularly at this time when a large percentage of servicemen had gone to war and closed up shop. They do not know when these men will return or how to contact them. They can of course get every telephone directory in the country, look in the classified sections and make up their own list, which indeed many have done. Some firms feel that if the man is listed in the classified directory and has a telephone he must be in business, so that too counts.

“But when you, Mr. X, break in ‘cold’ on a firm whose line you wish to represent they have no means of judging you except by your own representative—AND THAT IS YOUR LETTER. THAT AND ONLY THAT IS THE TEST. If your letterhead and your letter inspires confidence and looks as if you were somebody, you may be certain that a reply will be forthcoming. Businessmen as a rule answer correspondence if the letter looks worthwhile and inspires confidence. If you were on the other side of the fence

you would do exactly the same thing. Have we made ourselves fully understood?”

Mr. X took a deep breath and sadly admitted to the whole indictment and that perhaps he had been negligent. Too negligent in fact for his own good. He wanted to know further details on how to proceed, if we were in his shoes.

We pointed out to him that the radio service fraternity was not as bad as it was painted. Having worked with servicemen for some 15 years we have come to know them pretty well. We know that there are thousands of worthwhile servicemen who never got anywhere simply on account of slipshod business methods. We told Mr. X that we knew of a servicing concern which we turned down some years ago when they wanted to buy \$10.00 worth of merchandise. Their letterhead was of the cheapest imaginable type and the letter was written on an old battered typewriter. The letters could hardly be deciphered. By chance we went through the community one day and found out that this concern had the most thriving business in the town. The owner who had come up the hard way, evidently never appreciated what a letterhead or a letter meant and he did not think it important at all. We later found out that the concern actually was rated \$15,000 first credit, but his representatives which he sent out for years—namely the mangled letters—did not give any inkling of this.

If we were a serviceman we would invest—particularly at this time—in the most expensive letterhead that we could buy. We would have a first-class printer design it carefully and make it as impressive as possible. If we could not have it done in our own small community, we would make a special trip to a larger city where there are good printers who specialize in this sort of thing. It would not be necessary to have a steel engraved letterhead such as banks use, but we would insist on an excellent type of bond paper, water-marked if possible—it does not cost much more. Then we would invest in a good typewriter. If we cannot typewrite ourselves, we would get somebody in our community to do the work for us, because if we have a beautiful letterhead, yet have our letters typed by an amateur, that is worse than not having a letterhead at all. Every community has someone who can do professional typewriting. If we could not get a stenographer or typist for ourselves, for the time being we would see to it that each and everyone of our communications would be handled in this manner. A telephone number should also be given, because that is one of the first points any sales manager will automatically look for.

We asked our caller if we had made ourselves plain. The answer was: “Yes, all too plain. Now please tell me where I can go to have a good, first-class letterhead printed in a hurry?”

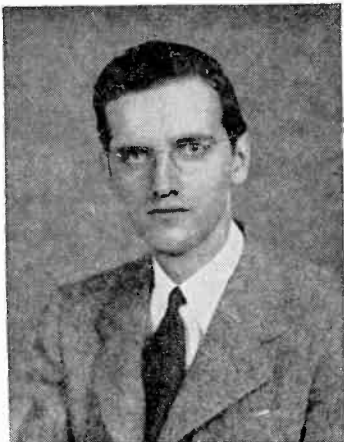

Fundamentals of Filament Circuits

By WILLARD MOODY

NRI Consultant

MANY students who begin early in the NRI Course to do radio servicing work are interested in how to calculate the necessary values of resistance in series filament circuits. Also, they want to understand how such circuits are connected and operated. Such series circuits are used in a.c.-d.c. sets and three-way portables, but not in a.c. receivers. The purpose of a filament circuit resistor is to control the amount of voltage fed to the tube filaments and to limit the circuit current. Unless the resistor has the proper ohmic value, the voltage may be too high or too low. To get the correct voltage and resistance a few rather simple calculations may be made.

In addition to the ohmic value of the filament circuit resistor, the wattage rating must be sufficiently high to permit operation without overheating of the resistor. To calculate power dissipation of a resistor, a simple calculation may be made. How these calculations are made is an interesting story for many beginners, but experienced technicians take such calculations easily and in stride.

Typical Circuits

Many radio receivers use circuits which are practically identical even though the sets may have been built by a number of different manufacturers. In Fig. 1, a simple, typical circuit is shown. A special 3 wire line cord is used. Usually, the cord will have colored leads at the set end and the black lead will connect to the rectifier plate circuit, red lead to the on-off switch, S, and white lead (resistance element connection) to the rectifier filament or, in this example, to the pilot lamp.

You should not, however, depend upon the color code of the cord leads to make the connections correctly. Always test the cord first, with an ohmmeter, to be sure that the replacement cord is in working condition and to identify the wires properly.

From the circuit diagram in Fig. 1, you can see that one prong of the plug is connected to a wire which conducts the current to the rectifier plate

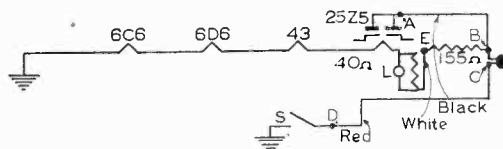

Fig. 1

circuit. Therefore, an ohmmeter test should show a very low resistance between A and B if the cord is in good condition. Also, a similarly low resistance should be indicated by an ohmmeter test between C and D. Between E and B a resistance equal to the line cord resistance value should be measured. In the example given in Fig. 1, the resistance is 155 ohms. To avoid making incorrect ohmmeter measurements, the 25Z5 may be removed from its socket, interrupting, then, the filament circuit continuity. Otherwise, it would be possible to get a low resistance reading through the filaments when the ohmmeter is placed between E and D, mak-

ing identification of the line cord wires less definite.

Of course, there is no reason why we are to be forced into using a line cord of the special 3 wire type and we find in many cases that the resistance is a wire-wound type of unit mounted inside or on top of the radio receiver chassis.

The wire-wound resistor develops a certain amount of heat within the radio cabinet. As the cabinet often will be small in size, the resistor heat combined with heat produced by the radio tubes may be sufficient to raise the temperatures of the radio parts to temperature values that are higher than desirable. Excessive temperature may cause premature failure of electrolytic condensers particularly and failure of other radio parts. Therefore, there is some advantage in using a line cord resistance, especially for midget sets. However, the line cord has its disadvantages, too, and is not readily replaced with ordinary wire in event of breakage. Using the re-

ment is 6 volts x 0.3 ampere ($P = E \times I = 1.8$ watts. The power supplied to the 43 filament is 25 volts x 0.3 ampere = 7.5 watts. The 6C6 is a voltage amplifier tube and requires less power for its operation than the 43 which is an audio power output tube.

Therefore, some tubes in an a.c.-d.c. receiver may use different filament voltages than other tubes,

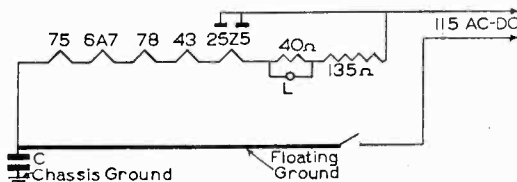

Fig. 2-B

according to the circuit design. A number of typical circuits are shown in Fig. 2. An examination of these circuits will show that in all cases the rectifier filament is located closest to the line cord resistance, followed by the power output tube. The usual sequence is then r.f., detector, as in Fig. 2-A. If the receiver is a superheterodyne, the sequence may be: rectifier filament, output, i.f., mixer, 2nd detector—1st audio. (See a tube chart. Study the pin connections of the most commonly used tubes so that the tube filament and other connections can be readily identified. A tube chart also will indicate the values of filament voltages used by tubes.) This sequence is illustrated in Fig. 2-C. In all of the examples that have been given, the pilot lamp has been assumed to be a 6 volt, brown bead, .15 ampere type.

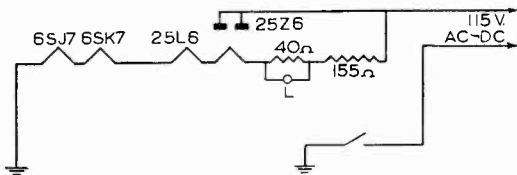

Fig. 2-A

sistor in the receiver, an ordinary two wire line cord can be employed.

Other Filament Circuits

The basic circuit shown in Fig. 1 is not limited to the tube types indicated in the drawing. For example, it would be perfectly all right to substitute, for the 6C6 filament, a 6J7, 77, or 6SJ7 filament. From a tube chart it can be determined that each of these filaments is rated at 6 volts and 0.3 ampere. This current of 0.3 ampere flows throughout the filament circuit and it is the same in all parts of that circuit—a fundamental principle you should remember.

Thus, although the *current* in the 43 filament is 0.3 ampere, there is no reason why the voltage across this filament cannot be higher than the voltage across the 6C6 filament. The 43 filament, because of the tube design, requires more power than the 6C6 filament. To get that increased filament power we must increase the filament voltage.

The power in watts supplied to the 6C6 fila-

The circuit of Fig. 2-B, however, uses a "floating ground," with the wire connected to the on-off switch isolated from the radio chassis by means

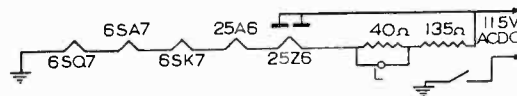

Fig. 2-C

of condenser C. Otherwise, the circuit is essentially the same as that of Fig. 2C.

Filament Circuit Calculations

Various values of resistances are used in filament circuits, according to the values of voltage and current that are to be handled. The calcula-

tion of the values is not a difficult job. In general, we simply assume a value of line voltage, add up the voltage drops in the filament circuit to obtain the sum and subtract that sum from the applied line voltage to obtain the voltage drop across the series resistance. Next, we divide by the filament circuit current. In this way, the resistance value in ohms is calculated. To illustrate this procedure, let us consider the circuit of Fig. 1, or that of Fig. 2-A.

From a tube chart, we find that the 6SJ7 or 6C6 tubes and 6D6 or 6SK7 tubes require 6 volts, the 43, 25L6, 25Z5 and 25Z6 tubes require 25 volts. The pilot lamp requires 6 volts for its operation.

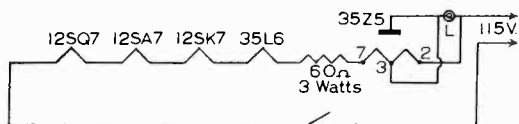

Fig. 3

In Fig. 1, therefore, the total voltage drop in the filament circuit, between point E and chassis, will be 68 volts. Assuming a line voltage of 115 volts, the voltage drop across the line cord resistance will be $115 - 68 = 47$ volts. Dividing 47 volts by the filament current of 0.3 ampere, a resistance of 156 ohms is calculated. This is a series circuit so the filament current is *not* the sum of the currents required by each tube. Instead, since the same current flows through each tube the current is that required by any *one* tube. Look up *any* of the tubes in a tube chart to learn the current flow through the series filament circuit resistor. The line cord resistance, however, is not extremely critical and the nearest commercial value of 155 ohms would be used.

When a line cord is used, only the resistance value in ohms need be calculated. When a wire-wound resistor is used, the wattage rating as well as the ohmic value must be indicated.

The power can easily be calculated. In the example given, $P = E \times I = 47 \times 0.3 = 14.1$ watts. Then, $14.1 \times 2 = 28.2$ watts and a 30 watt resistor could be installed in the radio receiver. A wattage rating of about twice the dissipated power value is employed so that the resistor will not be overheated. This is why 14.1 is multiplied by 2. Using a conservative rating is desirable.

The value of shunt resistance in parallel with the pilot lamp may be calculated by using a simple method—applying Ohm's Law. First, we

may assume that the normal current of the pilot lamp will be close to 0.15 ampere, since the lamp manufacturer definitely specifies this current. Since the total current flow is 0.3 ampere and 0.15 flows through the lamp, the current through the shunt must be the difference between the total current and the lamp current. Therefore, the shunt current is $0.3 - 0.15$ or 0.15 ampere.

Then, for a working voltage of 6 volts across the lamp terminals, the resistance of the lamp will be $R = E/I = 6/0.15 = 40$ ohms. To secure an equal division of the current, we may shunt the pilot lamp with an identical value of resistance—40 ohms. Under certain conditions, we should bear in mind, the pilot lamp may burn out. Then, the full current of the filament circuit will flow in the 40 ohm shunt resistance. Assuming the terminal voltage remains constant at 6 volts, and that the current is 0.3 ampere, the power is $P = EI = 6 \times 0.3 = 1.8$ watts. Then $1.7 \times 2 = 3.6$ watts and a 4 watt or 5 watt resistor could successfully be used in the circuit.

Special Circuits

The circuit indicated in Fig. 3 is a somewhat unusual one in comparison with the circuits previously considered. For one thing, the tubes are 0.15 ampere filament types. This can be determined by referring to a tube chart. Adding up the filament voltage drops in the set, it is found that the total voltage drop is 106 volts. The voltage ratings per tube are: 12SQ7 = 12, 12SA7 = 12, 12SK7 = 12, 35L6 = 35, 35Z5 = 35. Adding

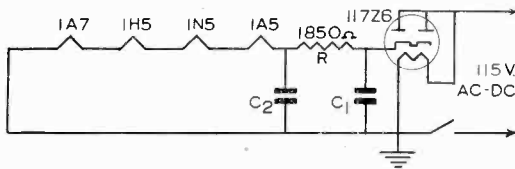

Fig. 4

these voltages gives us 106 volts which is subtracted from 115 to give a difference voltage of 9 volts. The required series resistance is, then, simply $R = E/I = 9/0.15 = 60$ ohms. The power is $P = E \times I = 9 \times 0.15 = 1.35$ watts. Twice the power is $1.35 \times 2 = 2.70$ and a 3 watt resistor could be used. Another unusual feature is that the rectifier plate current as well as the filament circuit current flows in the 2-3 section of the filament circuit. In effect, 2-3 is a shunt resistance which is connected in parallel with pilot lamp L. As the filament circuit current, alone, is somewhat small, the rectifier plate cur-

rent adds to the pilot lamp circuit current and permits normal illumination of the lamp.

In some three way portable radio receivers, we may find that the tube filaments, with the exception of the rectifier, are d.c. operated. The filaments are connected in series but are not connected directly to the power line. The arrangement of a typical circuit is indicated in Fig. 4. Assuming that a voltage of 1.5 volts appears across each filament, the total voltage drop will be 6 volts. Then, making the assumption that the circuit design is such that 100 volts appears across C1, the drop in the series resistance R will be $100 - 6 = 94$ volts. Dividing by the filament circuit current of 0.05 ampere, the resistance value is 1850 ohms. The power is $P = EI = 94 \times .05 = 4.7$ watts and twice $4.7 = 4.7 \times 2 = 9.4$ watts, so that a 10 watt resistor could be used in the circuit.

The above value is typical, but the correct value for a given make of radio should be determined by referring to the manufacturer's circuit diagram of the set you are servicing. The resistance value used will be determined by the receiver circuit design. Designers may use various values of filter capacitances, different tubes and parts, all of which will affect the B supply output and other voltages, thereby affecting the resistance values required for proper operation of the circuit.

— n r i —

A Nugget

There is a time in every man's education when he arrives at the conviction that envy is ignorance; that imitation is suicide; that he must take himself for better or worse as his portion; that though the wide universe is full of good, no kernel of nourishing corn can come to him but through his toil bestowed on that plot of ground which is given to him to till.

In Memoriam

The Yuletide was marred for NRI by the tragic death of one of its most popular employees, Ethel Coffman, who was killed in an auto accident just two days before Christmas.

Hardly more than a youngster when she came to work for us over eleven years ago, Ethel practically grew up at NRI. In the process she endeared herself to us all by the unfailing sweetness and gaiety of her disposition.

She will be missed and long remembered.

Marriage By Electronics

A typical example of B. F. Goodrich development in rubber

The electric current used to light your home alternates back and forth in the wires 60 times a second. In radio waves the electricity used changes its direction millions of times a second. Using these radio waves (electronics), scientists found they could produce heat, right down at the center of an object in a matter of seconds. With electronic cooking, bread might be baked without crust, in a cool oven.

Then scientists discovered that electronics could be used to cause chemical changes such as vulcanization of rubber. In vulcanizing, what happens is that molecules of raw rubber and sulphur are "married"—joined together to form a tougher, more elastic substance. Heat is usually used and the process has always been rather slow.

Now a new high-speed electronic method of vulcanization is beginning to be used. The B. F. Goodrich Co. is perfecting the process. This process makes the molecules join together in minutes instead of hours. Products are more uniform. Costs are reduced.

The new process has already been tried on a variety of products. Some of them may be cured in $\frac{1}{2}$ the time taken by the old method. (in the picture a small rubber part is being vulcanized in electronic waves that change direction 40 million times a second. (See our cover.) Many future products made by B. F. Goodrich, probably including tires, will be vulcanized by this method.

— n r i —

When You Ask Us For a Diagram

If you do not send us the model number of your receiver the only thing we can do is to send you a diagram using the tubes you mentioned or one using similar tubes.

The diagram we send you may or may not be the wiring diagram of your set. Always send the model number (*not the serial number*) of the receiver. The model number is nearly always on the cabinet, or the chassis. Some sets have a wiring diagram as well as the model number pasted on the bottom of the cabinet.

Sending us the model number will enable us to handle your request more quickly and get the diagram mailed back to you sooner than if we have to identify the set only by the tubes.

If you can not give the model number then be sure to give the type number of all the tubes in the set.

NEWS OF THE RADIO WORLD

BY

Willard R. Moody

An electronic device, the Sono Buoy, produced by Emerson Radio and Phonograph Corporation, New York, was reported by the Navy Department recently as being highly effective in anti-submarine warfare against the Nazi and Japanese. Radar sets, important in detecting sub-surface subs, needed auxiliary aid to pick up sounds of propellers when U-boats were submerged. The National Defense Research Committee and the office of Scientific Research and Development at the Underwater Sound Laboratory, New London, Connecticut, designed the Sono-Buoy to pick up underwater sounds and turned the model over to Emerson to be perfected. A plane carrying a special receiver tuned to the same frequency of the Buoy transmitter receives radio waves from the Buoy which reveal to the occupants of a plane whether or not the sub is under water and exactly where it is located. The buoys are expendable and sink after a few hours in water, thus making it unknown to the enemy that his presence is being detected by the instrument.

Another war innovation of electronics was announced recently when Remington-Rand Inc. displayed a television camera designed to fit into the nose of a bomb, permitting either the bombardier in the plane or the staff back at General Headquarters not only to follow the course of the bomb but to change its direction if necessary. The display was at Middletown, Conn. Bombs containing the Television apparatus were in use in the last days of the war, according to the firm. The camera is five inches square and nineteen and a-half inches long, containing a small motor that adjusts the shutter opening for light changes and a thermostatic unit which prevents fogging as the camera passes through different altitudes and temperature changes. The heart of the camera is the Vericon tube, two inches by one foot in size. In each bomb is packed a Television camera, storage battery, small dynamo, an electric power plant, a television transmitter, a radio receiver and a mechanism that radio-controls the bomb's fins and rudder. Through relaying from the plane, which launches the bomb, headquarters can receive the picture and can remotely control the bomb's course. The army is said to be planning further tests on rockets, with the probability of complete remote control thousands of miles from the target. Its lightness and extreme compactness give great possibilities for

commercial television use. James J. Lamb, Chief Engineer and Manager of the Electronic Division of Remington-Rand (formerly research engineer of the American Radio Relay League and QST) is credited with development of the camera, in cooperation with Philip S. Rand, Joseph A. Brustman and Marshall T. Wilder.

The power of radio advertising is illustrated by the experience of Lucky Strike cigarettes (American Tobacco Company). In each of the ten years from 1934 to 1944, the American Tobacco Company devoted a greater portion of its expenditures to Radio Advertising. Chesterfield and Camel cigarettes were advertised principally in newspaper and magazines. Lucky Strike sales now exceed the sales of its biggest competitors by substantial margins, and they have doubled in the past ten years.

The first two-way police radiotelephone system in the United States that has been designed to operate on a frequency above 100 megacycles is the Motorola 250-watt, 118-megacycle F.M. transmitter, recently installed by the Police and Fire Departments of Miami, Florida. The system operates twenty-four hours a day and twelve patrol cars in Miami's busy area are used. The equipment was built by the Galvin Manufacturing Corporation of Chicago (Motorola).

Television can provide a subtle yet powerful advertising medium, as well as a profitable merchandising line, for the radio retailer. The individual retailer can use Television locally to reach a high percentage of his own customers. Between the visual and the aural impressions given the audience via television, it will be an easy matter to implant in the minds of the audiences the trade name of the store, the address, the principal lines it handles, the personalities who will be handling the customers when they call.

Eldridge L. Johnson, 78, founder, and, until 1927, president of the Victor Talking Machine Company in Camden, recently died at his home in Morristown, New Jersey. He began experiments on the phonograph in 1900 in a tiny shop in Camden. Starting with limited capital, he built up the business into a multi-million dollar enterprise, selling it in 1927 for 40 million dollars.

Developing the Ability to Diagnose Receiver Troubles

By LEO M. CONNER

NRI Instructor

JOHNNY JONES the service ham, grabbed his meters and worked them fine, He tested this and he tested that; the trimmers he failed to align. The time grew short, the Boss did snort: "What kind of a guy have I hired?" The end of the day brought one relief, for Johnny, poor fellow, was fired.

The ability to locate quickly the cause of trouble in a defective receiving set marks the difference between an expert serviceman and a screw-driver mechanic. Too many servicemen, fellows who have been in the field for years, still test each and every part in a defective receiver until the bad one has been found. Such men are lucky to complete three or four jobs a day, working steadily at the bench.

The expert approaches a defective receiver in an entirely different manner. He does not start out by blindly testing parts nor is he tied down to one or two servicing techniques. He knows them all and chooses for each type of complaint the one which will give him useful information, the kind of information he needs to diagnose the trouble.

First he considers the receiver which is to be repaired. Sets coming in for servicing may be divided into two classes: those which are dead (do not play) and those which play improperly, that is, they have distortion, hum, oscillation, are weak, intermittent, etc.

In the case of a dead receiver it is first inspected for surface defects, to see if the tubes all light, if the antenna and ground connections are intact, if smoke is coming from the chassis, if the tube top caps are in place and if the speaker is plugged in. Should everything be apparently O.K. a circuit disturbance test is made, working back from the power tube to the input of the set.

In ninety-nine times out of one hundred this will isolate the defective stage. From here on the

procedure employed depends entirely upon the individual serviceman. After checking the condition of the tube, he may measure the operating voltages of the dead stage, point to point, or he may check electrode circuits for continuity with an ohmmeter. I generally use an ohmmeter because in a dead receiver some part in a voltage supply circuit has generally broken down and may easily be located by checking between points which yield useful information. A voltmeter could just as well be used but after finding the electrode which lacks voltage it will be necessary to check the circuit with an ohmmeter anyway. Why waste time?

Using this method, a serviceman can locate the cause of trouble in the average dead receiver in ten minutes or so. Correction of the defect may take longer, depending on his skill with tools, the nature of the defect and how cleverly the manufacturer has hidden the bad part away under mounting boards, shield cans, etc.



Naturally this does not complete the service job, for the rest of the tubes must be checked and the set operated for at least an hour to see if any other defects develop. If you work in a large shop an assistant can do this, even to the installation of the new part, making you, the expert, a sort of glorified diagnostician.

Perhaps all this sounds too easy and the time too short, but I know most experts will agree that a dead receiver is "duck soup" to the serviceman. Let us spend a little time with one.

Pretend that the Sparton model 580-X (Figure 1) is dead and to make matters easy suppose condenser C₄ has broken down, burning out resistor R₄. An inspection for surface defects reveals nothing so we start a circuit disturbance test.

Withdraw and replace the 42 tube; a click will be heard in the speaker. Touch the top cap of the 75 (volume control all the way on during

these tests); a shrill buzz is heard in the speaker showing that the set is alive from this point on. Touch the top cap of the 78; this may not produce a click even if the stage is operating. If no click is heard, removing and replacing the top cap connector will cause a click if a signal can pass through the stage. Repeat this procedure on the 6A7 top cap.

Bearing in mind that C_6 and R_2 are defective, will a click be heard when the top cap of the 6A7 tube is removed and replaced? Think hard for this is the fact upon which our diagnosis is based. The answer is that a click will be heard and this fact coupled with lack of reception points to oscillator failure.

I would look for causes of oscillator failure since ninety-nine times out of one-hundred the diagnosis would be correct. The hundredth time a signal killing defect, such as an open antenna coil or shorted tuning condenser, will exist between the 6A7 input (top cap and cathode) and the signal source which is the antenna.

Now if you don't understand why this click on the 6A7 comes through even with a dead oscillator you couldn't figure out the trouble. The reason follows: When there is a sudden change in current through a resonant circuit, oscillations are set up in the circuit at the resonant frequency. They only last momentarily, quickly dying out. The fact that the strength of the oscillations is not constant means that the signal produced in this manner is modulated, and when detected, can be heard. The technical name for this action is shock excitation.

When the top cap of the 6A7 is removed and replaced the plate current changes sharply and sets up a modulated I.F. signal in the I.F. amplifier which goes through the receiver circuits just like a program from a transmitter. The effect is comparable to that obtained when the output of an I.F. signal generator is fed in the input of the 6A7. It is worthy of note that the defect in parts C_6 and R_2 , while removing voltage from the oscillator anode grid, does not prevent plate current from flowing. If it did, no click would be heard when removing and replacing the 6A7 top cap and the trouble would simply be isolated to the 6A7 tube and its associated circuits instead of to a particular circuit.

Since we have diagnosed the trouble as a dead oscillator, what will we do now? We can verify the diagnosis or we can check for causes of oscillator failure. Therefore, you must know how to check the oscillator. One infallible check for oscillation is to measure the voltage across R_1 with a high resistance voltmeter. No voltage—no oscillation.

We are satisfied that the oscillator doesn't work, so look at the diagram. What does make the oscillator work? Here is the downfall of the screw-driver mechanic. He—sad to say—has no idea why or how the oscillator works; "it just do" and that's that! Shades of Marconi! If he doesn't know how or why it works, is it possible for him to determine why it won't work or what could stop it from working? No sir, it is not possible, so score one hundred points for a *theoretical* understanding of oscillators. Remember any kind of defect is possible in this circuit and you must have some idea of what you want to find. Look at the parts value. R_1 is supposed to be a 56,000 ohm resistor. We check it with an ohmmeter and find it to be 45,000 ohms. Have we found the trouble and shall we put in another resistor? No, because such a change in value of the oscillator grid resistor will not make the oscillator dead. How do I know that? Ah, ha! Score one hundred for practical experience. I have changed the value of many oscillator grid resistors at one time or another just to see what would happen. If the value is too low, the oscillator stops completely; if almost too low, it stops at low frequencies (set works on high frequency end of dial only) and if too high, the oscillator blocks, working intermittently and giving a chopped up reproduction on all stations.



HOW-?
WHAT-?
WHERE-?

Look again at the diagram and see what parts are most likely to break down. Those parts which have a high voltage across them or which carry considerable current. These are the plate winding of L_2 , condenser C_6 , and resistor R_2 . Trouble in any of them would remove plate voltage from the oscillator and would most certainly stop it from working. If you wish, confirm your suspicion by measuring for voltage between socket terminal 4 of the 6A7 tube and the chassis.

Lack of voltage shows the trouble and we now proceed to check its cause. Remove the 6A7, turn off the set, put one ohmmeter probe through hole 4, the other through hole 2. We should measure about 20,000 ohms, the approximate value of R_2 . L_4 is only a few ohms so its value won't register in comparison to that of R_2 . We don't get continuity so the circuit is open. The circuit disturbance test proved that there was voltage on socket terminal 2, placing the defect in either L_4 or R_2 . The resistor is checked first and we find it to be open, L_4 is checked, just in case, and it proves to be intact.

Would you immediately replace R_2 and turn on the set? The diagram shows the presence of C_6 and if it is broken down, R_2 would pass excess current and burn out so we first check C_6 and sure enough it is broken down. Replace it and the job is done.

Wait a minute! The parts list calls for a 400

SCHEMATIC DIAGRAM SPARTON SUPERHETERODYNE MODEL 580-X INTERMEDIATE FREQUENCY 456 K.C.

TOP VIEW OF ALL SOCKET CONNECTIONS

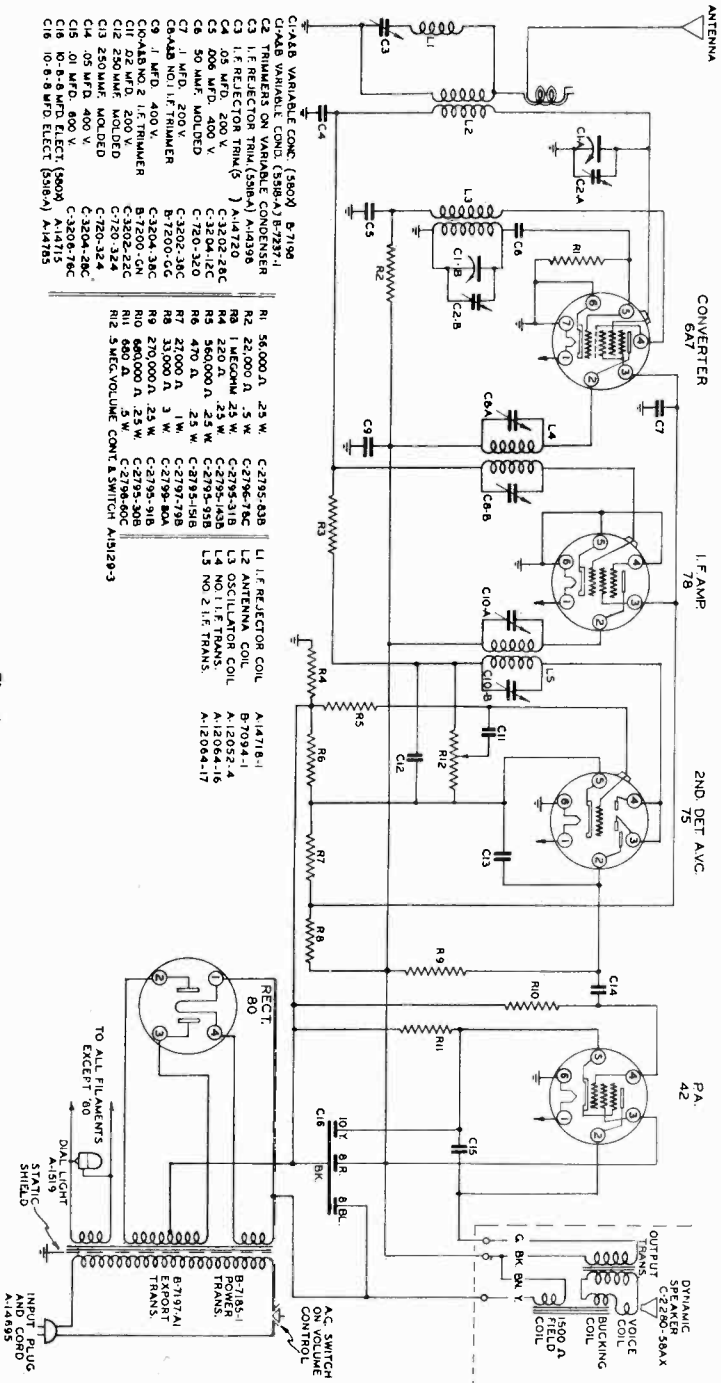

- C1-A,B VARIABLE COND. (360X) B7196
- C2 TRIMMERS ON VARIABLE COND. B7196
- C3 I.F. REFLECTOR TRIM. (398A) A14295
- C4 .05 MFD. 400 V.
- C5 .05 MFD. 200 V.
- C6 .05 MFD. 200 V.
- C7 .05 MFD. 200 V.
- C8 .05 MFD. 200 V.
- C9 .05 MFD. 200 V.
- C10 .05 MFD. 200 V.
- C11 .05 MFD. 200 V.
- C12 .05 MFD. 200 V.
- C13 .05 MFD. 200 V.
- C14 .05 MFD. 200 V.
- C15 .05 MFD. 200 V.

- R1 56,000 Ω .25 W. C2795-83B
- R2 22,000 Ω .5 W. C2795-145
- R3 1 MEGOHM .25 W. C2795-315
- R4 220 Ω .25 W. C2795-42B
- R5 560,000 Ω .25 W. C2795-92B
- R6 470 Ω .25 W. C2795-95B
- R7 27,000 Ω .1 W. C2795-80A
- R8 27,000 Ω .1 W. C2795-80A
- R9 270,000 Ω .25 W. C2795-30B
- R10 680,000 Ω .25 W. C2795-60C
- R11 680 Ω .5 W. C2795-60C
- R12 5 MEG. VOLUME CONT. & SWITCH. A1529-3

- L1 I.F. REFLECTOR COIL A14718-1
- L2 I.F. TERN. COIL B7094-1
- L3 OSC. I.F. TRANS. A12064-16
- L4 NO. 2 I.F. TRANS. A12064-17
- L5 NO. 2 I.F. TRANS. A12064-17

Fig. 1

volt condenser and you don't have a 400 volt condenser. Well, use a 600 volt condenser for it won't break down as easily as one rated at 400 volts. We check over our stock of parts and find many 600 volt condensers—.1mfd., .05mfd. and .01mfd., but no .006mfd.—what to do?

First what is C_5 there for anyway and what is the theory of its operation? C_5 is a bypass condenser and serves to keep the end of L_3 at R.F. ground potential. We realize that increasing the capacity of a condenser reduces its reactance and makes it a better bypass and therefore know that increasing the capacity of C_5 will have no ill effects. We grab the .01mfd. 600 volt condenser, the soldering iron, the resistor and with a deft flip of the wrist complete the



job and thus bring peace and music back to the home of the Sparton 580-X.

The improperly playing receiver is a horse of another color. There is no easy and definite procedure which will show up the defect quickly. The expert, however, is not stumped. He will check a few definite parts, then lo and behold—he has the bad one in a relatively short time. When he checks a certain part he is not doing so aimlessly, neither is he playing a hunch. He has catalogued the defect by its symptoms and knows what parts or circuits in the receiver could cause such trouble. This does not mean he has had previous experience with the same trouble in that particular set. He is simply applying effect to cause reasoning. He knows what can and what can't cause the trouble so he checks possible causes in the order of their likelihood.

With improperly operating sets a schematic is useful. Simply look at the schematic and figure out what can cause the trouble, then locate the part and check it with instruments or by substitution.

If a receiver hums, study first of all the filter system on the schematic. If electrolytic condensers are used, check them, preferably by substitution. Is the choke tuned; if so, what is the condition of its shunting condenser? Is a hum bucking coil used in series with the voice coil and could the connections have been reversed? Your eyes should next swing to the electrode supply circuits of the tubes, to see if resistance-capacitance filters are employed; if present, check them. If the schematic shows the A.F. amplifier to have potentially high gain, try new tubes even though the present ones check O.K. as cathode to heater leakage might not show up on the tube

tester. Then you might see if the positions of the control grid leads have any effect on the hum; by moving them around to different positions.

In an oscillating receiver your eyes will first be drawn to the by-pass and output filter condensers, then you might see a bleeder resistor which, if open, could increase the screen voltages to the point where oscillation could occur.

Does the set distort? If so, at high volume control setting or at low settings? If at low setting excessive bias on some tube is indicated while at a high setting the bias on some tube is too low. The schematic shows what could cause this so these points are checked first. You further know that distortion is due to some tube working off the straight part of its curve; perhaps the plate voltage on the first A.F. is too low and if there is a resistive-capacitive filter you check the condenser for excess leakage. Sufficient leakage to lower the plate voltage of the tube to the point of distortion would not affect the other B voltages due to the series filter resistor so you have to know what to check.

We are called in on a dead Sparton 601-B. (Figure 2). An inspection for surface defects with the set turned on shows the tubes and pilot lamp fail to light. On turning the set off we could check with an ohmmeter each section of the series filament circuit or we could test the tubes in a tube tester. Suppose we find that the section of the rectifier tube filament shunted by the pilot lamp, and the pilot lamp are burned out. In case of any other tube filament failure, we would just replace the tube and try the set. In this case, however,



examine the diagram closely. We see that the lamp shunts part of the filament of the 35Z5GT. Also, the plate is connected to this filament tap, so plate current flows through the pilot light and filament section in addition to the filament current.

This accounts for the pilot light being bright when the set is first turned on, then getting dim and finally lighting normally when the set works properly. When the set starts, the tube filaments are cold and have low resistance. Fairly high current flows through the lamp making it quite bright. As the tubes heat up, the filament resistance increases allowing less current to pass through the lamp and dimming its light. When the tube filaments get hot the heat is transferred to the cathodes, they start emitting electrons and current is drawn from the rectifier. Hence, the plate current flow serves to bring the pilot light back to normal brilliancy.

SCHEMATIC DIAGRAM
SPARTON SUPERHETERODYNE MODEL 601-B
INTERMEDIATE FREQUENCY 456 K.C.
 BOTTOM VIEWS OF ALL SOCKET CONNECTIONS

R.F.
12SK7GT

CONVERTER
12AB6GT

I.F. AMP
12SK7GT

2ND DET. & AVC
12SQ7GT

P.A.
35L6GT

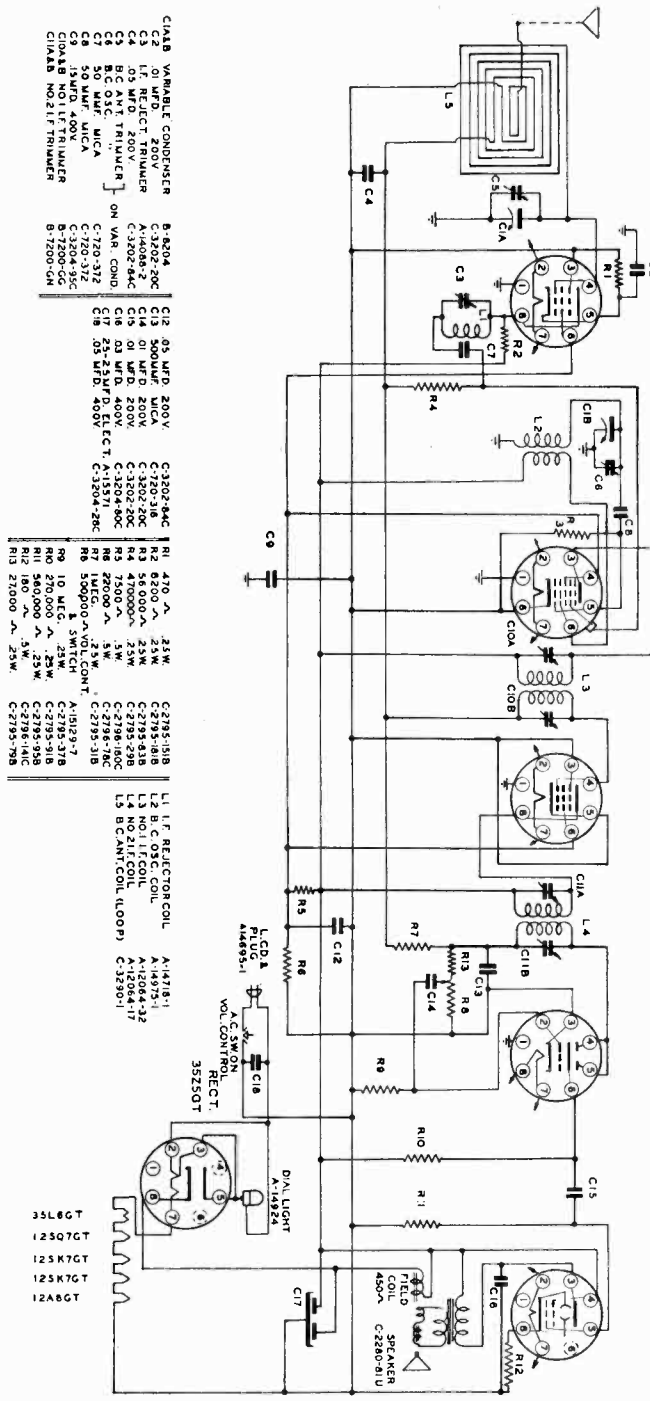

- | | | |
|-------|--------------------|------------|
| C1A8 | VARIABLE CONDENSER | B-8204 |
| C2 | 10 MFD. 200V | C-3202-20C |
| C3 | 10 MFD. 200V | A-14008-27 |
| C4 | RELECTOR TRIUMER | C-1320-20C |
| C5 | BC ANT. TRIUMER | C-1320-20C |
| C6 | BC ANT. TRIUMER | C-1320-20C |
| C7 | BC ANT. TRIUMER | C-1320-20C |
| C8 | 50 MFD. 400V | C-3200-37C |
| C9 | 15 MFD. 400V | C-3200-35C |
| C10A8 | NO.1 I.F. TRIUMER | B-1200-0A |
| C10A9 | NO.2 I.F. TRIUMER | B-1200-0A |

- | | | |
|-----|------------------|------------|
| C12 | 05 MFD. 200V | C-3302-84C |
| C13 | 500MFD. MICA | C-720-31B |
| C14 | 01 MFD. 200V | C-3202-20C |
| C15 | 01 MFD. 200V | C-3202-20C |
| C16 | 03 MFD. 400V | C-3204-90C |
| C17 | 25-25MFD. ELECT. | A-13571 |
| C18 | 05 MFD. 400V | C-3204-28C |
| R1 | 470 Ω | .5W |
| R2 | 6200 Ω | .25W |
| R3 | 45000 Ω | .25W |
| R4 | 7500 Ω | .5W |
| R5 | 27000 Ω | .5W |
| R6 | 2000 Ω | .5W |
| R7 | 5000 Ω | .5W |
| R8 | 10 MEG. & SWITCH | |
| R9 | 10 MEG. & SWITCH | |
| R10 | 500,000 Ω | .25W |
| R11 | 500,000 Ω | .25W |
| R12 | 180 Ω | .5W |
| R13 | 22000 Ω | .25W |

- | | | |
|----|---------------------|------------|
| L1 | I.F. REFLECTOR COIL | A-14218-1 |
| L2 | B.C. 05C. COIL | A-14204-32 |
| L3 | NO.1 I.F. COIL | A-14204-32 |
| L4 | NO.2 I.F. COIL | A-14204-32 |
| L5 | BC ANT. COIL (LOOP) | C-3290-17 |
| A1 | 12SK7GT | |
| A2 | 12AB6GT | |
| A3 | 12SQ7GT | |
| A4 | 35L6GT | |

Fig. 2

If too much current is drawn from the rectifier this would cause the lamp and filament section to burn out. Do the tubes in the set do this? Possibly if shorted, and we will remember to check for this later if we don't find the trouble elsewhere. The trouble could have been just a surge condition or could be a short circuit in the B supply. The most likely reason is broken down filter condensers for they could cause excess drain on the rectifier and they are a probable weak point in any set, because they have a high voltage across them. Also, practical experience gained from observation of many receivers tells me this.

Before going to the trouble of locating the condensers and unsoldering their leads for an ohmmeter test, let's make another test. Check the resistance across the output of the rectifier and see if it is normal. First, between what points shall we check? Between the rectifier cathode (terminal 8 of the tube socket) and the set side of the on-off switch. These points are readily located and the measurement made, an almost zero resistance reading showing the presence of a short. We then proceed to check the condensers and finding the input section of C_{17} bad, replace it.

Suppose on the other hand we obtain an ohmmeter reading of 30,000 ohms when making our test—is anything wrong? Look at the diagram and trace the path through which the ohmmeter current flows, adding up the resistance values. Starting at the cathode we go through the speaker field (450 ohms), R_5 (7,500 ohms) and R_6 (22,000 ohms). This makes a total of about 30,000 ohms so nothing is wrong here and the filter condensers are not shorted. We therefore check the tubes and may find a short in the 35L6GT which only shows up when the tube is hot as it is when checked in a tube tester. If we fail to find any trouble, it may have been the surge condition mentioned before. We must now replace the tube and pilot lamp to be sure. If everything is normal, we need not worry further as this surge condition is rare, being due to some power line voltage change at the moment the set was warming up in the home of the owner.

Now we are confronted with the toughest problem a serviceman must face. The Sparton 580-X is intermittent. We verify the complaint at the customers home, carefully check his aerial-ground-lightning arrester system and depart for the shop after assuring the customer we will phone him as soon as the trouble has been isolated.

At the shop we place the set in operation and

make an inspection for surface defects, then connect a high resistance D.C. voltmeter across the diode load resistor (volume control R_{12}). The voltmeter will deflect an amount depending on the diode current of the 75 type tube. If the signal reaching the 75 decreases this will be indicated on the meter. We let the set play and go about our other shop work and soon the intermittent occurs, the signal dropping to just a whisper.

On examining the voltmeter we find that its reading is just about the same as before, proving that the signal is still reaching the diode plates and is being rectified. The trouble therefore is between the volume control and the loud speaker.



We concentrate on this section of the receiver, pulling on leads and wiggling parts to see if we can bring back the volume. In between wiggles and pulls the set suddenly snaps back by itself and before we can catch our breath it cuts out again!

We continue to pull and wiggle and through carelessness our long nose pliers which we are using short the positive terminal of section 8I1, condenser C_{16} , to the chassis. We jerk back the pliers and the set starts to play. Now what, have we found the trouble—is this condenser bad? The set cuts out again and we momentarily short the condenser, the set immediately coming back to life. Definitely we have found something, but what? Can you conceive of any kind of trouble in this condenser which would cause intermittent reception of this type? The condenser is in the B supply circuit of all the tubes and therefore it is not breaking down because this would make the stages ahead of the 75 inoperative. We doubt if the condenser is opening up but we check it by unsoldering its B+ lead. As we thought, the intermittent action is not affected.

It is obvious however, that the sudden removal of B supply voltage has taken the stress off the defective part thus allowing it to heal itself. Let's look at the diagram and see which parts would most likely be affected. We can at once eliminate current supply parts since a defect in them would cause terrific noise and that is not the complaint. This leads us to the signal circuits and almost without hesitation to coupling condenser C_{14} . We try wiggling this condenser and the set cuts off. Another wiggle and it comes back on. There is evidently a poor contact between one of the condenser lugs and the foil of which the condenser is wound. To complete the job we install another .05 mfd. condenser rated at 600 volts. The set is then played an hour or two just to be sure there wasn't another intermittent part.



We have traced through the typical repair of an intermittent receiver. The part about shorting the filter condenser is *not* to be followed in jobs of this sort. It was introduced as being an accident because no service man would intentionally short the output of a receiver power pack. Such a short could damage other parts in the receiver. However, many servicemen have made such accidental shorts and have been puzzled and wasted time due to the effects we have described. You now know that it does not mean the part which was shorted was at fault and it could conceivably be in any of the A.F. signal circuits.

By this time you have a fair idea of the powers of deduction possessed by an expert. You perhaps wonder "will I ever be like that" and "can I ever learn to diagnose defective receivers"? The answer is YES both times and it will not be hard to gain this ability. Thousands of N. R. I. men have it and they got it through diligent study of radio fundamentals (theory) and by gaining practical experience.

To be a service expert you must have theory, and for your theory to be of any value, you must know how to use it. To get your theory you must study your text books with the idea of understanding them. It is not enough to simply read the books and get the answers to the test questions. You should learn and understand something new each time you complete a study lesson. This also applies to your experimental outfits—profit from them by thinking about what you are doing. It is not enough to blindly make a specified change in a circuit and answer the report statement. Analyze in your own mind just what has occurred in the circuit and the reason for the answer you make. Do all this and you are beginning to get some place.

Book learning *by itself* is not sufficient to give you this knowledge. Nowhere else does the old saying "knowledge and practice go hand in hand" hold so true. I can write an article about distortion and describe the causes and effects but the written word cannot tell you how distortion *sounds* so you will recognize this symptom in an improperly operating receiver. Then, too, I can tell you that non-linearity will cause distortion—just so many words, but once you place an improper bias on an amplifier tube causing the negative swings of the signal to be amplified less than the positive swings, you will know what non-linearity means in an amplifier and won't forget how it sounds.

This is how N. R. I. has solved your problem of gaining practical experience: Get a second hand A.C. superheterodyne which is in working condi-

tion, with at least five tubes. An all-wave receiver is not necessary but try and get a standard brand receiver such as Philco, General Electric, RCA or other well known makes. If you do not have A.C. power use a six volt receiver or an auto radio since they will give you the same experience as may be gained with an A.C. set.

This receiver is to be used as your experimental set and you are to dissect it just like a student doctor would a dead body. You however, have the advantage of the medical student in that your receiver is alive and kicking and you can get first hand information on its reaction to different illnesses and accidents. These troubles are to be introduced into the receiver by you and you are to note the effect on the sound of leaky condensers, open filters, burned out (open) resistors, etc.

When you get your receiver write to us giving its make, model number and the type numbers marked on the tubes used in it and the fact that the receiver is to be used for training purposes. We will send you a diagram together with suggestions for getting practical experience with it.

This is the only easy and sure way of getting started. Some men try to do service work with no experience to back them up and while they may succeed its a long hard

road full of disappointments so take my advice and follow a logical systematic method which will lead you quickly and surely to your goal of being an expert serviceman.

Now while theory and the N. R. I. plan will give you the ability to diagnose and repair defective receivers it will not let you decide which of a given number of parts is most likely to cause trouble. For example, in the Sparton 580-X, an overload on the 80 tube would cause its plates to become red hot. This could be caused by a break down in the filter condensers, a grounded B+ lead, a short between the screen and cathode of the 42 tube or a short between the filament winding of the 80 tube and the grounded static shield of the power transformer. What would you look for first? I would look for broken down filter condensers, then a shorted B+ lead, then a shorted tube and last a defective power transformer. I have never encountered a transformer defective in such a manner and would check it only as a last resort simply because the schematic shows it could cause trouble.

As a beginner you have no means of getting first hand information of this sort. You must get your experience second hand. Reference book 14X-1 which you receive early in your course, is



full of probable causes of different types of defects. Study this book and try to visualize the reasons why the listed causes will result in the described defects. It is an excellent policy to refer to this book when you encounter some unfamiliar receiver symptoms.

Another excellent source of second hand experience are the service notes, published in many of the popular radio magazines. As a matter of fact the true value of these notes lies in the fact that they tell you: Filter condensers are often defective, coupling condensers can cause intermittent reception and distortion, volume controls eventually get noisy and so on. The original purpose of service notes was to list weak points in receivers but sets are built better nowadays and weak points in a complete line seldom develop. Therefore service notes should be viewed as individual defects which might not again be encountered in the specified model. But read them and use them by remembering that a leaky coupling condenser in an Atwater Kent will cause distortion just as quickly in a Grunow.



The service facts presented in the News are checked to see if they are authentic—not so with all service notes. Johnny Jones made famous in verse at the start of this story, has a Sparton 580-X which distorts and, to his everlasting dishonor, finds that shorting R_6 in the voltage divider eliminates the distortion. So a service note is born, and all the other Johnny Joneses make a mental note to correct distortion by shorting resistors.

Now you, one day if not now, reason thusly: Resistor R_6 is the bias resistor for the 75 tube. If shorting it out removes distortion there is too much voltage across it. This is due either to a change in value of the resistor or to excess current through it. The resistor value is correct so those parts which, if bad in a certain way, could cause excess current are checked for such trouble. Resistor R_7 is checked to see if it has decreased in value as is R_6 , and we check for leakage in condenser C_{1a} .

The moral is to take service notes with a grain of salt and to forget about them if you can see that they are unreasonable.

— n r t —

Now they have a high frequency machine that is said to be able to cook a hot dog *after* it is put in the roll and wrapped in cellophane.

Page Twenty-four

How To Get Along With Others

Dr. James F. Bender, Director
The National Institute For Human Relations

There is a Right and a Wrong Way to Grumble

People who get along well with others know the value of grumbling—when and how to do it. It helps relieve the grumbler of tension, even though it causes tension in others at times. It is much better to grumble than to hold a gnawing, silent grudge. "To get it off the chest" is one of the old stand-bys in good human relations. In short, grumbling is a natural thing to do—like being born, or breathing, or getting the stomach ache. Unless we grumble at least once in a long while, we are suspected of being hypocritical. So, since we grumble, let's learn to do it right by recalling the rules.

The first rule is MAKE SURE YOU DON'T GRUMBLE TOO OFTEN. Novelty is a mighty attractive force in human relations, and the person who grumbles about every little thing is never taken very seriously. His associates soon learn to discount his grumbling. They say, "Oh, don't mind him, he's always grumbling about something or other." Or, "That's just his personality, he doesn't mean it." (If a woman grumbles, they say "That's how she got her crows' feet." Or, "She's never satisfied. You simply can't please her. Don't let her get you down.") And so the habitual grumbler seldom carries much weight. His is an unhappy existence because he isn't respected.

Our second rule goes something like this: GRUMBLE ONLY WHEN THERE'S SOMETHING WORTH GRUMBLING ABOUT. Things have a way of going wrong from time to time, and if we aren't feeling just right, we try to set them aright by grumbling. A workman grumbles because someone "borrows" his tools without asking permission. A truck-driver grumbles because of the old truck he must drive. The boss grumbles when his secretary leaves him in the lurch by running away to get married without giving notice. How do we know whether something is worth grumbling about? Two questions give the answer: Does it really matter in the long run? Does it affect other people as well as myself?

The third rule is: GRUMBLE WHERE IT WILL DO THE MOST GOOD. A salesman's wife not long ago said that her husband was always grumbling at home about the reports he had to fill out for his salesmanager. Yet she wasn't responsible for the reports; neither could she do anything about them. The man never once grumbled at a meeting of the sales force, nor paid the salesmanager a visit. . . . There is a reason for most of the things we have to do.

If we don't understand why we must do them, we ought to find out. Then if they still seem unreasonable, a good old-fashioned grumble is in order *before the person responsible* . . . be it husband, wife, foreman, or big boss. If we aren't brave enough to do this, then we should keep our grumbles to ourselves.

One of the happiest companies I know has an unwritten law that everybody there learns: **WHENEVER YOU HAVE SOMETHING TO GRUMBLE ABOUT, TELL IT DIRECTLY TO THE PERSON WHOM YOU BELIEVE TO BE RESPONSIBLE FOR THE CONDITION AND ASK HIM IF HE CAN'T DO SOMETHING ABOUT IT.** The result is there is little grumbling; no grumbling at all "behind your back"; and whatever grumbling there is, is wonderfully effective. That is what we call constructive grumbling. And that's the only kind men and women of good will tolerate. Because it's the right kind of grumbling, let's call it an American art.

— n r i —

Electronics Today and Tomorrow

By

E. H. ALEXANDER

Engineer, Control Division
General Electric Company
Schenectady, New York

The future of industrial electronics can best be predicted and influenced by extending the existing uses of electronics. Often, we are hardly conscious of progress being made right before our eyes but after a short time—even a few months in the electronic art—we look back and are surprised to see how fast we are progressing. Few branches of engineering can claim less elapse of time between the engineer's dream and the finished, working article, than electronics.

Microwaves

One of the most thought-provoking fields for future growth is the use of microwaves for industrial purposes. The great strides made during the war with microwaves (radar) for detection, direction, recognition and navigation open a new field. These ultra-high frequency radiations have some promise of supplanting light beams now used with photoelectric relays and their unique transmission possibilities of being "piped" around corners are interesting. Such waves (in the vicinity of 3000 megacycles) can be polarized, reflected and absorbed, suggesting some of the properties of light. For instance, the transparency of paper, thin wood and coarse wire screens to these waves compared with the opaqueness of wet paper, wet cloth and fine wire screens

suggests many uses. Just one is a moisture-content controller for a continuous process industry. A thickness gage is another possibility. Any metal surface reflects the microwave beam; it need not be a polished surface. Although the human body absorbs the waves, it will also reflect waves of sufficient intensity.

Already several future industrial applications of this new electronic tool are in developmental stages. The principle of the proximity fuse, for example, developed for explosive shells might find application in railway signalling or train control, who knows.

Dielectric Heat

Stepping down a little in the frequency spectrum, from 3000 megacycles to the range of 3 to 40 megacycles, we find electronic sources for dielectric heat increasing the productivity of many machines or processes and, indeed, the worker himself. Notably, the use of dielectric heat in the plastics moulding industry has been gratifying. Preheating of "sills" or "preforms" increases the product of the machine; allows the same piece to be moulded on a smaller press; and improves the quality of the finished piece. The drying of synthetic and natural fibres or yarn, while in continuous motion, seems justified because of improved quality and tensile strength. Even food technologists are looking to this source of internal heat for dehydration and sterilization of food products.

Thy-mo-trol (Electronic Motor Control)

Controlled electronic rectifiers have been used to supply regulated power to direct-current motors for more than 18 years, but only within the past four years has a packaged system for a complete, wide-range, variable speed drive come into its own. During this short period of rapid expansion we have seen a previous limit of 15 hp extended to an operating installation of a 40-hp drive. Now a 75-hp drive is in the building and we already look with eagerness to a prospective 600-hp drive. Electronic motor control for ship propulsion and even main-line locomotive drives is in the offing.

Electronic Inspection of Surfaces

The technique of the television camera has been suggested as a means for the inspection of surfaces of materials in motion such as strips of metal, cloth and rubber. There are, of course, many problems to be solved, particularly what to do with a signal of imperfection. However, no apparently insurmountable object stands in the way of accomplishment. Who knows but what centralized quality control system of the future will have instantaneous and integrated

pictures at one central point of the quality of several remote continuous processes. The accomplishment of this feat stands a much better chance, in my opinion, than, for instance, the radical improvement of the induction motor or the power transformer.

Electronic Control of Resistance Welding

Experience has proved that America's high standards of living have resulted in large measure from increased productivity of the worker. Perhaps no single tool of fabrication has contributed more to this increased productivity than electronically controlled resistance welding. In 1930, the production of steel evaporators for domestic refrigerators was increased by 400 per cent by this method of fabrication. In 1932 it made the use of stainless steel economically possible. Aircraft subassemblies, parts of high explosive shells, and the indispensable electronic tube were all made by this precision method of heat and pressure control.

Now, air-hardenable steels are joined by resistance welding, next annealed, and then tempered in one continuous sequence of precision-controlled events. It isn't careless speculation to predict that in the future the fabrication of large steel buildings and ships will be by this method. And *because of electronics* every joint will "write" on a permanent record its own certification of strength. An electronic weld recorder will do the job.

The versatility of resistance welding, when controlled electronically, offers tremendous possibilities for the future.

Light Sources

Although one has been inclined to neglect light sources as electronic devices, because of the incandescent predominance, such sources of light are coming into prominence. Beginning with the early neon-sign lighting, followed by sodium vapor and mercury vapor highway lighting, the fluorescent lamp appeared. The germicidal lamp and the Circleline and Slimline are more recent additions. All of these sources of light are electronic devices and their development reminds us that electronics will play a definite part in the future of light sources.

It is only natural to be enthusiastic about the future of electronics. After all, the electron is one of constituent particles of the atom and all of us have heard recently of great things going on in the exploitation of atomic energy. We need only, however, to concern ourselves with electrons freed from the bondage of matter, which is the science of electronics, to predict a bright future for this particular field of engineering.

Building the Bridge

An old man, going a lone highway
Came, at the evening, cold and gray,
To a chasm, vast, and deep, and wide,
Through which was flowing a sullen tide.
The old man crossed in the twilight dim;
The sullen stream had no fears for him;
But he turned, when safe on the other side,
And built a bridge to span the tide.
"Old man," said a fellow pilgrim near,
"You are wasting strength with building here;
Your Journey will end with the ending day;
You never again must pass this way;
You have crossed the chasm, deep and wide—
Why build you the bridge at the eventide?"
The builder lifted his old gray head:
"Good friend, in the path I have come," he said,
"There followeth after me today
A youth, whose feet must pass this way.
This chasm, that has been naught to me,
To that fair-haired youth may a pit fall be.
He, too, must cross in the twilight dim
Good friend, I am building the bridge for *him*."

WILL ALLEN DROMGOOLE

— n r i —

Mutual Relations

A company in its final essence is not brick and mortar, machinery, patents, etc., . . . it is a group of people. If these people are filled with jealousy of one another, and hatred, chiseling and pettiness prevail in their mutual relationships, we have as a result reduced effectiveness, lowered profits and prestige. On the other hand, honest, sincere teamwork — up and down — results in growth and real achievement.—MELVIN J. EVANS.

— n r i —

He Had To Get Home

Drunk (to splendidly uniformed bystander :)
Shay call me a cab, will ya?

Splendidly Uniformed Bystander: My good man,
I am not the doorman; I am a naval officer.

Drunk: Aw right, then call me a boat, I gotta
get home.

— n r i —

Larry: "Do you know, honey, if I had to do it
all over again, who I'd marry?"

Wifey: "No. Who?"

Larry: "You."

Wifey: "Oh, no you wouldn't."

— n r i —

Judge: Seems to me you've been coming up before
me for the past twenty years.

Vagrant: Can I help it if you don't get promoted.



N.R.I. ALUMNI NEWS

Harry R. Stephens	President
Ernest W. Gosnell	Vice-Pres.
Frank Zimmer	Vice-Pres.
Harry Andresen	Vice-Pres.
F. Earl Oliver	Vice-Pres.
Earl Merryman	Secretary
Louis L. Menne	Executive Secretary

HARRY R. STEPHENS OF DETROIT IS 1946 ALUMNI ASSOCIATION PRESIDENT

Zimmer of New York, Gosnell of Baltimore, Oliver of Detroit
and Andresen of Chicago are elected Vice Presidents

THE new President of the NRI Alumni Association is Harry R. Stephens, who made quite a reputation for himself as Secretary of Detroit Chapter. Stephens is a splendid fellow, reserved, conservative, thorough. He is very businesslike, steady as a clock, a good Radio man and a tireless worker for our Alumni Association. We could want nothing more and our Alumni members are to be congratulated upon making a good choice.

Pete Dunn, who ran on the Presidential ticket with Harry Stephens was the first to send congratulations. Pete, as we all know, has had a special government assignment which keeps him on the move quite a bit thereby making it difficult for him to keep in contact with Alumni affairs. Pete Dunn was President for four consecutive years. He is glad to see someone else get the honor. Pete will be heard from when he gets back with us.

Frank Zimmer of New York, Ernest W. Gosnell of Baltimore, F. Earl Oliver of Detroit, and Harry Andresen of Chicago were elected Vice

Presidents. Only Mr. Oliver is a hold-over. Zimmer, Gosnell and Andresen hold office for the first time in our National organization. This is a fine compliment to the members of New York, Baltimore and Chicago Chapters where these three newly elected officers have a popular following. Earl Oliver, of course, is very active in Detroit Chapter and fully deserves to be re-elected.

Earl A. Merryman, as expected, was re-elected Secretary, Earl is a favorite with our members and polls a heavy vote each year.

Louis L. Menne was re-elected Executive Secretary. He is Editor of NR NEWS and has many friends in the Alumni Association developed through his correspondence with members and his visits to local chapters.

Now, a big vote of appreciation to retiring officers and a big welcome to incoming officers.

Together we will all work for the betterment of Radiomen everywhere. All ready then for a prosperous 1946.



(Upper photo)—Phila-Camden Chapter meeting. Charles J. Fehn, 1945 President, is in front center with Harvey Morris at his left and Harry Schneider at his right.



(Left)—Charles J. Fehn, Chester Klabe, Laverne Kulp, and Harry Schneider, four of the officers who served Phila-Camden Chapter so well during 1945, are called up to receive the plaudits of the members.

Phila-Camden Chapter

Officers for 1946 were duly elected. They are as follows:

Chairman, Ed Rood
Vice Chairman, Harvey Morris
Recording Secretary, F. Armstrong
Financial Secretary, M. Tice
Treasurer, Charles J. Fehn
Sgt.-at-Arms, R. Meili
Librarian, J. McGovern

A special meeting was held for the purpose of holding our election and to do honor to Charles J. Fehn, our standby who was completing his term as National President of the NRI Alumni Association. Mr. Menne and Mr. Straughn of Washington came to Philadelphia to attend this meeting. Mr. Menne addressed the members with an inspirational talk, then presented Mr. Straughn who obliged with a very fine technical



J. B. Straughn, NRI Supervisor of Training, talks on Servicing AC-DC sets at Phila-Camden Chapter meeting.

talk. Our Washington visitors were accorded a grand reception.

Mr. Fehn also contributed a nice talk. He introduced a number of members, all of whom made a few remarks. We were pleased to have a considerable number of old-timers back with us including, of course, several veterans of the war.

The retiring officers were called forward and given a rousing cheer for an excellent job during the past year.

The new officers are very capable men who have big things planned for 1946. We have comfortable meeting quarters and facilities for making each meeting a fruitful one. All NRI men, whether students or graduates, are welcome.

Remember the meeting nights, first and third Thursday of each month in the Post Office Building, 4706 Comly St., Philadelphia 24, Pa. Let's back the new officers with a good attendance at every meeting.

HARRY SCHNEIDER, *Secretary.*

Detroit Chapter

Officers for 1946 are as follows:

Chairman, James A. Quinn
Vice Chairman, Bernard Hiller
Secretary, Val O. Guyton
Assistant Secretary, Jack W. Hasen
Financial Committee, Larry Upham, Jerome Vaerten
Librarian, Charles W. Mills

Jim Quinn, an old standby in our Chapter, will make a good chairman. He was the unanimous choice for the office—a real compliment to a very loyal member. Quinn will be ably assisted by a very capable staff of officers.

Our retiring chairman, Harold E. Chase, did a grand job and our members wish him to know his efforts in our behalf are fully appreciated. Incidentally, Mr. Chase was the speaker at our last meeting. He spoke on "Charges for Radio Servicing."

At a previous meeting Mr. Don Knight of the Detroit Edison Company gave us a good talk on "Interference." At still another meeting Mr. H. W. Dushane, recently released from war duty, gave us enough information to enable us to have a much better understanding of Radar.

New members are Clifton S. Bakewell and Jack Nashland. Names of two additional members who have just joined the chapter will be reported later. Our membership now totals 47, all active and interested in the affairs of our chapter.

Please note this new schedule of meetings. No more confusion as to meeting dates. We now meet on the first and third Fridays of each month. Get on the mailing list if you wish to attend meetings. Send name and address to the undersigned, at 13103 Stoepele, Detroit, Michigan. A postcard will do.

VAL O. GUYTON, *Secretary.*

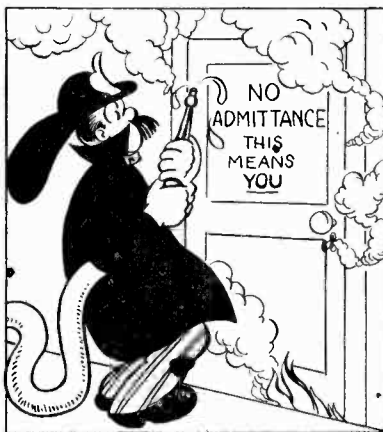

Here And There Among Alumni Members



Murray Dickson of Paducah, Kentucky is now operating his own service business specializing in marine radio telephone installations and service.

— n r i —

Tom Gibbes is back with the Tampa, Florida Police Department as operator after doing a swell job for two years as instructor for the Navy at NATTC, Corpus Christi, Texas.

— n r i —

M. L. Githens of the U. S. Airway Communications Station, Kansas City, Mo. is now Maintenance Technician in Charge. His salary has increased \$250 a month since he enrolled with NRI. Must be doing O. K.

— n r i —

Robert Lent has opened a Radio shop in Callao, Virginia and is making \$20 to \$30 a day.

— n r i —

Edward M. Schminke, who has one of the leading Radio stores in Newark, New Jersey is remodeling the entire service Department and also the show room. Is looking forward to having Fred Yanck back with him. Mr. Yanck is due for his Navy discharge after a grand job in the Service.

— n r i —

Joe K. Duckworth, who has his own Radio and Appliance business in Columbia, S. C. is State Commander, Disabled American Veterans, Department of South Carolina.

— n r i —

E. W. Gosnell of Baltimore, newly elected Vice President, has not missed a single meeting of Baltimore Chapter in more than five years. There is a fine record of attendance.

— n r i —

We are happy to have a letter from Dr. George B. Thompson, former Vice President of the NRI Alumni Association. Dr. Thompson has returned to his Los Angeles home after spending eight months in the desert recovering his health. Dr. Thompson informs us he is coming along nicely.

— n r i —

Got a nice calendar from Howard E. Sanford who conducts Sanford Radio, at 134-136 Sterling Place in Brooklyn, New York.

— n r i —

The boys of New York Chapter had a lot of fun with J. A. Dowie, their guest at a recent meeting. The photographer, a professional by the way, was coached to take some pictures just at the right moment. But they did not develop. That photographer is very popular with New York Chapter members—like Kelly is!

— n r i —

We received an exciting picture of Pfc. Samuel A. Gornick showing him in action against the Japs. A solid Marine, this man Gornick, who sends greetings to his fellow Detroit Chapter members.

Walden P. McKim, after sixteen months as Radio operator at sea, is now back at Radio station WJLD, Bessemer, Alabama. Mr. McKim recently got his 2nd Class Radio telegraph ticket. Gets \$67.50 for a 40-hour week with time and a half for overtime and double time for holidays.

— n r i —

Robert K. Ford of Philadelphia, Pa. makes about \$25 a week from spare time work. His regular job pays him a little more than \$10 a day so we must conclude Mr. Ford is doing quite well especially for a man who was doing odd jobs as a laborer when he enrolled with NRI.

— n r i —

John Keller is now Aircraft Communicator, Civil Aeronautics Authority, Martinsburg, Pa. Salary has gone up too.

— n r i —

About thirty miles from Washington is the progressive little city of Frederick, Maryland. of Barbara Fritchie fame. In this modern day, men such as graduate I. L. Hankey, Jr. continue to keep busy Frederick in the limelight. Mr. Hankey has a full time Radio business. He is a very progressive business man.

— n r i —

Serge A. DeSomov of New York, who is a member of the engineering staff of a large broadcasting chain, writes to suggest that NRI be commended for the lessons on sound engineering which he considers a very valuable part of the NRI course.

— n r i —

Harvey E. Horne of Erwin, N. C., is another NRI graduate who started a spare time Radio business and is now giving full time to it.

— n r i —

Roby C. Crook of Lexington, N. C. has a new partner, named David L. Heitman. Both are working full time and are doing a splendid business. They have a new store which they had built to their own ideas.

— n r i —

Frank J. Lhotsky of Cicero, Ill. does not permit a physical handicap to stop him. His right leg was amputated some years ago. At 64 years of age, working all alone, his Radio business shows a net profit of \$3,000 for 1945.

— n r i —

Albert G. Olthaus is in business at 3516 Warsaw Ave., Cleveland, Ohio, with a complete Radio and Appliance service. The firm is known as Olthaus-Fikpp Company.

— n r i —

Leander Arnold of Pontiac, Mich. has been working with Radio as a hobby since 1921 when speech and music was first broadcast over WWJ, Detroit. Since taking the NRI course his hobby pays him about \$25 a week for spare time work.

Chicago Chapter

Thanks to Mr. Leonard Sterling, supervisor of the West Park District we are permitted the use of one of the rooms of the Garfield Park Executive Building, 100 North Central Park Ave. for every second Wednesday of the month.

Two engineers of the Webster Company of Chicago, are to address us at our next meeting. They will speak on Record Players and Recorders.

Mr. Milton Coleman of Radolek again made a valuable contribution to our last meeting. He presented us with an alignment outfit which was raffled off. Mr. Coleman also spoke briefly on the Radio parts situation and gave us some valuable pointers.

A new committee has been appointed. It is the Entertainment and Planning Committee. The members are Harry Andresen, Steve Bognar, Ralph Petit, Burton Morrison and Harry Colton.

Election of officers will be held at our next meeting.

If you live in the Chicago area and wish to attend meetings please send your name and address to the undersigned at 2306 W. 51st St., Chicago, Ill.

LLOYD C. IMMEL, *Secretary.*

— n r i —

Baltimore Chapter

Officers elected for the year 1946 are as follows: Chairman, H. J. Rathbun
Vice Chairman, Lawrence Arthur
Recording Secretary, Percy Marsh
Treasurer, George Philips
Librarian, Ernest W. Gosnell
Sgt.-at-Arms, John Clark

Our retiring Chairman, Ernest W. Gosnell, has served us for five consecutive years. During all that time Mr. Gosnell did not miss a single meeting. Considering that these were war years, placing unusual demands upon the time of all of us as it did, this is a grand record of faithfulness to duty. It is fitting too, that the man who served as Vice Chairman during all this time should now be elevated to Chairman. We have reference to Mr. H. J. Rathbun, our Radio expert, who occupied the chair very little while understudy to the steady Mr. Gosnell. Now Mr. Rathbun takes over.

Mr. Menne and Mr. Straughn visited us. They always contribute something to our meetings.

Meetings are held every second and fourth Tuesday at Redmen's Hall, 745 West Baltimore St., at 8:15 P.M. All NRI men are welcome.

PERCY MARSH, *Secretary.*

New York Chapter

Our annual social party was held and what a party. Good music, good entertainment, plenty to eat and drink. Attendance—more than one hundred.

Mr. James A. Dowie, NRI Chief Instructor, was our honor guest. He was accompanied by Mr. Menne and Mr. Straughn. Mr. J. E. Smith was also expected but pressing business matters kept him in Washington.

Our Chapter members had everything planned in advance. A big vote of thanks is extended to all who served on various committees. In fact, at a recent meeting our Mr. Marshall moved for a special vote of thanks for Pete Peterson. This motion was seconded by Mr. Gomez and carried by a unanimous rising vote—a real tribute to a very deserving fellow. Pete Peterson took care of all the arrangements for food and refreshments. What a job he did!

The photographer, bless his heart, fell down badly on the pictures. We posed gracefully this way and smilingly that way, caught J. A. Dowie, J. B. Straughn and L. L. Menne in candid shots while they were speaking, took pictures of small groups and individuals, not to fail to mention a group picture of all present but the photographer must have been looking at the little birdie instead of through the lens—so what happens! Nothing! No go. Shes-a-no-good. What a disappointment to our members many of whom had placed an order for the group picture. We are now trying to get some detail into a few of the pictures and, if successful, will have some for next issue.

Anyway, thanks again to Wappler, Peterson, Kunert, Zimmer, Hirsch, Music, Remer, Newbeck, Fox, Bockelman, the musicians, and too many to mention—for a grand job done in true New York Chapter style.

We have had the usual good programs. Listen good reader, if you live in the New York area you are missing something if you fail to attend our meetings. Make a note now to remind you—meetings are held on the first and third Thursday of each month at St. Marks Community Center, 12 St. Marks Place, between Second and Third Aves., New York City.

LOUIS J. KUNERT, *Secretary.*

— n r i —

Sign Seen in Southern Maryland

Anyone caught on my property will be persecuted to the full extent of two mongrel dogs which ain't none too friendly with strangers and one dub'l barrel shot gun that ain't loaded with sofa pillars—durned if I ain't gettin' sick and tired of people trespassin' on my property!

Plans For 1946

Students and servicemen should look ahead to developments in the coming year and make an effort to prepare to take advantage of future opportunities. Those who are in the early stages of their training will find it well worthwhile to study hard the fundamental lessons since advanced lessons cannot be studied to the best advantage unless fundamentals are learned thoroughly.

The advanced student and serviceman will find it desirable to review fundamentals. Tying in with that review the practical and advanced knowledge will aid in securing complete mastery of basic principles. It is when you have learned to use and apply efficiently the basic principles of radio that you find it possible to do the best work.

In the year ahead, we are going to hear more and more about frequency modulation radio receivers, ultra-high frequency reception and antennas, television and electronic controls. To many men, however, the subjects of greatest interest will continue to be regular servicing of standard amplitude modulated receivers and, perhaps, an increased interest in servicing automatic record changers. And, of course, servicemen will always be interested in new test equipment and more efficient methods of servicing receivers. They will be interested, too, in planning shop improvements, arranging test panels, tools and equipment to secure highest efficiency and best appearance.

To the non-technical layman, appearance is important and the shop that is well equipped, workmanlike in appearance, not only is able to make a good impression upon customers but also is able to back up good first impressions with solid, conscientious and reliable servicing of customers' receivers.

J. A. DOWIE, *Chief Instructor.*

— n r i —

A party of tourists in Arizona came upon an Indian brave riding a pony. A heavily burdened squaw walked beside him. "Why doesn't the squaw ride?" asked the tourist. "She got no pony."

— n r i —

Californian: "Now in my state we can grow a tree that size in about a year. How long did it take you to grow that one?"
Floridan: "Can't say for sure, but it wasn't there yesterday."

— n r i —

Talkative lady: "A big man like you might be better occupied than in cruelly catching little fish."

Fisherman: "Perhaps you're right, but if this fish had kept his mouth shut he wouldn't be here."

Page Thirty-two

NATIONAL



FROM N. R. I. TRAINING HEADQUARTERS

Vol. 12

February-March, 1946

No. 1

Published every other month in the interest of the students and Alumni Association of the

NATIONAL RADIO INSTITUTE
Washington, D. C.

The Official Organ of the N. R. I. Alumni Association
Editorial and Business Office, 16th & You Sts., N. W.,
Washington, D. C.

L. L. MENNE, EDITOR

J. B. STRAUGHN, TECHNICAL EDITOR

NATIONAL RADIO NEWS accepts no paid advertising. Articles referring to products of manufacturers, wholesalers, etc., are included for readers' information only, and we assume no responsibility for these companies or their products.

Index

Article	Page
Repeat Business	2
How to Repair Dial Drives	3
Radio Business in Rural Community	8
Get a Letterhead	10
Fundamentals of Filament Circuits	12
Our Cover—Marriage by Electronics	15
News of the Radio World	16
Diagnosing Receiver Troubles	17
How to Get Along With Others	24
Electronics Today and Tomorrow	25
Alumni Election News	27
Chapter Activities	29
Here and There Among Alumni Members ..	30