

# NATIONAL RADIO NEWS



## IN THIS ISSUE

Modern Tone Controls

Circuit Analysis of an A.C.-Battery Portable

Alumni Association News

JUNE-JULY  
1942

VOL. 10  
No. 3



## DETERMINATION

Did you ever watch a steamroller — an old-fashioned one with clanging gears, escaping steam and great clouds of black smoke belching from the stack? Wasn't it a thrill to see that great machine level out obstacles in its path, leaving behind a perfectly smooth roadway?

The word "determination" always brings to my mind that picture of a steamroller—a machine which nothing can stop once the "full steam ahead" lever is thrown. The steamroller is determined to go places and do things—and it succeeds!

So, too, are *you* determined to go places, to achieve success and happiness. One by one you are completing your lessons, studying hard and making sure you understand everything; step by step you are approaching that greatest of all goals—SUCCESS.

Of course, the way is long and not always easy. But whenever the going gets a little tougher than usual or you feel a bit discouraged, just bring out that old determination, and back it up with every single ounce of ambition you have.

Be a human steamroller, always confident of your own power, always moving ahead, always succeeding. Keep that determination of yours alive every single minute. I'm with you, ready to help you over the bumps at any time—I'm determined to make *you* win.

J. E. SMITH,  
*President.*

# Modern Tone Controls

BY L. J. MARKUS

Technical Editor



L. J. Markus

WITH steady year-by-year improvement in the quality of broadcast programs, radio listeners have become more exacting in their demands for faithful reproduction. They have become tone conscious, and the thrill of getting distant stations has given way to an earnest desire to hear programs in homes exactly as they were produced in studios.

Many things may cause the program the listener hears to be different from the original studio presentation. Actual defects in receivers are the least important of these, because these defects can be cleared up by the radio serviceman. The real causes of poor quality in the reproduced pro-

grammers in the studios. Let us consider first the human ear and its weaknesses.

*What We Hear.* The response of the human ear is quite different at low loudness levels than at high loudness levels. The difference for the average ear is shown in Fig. 1. Curve A shows the intensity level needed at each audio frequency to make a sound seem the same low loudness to the ear. Note that at low frequencies, around 50 cycles, much more amplification (a higher intensity level as measured with instruments) is needed to make the ear hear the same loudness as at 1000 cycles. Expressed in another way, at low loudness levels the human ear is more sensitive to frequencies between 1000 and 4000 cycles than to either higher or lower frequencies.

At high loudness levels, however, the ear hears all frequencies just about equally as well, as shown by dotted curve B in Fig. 1. Unfortunately, this level is much too loud for the home.

Bear in mind that *loudness level* is a human response to sound, and not something which can be measured with instruments. *Intensity level* is the actual measured level of sound as measured by instruments connected to a microphone which picks up all sound frequencies equally well.

*Receiver and Loudspeaker.* Receiver circuits do not ordinarily amplify all audio frequencies equally well, and loudspeakers are even more apt to reproduce some frequencies better than others. The receiver design engineer can correct these deficiencies when permitted to do so, but in lower-priced receivers such correction is economically not possible. This is why lower-priced receivers differ so greatly in tone.

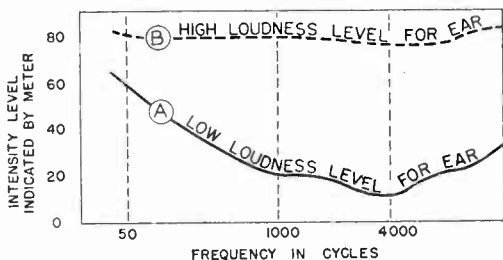

Fig. 1. These curves indicate that the average human ear is far from perfect at low loudness levels.

gram are three—the imperfection of the human ear, the imperfection of the average receiver-loudspeaker combination on the market today, and the fact that home radios operate under radically different acoustical conditions than do the

*Home Acoustics.* A receiver placed in a room with hard walls and a bare floor will seem to have considerably different tone than when placed in a room having porous walls, plenty of drapes, and rugs on the floor. The reason is that sounds are reflected from hard walls and floors but are absorbed by soft materials. In a bare room you hear a lot of reflected sounds along with the direct sound from the loudspeaker. The more the acoustics (absorption and reflection characteristics) of a room differ from those of the radio studio, the greater will the reproduced program differ in tone from the original.

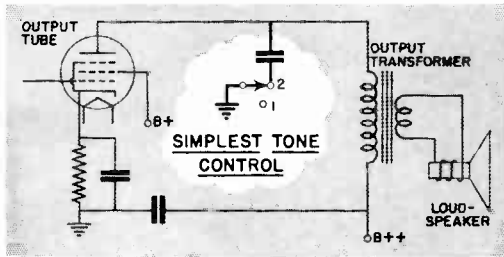

Fig. 2. In this tone control, the condenser lures higher audio frequencies directly to ground and thus makes bass notes predominate.

*Purposes of Tone Controls.* To help achieve faithful reproduction at loudness levels suited to the average home, despite deficiencies in the human ear, the receiver and the acoustics of the room, is one purpose of a tone control. Another purpose, and a very important one from a sales viewpoint, is to adjust the response of the system to suit any particular individual's personal tastes. Thus, some people prefer a boomy bass tone even though it is a distortion of the original program.

Simple tone control circuits may also be used to reduce the annoying effects of static, eliminate needle scratch when playing phonograph records, make a speaker's voice more "crisp" and intelligible, or reduce acoustic feed-back from loudspeaker to microphone in public address installations.

*Simplest Tone Control Circuit.* A condenser connected between the plate of an a.f. amplifier tube and ground, essentially as shown in Fig. 2, is the simplest practical method used in modern radio receivers to control tone.

With this arrangement, the tone control knob would have two positions. In position 1, which might be labeled "BRIGHT" or "TREBLE," no condenser is in the circuit, and hence all audio frequencies are passed uniformly. In position 2, which might be labeled "MELLOW" or "BASS," the condenser cuts down the medium and high

audio frequencies so as to give a bass-boosting effect which is usually preferred by listeners when the receiver is set at a suitably low loudness level for background music in a home.

The action of a tone control condenser can be explained in a few sentences. When in use, the condenser is always shunted across (in parallel with) the load in a signal circuit. At low audio frequencies, the reactance of the condenser is so high in comparison to the reactance of the load (the output transformer primary in Fig. 2) that by-passing of low-frequency signals is negligible. As frequency goes up, condenser reactance goes down, and more and more of the signal is by-passed to ground without passing through the load. Keeping some of the medium and high-frequency audio signals out of the load in this manner gives an apparent boost in the strength of bass or low-frequency signals, because the signal which is fed to the loudspeaker then has a higher proportion of bass notes than the signal fed to the tone control.

*Four-Position Tone Control.* By using several different condenser values, with a switch position for each, a choice of tone can be obtained. The example in Fig. 3 uses three condensers

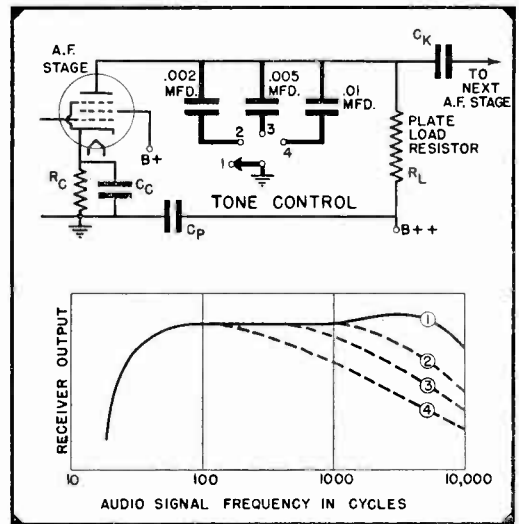

Fig. 3. Four-position tone control using condensers, with the response curve obtained for each position in an average modern receiver.

connected between a.f. amplifier stages, and gives four choices of tone. Curve 1 below the diagram shows the receiver response when there is no tone control condenser shunting the plate load resistor. Curves 2, 3 and 4 correspond to tone

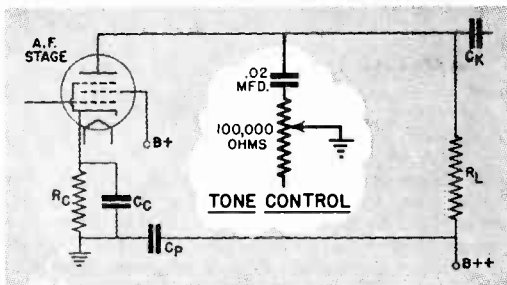

Fig. 4. Example of a continuously variable tone control consisting only of a condenser and a rheostat.

control switch settings 2, 3 and 4, and show how increasingly larger capacity values cause increasingly more suppression of higher audio frequencies.

If this tone control is set at position 4 when the volume level of the receiver is high, the bass notes will be amplified excessively for the requirements of the human ear, and the program will sound boomy. Many people prefer a strong bass response like this and will purposely set the tone control to give it, even though they thus destroy the fidelity of the program.

**Continuously Variable Tone Control.** Some people prefer a continuously variable type of tone control, in order to obtain exactly the desired tone correction at any loudness level. This is provided by the combination condenser-rheostat tone control circuit shown in Fig. 4.

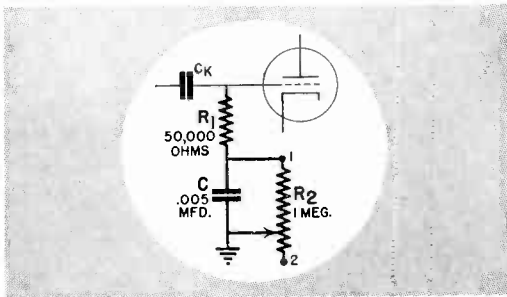

Fig. 5. Another continuously variable tone control arrangement for cutting down higher audio frequencies any desired amount.

When the rheostat is set at zero resistance, only the condenser is connected across the signal circuit (between plate and ground); high frequencies are then almost completely suppressed. Increasing the resistance in series with this condenser by advancing the tone control rheostat in-

creases the total impedance of the tone control path to ground, thus reducing the by-passing of high audio frequencies. When the maximum resistance of 100,000 ohms is in the circuit, practically all of the signal takes the path through plate load  $R_L$ , and there is no cutting of high frequencies.

This combination condenser-rheostat tone control is often used across the grid circuit of an a. f. stage. The action is the same, but the capacity value is lower (about .005 mfd.) and the rheostat value is higher (about 1 meg.).

**Another Way to Cut Highs.** A resistor, a rheostat and a condenser are the three parts employed in the tone control circuit shown in Fig. 5. This basic arrangement is well worth studying, because it is found in various forms in a great many modern receivers.

When the movable contact of the rheostat is at point 1, the condenser is short-circuited.  $R_1$  is

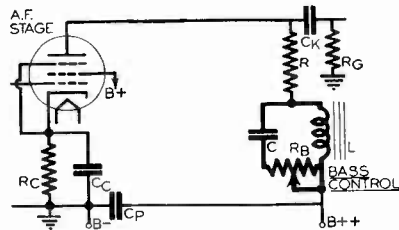

Fig. 6. Example of parallel resonant circuit (L-C) being used for tone control purposes.

now the only part across the grid circuit of the tube, and all audio signal frequencies are passed uniformly. When the arm of the control is moved a small amount away from point 1 (toward point 2), we have a low resistance in parallel with C. Now C has a shunting effect which increases with frequency. The combined impedance of the  $R_2$ -C path to ground therefore drops a certain amount at higher audio frequencies, so less voltage is developed across the grid circuit at the higher frequencies and we have cutting of highs.

As we increase the ohmic value of  $R_2$  by moving its contact toward point 2, condenser C has increasingly more effect on the combined impedance of  $R_2$ -C, and highs are cut still more. The result is increasingly greater emphasis of low frequencies. Maximum bass tone is obtained when  $R_2$  is set at 2.

**Boosting Bass By Resonance.** Resonant circuits are widely used to control the bass response of a receiver. A typical example is that in Fig. 6, where condenser C and iron-core inductance L form a parallel resonant circuit which has a

resonant frequency of about 50 cycles (C will ordinarily be about .1 mfd., and L about 100 henrys). At resonance this circuit acts as a high resistance which, being in series with resistor R governs the plate load impedance. The greater the resistance of the resonant circuit at resonance, the greater will be the boost in low-frequency response.

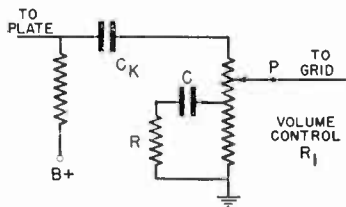

Fig. 7. Condenser C and resistor R connected in series across part of the volume control give automatic bass compensation.

high plate load impedance. The amplification of the stage is therefore increased in the low frequency or bass range around 50 cycles.

This parallel resonant circuit acts like a reactance of low ohmic value at frequencies higher than 50 cycles, under which condition resistor R governs the plate load impedance. The greater the resistance of the resonant circuit at resonance, the greater will be the boost in low-frequency response.

The resonant resistance can be varied over a wide range by adjusting the setting of potentiometer  $R_b$ . When all of  $R_b$  is in the circuit, the resonant resistance is quite low and there is little or no boosting of bass response. Maximum bass boosting is secured when all of  $R_b$  is shorted out.

*Automatic Bass Compensation.* The fact that the average human ear suffers a loss in low-frequency response at low volume levels has brought about the automatic bass compensation type of volume control illustrated in Fig. 7. Here again we find a combination of resistance, capacity and inductance controlling the voltage applied to the grid of a tube.



Fig. 8. Paul H. Thomsen, developer of the Tonalizer, demonstrates his latest 15-channel model. The channels are controlled by vertically-sliding levers arranged so the ends of the levers trace out the response curve to which the Tonalizer is set.

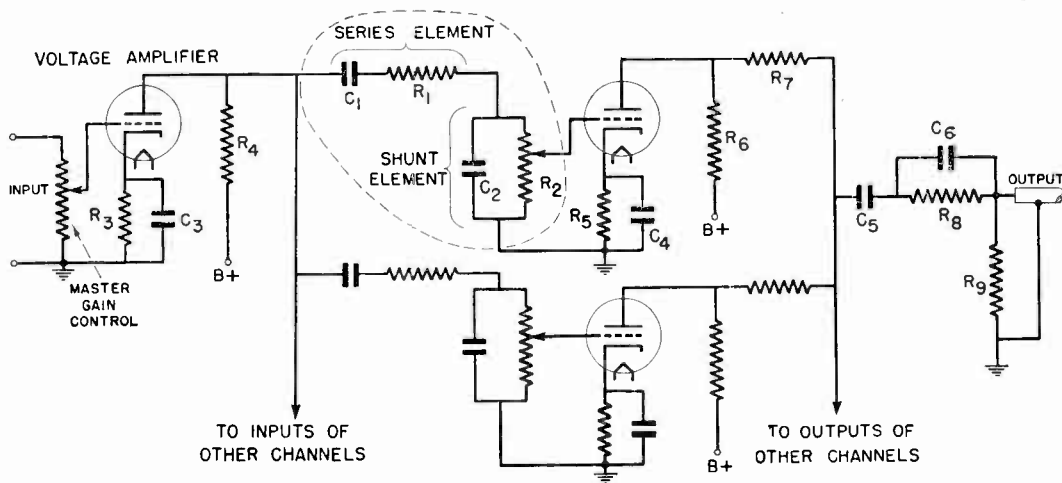

Fig. 9. Basic circuit arrangement employed in the Tonalizer developed by Paul H. Thomsen.

The circuit is so arranged that when volume is reduced by moving the volume control arm toward the grounded end, the high-frequency voltage applied to the grid is reduced; the result is automatically increasing emphasis of lower frequencies as volume is reduced, to compensate for the lowered response of the human ear to these frequencies at low volume.

**Treble Control.** The tone control arrangements discussed up to this point come under the general classification of *bass controls*, because they emphasize bass notes by cutting highs. Any of these arrangements can be used as a *treble control*, however, if the receiver is so designed that its response is broadly peaked at the high-frequency end of the a.f. spectrum. The treble control then cuts down this peak response, thereby giving the listener a choice between normal response and over-emphasis of the highs.

**Drawbacks of Simple Tone Controls.** Although the tone control arrangements ordinarily found in radio receivers work well enough for the average person, they fall far short of giving near-perfect correction of tone under all conditions, as is often required by the broadcast engineer, the recording engineer and the theatre owner.

**The Tonalizer.** Perfect tone correction means individual control over *each* frequency in the audio spectrum, with a means of changing that control as the loudness level of the reproduced program is changed. This is both an economic and engineering impossibility, but a practical approach to it has been developed by Mr. Paul H. Thomsen (former N.R.I. Communications

Consultant), in the form of a multi-channel amplifier which provides individual control over different groups of frequencies in the audio spectrum. This unit, shown with its inventor in Fig. 8, is known as the Tonalizer.

Basically, the Tonalizer consists of a single voltage amplifier stage and master gain control, followed by a number of selective channels in parallel, each controlling a definite band of frequencies and having its own amplifying stage. A conventional power pack furnishes operating voltages for all stages, making the Tonalizer a completely self-contained unit which can be inserted in an a.f. amplifier system and plugged into a 115-volt a.c. power outlet in a few minutes.

The voltage amplifier stage and master gain control of the Tonalizer, together with two of the channels and the method of mixing the signals at the output, are shown in Fig. 9. Ordinarily, about sixteen separate channels are used, but this number can be increased or decreased to meet special requirements. Naturally, the more channels there are, the more perfect is the control of tone and the greater is the cost of the manufactured unit.

All channels have identical arrangements of the selective circuit shown inside the dotted circle in the diagram, but the resistor and condenser values are different for each channel. The audio signals which make up a program come through the voltage amplifier stage, then divide up because each of the channels offers a low-reactance path for one particular group of these frequencies. Analysis of one channel will show us how it can provide this selective action.

Each selective circuit of the Tonalizer consists of a series element  $C_1-R_1$  and a shunt element  $R_2-C_2$ , which serve as a voltage-dividing network for signals traveling from the plate of the voltage amplifier stage to ground. The reactances of the series and shunt portions vary with frequency in such a way that maximum voltage is developed across  $R_2$  only at one particular frequency. This voltage drop across  $R_2$  is applied partially or completely to the grid of the amplifier tube for the channel, depending upon the setting of the movable contact of potentiometer  $R_2$ . The voltage drops off gradually at frequencies on either side of this value, and we thus secure selective action.

At low audio frequencies we can neglect the reactance of  $C_2$ , so we have only  $R_2$  in the shunt element. The reactance of  $C_1$ , however, will be high at low frequencies, and the net impedance of the series element will therefore be high in comparison to the net impedance of the shunt element. Therefore, most of the signal voltage will be dropped across series element  $C_1-R_1$ , and the output across  $R_2$  will be low at low frequencies.

At high frequencies, the reactance of  $C_1$  is so low that  $R_1$  is the principal factor in the series element. The reactance of  $C_2$  is likewise very low, making the net impedance of the shunt element very much lower than that of the series element. Most of the signal voltage will be dropped across  $R_1$  in the series element because the value of  $R_1$  is high with respect to the net impedance of the shunt element. Therefore, the output across  $R_2$  at high frequencies will also be low.

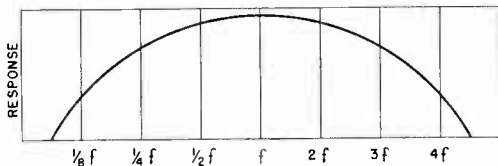

Fig. 10. Response curve for one channel of the Tonalizer.

However, there will be some intermediate frequency at which the net impedance of each element will cause a voltage to be developed across  $R_2$  which is much greater than the voltage developed at either high or low frequencies. This is called the peak frequency, and is designated as  $f$  in Fig. 10. It is at this frequency that maximum output from the channel is obtained.

Resistor  $R_2$  is a potentiometer, so connected that any portion of the a.f. voltage developed across it may be applied to the grid of the tube in its channel. In this way, the amount of voltage passed to the output of the Tonalizer for each

frequency group can be controlled without appreciably affecting the signal levels of the other frequency groups. When all controls are set to the same position, the over-all response of the Tonalizer is flat.

The general output level of all frequencies is governed by the setting of the master gain control preceding the voltage amplifier tube. The individual channel controls then become tone controls, each controlling a definite group of audio frequencies.

For a 16-channel Tonalizer, the lowest peak frequency is 15 cycles. Each succeeding channel has a peak frequency about 1.6 times that of the preceding frequency, at 23, 37, 60, 96, 154, 245, 394, 630, 1000, 2560, 4100, 6550, 10,300 and 16,480 cycles respectively. This overlap gives smooth control, with an average variation of about 5 db from one channel to the next.

The overlap, combined with the width of the response for each channel, prevents any one control from cutting any particular frequency entirely out of the circuit, even at the minimum-output position. To completely cut the 15-cycle response from the unit, the first six controls must be set at zero. The 15-cycle response will then be 30 db below the original level.

The latest model of the Tonalizer uses an ingenious system of levers to rotate the potentiometers in the channel controls. The positions of these levers with respect to each other actually trace the over-all response curve of the unit. Figure 11 gives you an idea of what the rear of this unit looks like above the chassis, while the front of this particular model can be seen in Fig. 8. A front view of a 16-channel Tonalizer using ordinary control knobs for each channel is shown in Fig. 12.

Fidelity and stability are just two of the outstanding problems which have been successfully solved in this final Tonalizer design. Neither amplitude nor frequency distortion are introduced—an obvious requirement in any instrument which is intended to check fidelity. Furthermore, stability and simplicity of operation are now so highly developed that the unit can be reset accurately to any particular type of response.

So far, Tonalizer units have been made up only on special order, in limited quantities. Manufacture and test under production methods present no greater problems than are encountered in ordinary receiver manufacture, so it is entirely possible that sound technicians will be able to secure factory-made units from radio equipment distributors after the war. Initial design problems make it inadvisable for anyone to attempt construction of his own unit, however.



**Tonalizer Applications.** The Tonalizer is of great assistance to the engineer who must determine the over-all response of an amplifier. All he needs to do is insert the Tonalizer between the amplifier and a constant-voltage, variable-frequency source. He adjusts the various frequency control levers or knobs until the output of the amplifier is constant for all frequencies, then reads his response at sixteen different frequencies directly from the

them in the theater amplifier the next morning when the show isn't running, with complete assurance that the results of the previous evening will be duplicated.

The Tonalizer has been successfully used for trouble-shooting in many large p.a. systems. In one particularly interesting job, a permanent p.a. installation in a church having very poor acoustic conditions, five other well-known p.a. engineers had tried without success to produce results acceptable to the church directors. All used high-quality equipment having flat electrical response. The Tonalizer showed that a rise of about 20 db in response was necessary between 50 and 5000 cycles to offset the acoustic conditions and make the system seem flat to listeners. When R-C equalizers were inserted in the church amplifier to duplicate the Tonalizer settings, fidelity was so good that listeners could scarcely tell whether or not the p.a. system was turned on. But complaints came promptly from those at the rear of the church when the system was turned off—convincing proof that the installation was now a success.

Broadcast and recording studios, as well as many industrial research laboratories, will find many uses for the Tonalizer. Its use certainly is not limited to the more obvious examples which have been given.

To sum up, the Tonalizer offers the ultimate in adaptability and flexibility of control, with complete freedom from interaction of controls never

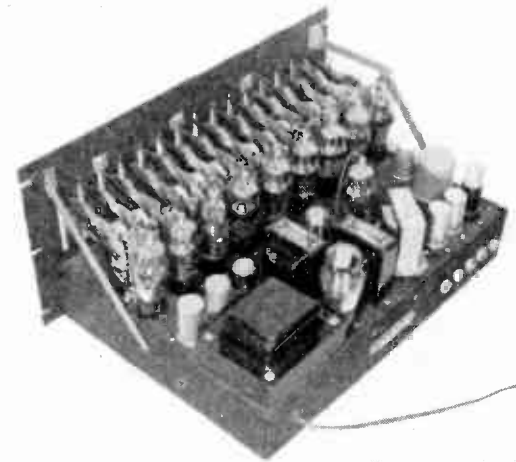

Fig. 11. Rear view of lever-type Tonalizer, showing gears and levers used to rotate the potentiometers in the various channels. Each double-triode 6F8G tube serves two channels.

settings of the individual controls. From this information, he can then design R-C equalizer circuits which can be inserted in the amplifier circuit to give the desired response.

The response curves of individual microphones, loudspeakers, and phonograph pick-ups can be determined in a similar manner with the Tonalizer and a supplementary high-quality a.f. amplifier.

Another application of the Tonalizer is its use in adjusting the response of a theatre sound system. Here the Tonalizer is introduced into the theatre a.f. amplifier, and the control levers are set to give the desired tone balance, as determined by listening in the audience. This is done when the regular show is running and with a normal audience, so that normal acoustic conditions exist.

From the settings of the controls after the desired response is once obtained, the installation engineer can easily calculate what compensation is needed, obtain the necessary parts and install

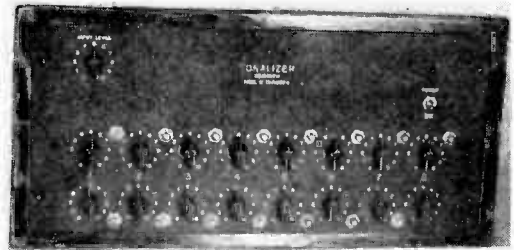

Fig. 12. This Tonalizer has sixteen separate control knobs for changing tone.

before obtained in a unit of this type. The sound technician is in for a real thrill when he hears the Tonalizer demonstrated for the first time.

— n r i —

Shakespeare never even dreamed of radio, yet you can find quite a few radio remarks in his works. Here are some of them: *His lecture will be done ere you have tuned*—The Taming of the Shrew; *'Tis no matter how it be in tune, so it makes noise enough*—As You Like It; *Ah, stand by*—Anthony and Cleopatra.

# Puzzling Radio Questions From Students

## Alien Receivers

*QUESTION: I would like to get some information on changing receivers owned by aliens to eliminate short wave reception. Just what must be done.*

**ANSWER:** According to the rules issued by the Office of the Attorney General on December 27, 1941, enemy aliens are forbidden to have, use, operate or possess any type of short-wave or long-wave receiving equipment. Only broadcast band reception is permitted. Notice the ruling refers only to enemy aliens which means aliens coming from countries with which we are at war, such as Japan, Germany and Italy.

If the enemy alien owns a multi-band or all-wave receiver, he can keep his set provided the short-wave and the long-wave sections of the receiver are so altered or modified that reception on these bands is impossible without the addition of parts and the substantial rebuilding of the set.

This means that you cannot just cut a few wires or change a connection here and there in such a set. You must actually remove the coils and parts associated with reception on any band except the standard broadcast band.

This means that a considerable modification of the receiver is necessary. Where individual coils are employed, the change will not be difficult although you may have to realign the radio. In other instances, you will find the coils are tapped or are on the same form with the broadcast band coils. In such cases, it is best to remove the original coils entirely, and obtain a set of broadcast band coils to use in their place.

On some of the large high-grade radios, the changes may be so involved or the reception may suffer to such an extent that it would really be better for the alien to purchase a midget set for the duration.

It is necessary to work closely with the local police in regard to such changes. Enemy aliens were supposed to have turned their receivers over to the police early in January. If the alien is of good character, the police will be permitted to release the set for a changeover by a serviceman. In such a case, be sure the permission has been obtained for the release of the set and find out just what is desired. In some instances, the police may require you to turn in the parts you take out of the set. In others, a sworn statement may be sufficient.

If you are approached by an alien who still has his radio and has not turned it in, then don't work on it. Advise the alien to turn the set in and obtain the proper permission to get it back. Remember, the police are just keeping these receivers in custody, as long as the aliens abide by the law. For failure to turn in the set, it can be seized and the alien may have penalties imposed. Therefore, be sure to advise any such customers that they must turn their receiver in to the police and obtain permission before you can work on the set.

If the local police cannot issue permits, then the nearest office of the Attorney General or the F. B. I. can issue the permission to alter radios.

## Aircraft Detectors

*QUESTION: I would like some information on aircraft detectors, of a type which could be built and used by civilians for spotting planes.*

**ANSWER:** Quite a number of problems are involved in any amplifier-microphone system used for airplane detection.

One of the greatest problems is that of the location of the equipment. The human ear possesses the remarkable ability of discriminating between various sounds. In other words, it is possible to listen for a particular sound and to hear that sound even in the presence of a rather high noise level. For example, you can listen to another person talking in a noisy location, and understand them.

A microphone, on the other hand, is incapable of separating sound in this manner. It picks up everything. As a result, the noise level may be amplified to the point where it will mask other sounds completely or may not be endurable. It is absolutely necessary that such a microphone be in the quietest possible location, otherwise this type of equipment cannot be used at all.

Two general types of systems may be made up. One is for the purpose of just detecting planes, without indicating their direction. The other type is directional.

The non-directional type of detecting equipment is considerably bothered by noises and can only serve as a warning that a plane is in the neighborhood. You would have to locate it by sight once it has been heard.

The directional type has less noise trouble, but

# Are Answered By N. R. I. Experts

it is possible to have it pointed in the wrong direction and thus miss the plane completely; and furthermore, the means of obtaining the directivity introduce a number of problems.

The development of the proper directional horn is quite an art. If you place a microphone in an ordinary horn, you will get a loud roar. This roar is produced by vibration of the sides of the horn. For this reason, the airplane detectors used for military services are especially constructed, with the horn sides several inches thick, made of materials which are acoustically dead. Furthermore, the shape and size of the horn is properly designed to prevent cavity resonance which can also produce a roar. Of course, the exact design of the military type airplane detector is a secret and no information is available on it.

The microphone and amplifier must be carefully protected from the weather. The microphone will have to be placed behind a cloth screen to keep wind from blowing on it, which will create noises and may destroy the microphone.

At the present time, satisfactory results are being obtained with human watchers. If your area is a critical defense area, consult with the local military authorities. Airplane detecting equipment of the military type may be made available through the Civilian Defense Organization, or directly from the local military authorities. In any event, a check with the military authorities will probably show that the location is already adequately protected.

If you wish to experiment, go ahead and do so. However, I wouldn't build anything unless there is some chance of it working. Therefore, if possible, borrow or rent an assembled amplifier and try it out to see just what can be expected before you obtain one for this purpose.

## Water-Cooled Tubes

**QUESTION:** *How is a water-cooled tube different from an ordinary type and how is the cooling accomplished?*

**ANSWER:** In the ordinary tube, the plate and all other elements are inside the glass envelope. Considerable heat is developed even inside receiving tubes.

In high-powered tubes, the removal of this heat becomes an important problem. In fact, until the

heat can be removed safely, it is impossible to get more than a certain amount of power from the tube.

By making the tube so that the plate is on the outside, it is possible to apply cooling means directly to the plate. Therefore, in the water-cooled tubes, we start with a long cylinder which is the plate. Inside this cylinder, the grids, filaments, cathodes and other elements are placed. In order to provide a means of supporting the elements; of seeing inside the tube to note the operation of the filament, and furthermore to make it possible to get the filament and grid leads out separate from the plate, a glass envelope is then welded to one end of this plate. The other end of the plate cylinder is sealed.

The elements themselves are then inside a metal cylinder and glass tube above the cylinder. The inside is evacuated just like any other tube, to get proper operation.

Instead of fitting a socket, this type of tube is constructed so that the plate cylinder sets down inside a water-tight jacket. The grid connections and filament connections come out of the glass portion of the tube.

The special jacket about the plate is fitted with hose connections, so that water can be circulated through the jacket. This means that the water is in contact with the outside surface of the plate of the tube, and hence will conduct heat away from the plate, as it circulates.

Only distilled water can be used, to prevent corrosion of the tube itself, and to lower the electrical conductivity of the water. The usual system consists of the pump forcing water through the jacket, a radiator or other means of cooling the water, a storage tank and a return to the pump.

Of course, this jacket is at the plate potential of the tube, so it must be carefully insulated. Rubber hoses are used to lead the water into the system. The hose is wound up in the form of a coil, or else the water is forced to flow through a coil shaped groove in a quartz block. Remember that an electrical conductor wound in the form of a coil will have inductance. Hence, by making the water flow through a coil-shaped device, we will get a choke-coil action, even though water is a poor conductor of electricity when it is pure. Hence, radio frequency energy does not escape through the water, which is used purely for the cooling of the plate of the tube.

# MR. RADIO MAN--- YOU HAVE A BIG JOB TO DO

BY JOSEPH KAUFMAN

N.R.I. Director of Education



Joseph Kaufman

**T**HIS fast-moving world with its lightning-like war makes radio communication the most desirable means of keeping armed forces in contact with each other, and keeping the world informed. This morning's news sounds stale on an evening broadcast—we want on-the-spot news—flash news—and radio is giving it to us.

Today we are building the greatest air force the world has ever seen. Tanks will be rolling off the assembly line by the thousands, each with radio equipment—mostly two-way communication systems. Let's not forget the scout cars, ships, and naval vessels, for they too need radio equipment. The infantry needs their "walkie-talkies"; the ground crews and staffs must have their central radio stations.

## Defense Factories Need You

America, the arsenal of democracy, has a big job ahead in building the radio equipment needed for victory. And those of you radio men who get jobs inspecting, installing, operating and repairing this radio equipment will be making real contributions toward that victory.

## Radar Units Need You

Very little is publically known about Radar, the radio device which locates airplanes. But both the Army and the Navy are planning hundreds of installations. They will need thousands of technicians to operate and maintain these Radar plane-locating stations. Some will be special enlisted men, while others will be trained civilian radio technicians.

The United States has the largest radio broadcasting system in the world, has more radio re-

ceivers than several other nations combined, and has the greatest number of radio technicians. These radio men are naturally among the first to be considered for important radio defense jobs.

Servicemen with the required educational background and experience are being taken from their regular work and even from less-essential war activities to handle these important radio jobs. We at N.R.I. are proud of the thousands of our graduates who have volunteered for active and civilian radio work with our armed forces. We are confident of their ability to produce.

Yes, radio men have already been taken in unbelievable numbers from factories, broadcasting stations and service shops. But these activities must go on in spite of the great withdrawal of trained men.

## Radio Manufacturers Need You

Radio receiver manufacturers have suspended the making of home radio receivers, for the duration of the war, but their production lines are now producing radio receivers and transmitters needed by our armed forces and those of our allies. In addition, special military equipment of a radio or electronic nature is being made on mass production lines that last year produced our broadcast receivers. Testers, inspectors and repair men who know radio are badly needed, some today and many more in the next few months. A job is waiting for men with radio training and experience. Are you preparing for your job as fast as you possibly can?

## Radio Stations Need You

Can you imagine what would happen if, one by

one, our broadcasting stations, airport and radio range airway stations, our coastal and point-to-point stations closed down for lack of manpower? Don't worry—they won't; our Government knows how important it is to keep them radiating. You can do your part just as patriotically by preparing to take over one of these operating jobs. For such a job you must get a government radio operator's license first; hundreds of men who have taken N.R.I. communications training have passed these examinations and are now serving as operators. With hard work, lots of study, and careful preparation, you too can qualify.

### The People Need You

Less spectacular but equally as important are the men who keep the home radio receivers of our nation in working order. This is a people's war—our freedom, our rights are at stake—and we don't want to be casual by-standers. What goes on every living hour concerns us, whether the news be bad or good. Win we will, no matter how tough the road. We can take it and the Government knows it, so it tells us the truth.

But life must go on, no matter how far away our hearts and minds may be. We must live and prepare for a better world, and we can do this job only if we know how to relax in a world bursting with a determination to see it through. Those of us left at home to produce the sinews of war and carry on the tasks of daily life must be good neighbors, maintain our friendships, take care of our gardens, and relax at our radios. Music, plays and comedies are a tonic for the well-being of our minds, and we shall continue to get them over our radios. Mr. Radioman, the people of this country need you to keep their home radio receivers playing. You can do this job and feel that you serve your country. You are needed today more than ever before.

### Radio Service Shops Need You

In April, the War Production Board stopped the manufacture of all civilian radio receivers. When the existing supply of new receivers is exhausted, servicemen will have to take over and keep sixty million receivers operating. It'll be a choice of getting the ailing receiver fixed or doing without—and very few people will be willing to do without their suddenly precious radio sets.

Good radio servicemen are getting scarcer every day, while the demand for them increases. In every large town or city, the classified advertising columns have requests for radio technicians. The same ad often appears day after day—a sure indication that radio men are not available. But you will be available if you roll up your sleeves and go to work. Radio is a technical profession that can't be mastered in a few weeks—that's why radio servicemen are scarce.

But YOU can speed up the day when you will be ready by going to work on those lessons in earnest.

### What About Radio Parts?

Sixty million radio receivers to keep operating—that's a big job in any language. Your Government considers it important to keep those sets in operation too, for you'll be one of the privileged few who can buy necessary replacement radio parts.

The radio condensers, resistors, coils and tubes that you use in a repair job are made by the very same people who made parts for the manufacturers of radio receivers. During peace time, about 15% of their production was used for replacements in radio servicing, and the rest went to manufacturers of radio equipment. These plants have not and will not stop production. A greater allotment of raw material has been granted them to keep these sixty million receivers going, even though the major portion of their production is now being used for war needs.

Let me cite one example as proof. We all know how valuable aluminum is in the production of aircraft. Yet the War Production Board permits the use of aluminum in fixed and electrolytic radio condensers, provided—and now we quote from W. P. B. Conservation Order M-1-e—that they are "used to replace defective condensers in existing radio receiving sets." If such valuable and highly restricted material as aluminum is released for repairing radio receivers, the importance of the radio men who will do the repair work can hardly be questioned.

### Make Your Minutes Count

As an N.R.I. student, no matter what prompted you to enroll for a radio training, you have a real job facing you. Let every spare minute count. We know that you have a living to make, your job is hard, the hours are long—and when you have a few spare hours, you want to relax. But never forget—men with radio training and experience are so valuable for our cause that to waste time which could be used to improve your radio ability is in effect, failure to aid your country at a time when every hour counts.

Roll up your sleeves, unbutton your collar and go to work. Master your N.I.I. Course. The road may be tough at times, but we at N.R.I. are willing helpers.

Your regular lessons have the necessary basic information, so learn as much of their contents as you possibly can. Do the experimental work of the Practical Demonstration Course with enthusiasm, for it will give you the practical experience which is so essential on any radio job. These experiments will also show you the why and how of radio circuits. Precious material is

sent to you, material for which the W. P. B. granted us priorities. Do not abuse this radio material, and do not let it gather dust. Work with your Radio Kits regularly, and you will acquire the knowledge and experience so essential to carrying on the job ahead of you.

Get practical bench experience. N.R.I. has a plan for acquiring practical experience at home, a plan that supplements the work you carry on with your kits. If you are a beginner, you will learn about this plan before you are half-way through your Course. More advanced students will know about this plan if they have read all their job sheets. You will need a radio chassis to carry on this work, and should make every effort to get one.

Work steadily, for spurts of enthusiasm are not enough. In time, your ability will be recognized. Your Government must set rigid requirements for certain jobs; perhaps you can qualify. If you can't, remember that the home fires must continue to burn, and you can do a big job right in your own locality. Study hard and long, to prepare yourself as fast as possible for your radio job in this war and for success in radio afterward.

— n r i —

### Contributed by a Student

Dear Editor Menne:

Your talk when you visited the Chicago Chapter was very interesting. You spoke of dollars for Radio servicemen, through training. Enclosed is a sketch I made of a man who needs the N.R.I. training. Perhaps you will find room to print it in the News.

Yours truly,

ARTHUR MILLER,  
1535 So. 58th Street,  
Chicago, Illinois.

Sketched by N.R.I. Student, Arthur Miller



Ouch! \*! \* - \*! You and your big ideas. I tell you I can't do this work by the eeney, meeney, minee, moe method!

## Our Cover Photograph

The Mirrophone, new Western Electric magnetic tape recording device, shown on the front cover of this issue, is being used by radio announcers, actors and in speech classes as an aid to speech improvement. The device records the subject's speech magnetically on a steel tape. The flip of a switch provides for immediate play-back. Thus, subject may detect and correct errors of pronunciation, emphasis, tone, etc. As it records, the mirrophone automatically erases—or de-magnetizes—previous recordings. The mirrophone is being used by a number of radio stations, by scores of school and college speech classes and dramatic groups and to train the thousands of new telephone operators and secretaries in war agencies and war industries.

— n r i —

## Book Review

### TELEVISION Today and Tomorrow

By Lee de Forest. The Dial Press, New York. 381 pages—\$3.75. Obtainable at most book stores.

In this new television book which is just off the presses, Dr. Lee de Forest presents the history of television and its future possibilities in a manner which makes interesting reading even for non-technical persons. In addition, the inventor of the triode radio tube has included a number of liberally-illustrated technical chapters devoted to the why and how of modern television systems. The author predicts that television will have even greater influence and usefulness than radio on our daily life.

— n r i —

## Newsboys Sell Defense Stamps

We have always had much admiration for any youngster who works on a newspaper route. In good and bad weather, he is on the job. He accepts responsibilities early in life and appreciates what it means to have others dependent upon him for an important service. He learns how to meet people, acquires self-confidence, is proud of the fact he earns his own spending money. Many of the great business executives in this country like to tell about the first dollar they earned—as a newsboy.

We got a real thrill the other day when the Treasury Department announced that nearly half a million newsboys in the United States are selling Defense Stamps, door to door on their routes. This total of a half million newsboy volunteers is in itself remarkable, but get this next sentence. *These boys are selling an average of 40 million Defense Stamps a month. Great work!*

# Novel Radio Items

—BY L. J. MARKUS—

By means of two-way short-wave radio, the business of the Great Bank of China continues amidst the chaos of falling bombs. Far below the ground at the bank headquarters in embattled Chungking, calm radio operators put through radio telephone calls to distant branch offices.

—n r i—

**The electron microscope, one of radio's newest offsprings, is now telling scientists exactly what happens when a metal is hardened by heating and then chilling rapidly. For example, they found that martensite, used for cutting metals at high speed, consists of alternate 100-atom thick layers of iron and iron carbide.**

—n r i—

*When nobody would contract to move one of the 215-foot self-supporting towers of WMBG in Richmond, Virginia, some 30 feet so as to change the directional pattern, the station staff did the job itself. Temporary guy cables were attached and were continually adjusted while the tower was pulled along a greased wood track to its new location.*

—n r i—

In the laboratory of one large radio factory, radio sets are being fed one after another to a million white ants. The purpose is to find a combination of insulating materials and set construction which will repel the white ants of tropical countries. Yes, receiver manufacturers now have ants in their plants!

—n r i—

Investigators of the FBI and FCC have discovered that medical diathermy machines are being used by spies for transmitting information to Berlin and Tokyo. With minor changes, these machines can be converted into highly portable short-wave transmitters with power of about 200 watts. You can help detect any of these machines in the hands of enemy agents by reporting suspicious signals to the nearest FBI or FCC office. The channels most used are 20 megacycles in daylight and 7 megacycles at night.

—n r i—

*Auto radio reception is possible for the entire length of the mile-long Liberty Tubes which carry auto traffic under Mount Washington, just south of Pittsburgh. Radio engineers installed antennas high on the mountain, and connected them through amplifiers to underground re-radiating antennas supported on insulators below the roof for the entire length of the tunnel.*

Radiophotos now come from Melbourne, Australia to San Francisco in a single jump across 7,420 miles of Pacific Ocean. The transmission time for a 5" x 7" photo is only ten minutes. Before the establishment of this first Australian radiophoto circuit on March 21, 1942, all Australian radiophotos came to New York by way of London.

—n r i—

Thinking that an electric dynamite cap was a radio condenser, a 20-year-old farm youth in Oklahoma connected the cap to his auto radio set to get rid of interference. Hospital attendants said he would recover.

—n r i—

*A signal generator which produces a "warble" signal distinctly different from existing police and fire alarms is the key unit in the RCA municipal air raid warning system which has been installed in a number of cities. Audio amplifier-loudspeaker units at strategic points about the city reproduce this signal at the required volume level.*

—n r i—

During a test blackout at Macon, Georgia, overzealous air-raid wardens of the WBML studio building pulled all electric switches, including one which blacked out WBML's control room. Fortunately, the announcer was familiar enough with the controls to push in plugs and flip switches in the dark, so the broadcast continued as per schedule.

—n r i—

Television audiences were treated to still another video program thrill when the burning of the giant steamship Normandie was flashed on television screens. From the 42nd floor of a skyscraper, Du Mont television camera operators used a powerful telephoto lens to cover the Hudson River waterfront. Although shooting against the sun, the pick-up showed the billowing clouds of smoke which soon filled the entire sky over the river.

—n r i—

*The production quota for electric fence controllers is 120% of its 1940 level. Farmers can thus get more of these cow-shocking units during wartime than before, even though radio parts are used in manufacture. One reason for this is that electrified single-wire fencing can be erected with less material and fewer man-hours than ordinary fencing.*



J. A. Dowie

# CIRCUIT ANALYSIS

of the

## GENERAL ELECTRIC LB-530

### A.C.-BATTERY PORTABLE

BY J. A. DOWIE

N.R.I. Chief Instructor

*Identifying Tubes.* When starting to identify tubes in a receiver, we often work by a process of elimination. That is, we identify certain tubes easily and, knowing what stages should be in a superheterodyne, the rest of the tubes must be in the heretofore unidentified stages. We can start from either end of the receiver, and this time we start with 1Q5GT tube. Since this tube feeds the loudspeaker, we know that it is the power output tube. We know that it should be fed by an audio voltage amplifier and we find its input coupled by a resistance network to the 1H5GT. The 1H5GT must, therefore, be the first a.f. tube. Its grid traces through a coupling condenser to the volume control, a known source of a.f. voltage. We see that the 1H5GT has a diode plate and is hence also a rectifier. It is resistance-coupled to the output of a 1N5GT tube and this resistance coupling might lead us to believe that the 1N5GT was the second detector, if it didn't feed a diode plate. There would be no sense in feeding an audio signal to a diode plate where it would be rectified, so the diode section of the 1H5GT is the second detector and also the a.v.c., since the control grid returns of some of the previous tubes are fed through R4 from the diode load.

Our knowledge of superheterodyne stage sequence tells us that the 1N5GT feeding the 1H5GT diode is an i.f. amplifier. It is transformer-coupled to another 1N5GT tube whose input is likewise fed from a transformer identified as an i.f. transformer by the tuned primary and secondary.

Thus we know that this 1N5GT is the first i.f. amplifier. It is fed by a 1A7GT whose input connects to the antenna loop and whose first grid

connects to a tank circuit through condenser C7. There is no remaining function, in a superheterodyne of this type, for the 1A7GT tube but converter-oscillator, and we have now identified all tubes in the receiver.

*Signal Circuits.* From the parts notation we see that the signal is picked up by L1, known as the Beam-A-Scope loop assembly. The expression "Beam-A-Scope" is a trade word used by General Electric to describe a shielded loop. We also see that additional pick-up may be obtained by means of an external loop L7 furnished with the receiver, and which may be plugged into the terminals which the manufacturer has provided. The two loops are inductively coupled together.

Loop L1 is tuned to resonance by condenser C1, and signals picked up by L1 undergo the usual resonance step-up. They are applied to the control grid and filament of the 1A7GT, the filament connection being through C10, which has essentially zero resistance at r.f. and i.f. values.

The first and second grids from the filament serve as oscillator electrodes, the second grid being the anode and the first the control grid.

The incoming signal and oscillator signal are mixed within the tube, and we have a strong i.f. beat signal developed across the primary of T4. The signal induced into the secondary is applied to the input of the 1N5GT first i.f. tube, the filament connection being through C10. The amplified signal now appears across the primary of T5 and is induced into the secondary where it is applied directly to the input of the second 1N5GT i.f. tube. The variations in the tube plate



current produce a large i.f. voltage across plate load resistor R5.

Through condensers C8, C21B and C9 the i.f. signal is applied across resistor R6. The voltage across R6 feeds the diode of the 1H5GT. The diode rectifies the signal and detection takes place. The a.f. signal appears across both R6 and R1; however, R1 is many times greater in value than R6 and the a.f. signal across R6 which, due to the circuit arrangement, cannot be passed on to the audio amplifier is negligible and can be forgotten.

I.F. signals are shunted around R1 by C9, and the d.c. component is fed through R4 as a.v.c. voltage to the control grids of the converter and first i.f. tubes, C10 acting as the a.v.c. filter condenser. That portion of the audio signal between the slider of R1 and ground is fed through C12 and appears across R7, in the grid input circuit of the 1H5GT triode section.

The amplified audio signal across plate load resistor R8, freed from any stray i.f. by C18, is applied across the grid input of the 1Q5GT through coupling condenser C13 and through C21B. The plate current of the 1Q5GT, varying at an audio rate and flowing through the primary of T1, induces a voltage into the secondary and the resultant current through the voice coil sets the cone in motion, producing sound waves.

C14, from the 1Q5GT plate to ground, prevents audio oscillation and, by by-passing the higher frequencies, cuts down on the third harmonics produced within the tube and hence on distortion.

*How the Tubes are Biased.* As in all battery filament type tubes, the control grid voltage is measured from the control grid to the negative side of the filament. The tubes all have their negative filament leads grounded, and the various grid voltages exist between the grids and chassis.

The 1H5GT is self-biased by convection currents through R7, which has a value of 4.7 megohms. We see that bias cells are used to provide control grid voltage for the 1Q5GT, and that convection currents are not used, since R9 has a value of 2.2 megohms and convection currents wouldn't produce much voltage across such a relatively low value of resistor.

Since bias cells cost money, we know that there must be a good reason why convection currents through a high resistance value weren't used. The reason is that the 1Q5GT tube is subject to gas, as are so many power output tubes. If a high value grid resistor is used, the gas current through it will drive the grid positive, increasing the plate current and releasing more gas. The result is serious distortion.

There is no minimum grid bias on the converter

and the two i.f. tubes, and none is required on these particular tubes, due to the low plate and screen voltages which are employed. When a signal is received, a.v.c. voltage is applied to the converter and first i.f. tube control grids.

*The Power Supply.* The power supply of this receiver, shown inside the dotted lines in Fig. 4, is as complicated as any you will meet in ordinary receivers. This is due to the switching system and the manner in which the circuit is drawn.

Before discussing the circuits in this supply, let us see its purpose. As we stated at the beginning, the receiver is an a.c.-battery operated unit. This means that the receiver can be operated anywhere. When an a.c. power line is not available, all power necessary for the operation of the receiver is supplied by the 2-volt built-in rechargeable battery. It is essential, therefore, that the rechargeable battery be installed at all times for operation in any position of the power selector switch. The tube filaments are heated directly by the 2 volts from the battery, while the necessary high voltage for the screen and plates of the tubes is furnished by a synchronous vibrator used in conjunction with a step-up power transformer and its associated filter circuit. The synchronous vibrator operates on the 2 volts from the battery.

Provision has been made to charge the battery directly from the house current without removing the battery from the receiver circuit. The receiver is designed for operation either on 110-125 volts a.c., 50-60 cycles, or 110-125 volts a.c., 25 cycles. Two charging positions are provided on the four-position power selector switch. The "Charge" position of this switch allows the battery to be charged at the rate of approximately 1.35 amperes from the house current during the period that the receiver is not being operated. The "a.c." position of the switch allows the receiver to be operated at the same time that the battery is being charged. Under this condition, however, it takes a considerably longer period for a partially discharged battery to be fully restored, due to the fact that current is taken from the battery to operate the receiver.

The battery charging unit consists of a stepdown transformer which converts the house current to approximately 5.5 volts on 50-60-cycle models; on 25-60-cycle models the voltage is 6.6 volts. This low voltage is then applied to a copper-oxide rectifier in a full-wave rectifier circuit which supplies the battery with a d.c. charging current.

*Charge Indicator.* The degree of charge of the battery can be determined by removing the back cover of the radio and referring to the charge ball indicators visible through the hole in the metal battery case.

If the battery is fully charged, three indicator balls will be visible at the surface of the liquid in the battery. When the battery discharges, these ball indicators will sink and disappear in the following order:

1. Green indicator sinks when approximately 10% of battery capacity has been discharged.

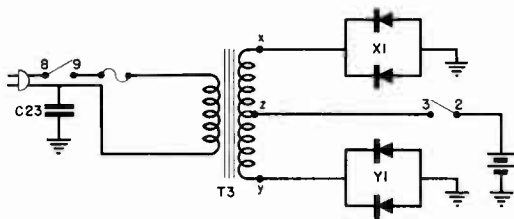

Fig. 1. Switch contacts 8-9 and 2-3 are closed in CHARGE position.

2. White ball sinks when 50% capacity has been discharged.

3. The red ball sinks when battery is 90% discharged.

On charge the balls rise or float in the reverse order and the charge is complete and may be stopped when all three balls appear in the opening.

**To Charge Battery.** The battery is charged by merely plugging the receiver power cord in the rated a.c. power outlet and turning the selector switch to "charge." Frequent checks should be taken of the charge indicator and when all indicator balls are visible, the battery is fully charged. Charging the battery after all indicator balls are visible will not harm the battery, except that it will evaporate the water faster. A completely discharged battery will be restored usually within 20 to 30 hours.

When operating the receiver from the a.c. house current, the battery is being charged at a slow rate. Thus even with a fully discharged battery, the receiver may be operated and the battery charged, at a slow rate, with the power selector switch turned to the a.c. position. Prolonged and repeated operation on this position will maintain the battery in a fully charged condition.

In Figs. 1, 2 and 3 we show simplified circuits of the power pack to bring out the connections of the three-position switch.

**Switch in Charge Position.** At Fig. 1 we have the connections employed when it is desired to charge the battery from the a.c. power line without operating the receiver. When the switch contacts, which are lettered to correspond to those in Fig. 4, are closed about 5½ volts a.c. is developed across the secondary of transformer T3.

When point X is negative, point Z is positive. Then electrons flow from X through rectifier X1 to the negative battery terminal, through the battery and back to Z. Electrons only flow through the copper-oxide rectifiers in a direction opposite to that indicated by the arrows. This, of course, blocks electron flow from point Y through Y1, since point Y is positive when X is negative. Normally you would expect the arrows on the rectifier to indicate electron flow but the arrows are drawn in the conventional manner to indicate current flow. There is no chance for you to get mixed up however since the battery polarity shows what the direction of electron flow must be. In charging electrons must flow into the negative and out of the positive battery terminal.

On the next half cycle, Y is negative and X is positive. Z is, of course, positive with respect to Y, although Z is negative with respect to X. Electron flow to X is blocked by X1. Electrons do flow from Y, going through the battery in the same direction as on the previous half cycle, adding to the charge of the battery and returning to Z through switch 2-3.

From this you can see we have a full-wave rectifier, first one half of the transformer second-

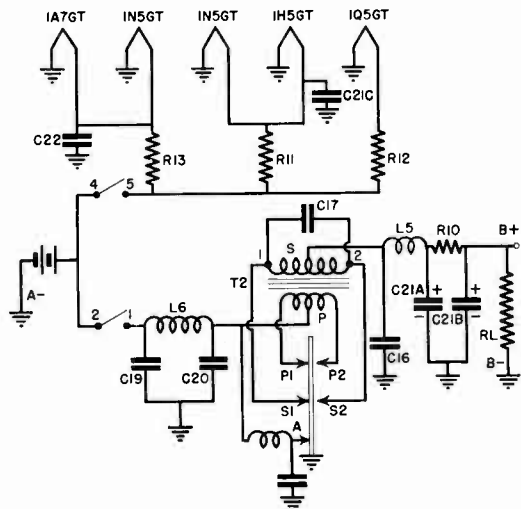

Fig. 2. Switch contacts 2-1 and 4-5 are closed in BATTERY position.

ary furnishing current to the battery and then the other.

**Switch in Battery Position.** In Fig. 2 we see how the battery is used as a source of power for the receiver. When the switch is thrown to the battery position, sections 4-5 and 2-1 are

closed. The filaments are supplied through section 4-5 and the series resistors marked R13, R11 and R12. As shown in Fig. 2, one side of each filament is grounded, as is the negative lead of the battery.

Through switch sections 2-1 the battery supplies current to the power transformer, the path being through L6 to the center tap on primary P of T2. The current then flows through the left-hand side of P to contact P1 on the vibrator, and to the ground side of the battery through the armature, which is always grounded. This causes a high voltage to be set up in secondary S of transformer T2. The voltage polarity is such that the left-hand side of S is negative and the center tap is positive. Electrons therefore flow from S to ground through vibrator contact S1 and the armature. These electrons then flow from -B through the receiver tubes, which we have shown as a resistor R1, just to make the circuit complete. Leaving the receiver, the electrons flow to +B, through filter resistor R10, choke L5 and to the center tap on S of T2, thus completing the circuit. At the same time the right-hand side of S is positive, and if the circuit through vibrator control S2 were not open electrons would tend to flow in a direction opposite to those taken through S.

This, of course, would result in the application of no B voltage to the receiver, since the voltage across the two secondary halves are always equal and opposite. However, the vibrator effectively blocks off the right-hand side of S as a voltage source at this time.

We see that contacts P1, S1 and A of the vibrator are all closed at the same time. While current is flowing through P1 and S1, it is also flowing through A and this energizes the armature coil in series with A, causing it to throw the armature to the right, opening contacts P1, S1 and A. Before the springiness of the armature throws it to the left again, the battery causes electrons to flow from the grounded armature (from the negative battery terminal) to P2, through half of primary P, through L6, the switch and to the positive battery terminal. This induces a voltage into the secondary which makes the secondary center tap positive, this time with respect to point 2.

The voltage between the center tap and 2 causes electrons to flow to ground (-B) through contact S2, through the receiver (RL) to +B, through R10, L5 and to the positive center tap on S.

Thus we have full-wave rectification and filter condensers C21A and C21B are constantly kept charged with the polarity shown, and these condensers then regulate the voltage across RL so that it receives a steady d.c.

The spring action of the armature throws it to the left, closing contacts P1, S1 and A, while opening P2 and S2. We are then ready for another round trip action.

*Switch in A.C. Position.* Figure 3 shows the switch set for a.c. and all the switch positions in this figure are closed, points 1-2-3 being joined as are points 4-5 and points 8-9.

The output voltage of the charger is impressed directly across the battery, charging it, while at the same time the battery is furnishing current for the operation of the tube filaments and the B supply. Since the charger furnishes the bat-

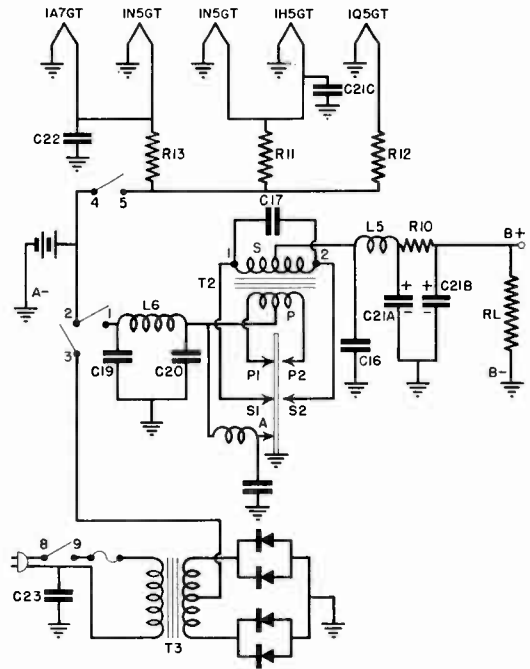

Fig. 3. Switch contacts 4-5 and 2-1-3 and 8-9 are closed in AC position.

tery a little more current than is drawn from it by the receiver, the battery will be slowly charged even though the set is in operation.

*Voltage Measurements.* Figure 5 shows the socket voltage diagram, and the voltages given on it are measured between the points indicated and the chassis. The battery voltage is measured across the battery terminals, and the vibrator voltage measured from B+ to the chassis. Condenser C21A is a readily identifiable point across which the B+ measurement may be made.

The precaution to use the 150-volt range of a 1000 ohms-per-volt meter isn't important al-

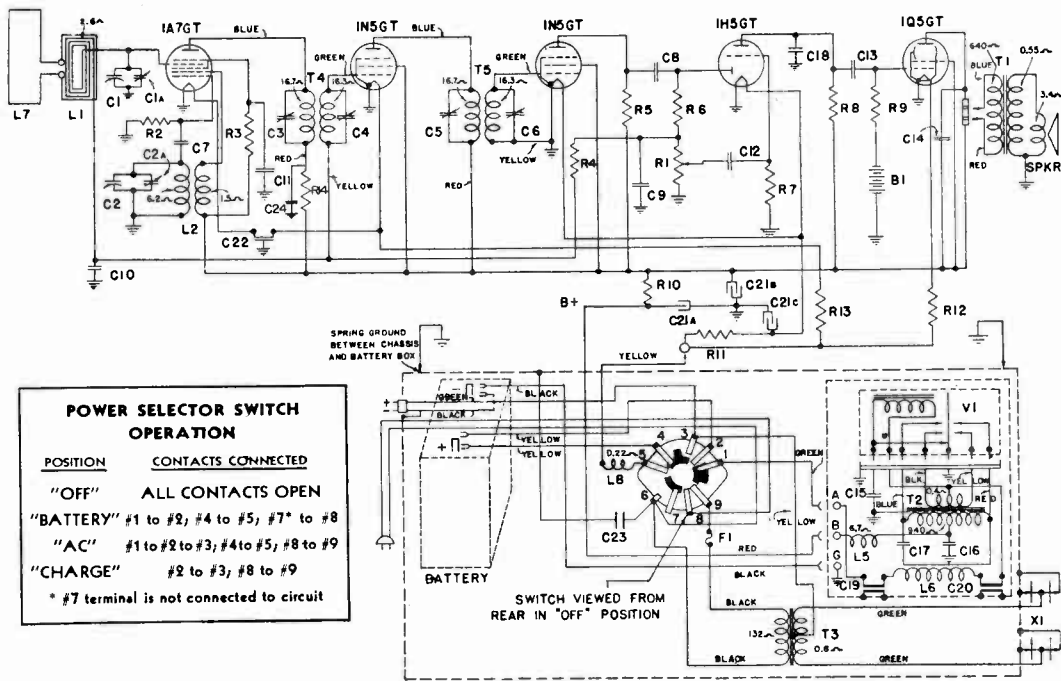

Fig. 4

Symbol	Description		
C-1, 2	CONDENSER—Tuning condenser and trimmers	R-8	RESISTOR—1.0 megohm, 1/2 W. carbon
C-7	CAPACITOR—47 mmf. mica	R-9	RESISTOR—2.2 megohm, 1/2 W. carbon
C-8, 9	CAPACITOR—100 mmf. mica	R-10	RESISTOR—1,000 ohm, 1/2 W. carbon
C-10	CAPACITOR—.05 Mfd., 200 V. paper	R-11, 12, 13	RESISTOR—8.2 ohm, 1/2 W. carbon
C-11	CAPACITOR—.01 Mfd., 200 V. paper	B-1	CELL—5.0 V. bias cell assembly
C-12, 13	CAPACITOR—.005 Mfd., 600 V. paper	L-1	BEAM-A-SCOPE—Loop antenna assembly (inside cover)
C-14	CAPACITOR—.01 Mfd., 600 V. paper	L-2	COIL—Oscillator coil
C-15	CAPACITOR—.01 Mfd., 200 V. paper	L-5	CHOKE—B choke
C-16	CAPACITOR—.05 Mfd., 200 V. paper	L-6	CHOKE—Vibrator choke
C-17	CAPACITOR—.006 Mfd., 100 V. paper	L-7	BEAM-A-SCOPE—External loop antenna
C-18	CAPACITOR—100 mmf., mica	L-8	CHOKE—Filament supply choke
C-19, 20	CAPACITOR—.05 Mfd., 120 V.	SW1	SWITCH—Power selector switch
C-21A, 21B	CAPACITOR—15 Mfd., 150 V. dry electrolytic	T-1	TRANSFORMER—Output transformer
C-21C	CAPACITOR—1200 Mfd., 2 V. dry electrolytic	T-2	VIBRATOR—Vibrator power transformer
C-22	CAPACITOR—.05 Mfd., 120 V. paper	T-3	TRANSFORMER—50-60 cycle rectifier step-down transformer
C-23	CAPACITOR—.05 Mfd., 600 V. paper	T-3	TRANSFORMER—25 cycle rectifier step-down transformer
R-1	VOLUME CONTROL—.05 megohm volume control	T-4	TRANSFORMER—1st I.F. transformer
R-2	RESISTOR—220,000 ohm, 1/2 W. carbon	T-5	TRANSFORMER—2nd I.F. transformer
R-3	RESISTOR—47,000 ohm, 1/2 W. carbon	V-1	VIBRATOR—Power supply synchronous vibrator
R-4	RESISTOR—2.2 megohm, 1/2 W. carbon	X-1	RECTIFIER—Copper oxide rectifier
R-5	RESISTOR—27,000 ohm, 1/2 W. carbon	Spkr	SPEAKER—PM speaker
R-6	RESISTOR—47,000 ohm, 1/2 W. carbon		
R-7	RESISTOR—4.7 megohm, 1/2 W. carbon		

though, if a higher range or a more sensitive meter is employed, the measured plate voltage of the 1H5GT will be a little higher than indicated. The resistance values in the plate supply circuits of the second i.f. and converter tubes are too low to cause much variation in plate voltage, due to voltmeter current drain through them. This observation naturally leads you to look up the values of these resistors R14 and

R5. You will find that the value of R14 is not given; evidently the factory draftsman forgot this; such errors sometimes creep into diagrams.

Suppose you must replace R14, what would you do? First you would consider the purpose of R14 in the circuit. It obviously is not used to purposely reduce plate voltage, and neither is it a plate load. It, together with C24, acts as a filter to keep

the signals in the plate circuit of the 1A7GT out of the B supply. From past experience and from observing many similar circuits, we know that the resistor value is not critical and that manufacturers use values between 1000 and 10,000 ohms for this purpose. We feel sure that the choice of an average value of about 5000 ohms will work nicely.

We can get a confirmation, if we wish, by means of Ohm's Law, which states that resistance equals voltage divided by current. Since the plate of the 1A7GT receives 78 volts and the i.f. screen from which R14 is fed receives 82 volts, 4 volts are dropped across R14. A tube chart tells us that the 1A7GT plate draws about .7 ma., so

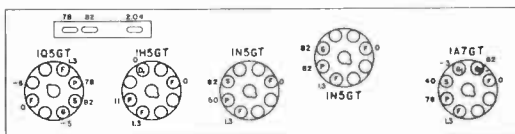

FIG. 5. SOCKET VOLTAGE DIAGRAM

Power Switch on "AC" With Charger Operating.  
 Battery Voltage 2.1 Volts.  
 Vibrator + "B" Voltage . . . 95.  
 Dial at 1000 KC, Zero Signal, Zero Volume.  
 All measurements Except Bias Battery and Filament Made  
 With 1000 Ohms Per Volt Voltmeter, 150 Volt Scale.

by simple division we arrive at a value of about 5900 ohms for R14. Experience tells us that 5000 ohms is satisfactory, but if actual trial shows it to be too low, a larger resistor may easily be inserted.

**Continuity Tests.** Continuity tests are made in the usual way between points at a positive potential and +B, and between those at a negative potential and -B, in this case the chassis. B+ is the red lead going from the junction of R10 and C21A to the B supply.

In any battery set the batteries must be disconnected for ohmmeter tests. This means the storage battery in this receiver. The bias cells need not be disconnected if you don't check from the grid of the 1Q5GT to chassis. However, a check across R9 is perfectly all right. To avoid short circuit readings through the closed vibrator contacts the vibrator, which is of the plug-in type, is removed, just as you would remove a tube.

**Expected Performance.** With the two stages of i.f., excellent sensitivity and adjacent channel selectivity may be expected. Some image interference, due to lack of preselection, may occur but turning the loop to a different position by rotating the entire receiver will sharply reduce the pick-up of undesired signals.

The 1Q5GT can't deliver much output power, so not a great deal of volume is to be expected. The

volume, as well as the tone quality, will be considerably lower than that expected from a table model receiver but will be entirely satisfactory for a portable.

— n r i —

## New Sprague Dry Electrolytics Replace Wet Aluminum Can Types

Due to their aluminum thread-neck cans, replacement wet electrolytic condensers are unobtainable because of war restrictions. Aluminum can type dry electrolytics are no longer available for the same reason. The new Sprague Type WR tubular cardboard dry electrolytics can be used successfully for replacements of both types. The WR units have a much higher voltage formation than standard dries, to insure standing up under the high peak voltages which are impressed on wet electrolytics. Also, they're built to handle the AC ripples that might cause standard 450 volt dry electrolytics to overheat to a point where



they break down. The diameter of a WR condenser is the same as that of standard wets, so they will fit the screw-type can mounting holes. Their metal feet can then be soldered to the chassis for firm mounting.

Sprague Type WR's are now available at jobbers in three sizes, WR-8 which replaces wet or dry electrolytics in capacities from 4 to 8 mfd.; WR-16 which replaces capacities from 12 to 18 mfd.; WR-25 which replaces capacities from 20 to 40 mfd.

— n r i —

## Ham and Eggs in Code

A conversation overheard in a diner:  
 Diner: F-U-N-E-X?  
 Waiter: S, V-F-X.  
 Diner: F-U-N-E-M?  
 Waiter: S, V-F-M.  
 Diner: O-K, M-N-X.

**A True  
Story of  
Success**

# How N. R. I. Lessons Took R. W. Frisbee from Sawmill To Radio Engineering Department

Mr. J. E. Smith, President  
National Radio Institute  
Washington, D. C.

Dear Mr. Smith:

I would like to tell you just a little about how the N.R.I. training has helped me along.

At the time I started your course as a minor, my parents, poor mill people, were opposed to my "wasting money on a correspondence course of any kind." So against their will I managed to get a Doctor friend to sign the enrollment for me, and the loan of some money to start the course with. At the time, I was working part time in a sawmill, hired to clean up the sawdust after working hours, also to pick out good pieces of lumber that might be on the "conveyer chain."

The reason for telling all this is to give you a clearer picture of the hard pull some of your students put up "to make the grade"—so on with the story. There was never a day went by but what the lessons were studied. Sometimes while on the job, quite a bit of the good lumber would get by on the conveyer chain, which was a large chain carrying sawdust and waste from the sawmill out to a large fire pit to be burned. It might be confessed now—the reason for its getting by was due to the fact I was reading a N.R.I. lesson!

At the age of seventeen I went to work in Dade City, Fla., as a serviceman, which was my first real radio service job. After three years there I left and started work servicing radios and selling retail for a radio company in Tampa, Fla. At times I led the entire sales force in sales, which I especially liked.

Page Twenty-two

Atlanta, Ga.

After three years with this concern another change was made. I left Tampa for Atlanta where I started work with a wholesale radio parts house. My job was covering most of Georgia, calling on radio servicemen, selling the repair parts and equipment, assisting with their technical and practical problems, also demonstrating and teaching the use of new test equipment. Holding service meetings was also a part of my job.

After three years with this company, a tube manufacturer offered me a position calling on the wholesale automotive and wholesale radio trade in Georgia, Florida, Alabama, Mississippi, Tennessee and South Carolina, which I took. I have been with them for three years. As you see I have moved upward every three years. Today I have been offered a job at our factory, in the engineering department, which I intend to accept.



R. W. Frisbee

Perhaps you are not interested in all this, but it does give you an idea of how things have been at this end of the acquaintance—by mail. During all this time, I have taught my brother quite a bit about radio—sufficient to give him a start in the service field, and to send a sister through school, not to mention supporting my parents for the past four years.

All this I have done through the use of knowledge acquired from a correspondence radio course,

and hard work.

About one year ago, I was able to locate my Doctor friend and repay him with interest for the loan he made a number of years ago, to just an ordinary mill hand. It gave me a great deal of pleasure to repay him.

Very truly yours,  
R. W. FRISBEE, 529 Peachtree St.



# RADIO-TRICIAN

REG. U.S. PAT. OFF.

# Service Sheet

Compiled Solely for Students and Graduates

NATIONAL RADIO INSTITUTE, WASHINGTON, D. C.

## Detrola 8 Tube Radio-Phono-Recorder Model 390

### ALIGNMENT PROCEDURE

Output meter connection ..... Across speaker voice coil  
 Connection of generator ground lead ..... To Chassis  
 Connection of generator output lead ..... See chart below  
 Dummy antenna value to be used in series with generator ..... See chart below  
 Position of volume control ..... Full on (Clockwise)

POSITION OF VARIABLE	GENERATOR FREQUENCY	DUMMY ANTENNA	GENERATOR CONNECTION	TRIMMERS ADJUSTED (IN ORDER SHOWN)
Open (Min. capacity)	455 kc.	.1 mfd.	Ant. section of variable	T2, T1
Min. capacity	1720 kc.	50 mmf.	Ant. Terminal	Oscillator Trimmer
Tune in signal from generator	1400 kc.	50 mmf.	Ant. Terminal	Antenna Trimmer

ALL ALIGNMENT OPERATIONS MUST BE DONE WITH THE MASTER CONTROL SWITCH IN THE NO. 1 (RADIO) POSITION.

### Recording Arm Adjustments

The recorder arm and recording head are adjusted at the factory for best operation. The following paragraph tells how to correct these adjustments should they, for any reason, become changed from their factory setting.

The bottom of the recording arm should be exactly 1/4 inch from the surface of the record. This should be measured beside the needle retaining screw on the end of the arm. The screw for making this adjustment can be found when the arm is raised, on a small platform near the hinge. Turning the adjusting screw to the left raises the arm, turning to the right lowers it. In making an adjustment turn the screw only a small fraction of a turn at a time.

Make a cut of at least ten or fifteen turns to see whether or not the needle is exerting the correct pressure on the record. This is correct when the groove cut by the needle is of approximately the

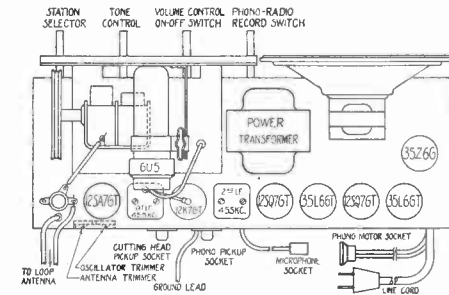

same width as the space between grooves. On top of the cutting arms is a flat head screw. Turning this screw to the right increases the depth of cut, to the left decreases it. This adjustment is quite critical and the screw should be turned not more than 1/4 turn at a time.

Readers who file Service Data in separate binders remove page carefully, trim on dotted line for same size as data published heretofore.

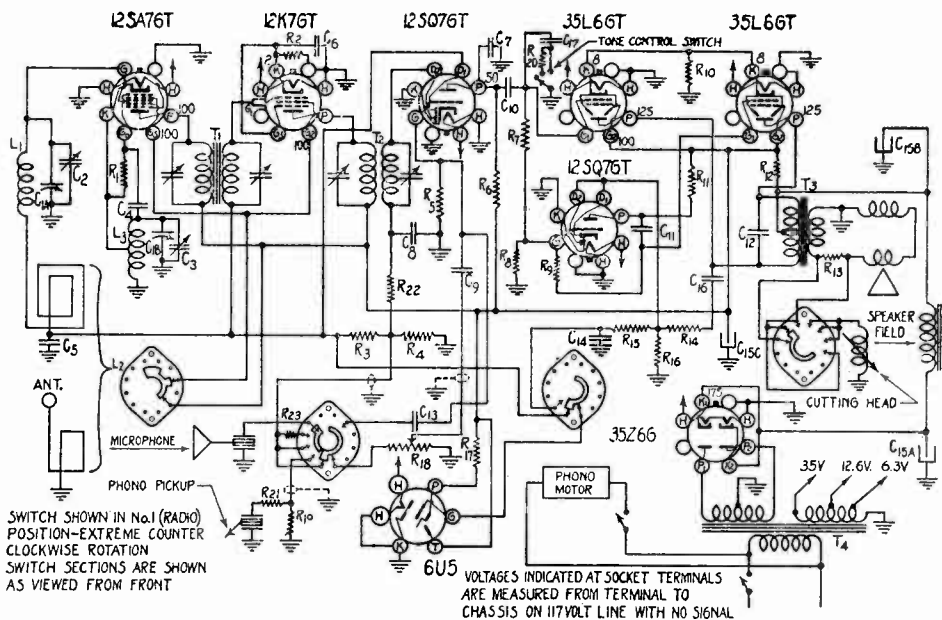

## DETROLA 8 TUBE RADIO-PHONO-RECORDER, MODEL 390

C1a, b	8911	Condenser, Variable (with Pulley)
C2, 3	8504	Condenser, Dual Trimmer
C15a, b, c	8425	Condenser, Electrolytic (20-250)—(20-150)—(20-150)
C4		Condenser, 100 Mmf. Mica
C5, 14		Condenser, 1 Mfd. 200 v.
C6		Condenser, .05 Mfd. 200 v.
C7		Condenser, 250 Mmf. Mica
C8		Condenser, 100 Mmf. Mica
C9		Condenser, .002 Mfd. 600 v.
C10, 16		Condenser, .01 Mfd. 400 v.
C11		Condenser, .05 Mfd. 400 v.
C12, 13		Condenser, .001 Mfd. 600 v.
C17		Condenser, .005 Mfd. 600 v.

Schematic Location	Part Number	Description
R3, 4, 14, 16		Resistor, 1 Meg. 1/3 Watt
R5		Resistor, 10 Meg. 1/3 Watt
R6, 7, 8, 9, 11		Resistor, 200M. 1/3 Watt
R10		Resistor, 120 Ohm, 1/2 Watt
R12		Resistor, 1000 Ohm, 1 Watt
R13		Resistor, 35 Ohm, 1/2 Watt
R15		Resistor, 2 Meg. 1/3 Watt
R17		Resistor, 1 Meg (in Tuning Tube Socket)
R19, 20, 21, 22		Resistor, 50M, 1/3 Watt
R23		Resistor, 4 Meg. 1/3 Watt

### General Information

In the recording positions (Positions 3, 4 and 5 of the Master Control Switch) the volume from the speaker is reduced. This is done automatically by the switch for three reasons, some of the power from the output tube is needed for operating the recording head, the volume level necessary for recording is too high for the average size room, and to prevent the sound from the speaker from reaching the microphone.

If the recording needle is not very sharp, the quality of the recording will be poor. A needle which has become dull through use or which has

been otherwise damaged should be replaced.

The Master Control Switch should always be turned to the No. 1 (Radio) position when listening to radio programs.

The pickup and the recording arms should always be placed on the rests provided for them when they are not in use, to protect them from damage.

Voltages indicated at socket terminals are measured with 1000 ohm per volt meter, on 117 volt line, no signal.





# RADIO-TRICIAN

REG. U.S. PAT. OFF.

# Service Sheet

Compiled Solely for Students and Graduates

NATIONAL RADIO INSTITUTE, WASHINGTON, D. C.

## Detrola AC-DC Superheterodyne, Model 425 Series

### ALIGNMENT PROCEDURE

**WARNING!** This information is to be used by a **COMPETENT SERVICE MAN ONLY** and not by an untrained person.

The following equipment is necessary to properly align this chassis:

1. A signal generator which will provide an accurately calibrated signal at the frequencies listed.
2. An output meter.
3. A non-metallic screw driver.
4. Dummy Antennae—.1 mfd., 200 mmf., 400 ohm.

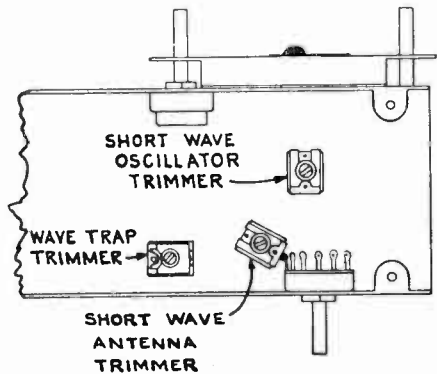

POSITION OF TUNING DIAL	GENERATOR FREQUENCY	DUMMY ANTENNA	GENERATOR CONNECTION	TRIMMERS ADJUSTED
High Freq. End	455 K.C.	.1 mfd.	12SA7 Grid	Align I.F. 4 Trimmers Wave Trap Trimmer Adjust to Min.
High Freq. End	455 K.C.	.1 mfd.	12SK7 RF	
Low Freq. End	540 K.C.	.1 mfd.	12SK7 Grid	Oscillator Trimmer Set limit of band
1400 K.C.	1400 K.C.	200 mmf.	Antenna Lead with Capacity plate in operating position.	Antenna Trimmer Tune to Max.
10 M.C.	10 M.C.	400 ohms.	Antenna Lead Capacity Plate in position.	Oscillator Trimmer Set limit of band
9.6 M.C.	9.6 M.C.	400 ohms.	Antenna Lead Capacity Plate in position.	Antenna Trimmer Tune to Max.

### TUBES:

- 1—12SK7—R.F.
- 1—12SA7—Oscillator—Converter
- 1—12SK7—I.F. Amplifier
- 1—12SQ7—Detector A.V.C.

- 1—12SQ7—Audio Amplifier
- 1—35L6GT—Power Output
- 1—35Z5GT—Rectifier

Readers who file Service Data in separate binders remove page carefully, trim on dotted line for same size as data published heretofore.

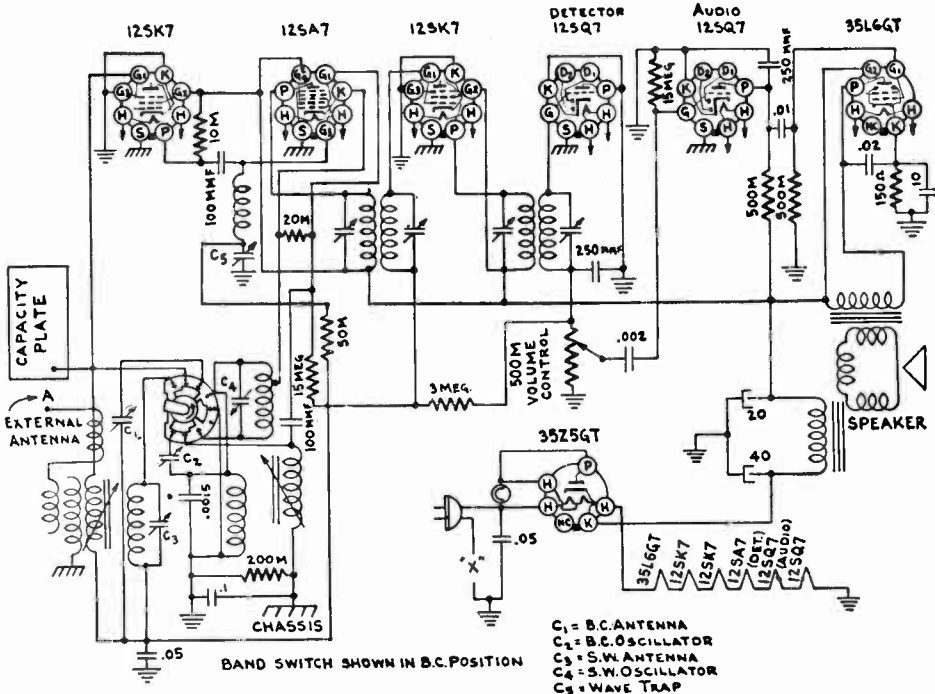
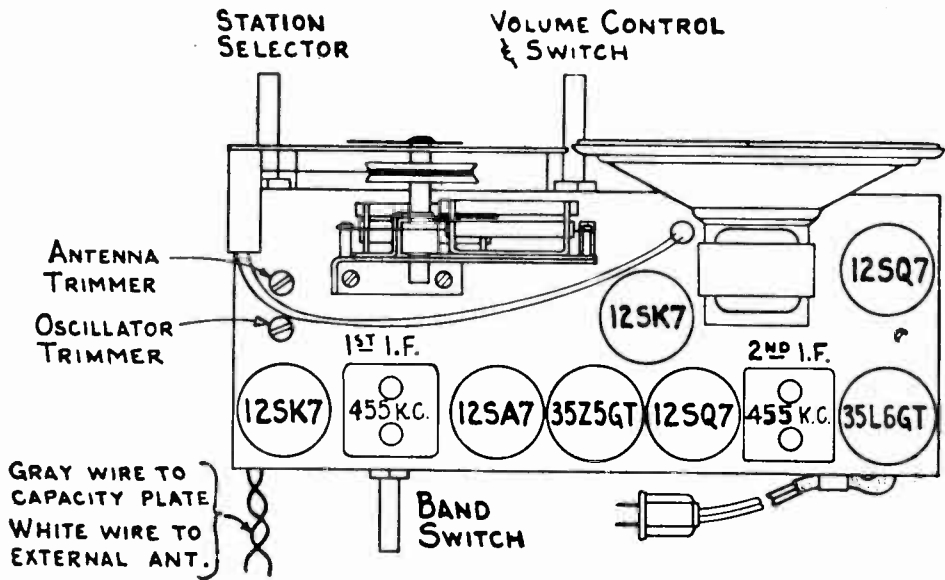

DETROLA AC-DC SUPERHETERODYNE, MODEL 425 SERIES



# N.R.I. ALUMNI NEWS

Edward Sorg .....	President
John Stanish .....	Vice-Pres.
Peter J. Dunn .....	Vice-Pres.
Louis J. Kumerl .....	Vice-Pres.
Chas. J. Fehn .....	Vice-Pres.
Earl Merryman .....	Secretary
Louis L. Menne .....	Executive Secretary

## OUR FIRST DUTY IS TO OUR COUNTRY

BY LOUIS L. MENNE

Executive Secretary

N. R. I. ALUMNI ASSOCIATION

As an organization and individually, we have a great opportunity to win distinction by going all out, with our Radio knowledge to help win the war.

Our Alumni Association is made up of several thousand trained radio technicians—the type of men so urgently needed by our government in military and civilian jobs. Let us put our shoulders to the wheel and do everything possible to help our government build a vast machine to insure Victory in the shortest possible time.

Hundreds of our members have enlisted and are serving in the Army, Navy, Marine or Air Corps. A great many others, who for one reason or another cannot serve as members of the enlisted service, are filling very important civilian jobs. Still others are keeping the millions of home radio receivers in tip-top operating condition so that our government can have instant communication with our civilian population to convey any necessary information which may be vital to our safety in this emergency.

If you wish information about where and how you can serve, write a neat letter setting forth your qualifications and send it to the United States Civil Service Commission, Washington, D. C., or to the Chief Signal Officer, Munitions Building, Washington, D. C., or to the Army Specialist Corps, Building M, Washington, D. C., or to the Navy Department, Washington, D. C. There are many other places where applications may be sent. Look at the bulletin board in your local Post Office. Ask a recruiting officer. Use your own initiative as much as possible in find-

ing out where you fit in and what seems to be best for you to do.

When you write a letter, be brief and to the point. Mention your experience, whether full time or part time, your age, your dependents, your Draft Classification, your education, your present employer, your place of birth and your citizenship. Confine your letter to essentials. Make it complete but easy to read, quickly. Keep in mind that government officials are extremely busy, have no time to answer questions which are not pertinent to the point.

If you are turned down on one application do not take it too much to heart. That particular agency may be looking for a certain type of applicant. The officials must use their best judgment and, no doubt, have many border line cases. If you do not get a favorable reply or interview, keep your chin up. Try something else. This is a war in which there is a job for every one of us to do. The government is working day and night to fit men into their proper places. It is a tremendous undertaking and requires the loyalty of every man. Every one of us in and out of the government service, is trying his very best to do his job well. Mistakes are bound to be made. It will not do to criticize. Keep trying—fighting.

N.R.I. Alumni members are making a record which will be written on the pages of history. We can be proud—extremely proud, to be identified with such an organization. We salute you, fellow patriots and urge you to put forth every ounce of energy to help preserve the ideals of our great country to which we owe so much and which now needs us in this hour of great peril.

# Here and There Among Alumni Members

*Harold Durham has stepped up. He is now studio control operator with WGRC, Louisville, Ky.*

— n r i —

*E. J. Manosh of Uxbridge, Mass., is leaving a \$10,000 a year business to join the Army. Says he will take up where he left off when he gets back. That's the spirit!*

— n r i —

*Charles J. Helmuth has changed locations from Atlantic City to Absecon, New Jersey, where he has a nice Radio Repair Shop.*

— n r i —

*John Keller of Pennsylvania is stepping into the job of Assistant Chief Aircraft Communicator.*

— n r i —

*M. C. Rhynes of Gonzales, Texas, operates Rhynes Radio Hospital. Has a tie-up with the local movie theater which gives him good advertising.*

— n r i —

*Millard D. Burris has been in business since May 1, 1941. Now he is taking larger space, has a sound truck and fine equipment. Is doing very well.*

— n r i —

*H. H. Lance is back in Indianapolis as transmitter engineer at station WIBC.*

— n r i —

*Floyd A. Roberts is back with the Gaston Music Co., Kearney, Nebr., after an absence of four years. He is earning twice as much as he was when he left. Has serviced 2024 Radios since August 11, which proves he is a valuable man.*

— n r i —

*P. E. Armstrong of Jamestown, N. Y., writes to say N. R. I. has made him a more valuable citizen to our country. He is teaching a government-sponsored night class in Radio.*

— n r i —

*W. A. Angel of Blytheville, Ark., not so long ago took his first radio job at \$20.00 a week, to get a start. Now he is making \$35.00, plus a bonus each week. Not bad!*

— n r i —

*L. C. Hoover of De Quincy, Louisiana, reports that his Radio service business has increased about 25%.*

— n r i —

*H. B. Hasty, Jr., of Charlotte, N. C., is teaching a class of Boy Scouts so they can qualify for their Radio Merit Badges.*

— n r i —

*Clifford D. Morris is Radio Serviceman for Washburn and Liles Radio and Electrical Store, Mena, Ark. Two other servicemen who preceded him are now in military service, one in the Army, the other in the Navy. Morris is kept busy trying to fill both jobs in the emergency.*

— n r i —

*T. M. McCormack is Radio Serviceman for Western Auto Store in Lexington, Kentucky.*

*Pete Dunn, National Vice President and member of Baltimore Chapter, is Air Raid Warden in his sector. Says he is having trouble getting some of his neighbors to black-out. A number of the boys have volunteered to make the rounds with him.*



— n r i —

*Edwin W. Holscher has a fine Radio business in Spencer, Iowa. His brother, Vic, also an N. R. I. man, was his chief assistant. Both men saw their duty. Ed took a Civil Service job as associate inspector of Signal Corps equipment, and Vic went into an aircraft plant as inspector of radio equipment on bombers. In the meantime the Radio business goes on under the capable management of Mildred E. Smith and experienced Radio servicemen.*

— n r i —

*Richard Oster is with the Naval Air Service, as first radioman, on a patrol bomber. Says he is meeting a lot of N. R. I. men in the Service.*

— n r i —

In all of these personal notices relating to men in the Service addresses are omitted for obvious reasons. Also, it is quite impossible to mention all of our members, but we like to hear from them and we are so very proud of what they are doing for Victory.

— n r i —

*Milo W. C. Wilson of Maryland is now working in an aircraft factory. Doing fine. Says he had to pinch his nickels to pay for N. R. I. training, but he has no regrets now.*

— n r i —

*Ed Seeburg of New Jersey is now an assistant engineer in the U. S. War Department. Has a big job and is doing it well.*

— n r i —

*Stanley Bartleman is with Farnsworth Radio and Television Corporation, Marion, Indiana.*

— n r i —

*Fred Kahlert is Radio Operator in a Coast Artillery outfit. We know Kahlert well. He was a frequent visitor at N. R. I.—a very interesting chap with a keen radio mind.*

— n r i —

*We are glad to know Mrs. Fisher, wife of Gus W., of Alamogordo, New Mexico, has recovered from a serious illness of pneumonia. Gus is now ready to take a job with Uncle Sam.*

— n r i —

*E. A. Charlton of Helena, Montana, now has the Philco line. Sales for last year were \$15,000.*



## Chicago Chapter

We have a very attractive membership card which was designed for us by Mr. Arthur Miller and printed by Mr. Joseph Pagano without cost to the Chapter. This is just another illustration of the type of cooperation we are getting from our members.

We have formulated plans for a membership drive. Our object is to have at least 150 members. In this connection our Chairman, our Secretary and a committee are functioning as one man and we are already getting results.

One of our meetings was held at Kaplan's Hall, 3900 West 26th Street. This was a fine meeting and well attended. Mr. Coleman of the Radolek Company again was our speaker. Through the courtesy of his Company he donated some tools to the Chapter. Our Mr. Miller also gave a very interesting lecture on technical problems for which he was enthusiastically applauded.

At each meeting it is our plan to have some entertainment and also serve refreshments. The committees are appointed for this. The members of these committees are: R. Pieriz, A. Kapischke, E. Kulpa, A. Miller, F. Opalecky and our Chairman, James Cada.

Many of our members are serving the government in one capacity or another. Patriotism runs deep in our Chapter. All of our meetings are opened with a pledge of allegiance to the flag of the United States.

Another meeting was held at the Chicago Lighting Institute in Chicago. The show was very entertaining and educational. New members introduced at this meeting were Villias Nowicki and John McNeill.

Our next report will give you the details regarding our meeting of May 13th and our party which is scheduled for the 16th of May. This is to be one of the social affairs for which Chicago chapter is well known.

The plan of meeting at various places has worked out well. However, it is necessary that members attend meetings regularly so that they may be advised of the meeting place for the meeting to follow. Those desiring information in this connection are invited to write or phone Chairman, James Cada, 2511 South Highland Ave., Berwyn, Ill., Phone, Berwyn 4589M, or Secretary, Harry Andresen, 3317 North Albany Ave., Chicago, Ill., Phone, Juniper 2857.

HARRY ANDRESEN, Secretary.

## New York Chapter

Quite a few of our members have gone into the Service, either Army or Navy or in civilian capacities. We miss them but we are glad to have well qualified Radio men ready to step into these important positions. Greetings to our members who are in the Service.

Donald Hildesheim built a demonstrator similar to the Dynamic Demonstrator. This he has turned over to the Chapter and we have found it very useful.

Many of our members have donated other pieces of testing equipment and we are now well supplied with material of this kind.

At every meeting we hold an open forum because this seems to be the most popular with our men. We also have a speaker or two. At some of our meetings we have been giving time to the practice of Code, a subject of great importance these days.

A Code Oscillator was built and donated by our member Robert Godas.

Ralph Baer is proving to be a real leader. He not only knows Radio Servicing thoroughly but equally important, he knows how to explain things so that it is understood by all of his listeners.

Our meetings as usual, are on the first and third Thursday of the month at Damanzek's Manor, 12 St. Marks Place, New York City (between 2nd and 3rd Avenues).

LOUIS J. KUNERT, *Secretary.*

— n r i —

## Detroit Chapter

Our program for the balance of this season has been prepared in advance. The following is the schedule.

May 22nd. Fred Clow is to conduct the meeting. His subject will be Circuit Laws: Ohm's and Kirchoff's. On June 12, H. R. Stevens will conduct the meeting. His subject will be, "Checking by Resistance."

On June 26, Harold Chase will lead the meeting in a discussion on Condensers. This will wind up our meetings until September. No meetings will be held in July and August.

At a recent meeting Earl Oliver discussed "Aligning and Use of the Oscillator" and at another meeting Henry Rissi gave us a splendid talk on Signal Tracing and locating defective stages.

Our Chapter has placed an order for an RCA Dynamic Demonstrator. We hope to receive this

very soon. It will be extremely beneficial in our discussions.

Until the end of June we will meet regularly at 2500 Jos. Campau on the second and fourth Friday of the month.

Chairman John Stanish has given us a fine administration. Detroit Chapter is stronger than ever.

F. EARL OLIVER, *Secretary.*

---

## Phila-Camden Chapter

National Vice President, Chas. J. Fehn is taking an active part in helping chapters in the East prepare good programs and give our members interesting and instructive meetings. Since he is also Treasurer of our Chapter he naturally is doing everything possible to aid our own local.

Former National President Clarence J. Stokes also is again able to attend meetings more regularly and is doing much to aid us. He introduced Mr. Samuel Alloway, a new student of N.R.I. who is taking up Radio, through the inspiration he received from Mr. Stokes.

Harvey Morris, pinch-hitting for Herman Doberstein who was unable to attend a meeting which he was to lead, gave us a practical servicing demonstration on a Grunow set which was dead at the time. After checking and finding the volume control was shorted, Harvey went about the business of disassembling the volume control, gave it the necessary repairs and restored the receiver to good performing condition. After placing the receiver in tip-top shape he spoke on the subject of Zero Beat method of aligning a set.

At another meeting we had a similar practical demonstration, this time on a Zenith. It was brought in with a very weak signal or volume output. After aligning the set it still had a weak signal so we proceeded with a point-to-point voltage test. The voltages proving about correct, we continued further checking and discovered the trouble to be a high resistance leak across the coupling condenser which caused over-loading of power amplifier. After replacing the condenser and realigning the set, the volume was everything that could be desired.

At our next meeting Mr. Morris, assisted by Mr. McCaffrey, will discuss IF Transformers. On May 21, we are again having our practical demonstration and a general discussion of servicing problems.

We meet at Extras Shop, N.E. Corner, Atlantic and Emeralds Sts., Phila., on the first and third Thursday of each month.

HAROLD S. STRAWN, *Secretary.*

## Baltimore Chapter

We have just made arrangements to continue holding meetings in our present quarters. This is an ideal location and the news that we are to stay here indefinitely was very pleasing to our members.

Our meetings are held regularly every second and fourth Tuesday of the month, at Redmen's Hall, 745 West Baltimore Street. We will continue our meetings right through the Summer.

Mr. H. J. Rathbun our Vice Chairman, has been giving us practical demonstrations in the servicing of receivers. Every meeting the members bring in a number of receivers and under the guidance of Mr. Rathbun we proceed to locate the trouble and make the repairs, insofar as it is practical for us to do so. This type of work is very interesting and beneficial to the members.

Mr. Harold Snyder who has been working with Mr. Rathbun, giving us practical demonstrations for many months, has been transferred to another city where he is filling a big job for the government. Mr. Snyder is a Radio Technician par excellence and he probably will be gone several months. The boys gave him a rising vote of thanks for his hard work in connection with our Chapter. We all hope he will be back soon but not until he has completed his important assignment for Uncle Sam.

Mr. P. E. Marsh was appointed Sergeant at Arms for the balance of this year.

On April 28, we had a rousing good meeting. At that time we held a Door Prize Drawing consisting of \$10 in Defense Stamps. Mr. Albert J. Komins carried away the major portion of these.

Mr. Peter J. Dunn, National Vice President of our Alumni Association and a regular attendant at Baltimore Chapter meetings is putting on a one man advertising campaign. He has had printed, at his own expense, 20,000 match books, with a patriotic slogan on one side and an advertisement for our local chapter on the other. Pete is a real booster for the Alumni Association.

Mr. E. W. Gosnell maintains his perfect record of never having missed a meeting since he was elected Chairman. He is doing a splendid job. Keeps things going, always has a good program which accounts for our fine attendance.

Some new men who have taken defense jobs in this area have been dropping in on us. All N.R.I. men are welcome at any of our meetings.

B. G. ULRICH, *Secretary.*



### Civil Service Job

I would like to inform you that I am now employed by the Civil Service Commission, and I want to thank you for informing me about this job. Your interest in my welfare is greatly appreciated and I can assure you that N. R. I. will always hold a warm spot in my heart. I also have the impression that the U. S. Signal Corps and Civil Service have a very high regard for the N. R. I. course of training.

JAMES KENNETH LILLARD,  
Atlanta, Ga.

— n r i —

### Wants More on Communications

I have been enjoying NATIONAL RADIO NEWS for some time. I think this magazine is tops. I especially like the articles on communication since I am now in the Army as an operator and also am studying N. R. I.'s course in communications. I would be glad to see more articles on communication in future issues.

JOHN C. STEPHENS,  
U. S. Army.

— n r i —

### Incalculable Value

Enclosed is renewal of membership of Henry Webb Thomas for one year in the N. R. I. Alumni Association.

Henry enlisted in the United States Signal Corps. I wrote him of the expiration notice and he requested that I renew his membership. He also requested that I express to you his appreciation of the assistance afforded him by his course with the National Radio Institute, and the up-to-the-minute information in NATIONAL RADIO NEWS, along with the other advantages of a membership in the N. R. I. Alumni Association. The knowledge gained therefrom has proven of incalculable value in his efforts in the Service of our country.

MRS. HENRY WEBB THOMAS,  
New Orleans, La.

### Article Was Helpful in Signal Corps

I wish to express my opinion of Mr. Kaufman's analysis of, "They are More Than Radio Parts," in the April-May issue of NATIONAL RADIO NEWS. I like every issue of it yet I have found this last issue of yours very comprehensive. It has been very helpful in connection with my work as Signal Corps Technician in the Air Corps.

NORMAN A. ZUEHL,  
San Antonio, Texas.

— n r i —

### Worth Its Salt

The RADIO NEWS is worth its salt any day. Keep up the good work. In these trying times both improved educational technique and fellowship are valuable assets to our fraternity.

GRANT W. SIMON,  
St. Paul, Minn.

— n r i —

### Radioman in Army Air Corps

I am in the Army Air Corps now and for the past three months have been a student at their radio school. Due to your fine training I have been able to maintain an average of around 91% in theory. This course is very comprehensive and fellows who have not had radio before have a very hard time. I hope to get an instructor's job here.

RICHARD E. BEMIS,  
U. S. Army.

— n r i —

### Technical Articles

I like the technical articles the best, especially the circuit analysis ones. They are a swell review of radio principles we are most apt to need in radio work.

GLENN THOMAS,  
St. Louis, Mo.

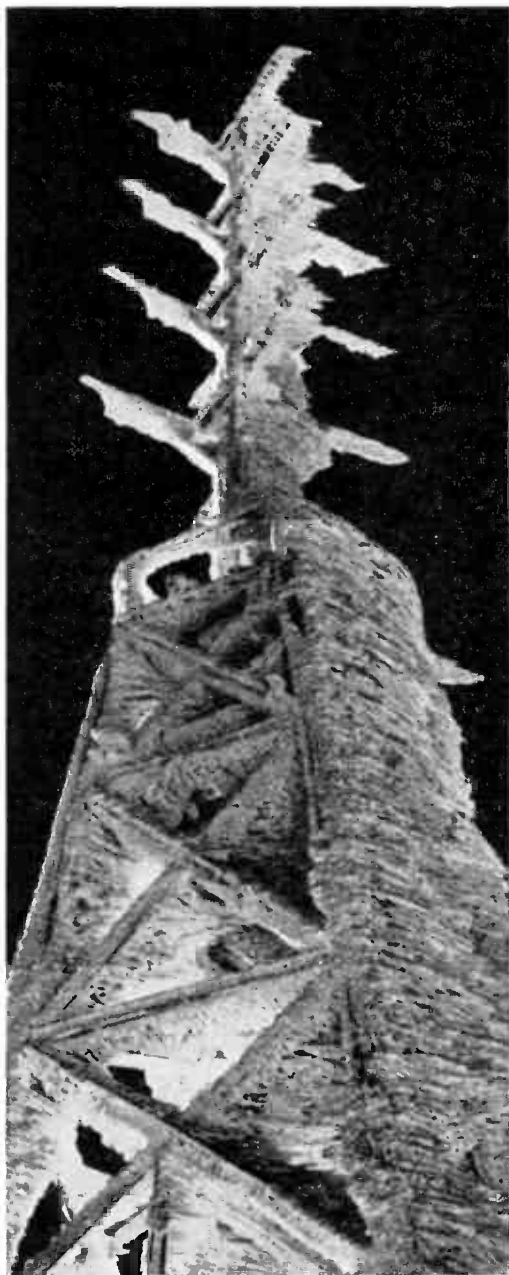

Courtesy General Electric Co.

The turnstile-type, transmitting antenna of f.m. station W39B was often covered with this interesting formation of heavy rime (frozen fog) last winter.

# NATIONAL RADIO NEWS

FROM N.R.I. TRAINING HEADQUARTERS

Vol. 10

June-July, 1942

No. 3

Published every other month in the interest of the students  
and Alumni Association of the

NATIONAL RADIO INSTITUTE  
Washington, D. C.

The Official Organ of the N. R. I. Alumni Association  
Editorial and Business Office, 16th & You Sts., N. W.,  
Washington, D. C.

L. L. MENNE, EDITOR

L. J. MARKUS, TECHNICAL EDITOR

NATIONAL RADIO NEWS accepts no paid advertising. Articles referring to products of manufacturers, wholesalers, etc., are included for readers' information only, and we assume no responsibility for these companies or their products.

## Index

Article	Page
Modern Tone Controls .....	3
Puzzling Radio Questions .....	10
You Have a Big Job to Do .....	12
Novel Radio Items .....	15
Circuit Analysis, A.C.-Battery Portable .....	16
A True Story of Success .....	22
Data Sheet—Detrola, Model 390 .....	23
Data Sheet—Detrola, Model 425 .....	25
Alumni News .....	27
Here and There Among Alumni Members ..	28
Chapter News .....	29
The Mail Bag .....	31