

NATIONAL RADIO NEWS



IN THIS ISSUE

How to Analyze a Receiver Diagram

Profitable Customer Relationship

Alumni Association News

AUG.-SEPT.
1941

VOL. 9
No. 10



The Value of Courtesy in Business

People complain more about discourteous and uninterested clerks than about any of the other faults a store or business can have.

You have a chance to use courtesy in every single dealing with your customers, regardless of whether you are working for some one else or have a radio service shop of your own. In every single branch of radio, courtesy is badly needed today.

Courtesy helps you to get ahead. Courtesy adds zest and enjoyment to your work. It is more fun to be courteous.

Courtesy develops good manners. Good manners are petty sacrifices which cost you nothing but which bring great returns and make you more popular.

How can you be courteous? Here are a number of ways:

Say "thank you," and be sure you sincerely mean it. Genuine courtesy comes from the heart.

Be especially courteous to those who don't buy from you, who cannot do you any good today, and then you can be sure of being sufficiently courteous to those who do buy. Courtesy becomes a habit if practiced long enough.

Be courteous even to the very lowest persons who serve you. Remember Owen D. Young's words to a pullman porter, "I wish I could always be sure of doing my job as well as you do yours."

Treat your customers as you would want to be treated if you were in their place. Learn what your customer wants, and give it—don't try to force your own ideas onto him. And give your courtesy with a smile. There is an old Chinese proverb which says, "A man who doesn't smile shouldn't keep a shop."

J. E. SMITH, President.

A Typical Receiver Diagram and How To Analyze It

By J. A. DOWIE

Chief Instructor

READING a schematic circuit diagram, once the principles of presentation are understood, is a matter of practice. Each part in a receiver can be represented by a symbol, so it is possible to look at a schematic circuit diagram and note how many resistors, coils, condensers, tubes, etc., there are. The electrical values of some of the parts may be noted on the diagram: even voltages at definite points of connection are often marked on a receiver diagram. Hence a schematic diagram helps when servicing, for the specified electrical value may be checked with the value measured with servicing equipment.

In a schematic circuit diagram, the parts represented by symbols are connected together, lines representing the connecting wires. Here you must realize that the connections shown in a schematic are not picture connections, as you have already learned from your home demonstration kits. Yet schematic circuit diagrams present the true electrical circuit connections, so that you can identify signal and supply circuits. Given a schematic showing how the various tubes receive their operating voltages, it is possible to check continuity in these circuits. To a serviceman this is highly important, for it permits him to check the actual connections with those intended by the manufacturer; this often leads to defects and is an aid in servicing.

No circuit diagram shows the exact location of each part on the chassis base; for this the beginner often needs a pictorial layout showing the

location of each part. The parts in the pictorial layout are labeled or marked, as for example C_{35} , R_2 , L_2 , etc., so that parts similarly marked on the schematic help you to connect the circuit diagram and the actual location of the parts. Unfortunately, very few service diagrams give pictorial layouts, so that the schematic itself must serve as a guide in locating parts. From your study of parts and with experience, you quickly learn how to recognize resistors, condensers, transformers, etc.; in fact, you will quickly be able to tell the difference between paper, electrolytic and mica condensers. With a little experience you will be able to identify the various stages, that is, the first detector, a.f. output, rectifier tube, etc. With this as a starting point, with the aid of a circuit diagram you will be able to trace any part in the chassis by simple analysis. Later in the course, plans for acquiring this ability will be presented, so you can learn how to identify parts in a chassis without a pictorial layout.



J. A. DOWIE
N. R. I. Chief Instructor

The knowledge of how the receiver works, how the various stages and circuits operate, is important in the servicing of a receiver, and is a fact that is not quickly appreciated by a beginner. Certain improper operations are noted by an actual listening test of the receiver which suggest definite circuit defects. By referring to the schematic circuit diagram, the study of certain portions of the schematic will suggest which stage, circuit and part is the possible offender. With a little skill, the serviceman can use the schematic as a service "tool."

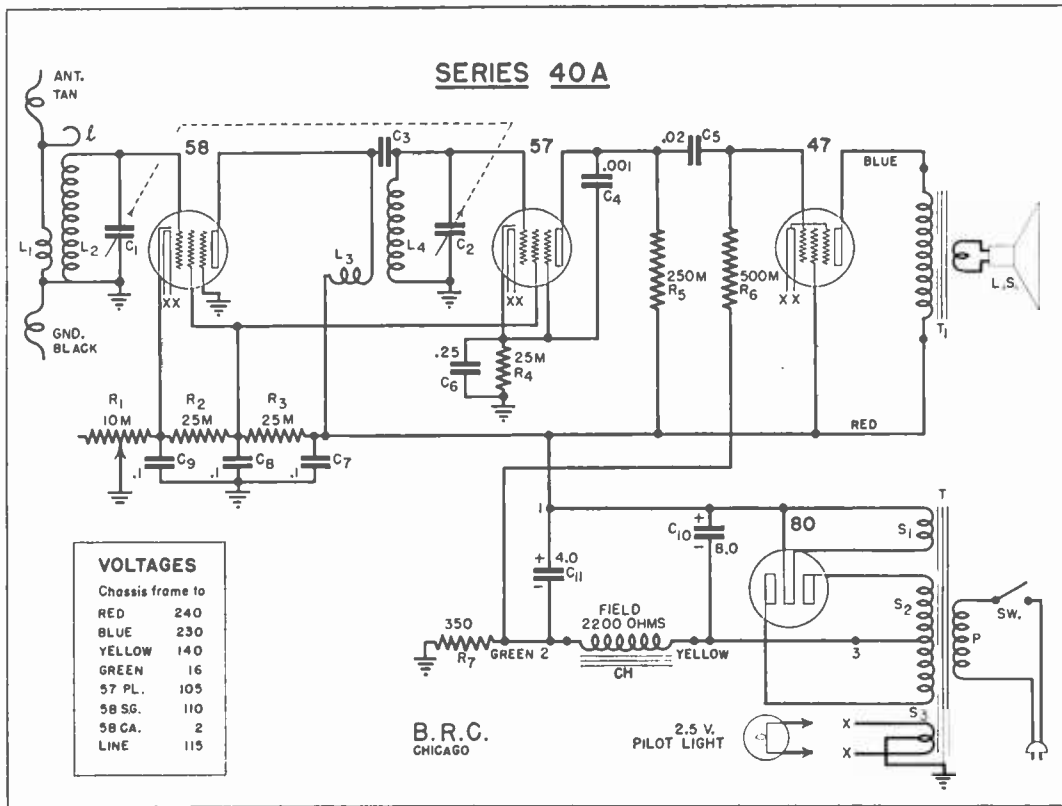

FIG. 1. Four tube tuned radio frequency receiver, A.C. operated with only two tuned circuit.

By studying a great number of schematic circuit diagrams, you begin to appreciate that certain capacity condensers are used in the r.f. sections as by-passes; a different capacity is used in a.f. circuits. You appreciate what are the normal values used as cathode resistors in voltage amplifier and output tubes, what sizes of variable resistors are used as diode loads, etc. This is of great value in servicing, for you do not have to get an exact replacement, nor do you have to calculate or look through charts for a proper replacement. Knowing what values to expect develops confidence and speeds up service work—do not ever get the idea that the electrical value of every part must be exactly as specified; some must, while others may vary as much as 30%.

To familiarize yourself with circuits, we will present a typical radio receiver in schematic form which we will analyze for you, showing you

how the tubes get their operating voltages, how the signal travels from antenna to loudspeaker, how associated control circuits work and tie into the general schematic.

In tracing supply and signal circuits, we will have to become practical, talking about voltages, currents, resonance step-up, reactance, etc. If you ever had the idea that a radio wave induces an electron flow into the antenna circuit and this electron current was acted on by the circuits so that the original antenna electrons reach the loudspeaker, drop that idea at once. You start with a signal voltage and current; the circuits along the line develop other signal voltages and currents until the loudspeaker is made to convert electric power to sound power. In other words, we don't try to follow electron movements in the circuits but deal entirely with the effects of the electrons, and these are, of

course, the signal voltages and signal currents.

Belmont Radio Corp.—Model 40A-AC

Considerable information regarding the Belmont Model 40A receiver, shown in schematic form in Fig. 1, may be obtained by analysis of the diagram, information that reveals what performance to expect and what circuits are continuous for purposes of receiver checks.

It is apparent that this receiver is a 4-tube affair, one tube, the type 80, being the rectifier. The technician knows that the 80 tube is a rectifier because he has met it many times in other diagrams and in the chassis of many receivers. Even if the tube were not labeled an 80 type tube, the symbol shows it has a filament and two plates, the latter connected to the power transformer high voltage secondary S_2 . Furthermore, the output of the tube is through a condenser input filter choke, and this is additional evidence that it is a rectifier tube of the full-wave type.

We have two resonant or tuning circuits, namely I_2-C_1 and I_4-C_2 , and one feeds to the other through a type 58 tube; hence the latter is an r.f. amplifier tube.

The output of the type 47 tube feeds a signal through the iron-core transformer T_1 to the loud-speaker L.S., hence the 47 tube is an audio output tube. This is further proved by the fact that the 57 tube connects to the 47 through a resistor-capacitor coupler, which is usually an a.f. coupling procedure.

Between the resonant circuit I_4-C_2 and the audio coupler $R_5-C_5-R_6$ is a type 57 tube. Since this tube receives r.f. and delivers a.f., it must be a detector or demodulator. There being no other tuned circuits or tubes, we can say that no oscillator exists in this circuit and the receiver is of the tuned radio frequency type.

Signal Circuits. Note that there are *tan* and *black* leads which connect to coil I_1 , the input of the antenna r.f. transformer. The diagram tells us that the *tan* wire is for an antenna down-lead connection, while the *black* lead is the ground connection. We know this about these two wires for the black one connects to the chassis and therefore must be the ground lead. Apparently leads instead of connection posts are used in this chassis. Even if this information were not given, it would be safe to assume that the black lead was the ground connection, a usual color-coding procedure.

A radio wave intercepted by the antenna system would cause an r.f. current to flow through I_1 and induce an r.f. voltage into the secondary coil I_2 . In addition, note the link l , which is indicated as being connected from that end of I_1 farthest from the ground; technicians would call

it the "hot" end of coil I_1 . This coil links by capacity to the grid end of coil I_2 , and thus we have capacity coupling between primary I_1 and secondary I_2 . Both inductive and capacitive coupling are used to insure more uniform transfer of the r.f. signal over the entire tuning range.

Going back to the signal, the r.f. voltage induced in I_2 , we continue by realizing that this voltage produces a current in I_2 and C_1 , and since this circuit is tuned to resonance (frequency of the desired signal), a large circulating (often called tank) current flows. Consequently, a larger r.f. voltage appears across I_2 and across C_1 than was induced into I_1 . You know that a series resonant circuit, of which this is an example, has the ability to step up the applied voltage.

Now the voltage across I_2 or C_1 is applied to the grid-cathode of the first amplifying tube. Purely by general preference of radio men, we think of the condenser voltage (C_1) as being applied to the grid-cathode of the 58 type tube; both I_2 and C_1 , however, have the same r.f. voltage.

But as you look at this diagram you can directly see the grid connection but not the cathode connection. It exists, however. Note that one terminal of C_1 is connected to the chassis, which is symbolized by a series of short horizontal lines that converge into an inverted cone. This symbol is used to represent the chassis and often the ground connection. Now identify condenser C_5 , a .1-mfd. condenser. It, too, is connected to the chassis and in addition to the cathode of the 58 tube. Since a .1-mfd. condenser is a low reactance path for any frequency between 500 and 1500 kilocycles (the range of this receiver), you definitely have an r.f. connection from the ground (or chassis) end of C_1 to the cathode of the 58 tube.

To be sure, the grid is biased negatively with respect to the cathode, as you will see when we take up the supply circuit, but the r.f. voltage drives the grid alternately more negative and less negative with respect to the cathode.

A d.c. current is flowing in the plate circuit which starts at the cathode, proceeds to plate and after passing through I_3 goes into the power supply. The r.f. voltage applied to the grid-cathode makes this d.c. current increase over the value and decrease below the value that would exist if only the grid d.c. bias voltage were present. We really have a pulsating d.c. current through I_3 and it is the r.f. part of this pulsating current that makes I_3 induce another r.f. voltage in I_4 . And because of the amplifying action of the 58 tube, the r.f. voltage induced in I_4 is greater than the voltage induced in I_2 . If you ever had the idea that the vibrating electrons in I_2 are forwarded to I_4 , get this idea out of your mind—we are transferring voltage and current effects, as we have shown here.

Not only is L_3 inductively linked to L_4 , but the r.f. voltage developed across L_3 is capacitively applied to L_4 . Once more the induced voltage in L_4 is stepped up by resonance. The r.f. voltage across C_2 is fed to the grid-cathode of the type 57 tube. The direct connection is definitely shown; the cathode connection is to chassis from the ground end of C_2 , and through C_6 to the cathode.

As a detector, the type 57 tube rectifies the modulated r.f. signal, and in the plate circuit condenser C_4 acts as a short-circuit path for any r.f. components. Actually the r.f. component flows from cathode to plate of the 57 tube, through C_4 and back to cathode, the energy of the r.f. signal being wasted as heat in the tube. Practically, the amount of r.f. energy is so small that it can be ignored; technicians say that C_4 by-passes the r.f., preventing it from reaching resistor R_3 .

Flowing through R_3 is a pulsating d.c. current, the varying component being the audio signal produced by detection. We can see the connection from the plate of the 57 tube to the plate end of resistor R_3 ; the return path to the cathode is a little obscure. However, follow the connection to the + terminal of C_{11} , through this condenser, to and through R_7 to chassis. Now from the chassis trace the path through C_6 to the cathode of the 57 tube. For an audio frequency current, both C_6 and C_{11} have low reactance (.25 and 4 mfd. respectively); the resistance of R_7 (being 350 ohms) is negligible with respect to R_3 (which is 250,000 ohms). We may therefore say that there is a negligible impedance path from R_3 to the cathode of the 57 tube. Most of the audio voltage is developed across R_3 , neglecting of course that developed in the tube itself.

Across R_5 is the condenser C_5 and resistor R_6 , the latter two items in series. Note that one end of R_6 goes to the — terminal of C_{11} and connects to R_3 through C_{11} . Only an a.c. voltage can flow through R_6 because C_5 blocks the d.c. current. Except for the very low audio frequencies, C_5 has negligible reactance, so we may say that R_6 and R_5 are in shunt as far as the signal is concerned. Hence the a.f. component of the pulsating current develops a voltage across R_5 and R_6 , the latter not affecting the d.c. conditions in the detector plate circuit.

The a.f. voltage across R_6 now feeds the grid-cathode of the last tube, the a.f. output tube. The grid connection is clearly seen, but the cathode connection needs clarification. In a type 47 tube, the cathode is also the filament. It connects to power transformer secondary S_3 , the connections not shown but indicated by the $\times\times$ marks. The center of secondary S_3 is connected to the chassis, and the chassis connects through R_7 to R_6 , thus completing the return connection of R_6 to the grid-cathode of tube 47.

Tube type 47 is one that will produce a large

current change for a normal grid voltage change. Hence the loudspeaker coupled to the plate-cathode of the output tube through the transformer gets a very large audio signal current. Transformer T_1 is selected to provide L.S. with the greatest power (voltage times current) that will produce negligible distortion. The return path for T_1 is through C_{11} , R_7 to S_3 and thence to filament.

Power Supply Circuits. Service technicians make a clear distinction between power supply and signal circuits. Once the supply for tubes is recognized, it may be neglected in considering the signal circuits, as we already have shown. Now let us turn to the supply system.

This receiver is a.c. operated, as we note the power transformer T ; switch SW controls the power, and when set to the ON position, the receiver works as soon as the tubes heat up. The voltage table tells us that the receiver is intended for a *line* voltage of about 115 volts; it will work satisfactorily from 105 to 125 volts.

The filaments of the 58, 57 and 47 type tubes require 2.5 volts a.c. or d.c.; here a.c. is applied from secondary S_3 . Primary P and secondary S_3 act as a step-down transformer. Note that the actual connections from the 58 and 57 filaments (as well as the 47 filament) to S_3 are not shown, but the $\times\times$ marks indicate the connection. This scheme is often used to simplify diagrams. The 80 type tube requires 5 volts, hence a special secondary S_1 is provided for heating its filament.

Let us trace the power pack circuit starting with point 1, thinking only of d.c. current flow and the path of electrons. We arrive at the cathode (or filament) of the 80 tube and since electrons flow from cathode to plate, we go to one plate (the one happening to be positive at the time) into an end terminal of secondary S_2 , then to the center of S_2 . From here we trace through the choke coil C_h to point 2. Either half of the secondary supplies an a.c. voltage to its plate, and when the terminals 1 and 2 are terminated in a load, electrons will flow in the direction previously traced. Since electrons cannot flow from plate to cathode, the current will be rectified, becoming a pulsating d.c. current. Condensers C_{10} and C_{11} will by-pass any fluctuations, and coil C_h will choke out any of the variations so that the current flowing to point 1 and from point 2 is uniform and without any ripple.

The tubes, in addition to voltage divider resistors R_1 , R_2 and R_3 , are the load on the power pack filter, and here is how we can see this load. Let's take the type 57 tube. When this tube is heated, electrons will flow from cathode to plate, and will continue through R_3 , which terminates at point 1. Tracing through the power pack we come to point 2, and through resistor R_7 to chassis. From the chassis we trace through R_4 to the

cathode, and this completes a power pack supply circuit.

By tracing through R_1 , cathode to plate of the type 58 tube and through L_6 , we again arrive at point 1 to complete this supply circuit. By starting with the center tap of S_3 , which connects to point 2 through R_7 , we see a d.c. connection to the filament of the 47 type tube, and from cathode to plate through the primary of T_1 , we arrive at point 1 to complete this supply circuit. Thus all cathode-plate tube circuits are supplied by the power pack, and only when the tubes heat so the cathodes will emit electrons.

But radio technicians look at this power supply from the voltage angle, the manner of thinking that you want to acquire. We can visualize points 1 and 2 as the terminals of a source, and since electrons flow into the + terminal of a source, point 1 will be + and terminal 2 will be - as shown. Of course, the d.c. voltage across C_{10} will be greater than across C_{11} , because of the voltage drop in C_{10} .

In this circuit point 2 is not at ground or chassis potential, because of the voltage drop in R_7 . In this receiver point 3 is the basic negative terminal of the power pack; point 1 is the basic positive terminal. Note that in one case we can say that the cathode (or filament) of the rectifier tube is the basic positive terminal, while the center tap of the high-voltage secondary S_2 is the basic negative terminal of the high-voltage d.c. source. With this in mind we can say that all other points in the supply circuits are negative with respect to point 1; all other points are positive with respect to point 3.

With these facts in mind, we can say that the chassis is positive with respect to points 2 and 3. Now let us see how the grid of the type 47 tube is made negative with respect to its cathode. Note that the cathode is connected to the chassis through S_3 , while the grid connects to point 2 through resistor R_6 . If the chassis is + with respect to point 2, then conversely point 2 is negative with respect to the chassis. Now we see that the grid is made negative with respect to chassis and its cathode. The d.c. voltage drop across R_7 is the C biasing voltage for the output tube.

Actually, in a class A amplifier the grid-cathode resistance inside of the tube is many megohms, and the .5-megohm value of R_6 in series is negligible. The grid-cathode is in shunt with R_7 and theoretically draws a minute current from the power pack, so small, however, that it would take the most sensitive current meters to detect it. But what is more important, since it is in shunt with R_7 it acquired the same d.c. voltage and with the proper polarity, thus giving us the C bias for the tube.

The plate of the 47 tube connects to point 1

through the primary of transformer T_1 , which has a very low resistance, probably about 500 ohms. Again the filament is connected to point 2 through R_7 . Thus the plate is made positive with respect to cathode; not the d.c. voltage across C_{11} , but that value less what is dropped in R_7 and T_1 .

Plate-cathode voltage of the 57 tube is derived in the same way, but the net plate-cathode d.c. voltage is less than what is across C_{11} by the drops in R_4 , R_5 and R_7 . A considerable amount of the supply voltage will be dropped in R_5 . Note that the table tells us that the red wire (point 1) is 240 volts with respect to chassis, the green wire 16 volts with respect to chassis; hence the voltage across C_{11} is the sum or 256 volts. Of course, if you measured the voltage from point 1 to the chassis, a value of 200 to 250 volts would be acceptable. The same table tells us that from the plate of the 57 tube to chassis there is 105 volts. Since the drop in R_4 is small, we can see that considerable voltage (almost one-half of the total supply) is dropped in R_5 .

The grid-cathode of the 57 tube is in shunt with resistor R_4 ; one end of R_4 is directly connected to the cathode, the chassis end connects to the grid through L_6 . Since the chassis end of R_4 is negative with respect to the cathode end, the grid is biased negatively, the exact voltage depending on the drop in R_4 .

In a similar manner the type 58 tube gets its plate and grid biasing voltages. Note, however, the cathode-chassis resistor R_1 is variable so that a variable C bias voltage can be applied to the grid of the first tube; this is the volume control. Voltage measurements are always taken with the volume control all the way ON. There must be a mechanical stop inside of the control which leaves 200 or 300 ohms in the circuit, so the cathode voltage (C_2) is never zero even with the control turned on full. Screen grid voltage is obtained for the 58 and 57 tubes by means of the voltage divider, consisting of R_2 and R_3 ; the table indicating that the screen grid-chassis potential is 110 volts.

All d.c. voltages are given with respect to chassis, so that in an actual measurement one voltmeter probe can contact the chassis and the other probe can be moved from point to point.

This brings up an interesting point, for you will note that there is a difference of 10 volts between the red wire and blue wire. The red wire is the + lead of C_{10} , and the blue wire the + lead of C_{11} . These wires connect together and therefore there must be the same voltage between them and the chassis. The factory information says different, but as you know better, you ignore this error in the manufacturer's voltage table. Always use your own judgment when confronted with a problem of this sort, as such errors sometimes creep

into the manufacturer's data.

D.C. Continuity Tests. A serviceman in carrying out continuity tests in the supply circuits of an a.c. operated receiver bears two important facts in mind. They are:

1. All positive tube electrodes, such as the plate and screen grid, are conductive to the cathode of the rectifier tube.
2. All negative tube electrodes, such as the cathode, the grid and often the suppressor grid, are conductive to either plate of the rectifier tube.

By fixing one ohmmeter connection either on the cathode or plate of the rectifier tube, continuity from any tube socket prong contact can be made. Let us check a few cases, using the 57 tube as an example.

- a. Trace from plate through R_p to point 1, to filament of 80 tube.
- b. Starting with the screen grid, second grid to right of the symbolic presentation of the filament, trace to and through R_a to point 1, to filament of the 80 tube.
- c. Trace from control grid through L_c , to chassis, through R_c through C_h to center of S_b , through either secondary winding to one plate of the 80 tube.
- d. From suppressor grid (grid between screen grid and plate), trace through R_s to chassis, and from here to the plate of the 80 tube.

Evaluation of Receiver Performance. To evaluate the performance of a receiver by circuit analysis requires experience, that is, actually operating a receiver and studying the diagram. Here we will apply our experience in order to give you a start.

If we neglect the rectifier tube in the performance, as this tube merely furnishes the operating potentials, we have only three tubes to work on the signal. Actually we have one r.f. amplifier stage and one audio power amplifier. We should not expect great sensitivity or loud reception on distant stations. In fact, a receiver of this type is used essentially for local and nearby stations, giving best volume on locals.

By using a long antenna, nearby and distant stations can be received, but since there are only two tuned circuits, selectivity will be poor (station interference may exist). In the country away from powerful stations, a long antenna is recommended but not too long, about 50 to 75 feet so a minimum of adjacent station interference will exist at night. In a city where several stations are broadcasting at one time, a short antenna,

preferably an indoor type, will be best and only local reception should be considered.

There is no reason why this receiver could not give fair quality: the larger the console and the better the loudspeaker, the better will be the reproduction. This can be judged when the receiver itself is inspected.

Effect-to-Cause Reasoning with a Schematic. We previously stated that a serviceman could listen to an improperly operating set, study the schematic and determine the probable cause of trouble. This ability is perhaps the most important asset possessed by the expert serviceman. It is gained through a knowledge of the purpose and action of each and every part in the receiver. This is why it is so important to fully master the fundamentals of radio. Students often find the fundamentals dry and uninteresting at first, but believe you me, they are important and a *must* item on your road to success.

The ability to listen and determine the most probable cause of trouble is also based on practical experience. This is something which cannot be gained by reading books. True, reference book 14X-1 contains probable causes of various troubles and is a big help, but who can condition his ears to troubles such as hum, the various types of distortion and noise, simply by reading about them? The answer of course is no one, and you must actually hear these defects in order to recognize them.

Does this mean that you have to start servicing receivers blindly to give yourself the experience you need? Not at all, for N.R.I. has a specially developed plan to give you in your own home the experience required of every service expert.

For this work we suggest that you pick up a five- or six-tube receiver in operating condition. When you get one write us, identifying the receiver and requesting a diagram for training purposes. Then we will send you full and complete information to get you started on this important part of your course.

Now suppose you were already an expert and that your ears were conditioned to work with your mind in solving receiver troubles. Let's see how you would use the diagram in servicing. If the receiver has a loud hum you look at the schematic and your eyes go at once to the filter system, because its duty is to deliver a hum-free supply of power to the tubes. Of course you see the two electrolytic condensers and check them for loss in capacity. This is done by putting other condensers of about the same size across them, and if the hum does not clear up you know that the condensers are all right. You may then check the remaining causes of hum or may resort to a stage elimination test to narrow your search.

There are not many stages in the set so you would simply proceed to check the remaining possibilities, namely cathode-to-heater leakage in the 57 tube and an open in the control grid return circuit of the 57 and 47 type tubes. These are the only points you would normally expect to be at fault.

Now if the set squealed when you tuned in a station and the volume control setting was advanced, you would know that the trouble was in the r.f. or detector stages. After checking to see if all shielding was in place, you would look at the screen grid circuit. Condenser C_4 was placed there to prevent oscillation, and you check it just as you did the electrolytics. If the condenser isn't bad, perhaps the screen voltage is too high. What could cause this? Opening up of resistor R_2 would result in excess screen voltage, so you check this resistor with an ohmmeter.

Condenser C_7 , if open, might cause oscillation, for C_{11} may not be a very good r.f. by-pass despite its large size. An open in C_4 is an unlikely source of oscillation, but you check it just the same. The wiping contacts between the rotors of the tuning condensers and the chassis are also checked. Suppose the contact on C_2 rotor was dirty and had a high resistance. Then the r.f. in circuit L_4-C_2 would flow through the wiping contact of C_7 to get to ground. This extra energy getting back into the input of the 58 tube could cause severe oscillation. You have gone through quite a procedure to locate the cause of the squealing, but the chances are better than three to one that you would have hit the nail on the head the first time when you checked C_7 .

Suppose you find that resistor R_7 is hot and smoking—what would you do then? You would look at the schematic to see what could be defective in such a way as to cause excess current to flow through R_7 . Would a short in C_{11} do this? No, because with C_{11} shorted, R_7 is not in the circuit and no current flows through it. You see at once, however, that if C_7 breaks down excess current will be drawn from the rectifier and that this current must flow back through R_7 and the speaker field.

You don't go to the trouble of unsoldering C_7 for an ohmmeter check—you simply measure the resistance between the rectifier filament and chassis. The resistance should be about equal to the sum of $R_2 + R_3$ (volume control all the way ON, set disconnected from power line). If you get a very low reading, C_7 could be causing the trouble, so you locate the condenser in the chassis, unsolder one lead, and give it a leakage test with your ohmmeter.

If the resistance is normal between the rectifier filament and the chassis, the trouble is not due to a short at this point. You now examine the schematic again. Since there is no short in the

B supply, the excess current is being drawn by some tube. The 58 and 57 tubes couldn't draw enough current to overheat the resistor to the point where it smoked, and this leaves the 47 as the troublemaker. You see that the grid is fed by a condenser, and if it is leaky the grid will receive a positive bias and the tube plate current will be excessive. Also, the tube might be gassy.

You check for these conditions by connecting your voltmeter across R_6 , with the positive probe on the grid end of R_6 . Normally there is no d.c. voltage across R_6 , but if you measure voltage you pull the 47 tube from its socket. If this causes the voltage to drop, the tube is drawing grid current due to gas, and another 47 will be required. On the other hand, a reading with the tube removed shows that C_7 is leaky and you install another condenser.

It is in this way that servicemen use diagrams in the repair of receivers. When you have studied various diagrams, you will learn all of the circuits in common use, and will be able in many cases to dispense with printed schematics, drawing on your knowledge of what must be in certain circuits and what to expect in the way of circuit arrangements in all sets.

— n r i —

Broadcasting, the Weekly Newsmagazine of Radio reports that the State of Pennsylvania purchased \$300,000 worth of radio equipment for the 160-mile super-highway across the State, providing for 24 radio-equipped watchers, 26 two-way radio patrol cars, 25 receiving sets, and two-way sets installed in tunnel ventilation buildings, maintenance cars, fire trucks and the cars of highway officials.

— n r i —

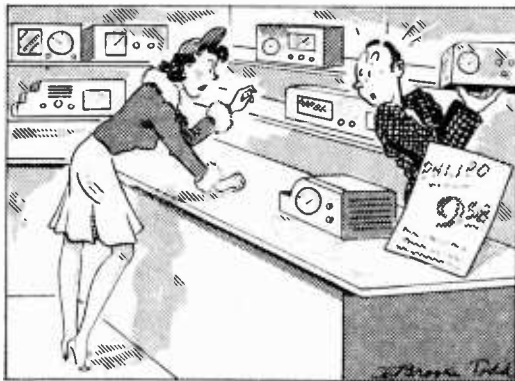

Idea from *Mechanix Illustrated*

"I want a gadget that will turn off the radio next door."

Now Is the Time to Plan for the Future

By E. R. HAAS

Vice President, National Radio Institute

With our nation confronted with the stupendous task of building up a formidable defense machine, as well as supplying friends of democracy the tools to carry on their struggle for freedom and liberty effectively, there is a definite feeling that we should ignore the future. But planning for the "day after tomorrow" is good sense and good business. Even the foes of all principles so dear to Americans have a long-range vision; we, too, must give the future serious attention. Naturally we want a better world to live in, one in which the developments of the past, present and future will make each living day a more happy one.

Experiences of the past have shown that stopping of a great program, such as that on which our country is now embarked, leads to considerable disorganization of national machinery and monetary structure. Yet if we visualize the possible bad effects of a changing situation, and take ways and means to combat them, then the change from one set of conditions to another can be made with the least amount of suffering or injury. This applies to our own personal problems as well as to the welfare of our nation.

It is not an idle rumor that some of the best brains in our government are tackling this problem of the future. Men who have the training and the experience needed to visualize what will come are today working on methods for handling these problems. That's thinking and planning for the future on a national basis. When you realistically visualize a problem that is still to come and work out a plan, the appearance of the difficulty finds you prepared . . . it can be handled without confusion.

We all appreciate our present national difficulty in getting enough raw and finished material to meet both civil and defense needs. Priority gives defense first claim on the material and facilities of the largest producing organizations in the world. And this national plant is being expanded more and more each month. Manufacturers know that the day is coming when defense needs will almost vanish, and nearly their entire productions will have to be used by industry and the public, customers who today get only second choice.

Industry and the public are not being entirely neglected, for the great majority of manufacturers are doing their level best to meet the demand; basic industries are expanding produc-

tion facilities so that both defense and the public shall be supplied.

Industries also are thinking of the future, planning ways and means of using their expanded producing machines so that the public will benefit—for they know their own welfare depends on this. Behind closed doors, every engineer, inventor and designer who can be spared from defense work is working on new or improved items for future production. There will be better electrical refrigerators, better household electrical appliances, new cooking utensils, materials and tools to make better homes, automobiles which will revolutionize our ideas of comfortable travel, even new flowers to fascinate our personal tastes.

Radio will contribute its share to help maintain an expanded national machinery. Just look at the things that you and I know are in the process of development and will emerge perfected at the right time, as the radio industry is planning. Frequency modulation will give us a new concept of tone fidelity, and freedom from noise. We will have reproduction in our home that will almost take our breath away—it will be so realistic. Television has been given the "go ahead," and the day is coming when we in our homes will be able to see as well as hear the best stage plays, be thrilled by the fine delivery of an orator, see the funny antics of the comedians, sit in at major national events or catastrophies.

To these basic changes coming in radio, we must not overlook the expansion of the established radio facilities and those industries that grew out of radio. Our present broadcasting system which uses amplitude modulation will not change; in fact, it will improve—we know that this is a fact because broadcasters are improving their stations, and no business man spends money on a declining project. Even f.m. will help the present system; many small local stations will go to f.m., helping to clear up interference between stations.

Public address systems, calling and intercommunication systems are increasing in number, and manufacturers with an eye on the future will help expand these facilities to an all-time high. Slowly and with little fanfare, electronic controls are creeping into industry and everyday life.

(Page 12, please)



RADIO-TRICIAN

REG. U.S. PAT. OFF.

Service Sheet

Compiled Solely for Students and Graduates

NATIONAL RADIO INSTITUTE, WASHINGTON, D. C.

RCA Victor 25BT-2 (RC-1004A) and CV-42 Electrifier

Alignment Procedure

Pre-Setting Dial.—With gang condenser in full mesh, the pointer should be set at the left-hand end dial calibration mark.

Step	Connect high side of test osc. to—	Tune test osc. to—	Turn radio dial to—	Adjust the following for maximum peak output
1	I-F grid in series with .01 mfd.	455 kc	Quiet point between 550 and 750 kc	C14, C15 (2nd I-F Trans.)
2	1st Det. grid in series with .01 mfd.			C12, C13 (1st I-F Trans.)
3	Antenna terminal in series with 200 mmfd.	1,720 kc	Tuning condenser rotor plates all out	C17 (osc.)
4		1,300 kc	1,300 kc signal	C9 (ant.)
5		455 kc	Quiet point between 550 and 750 kc	Adjust C22 for minimum output on strong 455 kc signal

Precautionary Lead Dress.—

1. The lead from the 3Q5 plate to output transformer should be dressed under clip and away from audio input leads.
2. All filament wires should be dressed close to chassis.
3. Keep AVC lead connecting C1 to antenna coil away from the 1A7GT plate.
4. Keep blue plate leads coming from I.F. transformers short and close to chassis.
5. Keep yellow leads connecting to oscillator coil away from trap coil.
6. Keep grid lead of 1N5GT RF tube away from 1A7GT grid.

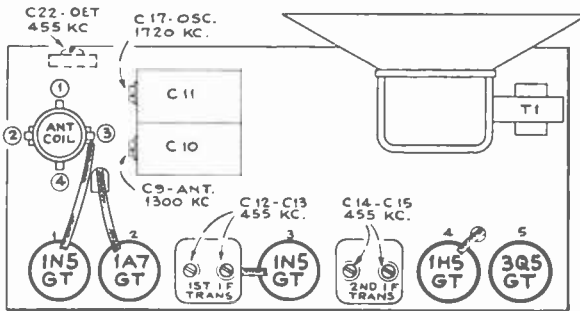

Remove any external ground connections when using the Electrifier.

CAUTION: Turn power switch off (counter-clockwise) when installing or replacing tubes or batteries.

DO NOT TURN THE "BATTERY-ELECTRIC" SWITCH TO ELECTRIC POSITION WHILE THE RECEIVER IS CONNECTED TO BATTERIES.

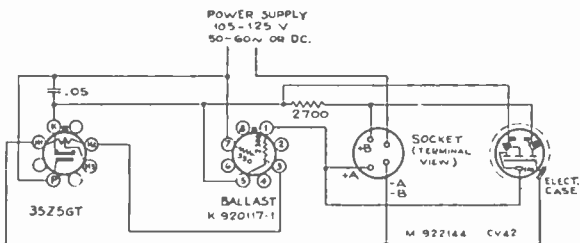

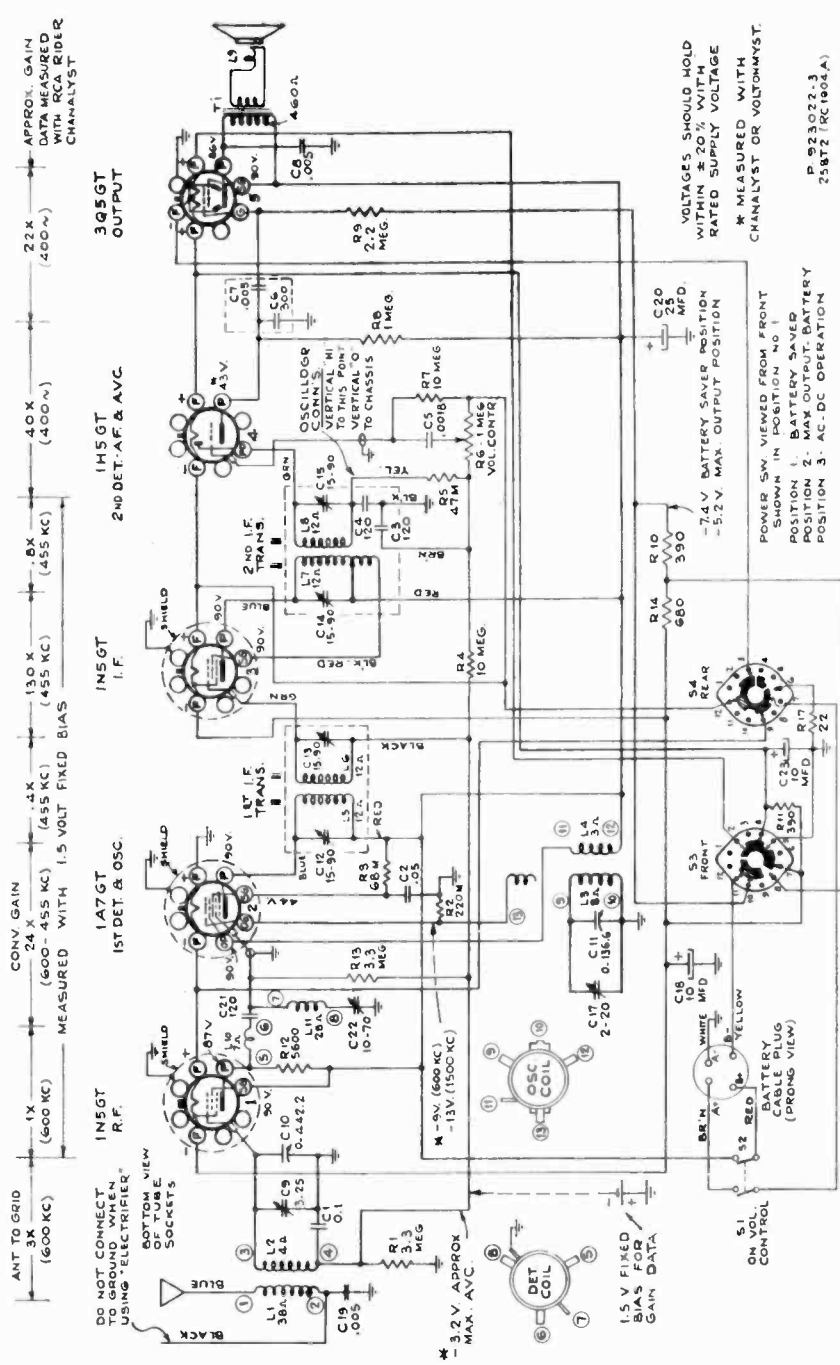

VOLTAGES SHOULD HOLD WITHIN $\pm 20\%$ WITH RATED SUPPLY VOLTAGE
 * MEASURED WITH CHANNELYST OR VOLTOHMYST.

POWER SW. VIEWED FROM FRONT SHOWN IN POSITION NO. 1
 POSITION 1. BATTERY SAVED
 POSITION 2. MAX OUTPUT. BATTERY
 POSITION 3. AC-DC OPERATION

P 923022-3
 258T2 (RC 1004A)

* - 3.2 V APPROX MAX. AVC.

1.5 V FIXED BIAS FOR GAIN DATA

ON VOLT CONTROL

BATTERY CABLE PLUG (PRONG VIEW)

DO NOT CONNECT TO GROUND WHEN USING "ELECTRIFIER" BOTTOM VIEW OF TUBE SOCKETS

APPROX. GAIN DATA MEASURED WITH CHANNELYST

Now Is the Time to Plan for the Future

(Concluded from page 10)

For a while they were widely proclaimed and used to fascinate the public, but today they find use in the most unsuspected places. I see a great expansion in the electronic control field alone. Watch the modern combination electric recorder-phonograph! It's here to stay, and this time we will get quality recordings and reproductions.

Radio communications will grow with "seven-league" strides once we go back to normal. Aviation radio alone will expand so much that it will take thousands of radio operators and technicians. I hear many well-informed men say that as soon as we get over our present job of making our democracy safe, we will become a "flying nation." Point-to-point communication is growing and will increase many fold; we are on the way to becoming one of the greatest marine nations in all history, and we will do it the American way with electronic and industrial controls. Ship radio operators will be in greater demand.

Yes, the future of trained radio men is even brighter than it has been. Note that I said *trained* radio men, for only trained technicians can handle the products of the present and those introduced in the future. Year after year the design of radio receivers and transmitters has been improved. The characteristics of the products have been held to close tolerances, so that today the radio tinkerer and what the industry likes to call the "saw-and-hatchet" radio man is entirely unfit to do a good service or maintenance job. With further progress and improvements in the offing, with entirely new systems appearing over the horizon, only trained radio men will fit into the picture.

Yes, plenty of young men are getting a quick hurry-up introduction to radio in the interest of national defense. But they will not be able to meet the competition of the man who has slowly and carefully added to his knowledge and experience. Hundreds of men thus trained are now taking the very same N.R.I. course that you are studying, so that they too will have a firm grasp of radio principles and methods. Today the demand is so great in industry for radio technicians that the partially trained man finds employment, but the day of reckoning is coming and only the best will survive.

Plan to stay in radio by giving your training efforts the attention they justly deserve, and then there can be no regrets. Remember it takes initiative, courage and hard work to master radio, for if it were so easy to acquire this training the demands of national defense would quickly be met. N.R.I. is ready to help you make the grade, but you must do the work.

Before I end this subject of planning for the future, I do want to point out that the prospects for the immediate future are quite bright for radio servicemen. Here is the way the best informed men in the radio field are thinking, and it sounds perfectly logical.

It is well known that it is becoming increasingly more difficult to get radio parts for the construction of home receivers. Actually, more radio parts and tubes are being made than ever before, but a vast quantity is being used for radio defense projects.

However, events will be so fast-moving that people will not allow themselves to be deprived of radio reception. In fact, the government feels that the nation as a whole must have complete broadcasting service at all times, because this is necessary for national defense and national well being.

Since new receivers may not be readily available, the older ones will be kept in working order by radio servicemen—and there are 54,000,000 receivers in the U.S.A. to keep in order. To keep receivers in working condition, servicemen must have replacement parts, and there is every indication that radio parts distributors will get replacement parts on a priority basis. Servicemen may have to prove that the new parts are required by turning in the defective ones, but they'll get these parts. Rigid control may not appear for some time; it may not come at all.

When older receivers have to be repaired, more work comes to the radio serviceman, and an era for profitable radio business is about to appear. For you, the newcomer, the prospects are bright, for national defense is taking more and more men from their service work into industry and the armed services, leaving you to carry on. The future for tomorrow and the day after tomorrow is as bright for the radio man as it ever has been. Prepare to be worthy of your position in radio.

— n r t —

Our Cover Photograph

The photo on the cover of this issue of the News shows E. Swaringen, senior operator, and C. L. Hopper, supervisor, at the zone and interzone telegraph console in the Springfield station of the Illinois State police radio system.

During the past three years of operation the apprehension of criminals has rocketed to record-breaking highs. Since the adoption of radio telephony, the percentage of stolen cars recovered has, for example, jumped from a scant 13% to a new high of 83%. Photograph through courtesy of Western Electric Co.

Puzzling Radio Questions From Students

Battery Testers

QUESTION: *I have seen a number of testers advertised, described as checking dry cell batteries accurately. What is the principle involved in these testers?*

ANSWER: Most of these testers are just ordinary voltmeters of appropriate ranges for the types of batteries to be tested. Usually a resistance is connected inside the unit, between the terminals, so that a reasonable load will be placed on the battery, then the true battery voltage can be measured.

The voltage developed by a battery depends on the materials used in making the battery and this voltage does not change. What happens is that with age, the zinc in the battery is eaten away, resulting in an increased amount of internal resistance. Hence if we measure a battery voltage with a voltmeter which does not draw much current, we may find the proper terminal voltage exists at all times, even with a battery which is practically dead.

On the other hand, if we draw a normal amount of current from the battery and then measure the voltage, we will come to a different result. In other words, the increased current flow through the internal resistance of the battery results in a voltage drop which is subtracted from the original battery voltage and is the voltage we will actually measure.

Therefore, in a properly designed battery tester, using a load resistor, we have an actual indication of the worth of the battery.

Ohms Per Volt

QUESTION: *I do not understand just what is meant by the "ohms-per-volt" rating on meters. Could you give me an example of this?*

ANSWER: The ohms-per-volt rating is a measure of the sensitivity of a meter. The higher this value, the lower the amount of current which will be drawn by the meter from the circuit, and hence the less effect the meter will have on the circuit.

The ohms-per-volt rating is determined by dividing the total resistance of the meter and the multipliers used, by the voltage range of the meter. For instance, if the meter has a resistance of 100,000 ohms and is designed to measure up to 100 volts, then the sensitivity of that meter is

said to be 1000 ohms per volt.

Knowing the sensitivity rating of the meter, we can find out how much current it will draw for full-scale deflection by dividing 100 volts by 100,000 ohms. This will give us .001 ampere or 1 milli-ampere.

If the sensitivity of the meter is 10,000 ohms per volt, then it will draw only 1/10 as much current as a 1000-ohm-per-volt meter.

In regard to measuring battery voltages or voltages in low-resistance circuits, the meters would give similar readings. However, when we try to measure in high-resistance circuits such as resistance-coupled amplifiers, we will find that the higher the sensitivity of the meter, the more nearly accurate will be our readings. You can see this if you remember that the current drain of the meter flows through the resistances in the circuit in addition to the tube current. If the resistance is high, even the small amount of current taken by the meter will upset the voltages considerably. This means that when the meter is connected we will read one voltage, but when the meter is removed the voltage will actually go up to a higher value than we measured.

For practical service work, d.c. voltmeters with sensitivities of 1000 ohms per volt or higher are considered standard.

Testing Vibrators

QUESTION: *How can vibrators be tested?*

ANSWER: There are several methods of checking vibrators. For those doing a great deal of service work on auto sets and farm radios, vibrator testers are available which operate similar to tube testers.

Another standard test is to use a simple circuit where the vibrator feeds into a transformer similar to the type for which it is designed and the proper load is connected on the output of the transformer. Then the amount of current drain from the battery is measured, and a voltage reading taken across the recommended load. A vibrator is in good condition when the maximum voltage output is obtainable for a minimum current drain from the storage battery.

The only trouble with this method of testing is that not enough information is available from manufacturers as to the limits of the current

Are Answered By N. R. I. Experts

drain or voltage output and load resistor specifications.

Finally, we can check the vibrator from the action of the receiver itself. That is, if you have a receiver which has lower than normal voltage (usually accompanied by a great deal of noise), then you should suspect the vibrator. To be sure it is the vibrator, first check the various filter, by-pass and buffer condensers to be sure they are all in good condition. Check for excess current drain through the power output tube. If everything appears normal with these parts, then the vibrator is probably the defective item and another can be tried.

Customer Complaints

QUESTION: I have a problem on which I would like your advice, although I know it is not a technical radio problem. I have just started in the service business and wonder how to handle complaints from customers properly, particularly when the cause of the complaint is something which I was not called on to repair.

ANSWER: The problem you have presented comes up frequently. There are many ways of handling such complaints, but I am glad to give my suggestions. First, don't let complaints worry you. No matter how good you are at servicing radios, you are going to get some call-backs. Once in a while this will be due to your work, thus usually being caused by defective apparatus which you unknowingly installed. The most general call-back, however, is some other part breaking down after a repair has been made, even though that part might have tested all right while you were repairing the receiver and may in no way be related to the actual repair.

Naturally, every time you have to go back to a customer, this represents an expense to you. Since you know that you are going to get some call-backs, provide yourself with a little insurance. In other words, add a little to the cost of every service job you handle. Set aside this amount in a fund which you can let grow. This fund can then be used to pay your expenses on those few cases where you do have to go back on a job. This procedure is followed by every one who must offer a guarantee, regardless of the type of business, as it is necessary that you be able to live up to your guarantee if you are going to earn a good reputation.

Also, call attention to any weakened or questionable parts. For instance, you may have to make a repair and notice that the electrolytic conden-

sers are leaky, some of the tubes are weak, or some other part is nearly ready to go. Where you notice such points, be sure to call them to the attention of the customer, preferably before making the repair. Be sure the customer understands that while you can repair the radio for a definite price, for a little more right now he can be more assured of satisfactory reception over a longer period of time. Stressing these points will help to make clear that you are not guaranteeing the entire radio.

This brings up the point of the guarantee itself which you make. All good servicemen guarantee their work, but don't try to guarantee the set longer than the manufacturer did. Ninety days is long enough and is as much time as a new set is guaranteed. When your business is large enough for you to have forms printed, your guarantee should be plainly stated on your bills and other forms. Don't be elaborate; just guarantee your work and the materials you use for the stated period of time.

Suppose a customer calls you back within your guarantee period. A certain amount of tact will have to be used in handling such customers when you go back. Some may be angry and others may just be anxious to get their radios repaired as quickly as possible. If the customer loses his temper, don't follow him but go to the other extreme. If his voice gets louder, make yours softer. Don't fail to listen closely to his complaints, then go to work to find out just what the trouble is. Naturally, if the trouble is with your work or parts, make the repair as quickly as possible. If the trouble is definitely not your fault, it does not hurt to inform the customer of this fact, but don't start an argument about it. Even if you win the argument, you usually lose the good will of the customer. You may be surprised to find how reasonable customers can be if proper tact is employed. Where the break-down is another part, not installed by you, at least the price of the part or parts can and should be charged.

In some instances, the remainder of the charge or your entire bill should be paid from your reserve fund.

In particular, if the item is a relatively inexpensive one and the customer is in a position to get you more business, through recommendations to his friends, generally it pays to make the replacement at no extra charge. You will find experience helps to teach you how to judge the reactions of your customers and the best way to handle this problem.

Inspiration of Wife Started

It is often said that back of most successful careers is the inspiration of a woman. It may be a mother, it may be a sister, but more often it is a wife. A patient, understanding wife realizes that she, too, must make some slight personal sacrifices so that her husband may have the necessary time and money to carry out the training program which he has planned for himself.

Every wife wants her husband to make good. She wants to be proud of him. She knows that the added cost of living, as a family grows, must come from added earnings. She knows, if they are to have that nice family car and the little home with the flower garden, her husband must have a steady job and an assured income with an occasional stepping up of earnings. She looks to her husband to provide these things but she knows, too, that he cannot do it without her help—her good cheer and sympathetic understanding.

Ray B. Linganfield of Glendale, California, thanks his lucky star for having met just such a girl. Ray started planning before he married. He knew it wouldn't do to trust to luck. He knew, too, that he couldn't make all of the jump at one time. He decided to study Radio—to get ready for something big in this vast field. He got an ordinary job in Radio for \$25 a week. Not big pay to be sure but it was a start.

Then, when he was ready, with the encouragement of his good wife, he went into business for himself. Today he owns the fine Radio business shown in the photograph on this page and does \$2,000 worth

of business a month. But let Ray tell his story in his own words. Here it is:

Dear Mr. Smith:

"I was an electrician by trade. One day, as I was doing some buying of supplies, I stumbled over some object on the street and when I got up to see what I had fallen over, I saw a sign that had these words printed on it: 'Join the Navy and see the World.' So I did just that.

"During my enlistment I had the opportunity to see the world, and one time at one of the beaches I won a crystal radio set. I took it aboard ship and tried to find out what made it click. The more I tried, the less I seemed to understand how a wire could pick a signal out of the air and bring it down to a crystal and through the earphones without any electricity.

"About this time I fell in love with a girl and she told me she would marry me when I was discharged from the Navy. Well, the time drew close when I was to be discharged and I was afraid that I couldn't support her. During the last year of my enlistment I read all the radio magazines that I could get hold of. Often I would read the National Radio Institute advertisement and one of the

testimonials mentioned about a young man who wanted to get married and didn't have a steady job—how he answered your advertisement and now he had a growing business and was making enough money to buy a home and a store and a car, and at the same time had a nice clean job. Needless to say, that was just what I wanted, and I wrote you to send me 'Rich Rewards in Radio.' That started me in radio.

"I found this kind of home study very interesting, and many nights I didn't go to bed so that I could finish one or two of the experiments in the course. While I was taking the N.R.I. course I would repair radios and it wasn't long before I had more than I could do in my spare time. I was an electrician at a movie studio and there were times when employment wasn't steady enough to feed a family of four. So one day my wife said to me:



Ray B. Linganfield

This Prosperous Radio Business

'Why don't you try to get into the radio business?'

"To make a long story short, I went to a music company and got a job at \$25 a week. During this period I devored all the time I could to your swell course; having the practical experience and the theory that you supplied, radio came very easy.

"It wasn't long before I decided to open up a repair store of my own. The first six months showed a net profit of \$1200. I am sending a picture of my store and one of myself. I am sorry that you can't see the test panel (it is behind that

large display in the center of the photo), but you can imagine what it looks like from what you can see of my place. My business now grosses over \$2000 a month.

"I owe you quite a lot, for I feel that your course helped me to be where I am today. Thanks for the interest that you have taken in me."

Sincerely,
Ray B. Linganfield
Ray's Radio Service
108 W. California St.
Glendale, Calif.



This is an interior view of Ray's store. Starting from scratch, Ray built this business through steady effort and a firm conviction that he could and would succeed in Radio.

Profitable Customer Relationships

By J. C. ABERNATHY

Flagstaff, Ariz.

Technical ability is not everything. You must know how to get and hold customers.

We are grateful to the editor of RADIO NEWS for permission to reprint this interesting article, which originally appeared in the June, 1941 issue of RADIO NEWS.

AS surprising as it may seem to many servicemen, the most important factor in the success of a radio service business is *not* the ability to repair a radio. Believe it or not, there are any number of servicemen who are excellent technicians, but who make only a limited living because they do not have, or have not cultivated, the ability to deal successfully with their customers.

When a subject as broad as "Profitable Customer Relations" is considered, it is necessary to tie down the discussion to certain main general classifications. To discuss the problem in terms of the large-city radio shop would put an entirely different slant on the subject from that which would result from a discussion of the problem of a shop located in the country (or a small town).

Therefore, let us form a basis on which both can operate.

Figure 1 shows the word *SERVICE* and opposite each letter is a word. These seven words form the basis of proper customer relations. They are:

1. Satisfaction.
2. Efficiency.
3. Reliability.
4. Value.
5. Interest.
6. Courtesy.
7. Energy.

Without any one of these factors, customer relations are bound to fail.

Satisfaction

The word "Satisfaction" completely sums up in any business every effort to be successful. *You must satisfy the customer.* If you do not do so, your business will not grow. To satisfy customers but partially results in a bare business existence with little or no prospect of future growth. To satisfy almost all customers *completely* is the

surest way to be successful and to develop a paying radio service business.

You will notice that I have qualified the above statement by saying "*almost every customer.*" This is done advisedly and in all frankness for there never was a business which or a business man who satisfied *every customer on every transaction.* It must be realized that the general public has a certain percentage of people who, ac-

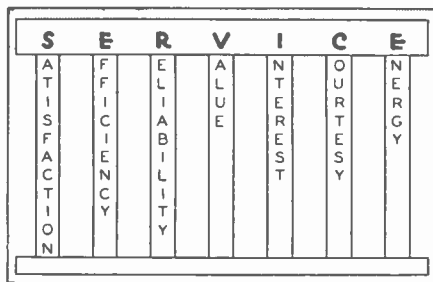

The seven pillars which underlie the word "SERVICE" must all be followed.

ording to organized society, are definitely insane. There is another group that is called "anti-social" (criminal), and in this classification can be placed the "dead beats"—those people who intentionally do not pay their bills. It is patently impossible to satisfy such people and no set of rules on courtesy will help do so.

However, getting back to the main object—that of customer satisfaction—it must be realized that all of the succeeding factors which we will discuss lead back to the main objective of satisfying as many customers as possible.

Efficiency

Under the classification of *efficiency* we can group

all of the technical knowledge, equipment and facilities of the serviceman for doing the best job in the shortest time.

Test equipment manufacturers have hammered for years on the value of modern service equipment as a means of increased shop efficiency. Manual publishers have tried to educate servicemen to the use of their manuals for greater service efficiency. Replacement part manufacturers have issued dozens of catalogs listing proper replacement parts for increased ordering efficiency. Textbook publishers offer the serviceman complete technical information from "a.f.c." to "zero bias"—all in the effort to speed up repair work.

You are not doing your best if you do not take advantage of every one of these helps to speed up your efficiency and cut down your "per-job" time.

Reliability

Reliability is the rock upon which you build your business house. Beware of any business practice which would weaken this foundation. Reliability is *business character*. Business character demands respect from your customers and is an assurance to them that your every dealing is "on the square."

If you think that you can't build a business on honesty and reliability, read the life of John Wanamaker and learn how he "built upon a rock." Next time you visit New York or Philadelphia, wander down the aisles of either great John Wanamaker store and see for yourself the fruits of an honest, reliable business policy. Stand next to the great bronze eagle in the center space of the Philadelphia store and listen to the magnificent tones of the *Wanamaker* organ as its notes float down over this busy hive of business activity. No matter how calloused you may have become to the idea of "get the money, honestly if possible, but *get the money*," you cannot help but feel the air of sound, solid, conservative reliability that has paid dividends for many decades.

Reliability, truthfulness, honesty—there are no substitutes for these.

Value

For value received! This is a legal phrase but one upon which is based all business transactions.

Have you given "value received" in every repair job? Or, have you skimmed on the quality or quantity of parts replaced in a customer's radio because you knew that he wouldn't know the difference?

I'll admit that it is a great temptation at times to "force" to install that condenser or to replace a coil with another "just as good." It's a great temptation to run up an imposing list of items

and services because you feel sure that you can "get away with it."

Let's look at the matter in "reverse English." What would you think of a man who overcharged *you* because he could take advantage of *your* lack of knowledge of values in *his* line? Aside from the unflattering terms with which you might describe him, he certainly would be a poor sort of man to betray *your* confidence, now wouldn't he? If you feel that way about a man who would "gyp" you, you should feel the same way toward the customers you serve.

Discard "shady" practices. This does not mean that you should allow yourself to fall prey to the wiles of those who would take unfair advantage of you, but learn to "size up" your customers and proceed accordingly. Remember that a man held for trial in the United States is deemed innocent until proven guilty. Treat your customers in the same manner. It's just *good business* and is another plank in the platform of correct customer relations.

Interest

Did you ever walk into a store with the idea of buying something and be met with such a stone wall of indifference that you finally decided to forget the whole thing? Have you ever dealt with people whom you felt sure didn't care whether you "lived or died" so long as they sold you something? What do you think of such people?

How do you react when a clerk seems interested in what you want, takes the time to explain the difference between two qualities, and acts as if your entrance were a *visit*, not an *intrusion*? If you are like other men (and there should be no reason either biological, or otherwise, to doubt this), you "expand" to this treatment and probably buy more than you had first expected to buy.

To be successful in any business you must first *like people*. You must take a vital, dynamic, living interest in your customers. You must study their likes and dislikes, and cater to them.

For instance, Mr. X is single, an enthusiastic golfer, but has no interest in baseball. Mr. Y likes baseball, has one child, and speaks rather disparagingly of golf. Mrs. Z has six children and a penchant for bridge.

Mr. X would consider you a terrible bore if you went into detail about what *your* baby did last night, or how poorly the local ball club was doing, but he would carry on quite a conversation with you regarding the last 18 holes he played.

Mr. Y, being an "only child" parent, will willingly swap baby experiences with you—particularly if you give him the impression that his child has a slight edge on yours. He will also discuss the ball

club situation with you. Golf is taboo.

Mrs. Z is just the person to ask regarding surecures for thumb-sucking or diaper rash—even though you don't intend to use them—and she might be interested in telling you how she won the last weekly bridge prize (or what poor cards she has been receiving).

Thus, a knowledge of your customers and their interests will make them *your* interests. Always try to get a *common meeting ground* between you and each of your customers—it will pay dividends.

Courtesy

No matter what your "make up" may be, you can learn to be courteous without too great an effort. Courtesy in a man is merely "being a gentleman." It is not necessary to be a Lord Chesterfield and use exaggerated gestures or talk. You need not be an authority on Emily Post and you don't have to wear "fancy" clothes.

Courtesy is aptly defined as *genuine and habitual politeness*. Courtesy is the logical step after interest because, if you are interested in people you cannot help but be polite to them and this is an act of courtesy.

It would be well to take a leaf from the South and cultivate the use of the terms "sir" and "ma'am." No man who *is* a man would hesitate to use the term "sir" in addressing another man. It is a conventional term of respectful address and does not imply any lack of inequality between serviceman and customer. Likewise, when addressing a woman, the term "ma'am," although a colloquialism, effects a nice shade of respect which any woman appreciates.

Another point which should be brought out under *courtesy* is *never to argue* with the customer. Also, never allow a customer to "*make you mad*." Remember that he is entitled to his opinion and even though you may think he is sixteen kinds of a fool, you are bound, as a tradesman, to respect his attitude. I know of one serviceman who always makes a practice of *lowering* his voice as the voice of an irate customer *mounts*. He always wins his point because the difference in voice levels invariably reminds his customer that the customer's voice is pitched at entirely too high a level.

Energy

The final word in our *S-E-R-V-I-C-E* set-up is "Energy." *Energy is the power by which anything acts effectively to move or change other things or accomplish any result.* (Funk and Wagnall's Dictionary.) Thus, the *energy* in service work is the effective effort and action which produces the resulting service.

Page Twenty

Remember the word "business" can be most readily defined as *busy-ness!* Busy-ness requires energy—unflagging and ever powerful.

You can't render service or hope to maintain satisfactory customer relations if you open shop at noon and take a day off every so often to go fishing. You must maintain normal office or shop hours and expect to be called out once in a while in the late evening or on a normal holiday. I am one who advocates a definite ten-hour day—8 a.m. to 6 p.m., 6 days a week, with other work done by appointment only. These sissies who advocate a 40-hour week should try running a service business (or any other shop) successfully on such short hours. It would be too, too divine if we could work 8 hours a day, 5 days a week, and

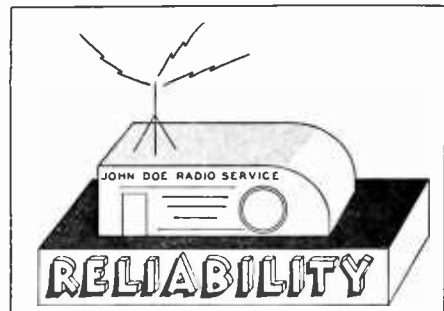

RELIABILITY is the foundation stone on which all good business is built.

make a comfortable living, but the plain facts of the case are that it *can't be done*.

Death and the time of radio breakdowns take no holidays!

Conclusion

If you find that you are not following these seven cardinal points of service and good customer-relations, resolve to incorporate them into your business life today!

Satisfy your customers so that they will return to you. Make your shop and yourself efficient so that you can turn out the work in a reasonable time and at a reasonable price. Found your business on the rock of reliability so that people whom you serve will have complete confidence in you. Give value for value received—don't cheat your customer if you expect not to be cheated. Develop an interest in your customers—make their interests yours so that they, in turn, will make *your* interest *theirs*. Be courteous by being genuinely and habitually polite. Lastly, put forth every bit of energy to make your business a success. *The lazy man cheats himself.*



RADIO-TRICIAN

REG. U.S. PAT. OFF.

Service Sheet

Compiled Solely for Students and Graduates

NATIONAL RADIO INSTITUTE, WASHINGTON, D. C.

RCA Victor 24BT-1 and 24BT-2 Chassis No. RC-1004-F

Pre-Setting Dial.—With gang condenser in full mesh, the pointer should be adjusted so that it is horizontal.

Step	Connect high side of test osc. to—	Tune test osc. to—	Turn radio dial to—	Adjust the following for maximum peak output
1	I-F grid in series with .01 mfd.	455 kc	Quiet point between 550 and 750 kc	C14, C15 (2nd I-F Trans.)
2	1st Det. grid in series with .01 mfd.			C12, C13 (1st I-F Trans.)
3	Antenna terminal in series with 220 mmfd.	1,720 kc	Tuning condenser rotor plates all out	C17 (osc.)
4		1,300 kc	1,300 kc signal	C9 (ant.)

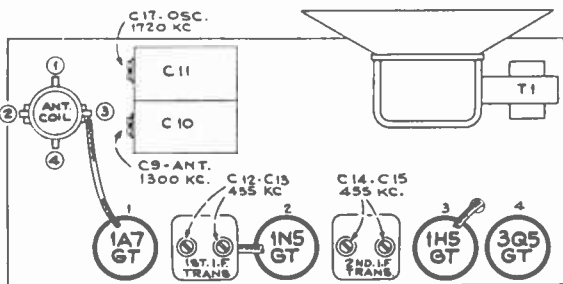

Precautionary Lead Dress.—

1. The lead from the 3Q5 plate to output transformer should be dressed under clip and away from audio input leads.
2. Keep AVC lead connecting C1 away from the 1A7GT plate.
3. Keep blue plate leads coming from IF transformers short and close to the chassis.
4. All filament wires should be dressed close to chassis.

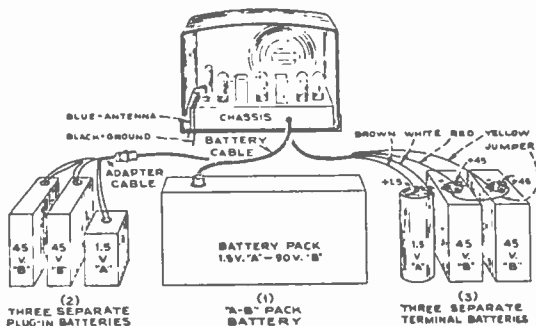

(2) THREE SEPARATE PLUG-IN BATTERIES

(1) "A-B" PACK BATTERY

(3) THREE SEPARATE TERMINAL BATTERIES

Readers who file Service Data in separate binders remove page carefully, trim on dotted line for same size as data published heretofore.



The Service Forum

Conducted by

J. B. Straughn, N. R. I. Service Consultant

Send in your service notes. We will re-word them for publication. To qualify your note for the NEWS you must have observed the same trouble on two or more identical receivers.

CROSLEY MODEL 1127 INTERMITTENT

I had a lot of trouble with the set cutting off when I touched the wire from resistor 27 to the selectivity switch. I removed this wire and found it to be in two pieces. The two wires had been tied in a knot, the free ends laid parallel with each other and then covered with insulating material. The diagram shows that there is to be direct connection and on wiring the circuit as per the diagram the set owner said it played better than when new.

JAMES R. JONES, Ohio.

RCA MODEL 14BT-1, REGENERATION 14BT-2 AND 14BK

This condition may be treated as follows: Make sure the grounding lug for the 1NG6T tube shield is fastened to tube socket connection No. 1, which is grounded to the chassis. See that the rim of the socket is soldered to the chassis. Realign the I.F. transformers stage by stage and do not make individual adjustments of the trimmers after alignment. 1N5 or 1A7 tubes with high mutual conductance should be replaced with those having normal gain.

PHILCO MODEL 40-710 DEAD OR INTERMITTENT

Check the B+ connection to the second I.F. transformer as the lead may have broken off at this point or may be making intermittent contact. If the dial pointer does not move properly when on short-waves, put powdered rosin on the string and this will prevent a jerky movement of the tuning condenser gang.

J. L. BAPNA, India.

FAIRBANKS MORSE 42T5B DRAIN ON B BATTERIES WITH SET OFF

This is due to the fact that there is a 20,000 ohm resistor connected from the -C 16½ volt lead to ground. Although the negative lead of the B batteries going directly to ground is broken by the on-off switch the batteries discharge through the C battery and the 20,000 ohm resistor. Removal of the resistor will not affect the operation of the receiver.

AIRLINE MODEL 62-228 WEAK OR DEAD

This is generally due to a shorted screen by-pass condenser. There are two condensers C7 and C14 having a capacity of .05 mfd. and .1 mfd. respectively. Use 600 volt replacement units.

AIRLINE MODEL 62-228 MAGIC EYE DOESN'T CLOSE UP

This can be eliminated by removing the voltage divider resistor R22 connected from the grid of the magic eye tube to ground. If fluttering of the eye is noted with this resistor out of the circuit connect a .05 mfd. 600 volt condenser from the grid of the tube to ground.

SILVERTONE MODEL 6325 LOW PLATE VOLTAGE

Check the electrolytic filter condensers and also the 50 ohm resistor in series with the plate of the 25Z6G type tube. These condensers should be checked not only with an ohmmeter for leakage but also by substitution to see if they are open.

SILVERTONE MODELS 6103-6109 PRODUCTION CHANGES

In order to broaden the selectivity those chassis identified with the addition of suffix number 1, have had the connections of the first I.F. transformer reversed and the blue wire now goes to B+ and the red wire to the plate of the detector-oscillator tube. This decreases the selectivity and makes for better push-button action. Some sets also have a 22,000 ohm resistor in place of the 40,000 ohm resistor marked R₂. Those chassis identified by the addition of suffix number 2 have a different first I.F. and second I.F. transformer, which results in a still greater decrease in selectivity. The value of R₂ in these chassis is 22,000 ohms.

SILVERTONE CHASSIS 101438 DEAD AT LOW FREQUENCY END OF BROADCAST BAND

Remove the 50 micro-microfarad mica condenser connected between the band switch and the 1CG mixer tube and wire direct. Also remove the 50-

(Page 29, please)

How-To-Study Suggestions

By DAVID H. SMITH
Chief Lesson Examiner



Force yourself to act enthusiastic about studying, and *you'll become enthusiastic* in a surprisingly short time. Shake yourself awake—get some life into you. Enthusiasm can be acquired. If you act enthusiastic long enough, you will soon *feel* enthusiastic. Just being enthusiastic about radio will make your progress twice as fast!

Start studying with a bang. You know, it's a lot easier to jump suddenly into a cold swimming pool than to get wet gradually. Say "I'm going to start," then instantly open your textbook and start in studying. Let your pencil sharpening, fingernail trimming, and day dreaming wait until you are through studying.

Relax while you are studying. Don't let yourself get under a tension. Take things easily and slowly. Don't worry if you have trouble in understanding something—if you can't understand it now, remember that a re-reading one or two days later will often clear things up magically.

If you are going to put in a long session of studying, say three or four solid hours, plan to relax completely for five minutes at the end of each hour. In that rest interval, close your eyes, lean back in your chair, and relax every muscle. Forget completely about your studies, your worries, your daily problems—just enjoy the relaxation. You will then be able to start in studying again completely fresh, and will not be tired at the end of your study period.

Here is a simple way in which you can cut down your sleeping requirements an entire hour and still feel more alert than you do now. Sleep for one hour early in the evening, either before or after your evening meal. If you can't sleep, lie down and relax. This one hour of relaxation or sleep early in the evening is equal to two hours of your regular sleeping period, so you will gain an entire hour each day in your life.

Relax whenever you can during the daytime—while you are waiting for some one, while you are riding in a car but not driving—whenever you have no particular duties to perform. Being under a tension makes you more tired than would a whole day of shoveling dirt or carrying rock. Tension is caused by your emotions—by what you think—so watch your thoughts. Don't even think thoughts which produce fatigue.

Worry will never speed things up, but it will tire you out and put you under a tension which reduces greatly your efficiency. Here is an easy way to avoid worrying when you have a problem. Instead of thinking about it every spare moment you have, debating it back and forth in your mind, write out on a sheet of paper all of the reasons for and against the problem at hand. Next, go over these reasons and weigh each one carefully. Then, *come to a decision*. After making this decision, stick to it. Devote all your energy to carrying out your decision, and you will magically avoid worry and confusion. If your decision is to wait a while and see what happens, as it should be with most of our problems, resolve that you will completely forget your worry-problem until the time for action arrives.

Novel Radio Items

—BY L.J. MARIKUS—

The largest radio audience in history was tuned in to the last fireside chat by President Franklin D. Roosevelt. A survey indicated that 70% of all radio families in the United States, or approximately 65,650,000 people were tuned in. In addition, the broadcast was short-waved to South America, Central America and Great Britain and was also rebroadcast in Canada. This gave an additional estimated 27,500,000 listeners.

—n r i—

When engineers in a western airplane factory suspected that secret aviation plans were being taken out of the files and copied, a unique radio man trap was set up to catch the criminal. Three different employees of foreign extraction were under suspicion, but no evidence could be secured by ordinary means. An almost colorless fluorescent powder known as willenite, widely used for screens of television cathode ray tubes and in fluorescent lamps, was scattered around the blueprint case. Under ordinary light, this powder was no more noticeable than ordinary dust. Twenty-four hours later, under various pretexts, clothing recently worn by each of the suspects was obtained and examined under ultra-violet light in a dark room. Two of the garments showed nothing unusual, but a multitude of tiny bright stars flashed into view around the pocket of the coat belonging to the third man—the guilty man.

—n r i—

An intercommunication system with sensitive microphones located at strategic points in a factory, warehouse or other commercial establishment makes it possible for the night watchman to cover the entire plant simply by turning a selector switch to each of the microphone locations in turn and listening for unusual noises. An inexpensive and noisy alarm clock could be placed at each microphone location as a precaution against tampering with the microphone. If the watchman did not hear the clock, he would know that the microphone had failed for some reason, and could make a personal inspection of that location.

—n r i—

A microphone which rises out of the ground near home plate when a foot lever is pressed was installed at a Wichita, Kansas, baseball park and used by the umpire to make announcements during a game.

—n r i—

Although power output in watts is widely accepted as a measure of the effectiveness of a standard broadcast station, this wattage rating

is meaningless for frequency modulation stations. Actual coverage in square miles is the yardstick for an f.m. station, for antenna location, antenna height and antenna gain must be considered along with power. Thus, doubling the height of the transmitting antenna will increase the area of effective coverage four times.

—n r i—

Each policeman in Atlantic City carries a portable receiver on his belt, with a headphone on one ear and an antenna over his shoulder. He can thus be called instantly by headquarters. Each receiver consumes about 11 cents worth of battery power per day.

—n r i—

Camera-sized portable radio sets with highly-directive built-in loop aerials are being purchased by the U. S. Army, and used to give troops experience in handling direction-finding equipment.

—n r i—

A new gadget which can be attached to any radio receiver indicates the total time the set has been in operation, the exact length of time of listening to each station, and the time when each station was tuned in. It is intended for use in making surveys of listening habits.

—n r i—

Forty successive wire-drawing dies are used to elongate 1 foot of 5/16-inch copper rod to 11,000 feet of No. 40 wire for radio parts.

—n r i—

When the electric organ at a Youngstown, Ohio church began reproducing swing music from a local radio station right in the middle of a sermon, radio engineers were called in. They explained that when an electric organ, public address system or audiophone hearing aid system is located in the immediate vicinity of a powerful radio station, a phenomenon known as "external cross-talk" may take place. The strong radio signals are picked up by wiring or exposed metal parts of the equipment, are demodulated at some poor electrical joint where contact resistance exists, and are then amplified and reproduced just as in a radio receiver. The remedy involves shielding of wiring and exposed parts.

—n r i—

Elevators in the office of the Phileo Corporation in Philadelphia provide "music with a lift." An eleven-tube console receiver with loop aerial is located at the top of the shaft, and is operated by wired remote control from a push-button panel within easy reach of the operator inside the elevator. Filters prevent motor noise pick-up.



N.R.I. ALUMNI NEWS

Dr. Geo. B. Thompson	President
Edward Sorg, F. E. Oliver	Vice-Pres.
Alfred E. Stock, Peter J. Dunn	Vice-Pres.
Earl Merryman	Secretary
Louis L. Menne	Executive-Secretary

Will Power—You've Got to Have It

By L. L. MENNE, Executive Secretary

N.R.I. Alumni Association

A great deal is written and spoken about will power. Some try to leave the impression it is a mysterious, elusive force. Others wrap it up in all sorts of technical terms, hinting it is a God-given power.

But when we strip it of all these high sounding phrases and carefully analyze it we find, after all, there is really nothing magical about will power. It is simply a determination to complete every task you begin, in spite of all the obstacles and stumbling blocks in your path.

Will power is the force that drives a man on to accomplishment—the human dynamo that pushes a man on from smaller to bigger and bigger jobs. It is the vital force back of most successful men today. All about us we see its results—big jobs being done by men who have the will power to do them.

We see men physically handicapped as a result of sickness or accident who, by sheer will power, have forged to the very top of their professions. The late Charles Steinmetz who became the recognized electrical wizard of the day is a shining example. In our own field—Radio—we, here at N.R.I., learn of lesser examples, but equally remarkable. Just the other day a graduate from North Carolina called on us. When he enrolled, some years ago, he was unable to walk because of a serious affliction. But he didn't give up and now he gets around fairly well. He licked his handicap. Moreover, he studied his course diligently, and today has one of the most prosperous Radio businesses in his community.

Another graduate does all his Radio servicing from a wheelchair. Still another, bed-ridden because of a serious automobile accident, which probably can't be overcome, conducts his Radio

store from his bed by a speaker system through which he talks with his customers. That's courage. That's will power. I mention these examples only to draw a comparison. They should be an inspiration to most of us.

Let's remember this; a man's chief asset is an undying, irresistible determination to win. The will to do—the will power to get ahead.

It's the fellow with will power enough to improve himself by work and study who gets first consideration when a job higher up is to be filled. It is only natural that he should. Employers are looking for men who can do a job better than the average and have the will power to keep behind a plan or idea until it is put across. Such men develop into executive material—because they have the ability to direct the work of others.

This desirable quality of will power cannot be acquired overnight. But it can be developed. Every new task is a challenge. To begin with you must immediately overcome the habit of putting off until tomorrow what you should do today. Admire men who are more successful than you. Try to follow in their footsteps. You must awaken—be alive to opportunity. You must believe in yourself. Your every action must show it. Soon people will see that you are above the average.

Yes, sir, you can develop a power which will not recognize the possibility of failure. Of course, you will not always succeed in everything but you will be sure you have given your best. And, man, when you get the habit of always giving your best—you are way ahead of the field.

"I'll find a way or make one." There's a slogan for you—that's will power.

Detroit Chapter

Following is a report of our recent special meeting. After roll call by the Secretary, Chairman Stanish introduced Mr. Kessel of United Motors Service and turned the meeting over to him. Mr. Kessel gave a short summary on radios, parts and accessories and the fact that money can be made in this line with a minimum of parts stock, if the serviceman is willing to exert a little effort.

Then with the aid of a simple chart he proceeded to prove that 75% of service income lies in Simplified Service and 25% in actual Technical Service. Mr. Kessel then went on to demonstrate simplified auto radio servicing by means of a light hammer of wood or rubber, a few good tubes to be used as substitutes and a good vibrator for the same purpose; and last but not least, some good old-fashioned headwork.

He also stressed the fact that in new installations one must use all parts supplied in the kit for a particular car, including condensers, suppressors, bond straps, shields, static collections, etc. He also emphasized the necessity of the final antenna adjustment with radio and antenna as used together in the car.

For minimum shop requirements he listed the following:

Wood top bench.
Screw driver, pliers, soldering iron, hookup wire.
A good battery and an antenna.
Small stock of tubes and vibrators.
Service helps in the form of Service Manuals and Parts references or catalogs.

He then concluded with a few demonstrations and explanations of neon sign noises; and the actual removal of motor noises by means of bonding and shielding, using the following:

A metal top bench to represent car chassis.
Spark coil to duplicate motor noises.
And an ordinary metal waste basket, to represent shielding.

Meeting adjourned at 10:30 to give everyone a chance to ask Mr. Kessel any questions they had in mind.

Number of members present—thirty.

Visitors—Mr. Brainerd, Mr. Dahlen, Mr. Eide, Detroit Representative, *Automobile Digest*.

Another meeting was devoted to the explanation and actual use of the Volt-Ohm-Meter section of the N.R.I. Tester.

There will be no meetings during July and August, but we will resume as usual the second Friday of September. 2500 Jos. Campau is still our home address.

F. EARL OLIVER, *Secretary*.

Baltimore Chapter

Since we moved our headquarters to Redmen's Hall, 745 W. Baltimore Street, our attendance has been on the increase. We have large quarters with every facility. Those of our members who have not been to recent meetings are urged to attend. They will be pleasantly surprised with our new quarters.

Another reason why our attendance has been good is because our Chairman Gosnell quickly dispenses with all business we have to transact and then we really get down to interesting work. We have been doing the experiments in the N.R.I. course. Starting with the very first experiment we have been going through the Instruction Manuals under the leadership of H. Z. Snyder and H. J. Rathbun. Mr. Snyder and Mr. Rathbun prepare themselves in advance. Consequently there is no time lost in reading from the Instruction Manual, except to guide us along the way.

We use a large table, big enough for all to get around and see what is going on. Snyder explains each step and occasionally goes to the blackboard to clarify some point. Rathbun handles the tools and as Snyder explains the operation Rathbun does the work. They are a good team—both expert Radio men who are doing a fine job for the members of our Chapter.

Chairman Gosnell sees that every man has an opportunity to ask any question he may have as we proceed. The entire plan is very interesting and productive. We deeply appreciate the interest taken by Chairman Gosnell, Mr. Snyder and Mr. Rathbun in this work.

Here is a point of importance. In order to get the quarters we now have it was necessary to change our meeting night. Therefore, the Chapter members voted to meet on the second and fourth Tuesday of each month. Please keep this change in mind. We will continue to meet right through the summer.

The Knight Portable Radio, which was raffled by the Chapter, was won by Louise Ulrich, sister to our Financial Secretary. We want to thank all of our members for the way they supported this raffle.

Pete Dunn proposed that our last meeting in July be a get-together to dedicate our new meeting place. Refreshments will be served. We expect a big turn-out.

Chairman Gosnell, who has been giving us bang-up meetings, has some other good things in mind to tackle in the coming months. All N.R.I. men in this area are most welcome to meet with us. Remember, Redmen's Hall, 745 W. Baltimore St., every second and fourth Tuesday of the month.

JOHN W. GRASSER, *Secretary*.

New York Chapter

Since our last report Chairman Gordy gave us a talk and demonstration on Photoelectric Cells. This was a very interesting talk and the members liked it very well. We had about forty-five present.

At every meeting Gordy is prepared to give us some good pointers on various subjects. We won't take space to go into details.

On other occasions when we do not have a speaker we hold our popular service forums. These go over big with our members because we discuss everyday servicing problems. A fellow can learn a great deal from these discussions.

While our attendance has been forty to fifty each meeting we feel that it should be decidedly better. Any man interested in Radio can get much valuable information from these meetings. We are always glad to welcome a new member or visitor. Ralph Baer is our latest new member. He was a visitor at two of our meetings before joining our Chapter. Now he is taking an active part in our work.

Meetings are held on the first and third Thursday of each month, 8:15 P.M. at Damanzeks Manor, 12 St. Marks Place, New York City.

L. J. KUNERT, *Secretary*.

Detroit Alumnus Visits N.R.I.



William Ankeny, popularly known to our Detroit members as Bill, was a recent visitor at N.R.I.

Bill returned to Detroit via Niagara Falls and Canada. He covered 1504 miles in two days and except for two flat tires, had a swell trip. Just before leaving the Institute, Ankeny and Menne were snapped, as shown above, which makes another addition to the unique and interesting Alumni Association scrapbook.

Page Twenty-eight

Chicago Chapter

Our last meeting, before discontinuing for the summer, was turned over to Mr. Ketelhut, who gave us a nice talk on reflected induction and capacity, also automatic frequency control.

New members are J. M. Skvarenina, L. D. Harvey and A. C. Miller.

While our regular meetings will be suspended during July and August we will, nevertheless, have a number of social events, the principal one being our annual picnic. Notices of the date will be mailed to all members. The committee in charge promises us a gay time. We will have a report regarding the picnic for the next issue of the News.

Our next regular meeting will be held the first Thursday in September, at our headquarters, Douglas Park Field House, 14th and Albany, Chicago.

JAMES CADA, *Secretary*.

Additions To N.R.I. Ham List

The following call letters have been reported since the last issue of the News. In spite of the large number of call letters so far reported, it is felt that there are many N.R.I. amateur operators whose call letters have never appeared in the News. If you are one of them, make it a point to report your call letters the next time you write N.R.I.

WSVQF—Charles H. Karel, Pittsburgh, Penna.

WSRNH—Donald L. Cameron, Bellwood, Penna.

W9AWD—E. A. Parsons, Pierce, Colo.

W9PUX—Raymond (Glasnapp), Emmetsburg, Iowa.

W5EGV—D. A. Nightingale, Bruni, Texas.

W7IMM—Alfred B. Zeigler, La Grande, Oreg.

W9MGQ—Stanley D. Bartleman, St. James, Minn.

W9PMH—Clyde Krueger, Rhinelander, Wis.

W8KXS—Robert P. Hunter, State College, Penna.

W1NHL—P. Parnanen, Westminster, Mass.

W4HUCW—M. J. Silvers, Raleigh, N. C.

Marshall Field's Twelve Things to Remember

1. The value of time.
2. The success of perseverance.
3. The pleasure of working.
4. The dignity of simplicity.
5. The worth of character.
6. The power of kindness.
7. The influence of example.
8. The obligation of duty.
9. The wisdom of economy.
10. The virtue of patience.
11. The improvement of talent.
12. The joy of originating.

The Service Forum (Continued from page 23)

000 ohm resistor from the same terminal on the tube socket and connect it across low frequency padder.

—————*n r i*—————

STEWART WARNER VIBRATOR HISS MODEL 112

Check the contact between the vibrator shield can and the case. If motor noise is extremely bad it will be worth while to try shielding the tone control leads and the pilot light wires.

—————*n r i*—————

SPARTON MODEL 301 HUM

If the filter condensers are not found to be the cause of the trouble and the control grid return circuits are not open, clean and tighten the ground connection on the large 7,000 ohm wire wound resistor.

—————*n r i*—————

RCA MODEL U-130 DISTORTION

Check for leakage in the .025 mfd. coupling condenser between the 6J5 phase inverter and the 6P6 type tube. Also check the .1 mfd. condenser between the 6J5 second audio and the control grid of the remaining 6P5 type tubes. For replacement purposes use condensers of the same capacity rated at 600 volts.

—————*n r i*—————

RCA MODEL U-123 INTERMITTENT RECEPTION

This has in some cases been traced to opening up of the 15,000 ohm screen supply resistor. Even if the resistor seems to check O.K. with an ohmmeter it will be worth while to try another.

—————*n r i*—————

RCA MODEL 91BK2 DEAD ON PUSH BUTTONS

If the receiver works normally on manual tuning inspect the push-button section of the antenna transformer as it may be open.

—————*n r i*—————

RCA MODEL 13K FADES AT LONG INTERVALS

Check condensers C85 and C86 with other 10 mfd. units. If one of these opens the receiver will fade. If an inspection shows nothing wrong it will still be best to try new condensers, both at the same time.

—————*n r i*—————

PHILCO MODEL IMPROPER MAGNETIC 37-116 TUNING ACTION

This condition is usually traceable to frequency drift in the magnetic tuning circuit. When replacing the magnetic tuning transformer Part No. 32-2217 it should be replaced with No. 32-2361. The new transformer padder is designed to prevent this frequency drift.

—————*n r i*—————

PHILCO MODEL 17 DISTORTION

Be on the lookout for an increase in the value of the 1 megohm carbon resistor in the plate and screen circuits of the silencer and first A.F. tubes.

MOTOROLA OSCILLATION ON HIGH MODEL 109K1 FREQUENCY END OF SHORT WAVE BAND

This trouble may be corrected by inserting a 60 ohm non-inductive resistor directly in the control grid lead of the grid cap of the mixer tube.

—————*n r i*—————

MOTOROLA IMPROVED MODEL 29B SENSITIVITY

To pep up the receiver replace the 1,000 ohm resistor in the cathode of the R.F. tube and the 820 ohm resistor in the cathode of the first I.F. tube with 400 ohm 1 watt resistors. When this has been done the receiver should be realigned.

—————*n r i*—————

MOTOROLA INTERMITTENT MODEL 29B

Check the bracket holding the tuning condenser as this sometimes touches the volume control lugs thus shorting out the signal.

—————*n r i*—————

KNIGHT MODEL NOISY WHEN IN B-10563 CABINET

If the receiver is not noisy when the chassis is removed from the cabinet the trouble may be due to the dial escutcheon rubbing against the dial. To eliminate this ground the escutcheon by running a wire from it to the receiver chassis.

—————*n r i*—————

GENERAL ELECTRIC MOTORBOATING MODEL K-66

This trouble particularly noticeable at low volume is due to opening up of the 4 mfd. screen bypass condenser for the I.F. stage. As a replacement you may use an 8 mfd. 450 volt unit.

—————*n r i*—————

GENERAL ELECTRIC INTERMITTENT MODEL F-63

Check to make certain that the front dial plate is bonded to the tuning condenser frame.

—————*n r i*—————

FIRESTONE DEAD MODEL R-1431

If the receiver is dead when in the cabinet but plays when the chassis is turned upside down on the workbench examine the interior of the vibrator can. If there is a burned lead this has undoubtedly sagged thus allowing a short to occur. Covering the lead with spaghetti tubing will eliminate a repetition of the trouble.

—————*n r i*—————

ARVIN MODEL 927 TUNING EYE DOESN'T WORK

Before checking the a.v.c. network and trying a new eye, check the 1 megohm resistor connected inside of the magic eye socket assembly. If the resistor is open you may install a new socket or you can disassemble the socket to install a new resistor.

Here and There Among Alumni Members

Lawton L. Reynolds of Okmulgee, Okla., is sound technician for S. F. Welsh Company, operating over Eastern Oklahoma. He has also been doing some work as instructor in Radio for the Government.

— n r i —

Graduate Orville R. Keister has been in Radio twenty-one years. He is operator of coast Radio station WMW, Manitowoc, Wisconsin.

— n r i —

Commenting on a picture in last issue of the News showing Chicago Chapter at a party in "high gear," Earl Bennett wants to know how high is high gear. You should know, Earl, you were there.

— n r i —

Charles F. Steinhoff has been promoted to Senior Communications Operator, Watch Supervisor, at the Cleveland Municipal Airport, Cleveland, Ohio.

— n r i —

Thomas B. Love is Staff Sergeant in the 18th Pursuit Squadron, stationed at Ft. Richardson, Anchorage, Alaska. He is an Airplane Mechanic, par excellence.

— n r i —

T. B. Herndon of Mansfield, Ia., called at the Institute to see Mr. Smith. He is President of a \$50,000 Radio corporation. The State of Louisiana called him in to act as head of the Acronautical Section for the state. Mr. Herndon was in Washington as the representative of the Governor of Louisiana.

— n r i —

Frederick H. Brill is control operator at WDRG, Hartford, Conn. Previous to accepting this fine job he held the position of Supervisor of Radio, N.Y.A. of Connecticut.

— n r i —

We have a letter from James G. Pope, who is Radio operator on board a British Merchant ship, informing us that he is again putting out to sea after a rest in his native England. He sends regards to the many friends he made when he visited Baltimore and Philadelphia Chapters while in port at these points. Good luck, Pope. Your courage in the face of dangerous duty has won great admiration for you.

— n r i —

Peter Van Bendegom is operator and maintenance man at Police Radio Station WPEB, Grand Rapids, Mich. He is also President of Grand Rapids Lodge, No. 97, Fraternal Order of Police. Quite a fellow.

— n r i —

W. B. Parrish of Frankfort, Ky., made enough money before graduating to pay for his course and part of his college education. He now has a prosperous Radio business, and owns his home. Did over \$10,000 in business during the last year.

We've been getting cards from some of our members who are on vacation. They are very much appreciated. All, as usual, are "having a good time—wish you were here." Yeah! We know what you mean, fellows. Happy motoring!

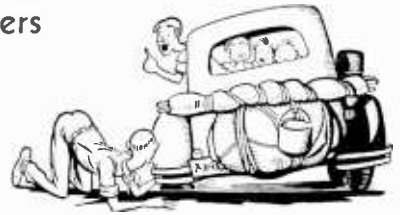

— n r i —

Did you hear the one about the fellow who wired his wife "wish you were here." The blitz was on because the telegraph company left the last "c" off of "here." Happy Landing!

— n r i —

Robert H. Dell of Arlington, N. J., has an interesting job with Western Electric as a tester—analyzing filter circuits. Says he never dreamed that there was so much test equipment or of such good quality and accuracy.

— n r i —

Charles E. Burch started work at WHUB, the day he got his commercial license. A month later he got an offer from WSIX, Nashville, Tenn., and that's where we find him today helping get the station lined up for increased power to 5,000 watts.

— n r i —

Harold R. Potter is working for RCA at Bloomington, Ind., as Radio trouble-shooter.

— n r i —

George LaBerge is Radio Operator at the Air Observers School at Prince Albert, Sask., Canada.

— n r i —

Another proud father! W. W. Moody of St. Louis, Mo., announces a baby girl at his house. Name—Joan Olivia Moody. Says she already shows signs of developing into a movie star.

— n r i —

And Leonard B. Little of Houston, Texas, tells us baby Patsy Ruth arrived at his house. He says he is going to train her to keep his books.

— n r i —

A little tough luck for Joseph Maciejewski sent him to the Bloomsburg, Penna., hospital for an operation. He is getting along nicely.

— n r i —

Speaking of operations our Assistant Publicity Director, Stuart M. Armstrong is recovering from an appendectomy, as this is written. With all of us at N.R.I. pulling for him he just had to get well in record breaking time.

— n r i —

We have just seen a copy of the Kentucky Peace Officers magazine which credits our member, Captain Roy E. McConnell of the Evansville, Ind. Police Department as probably having done more than any other individual toward the creation of an ether "net" to foil criminals in the Hoosier and Bluegrass states.



What We Like to Hear

The article by J. B. Straughn, "Developing the Ability to Diagnose Receiver Troubles" was perfect for the serviceman.

STANLEY GLADYS,
Arborg, Man., Canada.

— n r i —

Puzzling Radio Questions

I like the N.R. News. It is a big help. Puzzling Radio Questions is my favorite (if I have a favorite—it's all good.) By the way, I live near John J. Cleaver of Perth, Ont. (mentioned in last News). I must call on him.

W. E. BERRY,
Elphin, Ont., Canada.

— n r i —

One of Many Similar Letters

Every copy of NATIONAL RADIO NEWS is very interesting, but in the last two issues I found much food for thought. The article by J. B. Straughn on "Developing the Ability of Diagnose Receiver Troubles" was a lesson in itself. Of course I enjoy the rest of the News, too. Give us lots more like that "Receiver Troubles" and "Questions and Answers."

ROBERT E. STONE,
Dorchester, Mass.

— n r i —

Appreciated Comments

Congratulations on the "Puzzling Radio Questions and Answers." I would like to see more questions in future issues like those at the end of Mr. Kaufman's article, "Getting Practical Experience at Home." I put in a half hour's study on that circuit diagram in order to answer those questions and I believe such study is beneficial to most of us. Concerning the controversy over "Jay and Ozzie," I think our magazine can best serve us by devoting its pages to fact rather than fiction, although I admit their adventures are interesting.

ROBERT A. MILLER,
Roaring Spring, Penna.

Interesting Lessons

My last two lessons dealing with loudspeakers were very interesting. Before I started I thought there wasn't very much to learn about speakers in general, but now I realize I was wrong. I don't think I have studied any lesson or lessons that were more interesting than the lessons on loudspeakers.

DONALD KERLEY,
Elkin, N. C.

— n r i —

Wealth of Information

Are you staying up nights, Editor Menne? The last four issues of the NATIONAL RADIO NEWS have been extraordinary. I want to congratulate you on its improvement.

Those articles by Straughn, Kaufman, Scott and Armstrong contained a wealth of information, which should be illustrated on large, descriptive charts and neatly displayed on the walls of every radio shop and lab.

"Education and the Diffusion of Knowledge" was a timely article in your last issue. I am an admirer of Daniel Webster.

Maybe we can soon class Mr. J. E. Smith, the "wise man." His words of wisdom are delightful, inspiring and are truly a guide to follow! My wisdom teeth are gone but I can always digest the words of the wise.

CLYDE D. KIEBACH,
Washington, D. C.

— n r i —

Those Two Guys Again

I liked the instructions on "How to Court a Radio Girl" in a recent issue. By the way—can't we have more of Jay and Ozzie? They're the "cat's whiskers" when it comes to detecting the crooked guys. Put them to work again.

B. McGEHEE,
Arcadia, Fla.

Page Thirty-one

Adoption of Television Standards Paves Way for Commercial Service

Television can now make its nation-wide commercial debut under the auspices of regulations adopted by the Federal Communications Commission, effective July 1, 1941.

Whereas a year ago the Commission found the television industry divided, recent developments demonstrate the industry is "entirely in agreement that television broadcasting is ready for standardization." Accordingly, the Commission had adopted, in substance, the standards as proposed by the National Television System Committee at the March 20 hearing, as well as the rules and regulations submitted at that time.

These standards, observes the Commission, "represent, with but few exceptions, the undivided engineering opinion of the industry." They "satisfy the requirement for advancing television to a high level of efficiency within presently known developments."

This "go-ahead" signal fulfills the Commission's promise of last year that as soon as the industry's engineers were prepared to approve any single system the Commission would consider full commercialization. The showing made at the March hearing supported the Commission's previous action in declining to set standards when the industry was sharply divided and any attempt to have done so would have frozen the state of the art to the then unsatisfactory level of performance. The approved standards alleviate the problem of different receivers being required to "key" into varying competing transmission systems. The standards take cognizance of recent outstanding improvements in synchronizing signals which contribute materially to a more reliable operation.

Frequency modulation is required for the sound accompanying the pictures. Thus, television is now benefited by the recent developments of frequency modulation.

Other developments are provided for in the requirement that the standards be accorded six months of practical tests, at the conclusion of which further changes may be considered, with particular reference to color television. Program stations are encouraged to engage in experimental color work.

On the record made at the March hearing, the Commission fixes 15 hours a week as a reasonable minimum for program service.

The Commission adheres to the policy set forth in its report on the April, 1940, television hearing, which precludes more than three television stations being under the same control. This is to preserve the public benefits of competition in the use of the limited number of channels.

Page Thirty-two

NATIONAL RADIO NEWS

FROM N.R.I. TRAINING HEADQUARTERS

Vol. 9

August-September, 1941

No. 10

Published every other month in the interest of the students
and Alumni Association of the

NATIONAL RADIO INSTITUTE
Washington, D. C.

The Official Organ of the N. R. I. Alumni Association

Editorial and Business Office, 16th & You Sts., N. W.,
Washington, D. C.

L. L. MENNE, EDITOR

L. J. MARKUS, TECHNICAL EDITOR

NATIONAL RADIO NEWS accepts no paid advertising. Articles referring to products of manufacturers, wholesalers, etc., are included for readers' information only, and we assume no responsibility for these companies or their products.

Index

Article	Page
How to Analyze a Receiver Diagram	3
Now Is the Time to Plan for the Future	10
Service Sheet	11
Puzzling Radio Questions	14
A Prosperous Radio Business	16
Profitable Customer Relationships	18
Service Sheet	21
The Service Forum	23
How-To-Study Suggestions	24
Novel Radio Items	25
Alumni News	26
The Mailbag	31