

NATIONAL RADIO NEWS



IN THIS ISSUE

N. R. I. Plan for Getting Practical Experience

New Test Bench for Laboratory

Alumni Association News

APR.-MAY
1940

VOL. 9
NO. 2



DECISION

All the really worthwhile things in life are difficult to secure.

Most of the problems which affect your happiness are complicated.

The way to perform a difficult task is to go at it the best you know how, even though your method may not be correct.

You learn by *trying*.

Life is an art. It is mastered by experiment and patience.

If you have a job to do, but dread it—tackle the job right away and get it over with.

If your mind is cluttered up with a dozen half-finished matters, clean them up now.

What you are going to do some day may be a pleasant daydream, but what you are going to do *today* really means something.

Develop the habit of decisiveness. Learn to get things done. Make every day count for something.

E. R. HAAS
Vice President.

THE N. R. I. PLAN FOR GETTING PRACTICAL SERVICING EXPERIENCE AT HOME

By JOSEPH KAUFMAN,

N. R. I. Director of Education



Joseph Kaufman

THE bridging of the gap between theory and practice is a highly important part of any professional course of training. Regardless of how well a man understands the fundamental principles applying to his chosen career, he must have a certain amount of experience in applying these principles before he can consider his training completed.

If you are planning to enter the field of *radio servicing*, the one and only way for you to secure this practical experience is by actual work on radio receivers. If you are planning to enter the field of *communications*, actual work on radio receivers is equally as essential; familiarity with the basic receiver circuits and parts will be invaluable when you begin working with amateur or commercial radio transmitters.

The question of getting practical experience with radio receivers has been given serious consideration by the instruction department staff at N.R.I. Careful consideration of every conventional method showed each one to be more or less unsatisfactory, in one way or another, for N.R.I. students. A brief consideration of these rejected methods will make you appreciate the merits of N.R.I.'s own experience-getting method, developed especially to meet the requirements of students who must secure their radio training at home in their spare time.

The method which involves the building of a radio receiver from a kit of parts has been rejected, for the mere assembling of a receiver gives little experience in actual servicing problems. Furthermore, assembling a kit gives no experi-

ence whatsoever in locating parts on an unfamiliar chassis.

The long-drawn-out method of apprenticeship, whereby a beginner works for a radio man at little or no salary for a long period of time to secure experience, has been found entirely unnecessary. The average serviceman may have many faults in his techniques, and these would be passed on to the beginner; furthermore, many servicemen cannot explain why they make certain tests or arrive at certain conclusions, hence do not make good teachers. You cannot get practical experience merely by watching someone or by doing simple routine jobs.

Likewise, the method whereby a student takes in receivers for repair while he is still studying, primarily to get experience, takes more than average courage. Sometimes the student will run into trouble, and before he can solve the problem or get help from his instructor, the customer will become impatient and demand the return of the receiver. It is very embarrassing to return a receiver with the admission that you cannot fix it, even if the customer knows you are still a student.

The N.R.I. Plan. We have developed a simple, speedy method which allows you to secure practical experience right in your own home while you are studying your regular course. You don't even need a multimeter or signal generator for the first nine steps in this plan.

Briefly, our plan involves securing from one radio receiver chassis, practical experience equivalent to that normally obtainable only by successfully

servicing scores of different receivers. You check every part of this receiver with your tester, then introduce into the receiver each of the common servicing defects in turn, and apply the correct servicing techniques for each defect. You learn to recognize the sounds produced in the loudspeaker by each receiver defect; this gives you the ability to listen to an improperly operating receiver, then figure out and check those few parts which you know could cause the observed trouble. You get alignment experience, too, using the signal generator and output meter in your tester.

When to Start. Maximum benefit can be derived from the N.R.I. experience-getting plan only if you have a thorough understanding of the fundamental radio principles applying to each step of the plan. But there is no one correct starting time for this plan; *your confidence in your own ability is the best guide.* If you have had previous radio experience, you may feel qualified to start this plan quite early. On the other hand, if you have had no previous radio training or experience, you may think it best to wait until you have studied a few more lessons before starting the plan.

You can start the N. R. I. plan after finishing 20 or 25 lessons of the Fundamental Course, and divide your time between regular lessons, laboratory experiments and experience-getting in any desired manner. In other words, if you want to begin spare-time radio servicing work as soon as possible, you can concentrate on this plan, and finish it long before you complete your course. On the other hand, you may prefer to complete the N. R. I. plan and the course at the same time, so that you will be ready to start actual radio servicing work as soon as you receive your diploma. This plan will also help you to master the course, for you will actually be practicing the various servicing techniques at the same time that you study them.

If you are a student and have not already received complete instructions for the N. R. I. plan, you can be sure that you will receive these instructions at the appropriate point in your course. In other words, if you are just starting the N. R. I. course, there will be quite a few terms and instructions which are not entirely clear to you now. Do not let this worry you, because you will receive training covering these points, and will be given fully detailed instructions for each step in the plan.

To give you a general idea of what this plan is, and to show how thorough is the practical experience you can obtain with it, the thirty-four steps in the plan are given here in highly condensed form.

Step 1. Secure a Suitable Receiver. For the N. R. I. experience-getting plan you will need the

chassis and loudspeaker of a broadcast band a. c. superheterodyne receiver *which is in good operating condition and has from five to eight tubes.*

A recent model is not necessary; in fact, a set from three to five years old will be better suited to your needs. Try to get a well-known make, such as Philco, RCA-Victor, General Electric, Zenith, Grunow, Silvertone, etc.; one of the first three models is preferable, for we can then supply you with complete service information on your set, including pictorial layout diagrams. If you do not already have a suitable set, try to borrow one from a friend. There's hardly a neighborhood where some one does not have a suitable receiver for your purpose, tucked away in the basement or attic simply because one or two tubes are burned out; most people will gladly loan you a set like this, and will even pay for any new parts which are needed. Of course, you can purchase a set from a radio dealer for two or three dollars at the most, if you have to, but look around first among your neighbors and friends.

Step 2. Get Service Data on Your Receiver. Having secured a suitable chassis, write to us giving the make, the model number, and the type numbers of the tubes in it, and state that you intend to use this chassis for securing practical experience according to the N. R. I. plan. We will then send you all available service information pertaining to your receiver.

Step 3. Get Acquainted with the Schematic Circuit Diagram. Trace the signal from the antenna terminal to the loudspeaker. Trace through the power supply circuits to see how each tube gets its electrode voltages, and trace through special control circuits.

Step 4. Redraw the Circuit Diagram. On a large sheet of fairly heavy paper, preferably white or light-colored, redraw in pencil the schematic circuit diagram of your receiver, two or three times the original size.

Step 5. Trace Electrode Supply Circuits on the Circuit Diagram.

Step 6. Imagine Various Parts are Defective, and Determine How You Would Check Them with an Ohmmeter. Select a part at random on your enlarged circuit diagram and imagine it to be shorted, open or leaky (if a condenser). Figure out how you would check this part to prove that it was defective. Repeat this process of reasoning for at least twenty parts on your circuit diagram.

Step 7. Make a Tube Socket Connection Diagram. Draw an actual-sized bottom view of each tube socket in the receiver, and number the tube socket terminals.

Step 8. Identify All Stages on the Chassis. By

referring to the schematic circuit diagram and possibly also to the pictorial wiring diagram, identify (name) the function of each tube on the chassis.

Step 9. Identify All Parts on the Chassis. Locate on the chassis each part which is indicated on your enlarged circuit diagram.

Step 10. Make Electrode Continuity Tests. Make a continuity test of each electrode circuit with an ohmmeter. Referring to the circuit diagram each time, estimate what the resistance should be, then compare your estimate with the observed value. This step can well be repeated several times for the entire receiver, as it is a highly important part of the professional servicing technique for locating the defective part once the trouble has been isolated to the defective stage.

Step 11. Check Electrode Supply Circuits Part by Part with an Ohmmeter.

Step 12. Check All Resistors with an Ohmmeter.

Step 13. Check All Coils with an Ohmmeter.

Step 14. Check All Condensers with an Ohmmeter. The initial flicker of the ohmmeter pointer is an indication of the size and condition of the condenser.

Step 15. Measure All Tube Electrode Voltages.

Step 16. Check Performance of Receiver. Tune in local and distant stations at different parts of the tuning dial while the set is turned on and connected to a good outdoor antenna and good ground, so you become familiar with the sensitivity and selectivity characteristics, then try all controls. Check the tuning dial reading for each station against the station frequency as given in a radio log book or in newspaper radio programs, to see how accurately your receiver is calibrated. In your regular course you learn how to make a receiver track with (follow) the tuning dial readings, for this is a part of all receiver alignment procedures.

Step 17. Make a Circuit Disturbance Test. With the receiver in operation, carry out the circuit disturbance test ordinarily used for locating the defective stage in a dead receiver. (Complete instructions for making this test are given in your course.) Notice that sometimes you get clear-cut clicks, while at other times there is a squeal, growl or thump.

Step 18. Make a Defective Stage Isolation Test. With the receiver operating but the aerial disconnected, make a defective stage isolation test with your signal generator, just as you would for a dead receiver. The detailed procedure for this is given in your course.

Step 19. Make Resistors Defective. Turn off the receiver and introduce a defect in one of the resistors (open one lead, or connect a resistor across or in series with it to change the value). Try to figure what effect this defect will have on the performance of the receiver, then turn on the receiver and see exactly what happens. Now suppose that you were servicing a receiver which had exactly this same effect; figure a servicing technique which would locate the defect in the quickest possible time, then proceed to carry out this technique until you come logically to the defective resistor. Repeat this procedure for each resistor on the chassis in turn. Each time you go through this entire step for a resistor, you will be doing one servicing job. Thus, if there are fifteen resistors in the set and you go through the entire procedure for each, you will have acquired practical experience equivalent to that obtainable by servicing fifteen separate radio receivers, each having a different trouble.

Step 20. Make Condensers Defective. With the receiver turned off, introduce a defect in a condenser; you can disconnect one lead to create an open, you can short the condenser terminals to create a short, or you can shunt the condenser with a resistor of about 50,000 ohms in order to create a leaky condition. Turn on the receiver and check performance, then figure out a logical service technique for locating the defective part, and proceed to carry it out.

Step 21. Make Coils Defective. Introduce a defect (an open or a short) in one winding of an r. f. coil, then turn on the receiver and check performance. With the observed effect in mind, determine a logical service technique and apply it to the receiver until you find the defective coil. Remove the defect, then repeat the entire procedure for each other coil winding in the receiver.

Step 22. Make Tubes Defective. Create a low-emission defect in a tube in the receiver by inserting a filament rheostat (about 10 ohms) in series with one filament lead to the tube and setting it to lower the filament voltage for that tube to about 60% of the original value. Create a cathode-to-heater leak by connecting a 1,000-ohm resistor between the cathode and one heater terminal of a tube.

Step 23. Create a Dead Receiver. Make a list of the defects which will cause a dead receiver. Introduce each defect in turn, and apply standard tests to see if they will correctly locate the defective stage.

Step 24. Create Hum. Make a list of the defects which you believe will create hum, introduce these defects and apply appropriate servicing techniques.

Step 25. Create Distortion. Make a list of the defects which you think will create distortion,

then introduce these defects, apply the defective stage isolation test, and figure out and apply a logical procedure for locating the defect in that stage.

Step 26. Create Poor Sensitivity. Make a list of the defects which you think will create poor sensitivity, then introduce these defects to verify your assumptions, and carry out a logical servicing technique for locating the defect in each case.

Step 27. Create Poor Selectivity. Place a 1,000 to 25,000-ohm resistor across one winding of an r. f. coil to load the coil and create the effect of poor selectivity. Turn on the receiver, check performance, then carry out a logical servicing technique for locating the defect. Repeat for each other r. f. and i. f. coil. This step will train you to locate r. f. and i. f. coils which are defective because of excessive moisture or dirt in the windings.

Step 28. Create Oscillation. Make a list of the defects which will create oscillation, introduce these in turn, and apply logical servicing techniques.

Step 29. Create a Defective Loudspeaker. Introduce in turn the following defects in the loudspeaker: open voice coil; open field coil; shorted field coil; off-center cone; broken spider (simulated by loosening the screws which support the spider); metal filings or dirt in the air gap around the voice coil.

Step 30. Replace Parts. Remove completely from the receiver and replace, one at a time, at least one of each of the following parts: a resistor; a paper condenser; a mica condenser; an electrolytic filter condenser; an r.f. coil; an i.f. transformer; an audio transformer; a volume control; a multi-contact switch (if one is present); a tube socket; the loudspeaker; the power transformer.

Step 31. Check Each Alignment Adjustment. Connect your signal generator and output meter to the receiver in the proper manner for realignment, then vary the setting of each alignment trimmer in turn and note the effect on the output meter.

Step 32. Realign the Receiver. Refer to your service information for any special alignment instructions, then realign the receiver.

Step 33. Throw Receiver Completely Out of Line. Then Realign. Turn each alignment trimmer two or three turns in any direction, or tighten all alignment trimmer screws, then repeat the alignment procedure. This will correspond to the most difficult alignment job which you can encounter in actual practice.

Step 34. Overhaul the Receiver. An overhaul of

your receiver, just as if you were going to return it to a customer, completes your work on this one chassis. Replace all parts and wiring which you may have damaged, and resolder joints if necessary, then brush out and wipe off the chassis thoroughly and replace it in the cabinet.

If you have faithfully followed the procedure just described for a broadcast band receiver, you will be a long way toward securing the experience which you require. If you really want to start out in radio servicing with a confidence equal to that of a Radiotrician with years of experience, get a second and even a third chassis, and repeat the entire N.R.I. plan on these. Choose an all-wave superheterodyne, or at least a two-band a.c. superheterodyne receiver having somewhere between five and twelve tubes, for your second test. The third receiver can be defective, for by that time you should be able to repair it yourself.

The questionnaire at the end of this article illustrates the exact nature of the practical experience which can be obtained by means of the N.R.I. plan. These questions in mimeographed form were passed out at meetings of radio servicing organizations, along with complete servicing data on the Philco model 39-25 receiver to which the questions pertain, and prizes were awarded for the highest scores. Very few perfect grades were made; for men actively engaged in radio servicing work, an average of seven questions out of eleven were answered correctly. After the papers were graded, each question was analyzed and the defect was introduced in the receiver itself, so all could observe what actually happened.

A comparison of these questions with the steps of the N.R.I. plan will show plainly that any one carrying out the plan completely for a receiver similar to this set would have no trouble whatsoever in answering all of the questions correctly. Incidentally, this particular two-band receiver model would be ideal for use as the second chassis used in the N.R.I. plan, for it gives experience with push-button tuning adjustments along with conventional short-wave superheterodyne circuits.

Complete service information for this Philco 39-25 receiver is given on pages 13 and 14 of this issue, so that you can take the test examination yourself if you desire. In the first ten questions, a number of possible answers are given.

Encircle the one correct answer in each case, then write out in your own words an answer to question No. 11. Compare your answers with the correct answers as given on page 10 of this issue. Do not be discouraged, however, if you

miss most of the questions, for these are by no means easy. You are not expected to be able to answer even one of the questions until you have completed your N.R.I. training and followed out the N.R.I. plan for at least one chassis.

1. If grid coupling condenser #30 (for the 41 output tube) is open, the effect will be: *distortion; howling; a dead receiver; poor selectivity; burned-out 41 tube.*
2. If coupling condenser #27 (between the volume control and the 75 tube grid) is shorted when the volume control is at its maximum-volume setting and the set is tuned to a strong local station, the effect will be: *no change in performance; hum; distortion; motorboating; blocking (causing a dead receiver).*
3. If screen grid by-pass condenser #13 (for the 6ASG and 78 tubes) is open when the set is tuned to a weak signal, the effect will be: *degeneration; increase in volume; oscillation; loss in selectivity; loss in sensitivity.*
4. If resistor #14 (in the screen grid supply lead to the 6ASG and 78 tubes) is open, the effect will be: *a dead receiver; howling; hum; improved selectivity; increase in volume.*
5. If resistor #28 (in the grid circuit of the 75 tube) is open, the effect will be: *a dead receiver; increase in volume; hum; distortion; loss in selectivity.*
6. If resistor #43 (in the power pack circuit) is open, the effect will be: *howling; distortion; a dead receiver; hum; a burned-out 8 $\frac{1}{2}$ tube.*
7. If condenser #13 (the screen grid by-pass condenser for the 6ASG and 78 tubes) is shorted, the effect will be: *a dead receiver; howling; distortion; hum; a burned-out 8 $\frac{1}{2}$ tube.*
8. If condenser #30 (the grid coupling condenser for the 41 tube) is leaky, so that an ohmmeter connected across this condenser would indicate 50,000 ohms, the effect will be: *increase in volume; howling; a dead receiver; no change in performance; distortion.*
9. If electrolytic condenser #18 (below the 78 tube) is open, the effect will be: *howling; hum and loss of bass notes; a dead receiver; no change in performance; reduction in sensitivity and improvement in selectivity.*
10. If resistor #16 (below the 78 tube) is open, the effect will be: *increase in volume; a dead receiver; improvement in selectivity; howling; distortion.*
11. If condenser #35 (in the output circuit of the 41 tube) is shorted, describe briefly the effects which will be noted.

One-Tube Wireless Microphone Broadcasts to Any Home Radio

With the new Deluxe Mystic Mike wireless outfit illustrated here, speech or music can be broadcast to any radio receiver located in the same building. The unit is plugged into an electric outlet, and the receiver is then tuned to the carrier frequency of the unit. (This frequency can be set anywhere between 600 kc. and 1,000 kc. in the broadcast band by adjusting a trimmer condenser on the chassis of the unit.) A sensitive 200-ohm single-button carbon microphone is mounted at the front of the attractive molded bakelite cabinet. Jacks are provided at the rear of the chassis for plugging in a crystal phonograph pick-up, thus giving the equivalent of a modern wireless phonograph.

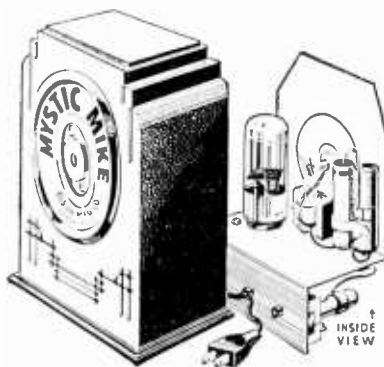

The unit utilizes a type 25A7GT combination pentode-diode tube in a modulated oscillator circuit essentially like the fundamental circuit of a wireless phonograph. A form of grid modulation is employed, with a simple bleeder system to furnish the required button current.

In tests at N. R. I., the Mystic Mike gave satisfactory clarity and volume when used about 75 feet away from a General Electric model A-82 receiver, with the speaker's lips about three inches away from the microphone.

The Deluxe Mystic Mike is made and sold by the Olson Manufacturing Co., 362 Wooster Ave., Akron, Ohio. Literature and prices can be obtained free on request from this firm; be sure to mention that you are an N.R.I. man.

— n r i —

Our Cover Photograph

In the land of ice and snow, up among the Eskimos, Father Hubbard (the Glacier Priest) uses an RCA sound recorder to record native chants for use with his famous Alaskan lectures. Compare the actual photograph, supplied us through the courtesy of RCA Manufacturing Co., Inc., with our artist's impression of this same scene on page 15, Novel Radio Items.

Use of Radio in Special Emergencies

This article was released to National Radio Institute by the Federal Communications Commission, Washington, D. C.

There is one class of radio station license issued by the Federal Communications Commission which, though little known, is playing an increasingly important role in the economic life of the nation. This particular type of license covers special emergency stations. These stations have already demonstrated their value in time of localized stress, and now loom as a valuable adjunct to the linking of communications for widespread protection of life and property.

Special emergency stations have rendered valuable service in regional disasters, such as the New England hurricane, and in time of flood when the normal means of communication are destroyed or are rendered inoperative. It would be difficult to obtain information as to casualties and extent of damage, and even more difficult to restore communication, were it not for the temporary facilities which can be rapidly established to meet such emergencies. The use of special emergency stations in this connection is probably the most spectacular use to which these stations are now put.

The Long Lines Division of the American Telephone and Telegraph Company, as well as many local telephone companies, have been issued licenses for special emergency stations. Special equipment has been designed for the purpose. This equipment can be stored in a chest. In time of emergency, it can be loaded in a truck, driven to the scene, and quickly and easily set up for operation. When so used, the design of these stations permits either communication between construction crews at the scene of the emergency or the interconnection of regular land lines in such manner that regular subscriber communication can be re-established.

Aside from service in time of disaster, these stations are in growing daily use by public utilities. For example:

The economic life of our country has become so dependent upon electricity that a sudden and complete disruption of electric service to any large metropolis would make that city practically uninhabitable. The network of interconnecting electric power lines has greatly reduced the hazards which would be created by failure of a single plant. However, constant vigilance is required to maintain the transmission lines, which constitute this network, for the most efficient service. As these transmission lines normally carry very high voltages, and since they cannot be disconnected for any extended period, close

coordination is needed between the working parties and the switching central at the power house.

Special emergency stations make this possible. Some utility engineers say the time is rapidly approaching when no power distribution system or gas, oil, or water distribution system operating over a large area will be considered fully equipped unless it has a radio communication system to augment the wire, telegraph, telephone, and carrier current communication systems.

There is a particular day-to-day emergency demand for radio communication by public utilities within the metropolitan districts. To illustrate: Should an automobile run into a light pole and knock it down, electrical voltages of dangerous potentials are exposed and endanger passers-by. Without radio communication, it is necessary for a service truck to be dispatched from some far quarter to the scene even though a truck with proper equipment might be working only a block or two away.

Inasmuch as the number of frequencies available for emergency assignment is extremely limited, it is required that those public service units eligible to receive emergency station licenses cooperate among themselves in the choice and use of frequencies so as to avoid duplication and interference. For this and other reasons it has become common practice for various public utilities in a single area to pool their needs, one utility requesting the license and rendering the service while the other utilities receive this service and contribute to the cost of operation on a pro-rated basis.

Recent Commission authorizations illustrate this arrangement. In the New York metropolitan area there are a number of public utilities, including the New York Telephone Company, which are eligible for and have need of special emergency radio communication. In order to reduce the capital investment and to receive the maximum benefits from this type of communication, the New York Telephone Company has taken the lead and is constructing a sufficient number of special emergency radio stations to serve all utilities in that metropolitan area.

This radio service will be made available for the handling of only such communications as meet the definition of emergency in the Commission's rules and regulations. In order that the cost of operation may be recovered, and to prevent this new system from becoming a burden on the general telephone subscriber, the telephone company is to make charges to the various utilities concerned.

The Value of a Good Credit Rating

By H. E. LUBER,

N. R. I. Director of Student Service



H. E. Luber

THOSE of our graduates who are in a part-time or full-time Radio business already know from experience the value of a good credit rating. Without it they could not progress very far. But to those of our students who have not been initiated into all angles of business affairs, I feel this matter of a good credit rating is important enough to deserve particular mention here.

When a business man walks into a bank to make a loan, he usually hands the banker a financial statement. The banker studies it carefully. He looks at the assets and liabilities. He makes some quick mental calculations. But there is one important asset which the statement does not show, one which counts very heavily when the banker weighs all the facts to determine whether the loan may safely be made.



This asset is the credit rating of the borrower.

Does the borrower always fulfill his promises? Does he pay his bills? Is he known to be prompt, or is he slow to pay and unreliable? Does he try to evade payments by resorting to technicalities? Has suit ever been brought against him to collect an account?

These are questions which the banker asks himself. He usually knows the answers, too. If not,

he can get the answers very quickly, for with so much business being done on credit these days, many organizations make a business of rating people.

Merchants, for example, are glad to sell their goods on open account to people who are rated as responsible. Let one of these creditors fail to pay his bills, however, and see what happens when he tries to open an account at some other store. He is turned down, because merchants have a central organization where people who are poor credit risks are reported. If a man won't pay one merchant, why should he be expected to pay another? The debtor thus loses his credit standing at all stores because he has abused his credit at one store.

"But," says the debtor, "there are plenty of business houses outside of my city who do business on credit. I'll send to them for what I want." That won't work, either, because these firms invariably check with the credit bureau in the city where the applicant lives or formerly lived. A bad credit rating, once acquired, is very hard to shake off.

Modern business has established an elaborate system of individual credit ratings. Every town of any size and consequence has its trade association. These associations maintain Credit Information Bureaus, which supply credit infor-



mation locally, and also maintain reporting services to other bureaus all over the country.

It is estimated that 70% of all business today is conducted on credit. Everything from daily newspapers to corporation financing (or government financing) is operated on the deferred payment plan.

The best security for a loan is character. A big factor in any man's character reputation is his willingness and ability to meet bills and obligations on time. Good credit is little more than reputation for reliability.

Prospective employers are interested in these things, too. No man wants a fellow working for him who hasn't the confidence of every one in the community—at least as far as his reliability is concerned. An employee is the agent of his employer. People get their impressions of a business from the actions of the employees. Moreover, no man wants an employee who hasn't a good clean reputation for responsibility.

Credit rating begins early in life. Black spots can never be removed. The man who starts out by evading payments "until his ship comes in" is forming a habit which is hard to break, and which may eventually be his most serious handicap to success.

We, at N.R.I., receive many requests for credit reports on students and graduates. These reports come from business houses and prospective employers. We are glad to have our students and graduates use us as a reference. It is a pleasure to give a deserving man a good recommendation. These reports are confidential and they are truthful. Business men are very careful not to damage a man's credit if the creditor is known to be honest and upright in his dealings, even if he may have had a bit of hard luck. But the man who will not try to live up to his obligations places no value on his credit rating, and soon finds that he has none.

Always keep in mind the value of a good credit rating. It is necessary for success in business. The best rule for establishing a good credit standing is never to buy anything you cannot afford. Once you have obligated yourself, make every sacrifice necessary to meet all payments as agreed.

Build up a good credit rating. You can't get along in the business world without it.

— n r i —

We all have day dreams of what we wish to be, or have, or do; and the high imaginary standard, like the good resolutions we form, aids us, often, to a higher and better life.—J. W. Howe.

Correct Answers to Questions Given on Page 7 of This Issue

1. A dead receiver. (Signal path is open.)
2. Blocking (causing a dead receiver). (Excess bias on the grid of the 75 tube, cutting off plate current.)
3. Oscillation. (Due to feed-back between the screen grid and the control grid.)
4. A dead receiver. (No screen grid voltage on these tubes, cutting down plate current.)
5. Distortion. (Improper grid bias, with its value depending upon the nature of the components.)
6. A dead receiver. (Open circuit in negative side of power pack output, so no d.c. voltage on tubes.)
7. A dead receiver. (No screen voltage.)
8. Distortion. (Incorrect C bias on the 41 output tube.)
9. Hum and loss of bass notes. (Bass notes are dropped across field coil instead of across output transformer.)
10. A dead receiver. (Oscillator does not function, due to lack of voltage on oscillator anode.)
11. With tone control at bass, set is dead and output transformer primary may burn out because it is across power pack. With tone control at treble, little or no effect will be noted.

— n r i —



Drawn for National Radio News by Jennings Berge.

"See—I've already found the trouble! Shouldn't take you more than a few minutes to get 'er playing again Now!"

The Laboratory Page

By GEORGE J. ROHRICH

The purpose of this department is to furnish supplemental experiments to students who have completed their Home Laboratory Course, but who wish additional laboratory experience. You are not required to perform these experiments, but you will gain increased knowledge by doing so.

Most of the material required will be that received as part of the Laboratory Course. Any other material necessary can be purchased very reasonably and will constitute an investment rather than an expense, as it will serve as replacements in service work or be useful in your shop later.



George J. Rohrich, Engineer
in Charge N. R. I. Laboratory

AN EXPOSITION OF EXPERIMENTS 31 AND 32

There are literally hundreds of places where troubles are encountered from time to time while students carry out the work in the experimental outfits. These troubles occur in the circuits of the experiments just as they do in any and all types of radio receivers and amplifiers.

When failure of an experiment does occur you have a splendid opportunity of getting some advanced as well as practical experience in servicing defective equipment. The tendency at first may be to feel discouraged in failing to make specified observations as directed in the instructions. However, if you will realize that you have the additional opportunity to carry out your servicing technique, then you will welcome the presence of *all* defects and really go to work in earnest in solving the new problems before you.

Although there are literally hundreds of places where disturbances can exist, the troubles arise from five conditions: 1, improper voltages; 2, poor connections; 3, improper wiring; 4, altered characteristics arising from abuse or aging; 5, defective parts.

Beginning with Experiment No. 31 in Outfit 41A-1 you may begin to experience some difficulty with improper voltages. This may result from several additional causes. Partly exhausted filament dry cells are probably the most common source. This occurs largely because idle batteries will deliver full voltage. Therefore, you may begin your test by measuring the voltages *before* putting them into service and believe that everything is in working order. However, partly exhausted batteries will show a different value

after being put into service and if you are not aware of this fact you may wonder just why failure results.

The thing to do is to measure the voltage values *after* the apparatus has been in use for some time. Furthermore, this measurement should be made *while the apparatus is in operation*. This is necessary because the voltage usually increases again immediately upon removal of the load.

Another source of improper voltage is caused by accumulation of dust and moisture. Apparatus which has been standing idle for long periods is most likely to be bothered by this condition. This has been traced as a cause of failure to obtain modulated signals in Exp. No. 31 by reducing the required rectified voltage existing across the grid leak and condenser in Fig. 41. Accumulated dust and moisture across the grid leak and grid condenser, as well as between the prongs of the vacuum tube reduces the total resistance from the required 2 megohms to a value around 500,000 ohms. This reduction in resistance is responsible for the reduction in the required rectified voltage.

Here the remedy should be obvious by this time. Clean all parts thoroughly, paying particular attention to the grid leak, the grid condenser, the mounting which supports these parts and include cleaning the base of the tube between its prongs. The socket also should be carefully cleaned.

Slight aging of the grid leak may sometimes lower its resistance. Use the second grid leak

which is available. As a final resort you may also try connecting the two grid leaks in series.

Poor connections may result from those made while connecting the apparatus from the diagrams and also from a hidden open circuit within a vacuum tube socket, meter, headphone or other piece of equipment. Those connections you make yourself need not be soldered. Just be sure they are tight. Tight connections on lugs are assured if you firmly wind three turns of the bare No. 24 wire around each connecting lug while pulling the wire slightly. Wind on an extra turn of the wire which includes a full turn of the insulated covering. This prevents exposed wiring from coming in contact with other wiring and other exposed metal parts.

Do not overlook testing the continuity of each vacuum tube socket by repeating Experiment No. 13. This will also give you a check on the condition of each vacuum tube.

Trouble is sometimes experienced because some tubes have a slightly longer filament. This makes the tube rather critical in regard to operating properly with only 1.5 volts. After a dry cell has been in use for a short while, the filament voltage drops to 1.2 volts and the type of tube with the longer filament will not give very good results.

In order to check up on the above condition, connect the transmitter as shown in Fig. 41 and then temporarily short circuit terminals 8 and 9 on the grid leak. The 0-50 voltmeter which is used as a 0-15 milliammeter should now register at least 10 volts, indicating that 3 ma. flow through the circuit after the tickler is turned where you get maximum reading. If the meter shows less than this value, then it is necessary to connect an extra dry cell into the filament circuit for the transmitter by following the procedure described in experiment No. 25.

When the above adjustment is made, then it is easy to obtain the specified reading on the 0-15 milliammeter and in most cases the reading will be greater. A steady reading while rotating the tickler proves the tickler coil is short-circuited. If so, exchange and rewire the receiver and transmitter coils. The defective tickler now is unused in the receiver.

After you get results remove the wire which you connected temporarily across terminals 8 and 9. The meter in the plate circuit should now fall to zero when modulation takes place. The two test prods of the receiver shown in Figure 41 now may be held on terminals 4 and 5 of the transmitter in order to check whether or not the transmitter is being modulated properly. If loud signals are not heard at terminals 4 and 5, then hold the two test prods across the terminals of the 1.5 volt dry cell of the receiver. The 0-5 milliammeter in the receiver circuit should de-

flect one way or the other, depending upon the manner in which the two test prods are held on the terminals of the dry cell. With an up-scale deflection, the 0-5 milliammeter should show approximately .5 milliamperes, that is, halfway between 0 and 1 on the scale.

A loud click also should be heard in the phone as one of the test prods is removed. Make and break the circuit several times to be sure that you hear the click in the phone and that you see a deflection on the meter. If you don't see a deflection on the meter but you do hear a click in the phone, this proves the meter is short-circuited. Be sure the ends of the wires attached to the meter do not touch its metal case.

Furthermore, if you do not hear a click in the phone then the phone may be defective. By short-circuiting terminals 4a and 5a temporarily with a short piece of wire and repeating the test across the dry cell, you should obtain a deflection on the meter if the phone is defective.

When you hear a click in the phone and obtain a reading on the meter, then you are ready to proceed with experiment No. 31. IF you cannot hear a signal from the transmitter in the phone at this time, then it would be well for you to test the tube in the receiver by holding the *black* test prod on the grid of the receiver tube and holding the *red* test prod on the *positive* terminal of the dry cell. The 0-5 milliammeter should show a deflection of approximately .1 milliamperes if the tube and the dry cell are in good condition. A click also should be heard in the phone as you make and break the circuit. If these tests are not satisfactory then the tube is defective.

If the above test shows a reading on the meter but a buzzing signal is not heard from the modulated oscillator, then this indicates that the variable condenser in the receiver is dusty, leaky or short-circuited.

Upon removing the condenser and turning the other condenser in the transmitter to zero, you will hear signals in the phone.

With the *black* test prod held on the *negative* terminal on the dry cell of the receiver and the *red* test prod held on the grid terminal of the tube, the 0-5 meter *will not register* when a buzzing signal is heard in the phone because the amount of rectified current flowing through the meter, phone and grid circuit from the *modulated* signal is not great enough even at resonance.

However, in experiment 32, with an *unmodulated* signal, sufficient current will flow through this circuit to show a small deflection on the meter, ranging between .2 ma. and 1.1 ma., provided the voltage of the filament's "A Battery" of one or two cells is more than 1.3 volts.



RADIO-TRICIAN

REG. U. S. PAT. OFF.

Service Sheet

Compiled Solely for Students and Graduates

NATIONAL RADIO INSTITUTE, WASHINGTON, D. C.

PHILCO MODEL 39-25

Alignment of Compensators

EQUIPMENT: (1) Signal Generator; Philco Model 077 Signal Generator which has a fundamental frequency range from 115 to 36,000 K. C. is the correct instrument for this purpose. (2) Output meter, Philco Model 027 Circuit Tester, incorporates a sensitive output meter and is recommended. (3) Philco Fiber Handle Screw Driver, part No. 27-7059, and Fiber Wrench, part No. 3164.

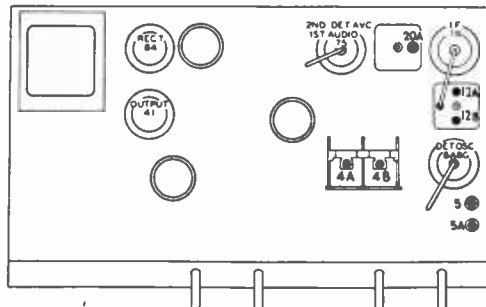

Location of Compensators

OUTPUT METER: The Philco 027 Output Meter is connected to the plate and cathode terminals of the Type 41 tube. Set the meter to use the 0-30 volt scale. After connecting the output meter

adjust compensators in the order as given below.

Signal Generator				Receiver			
Operations in Order	Output Connections to Receiver	Dummy Antenna (Note A)	Dial Setting	Dial Setting	Control Settings	Adjust Compensators in Order	Special Instructions
1	6A8G Grid	.1 mf.	470 KC	580 KC	Vol. Cont. max.	(20A) (12B) (12A)	
2	Ant. Ter.	100 mmf.	18.0 MC	18.0 MC	Vol. Cont. max.	(4B)	See Note B
3	Ant. Ter.	100 mmf.	1550 KC	1550 KC	Vol. Cont. max.	(5) (4A)	
4	Ant. Ter.	100 mmf.	580 KC	580 KC	Vol. Cont. max.	(5A)	
5	Ant. Ter.	100 mmf.	1550 KC	1550 KC	Vol. Cont. max.	(5)	

NOTE A—The "Dummy Antenna" consists of a condenser connected in series with the signal generator output lead (high side). Use the capacity as specified in each step of the above procedure. **NOTE B**—**DIAL CALIBRATION:** In order to adjust the receiver correctly the dial pointer must be aligned to track properly with the tuning condenser. To adjust the dial proceed as follows: With the tuning condenser closed, set the dial pointer on the extreme left index line at the low frequency end of the scale.

Readers who file Service Data in separate binders remove page carefully, trim on dotted line for same size as data published heretofore.

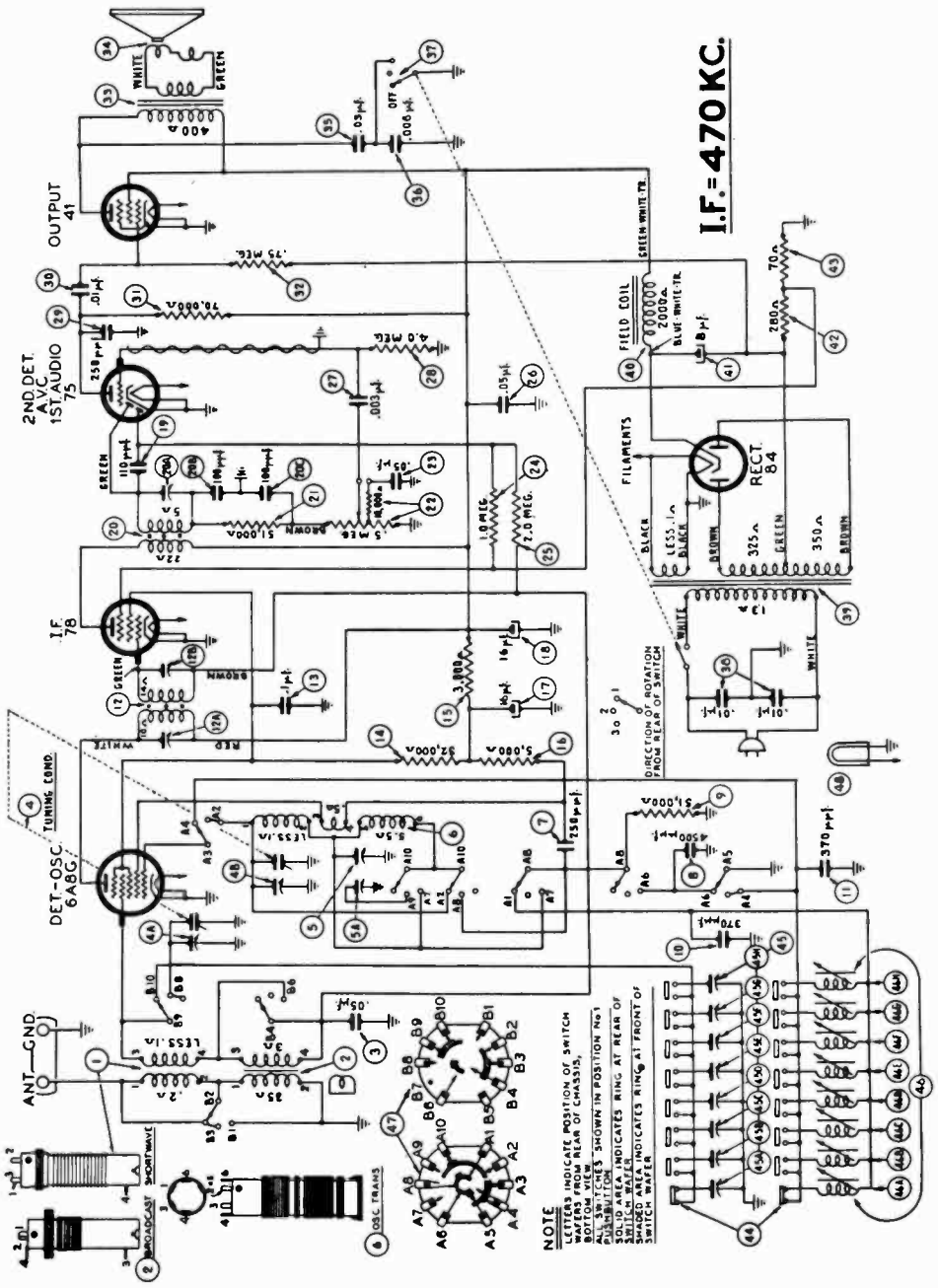

I.F. = 470 KC.

NOTE
 LETTERS INDICATE POSITION OF SWITCH
 WAFERS FROM REAR OF CHASSIS.
 ALL SWITCHES SHOWN IN POSITION NO. 1
 DISTRIBUTION
 SHADOWED AREA INDICATES RING AT REAR OF
 SHIELDING WAFER
 SHADOWED AREA INDICATES RING AT FRONT OF
 SWITCH WAFER

Novel Radio Items

—BY L. J. MARKUS—

Radio Factory Duplicates Tropical Humidity!

Before production is begun on General Electric receivers and radio parts intended for use in tropical countries, engineers first operate the units in a tropical humidity chamber where electric lamps under water tanks duplicate the extreme temperature and moisture conditions of the tropics. "Night" conditions are produced twice each day by turning off the lamps and allowing moisture to condense on the radio parts. The test is continued day and night until failure occurs.

— n r i —

Magnet Lifts 4,450 Times Own Weight!

A permanent magnet, smaller in size than a thimble and weighing only three-fourths of an ounce, has supported as much as two hundred pounds in tests. A special mounting of brass and iron makes this feat possible, for the sintered alnico magnet by itself lifts only five hundred times its own weight. Sintered alnico is an alloy of aluminum, nickel and iron as the basic ingredients.

and is made by pressing together the powdered metals and heating almost to the melting point. This powerful magnetic alloy is widely used in permanent magnet type radio loudspeakers.

— n r i —

Radio Device Can Change Your Voice!

A unique instrument employing radio principles has been developed by the Bell Telephone Laboratories for speech-studying purposes. This device, known as the "Vosyn," has controls which can be set so that your voice comes from the loudspeaker as that of a soprano, a child or an aged man, even though you are speaking naturally into the microphone. Special circuits cut out some audio frequencies and change others to give these effects.

— n r i —

Roaming Radio Shop!

Three hundred radio receivers in fifty different towns have been repaired by a traveling radio repair shop in Yugoslavia.



NOVEL USES FOR SOUND RECORDERS! To the far north with Father Hubbard (the Glacier Priest) went one RCA sound recorder, for the purpose of recording Eskimo chants, as well as fairy tales told by the natives in their own dialect. Many of the records made by Father Hubbard on this Alaskan expedition will be played at his lectures throughout this country.

A sound recorder accompanies practically every exploring expedition. Radio men brave tropic vegetation, storm, rain and water to get their assigned sounds. It is desirable to have the pick-up microphone as close as possible to the source of sound, in order to keep

out extraneous noises. This explains the center illustration above, where a radio man gets wet feet trying to catch the croaking of a bull frog for some future spooky radio drama.

But not all recorded sounds are natural. In the RCA-Victor recording studios in New York City, synthetic sounds produced by an elaborate radio instrument known as a "resonator" were fed into a sound recorder in order to produce phonograph records for treating deafness. Many different records were made, each varying in pitch and intensity according to the type of hearing defect they are intended to help. The synthetic sounds exercise the inactive

muscles of the inner ear. Helpful effects are noticed within ten days if the treatment works.

Recordings of unusual sounds are used chiefly in radio dramas, in stage and movie productions, and for lectures. Thus, when a dog was scheduled to appear on a radio program recently to receive a medal for attacking armed bandits, the program called for a barking of thanks by the canine hero. "Duke" refused to bark at the proper moment, but station engineers were prepared for such an emergency. A recording of appropriate barks was immediately put on the air, and the listening audience never knew the difference.

NEW TEST BENCH FOR N. R. I. LABORATORY

By GEORGE J. ROHRICH

Engineer in charge N. R. I. Laboratory

NEW radio receiver servicing techniques and new test instruments for radio servicing can be tried out and checked more thoroughly and more conveniently than ever before on the new and modern test bench which has recently been installed in the N. R. I. laboratory. On this bench is every conceivable facility for speedy radio receiver servicing, for radio research work, and for research and experimental work in connection with the N. R. I. course of instruction and the practical experimental training associated with the course.

It should be emphasized right from the start that this new N. R. I. bench is not intended as an example of a modern radio servicing bench. In fact, many of the instruments on this bench are primarily research and experimental units, and are entirely unnecessary for radio servicing work. With slight modifications, however, this general bench design could very easily be adapted to the requirements for a radio servicing business.

Because of the wide variety of instruments, made by different manufacturers in various sizes and shapes, it was impossible to secure a perfectly balanced and symmetrical arrangement of instruments on the panels. Nevertheless, as you step into the N. R. I. laboratory and view this new bench for the first time, you will be impressed with its trim, modern lines, with the dignified beauty of the individual instruments mounted on its panels, and with the convenience of the various switches and controls on the panels.

At the time of writing this article, overhead lights have not yet been installed on the bench.

Page Sixteen

Tentative plans call for the use of long aluminum reflectors containing the new 24" long fluorescent lamps, to provide a high-intensity, glareless illumination on the working surface of the bench.

The general constructional features of this bench can be seen in the three photographs accompanying this article.



George J. Rohrich, Engineer in charge of the N. R. I. laboratory, points to one of the spring catches which hold the instrument panels rigidly in position, yet make them instantly removable.

The general constructional features of this bench can be seen in the three photographs accompanying this article. The doors on the two bottom sections are mounted on invisible hinges, and swing open to reveal drawers for tubes and spare parts. Six additional small drawers just above the working surface of the bench provide conveniently accessible room for tools, test leads, and small radio parts. The doors at the upper two corners of the bench, likewise mounted on concealed hinges, swing open to reveal shelves for storage of portable instruments and less-often

used test instruments. These two compartments provide room for expansion, as the shelves can readily be removed and the doors converted into panels on which new instruments can be mounted.

Unique but simple is the method used for keeping the instrument panels in position. Each panel has four spring catches, which fit into corresponding receptacles on the bench. The entire panel can be removed by pulling firmly on its two handles. The test instruments themselves are mounted rigidly in their respective compartments, directly behind the openings cut in the panels.

Each instrument is thus in its own dust-proof compartment, yet readily accessible for attention at any time. Furthermore, whenever there is need to replace an instrument with a newer

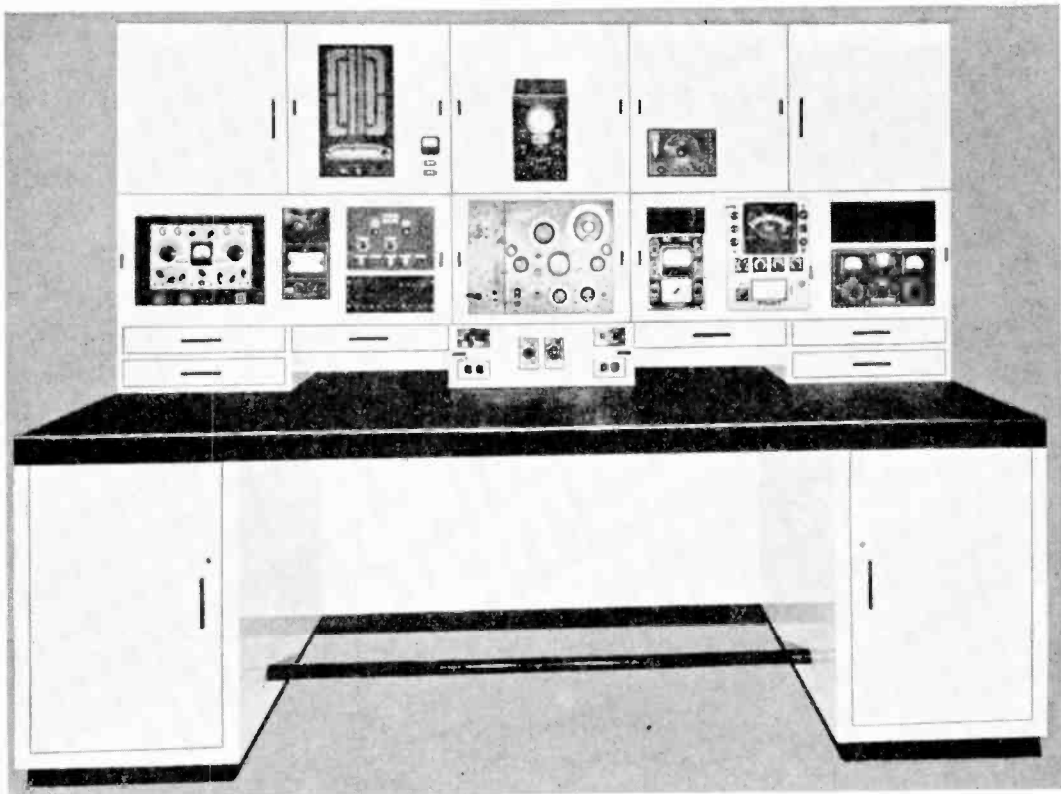

New N. R. I. workbench

model, or when it is desirable to rearrange one or more of the panels to provide room for extra instruments, it is a simple matter to discard the old panel and cut a new one having the desired openings. This feature makes the bench practically obsolescent-proof, thereby justifying the initial effort and expense involved in designing and building our bench.

Those who plan to construct a bench of their own somewhat along these lines will be interested in the materials used. The base of the bench was constructed chiefly from 5-ply plywood, with clear 1" white pine being used for the drawers. Ordinary $\frac{1}{4}$ " plywood covers the back of the bench above the working surface, while $\frac{5}{8}$ " plywood is used at the back of the base. The working surface is green linoleum, supported by 1" planking and a framework of 2" x 2" lumber. Stainless steel trim conceals the edges of the linoleum. The panels surrounding the instruments are of $\frac{1}{4}$ " hardwood plywood, reinforced by small backing strips on which the spring catches are mounted.

The white portions of the bench are finished with Duco refrigerator enamel, preceded by a number of preliminary coats of ordinary white paint. Each coat of paint was sanded carefully before the next was applied. The final white coat will be rubbed down with oil and pumice after it has hardened for several months, to give the smooth eggshell white finish which is characteristic of modern refrigerators. The black portions of the bench, including the foot rail, are finished in black enamel.

All electric power for the bench passes through the main control switch, located on the switch panel just above the center of the working surface. This switch is of the automatic circuit breaker type, and opens automatically whenever an overload occurs. This eliminates the need for replacing fuses.

A rather elaborate system of wiring was required to provide power for each of the many instruments on the panel while still making it possible to remove any one instrument readily. From the master control switch, lead-covered two-wire

cable was run to electrical outlets in each compartment. These outlets were of the inexpensive type which are mounted by means of a single wood screw. Lead-covered cable was chosen because it is easier to work with than flexible BX conduit, yet still provides complete shielding of all electric wiring so as to prevent interference. This same type of wiring is used in broadcast transmitters.

Now let me introduce to you the various instruments mounted on our bench. Starting with the top row of panels, and working from left to right, we come first to the General Electric model A-82 all-wave receiver, with an output meter mounted at its right. This meter is connected into the plate supply of one of the a.v.c. controlled tubes and hence provides an indication of the input r.f. carrier intensity. Below the meter are antenna and ground terminals of the receiver, along with audio output terminals which permit feeding the receiver output to the RCA model TMV-122-B cathode ray oscilloscope mounted in the next compartment. When this is done, the wave form of a person's voice or of a musical instrument can be seen on the fluorescent screen.

The continually-changing green-line pattern of an audio signal fascinates every one who sees it. Ask to have this connection made for you when you next visit the N. R. I. laboratory; it will give you a real insight into the characteristics of sound waves. If, perchance, you should tune the receiver to a southern station and a young lady happens to be speaking, you will learn the secret of that famous southern drawl. Practically every word ends in a perfect sine wave when spoken in this manner by a young lady having a highly trained voice. A man's voice, on the other hand, gives a highly jagged pattern. Incidentally, the oscilloscope is tilted downward for greater convenience in viewing the screen and adjusting the controls. Be assured, however, that it is rigidly mounted behind the panel, and cannot slide forward.

The last instrument at the right in the top row is an RCA model TMV-131-A audio oscillator. There is room in this particular compartment for several additional instruments, to be added in the future.

Starting at the left now on the bottom row of panels, we see first the famous Rider Chanalyst. Next to it is a Triplett model 1252 vacuum tube

voltmeter. Space is provided above this instrument for its test leads. This instrument is used for making voltage measurements in circuits where the current drawn by an ordinary voltmeter would upset voltage conditions. A vacuum tube voltmeter draws practically no current whatsoever from a circuit.

Next in line is a Clough-Brengle model O-MB wobulated signal generator. This instrument can provide any of the frequencies required for aligning and testing all-wave receivers, and in addition has provisions for varying or wobulating the r.f. carrier frequency over any desired range for cathode ray oscilloscope purposes.

Below the wobulated signal generator is a test panel having jacks to which the various radio receiving antennas on the roof of the N. R. I. building are connected. We can thus secure a choice of any desired antenna simply by plugging into the proper jacks on this panel.

In the center of the bottom row is our most prized possession, a General Radio type 605-A standard signal generator. This instrument is primarily intended as a frequency standard for checking the frequencies of other signal generators and for research work, and is far more accurate than is ever necessary for ordinary radio servicing work. It has a large number of controls, takes considerable study before it can be properly used, and is far more awkward to use than an ordinary signal generator; despite all this, it is in-

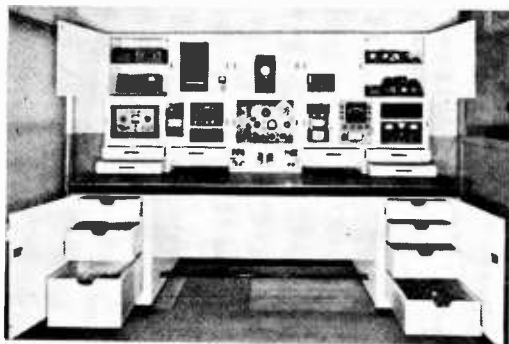

New bench with all doors and drawers open to show constructional features. Radio tubes are kept in racks in the lower right-hand drawer.

teresting to see some of our men using this \$400 instrument merely for aligning a \$10 midget set. At the right of the General Radio signal generator is a Weston 20,000-ohm-per-volt multimeter, with a compartment above it for the test leads. This is a typical radio servicing instrument, and is very impressive in appearance.

Next in line is a Triplett model 1612 tube tester, with a built-in roto-chart giving the control settings for testing various tubes. You will find this instrument on many a radio serviceman's bench.

Finally, we have the Triplett model 1640 capacity bridge, designed chiefly for laboratory tests and experiments with condensers.

The modern black and chromium handles for the doors, drawers and panels were made especially for us by the American Radio Hardware Co.

Police Radio News

A NEW two-way radiotelephone system with several major improvements has been announced by the Western Electric Company for use in police radio cars. The transmitter output has been stepped up to 15 watts, three times as much power as used previously, without appreciably increasing the drain on the car battery. This is made possible by several new circuits, including a coupling arrangement which transfers almost 100% of the energy from the high-frequency vacuum tubes to the antenna.

Another improvement has the effect of removing noise from around all incoming speech. Three elements in the receiving set combine to achieve this automatically. The first is an electrical network or equalizer which blocks out most electrical interference. Second, an improved automatic volume control maintains the speech at a constant level. The most interesting innovation, however, is a new type of vacuum tube relay used in the "codan" (abbreviation for carrier operated device anti-noise) circuit.

Carrier waves from the distant station actuate this device. In the absence of a signal, the codan shuts off the output of the receiving set. As a result, almost no sound comes through the handset receiver or loudspeaker except during periods of transmission. Unwanted sounds, such as ignition noise created by passing motor cars, or similar forms of electrical disturbance, produce negligible action in the codan.

The transmitter and receiver are built in the form of two compact units which slide into slotted mounting plates attached to the floor of the car's luggage compartment. This method of installation permits either unit to be interchanged easily between various cars of a fleet or to be quickly removed to the maintenance shop for inspection. A complete installation, including tune-up, mounting the telephone handset and monitoring loudspeaker, and mounting the miniature "on-off" switching panel, can be completed in a matter of minutes instead of hours. Resale value of the car is not affected, for no holes need be cut in the instrument panel or body of the car.

All tuning adjustments, including that of the high-efficiency circuit for coupling the antenna with the output tubes, can be made with an ordinary screw-driver or "trimmer" tool. A self-contained dynamotor in the transmitter and a vibrator element in the receiver comprise the power supply apparatus.



Courtesy Western Electric Co., Inc.

A—Phantom view of automobile equipped with new Western Electric 228A radiotelephone equipment, showing positions of all parts. B—System in use. Normally, the handset hangs from a special support above the loudspeaker, which in turn is above the starter pedal. C—Engineers making final adjustments or the transmitter unit, using an ordinary screw-driver. D—Transmitter unit (left) and receiver unit (right) with covers removed. The power supply fuse is shown being removed from its clips.

Puzzling Radio Questions From Students

Paper Condenser Markings

QUESTION: *What does the marking "outside foil" or "ground" mean when at one end of a paper condenser?*

ANSWER: Paper condensers are wound from two strips of metal foil, with paper between them as a dielectric. The outside layer of foil will act as a shield around the condenser if it is connected to the chassis. The notation "outside foil" or "ground" indicates the condenser lead which goes to this outside foil. This is the lead which should go to ground whenever the circuit calls for grounding of one condenser. If neither lead of the condenser is to be at ground potential, the condenser marking can be disregarded.

Using Ground Wire as Antenna

QUESTION: *I can obtain better results by connecting the ground wire to the antenna terminal of my receiver (leaving the ground terminal vacant) than by using normal antenna and ground connections. Why is this? I have a fairly long outdoor aerial.*

ANSWER: When employing the connection you describe, the power line is used as an antenna. As you know, one side of the power line is grounded, and the other side picks up radio frequency energy. In the receiver, capacity exists between the power transformer primary and the chassis. R.F. signals picked up by the power line travel through this capacity to the chassis, then flow through the chassis to the primary of the antenna transformer, and through this to the grounded antenna post. The r.f. current passing through the antenna transformer primary induces an r.f. voltage in the secondary of the transformer in the usual manner. Oftentimes, as in your case, the power line will give greater signal pick-up than a regular outdoor aerial.

Why Does the Pilot Lamp Flicker?

QUESTION: *In some of the new a.c.-d.c. receivers, I notice that the pilot lamp gets very bright when the set is first turned on, then dims gradually, and brightens up again after a while. Also, the pilot lamp flickers sometimes when the volume is turned up high. Please tell me what causes this.*

ANSWER: In a set such as you mention, the pilot lamp is connected across a portion of the rectifier tube filament, and the plate of the rectifier tube is connected directly to this tap on the filament. Part of the rectifier plate current thus flows

through the pilot lamp. When the set is first turned on, the cold filaments of the tubes in the receiver have low resistance; as a result, both filament current and pilot lamp current are high, and the lamp is bright. The tube filaments warm up rapidly, and their resistance increases correspondingly; filament and lamp currents thus decrease as the set warms up, and the lamp grows dim. Finally, when the tube cathodes have all been brought up to normal temperature by the filaments, the tubes begin drawing their plate currents from the power pack rectifier tube. Now it is the rectifier tube plate current flowing through the pilot lamp which makes its brilliancy increase.

When a strong station is tuned in, the current drain on the rectifier tube increases appreciably for each loud passage in the audio signal. A part of this varying rectifier tube plate current flows through the pilot lamp, making it flicker in time with the music or speech. Yes, all of these actions are quite natural.

Ordering Output Transformers

QUESTION: *When an output transformer is defective and no information is available as to its characteristics, how can I order the correct replacement unit?*

ANSWER: Ordinarily, it is best to order an exact duplicate replacement transformer from the manufacturer of the receiver or from a radio supply firm. When this is not feasible for any reason, however, servicemen usually use a universal output transformer having either a tapped primary or tapped secondary. Instructions furnished with these transformers tell how to choose the right tap and how to make connections, but you can do this yourself by trying various taps and choosing the one which gives the best output along with normal tone quality.

A conventional output transformer is not particularly difficult to order. The transformer must match the voice coil impedance to the recommended load impedance value for the output stage, and the transformer primary winding must be able to carry the plate load current of the output stage. The voice coil impedance is sometimes specified on the loudspeaker or in the service manual for the set; if it is not, measure the d.c. resistance of the voice coil and multiply it by 1.5 to get an approximate value for the a.c. impedance of the voice coil.

The recommended output tube load can be determined from a tube chart. Output transformers

Are Answered By N. R. I. Experts

are commonly listed either according to the impedances for which they are designed, or for use with certain types of output tubes and either push-pull or single-tube operation. When you cannot find a particular output tube in the transformer specifications, use a tube chart to locate other output tubes having the same recommended load impedance, and order a transformer designed for one of these tubes.

Voltage Ratings for Condensers

QUESTION: *I have a receiver in which a by-pass condenser is short-circuited. The original condenser had a voltage rating of 400 volts. Should I get a replacement condenser having this same voltage rating and the correct capacity value?*

ANSWER: Whenever possible, replacement by-pass condensers should have 600-volt ratings, to give you an ample margin of safety against future failure due to voltage breakdown. If the condenser fails within your guarantee period, the cost of doing the entire job over again to make good your guarantee and preserve your reputation will be many, many times the few pennies more which you pay for a 600-volt unit. To you, a one-cent saving per condenser would hardly amount to much in one year. To a manufacturer who turns out 100,000 receivers per year, however, a one-cent saving per by-pass condenser might well amount to over \$15,000 per year.

There seems to be some confusion as to what the voltage rating of a condenser actually represents. It is merely a rating giving the voltage which the condenser can safely withstand continuously without breaking down. Naturally, then, you can always use a higher voltage rating safely. The voltage rating of a paper condenser should be higher than the operating potential of the circuit, to give an ample margin of safety. A condenser must also withstand high surge voltages existing momentarily when a receiver is turned on. Because the value of this surge voltage is seldom known, most servicemen prefer to standardize on 600-volt paper condensers.

When ordering a replacement electrolytic filter condenser for an a.c. receiver, choose a unit with a d.c. working voltage rating of 450 or 475 volts, even though the original condenser had a lower rating; with small universal a.c.-d.c. receivers, filter condensers rated at 250 d.c. working volts give an adequate margin of safety, however. Electrolytic by-pass condensers will have voltage ratings of from 25 to 100 volts; these ratings are adequate, for electrolytic by-pass condensers

are used only in circuits where the applied voltage never exceeds the C bias for a tube.

Buying Radio Parts

QUESTION: *What parts should I stock in order to start a radio service business?*

ANSWER: The stock of parts actually needed to start a radio service business is surprisingly small. Furthermore, the closer you are to your radio parts jobber, the fewer parts you need. It is better to buy parts as needed than to buy in advance and run the risk of not selling your stock. Furthermore, moisture in the atmosphere can ruin certain radio parts such as coils and condensers, and all parts lose their bright, new appearance when stored on shelves too long. Therefore, carry in stock only those parts for which the demand is so great that they will be used up in a few months.

Here are a few suggestions. Get two each of .01, .05, .1, .25 and .5-mfd. by-pass condensers rated at 600 volts. Get two each of 8 and 16-mfd. electrolytic filter condensers rated at 475 volts d.c. working voltage, for a.c. receivers. Get two each of 5, 10 and 25-mfd. electrolytic by-pass condensers rated at 50 or 100 volts. Get two each of 8 and 16-mfd. electrolytics with 250-volt ratings for universal receivers. Due to limited space in these receivers, exact replacement filter condensers are generally necessary, however, and these should be ordered only as needed.

As to resistors, a kit of about twenty-five different 1-watt carbon resistors will do for a starter. Once you get started, you can order more of the most used sizes. Order wire-wound resistors only as needed.

It is not necessary to carry more than one brand of tube, if you choose a reliable, well-known brand. Your tube jobber can tell you which types of tubes move the fastest in your locality. Start out with as few tubes as you possibly can, and add to your assortment slowly, to avoid buying tubes you will never use.

It might be well to stock one or two universal type output transformers, one input push-pull transformer and an audio transformer, but as a rule it is better to order transformers only as needed. Start with about three i.f. transformers, rated at 456 kc., 260 kc. and 175 kc., respectively. You can use the 456-kc. unit in sets having an i.f. value of 465 kc. Don't try to stock r.f. coils or power transformers, as these vary greatly with receivers.

New Molded Sockets For Tiny Raytheon Tubes

A tiny socket which matches Raytheon's new Hearing Aid tubes is announced by American Phenolic Corporation, 1250 Van Buren Street, Chicago, Ill. It is molded of high-dielectric black bakelite, with a body diameter of only $\frac{1}{2}$ " and adds only $\frac{3}{32}$ " to the length of the tube (including prongs). A spring steel retainer holds the socket in place.



Specially designed contacts keep the contact resistance low, and won't introduce contact noises.

As the dimensioned illustration shows, these tubes are actually smaller than your little finger, and are true peanut-sized tubes. Characteristics are similar to those of ordinary radio tubes, however, so Radiotricians should have no trouble in servicing hearing aids employing the new tubes.

— n r i —

Building A Secretary

Here is a secretary that is simple to make, yet inexpensive. I believe many students and graduates may wish to build one like it.

Just the thing for preserving their school mail, textbooks, lessons and other records. If you see fit, pass the idea on in NATIONAL RADIO NEWS.

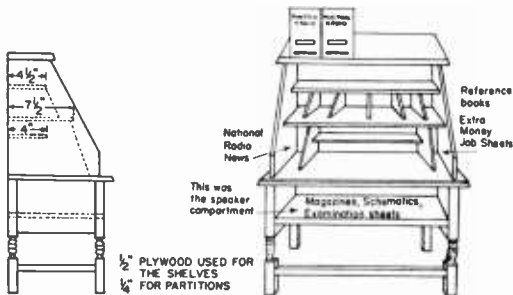

The one I have is made out of an old Radiola 18 which had the phonograph and record compartment above. I bought the set from a furniture store, which had taken it in trade on a new radio. It cost me \$3.50, with the chassis and phonograph in it.

Page Twenty-two

Since then I have made three more out of old Majestic Hi-boys. I sold them to people for their kiddies. I received \$7.00 apiece for them.

When making this desk, it is not necessary to take the cabinet apart, that is the sides; however the top is taken off in one piece, then sawed to fit.

I'm sorry that I'm not much of a draftsman, but I believe you can get a fair idea from the sketch.

MAX J. LEWIS, 5161 Junction,
Detroit, Mich.

— n r i —

Handy Way of Soldering for Those Without Power Supply Line

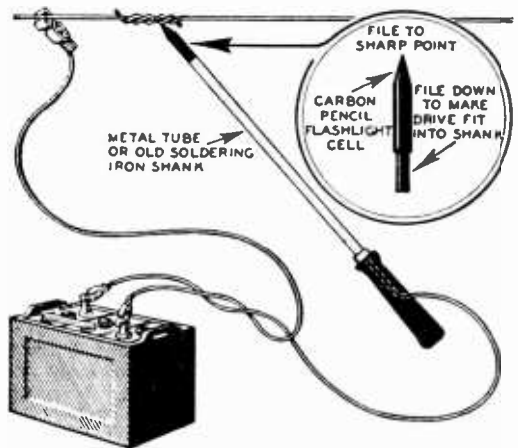

I have found a handy way of soldering which is very convenient to those who do not have access to a power supply line. I am describing it to you so you may pass it on to others through your NATIONAL RADIO NEWS, if you wish. The material required is: 1—6 volt battery, a piece of carbon obtained from a flashlight cell, two lead wires and an alligator clip.

CHARLES L. KINCAID,
Alderson, W. Va.

— n r i —

Some Amateur Call Letters Reported

W3INC—R. Bartolacci, Phillipsburg, N. J.
W8UHIJ—A. B. Lashock, Uniontown, Penna.
W2MMQ—K. Johnson, Peekskill, N. Y.
W9NBD—Arthur Elliott, Louisville, Ky.



RADIO-TRICIAN

REG. U.S. PAT. OFF.

Service Sheet

Compiled Solely for Students and Graduates

NATIONAL RADIO INSTITUTE, WASHINGTON, D. C.

PHILCO MODEL 18

ALIGNMENT

The intermediate frequency compensating condensers should be adjusted first. The intermediate frequency is 260 kilocycles. These compensating condensers are situated:

(a) 1st I. F. PRIMARY—(24), underneath chassis. Access from above through hole in sub-base, back of Tuning Condenser Assembly (5). Shield covers the hole and may be removed by prying with screw driver.

(b) 1st I. F. SECONDARY—(25), at rear of chassis, beneath the two vertically mounted electrolytic condensers (53) and (54). Accessible from rear of chassis.

(c) 2nd I. F. PRIMARY—(28), underneath chassis. Accessible from above through hole in chassis sub-base, in front of Type 42 (Driver; 2nd A. F.), and to right of Type 75 tube. The shield can be removed as under (a). The "OSC.; H. F." (15), the "DETECTOR" (11), and the "ANT.; H. F." (8) compensating condensers are then adjusted, in this sequence. The signal generator is set at 1500 K.C. for (15); at 1400 K.C. for (11) and (8). These are mounted upon the Tuning Condenser Assembly (5). (8) is mounted upon the condenser section nearest front.

The "OSC.; L. F." (18) compensating condenser, located at rear of chassis is adjusted next; with the signal generator set at 600

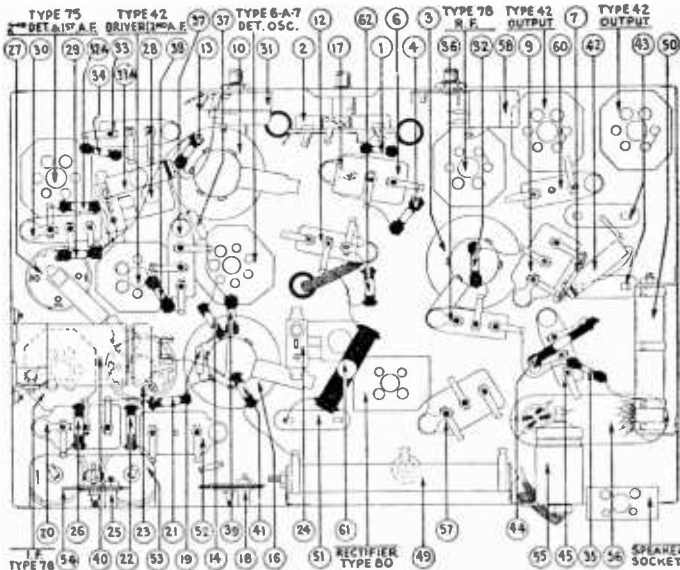

Bottom view of Chassis, showing parts

Tube Socket Voltages

Circuit	R. F.	Det. Osc.	I. F.	1st A. F. Driver	Output (Class "A")	Rectifier
Type Tube	78 6A7	78	75	42	42	42
Filament (F-F)	6.3	6.3	6.3	6.3	6.3	5.0
Plate (P-K)	210	210	210	120	205	280
Screen Grid (SG-K)						
(6A7)	80		80	200	300	300
G1-K		35				
G2-K		130				
Cathode (K-F)	2.8	2.8	5.3	0	0	0

All the above values were obtained from the underside of the chassis.

Volume control at maximum and station selector at 520 K. C.

K.C. It is accessible from rear of chassis. The Tuning Condenser (5) should be "rocked" while the "OSC.; L. F." adjustment is made.

The "Push-on Button" shields should be replaced over (24) and (28) after the adjustments are finished.

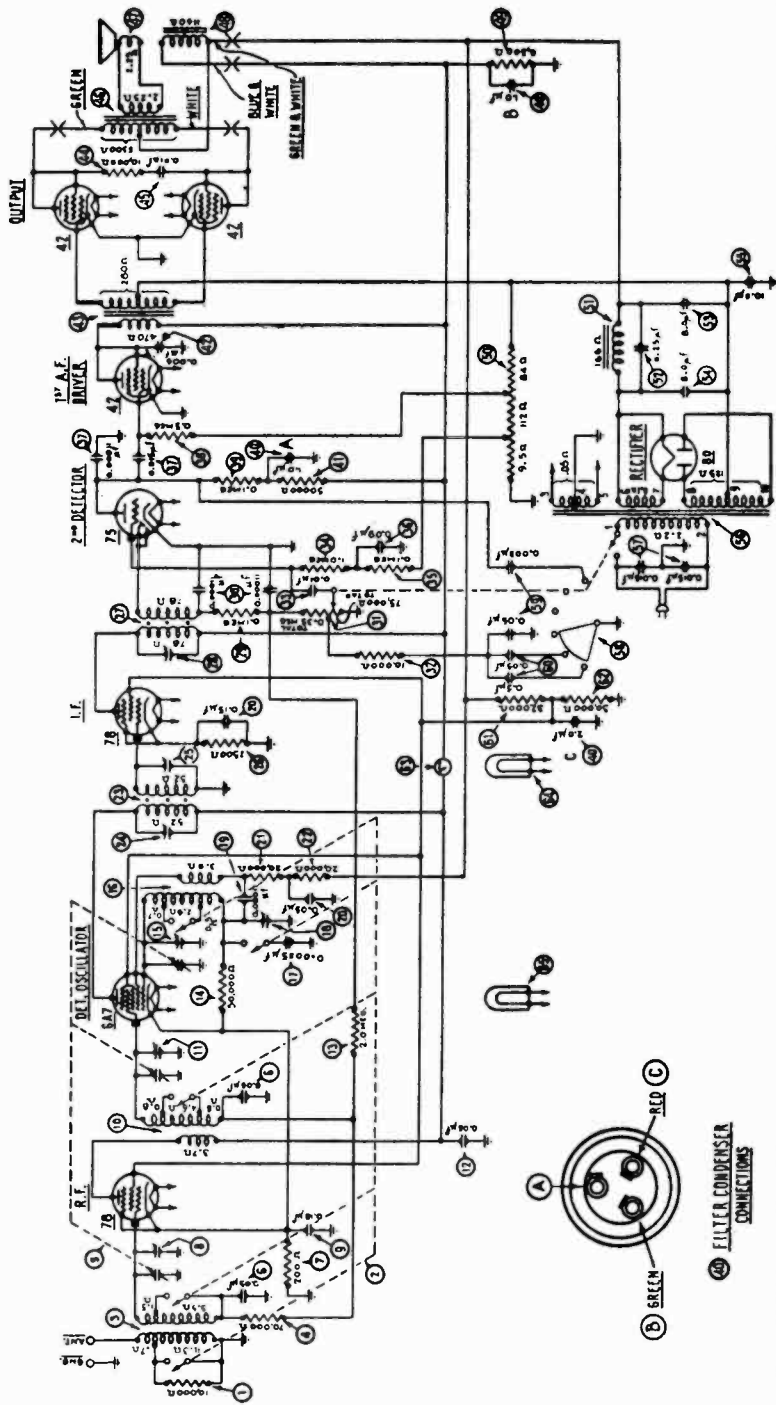

NOTE: In later production—(27)—a Resistor (240,000) (Red-Yellow-Yellow), Part No. 4410—(not shown in Schematic), is connected between line running from (18) to junction of (28), (29), and ground. (33)—a Condenser (.05), Part No. 30-4020—(not shown in Schematic), is connected between high side of Volume Control (42) and junction of (28), (29). (34) External Condenser in Tune Control circuit has but one section (in later production),—the .05 mfd. on point two. Point one goes directly to (27).
 NOTE: Values of primary and secondary of (46) Output Transformer, and value of (47) Voice Coil, are given in impedance at 200 cycles, 30 volts. The D. C. resistance of the primary is 350 ohms; of the secondary, .09 ohm, D. C. resistance of (47) is 1.11 ohm.

(46) FILTER CONDENSER CONNECTIONS

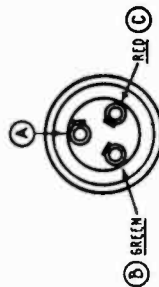



The Service Forum

Conducted by

J. B. Straughn, N. R. I. Service Consultant

Send in your service notes. We will re-word them for publication. To qualify your note for the NEWS you must have observed the same trouble on two or more identical receivers.

RCA MODEL 9TX31

DEAD

If the pilot light is burned out and the filament circuit checks open, see if the pilot light shunt resistor is burned out. This is a 24 ohm flexible resistor. As a replacement you can use a 25 ohm 10 watt resistor.

EDWARD H. EICHHOLTZ, Maine.

— n r i —

GENERAL ELECTRIC MODEL S42

WEAK

Look for a shorted 8,000 ohm resistor in the cathode to screen grid circuit of the oscillator tube.

J. K. PALMER, New Brunswick.

— n r i —

STEWART WARNER MODEL R100

WEAK

Look for a partially shorted resistor from screen grid to B+ which is in series with the volume control. Replace with 20,000 ohm 10 watts. Also check volume control to see that it is not burned out.

J. K. PALMER, New Brunswick.

— n r i —

SONORA MODEL D50

NO CONTROL OF VOLUME

Look for open in second section of voltage divider from B+. Replace with 12,500 ohm 5 watts.

J. K. PALMER, New Brunswick.

— n r i —

SENTINEL MODELS 63B AND 68B

DEAD

If there is no high voltage check to see if the .005 mfd. 400 volt condenser connected from one side of the secondary to ground is shorted. The buffer condensers are across the secondary. It sometimes happens that the short is intermittent and the vibrator points are badly burned and stick before the radio is brought in for service. This condenser should be changed if the vibrator gives trouble.

HOMER GROVE, North Dakota.

— n r i —

AIRLINE MODEL 403

DISTORTION

Check the 15 micro-microfarad I.F. coupling condensers for leakage.

INTERNATIONAL MODELS 66X, 86 AND 96

DEAD

Check the cathode bias resistors of the 6D6 combination detector oscillator tube. There are two of these resistors connected in series between the cathode and chassis. The one connected to the cathode has a value of 500 ohms while the one connected to the chassis has a value of 2,000 ohms. The 500 ohm section is the one which usually opens. By using a 1,000 ohm replacement at this point an increase in sensitivity will be noted.

F. N. WINDERWEEDLE, Louisiana.

— n r i —

STEWART WARNER MODEL 139A

INTERMITTENT

Try a new condenser in place of the .02 mfd. unit between the grid of the 11B5/25S and the center tap on the volume control. This condenser frequently opens up thus causing intermittent operation. A 600 volt replacement should be used.

— n r i —

SENTINEL MODEL 421

HUM MODULATION

Check to see if a good ground is used with the receiver. If hum is encountered only when the speaker is in the cabinet and additional filter condensers do not cure it, move the speaker back one or two inches from the baffle. This will reduce the low note response sufficiently to eliminate the hum but will not cause a noticeable change in tone quality.

— n r i —

PHILCO MODEL 38-116

IMPROVEMENT

To improve the holding characteristics of the magnetic tuning circuit a condenser Philco part No. 30-1097, 5 mmfd. should be connected from the grid of one of the 6J5G discriminator tubes to ground.

— n r i —

PHILCO MODELS 630 AND 635

OSCILLATION

If oscillation is noted when the volume control is advanced and at high settings of the tone control, keep the control grid lead of the 75 type tube away from the 42 type power tube.

(Page 27, please)



N.R.I. ALUMNI NEWS

Clarence Stokes	President
Dr. Geo. B. Thompson, F. E. Oliver	Vice-Pres.
Allen McCluskey, Alfred K. Stock	Vice-Pres.
Earl Merryman	Secretary
Louis L. Menne	Executive-Secretary

RADIO'S BIGGEST YEAR

By L. L. MENNE,

Executive Secretary, N. R. I. Alumni Association

With all statistics now available, the record shows that 1939 was the best the Radio industry has ever known.

Unit sales of Radio receiving sets reached the staggering total of 9,100,000. This was a gain of 30.4% over 1938 and a gain of 11.5% over the previous banner year of 1936.

Battery portables, in their first full year on the market, ran up a total of \$50,000 sales. Auto units sky-rocketed to 1,150,000 unit sales—a gain of 26.4% over the previous year. It is estimated that one out of every five automobiles is now carrying a Radio set.

Compact table models gained 15.4% in 1939 with 4,825,000 unit sales. Consoles had a jump of 16.9% with 1,800,000 sales.

Total value of all sets sold, according to *Business Week* and *Radio Retailing*, showed an increase of 18.75%—from \$240,000,000 to \$285,000,000 (these figures are based on list prices).

There's an industry for you! \$285,000,000 worth of Radio receivers were sold in one

year—last year. There's plenty of potential customers for Radio servicemen.

Cold figures are never very interesting. But only by the use of figures is it possible to show these gains. In no other way can we point out to you that \$285,000,000 worth of receivers were sold last year. Two hundred eighty-five million dollars is a lot of money, whether you write it in figures or spell it out. That's the value of Radio receivers sold last year in your business. That's the important point.

1940 is only a quarter gone, but manufacturers already predict that this will be a banner year in Radio. A presidential year—war news—improved business conditions—these are the factors which point to a big 1940 in Radio.

In a mammoth business such as Radio—growing, alive, pulsating with new developments and opportunities—there is plenty of money to be made by the go-getters. Pull up your belt another notch and get going—after your share of the rewards which Radio offers in 1940.

The Service Forum (Continued from page 25)

RCA MODEL 120

MOTORBOATING

This is generally due to an open in one of the three condensers located in the electrolytic block at the left of the tuning condenser gang. If one of the condensers is found to be bad it will be best to replace all of them to avoid future difficulty.

-----n r i-----

ZENITH MODEL 4K310

DEAD

Disconnect diode of 1H5G and check for leakage from tube prong to ground. If leakage exists it will be best to install a new tube socket.

-----n r i-----

ZENITH MODEL 4K401

OSCILLATION

Try a new 1A7 type tube. If motorboating is encountered check the ground connection on the electrolytic condenser which is made through a rivet to the chassis. A soldered connection should be made.

-----n r i-----

ZENITH MODEL 9S307

DISTORTION

A distortion which is similar to blocking of the A.V.C. system is generally caused by an open output filter condenser.

-----n r i-----

STROMBERG CARLSON

MODELS 150, 155, 160 AND 180

DISTORTED AND WEAK

Try a new 4 mfd. electrolytic condenser on the screen of the 6K7 audio amplifier. Leakage in this condenser lowers the screen voltage on the tube thus preventing it from operating on the straight portion of its characteristic curve. As a result distortion and weak reception takes place. In order to have a condenser with a high internal resistance it is advisable to use one rated at 475 volts.

-----n r i-----

RCA MODEL 96K6

OSCILLATION

If it is necessary to replace the audio coupling condenser, you should use a .0025 mfd. paper condenser, otherwise motorboating and oscillation will occur. The condenser should be rated at 600 volts.

-----n r i-----

MAJESTIC

MODEL 200

CRACKLING

NOISE

This is often due to a defective voltage divider and sections R1, R2, R3, R4 and R5 should be replaced.

-----n r i-----

PHILCO MODEL 60

INTERMITTENT HUM

This may be due to opening up of the .05 mfd. condenser used as the L.F. plate by-pass unit. This condenser is housed in the metal condenser block. The replacement value is not critical and anything between .05 mfd. and .5 mfd. may be used. The condenser you install should be rated at 600 volts. At the same time, check the remaining condensers in the block if further trouble of this nature is encountered.

SENTINEL MODEL 73B

AUDIO HOWLING

Clean the 500,000 ohm volume control with carbon tetrachloride. Shield the grid lead from the 6S7G to the grid bias cell. Try connecting a .002 mfd. condenser from the left side of the volume control to the chassis as this will give better bass response.

-----n r i-----

SENTINEL MODEL 36L

DISTORTION

Try new 48 type tubes and pilot lights. If the trouble continues proceed as follows: Looking at the bottom of the set and reading from the back to the front of the chassis, connect one end of a 6.25 ohm resistor to the third lug on the resistor strip (one side of the 32 volt power cord connects to this point) and the other end of the resistor to the first lug of the resistor strip. You should also be on the lookout for leakage in the .01 mfd. coupling condenser between the plate of the 75 and the control grid of the 76 audio driver tube.

-----n r i-----

MANTOLA MODEL 5Z

DISTORTION

This is often due to a short between the speaker field and the core. The wire in the field is not insulated, other than by enamel, and will short. Remove the field coil and install insulation.

-----n r i-----

SILVERTONE MODEL 4589

DEAD AT HIGH FREQUENCIES

This is usually due to a defect in the .0041 mfd. condenser in the oscillator circuit. You may replace the condenser with a .005 mfd. unit.

-----n r i-----

PHILCO MODEL 89

FRYING NOISE

This is usually caused by a partial open in one of the L. F. transformer windings. Check the windings with an ohmmeter. Any variation in the resistance reading indicates that the winding under test is open and a new transformer should be installed.

-----n r i-----

PHILCO MODEL 57

NOISY TUNING

Remove the receiver from the cabinet and see if wax has fallen between the variable condenser plates. This wax comes from the power transformer which is mounted directly above the condenser. The fact that some of the wax has melted out of the transformer does not mean that it is defective.

-----n r i-----

PHILCO MODEL 90

DEAD AT HIGH FREQUENCIES

Try connecting a 10,000 ohm resistor in parallel with the oscillator cathode resistor. Also suspect moisture absorption by either the coil or the trimmer condensers in the oscillator circuit.



Here and There Among Alumni Members

"We have a second harmonic, Elizabeth Anne—weight ten pounds. Born February 5. Father doing nicely," says Raymond V. Barnett, Beulah, No. Dak. Yeah! He would bc. Congratulations, Mr. and Mrs. Barnett.

—n r i—

Radio operator at Station WTMV, East St. Louis, Ill., is Erle E. White, who graduated in 1925. During all these years White has kept in frequent contact with us.

—n r i—

James Walmley of Moose Jaw, Sask., Canada has joined the Royal Canadian Air Force, as a wireless operator.

—n r i—

With the help of only his good wife, E. A. Charlton is doing a \$7,000 yearly business in Helena, Mont. His shop is known as "Radio Service" and is located on Main Street. Charlton was working for \$40 a month when he enrolled. Quite a difference!

—n r i—

Walter H. Smith, whose home is in Canada, is Radio operator on board ship and has made several trips to Europe, West Indies and South America. He says there is never a dull moment these days.

—n r i—

William Franklin Cook of the Instruction Department (Frank to us) is proud of a snapshot he took of a fancy bred bull. Says he is the prize winner to end all prize winners. That's some bull, Frank.

—n r i—

Wife say, "Confucius, he talk too much."

—n r i—

R. G. Wright, who operates Wright's Radio Shop at the oddly named town of Burnthouse, W. Va., writes that he lost all his records when his house burned. Hey, what is this!

—n r i—

R. James Hannon of Allenford, Ont., Canada, recently was appointed agent for RCA-Victor and has sold sixteen new sets in this small community. That's a good start.

—n r i—

Our deep sympathies are extended to T. S. Norton who lost his mother, suddenly and unexpectedly. It was she who encouraged Norton to study Radio. It must have been a source of satisfaction to her to see her son reach the position of Chief Radio Operator, Police Department, Hamilton, Ohio.

—n r i—

Our graduate R. Cooper Bailey of Richmond, Va., has been appointed instructor in Electrical Engineering Problems at the Virginia Mechanics Institute.

Arthur L. Bergom of Rockford, Ill., graduated in March, 1922. He writes to say he is now a Radio operator at one of the U. S. Civil Aeronautics Authority stations. Glad to have this good news from an old alumnus.

—n r i—

Earl G. Ross of Armdale, N. S., Canada is a public school teacher who took up Radio because of its increasing popularity as an educational subject.

—n r i—

Albert E. Vincent was recently elected Treasurer of the South Bend, Indiana, Amateur Communications Society.

—n r i—

Raymond R. Bourret who is a Flight Radio Officer with Pan American Airways is now addressed in care of Panair do Brasil, S. A., Aeroporto Santos Dumont, Rio de Janeiro, Brasil. He was formerly at headquarters in Miami.

—n r i—

George Chamberlain of Dawson Creek, B. C., Canada, recently married. Congratulations, George. And may all your troubles be—more Radios to repair.

—n r i—

Herbert C. Dodd and his very pleasant wife stopped at headquarters in Washington for a visit. They were motoring from their home in Toronto, Ont., Canada, to Florida for a winter vacation. Dodd, you remember, won a portable typewriter in a quiz broadcast. Since then he has also won a watch. The man is a human encyclopedia.

—n r i—

For the first time in ten years Earl Bennett of Chicago Chapter is not holding an office of one kind or another in the Alumni Association. We are giving him a rest, but we'll probably put him to work again in some capacity in 1941. We can't spare men like Earl.

—n r i—

Joseph D. C. Whitcomb of Orange, Mass., put on a spurt and with the extra Radio earnings he paid for the engagement ring he gave his girl. And, he is coming to Washington to visit. Or, will it be a honeymoon!

—n r i—

Ervin F. Lyke is Customer's Service Manager for Sears Roebuck & Co. at Elmira, New York.

—n r i—

Frank Brocsmen of Cincinnati is now Radio operator in the 22nd Reconnaissance Squad of Mechanized Cavalry of the Ohio National Guard.

—n r i—

R. S. Ewing is Representative for the exclusive distributors for RCA-Victor Radios in the Dept. of Esenintla, Guatemala, C. A. Last year he made \$960.00 in commissions through Radio sales, in addition to his regular Radio servicing business.

New York Chapter

The following were elected to serve as officers of this chapter for the year 1940:

Chairman—Irving Gordy
Vice Chairman—A. Burt
Secretary—Louis J. Kunert
Treasurer—J. H. Struble

There was strong sentiment for Alfred Stock to serve a second term as Chairman but he decided that Irving Gordy was the logical man for the job this year. Stock is doing exceedingly well in his business and he felt he would like to see someone else in the chair although he will continue to take a very active part in the affairs of our chapter. Gordy, by the way, is a thoroughly experienced Radio man who has contributed many articles on various Radio subjects to leading publications.

Kunert and Struble were nominated without opposition. They were unanimously re-elected.

Mr. Burt is an old stand-by who has been a member of our chapter for many years. He will fill the office of Vice Chairman with genuine credit to us.

Our chapter is proud of the fact that our own Alfred Stock was elected Vice President of the National organization.

At one of our recent meetings, Mr. Kevelson, Electrolytic Engineer of Solar Mfg. Corp., was our speaker. We owe a vote of thanks to Mr. Philip M. Gotthold of the sales department of this corporation for his valuable assistance in connection with this meeting.

At another of our meetings, F. E. Wenger of the engineering department of the Triplett Electrical Instrument Co., was our guest and principal speaker. More than sixty attended this meeting.

We alternate between speakers and our Service Forum. The Forum is presided over by our Chairman and these meetings are always well received by our members, who are free to ask any questions they desire and who receive full explanations.

At another of our meetings, we discussed the business end of a Radio service shop. The value of good business methods cannot be overestimated, and we think a meeting devoted to this subject every now and then is just as important as one devoted to the problems of Radio servicing.

Students and graduates in the New York Metropolitan area are always welcome. We meet regularly on the first and third Thursday of each month at Damanzek's Manor, 12 St. Marks Place, New York City.

L. J. KUNERT, *Secretary*.

Philadelphia-Camden Chapter

We are in the midst of a big campaign to increase our membership. The results have been most gratifying. We wish to make known to each student and graduate in this area that they are cordially invited to become members of this chapter either as full fledged members or as associate members. They will profit from the discussions which take place at our meetings and we will appreciate their support.

Mr. David S. Blackwell, our new Chairman, is giving us some splendid information at our meetings. Mr. Blackwell not only is a graduate of N. R. I., but holds a B.S. degree in Electrical Engineering. Those who fail to attend meetings regularly are really missing something worthwhile.

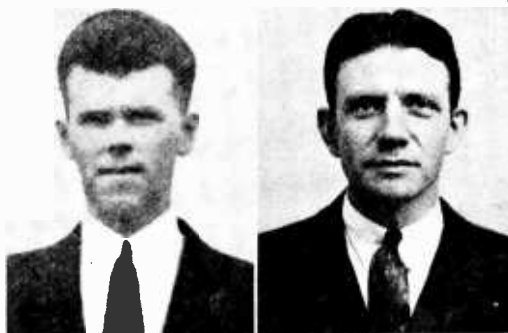

David S. Blackwell,
Chairman
Philadelphia-Camden Chapter

Norman Kraft,
Vice-Chairman

When we received word that Clarence Stokes, of our chapter, was elected President of the National organization of the N. R. I. Alumni Association for 1940, our Chairman arranged a surprise celebration for Mr. Stokes. This was in conjunction with one of our regular meetings, and the boys really had a rousing good time. There was plenty to eat and drink. Stokes addressed the chapter and was in his usual good form.

Our meetings have been devoted to a discussion of Radio problems generally, use of instruments, how to sell your Radio services, what to charge for Radio work, and matters of this kind.

Our chapter was established five years ago this spring, and we plan an anniversary party. Announcement will be sent to members in the regular way.

Meetings are held on the first and third Thursday of each month at the Longshore Radio Service, 4711 Longshore St., Tacony, Philadelphia.

JOHN BLASELLI, JR., *Secretary*.



Chicago Chapter

Our new Chairman, Clarence Schultz, is doing a good job and is getting fine support from our Vice Chairman, Ed. Sorg, and other officers. Earl Bennett has been giving us some splendid talks.

We have had no speakers outside of our own members because our fellows seem to like the less formal type of meeting where receivers are brought in, diagnosed and repaired.

Since our last report, we have had a number of new members. We have also had some visitors at our meetings. All are most welcome. We cordially invite N. R. I. men in Chicago and vicinity to drop in on us at Eckert Park Field House, 1400 W. Chicago Ave., on the first and third Thursday of each month.

ERIC JOHNSON, *Secretary.*



This happy group was snapped at a recent party sponsored by Chicago Chapter, and held at the home of Mr. and Mrs. Earl Bennett.

— n r i —

Baltimore Chapter

All of our recent meetings have been very interesting, but the one at which Mr. Joseph Kaufman, N. R. I. Director of Education, gave a talk on Frequency Modulation was the best attended and aroused most enthusiasm. Mr. Kaufman went into the subject thoroughly and clarified all of his points with blackboard illustrations.

At the close of his talk, Mr. Kaufman answered all questions. This led to a more or less informal discussion which was beneficial to all.

Pete Dunn, our Chairman, deserves credit for the good attendance at this meeting because he

Page Thirty

personally distributed posters in various Radio establishments, calling attention to the fact that Mr. Kaufman would be our speaker.

At one of our meetings, it was decided to arrange a business and social meeting for the entertainment of our National President, Clarence Stokes of Philadelphia. Plans are being formulated and announcement will be made to our members by mail.

Because unusual demands upon the time of W. B. Geise make it difficult for him to attend meetings regularly, he requested that he be relieved of the responsibilities of Secretary-Treasurer. Mr. Gralley, our former Chairman and recently elected Vice Chairman, volunteered to accept the duties of Secretary-Treasurer, and Mr. Geise was made Vice Chairman instead.

We are very glad to have our former Chairman, W. W. Jensen, back with us after a siege of illness.

Meetings are being held regularly on the first and third Tuesday of each month at Fishpaw's Hall, Baltimore and Gilmore Sts. Meetings start promptly at 8 P. M. in order that all business may be concluded in time for adjournment by 10 P. M. or shortly thereafter.

E. O. E. GRALLEY, *Secretary.*

— n r i —

Detroit Chapter

Since the last issue of the NEWS went to press, we held our annual election and the following were chosen to serve this chapter during 1940:

Chairman—John Stanish
 Vice Chairman—Everett Pike
 Secretary-Treasurer—F. E. Oliver
 Assistant Secretary—Louis Kolp
 Financial Committee—J. A. Quinn
 C. H. Mills
 Librarian—Wm. Ankenny
 Assistant Librarian—J. Frederick

Chairman Stanish and Secretary Oliver were re-elected without opposition. They pledged themselves to continue to give us the same interesting and constructive meetings as during their previous year of administration.

Our meetings are devoted principally to discussions of Radio problems. We bring into play the use of various instruments and all are given an opportunity to ask questions or volunteer information.

We meet at the comfortable quarters of the Radio Specialties Co., 11800 Woodward Ave., on the second and fourth Thursday of each month.

F. E. OLIVER, *Secretary.*



Thank You. Who Else Agrees?

Since enrolling with the National Radio Institute, I have received NATIONAL RADIO NEWS continually and think it's "tops." Please permit me to disagree with Mr. Kershaw of Little Neck, L. I. I can't see just why he wants our friends Jay and Ozzie left out. He admits they are interesting, as do we all, but I also think those little stories are very educational. They may be rather far fetched at the present time, but the tricks of Jay and Ozzie are all Radio possibilities of the future. I hope to see much more of "Electronics, Inc."

JACK ALLEN,
Superb, Sask., Canada.

----- n r i -----

Shall We Drop Novel Radio Items?

NATIONAL RADIO NEWS is a fine informative Radio publication and I enjoy the Laboratory Page, the Service Forum and any other articles pertaining to my line of Radio work. However, in criticism, please permit me to say that I agree with Mr. Lester Kershaw's letter in the December-January number in that I believe that "Novel Radio Items" could be replaced with more informative and worthwhile material.

W. S. WARING,
Redlands, Calif.

----- n r i -----

Kaufman, Is Your Friend Kidding?

All that is lacking in Mr. Kaufman's picture in the February-March issue of NATIONAL RADIO NEWS is his dog. The Radio certainly looks like a swell job. I believe Mr. Kaufman deserves a medal for being the first Radio man who has a good set at home. The decorating scheme of course is excellent—even the pipe matches.

S. RUTTENBERG,
Amperite Company, New York.

Puzzling Radio Questions Click

The new section in NATIONAL RADIO NEWS, "Puzzling Radio Questions," is certainly a worthwhile addition. Also the article on Loop Antennas was very informative. The NEWS is a fine magazine all the way through.

MILTON W. McRAE,
Presque Isle, Maine.

----- n r i -----

Liked Last Issue

Radio Altimeter for finding height of planes when in fog and other unfavorable weather, in the February-March issue of NATIONAL RADIO NEWS was very interesting. Also the Loop-Aerials article was very good. I *do* want more Electronics, yes indeed.

NORMAN A. ZUEHL,
Zuehl, Texas.

----- n r i -----

Frisco, Open Your Golden Gate

I see that William Sawyer would like to have a Chapter out here. I also am interested in having a chapter started here in San Francisco. I am proud to be a member of the N. R. I. A. A.

DAVID TORRE, JR.,
San Francisco, Calif.

----- n r i -----

He Means the News?

Hey!!! What I would like to know is, WHERE IS MY N. R. I. NEWS? If there is one thing that will get a howl out of me quicker than anything else it is to have something happen to my copy of the N. R. I. NEWS. I am CLAMORING for my NEWS. And when I say NEWS, I mean NEWS.

CHARLES DYKEMAN,
Dresden, N. Y.

New Wire-Wound Resistors Have Teledot Wattage Indicators

Every inch of wire used in the new Sprague Koolohm resistors is uniformly insulated with a hard, moisture-proof insulation developed especially for this purpose. It conducts heat away from the wire with amazing rapidity and is not damaged even by bright red heat. This insulation of the wire makes possible interleaved windings wherein wires touch but do not short. This feature, in turn, permits the use of larger, stronger wire to give higher resistances in smaller sizes.

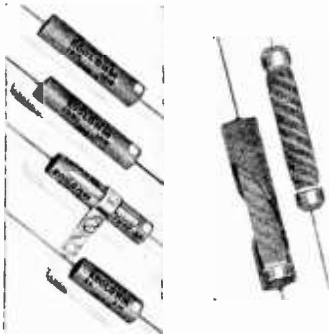

Left: Four types of Sprague Koolohm resistors; one is adjustable. Right: Sprague Koolohm resistors with outer ceramic casing removed, revealing interleaved insulated windings.

Koolohm windings are electrically insulated in a dark brown ceramic shell. They can be mounted in direct contact with the chassis or other grounded parts. On the end of each Koolohm resistor is a red Teledot wattage indicator, which automatically changes color when a 25% overload occurs. When the overload is removed, the Teledot returns to its original red color. N. R. I. students and graduates can obtain a complete descriptive catalog covering these Koolohm resistors *by writing to the manufacturer*. Sprague Products Company, North Adams, Mass.

— n r i —

Watch for Next Issue

Chief Dowie is working on an interesting technical article for the June-July issue—one which you will want to save for future reference. We also want to tip you off that Mr. Markus is preparing another hair-raising scientific fiction story featuring Jay and Ozzie of Electronics, Inc. Don't miss the NEWS. We have many good things in store for you in the next several issues.

NATIONAL



FROM N.R.I. TRAINING HEADQUARTERS

Vol. 9

Apr.-May, 1940

No. 2

Published every other month in the interest of the students and Alumni Association of the

NATIONAL RADIO INSTITUTE
Washington, D. C.

The Official Organ of the N. R. I. Alumni Association

Editorial and Business Office, 16th & You Sts., N. W.,
Washington, D. C.

L. L. MENNE, EDITOR

L. J. MARKUS, TECHNICAL EDITOR

NATIONAL RADIO NEWS accepts no paid advertising. Articles referring to products of manufacturers, wholesalers, etc., are included for readers' information only, and we assume no responsibility for these companies or their products.

Index

Article	Page
The N. R. I. Plan	3
Radio in Special Emergencies	8
The Value of a Good Credit Rating	9
Laboratory Page	11
Service Sheet, Philco 39-25	13
Novel Radio Items	15
N. R. I. New Test Bench	16
Puzzling Radio Questions	20
Police Radio News	22
Service Sheet, Philco 18	23
Service Forum	25
N. R. I. Alumni News	26
The Mailbag	31