



# **NATIONAL RADIO NEWS**

Aug.-Sept., 1934  
Volume 6  
Number 3

**Read the IMPORTANT Announcement  
by President Smith  
on page 2  
About the New, Bigger, and  
Better  
NATIONAL RADIO NEWS**

**TWENTIETH ANNI-  
VERSARY YEAR**

**OF THE NATIONAL  
RADIO INSTITUTE**

# **An Important Announcement!**

**E**VER since the publication of National Radio News was taken over by the N. R. I. Alumni Association, at which time it became their official organ, the News has been steadily improving—steadily growing.

New services have been offered students and Alumni of the National Radio Institute through the columns of the News. Bigger and better technical and business articles have been presented. Innumerable letters are on file from readers of the News, praising it, and many go so far as to say that National Radio News is the best publication of its kind available.

In the last issue of National Radio News, Alumni Association members received an entirely new and novel service, known as "Alumni Association News and Information Service." This addition was immediately so popular that the Editor of National Radio News was literally flooded with letters from readers stating their appreciation and requesting that this service be continued as a regular part of National Radio News. The enclosure of those "News and Information Service" sheets was merely as a test, however, to determine their popularity. Since this popularity has been proven, it is now planned to include the service directly in the News, rather than on a separate sheet. In order to do this—in order to care for the many new services—to permit more, bigger and better articles, it has been decided to increase the size of National Radio News. Beginning with the next issue National Radio News will be one-third larger than this issue. It will contain 32 pages instead of the 24.

The Editor of National Radio News feels sure that the additional benefits which can be given in this new, larger National Radio News, will be of great value to its readers and that it will be appreciated.

For the further convenience of our readers, in the future National Radio News will come to you flat, rather than folded.

The National Radio Institute was glad to cooperate with the N. R. I. Alumni Association in bringing this additional National Radio News value to the students and Alumni Association members of the National Radio Institute.

**J. E. SMITH**

*President.*

# The Service Forum

This is a new Department—a new service—brought to its readers by National Radio News. There is a wealth of material to be published in this Department—and we hope you will like it and make the best possible use of this information. Contributions are requested from our readers. Address them to "The Forum Editor, National Radio News, 1536 You St., Washington, D. C."

## PHILCO MODEL 15 TUNING CONDENSER SLIPPING

Replace the present spring, used to hold the drive cable under tension (part No. 6508) with new part No. 7776 which is heavier. The new spring will prevent the cable from slipping or the condenser rotor from dropping under its own weight.

— n r i —

## ALL SETS PILOT LAMPS FLICKERING

When this trouble is due to loosening of the lamp in its socket due to vibration, the lamp may be removed and the socket flattened slightly with a pair of pliers. This will place enough pressure on the lamp base to prevent it from working loose.

— n r i —

## ZENITH 34 HUM

This may be caused by a heater to cathode short in some of the 27 type tubes. Check for this trouble by trying new tubes known to be in good condition. Lack of volume may be caused by a poor contact at the end bushing on the condenser gang. This connection should be cleaned.

— n r i —

## BOSCH MODEL 28 REPLACING VOLUME CONTROL

The volume control on this receiver is not directly connected to the volume control knob but is driven by a pulley arrangement. If it is not possible to obtain a genuine replacement unit, use a 500,000 ohm volume control and place the volume control in the position formerly occupied by the pulley unit. Shielded wire should be run to the grid of the first R. F. tube and to the stator of the first condenser. The shielding on these wires should be grounded to the chassis. The shielding from ordinary shielded lead in wire may be used for this purpose.

## ATWATER-KENT MODELS LACK PEP 40, 42, 44, etc.

First check the detector plate to cathode R. F. bypass condenser and the grid suppressors. If they seem to be okay replace the detector plate bypass condenser with a 1 microfarad 200 volt unit. To do this connect the condenser from the yellow lead on the power pack cable template to the center post coming up from the sealing compound. The latter is a ground connection.

— n r i —

## PHILCO—ALL MODELS INTERMITTENT RECEPTION

Outside of defective tubes the most common cause for intermittent reception is to be found in bypass condensers which intermittently become open. Generally the coupling condensers are at fault. These condensers may be checked by probing through the eyelet on the condenser case with a sharp test instrument and by gently lifting up on the wire connected to the lug. If moving this wire causes the receiver to cut out, the condenser is defective and should be replaced with a new one.

— n r i —

## ALL RECEIVERS INSENSITIVE AT HIGH FREQUENCY ENDS

In superheterodynes using a screen grid tube as a combination detector oscillator, difficulty may be encountered in getting the oscillator to oscillate at the high frequency end of the dial. Changing tubes in this stage will generally remedy the trouble for a short time. Later, however, it will show up again. To make a permanent repair, decrease the size of the bias resistor connected from the cathode of the tube to the chassis. Decreasing the resistance by about one-third of its total value will give satisfactory results although it is wise to experiment in order to get a value which will result in greatest output. The way to check up on this is to connect an oscillator to the input of the receiver and an output meter to the output. Change resistors until best results are obtained—if necessary retune the receiver each time you try another resistor.



# A Few Words With The N.R.I. Director

E. R. Haas,  
Vice-President  
and Director

## Tell Your Experiences

Your experiences in Radio are interesting to your fellow students and graduates who are readers of National Radio News.

With the new, bigger, better National Radio News beginning next issue we will have more space to devote to such material and it is therefore requested that readers of National Radio News do all in their power to help keep the News as interesting as possible.

We want letters from you fellows out in the field for possible publication under what will be known as "My Most Thrilling Radio Experience."

If suitable material is received several of these letters will be published in each issue of National Radio News.

Now here's the kind of material we want:

You ship Radio operators tell us about some of your experiences where Radio was used for rescue work. Police Radio men can tell us some tales of criminal apprehension. You fellows in lighthouses and beacon stations and on the airways must certainly have had some thrilling experiences in which Radio played a major part.

Broadcast operators can tell us of some of the famous persons they have met either in the studio or on pickup jobs. Radio servicemen who have had the opportunity to service receivers in the homes of famous people—who have made outstanding successes in doing jobs where other men fell down, who have been called upon to do unusual Radio jobs—install or operate public address systems for famous persons or at notable gatherings.

We don't want any Baron Munchhausen tales—we want truths about the happenings in the every-day life of the Radio man.

Address all such material to "The Thrilling Experience Department," National Radio News, 16th and You Streets, N. W., Washington, D. C., and be sure to put a note on the bottom of your article as follows: "Permission for publication in National Radio News granted."

We prefer that you write on one side of the paper only and give your name, address and N. R. I. student number.

## Do You Have Nightmares?

Just how sure are you of yourself?

I don't mean the sureness, the aggressiveness, the swagger and bold front you show to the world—but how sure are you of yourself when you are all alone—at night—with no one around you—with plenty of opportunity to think?

How sure are you of your future? How sure are you of your job? How sure of success? Are you worried about what you've done in life—how well you are prepared to achieve and to progress?

Maybe you are, but most likely you have the same troubled thoughts that most fellows have—thoughts which make you entirely dissatisfied with what you've done in the past and what you may expect of the future.

If you are not troubled by such thoughts—we can only wish you good luck and hope that all of your beautiful dreams come true. But if you do have these nightmares (and very helpful nightmares they can be) let us offer you the formula which will go a long way toward relieving your mind. *The formula is simply study and work.*

But even this formula will not entirely correct the situation because in a measure dissatisfaction with conditions and future success usually go hand in hand. It is because young men are not entirely satisfied with their future prospects that they take definite steps toward remedying conditions and becoming more successful. It is because successful men are not satisfied that they go to even greater successes.

N. R. I. training has only one big objective—that is to help you by giving you what you need to help yourself. To this training it is only necessary to add the "work" element to iron out your fear by assuring success,

# Meet The Newest Member Of The N. R. I. Staff



Paul H. Thomsen  
N. R. I. Communications  
Consultant

**T**HIS is Paul H. Thomsen, fellows, who has just recently joined the National Radio Institute's Staff of Instructors. He is here to serve you in the capacity of Communications Consultant.

Mr. Thomsen, a native of Luverne, Minnesota, comes to the Institute with a background of experience which will make him of inestimable value to students and graduates of the N. R. I., and to readers of National Radio News. Although only twenty-seven years of age, he is a real old-timer in Radio, having gotten his start way back in 1919.

It was in those early days that he first became interested in Radio and started doing experimental work in transmitting and receiving, operating a licensed amateur spark transmitter with the assigned call letters of 9BNF. Even today, he maintains and operates his Amateur Station, W3LA (1 kw., crystal controlled, operating on 3513 and 7026 kcs.), located at his residence in Silver Spring, Maryland, which is a suburb of Washington.

In 1926 Mr. Thomsen came to Washington from Minnesota and became associated with Television Station W3XK, owned by the famous Television expert, C. Francis Jenkins. Under the direct supervision of Mr. Jenkins, Mr. Thomsen designed and built the greater majority of the equipment of W3XK and then became Chief Operator of both the experimental sight and sound stations W3XK and W3XJ, remaining with that organization from 1926 until he accepted a position with The Radio Research Company of Washington, D. C., in the fall of 1932. This organization was working on important contracts requiring special design of Radio receiving and transmitting equipment and for one year Mr. Thomsen remained with them until the contracts had been completed.

He then became associated with the Amalgamated Broadcasting Company, as Engineer in Charge of the Long Lines Department of that company's branch office in Washington, D. C.

So it is easy to see why this man was asked to join the Instruction Staff of the National Radio Institute. Few people know very much about Television at present, and it is felt that with Mr. Thomsen's knowledge, particularly from a practical point of view: he will be able to place N. R. I. students and graduates far in advance of the field in this subject.

He is a member of the American Radio Relay League, and also a member of the Institute of Radio Engineers. Now, that we have dis-

cussed this gentleman, let's hear what he has to say for himself, in his own words, as told to your Editor.

"I'm mighty glad," he said, "to be associated with an organization like the National Radio Institute. It is a real live institution—just what a Radio School should be. Its Staff is a fine body of men and women whose sole purpose seems to be to serve their students and graduates and to help them go forward to successful careers in Radio.

"I've only been here long enough to get a bird's-eye view of the whole situation, but that is long enough to know the kind of work that is being done. I have gone through the N. R. I. Course and see that the aim has been to make it as simple as possible and still keep it practical. Both purposes have been accomplished, and it is easy to see why so many N. R. I. students and graduates have made outstanding successes in the Radio Industry.

"Another feature of N. R. I. training which particularly appeals to me is the method used to keep the training material up-to-date. Nothing in the Course is allowed to go stale. There is never a day that some text books are not being revised to include the newest features in Radio. Just as soon as something new is invented or produced, it is carefully investigated and worked into the Course. N. R. I. students and graduates are assured of the very latest information at all times.

"Since I have had quite a bit of Television experience I imagine that our readers will look to me to make a statement about the future of Television. Well, to start out, I'm going to be a bit different. I'm *not* going to tell you that 'Television is just around the corner.' There are still several points which must be worked out in the laboratories—and the experimenters are making good progress. When these

(Page 19, please)

# KOA's New Aerial Tower

THE highest self-supporting tower in the United States used as an aerial has just been completed for Radio Station KOA, of the General Electric Company at Denver. The tower stands 470 feet high, and is a departure from the customary type of Radio antenna, where copper wires were stretched in "clothes-line" fashion between two towers. It will act as a vertical radiator of the Radio waves.

With the "clothes-line" antenna, a large part of the electrical energy released flows directly upward and is lost in space, whereas with the new type of radiator installed at KOA, a larger quantity of the broadcast waves follow the earth's surface. Those traveling upward do so at a much wider angle than from the old type antenna, and are reflected back to the earth's surface by the ionized stratosphere which blankets the earth. As a result, engineers expect a greater signal strength to be produced at a given distance as well as better local coverage.

Slender compared to others of its kind, the tower is 35 feet square at the base and tapers to a two-foot square at the top. It will withstand a wind of 125 miles an hour, and its 50-ton weight bears down equally, when no wind is blowing, on four huge porcelain "eggs" which insulate it from the ground. Several miles

of heavy copper rods are buried in trenches extending from the tower base in all directions. These rods, like the spokes of a great wheel, form the ground of the transmitter.

The transmitter itself, designed and installed by the Radio engineers of General Electric, was built in Schenectady and represents the most modern achievements of the Radio art. There are 52 tubes used, ranging in size from "peanut" to giant tubes as high as the average man, and which require the constant circulation of cool water to prevent disintegration from generated heat.

Station KOA, owned by the General Electric Company, will be operated by the National Broadcasting Company.

The photograph presented here, taken from the air, gives a fine view of the aerial tower of Radio Station KOA. Note how it dwarfs the buildings in the foreground.

Careful observation will show where the trenches were dug, at the base of the mast, for the copper rods used as a ground for the transmitter.

No longer is the aerial of a Radio station a makeshift proposition. They are now receiving as much engineering attention as the transmitter itself. In fact even more, in some instances, because engineers feel that there is still much development necessary in aerials to achieve maximum efficiency.

## WJSV Helps Save Life of Washington Boy

When someone speaks of an S O S, we usually think of a disaster at sea—of a foundering ship, wildly Radioing for assistance.

Well, here's one about a call for assistance from a broadcasting station that produced results. A short time ago, the superintendent of Children's Hospital here in Washington asked that an announcement be made over WJSV re-

questing volunteers to supply blood to a five-year-old boy who was weakened from Erysipelas. Two announcements produced 30 offers of blood. Of the 30, 3 matched the blood of the little boy, and one of these 3 was chosen for the transfusion. At the time we go to press the little "feller" is getting much better, and hospital authorities think he will recover. Congratulations, WJSV.

# RADIO-TRICIAN SERVICE SHEET

REG. U. S. PAT. OFF.



COMPILED SOLELY FOR STUDENTS & GRADUATES

## Airline, 32-Volt, Direct Current

Superheterodyne Receiver Cat. No. 62-93

### CAUTION

To avoid the danger of damage to the receiver and excessive current, the following facts should be understood:

The metal chassis is connected to one side of the line. In the 32-volt systems, either side of the line may be grounded. If the side of the line, not connected to the metal chassis, is grounded, and the metal chassis comes in contact with the external ground, the line will be short-circuited, resulting in an excessive current.

In any service work, therefore, on the 32 V. receiver, it is suggested that the chassis be kept on a wood or other insulated surface to avoid the above mentioned danger.

### POLARITY OF POWER SUPPLY

There is a red mark on the plug. The prong of the plug at which the red mark is placed must be plugged into the positive side of the line. Use a receptacle on the 32-volt line, from which the plug will not have to be removed after it has once been correctly inserted.

If the polarity of the line is not known, it may be determined with a voltmeter. A meter having a 50-volt range or higher, may be used. If the pointer deflects correctly, the positive post of the meter is connected to the positive side of the line.

If there is no way to determine the polarity of the line, insert the plug both ways, leaving it in a few minutes each time. The receiver should operate with the plug in one way. If it does not, withdraw the plug.

### ELIMINATING IGNITION AND GENERATOR NOISE

After the receiver is in working order, the following procedure must be followed in practically all cases, to eliminate ignition and generator noise caused by the charging plant. If the charging plant causes no noise, then of course, these steps do not have to be taken.

One spark plug suppressor must be placed on each spark plug of the engine. One spark plug for example would be required on a one-cylinder engine, and four must be used on a four-cylinder engine. To connect the

spark plug suppressor, remove the wire from the top of the plug, put the suppressor on, and attach the wire to the other end of the suppressor.

The generator condenser consists of two .5 mfd. sections in one unit. The two sections have one side grounded to the metal case of the condenser. Mount the condenser on the frame of the charging plant. This will ground it. Then connect the two leads to the charging switch, one on each side of the line.

In some large installations, where the charging unit is on only two or three times a week, the above steps do not have to be taken, as interference is only caused when the generating plant is in operation.

### CONDENSER ALIGNMENT

As the I. F. stages are fixed tuned, no I. F. alignment at the intermediate frequency of 175 K. C. is required.

First set the signal generator for a signal of exactly 1400 K.C. Connect the antenna lead from the signal generator to the antenna lead of the receiver, and the ground lead from the signal generator to the ground lead of the receiver. Set the dial pointer on the 1400 K.C. mark on the dial scale, and adjust the three trimmer condensers on the gang tuning condenser for maximum output, adjusting the oscillator trimmer, the one nearest the rear of set first.

As a rule no adjustment other than at 1400 K.C., as mentioned above, is required. If, after the receiver has been aligned at 1400 K.C., the sensitivity is still low at some portion of the band, adjust the signal generator to that setting and tune for maximum output with the station selector knob of the receiver. Then, without readjusting the trimmers, bend the slotted rotor plates on the front two sections of the gang, to obtain maximum output. Care should be taken not to bend these plates too far in an inward direction, as the condenser may short as a result.

After any adjustment of this nature, set the signal generator again for a signal of 1400 K.C., and check the adjustment of the tuning condenser trimmers at this frequency for maximum output.

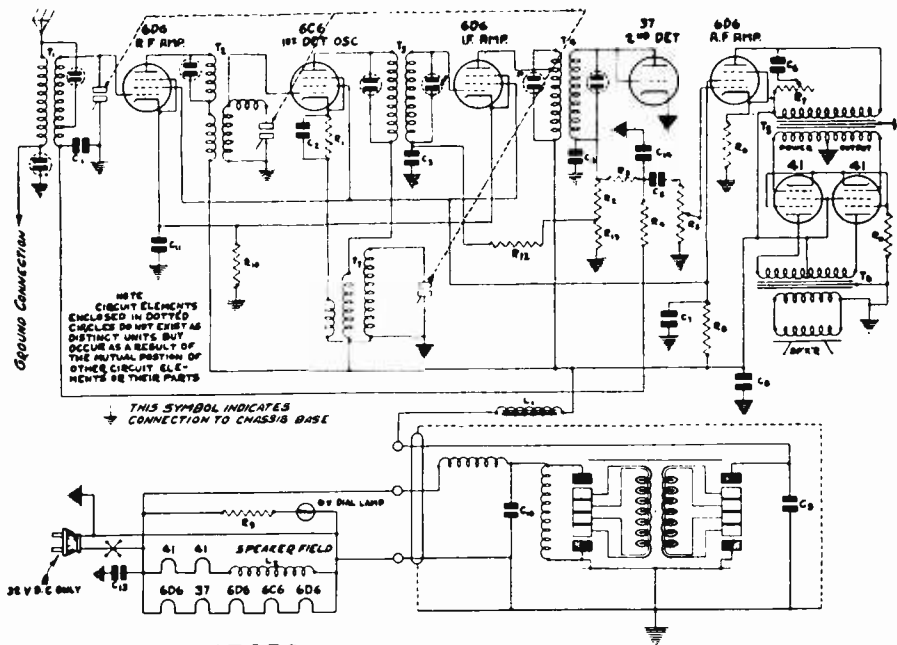

RESISTORS Fig. 1—Schematic Circuit Diagram.

Code	Resistance	Type
R1	4,500 ohm	Carbon
R2	150,000 ohm	Carbon
R3	100,000 ohm	Carbon
R4	2 megohm	Carbon
R5	1 megohm	Volume Control
R6	1,000 ohm	Carbon
R7	40,000 ohm	Tone Control
R8	20,000 ohm	Carbon
R9	144 ohm	Armoured Wire Wound
R11	340 ohm	
R10	200 ohm	Carbon
R12	1 megohm	Carbon
R13	50,000 ohm	Carbon

CONDENSERS			
Code	Capacity	Voltage	Type
C1	.050 mfd.	200 V.	Tubular
C2	.002 mfd.	600 V.	Tubular
C3	.050 mfd.	200 V.	Tubular
C4	250 mmf.	600 V.	Moulded
C5	.050 mfd.	200 V.	Tubular
C6	.050 mfd.	200 V.	Tubular
C7	1.50 mfd.	140 V.	Tubular
C8	8.00 mfd.	250 V.	Electrolytic
C11	.10 mfd.	400 V.	Tubular
C13	.50 mfd.	120 V.	Tubular
C14	250 mmf	600 V.	Moulded

### VOLTAGES AT SOCKETS

Input 32 Volts, Antenna Shorted to Ground

Type of Tube	Function	Plate Across Heater	Screen to Cathode	Grid to Cathode	Normal to Plate M.A.
6D6	R.F.	6.4	190	96 3.0(1)	7.5
6C6	1st D&O*	6.4	185	91 7.0(2)	1.6(2)
6D6	I.F.	6.4	190	96 3.0(1)	7.5
37	2nd Det.	6.4	0	0	0
6D6	1st A.F.	6.4	170	94 4.8(1)	5.0
41	Output	6.4	175	177 14.0	18.0

\* Detector and Oscillator

(1) Cathode to ground

(2) Subject to variation with dial setting



## C. Francis Jenkins, Inventor, Dies

**R**AUDIO mourns the passing of another eminent scientist, C. Francis Jenkins, of Washington, D. C.

His life is a typical illustration of a strong man's battle against adversity. On numerous occasions ill health retarded his progress; lack of funds with which to continue his researches frequently contributed to his troubles.



C. Francis Jenkins

Back in 1890, Dr. Jenkins began his inventive career. He had the idea that pictures could be made to move. He started out by taking ordinary photographic film, cementing strips together and in 1892 projected moving pictures upon a

screen. Later he added an arc light to the combination and so revolutionary was his idea that for a long time his machine was on exhibition in the National Museum. Ironically, Jenkins sold this invention for just a few dollars and later saw talking moving pictures grow into a billion dollar industry.

Several years later he had the distinction of building what might be termed the first automobile ever seen in Washington. It was a queer looking, steam driven buggy, steered by a tiller. His steam car achieved a maximum speed of 8 miles an hour, which was rapid transportation in those days.

He built the first automobile with an engine under a front hood—and is credited with building the first automobile bus.

In 1922 Dr. Jenkins gave his first demonstration of telephotography be-

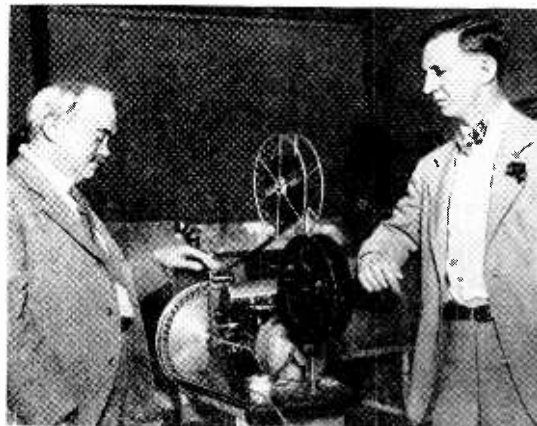

Dr. Jenkins demonstrating television apparatus to J. E. Smith.  
(An old photo)

## Famous Engineer Joins Institute Advisory Board

**N**ATIONAL RADIO NEWS is pleased to inform its readers that Dr. Alfred N. Goldsmith has accepted a post on the National Radio Institute's Advisory Board, filling the vacancy caused by the death of Major General George O. Squier.

Dr. Goldsmith is a graduate of Columbia University, an Electrical Engineer, specializing as well in Radio and sound motion picture engineering.

He was formerly Consulting Engineer of the General Electric Company, and Vice-President and General Engineer of the Radio Corporation of America. He is now a Consulting Engineer.



Dr. Alfred N. Goldsmith

Dr. Goldsmith stands very high in the electrical, Radio, and motion picture industries, being a fellow of the Acoustical Society of America, the American Physical Society, the American Institute of Electrical Engineers, the American Association for the Advancement of Science. He is also Past President and Fellow of the Institute of Radio Engineers, as well as President and Fellow of the Society of Motion Picture Engineers.

His wide range of experience in these various industries, will assist materially in the Institute's "all time" program of making the N. R. I. Course the best and the most practical Radio training available.

Dr. Goldsmith, National Radio News welcomes you.

An optimist is one who takes the cold water thrown on his ideals, heats it with enthusiasm and uses the steam to push ahead.

# Radio Employers Sound Optimistic Note

by H. E. LUBER, Manager N. R. I. Employment Dept.

**M**Y study of Radio Employment recently took me to Chicago where I conferred with approximately 50 executives of Radio organizations. I returned with a number of new ideas regard-

ing the outlook in the industry.

There is a distinctly optimistic trend among the majority of the men with whom I talked, most of whom are looking forward to and preparing for a decidedly forward and upward motion in all branches of Radio.

Even those who had been hard hit by general unsatisfactory business conditions admitted that the bottom of the depression had been passed and that the trend, although gradual, was upward. For this reason, since they saw signs of more business, I noticed a willingness on the part of those controlling the purse strings of these companies to spend more money to get more business. As an indication of the increasing willingness on the part of large concerns to spend more money to get business, a recent report of the National Broadcasting Company indicates that on May 1, 1934 their billed business and actual orders for 1934 already exceeded the total business for the entire year of 1933. In other words, the old vicious circle of depression has been broken.

It is generally known and admitted that the policies of our government have resulted in greater spending power for the public. More men are going back to work every day. More money is in circulation. The Radio Industry

will get its full share of the money so placed in circulation by the increased spending power of the public which will result in more Radio Employment—greater advances in the Radio Industry.

The large manufacturers placed a great deal of reliance on the service rendered by individual, independent service men after the sets are sold and installed in homes. They feel that the individual serviceman has a great future because he is an essential factor in the success and growth of the Radio Industry, and as proof of this feeling more and more of the Radio manufacturers are closely cooperating with the serviceman.

Many manufacturers are concentrating on two of the most popular items at the present time—automobile Radio and all wave sets. The DX fan is definitely back. No longer is the average set-owner satisfied to listen to local Broadcasting Stations—he wants France, Germany, Australia, police calls. And the public is gradually becoming educated to the fact that summertime reception conditions (heretofore a bugaboo) need no longer be a drawback to its summer Radio entertainment. Many of the foreign programs coming in on the short waves enjoy a fidelity of reception and absence of interference equal to the best wintertime domestic programs.

The trained Radio man will now come into his own, more than ever before.

One prominent executive told me that although he can always get plenty of men who are willing to do Radio work, and who claim the ability to do it, there is still a market for *real brains*—for men who can do a Radio job better than the average fellow—in other words, the properly trained Radio man. In every case the man with systematic training is preferred.

## A LETTER FROM LEE DE FOREST

DEAR MR. SMITH:

With you and all friends of Radio, especially us older lads, I was deeply grieved to learn of the unexpected death of General Squier, one of the victims of the past terrible winter in the East.

His is a loss not readily replaced, as we all realize who knew him.

You and the National Radio Institute are to be congratulated in finding so finely qualified a successor to General Squier in Dr. Alfred Goldsmith.

For both of these Radio Pioneers, I have always cherished great respect and most cordial friendship.

With all good wishes to the Institute and kindest personal regards,

Faithfully yours,

(Signed) LEE DE FOREST.

# At 65, What?

By THEODORE E. ROSE, N. R. I. Vocational Director

HOW will you be fixed, financially, when you're 65 years old? Ever stop to think about that? Or do you feel, like so many other fellows, that 65 is such a long way off—that you have so much time between now and then—that it is not yet time to give it any consideration?

I know that attitude. I'm a young fellow myself, and 65 didn't mean a thing to me except that I'd probably be bald-headed, have a forty-two inch waistline and maybe have to give up my golf. That was all the thought I gave the matter until a few days ago when I was reading some insurance statistics. Then I really started thinking and you will, too.

Let's take any 100 men 25 years old, and look into their futures. At the age of 65 here's what will have become of them:

- 1 is rich
- 4 are fairly well-to-do
- 5 are working for a living
- 36 are dead
- 54 are dependent upon charity

Fifty-four out of the 64 still living, or exactly 84 $\frac{3}{8}$ % will be saddling someone else with the burden of their existence. Not only will they be living very unpleasant lives themselves, but they will be retarding the progress of those on whom they depend for their daily bread. Very unhappy circumstances, you'll agree.

Now we come to the happy few—just 10 will have sufficient funds, or be capable of earning a living. Even the 5 who will be working do not represent such a favorable condition, because in most cases earning ability is fast decreasing at that age. It is important, therefore, that we make our successes as early as possible, get into the "fairly well-to-do" class before we reach the point where earnings begin to decline.

It is not hard to visualize the lives of those 100 men whom we have taken for an example. At the age of 25, practically all of them are

ambitious, determined to succeed. As the years go by some will fall by the wayside, either because of easy jobs with money for immediate expenses, or because they will have lost all desire to succeed. In any case many of them will be beaten before they are 40.

As the years continue to roll around, the tendency of the group will be more and more to let things slip, pay more attention to the everyday things and less attention to the future. Those who started to study will gradually fall out of line until they get to a day, when many will have passed out of life altogether, still more will depend upon charity, and only 10 will be working or have sufficient of the world's goods to enjoy life.

Sixty-four still alive. 10 self-supporting. Many of those who are unable to care for themselves will be solely responsible because they did not prepare themselves for the changing conditions of business and industrial life. Had they given more time to the study of the proper line of work, there would have been a much smaller number of that original 100 dependent upon charity, and many more than 10 would either be working or have plenty of money when they reached 65.

Now, and not years later, is the time to think of these things. No one wants to be a drawback to someone else when he is older. No one wants to burden his relatives, or public charities with his existence later on in life. Then take this matter seriously now and do the things necessary to prevent such a condition later on. Study! Work! Plan! Save!



## C. Francis Jenkins Dies—(continued from page 9)

fore Government officials, scientists and newspaper men. In 1923 he transmitted pictures by Radio of President Harding, Herbert Hoover and Governor Pinchot. Along with this work. Dr. Jenkins perfected a rapid moving picture camera, capable of photographing bullets in flight.

Dr. Jenkins built and developed a broadcasting station in Maryland, nearby to Washington, purchased an airplane to continue his experiments of broadcasting pictures from the air, and survived several very serious crashes.

His long struggles against cynicism and adversity were climaxed in 1928 by the sale of his Television patent to the Jenkins Television Corporation for \$250,000 in cash and stock valued at that time in the millions of dollars.

Dr. Jenkins has received many honors, including gold medals, honorary degrees by various engineering colleges and memberships in many scientific societies. Starting life on a small Government position in Washington, he scaled the heights of success in the scientific field.

# Design, Correction

(Section)

George Rohrich  
Engineer in Charge  
N. R. I. Laboratory



scale deflection, we know that when we connect an extra resistance in series with the meter, equal to the resistance of the voltmeter itself, then the deflection will be half of the original deflection. An example will illustrate this clearly.

Let us say the voltmeter has 10,000 ohms resistance. It may be a 0-10 voltmeter, a 0-15, a 0-50, or any other voltmeter, but when an extra 10,000 ohm resistance is connected in series with it, then the meter will show a half-scale deflection.

If we want to get a half-scale deflection with 5000 ohms, then the voltmeter must have 5000 ohms resistance. All that is necessary is to shunt the original 10,000 ohmmeter with enough resistance to reduce the total resistance to 5000 ohms, or any other convenient resistance, as shown in Figure 2. A variable resistance may be used to make this adjustment to suit any desired deflection, or used for the purpose of correcting an ohmmeter scale which reads incorrectly.

When the test prods of Figure 2 are held together, the deflection on the meter, even when using the shunt, will be the same as the deflection without the shunt, so the combination still is a voltmeter of the same voltage range as before, although the resistance of the meter circuit has been altered. If necessary we can reduce the total meter circuit to 10 ohms, simply by using a variable shunt as shown in Fig. 2.

There is one important thing which must be observed when using the method shown in Fig. 2 to reduce the meter circuit resistance, and that is that when the shunt is applied the current from the battery will increase. Obvi-

FOR the rapid servicing of modern Radio receivers, the ohmmeter is fast becoming the most dependable instrument for checking the condition of all circuits. Most servicemen realize this, but from the amount of correspondence received on the subject, they believe the ohmmeter is a mysterious device and know little of how to get the greatest benefit from its use.

This article will show there is nothing mysterious about the matter, as the design of an ohmmeter is based on the fact that a resistor connected in series with a voltmeter and battery will cause a lower reading on the meter, and that these readings can be marked in ohms.

By connecting resistors in series and parallel with any voltmeter it still remains a voltmeter, but we can get suitable deflections near the midpoint of the scale when low as well as high resistances are being tested and compared—that is, measured. All that is necessary is to make the voltmeter have high resistance when measuring high resistances and to make the voltmeter have low resistance when measuring low resistances.

In practical work we find that an ohmmeter scale is limited so the useful maximum reading is about 1000 times the useful minimum reading. This can be seen in Figure 1. That is, if the ohmmeter allows you to read 1 ohm at the low end, then you can read up to 1000 ohms at the high end of the scale. The meter circuit will have a resistance near 30 ohms. On the other hand if you have an ohmmeter which reads up to 1 megohm (1,000,000 ohms), then the lowest reading which can be read with accuracy is 1000 ohms. This meter circuit will have a resistance near 30,000 ohms. Even then the readings near the ends of the ohmmeter scale are bunched close together, so it is better to work with an ohmmeter with which the resistor under test causes a deflection near the center of the scale where there is the least trouble in reading the scale.

Every voltmeter has a definite amount of resistance. Disregarding what voltage a voltmeter may be reading with full scale or part

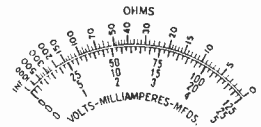

Fig. 1.

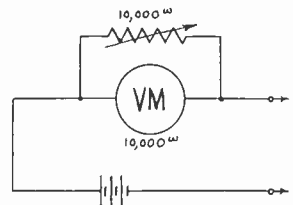

Fig. 2.

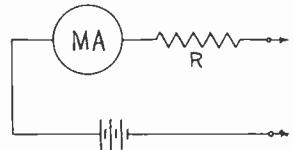

Fig. 3.

# and Use of Ohmmeters

1)

ously, we must not use such a low resistance shunt that the current from the battery will burn out the shunt or the part being tested.

In this respect it is well to select a voltmeter which gives a full scale deflection with little voltage and little current—a 1.5 voltmeter which requires less than 1 ma. would be the most ideal, as such a voltmeter would have more than 1500 ohms to start out with and this can be shunted even to a value as low as 10 ohms, and used with little danger of burning out a part being tested. The maximum current with a 10-ohm meter

circuit and 1.5 volts is 150 ma., as can be readily determined by Ohm's Law, and although this current is excessive for many devices, we find that most circuits which are constructed with small wire and subject to burning out with 75 or 100 ma., will have 30 ohms or more resistance. Then, when testing such a device, we place the 30 ohms in series with the 10 ohmmeter so the total resistance will be 40 ohms, and with the 1.5-volt battery the current will be only about 38 ma. Furthermore, most windings which have less than one ohm resistance are generally capable of carrying more than one ampere (1000 milliamperes), and therefore are safely

is used so the air cannot reach it freely for carrying off generated heat, it is customary to allow 1500 circular mills for each ampere. The cross-section area of various wires is shown in any wire table.

For instance a No. 30 wire has a cross-sectional area of approximately 100 circular mills. This wire may be used for carrying a maximum of .1 ampere where the wire is exposed and it may be used to carry a maximum of 66 milliamperes where the wire is confined to close places. A No. 30 wire will burn out with 10 amperes.

A No. 38 wire, one of the smallest used in meters and other delicate apparatus, has a cross-sectional area of 15.72 circular mills and it is rated to carry 16 ma. and 10 ma. under the two conditions. This wire will burn out with 2.5 amperes.

For ordinary purposes it may be remembered that a wire will not burn out until a current of 50 times to 150 times the allowable current-carrying capacity of the wire flows through the wire.

The average voltmeter consists of a series resistance used with a milliammeter as shown in Fig. 3.

The average voltmeter which is used for an ohmmeter has some form of compensating resistance so the meter needle may be set to the predetermined part of the scale marked for zero ohms, to allow for changes in battery voltages. This compensating variable resistance  $R_1$  is sometimes connected in series with the voltmeter as shown in Fig. 4, and sometimes in parallel with the milliammeter portion of the voltmeter, as shown in Fig. 5. The arrangement of Fig. 5 allows the ohmmeter indications to remain very accurate within the useful potential range of the battery employed. A vari-

(Page 14, please)

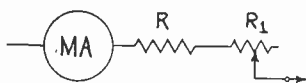

Fig. 4.

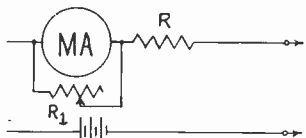

Fig. 5.

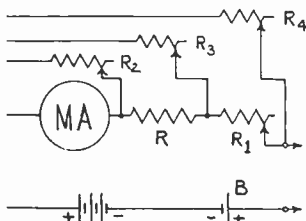

Fig. 6.

tested with this particular 1.5 voltmeter. A 3-volt voltmeter should not be shunted to a lower value than 30 ohms, while higher range voltmeters should be limited so the total current does not exceed 50 ma.

The current-carrying capacity of a wire used in any circuit or electrical instrument is dependent on the size of the wire. It is customary to allow 1000 circular mills of cross-sectional area for each ampere where copper wire is exposed to good ventilation. Where the wire

*In response to numerous requests for additional information on this subject, Mr. Rohrich gives us some really worthwhile information on the design, correction and use of ohmmeters.*

*The article on this subject is too long to appear fully in one issue of National Radio News, so the second and concluding section will appear in the October-November issue. Watch for it.*

# Design, Correction and Use of Ohmmeters

(Continued  
from page 13)

able milliammeter shunt adjuster for zero-ohm setting, as shown in Fig. 5, is much more accurate than the variable series method of battery compensation as used in some testers and in which the variable series resistor introduces appreciable errors.

Just how much error is introduced can be readily determined by taking a known precision resistor and testing it with the ohmmeter. If the reading does not fall on the exact marking of the scale, the meter resistance is not correct. This can be corrected by changing the meter resistance, by using variable series or shunt resistors in *any* part of the meter circuit until the correct reading is obtained for the resistor being tested, and again at the setting for zero ohms.

Remember, it is the meter resistance which affects the accuracy of the readings—not the battery voltage or the current in the circuit, although the battery voltage may have to be altered in some cases to aid in getting the desired deflections.

The value for the correct meter resistance is always indicated at the physical midpoint of the ohmmeter scale. That is, for a scale as shown in Fig. 1, the meter resistance must be 35 ohms to make the scale read direct. If the meter resistance is 70 ohms, all ohmmeter scale readings must be multiplied by 2. If the meter resistance is 350 ohms, all readings must be multiplied by 10, and so on.

Just what the correct "multiplier number" is for a particular scale can be determined when a precision resistor is tested. Let us say we have a 20,000 ohm precision resistor, which gives a reading of 20 on the scale of Fig. 1. Divide 20,000 by 20 and this gives us 1000 for the correct "multiplier number." All scale readings should be multiplied by 1000 to read the scale correctly.

On the other hand, let us say that the 20,000 ohm resistor gives us a reading of 25 instead. Then divide the 20,000 by 25, and this will give 800 for the correct "multiplier number." By obtaining the correct "multiplier number" in this manner, the deflections can be corrected on any ohmmeter scale by using simple arithmetic.

Instead of using such odd multiplier numbers as 800 or possibly 796 or some other inconvenient value, it is better to correct the meter resistance so the multiplier numbers will be some multiple of 10, such as 100, 1000, or 10,000, because it will be an easy matter then only to add the correct number of zeros to the original scale readings. To obtain this correction for the series type ohmmeter shown in Fig. 4, any one of the resistors,  $R_2$ ,  $R_3$ , or  $R_4$  may be added, as shown in Fig. 6, depending on the ease with which you can reach the inter-

nal connections of the ohmmeter. These variable resistors should have a maximum value of two to five times the resistance across which they will be connected. If the connections of  $R_3$  or  $R_2$  are used it is necessary to compensate the original setting of  $R_1$  for the zero setting. However, the setting of  $R_1$  is rarely affected if the connection of  $R_4$  is used, unless it is necessary to add or remove an extra cell of the ohmmeter battery. If you find it necessary to remove a cell from the ohmmeter battery, and find that this cannot be done because the cells of the battery are sealed in one unit, then connect an extra cell in series with either test lead but connected to buck the other battery voltage. That is, connect the negative terminal of the extra cell to the negative terminal of the regular battery as shown at B in Fig. 6. If the error becomes greater, reverse the extra cell at B and then readjust  $R_1$  until a reading of zero ohms again is obtained and finish the correction by changing  $R_4$  until the proper deflection is obtained when a precision resistor is being tested.

Where a shunt type of ohmmeter needs correction, such as shown in Fig. 5, additional resistors may be included in series and parallel so the circuit will be similar to that shown in Fig. 6, and a similar procedure followed as outlined above.

In order to increase the range of the ohmmeter it is obvious by this time that the meter resistance will have to be increased. To do this, add extra resistance in series with the ohmmeter and add extra cells to the battery, until it is again possible to obtain zero deflection in ohms. The correct "multiplier number" can be determined for the new arrangement as described previously.

In order to extend an ohmmeter scale ten times, we must have ten times the original meter resistance as indicated at the midpoint of the ohmmeter scale. The battery voltage generally has to be increased approximately ten times also. Bear this in mind, as sometimes it is desirable to extend an ohmmeter scale 10 times and one is surprised to learn what voltage battery is necessary. For instance, some ohmmeters use a 45-volt battery to read up to 1 megohm, and if one wishes to extend this to read up to 10 megohms, it will be necessary to use 450 volts which is not always available. Some servicemen have requested information for extending such an ohmmeter to 25 megohms and believed some mistake was made when they were informed that it would require 1.125 volts to obtain the necessary reading.

*Watch for the conclusion of this article in the next issue of National Radio News. It will be in the new, bigger, better News referred to elsewhere in this issue.*

# A Public Address Rental Agreement

A NUMBER of our readers have requested a standard form for use in connection with the rental of Public Address Systems. We have secured what appears to be a simple yet complete contract form. This should serve satisfactorily for individuals or firms doing an occasional job of this nature.

However, it is suggested that if the individual or firm does a great amount of this business, it would be better to engage an attorney well versed in local procedure to make up a special form. This is because laws in the various states make it necessary to change, slightly, the form of the contract.

## CONTRACT

This agreement made and entered into this.....day of....., 1934, by and between the BLANK RADIO CO., of Washington, D. C., Party of the first part, and Mr.....of....., Party of the second part.

### WITNESSETH:

That the said Party of the first part for and in consideration of the sum of \$....., (.....) agrees to furnish to the Party of the second part, One Public Address System and..... and be ready for an engagement of.....days at the..... on.....and to remain on location and operate equipment through the last performance given on the.....day of....., 1934.

### IT IS ALSO AGREED

That the Party of the second part shall furnish to the Party of the first part electricity of the alternating type of not less than 110 volts nor over 125 volts, to operate equipment on at no charge to the Party of the first part.

IT IS FURTHER AGREED THAT THERE SHALL BE NO OTHER CONTRACTS EITHER WRITTEN OR VERBAL THAT SHALL CHANGE OR ALTER THIS CONTRACT.

IT IS ALSO AGREED and understood, that the Party of the second part will and shall pay in cash \$..... (.....) to the Party or Parties duly authorized by the Party of the first part by twelve o'clock noon on....., 1934.

This contract made and entered into and signed in duplicate in the town of .....state of.....this.....day of..... 1934 by the duly authorized representatives of the parties hereto.

BLANK RADIO COMPANY,  
Party of the First Part.

WITNESS.....

.....  
Party of the Second Part.



# ALUMNI *News*



## What About a Code?

by L. J. Vanek,

Vice-President,  
N. R. I. Alumni Association

FOR many months industry and business have been talking and thinking in terms of "codes." We have all become "code minded." First skeptically, and later, with interest, we have watched and studied the propoundings of various codes. Industry has brought forth her codes—Big Businesses and Little Businesses have their codes. Today every line of endeavor has its code, some good, and some not so worthwhile.

Though almost a year has gone by since the beginning of N. R. A., yet the Radio Serviceman has no code. Many local organizations have some semblance of procedure, and it is true that a great deal of work has been done toward a code for the Radio man. The Institute of Radio Service Men has been working hard toward a national code for the servicemen.

But why not a "code" for ourselves—the students and graduates of the National Radio Institute? Not a code recognized by Government authorities, but a "Code of Ethics" to help govern our dealings with our customers, insuring intelligent and fair service; to help our fellow workers; to boost the National Radio Institute and exalt N. R. I. training.

The day of the "screw-driver mechanic" is past. Today the Radio man who can intelligently service any Radio receiver, or allied product, must be one who knows the why and wherefore. And who knows better than the N. R. I. graduate? Let us educate the public to the fact that the N. R. I. man is dependable.

Because of study and reasoning along with the ability to handle tools, the serviceman is

(Page 22, please)

## Toronto to Have Local

At the time we go to press with this issue plans are already well under way for the formation of a Local Chapter of the N. R. I. Alumni Association in the city of Toronto for the benefit of the members in that locality.

A meeting is planned for some time during the month of August in the city of Toronto and Alumni Association members and their friends, as well as students of the Institute in that locality, are invited to be present.

Definite date of the meeting can be ascertained from Mr. Arthur G. Ruse, 449 Roehampton Avenue, Toronto, Mr. Willis Forward, 26 Tichester Road, Toronto, or Mr. A. C. B. Verney, 67 Lawrence Avenue, West Toronto, who have been cooperating very closely with National Headquarters in the formation of this Local. All Alumni Association members in that territory will be notified by letter of the definite time and place of the meeting.

— n r i —

## Cleveland Picking Up Speed

After a number of serious reverses in their effort to successfully operate a Local Chapter in the Cleveland section the Local Chapter at that point is stepping on the gas and indications are that the sailing will be smoother from now on.

Readers of the News will remember that the Cleveland Local was organized just about the time of the bank failures and Cleveland probably suffered harder than any other city in the United States.

They were also handicapped for a great length of time due to the illness of their Chairman, Mr. Charles Jesse, but these adverse conditions have been eliminated and if we know anything about the boys in Cleveland, and we think we do, they are now ready to step out and do things. We expect to have much news from Cleveland in the next issue of the National Radio News.



# RADIO-TRICIAN SERVICE SHEET

REG. U. S. PAT. OFF.

COMPILED SOLELY FOR STUDENTS & GRADUATES



## General Electric Model C-67 32-Volt Direct Current Receiver

### POWER SUPPLY

Field excitation for the loudspeaker is obtained by connecting it directly across the 32-volt direct current supply. Heater excitation for the tubes described is obtained by connecting them in series and placing the entire circuit across the 32-volt line.

Plate and grid voltages for all tubes are obtained from a special plate supply unit which consists of a vibrator, a tube rectifier, a thermal voltage regulator and a special filter network for reducing hum or vibrator interference to a negligible degree. The purpose of the vibrator is to interrupt the direct current and apply it, first in one direction, and then in the opposite direction cross individual sections of the primary of the power transformer. The transformer steps the voltage up several times and applies it to the plates of the full-wave rectifier, Radiotron RCA-84. The filament of this tube is connected in series with the Amperite 5-16 voltage regulating tube. This regulating tube maintains a constant current through the rectifier filament over a wide variation of line voltages.

### LINE-UP ADJUSTMENTS

In operation, poor tone quality, or lack of proper sensitivity and selectivity are direct results of lack of alignment. In the event the receiver is to be aligned, carefully use the following procedure:

**I. F. Tuning Adjustments**—Two transformers comprising three tuned circuits (the secondary of the second transformer is untuned) are used in the intermediate amplifier. These are tuned to 175 K. C. and the adjustment screws are accessible at the back of the chassis. Proceed as follows:

Procure a modulated oscillator giving a signal at 175 K. C., a non-metallic screw-driver, and an output meter.

Short-circuit the antenna and ground terminals and tune the receiver so that no signal is heard. Set the volume control at maximum and connect a ground to the chassis.

Connect the oscillator output between the first detector control grid and chassis ground. Connect the output meter across the voice coil of the loudspeaker and adjust the oscillator output so that with the receiver volume control at maximum, a slight deflection is obtained in the output meter.

Adjust the primary of the second, and the secondary and primary of the first I. F. transformers until a maximum deflection is obtained. Keep the oscillator output at a low value so that only a slight deflection is obtained on the output meter at all times. Go over these adjustments a second time, as there is a slight interlocking of adjustments. This completes the I. F. adjustments.

**R. F. and Oscillator Adjustments**—The three-gang capacitor screws are accessible at the bottom of the chassis. The high frequency capacitor screws are located on the Range Switch. Proceed as follows:

Procure a modulated oscillator giving a signal at 1400 and 2440 K. C., a non-metallic screw-driver and an output meter.

Connect the output of the oscillator to the antenna and ground terminals of the receiver. Check the dial at the extreme maximum position of the tuning capacitor. The indicator should be at the last division. Then set the dial at 140, the oscillator at 1400 K. C., and connect the output meter across the cone coil. Adjust the oscillator output so that a slight deflection is obtained when the receiver volume control is at maximum.

With the Range Switch at the counter-clockwise position, adjust the three tuning condenser line-up capacitors until maximum deflection is obtained in the output meter. Then shift the oscillator to 2440 K. C., the Range Switch to the clockwise position, and the dial to 120. The three line-up capacitors located on the Range Switch should then be adjusted for maximum output.

When making both the I. F. and R. F. adjustments, the important point to remember is that the receiver volume control must be at its maximum position. Also, the minimum input signal, necessary from the oscillator, will permit a more accurate adjustment.



## Paul H. Thomsen

(Continued from page 5)

little difficulties are cared for, and they will be in time, then Television is due for a boom which will rival that which Radio itself enjoyed in the past few years.

"There is one thing of which I am certain, however, and that is that there are commercial possibilities of Television. I know that it will sell, once properly placed on the market, and these sales will result in good earning possibilities for Television salesmen, servicemen, operators, etc. It stands to reason that it will be very popular. Just look at the popularity of Radio. Yet Radio has its appeal only through the sense of hearing.

On the other hand, Television will make possible the use of another sense, sight, and should therefore make the programs doubly enjoyable. Just what type, system of scanning, or reception will be used in the commercial Television receivers is extremely difficult to say, however. I can say with definite assurance that the ultimate will be some form of electronic scanning such as the cathode ray tube with its necessary sweep circuits for automatic synchronizing and phasing, with its associated amplifiers. This does not mean that the mechanical methods will become obsolete. They will be even more popular than they are today because the scanning disc will never out-live its usefulness.

"So I think that I am quite safe in my prediction that when Television is finally placed on the commercial scale it will be salable and will offer great opportunities to the properly trained Television man. My advice, therefore, to the Radio man who is looking ahead, is to learn all he can about Television, and keep up with its new developments. *Be ready when it breaks.*"

## Chicago Hears E. R. Haas

Closely cooperating with the N. R. I Alumni Association, Mr. E. R. Haas, Vice-President and Director of the National Radio Institute, addressed the special meeting of the Alumni Association's Local Chapter in the city of Chicago. Mr. Haas' talk was on the subject of the value of the Alumni Association's Local Chapters to the individual man and to Radio. Mr. Haas has also addressed the up-and-coming Baltimore Chapter of the Association.

For life is a mirror of king and slave.

'Tis just what you are and do,

Then give to the world the best you have,

And the best will come back to you.

—Bridge

## Honorable Mention

(Continued from last issue)

This is a continuation of the "long-timers" list started in the last issue of National Radio News. The following men are Alumni Association members in good standing for the next five years:

### Five-Year Memberships

G. B. Thompson, Los Angeles, Calif.  
Roland Dorsey, Clarksville, Md.  
L. J. Vanek, Cincinnati, Ohio.  
A. Reuscher, New York, N. Y.  
L. T. Lemay, Manchester, N. H.  
P. E. Green, Philadelphia, Pa.  
D. D. Stevens, Castle Point, N. Y.  
I. A. Willett, Baltimore, Md.  
J. V. Williams, Pittsburgh, Pa.  
H. G. Watson, Newark, N. J.  
D. A. Burrell, Carleton, N. S., Canada.  
Walter Carson, Hyak, Wash.  
A. H. Ketelhut, Benton Harbor, Mich.  
C. E. Sutton, Louisville, Nebr.  
Mike Franconi, Avon, Conn.  
Kenneth Van DerWal, Albany, N. Y.  
C. J. Haaland, Chicago, Ill.  
Joseph Shanta, Vallejo, Calif.  
H. B. Smith, West Springfield, Mass.  
Wm. Simcek, Ferndale, Mich.  
G. R. Lenhart, Jr., Upper Darby, Pa.  
George Hanley, Suffern, N. Y.  
Timothy Sullivan, Auburn, N. Y.  
John Jacobs, San Francisco, Calif.  
A. Morgenthaler, Salem, Ore.  
M. Martin, New Westminster, B. C., Canada.  
C. T. Retter, Dayton, Ohio.  
G. W. Simon, St. Paul, Minn.  
C. W. Goldstein, St. Louis, Mo.  
E. F. Kopper, Buffalo, N. Y.  
H. F. Behre, San Francisco, Calif.  
I. J. Walters, Winnipeg, Man., Canada.  
A. DeBues, Winnipeg, Man., Canada.  
W. F. Sporrer, Baltimore, Md.  
M. Kaneshige, Honolulu, T. H.  
W. A. Adams, Honolulu, T. H.  
C. S. Bowman, Sacramento, Calif.  
H. G. Cellier, Lucerne, Switzerland.

### Four-Year Memberships

O. B. Hill, Moscow, Idaho.  
J. R. Ritz, Wheeling, W. Va.  
J. T. Redstone, Winnipeg, Man., Canada.  
Earl Dewing, Gillette, Wyo.

We have on file right now, eighty new Three-Year "long-timers" but have no room for their names. They will appear in the next issue.

## Executive Secretary to Speak

P. J. Murray, Executive Secretary of the N. R. I. Alumni Association, gave a talk before the New York Chapter of the Institute of Radio Service Men at a meeting held on July 9, 1934. His subject was "Increasing Summertime Radio Profits." The meeting was well attended by I. R. S. M. and N. R. I. Alumni who were extended special invitations to be present.

\* \* \*

Mr. Murray will be present at the first meeting of the new Toronto Local when it is held, sometime in August, and it is tentatively planned for him to address a special meeting of the Buffalo Local of the N. R. I. Alumni Association during the same month.

— n r i —

## Buffalo

From Buffalo, New York, the oldest Chapter of the N. R. I. Alumni Association, Ted Telaak, who holds two important posts in the organization, that of Chairman of the Buffalo Local and the Presidency of the National Association, reports favorable progress.

There is one thing that we have to hand the Buffalo boys. They have some crackerjack promotion men in that outfit. They have always been able to give their members good meetings and interesting ones, and they have always been able to keep their Local Treasury in very good condition.

Every time the treasury starts running a bit low, up jumps one of these famous promoters of theirs with a suggestion to bring home the bacon. First it was a card party and dance, then a general outing, then a raffle of a Radio Receiver. Just recently Mrs. Minne Roesch was very agreeably surprised to learn that she was the owner of a midget receiver raffled by the Buffalo Local.

Buffalo has long set the pace for other Locals to follow and some mighty fine ideas have developed at that Local. If plans now underway carry through satisfactorily there will be a special meeting at Buffalo this Summer with P. J. Murray, Executive Secretary, from National Headquarters in Washington as the guest speaker.

Summer Boarder: "But why are those trees bending over so far?"

Farmer: "You would bend over too, miss, if you wuz as full o' green apples as those trees are."

## Philadelphia Local

The new Philadelphia-Camden Local Chapter of the N. R. I. Alumni Association, still in the process of getting fully organized, is showing great promise. Ronald Clarkson, reporting as Acting-Secretary for the last meeting of the Local states that plans are underway for acquiring a suitable permanent meeting place.

A short discussion of static was very interesting to the members and a plan has been adopted for each member to have a complete list of other members engaged in service work so that they can be of assistance to each other on very short notice.

Plans were also discussed for building a short wave transmitter and receiver as soon as the permanent meeting place is acquired.

Members are being assigned topics for short talks on interesting subjects at future meetings and Mr. Louis Lyet, employed with R. C. A.-Victor, has promised a guest speaker for the next meeting.

Members of the Philadelphia-Camden Local have arranged to call on all Graduates in the vicinity, to acquaint them with the activities of the Local and build the membership up as large as possible. The Charter will remain open until September for the purpose of getting as many Charter members as possible.

All students and graduates in the Philadelphia-Camden area are invited to attend meetings of the Local. It is organized for your good and for the good of the Radio Industry. Attend the meetings, meet the officers and members, and become familiar with the good work which is being done. There is absolutely no obligation. Full information can be obtained by writing the Acting-Secretary, Mr. Clarence Stokes, 2728 Kensington Ave., Philadelphia, or to National Headquarters in Washington.

In addition to the Acting-Chairman and Acting-Secretary whose names are given above, the following officers have been elected temporarily for a period of three months:

Mr. Marvin Enders, Committeeman,  
Mr. Wm. Hobart, Committeeman.  
Mr. Chas. Felm, Librarian.  
Mr. H. L. Robinson, Sgt.-at-Arms.

— n r i —

President J. E. Smith, of the National Radio Institute, recently had an opportunity to meet Mr. Louis Lyet of the Philadelphia-Camden Local and talk over the future of the organization. Both agreed that there is much fine work to be done in that area and that the Alumni Association's Local Chapter can be a great factor in improving Radio Standards in that locality.

## Detroit

Believe it or not, fellows, you owe a lot of thanks to the officers and members of the Detroit Local.

A short time ago, we were considering ways and means of making our service to our members bigger and better when Detroit came through with a very worthwhile suggestion which was at once placed under consideration and with equal speed, adopted.

We refer to the increase in size of National Radio News. The Detroit boys suggested that the service be improved along this line and as a result, beginning with the next issue, your National Radio News, the official publication of the National Radio Institute Alumni Association, will be one-third larger, and will come to you flat instead of folded, for your convenience.

A further suggestion, made by an individual member of the Detroit Local will be followed shortly. This suggestion has to do with the publication of more intimately personal news about members of the Association. As a result, a special notice has gone out to all Local Chapters to dig up more of this material about their members, and it will be assured a place in the Alumni Section of National Radio News.

Good work, Detroit. constructive criticism is always gratefully received.

## Pittsburgh

The Pittsburgh Local held its meeting this month in the Blue Room of the Penn-Lincoln Hotel in Pittsburgh.

They are running a special series of talks on the subject of vacuum tubes, covering their manufacture, sale and use.

The talks are conducted by Mr. Joseph O'Shea, an authority on the subject. Mr. O'Shea has recently associated himself in the Radio business with two of the members of the Pittsburgh Local Chapter of the Association.

Congratulations and welcome to the new student member, Mr. C. W. Weyels, who has recently been admitted to the Local Chapter.

Albert Maas has been elected new Corresponding Secretary. George Weber, of the Local, is driving a new Pontiac. The New Deal, maybe.

-----n r i-----

The Chicago Local is leading the field of all Chapters of the Association in bringing new members in to their Local. Baltimore is a close second. How about it? The rest of you Locals going to stand for this?

## New York-Brooklyn

Two meetings of this Local have been held since they last reported in National Radio News. The first was held at the George Washington Hotel, the second at the Hotel New Yorker.

They have had an opportunity to hear Mr. E. F. Reihman, of R. C. A.-Victor, speak on "Service Problems of All Wave Receivers," and had a practical demonstration of the subject on the R. C. A.-Victor No. 140.

Newly elected officers of the Local are J. L. Kearns, Chairman; David Salzman, Vice-Chairman; Forrest B. Arnold, Recording Secretary; John H. Struble, Financial Secretary; Allen Arndt, Membership Secretary; Jos. G. Holub, Financial Committeeman.

Two fine lectures were given by R. V. Sutcliffe and W. W. MacDonald, both of Radio Retailing.

There is an outing for members in the fire now. All you members help cook this up and make it a big success.

## Baltimore

"Watch us grow" Baltimore, one of the youngest of the Local Chapters is living up to its motto. They have advanced to second place in the number of new members they are bringing into their group. It's spirit that counts, fellows.

Their Baltimore Bulletin, which they are publishing every month is meeting with widespread approval among the members. The old "southern hospitality" is very much in evidence at all meetings, and their plans for the future are great, indeed. They are at present the "most talked about" if not the largest Radio organization in the state of Maryland and intend to be the largest in short order.

Baltimore does not claim to be original in all of their plans. They copy whatever seems to be good, enlarge upon and improve the ideas, then put them into effect. For instance, the Cleveland spot system which was originally the idea of Mr. Jesse, Chairman at Cleveland, will in all probability be put into effect in Baltimore before the first snow flies.

The success at Baltimore? Surely, we can tell you the answer. A fine group of interested officers; hearty cooperation and willingness to work on the part of members, and extremely interesting meetings.

-----n r i-----

Some of the Locals may feel that they are being "short changed" in this issue of the National Radio News — that they didn't get sufficient space. It is because we are very short of space this time, fellows. With the next issue, however, we are going to have quite a number of extra pages and we'll give you all the room you need.

## What About a Code?

(Continued from page 16)

not a tradesman, but a professional worker. We must educate the public to view Radio servicing as a profession, and as such we should conduct ourselves as professional men.

We should strive to give the public honest, efficient service. N. R. I. men must shun "gyp" methods. The satisfied customer is your best advertisement; the "gypped" customer can ruin your business. Not only should we shun unethical practices, but we must educate the public against the "gypts." Of course, we must never condemn our legitimate competitors.

We must do our work in such a way that we can guarantee it and we must always stand by our guarantee.

The old business saying, "the customer is always right," should be kept before us in dealing with the public, especially when settling with dissatisfied customers. Many times it is well to call in a brother serviceman to help set your customer at ease.

We should maintain our prices in standing with those in our community. The better technicians can command more for their services, but the public soon learns that the "fifty-cent service call" man is a "gyp."

Let us remember that the National Radio Institute gave us the name Radio-Trician. Though many self-styled servicemen use the name, it belongs to the N. R. I. trained man only. Let us capitalize on the title and protect its use.

And so, after thinking through these few paragraphs, we might write a flexible but fair, Code of Ethics—a code that we might be governed by in furthering ourselves in our profession and in the esteem of the Radio public.

The following is a suggested Code of Ethics for N. R. I. Radio-Tricians:

1. To professionalize Radio servicing.
2. To give honest efficient service at honest prices.
3. To guarantee our work and stand behind our guarantee.
4. To use the best of materials, and deal with legitimate jobbers.
5. To promote a spirit of comradeship among the members of the Radio Service Profession.
6. To cooperate with all branches of the Radio Industry.
7. To boost the National Radio Institute and its trained men.
8. To use and protect the name "Radio-Trician." To remember "the customer is always right."

There are probably other points which should be included, but this is good enough for a starter. When we can tell customers that all N. R. I. Radio-Tricians live up to these standards it will increase confidence and reflect in our bankroll.

Page Twenty-two

# NATIONAL RADIO NEWS

Vol. 6  
No. 3

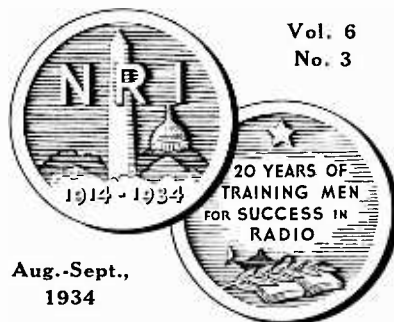

Aug.-Sept.,  
1934

Published bi-monthly in the interest of the students  
and Alumni Association of the

NATIONAL RADIO INSTITUTE  
Washington, D. C.

The Official Organ of the N. R. I. Alumni Association

P. J. Murray, Managing Editor

Associate Editors:

T. A. DeSchantz, Pittsburgh	T. J. Telaak, Buffalo
Chas. Jesse, Cleveland	E. R. Bennett, Chicago
F. X. Schachtner, Detroit	P. J. Dunn, Baltimore
Louis Iyet, Phila.-Camden	J. L. Kearns, N. Y.-Brooklyn

## Index

Article	Page
An Important Announcement . . . . .	2
Service Forum . . . . .	3
The Director's Page . . . . .	4
New Staff Member . . . . .	5
KOA's new Aerial Tower . . . . .	6
WJSV Saves Life . . . . .	6
Data Sheet Airline 62-93 . . . . .	7-8
C. Francis Jenkins, Dies . . . . .	9
Dr. Alfred N. Goldsmith . . . . .	9
Radio Employers Sound Optimistic Note	10
A Letter from Lee DeForest . . . . .	10
At 65, What? . . . . .	11
Design, Correction, Use of Ohmmeters . . . . .	12-13-14
Public Address Rental Agreement . . . . .	15
Alumni News . . . . .	16-19-20-21
Data Sheet General Elec. Model C-67	17-18
Mailbag . . . . .	23
Calcaterra Service . . . . .	24



# THE MAILBAG

## ROYCE WANTS INFORMATION

I am a newcomer to this Department, but have always liked the valuable dope which it contains. I'd now like to put up a matter for discussion in the Mail Bag and would like to hear from some of my fellow Radio men—get their opinions.

It is my feeling that a real first class Radio service job cannot be done in the customer's home without loss of time, to say nothing of what the lady of the house thinks about the serviceman after the receiver has been overhauled in her living room or kitchen (no matter how careful the serviceman may be not to make a mess of things).

I may be wrong about this—that's the reason I'm asking for opinions.

A. H. ROYCE, Winton, Wyoming.

*Let's have some ideas on this. Who'll answer Graduate Royce? Address your reply to the Mail Bag Editor, National Radio News, Washington, D. C.—Editor.*

## N. R. I. HAMS

D. Crouse, North Devon, N. B., Canada—VE1FZ.

Lynton Lemond, Fulton, Ky.—W9JBW.

T. J. O'Brien, Ipswich, Mass.—W1GWA.

W. L. Sonnenstuhl, Lidgerwood, N. D. —W9OSN.

## LIKES NEW ALUMNI SERVICE

I have just received the first of the special bulletins supplied as a special service of the N. R. I. Alumni Association to its members, "News and Information Service," and I think the information that you are giving in these sheets should be of much value to every one of our members and appreciated by all. Keep it up.

L. A. SCHLESINGER, Elkins Park, Pa.

## ANOTHER BOUQUET

I think the "News and Information Service" you have started for the N. R. I. Alumni Association is very good. Hope you will get enough favorable comments to warrant continuing it.

W. F. BERENS, Washington, D. C.

## A QUESTION HAS BEEN ASKED

R. W. Brunnell of Flora, Illinois, asks the following question of the Editor of the Mail Bag.

**"Is it necessary to disconnect automatic volume control from sets when aligning I.F., R.F., and Osc. circuits?"**

It is not necessary to disconnect the automatic volume control from a receiver when aligning the various stages.

If the output of the service oscillator is kept very low the automatic volume control will not function, and you will be able to note changes in output when the various adjustments are made.

If the receiver is equipped with a visual tuning device we can watch it instead of the output meter and make the adjustment when the device indicates that the signal is "tuned in best." When using the visual tuning device the output of the service oscillator should be high so that the automatic volume control will function. As you know, the automatic volume control indirectly operates the visual tuning device.

In some cases it is possible to disconnect the AVC entirely. If a separate AVC tube is used, its filament may be isolated by slipping a soda water straw over one of the filament prongs. The tube itself should not be removed from the circuit.

In other cases where the AVC tube also acts as a detector, the tube must be kept operating. However, the AVC return to the control grid of the tube can be grounded to the chassis, thus shorting out the AVC action. The sketch below shows how this may be done.—*Editor.*

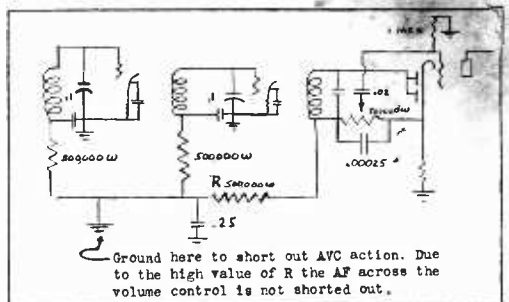

# Build Yourself a Valuable Radio Library with these Helpful FREE MANUFACTURERS' BOOKLETS and CATALOGS

## A FREE SERVICE DESIGNED TO SAVE YOU TIME AND MONEY

The cooperation of the manufacturers whose catalogs, literature and booklets are listed on this page, and the courtesy of the Calcatera Catalog Service, has made it possible for the N. R. I. Alumni Association to offer to readers of National Radio News a unique and money-saving service in obtaining Radio manufacturers' literature.

All that is necessary for you to obtain the catalogs or other literature listed on this page is to write the

numbers of the items in which you are interested on the coupon, fill in the information asked for and MAIL IT TO THE CALCATERA CATALOG SERVICE. DO NOT MAIL COUPONS TO THE NATIONAL RADIO INSTITUTE AS THAT WILL DELAY THE FILLING OF YOUR ORDER.

Stocks of the publications listed are kept on hand and they will be sent to you promptly, as long as the supply lasts.

2. HAMMARLUND 1934 PARTS CATALOG. 10 pages. Variable and adjustable condensers, sockets, coils, intermediate frequency transformers, chokes, etc., for broadcast and short wave work.

4. HAMMARLUND-ROBERTS 15 TO 200 METER COMET "PRO" SUPERHETERODYNE. Details of a receiver designed especially for laboratory, newspaper, police, airport and steamship use.

5. ELECTRAD 1934 CATALOG. 16 pages. Standard and replacement volume controls, Truvalt adjustable resistors, voltage dividers, vitreous enamelled fixed resistors, public address systems, etc.

6. AMPERITE REAL LINE VOLTAGE CONTROL. Characteristics, uses and chart showing the correct Amperite recommended by set manufacturers for their sets.

9. INTERNATIONAL 1934 RESISTOR CATALOG. Specifications and prices on International Metallized, Precision wire wound and enamelled wire wound resistors, motor Radio noise suppressors and resistor kits.

10. INFORMATION ON THE SUPPRESSION OF MOTOR RADIO NOISES. Circuits and data published by the International Resistance Company on how to overcome troublesome motor noises in auto Radio installations.

25. LYNCH NOISE-REDUCING ANTENNA SYSTEMS. This folder describes the two types of noise-reducing antenna systems perfected by the Lynch Mfg. Co. for both broadcast and short-wave reception. The transition type system can be used on both long and short waves while the shielded transmission line type is especially suited for broadcast receivers.

26. LYNCH AUTO RADIO ANTENNAS, FILTERS AND NOISE SUPPRESSORS. This folder describes a complete line of Lynch antennas, filters and ignition noise suppressors, especially designed for motor Radio installations. Complete data on how to eliminate motor Radio noise is included.

34. ELECTRAD SERVICEMEN'S REPLACEMENT VOLUME CONTROL GUIDE. A 44-page vest-pocket size booklet containing a revised, complete list, in alphabetical order, of over 2,000 different receiver models with the proper type of Electrad Control to use for replacements.

40. IRC RESISTANCE INDICATOR. A complete description of an instrument designed by the International Resistance Co. to enable servicemen and other Radio men to determine the exact resistance value of a defective resistor without the use of meters, wiring diagrams or specifications of the receiver circuit.

52. THE I. R. C. SERVICER. A free monthly journal organ published by the International Resistance Co. A sample copy will be sent on request through this service, after which you can subscribe to it, if you like it, by writing direct to the International Resistance Co.

56. SUPREME SERVICING AND TESTING INSTRUMENTS. A catalog containing complete descriptions of a new line of Supreme low-price analyzers, set testers, tube testers, ohmmeters, capacity testers, oscillators and universal meters.

57. HOW TO BUILD A HIGH-QUALITY CONDENSER OR RIBBON MICROPHONE. This circular describes the Superior Microphone Kit and instruction sheets with which it is possible to build, quickly and easily, a high-quality condenser or ribbon microphone. The kit is made by the Bruno Division of the Amperite Corporation.

59. THE IRC VOLT-OHMMETER. A folder describing the characteristics and uses of the International Resistance Co. Volt-Ohmmeter, a combination voltmeter and ohmmeter specially designed for the point-to-point method of troubleshooting. The instrument contains the Automatic Vacuum Relay feature which gives positive protection against burnouts.

60. AMERTRAN AUDIO AND POWER TRANSFORMERS AND CHOKE COILS FOR USE IN PUBLIC ADDRESS AMPLIFIERS AND RECEIVERS. A folder containing very complete information on the characteristics of a wide variety of AmerTran De Luxe and Silcor (popular priced line) audio and power transformers and chokes.

63. AMERTRAN MODERATE-PRICED, HIGH-QUALITY TRANSFORMERS AND CHOKES. This bulletin gives complete descriptions and prices on the new AmerTran Silcor line of moderate-priced audio and power transformers and chokes, designed for original and replacement use in radio receivers, amplifiers, public address systems and amateur transmitters. Many novel universal mounting features are incorporated in these units.

(Please Use Pencil and Print in Filling in Coupon)  
THE CALCATERA SERVICE NRN-834  
Thornwood, N. Y.

Please send me, without charge or obligation, the catalogs, booklets, etc., whose numbers I have filled in below.

Booklet Numbers: .....

My connection in Radio is checked off below.

Serviceman operating own business

Serviceman employed by:

Manufacturer

Jobber

Dealer

Servicing organization

Other

Jobber

Radio Engineer

Environmenter

Laboratory Technician

Professional or Amateur Set Builder

Licensed Amateur

Station Operator

Manufacturers' Executive

Student

Public Address Work

I buy approximately \$ ..... 00 of Radio material a month.

(Please answer above without exaggeration or not at all.)

Name .....

Address .....

City ..... State .....