

 **journal**

september/october

1970

CONAR CATHODE CONDUCTANCE TUBE TESTER



CATALOG PRICE

KIT 223UK	\$49.95
WIRED 223WT	\$75.95

NRI STUDENT & ALUMNI PRICE

KIT 223UK	\$44.80
WIRED 223WT	\$68.25

Tests all series string and up-to-date tubes as well as the standard base types—4, 5, 6, 7-pin large octal, loctal, 7, 9 and 10-pin miniatures, 5-pin nuvistor, novar and Compac-tron. Checks 17 individual filament voltages from .75 to 110 volts. Tests multi-section tubes, gas rectifiers and remote control gaseous types. Has open-close "eye" tests for cathode ray indicator tubes, and visible filament continuity check to show up open filaments re-gardless of pin position.

12 lever element selector-distribution system enables you to select the individual elements of the tube you're checking and simplifies cathode leakage tests and inter-element short tests. Most important this feature provides you with flexibility AND gives you insurance against obsolescence as new tubes reach the market.

Designed around the approved Electronic Industry Association's Emission Circuit, the Model 223 uses a precise, accurate, double-jeweled meter movement. It's balanced and factory calibrated within 2% accuracy. Large, easy to read—with clear plastic case and two 2-color scales.

Test sequence set up to reveal quickly open filaments and shorts. The time-saving fea-ture rejects an "open" or "shorted" tube and lets you proceed with more detailed checks right away. For maximum safety to you and the instrument, the test circuit is transformer isolated from the power line. Triple-window, high-speed, gear-operated roll chart is illumi-nated, easy to read, even in darkened areas. Lists over 2,000 tube types.

The instruction manual for the Model 223 is written with the same high standard that went into the circuit design—with HUGE picture diagrams to guide you every step of the way.

Building the Model 223 is easy. Using it is even easier. The operating simplicity makes it a pleasure to use. Just 10 lbs.—it's a pleasure to tote along on service calls, too.

SPECIFICATIONS

CASE: Black, leather-fabric; removable, hinged lid with safety catch; PANEL: Satin finish, aluminum; PANEL LETTERING: Red; METER: Double-jeweled D'Arsonval type; accurately balanced and factory calibrated to within 2% accuracy; ROLL CHART MECHANISM: Triple-window, high speed, gear operated; illuminated; SAFETY FEATURE: Test circuits transformer isolated from power line affords utmost safety to operator and instrument; POWER REQUIREMENTS: 50-60 cycle, 110-120 volt, AC only; WARRANTY: Standard EIA warranty on all parts; DIMENSIONS: Width 15¼"; length 10½"; depth 4¾". ACTUAL WEIGHT: 10 lbs.; SHIPPING WEIGHT: 13 lbs., Parcel Post Insured.

FREE

WITH YOUR
ORDER

2 TV ADAPTERS

WHICH ALLOW YOU TO TEST EMISSION OF
ALL 70°-90° and 110° PICTURE TUBES. A
\$6.00 VALUE! OFFER ENDS AUGUST 31, 1970

USE CONVENIENT ORDER BLANK ON PAGE 25

OUR COVER — Harold Turner, Technical Consultant, practices what he “preaches” in an article beginning on Page 2: that the oscilloscope probe is a versatile and indispensable servicing tool for the technician.



September/October

1970

VOLUME 27 NO. 5

CONTENTS

Oscilloscope Probes - - - Who Needs Them?2

Digital Techniques8

Ham News17

Employment Opportunities22

NRI Honors Awards24

Alumni News27

EDITOR AND PUBLISHER .William F. Dunn

MANAGING EDITOR Allene Magann

ASSOCIATE EDITORSJ.F. Thompson
H.B. Bennett

TECHNICAL EDITORE. B. Beach

ASSISTANT EDITORS Judy Rhodes
Kathy Kibsey
Marilyn Blackwood
Mary Ellen Riddle

STAFF ARTISTSArt Susser
Ernie Blaine

APOLOGIES . . .

... to students whose kits have been delayed.

We do plan ahead, and have continually carried a large inventory of components (well over half a million dollars worth) in order to be able to ship kits when they were due.

However, in spite of purchase orders being placed months in advance, strikes at our suppliers' plants and in trucking have resulted in parts not being here when needed.

Hopefully, the worst is over, and by the time this apology is in print, kits should be going out without delay.

Again, our sincere apologies.

MORRISON SMITH
NRI PRESIDENT

The NRI Journal is published bimonthly by National Radio Institute, 3939 Wisconsin Avenue, Washington, D.C. 20016. Subscription price is \$2.00 per year, single copy 35 cents. Second-class postage paid at Washington, D.C.

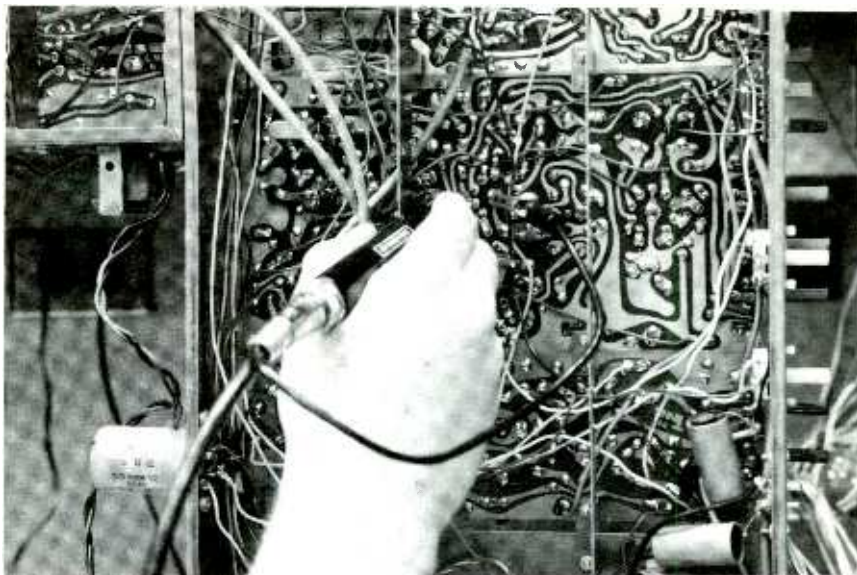

OSCILLOSCOPE PROBES

. . . *WHO NEEDS THEM?*

By HAROLD J. TURNER, JR.

You do, if you have a scope. Why? First of all, to prevent your test instrument from loading the circuit under test. In other words, to make sure that the circuit you are testing works exactly the same while you are measuring it as it does when no test equipment is used. Otherwise, your measurement may be misleading and you might spend hours trying to track down a very simple problem that exists only when the scope is connected. Second, the connection between any test probe and the scope is made with shielded cable, so noise pickup is greatly reduced. Finally, some probes are designed to allow your equipment to do special jobs that would be impossible otherwise.

Most oscilloscopes are sold without the probes needed to get the most use of this indispensable servicing instrument. Test equipment manufacturers market their products in this way because some potential customers will already have suitable probes and might object to paying for something they don't need. Probes are offered separately, either individually or in sets. Some scope users mistake this marketing practice for an assurance that they don't need probes. This is really unfortunate, since many technical people might then go for years without getting the greatest use of their test equipment. This article explains what types of probes are available, what they can do, and how *you* can use them.

THE DIRECT PROBE

The simplest probe consists of a piece of shielded cable with a connector at each end like the one in Fig. 1. At the oscilloscope end, of course, the connector must mate with whatever type of connector is used on the equipment. The other end is terminated in a probe housing you hold in your hand for testing circuits.

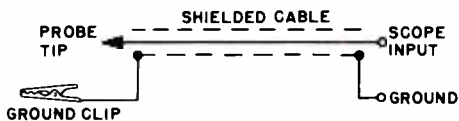

Fig. 1. The beginning: a direct probe.

Notice the ground wire connected to the shield at the probe end of each of the probes shown. This ground wire should be clipped to the ground circuit of the equipment under test at a point as close as possible to the measured point. No other ground connection should be made between the equipment under test and the test instrument. If you follow this simple precaution, you will be assured of a very low level of noise pickup.

The direct probe is a big improvement over ordinary test leads because the shielded cable greatly reduces noise pickup. However, the reduction of noise is not free: there is a fairly large capacitance between the center conductor and shield of the cable. The amount of capacitance depends on the type and length of the cable used, but it is usually about 100 pf. The input capacitance of a typical scope is much less than this, so the addition of the shielded cable greatly increases the effective input capacitance. Remember, we want to avoid loading the circuit

under test, and placing a capacitor from the test point to ground will certainly affect some circuits. In high impedance or high frequency circuits, this extra capacitance to ground acts as a low-pass filter, which will reduce the amplitude of high frequency signals and distort the shape of complex waveforms. Fortunately, there are many circuits that are not noticeably affected by this small extra capacitance, especially in low impedance and/or low frequency circuits. For example, you would use the direct probe in checking the ripple voltage in a power supply or in making stage-gain tests in an audio amplifier.

Only the direct probe permits the full gain of the oscilloscope to be used; all the other types of probes cause some loss of signal strength. This means that the direct probe should be used where the signal to be observed is very small, as long as the lack of isolation does not load the circuit. Now, let's see how we can get some isolation.

LOW CAPACITY PROBE

We cannot eliminate this troublesome capacitance, but we can compensate for it. The easiest way to do this is to add another capacitor in series with the probe end of the cable. Then, these two capacitors (the added one and the scope input capacitance, including the cable capacitance) will act as a voltage divider to reduce the strength of the signal applied to the scope input. At the same time, the effective capacitance from probe tip to ground is reduced.

Usually, a probe is designed so that the attenuation factor is 10:1. This means that the input capacitance also will be

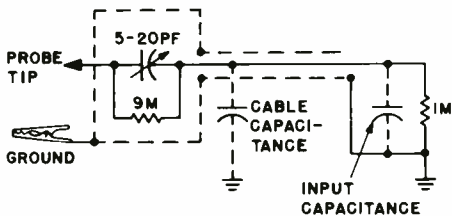

Fig. 2. Basic 10:1 low capacity probe. Adjustable capacitor in probe is set for flat response.

reduced by the same factor. The added capacitor will be very small, and the effective capacitance will be even smaller. Remember, capacitors in series add like resistors in parallel.

$$C_t = \frac{C_1 \times C_2}{C_1 + C_2}$$

However, since the scope input circuit consists of a resistance in parallel with a capacitance, if we add either a resistor or capacitor in series with the input, the frequency response of the scope will be affected. In most cases, this is undesirable. So, we must use a parallel resistor and capacitor in series with the input, as shown in Fig. 2.

The resistor value is made nine times that of the oscilloscope input resistance, and the capacitor is one-ninth the input capacitance (which is the same as nine times the capacitive reactance of the input capacitor). Thus, the input impedance will be ten times as high as it was with the direct probe, so the circuit loading will be only one-tenth as much. Of course, as you can see, this probe also reduces the sensitivity of the scope by a factor of ten to one, so very small signals may not be observed. Still, this type of probe is the

one you will need most often, since it keeps circuit loading to a minimum. Usually scope gain is high enough to offset the probe loss for all but very low level signals.

The series capacitor on such a probe is sometimes made adjustable to match the probe to the scope. The best way to do this is with a square wave generator furnishing a 1 kHz signal. First, connect the scope directly to the generator to make sure that the response is flat. Then, connect the low capacity probe between the two instruments. Naturally, there will be a 10:1 reduction in signal strength. But the important thing is the waveshape. You must adjust the capacitor so that the square wave looks just as it did without the probe: the top and bottom of the signal must be flat horizontal lines on the scope screen. This shows that the overall frequency response is flat; and the scope and its probe do not favor either high or low frequencies. The waveforms you will see when you make this adjustment are shown in Fig. 3. Even if your low capacity probe does not have an adjustable capacitor, you can still make this check to see if the probe is working properly.

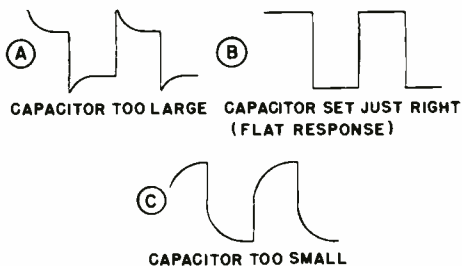

Fig. 3. Waveforms with various capacitor settings.

Fig. 4 shows a combination direct-low capacity probe. Notice that this probe differs from the low capacity probe described before — a second resistor has been added to the probe. This probe is designed for use with an oscilloscope having a 3.6 megohm input impedance. The two resistors in the probe are used, with the scope input resistance, as a 10:1 voltage divider. If only a single series resistor were used, as in Fig. 2, its value would have to be 32.4 megohms (9 times 3.6 megohms), and such a resistor is not available at reasonable cost. (Standard resistors are made in values as high as 22 megohms.) Also, on this probe, there is a small switch to allow selection of either direct or low capacity functions.

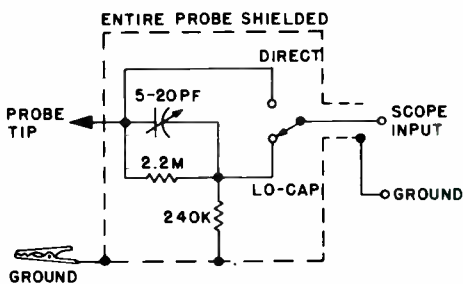

Fig. 4. A combination direct-low capacity probe.

RESISTOR ISOLATED PROBE

Using a resistor or capacitor alone in series with the probe will affect the frequency response, but there are cases where this is desirable. For example, in sweep alignment work, a resistor isolated probe (Fig. 5) is used to cause a rolloff of high-frequency response. This is a great help in sharpening the appearance of any markers on the response curve. (For details on why this happens, see pp.30-32

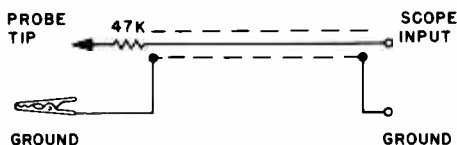

Fig. 5. Adding a resistor at the probe end of the cable isolates the circuit under test from the input capacitance.

of the RCA "Test Equipment-Book Two-Alignment Techniques" which is available from RCA Sales Corp., 600 N. Sherman Dr., Indianapolis, Indiana 46201. The price is 50 cents.) Also, since the probe acts as a low-pass filter, it prevents any rf or i-f signals from the receiver under test from getting into the scope and affecting the measurement. Remember, all it takes to make a low-pass filter is a series resistor and a shunt capacitor. The resistor is the one added in the isolation probe, and the capacitor is the cable capacitance. These two act together as any similar R-C network in filtering out high frequencies.

100:1 CAPACITIVE ISOLATION PROBE

Just as using a series resistor causes a rolloff of high frequencies, placing a capacitor in series with the probe will produce a loss of low frequency response. So, with a small, high voltage capacitor, we can make measurements of fairly high frequency signals of very large amplitude — at the plate cap of a TV horizontal output tube, for example. The only drawback is that high voltage capacitors are expensive and bulky. But here's a way to get around these obstacles: use the cathode-to-plate capacitance of a miniature high voltage rectifier tube (like the

1X2B) as shown in Fig. 6. The filament is not lit, and no other source of power is needed. All nine pins are soldered together, and this is one terminal of the capacitor. The other terminal is the plate cap, which makes a convenient probe tip. Fit the "capacitor" into one end of a 1/2" piece of plastic tubing and let the cable leave through the other end. Keep your hands well away from the tip of the probe while making measurements: this high impedance probe is very sensitive to noise pickup. It is a good idea to provide a contact wire or plate near the rear of the probe. Connect this wire or plate to the cable shield, and always remember to keep your hand in contact with this ground connection while you are using the probe to help reduce noise pickup.

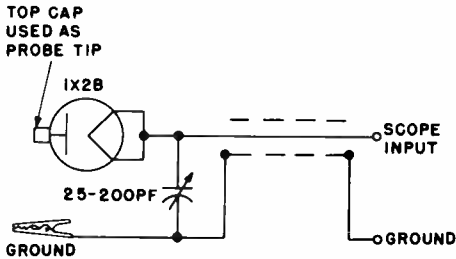

Fig. 6. A 100:1 low capacitance probe using a high-voltage rectifier tube as a small capacitor.

Adjust the shunt capacitor so that the attenuation is 100:1 at the frequency you will be using. Remember that this probe is frequency-sensitive, so its calibration is valid at only one frequency. If you plan to use your probe for testing the horizontal sweep circuits of TV receivers, here's an easy way to calibrate the probe. Locate the B+ boost line in an operating TV receiver. The horizontal pulse amplitude should be 10 to 50 volts peak-to-peak. Connect the scope *directly* to the

test point and set the vertical attenuator switch to the "100X" position, and adjust the vertical gain control for a certain amount (1 to 3 inches) of vertical deflection on the scope. Now, *without changing anything else*, insert the 100:1 probe between the TV and the scope and change the attenuator to "1X". Adjust the variable capacitor on the probe until the signal amplitude is the same as before, and your probe is calibrated.

This probe is useful for testing the horizontal output circuits of TV sets, especially at points marked "DO NOT MEASURE" on the schematic diagrams. The 100:1 voltage division provided by this probe will protect your scope from high-voltage transients present in these circuits. Just remember to connect the ground lead first and remove it last!

DETECTOR PROBES

Although the circuit of a detector probe (sometimes called "demodulator probe") shown in Fig. 7 is the most complex one of all we've seen in this article, this probe is no more than an ordinary AM detector circuit. In fact it is very similar to the diode detector circuits used in almost every radio and TV receiver. The purpose of this probe is to allow the scope to make accurate measurements of the modulation superimposed on very high-

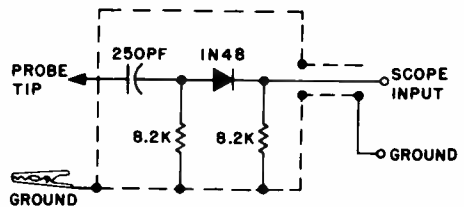

Fig. 7. A demodulator probe.

frequency carriers. For example, this probe will let you signal trace in the video i-f amplifier circuit of a TV receiver. The frequencies handled by this part of the set are far too high to be seen directly by the scope. (Remember most good service scopes go only as high as 4.5 MHz or so.) The signal must be modulated; otherwise the output of the probe would be simply a dc voltage, which wouldn't give much indication on the screen or your scope.



Fig. 8. A double banana plug.

IN CLOSING

Let me recommend a handy piece of hardware that has saved me much time over the last few years: the double banana plug. In case you haven't noticed, almost all brands of service scopes use a pair of five-way binding posts for the vertical input connection. Naturally you've seen that these posts will accommodate standard banana plugs, but also the spacing between these binding posts is

standardized at 3/4" (center-to-center), so you can use a dual banana plug (such as the H.H. Smith No. 210, shown in Fig. 8) instead of fumbling around with separate plugs or some makeshift arrangement. These connectors are available from most parts suppliers (including mail-order companies . . . but *not* from NRI) for about 72 cents — a good investment.

SUGGESTED READING

For more information on probes and related topics, try one or more of these books:

- * PROBES FOR TEST INSTRUMENTS by Zucconi & Clifford — Gernsback Library GL54 (\$2.50)
- * THE OSCILLOSCOPE (Third Edition) by G. Zwick-Gernsback Library GL498 (\$4.98)
- ABC'S OF ELECTRONIC TEST PROBES by R. F. Graf-Sams No. 20039 (\$2.95)
- * Gernsback Library books are available from CONAR. Sams books are sold by your local Sams dealer, or you can order from Howard W. Sams & Co., Inc. 4300 W. 62nd St., Indianapolis, Indiana 46268.

Want to know how to be ready for future opportunities in electronics? Learn digital techniques and your chances for success as an electronic technician and your usefulness in the electronics industry will be much greater.

In this article, the first of a series, we are going to give you the fundamentals of digital techniques so that you can understand the concepts behind them and begin to think about how these techniques will affect you and your work.

Digital Techniques

By **LOUIS E. FRENZEL**



To define digital we need something to compare it to. Let's compare or contrast it to analog techniques. At the same time we are going to have to define the term analog, but doing so will permit us to give you a better definition of the term digital.

In electronics there are basically two types of signals and techniques, analog and digital. Analog signals are the type that we are all most familiar with. Sine wave and similar signals are analog. An analog signal is one that varies smoothly or continuously but does not vary abruptly in steps. An analog signal can take on

an extremely wide variety of forms. Any voltage or current that varies smoothly or continuously, whether it is an ac signal or a dc signal, is considered to be analog. Several types of analog signals are shown in Fig. 1.

A digital signal on the other hand is essentially a series of pulses. Digital signals vary in discrete steps or increments. Digital signals are pulses of voltage generally switched between two fixed levels. Fig. 2 shows several types of digital signals. Notice that these signals switch between two voltage levels. In Fig. 2A, the two levels are 0 (ground) and +5

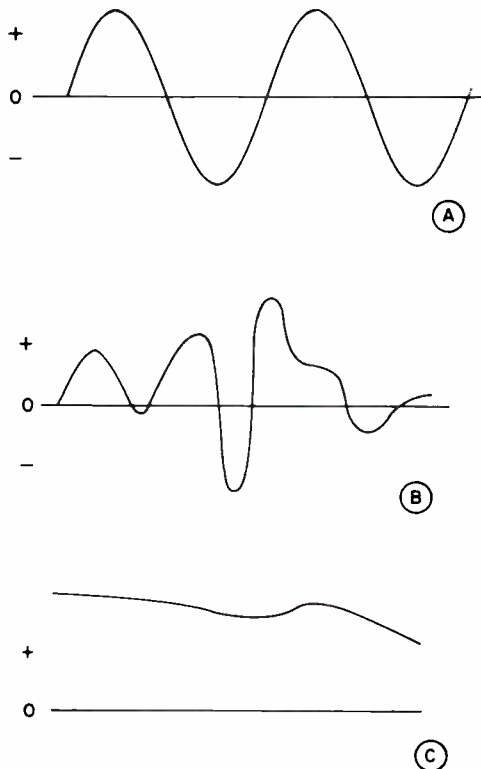

Fig. 1. Several types of analog signals: (a) a sine wave, (b) a random alternating voltage, and (c) a varying dc voltage.

volts. In Fig. 2B the signal alternates between the levels +3 and -3 volts, while in Fig. 2C, the levels 0 (ground) and -6 volts. This two-level, off-on or up-down fast switching signal is a characteristic of digital signals.

Now let's take this comparison of analog and digital methods a step further and define them in terms of devices and ideas already quite familiar to you. As an example, a light bulb can be either an analog or digital device depending upon how it is used. As you know, the amount of current through a light bulb can be varied to any value within its current range. We can vary the current through it

continuously and its brightness at the same time will also vary continuously over a wide range. Used in this way, the light bulb is an analog device. However, it can also be used as a digital device where the current through it or its brightness varies in discrete steps.

The most common way of using the light bulb as a digital device is to turn it off or on. The off condition represents no brilliance while the on condition represents some particular level of brilliance. The brilliance is not the important point, instead it is that the lamp is on as opposed to off. Because of this off-on characteristic we call the lamp binary in nature, where the term binary indicates a two-state device or signal.

Another example to illustrate this concept is the vhf channel selector switch on your television set. It is basically digital in nature since it can assume only discrete positions. It can be set to any one of thirteen positions, channels 2 through 13 and uhf. The volume control on your

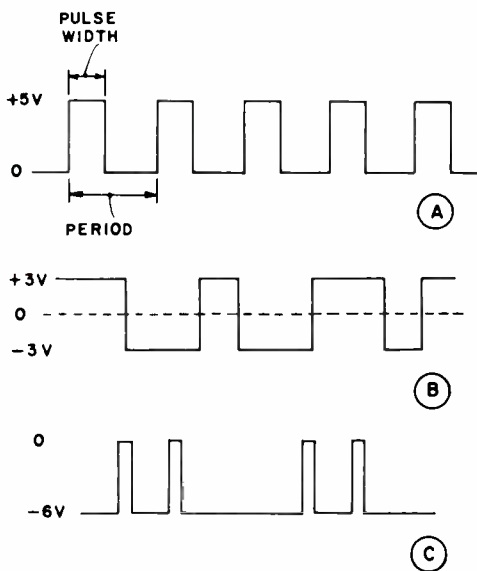

Fig. 2. Several types of digital signals.

television set, however, is analog in nature. You can vary the volume of the sound continuously over a wide range from completely off to extremely loud. You can set the volume control to any point between the two extremes.

The speedometer on your car is an analog device. It gives you an indication of your speed in miles per hour and it does it on a continuous basis. You read the speed on a dial that is usually calibrated in no smaller increments than 5 miles per hour. For speeds between the markings you must interpolate, or guess at, the exact speed.

The odometer portion of your speedometer, the part that indicates the number of miles traveled, indicates them with digits. Since the odometer records mileage in increments of one mile or in some cases one-tenth mile, it is a digital device. The odometer shows you the discrete steps for increments traveled in miles or tenths of a mile.

Another example of an analog device is the common clock or watch. Here the time is indicated continuously by the positions of the hands on a calibrated dial face. The second hand sweeps smoothly and continuously around in an analog fashion as do both hour and minute hands. Note the key words here, continuous and smoothly.

But there are digital clocks as well. You have probably already seen some of the newer digital clocks that give the time in discrete increments as small as a minute. Many of the newer AM-FM table model radios contain a built-in digital clock such as the one in Fig. 3. These clocks are mechanical but they show the difference between analog and digital techniques.

Your vtm or volt-ohm-milliamp meter is also an analog device. It reads or



Fig. 3. A digital clock in an AM-FM radio.

measures voltage and indicates its value by positioning a pointer on a meter scale. Any voltage between zero and some upper limit can be measured with the meter. The pointer moves smoothly or continuously as the analog voltage being measured varies. Other typical analog devices are thermometers, light meters used in photographic work, and slide rules.

Another example of a digital device is a switch. A switch is essentially an off-on or discrete positioning device. Most switches like slide or toggle switches have basically two positions, off and on. A rotary switch is also digital: it can assume only certain discrete positions.

WHERE ARE DIGITAL TECHNIQUES USED AND WHY?

Perhaps the greatest use of digital techniques today is in computers. Most of the growth of the computer industry during the past two decades has been in digital computers. Digital computers are used in all areas of business and industry today. They are extremely useful devices that can save man a tremendous amount of effort and greatly extend his capabilities.

Over the years digital computers have grown in capability, but have become smaller, cheaper and easier to use. As a result, their use has increased tremen-

dously. It is not too unreasonable to suspect that in the years to come each of us will need to know how to use a digital computer. There will be a lot of computers around and people will be needed to design, build, test, install and service them. If you know digital techniques you could qualify.

Figs. 4 and 5 show some of today's typical digital computer systems. The big system shown in Fig. 4 is typical of those found in business data processing applications. The small unit in Fig. 5 is widely used in scientific, engineering and control applications. Already such small but powerful computers have broken the \$10,000 price figure. Today you can buy a digital computer for less than \$5,000, and prices are still dropping.

Computers aren't the only application for digital techniques. Digital techniques are beginning to exist in almost every imaginable area of electronics.

COMMUNICATIONS. Instead of transmitting analog information over wire lines or by radio, data is being transmitted in digital form. It has been found that pulse



Fig. 5. A small computer used for scientific, engineering, and control applications.

type signals are easier to work with and are less susceptible to noise and other problems common in communications systems. Computers can communicate with one another by transmitting information over the telephone lines by using a combination of analog and digital techniques.

Telemetry systems, those systems used for transmitting measurement data from a remote location, almost always use digital techniques. In an unmanned satellite, sensors are used to monitor various envi-



Fig. 4. A large scale digital computer used in business data processing applications.

ronmental conditions such as temperature, light, radiation and other factors. The analog voltages produced by these sensors in response to the quantity being measured could be transmitted back to the earth via radio by modulating a carrier using conventional analog techniques. However, again it has been found that by converting the analog signals into digital signals, improvement in transmission and accuracy of the measurement can be achieved. Today a huge part of all telemetry systems used in satellites and missiles involve the use of digital techniques.

TEST INSTRUMENTS. Perhaps the most common of all electronic test instruments, the voltmeter, is gradually being replaced by the more sophisticated digital voltmeter (DVM). The DVM does the same job as the common voltmeter with meter pointer and dial face. The DVM measures voltage but instead of presenting the reading to the observer in the form of the position of a pointer on a meter face, the voltage is a display of decimal numbers.

A typical DVM is shown in Fig. 6. Notice that there is no meter face, simply a display of numbers that gives you a direct reading of the voltage being measured. Such an instrument, while generally higher in cost than analog voltmeters,



Fig. 6. A digital voltmeter.

is extremely convenient to use and read. More important, it can give more accurate measurements of voltages.

There are other digital instruments available such as the counter-timer unit shown in Fig. 7. This unit is widely used for measuring frequency and time intervals. Again the digital techniques provide a convenient decimal read-out of the exact quantity being measured, thereby eliminating man's need to interpolate continuous or analog meter scales to provide a reading. Greater accuracy and less error in measurement result.

There are many other digital instruments available today. There are electronic digital clocks for accurately keeping track of time in a digital rather than in an analog way. Special digital instruments for measuring other quantities such as temperature using digital techniques are also available.

A digital temperature measuring device

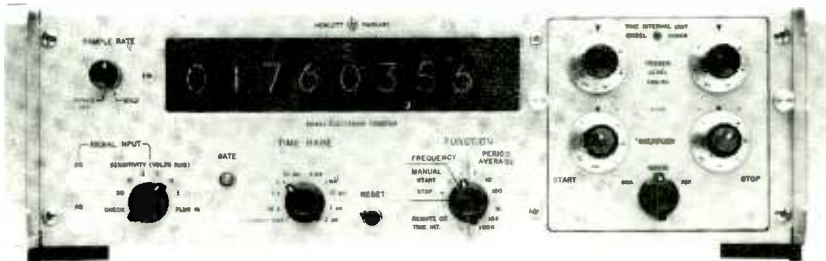

Fig. 7. A digital counter-timer.

and the digital voltmeter are analog-to-digital converters. They start by measuring analog quantities such as voltage or temperature and convert them to digital signals that can be displayed on a decimal read-out display.

SPECIAL INDUSTRIAL CONTROL SYSTEMS. Digital techniques are used in manufacturing plants and refineries where complex operations occur and must be accurately controlled. These systems use sensors to monitor various phases of the operation and the outputs of these sensors are then used to produce signals that will control the various operations that affect these factors in the process.

CONSUMER ELECTRONIC EQUIPMENT. Perhaps the biggest holdout against the use of digital techniques has been in common consumer items such as radio, TV, hi-fidelity and other products. However, even these are giving way to the use of digital techniques. Pulse techniques are widely used in television but such pulse techniques are not generally considered to be digital in nature. In pulse, as opposed to digital techniques, we are concerned with the amplitude, frequency and width or duty cycle of the pulse rather than the two-state nature of digital techniques where number and pattern of pulse are the key factors. However, digital techniques are gradually beginning to show up. An example is the circuitry for digital channel selection used in some recent color television sets. While consumer electronic devices will continue to use primarily analog techniques, more digital controls and circuits will gradually be added to increase versatility and improve performance.

Where are digital techniques used? The answer is almost everywhere in electronics. And their use will increase. Why are digital techniques used? Basically to

obtain greater accuracy of measurement, control or calculation or strictly for convenience.

THE LANGUAGE OF DIGITAL SYSTEMS

You have probably already gathered from the discussion here that, since digital techniques are those that involve discrete steps or pulses, the basic language of digital techniques is numbers. However, instead of using the familiar decimal number system using the digits 0 through 9, digital techniques use the binary number system.

We mentioned the term binary earlier and said that it refers to something with only two discrete states. The binary number system contains only two digits, 0 and 1. With these two digits any number or quantity can be easily represented.

To show you how the binary number system works, we should first review the more commonly known decimal number system. The decimal number system is a weighted, positional number system. What this means is that the position of a digit in a number determines its weight. For example, you know that the positions in the digital number system represent units, tens, hundreds, thousands, etc. Suppose that we take a number like 2785 and analyze it using the positional concept. This number has 5 units, 8 tens, 7 hundreds and 2 thousands. We can add them all together to obtain the number that we are representing:

$$2000 + 700 + 80 + 5 = 2785$$

What we are actually doing is multiplying the weight of the position (units, tens, etc.) by the number of those designated

with the digits 0 through 9 and adding the result. The number 936, for example is:

$$9 \times 100 + 3 \times 10 + 6 \times 1 = 900 + 30 + 6 = 936.$$

The binary number system is similar except that the weights of the numbers of the digit positions in this number system are 1, 2, 4, 8, 16, 32, etc. Each most significant weight is double the weight of the next least significant position. Consider the binary number 1011. The weights of each position reading from right to left are 1, 2, 4 and 8. To obtain the quantity being represented we simply add together the weights of the positions where a binary 1 occurs. In the number 1011 a 1 appears in the 1, 2, and 8 positions. We simply add these quantities together (8 + 2 + 1) to obtain the decimal number being represented, 11. Using the step-by-step procedure we get:

$$1 \times 8 + 0 \times 4 + 1 \times 2 + 1 \times 1 = 8 + 0 + 2 + 1 = 11$$

Each digit position in a binary number is known as a bit. The number 1011 is a 4 bit binary number. Each bit position may be either a binary 1 or a binary 0.

Just to be sure you understand how to convert from a binary number to a decimal number, consider the binary number 100100. This six bit binary number has positional weights reading from right to left of 1, 2, 4, 8, 16 and 32. To obtain the decimal equivalent of this binary number we add together the weights of the positions where a binary 1 occurs. Binary 1's occur in the 4 and 32 bit positions. Adding the numbers 4 and 32 together we get the decimal equivalent 36.

Why is the binary number system used

instead of the decimal number system in digital techniques? The answer to that question is relatively simple. In the binary number system there are only two digits to represent, the 1 and the 0. In the decimal number system there are 10 digits to represent, 0 through 9. It is a lot easier to obtain a reliable high speed electronic device to represent two states than it is to represent ten states.

The two binary digits are easily represented by simple devices such as a switch where off can represent binary 0 and on can represent binary 1. Two states can also be represented by a transistor that is either conducting or cut off. It can be represented by a light that is either off or on.

In digital systems the binary numbers are usually represented by two discrete voltage levels. Voltage levels of 0 and +5 volts for example are very commonly used in digital systems. To represent the ten states required in a decimal system, we would have to use something like a stepping relay or rotary switch. In any case such decimal techniques are extremely slow in operation, bulky and generally less reliable than binary techniques.

In all of our work we inherently use the decimal system and when working with digital equipment the problem of

BCD CODE	DECIMAL EQUIVALENT
0000	0
0001	1
0010	2
0011	3
0100	4
0101	5
0110	6
0111	7
1000	8
1001	9

TABLE I

Table I. The four bit binary code and corresponding decimal numbers.

converting from binary to decimal is always there. As a compromise a special type of binary code has been developed known as binary coded decimal (BCD). It combines some of the characteristics of both the binary and decimal number systems. Table 1 shows the four bit binary code used to represent the ten decimal digits. These four bit code groups are combined, then used to represent any decimal number. For example, the decimal number 631 in BCD code would be 0110 0011 0001. By representing the number 631 in the more conventional binary code we would have 1001110111. Most digital test instruments like clocks, DVM's and counters use the BCD system.

DIGITAL CIRCUITS

Digital circuits are the electronic circuits used to manipulate the digital signals. These circuits process the binary numbers represented by voltage levels or switch positions in a digital device. Digital circuits perform a wide variety of functions including decision making, control, and counting.

There are two categories of digital circuits: those that perform logical or decision-making operations and those that perform storage or counting operations. The digital circuits used for performing logical operations are the inverter, the AND gate, and the OR gate. The three symbols representing these circuits are shown in Fig. 8. All of these circuits are made up of transistors, resistors, diodes and other components. Old style logical circuits used vacuum tubes but today they are virtually nonexistent. All modern digital equipment uses transistorized circuits either in discrete component or integrated circuit form.

The inverter is a circuit that produces

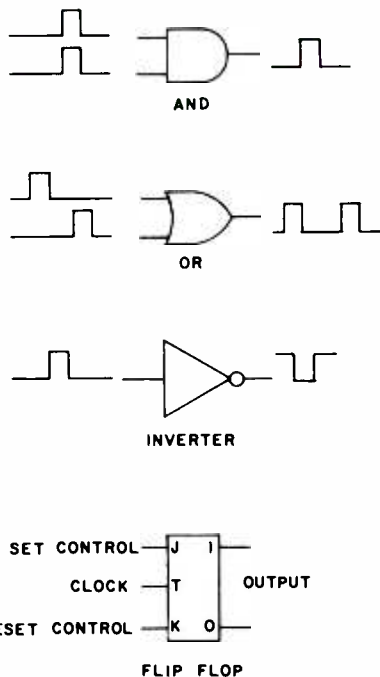

Fig. 8. The basic digital circuits.

an output signal that is the complement or opposite of the input signal. If we apply a binary 1 signal to an inverter, the output produced will be a binary 0. Applying a binary 0 input signal will produce an output signal of a binary 1.

An AND gate is a gate that has two or more inputs and a single output. The output becomes a binary 1 only if all of the inputs are binary 1 at the same time. Otherwise, the output is a binary 0. The AND gate is used as a coincidence detector to tell when input signals exist at the same time. The AND gate can also be used for control purposes by permitting a pulse train of digital signals to either pass through the gate or to be blocked or inhibited by a control signal on one of the inputs.

The third logic circuit is the OR gate which produces a binary 1 output if any

one of its inputs is a binary 1. The gate can have two or more inputs. Such a circuit is useful for providing an output that tells when any one of several input signals exists.

The other category of digital circuits is the storage or counting circuit. The most common circuit is the flip-flop shown in Fig. 8. The flip-flop has two stable states called set and reset. If it is reset it is said to be storing a binary 0. By using a number of flip-flops, one per bit, entire binary words or numbers may be stored.

By properly connecting flip-flops, counting operations can also be performed where the number of pulses appearing at the input to the counter can be recorded as a binary number stored in the counting flip-flop.

With just these few basic logic circuits, a fantastic variety of digital functions can be performed. In fact any digital system, even the most complex digital computer, is made up of nothing more than these simple circuits. In the next article we will explore these circuits in more detail.

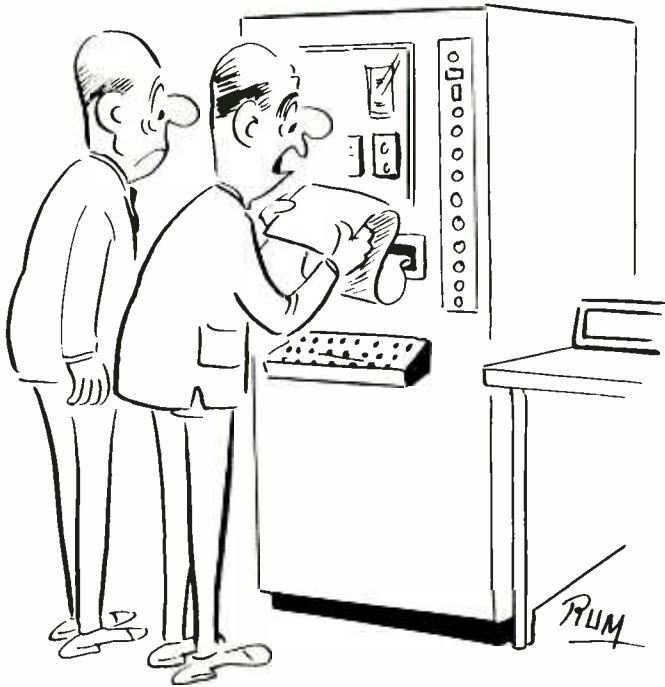

MORE VOLTS AND LESS HOURS . . . MORE VOLTS AND LESS HOURS . . .

HAM NEWS

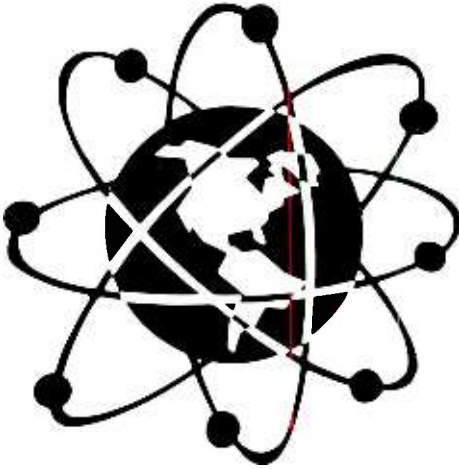

By Ted Beach, K4MKX

Here it is “back-to-school” time again and I am reminded by a note from Croft Von Schuriach Obradahuerto that learning the code is perhaps one of the biggest stumbling blocks of all for prospective hams. How well I can remember trying to get myself up to 5 WPM! Maybe a couple of practical hints from several years’ experience will help some of you in your study of Morse Code.

Croft says that he used a simple word/sound association which enabled him to memorize all the alphabetic characters in only a few hours. This may work well for some people, however I suggest the use of this crutch only for the more difficult characters. By more difficult I mean the “inverted” characters and the long characters such as F and L, Q and Y, D and U, G and W, and Z. You can make up your

own words, but the rhythm and accent should trigger the recognition of the letter. For example, I never had trouble with F, but I could *never* remember L. So in this case I chose a word which starts with F (the inverted letter) and has the accents and rhythm of L: fraternity – di-dah-di-dit; fra - ter’ - ni - ty.

For the letter Q, Croft suggests: Queen Kath - a - rine; dah-dah-di-dah. My choice was: Here comes the Queen. For Z how about: Darn old ze-bra; dah-dah-di-dit.

It’s usually best if you can select a word or phrase which also relates in some way to the letter you are trying to learn. However this is not always necessary just so long as the word or phrase triggers *your* recall of the letter. For this reason it

is probably best that you make up your own list rather than use mine or Croft's.

Remember, however, this is just a tool to be used to help learn the character sounds. It takes practice to learn the code, and the best practice is listening to the ham bands. You will hear all kinds of code, but these are the guys you will be working, so do a lot of eavesdropping as part of your code practice. It will really pay off.

You can practice code anywhere. I used to go around reading signs, street names, house numbers, highway signs – anything – spelling them out mentally in dits and dahs: di-di-dit, di-dah-di-dit, dah-dah-dah, di-dah-dah for SLOW. Dah-dit, dah-dah-

dah, di-dah-dit, dah, di-di-di-dit, di-dah-dah-dah-dah, di-di-dah-dah-dah, dah, di-di-dit for NORTH 12th, and so on.

Be very sure to use the dit and dah sounds in your mind or you will do yourself no good at all. Dots and dashes are out. You can also whistle or hum the code (softly!) for practice. You can do this *anywhere* and *anytime* and you will help your code tremendously.

Enough of the code lesson. My thanks to Croft for mentioning his word association idea; I hope it will help some of you master the code.

Here is the latest list of NRI students enrolled in the Course for Amateur Licenses who have their tickets:

Don	WN1KPO	N	Westminster, MA
E.P.	WN2MTY	N	Fairfield, NJ
John	W3KQJ	A	Berwyn, PA
Ernest	WN30GI	N	Ellicott City, MD
Andy	K4EJE	G	Hephzibah, GA
?	WN4PGZ	N	Sarasota, FL
Curtis	WN5BDQ	N	Robert Lee, TX
Gerald	WA6QOG	G	Blythe, CA
Judi	WA7JMV	C	FPO San Francisco, CA
Fred	K8BBH	G	APO San Francisco, CA
Bob	WB8GGY	-	Sandusky, OH
Bruce	WN8GQN	N	Nutter Fort, WV
Frank	WN8GYX	N	Findlay, OH
Tom	WN9DXK	N	Racine, WI
Richard	WN9DXT	N	Springfield, IL
Fr. Tim	WA9SLZ	G	Columbus, WI
Wilt	WN9BFT	N	Clayton, MO

John, W3KQJ, claims his rig is “ultra modern”, consisting of a BC348 receiver and a homebrew TZ40 transmitter. He is taking our course to upgrade to Extra and

would like to check in on the cw net. We'll be looking for you, John.

WN30GI got his ticket in February of this

year, having started his course in October of '69. That sounds like pretty rapid progress, Ernest. We hope you can keep up that rugged pace.

I might mention that some of the calls which appear in the lists of these pages come to me from our Lesson Grading section. When a Training Kit report for 1R, 2R or 3R has a note that the student has a ham ticket, we jot it down and list the call in the Journal. As a result, we get names like "E.P." which are the only thing the student has put in front of his last name. Subsequently he gets listed as "E.P." in our name column. WN4PGZ has me stumped, however. The name on her report is: F. Stevenson (Mrs.). Hence the (?) in the name column at left. Mrs. F. incidentally, appears to be moving right

Harold	WN1NWT	N	Greenwich, CT
Reggie	K2TEK	T	Corbettsville, NY
Walter	WA3GKF	A	West Wyomissing, PA
Ralph	WA3IVR	A	New Castle, DE
William	WA4NSA	T	Suffolk, VA
Jim	WB5BFE	A	Dallas, TX
Will	WB5BOS	G	Albuquerque, NM
Walter	WN5BQB	N	Huntsville, TX
Glenn	WA5TYO	T	Sulphur, LA
Doug	K7YDD	E	FPO San Francisco, CA
Steve	W8ANJ/KH6	G	FPO San Francisco, CA
Dick	WN8FFZ	N	Avon Lake, OH
Dave	WN8GOY	N	Mt. Clemens, MI
Clark	K9FYY	T	Findlay, IL
Peter	WA9KFC	A	Racine, WI
Gary	WNØASO	N	Vincent, IA
Jerry	WNØBEK	N	Iowa City, IA

WN1MWT is a recent Novice, but an NRI grad from way back. Harold says he graduated in 1932 at 23 years of age and now at 61 has repaired his last radio and finds amateur radio very much to his liking. Welcome aboard, Hal!

along also as she has her Novice ticket and already has 12 – 13 WPM after kit 1R.

WN8GYX would like to see about getting on 7160 KHz with some of the other NRI novices. Frank will have to wait a bit, however, as he does not yet have a transmitter! How do you know you'll like 7160, Frank? Do you already have the crystal?

WA9SLZ sent a QSL which has a photo of himself in front of a whole rack of equipment. Father Tim is one of two ministers in our lists this time. The other is Walter (WN5BQB), pastor of Wesley Memorial Methodist Church in Huntsville, Texas, who is enrolled in the NRI Communications course.

K2TEK says he would very much like to join our cw net but until he gets his General he will have to sit it out (how about K2TEK being a TECHnician?). Reggie is also a retiree (IBM for 42 years) who is just now getting back into amateur

radio. Keep at that code, Reggie; 13 WPM just seems fast!

Walter, WA3GKF, reports that on June 30 he passed his Advanced test with flying colors, coming up from General. Congratulations! The only confusing thing about Walter's note was his QTH; the envelope was postmarked "Reading", carried a return address of "West Lawn" and had an inside address of "West Wyomissing". Devoted sleuth work by my trusty secretary soon tracked down Walter to his true QTH: West Wyomissing, PA!

WA4NSA notes that there are many types of ham — the operator, the appliance operator, the CW Man, the silly side band man, the RTTY specialist and the inveterate tinkerer. He and I belong to the latter category. Bill says he very much enjoys delving into all areas of electronics; transmitters, counters, power supplies, digital circuits, ultrasonics and motors, to name a few. I guess a lot of us qualify for the same interests.

WB5BOS is a student in the NRI Color TV training course and has gotten his General ticket since enrolling with NRI. Will says that he has gone so deeply into his training that the "pennies" are a bit short for ham gear. Well, when you start fixing those expensive color TV sets, Will, it shouldn't take long to get enough scratch for a pretty decent rig. We'll be looking forward to hearing from you real soon — on the air!

It seems we have a husband/wife team, both hams and both NRI students. Judi (who wrote the letter) is WA7JMV in the Amateur course, and her OM is K7YDD, enrolled in our Math for Electronics

course. Both are presently stationed in the Philippines with the Navy, and are not allowed to operate by the local government. Some luck. Both are looking forward to coming stateside and being able to operate again (188 days, Judi says).

We finally snagged another one that we have been looking for (WAS). Our first Hawaii. Even if it is a /KH6. The postmark on the envelope says HI and that's what counts. Right? Anyway Steve, W8ANJ/KH6, says he really doesn't have a lot of time for hamming in the islands because of a full Navy schedule and part-time work as a radio station engineer. *And* he is studying every spare minute for his Advanced class license. No wonder he only gets on the air "occasionally". Thanks for Hawaii, Steve, and best of luck.



"POSITIVE FEEDBACK"



Robert L. Carlson, in his article on regulated IC power supplies in the July/August Journal, indicated that the base-collector junction of an inexpensive silicon transistor makes a good 5V to 7V Zener diode. While the reverse biased base-collector junction *will* act as a Zener, in all likelihood the breakdown voltage will be in the 15V to 25V range. It is the reverse biased *base-emitter* junction which makes the 5V to 7V Zener. The foil diagram and component layout on page 6 of the last edition of the Journal correctly show the transistor connected in this manner.

Another busy guy is Gary, WNØASO. Besides working 50 or so hours a week, he studies for the Communications course and has to keep up with his YML, three harmonics, two horses, one dog, one cat, two and a half acres, and a one-acre garden! Since he got his license in February, Gary has worked 21 states – all on 15 meters – and has Florida and California for DX. Oh yes, he also expected to go in July for his General or Advanced license. With that kind of drive I'm sure he made it!

WNØBEK wrote a very nice letter giving details of an inexpensive modification he made to a Conar 500 receiver to narrow the i-f passband for better selectivity. Jerry bought the 400/500 rig from

Duane, WB8EEJ and decided to add a two-pole, half-lattice crystal filter using surplus crystals. We haven't tried it yet, but I'm sure the mod is a good one. If anyone is interested, drop me a line and I'll send you a copy of Jerry's instructions. Jerry also said his QSL was a low budget item, being simply a 3 X 5 file card with all pertinent info rubber stamped on the card. It's a good looking card – and no need to buy 300 commercial cards and later have to change the "N" to "A" or "B" with a new license!

And with that, we'll have to pull the switch for this time. CUL

vy 73

Ted Beach – K4MKX



"HE WANTS US TO BE SURE THAT'S NOT A NASTY WORD IN MORSE CODE."

...HELP WANTED...

...HELP WANTED...

...HELP WANTED...

SERVICE KINGS, INC.
needs
RADIO-TV SERVICING TECHNICIANS

Contact: J.C. Pumphrey
Service Kings, Inc.
4210 Howard Ave.
Kensington, Md.
301-942-3600

SEARS
has many career opportunities
for experienced TV technicians
or recent graduates of electronics
schools. Top benefits,
locations throughout the U.S.

CONTACT:

The Service Manager
of your nearest
SEARS SERVICE CENTER
or the
Personnel Manager
of your nearest
SEARS retail store.

**POSITIONS AVAILABLE DEALING WITH HEAVY
DUTY INDUSTRIAL EQUIPMENT, 2-WAY RADIOS,
CLOSED CIRCUIT TV AND PAGING SYSTEMS.
REQUIRES AT LEAST 2ND CLASS FCC LICENSE.**

**CONTACT: MR. GLENN WHITE
DISTRICT SERVICE MANAGER
19-A BRADSTON STREET
BOSTON, MA 02118
617-445-4545**

MONTGOMERY WARD
has openings for
TV technicians or grads
of electronics schools.
Openings available in Wash.,
Md., and Va. areas.

CALL OR WRITE:

Pat F. Cosentini
Service Manager
7100 Old Landover Rd.
Landover, Md. 20785
301-322-3344

WANTED

*Experienced or well-trained two-way radio tech-
nicians. Ideal positions open for responsible men.
FCC second class license required.*

CONTACT

*Manager, Communications Department
Lafayette Radio Electronics
2025 Arden Way
Sacramento, Calif. 95825*

!!!!!!WANTED!!!!!!Field Service Technicians!!!!!!

Positions now available in the Graphic Communications Field. Technicians
needed to install and maintain such equipment as Electronic handwriters
and Facsimile units. Top starting salary and excellent benefits.

Contact Telautograph Corp., 1921 North Harlem Ave., Suite 108, Chicago, IL 60636
(312 622-7111)

UNIVERSITY POSITION OPEN FOR MAINTENANCE ENGINEER ON
CC – ITV FACILITY. ALL NEW EQUIPMENT, QUALITY BROAD-
CAST GEAR INCLUDING 10 CAMERAS AND THREE QUAD VTR's;
EXTENSIVE CAMPUS-WIDE RF, VIDEO DISTRIBUTION SYSTEM IN
THE WORKS.

LOCATED 1-1/2 HOURS NORTH NYC IN THE CATSKILLS.

PAID RETIREMENT PLAN, 20 DAYS VACATION, MANY OTHER
FRINGE BENEFITS. QUITE GOOD STARTING SALARY.

WRITE OR PHONE

KENNETH B. KNECHT

SUPERVISOR, TELEVISION ENGINEERING

STATE UNIVERSITY COLLEGE

NEW PALTZ, NEW YORK 12561

TELEPHONE 914-257-2523

WANT TO MAKE UP FOR LOST TIME?

*RCA has training programs for the inexperienced in basic TV service as well
as for the experienced technician in the latest solid-state circuitry. If you've
got some catching up to do, write:*

**T. G. MacNamara, Employment Manager
RCA Service Company, Cherry Hill, N.J. 08034**

**HELP WANTED: ZENITH DISTRIBUTOR IN ARIZONA HAS OPENINGS
THROUGHOUT THE STATE FOR TELEVISION BENCH MEN, OUTSIDE
MEN, AND TRAINEES WITH OUR DEALER ORGANIZATION.**

If interested, please contact:

MR. R. J. ENGARD

P.O. BOX 10704

PHOENIX, ARIZONA 85036

NRI HONORS PROGRAM AWARDS

For outstanding grades throughout their NRI course of study, the following May and June graduates received Certificates of Distinction along with their Electronics diplomas.

WITH HIGHEST HONORS

William D. Albaugh, Pittsburgh, Pa.
Robert E. Birdsong, College Park, Ga.
Richard W. Bonnet, Media, Pa.
Tim R. Butler, Powell, Tenn.
Eugene C. Furey, Old Forge, Pa.
William W. Goldbach, Bedford, Mass.
Kenneth J. Henson, Milford, Ohio
Robert Paul Jones, Syracuse, N.Y.
Jack Nixon Lyerly, Belmont, N.C.
Johnny R. McLain, Alton, Ill.
Preston Glynn Thomas, Colorado Springs, Colo.
John W. Yturri, Los Angeles, Calif.

WITH HIGH HONORS

Billy Alexander, Houston, Texas
Albert Alparone, Middlesex, N.J.
Rodney E. Bailey, Van Nuys, Calif.
George P. Bergner, Brooklyn, N.Y.
Vefa Besim, Nicosia, Cyprus
Elmer H. Blush, Jr., Arlington, Va.
Harold E. Bowman, Butte, Montana
Barrie W. Braden, Adrian, Michigan
David R. Braeger, Omaha, Nebraska
Robert A. Bruner, Mobile, Alabama
Larry Bunk, Windber, Pa.
Joseph J. Cangelosi, Warehouse Point, Conn.
Alfred P. Carney, Pine Beach, N.J.
James Nelson Carr, Stewartstown, Pa.
Calvin C. Cowdrey, Fremont, Ohio
Lawrence M. Cox, APO New York
Olen B. Dixon, Jr., Charleston, S.C.
Ross F. Drussell, Winona, Minnesota
Richard W. Edmonds, Bruin, Pa.
Guy B. Everett, East Gary, Indiana
Clifford J. Fink, Norwalk, Ohio
Fletcher F. Flickner, Pearland, Texas
Jack M. Fralinger, Towson, Md.
Roy D. Goff, Vienna, Va.
William A. Grimm, Uniontown, Pa.
Kevin G. Hanlon, St. John's, Nfld., Canada
Carl F. Haupt, Provo, Utah
William L. Hightchew, APO San Francisco
Richard E. Hildenbrand, Selden, N.Y.
Gary L. Hill, March AFB, Calif.

Eugene Hlady, Carrot River, SK., Canada
Clyde A. Jenkins, Bluff City, Tenn.
Gerald T. Kane, Omaha, Nebraska
Gary Don Kirk, Rainsville, Alabama
David A. Konvalinka, Peoria, Ill.
Hal C. Lakin, Novato, Calif.
Clermont Langlois, Levis, P.Q., Canada
Donald E. Mayhugh, Minot AFB, N.D.
James E. Mays, Jr., Vandenberg AFB, Calif.
Thomas L. McKenzie, Lusk, Wyoming
James R. McQuerrey, Marion, Ohio
Gerd Milde, Conquitlam, B.C., Canada
Steward R. Mundis, Pryor, Oklahoma
Jack Neff, Bradford, Ohio
Anthony J. Oliva, APO San Francisco
Edward V. Olson, San Diego, Calif.
Cecil A. Powell, Icard, N.C.
Charles W. Preston, Junction City, Kans.
Fred Reszutek, Freehold, N.J.
Linzie Rogers, Houston, Texas
John F. Rogus, Westmont, Ill.
Albine L. Sardinha, North Westport, Mass.
Thomas V. Schill, Huntington, W.Va.
Bill Shelby, Sr., Caruthersville, Missouri
Arnold J. Smisek, New Prague, Minnesota
John S. Smith, Annandale, Va.
Raymond L. Sofield, Jr., Bowie, Md.
Donald Stule, Silver Bay, Minnesota
Michael L. Summitt, Greencastle, Indiana
Charles A. Thearle, Hagerstown, Md.
Joseph A. Tomasko, Johnstown, Pa.
Raymond Tomaszkeski, Brooklyn, N.Y.

FOR SALE

NRI graduate would like to sell, cheap, very old but serviceable, varied assortment of tube types.

R.M. BAKER
Radio and TV
35 Gladstone Avenue
West Islip, New York

John J. Turek, Millington, Tenn.
 K. Vitols, Bar Falls, Ont., Canada
 Rodney H. Watson, Northfield, N.J.
 J. R. Whitley, Oklahoma City, Okla.
 Anthony C. Wilbourn, Florence, Ala.
 Terry W. Wiles, Plattsmouth, Nebraska

WITH HONORS

Bobby Allen, Hattiesburg, Miss.
 Don A. Amtsberg, Fort Bragg, N.C.
 Richard Balgos, New Orleans, La.
 James F. Barrows, Titusville, Fla.
 Danny J. Baum, Huron, S.C.
 Chester M. Bawol, Alamogordo, New Mex.
 Gerald W. Beebe, Kansas City, Missouri
 W. G. Blackledge, Pascagoula, Miss.
 Lawrence J. Brady, Long Island City, N.Y.
 John D. Brannon, Coraopolis, Pa.
 Ralph L. Brousseau, San Antonio, Texas
 Edward L. Brown, San Diego, Calif.
 Freddy W. Brown, Jay, Florida
 Joe L. Brown, Jr., Modesto, Calif.
 William Bush, Indianapolis, Ind.

Arthur T. Carter, Bridgeport, Conn.
 Roger W. Chack, Schofield, Wisconsin
 Warren C. Coffey, San Jose, Calif.
 James W. Daugherty, San Antonio, Texas
 Forrest C. Decker, St. Louis, Mo.
 Glen A. Deibert, Springlake, N.C.
 C. D. Drane, New Orleans, La.
 Carl G. Duncan, Amarillo, Texas
 Robert Eyster, Jr. Vienna, Ohio
 Larry R. Flory, Greenville, Ohio
 Reginald Fortier, Asbestos, P.Q., Canada
 Barry Edwin Gale, Yellowknife, NWT., Canada
 Philip R. Ginchereau, Lindenwold, N.J.
 Robert J. Greer, New Castle, Delaware
 Joe L. Grimes, Warrenton, Va.
 Robert G. Gutshall, Altoona, Pa.
 Claud W. Hale, Capitol Heights, Md.
 Robert W. Harper, Irwin, Pa.
 William S. Hollister, FPO San Francisco
 Richard F. Hunt, Wellesley Hills, Mass.
 James R. Jackson, Pasadena, Texas
 Eugene Frederick Jacobs, Tulsa, Okla.
 Carl A. Jewell, Griffiss AFB, N.Y.
 Ernest Johnson, Marydel, Md.

CONAR ORDER BLANK

J14

DIVISION OF NATIONAL RADIO INSTITUTE, 3939 WISCONSIN AVE., WASHINGTON, D.C. 20016

PLEASE PRINT

NRI STUDENT NUMBER

NAME

ADDRESS

CITY STATE ZIP

- CASH
- C.O.D. (20% Deposit required)
- ADD TO MY CONAR ACCOUNT
- NEW EASY PAYMENT PLAN (10% Deposit)

Quantity	Model	Name of Item	Price Each	Total

If you live in Washington, D.C., add sales tax.
 All prices are net, F.O.B. Washington, D.C.

TOTAL _____

ON NEW TIME PAYMENT ORDERS

please be sure to complete the Easy Payment Plan credit information form on the reverse side of this page and include 10% deposit with your order. ▶

Neil D. Johnson, Sandy Hook, Conn.
 T. F. Kandler, Pottstown, Pa.
 Donald G. Knight, Garden Grove, Calif.
 Richard J. Kozlowski, Reisterstown, Md.
 Remi Lacasse, Arvida, P.Q., Canada
 John J. Lind, Fairfax, Va.
 Delmar B. Lizotte, Richland, Wash.
 Ronald R. Mack, Philadelphia, Pa.
 William F. Mantz, Jr., Dover, Del.
 Terry M. Marcoux, Saginaw, Mich.
 George M. Marshall, Shackelfords, Va.
 Jack A. Massa, San Angelo, Texas
 J. Robert Mellis, Latham, N.Y.
 Floyd E. Miller, Savannah, Ga.
 Paul Leon Miller, Falls Creek, Pa.
 William Miller, Miami, Fla.
 Philip D. Neal, Collinsville, Miss.
 Karl W. Niemi, Thomaston, Maine
 William Weston Nutter, Pittsfield, Maine
 Richard P. Ohlendorf, Grand Haven, Mich.
 Wilfrid P. Orlang, Martinez, Ga.
 Casimire C. Paprota, Forked River, N.J.
 Leo N. Plette, Bossier City, La.
 Earl S. Post, Lancaster, Calif.

George Reckentine, Rome, N.Y.
 Allen L. Rice, APO New York
 Gerald F. Ritchie, Haverhill, Mass.
 Rufino Rodriguez, Jr., El Paso, Texas
 Ronald A. Roslawski, Kansas City, Mo.
 Fred Rowland, Cincinnati, Ohio
 Earl F. Schneider, Lehighton, Pa.
 Alexander Siebert, Willow Grove, Pa.
 Norbert E. Simon, Niceville, Florida
 Larry E. Smith, Beale AFB, Calif.
 Michael L. Smith, Xenia, Ohio
 Ulma W. Smith, Bossier City, La.
 Michael P. Socha, Philadelphia, Pa.
 Joseph T. Sollid, Antioch, Calif.
 Erven L. Spencer, Jr., Alamogordo, N.M.
 Edward Lee Stanger, Independence, Mo.
 Jack J. Stiglianese, Bronx, N.Y.
 Eric V. Tallberg, Jr., Beacon Falls, Conn.
 W. E. Taylor, Malvern, Arkansas
 Edgar E. Thebeault, Galion, Ohio
 Robert E. Uderjohn, Silverton, Oregon
 Robert E. Walker, Springfield, Vermont
 Frank H. Whitt, Jr., Columbus, Ohio
 K. W. Wilson, Ft. Worth, Texas

CONAR EASY PAYMENT PLAN

J14

CREDIT APPLICATION

Note: Easy payment plan credit applications cannot be accepted from persons under 21 years of age. If you are under 21, have this form filled in by a person of legal age and regularly employed.

Enclosed is a deposit of \$..... on the merchandise I have listed on the reverse side. I hereby apply for credit under the Conar Easy Payment Plan. The statements below are true and are made for the purpose of receiving credit.

Date Written Signature

CREDIT APPLICATION

Print Full Name Age

Home Address

City & State How long at this address?

Previous Address

City & State How long at this address?

Present Employer Position Monthly Income

Business Address How Long Employed?

If in business for self, what business? How Long?

Bank Account with Savings Checking

CREDIT REFERENCE (Give 2 Merchants, Firms or Finance Companies with whom you have or have had accounts.)

Credit Acct. with Highest Credit

(Name) (Address)

Credit Acct. with Highest Credit

(Name) (Address)

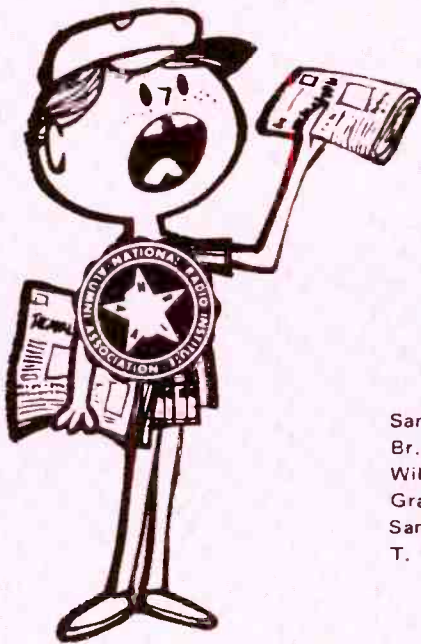

Alumni News

Sam Stinebaugh President
Br. Bernard Frey Vice-Pres.
William Sames Vice-Pres.
Graham Boyd Vice-Pres.
Samuel Antman Vice-Pres.
T. F. Nolan, Jr. Exec. Sec.



The first meeting of the newly organized Toronto Chapter of the NRI Alumni Association was held at the Scarborough office of the McGraw-Hill Company of Canada, Limited.

DETROIT CHAPTER ADJOURNS MEETINGS UNTIL SEPTEMBER

Mr. Berus brought in a transistor demonstration board for the May meeting. *Jim Kelly* performed experiments and explained their meaning and purpose.

After this section of the meeting an open discussion was held concerning various service problems. Everyone joined in the discussion.

At the June meeting, the last of the current season, sandwiches and coffee were furnished by *Leo Blevens and Charles Cope*. *Charlie Cope* brought down an intercom and all the members pitched in to find its troubles. The next meeting will be in September.

FLINT (SAGINAW VALLEY) CHAPTER HEARS MARINE ENGINEER

Mr. Richard Moore, the latest member of the Chapter, who is a Marine Engineer, gave a very interesting talk on marine radio and radio compass. He discussed the servicing and the problems that can occur in these instruments.

At the next meeting *Steve Avetta* had a black and white TV problem. *Gilbert Harris* used his B&K Analyt to pinpoint the defective part. After a short meeting, the members adjourned to the General Motors plant to see the new Uni Mate machine. This machine is programmed by magnetic tape. It is the very latest in industrial electronic machine tools, and can do most anything by tape command.

The big picnic was held on June 28 at the Industrial Mutual Association Park, and was a great success. It was an inter-

national affair with food from twenty different countries.

Mr. James Smith gave a talk at the July meeting about the Electronic Video Broadcaster Tape Unit. This is a tape deck similar to an automobile unit, but this one allows you to have home movies any time. There is one problem however, and that is the standardization of cartridges between RCA, CBS and Sony.

The final meeting found *Andrew Jobbagy, Gilbert Harris and Richard W. Moore* giving talks on various subjects including medical electronics, color TV set up, and marine navigation.

This has been a very active season for the Flint Chapter.

NEW YORK CHAPTER ENTERTAINS GUEST FROM NORTH AFRICA

Pete Carter brought a guest from a village of Sierra Leone, North Africa, who is attending a college in North Carolina.

The Chapter's color TV receiver was used by *Mr. Eddy and Mr. Crowe* to demonstrate convergence. *Mr. Bimstien* brought along his color bar generator which was used for this demonstration.

At the May meeting, *Mr. Pete Carter, Mr. Foggie and Mr. Eddy* discussed different electronics subjects.

At the June meeting *Pete Carter* demonstrated a high voltage problem in a Magnavox TV receiver. *Mr. Eddy and Mr. Carter* again worked together on the color set for more interesting demonstrations.

Mr. Lionel Williams entertained at the second June meeting with a car transistor radio which he used to demonstrate test equipment. He explained how easy it was to check out a set using the Sams Photofact information. This was the last meeting until the third of September.

NORTH JERSEY CHAPTER DISCUSSES TV's, TRANSISTORS

The film and recording which were to have been the May program were not obtained in time for the meeting. However, the evening was not lost, as everyone had something to talk about and discussions covered everything from A to Z. *Harry Ala* brought in an old TV set which motorboated and had no picture. Members corrected the sound, but the crt had a bent gun; a rather unusual defect which few of the members had ever seen.

The June meeting was devoted to transistor servicing in a little stereo record player, where both transistors were checked and found to be defective. The cause was a burnt resistor which had changed value. A TV set with sound trouble was also traced to a bad resistor in the audio section. Replacement of parts was the cure in both cases.

The July and August meetings will not be held because of the summer vacation.

PITTSBURGH CHAPTER VIEWS SLIDES

Jim Wheeler brought a Motorola TV to the June meeting and demonstrated purity and convergence using an RCA WR64B Color Bar Dot Crosshatch Generator. Then the members were asked to try it themselves. *Jack Benoit* using a

Zenith black and white TV, and an Eico Model 460 Scope, showed how to calibrate the scope and how to display several basic waveforms.

The July meeting consisted of a series of slides on color TV supplied by Howard W. Sams and Company, Inc. entitled "Color TV Review Series," explaining color TV theory and circuitry.

PHILCO-FORD AGENT FETES TEXAS CHAPTER

The San Antonio Chapter was entertained by *Mr. George Hartley*, who is a Philco-Ford Corporation Area Technical Representative. *Mr. Hartley's* talk covered two subjects, customer relations and Philco color circuitry.

This was an outstanding program because *Mr. Hartley* is an expert technician, businessman, and speaker. He devoted a great deal of his program to employee relations. As this was a group of mostly part-timers, this was most appropriate. The remainder of his program was devoted to technical hints, including peculiar Philco color circuits. He promised to come again within the next year.

Although the Chapter is not recessing for the summer, the members do not plan to have outside speakers until September. *Ernie Geisendorff*, Vice Chairman, will take the June program, *Sam Stinebaugh* the July program, and *Bob Bonge* will take the August program.

Two new members were admitted, *Mr. H. E. Ruess* and *Mr. Norman A. Bird*. Welcome to the Chapter, fellows.

SPRINGFIELD (MASS.) CHAPTER
CONTINUES COLOR STUDY

The June meeting was devoted to circuit analysis of the burst amplifier and color amplifier. Waveforms were shown on a scope for comparison with the manufacturers' patterns. The picture tube grid waveforms were also checked against the manufacturers' information. The members practiced setting up, tracking, and making other adjustments. The Vector-scope was used during these experiments.

The Chapter welcomed two guests at this meeting, *Mr. Dennis Rau and Robert Keenan*.

The July meeting had an unusually large turnout as we had scheduled the installation of our color picture tube. The mechanical and electrical methods of handling, mounting, and adjusting were keenly observed during the process.

Enthusiasm for this type of color training program is running so high that Chairman *Al Dorman* suggested three aids to speed up the training. First, to hold two meetings a month; second, to perhaps hold one meeting at his home; third, to hold a meeting on a day of the week other than Saturday.

Freddie Ablog demonstrated his Conar Color Bar Generator. *Carl Dionisi* showed his Leader 389 All Transistor Color Bar Generator. *Brother Bernard Frey* showed how he cured a color problem in a Conar Color TV by replacing a burst transformer.

The Chapter wants to thank *Frank Piantek* for constructing an adjustable chassis holder and adjustable mirror and stand for Chapter training use. Four new members were admitted: they are *John Hubeny, Dennis Rau, Robert Keegan and Arthur Byron* formerly of the San Francisco Chapter.

NRI JOURNAL CHANGE OF ADDRESS LABEL

Name _____

Student No. _____ Date _____

OLD ADDRESS

Street _____

City _____ State _____

NEW ADDRESS – after _____ 19 _____

Street _____

City _____ State _____

Zip Code _____

'TRICK OR TREAT'
FOR UNICEF!



DIRECTORY OF CHAPTERS

CHAMBERSBURG (CUMBERLAND VALLEY) CHAPTER meets 8 p.m. 2nd Tuesday of each month at Bob Erford's Radio-TV Service Shop, Chambersburg, Pa. Chairman: Gerald Strite, RR1, Chambersburg, Pa.

DETROIT CHAPTER meets 8 p.m., 2nd Friday of each month at St. Andrews Hall, 431 E. Congress St., Detroit. Chairman: James Kelley, 1140 Livernois, Detroit, Mich. VI 1-4972.

FLINT (SAGINAW VALLEY) CHAPTER meets 7:30 p.m., 2nd Wednesday of each month at Andrew Jobbagy's shop, G-5507 S. Saginaw Rd., Flint, Mich. Chairman: Andrew Jobbagy, 694-6773.

LOS ANGELES CHAPTER meets 8 p.m., third Friday of each month at Graham D. Boyd's TV Shop, 1223 N. Vermont Ave., Los Angeles, Calif., NO-2-3759.

NEW ORLEANS CHAPTER meets 8 p.m., 2nd Tuesday of each month at Galjour's TV, 809 N. Broad St., New Orleans, La. Chairman: Herman Blackford, 5301 Tchoupitoulas St., New Orleans, La.

NEW YORK CITY CHAPTER meets 8:30 p.m. 1st and 3rd Thursday of each month at 264 E. 10th St., New York City. Chairman: Samuel Antman, 1669 45th St., Brooklyn, N.Y.

NORTH JERSEY CHAPTER meets 8 p.m., last Friday of each month at Midland Hardware, 155 Midland Ave., Kearney, N.J. Chairman: William Colton, 191 Prospect Ave., North Arlington, N.J.

PITTSBURGH CHAPTER meets 8 p.m., 1st Thursday of each month in the basement of the U.P. Church of Verona, Pa., corner of South Ave. & 2nd St. Chairman: Tom Schnader, RFD 3, Irwin, Pa.

SAN ANTONIO (ALAMO) CHAPTER meets 7 p.m., 4th Friday of each month at Alamo Heights Christian Church Scout House, 350 Primrose St., 6500 block of N. New Braunfels St. (3 blocks north of Austin Hwy.), San Antonio. Chairman: R. E. Bonge, 222 Amador Lane, San Antonio, Texas.

SAN FRANCISCO CHAPTER meets 8 p.m., 2nd Wednesday of each month at the home of J. Arthur Ragsdale, 1526 27th Ave., San Francisco. Chairman: Isaiah Randolph, 60 Santa Fe Ave., San Francisco, Calif.

SOUTHEASTERN MASSACHUSETTS CHAPTER meets 8 p.m., last Wednesday of each month at the home of John Alves, 57 Allen Blvd., Swansea, Mass. Chairman: Oliva J. Laprise, 55 Tecumseh St., Fall River, Mass.

SPRINGFIELD (MASS.) CHAPTER meets 7 p.m., 2nd Saturday of each month at the shop of Norman Charest, 74 Redfern Dr., Springfield. Chairman: Al Dorman, 6 Forest Lane, Simsbury, Conn. 06070.

PHILADELPHIA-CAMDEN CHAPTER meets 8 p.m., 4th Monday of each month at K of C Hall, Tulip and Tyson Sts., Philadelphia. Chairman: Herbert Emrich, 2826 Garden Lane, Cornwell Heights, Pa.

SPECIAL OFFER FOR THE COLOR TV SERVICEMAN

GET OUR **\$22.³⁵**

ISOLATION TRANSFORMER **FREE**

WHEN YOU ORDER BOTH:

CONAR 5" WIDE BAND
OSCILLOSCOPE

AND

CONAR COLOR BAR
GENERATOR

(OR BUY ONE OF THESE TWO INSTRUMENTS AND
GET THE ISOLATION TRANSFORMER FOR ONLY \$7.00)

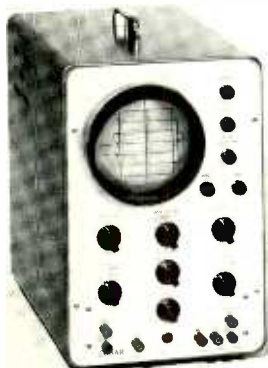

CATALOG
PRICE

KIT 250UK **\$99.90**

WIRED 250WT **\$139.50**

**STUDENT AND
ALUMNI PRICE**

KIT 250UK **\$82.90**

WIRED 250WT **129.75**

Shipped
Express collect



CATALOG PRICE

KIT 680UK **\$89.50**

WIRED 680WT **\$121.50**

STUDENT & ALUMNI PRICE

KIT 680UK **\$79.50**

WIRED 680WT **\$109.00**

The Conar model 250 features:

- Uses 2400 volts on the cathode ray tube—50% more than most scopes.
- Vertical gain control is calibrated for direct reading of peak-to-peak voltages.
- Two stage retrace blanking amplifier gives 100% retrace blanking at all frequencies produced by the scope sweep generator.
- Accurately measures ripple output of power supplies; checks auto radio vibrators dynamically.
- Intensity and focus controls use special insulated high voltage potentiometers to eliminate leakage and shock hazards.
- Has push-pull outputs balanced by separate phase splitter tubes in both horizontal and vertical amplifiers.
- Built-in flyback checker gives rapid, in-circuit testing of flybacks, transformers, yokes, coils, loopsticks.
- Sweep range—10cps to 500kc—five times the range of most other scopes, using special linearity circuit.

The Conar model 680 integrated circuit color bar generator features:

- Exclusive digital integrated circuits.
- Exclusive 4 crystal controlled oscillators.
- Exclusive AC or battery operation.
- Completely solid state.
- Color amplitude control.
- Color phase adjustment.
- Regulated power supply.
- Stability control.
- TV station sync and blanking pulses.
- Nine patterns.
- Red, blue and green gun killers.
- Compact, lightweight, portable.

**ORDER NOW AT YOUR SPECIAL STUDENT & ALUMNI PRICE.
BOTH FOR ONLY: KIT **\$162.40** OR WIRED **\$238.75****

(THIS SPECIAL OFFER EXPIRES AUGUST 31, 1970)

USE CONVENIENT ORDER BLANK ON PAGE 25

COLOR TV SERVICEMAN'S SPECIAL OFFER

GET OUR **\$22.35** ISOLATION TRANSFORMER FREE

WHEN YOU ORDER BOTH:

CONAR MODEL 250 WIDE-BAND 5" OSCILLOSCOPE **AND** CONAR MODEL 680 COLOR BAR GENERATOR

(OR BUY ONE OF THESE TWO INSTRUMENTS AND GET THE ISOLATION TRANSFORMER FOR ONLY \$7.00)

An Isolation Transformer is a must for color and black & white TV servicing. It reduces the shock hazard by isolating the equipment from the AC power line. It prevents "hot chassis" when servicing. The transformer works with 115 volts, 50-60 cycles. It comes with cord, plug, and standard AC receptacle. 300 watts, 4 $\frac{5}{8}$ " x 3 $\frac{7}{8}$ " x 5 $\frac{5}{8}$ ". Stock #7TO. 13 lbs.

SEE INSIDE BACK COVER FOR DETAILS

NRI JOURNAL
3939 Wisconsin Avenue
Washington, D. C. 20016

Second-class
postage paid
at Washington, D. C.

Mr Simble A Mix
170 N 12th St Box 923
Grover City Calif 95343
* 9/15/50
C134-1032 010

Expiration date for the Conar special offers has been extended to October 31, 1970. See inside front and back covers.