

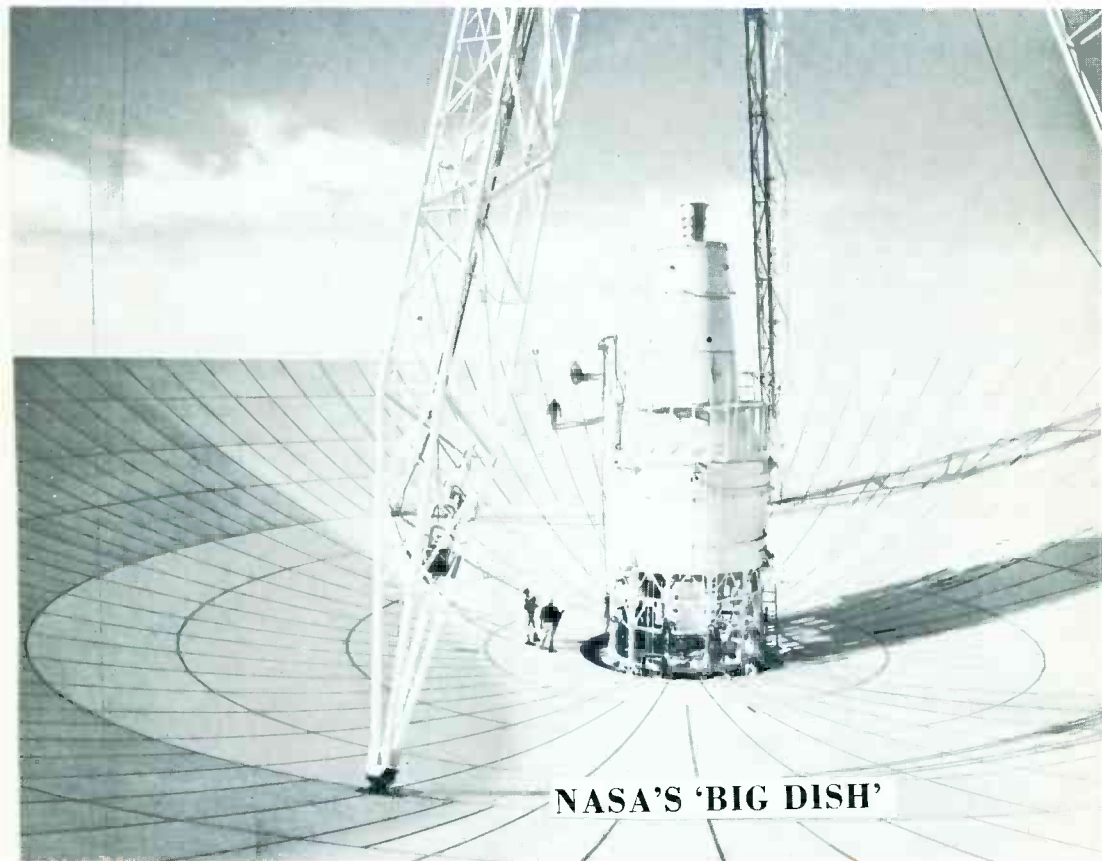

journal

January-February 1967

35 Cents



NASA'S 'BIG DISH'

**IN THIS
ISSUE:**

**NASA'S 'BIG DISH'
ALUMNI ASSOCIATION NEWS
PORTA-COLOR TV**

FREE from CONAR INTERTECH MULTIMETER

With purchase of either piece of equipment below, take your choice of Model M101 (1,000 Ohms), Model 220 (20,000 Ohms), Model 330 (30,000 Ohms), or Model 230 (30,000 Ohms). Here's your chance to get a needed piece of quality B & K test equipment and get a FREE BONUS of a handy multimeter valued at up to \$19.95. Order yours today. Offer ends March 1.



**COMPLETE WITH TEST
LEADS AND BATTERIES**

B & K TELEVISION ANALYST

FIND IT — FIX IT — IN HALF THE TIME!

TESTS B&W AND COLOR SETS. RF and IF: Supplies signals to test each stage in these sections. VIDEO: Reproduces complete test pattern. AUDIO: Provides FM modulated sound channel & 400 cps tone generator. COLOR: Generates white dot, crosshatch, color bar & rainbow patterns. NEGATIVE-BIAS SUPPLY: For sync overload and AGC troubles. Most useful instrument in TV servicing. Lets you satisfy more customers in less time. Actually pays for itself in time saved.



1076 WT
31 lbs.
Exp. Coll.

\$329.95

\$33 DOWN — \$15 PER MONTH

B & K TRANSISTOR RADIO ANALYST

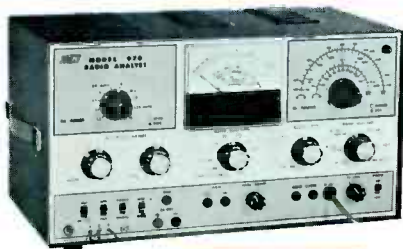

970 WT
26 lbs.
Exp. Coll.

\$199.95

\$20 DOWN — \$9 PER MONTH

IN-CIRCUIT OR OUT-OF-CIRCUIT TRANSISTOR TEST. Built-in power supply with a 5 amp output — low ripple. Vernier tuning AM/FM generator outputs: 250kc to 2000kc with AM; 10mc to 11.4mc with AM or FM. 400cps audio output or modulation. Separately adjustable audio modulation and RF output controls. All solid-state construction. Use it for FM or AM, auto, home and portable radios and transistorized TV and audio amplifiers.

USE YOUR CONAR CREDIT—ORDER BLANK PAGE 27

journal

JANUARY-FEBRUARY 1967
VOL. 24, NO. 1

Published every other month by the National Radio Institute, 3939 Wisconsin Avenue, N.W., Washington, D.C. 20016. Subscription \$2.00 a year. Printed in U.S.A. Second class postage paid at Washington, D.C.

Copyright 1967 By National Radio Institute
All rights reserved.



WORLD'S FINEST
ERSIN
MULTICORE
5-CORE SOLDER

NEW EASY
DISPENSER
PAK ONLY 69c

BUY IT AT RADIO-TV PARTS STORES

MULTICORE SALES CORP. WESTBURY, N. Y. 11591

CONTENTS

2. A PORTABLE COLOR TV

15. THE "BIG DISH"

18. CROSSWORD PUZZLE

19. COMMUNICATIONS

26. NRI HONORS AWARDS

29. ALUMNI NEWS

The U. S. Army Transportation Training Command at Fort Eustis has urgent need for the positions listed below:

1. Radio Transmitter Operator
2. Supervisory Television Production Technician
3. TV Production Aide
4. TV Equipment Installer and Repairer
5. TV Equipment Installer and Repairer Leader
6. TV Equipment Installer and Repairer Supervisor

Applications for Federal Employment, Standard Form 57, available at U. S. Post Offices, should be submitted to the Civilian Personnel Officer, Building 1303, Fort Eustis, Virginia, Attn: Mrs. Baker.

Editor and Publisher:
WILLIAM F. DUNN

Associate Editor:
HARRY BENNETT

Advertising Manager:
JACK THOMPSON

Editorial Assistant:
KATHY FERGUSON

Editorial Assistant:
SUE SUTPHEN

Technical Editor:
J. B. STRAUGHN

Alumni News Editor:
T. E. ROSE

Editorial Assistant:
JUDY ALLNESS

Managing Editor:
ALLENE MAGANN

Assistant Editor:
BEVERLY CROUCH

AN 11" PORTABLE COLOR TV

COMPACT GE MODEL UTILIZES NOVEL CIRCUITS, IN-LINE GUNS TO SAVE WEIGHT AND SPACE, SIMPLIFY CONVERGENCE PROBLEMS

By Art Widmann

AS TELEVISION DEVELOPED, we saw the black and white receivers grow from small 7" and 10" sets to giant 27" and 30" screens. Then the sizes settled down to 19", 21" and 23" standards. Black-and-white portables grew to an impressive volume, with competition revolving around weight and small sizes. The event of the 114° short-neck picture tube with the bonded face plate made really small light portables possible. Even those with fairly large screens could be easily handled with comparative ease.

We are now seeing new developments in color receivers. For years, the 21" round shadow-mask color tube was the industry standard. The limited volume of color receivers made it uneconomical for manufacturers to develop and market other tube sizes. The explosion of color sales in the last few years has changed all that. Manufacturers are now willing to invest the millions of dollars necessary to develop, manufacture and market new tube types. The 90° rectangular color tube made possible smaller, more attractive cabinet designs. Set manufacturers explore the market with color sets having various screen sizes and novel features. Each manufacturer strives for innovations that will give his set a competitive advantage in the market place.

The "innards" of color sets are changing, too. Here the challenge is how to attain a good color picture with the least expensive circuitry. Almost every new color set schematic that you examine shows at least a few circuit variations, if not radically new ways of handling the color signal. This means homework for the TV service technician. To keep up with the new circuits, circuit variations, and different adjustment procedures takes constant study.

In this article we will examine features of GE's 11" Porta-Color* TV. As the

*Registered Trademark.

name implies, this set is truly a portable color receiver, weighing in at only 24 lbs! It uses quite a few novel circuits to save weight and space.

After working with the usual large color receivers, one cannot help but marvel at the compactness of this receiver. The set is not much larger than many black-and-white portables of the same size screen. In fact it is smaller and lighter than black-and-white portables of a few years back. How did they do it? First of all, they took some shortcuts that are possible with a small screen receiver. They made good use of multi-function compactron tubes. They left out a few marginal features, such as a color-killer circuit. But the one thing that really makes the whole set possible is the picture tube. The 11SP22 color picture tube is a shadow mask tube with an array of tricolor phosphor dots on the screen. The radical difference is that the three guns are placed in a horizontal plane across the neck of the tube. This greatly simplifies convergence problems. Although some convergence adjustments are provided, the set doesn't even have a convergence adjustment board.

How about picture quality? When properly adjusted, the black-and-white picture appears to me to be equally as good as the average small screen portable. The color picture does not compare in color detail with large screen receivers. Still the color reception is very pleasing. My main objection is the grain visible at the normal viewing distance of 8' to 10'. You see the same thing in large color screens when you get up close. However, after watching a few programs you don't notice the grain and the picture is entirely satisfactory.

How about servicing the set? Like all compact portable receivers, it presents problems. The circuitry is concentrated

on a single horizontal circuit board. With the cabinet removed, the test adjustment points are reasonably accessible. Of course the set does not have a power transformer so it is imperative that you use an isolation transformer for servicing. This is for protection against electrical shock as well as protection for your test equipment. Once the set is properly buttoned up in its plastic cabinet, it is perfectly safe, with no exposed parts that could cause a shock hazard.

Troubleshooting and even some of the adjustments can give you trouble if you are not familiar with the circuitry. We will discuss circuit differences after we cover the unusual picture tube because some of the circuits depend on the capabilities of the color tube.

In-Line Gun Color Tube

As previously mentioned, the unusual feature of the 11SP22 color picture tube is that the three guns are in a horizontal line instead of a triangle. Fig. 1A shows

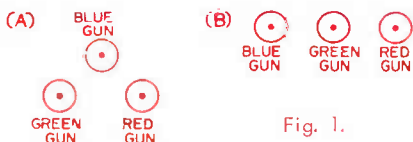

the usual color-gun arrangement (from the socket end) while Fig. 1B shows the color gun arrangement of the 11SP22.

When you start examining the geometry of this gun arrangement several things become obvious. First of all, instead of

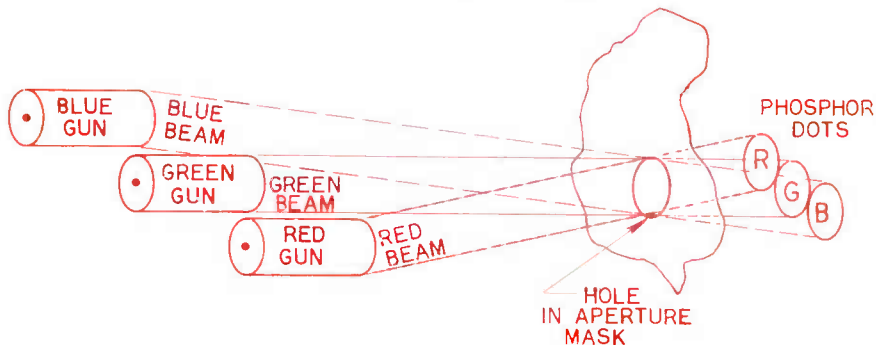

Fig. 2. The three beams converge at the aperture mask passing through a single hole to excite their corresponding phosphor dots.

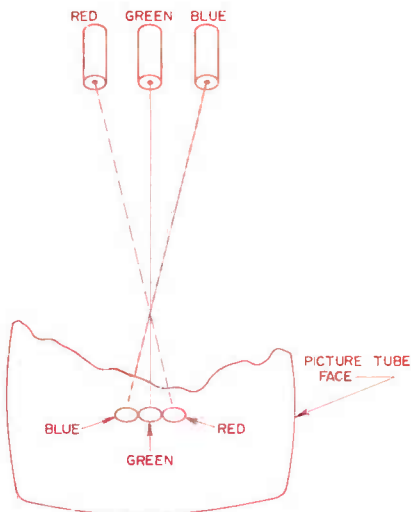

Fig. 3. Three dots in a horizontal line are excited by the three guns, as seen from the front of the picture tube.

thinking of the phosphor dots as triads, you must consider three of them at a time in a horizontal line. Fig. 2 shows how three phosphor dots are excited by the three in-line guns through one aperture of the shadow mask. Remember that Fig. 2 represents the dots on the face of the tube from inside the picture tube. The holes in the aperture mask are aligned directly over the green light producing phosphor dots. The electron beam from the green gun goes straight through the hole and strikes the dot. The electron beams from the red and blue guns pass through the aperture hole at an

angle. Therefore the red gun beam crosses over and strikes the red light producing phosphor dot while the blue gun beam crosses over and strikes the blue light producing phosphor dot.

Fig. 3 shows the dot pattern from the front of the tube. If you examine the dots in a horizontal line from left to right, the sequence is blue, green, red. When you examine a portion of the screen with a magnifying glass, it looks no different than other shadow mask, tricolor tubes.

The above gun arrangement simplifies convergence. Theoretically, with the beams properly converged horizontally, they would remain horizontally converged regardless of their vertical deflection. Likewise vertical convergence should be maintained, regardless of hori-

zontal deflection. The above assumptions would be true if the distance from the beam deflection centers to the mask remain the same throughout the scan. Since the distance increases at the screen edges for both vertical and horizontal scan, some dynamic corrections are necessary.

This dynamic convergence problem is handled for this receiver in a simple manner. A set of vertical convergence coils carry a waveform derived from the vertical sweep circuit. A set of horizontal convergence coils carry a waveform derived from the horizontal sweep circuit. The current through the convergence coils can be reversed for a step change in convergence effect. Or the coils can be removed from the circuit to eliminate the effect. These three possible

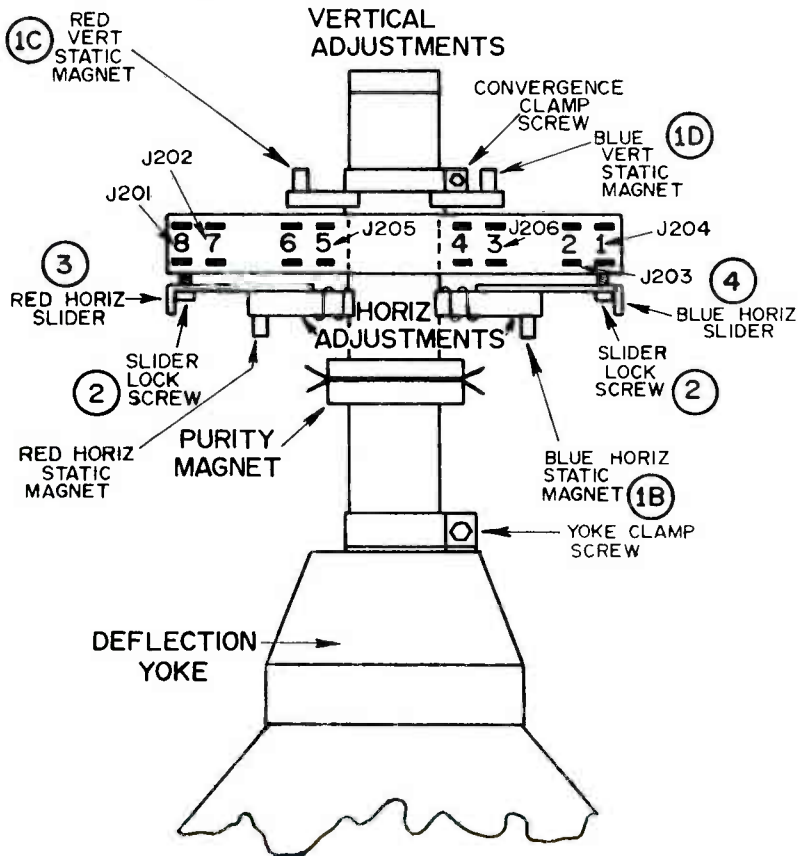

Fig. 4. Location of the convergence system components on the neck of the picture tube.

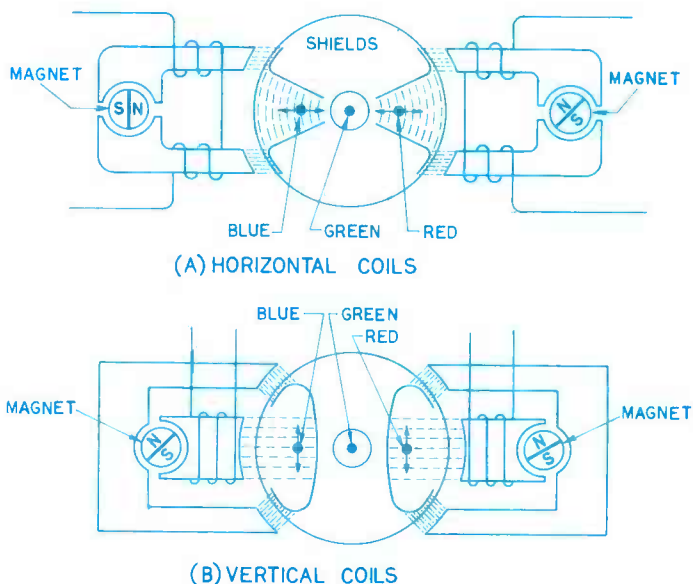

Fig. 5. Convergence system for in-line gun picture tube showing horizontal system (A) and vertical system (B).

settings for each set of coils are the only dynamic adjustment provided. No tilt or amplitude adjustments are provided. The small screen and the adjustable static magnets make this simple system practical.

The components that make up the convergence system are shown on the neck of the picture tube in Fig. 4. The purity magnet ring operates in the same way for this tube as for other color tubes. However, its effect seems less pronounced. Or maybe it just seems as if the tube requires less purity adjustment.

The operation of the convergence system is shown in Fig. 5. Notice the internal shields that isolate the beams of the guns. These shields minimize the interaction of adjustments. The cylindrical permanent magnet in each magnet assembly can be rotated to increase, decrease, or reverse the field of the magnetic circuit. Rotating these permanent magnets performs the static convergence adjustments. As shown in Fig. 5A, changing the magnet strength shifts the electron beam (red or blue) in a horizontal direction. The waveform in the

horizontal coil aids or opposes the permanent magnet field to effect a dynamic convergence correction. The shielded green gun beam is unaffected.

The vertical convergence assembly also produces a magnetic field through internal shields. The action is shown in Fig. 5B. Notice the field through the red and blue electron beams is in a horizontal plane so that the correction movement is in the vertical direction. Cylindrical permanent magnets are rotated to produce a field of the correct strength and direction to converge the beams vertically at the center of the tube (vertical static convergence). The current waveform through the center leg of the magnetic core assembly then aids or opposes the permanent magnet field to produce the vertical dynamic convergence correction.

Circuit Differences

Before we go into details on some of the unusual circuits, let's look at a block diagram of the receiver shown in Fig. 6. Even the block diagram shows considerable variation from most color TV receivers. Conventional uhf and vhf tuners

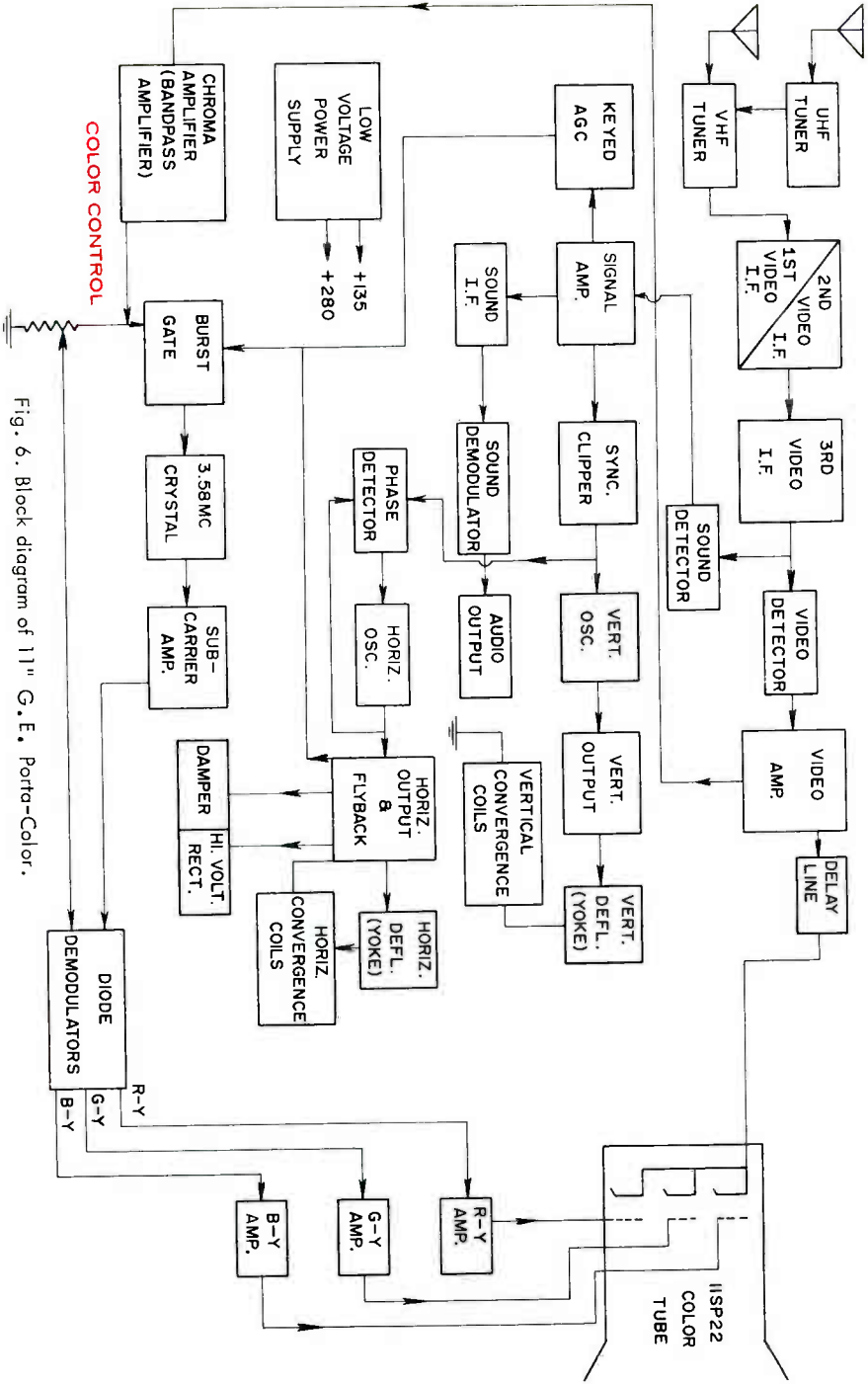

Fig. 6. Block diagram of 11" G.E. Porta-Color.

feed the i-f signal into a three-stage video i-f amplifier. This is a surprise, because many color sets use only two i-f stages. Also the first and second stages are stacked to operate from the +280 volt B+ line. This too is surprising because the +135-volt B+ supply is available. Like other color sets, the Porta-Color has two detectors--one for video and one to produce the sound i-f signal.

The sound detector diode produces a video signal that is fed to a signal amplifier stage. This stage provides three amplified signals: one for the keyed agc circuit, one for the 4.5-mc sound i-f, and one for the sync circuit. All of these circuits are quite conventional.

The receiver uses a single high-gain video amplifier stage to produce the luminance signal. The video signal at the plate of the video amplifier is fed through a delay line to the cathodes of the three guns of the color tube to produce the black-and-white picture information. A chroma take-off transformer in the cathode circuit of the video amplifier stage develops the color signal.

The color circuits are quite simple in this receiver. The bandpass amplifier is a conventional circuit. Its output feeds the color signal to the color control potentiometer and to the cathode of the burst gate stage. The amplified burst signal shock excites a 3.58-mc crystal. The

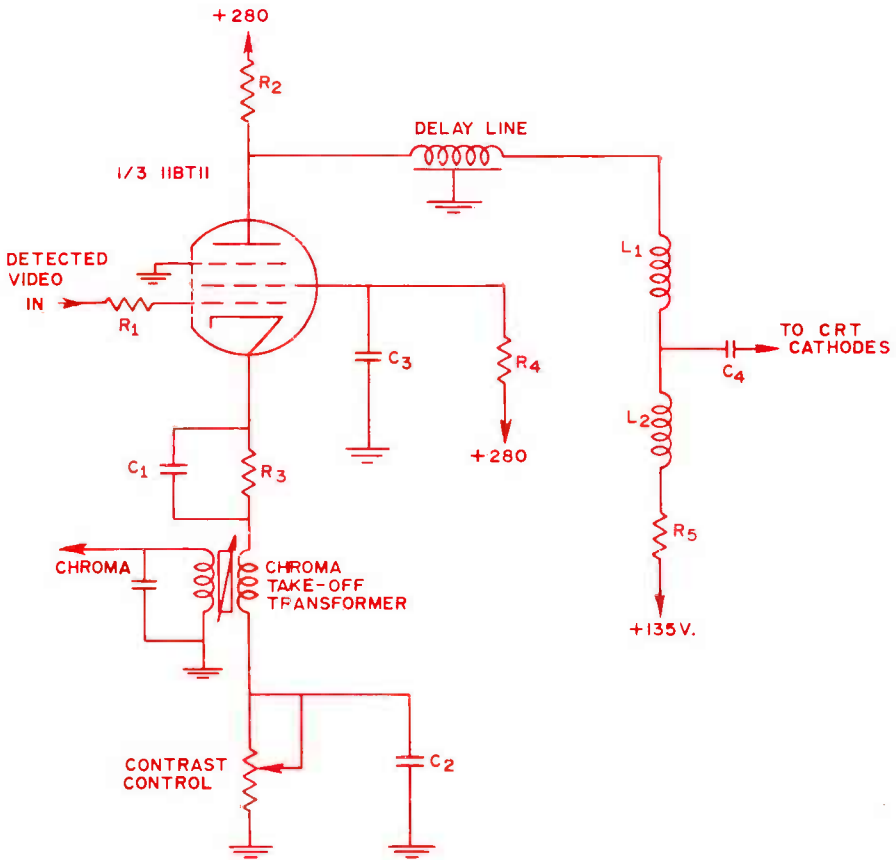

Fig. 7. The single video amplifier stage has a chroma take-off transformer in the cathode circuit.

continuous signal from the crystal is amplified by the subcarrier amplifier stage. This provides the subcarrier reinsertion signal to the color demodulators. The color signals from the color control provide the other signal to the color demodulator. The diode demodulator circuit produces the three color difference signals that are fed to three amplifier stages before being applied to the grids of the color tube.

Further examination of the block diagram shows that several circuits usually associated with color receivers are missing. The high voltage is neither adjustable nor regulated. Also there is no separate focus rectifier. The crt focus electrode is supplied from a choice of ground, +280 volts, or boost voltage to produce best focus as is often done for black-and-white tubes. Boost voltage is also used to activate the degaussing circuit.

Now let's examine the schematic diagram of some of these circuits.

Video Amplifiers.

The pentode section of an 11BT11 compactron tube is used for the single high-gain video amplifier stage. As shown in Fig. 7, the video signal at the plate drives the delay line. As you know, the delay line delays the luminous signal a fraction of a microsecond to compensate for the inherent delay in the narrow bandpass color amplifier. This allows the color signal and the luminous signal to arrive at the picture tube at the same time, so all the picture information is in register.

L1 and L2 are peaking coils used to extend the high frequency response of the video amplifier. This single video amplifier stage delivers over 90 volts peak-to-peak video signal to the picture tube.

Cathode follower action drives the chroma take-off transformer. As shown in Fig. 7, the primary winding of the chroma take-off transformer is in series with the cathode of the video amplifier tube. The adjustable transformer is tuned to the 3.58 mc color frequency to sepa-

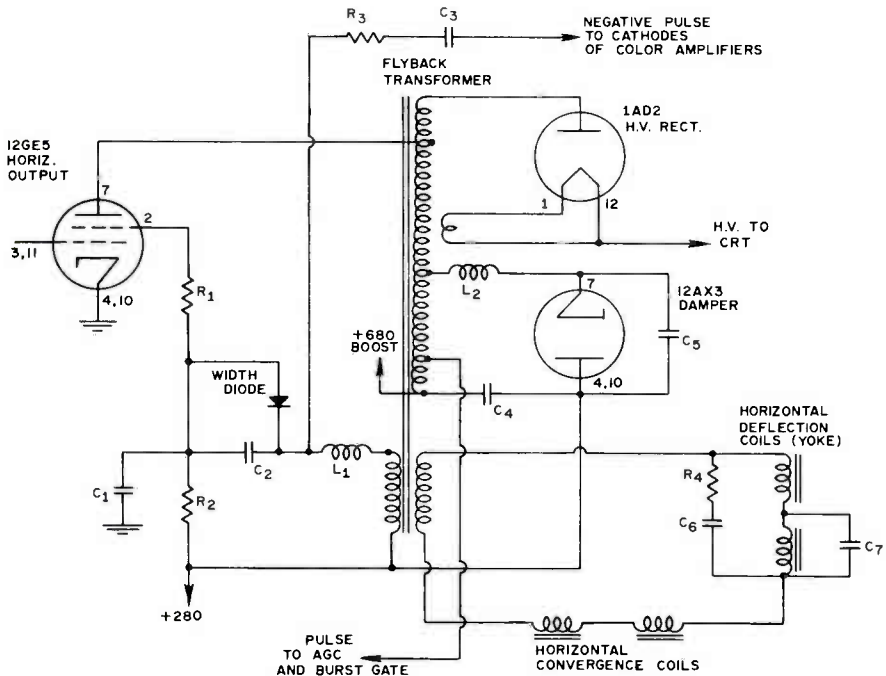

Fig. 8. Horizontal output and high voltage circuit.

rate the color signal from the composite video signal. The recovered chroma signal is applied to the chroma bandpass amplifier. Resistor R3 and the unshorted portion of the contrast control provides self-bias for the video amplifier stage. Both of these resistances are bypassed to prevent degeneration. Varying the contrast control adjusts the bias and therefore the amplitude of the plate signal.

Horizontal Output and High Voltage.

The horizontal output circuit closely resembles circuits often used in black-and-white receivers. As shown in Fig. 8, a 12GE5 output tube drives the horizontal output transformer. A 1AD2 rectifier produces the high voltage for the ultor anode of the color crt. A 12AX3 performs the circuit damping feature and develops the +680 boost voltage. The horizontal windings of the deflection yoke are connected across a separate winding on the flyback transformer. Notice that the horizontal convergence coils are in series with this circuit. Therefore, the horizontal deflection current also flows through the convergence coils providing a dynamic convergence correction waveform.

The width diode in the screen circuit of the horizontal output stage performs an important function. Notice how the diode is polarized in the circuit. A large negative horizontal pulse occurs at the junction of L1 and the diode. This negative pulse is applied to the cathode of the diode, causing it to conduct. The current through the diode returns back to the +280 volt supply through resistor R2. The voltage drop across R2 subtracts from the screen voltage reducing the output from the horizontal output stage. In turn, the amplitude of the pulse to the diode decreases as the output gets smaller. This reduces the diode current, allowing the screen voltage to rise, and which tends to increase the output of the stage. In this way, the diode circuit regulates the output and maintains the raster width constant under varying load conditions. Indirectly, it seems to do a fair job of regulating the high voltage. The raster shows no tendency to bloom at normal brightness levels.

The high voltage loading doesn't vary as much in this receiver as in most color

receivers. Normally, a color screen goes black when a blank screen is presented because direct coupling is used in the video and color circuits, or the circuits use dc restoration. In either case, the load on the high voltage supply is removed and the voltage tends to rise. In this receiver, ac coupling is used from the output of the video amplifier to the cathodes of the crt. Therefore the screen brightness is determined by an average of the video signal coupled through the capacitor. The screen normally never goes completely black and the high-voltage load variations are not so pronounced.

Color Subcarrier Circuit.

The circuit that generates the 3.58 mc subcarrier reinsertion signal for the color demodulators is shown in Fig. 9. As you know, the color information is contained in the 3.58 mc sidebands of the chroma signal. The 3.58 mc subcarrier is suppressed at the transmitter. Only a sample of the subcarrier is transmitted in the form of an 8-cycle burst on the back porch of the horizontal sync pulse. The receiver must generate a continuous wave 3.58 mc signal and synchronize it with the burst signal. This continuous signal is then reinserted into the receiver chroma sideband signal in the demodulator. In this way, the demodulator is able to recover the color information by detecting the instantaneous phase and amplitude of the received chroma sideband signals.

A conventional chroma amplifier stage separates the chroma signal from the composite video signal. As shown in Fig. 9, the amplified chroma signal is then fed to the cathode of the burst gate stage, a triode that is one-third of an 8BU11 compactron tube. The cathode is returned to ground through a 500-ohm color control potentiometer, P1. Thus a variable amplitude chroma signal is available at the slider of the color control. This signal is fed through peaking coil L3 to the color demodulators. The operation of the burst gate stage has no effect on the chroma signal developed on the color control and coupled out to the demodulators.

The burst gate triode is normally held cut-off by a negative charge on capaci-

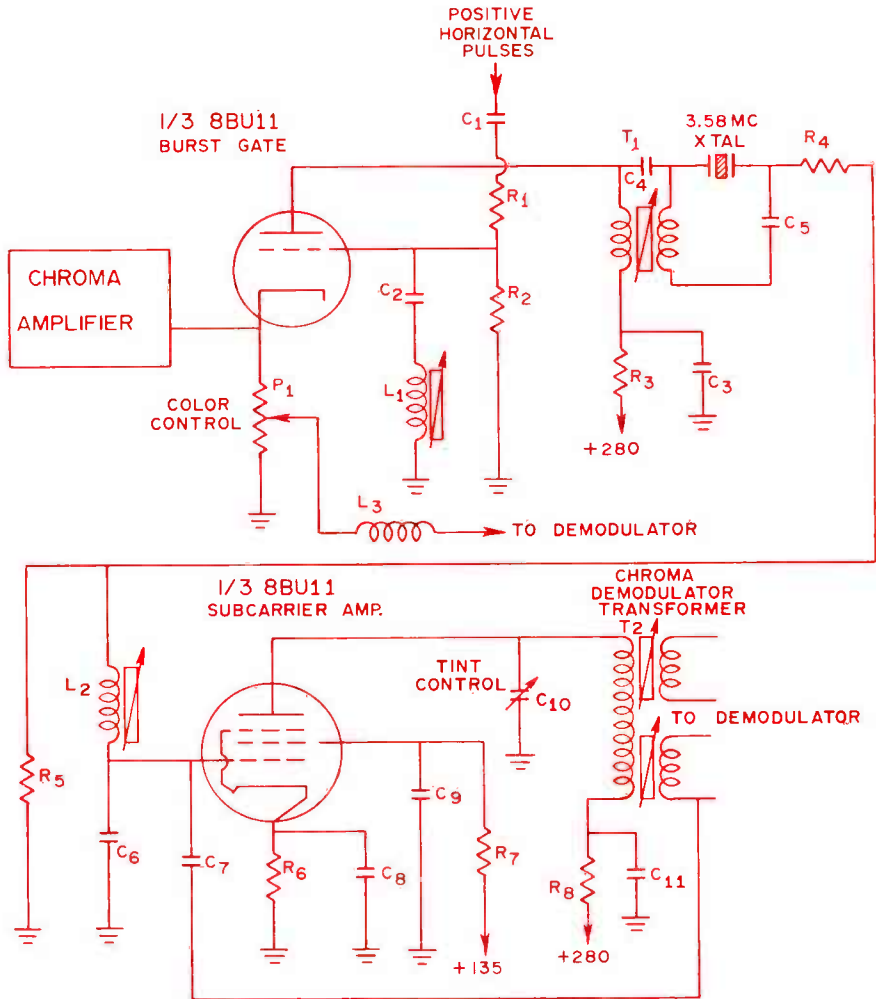

Fig. 9. The color subcarrier circuit uses the ringout from a 3.58 mc crystal.

tors C1 and C2. The negative contact bias is developed by grid current. Each horizontal period, a large positive horizontal pulse is coupled through C1 and R1 to the control grid. The grid draws current, charging C1 and C2. Then, while the tube is still conducting the burst signal arrives on the cathode. Capacitor C2 and L1 form a series-resonant circuit at 3.58 mc. Therefore the grid is at signal ground potential to the burst frequency and an amplified burst signal appears on the plate. At the end of the horizontal pulse, the tube goes out of con-

duction and grid bias holds it cut-off until the next horizontal pulse arrives. In this way the tube is gated on only during the arrival of the burst signal and rejects the rest of the color signal.

The amplified burst signal on the plate of the burst stage is coupled through transformer T1 to the 3.58 mc crystal. As you know, the crystal acts like a very high-Q circuit, resonant at 3.58 mc. The 8-cycle burst signal shock-excites the crystal, causing it to ring. The crystal ringout oscillations remain exactly in

phase with the burst signal. The crystal oscillations are coupled through R4 and L2 to the grid of the subcarrier amplifier, a pentode section of an 8BU11. Inductance L2 and capacitor C6 form a series-resonant circuit at 3.58 mc. This arrangement applies at high-amplitude signal to the grid without undue loading of the crystal circuit. Limiting on the grid of the tube produces an equal-amplitude signal for the duration of each line.

The amplified continuous wave subcarrier signal is coupled through the chroma demodulator transformer to the color demodulators. A capacitive tint control, C10, is placed in the plate circuit of the subcarrier amplifier. Varying C10 shifts the phase of the subcarrier signal and thereby determines the demodulation axis. This, of course, adjusts the hue or tint of the displayed color picture.

Notice feedback capacitor C7, connected from a secondary winding of T2 to the grid of the subcarrier amplifier. This capacitor is only about 1 to 3 pf. The feedback arrangement tends to hold the signal at a constant amplitude for the duration of each horizontal line.

Color Demodulators.

A pair of balanced demodulators are used to demodulate the color signal and recover the color difference signals. As shown in Fig. 10, a B-Y demodulator produces the B-Y color difference signal. An R-Y demodulator produces the R-Y color difference signal. The R-Y and the B-Y signals are matrixed in a resistive network to produce the resultant G-Y color difference signal. The 3.58 mc subcarrier reinsertion signal is applied to the two demodulators through the chroma demodulator transformer. A separate secondary winding is provided for each demodulator. The chroma signal, from the color control potentiometer, is capacitively coupled into each of the demodulators.

The two demodulators are essentially identical circuits except for a phase-shift in the subcarrier signal circuit. The physical placement of the transformer windings and capacitor C2, across the transformer secondary, shifts the phase of the subcarrier signal that is applied to the B-Y demodulator. This arrangement sets the 90° phase difference between the two demodulators so that one demodulates on the R-Y axis and the other on the B-Y axis.

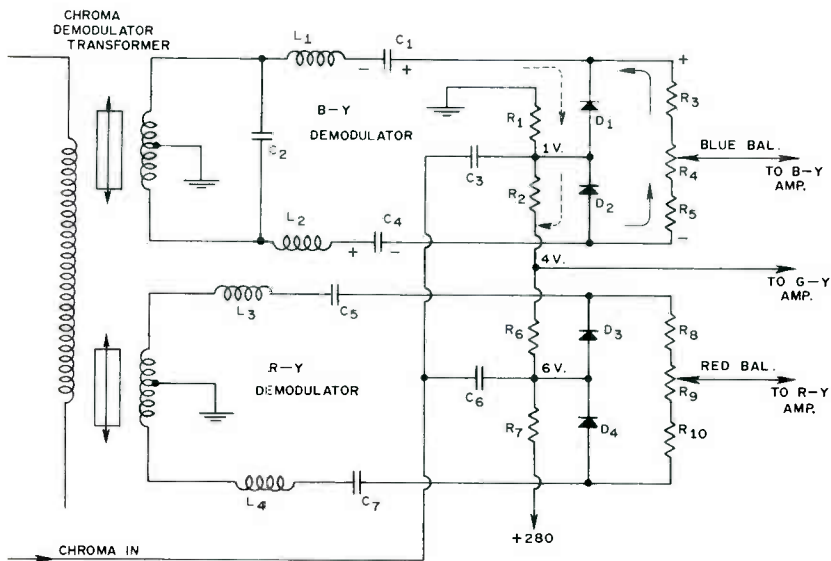

Fig. 10. Color demodulation is performed in a pair of balanced diode demodulators.

Let's examine the operation of one demodulator circuit with only the subcarrier signal applied. The 3.58 mc subcarrier signal is applied to diode D1 through C1 and L1 from the secondary of the transformer. The other end of this transformer winding applies a 3.58 mc signal that is 180° out-of-phase through L2 and C4 to diode D2. Thus when the subcarrier signal to D1 swings negative, the subcarrier signal to D2 swings positive and both diodes conduct an equal amount. During the next half cycle, both diodes are backbiased so neither diode conducts.

When diode D1 conducts, capacitor C1 is charged with the polarity shown. The dotted arrow shows the electron flow from capacitor C1 through diode D1. The charge on C1 places a positive potential at the top of R3, causing current to flow up through R3, as shown by the solid arrow. The charge on C1 is replenished each time the subcarrier signal that is coupled through C1 swings in a negative direction.

When diode D2 conducts, capacitor C4 is charged with the polarity shown. The dotted arrow shows the electron flow through diode D2 to capacitor C4. The charge on C4 places a negative potential at the bottom of R5, causing current to flow up through R5, as shown by the solid arrow. The charge on C4 is replenished each time the subcarrier signal that is coupled through C4 swings in a positive direction.

Capacitors C4 and C1 discharge through R5, R4, and R3, producing a voltage drop with the top of R3 positive and the bottom of R5 negative. The blue balance pot, R4, is adjusted so that the potential difference between the R4 slider and the junction of D1 and D2 is zero volts. Adjusting R4 compensates for normal parts tolerances in the value of R3 and R5 and slight differences in the characteristics of the diodes. With R4 properly adjusted, the dc level of the output to the B-Y amplifier remains at the same value as the dc drop across R1, which is about 1 volt dc.

When a chroma signal is coupled through C3 to the junction of D1 and D2, the conduction of the diodes becomes unbalanced

and changes the output of the demodulator. As you know, the chroma signal is a 3.58 mc sine wave whose amplitude represents the saturation of the color being transmitted and whose phase in relation to the subcarrier represents the hue of the color being transmitted. Thus the instantaneous phase and amplitude of the chroma signal increases or decreases the conduction of D1 and D2. If the chroma phase is such that it increases the conduction of D1, it also decreases the conduction of D2. Increased conduction of D1 makes the top of R3 more positive while the decreased conduction of D2 makes the bottom of R5 less negative. This unbalanced condition causes the output at the slider of R4 to rise above the 1-volt level, representing a B-Y output signal. On the other hand, if the chroma phase is such that it decreases the conduction of D1 and increases the conduction of D2, the output drops below 1-volt level, representing an opposite value B-Y output. In this way the balanced diode circuit demodulates the chroma signal, producing the B-Y color difference output signal. The R-Y demodulator works in a similar manner to demodulate the chroma signal on the R-Y axis and produces an R-Y color difference output signal.

The outputs from the demodulators are inverted by the color difference amplifiers. Therefore the demodulators are set up to produce $-(B-Y)$ and $-(R-Y)$ signals at the balance pot. After being inverted by the difference amplifiers, they become the B-Y and R-Y signals that are required at the control grids of the color tube.

Positive values of the B-Y signal are available at the junction of D1 and D2. Thus when diode D2 conducts more and D1 conducts less, causing the output at the slider of R4 to go in a negative direction, the voltage at the junction of D1 and D2 goes in a positive direction. Likewise, a positive value of R-Y is available at the junction of D3 and D4. These positive color difference signals are used to recover the G-Y color difference signal.

The G-Y color difference signal is produced by matrixing the B-Y and the R-Y color difference signals. Resistors R7, R6, R2, and R1 form a voltage-divider

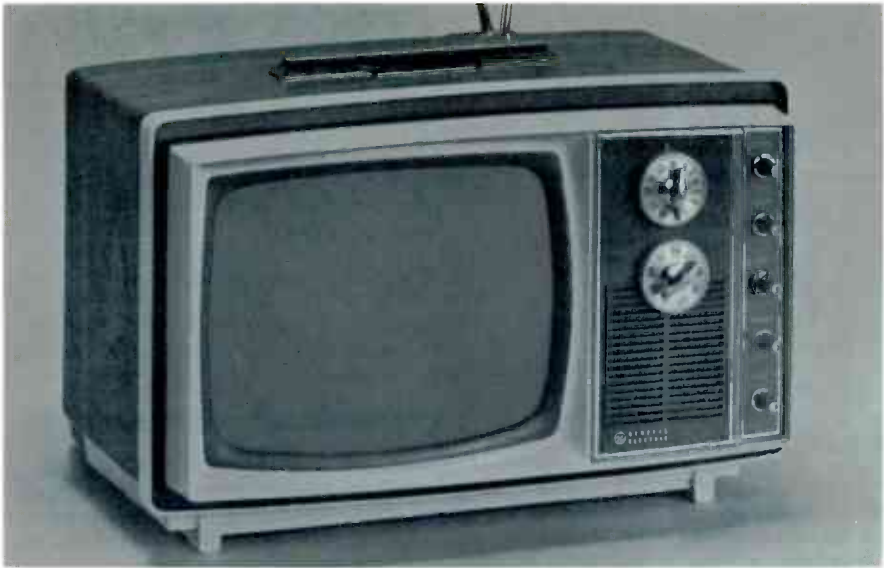

Courtesy General Electric

between +280 volts and ground. R7 is a 1-megohm resistor that drops the voltage to 6 volts at the junction of R6 and R7. The junction of R2 and R6 (G-Y output) drops to 4 volts while the junction of R1 and R2 drops to 1 volt. Unbalanced diode currents representing a B-Y output from the B-Y demodulator raise or lower the voltage at the junction of R1 and R2. Likewise, the output of the R-Y demodulator is superimposed on the dc voltage at the junction of R6 and R7. Thus the G-Y output at the junction of R2 and R6 is raised and/or lowered by the outputs from both the B-Y and the R-Y demodulators. This matrix performs the function of combining the correct proportions of the blue and red color difference signals to form the -(G-Y) color difference signal. Since the -(G-Y) signal is inverted by the G-Y color difference amplifier, it becomes G-Y, which is the correct signal for the green gun of the picture tube.

The color difference signals are direct-coupled to three color difference amplifiers before they are applied to the control grids of the color picture tube. Although the demodulators are labeled R-Y and B-Y, they do not demodulate exactly on these axes. Therefore, a correction signal is developed in the common cathode circuit of the three color difference

amplifiers. The common cathode circuit also provides part of the drive signal for the G-Y amplifier. The cathode correction circuit is similar to many conventional sets that use "X" and "Z" demodulators.

We have not attempted to cover all the new circuits in this receiver. Since the receiver represents an almost totally new design, there are more circuit variations than can be conveniently covered in a single article.



"You've got the order. There's something about you that I like."

what's ?

new ●



THE IC REVOLUTION - - - - -

Integrated circuitry lies at the heart of a revolution in electronics. Tiny electronic "chips" or miniature integrated circuits can perform the function of 200 transistors, 18 resistors, and 2 capacitors! A few chips, each about the size of a pin-head, can hold enough circuitry for a dozen computers or a thousand radios. Already in use are a two-way radio which can be fitted inside a signet ring; a hearing aid which can be worn entirely inside the ear; a desk-top computer the size of a typewriter which can perform 166,000 operations per second; a tiny TV camera weighing 27 ounces and requiring 4 watts of power which uses a one-inch vidicon camera tube.

Many electronic miracles are foreseen as a result of chips. Soon, money may be outmoded as a means of exchange! An electronic charge account card will be used instead; the owner's employer will credit his account at the end of a week's work and merchants will charge purchases against it. Doctors will give patients a pill-sized camera to swallow and view an internal examination on a TV screen as the camera passes through the digestive tract.

Homes of the future might even include a flat-screen TV which can be hung on the wall like a picture, computer-stocked refrigerators, electronically-planned menus, even computerized calorie-counting. A vacuum cleaner will probably be available which will vacuum during the night as the housewife sleeps. Finally, test instruments built into electrical appliances will make troubleshooting and repair virtually automatic.

'CALLING ALL BUSES' - - - - -

Buses of the Dallas Transit Company will soon be linked by a complete radio communications system through which the company can contact each or all of its buses, relaying new directions and new schedules. Each bus driver, in turn, can contact a central dispatcher in the event of a burglary, a passenger emergency, or an accident along his route. The complete communications system, supplied by Motorola, includes a coded "squelch" which alerts the bus driver of an incoming call from the central dispatcher and insures a private conversation inaudible to the passengers.

DETECTING IN THE JUNGLE - - - -

Various detectors for distinguishing human movements from other animal movements in the jungle are being tested by the Army and the Marines for use in Vietnam. The Geoscience division of Texas Instruments, Inc. is supplying seismic detectors which can register all earth movements within several thousand yards of the detector itself. A trained operator can tell the difference between animal and human movements, which are amplified and then converted to audio tone signals. The Army is also studying "odor detectors" from Beckman Instruments which may pick up human smells from hidden enemy soldiers.

AC-DC PAIN RELIEVERS - - - - -

Direct current or high-frequency ac from a needle inserted into the upper spinal column is now being used to relieve persistent pain. The method, which gives immediate relief measurable in months, is used chiefly in advanced cases of cancer but also has value in treating chronic pain from other causes. Treatment can be given under a local anesthetic and the problem of drug addiction does not arise.

DIRECT-DIALING EUROPE - - - - -

Lowell Wingert, vice-president of the Long Lines Department of American Telephone and Telegraph dialed 200-2-33-10-11 recently in Philadelphia and Jean Rouviere answered the phone in Geneva, Switzerland! Mr. Wingert told onlookers that direct dialing between central offices in New York City and several European cities will be introduced on an experimental basis shortly.

NOT AVAILABLE IN KIT FORM

NASA'S 'BIG DISH'

The world's most powerful space tracking and communications instrument weighs 800 tons, is 21 stories high, and maintains contact to 77 million miles.

FAR OUT IN CALIFORNIA'S Mojave Desert, nestled in a natural bowl-shaped terrain, is an enormous dish-shaped structure 21 stories high which represents the ultimate -- at least for today -- in antennas.

It's the 210-foot long-range tracking antenna at Goldstone, Cal. -- the electronic ears of scientists of the National Aeronautics and Space Administration who are monitoring signals from deep space -- the farthest reaches man hopes to probe in this decade. The huge antenna will be a key instrument next year and the year after when the U.S. launches "Pioneer E", enabling scientists to observe solar events through a period of maximum storm activity on the sun in 1969.

Pioneer VI, now orbiting the sun, is being tracked by Goldstone's "Big Dish", maintaining contact at a distance of 77 million miles. Contact is expected to continue at least to 130 million miles.

The Goldstone antenna replaced an older 85-foot antenna, increasing for ground controllers the data rate (amount of information obtainable in a given period of time) from eight to 64 bits-per-second. The rate is controlled by the noise level in the radio reception. The low rate was required for the smaller dish's antenna to sort out the eight-watt signal from background noise generated in space. For the same reason, the data rate for the new antenna will have to be reduced as the spacecraft passes beyond 100 million miles from Earth.

The Goldstone facility occupies a 68-square-mile area and consists of four separate stations, the largest of which has a tracking system of antennas capable of reaching to the very edge of the solar system.

It was at Goldstone that the TV signals from the Ranger VI mission were received and recorded, giving the world its first close-up photographic coverage of the moon's surface -- the first step toward landing men on the moon.

The facility operates on a frequency range of from 2110 to 2120 million cycles per second for transmission of commands from Earth to a spacecraft and from 2290 to 2300 million cycles per second for receiving signals from spacecraft.

Of particular interest to the TV and radio technician is the fact that the same basic technology that brings radio and TV into the home still is the only truly practical means known today of communicating with spacecraft at deep space distances. The system uses radiation of electromagnetic waves through space.

The big difference is in the magnitude of the problem of how to overcome the great loss of energy of a signal that occurs over the vast distance it must travel. Solving this problem has brought nearly to a theoretical and technological limit the evolution of antenna, receiver and transmitter capabilities. The past six years have seen the capability increased more than a thousand times.

To overcome this space loss, antennas are designed for extremely high gain and transmitters send out a very strong signal. Standard ground transmitters operate at power levels of 10 kilowatts. Goldstone now has an advanced capability of transmitting 100 kilowatts. The transmitter on a spacecraft is very limited in power.

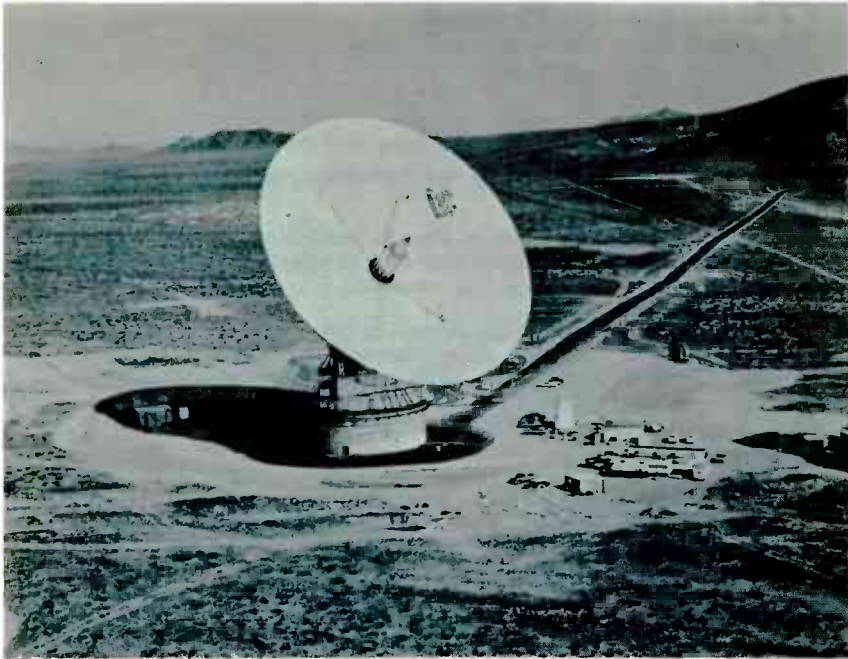

National Aeronautics and Space Administration

The Ranger VII used two 60-watt transmitters to send back to Earth the images recorded by the six TV cameras. Development of more powerful transmitters for spacecraft is continuing.

The frequency of the signal received on the ground varies widely. Thus, receiver tuning must be changed continually. Both spacecraft and ground receivers use a phase-lock method of signal detection which maintains an automatic frequency control and keeps the receiver locked in tune with the received frequency.

Receiver performance is measured by the ability to pick up the weak signal from the spacecraft transmitter and separate it from surrounding noises originating in the Earth's atmosphere and from lunar, solar and galactic sources.

The receivers have a very low threshold and, to overcome internal electronic noise in the system itself, advanced methods of ultra-low-noise signal amplification have been developed. A traveling-wave maser amplifier is used. It consists basically of a synthetic ruby crystal immersed in liquid helium to keep it at a very low temperature. It operates with a "pumped-in" source of microwave energy to augment the strength of the incoming signal without generating much internal system noise.

Here are brief descriptions of the components of the tracking system:

The antenna is a parabolic reflector, 210 feet in diameter. The reflector is a perforated metal mirror. The operating structure contains more than 8,000 pounds of electronic and operating equipment. The antenna is steerable; its major radiation pattern can be shifted in any direction to follow spacecraft by means of a polar-mounted gear system, operated in a slave mode, with instructions fed by a computer.

The reflecting surface of the antenna collects the radio energy which is fed into the sensitive receivers. The antenna can detect signals so faint that the radio-frequency energy is calculated to be about equivalent to that radiated by a 1-watt light bulb at a distance of 75 to 80 million miles. The receiver has four separate channels, and the information in each of the channels is dispersed by distribution amplifiers in the receiver system to proper destinations in the telemetry instrumentation and data-handling systems in the control room.

Sending a command to a spacecraft is somewhat the reverse process of receiving a signal. The transmitter is rated at 10 kilowatts. The power level is very low -- just a few watts. This signal is amplified in the power amplifier to at least 10,000 watts. The transmitter normally is used with a diplexer, permitting simultaneous operation of both a transmitter and a receiver at different frequencies on a single antenna.

The "Big Dish" weighs about 20 million pounds. It is mounted on a silo-type concrete foundation sunk 38 feet underground. The reflector and its supporting structure, which together weigh 5 million pounds, rotate on a pressurized oil film that acts as a friction-free bearing. The gear system is driven by motors with a combined maximum capacity of 1300 horsepower. So precisely aligned and balanced is the system that it can be elevated from looking at the horizon to looking straight up in three minutes. The pedestal is two stories high and weighs about 10 million pounds. The walls are 42-inch thick solid reinforced concrete with concrete footings extending 13 feet underground.

And it's not available in kit form.

... **COLLIN WESCHKE**

**the child
born less
than
perfect...**



... shadows many lives

One family in ten knows the tragedy of having a defective child. Almost 80% of all birth defects can be treated. Your March of Dimes contribution helps to finance more care and more research to find ways to prevent birth defects.

JOIN MARCH OF DIMES

In Memoriam

Since the last issue of the Journal we have received word that the following members of the Alumni Association have passed away. We extend the sympathy of the Alumni Association to their families.

Mr. Ray F. Anthony
Tulsa, Oklahoma

Mr. Martin G. Bayliss
Maple Shade, New Jersey

Mr. Frank Borer
Lorin, Ohio

Mr. Chase E. Brown, Sr.
Indianapolis, Indiana

Mr. John B. Brown
Salina, Kansas

Mr. Paul A. Wangerin
Houston, Texas

ELECTRONICS CROSSWORD PUZZLE

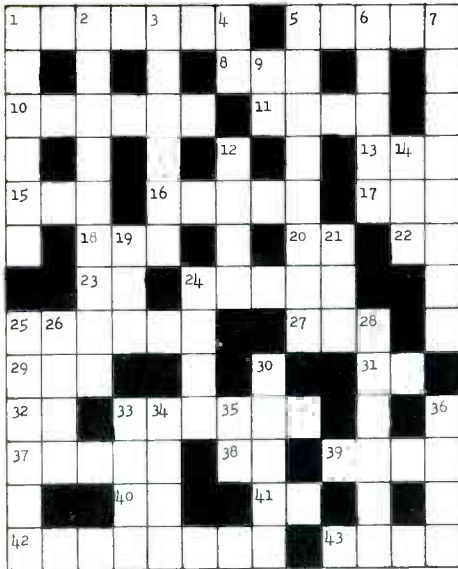

Solution on Page 32.

By James R. Kimsey

ACROSS

1. A damping device, sometimes adjustable.
5. Electrodes of a battery.
8. Electrostatic unit (abbr.).
10. A positive recording produced directly from the metal master or negative.
11. Vipers.
13. To dine.
15. Mistake.
16. The tube which prevents AVC from going positive.
17. Large city in Brazil.
18. Automatic Volume Expansion (abbr.).
20. The plate current goes where when the grid is driven positive?
22. Master Oscillator (abbr.).
23. Eliot, famous author (first initials).
24. A metal or carbon block used to make contact with a moving part in an electrical circuit.
25. The higher audio frequencies.
27. Concealed.
29. Round metal bar.
31. Three feet equal one (abbr.).
32. Suffix denoting alcohol.

33. The fixed set of plates in a variable capacitor.
37. In a cathode-ray tube, the electrode or combination of electrodes to which is applied the highest dc voltage.
38. _____ gate. Whose output is energized when one or more of the inputs is in its prescribed state.
39. A dark area caused by overloading of the camera tube.
41. Cubic Centimeter (abbr.).
42. A vacuum tube that has been evacuated to a high degree (2 wds.).
43. The material or space about which a coil is wound.

DOWN

1. _____ tube, used in television to cut off shock-excited oscillations when the magnetic field collapses.
2. A choke is _____ when an increase in dc reduces its inductance. _____ ceiving system.
3. Type of crystal oscillator circuit.
4. Transverse electric (abbr.).
5. _____ - _____ circuit, or two tubes so arranged that the tubes operate alternately into a common load.
6. An optical maser which amplifies light by stimulating atomic radiation within a ruby crystal.
7. A voltage or current waveform that rises linearly to its peak and then drops rapidly back.
9. Continent below Mexico (abbr.).
12. Two of a kind.
14. To point or direct.
19. Vestigial Sideband (abbr.).
21. 21st letter in Greek alphabet.
24. Rays consisting of negatively-charged particles or electrons.
25. In a modulated wave, the regions of minimum output.
26. A lack of vertical synchronization causing the picture to move upward or downward on the monitor.
28. An electric motor or generator.
30. Any physical cause that can produce motion, or change the motion of a body.
33. Exchanged for money.
34. Horse's gait.
35. Toward.
36. A microwave term specifying the type of oscillation occurring in a line, waveguide, cavity or tube.



BY STEVE BAILEY



DEAR STEVE:

Please explain what the alpha cut-off frequency of a transistor is, and how the new value of alpha is determined at the cut-off point.

R. R., S. C.

A transistor is similar to all other electronic components in that it is useful only up to a certain point. In a transistor, this point is the alpha cut-off frequency.

If a transistor is used in a circuit where the operating frequency reaches the alpha cut-off frequency, the current gain will decrease. The value of alpha at this point will be equal to .707 times the value of alpha at a frequency below cut off when the transistor is operating properly.

For example, assume that a transistor with an alpha cut-off frequency of 100 kc has an alpha value of .5 at an operating frequency of 50 kc. Should the operating frequency increase to 110 kc, it will pass the cut-off point. The current gain will drop to .707 of its value at 50 kc. The new value of alpha will be $.707 \times .5$, or .3535.

As you can now see, a transistor must be used in the frequency range for which it is designed. Under no circumstances should a transistor be used in a circuit where the operating frequency is equal to or greater than the transistor's alpha

cut-off frequency. In such a case, the gain will be too low for proper circuit operation.

DEAR STEVE:

Would you explain the current and voltage relationships in step-up and step-down transformers? I am currently studying lesson 9BB.

N. M., S. C.

In both step-up and step-down transformers, the current-voltage relationships are opposite and inversely proportional. For example, in the circuit shown below, we have a 10:1 step-down transformer connected across a 100-volt source. The load resistance is 10 ohms.

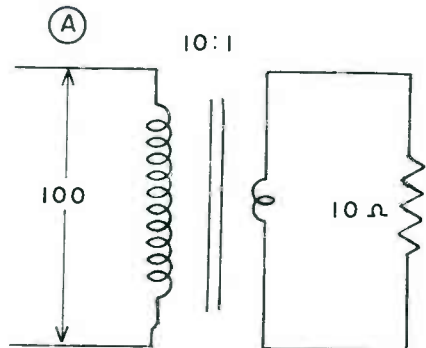

According to Ohm's Law, the secondary current is equal to

$$I = \frac{E}{R}$$

Since this is a 10:1 step-down transformer, the secondary voltage will be one-tenth the primary voltage, or 10 volts. So,

$$I = \frac{E}{R} = \frac{10}{10} = 1 \text{ ampere}$$

Earlier we said that the relationships are inversely proportional. This means that since the voltage ratio is 10:1 step-down, the current ratio will be 1:10 step-up. So, we can say that the primary current is equal to one-tenth the secondary current or .1 ampere.

To illustrate the situation with a step-up transformer, let's turn the situation around as shown below. Here, we have a 1:10 step-up transformer. The applied voltage is 10 volts. The secondary load remains at 10 ohms.

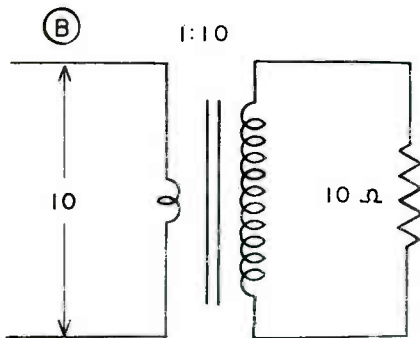

Since this is a 1:10 step-up transformer, the secondary voltage will be 10 times the primary voltage or 100 volts. The secondary current is equal to

$$I = \frac{E}{R} = \frac{100}{10} = 10 \text{ amperes}$$

To find the primary current, reverse the voltage turns-ratio. It will be 10:1 step-down. Thus, the primary current is 10 times the secondary current or 100 amperes.

These calculations can be checked easily since the power in the primary is always equal to the power in the secondary. The primary power is equal to

$$P = E \times I = 10 \times 100 = 1000 \text{ watts}$$

The secondary power is equal to

$$P = E \times I = 100 \times 10 = 1000 \text{ watts}$$

As you can see here, the powers are equal and the current-voltage relationships are opposite, but inversely proportional. The current is stepped up in a step-down transformer, but stepped down in a step-up transformer.

DEAR STEVE:

In lesson 13BB, the three basic transistor circuits and their characteristics are given. These characteristics include the input and output impedances. Could you tell me what these consist of?

S. C., Md.

To begin with, you must understand that when we speak of impedance, we are referring to the signal impedance. This is the signal voltage divided by the signal current. Thus, if the current is high, the circuit impedance must be low. If the current is low, then the circuit impedance must be high.

In Fig. 1, we have shown a common emitter circuit. Here, the input signal is applied between the base and emitter. The base will draw very little current, so the input signal current consumption is very low. For this reason, the input impedance is high.

In the collector circuit, there will be a considerable current flow, so we have a medium value of output impedance.

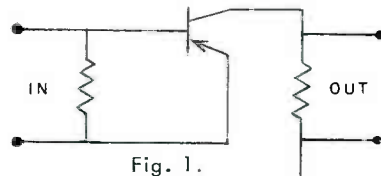

Fig. 2 shows a common base circuit. In this circuit, the emitter will draw a high current from the signal source, so the input impedance is quite low.

The collector current is equal to the difference between the emitter and base currents. Therefore, we have considerably less signal flowing in the collector circuit than in the emitter circuit. Because of this low value of output current, we say that the output impedance is high.

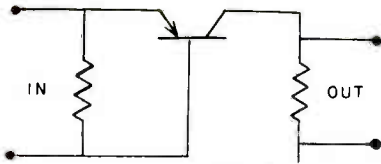

Fig. 2.

The circuit shown in Fig. 3 is a common collector circuit. The input signal is applied between the base and emitter. However, the output signal is taken from across the emitter resistor, so it will oppose the input signal. Therefore, the net input voltage is considerably reduced. This results in a decrease in the current drawn by the common collector input. Thus we say that the input impedance is high.

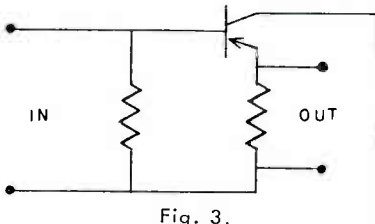

Fig. 3.

There will be a high current flow in the emitter circuit, so the output impedance is low. It can be considered to be about equal to the value of the emitter resistor since this is where the signal is taken off.

DEAR STEVE:

How do you go about finding the turns-ratio of an impedance-matching transformer? Would you illustrate the method with an example?

C. G., Calif.

You can determine the turns-ratio of a transformer if you know the input impedance and the load impedance. The formula is

$$\frac{N1}{N2} = \sqrt{\frac{Z1}{Z2}}$$

where N1 equals the primary turns, N2 equals the secondary turns, Z1 equals the input impedance, and Z2 equals the load impedance. This formula is given on page 17 of lesson 9BB.

As an example, assume you have a transformer where the primary connects to a

circuit with an impedance of 2000 ohms. You wish to obtain an impedance match with a circuit with an impedance of 100 ohms. To find the turns-ratio, we insert these values into the formula.

$$\frac{N1}{N2} = \sqrt{\frac{2000}{100}}$$

$\frac{2000}{100}$ is a fraction we can reduce by dividing each part by "100".

$$100 \div 100 = 1 \text{ and } 2000 \div 100 = 20.$$

Therefore,

$$\frac{N1}{N2} = \sqrt{\frac{20}{1}}$$

Now, we find the square root of each part. The square root of 1 is 1 and the square root of 20 is 4.5. Thus, the turns-ratio is 4.5:1.

A transformer with this turns-ratio will match an impedance of 2000 ohms to an impedance of 20 ohms so that maximum power transfer can take place.

DEAR STEVE:

How is the amplification factor of a tube determined?

P. W., Puerto Rico

The amplification factor of a tube can be found using the formula

$$\mu = \frac{\Delta E_p}{\Delta E_g}$$

The symbol "Δ" is known as a delta symbol and stands for a change in quantity. Thus, the amplification factor is equal to a change in plate voltage, required to obtain a certain change in plate current, divided by the change in grid voltage, required to obtain the same change in plate current.

To illustrate this, assume you have a tube that operates with a plate voltage of 100 volts, and a grid voltage of two volts. You wish to change the plate current from 10 ma to 15 ma. So, you start by increasing the plate voltage while maintaining the same grid voltage. You find that by increasing the plate voltage to 150 volts, you obtain the proper plate current.

Now you wish to find out how much of a change in grid voltage is required to obtain the same change in plate current. To do this, you restore the plate voltage to 100 volts and begin changing the grid voltage. With a change in grid voltage of two volts, you are able to obtain the proper plate current. Now, looking at our results, we see that a change in plate voltage of 50 volts had the same effect on the plate current as a change in grid voltage of 2 volts. Thus,

$$\mu = \frac{\Delta E_p}{\Delta E_c} = \frac{50}{2} = 25$$

Remember that since the grid is located so much closer to the cathode than the plate, it will have a greater effect on the plate current. This is why it takes only a very small change in grid voltage to obtain a large change in plate current.

DEAR STEVE:

I don't understand how to use the formula given in lesson 6BB for finding the total inductance of coils connected in series. Also, what does the term "2M" mean?

M. A. B., Va.

When coils are connected in series, their inductances will add. However, if they are placed near each other, the inductance of one will affect the inductance of another. We call this mutual inductance. The symbol for mutual inductance is the letter "M". This will affect the total inductance of the circuit, so it must be taken into consideration.

The main thing to consider now is whether the mutual inductances will aid or oppose each other. If the magnetic lines of force produced by the coils are flowing in the same direction, they will aid each other. However, if they are not flowing in the same direction, they will oppose each other. Therefore, we have a formula for determining the total inductance when the mutual inductances are aiding and another for when they are opposing.

If you have two coils connected in series and their fields are aiding, you use the formula

$$L_T = L_1 + L_2 + 2M$$

The term "2M" means that you are to

multiply the mutual inductance by 2. This is because you have two magnetic force fields present. Then, you add that number to the sum of $L_1 + L_2$ which gives you the total inductance.

If the fields are opposing, you use the formula

$$L_T = L_1 + L_2 - 2M$$

Again, you multiply the mutual inductance by 2. This time, however, you subtract the answer you get from the sum of $L_1 + L_2$.

DEAR STEVE:

In the formula $Q = \frac{X_L}{R}$ in lesson 6BB, does

"R" stand for the dc resistance of the coil or the ac resistance? If it is ac resistance, what is the difference between it and inductive reactance?

E. R., N. J.

In the formula you have given, R stands for ac resistance. This is the non-reactive opposition offered by a conductor to the flow of an alternating current through it. The opposition takes the form of skin effect, eddy current, hysteresis, dielectric, absorption, and radiation losses. Of these, skin effect is the most prominent. This occurs because when the frequency of an alternating current flowing in a conductor is increased, the electrons flowing tend to move toward the surface of the conductor. As the frequency is increased further, the electrons crowd more toward the conductor surface. Since the area of electron flow has decreased considerably by the shift from the center of the conductor to the surface, the resistance is effectively increased.

The primary difference between this and inductive reactance is that inductive reactance is directly proportional to changes in frequency. AC resistance, on the other hand, is basically the same as dc resistance at low frequencies. It is only at high or very high frequencies that its presence becomes felt.

In addition, ac resistance is due to losses in the wire itself, whereas inductive reactance is the result of an opposing induced current flow.

EMPLOYMENT OPPORTUNITIES

The following firms have requested that they be listed as continuing prospective employers of NRI graduates in the designated capacities:

WEINSCHEL ENGINEERING Co., Inc.
Gaithersburg, Maryland 20760 has immediate openings in Engineering, Repair, and Test Departments. Permanent positions and excellent chance for advancement. Evening and weekend interviews. Contact Mrs. Karen Syence at (301) 948-3434 or write Weinschel Engineering Co., Inc.

WESTERN UNION TELEGRAPH CO.
1405 G Street, NW, Washington, DC. Needs electronics technicians. Write or telephone B. L. Krise, Manager, Technical Services.

GENERAL TELEPHONE OF INDIANA, INC.
501 Tecumseh Street, P.O. Box 1201, Fort Wayne, Ind. 46801. Openings in exchange offices in Indiana.

ARFAX TELEVISION AND RADIO SALES AND SERVICE, 1420 Chain Bridge Road, McLean, Va. Needs TV serviceman for bench or outside work. Experience to include color if possible. Call 356-3600. Ask for Mr. Lake or Mr. Onfrychuk.

POLITO COMMUNICATIONS, INC.,
101 Walnut Street, Rochester, N. Y. has positions available for four or five technicians to service two-way radio equipment. Minimum requirement is a second class radio telephone license. Contact Mr. Joseph Carl Polito.

SUN ELECTRIC CORP., 5708B Frederick Ave., Rockville, Md. is looking for electronics technicians.

RADIO STATION WKRZ,
Oil City, Pennsylvania wishes to employ several first class engineers on its staff.

STATION WFMD,
Frederick, Md. Needs technicians with 1st class licenses.

RCA SERVICE COMPANY, Camden, N.J. Needs TV Servicemen at most RCA Service Factory Service Branches. Technical School training essential, prefer B/W and Color Service experience. Apply at the nearest RCA Branch or write W. R. Speck, RCA Service Co., Cherry Hill, N.J.

THE CHESAPEAKE CORP., West Point, Va. Needs a number of Electronics Technicians. No actual experience is needed, but a good Technical school education very desirable. Applicants should see or write Mr. J. W. Hockman, Personnel and Training Manager.

SIMPSON ELECTRIC COMPANY
5200 Kinzie St., Chicago, Ill. 60644
Openings for technicians, design and development engineers, electro-mechanical and production engineers.

AUDIO FIDELITY CORPORATION
6521 West Broad, Richmond, Virginia
Needs two repairmen in Richmond office and possibly one in Roanoke.

UNITED AIRLINES
Wash. Nat'l. Airport, Washington, D. C.
Expects a continual need for radiotechnicians throughout their system in 1967. Would be interested in talking to any graduates interested in employment.

GENERAL ELECTRIC COMPANY, Appliance Park, 6-221, Louisville, Ky. 40225 has openings available throughout U. S. A. with good pay, excellent working conditions, full benefit package. Specialized on-the-job training provided. Consult local telephone directory for factory service operations or write to above address for location of District Product Service Manager nearest you.

COMMUNICATIONS ENGINEERING CO.
(Division of Sytan Electronics) 306 Kennedy St., NW, Washington, DC. Needs technicians with FCC licenses. Openings in TV, Audio, 2-way radio, etc. Call Mr. Brown, 451-5700.

STATEMENT OF OWNERSHIP, MANAGEMENT AND CIRCULATION (Act of October 23, 1962; Section 4369, Title 39, United States Code).

1. Date of Filing: January 1, 1967
2. Title of Publication: NRI Journal
3. Frequency of issue: bimonthly
4. Location of known office of publication: National Radio Institute, 3939 Wisconsin Ave., N. W., Washington, D. C. 20016.
5. Location of the headquarters or general business office of the publication: 3939 Wisconsin Ave., N. W., Washington, D. C. 20016.
6. Editor and Publisher: William F. Dunn, 8802 Fox Hills Trail, Potomac, Md; Managing Editor: Allene Magann, 2028 N. Vermont, Apt. 202, Arlington, Va. 22207.
7. Owner (if owned by a corporation, its name and address must be stated and also immediately thereunder the names and addresses of stockholders owning or holding 1 percent or more of total amount of stock. If not owned by a corporation, the names and addresses of the individual owners must be given. If owned by a partnership or other unincorporated firm, its name and address, as well as that of each individual must be given).

Susan Smith Bartlett, 1 Highland Ave., Dover, Delaware.

Elsie Smith Davis, RFD 1, Rochester, New Hampshire.

Carol Smith Galbraith, 430 E. Ledbetter Drive, Dallas, Texas.

Michael Morrison Galbraith, 728 W. Dempster St., Apt. 110H, Mt. Prospect, Ill. 60057.

Gail Alexandra Peek, 1119 Crest Lane, McLean, Virginia.

The National Radio Institute Charitable Trust, c/o J. E. Smith, 1121 Crest Lane, McLean, Virginia.

James E. Smith, Estate of Sarah Morrison Smith, 1121 Crest Lane, McLean, Virginia.
Emma Smith Stuart, RFD 9, Webber Hill, Kennebrook, Maine.

James Morrison Smith, James Morrison Smith, Jr., Terry Morrison Smith, 1123 Crest Lane, McLean, Virginia.

Lee Morrison Smith, Kingston Manor, 3200 Longview Drive, Apt. 7, Bloomington, Indiana.
Marjory M. S. Sarich, Charles B. Sarich, James R. Sarich, 1125 Crest Lane, McLean, Virginia.

David H. Smith, RFD 1, Box 395, Rochester, New Hampshire.

8. Known bondholders, mortgagees, and other security holders owning or holding 1 percent or more of total amount of bonds, mortgages or other securities (if there are none, so state): none.
9. Paragraphs 7 and 8 include, in cases where

the stockholder or security holder appears upon the books of the company as trustees or in any other fiduciary relation, the name of the person or corporation for whom such person is acting, also the statements in the two paragraphs show the affiant's full knowledge and belief as to the circumstances and conditions under which stockholders and security holders who do not appear upon the books of the company as trustees, hold stock and securities in a capacity other than that of a bona fide owner. Names and addresses of individuals who are stockholders of a corporation which is itself a stockholder or holder of bonds, mortgages or other securities of the publishing corporation have been included in paragraphs 7 and 8 when the interests of such individuals are equivalent to 1 percent or more of the total amount of the stock or securities of the publishing corporation.

10. This item must be completed for all publications except those which do not carry advertising other than the publisher's own and which are named in Sections 132.231, 132.232, and 132.233, postal manual (Sections 435a, 435b, and 4356 of Title 39, United States Code).

A. Total number copies printed (Net Press Run) November/December 1965 through September/October 1966: 231,750; average number copies each issue during preceding 12 months: 38,625; single issue nearest to filing date: 36,000.

B. Paid Circulation.

1. Sales through dealers and carriers, street, vendors and counter sales: none.

2. Mail Subscriptions: average number copies each issue during preceding 12 months: 117; single issue nearest the filing date: 102.

C. Total Paid Circulation: Average number copies each issue during preceding 12 months: 12,451; single issue nearest to filing date: 12,815.

D. Free Distribution (including Samples) By Mail, carrier or other means: average number copies each issue during preceding 12 months: 22,286, single issue nearest to filing date 21,430.

E. Total Distribution (Sum of C and D): Average number copies each issue during preceding 12 months: 35,067; single issue nearest to filing date 33,881.

F. Office use, Left-over, unaccounted, spoiled after printing: average number copies each issue during preceding 12 months; 3,541; single issue nearest to filing date: 2,119.

G. Total (sum of E and F--should equal net press run shown in A): 38,625.

I certify that the statements made by me above are correct and complete. Allene Magann.



TEXAN TRANSMITS THANKS TO NRI FOR AID IN CAREER PREPARATION

Communications graduate Glenn Welch of Abilene, Texas was only 17 when he began study with NRI. After graduation, he got his First-Class Radiotelephone License and soon was Chief Engineer of Radio Station KERC in Eastland, Texas. Now 23, he has been a transmitter engineer for KRBC-TV for two years, doing transmitter maintenance as well as his regular transmitter duty stint. During the time he has been at the station,

its power has been increased from 145KW ERP to 316KW ERP. In the photo above, he is shown on duty at the station. How does he feel about NRI? In his own words, "I could not have reached this point of success without the excellent preparation from NRI's Complete Communications Course, which I feel is the best there is. I have recommended it to a number of people and will continue to do so in the future."

NRI HONORS PROGRAM AWARDS

During the months of September and October, 1966, the following NRI graduates received, in addition to their NRI electronics diplomas, CERTIFICATES OF DISTINCTION under the NRI Honors Program for outstanding grades throughout their NRI training. This distinction is made part of their permanent NRI records and appears on all transcripts of records requested. NRI's worldwide leadership in electronics training is represented by these outstanding graduates from almost every area of the United States, from Mexico and Canada, and from other foreign countries. It's not surprising, either, to know that the Armed Forces, which place an emphasis on training and career planning, are exceptionally well-represented by the number of NRI honors graduates.

WITH HIGHEST HONORS

Larry E. Anderson
Detroit, Mich.

George Bitte
Riga, Latvia, USSR

Vernon Lee Carlson
Terre Haute, Ind.

James W. Dodd
Limestone, Maine

Henry J. Dombrosky
Wellsburg, W. Va.

Patrick J. Hartnett
Troy, N. Y.

Robert W. Lawless
Bronx, N. Y.

Thomas O. Neilson
Winston-Salem, N. C.

Wesley E. Pitts
Alexandria, Va.

John P. Reifsteck
Kirkwood, Mo.

Lawrence Weiner
Orlando, Fla.

James A. Weston
Winston-Salem, N. C.

Rev. David C. White
Stanley, N. C.

Randall Young
Cridersville, Ohio

WITH HIGH HONORS

Jacob B. Armillei
Teaneck, N. J.

Ronald P. Arns
Clay, N. Y.

James E. Balcom
Plainfield, Ind.

Alan R. Ballman
Baltimore, Md.

James L. Bauer
New London, Wis.

Gurmit Singh Bhogal
Willenhall (Staffs) England

S. Bodi
Shawinigan Falls, Canada

E. W. Brizendine
Spokane, Wash.

Robert Bryant
Brooklyn, N. Y.

Clarence E. Churches
Reseda, Calif.

Forrest P. Davis
Newport, Minn.

Jack Davis
Chicago, Ill.

Ian E. Dudley
N. Syracuse, N. Y.

F. Richard Eckert
Middlesex, N. J.

Louis Fiset
Rimouski, P. Q., Canada

Gordon L. Geisler
Fort Sill, Okla.

Claud M. Goad
Mangum, Okla.

Isadore J. Holl
Port Austin, Mich.

Louie E. Johnson
Columbus, Ga.

Earl Kaplan
Washington, D. C.

Ronald Kaplan
Lake Park, Fla.

James L. Maddox, Jr.
Alexandria, Va.

Orville W. Main
Tinley Park, Ill.

Robert E. McDonald
Lakewood, Ohio

William L. McGarry
Glen Burnie, Md.

Rodney H. Mill
West Hyattsville, Md.

Harry J. Noyes
Riverdale, Md.

Jerry T. Nuffer
APO San Francisco

Harold Pare, Jr.
New Orleans, La.

John D. Reid
Everett, Wash.

George M. Wicker
Aiken, S. C.

Robert Eckhardt
FPO New York

Martin J. Roman
Pleasantville, N. J.

Fred E. Yates
N. Las Vegas, Nev.

Victor F. Eichburg
Indianapolis, Ind.

Eugene Sammons
Safety Harbor, Fla.

WITH HONORS

Lawrence J. Eppers
Kinosh, Wis.

Theodore J. Sobalo
Everett, Mass.

Billy J. Balentine
Murray, Ky.

Roberto Antonio Ferrier
Caracas, Venezuela, S. A.

Arthur W. Spoor
APO San Francisco

Forrest Duane Bandt
Kismet, Kans.

Thomas Berkley Fuller
Axton, Va.

Francis J. Swain
Glenfield, Pa.

Kenneth Barkhouse
Scarborough, Ont., Canada

George M. Gardner
St. Paul, Minn.

Robert R. Travis
Detroit, Mich.

Robert F. Brimicombe
Danvers, Mass.

Herbert J. A. Hengeveld
Aruba, Neth. Ant.

Isidore J. Tremblay
Keene, N. H.

Stephen E. Carter
Washington, D. C.

Franklin T. Hood
Rehobeth Beach, Del.

Alton Tucker, Jr.
Afton, N. Y.

Graves Dixon
Memphis, Tenn.

Jack B. Howard
Alhambra, Calif.

James P. Waananen
Payson, Ariz.

Gordon J. Dunning
Berkeley, Calif.

Walter G. Jenkins
Terre Haute, Ind.

CONAR ORDER BLANK

IM

DIVISION OF NATIONAL RADIO INSTITUTE, 3939 WISCONSIN AVE., WASHINGTON 16, D.C.

PLEASE PRINT

NRI STUDENT NUMBER

NAME

CASH

ADDRESS

C.O.D. (20% Deposit required)

EASY PAYMENT PLAN (10% Deposit)

CITY

ZONE

STATE

Quantity	Model	Name of Item	Price Each	Total
If you live in Washington, D.C., add 3% sales tax. All prices are net, F.O.B. Washington, D.C.				TOTAL

ON TIME PAYMENT ORDERS please be sure to complete the Easy Payment Plan credit information form on the reverse side of this page and include 10% down payment with your order.

Thomas W. Karnes D. D. S.
San Mateo, Calif.

Lawrence Michaels
St. Clair Shores, Mich.

Ole Salazar
Silverton, Colo.

Bobbie L. Kirkland
FPO New York

Victor C. Murphy
Oreland, Pa.

Paul L. Schlegel
Grand Island, N. Y.

Jerry Kramer
Pleasant Lake, N. Dak.

Ray Nunnally
St. Louis, Mo.

Nelson J. Smith
Dayton, Ohio

Richard F. Lennon
Weehawken, N. J.

Thomas W. Osborne
Tennille, Ga.

Gilbert K. Uda
APO New York

Robert E. Liebfried, Jr.
APO Seattle

Donald E. Parsons
Louisville, Tenn.

Susie Vaira
Culbertson, Mont.

Elizalde S. Loyola
Manila, Philippines

Marvin J. Paulson
Estevan, Sask., Canada

Jack F. Weber
Hamilton, Ohio

R. Dean Marts
Aurora, Colo.

Ross Pelt
Hugo, Okla.

Edward J. Westnedge
APO San Francisco

Bob Mengering
Regina, Sask., Canada

Lincoln C. Rich
Hampton, N. H.

Thomas D. Williamson
Loring AFB, Maine

Ronald C. Michael
Keyser, W. Va.

Miguel Ruelas
Grulla, Texas

Jackie D. Winter
Fresno, Calif.

CONAR EASY PAYMENT PLAN

IM

Note: Easy payment contracts cannot be accepted from persons under 21 years of age. If you are under 21, have this sheet filled in by a person of legal age and regularly employed.

Enclosed is a down payment of \$ _____ on the equipment I have listed on the reverse side. Beginning 30 days from the date of shipment I will pay you \$ _____ each month until the total payment price is paid. You will retain title of this equipment until this amount is fully paid. If I do not make the payments as agreed, you may declare the entire unpaid balance immediately due and payable, or at your option, repossess the equipment. Your acceptance of this will be effected by your shipment to me of the equipment I have listed.

Date _____ Your written signature _____

CREDIT APPLICATION

Print Full Name _____ Age _____

Home Address _____

City & State _____ How long at this address? _____

Previous Address _____

City & State _____ How long at this address? _____

Present Employer _____ Position _____ Monthly Income _____

Business Address _____ How Long Employed? _____

If in business for self, what business? _____ How Long? _____

Bank Account with _____ Savings Checking

CREDIT REFERENCE (Give 2 Merchants, Firms or Finance Companies with whom you have or have had accounts.)

Credit Acct. with _____ Highest Credit _____
(Name) (Address)

Credit Acct. with _____ Highest Credit _____
(Name) (Address)



Alumni News

Eugene de Caussin President
Edward Bednarz..... Vice President
Isaiah Randolph..... Vice President
Joseph Bradley..... Vice President
Harvey Morris..... Vice President
Theodore E. Rose..... Executive Sec.

ALUMNI CHAPTERS RE-EXAMINE THEORIES AND APPLICATIONS OF SERVICING TECHNIQUES

SPRINGFIELD (MASS.) CHAPTER was greeted with a very pleasant surprise by Norman Charest, at whose Radio-TV shop the meetings are held. He cleared the whole place out and had the walls panelled. And what a beautiful job it is!

The last issue of the Journal mentioned that the Chapter had received its Transistor Radio Demonstration Board. It has already proved its value. Secretary Brother Bernard Frey assembled the board and it was put to use at the very next meeting. At the meeting which followed, members reviewed the techniques for isolating dc problems in transistor equipment taken up at the previous meeting. The members asked many questions, and these points were all cleared up.

The program then proceeded to techniques for isolating ac problems. Using the board, Brother Bernard showed some signal injection techniques, such as the pen-generator, the volume control and the resistor click test.

Brother Bernard is taking the members through the same course given to RCA Service Company Servicemen. There's a lot of material to go through yet. The members are really enjoying it, seeing all the experiments on a 4 x 8' board and watching the results on the meters before

them. Members are free to ask questions and to suggest other problems.

GUEST SPEAKERS HIGHLIGHT PHILADELPHIA MEETINGS

PHILADELPHIA-CAMDEN CHAPTER welcomed Mr. Roy Gumm, Product Service Manager for Radios for the Philco Corporation, as guest speaker. Mr. Gumm's subject was the Transistor, and his style was unique and intriguing: he approached the subject as though he were telling a fairy tale, explaining it in a language that was easy to follow. He used slides to help him along. The members were fascinated -- not one left the meet-



Philco's Roy Gumm conducts his interesting discussion of the Transistor at a meeting of the Philadelphia-Camden Chapter.

ing early. The Chapter hopes to bring Mr. Gumm back for another lecture in January.

The next meeting was also outstanding. It was the meeting to which J. B. Straughn and Executive Secretary Ted Rose were to make their annual visit. Ted Rose was accompanied by Joe Schek, Senior Consultant of NRI, instead of J. B. Straughn. Joe used a CONAR Custom 70 TV set to demonstrate how trouble symptoms are related to circuit faults. Several dozen circuit defects were introduced in various sections of the set and the resulting trouble symptoms that appeared on the screen were analyzed and discussed by the speaker and by the Chapter members. Diagrams of the Custom 70 were distributed so that the members could better understand how the circuit malfunction would cause the related operating faults.

Not to be outdone by Joe Schek, Chapter Member Norman Roton followed with a highly effective presentation of the proper steps to take in converging a Color-TV receiver. Norman went to considerable trouble to make his demonstration as practical as possible; he even carried his large console Color-TV set up three flights of stairs to the meeting room. The members were deeply appreciative and highly enthusiastic about Norman's well-planned demonstration and felt that they had gathered a great deal of up-to-date color set convergence information from it.

Due to the efforts of these two speakers and to their excellent programs, this was one of the Chapter's truly great meetings.

SAN ANTONIO STUDIES COLOR-TV FUNDAMENTALS

SAN ANTONIO (ALAMO) CHAPTER is continuing to feature slide-tape presentations from the Howard Sams' Company. At a recent meeting, one of these presentations dealt with "Fundamentals of the Color TV System" and another with "Receiver Circuit Fundamentals". At the next meeting, two more were shown, entitled "Color TV Circuit Analysis" and "Installation and Maintenance". The members feel that these presentations are very practical and helpful.

Sam Stinebaugh built a stand for the blackboard recently purchased by the Chapter. The board will be used in connection with lectures and demonstrations.

NORTH JERSEY CHAPTER CONSIDERS LASERS

NORTH JERSEY CHAPTER members were fascinated by a program conducted by a representative of the Bell Telephone Company consisting of a lecture and films. The representative explained and demonstrated the laser beam light and how it is used to carry the sound of music and the voice. The laser beam is also used in hospitals. The films depicted the uses of the laser light.

The next meeting was devoted entirely to troubleshooting, and the Chapter made use of all its equipment. Members were asked to bring in any unit with odd troubles. Many new methods and ideas were brought forth. Vice-Chairman George Stoll supervised the program, and it was indeed a fruitful evening.

HAGERSTOWN EXAMINES SERVICING GUIDELINES

HAGERSTOWN (CUMBERLAND VALLEY) CHAPTER held a meeting in a new location -- Lincoln Lectronics, a radio-TV sales and service shop located on Route 30 on the outskirts of Chambersburg. It happened to be the meeting at which J. B. Straughn and Ted Rose, of the NRI staff, made their annual visit. Mr. Straughn delivered a fine talk on tube history and theory and on various kinds of test instruments and their use in practical radio-TV servicing.

The members decided that they will dig into the servicing of color-TV sets as well as study for FCC Licenses.

DETROIT INVESTIGATES TRANSISTOR UNITS

DETROIT CHAPTER re-elected its entire slate of 1966 officers to serve in 1967: James J. Kelley, Chairman; John Nagy, Vice-Chairman; Roy Miller, Secretary; John Korpalski, Assistant Secretary; F. Earl Oliver, Treasurer; Leo Blevins and Asa Belton, Financial Com-

mittee; and Asa Belton, Sergeant-at-Arms. Our congratulations, gentlemen!

Earl Oliver presented an interesting film by Sylvania entitled "Color Ideas." Another meeting featured a demonstration by Chapter Member John Nagy, who had a new transistor mixing unit used in P. A. work. John brought all the equipment he used in a recent installation and showed how all the units are hooked up so that the sound can be heard by the audience or by groups of people wherever they are assembled. He discussed in detail the new unit that he brought with him, and this led to a decision by the members to brush up on solid-state theory and servicing.

NEW YORK CHAPTER INCREASES RANKS

NEW YORK CITY CHAPTER's newest members are Jose Perez, Stewart Berry, both graduates, and Horace Batson, student. Welcome to the Chapter, gentlemen!

A discussion of various servicing problems -- from the effects of a vacuum cleaner on color-TV to intermittent hum in a car radio -- was held under the leadership of Ontie Crowe. Joe Bradley demonstrated aligning a transistor set using a scope and a sweep generator, which was then used to show the i-f response on the scope. Joe also showed how a small battery-operated square-wave generator could be used to test the bandpass of an amplifier.

Dave Spitzer repaired and demonstrated a Precise Signal Generator brought in by Charles Vevo. The instrument had apparently not been used for some time; it did not work instantly but required new lead terminations, among other things.

Another meeting featured three moving picture films, "Krystallos", "The Transistor", and "Similarities in Wave Behavior". These were projected by Dave Spitzer. Al Bimstein gave an effective talk and blackboard demonstration of information obtained from representatives of the GC Company on uhf and color-TV aerials. Both Ontie Crowe and Al Bimstein then led a detailed discussion of

various TV tuners, their operation and adjustment. Quite a few members joined this discussion with enthusiasm; the talk proved to be of considerable benefit to them, and a good deal of shared experiences and specific cases were cited. Several schematics and a number of actual tuners were distributed to the audience to illustrate various points.

FLINT MEMBERS ENJOY 'MAN AND IDEA' FILM

FLINT (SAGINAW VALLEY) CHAPTER members were guests of the Channel Master Company and the Taylor Electronic Supply Company of Flint on two separate occasions. The first was a lecture about CATV from a business standpoint -- that is, the opportunity for profit which it offers to the service technician. The second part of this program was held at the following meeting; installation and repair of Channel Master Antenna TV Systems were the subjects. Part of this program was on film; the other part was a lecture.

A large part of the next meeting was devoted to showing a Sylvania movie entitled "Man and Idea -- How To Be Creative". It showed specifically how the compactron tube and the color tube began as ideas and how they progressed from that point. There was a very good turnout at this meeting. The movie was shown four times.

The two most recent additions to the Chapter are new members Stephen Avetta, Flint, and Leroy W. Massman, Lexington, Michigan. Welcome to the Chapter, gentlemen!



One of the groups which saw the film "Man and Idea" at a Saginaw Valley meeting.

DIRECTORY OF ALUMNI CHAPTERS

DETROIT CHAPTER meets 8:00 P. M., 2nd Friday of each month, St. Andrews Hall, 431 E. Congress St., Detroit. Chairman: James Kelley, 1140 Livernois, Detroit, Mich., VI-14972.

FLINT (SAGINAW VALLEY) CHAPTER meets 8:00 P. M., 2nd Wednesday of each month at Andrew Joblagy's Shop, G-5507 S. Saginaw Rd., Flint. Chairman: Clyde Morrisett, 514 Gorton Ct., Flint, Michigan., 235-3074.

HAGERSTOWN (CUMBERLAND VALLEY) CHAPTER meets 7:30 P. M., 2nd Thursday of each month at George Fulk's Radio-TV Service Shop, Boonsboro, Md. Chairman: Robert McHenry, RR2, Kearneysville, W. Va. 25430.

LOS ANGELES CHAPTER meets 8:00 P. M., 2nd and last Saturday of each month, 4912 Fountain Ave., L. A. Chairman: Eugene DeCausin, 4912 Fountain Ave., L. A., NO 4-3455.

MINNEAPOLIS-ST PAUL (TWIN CITIES) CHAPTER meets 8:00 P. M., 2nd Thursday of each month, at the homes of its members. Chairman: Edwin Rolf, Grass-ton, Minn.

NEW ORLEANS CHAPTER meets 8:00 P. M., 2nd Tuesday of each month at Galjour's TV, 809 N. Broad St., New Orleans, La. Chairman: Herman Blackford, 5301 Tschoupitoulas St., New Orleans, La.

NEW YORK CITY CHAPTER meets 8:30 P. M., 1st and 3rd Thursday of each month, St. Marks Community Center, 12 St. Marks Pl., New York City. Chairman: John Schumott, 1778 Madison Ave., NYC. 722-4748.

NORTH JERSEY CHAPTER meets 8:00 P. M., last Friday of each month, Players Club, Washington Square (1/2 block west of Washington and Kearney Avenues), Kearney, N. J. Chairman: George Schopmeier, 935-C River Rd., New Milford, N. J.

PHILADELPHIA-CAMDEN CHAPTER meets 8:00 P. M., 2nd and 4th Monday of each month, K of C Hall, Tulip and

Tyson Sts., Philadelphia. Chairman: John Pirrung, 2923 Longshore Ave., Philadelphia, Pa.

PITTSBURGH CHAPTER meets 8:00 P. M., 1st Thursday of each month, 436 Forbes Ave., Pittsburgh. Chairman: Joseph Burnelis, 2268 Whited St., Pittsburgh, Pa.

SAN ANTONIO (ALAMO) CHAPTER meets 7:00 P. M., 4th Friday of each month, Beethoven Home, 422 Pereida, San Antonio. Chairman: Sam Stinebaugh, 318 Early Trail, San Antonio, Texas.

SAN FRANCISCO CHAPTER meets 8:00 P. M., 2nd Wednesday of each month, 1259 Evans Ave., San Francisco. Chairman: Isaiah Randolph, 523 Ivy St., San Francisco, Calif.

SOUTHERN MASSACHUSETTS CHAPTER meets 8:00 P. M., last Wednesday of each month at home of John Alves, 57 Allen Blvd, Swansea, Mass. Chairman: Daniel DeJesus, 125 Bluefield St., New Bedford, Mass.

SPRINGFIELD (MASS.) CHAPTER meets 7:00 P. M., last Saturday of each month at shop of Norman Charest, 74 Redfern Dr., Springfield, Mass. Chairman: Joseph Gaze, 68 Worthen St., W. Springfield, Mass.

1	D	A	S	H	3	P	O	T	5	P	O	L	E	7	S	
	A		A		I	8	E	9	S			A		A		
10	M	O	T	H	E	R		11	A	S	P	S		W		
	P		U		R		12	P		H		13	E	14	A	T
15	E	R	R		C	L	A	M	P		17	R		18	I	O
	R		19	A	V	E		I	20	U	P		22	M	O	
		23	T	S		25	B	R	U	S	H					T
25	T	26	R	E	B	L	E		27	H	I	28	D		H	
29	R	O	D					T	30	F		31	Y	D		
32	L		33	S	34	T	A	T	35	O	R		N	36	M	
37	U	L	T	O	R		38	O	R		39	H	A	L	O	
	G			40	L	O			41	C	C	M	D			
42	H	A	R	D	T	U	B	E			43	C	O	R	E	

FREE from CONAR INTERTECH MULTIMETER

With purchase of either piece of equipment below, take your choice of Model M101 (1,000 Ohms), Model 220 (20,000 Ohms), Model 330 (30,000 Ohms), or Model 230 (30,000 Ohms). Here's your chance to get a needed piece of quality B & K test equipment and get a FREE BONUS of a handy multimeter valued at up to \$19.95. Order yours today. Offer ends March 1.



COMPLETE WITH TEST
LEADS AND BATTERIES

B & K DYNAMIC MUTUAL CONDUCTANCE TUBE TESTER

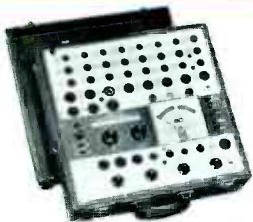

707 WT
17 lbs.
Exp. Coll.

\$189.95

\$19 DOWN — \$9 PER MONTH

Tests: New and old types including Nuvistors, Novars, 10-pin tubes, 12-pin Compactrons, European Hi-Fi tubes, voltage regulators, and most industrial types. Makes tests under actual set operating conditions. Provisions for future sockets. Checks each section of multi-section tubes for all shorts grid emission, leakage and gas. The adjustable grid emission test provides sensitivity to over 100 megohms. Makes a quick "life" test. Tests more color TV tubes faster than any equipment previously available.

B & K COLOR GENERATOR

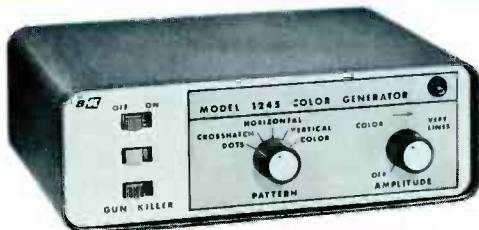

1245 WT
6 lbs.
Par. Post. Ins.

\$134.95

\$14 DOWN — \$6 PER MONTH

Small, lightweight solid-state. Checks and adjusts: convergence, demodulator alignment, color sync, color fit, horizontal and vertical size, linearity and overscan. Dots only one raster line high and .25 usec. wide for most accurate convergence. Free of retrace lines. Precise waveforms permit accurate setting color killer control with a B&W telecast. Built-in gun killer works on any picture tube. Station quality waveforms. All transistor design.

USE YOUR CONAR CREDIT—ORDER BLANK PAGE 27

FREE

WITH YOUR ORDER
KEY BEAM

A LIFETIME OF LIGHT ON YOUR KEY

- 1st micro-miniature light
- Lifetime Guarantee

\$2.95 value

Use the handy order form on page 27
Offer ends March 1, 1967



TRANSISTOR RADIO ANALYST SALE

MODEL 960
FOR AM PORTABLES

YOU SAVE \$10.45 and PROFIT from transistor radio servicing. Model 960 has exclusive new DYNA-TRACE Single-Point Probe, plus metered power supply and VTVM. Complete signal-generating source. "Good-Bad" scale for both leakage and Beta. Complete with Japanese to American transistor cross-reference chart. 117 V, 50-60 cycle AC. It's a CONAR-recommended Best Buy!

Reg. \$99.95

**NOW
\$89.50**

960 WT
9½ lbs.
Exp. Coll.
\$5 MO.

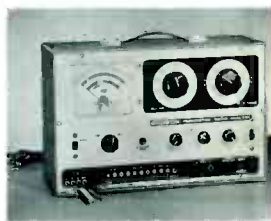

HANDY ORDER FORM ON PAGE 27 — USE YOUR CONAR CREDIT

NRI JOURNAL
3939 Wisconsin Ave.
Washington D. C. 20016

Mr. Willard F. Velline
1322 S. 14th
Fargo, N. Dak. 58101

250223-G

Second-class
postage paid
at Washington, D. C.