

NAB STANDARD

*Magnetic Tape Recording
and Reproducing (Reel-to-Reel)*



April, 1965

Engineering Department

NATIONAL ASSOCIATION OF BROADCASTERS

1771 N Street N.W. • Washington, D.C.

NAB MAGNETIC TAPE RECORDING AND REPRODUCING STANDARDS

REEL-TO-REEL

FOREWORD

The NAB Recording and Reproducing Standards Committee was originally organized in 1941. Standards proposals issuing from the Committee have been adopted by the Board of Directors in 1942, 1949, 1950, and 1953. The Standards contained herein were adopted by the Board on January 29, 1965.

These standards and recommended good engineering practices are for the guidance of the broadcasting industry and represent the contributions of many of the nation's authorities on the various phases of recording as used by the industry. The NAB Recording and Reproducing Standards Committee has also benefited by contributions made by several international organizations. The Committee was open to participation by any interested individual or organization and consisted of representatives from the manufacturers, broadcasters and producers. Close liaison was maintained with other organizations (as well as foreign countries) to insure the maximum degree of coordinated understanding and recommended standardization, to permit interchangeability, and, at the same time, to embrace the latest technological advances of the art.

Nothing in these standards prohibits or discourages continued progress or advancement of the art. On the contrary, these standards are intended to stimulate continued scientific exploration in the field of recording. It is anticipated that when new techniques and developments are evident, the NAB Recording and Reproducing Standards Committee may request submissions thereon looking toward any needed amendments and additions to keep pace with the art as it affects all forms of AM, FM and TV broadcasting.

These standards are written to cover full track, two track, and four track magnetic recording systems operating at $7\frac{1}{2}$ inches per second, the speed established as the preferred tape standard speed for program exchange. These standards also contain the supplementary tape speed standards of 15 and $3\frac{3}{4}$ inches per second in the body of the main high-performance standard.

A second set of standards are contained within the overall framework of these standards. This section is titled "Special Purpose Limited Performance Systems." These specifications are intended to permit interchangeability between recorders where portability and weight are the primary considerations and technical perfection is made secondary to accomplish this greater portability. It is essential that anyone studying these standards appreciate the difference in purpose of these two sets of standards.

Basic to these standards are physical and mechanical properties such as tape speeds, tape specifications, track width, reel specifications, and tape wind and storage conditions.

To simplify compliance with these standards, the specifications called for are referenced to "Standard Test Tapes," which tapes are the primary tools in determining compliance. Three sets of annex cover the details of how such standard test tapes are made and calibrated so that they may be reproduced in the field with the proper equipment.

A glossary of terms is included to further clarify the text.

Recording systems which comply with the "Standard Systems" specifications in the main body of the standard shall be designated as "NAB Standard Recorders". Such recording systems as do not meet these specifications shall be designated as "NAB Special Purpose Recorders," if they meet the Special Purpose Limited Performance System specifications.

The following organizations contributed to the formulation of these standards:

American Broadcasting Company, N. Y.
Ampex Corporation, Redwood City, Calif.
Audio Devices, Inc., New York, N. Y.
Broadcast Electronics, Inc., Silver Spring, Md.
Capitol Records, Hollywood, Calif.
Collins Radio Company, Dallas, Tex.
Columbia Broadcasting System, New York, N. Y.
Eastman Kodak Company, Rochester, N. Y.
Michigan Magnetics, Inc., Vermontville, Mich.
Midwestern Instruments, Tulsa, Okla.
Minnesota Mining & Manufacturing Co., St. Paul, Minn.
National Broadcasting Company, New York, N. Y.
RCA Broadcast Division, Camden, N. J.
RCA Record Division, Indianapolis, Ind.
Reeves Soundcraft, Danbury, Conn.
V-M Corporation, Benton Harbor, Mich.
WSVA, Harrisonburg, Va.
WWDC, Washington, D. C.

NAB MAGNETIC TAPE RECORDING AND REPRODUCING STANDARDS

—REEL-TO-REEL—

1. PHYSICAL AND MECHANICAL SPECIFICATIONS

Magnetic Tape Dimensions

1.01 Width. It shall be standard that magnetic tape width shall be 0.246 inches \pm 0.002 inches for nominal one-quarter inch sound recording tape.

1.02 Thickness. It shall be standard that the thickness of magnetic tape shall not exceed 0.0022 inches.

1.03 Length. It shall be standard that magnetic tape be supplied in the following minimum lengths:

Nominal Reel Dia.	Nominal Hub	1.5 mil base	1.0 mil base	0.5 mil base
3 in.	1.75 in.	125 ft.	200 ft.	300 ft.
5 in.	1.75 in.	600 ft.	900 ft.	¹
7 in.	2.25 in.	1200 ft.	1800 ft.	¹
10.5 in.	NAB 4.5 in.	2500 ft.	3600 ft.	¹
14 in.	NAB 4.5 in.	5000 ft.	7200 ft.	¹

Magnetic Tape Wind

1.04 It shall be standard that tape shall be wound with the oxide coated surface facing toward the hub of the reel.

1.04.01 Recorded tape normally should be wound so that the start of the program material is at the outside of the reel.

1.04.02 It is good engineering practice when storing recorded tapes for long periods of time that the start of the program material be at the inside next to the hub. Tapes so stored or shipped shall be clearly marked to prevent accidental playing in the reverse direction.²

Magnetic Tape Level and Uniformity

1.05 It shall be standard that magnetic tape shall have an average output level at 400 cps at a tape speed of 7½ ips which is uniform within \pm 0.5 db throughout a given reel.

1.05.01 This measurement is to be made at the NAB Standard Reference Level and read on a Standard Volume Indicator (ASA Standard C16.5-1961) with bias adjusted for maximum output for the tape under test.

1.06 It shall be standard that magnetic tapes of any specified type shall have an average output at 400 cps at a tape speed of 7½ ips which is uniform within \pm 1 db from reel to reel.

1.06.01 This measurement is to be made at the NAB Standard Reference Level and read on a Standard Volume Indicator (ASA Standard C16.5-1961) with bias adjusted for maximum output for the tape under test.

Magnetic Track Designations

1.07 It shall be standard that in multitrack recordings, Track One shall be the top track when the tape is moving from left to right with the coated side facing away from the observer and with the leader to the right. The next lower track is designated Track Two, and so on.

¹ Not recommended.

² Tapes stored with the end of the program toward the outside of the reel will have slightly less preprint than postprint. This is generally desirable because postprint tends to be masked by the program material and reverberation effects. Also, rewinding a tape immediately before playing tends to reduce print-through. Another advantage of rewinding before playing is that stresses are relieved and any adhesion of adjacent layers of tape will be eliminated. A further advantage is that tape wound on the take-up reel in the play mode of operation usually is wound more smoothly than when wound at high speed. Therefore, there is less chance of damage during storage or shipment or due to temperature and humidity changes.

Magnetic Track Dimensions

1.08 It shall be standard that the recorded magnetic track for full track recordings be 0.238 inches $\pm 0.010 - 0.004$ inches in width.

1.09 It shall be standard that the recorded tracks for two track monophonic or stereophonic recordings be 0.082 ± 0.002 inches in width with a center-to-center spacing of 0.156 ± 0.004 inches.

1.10 It shall be standard that the recorded tracks for four track recordings shall be $0.043 + 0.000 - 0.004$ inches in width. The center-to-center distances between Tracks 1 and 3, and between Tracks 2 and 4 shall be $0.134 + 0.002 - 0.000$ inches. The four tracks shall be equally disposed across the tape with a tape width of 0.244 inches and the outer edges of Tracks 1 and 4 coincident with the edges of the tape.

Two Track Stereophonic Recordings

1.11 It shall be standard that for two track stereophonic recordings, Track 1 shall carry the recording for the left-hand channel as viewed from the audience, and Track 2 shall carry the recording for the right-hand channel.

1.12 It shall be standard that for two track stereophonic recordings, the tracks shall be recorded with head gaps in line and phased for reproduction on equipment so connected that when a full track tape is reproduced, it produces in-phase signals in the two channel outputs.

Four Track Monophonic Recordings

1.13 It shall be standard that for four track monophonic recordings, the track recording sequence shall be 1-4-3-2.

Four Track Stereophonic Recordings

1.14 It shall be standard that Tracks 1 and 3 shall be used simultaneously for one direction of tape travel and Tracks 2 and 4 for the other direction. Tracks 1 and 3 shall be used first as the tape is unwound from the supply reel.

1.15 It shall be standard that Tracks 1 and 4 shall carry the recording for the left-hand channel as viewed from the audience, and Tracks 2 and 3 shall carry the recording for the right-hand channel.

1.16 It shall be standard in four track stereophonic recordings that Tracks 1 and 3 and Tracks 2 and 4 shall be recorded with the head gaps in line and shall be phased for reproduction on equipment so connected that when a full-track tape is reproduced it produces in-phase signals at the two channel outputs.

Magnetic Tape Reel Dimensions ($\frac{1}{4}$ inch tape)

1.17 It shall be standard that NAB magnetic tape reels for $\frac{1}{4}$ inch tape be identified as Type A or Type B reels.

1.17.01 It shall be standard that NAB Type A reels shall include $10\frac{1}{2}$ or 14 inch metal or filled plastic reels with a nominal 3 inch center hole and shall conform to the dimensions and specifications of Figure 1 and Table 1.

1.17.02 It shall be standard that NAB Type B reels shall include all filled or unfilled plastic reels with a nominal $\frac{5}{16}$ inch center hole and shall conform to the dimensions and specifications of Figure 2 and Table 2.

2. SPECIFICATIONS FOR STANDARD SYSTEMS

The following systems specifications apply to all high quality magnetic recording and reproducing equipment used for music and speech programs where superior performance is of primary importance.

Magnetic Tape Speeds

2.01 Preferred Speed. It shall be standard that the preferred tape speed be $7\frac{1}{2}$ inches per second $\pm 0.2\%$.

2.01.01 The tolerance on tape speed shall apply to any portion of the reel of tape in use and shall be measured by the method described in Annex A.

2.02 Supplementary Tape Speeds. It shall be standard that 15 and $3\frac{3}{4}$ inches per second $\pm 0.2\%$ be supplementary tape speeds.

2.02.01 The tolerance on tape speed shall apply to any portion of the reel of tape in use and shall be measured by the method described in Annex A.

Standard Reference Level

2.03 It shall be standard that the NAB Standard Reference Level shall be that 400 cps level which is equal to the recorded level on the NAB Primary Reference Tape.³

Standard Recorded Program Level⁴

2.04 It shall be standard that recorded program material shall produce the same reference deflection on a Standard Volume Indicator (ASA Standard C16.5—1961) as that produced by a 400 cps sine wave signal recorded at the NAB Standard Reference Level.

Standard Reproducing System Response^{5, 6, 7}

2.05 It shall be standard that the Reproduce System Response at $7\frac{1}{2}$ inches per second from a $7\frac{1}{2}$ NAB 65 Test Tape shall be within the tolerance limits shown in Figure 3a, between 30 cps and 15 kc. The positive tolerance shall not be exceeded beyond these frequency limits.

2.06 It shall be standard that the Reproduce System Response at 15 inches per second from a 15 NAB 65 Test Tape shall be within the tolerance limits shown in Figure 3b, between 30 cps and 15 kc. The positive tolerance shall not be exceeded beyond these frequency limits.

2.07 It shall be standard that the Reproduce System Response at $3\frac{3}{4}$ inches per second from a $3\frac{3}{4}$ NAB 65 Test Tape shall be within the tolerance limits shown in Figure 3c, between 50 cps and 10 kc. The positive tolerance shall not be exceeded beyond these frequency limits.⁸

Standard Recorded Response

2.08 It shall be standard that the Standard Recorded Response shall be within the tolerance limits shown in Figure 4a, b or c, depending upon the tape speed.

³ The NAB Primary Reference Tape is a tape of the normal general purpose type which has been selected for average characteristics of output, sensitivity and distortion. The 400 cps recording on it was made at $7\frac{1}{2}$ ips with bias adjusted for maximum output, at an output level 8 db below that which produced 3% third harmonic distortion. This does not imply a failure to meet the 10 db overload margin of footnote 4. It is rather, a practical convenient method of specification consistent with the magnetic recording and reproducing process. Since neither the tape nor the measurement conditions can be duplicated exactly in the field, all NAB Standard Test Tapes contain a 400 cps recording at the NAB Standard Reference Level within ± 0.25 db as a means for making this level available.

⁴ It is well established that at least a 10 db margin is required between the sine wave load handling capacity of a system and the level of program material as measured by a Standard Volume Indicator (ASA Standard C16.5—1961). These peak levels are believed to be approximately the maximum flux which can be recorded on presently available tapes without excessive distortion. This is also substantiated by practical experience.

⁵ It is recommended that the Standard Reproducing System response roll off at the rate of at least 6 db per octave beyond the frequency limits specified.

⁶ Basic Reproducing Characteristics are defined in Annex B. The curves are shown in Fig. 5 and the values listed in Tables 3 and 4. Precise methods of measuring and calibrating a reproducing system are discussed in Annex C. A reproducer calibrated by these methods and meeting all of the specifications of this Standard is considered suitable for measuring and calibrating Standard Test Tapes.

⁷ Since NAB Standard Test Tapes are recorded across the full width of the tape, per section 4.02, a low frequency boost may be expected when the test tape is reproduced on a head of less than full track width. Refer to the instructions supplied with the test tape for further details.

⁸ It should be noted that full track operation at the lower tape speeds may cause some difficulty in consistently meeting the frequency response standards due to possible tape skew and the resultant azimuth errors.

2.08.01 The recorded response is defined as the difference between the over-all record-reproduce response and the reproduce response from an NAB Standard Test Tape of the same speed.^{9, 10}

2.08.02 The measurement of recorded response shall be made at the same level as that on the NAB Standard Test Tape. Normal operating bias shall be used.

Signal-to-Noise Ratio^{11, 12}

2.09 It shall be standard that the unweighted signal-to-noise ratio shall be not less than the following:

Tape Speed	Full Track	Two Track	Four Track
15 ips	50 db	45 db	not used
7½ ips	50 db	45 db	45 db
3¾ ips	46 db	46 db	45 db

2.09.01 Unweighted noise shall be measured over the frequency range of 20 cps to 20 kc. The response of the measuring system shall be uniform ± 0.3 db from 30 to 15,000 cps. Response at 20,000 cps shall be 3 db below the 400 cps value, falling at the rate of at least 12 db per octave above 20 kc. The noise measurement shall be made using a tape previously recorded with bias but with no signal. The reference signal level shall be the 400 cps NAB Standard Reference Level and the indicating meter shall have the dynamics of the Standard Volume Indicator (ASA Standard C16.5-1961). The measuring system shall have a full-wave rectified average measurement law.

2.10 It shall be standard that the weighted signal-to-noise ratio shall be not less than the following:^{13, 14, 15}

Tape Speeds	Full Track	Two Track	Four Track
15 ips	58 db	53 db	not used
7½ ips	60 db	55 db	52 db
3¾ ips	57 db	54 db	52 db

2.10.01 Weighted noise shall be measured using the weighting curve of Figure 6 in the measuring circuit. This curve is based on the ASA "A" curve (ASA Standard S1.4-1961). The noise measurement shall be made using a tape previously recorded with bias but with no signal. Calibration is made (with the weighting network inserted) at 1000 cps using the 1000 cps Standard Level which is included for this purpose on the NAB Standard Test Tape. The indicator meter shall have the dynamics of the Standard Volume Indicator (ASA Standard C16.5-1961) and the measuring system shall have a full-wave rectified average measurement law.

⁹ The recording equalization of a recorder/reproducer should be adjusted for an over-all response which matches as nearly as possible the response of the reproducer from the NAB Standard Test Tape. This response is standardized, rather than the simple over-all record-reproduce response, in order to assure better interchangeability of recorded tapes.

¹⁰ An alternate definition of a Recorded Characteristic could be in terms of measured surface induction or remanent flux in free space. However, since such measurements are of limited value, particularly when used with ferromagnetic heads at short wave lengths, the definition in 2.08.01 has been accepted as more useful for the purpose of this Standard.

¹¹ These measurements are intended to give a measure of noise in terms of the NAB Standard Reference Level; they are therefore figures of merit for comparisons of system noise. They do not, however, take into account the program level which may be recorded on a particular tape without excessive distortion. It should be borne in mind that the peak signal-to-noise ratio may be approximately 10 db better than the figures given when the NAB Standard Recorded Program Level is used on general purpose tape.

¹² The use of 3¾ ips full-track recordings may present practical difficulties in maintaining azimuth.

¹³ See footnote 12.

¹⁴ The weighted noise measurement employs a frequency response similar to that of the ear at low volume levels and is intended to give a more useful indication of the subjective signal-to-noise ratio than the unweighted measurement. The noise measurement is approximately comparable to that obtained by the use of a 500 to 15,000 cps filter in disc noise measurements.

¹⁵ Note that the weighted signal-to-noise ratio is poorer at 15 ips than at 7½ ips. This is due to the fact that the reproduce amplifier equalizations remains the same for both speeds while the tape noise increases with tape speed.

Distortion ¹⁶

2.11 It shall be standard that the over-all record reproduce system total harmonic distortion including tape shall be less than 3% rms for a 400 cps sine wave signal recorded to achieve a reproduce level 6 db above the NAB Standard Reference Level.

Flutter

2.12 It shall be standard that in the reproduce mode the unweighted flutter content when reproducing an essentially flutter-free recording of 3 kc at any portion of the reel of tape in use shall not exceed the following:

Tape Speed	Flutter (rms)
15 ips	0.15%
7½ ips	0.20%
3¾ ips	0.25%

2.12.01 Unweighted flutter content shall be measured over the frequency range of 0.5 cps to 200 cps. The response of the measuring system shall be 3 db down at 0.5 cps and 200 cps, and falling at a rate of at least 6 db per octave below and above these frequencies, respectively. At low frequencies where the meter pointer follows the wave form, the maximum deflection shall indicate the rms value. The indicating meter shall have the dynamics of the Standard Volume Indicator (ASA C16.5-1961), a full-wave rectified average measurement law, and shall be calibrated to read the rms value of a sinusoidal frequency variation.

2.12.02 It shall be standard that the meter be read for random periods throughout the length of the tape, noting the average of the peak readings, but excluding random peaks which do not recur more than three times in any 10-second period.

2.13 It shall be standard that in the reproduce mode the weighted flutter content when reproducing an essentially flutter-free recording of 3 kc at any portion of the reel of tape in use shall not exceed the following:¹⁷

Tape Speed	Flutter (rms)
15 ips	0.05%
7½ ips	0.07%
3¾ ips	0.10%

2.13.01 Weighted flutter shall be measured over the frequency range of 0.5 to 200 cps. The response of the measuring system shall be as specified in Figure 7. At low frequencies where the pointer follows the wave form, the maximum deflection shall indicate the rms value. The indicating meter shall have the dynamics of the Standard Volume Indicator (ASA C16.5-1961), a full-wave rectified average measurement law, and shall be calibrated to read the rms value of a sinusoidal frequency variation.

2.13.02 It shall be standard that the meter be read for random periods throughout the length of the tape, noting the average of the peak readings, but excluding random peaks which do not recur more than three time in any 10-second period.

Crosstalk ¹⁸

2.14 It shall be standard that for two or four track monophonic systems and for four track

¹⁶ The recording amplifier should not overload with high frequency input signals equal in level to the maximum expected low frequency levels. In practice, this means that the recording high frequency pre-emphasis may place an additional demand on the undistorted amplifier output. Distortion of this type is not normally detected by harmonic distortion measurements. Bias leakage into the record or reproduce amplifier circuits may be a source of additional distortion.

¹⁷ The weighted flutter measurement employs a frequency response similar to the sensitivity of the ear to frequency variations versus the frequency of these variations ("flutter rate") and is intended to give a more useful indication of the subjective effect of flutter than the unweighted measurement.

¹⁸ These measurements shall be made at the recorded level of the frequency response portion of the NAB Standard Test Tape, and must be made with a tuned voltmeter in order to eliminate the effect of noise. The reference level shall be the 400 cps tone in the frequency response portion of the NAB Test Tape.

stereophonic systems, the adjacent track signal-to-crosstalk ratio shall be not less than 60 db in the range from 200 cps to 10 kc.¹⁹

2.14.01 For these measurements, bias shall not be applied to the unrecorded tracks.

Stereophonic Channel Separation

2.15 It shall be standard that with stereophonic systems channel separation shall be not less than 40 db between the frequencies of 100 cps and 10 kc.

2.15.01 For measurements of stereophonic systems, bias shall be applied to both tracks.

3. SPECIFICATIONS FOR SPECIAL PURPOSE LIMITED PERFORMANCE SYSTEMS

The use of lightweight portable magnetic recorders is recognized in this section of the Standard. It presents what are considered to be the minimum acceptable performance requirements where adequate voice intelligibility and interchangeability of recorded tapes are of primary importance. Systems meeting these specifications are not suitable for maximum fidelity recording of speech or music.

Tape Speeds

3.01 It shall be standard that tape speeds for Special Purpose Magnetic Recording and Reproducing Systems be $7\frac{1}{2}$, $3\frac{3}{4}$, or $1\frac{7}{8}$ inches per second, $\pm 2\%$ as measured at any portion of the reel of tape in use, and shall be measured by the method described in Annex A.

Flutter

3.02 It shall be standard that in the reproduce mode, unweighted flutter content, when reproducing an essentially flutter-free recording of 3 kc, shall not exceed 0.5% rms at any portion of the reel of tape in use.

3.02.01 Unweighted flutter content shall be measured over the frequency range of 0.5 cps to 200 cps. The response of the measuring system shall be 3 db down at 0.5 cps and 200 cps, and falling at a rate of at least 6 db per octave below and above these frequencies, respectively. At low frequencies where the meter pointer follows the wave form, the maximum deflection shall indicate the rms value. The indicating meter shall have the dynamics of the Standard Volume Indicator (ASA C16.5-1961), a full-wave rectified average measurement law, and shall be calibrated to read the rms value of a sinusoidal frequency variation.

3.02.02 It shall be standard that the meter be read for random periods throughout the length of the tape, noting the average of the peak readings, but excluding random peaks which do not recur more than three times in any 10-second period.

Standard Recorded Program Level^{20, 21}

3.03 It shall be standard that recorded program material shall produce the same reference deflection on a Standard Volume Indicator (ASA Standard C16.5-1961) as that produced by a 400 cps sine wave signal recorded at the NAB Standard Reference Level.

Reproducing System Response²²

3.04 It shall be standard that the Reproduce System Response from an appropriate NAB Test Tape shall be within the tolerance limits shown in Figure 8.

¹⁹ It should be recognized that two-track monophonic tapes which are duplicated on stereophonic equipment will have the crosstalk characteristics of a stereophonic system and therefore may not meet this crosstalk specification.

²⁰ It is well established that at least a 10 db margin is required between the sine wave load handling capacity of a system and the level of program material as measured by a Standard Volume Indicator (ASA Standard C16.5-1961). These peak levels are believed to be approximately the maximum flux which can be recorded on presently available tapes without excessive distortion. This is also substantiated by practical experience.

²¹ At a speed of $1\frac{7}{8}$ ips, it may be advisable to record certain types of program material at a lower level to avoid distortion.

²² Basic Reproducing Characteristics are defined in Annex B. The curves are shown in Fig. 5 and the values listed in Tables 3 and 4.

3.04.01 This specification represents the minimum acceptable limits, and is not intended to restrict the frequency range of voice recording systems which have the inherent capability of wide-range recording, without distortion. It is, however, often considered desirable to limit the extreme low frequency response for improved speech intelligibility.

Recorded Response

3.05 It shall be standard that the Recorded Response shall be within the tolerance limits shown in Figure 8.

3.05.01 The recorded response is defined as the difference between the over-all record—reproduce response and the reproduce response from an NAB Standard Test Tape of the same speed.

3.05.02 The measurement of Recorded Response must be made at the same level as that on the Standard Test Tape. Normal operating bias shall be used.

3.05.03 It is recommended that the Recorded Response be attenuated below 100 cps at the rate of approximately 6 db per octave in order to improve speech intelligibility. A similar attenuation above 5 kc is recommended in order to reduce the chance of high frequency tape overload at the lower tape speeds.

Signal-to-Noise Ratio

3.06 It shall be standard that the unweighted signal-to-noise ratio shall be not less than the following:

Full Track	46 db
Two Track	43 db
Four Track	40 db

3.06.01 Unweighted noise shall be measured over the frequency range of 20 cps to 20 kc. The response of the measuring system shall be uniform ± 0.3 db from 30 to 15,000 cps. Response at 20,000 cps shall be 3 db below the 400 cps value, falling at the rate of at least 12 db per octave above 20 kc. The noise measurement shall be made using a tape previously recorded with bias but with no signal. The reference signal level shall be the 400 cps NAB Standard Reference Level and the indicating meter shall have the dynamics of the Standard Volume Indicator (ASA Standard C16.5-1961). The measuring system shall have a full-wave rectified average measurement law.

4. STANDARD TEST TAPES

4.01 The NAB Standard Test Tapes for reel-to-reel equipment shall be designated as follows:

Speed	Test Tape
15 ips	15 NAB 65
7½ ips	7½ NAB 65
3¾ ips	3¾ NAB 65
1⅞ ips	1⅞ NAB 65

4.02 All test tapes shall be recorded across the full width of the tape.

4.03 Each NAB Standard Test Tape shall contain five parts as defined in the following sections:

4.03.01 An azimuth adjustment tone of 60 seconds duration at the following frequencies:²³

Speed	Frequency
15 ips	15 kc
7½ ips	15 kc
3¾ ips	10 kc
1⅞ ips	5 kc

²³ The recorded level shall be the same as that of the corresponding frequency in the Frequency Response portion of the tape. The recorded azimuth shall be at 90 degrees ± 1 minute with respect to the edge of the tape.

4.03.02 A 400 cps sine wave signal of 20 seconds duration at the following level referred to the NAB Standard Reference Level:

Speed	Level
15 ips	0 db
7½ ips	-10 db
3¾ ips	-15 db
1⅞ ips	-15 db

4.03.03 A frequency response test containing the following frequencies at the indicated recorded levels. Each tone shall be approximately 12 seconds in duration and preceded by a voice announcement. The signal frequencies are recorded on these tapes in such a manner that they would supply a constant output level when reproduced on an Ideal Reproducing System.²⁴ The relative levels are measured during manufacture of the tape on a reproducing system of known, defined characteristics which are determined by the method described in Annex C.

15 ips 0 db	7½ ips -10 db	3¾ ips -15 db	1⅞ ips -15 db
15 kc	15 kc		
12 kc	12 kc		
10 kc	10 kc	10 kc	
7.5 kc	7.5 kc	7.5 kc	
5 kc	5 kc	5 kc	5 kc
2.5 kc	2.5 kc	2.5 kc	2.5 kc
1 kc	1 kc	1 kc	1 kc
750 cps	750 cps	750 cps	750 cps
500 cps	500 cps	500 cps	500 cps
250 cps	250 cps	250 cps	250 cps
100 cps	100 cps	100 cps	100 cps
75 cps	75 cps	75 cps	75 cps
50 cps	50 cps	50 cps	50 cps
30 cps	30 cps	30 cps	30 cps

4.03.04 A 400 cps sine wave signal of 20 seconds duration at the NAB Standard Reference Level.²⁵

4.03.05 A 1000 cps sine wave signal of 60 seconds duration at the NAB Standard Recorded Program Level. (See Section 2.04)

²⁴ See Annex B of this Standard for a definition of The Ideal Reproducing System and the equalization to be used. Note that the curves of Figure 5 are frequency response curves of the Ideal Reproducer with constant flux in the core of the Ideal Head instead of the basic amplifier curve which was used in the 1953 NAB Standard. The concept of expressing a curve in terms of time constants remains unchanged and it is still necessary to modify the amplifier response to compensate for practical reproduce head losses in a Standard Reproducing System.

²⁵ The level on the NAB Primary Reference Tape is that of a 400 cps tone at a tape speed of 7½ ips, and thus represents λ wavelength of 18.75 mils. Test Tapes for speeds other than 7½ ips are recorded such that they would supply the same ideal head flux at the same wavelength as the Primary Reference Tape, when measured on an Ideal Reproducing System.

ANNEX A

Methods of Tape Speed Measurement

It shall be standard that tape speed be measured by applying the one-quarter inch wide circumference of a precision pulley mounted on precision low friction bearings to the surface of the tape between the capstan and head assembly. The rotational speed of the pulley when driven by the tape may be measured by the use of an ac tachometer generator or by a stroboscope disc mounted on the pulley's flat surface. Tests of tape speed shall be made relative to the power line frequency.

It must be recognized that tape speed depends to some extent on tape thickness and tension, and on room temperature and humidity. Therefore, speed checks should be made under normal operating conditions with the machine adjusted according to manufacturer's recommendations.

Measurements shall be made with a tape the thickness of which is 0.0019 inches \pm 0.0002 inches which corresponds to the thickness of nominal 1.5 mil base tape.

A suggested design for a practical stroboscope disc consists of a pulley with a diameter of 1.4305 +0.0002 -0.0000 inches upon which is attached a printed disc having 72 and 36 equally spaced dots or solid lines. A neon lamp operating from the 60 cps motor supply flashes at a 120 cps rate. The stroboscope disc, when illuminated by this lamp, will indicate 7½ and 15 ips tape speeds, respectively. For 3¾ ips operation, a diode in series with a neon lamp is required so that the lamp will flash at a 60 cps rate.

It shall be standard that when using a stroboscope disc as recommended above, no more than 14 dots per minute shall drift past a fixed reference point in either direction for 7½ or 15 ips operation. For 3¾ ips operation the drift per minute shall not exceed 7 dots on the 36 dot disc. These limits of drift correspond to the speed tolerance limits of \pm 0.2%.

Ideal Reproducing System

It shall be standard that the NAB Ideal Reproducing System is a theoretical reproducer system. It consists of an "ideal" reproducing head¹ and an amplifier the output voltage of which shall conform to the voltage-frequency curve of Figure 5, with constant flux vs frequency in the core of the head.²

The curve of voltage vs frequency shall be uniform with frequency except where modified by the following equalizations:

- a. The voltage attenuation of a single resistance-capacitance high-pass filter having an RC time constant t_1 .
- b. The inverse of the voltage attenuation of a single resistance-capacitance low-pass filter having an RC time constant t_2 .

The curve expressed in decibels is represented by the following expressions:

$$\text{Where: } N_{ab} = 20 \log_{10} \omega t_1 \sqrt{\frac{1 + (\omega t_2)^2}{1 + (\omega t_1)^2}}$$

$$\omega = 2\pi f$$

f = frequency

And, t_1 and t_2 are as follows:

Tape Speed	t_1	t_2
15 ips	3180 μ s	50 μ s
7 $\frac{1}{2}$ ips	3180 μ s	50 μ s
3 $\frac{3}{4}$ ips	3180 μ s	90 μ s
1 $\frac{7}{8}$ ips	3180 μ s	90 μ s

¹ An "ideal" reproducing head is defined as a ferromagnetic ring head, the losses of which are negligible. This means that the gap is short and straight, the long wave-length flux paths are controlled so that no low-frequency contour effects are present and the losses in the head materials are negligibly small.

² It is recognized that the flux in the core of an "ideal" head is not necessarily the same as the surface flux on a tape in space for various reasons. Since most of these effects are not readily measured, it has been decided to base this standard on "ideal" head core flux rather than surface induction.

ANNEX C

Primary Calibrated Reproducing System ¹

A Primary Calibrated Reproducing System used for the purpose of calibrating Standard Test Tapes shall meet the following specifications:

- A. The system response shall not deviate more than ± 3 db from the ideal over the frequency range of interest.
- B. Electrical—Apparent core loss at the highest frequency of interest shall not exceed 3 db, undamped head resonance shall not exceed 3 db and amplifier deviation from the Ideal Response shall not exceed ± 3 db.
- C. Magnetic—Head gap losses shall not exceed 3 db at the highest frequency of interest and the head contour effect curve shall not deviate more than ± 2 db from the average.

Electrical losses shall be determined from measurements of the amplifier frequency response characteristic and the reproduce system output voltage characteristic with constant flux vs frequency in the head core.

Magnetic losses shall be determined from calculations of gap loss and measurements of head contour effects.

The following paragraphs specify the methods by which these characteristics shall be measured and the reproduce system calibrated. The procedure is to determine the various losses independently and consider them as deviations from the theoretical "Ideal Reproducing System."

Electrical Measurements

Three response frequency curves shall be made. First, the amplifier response alone with voltage directly proportional to frequency (voltage doubles for each octave frequency increase) measured by conventional methods; second, the head and amplifier response measured by applying a small voltage proportional to frequency across a low resistance connected in series with the head, and finally, the head and amplifier response measured with a constant flux vs frequency induced into the core of the reproduce head. The third measurement can be made by placing a fine wire over the head gap, securing it firmly in place, and feeding constant current through the wire. Although the resultant flux distribution is not identical to that from a tape, it is considered to be satisfactory for the purposes of this measurement. Ideally the third curve would follow the Standard Reproducing Characteristic as shown in Figure 5. However, in practice the curve may vary from the ideal because of head resonance effects, and apparent core losses. Resonance effects are determined by comparing curves 1 and 2 while apparent core losses are identified by comparing curves 2 and 3.

Magnetic Measurements

A curve of approximate gap loss vs frequency shall be calculated from the following expression:

$$\text{Gap loss} = -20 \log_{10} \frac{\sin [(180^\circ) (d/\lambda)]}{\pi d/\lambda}$$

where d = null wavelength

λ = wavelength at which the gap loss is calculated.

The null wavelength is determined by finding the recorded wavelength at which the reproducing head output reaches a distinct minimum of at least 20 db below maximum output. It is desirable to make this measurement at $1/2$ or $1/4$ normal speed and with a tuned voltmeter with no greater than a one-third octave band width. In order to reach the 20 db null the head gap edges must be sharp, straight and parallel.

¹ An NAB Standard Reproducing System need not fulfill the requirements for a Primary Calibrated Reproducing System as described in this Annex.

In order to determine that a gap meets these requirements visual examination of the gap at about 1000x magnification is necessary. This may be accomplished with a toolmaker's microscope or with suitable photomicrographs taken at several locations along the gap. It has been shown that the null wavelength will be 1.14 times the optical gap length for a perfectly constructed head.² In practice it is usually greater. However, it is recommended that the null wavelength not be greater than 1.25 times the optical gap length for this application.

A curve of the low frequency reproducing response shall be made using a constant current vs frequency recording made with normal bias and the result compared to the curve of reproduce system response with constant flux vs frequency induced into the head core (Curve 3 above), in order to determine contour effects. This reproducing response curve ideally should follow the Standard Reproducing Characteristic at frequencies below approximately 750 cps at 7½ inches per second. In practice it is known that all of the flux from a tape at long wavelengths does not enter the head core. The amount that does enter varies with wavelength depending upon the length of tape to head contact, the shields in and around the head and the shape of the pole pieces.

It is important to accurately measure frequency when making the recording so that slight frequency errors are not interpreted as response errors. It is recommended that the slope of the contour effects curve not exceed 10 db per octave so that a frequency error of ½% will result in a response error of not more than 0.07 db.

Calibrated System Response

Having determined the various losses or deviations from the Ideal System Response, a calibration of the actual system is obtained as follows: From the system response curve, Curve 3 under Electrical Measurements, subtract the gap loss curve at high frequencies and algebraically add the low frequency portion by the contour effect curve. The resulting curve is the reproducing system response for constant available flux from a tape. The difference between this curve and the Standard Reproducing System Characteristic represents the deviation from the ideal response.

² W. K. Westmijze, "Studies on Magnetic Recording" Philips Research Reports, Vol. 8, No. 3, pp-161-183, 1953.

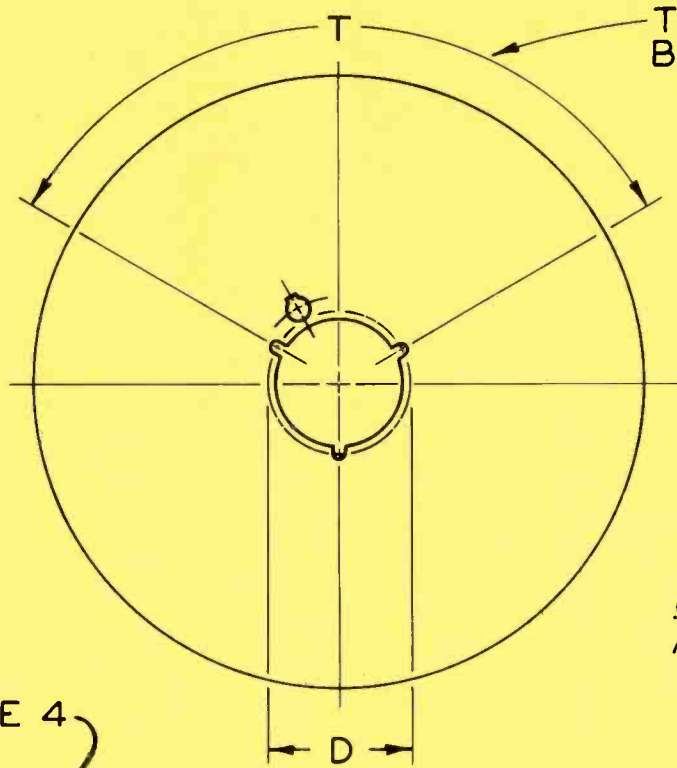

T DIM. TOLERANCE TO BE NON ACCUMULATIVE

ENLARGED SLOT
DETAIL
(3 PLACES)

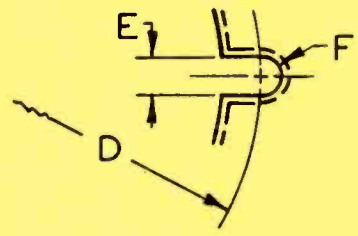

FLANGE TO PROVIDE
.015 (NOM) CLEARANCE
AT ASSY WITH HUB

SEE NOTE 4

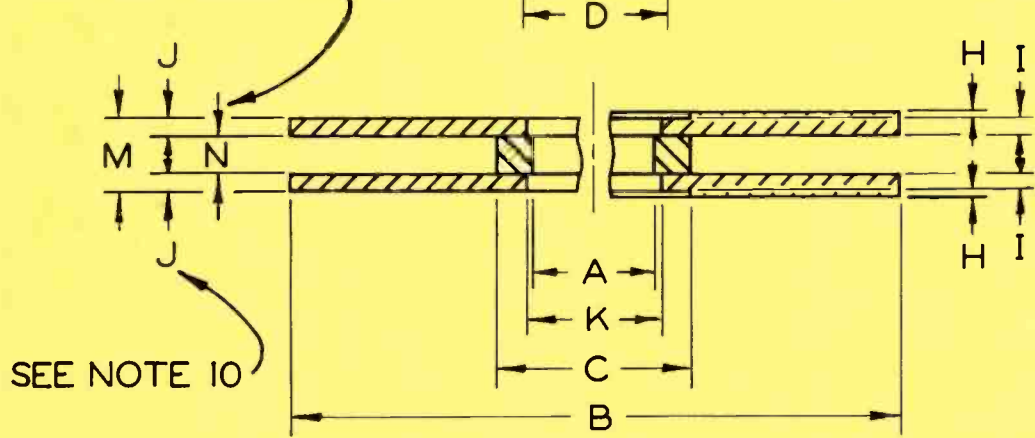

ASSEMBLED
REEL

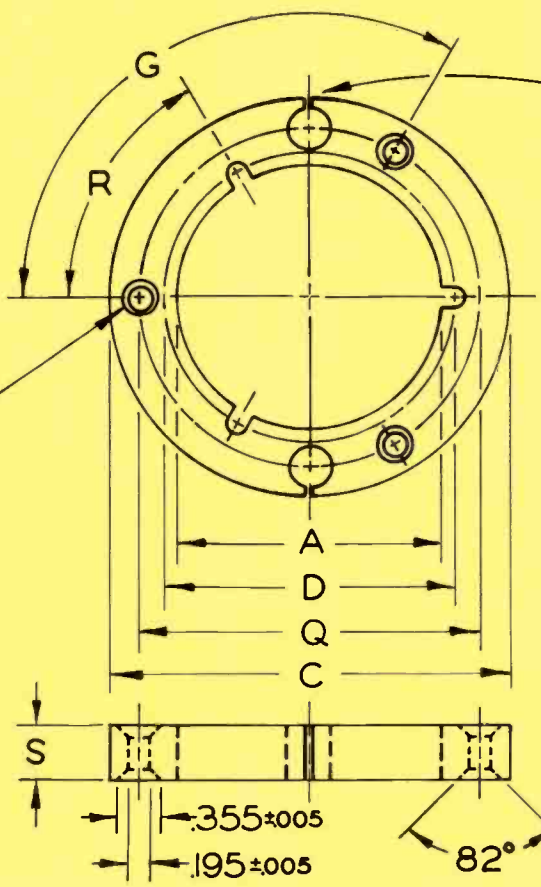

THREADING SLOT (.065
MAX. SLOT OPENING AT
HUB O.D.)

HUB

3 HOLES
IDENTICAL

NAB TYPE A
REELS
FIGURE I

TABLE 1
DIMENSIONS FOR NAB TYPE A REELS
METAL OR FILLED PLASTIC THREE-INCH CENTER HOLE

	<i>Metal</i>	<i>Plastic</i>
A	3.002 + 0.006 — 0.000	3.010 + 0.015 — 0.000
B	10.500 or 14.000 + 0.020 — 0.010	10.500 ± 0.020
C	4.500 ± 0.010	4.500 ± 0.015
D	3.250 + 0.008 — 0.002	3.250 + 0.020 — 0.000
E	0.219 + 0.010 — 0.000	0.219 + 0.013 — 0.000
F	0.109 + 0.005 — 0.000	0.109 + 0.007 — 0.000
G	120 degrees ± 0.25 degrees	Not applicable
H	0.025 maximum	0.060 maximum
I	0.080 maximum	0.115 maximum
J	0.055 maximum	Not applicable
K	3.031 + 0.006 — 0.000	Not applicable
M	0.462 ± 0.020	0.485 + 0.040 — 0.000
N	0.350 ± 0.005 See Note 4	0.285 ± 0.015
Q	3.875 ± 0.002	Not applicable
R	60 degrees ± 0.25 degrees	Not applicable
S	0.350 ± 0.005	Not applicable
T	120 degrees ± 1/4 degrees	120 degrees ± 1/4 degrees

NOTES FOR FIGURE 1

1. Reels shall have dimensions in inches as shown in Figure 1 and Table 1.
2. Flanges may have cut outs of random shape. The flange open area shall not exceed 50 per cent of the total flange area.
3. Threading slots are shown on the figure but are optional.
4. Dimension N is the distance between flanges at the hub and shall not vary more than ± 0.050 inches when measured from the hub to the periphery of the flanges. Flange wobble shall not extend beyond the hatched areas of Figure 1.
5. The outside cylindrical hub surface (Dimension C) shall be concentric to the center diameter (Dimensions A) within 0.010 inches total indicator reading (TIR), and the flange rim (Dimension B) shall be concentric to the center hole within 0.050 inches TIR.
6. The reel lateral mounting surfaces in the area of Dimension C of both sides of the reel shall be parallel to each other within 0.010 inches at the C diameter when machinist's flats are put in firm contact with each side. The distance between the two machinist's flats is Dimension M.
7. The outside cylindrical hub surface (Dimension C) shall have a taper no greater than 0.002 inches for metal reels and 0.003 inches for plastic reels.
8. Reels shall be symmetrical in that they shall mount and be functional when mounted on either lateral mounting surface.
9. The flanges shall be fastened to the hub with three or more fasteners which shall not protrude above the lateral mounting surface.
10. Dimension J represents flange thickness only for the NAB type A metal reel.

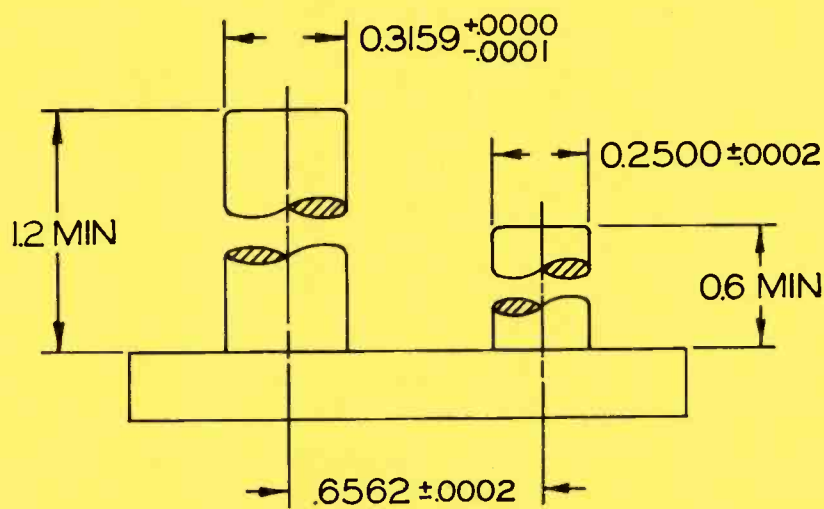
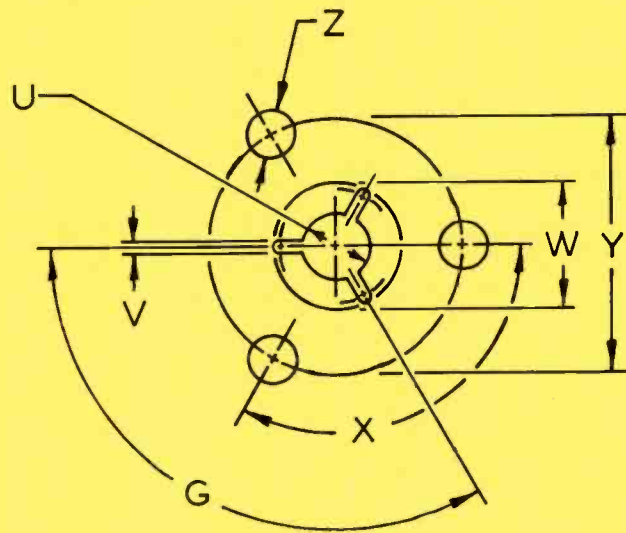
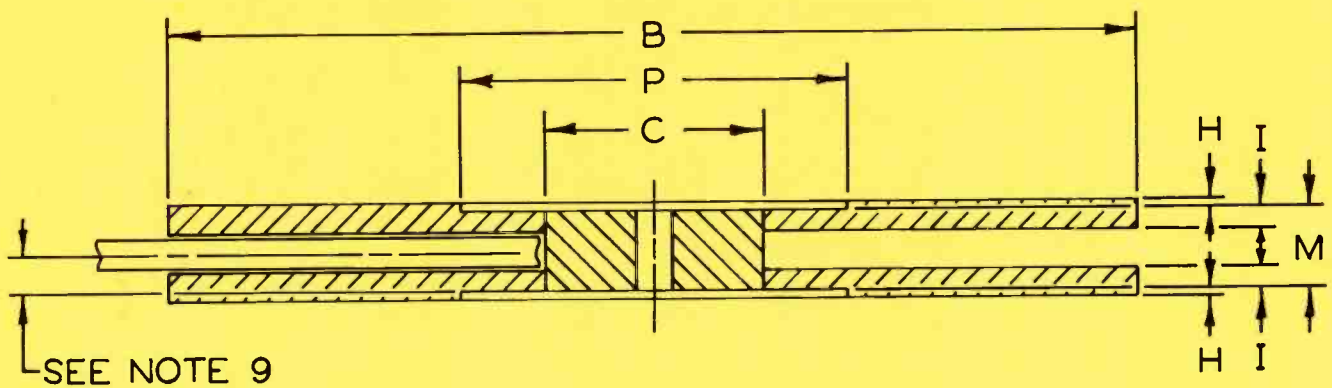

NAB TYPE B REEL AND DRIVE HOLE GAUGE
FIGURE 2

TABLE 2
DIMENSIONS FOR NAB TYPE B REELS
PLASTIC WITH NOMINAL 5/16" CENTER HOLE

Nominal Size 3	5	5	7	7	Tolerance	10 1/2	Tolerance
B 2.938	5.000	5.000	7.000	7.000	+ 0.031 — 0.000	10.500	± 0.020
C 1.750	1.750	3.000	2.250	4.000	± 0.010	4.500	± 0.015
G 120°	120°	120°	120°	120°	± 0.5°	120°	± 0.5°
H 0.050	0.050	0.050	0.050	0.050	Maximum	0.060	Maximum
I 0.115	0.115	0.115	0.115	0.115	Maximum	0.115	Maximum
M* 0.485	0.485	0.485	0.485	0.485	+ .040 — 0.000	0.485	+ 0.040 — 0.000
P 1.750	1.750	2.250	2.250	2.250	Minimum	4.500	Minimum
U 0.319	0.319	0.319	0.319	0.319	± 0.003	0.319	± 0.003
V 0.063	0.063	0.063	0.063	0.063	± 0.005	0.063	± 0.005
W 0.625	0.625	0.625	0.625	0.625	± 0.005	0.625	± 0.005
X**							
Y**							
Z**							

* See note 9.
 ** See note 3.

NOTES FOR FIGURE 2

1. Reels shall have dimensions in inches as shown in Figure 2 and Table 2.
2. Flanges may have cut outs of random shape and size, however, flange open area must not exceed 50% of the area between dimensions B and C.
3. Reels may have one, two or three drive holes and must fit on the gauge shown on Figure 2. If more than one drive hole is used, they shall be symmetrically spaced around the center hole.
4. Reels are to be constructed so that any profile section taken through the center axis of the reel will fall within the hatched envelope of Figure 2. This includes warpage and lateral run out of the flanges. Bosses, ribs or other raised designs are permitted on the outside of the flange surfaces but they shall not extend beyond the envelope of Figure 2 when the reel is rotated on its center axis.
5. The reel hub should be provided with a suitable method of tape attachment. Threading slots are optional, but, if used, shall not be wider than 0.065 inches at the hub surface.
6. The outside cylindrical hub surface (Dimension C) shall be concentric to the center diameter (Dimension U) within 0.010 inches total indicator reading (TIR), and the flange rim (Dimension B) shall be concentric to the center diameter within 0.020 inches TIR.
7. The outside cylindrical hub surface (Dimension C) shall have a taper in relation to either lateral mounting surface no greater than 0.003 inches.
8. Reels shall be symmetrical in that they shall mount and be functional when mounted on either lateral mounting surface.
9. The intent of this Standard is to accept all plastic reels with an M dimension between 0.485 inches and 0.525 inches. With guides set for a nominal tape path center line of 0.243 inches above the reel mounting surface there will be no flange interference with the tape with the I dimension held at 0.115 inches or less and the M dimension at a minimum. A larger M dimension will merely raise the upper flange further away from the upper edge of the tape.

FIGURE 3

NAB STANDARD REPRODUCING
SYSTEMS RESPONSE LIMITS

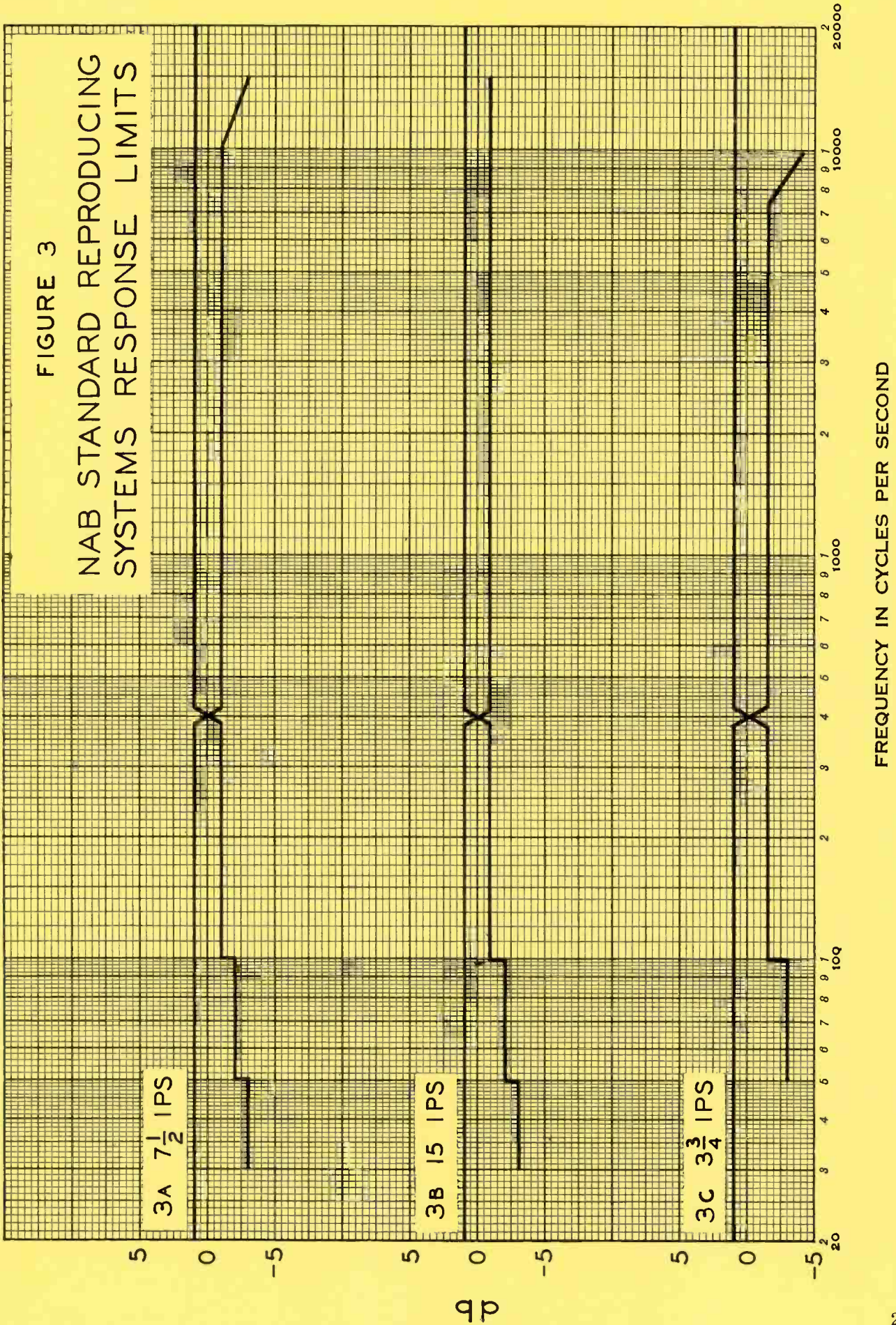

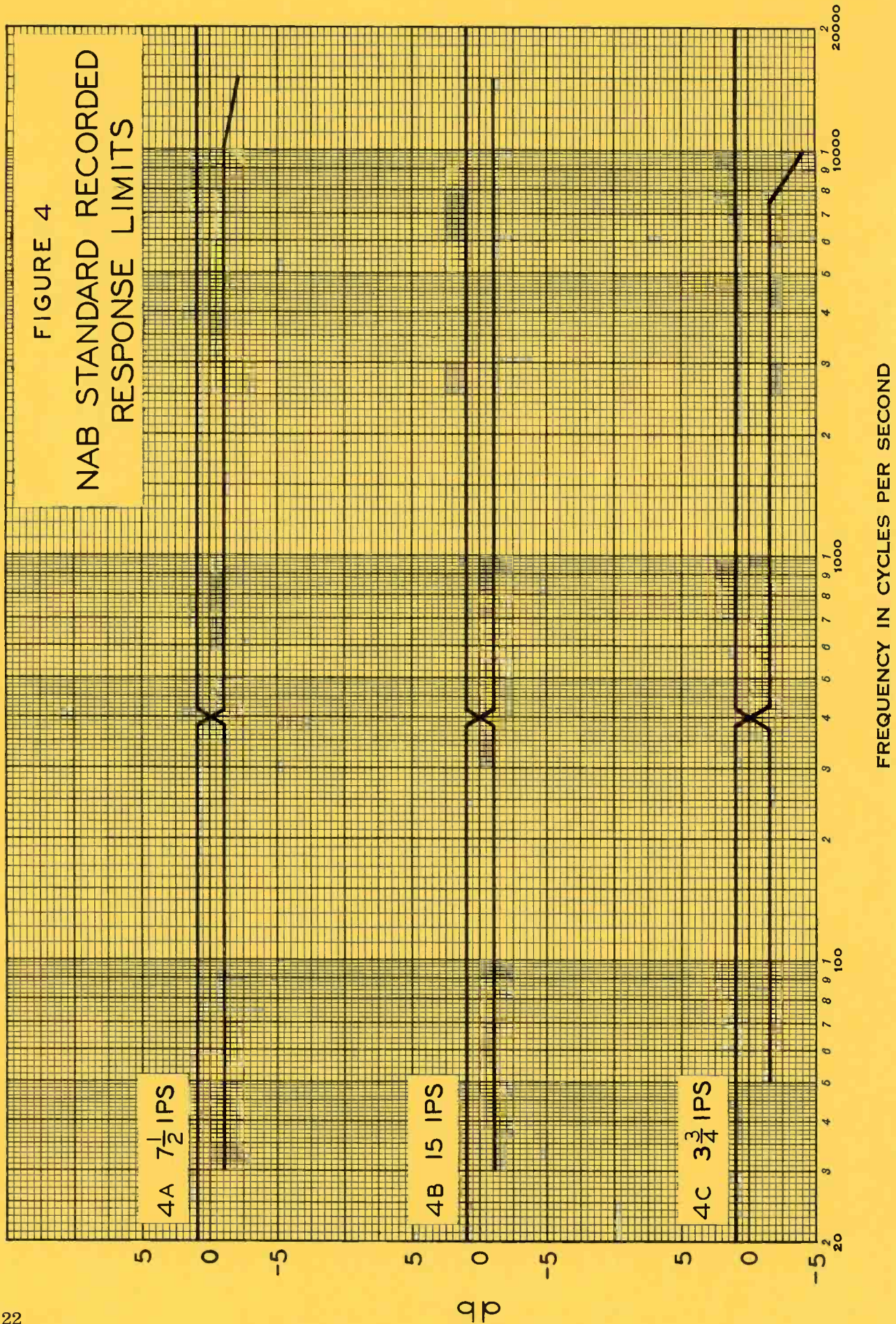

FREQUENCY IN CYCLES PER SECOND

FIGURE 5

NAB STANDARD
REPRODUCING CHARACTERISTIC
REPRODUCING AMPLIFIER OUTPUT FOR
CONSTANT FLUX IN THE CORE OF
AN IDEAL REPRODUCING HEAD

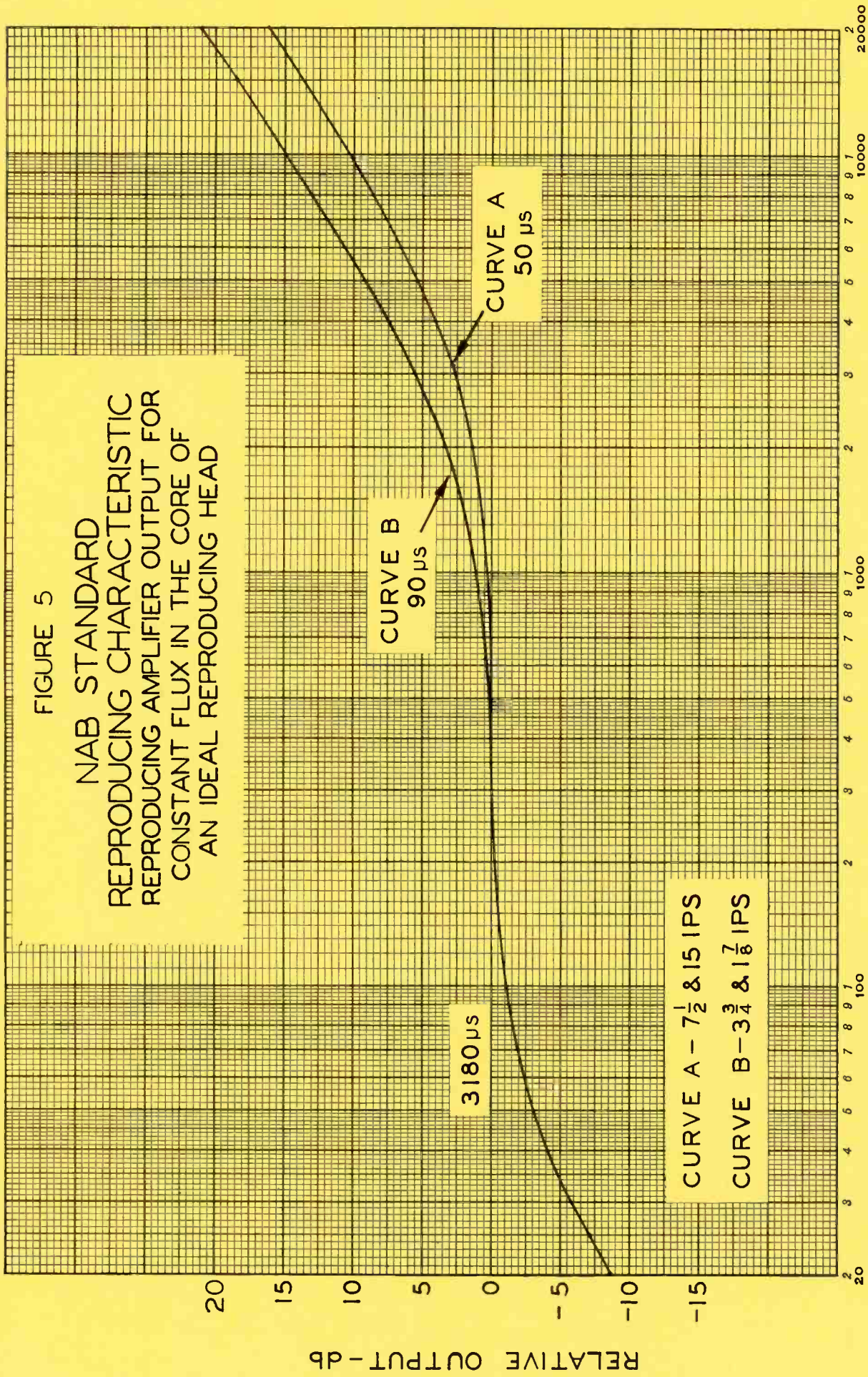

FREQUENCY IN CYCLES PER SECOND

TABLE 3

NAB STANDARD REPRODUCING CHARACTERISTIC

7½ and 15 ips (3180 and 50 μs)

Reproducing Amplifier Output for Constant Flux
in the Core of an Ideal Reproducing Head

<i>Frequency</i>	<i>Response</i>	<i>Frequency</i>	<i>Response</i>
20 cps	- 8.6 db	1.5 kc	+ 0.9 db
25	7.0	2	1.45
30	5.8	2.5	2.1
40	4.1	3	2.75
50	3.0	4	4.1
60	2.3	5	5.4
70	1.8	6	6.6
75	1.6	7	7.7
80	1.4	7.5	8.2
90	1.2	8	8.6
100	1.0	9	9.5
150	0.45	10	10.35
200	0.2	11	11.1
250	0.1	12	11.8
300	- 0.1	13	12.5
400	± 0	14	13.1
500	+ 0.1	15	13.6
600	0.1	16	14.2
700	0.2	17	14.7
750	0.2	18	15.2
800	0.2	19	15.6
900	0.3	20	+ 16.1
1 kc	+ 0.4 db		

TABLE 4

NAB STANDARD REPRODUCING CHARACTERISTIC

$1\frac{7}{8}$ and $3\frac{3}{4}$ ips (3180 and 90 μ s)

Reproducing Amplifier Output for Constant Flux
in the Core of an Ideal Reproducing Head

<i>Frequency</i>	<i>Response</i>	<i>Frequency</i>	<i>Response</i>
20 cps	- 8.8 db	1.5 kc	+ 2.2 db
25	7.2	2	3.4
30	5.9	2.5	4.6
40	4.2	3	5.7
50	3.2	4	7.7
60	2.4	5	9.4
70	1.9	6	10.8
75	1.7	7	12.1
80	1.6	7.5	12.6
90	1.3	8	13.2
100	1.1	9	14.15
150	0.6	10	15.0
200	0.4	11	15.8
250	0.2	12	16.6
300	0.15	13	17.2
400	\pm 0	14	17.9
500	+ 0.1	15	18.5
600	0.3	16	19.0
700	0.5	17	19.6
750	0.55	18	20.0
800	0.6	19	20.5
900	0.8	20	+ 21.0
1 kc	+ 1.0 db		

FIGURE 6
WEIGHTING CURVE FOR WEIGHTED
NOISE MEASUREMENTS

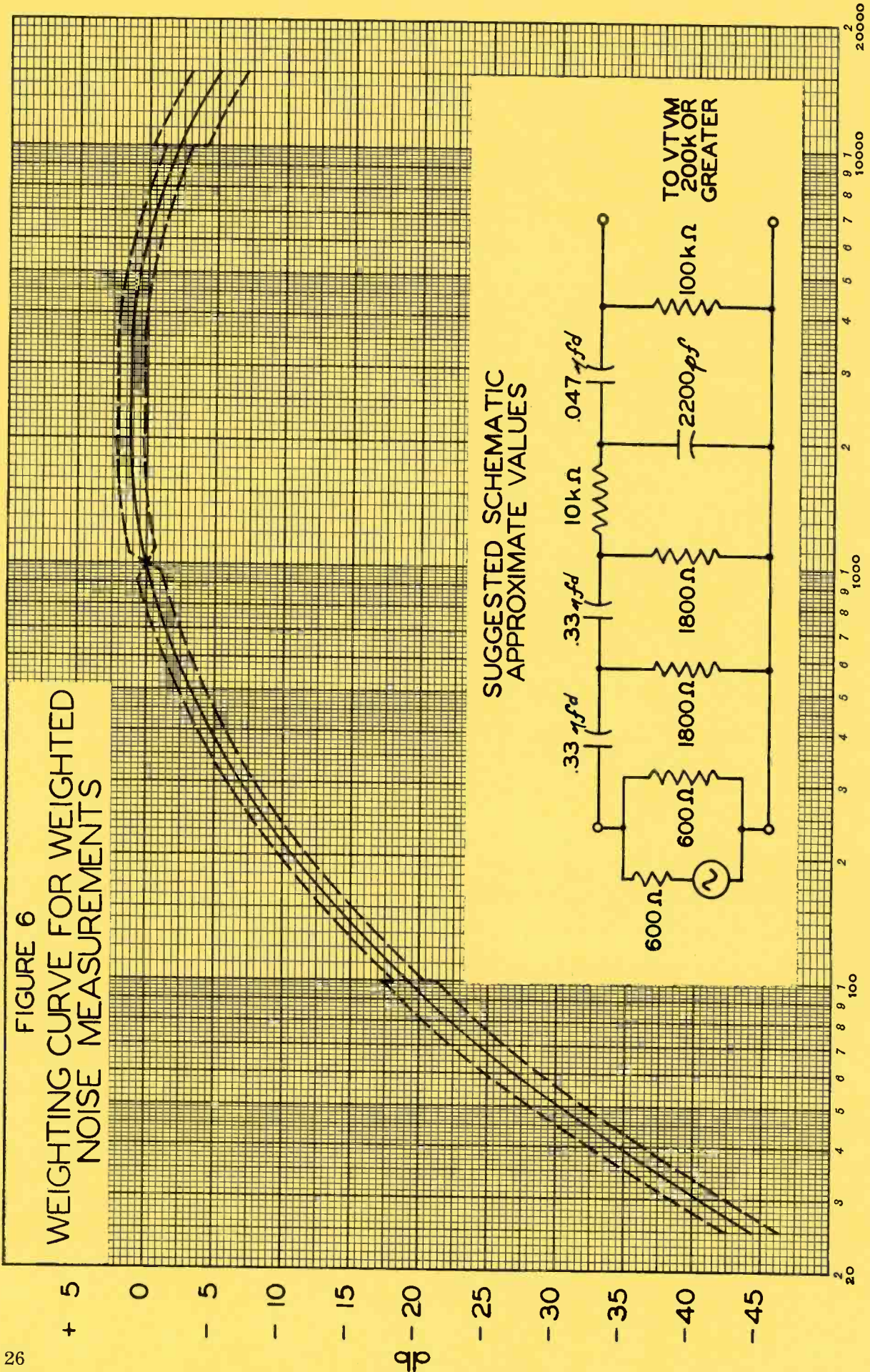

SUGGESTED SCHEMATIC
APPROXIMATE VALUES

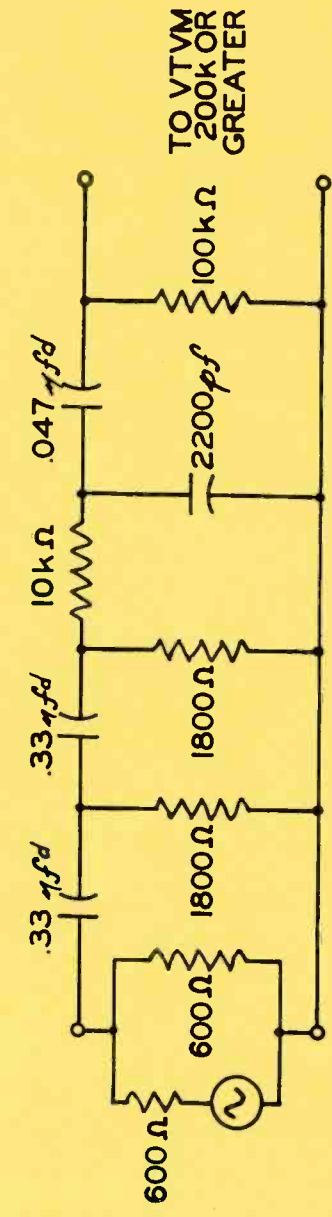

TO VTVM
200K OR
GREATER

FREQUENCY IN CYCLES PER SECOND

FIGURE 7

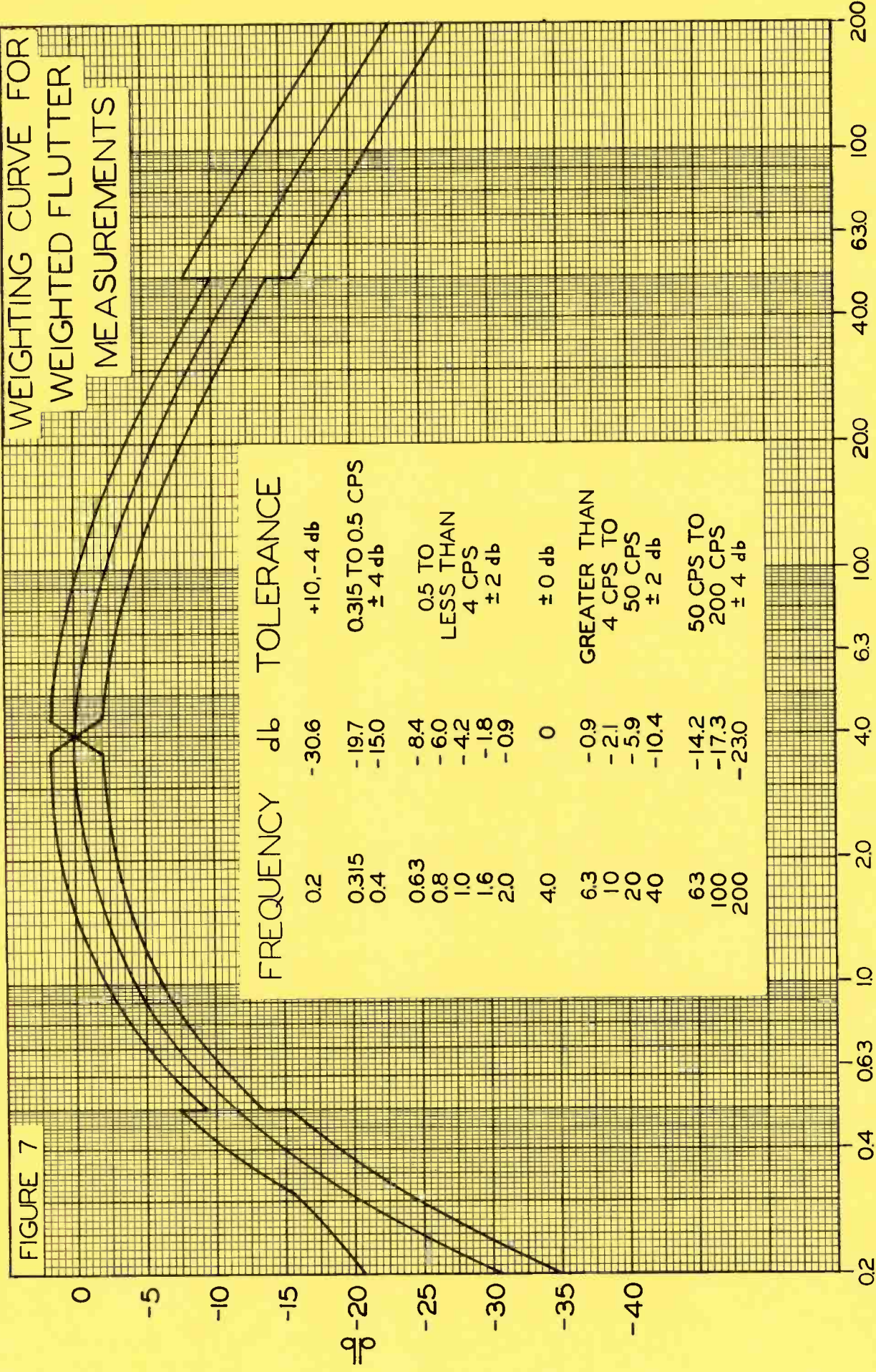

FREQUENCY IN CYCLES PER SECOND

FIGURE 8

N A B REPRODUCING SYSTEM
& RECORDED RESPONSE LIMITS
SPECIAL PURPOSE LIMITED PERFORMANCE
SYSTEMS. APPLICABLE TO $7\frac{1}{2}$, $3\frac{3}{4}$, $1\frac{7}{8}$ IPS

REPRODUCING RESPONSE LIMITS

RECORDED RESPONSE LIMITS

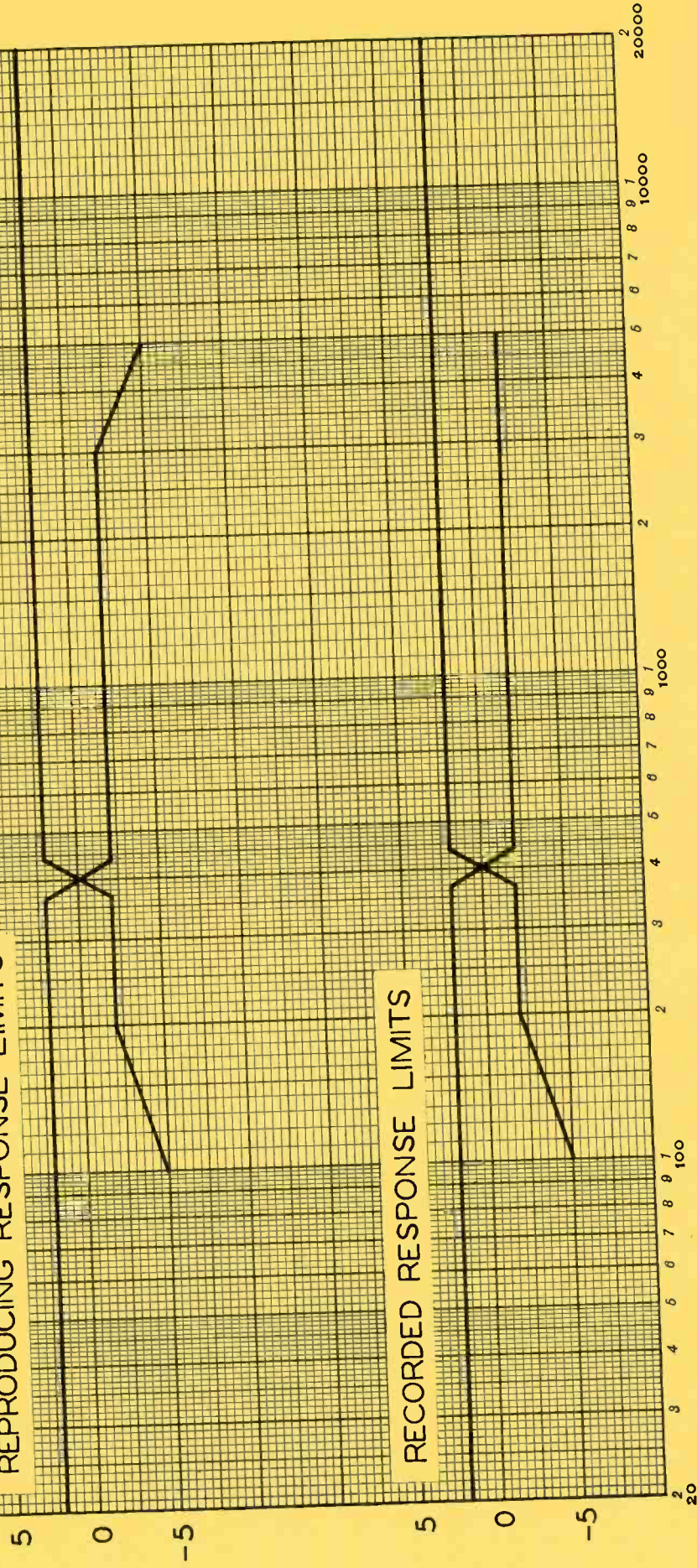

FREQUENCY IN CYCLES PER SECOND

GLOSSARY OF MAGNETIC TAPE

RECORDING AND REPRODUCING TERMS AND DEFINITIONS

AZIMUTH LOSS. The signal loss due to misalignment of the playback head gap and the recorded signal.

BIAS. See Magnetic Biasing.

CAPSTAN. The spindle or shaft which drives the pressure roller and tape.

CONTOUR EFFECT. The alteration of the voltage output from a magnetic reproducing head at long wavelengths due to the shape of the pole pieces and the presence of magnetic shielding close to the tape.

DISTORTION, HARMONIC. Distortion characterized by the appearance in the output of harmonics of the fundamental frequency when the input wave is sinusoidal.

DISTORTION, PER CENT HARMONIC. A measure of the Harmonic Distortion in a system or component, numerically equal to 100 times the ratio of a root-mean-square voltages (or currents) of each of the individual harmonic frequencies, to the root-mean-square voltage (or current) of the fundamental.

EQUALIZATION. Equalization is the process of modifying the amplitude-frequency response characteristics in a recording and reproducing system, for one or both of the following purposes:

- 1) To produce a flat overall frequency response.
- 2) To match the signal handling capabilities of the recording system to the frequency distribution of the signal to be recorded and/or to minimize the audible noise of the reproducer, in order to produce the maximum audible signal-to-noise ratio.

EQUALIZER. A device designed to modify the amplitude-frequency response of a system or component.

FLUTTER. In recording and reproducing, flutter is the deviation of frequency which results in general from non-uniform motion during recording, or reproduction.

NOTE: The term "wow" usually refers to flutter occurring at a relatively low rate, as for example, a once-per-revolution speed variation of a phonograph turntable.

FREQUENCY RESPONSE. The relative output vs frequency of a recording or reproducing system. A more specific term than "frequency range," and usually presented in the form of a curve plotted with frequency as the ordinate and the output in db as the abscissa.

GAP LENGTH, PHYSICAL. The physical distance between adjacent surfaces of the pole tips of a magnetic head measured in the direction of tape travel.

GAP LENGTH, EFFECTIVE. The recorded wavelength at which the output of a magnetic head goes through the first null point.

NOTE: The effective gap length is greater than the physical length for both theoretical and practical reasons.

HEAD ALIGNMENT. Positioning of the record and reproduce heads on a tape recorder so that their gaps are mutually parallel and perpendicular to the path of travel of the tape.

LEVEL, RECORDED. The recorded level on a magnetic tape is the level measured by a standard reproducing system with respect to the NAB Standard Reference Level, expressed in decibels.

MAGNETIC BIASING. Magnetic biasing is the simultaneous conditioning of the magnetic recording medium during recording by superposing an additional magnetic field upon the signal magnetic field.

NOTE: In general, magnetic biasing is used to obtain a substantially linear relationship between the amplitude of the signal and the remanent flux density in the recording medium.

- MAGNETIC BIASING, AC.** The ac magnetic biasing is magnetic biasing accomplished by the use of an alternating current usually well above the signal frequency range, in the recording head.
- MAGNETIC HEAD.** A transducer for converting electrical signal currents into magnetic signals for storage on magnetic media, for converting stored magnetic signals into electrical signals, or for erasing stored magnetic signals.
- NOTE:** A ferromagnetic head is one in which the permeability of the material is much greater than one, being most often several thousand.
- MAGNETIC HEAD CORE.** The high permeability structure which forms the head gap and supports the head winding.
- MAGNETIC RECORDING HEAD.** A magnetic head for transforming electric signals into magnetic signals for storage on magnetic tape.
- MAGNETIC REPRODUCING HEAD.** A transducer for converting magnetic signals on magnetic tape into electric signals.
- NOISE (AUDIO FREQUENCY).** Any electrical disturbance including both hum and hiss introduced from sources extraneous to the signal.
- NOISE, UNWEIGHTED.** The noise measured within the audio frequency pass band using a measuring instrument which is uniform in response with respect to frequency over some specified pass band.
- NOISE, WEIGHTED.** The noise measured within the audio frequency pass band using a measuring instrument which has a frequency selective characteristic. The sensitivity is usually greatest in the frequency range where the ear is most sensitive.
- POST-EMPHASIS.** That portion of the equalization which is applied in the reproducer.
- PRE-EMPHASIS. (PRE-EQUALIZATION).** That portion of the equalization which is applied in the recorder.
- PRINT-THROUGH.** The undesired transfer of a recorded signal from one layer of magnetic tape to adjacent layers.
- RING HEAD.** A magnetic head in which the magnetic core material forms an enclosure with one or more gaps. The magnetic tape bridges one of these gaps and is contacted by the pole pieces.
- SURFACE INDUCTION.** The flux density at right angles to the surface of the tape in a medium of unity permeability and not in contact with a reproducing device.
- TEST TAPE.** A test tape is a recording of various known frequencies at known amplitudes, usually for the purpose of testing and measuring reproducing equipment.
- WEIGHTING CHARACTERISTIC.** The shaped response-frequency characteristic of a measuring device used to produce more realistic indications of the subjective effects than are obtained with unweighted (flat) measurements.

