

Scanning - Shortwave - Ham Radio  
Equipment - Computers - Antique Radio

25<sup>th</sup>  
Anniversary

# Monitoring Times

A Publication of Grove Enterprises

Volume 26, No. 6  
June 2007

U.S. \$5.95  
Can. \$5.95  
Printed in the  
United States



## Have Radio Will Travel



### *In this issue:*

- Monitoring the Military on the Emerald Coast
- The CAP VHF Radio Network
- VOA's Dixon Relay Station
- MT's HD Radio Report:  
*Boston Acoustic HD Receptor*  
*Radio Shack Accurian HD*



# AR-ALPHA

## Communications Receiver

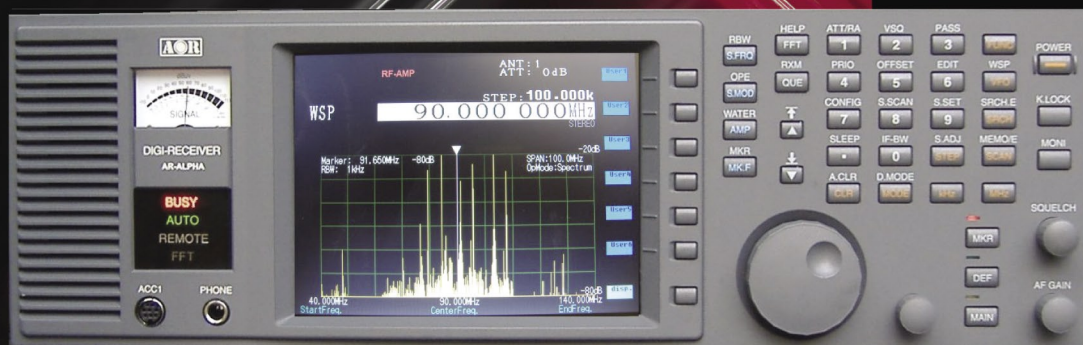

- Multi-mode unit capable of receiving AM (synchronous), ISB, RZ-SSB, USB, LSB, CW, WFM including FM stereo, NFM, APCO-25 digital, and TV in both NTSC and PAL formats
- 6-inch TFT color panel can display received video signals or depict spectrum activity over a wide choice of bandwidths including a "waterfall" function to show signal activity over a specified time period

## Welcome to the Future!

**AOR proudly introduces the AR-ALPHA, the first in a new class of professional monitoring receivers! Designed to cover 10KHz to 3.3GHz, with no interruptions,\* this receiver features a 6-inch color TFT display, five VFOs, 2000 alphanumeric memories that can be computer programmed as 40 banks of 50 channels, 40 search banks, a "select memory" bank of 100 frequencies, and a user designated priority channel. It includes APCO-25 digital and a DVR with six channels that can record up to a total of 52 minutes audio. Monitoring professionals will appreciate the world class engineering and attention to detail that makes the AR-ALPHA such an amazing instrument.**

- Composite video output on the rear panel of the unit
- Selectable IF bandwidths: 200 Hz, 500 Hz, 1 KHz, 3 KHz, 6 KHz, 15 KHz, 30 KHz, 100 KHz, 200 KHz and 300 KHz along with the ability to shift the IF.
- CTCSS and DCS selectable squelch functions
- DTMF tone decode
- Built-in voice-inversion descrambling
- CW pitch control, AGC, AFC
- Auto-notch feature
- User selectable spectrum display function from 250 KHz through 10 MHz in 1 KHz increments. Above 10 MHz bandwidth, it can display 20 MHz, 50 MHz, 100 MHz or 1 GHz, but above 20 MHz bandwidth, no audio will be available
- Resolution bandwidth is also user-selectable in increments of 1 KHz, 4 KHz, 32 KHz, 64 KHz, and 128 KHz.
- Fast Fourier Transform (FFT)
- Rear panel connections include 12 VDC power, RS-232C, USB 2.0, I/Q output with 1 MHz bandwidth, two antenna ports (one SO-239 and one Type N) and up to four antennas may be selected through the receiver's controls with the optional AS5000 antenna relay selector.
- Use desktop or with 19" rack mount

**The AR-ALPHA redefines excellence in professional monitoring receivers. No wonder so many monitoring professionals including government, newsrooms, laboratories, military users and more, rely on AOR.**



**AOR U.S.A., Inc.**  
20655 S. Western Ave., Suite 112, Torrance, CA 90501, USA  
Tel: 310-787-8615 Fax: 310-787-8619  
info@aorusa.com • www.aorusa.com

*Specifications subject to change without notice or obligation.  
\*Documentation required for qualified purchasers in the USA.*

# Is this the ultimate scanner?

After the introduction of the award-winning range of high-performance software-defined HF receivers, here are the world's first high-performance software-defined VHF/UHF scanners available in both PCI (internal card) and USB (external "brick") form-factors. Who else could bring you such winning solutions but WiNRADiO?

External or internal model, the choice is yours!



## WR-G315i receiver: No clutter on your desk

The WiNRADiO WR-G315 is a software-defined VHF/UHF receiver (9 kHz to 1800 MHz, extendable to 3500 MHz using an optional downconverter). Two models exist, WR-G315i (internal) and WR-G315e (external) with identical RF performance.

The WR-G315 offers an unparalleled flexibility given its SDR architecture, respectable dynamic range, extremely low noise floor and high sensitivity. Many useful features complement the receiver, such as several spectrum analyzers, calibrated S-meter, continuously variable IF bandwidth, several types of analog and digital squelch, programmable task management and many others; all ensuring this receiver's capability of filling the role of a high-performance monitoring and surveillance scanner as well as a calibrated measuring receiver, all in one.



## WR-G315e receiver: Portable and powerful

- 9 kHz-1800 MHz frequency range (except cellular bands where required by law)
- Optional 3500 MHz downconverter
- Optional decoders such as DRM and APCO
- Tracking front-end filters
- Dual-loop AGC and AFC
- Software-defined demodulation
- Excellent sensitivity
- Fast scanning speed
- Multiple squelch modes
- Real-time spectrum analyzer
- Hit counter and logger
- Accurate S-meter
- Signal test and analysis functions
- Continuously adjustable IF bandwidth
- Adjustable digital audio filter
- Digital Bridge™ compatible
- Standard PCI card or USB box
- Easy "Plug and Play" installation

Visit our website for more details.

[www.winradio.com](http://www.winradio.com)  
...the future of radio.™



*Lead Story*

## Radio on the Road

By Janice Laws

Under the surface of many a hobbyist's fascination with radio is a repressed desire to visit distant states or countries. Janice Laws and her husband Steve have done just that, combining the best of both worlds by traveling *and* listening, but it takes careful planning. If you plan to travel with your radio this summer, turn to page 8 for good advice.

*On Our Cover*

Photos by Janice Laws: Background - The twin Petronas Towers in Kuala Lumpur, Malaysia (digitally altered). Inset photos: Road post outside Dili, East Timor; Wat Po temple in Bangkok, Thailand; Janice poses with Horus (the bird god) at Giza, Egypt, "in a galabiya (traditional Arab garb) and my fetching safari hat and socks and sandals ..."

## C O N T E N T S

### Military Monitoring on the Emerald Coast..... 12

By John Harr

Along the Gulf shore in the Florida panhandle is a stretch of coastline rich with military communications from all three branches of the armed forces. Treat yourself to the whitest sands and best vacation spot on the coast while indulging in milscan heaven!

### An Interview with Irwin Gonshak..... 15

By Tara Meehan

"Everything old is new again." Irwin Gonshak's long career in writing and producing radio dramas is as exciting as it ever was, and he sees no end to its potential for educating, inspiring, and entertaining.

### FM Radio in the 1950s..... 16

By Bruce Elving

"What's FM?" is the question one mobile FM listener often heard when explaining that funny antenna mounted on his car. Fifty years ago FM stations were a novelty and receiving FM in the car required cobbling together your own equipment.

### VOA's Dixon Relay Station ..... 18

By Merrill Stevenson

Curious about what happened to the Voice of America relay station at Dixon, California, the author tried asking the VOA with no response. Finally, he and his wife jumped in the car and went to explore for themselves. They discovered and photographed the abandoned facility, empty watchtower looking for intruders, antennas still standing at the ready...

## Reviews

Alinco introduces a new wide coverage pocket scanner, the DJ-X30T. Despite the fact it will not follow trunk systems, it's amazing the features and performance they can pack into such a tiny package – even room for a keypad (see page 66).



Monitoring Times begins a series on "HD Radio," which will eventually cover all models currently on the US market. We review two this month: the Boston

Acoustics Receptor and the Radio Shack Accurian HD Radio (see page 68).



In the market for a new computer? John Catalano helps demystify critical specs for better comparisons, and shares his first experience with the new Windows Vista operating system (page 72).





**MONITORING TIMES**  
 (ISSN: 0889-5341;  
 Publishers Mail Agree-  
 ment #1253492) is  
 published monthly  
 by Grove Enterprises,  
 Inc., Brasstown, North  
 Carolina, USA.

Copyright © 2007 Grove Enterprises, Inc.  
 Periodicals postage paid at Brasstown,  
 NC, and additional mailing offices. Short  
 excerpts may be reprinted with appropri-  
 ate credit. Complete articles may not be  
 reproduced without permission.

**Address:** 7540 Highway 64 West,  
 Brasstown, NC 28902-0098  
**Telephone:** (828) 837-9200  
**Fax:** (828) 837-2216 (24 hours)  
**Internet Address:** [www.grove-ent.com](http://www.grove-ent.com) or  
[www.monitoringtimes.com](http://www.monitoringtimes.com)  
**Editorial e-mail:** [editor@monitoringtimes.com](mailto:editor@monitoringtimes.com)  
**Subscriptions:** [order@grove-ent.com](mailto:order@grove-ent.com)

Subscription Rates: \$28.95 in US; \$39.50  
 Canada; and \$58.50 foreign elsewhere,  
 US funds. Label indicates number of is-  
 sues left. Renewal notice is cover sheet 3  
 months before expiration. **See page 76**  
**for subscription information.**

**Postmaster:**  
 Send address changes to *Monitoring Times*,  
 7540 Highway 64 West, Brasstown, NC  
 28902-0098.

**Disclaimer:**  
 While *Monitoring Times* makes an effort  
 to ensure the information it publishes is  
 accurate, it cannot be held liable for the  
 contents. The reader assumes any risk for  
 performing modification or construction  
 projects published in *Monitoring Times*.  
 Opinion or conclusions expressed are  
 not necessarily the view of *Monitoring*  
*Times* or Grove Enterprises. Unsolicited  
 manuscripts are accepted. SASE if material  
 is to be returned.

**Owners**

Bob and Judy Grove  
[judy@grove-ent.com](mailto:judy@grove-ent.com)

**Publisher**

Bob Grove, W8JHD  
[bobgrove@monitoringtimes.com](mailto:bobgrove@monitoringtimes.com)

**Managing Editor**

Rachel Baughn, KE4OPD  
[editor@monitoringtimes.com](mailto:editor@monitoringtimes.com)

**Assistant Editor**

Larry Van Horn, N5FPW

**Art Director**

Bill Grove

**Advertising Svcs.**

Beth Leinbach  
 (828) 389-4007  
[bethleinbach@monitoringtimes.com](mailto:bethleinbach@monitoringtimes.com)

**TABLE OF CONTENTS**

**Departments:**

Letters ..... 4  
 Communications ..... 6  
 Stock Exchange ..... 75  
 Advertisers Index ..... 75

**First Departments**

**Getting Started**  
 Beginners Corner ..... 20  
*Do-It-Yourself Satellite Radio*  
 Ask Bob ..... 22  
 The MT Help Desk ..... 23

Scanning Report ..... 24  
*Matching the Scanner to the System*  
 Utility World ..... 28  
*All About HF DL*  
 Digital Digest ..... 31  
*Venezuelan Navy Network*

Global Forum ..... 32  
*Where is Radio República?*  
 Broadcast Logs ..... 35  
 Programming Spotlight ..... 36  
*Country Music Worldwide*  
 The QSL Report ..... 38  
*Word to the Wise DXer on IRCs*

English Language SW Guide ..... 39

**Second Departments**

Milcom ..... 52  
*The CAP VHF Radio Network*  
 AM Bandscan ..... 54  
*March 23rd: The Day the DX Died?*  
 Boats, Planes, TRAINS ..... 56  
*Monitoring the Powder River Basin*  
 Below 500 kHz ..... 58  
*Warm Weather Tips*  
 Outer Limits ..... 59  
*Radio Azteca Dominates Fest*  
 On the Ham Bands ..... 60  
*Having Fun on Field Day*

**Technical Departments**

Antenna Topics ..... 62  
*Using an "Antenna Tuner"*  
 Radio Restorations ..... 64  
*More on Trans-Oceanic and BC-348*  
 First Look ..... 66  
*Alinco DJ-X30T Scanner*  
*Boston Acoustics Receptor &*  
*RS Accurian HD Radios*  
 On the Bench ..... 70  
*Frugal Guide to DRM Reception*  
 Computers & Radio ..... 72  
*The 2007 Computer Landscape*  
 What's New ..... 74

**EDITORIAL STAFF** Email [firstname.lastname@monitoringtimes.com](mailto:firstname.lastname@monitoringtimes.com)

TJ "Skip" Arey.....	On the Ham Bands	Clem Small .....	Antenna Topics
Rachel Baughn .....	Communications	Doug Smith.....	American Bandscan
.....	Letters to the Editor	Hugh Stegman .....	Utility World
.....	What's New?	Ernest Robl.....	Trains
Kevin Carey .....	Below 500 kHz	Gayle Van Horn .....	Frequency Manager
John Catalano .....	Computers & Radio	.....	Broadcast Logs
Mike Chace.....	Digital Digest	.....	QSL Corner
Jim Clarke .....	First Look	Larry Van Horn.....	Milcom
Marc Ellis .....	Radio Restorations	.....	First Look
Bob Grove .....	Ask Bob	.....	MT Help Desk
Glenn Hauser .....	Global Forum	Dan Veeneman .....	Scanning Report
Chris Parris .....	Fed Files	Ron Walsh.....	Boats
Ken Reitz.....	Beginners Corner	Fred Waterer.....	Programming
Lee Reynolds .....	First Look	.....	Spotlight
Iden Rogers.....	Planes	George Zeller.....	Outer Limits

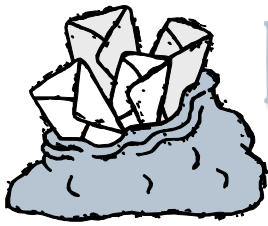

# LETTERS TO THE EDITOR

This column is open to your considered comments. Opinions expressed here are not necessarily those of *Monitoring Times*. Your letters may be rephrased or shortened for length and clarity. Please mail to Letters to the Editor, 7540 Hwy 64 West, Brasstown, NC 28902, or email [editor@monitoringtimes.com](mailto:editor@monitoringtimes.com)  
Happy monitoring!  
- Rachel Baughn, KE4OPD, Editor

## Antique Telephones

"[Ken Reitz's] very interesting and informative *On The Bench* article in the December 2006 issue of *Monitoring Times* struck my attention. For decades I have been fascinated with antique telephones. In Houston we have a fascinating museum with every imaginable and unimaginable device, the oldest item of which I believe is the city's first telephone directory dated 1894.

"I would also recommend the New England Telephone Company Museum in that company's building on Post Office Square in Boston.

"When in the late 1950s I was serving in the U.S. Seventh Army in West Germany, there were still many of the so-called 'French phones' - those with the mouthpiece extended upward to meet the mouth. I wrote to the Ericsson Telephone Company in Sweden, asking them to consider selling one to me. Within three weeks, a wooden box arrived with a beautiful 1896 magneto phone, pristine in its finish ... saying it was a gift to me... In the Army I was a Battalion clerk. Instead of the 'Army drab' canvas-wrapped magneto field phone on my desk, I actually used the Ericsson.

"Recently I compiled a list of Houston's named telephone exchanges which existed until their demise in the late fifties and early sixties of the last century ... I offered it to the Houston Public Library which, to my utter surprise, accepted it readily for 'The Houston Collection,' found in the former Julia Ideson Library on Library Plaza here.

"Thank you for your very meaningful article *Antique Telephones: Durable. Cheap and Still Useful.*"

John B. Victory

## Antique Scanners

"There is a nice yahoo group called <http://groups.yahoo.com/group/vintagescanners/>. It's pertaining to mainly older crystal and vintage era marvels of the scanning world; we offer advice on repairs, where to buy what, and just sharing photos of what we may have.

"A recent discussion got me to thinking, there was a company that put out a nice bunch of high tech looking stuff, very high dollar as I recall, but it was Air Command, or some thing like that; maybe 'Airscope?' Does anyone remember it?"

"And, what became of Fox, the old radar detector outfit? They made one of the best scanners of the time. I think they made a CB or two, plus a couple of antennas, also, but I think there were only two scanner models. In 1980 I bought both, and, boy, were they great: digital display, direct key entry, total ease of program, 16 channels, with red LEDs on the front. They were small, very light, easy to mount, had oodles of accessories. I lost both of them in 92 and I've never seen or heard of another one.

"Fox was so far ahead of every body else then, even Electra, though they had some nice stuff. But I hated Electra's programming, and their offset crystals were hard to locate. Well, anyhow maybe some day you folks could do something on Fox. I wonder

how many are still around? Every now and then I run across some old vintage scanner but never one of those."

Emmitt Jackson KE5KCZ

In the *MT* photo archives I found pictures of Fox Marketing's BMP 10/60 Scanner and the FOX PAC 100 FXR Scanner. Tell Emmitt at



[emmittjackson@hotmail.com](mailto:emmittjackson@hotmail.com) if you see one of these around!

## Tantalizing New Technology

"I have been a SW listener since the '60s and have enjoyed the world radio scene from then until now. I recently came into a WI-FI Radio and am now addicted to world-wide radio service via the internet. My radio has over 5000 stations and can be indexed by both genre and location. The sound is great ... I would enjoy reading about others' finds out there in internet radio. Don't get me wrong, I still enjoy listening to short wave radio and will continue to do so."

Glenn Blanco, Aurora CO

"I read your recent [April *Global Forum*] with great interest. I have been a SW listener and DX for nearly 33 years and I welcome DRM with open arms! I agree that the broadcasters could have chosen their frequencies in a more analogue friendly way as the actual frequency becomes irrelevant once the Alternative Frequency Signalling (AFS) info is included in the broadcast data.

"Have all these opponents of DRM noticed that the bands get emptier each year and that QSL requests don't actually compensate for the missing feedback from listeners? Countries fund these services to get their messages to the general public and are continually searching for the most effective way to do this.

In my view DRM is the last hope for a revival in the use of SW frequencies. There are benefits for the broadcaster (lower costs) and the listener (better audio, automatic tuning, data). The broadcasters are committed to digitizing all their output and will opt for one or other of the current systems. It is going to happen and I would rather have DRM services than noise!

"I rarely listen to analogue any more, it is just too awful! I usually hop between the BBC and Deutsche Welle during the day on DRM and then use a Reciva-based wifi radio in the evenings via broadband to listen to RFI, Radio Australia, etc."

Kevin Ryan, United Kingdom

[In response to Sep 2006 *The Magic of Radio* by Jim Clarke] "I, too, lost the interest like you. I rediscovered it a slightly different way: I have one of those faceless radios with digital this and that, but

being technically better than the older radios, I use the interface option and Ham Radio Deluxe for the analogue display and band monitoring functionality with Spectrum Lab to see the audio spectrum as well.

"I now have a small range of computer controlled radios looking and being what I want them to be. I have even got hold of a USB tuning knob so I can use it to tune the IC-PCR1000 and Kenwood TS940SAT. I don't even have to touch the radio and I can use VoIP to hear the audio remotely over my network at home or work and to remotely control the radios via the LAN or Internet.

"So as long as I am in a place with internet connectivity, I can play radio in my remote shack..."

Mike Coleman G1YVR / M0GBY

## True or False?

"I found Kevin Ryan's comments regarding DRM (above) being the last hope for shortwave broadcasting fascinating. In fact, it has been a common theme among radio hobbyist for the last two to three years now that the shortwave broadcast service is dying.

"But evidently someone forgot to tell the shortwave broadcasters that their HF service is on life support. Yes, some of them have left the shortwave bands, and a few familiar voices are missing. I have been watching from the sidelines as that industry has fought the amateur radio community and other radio services tooth and nail for additional spectrum space. I have monitored US broadcasters transmitting outside the normal SWBC bands, claiming there is no room for them in the regular broadcast allocations.

"For instance, take the case of the 40 meter (7 MHz) ham band. Hams have been trying to harmonize this band worldwide since it was taken from them just prior to World War II. And as late as the last international conference in 2003, broadcasters were trying to foil that attempt. Hams won a partial victory during that 2003 conference, and broadcasters will have to move out of 7100 to 7200 kHz in Regions 1 and 3 by March 29, 2009. This marks the first time in the history of internationally coordinated radio spectrum allocations that an HF broadcasting band was shifted to accommodate the needs of another service.

"Broadcasters are fond of speaking of their unfulfilled requirements for spectrum between 4 and 10 MHz. But dying services do not spent enormous amounts of time and money at international conferences fighting for more spectrum space if they do not need it.

"Insiders will tell you that HF broadcasters are hoping to compete with satellites and the Internet by leapfrogging from the noise and distortion of double-sideband AM to a brave new digital world, and continue to argue that they will need more spectrum to accomplish the transition.

"So is shortwave broadcasting dying? The evidence would indicate it isn't."

Larry Van Horn, MT Assistant Editor

# AOR SR2000 Frequency Monitor

## Seeing is Believing!

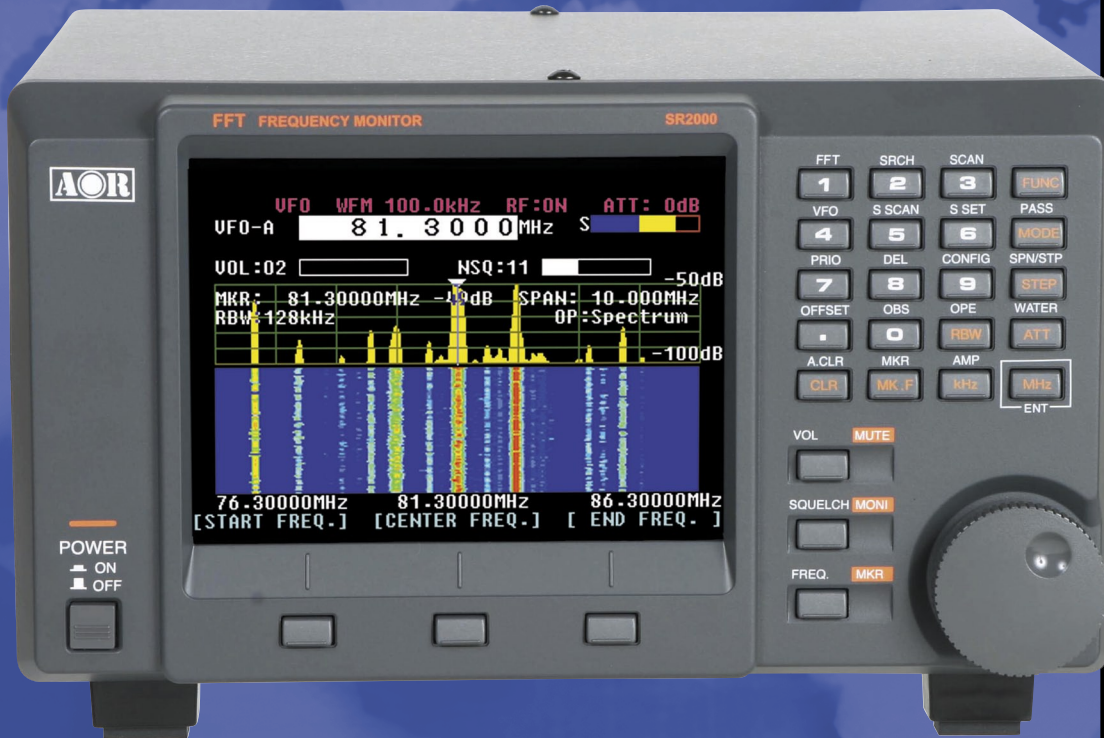

**The SR2000 is an ultra-fast spectrum display monitor with a high quality triple-conversion receiver**

*AOR puts the power of FFT (Fast Fourier Transform) algorithms to work in tandem with a powerful receiver covering 25 MHz ~ 3 GHz continuous.*

*The result is a compact color spectrum display monitor that's ultra-sensitive, incredibly fast, yet easy to use. The SR2000 is perfect for base, mobile or field use and can also be used in combination with a personal computer. It's another example of why so many Federal and State law enforcement, military units, surveillance agencies, government users, hospitals, RF labs, News Media and monitoring professionals rely on AOR, the Serious Choice in Advanced Technology Receivers.*

**High Speed FFT Search**  
– Scans 10 MHz in as little as 0.2 seconds!  
Instantly detects, captures and displays transmitted signals.

- FFT (Fast Fourier Transform) high speed display
- Displays up to 10MHz of spectrum bandwidth
- 5 inch TFT color LCD display
- Waterfall (time) display function
- High speed FFT search quickly captures new signal transmissions
- Versatile color display uses state of the art digital signal processing
- Average or peak value readings
- Frequency coverage: 25MHz ~ 3GHz (no gaps)
- Ultra-stable, high-sensitivity triple-conversion receiver
- AM/NFM/WFM/SFM receive modes
- 1000 memory settings (100ch x 10 memory banks)
- Easy menu-driven operation
- PC control through serial port (or optional USB interface)

## SR2000

**Standard Accessories:**  
AC adapter, control cables



**AOR U.S.A., Inc.**  
20655 S. Western Ave., Suite 112, Torrance, CA 90501, USA  
Tel: 310-787-8615 Fax: 310-787-8619  
info@aorusa.com <http://www.aorusa.com>

Authority on Radio Communications

*Specifications are subject to change without notice or obligation. Product intended for use by government or authorized users in the USA, documentation required.*



# COMMUNICATIONS

## FCC AND BROADCASTING

### Digital Deadlines

Everywhere you look, there's a deadline looming for another service to complete their conversion to digital operation. Let's remind you of three, in order of imminence.

#### 1. Cellphones

If you're still using an analog cellular phone, it will be not only passé but defunct, come February 18, 2008. Only a relatively small number (a million or so) analog phones are still in use, but many of those are in marginally-served rural areas where it's "analog or nothing."

Other applications which may be adversely affected include owners of cars equipped with analog OnStar systems, and some building security alarm systems. Digital phones also create a buzz in hearing aids. The FCC requires that 50 percent of all digital wireless handset models offered by manufacturers or carriers must be compatible with hearing aids by the February 18 deadline.

#### 2. Television

The long-anticipated switch to digital television takes place February 17, 2009. Will all stations be ready? Probably not.

Some stations are currently protecting analog stations that won't be there after 2009; some stations will be changing channels back to VHF assignments or into a permanent UHF assignment. Some can't move until a channel is vacated. There's a lot of field work to be done before ordering a system, and there is a shortage of skilled RF and antenna engineers.

In light of all that remains to make this a fully digital television nation, could the Feb. 17, 2009 deadline slip?

According to an FCC spokesperson, the official position is that the date is for keeps, as it was congressionally mandated.

Will all consumers be ready? Almost definitely not.

With the deadline less than two years away, concerns have been growing that not enough people are aware of the switch-over or what will need to be done to make sure their sets still work. Digital converter boxes aren't likely to go on sale until next January.

#### 3. FAA

The Federal Aviation Administration will set US carriers a 2017 deadline to fit their fleets with VHF datalink Mode 2 (VDL-

2) equipment. The equipment can send and receive controller-pilot datalink communications (CPDLC) as well as company or engineering information now handled by the lower capacity ACARS datalink system.

The proposed deadline is three years ahead of the FAA's recently announced 2020 mandate for aircraft to carry automatic dependent surveillance - broadcast (ADS-B) equipment in order to fly in certain airspace.

Meanwhile, FAA analysis shows that existing 25kHz channel spacing between VHF radio channels will be adequate until 2022, although additional spectrum will eventually be needed.

### Let the Bidding Begin...

A group of Silicon Valley venture capitalists and technology investors is competing for the rights to the radio spectrum liberated by television's mandated transfer to digital signals, mentioned above. Interestingly, the group, Frontline Wireless, was assembled by former Federal Communications Commission Chairman Reed E. Hundt.

### One Week Filing Window

For the first time in 6 years the Federal Communications Commission (FCC) is accepting applications for non-Commercial Educational (NCE) radio stations, starting Friday October 12, 2007 to Friday October 19, 2007.

There are a limited amount of spots and only one week in which to apply. Applicants must have an educational mission, no individual ownership is allowed, applicants must be non-profit organizations. Peggy Berryhill, Director of Services and Planning for Native Public Media, is urging native tribes to start the paperwork now to be ready for the window.

"If we don't supply our own voices who will?" says Berryhill.

### History Repeats Itself

The Copyright Arbitration Royalty Panel has refused an appeal to change their recommended royalty payments on webcasters based on per song per listener hours. The ruling was to go into effect May 15th, instantly bankrupting several online broadcasters, unless Congress were to step in. Many wireless broadcasters planned a "Day of Silence" May 8th to strengthen their case.

There is fascinating background on the history of the royalty issue at the Radio and Internet Newsletter site at [www.kurthanson.com](http://www.kurthanson.com). (Seems content owners have always

thought new technology would put them out of business – first piano rolls, then radio, then VCRs ...) The Day of Silence was inspired by a 1927 demonstration to galvanize public opinion, which you can read about at <http://earlyradiohistory.us/buildbcb.htm>

Protesting the lack of government regulation and oversight, KFI and ten other Pacific Coast stations presented what they termed an *Interference Hour*. The stations changed their wavelengths as to interfere seriously with one another. After an hour of squeals, howls, indistinguishable announcements, and distorted music, the stipulated wavelengths were resumed, following which pleas were made from each of the stations in support of the radio bill before the Senate. It definitely got Congress' attention.

## AMATEUR RADIO

### Repeater Interference to Military Radars

The US Air Force has asked the FCC to order dozens of repeater systems to either mitigate interference to "PAVE PAWS" radars or shut down. The situation affects 15 repeaters in the vicinity of Otis Air Force Base on Cape Cod, Massachusetts, and more than 100 repeaters within some 140 miles of Beale Air Force Base near Sacramento, California. Amateur Radio is secondary to government users from 420 to 450 MHz and must not interfere with primary users.

PAVE PAWS (Phased Array Warning System) is a missile and satellite detection and tracking system. The Cape Cod and Sacramento sites are the only remaining operational facilities in the US. Unfortunately, their facilities occupy essentially the entire 70 cm band.

As a "first step" to mitigate the interference until other solutions can be found, the ARRL is recommending that all affected repeater owners reduce power – possibly to as little as 5 W effective radiated power (ERP).

### Background Check Update

The latest word from American Red Cross officials, who met recently with ARRL representatives, is that Amateur Radio Emergency Service (ARES) members volunteering to support Red Cross disaster relief or recovery operations would not have to submit to a Red Cross background check unless their volunteer stints extended beyond seven days.

"Communications" is compiled by editor Rachel Baughn ([editor@monitoringtimes.com](mailto:editor@monitoringtimes.com)) from newscippings submitted by our readers. Many thanks to this month's fine reporters: Anonymous, Bob Grove, Norman Hill, Rick Kissell, Dave Martin, Jerry None, Ken Reitz, Doug Robertson, W. Schweikert, Doug Smith, Larry Van Horn, and Ed Yeary.



### DX Tuners Site Shuts Down

As of April 20, the website that allowed hobbyists to use receivers located around the world by remote control via the internet, has been shut down. Kelly Lindman reports that that after 10 years of running the site with the help of friends and supporters, and 20 years in the IT business, he has decided it is time to try something else. He says, "I have been trying to find other solutions to continue running DxTuners but I have found it too complex for anyone else to run without my help."



"I would like to thank all my friends, subscribers and especially my dedicated crew who supported me over the years. [www.dxtuner.com/](http://www.dxtuner.com/)

### Take a Wok on the Wild Side

Kiwi ingenuity which turned a kitchen wok into a microwave dish has been in the news and on the internet lately. North Otago's newest television station, 45 South, needed to transmit its signal from its studio to the top of Cape Wanbrow, but didn't have the budget for a \$20,000 microwave dish.

45 South volunteer Ken Jones had already designed a wok transmitter for his own home when he wanted to provide wireless broadband capability. Along with friend Murray Bobbette they worked out mathematical equations to prove the curved metal face of a wok would have the same effect as a small satellite dish.

His solution and many other homebrew microwave and broadband projects can be found at [www.usbwifi.orcon.net.nz/](http://www.usbwifi.orcon.net.nz/)

### Don't Believe It !

The British *Independent* reported that, "A limited study ... has found that bees refuse to return to their hives when mobile phones are placed nearby," suggesting that mobile phones may therefore be partially responsible for the phenomenon known as "Colony Collapse Disorder." The *Independent* based its mobile-phone theory on a paper by German researchers at the University of Koblenz-Landau.

However, Physicist Jochen Kuhn and his colleagues in Landau used the base for a cordless phone actually placed inside the hive. "Honeycomb area and mass showed a disadvantageous trend for the radiated bees," said Kuhn in an interview with *Spiegel Online*, "with no statistical significance."

Other, much more likely causes for colony collapse exist, such as genetically modified crops, pesticides, in-breeding, disease, and climate change.

### France Selects DRM Standard

The French Authorities have chosen the DRM standard (Digital Radio Mondiale) to reawaken interest in the AM band (short-wave, medium-wave and long-wave). The Industry Minister, Mr. François Loos, indicated this choice during his speech in Radio France on last March 13th.

Digitalization will make it possible to provide better sound quality and improve listening comfort, for example by providing the possibility of pausing a programme. According to François Loos, "from now on the mechanics are in place to provide digital radio to the French within one year."

The DRM Consortium is very pleased with the French decision and will continue to facilitate the launch of digital radio in France. It will continue to support all possible synergies between the standards so that future digital receivers, at an affordable price, will offer the widest possible choice to listeners.

# Let's Make a Deal!

Your favorite communications company doesn't just **SELL** radios, we **BUY** them as well!

Grove trade-ins are a **win-win program!** You receive an excellent allowance for your used receiver or scanner, and when you buy a trade-in from Grove, you're assured of a **fully-tested and guaranteed** radio at a **bargain-basement price!**

Why go through the hassle and delay of trying to sell your radio and buy another all on your own when you can depend on Grove's **legendary customer service?** We've bought and sold thousands of radios, making us the country's **number one choice for trade-ins!** With such activity, our inventory changes daily, so stop by our web site right now at [www.grove-ent.com/hmpgbbb.html](http://www.grove-ent.com/hmpgbbb.html), and visit us often!

*All of our previously-owned equipment is tested and guaranteed against defects for 90 days. This list is updated frequently, visit often to catch outstanding bargains!*

[www.grove-ent.com/hmpgbbb.html](http://www.grove-ent.com/hmpgbbb.html)

**GROVE**

Visit our website **TODAY!**

7540 Highway 64 West  
 Brasstown, N.C. 28902  
 800-438-8155 US & Can.  
 828-837-9200  
 Fax 828-837-2216  
 e-mail: [order@grove-ent.com](mailto:order@grove-ent.com)  
 web: [www.grove-ent.com](http://www.grove-ent.com)

Grove is **Always** your **Best Value.**



# Radio on the Road

## ***DXing and listening while traveling***

By Janice Laws

**A**s a young child I was fascinated by my big brother's shortwave radio, (a Lafayette HA600A circa 1967). It glowed and crackled in the dark as we listened to far away places like London, Moscow, and Havana. My imagination was sparked, and I dreamt of what these places must look like.

It's been almost 35 years since that beginning in the radio listening hobby. The love of listening to broadcasts from foreign lands soon led to an intense desire to visit these places and experience them first hand.

Thus far I have traveled to 33 countries, 26 states in the USA, and 5 provinces in Canada. Through the years I have enjoyed radio listening and traveling, and radio listening *while* traveling. I'd like to share with you my experiences – good and bad – so that you might have as much fun as I've had with radio on the road.

### **Leaving home**

When we have the occasion to venture out of our regular listening area, we are given the opportunity to hear new stations, or to listen to ones we have previously tried to hear from far away with a clarity we cannot get at home. We get to see and experience the communities from which and to which the stations broadcast. We can acquire a new understanding of the cultures and context from which the radio stations derive their programming.

Though not an aspect often advertised to travelers as an attraction, we get to see into other worlds without the sterilization and commercialization that occurs at regular tourist traps.

Let's look at the most important things we need to consider for our journeys with radio: location, opportunity, time available, equipment, and research materials.

### **Location**

Where are we going, and how much control do we have over the choice of destination and accommodations to get the best radio reception? As a hobbyist, it is torture if we are in an exotic area and have no ability to practice our hobby.

Interference being the big hindrance it is, we advise staying away from power lines and transmission towers. One may investigate these things before leaving home on maps provided on [mapquest.com](http://mapquest.com) or [maps.google.com](http://maps.google.com). Satellite images on [earth.google.com](http://earth.google.com) offer great views, so that you can get a good idea of the terrain as well.

Structure, direction of windows, location of rooms, and the possibility of extending antennas are all considerations when choosing a hotel. Bodies of water enhance reception and minimize obstruction by buildings. Height is also important, and if you can get a top floor of a high-rise hotel you can have some good reception.

Proximity to cities can be a blessing or a curse: Outside of populated areas we have less RF (radio frequency) interference on AM and shortwave, but for FM and scanner enthusiasts, the city is where you want to be for the action. On the other hand, some big cities have so many kinds of noises from people, traffic, and electrical sources, that it makes most listening difficult.



*In a city like Cairo it's advisable to carry your valuables where you can see them.*

State and national parks are great for quiet areas; just check for underground wiring or choose non electric sites. When camping, my husband and I have put up some great antennas in trees. When attached to a coax connector and run into the tent, it has also worked great for the portable TV, too, as it uses the same plug.

Constraints dictated by the location may



*When camping, look for buried utilities or primitive sites for best reception.*

limit the variety of frequencies you can access, but sometimes local catches can be just as rewarding and fun to hear. The "life is like a box of chocolates" theory always applies: Wherever you are, "you never know what you're gonna get."

### **Opportunity**

Depending on when and where you travel, one must weigh the amount of time to devote to radio listening versus time devoted to other reasons for the visit. Friends, family, or business may at times prevent us from doing all the listening we wish to do. Here are some things to consider in finding the best compromise.

How much time will you have to devote to listening, and can your schedule be adapted to be able to listen during optimal hours for the bands you prefer? Research and make wise choices.

How much may family, friends and co-workers judge your hobby time as strange or exclusionary? Start talking about your radio listening hobby before or at the beginning of your trip. Let folks know how excited you are about the prospect of hearing new things and how important this is to you. It is also good to try to arrange time to do your listening in advance, such as allowing the others to plan an activity without you. Alternatively, you could also invite them to participate and learn to enjoy our hobby, too.

Either way, compromises will often have to be made, so keep your expectations reasonable and you will have the best experiences, I guarantee you.

## Equipment

What to bring and how much do you lug around during the trip? This may depend a great deal on your means of transportation and whether you have one or many destinations. When traveling by car to a single destination, and depending on the length of the stay, consider bringing bigger rigs, power supplies, antennas, and accessories that will satisfy your hobby needs.

I have a Grundig satellite 800 which is a great multiband radio, but quite large. I have some 100ft dipole antennas, and amplified antennas like the Quantum loop active AM antenna. Active antennas are electronically amplified to enhance reception and are good for indoor use. I have various power supplies and several specialty radios (subcarrier radios, weather radios, etc.), and our laptop computer for online research, all of which I will pack into the car when going on a trip where I can set up comfortably and have access to electricity and the internet.

When traveling by plane to multiple destinations or to destinations of questionable security, I may only bring smaller portables like my Radio Shack DX-398 (same as the Sangean 909) and a Kaito 1102, both very good multiband radios, in my humble opinion. Also, ear buds for privacy (mine and others), a small wire antenna for better shortwave reception, and maybe the Radio Shack passive AM loop antenna. It looks like a hollow Frisbee and requires no battery or power supply, but is great for nulling one frequency to hear another.

Again, when traveling by plane, keep your equipment simple: antennas can be fashioned out of simple copper wire you may purchase when you have arrived. Bring the right plug for your radio's external antenna and attach the wire later. It is always good to know to find the nearest Radio Shack or other electronics store where you can pick up stuff you forgot or can't carry. I also carry a small, "disposable" radio, usually with just AM/FM bands, that I can put in my pocket for quick and easy casual listening while waiting in line or at the beach.

Batteries are a better bet than risking frying your radio with some strange foreign current or an unprotected, poorly regulated power supply that may cause interference at best, and electrocute you or catch fire at worst. A good power supply adapter for foreign outlets can be expensive for such little use and can be heavy to carry. I brought one on a trip to Europe once and it weighed more than my radio: I really regretted bringing it.

The new rechargeable nickel metal hydride batteries last a long time and you can either recharge them on the road or decide to switch to disposables if they crap out. If you are like me and are plugged in all night, you want to make sure you have lots of batteries on hand. Some radios like the Kaito 1102 have internal rechargeable batteries – a very nice feature.

Another fun device to have if traveling with another person is an FRS (Family Radio Service) radio. These radios function like low-power, un-

licensed walkie-talkies, so you can stay in touch in public places when you are out of sight of your companion. While in Florida, my husband and I talked over one mile from the condo to the beach. This is exceptional; the condo being on the 3<sup>rd</sup> floor, the lack of buildings in between, and the proximity to the ocean sure helped. Unlike Fessenden's historic first call over radio (asking Mr Theissen if it was snowing), I casually asked my husband for suntan lotion. How far we have come in 100 years!



*Family Radio Service came in handy for communicating between the hotel and the beach. The DX wasn't bad, either.*

Antennas, which can greatly enhance reception, can be strung up inside or outside and can be any length, depending on your location and tolerance of hotel staff and neighbors. Palm trees make great towers, and a golf ball and some duct tape will get you up in one and anchor it for temporary installation.

Black is the color of choice for wire, as it is almost invisible: the thinner the better. Rolling out a wire along a beach can get good reception, too, but keep an eye on it so that seagulls and crabs don't make off with it. Don't laugh: I've seen a seagull pick up the stick I had taped to the end of the long wire, surely drawn by the shininess of the tape.

## Security concerns

Airport security will require you to prove that your radio functions, so have good batteries in the radio to show it is operational. Avoid leaving the radio on such strange stations as numbers stations and clandestine broadcasts! This will arouse suspicion in these days of security concerns. Put it on an FM pop station, if possible, and, if asked strange questions like "What is this?" give simple answers like "It's a radio." Don't venture into lengthy explanations unless asked – the old fear of the unknown may come into play. Trust me on this: I made the mistake once of saying "shortwave radio," and immediately a barrage of other questions followed. The officer, thinking the radio was a ham radio and had transmitting capabilities, wanted to see my license, etc.

*Passport to Worldband Radio* has amazingly similar advice to mine in a section called "Have radio, will travel." I especially concur with the advice to make sure your radio looks plain, worn, and old. My Radio Shack DX-398 is black, rectangular and has stickers on it: it looks like an old transistor my dad would carry. Most wouldn't know it's worth as much as an iPod.

Scanners, amateur radio equipment, and even some FRS radios may require licenses or be illegal where you are going. Research your destination with a local club or fellow hobbyist who has traveled where you are going. North Korea doesn't even allow any radios or cell phones or cameras, but I don't imagine you will be going there anytime soon.

Carrying one's equipment and keeping it safe is always a concern. Airports, train stations, bus depots, etc. are rife with pickpockets, con artists, and thieves. I always have my stuff in the bottom of a backpack I carry everywhere and keep on my front when in crowded places. I have a belly bag for my money and passport, all of which I have padlocked at all times. In Cairo, Paris, and Rome, attempts have been made to rob me, all unsuccessful. But one must stay alert and use all security devices such as hotel safes, etc. when available.

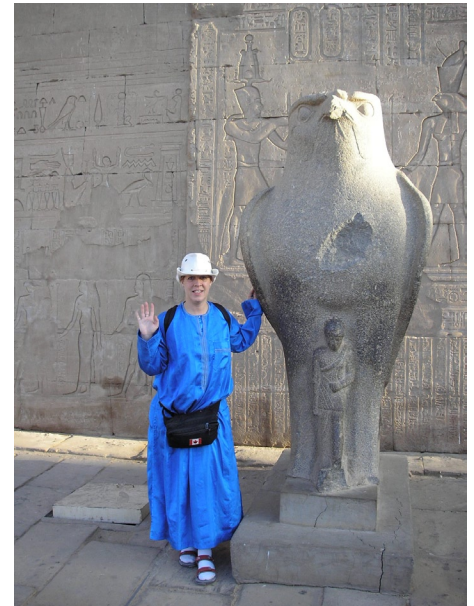

*In addition to carrying valuables in front, one must also observe local customs regarding appropriate dress.*

Be discreet with use of equipment and showing money. Avoiding jewellery and fancy clothes also helps reduce visibility. I also put non valuables such as toiletries in the outside pockets of my knapsack – that's what they got in Paris. When I felt the bump, I turned and found my outer pouch opened and a trail of toilet paper hanging in the breeze! To my amazement, the pickpocket was just a teenager.

Radios and accessories are best kept in zip-lock bags to avoid water and other spills that can occur when it is in your bag with other stuff, especially a cold water bottle that sweats on a hot, humid day. Don't put radios in your checked luggage unless really, really carefully wrapped. I once saw my suitcase plummet 20 ft out of a plane onto the tarmac in East Timor – gasp!

Also, don't let any well-meaning porter touch the bag containing your radio. Leaving Georgia (the state, not the country), a porter dropped my bag with my Sony ICF2010 (another great portable, but twice the size of my DX398). Finding someone in Florida to repair the damage later was difficult and costly, as many repair

shops are not familiar with shortwave radios.

Nonetheless, be prepared to lose your equipment. Do not bring anything abroad you will be heartbroken parting with. For various reasons one may have to leave stuff behind, such as getting robbed, losing stuff, or breakage. Or, as happened to me in Haiti, I had an analog shortwave portable in which I could see cockroaches and ants running about behind the tuning bar by the end of my stay. It quickly became a gift to our guard, who didn't seem to mind the wildlife the radio contained.

## Research, frequency lists and logging

Sources on the net that are very useful include: **Radio Locator** for looking up stations by frequency, call letters or location; **Primetime Radio Shortwave** for shortwave frequencies by time; the **Free Radio Network** for pirate radio stations; **Spy Numbers Station Database** for clandestine and spy stations; **Zipcode FM locator** for finding stations by zip code and stations' home websites. (This trick is particularly good for IDing e-skip by simulcasting the webstream with your radio.)

Researching targets before you leave home is always a good idea, as you know what you are looking for and what not to miss when in an area close enough to get a rare catch. Be reasonable about your targets, as it is hard to listen to everything unless you are on a DXpedition (an organized trip for the sole purpose of radio listening).

I bring photocopies of target frequency lists and pen and paper for logging and later identification of new stations. I have a habit of ripping the blue pages out of the *Passport to Worldband Radio* and the AM station lists for the region I am visiting from the *WRTH (World Radio and TV Handbook)*, to reduce the weight of my baggage. The *Monitoring Times* frequency list comes in handy when looking for a shortwave English broadcast, is good to read while waiting, and serves as support in my backpack to keep stuff inside from gouging me in the back.

On the road in a car, bigger reference books are good to have. The National Radio Club's *AM Log Book* and *Nighttime Pattern Book* are great and are updated regularly. Elving's *FM Atlas* is great for North American FM, and Hutching's *Radio on the Road* is good for finding stations for specific program content. These two are also smaller and can be carried on a plane as well.

Documentation of our catches is always great to bring home and enter into our log books. Aside from the obvious paper and pen, I now use my mp3 player that has a microphone and FM record feature to record some audio. The old tape recorder method was cumbersome, but new technology now gives me a device the size of a Tic-Tac box on which I can record my catches. However, I must admit I am sometimes remiss in sorting it all out when I get home.

I did use a mini-disc recorder and an amplified microphone one time, but all this was quite expensive and I worried about losing the equipment, and still had to transfer it all when I got home. My Creative Labs mp3 player allows

## RESOURCE LIST

**Passport to World Band Radio** - [www.pass-band.com/](http://www.pass-band.com/)

An international shortwave frequency guide (blue pages), worldwide broadcasts in English, station and equipment review book.

**World Radio and TV Handbook** - [www.wrth.com/](http://www.wrth.com/)

Guide for AM, FM and TV around the world. Good MW guide by frequency and region.

**FM Atlas** - <http://members.aol.com/fmatlas/home.html>

Complete list of FM stations in North America listed by frequency, state and maps.

**National Radio Club** - [www.nrcdxas.org/](http://www.nrcdxas.org/)

Where to purchase AM Log Book, a list of all AM stations in US and Canada and the Antenna Pattern Book, maps showing daytime and night time coverage areas of US, Canada, and some Mexican stations.

**Zip Code Signal** - [www.v-soft.com/ZipSignal/default.htm](http://www.v-soft.com/ZipSignal/default.htm)

Searchable database to find the field strengths of AM day, AM Night and FM stations within U.S. postal zip codes throughout the U.S.

**Radio-Locator** - [www.radio-locator.com/](http://www.radio-locator.com/)

Good site for searching info about US and Canadian AM-FM stations including links to web sites, power and antenna info with coverage area maps.

**Online AM Logbook** - [www.amlogbook.com/](http://www.amlogbook.com/)

Great online database of Canadian and US AM Stations listed by state, city, or frequency including AM Stereo and IBOC stations. Updated frequently.

**Radio Plus+ DxTools** - [www.dxtools.com/](http://www.dxtools.com/)

Where to order Quantum Loop antenna products.

**Primetime Shortwave** - [www.primetimeshortwave.com/](http://www.primetimeshortwave.com/)

Comprehensive guide for English shortwave broadcast schedules with lots of cool radio related links.

**Spy Number Stations** - [www.spynumbers.com/](http://www.spynumbers.com/)

Lots of good information on everything you need to know about spy number stations on SW.

**Free Radio Network** - [www.frn.net/](http://www.frn.net/)

The Definitive Pirate radio site! Check out the Grapevines where you can post logs, info, and just hang out with other pirate radio listeners and even the operators themselves.

**DX FM** - [www.dxfm.com/](http://www.dxfm.com/)

FM and TV DX resources with very frequent updates of dx openings and listener reports especially during e-skip season. Live TV DX Cam and updated FM-AM-TV-DTV spreadsheets available for download.

me to dump the audio straight onto my computer and to rip audio straight to mp3 from any outside source.

I also tried to use my video recorder to record with some success, but again found it inconvenient transferring the audio later.

## Other fun stuff

I have kept pictures of RDS (radio data systems) station IDs from my trip to Belgium, Netherlands, Germany and Luxemburg. My DX-398 also has that capability and they can be kept in memory. Many car radios can capture the RDS information also. It's a great way to ID stations, especially during e-skip. (E-skip is a radio anomaly where you hear far away FM stations come momentarily drifting in, sometimes

from over a 1000 miles away!)

I also found this particularly handy when listening to FM from a plane; when not being able always to make out the ID, RDS helped. Listening to FM from planes is a fun way to pass the hours on long flights, as well as being able to chart your progress. From Montreal to Cairo, I heard stations from France, Spain, Italy, Greece, and Malta drifting in and out on FM. AM is pretty useless, as the plane causes too much interference. FM is tricky, as you need to be in a window seat to extend your antenna or else sit next to someone who doesn't mind you extending your antenna to the window.

Always follow take off, landing, and in-flight electronic device rules. I also suggest being discreet and putting the antenna under a blanket. Again, we are talking about radios for listening only; avoid any device that transmits. Who knows if any device will really "bring down the plane," but do you really want to find out?

FM from a plane is constantly changing as you fly over sites. You can stay on one frequency and the stations will change and fade in and out quite quickly. It is often hard to ID stations, and I find myself going frantically up and down the dial at the top of the hour for IDs. All in all, DX-ing from a plane is often better than the in-flight movie.



Reception on board a train or plane is dependent on sitting next to the window.

## Other means of transportation

Trains can be tricky, depending on where you are seated. The train can prove a difficult place from which to receive a signal. But the fact they are always moving can provide some interesting local catches not often heard. And, of course, the train enthusiast may come armed with the train company's frequencies and a scanner to have a more interactive ride listening to the crew's chatter. Security is not oppressive on trains, so one may easily bring a handheld scanner and have room to set up one's radio in peace.

Cruise ships are great, for they move at night and have open decks from which one can sit and listen for hours. The weather and occasional conga lines coming out of the bar may be annoying, but, overall, it's a good listening location due to the water path that enhances reception. When docked, you can hear many local stations, but sometimes finding a public area that doesn't have piped-in music can be a challenge.

Automobiles and buses can be noisy on AM, and one has little opportunity to extend a portable antenna. I use a CB (citizens band radio) antenna and listen to the truckers for traffic reports on a hand held CB radio. This is still a fun way to hear some local gossip and all about the height of the skirt of the lady in the four-wheeler that just went by. And it may be you they are talking about – well, if you have a skirt. And aren't they surprised when you key up and tell them you are listening?!

The car radio is usually the best equipment on which to listen. Many stock radios have given me some great catches, especially during e-skip. Driving in the Florida Keys, I heard tons of Cuban stations on AM and FM. I even heard TV audio on 87.7 from Cuba. Since cars have a directional antenna, I have done some weird maneuvers in parking lots to get just the right angle to get a good signal. I just wave and smile, and when they see my blonde hair, people dismiss my erratic driving.



With RDS, IDing your DX is as easy as a snapshot.

While driving at night, one can easily assess the quality of propagation in North America by tuning in the clear channel power houses stations on AM that are protected at night. I heard Montreal stations like 690 kHz and 940 kHz easily from Savannah, Georgia, which was not uncommon, but a fun catch for me.

Many other anomalies may appear on the air waves from low power community stations, transmitter-equipped real estate signs, pirate stations, travelers information stations, satellite radio FM relays to people's car radios, houses with Christmas lights synchronized to music on FM, and weather radio stations. All of these can be heard on a regular car stereo!

## Final thoughts

### The never-ending variety of radio:

Of course, one may have ham radio equipment and communicate with fellow hams on the road; scanners to hear public security services, military, airports, taxis, cell phones and a plethora of other stuff (these subjects are better covered in other columns by more knowledgeable folks than I); a radio with longwave with which to hear beacons in NA and some great broadcasters in Europe; subcarrier radio with which you often hear diverse ethnic stations and books for the blind; shortwave to hear the world and, depending where you are, pirates, number stations, clandestine stations, strange foreign governments, preachers, politicians,

music, and all manner of oddballs on the air.

### Things to remember:

- AM in Europe is in 9 kHz steps; sideband capabilities are needed for American Forces Network broadcasts on shortwave, and for shortwave ham chatter; FM in other countries can be on even number frequencies, not odd.
- Radio Locator also gives the location of the stations' transmitters. My husband and I have gone transmitter hunting and we have identified and photographed the towers we pass on the road.



Silly me, forgetting the Eiffel tower bristles with antennas.

### Things learned:

- Sometimes I don't think ahead. Silly me, trying to listen to my radio from the top of the Eiffel tower. The whole reason it has stayed up after the expo for which it was built in 1889 was to house broadcast antennas!
- Mexico was beautiful, but aside from border blasters from the USA on AM and a lot of Spanish preachers ("...es la dia de Jesus, hermanos y hermanas..."), I did not hear much else because I didn't bring good enough antennas on that trip.
- As one would imagine, it's also hard to know what you are hearing in that part of the world unless you speak pretty good Spanish.
- The sunspot cycle can make some bands out of reach. Other anomalies are solar flares, time of year, and amount of daylight. In Amsterdam I couldn't stay awake much past sunset, which was at 10pm when I was there during the summer.
- Also, in Egypt, Thailand, Malaysia, Indonesia, it was really a challenge to understand what you were listening to. Some English broadcasts and local relays of BBC, VOA, etc... were all I could ID for sure. A lot of logs were scratchings in my Passport blue pages by-frequency and some deciphering of local dialects; not often legit IDs, lots of presumed. I am pretty good with languages and usually study a country's language before I visit so I can communicate my basic needs, avoid ordering any odd animals parts in a restaurant, and ID radio stations.
- Lastly, if you really can't go anywhere, there is always **DXtuners.com** for remote radio listening from foreign lands. [Ed note: Sadly, DXtuners just closed its doors; see 'Communications.' A few similar sites exist.]

I have fond memories of listening to radio around the world over the years ... Listening to nearby FM stations, during the war in the Balkans, as we cruise the Adriatic Sea past the former Yugoslavia ... Tuning in to Dutch pirates on shortwave, while in the Netherlands, defiantly daring authorities to catch them ... Listening to U2's *Beautiful Day* play on a local FM station while driving around East Timor and seeing the

hope on the faces of the people in their newly independent country ... Hearing an ESPN relay from an Armed Forces Network FM station from somewhere in the Middle East as I lay on a beach on the Red Sea in Egypt, wondering what the military men and woman who were also listening were doing at that moment...

... Listening to news from home on Radio Canada International ... That becomes oh-so-important when you are so far from family and friends. After the Dawson College shooting in Montreal in September 2006, I was in Egypt and I tuned to them first to hear the details of the tragedy so I could surmise if my dear uncle, who works there, was alive or dead.

I have been blessed to be able to combine my two favorite activities over the years and hope to continue to do so for the rest of my life. So remember – *Life's a trip: log it!*

Janice Laws and her husband Steve Karlock are the hosts of the *International Radio Report Sunday 1430 UTC on CKUT 90.3 FM, Montreal* - [www.ckut.ca](http://www.ckut.ca) and members of the *Canadian International DX Club (CIDX)* [www.anarc.org/cidx/](http://www.anarc.org/cidx/)

### From the Editor:

If you're like me, the foregoing article just whets the appetite. This is all good information, Janice, but I'll never catch up with the number of countries you've visited. What did you hear when you visited those 33 countries?! Readers, let us know if you would like us to continue with a series of reports on Janice and Steve's monitoring in various parts of the world.

## LED Light Bulbs

**Burn the midnight oil at your monitoring station without burning up your power bill!**

- **Energy Efficient:**  
3 watts
- **Economical:**  
Run it for 12 hrs/day for a whole year for about 80 cents!
- **Durable:**  
60,000 hour bulb life
- **Versatile:**  
Reading light, porch light, ambient light
- **Quality:**  
36 white LEDs, broad beam of light, never gets hot, 2-year warranty



Available in 120 V (#VVP) & 12 V (#12P)  
\$44<sup>95</sup> Incl. FREE U.S. Shipping

C. CRANE COMPANY

**FREE CATALOG!**

800-522-8863 • [ccrane.com](http://ccrane.com)





**F-15 Eagle Static Display at Tyndall AFB, Florida**

is the headquarters for training for the Navy and Marines. Dozens of training flights depart Sherman Field at the installation each day and the VHF/UHF air bands will produce many hits on frequencies in use on these training flights.

Of most importance, however, is the fact that the Blue Angels, the Navy's Flight Demonstration Team, call Sherman Field home. If you are in the area between late March and early November, the team holds a practice show each Tuesday and Wednesday morning from 8:30 to 9:30. This show is open to the public and is conducted behind the Naval Air Museum on the Air Station. Admission is free.

I attended one of these practice sessions last year and loaded my scanner with the frequencies for the Blue Angels. I had a great time watching the show, complete with radio communications, and I avoided the crowds typically encountered at an air show. I also got some great photographs of the Blue Angels in action. The installation's support forces utilize a VHF Motorola SmartNet II APCO

25 digital/analog trunk system in the 148-150 MHz range.

Like Sherman Field on NAS Pensacola, Whiting Field, just north of Milton, is a busy center of Navy training flight activity. The installation is responsible for primary training for fixed wing air crews and advanced training for helicopter pilots. Again, the VHF/UHF

bands in the vicinity of Whiting Field will reveal numerous air-to-air and air-to-ground communications. I have observed and listened to the aircraft from Whiting while taking the family on a tubing trip down the Blackwater River, courtesy of one of the several canoe and tubing outfits that provide the service in the Milton area. Best of both worlds!

Leaving Santa Rosa County and traveling further east on US 98 will bring you to Hurlburt Field, home of the Headquarters for Air Force Special Operations. This installation, formerly an auxiliary field of Eglin AFB, hosts AC-130H Specter gunships, MH-60 helicopters, and the newest addition to the Special OPS fleet, the CV-22 Osprey tilt-rotor aircraft.

Hurlburt Field utilizes the Eglin AFB Motorola APCO 25 digital trunk system for support activities. Most communications are in the clear, but critical activities, such as aircraft maintenance, use encryption. Surprisingly, security and law enforcement transmissions are in the clear.

Nighttime will often present an opportu-

nity to hear the Special OPS School conducting training on the Eglin military reservation and waterways in the area using the trunk system. From my house near Hurlburt I can often see and hear an AC-130H, call sign "Spooky 1," conducting practice firings of its 25mm guns, 40mm cannons, and 105mm howitzer in the evenings between 6:00 pm and 10:00 pm. Hurlburt air crews perform multiple training missions each day over Eglin's land and water training and test areas.

Traveling a few miles further east and north to Valparaiso will bring you to Eglin Air Force Base. This base has the largest land area of any installation in the United States. It also controls thousands of square miles of the Gulf of Mexico as an extended range for weapons testing. Although the main base lies close to Valparaiso, the extended land area comprised of multiple test and evaluation ranges extends through three counties and makes up a large piece of the Florida Panhandle.

The two largest organizations using Eglin's unique land and sea operating areas are the 33<sup>rd</sup> Fighter Wing and the 46<sup>th</sup> Test Wing. The 33<sup>rd</sup> flies F-15 Eagles and occupies the northwest portion of the main base. The 46<sup>th</sup> occupies the main flightline and flies an assortment of aircraft, including F-16 Fighting Falcons, F-15 Eagles, T-38 Talons, A-10 Warthogs, and other aircraft as required to test new weapon systems.

Another important installation on the Eglin reservation is Duke Field. Duke is the home of the reserve component of Air Force Special Operations. These airmen fly the MC-

# WiNRADiO G315i

**THE BEST IS NOW EVEN BETTER; ENTER... THE WiNRADiO WR-G315!**

Setting the standard for computer-hosted, software-defined receivers (SDR), WiNRADiO has announced this new, advanced, 2/3-length PCI-card receiver with multimode detection (AM, AMS, LSB, USB, DSB, ISB, CW, FM) and wideband frequency coverage (9 kHz-1800 MHz, optionally expandable to 3500 MHz, less cellular on consumer models). Its on-board DSP allows powerful demodulation capabilities, notch filtering and noise blanker, and accommodates future upgrades, all in software.

Not only a flexible receiver, but a reliable test instrument as well, the new 315 series has a calibrated, on-screen signal strength meter (dBm, uV, S-units); 90 dB spur-free dynamic range; extraordinary sensitivity (down to the -140 dBm range); a professional-level, multifunction, spectrum analyzer (RF and audio) with surveillance-style recording; and 1 Hz tuning accuracy! IF bandwidth is continuously adjustable from 1 Hz-15 kHz (a wideband FM option is available).

Several receivers can be multitasked for automatic multi-channel monitoring and recording, limited only by the number of PCI slots in your computer. Each receiver offers virtually unlimited storage (your computer hard-drive); multiple scanning, tuning and squelch options; and fast, 50-channel-per-second scanning speed! An SMA antenna connector and an audio output jack are provided as well.

A model WR-G315e is also available as an external module, eminently suitable for portable/mobile laptop applications. Both models operate on a PC with at least 500 MHz Pentium CPU and Windows 98/ME/2000/XP.

For more details, see our web page: <http://www.grove-ent.com/wr315i.html> (PCI card receiver) and <http://www.grove-ent.com/G315E.html> (external module receiver).

Included are: Application software, user's manual, flexible-wire test antenna, audio patch cord, and BNC-to-SMA antenna adapter



**Order NOW!**

**Order RCV64 (external):**  
Only \$ **2,049**<sup>95\*</sup>

**Order RCV54 (internal):**  
Only \$ **1,899**<sup>95\*</sup>

\* plus \$24.95 (RCV54) or \$28.95 (RCV64) Priority Mail or UPS Ground shipping in the US

# GROVE

**800-438-8155**

**828-837-9200 fax: 828-837-2216**

**WWW.GROVE-ENT.COM**

order@grove-ent.com  
7540 Highway 64 West  
Brasstown, NC 28902

130E Combat Talon I and MC-130P Combat Shadow, which provide air-to-air refueling for Special OPS helicopters.

Eglin is also the host installation for the Army's Camp Rudder, the training camp that provides the final 18 days of training for Army Rangers. The base and the vast land ranges are served by the same Motorola APCO 25 digital trunk system that serves Hurlburt Field and Duke Field through a system of repeaters located on towers at strategic locations. During the day, the trunk system is very active with the traffic from the support activities at the base. At night, I can often hear the Army Rangers from Camp Rudder conducting night training in the swamps and forests on the Eglin reservation on the same system. The VHF and UHF aircraft bands are busy around the clock, controlling air traffic and access to the various ranges and auxiliary fields in the operating area.

Leaving the central part of the Emerald Coast and continuing east along the coast through Panama City will bring you to Tyndall Air Force Base. U.S. Highway 98 passes through the base with the secure areas to the north and south of the highway. Tyndall is the home of the 43<sup>rd</sup> Fighter Squadron, which has been entrusted with training and evaluation on the new F-22 Raptor. Tyndall utilizes a Motorola Type II SmartZone digital trunk system for support communications. The system uses the 406 MHz to 420 MHz military land mobile band. As with the other military installations, the VHF/UHF air band is active with communications to and from the aircraft and controllers. I have often observed the stealthy F-22 during departures and approaches to the runway at the base.



## What equipment do you need?

Almost all of the military FM trunked traffic along the Emerald Coast is in digital mode. Therefore, to get the most out of monitoring this area a digital scanner is required. In addition, the Eglin System is located in the 380 MHz portion of the military air band and not all digital scanners are capable of operating in digital trunking mode in this frequency range.

To monitor the aircraft traffic, a radio that will receive the VHF air band – 118 MHz to 136 MHz in AM mode – is required at a minimum. The military also uses the UHF air band, 225 MHz to 400 MHz in AM mode, for aircraft communications. Again, not all scanners will receive in the military UHF air band, so plan accordingly. My Uniden BCD-396T and BCD-996T both provide excellent results on all of these transmissions.

## Check It Out!

Bottom line: If you are planning a vacation to the panhandle of Florida, be sure to take your radios. There is a wealth of military communications to monitor. I doubt you will find any 100 mile stretch of coastline with more military activity than the Emerald Coast.

## FREQUENCY LIST (MHZ)

### Sherman Field, Naval Air Station Pensacola Air Field

Automatic Terminal Info (ATIS)	267.6
Sherman Ground Control	121.7
	336.4
Sherman Tower	120.7
	340.2
Pensacola Approach	270.8
	120.65
Pensacola Departure	120.65
	270.8
	125.35
Class C Airspace	120.05
	372.0
Pilot to Metro Service (PMSV)	359.6
Radar	239.05
	285.625
	288.325
	314.0
	348.725
	383.8
Sherman Base Ops	312.1
Sherman Clearance	134.1
	268.7

### Naval Air Station Pensacola Trunk System

System ID: 390Ch	
Type: Digital/Analog P25	
Base	143.000
Spacing	25
Offset	380
Control Channels	149.350

### Whiting Field Air Field

Automatic Terminal Info (ATIS)	273.575
South Whiting Ground	346.8
South Whiting Tower	121.4
	348.675
Pensacola Approach	124.85
Pensacola Departure	124.85
Clearance	355.6
Base Ops	233.7
Pilot to Metro Service (PMSV)	316.95
Radar	278.1
	290.1
	362.2

### Hurlburt Field Air Field

Automatic Terminal Info (ATIS)	360.675
Hurlburt Ground	123.975
	275.8
Hurlburt Tower	126.5
	291.1
Eglin Approach	132.1
Eglin Departure	132.1
Radar	132.1
Command Post	143.0
	251.25
Pilot to Metro Service (PMSV)	390.75

### Eglin AFB Air Field

Automatic Terminal Info (ATIS)	134.625
	273.5
Eglin Ground	121.8
	335.8
Eglin Tower	118.2
	122.8

Eglin Approach	353.65
	125.1
	132.1
	281.45
	360.6
Eglin Departure	125.1
	132.1
	281.45
	360.6
Clearance Delivery	127.7
	377.2
Airspace ATIS	133.0
Command Post	379.15
	318.05
	328.025
	372.8
	390.9
Emergency	121.5
	243.0
Pilot to Metro Service (PMSV)	342.5
Radar	124.05
	340.9
	391.2
VFR	132.1

### Eglin AFB Motorola Trunk System

System ID: 781824-0332	
Type: Digital P25	
Control Channels	386.4625 (Site 2)
	386.4250 (Site 3)
	385.0125 (Site 4)
	385.0625 (Site 5)
Talk Groups	40XXX = Eglin AFB
	42XXX = Hurlburt Field

### Duke Field Air Field

Duke Ground	251.125
Duke Tower	133.2
	290.425
Eglin Approach	125.1
	132.1
	281.45
	360.6
	132.1
Eglin Departure	120.9
	290.5
	120.9
Command Post	225.75
Emergency	121.5

### Tyndall AFB Air Field

Automatic Terminal Info (ATIS)	254.4
Tyndall Ground	121.9
	259.3
Tyndall Tower	133.95
	384.4
Approach/Departure	119.1
	119.75
	124.15
	125.2
	136.4
	338.35
	341.7
	379.3
	392.1
Clearance Delivery	118.05
	289.4
Command Post	381.3
Pilot to Metro Service (PMSV)	344.6
	290.625

### Tyndall AFB Motorola Trunk System

System ID: A810h	
Type: Digital/Analog P25	
Base	406.100
Spacing	12.5
Offset	380
Control Channels	406.36250
	406.56250
	406.96250



# Interview with Irwin Gonshak

By Tara Meehan

**R**adio as a medium has undergone revolutionary changes in recent times with the burgeoning popularity of listening options other than mainstream AM/FM stations. The move away from terrestrial radio has served to energize proponents of the classic short radio drama format.

Irwin Gonshak is one such supporter. As Chair of the Writers Guild of America East Radio Drama Committee, Mr. Gonshak is moving headlong towards reviving the genre. He was kind enough to take some time to discuss his plans with *Monitoring Times*.

**MT - Your urgency to promote and in essence reintroduce the short radio drama is palpable. Why is the timing right for the resurgence of the genre?**

**Mr. Gonshak** - In the golden age of radio drama: morning/afternoon serials were 15 minutes; evening dramas were half-hour programs (both included time for ads). Contemporary radio dramas could be 5 minutes to be in sync with attention span of listeners today. Short radio dramas could easily fit into the schedule of talk/music formats, the same way news, weather and driving conditions are part of these formats. Today's America is America on the run, bombarded by short bursts of information. Also technological advancements make it easy to produce and edit dramas quickly and cheaply.

**Do you think the growing popularity of talk radio and its penchant toward the controversial has in some way aided the short radio comeback?**

I find most talk stations consist of long rants. From my long experience, I know that radio drama can handle any subject, from Einstein's Theory of Relativity to Lincoln's Gettysburg Address with creativity, entertainment and education. I once discussed with the Voice of America of doing short radio dramas on Public Health Learnings, which would be broadcast abroad.

**Your career in short radio drama spans six decades starting with *Eternal Light* in 1958. What is most fascinating to you about short radio drama?**

You can do anything with radio drama.

You don't need expensive sets, travels, cameras, production camps, etc. With the human voice, music, sound you can reproduce any scene imaginable – go to the moon, seven leagues under the sea.

**With the entertainment choices in abundance for young people ranging from the Ipod to video games, how would you go about sparking their interest in radio drama?**

Colleges and high schools have the facilities and staff to produce radio dramas as part of the school activities. History, English, Drama Departments can contribute to the productions. Another step will be a college/high school radio drama festival with the support of the WGAE and the Intercollegiate Broadcasting System, which has a thousand college/high school radio station members.

Introduce the younger generation to the art of radio drama and they can carry on the campaign to make radio drama part of the broadcast dial. WGAE and IBS Web sites could have audio files of the festival which college/high school radio stations nationwide could download and broadcast.

**Are script formats similar to those of TV and film?**

TV and radio script formats are not that different from radio scripts. The one big difference is that radio drama scripts frequently have a first person or third person narrator to give intimacy to the performance and direction to the listener. Great sources of material for radio dramas are the thousands of short stories on the library shelf just waiting to be adapted. One advantage of doing adaptations is that the story and structure are there; all the writer has to do is turn it into a radio script.

**What has been the feedback from the radio and performance communities?**

Actors, writers, directors, performers, engineers, etc. are always eager to work, and they enjoy using their talents to produce radio dramas. The bottom line is to get the powers-that-be in the broadcast industry to fund the revival of radio drama. They have to be convinced that there are profits to be made in the radio drama enterprise.

**Is it difficult to obtain funding for short radio**

**drama programming?**

From my experience, I've learned that funding sources have a warm spot, a nostalgic feeling towards radio drama. I have won many grants to produce educational radio dramas.



**What could small local radio markets do to start up short radio programming on their airwaves?**

Local radio markets should introduce short radio dramas into the format they have already; Bloomberg Radio could have thrillers with a business background, rock stations could have action dramas with rock themes and rock musicians; classical music stations could feature sedate, erudite dramas; etc.

Radio drama is a great art form. The American audience deserves to be informed and entertained by this art form, be it 2 minutes, 10 minutes, 30 minutes, an hour. Cheers for radio drama and its rebirth on mainstream radio for a mass audience.

Currently Irwin Gonshak is radio producer for Teachers & Writers Collaborative and he produces a series called *Everything Goes?* – literary readings, talks, discussions, dramas – on all subjects, broadcast every weekday from 6:30-7p.m. on WNYE 91.5 FM.

**DIGITAL ACCURACY  
FOR VINTAGE RECEIVERS**

DD-101H/U Universal Digital Dial  
Pre-programmed for all Hammarlund models as well as all other single conversion receivers including National, Hallicrafters, and others.  
Can Be Installed Without Soldering  
\$100.00 Plus \$10.00 Shipping  
ELECTRONIC SPECIALTY PRODUCTS  
3054 MOORE DR., OVIEDO, FL 32765  
407-366-4859 • espelectronics.com

# The Mystery of the Dixon Voice of America Relay Station

By Merrill Stevenson KG6AMW

**M**y interest in radio goes back many years. As a youth I would experiment with simple wire antennas and attempt to tune in distant AM stations on my father's old cathedral radio. Later, I used a Hallicrafters S-120 shortwave radio along with a trap antenna to listen to the BBC, Radio Australia, and the Voice of America "VOA."

Recently, I was talking an old friend who is an avid shortwave listener, and the subject of VOA programming and history came up. We both agreed that at some point the VOA operated a relay station in northern California near the town of Dixon, but were unsure of its current status. I began to reflect back and wondered whatever happened to Dixon VOA.

The history of the VOA Dixon Relay Station goes back more than sixty years. Though not as famous as Bethany, Ohio, or Greenville, North Carolina, it played a role in the VOA success story. Prior to the inception of VOA, there were a number of shortwave broadcast stations in the United States of America operated by the National Broadcasting Company, Columbia Broadcasting System, General Electric, Westinghouse, Associated Broadcasters, Crosley Radio Corporation, Worldwide Broadcasting Foundation and the WCAU Broadcasting Company. Prior to World War II, the United States Government contracted with some of these companies for broadcast-

ing government programming.

With the outbreak of World War II, the government opened a new agency, the Office of War Information (OWI) the genesis of the Voice of America. Following Pearl Harbor, the federal government decided to go forward with its own shortwave broadcast under the Voice of America program. As part of process, they acquired interest in the broadcasting facilities at Delano and Dixon, California, in the early mid 1940s to transmit programs to the Far East and the Pacific Rim.

I contacted the VOA on several occasions to gain information on Dixon, but in each case, they never responded. So, my wife and I decided to take a Sunday morning drive out to the town of Dixon for breakfast and from there do some exploring in the countryside and see if we could find it.

Using a street map guide, I located several government communications facilities in the general area. As we drove out further and further out into the countryside, risking getting lost on roads that seem to become more and more decrepit, we began to notice radio towers on the far horizon. Then, little by little, the wire antennas began to appear and finally, there it was – acres and acres of wire antennas along with a number of old buildings – now, which one?

Of the four original major domestic VOA

transmitting facilities, Dixon remains one of the least known. Greenville, North Carolina, and Delano, California, locations continue to be operated and maintained by the VOA. Bethany, Ohio, was decommissioned in the mid 1990s, but has an active restoration program underway to preserve the facility, though the antennas are gone. We finally arrived at Radio Station Road, and we stopped the car and got out to have a closer look to see if we located the VOA facility. It wasn't easy to determine, since there are two other facilities with old buildings and big antennas nearby.



Figure 1 - The former Voice of America Relay Station in Dixon California from a distance.



Figure 2 - Driveway up to main building.



Figure 3 - Although the facility closed sometime ago, you can still see the rhombic antennas in the background.

To the south of the main VOA structure is what appears to be the original ATT/NBC broadcasting facility, while next door is an abandoned naval communications facility. The style of construction of the building in these photos matches the other domestic VOA facilities, which have a concrete/stucco appear-

ance along with a very high tower connected to the building. The purpose of the observation tower is for viewing the surrounding area for security reasons. It looks like we found the VOA facility at last.



**Figure 4 - The building's main entrance - note the main security tower which was a standard feature on this as well as other VOA facilities in the US.**

The heart of the site is, of course, the transmitters and antennas. Most prominently visible are two larger dipole arrays, consisting of rows and columns of dipoles, known as a curtain antenna and rated up to 500 kilowatts. The VOA favored these antennas because of their ability to handle high power, while offering different angles of signal radiation to reach various parts of the globe.



**Figure 5 - Dipole arrays consisting of rows and columns of dipoles known as a curtain antenna. These antennas are rated up to 500 kilowatts.**



**Figure 6 - Another view of the curtain dipoles from a distance.**

The Collins and General Electric AM transmitters were the standard workhorses

for VOA Dixon. When the VOA took over, they inherited several transmitters, including a 100 kilowatt General Electric transmitter and smaller RCA shortwave transmitters. Later, three Collins 250 kilowatt transmitters were added to Dixon in the late 1960s to improve the broadcast.

With the advent of newer satellite-based technology, VOA Bethany and Dixon stations were no longer needed as much, and they were decommissioned. Transmissions from the Dixon Relay Station ceased in 1983. Since this time, the facility has remained closed and for the most part unused, although it's interesting that the antennas remain. Rumor has it that a private company moved into the facility recently and is using it for commercial marine HF communications; however, I was unable to confirm this.



**Figure 7 - VOA Dixon Relay Station from another angle.**



**Figure 8 - VOA Dixon power substation.**

The broadcast history of the VOA is an interesting one, and the Dixon relay station played a major role along with the other VOA stations in California, Ohio, and North Carolina. Fortunately for us who have an interest in radio history, these facilities still exist, but for how long we don't know.

## Longwave Resources

✓ **Sounds of Longwave** CD or Audio Cassette (please specify) featuring WWVB, Omega, Whistlers, Beacons, European Broadcasters, and more!  
**\$13.95** postpaid

✓ **The BeaconFinder** A 65-page guide listing Frequency, ID and Location for hundreds of LF beacons and utility stations. Covers 0-530 kHz.  
**\$13.95** postpaid

**Kevin Carey**  
P.O. Box 56, W. Bloomfield, NY 14585

## INFORMATION & ORDERING WWW.SCANCAT.COM

INTERNET DOWNLOADS AVAILABLE  
**ORDER TOLL FREE**  
**888-722-6228**

**NEW!** All-In-One COMBO CD

Reg.  
ScanCat-Lite-Plus.....\$29.95  
Mr. Scanner FCC Public Safety .....\$29.95  
Nat-Com's FCC Scancat Files .....\$9.95  
Bonus List Of Frequencies.....\$15.00  
**\$84.85**

**SPECIAL \$49.95**

## SCANCAT®

Since 1989, The Recognized  
Leader in Computer Control

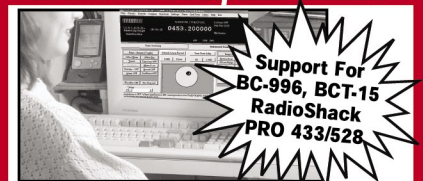

**Once you use SCANCAT with YOUR radio, you'll NEVER use your radio again WITHOUT SCANCAT!**

**ScanCat-Lite-PLUS**

Limited Time \$29.95 Intro Special

**Program Your Scanner**

**As Easy As 1-2-3-CLICK!**

SC-Lite Supports PRO-83, PRO-95, PRO-96, BC246 & over 15 more Trunking Scanners

**Scancat-Gold for Windows**

Version 8.50 \$99.95

Supports all radios in ONE program - share files with all radios.

Two Scanning modules:

A Simple Basic Module - for beginners  
**Plus**—An Advanced Scanning System for the "experts".

**Scancat-Gold for Windows-SE -**

**\$159.95**

**All the features of our "Standard Scancat" plus additional functions.**

- Long term logging of frequencies to hard drive.
- Record Audio to hard drive using sound card.
- Improved spectrum analysis with several great graphical analysis screens.

**Skysweep Decoder Software**



Order On Line \$99.95

**Advanced Digital Signal Processing Software For HF/VHF Applications**

All you need is any Windows® soundcard demo on our website



**COMPUTER AIDED TECHNOLOGIES**

P.O. Box 18285 Shreveport, LA 71138

ORDERS: (318) 687-4444 FAX: (318) 686-0449

Info/Tech Support: (318) 687-2555

(9 a.m. - 3 p.m. Central M-F)

INTERNET DOWNLOADS AVAILABLE  
**INFORMATION & ORDERING**  
**WWW.SCANCAT.COM**

# FM Radio in the '50s

## A look back at mobile and in-home listening

By Bruce F. Elving

**T**oday, we take for granted the ability to hear FM radio in a moving automobile. But 50 years ago, when AM reigned supreme, it was an entirely different story.

As a teenager, I used a round-about system for hearing the 88 to 108 megacycles' band. It consisted of a DC-to-AC inverter plugged into the car's lighter socket and a table model radio with tubes! The antenna was mounted to a side mirror, with transmission line going to the radio placed on a wooden table below the dash. I bought an antenna from the local transit company, after the demise of "bus radio"; the antenna had been used to receive the former WEBC-FM 92.3 Duluth MN.

Around that time, longtime hobbyist David F. Thomas, Proctorville, OH, submitted an article to my DX column in the Newark News Radio Club. His system was a little less primitive than what I used. It consisted of an FM converter, which played through his AM car radio. Gonset made equipment for amateur radio operators, and the company offered a device to accommodate the relatively few people who wanted to try FM on the road.

Thomas reported on a trip west in 1957. Entire states were found to be FM free, with almost no interest shown in FM, except in a few places. One of the bright spots was Mount Vernon IL. The chief engineer of WMIX-FM 94.1 said: "I have always contended that all [radio] broadcasting should be FM ... It is a known fact that North Carolina was more FM conscious than all the other states combined. In fact, it at one time went so far as to ask Zenith to ship its entire production into North Carolina (1947). Many think that if the other states had become FM-minded like North Carolina that FM would be well-established today [1957], instead of there being so many AM stations."

On his trip west, Thomas discovered that where FM was a straight duplication of the AM station, it had done very little advancing; but in the areas where it was not duplicated and offered something different, it had done well and was improving, as with KCMS 102.7 Manitou Springs, CO, with its beautiful music format.



He also commented on how the reception was. This was beneficial to people reading the article who had never heard FM in a moving vehicle: Shielding was often found in Colorado; and KRNW (97.3 Boulder) was almost 100 percent solid on top of Lookout Mountain, and two miles away it was not readable.

Another thing handicapping reception was that his mobile whip antenna was vertical, whereas all the FM stations of that time were horizontally polarized. Now most FM stations are circular, with both horizontal and vertical polarization for better mobile reception.

KRSN-FM 98.5 Los Alamos, NM, was in the process of being sold when heard, and KOA-

FM 95.7 Denver was ending its FM programs. [KOA-FM (now KRFX) later returned to the air on 103.5.]

KRSN-FM found interest poor in New Mexico due to the lack of FM stations, as only three in the state were operating regular schedules. [The 98.5 station in Los Alamos is now KABG, "The Big Oldies."]

KHFM 96.3 Albuquerque, on the other hand, found that interest was growing in their section. They were the first commercial FM station in the state, and they noted that to succeed with FM, it *must* broadcast a type of music not obtainable on AM and must also cater to small specialized audience groups. How different that is from the

Radio Station KRSN

AM 1490 KC  
FM 98.5 MC

# KOA

## NATIONAL BROADCASTING COMPANY, INC.

A SERVICE OF RADIO CORPORATION OF AMERICA

NBC BUILDING, Denver 2, Colorado

wide-appeal programming found on FM today!

In over 100 FM reports Thomas sent out, over 90 percent of the stations said this was their first mobile report. Most of the FM stations were interested in DX reports, especially those with no AM outlet. Notes on reception of the stations' FM signals gave them talking points to local sponsors.

### FM in New York 50 Years Ago

Not a mobile listener, but a reporter to the DX column of 50 years ago was Stephen M., who sent in a report in August, from New York City. He talked about a new station expected on 104.3, which was to have used the WFMX call letters. "This station is going to be on the air shortly with an entirely new kind of transmission. If I understand it correctly, they'll be broadcasting two different programs on the same carrier. They are located in the Hotel Pierre in New York City. This, by the way, makes the second station in the Pierre, the other being WBAI (99.5), also a relatively new station."

[WBAI at that time was commercial; a few years before its being acquired by the Pacifica Foundation.] The two programs probably would be the main station (monaural, since FM stereo was not yet approved) and an FM subcarrier (most likely a music service to stores without commercials). That station is now WAXQ, "Classic Q 104.3."

Another early reporter was Albert J. Sauerbier, Jersey City, New Jersey, who pursued the do-it-yourself method of hearing FM audio, with a Fisher 80T tuner along with amplifier. He constructed a bass reflex cabinet of 3/4 inch plywood and used the new type Altec-Lansing "Biflex" speaker. An Amphenol turnstyle antenna was ready to hoist up on his roof. His log total using an indoor antenna was 30 stations, including WFMX, WSHS 90.3 Floral Park, NY, and stations as far away as Philadelphia. WPAT-FM 93.1 Paterson NJ, WVNJ-FM (now WHTZ) 100.3 and WNEW-FM (now WWFS) 102.7 New York were not yet on the air, permitting reception of such Philly stations as WIP-FM (now WMMR) 93.3 and WPEN-FM (now WMGK) 102.9.

WNEW-FM/WWFS New York had an interesting predecessor on 102.7. It was WHFI West Paterson, NJ, which might have been off the air in 1957, since it had just received a construction permit to move to New York City. Typical of some

big-city stations, WMGM-FM 100.3 New York had just turned in its license because the outlook for commercial FM was so dismal at the time. It was difficult to sell advertising time on FM, and attention was turned to television, then perceived to be a newer and more glamorous medium. It would be several years later that WVNJ-FM Newark was to appear on that frequency, ultimately followed by "Z-100," WHTZ.

Imagine the day when your favorite station did not come on the air until late in the afternoon, or might have left the air early in the evening. That was the case with WSB-FM 98.5 Atlanta, which signed on at 3 p.m. and left the air at 11 p.m. daily. WAGA-FM (now "V 103," WVEE) 103.3 there was on Monday through Friday 7 a.m. to 7 p.m. Jim Cumbie in Dallas said KNER 88.1 there, with only 10 watts' power, was on 3 p.m. to 6 p.m.

My 1957 Newark News Radio Club column was, however, optimistic about the future of FM radio. It noted a net loss of four stations using the commercial part of the FM band (92-108 MHz), while in the educational band (88-92 MHz) there was a gain of 12. This resulted in a gain of eight FM stations nationally. That caused me to prophesy: "I think this growth will not only continue, but it will accelerate in the years to come," which, of course, is what has happened.

### "What is FM?" they asked.

John Ebeling, Bloomington, MN, has further recollections of FM on the road: "Brings back memories of when we went to San Diego in 1959 with a 1957 Plymouth ... I had a Satchell Carlson FM tuner (from a TV set) powered by a dropping resistor under the hood, as the tuner was a 6 v d-c unit. I had a homemade halo antenna fastened to my vertical AM antenna. Every time we stopped for gas and an oil check, the guys would ask me what that was under the hood! I had to explain numerous times that it was for powering my FM tuner; then they asked "What's FM?" It worked pretty well in the Los Angeles area, as the transmitters were up high.

"Those were the days when only horizontal polarization was used, hence the horizontal halo antenna."

### The Scene Today

Receiving FM radio on the go is remarkably easy now, when you consider that almost all

stations have circular polarization, FM station powers are generally greater than in the '50s, there are more stations (some would say too many!) and, most importantly, FM radios are universally available.

If you're willing to pay subscribing fees, XM and Sirius are also available, along with conventional FM and AM. While it may be argued that program choices, especially among commercial FM stations, tend toward sameness across the dial, the types of stations and signals you might enjoy both locally and for mobile DX have considerable variety. That variety includes commercial and noncommercial educational stations, community radio, FM translators, low power stations, and - soon to be heard in cars - special "HD Radio" stations.



[Bruce Elving is an FM DX listener and publisher of the FM Atlas, now in its 20th edition, which can be obtained from "FM Atlas," PO Box 336, Esko MN 55733-0336, at \$22 postpaid. He also publishes FMedia! newsletter. He holds a Ph.D. from Syracuse University in instructional communications. His website: <http://members.aol.com/fmatlas/home.htm>. The HD logo is used with permission of the iBiquity Corporation.]



PAR ELECTRONICS → EF-SWL



The Par EF-SWL is an end-fed short wave antenna optimally designed for 1-30 MHz reception. The radiator is 45 feet of genuine #14 gauge black polyethylene coated Flex-Weave wire (168 strands of #36 gauge woven copper). This material is very strong yet can easily be coiled like a rope for portable work. The UV resistant matchbox houses a wideband 9:1 transformer wound on a binocular core. Unlike other transformers, external stainless studs on the matchbox allow the user to configure the primary and secondary grounds for best noise reduction at their particular location. Output is via a silver/teflon SO239 connector.

Par EF-SWL Order #2205 \$57.95

Universal also carries the Par MON3 omni VHF-UHF base antenna and Par RF filters.

Note: Orders under \$100 ship UPS for only \$6.95.

**Universal Radio**  
 6830 Americana Pkwy.  
 Reynoldsburg, OH 43068  
 ♦ Orders: 800 431-3939  
 ♦ Info: 614 866-4267  
 ♦ Fax: 614 866-2339  
[www.universal-radio.com](http://www.universal-radio.com)

WSOU 89.5	WIP 93.3	WQXR 96.3	WTC 98.3	WBFM 101.9
WKCR 89.9	WRRC 93.5	WRCA 97.1	WOR 98.7	WPEN 102.9
WSHS 90.3	WNYC 93.9	WTOA 97.5	WSNJ 98.9	WPAS 103.9
WFUV 90.7	WJLK 94.3	WEVD 97.9	WVAZ 99.1	WFLX 104.3
WHYY 90.9	WABC 95.5	WCAU 98.1	WBAI 99.5	WKLP 104.7
WHOM 92.3	WFLN 95.7	WHLI 98.3	WCBS 101.1	WWRL 105.1

## Do-It-Yourself Satellite Radio

A few months ago XM and Sirius satellite radio announced they intended to merge their operations into one satellite radio monopoly (oops, I meant "...the next logical step in the evolution of audio entertainment," as explained by Sirius CEO Mel Karmazin at the time). Shortly after the announcement was made, I received an e-mail from MT Editor, Rachel Baughn, a Sirius subscriber, which said succinctly: "Humph...I'm sure this doesn't bode well for WRN."

She was referring to the fact that Sirius carries the satellite fed line-up of international shortwave programming on World Radio Network. She was implying that with the merger there was bound to be a shuffling of the programming line-up and that WRN could be among the first channels jettisoned. Aside from having an unusually pessimistic thought, she may be proved right. Satellite TV and satellite radio cater to the wide popular tastes in the middle of American culture and tend to nip the stuff at the margins whenever they're faced with a bandwidth or budget crunch.

My advice to her was: "...now is the time to go FTA (Free-To-Air)...put in a small Ku-band FTA system and you'll get WRN and Radio Netherlands for free!"

### ❖ Exploring FTA Satellites

Over the last ten years broadcast satellite transmissions have gradually switched from analog to digital. The standard for these digital broadcasts is an MPEGII format used by various companies which sometimes encrypt their transmissions using an assortment of encryption schemes. When the MPEGII format is not encrypted it may be received on any MPEGII FTA receiver. If the MPEGII format is encrypted it may be received only on receivers equipped to decode that particular encryption scheme.

Different video and audio signals, which may or may not be related in content, can be sent on the same transponder. Most MPEGII FTA receivers will sort the signals according to whether they're TV and Radio. As many as ten video signals can be sent on the same transponder, though audio and video quality will suffer, the more signals are added to the same transponder.

FTA MPEGII transmissions are found on virtually all satellites in both the C and Ku-bands. But, those found on Ku-band are of interest here, because they are received on dishes

as small as 3-ft across. That means that Ku-band FTA systems may be used anywhere: in suburban homes, in apartments, high-rise condos, trailer parks, you name it. The FCC allows viewers to use stand-alone satellite TV systems with dishes as small as 3 feet. Home Owners Associations, landlords and others arbiters of style are not allowed to restrict the use of these systems. FCC rule supersedes local, municipal, county and/or state law in this matter.

One of the satellites most populated with MPEGII FTA transmissions is Galaxy 25 located at 97° W. That's where World Radio Network and Radio Netherlands Worldwide are located. Check out the list in the chart of some of the more interesting radio stations available in MPEGII. Most are active 24/7.

### ❖ Where to Buy MPEGII Systems

Tens of thousands of MPEGII FTA systems are sold in the U.S. every year and they're widely available. Most are bought by foreigners living and/or working in the States who need to have programming from the homeland which is not available on their local cable systems or over the air. That's why there is so much programming from Asia and the Middle East on G25. The small MPEGII FTA systems are easily installed and easily moved, allowing viewers and listeners to watch and listen to programming in their own language no matter where they live.

The explosion of these small dish sales has driven the cost down considerably. Expect to pay



**Globecast World TV system: dish, LNB and receiver with built-in smart card for Globecast subscription channels costs \$179. (Courtesy: Globecast World TV)**

### WHERE TO BUY MPEGII FTA SYSTEMS

Dave's Web Shop  
[www.daveswebshop.com/satmain.shtml](http://www.daveswebshop.com/satmain.shtml)  
Carries Coship FTA receiver.

Global Communications  
608-546-2523 [www.global-cm.net](http://www.global-cm.net)  
Has extensive list of multi-feed mounts and receivers.

Sadoun Satellite Sales  
888-519-9595 [www.sadoun.com](http://www.sadoun.com)  
Has everything for all types of MPEGII FTA reception

Skyvision  
800-500-9275 [www.skyvision.com](http://www.skyvision.com)  
Has complete line of FTA receivers and dishes. Excellent tech support. Check out their warehouse clearance listing for even bigger savings.

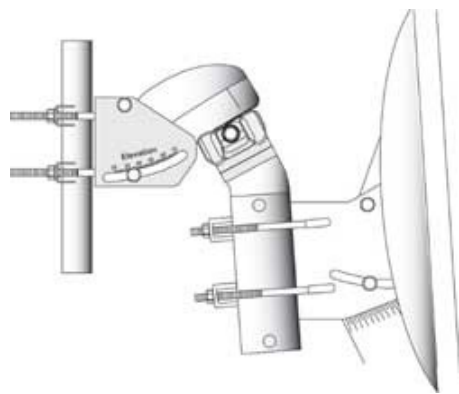

**Skyvision offers this SG-2100 motorized mount for Ku-band dishes. You can program your one dish to access dozens of satellites from horizon to horizon for \$120. (Courtesy: Skyvision)**

under \$200 for an entire system: dish, LNB and receiver. Typically the only thing you'll have to add is the cable to go from the dish to the receiver in your home or apartment. I've compiled a small list of places to buy MPEGII FTA systems (see below), but there many more retailers for this equipment.

Only one system, the one sold by Globecast World TV, can receive encrypted programming broadcast on transponders leased by Globecast. It may be used to tune in all MPEGII FTA programming on any C or Ku-band satellite as well. After having used one for several years I've found that it's not as fast as other similar receivers that I also use (the Fortec and Coship



*Multi-feeds for your Ku-band dish allows reception of several satellites. Switching is done with a DiSEqC switch. (Courtesy: Global Communications)*

models work much better). But, it remains the only model which has the built-in card reader needed for Globecast encrypted channels. For



*Sadoun DiSEqC switch handles up to 4 different LNBs on the same dish or 4 LNBs on 4 different dishes. Cost is \$16 and comes with a plastic weather cover. (Courtesy: Sadoun Sales)*

complete information about subscriptions to Globecast channels visit their web site: [www.globecastworldtv.com](http://www.globecastworldtv.com).

### ❖ Installing and Using an MPEGII Receiver

Most complete systems come with a roof/wall mount which bolts to the roof or side of the house. You may prefer to do a ground mount somewhere in your yard. Use a 6-ft length of galvanized plumbing pipe, found at any hardware supply, the same outside diameter as the roof mount pipe that came with your system. You'll need to pound it into the ground 3 feet (make certain it's plumb!) and mount the dish on top, using the instructions that came with the system.

Once the dish with LNB are mounted, you'll need to bring the receiver and a small TV set out to the site to find the satellite. The Globecast system includes a sheet that allows you set the azimuth and elevation for reception of G25 according to your own latitude and longitude. If you're using another system, you can find the satellite coordinates at [www.satsig.net/ssazelm.htm](http://www.satsig.net/ssazelm.htm) or <http://sadoun.com/Sat/Installation/Satellite-Heading-Calculator.htm>. Coordinates for any satellite may be found at either site.

Hook the receiver up to the LNB with a short piece of RG/6 coax. Connect the receiver

output to the TV's antenna input. Set the receiver to output on either channel 3 or 4. Now, plug both the TV and the receiver into a long extension cord. Using the directions that came with your receiver, get to the "set-up" mode and follow directions. You may need to have the parameters of the channel you want to watch programmed into the receiver along with the Ku-band antenna information.

If you did your calculations right and everything is set up, you may get a signal right away. Now it's just a matter of peaking the dish (turning it slightly east or west and moving it slightly up or down to get the strongest possible signal). Once you've done that, you can start searching for other signals on the satellite. Some receivers, Coship for example, can do a "blind search," which means that it will search all the transponders on the satellite for any MPEGII signal.

Now, it's possible to add a couple of extra LNBs to the Ku-band dish you just installed in order to pick up other satellites. Or, you can add extra Ku-band dishes aimed at other satellites. These LNBs or dishes are hooked together with a Digital Satellite Equipment Connector (DiSEqC) switch. Most DiSEqC switches can accommodate four different LNBs. Either way, you'll now have what I call a "poor-man's-satellite-radio" system.

With all dishes or LNBs connected to the same receiver, you can switch among the four satellites instantly to get to different programming on different satellites. You can also outfit your dish with a small electric motor to drive the dish to the location of various FTA satellites. Adjusting each LNB on a multi-feed dish is tricky. I used the multi-dish feed because I had so many extra Ku-band dishes lying about. Either way, this system has no moving parts.

The software built into most FTA receivers allows you to make a "favorites" list of radio stations. By staying in this list you can scroll up and down the channels and hear only the ones you want to hear, without having to have a TV screen to see what you're doing. It's an amazing system!

### ❖ But, Wait, There's More!

Until now I've not even mentioned the main reason for the existence of MPEGII FTA receivers: video. Yes, there are dozens of interesting video channels which you'll pick up with your FTA system in addition to the radio. One of the most interesting stations is MHz World View ([www.mhzworldview.org](http://www.mhzworldview.org)) which is an alternative American public broadcasting network which features news programs from around the world, world beat music shows, and the International Mystery series, the best mystery series on any network. MHz World View is currently FTA, but if it encrypts it will be available only on Globecast World TV receivers. That's a strong reason for going with a Globecast system.

Other TV channels of note are: Al Jazeera English (G25) and NBC News Channel (AMC1).

Regardless of what system you get and what you end up listening to, I hope you'll show your support for those channels you listen to most often when they have a fund raiser. Unlike



*DIY Ku-band dish installation kit from Sadoun Satellite Sales: \$25. Comes complete with a little compass! (Courtesy: Sadoun Sales)*

most of the channels on either satellite radio service, these channels are worth it!

### WHAT'S ON WHERE:

Ku-Band MPEGII FTA Radio Stations of Note

**Galaxy 11 (91°W)**  
Yesterday USA (Old Time Radio 24/7) [www.yesterdayusa.com](http://www.yesterdayusa.com)

**Galaxy 25 (97°W)**  
Radio Netherlands World Wide 1 (Dutch) [www.radionetherlands.nl](http://www.radionetherlands.nl)  
Radio Netherlands World Wide 2 (English)  
Radio Netherlands World Wide 3 (Spanish)  
World Radio Network (English North America) [www.wrn.org](http://www.wrn.org)

World Radio Network (Multi-lingual North America)  
World Radio Network (French)  
40 Channels of commercial free music formats

**AMC 1 (103°W)**  
WCPE-FM (Wake Forest, NC) Non-commercial classical music 24/7 [www.theclassicalstation.org](http://www.theclassicalstation.org)

**Galaxy 10R (123°W)**  
KEXP-FM (Seattle, WA) Non-commercial eclectic music 24/7 [www.kexp.org](http://www.kexp.org)



**Best Scanner Antenna**  
Best obstruction-penetrating in user surveys and testimonials.  
**NILJON ANTENNAS**  
Grove Enterprises 800-438-8155  
[www.grove-ent.com](http://www.grove-ent.com)  
Universal Radio 800-431-3939  
[www.universal-radio.com](http://www.universal-radio.com)

**Q.** *I have an AM radio tuner with two screws on the back marked "ANTENNA." What's the best way to hook this up, and do I need an earth ground? (Email)*

**A.** The same way you'd hook up a shortwave antenna. If one of the screw terminals is marked with a "G" (ground), then it should be connected to the shield of the coax that goes to an outdoor antenna; otherwise, you can choose either screw.

You really don't need an antenna much longer than 30-50 feet to get everything you want; signals in that portion of the spectrum are obscured more by natural noise (static from worldwide thunderstorms), so a larger antenna simply amplifies both the signal and the noise – no real improvement!

Your best pickup will be made with the broadside of the antenna facing the compass direction of the signal(s) you want to hear; in other words, the signal arrives perpendicular to the wire.

You can connect the center wire and shield of the coax at (or near) the center of the antenna where it is split in half by an insulator, or you can connect just the coax center wire to the end of a random wire antenna, but the shield must be connected to its screw on the tuner.

Your primary enemy will be electrical noise emanating from power lines (in your home, your neighbors' homes, and the main distribution line) and radiated interference from home electronics. That's why the outdoor antenna and a shielded transmission line are so important.

While an earth ground won't increase signal strength in reception, it sometimes helps reduce electrical noise interference.

**Q.** *Is there a reliable way to disable an imbedded RFID tag? (Mark Burns, Terre Haute, IN)*

**A.** Yes, a microwave oven will destroy a Radio Frequency IDentification tag, but, of course, could also damage what it's in – like a fabric which might catch fire. An RFID tag can also be disabled by simply wrapping or shielding it with metal foil, or simply putting it inside a metal enclosure which acts like a signal reflecting or absorbing Faraday cage.

The maximum range of a passive RFID tag is about 10 feet, since it has no power of its own and uses the energy from the reading device to radiate its response, but active RFID tags contain batteries, allowing them to radiate a signal much farther.

**Q.** *Does the Canadian Coast Guard verify SWL reception reports with QSL cards? Is there a good translation program that allows me to send verification reports to Russian stations? (Roger Henderson, Memphis, TN)*

**A.** Most utility stations consider shortwave listening reports an intrusion on private communications, so QSLs and other verification responses are few and far between – if ever – including the Canadian Coast Guard. However, English is a second language in many countries, so you might as well send the veri in your native language, along with a prepaid International Reply Coupon (IRC) and hope for a response.

However, there are free translation services available on the Internet, including Google's Gmail, which translates your message directly to Russian Cyrillic (or any other common language). Another is Alta Vista's Babbelfish.

**Q.** *I did radio checks in the military and often wondered, how could an SSB signal travel farther than a full-carrier AM signal? (Gary Hickerson)*

**A.** It doesn't. RF is RF, and the same amount of radio frequency energy, radiated from the same antenna on a given frequency at a give time, will travel the same distance. What actually happens is at the receiving end.

A single sideband is narrower in bandwidth (occupies less spectrum) than a full carrier with its double sideband, so the receiver automatically selects a narrower filter in that mode, thus reducing the amount of competing noise spectrum that it receives. The net result is that it can hear weaker (more distant) signals, thus giving the (erroneous) impression that the SSB traveled farther. The same effect is seen with even narrower CW signals.

**Q.** *While CB radios for car or home often included SSB mode, and CB walkie-talkies have AM and occasionally FM, are there any CB walkie-talkies with SSB? I remember seeing an ad for one years ago. (Michael, email)*

**A.** That must have been *many* years ago. I've never seen a CB walkie-talkie with SSB capability, and I doubt that any currently exists. SSB is generally included on upper end CBs for maxi-

um range, but walkie-talkies, with their short antennas, are intended for local convenience, not crowded-band competition or extended range.

**Q.** *As a newcomer to shortwave, I'm wondering if there is an optimal wire antenna length for reception and does the direction matter? Will simple bell wire work for the antenna and feedline? (Ken Eiker, email)*

**A.** Proper antenna length is critical for transmitting, but not receiving. This is because a transmitter needs to have the correct antenna length to match the impedance of the cable and transmitter to avoid reflected power losses, but a shortwave receiver only needs enough antenna length to pick up enough signal strength to overcome the receiver's own internally-generated circuit noise.

Modern shortwave receivers don't need more than 20-50 feet of antenna to hear worldwide signals. The antenna should be erected as high as practical (at least 15-20 feet) and away from electrical interference sources like your house and power lines.

A wire antenna picks up signals off its side (perpendicular to the wire) and ignores signals arriving off the ends. The theoretical pattern, then, would be like holding a loosely-inflated balloon with two opposing fingers pressing in on it. The dimples would be the ends of the wire and represent nulls (minima) in the received signals.

While the antenna wire can be thick or thin, insulated or bare, stranded or solid, the transmission line should be coax (RG-6/U, RG-59/U, RG-59/U, RG-8M or X, etc.). You can even use the thinnest of all, RG-174/U for runs of under 100 feet or so on shortwave frequencies (not on higher scanner frequencies). TV twinlead can also be used, but, because it is unshielded, it is vulnerable to signal-absorption losses from moisture and nearby downspouts or metal window framing.

Coax is highly recommended, because its shielding rejects electrical noise from household wiring and electronic appliances as it comes into your home. You can attach the center wire of the coax to one end of the wire and leave the shield unattached, or you can put an insulator at or near the center of the wire antenna and connect the coax shield to one side and the center conductor to the other. At the receiver, the shield must be attached to the radio in the normal manner.

Questions or tips sent to Ask Bob, c/o MT are printed in this column as space permits. Mail your questions along with a self-addressed stamped envelope in care of MT, or e-mail to [bobgrove@monitoringtimes.com](mailto:bobgrove@monitoringtimes.com). (Please include your name and address.)



**Q.** I understand that the CAP-Flight callsign is used by the Civil Air Patrol. Do you have any additional information on how this callsign is used and why? (Several readers via email)

**A.** The CAP-assigned aircraft callsign CAPFlight XXXX is considered an air carrier callsign by the FAA. It may, if conditions permit, be transmitted using the FAA-prescribed group form described below. Only the CAP-Flight callsign may be transmitted in this way, and CAP flight crews can use a digit-by-digit pronunciation when required by conditions.

The group form of this callsign is the pronunciation of a series of numbers as the whole number, or pairs of numbers they represent rather than pronouncing each separate digit. Note that "zero" is pronounced "ze-ro," not "oh" and that 4-digit numbers are always pronounced as two pairs.

For example: CAPFlight forty-two twenty seven, CAPFlight two thirty-two, CAPFlight seventeen zero six, CAPFlight nine eleven, and CAPFlight ninety-nine zero one.

The first two digits of the CAPFlight callsign indicate the unit the aircraft is assigned to. Here is the last known public list of those first two digits and the Region/Wings with which they are associated.

CAP Flight 01##	Alabama
CAP Flight 02##	Arizona
CAP Flight 03##	Arkansas
CAP Flight 04##	California
CAP Flight 05##	Colorado
CAP Flight 06##	Connecticut
CAP Flight 07##	Delaware
CAP Flight 08##	Florida
CAP Flight 09##	Georgia
CAP Flight 10##	Idaho
CAP Flight 11##	Illinois
CAP Flight 12##	Indiana
CAP Flight 13##	Iowa
CAP Flight 14##	Kansas
CAP Flight 15##	Kentucky
CAP Flight 16##	Louisiana
CAP Flight 17##	Maine
CAP Flight 18##	Maryland
CAP Flight 19##	Massachusetts
CAP Flight 20##	Michigan
CAP Flight 21##	Minnesota
CAP Flight 22##	Mississippi
CAP Flight 23##	Missouri
CAP Flight 24##	Montana
CAP Flight 25##	National Capital
CAP Flight 26##	Nebraska
CAP Flight 27##	Nevada
CAP Flight 28##	New Hampshire
CAP Flight 29##	New Jersey
CAP Flight 30##	New Mexico
CAP Flight 31##	New York
CAP Flight 32##	North Carolina
CAP Flight 33##	North Dakota
CAP Flight 34##	Ohio
CAP Flight 35##	Oklahoma
CAP Flight 36##	Oregon

CAP Flight 37##	Pennsylvania
CAP Flight 38##	Rhode Island
CAP Flight 39##	South Carolina
CAP Flight 40##	South Dakota
CAP Flight 41##	Tennessee
CAP Flight 42##	Texas
CAP Flight 43##	Utah
CAP Flight 44##	Vermont
CAP Flight 45##	Virginia
CAP Flight 46##	Washington
CAP Flight 47##	West Virginia
CAP Flight 48##	Wisconsin
CAP Flight 49##	Wyoming
CAP Flight 50##	Alaska
CAP Flight 51##	Hawaii
CAP Flight 52##	Puerto Rico
CAP Flight 60##	California
CAP Flight 61##	Alaska
CAP Flight 91##	Northeast Region
CAP Flight 92##	Middle East Region
CAP Flight 93##	Great Lakes Region
CAP Flight 94##	Southeast Region
CAP Flight 95##	North Central Region
CAP Flight 96##	Southwest Region
CAP Flight 97##	Rocky Mountain Region
CAP Flight 98##	Pacific Region
CAP Flight 99##	Congressional Squadron
CAP Flight 99##	National Commanders Squadron

The last two digits of these callsigns are assigned to a specific aircraft, and the whole callsign is, for the most part, a static callsign. The list below of Mississippi Wing CAP aircraft illustrates this concept.

CAPFlight Callsign	Aircraft Type	Aircraft Home Base
CAP Flight 2219	Cessna 172R	Golden Triangle Regional/Columbus
CAP Flight 2222	Cessna 172N	Tupelo Regional Airport
CAP Flight 2231	Cessna 182R	Trent Lott International Airport, Pascagoula
CAP Flight 2237	Cessna 182T	Olivia Regional Airport
CAP Flight 2242	Cessna 172P	Unknown airport
CAP Flight 2253	Cessna 172P	Ripley Airport
CAP Flight 2264	Cessna 172S	Hattiesburg Muni Airport
CAP Flight 2275	Cessna 182R	Olivia Regional Airport
CAP Flight 2286	Cessna 172P	Key Field Airport
CAP Flight 2292	Cessna 172S	Hawkins Field

**Q.** Do you have any frequency information on the new Skynet 5A military communications recently launched into geostationary orbit? (Anonymous in Europe via email)

**A.** Skynet 5A is the first of the new generation of British military communications satellites. It was launched on March 11, 2007, by Ariane Space. Skynet 5A was initially placed into the geostationary Clarke Belt at about 177 degrees West, where it underwent testing by the U.S. Air Force Satellite Control Facility. It was then relocated to its operational slot at 1 degree West, where it will be commanded by RAF Oakingham.

The following UHF frequencies have been recently reported for this satellite:

245.800 MHz	25 kHz bandwidth
249.480 MHz	10 kHz bandwidth
249.530 MHz	10 kHz bandwidth
249.850 MHz	10 kHz bandwidth
250.130 MHz	10 kHz bandwidth
250.200 MHz	10 kHz bandwidth
257.700 MHz	25 kHz bandwidth
261.200 MHz	25 kHz bandwidth

You can find the latest frequency information including S-band TT&C and SHF satcom frequencies at [www.uhf-satcom.com:80/skynet5a/](http://www.uhf-satcom.com:80/skynet5a/). Thanks to Mr. Paul J. Marsh and all the gang at [UHF-satcon.com](http://UHF-satcon.com) for the heads up on this new military satellite.

**Q.** Many years ago (approximately 10+), I often used to hear U.S. Military MARS stations and was able to QSL a number of them. An enforced absence from the DXing scene meant that I lost track of current frequencies, etc. My question, is there a list (or lists) of MARS stations and frequencies that I could obtain in order to pick up this side of my hobby again? (Fr. Jim, New Zealand via email)

**A.** In short, I am afraid the answer is "no," Jim. All three MARS services now protect their frequencies, their callsigns, and members' identities under the For Official Use Only (FOUO) umbrella. All three services (Air Force, Army, Navy/Marine Corps/Coast Guard) have strict no QSL policies.

In the ten years you have been gone, MARS has pretty much lost their military support missions, and so they keep their service alive by aligning their communications capability with the Department of Homeland Security and SHARES, to name a couple of services. There is next to no formal traffic passed on any of their frequencies these days, so you will pretty much hear mostly ragchewing during most of their HF radio nets.

In the case of Navy MARS, I can't remember the last time I heard or saw a ship reported on any of their MARS nets other than digital traffic. The major exception to this rule is the US Air Force MARS phone patch nets. They do handle quite a few patches daily for Air Force aircraft. The primary frequency to monitor is 13927.1 kHz in upper sideband.

Bottom line is, it looks like best days of the three MARS services are behind them, from a monitor's point of view, I am sorry to say.

## Matching the Scanner to the System

**O**ne fundamental question for new or returning listeners is which scanner to buy. With so many new and used scanners on the market with widely varying features and prices, how should you go about selecting the right scanner for your needs?

### ❖ Modern Scanners

Dan,

After a "very long interval" my interest in scanning has returned. However on doing research on "Trunk Tracking" I find that have been left in the dust when it comes to the modern scanners.

I am hoping you might offer some suggestion as to a model to purchase. I am listing my interests below, in order of importance to me:

1) A handheld

2) Will be used in the Washington, DC area to chiefly monitor the local police and fire departments

3) Would like something not too difficult to program

Would appreciate any suggestions you might offer as to scanners that might fit my requirements.

Gene in Washington, DC

Municipal public safety agencies in the nation's capitol operate primarily on a Motorola Type II trunked radio system. The system uses both analog and APCO-25 digital transmissions, so to hear everything you will need a "digital-capable" scanner.

Because this is a Type II system with the older 3600-baud control channel, any of the digital scanners will work fine for this system. However, some agencies outside the Capitol Beltway are exclusively APCO-25 and use a newer control channel method, so a more recent "APCO Project 25 trunking" scanner may be worthwhile if you intend to monitor these agencies.

Since you've indicated a preference for handhelds, your choices would include the PRO-96 from Radio Shack, the Uniden BC396T, and the Uniden BC-296D.

### Digital-capable Handheld Scanners

Scanner	Manufacturer	Track P-25
PRO-96	GRE	Yes
BC-250D	Uniden	No
BC-296D	Uniden	Yes
BCD396T	Uniden	Yes

The PRO-96 is a handheld scanner built by GRE and introduced through Radio Shack in 2003.

It supports APCO Project 25 systems, including P-25 trunking. The PRO-96 comes with a feature called Virtual Scanner ("V-Scanner"), which allows the user to select a set of pre-programmed frequencies for major metropolitan areas within the United States. One of those areas, designated V-Scanner #6, is for the Washington, D.C.-Virginia-Maryland metropolitan area and includes a bank of frequencies identified as the DC Fire and Emergency Medical Services (EMS) system. Through a short series of keypad entries, V-Scanner #6 can be made active and put into service immediately. However, because these frequencies were current when the scanner was manufactured, they may eventually become out of date and no longer useful. When that happens, there is a second option for loading frequencies.

Rather than having to enter each frequency into the scanner by hand via the front keypad, all of the digital scanners listed above can also be programmed via a computer connection. With the proper computer software and cable, along with a data file of frequencies, the scanner can be brought up-to-date very quickly with a personal computer.

Win96 is a software program that can be used to program the PRO-96 as well as manage the V-Scanner functionality. It also has the capability of reading ("importing") and writing ("exporting") data files of frequencies. This allows the user to download data files from the Internet and import them into the scanner. Win96 is available from the StarrSoft web site at [www.starrsoft.com/software/Win96](http://www.starrsoft.com/software/Win96).

The interface cable you'll want for the PRO-96 is Radio Shack part number 20-047, which connects the scanner to a computer via USB. If you have an older computer with an RS-232 port, you may have to hunt around for part number 20-289.

There is a Yahoo! group dedicated to the PRO-96, which can be found at <http://groups.yahoo.com/group/PRO-96>. The group has more than 2,000 members and maintains an extensive collection of data files, including one for the DC Metro area.

The newest Uniden digital handheld is the BCD396T, a very capable scanner with a number of convenient features. It can be programmed using a computer connection and comes with the proper interface cable. Uniden provides a relatively simple software program called UASD396 for frequency loading and control; however, many users have opted to purchase third-party programs with additional capability. One popular program is called

ARC396 and is available through the Butel software web site at [www.butelsoftware.com](http://www.butelsoftware.com). Due to the complexity of the BCD396T, I would strongly recommend the use of a software program such as UASD396 or ARC396.

Like most modern scanners, the BCD396T has a dedicated Yahoo! group with files and other helpful resources. You can find this group at <http://groups.yahoo.com/group/BCD396T>.

There are a variety of opinions on the relative merits of the BCD396T versus the PRO-96, and some features may be more important to you than others. On the pro side, the BCD396T offers a very flexible memory management scheme with room for many systems, has good audio output and is physically much smaller than the PRO-96.

On the con side, the BCD396T appears to be less sensitive than the PRO-96, does not equalize the volume level on subsequent transmissions, and consumes batteries much more rapidly. Either scanner has a street cost of around \$500, although occasional sales may shave \$100 or so off that price.

### ❖ Washington, D.C. Public Safety Radio

Washington D.C. metropolitan trunked radio system operates in two bands, 460 MHz and 800 MHz. In general, police use the 460 MHz band, while the Fire and Emergency Medical Services (EMS) personnel use 800 MHz frequencies. Most of the transmissions are digital and some are also encrypted.

Because the 460 MHz band does not have a standard plan, you will need to program your scanner with a "Custom Frequency Table" that instructs it how to locate frequencies for this system. You will need to make two entries, as follows:

Base: 453.4500 MHz,  
Spacing: 12.5 kHz, Offset: 380  
Base: 460.0250 MHz, Spacing: 12.5 kHz, Offset: 480

Frequencies used are:

453.4500, 460.0250, 460.1000, 460.1500, 460.2000, 460.2500, 460.2750, 460.3250, 460.3500, 460.3750, 460.4000, 460.4250, 460.4500, 460.4750, 460.5000 MHz

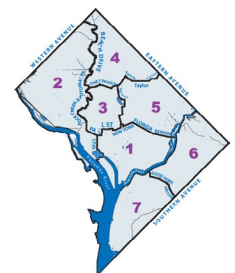

The 800 MHz part of the system does not require any custom frequency table entries. The frequencies in use are:

852.6125, 852.6375, 852.6625, 852.6875, 852.7125, 852.7375, 852.7625, 852.7875, 855.2125, 855.2375, 855.4625, 856.9875, 857.9875, 858.9875, 859.9875, 860.98750 MHz

Decimal	Hex	Description
1616	065	Dispatch
1632	066	Main
1648	067	Fireground (Primary)
1680	069	Fireground 5
1696	06A	Fireground 1
1712	06B	Fireground 7
1744	06D	Fireground 9
1760	06E	Fireground 2
1824	072	Fireground 3
1888	076	Fireground 4
1904	077	EMS 1 (East)
1920	078	EMS 2 (West)
1936	079	EMS 3 (Rescue Assignments)
1968	07B	Administration
2000	07D	Maintenance
2048	080	Training
2064	081	Investigations
2080	082	Inspectors
2640	0A5	Fire Boat

The Metropolitan Police Department has divided up the city into seven districts.

Metropolitan Police Districts		
16400	401	District 1 (Operations)
16432	403	District 2 (Operations)
16464	405	District 3 (Operations)
16496	407	District 4 (Operations)
16528	409	District 5 (Operations)
16560	40B	District 6 (Operations)
16592	40D	District 7 (Operations)
16624	40F	City-wide 1 (simulcast on 159.150 MHz)
16656	411	Special Operations
16784	419	District 1 (Tactical)
16816	41B	District 2 (Tactical)
16848	41D	District 3 (Tactical)
16880	41F	District 4 (Tactical)
16912	421	District 5 (Tactical)
16944	423	District 6 (Tactical)
16976	425	District 7 (Tactical)
17360	43D	Special Events
17392	43F	Special Events
18032	467	Emergency Communications Center
18096	46B	Emergency Communications Center
18160	46F	Emergency Communications Center
18896	49D	Aviation
19760	4D3	Secret Service (Patch)
20496	501	Capitol Police
20528	503	Capitol Police
20560	505	Capitol Police
20592	507	Capitol Police
20624	509	Capitol Police

Welcome back to scanning, Gene, and let us know how you make out.

### ❖ Palos Heights, Illinois

*Hello,  
I live in Palos Heights, IL (60463) and I have the Radio Shack PRO-89 scanner and am trying to listen to local police, fire, ambulance, etc. Do I need a better scanner to listen to these types of units? Do I need trunking, P-25, etc?*

*Any help would be appreciated – I am new to scanning!*

Mike

Palos Heights is a city of about 12,000 people located just southwest of Chicago in Cook County, Illinois. Palos Heights police and fire are dispatched from a combined operations center known as South West Central Dispatch (SWCD), which handles routine and emergency calls for a number of public safety agencies in southwestern Cook County. The facility itself is actually headquartered on West College Drive in Palos Heights.

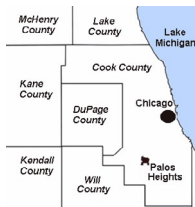

Police dispatch occurs on 470.8625 MHz for Palos Heights and adjacent communities. Fire dispatch for Palos Heights, Palos Hills and Palos Park can be heard on 154.070 MHz.

The Radio Shack PRO-89 was introduced in 2000 as a handheld race scanner and includes features intended to make it useful for NASCAR race monitoring. It is capable of monitoring conventional analog radio transmissions in VHF, UHF and 800 MHz bands and can store up to 200 channels in 10 banks.

Since the SWCD frequencies operate in conventional (non-trunked) mode and carry analog traffic, your PRO-89 should work just fine for your local area.

### ❖ Valentine, Nebraska

*Dan,  
I am in Nebraska and we have monitored the police department in the town of Valentine for years. All of a sudden they went to high band because they were having lots of problems on low band. So we were picking them up fine, and then all of a sudden it started making that loud buzz noise when the dispatch talks. You can hear the police cars but the dispatch has the buzz noise. ...I don't want to get a scanner upgrade if it will do no good.*

*They have just changed to high band on 154.978 MHz. But the one side from dispatch is a constant buzz. They either went digital or on trunking. And if trunking it is probably the new trunking and the old will not work.*

*I have an older Bearcat scanner. I would not want to upgrade to a digital scanner if you don't think that's the problem.*

John in Nebraska

Valentine is a town of about 2,800 residents located about 250 miles northwest of Omaha, near the border with South Dakota. It is the county seat for Cherry County, which is home to just over 6,000

#### Valentine, Nebraska

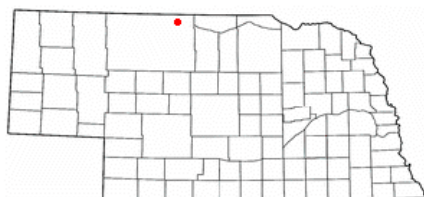

people. County population peaked in the 1920s and has been declining since then.

Cherry County has by far the largest geographic area of any county in Nebraska, covering an area of about 6,000 square miles. This makes the county larger than the state of Connecticut and nearly three-quarters of the size of New Jersey.

This expanse and low population density create a challenge for public safety agencies to provide timely service. Most agencies use radio equipment operating in the VHF (Very High Frequency) band, which is commonly covered by both old and new consumer scanners.

I did not find a frequency listing in the FCC database for 154.978 MHz in Nebraska; however, I did find that 155.640 MHz is licensed to the Valentine Police Department. The police department is not trunked with just that single frequency, and, although it is technically possible, I would be quite surprised if the dispatch-to-officer talk path was digital while the officer-to-dispatch talk path was analog. Such a situation may occur in a misconfigured system or arise after certain types of equipment failure, but it would be useful for it to continue for any length of time.

Here are some other frequencies to check:

Frequency	Description
152.3975	Valentine Schools
153.740	Sheriff
153.800	Sheriff
153.815	County Fire
154.145	Sheriff
154.980	Sheriff
155.430	Sheriff
155.475	Law Enforcement Mutual Aid
155.640	Valentine Police
155.805	Emergency Medical Services (North)
155.895	Sheriff
155.940	Valentine Public Works
156.135	Sheriff
158.820	Emergency Medical Services (North-west)
158.955	Emergency Medical Services (South)

EMS frequencies may also carry Sheriff Department radio traffic.

Nebraska State Patrol operates at even lower frequencies. Depending upon your location, you should be able to hear them on 42.34, 42.46 and 42.48 MHz. Other statewide public safety frequencies include:

39.82	Emergency Medical Service
39.90	Sheriff
39.98	Fire

### ❖ Parker County, Texas

*Parker County, Texas, has just signed a contract with Motorola to install a VHF Project 25 system. The contract was for 3.7 million dollars, which includes equipping all 21 fire departments with mobiles and some handhelds.*

*The system is scheduled to go operational near the end of the year.*

John in Greenwood

Parker County is located just west of Fort Worth and is one of a dozen counties that make up the Dallas-Fort Worth "Metroplex." It is home to about 100,000 people.



The county currently operates a Logic Trunked Radio (LTR) system on five frequencies:

**LCN Frequency**

01	866.5625
05	867.0375
09	867.4875
13	867.9875
17	868.6875

Talkgroups on the system include:

0-01-010	County Precinct 1
0-01-020	County Precinct 2
0-01-030	County Precinct 3
0-01-040	County Precinct 4
0-01-050	County All Precinct Call
0-09-005	Texas Department of Transportation
0-09-041	County Marshals
0-09-043	County Marshals
0-09-067	Parker County Sheriff
0-09-070	Parker County Sheriff (Dispatch)
0-09-090	Parker County Sheriff
0-09-120	Texas Department of Public Safety
0-13-088	Parker County Fire Marshal
0-13-200	County Search and Rescue
0-13-225	County Emergency Management
0-17-120	All Call

The county also uses some VHF frequencies outside the LTR system:

154.250	Fire (Northeast)
154.340	Fire (Dispatch)
154.725	Sheriff

The new digital system will replace the problematic LTR equipment, which in the past has left some firefighters unable to communicate. The ten-year contract with Motorola includes a new mobile radio and two portable handheld radios per fire vehicle. The Sheriff's Department, county commissioners and constables, as well as the county attorney will also receive new radios.

**❖ Chicago, Illinois Update**

In your March 2007 column you stated that 155.830 MHz is common fireground. Primary fireground is 153.830 MHz. Chicago used to use this as their fireground but changed to 154.295 MHz.

Also, 470.4375 MHz is the rebroadcast

frequency for ISPERN and 470.3625 MHz is used for IFERN (no longer known as NIFERN) I'm sure you have heard from many members of CARMA on this.

Enjoyed the article anyway. Good health to you,

Ric in Illinois

CARMA is the Chicago Area Radio Monitoring Association and is an excellent source of information for scanner listeners in Chicagoland. You can visit their web site at [www.carmachicago.com](http://www.carmachicago.com) and if you're in the area, join them at one of their local get-togethers. CARMA members do a great job of keeping up with frequency changes, agency names and responsibilities, and generally make scanning in northern Illinois more enjoyable.

**❖ MPT-1327**

Hi,

I saw your column and thought that I would drop you a line. There is a MPT-1327 system that is operated by Basin Electric Coop based out of Bismark, North Dakota. I found some of the sites here and submitted it to radio-reference.com. I just found this system recently so I am using trunk view to get information.

Rodney in North Dakota

We spend a lot of time discussing the more common trunked radio technologies, including new digital systems that use the APCO Project 25 standards. However, there are other standards available for radio networks, including one called MPT-1327.

MPT-1327 is a trunked radio standard commonly used in Europe and parts of Canada, with installations in more than 80 countries. It originated from the British Ministry of Post and Telecommunications (MPT) in the late 1980s and has grown in popularity outside of the United States since then. It uses a digital control channel and one or more analog voice channels (called *Traffic Channels* in MPT-1327). Each user is assigned a unique identifier made up of a three-digit *prefix*, a four-digit *fleet number*, and a two- or three-digit *call number*.

There are a few options available to hobbyists for monitoring MPT-1327 systems. Rodney is using a software program called TrunkView, available from [www.linato.net/trunkview](http://www.linato.net/trunkview). It decodes the MPT-1327 control channel and works with a number of popular radios.

UniTrunker is another software program that can decode control channel messages from a number of trunked radio systems, including MPT-1327. It is available for download, along with instructions, from the Radio Reference web site at <http://wiki.radioreference.com/index.php/UniTrunker>.

Basin Electric Power Cooperative is a 46-year-old wholesale generation and distribution cooperative providing electric service in nine states in the central part of the United States: Colorado, Iowa, Minnesota, Montana, Nebraska, New Mexico, North Dakota, South Dakota

and Wyoming. Last year they began replacing their old conventional radio equipment with new radios and repeaters in the nearly 2,000 miles of transmission line infrastructure. The new system uses MPT-1327 in the UHF band.

Here are some identified sites and frequencies, organized by state. If readers know of more sites or active frequencies, please send me an e-mail with that information.

**Colorado**

Cornish	451.7000, 452.6750
Willard	451.0250, 452.6250

**Iowa**

Larchwood	451.1625, 452.4250
-----------	--------------------

**Nebraska**

Dix	461.2250, 462.0000
Harrisburg	452.2750, 452.6500
Sidney	462.3000, 463.2250
Stegall	451.0250, 451.9750

**North Dakota**

Benedict	462.4500, 463.4750
Beulah	461.1250, 461.3250
Bismarck	452.4000, 452.8000, 461.9000, 462.5000, 463.5000
Burnstad	451.0250, 451.5250
Columbus	451.2500, 451.7500
Driscoll	451.6000, 452.2750
Forbes	451.3250, 462.6500
Hensler	451.7000, 452.6500
Killdeer	451.2125, 452.0250
New Hradec	451.1125, 451.6750
New Salem	461.6625, 463.9250
Ross	452.3500, 452.6500
Stanton	462.0000, 463.6500
Strasburg	451.2250, 451.7500

**South Dakota**

Broadland	452.3000, 452.8000
Crandell	451.1000, 452.8500
Gettysburg	451.1625, 451.6750
Highmore	451.2500, 451.6250
Lead	451.2000, 451.6500
Leola	451.2000, 451.7000
Lowry	451.0750, 451.5000
Martin	451.2125, 452.3000
Philip	451.1125, 451.6750
Rapid City	451.2500, 452.1750
Turkey Ridge	451.1250, 451.7500
Vermillion	451.2000, 452.6500
Watertown	451.2125, 451.6500
White Lake	452.2750, 452.8500

**Wyoming**

Buffalo	451.1500, 452.3250
Cheyenne	451.1125, 452.0000
Gillette	462.1750, 462.5250
Spotted Horse	461.7750, 462.2250
Wheatland	451.2125, 451.8500
Wright	462.3000, 463.2250

That's all for this month. Please continue to send your questions, comments, and frequency listings to me at [danveeneman@monitoringtimes.com](mailto:danveeneman@monitoringtimes.com), and check my web site at [www.signalharbor.com](http://www.signalharbor.com) for more radio-related information. Until next month, happy scanning!

(Ed. note: We get many requests for frequencies but few submissions from folks on the West Coast. What are you hearing? Your fellow hobbyists would like to know!)

# Big Savings on Radio Scanners

## Uniden® SCANNERS



### Bearcat® 796DGV Trunk Tracker IV with free scanner headset

Manufacturers suggested list price \$799.95  
**CEI Special Price \$519.95**

1,000 Channels • 10 banks • CTCSS/DCS • S Meter  
**Size: 6 15/16" Wide x 6 9/16" Deep x 2 3/8" High**

**Frequency Coverage:** 25,000-512,000 MHz., 806,000-956,000 MHz. (excluding the cellular & UHF TV band), 1,240,000-1,300,000 MHz.

When you buy your Bearcat 796DGV TrunkTracker package deal from Communications Electronics, you get more. The GV means "Great Value." With your BC796DGV scanner purchase, you also get a **free deluxe scanner headphone** designed for home or race track use. Headset features independent volume controls and 3.5 mm gold right angle plug. The 1,000 channel Bearcat 796DGV is packed with features to track Motorola Type I/II/III Hybrid, EDACS, LTR Analog Trunk Systems and Motorola APCO 25 Phase I digital scanner including 9,600 Baud C4FM and CQPSK. Also features control channel only mode to allow you to automatically trunk many systems by simply programming the control channel, S.A.M.E. weather alert, full-frequency display and backlit controls, built-in CTCSS/DCS to assign analog and digital subaudible tone codes to a specific frequency in memory, PC Control and programming with RS232C 9 pin port (cable not supplied), Beep Alert, Record function, VFO control, menu-driven design, total channel control and much more. Our CEI package deal includes telescopic antenna, AC adapter, cigarette lighter cord, DC cord, mobile mounting bracket with screws, owner's manual, trunking frequency guide and one-year limited Uniden factory warranty. For maximum scanning enjoyment, order magnetic mount antenna part number ANTMMBNC for \$29.95. For complete details, download the owners manual from the [www.usascan.com](http://www.usascan.com) web site. For fastest delivery, order on-line at [www.usascan.com](http://www.usascan.com).

### Bearcat® BCT8 Trunk Tracker III

Manufacturer suggested list price \$299.95  
**CEI Special Price \$169.95**

250 Channels • 5 banks • PC Programmable  
**Size: 7.06" Wide x 6.10" Deep x 2.44" High**

**Frequency Coverage:** 25,000-54,000 MHz., 108,000-174,000 MHz., 400,000-512,000 MHz., 806,000-823,987.5 MHz., 849,012.5-868,995.0 MHz., 894,012.5-956,000 MHz.

The Bearcat BCT8 scanner, licensed by NASCAR, is a superb preprogrammed 800 MHz trunked highway patrol system scanner. Featuring TrunkTracker III, PC Programming, 250 Channels with unique BearTracker warning system to alert you to activity on highway patrol link frequencies. Preprogrammed service searches makes finding interesting active frequencies even easier and include preprogrammed police, fire and emergency medical, news agency, weather, CB band, air band, railroad, marine band and department of transportation service searches. The BCT8 also has preprogrammed highway patrol alert frequencies by state to help you quickly find frequencies likely to be active when you are driving. The BCT8 includes AC adapter, DC power cable, cigarette lighter adapter plug, telescopic antenna, window mount antenna, owner's manual, one year limited Uniden warranty, frequency guide and free mobile mounting bracket. For maximum scanning enjoyment, also order the following optional accessories: External speaker ESP20 with mounting bracket & 10 feet of cable with plug attached \$19.95. Magnetic Mount mobile antenna ANTMMBNC for \$29.95.



### Bearcat® BCD396T Trunk Tracker IV

Suggested list price \$799.95/CEI price \$519.95

APCO 25 9,600 baud compact digital ready handheld TrunkTracker IV scanner featuring Fire Tone Out Paging, Close Call and Dynamically Allocated Channel Memory (up to 6,000 channels), SAME Weather Alert, CTCSS/DCS, Alpha Tagging. **Size: 2.40" Wide x 1.22" Deep x 5.35" High**

#### Frequency Coverage:

25,000-512,000 MHz., 764,000-775,987.5 MHz., 794,000-823,987.5 MHz., 849,012.5-868,976.5 MHz., 894,012.5-956,000 MHz., 1,240,000 MHz.-1,300,000 MHz.

The handheld BCD396T scanner was designed for National Security/Emergency Preparedness (NS/EP) and homeland security use with new features such as **Fire Tone Out Decoder**. This feature lets you set the BCD396T to alert if your selected two-tone sequential paging tones are received. Ideal for on-call firefighters, emergency response staff and for activating individual scanners used for incident management and population attack warning. **Close Call Radio Frequency Capture** - Bearcat exclusive technology locks onto nearby radio transmissions, even if you haven't programmed anything into your scanner. Useful for intelligence agencies for use at events where you don't have advance notice or knowledge of the radio communications systems and assets you need to intercept. The BCD396T scanner is designed to track Motorola Type I, Type II, Hybrid, SMARTNET, PRIVACY PLUS, LTR and EDACS® analog trunking systems on any band. Now, follow UHF High Band, UHF 800/900 MHz trunked public safety and public service systems just as if conventional two-way communications were used. **Dynamically Allocated Channel Memory** - The BCD396T scanner's memory is organized so that it more closely matches how radio systems actually work. Organize channels any way you want, using Uniden's exclusive dynamic memory management system. 3,000 channels are typical but **over 6,000 channels are possible** depending on the scanner features used. You can also easily determine how much memory you have used and how much memory you have left. **Preprogrammed Systems** - The BCD396T is preprogrammed with over 400 channels covering police, fire and ambulance operations in the 25 most populated counties in the United States, plus the most popular digital systems. **3 AA NiMH or Alkaline battery operation and Charger** - 3 AA battery operation - The BCD396T includes 3 premium 2,300 mAh Nickel Metal Hydride AA batteries to give you the most economical power option available. You may also operate the BCD396T using 3 AA alkaline batteries. **Unique Data Skip** - Allows your scanner to skip unwanted data transmissions and reduces unwanted birdies. **Memory Backup** - If the battery completely discharges or if power is disconnected, the frequencies programmed in the BCD396T scanner are retained in memory. **Manual Channel Access** - Go directly to any channel. **LCD Back Light** - A blue LCD light remains on when the back light key is pressed. **Autolight** - Automatically turns the blue LCD backlight on when your scanner stops on a transmission. **Battery Save** - In manual mode, the BCD396T automatically reduces its power requirements to extend the battery's charge. **Attenuator** - Reduces the signal strength to help prevent signal overload. The BCD396T also works as a conventional scanner to continuously monitor many radio conversations even though the message is switching frequencies. The BCD396T comes with AC adapter, 3 AA nickel metal hydride batteries, belt clip, flexible rubber antenna, wrist strap, SMA/BNC adapter, RS232C cable, Trunk Tracker frequency guide, owner's manual and one year limited Uniden warranty. Not compatible with AGEIS, ASTRO or ESAS systems. Order on-line at [www.usascan.com](http://www.usascan.com) or call 1-800-USA-SCAN.



### Bearcat® BC246T Trunk Tracker III

Suggested list price \$399.95/CEI price \$214.95

Compact professional handheld TrunkTracker III scanner featuring Close Call and Dynamically Allocated Channel Memory (up to 2,500 channels), SAME Weather Alert, CTCSS/DCS, Alpha Tagging. **Size: 2.72" Wide x 1.26" Deep x 4.6" High**

#### Frequency Coverage:

25,000-54,000 MHz., 108,000-174,000 MHz., 216,000-224,980 MHz., 400,000-512,000 MHz., 806,000-823,987.5 MHz., 849,012.5-868,987.5 MHz., 894,012.5-956,000 MHz., 1,240,000 MHz.-1,300,000 MHz.

The handheld BC246T TrunkTracker scanner has so many features, we recommend you visit our web site at [www.usascan.com](http://www.usascan.com) and download the free owner's manual. Popular features include **Close Call Radio Frequency Capture** - Bearcat exclusive technology locks onto nearby radio transmissions, even if you haven't programmed anything into your scanner. **Dynamically Allocated Channel Memory** - Organize channels any way you want, using Uniden's exclusive dynamic memory management system. 1,600 channels are typical but **over 2,500 channels are possible** depending on the scanner features used. You can also easily determine how much memory is used. **Preprogrammed Service Search (10)** - Makes it easy to find interesting frequencies used by public safety, news media TV broadcast audio, Amateur (ham) radio, CB radio, Family Radio Service, special low power, railroad, aircraft, marine, racing and weather frequencies. **Quick Keys** - allow you to select systems and groups by pressing a single key. **Text Tagging** - Name each system, group, channel, talk group



ID, custom search range, and S.A.M.E. group using 16 characters per name. **Memory Backup** - When power is lost or disconnected, your BC246T retains the frequencies that were programmed in memory. **Unique Data Skip** - Allows the BC246T to skip over unwanted data transmissions and birdies. **Attenuator** - You can set the BC246T attenuator to reduce the input strength of strong signals by about 18 dB. **Duplicate Frequency Alert** - Alerts you if you try to enter a duplicate name or frequency already stored in the scanner. **22 Bands** - with aircraft and 800 MHz. The BC246T comes with AC adapter, 2 AA 1,800 mAh nickel metal hydride batteries, belt clip, flexible rubber antenna, wrist strap, RS232C cable, Trunk Tracker frequency guide, owner's manual and one year limited Uniden warranty. For more fun, order our optional deluxe racing headset part #HF24RS for \$29.95. Order now at [www.usascan.com](http://www.usascan.com) or call 1-800-USA-SCAN.

## Buy with Confidence

### Order on-line and get big savings

For over 36 years, millions of communications specialists and enthusiasts worldwide have trusted Communications Electronics for their mission critical communications needs. It's easy to order. For fastest delivery, order on-line at [www.usascan.com](http://www.usascan.com). Mail orders to: Communications Electronics Inc., P.O. Box 1045, Ann Arbor, Michigan 48106 USA. Price includes \$30.00 UPS Ground shipping/handling/insurance per scanner to a street address in the continental USA excluding Alaska. Add \$20.00 shipping for all accessories. For shipments to Canada, Puerto Rico, Hawaii, Alaska, Guam, P.O. Box, APO/FPO, USPS Priority Mail or UPS 2 business day delivery, add \$30.00. Michigan residents add sales tax. No COD's. For Bearcat scanners your satisfaction is guaranteed or return item in unused condition in original packaging within 61 days for refund, less shipping charges. 10% surcharge for net 10 billing to qualified accounts. All sales are subject to availability, acceptance and verification. Prices, terms and specifications are subject to change without notice. We welcome your Discover, Visa, American Express, MasterCard, IMPAC or Eurocard. Order toll free, call 1-800-USA-SCAN or 1-734-996-8888 if outside Canada or the USA. FAX anytime, dial 1-734-663-8888. Dealer and international inquiries invited. Order your radio scanners from Communications Electronics today.

For credit card orders call  
**1-800-USA-SCAN**

e-mail: [cei@usascan.com](mailto:cei@usascan.com)

[www.usascan.com](http://www.usascan.com)

PO Box 1045, Ann Arbor, Michigan 48106-1045 USA  
 For information call 734-996-8888 or FAX 734-663-8888

**COMMUNICATIONS ELECTRONICS INC.**  
 Emergency Operations Center

## More Radio Products

Save even more on radio scanners when purchased directly from CEI. Price includes delivery in the continental USA excluding Alaska.

Bearcat 8987 500 channel TrunkTracker III base/mobile.....	\$209.95
Bearcat 796DGV 1,000 channel TrunkTracker III base/mobile.....	\$519.95
Bearcat BCD396T APCO 25 Digital scanner with Fire Tone Out.....	\$519.95
Bearcat 246T up to 2,500 ch. TrunkTracker III handheld scanner.....	\$214.95
Bearcat Sportcat 230 alpha display handheld sports scanner.....	\$184.95
Bearcat 278CLT 100 channel AM/FM/SAME WX alert scanner.....	\$129.95
Bearcat 248CLT 50 channel base AM/FM/weather alert scanner.....	\$104.95
Bearcat 92XLT 200 channel handheld scanner.....	\$109.95
Bearcat 72XLT 100 channel handheld scanner.....	\$99.95
Bearcat BR330T up to 2,500 ch. TrunkTracker III with Tone out.....	\$274.95
Bearcat BCT8 250 channel information mobile scanner.....	\$169.95
Bearcat 350C 50 channel desktop/mobile scanner.....	\$104.95
AOR AR16BQ Wide Band scanner with quick charger.....	\$199.95
AOR AR3000AB Wide Band base/mobile receiver.....	\$1,079.95
AOR AR5000A+3B Wide Band 10 KHz to 3 GHz receiver.....	\$2,599.95
AOR AR8200 Mark III Wide Band handheld scanner.....	\$594.95
AOR AR8600 Mark III Wide Band receiver.....	\$899.95
AOR AR-ONE Government/Export sales only 10 KHz-3 GHz.....	\$4,489.95
Scancat Gold For Windows Software.....	\$99.95
Scancat Gold For Windows Surveillance Edition.....	\$159.95

Visit [WWW.USASCAN.COM](http://WWW.USASCAN.COM) • 1-800-USA-SCAN

## HFDL: Everything You Ever Wanted to Know

**H**igh-Frequency Data Link (HFDL) is one of the best digital modes available to utility listeners, as it allows them to receive signals directly from aircraft. Some people just think it's fun to hear an industry at work. Others keep logs of every new plane heard, or feed the output of their decoders to elaborate programs written for hard-core aviation buffs.

Unfortunately, HFDL can have a relatively steep learning curve. It has a lot of frequencies and schedules, and they change often. Its written documentation varies between esoteric and downright opaque.

Come along this month, as we attempt to demystify HFDL and help hobbyists actually find meaningful information from it. Boot up your computer, and let's go.

### ❖ The Absolute Basics

HFDL is a high-frequency (HF: shortwave, 3-30 megahertz) data link protocol allowing 14 worldwide ground stations to communicate reliably with participating aircraft via the ionosphere. It adapts to changing band conditions, and continually monitors its own performance.

## ARINC

The HFDL standard and system is proprietary to Aeronautical Radio, Incorporated, which everyone calls ARINC. When this company started in 1929, it was owned by the airlines. Its purpose was to provide and coordinate all US airline radio communications, and to maintain

the necessary licenses. Since 2005, these licenses are held by an ARINC spin-off called Aviation Spectrum Resources, Incorporated.

ARINC has grown into a worldwide communications player, with offices in several countries. It offers a huge array of products and services for transportation and defense. HFDL integrates into its overall system in two ways.

First, it is part of an automated GLOBALink mode which seamlessly integrates HF, satellite, and Very High Frequency (VHF) airplane communication. This achieves a global coverage which is transparent to the user. For example, HFDL is the only working mode for flights crossing over the North Pole between North America and Europe.



Second, HFDL's data protocol can carry Aircraft Communications Addressing and Reporting System (ACARS) messages. This is another ARINC network, more associated with VHF, which (in its current mode) allows the exchange of short, text-based messages between ground and the cockpit. ACARS messages typically contain flight paths, weather, arrival information for airports, and such informal company chatter as sports scores.

For our purposes, the most relevant HFDL standard is ARINC Report 635-3 (HF Data Link Protocols). It's available from ARINC at their web site, for US \$144.

Hams having some experience with "packet"

radio, a system similar to HFDL, will already know many of the basics. For example, both radio modes are structured in layers. In the case of HFDL, these layers are physical, link, and subnetwork. We need not be concerned with the subnetwork layer, as we're just receiving the signals.

### ❖ The Physical Layer

This is the lowest level, where the real nuts and bolts of radio communication take place. HFDL is sent in upper-sideband (USB), on voice channels in the civil aero mobile service. Tune the assigned frequency, with a filter passband around 2.5 kilohertz (kHz). As with most digital modes, stronger signals will have much fewer errors.

Hobbyists have a choice of several sound card programs to decode HFDL signals under Windows, Mac, and maybe Linux. The receiver's audio output is connected right to the computer. HFDL is rather processor-intensive, and works better on newer machines which have the horsepower to get it done.

The underlying mode uses a single-tone radio modem with a carrier audio frequency of 1440 hertz (Hz). Symbol speed is 1800 baud, but there are four data rates depending on channel quality. These are 300, 600, 1200, and 1800 bits per second. Modulation is M-ary phase shift keying, where M is 2, 4, or 8 depending on bit rate. 300 and 600 bps are the most commonly encountered rates.

Every data burst begins with a short and distinctive beep, which establishes the 1440-Hz reference. This is evaluated by the software's automatic frequency control, correcting for drift, tuning inaccuracy, Doppler shift, and so on. The corrected difference is shown as a "frequency error," which sounds more scary than it is. For our purposes, it is not much of a factor, unless it's huge.

Like most HF utilities, HFDL changes its active frequencies several times a day, in order to adapt to band conditions. The major challenge facing listeners is finding active frequencies with sufficient signal for a good decode. Experience and good logging go a long way to help.

One of many smart things the HFDL network does is to store its entire master frequency list in a common database called the system table. The table's version number increases by one every time ARINC changes it, usually for seasonal reasons. Ground stations get the new table right away. The aircraft receivers check the number and download the new table if it doesn't match.

This download is easy enough to copy and save, but time is of the essence, because most

HFDL Ground Stations		
##	Station	Position
00	Not Used	
01	San Francisco (Dixon), CA	121 45 34 W, 38 22 48 N
02	Molokai, Hawaii	157 10 46 W, 21 10 47 N
03	Reykjavik, Iceland	21 50 59 W, 64 4 47 N
04	New York (Riverhead, Long Island), NY	72 38 22 W, 40 52 47 N
05	Auckland, NZ	174 48 35 E, 37 1 10 S
06	Hat Yai, Thailand	100 23 24 E, 6 56 23 N
07	Shannon, Ireland	8 55 46 W, 52 43 48 N
08	Johannesburg, S. Africa	28 12 35 E, 26 7 46 S
09	Barrow, Alaska	156 46 46 W, 71 18 0 N
10	Annapolis MD (off air)	
11	Not used	
12	Not used	
13	Santa Cruz, Bolivia	63 7 46 W, 17 40 11 S
14	Krasnoyarsk, Russia	92 18 0 E, 56 6 0 N
15	Al Muharraaq, Bahrain	50 39 0 E, 26 16 12 N
16	Agana (Barrigada), Guam	144 48 0 E, 13 28 11 N
17	Gran Canaria (Telde), Canary Islands	15 23 23 W, 27 56 59 N

planes get updated within a few days. Fortunately, lucky utility listeners who have gotten the information typically post it right to the Internet. This is just one reason to join HF DL groups or mailing lists.

This table is handled in different ways by different hobby programs. Usually, you have to look up the frequencies yourself. The computer programs evaluate the “frequency word” sent by ground stations and output the result as table column numbers, or phrases like “3rd highest frequency used.”

There’s one US \$35 shareware program – Charles Brain’s slick PC-HFDL – which gets around the table look-up problem. When and if you get lucky and intercept one of these system table downloads, PC-HFDL crunches the result into a data file. Next time you run it, the numbers miraculously change to the actual kilohertz. This data file can easily be copied and sent over the Internet to less lucky PC-HFDL users.

At press time, the current System Table was number 31 in decimal, or 1F in the hexadecimal (base 16) notation often used by computer programs. This column doesn’t have room for the whole table, but its web site does. It should be posted there by the time anyone sees this, along with the data file for PC-HFDL.

### ❖ The Link Layer

Having found and decoded a signal, we now need to process the data in it. HF DL does this with a link layer protocol. This breaks up the incoming ones and zeroes into the relevant data structures, which are then parsed into useful information.

The HF DL module in SkySweeper, another popular program, can be configured for “full decode.” This will extract and format absolutely everything specified by ARINC 635-3. Your computer screen will scroll madly, and you’ll see what an amazing amount of information gets crammed into these 3-second data bursts. Most of this is background stuff, used by the network

to handle quality control issues relating to radio propagation and equipment performance.

PC-HFDL allows the user to select out the “good stuff,” up to a point. SkySweeper has a somewhat lesser capability here. This is done by selecting which message types or elements to print. Unfortunately, the names for these are kind of geeky.

HF DL’s message types are uplinks (ground to air), downlinks (air to ground), and squitters. A “squitter” in aeronautical radio refers to any unsolicited data burst, usually from aircraft radar transponders, but in this case from the ground stations. These use a special data type called SPDU, for Squitter Protocol Data Units. They repeat every 32 seconds, with station information and extensive protocol data establishing the time slots used by the interference-avoiding multiple-access system.

The presence of squitters is usually a good way to tell an active frequency. It’s good to turn on their display at the beginning. They not only ID the ground station, but also list all frequencies being used across the network at that moment, three stations at a time. I like to save these to a file, until I have data for all the various times of day. After this, it’s easy to keep up with minor changes until the next System Table comes out.

PDU or “PREAM” refers to the signal preamble. This is useful for tuning and a general sense of what’s going on.

BDU are Basic Data Units. These are the smallest units of the HF DL transmissions. Next larger structures are the LPDU, or Link Protocol Data Units. These are the data blocks that make up larger message elements.

MPDU are Media Access Protocol Data Units, comprised of several LPDU which handle various nuts-and-bolts functions, among them the logging of aircraft onto and off of the system. MPDU will often show the sequential session ID number assigned by the ground station each time an aircraft establishes contact with it.

Logins and logouts are nice to intercept, because the airplane will pass its registration and also its unique identification address number assigned by the International Civil Aviation Organization (ICAO). This ICAO address is a 24-bit string, usually shown in hex. Different hex blocks correspond to different countries, and there are Internet databases where the individual aircraft can be looked up. By the way, PC-HFDL versions older than 2.03 evaluate this address incorrectly, but any later versions are fine.

MPDU are also used to encapsulate the previously mentioned ACARS messages. These are fun, to say the least.

Most of the other useful information is in the HFNPDU, High-Frequency Network Protocol Data Unit. This is a user section, whose various LPDU can have different types of communication. Many aircraft will pass their positions and flight numbers every few minutes, allowing software to plot them on a map. In this manner, you can follow flights around the world, as long as they stay within HF range.

### ❖ HF DL’s Future

While VHF ACARS is being modified to increase throughput and overall capacity, the HF DL standard seems only to need minor tweaks relating to network latency. HF DL started slowly, but it has grown steadily as ARINC signed up new customers who equipped more planes in their fleets. It’s been especially attractive to cargo airlines, since freight doesn’t need to make phone calls from the cabin. HF DL frequencies are starting to sound a lot busier.

The newest ground station, Canary Islands in the East Atlantic, completes the originally planned network. These stations use large, expensive radio sites, often near airports. Some are more heavily loaded than others. The Atlantic network has redundancy, but other routes have not needed it. If this changes, ARINC might possibly add capacity by putting in another ground station.

There has been some concern over security and the divulging of messages. Folks, I have to advise you to keep your cool, keep it legal, and use your common sense. We want to keep this hobby.

Happy landings until next month.

### Useful References

Get PC-HFDL:  
[www.chbrain.dircon.co.uk/pchfdl.html](http://www.chbrain.dircon.co.uk/pchfdl.html)

Yahoo! HF DL Group:  
<http://groups.yahoo.com/group/hfdl/>

ARINC:  
[www.arinc.com/](http://www.arinc.com/)

Radio Wiki with System Table:  
<http://wiki.radioreference.com/index.php/HFDL>

John Catalano’s Computers & Radio column “HF ACARS With PC-HFDL” November 2006, pp. 72-3  
[www.monitoringtimes.com/mtsubscrib3er/mtc&r1106.pdf](http://www.monitoringtimes.com/mtsubscrib3er/mtc&r1106.pdf)

Utility World web site  
[www.ominous-valve.com/uteworld.html](http://www.ominous-valve.com/uteworld.html)

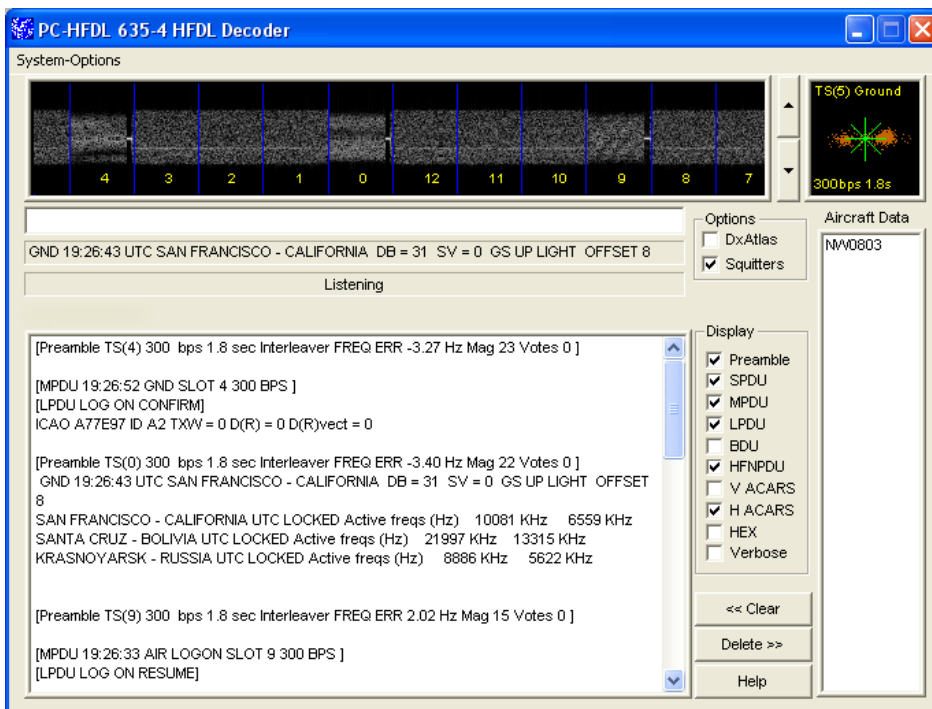

### ABBREVIATIONS USED IN THIS COLUMN

AFB.....	Air Force Base
ALE.....	Automatic Link Establishment
AM.....	Amplitude Modulation
AWACS.....	Airborne Warning and Command System
CAMSLANT ...	Communication Area Master Station, Atlantic
CW.....	On-off keyed "Continuous Wave" Morse telegraphy
EAM.....	Emergency Action Message
FEMA.....	US Federal Emergency Management Agency
HF-GCS.....	High-Frequency Global Communication System
G06.....	AM "5-figure numbers" in German
LDOC.....	Long-Distance Operational Control
LSB.....	Lower Sideband
M08a.....	Cuban 3-msg CW, ANDUWRIGMT = 1-0
MX.....	All Russian single-letter CW beacons/markers
MARS.....	Military Affiliate Radio System
Meteo.....	Meteorological
NCS.....	US National Communications System
PSK31.....	Phase-Shift Keying teleprinting at 31.25 baud
S21.....	AM "numbers" in Russian
SAM.....	Special Air Mission
SK01.....	Cuban "numbers" in PSK31
Unid.....	Unidentified
US.....	United States
USCG.....	United States Coast Guard
UK.....	United Kingdom
V02a.....	"Atencion" Spanish numbers, 3-msg format
X06.....	Russian Intelligence "Mazielka" 6-tone calling

All transmissions are USB (upper sideband) unless otherwise indicated. All frequencies are in kHz (kilohertz) and all times are UTC (Coordinated Universal Time). "Numbers" stations have their ENIGMA (European Numbers Information Gathering and Monitoring Association) designators in ().

184.325	WMG-"Lowfer" hobby beacon, Pittsburg KS, very slow CW (mode QRSS10), at 2223. (Tom Severt-KS)
2330.8	"P"-Russian Navy CW channel marker (MX), Kaliningrad, also on 3593.7 and 3837.0, at 2111. (Ary Boender-Netherlands)
2749.0	Halifax Radio-Canadian Forces, NS, weather at 0453. (Severt-KS)
4325.9	"R"-Russian CW channel marker (MX), Izhevsk, also 5465.9, at 2054. (Boender-Netherlands)
4331.0	4XZ-Israeli Navy, Haifa, coded CW message at 4331. (Severt-KS)
4414.0	Echo Foxtrot-US Navy, USS Enterprise Link-11/16 coordination net, working Delta, Echo, Hotel, Juliet, Kilo, Mike, and November, at 0321. (Mark Cleary-SC)
4446.5	T2Z3-US Army 2-3rd Aviation, calling helicopter R00082, ALE at 2018. (Cleary-SC)
4557.8	"P"-Russian CW cluster beacon (MX), Kaliningrad, also 5153.8, at 2058. (Boender-Netherlands)
4558.0	"C"-Russian CW cluster beacon (MX), Moscow, also 5154 and 7039, at 2056. (Boender-Netherlands)
4854.0	"The Russian Lady"-Unknown (S21), callup "454," then "978 32," and message in 5-figure groups, at 1842. (Mike L-West Sussex, UK)
5078.5	Echo Whiskey-USS Enterprise air defense net, working Echo and Juliet, at 1204. (Cleary-SC)
5296.5	R23683-US Army 172nd Medical helicopter, calling TC111, 1-111th Aviation in ALE, at 1826. (Patrice Privat-France)
5550.0	American 182-American Airlines Boeing 777, working New York at 2335. (Allan Stern-FL)
5696.0	CAMSLANT Chesapeake-USCG, VA, calling "U-7-B," also tried 8983, at 0020. (Severt-KS)
5732.0	Panther-US Drug Enforcement Administration, Bahamas, calling Shark 13 (USCG Cutter Mohawk, WMEC 913), at 1757. (Cleary-SC)
5899.0	Cuban PSK31 numbers (SK01), using the M08a cut-number format but then repeating messages in normal numbers, at 0503. (Severt-KS)
6697.0	Milk Weed-US Military, sent a 28-character EAM and stood by for traffic, at 0320. Bake Light [Bakelite? -Hugh], probably same net, with same EAM and standby at 0340. (Jeff Haverlah-TX)
6761.0	Ethyl 58-US Air Force tanker, working US Air Mobility Command transport Reach 571 regarding refueling, at 0416. (Stern-FL)

6855.0	Cuban Spanish AM "numbers" (V02a), "new" voice, callup "92543 60303 95908," at 1601. V02a new voice, usual interference to/from Family Radio broadcast, callup "11135 35281 53548," at 2102. (Cam Castillo-Panama)
6988.0	Lima Romeo-Unknown US military, with EAM at 0153. (Severt-KS)
7038.7	"D"-Russian CW cluster beacon (MX), Odessa, at 2056. (Boender-Netherlands)
7527.0	Juliet 41-USCG helicopter, working CAMSLANT (USCG, VA) at 1545. (Cleary-SC)
7887.0	Cuban Spanish AM "numbers" (V02a), callup "61674 02458 20816" in the "new" voice, at 2001. (Castillo-Panama)
8045.0	2004-Italian Financial Police, working 2508, ALE at 2334. (Ron Perron-MD)
8055.0	"The German Man"-Russian intelligence (G06), callup "308," ended "00000" at 1904. (Mike L-UK)
8125.0	ITALIA-Mexican military "countries" net, calling INGLATERRA ("England"), ALE at 2233. (Perron-MD)
8294.0	WJK-TransMontaigne Operating Company, Miami, FL, working unid vessel regarding a berth in Port Everglades, at 1932. (Cleary-SC)
8760.0	PUN-Unknown beacon, CW and occasional AM voice identifier "Pista Las Peñas," also on 10512, 14015, and 21024, at 2135. (Castillo-Panama)
8992.0	Offutt-US Air Force HF-GCS, with a long 201-character EAM at 1017. Offutt, several 6-character EAMs "for Coal Strike," at 1240, 1300, 1405, and 1418. (Haverlah-TX)
9025.0	Sentry 40-US Air Force E-3 AWACS, ALE-initiated patch via Diego Garcia to Raymond 24 (Tinker AFB, OK), at 2159. (Cleary-SC)
9414.5	TYLER-Texas Health Service, TX, working TSC (US Customs), in ALE at 1528. USDAHQ1-US Department of Agriculture, DC, working WGY9030, FEMA, at 1620. (Jack Metcalfe-KY)
10330.0	WDA7049-Unknown station working WDA608? and others in packet radio, under All India Radio broadcast, at 1515. (Ed Henderson-SC)
10588.0	WGY901-FEMA Region 1, MA, weekly check with WGY908 (FEMA Region 8, CO), at 1403. (Cleary-SC)
10780.0	KING 55-US Air Force HC-130, working Cape Radio, Cape Canaveral Air Force Station, FL, at 2118. (Cleary-SC)
11175.0	SAM 93-US Air Force Distinguished Visitor flight, working Puerto Rico HF-GCS, at 1150. (Haverlah-TX)
11232.0	Sentry 60-US Air Force E-3 AWACS, patch via Trenton Military to Raymond 24 (Tinker AFB, OK), at 1739. (Cleary-SC)
11244.0	Meat Hook-US Military, 32-character EAM simulcast on 6697, then stood by for traffic, at 0320. (Haverlah-TX)
12224.0	Unid-Russian 6-tone calling mode (X06), repeating "463125," at 1505. (Mike L-UK)
13339.0	AeroMexico-Company dispatch on LDOC, passing Mexico City weather to an unheard aircraft in Spanish, at 1915. (Perron-MD)
13488.0	BELLCNTYHLTH-possibly Bell County Health Department, TX, ALE sound, also on 5823 LSB, 9414.5, and 10202, at 1445. (Metcalfe-KY)
13927.1	Sentry 61-US Air Force E-3 AWACS, patch via MARS AFA6PF, CA, to Tinker Meteo, OK, at 2200z. (Stern-FL)
14606.1	Shark 21-US Joint Task Force, patch via AFA6PF to Davis Monthan Meteo, at 1712. (Stern-FL)
15094.0	KNY98-US National Telecommunications Coordination Network, working 050NCS, NCS regional manager net, also on 4490, ALE at 1737. (Perron-MD)
16201.0	FC6-FEMA, TX, calling OK6, Oklahoma State Emergency Operations Center, ALE at 1501. (Perron-MD)
17436.0	Cuban PSK31 numbers (SK01), using modified M08a format, at 1700. (Chris Smolinski-MD) V2a, following Salsa music with callup "20723 36612 12382" and message, at 1700. SK01, PSK31 on AM carrier, sent apparent test message in M08a cut format, but message had no 9's, at 1733. (Severt-KS) Cuban V02a, "old" voice in progress, AM at 1710. (Castillo-Panama)
17478.0	Cuban V2a, quickly replaced by SK01 message in PSK31, interrupted by Radio Havana Cuba and then back to SK01, at 1600. (Severt-KS)
17487.0	494FEMAUX-FEMA, Denver, CO, calling NCS250, NCS regional manager net, ALE at 1807. (Perron-MD)
20810.6	KWG41-US State Department, DC, ALE sounding, also on 18248.6, at 1739. (Perron-MD)



## Venezuelan Navy Network

This month we focus on a large network operated by the Venezuelan Navy which should provide an easy catch in voice or ALE for anyone in North America and Western Europe.

As does the Venezuelan Army, their Navy has a busy network of ALE-connected stations on HF radio. Regular ocean-going vessels, as well as Coast Guard, Marine Infantry and River/Border Patrol Forces, all feature in this system and provide a variety of listening at most times of the day here in the US.

The frequency list in use is extensive, and includes the following channels (U=USB, L=LSB):

5334L, 5439L, 6248L, 6357L, 6810L, 6810U, 6888L, 6890U, 6894L, 6895U, 7849U, 8260L, 8273L, 8285L, 8297L, 8340L, 8358L, 8810L, 8825L, 8500U, 8582L, 9017L, 9075L, 9190U, 9350L, 9355L, 9380L, 9400L, 10272U, 10600U, 10650L, 12220L, 12480L, 12537U, 12583L, 12546L, 13500U, 14790L, 16716L, 17080L, 19098L, 19200U, 20400L

There are two systems of identifiers in use by stations: regular calls indicated by shortened place names or vessel hull numbers, and pseudo-tactical calls using various combinations of four characters with mixed letters and numbers. True tactical calls would change on a daily basis, but many of the Venezuelan calls have remained the same for at least a couple of years, and although this has not yet been fully analyzed, they are also likely to be tied to specific locations or units.

Voice traffic is used, in addition to MIL-188-110A high speed modems, although modem traffic is encrypted after a distinctive "TEQTE-QTEQ..." lead-in – the same as that used by the Army and National Guard units.

### ❖ ALE Identifiers Heard

CGA	Navy HQ, Caracas
ARMARIO	Naval Base Agustin Armario, Puerto Cabella
BNARCO	Commander, Naval Base Agustin Armario, Puerto Cabella
BNA	Naval Base Agustin Armario, Puerto Cabella
BNF	Naval Base Juan Crisostomo Falcon, Punto Fijo
BNG	Naval Base Francisco Gutierrez or Guira
BO-11	Navy Support Ship "Punta Brava"
BDIRCO	Combat Engineer Battalion
BRIFFR1	River Infantry Brigade Base Franz Iribarren, Puerto Ayacucho
COFFR1	Commander River Navy Base Franz Iribarren, Puerto Ayacucho
COFFMU2	Commander River Navy Base Jacinto Munoz, El Amparo
COFOA2	Commander River Navy Base Orinoco-Apure, San Fernando
DCCOP	Direccion de Coordinacion Y Control Operacional, Caracas

DHN	Navy Hydrographic Directorate, Caracas
PUNTABRAVA	Navy Support Ship "Punta Brava"
BRION	Navy Frigate, "Almirante Brion"
CAPANA	Navy Landing Ship "Capana"
LLANOS	Navy Amphibious Support Ship, "Los Llanos"
SUCRE	Navy Frigate "Mariscal Sucre"
FALCON	Naval Base "Mariscal Juan Crisostomo Falcón"
F-21	Navy Frigate "Mariscal Sucre"
F-22	Navy Frigate "Almirante Brion"
F-23	Navy Frigate "General Urdaneta"
F-24	Navy Frigate "General Soublette"
F-25	Navy Frigate "General Salom"
F-26	Navy Frigate "Almirante Garcia"
G11	Coast Guard Frigate "Almirante Clemente"
GC11	Coast Guard Frigate "Almirante Clemente"
G12	Coast Guard Frigate "General Jose Trinidad Moran"
T-61	Navy Landing Ship "Capana"
T-63	Navy Landing Ship "Gojaira"
T-64	Navy Landing Ship "Los Llanos"
T-81	Navy Oiler "Ciudad Bolivar"
PC-13	Missile Boat "Independencia"
RIONEGRO	National Guard patrol craft
PNFAx	River Patrol Post #x, Rio Orinoco-Apure
PNENx	River Patrol Post #x, Unknown
PNMEx	River Patrol Post #x, Rio Meta
PNIVx	River Patrol Post, Isla Vapor
PNRN	River Patrol Post #x, Rio Negro
PR1	Unknown
PR2	Unknown
PR4	Unknown
VARGAS	Coast Guard HQ, La Guaira, Estado Vargas

Tactical calls used by the River Patrol vessels and bases:

1EW1, 1FS8, 1HG9, 1LY3, 1PA5, 1PZ2, 1W1S, 1XV7, 2IV1, 2P02, 2TB9, 2IU1, 2VBV, 2XM7, 3SK2, 3W2J, 4EW7, 4GE1, 4SK2, 5AL1, 5JL1, 5LY1, 5EA3, 5J4L, 5W04, 5ZC8, 6E78, 6EW7, 6GY2, 6T4T, 7R8C, 7RC4, 8AV4, C7T7, G4Q0, P0I2, Q2Q2, S9F2, T54W, T5L1, T8R1, V8X9

One of the most interesting catches on this network is the copious use of ALE data messages, some transmissions lasting in excess of 20 minutes continuously, sending information such as shipping movements, moorings, river levels and other navigation data between stations. Why the stations don't switch to their 110A modems and send this stuff in a few seconds is a mystery!

Here is the header from a typical operations report between stations 4GE1 and 4SK2:

```
NR.-P-Q DIC 06
OFL NR 039
DE ET 14.6
PARA UT 14.6.2
INFO CGTGR SC-PLAX-2
006/GT.14.6

REPORTE DE ACTIVIDAD
CGT 14.6-0003 DIA 03DIC06

ACTIVIDADES :
1.1 SE EFEALICION LENVECTORES BOMBA 006/GT.14.6
```



### REPORTE ACTIVIDADES ORD-OP-CGT 140003 DIC06

Other reports, like this one, list various ship movements during the day's patrol activities, showing the ship callsign, flag and type of cargo:

#### 2) SE EFUO CONMA A SEIS BUQUES DE SALIDA.

NOMBRE	IGLAS	BARA	PUERTO DESTINO	CARGA
ICARO	3PGV3	PANAMENA	USA	58.393 CRUDO
NIKOPIOS	H9JH	PANAMENA	JAMAICA	LASTRE
CAPE ANCONA	P3ZT7		CHIPR	
IOTA			EUROPA	413.055 CRUNA
VEGATORM	LXB6	LIBERIANA	JOLWARI	
ALMIRANTE BRI	YYJR	VENEZUELA	CURAZAO	438.000 CRUD

Coincidentally, a couple of the ships listed in this report had unloaded in Portland (Maine) Harbor a few weeks earlier. Tune into this extensive network for some interesting catches.

### ❖ New Missionary Net?

A newly heard net has surfaced on 11029.2kHz. This net uses PACTOR and PACTOR-II with outstations calling the hub with selcal "NETCCS" which may well be Caracas, Venezuela. Traffic on the network consists of emails and files in Spanish of a religious nature, indicating that this is possibly another network supporting the work of missionaries in the Amazonian part of Venezuela. Here is an excerpt of a message from the network (typos and all):

*Creo que escribiste algo un ssaludo deaño nuevo pues no nos habiamos comunicado. La semana pasada vieomar y me dijo que habia hablado contigo por telefono. Me conto tambien mama estaue te trajeste a la h Bueno Bueno esa sera tu misionSiempre bien a alguien escadena sigue y Diao llevacopara que veas como decogdifica este sistema otra cosa que no es lni numeros.*

We've covered other Caribbean and South American missionary networks (see June 2004 *Digital Digest*), most notably those supported by YES (Yielded Evangelical Servants) and MAF (Mission Aviation Fellowship), many of which are still in operation today.

Until next month, enjoy your digital DX.

### RESOURCES

Venezuelan Navy [www.armada.mil.ve](http://www.armada.mil.ve)

## Where is Radio República?

Radio República, clandestine to Cuba from Miami, transmits via WRMI, Canada, and Germany, as detailed last month, but another daily 6-hour broadcast on the 6 MHz band remains elusive as to its transmitter site. This had previously been pinned on Rampisham, UK, by monitoring, but VT Communications denies it has anything to do with it, and these broadcasts do not appear on its schedules, or in HFCC registrations (causing a bit of a problem for Canada and Vatican; see below).

In A-07 Yimber Gaviria, Colombia, monitored the latest changes, which do not even appear accurately on R. República's own website: 2200-2400 6135, 0000-0200 6155, 0200-0400 6100. This transmitter generally puts a good signal into the USA, though it is heavily jammed. European and North American monitors with direction-finding capability, and/or those who can use propagational clues, could help pin down

this mystery (as could Europeans approaching suspect sites in the dead of night to evaluate groundwave strength).

The ITU monitoring report for the first quarter of 2007 at [www.itu.int/ITU-R/terrestrial/monitoring/files/pdf/files/313.pdf](http://www.itu.int/ITU-R/terrestrial/monitoring/files/pdf/files/313.pdf) includes several logs of Radio República on 6135, but strangely, none on its other frequencies. ITU says Cuba is responsible for it, which is a stretch, considering that it is anti-Castro and Cuba jams it. Not a single log includes a bearing, but the monitoring station in Hungary rates its strength as 47-54 dB, which is consistent with a European site rather than North American.

### A-07 AOKI Frequency Schedules

This list is updated every day, says S. Hasegawa of Nagoya DX Circle. An excellent reference: [www.geocities.jp/binewsjp/bia07.txt](http://www.geocities.jp/binewsjp/bia07.txt)

**ALASKA** KNLS keeps posting contradictory schedules for itself on website, depending on whether you access them from the English page or the Chinese and Russian pages. Well into April for A-07, is English at 1000-1100 on 7355 or 6890? At 1200-1300 they are agreed on 7355, but is it also on 9780 or 9920? (gh)

**ALBANIA** R. Tirana added a second frequency for Albanian to NAM at 2300-2430, 9460, but the transmitter soon went down; just as well, as that happened to be exactly the same time and frequency for Cairo's English to NAM, ex-11950 (gh)

**ARGENTINA** RAE A-07 English: M-F 1800-1900 9690 15345 Eu; Tu-Sa 0200-0300 11710 NAM. 15345 continues with hours in Italian, French and German until 2200, then two hours in Spanish. On Saturdays, 15345 runs from 2000 until 0230 in Spanish, usually sports from Radio Nacional (via José Miguel Romero, DX Listening Digest) And on 15345 Sundays from 1400 until 0300 UT Mondays (Aoki A-07)

This season, Spain began using 15345, too, until 2200, exacerbating an already bad collision with Morocco, scheduled 1500-2200; more under SPAIN (gh) One day Spain was missing and RAE was heard in Italian at 1900 with an incredibly good signal (Francesco Cecconi, Italy, *Noticias DX*; Dario Monfeirni, Italy, *bclnews.it* yg) Then in April, RAE was off the air with transmitter problems (Arnaldo Slaen, Argentina, DXLD)

**BELARUS** R. Belarus English at 2000-2200: back on 7105 with a powerful, unobstructed signal. The other two transmitters are on 7390 and 7440, both with weaker signals than 7105 and suffering some sideband splash. Each frequency sounds somewhat different; 7105 has loud audio with lots of compression, 7390 is clearly undermodulated, 7440 does not use much dynamic compression, either, but has more modulation depth than 7390. It seems that 7105 is their 250 kW transmitter, 7390 a 75 kW which is actually 15 x 5 kW (former jamming transmitters) and 7440 a unique elder transmitter, rated as 150 kW (Kai Ludwig, Germany, DXLD)

**BOLIVIA** R. Logos, Santa Cruz de la Sierra, on 4865, 2236-2244, with German preacher, QRM de Brasil. A few weeks later was VG with ballads at 2209-2215 and // 6165 which had QRM from Croatia (Carlos Gonçalves, Portugal, DXLD) Presumed this on 6165 at 2345 with slow long religious songs, blocked at \*2358 by R. Nederland via Portugal (Giampiero Bernardini, Italy, *ibid.*) RN not opening until 2358 gives this another hour window, if you aren't hearing Croatia, China or Vietnam (gh)

**CANADA** RCI English from Sackville site, A-07:

1505-1704 9515 NE USA  
1800-1859 15235 Af  
2000-2059 15325 Eu  
2305-2400 (Tu-Sa 0104) 6100 C USA.

[non] New relay sites of RCI in A-07: Madagascar, 0300-0359 11790 Arabic; Santa Maria di Galeria, Italy (Vatican), 0200-0259 5955 Arabic; 0300-0359 7230 Arabic; 1900-1959 13730 French; 2100-2159 7370 French (via Bill Westenhaver, RCI)

Sackville leapfrogging spurs monitored: 0140-0155+ fair 6340.04 spur of 6009.96-Radio Sweden in English and very weak 5844.92 spur of 6175-Voice of Vietnam. 165.04 kHz separation between each frequency. I was surprised to find 6010 slightly off frequency. Also at 0250-0300 weak 6310 spur of 6040-Vatican Radio in

*All times UTC; All frequencies kHz; \* before hr = sign on, \* after hr = sign off; // = parallel programming; + = continuing but not monitored; 2 x freq = 2nd harmonic; B-06=winter season; A-07=summer season; [non]=Broadcast to or for the listed country, but not necessarily originating there; u.o.s. = unless otherwise stated*

English. Barely audible 5905 spur of 6175-Voice of Vietnam in English. 135 kHz separation between each frequency (Brian Alexander, PA, DXLD)

**CENTRAL AFRICAN REPUBLIC** More on last month's lead item about Radio ICDI: a story in French from the ACAP agency said its installation at Boali, 80 km NW of Bangui, had been authorized on March 17. Boali has a reliable electrical supply and is at a higher altitude than Bangui. Official opening is planned for August, after a test period not only on 6030 but also 7160 kHz. Its coverage radius is one megameter, the entire country.

7160 is absolutely no good in the mornings before 0600, since BBC Ascension is on there 0300-0600 at 65 degrees! At 16-20 it might work with possibly weak signals from China to cope with plus Romania at 18-19 (gh, *World Of Radio*) Heard on 6030 at 0500-0600, 1900-2000, probably the new station called La Voix de la Grace (Rumen Pankov, R. Bulgaria Espacio DX)

**CHILE** 12275, spur from CVC La Voz, 0200-0230+, 11970 & 11665 mixing together with Spanish religious programming. 305 kHz separation (Brian Alexander, PA, DXLD)

I then heard amazingly strong signal from this around 0115 on 12275; could have mistaken for fundamental, but also heard many other mixes among the three transmitters on 25m at this time, the other being Portuguese on 11745, all of which are running from 0100 to 0400: 11360, 11520, 11585, 12115, 12195.

There are also three transmitters on 49m at 0800-1100, 5960, 6070 and 6110v, which would theoretically produce mixing products on 5810v, 5850, 6030v, 6150v, 6180 and 6260v, but most of them harder to detect due to interference (gh, OK)

The 6110 Portuguese frequency at 0400-1100 varies around 6109.77, terrible het against R. Japan via Canada at 0500 (Wolfgang Büschel, Germany, DXLD)

**CHINA** [and non] As of early April, Firedrake against Sound of Hope was on 10300, ex-10200, 10400, heard around 1330 (gh, OK)

**COLOMBIA** La Voz del Guaviare, 6035, audible on second harmonic, 12070, on a Saturday at 1330 until Sweden blocked at 1400; also at other times when V. of Russia not on 12070, such as Sunday 2113 with local football game; weekdays Tex-Mex music at 2252, plus lots of ads (Raúl Saavedra, Costa Rica, DXLD)

Radio Lider, 6139.8, remained active most of March, but not heard since the 25th (Manuel Méndez, Spain, DXLD; Roger Chambers, NY, ODXA) See <http://www.cadenamelodia.com/> for pictures and reception reports (Henrik Klemetz, Sweden, HCDX)

La Voz de tu Conciencia, 6010v, continued to be heard the first week in April, but Marfil Estéreo, 5910v, was missing (Yimber Gaviria, Colombia, DXLD)

**CROATIA** [and non] English from V. of Croatia: 2215-2230, 0200-0230, 0600-0603, 1000-1003, 1600-1630, 1805-1815 (Glas Hrvatske website) Frequencies not specified, but should be on domestic and German relays when the time fits (gh) *Croatia Today* news heard at 2215-2230 on 6165, co-channel Chad (Brian Alexander, PA, DXLD) Domestic site at Deanovec, non-directional: 0358-

0757 6165 100 kW; 0758-1157 9830 100 kW; 1158-2257 6165 100 kW; 2258-0357 6165 10 kW (DX Mix News, Bulgaria) Via Germany: 2200-0500 9925, 0400-0700 9470, 0600-1000 11610. Spanish at 2230-2255, 0230-0255 (Marcelo A. Cornachioni, Argentina, Conexión Digital)

**EGYPT** R. Cairo A-07 English: 1215-1330 17835 SEAs; 1600-1800 11740 C&SAf; 1900-2030

15375 Waf; 2115-2245 9990 Eu; 2300-2430 9460 ENAm; 0200-0330 7270 NAM. Arabic to NAM: 1100-0300 12050; 0030-0430 9460. Arabic to C&SA: 2330-0045 9460 9735. Spanish to N/C/SA: 0045-0200 7270 9360 6135 (via Alokesh Gupta, India, DXLD)

**ETHIOPIA** Friends in East Africa tell me that Voice of the Tigray Revolution disappeared from its new frequencies of 5980 and 9650 (Chris Greenway, UK, DXLD) Yes, both are empty from 1630 past 1700 (Jari Savolainen, Finland, *ibid.*) Moved down to 5970 where heard opening in vernacular at 0400 after 5-minute IS (Martien Groot, Netherlands, *ibid.*)

**GABON** [and non] Africa Number One, property of the state of Gabon and the French company SOFIRAD, could pass into the hands of Libya. Kadhafi would pay 5 megaeuro for the widely-heard station, although it has lost money from the outset. Because of the satellite and internet era, Moyabi is no longer a valuable shortwave relay site. A confidential letter says that Gabon is amenable to the deal, as long as 250 employees, journalists and technicians, retain their jobs. Kadhafi may not be too wild about that, but it would give him a means to spread his ideas (Centrafrique Press and Mamboundou2005 via Bernd Trutenau, DXLD, summary translation by gh) This ties in with earlier reports that Moyabi is the source of jamming against Sawt al-Amal, the anti-Kadhafi clandestine; see LIBYA [non] (gh)

**GERMANY** CVC will cease all transmissions via facilities in Germany after May 31. Last year they already canceled all outlets via Jülich, keeping only a single Wertachtal transmitter for Africa, and this will now end, too [replaced by one in Zambia, q.v.]. Quite remarkable, since they have bought the Jülich station and will take it over after T-Systems Media&Broadcasting terminates its operations at Jülich on New Year's Eve. What will happen with this station then? (Kai Ludwig, Germany, DXLD)

**GREECE** V. of Greece A-07 program schedule in Greek includes these shows in English: Daily [exc. Tue] 0600-0700 11645 Radio Filia from domestic service; Sat 1305-1400 9420 15630 & Sun 0200-0300 7475 9420 15650 *Hellenes Around the World*; Sun 0905-1000 9420 15630 & 2305-2405 7475 9420 15650 *Greek In Style* music (John Babbis, MD, DXLD) Times vary somewhat.

The Olympia Radio relay of VOG continued in A-07 but on a different schedule, monitored 0600-1100 on 9935, 1100-1700 on 12120, but untraced at other times. 12120, running 4 seconds behind Avlis 9420, collided with KTRW (Wolfgang Büschel, Germany, *World Of Radio*)

**GUATEMALA** On the first day of A-07, on 4799.8, Radio Buenas Nuevas, heard at 0415-0429\* closing down with time check indicating Guatemala was on UT -5, DST, but two weeks later, time given was UT -6 (Manuel Méndez, Spain, DXLD)

**ISRAEL** Israel Radio A-07 English, to NAM/WEU u.o.s.: 0330-0345 9345, 11590 (from 1 September 7530), 17600-CAM/Au. 0930-0945 15760, 13855; 1730-1745 9345, 11590, 13675; 1900-1925 9400, 11590, 15640-Saf (via Moshe Oren, Bezeq, DXLD) At times the 1900 broadcast was heard on 11605 instead of 11590 (Steve Lare, MI, Wolfgang Büschel, Germany, DXLD)

Israel's A-07 sked deleted Arabic, which had been on the single frequency 5915 and an old 20 kilowatt transmitter into a bi-directional dipole antenna at 40/220 degrees. Another nail in the coffin of a once prolific shortwave broadcaster. Israel should be talking more to its Arab neighbors rather than shutting down the service. At one time, up to 4 frequencies were used for Arabic (Alan Holder, Isle of Wight, DXLD)

**ITALY** There was no new QSL in the B-06 season because there was a possibility of closing SW transmission. There will be a new one for the next period. Rai will continue in HF broadcasting, thinking about switching some programs into DRM (Mario Ballabio, RaiWay Monitoring Centre, Monzak, Italy, to George Poppin, CA, DXLD)

**JAPAN** Beginning with A07 schedule, the duration of *World Interactive* program in which DX Express had been aired was shortened from 50 to 20 minutes. So DX Express was omitted from the program until listeners' voices became louder requesting the resumption of this program (Toshimichi Ohtake/JSWC, Japan, DSWCI DX Window)

**KOREA NORTH** [non] Following Shiokazze via Taiwan on 9485, at 1330-1400 is another clandestine broadcast in Korean (Jari Savolainen, Finland, DXLD) It's Radio Free Chosun, also at 2000-2030 on 9785; see [www.rfchosun.org/main.html](http://www.rfchosun.org/main.html) (Toru Yamashita, Asian Broadcasting Institute, *ibid.*) ID at 1330 UT is "Sayu Chosun Pansong im nida" meaning "This is Radio Free Korea" (Takahito Akabayashi, Japan, BC-DX)

Interesting: A "whois" query on the [rfchosun.org](http://rfchosun.org) domain finds this registrant with an address in Pyongyang, North Korea, but I believe it's actually some organization in South Korea doing this (Sonny Ashimori, Japan, *ibid.*)

**KOREA SOUTH** [and non] KBS World Radio A-07 shows the evening relay via Sackville on 9560 cut English to half an hour at 0230 (via John Norfolk, DXLD) to accommodate a new semihour in Spanish at 0200 on same, also some bearing 277 degrees toward California. Latin Americans had been clamoring for a relay in the evening, but this won't help them much, and deprive North Americans of the full English hour (gh) Yes, reception is still very poor here (Raúl Saavedra, Costa Rica, DXLD)

**KURDISTAN** [non] Denge Mezopotamya in Kurdish: 0400-1500 on 11530, 116 degrees via Moldova, stepping up from 300 to 500 kW at 1200; the morning broadcast on 7590 is not active (DX Mix News, Bulgaria) Sometimes audible here with exotic music (gh, OK)

**LAOS** [non] Suab Xaa Moo Zoo in Hmong: daily 2300-2330 on 11650 via Taiwan, 100 kW, 250 degrees to Asia, new for A-07 (DX Mix News, Bulgaria) A religious program produced by the Christian & Missionary Alliance, Colorado Springs. More info: [www.hmongdistant.org](http://www.hmongdistant.org) (Bernd Trutenau, Lithuania, DXLD)

**LIBYA** [non] Sawt-al-Amal in Arabic: 1200-1400 via Moldova, 250 kW, 250 degrees; frequency jumps among: 17632.5 / 17637.5 / 17642.5 / 17647.5 / 17652.5 / 17657.5 / 17662.5 / 17667.5 / 17672.5 (DX Mix News, Bulgaria) to avoid jamming.

**MALDIVE ISLANDS** [non] We had a last-minute cancellation by Minivan Radio, ending its broadcasts on March 24, just before the A07 season began and the frequency change [to 11725 via Germany] would have taken place. They say they expect to get a license from the Maldives government for an FM station within the next month or so. We wish them all the best, but I am very skeptical that the government will allow them to broadcast locally, at least with any degree of freedom of expression (Jeff White, RMI, DXLD) Minivan reversed their 'quitting SW' plans a few times before (gh) The government announced that there will be only 5 FM frequencies available for private broadcasters. This further increases the pressure on broadcasters to accept government contracts, or risk losing out on a license to competitors. To make matters worse, the Ministry of Information has so far failed to provide information on how to apply for an FM license and one of the five frequencies (Andy Sennitt, *Media Network* blog)

**MÉXICO** XEYU, Radio UNAM, 9599v, was off the air for two weeks, then returned March 19 (Julián Santiago Diez de Bonilla, DF, DXLD) Since then heard irregularly and only poorly, mostly in the daytime (gh, OK)

**MICRONESIA** As of April 12, still no reports of PMA, last month's lead story, returning to 4755 for regular service; see PERÚ (gh)

**MONGOLIA** The Mongolian Radio 2nd program, Hoh Tenger on 7260, has English News at 0840-0900 Tue, Thu and Sat. English ID as "Blue Sky Radio" (S. Aoki via S. Hasegawa, NDXC)

**MOROCCO** See ARGENTINA

**NIGERIA** [non] Radio Saa, the Hausa clandestine (?), Wed & Sat 1600-1700 on 15180, which started in March continued on the same schedule in A-07, but still mostly music (gh) And in A-07 colliding with BBC in Arabic on 15180 (Wolfgang Büschel, Germany, DXLD) Great planning! BBC Arabic has used this summer frequency for years (gh)

**PAKISTAN** R. Pakistan's 17835 transmitter is totally faulty. Fluttery clipping broadcast signal, program content not understandable, in English at 0730-0830. // 15100 at 0800 news. Maybe same transmitter: Urdu on 7530 at 1700-1900 with terrible modulation spurs like a fence at 111.5 kHz away on 7416-7421, 7639-7644, and also weaker on 7752-7753, 7856 kHz (Wolfgang Büschel, Germany, DXLD and harmonics yg)

PBC A07 other English is at 1600-1615 on 9380, 11550, 11570 (via Alokesh Gupta, India, DXLD)

**PERÚ** Radio Huanta Dos Mil, Huanta, sometimes heard on 4746.89, such as at 2331-2340 in Spanish and Quechua. Four days later it had jumped to 4754.97 during the same hour (Nicolás Eramo, Argentina, *World Of Radio*) Also on 4754.94 at 0005 (Arnaldo Slaen, *ibid.*) But later in April it was back to 4746.89 at 0120 with religious program (Eramo, DXLD) So if also on air in local mornings, not only Brasil's R. Imaculada Conceição, but this could block or confuse, with weak signals any reappearance of PMA Micronesia on 4755 (gh)

**POLAND** [non] Polish Radio External Service A-07 English on SW: 1200-1259 9525 11850, 1700-1759 7140 7265 (PRES website via John Norfolk, DXLD) Not specifying these are relayed via Germany; and 7140 briefly via FINLAND, while 9525 and 7265 are at 300 degrees, 11850 is at 359 and 7140 at 20 degrees, northward toward Scandinavia (gh) Poland has traditionally very close ties to all states on Baltic Sea, and these will still cover a lot of northern UK (Wolfgang Büschel, Germany, DXLD)

PRES also started daily semihour in Hebrew, 1800 on 9695 (website via Paul Gager, HCDX) via Wertachtal. Not only the first ever broadcasts in Hebrew via a transmitter in Germany but also the first transmissions of Polskie Radio for a target area outside Europe after many years (Kai Ludwig, DXLD) Originally it was unclear whether this would be on SW or domestic service only (gh) Called Kol Polin (Voice of Poland). There are about 30,000 people with Jewish roots in Poland today (BBC News via Dragan Lekic, Serbia, DXLD) The prolonged Esperanto broadcasts were finally replaced by Ukrainian for A-07 (Jacek Szymik, Poland, *shortwave* yg)

**ROMANIA** RRI A-07 English:

1200-1300 11875 15220  
1700-1800 9635 11735  
2030-2100 9515 11810 11940 15465  
2200-2300 7185 9675 9790 11940  
0000-0100 9775 11790  
0300-0400 6150 9645 11895 15220  
0530-0600 9655 11830 15435 17770  
(via Kraig Krist, *World Of Radio*)

**RUSSIA** Voice of Russia A07 English schedule is now available all on one page at [www.ruvr.ru/main.php?lng=eng&w=129&p=](http://www.ruvr.ru/main.php?lng=eng&w=129&p=) and with handy links to full program schedules. NAM portion:

0100-0200 13775 9665 7250  
0200-0300 13775 13635 9860 9665  
0300-0400 13775 13635 12065 (9880 until July 31) 9860 9665 9515 9435 (5900 from August 1)  
0400-0500 13775 13635 (9880 until July 31) 9860 9515 9435 (5900 from August 1) (gh)

**SAUDI ARABIA** The 3-hour English broadcast from BSKSA on 17660 at 1600 reported last month did not last past March 25 into A-07, as that frequency began closing at 1557 after French (Mike Barraclough, Noel Green, UK, DXLD) Although on occasion the 1400 broadcast on 17660 was in English instead (Bernie O'Shea, Ont., *ibid.*) Usually colliding with Afropop music distraction until 1531 (gh) English still heard 1000-1230 on 15250 (Barraclough, *ibid.*) But blocked by VOA [Philippines] until 1100 (Iwao Nagatani, *Japan Premium*) Call of Islam service from 1500 on 15435 and new // 15225 ex-15425 (gh, OK)

**SERBIA** [and non] International Radio Serbia continued to be very difficult to hear even in Europe on 6100 with a low-power transmitter and QRDRM,

but at 1500 audible with strong but distorted spurs on 6686 and 5514 (Jari Savolainen, Finland, DXLD)

All languages shifted one hour earlier for A-07 on 6100 at 1300-2100, with English at 1300 and 1830 (DX Mix News, Bulgaria) Finally audible one day, but not the next, on 6099.971 at 1745 using USB mode, and 300 Hz pass band tuning adjustment to avoid Luxembourg 6090-6095-6100 DRM (Wolfgang Büschel, Germany, DXLD)

Signal strength varied from nil to strong. DRM splatter from 6095. This was not via Bijeljina (250 kW), but via an unstable transmitter (Roland Schulze, Germany, DSWCI DX Window)

DRM should be moved to specific band segments where it will not cause such interference (Francesco Ceconi, bclnews.it yg) This modest proposal keeps being made, and keeps being ignored by the DRM proponents. I think they fear that if DRM does not "make a noise" in the middle of broadcast bands, it will be even more marginalized and unnoticed; not acknowledging that the noise it makes annoys countless listeners who might be more favorably disposed toward DRM if it were in exclusive non-interfering bands (gh)

International Radio Serbia is practically in "limbo" status, because it is now just a part of the Serbian state broadcaster. Funding is getting scarce, and as International Radio Serbia can no longer rely on "federal" funding (as was the case until Montenegro left the state union), its future status is not certain (Igor from Serbia, BC-DX)

**SOMALIA** At 1813 on 6950 (AM) noted a station with Horn of Africa type music and talks in a language that sounds Somali. At 1852 Qur'an, announcement and off at 1859. There is a station in Baidoa, called Radio Bay - *Codka Jamhuuriyada Soomaaliya* which was reported to be on some unknown shortwave frequency. Finnish Afro-DX guru Mr. I. Parviainen told me he has been hearing Radio Bay on 6950. Transmitter is a bit unstable and hopping to a split frequency for a few seconds at times (Jari Savolainen, Finland, DXLD) Also heard here; sounded like national anthem at 1859 (Björn Fransson, Gotland, Sweden, *ibid.*) Fair signal, sometimes better in LSB to avoid utility transmission (Giampiero Bernardini, Italy, *ibid.*)

**SOUTH AFRICA** Channel Africa A-07 English: 0300-0355 5960, 0300-0500 3345, 0500-0555 9685, 0500-0800 7240, 0600-0655 15255, 0800-1200 9620, 1400-1600 9620, 1500-1555 17770, 1700-1755 15235, 2000-2200 3345 (SENTECH) All to various parts of Africa; well heard here on 9685; 7240 collides with Portugal, like A-06 (gh, OK)

**SPAIN** Radio Waves, the REE DX program in English, has been retimed, heard on the North American service at 0023-0034 UT Sunday on 6055. On occasions, there are only a couple of "radio songs," no DX news or shortwave items. It's now a repeat of the original airing on UT Wednesdays about the same time (John Norfolk, DXLD)

For A-07, REE's weekly 5-minute newscasts in minority, or rather "co-official" languages, Catalan, Galician and Basque air at 1240-1255 on 21570, 17595, 15585, 15170, 9765, the last two via Costa Rica (via José Bueno, DXLD) Really, these deserve a lot more on REE than a token 5 minutes a day each with no repeats unlike most other shows (gh)

**SRI LANKA** SLBC in English: 0100-0430 (Sun 0515) on 6005, 9770, 15745 (Jose Jacob, India, *World Of Radio*) Much, but not all of that is paid Christian religion (gh) 15745 was missing for over two weeks, then returned putting a creditable signal into Nepal (David Woolan, Kathmandu, *ibid.*)

**SYRIA** Radio Damascus, 2110 Arabic music. 2115-2130+ English news, commentary, weak on 9330. Poor reception riding on top of WBCQ broadcasting in LSB. Must use ECSS-USB to avoid WBCQ. // 12085 with strong carrier but very low modulation (Brian Alexander, PA, DXLD)

**THAILAND** [and non] R. Thailand A-07 English via Udorn, with azimuths:

0530-0600 17655 321 Eu  
1230-1300 9835 132 SEAs/Au  
1400-1430 9805 132 SEAs/Au  
1900-2000 7155 329 Eu  
2030-2045 9680 321 Eu  
0000-0030 9570 276 Af  
And relays via USA remain:  
0030-0100 5890 190 Greenville  
0200-0230 5890 180 Delano (gh)

**UKRAINE** Radio Ukraine International A07 English: 1100-1200 15675 (9950), 277 degrees from Kharkiv to WEu; 2100-2200 7510 (5830) 290 degrees from Kharkiv to WEu; 0000-0100 & 0300-0400 7440 (5820), Lviv 307 degrees to NEAm. Kharkiv 100 kW, Lviv 500 kW. At the end of Sept, parenthesized frequencies may replace the other ones (Olex Yegorov, RUI, via Alokesh Gupta, DXLD)

The 'Lvov' site is more precisely at Krasne, replacing 'Simferopol' which was really 300 km away at Kopani or Luch, nominal power decreased from 1000 to 500 kW, but Krasne has modern curtains instead of rhombic antennas so should put out better signals. Krasne returns to SW after five years (Kai Ludwig, Germany, and Olle Alm, Sweden, DXLD)

**USA** While 15580 had been the afternoon Greenville frequency in B-06, putting a great VOA English signal off the back into CNAm, now in A-07 15580 is Botswana 350 degrees at 1800-2100, still audible but not so great. The big 94-degree signal from GB has moved to 15445, the two // at 1900-2100, so missing the music hour which follows. 15580 then remains until 2200 but at 2100 switches to Morocco at 132 degrees. However, *Music Time in Africa* should still be Sat/Sun at 2000-2100 (gh, OK)

VOA Special English at 0130 on 6000 mixed with RHC in English (Yimber Gavia, Colombia, *World Of Radio*) Greenville is now scheduled with Special

English on 6000, UT Tue-Sat 0130-0200 at 174 degrees. You'd think everyone, especially IBB, would know by now that Habana makes extensive use of 6000, but it's not in HFCC, so it doesn't exist! (gh)

Private shortwave station A-07 Schedules from FCC: [www.fcc.gov/ib/sand/neg/hf\\_web/A07FCC01.TXT](http://www.fcc.gov/ib/sand/neg/hf_web/A07FCC01.TXT) (via Jim Moats, Thomas Moyer, DXLD) Including 50 kW Oregon vapor station KTMI still pending, with azimuths:

9820 0700 1100 KTMI 309  
9845 0200 0400 KTMI 130  
11570 0100 0500 KTMI 70

Another 50 kW phantom station still appears:

7355 2200 0200 WRNO 20  
7395 2200 1500 WRNO 20  
15420 1400 2300 WRNO 20

One can't help but wonder, after all this time, if the new owners of WRNO have any intention whatsoever of ever putting it on the air, or just use it as a fund-raising device from the gullible. Both KTMI and WRNO are shown as on the air 7 days a week, every day thru 28 Oct (gh)

For at least the first three weeks of A-07, WEWN's website schedule showed 5010 in use at 0000-0500, but it was never to be heard, just 5810 in English. Perhaps 5010, another transmitter on another azimuth, was a typo for 5810; in some fonts, a crossed zero looks a lot like an eight, but if so, they did it five times. 5010 did not appear in FCC or HFCC listings either. Maybe one big SNAFU (gh)

[non] Aoki A-07 list shows LDS Church, Sunday 1000-1200 via Ascension 250 kW on 17675, 21520 (Joe Hanlon, NJ, *World Of Radio*) Probably BYU Radio which in 2005-2006 was in DRM via UK on 9750; anyone confirm? (gh)

**URUGUAY** After several months as a silent SW country, two low-power SODRE transmitters reappeared in mid-March, Radio Uruguay, relaying CX26 1050 kHz, at 1217; and on 9620, Emisora del Sur, relaying CX38 1290 kHz, heard at 1251 (Horacio Nigro, Montevideo, DXLD) Varies on high side of 9620: measured on 9620.37 at 2200 ID by Renato Bruni, Italy (Andy Lawendel, *ibid.*) Only 350 watts, also heard at 2350 hitting Spain; the sked on MW is not 24h, but 1000-0300 (Nigro, *ibid.*) However, 9620+ was heard at 0947 with combined news programming (Samuel Cássio Martins, Brasil, *condig* list) Try for this during a window 2200-2300 (Bob Hill, MA, via BC-DX) 6125 is blocked in the evening by Spain (Harold Frogde, MI, *MARE Tipsheet*) As high as 9620.56v at 2025, not // 6125 (Nicolás Eramo, Argentina, DXLD)

**VATICAN** [non] Checking out R. República on 6100 at 0200-0400, I found it colliding with RCI Sackville until 0205, and with Vatican Radio after 0230. That's also a relay via Sackville at 240 degrees in French, English at 0250 // 7305, and Spanish until 0400. Apparently VR and RCI were unaware of República on 6100, which never appears in HFCC, made worse by the mandatory Cuban jamming (gh) VR notified me that they were changing to 6040. That collides with Spain via Costa Rica, and R. Clube Paranaense, Brasil (Héctor Frias, Chile, *World Of Radio*) VR has another new relay via Canada, 0030-0230 on 9610 in Portuguese and Spanish (Joe Hanlon, NJ) Both aimed 176 degrees. See also CANADA (gh)

**VENEZUELA** R. Amazonas, Puerto Ayacucho, occasionally active, heard on 4939.7, at 0220-0245 in late January with dance music, ID, // 5128.8v distorted spur. The day before at 2137-2155 with football, heard only on very distorted 5136.4v (Rafael Rodriguez, Colombia, *playdx* yg) This only remaining SW station here, has been varying between 5130 and 5140, overmodulated and incomprehensible, heard at 1300-1400, instead of its correct 4940. I don't understand how the engineers at the station cannot be aware of the problem. They should take it off the air and fix it (José Elías Díaz Gómez, Venezuela, *World Of Radio*)

**ZAMBIA** [and non] From June 1, CVC replaces English broadcasts to W Africa via Wertachtal, Germany, with another 100 kW transmitter at its station here aimed 315 degrees: 0500-0600 9430, 0600-0900 13650, 0900-1500 13590, 1500-1800 15715, 1800-2100 5940. The original transmitter is scheduled non-directionally at 0600-1500 on 6065, 1500-0600 on 4965 (DX Mix News, Bulgaria) 315 also toward NAm (gh)

**ZIMBABWE** ZBC, normally on 3396, was on 4828 instead on a couple of occasions in March, at 1725. They can't decide which to use (Jari Finland, DXLD) Then back on 3396, such as 0034-0110+ with choral music (Brian Alexander, PA, DXLD) Maybe testing because of this:

Zimbabwe is setting up a new shortwave radio station, News 24, to counter what it calls Western propaganda against President Robert Mugabe, partly funded by the Iranian government. It will go on air before 18 April, the 27th anniversary of Mugabe's regime coming to power (Angola Press via Mike Terry) The transmitters near Gweru are widely reported to have been donated by the Chinese government, so apparently Zimbabwe is able to count on both countries for technical assistance. No frequencies given (Andy Sennitt, *Media Network* blog) Check the previously used 3306, 3396, 4828, 6045 (Chris Greenway, UK, DXLD)

Or some brand-new ones, perhaps above 6 MHz band. Must have been a difficult choice for Mugabe, as any SW transmitter for this cannot be used to jam the opposition! Has News 24 really appeared? There were several false starts before (gh)

[non] Following the severe beating of the opposition leader, V. of the People started a new morning transmission via Madagascar, 0359-0457 on 9765 (Andy Sennitt, RNW, DXLD) Heard well with local language and music, numerous English IDs (Brian Alexander, PA, DXLD)

*Until the Next, Best of DX and 73 de Glenn!*

# BROADCAST LOGS

NOTEWORTHY LOGS FROM OUR READERS

Gayle Van Horn, W4GVH

gaylevanhorn@monitoringtimes.com

http://mt-shortwave.blogspot.com

## 0005 UTC on 15360

SINGAPORE: BBC World Service relay. Announcer duo, English newscast // 15285 SIO 333; //17615 SIO 333, //9605 SIO 333 and 5970 SIO 232 via **Oman** relay. **BBC WS** relay via **Cyprus** 7130, 0340 // 7160 **Ascension Island** relay. (Stewart MacKenzie, Huntington Beach, CA)

## 0103 UTC on 13760

NORTH KOREA: Voice of Korea. English newscast on the Great Leader and the *African Asia Committee* // 15180 SIO 444, 11785 SIO 333. (MacKenzie) **Pyongyang BC Station** 3320, 1256-1315 with patriotic anthem and text. (John Wilkins, Wheat Ridge, CO)

## 0325 UTC on 7390

SOUTH AFRICA: Channel Africa. Popular music program with SIO 333. 7240, 0503 with news on Senegal elections. (Howard Moser, Lincolnshire, IL) 3345, 0418 with financial news. (Joe Wood, Greenback, TN)

## 0338 UTC on 15425

RUSSIA: Voice of Russia via Petropavlovsk. Two announcers present classical music feature, *Russian Ballet History in the Musical Tales* program // 7350 via **Deutsche Welle Petropavlosk relay**, 15320 at 0048. (MacKenzie)

## 0433 UTC on 3291

GUYANA: Voice of. BBC World Service news relay with sports roundup. (Wood) Audible at 1015 UTC with local ads and info. (Dave Valko, PA/Cumbre DX)

## 0503 UTC on 5025

CUBA: Radio Rebelde. Spanish. Good signal for long string of Beatles classic tunes to announcer. (Wood) **Radio Havana** 11800, 0022 with IDs. **China Radio Int'l Cuban relay** 13740 at 1540. (Bob Fraser, Belfast, ME)

## 1035 UTC on 5952.41

BOLIVIA: Radio Emisoras Pio XII. Spanish news items with good signal. Bolivian **Radio Panamericana** 6105.49, 1050-1100. **Radio Yura** 4716.64, 0018-0035 **Radio Pio Doce** 5952.35, 1038-1048. (Chuck Bolland, Clewiston, FL)

## 1048 UTC on 6173.87

PERU: Radio Tawantinsuyo. Spanish canned ID every minute over Peruvian music. Peruvian stations **Radio La Hora** 4857.5, 1020-1030; **Radio Cuzco** 6193.08, 1101-1122; **Radio Altura** 5014.4, 0215-0230. **Radio Victoria** 6019.48, 0825-0835 (Bolland)

## 1050 UTC on 3329.61

PERU: Ondas del Huallaga. Spanish. Lively Peruvian huyano tunes to lady's "canned" station promo. Voice-over identifications to lengthy commercial block that continued past 1105. Decent signal suffering CHU interference. (Valko) Peruvians in Spanish: **Radio Melodia** 5939.17, 2328-2340; **Radio Union** 6114.83, 0923-0945; **Radio Municipal** (tentative) 3172.57, 0940-0945. (Bolland)

## 1200 UTC on 3266.42

INDONESIA: RRI-Gorontalo. Jakarta news relay to 1213, then local programming to 1226 when plug was unceremoniously pulled. Fair at tune-in and improving by closedown. Indonesians: **RRI-Makassar** 4749.96, 1401. **RRI-Serai** 4604.95, 1357-1434. **RRI-Makassar** 4750, 1015-1025; **RRI-Pontianak** 3976.06, 1325-1344. (Wilkins) **RRI-Fak Fak** 4789.94, 1208-1220. (Bolland)

## 1200 UTC on 3335

PAPUA NEW GUINEA: Radio East Sepik. English news and commentary possibly via NBC network. Island and pop music on rechecks to local studio Pidgin past 1300. Closedown around 1325. PNGs: **Radio East New Britain** 3385, 1216-1315. (Wilkins) **Radio Manus** 3315.10, 1100-1110. (Bolland)

## 1210 UTC on 11675

NETHERLANDS ANTILLES: Radio Netherlands relay. News on the Middle East with focus on Iran. SIO 554. (Fraser) 15525, 1900 with *Vox Humana*. (Wood)

## 1258 UTC on 6049.65

MALAYSIA: Asyik FM via Kajang. Presumed, with announcers chatting in unknown language. Vocal tune at 1312, to more talk and two phone calls. Good signal. (Wilkins)

## 1330 UTC on 15105

ROMANIA: Radio Romania Int'l. *Happiness* program with SIO 454 //17745 SIO 352. (Fraser).

## 1335 UTC on 9580

AUSTRALIA: Radio Australia. *Rural Report* with focus on salt water crocodile nuisance. SIO 453. (Fraser) 17795, 2336-2348 with item on Chinese workers in China, // 17785 SIO 444; 17750 SIO 333, 15240 SIO 333. (MacKenzie)

## 1344 UTC on 4739.7

VIETNAM: Son La BC (tentative). Exotic vocals and flute music to end of transmission. Signal generally poor, though improved slightly by 1400 closedown. Heard on subsequent rechecks with same format and signal at threshold level. (Wilkins)

## 1420 UTC on 15140

OMAN: Radio Sultanate of Oman. Techo music at tune-in, followed by music from ABBA. Clear station ID at 1430 to world newscast. Continued pop music tunes to 1500 fade-out. Arabic service noted past 1500 recheck into Quran. (Tim Marecki, Tallahassee, FL)

## 1635 UTC on 15160

FRANCE: Radio France Int'l. Report on Ghana's independence anniversary // 15605 w/ SIO 452. (Fraser) **Radio Taiwan Int'l via France** 11850, 1752-1757. (Wood)

## 1715 UTC on 11690

JORDAN: Radio Jordan. Live broadcast of a Middle East peace conference to one identification pause. SIO 453. (Fraser)

## 1725 UTC on 4828

ZIMBABWE: Radio Zimbabwe. Signal also observed on 3396 kHz, on at least during two checks in the evening. (Jari Savolainen, Kuusankoski, Finland) Fair signal monitored at 3396v, 0422-0441 in vernacular language and Afro pops. (Wood)

## 1801 UTC on 21470

ASCENSION ISLAND: BBC WS relay. *World Briefing* program and mentions of several African nations for good signal. (Wood) **BBC WS Greenville relay** 11675, 2015 report on Shanghai. (Fraser)

## 1820 UTC on 17775

USA: KVOH. Spanish program *Hour of the Day*; USA stations audible: **VOA Greenville relay** 21495, 1758 with ID and freqs. **KJES** 15385, 1905 prayers to *Ava Maria*; **KTBN** 15590, 1843 writings of Voltaire. (Wood) **WWRB** 12180, 1942-2000. (Harold Frodge, Midland, MI)

## 1939 UTC on 6925USB

PIRATES: KIPM relay. Radio drama and mentions of transmitter location amid poor signal. **The Crystal Ship** 6875, 2321-0005\*; **WBNY** 6950USB 2341-0000\*; **Sunshine Radio/Grasscutter Radio** 6925USB, 2354-0022\* (Wood)

## 2010 UTC on 15120

NIGERIA: Voice of. *Newsdesk to Sports Roundup* with station identification, SIO 353. (Fraser) 7255, 0457. (Moser) 7255, 2151-2200. (Jim Evans, Germantown, TN).

## 2015 UTC on 5930

CZECH REP: Radio Prague. Report on the economy boom in Ireland and the Czech Republic. (Fraser) 7345, 0403-0408 discussion on Czech architecture with poor quality. (Wood)

## 2040 UTC on 6985

ISRAEL: Kol Israel. Spanish off abruptly, then back on with weaker signal at 2100. Tone, identification and news in Hebrew. SIO 343. (Frodge) Hebrew 7545, 2137-2150. (Evans) Israel's **Galei Zahal** (tentative) 6973.26, 2346-2353. (Frodge).

## 2157 UTC on 7190

TUNISIA: RTV Tunisienne. Arabic text to world newscast at 2200. Brief segment of Arabic music at 2204. Moderate signal, two male announcers. (Evans)

## 2236 UTC on 9800

CANADA: Radio Canada Int'l. DRM service monitored with program on farming and two music tunes. Noted more signal drop outs during song. (Kraig Krist KG4LAC, Manassas, VA)

## 2300 UTC on 7370

VATICAN STATE: Vatican Radio. DRM service monitored with *World Day of Water*, and comments on importance of not being petty. (Krist) **Voice of Russia via Vatican relay** 7350, 0440-0500. (Wood) monitored 7350 to 0512. (Moser)

*Thanks to our contributors – Have you sent in YOUR logs?  
Send to Gayle Van Horn, c/o Monitoring Times  
English broadcast unless otherwise noted.*

# PROGRAMMING SPOTLIGHT

WHAT'S ON WHEN AND WHERE?

Fred Waterer

[fredwaterer@monitoringtimes.com](mailto:fredwaterer@monitoringtimes.com)

[www.doghousecharlie.com/radio](http://www.doghousecharlie.com/radio)

## Country Music Worldwide

**S**ure, country music is sometimes the butt of jokes. Some people just don't like it. When I was younger I wouldn't be caught dead listening to it. That is, until I actually listened to it. You can find country music's influence at the root of many, many types of music including Folk, Rock, Gospel, and so many others. Bill Haley and Elvis Presley may have heralded the Rock era, but did you know Haley was a champion yodeler, who stumbled into Rock and Roll quite by accident? And that one of Elvis' first big hits was "Blue Moon of Kentucky," a Bill Monroe standard?

Country music on the radio is as old as radio itself in North America, and as American culture has spread throughout the world, what we think of as country music has gone with it. And thrived.

### ❖ In the beginning...

The first country "hit" was recorded on June 13 or 14, 1923, in Atlanta. Called "Little Old Cabin in the Lane," it featured "Fiddlin' John Carson."

"Polk Brockman ran a furniture store in Atlanta and in order to market phonographs had developed a flourishing business selling "race" 78rpm recordings. In 1923, Ralph Peer arrived in Atlanta looking for black talent to record. Brockman imposed on him to record local fiddle champion, Fiddlin' John Carson. Peer recorded Carson, but was unimpressed and issued this recording without even a label to the Atlanta market only. This first issue sold out, and when Brockman ordered more copies, Peer realized there might be gold in them thar hills. This recording is acknowledged as the first country tune to be recorded and marketed on a commercial basis."

You can download and hear this song at [www.archive.org/details/Cabin](http://www.archive.org/details/Cabin)

### Radio soon followed

One of the longest running radio programs in North America (and perhaps one of the most famous) is the *Grand Ole Opry* from Nashville. It originated as the *WSM Barn Dance* and acquired its more famous name by a quirk of fate.

*"The change reportedly came about in an accidental way, the result of an ad lib by announcer George D. Hay, who called himself 'The Solom Old Judge,' and who had originated the National Barn Dance on WLS in Chicago in 1924. Apparently, the WSM Barn Dance came on the air immediately after a broadcast of the NBC Music Appreciation Hour, conducted by Dr. Walter Damrosch. Hay opened the program by saying: 'For the past hour, you have been listening to Grand Opera. Now we will present Grand Ole Opry!'"*

[www.southernmusic.net/grandoleopry.htm](http://www.southernmusic.net/grandoleopry.htm)

*"I don't like country music, but I don't mean to denigrate those who do. And for the people who like country music, denigrate means 'put down'"* (Bob Newhart)

[http://en.thinkexist.com/quotes/bob\\_newhart/](http://en.thinkexist.com/quotes/bob_newhart/)

The first performer on the program was a fascinating character, Uncle Jimmy Thompson. He appeared on the show at quite an advanced age, but was by all accounts, a "fiddle" virtuoso. Not to mention a throwback: He was born in 1848, and in turn had been taught to play by – among others – elderly veterans of the Revolutionary War!

Thompson came to Nashville to see his niece, who was staff pianist at WSM. He met the station owner and before long had talked himself into an on-air slot. Uncle Jimmy claimed he knew over a thousand songs and was the early star of the Opry.

The Opry has thrived to this very day, still broadcast via radio station WSM and now also available via television on a number of networks in the US and Canada. My father made the pilgrimage to the Ryman Auditorium for the Opry in 1947, meeting many of the stars and getting a few autographs. Sixty years later, my friend Shannon Mattingly from Kentucky made a similar pilgrimage. Both trips created memories to last a lifetime (see photos).

Country music was extremely popular, especially in rural areas. After all it was basically folk music. Plus, it didn't require a lot of instruments to play. And radio allowed the music to get everywhere, adding to its popularity.

"My mother (in the Ottawa valley) bought our first radio during the Depression. Somehow she found the two dollars down and two dollars a month..."

"...On Saturday nights the whole family would gather around to listen to Foster Hewitt's hockey broadcast and the big barn dance program which came from Nashville. That radio made us feel part of what was going on." (*Signing On*

– *The Birth of Radio in Canada* by McNeil and Wolfe, p75)

This was true in Western Canada as well, where a young man in Saskatoon could parlay his musical skills and hours of listening to distant programs into a weekly show with two of his friends on CFQC.

Stuck in the center of a vast prairie, what else would they call themselves but "The Hawaiian Trio"! They played a mixture of "Hawaiian" music (one had a steel guitar) and old favorites, and catered to requests from "shut ins." That young man was my father.

### Fast forward to 2007

Country music is popular throughout the world. No doubt this popularity has been aided by radio, as well as other factors. Just a few minutes on the internet turns up references to country and western music in many diverse places.

Recently, there was a delightful story about a country music/cowboy festival, held in Japan of all places.



"I love everything about horses," he says, insisting on being called 'Johnnie.' 'If only I wasn't a city boy from Kyoto.'"

And in Smolensk, Russia, one can find the CountryBandists (the name in Russian is a play on the word Contraband). According to their website:

"In 1997 they took part in the country music festival in Lithuania 'Visagino-Country.' In 2000-2002 they took the stage of the European World of Bluegrass (EWOB) festival in Holland. In 2001 they won at the festival the second place. I gave their music a listen, what a fascinating fusion of country and Russian folk melodies!"  
<http://countrybandists.ultramax-music.com/about.htm>

There are a number of listening options on shortwave and, not surprisingly, the main source of country music on the international bands is in Nashville at WWCR, which also bills itself at times as World Wide Country Radio.

### ❖ Country goes to church

A number of Christian programs on WWCR feature country music. Two particularly lively options are the *Smoky Mountain Cowboy Church* and the *Nashville Cowboy Church*.

Each program's website promises "a fast moving, well-paced interdenominational service featuring your favorite country music artists, as well as local songwriters performing their personal favorite gospel songs, combined with the music and ministry of (their) Co-Hosts... (These) program(s) are) broadcast into over 110 countries, reaching millions through WSM Radio and WWCR (World Wide Country Radio)."

#### *Smoky Mountain Cowboy Church*

"Pat Corn, Cowboy Church Co-Host, is a performer, teacher, composer, arranger, author, and inspirational speaker. He is also the leader of the Smoky Mountain Cowboy Church Band. The band has been receiving rave reviews from all who hear them. You will be inspired by Pat's musical abilities as well as his inspirational message this Sunday.

"Jason Hall is a Co-Host along with Pat

Corn. During the season, Jason lives at the American Jukebox Theater, performing six nights a week with the 50's rock & roll show, three matinees a week with the country show, and every Sunday in some capacity with Cowboy Church, whether co-hosting, performing or a member of the audience. Cowboy Church has also brought out one of Jason's hidden talents – songwriter."

*Smoky Mountain Cowboy Church* airs live on WWCR Shortwave Radio Sunday at 1500 UTC and on [www.smokymountaincowboy-church.com](http://www.smokymountaincowboy-church.com) Go to the Live Broadcast page on this site.

*Nashville Cowboy Church* airs live on WWCR Shortwave Radio Sunday at 1400 UTC and on [www.nashvillecowboychurch.com](http://www.nashvillecowboychurch.com) Go to the Live Broadcast page on this site.

It can also be found on XM Satellite Radio; Channel: Hanks Place; Sunday, 9:00am EST, 9:00pm EST

### ❖ World Wide Country Radio

There are two contradictory schedules for *World Wide Country Radio* at the WWCR website. The more recent one lists the program as being on the air at the following times: M-F at 1000 UTC on 15825 kHz and M-F at 1100 UTC on 5070 kHz.

*Country Crossroads* M-F at 1300 UTC on 9985 kHz

### ❖ Ken's Country Classics

This show was once heard on WWCR; however, more recently one needs to tune to WRVU online. Ken is a treasure and is billed as "the oldest living country deejay." I used to enjoy listening to his *Country Classics*, as well as his *Old Record Shop* program, a chance to hear very old and very rare recordings indeed.

Check the WRVU schedule at [www.wrvu.org](http://www.wrvu.org), where you can also listen to the webcasts. *Ken's Country Classics* and *The Old Record Shop* "air" back to back on Mondays from noon-2pm CT.

### ❖ VoA

#### *Country Hits USA*

"Country Hits USA host Mary Morningstar joined VOA in 1978 as a music library staff member and later to the position of writer and producer.

"Mary has traveled to Nashville to cover the International Country Music Fan Fair and the Country Music Association Awards.

"She has been studio director for *Border Crossings* since its inception in 1998."

[www.voanews.com/english/Entertainment/MusicMix-presenters.cfm](http://www.voanews.com/english/Entertainment/MusicMix-presenters.cfm)

Host Mary Morningstar wraps up the week-day offerings with the top country music hits debuting on Billboard's "Hot Country Singles" chart.

#### Where to Listen via Shortwave:

Africa 9850, 15580 kHz  
Middle East & Europe 96.9 FM, 9825 kHz, 15195 kHz, 15445 kHz  
Asia & Pacific 7.125, 9.5813.69, 15.105 MHz  
17.715 kHz & 13.795 kHz (medium wave)

[www.voanews.com/english/Entertainment/musicmix-countryhits.cfm](http://www.voanews.com/english/Entertainment/musicmix-countryhits.cfm)

### ❖ Radio Australia

#### *Saturday Night Country*

For the best part of the last decade, John Nutting has hosted this weekly show across Australia on Local ABC Radio stations and across the world on Radio Australia and through streaming audio via the World Wide Web. John Nutting is country music. He has spent the last twenty years working throughout Australia, playing and promoting the music he loves and every Saturday Night, he hosts the national programme, *Saturday Night Country* - considered the "flagship" of country music in Australia. Saturdays at 1200 UTC on 5995, 6020, 9560, 9580 and 9710 kHz

#### *Australian Country Style*

John Nutting also hosts *Australian Country Style*. The program can be heard Sundays at 03:30 and 06:30, Friday at 20:30 and Saturday at 18:30

### ❖ BBC

I seem to recall that at one time there was a World Service program dedicated to country music. If it's still there, I couldn't find it.

However for those of you who listen to BBC via the internet, there is a multitude of shows. In fact, there are no less than 74 different programs listed in the Folk and Country category!

Click [www.bbc.co.uk/radio/](http://www.bbc.co.uk/radio/) (make sure you have it set to "UK Version"), and then click "Music," then "Folk and Country."

Some highlights include:

#### Bob Harris - Saturday

Classic tracks and new releases.

#### Dave Cash -

The UK Top 20 Country Artist and Compilation charts

#### Nick Barraclough -

New Country, with the latest tunes, news and gossip.

### ❖ CBC/RCI

There is no dedicated country music program on CBC. However, check out CBC programming around such special events as the East Coast Music Awards. Last Christmas one of the nicer shows on CBC was *French Canadian Prairie Christmas*, which had a decidedly country/Metis flavor.

*CBC North* during its local programming will feature a lot of country music as well, often in Inuktitut or Cree.

### Books by Ernest H. Robl:

*THE BASIC RAILFAN BOOK*

*UNDERSTANDING INTERMODAL*

*THE POWDER RIVER BASIN*

Detailed descriptions at

<http://www.robl.w1.com>



## Word to the Wise DXer on IRCs

Every once in a while, I read of a hobbyist getting caught in a postal *faux pas*, and unfortunately the following is a perfect example.

Recently, a DXer went to his post office to purchase an International Reply Coupon (IRC). These coupons help defray postal expenses of an overseas station when you are requesting a return verification (QSL). The clerk attempted to sell our DXer IRCs that expired December 31, 2006. When it was brought to their attention, the clerk stated, "We've been selling these all along. We just put a ten cent stamp on them because the price has gone up and no one has complained."

Despite what a seemingly informed clerk or even a supervisor informs you, the 2006 IRCs have expired, and will not be valid overseas. In fact, postal regulations state the cut-off date for sale was August 31, 2006. Unfortunately, the post office receives no automatic distribution of the new IRCs, but instead must order them from their local Stamp Distribution Office (SDO) or Stamp Service Center (SSC).

Post office regulations also state that "under no circumstances should an expiring IRC be sold on or after September 1, 2006." Expired IRCs were to have been mailed to the Eagan ASC Finance Branch in Eagan, Minnesota, before October 13, 2006.

All new IRCs are properly denominated at the sale price of \$1.85 and no longer require the additional 10-cent stamp. Foreign-origin IRCs, as well as returned US-issued IRCs, remain redeemable by customers at the Post Office, branches or postal stations.

The DXer in question showed the postal document to the supervisor, who was very appreciative and asked to keep it! I guess that just goes to show ya...sometimes the left hand doesn't know what the right is doing. Don't let this happen to you.



### ASCENSION ISLAND

Family Radio Worldwide relay 11875 kHz. Partial data card unsigned, plus station stickers and religious literature. Received in 50 days for two IRCs and a souvenir applause card. QSL address: Family Station Worldwide Inc., 290 Hegenberger Rd., Oakland, CA 94621-1436 USA. (Joe Wood, Greenback, TN)

### CANADA

Radio Canada Int'l via Kunming, China 11675 kHz. Full data Maple Leaf Mailbag card, unsigned, plus two special souvenir CDs and schedule. Received in ten days after an English followup. Station address: P.O. Box 6000, Montréal, Québec, H3A8 Canada. (John Wilkins, Wheat Ridge, CO)

### CLANDESTINE

Radio Republica 9955 kHz. No data verification on station letterhead with handwritten "thank you for your report." Received in 93 days for an English report, one U.S. dollar and an address label (used on reply). Station address: Directorio Democratico Cubano, P.O. Box 110235, Hialeah, FL 33011 USA. (Bill Wilkins, Springfield, MO) Reports may also be directed to: WRMI, c/o Jeff White, 175 Fontainebleau Blvd., Suite 1N4, Miami, FL 33172 USA.

Radio Zamaneh 6245 kHz. (via Mykolaiv, Ukraine). Full data QSL card signed by Mehdi Jami-Director, plus friendly greeting. Received in 23 days for an English report. QSL address: Linnaeusstraat 35-F, 1093 EE Amsterdam, The Netherlands. (Arnaldo Slaen, Buenos Aires, Argentina) Initial email report to [contact@radiozamaneh.com](mailto:contact@radiozamaneh.com) with an MP3 audio attachment. Received QSL/postcards in two months, signed by M. Jami-RZ Director [medhi.jami@gmail.com](mailto:medhi.jami@gmail.com) (Ed Kusalik, Alberta, Canada)

### ECUADOR

Time/Signal Station-HD2IOA, 3810 kHz. Full data letter signed by Capitan Rafael Cabello Peñafiel, Captain de Fragata EM.-Subdirector Technico, plus station card confirming my reception. Received via registered mail in 32 days for an English report, one IRC and a souvenir applause card. Station address: HD2IOA, Instituto Oceanografico de la Armada, (INOCAR), via Puerto Maritimo, Código Postal 940, Guayaquil, Ecuador. (Wood)

### GUATEMALA

Radio Verdad 4052.5 kHz. Full data station QSL card, signed by Edgar Amilcar Madrid. Received in ten days for a Spanish email to [radioverdad5@yahoo.com](mailto:radioverdad5@yahoo.com) Station address: P.O. Box 5, Chhiquimula, Guatemala, Central America. (Manuel Méndez, Lugo, Spain)



### MEDIUM WAVE

KTIQ 1660 kHz AM. Prepared QSL card, signed by Reneé Garcia, plus business card of Yolanda Navarro-Program Director. Received in eight months after two different reports and eight follow ups since 2002. Station address: 1175 Fairview Dr., Merced, CA 95342 USA. (Wilkins)

WISN 1130 kHz AM Milwaukee, WI. Verification letter signed by Al Hajny-Director of Engineering. Received in ten days for a CD report and SASE, for a 2005 DX Test to the new Chief Engineer. Station address: 12100 West Howard Ave., Greenfield, WI 53228 USA. (Patrick Martin, Seaside, OR)

WRKO 680 kHz AM Boston, MA. Verification statement signed by John Uenyl (?) at bottom of my AM reception report. Received in 100 days. Station address: 20 Guest Street, Third Floor, Brighton, MA 02135-2040 USA. (Martin)

### PALAU

Radio Free Asia via T8BZ Koror, 13775/15660 kHz. Full data (except program name) Voice of Hope color globe card, plus personal note signed and stamped as confirmed via Ben Chan. This is for Vietnamese broadcast logged in Bao Loc, Lam Dong, Vietnam. Received in 20 months. Station address: Ben Chan-T88BC-Engineering Manager, High Adventure Ministries, Palau, T8BZ, P.O. Box 66, Koror 96940, Republic of Palau. (Wendel Craighead, Prairie Village, KS)

### PIRATE

This is Not the BBC 6925 kHz USB. Verification letter that included, "Thank you for your reception report." Letter informed me "We must unfortunately inform you that you did not, I repeat did not hear the BBC." Note included a bogus "Anywhere USA" address. Received in nine days for pirate report posted at The FRN Grapevines link [www.frn.net/vines/](http://www.frn.net/vines/) from the Free Radio Network website [www.frn.net/](http://www.frn.net/) (Andrew Yoder/Cumbre DX)

### VATICAN CITY STATE

Radio Vaticana 7335 kHz. Beautiful full data color antenna towers, unsigned, plus brochure and program schedule. Received in 41 days for an English report. Station address: 00120 Città del Vaticano, Vatican City State. (R.W. Parker, Gerryville, PA) [www.vaticanradio.org](http://www.vaticanradio.org)

### VENEZUELA

Radio Amazonas 4940 kHz. Full data computer-generated card in Spanish, signed by Sr. Jorge Garcia Rangel-QSL Manager, plus two personal letters (Spanish and English). Received in 419 days for an English report and two U.S. dollars. Station address: Radio Amazonas, Atencion: Sr. Jorge Garcia Rangel QSL Manager, Calle Roma, Qta: Costa Rica No. A-16, Urbanización Alto Barinas, Barinas 5201 Venezuela. (Scott R Barbour Jr., Intervale, NH)





## HOW TO USE THE SHORTWAVE GUIDE



0000-0100 twhfa USA, Voice of America 5995am 6130ca 7405am 9455af  
 ① ② ⑤ ③ ④ ⑥ ⑦

### Convert your time to UTC.

Broadcast **time on** ① and **time off** ② are expressed in Coordinated Universal Time (UTC) – the time at the 0 meridian near Greenwich, England. To translate your local time into UTC, first convert your local time to 24-hour format, then add (during Daylight Saving Time) 4, 5, 6 or 7 hours for Eastern, Central, Mountain or Pacific Times, respectively. Eastern, Central, and Pacific Times are already converted to UTC for you at the top of each hour.

Note that all **dates**, as well as times, are in UTC; for example, a show which might air at 0030 UTC *Sunday* will be heard on *Saturday* evening in America (in other words, 8:30 pm Eastern, 7:30 pm Central, etc.).

### Find the station you want to hear.

Look at the page which corresponds to the time you will be listening. English broadcasts are listed by UTC **time on** ①, then alphabetically by **country** ③, followed by the **station name** ④. (If the station name is the same as the country, we don't repeat it, e.g., "Vanuatu, Radio" [Vanuatu].)

If a broadcast is not *daily*, the **days of broadcast** ⑤ will appear in the column following the time of broadcast, using the following codes:

<u>Codes</u>	
s/Sun	Sunday
m/Mon	Monday
t	Tuesday
w	Wednesday
h	Thursday
f	Friday
a/Sat	Saturday
occ:	occasional
DRM:	Digital Radio Mondiale
irreg	Irregular broadcasts
vl	Various languages

### Choose the most promising frequencies for the time, location and conditions.

The **frequencies** ⑥ follow to the right of the station listing; all frequencies are listed in kilohertz (kHz). Not all listed stations will be heard from your location and virtually none of them will be heard all the time on all frequencies.

Shortwave broadcast stations change some of their frequencies at least twice a year, in April and October, to adapt to seasonal conditions. But they can also change in response to short-term conditions, interference, equipment problems, etc. Our frequency manager coordinates

published station schedules with confirmations and reports from her monitoring team and MT readers to make the Shortwave Guide up-to-date as of one week before print deadline.

To help you find the most promising signal for your location, immediately following each frequency we've included information on the **target area** ⑦ of the broadcast. Signals beamed toward your area will generally be easier to hear than those beamed elsewhere, even though the latter will often still be audible.

#### Target Areas

- af: Africa
- al: alternate frequency (occasional use only)
- am: The Americas
- as: Asia
- ca: Central America
- do: domestic broadcast
- eu: Europe
- me: Middle East
- na: North America
- oc: Oceania
- pa: Pacific
- sa: South America
- va: various

### Shortwave Broadcast Bands

kHz	Meters
2300-2495	120 meters (Note 1)
3200-3400	90 meters (Note 1)
3900-3950	75 meters (Regional band, used for broadcasting in Asia only)
3950-4000	75 meters (Regional band, used for broadcasting in Asia and Europe)
4750-4995	60 meters (Note 1)
5005-5060	60 meters (Note 1)
5730-5900	49 meter NIB (Note 2)
5900-5950	49 meter WARC-92 band (Note 3)
5950-6200	49 meters
6200-6295	49 meter NIB (Note 2)
6890-6990	41 meter NIB (Note 2)
7100-7300	41 meters (Regional band, not allocated for broadcasting in the western hemisphere) (Note 4)
7300-7350	41 meter WARC-92 band (Note 3)
7350-7600	41 meter NIB (Note 2)
9250-9400	31 meter NIB (Note 2)
9400-9500	31 meter WARC-92 band (Note 3)
9500-9900	31 meters
11500-11600	25 meter NIB (Note 2)
11600-11650	25 meter WARC-92 band (Note 3)
11650-12050	25 meters
12050-12100	25 meter WARC-92 band (Note 3)
12100-12600	25 meter NIB (Note 2)
13570-13600	22 meter WARC-92 band (Note 3)
13600-13800	22 meters
13800-13870	22 meter WARC-92 band (Note 3)
15030-15100	19 meter NIB (Note 2)
15100-15600	19 meters
15600-15800	19 meter WARC-92 band (Note 3)
17480-17550	17 meter WARC-92 band (Note 3)
17550-17900	17 meters
18900-19020	15 meter WARC-92 band (Note 3)
21450-21850	13 meters
25670-26100	11 meters

#### Notes

- Note 1 Tropical bands, 120/90/60 meters are for broadcast use only in designated tropical areas of the world.
- Note 2 Broadcasters can use this frequency range on a (NIB) non-interference basis only.
- Note 3 WARC-92 bands are allocated officially for use by HF broadcasting stations in 2007.
- Note 4 WRC-03 update. After March 29, 2009, the spectrum from 7100-7200 kHz will no longer be available for broadcast purposes and will be turned over to amateur radio operations worldwide.

### MT MONITORING TEAM

**Gayle Van Horn**  
 Frequency Manager  
 gaylevanhorn@monitoringtimes.com

**Daniel Sampson**  
 danielsampson@monitoringtimes.com

**Larry Van Horn, MT Asst. Editor**  
 larryvanhorn@monitoringtimes.com

### Thank You ...

#### Additional Contributors to This Month's Shortwave Guide:

Rich D'Angelo/*NASWA Flash Sheet*; Alokesh Gupta, New Delhi, India; Anker Petersen/*DX Window*; Arnaldo Coro, CO2KK/R. Havana; Bernd Trutenau, Lithuania; Ivo Ivanov; Alan Roe, UK; Adrian Sainsbury/R.NZ Intl; Harold Sellers/*ODXA/DX Ontario*; Raimonds Kreicbergs, Lithuania; Sakthi Vel, India; Wolfgang Bueschel, Germany; Andreas Volk, Germany; *BCL News*; *Cumbre DX*; *DX Mix News*, *Bulgaria*; *Hard Core DX*; *NASWA Journal*; World Wide DX Club-Top News.

**GLENN HAUSER'S  
 WORLD OF RADIO**  
<http://www.worldofradio.com>

For the latest DX and programming news, amateur nets, DX program schedules, audio archives and much more!

**0000 UTC - 8PM EDT / 7PM CDT / 5PM PDT**

0000 0005	Greece, Voice of	7475eu	9420eu	15640eu
0000 0015	Japan, Radio Japan/NHK World			13650as
		17810as		
0000 0027	Czech Rep, Radio Prague	7345na	9440na	
0000 0030	Australia, HCJB Global	15525va		
0000 0030	Australia, Radio	9660as	12080as	13670as
		15240pa	17715as	17750va
		17795va		
0000 0030	Burma, Dem Voice of Burma	5955eu		
0000 0030	Egypt, Radio Cairo	9460na		
0000 0030	UK, BBC World Service	3915as	5970as	
		17615as		
0000 0030	USA, Voice of America	7555as		
0000 0045	India, All India Radio	9690as	9705as	
		11620as	11645as	13605as
0000 0045	USA, Family Radio Worldwide FL			17805am
0000 0057	Canada, Radio Canada Intl	11700as		
0000 0058	Germany, Deutsche Welle	7245as	13730as	
		15595as		
0000 0059	Spain, Radio Exterior Espana	6055na		
0000 0100	Anguilla, University Network	6090am		
0000 0100	Australia, ABC NT Alice Springs		2310do	
		4835do		
0000 0100	Australia, ABC NT Katherine	5025do		
0000 0100	Australia, ABC NT Tennant Creek		4910do	
0000 0100	Canada, CFRX Toronto ON	6070na		
0000 0100	Canada, CFVP Calgary AB	6030na		
0000 0100	Canada, CKZN St John's NF	6160na		
0000 0100	Canada, CKZU Vancouver BC		6160na	
0000 0100	China, China Radio Intl	6020na	6075as	
		9570as	9725as	11885as
		15115as		
0000 0100	Costa Rica, University Network		5030va	
		6150va	7375va	9725va
0000 0100	Guyana, Voice of	3291do		
0000 0100	Japan, Radio Japan/NHK World		6145na	
0000 0100	Malaysia, RTM/Trax FM	7295as		
0000 0100	Netherlands, Radio	9845na		
0000 0100	New Zealand, Radio NZ Intl	13720pa		
0000 0100	New Zealand, Radio NZ Intl	15720pa		
0000 0100	Papua New Guinea, Wantok R. Light		7120va	
0000 0100	Romania, Radio Romania Intl	9775na	11790na	
0000 0100	Russia, Voice of	7250na	9665na	12755na
0000 0100	Singapore, MediaCorp Radio	6150do		
0000 0100	UK, BBC World Service	6195as	9580as	
		9740as	11955as	15335as
0000 0100	UK, Bible Voice BC	5980me		
0000 0100	Ukraine, Radio Ukraine Intl	7440eu		
0000 0100	USA, American Forces Radio	4319usb	5446usb	
		5765usb	6350usb	7811usb
		12133usb	13362usb	
0000 0100	USA, Family Radio Worldwide FL		6065am	
		9595am	11835am	
0000 0100	USA, KAIJ Dallas TX	5755va		
0000 0100	USA, KTBN Salt Lake City UT	7505na	15590na	
0000 0100	USA, WBCQ Monticello ME	5110am	7415na	
		9330na		
0000 0100	USA, WBOH Newport NC	5920am		
0000 0100	USA, WEWN Vandiver AL	5810va		
0000 0100	USA, WHRA Greenbush ME	7520na		
0000 0100	USA, WHRI Cypress Creek SC		9515am	
0000 0100	USA, WHRI Cypress Creek SC		7490am	
0000 0100	USA, WINB Red Lion PA	9265am		
0000 0100	USA, WRMI Miami FL	9955va		
0000 0100	USA, WTJC Newport NC	9370na		
0000 0100	USA, WWCR Nashville TN	5070na	7465na	
		13845na		
0000 0100	USA, WWRB Manchester TN	5745am		
0000 0100	USA, WWRB Manchester TN	3185va	5050va	
		6890na		
0005 0100	Canada, Radio Canada Intl	6100na		
0030 0045	Germany, Pan American BC	6165as		
0030 0100	Australia, Radio	9660as	12080as	13670as
		15240pa	15415as	17750va
		17795va		
0030 0100	Lithuania, Radio Vilnius	9875na		
0030 0100	Thailand, Radio	5890na	9570af	skd0607
0030 0100	UK, Bible Voice BC	5955as		
0030 0100	USA, Voice of America	9715va	9780va	
		11725va	15185va	15205va
		15560va	17820va	
0035 0058	Sun/Mon	Austria, Radio Austria Intl	9870am	
0043 0058	twhfa	Austria, Radio Austria Intl	9870am	
0055 0100		Italy, RAI Italia	11800na	

**0100 UTC - 9PM EDT / 8PM CDT / 6PM PDT**

0100 0104	Canada, Radio Canada Intl	6100na
0100 0115	Italy, RAI Italia	11800na

0100 0127	Czech Rep, Radio Prague	6200na	7345na
0100 0128	Hungary, Radio Budapest	6040na	
0100 0128	Vietnam, Voice of	6175na	
0100 0130	Slovakia, Radio Slovakia Int	5930na	9440sa
0100 0157	China, China Radio Intl	6020na	6075as
		9410na	9570na
		9790na	11870as
			15115as
			15785as
0100 0200	Albania, Radio Tirana	6115eu	7425eu
0100 0200	Anguilla, University Network	6090am	
0100 0200	Australia, ABC NT Katherine	5025do	
0100 0200	Australia, ABC NT Tennant Creek		4910do
0100 0200	Australia, Radio	9660as	12080as
		15240pa	15415as
		17750va	15515as
			17715as
			21745va
0100 0200	Canada, CFRX Toronto ON	6070na	
0100 0200	Canada, CFVP Calgary AB	6030na	
0100 0200	Canada, CKZN St John's NF	6160na	
0100 0200	Canada, CKZU Vancouver BC		6160na
0100 0200	Costa Rica, University Network		5030va
		6150va	7375va
			9725va
0100 0200	Cuba, Radio Havana	6000na	6180na
0100 0200	Guyana, Voice of	3291do	
0100 0200	Indonesia, Voice of	9525as	11785pa
		15150al	
0100 0200	Japan, Radio Japan/NHK World		5960va
		11780as	11935na
		17560va	15235as
			17810as
			17825va
0100 0200	Malaysia, RTM/Trax FM	7295as	
0100 0200	Netherlands, Radio	9845na	
0100 0200	New Zealand, Radio NZ Intl	13720pa	
0100 0200	New Zealand, Radio NZ Intl	15720pa	
0100 0200	North Korea, Voice of Korea	7140as	9345as
		9730am	11735am
			13760am
			15180am
0100 0200	Papua New Guinea, Wantok R. Light		7120va
0100 0200	Russia, Voice of	7250na	9665na
0100 0200	Singapore, MediaCorp Radio	6150do	
0100 0200	Sri Lanka, SLBC	6005as	9770as
0100 0200	Taiwan, Radio Taiwan Intl	11875as	15465na
0100 0200	UK, BBC World Service	6195as	9410as
		9580as	11750as
			11955as
			15335as
0100 0200	UK, Bible Voice BC	5945me	
0100 0200	USA, American Forces Radio	4319usb	5446usb
		5765usb	6350usb
			7811usb
			10320usb
0100 0200	USA, Family Radio Worldwide FL		6065am
		9595am	
0100 0200	USA, KAIJ Dallas TX	5755va	
0100 0200	USA, KTBN Salt Lake City UT	7505na	
0100 0200	USA, KWHR Naalehu HI	17655as	
0100 0200	USA, Voice of America	7430va	9600va
		11705va	
0100 0200	USA, WBCQ Monticello ME	5110am	7415na
		9330na	
0100 0200	USA, WBOH Newport NC	5920am	
0100 0200	USA, WEWN Vandiver AL	5810va	
0100 0200	USA, WHRA Greenbush ME	5890na	
0100 0200	USA, WHRI Cypress Creek SC		7490am
0100 0200	USA, WINB Red Lion PA	9265am	
0100 0200	USA, WRMI Miami FL	9955va	
0100 0200	USA, WRMI Miami FL	7385na	
0100 0200	USA, WTJC Newport NC	9370na	
0100 0200	USA, WWCR Nashville TN	5070na	5935na
		7465na	
0100 0200	USA, WWRB Manchester TN	5745am	
0100 0200	USA, WWRB Manchester TN	3185va	5050va
		6890na	
0100 0200	Uzbekistan, CVC International		11790as
0105 0128	Sun/Mon	Austria, Radio Austria Intl	9870am
0113 0128	twhfa	Austria, Radio Austria Intl	9870am
0115 0130	Sat	Australia, HCJB Global	15405va
0130 0200		Iran, Voice of the Islamic Rep	6120na
0130 0200		Lithuania, Radio Vilnius	7325na
0130 0200		Sweden, Radio	6010na
0130 0200	twhfa	USA, Voice of America	13740va
0140 0200		Vatican City, Vatican Radio	5915va
0143 0158	twhfa	Austria, Radio Austria Intl	9870am

**0200 UTC - 10PM EDT / 9PM CDT / 7PM PDT**

0200 0215	Croatia, Croatian Radio	6165na	9925eu
0200 0227	Iran, Voice of the Islamic Rep	6120na	7160na
0200 0230	South Korea, KBS World Radio		15575sa
0200 0245	USA, Family Radio Worldwide FL		11835na
0200 0257	China, China Radio Intl	9550as	11770as
		13640as	
0200 0300	Anguilla, University Network	6090am	
0200 0300	Argentina, RAE	11710am	
0200 0300	Australia, ABC NT Alice Springs		2310do
		4835do	

0200	0300	Australia, ABC NT Katherine	5025do		
0200	0300	Australia, ABC NT Tennant Creek	4910do		
0200	0300	Australia, Radio 15240pa	15415as	15515as	17750va
0200	0300	Bulgaria, Radio 9700na	11700na		
0200	0300	Canada, CFRX Toronto ON	6070na		
0200	0300	Canada, CFVP Calgary AB	6030na		
0200	0300	Canada, CKZN St John's NF	6160na		
0200	0300	Canada, CKZU Vancouver BC		6160na	
0200	0300	Costa Rica, University Network		5030va	
0200	0300	6150va	7375va	9725va	
0200	0300	Cuba, Radio Havana	6000na	6180na	
0200	0300	Egypt, Radio Cairo	7270na		
0200	0300	Guyana, Voice of 3291do			
0200	0300	Malaysia, RTM/Trax FM	7295as		
0200	0300	Netherlands, Radio	9405va		
0200	0300	DRM New Zealand, Radio NZ Intl	13720pa		
0200	0300	DRM New Zealand, Radio NZ Intl	15720pa		
0200	0300	North Korea, Voice of Korea	13650as	15575as	
0200	0300	vi Papua New Guinea, Wantok R. Light	7120va	15115va	
0200	0300	Philippines, Radio Pilipinas	12025va	15115va	
0200	0300	15230va			
0200	0300	Russia, Voice of 9665na	9860na	13635na	
0200	0300	13775na			
0200	0300	Singapore, MediaCorp Radio	6150do		
0200	0300	Sri Lanka, SLBC	6005as	9770as	15745as
0200	0300	Thailand, Radio	5890na		
0200	0300	UK, BBC World Service	6030af	6195as	
0200	0300	11750as	11955as	15310as	15335as
0200	0300	15360as	17790as		
0200	0300	USA, American Forces Radio	4319usb	5446usb	
0200	0300	5765usb	6350usb	7811usb	10320usb
0200	0300	12133usb	13362usb		
0200	0300	USA, Family Radio Worldwide FL		5985am	
0200	0300	11855am			
0200	0300	USA, KAIJ Dallas TX	5755va		
0200	0300	USA, KJES Vado NM	7555na		
0200	0300	USA, KTBN Salt Lake City UT	7505na		
0200	0300	USA, KWHR Naalehu HI	17655as		
0200	0300	USA, WBCQ Monticello ME	5110am	7415na	
0200	0300	9330na			
0200	0300	USA, WBOH Newport NC	5920am		
0200	0300	USA, WEWN Vandiver AL	5810va		
0200	0300	USA, WHRA Greenbush ME	5890na		
0200	0300	USA, WHRI Cypress Creek SC		7490am	
0200	0300	USA, WINB Red Lion PA	9265am		
0200	0300	sm USA, WRMI Miami FL	9955va		
0200	0300	twhf USA, WRMI Miami FL	7385na		
0200	0300	USA, WTJC Newport NC	9370na		
0200	0300	USA, WWCR Nashville TN	3215na	5070na	
0200	0300	5935na	7465na		
0200	0300	mtwhfa USA, WWRB Manchester TN	5745am		
0200	0300	USA, WWRB Manchester TN	3185va	5050va	
0200	0300	6890na			
0200	0300	Uzbekistan, CVC International		11790as	
0200	3000	Taiwan, Radio Taiwan Intl	5950na	9680am	
0215	0230	Nepal, Radio	3230as	5005as	6100as
0230	0258	Hungary, Radio Budapest	6195na		
0230	0258	Vietnam, Voice of 6175na			
0230	0300	twhf Albania, Radio Tirana	6115eu	7425eu	
0230	0300	North Korea, Voice of Korea	9560na		
0230	0300	South Korea, KBS World Radio		9560na	
0230	0300	Sweden, Radio	6010na		
0245	0300	India, All India Radio	7420as		
0245	0300	Myanmar, Radio	9730do		
0250	0300	Vatican City, Vatican Radio	6040va	7305va	
0255	0300	vi Rwanda, Radio	6055do		

### 0300 UTC - 11PM EDT / 10PM CDT / 8PM PDT

0300	0320	Vatican City, Vatican Radio	6040va	7305va	
0300	0327	15560va			
0300	0327	Czech Rep, Radio Prague	7345na	9870na	
0300	0330	Egypt, Radio Cairo	7270na		
0300	0330	Myanmar, Radio 9730do			
0300	0330	Philippines, Radio Pilipinas	12025va	15115va	
0300	0330	15230va			
0300	0330	USA, KJES Vado NM	7555na		
0300	0330	USA, Voice of America	4930af	6080af	
0300	0330	7340af	9885af	12080af	15580af
0300	0330	USA, WBCQ Monticello ME	9330am		
0300	0330	Vatican City, Vatican Radio	9660af		
0300	0355	South Africa, Channel Africa	5960af		
0300	0357	China, China Radio Intl	9690na	9790na	
0300	0357	11770as	13750as	15110as	15120as
0300	0359	15785as			
0300	0400	South Africa, Channel Africa	3345af		
0300	0400	Anguilla, University Network	6090am		

0300	0400	Australia, ABC NT Alice Springs		2310do	
0300	0400	4835do			
0300	0400	Australia, ABC NT Katherine	5025do		
0300	0400	Australia, ABC NT Tennant Creek		4910do	
0300	0400	Australia, Radio 9660as	12080as	13670as	
0300	0400	15240pa	15415as	15515as	17750va
0300	0400	21725va			
0300	0400	twhf Canada, CBC NQ SW Service		9625na	
0300	0400	Canada, CFRX Toronto ON	6070na		
0300	0400	Canada, CFVP Calgary AB	6030na		
0300	0400	Canada, CKZN St John's NF	6160na		
0300	0400	Canada, CKZU Vancouver BC		6160na	
0300	0400	Costa Rica, University Network		5030va	
0300	0400	6150va	7375va	9725va	
0300	0400	Cuba, Radio Havana	6000na	6180na	
0300	0400	Germany, Deutsche Welle	11695as	13810as	
0300	0400	Guyana, Voice of 3291do			
0300	0400	Japan, Radio Japan/NHK World		21610pa	
0300	0400	Malaysia, RTM/Trax FM	7295as		
0300	0400	Malaysia, RTM/Voice of Malaysia		6175as	
0300	0400	9750as	15295as		
0300	0400	DRM New Zealand, Radio NZ Intl	13720pa		
0300	0400	DRM New Zealand, Radio NZ Intl	15720pa		
0300	0400	North Korea, Voice of Korea	7140as	9345as	
0300	0400	9730as			
0300	0400	vi Papua New Guinea, Wantok R. Light	7120va		
0300	0400	Romania, Radio Romania Intl	6150va	9645na	
0300	0400	11895va	15220va		
0300	0400	DRM Russia, Voice of 15735as			
0300	0400	DRM Russia, Voice of 9435na	9515na	9665na	
0300	0400	9860na	9880na	12065na	13635na
0300	0400	vi Rwanda, Radio 6055do			
0300	0400	Singapore, MediaCorp Radio	6150do		
0300	0400	Sri Lanka, SLBC	6005as	9770as	15745as
0300	0400	Taiwan, Radio Taiwan Intl	5950am	15215sa	
0300	0400	Turkey, Voice of 5975va	7270va		
0300	0400	Sun UK, BBC World Service	11760as		
0300	0400	UK, BBC World Service	3255af	6005af	
0300	0400	6030af	6190af	6195as	9750af
0300	0400	12035af	15310as	15360as	15575as
0300	0400	17760as	21660as		
0300	0400	Ukraine, Radio Ukraine Intl	7440na		
0300	0400	USA, American Forces Radio	4319usb	5446usb	
0300	0400	5765usb	6350usb	7811usb	10320usb
0300	0400	12133usb	13362usb		
0300	0400	USA, Family Radio Worldwide FL		6065na	
0300	0400	9505na	11740na	15255na	
0300	0400	USA, KAIJ Dallas TX	5755va		
0300	0400	USA, KTBN Salt Lake City UT	7505na		
0300	0400	USA, KWHR Naalehu HI	17655as		
0300	0400	USA, WBCQ Monticello ME	5110am	7415na	
0300	0400	USA, WBOH Newport NC	5920am		
0300	0400	USA, WEWN Vandiver AL	5810va		
0300	0400	USA, WHRA Greenbush ME	5890na		
0300	0400	USA, WHRI Cypress Creek SC		7315am	
0300	0400	mtwhf USA, WHRI Cypress Creek SC		5835am	
0300	0400	USA, WINB Red Lion PA	9265am		
0300	0400	USA, WRMI Miami FL	9955va		
0300	0400	USA, WTJC Newport NC	9370na		
0300	0400	USA, WWCR Nashville TN	3215na	5070na	
0300	0400	5765na	5935na		
0300	0400	USA, WWRB Manchester TN	3185va	5050va	
0300	0400	Uzbekistan, CVC International		13680as	
0300	0500	vi/mtwhf UK, Sudan Radio Service	7120af		
0330	0335	Bahrain, Radio Bahrain	6010as		
0330	0345	Israel, Kol Israel	9345eu	11590va	17600va
0330	0357	Czech Rep, Radio Prague	9445as	11600as	
0330	0358	Vietnam, Voice of 6175am			
0330	0400	UK, BBC World Service	15420af		
0330	0400	USA, Voice of America	4930af	6080af	
0330	0400	9885af	12080af	15580af	
0330	0400	twhf USA, WBCQ Monticello ME	9330am		

### 0400 UTC - 12AM EDT / 11PM CDT / 9PM PDT

0400	0430	Australia, Radio 9660as	12080as	13670as	
0400	0430	15240pa	15515as	15750va	21725va
0400	0430	mtwhf France, Radio France Intl	7315af	9805af	
0400	0430	Sri Lanka, SLBC	6005as	9770as	15745as
0400	0430	USA, Voice of America	4930af	6080af	
0400	0430	9575af	11835af	12080af	15580af
0400	0430	Sat/Sun USA, WWRB Manchester TN	5745am		
0400	0445	USA, Family Radio Worldwide FL		6065na	
0400	0457	9505na			
0400	0457	China, China Radio Intl	6020na	6080as	
0400	0458	9560as	9755as	13750as	15120as
0400	0458	15785as	17725as	17855as	
0400	0458	DRM New Zealand, Radio NZ Intl	13720pa		
0400	0500	DRM New Zealand, Radio NZ Intl	15720pa		
0400	0500	Anguilla, University Network	6090am		

0400	0500	Armenia, CVC International	15515as	
0400	0500	Australia, ABC NT Alice Springs	2310do	
		4835do		
0400	0500	Australia, ABC NT Katherine	5025do	
0400	0500	Australia, ABC NT Tennant Creek	4910do	
0400	0500	Canada, CBC NQ SW Service	9625na	
0400	0500	Canada, CFRX Toronto ON	6070na	
0400	0500	Canada, CKZN St John's NF	6160na	
0400	0500	Canada, CKZU Vancouver BC	6160na	
0400	0500	Costa Rica, University Network	5030va	
		6150va	7375va	9725va
0400	0500	Cuba, Radio Havana	6000na	6180na
0400	0500	Germany, Deutsche Welle	7225af	7245af
		12045af	15445af	
0400	0500	Guyana, Voice of 3291do		
0400	0500	Malaysia, RTM/Trax FM	7295as	
0400	0500	Malaysia, RTM/Voice of Malaysia	6175as	
		9750as	15295as	
0400	0500	Netherlands, Radio	6165na	
0400	0500	Papua New Guinea, Wantok R. Light	7120va	
0400	0500	Russia, Voice of	9435na	9515na
		9880na	13635na	13775na
0400	0500	Russia, Voice of	15735as	
0400	0500	Rwanda, Radio	6055do	
0400	0500	Singapore, MediaCorp Radio	6150do	
0400	0500	Uganda, Radio	4976do	5026do
0400	0500	UK, BBC World Service	3255af	6005af
		6190af	7120af	7160af
		11760as	12035af	12095eu
		15360as	15460af	15565eu
		17760as	17790as	21660as
0400	0500	USA, American Forces Radio	4319usb	5446usb
		5765usb	6350usb	7811usb
		12133usb	13362usb	10320usb
0400	0500	USA, Family Radio Worldwide FL	6855na	
		7780va	9715am	
0400	0500	USA, KAIJ Dallas TX	5755va	
0400	0500	USA, KTBN Salt Lake City UT	7505na	
0400	0500	USA, KWHR Naalehu HI	17655as	
0400	0500	USA, WBCQ Monticello ME	5110am	7415na
0400	0500	USA, WBOH Newport NC	5920am	
0400	0500	USA, WEWN Vandiver AL	5810va	
0400	0500	USA, WHRA Greenbush ME	5890na	
0400	0500	USA, WHRI Cypress Creek SC	5835am	
0400	0500	USA, WHRI Cypress Creek SC	7315am	
0400	0500	USA, WHRI Cypress Creek SC	7355am	
0400	0500	USA, WMLK Bethel PA	9265va	
0400	0500	USA, WRMI Miami FL	9955va	
0400	0500	USA, WTJC Newport NC	9370na	
0400	0500	USA, WWCR Nashville TN	3215na	5070na
		5765na	5935na	
0400	0500	USA, WWRB Manchester TN	3185va	5050va
		6890na		
0400	0500	Uzbekistan, CVC International	13680as	
0430	0500	Australia, Radio	9660as	12080as
		15240pa	15415as	15515va
		21725va		17750va
0430	0500	Nigeria, Radio/Kaduna	6090do	
0430	0500	Swaziland, TWR 3200af	4775af	
0430	0500	USA, Voice of America	4930af	4960af
		9575af	11835af	12080af
0430	0500	USA, WWRB Manchester TN	5745am	
0445	0500	Italy, RAI Italia	6110af	6145af
				7235af

**0500 UTC - 1AM EDT / 12AM CDT / 10PM PDT**

0500	0507	Canada, CBC NQ SW Service	9625na	
0500	0515	Sri Lanka, SLBC	6005as	9770as
0500	0530	France, Radio France Intl	9805af	11995af
		13680af		
0500	0530	Germany, Deutsche Welle	5945af	9700af
0500	0530	Vatican City, Vatican Radio	4005eu	7250eu
		9660af	11625af	13765af
0500	0555	South Africa, Channel Africa	9685af	
0500	0557	China, China Radio Intl	6020na	6190na
		9560af	11710as	11880as
		15465as	17505as	17540as
		17855as		17725as
0500	0559	South Africa, Channel Africa	7240af	
0500	0600	Anguilla, University Network	6090am	
0500	0600	Armenia, CVC International	15515as	
0500	0600	Australia, ABC NT Alice Springs	2310do	
		4835do		
0500	0600	Australia, ABC NT Katherine	5025do	
0500	0600	Australia, ABC NT Tennant Creek	4910do	
0500	0600	Australia, Radio	9660as	12080as
		15160as	15240pa	15515as
				17750va
0500	0600	Bhutan, BBS	6035as	
0500	0600	Canada, CFRX Toronto ON	6070na	
0500	0600	Canada, CKZN St John's NF	6160na	

0500	0600	Canada, CKZU Vancouver BC	6160na	
0500	0600	Costa Rica, University Network	5030va	
		6150va	7375va	9725va
0500	0600	Cuba, Radio Havana	6000na	6060na
		6180na	9550va	9600va
0500	0600	Germany, CVC Intl/Voice Africa	9430af	
0500	0600	Guyana, Voice of 3291do		
0500	0600	Japan, Radio Japan/NHK World	5975eu	
		6110na	7230eu	15195as
		21755pa		17810as
0500	0600	Malaysia, RTM/Trax FM	7295as	
0500	0600	Malaysia, RTM/Voice of Malaysia	6175as	
		9750as	15295as	
0500	0600	New Zealand, Radio NZ Intl	9615pa	
0500	0600	DRM	New Zealand, Radio NZ Intl	9440pa
0500	0600	Nigeria, Radio/Kaduna	4770do	6090al
0500	0600	Nigeria, Voice of/ Ext. Svc Lagos		15120va
0500	0600	vl	Papua New Guinea, Wantok R. Light	7120va
0500	0600	Russia, Voice of	17635pa	21790pa
0500	0600	DRM	Russia, Voice of	15735as
0500	0600	Singapore, MediaCorp Radio	6150do	
0500	0600	Swaziland, TWR	3200af	4775af
0500	0600	Uganda, Radio	4976do	5026do
0500	0600	UK, BBC World Service	3255af	6005af
		6190af	6195af	7160af
		11695af	11760as	11765af
		12095eu	15310as	15360as
		15565eu	17640af	17760as
		17885af	21660as	17790as
0500	0600	vl/ mtwhf	UK, Sudan Radio Service	9525af
0500	0600	Ukraine, Radio Ukraine Intl	9945eu	
0500	0600	USA, American Forces Radio	4319usb	5446usb
		5765usb	6350usb	7811usb
		12133usb	13362usb	10320usb
0500	0600	USA, Family Radio Worldwide FL	6855na	
		9355va		
0500	0600	USA, KAIJ Dallas TX	5755va	
0500	0600	USA, KTBN Salt Lake City UT	7505na	
0500	0600	USA, KWHR Naalehu HI	11565as	13650am
0500	0600	USA, Voice of America	4930af	6080af
		12080af	15580af	
0500	0600	USA, WBCQ Monticello ME	5110am	7415na
0500	0600	USA, WBOH Newport NC	5920am	
0500	0600	USA, WEWN Vandiver AL	5850va	
0500	0600	USA, WHRA Greenbush ME	6145na	
0500	0600	USA, WHRI Cypress Creek SC	5835am	7355am
0500	0600	USA, WMLK Bethel PA	9265va	
0500	0600	USA, WRMI Miami FL	9955va	
0500	0600	USA, WTJC Newport NC	9370na	
0500	0600	USA, WWCR Nashville TN	3215na	5070na
		5765na	5935na	
0500	0600	USA, WWRB Manchester TN	3185va	5050va
0500	0600	Uzbekistan, CVC International	13680as	
0500	0600	Zambia, CVC International	9430af	
0505	0520	m	Austria, Radio Austria Intl	17870me
0505	0530	Sat/Sun	Austria, Radio Austria Intl	17870me
0515	0530	Rwanda, Radio	6055do	
0525	0600	vl	Ghana, Ghana BC Corp	4915do
0530	0600	Romania, Radio Romania Intl	9655va	11830va
		15435va	17770va	
0530	0600	vl	Rwanda, Radio	6055do
0530	0600	Thailand, Radio	17655eu	
0535	0600	Sat/Sun	Austria, Radio Austria Intl	17870me
0545	0600	twfh	Austria, Radio Austria Intl	17870me

**0600 UTC - 2AM EDT / 1AM CDT / 11PM PDT**

0600	0603	Croatia, Croatian Radio	6165eu	9470eu
		11610eu		
0600	0615	as	South Africa, TWR11640af	
0600	0630	Australia, Radio	9660as	12080as
		15160as	15240pa	15515as
				17750va
0600	0630	mtwhf	France, Radio France Intl	7315af
			11995af	13680af
				15160af
0600	0630	Germany, Deutsche Welle	7310af	15275af
0600	0630	Nigeria, Radio, Natl Svc/Abuja	7275do	
0600	0645	mtwhf	South Africa, TWR11640af	
0600	0655	South Africa, Channel Africa	15255af	
0600	0657	China, China Radio Intl	11750af	11870as
		11880as	13660as	15140as
		17505as	17540as	17710as
0600	0658	New Zealand, Radio NZ Intl	9615pa	
0600	0658	DRM	New Zealand, Radio NZ Intl	9890pa
0600	0700	Anguilla, University Network	6090am	
0600	0700	Armenia, CVC International	15515as	
0600	0700	Australia, ABC NT Alice Springs	2310do	
		4835do		
0600	0700	Australia, ABC NT Katherine	5025do	
0600	0700	Australia, ABC NT Tennant Creek	4910do	
0600	0700	Australia, CVC International	15335as	

0600	0700	Canada, CFRX Toronto ON	6070na	
0600	0700	Canada, CFVP Calgary AB	6030na	
0600	0700	Canada, CKZN St John's NF	6160na	
0600	0700	Canada, CKZU Vancouver BC	6160na	
0600	0700	Costa Rica, University Network	5030va	
		6150va	7375va	9725va
0600	0700	Cuba, Radio Havana	6000va	6060va
		6180na	9550va	9600va
0600	0700	Germany, CVC Intl/Voice Africa		15640af
0600	0700	Ghana, Ghana BC Corp	4915do	
0600	0700	Greece, Voice of	11645eu	
0600	0700	Guyana, Voice of 3291do		
0600	0700	Japan, Radio Japan/NHK World	7230eu	
		11740as	11760as	13630va
		17870pa	21755pa	
0600	0700	Liberia, ELWA	4760do	
0600	0700	Malaysia, RTM/Trax FM	7295as	
0600	0700	Malaysia, RTM/Voice of Malaysia		6175as
		9750as	15295as	
0600	0700	Nigeria, Radio/Kaduna	4770do	6090al
0600	0700	Nigeria, Voice of/ Ext. Svc Lagos		15120va
0600	0700	Papua New Guinea, Wantok R. Light		7120va
0600	0700	Russia, Voice of	17635pa	21790pa
0600	0700	Singapore, MediaCorp Radio	6150do	
0600	0700	Solomon Islands, SIBC	5020do	9545al
0600	0700	Swaziland, TWR	3200af	4775af
0600	0700	UK, BBC World Service	17885af	
0600	0700	UK, BBC World Service	6005af	6190af
		7320eu	7475eu	9410va
		11695as	11760as	11765af
		12095af	15310as	15360as
		17640af	11760as	17790as
0600	0700	USA, American Forces Radio	4319usb	5446usb
		5765usb	6350usb	7811usb
		12133usb	13362usb	10320usb
0600	0700	USA, Family Radio Worldwide FL	6000am	
		7780va	9680na	11530af
0600	0700	USA, KAIJ Dallas TX	5755va	
0600	0700	USA, KTNB Salt Lake City UT	7505na	
0600	0700	USA, KWHR Naalehu HI	11565as	13650am
0600	0700	USA, Voice of America	6080af	6180af
		12080af	15580af	
0600	0700	USA, WBCQ Monticello ME	5110am	7415na
0600	0700	USA, WBOH Newport NC	5920am	
0600	0700	USA, WEWN Vandiver AL	5850va	7570va
0600	0700	USA, WHRA Greenbush ME	7490na	
0600	0700	USA, WHRI Cypress Creek SC	7335am	
		7365am		
0600	0700	USA, WMLK Bethel PA	9265va	
0600	0700	USA, WRMI Miami FL	9955va	
0600	0700	USA, WTJC Newport NC	9370na	
0600	0700	USA, WWCR Nashville TN	3215na	5070na
		5765na	5935na	
0600	0700	USA, WWRB Manchester TN	3185va	
0600	0700	Vanuatu, Radio	4960do	
0600	0700	Yemen, Rep of Yemen Radio	9780me	
0600	0700	Zambia, CVC International	13650af	
0630	0700	Australia, Radio	9660as	12080as
		15160as	15240pa	15415as
		17750va		15515as
0630	0700	Bulgaria, Radio	9600eu	11600eu
0630	0700	UK, BBC World Service	11990af	
0630	645	Vatican City, Vatican Radio	4005va	6185eu
		7250eu	9645eu	11625eu
		13765eu	15570af	15595af
0645	0700	Albania, TWR Europe	11865eu	
0645	0700	Monaco, TWR Europe	9800eu	
0659	0700	DRM	New Zealand, Radio NZ Intl	7145pa

**0700 UTC - 3AM EDT / 2AM CDT / 12AM PDT**

0700	0705	UK, BBC World Service	6005af	
0700	0727	Czech Rep, Radio Prague	9880eu	11600eu
0700	0730	France, Radio France Intl	11725af	15605af
0700	0730	Slovakia, Radio Slovakia Int	9440pa	15460pa
0700	0745	USA, Family Radio Worldwide FL	7780va	
0700	0757	China, China Radio Intl	11785eu	11880as
		13660as	13710as	15350eu
		17490as	17540as	17710as
0700	0800	Albania, TWR Europe	11865eu	
0700	0800	Anguilla, University Network	6090am	
0700	0800	Australia, ABC NT Alice Springs		2310do
		4835do		
0700	0800	Australia, ABC NT Katherine	5025do	
0700	0800	Australia, ABC NT Tennant Creek		4910do
0700	0800	Australia, CVC International	15335as	
0700	0800	Australia, Radio	9660as	9710as
		13630as	15160pa	15240pa
		17750va		15415as

0700	0800	Canada, CFRX Toronto ON	6070na	
0700	0800	Canada, CFVP Calgary AB	6030na	
0700	0800	Canada, CKZN St John's NF	6160na	
0700	0800	Canada, CKZU Vancouver BC	6160na	
0700	0800	Costa Rica, University Network	5030va	
		6150va	7375va	9725va
0700	0800	Germany, CVC Intl/Voice Africa		15640af
0700	0800	Ghana, Ghana BC Corp	4915do	
0700	0800	Guyana, Voice of 3291do	5950do	
0700	0800	Liberia, ELWA	4760do	
0700	0800	Liberia, Star Radio		9525af
0700	0800	Malaysia, RTM/Trax FM	7295as	
0700	0800	Malaysia, RTM/Voice of Malaysia		6175as
		9750as	15295as	
0700	0800	Monaco, TWR Europe	9800eu	
0700	0800	Myanmar, Radio	9730do	
0700	0800	New Zealand, Radio NZ Intl	6095pa	
0700	0800	New Zealand, Radio NZ Intl	6095pa	
0700	0800	New Zealand, Radio NZ Intl	7145pa	
0700	0800	Nigeria, Radio/Kaduna	4770do	6090al
0700	0800	Nigeria, Voice of/ Ext. Svc Lagos		15120va
0700	0800	Papua New Guinea, Wantok R. Light		7120va
0700	0800	Russia, Voice of	17495pa	21795pa
0700	0800	Singapore, MediaCorp Radio	6150do	
0700	0800	Solomon Islands, SIBC	5020do	9545al
0700	0800	Swaziland, TWR	4775af	9500af
0700	0800	Taiwan, Radio Taiwan Intl	5950am	
0700	0800	UK, BBC World Service	9470eu	
0700	0800	UK, BBC World Service	6190af	7320eu
		9470eu	9860af	11695as
		11765af	11955as	12095af
		15360as	15400af	15575as
		17830af	21660as	17760as
0700	0800	UK, BBC World Service	17885af	
0700	0800	Ukraine, Radio Ukraine Intl	9945eu	
0700	0800	USA, American Forces Radio	4319usb	5446usb
		5765usb	6350usb	7811usb
		12133usb	13362usb	10320usb
0700	0800	USA, Family Radio Worldwide FL	5985na	
		6855na	9505am	9715am
0700	0800	USA, KAIJ Dallas TX	5755va	
0700	0800	USA, KTNB Salt Lake City UT	7505na	
0700	0800	USA, KWHR Naalehu HI	11565as	13650am
0700	0800	USA, WBCQ Monticello ME	5110am	7415na
0700	0800	USA, WBOH Newport NC	5920am	
0700	0800	USA, WEWN Vandiver AL	5850va	7570va
0700	0800	USA, WHRI Cypress Creek SC	7335am	
		7365am		
0700	0800	USA, WMLK Bethel PA	9265va	
0700	0800	USA, WRMI Miami FL	9955va	
0700	0800	USA, WTJC Newport NC	9370na	
0700	0800	USA, WWCR Nashville TN	3215na	5070na
		5765na	5935na	
0700	0800	USA, WWRB Manchester TN	3185va	
0700	0800	Vanuatu, Radio	4960do	
0700	0800	Zambia, CVC International	13650af	
0715	0750	Albania, TWR Europe	11865eu	
0715	0750	Monaco, TWR Europe	9800eu	
0730	0800	Australia, HCJB Global	11750pa	
0730	0800	Pakistan, Radio	15100eu	17835eu

**0800 UTC - 4AM EDT / 3AM CDT / 1AM PDT**

0800	0900	USA, WWRB Manchester TN	3185va	
0800	0820	Albania, TWR Europe	11865eu	
0800	0820	Monaco, TWR Europe	9800eu	
0800	0825	Malaysia, RTM/Voice of Malaysia		6175as
		9750as	15295as	
0800	0830	Australia, ABC NT Katherine	5025do	
0800	0830	Australia, ABC NT Tennant Creek		4910do
0800	0830	Myanmar, Radio	9730do	
0800	0830	Pakistan, Radio	15100eu	17835eu
0800	0845	Guam, TWR/KTWR	11840pa	
0800	0845	USA, Family Radio Worldwide FL		9930af
0800	0857	China, China Radio Intl	11620eu	11785eu
		11880as	13710as	15350as
		17490as	17540as	15465eu
0800	0900	Anguilla, University Network	6090am	
0800	0900	Australia, ABC NT Alice Springs		2310do
		4835do		
0800	0900	Australia, CVC International	15335as	
0800	0900	Australia, HCJB Global	11750pa	
0800	0900	Australia, Radio	5995va	9580va
		12080as	13630va	15415as
				17750va
0800	0900	Canada, CFRX Toronto ON	6070na	
0800	0900	Canada, CFVP Calgary AB	6030na	
0800	0900	Canada, CKZN St John's NF	6160na	
0800	0900	Canada, CKZU Vancouver BC	6160na	
0800	0900	Costa Rica, University Network	5030va	
		6150va	7375va	9725va
				11870va

0800 0900		Germany, CVC Intl/Voice Africa	15640af
0800 0900 vl		Ghana, Ghana BC Corp	4915do
0800 0900 vl		Greece, Voice of	15630eu
0800 0900 mtwhf		Guam, TWR/KTWR	11840pa
0800 0900		Guyana, Voice of 3291do	5950do
0800 0900		Indonesia, Voice of	9525as 11785pa
		15150al	
0800 0900 a		Latvia, Radio SWH	9290eu
0800 0900 vl		Liberia, ELWA	4760do
0800 0900		Malaysia, RTM/Trax FM	7295as
0800 0900		New Zealand, Radio NZ Intl	6095pa
0800 0900 DRM		New Zealand, Radio NZ Intl	7145pa
0800 0900		Nigeria, Radio/Kaduna	4770do
0800 0900		North Korea, Voice of Korea	9570as
0800 0900		Papua New Guinea, NBC	4890do
0800 0900 vl		Papua New Guinea, Wantok R. Light	7120va
0800 0900		Russia, Voice of	17495pa 17635pa
0800 0900 DRM		Russia, Voice of	12060eu 15780eu
0800 0900		Singapore, MediaCorp Radio	6150do
0800 0900 vl		Solomon Islands, SIBC	5020do
0800 0900		South Africa, Channel Africa	9620af
0800 0900		South Korea, KBS World Radio	9570as
0800 0900		Swaziland, TWR	4775af 6120af
0800 0900		Taiwan, Radio Taiwan Intl	9610as
0800 0900		UK, BBC World Service	9480eu
0800 0900 DRM		UK, BBC World Service	6190af 7320eu
0800 0900			9470eu 9740as 9860af 11760me
			15310as 15360as 15400af 15485af
			17760as 17790as 17830af 17885af
			21470af 21660as
0800 0900 Sat/Sun		UK, BBC World Service	6195as 15575as
0800 0900 f		UK, Bible Voice BC	5945eu
0800 0900 Sat		UK, Bible Voice BC	5945eu
0800 0900 Sun		UK, Bible Voice BC	5945eu
0800 0900		Ukraine, Radio Ukraine Intl	9945eu
0800 0900		USA, American Forces Radio	4319usb 5446usb
			5765usb 6350usb 7811usb 10320usb
			12133usb 13362usb
0800 0900		USA, Family Radio Worldwide FL	5985na
			6855na
0800 0900		USA, KAIJ Dallas TX	5755va
0800 0900		USA, KNLS Anchor Point AK	7355as
0800 0900		USA, KTVN Salt Lake City UT	7505na
0800 0900		USA, KWHR Naalehu HI	9930as 11565as
0800 0900		USA, WBOH Newport NC	5920am
0800 0900		USA, WEWN Vandiver AL	5850na 7570va
0800 0900		USA, WHRI Cypress Creek SC	7315am
			7335am
0800 0900		USA, WMLK Bethel PA	9265va
0800 0900		USA, WRMI Miami FL	9955va
0800 0900		USA, WTJC Newport NC	9370na
0800 0900		USA, WWCR Nashville TN	3215na 5070na
			5765na 5935na
0800 0900 vl		Vanuatu, Radio	4960do
0800 0900		Zambia, CVC International	13650af
0805 0900 mtwhf		Guam, TWR/KTWR	15170as
0815 0845 Sat		UK, Bible Voice BC	9655eu
0830 0900		Australia, ABC NT Katherine	2485do
0830 0900		Australia, ABC NT Tennant Creek	2325do

**0900 UTC - 5AM EDT / 4AM CDT / 2AM PDT**

0900 0900		USA, WBCQ Monticello ME	5110am 7415na
0900 0915 Sun		UK, Bible Voice BC	5945eu
0900 0927		Czech Rep, Radio Prague	9800eu 21745as
0900 0930		Australia, HCJB Global	11750pa
0900 0945 Sun		UK, Bible Voice BC	5945eu
0900 0957		China, China Radio Intl	11620as 15210as
			15350as 17490eu 17690as 17750as
0900 1000		Anguilla, University Network	6090am
0900 1000		Australia, ABC NT Alice Springs	4835do 2310do
0900 1000		Australia, ABC NT Katherine	2485do
0900 1000		Australia, ABC NT Tennant Creek	2325do
0900 1000		Australia, CVC International	11955as
0900 1000		Australia, Radio	9580va 9590va 15415as
0900 1000		Bhutan, BBS	6035as
0900 1000		Canada, CFRX Toronto ON	6070na
0900 1000		Canada, CFVP Calgary AB	6030na
0900 1000		Canada, CKZN St John's NF	6160na
0900 1000		Canada, CKZU Vancouver BC	6160na
0900 1000		Costa Rica, University Network	5030va 6160na
			6150va 7375va 9725va 11870va
			13750va
0900 1000		Germany, Deutsche Welle	15340as 17770as
0900 1000 vl		Ghana, Ghana BC Corp	4915do
0900 1000 vl/Sun		Greece, Voice of	9420eu 15630eu
0900 1000		Guyana, Voice of 3291do	5950do
0900 1000 vl		Liberia, ELWA	4760do
0900 1000		Malaysia, RTM/Trax FM	7295as

0900 1000		New Zealand, Radio NZ Intl	6095pa
0900 1000 DRM		New Zealand, Radio NZ Intl	7145pa
0900 1000		Nigeria, Radio/Kaduna	4770do 6090al
0900 1000		Papua New Guinea, NBC	4890do
0900 1000 vl		Papua New Guinea, Wantok R. Light	7120va
0900 1000		Singapore, MediaCorp Radio	6150do
0900 1000 vl		Solomon Islands, SIBC	5020do 9545al
0900 1000		South Africa, Channel Africa	9620af
0900 1000 DRM		UK, BBC World Service	9480eu
0900 1000 smtwhf		UK, BBC World Service	9605as
0900 1000		UK, BBC World Service	6190af 6195as
			7320eu 9470eu 9740eu 9860af
			11760me 15310as 15360as 15400af
			15575as 17760as 17830af 17885af
			21470af
0900 1000		USA, American Forces Radio	4319usb 5446usb
			5765usb 6350usb 7811usb 10320usb
			12133usb 13362usb
0900 1000		USA, Family Radio Worldwide FL	5985na
			6885na 9755am
0900 1000		USA, KAIJ Dallas TX	5755va
0900 1000		USA, KTVN Salt Lake City UT	7505na
0900 1000		USA, KWHR Naalehu HI	9930as 11565as
0900 1000		USA, WBCQ Monticello ME	5110am 7415na
0900 1000		USA, WBOH Newport NC	5920am
0900 1000		USA, WEWN Vandiver AL	5850na
0900 1000		USA, WHRI Cypress Creek SC	7315am
			7335am
0900 1000		USA, WRMI Miami FL	9955va
0900 1000		USA, WTJC Newport NC	9370na
0900 1000		USA, WWCR Nashville TN	5070na 5765na
			5935na 9985na
0900 1000		USA, WWRB Manchester TN	3185va
0900 1000 vl		Vanuatu, Radio	4960do
0900 1000		Zambia, CVC International	13650af
0930 0945		Israel, Kol Israel	13855eu 15760eu
0930 1000 Sun		Italy, IRRS	9510eu
0930 1000		Lithuania, Radio Vilnius	9710eu

**1000 UTC - 6AM EDT / 5AM CDT / 3AM PDT**

1000 1003 mtwhf		Croatia, Croatian Radio	9830pa
1000 1030		UK, BBC World Service	9605as 21660as
1000 1057		China, China Radio Intl	6040as 11610as
			11635as 13590as 13620as 13720as
			15190as 15210as 15350eu 17490as
			17690as
1000 1058		New Zealand, Radio NZ Intl	6095pa
1000 1100		Anguilla, University Network	11775am
1000 1100		Australia, ABC NT Alice Springs	4835do 2310do
1000 1100		Australia, ABC NT Katherine	2485do
1000 1100		Australia, ABC NT Tennant Creek	2325do
1000 1100		Australia, CVC International	11955as
1000 1100 DRM		Australia, CVC International	9760eu
1000 1100		Australia, HCJB Global	15540va
1000 1100		Australia, Radio	9580va 9590va 15415as
1000 1100 drmm		Austria, CVC International	11815eu
1000 1100		Canada, CFRX Toronto ON	6070na
1000 1100		Canada, CFVP Calgary AB	6030na
1000 1100		Canada, CKZN St John's NF	6160na
1000 1100		Canada, CKZU Vancouver BC	6160na
1000 1100		Costa Rica, University Network	5030va 6160na
			6150va 7375va 9725va 11870va
			13750va
1000 1100 vl		Ghana, Ghana BC Corp	4915do
1000 1100		Guyana, Voice of 3291do	5950do
1000 1100		India, All India Radio	7270as 13695va
			15020as 15260as 15410as 17510pa
			17800as 17895pa
1000 1100 Sun		Italy, IRRS	9510eu
1000 1100		Japan, Radio Japan/NHK World	6120na
			9650va 9695as 11730as 11890pa
			17585eu
1000 1100 vl		Liberia, ELWA	4760do
1000 1100		Malaysia, RTM/Trax FM	7295as
1000 1100		Netherlands, Radio	13710as 12065as
			13820as
1000 1100 DRM		New Zealand, Radio NZ Intl	7145pa
1000 1100		Nigeria, Radio/Kaduna	4770do 6090al
1000 1100		Nigeria, Voice of/ Ext. Svc Lagos	7255af
1000 1100		North Korea, Voice of Korea	6185as 6285am
			9850as
1000 1100		Papua New Guinea, NBC	4890do
1000 1100 vl		Papua New Guinea, Wantok R. Light	7120va
1000 1100		Saudi Arabia, BSKSA	15250as
1000 1100		Singapore, MediaCorp Radio	6150do
1000 1100 vl		Solomon Islands, SIBC	5020do 9545al
1000 1100		South Africa, Channel Africa	9620af
1000 1100		UK, BBC World Service	6190af 6195as

			7320eu	9470eu	9740as	9860af	
			11760me	15310as	15575as	17760as	
			17790as	17885af	21470af		
1000	1100	Sat/Sun	UK, BBC World Service	15400af			
1000	1100		USA, American Forces Radio	4319usb	5446usb		
			5765usb	6350usb	7811usb	10320usb	
			12133usb	13362usb			
1000	1100		USA, Family Radio Worldwide FL		5950na		
			5985na	6855na	9755am		
1000	1100		USA, KAIJ Dallas TX	5755va			
1000	1100		USA, KNLS Anchor Point AK	6890as	7355al		
1000	1100		USA, KTBN Salt Lake City UT	7505na			
1000	1100		USA, KWHR Naalehu HI	9930as	11565as		
1000	1100		USA, WBCQ Monticello ME	5110am	7415na		
1000	1100		USA, WBOH Newport NC	5920am			
1000	1100		USA, WEWN Vandiver AL	5850na			
1000	1100		USA, WHRI Cypress Creek SC	7335am	7315am		
			7335am				
1000	1100		USA, WRMI Miami FL	9955va			
1000	1100		USA, WTJC Newport NC	9370na			
1000	1100		USA, WWCR Nashville TN	5070na	5765na		
			5935na	15825na			
1000	1100		USA, WWRB Manchester TN	3185va			
1000	1100		Zambia, CVC International	13590af			
1030	1057		Czech Rep, Radio Prague	9880eu	11665eu		
1030	1058		Vietnam, Voice of 7285as				
1030	1100		Iran, Voice of the Islamic Rep	15460as	17660as		
1030	1100		UK, BBC World Service	9605as	11945as		
			15285as	15360as	21660as		
1030	1100	Sun	UK, Bible Voice BC	5950as			
1059	1100		New Zealand, Radio NZ Intl	9870pa			

**1100 UTC - 7AM EDT / 6AM CDT / 4AM PDT**

1100	1127		Iran, Voice of the Islamic Rep	15460as	17600as		
1100	1128		Vietnam, Voice of 9840as	7220as	7285as		
1100	1130		Australia, HCJB Global	15540va			
1100	1145		USA, Family Radio Worldwide FL	9550am			
			9755am				
1100	1155		Saudi Arabia, BSKSA	15250as			
1100	1157		China, China Radio Intl	5955as	6040na		
			11660as	11795as	13590as	13645as	
			13650as	13720as	17490eu		
1100	1158	DRM	New Zealand, Radio NZ Intl	7145pa			
1100	1200		Anguilla, University Network	11775am			
1100	1200		Australia, ABC NT Alice Springs	4835do	2310do		
			4835do				
1100	1200		Australia, ABC NT Katherine	2485do			
1100	1200		Australia, ABC NT Tennant Creek		2325do		
1100	1200		Australia, CVC International	13635as			
1100	1200		Australia, Radio	5995va	6020va	9475as	
			9560pa	9580va	9590va	12080as	
1100	1200	Sat/Sun	Canada, CBC NQ SW Service		9625na		
1100	1200		Canada, CFRX Toronto ON	6070na			
1100	1200		Canada, CFVP Calgary AB	6030na			
1100	1200		Canada, CKZN St John's NF	6160na			
1100	1200		Canada, CKZU Vancouver BC		6160na		
1100	1200		Costa Rica, University Network	6150va	7375va	9725va	11870va
			13750va				
1100	1200	vl	Ghana, Ghana BC Corp	4915do			
1100	1200	Sun	Italy, IRRS	9510eu			
1100	1200		Japan, Radio Japan/NHK World	9695as	11730as		6120na
			9695as	11730as			
1100	1200	vl	Liberia, ELWA	4760do			
1100	1200		Malaysia, RTM/Trax FM	7295as			
1100	1200		Netherlands, Radio	11675na			
1100	1200		New Zealand, Radio NZ Intl	9870pa			
1100	1200		Nigeria, Radio/Kaduna	4770do	6090al		
1100	1200		Nigeria, Voice of/ Ext. Svc Lagos		7255af		
1100	1200		Papua New Guinea, NBC	4890do			
1100	1200	vl	Papua New Guinea, Wantok R. Light		7120va		
1100	1200		Singapore, Radio Singapore Intl	6150as	6080as		
			6150as				
1100	1200		South Africa, Channel Africa	9620af			
1100	1200	Sat/Sun	UK, BBC World Service	9660am	15400af		
			15575as				
1100	1200		UK, BBC World Service	6190af	6195as		
			7320eu	9470eu	9480va	9740as	
			9860va	11760me	15310as	17760as	
			17790as	17885af	21470af		
1100	1200	mtwhf	UK, BBC World Service	15575as	17830af		
1100	1200	Sat/Sun	UK, Bible Voice BC	5950as			
1100	1200		Ukraine, Radio Ukraine Intl	15675eu			
1100	1200		USA, American Forces Radio	4319usb	5446usb		
			5765usb	6350usb	7811usb	10320usb	
			12133usb	13362usb			
1100	1200		USA, Family Radio Worldwide FL		5985na		
			7780am	9625am			
1100	1200		USA, KAIJ Dallas TX	5755va			

1100	1200		USA, KTBN Salt Lake City UT	7505na			
1100	1200		USA, KWHR Naalehu HI	9930as			
1100	1200		USA, WBOH Newport NC	5920am			
1100	1200		USA, WEWN Vandiver AL	5850na			
1100	1200		USA, WHRI Cypress Creek SC	9660am	6095am		
			9660am				
1100	1200		USA, WINB Red Lion PA	9265am			
1100	1200		USA, WRMI Miami FL	9955va			
1100	1200		USA, WTJC Newport NC	9370na			
1100	1200		USA, WWCR Nashville TN	5070na	5765na		
			5935na	15825na			
1100	1200		USA, WWRB Manchester TN	3185va			
1100	1200		Zambia, CVC International	13590af			
1115	1130	mtwhf	UK, Bible Voice BC	5950as			
1130	1145		UK, BBC World Service	7135as	11920as		
1130	1200		Australia, HCJB Global	15400va			
1130	1200	mtwhfa	Australia, HCJB Global	15425va			
1130	1200		Bulgaria, Radio	11700eu	15700eu		
1130	1200		Guam, AWR/KSDA	15435as			
1130	1200	mtwhf	UK, BBC World Service	9660am			
1130	1200		Vatican City, Vatican Radio	15595va	17765va		

**1200 UTC - 8AM EDT / 7AM CDT / 5AM PDT**

1200	1215	f	UK, Bible Voice BC	5950as			
1200	1230	Sun	Australia, HCJB Global	15425va			
1200	1230		France, Radio France Intl	21620af	15275af	17815af	
			21620af				
1200	1230		Germany, AWR Europe	15435as			
1200	1245		USA, Family Radio Worldwide FL	5985na	5950na		
			5985na				
1200	1257		China, China Radio Intl	9730as	9760as	9955as	9460as
			11760as	11980as	13610as	13645eu	
			13650as	13790eu	17490eu		
1200	1258		New Zealand, Radio NZ Intl	9870pa			
1200	1259		Canada, Radio Canada Intl	9660as	15170as		
1200	1259		Poland, Radio Polonia	9525eu	11850eu		
1200	1300		Anguilla, University Network	11775am			
1200	1300		Australia, ABC NT Alice Springs	4835do	2310do		
			4835do				
1200	1300		Australia, ABC NT Katherine	2485do			
1200	1300		Australia, ABC NT Tennant Creek		2325do		
1200	1300		Australia, CVC International	13635as			
1200	1300		Australia, Radio	5995va	6020va	9475as	
			9560pa	9580va	9590va		
1200	1300	Sat/Sun	Canada, CBC NQ SW Service		9625na		
1200	1300		Canada, CFRX Toronto ON	6070na			
1200	1300		Canada, CFVP Calgary AB	6030na			
1200	1300		Canada, CKZN St John's NF	6160na			
1200	1300		Canada, CKZU Vancouver BC		6160na		
1200	1300		Costa Rica, University Network	6150va	7375va	9725va	11870va
			13750va				
1200	1300	vl	Ghana, Ghana BC Corp	4915do			
1200	1300		Malaysia, RTM/Trax FM	7295as			
1200	1300	DRM	New Zealand, Radio NZ Intl	7145pa			
1200	1300		Nigeria, Radio/Kaduna	4770do	6090al		
1200	1300		Nigeria, Voice of/ Ext. Svc Lagos		7255af		
1200	1300		North Korea, Voice of Korea	9650na			
1200	1300		Papua New Guinea, NBC	4890do			
1200	1300	vl	Papua New Guinea, Wantok R. Light		7120va		
1200	1300		Romania, Radio Romania Intl	11875eu	15220eu		
1200	1300		Singapore, Radio Singapore Intl	6150as	6080as		
			6150as				
1200	1300		South Korea, KBS World Radio		9650na		
1200	1300		UAE, AWR Africa	15140as			
1200	1300		UK, BBC World Service	6190af	6195as		
			7320eu	9470eu	9480am	9740as	
			9660am	9860af	11750as	11760me	
			15310as	15575as	17790as	17885af	
			21470af				
1200	1300	mtwhf	UK, BBC World Service	17830af			
1200	1300		USA, American Forces Radio	4319usb	5446usb		
			5765usb	6350usb	7811usb	10320usb	
			12133usb	13362usb			
1200	1300		USA, Family Radio Worldwide FL	17750am	17555am		
			17750am				
1200	1300		USA, KAIJ Dallas TX	5755va			
1200	1300		USA, KNLS Anchor Point AK	9780as	9920al		
1200	1300		USA, KTBN Salt Lake City UT	7505na			
1200	1300		USA, KWHR Naalehu HI	12130as			
1200	1300		USA, Voice of America	6140va	9645va		
			9760va	11680va			
1200	1300		USA, WBOH Newport NC	5920am			
1200	1300		USA, WEWN Vandiver AL	5850na			
1200	1300		USA, WHRA Greenbush ME	17650na			
1200	1300		USA, WHRI Cypress Creek SC	9660am	9495am		
			9660am				
1200	1300		USA, WINB Red Lion PA	9265am			
1200	1300		USA, WRMI Miami FL	9955va			

1200 1300	USA, WTJC Newport NC	9370na	
1200 1300	USA, WWCR Nashville TN	7465na	9985na
	13845na	15825na	
1200 1300	USA, WWRB Manchester TN	3185va	
1200 1300 DRM	Vatican City, Vatican Radio	13770am	
1200 1300	Zambia, CVC International	13590af	
1205 1220 m	Austria, Radio Austria Intl	6155va	13730va
	17715va		
1205 1230 Sat/Sun	Austria, Radio Austria Intl	6155va	13730va
	17715va		
1215 1230 twhf	Austria, Radio Austria Intl	17715va	
1215 1300	Egypt, Radio Cairo	17835as	
1230 1258	Vietnam, Voice of 9840as	12020as	
1230 1300	Bangladesh, Bangla Betar	7185as	
1230 1300	Sweden, Radio 13580va	15240na	15735va
1230 1300	Thailand, Radio 9835va		
1230 1300	Turkey, Voice of 13685eu	15450eu	
1235 1300 Sat/Sun	Austria, Radio Austria Intl	6155va	13730va
	17715va		
1245 1300 Sat	Australia, HCJB Global	15425va	
1245 1300 twhf	Austria, Radio Austria Intl	6155va	13730va
	17715va		
1245 1300 m	Austria, Radio Austria Intl	17715va	
1255 1258	Finland, YLE/Radio Finland	13715do	15400do

**1300 UTC - 9AM EDT / 8AM CDT / 6AM PDT**

1300 1329	Czech Rep, Radio Prague	13580eu	17540as
1300 1330	Egypt, Radio Cairo	17835as	
1300 1330	Germany, Universal Life	15750as	
1300 1330 Sun	Italy, IRRS	15750as	
1300 1330	Turkey, Voice of 13685eu	15450eu	
1300 1357	China, China Radio Intl	5955as	9570na
	9650as	9730as	9765as
	9870as	11640as	11760na
	11980as	13610eu	13630eu
	13790as	15260as	17625as
1300 1400	Anguilla, University Network	11775am	
1300 1400	Armenia, CVC International	15615as	
1300 1400	Australia, CVC International	13635as	
1300 1400	Australia, Radio 5995va	6020va	9560as
	9580va	9590va	
1300 1400 Sat/Sun	Canada, CBC NQ SW Service		9625na
1300 1400	Canada, CFRX Toronto ON	6070na	
1300 1400	Canada, CFVP Calgary AB	6030na	
1300 1400	Canada, CKZN St John's NF	6160na	
1300 1400	Canada, CKZU Vancouver BC		6160na
1300 1400	Costa Rica, University Network		9725va
	11870va	13750va	
1300 1400	Germany, Overcomer Ministries		6110na
1300 1400 vl	Ghana, Ghana BC Corp	4915do	
1300 1400 vl/Sat	Greece, Voice of 9420eu	15630eu	
1300 1400 s	Latvia, Radio SWH	9290eu	
1300 1400	Malaysia, RTM/Trax FM	7295as	
1300 1400 DRM	New Zealand, Radio NZ Intl	7145pa	
1300 1400	New Zealand, Radio NZ Intl	6095pa	
1300 1400	Nigeria, Radio/Kaduna	4770do	6090al
1300 1400	Nigeria, Voice of/ Ext. Svc Lagos		7255af
1300 1400	North Korea, Voice of Korea	9570va	9770sa
	11710na	12015eu	
1300 1400	Papua New Guinea, NBC	4890do	
1300 1400 vl	Papua New Guinea, Wantok R. Light		7120va
1300 1400	Singapore, Radio Singapore Intl		6080as
	6150as		
1300 1400	South Korea, KBS World Radio		9570na
	9770as		
1300 1400	UK, BBC World Service	6190af	6195as
	7320eu	9740as	9860af
	11760me	15310as	15420af
	17885af	21470af	17790as
1300 1400 Sat/Sun	UK, BBC World Service		15575as
1300 1400 mtwhf	UK, BBC World Service		17830af
1300 1400	USA, American Forces Radio	4319usb	5446usb
	5765usb	6350usb	7811usb
	12133usb	13362usb	10320usb
1300 1400	USA, Family Radio Worldwide FL		11830na
	11865na	11910na	17750na
1300 1400	USA, KAIJ Dallas TX		9480va
1300 1400	USA, KTNB Salt Lake City UT		7505na
1300 1400	USA, KWHR Naalehu HI		12130as
1300 1400	USA, Voice of America		9645va
1300 1400 w f	USA, WBCQ Monticello ME		9330am
1300 1400	USA, WBOH Newport NC		5920am
1300 1400	USA, WEWN Vandiver AL		5850na
1300 1400	USA, WHRA Greenbush ME		17650na
1300 1400	USA, WHRI Cypress Creek SC		9495am
	9840am		
1300 1400 Sat/Sun	USA, WHRI Cypress Creek SC		11785am
1300 1400	USA, WINB Red Lion PA		13570am
1300 1400	USA, WRMI Miami FL		9955va

1300 1400	USA, WTJC Newport NC	9370na	
1300 1400	USA, WWCR Nashville TN	7465na	9985na
	13845na	15825na	
1300 1400	USA, WWRB Manchester TN	9385na	
1300 1400	Zambia, CVC International	13590af	
1330 1357 DRM/f-a	Czech Rep, Radio Prague	9850eu	
1330 1400 DRM	Canada, Radio Canada Intl	7240eu	
1330 1400 twhfa	Guam, AWR/KSDA	15275as	
1330 1400	India, All India Radio	9690as	11620as
	13710as		
1330 1400	Laos, National Radio		7145as
1330 1400	Sweden, Radio 15240na		15735va
1330 1400	UK, BBC World Service		7465eu
1345 1400	Guam, TWR/KTWR		9975as

**1400 UTC - 10AM EDT / 9AM CDT / 7AM PDT**

1400 1415 t h	Germany, Pan American BC		13645me
1400 1415 twf	Russia, FEBA		9500eu
1400 1430	Australia, Radio 5995va	6080va	7240as
	9590va		
1400 1430 fa	Guam, TWR/KTWR		9975as
1400 1430 DRM	Romania, Radio Romania Intl		9600eu
1400 1430	Thailand, Radio 9805va		
1400 1457	China, China Radio Intl	5955as	9560as
	9765as	9870eu	11660as
	11765as	11775na	13610af
	13710na	13740na	13790as
	17630as		
1400 1500	Anguilla, University Network		11775am
1400 1500	Armenia, CVC International		15615as
1400 1500	Australia, CVC International		13635as
1400 1500 Sat/Sun	Bhutan, BBS		6035as
1400 1500	Canada, CBC NQ SW Service		9625na
1400 1500	Canada, CFRX Toronto ON		6070na
1400 1500	Canada, CFVP Calgary AB		6030na
1400 1500	Canada, CKZN St John's NF		6160na
1400 1500	Canada, CKZU Vancouver BC		6160na
1400 1500	Costa Rica, University Network		9725va
	11870va	13750va	
1400 1500	France, Radio France Intl	5920as	7180as
	9580af	15615af	
1400 1500 a	Germany, Overcomer Ministries		17810eu
1400 1500	Germany, Overcomer Ministries		6110eu
	13810va		
1400 1500 vl	Ghana, Ghana BC Corp		4915do
1400 1500 mtw	Guam, TWR/KTWR		9975as
1400 1500	India, All India Radio		9690as
	13710as		
1400 1500 Sun	Italy, IRRS		6125eu
1400 1500	Japan, Radio Japan/NHK World		7200as
	11730as	11840pa	
1400 1500	Jordan, Radio 11690na		
1400 1500	Libya, Voice of Africa		17660af
	17850af	21695af	17725af
1400 1500	Malaysia, RTM/Trax FM		7295as
1400 1500	Netherlands, Radio		9345as
	11835as		
1400 1500 DRM	New Zealand, Radio NZ Intl		7145pa
1400 1500	New Zealand, Radio NZ Intl		6095pa
1400 1500	Nigeria, Radio/Kaduna		4770do
1400 1500	Nigeria, Voice of/ Ext. Svc Lagos		6090al
1400 1500	Oman, Radio Oman		7255af
1400 1500 vl	Papua New Guinea, Wantok R. Light		15140as
1400 1500	Russia, Voice of 6045as		7120va
	11755as	15695as	9745as
1400 1500 DRM	Russia, Voice of 9450eu		
1400 1500	Singapore, MediaCorp Radio		6150do
1400 1500	South Africa, Channel Africa		9620af
1400 1500	Taiwan, Radio Taiwan Intl		15265as
1400 1500 Sat	UK, BBC World Service		12095af
1400 1500 mtwhf	UK, BBC World Service		17830af
1400 1500	UK, BBC World Service		6190af
	7320eu	9740as	9860af
	11920as	15310as	15575as
	21660af		21470af
1400 1500 Sat/Sun	UK, Bible Voice BC		11695as
1400 1500	Ukraine, Radio Ukraine Intl		7530eu
1400 1500	USA, American Forces Radio		4319usb
	5765usb	6350usb	7811usb
	12133usb	13362usb	10320usb
1400 1500	USA, Family Radio Worldwide FL		11830na
	11910na	13695na	17750am
1400 1500	USA, KAIJ Dallas TX		9480va
1400 1500	USA, KJES Vado NM		11715na
1400 1500	USA, KNLS Anchor Point AK		7355as
1400 1500	USA, KTNB Salt Lake City UT		7505na
1400 1500	USA, KWHR Naalehu HI		9930as
1400 1500	USA, Voice of America		4930af
	7125va	9760va	13570va
			15185va



1400	1500	15195va	15580af	17685af	17895va
1400	1500	USA, WBCQ Monticello ME	9330am		
1400	1500	USA, WBOH Newport NC	5920am		
1400	1500	USA, WEWN Vandiver AL	9955na		
1400	1500	USA, WHRA Greenbush ME	17650na		
1400	1500	USA, WHRI Cypress Creek SC		9840am	
		11785am			
1400	1500	USA, WINB Red Lion PA	13570am		
1400	1500	USA, WRMI Miami FL	7385na		
1400	1500	USA, WTJC Newport NC	9370na		
1400	1500	USA, WWCR Nashville TN	9985na	12160na	
		13845na	15825na		
1400	1500	USA, WWRB Manchester TN	9385na		
1400	1500	Zambia, CVC International	13590af		
1415	1430	Nepal, Radio	3230as	5005as	6100as
		7165as			
1415	1445	m UAE, FEBA	12025eu		
1430	1445	s Germany, Pan American BC	13645as	13820as	
1430	1445	twf UAE, FEBA	12025eu		
1430	1500	Australia, Radio	5995va	6080va	7240as
		9475as	9590va	11660pa	
1430	1500	Myanmar, Radio	5986as		
1430	1500	DRM South Korea, KBS World Radio		9770eu	

**1500 UTC - 11AM EDT / 10AM CDT / 8AM PDT**

1500	1510	mtwhfa	Turkmenistan, Turkmen Radio	5015eu	
1500	1528	Sun	Hungary, Radio Budapest	6025eu	9610eu
1500	1528		Vietnam, Voice of 9550va	9840va	12020va
			13860va		
1500	1530	vl	Eritrea, Bana Radio	5100do	
1500	1530		Guam, AWR/KSDA	11640as	
1500	1530		Nigeria, Radio, Natl Svc/Abuja		7275do
1500	1530		UK, BBC World Service	9695af	11860af
			15420af		
1500	1545		Sweden, IBRA Radio	7340as	
1500	1545		USA, Family Radio Worldwide FL		15770am
1500	1555		South Africa, Channel Africa	17770af	
1500	1557		Canada, Radio Canada Intl	11675as	17720as
1500	1557		China, China Radio Intl	5955as	6100as
			7160as	7325eu	9740eu
			9870as	11775af	11965na
			13685as	17630as	
1500	1559		Germany, Overcomer Ministries		17815na
1500	1559		South Africa, Channel Africa	9620af	
1500	1600		Anguilla, University Network	11775am	
1500	1600		Armenia, CVC International	15615as	
1500	1600		Australia, CVC International	13635as	
1500	1600		Australia, Radio	5995va	6080va
			9475as	9590va	7240as
1500	1600	Sat/Sun	Canada, CBC NQ SW Service		9625na
1500	1600		Canada, CFRX Toronto ON	6070na	
1500	1600		Canada, CFVP Calgary AB	6030na	
1500	1600		Canada, CKZN St John's NF	6160na	
1500	1600		Canada, CKZU Vancouver BC		6160na
1500	1600	DRM	China, China Radio Intl	9750eu	
1500	1600		Costa Rica, University Network		9725va
			11870va	13750va	
1500	1600		France, Radio France Intl	15605af	17605af
1500	1600		Germany, CVC Intl/Voice Africa		15715af
1500	1600	vl	Ghana, Ghana BC Corp	4915do	
1500	1600		Japan, Radio Japan/NHK World		6190as
			7200as	9505va	9525na
					11730as
1500	1600		Jordan, Radio	11690na	
1500	1600		Libya, Voice of Africa	17660af	17725af
			17850af	21695af	
1500	1600		Malaysia, RTM/Trax FM	7295as	
1500	1600		Netherlands, Radio	9345as	9890as
			11835as		
1500	1600	DRM	New Zealand, Radio NZ Intl	7145pa	
1500	1600		New Zealand, Radio NZ Intl	6095pa	
1500	1600		Nigeria, Radio/Kaduna	4770do	6090al
1500	1600		North Korea, Voice of Korea	7570eu	9335na
			11710na	12015eu	
1500	1600	vl	Papua New Guinea, Wantok R. Light		7120va
1500	1600		Russia, Voice of	4965me	4975me
			9625as	9660as	11985me
1500	1600		Singapore, MediaCorp Radio	6150do	
1500	1600		UAE, AWR Africa	11670as	
1500	1600	Sat	UK, BBC World Service	12095af	
1500	1600	mtwhf	UK, BBC World Service	17830af	
1500	1600		UK, BBC World Service	5975as	6190af
			6195as	7320af	9740as
			11750as	11760as	11920as
			15400af	15485af	21470af
1500	1600	f DRM	UK, China BS VT Digital	9710eu	
1500	1600	vl/ mtwhf	UK, Sudan Radio Service	15575af	
1500	1600		USA, American Forces Radio	4319usb	5446usb
			5765usb	6350usb	7811usb
			12133usb	13362usb	10320usb

1500	1600		USA, Family Radio Worldwide FL		11830na
			11910na	17750am	
1500	1600		USA, KAIJ Dallas TX	9480va	
1500	1600		USA, KJES Vado NM	11715na	
1500	1600		USA, KTBN Salt Lake City UT	7505na	15590na
1500	1600		USA, KWHR Naalehu HI	9930as	
1500	1600		USA, Voice of America	4930af	6080af
			6160va	7125va	9590va
			13735va	15105va	15195va
			15580va	17895va	15550va
1500	1600		USA, WBCQ Monticello ME	9330am	
1500	1600		USA, WBOH Newport NC	5920am	
1500	1600		USA, WEWN Vandiver AL	9955na	
1500	1600		USA, WHRA Greenbush ME	17650na	
1500	1600		USA, WHRI Cypress Creek SC		9840am
			11785am		
1500	1600		USA, WINB Red Lion PA	13570am	
1500	1600		USA, WRMI Miami FL	7385na	
1500	1600		USA, WTJC Newport NC	9370na	
1500	1600		USA, WWCR Nashville TN	9985na	12160na
			13845na	15825na	
1500	1600		USA, WWRB Manchester TN	9385na	
1500	1600		Zambia, CVC International	15715af	
1505	1520	m	Austria, Radio Austria Intl	13775ca	
1505	1530	Sat/Sun	Austria, Radio Austria Intl	13775ca	
1505	1600	DRM	Canada, Radio Canada Intl	9800na	
1505	1600		Canada, Radio Canada Intl	9515na	
1510	1545		Swaziland, TWR	4760af	
1515	1530	twhf	Austria, Radio Austria Intl	13775ca	
1530	1545		India, All India Radio	7255as	9910as
1530	1550		Vatican City, Vatican Radio	12065va	13765va
			15235va		
1530	1600		Germany, AWR Europe	15225as	
1530	1600		Iran, Voice of the Islamic Rep	7330as	
1530	1600	mha	UK, Bible Voice BC	12035as	
1530	1600		USA, Voice of America	6160va	9590va
			9760va	12080va	15550va
1535	1600	Sat/Sun	Austria, Radio Austria Intl	13775ca	
1545	1600	m	Austria, Radio Austria Intl	13775ca	
1545	1600	twhfa	Austria, Radio Austria Intl	13775ca	
1545	1600	s	Germany, Pan American BC	13820me	

**1600 UTC - 12PM EDT / 11AM CDT / 9AM PDT**

1600	1605	DRM	Canada, Radio Canada Intl	9800na	
1600	1605	Sun	Croatia, Croatian Radio	6165eu	
1600	1615	mtwhfa	Croatia, Croatian Radio	6165eu	
1600	1615		Pakistan, Radio	9380va	11550af
1600	1620	mtwh	Moldova, Radio DMR Pridnestrovye		6235eu
1600	1627		Iran, Voice of the Islamic Rep	6160as	7330as
1600	1628		Vietnam, Voice of 7280va	9550va	9730va
			11630va	13860va	
1600	1630	vl	Eritrea, Bana Radio	5100do	
1600	1630	h	Germany, Pan American BC	13820me	
1600	1630		Guam, AWR/KSDA	11640as	11805as
1600	1630		Myanmar, Radio	9730do	
1600	1630	Sat/Sun	Swaziland, TWR	4760af	
1600	1640	f	Moldova, Radio DMR Pridnestrovye		6235eu
1600	1645		USA, Family Radio Worldwide FL		11830na
			11865na	17750am	
1600	1657		China, China Radio Intl	6100af	9570eu
			11900eu	11940eu	11965af
1600	1657		Czech Rep, Radio Prague	5930eu	17485af
1600	1658		Germany, Deutsche Welle	6170as	9485as
			15640as		
1600	1700		Anguilla, University Network	11775am	
1600	1700		Australia, CVC International	13635as	
1600	1700		Australia, Radio	5995va	6080va
			9475as	9710va	11660pa
1600	1700	Sat	Canada, CBC NQ SW Service		9625na
1600	1700		Canada, CFRX Toronto ON	6070na	
1600	1700		Canada, CFVP Calgary AB	6030na	
1600	1700		Canada, CKZN St John's NF	6160na	
1600	1700		Canada, CKZU Vancouver BC		6160na
1600	1700		Canada, Radio Canada Intl	9515na	
1600	1700		Costa Rica, University Network		11870va
			13750va		
1600	1700		Egypt, Radio Cairo	11740af	
1600	1700		Ethiopia, Radio	7165af	9560af
1600	1700		France, Radio France Intl	7170af	9730af
			15160af		
1600	1700		Germany, CVC Intl/Voice Africa		15715af
1600	1700	s	Germany, Overcomer Ministries		17815na
1600	1700		Germany, Universal Life	7285va	
1600	1700	vl	Ghana, Ghana BC Corp	4915do	
1600	1700	f	Italy, IRRS	7285eu	
1600	1700		Jordan, Radio	11690na	
1600	1700		Malaysia, RTM/Trax FM	7295as	
1600	1700	DRM	New Zealand, Radio NZ Intl	7145pa	
1600	1700		New Zealand, Radio NZ Intl	6095pa	

1600	1700		Nigeria, Radio/Kaduna	4770do	6090al
1600	1700		North Korea, Voice of Korea	9515va	11545af
1600	1700	vl	Papua New Guinea, Wantok R. Light		7120va
1600	1700		Russia, Voice of	6070as 7350as	7370eu
			9405as 9890eu	11985va	12055va
			12115va		
1600	1700	vl	Rwanda, Radio	6055do	
1600	1700		South Korea, KBS World Radio		9515eu
1600	1700		Taiwan, Radio Taiwan Intl	11550as	15515as
1600	1700		UK, BBC World Service	3255af	3915as
			5975as 6190af	6195as	7320eu
			9510as 11760as	11920as	15400af
			15485af 17840af	21470af	21660af
1600	1700	DRM	UK, BBC World Service	7465eu	
1600	1700	mtwhf	UK, BBC World Service	17830af	
1600	1700	Sat/Sun	UK, BBC World Service	9695af	11860af
			12095af		
1600	1700	vl/ mtwhf	UK, Sudan Radio Service	15575af	
1600	1700		USA, American Forces Radio	4319usb	5446usb
			5765usb 6350usb	7811usb	10320usb
			12133usb 13362usb		
1600	1700		USA, Family Radio Worldwide FL		6085am
			13695na 18980va	21455va	21525af
1600	1700		USA, KAIJ Dallas TX	9480va	
1600	1700		USA, KJES Vado NM	11715na	
1600	1700		USA, KTNB Salt Lake City UT	15590na	
1600	1700		USA, KWHR Naalehu HI	9930as	
1600	1700		USA, Voice of America	4930af	6080af
			12080va 13600va	15580af	17895va
			9330am		
1600	1700		USA, WBOH Newport NC	5920am	
1600	1700		USA, WEWN Vandiver AL	9450va	
1600	1700		USA, WHRA Greenbush ME	17640na	
1600	1700		USA, WHRI Cypress Creek SC		9840am
			11960am		
1600	1700		USA, WINB Red Lion PA	13570am	
1600	1700	smtwhf	USA, WMLK Bethel PA	9265va	17495va
1600	1700		USA, WRMI Miami FL	9955va	
1600	1700		USA, WTJC Newport NC	9370na	
1600	1700		USA, WWCR Nashville TN	9985na	12160na
			13845na 15825na		
1600	1700		USA, WWRB Manchester TN	9385na	
1600	1700		Zambia, CVC International	15715af	
1615	1630		Vatican City, Vatican Radio	4005va	7250va
			9645va 15595va		
1615	1645	mtwhf	Swaziland, TWR	6130af	
1630	1700		Guam, AWR/KSDA	6155as	
1630	1700		Slovakia, Radio Slovakia Int	5920eu	6055eu
1630	1700	Sun	Swaziland, TWR	6130af	
1630	1700	Sat	Swaziland, TWR	6130af	
1630	1700	Sun	UK, Bible Voice BC	9460me	
1640	1650	mtwhfa	Turkmenistan, Turkmen Radio		4930eu
1640	1700	mtwhf	UK, Bible Voice BC	9460me	
1645	1700	f	Sweden, IBRA Radio	9830as	
1645	1700		Tajikistan, Tajik Radio	7245as	
1645	1700	Sat	UK, Bible Voice BC	9460me	

**1700 UTC - 1PM EDT / 12PM CDT / 10AM PDT**

1700	1704		Canada, Radio Canada Intl	9515na	
1700	1715		Swaziland, TWR	3200af	
1700	1715	mtwhf	UK, Bible Voice BC	9460me	
1700	1720	mtwh	Moldova, Radio DMR Pridnestrovye	6235eu	
1700	1727		Czech Rep, Radio Prague	5930eu	17485af
1700	1730		France, Radio France Intl	11615af	
1700	1730		Jordan, Radio	11690na	
1700	1730		USA, Voice of America	6080af	15580af
1700	1740	f	Moldova, Radio DMR Pridnestrovye	6235eu	
1700	1745		UK, BBC World Service	9630af	
1700	1750	DRM	New Zealand, Radio NZ Intl	7145pa	
1700	1755		South Africa, Channel Africa	15235af	
1700	1757		China, China Radio Intl	6100af	9570af
			9695af 11900af	11940af	13760af
1700	1759		Poland, Radio Polonia	7140eu	7265eu
1700	1800		Anguilla, University Network	11775am	
1700	1800		Australia, CVC International	13635as	
1700	1800		Australia, Radio	5995va 6080va	7240as
			9475as 9580va	9710va	11660pa
			11880pa		
1700	1800	Sat	Canada, CBC NQ SW Service		9625na
1700	1800		Canada, CFRX Toronto ON	6070na	
1700	1800		Canada, CFVP Calgary AB	6030na	
1700	1800		Canada, CKZN St John's NF	6160na	
1700	1800		Canada, CKZU Vancouver BC		6160na
1700	1800		Costa Rica, University Network		11870va
			13750va		
1700	1800		Egypt, Radio Cairo	11740af	
1700	1800		Eq. Guinea, Radio Africa	15190af	
1700	1800		Germany, CVC Intl/Voice Africa		15715af
1700	1800		Germany, Universal Life	7285va	

1700	1800	vl	Ghana, Ghana BC Corp	4915do	
1700	1800	f	Italy, IRRS	7285eu	
1700	1800		Japan, Radio Japan/NHK World		9535va
			11970eu 15355af		
1700	1800		Malaysia, RTM/Trax FM	7295as	
1700	1800		New Zealand, Radio NZ Intl	6095pa	
1700	1800		Nigeria, Radio/Kaduna	4770do	6090al
1700	1800		Nigeria, Voice of/ Ext. Svc Lagos		15120va
1700	1800	vl	Papua New Guinea, Wantok R. Light		7120va
1700	1800		Romania, Radio Romania Intl	9535eu	11735eu
1700	1800		Russia, Voice of	7350as 9405as	9850af
			11510af 11985af		
1700	1800	Sat/Sun	Russia, Voice of	9820eu	9890eu
1700	1800	vl	Rwanda, Radio	6055do	
1700	1800		Taiwan, Radio Taiwan Intl	15690af	
1700	1800	mtwhf	UK, BBC World Service	17830af	
1700	1800	DRM	UK, BBC World Service	1296eu	7465eu
1700	1800		UK, BBC World Service	3255af	3915as
			5975as 6190af	6195eu	7320eu
			7380af 9410va	9510as	11955as
			12095af 15400af	15485af	17840af
			21470af		
1700	1800	Sat/Sun	UK, Bible Voice BC	9460me	
1700	1800	vl/ mtwhf	UK, Sudan Radio Service	11705af	
1700	1800		USA, American Forces Radio	4319usb	5446usb
			5765usb 6350usb	7811usb	10320usb
			12133usb 13362usb		
1700	1800		USA, Family Radio Worldwide FL		13690na
			17795am 18980va	21455va	
1700	1800		USA, KAIJ Dallas TX	9480va	
1700	1800		USA, KTNB Salt Lake City UT	15590na	
1700	1800		USA, KWHR Naalehu HI	9930as	
1700	1800	Sat/Sun	USA, Voice of America	4930af	
1700	1800		USA, WBCQ Monticello ME	9330am	17495am
1700	1800		USA, WBOH Newport NC	5920am	
1700	1800		USA, WEWN Vandiver AL	9450va	15390va
1700	1800		USA, WHRA Greenbush ME	15705na	
1700	1800		USA, WHRI Cypress Creek SC		9840am
			11960am		
1700	1800		USA, WINB Red Lion PA	13570am	
1700	1800	smtwhf	USA, WMLK Bethel PA	9265va	17495va
1700	1800		USA, WRMI Miami FL	9955va	
1700	1800		USA, WTJC Newport NC	9370na	
1700	1800		USA, WWCR Nashville TN	9985na	12160na
			13845na 15825na		
1700	1800		USA, WWRB Manchester TN	9385na	12180na
			15250va		
1700	1800		Zambia, CVC International	15715af	
1705	1800	DRM	Canada, Radio Canada Intl	9800na	
1715	1800	t	UK, Bible Voice BC	9460me	
1730	1745		Israel, Kol Israel	9345eu	11590va
1730	1745	mtwhf	UK, United Nations Radio	7130va	13675eu
1730	1800		Bulgaria, Radio	5900eu	9600eu
1730	1800		Guam, AWR/KSDA		9980me
1730	1800	vl	Liberia, ELWA	4760do	
1730	1800		Philippines, Radio Pilipinas	11720va	15190va
			17720va		
1730	1800		Swaziland, TWR	9500af	
1730	1800	DRM	Sweden, Radio	5955eu	
1730	1800		Sweden, Radio	6065va	
1730	1800	Sun	UK, Bible Voice BC	9730me	
1730	1800		USA, Voice of America	6080af	15410af
			15580af		
1730	1800	mtwhf	USA, Voice of America	4930af	13755af
			15775af		
1730	1800		Vatican City, Vatican Radio	11625af	13765af
			15570af		
1745	1800		Bangladesh, Bangla Betar	7185as	
1745	1800		India, All India Radio	7410eu	9445af
			9950eu 11620eu	11935af	13605af
			15075af 15155af	17670af	
1751	1800	DRM	New Zealand, Radio NZ Intl	9440pa	

**1800 UTC - 2PM EDT / 1PM CDT / 11AM PDT**

1800	1815	t	UK, Bible Voice BC	9460me	
1800	1815	Sat	UK, Bible Voice BC	7210me	
1800	1828		Vietnam, Voice of	5955eu	7280va
1800	1830	w	Austria, AWR Europe		15315af
1800	1830	f	Italy, IRRS	7285eu	
1800	1830		Nigeria, Radio, Natl Svc/Abuja		7275do
1800	1830		South Africa, AWR Africa	3215af	3345af
			9610af		
1800	1830		UK, BBC World Service	5975as	11955as
1800	1830		USA, Voice of America	6080af	15580af
			17895af		
1800	1830	Sat/Sun	USA, Voice of America	4930af	
1800	1845		USA, Family Radio Worldwide FL		17535af
1800	1850		New Zealand, Radio NZ Intl	6095pa	
1800	1850	DRM	New Zealand, Radio NZ Intl	9440pa	

1800	1857	China, China Radio Intl	9600eu	11940eu
		13760eu		
1800	1859	Canada, Radio Canada Intl	9530af	11765af
		15235af 17810af		
1800	1900	Anguilla, University Network	11775am	
1800	1900	Argentina, RAE	9690eu	15345eu
1800	1900	Australia, Radio	6080va	7240as 9475as
		9500as	9580va	9710va 11880pa
1800	1900	Bangladesh, Bangla Betar	7185eu	
1800	1900	Canada, CFRX Toronto ON	6070na	
1800	1900	Canada, CFVP Calgary AB	6030na	
1800	1900	Canada, CKZN St John's NF	6160na	
1800	1900	Canada, CKZU Vancouver BC		6160na
1800	1900	Canada, Radio Canada Intl	9800na	
1800	1900	Costa Rica, University Network		11870va
		13750va		
1800	1900	Eqt. Guinea, Radio Africa	15190af	
1800	1900	Germany, CVC Intl/Voice Africa		13820af
1800	1900	Germany, Universal Life	7285va	
1800	1900	Ghana, Ghana BC Corp	4915do	
1800	1900	India, All India Radio	7410eu	9445af
		9950eu	11620eu	11935af 13605af
		15075af	15155af	17670af
1800	1900	Liberia, ELWA	4760do	
1800	1900	Malaysia, RTM/Trax FM	7295as	
1800	1900	Netherlands, Radio	6020af	7125af
		11655af		
1800	1900	Nigeria, Radio/Kaduna	4770do	6090al
1800	1900	Nigeria, Voice of/ Ext. Svc Lagos		15120va
1800	1900	North Korea, Voice of Korea	7275eu	12015eu
1800	1900	Papua New Guinea, Wantok R. Light		7120va
1800	1900	Philippines, Radio Pilipinas	11720va	15190va
		17720va		
1800	1900	Russia, Voice of	7370eu	9745af 9850af
		9890eu	11510af	11630eu
1800	1900	Rwanda, Radio	6055do	
1800	1900	South Korea, KBS World Radio		7275eu
1800	1900	Swaziland, TWR	3200af	9500af
1800	1900	Taiwan, Radio Taiwan Intl	3965eu	
1800	1900	UK, BBC World Service	1296eu	
1800	1900	UK, BBC World Service	3255af	5995as
		6190af	6195eu	7380af 9410va
		12095eu	15400af	17795af 21470af
1800	1900	UK, BBC World Service		17830af
1800	1900	UK, BBC World Service		1296eu
1800	1900	UK, Bible Voice BC		9730me
1800	1900	USA, American Forces Radio	4319usb	5446usb
		5765usb	6350usb	7811usb 10320usb
		12133usb	13362usb	
1800	1900	USA, Family Radio Worldwide FL		13690af
		13800na	17795am	18980va
1800	1900	USA, KAIJ Dallas TX		9480va
1800	1900	USA, KTNB Salt Lake City UT		15590na
1800	1900	USA, WBCQ Monticello ME		7415am
1800	1900	USA, WBCQ Monticello ME		9330am 17495am
1800	1900	USA, WBOH Newport NC		5920am
1800	1900	USA, WEWN Vandiver AL		9450va 15390va
1800	1900	USA, WHRA Greenbush ME		15705na
1800	1900	USA, WHRI Cypress Creek SC		9840am
		11960am		
1800	1900	USA, WINB Red Lion PA		13570am
1800	1900	USA, WMLK Bethel PA		9265va 17495va
1800	1900	USA, WRMI Miami FL		9955va
1800	1900	USA, WTJC Newport NC		9370na
1800	1900	USA, WWCN Nashville TN		9975na 12160na
		13845na	15825na	
1800	1900	USA, WWRB Manchester TN		9385va 12180na
		15250va		
1800	1900	Yemen, Rep of Yemen Radio		9780me
1800	1900	Zambia, CVC International		5940af
1805	1810	Croatia, Croatian Radio		6165eu
1805	1815	Croatia, Croatian Radio		6165eu
1830	1858	Serbia, International Radio Serbia		6100eu
1830	1900	Slovakia, Radio Slovakia Int		5920eu 7345eu
1830	1900	Turkey, Voice of		9785eu
1830	1900	UK, BBC World Service		6005af 9485as
		9630af		
1830	1900	UK, Bible Voice BC		9730me
1830	1900	UK, Bible Voice BC		9460me
1830	1900	USA, Voice of America		4930af 15410af
		15580af	17895af	
1845	1900	Albania, Radio Tirana		6035eu 7465eu
1845	1900	Congo, RTV Congolaise		4765af 5985af
1845	1900	UK, Bible Voice BC		7210me
1851	1900	New Zealand, Radio NZ Intl		11675pa

**1900 UTC - 3PM EDT / 2PM CDT / 12PM PDT**

1900	1903	Bahrain, Radio Bahrain	6010as	
1900	1905	Canada, Radio Canada Intl	9800na	

1900	1915	Congo, RTV Congolaise	4765af	5985af
1900	1925	Israel, Kol Israel	9400eu	11590va 11605af
		15640af		
1900	1928	Hungary, Radio Budapest	3975eu	6025eu
1900	1928	Vietnam, Voice of 7280va		9730va
1900	1930	Germany, Deutsche Welle	9895af	15620af
		17820af		
1900	1930	Philippines, Radio Pilipinas	11720va	15190va
		17720va		
1900	1930	Turkey, Voice of	9785eu	
1900	1930	UK, Bible Voice BC		6015eu
1900	1930	UK, Bible Voice BC		7260af 9460me
1900	1930	India, All India Radio		7410eu 9445af
1900	1945	9950eu	11620eu	11935af 13605af
		15075af	15155af	17670af
1900	1945	USA, Family Radio Worldwide FL		6085am
1900	1950	New Zealand, Radio NZ Intl		11725pa
1900	1957	China, China Radio Intl		7295va 9435va
		11940va	13760va	
1900	1957	Netherlands, Radio		15315na 17660va
		17735af		
1900	2000	UK, BBC World Service		1296eu
1900	2000	Anguilla, University Network		11775am
1900	2000	Australia, Radio	6080va	7240as 9500as
		9580va	9710va	11880pa
1900	2000	Canada, CFRX Toronto ON		6070na
1900	2000	Canada, CFVP Calgary AB		6030na
1900	2000	Canada, CKZN St John's NF		6160na
1900	2000	Canada, CKZU Vancouver BC		6160na
1900	2000	Costa Rica, University Network		11870va
		13750va		
1900	2000	Egypt, Radio Cairo		15375af
1900	2000	Eqt Guinea, Radio Africa		15190af
1900	2000	Germany, CVC Intl/Voice Africa		13820af
1900	2000	Ghana, Ghana BC Corp		4915do
1900	2000	Liberia, ELWA		4760do
1900	2000	Malaysia, RTM/Trax FM		7295as
1900	2000	Netherlands, Radio		5905af 7115af
		11655af	17810af	
1900	2000	New Zealand, Radio NZ Intl		11675pa
1900	2000	Nigeria, Radio/Kaduna		4770do 6090al
1900	2000	Nigeria, Voice of/ Ext. Svc Lagos		15120va
1900	2000	North Korea, Voice of Korea		7100af 9975va
		11535va		
1900	2000	Papua New Guinea, NBC		4890do
1900	2000	Papua New Guinea, Wantok R. Light		7120va
1900	2000	Russia, Voice of		7195eu 9890eu
		12070eu		
1900	2000	Rwanda, Radio		6055do
1900	2000	Solomon Islands, SIBC		5020do 9545al
1900	2000	Swaziland, TWR		3200af
1900	2000	Uganda, Radio		4976do 5026do
1900	2000	UK, BBC World Service		3255af 5995as
		6005af	6190af	9410af 9455af
		9485as	9630as	15400af 17795as
1900	2000	UK, BBC World Service		17830af
1900	2000	UK, Bible Voice BC		9470me
1900	2000	Ukraine, Radio Ukraine Intl		7490eu
1900	2000	USA, American Forces Radio		4319usb 5446usb
		5765usb	6350usb	7811usb 10320usb
		12133usb	13362usb	
1900	2000	USA, Family Radio Worldwide FL		13690na
		13800na	17795am	17845af 18930eu
1900	2000	USA, KAIJ Dallas TX		9480va
1900	2000	USA, KJES Vado NM		15385na
1900	2000	USA, KTNB Salt Lake City UT		15590na
1900	2000	USA, Voice of America		4930af 4940af
		6080af	7480va	9670va 15410af
		15445af	15580af	17895af
1900	2000	USA, WBCQ Monticello ME		7415am 9330am
		17495am		
1900	2000	USA, WBOH Newport NC		5920am
1900	2000	USA, WEWN Vandiver AL		9450va 15390va
1900	2000	USA, WHRA Greenbush ME		13710na
1900	2000	USA, WHRI Cypress Creek SC		9840am
		17650am		
1900	2000	USA, WINB Red Lion PA		13570am
1900	2000	USA, WMLK Bethel PA		9265va 17495va
1900	2000	USA, WRMI Miami FL		9955va
1900	2000	USA, WTJC Newport NC		9370na
1900	2000	USA, WWCN Nashville TN		9975na 12160na
		13845na	15825na	
1900	2000	USA, WWRB Manchester TN		9385va 12180na
		15250va		
1900	2000	Zambia, CVC International		5940af
1915	2000	UK, Bible Voice BC		9470me
1930	2000	Germany, Pan American BC		5850me
1930	2000	Iran, Voice of the Islamic Rep		6010eu 6255eu
		7370af	9855af	11695af
				6250eu
1930	2000	Lithuania, Radio Vilnius		6250eu
1930	2000	Sweden, Radio		6065va

1930	2000	Sun	UK, Bible Voice BC	7260af	
1935	1955		Italy, RAI Italia	5960eu	9845eu
1945	2000	Sat	UK, Bible Voice BC	6015va	
1945	2000	DRM	Vatican City, Vatican Radio	9800na	
1950	2000		Vatican City, Vatican Radio	4005eu	5885eu
			9645eu		
1951	2000		New Zealand, Radio NZ Intl	15720pa	

**2000 UTC - 4PM EDT / 3PM CDT / 1PM PDT**

2000	2015	s	Germany, Pan American BC	5850me	
2000	2015	Sat	UK, Bible Voice BC	6015va	
2000	2020		Vatican City, Vatican Radio	4005af	5885af
			9645af		
2000	2027		Czech Rep, Radio Prague	5930eu	11600va
2000	2030	mtwhfa	Albania, Radio Tirana	7465eu	
2000	2030		Egypt, Radio Cairo	15375af	
2000	2030		Germany, AWR Europe	15235as	
2000	2030	f	Germany, Pan American BC	5850me	
2000	2030		Iran, Voice of the Islamic Rep	6010eu	6255eu
			7320af	9855af	11695af
2000	2030		Lithuania, Radio Vilnius	6250eu	
2000	2030		Swaziland, TWR	3200af	
2000	2030		Turkey, Voice of	6195eu	
2000	2030	Sun	UK, Bible Voice BC	6015va	
2000	2030		USA, Voice of America	4930af	4940af
			6080af	15455af	15580af
2000	2030		Vatican City, Vatican Radio	7365af	9755af
			11625af		
2000	2030	DRM	Vatican City, Vatican Radio	9800na	
2000	2045		USA, Family Radio Worldwide FL		17750eu
2000	2050	DRM	New Zealand, Radio NZ Intl	11675pa	
2000	2057		China, China Radio Intl	5960eu	7190eu
			7285eu	9440va	9600eu
			11640as	13630af	
2000	2057		Germany, Deutsche Welle	7130af	11795af
2000	2059		Canada, Radio Canada Intl	5850eu	7235eu
			15325eu		
2000	2100		Anguilla, University Network	11775am	
2000	2100		Australia, ABC NT Alice Springs		2310do
			4835do		
2000	2100		Australia, ABC NT Katherine	2485do	
2000	2100		Australia, ABC NT Tennant Creek		2325do
2000	2100		Australia, Radio 6080va	7240as	9500as
			11650pa	11660pa	11880pa
2000	2100		Canada, CFRX Toronto ON	6070na	
2000	2100		Canada, CFVP Calgary AB	6030na	
2000	2100		Canada, CKZN St John's NF	6160na	
2000	2100		Canada, CKZU Vancouver BC		6160na
2000	2100	DRM	Canada, Radio Canada Intl	9800na	
2000	2100		Costa Rica, University Network		13750va
2000	2100		Eqt Guinea, Radio Africa	15190af	
2000	2100		Germany, CVC Intl/Voice Africa		13820af
2000	2100		Germany, Deutsche Welle	11865af	15205af
2000	2100	vl	Ghana, Ghana BC Corp	4915do	
2000	2100		Indonesia, Voice of	9525eu	11785eu
			15150al		
2000	2100	vl	Liberia, ELWA	4760do	
2000	2100		Malaysia, RTM/Trax FM	7295as	
2000	2100		Netherlands, Radio	5905af	7115af
			17810af		
2000	2100	Sat/Sun	Netherlands, Radio	15315na	17660va
			17735na		
2000	2100		Nigeria, Radio/Kaduna	4770do	6090al
2000	2100		Nigeria, Voice of/ Ext. Svc Lagos		15120va
2000	2100		Papua New Guinea, NBC	4890do	
2000	2100	vl	Papua New Guinea, Wantok R. Light		7120va
2000	2100		Russia, Voice of	9890eu	12070eu
2000	2100	vl	Rwanda, Radio	6055do	
2000	2100	vl	Solomon Islands, SIBC	5020do	9545al
2000	2100		South Africa, Channel Africa	3345af	
2000	2100	mtwhf	Spain, Radio Exterior Espana	9665eu	11625af
2000	2100	vl	Uganda, Radio	4976do	5026do
2000	2100		UK, BBC World Service	3255af	6005af
			6190af	9410af	9455af
			15400af		9630af
2000	2100	mtwhf	UK, BBC World Service	17830af	
2000	2100	DRM	UK, BBC World Service	1296eu	
2000	2100		USA, American Forces Radio	4319usb	5446usb
			5765usb	6350usb	7811usb
			12133usb	13362usb	
2000	2100		USA, Family Radio Worldwide FL		3230af
			17725am	17845af	18980va
2000	2100		USA, KAIJ Dallas TX	9480va	
2000	2100		USA, KJES Vado NM	15385na	
2000	2100		USA, KTBN Salt Lake City UT	15590na	
2000	2100		USA, WBCQ Monticello ME	7415am	9330am
			17495am		
2000	2100		USA, WBOH Newport NC	5920am	
2000	2100		USA, WEWN Vandiver AL	9450va	15220va

2000	2100	mtwhf	USA, WHRA Greenbush ME	7400na	
2000	2100	Sat/Sun	USA, WHRA Greenbush ME	11885na	
2000	2100		USA, WHRI Cypress Creek SC		17650am
2000	2100	Sat/Sun	USA, WHRI Cypress Creek SC		9840am
2000	2100	mtwhf	USA, WHRI Cypress Creek SC		13670am
2000	2100		USA, WINB Red Lion PA	13570am	
2000	2100	smtwhf	USA, WMLK Bethel PA	9265va	17495va
2000	2100		USA, WRMI Miami FL	9955va	
2000	2100		USA, WTJC Newport NC	9370na	
2000	2100		USA, WWCR Nashville TN	9975na	12160na
			13845na	15825na	
2000	2100		USA, WWRB Manchester TN	9385va	12180na
			15250va		
2000	2100		Zambia, CVC International	5940af	
2005	2100		Syria, Radio Damascus	9330eu	12085eu
2020	2100		Belarus, Radio	7105eu	7390eu
			7440al		
2025	2045		Italy, RAI Italia	5970va	11875va
2030	2045		Thailand, Radio	9680eu	
2030	2058		Vietnam, Voice of 7280va		9550va
			13860va		9730va
2030	2100		Cuba, Radio Havana	9505va	11760va
2030	2100	DRM	Netherlands, Radio	9800na	
2030	2100		Romania, Radio Romania Intl	9515va	11810va
			11940va	15465va	
2030	2100		Turkey, Voice of	7170va	
2030	2100		USA, Voice of America	4930af	6080af
			7555as	15445af	15580af
2030	2100	Sat/Sun	USA, Voice of America		4940af
2045	2100		India, All India Radio	7410eu	9445eu
			9910pa	11620va	11715pa
2045	2100	DRM	Vatican City, Vatican Radio	9800am	
2051	2100	DRM	New Zealand, Radio NZ Intl	13730pa	

**2100 UTC - 5PM EDT / 4PM CDT / 2PM PDT**

2100	200	DRM	Canada, Radio Canada Intl	9800na	
2100	2127		China, China Radio Intl	11640af	13630af
2100	2128		Hungary, Radio Budapest	6025eu	9525af
2100	2130		Australia, ABC NT Katherine	2485do	
2100	2130		Australia, ABC NT Tennant Creek		2325do
2100	2130		Austria, AWR Europe	11955af	
2100	2130	Sat	Canada, CBC NQ SW Service		9625na
2100	2130		Cuba, Radio Havana	9505va	11760va
2100	2130		Nigeria, Radio, Natl Svc/Abuja		7275do
2100	2130		North Korea, Voice of Korea	3955eu	
2100	2130		South Korea, KBS World Radio		3955eu
2100	2130		Turkey, Voice of	7170va	
2100	2130		USA, Voice of America	6080af	7555as
			15580af		
2100	2130	DRM	Vatican City, Vatican Radio	9800na	
2100	2145		USA, Family Radio Worldwide FL		13800na
			17795am	18980va	
2100	2157		China, China Radio Intl	5960eu	7190eu
			7285eu	9600eu	9800eu
2100	2157		Germany, Deutsche Welle	15205af	
2100	2159	smtwhf	Germany, Overcomer Ministries		7310eu
2100	2159	Sat/Sun	Spain, Radio Exterior Espana	9840eu	11625af
2100	2200		Anguilla, University Network	11775am	
2100	2200		Australia, ABC NT Alice Springs		2310do
			4835do		
2100	2200		Australia, Radio	9500as	9660as
			11695pa	12080as	13630as
2100	2200		Bulgaria, Radio	5900eu	9700eu
2100	2200		Canada, CFRX Toronto ON	6070na	
2100	2200		Canada, CFVP Calgary AB	6030na	
2100	2200		Canada, CKZN St John's NF	6160na	
2100	2200		Canada, CKZU Vancouver BC		6160na
2100	2200		Costa Rica, University Network		13750va
2100	2200		Eqt Guinea, Radio Africa	15190af	
2100	2200		Germany, Deutsche Welle	9735af	11865af
2100	2200	vl	Ghana, Ghana BC Corp	4915do	
2100	2200		Guyana, Voice of	3291do	5950do
2100	2200		India, All India Radio	7410eu	9445eu
			9910pa	11620va	11715pa
2100	2200		Japan, Radio Japan/NHK World		6035va
			6055eu	6180eu	11855af
			17870pa		17825na
2100	2200	vl	Liberia, ELWA	4760do	
2100	2200		Malaysia, RTM/Trax FM	7295as	
2100	2200		New Zealand, Radio NZ Intl	15270pa	
2100	2200	DRM	New Zealand, Radio NZ Intl	13730pa	
2100	2200		Nigeria, Radio/Kaduna	4770do	6090al
2100	2200		North Korea, Voice of Korea	7570eu	12015eu
2100	2200		Papua New Guinea, NBC	4890do	
2100	2200	vl	Papua New Guinea, Wantok R. Light		7120va
2100	2200		South Africa, Channel Africa	3345af	
2100	2200		Syria, Radio Damascus	9330eu	12085eu
2100	2200		UK, BBC World Service	3255af	3915as
			6005af	6190af	6195as
					11675am

2100	2200	11945as	12095af	13640am	15400af	
2100	2200	USA, Radio Ukraine Intl	7510eu			
		USA, American Forces Radio	4319usb	5446usb		
		5765usb	6350usb	7811usb	10320usb	
		12133usb	13362usb			
2100	2200	USA, Family Radio Worldwide FL		3230af		
		11565eu	17795am	17845af		
2100	2200	USA, KAIJ Dallas TX		9480va		
2100	2200	USA, KTBN Salt Lake City UT		15590na		
2100	2200	USA, WBCQ Monticello ME		7415am	9330am	
		17495am				
2100	2200	USA, WBOH Newport NC		5920am		
2100	2200	USA, WEWN Vandiver AL		9450va	15220va	
2100	2200	mtwhf USA, WHRA Greenbush ME		7400na		
2100	2200	Sat/Sun USA, WHRA Greenbush ME		11885na		
2100	2200	mtwhf USA, WHRI Cypress Creek SC			13670am	
2100	2200	Sat/Sun USA, WHRI Cypress Creek SC			9840am	
2100	2200	USA, WINB Red Lion PA		13570am		
2100	2200	mtwhfa USA, WRMI Miami FL		9955va		
2100	2200	Sun USA, WRMI Miami FL		7385na		
2100	2200	USA, WTJC Newport NC		9370na		
2100	2200	USA, WWCR Nashville TN		9975na	12160na	
		13845na	15825na			
2100	2200	USA, WWRB Manchester TN		9385va	12180na	
		15250va				
2115	2200	Egypt, Radio Cairo		9990eu		
2130	2157	Czech Rep, Radio Prague		9410af	11600na	
2130	2200	Australia, ABC NT Katherine		5025do		
2130	2200	Australia, ABC NT Tennant Creek			4910do	
2130	2200	mtwhfa Canada, CBC NQ SW Service			9625na	
2130	2200	Guam, AWR/KSDA		11850as		
2130	2200	Sweden, Radio		6065va	7420va	

**2200 UTC - 6PM EDT / 5PM CDT / 3PM PDT**

2200	2210	Syria, Radio Damascus		9330eu	12085eu	
2200	2230	DRM Germany, Deutsche Welle		9800na		
2200	2230	India, All India Radio		7410eu	9445eu	
		9910pa	11620va	11715pa		
2200	2230	vi Liberia, ELWA		4760do		
2200	2230	Papua New Guinea, NBC		4890do		
2200	2245	Egypt, Radio Cairo		9990eu		
2200	2245	USA, Family Radio Worldwide FL			15770af	
2200	2257	China, China Radio Intl		7175as	9590eu	
2200	2258	DRM New Zealand, Radio NZ Intl		13730pa		
2200	2258	New Zealand, Radio NZ Intl		15270pa		
2200	2300	Anguilla, University Network		6090am		
2200	2300	Australia, ABC NT Alice Springs			2310do	
		4835do				
2200	2300	Australia, ABC NT Katherine		5025do		
2200	2300	Australia, ABC NT Tennant Creek			4910do	
2200	2300	Australia, Radio		9660as	13620pa	13630va
		15230pa	15240va	15515va	17785va	
2200	2300	smtwhf Canada, CBC NQ SW Service			9625na	
2200	2300	Canada, CFRX Toronto ON		6070na		
2200	2300	Canada, CFPV Calgary AB		6030na		
2200	2300	Canada, CKZN St John's NF		6160na		
2200	2300	Canada, CKZU Vancouver BC			6160na	
2200	2300	Costa Rica, University Network			13750va	
2200	2300	Eqt Guinea, Radio Africa		15190af		
2200	2300	vi Ghana, Ghana BC Corp		4915do		
2200	2300	Guyana, Voice of 3291do				
2200	2300	Malaysia, RTM/Trax FM		7295as		
2200	2300	Nigeria, Radio/Kaduna		4770do	6090al	
2200	2300	vi Papua New Guinea, Wantok R. Light			7120va	
2200	2300	Romania, Radio Romania Intl		7185va	9675va	
		9790va	11940va			
2200	2300	vi Solomon Islands, SIBC		5020do	9545al	
2200	2300	Taiwan, Radio Taiwan Intl		15600eu		
2200	2300	Turkey, Voice of		6195va		
2200	2300	UK, BBC World Service		5955as	5965as	
		5975am	6195as	7105as	9740as	
		12095af	13640am	15400af		
2200	2300	USA, American Forces Radio		4319usb	5446usb	
		5765usb	6350usb	7811usb	10320usb	
		12133usb	13362usb			
2200	2300	USA, Family Radio Worldwide FL			11740na	
2200	2300	USA, KAIJ Dallas TX		9480va		
2200	2300	USA, KTBN Salt Lake City UT		15590na		
2200	2300	USA, Voice of America		7215va	7555as	
		9415va	11725va	15185va		
2200	2300	mtwhf USA, WBCQ Monticello ME		5110am	17495am	
2200	2300	USA, WBCQ Monticello ME		7415am	9330na	
2200	2300	USA, WBOH Newport NC		5920am		
2200	2300	USA, WEWN Vandiver AL		9975va	15745va	
2200	2300	USA, WHRA Greenbush ME		11885na		
2200	2300	mtwhfa USA, WHRI Cypress Creek SC			9515am	
2200	2300	Sun USA, WHRI Cypress Creek SC			7490am	
2200	2300	USA, WINB Red Lion PA		13570am		

2200	2300	USA, WRMI Miami FL		9955va		
2200	2300	USA, WTJC Newport NC		9370na		
2200	2300	USA, WWCR Nashville TN		5070na	7465na	
		9985na	13845na			
2200	2300	USA, WWRB Manchester TN		6890va	9385va	
		12180na	15250va			
2200	2300	Sat/Sun USA, WWRB Manchester TN		3185na	15250va	
		15250va				
2205	2230	Italy, RAI Italia		11895va		
2215	2230	Croatia, Croatian Radio		6165eu	9925eu	
2230	2257	Czech Rep, Radio Prague		7345na	9415na	
2230	2300	Guam, AWR/KSDA			15320as	
2230	2300	Papua New Guinea, NBC			9675do	
2230	2300	USA, Voice of America		7260va	9570va	
		13725va	13755va	15145va		
2245	2300	India, All India Radio			9705as	9950as
		11620as	11645as	13605as		
2259	2300	DRM New Zealand, Radio NZ Intl			15720pa	

**2300 UTC - 7PM EDT / 6PM CDT / 4PM PDT**

2300	0000	Anguilla, University Network		6090am		
2300	0000	Australia, ABC NT Alice Springs			2310do	
		4835do				
2300	0000	Australia, ABC NT Katherine		5025do		
2300	0000	Australia, ABC NT Tennant Creek			4910do	
2300	0000	smtwhf Canada, CBC NQ SW Service			9625na	
2300	0000	Canada, CFRX Toronto ON		6070na		
2300	0000	Canada, CFPV Calgary AB		6030na		
2300	0000	Canada, CKZN St John's NF		6160na		
2300	0000	Canada, CKZU Vancouver BC			6160na	
2300	0000	Costa Rica, University Network			13750va	
2300	0000	Cuba, Radio Havana		9550va		
2300	0000	Egypt, Radio Cairo		9460na		
2300	0000	vi Ghana, Ghana BC Corp		4915do		
2300	0000	Guyana, Voice of 3291do				
2300	0000	India, All India Radio		9705as	9950as	
		11620as	11645as	13605as		
2300	0000	Malaysia, RTM/Trax FM		7295as		
2300	0000	New Zealand, Radio NZ Intl		13730pa		
2300	0000	DRM New Zealand, Radio NZ Intl		15720pa		
2300	0000	Papua New Guinea, NBC		9675do		
2300	0000	vi Papua New Guinea, Wantok R. Light			7120va	
2300	0000	Singapore, MediaCorp Radio		6150do		
2300	0000	vi Solomon Islands, SIBC		5020do	9545al	
2300	0000	UK, BBC World Service		3915as	5965as	
		6195as	9740as	11945as	11955as	
		12010as				
2300	0000	USA, American Forces Radio		4319usb	5446usb	
		5765usb	6350usb	7811usb	10320usb	
		12133usb	13362usb			
2300	0000	USA, Family Radio Worldwide FL			15255am	
		17750am				
2300	0000	USA, KAIJ Dallas TX		9480va		
2300	0000	USA, KTBN Salt Lake City UT		15590na		
2300	0000	USA, Voice of America		7260va	7555as	
		9570va	13725va	13755va	15145va	
2300	0000	USA, WBCQ Monticello ME		5110na	7415am	
		9330am	17495am			
2300	0000	USA, WBOH Newport NC		5920am		
2300	0000	USA, WEWN Vandiver AL		9975va	15745va	
2300	0000	USA, WHRA Greenbush ME		7520na		
2300	0000	mtwhfa USA, WHRI Cypress Creek SC			9515am	
2300	0000	USA, WINB Red Lion PA		9265am		
2300	0000	USA, WRMI Miami FL		9955va		
2300	0000	USA, WTJC Newport NC		9370na		
2300	0000	USA, WWCR Nashville TN		5070na	7465na	
		9985na	13845na			
2300	0000	USA, WWRB Manchester TN		3185na	5050na	
		6890na	15250va			
2300	2300	Bulgaria, Radio		9700na	11700na	
2300	2315	Nigeria, Radio/Kaduna		4770do	6090al	
2300	2330	Australia, Radio		9660as	12080as	13630pa
		13670pa	15230pa	15240va	17785va	
		17795va				
2300	2345	USA, Family Radio Worldwide FL			11740na	
2300	2345	DRM Vatican City, Vatican Radio		7370am		
2300	2357	China, China Radio Intl		5915as	5990am	
		6145na	7180as	11685as	13680na	
2305	0000	Canada, Radio Canada Intl		6100na		
2305	0000	Greece, Voice of		7475eu	15650eu	
2330	0000	Australia, Radio		9660as	12080as	13620pa
		13670pa	15230pa	15415va	17750va	
		17785va	17795va			
2330	0000	Burma, Dem Voice of Burma		5955eu		
2330	0000	Lithuania, Radio Vilnius		7325na		
2330	0000	UK, BBC World Service		9580as		
2330	2358	Vietnam, Voice of		9840as	12020as	
2330	2359	DRM Sweden, Radio		9800na		

## The CAP VHF Radio Network – Frequencies in Transition

The August 2006 issue of the Civil Air Patrol (CAP) North Central Region newsletter ([http://ncr.cap.gov/images/ncr/pao/pdf/NCR\\_News\\_2006\\_08.pdf](http://ncr.cap.gov/images/ncr/pao/pdf/NCR_News_2006_08.pdf)) had a detailed article on future CAP communications developments and a time line regarding the conversion to their new, self-proclaimed “sensitive” VHF frequencies. From page 9 of this newsletter:

“2007 may be the most demanding year in the history of CAP for the organization’s Communications program. During the summer of 2007, every VHF-FM radio frequency used by CAP will be changed by order of the federal government, requiring changing out of every VHF ‘repeater’ used by CAP and reprogramming of every corporate and member-owned radio used on the ‘CAP frequencies.’

“CAP’s radio communications are regulated by the National Telecommunications Information Administration (NTIA), as opposed to civilian frequencies which are regulated by the Federal Communications Commission. During 2007, CAP will be implementing new technical standards required by the NTIA and the Air Force. Among the changes mandated by the new standards will be operation on new ‘narrow band’ frequencies, meaning physically changing the hardware of every VHF radio repeater used by CAP, nationwide, including 75 in North Central Region. Between 1995 and 2006, CAP has received over \$23 million dollars in Air Force funding to acquire new equipment meeting the more stringent technical standards, which will be fully implemented in 2007.

“The typical wing will need to plan for the following steps:

- By April 1, 2006, each wing will receive their new repeaters. Each repeater, packaged for transport, will be the size of a refrigerator and will weigh 300 pounds. A forklift will probably be needed to unload the repeater, but once unpacked, it should be possible to transport with a handcart.
- At each repeater site, between April 1 and September 30, the old repeater must be removed from service and the new repeater, operating on new frequencies, must replace it.
- Prior to beginning the program of switching repeaters, every radio in the wing will need to be reprogrammed to include both “old” and “new” frequencies.
- After the last repeater has been switched out, every radio will have to be reprogrammed again to eliminate the “old” frequencies, which will become the territory of other federal agencies.
- Some repeater sites may need a formal process of coordinating frequencies with other users of the site.

• During the transition period, users from other agencies may appear on both the old and new frequencies. CAP must work with these other agencies to try to support our missions while not causing unnecessary interference to their missions.

- Current “old” CAP VHF-FM frequencies may not be used by CAP used after September 30, 2006. The overall project of converting to new frequencies will affect 587 repeaters across the country and thousands of individual radios, making it one of the biggest projects CAP has ever undertaken, as an organization.

“Mark Kunkowski, of CAP’s National Technology Center, told comm managers in Reno that they need to be planning for this effort NOW in order to ensure a smooth conversion to the new frequencies. He said that the list of new frequencies should be ready to release to comm managers soon. In order to have access to the list of new frequencies, members must have agreed to the Non-Disclosure Agreement at the conclusion of the Operational Security training announced recently.”

I originally published a complete list of all the new CAP VHF frequencies in the November 2006 issue of this column in *Monitoring Times*. In answer to some speculation as to my sources, these frequencies were found on a publicly available website; they were *not* obtained directly through any official CAP sources.

However, to recap, below are both the old (official) and new VHF frequencies for the CAP, and their aeronautical and HF frequencies.

### Old CAP Frequency Set

Until September 30, 2007, at the latest, the national standard frequency and tone encode assignments that CAP mandated in their corporate radio were:

148.1500 MHz	Simplex (100 Hz PL) <ch 1>
148.1250 MHz	Simplex (100 Hz PL) <ch 2>
148.1375 MHz	Simplex (100 Hz PL) <ch 3>
149.5375 MHz	Simplex (100 Hz PL) <ch 4>

Other VHF LMR frequencies mentioned in official CAP documents include: 149.895

(packet), 149.925 (packet), 143.750 (voice), and 143.900 (voice).

### New CAP Frequency Set

There will be an extensive usage of repeater output/inputs and PL tones as part of the new channel bandplan for CAP. This new channel plan is not known and won’t be until it is placed into service and monitors have a chance to sort through what is being heard. The frequencies to watch include:

Simplex	138.0125	140.6375	142.2250
	150.1625	150.5625	150.6375 MHz
Repeater	143.7250	143.9000	148.1750
	148.7750 MHz		

The CAP aeronautical frequencies listed in official documents include: 121.600 (practice beacons), 121.775 (practice beacons), 122.900 (AM voice), and 123.100 (AM voice). These are not expected to change as they are not impacted by LMR narrow banding.

HF radio frequencies used by CAP include:

2371.0	2374.0	4466.0	4469.0	4477.0
4506.0	4509.0	4522.0*	4582.0	4585.0
(National Calling Frequency) 4601.0				
4604.0	4627.0	4630.0	5006.0*	5711.0*
6806.0*	7341.0	7602.0*	7635.0	(National Calling Frequency) 7920.0
8012.0*	9047.0*	10162.0*	11402.0*	12081.0*
13415.0*	14357.0*	14902.0	17412.0*	
18205.0	19814.0*	20873.0 kHz		

Most of the CAP HF communications are voice in the upper sideband (USB) mode, but this group is starting to use more of the automatic link establishment (ALE) protocol, frequencies indicated by an asterisk. You will also encounter other digital modes on these frequencies, including packet comms.

### Colorful CAP Callsigns

The CAP organization uses a variety of callsigns in their various radio networks. CAP mission aircraft use the callsign *CAPflight*, followed by a four digit number (see this month’s *MT Help Desk* column for a complete list).

Personnel assigned positions in CAP headquarters use the *Headcap* callsign. The list that follows in Table 1 is the last publicly available list of these callsigns and the positions they represent.



**TABLE 1: HEADCAP CALLSIGNS**

Headcap 1	National Commander
Headcap 2	National Vice Commander
Headcap 3	National Chief of Staff
Headcap 4	Chief of Communications
Headcap 5	Chief of Chaplain Service
Headcap 6	National Finance Officer
Headcap 7	National Legal Officer
Headcap 8	National Controller
Headcap 9	Special Assistant/Communications
Headcap 10	National Safety Officer
Headcap 11	National Inspector General
Headcap 12	Inspector General Operations
Headcap 13	Education/Training Committee, Chair
Headcap 14	STEP Committee, Chair
Headcap 15	Development Committee, Chair
Headcap 16	Operations Committee, Chair
Headcap 17	Counterdrug Committee, Chair
Headcap 18	Advanced Technology Committee, Chair
Headcap 19	General Counsel
Headcap 20	Director of Homeland Security
Headcap 21	Homeland Security Advisor
Headcap 22	National Operations Center
Headcap 23	Rapid Response Coordinator
Headcap 24	FEMA Coordinator
Headcap 25	New Madrid Fault Committee, Chair
Headcap 26-27	Legislative Coordinator
Headcap 28	National Historian
Headcap 29	National Curator
Headcap 30-31	National Commander's Staff
Headcap 32	National Commander's Special Advisor
Headcap 33	National Technical Center (NTC)
Headcap 35	NCS SHARES Coordinator
Headcap 36	Chief of Emergency Services
Headcap 37	Chief, Emergency Services Plans
Headcap 38-39	National Operations Staff
Headcap 40	Assistant Chief of Communications
Headcap 41	Frequency Manager
Headcap 42	Chief of Communications Plans
Headcap 43	National Communications Staff
Headcap 44	National Commander's Staff
Headcap 45	Chaplain Communications
Headcap 46-49	National Technology Center
Headcap 50-59	CAP Supply Depot
Headcap 60-61	Operations Committee, Comm Rep
Headcap 62-69	National Communications Volunteer Staff
Headcap 70	National Operations Center Chief
Headcap 71-79	National Operations Center
Headcap 90-99	National Headquarters, Special Activities
Headcap 100	CAP Master Net Control Station
Headcap 101-108	CAP Brig Generals
Headcap 350	HF Test Station

Each region and wing is assigned a unit tactical callsign. The tactical callsign plus a

serially assigned number comprise the complete CAP tactical callsign. Serially assigned numbers do not exceed four digits.

Tactical callsigns 1 through 5 in each region/wing are assigned to particular posts, regardless of changes in staffing. Assignment of tactical callsigns 1 through 5 for each region/wing are as follows:

- 1 Region/wing commander
- 2 Region/wing vice commander
- 3 Region/wing chief of staff
- 4 Region/wing director of communications
- 5 Region/wing chaplain

The callsigns that follow in Table 2 are used by region/wings on ground tactical nets.

**TABLE 2: REGION/WING GROUND TACTICAL CALLSIGNS**

Abenaki ###	New Hampshire
Alabama CAP ###	Alabama
Aspen Gold ###	Rocky Mountain Region
Avenging Spirit ###	National Headquarters Special Use
Beaver Fox ###	Oregon
Black Granite ###	Montana
Blue Mesa ###	Colorado
Blue Mound ###	Wisconsin
Cajun CAP ###	Louisiana
CAP Great Lakes ###	Great Lakes Region
CAP Kitty Hawk ###	North Carolina
CAP Stone ###	Northeast Region
CAP West ###	Southwest Region
CAP-USAF PARD ###	National Headquarters
Charter Oak ###	Connecticut
Diamond Flight ###	Delaware
Down East ###	Maine
Firebrand ###	Hawaii
Florida CAP ###	Florida
Free State ###	Maryland
Georgia CAP ###	Georgia
Grasslands ###	South Dakota
High Plains ###	Wyoming
Hill CAP ###	West Virginia
Hill Thunder ###	Congressional Squadron
Iowa CAP ###	Iowa
Jefferson ###	Virginia
Jet Pilot ###	Kentucky
Middle East ###	Middle East Region
Mississippi CAP #####	Mississippi
Missouri CAP ###	Missouri
Narragansett ###	Rhode Island
Nat CAP ###	National Capitol
North Central ###	North Central Region
Oil Well ###	Oklahoma
Patriot ###	Massachusetts
Peace Garden ###	North Dakota
Penn CAP ###	Pennsylvania
Puerto Rico CAP ###	Puerto Rico
Red Cloud ###	Nebraska
Red Dragon ###	New Jersey
Red Fire ###	Indiana
Red Fox ###	Illinois
Red Robin ###	Michigan
Red Rock ###	Arizona
Red Thunder ###	Ohio
Sand Lapper ###	South Carolina
Ship Rock ###	New Mexico
Silver State ###	Nevada
Sourdough ###	Alaska
Southeast CAP ###	Southeast Region
Spotted Owl ##	Washington
Star Fish ###	Minnesota

Star Garnet ###	Idaho
Tennessee CAP ##	Tennessee
Texas CAP ###	Texas
Uncle Mike ###	Utah
Vermont CAP ###	Vermont
Western ###	Pacific Region
White Peak ###	New York
Wild Wood ###	Arkansas
Yellow Brick ###	Kansas
Yosemite ###	California

We will have more details on all of this as events play out. If you hear any activity on the new system, especially after September 30, 2007, we would appreciate any field reports at the email address in our masthead.

## ❖ New Military Trunk Systems Uncovered

Longtime *MT* reader Mac MacCormick, KF4LMT (<http://kf4lmt.blogspot.com/>) has uncovered a new VHF high band trunk radio system at Shaw Air Force Base (AFB), South Carolina. Late last year I emailed Mac some frequencies that I uncovered while doing some research for a possible new VHF military trunk system in South Carolina. I fully believed that the system was located at either Shaw AFB or McEntire ANGB.

Mac made the trip into the area around Shaw and confirmed that the system was being used at that base. Here are the details on this new military trunk radio system:

### Shaw AFB Trunked System

System Type: Motorola 9600 baud APCO-25

System ID: 16D

Site ID: 101 (T0101) WACN: BEE00

Base Frequency: 162.0000 MHz, Step: 12.5 kHz, Offset: 380

163.4125	Control Channel
163.4625	Control Channel
164.5000	Control Channel
164.9625	Control Channel
165.0125	Digital Voice
165.1875	Digital Voice
165.2250	Digital Voice
165.4125	Digital Voice
166.0000	Digital Voice
166.2250	Digital Voice

### Talkgroups

19	Fire? - FIRE DEPARTMENT working RADIO MAINTENANCE
20	Unknown user/usage - reference to personnel not in uniform going to "the 79th side"
21	Unknown user/usage
25	Police? - SHAW working DELTA #, references to "the sub-station" (these just "sounded" like law enforcement
28	Squadron talkgroup? - Unidentified passing aircraft maintenance codes, reference to sending someone to "the 79th side" (probably related to similar traffic on TG 20)
34	Tower/Ground Control? - Barrier Maintenance working Shaw Tower - unidentified reference switching runways
42	POL? - unidentified reference "amount needed" for aircraft 907

And that does it for this month, Until next time, 73 and good hunting.

## March 23<sup>rd</sup>, 2007: The Day the DX died?

The FCC has adopted final rules for “high definition,” HD Radio (IBOC-in band on channel). A few highlights of the news release:

- No prior FCC approval is required to begin digital operation.
- AM stations had only been allowed to operate their digital signals during the day. Nighttime operation is now authorized.
- Stations must offer at least one free program stream, simulcasting their analog signal. FM stations may broadcast additional program streams, either free or subscription. (AM IBOC doesn't offer enough bandwidth for additional program streams.)
- Rules such as EAS (emergency alert systems), legal IDs, political advertising, etc. will be applied to all program streams of the digital signal.
- The IBOC technical specifications allow for digital-only stations with no analog signal. The FCC will not allow such digital-only operation at this time.
- No deadline has been set for shutting down analog radio and going digital-only.

As of deadline, the text of the new rules has not yet been released. In any case, rules like this usually take effect 30 days after publication in the *Federal Register*, which in turn usually takes 7-10 days after the FCC News Release. Counting forward from March 23<sup>rd</sup>, I would expect the new HD rules to have gone into effect around the first of May. Visit my blog (<http://americanbandscan.blogspot.com>) for the latest information.

What will happen when the nighttime IBOC starts? Good question...

Many of the 50,000-watt clear-channel stations are already equipped for HD Radio and are running it during the day. For these stations it will be simply a matter of disconnecting the timer and allowing the digital signal to remain on the air at night. There is likely to be a sharp spike in interference in the 640-1220 and 1500-1580 kHz bands.

Relatively few regional-channel and local-channel stations have installed IBOC. At the very least, stations will have to acquire and install new equipment to operate IBOC at all, let alone at night. This will be more difficult for regional-channel stations; those which have significant power at night are almost always directional. Many will require difficult and expensive antenna adjustments before HD will work.

The new rules don't make it much easier (from a regulatory standpoint) to install IBOC; it was already pretty easy. So I think most AM

stations that are interested in IBOC have already installed it. We'll see a few more AM IBOC stations, but we won't see a huge stampede.

I think the regional channels will be an island of DX among the buzz. 540-630, 900-990, 1230-1490, and 1590-1700 will be relatively IBOC-free and a good place to look for DX.

I know many other DXers don't share my optimistic viewpoint. Those who know me, know I'm a relatively optimistic person, and I try to see the good in any situation. I do honestly believe that a DX hobby that survived all-night operations, satellite-fed formats, automation, and the breakup of the clear channels, will survive IBOC.

Some engineers have expressed a much less optimistic vision. Indeed, I've heard from some who believe IBOC could kill not only the AM DX hobby, but AM radio itself. The theory goes that the massive interference to routine listening could drive enough listeners to FM, Sirius, XM, and MP3 players to make AM radio unprofitable. I can't say I see this happening. But the fact that engineers *inside the industry* see it as a possibility is a rather scary story...

Rumor has it the permittee of two new FM stations in North Carolina had proposed to sign the stations on as digital-only operations. (His choice of call letters – WHDX and WHDZ – would tend to confirm that rumor!) Unless he receives Special Temporary Authority, it seems unlikely this will be permitted.

### ❖ HD DX

One February morning, I was hit with a bout of insomnia. I turned on the ham rig and started DXing the AM dial. On 1030, I noticed the obvious sign of an IBOC digital sideband, completely covering the channel, and another sideband on 1050. Obviously, a station with IBOC was coming in on 1040, and upon selecting that frequency I heard WHO, Des Moines, Iowa, with a full local-quality analog signal.

I promptly disconnected the antenna from the ham rig and hooked it to the HD radio. Almost immediately, the WHO call letters appeared on the radio's screen. A few seconds later, I was surprised to hear a significant improvement in the WHO audio – and realized I was listening to WHO's digital signal. The digital signal remained in for about 90 seconds, before WHO

took a shallow fade and went back to analog. I tried again about five minutes later and received a few seconds of digital audio.

Des Moines is roughly 450 miles away. This marks the first time I've received digital audio from a distant station; my previous AM HD DX record is local WPLN-1430 at about 25 miles. On FM I've done a *bit* better – WPLN-FM and WNRQ-FM are about 30 miles away. I'm neither the only, nor the first, DXer to receive HD digital audio from a distant station, but it's sure a big milestone in my DX career! Other DXers have received FM HD DX (including E-skip); I expect to receive some this summer.

HD DX is not easy, but it *is* possible.

### ❖ FM translators of AM stations

Translators are low-powered relay stations. They pick up the signal of a regular (“primary”) station and rebroadcast it on a different frequency, into an area not able to reliably receive the main transmitter. While an FM translator may change “primary” stations at will, it must specify a primary station – and that station must be FM. Low-power FM relays of AM stations are legal in Canada, but not in the U.S..

In March, three FM translators received Special Temporary Authority to relay AM stations. W263AI (100.5) and W270AF (101.9) in Murfreesboro, Tennessee, are relaying WGNS-1450. W232AX (94.3) in Rock Hill, South Carolina, is relaying WRHI-1340.

Small AM operators have been clamoring for this kind of authority for several years now. Given the timing of the announcement, I really have to wonder if it's a “bone” thrown to small



*I did it! Visual evidence of my reception of WHO-HD, Des Moines, Iowa.*



AM operators, who fear they're about to be clobbered by HD Radio interference? If so, the small stations may be rather disappointed by the slow process for getting a translator licensed...

### ❖ New San Francisco station

It's not every day you see a new AM station. It's even less often you see one in one of America's ten largest cities. (I think the last one was WOPA-1200 in Chicago, in the 1980s.) This spring, San Francisco got its first new station since KIQI-1010 came on the air in 1957.

KTRB-860, however, is not a completely new station. It moved from Modesto, about 90 miles to the east. The station "stunted" for about a month with music from San Francisco's "Summer of Love," 1967. The temporary format was much appreciated by West Coast listeners, but we knew it couldn't last. In late March the regular format began. You probably wouldn't be surprised to learn KTRB is a talk station.

KTRB's owners were not prepared to give up on Modesto, though. With the 860 kHz station moved to San Francisco, another frequency became usable in Modesto. New station KMPH has come on the air there on 840 kHz.

### ❖ New FM & TV stations

Here's something else that doesn't happen every day: a new VHF TV station. Even better, it's a new low-band VHF TV station, which may be DXed via sporadic-E (and we're at the peak of the season). KPTW is a PBS affiliate on channel 6 in Casper, Wyoming. It may not, however, be as easy a catch as one might hope. While KPTW holds a full license, it's operating with only 330 watts of power. This is only about double what its previous incarnation – as TV translator K06KH – used. KPTW relays KCWC channel 4.

And on FM, here's one that probably won't see the light of day: Akiachak School in southwest Alaska has applied for a non-commercial radio station. The station would operate with 50 watts of power, on 87.9 MHz. This choice of facilities is a problem on two fronts: both the proposed frequency and the proposed power are inconsistent with FCC policy.

With regard to 87.9 MHz, FCC regulation 73.501(a) says that this frequency is only available to existing Class D stations required to change to a new frequency. The Akiachak station is, of course, new. There are also strict conditions for distance from Canada, Mexico, and channel 6 TV stations, but those conditions are not a problem in this part of Alaska!

FCC regulations are a bit ambiguous about the creation of a new 50-watt FM station. Regulation 73.511(a) says new FM stations must use at least the Class A minimum power of 100 watts – but 73.512(c) says that the prohibition on new Class D stations doesn't apply in Alaska.

Why this applicant would choose 87.9 is beyond me. This is a VERY isolated area. I can only find five FM stations within 100 miles. Almost the entire FM band – including all frequencies above 100.9 MHz or below 91.1 – would seem to be available. And surely a school that could afford to run a 50-watt station could install a slightly larger antenna and/or transmitter to

reach 100 watts ERP?

Sometimes the FCC does strange things in Alaska. You never know...

### ❖ Till next month

Have you tried DXing IBOC? Write me at 7540 Highway 64 West, Brasstown NC 28902-0098, or by email to dougsmith@monitoringtimes.com. Good DX!

### REFERENCES:

- <http://americanbandscan.blogspot.com>  
My AM DX blog
- [http://hraunfoss.fcc.gov/edocs\\_public/attachmatch/DOC-271699A1.pdf](http://hraunfoss.fcc.gov/edocs_public/attachmatch/DOC-271699A1.pdf)  
FCC news release on final IBOC rules
- [www.pappastv.com/pressdetail.php?id=97&prYr=2007](http://www.pappastv.com/pressdetail.php?id=97&prYr=2007)  
News release on the debut of KTRB-860 as a San Francisco station

### NEW AM STATIONS ON THE AIR

Deer Lodge, Mont.	1400	KBCK	1,000/1,000 ND
Burbank, Wash.	1560	KVAN	10,000/700 DA-2 (reported by several DXers; Burbank is near Kennewick.)

### NEW AM STATION PERMITS GRANTED

Opp, Ala.	1590	500/190 DA-2
Saraland, Ala.	770	38,000/800 DA-2 (near Mobile)
Ajo, Ariz.	1340	250/250 ND
Gibsonia, Fla.	700	2,500/250 DA-2
Lake City, Fla.	1450	1,000/1,000 ND
Savannah, Ga.	1520	50,000/700 DA-2
Orono, Me.	1530	50,000/600 DA-3
Lovelock, Nev.	1450	1,000/1,000 ND
Winnemucca, Nev.	1340	250/250 ND
Mount Royal, Ore.	1130	25,000/490 DA-2; call letters KTRP assigned
Gatineau, Que.	1670	1,000 ND (Children's programming in French; Gatineau is near Ottawa.)

### NEW AM STATION APPLICATIONS DISMISSED

Mountain Ranch, Cal.	1340
Jobos, P.R.	660
Pierre, S.Dak.	1400

### APPLICATIONS FOR NEW AM STATIONS

San Luis Obispo, Cal.	1580	1,000/1,300 DA-2
Houghton, Mich.	1340	1,000/720 ND (in the Upper Peninsula)
Fitzwilliam Depot, N.H.	870	780/400 DA-N (near Keene)
Montreal, Que.	650	5,800 DA-1 or DA-2*; French religious
Montreal, Que.	1400	1,000 ND*; ethnic
Montreal, Que.	1410	10,000 DA-2*; ethnic
Rhineland, Wis.	640	620/420 DA-N
Big Horn, Wyo.	1370	10,000/250 DA-N (near Sheridan)

\* Details not released. 1410 probably specifies the same facilities as CFMB, which operated on 1410 before moving to 1280 a few years ago.

### CALLSIGNS ASSIGNED TO NEW STATIONS

Cameron, Ariz.	1450	KYNN
Hilo, Hawaii	1590	KIXC
Tonopah, Nev.	1400	KTNP
Berlin, N.H.	1490	WRTN
Charlestown, R.I.	1370	WKFD
Cameron, S.C.	1490	WTQS

### OTHER STATION CHANGES

Station locations changed:  
San Francisco, Cal. 860 KTRB 50,000/50,000 DA-2 (moved from Modesto)

Changes in station location granted:  
Waverly, Mich. 1080 WOAP 50,000 DA-D (to move from Owosso. Waverly is near Lansing.)

Changes in station location requested:  
Ripley, Ohio 1180 KELE 1,000 ND-D (to move from 1360 in Mountain Grove, Mo.)

## MT READERS ONLY

To access the restricted website for the month starting June 1, go to [www.monitoringtimes.com](http://www.monitoringtimes.com), click on the key, and when prompted, enter "mtrader" under the user name. Your password for June is "gonset" – Check in each month for new material!



## Train Monitor's Paradise - The Powder River Basin

If you want to see America's busiest freight lines, head to northeastern Wyoming. That area, of course, is the core of the Powder River Basin, which also extends into southern Montana.

What the name Powder River Basin (PRB) brings to mind is coal. The PRB contains America's largest reserves of low-sulfur coal – the most desirable coal for many applications because it requires fewer pollution controls and results in fewer objectionable emissions when burned. The coal in the PRB is also relatively easy to get at, being only a short distance below the surface, also making it cheaper to mine than at many other locations.

So, some two dozen huge mines load somewhere between 50 and 100 coal trains per day. Most of those trains number in the 120+ car range. The PRB is served by the two largest railroads in the U.S. – BNSF and Union Pacific, which share a major part of the trackage in the core area, but which also have their own facilities in the area.

In this sparsely populated area – mule deer and antelope outnumber people in much of the PRB – the scope of both the mining and railroad operations is enormous. Some of the heavy duty railroad lines have four main tracks – and they still have traffic jams.

Though this isn't the place to go into detailed travel information, it's worth noting that the area has good roads and good accommodations in the towns of Douglas, Gillette, and Sheridan. Yes, you still need to take precautions here, as when traveling in any sparsely populated areas. And, you need to be aware that these largely treeless grasslands provide little protection from sometimes extreme weather. In the summer, the sun can be blazingly hot, while the winter (and even spring and fall) can bring snow and harsh winds.



*Track maintenance machines (ballast regulators) in front of the loading silos of one of the Powder River Basin mines. Behind them, on a lower level, a coal train is on the loading loop of the mine.*

(I provide more information about travel in the PRB in my guidebook to the area.)\*

But you want to know what you will hear on the radio during a visit. The answer is plenty, if you know where to listen.

### ❖ Shared railroading

First, you need to know that along the north-south spine of the area – the Orin Line shared (except for the northernmost tip) by BNSF and UP – you will hear the most radio traffic on BNSF channels.

That's because, although the two railroads jointly own the line and share expenses related to maintenance and new track construction, BNSF handles the dispatching and manages the maintenance and construction work, a major part of which is farmed out to contractors. So, if a UP train needs to talk to a dispatcher, it will talk to the BNSF dispatcher on a BNSF channel.

The BNSF dispatching center that handles the PRB does have a UP presence and coordinates with UP dispatchers on trains entering and leaving the area. UP has a staging yard at Bill on the Orin Line, where UP trains talk to the UP yardmaster on a UP channel.

But, in such a busy area, one of the surprises will be what you will *not* hear on the BNSF road channels assigned to various lines in the region – conversations between trains and dispatchers. Or, at the least, you will hear very few of these conversations, typically only when a dispatcher needs to talk to a train.

Train to dispatcher conversations are usually done on BNSF PBX channels. And, that gives us a chance to talk about PBX channels.

### ❖ PBX channels

PBX is an abbreviation for private branch exchange, a term going back all the way to the time when telephone exchanges were still staffed by operators who plugged and unplugged lines to set up circuits.

Today, a PBX is any telephone switching node that is not owned by a telephone company. Most larger companies now have electronic PBX equipment. Want to call someone else within the building or even elsewhere in the company? The phone call usually never leaves the company's internal circuits, and no commercial phone company is involved.

Because of the amount of voice and data communications required, railroads have some of the most extensive PBX networks of any businesses. (Worth noting: SPRINT, the telecommunications company, once stood for Southern Pacific



*Outbound (southbound) loaded Union Pacific unit coal train passing an inbound empty train at Logan Hill on the south end of the Orin Line in southeastern Wyoming. The plastic dome on the lead locomotive protects an antenna array, including the one needed for remote control of other locomotives further back in the train.*

Railroad Internal Network Telecommunications. Southern Pacific, after upgrading its network, found that it had excess capacity and ultimately spun off a telecommunications company!)

On a PBX channel the remote base station is tied into the railroad's PBX network. A railroad employee can place a call anywhere within that network – or even outside it – through that base station.

The calling employee switches his radio to the PBX channel and uses a tone sequence to activate the base station. The base station then responds with a dial tone or some other indication that it is active. The employee then tones the number he wants to talk to.

The employee – an engineer, conductor, or track inspector – can directly dial a specific dispatcher; a maintenance employee can order spare parts or other supplies; and an engineer who is having problems with one of his locomotives can dial technical support to get assistance.

Yes, railroad employees increasingly carry company-issued or personal cell phones, but those calls have to be paid for by someone, and there are remote areas where there is no cell phone coverage. Plus, use of a PBX channel has the advantage of letting others in the area listen in on and participate in the call.

If there are a number of employees in an area working on a project, one employee can announce on the road channel that he is making a PBX channel call, and all others interested in that call can also switch to that channel. No, multiple parties cannot talk at the same time, but the primary caller can ask someone else to participate after he stops holding down his transmit button.

Obviously, with a PBX channel call, the

caller cannot simply “hang up” to terminate the call. Instead, someone has to transit a tone sequence to disconnect the remote base station from the network and have it go back into dormant mode.

You’ll also find PBX channels used by other railroads, but nowhere are they used as much as in the PRB.

### ❖ Back to the PRB

Okay, now that we know that a substantial amount of business is transacted on PBX channels, what about the road channels? As already mentioned, the road channel is the one monitored by all trains and employees. Train crews can talk to each other on that channel.

Each of the mines is also on the road channel. On entering a mine’s loading loop, the train calls the mine for permission to proceed to and through the loading silo. If there is any problem with the loading process, the mine can tell the crew to stop.

When the loading process is completed, the mine gives the train crew a report on the total number of cars and tons of coal loaded. (Cars are weighed in motion as they leave the loading silo. Knowing the empty weight of their train, the crew then knows the total weight of their loaded train.)

Rail traffic on the PRB main lines is so heavy that almost all normal movements are made using lineside signal lights, with very little radio conversation. But, that then leaves the road and PBX channels open for other conversations.

In the northernmost section of the Orin Line, there is one section that is known as “Absolute Alley,” because light signals governing movement on the main line, crossovers between the main lines, and for entering and leaving mine spurs are spaced so closely. (An absolute signal is any signal light that cannot be passed when displaying red, without getting special permission from the dispatcher.)

### ❖ Remote Locomotives and Helpers

Most trains operating in the PRB have three high-horsepower modern diesel-electric locomotives, usually two units up front and an unmanned, remotely controlled unit at the rear. Some trains that will have to head over substantial grades may carry an extra unit or two with them. Occasionally, when the railroad is short of modern high-horsepower, a few trains with older power may also have more of these units up front.

BNSF trains leaving the north end of the Orin Line can usually do so without further assistance in the immediate area. BNSF trains westbound through Sheridan will usually get assistance from a manned set of helper locomotives in that area. Several helper sets are usually based out of Sheridan.

BNSF trains headed east into Nebraska will get assistance from manned helper sets at Crawford, Neb., to get over Crawford Hill.

There’s a substantial grade at the south end of the Orin Line, known as Logan Hill. Most loaded coal trains can just barely make it over that hill with their normal road power. But, should any one of the train’s units fail or not be able to produce

full power, the train quickly gets into trouble. And one train in trouble can cause a major traffic jam in that busy area.

Therefore, both BNSF and UP maintain manned helper engines – usually one high-horsepower unit or two older units – to help out any such trains. The helper unit will at least get the loaded train southbound over Logan Hill. Even with only two operable units, trains can then make it to the nearest yard or terminal (Bill, Wyo., for UP; Guernsey, Wyo., for BNSF) to have the faulty unit worked on or replaced.

So, around Logan Hill, you’ll hear the BNSF dispatcher talking to both the BNSF and UP helper units to tell them their next assignment – and then the helpers talking to the train they are assisting as the couple up, push, and then uncouple.

### ❖ More Information

Interested in more information about the PRB? Start by ordering a state map and guide from [www.wyomingtourism.org](http://www.wyomingtourism.org). You can also find more detailed maps in the DeLorme state atlas for Wyoming.

By the time you read this, a long-awaited updated version of the Altamont Press *Mountain Plains* should be available. That timetable, which had been out of print for years, provides route data and includes several maps.

You can also electronically explore the area through various online map services and a variety of fan sites. And, my own guide to the Powder River Basin is still available.\*

The accompanying table provides key frequencies used in Wyoming and Colorado. We’ll get to Colorado in a future column.

### Powder River Basin Frequencies

Colorado-Wyoming Trip

See notes at end.

Ch.	RR	Freq.	Use/Description	AAR
01	UP Y [SP 4]	160.455	PRB: UP Yardmaster Bill, WY Also Leyden-Dotsero(E/W Moff.)	23/23
02	BN 2 UP M	160.920	PRB: Alliance, NE-Sterling, CO; Gillette-Huntley; Prospect-Arvada Also Craig Br. (Bond-Phippsburg)	54/54
03	BN 3	161.100	PRB: Guernsey-Reno, WY	66/66
04	BN 4	161.160	Casper, WY-Denver, CO; Denver-Cheyenne (old)	70/70
05	BN A	161.205	BNSF Special agents	73/73
06	BN 6	161.280	McCook, NE-Denver; Crawford; Laurel-Casper	78/78
07	BN 7	161.385	PRB: Eagle Butte-Cordero, WY; Gillette-Edgemont; Crawford yard	85/85
08	BN 8	161.415	BNSF NE and CO various	87/87
09	BN P	160.665	PRB: PBX-3 Rocky Butte	37/37
10	BN P	160.620	PRB: PBX-4 Roberts Flats	34/34
11	BN P	161.130	PRB: PBX-5 Douglas	68/68
12	UP 1	160.410	UP Cheyenne Yard; Laramie Yard	20/20
13	UP	160.740	UP Laramie DS.; Sherman Hill; PRB(feeder). Morrill, NE; Yoder Sub.	42/42
14	UP	160.890	PRB: UP Shawnee Jct.	52/52
15	UP C	160.470	Cheyenne DS; Sherman Hill; Ft. Collins; Boulder	24/24
16	UP M	452.900	Repeater: Leyden-Moffat	—
17	UP-M	457.900	Repeater: Bond-Dotsero	—
18	UP Y	160.680	Cheyenne Yard	38/38
19	SP3b	161.565	Moffat T.; Phippsburg-Craig	/97
20	SP3a	160.395	Moffat T.; Phippsburg-Craig	19/

- The table represents a 20-channel scanner setup which I’ve used for several trips to Colorado and Wyoming. These channels include the most important frequencies for the Powder River Basin, as well as for parts of Colorado near Denver. Denver is a good starting and ending point for a trip to the PRB, as it has a much larger airport, more airlines and more airport services, than any you would find in Wyoming.
- Important: Many of the above frequencies are used at multiple locations, not all of which could be listed in the above table. In other words, continue to scan all of the above frequencies, whether you are in Wyoming or Colorado. I’ll cover some of the more interesting Denver area rail activities in a future column.
- The second column shows the heritage of the frequencies. BN frequencies are now used by BNSF; SP frequencies now belong to UP.
- Additional frequencies can be found in the Altamont Press Mountain Plains railfan timetable.

\* *The Powder River Basin: A Guide to America’s Power Railroad Base*, 2nd ed., 2000. \$21.95 + \$4.05 shipping in U.S. (+\$1.48 tax for NC residents) by check or money order to Ernest H. Robl, Book Orders, P.O. Box 3270, Durham, NC 27715-3270. See [www.robl.w1.com](http://www.robl.w1.com) for more information.

## Warm Weather Tips

If you've been in the longwave hobby for any length of time, you know that summer can be a tough time for monitoring. Natural static (QRN) tends to be higher during the warmer months, often covering all but the strongest signals. Still, it is not a time to hang up the headphones, and it could even present some opportunities that are not available at other times of the year. This month we'll present some tips for getting the most out of your warm-weather listening.

### ❖ Get Started Early

The late "Longwave Wizard" Ken Cornell once took me to task for referring to summer as "the close of the longwave DX season." He felt that there was still plenty to be heard, but that one must look for signals in the morning, say, before 10 o'clock. Ken was right. Frequently, the noise levels are quite low at these hours, and there's still some nighttime skip in effect – especially on the higher LW frequencies. I'm reminded that one of my best Lowfer loggings was made at around 10:00 a.m. local time.

### ❖ Try a Smaller Antenna

This may sound like strange advice for a band that most people associate with big antennas, but remember, we're talking about *reception* here. True, a transmitting station requires a large antenna for reasonable efficiency, but the listener can do quite well without such formalities. In fact, a random "longwire" antenna or other large array can actually become a "noise collector" when used on the low and medium frequencies.

Quite often, the ferrite loop antenna inside most LW portables will provide good results. These antennas are highly directional, which can be an aid in eliminating unwanted noise. A box-frame loop is another excellent choice for receiving. Several articles have appeared in *MT* over the years with construction details, including the September 1992 edition of *Below 500 kHz*. An active antenna designed specifically for LF is another low-noise option.



**John Giroux, N2LCX (NY) provided this close-up photo of a rare General Electric Type AS-1C Radio Range/**

**AM Broadcast receiver. He had the unit listed for sale at an online auction site.**

### ❖ Take a Trip

Summer is the traditional time for vacations. Why not pack up your portable receiver, a beacon directory, and your logbook for some new-to-you signals. Imagine the excitement of tuning the band with an entirely new set of signals to listen to!

The pleasant weather of summer is also ideal for tracking down local beacons. All you'll need is your portable, a local map, and a compass. By plotting two or more bearings on a map, it is possible to zero in on any local station. This time-proven technique is known as *triangulation*.

Another activity well suited to summer is Natural Radio. If you've never explored this aspect of longwave, why not take the plunge? You won't hear the familiar sounds of beacons down here, but you will be treated to the music of the Earth – whistlers, sferics and tweeks. If you're lucky, you might even hear the beautiful dawn chorus. A simple, yet effective natural radio receiver was described in the March and April 2006 editions of this column.

### ❖ Magic Moments

Inevitably, summer brings with it a few power outages. You can take advantage of these "radio quiet" events by keeping some fresh batteries on hand. With virtually all computers, TVs, fluorescent lights, motors, and other static-generating equipment shut down, the result should be static-free listening for you – at least for a little while. You might even discover some signals you never knew were there. Keep your logbook handy, and happy listening.

### ❖ 500 kHz Experiment News

From *The ARRL Letter*, Volume 26, No. 12 comes this excerpt about the ARRL 500 kHz experiment (WD2XSH):

ARRL 500 kHz Experiment ([www.500kc.com](http://www.500kc.com)) Coordinator Fritz Raab, W1FR, reports that a total of 16 participating stations have been active on the air since the experiment got under way in late 2006. The FCC Office of Engineering and Technology granted the WD2XSH experimental license to the ARRL last September. Raab says the low-frequency investigation has demonstrated ground-wave communication at distances of 100 miles in New England, in the Gulf Coast states and in Colorado.

"This might not sound very dramatic, but it is very important, as no current amateur band has the capability for beyond-line-of-sight

communication that does not depend upon the whims of the ionosphere," Raab told ARRL Headquarters. In his second quarterly Project Status Report ([www.500kc.com/#report2](http://www.500kc.com/#report2)), Raab noted that during the past three months, WD2XSH participants have racked up another 2250 hours of operation, bringing the total to 4629. As of the end of February, the project had recorded 75 two-way contacts and more than 3100 reception reports via its Web site.

Raab says most of the records for QSO and reception distances set in the experiment's first three months have not been broken. "The longest distance over which a QSO has been maintained is 884 miles – from New Hampshire to Tennessee," he notes. WD4XSH/10 (W4DEX operator) completed a crossband (500 kHz/137 kHz) QSO with WD2XNS (W1VD operator) in Connecticut. Stations have been using CW or very slow-speed CW (QRSs).

Even daylight contacts have been completed via ground wave. These include a 127-mile path between Massachusetts and Connecticut and an 87-mile path between Mississippi and Louisiana. "The Mississippi-Louisiana link has proven reliable multiple times at all times of the day or night," he commented. Daytime ground wave reception also has been reported over paths of 25 miles and 150 miles.

"These QSOs and reception reports provide preliminary verification of the capability for amateurs to use this band for regional emergency communication that does not depend upon the ionosphere," Raab said.



**Here's a shack photo from reader Doug Neller (IL). His gear lineup includes a Grundig YB-400PE, Realistic DX-160, DX-302, Kenwood R-1000 and GE Superadio. Scanners shown are Uniden Bearcat BC860XLT and Realistic PRO-58. Doug's receiving antenna is a 100 Ft. copper wire oriented in an East-West direction.**

## Radio Azteca Dominates Fest

In March at the 20<sup>th</sup> annual Winter Shortwave Listeners Festival in Kulpsville, Pennsylvania, as usual the local airwaves in the hotel were saturated with low-powered pirate transmitters that often are not audible even in the hotel's parking lot. Several pirate stations got nearly saturation airplay from multiple transmitters on medium wave, shortwave, and FM.

By far the dominant station selected for relay at the Fest this year was Bram Stoker's **Radio Azteca**. This veteran station features a novel format of parody and comedy sketches about DXers and DXing. It found an entertaining venue for its marathon relay broadcasts at the Fest, where several of the targets of this station's humor were present.

As we see here, Stoker is also a good verifier of reception reports. This month's QSL features a green frog station sticker that certifies that the verification is indeed valid.

Several other stations materialized during lengthy low power relays of pirate programming at the Fest. Europirates were represented at the Fest by Andy Walker, a man with 30 years of broadcasting experience on a number of European pirate stations.

Festmeisters John Figliozzi and Richard Cuff have announced that the 21<sup>st</sup> annual Winter Shortwave Listeners Festival has been scheduled for March 7-8, 2008 (see [www.swlfest.com](http://www.swlfest.com)).

### ❖ BLANDX Returns

Bill Kyle, the CEO of the BLANDX Corporation, announces that the 2007 edition of *BLANDX* has been released. This outstanding and long-running parody of DX magazines, club bulletins, and DXing may not be well known in the radio monitoring community, but it is some of the funniest stuff that has ever been printed about shortwave radio.

Some of the comedy covers pirate DXing, but similar to *MT* it also covers other aspects of radio monitoring with devastating barbs. Like many other DX publications, *BLANDX* has migrated to the internet. You can view the latest hilarious edition at their web site at [www.blandx.com](http://www.blandx.com).

### ❖ Greek Pirate

We have several loggings this month of a rarity. Radio Odyssey, a pirate station based in Greece, has been transmitting at times on 6308 kHz with a sufficient signal that it is being heard at times in North America. Local sunset on weekends is the best time to try for it in eastern portions of North America. They have been using [odyssey.greece@yahoo.gr](mailto:odyssey.greece@yahoo.gr) as an e-mail address for recep-

tion reports. You will need some luck at a favorable time to hear Radio Odyssey, but it is possible to log this tough catch when conditions are good.

### ❖ Odd Numbers Voice

Allen Lutins reports that he is hearing a numbers station on 6856 kHz around 2130 with a new female voice reading the five digit numbers. He says that it is smoother sounding than the usual synthesized voices on these covert stations. Has anybody else been hearing this one?

### ❖ Radio Free Mt. Airy

Another source of North American pirate radio loggings has materialized on the internet. This blog-style web site at the URL of [www.rfma.net](http://www.rfma.net) mixes fresh data about both shortwave pirate activity and also quasi-pirates who receive relays on licensed stations such as **WBCQ**. The web site is worth a look if you want to see what some others have been hearing very recently.

### ❖ Homebrew Rigs

A QSL to Terry Kreuger from **Channel Z Radio** noted that in addition to his own station, several other pirates are using transmitters that they constructed and built themselves. According to the Channel Z operator, some of those stations include **WAZU**, **WKZP** ("K-ZAP"), **Ground Zero Radio**, and **Liquid Radio**.

### ❖ Pirate Goes Legit

Thanks to Larry Magne, we can report that the station owner and manager Mark Aulabaugh on country music **KSEY-FM** in Seymour, TX, used to operate a pirate called "The Nifty 950 -WKMI" from his basement when he was a kid. You can see a photo of this former pirate operation on the KSEY web site at [www.radioksey.com/Staff/ksey\\_fm\\_staff.html](http://www.radioksey.com/Staff/ksey_fm_staff.html)

### ❖ What We Are Hearing

*Monitoring Times* readers heard more than two dozen different pirate radio stations this month. You can hear them, too, if you use some simple techniques. Pirate radio stations never use regularly announced schedules, but shortwave pirate broadcasting increases noticeably on weekends and major holidays. You sometimes have to tune your dial up and down through the pirate radio band to find the stations, but more than 95% of all North American shortwave pirate broadcasts are heard on **6925 kHz**, plus or minus 30 or 40 kHz.

**Channel Z Radio**- Sort of like the old North American

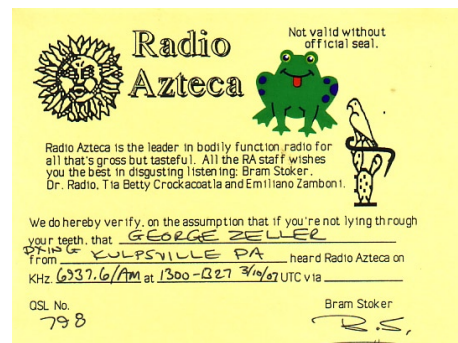

Pirate Relay Service, this one relays other stations, especially Europirates, both from Europe and from North America. (Uses [channelzradio@gmail.com](mailto:channelzradio@gmail.com) e-mail)

**Cupid Radio**- Rinus' Dutch Europirate is still being heard from time to time in North America on 15070 kHz and other frequencies above 6300 kHz. (Uses [cupidradio@hotmail.com](mailto:cupidradio@hotmail.com))

**Deliverance Radio**- They always use the theme music from the movie by the same name. (None)

**Grasscutter Radio**- Classic rock music is the main theme at this friendly pirate. (Uses [grasscutterrada@yahoo.com](mailto:grasscutterrada@yahoo.com) e-mail)

**Happy Halloween**- This one appeared way out of season around St. Patrick's Day. (None)

**Happy Hanukkah**- Another holiday favorite got confused by the calendar and appeared in March. (None)

**James Bond Radio**- James Bond film songs and "Bond, James Bond" identifications are normally their entire programming. (None)

**KIPM**- Alan Maxwell's "Illuminati" existential psychological dramas are among the most complex productions on the radio today, whether licensed or pirate. (announces Elkhorn)

**MAC Shortwave**- Paul Star's tribute to old top 40 radio uses several frequencies such as 3275, 6850, and 6925 kHz. (Uses [macshortwave@yahoo.com](mailto:macshortwave@yahoo.com) e-mail)

**Mystery Radio**- This rock music Europirate is still being heard in North America on 6220 kHz just prior to local sunset on days of good propagation. (Uses [radio6220@hotmail.com](mailto:radio6220@hotmail.com) and [mysteryradio@hotmail.com](mailto:mysteryradio@hotmail.com) e-mail)

**Old Vampire Radio**- It was Halloween in March for several of the seasonal stations this year. (None)

**Pancho Villa**- Not to be confused with the Voice of Pancho Villa, this one plays rock music with identifications in multiple languages. (None)

**Radio Azteca**- Bram Stoker continues to host one of the best DX humor pirate stations in broadcasting history. (Belfast)

**Radio Ice Cream**- The Ice Cream Man has added station jingles to his rock music format. (Belfast)

**Radio Maple Leaf**- They sign on with the Canadian national anthem, but otherwise the station mainly promotes shortwave pirate radio. (None)

**Radio Odyssey**- This Greek pirate created some excitement during the late winter with some broadcasts from Greece on 6310 kHz that were heard in North America. (Uses [odyssey.greece@yahoo.gr](mailto:odyssey.greece@yahoo.gr))

**Radio Pigmeat International**- This now veteran station has little to do with pigs. Instead it programs rock music. (Belfast)

**Radio Piraña Internacional**- The most prominent South American pirate was still heard occasionally on 6307 kHz during the early spring both around 1100 and 2300 UTC. Their web site at [www.geocities.com/radio\\_piranha/](http://www.geocities.com/radio_piranha/) sometimes provides updates. (Santiago and uses [rpi@radiopirana.com](mailto:rpi@radiopirana.com))

**Radio Porn**- This new one claims to be broadcasting racy programming for the blind. (None)

**Sunshine Radio**- Their female announcer hosts a rock music format. (Uses [sunshineradio@yahoo.com](mailto:sunshineradio@yahoo.com))

*Continued on page 61*

## Having Fun on Field Day

**A**h yes, it is June once again – time for the ARRL Field Day, this year occurring on Saturday and Sunday, June 23-24. My ham career contains dozens of funny stories about various Field Day expeditions with the clubs I have been a part of over the years. There was the year the generator blew up and, in addition to taking us off the air, came awfully close to starting a forest fire. And then there was the time when our group set up in a field that, as we discovered late Saturday night, was the local "Lovers Lane."

Still, that was better than the year we discovered we shared the field with thousands (and I do mean thousands) of ticks. I have been to Class A Club operations so large they used a computer network to maintain the logs. I have also gone out on my own out into the woods with a battery, a piece of wire, and a small QRP rig to operate Class B-Battery. In spite of the occasional strangeness, it is still always a fun time.

If you are not affiliated with a nearby amateur radio club, this would be a good time to get to know some folks and go give a hand at their particular Field Day operation. And while we are on the subject, let's take a look at how you can make yourself useful to any gathered group of Field Day folks.

### ❖ Come Early and Leave Late

Not all folks attempt to stay on site for the duration of the entire Field Day weekend. I kind of like being lulled to sleep by the sound of the generator in the distance, but this may not be your cup of tea. That said, setting up and tearing down is an "all hands on deck" proposition. You owe it to the group – and, I would argue, you earn your operating time – by rolling up your sleeves to help get the station on the air and then properly taken down at the end of the activity.

There is always the guy who shows up in time for the hot dogs, but not for the set-up. Don't get that reputation with the folks on your team. Besides, figuring out how to set up a Field Day station and dealing with all the little problems that crop up (Hey, where did that bag of barrel connectors go?) is probably the most fun you can have on Field Day weekend.

### ❖ Be Prepared to Stay

I know lots of folks who arrive at Field Day with the plan of just grabbing a few hours sleep sitting in their car. These are usually the folks who can't stand up straight on Sunday morn-



ing and they also make a lot of funny grunting noises when it is time to take the site down on Sunday afternoon. You can avoid being one of these sad individuals with a little prior planning.

If you are going to stay on site for the major part of the Field Day weekend, be sure to give a lot of thought to your basic life needs during that time period. Since my spouse and I like to play in the outdoors, I know where my tent, sleeping bag, and other camping gear are. I also know that everything is in working order and ready to go. You do not want to show up on the Field Day site and discover you left the tent pegs or your air mattress at home.

And, though we are only talking about the better part of two days, remember to bring a change of clothes, basic toiletries, any medicines you regularly take, and maybe a few you only need after eating one too many Field Day hot dogs. Oh yeah...don't forget the rain gear. Your radios may be under a tent fly but you won't always be.

### ❖ Food Glorious Food

Field Day hot dogs for lunch on Saturday, followed by Field Day hot dogs for dinner on Saturday night, followed by Field Day hot dogs for breakfast on Sunday morning... get the picture? While much of the food most clubs pull together for Field Day is tasty and filling, it usually is of a nature that would make a Cardiologist cringe. You may want to supplement what the Club larder provides with a few things you enjoy yourself. I was involved one year with a club that included in its membership both a professional chef and a woman who ran a catering business. Not a hot dog in sight, but the grilled Mahi Mahi with stir fried vegetables was to die for!

### ❖ We Have the Tools, We Have the Talent

I am one of those folks who travel with a Swiss Army Knife, a Gerber Multi Tool and my trusty U.S. Army issue P-38 Can Opener wherever I go, so I can usually be counted on in a pinch to perform fixes, both major and minor. As Colonel Murphy would clearly predict, the tool you will need on your Field Day site will be the one you left at home. You need to be able to solder a coax connector *and* replace the spark plug on a generator on Field Day weekend. Pack your tool box accordingly.

### ❖ Remember to Have Fun

FIELD DAY IS NOT A CONTEST!! Keep this in mind and shy away from folks who think it is. Field Day is mostly about showing how hams can pull together to get on the air when the power goes out and there is a need to set up under emergency conditions. It is also about fellowship, fun and most importantly, showing non-hams what ham radio is all about.

Field day is a great time to make new radio friends as well as renew old acquaintances. Keep these things in mind when others around you are trying to turn this operating event into the CQWW WPX contest and you will be a lot happier throughout the Field Day weekend.

## WEBSITE OF THE MONTH

### Skycraft Parts & Surplus

<http://www.skycraftsurplus.com/index.asp>

Good surplus stores are hard to find. There once was a time, not all that long ago, when one or two worthy surplus outlets could be found in any major city in the land. A ham could spend a fine Saturday afternoon poking through bins of surplus parts in search of the components for all manner of projects.

Sadly, those days are gone. So, when word of a good mail order supported surplus store comes my way, I like to share it. Skycraft Parts & Surplus have the benefit of being in business for over 30 years. They also benefit from not being all that far away from Cape Canaveral and the Kennedy Space Center.

Like any good surplus supply house, it would be hard to tell you from day to day what they have available on their site. All I can really say is that they have tons of *cool stuff!* They have great prices on mil-spec shielded cables and lots of hard to find parts. They have a mailing list you can register for on the Web site and

they ship just about anywhere. Give their site a look.

## SOFTWARE OF THE MONTH

You probably don't need me to tell you that there are dozens of great software programs floating around on the Internet that are designed for the amateur radio hobby. Most are available as freeware or, at least, reasonably priced shareware. But one thing has always troubled me about these otherwise wonderful resources. Other than "word of mouth," there are few ways to verify the quality of many of these online resources. True, as hams, we have a sense of being "all in this together" and few, if any, folks would intentionally put a bad program out for his brother and sister hams to stumble over. Still, it is more fun to play radio than it is to debug code. So, I was pleased to see a recent release by The American Radio Relay League.

### THE ARRL SOFTWARE LIBRARY

Version 2.0, ISBN: 0-87259-982-5  
Microsoft Windows™ compliant CDROM  
\$19.95; Order No: 9825  
The American Radio Relay League  
225 Main Street, Newington, CT 06111-1494  
[www.arrl.org](http://www.arrl.org)

There have been many amateur radio CD software compilations over the years. Most are little more than collections of the same sort of thing you can find on a basic Web search on your own, hardly worth the expense. The ARRL Software Library stands apart from these other efforts in that they provide a collection of proven software that has been vetted through the editorial and technical staff of the League itself. That fact alone makes this disk worth looking into.

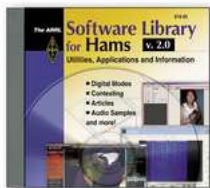

The CD is designed to run under Microsoft Windows™ 2000 or XP on a 400 MHz Pentium PC with 256 Mbytes of RAM or better. You will also need a Sound Card to listen to the audio files provided on the disk and, more importantly, to take full advantage of the many sound-card-based digital mode programs that come in the Software Library. I expect that the hardware and operating system limitations are more a function of some of the programs provided than the disk itself. Some of the provided programs may operate using a more modest system.

Much of the text in the collection is provided in Adobe .pdf file format. Not to worry, a free version of Adobe Reader is provided on the disk in case you do not already have it installed on your PC.

Once you take a look at the files on the disk, you will quickly discover that things are weighted heavily toward digital communication. The disk includes excerpts from several other League publications and books that serve to give a good overview of how to

set up a digital mode amateur communications system. These include chapters from Stan Horzepa, WAILOU's book "APRS: Moving Hams on Radio and the Internet" and Steve Ford, WB8IMY's book "The ARRL HF Digital Handbook." Both have been reviewed at length in this column in the past. There are also many reprinted articles from past issues of *QST* magazine.

With a modern PC and Sound Card, in many cases, you will need little more than the information in these book excerpts and the various programs provided to get your feet wet in all the latest digital operating modes on LF, HF and VHF. Software for RTTY, PSK31, Hellsreiber, Packet, SSTV and other modes are all on the disk. You can explore the more exotic modes such as WJST, popular for operating using meteor scatter and moonbouncing. Further, you can even experiment with digital voice. The *WinDRM* program is provided to allow you to try this exciting new form of ham communication. Or you can go "Old School" with the CW to text translation program provided.

And as they say in those late night TV commercials: "But wait... There's more!" There is a copy of *Morse Runner*, a great program that simulates actual contest conditions for CW operation. I have used this tool to hone my skills before jumping into the fray on busy contest weekends. And while we are on the subject of contesting, how about a nice logging program? The *NIMM Logger* is hard to beat without spending at least three times the cost of this entire disk full of programs.

I have only given a few highlights about the information on this disk; space does not allow me to delve into the programs for Weather Satellites, Hamsats, video and PowerPoint™ presentations, and an extended look at Winlink 2000, including software packages to support this system. This disk is a worthy addition to any ham's collection.

This year for Field Day, I plan to operate Class E – Emergency Power VHF/UHF ONLY! I want to try something a bit different. I will look for you on the bands. And, as always, at all other times, I will see you at the bottom end of 40 meters.

### UNCLE SKIP'S CONTEST CALENDAR

**ARRL June VHF QSO Party**  
Jun 9 1800 UTC - Jun 11 0300 UTC

**West Virginia QSO Party**  
Jun 16 1600 UTC - Jun 17 0200 UTC

**SMIRK Contest**  
Jun 16 0000 UTC - Jun 17 2400 UTC

**Kid's Day Contest**  
Jun 16 1800 UTC - 2400 UTC

**ARRL Field Day**  
Jun 23 1800 UTC - Jun 24 2100 UTC

**QRP ARCI Milliwatt Field Day**  
Jun 23 1800 UTC - Jun 24 2100 UTC

**His Maj. King of Spain Contest (SSB)**  
Jun 23 1800UTC - Jun 24 1800 UTC

## Outer Limits continued from Page 59

- com e-mail)
- The Crystal Ship-** "The Poet" at the "Voice of the Blue States Republic," still broadcasts on randomly selected frequencies including 1710, 3320, 3346, 3275, 6875, 6925, and 9057 kHz. Rock music and leftist political commentary always dominate. (Belfast and uses [tcshortwave@yahoo.com](mailto:tcshortwave@yahoo.com) e-mail)
- This Is Not the BBC-** This new pirate had no trouble convincing listeners that they were not the British Broadcasting Corporation. (None)
- Voice of Captain Ron Shortwave-** Captain Ron is the DJ on this rock music pirate. (Uses [captainronswr@yahoo.com](mailto:captainronswr@yahoo.com))
- Voice of Pancho Villa-** As usual, this once a year pirate station materialized for his 25<sup>th</sup> anniversary broadcast at 0500 UTC at the Winter SWL Festival in Kulpville, PA. In the show it was determined that Pancho (and not Glenn Hauser) was the father of Anna Nicole Smith's baby. (Blue Ridge Summit)
- WBZO-** This rock music pirate also is a malicious parody of a certain DXer. (None)
- WDDR-** This veteran rock music pirate is back, with an unusual method of correspondence. (Uses [www.wddr1027.com/forum](http://www.wddr1027.com/forum) for reports; also try Belfast)
- WNKR-** There have been several recent North American relays of rock music programming from Europirate Western North Kent Radio, usually from the North American version of **Channel Z Radio**. (Uses [wnkr@rock.com](mailto:wnkr@rock.com) e-mail)
- WTQR-** Using a slogan of "Twentieth Century Radio," they play rock music from that century. (Belfast)

## ❖ QSLing Pirates

Reception reports to pirate stations require three first class stamps for USA maildrops or \$2 US to foreign locations, especially in Europe where the value of the US dollar has plunged considerably. The cash defrays postage for mail forwarding and a souvenir QSL to your mailbox. Letters go to these addresses, identified above in parentheses: PO Box 1, Belfast, NY 14895; PO Box 109, Blue Ridge Summit, PA 17214; PO Box 146, Stoneham, MA 02180; Casilla 159, Santiago 14, Chile; Argonstraat 6, 6718-WT Ede, Holland, and PO Box 293, Merlin, Ontario N0P 1W0. Unfortunately, PO Box 69, Elkhorn, NE 68022 is announced as a no longer valid address, although a few pirates announce it, and some claim to still be getting replies through it.

Some pirates prefer e-mail, bulletin logs or internet web site reports instead of snail mail correspondence. The best bulletin for submitting pirate loggings with a hope that pirates might QSL is now the e-mailed Free Radio Weekly newsletter, still free to contributors via [yukon@tm.net](mailto:yukon@tm.net). A few pirates will sometimes QSL reports left on the outstanding Free Radio Network web site, at [www.frn.net](http://www.frn.net).

## ❖ Thanks

Your loggings and news about unlicensed broadcasting stations are always welcome via 7540 Highway 64 W, Brasstown, NC 28902, or via the e-mail address atop the column. We thank this month's valuable contributors: Skip Arey, Beverly, NJ; Jerry Berg, Lexington, MA; Artie Bigley, Columbus, OH; Harold Cones, Newport News, VA; Ross Comeau, Andover, MA; Richard Cuff, Allentown, PA; Ross Comeau, Andover, MA; Gerry Dexter, Lake Geneva, WI; Rich D'Angelo, Wyomissing, PA; John Figliozzi, Halfmoon, NY; Bill Finn, Philadelphia, PA; Harold Frodge, Midland, MI; John Herkimer, Caledonia, NY; Terry Kreuger, Clearwater, FL; Ed Kusalik, Coaldale, Alberta; Chris Lobdell, Tewksbury, MA; Allen Lutins, Johnson City, NY; Greg Majewski, Oakdale, CT; Larry Magne, Penn's Park, PA; George Maroti, Mount Kisco, NY; A. J. Michaels, Blue Ridge Summit, PA; Don Moore, Des Moines, IA; Horacio Nigro, Montevideo, Uruguay; John Poet, Belfast, NY; Lee Reynolds, Lempster, NH; Martin Schoech, Eisenach, Germany; Andy Walker, UK; Bob Wilkner, Pompano Beach, FL; Joe Wood, Greenback, TN; and Bob Zanotti, Emmmental, Switzerland.

## Should I Be Using an “Antenna Tuner”?

Let's consider the flow of radio-frequency (RF) current during the transmission and reception of a radio signal. Any circuit in which RF current flows, offers some opposition to that flow. One kind of opposition, called “resistance,” converts some of the RF current to heat, and that serves no useful purpose. Another kind of opposition, called “impedance,” has a different effect.

To explore the effect of impedance, let's consider a hand-held transceiver (HT). The HT's antenna connects directly to its antenna-input circuit with no feedline involved. When the HT's transmitter output circuit and the antenna's feedpoint (where the feedline attached to the antenna) have impedances equal to each other, then we have maximum transfer of RF current from transmitter to the antenna.

During reception, the antenna, due to the signals it receives, becomes the source of RF current. The HT's receiver becomes recipient of that current. If the feedpoint of the antenna itself has the same impedance as is offered by the HT's antenna-input circuit, then maximum current transfer occurs from antenna to receiver.

When the impedance of a current source and the recipient of that current (called the “load”) are equal, they are “impedance matched.” Otherwise, they are “mismatched,” and then some current from the source is not accepted by the load. The greater the mismatch, the less current is transferred to the load.

### ❖ When a Feedline is Used

Consider now a base-station transceiver which utilizes a feedline between transceiver and antenna (fig. 1). Often we find a mismatch

between a transceiver and its feedline, and/or between the feedline and the antenna. One popular device for matching impedances at the transmitter-feedline connection is the so-called “antenna tuner.” Actually the tuner doesn't tune the antenna: it tunes the whole antenna system (feedline and antenna combined, fig. 1).

### ❖ When to Use an Antenna Tuner

For modern transmitters, the most common RF output-circuit impedance is approximately 50 ohms. The most commonly utilized feedline also has a characteristic impedance of 50 ohms. Although relatively few antennas have 50-ohm feedpoint impedances, there are some simple techniques that can be used to allow an antenna's feedpoint impedance to be transformed to present a 50-ohm impedance to a feedline. If the impedances of the transmitter's output circuit, feedline, and antenna feedpoint are all equal, then the entire antenna system is impedance matched. In this case, no antenna tuner is needed.

But many operators change operating frequency frequently. And even if they have a matched system initially, that match will become a mismatch if they change frequency by a significant amount. An antenna tuner is a convenient means of re-establishing the impedance match between the transmitter and the antenna system.

Another reason for using an antenna tuner is that then we can successfully utilize almost any conductor of reasonable size as an antenna. Just ask Kurt N. Sturba: using an antenna tuner he even gets an impedance match between his transmitter's output, and such remarkable antenna systems as a feedline

to a lawn chair or a grocery cart! And he communicates using them, too!

### ❖ What Tunes an Antenna?

As mentioned above, an antenna tuner doesn't tune the antenna: it tunes the whole antenna system. Tuning the antenna would mean changing its resonant frequency (the frequency at which it responds best). To actually tune the antenna, you would need to do something like change the length of its elements or add capacitors (one example of which are the “capacity hats” mentioned in the Radio Riddle below) or inductors (coils) to the elements.

Although an antenna tuner, when properly adjusted, provides a good impedance match between the transmitter or receiver and the antenna system, the antenna itself remains tuned to the same frequency as it was before adjusting the antenna tuner. The components of the tuner have provided an impedance match between the transmitter or receiver and the antenna system: they have not tuned the antenna.

Coincidentally, because the frequency to which the antenna is tuned is not changed by the tuner, the antenna's radiation (and reception) pattern will change with significant changes in frequency. So, although an antenna tuner can provide an impedance match between transmitter and antenna system at many different frequencies, we may find significant changes in the way the antenna distributes its RF power in space at those different frequencies.

### ❖ Impedance Matching for Reception

Sometimes using an antenna tuner for receiving is not worthwhile. Let's see why. Electrical noise is a serious enemy of good reception. This is true whether the noise is received via the antenna (static) or whether it comes from the circuits of the receiver itself (internal noise). The quality of reception depends in large part on the strength of the desired received signal as compared to the strength of any noise, received or internal, present in the receiver.

From around the mid to top portion of the high-frequency band and higher in frequency, a receiver's internal noise level is typically greater than is the noise received via the antenna. Thus, the level of received

Fig. 1. AN ANTENNA TUNER CONNECTED BETWEEN A TRANSCEIVER AND AN ANTENNA SYSTEM.

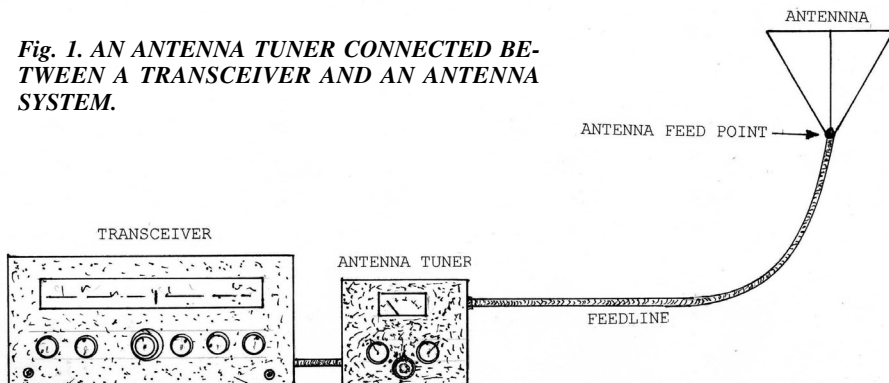



**This Month's Interesting Antenna-Related Web site:**

A discussion of antenna tuners:  
[http://en.wikipedia.org/wiki/Antenna\\_tuner](http://en.wikipedia.org/wiki/Antenna_tuner)

A discussion on the use of antenna tuners:  
[www.hard-core-dx.com/nordicdx/antenna/special/notuner.html](http://www.hard-core-dx.com/nordicdx/antenna/special/notuner.html)

noise is insignificant compared to the level of internal noise. And so, increasing the level of signal input to the receiver, whether by using an antenna tuner, or whatever reason, raises the received signal higher above the overall noise. This results in better reception.

However, below about the top to mid portion of the high-frequency band, the received noise level is the dominant noise: it is typically higher than the receiver's internal noise. Received noise is an RF signal just as is the desired signal. So if an antenna tuner is used to increase the match between the antenna system and the receiver's antenna input at these lower frequencies, any increase in the desired signal's strength is accompanied by a similar increase in the undesired, received noise level. This means that the ratio of the signal to the noise doesn't change, and so reception is not improved.

So as a rule, at these lower frequencies, the use of an antenna tuner for reception is usually of little or no value. Exceptions to this rule can be found in areas that are relatively electrically-quiet, such as the far upper latitudes.

## RADIO RIDDLES

### Last month

I asked: "So now you know about a hat that wears an antenna. But does an antenna ever wear a hat?"

No, we're not really talking about the tiny plastic, decorative football helmets stuck atop some automobile antennas. But there are actually two kinds of antenna hats that serve a useful function. Capacity hats usually consist of a disk-shaped wire frame attached to the upper portion of a vertical antenna. They lower the antenna's resonant frequency, making the

use of shorter antennas practical.

At microwave frequencies, a different kind of "antenna hat," a plastic antenna cover, is used to attenuate incoming or outgoing RF waves during antenna performance testing.

### This Month

What happens to the current that is unable to pass from the feedline to the antenna at a mismatched feedline-antenna connection? Does it just disappear, turn to heat, fade away, or what?

You'll find an answer to this month's riddle, another riddle, another antenna-related web site or so, and much more, in next month's issue of *Monitoring Times*. 'Til then Peace, DX, and 73.

### ❖ And So

As discussed above, for receiving applications on the lower frequencies your reception is usually as good without an antenna tuner as with one.

For receiving at frequencies above something like 15 to 20 MHz, matching of impedances is usually important for reception of weaker signals.

For transmitting at any frequency, the correcting of a mismatch between the transmitter's output circuit and the antenna system is generally advisable.

Quite a variety of antenna-tuner designs are available from various radio suppliers.

They are offered in a wide range of prices and power ratings. You can find them in amateur-radio magazine ads, at ham flea markets, and at online auctions.

## Antenna Designer

New Version 2.1 for Microsoft Windows 95 and 98  
Computer program helps you design and build 17 different antennas from common materials. Based on Antenna Handbook by W. Clem Small.

**Only \$39.95**

\$5 S/H on all orders  
CA residents add 8.5%  
Shipped on CD ROM

Send check or money order to:

Small Planet Systems  
623 Mangels Avenue  
San Francisco, CA 94127

[www.smallplanetystems.com](http://www.smallplanetystems.com) 415-337-9394

Listening is only half the fun...  
**POPULAR COMMUNICATIONS** is the other half.

If you enjoy radio communications in all its variety, you'll love *Popular Communications*

Since 1982 *Pop'Comm* has delivered thousands of pages of great reading for both the radio enthusiast and the professional communicator.

Name your favorite interest... *Popular Communications* is there for you. Whether you're into Short-wave Listening, Scanner Monitoring, searching out Pirate Radio broadcasters, CB Radio, Satellite Broadcasting, ACARS, or Ham Radio; you name it, we cover it, every month.

*Popular Communications*

Subscribe today and save up to 58% off the newsstand price. Save even more with two or three year subs!

**YES! Enter my Subscription to Popular Communications today!**



Name \_\_\_\_\_

Address \_\_\_\_\_

City \_\_\_\_\_ State \_\_\_\_\_ Zip \_\_\_\_\_

( ) Check ( ) MasterCard ( ) VISA ( ) AMEX ( ) Discover

Card No. \_\_\_\_\_ Expires \_\_\_\_\_

Signature \_\_\_\_\_

	USA	Canada/Mexico	Foreign Air Post
1 Year	<input type="checkbox"/> 28.95	<input type="checkbox"/> 38.95	<input type="checkbox"/> 48.95
2 Years	<input type="checkbox"/> 51.95	<input type="checkbox"/> 71.95	<input type="checkbox"/> 91.95
3 Years	<input type="checkbox"/> 74.95	<input type="checkbox"/> 104.95	<input type="checkbox"/> 134.95

Allow 6 to 8 weeks for delivery

**FOR FASTER SERVICE FAX 1-516-681-2926**

MT 01

**Popular Communications** 25 Newbridge Road, Hicksville, NY 11801 Telephone (516) 681-2922

## More on the Trans-Oceanic and BC-348

I thought I had finished with the Trans-Oceanic project in the April issue. But, as this is being written, the April issue has just hit the stands and stimulated several reader comments. They were reactions to my having put my foot in my mouth while describing the i.f. alignment process. The e-mails that came back to me over this point were so interesting that I may just decide to plant controversial comments in future restoration discussions!

Here's what happened: the T-O service literature for my Model B600 suggested sliding a sheet of metal under the chassis (which was out of the cabinet at this stage) during the alignment. The idea was to simulate the presence of a battery pack that would normally be in the cabinet below the chassis. My rash remark was that I was going to forget the metal because the Trans-Oceanic would likely never again be operated from a battery pack.

### ❖ Battery Packs for Tube Longevity

The remark probably still applies to my radio, but what I hadn't taken into consideration were the many T-O enthusiasts who not only like to work on the sets, but enjoy listening to them frequently. These hard-core folks worry about the effect of our higher present-day line voltages on the fragile tube filaments, as well as the high inrush current that flows when power is applied to the filaments while they are cold. For example, here's a quote from an e-mail received from Jay Policow:

I had one comment about your Trans Oceanic Restoration. You said that these radios will not likely be powered by batteries ever again. You should know that there is a huge market for battery packs for these units...the best of which is linked below:

[cgi.ebay.com/Zenith-Trans-Oceanic-Transoceanic-Antique-Radio-Battery\\_W0QQitemZ120102898306QQcategoryZ9330QssPageNameZWDVWQQRdZ1QQcmdZViewItem](http://cgi.ebay.com/Zenith-Trans-Oceanic-Transoceanic-Antique-Radio-Battery_W0QQitemZ120102898306QQcategoryZ9330QssPageNameZWDVWQQRdZ1QQcmdZViewItem).

(Note: "The manufacturer seems to sell the packs by individual e-Bay auctions, but—says Jay—can also be reached by e-mail for possible negotiated sales. The supply operates from 9 D-cells and is fully regulated—m.e.)

I have used one of these battery packs for several years as have several of my collector friends and can attest to its excellence. It generates absolutely no noise and allows portable operation—the way these radios were meant to be used! The battery pack also allows you to

isolate the radio from powerline borne noise.

Of course, there are lesser battery packs out there, too. Some utilize an array of AA or 9-volt cells, but the D cell model is by far the most deluxe—offering soft start, stabilized voltages, even an output connector to plug directly into the original lamp plug. This pack is 100% plug and play and delivers about a 100 hour life on a set of D alkaline cells. Even though my A600L is completely restored, I seldom need to operate it on AC anymore. This battery pack is an awesome addition for a Trans Oceanic owner.

I don't know if you belong to any Yahoo chat groups, but there is one for the Trans oceanic which is truly superb: <http://groups.yahoo.com/group/thetransoceanicfanatic/?yguid=87007587>

Here are selected comments from another interesting note—this one from Chuck Cassidy, AC7GZ.

I am an avid reader of the "Radio Restorations" column (actually I read the entire magazine about 4 times cover to cover). I did want to make one comment regarding the statement "there would be little chance of this set ever operating again with any kind of a battery pack..."

I cringe when I read such comments because the utilities have (mostly deliberately) set transformer taps on distribution systems so that the "nominal" 110V which was common in the 1950s has crept up to 120V and higher. Here in Chandler, Arizona, where I live, I routinely see 123V as read on a Fluke 23 VOM which has been recently checked. As of this writing, it is at 119.6.

As original purchasers of the Zeniths noted, tube life while operating from the AC line was noticeably shorter than when operating with batteries. It became clear that the filament voltages ran significantly higher than the maximum 1.4 VDC tube ratings. Imagine what 1.56V will do to those tiny filaments!

A very cheap and easily assembled 90-volt "B" battery pack can be constructed using Walgreen's "Heavy Duty" 9V cells, which regularly sell for about 99 cents each. Ten batteries snap together in series fashion very easily and can be joined with electrical tape. To make the 9-volt "A" battery, series-connect three Radio Shack 2-D cell holders. One thing you might note is that even standard (not to mention alkaline) 9V and D cells of modern manufacture are far superior to the 1950's

vintage A/B battery packs. The tiny filament and plate currents barely stress them. I have a T-O which has been operating (infrequently) for about 8 years on one such pack.

For AC line operation I recommend a neatly packaged inrush current limiter made by Zim Electronics. (There's a 150-watt unit for \$34.95 and a 300-watt unit for \$39.95—S&H extra. An AC voltmeter on the panel confirms operation. Order directly from ZIM Electronics, 205 Brigham Hill Rd., Milton, VT 05468 or visit the *Electric Radio Magazine* web site at [www.ermag.com](http://www.ermag.com) for more info or to order on line—m.e.).

### ❖ Other T-O Comments

Craig, N3TPM, sent some info on a transistorized dynamotor substitute for the BC-348—which I'll unveil after we get a little deeper into our '348 restoration. But also included in Craig's note was a reference to an article on the construction of a hollow-state replacement for the rare T-O 1L6 converter tube. It can be found on the web site of the Michigan Antique Radio Club. Get to it by Googling "Robert Pierfelice" (the author's name), or go to [www.antiqueradios.com/marc/116.html](http://www.antiqueradios.com/marc/116.html)

I also heard from Mark Schoonover, KA6WKE, reacting to a comment I had made early in the Trans-Oceanic restoration. I was hoping that the multi-section electrolytic would turn out to be good (which luckily turned out to be true), because it was going to be tough to find room for four individual replacements under the chassis. Mark reported that he solved a similar problem in a friend's radio by removing the capacitor's guts and installing individual replacements within the can.

Finally, as long as we've reopened the T-O restoration issue, here's a PS from your column author. It applies to testing tubes in the Trans-Oceanic and to most other "three way" portable radios that operate from either a.c./d.c. power or a battery pack. Do not have the radio plugged in and turned on when removing and replacing the tubes!

In these sets, the filaments operate from the radio's "B" supply when the set is running on "plug in" power. Since they are series-connected, all the filaments go out when one tube is removed—removing all the load from the power supply. Without a load, the power supply filter capacitor will charge up to about 150 volts. Plug the tube you've just finished testing back into the set and the 150 volts will appear across the filament string instead of the

usual low voltage (8.4 volts in the case of our T-O)—instantly burning out at least one filament.

Some radios (not including the T-O) have a bleeder resistor that prevents such accidental charge-ups. But don't count on it!

## ❖ A First Look at Our BC-348

Returning to the BC-348 project we introduced in the May issue, it's time to unveil the actual specimen that will be the subject of our restoration. It happens to be a BC-348-R, which means (see the chart for "Group 2" in the May issue) that it has "double ended" (top grid cap) r.f. and detector tubes, a 6K6 audio output tube, and a 200-500 kHz LF band.

## ★ ★ BC-348 RECEIVER



*After World War II, hams and SWLs snapped up BC-348s at bargain prices (from a 1947 Radio Shack ad).*

Like most of the surplus gear that was in popular use right after World War II, this one was, at one time, "converted" (that is, modified to run on 115 volts). Its 28-volt dynamotor had been removed, and the 115-volt power supply that once replaced it is now missing. The only signs of that are the stubs of the owner-installed connecting wires that were cut when it was removed.



*The front panel view of our BC-348-R reveals a lot of cosmetic problems. Non-matching knob at lower left (to be replaced, of course) is from an aircraft audio control box of the same vintage.*

The friend from whom I acquired this set told me that he had to search around for quite awhile to find me a cabinet. And, since I knew that the radio had been shed-stored for some time without one, I wondered about what I would find when I looked within. It turned out that the cabinet was identified as being for a

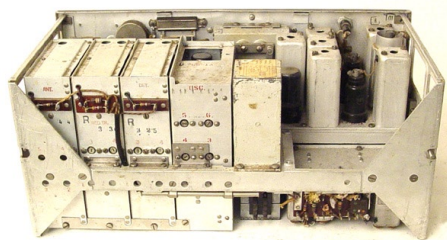

*Inside, the set looks dingy, but has no sign of corrosion or mouse occupancy.*

BC-348-N, but I was happy to have it!

As expected, the insides of the radio were kind of dirty but—since they were mostly aluminum—I found no rust or corrosion. It looked like most of the dirt would clean off with a little soap and elbow grease. And, being cabinetless, the receiver had—at least—never become a secluded private home for generations of mice.

Cosmetically, this set is going to be a bit of a problem. The paint is dirty and chipped in places. Someone had run a red marking pen around the perimeter of the bottom half of the dial bezel. For reasons equally unknown, the background of the identification tag had been painted over, though all markings had been crudely masked so they would not be obliterated.

The removable front-panel plate that gives access to the r.f. deck wiring for servicing was originally missing, but my friend had really helped me out here by fabricating a very nice replacement. I would have to do something about its finish, though, because the fresh semi-gloss paint wasn't quite at home with the worn flat black crackle on the rest of the radio.



*"CAATC" asset tag suggests that this radio might have made several Atlantic crossings aboard a Pan American Airways flying boat (see text).*

An unusual asset tag on the upper-right-hand corner of the panel suggested that this set may have had a very interesting past. It is marked "CAATC No. 1092" and indicates that the set was issued to Pan American Airways and that its weight is 39.2 pounds.

We know that the Civil Aeronautics Administration was formed by President Roosevelt in 1940 and given responsibility for, among other things, air traffic control. At the onset of World War II, the CAA widened its ATC operations tremendously, utilizing radio communication. Eventually they were communicating not only from control tower to plane, but also with planes en route to their destinations.

At the start of World War II, Pan American Airways was our only carrier experienced in flying international routes. Its facilities, equipment and expertise were immediately pressed into government service. Pan Am navigators trained their Army Air Corps counterparts. Using the company's fleet of big Boeing B-314 flying boats (or "Clippers"), the luxurious interiors gutted for carrying cargo, Pan Am made countless Atlantic crossings during the war. In 1942 alone, for example, the Clippers made over 1200 Atlantic crossings, carrying over three million pounds of war material.

So, it might not be too outrageous to imagine that the "CAATC" designation on my tag might stand for "CAA Traffic Control" and that this BC-348 radio might well have been assigned to Pan Am for installation in one of the fabled Boeing flying boats. More on the project next month. In the meantime, let me know your thoughts about this interesting CAA asset tag!

## Daniel Sampson's PRIME TIME SHORTWAVE

<http://www.primetimeshortwave.com>

Your guide for up-to-date English shortwave schedules sorted by time, country and frequency plus a DX media program guide and newsletter

## JOIN THE AWA

**Antique Wireless Association**

*The original and largest historical radio-collector group*

• Publishes *The AWA Journal*, Marc Ellis, Editor, with:

- Battery and AC receiver restoration
- Vacuum-tube history and collecting
- Old-time amateur-radio contests
- Communications receivers
- Free want-sell-swap ads
- Early television
- Horn loudspeakers
- News of U.S. and foreign clubs



• Produces the famous annual Rochester meet

• Maintains unique radio-TV museum

Membership is only \$20 per year in U.S.; \$25.00 elsewhere.

Mail check to:

AWA Membership - P.O. Box 421, Dept. 2 Bloomfield, NY 14469-0421

<http://www.antiquewireless.org>

[awamembership@rochester.rr.com](mailto:awamembership@rochester.rr.com) (585) 392-3088

**FREE SAMPLE COPY!**

**ANTIQUE RADIO CLASSIFIED**

*Antique Radio's Largest-Circulation Monthly Magazine*

Articles - Classifieds - Ads for Parts & Services

Also: Early TV, Ham Equip., Books,

Telegraph, 40's & 50's Radios & more...

Free 20-word ad each month. Don't miss out!

1-Year: \$39.49 (\$57.95 by 1st Class)

6-Month Trial - \$19.95. Foreign - Write.

A.R.C., P.O. Box 802-P14, Carlisle, MA 01741

Phone: (978) 371-0512; Fax: (978) 371-7129

Web: [www.antiqueradio.com](http://www.antiqueradio.com)

## Alinco DJ-X30T Scanner

By Larry Van Horn, N5FPW

**A**linco has released a new wideband handheld scanner – the DJ-X30 – that has several innovative features not found on any other scanner in today’s marketplace.

The DJ-X30 handheld offers continuous frequency coverage from 100 kHz to 1299.995 MHz (except for the mobile and base cellular bands). Reception modes include AM, narrow-band FM and wideband FM. This scanner is a conventional scanner, with no trunking capability.

### ❖ What’s in the box

The DJ-X30 box contains the following items: Instruction manual, whip antenna (SMA connector), face-panel, rubber cushion, belt clip, hand strap, and screws (one for the belt clip, and two as spares for the key cover). Unfortunately, the AC adapter is not included (an optional accessory).

### ❖ Features

As I mentioned in my opening paragraph, there are some neat features with this scanner. For instance, the earphone cord can be used as an antenna to receive FM broadcast and other stronger signals without using an external antenna. I did find that it provides a slight improvement in the VHF/UHF bands reception when compared to the rubber duck antenna.

When compared to its earlier DJ-X siblings, the X30 has a key pad for advanced operation, or you can replace it with a key pad cover for simpler operation. You can choose whether or not you want the keypad mounted on the radio. This easy to use design makes it simple to program the frequencies you want and those you wish to skip during the scans. You can also activate/deactivate the memory skip function on a temporary basis, so you don’t have to reprogram the skip setting in the memory mode every time you want to scan more frequencies.

Another interesting feature is automatic input switching. By connecting an optional remote controller to the earphone jack and connecting an MP3 player or other portable audio device to the controller, you can listen to music and hear scanner traffic when the X30 receives a signal.

The X30 has a cable clone function that allows you to copy settings and various data to other X30 scanners. The PC connection function allows you to edit settings and data via a personal computer.

Another interesting feature is the tone

scquelch. It supports reverse tones, which are used by a lot of business communications providers. There is also a wild key function. This feature allows you to quickly jump to a frequently used set of mode functions of the operator’s choosing.

Scan speed is selectable (five different levels). A faster scan speed can be used when you only want to monitor strong signals. A slower scan speed can be used to detect weaker signals.

Other features include an illuminated LCD, FM stereo earphone jack, the removable SMA antenna, 1000 alphanumeric memories, and an attenuator.

### ❖ Optional Accessories

There are several optional accessories for the DJ-X30. They include:

- EDS-12 Wired remote for control of basic functions.
- ERW-4C PC Interface Serial RS232 Cable [DB-9F]
- ERW-7 PC Interface USB Cable
- ESC-44 Soft carry case
- SMA-BNC This RF adapter lets you connect a BNC type antenna to the SMA antenna jack
- SMA-SO239 Low-loss 4 foot (1.2 m) LMR100 RF adapter cable to safely connect a PL259 type antenna to the SMA antenna jack

Three more accessories are not currently available, but will be released at a later date. These include:

- EBP-57N Ni-MH Battery pack 3.4V 1800 mAh
- EDC-154A Drop in trickle charger
- EDH-33 Cigar plug DC conversion cable (12VDC/24VDC to 6 VDC)

### ❖ Bottom Line

Out of the box, AM/Shortwave reception using the stock rubber duck or the built-in bar antenna is poor. We added a good passive



Overall Rating [2-3/4 stars]

external antenna, and shortwave reception improved considerably, but the AM broadcast band reception was still poor. Using an active antenna proved to be a disaster, with the radio de-sensing due to receiving more signal than the radio could handle.

Unfortunately, there is no SSB/CW mode capability. This limits the utility of shortwave reception to only shortwave broadcast stations (about 15-20% of the shortwave frequencies covered by this unit).

Overall, I thought VHF/UHF reception was good. I was especially impressed with the FM broadcast band reception. I was able to hear several stations here in western North Carolina that I have not heard on several other scanners we have tested.

The biggest downside to this radio is the lack of trunking capability, nor does it have an APCO-25 digital decoder. This limits scanner reception to conventional, analog scanning.

The LCD screen was easy to read, programming was easy to do with the key pad installed and the manual was well written.

If you live in an area that has not moved into the trunking/P-25 communications scene,

MT First Look Rating (0-10 scale)	
ALINCO DJ-X30 SCANNER	
Audio Quality .....	7
Audio Levels .....	8
Backlight/Display .....	7
Ease of Use .....	7
Feature Set .....	5
Keyboard/Control Layout ...	8
Overall Construction .....	7
Overall Reception .....	6
Owners Manual .....	7
Sensitivity .....	5
Selectivity .....	6
Spectrum Usability .....	6

and you don't use this radio as your primary shortwave radio, the DJ-X30 is a nice wideband scanner you can carry with you.

The Alinco DJ-X30 is available from several ham radio and scanner dealers. List price is \$239.00, with a street price around \$195.00.

**Table One: Miscellaneous Specifications**

**Receiving Range:**

100 kHz to 1299.995 MHz (Cellular frequencies blocked)

**Modes:** FM-Wide, FM-Narrow and AM

**Channels:** 1000 (10 banks of 100 channels)

**Tuning Steps:**

5/6.25/8.33/10/12.5/15/20/25/30/50/100/125/150/200/1000 kHz (1 kHz LW/MW).

**Selectivity**

AM/FM: 12 kHz @ -6dB, 35 kHz @ -60 dB

WFM: 130 kHz @ -6dB

**System:** Triple-conversion Superheterodyne (FM-N/AM)

Double-conversion Superheterodyne (FM-W)

First IF Frequency: 243.95 MHz

Second IF Frequency: 39.15 MHz (FM-N/AM), 10.7 MHz (FM-W)

Third IF Frequency: 10.7 MHz (FM-W)

Audio Output: 100 mW 8 ohm

Antenna impedance: 50 ohms

Antenna terminal: SMA

External Supply voltage: 5.4 - 6 VDC

Internal Supply voltage: 2.4 - 3 VDC

Ground: Negative

Current consumption: 140 ma, 80 ma in standby, 26 ma battery save

Operating temperature: 14° to 140° F or -10° to 60° C

Frequency stability: ± -7 to +3 ppm

Weight: 6 oz (65 g)

Dimension without projection:

2.28 x 3.9 x 1.26 inches (8 x 99 x 32 mm)

Specifications certified in accordance with FCC Rules and Regulations Part 15, Subpart C, as of date of manufacture.

Features, specifications, and availability of optional accessories are all subject to change without notice.

**Read a Good Label Lately?**

You could learn a lot! Look at your MT label before you throw your wrapper away - it tells you how many issues you have left in your subscription. If two or less, renew right away to avoid missing an issue. Keep those MTs coming and we guarantee you'll learn a lot!

**WARNING:** If you get a neon yellow wrapper on your magazine, don't throw it away: That is your renewal notice! Cut the card out of the wrapper and send it in with your payment. You'll get two notices and then it expires. So take care, don't let your subscription die!

# FREE SPEECH RADIO WBCQ Shortwave

7.415 - 9.330 - 5.110 - 18.910

wbcq.com

spacetransmissions.com



*We are the only free speech shortwave station on the planet*

## Welcome to the Micro Standard!

*Once again, Alinco engineers have redefined miniature electronics technology. With its leading edge "credit card" size radios, Alinco proves performance and quality can be found in micro-size receivers. Now, you can put all the action on fire, public safety, aircraft, weather, Amateur Radio and many other exciting frequencies right into your pocket with this trio of high performance wide band receivers.*

**DJ-X7T Wide Range Pocket Size Communications Receiver**  
100KHz to 1.3GHz\* Triple conversion AM/NFM; double conversion WFM, plus FM, SW, and TV

Super small "credit card" size delivers AMAZING audio quality in a size and weight (as thin as 14.5 mm, as light as 103g) that you can take almost anywhere. Easy to read illuminated LCD, 1,000 memory channels, five operating modes, three different antenna modes, easy to program with free downloadable software (optional cable required), cable-clone, and a long-lasting Lithium ion battery! Standard adapter charges the Li-Ion battery AND operates with AC power, even at the same time, so you can listen while charging.

**DJ-X2000T Multimode Wide Range "Intelligent Receiver"**  
100KHz to 2.15GHz\*

Experience monitoring on a whole new level with the DJ-X2000T "Intelligent Receiver". This triple conversion handheld receiver offers many unique features such as Flash Tune™ which locks onto nearby signals, Transweeper™ "bug" detector, and Channel Scope™ spectrum display. It also has 2000 memory channels, alphanumeric labeling, RF frequency counter, digital sound recorder, and receives AM, WFM, NFM, LSB, USB, CW and FM stereo.\*\* Super extras include an on-line "help" feature, 20 scan programs, computer programmable capabilities (download free software from Alinco website), CTCSS decode, two level attenuator, field strength meter, and more!

**DJ-X3TD Multimode Wide Range Communications Receiver**  
100KHz to 1.3GHz\*  
WFM mono and stereo\*\*, NFM, AM

Small but powerful triple conversion receiver with excellent audio, SMA flex and internal ferrite bar antennas, large easy-to-read display, 700 memories, NiMH battery, four scan modes, and dry cell battery pack. Computer programmable with free control software from www.alinco.com

**WWW.ALINCO.com**

Distributed in North America by Ham Distribution, Inc., 15 South Trade Center Pkwy, #B5, Conroe, Texas, 77385.  
Phone: 936-271-3366. Fax: 936-271-3398. email: Alinco@consolidated.net

Specifications subject to change without notice or obligation. \*Cellular blocked in USA. Unblocked versions available to qualified users, documentation required. \*\*Optional stereo headphones required.

# Monitoring Times HD Radio Report

## Part 1 - Boston Acoustics Receptor HD

**B**oston Acoustics (BA) has enjoyed a reputation for quality Hi-Fi components for several decades. Their speaker systems have always been among the best. For several years, this company has marketed a monaural table top radio known as the Receptor. It's a high ticket model designed to compete with similar Bose and Kloss models.

Last year BA was among the first to introduce a table radio capable of tuning the new HD Radio signals. Their approach was to use the existing Receptor model, add HD capability to the receiver, and add a second speaker. The two units are tethered by a coaxial speaker cable.

The Receptor HD is a competent radio all around. It has a very small desk/tabletop footprint, making it easy to place in the office, kitchen, bedroom or den. It has the smallest remote control of all the tabletop sets; it's easy to use, with buttons and a menu display which is fairly intuitive. It has 20 station presets, which can be assigned in any combination on either



band. That's a plus, because with the addition of HD multicasting, consumers need more than just a few presets to add their extra favorites.

Despite the generally excellent design and sturdy construction, the radio comes up a little short in certain areas. For instance, the cable between the two units could be a good thing when used on a desk as a combination radio/computer audio source. But, a longer cable would have allowed more separation between the two units, similar to the way powered speakers are used. At the length it is now, one speaker has to be in front of the monitor, while the other is to the side.



Given the audio heritage of this radio, the sound should be better than it is. Even though it's possible to adjust the audio, I found the sound too bass-heavy which, when compared to other HD Radio sets, gave the overall sound a mushy quality. However, the audio balance was noticeably improved when tuned to an HD Radio station.

### MANUFACTURER'S SPECIFICATIONS

#### Features:

Station Presets: 20 AM FM Total  
Alarms: 2  
Sleep function: 60 minutes in 10 minute increments  
Tuning: Multi-function tuning knob for direct tuning or by presets

#### Connections:

AM external antenna terminals (300 Ohms)  
FM external antenna (75 Ohms)  
Aux input mini jack (for MP3 player, CD player or computer audio)  
Headphone output jack (8 Ohms)  
Second speaker output jack  
12 volt DC power jack

#### Dimensions:

Cabinet size: 4"H x 7 1/2"W x 6"D  
Second Speaker Dimensions: 4"H x 4 3/8"W x 6"D  
Weight: 3 lbs. 14 oz.  
Remote Control: 1 1/2"H x 3 1/2"W x 1/4"D uses CR2025 3 volt battery

**Warranty:** One year limited warranty.



*Boston Acoustics, famed Hi-Fi label, makes this unusual two part HD Radio called the HD Receptor. (Courtesy: Boston Acoustics)*

The display is unusually bright, even by the new blue HD Radio display standards. I found that even using the controls to dim the display, it was still too bright in a dark room. On the high position it's possible to read a book by the light of the display.

### INTRO TO HD RADIO

Stung by the rapid acceptance of satellite radio, the National Association of Broadcasters (NAB) is spending a lot of money this year to push the concept of HD Radio (loosely, "high definition" radio, i.e., digital). You may have seen the "HD Radio Discover it!" ads touting "New Music, New Sounds With No Subscription Fee!" The intimation is that there are new radio stations in your area with amazing programming you've never heard before. So, obviously, don't sign up with satellite radio!

As is often the case in the hi-tech world, the public relations people are months, if not years, ahead of the rest of the industry. The reality is that in some locations, mostly urban areas, there are HD Radio stations which multicast or transmit additional program material on second or third HD channels. But, at present, most HD Radio stations on the air have no multicast. The reason there are no commercials on the multicast channels is that the FCC bans them during this early phase of HD Radio acceptance. Of course, there won't be subscription fees, because they play commercials on the main channel just like they've always done. Still, the sound does live up to the hype when the stations are paying attention to how hard they're driving the audio.

HD Radio and the products that receive it will no doubt improve over the next several years. The wider implementation of HD Radio transmissions throughout the country may bring more interest to

the FM band, but the future of HD Radio on AM is another story. Until recently, the FCC required AM stations to turn off their HD signals at sundown. Even so, during the day the audio is as good as analog FM is today (real AM Stereo!). AM stations are not allowed to multicast.

There has been a lot of disappointment expressed nationwide regarding reception of FM HD Radio signals. One reason is that the FCC requires stations to transmit the HD portion of their broadcast signal at one tenth the power of the analog signal. Eventually, of course, the signals will go to full power, but for now, this fact results in HD signals falling far short of their analog counterpart. And, it makes HD mobile nearly impossible.

Manufacturers have tried to remedy this by including a folded dipole "T" antenna for FM reception and a small AM loop antenna with each unit. Even in cases where such an antenna helps HD reception, how do you install it? You tack it to the wall behind the radio. Gee, that looks great!

All AM loops used by all HD Radios are identical. Somewhere in China there is a company working overtime to crank out an AM loop antenna not worth the space in a landfill that it takes to bury it. I've found that all HD Radios benefit most from a real AM loop antenna such as the Terk AM Advantage. Still, don't get your hopes up on AM HD reception. Unless you live in the first broadcast contour of the station, you'll get only analog reception.

One really great idea with the Receptor HD is that basic instructions for setting the presets are printed under the flip-up panel on top of the radio, making it impossible to forget how to set and cancel the presets.

When it was the only HD Radio on the market it would have been easy to overlook the flaws. But, with other HD Radios now available with better features and lower price, the Receptor HD is going to have to introduce a second

generation with some refinement or additional features to remain competitive.

#### ❖ Where to Buy:

The Boston Acoustics Receptor HD is widely available at many consumer electronics stores, including Tweeter and B & B Electronics. It's also found at catalog and on-line retailers such as Crutchfield ([www.crutchfield.com](http://www.crutchfield.com); 1-888-955-6000), C. Crane ([www.ccrane.com](http://www.ccrane.com); 800-

522-8863 or 707-725-9000), J&R Electronics ([www.jr.com](http://www.jr.com); 800-806-1115) and Hammacher Schlemmer ([www.hammacher.com](http://www.hammacher.com); 800-321-1484). The BA Receptor is also available direct from Boston Acoustics ([www.bostonacoustics.com](http://www.bostonacoustics.com); 978-538-5000) for \$299.99 with free UPS ground shipping. Prices at other retailers varied within \$20 of the BA price; some retailers offer free shipping while others don't. It pays to check out all the retail sources and compare.

## Part 2 - Radio Shack's Accurian HD Radio

Last winter Radio Shack wasted no time getting an HD radio to the market to cash in on Christmas sales. In fact, they were available by Thanksgiving at a deep discount. Sales were so brisk they quickly depleted supplies. Among the early buyers were radio station engineers who were snapping them up to monitor their new HD transmitters. It was a sensational sales success. What the engineers liked most was the price. While early HD Radio sets were selling in the \$300 range, here was one on sale for \$99!

Radio Shack calls its HD Radio the Accurian HD, and it's one of several products in the Accurian audio stable carried in Radio Shack stores. The Accurian design turns the radio almost literally on its head. Instead of having a deep speaker cabinet as all the others do, Radio Shack's model is upright. The advantage here is that it presents the smallest desktop footprint of all HD Radio models to date. That's an issue for small desks or kitchen countertops, for that matter.

The clean lines and swept back cabinet with only one big knob in the center gives the radio what can only be described as a futuristic-retro look. One result of the upright design is that it

requires shallow speakers, resulting in a sound that lacks any real depth. If you're not looking for a booming bass, you may have found the right HD Radio in the Accurian HD.

As with most tabletop HD Radio sets, the Accurian has what have become HD Radio standard features: a front mounted mini jack input for your MP3 player (or computer audio output or a CD player), the ubiquitous blue HD Radio display panel (this one much less hard to live with than others), which shows the frequency, signal strength, and station call letters. When tuned to an HD station, it also displays the station logo ("Mix 99" for example), the HD Radio symbol, plus any pertinent music information the station may be broadcasting, such as song title, artist, album, etc. Keep in mind that the display will only show what the station is transmitting. Some stations have very little information in their data stream; others take full advantage of this feature.

The Accurian uses a remote control which is nearly identical to the one used by Boston Acoustics' Receptor HD. It's the smallest one used by any of the HD Radios and yet has all the functions of the buttons on the front panel. One interesting note is that there's a molded slot in the back of the

Accurian which can hold the remote when you're not using it.

Reception on the Accurian is not sensational. As with all HD Radios, it benefits from an external antenna. If you live in a large urban area, you may have good results with the folded dipole "T" antenna all of the radios are packaged with. If not, you'll definitely need an outside antenna. If that doesn't do the job, you'll need to add an antenna pre-amplifier and possibly a rotator to lock in the digital signals. While the Accurian allows adjustment of the audio according to the type of music, i.e. Rock, Classical, Jazz, I found very little difference among the settings.

At the often offered sale price of \$99, the Accurian is the best value for consumers wanting to see what HD Radio is all about without spending a fortune.

#### ❖ Where to Buy:

The Radio Shack Accurian HD is available at most Radio Shack retail outlets and via the Radio Shack web site ([www.radioshack.com](http://www.radioshack.com)). The list price is \$199.99, but it routinely sells for \$149.99 with a \$50 mail-in rebate. Look for even deeper discounts at typical gift giving times such as graduation, Father's Day and Christmas. The Accurian has been found for as low as \$99 at these times.

Not all Radio Shack stores carry the product. Shipping and handling from the Radio Shack web store is typically under \$10. Check your phone book or the online store finder for a store near you.

#### MANUFACTURER'S SPECIFICATIONS

##### Features:

Remote Control: 1 1/2"H x 3 1/2"W x 1/4"D  
uses CR2025 3 volt battery

##### Connections:

AM external antenna terminals (300 Ohms)  
FM external antenna (75 Ohms)  
Aux input mini jack (for MP3 player, CD player or computer audio)  
Headphone output jack (8 Ohms)  
12 volt DC power jack

##### Specifications:

Cabinet size: 6.97"H x 12"W x 6.61"D  
Weight: 5 lbs.

**Warranty:** Limited 90 days



Clean lines, clean sound and a small foot print make the Accurian HD radio from Radio Shack a versatile desk top radio at an affordable price. (Courtesy: Radio Shack)

## Frugal Guide to DRM Reception

By Kraig Krist

### ❖ The DRM Challenge

DRM (Digital Radio Mondiale) has been around since March 1998<sup>1</sup>. For the shortwave listener, DRM promises better reception quality, nearing that of FM. For the broadcaster, DRM promises less transmitter power than existing analog broadcasts. DRM also promises additional services during the broadcast, including textual and graphics.

Some in the hobby have complained about the lack of available DRM receivers or the lack of affordable DRM receivers. Some in the hobby have complained about the hash a DRM signal creates to nearby analog signals.

To me, DRM presents a challenge. I'm a DXer and an SWL. I enjoy listening to interesting programming. I regularly tune into favorite broadcasts. However, I really enjoy the excitement and challenge of hearing a rare transmission – the excitement of chasing DX – hearing the almost impossible broadcast because of transmitted power, transmitter location, or broadcast target. I'm the type of person who will get out of bed at 2 a.m. simply to listen for rare DX. DRM broadcasts are DX and I was missing out.

I offer the following, in hopes others will find the information useful. I also encourage others to try listening to DRM broadcasts without purchasing expensive DRM receivers and/or electronically modifying their receivers for DRM reception. This is not an article on the merits of DRM. Nor is this an article on the shortcomings of DRM.

### ❖ Research

Researching at the DRM website<sup>2</sup>, I learned about DRM and the requirements for receiving and decoding a DRM signal. A DRM transmitter sends a digital signal (meaning 0s and 1s) through the air to the receiver. The receiver decodes the 0s and 1s into audio we can understand. Since DRM-enabled receivers are either, at this time, very costly or not available, we can employ a PC to decode the digital 0s and 1s.

### Basic flow of DRM reception using a PC to decode the DRM transmission:

Receiver=> Audio cable connected to receiver's lineout connection=> Other end of audio cable connected to PC's soundcard line-in or microphone connection=> DRM decoding software running on PC=> broadcast decoded and sent to speakers=> happy listener!

A 12 kHz audio signal is needed for decoding the DRM signal. The 12 kHz signal is within range of most PC soundcards. The DRM website<sup>3</sup> has instructions for modifying a number of shortwave receivers to obtain the 12 kHz audio signal for DRM reception.

Some recent shortwave receivers and amateur transceivers have a tap providing a 455 kHz IF signal. An inexpensive circuit board is available<sup>4</sup> for converting a receiver's 455 kHz IF signal into the necessary 12 kHz audio signal. One must open the receiver and solder connections from the converter at the appropriate locations. Unfortunately, my receiver, a JRC NRD-545, does not have a tap providing either a 455 kHz IF signal or the 12 kHz audio signal.

Doing soldering, etc. to the NRD-545 seemed a drastic step just to sample a DRM broadcast. Since I was going into the unknown, I was not sure DRM reception would be successful. I didn't want to invest a lot of time and effort up front for something that could turn out to be a bust. There had to be a better way.

### ❖ DReaM

Fortunately, there *is* a better way. I hope radio hobbyists wanting to hear DRM broadcasts will also easily do so as described in this article.

Searching the internet, I discovered shareware software called DReaM, used for DRM decoding. DReaM.exe is available from the Sourceforge<sup>5</sup> website. At the time of writing, the latest version of the downloadable DReaM.exe is version 1.2.4. Sourceforge also has the DReaM source files available for those wanting to compile their own version of DReaM (latest downloadable DReaM source is version 1.6.25). Additional files and libraries are needed if one wants to compile the source files into DReaM. The Sourceforge website<sup>6</sup> contains detailed instructions on the needed additional files and libraries and the steps necessary to accomplish the compilation.

Initially, I wanted to keep things as simple as possible to experience DRM. I felt my current PC, an HP D530 workstation running Windows XP Pro, 2.8 GHz CPU, 2 GB RAM and onboard sound was up to the task. Therefore, I downloaded the latest compiled version of DReaM.exe from the Sourceforge website<sup>7</sup>. A DLL<sup>8</sup>, qt-mt230nc.dll, is also needed for DReaM.exe to work. The DLL is also available from Sourceforge<sup>9</sup>.

Download the DReaM.exe zip and the qt-mt230nc.dll. Create a folder with a meaningful

name, for example, DReaM 1.2.4, and unzip the DReaM zip package into this folder. Copy the qt-mt230nc.dll into the same folder.

Connect an audio cable to the receiver's lineout connection. Connect the other end of the audio cable to the PC's soundcard line-in or microphone in connection.

### ❖ Initial failure

Now I needed a way of obtaining the required 12 kHz signal for DRM decoding. The NRD-545 bandwidth control allows tuning the IF filter continuously within the range 10 Hz to 9.99 kHz. Using the max of 9.99 kHz gets me close to the required 12 kHz, but I was short of 12 kHz.

The NRD-545 pass band shift allows shifting the IF filter +/- 2.3 kHz.  $9.99 + 2.01 = 12$  kHz. I set the receiver's pass band shift to +2.01 kHz. I thought I was close enough, so I enabled the PC's volume control and turned on the PC's speakers. I tuned into a DRM transmission. I would hear the DRM hash, so I knew a DRM signal was being received. I double clicked the DReaM.exe, hoping to hear a DRM broadcast. Unfortunately, I got nothing other than "scanning" as shown in figure 1.

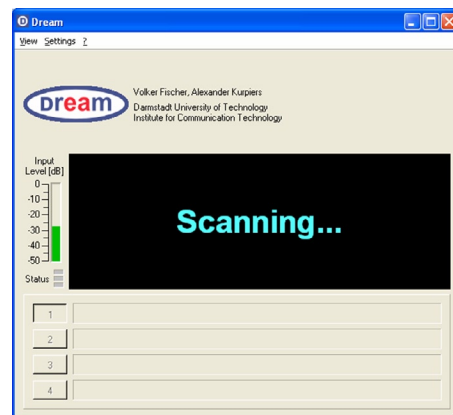

Other than the I/O interface, in DReaM's Evaluation Dialog, I was not getting indicator locks as shown in figure 2. All 6 indicators – MSC CRC, SDC CRC, FAC CRC, Frame Sync, Time Sync Acq and I/O Interface – must be either all green or a combination of green and yellow for successful DRM decoding. Get to the Evaluation Dialog by clicking View and then click Evaluation Dialog.

Time to reevaluate the receiver's settings: I suspected only setting the receiver's bandwidth



control to 9.99 kHz and setting the receiver's pass band shift to +2.01 kHz were not enough. I began experimenting with the receiver's settings.

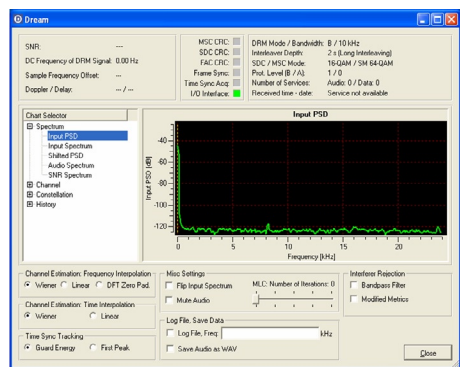

### Required settings

I experimented with various settings. I tried upper sideband, lower sideband, RTTY, CW, and various combinations of bandwidth control and pass band shift. I finally had success using the following combination. Please note: these settings worked for me, but receivers, even the same type from the same manufacturer, are often internally different due to firmware versions. Therefore, experiment to find the optimal settings for the receiver in use.

- Receiver in RTTY mode.
- Receiver's bandwidth control set to 9.99.
- Receiver's pass band shift set to +2.3 kHz.
- Tune receiver 2.8 kHz below actual broadcast frequency. For example, a DRM broadcast on 9800 kHz, tune the receiver to 9797.20.
- Set receiver's DSP shape filter (digital IF filter attenuation slope) to loose. Sharp is the default NRD-545 setting. Might be called some other name on other receivers. A setting of "sharp" helps when listening in a crowded band.
- Set receiver's AF gain to the 9 o'clock position (3rd tick mark from the left bottom). It is very important to not overdrive the volume. If the volume is too high then decoding will fail.
- Set receiver's tone control fully clockwise.
- Set DREAM Evaluation Dialog MLC to 1. Experiment with this setting for best performance.
- Due to a local MW station close to my QTH, I also had to set DREAM Evaluation Dialog Interferer Rejection Bandpass Filter on.

Ensure PC's firewall, antivirus and any other applications are disabled.

### Success

Figure 3 is a screen shot of TDP broadcast-

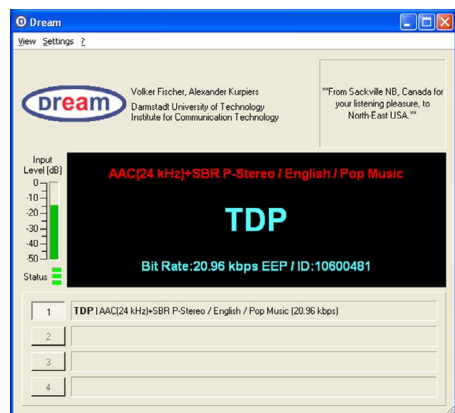

ing DRM on 9800 kHz. Notice Input Level. Adjust Receiver's AF Gain to keep bar in the green. A little red is OK. However, a lot of red in the input level will cause DRM decode to fail.

DREAM's Evaluation Dialog of TDP broadcasting DRM on 9800 kHz. Figure 4 shows green lights on all the indicators!

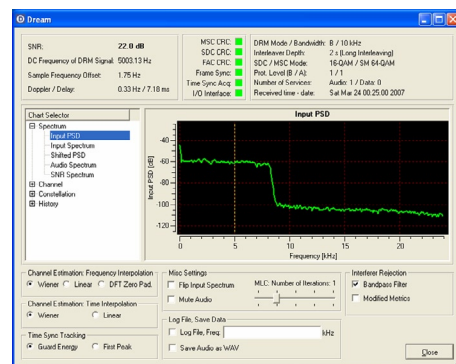
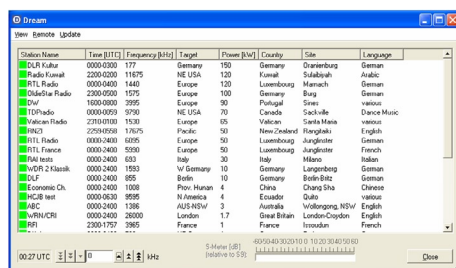

Figure 5 shows the NRD-545 settings.



DREAM has a built-in DRM broadcast schedule as shown in figure 6. See by clicking View, Stations Dialog. The Stations Dialog also has the ability to update the list via the internet. Do the update, via the internet, when not decoding a DRM transmission. Also, check the DRM website<sup>10</sup> for DRM broadcasts and frequencies.



Using the PC's volume control, mute the line-in or microphone to prevent hearing the DRM hash as shown in figure 7. We only wish to hear the decoded DRM broadcast through the speakers.

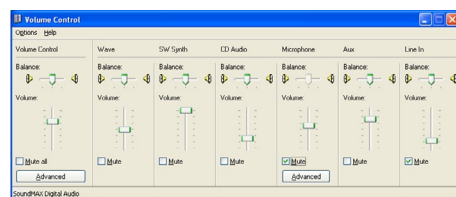

DRM allows me to, once again, hear English from HCJB in Ecuador. Figures 8 and 9 are screen shots of HCJB broadcasting DRM on 9595 kHz.

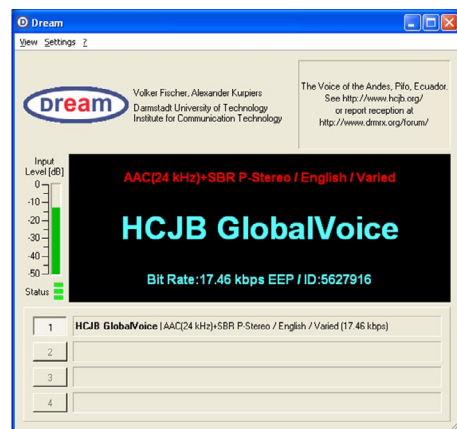

I mentioned that DRM provides text and graphic ability. Figure 10 shows a screen shot of textual data sent along with the Deutsche Welle DRM transmission on 3995 kHz.

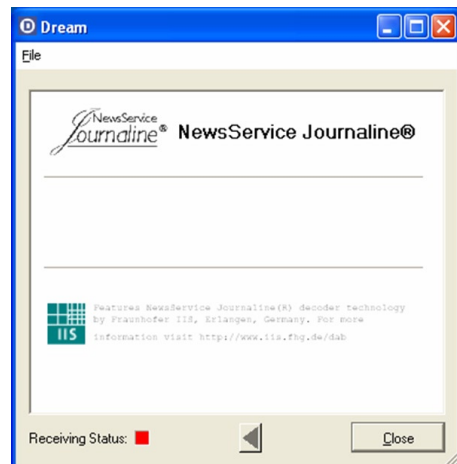

### SINPO

Unlike an analog signal, a digital signal is either heard or it is not heard. There is nothing in between. Therefore, when writing reception reports, in my opinion, the SINPO rating is not necessary. Here is an example of the Radio Conditions section of a recent reception report on a DRM broadcast.

“Radio Conditions: SINPO doesn't apply to DRM transmissions. A digital transmission is either successfully received and heard or it is not heard at all. Overall, reception was reliable and understandable. There were a few dropouts especially during the songs. The audio sounded too compressed – somewhat like cell phone audio.”

continued on page 75

## The 2007 Computer Landscape - Hype, Confusion & Reality

**M**uch has changed in the computer world since I started writing this column over fifteen years ago. Although the changes in this industry have always been quick and continuous, the last few years have proven to be even more frenetic.

This month we'll look at new developments in PC hardware. We'll try to navigate through the maze of marketing buzzwords and hype so you can make an informed purchase. Then we'll get a hands-on first impression of Windows Vista Home Basic operating system (OS) and mention other OS. That's a lot to get through, so let's get started with hardware.

### ❖ Hardware Considerations

From its early days the brain of a PC, the microprocessor or central processing unit (CPU) governed the power of the computer. Thus, knowing the speed at which a CPU calculates and moves data was all the information you needed (well, almost) to determine the "power" of a computer.

The CPU speed wars between the two major CPU manufacturers, Intel and AMD, pushed CPU clock speeds from 3 MHz to an unbelievable 3000+ MHz! No matter what type of CPUs we were comparing, the higher the clock speed, the "more powerful" the computer.

### Caveat Emptor

This maximum-clock-frequency approach worked fine when considering a single CPU family, for example, different Intel Pentium 3s. However, when comparing performance between CPUs in different families, things are not that simple. Due to differences in input/output data handling and internal structures, clock comparisons alone are no longer valid to determine performance.

For example, a 1GHz Celeron was not as "powerful" as a 900 MHz Pentium 3. Yet many people "upgraded" to the higher speed Celeron, thinking they were getting a more power. AMD followed suit, marketing their lower capability Duron line of CPUs.

Lower priced PCs with higher clock speeds hit the market. The marketing play worked for many years. Few buyers realized that, for these CPUs, along with the higher clock speed came a lower performance for many applications.

### Things Get Worst

With the CPU war raging between Intel and AMD, Intel changed its CPU naming system a few years ago. Now, no longer would the buyer be able

to immediately compare CPUs, even within the same family. Instead of being called a Pentium 4, 2.8MHz Clock with a front side bus speed (FSB) of 533 MHz, it became a Pentium 511.

This naming system left the consumer completely in the dark as far as the CPU's performance. Further, it made comparisons between PCs using AMD chips and PCs using Intel chips a nightmare.

### Maxing Out!

As the CPU speed race wars continued, Intel realized that they could not economically manufacture a 4.2 MHz CPU. And even if they could make them, the internal heat generated by the device was next to impossible to remove before causing massive thermal failure ... bye-bye CPU, resulting in dead computer.

Borrowing from an idea that was first conceived of thirty years ago, Intel decided to share the computing effort between two processors. Simplistically, if the two worked in parallel, supporting each other, they could effectively double their individual computing power. In addition, this structure lends itself to more complex data architecture and enhanced multi-tasking performance. These are just some of the benefits of this multi-core processor approach.

Notice that each chip only needs to work half as hard, as compared to only one doing all the work. Half the effort means half the heat. And now even better, the heat was now spread between

two separate CPU "cores."

The manufacturers were happy, since a two-chip method resulted in two separate smaller chips, instead of one huge device. The area of a chip directly affects the manufacturing yield and therefore its difficulty to make. All these directly affect cost of manufacturing.

In practice, both cores are assembled in one package. The Dual Processor was introduced in mid 2005. The announced Pentium 4.2 MHz never saw the commercial light of day.

### Now Slower is OK?!

With the dual core processor came a different way of evaluating CPU power. We now effectively have two CPU cores working in tandem in one package. If they are both running at 1.6MHz, their results can be as powerful as a single core CPU running at almost 3 MHz! And, as a bonus, they will consume less total power.

Today, dual core processors are the standard, most common CPUs for new PC and MAC systems. They have nomenclatures such as Intel® Core™ Duo processors (originally called the Pentium D family). One member of this family is the T2060. This is a dual core processor running at a clock speed of 1.60 MHz, with an FSB of 533 MHz and 1MB L2 cache memory. Intel is now also producing their Core 2 Duo processors.

### The Duel Continues

AMD released similar dual core products

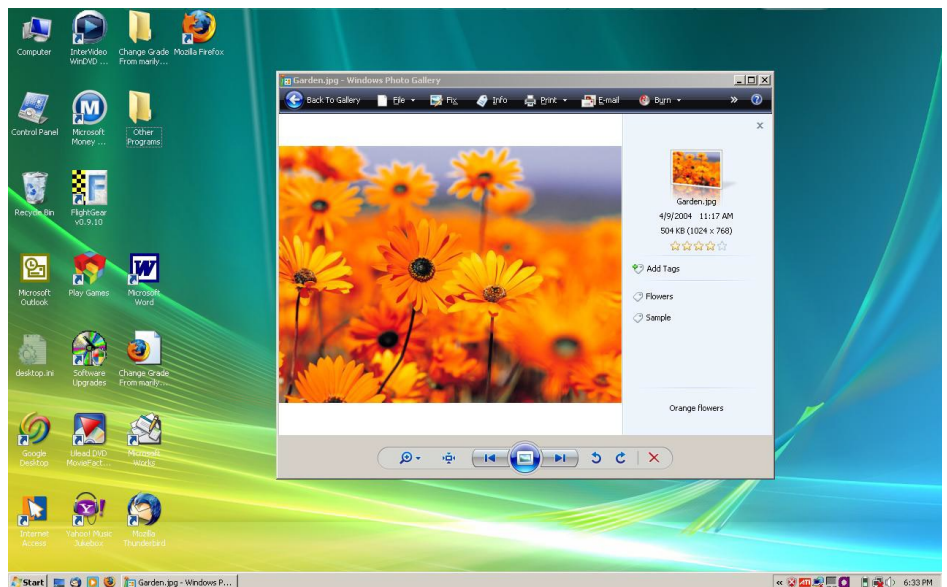

Figure 1 – Eye-Catching Opening Screen & Desktop of Windows Vista Home Basic

such as their Athlon X2 dual core processors.

Who is winning the war? It seems to depend on the reviewer's allegiance. Click on [http://reviews.cnet.com/4520-10442\\_7-6389077-1.html](http://reviews.cnet.com/4520-10442_7-6389077-1.html) to get an early comparison of the two. Let's just say both companies have comparable products. My opinion is that Intel has a slight edge in performance and AMD takes the prize for value.

This is just the beginning of the era of multi-core processors. A quad (4) core processor is soon to be available from Intel, designated the Core 2 Quad Processor Q6600.

If you are buying a new computer, go for the dual core processor, even if it costs a few dollars more. It will provide you with the power to run your existing applications and operating system faster, while giving you the potential for newer operating systems and applications. However, if you are running the new Windows Vista operating system, that introduces new considerations as we see below.

## ❖ Software: A First Look at Vista

After watching me try to squeeze every bit of life out of a laptop made last century, my wife gave me a new notebook computer for my birthday this March. It has a T2060 dual core CPU and came with 512Meg of RAM running Windows Vista Home Basic, version 6.0. build 6000. Vista currently comes in four flavors: Basic, Premium, Business and Ultimate.

The desktop screen is spectacular! See Figure 1. The display ran the full spectrum of colors. Icons appear picture-like and the complex background gave a three dimensional feel. Wow! (Is Wow trademarked by Microsoft?!)

### Downside

The problem was that it took almost two minutes from turn-on to display the desktop! Not a good start to my birthday. Worst yet, clicking on a desktop icon to open an application seemed to do nothing. "What luck! I've got a defective notebook," I thought. Just then, after waiting almost 20 seconds, the application began to open. Welcome to the downside of Vista.

Checking the web, I found many people had the exact same experience with Vista. The general comment was that Vista was slower than XP when installed on the same PC.

The Microsoft website indicated that my 512 Meg of RAM was the recommended amount for Vista Basic. Thinking back over a decade ago, I remembered going from Windows 3.1 to Windows 95 and how I was disappointed with the sluggish performance of 95 until I vastly increased the RAM in my PC.

### Getting More Speed

Once opened, RAM is not usually returnable, at least not for a full refund. Fearlessly, I crossed my fingers, paid my \$105 and bought a stick of 1 Gig of RAM to add to my existing 512 MEG.

That did the trick. Vista Basic is now (in most application) as fast as XP. Initial turn-on is better but still slow. Therefore, I recommend that your system has at least 1.5 Gig of RAM to run Vista Home Basic.

Although very impressive, some of the visual

effects of Vista rob valuable PC performance. You can speed up things by doing the following:

1. Go to Start Menu
2. Go to Control Panel
3. In Control Panel select "Performance Information and Tools"
4. At Left of screen click "Adjust Visual Effects"
5. Then choose "Adjust For Best Performance"
6. Now select "Advanced" Tab at the top of the screen.
7. Now under "Processor scheduling" check "Adjust for best of Programs"

That will get you some more performance.

### Want More?

Unnecessary programs running in the background are another source of performance degradation. Before you proceed, set a "restore point" for your system. Consult the Help file for exact details. If you make a mistake, this may allow you to undo it. Now, after being warned, try this:

- A. Go back to the Performance Information and Tools menu.
- B. Select "Manage Startup programs"
- C. Then Carefully, **Very Carefully**, stop programs from starting that you don't need. Do not prevent critical programs from starting or you will be in major trouble and will need to use your restore point.

After a doing all these things and upgrading my RAM to a total of 1.5 Gig, my Vista runs pretty fast.

### Questions Still Linger

What radio monitoring programs will work with Vista? Good question, and one which I will be exploring and reporting on in coming columns. But I am worried about running some of my long time favorites under Vista.

Also, I'm still not sure that Vista is as fast Windows XP. From the volume of Internet active on this subject, others people feel the same. In fact, many new PC owners, whose computers came with Vista installed, have opted to wipe it out and re-install XP. But in some computers this has caused a whole other set of problems.

New computers have been designed with hardware to work with Vista. Therefore for some new PCs, hardware drivers are only available for Vista. These drivers are critical, since they connect the operating system to PC hardware such as the video card, USB ports, keyboard or mouse.

Here is the problem: For some new PCs XP operating system drivers may not exist or may have been withdrawn by the PC manufacturer. Yes, that has happened. Why? Good question.

But without XP drivers written expressly for your PC hardware, you make never get your PC operational under XP. At best, a partially functioning PC will result. After spending a bundle on a new PC this would not be a good result.

Therefore, for maximum OS flexibility, before you buy a new computer, check that the PC's manufacturer provides both Vista and XP driver support.

### Buying a New XP Computer

Believe me, I tried. I spent a day going from Best Buy to Circuit City to CompUSA. I even checked Sam's Club. All the salespeople reported

the same story. They were instructed to "immediately" pull non-Vista PCs off the shelf when Vista powered PCs came in to the store. (The power of Microsoft!) Therefore today, if you buy a new PC you have no choice of operating systems ...it's Vista.

Once you own it, are there non-Windows OS alternatives?

## ❖ Looking Past Windows

Microsoft is the biggest kid on the OS (operating system) block, but not the only one. Linux, a totally free operating system, has been around for a while. It is gaining acceptance as Microsoft pushes its prices higher and tries fixing critical problems with weekly patches. Linux versions of most common applications, such as word processing and spreadsheets, are available for downloading. Check out the Linux webpage at [www.linux.org/](http://www.linux.org/). You can find Linux radio application software at [www.ac6v.com/software.htm](http://www.ac6v.com/software.htm), [www.radio.org/linux/](http://www.radio.org/linux/) and [www.amsat.org/amsat/ftpsoft.htm](http://www.amsat.org/amsat/ftpsoft.htm) to name a few sites.

The new MacBook Pro computers have dual core Intel processors. Using the free Boot Camp program, these Macs are capable of running both Windows XP and the MAC X operating systems. However, only these Macs can run both. See last month's column for a review of a few MAC radio programs.

Remember that we have just looked at Vista Home Basic, the simplest, cheapest version of the Vista versions. There is no question Vista is still undergoing major development. This has always been the case with newly released Microsoft operating systems. We pay to be their beta testers. Ultimately, Vista will someday be as solid as XP has finally become.

## ❖ How Do You Choose?

Right now, choosing a new computer is more difficult than ever. First decide the major tasks your computer is going to be performing. Then, make a decision on the exact CPU, operating system, and graphics capability that fit your requirements ... and pocketbook.

As for me, I have always tried to stay a Windows operating system behind the current one. For example, although I had Windows XP on one of my PCs, until two years ago, Windows 98SE was my main OS. Most of the major bugs were fixed and a HUGE base of all types of applications, which ran happily in 98SE, was available. But I kept on eye on XP development by using XP on my other PC.

I intend to follow the same plan with Vista. My Windows XP machine has become my mainstay, with my new notebook giving me a window (sorry for the pun) into the new Vista.

I'm sure that Vista, with all of its great graphics and computing capabilities, will eventually take the place of XP. However, until I can assess the magnitude of Vista's incompatibility with my favorite monitoring and radio programs, and Microsoft works out the major bugs in Vista, I'm sticking with XP. As I said, compatibility of monitoring programs with Vista will be the subject of a future column.

OK. Now, how do I get Vista to run DOS?!

# What's NEW

Tell them you saw it in *Monitoring Times*

## Crystal Radio Projects

As technology speeds ahead at a head-spinning pace, many radio experimenters delight in returning to the days of old, marveling once again at the reception of signals during a simpler time.

Crystal radio sets require no external source of power; they derive their earphone volume purely from the signal voltage itself. Medium wave AM broadcasters are the most common targets for reception, but shortwave broadcasters, CB stations and even aircraft communications can be heard as well.

Publishers of the Xtal Set Society Newsletter periodically assemble articles and projects into book form; their latest assemblage of volumes 12 and 13 is such a publication.

135 well-illustrated pages contain instructional details on building your own headset and cat's whisker crystal, simple one-tube projects, amplifiers, coil winding, paper-box radios, shortwave crystal sets, crystal detectors, antenna recommendations and much more.

And if you would like a head start, the Society also offers do-it-yourself kits.

*Crystal Radio Projects* Volumes 12 and 13 is available for \$15.95 plus \$4.95 shipping from the Xtal Set Society, PO Box 3636, Lawrence, KS 66046. Phone them at (405) 517-7347 or visit their website at [www.midnightscience.com](http://www.midnightscience.com).

— Reviewed by Bob Grove

## Listening to Longwave

Most *Monitoring Times* readers are familiar with the shortwave spectrum, but many of you are not familiar with the spectrum below the AM broadcast band – the longwave radio spectrum. *MT Below 500* columnist, Kevin Cary, WB2QMY, has written a nontechnical introduction to the fascinating “basement band” of the radio spectrum. *Listening to Longwave - The World Below 500 kiloHertz* is an up-to-date look into the interesting world of radio below 500 kHz.

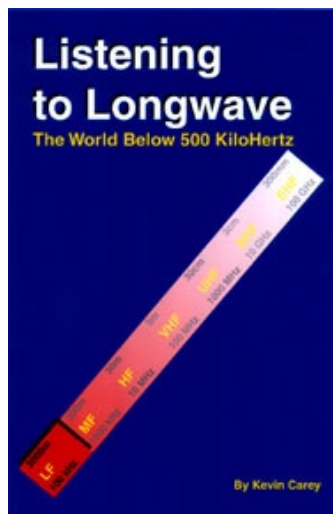

Key chapters include:

- Who is on the air, and when and where to listen to longwave communications.
- Transmitters (lower), receivers, converters and antennas for longwave.
- Longwave listening tips for beacon hunters, logging your catches, and equipment.
- Unusual users of the longwave spectrum – navigation systems and military users.
- Monitoring the sounds of nature – Whistlers, Tweaks, Dawn's Chorus and other atmospheric.
- Background information on navigation beacons, time stations, longwave broadcasters and NAVTEX weather broadcasts.
- Transmit and Receiving equipment for the Lower license free experimenter's band.
- Reference section that includes books and periodicals; clubs, groups and organizations; manufacturers and distributors of longwave related products; and useful internet websites.

This is a great book for the beginner who wants an overview of monitoring the longwave spectrum, and for oldtimers looking for a new band to challenge.

*Listening to Longwave - The World Below 500 kiloHertz* is published by Universal Radio Research. It is perfect bound, with a color cover and has 98 pages.

You can order your copy of this excellent beginner's guide from Universal Radio, Inc., 6830 Americana Parkway, Reynoldsburg, OH 43068-4113 (800-431-3939) or on their website at [www.universal-radio.com](http://www.universal-radio.com). Order book number 0024, \$6.95 plus shipping.

— Reviewed by Larry Van Horn

## ARRL RFI Book

Our high-tech era brings convenience at the expense of radio interference. Power lines, telephones, computers, lighting fixtures, electronic accessories, home appliances, TV sets, radio equipment and other electrically-operated devices are a limitless source of unwanted signals.

The most comprehensive volume devoted to curing radio frequency interference (RFI) problems is unquestionably this second edition of the formidable *RFI Book* from the American Radio Relay League (ARRL).

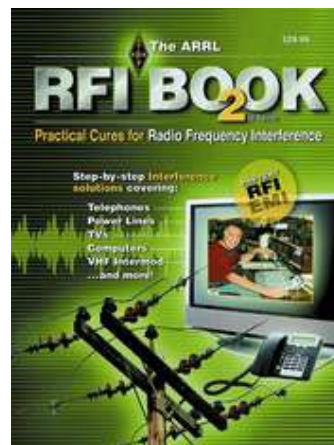

More than 300 pages of professionally-illustrated articles contain advice and construction details for minimizing interference for virtually any RFI challenge that arises. And, if you're interested in radio direction finding (RFI) to track down that offending signal, there's a chapter on building a variety of RDF antennas as well.

This latest volume contains a reprint of the *FCC Interference Handbook*, a contact list for manufacturers of home electronics equipment, and a resource guide for commercial RFI filters.

The exhaustive *RFI Book* is available for \$29.95 plus shipping from the ARRL.\*

— Reviewed by Bob Grove

## Repeater Directory

Some publications from the American Radio Relay League are such stand-bys that we don't fully appreciate the breadth of information they contain until we

review a new edition. Such is the 36th edition of the *ARRL Repeater Directory* for 2007-2008. No, don't yawn! What's ho-hum about the book with the greatest potential of actually getting new hams on the air?

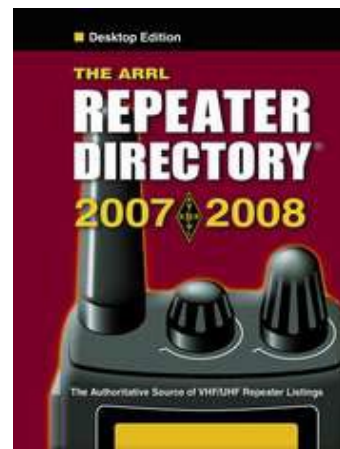

The bulk of the *Repeater Directory* – which comes in a condensed, pocket size or the new, large-print desktop version – is made up of periodically updated listings of active repeaters, along with all the pertinent information to access each repeater. The repeater listings are divided into frequency range (or repeater type, such as APCO 25 or Echolink), then by state regions, for quick look-up.

But that's not all. In plain, practical language, chapters give an invaluable overview of good operating practices, repeater and emergency message handling, band plans, repeater lingo and hints, and the names and addresses of regional frequency coordinators.

As ARRL Chief Executive Officer David Sumner K1ZZ says, “Our service benefits from you actively using your license, and the systems listed herein provide a way for you to do so.”

The large-print directory, available for the first time by popular request, is \$15.95 from the ARRL.\*

The traditional pocket-sized version is also available at \$10.95. Or call and ask about the *TravelPlus for Repeaters* CD, which combines the repeater listings in a map-based software which can be used with GPS.

— Reviewed by Rachel Baughn

## ARRL Periodicals on CD-ROM

The American Radio Relay League has released their 2006 anthology of their popular journals on a compact, fully searchable CD-ROM. Every word and photo published throughout the year is included for *QST* – the official membership journal of the ARRL; *NCJ* – *National Contest Journal*; and *QEX Forum for Communications Experimenters*.

Using the Adobe Acrobat engine you can search the full text of every article by entering titles, call signs, names – almost any word. You can see every word, photo (including color images), drawing and table in technical and general interest features, columns and product reviews, plus all advertisements. And you can even print what you see, or copy it to other applications. Web links appearing in the article can be used to launch your Web browser to view additional information.



In addition to the features above, ARRL Periodicals on CD-ROM includes source code for software projects and PC board etching patterns. And the 2006 version also includes Section News and ARRL Contest Results – with individual scores and Contest Soapbox.

Minimum System Requirements (Windows): Intel Pentium processor or higher. (Macintosh): PowerPC processor. 128 MB of RAM, 90 MB of available hard-disk space for either system.

The *ARRL Periodicals on CD-ROM* is published by The American Radio Relay League, Inc. and costs \$19.95 plus shipping and handling.\*

– Reviewed by Larry Van Horn

## Music Radio: A Review

The enjoyment of old time radio (OTR) is not the same as the enjoyment of the DX hobby, but some of us enjoy both interests. The enjoyment of OTR can take the form of remembering the actual good old days of the golden age of radio (about 1930 into the fifties) if one was born soon enough, listening to reruns of some programs on some broadcasting stations, listening to OTR audio streams on the Internet, or listening to and collecting your own OTR product.

Like any hobby, OTR has developed a library of current and prior books about radio programming. Here is one that I have enjoyed,

published in 2005.

The book's complete title is: *Music Radio - The Great Performers and Programs of the 1920s Through Early 1960s*. I met the author, Jim Cox, at an OTR convention in El Segundo, CA, three years ago. Jim is not only a very pleasant man, but he is a prolific author of OTR books. They include books about radio soap operas, crime fighters, audience participation shows, and the fading of the golden age of radio into the early stages of what we know now as broadcast programming.

*Music Radio* is basically a history of music as heard on American radio. The names of many familiar artists and groups are found in the book, as well as sponsors, dates and times of broadcasts, and the networks carrying the programs. Not only will you find history, some anecdotes, and insider viewpoints in the book, but Jim introduces each subject with his informed and expert analysis.

I will list the chapters here so that the variety of musical themes he covers will be better understood: The Bell Telephone Hour; The Big Bands; The Bing Crosby Show; The Chamber Music Society of Lower Basin Street; Cities Service Concerts; The Classics; The Contests; The Disc Jockeys; The Fred Waring Show; Grand Ole Opry; The Horse Operas; The House Bands; The Hummert Musicales; The Kate Smith Show; The Railroad Hour; The Sacred Singers; The Vocalists; The Voice of Firestone; and Your Hit Parade.

*Music Radio: The Great Performers and Programs of the 1920s through Early 1960s* by Jim Cox is published by McFarland & Company (Box 611, Jefferson, NC 28640; 800-253-2187; [www.mcfarlandpub.com](http://www.mcfarlandpub.com)). The 380pp. hardcover book costs \$55. However, I will cheerfully loan this book to any AWA member if it not already on loan. Let me know if you are interested in borrowing it, and let our editor know if you want more book reviews. My small radio library includes mostly OTR subjects, although I also have some antique radio histories and price guides.

– Andy Ooms, Pine, AZ; [oomspine@msn.com](mailto:oomspine@msn.com)

\* ARRL books are available from ham radio dealers and on the ARRL website ([www.arrl.org](http://www.arrl.org)). You can also order League publications on their toll-free telephone line 1-888-277-5289 (Outside the US +1-860-594-0355), or via snail mail to ARRL Publication Sales Department, 225 Main Street, Newington, CT 06111-1494 USA.

*Books and Equipment for announcement or review should be sent to What's New, c/o Monitoring Times, 7540 Highway 64 West, Brasstown, NC, 28902. Press releases may be faxed to 828-837-2216 or emailed to [Rachel.Baughn@monitoringtimes.com](mailto:Rachel.Baughn@monitoringtimes.com).*

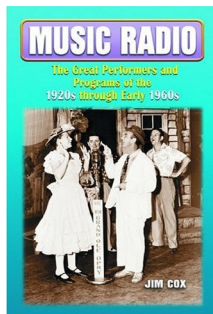

*On the Bench continued from page 71*

## ❖ Conclusion

DRM provides exciting listening and DX-ing opportunities. While using a PC may not be convenient, at least we can hear and sample DRM broadcasts now. I encourage shortwave radio hobbyists to try DRM, especially since the shareware DReaM is free, it is possible to receive a 12 kHz audio signal without modifying a receiver, and simply because it is fun.

DRM reception is not always 100 percent. At times the audio will drop out at exactly the wrong time. Or, at times, the audio sounds, to me, tinny, somewhat like cell phone audio. However, these are not deterrents. These simply present challenges.

Why would someone endure, at times, drop outs, tinny audio, the need to download software, the need to use a PC? Because the same person will get out of bed at 2a.m. to chase that elusive DX.

\*\*\*\*\*  
Kraig Krist, Manassas, VA  
KG4LAC – Amateur radio  
KDX4KWK – All-Band Radio Monitor

- <http://www.drm.org/consortium/history.php>
- <http://www.drm.org>
- [http://www.drmrx.org/receiver\\_mods.html](http://www.drmrx.org/receiver_mods.html)
- 455 kHz IF to 12 kHz adapter available from <http://www.sat-schneider.de/DRM/DRM.htm> See Universal DRM - miniature mixer unit
- Sourceforge website, location of much shareware including DReaM, <http://drm.sourceforge.net>
- Sourceforge DRM compile instructions <http://drm.sourceforge.net/installation.html>
- DReaM.exe download site <http://drm.sourceforge.net/forums>
- From the Microsoft Developer Network Library KB815065 "A DLL is a library that contains code and data that can be used by more than one program at the same time."
- <http://prdownloads.sourceforge.net/net-clipboard/qt-mt230nc.dll?download>
- <http://www.drm.org/livebroadcast/livebroadcast.php>

### Read a Good Label Latefy?

You could learn a lot! Look at your MT label before you throw your wrapper away - it tells you how many issues you have left in your subscription. If two or less, renew right away to avoid missing an issue. Keep those MTs coming and we guarantee you'll learn a lot!

**WARNING:** If you get a neon yellow wrapper on your magazine, don't throw it away: That is your renewal notice! Cut the card out of the wrapper and send it in with your payment. You'll get two notices and then it expires. So take care, don't let your subscription die!

# Stock Exchange

**LINE ADS**

NON-COMMERCIAL SUBSCRIBER RATES: \$.25 per word. All merchandise must be personal and radio-related.  
 COMMERCIAL, NON-SUBSCRIBER, AND MULTIPLE SALES RATES: \$1.00 per word. Commercial line ads printed in bold type.

Ads for Stock Exchange must be received 45 days prior to publication date. All ads must be paid in advance to Monitoring Times.  
 Ad copy must be typed for legibility.

**1-3/4" SQUARE DISPLAY AD:**

\$50 per issue if camera-ready copy or, \$85 if copy to be typeset. Photo-reduction \$5 additional charge. For more information on commercial ads, contact Beth Leinbach, 828-389-4007.

**Subscribe to MT for as little as \$15.50 (U.S. Second Class Mail)**

7540 Hwy. 64 W.; Brasstown, NC 28902  
 1-800-438-8155 US and Can.; 828-837-9200; Fax 828- 837-2216  
 e-mail order@grove-ent.com

	6 months	One Year	Two Years	Three Years
US Rates	<input type="checkbox"/> \$15.50	<input type="checkbox"/> \$28.95	<input type="checkbox"/> \$51.95	<input type="checkbox"/> \$76.95
US 1st Class	<input type="checkbox"/> \$30.00	<input type="checkbox"/> \$57.95	<input type="checkbox"/> \$112.00	<input type="checkbox"/> \$168.00
Canada Surface*	<input type="checkbox"/> \$20.50*	<input type="checkbox"/> \$39.50*	<input type="checkbox"/> \$75.95*	<input type="checkbox"/> \$112.95*
Foreign International*	<input type="checkbox"/> \$30.75*	<input type="checkbox"/> \$58.50*	<input type="checkbox"/> \$114.95*	<input type="checkbox"/> \$171.50*
Electronic Subscription		<input type="checkbox"/> \$19.95	<input type="checkbox"/> \$38.90	<input type="checkbox"/> \$57.85

\*All payments must be in U.S. Funds drawn on a U.S. Bank!

Attention all those wanting to know what's going on with ham radio in the New Orleans area, check out: <http://groups.yahoo.com/group/GNOAmateurRadio/>

For Sale: Sony ICF77 and ICF2010 in mint condition. Asking \$500 each. Call Ben, 732-238-3438 or cell 646-662-8635.

Blogs offer an opportunity for columnists to share information that does not make their columns. The news might be too timely for deadline, too short, confined to a small geographical area, too far away to be heard in North America, or even off the columnist's regular "beat." Bookmark these blogs for frequent visits!

- MT: AMERICAN BANDSCAN  
<http://americanbandscan.blogspot.com/> - by Doug Smith
- MT: EDITOR'S DESK  
<http://mt-editor.blogspot.com/> - by Rachel Baughn
- MT: FED FILES  
<http://mt-fedfiles.blogspot.com/> - by Chris Parris
- MT: MILCOM  
<http://mt-milcom.blogspot.com/> - by Larry Van Horn
- Larry's Monitoring Post  
<http://monitor-post.blogspot.com/> - by Larry Van Horn
- MT: SHORTWAVE  
<http://mt-shortwave.blogspot.com/> - by Gayle Van Horn
- MT: UTILITY WORLD  
<http://mt-utility.blogspot.com/> - by Hugh Stegman

**Time to Renew?** Your label will tell you how many issues remain in your subscription. When it's time to renew, your MT will arrive with a bright yellow cover sheet with the renewal form. Renew by the second notice to avoid missing an issue!

**Join the Club!**

Open to hobbyists worldwide, the **CANADIAN INTERNATIONAL DX CLUB** is Canada's national, general coverage radio club serving members since 1962.

For a free sample of our monthly electronic newsletter, **Messenger**, please e-mail CIDX at:

[cidxclub@yahoo.com](mailto:cidxclub@yahoo.com)  
 Web: [www.anarc.org/cidx/](http://www.anarc.org/cidx/)

**HUGE 100 PAGE CATALOG**

- Shortwave & Ham Gear
- Scanners & RTTY/FAX
- Antennas & Accessories
- Radio Books & CDs.

Send \$1 to **Universal Radio**  
 6830 Americana Pkwy.  
 Reynoldsburg, OH 43068  
 Tel. 800 431-3939  
[www.universal-radio.com](http://www.universal-radio.com)

**C Ku Satellite Equipment**

Big Dish • FTA Dish • Parts  
 LNBs • Switches • Feeds  
 Shortwave • Ham Gear  
 CB Radios • Scanners  
 Antennas • Cables • Accessories  
 Books • Electronic Parts  
**Dave's Hobby Shop**  
 600 Main • Van Buren, AR  
 479-471-0751  
[www.daveswebshop.com](http://www.daveswebshop.com)

**Listening In**

That's what we do and who we are!  
 Since 1974

Acclaimed worldwide as one of the top publications for radio listeners. Get a free sample of our electronic monthly magazine and see for yourself.

E-mail us and mention this ad

**Ontario DX Association**  
 155 Main St.N., Apt. 313  
 Newmarket, Ontario L3Y 8C2 Canada  
 E-mail: [listeningin@rogers.com](mailto:listeningin@rogers.com)  
[www.odxa.on.ca](http://www.odxa.on.ca)

**Satellite Dish Parts**

Residential and Commercial  
 Get it all with just one call!



**Melts snow and ice!**  
 Simply attach to your existing dish—works on metal dishes up to 1.2m!

[www.icezapper.com](http://www.icezapper.com)  
[www.skyvision.com](http://www.skyvision.com)

800-500-9275

Cumbre DX is the world's best shortwave DX publication. We feature news and loggings that you just won't find elsewhere. But the best part about Cumbre DX is that it is absolutely

**FREE!**

Send and email to [cumbredx@yahoo.com](mailto:cumbredx@yahoo.com) or visit our website at [www.cumbredx.org](http://www.cumbredx.org) to subscribe.

Alinco ..... 67

Antique Radio..... 65

Antique Wireless ..... 65

AOR..... Cover 2, 5

C Crane..... 11

Carey, Kevin..... 17

CIDX..... 75

Communications Electronics..... 27

Computer Aided Technology ..... 17

Cumbre DX..... 76

Dave's Hobby Shop..... 76

Electronic Specialty Products..... 15

Grove Enterprises ..... 7, 13, Cover 3

Hauser, Glenn ..... 39

ICOM ..... Cover 4

Nil-Jon..... 21

ODXA ..... 76

Popular Communications ..... 63

Prime Time Shortwave ..... 65

Robl, Ernest..... 37

Skyvision ..... 76

Small Planet Systems ..... 63

Universal Radio ..... 19, 76

WBCQ ..... 67

WiNRADiO ..... 1

# GROVE

## Your Source for Scanners, Receivers, Accessories, and Publications

Established in 1979 by well-known communications expert Bob Grove, Grove Enterprises has become a world leader in radio monitoring equipment, accessories, and publications.

If you decide you don't like a product, Grove Enterprises doesn't penalize you for it. There is NO restocking fee so long as you call our toll free number for a return authorization within fifteen days of shipment and the item is returned in new condition. Once the item is received we will give you credit toward another item or issue a full refund (less shipping charges). Software cannot be returned if opened.

That's it! No hassle! No negotiations! Just call 1-800-438-8155 and our friendly staff will assist you with a return authorization number.

**Grove means service and quality. You won't find better customer service anywhere.**



Shipping/ Handling Charges	
Total Order	Shipping Charges
\$1-\$29.99	\$3.00
\$30-\$49.99	\$6.95
\$50-\$99.99	\$8.95
\$100-\$399.99	\$12.95
\$400-\$899.99	\$16.95
\$900-\$1499.99	\$20.95
\$1500-\$1999.99	\$24.95
\$2000-\$2499.99	\$28.95
\$2500+	\$32.95

[www.grove-ent.com](http://www.grove-ent.com)

UNIDEN		
BR330T	SCN30	\$259.95
BCD396T	SCN47	\$524.95
BC898T	SCN44	\$199.95
BCT8	SCN08	\$169.95
BC246T	SCN46	\$209.95
BCD996T	SCN48	\$524.95
BCT15	SCN15	\$229.95



ICOM		
R3	SCN 7	\$349.95
R5	SCN 2	\$199.95
R20	SCN 20	\$509.95

ALINCO		
DJ-X10T	SCN 1	\$319.95
DJ-X2000T	SCN10	\$519.95
DJ-X7T	SCN 3	\$169.95



AOR		
AR8200IIIB	SCN51	\$579.95

RAMSEY		
ABM1 Air Band Monitor	SCN05	\$149.95

ANTENNAS & CABLES		
Grove Hidden Flex-tenna	ANT49	\$19.95
Austin Condor	ANT 14	\$29.95
Grove Scanner Beam II	ANT 18	\$64.95
Procomm CD144M/BN mag mount antenna	ANT50	\$19.95
800 MHz for handhelds	ANT 22	\$29.95
800 MHz base w/ right-angle conn.	ANT 23	\$34.95
OMNI II Scanner	ANT 5	\$29.95
Grove Flex-tenna HVU	ANT45	\$14.95
Grove Flex-tenna VU	ANT46	\$9.95
Professional Wideband Discone	ANT 9	\$94.95
Scantenna + 50' coax	ANT 7	\$49.95
Nil-jon Multi-band base antenna	ANT10MBS	\$94.95
Nil-jon Mobile antenna w/ NMO mount	ANT10NMO	\$74.95
AOR DA3000 Aerial Discone	ANT 11	\$139.00
AOR MA500 Wide Range	ANT 12	\$99.00
AOR SA7000 super-wide receiving	ANT 39	\$199.95
Range Extending Mobile Mag Mount	ANT 3	\$24.95
WiNRADiO AX-31B Active UHF Ant.	ANT 4	\$119.95
Grove Universal Telescoping Whip	ANT 6	\$14.95
Nil-Jon Super-M Superior Mobile Ant.	ANT 10	\$79.95
Create CLP51301N Log-Periodic Ant.	ANT 16	\$409.95
Create CLP51302N Log-Periodic An.	ANT 17	\$299.95
50' of RG-6U cable	CBL 50	\$19.95
100' of RG-6U cable	CBL 100	\$24.95

MISCELLANEOUS ACCESSORIES		
Universal Cigarette Adaptor	DCC 3	\$12.95
Ramsey Broadband Preamp	PRE 2	\$59.95
Scancat Gold for Windows	SFT 2W	\$99.95
Scancat Gold for Windows SE Upgrade	SFT 2SE	\$59.95
Scancat-Lite Plus	SFT 19	\$29.95
PAR VHF Intermod Filter 152MHz	FTR 152DS	\$69.95
PAR VHF Intermod Filter 158MHz	FTR 158DS	\$69.95
PAR VHF Intermod Filter 462MHz	FTR 462DS	\$69.95
FM Trap Filter 88-108MHz	FTR-FMDS	\$69.95
PAR NOAA Weather Filter 162 MHz	FTR 162DS	\$69.95
Yaesu SP-8 Speaker	SPK 4	\$159.95
GRE Superamplifier	PRE 1	\$59.95
VS6 Mobile Speaker	SPK 7	\$14.95
Speco DMS-3P Extension Speaker	SPK 3	\$49.95
DC SIX Audio Restoration, Enhancement & Editing Software	SFT18DS	\$199.00

# GROVE

**(800) 438-8155**

**CALL TODAY!**

Grove Enterprises, Inc. - [www.grove-ent.com](http://www.grove-ent.com)  
 (800) 438-8155; (828) 837-9200; fax: (828) 837-2216  
 7540 Hwy 64 W; Brasstown, NC 28902 - email: [order@grove-ent.com](mailto:order@grove-ent.com)

0.01 to 3299.999 MHz\*\* Coverage • Record and Save Audio in WAV Format • USB Cable Connection

# WHO SAYS THE WORLD IS ROUND?

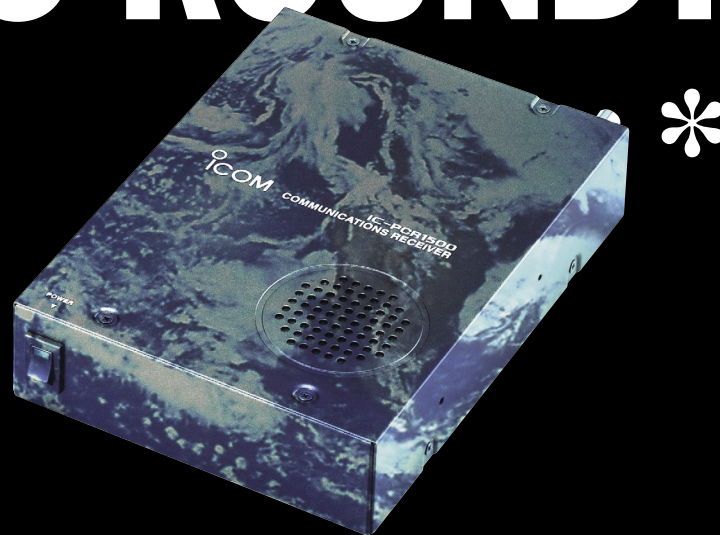

## **NEW** IC-PCR1500

PC Controlled Wideband Receiver

**NOW AVAILABLE**



Also now available: **IC-R1500**

A remote control head allows you to take the radio mobile. Cable included. No PC required, but you may connect the R1500 to a PC when not using the control head. Your choice. Visit your authorized Icom dealer today.

**For free literature:**  
425.450.6088 or  
[www.icomamerica.com](http://www.icomamerica.com)

\* Neat, look huh? It's just advertising. The radio is actually black. Very attractive, yes. But black. If we had put a black radio on this ad, the headline would not have been as quick to read. So we made up this look. Black is nice. Think of it as seeing the world from the night side. It's still there. You just can't see it. Can't get over it? If you send us \$5000.00 USD, we'll make up the radio look just like this for you. Is it worth it? Not to most people. But you're not most people. Are you? E-mail [icom@icomamerica.com](mailto:icom@icomamerica.com) with "worldPCR" in the subject line for more info. \*\* Cellular frequencies blocked.

©2006 Icom America Inc. The Icom logo is a registered trademark of Icom Inc. All specifications are subject to change without notice or obligation. 8760

 **ICOM**<sup>®</sup>