

ICD 08559

FEBRUARY 1990 \$2.50
CANADA \$3.50

MODERN ELECTRONICS™

THE MAGAZINE FOR ELECTRONICS & COMPUTER ENTHUSIASTS

- Using DC Voltmeters in Electronics Troubleshooting
- Experimenting With A Geiger Counter

Also Featured:

- Two-Digit Giant Numeric Display
- Collecting Antique Radios
- A Color Analyzer for Darkrooms
- Panasonic Answering Machine Interface for Two Lines

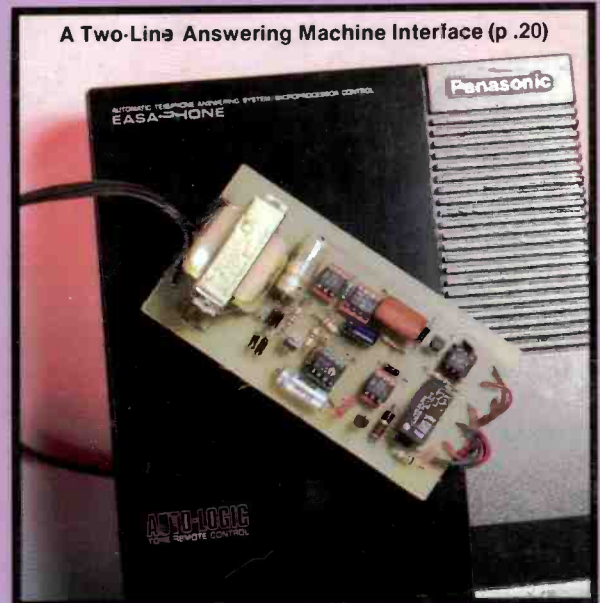

A Two-Line Answering Machine Interface (p. 20)

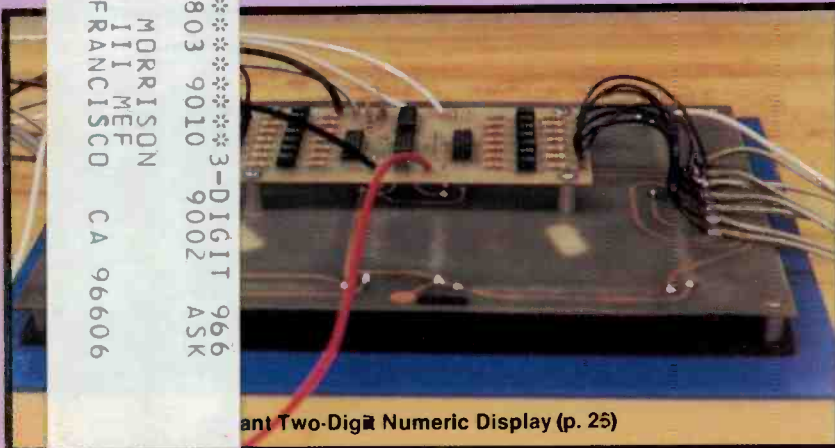

Two-Digit Giant Numeric Display (p. 25)



AST's Workstation/386SX Computer (p. 65)

*****3-DIGIT 966
 03 00841803 9010 9002 ASK

 ROBERT P MORRISON
 1ST FTIU III MEF
 FPD SAN FRANCISCO CA 96606

Bulk Rate
 U.S. Postage
 PAID
 Permit No. 79
 Gordonsville, VA
 22942

Plus: Evaluating AST's Workstation/386SX Computer, QAPLUS's CheckIt Diagnostic Software, Computer Aided Technology's CAT Reader OCR Software • A 12-Bit Serial CMOS D/A Converter • Latest Technical Books & Literature . . . more.

HARDWARE NEWS

New Dauphin LapPRO-386SX Packs a Powerful Punch for the Price

Dauphin Technology, an aggressive new Midwest-based laptop manufacturer, has come up with a high-performance 386SX-based laptop that offers 386 power at a 286 price. The price alone will turn a lot of heads. But a closer look at the machine itself reveals first-rate engineering, exceptional performance, and loads of standard features that would cost extra on most computers.

With a list price of \$4,995 and an introductory price of only \$3,695, Dauphin Technology has strategically positioned itself to compete head on with rival 286 models in the same price range. Since 386SX technology provides both present and future applications, the choice between a 286 and a 386SX of comparable cost will be an obvious one for many. Users opting for the LapPRO-386SX will have a laptop with more power, speed, memory and versatility along with the technology to serve them through the next decade and beyond.

Among its many prominent features is a 40 M-byte, 28 millisecond hard drive and 2 M-bytes RAM. Its ability to facilitate DOS, multitasking and multiuser functions, plus all the new 32-bit 80386 software makes it a necessity for anyone who requires the power of a high-end desktop model while away from the office.

Last Fall, Dauphin introduced its first laptop model based on an 80286 microprocessor. Though a late-comer to the market, the LapPRO-286 earned considerable praise for combining the most advanced features with quality engineering and price performance.

Both models from Dauphin Tech offer a 40 M-byte, 28 millisecond hard drive, a 3.5" floppy drive, two serial ports, one parallel port, a high contrast blue on white CGA/EGA LCD, an internal power supply offering four power options including battery pack, and a dedicated numeric keypad. Options include a 2400 or 4800 BAUD internal modem, math co-processor, 100 M-byte hard disk drive, and external floppy drive and keyboard ports.

The LapPRO-386SX sports a processor speed of 16 and 8 Mhz with zero wait states. It offers 2 M-bytes of Ram on board expandable to 4 M-bytes. Its



Dauphin Technology has priced its 80386SX laptop to compete head-on with rival 286-based models.

Features include:

- 80386SX Processor, 8 & 16 Mhz, Zero Wait States
- Multitasking Capabilities
- Multiuser Access
- 32-bit Software Compatibility
- 40 M-byte, 28 Millisecond Hard Drive
- 3.5" Floppy Drive
- 2 M-bytes RAM, Expandable to 4 M-bytes
- Internal Modem Option

external monitor port supports CGA, EGA and VGA.

The LapPRO-286 provides 1 M-byte RAM which is expandable to 4 M-bytes and an 80286 processor running at 8 or 12 Mhz with zero wait states.

Both models offer the highly acclaimed Digital Research Operating System (a.k.a. DR DOS) which is similar to and compatible with MS DOS. The more distinguishing advantages of DR DOS include on-line help, system utilities such as file retrieval, special security features and an ability to embed software in ROM. Alphaworks integrated software and LapLink file transfer software are also included with each laptop.

Judging by its first two laptop offerings, Dauphin Technology could very well be on its way to becoming a major player in the hardware arena. Though Dauphin Technology is relatively new to the computer industry, Alan Yong, founder, is not. In 1981, Yong incorporated Manufacturing and Maintenance Systems which is now recognized as the leading manufacturer and distributor of industrial alignment systems worldwide. The MMS REACT Alignment Systems, used to align rotating equipment in manufacturing plants, employ a proprietary portable computer and software for alignment calculations and maintenance records.

Given Yong's prior experience in portable computer development, the shift toward developing laptops seemed like a natural move. Yong is determined to build another successful company and his determination shows in the design configurations of these first offerings, a promising start.

Distribution channels for Dauphin Tech products are indeed far reaching and ambitious and include dealers, VARs, OEMs (for private label distribution), along with corporate, educational and government sales. The private label arrangement offered by Dauphin represents an ideal opportunity for OEMs to get into the fast-moving laptop market quickly. And the discounts on corporate quantity purchases are so generous that corporate managers of information systems will undoubtedly regard Dauphin as a serious contender for their business.

In keeping with its aggressive sales approach, Dauphin Technology is currently offering an unbeatable introductory price on both models. End-users would be well advised to invest in a high-performance laptop from Dauphin Tech now.

For more information on Dauphin Tech's laptop line, contact Dauphin Technology in Lombard, Illinois at 312-627-4004. And in the meantime, watch for more surprises from this up-and-coming manufacturer.

MS DOS is a trademark of Microsoft Corp.
DR DOS is a trademark of Digital Research Inc.
LapLink is a trademark of Travelling Software Inc.
AlphaWorks is a trademark of Alpha Software Inc.
LapPRO is a trademark of Dauphin Technology Inc.
MMS and REACT are trademarks of Manufacturing and Maintenance Systems Inc.

CIRCLE 67 ON FREE INFORMATION CARD

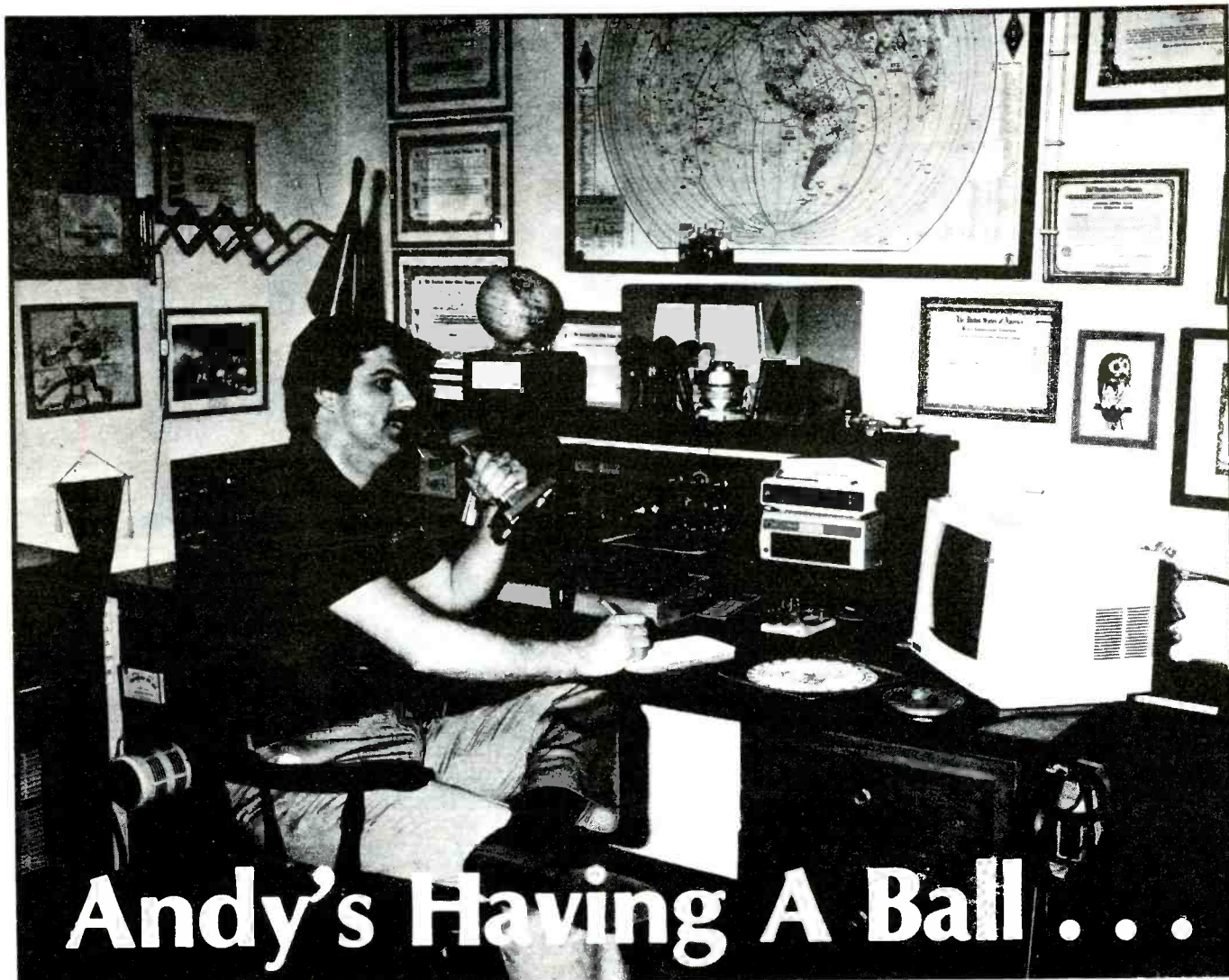

Andy's Having A Ball . . .

and you can too!

Andy is a Ham Radio operator and he's having the time of his life talking to new and old friends in this country and around the world.

You can do it too! Join Andy as he communicates with the world. Enjoy the many unique and exclusive amateur bands . . . the millions of frequencies that Hams are allowed to use. Choose the frequency and time of day that are just right to talk to anywhere you wish. Only Amateur Radio operators get this kind of freedom of choice. And if it's friends you're looking to meet and talk

with, Amateur Radio is the hobby for you. The world is waiting for you.

If you'd like to be part of the fun . . . if you'd like to feel the excitement . . . we can help you. We've got all the information you'll need to get your Ham license. Let us help you join more than a million other Hams around the world and here at home. Who are we? We're the American Radio Relay League, a non-profit representative organization of Amateur Radio operators.

For information on becoming a Ham operator
circle number 11 on the reader service card or write to:

AMERICAN RADIO RELAY LEAGUE

Dept CQ, 225 Main Street
Newington, Conn. 06111.

This space donated by this publication in cooperation with the American Radio Relay League.

HAM RADIO IS FUN!

It's even more fun for beginners now that they can operate voice and link computers just as soon as they obtain their Novice class license. You can talk to hams all over the world when conditions permit, then switch to a repeater for local coverage, perhaps using a transceiver in your car or handheld unit.



Your passport to ham radio adventure is TUNE-IN THE WORLD WITH HAM RADIO. The book tells what you need to know in order to pass your Novice exam. Two cassettes teach the code quickly and easily.

Enclosed is my check or money order for \$19.00 plus \$3.50 for shipping and handling or charge my

() VISA () MasterCard () Am. Express

Signature _____

Acct. No. _____

Good from _____ Expires _____

Name _____

Address _____

City _____ State _____ Zip _____

ME

THE AMERICAN RADIO RELAY LEAGUE
225 MAIN ST.
NEWINGTON, CT 06111

CIRCLE 79 ON FREE INFORMATION CARD

MODERN ELECTRONICS

THE MAGAZINE FOR ELECTRONICS & COMPUTER ENTHUSIASTS

FEBRUARY 1990

VOLUME 7, NUMBER 2



16

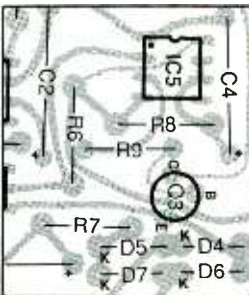

20

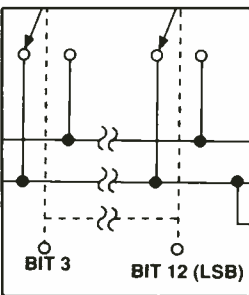

62

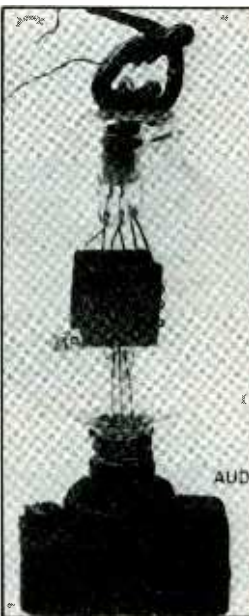

47

FEATURES

- 16 Using DC Voltmeters**
Troubleshooting direct-coupled differential and Darlington amplifiers. *By Robert G. Middleton*
- 20 Two-Line Telephone Answering-Machine Interface**
Automatically switches a single telephone answering machine between two separate phone lines. *By Anthony J. Caristi*
- 26 "Big Score" Counter Display**
Giant numeric display is ideal for keeping game score, tallying customers, etc. *By Walter W. Schopp*
- 36 Color Film Processing Analyzer**
Takes the guesswork out of determining best color balance for processing color negatives and slides to assure consistent results. *By Maurice P. Richardson*
- 47 Down Memory Lane**
Nostalgic look at the early days of radio and some thoughts on collecting antique radios. *By Joseph J. Carr*

PRODUCT EVALUATIONS

- 65 Product Evaluation**
AST Premium Workstation/386SX: Blazing Speed in a Compact Box. *By TJ Byers*

COLUMNS

- 54 Electronics Notebook**
Experimenting With a Geiger Counter. *By Forrest M. Mims III*
- 62 Solid-State Devices**
A 12-Bit Serial Daisy-Chain CMOS D/A Converter. *By Joseph Desposito*
- 68 PC Capers**
Diagnostic & CAT Reader OCR Software Packages. *By Ted Needleman*
- 72 Communications**
Ace's Model AR900 Portable Scanner. *By Louis A. Smith*

DEPARTMENTS

- 6 Editorial**
Long-Term Commitments. *By Art Salsberg*
- 7 Letters**
- 8 Modern Electronics News**
- 10 New Products**
- 79 Books & Literature**
- 86 Advertisers Index**

THE B.I.R.D.^{T.M.}

Battery operated InfraRed Detector

Parts Express introduces the first Battery operated InfraRed Detector pen.

This compact device will instantly confirm operation of infrared emitting products.

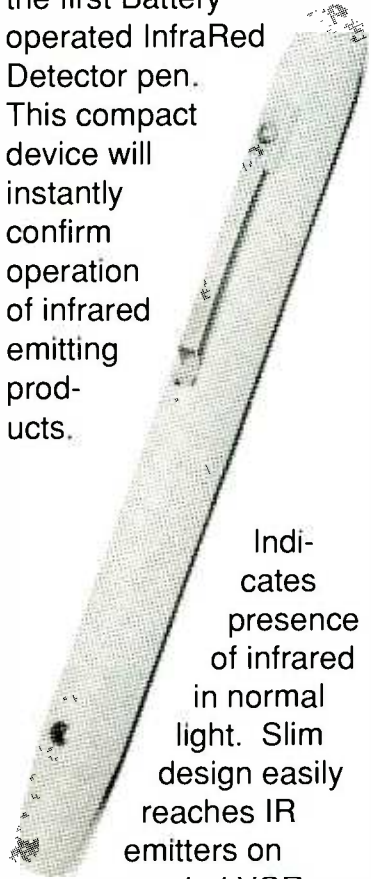

Indicates presence of infrared in normal light. Slim design easily reaches IR emitters on crowded VCR circuit boards. This

low cost and easy to use instrument will soon become standard equipment for all technicians in the consumer electronics repair industry.

**CALL TOLL FREE
1-800-338-0531**



340 E. First St.
Dayton, Ohio 45402
Phone: 513-222-0173
FAX: 513-222-4644

CIRCLE NO. 153 ON FREE INFORMATION CARD

EDITORIAL

Long-Term Commitments

In our competitive world, it's difficult to get industry standards that everyone abides by unless it's a radio-wave communications one that is set down by the FCC. As a consequence, we got both 45-rpm and 33 $\frac{1}{3}$ -rpm records, Beta and VHS VCRs, 8-mm and VHS camcorders, digital and analog multimeters, and so on. For the end user, you pay your money and make your choice, risking a loss in one way or another down the line if your choice doesn't become dominant for a fair amount of time.

Remember those 45-rpm record changers? They were whipped by the 33 $\frac{1}{3}$ -rpm changers (which yielded, in turn, to single-play machines), which had adapters to play the 45s. If one were making such a decision today, a CD player should be the product of choice if you don't have an enormous collection of LPs you wish to retain.

Many years ago, you would have seen buyers line up to purchase digital LED wristwatches. Not long after, liquid-crystal display watches displaced them. Today, analog faces are in vogue, with digital electronics hidden within the case. At one time some of you had to make a choice between laser video disks and videocassette machines, or between open-reel audio tape machines or cassette machines, between stereo or four-channel sound, etc.

Among the buying choices that many of us are or will be facing is the type of bus employed by MS-DOS computers: ISA (Industry Standard Architecture), which is the common one used by PC- and AT-type computers, MCA (Micro Channel Architecture), which is IBM's newest two-year-old design, and EISA (Extended ISA), which is the independent MS-DOS computer makers' answer to IBM's MCA. The latter two buses are needed to handle the latest Intel 32-bit microprocessors, the 80386 and 80486.

Most readers are aware that IBM machines with MCA buses and some independents who are licensed by IBM to use the MCA bus have product on the market (about 1 $\frac{1}{2}$ -million units). Machines with the EISA bus, on the other hand, are just beginning to emerge (about 50,000 units). The latter, therefore, has to play catch

up, including device and board makers for EISA machines. Additionally, you likely know that MCA only handles MCA-type plug-in boards, while EISA will accept the ISA boards currently used with PC- and AT-type computers, as well as newly designed EISA boards used with '386 and '486 microprocessors.

Political and business ramifications are commonly known, too. That is, the so-called gang of nine led by Compaq rebelled at paying IBM heavy license fees and royalties for its MCA development and wanted a backward-compatible bus that would allow boards from the millions of 16-bit PCs to be plugged into new computers with an EISA bus. Moreover, EISA-bus supporters, now numbering almost 200 companies (with some hedging bets by also getting licensed for IBM's MCA bus), did not want to be at the beck and call of IBM whenever Big Blue decides to change specifications.

So with three major MS-DOS bus standards (there are others), which one would you choose if you're buying an MS-DOS computer? To buy into the future (it's predicted that by 1993, sales of 16-bit machines will dip below 50% of the market) it would have to be one or the other of the newer 32-bit bus ones.

There are similarities and differences between the two new buses. To sum up the end results, IBM's Micro Channel Architecture is thought to be technically better, while EISA's offers compatibility with older 16-bit boards. On the former, MCA only has to support one type of interrupt, while EISA has to handle two basic signal types. With the need to accommodate only one type of edge connector, MCA's mechanical design is simpler. Furthermore, it lends itself naturally to handling more compact add-in boards (36 sq. in. vs. 63 sq. in.). In contrast, the EISA bus has two sets of connectors on a bi-level design. The lower level contains pins for the EISA boards, which are notched to allow it to be fully inserted into the connector, while the upper level is for the ISA boards, which cannot be fully inserted.

Another important technical asset featured by the MCA bus is said to be its superior containment of electromagnetic

radiation by employing a better distributed power and ground system. Furthermore, the system doesn't have to contend with noise spikes that the ISA bus is susceptible to because of its edge-triggered interrupts.

In contrast, compatibility with existing and future products is the hallmark of EISA. After all, no one wants their investment to be obsolete. But how big a deal is this, really? Not as great as one would think at first blush! For example, much of the new machine's memory is already built in, as are parallel and serial ports, and video interfaces. There are indeed some add-on boards with functions that aren't yet available for EISA or MCA, or are very costly if they are. So for some, this feature might serve well. Since most people won't scavenge a working older model, it likely means that using old boards in other PCs will not be a widespread practice. Insofar as the reputed

technical superiority of MCA, this is challengeable. According to some EISA proponents, just the opposite is true, citing standardized I/O bus timing as compared to MCA's looser clock cycles.

Examining all aspects, I can't see at this time which one will be the long-term winner, if any. The key will be the depth and breadth of add-on boards that are available for a bus, I think. In this respect, they're essentially equal right now. System speeds are about the same, too, with one bus type faster one month, and another playing one-upmanship the next time out.

I conclude at this moment in time that it doesn't much matter which bus the machine you buy has. Both are expected to run along as competitors when EISA-type makers line up their guns after a two-year head start that MCA machines have had.

You'll be making a long-term commit-

ment to a machine unit, whichever the bus. More important, assuming that there's continued device and add-on-board support for both types, is the price you pay for what you get and the quality of technical support. Neither will pay off until there's enough good 32-bit software to make such a purchase worthwhile, not to mention faster and more functional peripherals to also take advantage of the computer's speed.

Alternatively, there'll still be plenty of buyers for the old ISA/AT type of computer. They're cheap, and have add-on boards and good software programs galore. Not everyone needs to have the use of the fastest gun in town.



LETTERS

The Chargecard

• We appreciate your mention of our product, PC-MOS, in "Choosing the Right Computer Power" in the October 1989 issue of *Modern Electronics*. However, there is a correction we'd like to make. The statement on page 21, "For the most part right now, this means you cannot use any of a number of 386 operating systems such as Microsoft Windows 386, PC-MOS/386 (The Software Link, Atlanta, GA) . . ." is simply not true. PC-MOS will run on an 80286 computer in conjunction with memory-management hardware, such as All Computer's "All Chargecard," a credit-card-size memory-management unit that plugs directly into the 80286 chip socket and does not require an expansion slot.

In addition to accessing the extended memory of an 80286 chip, All Chargecard can access any system-board memory, including: the 384K extended memory on the PS/2 and many AT compatibles;

any extended memory on boards like AST's Advantage and IBM's Memory Expansion option; and any expanded memory one might have on boards like Intel's Above Board. Memory becomes a pooled resource, available to any program at any time.

The All Chargecard gives users up to 960K of real DOS memory and allows them to run larger expanded-memory applications under the Lotus/Intel/Microsoft Memory Specification (LIM EMS) and AST/Ashton-Tate Enhanced Expanded Memory Specification (EEMS) using extended memory. The user can also run RAM disks, which are not lost when resetting the computer with a warm boot.

As an example, both The Software Link's marketing/public relations department and corporate publications department are currently running PC-MOS on an 80286 microcomputer. However, in applications where there are more than

a couple of users, TSL does recommend running PC-MOS on an 80386 computer.

Cathleen S. Robson
The Software Link
Norcross, GA

Letter of Commendation

• I would like to commend *Modern Electronics* and author Adolph Mangieri. I built the "Full-Screen Video Inverter" described in the September 1989 issue but had a problem with it. So I wrote to your magazine. My letter was forwarded to Mr. Mangieri, who wrote back to me and offered some suggestions. A few days later, I received a second letter from Mr. Mangieri containing a circuit fix that eliminated my problem. I made the modification and the circuit now works perfectly.

It is indeed pleasant to experience such honest concern for the reader today, from

(Continued on page 85)

FAX MACHINE SERVICE TRAINING. Mitsubishi Electric ran service and installation seminars on facsimile machines. The two-day courses provided across the country in eight major markets was said to equip any independent service technician with the basic service skills needed for virtually any fax brand on the market. Classes were limited to 25 attendees. Each lecture was followed by a lab session in which students practiced diagnosing and solving problems that were intentionally wired into actual fax machines. Cost was \$295, which included all video and written material. For information on future fax technical training seminars, call Mitsubishi at 714-220-2500.

PC EARTHQUAKE DAMAGE. The computer and electronics industry came away from the recent West Coast earthquake in pretty good shape, we thought. Nevertheless, computer equipment and software insurer SAFEWARE (Columbus, OH) says that earthquake damage to personal computers will exceed \$100-million. That makes this catastrophe the year's third largest source of losses, exceeded only by theft (#1) and electrical damage (#2). According to a company spokesman, computers on acoustic mats survived better.

HF PACKET RADIO GRANT. The ARRL got a ten-grand grant from the Federal Emergency Management Agency (FEMA) for high-frequency packet radio modem and protocol development. It will be used to fund out-of-pocket costs (excluding labor or overhead) for volunteer participants in the development program. The ARRL says that about 100,000 packet radio units have been built by or sold to hams throughout the world. Presently, packet radio operates effectively at VHF (above 30 MHz), while at HF (3 to 30 MHz), reception is often poor due to fading and interference. Designers wishing to participate in the program can contact Lori Weinberg at ARRL, tel. 203-666-1541.

WORLD ELECTRONIC SPEED RECORD. Westinghouse Electric researchers at its Pittsburgh Science & Technology Center claim to have built a digital electronic shift register with the fastest data-handling speed ever reported for such a circuit. Built with low-temperature niobium superconductor devices, it was reported to successfully handle 3.33 gigabit of data per second, beating out the previous record of 3.2 Gb/s made with a gallium arsenide IC. Superconducting shift registers also have the advantage of requiring much less power, a highly important consideration since one of its prime applications will be for satellite communications where power is at a premium. The company's stated goal is to hit 10 gigabits per second by next year. Shift registers are used to reduce high-frequency, high-data-rate information to signals that computers can handle.

RECHARGEABLE LITHIUM BATTERY. Sanyo has introduced a new 3-volt lithium battery that can be recharged. The button-type device can replace two nickel-cadmium cells, while providing two to three times the energy density, says a company spokesman. It's expected to be used in size-critical portable applications as a power supply and for backing up computer memories and real-time clocks. Sample quantities are \$2.75 each, with OEM quantities available in the late third quarter.

Radio Shack Parts Place SM

BIG SELECTION AND LOW PRICES—COME IN TODAY!

Join the Fun of Ham Radio

Novice and General Class Study Packages Prepared by Gordon West, WB6NOA

19⁹⁵ Each Durable Storage Binder Included



Novice. Two self-paced code cassettes, study guide with exam questions, answers and full explanations, FCC Form 610. #62-2402
General. The speedy way to upgrade! Includes test questions, answers and explanations, two speed-building code tapes. #62-2404

Battery Special-Order Service



In addition to our large in-store stock, Radio Shack can now supply almost any battery. Our expanding selection even includes special batteries for walkie-talkies and pagers. Batteries are sent from our warehouse to the Radio Shack near you. Never a postage charge!

RS-232 Connectors and Accessories

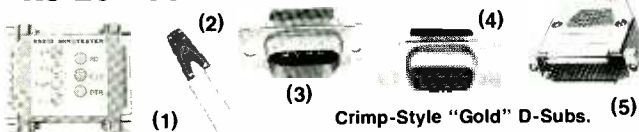

(1) **Inline RS-232 Tester.** Seven LEDs pinpoint problems fast. D-sub 25. #276-1401 14.95
 (2) **D-Sub Pin Crimper.** This pro-quality tool accepts #20, #24 and #28 pins. #276-1595 9.95

Crimp-Style "Gold" D-Subs. (5)

Fig.	Description	Cat. No.	Each
3	Male-9	276-1427	.99
4	Female-9	276-1428	1.19
..	Male-25	276-1429	2.49
..	Female-25	276-1430	2.99

(5) **9-Position Hood.** #276-1513, 1.49
25-Position Hood. #276-1536 1.99

Super Speaker Accessories



(1) **MEGACABLE™.** 12-ga. braided pure copper. #278-1268 Per Foot 99¢
 (2) **Speaker Terminal Plate.** For large speaker wires. Features special-design 3/4" diameter knobs. Mounts in 3/8 x 2 9/16" hole. #274-626 4.99
 (3) One red, one black knob as above, less plate. #274-619 Set of 2/5.95
 (4) **Large Gold-Plated Terminals.** 4 red, 4 black. #64-401 Set of 8/4.99

Project Lighting



(1) **Jumbo 5000 mcd LED.** Big, bright. #276-086 4.99
 (2) **Blinking LED Indicators.** Red. #276-036 1.29
 Green. #276-030 1.29
 (3) **12-Volt Flashing Lamps.** #272-1097 Set of 3/1.29

Switch Bargains

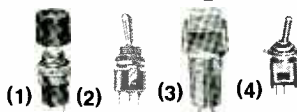

(1) **SPST Momentary Button.** #275-1556 1.99
 (2) **SPDT Toggle.** 5A at 125VAC. 7/16" stem. #275-603 1.59
 (3) **SPST Push On/Push Off.** 3A at 250VAC. #275-617 1.39
 (4) **PC-Mountable Light-Duty SPST.** #275-645 1.99

Inductor Values

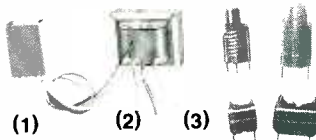

(1) **1:1 Audio Transformer.** Z: 600-900Ω. #273-1374 3.59
 (2) **Audio Output Transformer.** #273-1380 1.69
 (3) **Inductor Assortment.** 30 pieces! #273-1601 1.98

Posts and Plugs

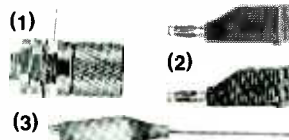

(1) **Metal Grounding Post.** With knurled grip. #274-667 99¢
 (2) **Stackable Banana Plugs.** #274-734 Set of 2/1.59
 (3) **14" Test Cables With Clips.** #278-1156 Set of 10/3.99

Hobby Motor



For robotics, models, projects. 8300 RPM maximum. Operates 1 1/2 to 3VDC. About 1 1/2" long, 15/16" dia. #273-223 99¢

TNC Adapters

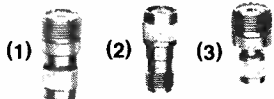

Here's just a sample of our big selection of RF adapters.

Fig.	Accepts	Plugs Into	Cat. No.	Each
1	PL-259	Female TNC	278-118	3.49
2	TNC Male	TNC Female	278-143	3.99
3	PL-259	Mini UHF	278-174	3.99

Lighted Switches



(1) **SPST.** Rated 5A at 250VAC. Includes 12-volt lamp. UL listed. #275-678 6.99
 (2) **SPDT Push-On/Push-Off.** Rated 3A at 125VAC. Includes 12-volt lamp. #275-676 6.49

"Gold" Adapters

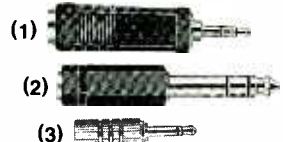

(1) Accepts 1/4" stereo plug. Plugs into 1/8" stereo jack. #274-875 2.99
 (2) Accepts 1/8" stereo plug. Plugs into 1/4" stereo jack. #274-876 2.99
 (3) Accepts 1/8" stereo plug. Plugs into 1/8" mono jack. #274-877 2.99

Soldering Accessories



(1) **Dual-Wattage Iron.** Go from 15 to 30 watts with the flick of a switch. Has a replaceable tip and it's 8 1/4" long. UL listed AC. #64-2055 8.95
Chisel Tip. #64-2056 1.19
Replacement Tip. #64-2065 99¢
 (2) **Vacuum Desoldering Tool.** #64-2120 6.95

Extra-Feature LCD DVM



79⁹⁵

Capacitance and HFE Ranges

Top-quality digital voltmeter with an easy-to-read 0.5" LC display. Measures AC/DC volts and current, resistance, capacitance, transistor gain. With probes. #22-194

B-Board and Jumpers



(1) **Deluxe Breadboard.** Molded 2 1/4 x 6 1/2" board is mounted on a 7 x 4" steel base with rubber feet. Features 640 plug-in points and three binding posts. #276-169 19.95
 (2) **Breadboard Jumper Wire Kit.** Includes 140 insulated, pre-stripped wires in a handy, snap-shut box. #276-173 Set 4.95

Over 1000 items in stock! Binding Posts, Books, Breadboards, Buzzers, Capacitors, Chokes, Clips, Coax, Connectors, Fuses, Hardware, ICs, Jacks, Knobs, Lamps, Multitesters, PC Boards, Plugs, Rectifiers, Resistors, Switches, Tools, Transformers, Transistors, Wire, Zeners, More!

Prices apply at participating Radio Shack stores and dealers

Radio Shack®
The Technology Store™

A DIVISION OF TANDY CORPORATION

CIRCLE 80 ON FREE INFORMATION CARD

For more information on products described, please circle the appropriate number on the Free Information Card bound into this issue or write to the manufacturer.

Digital Logic Analyzers

Heath/Zenith Computer Based Instruments has added two PC-based digital logic analyzers to its line of high-performance test equipment. The Models ST-4800 and ST-4750 are 32- and 16-bit analyzers, respectively. Both are designed to aid in testing and debugging hardware and software at sample rates up to 50 MHz, and both offer dual sample memories with 4,000 bits of storage per channel. These analyzers feature



internal clocking from 20 ns to 40 ms in both state and timing mode. An external clocking feature also provides for synchronous testing. Both units trigger internally on any pattern of up to 16 channels. External triggering offers pulse widths as narrow as 10 ns, with a choice of leading or trailing edge.

These analyzers are designed to operate with other computer-based instruments through Heath/Zenith's Versatile Instrument Operating Software (VIOS). This integrated system permits combining the analyzers with others of the company's SW-3020 instruments. Under VIOS, commands can be directed to other instruments from the analyzer menu. Setup conditions and data are on floppy disk. With this arrangement, one can compare test data with future samplings or conduct an analysis of all accumulated data.

Both state and timing modes of operation offer search capability and built-in printer drivers for hard-copy output. The timing mode features a built-in pattern range of $\times 1$ to $\times 64$, while the state mode offers a built-in pattern recognizer that provides for displays of user-defined mnemonics in place of specified bit patterns.

CIRCLE NO. 164 ON FREE INFORMATION CARD

Under-Desk Mouse Tray

The Model 601 Underdesk Mouse Tray from MicroComputer Accessories, Inc. (Los Angeles, CA) can be mounted to the underside of a desk or table top to permit easy access and storage of a mouse. It extends and retracts on glides. The tray is designed to permit the user to operate the mouse near his keyboard, without occupying valuable desk-top space.

A 10-inch-wide textured rubber pad mounted to the tray provides an

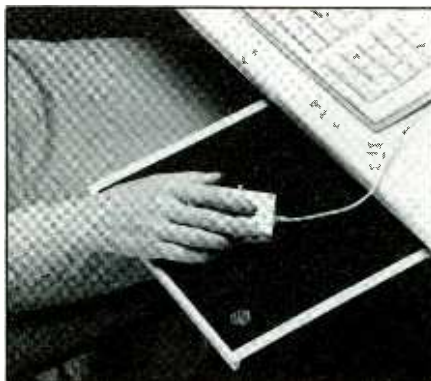

ideal surface for maneuvering the mouse and can also hold an optical grid. A small compartment located inside the tray and directly under the mouse pad provides storage space for the mouse and other supplies. The steel-constructed Underdesk Mouse Tray measures $14\frac{1}{4} \times 10\frac{1}{2} \times 2\frac{3}{8}$ inches and is platinum in color. \$29.95.

CIRCLE NO. 165 ON FREE INFORMATION CARD

"Big-Screen" LCD TV

Casio offers the only "big-screen" portable 4-inch color LCD TV receiver, Model TV8500, now sold in

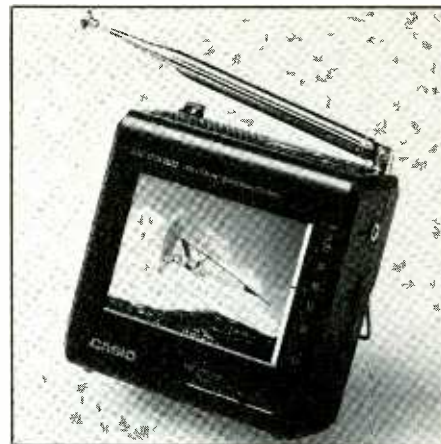

the U.S. It features a high-resolution liquid-crystal display with HQ-M2 passive matrix system, Casio's latest high-quality matrix technology. A high-luminance fluorescent material behind the display provides back-lighting for easy viewing.

The TV receiver tunes vhf Channels 2 through 13 and uhf Channels 14 through 69 via up/down pushbuttons located on the top of the enclosure. A vhf/uhf telescoping antenna is built in, as is an earphone jack and an external antenna jack for connection to a home antenna or cable system. Operation is from six AA cells, an optional ac adapter or an optional car adapter.

Measuring just $4\frac{1}{2}$ "W \times $4\frac{1}{2}$ "H \times $1\frac{1}{8}$ "D, the tiny TV receiver weighs 18.5 ounces. It comes with earphone and soft carrying case. \$449.95.

CIRCLE NO. 166 ON FREE INFORMATION CARD

Disguise Ham Antenna

A new On-Glass® disguise Amateur-radio antenna for the 2-meter band has been introduced by Antenna Specialists. The Model AP-143 borrows the "pigtail" configuration of cellular antennas to disguise the presence of professional radio equipment inside a motor vehicle. The antenna's On-Glass design uses capacitive coupling of transmissions through the glass on which it is mounted for quick, no-holes installation. It requires no ground plane.

(Continued on page 14)

How to build a high-paying career, even a business of your own, in computer programming.



**RICK BRUSH,
NRI PROGRAMMER/ANALYST**

Start with training that gives you hands-on programming experience—at home and at your own pace. Training that begins with BASIC, then continues with Pascal, C, and COBOL—today's hottest computer languages. Training that even includes a powerful IBM-compatible computer, modem, and programming software you keep.

Start with real-world training. The kind of training only NRI provides.

Now with NRI's new at-home training in Computer Programming, you can be one of today's highly paid, creative team of computer wizards who give computers the power to carry out an astonishing range of business, professional, and personal applications. Now, with NRI, you can be a computer programmer, ready to build a high-paying career—even a business of your own—making computers do anything you want them to do.

The only programming course that includes a powerful computer system and software you keep.

Unlike any other school, NRI gives you hands-on programming experience with a powerful IBM compatible West Coast computer system, including 2400



Only NRI gives you an IBM-compatible computer with modem, 640K RAM, disk drive, monitor, and software—BASIC, Pascal, C, and COBOL—all yours to keep!

baud internal modem, 640K RAM, disk drive, monitor, and invaluable programming software—BASIC, Pascal, C, and COBOL—all yours to keep.

You get the experience and the know-how, the computer and the software to get to the heart of every programming problem, design imaginative solutions, then use your choice of four key computer languages to build original, working programs.

No matter what your background, NRI gives you everything you need to succeed in programming, today's top-growth computer career field.

You need no previous experience to build a successful programming career with NRI training. Indeed, your NRI lessons start by walking you step by step through the fundamentals, giving you an expert understanding of the programming design techniques used every day by successful micro and mainframe programmers. And then the fun really begins.



You master today's hottest computer languages, gaining the skills you need to build programs for a wide variety of real-world applications.

With your personal NRI instructor on call and ready to help, you use your computer and software to actually design, code, run, debug, and document programs in BASIC, Pascal,

C, and COBOL. Then, rounding out your training, you use your modem to "talk" to your instructor, meet other NRI students, even download programs through NRI's exclusive programmers network, PRONET.

Your career in computer programming begins with your FREE catalog from NRI.

For all the details about NRI's at-home training in Computer Programming, send the coupon today. Soon you'll receive NRI's fascinating, information-packed, full-color catalog.

Open it up and you'll find vivid descriptions of every aspect of your NRI training. You'll see the computer system included in your course up close in a special, poster-sized foldout section. And, best of all, you'll find out how your NRI training will make it easy for you to build that high-paying career—even a business of your own—in computer programming.

Send for your NRI catalog today. It's yours, free.

If the coupon is missing, write to us at the NRI School of Computer Programming, McGraw-Hill Continuing Education Center, 4401 Connecticut Avenue, NW, Washington, DC 20008.

IBM is a Registered Trademark of the IBM Corporation

NRI School of Computer Programming

McGraw-Hill Continuing Education Center
4401 Connecticut Avenue, NW
Washington, DC 20008



YES! Please rush me my FREE catalog describing NRI's at-home training in Computer Programming.

NAME _____ (please print) AGE _____

ADDRESS _____

CITY/STATE/ZIP _____ Accredited by the National Home Study Council 5414-020

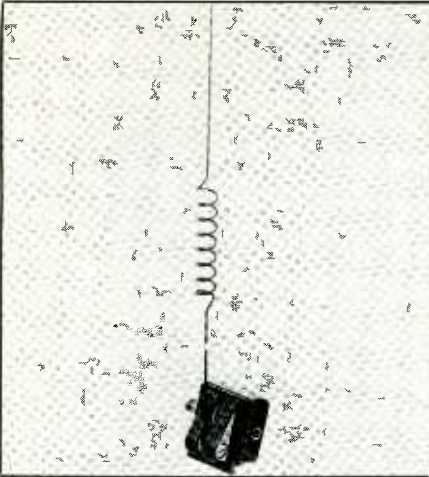

Featured is a 26-inch stainless-steel whip element that is covered in black Dura-Coat™ finish for long service life. The antenna has a power rating of 100 watts continuous and 150 watts intermittent. VSWR is rated at less than 1.5:1.

CIRCLE NO. 167 ON FREE INFORMATION CARD

Voltage-Regulator Modules

The Electrovert/Wieland (New Rochelle, NY) FSR series voltage-regulator modules transform ac voltages from a transformer into stabilized dc in the 5-to-24 volt range with very low hum level. Built into a compact housing, the regulators feature: universal foot for mounting on all types

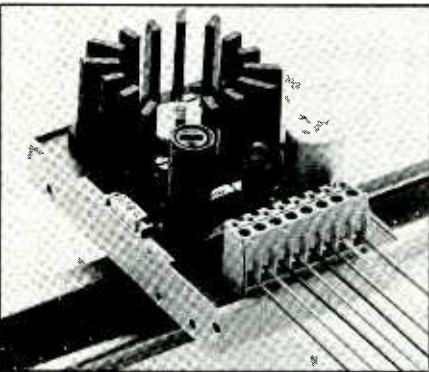

of DIN rails; arc-suppression diode protection; integrated thermal overload protection; twin terminals for input and output; test plug stud; and green LED output-available indicator. Separate units with 5, 12, 15 and 24 volts are available. \$59 each.

CIRCLE NO. 168 ON FREE INFORMATION CARD

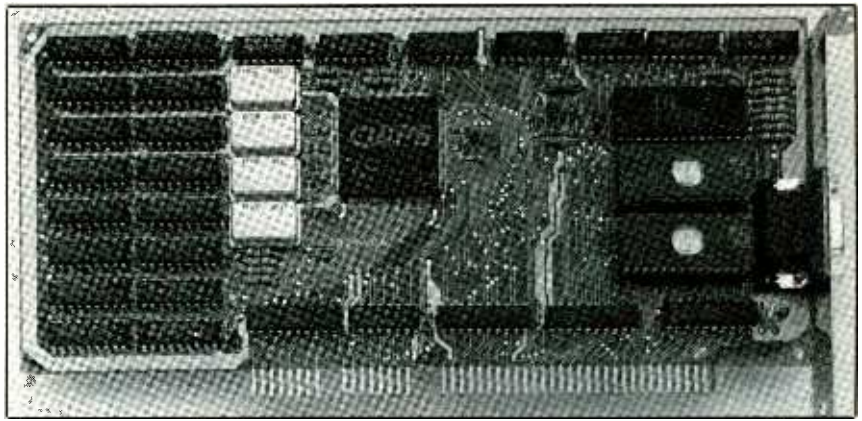

1,024 VGA Board

Boca Research, Inc. (Boca Raton, FL) now has a VGA board that offers 1,024 × 768-pixel resolution for IBM AT and other 80286- and 80386-compatible computers. Designed to enhance graphics displays when used with analog 15-pin VGA and multiple-frequency monitors, it offers 1,024 × 768- and 800 × 600-pixel graphics resolution with 16 colors and is said to be 100 percent register-level compatible with standard 640 × 480-pixel VGA, EGA, CGA, MDA and Hercules Graphics Card modes.

An on-board autoswitch feature automatically adjusts to the video pre-VGA mode required, depending on the application in use. This feature also automatically recognizes the attached monitor and adapts to the correct video mode.

In addition to 16-color, high-resolution drivers, the 1024 VGA includes software drivers that display

640 × 480-pixel graphics in 256 simultaneous colors from a palette of 256,000 colors. Drivers for Windows/286/386, OS/2 Presentation Manager, GEM, AutoCAD, and Framework II are included. Drivers included for both 1,024 × 768-pixel and 800 × 600-pixel resolutions are: Windows/286 2.03,2.1; Windows/386 2.1; OS/2 Presentation Manager 1.1; GEM 2.2,3.0; Ventura Publisher 1.0,1.1,2.0; AutoCAD 2.62,9.0, 10.0; and Framework II 1.0. Text can be displayed in 132-column format for a variety of spreadsheets and word processors.

The board's 16-bit design is said to deliver increased graphics and text speeds. A single VLSI graphics chip enables it to access 512K of video memory in 16-bit increments. Installation is easy, requiring neither jumpers nor switches to be set. A diagnostic program is provided to verify proper functioning of both board and monitor. \$395.

CIRCLE NO. 174 ON FREE INFORMATION CARD

Infrared Detector Pen

The B.I.R.D. from Parts Express (Dayton, OH) is said to be the first battery-powered infrared detector pen on the market. It instantly confirms operation of infrared-emitting devices, such as wireless remote controllers, VCR tape-stop circuits, infrared sources in alarm systems and more. A LED in the top of the pen lights when IR radiation is detected

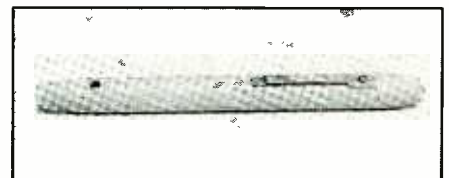

under normal lighting conditions. The slim design of the pen arrangement makes it easy for The B.I.R.D. to reach into crowded VCR circuit boards and assemblies.

CIRCLE NO. 175 ON FREE INFORMATION CARD

Audio/Video Switchers

Two new switching devices that simplify audio/video/TV hookups are available from Ambico (Norwood, NJ). The Model V-0780 audio/video control center permits automatic switching between any three stereo A/V sources. With this unit installed, VCRs, audio sound units, camcorders, etc., can be left permanently connected into a system. Source selection is via pushbutton

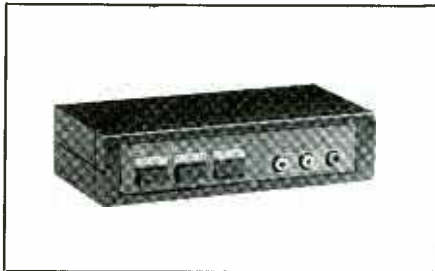

switches. All inputs and outputs are made via phono jacks. The output connects to a VCR or TV/monitor.

The Model V-0785 is a TV control center that permits automatic switching between any two cable/antenna sources and one composite audio/video source. This unit features two r-f-type inputs. A video game console or computer can be hooked up to the composite A/V input. This unit also features source selection via pushbutton switch. An r-f-type output connector permits easy connection to any TV receiver or VCR. \$24.95 each.

CIRCLE NO. 176 ON FREE INFORMATION CARD

24-Pin Printer

Okidata's new Microline 380 printer for professional and home use features a 24-pin printhead, six resident letter-quality fonts and professional paper handling. Fonts are selectable from the front panel of the printer or under software control. The font panel has LEDs for easy identification of font and pitch selected. Resident fonts include Courier, Helvette, Roman, Orator, Prestige and Gothic in 10 to 20 characters per inch, plus proportional spacing. The user can

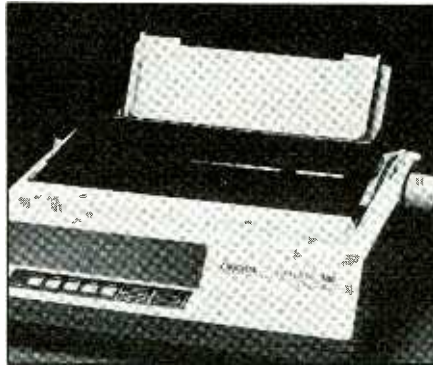

add such other features like double high/wide, outline, shadow and Italics effects.

A built-in push tractor provides professional paper handling for fan-fold paper and forms. Additionally, the 380's paper park feature allows the user to switch from continuous forms to cut-sheet paper. Power-assisted paper loading loads in single sheets, and a short-forms tear bar eliminates paper wastage. Rear, bottom and top paper paths handle lab-

els, multi-part invoices, checks, letterhead stationery, card stock, envelopes and more. An optional pull tractor and single-bin cut-sheet feeder enhance productivity and paper handling. \$529.

CIRCLE NO. 177 ON FREE INFORMATION CARD

Security Light Switch

The simplicity of a wall-type light switch and the security offered by a motion sensor are combined in the new Model SL-6120 Reflex™ motion-sensing security system and convenience light switch from Heath Reflex Brand Group. Featuring SECURITY and RANDOM modes, the switch also allows the user to choose between three other modes. The five operating modes include both ON and OFF, which permit the switch to be used as a conventional light switch.

Set to AUTO, the switch automatically
(Continued on page 81)

M O R E T H A N LOGIC



286 SupersPort Laptop by Heathkit®

Your logical source for quality computer and electronic product needs, the **FREE Heathkit Catalog** is your key to a fun and exciting hobby. The Heathkit Catalog contains powerful kit laptop and desktop computers, test instruments, weather equipment, and home theater components, plus self-study electronics courses. Order your **FREE Heathkit Catalog** today! It's the logical thing to do!

1-800-44-HEATH
(1-800-444-3284)

Send to: Heath Company, Dept. 079-864
Benton Harbor, Michigan 49022

Name _____

Address _____

City _____

State _____

Zip _____

A subsidiary of Zenith Electronics Corporation

CIRCLE 82 ON FREE INFORMATION CARD

February 1990 / MODERN ELECTRONICS / 15

Using DC Voltmeters

Troubleshooting direct-coupled differential and Darlington amplifiers

By Robert G. Middleton

Direct-coupled differential and high-gain Darlington-amplifier circuitry are routinely used in modern electronic circuits. Like most other circuits, you can troubleshoot these circuits with just a dc voltmeter (or with a multimeter in this mode). To do the job properly, though, you must become familiar with how these circuits operate, the type of performance they are supposed to deliver and any special characteristics that must be taken into account during any analyses. In previous articles dealing with use of the dc voltmeter in troubleshooting, we discussed basic circuit designs (see "Troubleshooting With DC Voltmeters," October 1988, and "How To Use DC Voltmeters," June 1989).

We will begin our discussion this time around with the differential amplifier. Then we will tackle the Darlington amplifier.

Practical Considerations

As can be seen in Fig. 1, the basic differential amplifier is essentially a "twinning" of the basic emitter-biased common-emitter stage. The first transistor in this circuit operates as a common-emitter amplifier with emitter feedback, the second as a common-base amplifier. The second transistor is emitter-driven by the first transistor. Thus, if the collector voltage increases in the first transistor, the collector voltage in the second transistor decreases.

Troubleshooting the differential amplifier circuit is a relatively easy

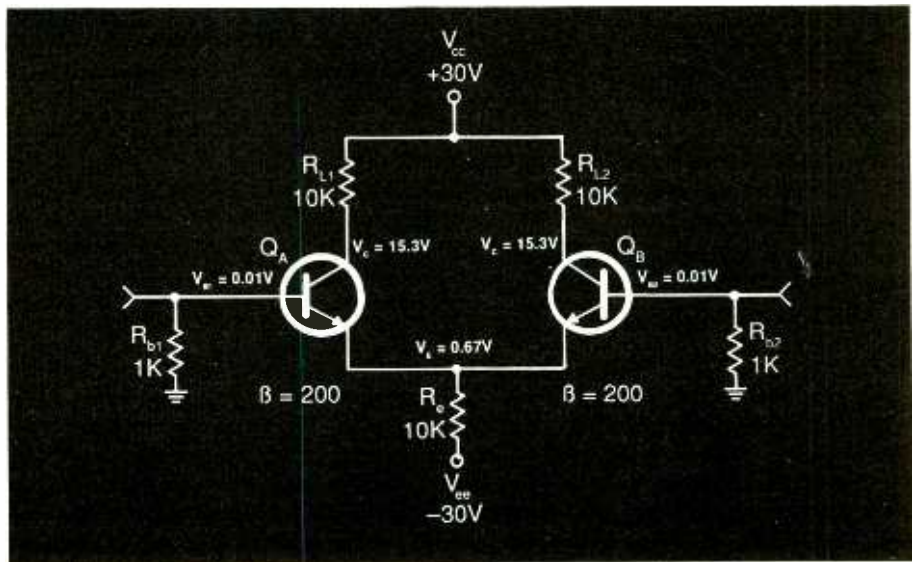

Fig. 1. The basic differential-amplifier circuit configuration.

task—if you take some practical considerations into account. To this end, we will start off by looking at the effects off-value parameters have on the dc voltage-distribution patterns in the circuit. It is helpful to start by observing the action in the first half of the circuit and to disregard the second half for the time being. The first half-circuit arrangement is illustrated in Fig. 2, which we will use to follow the changes in dc voltage-distribution patterns that result from off-value parameters.

If the value of R_L goes high in Fig. 2, V_C goes low but only a very slight change occurs in V_B and V_E . You will discover that these patterns are quite different from those that result when R_b goes low or high in value. When R_b goes high, V_C changes a little and V_B and V_E both go high. Conversely, when R_b goes low, V_C changes slightly and V_B and V_E both go low. Thus,

you should have no difficulty distinguishing between these two faults.

Now consider what happens when R_e goes off-value. When R_e doubles in value, V_C goes high and both V_B and V_E go low. If R_e decreases 30 percent in value, V_C goes low but very little change occurs in V_B and V_E . The condition where R_e goes low can be confused with that of R_L going high. Thus, a further test must be made to resolve the ambiguity. Here you apply a trick of the trade in which you turn off power to the circuit and make an in-circuit measurement of the resistance of R_e with your ohmmeter connected between the base of the transistor and circuit ground.

If the voltmeter indicates zero while you are making the resistance measurement, you can conclude that the base-emitter junction is not leaky and that the ohmmeter reading is valid. You now know whether the

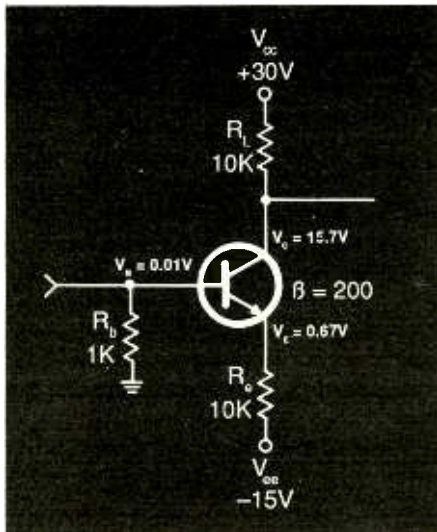

Fig. 2. The first half of the basic differential-amplifier configuration.

value of R_e is normal or not. If R_e is normal, you can logically reason that the value of R_L is high and turn your attention to this resistor. The resistance of R_L can be measured in-circuit with a low-power ohmmeter (one whose test voltage is not high enough to send a semiconductor junction into conduction), provided that the transistor first passes a turn-off test.

Next, in the event that beta goes low, such as from 200 to 50, V_C changes very slightly and V_B and V_E both go high. This ambiguity can be resolved by means of a two-step trick of the trade: conducting a turn-off test of the transistor to check collector-junction leakage, and then, if the transistor passes the turn-off test, turn off power to the circuit and make an in-circuit resistance measurement of R_b with a low-power ohmmeter. If R_b measures its rated value, you can logically conclude that the beta value is low and that the transistor must be replaced.

Differential-Amplifier Characteristics

You can now ask how the half-circuit dc voltage-distribution patterns in Fig. 1 apply in the differential circuit configuration. You will find that in

half-circuits the foregoing patterns and test principles are essentially the same for both arrangements. For example, if the value of R_{L1} is high in Fig. 2, V_{C1} goes low and very little change will occur in V_{B1} and V_{E1} . However, once again, an ambiguity arises due to the fact that the second transistor is emitter-driven by the first transistor, with the result that V_{C2} goes high when V_{C1} goes low. In the first analysis, you cannot conclude whether the fault is in the first half-circuit or the second.

Once again, a novel trick of the trade comes to the rescue: the voltage-forcing test technique. You apply the output of a variable-voltage power supply to the circuit between the collector of the first transistor and circuit ground. When the output from the supply is adjusted to 15.3 volts, in this example, the first half-circuit looks like a normal arrangement to the second half-circuit. Thus, if the fault is in the first half-circuit, the collector voltage of the second transistor will go to its normal value.

If the fault is in the second half-circuit, the collector voltage of this transistor will not go to normal. Instead, it will go to an off-normal level that is determined by the particular fault that exists in the second half-circuit. Effectively, the voltage-forcing test technique splits the differential circuit configuration into two independent half-circuit configurations. With the collector voltage clamped to normal value in the first half-circuit, you can check out the second half-circuit as if the first half-circuit does not exist.

If there is evidence of a fault in the first half-circuit, you can use the voltage-forcing test procedure to clamp the collector voltage to normal value in the second half-circuit. Then you can check out the first half-circuit as though the second half-circuit does not exist.

Bear in mind that the voltage-forcing test technique does not physically

isolate one half-circuit from the other. It effectively isolates a half-circuit inasmuch as it forces the clamped stage to operate at a normal collector voltage and makes it look normal to the unclamped stage.

One reservation must be kept in mind. The voltage-forcing test technique is based upon the assumption that the fault is in the resistive circuitry and that the transistor is okay. To take an extreme example, if the transistor in the first half-circuit is shorted from collector to emitter, clamping the collector voltage to normal value cannot make the first half-circuit look normal to the second half-circuit. Thus, if voltage-forcing tests provide inconclusive data, you must start unsoldering connections.

DC-Versus-AC Circuit Action

It was noted that the second transistor in the Fig. 1 circuit is emitter-driven by the first transistor with the first transistor operating as a common-emitter amplifier with emitter feedback and the second transistor operating as a common-base amplifier. This is an aspect of ac circuit action, wherein the first transistor is base-driven by the input signal voltage, with the output taken at the collector of the second transistor.

There is also the converse aspect to ac circuit action, wherein the second transistor is base-driven by the signal input voltage, with the output taken at the collector of the first transistor. In this mode of operation, the second transistor operates as a common-emitter amplifier with emitter feedback and the first transistor operates as a common-base amplifier.

Again, as is often the case, the bases of the transistors are driven by a push-pull, or double-ended, signal voltage, with outputs taken at the collectors of both transistors. These features of ac circuit action are completely separate from consideration of dc circuit action.

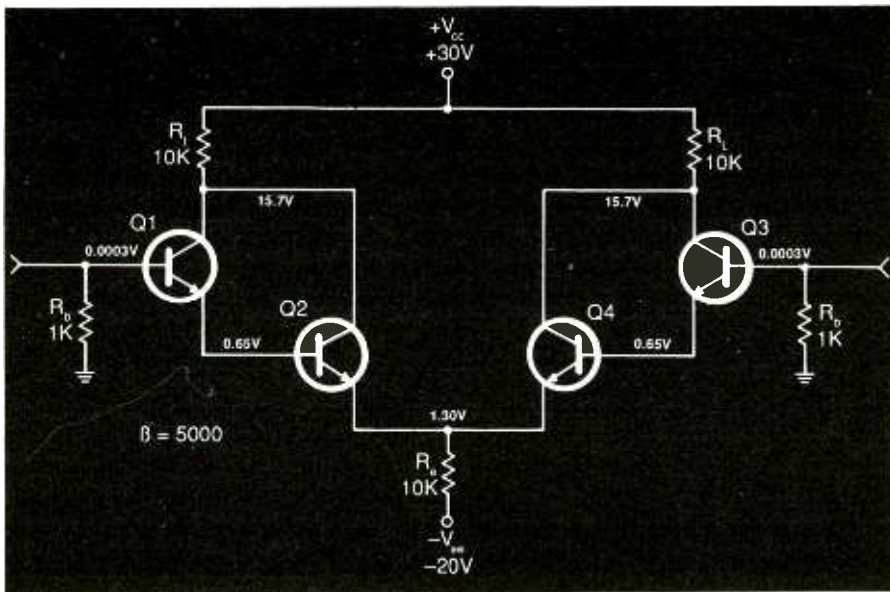

Fig. 3. Basic Darlington amplifier circuit configuration.

The common-emitter configuration is equivalent to the common-base configuration from the viewpoint of dc voltage distribution. This is just another way of saying that the transistors in a differential amplifier are biased for class-A operation and that either or both transistors can be driven by the input signal voltage.

Considering signal-voltage gain of the balanced differential amplifier, with push-pull drive and push-pull output utilized, there is practically no difference between a simple single-ended configuration, as shown in Fig. 2, and double-ended configuration, as shown in Fig. 1. However, from the viewpoint of immunity to drifting, the differential amplifier is far superior to the single-ended amplifier. If temperature increases and the barrier potentials of the transistors drift accordingly, the resulting common-mode error cancels out and collector-to-collector output is virtually unaffected.

Darlington Amplifiers

High-gain Darlington circuitry and its dc voltage-distribution patterns differ somewhat from those that characterize single-transistor config-

urations. A basic differential Darlington common-emitter amplifier circuit arrangement is depicted in Fig. 3. This circuit employs two Darlington pairs—one consisting of transistors Q1 and Q2, the other consisting of transistors Q3 and Q4. Here, Q1 operates as a typical common-emitter stage, with Q2 its active load and resistor R_{L1} its passive load. Similarly, Q3 functions as a simple common-emitter stage with Q4 and R_{L1} acting as its active and passive loads.

It is helpful in troubleshooting electronic circuits to sectionalize the Fig. 3 circuitry to more easily follow circuit action. Thus, in Fig. 4, you are concerned with two basic Darlington circuits contained in the differential circuit configuration.

You start off with the Darlington emitter-follower. This is similar to a conventional emitter-follower stage, except that Q_A has an active emitter load and Q_B has a conventional passive emitter load. At this point, you should note that the Darlington emitter-follower stage provides greater current (power) gain than does an ordinary single-transistor emitter-follower stage. However,

the Darlington arrangement does not provide any additional voltage gain when compared with a conventional single-transistor stage.

Note also with regard to Fig. 4 that there are two barrier-potential drops present in the Darlington emitter-follower. The base-emitter potential of Q_A will be approximately 0.65 volt. In turn, the total barrier-potential drop in this branch is approximately 1.3 volts. This is a very practical point to consider. For example, if you measure 0.65 volt from base to emitter for Q_A but only 0.1 volt from base to emitter for Q_B , you would immediately conclude that Q_B has serious base-emitter leakage, and means this transistor must be replaced.

Next, consider the common-emitter amplifier arrangement shown schematically in Fig. 4(B). This is the circuit for the Darlington compound pair in a common-emitter configuration, or a compound amplifier circuit. Here you should note that the chief difference between Fig. 4(B) and a single-transistor arrangement is that the former has a much higher dc beta value. For this reason, a Darlington pair is also commonly referred to as a "beta multiplier."

As a rough rule of thumb, the effective beta value of a Darlington pair is the product of the individual beta values of the two transistors that make up the Darlington pair. In practice, though, the actual beta value is somewhat less than the arithmetic product of the two transistor betas. However, the dc beta of the Darlington pair is always greater than that of a single transistor stage.

Due to the greatly increased beta value, the voltage gain of the Fig. 4(B) Darlington stage is much greater than if a single transistor had been used. It is worthwhile at this juncture to repeat an important point: there are two barrier-potential voltage drops in a compound amplifier circuit, and the total barrier-potential drop in the branch is normally approximately 1.3 volts.

Figure 5 shows the two sections depicted in Fig. 4 combined. Resistor R_b is included in Fig. 5 to complete the bias circuit. This arrangement is half of the complete Darlington differential amplifier circuit configuration shown in Fig. 3. This breakdown facilitates analysis of off-value dc-voltage distribution patterns.

Practical Considerations

Note in Fig. 3 that the base voltages for Q_1 and Q_3 are normally the same and are much lower than for a differential amplifier made up of single transistors. The base potential for the single-transistor version was approximately 10 millivolts. The Darlington pair operates at a base potential of only 0.3 millivolt, thanks to its inherent beta-multiplication action. The emitter potential for the single-transistor arrangement was 0.67 volt, whereas the emitter potential for the Darlington arrangement is 1.3 volts. This difference is due mainly to the fact that there are two base-emitter barrier-potential drops in the Darlington circuit.

Now to examine the effect off-value parameters have on the dc voltage-distribution patterns for the Fig. 3 configuration. You start by following the action in the first half of the circuit while disregarding the second half (Fig. 5). Note first that if R_L goes high, V_C goes low and only a very slight change in V_B and V_E occurs. For example, if R_L increases in value from 10,000 ohms to 15,000 ohms, V_C drops from 16.3 volts to 9.5 volts, but virtually no change occurs in V_B and V_E .

Next, if R_L goes low, V_C goes high, and only a very slight change occurs in V_B and V_E . As an illustration of this effect, if R_L decreases in value from 10,000 ohms to 5,000 ohms, V_C rises from 16.3 volts to 25.9 volts, again with virtually no change in V_B and V_E . (The normal value of 16.3 volts in Fig. 5 might appear to be a bit high, but the emitter potential is cor-

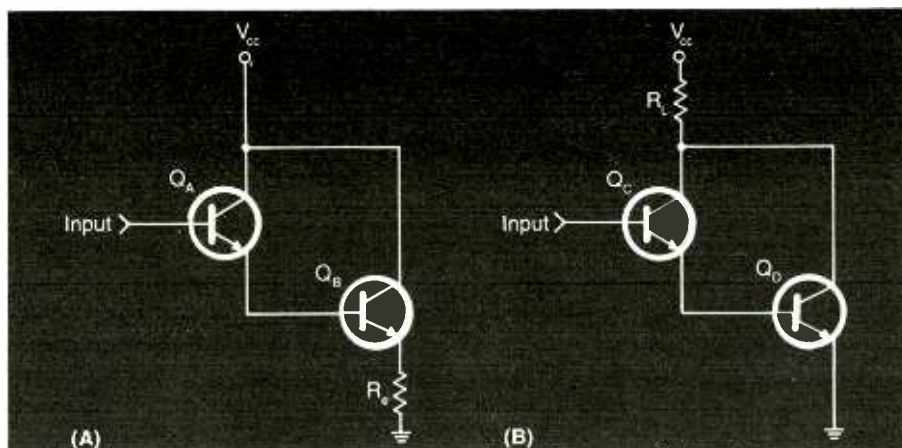

Fig. 4. Basic Darlington circuits: (A) emitter-follower and (B) compound amplifier.

respondingly high, whereby the collector-emitter potential is 15 volts, so that the stage is operating in class A.)

You will discover that the foregoing patterns are quite different from the patterns resulting from the values of R_b going high and R_b going low. Thus, if R_b increases in value from 100 ohms to 100,000 ohms, V_C will decrease from 16.3 volts to 15.7 volts and V_B will increase from 0.3 millivolt to 30 millivolts and V_E will decrease from 1.3 volts to 0.72 volt. Conversely, if R_b decreases in value from 1,000 ohms to 10 ohms, V_C will decrease—perhaps unexpectedly—from 16.3 volts to 15.7 volts and V_B will decrease from 0.3 millivolt to a negligible 3 microvolts!

Now consider the dc voltage-distribution pattern that results from R_c going high. When R_c doubles in value from 10,000 ohms to 20,000 ohms, V_C goes high from 16.3 volts to 23.2 volts, V_B goes low from 0.3 millivolt to 0.1 millivolt and V_E remains virtually unchanged. Conversely, when R_c decreases 50 percent in value from 10,000 ohms to 5,000 ohms, V_C goes low from 16.3 volts to 2.6 volts, V_B goes high from 0.3 millivolt to 0.5 millivolt and V_E remains virtually unchanged. These are unambiguous patterns inasmuch as the V_B and V_E states clearly identify the culprit. Of course, to conduct

these tests, you must use a meter that provides sufficient accuracy to resolve 0.1-millivolt readings.

Finally, consider the effect of a low beta value in one of the transistors. The result of this situation will be that the net beta value of the circuit will be subnormal. To cite a "catastrophic" example, suppose that one transistor becomes almost "dead" such that its beta value is only 10. In this situation, V_C holds almost constant and increases from 16.3 volts to only 16.6 volts. However, V_B now increases enormously, from 0.3 millivolt to 134.1 millivolts and V_E increases significantly from 1.3 volts to 1.59 volts. Here again, the pattern is unambiguous and clearly identifies the culprit.

Darlington Differential-Amplifier

Returning to Fig. 3, observe now how the half-circuit dc-voltage distribution patterns cited above apply to the differential circuit configuration. The first thing to remember is that insofar as the half-circuits are concerned, the patterns are essentially the same for both halves of the differential amplifier. However, a practical procedural difficulty is now encountered in the differential arrangement due to the fact that the second transistor is emitter-driven by the

(Continued on page 76)

A Two-Line Telephone Answering-Machine Interface

Automatically switches a single telephone answering machine between two separate phone lines

By Anthony J. Caristi

Are there two separate telephone lines servicing your home or business and only one typically single-line telephone answering machine? If so, our "Two-Line Answering-Machine Interface" may be just what you need to maximize operation of your telecommunications system—without spending additional money for a second answering machine.

Our low-cost (to build) Two-Line Telephone Answering-Machine Interface lets you share the single answering machine you now have with two separate telephone lines and does so automatically. The easy-to-build two-way interface automatically senses which line has an incoming call on it, switches over to that line and operates in the normal manner of the machine. It permits transmission of the outgoing message and recording of incoming messages on whichever line to which it is switched, just as if you had two answering machines. Furthermore, the project does not interfere in any way with normal operation of either line, and prevents the loss of a call on one line while it is busy with the other. The Interface can be disabled on either or both lines, when desired, by means of front-panel switches.

Should a second call be incoming on the other line while the answering

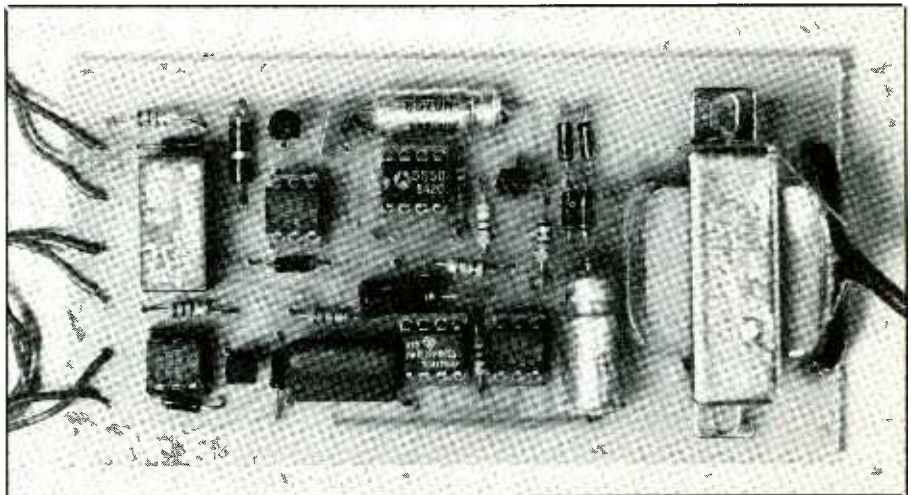

machine is in use, the caller will hear a busy signal. One minute later, when the call on the first line has been completed, both lines and the answering machine are free to accept the next incoming call.

Automatic switching is accomplished by a miniature DIP relay, which provides proper isolation to each telephone line. In addition, three optical isolators provide complete isolation between the telephone lines and solid-state circuitry inside the project.

About the Circuit

As can be seen in the schematic diagram shown in Fig. 1, the heart of the project is *K1*, a dpdt miniature DIP relay. This relay connects the answering machine to whichever telephone

line is receiving an incoming call, identified as Line 1 and Line 2. During standby, when both lines are idle, the normally-closed contacts of the relay provide connection between primary (most-active) Line 1 and the answering machine. Any activity on this line results in normal operation of the answering machine.

When the answering machine is busy with Line 1, it is necessary to temporarily prevent a call from coming in on Line 2. This is accomplished with optical isolator *IC1*, *Q1* and associated components. The optoisolator contains a light-emitting diode and a phototransistor. The transistor is normally held in cutoff and conducts current only in response to light generated by the internal LED.

When the answering machine has

seized Line 1 in response to an incoming call, the dc current drawn by the machine causes the LED in *IC1* to light. The energy from the internal LED sends the internal transistor into conduction. This transistor is connected in a Darlington configuration with *Q1*. Thus, when the internal transistor conducts, it sends *Q1* into saturation. As a result, *R1* is connected across Line 2, making it "busy."

Any caller on this line at this time will receive a busy signal as long as the answering machine is in operation with Line 1. When the machine disconnects from its incoming call, LED current in *IC1* goes to zero. This releases Line 2 from the current draw by *R1*. The circuit is restored to standby to await the next incoming call on either line.

As long as no call comes in on Line 2, *K1* is not energized and the answering machine is connected to Line 1 through its normally-closed contacts. When a caller rings Line 2, the 90-volt, 20-Hz ring signal is detected and processed by *IC3*. This is a specialized chip that has been designed to serve as a telephone ring detector.

Contained inside *IC3* are a bridge rectifier and regulator powered by the ring signal that appears across the telephone line when a call is incoming. This arrangement produces a +5-volt dc output at pin 4 and drives current into the LED inside *IC4*.

The transistor inside *IC4*, connected between pins 4 and 5, is normally held in cutoff in the absence of current through the LED. When the ring signal across Line 2 illuminates the internal LED, the transistor conducts and causes the voltage at pin 5 of *IC4* to go to near 0 volt. In turn, this triggers 555 timer *IC5*, which is connected as a one-shot or monostable multivibrator.

The timed cycle for *IC5* is determined by timing components *R8* and *C3*. This cycle is approximately equal to the time constant represented by the quantity *R* times the quantity *C*.

For the values shown in Fig. 1 and specified in the Parts List, the timed cycle is just shy of 1 minute. The elapsed time of this cycle can easily be modified by selecting a different value for the timing capacitor or timing resistor.

During the timed cycle of *IC5*, pin 3 of the chip rises from zero to about V_{dd} . In turn, this forward biases *Q3* and allows collector current to flow in the coil of *K1* and between pins 1 and 2 of *IC2*.

When current flows in its coil, the contacts of the relay transfer allow the answering machine to respond to the ring signal across Line 2 to permit answering the incoming call. The RC time constant of *IC5* permits sufficient time for the caller to record his or her message.

At the end of the timed cycle of *IC5*, pin 3 goes to 0 volt and cuts off *Q3*. This causes the relay coil to deenergize, with the result that the answering machine is restored to its original connection to Line 1.

During the timed cycle of *IC5*, when the answering machine is connected to Line 2, Line 1 must temporarily be placed in busy status, as explained above when the answering machine was busy with Line 1. This is accomplished in a similar manner using optoisolator *IC2*, transistor *Q2*, and associated components. The current drawn by the LED inside *IC2* in response to the timed cycle of *IC5* ensures that Line 1 is held in busy status during the timing cycle. Light emitting diode *LED1* in series with the collector of *Q3* and *IC2* provides visual indication of the status of *IC5*.

Switches *S1* and *S2* shown connected in series with each telephone line permit the circuit to be partially or totally disabled from operation.

Power to operate the circuit is provided by the 12-volt secondary of transformer *T1*. The stepped-down ac voltage at the secondary of *T1* is converted to pulsating dc by the full-wave bridge rectifier composed of *D4*

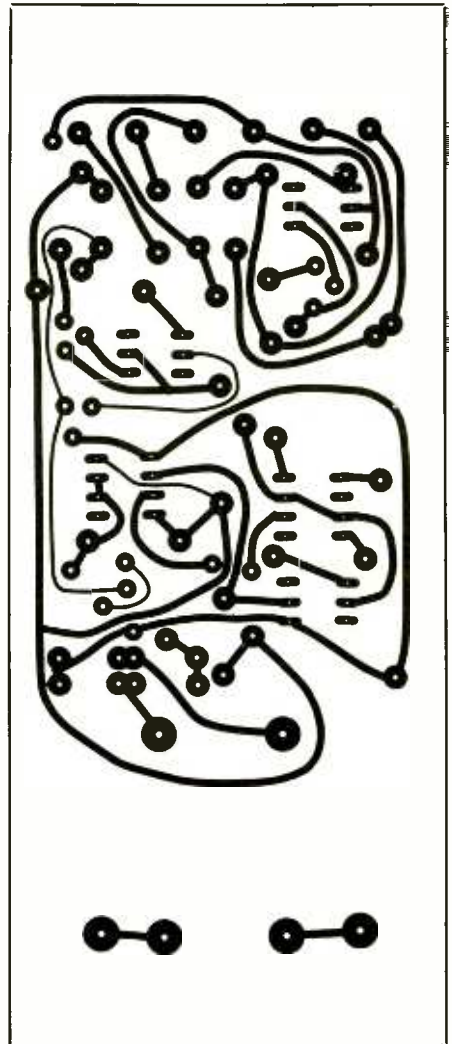

Fig. 2. Actual-size etching-and-drilling guide for project's printed-circuit board.

through *D7* and smoothed to approximately 15 volts of pure dc by capacitor *C1*. During the active time of *K1* and *IC2*, the additional current drawn by these components causes the voltage of the power source to decrease somewhat. However, *IC5* is essentially immune to power-source fluctuations and functions properly with the reduced voltage source.

Construction

Because this circuit does not require special layout or conductor routing,

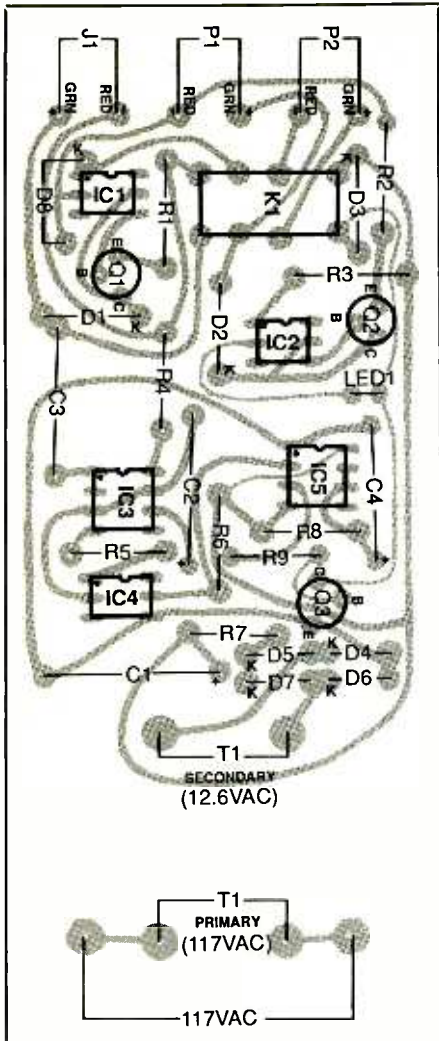

Fig. 3. Wiring guide for pc board. Use this as a rough guide for point-to-point wiring of project on perforated board.

you can use any traditional wiring medium to build it. You can assemble the entire circuit on a single compact, single-sided printed-circuit board (see lead photo). Alternatively, you can assemble it on perforated board that has holes on 0.1-inch centers, using suitable Wire Wrap or soldering hardware.

If you opt for a pc board for the project, you can fabricate your own using the actual-size etching-and-drilling guide shown in Fig. 2. You also have the choice of purchasing a ready-to-wire pc board from the

source given in the Note at the end of the Parts List.

We will assume from here on that you are wiring the circuit on a pc board. Therefore, place the board on your work surface oriented as shown in Fig. 3. (Note: if you are using perforated board and point-to-point wiring, use Fig. 3 as a rough guide to component layout.)

Whichever method you use to wire the project, be sure to use sockets for all ICs and the optical isolators. If you cannot locate six-pin sockets for the latter, you can carefully cut down standard sockets or substitute Molex Soldercon socket strips.

Begin wiring the board by installing and soldering into place the IC sockets. Do *not* plug the ICs into the sockets until after you have confirmed that all wiring is properly done. Proceed with installation of the resistors, diodes and capacitors. Make sure the diodes and electrolytic capacitors are properly polarized before soldering their leads to the copper pads on the bottom of the board.

A circuit option allows you to select the timed cycle of IC5. If you feel that the specified timing of about 1 minute is not suitable for your application, you can increase or decrease the time as desired. The easiest way to do this is to change the value of C3. Timing is a direct function of the value of this capacitor. For example, increasing the value to 100 microfarads will result in approximately a 2-minute cycle. It is not recommended that timed cycles longer than 5 minutes be used. Be sure to use a low-leakage electrolytic capacitor as your timing component.

Transistors Q1 and Q2 are high-voltage types that can bear up to the 90-volt ac ring signal. Do *not* use ordinary low-voltage types in this part of the circuit. Install the transistors on the circuit-board assembly, double check that the basings are correct and solder the leads into place. Then install the relay and power trans-

former on the board, using suitable machine hardware to secure the latter into place. When wiring the transformer to the board, make absolutely certain you plug the leads from the primary and secondary into the appropriate holes before soldering them into place.

When you have completed assembly of the circuit board, only the switches, LED, neon-lamp assembly and fuse (and its holder) should remain. Having reached this point, very carefully examine the circuit-board assembly for any connections you might have missed soldering, poorly soldered connections and solder bridges, the latter especially between adjacent IC pads. Solder any missed connections and reflow the solder on any suspicious connection. Remove any solder bridges with a desoldering braid or a vacuum-type desoldering tool.

Hookups to the telephone lines and answering machine must be made through cables terminated in modular telephone connectors. This is an FCC requirement for all telephone accessory devices and *must* be rigidly observed. The modular-connector arrangement allows quick disconnect from the telephone lines should a problem occur.

The cables for each telephone line can simply be one long telephone extension cord with a modular connector at each end. The cord can be cut in half to provide the two cords needed. Carefully remove about a 1½-inch length of the outer plastic jacket from the cut end of each cable to gain access to the inner conductors.

Most such cables contain four conductors that may be color coded red, green, yellow and black. Only the red- and green-insulated conductors (usually negative and positive, respectively) are used in this project. Therefore, cut away any other conductors the cord might have to prevent them from causing problems when the project is put into service.

Then strip $\frac{1}{4}$ inch of insulation from the ends of both remaining conductors in both cables.

If your cable is not color coded, the desired conductors will be the pair in the center of the cable. You can verify that you have selected the proper pair by connecting a dc voltmeter or a multimeter set to the dc-volts function (set it to indicate at least 50 volts) across the selected bared ends of the conductors. Now, making sure to isolate the exposed ends of the conductors from each other, plug the modular connector into any active telephone jack and note the meter reading, which should be about 48 volts.

Be sure to perform the above test on *both* cables, since it is mandatory that the polarity of your cables be known. Mark the two wires of each cable positive and negative, as determined by the polarity of the readings obtained with the meter.

Many telephone cords have "tinsel" wire conductors. Though this type of wire produces a very flexible cable, it is also very fragile. Therefore, it is not suitable for connection to the circuit board. If your cables are this type, you must carefully remove some insulation at the cut ends to expose a short length of the tinsel wire. Then splice and solder a short piece of insulated, stranded 24-gauge copper wire to the ends. When the connections cool, tape the splices securely or use small-diameter heat-shrinkable tubing to prevent breakage.

An alternate method to splicing is to use insulation-piercing crimp-type lugs that make contact with the tinsel. When properly done, this method produces a secure termination to the fragile conductors.

You are free to make any type of connection you wish to your answering machine, since it is your property and will not be connected directly to any telephone line. However, since the machine already has a modular connector on the end of its cable, it

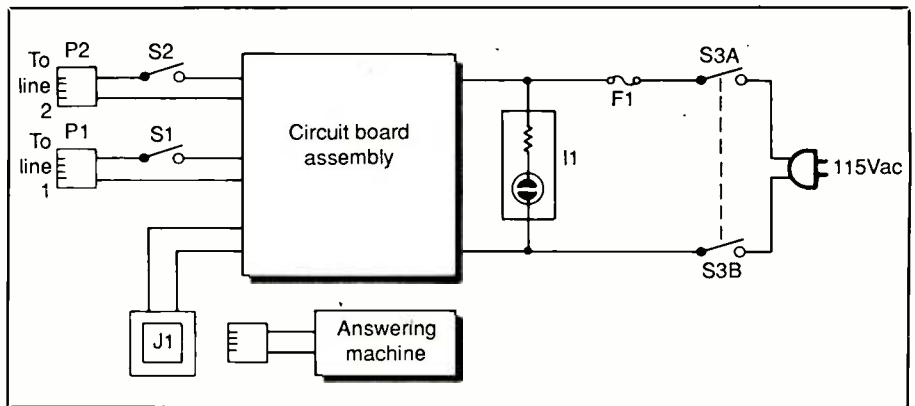

Fig. 4. Interconnect wiring guide for circuit-board assembly to power, telephone and answering-machine lines.

makes good sense to obtain a female modular receptacle (jack) to make the connection to the project. Such connectors are available in several different styles.

As with the telephone-line connections, you should know the polarity of the conductors in the answering machine cable. If you use a commercial modular jack for your project, the green-insulated conductor will be positive, the red-insulated conductor negative. Once again, the yellow- and black-insulated conductors are not used and should be snipped off.

Any enclosure that will accommodate the circuit-board assembly and has panel space on which to mount the switches, neon-lamp assembly and LED and to provide access for the ac line cord and cables will do fine. Drill the mounting holes for the circuit-board assembly, fuse holder, neon-lamp assembly, LED and switches and entry holes for the ac line cord and cables. If you use a metal enclosure or drill holes through a metal panel, deburr the holes to remove sharp edges and line those for the cables and line cord with small rubber grommets.

Label the switches according to function and position and Line 1 and Line 2 entry holes. If you are using a dry-transfer lettering kit, spray two

or more light coats of clear acrylic over the legends to protect them from scratching. Allow each coat to dry before spraying on the next.

Mount the switches, LED, neon-lamp assembly and fuse holder in their respective holes. Route the free ends of the ac line cord and telephone cables through their respective holes and tie strain-relieving knots in them about 5 inches from the free ends. Tightly twist together the fine wires at the exposed ends of each line cord and cable conductor and sparingly tin with solder.

Referring to Fig. 4, crimp and solder the green-insulated conductor of Line 1 and Line 2 to one lug of S1 and S2, respectively. Route the red-insulated conductors of both cables to the indicated holes in the circuit-board assembly and solder into place. Bridge the remaining lugs of these switches and the circuit-board assembly with appropriate lengths of hookup wire. (Note: If you use stranded hookup wire in this project, always tightly twist together the fine conductors exposed after stripping and sparingly tin with solder.)

Now wire the free end of the cable that goes to the answering machine as shown. Note that this cable must be terminated in a jack, rather than the plug arrangement used on the other

two telephone cables. However, you can use a standard plug-type cord for this cable and make the interconnection with a jack-to-jack adapter. When wiring this cable to the circuit-board assembly, make certain you observe proper polarity.

Strip ¼ inch of insulation from both ends of four 5-inch long stranded hookup wires and prepare the ends as noted above. Plug one end of each wire into the holes labeled 117 VAC and LED1 in Fig. 3 and solder into place. Tie a loose knot in the wire coming from the cathode hole for LED1. Then mount the circuit-board assembly to the floor of the enclosure, using ½-inch spacers and suitable machine hardware.

Determine which LED lead connects to the cathode and clip it to a length of ½ inch. Plug the LED into the hole drilled for it in the enclosure panel. If necessary, use a dab of fast-setting epoxy cement or silicone adhesive to hold the LED in place.

Undo the knot in the LED1 cathode wire coming from the circuit-board assembly and slide a 1-inch length of small-diameter heat-shrinkable tubing over its free end. Solder the free end of this wire to the cathode lead stub of the LED. Then repeat the process for the anode lead and wire. When the connections cool, slide the tubing over the connections until it is flush with the bottom of the LED's case and shrink into place.

Now wire the primary circuit of the power supply. Start by crimping and soldering the conductors of the line cord to two lugs of POWER switch S3. Bring one lead of the neon-lamp assembly and the end of one of the two unconnected wires coming from the circuit-board assembly to one toggle lug of this switch and crimp and solder the two to the lug. Crimp and solder the free end of the other circuit-board assembly wire and the other lead of the neon-lamp assembly to

(Continued on page 80)

Now Available!

The Second Annual



Amateur Radio 1990 Equipment Buyer's Guide



The Active Ham's Complete Annual Reference Master

This **enlarged** and **improved** master directory and buyer's guide will serve you day in and day out in searching out new gear, comparing new models, locating dealers near you and mail-order retailers around the country. It'll help you buy more wisely with its multi-reference concept to help you wend your way through the buying maze.

COMPLETE PRODUCT INFORMATION

It's a single-volume source book of the latest Amateur Radio gear all sectioned by equipment type for easy reference by CQ's seasoned editorial staff:

- Complete product descriptions.
- Technical specifications.
- Retail prices.
- Equipment photographs.

WHO'S WHO IN THE AMATEUR RADIO BUSINESS

It's a Buyer's Guide filled with the kind of support information you've always needed, but couldn't easily get: Dealer listings state-by-state (including branches), names and calls for key personnel, top lines carried, whether or not trade-ins are accepted or on-site repairs are made . . . and so on.

BUYING TIPS FROM THE EXPERTS

Great articles on the in's and out's of purchasing Amateur equipment. The experts give you the inside scoop on everything from antennas to transceivers to making your first packet contact . . . and lots more.

ORDER YOUR BUYER'S GUIDE TODAY!

Don't miss the single most valuable buying guide in the Amateur Radio field. Send only **\$4.95** today. Foreign: \$6. U.S. funds. Foreign orders are payable in U.S. funds only by check drawn on a U.S. bank, or by U.S. Postal Service Money Order.

YES, please send my copy of 1990 EQUIPMENT BUYER'S GUIDE for only \$4.95 postage paid.

Date _____ Number of Copies _____

Name _____ Call _____

Address _____

City _____ State _____ Zip _____

Check MasterCard VISA

Card No. _____ Expires _____

Signature _____

(Signature required on all charge orders)

**Mail to: CQ Communications, Inc.
76 North Broadway, Hicksville, NY 11801**

“Big Score” Counter Display

Giant numeric display is ideal for keeping game score, tallying customers, etc.

By Walter W. Schopp

Large-size digital displays are becoming more and more popular in bakeries, fast-food establishments and other locations to indicate the customer to be served or an order that is ready. Such displays are often found on arcade and other games for keeping score. Now you can have a similar digital-numeric display to keep score of the basketball games you play in your driveway, tennis games in your backyard, shuffleboard games on your patio, etc., with the “Big Score” counter to be described.

Consisting of a single two-digit system that counts from 1 to 99, “Big Score” has 6-inch-high digits (actually, you can make the digits any height you wish). Two such counters built into a single enclosure and sharing a common power supply permit keeping score of two opponents or sides in a game. The counters are individually actuated by pressing separate count buttons for each point scored. Since the two counters in this arrangement are powered by the same supply, a single reset switch sets both simultaneously to zero at the start of a game. If three or more sides or players are to be tracked, additional two-digit counters can easily be built into the same enclosure.

About the Circuit

Shown in Fig. 1 is the complete schematic diagram of the basic “Big Score” counter circuit, minus its ac-operated power supply. Dual cascaded CMOS counter chip *IC1* pro-

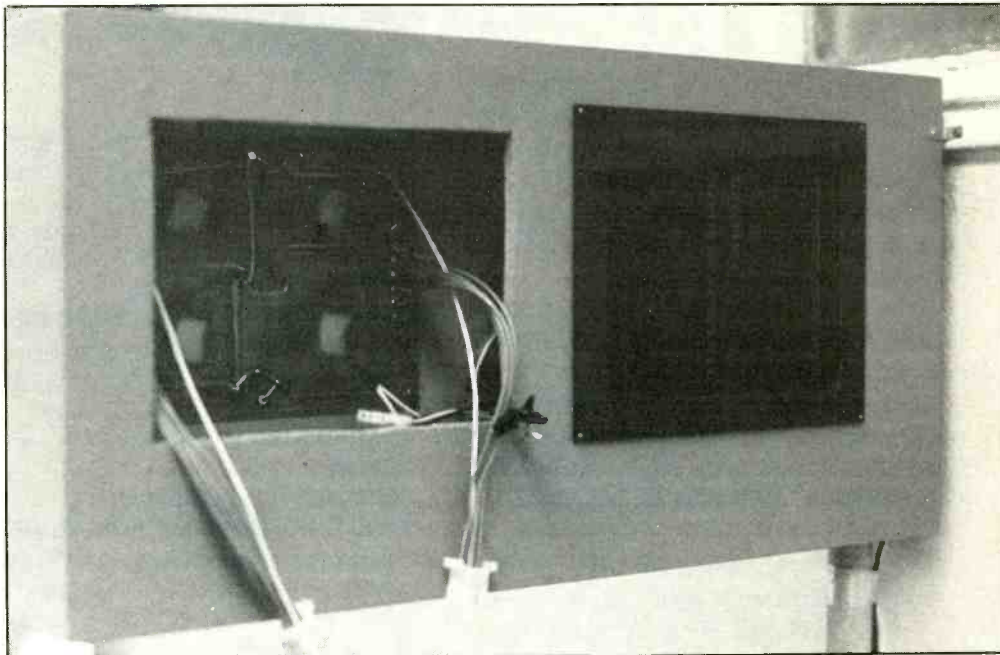

vides counting functions for up to a maximum of 99. The units and tens outputs go directly to decoder drivers *IC2* and *IC3*. In turn, the outputs of these driver chips drive optical isolators *IC5* through *IC18*.

Contained inside each optical isolator are a light-emitting diode and a light-sensitive npn transistor. When the LED inside a given optical coupler is turned on, the internal transistor conducts. Resistors *R1* through *R14* shown connected between the outputs of the driver chips and inputs of the optical isolators serve as current limiters for the internal LEDs of the latter.

Optical isolators *IC5* through *IC18* isolate the lower CMOS voltage from the higher voltage used for driving the numeric displays. The transistor

inside each optical coupler is series connected with one segment in each display decade and serves as an on/off power switch for the decade's segment to which it is connected.

Schmitt NAND gates *IC4B* and *IC4D* are shown wired together to serve to provide a single AND function. This gate pair is used to cascade the dual counters. Gate *IC4A* inverts the voltage used to reset the counter, and gate *IC4C* provides debouncing for the input pulses applied by COUNT switch *S1*.

The outputs from *IC2* and *IC3* are designed to drive a single LED, with voltage limited to the supply potential of the chip. In the “Big Score,” each segment in the numeric display is made up of a bargraph display network that contains 10 LEDs, though

10 discrete LEDs could just as easily have been used. Choice of the bargraph-type display, however, saves a lot of layout work and time spent in aligning a battery of discrete LEDs.

Each display segment requires 24 volts dc at a minimum of 10 milliamperes. With the circuitry shown in Fig. 1, digital numeric displays containing a greater number of LEDs per segment are possible simply by increasing the number of LEDs in each segment and increasing the voltage applied to each LED segment string to bring them to full brightness.

The values of series resistors *R15* through *R28* were chosen to drop the supply potential required for each segment in the display. If a different potential is used to power the LEDs or/and a greater number of LEDs are used per segment, the values of these resistors will have to be adjusted to limit the current for each string of LEDs that make up a given segment to about 10 milliamperes.

Shown in Fig. 2 is the schematic diagram for a power supply circuit that can be used to power the basic circuit shown in Fig. 1 when it uses the specified bargraph-type LED segments for the display. This power supply provides both the 12 volts dc required by the CMOS circuitry and the 24 volts dc required to drive the display segments. Current for the display section must be at least 300 milliamperes.

Construction

Because there is nothing particularly critical with regard to component layout and conductor runs, you can assemble the Big Score circuitry on standard printed-circuit board or perforated board that has holes on 0.1-inch centers using suitable Wire Wrap or soldering hardware. If you elect pc construction, you can fabricate the needed single-sided board using the actual-size etching-and-drilling guides shown in Fig. 3 through Fig. 5 for the main electron-

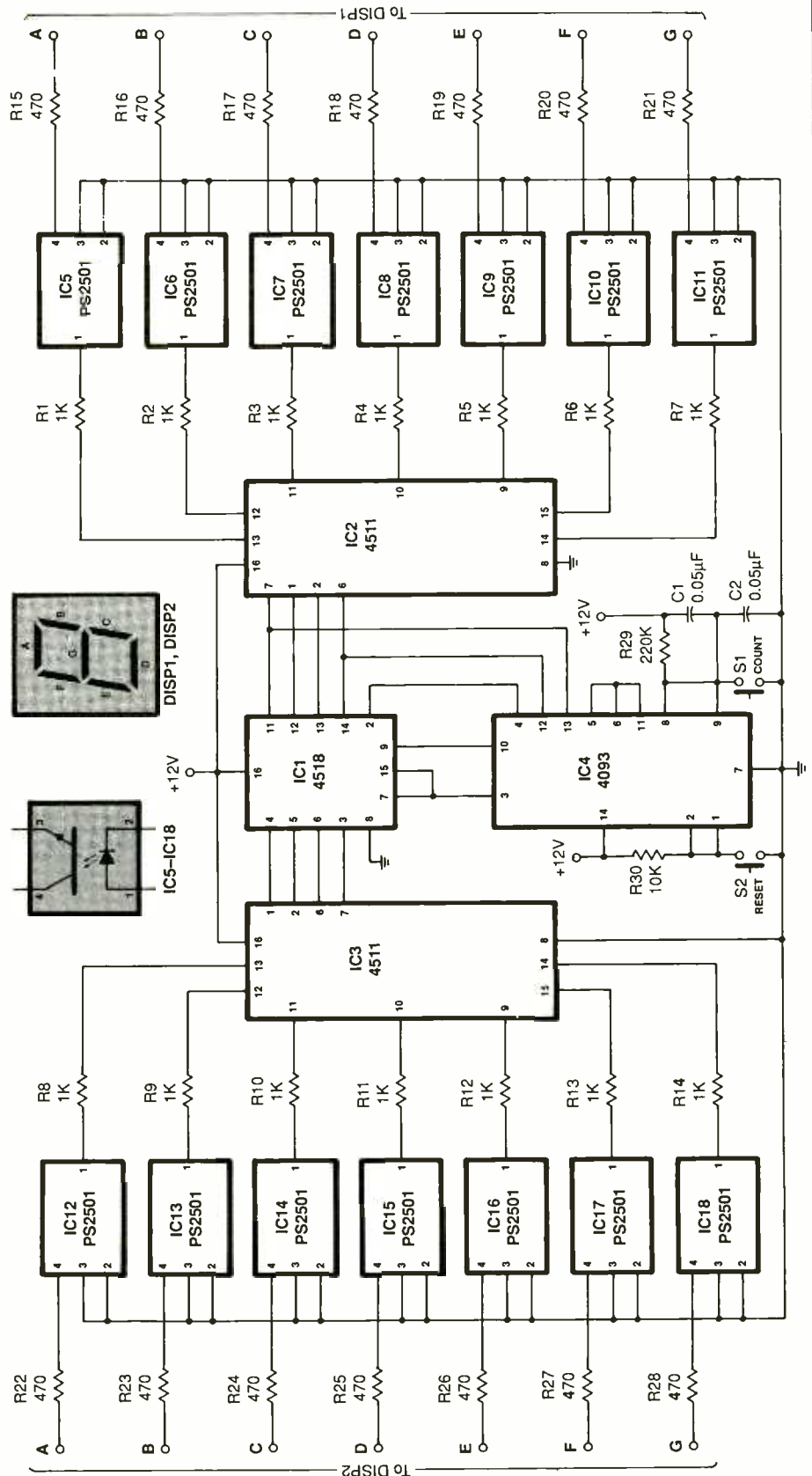

Fig. 1. Complete schematic diagram of two-decade counter/display circuitry for Big Score scoreboard, less its ac-operated power supply.

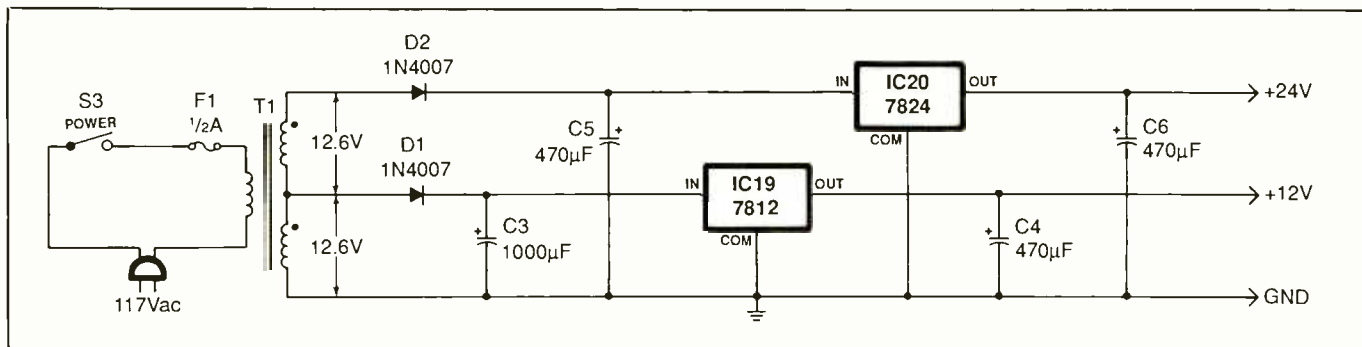

Fig. 2. Ac-operated power supply for project. This supply is designed to accommodate two two-decade counter/display circuits to provide "Home Team" and "Visitor" score displays.

ics package, LED display subsection and power-supply module.

From here on, we will assume you are using printed-circuit construction. Begin assembling the project by wiring the main electronics package board as shown in Fig. 6. Orient the pc board as shown and install first the 10 jumper wires in the indicated locations. You can use bare solid hookup wire for the shorter jumpers but use only insulated wire for the two longest.

Continue wiring this board by installing and soldering into place the sockets for IC1 through IC4. Use Molex Soldercon socket strips for optical isolators IC5 through IC18. (Note: Though sockets are optional for the ICs and optoisolators, they are highly recommended because they ease the task of replacing devices should any fail during the life of the project.) Do *not* plug the ICs into the sockets until after preliminary voltage checks have been performed and

you are certain that the project is correctly wired.

If you wish, you can plug the 14 optical isolators into their respective locations at this time. If you do so, make certain that they are oriented as shown and that all pins engage the Soldercon strips.

Continue wiring the main board by installing and soldering into place the various resistors and then the capacitors. This done, strip ¼ inch of insulation from both ends of two 10-inch-long hookup wires. If you are using stranded hookup wire, tightly twist together the fine conductors at both ends of all wires and sparingly tin with solder. Then plug one end of these wires into the holes labeled +12V and GND. The other ends of these wires will be connected later to the power-supply assembly.

In a similar manner to the above, strip ¼ inch of insulation from both ends of 14 12-inch-long hookup wires. Once again, if you are using stranded wire, prepare the ends as detailed. Then plug one end of these wires into the holes in the main circuit-board assembly labeled A through G along the left and right sides of the board and solder into place. The holes for COUNT and RESET switches S1 and S2 will be occupied later, during final assembly.

Temporarily set aside the main electronics package circuit board assembly and place in front of you the LED display board, orienting it as

PARTS LIST

Semiconductors

- D1, D2—1N4007 or similar silicon rectifier diode
- IC1—CD4518 dual counter
- IC2, IC3—CD4511 7-segment decoder/driver
- IC4—CD4093 quad Schmitt-trigger NAND gate
- IC5 thru IC18—PS2501 optical isolator (NEC)
- IC19—7812 + 5-volt regulator
- IC20—7824 + 24-volt regulator

Capacitors

- C1, C2—0.05-µF, 50-volt ceramic disc
- C3—1,000-µF, 35-volt electrolytic
- C4, C5, C6—470-µF, 16-volt electrolytic
- C7—0.01-µF, 50-volt ceramic disc

Resistors (¼-watt, 10% tolerance)

- R1 thru R14—1,000 ohms
- R15 thru R28—470 ohms
- R29—220,000 ohms
- R30—10,000 ohms

Miscellaneous

- F1—½-ampere slow-blow fuse
 - S1, S2—Momentary-action spst push-button switch
 - S3—Spst toggle switch (optional—see text)
 - T1—Dual-12-volt pc-type power transformer (see Note below)
- Printed-circuit boards or perforated board with holes on 0.1-inch centers and suitable Wire Wrap or soldering hardware (see text); sockets for IC1 thru IC4; Molex Soldercon socket strips for IC5 thru IC18 (see text); holder for F1; materials for enclosure (see text); ac line cord with plug; light-duty two-conductor zip cord; suitable housings for S1 and S2 (see text); 4-40 machine hardware and threaded spacers; 4-40 set screws (see text); hookup wire; solder; etc.

Note: Power transformer is EWC Part No. PC24-1000B20, available from Digi-Key Corp., P.O. Box 677, Thief River Falls, MN 56701-0677 as Cat. No. T124-ND.

Discover Your Career Potential In The Fast-Growing Field Of High-Tech Electronics!

CIE Gives You The Training You Need to Succeed...
At Your Own Pace...& In Your Own Home!

If you're anxious to get ahead...and build a *real* career...you owe it to yourself to find out about the Cleveland Institute of Electronics!

CIE can help you discover your career potential in the fast growing field of high-tech electronics. A career that will challenge and excite you every day...reward you with a powerful feeling of personal accomplishment...and deliver a level of financial security you may have only dreamed of before!

As the leading school in home-study electronics, CIE has helped over 150,000 students in the U.S.A. and over 70 foreign countries get started in this exciting field. To find out how CIE could be helping you...read on...then send for a CIE catalog TODAY!

A Growing Need For Trained Professionals!

The career opportunities shown here are only a few of the challenging, high-paying careers you could enjoy as an electronics technician.

You could be the "brains" behind the scenes of an exciting TV broadcast...trouble-shoot life-saving medical equipment...design exotic new aeronautics systems...CIE's job-oriented programs offer you the quickest possible path to the career of your dreams! And CIE also features military and union re-training, to build on what you already know.

Dozens Of Fascinating Careers To Choose From!

Even if you aren't sure which career is best for you, CIE can get you started with core lessons applicable to *all* areas of electronics. As you advance, CIE makes job opportunities available to you through the bimonthly school paper, *The Electron*.



Data Communications



Automotive Electronics



Avionics



Computer-Assisted Manufacturing



Consumer Electronics



Military Electronics

Personal Training From A Renowned Faculty.

Unlike the impersonal approach of large classroom study, CIE offers you one-on-one instructional help 6 days a week, toll-free. Each CIE lesson is authored by an independent specialist, backed by CIE instructors who work directly with you to answer your questions and provide technical assistance when you need it.

Practical Training... At Your Own Pace.

Through CIE, you can train for your new career while you keep your present job. Each course allows a generous completion time, and there are no limitations on how fast you can study. Should you already have some electronics experience, CIE offers several courses which start at the intermediate level.

"State-Of-The-Art" Facilities & Equipment.

In 1969, CIE pioneered the first electronics laboratory course, and in 1984, the first Microprocessor Laboratory. Today, no other home study school can match CIE's state-of-the-art equipment. And all your laboratory equipment is included in your tuition cost. There is no extra charge—it's yours to use while you study at home and on the job after you complete your course!

Earn Your Degree To Become A Professional In Electronics!

Every CIE course you take earns you credit towards the completion of your Associate in Applied Science Degree, so you can work towards your degree in

stages. And CIE is the only school that awards you for fast study, which can save you thousands of dollars in obtaining the same electronics education found in four-year Bachelor's Degree programs! Write for details today!

Send For Your Catalog Today!

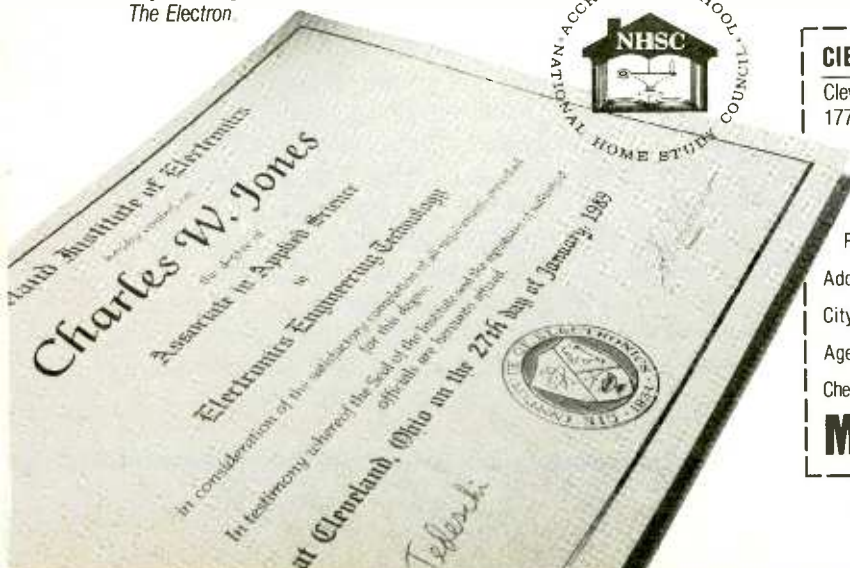

CIE World Headquarters

Cleveland Institute of Electronics, Inc.
1776 East 17th St., Cleveland, Ohio 44114

AMO-165

YES! Please send me your independent study catalog (For your convenience, CIE will have a representative contact you—there is no obligation.)

Print Name _____

Address _____ Apt # _____

City/State/Zip _____

Age _____ Area Code/Phone No. _____

Check box for G.I. Bill bulletin on educational benefits: Veteran Active Duty

Mail This Coupon Today!

shown in Fig. 7. Making absolutely certain that you properly orient each, plug the 14 LED bargraph displays into their respective locations before soldering any pins to the copper pads on the bottom of the board.

Prepare a 12-inch length of hookup wire as described above, plug one end into either hole labeled +24V and solder into place. Other than to interconnect this board with the power supply and main circuit-board assembly, this is all there is to assembling the LED display board.

Now wire the power supply board. Orient this board in front of you as shown in Fig. 8 and begin wiring it by installing the two rectifier diodes and 7812 and 7814 voltage regulators. Make certain that the diodes are properly oriented and the regulators are properly based before soldering any leads or pins to the copper pads on the bottom of the board. Then install and solder into place nonpolarized capacitor C7. Follow up by installing electrolytic capacitors C3 through C6 and power transformer T1 in the appropriate locations, making sure that each is properly oriented before soldering it into place.

Prepare two 6-inch lengths of hookup wire as described above. Plug one end of these wires into the holes labeled +12V and GND and solder them into place. The other ends will be terminated later in appropriate holes in the main electronics package circuit-board assembly.

The three circuit-board assemblies are now wired and ready for interconnection and installation inside a suitable enclosure. The enclosure should be fronted with a sheet of red transparent plastic to aid in readability of the display. This plastic sheet should have exactly the same length and width dimensions as the LED display board and be 1/8 inch thick.

Drill mounting holes in the four corners of the plastic filter in the same locations as they are in the LED display board. For now, just mark the center points of the four mounting holes; do not drill them until you read further to determine how you will actually assemble the various elements that make up the project.

Use solid pine (or other lumber), plywood or Masonite to fabricate the frame of the enclosure and thin plywood or Masonite for the rear panel.

Make the frame with mitered or butt-joined corners and sufficiently deep to accommodate the various elements as shown in the assembly drawing in Fig. 9, including areas for the optional POWER switch and required fuse holder. The interior length and width of this frame should exactly match the same dimensions of the plastic sheet, and the back panel should be exactly the same length and width as the outer dimensions of the frame.

Glue and nail the frame together. Then nail the back panel into place but do not drive the nails all the way in. You want the back panel to hold the frame squared up as the glue dries but be removable afterward to facilitate final assembly. When the glue dries, gently drop the red transparent display filter sheet into the open front of the frame and mark the locations of the mounting holes in the latter on the former.

Remove and set aside the filter and rear panel, but leave the nails in the latter so that you can replace it in the same orientation later on. Then drill 1/8-inch-diameter holes in the four marked locations through the rear panel. Drill a hole through one frame wall for the POWER switch but do not mount the switch in place at this time. Also drill three small holes through the same wall to provide entry for the cables from the COUNT and RESET switches and ac line cord.

Sand and finish the frame as desired. You can give it one or more coats of oil stain, followed with one or more coats of polyurethane if it is solid lumber. Alternatively, you can paint it a color of your choice if it is made from plywood or particle board. When the finish has thoroughly dried, mount the POWER switch (if used) in its hole. (If you used reasonably thick material for the frame, use a switch that is designed for mounting on a thick panel.) With this switch in place, mount the fuse holder in a convenient location with a small wood screw.

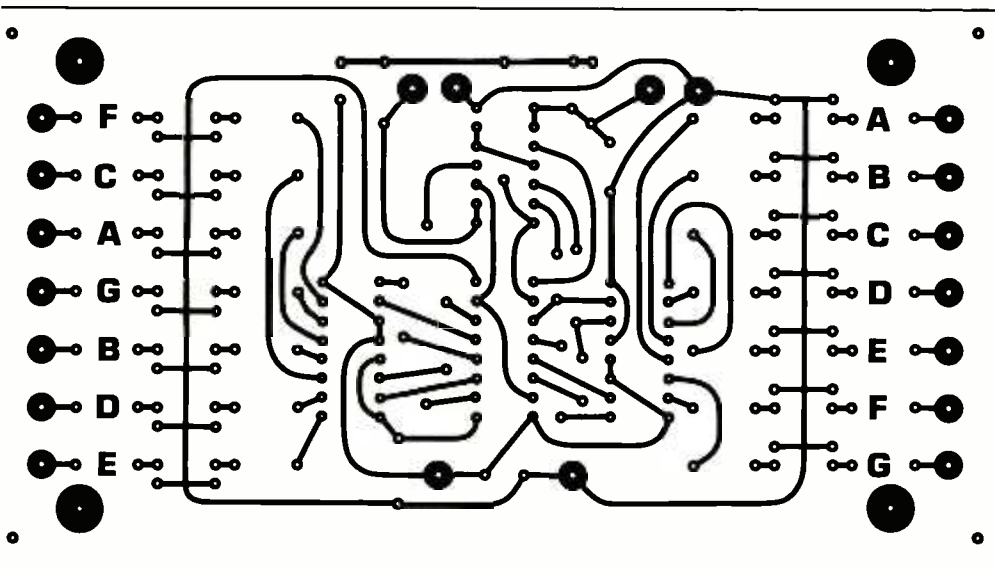

Fig. 3. Actual-size etching-and-drilling guide for main electronics package printed-circuit board.

Referring now to Fig. 9, begin putting together the various elements that make up the project. The assembly drawing shows use of set screws to secure the LED display circuit-board assembly to the red acrylic filter. If you go this route, install 4-40 \times $\frac{1}{4}$ -inch set screws as follows. First drill suitably sized holes in the four marked locations on the filter and pre-thread these holes with an ordinary 4-40 screw. Then screw the set screws into the holes until they are flush with the front surface of the filter. Then screw a 4-40 threaded standoff onto the protruding end of each set screw.

If you have difficulty locating suitable set screws, you can take an alternative route. Instead of using set screws, make the mounting holes in the filter large enough to accommodate 4-40 machine screws without binding and thread the standoffs onto the protruding ends of the screws. For most people, this may be the simpler of the two mounting methods.

The length of the threaded standoffs needed for mounting the LED display circuit-board assembly to the filter depends on the height of the LED bargraph elements used. Most LED bargraph displays are $\frac{3}{8}$ inch high, but check to make sure before selecting a standoff length. The tops of the displays must be as close as possible to the inside surface of the filter.

Once the LED display circuit-board assembly has been mounted to the plastic filter, proceed with the remainder of assembly. Proceed with this as shown in Fig. 9, using suitable length 4-40 machine screws and standoffs. Before mounting the power-supply circuit-board assembly, plug the free end of the wire coming from the hole labeled +24V into either hole labeled the same way in the display board assembly from the rear of the latter and solder it into place.

Next, set the main electronics package circuit-board assembly near both the LED display and power-supply circuit-board assemblies.

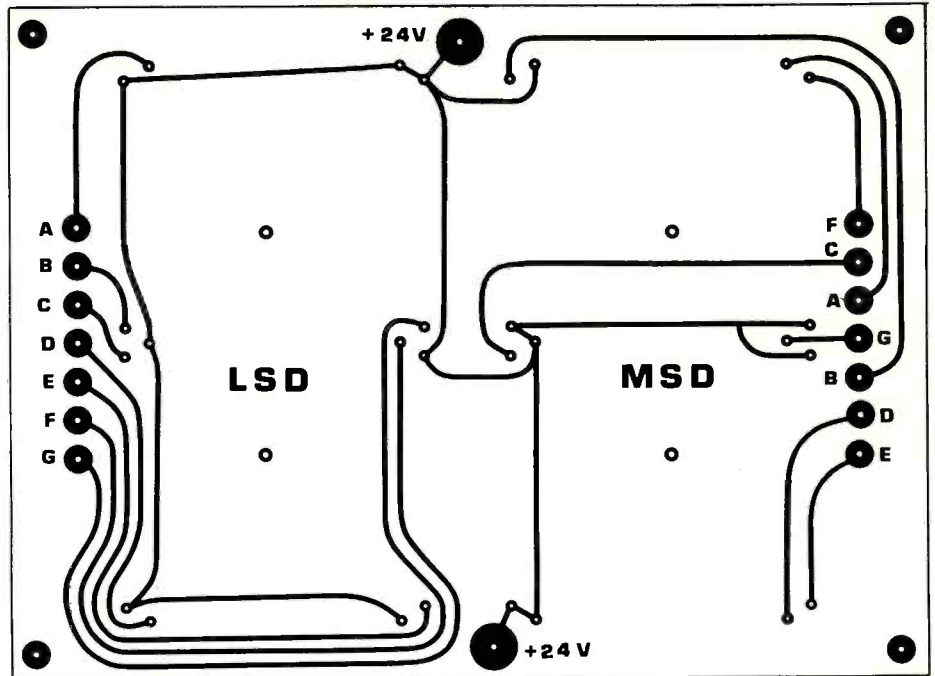

Fig. 4. Etching-and-drilling guide for LED display printed-circuit board, shown here 50 percent of actual size..

Making absolutely certain you select the correct wire in each case, plug the free ends of the wires coming from the holes labeled A through G along the right side of in the main electronics package circuit-board assembly as

viewed in Fig. 6 into the *same* lettered holes along the right side of the LED display board (see Fig. 4) and solder each into place as you go.

Repeat the entire procedure for the wires that bridge the two assemblies

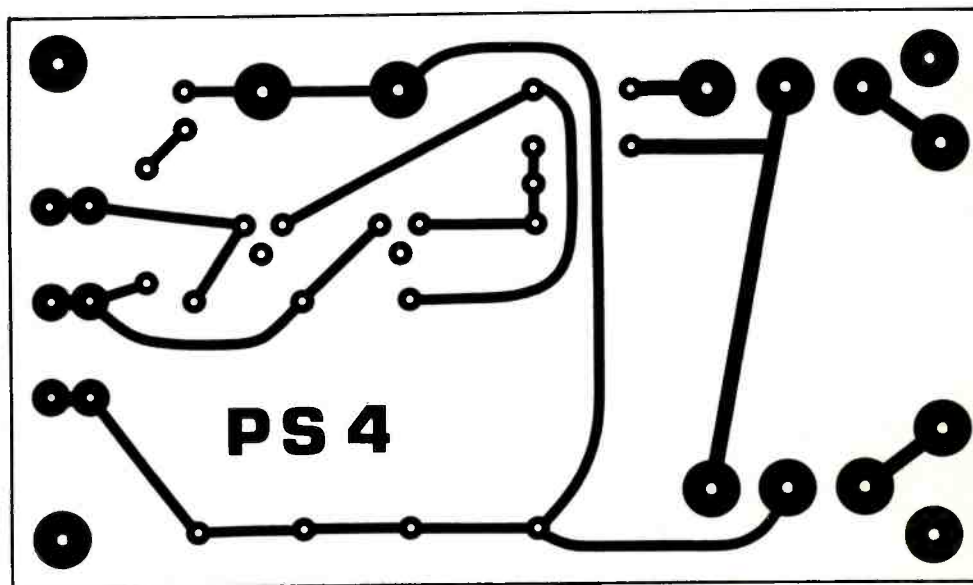

Fig. 5. Actual-size etching-and-drilling guide for power-supply pc board.

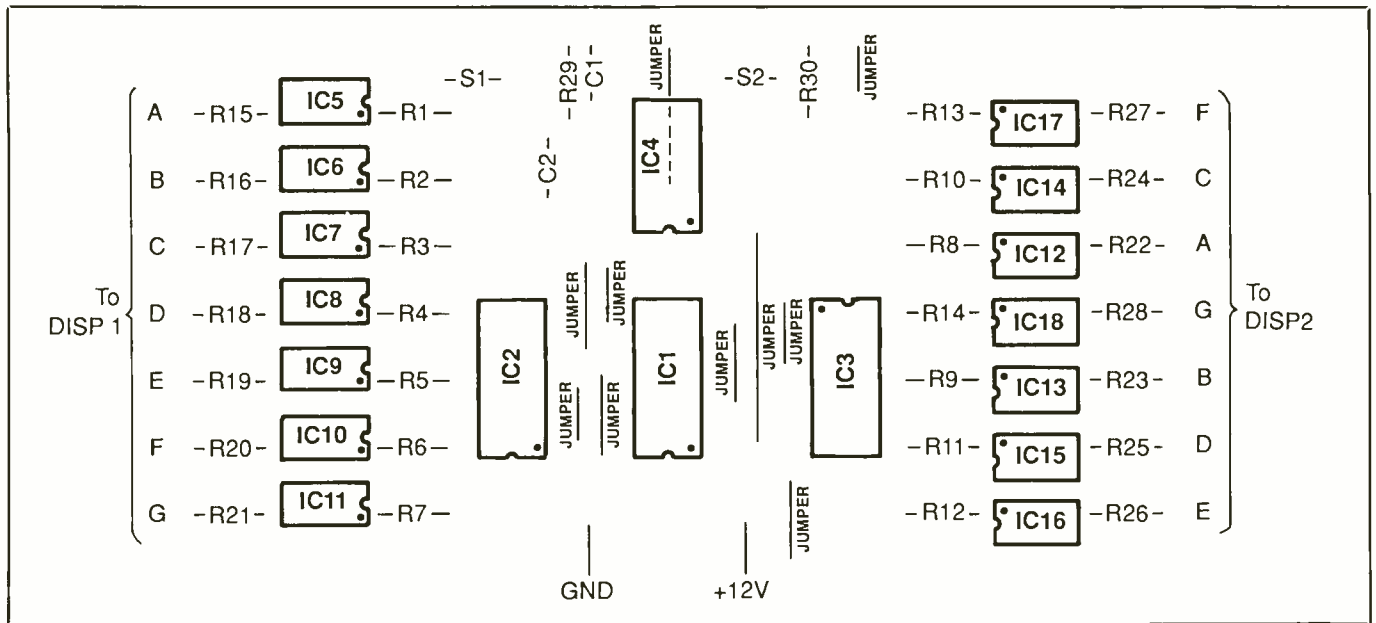

Fig. 6. Wiring guide for main electronics package board.

along their left sides. You will note that the hole sequences in both cases on both sides of the two circuit-board assemblies match from top to bottom. Note, too, that all wires must be plugged into the rear or solder side of the LED display board assembly. When you are finished with this wiring, go over it carefully to assure that it is correct.

Locate the two remaining wires coming from the power-supply circuit-board assembly and plug them into the holes at the bottom of the main electronic package assembly. Again, make absolutely certain that these wires are properly polarized (+12V to +12V and GND to GND) before soldering them into place.

Use stranded hookup wire, prepared as described above, to bridge from one lug of the fuse holder to one 117VAC hole in the power-supply circuit-board assembly and from the other lug of the fuse holder to one lug of the POWER switch (if used). Route the ac line cord through the hole you drilled for it in the frame wall. Tie a strain-relieving knot in it about 6 inches from the unfinished end inside the frame. Tightly twist together the fine wires in each conductor and

sparingly tin with solder. Plug one conductor into the remaining 117VAC hole in the power-supply circuit-board assembly and solder into place. Crimp and solder the other conductor to the other lug of the POWER switch. Plug the fuse into the

fuse holder. Then temporarily mount the power-supply circuit-board assembly into place.

Determine how long you want the light-duty two-conductor zip-cord cables to be for the COUNT and RESET switches and cut them to length.

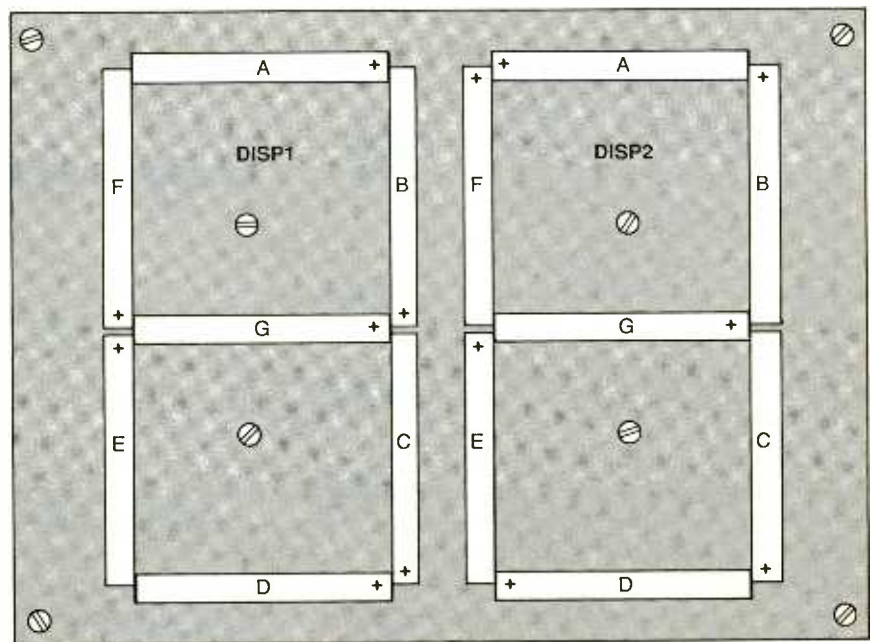

Fig. 7. Wiring guide for LED display board. Note that this is a view from the component side of the board.

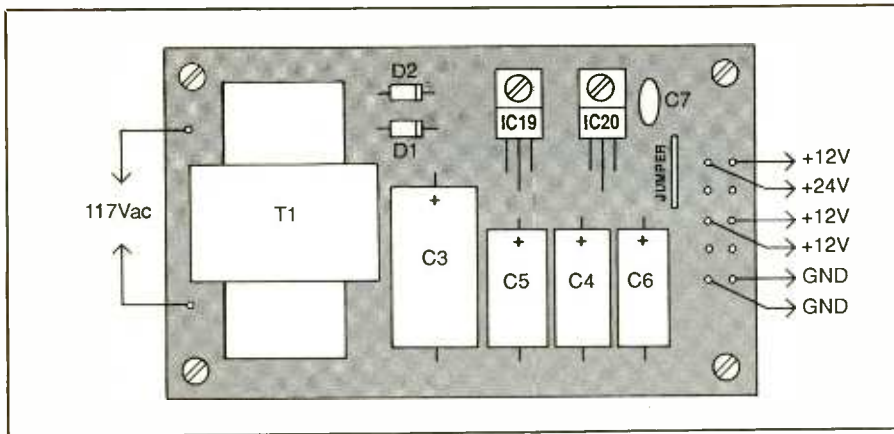

Fig. 8. Wiring guide for power-supply board.

They can be any reasonable length that will permit reliable counting and resetting action. Strip $\frac{1}{4}$ inch of insulation from both conductors at both ends of each cable. Tightly twist together the exposed fine wires and sparingly tin with solder.

Route one end of each cable through the holes you drilled for them in the frame and tie a strain-relieving knot in each about 8 inches from the ends inside the frame. Plug the end of one cable into the holes labeled TO S1 in the main electronics

package circuit-board assembly and solder into place. Do the same for the other cable and the holes labeled TO S2. Temporarily mount this assembly into place.

Drill a small hole through the center of the bottom of each of two plastic 35-mm film canisters or other suitable enclosures. Route the free ends of each cable through the drilled holes and tie a strain-relieving knot in each about 2 inches from the end inside the canister.

Drill or punch a suitably sized hole through the center of the lids of both canisters and mount the two normally-open, momentary-action push-button switches. Mount the switches in place, crimp and solder the ends of the cable conductors to their lugs and snap the lids onto the respective canisters. If you know which cable operates which function, label the canisters accordingly; if not, wait until you operate the project and then apply appropriate labels.

Checkout & Use

Make sure no integrated circuits are plugged into the IC1 through IC4 sockets on the main electronics package circuit-board assembly. Clip the common lead of a dc voltmeter or multimeter set to the dc volts function to the negative (-) lead of C4 or C6 on the power-supply circuit-board assembly.

Plug the project's line cord into an ac outlet and set the POWER switch (if used) to "on." As you take the following voltage measurements, make absolutely certain that you do not touch the primary circuit of the power transformer.

Touch the meter's "hot" probe to the positive (+) leads of C4 and then C6 and note the readings obtained. They should be +12 and +24 volts, respectively. If you do not obtain either reading, immediately power down the project and pull its line cord from the ac outlet. Check out the power supply for proper orienta-

(Continued on page 86)

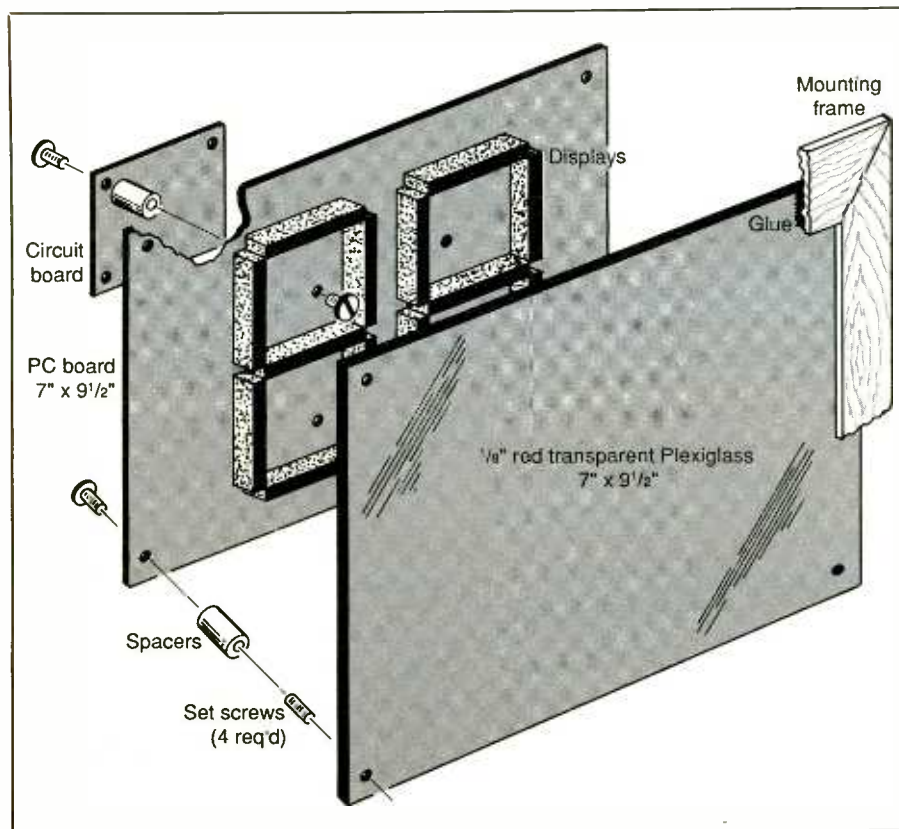

Fig. 9. Assembly drawing shows how various elements that make up project mount to each other using suitable machine hardware and standoffs.

A Color Film Processing Analyzer

Takes the guesswork out of determining the best color balance for processing of color negatives and slides to assure consistent results

By Maurice P. Richardson, W3TTR

Color film processing has become a practical and fascinating amateur darkroom activity. Once initiated, though, the photographer soon discovers that a degree of standardization and process control is essential if he hopes to achieve consistent results. Electronics can come to the rescue here. For example, one aspect of color printing that can benefit from electronics is measurement of the color balance of the imaging light projected by an enlarger. Whether printing from negatives or from slides, color balance is controlled by measurement and adjustment of the relative amounts of three primary colors projected onto the photographic paper. Enlarger filters inserted into this light path are used to vary the ratios between these primaries, until a satisfactory color balance in the print is obtained.

Being a subjective judgment, the initial "correct color balance" must be determined by trial and error. Unfortunately, one cannot assume that subsequent prints would just use the same filter setup because spectral transmission varies from film to film and the spectral sensitivity or balance varies from batch to batch of color paper. Hence, subjective adjustment of a projected image is difficult and inaccurate and is usually wasteful of materials. This is where electronic instrumentation can give a high yield of

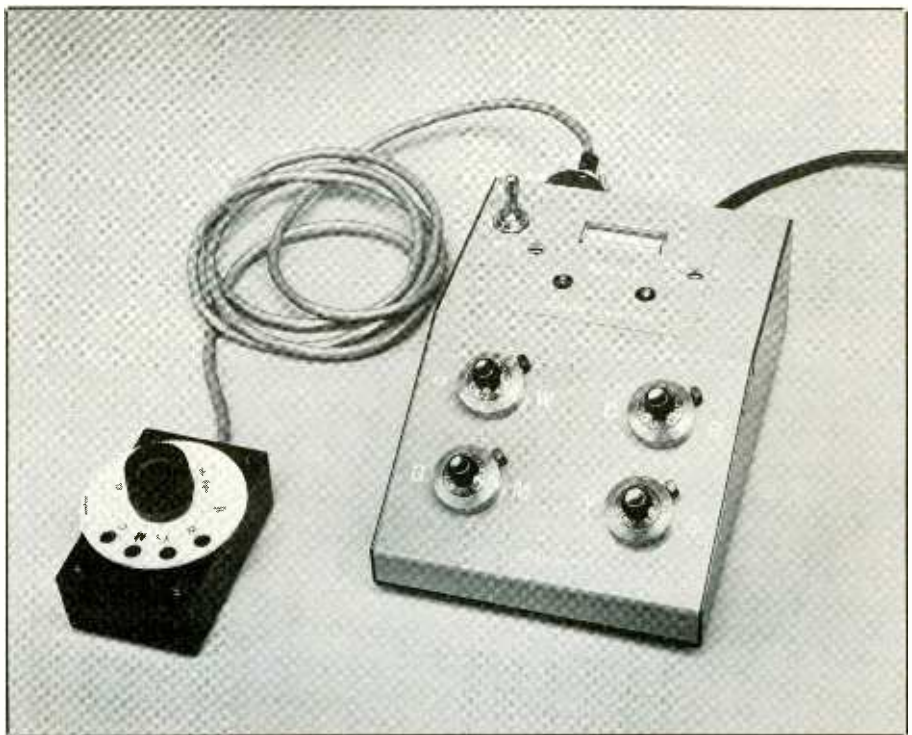

correctly balanced prints, using a so-called Color Analyzer like the one we describe here.

The primary purpose of a color analyzer in a photographic darkroom is to minimize the amount of trial and error involved in making color prints. It will improve the accuracy of exposure time and color balance from print to print and thereby produce a higher and faster yield of satisfactory prints. The Color Analyzer described here is designed to work with an enlarger in establishing the correct ex-

posure time and proper color balance with a minimum of trials.

Color Analyzer Basics

In color photography, the visible spectrum is split into three regions or channels, called "primaries." Suitable mixtures of primaries—composed of red, green and blue light—have been found to reasonably reproduce most colors found in nature. Each of these "additive" primary colors has an associated "subtrac-

tive" color as well that complements it. Dichroic enlarger heads are fitted with subtractive primary filters, namely cyan, magenta and yellow.

In keeping with the complementary concept, only the yellow filter in the dichroic head will effect the amount of blue in the spectrum of light output from the enlarger. The cyan and magenta filters will have minimal effect on the output of blue light. However, as the yellow filter is introduced into the enlarger's light path, blue light output becomes attenuated. Adding more yellow filtration subtracts more blue light from the enlarger's output. Similarly, adding a magenta filter to the light path will reduce green output, while adding cyan reduces red output.

The Color Analyzer "measures" the amount of each additive primary color required to produce a satisfactory color print from a particular film with a particular print paper. To do this, a "probe" with a photosensitive cell is placed on the enlarger easel. This arrangement also includes a means of inserting primary filters above the photocell. Thus, there are pairs of band-reject filters in the enlarger and associated bandpass filters in the probe. These pairs of filters are selected with sufficiently narrow bandwidths that the primaries do not overlap each other. Additionally, the cumulative bandwidth covers the spectral bandwidth of color film.

To measure the amount of blue light coming from the enlarger's output, a blue filter is inserted above the photocell. To alter the amount of blue light output, the yellow filter in the enlarger head is adjusted. A green filter at the probe is used to determine the amount of green primary, which can be altered by use of a magenta filter in the enlarger. The red light viewed by the red probe filter is adjusted by the cyan enlarger filter.

With a probe capable of independently "looking at" the amount of light of each primary color that comprises the projected image, the rest of

the Color Analyzer is dedicated to measuring and storing this information for future recall and comparisons. Some analyzer designs are capable of measuring exact density, as is the case with densitometers. Or they can read out exact amounts of filtration to be added or removed from the light path. However, a much simpler concept will serve very well to produce satisfactory color prints. This is the "nulling" concept in which an electronic bridge is used to balance or "null" each primary channel under reference conditions and then store this data for future recall when making another print.

The same nulling circuit can also be used to "measure" and store exposure data. The null measurement method is chosen for our Color Analyzer because it requires no instrument or meter calibration and results in simple electronic circuits. The Analyzer then consists of a probe with associated filters, connected to an enclosure that houses a bridge circuit, balancing controls for the three primary channels and another for exposure, and a suitable display device.

A meter display—often a zero-center type—is generally used so that the pointer can swing above and below the balance point. A meter of this type is optional in our Analyzer. A more convenient display can be created with just two light-emitting diodes. One LED will be on when the bridge is above balance, the other when it is below balance. At the exact balance point, both LEDs will be lit because of the "toggle" action of the circuit. The LEDs are easy to see under total-dark conditions, and no meter illumination is needed.

Though photomultiplier tubes like the 931-A have a flatter bandpass sensitivity than do cadmium-sulfide (CdS) devices, our null-type Analyzer has no such requirement. The important concern in this project is the ability to recall the values initially entered when calibrating it. This is ensured by operating the sensor in

the region below saturation.

In the subject analyzer, ND filters were added to bring the light levels close together in terms of the cell resistance corresponding to each channel. With white light being analyzed, the voltages applied to the op-amp input of the Color Analyzer are essentially similar across all channels at a given light intensity.

Selection of a suitable light sensor for the probe requires some compromise in balancing critical parameters. Basic selections are between photoemissive, photovoltaic, photoconductive junction devices, and photoconductive non-junction types. Junction types, such as photodiodes and phototransistors are hardly sensitive enough for this application, and photovoltaic devices are less sensitive than desired. Sensitive photomultiplier vacuum tubes that have gains of a million times following the emissive source are physically large and require high voltage on the dynode string. Care must be exercised to design a safe instrument with 1,000 volts involved.

The CdS bulk conductive sensor offers adequate sensitivity, much smaller size, and requires only a few volts to function. Such a photocell is satisfactory for the probe to be used with our Color Analyzer. The somewhat slow response time of the CdS material is not a problem, especially under the light-level conditions encountered when working under an enlarger in the darkroom.

The infrared response of the cell should be as low as possible. Some surplus conductive cells have responses that peak in the red and IR and, thus, are unsatisfactory for the Analyzer. Ideally, the cell should have a response limited to the visible spectrum. A close match to the human eye response is available in CdS, and it is this, as well as other considerations, that made it the choice for this project.

A Clairex type CL705HL is the photocell of choice because it has a

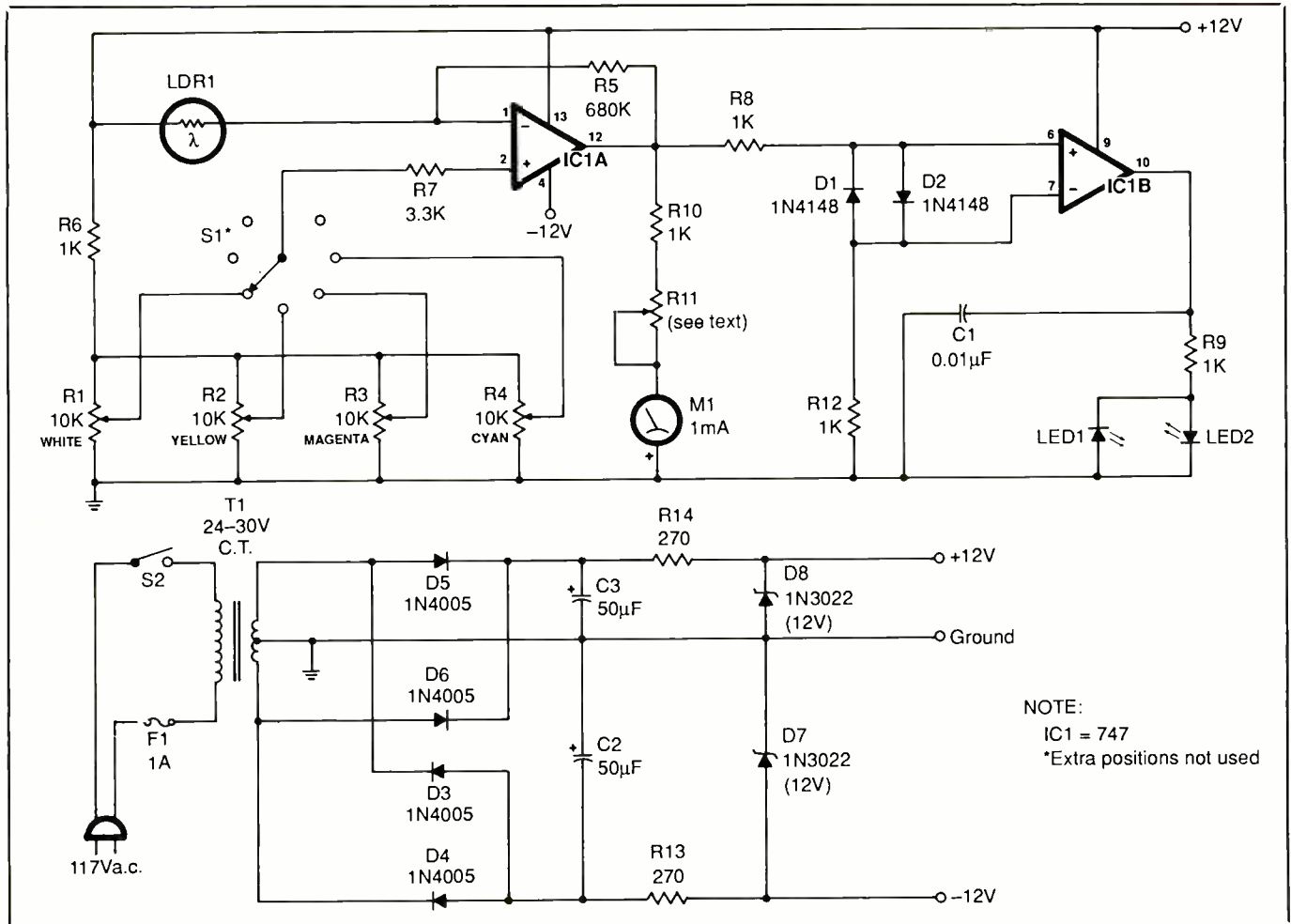

Fig. 1. Complete schematic diagram of the circuitry used in the Color Analyzer.

(type 5) Cds sensitive material with peak response at 5,500 Angstroms, closely matching the eye. Its resistance varies from nearly 20 megohms in the dark to 28,000 ohms at 2 foot-candles of illumination.

If another cell is substituted, its spectral response and resistance characteristics should closely match those of the CL705HL. Of course, low infrared response is mandatory. Be aware, though, that various manufacturers do not designate sensitive materials in the same way. For example, Vactec types 0 and 3 are similar to Clairex Type 5. Resistance ratios also vary considerably between products of various manufacturers. With the foregoing in mind, the Vactec

VT-333 is a possible substitute for the specified Clairex cell.

About the Circuit

As shown in the schematic diagram of the project in Fig. 1, the circuitry for the Color Analyzer is relatively simple. It is built around two inexpensive 747 operational amplifiers in a single package, designated as *IC1* here. The photocell probe, *LDR1*, converts variations in light intensity into changes in cell resistance that, in turn, translate into changes in voltage that are fed to the circuitry.

A convenient circuit approach uses a bridge configuration that has the CdS cell as one arm of the bridge and

is connected between the pin 1 inverting (-) input of *IC1A* and ground to operate this op-amp stage in a differencing-amplifier configuration. Because the Color Analyzer will be used in a darkroom where temperatures will be at a comfortable level and functions in a nulling mode, many of the problems associated with common-mode rejection, offset voltage and bias currents, and temperature stability can essentially be circumvented or ignored.

In this application, using a photoconductive cell like *PCI*, an amplifier configured as a current-to-voltage converter is appropriate.

A second op amp, *IC1B*, in the circuit is configured as a comparator to

NOTE:
IC1 = 747
*Extra positions not used

PARTS LIST

Semiconductors

D1,D2—1N4148 or similar small-signal silicon diode

D3 thru D6—1N4005 or similar 600-volt, 1-ampere silicon rectifier diode

D7,D8—1N3022 or similar 12-volt zener diode

LED1,LED2—Light-emitting diode

IC1—747 dual operational amplifier

Capacitors

C1—0.01- μ F, 50-volt Mylar

C2,C3—50- μ F, 35-volt miniature electrolytic

Resistors (1/2-watt, 5% tolerance)

R5—680,000 ohms

R6,R8,R9,R10,R12—1,000 ohms

R7—3,300 ohms

R13,R14—270 ohms

R1 thru R4—10,000-ohm, multi-turn, linear-taper potentiometer (see text)

R11—10,000- to 100,000-ohm trimmer potentiometer (see text)

Miscellaneous

F1—1-ampere slow-blow fuse

J1—Octal plug (optional—see text)

LDR1—Clairex CL705HL or similar photoconductive cell (see text)

M1—1-mA or greater sensitivity, zero-center meter movement

P1—Octal socket (optional—see text)

S1—Non-shortening wafer-type rotary switch with 30-degree indexing

S2—Spst slide or toggle switch

T1—24- to 30-volt, 100-mA power transformer

Printed-circuit board or perforated board with holes on 0.1-inch centers and suitable Wire Wrap or soldering hardware (see text); suitable enclosures for electronics package and probe assembly (see text); control knobs and dialplates (see text); fuse holder; 8-conductor cable; ac line cord with plug; 2 \times 2-inch Kodak Wratten gelatin filters (see text for details); 0.5 and 1.0 neutral-density filters; dry-transfer lettering kit; clear acrylic spray; 1/2-inch spacers; machine hardware; heat-shrinkable or plastic tubing; hookup wire; solder; etc.

Note: Kodak gelatin and neutral-density filters and the publications mentioned at the end of the article are available from any Kodak products dealer.

drive light-emitting diodes *LED1* and *LED2*, which are connected in reverse polarity in parallel with each other. With the arrangement shown, the comparator monitors a zero-voltage condition at the output of the first op amp. At 0 volt, *IC1B* lights both LEDs simultaneously (the result of inherent crossover instability). However, at any potential at pin 12 of *IC1A* that is above or below the zero-balance condition, depending upon polarity, only one or the other LED will be on. Thus, the LEDs make up a convenient indicator of null conditions, with excellent resolution, under standard color dark-room viewing conditions.

Construction

The circuit design and mechanical concepts of this project have been deliberately kept simple to make the Color Analyzer easy to duplicate and to accommodate different methods of construction that may depend on availability or components and personal preferences.

Component layout and conductor runs in this project are not critical. This means that you can use any method of construction that pleases you to build and wire the circuitry. If you wish to use a printed-circuit board, for example, you can home fabricate one using the actual-size pc guide shown in Fig. 2.

Alternatively, you can substitute a perforated board that has holes on 0.1-inch centers and suitable Wire Wrap or soldering hardware. Whichever technique you choose, though, be sure to use a socket for *IC1*.

Assuming you opted for printed-circuit construction, set the ready-to-wire pc board in front of you in the orientation shown in Fig. 3. All components except the power transformer, fuse in its holder, POWER switch, two LEDs, photocell, rotary switch and optional meter movement mount directly on the pc board.

Begin wiring the board by install-

ing and soldering into place the socket for the IC. Do *not* plug the IC into the socket until after you have checked out the circuit. Then install and solder into place the single jumper wire at the location specified at the lower-left of the board. You can use either bare solid hookup wire or cut-off resistor lead for this jumper.

Next, install and solder into place the resistors, including pc-mount trimmer control *R11*. Continue wiring the board by installing and soldering into place the capacitors, small-signal, rectifier and zener diodes. Make certain that the electrolytic capacitors and all diodes are properly polarized before soldering their leads to the pads on the bottom of the board.

An optional meter movement capability is built into the pc board. If you plan on adding this meter, one lead that goes to it comes from the indicated hole near trimmer *R11*. The other other lead comes from any ground point in the circuit, such as the chassis of the project's metal enclosure. If you decide against including this meter movement, eliminate *R11* and *R10*.

Strip 1/4 inch of insulation from both ends of six 6-inch lengths (five wires if you decide against using the optional meter movement). If you are using stranded wire, tightly twist together the exposed fine conductors at all ends and sparingly tin with solder. Plug one end of the wires into the holes labeled END OF R1-R4, GROUND END OF R1-R4, LEDS and, if you are using the meter, METER + and solder all connections.

If you do decide to incorporate into the project the optional analog meter movement, select one that has a zero-center pointer position and a 1-milliamperere or better sensitivity. The types of meter movements originally intended for aiding in FM stereo tuning are virtually ideal for this application.

The type of potentiometer controls you use for this project can be single-

The Theory of Color

The relationships between the additive and subtractive primary colors are often confusing to the amateur photographer. Additive primaries are encountered in the color-TV receiver picture tube. A close look at the screen of a turned-on TV receiver reveals that sets of three color dots or tiny bars glow with red, green and blue light. When all three colors are glowing at the same intensity, the result is white. Varying the relative intensities of these three basic primary colors makes it possible to reproduce most natural colors.

Subtractive primaries are less understood, but the concept is fairly simple to comprehend. Each subtractive primary is the color that results from removing (subtracting) one of the additive primaries from white light. Thus, removal

of blue from white light leaves red and green, which translates into yellow light to the human eye. A yellow filter subtracts blue from white light because yellow is complementary to blue. Hence, a yellow filter is called "minus blue."

In the same manner, removing green from white light leaves red and blue, a result we know as the color magenta. A magenta filter, then, is called "minus green." Finally, removing red from white light leaves blue and green, which leaves the color we know as cyan. Since a cyan filter removes red, it is called "minus red."

From the foregoing, it should now be obvious that the subtractive colors are simply the hues that result from literally "subtracting" additive primary colors from white light.

turn types with dial scales lettered onto the enclosure in which the project will be housed. The dial scales must be capable of good resolution if settings are to be logged and recaptured when going from one film type to another (this necessitates resetting the potentiometer controls to obtain balanced conditions).

If you plan on regularly using several types of film, dial settings may have to be set often. This requires good resolution. For this reason, I incorporated multiple-turn potentiometers with locking dials, as illustrated in the lead photo. This type of potentiometer is a bit expensive, but the degree of resolution their verniers provide, coupled with smooth balancing action and locking capabilities, justified their extra cost.

Selection of the enclosure in which the circuitry is to be housed is predicated on having enough room inside to comfortably accommodate the circuit-board assembly and power transformer on the floor; the potentiometer controls, POWER switch and LEDs (and meter movement, if used) on the top panel; and the fuse holder

and entry holes for the ac line cord and cable from the probe assembly on the rear panel. This should be of all-metal construction. The enclosure shown in the lead photo is a standard LMB instrument case that measures $7 \times 5 \times 2\frac{1}{2}$ inches and has a sloping control panel. This particular enclosure is a bit cramped inside; so a slightly larger one is suggested.

Machine the enclosure as needed. Drill the four mounting holes for the circuit-board assembly and power transformer through the floor panel. Drill one more hole through the floor of the enclosure near the center of the rear wall to accommodate a chassis lug. Then, referring to the lead photo, drill the mounting holes for the potentiometer controls, POWER switch and LEDs, and cut the slot for the meter, in the top panel.

Drill the mounting hole for the fuse holder and entry hole for the ac line cord through the rear panel. For entry of the cable from the probe assembly, you have two options. The simpler of the two is to just drill a hole and pass the cable through to connect it to the circuitry. A more

professional option is to drill or punch a much larger hole in which you install a chassis-mount octal socket and terminate the cable in an octal plug that will permit disconnection of the cable for storage purposes. Whichever way you decide to go, make a suitable size hole.

When the enclosure has been fully machined, deburr all holes to remove sharp metal edges and then line the entry hole for the ac cord with a rubber grommet. Pass the free end of the line cord through the grommet and tie a strain-relieving knot in it about 5 inches from the unfinished end inside the enclosure. Tightly twist together the fine wires in each conductor and sparingly tin with solder.

If you are not planning on using an octal socket/plug arrangement to interconnect the probe assembly and electronics package, line the hole drilled for this cable with a suitable rubber grommet and pass one end of a 36- to 48-inch-long eight-conductor cable, preferably with color-coded conductors, through the grommet. Secure the cable in place about 10 inches from its free end inside the enclosure with a plastic cable tie (drill a mounting hole in the rear panel to accommodate the machine hardware that will hold the tie in place).

Should you decide to use the socket/plug arrangement, mount the socket in its hole in the rear panel with suitable machine hardware. Then mount the fuse holder, using suitable machine hardware. Label the front panel as needed (see lead photo) with a dry-transfer lettering kit. When the legends are in place, protect them with two or more light coats of clear spray acrylic. Allow each coat to dry before spraying on the next.

Continue assembly by mounting the POWER switch and four potentiometer controls in their respective holes and the meter, again if used, in its slot. Line the two remaining holes in the top panel with panel clips or small rubber grommets.

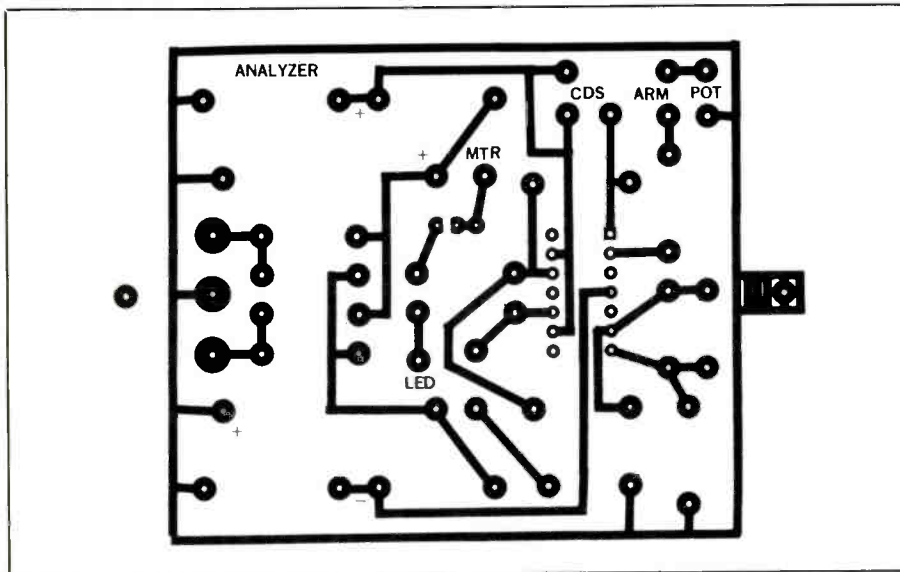

Fig. 2. Actual-size etching-and-drilling guide to use for fabricating printed-circuit board on which to build project's circuitry.

Identify the cathode leads of the two LEDs and form a small hook in each. Trim both cathode leads to a length of 1/2 inch and form a small hook in each stub. Crimp and solder an 8-inch length of hookup wire to each LED cathode lead. Slide a 1-inch length of small-diameter heat-shrinkable tubing over the end of the

wire and on up to the bottom of the LED cases to cover the connections. Shrink the tubing into place.

Clip the anode leads of the LEDs to a length of 1/2 inch. Then slip the LEDs into their panel clips or grommets. Bring the wire attached to one LED toward the anode lead stub of the other and determine where to

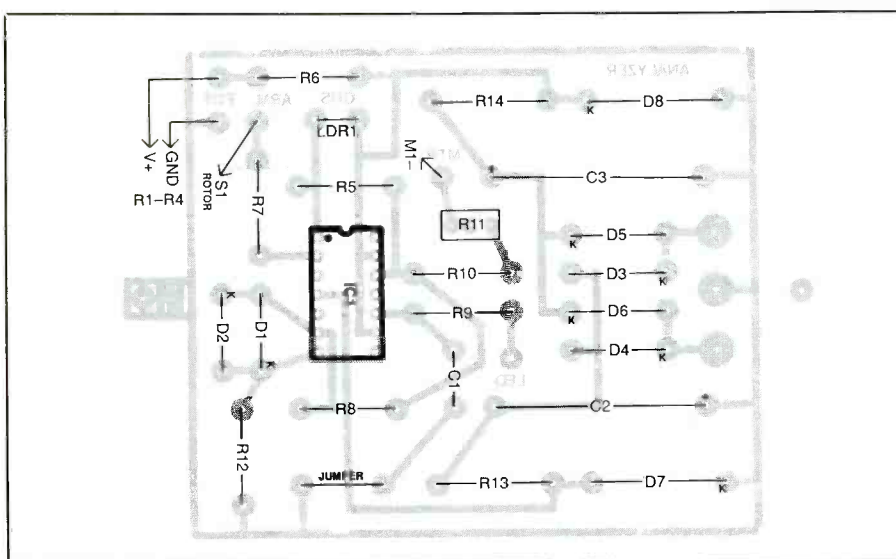

Fig. 3. Wiring guide for printed-circuit board. Use this as a rough guide to component layout when assembling circuitry on perforated board.

gently strip away some of the insulation to permit making a secure mechanical and electrical connection. Do not stress the wire or leads. Crimp the free end of the LED's anode lead stub to the exposed wire and solder the connection. When the connection has cooled, insulate it with electrical tape. Repeat the entire procedure for the other wire and anode lead stub. When you are done, carefully strip 1/4 inch of insulation from the ends of the remaining wires.

Plug the end of one of the wires attached to the LED pair into the hole labeled LED in the circuit-board assembly and solder into place. Terminate the other LED wire in a No. 6 chassis lug. Locate the wire labeled M1 and crimp and solder its free end to the negative (-) lug of the meter movement. Then strip 1/4 inch of insulation from both ends of a 5-inch-long hookup wire, terminate one end in the same chassis lug to which the LED wire is connected and solder the connection and crimp and solder the other end of this wire to the positive (+) meter lug.

Assuming you are using the octal socket/plug arrangement for interconnecting the probe assembly and electronics package, crimp and solder the free ends of the wires coming from the circuit-board assembly to the appropriate lugs on the socket. Otherwise, remove 3 inches of outer plastic jacket from the cable already installed. Strip 1/4 inch of insulation from the free ends of the exposed conductors. Tightly twist together the fine wires in each conductor end and sparingly tin with solder.

Plug two of the conductor ends into the LDR holes just above R5 in the circuit-board assembly and solder into place. Similarly, plug the ends of the remaining conductors into the switch and potentiometer holes at the upper-left of the board and solder the three connections. Write down on a piece of paper the insulation color used for each connection.

Mount the power transformer to

the floor of the enclosure with suitable machine hardware. Plug the free ends of the transformer's secondary leads into the indicated holes in the circuit-board assembly and solder the three connections. Make sure you plug the center-tap lead into the appropriate hole before soldering any leads into place.

Mount the circuit-board assembly into place, using 1/2-inch metal spacers and 4-40 x 3/4-inch machine screws, nuts and lockwashers. Secure the chassis lug that terminates the LED and meter wires to the floor of the enclosure with a 4-40 x 1/4-inch machine screw and nut to assure a solid electrical ground.

The probe used with your Color Analyzer requires that the optical bandpass filters be placed in the path of light reaching the photocell. The probe is designed in a simple mechanical concept so that it can easily be duplicated. It consists of a housing for the photocell plus a means of placing each of the three color filters sequentially over the photocell. The detent action needed is conveniently supplied by a wafer-type rotary switch that has conventional 30-degree indexing.

By using a 2 1/2-inch-diameter dialplate disc as a knob skirt, the filter aperture holes can be drilled on a 1-inch radius and will then be centered 1/2 inch apart along this arc. With the photocell window being approximately 1/4 inch in diameter, each filter window should have a similar opening.

The disc should be painted white and fitted with a 1-inch diameter control knob. A simple opaque metal or plastic box that measures 3 x 2 x 1 inches comfortably accommodates the rotary switch and photocell. If your enlarger easel is metal, a nice touch is to cement a square of plastic magnet to the bottom of the enclosure to hold the probe in position on the easel during analyses to keep it from moving as you switch channels. The switch is centered on the 2 x 3-

inch surface, and the photocell is exactly 1 inch away from the switch axis to align the photocell precisely under the filter viewing windows.

Make sure when you assemble the probe that the photocell protrudes above the top panel of the enclosure about 1/8 inch and that you place a short cylinder made from opaque plastic (or even cardboard) sleeving around the photocell to serve as a light shield.

The dialplate that has the filter windows in it must secure as close as possible to the top of the sleeving so that the only light that reaches the photocell comes through one of the windows in the dialplate. Of course, the fit should be just tight enough to permit the dial to be rotated easily without having the filters scrape across the top of the sleeving.

The windows are fitted on the dialplate with color filters cemented into or over the holes. (Do this *after* you paint and letter the dialplate.) You need cyan, magenta and yellow filters (see "The Theory of Color Box" for details on the use of these filters during processing). A fourth window is included for viewing white light for determining exposure. This last window has no filter in or on it. Additional switch positions bring undrilled portions of the disc over the photocell to provide a "dark slide."

After performing the mechanical work, wire the rotary wafer switch and LDR according to the details given in Fig. 1. Make sure you follow the proper color coding for the insulation in the various conductors in the cable. If you are using the octal socket/plug arrangement, wire the plug in the proper sequence.

The initial probe concept has proven to be quite satisfactory in actual use. The red, green and blue reading filters can be Wratten No.s 25, 99 and 98 or 92, 99 and 47B. For color slides, Kodak suggests using filter No.s 29 red, 61 green and 47B blue filters that are used for tri-color printing.

Tri-color filters can be used for analyzing both color slides and negatives. However, if you work with only negatives, you may prefer the other filter set.

Alternatively, it might be feasible to add to the basic project another set of an extra set of viewing ports to the probe filter disk, opposite the ones already described, and include *both* sets of filters to optimize both negative and slide analyses. Wafer-type rotary switches with up to 12 detented positions are readily available to make this a practical possibility. With such an arrangement, you would simply make cross-connections to utilize both sets of filters. Hence, the windows for both the No.s 47B and 98 filters will feed into the same blue channel. Similarly, other cross-connections would feed the red and green filters into the respectively named channels. Only one white-light channel and associated neutral-density filter is required for exposure determination.

Finish wiring the project by interconnecting the potentiometer controls as indicated in Fig. 1. Similarly, interconnect the ac line cord, fuse holder, POWER switch and primary side of the power transformer. Use heat-shrinkable or plastic tubing to insulate the one line-cord/primary winding lead connection that is not self-supporting.

When you have come this far and still do not have *ICI* installed in its socket, you are ready to perform initial voltage checks. For this, you need a dc voltmeter or a multimeter set to the dc-volts function. Clip the meter's common lead to a convenient point that is at chassis ground.

Plug the Color Analyzer's line cord into an ac outlet, and set the POWER switch to its ON position. Touch the meter's "hot" probe to receptacles 9 and 13 of the IC socket and note the readings obtained. Both should be approximately +12 volts. Then touch the "hot" probe to receptacle 4 of the IC socket and, once again,

note the rearing obtained. It should be approximately -12 volts.

If you do not obtain the proper meter reading at any point, power down the project and unplug its line cord from the ac outlet. Rectify the problem before proceeding. If you obtained a reverse polarity, check *D5* through *D10* for proper polarity. Similarly, check the orientations of *C2* and *C3*. Do *not* proceed until you have rectified the problem.

Using the Analyzer

This Color Analyzer works in conjunction with only a color enlarger. The enlarger with which it is used should be fitted with a dichroic filter head, rather than be a type that uses CP filters, to circumvent the changes in density that occur when stacking CP filters.

In use, the Analyzer will help provide exposure consistency, as well as correct printing filtration. However, it will be no better than the data entered into its "memory." This is because this data is what makes up the standard of comparison for subsequent prints of the same general type with a given type of film on a given type of paper. Consequently, the first step in utilizing this project is to store some pertinent data in memory, which is initially empty.

Of course, as is common to all types of color analyzers, there is a rub. That is, the standard of comparison must be "home made" because it is first necessary to make an excellent-quality color print by the trial-and-error method, adjusting exposure first until correct density is obtained and then zeroing in on color balance. Trial prints must be made and remade until the best possible color balance is obtained. For this, it is best to work with a photograph that is representative of those that will usually be printed.

Once you have obtained what you deem to be a perfect print, do *not* touch the enlarger settings. Log the

exposure time and lens opening you used to make this print. Also, record the print size or height of the enlarger over the easel. These values must then be stored in the Color Analyzer's memory, where they will become the reference standards that are to be duplicated in subsequent prints.

Turn off all lights in your darkroom, including any safelights, and turn on the enlarger. With the reference film still in the enlarger, ascertain that the lens f-stop is the same as was used to make the reference print. This will usually be the f-stop that gave a 10-second exposure time, which is a common standard for color papers.

Place the probe on the easel and switch it to the WHITE position. Then adjust the setting of the appropriate potentiometer control until the meter on the Color Analyzer nulls and both LEDs light to indicate a balanced condition.

Switch progressively through the three color channels, nulling the balance for each channel with the appropriate potentiometer control in each case. Then repeat the entire process to fine tune the settings. Before continuing, record the dial settings obtained for each channel so that they can be recalled as needed.

(Note: As you operate the Color Analyzer, if you observe that the left LED lights or the meter's pointer moves down-scale as you rotate the potentiometer controls clockwise, the controls are wired backward. In this case, you should power down the project and transpose the connections that go to the left and right lugs of all pots. If the LEDs light in the proper sequence but the meter's pointer moves in the counter direction, it is a simple matter to reverse the connections to the meter's lugs.)

Your Color Analyzer is now calibrated with stored reference data. It will now attempt to make all subsequent prints attain this same color balance. Remove the reference film from the enlarger carrier and replace

it with a new unknown film.

With the new film in place, return the project to the WHITE channel position and adjust the lens opening, if necessary, to obtain a null condition in the exposure channel. Adjustment may be needed because various films have different densities.

Next, walk through the color channels on the Analyzer, adjusting the filters in the enlarger to regain nulls as needed. Again, repeat the entire procedure to fine tune.

In this procedure, the important thing to bear in mind is that the potentiometer controls are to be touched only during calibration with the reference film. They are not to be touched thereafter. Only the enlarger is to be adjusted to make the new unknown film results agree with the data stored in the Color Analyzer.

The enlarger will now attempt to make any new print match the reference by making the color values and illumination match the original values. If the reference photo was of an orange and the new photo is of a lemon, the Analyzer will attempt to make the lemon the color of an orange. Thus, the Analyzer is truly a comparator that wants to make color values the same from print to print.

Once you understand this fundamental concept of color analyzers, utilization of this project becomes a straightforward proposition. References can be expanded so that data is compiled and logged for such important values as flesh tone, neutral gray or even pure white (as in clouds).

Amateur photographers seldom include a gray card in their photos, or there may not always be a flesh tone in a picture. So some additional ways of storing reference data will prove to be invaluable. The concept of "integrating to gray" or scrambling the color mix is a very useful technique to use. Enlarger light passing through a given film is mixed or scrambled by placing a matte plastic diffuser just below the lens. If an enlarger has a swing-away red filter just below the

lens, this can be replaced with a thin translucent white plastic disc that will mix the color to a neutral hue. This is then projected to the probe and is analyzed in the usual manner.

If the intensity of the light at the easel is very low after it passes through a mixer, you can drop the enlarger head closer to the probe while checking the color values. Alternatively, you can raise the probe on some support to place it closer to the lens while taking readings. Bear in mind that enlarger and probe must be back in "normal" positions when making exposure readings.

As you use the diffuser, you will notice that the projected image will be out of focus and the easel will be illuminated with uniform light. Under these conditions, the probe is placed at the center of the easel to take color readings, which position even sidesteps any concerns for cosine correction. Over a random spread of many types of pictures, the technique of scrambling the image and taking color-balance readings in this manner will produce a very high percentage of well-balanced prints with a minimum of "remakes." That is, a pleasing number of first prints will be correctly balanced.

Using the specified photocell under quartz-iodide enlarger light sources with the color filters required reveals unequal composite sensitivities between the four Analyzer channels (including the white channel). Sensitivity to red and green is greater than it is to blue. To equalize these values, neutral-density filters are added in the windows for red and green. A neutral-density value of 0.5 is approximately correct.

In the white-light aperture, two layers of neutral-density filter (1.0 + 0.5) reduce brightness to approximately the level of the color channels. This adjustment of brightness results in nearly equal sensitivities for all four analyzer channels, simplifying the electronics as well as contributing to convenient project use.

The result of trimming the channel filters with added neutral density brings the operating range of the photocell to a resistance range between 1 megohm and 10 megohms for typical light intensities on the enlarger easel. This is the linear, low-memory region of the photocell above the dark resistance level but is also well below the saturation level where linearity disappears and memory effects increase.

The probe detent includes positions where the photocell is covered by the skirt on the knob to serve as a dark slide. This allows the photocell to be covered when the Color Analyzer is not in use or when the white light in your darkroom is turned on. This helps in preventing the memory hang-up following exposure of a CdS cell to bright light.

Fastidious workers will discover that there are variations in color balance from one batch of color paper to another. Usually, the manufacturer of the paper gives data on color adjustments required from batch to batch. Or it may be useful to make a reference print from a new batch of paper and then log the newly adjusted filter values and new analyzer settings. It is also necessary to create new reference data when going from one film type to another or from one manufacturer to another.

It will soon become obvious that good data logging is mandatory if there is much switching between films and papers. Care in setting the potentiometer controls and determining dial settings, as well as the logging of all reference values, are essential if your Color Analyzer is to deliver the excellent results and high print yield that its design is capable of providing.

If you wish to carefully match the bandwidths of the analysis channels to specific films, it is highly recommended that you obtain copies of such Kodak publications as "Printing Color Negatives," "Printing Color Slides" and "Kodak Filters for Scientific and Technical Uses." These contain much useful information to the beginning and professional photographer who wants to do his own color film and slide processing. "Introduction to Color Photographic Processing" and "Color Printing Techniques" in the Kodak Workshop Series give valuable information on the entire darkroom sequence of exposure and processing of color materials. **ME**

MODERN ELECTRONICS

Order Back Issues

BACK ISSUE ORDER FORM

Please send me the following issues of *Modern Electronics* @ \$2.50 each:

Month(s) & Year(s): _____

Number ordered @ \$2.50 each: _____

(Your order may be tax deductible.)

Total Payment Enclosed: _____

(Check or M.O. only.)

NAME: _____

STREET ADDRESS: _____

CITY: _____ STATE: _____ ZIP: _____

Down Memory Lane

A nostalgic look at the early days of radio and some thoughts on collecting antique radios



By Joseph J. Carr

In 1916, an enthusiastic young employee of American Marconi Wireless, David Sarnoff, wrote a now-famous memorandum to his supervisor concerning the future of radio as a home-entertainment medium. Four years before Frank Conrad of Westinghouse made the first official radio broadcast on KDKA out of Pittsburgh, a visionary young Sarnoff saw the huge potential of bringing into the home via the airwaves news, concerts and other forms of audio entertainment.

Sarnoff went on to found Radio Corporation of America (RCA) and guide it to becoming a corporate giant. Initially, though, because ra-

dio was in its infancy and most radio transmitters were of spark-gap design that was not suitable for voice broadcasting, few people took his vision seriously. Sarnoff was correct, but his vision had to await the development of lower-cost vacuum tubes in the early 1920s to make possible widespread ownership of radio receivers. As prophetic as his vision was, however, on one point Sarnoff was wrong: his estimate that radio was a \$75,000,000 industry was conservative by almost an order of magnitude, it was more in the range of \$700,000,000!

To begin our tour down memory lane, let us take a brief look at early vacuum-tube radios and trace their general development as a commercial product from the 1920s to the late

1940s. Then we will look at the hobby of antique radio collecting.

Tracing Radio's Roots

Without the invention of the vacuum tube, there would have been no radio—nor TV or any of the other r-f communication wonders we have all come to depend on.

Though vacuum tubes began to be manufactured in the first decade of this century, it was not until the post-World War I period that they became the basis of a firmly established, viable industry. Even then, vacuum tubes were extremely expensive—with the least expensive of them costing as much as a weeks salary. My ham radio mentor and former FCC official involved in radio from the mid-1920s, the late McIvor Parker (W4II), once told me how he saved for months in 1927 to buy three vacuum tubes at \$7.50 each to build a shortwave radio receiver only to have a careless slip with a screwdriver instantly burnt out the filaments of all three tubes. To a young radio enthusiast, that fatal slip was a tragic event and a financial disaster.

Radio construction techniques evolved with the passing of the years. As a result, specific styles of construction can be used to date a radio to within a few years of its manufacture date. Prior to 1920, radios bore a strong resemblance to scientific apparatus. Indeed, early radios *were* basically scientific devices.

About 1920, the breadboard type of construction shown in the photo in Fig. 1(A) was popular. In this type of construction, the components were

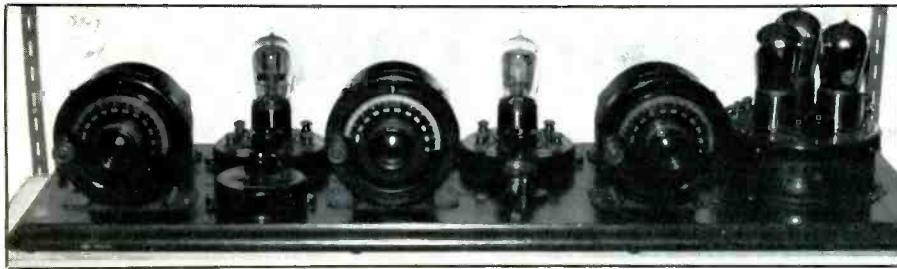

(A)

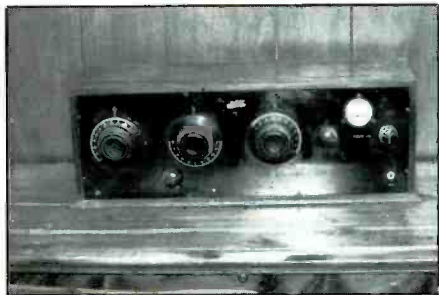

(B)

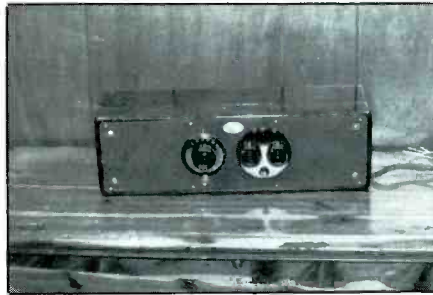

(C)

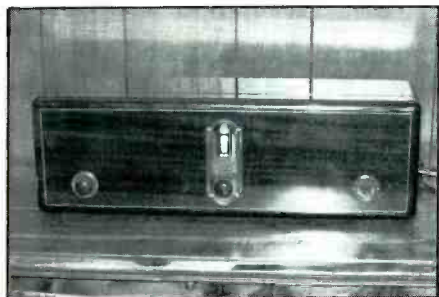

(D)



(E)

Fig. 1. Tuned Radio-Frequency (TRF) radio models from the 1920s: (A) Atwater-Kent "breadboard"; (B) Multi-tuning-knob TRF; (C) 1926 Atwater-Kent single-knob battery operated; and (D) 1928 RCA Radiola-17. (E) is an inside view of the Radiola-17.



Fig. 2. Cathedral radios are probably the most representative of early American radio design.



Fig. 3. Example of a Tombstone model radio from the 1930s.

mounted on the top surface of a large rectangular board that served as the base of the receiver. Point-to-point wiring that interconnected the components was performed on the underside of the breadboard. Separate sets of tuning components were provided for each of the three r-f circuits that made up the radio's circuit. The fine art of ganging controls had not been invented as of that time (or at least was not widely used). These radios are a bit costly today, averaging \$600 and up, because they are quite rare. Fortunately, many other antique radios from the 1920s are less rare and,

thus, fairly inexpensive.

Breadboard construction was not altogether satisfactory for home radios once they were intended for other than the "wireless" enthusiast. As broadcasting became a viable medium, radio design became oriented more towards family listening and less toward the lone wireless listener. Some of the first low profile table radio models appeared in the early to mid-1920s.

Like breadboard radios, many early table radios had two or three separate tuning controls, as shown in Fig. 1(B). By the end of the 1920's, how-

ever, "three dialers" were disappearing and a more modern form of radio with a single control and window dial were coming on the scene. Figures 1(C) and (d) are photos of a 1926 Atwater-Kent in the author's collection and a 1928 RCA Radiola 17. None of these radios had the superheterodyne circuitry that has become almost universal in modern radios—they were TRF (tuned radio-frequency) in design. Many of these radios use an external horn-shaped speaker that adds a touch of class when the radio is on display. As the Fig. 1(E) view inside one shows, many of these radios are



Fig. 4. Round radio is characteristic of early design popular in Britain.



Fig. 5. A console radio manufactured in the late 1930s.

people! But times change, and with more mass-market consoles beginning to appear in the late 1930s the radio became an everyday piece of furniture in many homes.

One of the many wonders of electronics over the years has been miniaturization. Although by today's standards nothing produced in the 1930s and 1940s was "miniature" in size, to a late-1930s buyer the small "mantelpiece" and midget table models (see Fig. 6) were a triumph of miniaturization for the time. In the late 1940s and early 1950s, the table model radio was still a popular item and often sported an FM band as well the traditional AM band (see Fig. 7).

Early Vacuum Tubes

The vacuum-tube complement of a radio receiver is often used to establish the approximate date of manufacture of the set. One of the best guides to this matter is detailed in *The Radio Collector's Directory and Price Guide*, in which a chart of tubes and their dates is presented. Figure 8 shows several different types of very early vacuum tubes. At the far right is the DeForest Audion tube, which proved unreliable as well as expensive. The Type N and Type J tubes, also shown, were made by AT&T for use in U.S. Navy receivers. The Type-J incorporated an oxide-coated cathode (1913), and was eventually miniaturized into the Type-N (1920).

Tubes in the 1920s generally had four-pin bases and envelopes, as shown in Fig. 9. Typical type numbers included 200A, 201A, WD-11 and WD-99. By 1930, the first digit of the tube type number was generally dropped, so common type numbers then current included tubes such as the '30, '37, and '45. Many of these late 1920s and early 1930s radio tubes had five-pin bases and glass envelopes. Starting in about 1932, six- and seven-pin types became available. Some also included a grid cap on the top of the tube (Fig. 10).

quite handsome inside, looking like a gleaming early version of our best technologies.

Perhaps the one design that truly represents early-period American radios is the cathedral (also known as "gothic" and upright) model shown in Fig. 2. The cathedral radio typically stood 18 to 22 inches tall, with a base that measured between 12 and 16 inches square. One-knob tuning was generally featured, and the speaker was integral to the radio cabinet. These radios were made from the late 1920s until the early 1930s.

Another popular American radio design was the "tombstone upright" shown in Fig. 3. These radios were approximately the same size as or possibly a little larger than the Cathedral. The Tombstone radio's cabinet, being more squared off, cost perhaps a bit less to manufacturer

than the curved cabinet of the cathedral radio. Tombstone radios were produced from the early to mid-1930s.

British radio manufacturers of the same period produced radio designs that differed from those in the USA. What the tombstone and cathedral models were to American buyers, the round model shown in Fig. 4 was to the British user. Companies like Edystone and Pye made radios in Britain that paralleled and in some ways surpassed American designs.

Also becoming popular in the late 1930s and 1940s were the "modern" console, or floor-model radio (see Fig. 5). Large consoles made in the 1920s were extremely expensive, which limited their purchase to affluent buyers. One model that retailed for \$795, according to an advertisement of the period, cost seven months salary for many working



Fig. 6. A small table model or "mantelpiece" radio.

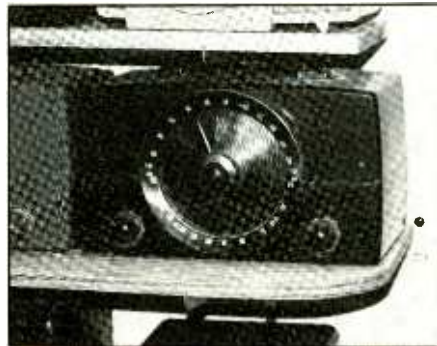

Fig. 7. An AM/FM Zenith table model radio from the early 1950s.

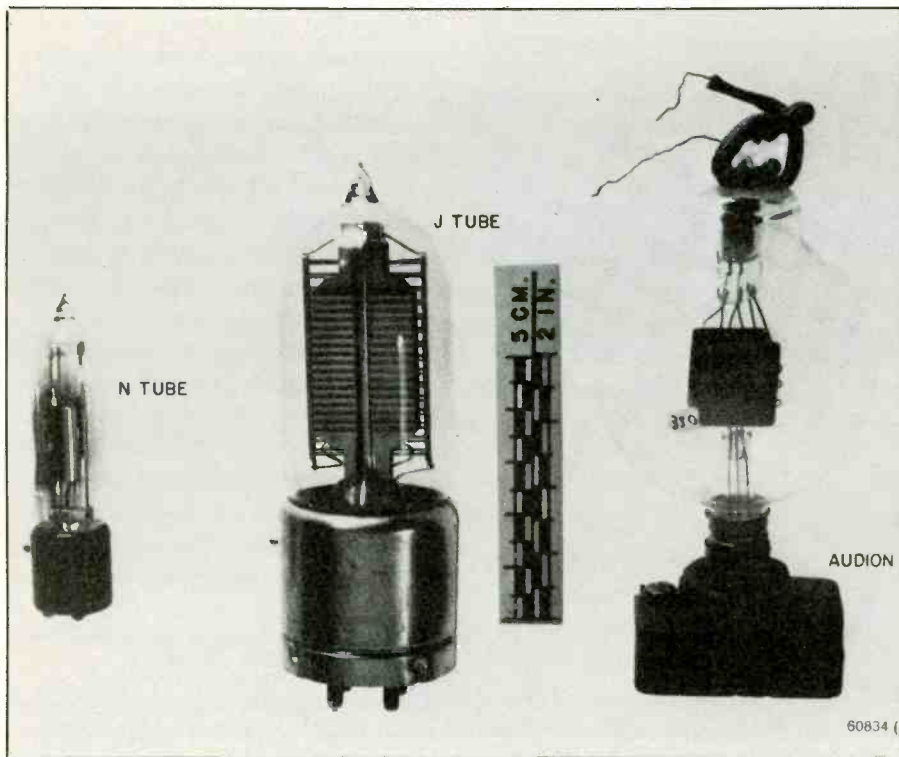

Fig. 8. Shown here are examples of very early radio receiver tubes. (Photo courtesy Naval Research Laboratory).

The late 1930's saw the development of eight-pin metal-can octal tubes. These tubes had a special base with a ridge-keyed plastic prong in the center that permitted the tube to be plugged into its socket in only one way—the correct one. Previous tube bases were keyed by making two of the pins larger than the others. Also available in that era was the eight-pin Loctal socket. Because the Loctal tube has the ability to lock into its socket, these tubes were used extensively in World War II radio receivers.

Just prior to World War II, the glass miniature tube was invented, starting with the seven-pin version and graduating to the 9-pin version a little later. These became the standard for vacuum tubes right into the transistor era when tubes of all sorts began to fade from the scene. Although the Nuvisor, the Lighthouse and the Acorn tubes were also invented (for vhf, uhf and microwave applications), they had limited or no

use in consumer radio receivers.

Televisions receivers also represent an electronic collectible, although they are not as popular as radios. TV receivers were made in the late 1930s for experimental broadcasts, even though commercial exploitation of the technology had to await the end of World War II. In 1989, an interview with sportscaster Red Barber marked the 50th anniversary of the first baseball game broadcast. In 1939, Barber became the first sports telecaster by giving the play by play over TV for a Brooklyn Dodgers game. Barber also did the first TV commercial during the game. Like earlier radio sets, TV receivers were very expensive in the early days. Figure 11 shows the first TV set to sell at retail for less than \$100.

Collecting Antique Radios

Collecting antique radios is a growing hobby and is still more in the

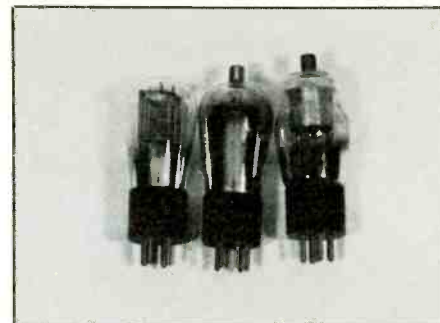

Fig. 9. Typical early commercial radio tubes.



Fig. 10. Some early 1930s tubes sported a grid cap.

hands of enthusiasts than dealers. As a result, except for a very few models, prices are still quite low. I bought a Stewart-Warner shortwave receiver (c. 1939) in easily repairable condition for just \$50. The Atwater-Kent radio shown in Fig. 1(C) and the RCA Radiola-17 radio shown in Fig. 1(D), cost me \$60 in "complete but not working" condition at a local antique radio swapmeet. Many offerings are sold in working condition and at reasonable prices.

People who are into antique radio collecting are a generally delightful lot who seem, for the most part, eager to talk about their radio hobby at length and helpful to newcomers. Some have extensive collections of antique radios (see Fig. 12) consisting of large numbers of assorted pieces. Others specialize, collecting only one brand or type, like Zeniths or Philcos or cathedral models made by all vintage manufacturers.

A number of people also buy and

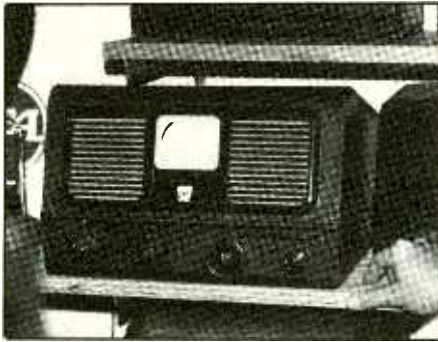

Fig. 11. This early TV receiver was made to sell for less than \$100.

restore a few pieces that are particularly nice to own, or hold some nostalgia for them personally. And some people in the hobby not only collect radios but repair them as well. Hobby interests are quite diverse, as you can see. It's a fun hobby, especially for anyone who is not afraid to learn how to repair radios!

If you are interested in collecting antique radios, a good place to get your feet wet is at a hamfest like the annual Mid-Atlantic Radio Club meet. It was at just such a hamfest that I became interested in the hobby. (I was a little taken aback to discover that some of the antique radios I saw on a station wagon tailgate were models I had serviced under warranty!) Most major hamfests these days have at least some minor representation from the antique radio crowd.

If you wish to go deeper into the subject of collecting antique radios than has been possible in this article, obtain *The Radio Collector's Directory and Price Guide* by Robert E. Grinder and George H. Fathauer from Ironwood Press, Box 8464, Scottsdale, AZ 85252. In this book, the authors give guidelines on identifying the approximate ages of vintage radios. The included price guide lists a large number of radio receivers by model and first year of manufacture for a variety of vintage radios. Bear in mind, though, that prices given are only guidelines. Actual

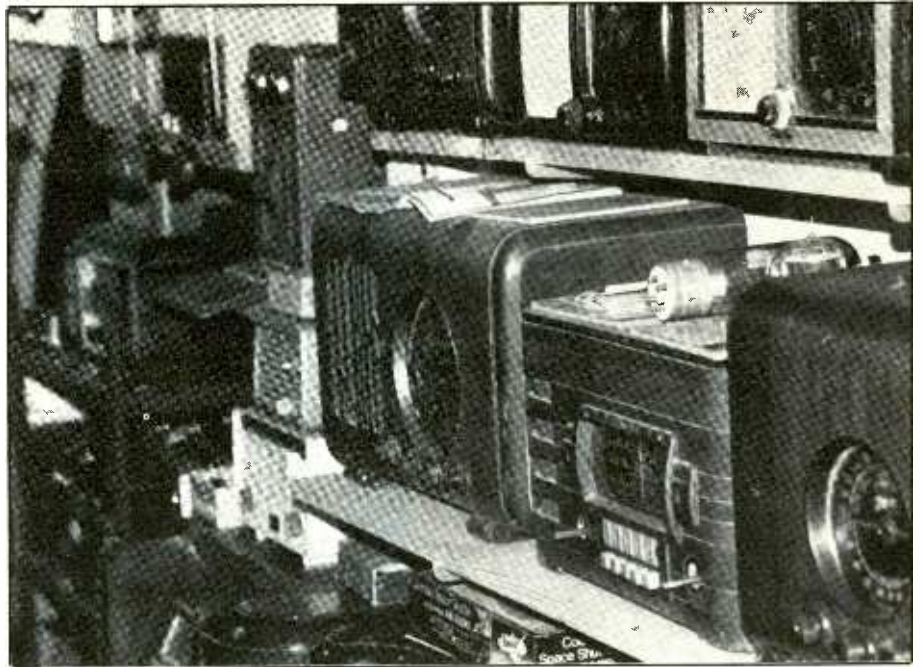

Fig. 12. An enthusiast's collection of antique radios.

price for a given antique radio depends upon a number of factors, including make and model, year of manufacture, operating condition, rarity, etc. Prices in the book that have changed will almost certainly have done so in the upward direction.

There are a couple of other sources you might want to check out as well. One is Edward A. Herron's *Miracle of the Airwaves: A History of Radio*

(Julian Messner). Published in 1969, this book may be difficult to find. A more-recent source is Morgan E. McMahon's *Vintage Radio, Third Edition* (1980) from Vintage Radio of Rolling Hills Estates, CA.

I wish to thank Joe Koester, president of the Mid-Atlantic Radio Club, for permission to photograph part of his collection of antique radios for this article. **ME**



MODERN ELECTRONICS

76 N. Broadway, Hicksville, NY 11801

Yes! **MODERN ELECTRONICS** is just the magazine I've been looking for. Start sending it to me now! I understand that I may cancel at any time for any reason, and receive a full refund on my unused subscription.

- 1 year - 12 issues \$17.97
- 2 years - 24 issues \$33.00
- 3 years - 36 issues \$48.00

Paid by: Check Money Order MasterCard VISA
My account number is:

--	--	--	--

Canada and Mexico - one year \$20.00 US, two years \$37.00 US, three years \$54.00 US. Foreign - one year \$22.00 US, two years \$41.00 US, three years \$60.00 US.

Name _____

Street _____

City _____ State _____ Zip _____

Experimenting With a Geiger Counter

By Forrest M. Mims III

Last summer, my son Eric and I spent ten days in New Mexico measuring the Earth's ozone layer and the ultraviolet radiation from the Sun. We also took along a Radalert™ nuclear radiation monitor and measured the natural background radiation across Texas and New Mexico.

Some of our findings with the Radalert, which is shown in Fig. 1, were so interesting that I'll describe them later. I'll also describe some interesting experiments you can perform with a radiation monitor like the Radalert. First, though, let's review some radiation basics to get terms and definitions straight.

Radiation

The term "radiation" is used to describe both electromagnetic radiation and streams of subatomic particles. Electromagnetic radiation includes everything from kilometers-long radio waves to tiny X-rays and gamma rays.

Sources of Background Radiation

Earlier, I noted that some background radiation originates from cosmic rays. Additional natural radiation comes from the Earth's crust. The most important source of this radiation is radon, an odorless, invisible gas that weighs approximately 7.5 times more than air. The two main forms of this radioactive gas are radon-222 and radon-220. Radon-222 is formed by the decay of uranium-238, and radon-220 is produced during the decay of thorium-232. According to *Radiation: Doses, Effects, Risks* (United Nations Environment Programme, 1985), the source of some of the facts about radon that follow, radon-222 is apparently 20 times more important than radon 220.

While radon emerges from the soil and rock all over the Earth, some locations on the globe are particularly "hot" with it. For example, the radiation dose on a hill near Pocos de Caldas in Brazil is 800 times the average. The beach at a nearby



Fig. 1. The Radalert radiation monitors. (Courtesy International Medcom)

coastal town has a radiation dose that is some 560 times the average because of its very high thorium content.

Dangers associated with accumulation of natural radon in houses, office buildings, factories and schools have received considerable publicity in recent years. Sometimes, radon is contributed by building materials. For example, in some areas, houses have been built on the tailings from uranium mines. Bricks are sometimes made from radioactive blast

furnace slag and fly ash from coal-fired power plants.

Radioactive substances like phosphogypsum and alum shales have been used to make plasterboard, blocks, cement and other building materials. Sand and gravel can be slightly radioactive, as well. A scientist once told me that he traced a high background count in a particular neighborhood to granite headstones in a nearby cemetery.

The most important source of radon inside buildings is usually the ground on which they are built. Basements and lower stories can develop particularly high concentrations of the gas. A study of some houses in Helsinki, Finland, revealed that radon levels inside were more than 5,000 times greater than that outside. Ventilation systems can be used to blow inside contaminated air to the outside of the homes. Paint, wallpaper and other covering materials can help in preventing the gas from seeping through floors and walls.

Well water, especially from very deep wells, sometimes contains radon. The main problem here is when the radon emerges from the water. A Canadian study showed that radon increased dramatically in a closed bathroom during a shower with contaminated water. More than an hour was required for the radon level to return to the level it was at before the shower was taken.

Nuclear power plants, atmospheric nuclear explosions, radioactive waste and medical and dental X-ray machines are also sources of radiation. Figure 3,

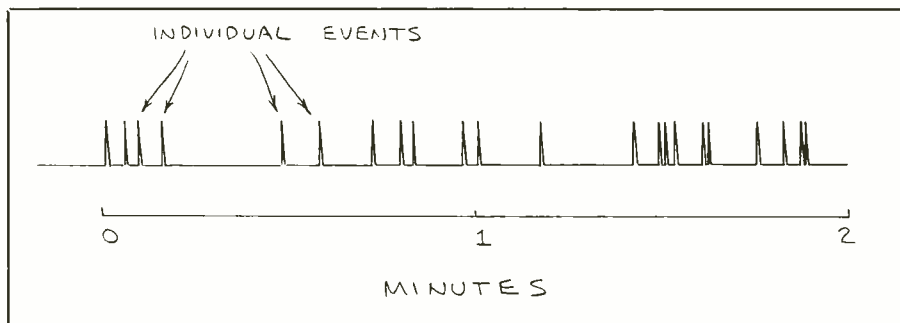

Fig. 2. Typical background radiation count in author's office.

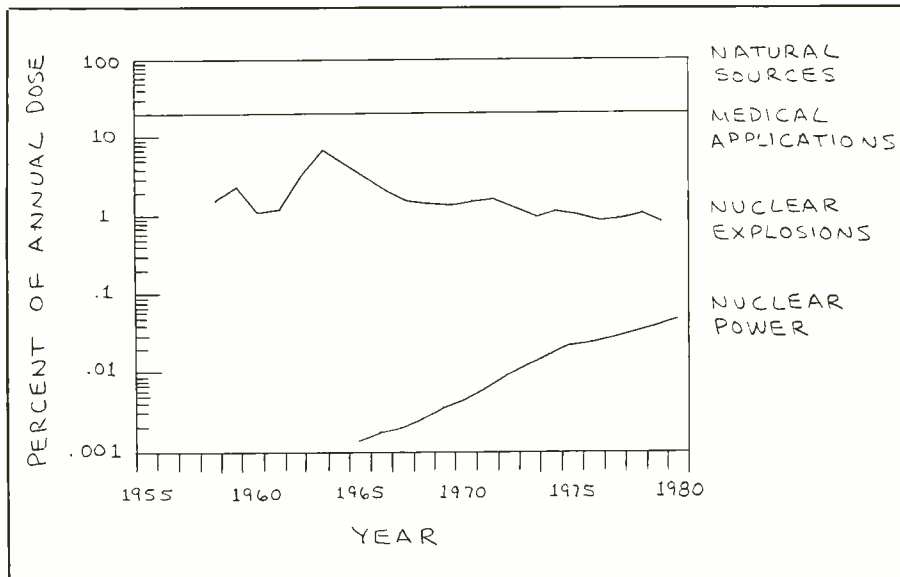

Fig. 3. Annual radiation received from various sources.

adapted from *Radiation: Doses, Effects, Risks* (p. 28), shows the annual trend of major non-natural sources of radiation as a percentage of the average background radiation. The contribution of medical diagnostic X-rays is assumed to remain a constant 20 percent of the background rate. The dose from atmospheric nuclear explosions peaked around 1963 at around 7 percent of background and fell to around 0.8 percent in 1980.

Contribution from nuclear power plants, though very small, has risen from 0.001 percent in 1965 to around 0.035 percent in 1980. This is still an almost negligible percentage of the background dose. At least, that was the case prior to the nuclear power plant explosion and fire at Chernobyl in the Soviet Union in 1986. This disaster scattered highly radioactive material around the immediate area of the power plant. It also pumped large quantities of radioactive ash into the troposphere, where it was blown elsewhere in the Soviet Union and over many European countries.

Harry Helms, a former columnist for *Modern Electronics*, was touring the Soviet Union in 1986 and was in Kiev during the Chernobyl accident. As Harry later

wrote in *Popular Communications* in "DXing from the USSR" (Sept. 1986, p. 20), "It was horrible! Bizarre glowing genetic mutations were attacking the populace! Oh, the screams of the children!" (As Harry explained in his article, this is actually a slightly exaggerated account he was momentarily tempted to give when he was interviewed by personnel from a New York television station.)

Having learned a valuable lesson about the value of a portable shortwave receiver in a country that refused to tell the truth about what happened at nearby Chernobyl, Harry returned home safely. He also brought back some samples from Chernobyl in the form of a contaminated shoe and a slight increase in his thyroid count. (The latter has proved rather beneficial, since Harry can now read in bed without a night light.)

Background Count Survey

During our summer trip to New Mexico, Eric and I didn't encounter anything like the nuclear catastrophe Harry Helms experienced in the Soviet Union. However, the Radaalert we took along did indicate a higher than average background count in

several locations in the scenic Jemez Mountains in northern New Mexico.

The first atomic bomb was largely developed and assembled in Los Alamos, the most famous city in the Jemez Mountains. Many thousands of years earlier, a considerably more powerful bomb exploded a few miles from the present city of Los Alamos, leaving behind what is believed to be the largest volcano caldera in the world. It also left behind a means by which ground water can be contaminated by radioactivity, presumably radon and its decay products.

In the 1970s, I used to take church kids on lengthy bicycle camping trips through the Jemez Mountains. One of the treats of those trips was soaking in the hot springs found in the region. Little did we suspect that those springs could be sources of radon.

The first clue that Eric and I had that the springs might emit radon was when we stopped at Soda Dam, an unusual formation carved by hot springs near the village of Jemez Springs. Eric immediately noticed an increase in the background count over the approximately 20 counts per minute (cpm) we'd measured over the preceding hour. The new count was about 54 cpm. Eric placed the Radaalert near a pool fed by a small spring that flows from the rock adjacent to the highway. When we returned after exploring the area for 20 minutes, the geiger counter indicated an average count of 74 cpm. When Eric held the counter near the warm (111.4° F) water bubbling out of the rock, the count jumped to 95 cpm.

Away from the hot springs, the background count fell to around 24 cpm. The typical count in Los Alamos was around 19 cpm. In some areas, however, the count increased dramatically. For example, at the entrance to a facility designated Tech Area 51/54, the count raced up to between 70 and 99 cpm. (At our home in south Texas, the Radaalert indicates a typical background count of about 11 or 12 cpm.) Eric and I wondered how high the count might be beyond the sign that restricted our access.

The Los Alamos Science Museum, one of the best science museums I've visited,

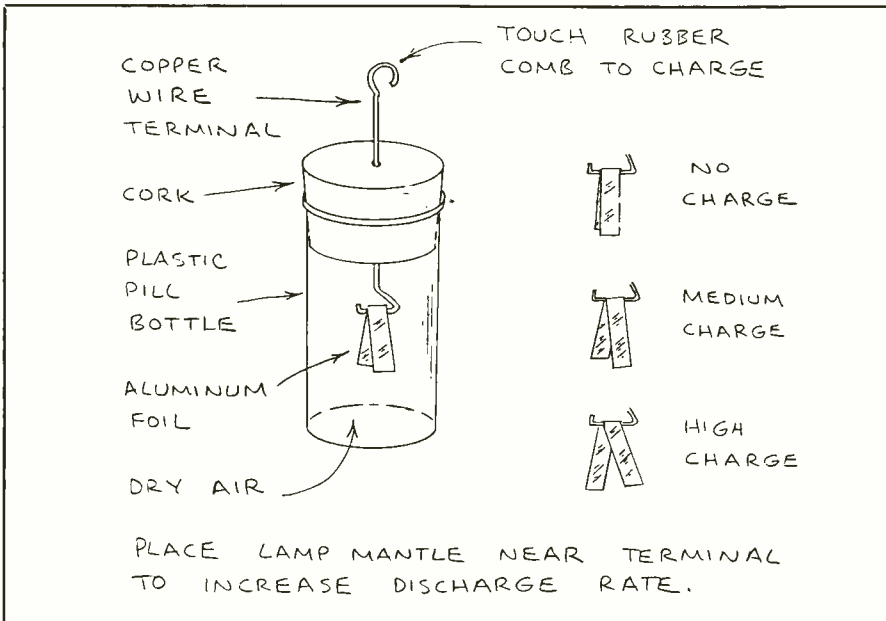

Fig. 4. A simple electroscope for detecting ionizing radiation.

provided us with our highest radiation count of the trip. The background rate outside the museum was around 18 cpm, and the count inside the museum was a comfortable 25 cpm. The increase may have been contributed by some samples of radioactive materials being displayed, including a block of radium that elicited a count of 2,383 cpm (the highest we encountered on our trip) when the geiger counter was placed atop it.

It's interesting to note that the Rad-alert indicates a count of several hundred cpm when flown aboard a commercial jet aircraft flying at an altitude of about 30,000 feet. At this altitude, most of the Earth's atmosphere is below the airplane and cosmic radiation is substantially more intense than at the Earth's surface.

Detecting Radiation

Many different methods for detecting radiation have been developed. Some provide an instantaneous indication of the presence of radioactivity. Others indicate the cumulative exposure received over a period of time.

Ordinary photographic film is a good example of the latter. It is the oldest method used for detecting radiation and is still widely used. The most common application for film is the production of X-ray images. Film badges are often used to monitor the radiation exposure of people who must work around radiation sources.

Radiation can also be detected with an electroscope. Figure 4 shows how to make a simple electroscope that will detect the radiation emitted by a thorium-impregnated lamp mantle. The leaves are made from smooth, clean aluminum foil. A small plastic pill container or a small glass container can be used to hold the leaves. For best results, squirt some dry air from a can of compressed air into the container just before placing the foil leaves and the stopper in it.

When the terminal of the electroscope is touched by a comb that has been drawn through your hair or rubbed across a sweater, the static charge built up on the comb is transferred to the terminal and two aluminum leaves. This will cause the leaves to become charged at the same polarity and, thus, to repel each other. Therefore, they fly apart.

As the static charge dissipates through the surrounding air, the leaves will gradually fall back toward each other. The presence of ionizing radiation near the terminal of the electroscope will ionize nearby molecules, thereby increasing the conductivity of the surrounding air. This causes the charge to leak away faster than normal. A relative indication of the level of radioactivity can be determined by monitoring the length of time required for the charged leaves to fall a fixed distance. You can place a small card with evenly spaced lines inscribed on it behind but not touching the leaves to use as a calibration guide.

One of the most sensitive detectors of radiation is the scintillation detector. Radiation passing through liquid or plastic impregnated with a luminescent additive causes flashes of light that are then detected by sensitive photomultiplier tubes.

Various kinds of semiconductor diodes can also function as radiation detectors. Even ordinary silicon diodes and solar cells can detect certain kinds of high-energy radiation. Individual bits of data stored in high-density dynamic RAMs can be altered by radiation. When this problem was first studied, the culprit turned out to be alpha radiation emitted by the RAM's ceramic package!

The Rad-alert Eric and I used detects radiation by means of a Geiger-Mueller (G-M) tube. A typical G-M tube like the one depicted in Fig. 5 consists of a sealed, electrically conductive tube that contains argon, air or other gases and a single wire electrode. If alpha particles are to be detected, the tube is equipped with a thin "window" of mica or Mylar.

In operation, a potential just below the breakdown voltage of the G-M tube is placed across the wire electrode and the tube's conductive wall. A radioactive particle that enters the tube causes the molecules of gas along its path to become ionized. This provides a momentary low-impedance path between the tube's electrodes over which a burst of current flows.

So that the tube can be ready to respond to a rapid series of ionizing particles, a substance known as a "quenching agent" is usually added to the gas. This

agent causes the gas to rapidly de-ionize after the passage of a particle so that a new particle can be detected.

Figure 5 also provides a generalized schematic diagram of how a high-voltage charge is applied to a G-M tube. Depending on the particular tube used, a potential of 250 to 500 volts is used. The purpose of series resistor $R1$ is to limit the current that flows through the tube to a safe value. Therefore, $R1$ usually has a resistance of at least several megohms.

The current pulse through a G-M tube can easily be amplified to produce a "click" or "pock" sound or to flash a LED. In high radiation fields, clicks emerge as a raspy "buzz." Many personal radiation monitors include an integrated circuit that accumulates a series of current pulses before emitting a "chirp" or flashing a LED. Both methods provide a simple means for indicating the relative radiation level in real time. An analog meter movement or digital numeric display can be used to indicate the radiation level as well.

The Radalert includes a digital numeric counter that provides either a running total of detected events or the number of events for the previous minute. A LED flashes each time an event occurs. An audible click is optional. A particularly useful feature of the Radalert is that it can be set to sound an alarm when a user-specified number of counts is reached.

Experimenting With a Geiger Counter

Most people don't realize that their bodies are being constantly bombarded by ionizing radiation and that a surprising number of household substances are slightly radioactive. Any Geiger counter can be used to detect and indicate the ever-present background count and presence of radiation.

It's important to know that the accuracy of the count you measure is determined by the count rate and time during which the radiation is monitored. Nomograms for quickly determining the time needed to arrive at 0.9 and 0.95 count err-

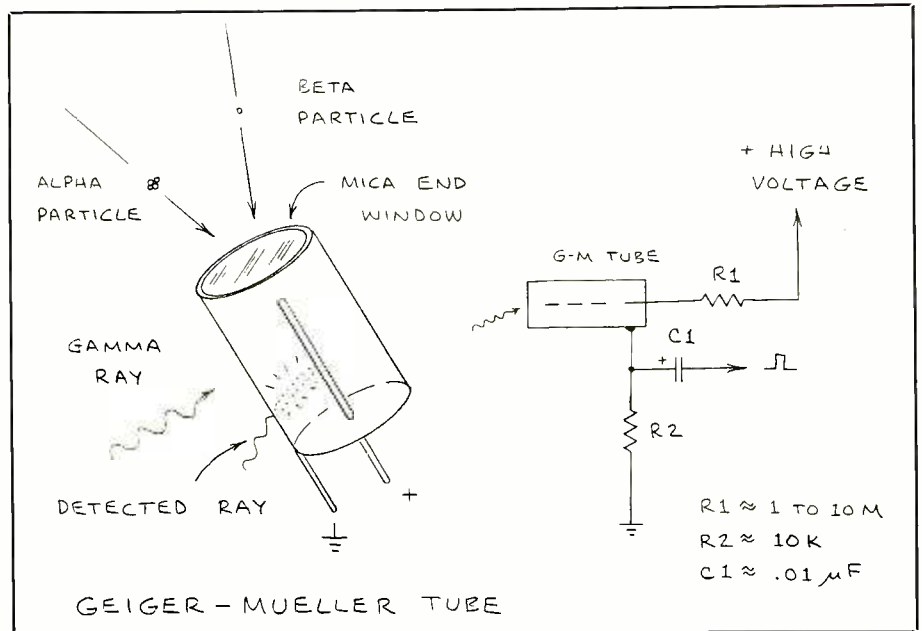

Fig. 5. Geiger-Mueller tube construction details and operation.

or rates are given in the *Radiological Health Handbook*, a thick guide to nuclear radiation published by the old U.S. Department of Health, Education and Welfare. I recently purchased a new copy of this 1970 document at a university book store. You might be able to find this reference work at a technical library, or you can determine if it is still available by writing the U.S. Government Printing Office, Washington, DC 20402.

Figure 6 is extracted from one of the nomograms given in the *Radiological Health Handbook* (p. 118). The nomogram was apparently developed by Jarrett and published in an earlier government document. As you can see by referring to this nomogram, a low count rate must be monitored for a fairly long time to achieve an error rate of 0.9 count. For example, if the average background rate in your area is about 10 cpm, counting for only 1 minute gives a 0.9 error of nearly 2 cpm. Counting for 30 minutes, improves the 0.9 error to 0.95 cpm.

Camping lantern mantles that contain thorium are radioactive. Several years ago, I took a Monitor 4 to a sporting goods store and stuffed it inside a cluster

of a hundred or so Coleman lamp mantles hanging from a pegboard. The rash of clicks from the counter quickly attracted a crowd of customers and a sales clerk, all of whom nervously kept their distance as I explained what I was doing.

A Coleman mantle placed on a flat surface gave a reading of from 0.1 to 0.2 milliroentgens per hour (mR/hr) when the end window of a Geiger counter was placed directly adjacent to the mantle. When the mantle was rolled into a tight bundle, the reading increased from 0.4 to 0.5 mR/hr. The count rate dropped only slightly when a piece of paper was placed between the lamp mantle and a G-M tube. Therefore, it appears that most of the radiation detected is in the form of beta particles emitted by the radium-228 byproduct of the thorium in the mantle.

The Staticmaster IC200 static-eliminating brush contains tiny beads of encapsulated polonium-210. This alpha-particle generator ionized nearby air, thereby permitting dust-attracting static charges to leak away when a dielectric surface, such as a vinyl record, is brushed. Even though the radiation level adjacent to the polonium-210 microbeads exceeds 50

Put Professional Knowledge and a
COLLEGE DEGREE
 in your Technical Career through
HOME STUDY

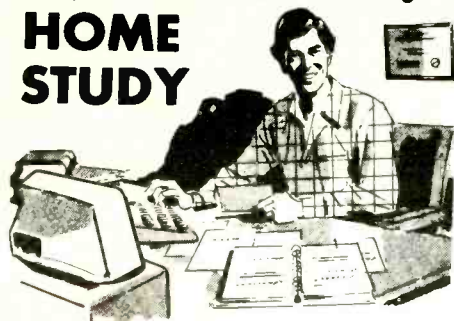

Add prestige and earning power to your technical career by earning your Associate or Bachelor degree through directed home study.

Grantham College of Engineering awards accredited degrees in **electronics and computers.**

An important part of being prepared to *move up* is holding the right college degree, and the absolutely necessary part is knowing your field. Grantham can help you both ways—to learn more and to earn your degree in the process.

Grantham offers two degree programs—one with major emphasis in **electronics**, the other with major emphasis in **computers**. Associate and bachelor degrees are awarded in each program, and both programs are available completely by correspondence.

No commuting to class. Study at your own pace, while continuing on your present job. Learn from easy-to-understand lessons, with help from your Grantham instructors when you need it.

Write for our free catalog (see address below), or phone us at toll-free 1-800-955-2527 (for catalog requests only) and ask for our "degree catalog."

Accredited by
 the Accrediting Commission of the
 National Home Study Council

GRANTHAM
College of Engineering
 10570 Humbolt Street
 Los Alamitos, CA 90720

ELECTRONICS NOTEBOOK...

mR/hr, a few centimeters away, it is virtually undetectable because of the blocking ability of the intervening air.

To check for radioactive substances around your home, first measure the average background count for at least 5 minutes. Then place a Geiger counter near suspected items for 5 minutes and compare the difference in readings. Several years ago, I made such a check on a day when the background count averaged 11 cpm. A glazed brick gave a reading of 16 cpm. More recently, a color TV receiver gave a reading of 28 cpm on a day when the background count averaged 16 cpm.

Other household items that can be checked are ceramic pottery, bricks and watches and clocks whose hands are coated with radium-impregnated luminescent paint. Earthenware may be glazed with orange or red pigment that contains uranium oxide.

An interesting project would be to compile a list of everyday radioactive products. Indeed, that's exactly what my youngest daughter, Sarah, and I will do the next time we accompany my wife to a multi-acre shopping facility that sells

every conceivable household product, including a wide range of earthenware. While my wife shops, Sarah and I will conduct our radiation survey, perhaps alarming a few customers in the process.

The Radalert that Eric and I used during our New Mexico science trip is manufactured by International Medcom (7497 Kennedy Rd., Sebastopol, CA 95472). This instrument indicates either accumulated count or counts per minute on a liquid-crystal numeric display. One of its most important features is an output jack that permits the device to be coupled to an external circuit, recorder or computer. Price of the Radalert is \$275 factory assembled or \$185 in kit form, plus \$4 postage and handling. For additional information, you can call 707-823-0336.

The Monitor 4 is a basic instrument that I've used to check the radioactivity of several common materials described below. This instrument indicates radioactivity by means of a flashing LED, audible beeper and analog meter movement. Availability is from Markson (10201 S. 51 St., Phoenix, AZ 85044), and current catalog price is \$215. The Markson cata-

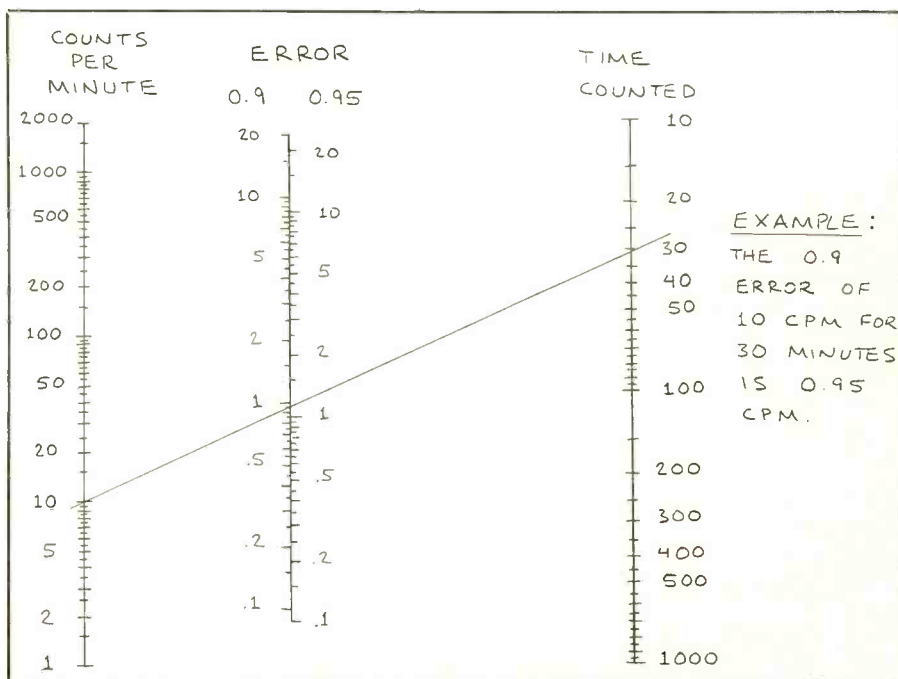

Fig. 6. Error rates of 0.9 and 0.95 for a radiation counter.

log also lists the RDX Monitor basic radiation counter that sells for only \$109. To order, call 800-528-5114.

The 1989-90 catalog from Davis Instrument Mfg. Co. (513 E. 36 St., Baltimore, MD 21218) lists at least seven different radiation monitors and survey meters. The Prima IIb is a minute pocket-size unit made by Nuclear Associates that emits audible chirps in direct proportion to the detected radiation level. Price is \$215 for this little gem. Also listed is a personal digital dosimeter that provides a numeric readout of radiation level. This pocket-size monitor sells for \$325. To order, call 800-368-2516.

Still another option is to build your own Geiger counter. Here, the best deal I've seen is a Geiger-counter kit sold by The Electronic Goldmine (P.O. Box 5408, Scottsdale, AZ 85261). Priced at only \$59.95, this basic kit is less expensive than many G-M tubes. Indeed, the only reason I didn't include in this column construction plans for some Geiger-counter circuits I've developed is that this new kit is so much less expensive to build than anything I could offer.

Going Further

The Geiger counter is a fascinating tool with many uses. Besides using one to survey your home and work environments, you might find some surprises by taking a small radiation monitor along on trips and vacations. If you have children, they and you can learn much about how background radiation is affected by both altitude and location as you travel by car or train. The effect of altitude is especially dramatic if you travel by plane.

For several months, my eldest daughter has used a Geiger counter to study the effects of solar flares on background radiation. Her results will be the basis for a fascinating science-fair project.

You can even capitalize on the unpredictable nature of radiation to make a random-number generator for your computer. Details for this and some simple driver programs are given in my *Forrest Mims's Computer Projects* (Osborne/McGraw-Hill, 1985, pp. 55-60).



Ionizing radiation is a subject that gen-

erates considerable controversy, especially when so-called minimum acceptable dose levels are discussed. One side believes strongly that the best level of exposure is no exposure at all and that any exposure whatsoever imposes a possible

health risk. The other side claims that the health risk of small exposure levels is statistically insignificant and back up their position by pointing out that we are all subjected to constant bombardment by natural background radiation.

ME

HITACHI SCOPES AT DISCOUNT PRICES

Digital Storage Scopes  VC-6025 20MS/S 50MHz Bandwidth 2K Word Memory Capacity \$2349.00 Advanced storage functions create new dimensions in scopes such as one shot observation, ticker free display, bright display for even high speed event, trace observation for low speed event, hard copy by plotter and data output to computer. VC-8045 100MHz 40MS/S 4K word Memory cap. (call) All Hitachi scopes include probes, schematics, and Hitachi's 3 year worldwide warranty on parts and labor. Many accessories available for all scopes.		V-212  \$435 List \$595 Save \$160 DC to 20MHz Dual Channel	 V-1060 List \$1595 \$1,359 DC to 100MHz Dual Channel • Delayed Sweep • CRT Readout • Sweep Time • Autoranging • Trigger Lock • 2mV Sensitivity																							
V-422 40MHz D.T., 1mV sens., DC Offset Vert Mode Trigger, Alt Mag V-423 40MHz D.T., 1mV sens., Delayed Sweep, DC Offset, Alt Mag V-425 40MHz D.T., 1mV sens., DC Offset, CRT Readout, Cursor Meas V-660 60MHz D.T., 2mV sens., Delayed Sweep, CRT Readout V-1065 100MHz D.T., 2mV sens., Delayed Sweep, CRT Readout, Cursor Meas V-1100A 100MHz Q.T., 1mV sens., Delayed Sweep, CRT Readout, DVM, Counter V-1150 150MHz Q.T., 1mV sens., Delayed Sweep, Cursor Meas, DVM, Counter	<table border="1"> <thead> <tr> <th>LIST</th> <th>PRICE</th> <th>SAVE</th> </tr> </thead> <tbody> <tr> <td>\$940</td> <td>\$740</td> <td>\$200</td> </tr> <tr> <td>\$1,025</td> <td>\$825</td> <td>\$200</td> </tr> <tr> <td>\$1,070</td> <td>\$849</td> <td>\$221</td> </tr> <tr> <td>\$1,295</td> <td>\$1,145</td> <td>\$150</td> </tr> <tr> <td>\$1,895</td> <td>\$1,570</td> <td>\$225</td> </tr> <tr> <td>\$2,450</td> <td>\$2,095</td> <td>\$355</td> </tr> <tr> <td>\$3,100</td> <td>\$2,675</td> <td>\$425</td> </tr> </tbody> </table>	LIST	PRICE	SAVE	\$940	\$740	\$200	\$1,025	\$825	\$200	\$1,070	\$849	\$221	\$1,295	\$1,145	\$150	\$1,895	\$1,570	\$225	\$2,450	\$2,095	\$355	\$3,100	\$2,675	\$425	
LIST	PRICE	SAVE																								
\$940	\$740	\$200																								
\$1,025	\$825	\$200																								
\$1,070	\$849	\$221																								
\$1,295	\$1,145	\$150																								
\$1,895	\$1,570	\$225																								
\$2,450	\$2,095	\$355																								
\$3,100	\$2,675	\$425																								

ELENCO PRODUCTS AT DISCOUNT PRICES

20MHz Dual Trace Oscilloscope  \$375 MO-1251 • 6" CRT • Built in component tester • TV Sync	FREE DMM with purchase of ANY SCOPE SCOPE PROBES P-1 65MHz, 1x, 10x \$19.95 P-2 100MHz, 1x, 10x \$23.95	35MHz Dual Trace Oscilloscope  \$495 MO-1252 • High luminance 6" CRT • 1mV Sensitivity • 6KV Acceleration Voltage • 10ms Rise Time • X-Y Operation • Z Axis • Delayed Triggering Sweep
--	--	--

Top quality scopes at a very reasonable price. Contains all desired features. Two 1x, 10x probes, diagrams and manual. Two year guarantee.

PRICE BREAKTHRU on Auto Ranging DMMs 3 to choose from: MDM-1180 \$24.95 MDM-1181 \$27.95 MDM-1182 \$29.95 • 3 1/2 LCD Display • 27 Functions • Auto/Manual Ranges • Audible Continuity • Data Hold (MDM-1182) • 1% Accuracy (MDM-1181)	True RMS 4 1/2 Digit Multimeter M-7000 0.5% DC Accuracy 1% Resistance with Freq. Counter and deluxe case	Multimeter with Capacitance and Transistor Tester \$55 CM-1500 Reads Volts, Ohms, Current, Capacitors, Transistors and Diodes with case	Digital Capacitance Meter CM-1550 9 Ranges 1pF-20,000f 5% basic accy Zero control with case	Digital LCR Meter LC-1801 \$125 Measures Coils 1uH-200H Caps 1pF-200uF Res 01-20M
	Bench DMMs M-3500 \$125 3 1/2 digit 1% accy M-4500 \$175 4 1/2 digit 0.5% accy	AC Current Meter ST-1010 1000 Amps Data/Peak Hold 8 Functions Deluxe Case \$69.95	Solderless Breadboards 9436 SHOWN 9430 1,100 pins \$15 9434 2,170 pins \$25 9436 2,860 pins \$35 All have color coded posts	AC Clamp-On Current Adapter ST-265 \$25.00 0-1000A AC Works with most DMM

Soldering Station Temperature Controlled SL-30 \$99 Digital display Temp range: 300F-200F Grounded tip Overheat protect	Color Convergence Generator SG-200 Finest in the industry 10 rock steady patterns \$69.95	10MHz Oscilloscope S-3000 \$275 10MHz DC or AC Triggered Sweep Calibrated Vert & Hor Reads Volts & Freq	Temperature Probe M-110CF \$29.95 Semiconductor type Range -58F-302F Fits most digital multimeters	Autoranging DMM M-5000 \$45 9 Functions Memory and Data Hold 1/2 % basic accy 3 1/2 digit LCD
Wide Band Signal Generators SG-9000 \$129 RF Freq 100K-450MHz AM Modulation of 1KHz Variable RF output SG-9500 with Digital Display and 150MHz built-in Freq Ctr \$249	TRIPLE POWER SUPPLY XP-620 Assembled \$65 Kit \$45 2 to 15V at 1A, -2 to -15V at 1A (or 4 to 30V at 1A) and 5V at 3A Contains all the desired features for doing experiments. Features short circuit protection! all supplies	Function Generator Blox #9600 \$28.95 Provides sine, tri, squ wave from 1Hz to 1MHz AM or FM capability	Decade Blox #9610 or #9620 \$18.95 #9610 Resistor Blox 47 ohm to 1M & 100K pot #9620 Capacitor Blox 47pF to 10MFD	

Digital Triple Power Supply XP-765 \$249 0-20V at 1A 0-20V at 1A 5V at 5A Fully Regulated. Short circuit protected with 2 Limit Cont. 3 Separate supplies XP-660 with Analog Meters \$175	Quad Power Supply XP-580 \$59.95 Fully regulated and short circuit protected XP-575 without meters \$39.95	LEARN TO BUILD AND PROGRAM COMPUTERS WITH THIS KIT! INCLUDES: All Parts, Assembly and Lesson Manual MODEL MM-8000 \$129.00 Starting from scratch you build a complete system. Our Micro-Master trainer teaches you to write into RAMs, ROMs and run a 8085 microprocessor, which uses similar machine language as IBM PC. You will write the initial instructions to tell the 8085 processor to get started and store these instructions in permanent memory in a 2816 EPROM. Teaches you all about input and output ports, computer smarts. Build your own keyboard and learn how to scan keyboard and display. No previous computer knowledge required. Simple easy to understand instruction teaches you to write in machine language.
Four-Function Frequency Counters F-100 120MH \$179 F-1000 1.28M \$259 Frequency, Period, Totalize, Self Check with High Stabilized Crystal Oven Oscillator, 8 digit LED display	GF-8016 Function Generator with Freq. Counter \$249 Sine, Square, Triangle Pulse, Ramp, 2 to 2MHz Freq Counter - 1 - 10MHz GF-8015 without Freq. Meter \$179	

WE WILL NOT BE UNDERSOLD!
 UPS Shipping: 48 States 5%
 (\$10 Max) IL Res., 7% Tax

C & S SALES INC.
 1245 Rosewood, Deerfield, IL 60015
 (800) 292-7711 (708) 541-0710

15 Day Money Back Guarantee
 2 Year Warranty
 WRITE FOR FREE CATALOG

A 12-Bit Serial Daisy-Chain CMOS D/A Converter

By Joseph Desposito

Electronic circuits are often classified as either digital (ones with NAND gates and flip-flops) or analog (ones with op amps). Some circuits, however, contain both digital and analog components, and these are joined together by either a digital-to-analog (D/A) converter or an analog-to-digital (A/D) converter. This month we will take an in-depth look at the DAC-8143, a 12-bit serial-input digital-to-analog converter recently introduced by Precision Monolithics, Inc. (Santa Clara, CA) as well as other D/A converters produced by that company.

Device Background

The DAC-8143 is a CMOS D/A converter that uses an R-2R resistor ladder network. A simplified circuit of the device is shown in Fig. 1. The inverted R-2R ladder network consists of silicon-chrome, thin-film resistors and 12 pairs of NMOS current-steering switches. These switches steer binary-weighted currents into either I_{OUT1} or I_{OUT2} . Switching current to I_{OUT1} or I_{OUT2} yields a constant current in each ladder leg, regardless of digital input code. This constant current results in a constant input resistance at V_{REF} equal to R (typically 11,000 ohms). The V_{REF} input may be driven by any reference voltage or current, ac or dc, that is within the limits of the device's maximum ratings.

The 12 output current-steering switches are in series with the R-2R resistor ladder, and therefore can introduce bit errors. Thus, the switches were designed with "on" resistances binary scaled so that the voltage drop across each switch remains constant. If, for example, switch 1 of Fig. 1 was designed with an "on" resistance of 10 ohms, switch 2 for 20 ohms, etc., a constant 5-mV drop would then be maintained across each switch.

To further ensure accuracy across the full temperature range, permanently "on" MOS switches are included in series with the feedback resistor and the R-2R ladder's terminating resistor. The simplified DAC circuit of Fig. 1 shows the location of these switches.

switches are equivalently scaled to two times switch 1 (MSB) and top switch 12 (LSB) to maintain constant relative voltage drops with varying temperature.

Device Details

DAC-8143 is a 12-bit serial input multiplying D/A converter. The control logic shown in Fig. 2 forms an interface in which serial data is loaded, under microprocessor control, into the 12-bit input shift register and then transferred, in parallel, to the 12-bit DAC register. The DAC-8143 device also features buffered serial data output.

Serial data in the input register (MSB first) is sequentially clocked out to the SRO pin (see Fig. 2) as the new data word (MSB first) is simultaneously clocked in from the SRI pin. This buffered data follows the digital input data (SRI) by 12 clock cycles and is available for daisy-chaining additional DACs. The strobe inputs are used to clock in/out data on the rising or falling (user-selected) strobe

edges. When the shift register's data has been updated, the new data word is transferred to the DAC register with use of LD1 and LD2 inputs.

The device is designed for multiple serial DAC systems. It greatly simplifies serially daisy-chaining one DAC after another. The DAC-8143 also minimizes address decoding lines, allowing for simpler logic interfacing. It permits three-conductor interfacing for any number of DACs: one data line, one CLK line, and one load line.

Separate LOAD control inputs allow simultaneous output updating of multiple DACs. An asynchronous CLEAR input resets the DAC register without altering data in the input register.

Device Application

The circuit illustrated in Fig. 3 can be used with an ac or dc reference voltage. Output of each circuit will range between 0 V and +10 V, depending upon the digital input code. The relationship between

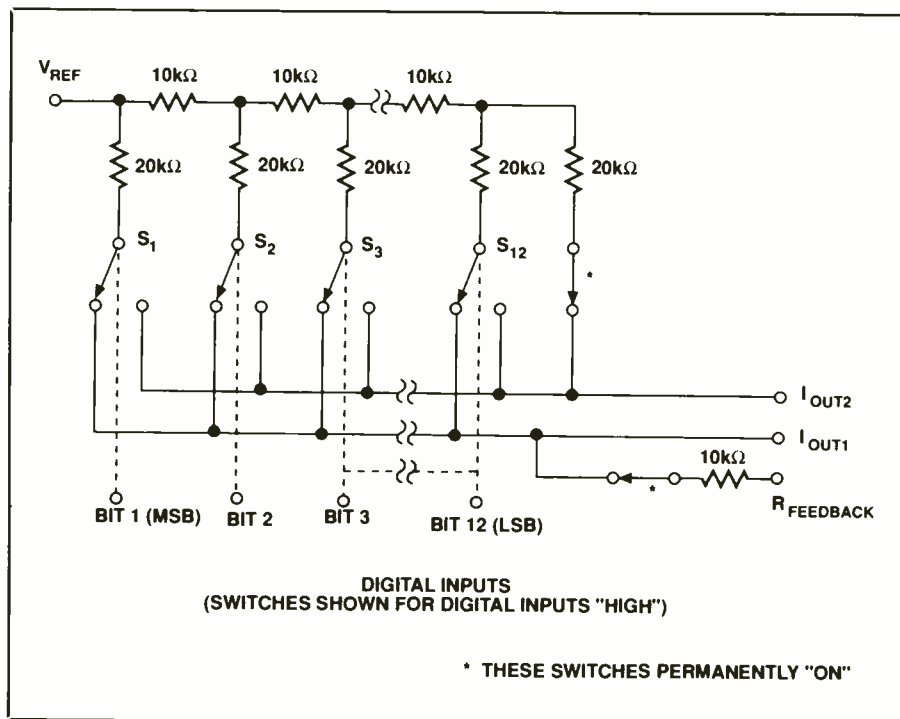

Fig. 1. Schematic diagram of a simplified circuit of the DAC-8143 D/A converter.

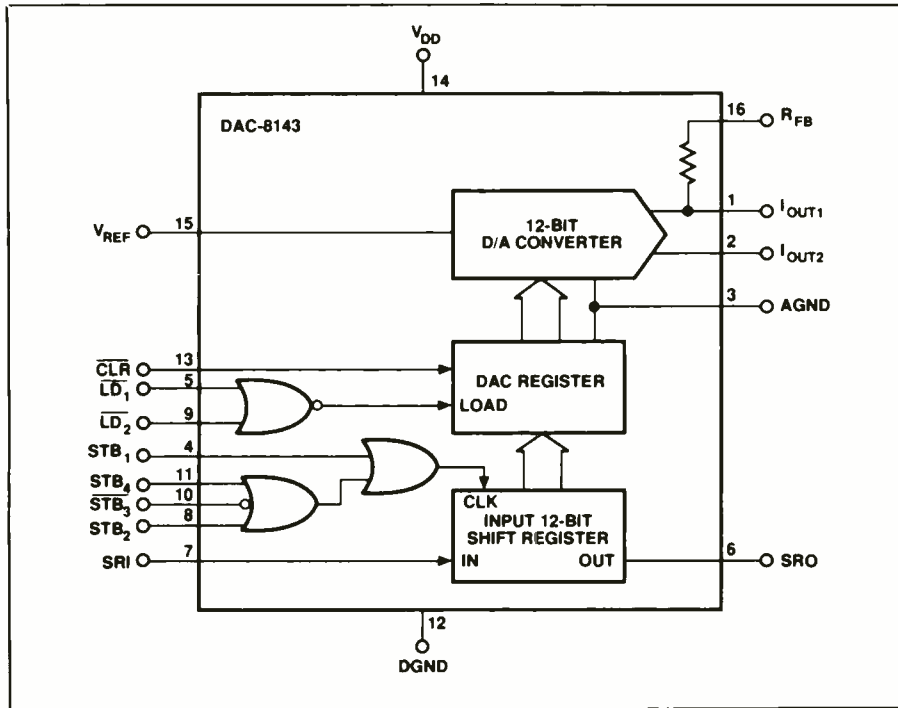

Fig. 2. Logic control forms an interface in which serial data is loaded under microprocessor control into 12-input shift register and then transferred to 12-bit DAC register..

The transfer function is modified when the DAC is connected in the feedback of an operational amplifier, as follows: $V_o = -V_{in}/(A^1/2^1) + (A^2/2^2) + (A^3/2^3) + \dots + (A^{12}/2^{12})$. This transfer function is the division of an analog voltage (V_{REF}) by a digital word. The amplifier goes to the rails with all bits "off" since division by zero is infinity. With all bits "on," gain is $1 (\pm 1 \text{ LSB})$. Gain becomes 4,096 with the LSB, bit 12, "on."

Device Specs

The DAC-8143 offers a maximum non-linearity and differential nonlinearity error of $\pm 1/2$ LSB, and gain error of ± 1 LSB. It operates with $V_{DD} = +5 \text{ V}$ and dissipates less than 0.5 mW with digital inputs at 0 V or +5 V, and 10 mW with digital inputs at either TTL level.

the digital input and analog output is shown in the Table. V_{REF} voltage range is the maximum input voltage range of the op amp or $\pm 25 \text{ V}$, whichever is lowest.

The transfer function for DAC-8143

connected in the multiplying mode is shown in Fig. 3. Here, $V_o = -V_{in} (A^1/2^1) + (A^2/2^2) + (A^3/2^3) + \dots + (A^{12}/2^{12})$, where A_x assumes a value of 1 for an "on" bit and 0 for an "off" bit.

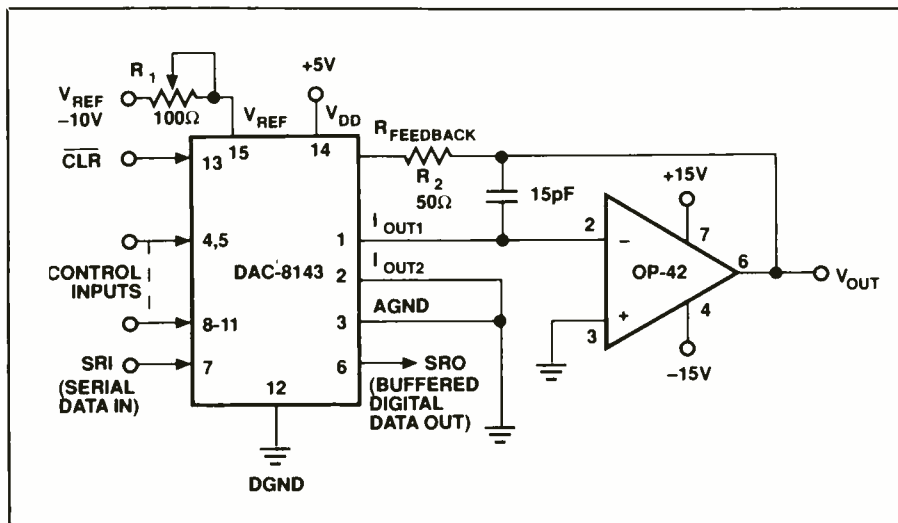
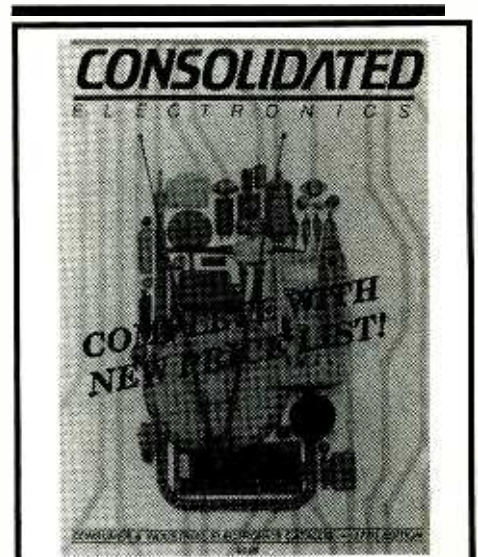

Fig. 3. A DAC-8143 circuit that can be used with an ac or dc reference voltage.



THE ULTIMATE ELECTRONICS CATALOG

Order your 260 page catalog and price list with over 14,000 money saving electronic parts and equipment! Send \$3.00 in a check or money order, or call 1-800-543-3568 today and use your Mastercard or Visa. Consolidated Electronics, Incorporated 705 Watervliet Ave., Dayton, Ohio 45420-2599

Name _____
 Address _____
 City _____ State _____ Zip _____

CIRCLE NO. 162 ON FREE INFORMATION CARD

SOLID-STATE DEVICES...

Unipolar Codes Table

DIGITAL INPUT		NOMINAL ANALOG OUTPUT	
MSB	LSB	$(V_{OUT}$ as shown in Figures 7 and 8)	
1 1 1 1	1 1 1 1	1 1 1 1	$-V_{REF} \left(\frac{4095}{4096} \right)$
1 0 0 0	0 0 0 0	0 0 0 1	$-V_{REF} \left(\frac{2049}{4096} \right)$
1 0 0 0	0 0 0 0	0 0 0 0	$-V_{REF} \left(\frac{2048}{4096} \right) = -\frac{V_{REF}}{2}$
0 1 1 1	1 1 1 1	1 1 1 1	$-V_{REF} \left(\frac{2047}{4096} \right)$
0 0 0 0	0 0 0 0	0 0 0 1	$-V_{REF} \left(\frac{1}{4096} \right)$
0 0 0 0	0 0 0 0	0 0 0 0	$-V_{REF} \left(\frac{0}{4096} \right) = 0$

NOTES:

- Nominal full scale for the circuits of Figures 7 and 8 is given by $FS = -V_{REF} \left(\frac{4095}{4096} \right)$
- Nominal LSB magnitude for the circuits of Figures 7 and 8 is given by $LSB = V_{REF} \left(\frac{1}{4096} \right)$ or $V_{REF} (2^{-n})$

The DAC-8143 is available in Cerdip and plastic DIP packages, and comes in both military and extended industrial temperature ranges. One-hundred-piece pricing starts at \$6.53 for plastic DIP to \$41.40 for military grade.

Other PM D/A Converters

The DAC-8228 and DAC-8229 are monolithic dual 8-bit voltage output CMOS D/A converters. The DAC-8228 was designed for single supply operation in hard disk drive and other computer peripheral applications. With its two internal amplifiers, the DAC-8228 replaces the AD7528/AD7628 plus two external amplifiers.

DAC-8228 is also pin compatible with both devices. Data sheet specifications are tested and guaranteed under hard disk drive operating voltage conditions: +2.5 V or +5 V applied to analog ground terminal, and V_{REF} connected to

analog ground. Although the DAC-8228 is primarily designed for hard disk drive applications, the device can also serve those applications requiring unipolar positive output voltage.

Applications requiring a bipolar output voltage swing can use the DAC-8229, designed to operate with dual supplies. An external reference input determines full-scale output. The DAC 8229 can also be used in the multiplying mode with an ac input to provide a digitally-controlled ac attenuator.

Ac bandwidth for the DAC-8229 can easily handle frequencies of up to 500 kHz, excellent for audio applications. Other applications include digital offset and gain adjustment, servo controllers, and digital-to-synchro converter circuits.

Both the DAC-8228 and DAC-8229 offer adjustment-free internal CMOS op amps, are TTL-compatible over the full power supply range up to +15 V and

have fast interface timing, $t_{WR} = 50$ ns (write pulse width).

Eliminating two external amplifiers permits users to achieve an overall cost savings when employing either device. These savings are realized from reduced size, and engineering, manufacturing, and customer service costs (those costs associated with field repairs or customer returns, which is reduced by the lower component count).

Both DAC-8228 and DAC-8229 are available in plastic DIP and Cerdip packages in the extended industrial temperature range. DAC-8229 is also offered in the military temperature range.

Pricing in 100-piece quantities for both starts at \$3.95 for plastic DIP and \$22. for the DAC-8229 military version.

The PM-7628

The PM-7628 is an alternate source D/A converter to the AD7628. It contains two eight-bit current-output internally latched CMOS D/A converters that are fully TTL-compatible. The PM-7628 guarantees specifications for operation down to the popular +5-V supply condition where the AD7628 does not. The PM-7628 is also guaranteed for operation at +12 V and +15 V.

Applications for the PM-7628 include digital offset and gain adjustment, digitally controlled audio attenuators, disk drives, and digital to synchro-converter circuits, among others.

Design of the PM-7628 includes a fast microprocessor interface timing specification ($t_{WR} = 60$ ns), minimizing the need for wait states in microprocessor-controlled application. Improvements in device design and processing extend the minimum operating temperature range to -40° to $+85^{\circ}$ C enabling the device to service commercial, industrial, and telecommunications temperature ranges.

The PM-7628 is available in Cerdip, plastic DIP, SOL-20 and PLCC packages. Plastic DIP package prices range from \$3.50 each in 100-piece lots for the extended industrial temperature range and \$16 each in 100-piece lots for the military temperature range. **ME**

AST Premium Workstation/386SX: Blazing Speed in a Compact Box

By TJ Byers

AST Research has introduced a new '386 PC, the AST Premium Workstation/386SX, that's sure to turn more than a few heads. Built around Intel's 386SX chip, this mini speedster runs circles around most full-blown 16-MHz 80386 PCs, yet it costs no more than a high-speed AT.

This \$2,695 AST Premium Workstation/386SX is housed in a trim 15 by 16-inch cabinet that's only 4 inches tall. The system comes with your choice of a 5¼-inch 1.2MB drive as the Model 5 or 3.5-inch 1.44MB drive as the Model 3 floppy drive, plus 1MB of RAM memory, one parallel and two serial ports, DOS 3.3, and GWBASIC. Options include a 40MB or 110MB hard disk and a monochrome or VGA video controller.

Despite its small size, the Workstation/386SX packs a punch that makes most 32-bit-bus 80386 machines blush from embarrassment. On DOS-specific test, it's far and away the fastest 386SX machine we've ever seen.

Memory Caching

The reason for the Premium's blazing speed is memory caching. Memory caching is a lot like disk caching in that the most often used information is stored in selected RAM for faster access. Imagine the cache as being a kitchen pantry and the system memory as being the supermarket. In the pantry is stored the items you use most often. However, should you need something that's not in the pantry, you must journey to the supermarket to get it, a procedure that's considerably more time consuming than simply opening a cupboard door. This is how memory caching works.

In the Premium Workstation/386SX, the memory cache consists of 32K of very fast, 25-ns static RAM. (Static RAM chips are used instead of less-expensive dynamic RAM chips because they don't require a refresh cycle to maintain the stored data, resulting in faster access

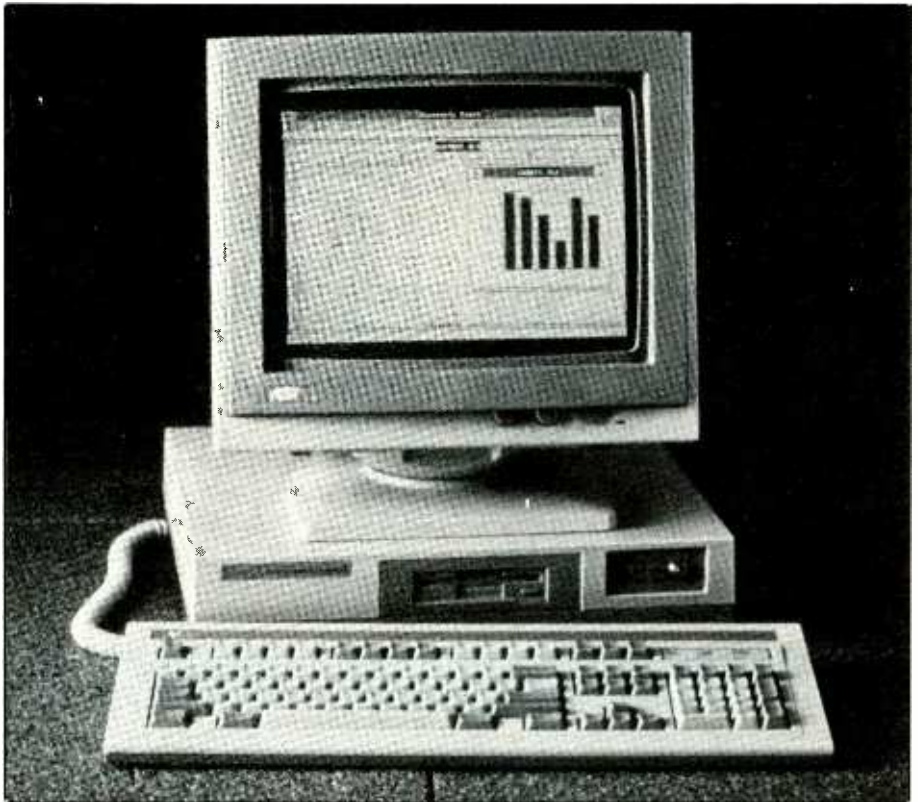

times.) When memory access is required, the CPU first looks in the memory cache. If the data is present in the cache, it's transferred to the CPU in approximately a quarter of the time it takes to get it from system memory.

If the required information is not in the cache, the CPU accesses it from system RAM. At the same time, the data is also copied to the memory cache and tagged as being the most-recently used. Because the cache is limited to 32K, the machine makes room for the new data by purging the cache of its least-used data.

To improve cache performance, more than just the requested byte is copied to the cache. Data bytes immediately surrounding the fetched byte are also placed in the cache. This isn't unlike the way you shop. Instead of making a trip to the supermarket every time you need an item, you usually pick up other things you

know you'll be needing in the immediate future. Because data is sequentially written to RAM, this scheme proves quite effective because the chance of finding the next desired data byte in cache is improved. The percentage of times the CPU gets its data from the cache as opposed to going to system memory is called the "hit rate." The Premium Workstation/386SX's hit rate exceeds 90 percent.

Under the Hood

The Premium Workstation/386SX's motherboard contains almost exclusively surface-mounted components. Located on the motherboard are one parallel and two serial ports, floppy-disk controller, and an IDE (Integrated Drive Electronics) hard-disk interface.

The IDE hard disk is unique in that all the electronics for its control and opera-

PRODUCT EVALUATIONS . . .

tion are built into it. The computer doesn't have to supply anything except a data interface, like the one built into the Premium's motherboard. The IDE interface connects directly to the Premium's 8-MHz expansion bus, allowing the computer to treat the hard disk as through it is an adapter card. Because of this unique talent, the IDE hard disk is able to deliver performance that's equal to a more expensive ESDI hard disk (which requires an external controller card). The AST Premium Workstation/386SX Model 45V, which lists for \$3,695, comes standard with a 40MB IDE hard disk and VGA video controller. An optional 110MB IDE hard-disk drive (\$1,500 list price) is available.

A proprietary daughtercard video con-

troller attaches to the motherboard through a special connector. Two video cards are available: monochrome with CGA emulation and VGA. The motherboard also has a socket for an 80387SX math coprocessor.

The machine comes with 1MB of system memory, 896K of which is user-accessible (counting shadow RAM). The memory plugs into the motherboard via six SIMM (single in-line memory module) sockets. The six sockets are divided into three banks of two sockets apiece, which allows you to mix SIMM types between banks (you don't have to throw away the four 256K SIMMs that come with the machine before installing 1MB SIMMs, as some computers require). Fully loaded with 1MB modules, the

Premium supports 6MB of 16-MHz RAM. Up to 16MB of RAM can be installed, but RAM beyond 6MB must be installed using conventional adapter cards that run at only 8 MHz.

Room for two 16-bit adapter cards is provided in the Premium Workstation/386SX. Because the system unit is only 4 inches tall, though, the cards must lie on their sides horizontally, rather than stand upright. While two expansion slots doesn't sound like much, it's as many as several PCs have free after the disk drive controllers, I/O card, and video board are installed.

User Comments

ROM-based setup makes the Premium

The 80386 Vs. the 80386SX

When you buy an 80386SX machine, you give up something, but what? The basic difference between the 80386 and 80386SX is the width of the data and address buses.

Point number one: the 80386 has 34 memory address lines with access to 4GB (4-billion bytes) of physical memory, whereas the 80386SX has only 24 address lines that limits it to 16MB. However, the address limit of DOS is 1MB and the address limit of OS/2 is 16MB, making this a moot point.

The bigger issue is the 16-bit data bus of the 80386SX as opposed to the 32-bit bus of the 80386. Theoretically, the 16-bit bus is only half as fast as the 32-bit bus of the 80386 because it takes twice as long to funnel data through it. However, few programs take advantage of the 32-bit external bus, relying instead on the 32-bit features inside the chip, rather than on its 32-bit input. In fact, benchmark tests reveal that 95 percent of today's 80386-specific software operates just as fast on an 80386SX PC as it does on a more-expensive 80386 PC.

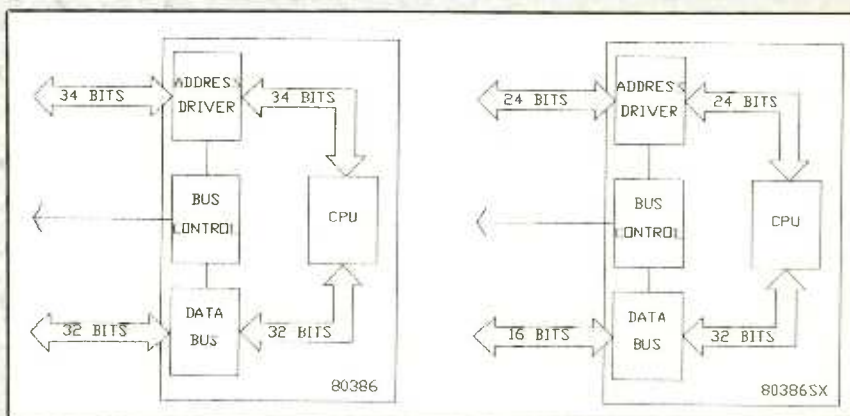

Intel Microprocessor Comparisons

	8088	80286	80386SX	80386
Data bus size (bits)	8	16	16	32
Maximum memory	1MB	16MB	16MB	4GB
16-bit real mode	Y	Y	Y	Y
16-bit protected mode	N	Y	Y	Y
Virtual 8086 mode	N	N	Y	Y
32-bit protected mode	N	N	Y	Y

Workstation/386SX a pleasure to use. Instead of using a floppy disk to make setup changes to the system, you simply request the built-in setup menu from the computer's keyboard.

Beyond the usual date, time, and disk-type choices, there are some rather unique options from which to choose, like being able to have the system boot with NumLock on or off, among others. Speed can be toggled between 16 and 8 MHz for speed-sensitive applications. BIOS relocation that copies the system BIOS and video BIOS into faster shadow RAM (system memory located between 768K and 1,024K) is also available.

System and keyboard password protection are also provided with the AST Premium Workstation/386SX. When system password protection is enabled, you're required to enter a password during boot-up before you can access the system. Keyboard password protection allows you to disable the keyboard so that you can lock out the system while it remains running.

AST's utility disk contains a hard-disk cache and an expanded-memory manager that lets you use RAM beyond 1MB as LIM 4.0 expanded memory for applications like *Lotus 1-2-3* and *AutoCAD*. Also on the diskette are a RAM disk and print spooler utility.

On benchmark tests using popular applications like *Lotus 1-2-3* the Premium Workstation/386SX outdistanced virtually every 386SX machine by about 25 percent. It bested the speed of the Compaq Deskpro 386/16 by 10 percent.

Conclusions

It used to be that the instruction code of the PC's 8088 processor was enough to satisfy any programming needs. Now, however, modern applications are more demanding, and many are tapping into the power that the 80386 chip has to offer, with popular software applications packages like *Windows/386* and *Paradox/386* leading the way.

All indications point to the fact that

AST Premium Workstation/386SX Facts

CPU	80386SX
Speed	8/16 MHz
Coprocessor	80387SX
RAM	6MB
RAM type	100-ns SIMMs
Parallel ports	1
Serial ports	2
Adapter slots free	2
Warranty	1 year
List price	\$2695
Manufacturer	AST Research
Address	Inc., 2121 Alton Ave., Irvine, CA 92714
Telephone	(714) 863-1333

unless your next PC has 386 capabilities, you're going to be left behind in the dust. Not everyone can afford an 80386 PC. Which is why it's fortunate that we have the 386SX alternative.

Although the AST Premium Workstation/386SX isn't the least-expensive 386SX machine around, it's certainly the smallest and fastest. Moreover, AST has put everything but a kitchen sink into this system and tossed in a generous bundle of software that includes DOS 3.3 and GWBASIC. So the only extra-cost item you have to buy is a video display monitor of your choice. **ME**

CIRCLE NO. 157 ON FREE INFORMATION CARD



PACKARD BELL
America grew up listening to us. It still does.

PACKMATE 286 COMPUTER WITH VGA COLOR MONITOR



- 80286 microprocessor (operates at 12 MHz).
- One 3-1/2" 1.44 MB floppy drive.
- One 5-1/4" 1.22 MB floppy drive
- 30 MB hard drive. • 1 MB RAM on mother board; expandable to 3 MB.
- Includes VGA 14" color monitor & VGA card.
- High res. monitor: 480 x 600, & 256 colors.
- IBM compatible. • AT compatible.
- 8 expansion slots. • Dual FDD/HDD controller.
- 2 half height drive cavities exposed.
- 1 half height drive cavity enclosed.
- 2 serial ports. • 1 parallel port.
- System configuration in CMOS with battery back-up.
- Included software: MS DOS 3.3 & GW BASIC.
- 145W Universal power supply.
- Socket for 80287 co-processor on motherboard.
- Zero wait state. • One Year Warranty!

FACTORY NEW! FACTORY PERFECT!

Due to a special arrangement, we were able to obtain a large inventory of these computers with color monitors. As a result, we can now offer them to you at **HUGE SAVINGS!**

Manufacturer's Suggested Retail
\$3,449.00

DAMARK PRICE:
\$1499

Item No. B-1751-132142
Insured Ship/Hand.: \$39.00

FOR FASTEST SERVICE CALL TOLL FREE 1-800-729-9000



DAMARK INTERNATIONAL, INC.
6707 Shingle Creek Parkway, Minneapolis, MN 55430
Customer Service • 612-566-4940

Please rush me: Packard Bell Computer(s) @ \$1499 each, plus \$39.00 s/h each. Item No. B-1751-132142. MN res. add 6% sales tax.

Name _____
Address _____
City, State, Zip _____
 Check/MO VISA Master Card Discover
Card No. _____
Exp. Date _____ / _____ Ph. # () _____
Signature _____

DELIVERY TO 48 U.S. STATES ONLY

Diagnostic & CAT Reader OCR Software Packages

By Ted Needleman

Sometimes I think that there's an evil spirit that inhabits PCs. In my work, I use PCs a lot. Because of this, it's not unusual for me to get more than my share of error messages. So I'm no longer surprised should the line "GENERAL FAILURE ON DRIVE X" or "INVALID DRIVE" pop up on my screen.

Most of us are no stranger to an occasional problem with our systems. In accordance with Murphy's Laws, these problems always happen at the most inopportune time. At these times, you have two options—to take the system to a dealer with a good service department or to try and troubleshoot the problem yourself.

While many of you have well-equipped shops, in many cases there's little need to drag out logic analyzers, oscilloscopes, or other fancy test equipment. What you will need is a good diagnostic package. In last February's column, I mentioned a package, QAPLus, that I'd seen at COMDEX. Shortly after that column was written, I received an updated version named CheckIt from TouchStone Software, who I've been told licensed it from Diagsoft, QAPLus's developer. I've been using it for the last year (and through two revisions), and it's something that most of you should have on your shelf as part of your PC troubleshooting kits.

CheckIt is a relatively complete piece of diagnostic software. Meant for non-Micro Channel PCs (that is, standard bus 8088, 8086, 80286 and 80386 systems), it contains a complete suite of tests that can determine the status of your motherboard and expansion card memory (even down to pinpointing the location of a bad memory chip), hard and floppy disks, video cards, I/O ports and several other parts of your computer. It is supplied on two floppies, and can be installed on a hard disk or used from copies of the supplied diskettes. Like most serious-use PC software today, it's not copy-protected, but the license limits its use to a single system at one time.

As a diagnostic tool, CheckIt is very easy to use. When you run the program, it

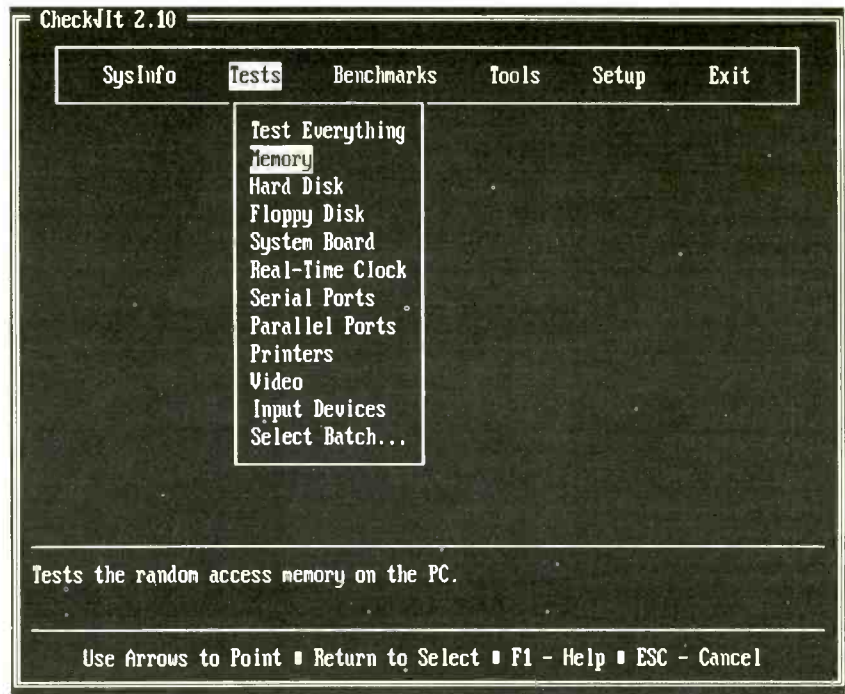

Fig. 1. A pull-down submenu lists the various diagnostic tests available with CheckIt.

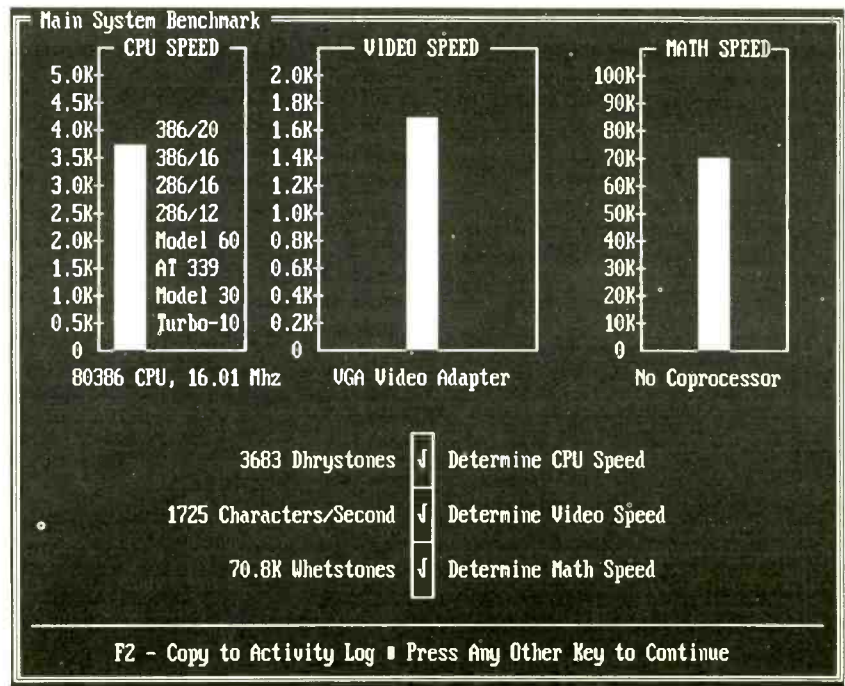

Fig. 2. CheckIt provides CPU, video, and math benchmarks that are useful in comparing computer systems and evaluating upgrades.

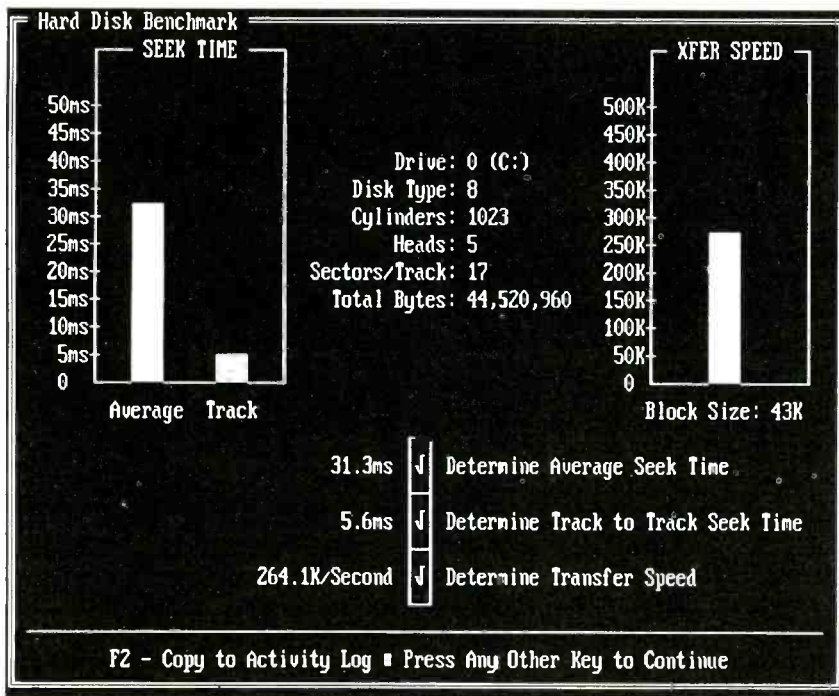

Fig. 3. CheckIt's hard-disk benchmarks give important information to the computer user.

automatically checks out the configuration of the PC it's being run on, then presents you with a set of menus on the top of the screen. You simply pull-down the menu you need, and use the cursor arrow keys to select the function you wish to perform. At any time, pressing the F1 key will get you an explanation of what the highlighted selection does. A more comprehensive discussion of each test and in many cases what the results mean, is contained in the manual.

Figure 1 shows the test submenu. Under each of these selections you have additional options. For example, when testing RAM, you can choose specific segments (if you suspect that a known area is bad), determine which of several different types of test patterns should be used, and limit the number of times the memory test is run should you not want it to be run indefinitely.

Another example of CheckIt's flexibility is the tests it conducts on the serial and parallel I/O ports. These include both internal and external loopback tests. The

external loopback tests require a special jumper plug, which few people (myself included) have.

There are illustrations included in the documentation on how to wire one up, but so far, I just haven't had the time. Using the external loopback allows the diagnostic to test the ports at greater speed, and to assure with greater confidence that the ports are not defective. But for those of us without the loopback plug, an internal test can offer some indication of how well the ports are working.

In addition to the diagnostics, CheckIt performs three more very useful functions. There is a set of System Tools that allow you to reset the CMOS setup table time and date values or perform a low-level format on a hard disk. Actually, you can perform this low-level format with most hard disk controllers using the DOS DEBUG command to access the disk controller card's BIOS. However, remembering the address, or finding the documentation that gives instructions on how this is accomplished, is much more diffi-

NEW SUPER LONG PLAY TAPE RECORDERS

12 Hour Model — \$119.00*
USES D-120 TAPE

Modified Panasonic Slimline, high quality, AC-DC Recorders provide 6 continuous hours of quality recording & playback on each side of cassette for a total of 12 hours. Built-in features include:
• Voice level control, • Digital counter, etc. TDK DC 120 Cassette Furnished.



PHONE RECORDING ADAPTER

Records calls automatically. All Solid state connects to your telephone jack and tape recorder. Starts recording when phone is lifted. Stops when you hang up.

\$28.50*
FCC APPROVED

VOX VOICE ACTIVATED CONTROL SWITCH

Solid state. Self contained. Adjustable sensitivity. Voices or other sounds automatically activate and control recorder. Uses either recorder or remote mike. \$28.50*

*Add for ship & hdg. Phone Adapter & Vox \$1.50 ea. Recorders \$4.00 ea. Cal. Res. add tax. Mail order, VISA, M/C, COD's OK. Money Back Guarantee. Qty. disc. avail. Dealer inquiries invited, Free data.

AMC SALES INC. Dept M9335 Lubec St., Box 928, Downey, CA 90241 Phone (213) 869-8519

CIRCLE NO. 170 ON FREE INFORMATION CARD

ATTENTION! ELECTRONICS TECHNICIANS

EARN YOUR B.S.E.E. DEGREE THROUGH HOME STUDY



Our New and Highly Effective Advanced-Placement Program for experienced Electronic Technicians grants credit for previous Schooling and Professional Experience, and can greatly reduce the time required to complete Program and reach graduation. No residence schooling required for qualified Electronic Technicians. Through this Special Program you can pull all of the loose ends of your electronics background together and earn your B.S.E.E. Degree. Upgrade your status and pay to the Engineering Level. Advance Rapidly! Many finish in 12 months or less. Students and graduates in all 50 States and throughout the World. Established Over 40 Years! Write for free Descriptive Literature.

COOK'S INSTITUTE OF ELECTRONICS ENGINEERING

4251 CYPRESS DRIVE JACKSON, MISSISSIPPI 39212

CIRCLE NO. 169 ON FREE INFORMATION CARD

PC CAPERS...

cult to do than when using the CheckIt's System Tool.

CheckIt also has a set of performance benchmarks that come in handy when you need to compare systems or decide if an upgrade has been worth the bother. These benchmarks include system benchmarks (Fig. 2) which show CPU computational power in Dhrystones, video speed, and math speed in Whetstones, and hard disk benchmarks (Fig. 3). You don't really have to understand exactly what these units of measure represent to be able to estimate whether a substantial change in them is significant, but a more detailed description than given in the documentation wouldn't hurt.

One of the most helpful functions that CheckIt performs, at least as far as my use of the product, is the set of SysInfo displays (Fig. 4). These detail the system configuration, interrupt usage, and DOS Device Drivers installed. I am usually installing and removing a variety of peripheral adapter cards in the various PCs I use, and keeping track of what interrupts are being used in a particular system is close to impossible. Running this function on a system before I install a new card has saved hours in troubleshooting interrupt conflicts and, to me, is worth the product's reasonable \$149.95 cost.

There are things CheckIt doesn't do, of course. For instance, it won't help you align a floppy disk. You need a special alignment disk (and usually an oscilloscope) to do this. And CheckIt also won't make some of your decisions for you; you'll need to have some idea of what and where the problem might lie in order to fix it. A good book like Scott Mueller's *Upgrading and Repairing PCs* (QUE Books) is a useful adjunct to troubleshooting tasks.

All things considered, though, CheckIt has saved me hours of time in the ten months or so that I've had it. If you do much PC troubleshooting, whether of your own or other people's systems, this is one package that can be very useful.

CAT Reader OCR Software

With every day that goes by, we expect

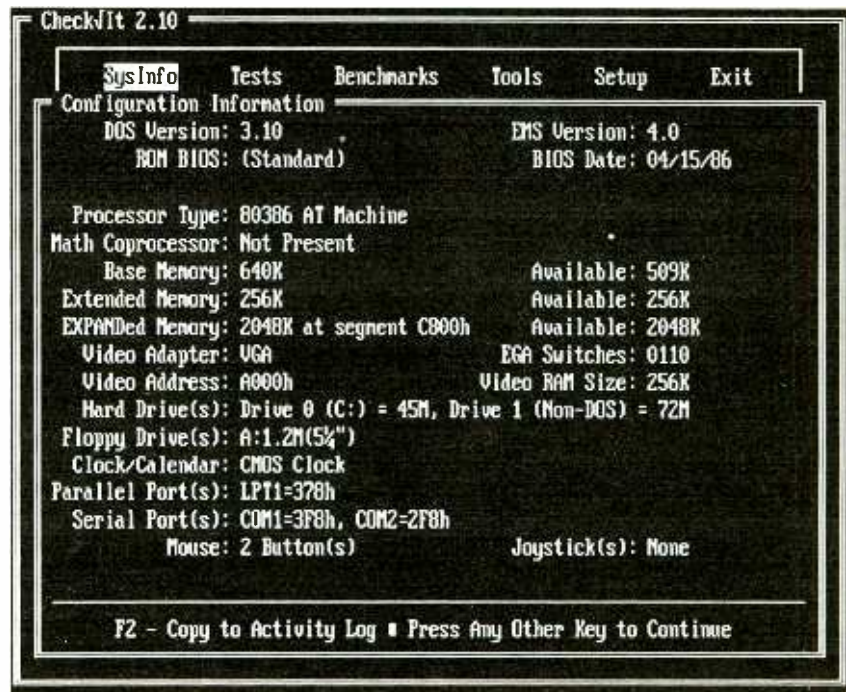

Fig. 4. The SysInfo menu in CheckIt gives vital configuration information. Additional menu choices provide data on interrupt and DOS device driver usage.

more and more impressive tasks from our hardware and software. With the ready availability of scanners, both hand-held and page readers, Optical Character Recognition (OCR) seems like a good use to put this hardware to. After all, it would be nice to have the ability to have your computer simply "read" a previously typed page, or a page out of a book or magazine, and store in ASCII format or in another format your word processor could use. This makes it easy to include explanations, comments, and definitions into your own reports and other documents, eliminating the hassle of retyping.

Over the last year or so, I've been playing with a variety of both hand and page scanners. I've also tried a few OCR packages ranging in price from inexpensive to very expensive. CAT Reader, from Computer Aided Technology, is one of the less expensive packages that I've tried. Not only is it reasonably priced, but it is especially designed to be used with a number

of the more popular hand-held scanners. It differs from many of the other available OCR packages in two ways. The first of these is that for the scanners it supports, which includes those from The Complete PC, DFI, GeniScan, Logitech, Mitsubishi, NISCAN, and SkySCAN, the scanner can be controlled directly through the CAT Reader software. This saves an entire step; that of having to scan a page with the scanner's software, save the image as a TIF file, then exit the scanner's package to run the OCR software. Instead, you just select the SCAN choice from CAT Reader's menu, and scan away.

The second area the software is different from most OCR packages is in its tolerance for skew. One major problem in using a hand-held scanner, whether for text or graphics, is that it is almost impossible to drag the unit across a page exactly vertical, and at precisely the same speed across every point on the page. This results in an image file with the image usu-

ally at a slight angle, and often with inconsistent vertical spacing. As OCR software often works through pattern recognition, the software may have difficulty in recognizing the angled, and sometimes compressed or stretched image of a scanned character.

CAT Reader has been designed from the start to be more lenient about this skew angle. While a page reader may also introduce a skew angle of a few degrees while scanning, CAT Reader can accept an image where the text is skewed up to 10 degrees, considerably more than most software would even attempt.

Of course, with this much skew in a page, it is unlikely that you'd get very many characters recognized immediately. You'll probably have to train the software to some extent.

Training is another CAT Reader feature. While CAT supplies two sample fonts, which cover many of the fonts used in books, magazines, and office printers, for the best recognition, you'll have to train the software to recognize those fonts you use most often. This is an easy process, and usually takes just a few minutes to accomplish.

Installing and using CAT Reader is easy. The package requires 640K of RAM, DOS 3.X and a hard disk, so all that is necessary is to create a new subdirectory and copy files from two of the three disks enclosed with the package. The first disk contains programs, while the second contains starter font libraries designed for the particular hand scanner you will be using. Users of Logitech's ScanMan are required to copy Font Disk 2, all other supported scanners will copy Font Disk 1.

Once the software has been installed, change to the hard disk subdirectory and type INSTALL. This process takes you through configuring the CAT Reader software for the particular scanner you are using, including the I/O address the scanner expects to see. By performing this configuration, you enable the CAT software to control the scanner. This process took us less than 5 minutes to do.

After installing the software, I scanned in several pages of text using a Complete

Half-Page Scanner from the Complete PC. The scanner responded correctly to the SCAN command in CAT Reader's menu. I did, however, have to train the software to recognize the text, even though the documents were printed in Times Roman, a very common font.

The software seemed to have the most difficulty when characters in the original text were closely spaced to each other. The most common failure in recognition were combinations such as "fi." This is a failing common to many OCR packages, regardless of their cost. OCR is also sensitive to the contrast/brightness settings used during scanning and the quality of the original document. Again, all OCR packages have these same limitations.

Another consideration when looking at OCR software is the accuracy rate. Many OCR packages claim rates up to 99 percent and better. Few achieve anywhere near this in real use, and almost none achieve high accuracy rates without some font training.

My first run through with CAT Reader yielded about 80 to 85 percent accurate recognition of characters. Fifteen or 20 minutes of training improved this to over 90 percent, which was boosted to 95 to 97 percent by judicious adjustment of the brightness/contrast controls on the scanner I was using.

All things considered, this is an acceptable recognition rate for most applica-

tions, and is considerably less than my own error rate when typing (as you might guess, I'm not a particularly good typist). As with many typed documents, a run through of your OCR'd document with a good spell checker is a must.

CAT Reader is an excellent piece of software. It is priced very reasonably for what it offers, performs well, and is simple to set up and use. Unless you have a critical OCR application, it should easily fit the bill. CAT Reader is available both from the developer and two special versions from The Complete PC. These versions from Complete PC are optimized for their scanners. **ME**

Products Mentioned

CheckIt
Price: \$149.95
TouchStone Software Corp.
909 Electric Avenue
Seal Beach, CA 90740
(800) 531-0450
(213) 598-7746

CAT Reader OCR
Price: \$299
Computer Aided Technology
7411 Hines Pl.
Dallas, TX 75235
(214) 631-6688

SUBSCRIBER SERVICE

CHANGE OF ADDRESS

Planning to move? Please let us know six weeks in advance so you won't miss a single issue of **MODERN ELECTRONICS**

Attach old label and print new address in space provided. Also include your mailing label whenever you write concerning your subscription to insure prompt service on your inquiry

Modern Electronics
76 N. Broadway,
Hicksville, NY 11801

ATTACH LABEL HERE

NEW ADDRESS HERE

PLEASE PRINT

NAME _____

ADDRESS _____

CITY _____ STATE _____

DATE _____ ZIP _____

Ace's Model AR900 Portable Scanner

By Louis A. Smith II, N3BAH

For some time now, there's been a need for an affordable multi-mode portable receiver that covers a number of vhf/uhf Amateur radio bands. Conventional scanners usually cover just 2 meters and a portion of 440 MHz (FM only) but not much else of interest to the ham. With the expansion of Ace Communications' AOR line of monitor receivers, the ham can now choose from among several units that cover pertinent portions of our spectrum. With the introduction of the Model AR900, Ace has come through with a receiver that incorporates the strong points of the earlier Model AR880, plus some welcome improvements.

Overview

The AOR AR900 scanning programmable portable receiver is a compact and lightweight addition to the Ace line-up. It represents an expansion of the company's earlier hand-held unit. Assembled in Japan, the AR900 offers frequency coverage of 27 to 54, 108 to 174, 406 to 512 and 830 to 950 MHz with no "gaps" or restricted portions of these bands.

AM and narrow-band FM are selectable for any frequency, and you have the option of entering your own frequencies or allowing the on-board microprocessor to locate them automatically, using a handy search mode. Available are 100 channels that are grouped in five banks of 20 channels each. You can also program selectable search increments of 5, 10, 12.5, 25 or 30 kHz, depending on band or segment of a band, according to particular individual needs.

This receiver is powered by an internal Ni-Cd battery pack and comes with plug-in wall charger and two flexible antennas for optimum reception on various bands. Optional accessories include an ear-phone, leather carrying case, automotive cigarette-lighter power adapter and base and mobile antennas.

Measuring just 5.75"H x 2"W x 1.5"D and weighing a mere 12 ounces (including battery pack), the AR900 is one of the smallest, lightest scanning receivers presently marketed. It is perfect for

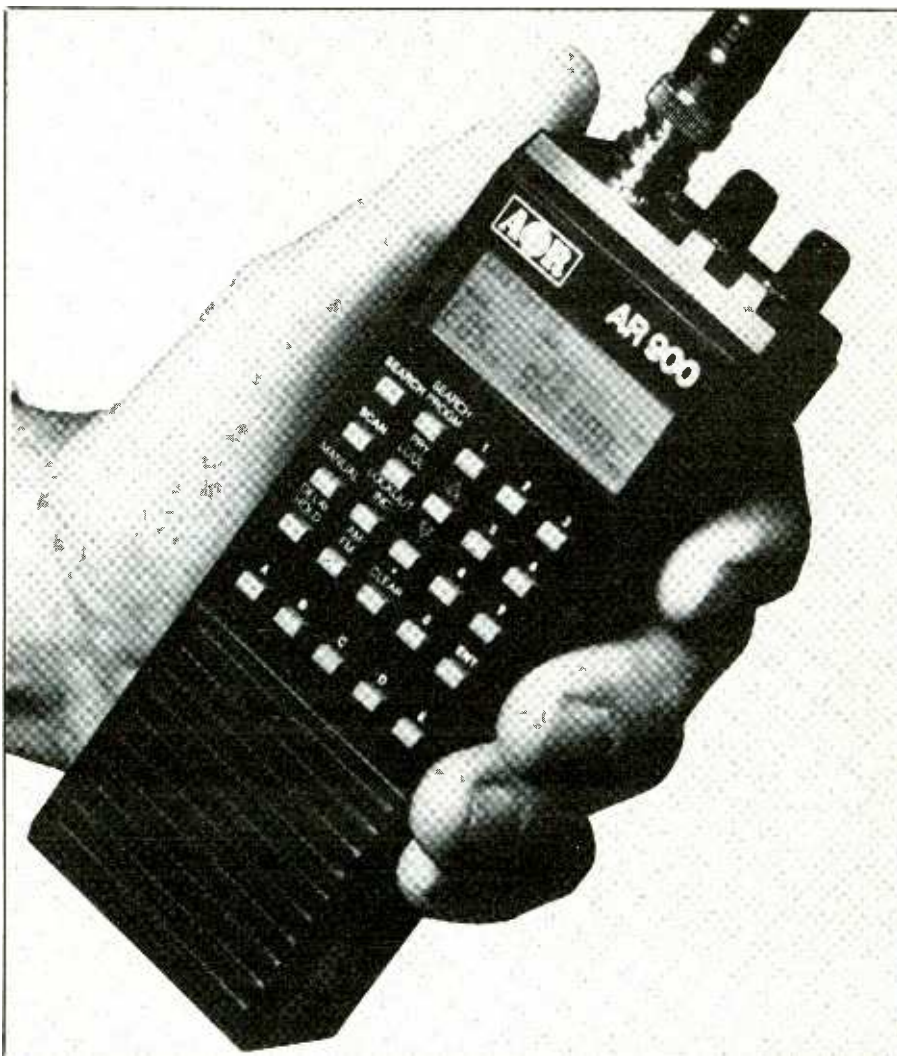

carrying in a pocket or hung from your belt with the attached belt clip.

Operation

The front-panel keypad can at first appear to be quite intimidating, especially if you're not accustomed to using such receivers. The functions provided by the 25-key pad are easily mastered, however, and after about a week of operating the receiver using them, the key sequences required can become second nature.

When first powered up, the AR900 is in scan mode, with all 100 channels in the re-

pertoire. The channels are grouped in five banks labeled A through E. They can be included or locked out from scanning by the toggle action of the associated letter-legend keys.

Channel numbers as shown in the receivers liquid-crystal display window consists of the bank letter (A, B, C, D or E). This is followed by the channel number within the bank. For example, the third channel in bank "D" would appear as D03 in the display.

Channel frequencies are programmed by manually stopping on the desired channel, keying in the frequency in mega-

hertz, selecting AM or FM and pressing the ENT key. Any channel can be directly accessed while in manual mode by keying in the alphanumeric designator for that channel, such as A14, B06, etc. Each channel can be programmed in any combination of frequency and AM/FM mode. Frequencies are permanently stored in memory without need for a memory battery. They can be over-written at any time simply by repeating the programming steps.

Just as the AR900 has five banks of scanning channels, it also has five programmable search ranges that permit you to locate five frequencies between two limits you select, specifying AM or FM and search increments as well. To program a range, you are required to press a SEARCH PROGM key, select the "A" key (to program this range, or another lettered key to program a different range) and either AM or FM for the range. You then enter the lower-limit frequency, press LL/UL, enter the upper search limit, toggle with the INC key to the desired search increment for the range, and once again press the ENT key and letter designation key of the range you've programmed. The same sequence is repeated for all other letter-designated ranges, and all are retained in permanent memory.

Once a search range has been programmed, you can switch from scanning to searching at any time by pressing the SEARCH key, followed by the letter key for the desired search range. Only one range can be searched at a time, and the microprocessor doesn't step to any other range when search of a selected range is done. You can also change from one range to another at any time simply by pressing the corresponding letter key.

During a search, the microprocessor will "bounce" between limit frequencies. That is, it will start at the lower limit and proceed to the upper limit and then begin descending from the upper back to the lower limit. Search direction can be changed at any time by pressing either the up or down direction arrow key, followed by pressing SEARCH.

A delay feature is provided for use with either scanning or searching. During scanning, the delay keeps the scanner

Ace AR900 Search/Scan Programming Frequency Increments					
Band (MHz)	5	10	12.5	25	30
27.0-54.0	X	X		X	
108.0-135.995			X	X	
137.0-174.0	X	X		X	
406.0-512.0			X	X	
830.0-868.995			X	X	
870.0-889.988				X	X
891.0-950.0			X	X	X

The default increment for all ranges is 25 kHz. Note that sub-bands 136 to 136.995, 869 to 869.995 and 890 to 890.995 MHz could not be searched with test unit (see text).

paused on a frequency for approximately 4 seconds following a transmission to facilitate monitoring simplex systems. While searching, the delay functions to keep the search paused on an active frequency for 3 seconds after transmission ceases or to remain on a frequency once it is located (the HLD mode). Search can then be resumed by pressing the SEARCH key. Scan and search can be activated in their respective modes via the toggle action of the DELAY/HOLD key.

When you locate a frequency of interest while searching, you can immediately program it into a scan channel by pressing the ENT key, followed by entering the channel's alphanumeric designator.

Specifications

Sensitivity and selectivity for the AR900 are good, given the wide range of frequencies covered. Specifications of 0.4 μ V for 27 to 54 and 136 to 174 MHz, 0.8 μ V for 108 to 136 MHz, 0.5 μ V for 406 to 512 MHz and 1.0 μ V for 830 to 950 MHz are as good as or better than those for other such receivers on the market that sport lesser frequency coverage.

Optimum reception can be assured by choosing between the two flexible antennas included with the receiver. One antenna is thinner and is useful for 406 MHz on up. The other, thicker, "ducky" antenna is best for frequencies up to uhf.

Intermediate frequencies for the re-

ceiver are 21.4 and 54 MHz, depending on band selected, and 455 kHz. The receiver's selectivity is good, with channel bleed-over being experienced only when the receiver was physically close to a transmitter operating on a nearby frequency. No published specification for selectivity was given.

Volume level from the receiver's internal speaker is adequate. It's rated at 200 mW. In a noisy environment, the optional earphone is a must, however. For use in a mobile installation, I'd recommend use of an amplified speaker, though.

The included Ni-Cd battery pack and ac adapter/charger team up to provide about 6 hours of operation on a full charge, given the receiver's requirements of 6 volts at 65 mA current drain. Extensive use of the light provided to backlight the display under dim lighting conditions can shorten operating time, and using the radio while it's charging can also lengthen the time required for full charge.

Whether you're programming a scan channel or a search range, you should keep in mind the ability to select between AM and FM reception. For Amateur bands like 10 and 6 meters, this capability comes in handy.

User Comments

From the point of view of a seasoned vhf/uhf operator, the AR900 is a pleasure to use. All key sequences are logical and

COMMUNICATIONS ...

easy to remember, and the large, easy-to-interpret LCD display window provides information in an understandable format. The unit's 100 channels provide ample space for the many repeater and simple frequencies you'll be able to monitor from the five Amateur bands receivable by the AR900.

Grouping of the channels into banks provides an easy way to separate various geographic channel patterns, uses, etc., for quick recall. Experience proved that the best possible configuration for frequencies was to keep those in the same frequency band and mode in the same bank. This minimizes missing of a transmission and keeps the scan rate up at maximum. Such pointers help you get the most out of any such unit that covers a bandwidth of hundreds of megahertz.

In addition to the usual vhf/uhf public safety bands, Amateur coverage that includes all of 10, 6 and 2 meters, and 420 to

450 and 902 to 928 MHz! With the option of selecting between AM and FM reception on any band, the receiver's versatility becomes apparent. It is possible to be keeping simultaneous tabs on a multitude of channels and modes, from 10-meter FM to your favorite 2-meter repeater and maybe even experimental operations on the new 900-MHz band. (The compact size of the receiver precluded an r-f front end that is needed to cover 220 MHz).

A scan rate of 15 channels per second gives good coverage, keeping in mind that generally no one would be scanning more than two channel banks at one time. Add to this the inclusion of a selectable priority feature, which checks the frequency in channel 1 about once every 3 seconds, and you have a pocket-size programmable receiver that's hard to beat.

The ac adapter/charger jack is located on the left side of the receiver, and a 2" internal speaker is located on the lower

third of the front panel, just below the keypad. The battery compartment is located behind a slide panel on the lower half of the rear panel.

The large LCD display located above the keypad is packed full of useful information. In addition to displaying whether you're in the scan or manual mode, frequency and channel number selected, the display indicates which channel banks are in the repertoire. The status of delays, a scan/search indicator and channel lockouts are also shown, as is a BAT LOW indicator when recharging is required.

One welcome change in the AR900's display is that it gives a full megahertz readout, which is a display of the exact frequency within 1-kHz accuracy, and the mode for all channels. Previous to this, Ace has used an offset button with its hand-held radios to achieve 12.5-kHz spacing in the uhf bands, but this wasn't reflected in the display of the AR900.

Over 75,000 active amateurs in over 125 countries throughout the world read and enjoy a different kind of ham magazine every month. They read CQ.

It's more than just a magazine. It's an institution.

SUBSCRIBE TODAY!



CQ The Radio Amateur's Journal
76 N. Broadway, Hicksville, NY 11801

Please send me CQ for Life 3 Years 2 Years 1 Year

New Renewal Start with _____ issue 1 years - 12 issues \$19.95 (Save \$10.05) 2 years - 24 issues \$38.00 (Save \$22.00) 3 years - 36 issues \$57.00 (Save \$33.00)

Name _____ Call _____
Street _____
City _____ State _____ Zip _____

Charge My Order To: Payment Enclosed \$ _____
 MasterCard My account number is: _____
 VISA

This receiver's display eliminates cumbersome mental math.

A good display light is provided for viewing the display under low-light conditions and is activated by pressing a pushbutton switch on the top of the unit. Next to the light switch is another button that locks the keypad to prevent inadvertent entries when the receiver is carried in a pocket. Rotary VOLUME and SQUELCH controls and a BNC antenna connector and miniature earphone jack are also mounted on the top of the unit.

I didn't experience problems with the scan delay and sensitivity. However, I did have a problem with the incidence of "birdie" frequencies, which hindered reception and caused annoying interruptions in the search mode. Many of the frequencies on which the birdies were encountered were in the aeronautical and public safety bands. Another area that could use improvement is the instruction manual, which provides only sparse information and could be confusing to someone who hasn't used similar equipment. A notable omission from the manual was a schematic (or even a block diagram) of the unit.

Frequency coverage is software based and, thus, programming is controlled not by the PLL lockup limits but by manufacturer-set limits that cannot be exceeded. This effectively nullifies any attempts at keypad tricks to monitor frequencies outside the set bands. This leads to several interesting observations. As previously noted, during set-up of a search range, you're given the opportunity to select a search increment of your choice. For example, in searching 28 to 29.7 MHz, it would be wise to choose 5 kHz to check the maximum number of frequencies for activity, but in searching the uhf public safety band, 12.5 kHz would be more appropriate. Ranges beyond 830 MHz could use 12.5-, 25- or even 30-kHz step increment, depending on segment and radio services assigned.

When programming a channel frequency or setting upper and lower search limits, frequencies must conform to one of the available increments in that band. For example, you couldn't program a frequency of 154.0125 MHz or 440.005

MHz because increments of 12.5 kHz and 5 kHz aren't available in these bands.

Where to use which increment is critical to gaining maximum benefit from the AR900, and failure to use the correct increment can result in an "SR ERR" or "FR ERR" error message appearing in the display window. (The Table includes a listing of bands and available increments to assist users in appropriate programming and give you some idea of the actual frequency capabilities of the AR900 receiver.)

One notable problem I encountered was the inability of the receiver to search all or part of the 136-to-136.995-, 869-to-869.995- and 890-to-890.995-MHz sub-bands. Despite the fact that the manual indicates that these ranges can be searched, the software caused the microprocessor to generate an error message whenever I attempted to search any range that includes all or part of these 1-MHz-wide sub-bands. This is apparently a software problem because these ranges mark the

border between other contiguous bands that use differing search increments. My unit was one of the first off the assembly line, and Ace informs me that the company is aware of this problem in early production units and should be corrected by the time you read this.

Perhaps the most striking feature of the Ace Model AR900 pocket-size monitor is its coverage of so many radio services and bands. Not only are five ham bands covered, but a plethora of public safety, marine and government channels are included, as is the entire vhf aircraft band. This receiver provides something for every monitoring taste and makes a useful addition to any emergency operation. Its \$300 price tag, good sensitivity and memory capacity make the AR900 a practical addition to the gear of any Amateur or radio hobbyist interested in a pocket vhf/uhf receiver for Amateur listening and public safety monitoring. **ME**

CIRCLE NO. 155 ON FREE INFORMATION CARD

FRANKLIN-BELLE PUBLISHERS
The Antenna People Present:

●MAGAZINES●

●*antenneX*—A monthly magazine
all about antennas. Read in 40+
countries.....\$15.97

●BOOKS●

●*Rules of the Antenna Game*
By Ted Hart, W5QJR.....\$9.95

●*Small High Efficiency Antennas*
By Ted Hart, W5QJR.....\$19.95

●*Electronics for the Radio Amateur*
By James G. Lee, W6VAT.....\$19.95

●SOFTWARE (IBM)●

●*Transmitting Loop Antenna*.....\$17.75

●*Transmission Line Antenna*.....\$17.75

●*Antenna Utilities-Series 1*.....\$27.75

●*Noise Analysis Program*.....\$9.75

●*Capacitor Design Program*.....\$9.75

●OTHER●

●*Wiperless Capacitor Plans*.....\$4.95

**TO ORDER—Send Check or MO plus
\$1.50 S&H per item (except magazine)
Texas residents add 7.5% sales tax, TO:**

FRANKLIN-BELLE PUBLISHERS
4639 Corona, Suite 12
Corpus Christi, TX 78411
(512) 852-0446

CIRCLE 77 ON FREE INFORMATION CARD

**Be an FCC
LICENSED
ELECTRONIC TECHNICIAN!**



Earn up to
\$30 an hour
and more!

Learn at home in spare time
No previous experience needed!

No costly School. No commuting to class. The Original Home-Study course prepares you for the "FCC Commercial Radiotelephone License". This valuable license is your "ticket" to thousands of exciting jobs in Communications, Radio-TV, Microwave, Computers, Radar, Avionics and more! You don't need a college degree to qualify, but you do need an FCC License. **No Need to Quit Your Job or Go To School** This proven course is easy, fast and low cost! **GUARANTEED PASS**— You get your FCC License or money refunded. **Send for FREE facts now. MAIL COUPON TODAY!**

COMMAND PRODUCTIONS
FCC LICENSE TRAINING, Dept. 220
P.O. Box 2824, San Francisco, CA 94126
Please rush FREE details immediately!

NAME _____
ADDRESS _____
CITY _____ STATE _____ ZIP _____

first transistor, with the result that the Q_3 collector goes high in the event that the Q_1 collector goes low. Thus, you must employ a procedure that will determine whether a half-circuit fault is in the first or the second half-circuit.

Here, the voltage-forcing test technique does yeoman service. You use a variable-voltage bench power supply to apply power between the collector of Q_1 and circuit ground. When the test potential is adjusted to 15.7 volts (in this example), the first half-circuit looks like a normal arrangement to

the second half-circuit. Accordingly, if the fault is in the first half-circuit, the collector voltage at Q_3 will go to a normal value.

If the fault is in the second half-circuit, the collector voltage at Q_3 will not go to a normal value. Instead, it will go to an off-normal value that is determined by the particular fault in the second half-circuit.

Functionally, the voltage-forcing technique splits the differential configuration into two independent half-circuit arrangements. Thus, you can clamp the Q_1 collector voltage to

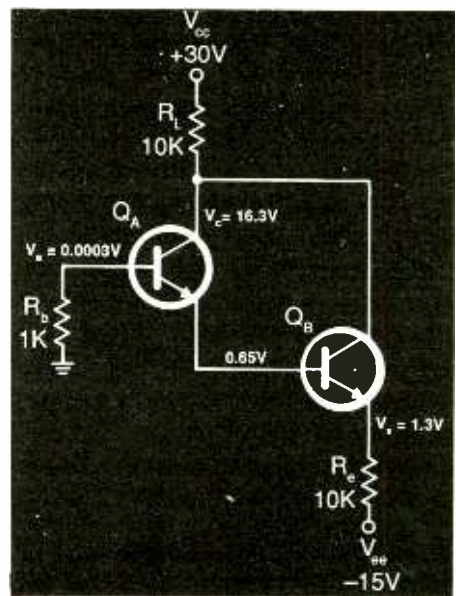

Fig. 5. First half of basic Darlington differential amplifier in Fig. 1.

normal value and turn your attention to the second half-circuit as though the first half-circuit does not exist. Conversely, if there is evidence of a fault in the first half-circuit, the collector of Q_3 can be clamped to normal value and you can then check out the first half-circuit as though the second half-circuit does not exist.

There is one reservation to bear in mind with regard to the above: the voltage-forcing technique is based upon the assumption that the fault is in the resistive circuitry and that the clamped transistor is workable. This assumption is justified in the event that a rise in the Q_1 collector voltage, for example, is reflected as an equivalent fall in the Q_3 collector voltage.

On the other hand, in the event that substantially non-symmetrical "mirror-image" patterns are encountered, you have no choice but to turn to "last-resort" procedures and start unsoldering connections. As an example, suppose there is a solder short circuit from the collector of Q_3 to R_e . In such a case, it is pointless to clamp the collector of Q_3 to normal voltage because the second half-circuit will look like a disaster to the first half circuit.

ME

SUBSCRIBE NOW & SAVE!

They're Here! FUN PROJECTS

You'll want these two exciting project books, packed with complete plans for building a wide variety of useful electronic devices.

Look at what you can build & take pride in:

- *Digital voltmeter accessories—high-frequency ac probe, true-rms adapter, temperature probe
- *Car projects—anti-theft alarms, engine tachometer
- *Life-saving detectors—gases & microwave leaks

The Fun Projects are capped by introductory information on building projects and kits (tools needed, parts sources, etc.) and advanced design techniques that illustrate how a designer thinks and plans when putting together a practical end product.

From beginning to end, MODERN ELECTRONICS FUN PROJECT BOOKS are for you! Order them today for a fast start in the world of electronics.

MODERN ELECTRONICS
76 N. Broadway, Hicksville, NY 11801

Order Date: _____

Name _____
 Address _____
 City _____
 State _____ Zip _____
 () Check () MasterCard () VISA
 Card No. _____
 Expires _____
 Signature _____

QTY	Title	Price	Total
	First Book of Modern Electronics Fun Projects	\$12.95 ea.	
	Second Book of Modern Electronics Fun Projects	\$12.95 ea.	
Total			
*Shipping			
Grand Total			

*Shipping charges \$2 per order. Orders processed day received, but please allow 30 days for delivery.

Sound Recording Handbook. By John M. Woram. (Howard W. Sams & Co., Inc. Hard cover. 586 pages. \$49.95.)

Over the years, quite a number of books have been written and promoted as being the "authoritative" reference on one topic or another in the audio field. Though this is yet another such book, it should not fall along the wayside as so many have. This book should take stage center and hold it for a long time because of its wide range of topics and depth of coverage. It zeroes in on just sound recording—which in itself is an extensive topic.

Written to be used by both the professional and amateur, the book begins with a chapter on basic theory and then goes on to detailed discussions of music, electronics and psychoacoustics. Once the foundation is laid, the author deals with microphones and special-purpose microphones in two separate chapters and devotes a full chapter to monitor speaker systems. Associated processes of delay and reverberation are given their own chapter, as are equalization and dynamic range. Tape and tape heads comprise another chapter, and tape transports are handled separately. Noise-reduction techniques are then scrutinized, and, finally, an in-depth discussion of consoles closes the main text.

Also included in this massive volume are four appendices. One details the SMPTE time code. The second is a glossary of technical terms, the third a comprehensive list of abbreviations, acronyms and symbols, and the final one an extensive bibliography and list of references for further reading.

This is a comprehensive book. Its text is easy to understand. It is fully illustrated with line drawings, graphs, photos and tables, each incorporated into the text material to aid or clarify certain points. All in all, this book is well worth its moderate cost if you are a sound recording professional or a serious amateur. It is a motherlode of important information packed into a single volume.

NEW LITERATURE

Full-Line Catalog. New from Leader Instruments is a 96-page full-line catalog that lists and fully describes more than

100 test instruments and accessories. Full-color Catalog No. 21 contains "A Guide to Basic Needs" that describes the different stages of electronic testing and the instruments required. Applications for various instruments, including digital and analog oscilloscopes, audio and video products, signal generators, frequency counters and power supplies are sprinkled throughout the catalog. New products featured in this edition include a 100-MHz CRT readout and other oscilloscopes, NTSC and PAL vectorscopes, video sweep generator, 60-MHz RGB video generator and more. For a free copy of Catalog No. 21, write to: Leader Instruments Corp., 380 Oser Ave., Dept. ME, Hauppauge, NY 11788.

Full-Line Catalog. Electronic Development Corp. has a new 70-page 1989/1990 catalog that lists the company's complete line of calibrators, reference standards and sources. The catalog gives detailed specifications for all products listed. Several new instruments/systems have been added to this edition, including a watt-hour calibration system, electronic phantom load and power analyzer. For a copy, write to: Robert B. Ross, Electronic Development Corp., 11 Hamlin St., Boston, MA 02127.

Full-Line Catalog. A catalog that lists and describes its complete line of products for use in the electronics industry to prevent electrostatic discharge damage is available from H&S Industries. The 16-page publication highlights products ranging from simple wrist grounding devices to sophisticated flooring systems and test equipment. Among the other items listed are ground cords, finger cots and gloves, ESD chairs, conductive clipboards, labels and posters, parts cups and bins, and conductive tape. For a copy, write to: H&S Industries, 402 W. Arrow Hwy., #14, San Dimas, CA 91773.

Tools Catalog. A new 168-page, full-color catalog from Jensen Tools lists and fully describes tools and test equipment for use in electronics. Included in the listings are Jensen's full line of specialized field-service tool kits, hand and power tools in inch and metric measure, test equipment, soldering supplies, static-control devices, work-holding devices, lighting and special optical aids, etc. For a free copy, write to: Jensen Tools Inc., 7815 S. 46 St., Dept. ME, Phoenix, AZ 85044.

MOUSER ELECTRONICS

consider the SOURCE

Make MOUSER Electronics your factory-authorized source for over 80 quality electronic component manufacturers like:

AUGAT, TECCOR, AMP, GE, & SGS-Thomson.

And then add: coast-to-coast distribution, same-day shipping, toll-free ordering and the full support of MOUSER's 25 years of proven customer service experience.

Call today for your complimentary subscription to the latest MOUSER Electronics Catalog. Just dial:

1-800-992-9943

CIRCLE NO. 152 ON FREE INFORMATION CARD

LEARN VCR CLEANING/MAINTENANCE/REPAIR

EARN UP TO \$1000 A WEEK, WORKING PART TIME FROM YOUR OWN HOME!



THE MONEY MAKING OPPORTUNITY OF THE 1990'S

IF you are able to work with common small hand tools, and are familiar with basic electronics (i.e. able to use voltmeter, understand DC electronics) . . .

IF you possess average mechanical ability, and have a VCR on which to practice and learn . . . then we can teach YOU VCR maintenance and repair!

FACT: up to 90% of ALL VCR malfunctions are due to simple MECHANICAL or ELECTRO-MECHANICAL breakdowns!

FACT: over 77 million VCRs in use today nationwide! Average VCR needs service or repair every 12 to 18 months!

Viejo's 400 PAGE TRAINING MANUAL (over 500 photos and illustrations) and AWARD-WINNING VIDEO TRAINING TAPE reveals the SECRETS of VCR maintenance and repair— "real-world" information that is NOT available elsewhere!

Also includes all the info you'll need regarding the BUSINESS-SIDE of running a successful service operation!

FREE INFORMATION CALL TOLL-FREE 1-800-537-0589

Or write to:
Viejo Publications, Inc.
3540 Wilshire Blvd., Ste 310
Los Angeles, CA 90010 Dept. ME

CIRCLE NO. 151 ON FREE INFORMATION CARD

B & B, Inc.

UNIQUE Electronics

1-800-826-7623

MESSAGE STOPPER®



Automatically stops your answering machine when you pick up any phone!

ONLY \$15.95

ALL IN ONE REMOTE

Tired of having 3 or 4 different remotes on the coffee table? Then this remote is for you!



YOUR COST \$59.95

MTS TV STEREO DECODER



Hear true stereo TV sound. Receives bilingual programming. Dolby Noise Reduction®. Sleek high-tech technology.

SPECIAL \$99.95

WIRELESS DOOR CHIME



Now have remote door chimes with no wiring! Simply plugs into any electrical outlet. Effective up to 50 feet apart.

PRICE \$30.00

INDOOR FM STEREO ANTENNA

Superb antenna isolates the main FM signal. No more FM station drift or fading with the Beamaster. Features built-in amplifiers, adjustable gain control.

EACH \$49.95

2 FOR \$39.95 EACH



1-800-826-7623



4030 BEAU D-RUE DRIVE
EAGAN, MN 55122
(612) 452-8420

CIRCLE 98 ON FREE INFORMATION CARD

Two-Line Interface (from page 25)

one lug of the fuse holder. Then bridge the remaining lug of the fuse holder and the other switch toggle with a length of hookup wire. Finally, plug a ½-ampere slow-blow fuse into the holder.

Checkout & Use

At this point, you should still have no ICs or optical isolators plugged into the sockets on the circuit-board assembly. The checkout procedure to be described will guide you through operation of the circuit in a logical and orderly sequence, testing each part of the circuit as you go. The only test instrument you need is a dc voltmeter or a multimeter set to the dc-volts function.

The first part of the procedure is to verify operation of the power supply. Begin by plugging the line cord into an ac outlet and set *S3* to "on." Be very careful not to come in contact with any of the transformer primary or fuse circuit wiring, since this part of the circuit represents a potentially lethal shock hazard.

Connect the meter's common probe to circuit ground, such as the negative (-) lead of *C1*. Touch the meter's "hot" probe to the positive (+) lead of *C1* and observe the reading obtained, which should be approximately +15 volts. If you obtain the proper reading, unplug the project from the ac outlet and allow time for *C1* to discharge.

If you do not obtain the proper voltage reading across *C1*, you must troubleshoot the circuit before proceeding with the checkout. Check the orientations of *D4* through *D7* and *C1*. Measure the resistance between the positive side of *C1* and circuit common to verify that the +15-volt supply is not shorted to anything. Normal indication will be in excess of 10,000 ohms. Verify that the transformer secondary is delivering about 12 to 14 volts ac to the bridge rectifier.

If the power supply is operating properly, plug only *IC2* and *IC5* into their respective sockets, making sure

they are properly oriented (see Fig. 3) and that no pins overhang the sockets or fold under between ICs and sockets. All ICs and optoisolators on the circuit board face the same direction.

Next, verify that *IC5* is operating. To do this, apply line power to the circuit. If *LED1* turns on when power is first applied, *IC5* has been triggered by the sudden application of power. Wait about a minute for it to extinguish as *IC5* times out. Then use a short length of wire to momentarily (1 second or less) short together pins 1 and 2 of *IC5*. This triggers *IC5* and causes *LED1* to turn on. You may also hear the relay click as it energizes. The LED should remain on for about a minute, then extinguish.

If you do not obtain the correct response, rectify the problem before proceeding to final checkout. Check the orientations of *IC2*, *IC5*, *C3*, *Q3*, *D3* and *LED1*. Measure the voltage at pin 3 of *IC5* to verify that it goes positive when the circuit is triggered. If *LED1* is on but fails to turn off after a minute or so, measure the voltage across *C3* to verify that it begins charging when the one-shot is triggered. When the charge on *C3* reaches about ⅔ *V_{dd}*, the capacitor is suddenly discharged, causing the LED to be extinguished.

Final checkout verifies operation of the remainder of the project using your two telephone lines and a pair of telephones. You do not need the answering machine connected at this time. With power to the project disconnected, insert the remaining ICs into their respective sockets, observing proper orientations and seating.

The first test verifies that the Line 1 and answering machine cables are connected through the relay. Plug the Line 1 cable of the project into the Line 1 telephone jack. Plug a telephone into the answering machine jack on the project. Without powering up the project, pick up the handset of the telephone instrument connected to the project and verify that you hear a dial tone. If so, wiring to

the closed relay contacts is correct. Otherwise, disconnect the project from line 1 and use an ohmmeter to locate the fault, which can be either a miswired or bad connection in the cables or at the relay.

The next test verifies operation of *IC1* and *Q1*. Plug the two cables of the project into Line 1 and Line 2 telephone jacks. Do not inadvertently interchange these two cables. Plug a telephone instrument into the remaining cable of the project, but do not power up the project.

Using the telephone connected to the project, dial the telephone number of Line 2. You should hear a busy signal even though no one is using Line 2, since the current drawn by the telephone will activate *IC1* and *Q1*. If you do not obtain a busy signal, check the wiring of telephone cable for Line 2, *IC1*, *Q1*, *R1* and *D1*.

The next test checks operation of

IC3, *IC4* and the relay. Temporarily remove *IC1* from its socket. Connect the Line 2 cable into telephone receptacle 2. Disconnect the Line 1 cable from the Line 1 telephone jack. Connect a telephone instrument to the answering machine jack on the project. Set the POWER switch to "on." If *LED1* turns on, wait until it goes out.

Go to any telephone that is connected to Line 1 and dial the number for Line 2. This should activate *LED1*, cause the relay to switch over to Line 2, and ring the telephone connected to the project. If you do not obtain these results, check components *IC3*, *IC4* and *K1*.

The last part of the checkout procedure checks *IC2* and *Q2*. With power turned off, replace *IC1* in its socket. Plug the two telephone line cables of the project into their respective telephone jacks and turn on power.

Momentarily short together pins 1

and 2 of *IC5* with a short length of wire to trigger the chip and turn on *LED1*. During the timed cycle, go to any telephone that is connected to Line 2 and dial the number of Line 1. You should obtain a busy signal because *IC2* and *Q2* have been activated. If you do not obtain a busy signal, check the wiring of components *IC2*, *Q2*, *R2* and *D2*.

This completes the checkout of your project. To demonstrate automatic operation, connect the project to the two telephone lines and answering machine, as shown in Fig. 4. Have a friend call you on Line 1, leaving a message on the answering machine. Then repeat the test on Line 2. When this is done the project will automatically switch the answering machine to Line 2 to answer the call. When *LED1* extinguishes the machine will again be automatically connected to Line 1. **ME**

NEW PRODUCTS . . . (from page 15)

cally turns on lights when someone enters the room. The unit also warns the user when room lighting is about to be turned off by dimming them for a brief period of time. In SECURITY mode, the lights begin to rapidly

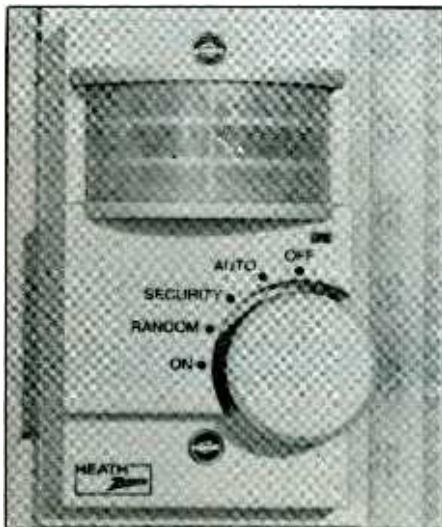

flash on and off when someone enters the room to warn an intruder that a security system is installed. The lights also remain on to indicate that an intrusion has occurred. In RANDOM setting, a built-in timer turns the lights on in a random manner for up to 4.5 hours after dusk and for a varying period of time each day.

Other features include a test LED that indicates that the motion sensor is covering the desired area and a passive infrared motion sensor. The switch also utilizes an adjustable photocell that permits the user to determine at what light level he wants the light to begin operating. To provide a greater coverage area and more reliable sensing of movement, the unit employs a large Fresnel lens. It can switch up to 500 watts of incandescent lighting. \$34.97.

CIRCLE NO. 178 ON FREE INFORMATION CARD

5000 RESISTORS!



RESISTOR KIT

Great for electronic hobbyists, R&D labs.

\$69⁹⁵

plus \$5.00 postage & handling

5000 quality 1/4w 5% carbon film resistors in a durable 50 drawer cabinet, 50 popular values (100 each) from 10Ω to 1MΩ.



ORDER LINE

1-800-933-3200

(Call 24 hrs. a day)



OR

Send check or money order to:

ProtoLab

P.O. Box 1314
St. Charles, MO
63302
(sorry no C.O.D.'s)

CIRCLE NO. 163 ON FREE INFORMATION CARD

SURVEILLANCE TELEPHONE



This is a normal functioning telephone! EXCEPT it has a secret built in monitor. Only YOU can call and monitor all conversations, using a secret code, and never be detected! **Range Unlimited**

\$175.00 - 6 month Warranty - Phone Tap Catalog \$3.00
LISTEN ELECTRONICS, 603 Eighth, Muskogee, OK 74401
1-800-633-TAPS

Unlock the Mystery of the Automobile Computer!

Build Your Own Diagnostic Scan Tool!

The Key To Understanding the Modern Electronically Controlled Automobile Engine Access Stored ECM Data Read-Out Fault Codes Challenging NEW Electronic Assembly KIT—PLANS—PARTS—ASSEMBLED/TESTED UNITS

Call 1-800-535-3091 or write for complete information Dept M20
S & M Electro-Tech P.O. Box 34334 Blaine, MN 55434



CABLE-TV BOXES

Descramblers • Converters
FREE CATALOG

TRANS-WORLD CABLE CO.
12062 Southwest 117th Ct., Suite 126
Miami, Florida 33186
800-442-9333

REMOTE CONTROL KEYCHAIN

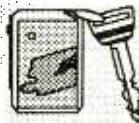

Complete w/mini-transmitter and +5 vdc RF receiver Fully assembled including plans to build your own auto alarm Write for more information—Quantity discounts available

ONLY \$19.95

Check, Visa or M/C 30 days refund Add \$3 shipping

VISITECT INC. / Dept. M (415) 872-0128
PO BOX 5442, SO. SAN FRAN., CA 94080

ANTIQUE RADIO CLASSIFIED

Free Sample!

Antique Radio's Largest Circulation Monthly. Articles, Ads & Classifieds.

Also: 40's & 50's Radios, Ham Equip., Early TV, Books & more. Free 20-word ad each month.

6-Month Trial: \$11. 1-Yr: \$20 (\$30-1st Class). A.R.C., P.O. Box 802-L2, Carlisle, MA 01741



CIRCLE NO. 160 ON FREE INFORMATION CARD

ELECTRON TUBES OVER 3000 TYPES IN STOCK!

Also capacitors, transformers and parts for tube type equipment. Send \$2.00 for 26 page catalog.

ANTIQUE ELECTRONIC SUPPLY

688 W FIRST ST. TEMPE, AZ 85281
PHONE 602/894-9503 FAX 602/894-0124

Cable Converters And Descramblers

Why Pay a High Monthly Fee? For FREE Catalog Call or Write

CABLE CONNECTION

1304 E. CHICAGO ST.-SUITE 301
ALGONQUIN, IL 60102
(708) 658-2365
No Illinois Orders

MODERN ELECTRONICS MART

Classified Commercial Rates: \$1 per word, 15-word minimum (\$15.00) prepaid. (Word count includes name and address; ZIP code and abbreviation each count as one word; P.O. Box number and telephone number count as two words each.) Indicate free category heading (**Computers, Communications, Electronics, Video** or **Miscellaneous**). A special heading is available for a \$6 surcharge. First word only is set boldface caps at no charge. Add 20% for additional boldface words.

Non-Commercial Rates: FREE to subscribers, as space permits; maximum 15 words. A recent MODERN ELECTRONICS mailing label must accompany ad.

(All advertisers with P.O. Box addresses must supply permanent address and telephone number. Copy is subject to publisher approval.)

Mailing Information: Copy must be received by the publisher by the 25th of the third month preceding the cover date. Send Advertising material with check or money order or credit card information (Visa or MasterCard only) with number and expiration date to: MODERN ELECTRONICS, Classified Department, 76 N. Broadway, Hicksville, NY 11801.

VIDEO

DESCRAMBLERS. All brands. Special: Combo Jerrold 400 and SB3 \$165. Complete cable descrambler kit \$39. Complete satellite descrambler kit \$45.00. Free catalog. MJO INDUSTRY, Box 531, Bronx, NY 10461-0531.

VHS-VCR Repair Solutions Sets I, II, III, IV, V. Each contains 150 symptoms and cures, cross reference chart, free assistance, \$11.95 each all five \$49.95. Eagle Electronics Box A, 52053 Locks Lane, Granger, IN 46530.

T.V. NOTCH FILTERS, SURVEILLANCE EQUIPMENT, BROCHURE \$1.00. D. K. VIDEO, BOX 63/6025, MARGATE, FL 33063 1-(305) 752-9202.

CABLE TV CONVERTERS/DESCRAMBLERS. All major brands. Are you tired of ordering cable TV equipment and receiving inferior merchandise, **NOT AT K.D. VIDEO.** We are a well established company that will offer you the best quality, service and prices. **OUR UNITS HAVE WORKED WHERE OTHERS HAVE FAILED.** Call TOLL FREE 1-800-327-3407. K. D. VIDEO INC., P.O. BOX 29538, MLPS., MN 55429.

PROJECTION TV . . . Convert your TV to project 7 foot picture . . . Easy! . . . Results comparable to \$2,500 projectors . . . **PLANS AND 8" LENS** \$24.95 . . . Professional Systems available . . . Illustrated Catalog FREE . . . **MACROCOMA**, 15MF Main Street, Washington Crossing, Pennsylvania 18977. Creditcard Orders 24 HRS. (215) 736-3979.

ELECTRONICS

ELECTRONIC KITS! Tracking Transmitters! Voice Disguisers! FM Bugs! Phone Devices! Detectors! More! Catalog \$1.00: XAN-DI ELECTRONICS, Box 25647, "VV", Tempe, AZ 85285-5647.

TUBES, New, up to 90% off, S.A.S.E., Kerby, 298 West Carmel Drive, Carmel, IN 46032.

LASER LISTENER II, other projects. Bugging, descrambling, false identification, information. Plans, kits, other strange stuff. Informational package \$3.00 refundable. DIRIJO/BOND ELECTRONICS, BOX 212, LOWELL, NC 28098.

PROTECT YOUR HOME AND BUSINESS FROM ELECTRONIC EAVESDROPPING AND WIRE TAPPING! COMPLETE COUNTER MEASURES CATALOG, \$3.00 (REFUNDABLE.) DIVERSIFIED WHOLESALE PRODUCTS, BOX 1275-ME, REDONDO BEACH, CA 90278.

KINETIKITS from KINETICO: electronic kits outputting light or sound. Free catalog: KINETICO, P.O. Box 1634, NY, NY 10114-0508.

MINIATURE Electronics like James Bond. Catalog \$3.00, refundable. F & P Enterprises, Box 51272, Palo Alto, Calif. 94303-H.

PRIVACY PROBLEM - Need Information? New Electronic Surveillance, Debugging, Protection Catalog \$5.00 Kits - Assembled. TECHNOLOGY SERVICES, 829D Ginette, Gretna, LA 70056.

DETECTION - Surveillance, Debugging, Plans, Kits, Assembled Devices. Latest High Tech Catalog, \$5. DETECTION SYSTEMS, 2515 E. Thomas, #16-864H, Phoenix, Arizona 85016.

RECYCLED electronic parts assortment semis, heatsinks, knobs, pots, etc. \$5.00 + \$2.00 S&H. Money back guarantee. C & A ELECTRONICS, 6915 Triangle Drive, Iroquois, KY 40214.

COMMUNICATIONS

COMMUNICATIONS PLANS, BOOKS, KITS! AM/FM broadcasting (licensed/unlicensed), 1750 Meter transceivers, ham/CB amplifiers, surveillance bugs, more! FREE catalog, PAN-COM, Box 130-ME02, Paradise, CA 95967.

LISTEN to the world! Huge catalog of short-wave receiving equipment including radio teletype and facsimile. **Universal Radio**, 1280 Aida Drive, #ME, Reynoldsburg, OH 43068.

COMPUTERS

ENGINEERING Software, PC/MSDOS. Hobbyists - Students - Engineers. Circuit Design \$59, FFT Analysis \$69, Mathematics \$49, Logic Simulation \$49, Circuit Analysis \$29. FREE Catalog, (614) 491-0832, **BSOFT SOFTWARE**, 444 Colton Rd., Columbus, OH 43207.

INTEGRATED CIRCUITS

7400 TTL		7400 CMOS		74HC00	
Part	Price	Part	Price	Part	Price
7400N	35	7400AN	35	74HC00	28
7400P	35	7400AP	35	74HC00P	28
7400N	35	7400AN	35	74HC00	28
7400P	35	7400AP	35	74HC00P	28
7400N	35	7400AN	35	74HC00	28
7400P	35	7400AP	35	74HC00P	28

INTEGRATED CIRCUITS

7400 TTL		7400 CMOS		74HC00	
Part	Price	Part	Price	Part	Price
7400N	35	7400AN	35	74HC00	28
7400P	35	7400AP	35	74HC00P	28
7400N	35	7400AN	35	74HC00	28
7400P	35	7400AP	35	74HC00P	28
7400N	35	7400AN	35	74HC00	28
7400P	35	7400AP	35	74HC00P	28

INTEGRATED CIRCUITS

7400 TTL		7400 CMOS		74HC00	
Part	Price	Part	Price	Part	Price
7400N	35	7400AN	35	74HC00	28
7400P	35	7400AP	35	74HC00P	28
7400N	35	7400AN	35	74HC00	28
7400P	35	7400AP	35	74HC00P	28
7400N	35	7400AN	35	74HC00	28
7400P	35	7400AP	35	74HC00P	28

INTEGRATED CIRCUITS

7400 TTL		7400 CMOS		74HC00	
Part	Price	Part	Price	Part	Price
7400N	35	7400AN	35	74HC00	28
7400P	35	7400AP	35	74HC00P	28
7400N	35	7400AN	35	74HC00	28
7400P	35	7400AP	35	74HC00P	28
7400N	35	7400AN	35	74HC00	28
7400P	35	7400AP	35	74HC00P	28

DISC CAPACITORS

Part	Price	Part	Price	Part	Price
P4129	1200/1K	2.25	P4307	047/1/25	7.91
P4130	1800/1K	2.25	P4308	100/1/25	1.61
P4131	1800/1K	2.25	P4418	1000/2/75	7.5
P4132	2200/1K	2.25	P4419	1500/2/75	7.5
P4133	2200/1K	2.25	P4420	2200/2/75	7.5

INTEGRATED CIRCUITS

7400 TTL		7400 CMOS		74HC00	
Part	Price	Part	Price	Part	Price
7400N	35	7400AN	35	74HC00	28
7400P	35	7400AP	35	74HC00P	28
7400N	35	7400AN	35	74HC00	28
7400P	35	7400AP	35	74HC00P	28
7400N	35	7400AN	35	74HC00	28
7400P	35	7400AP	35	74HC00P	28

INTEGRATED CIRCUITS

7400 TTL		7400 CMOS		74HC00	
Part	Price	Part	Price	Part	Price
7400N	35	7400AN	35	74HC00	28
7400P	35	7400AP	35	74HC00P	28
7400N	35	7400AN	35	74HC00	28
7400P	35	7400AP	35	74HC00P	28
7400N	35	7400AN	35	74HC00	28
7400P	35	7400AP	35	74HC00P	28

INTEGRATED CIRCUITS

7400 TTL		7400 CMOS		74HC00	
Part	Price	Part	Price	Part	Price
7400N	35	7400AN	35	74HC00	28
7400P	35	7400AP	35	74HC00P	28
7400N	35	7400AN	35	74HC00	28
7400P	35	7400AP	35	74HC00P	28
7400N	35	7400AN	35	74HC00	28
7400P	35	7400AP	35	74HC00P	28

INTEGRATED CIRCUITS

7400 TTL		7400 CMOS		74HC00	
Part	Price	Part	Price	Part	Price
7400N	35	7400AN	35	74HC00	28
7400P	35	7400AP	35	74HC00P	28
7400N	35	7400AN	35	74HC00	28
7400P	35	7400AP	35	74HC00P	28
7400N	35	7400AN	35	74HC00	28
7400P	35	7400AP	35	74HC00P	28

DISC CAPACITORS

Part	Price	Part	Price	Part	Price
P4129	1200/1K	2.25	P4307	047/1/25	7.91
P4130	1800/1K	2.25	P4308	100/1/25	1.61
P4131	1800/1K	2.25	P4418	1000/2/75	7.5
P4132	2200/1K	2.25	P4419	1500/2/75	7.5
P4133	2200/1K	2.25	P4420	2200/2/75	7.5

INTEGRATED CIRCUITS

7400 TTL		7400 CMOS		74HC00	
Part	Price	Part	Price	Part	Price
7400N	35	7400AN	35	74HC00	28
7400P	35	7400AP	35	74HC00P	28
7400N	35	7400AN	35	74HC00	28
7400P	35	7400AP	35	74HC00P	28
7400N	35	7400AN	35	74HC00	28
7400P	35	7400AP	35	74HC00P	28

INTEGRATED CIRCUITS

7400 TTL		7400 CMOS		74HC00	
Part	Price	Part	Price	Part	Price
7400N	35	7400AN	35	74HC00	28
7400P	35	7400AP	35	74HC00P	28
7400N	35	7400AN	35	74HC00	28
7400P	35	7400AP	35	74HC00P	28
7400N	35	7400AN	35	74HC00	28
7400P	35	7400AP	35	74HC00P	28

INTEGRATED CIRCUITS

7400 TTL		7400 CMOS		74HC00	
Part	Price	Part	Price	Part	Price
7400N	35	7400AN	35	74HC00	28
7400P	35	7400AP	35	74HC00P	28
7400N	35	7400AN	35	74HC00	28
7400P	35	7400AP	35	74HC00P	28
7400N	35	7400AN	35	74HC00	28
7400P	35	7400AP	35	74HC00P	28

INTEGRATED CIRCUITS

7400 TTL		7400 CMOS		74HC00	
Part	Price	Part	Price	Part	Price
7400N	35	7400AN	35	74HC00	28
7400P	35	7400AP	35	74HC00P	28
7400N	35	7400AN	35	74HC00	28
7400P	35	7400AP	35	74HC00P	28
7400N	35	7400AN	35	74HC00	28
7400P	35	7400AP	35	74HC00P	28

DISC CAPACITORS

Part	Price	Part	Price	Part	Price
P4129	1200/1K	2.25	P4307	047/1/25	7.91
P4130	1800/1K	2.25	P4308	100/1/25	1.61
P4131	1800/1K	2.25	P4418	1000/2/75	7.5
P4132	2200/1K	2.25	P4419	1500/2/75	7.5
P4133	2200/1K	2.25	P4420	2200/2/75	7.5

The Dig. Key volume discounts and service charges are simple to apply. Most items sold by Dig. Key may be combined for a volume discount. Items that are not discountable are identified by the suffix "ND". Shipping terms are FOB destination, except for the following items which are FOB shipping point. To the extent of the applicable discount, the non-discountable items will be shipped at the applicable discount rate. We pay all applicable insurance charges to addresses in the U.S., Canada and Mexico and will accept payment by check or money order. Dig. Key only ships Dig. Key products with the Dig. Key logo. If you have any questions, please call us at 218-681-6674. When ordering by phone, call 1-800-34-4539. All prices are in U.S. dollars. We accept VISA and MasterCard. We accept orders by fax. We have a 24-hour fax order line. We have a 24-hour fax order line. We have a 24-hour fax order line. When ordering by phone, call 1-800-34-4539. All prices are in U.S. dollars. We accept VISA and MasterCard. We accept orders by fax. We have a 24-hour fax order line. We have a 24-hour fax order line. We have a 24-hour fax order line. You may pay by check, money order, MasterCard, VISA or C.O.D. All prices are in U.S. dollars. We accept orders by fax. We have a 24-hour fax order line. We have a 24-hour fax order line. We have a 24-hour fax order line. If returned within 90 days from receipt with a copy of your invoice, "PRICE SUBJECT TO NOTICE".

HANDLING CHARGES				VOLUME DISCOUNT			
No.	0.00-24.99	25.00-49.99	\$2.00	0.00-9.99	10.00-49.99	50.00-99.99	100.00+
			None	5%	10%	15%	20%
			None			25%	30%
			None			35%	40%



PICKS UP A WHISPER 50 FEET AWAY!

The model WAT-50 miniature FM transmitter uses a 4-stage circuit NOT to be confused with a simple wireless microphone. Simply snap the unit on top of a 9V battery and you can hear every sound in an entire house up to 1 mile away! Use with any FM radio. Tunes to any frequency from 70mhz - 130mhz. Easy to assemble kit includes all parts and instructions. Only 29.98 tax incl.



The **WIRELESS TELEPHONE TRANSMITTER** model WTT-20 is only about the size of a dime, yet transmits both sides of a telephone conversation to any FM radio with crystal clarity. Completely automatic. Uses power from the telephone line itself - never needs a battery! Up to 1/4 mile range. Tunes from 70mhz - 130mhz. Easy to assemble kit includes all parts and instructions. Only \$29.98 tax incl.

Call or send MO, VISA, MC for immediate delivery. Single kit orders include \$1.50 S&H. FREE SHIPPING on orders of 2 or more. All orders shipped by U.S. Mail. COD add \$4.00. Personal checks allow 21 days.

DECO INDUSTRIES
BOX 607, BEDFORD HILLS, NY 10507
914-232-3878

CIRCLE NO. 172 ON FREE INFORMATION CARD

General Technics
 Quality Computer Systems
(516) 981-9473
 Save hundreds of dollars assembling Your own IBM Compatible Computers.
Complete AT Computer System \$675
 Amber Monitor, 512k Memory, 101 Enhanced Keyboard, 1.2m Floppy Drive
 12 mhz 80286 Mother Board, Hard/Floppy Controller Card, Instruction Manual
FREE CATALOG
 P.O. Box 2676, Lake Ronkonkoma, NY 11779

CABLE T.V. CONVERTERS
 Jerrold®, Oak, Scientific Atlantic, Zenith, & many others. "New" MTS stereo add-on: mute & volume. Ideal for 400 & 450 owners!
 1-800-826-7623
B & B INC.
 4030 Beau-D-Rue Drive, Eagan, MN 55122

Surface Mount Chip Component Prototyping Kits—
Only \$49.95

CC-1 Capacitor Kit contains 365 pieces, 5 ea. of every 10% value from 1pf to .33µf. CR-1 Resistor Kit contains 1540 pieces; 10 ea. of every 5% value from 10Ω to 10 megΩ. Sizes are 0805 and 1206. Each kit is ONLY \$49.95 and available for Immediate One Day Delivery!

Order by toll-free phone, FAX, or mail. We accept VISA, MC, AMEX, COD, or Pre-paid orders. Company P.O.'s accepted with approved credit. Call for free detailed brochure

COMMUNICATIONS SPECIALISTS, INC.
 426 West Taft Ave. • Orange, CA 92665-4296
 Local (714) 998-3021 • FAX (714) 974-3420
Entire USA 1-800-854-0547

CIRCLE NO. 159 ON FREE INFORMATION CARD

8051 CROSS-DISASSEMBLER. PC/MSDOS, Debugs/reconstructs source code. Generates Labels, Xref lists and ASCII equiv. \$79. Others avail, write for details DATA SYNC ENGINEERING, BOX 288 - DEPT L, FRANKLIN, NJ 07416.

CABLE EQUIPMENT

CABLE TV Secrets - the outlaw publication the cable companies tried to ban. HBO, Movie Channel, Showtime, Descramblers, Converters, etc. Suppliers list included. \$8.95. Cable Facts, Box 711-ME, Pataskala, Ohio 43062.

SPACE WARS

PENTAGON Valentine's Day Present. Give it to your favorite commanding officer or civilian. Send \$2.00, check or money order, to Steve Wilson, 1235 Dunning Lane, Modesto, CA 95351.

TALKING TELEPHONE PARTS

AS featured in Modern Electronics (Oct. 1989). Two-Sided PC Board, \$21.50; G8870 DTMF Receiver Chip, \$10.50; Programmed 74188 PROM, \$5.75; 3.58 MHz Crystal, \$1.75. Steve Sokolowski, P.O. Box 5835, Spring Hill, Florida 34606. Plus \$2.25 Shipping/Handling.

GLOBAL CABLE NETWORK

CABLE TV converter and descrambler bargain headquarters! Tocom, Scientific Atlanta, Zenith, Hamlin, Pioneer. Jerrold 400 DRX-3DIC w/remote \$134. OAK M35B \$60. Quantity discounts! Order yours today! VISA-MC-COD 800-327-8544.

MISCELLANEOUS

ASIAN LADIES want correspondence for friendship, marriage, SUNSHINE INTERNATIONAL, Dept. TW, Box 5500, Kailua-Kona, HI 96745. (808) 325-7707.

STRESSED Out? Relaxation technique easily learned with the aid of a simple electronic device. NOT hypnosis! Plans \$9.95. Blue Chip Engineering, P.O. Box 1100, Walnut, CA 91789.

DANCE Like A Pro. Exciting report reveals how you can use a VCR to learn almost any dance step. Send \$15.00 payable to P.A. Perez, P.O. Box 7610, Alhambra, CA 91802.

DON'T Get Ripped Off! When Buying Used Cars. Mechanic For 35 Years Gives Professional Secrets For Knowing Great Deals From Lemons. Send \$6.50 CIRCUITEX, Box 653, Berea, OH 44017.

CLASSIFIED ADVERTISING ORDER FORM

Mail this form with payment to MODERN ELECTRONICS, Classified Dept., 76 N. Broadway, Hicksville, NY 11801.

Name: _____
 Street Address: _____
 City: _____ State: _____ Zip: _____

Check category you wish to be listed under or note a special heading (\$6 additional) you want.
 Audio Communications Computers Electronics Video
 Miscellaneous Wanted Special Heading

PRINT EACH WORD SEPARATELY. Note that P.O. Box numbers* and telephone numbers must be counted as two words each. Circle additional words you wish boldfaced at 20% more each (initial boldface word is free). Minimum charge is for 15 words.

Free Boldface	2	3	4
5	6	7	8
9	10	11	12
13	14	15 (\$15)	16 (\$16)
17 (\$17)	18 (\$18)	19 (\$19)	20 (\$20)

(PLEASE ADD)

\$ _____ Extra Bold Words @ 20 cents \$ _____ Special Heading (\$6)

TOTAL PAYMENT ENCLOSED (Check or Money Order): \$ _____

Payment may also be made by MasterCard or Visa. For this, please fill in information below.

Credit Card Number _____ Expire Date _____

LETTERS... (from page 7)

both *Modern Electronics* and Mr. Mangieri.

Donald W. Long
Herkimer, NY

An Exemplary Magazine

• I continue to derive great pleasure and benefit through reading your exemplary magazine, and I am especially gladdened to see that even though there is such great interest in computers these days you have not gone overboard in favoring them in selecting your articles. My special interests are the items written by Forrest Mims and Anthony Caristi, with articles and projects outlined so thoroughly for hobbyist and professional alike. Keep up the good work—your writers are doing a fantastic job!

Peter Holman
New York, NY

Manufacturer Information

• The "Early-Warning Intrusion Alarm" project in the September 1989 issue of *Modern Electronics*, featuring the IRD1000 infrared motion-detection module, came as a timely bit of information. I am working on a design of my own that requires an infrared detection module but have been unable to locate a suitable unit. The IRD1000 module appears to be ideally suited to my needs. However, I have had no success in finding a mailing address or telephone number for the manufacturer, Infrared, Inc. Any information you could pass along would be greatly appreciated.

Mark C. Hensel
Uncasville, CT

You can write to Infrared, Inc. at P.O. Box 47, Parlin, NJ 08859 or call: 201-536-4455.—Ed.

MODERN ELECTRONICS
76 N. Broadway, Hicksville, NY 11801

FREE INFORMATION SERVICE

For further information on products, dealers, or literature in this issue, circle the appropriate numbers below. Be sure to include your name and address before mailing.

1	2	3	4	5	6	7	8	9	10	11	12
13	14	15	16	17	18	19	20	21	22	23	24
25	26	27	28	29	30	31	32	33	34	35	36
37	38	39	40	41	42	43	44	45	46	47	48
49	50	51	52	53	54	55	56	57	58	59	60
61	62	63	64	65	66	67	68	69	70	71	72
73	74	75	76	77	78	79	80	81	82	83	84
85	86	87	88	89	90	91	92	93	94	95	96
97	98	99	100	101	102	103	104	105	106	107	108
109	110	111	112	113	114	115	116	117	118	119	120
121	122	123	124	125	126	127	128	129	130	131	132
133	134	135	136	137	138	139	140	141	142	143	144
145	146	147	148	149	150	151	152	153	154	155	156
157	158	159	160	161	162	163	164	165	166	167	168
169	170	171	172	173	174	175	176	177	178	179	180

Insert issue date here _____
(month) (year)
(must be completed to process)

Name _____

Company Name _____

Address _____

City _____ State _____ Zip _____

Phone _____

CABLE-MATE, INC.
Are You Tired of Paying
Outrageous Fees?

All makes and models of cable equipment shipped within 24 hrs. Quantity discounts. For free catalog send S.A.S.E. to: Cable-Mate, Inc., 214 N. Main St., Algonquin, IL 60102. C.O.D. orders accepted. **CALL FOR PRICES TODAY!!**

VISA (708) 658-2121 MasterCard
*No Illinois orders
Hours—8:00 am-5:00 pm central time

CABLE TV CONVERTERS IN STOCK

Stocking all types of converters: Panasonic, Jerrod, Tocom, Pioneer, Scientific Atlanta, Zenith, Oak, Hamlin, Eagle, and others.

Call or write for **FREE CATALOG**
Mon - Fri 10 to 6 Eastern Time

VIDEO-LINK Enterprises, Inc.
520 Glenbrook Rd. Suite 202
Stamford, CT 06906
Orders: 800-622-9022
Catalog & Info: 203-975-7543

ALL ELECTRONICS CORP.

★QUALITY PARTS ★DISCOUNT PRICES ★FAST SHIPPING

10 AMP SOLID STATE RELAYS

ELECTROLIF S2181 CONTROL
Rated 5.5 to 10 Vdc (will operate on 3-32 Vdc)
LOAD: 10 amp @ 240 Vac
2 1/4" X 1 3/4" X 7/8"

CAT# SSR1Y-10B \$9.50 each
QUANTITY DISCOUNT
10 for \$85.00 • 25 for \$175.00
50 for \$300.00 • 100 for \$500.00

STROBE KIT

Variable rate strobe kit, flashes between 60 to 120 times per minute. Will operate on either 6 or 12 Vdc depending upon how you wire the circuit. Comes complete with P.C. board and instructions for easy assembly.
CAT# STROBE-1 \$7.50 each

CASSETTE MECHANISM

Alpine cassette transport mechanism includes stereo tape head, Mitsubishi # MET-3RF2B 13.2 Vdc motor, belt, pulleys, capstan, fast-forward, rewind and eject actuator. Does not include amplifier section.
6 1/2" X 5 1/4" X 1 3/4"
CAT# CMEC-5 \$7.50 each
10 for \$65.00

PIEZO WARNING DEVICE

Model # PWB-440
High pitched audible alarm. Operates on 3-20 Vdc @ 30 ma. 1" high x 7/8" dia. P.C. board mount.
CAT# PWB-44 \$17.95 each

XENON TUBE

1" long flash tube with 1/2" end and flash leads. Ideal for electronic flash or strobe projects.
CAT# FLT-2 2 for \$1.00

NICKEL-CAD BATTERIES (RECHARGEABLE)

Standard AA size
Nenacore P-18AA
1.2 volt @ 180 MAH
CAT# NCB-AA32 \$1.50 each
10 for \$12.50 • 100 for \$125.00

SPECIAL AA SIZE

Nenacore P-18AA
1.2 volt @ 180 MAH
CAT# NCB-AA 2 for \$1.00
10 for \$12.50 • 100 for \$125.00

TRANSISTORS

2N2222	NPV	TO-18	5 for \$1.00
2N2906	PNP	TO-18	3 for \$1.00
2N2930	PNP	TO-18	3 for \$1.00
2N3055	NPV	TO-18	\$1.00 each
2N4339	PNP	TO-18	\$1.50 each
2N4403	NPV	TO-18	5 for \$1.00
2N4404	PNP	TO-18	5 for \$1.00
2N5402	PNP	TO-18	5 for \$1.00
2N5403	PNP	TO-18	5 for \$1.00
2N5404	PNP	TO-18	5 for \$1.00
2N5405	PNP	TO-18	5 for \$1.00
2N5406	PNP	TO-18	5 for \$1.00
2N5407	PNP	TO-18	5 for \$1.00
2N5408	PNP	TO-18	5 for \$1.00
2N5409	PNP	TO-18	5 for \$1.00
2N5410	PNP	TO-18	5 for \$1.00
2N5411	PNP	TO-18	5 for \$1.00
2N5412	PNP	TO-18	5 for \$1.00
2N5413	PNP	TO-18	5 for \$1.00
2N5414	PNP	TO-18	5 for \$1.00
2N5415	PNP	TO-18	5 for \$1.00
2N5416	PNP	TO-18	5 for \$1.00
2N5417	PNP	TO-18	5 for \$1.00
2N5418	PNP	TO-18	5 for \$1.00
2N5419	PNP	TO-18	5 for \$1.00
2N5420	PNP	TO-18	5 for \$1.00

WALL TRANSFORMERS

120V AC
DIRECTLY
NTO 120V AC
OUTPUT

8 Vdc @ 200 mA. CAT# DCT-420 \$2.25
6 Vdc @ 750 mA. CAT# DCT-475 \$3.50
9 Vdc @ 750 mA. CAT# DCT-495 \$3.50
12 Vdc @ 800 mA. CAT# ACT-1293 \$3.50
18 Vdc @ 1 amp. CAT# ACT-1668 \$3.50

LED'S

STANDARD JUMBO
DEFUSED T1.34 size
RED CAT# LED-1
10 for \$1.50 • 100 for \$13.00
GREEN CAT# LED-2
10 for \$2.00 • 100 for \$17.00
YELLOW CAT# LED-3
10 for \$2.00 • 100 for \$17.00

FLASHING LED
with built-in flashing circuit
operates on 3 volts

RED 81.00 each
CAT# LED-4 10 for \$6.50
GREEN 81.00 each
CAT# LED-4G 10 for \$6.80

BI-POLAR LED
Light Red or blue.
GREEN the other. 1 amp. 100
CAT# LED-4 - 2 for \$1.70

LED HOLDER
Two pins holder.
CAT# LED-1 10 for \$1.00

SWITCHES

1/2" MTDP series. 3/4" X
1/2" wip. rectangular.
low profile. P.C. MOUNT.
Push to close. RATED 0.1 amp switching, 0.25
amp carry current. P.C. mount. CAT# PE6
80¢ each • 10 for \$6.00 • 100 for \$60.00

10 POSITION MINI-ROTARY
Onyhalb 58P28-01 | 09-C
Silver rotary switch. Non-shorting.
1 deck, 10 positions. 125° dia.
shaft & .375" long. .377" behind
low profile. P.C. MOUNT.
CAT# MRS-10 \$2.50 each

HALL EFFECT SWITCH
NICHIA/SHIMADU-08E3
Standard keypad switch with hall
effect sensor. Snaps into 5/16"
square chassis hole. Hall-effect
sensor slides easily from switch
and can be used in other applications.
CAT# HSW-1 4 for \$1.00
10 for \$2.00 • 100 for \$10.00

SPDT PUSHBUTTON
Marquardt 1843
Rated 5 amps @ 125/250 Vac.
Black plastic pushbutton.
Switch body: .82" X .84" X .60"
CAT# P8-18 \$1.45 each • 10 for \$11.50 each

N-CHANNEL MOSFET

CAT# NCF 511
\$1.00 each • 10 for \$8.00
LARGE QUANTITY AVAILABLE

OPTO SENSOR

U shaped package with mounting
leads. 1/8" spacing. 3/4" mounting
holes. CAT# OSA-6 50¢ each
10 for \$4.50 • 100 for \$40.00

RELAYS

12 VOLT D.C. COIL S.P.D.T.
Omron Q2E 184P
4 Amp contacts
1.68" dia. min. with pins on DIP spacing
Sugar cube size.
611" X .42" X .44" high.
P.C. mount with pins on DIP spacing.
CAT# RLY-787 \$1.50 each

120 VOLT A.C. - D.P.D.T.
OMRON Q2E 120V-01
1:100 amp coil
1.702" X 1.578" X
1.687" Clear
polycarbonate cover. Gold plated
solder or socket mount terminals.
CAT# RLY-288 \$3.50 each

CALL OR WRITE FOR OUR FREE CATALOG OVER 4000 PARTS!

MAIL ORDERS TO:
ALL ELECTRONICS
P.O. BOX 567
VAN NUYS, CA 91408

TXW-S10101018 (ALL ELECTRONIC)

OUTSIDE THE U.S.A.
SEND \$2.00 POSTAGE
FOR A CATALOG!!

ORDER TOLL FREE
800-826-5432
INFO: (818)904-0524
FAX: (818)781-2653
MINIMUM ORDER \$10.00
QUANTITIES LIMITED
CALIF. ADD SALES TAX
USA: \$3.00 SHIPPING
FOREIGN ORDERS
INCLUDE SUFFICIENT
SHIPPING. NO C.O.D.

CIRCLE 81 ON FREE INFORMATION CARD

**Renaissance Software Library
TOP 20 SOFTWARE HITS!**

\$3.00/disk - \$2.50/disk for 10+

- 1 - disks 190-192 - PC-File:db - a top notch database program - fully dBase3 compatible (3 disks)
- 2 - disk 271 - The Draw - great ANSI drawing/animation
- 3 - disks 185, 186 - QModem 4.1 - The standard in modern communications programs. (2 disks)
- 4 - disk 1120 - Total Ham! - a great multi-function logging/operating aid for the radio amateur.
- 5 - disk 1149 - GeoClock - a real time grayline map of the Earth. Like DX-Edge. (order disk 1:50 for EGA/VGA)
- 6 - disk 1089 - Mapper EGA - nice world map that shows grayline, beam headings, distance, MUF, LUF and more!
- 7 - disk 1249 - World 29! - World map program that allows you to zoom in on any location. Includes built-in hurricane tracker.
- 8 - disk 20 - SimCGA - allows you to run CGA programs on a monochrome monitor.
- 9 - disk 51 - AutoMenu - THE industry standard in easy to use menuing programs.
- 10 - disk 290 - FlowDraw - a top shareware flowcharting/schematic diagramming system with WYSIWYG.
- 11 - disk 211 - As Easy As - version 4.0 of THE Lotus 1-2-3 spreadsheet clone
- 12 - disk 728 - Personal C Compiler - a great shareware C compiler. With editor, library, make and debugger.
- 13 - disk 1099 - TS440 & TS940 Rig Control - control your Kenwood rig with your computer.
- 14 - disk 735 - GTE's DOS Tutor - a top notch, easy to use graphically oriented interactive DOS tutor.
- 15 - disk 1081 - Ham Radio 1 - Packet related YAPP & PackTalk terminal programs.
- 16 - disk 1110 - KTEA's DX Contest Logger - ver 4.25 of the standard contest logger
- 17 - disk 1145 - PK232 Packet terminal program - dedicated term. prog. for the PK232
- 18 - disk 1143 - KAM RTTY - dedicated RTTY/CW/AMTOR/ASCII terminal program for the KAM TNC's.
- 19 - disk 1250 - World Atlas - a top information atlas.
- 20 - disks 200, 201 - WAMPUM - dBase 3 clone

1-800-525-7235 to order (Visa/MC -9-5 CST) or send check/MO (add \$3.00 s/h) - call (205)757-5928 or write for free catalog!

**Renaissance Software Library
Box 640 - Killen - AL - 35645**

CIRCLE NO. 173 ON FREE INFORMATION CARD

RS#	ADVERTISERS' INDEX	Page #
170	AMC Sales	69
79	ARRL	4
81	All Electronics	85
160	Antique Radio Classified	84
98	B&B Inc.	80, 82
161	C&S Sales	61
-	Cable Connection	84
-	Cable-Mate Inc.	85
-	Cleveland Institute of Elec	31
-	Command Productions	75
159	Communications Specialists	84
162	Consolidated Electronics	63
169	Cook's Institute	69
-	Damark International	67
67	Dauphin Technology	Cov. II
172	Deco Industries	84
8	Digi-Key Corp.	83
130	Fordham Radio Supply	Cov. IV
77	Franklin-Belle Publishers	75
-	General Technics	84
179	Global Cable Network	86
-	Grantham	58
82	Heath Co	15
-	Listen Electronics	82
-	Modern Electronics Books	76
152	Mouser Electronics	79
-	NRI Schools	13
-	Pacific Cable Co., Inc.	5
153	Parts Express International	6
50	Penn Research	86
163	ProtoLab	81
80	Radio Shack	9
173	Renaissance Software	86
-	S&M Electro-Tech	84
-	Trans World Cable Co.	84
-	Video-Link Ent, Inc	85
151	Viejo Publications	79
-	Visitect Inc	84
-	WEKA Publishing	Cov. III

Big Score (from page 35)

tion of the diodes and electrolytic capacitors and proper basing and types of the voltage regulators. Do not proceed until you are sure you have rectified the problem.

Once you obtain the proper readings from the power supply, touch the meter's "hot" probe to pin 16 of the IC1 through IC4 sockets, noting the reading obtained in each case. The proper reading at each socket is +12 volts. Touching the "hot" probe to the unoccupied +24V pad on the LED display board should yield a reading of +24 volts. If you do not obtain the appropriate reading in any or all cases, power down the project and rectify the problem.

When you have ascertained that the proper voltage readings appear in all cases, power down the project and allow sufficient time for the charges to bleed off the electrolytic capacitors in the power supply. Then install the ICs in their respective sockets. Make certain you plug the correct IC type into each socket and that no pins overhang the sockets or fold under

between ICs and sockets as you push them home.

Once again power up the project. If numbers other than "00" appear in the display, press and release the RESET switch. If the display resets to "00," the switches are properly labeled; if the display does not reset to "00," relabel the switches. On the other hand, if there is still no resetting action with either switch, once again power down the project and troubleshoot it to rectify the problem.

Assuming you obtain proper resetting action, try operating the COUNT switch several times slowly. You should note the numbers in the display count up with each switch closure. If not, there is a problem with the wiring for this switch's cable.

Make certain that the project is operating properly by alternately counting up with the COUNT switch and resets to "00" with the RESET switch. Do this several times to make sure that the project is operating reliably.

When you have ascertained that the project is operating properly, power it down, unplug its line cord and proceed to final assembly. This simply consists of mounting the power-supply/main electronics package/LED display/filter assembly to the rear panel with suitable machine hardware and standoffs or spacers and securing the back panel in place with glue and nails.

One final note is in order. The power supply in this project was designed to handle two two-decade numeric displays to permit "Home Team" and "Visitor" score displays. If you wish, you can duplicate the LED-display and main-electronics-package subassemblies, house them alongside the first two-decade display and use separate COUNT and RESET switches for each. Note, too, that the picture-frame molding shown in partial detail in Fig. 9 is an option that adds a finished touch to the project. If you decide to use this molding, miter-cut its corners and finish it as desired.

CABLE TV DESCRAMBLERS!



BARGAIN HEADQUARTERS!

- JERROLD - TOCOM - HAMLIN
- SCIENTIFIC ATLANTA - ZENITH

Oak M35B ONLY \$60
6 month warranty! We ship C.O.D!
Lowest retail/wholesale prices!
FREE CATALOG:
Global Cable Network
1032 Irving St. Suite 109
S.F., CA 94122

ORDER TODAY! 800-327-8544

CIRCLE NO. 179 ON FREE INFORMATION CARD

FINALLY!

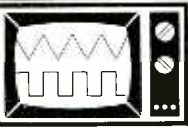

An interesting and worthwhile project. This EASY-TO-BUILD circuit lets you use any regular TV set as a simple OSCILLOSCOPE. No modifications to TV! Tiny, 9v battery powered. Goes anywhere! Order now! Ask for our FREE CATALOG of other plans and kits!

DETAILED PLANS: \$7.95
TV-SCOPE
PENN RESEARCH, Box 3543
Williamsport, PA 17701

CIRCLE 50 ON FREE INFORMATION CARD

9 Reasons you'll really enjoy The Modern Electronics Manual



1. Filled with practical, useful projects

Over 400 pages of how-to information that's easy-to-follow and makes projects faster, easier and more enjoyable. Now you can build your own electronic components in wide range of areas—from telecommunications to stereos, computers, radio and TV.



2. Circuit layouts on acetate—Save you time and effort

Here's how to eliminate the most time consuming step of almost any project—fabricating the printed circuit you need. The Manual gives you the board layout in black on a clear acetate. Just place the acetate over a photosensitive PC copper baseboard, expose it to light, develop it, and you have your own printed circuit board specially crafted for each project.



3. Save money by doing things yourself

Build things for the home and office that make your life easier and more pleasant, and give you more efficiency. Learn when to call the repair man and



Look how easy it is to make your own printed circuits now

1. Select the board layout you want.
2. Place it on top of a photo-sensitive copper baseboard and expose to sunlight, spotlight or incandescent bulb.
3. Etch away unwanted material in bath solution to create your printed circuit.
4. Attach components and solder to board.
5. Plug it in and use it.



when you can fix it yourself. Save unneeded service calls.



4. Sources of supply

Your Manual gives you listings of firms that sell electronic components through stores and through the mail.



5. Professional "hints and kinks"—tips, & new techniques

Professional techniques are explained in detail, step-by-step. You learn the easy shortcuts as well as the pitfalls to look out for.



6. Keep on top of what's new

Advances in electronics occur rapidly today, so we send regular updates to give you insight into new technologies and how you can work with it.



7. Trouble-shooting techniques

Build your understanding from the ground up. Learn the technology

and how it works, then the applications, the maintenance and repair procedures.



8. Well-organized, easy to access information

The FREE, sturdy 3-ring Binder with Index Tabs organizes material so you find what you need quickly.



9. Publisher's Moneyback Guarantee

There's absolutely no risk in taking a look at **The Modern Electronics Manual**. You pay nothing unless you are completely satisfied it's for you. If you have paid already you will receive a full 100% of your money back.

No Risk Trial Certificate

Just return the coupon below or the attached card and we'll send you the Manual to look over in the comfort of your home or office. Take the time it deserves to examine it carefully and then decide.

Send for your no risk look today.

Here are just some of the subjects covered:

Electronic components and their characteristics
Hand tools for electronic kit building
Electronic component handling
Electrical soldering techniques
Sources of electronic components and supplies
Printed circuit board layout techniques
Making printed circuit boards
Surface mount technology
Electrical safety
Basic radio
Basic TV
Solid state darkroom timer
Electrical surge protection
Amplifier for your Walkman
Basic telephone
Telephone testing set
Cellular telephone
Night light that turns on when telephone rings

Introduction to Satellite TV
Facsimile fundamentals
Guide to using computer bulletin boards
Short wave radio
Digital logic fundamentals
A DOS tutorial
BASIC programming tutorial
Video display adapters for PCs
Laser printing
Installing accessory cards in your PC
Installing a hard/fixed disk drive
Managing data on your hard drive
Electrical desoldering techniques
Audible voltage continuity tester
General diagnostic techniques
Ground fault-interrupter
Cost effective function generator
Double sided printed circuit boards
Soldering iron idler
Improving antenna reception performance



To order your Manual right away, call 1-800-222-WEKA

The Modern Electronics Manual
97 Indian Field Road, Greenwich, CT 06830

YES, send me The Modern Electronics Manual for only \$69.95 (plus \$4.50 for shipping and handling). Enclosed is my check or credit card number and signature. I understand if I am not completely delighted I can return the Manual at any time and receive a complete 100% refund.

Bill me Payment enclosed Charge my Visa MasterCard
Acct. No. _____ Exp. Date _____

Signature _____

Name _____

Address _____

City, St, ZIP _____

All orders must be signed to be processed.

If I elect to keep the Manual, I understand I'll also receive supplements 4 to 5 times a year at 25¢ per page to ensure my Manual remains completely up to date. I'll be billed with each separate supplement and can return them unpaid if I'm not satisfied. I can also cancel further supplements at any time.

TROUBLESHOOTERS!

PRECISION HAND-HELD INSTRUMENTS



B & K Precision Test Bench™

- 41 range voltmeter • Ammeter
- Ohmmeter • Frequency counter
- Capacitance meter • Logic probe
- Transistor & diode tester • Extra large LCD display

Model 388-HD
Reg. \$129.95 **\$119⁰⁰**



SCOPE Digital Multimeter

- 11 Function, 38 ranges including Logic Level Detector, Audible and Visual Continuity, Capacitance & Conductance measurements

Model DVM-638
Reg. \$87.50 **\$79⁹⁵**



SCOPE 3 1/2 Digit LCD Mini Meter

- 0.5% accuracy • AC/DC Voltage
- DC current • Resistance • Diode test • 300 hrs. battery life
- Overload protection: DC 500V, AC 350V, ohms - 250V DC/AC

Model DVM-630
Reg. \$50.00 **\$32⁵⁰**



SCOPE Hand-Held 3 1/2 Digit LCR Meter

- Measure capacitance, resistance and inductance • Overload protection • Includes test leads, test clips, 9V battery and spare fuse

Model LCR-680
\$119⁹⁵



SCOPE Pocket Size Audio Signal Generator

- Sine/square wave patterns • 20Hz to 150 KHz • Battery operated
- Frequency accuracy ±3% (or less)
- Output 12V rms max. (no load)
- Low battery indicator • Test leads & 9V battery included

Model RC-555
Reg. \$69.95 **\$59⁹⁵**

DUAL TRACE OSCILLOSCOPES



A.W. SPERRY 20 MHz OSCILLOSCOPE

- Built-in component checker
- Z-axis input • Low power consumption • TV Video sync filter • High-sensitivity XY mode
- Front panel trace rotator
- Includes 2 test probes

Model 620C **\$349⁹⁵**

HITACHI 35 MHz OSCILLOSCOPE

- 19 calibrated sweeps • 6" CRT with internal graticule, scale illumination & photographic bezel • Auto focus
- XY operation • TV sinc separation • Includes 2 probes (10:1 and 1:1)

Model V-355 **\$598⁰⁰**
Reg. \$899.95



TRAINERS AND TOOLS

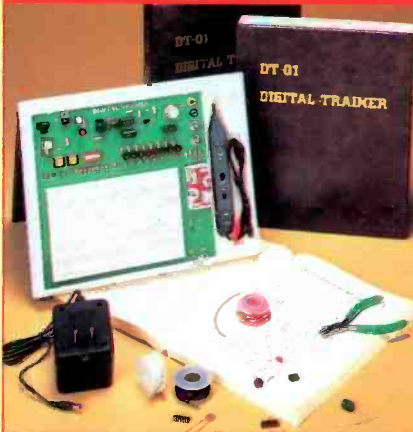

SCOPE DIGITAL TRAINER

- Learn logic circuits and equipment design • Connects to oscilloscopes, signal generators and more • Logic probe included • Solderless breadboard and crib sheets help you build almost any circuit
- Runs off 4 "AA" batteries or AC adapter (included)

Model DT-01 **\$110⁰⁰**
Reg. \$149.95

ALL PURPOSE 92-PC. TOOL CASE

- Complete kit for home, workshop and auto • Includes 52-pc. socket set with extenders
- 2 tool pallets with roomy rear storage compartments
- Attractive, rugged carry case

Model FTK-28
Reg. \$169.95

\$129⁹⁵



ASK FOR YOUR FREE CATALOG
Fordham TOLL FREE 800-645-9518

260 Motor Parkway
Hauppauge, New York 11788



Money orders, checks accepted
C.O.D.'s require 25% deposit.

Service & Shipping Charge Schedule Continental U.S.A.

FOR ORDERS	ADD
\$0-50	\$4.50
\$51-100	\$6.00
\$101-200	\$8.00
\$201-300	\$9.00
\$301-400	\$10.00
\$401-500	\$12.00
\$501-750	\$15.00
\$751-1,000	\$17.50
\$1,001-1,250	\$20.00
\$1,251-1,500	\$25.00
\$1,501-2,000	\$30.00
\$2,001 and up	\$35.00

CIRCLE NO. 130 ON FREE INFORMATION CARD