

THE PRACTICAL MAGAZINE FOR PERSONAL COMPUTERS & MICROCONTROLLERS

ComputerCraft

Formerly  MODERN ELECTRONICS

October 1991 \$2.95
(Canada \$3.95)

Install A PC Tape Backup System
Build An Automatic Printer Selector
EPROM Programming Techniques

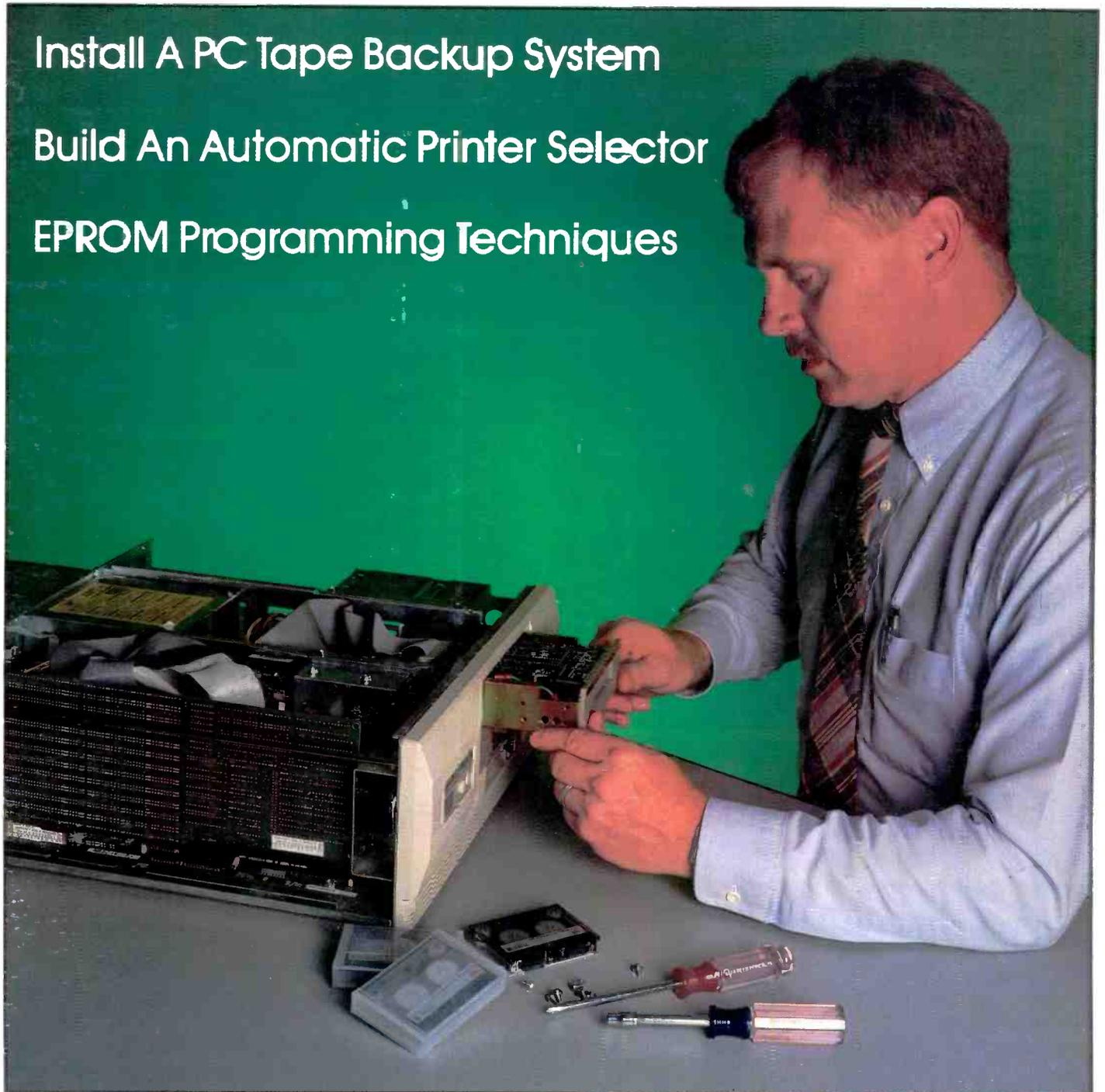

ELF Monitor Checks Emissions

An Optical Output Port For Your PC

A Microcontrolled Telephone Call Director

Save on Computers at ACP!

"Buy with Confidence! 16 Years Experience and Still Delivering



Coprocessors

intel	
8087-2	\$79 8087-1 99
80287-8	99 287-10 129
80287XL	109 287XL 189
80387-16	179 387-20 229
80387-25	229 387-33 229
387SX-16	135 387SX-20 145

AMD	
80C287-10	\$79 287-12 99

IIT	
2C87-8	\$75 2C87-10 79
2C87-12.5	119 2C87-20 139
3C87-16	179 3C87-20 189
3C87-25	199 3C287-33 219
387SX-16	199 387SX-20 159

Chips/Modules

256Kx1-80	\$2.29	256Kx1-10	2.19
256Kx4-80	5.49	256Kx4-10	5.19
1Mbx1-70	4.99	1Mbx1-80	4.99
64Kx1-12	1.99	4Mbx1-80	24.99
256X9-10	9.99	4Mbx1-70	26.99
1Mbx9-80	47.99	4Mbx9-80	179.99

Call for all types memory module prices

Closeouts!

IBM	
Music Feature	149.95
Optical Drive	249.95
1200Modem PS/2	29.95
Modem PC Convertible	29.95
370 Option Card XT	79.95
GP1B 488 Card	88.95
Graphics CGA card	19.95
512/2Mb Card AT OK	29.95
DisplayWrite 4/2	49.95
Data Migration PS/2	29.95
AST	
Advantage 2	79.95
AST 4-Port/DDS	99.95
MISC	
Laptop Case	19.95
Cricket Graph v3.0	39.95
Calendar Creator 3.0	14.95

Motherboards

ACP 286-12 mini AT	\$79
ACP 286-16 mini AT	109
ACP 386SX-16/20	249/299
ACP 386-33 w/cache	549
ACP 486SX-25	Call
ACP 486-33 w/cache	1599

*All with CPU and BIOS

Mylex	
MTI386/33 w/64K cache	799
MXA386/33 w/128K	1099
MTX386SX-16/20	399/449
MAE486/33 w/128K EISA	2199

Orchid	
386/40 New! 40MHz	699

Monitors

Standard VGA 14" 41	\$248
ACP Hi-res VGA 14" 31	279
ACP SuperVGA 14" 28	339

NEC	
Multisync 2A/3D	439/599
Multisync 4DS/5D	949/2219

SONY	
Trinitron 1302/1304	549/599

SAMSUNG

CJ4681'B' VGA 14" 31	249
CJ4681 VGA 14" 31	299
CJ4685 VGA 14" 41	269
CSA7571 SuperVGA 17"	849
ML4571'B' TTL 14" white	109
MZ4571'B' TTL 12" amber	69

Modems

ACP 2400 internal w/sw	\$68
ACP 2400 external	92
2400 internal w/send FAX	95

intel	
2400B Classic/MNP	139/192
2400B External/MNP	165/215
9600 External	494

Practical Peripherals	
Pocket 2400	98
9600 v 32/42B/S	445

Hayes

Pocket Edition 2400	138
---------------------	-----

Boards

ATI	
VGA Basic-16	\$74
VGA WonderXL/256K	185

Boca	
BocaRAM AT Plus	125
BocaRAM AT Plus(SIMM)	119
BocaRAM AT Plus I/O	129
Boca SuperVGA w/1Mb	169

DFI	
Memo 2000A-OK to 2Mb	99
Megalith-OK to 4Mb AT	119

intel	
AboveBoard Plus 8 w/2Mb	398
AboveBoard Plus 8 I/O	449
AboveBoard Plus w/512K	277
SatsFAXton	319

Orchid	
ProDesigner IIs w/1Mb	279
ProDesigner II w/512K	169
ProDesigner II w/1Mb	249

Paradise	
Basic VGA-8 bit	95
VGA 1024 256/512K	147/195

USI	
Image800 VGA w/256K	69
Image1024 VGA w/512K	89
Ultra1024 SuperVGA 1Mb	139
Ultra non-interlaced 1Mb	169

Printers

Canon	
BJ-10e Bubble Jet	329

CITIZEN	
GSX130/GSX140	259/319
200GX/GSX145	169/425
PN48 Portable 2.5lbs	399

OKIDATA	
ML390/7391	438/595
Okilaser400/840	626/1625

NEC	
SilentWriter Mod 90	1499
SilentWriter Mod 990	2995

SAMSUNG



FREE! Over \$500 worth of Software pre-loaded on the hard drive... Ready to use! 386SX Includes:

1. Microsoft Windows 3.0
2. MS-DOS 5.0
3. YourWay windows integrated word processor, database, calendar, event list
4. Norton Backup
5. Norton Utilities
6. Prodigy

Special Video Offer! See before you buy. We will send you a complete Video describing all the software and the all new Sensor line of computers only \$5.00 refundable with purchase.

386SX SuperVGA	1595
386SX-16MHz w/2Mb 40Mb HD	144Mb FD. SuperVGA w/ 31 dot. 2400 baud modem, mouse, 6 months on-site service, plus FREE! Software
286 Color VGA	995
386SX-16MHz w/2Mb 40Mb HD	144Mb FD. SuperVGA w/ 31 dot. 2400 baud modem, mouse, 6 months on-site service, plus FREE! Software similar to above with Geoworks, and Office Manager

PCPartner XE



PC Partner All New Models!

- 1 Year On-Site Service
- Totally Integrated Systems
- Systems Shipped in One Box
- FREE! Software Bundled

PCPartner 386Xi	1595
Complete 386SX VGA System #1	386SX-16MHz w/2Mb 100Mb HD 1.2 and 1.44Mb FDD. Color VGA, mouse, 1 year on-site service, plus FREE! Software including Windows 3.0, Windows Works and HyperDOS
PCPartner 386Xi	1195
Complete 386SX VGA System #2	386SX-16MHz w/1Mb 40Mb HD 1.2 and 1.44Mb FDD. Color VGA, mouse, 1 year on-site service, plus FREE! Software including Windows 3.0, Windows Works and HyperDOS
PCPartner LX286	995
Complete 286 VGA System #3	286-12MHz w/1Mb 40Mb HD 1.2 and 1.44Mb FDD. Color VGA, mouse, 1 year on-site service, plus FREE! Software including DOS 5.0, Lotus Works and HyperDOS

HYUNDAI	
LT3 Laptop	\$849
1Mb RAM • 286-10	
20Mb HD • 1.44Mb FD	
Backlit LCD Screen • Par/Ser	

SHARP	
6641 386SX-20	\$2799
Notebook New!	
40Mb HD • 386SX-20 • 2Mb RAM	
6 lbs • Backlit VGA paper white	
PC5741 386SX Laptop	
Reduced! 386SX-20 • 2Mb RAM • 1.44 FD	
• 40Mb HD • LCD VGA paper white	
• Battery Operated • Handsome Black Case • Ser/Par/VGA/EGA ports	
Save over \$1000.00	\$1595
Color 386-20 Laptop	
Reduced! 386DX-20 • 2Mb RAM • 1.44 FD	
• 40Mb HD • VGA Color • 4 slots	
• Handsome Black Case • Ser/Par/VGA/Mouse ports • Loaded! Totally Powerful!	
Save over \$2000.00	*Call

Special Purchase!

\$3000V PC/XT™	249
8088-10MHz w/640K, 360K FD 5 slots	
\$500/550 PC/AT™	399
286-12MHz w/512K, 1.2Mb FD, 8 slots	
SD630 PC/AT™	449
286-12MHz w/640K, 1.2Mb FD 5 slots	
PC Terminal 286	339
286-10 w/640K MDA, 5 slots, Novell	
SD700 386SX-16	599
386SX-16MHz, 1Mb, 1.2Mb FD 5 slots	
S800 386DX-20	899
386DX-20MHz 512K, 1.2Mb FD 5 slots	
\$5200 Laptop	999
286-12MHz 1Mb, 1.44Mb FD, Gas Plasma Display, 30Mb HD, Ser/Par/Ck	
Factory reserved in new original condition, includes Samsung's 90 day warranty	Supply Limited

PCPartner XL



Free Offer!

PCPartner XL 1979

Complete 6 lb. 386SX Notebook

386SX-20MHz w/1Mb 40Mb HD

1.44Mb FDD LCD Display mouse, plus FREE! Software including Windows 3.0, Prodigy, HyperDOS and Power Up Address Book Plus, Calendar Creator and Top Priority (additional \$229.00 retail value)

Advanced

We do Upgrades or Do-it Yourself and Save!

Advanced 286-12	\$249
286-12 Motherboard w/OK, Case, 250w PS, 101 Keyboard	
Advanced 386SX-16	549
386SX-16 Motherboard, OK Case, 250w PS, 101 Keyboard	
Advanced 386SX-20	599
386SX-20 Motherboard, OK Case, 250w PS, 101 Keyboard	
Advanced 386-25 w/cache	749
386-25 Motherboard, OK Case, 250w PS, 101 Keyboard	
Advanced 386-33 w/cache	849
386-33 Motherboard, OK Case, 250w PS, 101 Keyboard	
Advanced 386-40 w/cache	949
386-40 Motherboard, OK Case, 250w PS, 101 Keyboard	
Advanced Mylex486-33 w/cache	2399
486-33 Motherboard, OK Case, 250w PS, 101 Keyboard	

SPECIAL AMD BUNDLE

80C287-10 COPROCESSOR	
Regular Price	\$79
TOUCHSTONE CHECKIT v2.1	
Regular Price	\$29
SALE PRICE BOTH FOR ONLY	
80C287+Checkit v2.1	\$99

Bulk Disks

5.25" DS/DD (360K)	low as 20¢
Qty 500 20¢ Qty 100 21¢ Qty 25 25¢	
5.25" DS/HD (1.2Mb)	low as 35¢
Qty 500 35¢ Qty 100 37¢ Qty 25 39¢	
3.5" DS/DD (720K)	low as 34¢
Qty 500 34¢ Qty 100 36¢ Qty 25 39¢	
3.5" DS/HD (1.44Mb)	low as 58¢
Qty 500 58¢ Qty 100 62¢ Qty 25 65¢	

Formatted

5.25" DS/DD IBM (360K)	26¢
Qty 500 26¢ Qty 100 29¢ Qty 25 32¢	
5.25" DS/HD IBM (1.2Mb)	49¢
Qty 500 49¢ Qty 100 52¢ Qty 25 57¢	
3.5" DS/DD IBM (720K)	49¢
Qty 500 49¢ Qty 100 52¢ Qty 25 57¢	
3.5" DS/DD MAC (800K)	59¢
Qty 500 59¢ Qty 100 62¢ Qty 25 68¢	
3.5" DS/DD IBM (1.44Mb)	89¢
Qty 500 89¢ Qty 100 92¢ Qty 25 98¢	

Color Disks

5.25" DS/DD (360K)	Qty 50 35¢
5.25" DS/HD (1.2Mb)	Qty 50 59¢

12 colors to choose from

Low Price-Best Quality-Lifetime Warranties

All Disks meet or exceed ANSI Standards

Advanced Computer Products, Inc.

1310 E. Edinger, Santa Ana, CA 92705 • FAX 714-558-1603 • Customer Service 714-558-1356 • Sales 714-558-8813

We accept MC/VISA/AMEX, no surcharge for credit cards. Your card not charged until we ship. *Our 30 Day Guarantee does not refund shipping and handling charges. Drive must be in original package and in original undamaged condition. 1 Year replacement may have some restrictions. Prices and availability subject to change without notice. We ship FEDEX or UPS

Call or FAX your order 800-FONE-ACP

since 1976

VISA MasterCard American Express

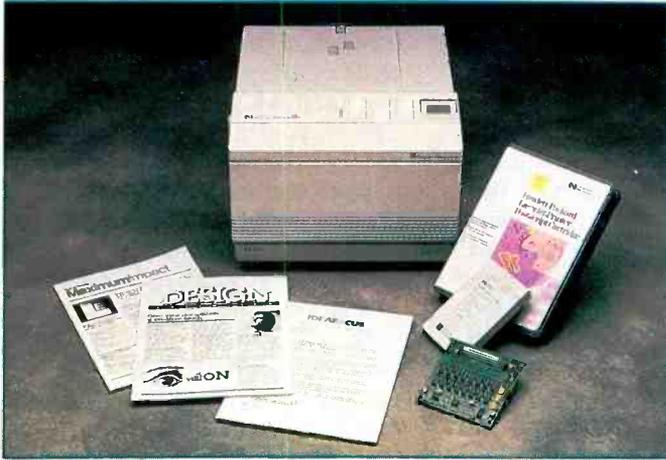

56

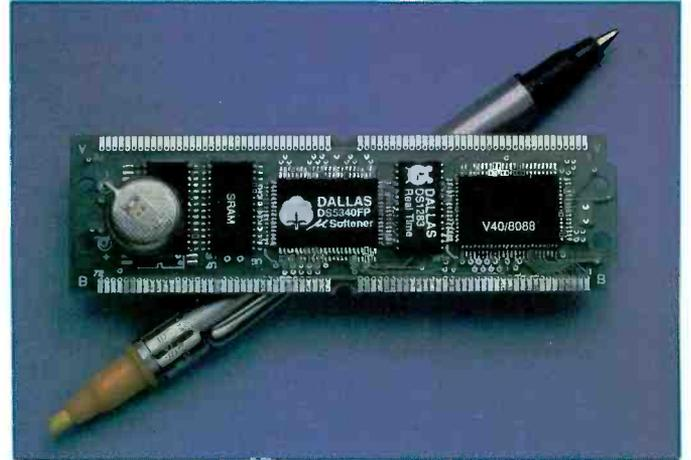

82

UPGRADING & ENHANCING

- 18 PC Tape Backup Systems**
By Roger C. Alford
Tips on selecting a tape drive for your needs and how to install both internal and external units.
- 26 An Automatic Printer Selector**
By Nick Goss
Selects between two printers from inside your programs.

APPLICATIONS

- 36 The "C" Word**
By Hardin Brothers
Pros and cons of the C and C++ programming language.
- 40 EPROM Programming**
By Jan Axelson
Tools and techniques for programming EPROMs used with dedicated and embedded computers.
- 46 Computers at the Dayton Hamvention**
By Peter R. O'Dell
Biggest ham-radio convention in the US treated attendees to a large contingent of computer and software at flea-market prices.
- 48 Build an ELF Monitor**
By John Iovine
Milligauss meter lets you check extremely-low electromagnetic

emissions from electrical equipment.

- 52 On Line With Computer Graphics**
By SF Sparrow
A fast tour of graphics available by modem.
- 62 Ring Director II**
By Mark V. Lucas
Upgraded microcontrolled telephone accessory adds modes that greatly improve upon the original design.

REVIEWS

- 56 Hewlett-Packard's New LaserJet IIIP**
By Joseph Desposito
State-of-the-art in low-cost laser printing as defined by the newest printer from the leader in the technology.
- 60 Publishing the Old-Fashioned Way**
By Joseph Desposito
LeBaugh Software's *LePrint* uses codes embedded in text instead of the traditional page-on-screen approach to desktop publishing.
- 84 Covert Action From the Files of a Super-Spy**
By SF Sparrow
MicroProse's new computer game is for anyone who wants to be a super-spy but is afraid of getting shot at.

COLUMNS

- 72 Forrest M. Mims III**
An Optical Output Port For Your Computer.
- 76 Ted Needleman**
More On Digital Imaging For Computers.
- 82 Joseph Desposito**
Flash Memory, a Flip-Stik And a New Kind of Battery.
- 84 The World On-Line**
By Stan Veit
Free and Nearly-Free Software; Computer Viruses; and Compression/Decompression Packages.

DEPARTMENTS

- 4 Editorial**
By Art Salsberg
- 6 Letters**
- 8 What's Happening?**
- 10 What's New!**
By Peter R. O'Dell
A Roundup of New Computer and Electronic Products.
- 89 Advertisers Index**

ON THE COVER: Moderately priced tape backup drives give practical insurance against program and data losses, while providing large data-storage media and fast operation as compared to floppy diskettes.

Photo by Lorinda Sullivan

EDITORIAL STAFF

Art Salsberg
Editor-in-Chief

Alexander W. Burawa
Managing Editor

Dorothy Kehrwieler
Production Manager

Emily Kreutz
Production

Elizabeth Ryan
Art Director

Barbara Terzo
Assistant Art Director

Susan Reale
Artist

Pat Le Blanc
Florence V. Martin
Phototypographers

Hal Keith
Illustrator

Bruce Morgan
Photographer

**Bud Aaron, Roger C. Alford, Jan Axelson,
Tom Benford, Hardin Brothers, TJ Byers,
Joe Desposito, Nick Goss, John McCormick,
Martin Meyer, Forrest Mims III,
Ted Needleman, Peter R. O'Dell, SF Sparrow**

Contributing Editors

BUSINESS STAFF

Richard A. Ross
Publisher

Art Salsberg
Associate Publisher

Dorothy Kehrwieler
General Manager

Frank V. Fuzia
Controller

Catherine Ross
Circulation Director

Melissa Kehrwieler
Carol Minervini
Data Processing

Denise Pyne
Customer Service

ADVERTISING SALES

Eric Teitelbaum
Margaret Milanese

(516) 681-2922
FAX: (516) 681-2926

Karen Nauth
Sales Assistant

Offices: 76 North Broadway, Hicksville, NY 11801. Telephone: (516) 681-2922. FAX (516) 681-2926. ComputerCraft (ISSN 1055-5072) is published monthly by CQ Communications, Inc. Subscription prices (payable in US Dollars only): Domestic—one year \$18.97, two years \$36.00, three years \$53.00; Canada/Mexico—one year \$21.00, two years \$40.00, three years \$59.00; Foreign—one year \$23.00, two years \$44.00, three years \$65.00. Foreign Air Mail—one year \$76.00, two years \$150.00, three years \$224.00.

U.S. Government Agencies: Subscriptions to ComputerCraft are available to agencies of the United States government, including military services, only on a cash with order basis. Requests for quotations, bids, contracts, etc. will be refused and will not be returned or processed.

Entire contents copyright 1991 by CQ Communications, Inc. ComputerCraft or CQ Communications Inc. assumes no responsibility for unsolicited manuscripts. Allow six weeks for delivery of first issue and for change of address. Printed in the United States of America.

Postmaster: Please send change of address notice to ComputerCraft, 76 North Broadway, Hicksville, NY 11801.

The Plague

Computer viruses abound, we're told, with some 70% of them affecting IBM-type machines. They started around the time that microcomputers were being developed, serving as fun and games by system programmers among themselves, then spreading to computer professionals at colleges. A favorite here was the Cookie Monster virus that popped up suddenly on a victim's screen. Typing the word, "Cookie," eradicated it. By 1986, however, viruses spread to the innocent computer population at large, small as it was then. They became increasingly destructive and took a variety of forms.

I've never had a computer virus; so I can't speak first-hand about them. But from what I've heard, they can be disastrous. These inventive programs, created by malicious people, are programs that are unknowingly picked up by a computer user. They alter or destroy programs or data. Moreover, they are infectious, attaching themselves to other computers through networks and disks. What can they do? They can change a spreadsheet's figures; they can erase files; they can cause a program to sporadically crash; they can destroy all of a hard disk's data; they can cause a program to run very slowly.

A study by Certus International, which sampled 2,500 large computer sites that had 400 or more microcomputers, revealed that 26% of the PCs had a virus in January 1991! This is scary. Furthermore, new viruses are continually being created, increasing from four known viruses in 1986 to nearly 180 new ones emerging in 1990.

As a result of this insidious threat, a host of anti-virus programs have been produced to identify and eradicate them. But new viruses crop up regularly. There's no way to positively prevent viruses from attacking your system, but you can minimize the possibility of getting hit by them by following certain precautions.

If you don't introduce software that is not bought new in shrink-wrap plastic packaging, your chances of being infected are immeasurably reduced. But what do you do about

communications on a bulletin board, using data from someone else or a terrific utility that your friend gives you (and who knows where he got it)? If you're an active computer user, you certainly don't want to limit your computing possibilities. So the alternative is to be extra careful.

First and foremost, make regular backups of your hard-disk drive's information. When you download data, use a floppy disk to store the data, not the hard disk. Then check out the material with a virus-detection program before transferring it to your hard disk. Double-check everything that's stored on backup matter to be as certain as you can that you have not contracted a virus by one means or another that originally escaped you.

Given the situation, do not exchange disks with any other users or even run programs from questionable sources. Since the boot part of a system disk is a favorite location of a virus, do not use a system floppy disk to copy a program or use one supplied by someone else. And try not to let anyone else use your PC. Keep an eye on your COMMAND.COM file, too, looking for any size changes.

Be especially wary if you download programs from electronic bulletin boards. Even corporate and educational mainframes can be troublesome since so many people now telecommunicate work from home.

Do buy yourself a good anti-Virus program, of course, and use it regularly. For some succinct information about viruses, you might want to get "Computer Virus Survival Guide" from the National Computer Security Association (Suite 309, 4401-A Connecticut Ave. NW, Washington, DC 20008 or call them at 717-258-1816 any day at any hour). The 50-page booklet costs \$5 and is worth the price. Follow the old adage "Better safe than sorry."





UNICORN ELECTRONICS

10010 Canoga Ave., Unit B-8
Chatsworth, CA 91311

SINCE 1983 — YOUR I.C. SOURCE — AND MUCH MORE!!
NO SHIPPING CHARGES ON PRE-PAID ORDERS!*
NO CREDIT CARD SURCHARGE!
SCHOOL P.O.'s WELCOME!

LASER DIODES

STOCK #	MFG.	WAVE-LENGTH	OUTPUT POWER	OPER. CURR.	OPER. VOLT.	PRICE
LS9220	TOSHIBA	660 nm	3 mW	85 mA	2.5v	129.99
LS9200	TOSHIBA	670 nm	3 mW	85 mA	2.3v	49.99
LS9201	TOSHIBA	670 nm	5 mW	80 mA	2.4v	59.99
LS9211	TOSHIBA	670 nm	5 mW	50 mA	2.3v	69.99
LS9215	TOSHIBA	670 nm	10 mW	45 mA	2.4v	109.99
LS3200	NEC	670 nm	3 mW	85 mA	2.2v	79.99
LS022	SHARP	780 nm	5 mW	65 mA	1.75v	19.99
SB1053	PHILLIPS	820 nm	10 mW	90 mA	2.3v	9.99

Dynamic RAMS

STOCK #	DESC.	SPEED	1-24	25-99	100+	STOCK #	SPEED	1-24	25-99	100+
41256-60	256K x 1	60 ns	2.59	2.46	2.21	2716	450 ns	3.29	3.13	2.82
41256-80	256K x 1	80 ns	2.19	2.08	1.87	2732	450 ns	4.19	3.98	3.58
41256-100	256K x 1	100 ns	1.99	1.89	1.70	2732A	250 ns	3.29	3.13	2.82
41256-120	256K x 1	120 ns	1.89	1.80	1.62	2764	250 ns	3.49	3.32	2.99
41256-150	256K x 1	150 ns	1.79	1.70	1.53	2764A	250 ns	3.09	2.94	2.65
511000-70	1 meg x 1	70 ns	5.49	5.22	4.70	27128	250 ns	4.79	4.55	4.10
511000-80	1 meg x 1	80 ns	5.29	5.03	4.53	27C128	250 ns	4.79	4.55	4.10
511000-10	1 meg x 1	100 ns	5.09	4.84	4.36	27256	250 ns	4.59	4.36	3.92
514256-70	256K x 4	70 ns	6.49	6.17	5.55	27C256	250 ns	4.29	4.08	3.67
514256-80	256K x 4	80 ns	6.09	5.79	5.21	27512	250 ns	5.49	5.22	4.70
514256-10	256K x 4	100 ns	5.69	5.41	4.87	27C512	250 ns	5.49	5.22	4.70
541000-80	4 meg x 1	80 ns	26.99	25.64	23.08	27C1024	200 ns	10.99	10.44	9.40
544256-80	1 meg x 4	80 ns	31.99	30.39	27.35	27C2048	200 ns	21.99	20.89	18.80

EPROMS

LASER TUBES

STOCK #	WAVELENGTH	OUTPUT POWER (MIN.)	OUTPUT POWER (MAX.)	BEAM DIAM.	BEAM DIVERG.	POLARIZATION	OPERATING VOLTAGE	OPER. CURR.	FIRING VOLT.	MIN. SERIES RES.	SIZE D X L (IN MM)	WT. (GM.)	BRH CL.	PRICE 1-9	10+
LT7770	543nm (Green)	0.5mW	1.0mW	0.71mm	≤ 1.2 mrad	random	1750v ± 110v	6.5 mA	≤ 8 kV	81k Ω	37 x 350	200	II	799.99	749.99
LT7650	632.8nm (Red)	0.5mW	2.0mW	0.49mm	≤ 1.7 mrad	>100:1	1000v ± 100v	3.5 mA	< 7 kV	68k Ω	25 x 146	70	IIla	529.99	479.99
LT7656	632.8nm (Red)	0.5mW	2.0mW	0.34mm	≤ 2.4 mrad	random	1050v ± 100v	2.8 mA	≤ 8 kV	82k Ω	22.5 x 118	60	IIla	134.99	124.99
LT7655	632.8nm (Red)	0.5mW	2.0mW	0.49mm	≤ 1.7 mrad	random	1000v ± 100v	3.5 mA	≤ 7 kV	68k Ω	25 x 150	70	IIla	144.99	134.99
LT7655S	632.8nm (Red)	1.0mW	2.0mW	0.49mm	≤ 1.7 mrad	random	1000v ± 100v	3.5 mA	≤ 7 kV	68k Ω	25 x 150	70	IIla	159.99	144.99
LT7632	632.8nm (Red)	1.2mW	3.0mW	0.61mm	≤ 3.0 mrad	random	1300v ± 100v	3.5 mA	≤ 7 kV	81k Ω	20 x 210	70	IIla	249.99	229.99
LT7621S	632.8nm (Red)	2.0mW	5.0mW	0.75mm	≤ 1.2 mrad	random	1300v ± 100v	5.0 mA	≤ 7 kV	68k Ω	30 x 255	140	IIla	204.99	191.99
LT7634	632.8nm (Red)	2.0mW	5.0mW	0.75mm	≤ 1.2 mrad	>500:1	1300v ± 100v	5.0 mA	≤ 7 kV	68k Ω	30 x 255	140	IIla	209.99	194.99
LT7621MM	632.8nm (Red)	5.0mW	15mW	1.0mm	≤ 2.5 mrad	random	1250v ± 100v	6.5 mA	≤ 7 kV	68k Ω	30 x 255	140	IIlb	359.99	334.99
LT7627	632.8nm (Red)	5.0mW	15mW	0.80mm	≤ 1.1 mrad	random	1900v ± 100v	6.5 mA	≤ 8 kV	81k Ω	37 x 350	200	IIlb	369.99	344.99
LT7628	632.8nm (Red)	5.0mW	15mW	0.80mm	≤ 1.1 mrad	>500:1	1900v ± 100v	6.5 mA	≤ 8 kV	81k Ω	37 x 350	200	IIlb	389.99	364.99
LT7627MM	632.8nm (Red)	10mW	30mW	1.2mm	≤ 4.0 mrad	random	1750v ± 100v	6.5 mA	≤ 8 kV	81k Ω	37 x 350	200	IIlb	479.99	444.99

Laser Pointer



- Output: 3.5 mW
 - Wavelength: 670NM
 - Power Supply: 2xAAA Batteries (included)
 - Beam: Approx. 3" @ 100 yards
- Quantity Discounts Available

STOCK #	PRICE
LSPOINT	\$199.99

Power Supply



- Input: 115/230V
- Output: +5v @ 3.75A
+12v @ 1.5A
-12v @ .4A
- Size: 7" L x 5 1/4" W x 2 1/2" H

STOCK #	PRICE
PS1003	\$19.99

Collimator Pen



- Output: 2.5 mW (max.)
- Current: 90-150 mA
- Op. Volt.: 2.2-5.5V
- Wavelength: 820NM
- Data Sheet inc.

STOCK #	PRICE
SB1052	\$39.99

Disc Drive & Computer Cleaning Kit



Not just a drive cleaner—but a complete computer cleaning kit. Includes swabs, head cleaning fluid, anti-static cleaner, screen wipes and cleaning diskette.

STOCK #	PRICE
SB1099 3 1/2" Kit	\$6.99
SB1100 5 1/4" Kit	\$6.99

Disc Drive Head-Cleaning Kit



Includes cleaning fluid and head-cleaning diskette

STOCK #	PRICE
SB1105 3 1/2" Drive Kit	\$1.99
SB1106 5 1/4" Drive Kit	\$1.99

Anti-Static Screen Wipes



For static-sensitive applications
Dispenser packs, individually wrapped

STOCK #	PRICE
SB1104 Dispenser pack of 25 wipes	\$1.99
SB1107 Dispenser pack of 100 wipes	\$4.99

Robotic Arm Kit



Robots were once confined to science fiction movies. Today, whether they're performing dangerous tasks or putting together complex products, robotics are finding their way into more and more industries. The Robotic Arm Kit is an educational kit that teaches basic robotic arm fundamentals as well as testing your own motor skills. Command it to perform simple tasks.

STOCK #	PRICE
YO1	\$49.99

Avoider Robot Kit



An intelligent robot that knows how to avoid hitting walls. This robot emits an infra-red beam which detects an obstacle in front and then automatically turns left and continues on.

STOCK #	PRICE
MV912	\$49.99

ORDER LINE — (800) 824-3432



INTERNATIONAL ORDERS — (818) 341-8833

FAX ORDERS — (818) 998-7975

TECHNICAL SUPPORT — (818) 341-8833

- 15.00 MINIMUM ORDER
- UPS BLUE, RED & FEDERAL EXPRESS SHIPPING AVAILABLE
- OPEN MON-FRI 9:00 AM - 6:00 PM, SAT 10:00 AM - 3:00 PM PDT
- CA RESIDENTS ADD 7% SALES TAX
- CALL FOR QUANTITY DISCOUNTS
- CALL FOR FREE CATALOG (FOR 1ST CLASS DELIVERY OR CATALOGS DELIVERED OUTSIDE THE U.S. — SEND \$2.00)
- WE CARRY A COMPLETE LINE OF ELECTRONIC COMPONENTS



*NO SHIPPING CHARGES ON PRE-PAID ORDERS DELIVERED IN THE CONTINENTAL U.S. CIRCLE NO. 157 ON FREE INFORMATION CARD

More Reader Comments

• As a new subscriber, I'm totally enjoying what I read in *ComputerCraft*. I've really learned a lot from your articles and am looking forward to more. I'd come to the conclusion that most computer magazines weren't intended to be read by a hobbyist or anyone who uses less than a 386 (with all options) waiting to upgrade to a 486.

I'm an Amateur Radio operator and use an old XT with 20M hard drive. It's

more than adequate for anything pertaining to ham radio. The big problem I and other hams have with computers is the "garbage" (rfi) generated by them. If I get a new computer, it would be because I want the FCC Class B rating.

Jim Berry
Marysville, WA

• I enjoyed the April and May 1991 issues of *ComputerCraft*. I think it's a great magazine for beginners like me. I've never had hands-on experience with elec-

tronics or microprocessors, though I have been using PCs and workstations for several years. As a student in computer science/engineering, I'd like to learn more about the electronic hardware in the computers I use. Textbooks don't give the information I need.

Please include more tips on microprocessors (experiments for beginners) similar to the "Computer Keyboards..." article in the May and June issues.

Chi Do
Everett, WA

• I purchased your magazine for the first time a few weeks ago, and I'm very impressed. I haven't had my computer very long, but I work with electronics and microprocessors. *ComputerCraft* is just what I'm looking for to interface and understand all of what my computer can do for me.

William Fray
Kansas City, MO

Address Errata

• The June 1991 issue of *ComputerCraft* published a letter from Frank Thornton of Springfield, IL describing our 8031 microcontroller modules that he uses in the classes he teaches. The address given for our company was incorrect. We can be reached at:

Cottage Resources Corp.
Suite 3-672
1405 Stevenson Dr.
Springfield, IL 62703
Tel.: 217-529-7679

Tim McDonough
President

• The review on *The Snooper* disassembler in the September issue gave misinformation about the company that produces the program. The correct company name, address and telephone numbers are as follows:

Central Computer Products
330 Central Ave.
Fillmore, CA 93015
Tel.: 1-800-456-4123 or 805-514-4189
Fax: 805-524-4026

The Editors

Programming Glitch

• An error appears in the second BASIC program printed on page 96 of my Cyber Supply article that appeared in the September issue of *ComputerCraft*. The "05" shown between 40 and OUT should be deleted for the program to run properly.

Nick Goss

48 HOUR SHIPPING

ELENCO & HITACHI PRODUCTS AT DISCOUNT PRICES

48 HOUR SHIPPING

Hitachi RSO Series

(Portable Real-time Digital Storage Oscilloscopes)

VC-6023 - 20MHz, 20MS/s	\$99/mo*
VC-6024 - 50MHz, 20MS/s	\$120/mo*
VC-6025 - 50MHz, 20MS/s	\$136/mo*
VC-6045 - 100MHz, 40MS/s	\$125/mo*
VC-6145 - 100MHz, 100MS/s	\$200/mo*

RSO's from Hitachi feature roll mode averaging, save memory, smoothing, interpolation, pretriggering, cursor measurements. These scopes enable more accurate, simpler observation of complex waveforms. In addition to such functions as hardcopy via a plotter interface and waveform transfer via the RS-232C interface. Enjoy the comfort of analog and the power to digital.

20MHz Elenco Oscilloscope

\$375

- MO-1251
- Dual Trace
- Component Tester
- 6" CRT
- X-Y Operation
- TV Sync
- 2 P-1 Probes

LEASING AVAILABLE

For all Hitachi Scopes - Call for details
* Based on 24 months except V-1150, VC-6045, VC-6145 (36 months)

Hitachi Portable Scopes

DC to 50MHz, 2-Channel, DC offset function, Alternate magnifier function.

V-525 - CRT Readout, Cursor Meas.	\$1,025
V-523 - Delayed Sweep	\$995
V-522 - Basic Model	\$895
V-422 - 40MHz	\$795
V-223 - 20MHz delayed sweep	\$695
V-212 - 20MHz	\$425

HITACHI COMPACT SERIES SCOPES

This series provides many new functions such as CRT Readout, Cursor measurements (V-1085/1065/665), Frequency Ctr (V-1085), Sweeptime Autorange, Delayed sweep and Trigger Lock using a 6-inch CRT. You don't feel the compactness in terms of performance and operation.

V-860 - 60MHz, Dual Trace	\$1,195
V-865 - 60MHz, DT, w/cursor	\$1,345
V-1060 - 100MHz, Dual Trace	\$1,425
V-1065 - 100MHz, DT, w/cursor	\$1,605
V-1085 - 100MHz, QT, w/cursor	\$1,295/mo*
V-1100A - 100MHz, Quad Trace	\$125/mo*
V-1150 - 150MHz, Quad Trace	\$115/mo*

FREE DMM with purchase of ANY SCOPE

SCOPE PROBES
P-1 65MHz, 1x, 10x \$19.95
P-2 100MHz, 1x, 10x \$23.95

BECKMAN TEST EQUIPMENT

All Models Available
Call for special price

Digital Capacitance Meter

CM-1550B
\$58.95

9 Ranges
1pF-20,000pF
5% basic accy
Zero control w/ Case
Big 1" Display

Digital LCR Meter

LC-1801
\$125

Measures:
Coils 1uH-200uH
Caps. 1pF-200uF
Res. 0.1-20M

Multimeter with Capacitance & Transistor Tester

\$55 CM-1500B

Reads Volts, Ohms
Currents, Capacitors,
Transistors and
Diodes / with case

FLUKE MULTIMETERS

All Models Available
Call for special price

Quad Power Supply

XP-580
\$59.95

2-20V @ 2A
12V @ 1A
5V @ 3A
5V @ 5A

Fully regulated and short circuit protected

Triple Power Supply

XP-620
Assembled \$65
Kit \$45

2 to 15V @ 1A,
2 to 15V @ 1A
(or 4 to 30V @ 1A)
and 5V @ 3A

All the desired features for doing experiments.
Features short circuit protection, all supplies

AM/FM Transistor Radio Kit

with Training Course
Model AM/FM 108
\$26.95

14 Transistors + 5 Diodes
Makes a great school project

True RMS 4 1/2 Digit Multimeter

M-7000
\$135

05% DC Accuracy
1% Resistance
with Freq. Counter
and Deluxe Case

Soldering Station

Temperature Controlled
SL-30 \$99

Digital display
Temp range:
300F-900F
Grounded tip
Overheat protect

Color Convergence Generator

SG-200
\$69.95

Final in the industry
10 rock steady patterns

Digital Triple Power Supply

XP-785
\$249

0-20V @ 1A
0-20V @ 1A
5V @ 5A

Fully Regulated, Short circuit protected with
2 Limit Cont., 3 Separate supplies
XP-660 with Analog Meters \$175

Four-Function Frequency Counters

F-100 120MH
\$179

F-1000 1.2GH
\$259

Frequency, Period, Totalize,
Self Check with High Stabilized Crystal Oven
Oscillator, 8 digit LED display

GF-8016 Function Generator

with Freq. Counter
\$249

Sine, Square, Triangle
Pulse, Ramp, 2 to 2MHz
Freq. Counter, 1 - 10MHz

GF-8015 without Freq. Meter \$179

Function Generator

Box
\$96.00

Provides sine, triangle, square
wave from 1Hz to 1MHz
AM or FM capability

MOVIT EDUCATIONAL ELECTRONIC ROBOT KITS

The MOVIT line is a series of computerized battery robot kits that can teach the basic principles of robotic sensing and locomotion. Each of the kits features pre-assembled PC boards, hardware and mechanical-drive systems. Only basic hand tools are required for assembly. These fascinating robots allow you to experience and learn any one of the following features: sound sensor, remote control, infra-red sensor, wired control and/or programmable memory.

MV-912 Avoider Infra-red	\$49.95	MV-939 Medusa Sound Sensor	\$29.95
MV-915 Piper mouse Sound Sensor	\$45.95	MV-983 Line Tracker Infra-red	\$45.95
MV-918 Peppy Sound Touch	\$29.95	MV-996 Manta Sound Touch	\$29.95
MV-931 Mr. Bootman Wire Control	\$35.95	Y-31 Robotic Arm Robotic Cont	\$45.95
MV-932 Central Theme Control	\$45.95	B7-802 Grand Piano Eter Piano	\$29.95
MV-936 S.Cargo Sound Sensor	\$45.95	B7-805 Roulette Digital Wheel	\$35.95

Learn to Build and Program Computers with this Kit

Includes: All Parts, Assembly and Lesson Manual
Model
MM-8000
\$129.00

Starting from scratch you build a complete system. Our Micro-Master trainer teaches you to write into RAMs, ROMs and run a 8085 microprocessor, which uses similar machine language as IBM PC.
Robotics Kit for above (MM8010) \$1.95

Wide Band Signal Generators

SG-9000 \$129

RF Freq. 100k-450MHz All Modulation of 1kHz Variable RF output
SG-9500 w/ Digital Display & 150MHz built-in Counter \$249

C & S SALES INC.
1245 Rosewood, Deerfield, IL 60015
(800) 292-7711 (708) 541-0710

WE WILL NOT BE UNDERSOLD!
UPS Shipping: 48 States 5%
(\$3 Min \$10 Max) Shipping
IL Res.: 7% Tax FAX: 708-520-0085

15 Day Money Back Guarantee
2 Year Warranty Prices Subject to Change
WRITE FOR FREE CATALOG

CIRCLE NO. 105 ON FREE INFORMATION CARD

6 / COMPUTERCRAFT / October 1991

Say You Saw It In ComputerCraft

www.americanradiohistory.com

PARTS PLACESM



(1) **NEW! "Shirt Pocket" Multimeter.** Take it along! Features LCD display, autoranging with manual override, continuity sounder. Measures to 400 volts AC/DC and resistance. With fold-up vinyl case, manual and replaceable batteries. #22-169 27.95

(2) **NEW! Building Power Supplies.** Easy-to-understand, 96-page book explains linear and switching supplies. Includes complete plans for building five useful supplies with Radio Shack parts. #276-5025 4.95

(3) **Mini Audio Amplifier.** Great for computer voice/music synthesis, signal tracing and more. Has a built-in speaker, 1/8" headphone jack, 1/8" input jack and volume control. Put one on your bench today! #277-1008 11.95

(4) **Digital Logic Probe.** LEDs and tone outputs reveal logic states instantly. It's the fast way to check operation and pinpoint problems in all types of digital circuits. #22-303 16.95

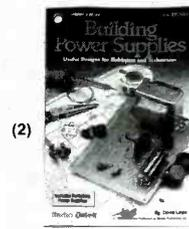

(2)



(4)

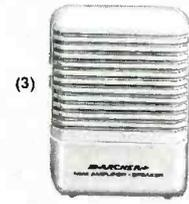

(3)

Parts Special-Order Hotline. Your local Radio Shack store stocks over 1000 popular electronic components. Plus, we can special-order over 10,000 items from our warehouse—linear and digital ICs, transistors and diodes, vacuum tubes, crystals, phono cartridges and styli, even SAMS[®] service manuals. Your order is sent directly to your Radio Shack store and we notify you when it arrives. Delivery time for most items is one week and there are no postage charges or minimum order requirements.

(1) **Shielded RS-232 Jumper Box.** Top-quality inline D-sub 25 adapter. Wire the included jumper wires and board to suit your need. #276-1403 9.95

(2) **Computer RS-232 Tester.** Dual-color LEDs monitor seven data/control lines to help you spot problems quickly. D-sub 25. Connects inline. #276-1401 14.95

(3) **Grounded-Tip Soldering Iron.** 15W. #64-2051 7.49

(4) **Vacuum-Type Desoldering Tool.** #64-2120 6.95

(5) **Locking Forceps.** 6" long. Stainless. #64-1866 4.95

(6) **Rosin Soldering Paste Flux.** 1 oz. #64-021 1.79

(7) **Lead-Free Solder.** 96% tin, 4% silver. 0.25 oz. #64-025 1.99

(8) **10-Amp Microwave Oven Fuses.** #270-1256 Pkg. of 2/1.29

(9) **2-Amp Fast-Acting Fuses.** #270-1275 Pkg. of 3/79c

(10) **5-Amp "Blade" Vehicle Fuses.** #270-1205 Pkg. of 2/89c

Computer/Printer/Business Machine AC Power Cords. 6 feet long.

(11) **Extension.** Just plug in to lengthen existing cord. #278-1259 4.99

(12) **With Space-Saving 90° CEE Connector.** #278-1260 5.99

(13) **With Straight CEE Connector.** #278-1257 3.99

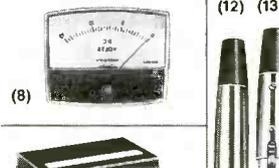
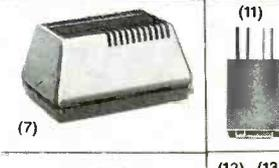
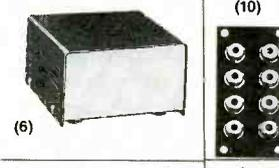
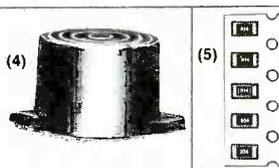
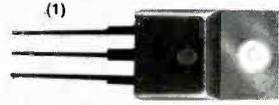
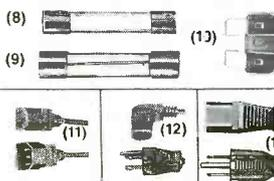
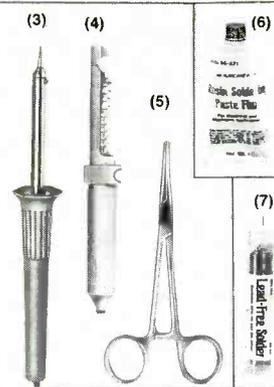
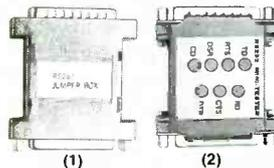
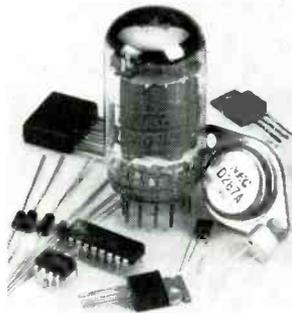

(1) **Voltage Regulator ICs.** Feature built-in overload protection and thermal shutdown. Great for custom projects. Maximum input: 35VDC. 7805. 5V. #276-1770 1.19
7812. 12V. #276-1771 1.19

(2) **Low-Voltage Motor.** Just the thing for science projects, robotics and solar power demos. Operates from 1 1/2 to 3VDC. About 1 1/2" long. #273-223 99c

(3) **High-Speed 12VDC Motor.** Up to 15,200 RPM, no load. About 2" long. #273-255 2.99

(4) **"Ding-Dong" Chime.** This IC and mini-speaker combo is ideal for a customer-entry alert or doorbell. Produces 80 dB sound pressure at 12VDC. Operates from 6 to 18VDC. #273-071 8.99

(5) **Surface-Mount Resistors.** 200-piece assortment of 15 popular values. Rated 1/8 watt, 5%. #271-313 Set 4.99

(6) **Metal Project Cabinet.** An attractive, easy-to-drill housing at a low price. 3 x 5 1/4 x 5 7/8". #270-253 6.79

(7) **Power Supply Project Case.** Vented 2 1/2 x 4 5/8 x 3 1/4" molded case. #270-287 3.99

(8) **0 to 15 DC Voltmeter.** Quality jeweled movement. #270-1754 7.95

(9) **Box/Board Combo.** Molded enclosure plus predrilled 2 x 3 1/8" board, labels and more. #270-291 4.99

(10) **Eight-Position Audio Phono Jack Board.** #274-370 1.69

(11) **1:1 Audio Transformer.** Z: 600-900Ω. #273-1374 3.59

(12) **Three-Pin XLR Mike Plug.** Metal body. #274-010 2.99

(13) **Three-Pin XLR Inline Socket.** #274-011 2.99

(14) **Three-Pin XLR Panel Socket.** #274-013 3.69

Since 1921 Radio Shack has been the place to obtain up-to-date electronic parts as well as quality tools, test equipment and accessories at low prices. Our 7000 locations are ready to serve you—NOBODY COMPARES

Prices apply at participating Radio Shack stores and dealers. Radio Shack is a division of Tandy Corporation

Radio Shack
AMERICA'S TECHNOLOGY STORE

CIRCLE NO. 123 ON FREE INFORMATION CARD

NCR's Pen-Based Notepad. NCR Corp. announced its model 3125 pen-based notepad computer, a mobile machine with true handwriting-recognition capabilities. Users print directly onto a digitized screen with a cordless pen to input data, which may be in both upper-case and lower-case block print letters, gestures and annotations. It adapts to multiple handwriting styles. The lightweight (3.9 lbs.) notepad supports both *GO Corporation's* Pen-Point operating system and *Microsoft's* Windows for Pen Computing, as well as MS-DOS. Based on an Intel 386 microprocessor, it runs at 20 MHz and comes with 4M of RAM, expandable to 20M. Nonvolatile flash erasable programmable ROM (FEPRM) memory is available for protection against data loss. *The base unit lists for \$4795.*

More than 100 independent software vendors have committed to produce applications that take advantage of specific pen features in *Microsoft Windows* graphical environment for Pen Computing. *Windows for Pens* will be offered with NCR's *Notepad*.

Grid Systems Corp. too, has a handheld computer that uses an electronic pen instead of a keyboard to enter data (capital letters only). The 4.5-lb. unit, with a base price of \$2370, uses a 10-MHz 80C86 CPU and comes with 1M of RAM. It uses the familiar MS-DOS.

Computer SuperCenters. Tandy Corporation announced plans for a new nationwide chain of computer SuperCenters to sell America's best-known PCs (including IBM, Apple, Compaq and Tandy) at low prices. To be called "Computer City," they will have about 20,000 square feet of selling space, a service facility and warehousing. In addition, Computer City Super-Satellites will be opened to complete coverage of metropolitan markets. The chain will also carry more than 5,000 additional computer products and supplies, along with a full range of personal office equipment and training options. Tandy-brand computers will also still continue to be sold by Tandy's Radio Shack division.

Computer Glasses. Visual stress at the VDT is a common complaint of computer users, especially if an operator uses bifocal or trifocal lenses that cause him to modify head position to get proper screen display viewing. Doing this for long hours often causes headaches and neck or back pain. Technica, a progressive spectacle lens from American Optical Corp. (Southbridge, MA) reportedly provides better visual comfort and performance at a computer worksite, offering virtually an uninterrupted field of vision for near and intermediate work. Spectacle lens dispensers throughout the nation sell the occupational lenses.

The target area, a video display terminal, has not been neglected either by some manufacturers. Copam (Fremont, CA) has a line of moderately priced super VGA and monochrome monitors that are designed with low "radiation" that exceeds Sweden's standards, although there is no absolute proof at this time that VDT radiation is really potentially hazardous.

PCs Run Apple Macintosh Software. A full-length PC add-in board with associated software, called Andor One from Hydra Systems Inc., San Jose, CA, allows IBM PCs and compatibles to directly run Apple Macintosh software from XTs to 486s. The system reportedly displays square monochrome Mac pixels on a PC EGA/VGA monitor with twice the computing performance of a Mac SE or Mac Classic. The Andor One ships with two empty ROM sockets; the end user or has to install Mac ROMs in the An-

dor One. Up to 4M of onboard RAM are accommodated. The board includes an AppleTalk-compatible RS-422 connector, and users can switch back and forth between PC and Mac modes by simply pressing both shift keys on the PC's keyboard. The TSR software occupies about 60K of the PC's RAM. \$995.

In another extension of a PC's utility, Galaxy Networks (Canoga Park, CA) introduced a new modem family, Gemini, that directly connects an IBM personal computer to an IBM main-frame computer with no extra hardware required (no protocol converter at the main frame site or synchronous plug-in card at the PC). The modem also supports all standard PC dial-up standards. \$1988.

New Multi-Language Software. Frontier Software Services (Winchester, MA) announced its *Translator's Apprentice* software toolkit that makes it easy for developers to write programs that will run in multiple languages. The \$175 package is available for English, French, Spanish and Russian.

EZ Japanese Writer from EJ Bilingual Inc., Torrance, CA (213-320-8139) is claimed to make it easy to write in Japanese. The IBM-compatible software provides basic translation of English documents into written Japanese, with a vocabulary of about 50,000 words and the ability to add another 20,000 words to a user dictionary. It displays an English/Japanese language split screen, as well as a combined English/Japanese screen with alternate lines for each language. The program requires 3M of hard-disk space and a KanjiBoard installed in an expansion slot.

Ventura Software Promotion. Ventura Software Inc. announced a special promotion of purchasers of its *Ventura Publisher* desktop publishing software. Purchasers of *Ventura Publisher Windows 3.0 Edition* are offered a free package of productivity software and accessories with retail value ranging from \$509 to more than \$700. The offer extends through October 15, 1991, and excludes upgrades and network nodes. . . . The company also announced *Ventura DataBase Publisher*, a new DBS that enables users to easily style and prepare database information for publishing in *Ventura Publisher*, *PageMaker* and *Interleaf*. It will list for \$695.

Learning & Training Tools. A new, free demo disk from Massteck Ltd., P.O. Box 1130, Littleton, MA demonstrates *Max-Route* for autorouting and manual routing of PC boards. The tutorial on the interactive autorouter uses shove routing technology to minimize vias (plated-through holes) and to straighten corners. The 20-minute program is compatible with most design software, including *P-CAD*, *PADS-2000*, *Tango*, *Protel*, *EE-Designer* and *Cadstar*. The free demo is on 5 1/4" disk.

High Tech Video Productions, San Diego, CA (800-876-TAPE) has introduced training and reference videocassette tapes for Omaton's *Schema III*, *Schema-PCB* and all Schema Utilities. Each video covers basic, intermediate and advanced levels. An introductory price for each is \$129 per topic, reduced from \$149 each, or \$299 for all three.

Educational Systems, Inc. announced an innovative MICRO-REF SmartPad—a mousepad help system for software that comes with a see-through cover that holds at-a-glance operating commands for popular PC software. Mousepad templates are available for *WordPerfect 5.1*, *Windows 3.0* and *Write Your Own*, with other titles to be available soon. The pad measures 8 1/2" x 10", and the working surface is textured polycarbonate to inhibit static electricity build-up. Retail prices range from \$9.95 to \$19.95 for various combinations of pads and templates.



MICRO-TECH USA



America's largest PD/Shareware Distributor

Currently over 200,000 programs available and growing! Order our 200+ page catalog for just \$7.95.

Limited offer: 4 free disks of your choice. 100% guaranteed high quality and virus free.

PRINTING

- Typesetter PC**
Great desktop publishing program. Mix graphics, test fonts. Requires 512K, 9 pin printer
- Form Master:**
Create your own business forms and legal form's. Rated best form program.
- Letter Heads Plus**
Design and print custom letterhead, envelopes and labels.

WORD PROCESSING

- PC Write 3.03**
Top rated program with spell checker. A must for the writer.
- Intext**
New word processing in 7 European languages.
- Hyper-world (4 disks)**
New hyper text word processor and free form database with appointment calendar.

GRAPHICS

- PC-Key draw**
Powerful CAD design system. (4 disks)
- Dancad 3D (2 disks)**
The best there is for 3D wireframe with all conceivable options.
- Printmaster Graphics Library #4**
New 400 great graphics.
- Printshop Graphics Library #3 and #4**
2 disks. Over 600 graphics. All new.
- Charts unlimited**
A design tool for creating any kind of chart.

WINDOWS

- Icons**
Over 250 icons to be used with Windows 3.0
- Unicom**
At last a super communications program for Windows. Supports X, Y, and Z modem protocols among others.
- Window Press**
Great form maker for Windows 3.0 or with different fonts, lines, arcs, circles, pies, bars, etc. Precision to 1/10 mm. Source code included.

WORD PERFECT 5.0/5.1

- PC - Draft III (2 disks)**
- WP - Arts/Graphics (2 disks)**
- WP - Learning System (2 disks)**
- WP - Macros (2 disks)**
- WP - Menu-mice (2 disks)**
- WP - Tools (2 disks)**

BUSINESS/ACCOUNTING

- PC Payroll**
A complete menu-driven payroll system (2 disks)
- PC Loans**
Keep track of those nasty loans
- Year Planner**
A super calendar and organizer program
- Employee Management System 4.0**
Highly accurate personality/position analysis

- PC Yellow Pages (5 disks)**
One of the most effective marketing tools I've seen. Address merge, labels, fax mail, built in database registered version comes complete with data for your own area (HD required)

DATA BASE

- Wampum**
An excellent d-base compatible package.
- PC File 5.0 (3 disks)**
Jim Button's best. PC mag editors choice (Req 3.0 DOS or up)

SPREAD SHEETS

- 123 Power Worksheets (2 disks)**
Powerful worksheets for Lotus 1-2-3.
- Lotus Templates**
Some ready-made templates. Don't spend hundreds and miss this one. It's a bargain for sure.

UTILITIES

- HD Backup**
An easy to use program for backing up your hard drive
- Quick Cache (2 disks)**
This one will speed up your computer big time.

Virus Killers

Several virus programs on one disk. Why buy them separate?

Back & Forth

New load up to 20 programs at once. You won't believe it until you see it. Order this one now! (HD required)

GAMES

PC Risk

You played it on a board. Now play it on a computer. Same as the board game, but a lot less.

3D Chess

This one is good. You can even ask the computer for help.

Striker

Fly your copter through enemy fire. Arcade quality game.

PC Rail Road

A must for model train buffs. Control your trains on increasingly complex layouts but don't worry. An automatic collision avoidance system is built in. It took a few minutes to evaluate this one and hours to turn it off!

Megapoly

You have inherited \$100,000. Your challenge is to become rich in 20 years. Very good game.

Dominate

A computer wargame. Better and more sophisticated and involved than Risk.

We have the best in games for mono, CGA, VGA, and Super VGA.

PRICE BREAK

1-9	\$2.50 ea.	10-19	\$2.00 ea.
20-49	\$1.50 ea.	50-99	\$1.00 ea.
Over 100	\$0.89 ea.		

All new selections's with updates every month. Select 4 free disks with purchase of catalog. Important: For multi-disk sets, count all disks in a set.

Please specify 5.25" 3.5" (add \$1.00 each)

Name _____

Address _____

City/State/Zip _____ Ph () _____

VISA/MC # _____ Exp. Date _____

Signature _____

Disks Ordered _____ x \$ _____ = \$ _____

For a catalogue, add \$7.95 \$ _____

For 3.5" disks, add \$1.00 each \$ _____

Shipping and Handling \$ 4.00 _____

Foreign Shipping, add \$6.00 \$ _____

Washington State Residents add 8.1% sales tax \$ _____

Total \$ _____

Method of payment

check money order VISA/Mastercard

MICRO-TECH USA

P.O. Box 59403, Renton, WA 98058-0403



DMPs With Scalable Fonts

Epson America introduced three new dot-matrix printers that incorporate scalable fonts, enhanced graphics, faster speeds, four paper paths and additional paper-



handling features. The three models are the narrow-carriage LQ-570 for personal use, narrow-carriage LQ-870 for business use and LQ-1170 wide-carriage business printer. The new control language, Epson ESC/P 2, is an extension of ESC/P, the *de-facto* standard for dot-matrix printers (commonly called Epson LQ). Fonts are scalable from 8 to 32 points. Graphics can be printed at 360 x 360 dots per inch. Print drivers are included for most popular software. The LQ-570 prints at up to 315 cps in draft mode. \$499.

CIRCLE NO. 1 ON FREE CARD

Flash Memory

The FlashCard from Cardinal Technologies stores Digital Research (DR) DOS operating system and other application software in Read-Only memory (ROM) chips called "flash memory," ready to be accessed at any time. Unlike other ROM chips, the flash memory chips are reprogrammable without removing the card from the PC. Contents of the FlashCard can be changed at any time. Utility software enables users to load any application software onto the card. Once programmed, the card can be "write pro-

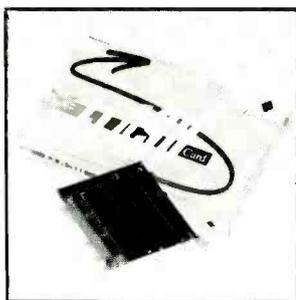

tected," virtually ensuring viral immunity. The card works in any industry-standard expansion slot. Price is \$199 for the FlashCard with (DR) DOS 5.0 installed.

CIRCLE NO. 2 ON FREE CARD

PC Remote Control

The AirMouse Remote Control from Selectech is a simple-to-use remote control device for all interactive computer and video systems. It works with IBM/compatible, Macintosh and Amiga computers using an infrared link to point to the screen and select a function with a single button touch. The AirMouse Base Station connects directly to the computer via an RS-232

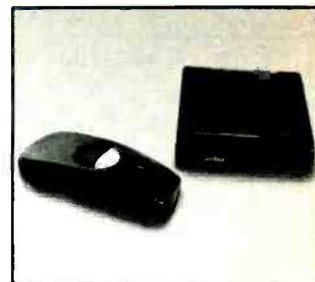

serial line. Range between the Air Mouse and Base Station is about 10 meters. \$595.

CIRCLE NO. 4 ON FREE CARD

Computer Scope

Vernier Software will transform your computer into a storage oscilloscope and data collector with the company's MultiPurpose Lab Interface (MPLI) and software. The package accommodates a wide variety of sensors, including voltage, pH, force,

temperature, light, magnetic field, pressure and microphones, among others. In the oscilloscope mode, the unit samples at a 75,000-times-per-second rate at least. The system consists of a 12-bit interface board, interface box and software. \$310.

CIRCLE NO. 5 ON FREE CARD

386SL Notebook Computer

Zenith Data Systems's new MastersPort 386SL taps advantages of the Intel 386SL and offers up to 8 hours of use on a single battery. The 6.8-lb notebook is designed to conserve both the system's battery power and the user's time. A "rest" mode preserves running applications and consumes about the same amount of power required to light a LED. The user can resume operation at the push of a button up to weeks later. In the "stand-by" mode, the user has immediate access to an application with a single keystroke. A "panic save" feature prevents loss of data



when the system's main battery runs down. There's also an unattended modem operation feature that permits the modem to awaken the system from the rest mode and accept incoming data. MastersPort 386SL features a VGA display with 32 shades of gray, full-size 82-key keyboard, 2M of RAM and a "rest aware" 60M hard disk. \$4,999.

CIRCLE NO. 3 ON FREE CARD

Circuit-Repair Goop

Planned Products introduces the 2400 Circuit Works Conductive Epoxy Kit for quick, solderless connection and conductive bonding applica-



tions in electronic design, prototype and repair. The Circuit Works conductor is a two-part silver-epoxy featuring excellent electrical conductivity, aggressive bonding and quick room-temperature curing in about 10 minutes. It's ideal for situations where heat might damage or destroy components. Each kit contains 12 grams of silver-epoxy in two tubes for precise, repeatable dispensing and easy handling. \$15.

CIRCLE NO. 6 ON FREE CARD

Weather Software

WeatherBank is shipping version 4.0 of *WeatherBrief*, a software package that generates both EGA and VGA weather maps and graphics from data taken over the phone line from WeatherBank. Enhancements include broadcast-quality national and international maps plus increased weather coverage. The software is menu-driven and provides weather charts of surface and upper-air conditions. A user preselects categories of weather data and the geographic areas desired. The program then automatically downloads the appropriate data and stores it on hard disk. Global coverage includes North America, South America, Asia, Africa, Australia and the Pacific Rim. On a more regional level, *WeatherBrief* 4.0 can provide an instant "snapshot" of lightning activity in an area as small as 10 x 10 miles throughout the US. Software price is \$50; on-line time starts at 10 cents per minute.

CIRCLE NO. 7 ON FREE CARD

New DTP Books

Type from the Desktop By Clifford Burke

(Ventanna Press. Soft cover. 226 pages. \$23.95)

Desktop publishing has revolutionized the publishing industry, particularly at the low end. It is a powerful tool in the hands of a skilled designer for creating things of great beauty. In the hands of the unskilled, DTP output typically ranges from the mediocre to the hideous. Burke's text is a crash course in design for those who know more about batch files than design and layout. Several popular type faces (fonts) are discussed, including where to make the best use of them. There's even a short section that discusses such esoteric topics as service bureaus and selecting paper with conservation in mind. This text may not turn the reader into a skilled designer, but it can keep him from making most of the more common blunders.

The Makeover Book By Roger C. Parker

(Ventanna Press. Soft cover. 282 pages. \$17.95)

Self-taught DTPers often reach a stage where they recognize that their products have visual and design shortcomings. Knowing something is wrong is one thing; having some idea of how to fix it is another. Chock-full of real-life before-and-after examples, this book demonstrates how design abstracts translate to specifics. The examples are divided into categories that reflect the most common applications of DTP. Most readers will find Parker's style and approach as comfortable as it is informative. This book is ideal for the person who needs to occasionally produce documentary and promotional material.

New VGA Adapter

ATI Technologies has a new VGA adapter card for 8- and 16-bit industry-standard buses. The VGAWonder XL series come with memory configurations of 256K, 512K and 1M (256K and 512K models can be expanded to 1M). These boards feature 100% VGA register compatibility and both analog and digital ports for total compatibility.

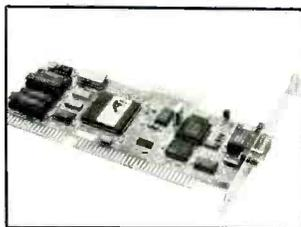

The VGAWonder XL supports 72-Hz refresh rate in 1,024 × 768, 800 × 600 and 640 × 480 resolutions.

CIRCLE NO. 8 ON FREE CARD

On-Line UPS

Superior Electric's Stabiline uninterruptible power supplies provide a reliable source of continuous sine-wave ac power for computers and other voltage-sensitive equipment. They protect systems and their data from the harmful effects of blackouts, brownouts, sags, surges, spikes and transients. Extended back-up is provided during sustained brownouts because batteries aren't called upon until utility voltage drops below 96 volts ac on 117-volt models. These units operate at an extremely high frequency and use MOSFET semiconductor components for small

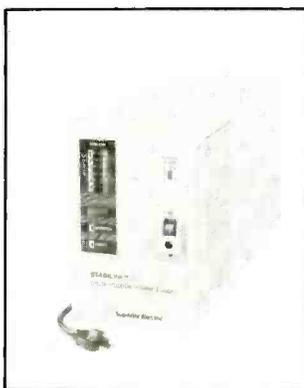

size, light weight, quiet operation and high efficiency. They have RS-232 interfaces to interact with commercially available computer operating systems. Prices start at \$1,150.

CIRCLE NO. 9 ON FREE CARD

LAN Clock Setter

Novell users can now synchronize both individual systems and complete networks to the international time standard, eliminating DOS-clock drift and providing absolute time to 50-ms accuracy with the Odetics CTS-10 Computer Time Standard Board and Benning Computer Systems *RTCtools*. When using *NetWare* 3.0 or later, the CTS-10 can be installed into the file server, providing an absolute time standard for the entire network. In other *NetWare* environments, the CTS-10 can be installed in a workstation, and *RTCtools* can be used to update the file-server clock to UTC.

The CTS-10 board is really a shortwave radio receiver

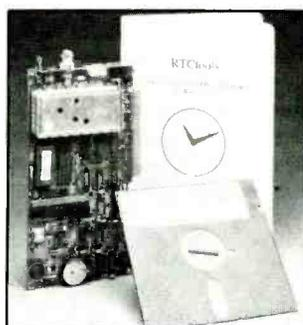

that decodes time and date information from radio signals broadcast from WWV and WWVH stations operated by the National Institute of Science and Technology. This time is synchronized to coordinated universal time (UTC). An external antenna is required. CTS-10 antenna, \$395; *RTCtools*, is priced at \$100.

CIRCLE NO. 10 ON FREE CARD

New Geoworks Version

Version 1.2 of *GeoWorks Ensemble*, the graphical environment and applications package, includes a 100,000-word dictionary, support for both color and black-and-white PostScript printers, support for 300 additional printers, and Tetris, the popular Russian game. *GeoWorks* applications consist of the GUI, a word processor, drawing program, file manager, address and phone book, appointment calendar and communications module. The new version offers international preferences for date, time and currency, a DOS-based diagnostic system to facilitate installation, an expanded library of 50 new program icons for the DOS Room, several screen savers and a library of document templates for small businesses, including memos, invoices and purchase orders. \$200 (free upgrade for registered users).

CIRCLE NO. 11 ON FREE CARD

Carpal Tunnel Support

Carpal.Eez from Viziflex Seels offers relief for computer users who suffer from Car-



pal Tunnel Syndrome (also known as repetitive motion disorders). Carpal.Eez butts up against the front edge of the keyboard and fits snugly and securely under it. This biomechanical aid provides the needed support and a safer wrist angle to help in reducing ligament-straining repetitive wrist motions while operating the computer. It also assures comfortable hand and wrist action.

CIRCLE NO. 12 ON FREE CARD

Handheld Scope/Meter

Fluke has a new series of handheld service instruments that combine a 50-MHz dual-channel digital-storage oscilloscope with a feature-packed digital multimeter, all in a sealed industrial package weighing only 3.3 lb., with LCD readout. The Models 93, 95, and 97 ScopeMeters offer sophisticated oscilloscope features while maintaining ease-of-use through such features as autoset, waveform and set-up memory, combined display of meter results and waveforms, convenient menus and softkeys.

Oscilloscope features include a 40-ns glitch-capture time; storage capabilities of up to eight waveforms and ten setups and autoset (automat-



ically sets volts per division; time per division; position and triggering controls for any input signal). Multimeter capabilities include: minimum/maximum recording; touch hold; relative and percent-relative modes; dBm, dBV, dBW; and autoranging. There's also a tester mode for checking components and a signal generator with sine/square waveforms.

With the included probes, the ScopeMeters are capable of floating high-voltage measurements to 600 volts rms. The same probe is used for both oscilloscope and multimeter voltage measurements. An optically isolated RS-232 interface is standard on the 90 series for instrument calibration. On the model 97, the serial port can be used for remote control, to read waveforms and to print. \$995 to \$1,595.

CIRCLE NO. 13 ON FREE CARD

DMM On A Card

Global Specialties's new PCI-DMM is an intelligent digital multimeter on a card for IBM/compatibles. It pro-

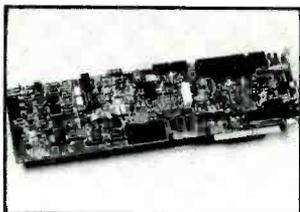

vides all the usual functions of the instrument, and the software creates an easy-to-use front-panel emulation. The computer provides data storage, graphics and programming capability. PCI-DMM relies on the computer mouse to operate the controls on the screen panel. Chart-recorder and data-logger functions are standard. Resolution is a full 4½ digits, and functions include ac/dc volts, ac/dc current, resistance, capacitance and decibels. Other features include relative or absolute measurements, short- or long-range averaging times and automatic range selection. \$795.

CIRCLE NO. 14 ON FREE CARD

Dual-Wattage Soldering Station

The Ungar UTC SS Professional Soldering Station is a 21/35-watt soldering iron with a fully grounded tip. The all-in-one unit includes a power base with built-in control-



ler, dual-wattage soldering iron with an anti-slip handle and coil-spring iron holder with a ceramic mouthpiece that provides a safe standby position for the hot iron. It also features a convenient contamination-free sponge that enables the user to maintain a clean, well-tinned tip. \$60.

CIRCLE NO. 15 ON FREE CARD

Windows Security

Rupp Corporation's FastLock Plus meets security needs of Windows users by offering several levels of data security. The program consists of two modules, *FastLock* and *Plus*, that complement each other. *FastLock*'s Master Password feature allows a MIS manager, for example, to create a separate password capable of overriding an individual password in case of an emergency, or if the individual forgets his password. Logon, a *Plus* module, requires each user to enter both the program password and his own individual account name

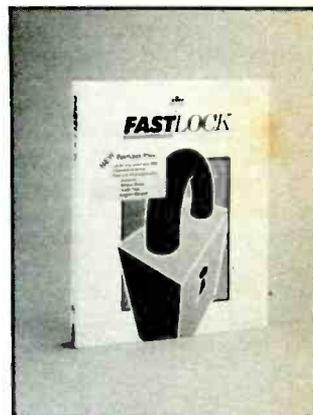

to gain entry. Several other modules and configurations add to the versatility of the program. \$85.

CIRCLE NO. 16 ON FREE CARD

Scanner Adapter

Computer Aided Technology (CAT) has a product for those wishing to use a hand scanner with a laptop computer. The CAT Hand Scan Adapter LPT is a pocket-sized external

hardware piece that allows most hand-held scanners to connect directly to a parallel port. The unit measures 2.3" × 4.7" × 0.8" and requires a 12-volt adapter.

CIRCLE NO. 17 ON FREE CARD

New Programming Books

Advanced MS-DOS Batch File Programming, Second Edition

By Dan Gookin

(Windcrest/McGraw-Hill. Hard cover. 494 pages. \$36.95)

MS-DOS contains a moderately powerful programming language in the form of the batch-file language. The documentation Microsoft provides with DOS is so sketchy and obtuse that few users make extensive use of it. Gookin fills that void with this text. Starting with elementary batch files for changing directories and starting programs, he quickly carries the reader into far more complex regions. Working your way through all the examples in the book should qualify you as a DOS power user as well as first class batch-file programmer. The publisher also of-

fers a disk containing the programs used in the book.

Intel's Official Guide to 386 Computing

By Michael Edelhart

(Intel/Osborne/McGraw-Hill. Soft cover. 366 pages. \$29.95)

Edelhart covers topics that include how to enhance an 80386-microprocessor-based computer for maximum power, upgrading an 80286 PC to a 386 system, and getting the most from Windows and UNIX on a 386. The book also covers how to make applications run better on a "386," including the 386SX, 386SL and i486 CPUs. Other topics covered include 386 microprocessor hardware, system software and applications software. Finally, there is a guide to 386 programming tools.

Seamless Banner Paper

Micro Format's Banner Band is a roll of continuous nonperforated 20-pound paper use-



ful for computer-generated banners, family trees and architectural and design plans. The product line comes in two widths to accommodate both standard and wide-carriage printers and in 45-foot and 150-foot lengths. Several colors are available, as is a parchment-finish paper for programs that trace family trees and animal pedigrees. \$12 to \$20 per roll.

CIRCLE NO. 21 ON FREE CARD

Free Catalog

American Design Component's new 1992 catalog is now available. The 54-page catalog is geared to the needs of manufacturers engineers, researchers, hobbyists, students, computer buffs and tinkers. Products covered include ICs, crystals, fans, connectors, semiconductors, batteries, LEDs etc.

CIRCLE NO. 18 ON FREE CARD

PC "Automater"

Powerpak from The Pendulum Group is a hardware product that complements the company's popular *Auto-Might* event scheduling software. It allows a user to power on or off an IBM/compatible computer (and other devices) from a remote location. Users can have *Powerpak* turn on a computer at a preselected time and automatically turn off the computer after running an application. *Powerpak* includes a copy of *Auto-Might*. \$379.

CIRCLE NO. 22 ON FREE CARD

Home Voice Mail

Radio Shack expands the RL line of home computers with two Tandy 1000 RLX models based on a 10-MHz 80286 CPU. Both models come with a 3½" floppy drive, a single expansion slot, Tandy *Desk-Mate* and *DeskMate Home Organizer*, VGA video, standard I/O ports and a mouse.



With a "voice message" option, the 1000 RLX can become a voice-mail center for the home. Family members have the option of leaving either a written message or a voice message for other family members in the Home Organizer message center. \$800 floppy-drive version, \$1,200 40M hard-drive version.

CIRCLE NO. 23 ON FREE CARD

New NCR Computers

NCR's 3120 is a notebook computer weighing only 5.6 pounds and measuring only 1.7" high. Using a 20-MHz Intel 386SX, the NCR 3120 includes either a 30M or 60M hard drive and a 1.44M floppy. The system also has a VGA LCD screen, an external bus connector and serial, parallel, mouse and video ports.

A battery provides up to 2 hours operating time. Other features are 1M RAM (expandable to 5M), 86-key keyboard and internal modem slot. Prices start at \$3,995.

CIRCLE NO. 24 ON FREE CARD

NCR also has a new entry-level personal workstation, the NCR 3335, based on the Intel 486SX processor. It is upgradable to 25 or 33 MHz and is

designed to accommodate future higher-performance chipsets. The 3335 includes a MicroChannel chipset, high-performance Super VGA graphics chipset, optimized design for maximum performance in a multitasking environment, dual-ported interleaving memory expandable to 64M and intelligent SCSI controller. \$5,395 and up.

CIRCLE NO. 25 ON FREE CARD

DO YOU HAVE OVER 25 PERSONAL COMPUTERS? DO THEY EVER BREAK? THEN WE CAN SAVE YOU BIG BUCKS!

HOW? By doing the following:

- Reduce Downtime
- Cut Inventory Cost
- Cut Actual Repair Time
- Increase Technician's Job Satisfaction

These drives cost \$120 to replace. You can fix 90% of them with a ten minute adjustment.

NAC TEACHES TECHNICIANS ADVANCED HANDS-ON REPAIR AND MAINTENANCE OF PC AND PS/2 HARDWARE, NOVELL NETWORKS, AND PRINTERS.

This PS/2 Monitor could cost you \$40 or less to repair. Are you currently paying \$300 to get this repaired?

Laser printer problems can cost you \$350 per visit. Let us show you how to do your own service for under \$20!

For More Information Call:

**National
Advancement
Corporation**

2730-J South Harbor Blvd.
Santa Ana, CA 92704

National 800-832-4787
California 800-443-3384

CIRCLE NO. 119 ON FREE INFORMATION CARD

No other training to troubleshoot computers

Only NRI walks you through the step-by-step assembly of a powerful 386sx computer system you train with and keep—giving you the hands-on experience you need to work with, troubleshoot, and service today's most widely used computer systems. Only NRI gives you everything you need to start a money-making career, even a business of your own, in computer service.

No doubt about it: The best way to learn to service computers is to actually build a state-of-the-art computer from the keyboard on up. Only NRI, the leader in career-building at-home electronics training for more than 75 years, gives you that kind of practical, real-world computer servicing experience.

Indeed, no other training—in school, on the job, *anywhere*—shows you how to troubleshoot and service computers like NRI.

Get inside the West Coast 386sx computer system... and experience all the power and speed of today's computer technology!

With NRI's exclusive hands-on training, you actually build and keep the powerful new West Coast 386sx/20 MHz mini tower computer system.

You start by assembling and testing your computer's 101-key "intelligent" keyboard, move on to test the circuitry of the main logic board, install the power supply and 1.2 meg high-density floppy disk drive, then interface your high-resolution monitor.

What's more, you now go on to install and test a powerful 40 meg IDE hard disk drive—today's most-wanted computer peripheral—included in your course to

NEW!
386sx/20 MHz
Mini Tower
Computer!

DIAGNOSTIC HARDWARE AND SOFTWARE

R.A.C.E.R. plug-in diagnostic card and QuickTech menu-driven software, both from Ultra-X, give you hands-on experience with today's professional diagnostic tools

MONITOR

High-resolution, nonglare, 14" TTL monochrome monitor with tilt and swivel base

DIGITAL LOGIC PROBE

Simplifies analyzing digital circuit operation

DIGITAL MULTIMETER

Professional test instrument for quick and easy measurements

SOFTWARE

Train with MS-DOS, GW-BASIC, and popular Microsoft Works applications software

DISCOVERY LAB

Complete breadboarding system lets you design and modify circuits, diagnose and repair faults

LESSONS

Clear, illustrated texts build your understanding of computers step by step

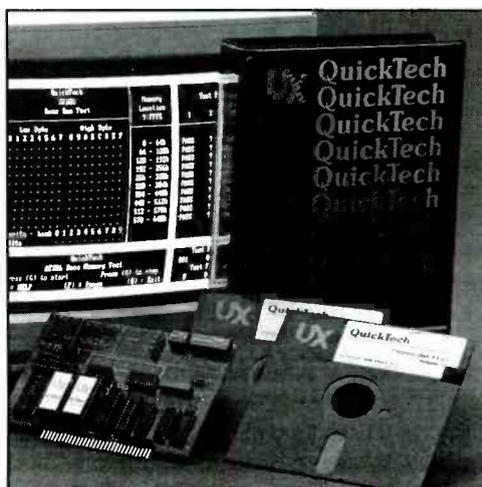

dramatically increase your computer's data storage capacity while giving you lightning-quick data access. But that's not all!

Professional diagnostic hardware and software makes troubleshooting fast and accurate

Your NRI training now includes a remarkable diagnostic package that allows you to quickly locate and correct defects in IBM XT, AT 80286/80386, and

shows you how and service like NRI!

NEW! 40 MEG HARD DISK DRIVE!

You install this 40 meg IDE hard disk drive internally, for greater data storage capacity and data access speed

NEW! 386sx/20 MHz MINI TOWER COMPUTER!

Features 32-bit 80386sx CPU, 1 meg RAM, 64K ROM, 1.2 meg high-density floppy disk drive

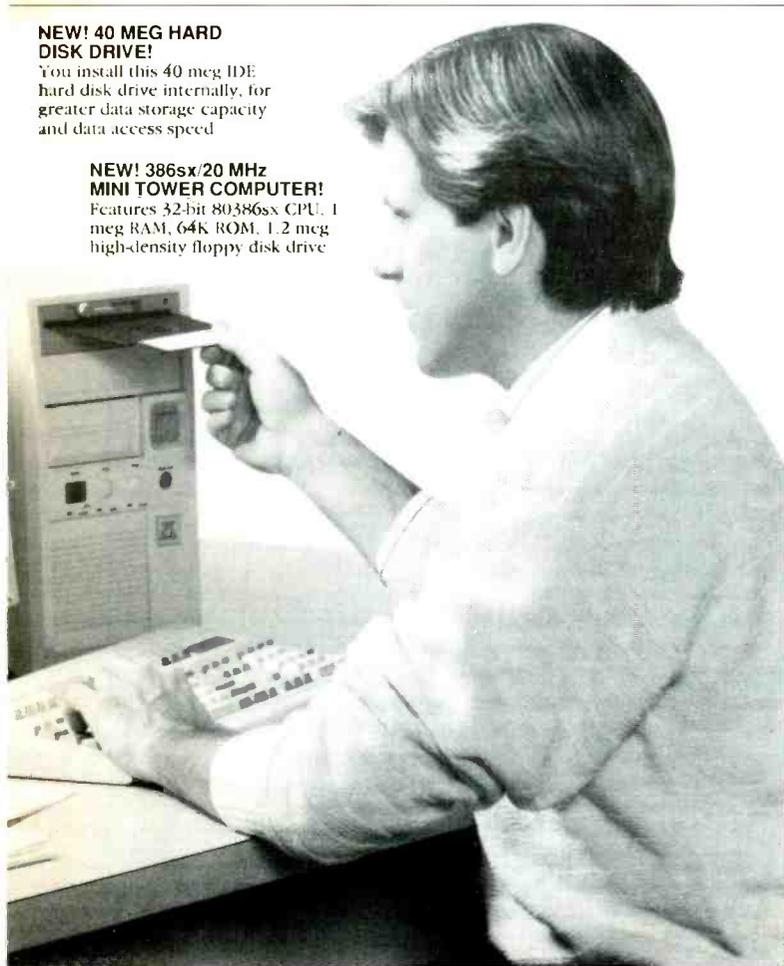

NRI gives you the confidence and the know-how to step into a full-time, money-making career as an industry technician, even start a computer service business of your own!

No experience necessary... NRI builds it in

With NRI, you learn at your own pace in your own home. No classroom pressures, no night school, no need to quit your present job until you're ready to make your move. And all throughout your training, you have the full support of your personal NRI instructor and the NRI technical staff, always ready to answer your questions and give you help whenever you need it.

FREE catalog tells more. Send today!

Send today for NRI's big, free catalog that describes every aspect of NRI's innovative computer training, as well as hands-on training in TV/video/audio servicing, telecommunications, industrial electronics, and other high-growth, high-tech career fields.

If the coupon is missing, write to NRI School of Electronics, McGraw-Hill Continuing Education Center, 4401 Connecticut Avenue, NW, Washington, DC 20008.

IBM is a registered trademark of International Business Machines Corp. QuickTech and R.A.C.E.R. are registered trademarks of Ultra-X, Inc. West Coast is a member of the Syntax Group.

compatible computers.

You'll use your Ultra-X QuickTech diagnostic software to test the system RAM and such peripheral adapters as parallel printer ports, serial communications ports, video adapters, and floppy and hard disk drives. You'll go on to use your R.A.C.E.R. diagnostic card, also from Ultra-X, to identify individual defective RAM chips, locate interfacing problems, and pinpoint defective support chips.

This ingenious diagnostic package is just one more way

NRI School of Electronics

McGraw-Hill Continuing Education Center
4401 Connecticut Avenue, NW
Washington, DC 20008



For career courses approved
under GI Bill
 check for details

Check one FREE catalog only

- MICROCOMPUTER SERVICING
- TV/Video/Audio Servicing
- Industrial Electronics & Robotics
- Telecommunications
- Basic Electronics

- Computer Programming
- Security Electronics
- Electronic Music Technology
- Desktop Publishing
- PC Software Engineering Using C

Name _____ (Please print) _____ Age _____

Address _____

City/State/Zip _____ Accredited Member, National Home Study Council _____ 4-101

PC Tape Backup Systems

Tips on selecting one for your needs and how to install both internal and external units

It's not a question of if you'll lose your hard-disk data—it's when. You've probably heard these words before, but facts remain facts and your hard disk, being a highly mechanical component, is still the most failure-prone part of your computer system. It also just happens to be the part that holds your valuable megabytes of system files and data.

It's unfortunately true that many PC users don't recognize their need for hard-disk backup until after they need it . . . and then it's too late! The more valuable your data, the more compelling backup becomes. Besides hard-disk crashes, backing up your hard disk can help you recover from other disasters, including inadvertent file loss, fire or flood, viruses and computer theft. Backing up your hard disk is like buying data protection insurance.

You can back up your hard disk on any of several possible media types, including floppy disk, optical disk, Bernoulli drive and tape. The floppy-disk option is slow and requires many disks during a time-consuming attended backup operation. In contrast, a tape backup system is usually the best option for most PC users. It's reasonably priced, its media is relatively low in cost and the system is fairly fast in operation. Tape backup systems also generally support unattended backup operation, and standards exist that can allow backup tapes to be transferred between drives from different manufacturers.

With the foregoing in mind, let's take a look at what's available in tape backup systems, with an eye toward simplifying the selection process. We will also discuss how to install a tape backup system.

Tape Backup Alternatives

There are many types of tape backup



alternatives available from which to choose. Among the most popular are the quarter-inch cartridge (QIC) based units, which revolve around two tape cartridge standards (DC 6000 and DC 2000) originally introduced by 3M. Current QIC systems offer storage capacities ranging from 40M to 525M, with 1.3G drives coming soon. QIC is by far the sales volume leader for backing up personal systems and is probably the best choice for most users among the existing alternatives. Because of this, much of this article will be dedicated to exploring QIC in greater detail.

Data cassette, or D/CAS, is another

tape backup alternative that can typically store up to about 60M of data. D/CAS is generally cost effective and is a reasonable choice for individual users with modest hard-disk sizes. But it hasn't seen the same level of industry acceptance as many of the other tape backup alternatives. D/CAS is also the name of an industry association that sets standards for these drives, including D/CAS-25 for 50M to 60M tape backup systems. D/CAS is now also available in a 160M format (from Maynard Electronics and other vendors), and a 600M format is forthcoming.

Four millimeter (4-mm) Digital

Audio Tape (DAT) is, like CD-ROM, another example of how digital consumer electronics is being applied to the computer world. DAT drives currently offer up to 2G of tape backup storage, and greater-capacity drives are expected soon.

Eight millimeter (8-mm) cartridge backup is the current capacity leader at 5G, with 8G capacity on the horizon. As with DAT systems, 8-mm drives are primarily geared toward backing up local-area networks.

Tape drives come in both internal and external configurations, and with a variety of interface options. Some connect to your PC's floppy-disk drive controller, others include a proprietary controller board and still others operate with a standard SCSI (Small Computer System Interface) controller. Some are even designed to connect to your computer's serial or parallel port.

Selecting the right tape backup system involves choosing from among a number of tradeoffs, including cost, tape storage capacity, data transfer rate, data compression support, software features and tape system standardization.

A Close Look at QIC

QIC (pronounced "quick") tape backup systems are based on standards developed by Quarter Inch Cartridge Drive Standards Inc. (or the QIC committee), a company consisting of nine vendors and 29 affiliate members that are dedicated to the development and support of QIC tape-drive standards to aid proliferation of QIC tape systems. The QIC committee has adopted nearly 40 standards to date, many of which are now implemented in popular tape backup systems.

As the name implies, quarter-inch cartridges are data-storage cartridges that use magnetic tape that's approximately a quarter-inch wide. Two basic sizes of quarter-inch tape cartridges exist. The DC 6000 (previously called DC 600) or standard data cartridge was patented by 3M and introduced in 1971. The cartridge measures approximately 4" x 6" and is about 5/8" thick and typically costs \$25 to \$30.

The DC 2000 or mini data cartridge was introduced later by 3M, measuring approximately 2 1/2" x 3"

Table 1. Common QIC Standards

Standard	Tape	Description
<i>Tape Formats</i>		
QIC-24	DC 6000	60M standard capacity tape
QIC-120	DC 6000	125M standard capacity tape
QIC-150	DC 6000	150M standard capacity tape
QIC-525	DC 6000	525M standard capacity tape
QIC-40	DC 2000	40M standard capacity tape, floppy controller
QIC-80	DC 2000	80M standard capacity tape, floppy controller
<i>Interfaces</i>		
QIC-02		QIC tape drive intelligent interface
QIC-36		QIC tape drive basic interface
QIC-104		SCSI implementation for QIC-compatible storage devices
QIC-121		SCSI-2 implementation for QIC-compatible storage devices
<i>Data Compression</i>		
QIC-122		Data-compression format for QIC tape drives (Stac algorithm)
QIC-123		Registry of data algorithm identifiers for QIC tape drives

and about 1/2" thick and typically costing \$15 to \$25.

The basic design of these cartridges is now defined in an ANSI (American National Standards Institute) standard. Both cartridges are available in various tape lengths, with DC 6000 tapes obviously tending to have greater capacities than DC 2000 tapes.

Although tape backup systems using the DC 2000 mini data cartridges have achieved the greatest popularity among individual PC users, DC 6000-based drives are also popular and should be considered for single-system use. Most DC 2000 tape systems conform to the QIC-40 and QIC-80 standards, representing nominal 40M and 80M tape capacities, respectively. Longer tape lengths and incorporation of data compression techniques, however, have increased these capacities three-fold. My Colorado Memory Systems Jumbo 250 tape drive, for example, conforms to the QIC-80 standard and can store 80M of data on a DC 2080 mini data cartridge (notice how the last three digits of the tape number indicate the nominal tape storage capacity).

Floppy-tape drives tend to offer only modest performance when compared to other tape drives because of the data-transfer rate limitations of the PC floppy-disk interface. The problem is worse on a PC or XT machine than on an AT machine, since most XTs have a floppy-disk controller that supports only the 250K-bit-

per-second (bps) data-transfer rate used with 360K floppy-disk drives, while AT floppy controllers are designed to operate at twice this speed. Some newer AT floppy controllers even support an enhanced 1M-bps transfer rate. While your tape drive may not normally take advantage of this "turbo" transfer rate, some tape drive suppliers offer the 1M-bps data-transfer rate on their optional stand-alone controller boards for faster operation.

Some floppy-tape drives are designed for a single specific floppy data-transfer rate. It's best to determine ahead of time if the drive operates at a fixed transfer rate (either 250K bps or 512K bps) or if the drive can adjust its data-transfer rate to get the maximum benefit from the system it's operating in (as most do). Some tape drive suppliers give you a clue by saying their drives are "PC compatible" (i.e., 250K bps operation) or "AT compatible" (512K-bps operation), but it's best to verify this with the drive vendor before buying. Drives requiring a 512K-bps data-transfer rate won't operate on PC or XT machines, and drives that operate at only 250K bps will perform unnecessarily slow on AT systems.

Floppy-tape drives offer the greatest level of functional standardization and vendor-to-vendor compatibility of any of the QIC tape drive systems. The QIC-40 and QIC-80 standards describe both the physical

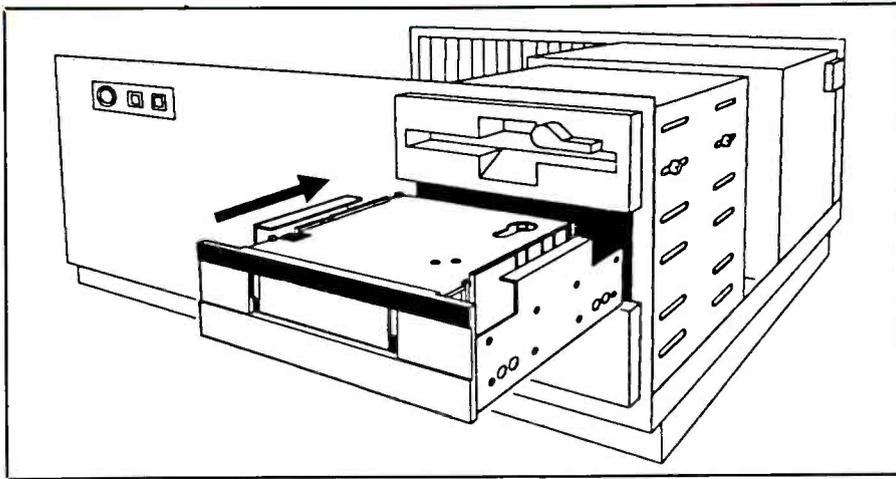

For internal tape-drive installation, slide the drive into an available 5 1/4" drive bay. (Courtesy Colorado Memory Systems Inc.)

and logical data formats, whereas other QIC standards specify only the physical format. The physical format specification consists of such information as how many tracks are on the tape, width of each track and track positions. The logical format specification includes details on how the data is written to the tape, describing what information is to be written where, and how it's to be interpreted. The logical data format specification of floppy-tape drives generally allows backup tapes to be interchanged between tape drives from different manufacturers. This level of compatibility is less prevalent, but not nonexistent, among other QIC tape drives.

Using the newer DC 2120 cartridge, however, the same drive can store 120M of data. By enabling its data-compression algorithm, which typically provides a 2:1 data-compression ratio, effective capacity is again doubled to about 240M. Consistently, I get very close to an average 2.0:1 compression ratio when backing up the files on my hard disk, verifying manufacturer claims. I've never been even close to having a problem fitting the 180M of files on my hard disk onto a single DC 2120 mini data cartridge. Even the contents of my entire 210M hard disk, were it fully loaded, should fit comfortably on a single tape.

QIC-40 and QIC-80 tape drives are designed to connect to the Drive B connector on your PC's floppy-disk drive controller. Thus, they're often referred to as floppy-tape drives.

Lack of a separate controller board accounts, at least in part, for the relative economy of these drives.

Since most PC-compatible systems are designed to support only two floppy devices, an obvious problem occurs in systems that have two floppy-disk drives installed: How can you connect the tape drive when a floppy drive is already using the needed connector? One approach, clearly, is to remove the second floppy and install the tape drive using the freed Drive B connector. If this is undesirable (as it was for me), many vendors offer separate controller boards for their tape drives that allow the drive to be used without using your existing floppy controller. You can expect to pay an additional \$100 to \$200 for this luxury, though.

Essentially, the controller board acts like a standard floppy-disk controller, but it doesn't appear in the standard PC floppy interface I/O addressing space. Some vendors, like Colorado Memory Systems, offer multiple interface board choices, including a standard AT bus interface board, an interface board with built-in fast hardware data compression, and a Micro Channel interface board. QIC-40 drives are available for as low as about \$300, with typical floppy-drive prices ranging between \$400 and \$800.

Because of their operation on your PC's floppy-disk controller, QIC-40 and QIC-80 tape drives must preformat the DC 2000 tapes before they can be used. This process generally takes a while, typically requiring

about 1 minute per megabyte, and allows the tape drive to essentially appear to the floppy controller as a floppy disk drive with 1K-byte sectors. The QIC standards specify how the tracks of the tape are mapped to the sectors, tracks and sides of what the floppy controller thinks is a floppy-disk drive. To help save time, preformatted tapes are now available.

DC 6000-based tape drives are based on other QIC standards, supporting a variety of different capacities. Since these drives require their own controller board (generally sold separately), QIC standards are available not only for the tape formats, but also for tape controller interfaces. Table 1 lists several of the most common QIC standards.

With the exception of the 60M QIC-24 standard, the number in the QIC tape format standards specifies the "standard" maximum tape capacity for the drive. For example, the increasingly popular QIC-150 standard specifies a 150M tape capacity (although 250M can now be stored on newer extended-length data cartridges that are now available).

In addition to the QIC standards specified in Table 1, some new standards have been emerging, which should begin appearing in real products soon. QIC-380 takes the DC 2000 mini data cartridge to new heights with 380M of storage. QIC-1350 promises DC 6000 capacities to 1.35G. DC 6000-based drive systems range in price from about \$800 to \$2,500 and are available in both internal and external configurations.

Among the controllers for the DC 6000 tape drives, the intelligent QIC-02 controller is a popular choice, and many drivers have been written for these controllers to support non-DOS operating systems. The QIC-36 controller provides the most basic level of functionality at lowest cost. QIC-104 is a SCSI interface standard that also specifies the SCSI command set to be used with the interface. Similarly, QIC-121 is an SCSI-2 interface standard, representing support for the latest ANSI SCSI interface standardization efforts.

Some external tape drives are now available with serial and/or parallel interfaces, allowing tape backup for any PC-compatible, regardless of the availability of floppy-disk controller



Altex Electronics, Inc.

TO ORDER CALL 1(800) 531-5369



Mail Order Dept., 11342 IH-35 North, San Antonio, TX 78233 - (512) 637-3200; Hours 7am-7pm M-F, 10-2pm Sat. FAX (512) 344-2985

TERMS: For C.O.D. orders add \$3.30. Minimum \$25. For orders under \$99 add \$3.00 handling charge plus FRT. For orders over \$99, actual FRT charges apply. P.O.'s accepted from approved accounts. Texas residents add 8 1/4% sales tax. All returns require RMA# and must be returned in original condition. Subject to 15% restocking fee. Prices and product descriptions subject to change. CALL FOR CURRENT PRICING. We are not responsible for typographical errors.

MOTHER BOARDS

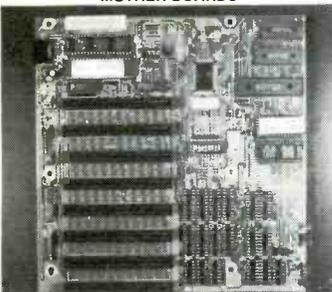

Part#	Description	Each
D11-XT	Turbo 10 MHz Mini XT Motherboard	\$59
D11XT-640	Same as D11-XT w/640K installed	\$109
DFI286-12/E	12 MHz 286 Mini Motherboard	\$109
DFI286-16/E	16 MHz 286 Mini Motherboard	\$119
MB386SX	Turbo 386 16 MHz SX Motherboard	\$299
MB386-25	386 25 MHz Motherboard	\$679
MB386-33C	386 33 MHz Motherboard	\$729

MEMORY BOARDS

All memory boards come with 0/K. Call for pricing with memory.

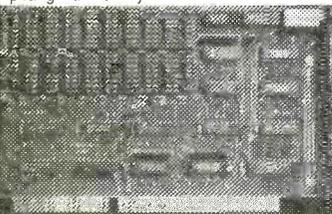

Part#	Description	Each
MEMO-576	576K Rambom board	\$29
MEMO-2000A	EMS 4.0 Memory Board 2 MEG AT	\$89
MEMO-2000X	EMS 4.0 Memory Board 2 MEG XT	\$79
MEGALITH	Enhanced EMS Memory Board, 4 MEG AT	\$119
IFC-47	128K AT Memory Board	\$67
IFC-60	AT Plus - Up to 8 MEG RAM	\$119
IFC-60A	AT Memory Board 8 MEG Using SIMMS	\$119
IFC-62	PS-2 MOD 50 60 EMS up to 2 MEG	\$129
IFC-64	PS-2 - EMS up to 2 MEG	\$99

IIT MATH CO-PROCESSORS

2C87-12	For 286 up to 12.5 MHz	\$89
2C87-20	For 286 up to 20 MHz	119
3C87-16SX	For 386SX up to 16 MHz	129
3C87-20SX	For 386SX up to 20 MHz	149
3C87-25	For 386 up to 25 MHz	179
3C87-33	For 386 up to 33 MHz	199

CALL FOR PRICING ON DYNAMIC MEMORY AND MEMORY MODULES

DISK CONTROLLER BOARDS

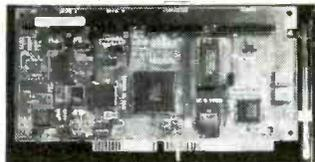

Part#	Description	Each
IFC-16	2 Floppy Controller Board XT/AT	\$25
IFC-14	2 Floppy Controller Board PC/XT	\$13
IFC-15	Disk I/O Board Serial, Parallel, Clock Game PC/XT	\$25
IFC-24	Fixed Disk MF w/2 Floppy Controller AT	\$69
IFC-26	Floppy, Fixed Disk RLL Controller AT	\$129
IFC-27	AT 2 IDE 4/Floppy Controller	\$29
IFC-27X	XT 2/IDE 4/Floppy Controller	\$69
IFC-28	XT MFM Hard Drive Controller Board	\$40
IFC-29	RLL Fixed Disk Controller Board PC/XT	\$57
IFC-54	Add On Floppy Board XT/AT	\$49
ST-01	8 Bit SCSI Controller	\$29
ST-02	8 Bit SCSI/Floppy Controller Board	\$47
IN-2000	16 Bit SCSI Hard/Floppy	\$225

EXPANSION BOARDS

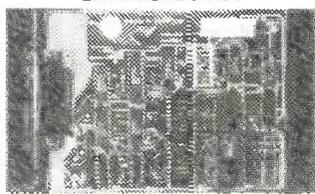

Part#	Description	Each
IFC-12	Serial Board PC/XT	\$11
IFC-25	2 Serial, Parallel, Game Board XT/AT	\$16
IFC-13	Parallel Board XT/AT	\$9
IFC-19	Clock Board PC/XT	\$10
IFC-19B	Chipchip for PC/XT	\$24
IFC-20	Game Board XT/AT, 2 Ports	\$9

COMMUNICATION BOARDS

Part#	Description	Each
MS-400X	Multi-Serial Board for PC/XT	\$69
MS-400A	Multi-Serial Board for PC/AT	\$99
MS-422X	Dual RS-232/422 Serial Card for PC/XT	\$59
MS-422A	Dual RS-232/422 Serial Card for PC/AT	\$69
MU-440	Multi-User Board	\$139

VIDEO BOARDS

Part#	Description	Each
IFC-32	Mono Board w/printer port XT-AT	\$16
IFC-33	Color Graphics w/printer port XT-AT	\$25
IFC-42	640x480 VGA Card	\$69
IFC-42C	BOCA Super VGA Card	\$159
VG-3000	Video Adapter Board w/256K	\$79
VG-7000	Super VGA w/512K	\$139

RELISYS MONITORS



Part#	Description	Each
RM9503	Monochrome PS/2 (800 x 350, 400, 480)	\$149
RE9514	Super VGA (1024 x 768) Unlimited Colors	\$359

LASER MONITORS

Part#	Description	Each
MON-05	Monochrome TTL Amber 12"	\$89
MON-06	Paper White TTL 14" (640 x 240) 14"	\$112
MON-10	CGA/RGB VGA 41 Dot Pitch (640 x 480) 14"	\$239
MON-07	VGA 41 Dot Pitch (640 x 480) 14" Super VGA	\$269
MON-08	Super VGA (1024 x 768) Unlimited Colors 14"	\$399

POWER SUPPLIES



Part#	Description	Each
PS-150	150 watt XT Power Supply	\$39
PS-150UL	Same as PS-150 - UL Listed	\$69
PS-200M	200 watt XT power Supply	\$49
PS-200MUL	Same as PS-200M - UL Listed	\$89
PS-200	200 watt AT Power Supply	\$59
PS-200UL	Same as PS-200 - UL Listed	\$89
PS-220	220 watt Vertical Case Power Supply	\$79
PS-200MINI	200 watt Baby Vertical Case Power Supply	\$59

DISK DRIVES



Part#	Description	Each
DDD-04	5 1/4 inch DSDD 360K black faceplate	\$59
DDD-05	5 1/4 inch DSDD 360K beige faceplate	\$59
DDH-06	5 1/4 inch DSHD 1.2MB beige faceplate	\$75
DDH-09	3 1/2 inch 720K beige w/brkt	\$69
DDH-10	3 1/2 inch 1.44MB beige w/brkt	\$79
RAIL01	AT Drive Rail Kit	\$1.99
FP-BLK	1/2 Height Black Faceplate	\$2.49



Part#	Description	Each
5.25KITFD	Floppy Drive Kit	\$9.95
5.25KITHD	Hard Drive Kit	\$9.95

COMPUTER CASES

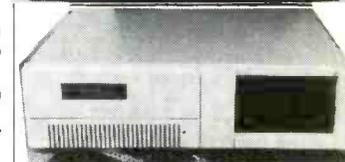
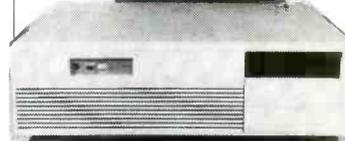

Part#	Description	Each
STC-03	Baby AT Case	\$39
STC-04	Regular AT Case	\$59
DAB-103	DFI Slimline Case w/200 Watt Power Supply	\$139
STC-05	Baby Vertical w/200 Watt Power Supply	\$89
CASE-TH8	Regular Vertical w/300 Watt Power Supply	\$249

KEYBOARDS

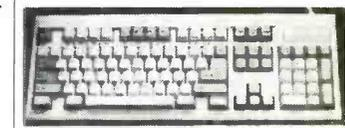

Part#	Description	Each
K-156	(XT,AT) 101 keys with regular footprint for XT or AT.	\$49
K-160	Narrow Footprint 101 keys XT or AT.	\$49
K-158	Small Footprint 101/102 keys. 22 percent smaller than regular footprint.	\$49
K-158-1	Small Footprint Spanish Language	\$55

HARD DRIVES



Part#	Description	Each
ST-225	20 MB MFM 65 MS Hard Drive 5-1/4"	\$199
ST-238	30 MB RLL 65 MS Hard Drive 5-1/4"	\$219
ST-251	40 MB MFM 28 MS Hard Drive 5-1/4"	\$259
ST-157	40 MB 28 MS IDE Hard Drive 3-1/2"	\$209
ST-1102A	89 MB IDE 19 MS Hard Drive 3-1/2"	\$359
ST-296N	84 MB SCSI 19 MS Hard Drive 5-1/4"	\$369
ST-1144A	130 MB IDE 19 MS Hard Drive 3-1/2"	\$419
ST-1239A	210 MB IDE 15 MS Hard Drive 3-1/2"	\$639
ST-1239N	204 MB SCSI 15 MS 10MPBS Data Transfer Rate Hard Drive 3-1/2"	\$649

TO ORDER (800) 531-5369

FAX (512) 344-2985

TO ORDER (800) 531-5369

FAX (512) 344-2985

TO ORDER (800) 531-5369

FAX (512) 344-2985

TO ORDER (800) 531-5369

FAX

TO ORDER (800) 531-5369

FAX (512) 344-2985

TO ORDER (800) 531-5369

FAX (512) 344-2985

TO ORDER (800) 531-5369

FAX (512) 344-2985

TO ORDER (800) 531-5369

FAX

connections or free expansion slots. While these interfaces are inherently slower than those for standard tape drives, overnight unattended operation makes their slow speed tolerable for many users.

Additional benefits from external parallel or serial interface drives include the ability to back up hard disks in laptops and other portable computers and the ability to use the same tape drive with multiple systems. The parallel interface is much faster than the serial link, but it operates only on systems that support bidirectional parallel-port operation.

External tape drives usually use a separate controller card, have a case and sometimes a power supply. With them, there may well be a few choices to be made on a controller card, such as selecting starting address for an I/O port, a DMA (direct memory access) channel and an interrupt number. Manufacturers generally ship cards with default settings, but they might require changing if there's a conflict with other devices on the computer that are using them. The card may use DIP switches or pin jumpers to effect a change.

As an example, if a port address is being used by some device that the default is set to, you can change the address from, say, 0338H to 0300H by following the card maker's instructions that accompany the card. The same holds true for an interrupt (IRQ) number. If a device (printer, hard drive, network card, etc.) is using the controller card's default setting, change it to an unused IRQ. Follow this procedure for choosing a DMA channel number, too. Diagnostic software, such as *CheckIt*, will reveal which devices are using what configurations and which configurations are not in use.

Because they don't use a floppy-disk controller, DC 6000-based tape drives don't require tape preformatting, saving you a potentially long operation each time you buy a new tape. Data compression has been an increasingly hot topic in data-storage the last couple of years. Several products, such as Expanz! from InfoChip Systems and Stacker from Stac Electronics, now offer "lossless" data compression for data stored on a hard disk, typically doubling hard-disk capacity and operating transpar-

ently to normal disk operation. Similar (and often the same) compression algorithms are now being applied to tape backup systems to effectively achieve higher storage capacities.

The data-compression algorithm developed by Stac Electronics has become popular, and Stac offers a chip that implements the function in hardware for fast operation. The QIC committee has adopted the Stac compression algorithm as a standard (QIC-122), and other algorithms can be supported on a "registry" basis. The QIC committee has set up QIC-123 as a registry of identifiers for data-compression algorithms.

Data compression can reduce file sizes by 50% or more, and they can be implemented in software or hardware. While the net result is the same, software implementation tends to result in a noticeable performance reduction because of the time required to compress the data. Hardware-based compression, such as implemented by the popular Stac chip, permits fast data compression, sometimes even increasing overall drive performance, compared to no-compression operation.

In addition to reduced performance, data compression can create other undesirable side effects. Compression can induce format incompatibilities between tape drives from different manufacturers and can even result in *larger* file sizes when attempting to compress files that have already been compressed.

Using data compression can also make the number of tape cartridges required for a backup uncertain. For example, since the actual data-compression ratio from hard disk to tape drive can't be predetermined, the control software for my Colorado Jumbo 250 tape drive gives me a warning at the start of each backup, stating that more than one tape may be required to back up the drive. This message appears any time the amount of data to be backed up exceeds the uncompressed capacity of the tape. My drive always compresses down to about 2:1, but compression does introduce a certain amount of uncertainty and will vary from user to user, based on the types of files being compressed. Overall, the drawbacks are pretty minor, and compression is a great thing to have.

In general, DC 2000-based tape-backup systems are more economical than their DC 6000 counterparts and are the best choice for most individual (non-networked) PC users. With individuals often using large hard disks, however, DC 6000 drives may sometimes prove to be a more appropriate choice. DC 6000 drives also offer faster backup operation, often exceeding 5M/minute, compared to the typical 1M to 2M per minute for DC 2000 drives.

Another DC 6000 time saver comes from the fact that these drives have separate read and write heads; so they can perform a verify-after-write operation "on the fly." DC 2000

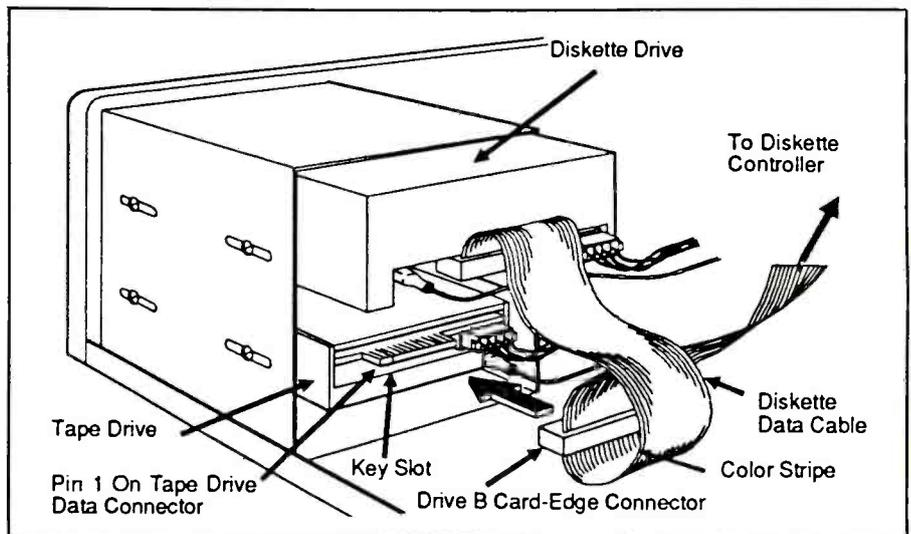

Once the internal tape drive is installed and secured in place with supplied screws, connect the diskette drive and power cables to it as shown. (Courtesy Colorado Memory Systems Inc.)

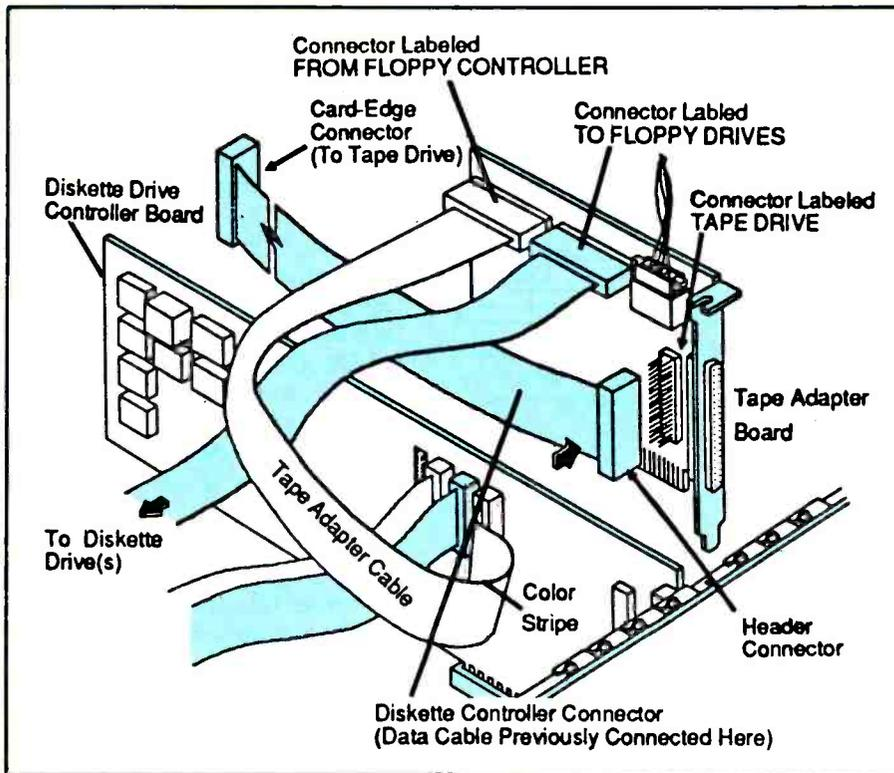

If you have two floppy-disk drives you want to keep when you add an internal tape drive, you must use a separate controller board for the latter. Tape-drive adapter board works in concert with floppy-disk drive controller as shown. (Courtesy Colorado Memory Systems Inc.)

drives, on the other hand, require a separate verify pass to verify the written data. For most individual users, tape backup speed isn't usually critical, since backup is generally performed in an unattended mode during hours the computer is otherwise normally idle (and the user is asleep).

In making the QIC decision for a tape-backup system, you must first determine the tape capacity you need. Then you must, of course, take a close look at your budget. When looking at various alternatives, consider the cost of the tape drive controller board, if required (or if desired, in order to keep your two-floppy system intact), and make sure the tape-backup software is included in the price of the drive. Though most tape-backup systems include the controlling software, not all do. If you need to purchase additional software, you must figure this into the overall cost of the system.

When determining what capacity to select, consider the capacity of your existing hard drive, as well as any additional hard-drive capacity you may add in the future. Choose a tape system that can back up your en-

tire hard disk on a single tape cartridge, allowing total disk backup during unattended operation.

As you look at different tape-backup alternatives, consider the features of the backup software as well. Good software can be a tremendous benefit in the overall use of your tape-backup system. Software features to look for, based on your own personal requirements, include unattended backup operation (a "must"), tape cataloging, loadable device drivers, password protection, built-in error correction, foreign-language support, batch-file operation support and use of expanded memory for more-efficient operation. Some standard tape-backup utilities now support many QIC-40/80 tape drives, most notably *PC Tools Deluxe* from Central Point Software.

One word of caution: QIC does not always mean QIC. Not all suppliers of tape drives that use 1/4" cartridges conform to QIC standards. Irwin Magnetics (now Irwin Products Group, an Archive company), for example, offers several tape drives that attach to a PC's floppy controller and use DC 2000 tape car-

tridges, but its drives (that is, the tape data formats) don't conform to QIC standards. If you're merely backing up data for your own use and are confident your tape drive manufacturer will be around for a long time to support you, then going with a proprietary tape format may be no problem. If you prefer to stick with QIC standards, make sure you select a tape-backup system that conforms.

Popular QIC tape-backup system manufacturers include Colorado Memory Systems, Archive Corp., Tallgrass Technologies, Everex Systems and Maynard Electronics, among many others.

Installing a Tape Drive

Tape drive installation is reasonably straightforward and depends on the tape-drive configuration you choose. However, there's a lot of commonality in the installation of different drive types, with some drives having certain installation peculiarities that must be addressed, as outlined by the manufacturers. I'll now outline typical tape-drive installation procedures here, but you should refer to the installation manual included with the tape drive for specific issues related to your drive.

External DC 6000 Tape Drives. External tape drives are easy to deal with, since they only require installation of the controller board. Depending on the drive, power for the tape drive may come from the controller board, or it can come directly from your ac wall outlet.

Keeping your system plugged in (but turned off) to keep yourself grounded, remove the cover from your system. Locate an available expansion slot, remove the storage cover plate and install the board into the slot. If the board requires a 16-bit AT slot, make sure you install it in a 16-bit slot. Secure the board with a screw in the board's cover plate. Securely connect the data cable between the controller board and the tape drive, and connect power to the drive, as required. Power up your system, install the tape-backup software and proceed to verify proper tape drive operation.

If you encounter problems, make sure the board is firmly seated in an appropriate slot and that the data cable is screwed on tightly at both con-

necter ends. Once you have confirmed proper functionality, turn off system power and replace your computer chassis cover.

Internal DC 2000 Tape Drives. If you have two floppies installed in your system and wish to install a tape drive internally, either remove one drive (Drive B) or purchase a separate controller board for your tape drive. With your system still plugged in and turned off, remove the cover of the system unit and locate an available drive bay. Many DC 2000 tape drives will fit in a 3½" floppy drive bay, although some require a standard half-height 5¼" bay. If you have an AT system, you may need to attach slides to the sides of the tape drive.

Slide the drive part way into the drive bay and connect the data cable. This will be either a second 34-pin card-edge connector on the same cable as your existing drive A floppy, or the cable that came with your optional controller board. *Make sure you correctly orient the data cable so that pin 1 of the cable is on the pin-1 side*

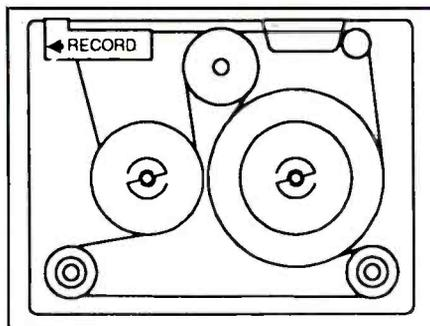

Tape cartridges have slide switches that can be set to protect tape from being written to. (Courtesy Colorado Memory Systems Inc.)

of the tape drive's connector. The data cable generally has a red, blue or brown stripe along one edge to indicate the pin 1 side of the cable. Refer to your drive manual, if necessary, to determine the pin-1 side of the drive's interface connector.

Now connect a power connector from your system power supply to the drive. If you have no power connectors available, you can purchase a power splitter cable from any of numerous sources that allows you to convert the power connector going to your floppy drive into two parallel power connectors.

If an optional interface board is being used, find an open slot and install the board, making sure the board is firmly seated. Secure the board tightly with a screw in its cover plate. Attach the tape drive's data cable to the controller board, again making sure that pin 1 is correctly positioned.

With cables connected, slide the tape drive the rest of the way into the drive bay and secure it with screws. Tape drives are often secured with two screws on one side of the drive, although some AT drives require front-mount screw attachments. Some drives, like my Colorado Jumbo 250, also require a separate ground-wire connection to be made. In such a case, attach the ground wire per the drive's installation manual.

Power up your system, install the tape-backup software, and proceed to verify proper tape-drive operation. If you experience problems, recheck your cable connections (and your pin-1 orientations), make sure power is being applied to the drive and make sure the controller board,

if present, is firmly seated. Once you've confirmed proper operation, turn off your system and replace the system chassis cover.

AT systems should be configured for "no drive" for floppy Drive B in the system Setup. This is the default configuration, and needs only be changed if you removed a floppy drive in the process of installing your tape drive.

Internal DC 6000 Tape Drives. Internal DC 6000 drives install basically the same way as DC 2000 drives that have the optional controller board, as previously described. DC 6000 drives typically require a half-height 5¼" drive bay.

Tape Drive Quirks

As wonderful as they are, tape drives have been known to exhibit a number of quirks in various circumstances. One common one is improper or inconsistent operation at high CPU speeds. Your tape-drive manual or the manufacturer's technical support people may suggest that you change your computer to non-turbo or slow speed mode if you experience unexplainable anomalies. Also, as a general rule, make sure you always perform a verify operation with your backup. Most floppy-tape systems give you this choice, and you should always accept. This will help ensure that your data actually got put onto the tape as expected.

Summary

A tape backup system can eliminate a lot of potential grief. With modest prices and high storage capacities, the tape-backup alternative makes a lot of sense for most personal computer users. It's even wise to keep an off-site backup of your data in case of fire or flood. Remember, your hard disk is a time bomb . . . don't wait until it's too late!



Roger Alford

U.S. CYBERLAB



'EXTREME' HIGH TECHNOLOGY

KITS, PRODUCTS, MATERIALS

Nick Goss says, "This catalog is a 'must' for every serious Scientific Experimenter! Better order your copy today. These are the products you have been waiting for!"

Come join the Cyberlab Team and start living the adventure by building scientific kits that contribute directly to your own personal technological power base!

U.S. CYBERLAB, INC.

RT 2 BX 284, CYBER FACILITY
WEST FORK, AR 72774
(501) 839-8293 VOICE MAIL

CIRCLE NO. 129 ON FREE INFORMATION CARD

B. G. MICRO

P. O. Box 280298 Dallas, Texas 75228

(214) 271-5546

FAX (214) 271-2462



FAN

Brand New from McLean Eng.
A Division of Zero Corp.
Square 4-11/16" by 1.5"
Thick 10" Wire Leads
120V - 60hz - .12 amps - 110CFM
Metal Housing - 5 Plastic Blades
UL and CSA Approved
\$5.95 ea.

BATTERY

Brand New - '91 Date Code
Rechargeable Sealed Battery
6 Volts @ 4 Amp/h
Measures: 4" Tall - 2-3/4" Wide
1-3/4" Thick - A Steal at
\$6.95 ea. or 4 for \$25.50

DISPLAY DEVICES

4MT07 By Futaba
Vacuum Fluorescent Clock
And Timer - 4 Digit Display
Easy to Read - Easy to Use.
3" Character Height
With Data 79c

LTP 1157AE
1.2" 5x7 Matrix Displays
5x7 Array with x.y select.
This Red Orange Matrix Can Be
Stacked Horizontally. Choice of
Two Matrix Orientation-Cathode
Column, Anode Row. Great For
"Moving Message" Signs.
\$1.19 Ea., 8/\$6.95, 100/\$75.00

74LS

LS00 .14	LS114 .25	LS241 .60
LS01 .14	LS122 .35	LS242 .65
LS02 .14	LS123 .45	LS243 .50
LS03 .14	LS124 1.35	LS244 .55
LS04 .14	LS125 .30	LS245 .55
LS05 .14	LS126 .35	LS251 .45
LS08 .14	LS132 .35	LS253 .40
LS09 .14	LS133 .25	LS257 .35
LS10 .14	LS136 .28	LS258 .45
LS11 .14	LS138 .35	LS259 1.00
LS12 .20	LS139 .35	LS260 .40
LS13 .25	LS145 .75	LS266 .30
LS14 .30	LS148 .35	LS273 .75
LS15 .20	LS151 .35	LS279 .30
LS20 .14	LS153 .35	LS280 .80
LS21 .16	LS154 .85	LS283 .35
LS22 .16	LS155 .50	LS290 .70
LS26 .14	LS156 .42	LS293 .50
LS27 .20	LS157 .30	LS298 .65
LS28 .15	LS158 .25	LS299 1.00
LS30 .14	LS160 .25	LS322 1.30
LS32 .16	LS161 .35	LS323 2.25
LS33 .25	LS162 .45	LS348 .75
LS37 .24	LS163 .36	LS353 1.00
LS38 .24	LS164 .45	LS357 .80
LS42 .35	LS165 .60	LS363 .75
LS51 .15	LS166 .75	LS364 .75
LS54 .20	LS169 .90	LS365 .30
LS55 .20	LS170 .45	LS366 .28
LS73 .33	LS173 .60	LS367 .35
LS74 .22	LS174 .35	LS368 .30
LS75 .25	LS175 .35	LS373 .50
LS83 .30	LS181 1.25	LS374 .45
LS85 .45	LS191 .45	LS375 .35
LS86 .20	LS192 .65	LS377 .75
LS90 .35	LS193 .65	LS378 .80
LS92 .30	LS194 .40	LS390 .80
LS93 .25	LS195 .52	LS393 .75
LS95 .30	LS196 .55	LS399 1.00
LS96 .33	LS197 .75	LS541 1.20
LS107 .28	LS221 .50	LS645 .75
LS109 .20	LS240 .50	LS646 .75
LS112 .25		LS670 .80
LS113 .25	25LS2569	1.50

THE \$25 NETWORK

Try The 1st Truly Low Cost LAN

- Connect 2 or 3 PCs, XTs, ATs
- Uses serial ports and 5 wire cable
- Runs at 115 K baud
- Runs in background, totally transparent
- Share any device, any file, any time
- Needs only 14K of ram

Skeptical? We make believers!

SUPER BUYS

2016 P-15
2K x 8 N-MOS
Trimmed Leads,
But will Fit in Sockets.
Super Buy
10/2.95 105/22.00

2N4401
Super 2N3904 NPN
Switching Transistor
40V-TO-92 — P.C. Leads
15/1.00 1000/20.00

80C32
C-MOS By Matra - 12MHZ
3.95

LM350T	2.65
LM338K	4.95
16L8-15 TI-B-PAL	1.25
8088-2	3.25
8742	7.00

WIRE WRAP

Dual Wrap - 2 Level		
14 Pin	10/2.50	100/20.00
16 Pin	10/2.50	100/20.00
20 Pin	10/3.50	100/30.00

SOCKETS

Low Profile SOLDER TAIL		
6 Pin	14/1.00	
8 Pin	13/1.00	
14 Pin	13/1.00	
16 Pin	13/1.00	
18 Pin	13/1.00	
20 Pin	13/1.00	
22 Pin	13/1.00	
24 Pin	8/1.00	
28 Pin	7/1.00	
40 Pin	7/1.00	
68 Pin PLCC	.79	
84 Pin PLCC	.89	

BUY \$10
GET \$1.00 - FREE CHOICE

6500/6800

6502	2.00	6821	1.00
6520	1.25	6845P	2.20
6522	2.70	6845S	2.20
6530	3.00	6850	1.75
6532	4.25	6852	3.50
6545	2.10	6860	3.95
6551	2.40	68681	3.00
6800	1.40	68A09EP	1.29
6802	2.50	68A40	4.00
6803	3.00	68A54	3.00
6805	2.95	68B09	4.00
6809EP	2.75	68B10	2.00
6809P	2.50	68B45	4.95
6810	1.25	68B54	4.00

TEXT TO SPEECH BOARD

PC/XT COMPATIBLE. MAKE YOUR COMPUTER TALK!

PRICE CUT \$69⁹⁵

ASSEMBLED & TESTED
ADD \$3.50 SHIPPING
& HANDLING



A VERY POWERFUL AND AMAZING SPEECH CARD. USES THE GENERAL INSTRUMENTS SPO256-AL2 SPEECH CHIP AND THE CTS256A-AL2 TEXT TO SPEECH CONVERTER.

THIS BOARD USES ONE SLOT ON THE MOTHERBOARD AND REQUIRES A COM SERIAL PORT. BOARD MAY ALSO BE USED IN A STAND ALONE ENVIRONMENT (EXTERNAL POWER SUPPLY) WITH ALMOST ANY COMPUTER THAT HAS A RS232 SERIAL PORT. TO USE THE BOARD IT IS ONLY NECESSARY TO SEND ENGLISH TEXT TO THE RS232 INPUT ON THE BOARD. THE BOARD INCLUDES A 1500 BYTE TEXT BUFFER AND HANDSHAKE LINE TO ALLOW YOU TO SEND DATA TO THE BOARD; THE SAME AS YOU WOULD SEND DATA TO AN RS232 SERIAL PRINTER. YOU CAN SET UP BATCH FILES THAT WILL MAKE YOUR COMPUTER GREET YOU WITH "GOOD MORNING MASTER," ETC. EVERY TIME YOU TURN IT ON.

DEMONSTRATION SOFTWARE AND A LIBRARY BUILDING PROGRAM ARE INCLUDED ON A 5 1/4 INCH PC/XT DISKETTE. FULL DOCUMENTATION AND SCHEMATICS ARE ALSO INCLUDED.

FOR INFORMATION ON A LOW COST SPEECH SYNTHESIZER SYSTEM FOR THE VISUALLY IMPAIRED, PLEASE SEND FOR FREE PACKET T.M.1.

STAND ALONE POWER SUPPLY
FOR ABOVE
ADD \$2.50 SHIPPING & HANDLING

\$19⁹⁹

STATIC RAM

2016-2KX8 200 n.s.	1.00
2101-1 - 256X4 500 n.s.	.75
21L02-1 350 n.s.	.65
2102AL-4 L.P. 450 n.s.	.49
2111-1 256X4 500 n.s.	1.00
2112A-2	2.50
2114L-3 1KX4 300 n.s.	.45
2125A-2 1KX1 70 n.s.	1.70
2147 4KX1	1.95
6116P-4	1.00
6117	1.20
6264-15	1.40
62256 32KX8	5.75

EPROM SPECIAL

We bought a large quantity of 2708s, 2716s, 2532s, 2732s, 2764s, 27128s, 27512s and 27256s from a computer manufacturer who redesigned their boards. We removed them from sockets, erased and verified them, and now we offer the savings to you. Complete satisfaction guaranteed.

Your Choice		
2708	1.20	10/8.00
2716	1.75	10/15.00
2532	2.00	10/17.50
2732	2.00	10/17.50
2764	2.25	10/20.00
27128	3.20	10/27.50
27256	3.85	10/32.50
27512	5.10	10/45.00

DYNAMIC RAM

2108-4 8KX1	1.50
2118-4 16KX1-5Volt	.70
4027-4KX1-250 n.s.	.80
4116-16KX1-250 n.s.	.40
4116-16KX1-200 n.s.	.75
4116 16KX1-150 n.s.	.90
4164 150 n.s.	.49 or 9/3.50
4164 120 n.s.	1.10
4164-100 n.s.	1.40
TMS4416-16KX4-150 n.s.	2.75
4464-150 n.s.	1.60
4464-120 n.s.	1.75
4464-100 n.s.	1.95
4464-80 n.s.	2.10
41256 150 n.s.	1.25 or 9/9.95
41256 120 n.s.	1.40
41256 100 n.s.	1.45
41256-80 n.s.	1.65
41256-60 n.s.	2.30
1 Meg - 100 n.s.	4.90
1 Meg - 80 n.s.	5.20
414256-80 n.s. 256 x 4	5.40

SIPPS & SIMMS AVAILABLE

THREE CHIP SET

16450, 1488, 1489
B.G. SPECIAL
\$6.95

8000/80000

8031	2.95	8251	1.10
80C32 12	3.95	8253-5	1.75
8035	1.00	8254	1.80
8039	1.00	8255	1.50
8085	1.55	8255-5	1.75
8086	1.55	8257	1.50
8087	87.50	8259A	1.85
8087-1	167.50	8259C-5	2.10
8087-2	127.50	8275	10.95
8088	2.20	8279	2.25
8088-2	3.25	8284	1.49
8155	2.25	8286	3.50
8156	2.25	8287	2.49
8202A	8.00	8288	3.50
8212	1.25	8530	3.00
8214	2.00	8741	7.00
8216	1.25	8742	7.00
8224	1.25	8748	7.00
8228	1.75	8749	7.00
8237-5	2.80	8755	7.00
8243	1.75	80286-8 PLCC	8.50
8250	2.95	80287-8	125.00
(16450)	6.50	80287-10	135.00
(16550)	15.00	V-20-10MHZ	6.50

TERMS: (Unless specified elsewhere) Add \$3.25 postage, we pay balance. Orders over \$50.00 add 85c for insurance. No C.O.D. Texas Res. add 8 1/4% Tax. 90 Day Money Back Guarantee on all items. All items subject to prior sale. Prices subject to change without notice. Foreign order - US funds only. We cannot ship to Mexico or Puerto Rico. Countries other than Canada, add \$9.00 shipping and handling.

SEND FOR FREE CATALOG! OVER 150 NEW ITEMS!

SEND FOR FREE CATALOG! OVER 150 NEW ITEMS!

An Automatic Printer Selector

Adapter allows you to select between two printers from inside your programs

Many computer users now have two or more printers connected to their systems. In most cases, an older dot-matrix printer is used for documentation and “rough-drafts,” while a letter-quality or laser printer is used for actual correspondence. Our Cyber Switch will let you automatically switch between your printers from inside virtually any PC program. A manual-select switch is also provided for times when you want to force selection of a particular printer. The Cyber Switch is easy to build and will enhance your printing system directly.

About Parallel Printers

For many years, the *de-facto* standard for parallel printers in the personal computer industry has been the Centronics standard. Although the connectors appear somewhat unusual to the first-time user, their performance is excellent. These “Champ” connectors are robust and offer 36 individual terminals for control, data and ground-return paths. Eight lines (denoted D1 through D8) provide parallel data to the printer from the host computer system. These data lines use standard 0- and 5-volt digital levels to transfer data one byte at a time.

To synchronize this data transfer, a provided strobe latches each data byte directly into the printer input. Several other lines, called control lines, return information from the printer to the host computer. The most common of these are the “busy” and “paper” lines. Additionally, some printers utilize the “acknowledge” line to form a tight feedback loop to the host system.

During operation of the parallel port, data is presented at the D1 through D8 data transfer lines. Next, the host computer printer driver rou-

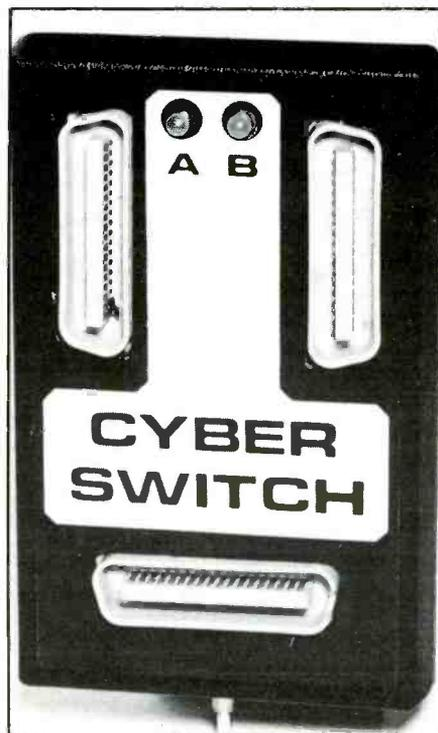

tine checks the status of the Busy and Paper lines. If the printer is loaded with paper, and isn't currently too busy to receive data, the host computer sends a negative-going strobe pulse to the printer. This strobe action latches the eight-bit data byte into the printer's internal data latch. After the data has been transferred, the printer begins the actual printing process for that character.

If the printer is of the older dot-matrix type, it may not have a RAM buffer. In these older units, each character to be printed is transferred and printed directly. Under these conditions, the printer created a “busy” signal as it printed each individual character.

Today's printers have a buffer that can hold from several thousand to many millions of characters. In these

printers, data can be transferred to the printer buffer at high rates of speed. As a result, the host computer is free to continue with other tasks while the printer works at its own printing pace.

In the early days of microcomputing, ribbon cables were commonly used to connect together the printer

PARTS LIST

Semiconductors

D1 thru D10—1N4148 signal diode
LED1,LED2—Red light-emitting diode
U1—74HC4040 binary counter
U2—74HC74 dual flip-flop
U3—Not used
U4—74HC04 hex inverter
U5,U7—74LS645 octal bus transceiver
U6,U8—74LS367 tri-state buffer
U9—74HC00 quad 2-input NAND gate
U10—78L05 +5-volt regulator
Q1,Q2,Q3—VN0300 hex field-effect transistor

Capacitors

C1,C2—10- μ F, 16-volt tantalum
C3,C4—0.22- μ F, 16-volt tantalum

Resistors (1/4-watt, 5% tolerance)

R1,R2—10,000 ohms
R3 thru R7—1,000 ohms
R8,R9—470 ohms

Miscellaneous

Printed-circuit board; suitable enclosure (Pactec HP series black or similar); 9-volt, 200-mA plug-in power supply; three IDC-type AMP Champ connectors (plugs); materials for making cables (see text); dpdt toggle switch with center-off position; hookup wire; solder; etc.

Note: The following items are available from U.S. Cyberlab, Inc., Rte. 2, Box 284 Production Facility, West Fork, AR 72774 (502-839-8293): Complete kit of parts, including front panel, enclosure, pc-board, connectors and all components, but not Molex Soldercons, \$89.95; ready-to-wire pc-board (no plated-through holes), \$9.95. Add \$4.95 P&H. Arkansas residents, please add 5% state sales tax.

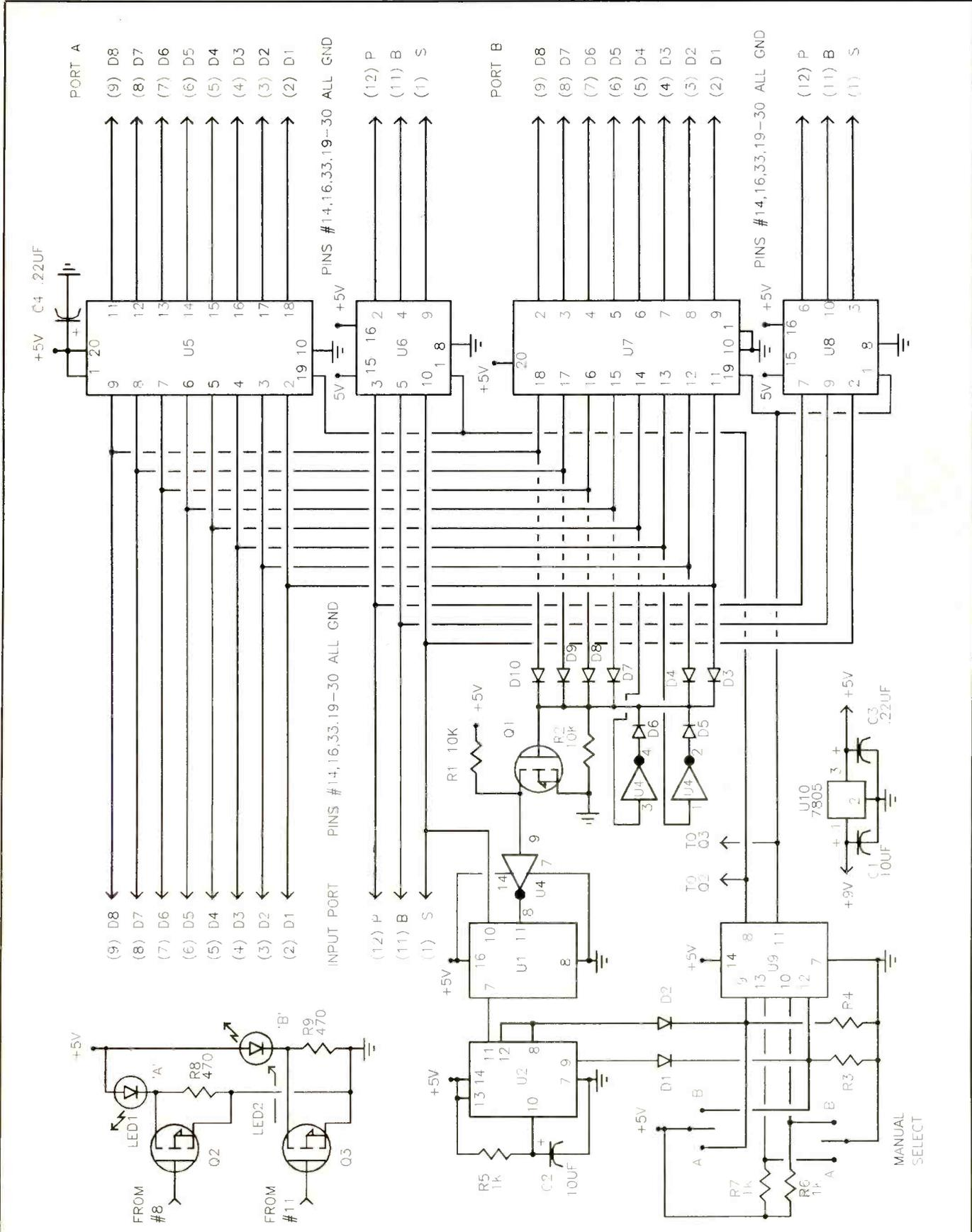

Fig. 1. Complete schematic diagram of Cyber Switch circuitry.

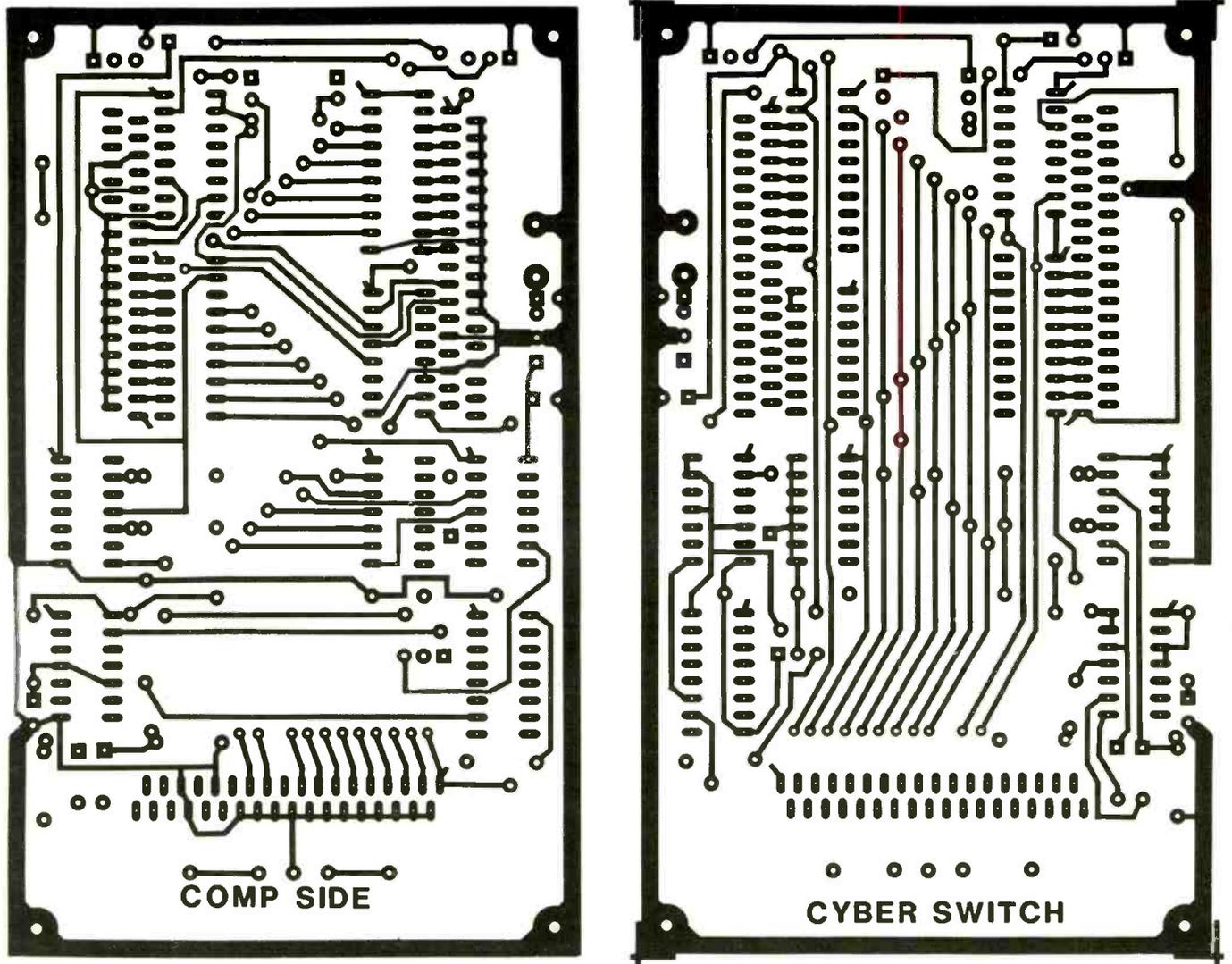

Fig. 2. Actual-size etching-and-drilling guide to use for home fabricating printed-circuit board for project.

and host computer. In today's carefully regulated industry, shielded cables with individual twisted-pair lines are used to minimize radio-frequency emissions. Consequently, each individual data and status line has a separate ground-return conductor. You should familiarize yourself with the parallel printer interface connections.

About the Circuit

The Cyber Switch circuit is very straightforward. Printer selection is accomplished using digital bus-transceiver technology afforded by the 74LS645 and 74LS367 ICs in Fig. 1. Notice that the data input lines to the Cyber Switch are routed through *U5* for Printer A and *U7* for Printer B, and on to the individual Champ connectors.

The versatile 74LS645 bus transceivers have the ability to direct and buffer data bi-directionally. Additionally, these devices are able to put their data output lines into a tri-state, or high-impedance, mode. In this manner, multiple devices can be connected together in a "one-of" configuration.

Pin 1 of *U5* and *U7* control the data transfer direction. In the Cyber Switch application, these pins are hard-wired to properly configure the data paths. Pin 19 of *U5* and *U7* control the output condition of the devices. When +5 volts (logic high) is applied to pin 19, the output of the device is disabled and allowed to "float." This output-enable feature is used to select the desired printer.

In addition to controlling data transfer from input port to either

printer, a method is needed for routing the strobe line on terminal 1 and "busy" and "paper" status lines. This is accomplished with 74LS367 tri-state hex buffers *U6* and *U8* which are controlled with the same enable signals that select *U5* and *U7*.

Next, notice that *U9*, a 74HC00, is used to perform actual printer selection. Chip *U9* is connected directly to the manual printer select switch, as well as to the automatic software selection circuitry. Chip *U9* is a quad two-input NAND gate.

Recall that *U5*, *U6*, *U7* and *U8* are all "active-low" devices. That is, only a low logic level applied to their "output enable" line will result in data transfer. This action allows us to "deselect" a particular printer by simply keeping the associated "output-enable" line high at all times. In

Double-Sided Boards

You may not be familiar with double-sided circuit card fabrication. In most cases, double-sided printed circuit fabrication is well beyond the capability and facility afforded the experimenter. In high-volume production printed-circuit houses, the copper-foil circuitry on each side of the double-sided card stock is chemically plated through holes (called vias) in the card material. In this manner, signals can pass back and forth between the different sides of the printed circuit.

It's interesting to note that in recent years multi-layer printed-circuit boards can have many layers, each connected through vias to the associated circuitry. The Cyber Switch design is such that you can make the double-sided printed-circuit board at home, using essentially the same techniques you'd employ for fabricating two separate single-sided printed-circuit cards.

To make the Cyber Switch pc card yourself, begin by obtaining some double-sided circuit material. This is available in blank and pre-sensitized form,

assuming you're using the direct-contact ultraviolet process. Printed-circuit materials are available from many sources, such as Mouser Electronics (800-346-6873) and Cyberlab.

With pc blank in hand, transfer the four mounting hole positions from the artwork to the copper surface of the bare blank. You can do this a sharp pin or awl or an X-acto™ knife. Next, drill these four holes with a No. 68 bit. This will allow you to register the artwork on the printed-circuit blank while exposing each side.

Be sure to keep track of which side of the artwork is inside and which is outside. Otherwise, it's entirely possible to make the board inside-out! Next, develop and etch the board as you would a single-sided card. (Be careful not to scratch the back-side of the board when agitating it in the etchant.)

When etched, the board will be a double-sided printed-circuit card that has obviously *not* been plated-through. This means that you have to physically solder several IC pins on the top side of

the circuit to allow connection through the board. Additionally, you complete the conductor paths from one side of the board to the other by soldering No. 22 solid bare wire into the via holes. Make sure you solder these wire feed-throughs to the copper pads on *both* sides of the board.

The above process may be a little more time-consuming than for a single-sided board, but it's well worth the effort. You'd be surprised to know how many commercial product prototypes are built in this manner. It's popular because it lets design engineers run prototype boards in-house and is very inexpensive to use.

The only major limitation to this process, aside from the time necessary to populate the card, is the fact that some connectors won't permit soldering underneath them on the top (component) side of the board. This is why the Cyber Switch was designed to use solder connections only on the non-component side of the board for the connectors.

manual mode, this is accomplished by using two pull-up resistors and a center-off switch.

With the switch in its center (automatic) position, the pull-up resistors assure a high-level input to *U9*. However, if the switch is moved to either of its two other positions, it pulls down the associated input and forces the gate output to a logic high. This inhibits the "not-selected" printer, regardless of the condition of the "automatic" input.

The automatic (software) circuit is very simple. Notice from Figure 1 that the inputs to the diodes are all derived directly from the input data lines. Data lines *D3* and *D4* are inverted through 74HC04 hex inverter *U4*. This arrangement provides a simple method for detecting the binary code 0CH, which is the form-feed control code for most printers.

Notice in Fig. 2 that the output of the FET is connected to the RESET input of 74HC4040 binary counter *U1*, through *U4*. Each time the host computer transmits a 0CH form-feed command, the Cyber Switch decodes it and increments counter *U1*. A logic high appears at OUTPUT pin 2 of *U1* after the Cyber Switch receives three

successive form-feed commands. This is the control format that causes the project to toggle the active printer back and forth.

Integrated circuit *U2* is a 74HC74 dual flip-flop configured to provide a divide-by-2 function. It receives its clock input signal directly from *U1*. In normal printer operation, essentially random patterns of data reach *U3*, creating a constant stream of reset pulses at *U1*'s RESET input. As a result, *U1* never reaches a sufficiently high count to toggle *U2*; consequently, it never changes the active printer selection. Chip *U2* also drives the two LEDs that indicate which printer port is selected.

Construction

Cyber Switch is best assembled on a double-sided printed-circuit card. It isn't necessary to use plated-through holes because the Cyber Switch circuit card permits top-soldering. You can fabricate your own pc board or purchase a ready-to-wire board from the source given in the Note at the end of the Parts List.

Use the actual-size etching-and-drilling guide shown in Fig. 2 to fa-

bricate your own pc board (see the Double-Sided Boards box for details on how to do this). After etching the pc blank, use a No. 68 bit to drill component-mounting holes. The Champ (Centronics) connector recommended for this project is an insulation-displacement (IDC) type and requires a No. 54 bit. The mounting holes at the four corners of the board should be drilled with a 1/4" bit.

Referring to Fig. 3, begin populating the board by mounting and soldering into place the resistors, capacitors, jumpers and feed-through wires. Next, mount the Champ connectors and ICs. If you wish to delay installation of the ICs on the board until after you've conducted preliminary voltage checks and are certain that the board has been properly wired, you can do so. Another alternative is to use Molex Soldercon socket strips that permit soldering access on both sides of the board and delay plugging the ICs into the sockets until after you test the assembly.

Now mount and solder voltage regulator *U10* into place. Using a dc voltmeter or DMM set to the dc-volts function, check the output of the 9-volt dc power-supply module. Mark

each lead according to polarity and then unplug the supply and insert the two leads into the polarity-correct holes in the pc board and solder into place. Finally, mount the manual selector switch on the board and wire it as shown in Fig. 1.

You can purchase printer cables (needed to operate the Cyber Switch) pre-assembled or make them yourself using ribbon cable and IDC connectors. If you use a male connector on the board, your printer cable must be equipped with a male connector on one end and a female connector on the other end. However, if you want to have a male connector at each end, simply use a female connector on the circuit board.

Start making the cable by identifying the pin-1 marking on the ribbon cable. This is usually indicated by a blue or red stripe that runs the length of the conductor. If your ribbon cable doesn't have a stripe, make a stripe with a permanent marker. It's very important that you know from one end to the other, which is pin 1.

Slip the ribbon cable into the connector until the cable is flush with the back of the connector. Make sure the cable lines up directly over the insulation-piercing tines on the connector. Next, press the back-plate of the connector into the ribbon cable, using a vise or channel-lock pliers. (A vise works much better. If you use channel-lock pliers, place a piece of printed-circuit blank over the open end of the connector to keep the pliers from damaging the connector pins.)

The IDC connector snap locks when it has been pressed into proper position.

Check the integrity of the connection to make sure all pins are solidly connected. Then repeat the process with the connector at the other end of the cable. To validate the cable, check it with an ohmmeter or audible continuity tester. Check continuity from pin 1 of one connector to pin 1 of the other connector, from pin 2 to pin 2, and so on.

Make two or more same-size photocopies of the front panel artwork shown in Fig. 4. Trim these to size and then use rubber cement or contact spray adhesive to tack one copy to the front panel of the enclosure. Use this to transfer the hole dimensions to the enclosure panel. This

done, use a hot knife to cut the various holes for the Champ connectors and a smaller hole along the top of the enclosure for the power cord to enter. A second small hole is needed at the bottom of the enclosure to allow the neck of the manual selector switch to pass through.

A hot-knife is a small razor-sharp

knife fitted to the end of a soldering iron and is used to very precisely cut holes in plastic. If you don't already have one, you can obtain a hot knife from a hardware store. It's a good investment that you'll use whenever you build a project that requires a home-machined plastic enclosure.

When using a hot knife, work very

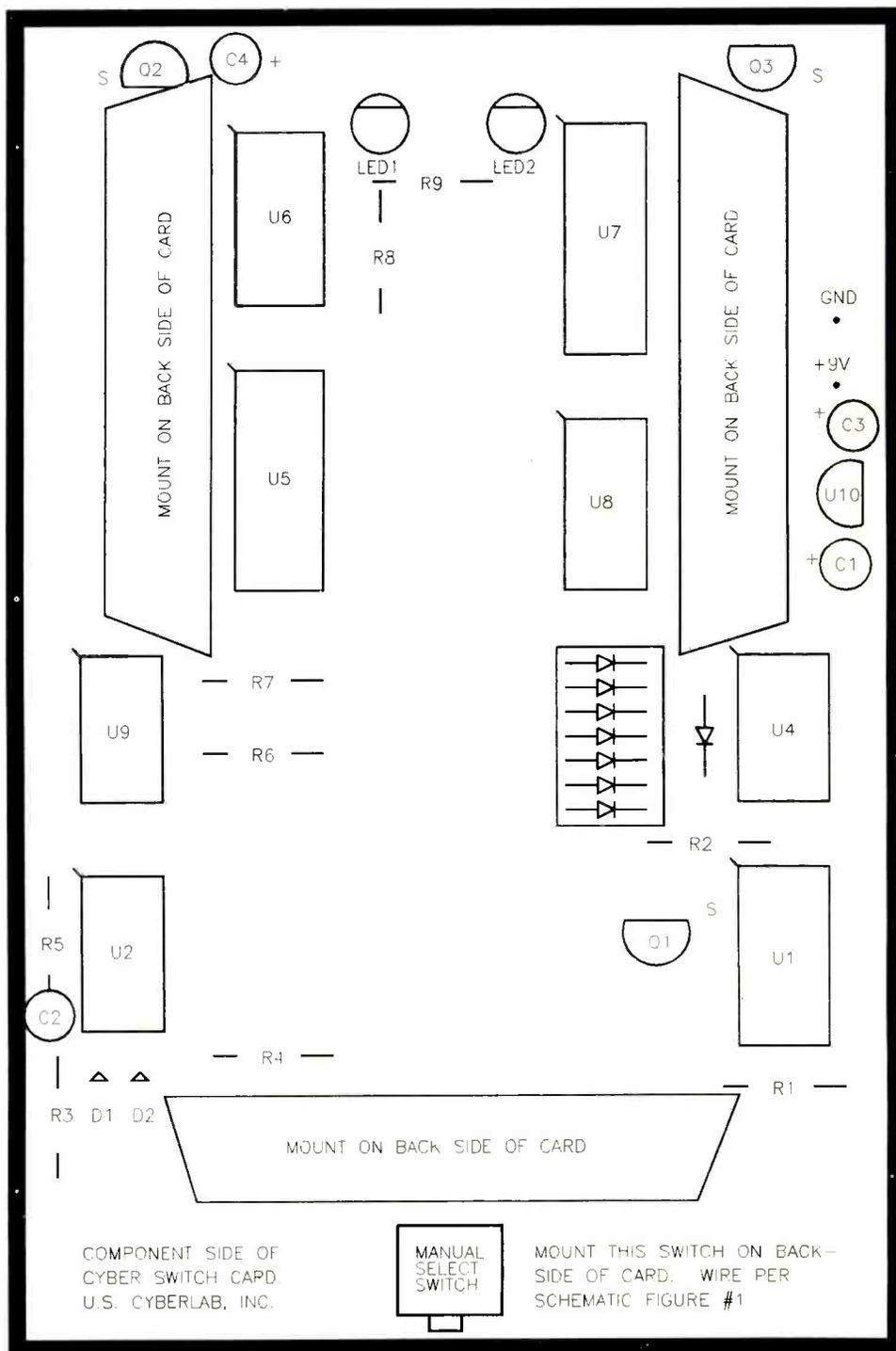

Fig. 3. Wiring guide for pc board.

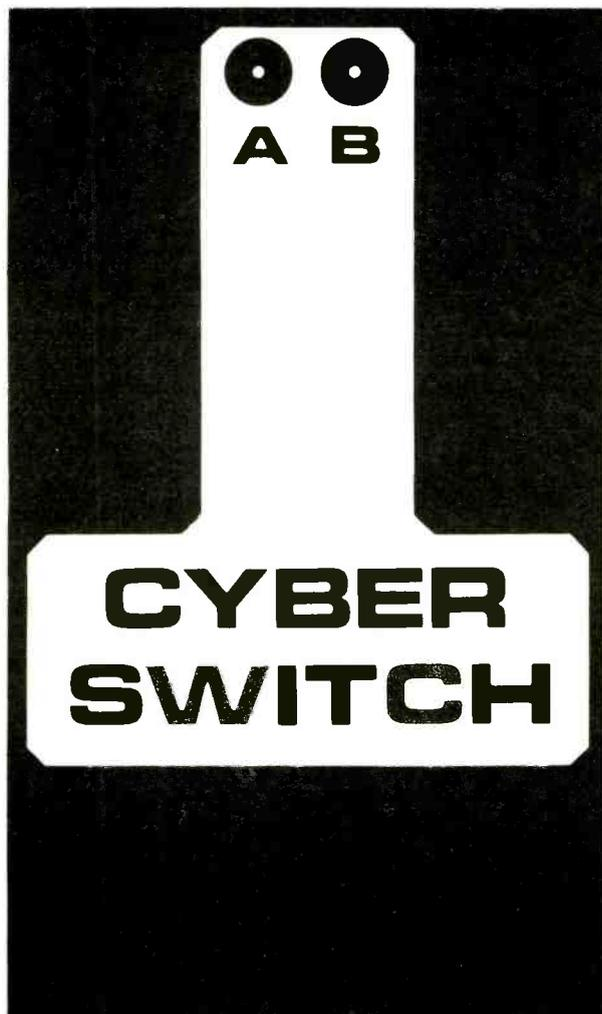

Fig. 4. Actual-size artwork for front panel of project's enclosure.

carefully. If you haven't used a hot knife before, start by making the holes for the connectors under-sized until you're comfortable with the cutting process. You can trim to final dimensions later. Always remember to thoroughly clean the tip of your hot knife, allow it to cool and then stow it safely away for the next time you need it.

Test fit everything in the enclosure. Make sure there's plenty of clearance around the connectors so that they mate properly with the interconnect cables. When you're satisfied with hole sizing and spacing, peel the initial front panel artwork off the enclosure. Trim a second photocopy of the panel applique for a perfect fit on the enclosure's front panel. Then rubber cement the final applique in place.

It's sometimes useful to run a No. 2 pencil around the inside of the con-

ductor holes where the edge of the front panel applique meets the plastic. This masks cut marks and blends the front panel into the black plastic of the enclosure.

Checkout & Use

Begin checking out the project by plugging the Cyber Switch power-supply module into an ac outlet. Using a voltmeter or DMM, measure the voltage at pin 1 of regulator *U10* and note if you obtain a reading of +5 volts. If not, quickly disconnect the power supply, and begin to trace the circuit for shorts or opens.

When you're satisfied that the problem has been located and fixed, measure the voltage at pin 1 of *U10* again. Then check for the presence of +5 volts at the V+ pins of all ICs (or the respective socket pins if you delayed installing the ICs themselves).

Earn Your B.S. Degree in ELECTRONICS or COMPUTERS



By Studying at Home

Grantham College of Engineering, now in our 41st year, is highly experienced in "distance education"—teaching by correspondence—through printed materials, computer materials, fax, and phone.

No commuting to class. Study at your own pace, while continuing on your present job. Learn from easy-to-understand but complete and thorough lesson materials, with additional help from our instructors.

Our Computer B.S. Degree Program includes courses in BASIC, PASCAL and C languages — as well as Assembly Language, MS DOS, CADD, Robotics, and much more.

Our Electronics B.S. Degree Program includes courses in Solid-State Circuit Analysis and Design, Control Systems, Analog/Digital Communications, Microwave Engr, and much more.

An important part of being prepared to *move up* is holding the right college degree, and the absolutely necessary part is knowing your field. Grantham can help you both ways—to learn more and to earn your degree in the process.

Write or phone for our free catalog. Toll free, 1-800-955-2527, or see mailing address below.

•
Accredited by
the Accrediting Commission of the
National Home Study Council

•
GRANTHAM
College of Engineering
Grantham College Road
Slidell, LA 70460

Once you're confident that everything is properly wired, unplug the power supply from the ac socket. Plug the ICs into their respective sockets (make sure that no pins overhang any socket pin) or plug the ICs into the holes in the board and solder them into place—on *both* sides of the board where the hole pairs are supposed to be vias. Make absolutely certain that each IC is properly oriented before soldering its pins into place or plugging it all the way into the socket pins.

Next connect the unit, using printer cables, to the host computer and one printer. (It's always best to turn off your computer and printer before plugging and unplugging printer cables.) With the computer and printer interconnected, turn on both devices and plug in the Cyber Switch. Next,

load a BASIC interpreter into your computer and enter the following BASIC program lines:

```
10 LPRINT "NOW IS THE TIME"
20 GOTO 10
```

This done, type LLIST to force a listing at your printer. With the Cyber Switch set to the position to select your printer, it should print, "NOW IS THE TIME." Next, flip the manual print-select switch to the other position and try to print again by typing LLIST. Now the printer should do nothing. The Cyber Switch can be operated from BASIC in the automatic mode. To do this, enter and run the following program:

```
10 REM THIS ROUTINE WILL TOGGLE
THE CYBER SWITCH
20 FOR I = 1 TO 3
```

```
30 OUT (888),12:OUT (890),1:OUT (890),0
40 NEXT I
```

This program is for AT-style computers. If you're using the parallel printer port on a monochrome card, the port numbers change to 956 and 958, respectively. If you're in doubt about the port number your computer uses, check your user's manual.

To set up and use the Cyber Switch in non-BASIC environments, I recommend using the TSR (terminate and stay-resident) generator program VIA 2.0 program available from Portable Computing Systems, Inc. of Dallas Texas (1-800-749-4917). With VIA 2.0, it's possible to create a "hot key" that automatically forces the three form feeds needed to change the current printer status. Consult the VIA 2.0 manual for detailed instructions about creating hot-key macros.

With VIA 2.0 loaded in memory, it's possible for you to automatically switch printers "on-the-fly" from within almost all popular software environments. You'll also find VIA 2.0 very useful in operating the Cyberlab Storm Monitor, Cyber Print and Cyber Supply projects previously published in *ComputerCraft*, as well as a myriad of other devices.

The Cyber Switch gives you the ability to switch between a documentation printer and letter-quality printer at will. This can be very handy when debugging a new program and running various applications. Keep in mind that the Cyber Switch has other uses as well. For example, consider using the Cyber Switch with your CAD software to toggle between a printer and a plotter. It's also convenient to use the Cyber Switch in conjunction with the Cyber Print and Cyber Supply units, to provide extended performance for your system.

AWARD BIOS ROMS

Upgrade your IBM XT, AT, or XT/286/386 Compatible. Add support for 3.5" 1.44Mb Floppies, 101/102 Keyboard F11 & F12 keys, ESDI and IDE Hard Drives. Full Technical Support - Call or write for FREE Catalog.

Authorized Award Distributor.

KOMPUTERWERK

851 Parkview Blvd., Pittsburgh, PA 15215

Orders 800 423-3400 - Technical Support (412) 782-0384

CIRCLE NO. 114 ON FREE INFORMATION CARD



CONSOLIDATED ELECTRONICS
VOLUME I - TEST EQUIPMENT
CONSUMER & INDUSTRIAL ELECTRONICS, 10TH EDITION

CONSOLIDATED ELECTRONICS

Get two of the most valuable electronic catalogs ever! These 2 catalogs contain over 16,000 hard to find electronic parts & equipment. VOL. I - features 112 pages of high quality test equipment. VOL. II - features 144 pages of electronic parts, tools & cross references. Send \$5 check or money order, or call today & use your VISA or MasterCard.

1-800-543-3568



CONSOLIDATED ELECTRONICS
VOLUME II - PARTS & ACCESSORIES
CONSUMER & INDUSTRIAL ELECTRONICS, 10TH EDITION

CONSOLIDATED ELECTRONICS, INCORPORATED 705 WATERVLIET AVENUE DAYTON, OHIO 45420-2599
FAX: 1-(513)-252-4066 / TEL: 1-(513)-252-5662 / TELEX: 288 229 / COMPUSERVE: 76057, 3347 / EASYLINK: 62850013

CIRCLE NO. 107 ON FREE INFORMATION CARD



Nick Goss

TOP SECRET

CONSUMERTRONICS

2011 CRESCENT DR., P.O. DRAWER 537
ALAMOGORDO, NM 88310

1-505-434-0234

FAX 1-505-434-0234 (orders only). Mon.-Sat. 8AM-9PM MST Voice & Manual FAX. 9PM-8AM Auto. FAX. Add \$4 ship. (USA, Canada). All items are in stock. COD (UPS cash only), VISA, MasterCard OK. FREE CATALOG with order, else \$2. In business since 1971. As seen on TV. John Williams - former Senior Engineer (Lockheed), NMSU Professor of Computer Science.

OFF-THE-SHELF HARDWARE

Van Eck System, Shriek Module, Voice Disguisers, Hearing Assistor, Diabetes Alarm, 6th Sense Communicator, The Levitator, Resonant Coils, Biomedical Stimulators, Fax Junk Call Killer, Long Range Eavesdropper - more! Assembled and tested (no kits) \$7 for descriptions.

COMPUTERS

HARD DRIVE MANUAL

Relates to all hard drive and controller implementations (emphasis on PCs). How to select, interface, initialize, set up, use, maintain, troubleshoot and repair them. How to protect them from mistakes, sabotage, prying eyes, sticky fingers. How to recover damaged and lost files. Includes software reviews. Loaded with info, advice and tips. \$29.

DISK SERVICE MANUAL

Maintain, troubleshoot, repair, adjust, align floppy drives without special equipment or software - 5.25"/3.5"/8", PC/XT/AT/386/486, Apple, Commodore, Kaypro, Tandy, Epson, Atari, TI, HP, DEC, etc. systems. All floppies need regular upkeep. \$29.

DISK DRIVE TUTORIAL

Theory and practical facts on floppy drives, disks, FDCs, formatting, software protection. Systems described above. Invaluable advice and tips on how to best select, interface and use drives and disks. \$19.

PRINTER/PLOTTER MANUAL

Types, descriptions, specs and 100+ interfaces (parallel, serial). Detailed plans for X-switchers, buffers, and serial-to-parallel and parallel-to-serial interfaces, breakout devices. Many buy, use, service, repair tips. \$19.

SUPER RE-INKING METHOD

Re-ink cloth ribbons for about 50 cents and 10 minutes each. Plans for el cheapo motor-driven re-inker. Commonly used ink (5 colors) and carrier described. \$9.

COMPUTER PHREAKING

TRJAN HORSES, VIRUSES, WORMS, etc. and countermeasures. Includes disk with 250K+ of hacker text files and utilities, and legendary FLUSHOT+ protection system (Ed. Choice, PC Magazine). Dozens of computer crime and abuse methods and countermeasures. How systems are penetrated, BBS advice, password defeats, glossary, much more! Manuals + Disks* \$39.

BEYOND VAN ECK PHREAKING

Eavesdropping on VDT and TV video signals using an ordinary TV! Ranges up to 1 KM. Plans, countermeasures. Includes legal Van Eck uses, and original Top Secret Van Eck design! \$29.

ABSOLUTE COMP. SECURITY

Dozens of simple, versatile, secure computer security methods and tips. Plus our invulnerable Cipher Program (in .COM and its .BAS source). Plus \$1,000 CIPHER CONTEST rules with ciphertext. Manual + Disk* \$29.

CRYPTANALYSIS TECH.

Five powerful menu-driven crypto programs (in .COM and their .BAS sources) to analyze, decrypt "secure" ciphertexts. Worked-out examples. Recommended in the prestigious COMPUTERS & SECURITY. Manual + Disk* \$29.

SOFTWARE PROTECTION

Unique system that highly discourages costly software piracy while not interfering with legit archival copies. No known way to defeat. No special equipment required. Easy, automatic to install on your disks. Can be used with any other protection system. Manual + Disk* \$59.

BRAIN VIRUS ANTIDOTE

The PAKISTANI BRAIN VIRUS plagued dozens of institutions, businesses. The mildly destructive original version has been hacked into highly virulent strains. BVA consists of the antidote, source code and write-up. Disk* (NOT infected) \$19.

AL DEVELOPMENT SYSTEM

Powerful program for creating/editing AL source code. Like sophisticated wordprocessor with many unique and powerful AL features. Includes tutorial and program for integrating AL routines into compiled BASIC programs. Manual + Disk* \$29.

C DEVELOPMENT SYSTEM

Powerful program for creating/editing C source code. Like sophisticated wordprocessor with many unique and powerful C features. Manual + Disk* \$29. *****

*Software supports PCDOS, MSDOS, PS/2; Mono., Herc., CGA, EGA, VGA, 5.25", 3.5", hard (specify your floppy drive size).

ELECTRONICS

PHONE COLOR BOXES

Designed by Phone Phreaks! 15 phone color boxes described. Dozens circuits, programs. Plus call forwarding, conferencing, phreak history. Plus 50 useful and legal phone circuit plans. More! Manual \$29.

ROBOFONE AUTODIALER

Powerful, versatile, menu-driven program allows you to dial any number (up to 10K) or mix of local and long distance numbers in any order, over any length of time, whether busy or answered (your choice) and log the times, commands and results to monitor, printer and/or disk. Quick-dial directory of up to 600 numbers. BUSY redial options. Direct modem command and control. All result codes, including Voice and Ringing. Optional shell to terminal program upon Connect. Exit to menu or DOS (for batching). Ideal "Wargames" power dialer, phone call logger and telemarketing dialer. Manual + Disk* \$29. With compatible LABELS and LETTERS programs \$49.

VOICE MAIL BOX HACKING

How Voice Mail Box (VMB) systems are used and the specific ways they are hacked. Includes ASPEN, MESSAGE CENTER, BIX, EZ, SYDNEY, PHONE MAIL, AUDIX, etc. Absolutely required for all vsyops, users! \$29.

VOICE DISGUISER

Plans for neat devices to change voice pitches. Effective against snoops using voice analyzers; to conceal gender for women living alone; for anti-intrusion systems; for music accompaniment; for gags. Voice sounds natural. \$19.

PHONE RECORD. INTERFACES

Plans for undetectable (ultra-high impedance), indestructible TELERECORDER to record phone conversations. Also monitors for bugs and taps. Plus simple FM xmitter addition and the ear-piercing SHRIEK CIRCUIT plans. \$14.

RADIONICS MANUAL

Exciting electronic and electromagnetic therapeutic and diagnostic devices (mostly experimental). History, descriptions, plans (dozens), availabilities of Radionics Devices from early to modern. \$29.

HEAL THYSELF

Many electronic medical devices are now licensed by the FDA for therapies. Plans for three major different devices that you can build and use yourself. Save \$ Thousands! Plus details on many other devices. \$19.

BIO-SPECTRUM ANALYSIS

Summary of the biologic effects of electromagnetic fields from DC to the near-infrared (0-300 GHz). Bands include: 6 ELF, VLF, LF, MF, HF, VHF, UHF, SHF, EHF. Special emphasis on DC, 50 Hz, 60 Hz, 2.45 GHz (microwave ovens), 3 GHz (radar). Graphical spectrum display includes frequency, researcher, date, source, effects, subject type and signal attributes. Also includes FCC assignments and physical properties. \$29.

EM BRAINBLASTER

Tutorial and plans for powerful ELECTROMAGNETIC WEAPONS and LAB DEVICES. Optimum circuits, freqs, waveforms, intensities. Comprehensive. MIND BOGGLING! \$29.

UNDER ATTACK!!

ELECTROMAGNETIC INTERFERENCE (EMI) and ELECTRONIC WEAPONS cause INEXPLICABLE MANIFESTATIONS! These attacks can cause cancer, birth defects, psychological and neurological disorders, cardiovascular and immune system failures, etc. Destructive to people, pets, livestock, plants, equipment. INCLUDES ACTUAL CASES (which we have investigated and documented) OF ATTACKS ON PEOPLE BY EM WEAPONS! And includes how you can verify and pinpoint the source of the EMI/electronic attack, and specific countermeasures you can take. \$39.

HIGH VOLTAGE DEVICES

HV devices plans: Stun Gun, Taser, Prod, Cane, Umbrella, Zapper, RF/Radar/Audio Jammer, Flasher, Blaster, Jacob's Ladder, Plasma and Van de Graaff Gens., Fence Charger, Geiger Counter, Ozone Gen., Fish Stunner, Pest Killer, Plant Stimulator, Kirlian, Magnetizer, etc. SHOCKING! \$12.

SECRET & SURVIVAL RADIO

Optimum survival and security radio equipment, methods, frequency allocations and voice/data scrambling/encoding. Includes small receivers/xmitters, telemetry, antenna optimizations, remote monitoring and control, security, surveillance, and ultrasonic, fiberoptic and infrared commo. More! 70+ circuit plans, tables. \$29.

TV DECODERS/CONVERTERS

Tutorial and plans for several TV decoders and converters. Plus satellite TV component purchase and use tips. \$14.

STEALTH TECHNOLOGY

Police radar is fascinating. It also has error rates of 10%-20%! Every known. Error mode - Method and material to minimize radar reflections - Strategy and tactic to fight unjust radar tickets (that cost you a fortune in insurance) - Method to detect and jam signals - fully described! \$19.

THE "GOLDFINGER"

Tired of digging up rusty nails and bottle caps? The "Goldfinger" detects GOLD, SILVER, PLATINUM, COPPER and ALUMINUM while rejecting all ferromagnetics. Plans. \$14.

THE "SILKWOOD"

The "Silkwood" detects X- and Gamma Rays, and Alpha and Beta particles. Simple, pocket-size, 9-volt battery-operated rad detector requires no Geiger-Mueller tubes or high voltages. 95%-linearity between 10-1,000 rads/min. Indicates to less than 0.1 rad/min. Check out your job, home, possessions. Prospect for minerals. And a lifesaver for nuclear survival situations. Plans. \$14.

POOR MAN'S SUPER LASER

Ruby rod laser plans. Used in intrusion systems, weapons targeting, precise optical alignments, seismography, signaling and commo, strobes, holography, science projects, etc. Includes a list of dozens of sources for ruby rods and other parts. \$14.

AIR COILS

AIRCILS is a powerful scientific program for designing round and square air coils. Returns inductance/number-of-turns when number-of-turns/inductance and dimensions are specified. Returns min. wire gauge for any current, and capacitance for LCs. Disk* \$19.

ENERGY

KW-HR METERS

How without meters work, calibration, error modes (many), ANSI Standards, etc. Demand, Pole and Polyphase Meters. Experimental results. \$19.

STOPPING POWER METERS

As reported on CBS 60 MINUTES! How certain electrical loads (simply plugs into an outlet) can slow down watt-hour meters - even stop them - while drawing full loads! Also describes meter creep, overload droop. \$19.

THE I.G. MANUAL

External magnetic ways to slow down and stop watt-hour meters while drawing full loads. \$19.

GAS FO' ALL

Every known vulnerability of gasoline and diesel fuel pumps and dispensers. \$19.

LIBERATE GAS & WATER

How gas and water meters can be reversed using simple household equipment. \$19.

VORTEX GENERATOR

Heat/cool with simple, amazing 3-port device. Uses no moving parts, electricity, fossil fuel, liquid or freon. Guaranteed scientifically sound. Plans. \$14.

LOADFINDER

Quick, simple, accurate and inexpensive method to determine the inductance and resistance of any AC load (in situ) between 0.1 and 100 amps, and the capacitance for PF=1. Real power, imaginary power and apparent power explained, and how each affects your bill! Requires only an AC voltmeter, the simple circuit described and high school algebra ability. Completely worked out example. Save energy! \$9.

MDVR METHOD

Plans for the effective and inexpensive MDVR Method to legally save electrical energy (30%-60%)! Develops optimum efficiency, safety and versatility, and saves wear and tear - all without significant loss of performance or service. \$12.

RIPPLED OFF!

Line ripple and transients waste money, cause equipment to malfunction, lose data and endanger users. And utilities use line current ripple to remotely control your equipment and the dreaded Peak Demand Meter! Includes plans for ripple/transient eliminator. \$9.

FINANCIAL

ATM'S

ATM crimes, abuses, security, vulnerabilities 100+ methods described - from Reg. E to ciphers. Case histories, law, countermeasures, detailed security checklist. Internal photos, figures! Still unsolved: One crook stole \$237,000 from one bank's ATMs! \$39.

CREDIT CARD SCAMS

Cardholders, merchants and banks suffer \$ Billions losses annually because of credit card fraud. Describes every known means of credit card fraud and scams. Protect yourself! \$29.

CREDIT REPORTING ENTITIES

Giant commercial and government databases now contain millions of financial, employment, medical, family history, lifestyle, criminal, religious and political files on most Americans. These files are instantly accessible to thousands of people. Data is often erroneous, incomplete, obsolete or repetitious - often costing people credit and jobs - even their freedoms! How to protect your privacy and security. Comprehensive. \$29.

ULTIMATE SUCCESS MANUAL

Underpaid? Harassed? Manipulated? Stuck in a dead end job? Expected to be laid off or fired? Sick of office politics? Job/division/company moving to Timbuktu? The ultimate no-hold-barred Machiavellian techniques for finding, obtaining, optimizing and keeping top jobs and benefits. THE RULES OF THE GAME FOR A GAME WITHOUT RULES! From resume to CEO. \$29.

GOVERNMENT LAND GRAB

You can force the Government to sell you prime land at ridiculously low prices with no competing bids allowed because of a little-known 100+ year old Federal Law! One man legally forced the Government to sell him 160 acres of prime forest land for \$400 - appraised at \$1,600,000! Another got 19 prime acres in Phoenix, AZ for \$47 - appraised at \$376,000! Complete details and proof. \$19.

STOCKPRO

Unique, powerful, shrewd, unconventional common stock investment strategy. Created for NMSU, and basis of expensive consulting system. Manual + Disk* \$29.

PHYSICAL SURVIVAL

ORDER OF THE MAGNITUDE

THE MOST COMPREHENSIVE SURVIVAL BOOK EVER WRITTEN! Topics include electronics, computers, energy, weapons, concealment, revenge, alarms, etc. Helps you survive today! and in the Day After. Absolutely required! Field-expedient use of technology typically in a lower-intensity conflict environment. Full emphasis. \$49.

SURVIVAL GUNS & AMMO

THE ULTIMATE FIREARMS SURVIVAL MANUAL! Describes optimum guns and ammo, conversions, silencers, explosive devices, improvised weapons, End Times scenarios, retreats, etc. \$19.

SILENCE IS GOLDEN

How acoustic silencers are designed from simple, cheap, commonly-available materials. \$9.

ROCKET'S RED GLARE

How to design and build solid-propellant amateur and survival rockets. Special emphasis on the formulation, manufacture and installation of propellants, motors, igniters, etc. Includes list of commonly available materials. And the design of launch pads and electronics. \$29.

COMBAT/SURVIVAL FITNESS

Weight training for combat, survival, police, martial arts, contact sports, brawling and street fighting! Scientifically designed to maximize the explosive power, speed, quickness, agility, endurance and hardness for combat and survival. SURVIVAL OF THE FITTEST - There are no second-place winners! \$19.

FIREWORKS!

Describes how firecrackers (M-80s, block-busters, cherry bombs), rockets (match, bottle, large), volcanoes and fountains, sparklers and safety fuses are made and colored. \$9.

MISCELLANEOUS

TECH. RESEARCH SERVICES

Unique 51+k electronic and computer design articles in database accessible by title and subject. Digital, uP, uC, analog, hybrid, nomenclature, software. Provide us keys, we return list \$25 search fee (1-20 keywords/phrases; you may combine unrelated topics). Saves you R&D \$\$\$! Powerful RES-SNAP program will allow your own searches thru popular electronic books, magazines and your files. Disk* \$95.

SPECIAL PROJECTS

We design, build, repair, modify, maintain and consult on any device, system or project - computerized, electronic, electrical, mechanical, optical. Many invention prototypes. Confidentiality guaranteed! Describe and include \$25 fee (does not obligate you). We then provide you cost, time estimates.

MMPI PERSONALITY GAME

What exactly is your personality? How does it compare with others you care about? Do you have more than one? Much more than just a game, the MPG is a zany, satirical, insightful, realistic and critical hands-on education about personality testing. Mind-boggling and a real blast! Manual + Disk* \$49.

NUMEROLOGY PROGRAM

Religion and science are filled with numbers that have special meanings. Enter a name or phrase into NUMERMAN and watch the dozens of equivalent numbers displayed - derived from ancient and modern algorithms. Whether numbers have special meaning to you or just for fun and games, NUMERMAN is numero uno! Disk* \$19.

PREVENT/CURE DENTAL DISEASE

About 70% of all tooth losses are caused by "gum disease" - not tooth decay! Simple, little-known method developed by a Government scientist is inexpensive and really works. \$9.

TAP NEWSLETTER

TAP was a controversial technological survival newsletter published by the Yuppies until the mid-1980s, and is a goldmine of hard-to-find technological information from ATMs to Zapping (just about everything). And of great historical and nostalgic value. Issues 1-91. \$2 per back issue, \$150 for entire set.

SOLD FOR EDUCATIONAL PURPOSES ONLY.

The "C" Word

"When I make a word do a lot of work like that," said Humpty Dumpty, "I always pay it extra."

"Oh!" said Alice. She was much too puzzled to make any other remark.

Lewis Carroll, *Through the Looking Glass*

Humpty Dumpty was talking about his (mis)use of the word "impenetrable," but if you're considering learning C++ programming, you might think he was talking about computer programs. To the novice, C++ can seem impenetrable, and it often lets one word do an awful lot of work.

Programmers are always searching for the ideal language. But "ideal" is usually defined in terms of the project at hand. Sometimes it means that you want easy access to all of a computer's resources, including video memory, ports, interrupts and timers. At other times, "ideal" means a language that finds bugs for you and doesn't let you accidentally write to a serial port when you mean to send data to a parallel printer. And at yet other times, you probably want a language that gets as much work done with as few commands as possible; one that hides the details of the computer so you can concentrate on problem solving, or that helps you ignore the complexities of writing a program for DOS or (shudder) Microsoft *Windows*.

No language meets all of these requirements equally well and none ever will. But C++ comes close, especially if you generally work on the same class of problems. If you haven't yet looked at C++, you're in for both some surprises and some confusion. But that's getting ahead of the story.

The Popularity of C

In the late 1970s and early 1980s, the primary language for developing

complex desktop computer programs was assembly language. Nothing else gives a programmer as much access to all of a computer's resources while producing programs that are as compact and as fast as possible. Until the advent of fast 80286 AT-compatible computers, however, desktop machines were just too small and too slow to handle complex programs written in any other language. Try running a large dBASE program on a 4.77-MHz PC and you'll immediately see why programmers needed to get every ounce of speed possible out of their applications.

But assembly-language programs are difficult to write and maintain. If you write in a high-level language like Pascal or BASIC, you know that a single line can present complex information on the screen or perform multiple trigonometric calculations. In assembly language, the same tasks may require dozens or hundreds of lines of code.

Assembly language is also difficult to handle when two or more programmers are working on the same project. Because there are no standard ways to set up registers to call a function or return a value, errors often creep into a project that are difficult to locate in several thousand lines of code.

The C language, originally developed at Bell Labs by Dennis Ritchie in the 1970s, seemed by the mid-1980s to be the answer for programmers who wanted to write tight, fast code for large projects. It gives programmers control over the computer that's comparable to assembly lan-

guage. At the same time, C has many of the features of high-level languages. Modern auxiliary tools, including debuggers, lint programs (which search through multiple source code files looking for possible errors) and version control programs, make it possible to manage large C programs with a minimum of headaches.

The C language itself has been described as assembly-language with high-level syntax. Part of the reason for this description is C's unique organization. Unlike most languages, C is really two separate pieces. One piece is a library of functions that manage input and output, string manipulations and access to files, memory and other parts of the operating system. C programs make calls to this standard library in the same way they make calls to the functions and procedures that a programmer develops as part of a project. It's a simple matter to replace parts of the standard library with your own functions if your project has special needs.

Other modern languages, like Pascal and BASIC, have functions built into the language and language definition. For example, all forms of BASIC include a PRINT statement as a built-in command. In C, the comparable `printf()` function is part of the standard library. The difference may seem subtle, but it gives C programmers much more control over their programs. For example, traditionally, the text output commands in most languages (including C) automatically included support for floating-point numbers, which usually require several thousand bytes of additional

code. It was possible to rewrite the C `printf()` function to do away with floating-point support if you knew that you could restrict your program to various kinds of integer values. You can also rewrite library functions for special tasks, like preparing a program that will be stored inside a ROM chip.

C's second strength is its wide range of variable types. Its fundamental types include signed and unsigned characters or bytes, short integers and long integers (represented as one-, two- and four-byte values on PCs), and both short (four-byte) and long (eight-byte) floating-point values. These are much the same as in other languages, but C lets you add your own data types as well, including arrays, structures and unions. A structure is a combination of two or more types in a new data type, and a union is two ways of identifying the same bytes in a data structure. Since structures can include arrays and other structures, it's possible to build very sophisticated data types with a minimum of effort.

The most powerful C data type is a pointer, which contains the address of another data item. Pointers can contain the address of structures, arrays and even other pointers. The C language contains instructions for pointer arithmetic and manipulating the data at the address in a pointer.

Pointers are powerful enough to nearly equal assembly-language's free access of all accessible memory in a computer; they're also powerful enough to cause many obscure errors in C programs. They give a programmer full access to, and responsibility for, the computer's memory system.

One final and very powerful feature of C pointers is that they can point to functions so functions can receive addresses of other functions. For example, a generic sort routine can be called with the addresses of functions that compare and swap data of a particular data type. The sort algorithm then can be written with no concern about the types of data that it is sorting.

C also has more operators than do most languages. It has a full set of arithmetic operators (addition, subtraction, multiplication, division, a modulus operator, and others) that work with both integer and floating-

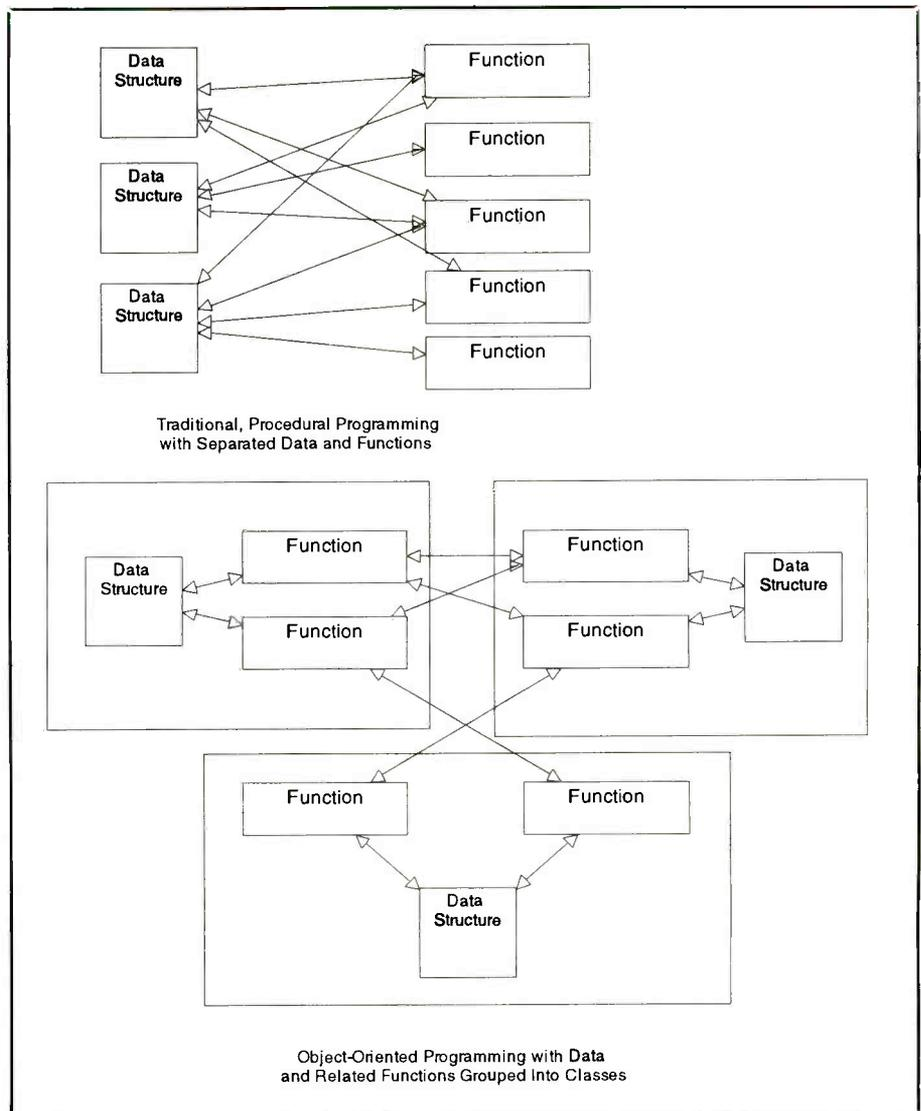

In traditional procedural programming (A), data and functions are separated. In object-oriented programming (B), as in C++, data and related functions grouped into classes.

point data types. It also includes operators for bit shifting, logical operations (AND, OR and NOT) and working with pointers.

Finally, C's built-in preprocessor gives programmers the flexibility to create macro commands, rename complicated data types and perform conditional compilation. It's a simple matter, for instance, to compile a program one way during debugging and another way for a final production version.

Until recently, the international standard for C compilers and the language as a whole was a small book called *The C Programming Language* by Brian Kernighan and Dennis Ritchie. This book was often re-

ferred to as "K&R" by C programmers and was used as the final arbiter of how C constructs should work.

Over the last couple of years, though, C has gone through a transformation as it was standardized, first in the United States by ANSI, and then internationally by ISO. Standard C has a clearer definition, a more powerful preprocessor and a better chance to catch programmer errors than K&R C. The C standards also define the minimum function library that must be included with a conforming C compiler.

Nearly every C compiler now conforms to the ANSI standard. C has grown from an early systems and low-level language to a full-blown

application language. With modern debuggers and development systems, it's also as easy to learn as any other modern language. If you don't know how to program at all, Microsoft's Quick C and Borland's Turbo C are both excellent learning environments (and both are also quite useful for application development).

A Better C

In order to make some extremely complex programs easier to understand and maintain, Bjarne Stroustrup at AT&T developed the C++ language, beginning in the early 1980s. C++ brings a number of improvements to C, including object-oriented programming. But one of its most interesting features is that it's almost identical to C. With very few exceptions, a C++ compiler will accept and compile normal C code. Programmers who move from C to C++ can ignore nearly all of C++'s changes and simply continue to write programs in C.

Among C++'s new features are some very simple and powerful input and output commands. Some programmers turn to C++ at first just to get around the awkwardness sometimes associated with C's `printf()` and `scanf()` library functions.

But C++ is much more than C with a few embellishments. Originally called "C with Classes," C++ gives C programmers a complete object-oriented programming system that uses normal C syntax. To really get the most out of C++, programmers have to unlearn many of their old ways of thinking and approach programs from a new perspective.

Object-oriented programming is a radical departure from the procedural programming embodied in traditional languages like C, Pascal, BASIC, FORTRAN and COBOL. In all of those languages, programmers create data structures and separate functions or procedures that operate on the data. If, late in a large project, you find that you must alter a data structure, you may find that you have to make changes to dozens or hundreds of functions to support the change. If you overlook a function that should be changed, it can end up turning your carefully crafted data structures into complete chaos.

In object-oriented programming, programmers focus on data and include functions definitions as part of their data declarations. Normally, only functions that are part of a data structure have access to that data. The data and the functions that operate on the data are bound together into a package called objects or, in C++, classes. If you change a data structure, theoretically, you'll have to change only the few functions that are defined with and have access to that data.

A C++ program works by first defining data structures or classes and then creating "instances" of those classes. Most of the program usually consists of passing "messages" to those data items. These are really commands to run one of the internal functions associated with the data and, perhaps, return a value. Although this sounds like it might lead to very inefficient code, C++ can often produce programs that are shorter than are their procedural counterparts.

Another important concept in object-oriented programming and C++ is "overloading," or polymorphism. Most of C's operators can be overloaded, which means that their action changes, depending on the objects that they act upon. For example, you could create a matrix class. Part of the class definition might be to overload the "+" operator, so that this line performed matrix addition:

```
MatrixC = MatrixA + MatrixB
```

The result is code that is easier to read and debug than something like:

```
matrix_add(&MatrixC, &MatrixA, &MatrixB)
```

In C++, you can also overload function names. You might, for example, have a `clear_screen()` function that clears a text screen using the present foreground and background colors. You might then decide to write another `clear_screen()` that clears the screen to whatever colors you specify. C++ allows you to give the functions identical names because they receive different numbers and types of arguments. You don't have to remember a variety of different names for functions that differ by only a slight amount.

Most important, C++ supports inheritance. This means that you can take the code (in source code or compiled form) for a class (ClassA, for example) and create a new class (ClassB) that has all of ClassA's data and functions, plus whatever you need to add to make your new class perform in your program.

In procedural languages, if you want to use a library function but modify it slightly, you must often tweak the source code to make it behave correctly. But doing so may make other functions break and you soon have a mess of debugging to do that you didn't expect. In C++, if a library class doesn't do exactly what you want, it's a simple matter to create a new class that inherits the original class and adds new data members or functions.

Every class may have two special functions: a "constructor" and a "destructor." The constructor function is called whenever it creates an instance or data item of the class. Destructors are called whenever the program releases a data item. For example, if a graphics program has a class of rectangles, the rectangle constructor would be called whenever the program creates a new rectangle. Normally, the constructor simply creates space for the class data items on the heap and perhaps puts initial values into each data item. But at times, a constructor can do a great deal of work, perhaps displaying graphics, performing complex calculations or manipulating several data files.

At such times, a seemingly simple program statement, like one creating an array of 100 rectangles, can invoke hundreds or thousands of lines of code, since each member of the array triggers the constructor function. If the class has a long inheritance, the constructor of each parent class can also be invoked automatically when a new class member is created.

This would be a good time to show a program written in both C and C++ and discuss their differences. However, the exercise would probably be boring and uninteresting, since C++ looks very much like C. It has an additional comment symbol; otherwise, it's difficult to tell the difference between a C program and a C++ program, unless you're very familiar with each language.

C++ is also difficult to demonstrate quickly because it's a language that's best suited for large, complex projects. If you have a short program of 500 lines or so, C++ is probably more trouble than it's worth. But if you routinely work on large projects that average thousands or tens of thousands of lines of code, C++ can be a tremendous help. Used correctly, many C++ classes can be recycled from one project to another with little or no change. And when you need to change a class, you can do so with inheritance, not by modifying proven source code.

"If you have a short program of 500 lines or so, C++ is probably more trouble than it's worth."

Luckily, you don't have to make a choice between C and C++, at least not when you buy a compiler. The two largest vendors of C++, Borland International and Zortech Inc., sell combination packages. When you buy a C++ compiler, you also get an ANSI-conforming C compiler in the same package. Both also have excellent debuggers and other tools available as part of a combination C and C++ programming package.

C++ is excellent for medium and large projects. As you build your own library of classes or buy libraries from others, you'll be able to get more done with less coding. For example, one library I've looked at recently would allow you to create a multi-file text editor with less than 100 lines of your own code. The file-handling classes and editing classes in the library do all the real work. And if you don't like the way the editor works, it's a simple matter to create your own editor class that inherits from the one in the library and adds to it the new features that you want to implement.

If you're a C programmer, you owe it to yourself and your future programming career to start learning C++. But don't attempt to learn C++ until you're comfortable with C, its data structures and its pointers. C++ is an excellent application language, but it's suited for experienced programmers, not beginners. ■

BUILD A DIGITAL STORAGE SCOPE



As Part Of
The Complete **\$199.95**
Modern
Electronics Computer Lab.

FEATURES

- 20 Mhz/sec Sample Rate
- .5 us to 5 sec/div Sweep Rates
- LCD with 64 x 240 Dot Resolution
- Provisions for Adding Optional Second Channel
(Requires 5V, +/-12V Power Supply)

- Vertical Sensitivity .01 v/div AC/DC Coupled
- Ext. Trigger Input
- Single Sweep Mode
- Screen Freeze Mode

\$199.95

Postage & Handling (\$6.50)

OPTIONS: Add an 8 channel Logic Analyzer and view up to 8 digital signals simultaneously. . . perfect for viewing CPU Bus signals . . . **\$59.95** + Postage & Handling (\$3.00)

Power Supply Kit . . . **\$34.95** + (\$4.00) P.H. • Matching Black Steel Cabinet . . . **\$37.50** + (\$4.50) P.H.

Deluxe 100 Mhz Scope Probe with 10:1 Switch . . . **\$27.50** + (\$3.50) P.H.

EXPAND YOUR LAB . . . Add A Dual Channel Function Generator With An Add On 23 Channel Digital Signal Generator

• The Function Generator features two separate Sine, Triangle, Ramp and Square wave generators. 10 Hz to 100 KHz. Ideal for upcoming Analog and Modulation theory experiments. (Requires 5V, +/-12V Power Supply)

\$69.95 + Postage & Handling (\$4.00)

• Add a 23 channel Digital Signal Generator + an 8088 based Computer Experimenter Platform to the Function Generator Board . . . This project operates as a stand alone Digital Signal Generator, capable of generating 23 different digital signals simultaneously. Custom signal generator programs, as well as 8088 based computer experiments can be down loaded from any IBM compatible. Learn about Computers, Digital Circuits and Assembly Language Programming in upcoming articles. . . **\$69.95** + Postage & Handling (\$4.00)

OPTIONS: Power Supply Kit . . . **\$34.95** + (\$4.00) P.H. • Matching Black Steel Cabinet . . . **\$37.50** + (\$4.50) P.H.

COMPLETE YOUR LAB . . . With A Prototyping Station

• Features both solderless and wire wrapping prototyping systems. With cables connecting 80 signals from the Digital Signal/8088 Computer Experimenters Platform to the Prototyping Station.

\$69.95 + Postage & Handling (\$4.00)

OPTIONS: Power Supply Kit . . . **\$34.95** + (\$4.00) P.H.
Matching Black Steel Cabinet . . . **\$37.50** + (\$4.50) P.H.

MasterCard / Visa Accepted

(203) 355-2659



**NETRONICS RESEARCH
AND DEVELOPMENT LIMITED**
333 Litchfield Road • New Milford, CT

CIRCLE NO. 120 ON FREE INFORMATION CARD

contact east

PRODUCTS TO SERVICE ELECTRONIC EQUIPMENT

Same Day Shipment
To Order, Call (508) 682-2000



FREE CATALOG TEST INSTRUMENTS & HARD-TO-FIND TOOLS

Packed with over 10,000 quality products for testing, repairing, and assembling electronic equipment. A full selection of test instruments, power protection equipment, precision hand tools, tool kits, soldering supplies, and much more. Products are shown in full color with detailed descriptions and pricing. All products come with a 100% satisfaction guarantee. SAME-DAY shipment program.

In a hurry to receive your catalog?

Call (800) 225-5370

In Massachusetts call (508) 682-2000

Contact East, Inc., Dept. R487
335 Willow St., No. Andover, MA 01845

CIRCLE NO. 108 ON FREE INFORMATION CARD

LEARN to CLEAN/MAINTAIN/REPAIR CAMCORDERS



EARN \$85
AN
HOUR!

HUGE EXPANDING MARKET!

Work from your home - part-time or full-time!
No prior experience needed - Average mechanical ability only requirement for your success! Over 15 million camcorders in use - Over 5 million expected to be sold in 1991 alone!

It is a fact that the vast majority of camcorder malfunctions (just like VCRs!) are due to simple mechanical failure. . . We can show you how to easily fix those breakdowns and earn an average of \$85.00/Hr. while working at home!

Get In Now - Soon camcorders will be like VCRs, i.e., one in almost every home.

For a camcorder cleaning job you can earn \$65.00 for less than 30 minutes work.

For a camcorder repair job you can earn over \$100.00.

FREE INFORMATION PACKAGE call or write:

Toll-Free 1-800-537-0589

Viejo Publications, Inc.

5329 Fountain Ave., Dept. CCC
Los Angeles, CA 90029

CIRCLE NO. 131 ON FREE INFORMATION CARD

EPROM Programming

Tools and techniques for programming EPROMs used with dedicated and embedded computers

Anyone who is involved with designing or building projects that use dedicated or embedded computers eventually faces the challenge of EPROM programming: how to get the object code created by an assembler or compiler into the EPROM, EEPROM or other memory device, where it will reside in the completed project. In this article, we discuss EPROM/EEPROM programming, including details on the use of EPROM/EEPROMs, what you need to know before programming one and how to choose programming hardware. We'll also examine two EPROM programmers from Needham's Electronics.

Why Use EPROMs?

Compared to the disk storage devices used in most desktop computers, the EPROM (erasable programmable read-only memory) offers low-cost storage with minuscule power consumption. It has no moving parts and, thus, requires no complicated support circuitry.

A disadvantage to EPROMs is that their contents are less easily altered than a disk's contents. Once a bit in an EPROM is programmed, it can't be erased unless the entire EPROM is erased by exposing the EPROM to ultraviolet light for several minutes. Flash EPROMs and EEPROMs are electrically erasable, but programming these still involves meeting special—and critical—electrical and timing requirements.

Because of the above characteristics, EPROMs and EEPROMs are most often used for permanent or seldom-altered storage of programs and such other unchanging information as lookup tables (though recent improvements in Flash EPROM technology are changing this situation).

EPROMs and other memory ICs

are programmed with special hardware. This can be a stand-alone device, a device that communicates over a serial or parallel interface with a desktop computer or terminal or a circuit card that plugs into the expansion bus of a desktop computer.

Programming

When an EPROM is used to store a program, its data is contained in an object file created by an assembler or compiler. You then need a way to get the object file into the EPROM. This is the job of an EPROM programmer. If your object file is on a disk, the programmer must be able to communicate with your computer via a serial, parallel or bus interface.

Before proceeding with programming, you must know the answers to a few questions:

(1) What size EPROM do you need? You can determine this from the listing file generated by your assembler. If you suspect your program may be expanded later, you may want to use a larger-than-needed EPROM in your system from the beginning to allow for this eventuality.

(2) What programming algorithm and voltages does the EPROM or other device require? Early EPROMs used a programming process (or algorithm) that required a 50-millisecond pulse to program each byte, with a special programming voltage (V_{pp}) applied to one pin. As EPROM technology has developed, newer and faster algorithms have also been developed. Two such algorithms are Intelligent and Quick Pulse programming, both developed by Intel Corp. but recommended by other manufacturers as well.

Newer algorithms use much shorter programming pulses. For reliable programming, in addition to generating V_{pp} , V_{cc} must be raised—to +6

volts for Intelligent programming and to +6.25 volts for Quick Pulse. Many EPROM programmers permit you to choose from among several algorithms. Each manufacturer's data sheet should state the recommended programming algorithm for that device. Most EPROMs made after 1984 contain a special A9 identifier byte, which can be read by placing +12 volts on address pin A9. Some EPROM programmers can read the identifier to automatically determine the recommended algorithm for that particular device.

What should you do if your programmer doesn't support your device's recommended algorithm? In general, you should be safe using a slower algorithm than the recommended one. But be sure to use the recommended voltages. Most modern EPROMs use a V_{pp} of 12.5 volts (12.75 volts for Quick Pulse), but older types require 21 or 25 volts, which would be lethal to the newer EPROMs.

Devices other than EPROMs have different programming requirements. Most EEPROMs can be programmed entirely from 5 volts, and Flash EPROMs have specific erase/programming procedures that must be followed.

(3) In what format is your object file? Your file must be in a format that your programmer can understand. All object files contain the codes that will be stored in an EPROM, but the codes may be stored in any of several formats, including binary, ASCII hex, Intel Hex and Motorola S-record. For example, a source file might include a statement like:

```
MOV ACC,1A
```

However, EPROM programmers can't understand the statement in this form. Before the EPROM is pro-

grammed, the information must be translated into binary codes like:

11100101 00011010

A file consisting of such binary codes is called a binary file.

In addition to reading binary files, many EPROM programmers can read information in a format called ASCII hex (or one of its variations). To understand why ASCII hex is used, look at how computers display information.

In most text files, like those produced by word-processing programs, each character is stored as an ASCII code. ASCII codes are simply a series of numbers, each of which represents a character—a letter of the alphabet, number, punctuation mark or other symbol. Most programming references include a chart of ASCII codes.

In ASCII, the digits 0 to 9 are represented by the codes 30h to 39h, in sequence. (The “h” indicates hexadecimal, or hex, format.) For example, the code for “1” is 31h, *not* 01h as you might expect. The letters A through F, which in hex signify the decimal values 10 through 15, are represented by the ASCII codes 41h through 46h. When you display or print an ASCII file, the codes are translated on-screen or printed out into the letters of the alphabet and other characters they represent.

If you try to display or print a binary file directly, its contents will also be translated into ASCII characters, which may include letters, numbers and other symbols, as well as beeps, blanks, backspaces and other undesired effects. The result is characters that appear to have little relation to the file’s contents.

If you want to examine or edit a binary file, you must put it in a more human-readable form. This is where ASCII hex comes in. If you convert a binary file to ASCII hex and then display or print it, you’ll see each of the original bytes expressed as a two-character hex number. This makes it easy for you to examine and, if desired, edit the codes.

Converting from binary to ASCII hex consists of the steps (using the previous example statement):

(1) Express each byte as a two-character hex number like

E5 1A (“straight” hex)

Table 1. Motorola S-Records Fields In Order Shown

Field	Characters	Contents
Record Type	2	S0 = header, descriptive information S1 = 16-bit addressing S2 = 24-bit addressing S3 = 32-bit addressing S7 = end of file, 32-bit S8 = end of file, 24-bit S9 = end of file, 16-bit
Record Length	2	Number of character pairs in record, excluding record type and record length
Address	4, 6 or 8	Begin loading data at this address
Code/Data	0-2n	Code, data or descriptive information
Checksum	2	Checksum is calculated as follows: 1. Add values represented by character pairs in record-length, address and code/data fields; 2. Take the 1’s complement of result; 3. Checksum is least-significant byte of 1’s complement.

S123C000CE10001C26801D0C805F4F4C27037EC00B5CD13527037EC00A1
F0080061D008050
S10CC0207EC0091C00807EC009E9
S9030000FC

(2) translate each hex character to its ASCII code, like

45 35 31 41 (ASCII hex).

EPROM programmers that read

ASCII hex must convert the codes back into binary before programming. Format-conversion utilities are also available on some hardware-oriented BBSs and are included with some programming hardware.

Table 2. Intel Hex Record Fields In Order Shown

Field	Characters	Contents
Record Mark	1	Colon (:) indicates Intel hex format
Record Length	2	Number of character pairs in data field;
Address	4	Begin loading data at this address (0000 if unneeded)
Record Type	2	Indicates contents of data field, if any: 00 = data 01 = end of file 02 = segment address for extended addressing 03 = starting address
Data	0-2n	Code, data or address
Checksum	2	Checksum is calculated as follows: 1. Add values represented by character pairs in record-length, address, record-type and data fields; 2. Take 2’s complement of result; 3. Checksum is least-significant byte of 2’s complement.

Example file in Intel hex format:

```
:108000007590FF111475907F11147590BF11147540
:0A801000903F1114780379007A0004
:00000001FF
```

Since a pair of ASCII codes represents one byte, an ASCII hex file is always twice as long as the binary file it represents.

Two variations on ASCII hex format are Intel Hex and Motorola S-records, which are similar in purpose but slightly different in format. Both store data in ASCII hex format and provide additional information as well. These formats are especially useful when you transmit data from one system to another, for two reasons. One is that they permit you to specify where in memory to load the data. The other is that they provide error checking, which is important if you transmit over a link that may introduce errors due to noise or other transmission problems.

As you might suspect, Intel hex is most often used with Intel products, and Motorola S-records with Motorola products, but either format can be used with any file, so long as you have a way to extract the information in the file.

Both formats present information in character strings called records that are made up of smaller strings called fields. A file consists of a series of records, with each record terminating in a carriage return/line feed. Normally, you can use the formats without concerning yourself with their specifics, but Tables 1 and 2 give details for those of you who are interested.

Stand-Alone Programmer

As examples of popular types of EPROM programmers, I recently tried out two models, both from Needham's Electronics. The SA-10 is a stand-alone device that can also communicate with a desktop computer or computer terminal. The PB-10 is a circuit board that plugs into an expansion slot of an IBM-compatible computer.

The SA-10, pictured in Fig. 1, is a full-featured and versatile programmer that accommodates EPROMs with capacities ranging from from 2K (2,716) bytes to 512K bytes (4M bits), as well as EEPROMs and Flash EPROMs. Its four-line liquid-crystal display and hex keypad allow you to use the programmer as a stand-alone device. By browsing through the menus, you can select a device type,



Fig. 1. The SA-10 programmer has a four-line display and hex keypad that permit stand-alone operation. The programmer can also be cabled to a computer or terminal for remote operation.

read an IC's contents into the SA-10's memory, verify that an IC is erased, program an IC with the data stored in the SA-10's memory and verify that programming was successful. You can even enter text (file and macro names, for example), by stepping through the alphabet and selecting characters one by one.

If you prefer, you can cable the SA-10 to a personal computer or computer terminal and use your computer's video display and keyboard to communicate with the SA-10. Three connectors are provided: a 36-pin female Centronics-type parallel connector and two male DB-25 connectors that separately connect to a serial port on a computer or computer terminal and to a parallel printer directly to the SA-10.

The programmer has a single 40-pin ZIF (zero-insertion-force) socket for easy insertion and removal of ICs. Smaller ICs use only the bottom rows of the socket.

The SA-10 reads binary, ASCII hex, Intel Hex and Motorola S-record files. Data to be programmed is first read into the SA-10's buffer memory. Standard memory is 128 kilobytes, expandable to 4M. You

can view, edit, search, fill and copy data in the buffer. You can place data anywhere in the buffer, and you can program any portion of the buffer into an IC. You can program an entire EPROM, or just a single byte, if that's all you require.

A Flash EPROM inside the SA-10 permits nonvolatile storage of configurations, file names and macros. If you find that you frequently repeat the same sequence of operations, you can save the sequence as one of 100 macros that you then can execute by selecting a single menu item.

Firmware upgrades (to support programming of new devices, for example) are released on disk and on Needham's BBS. You can install the upgrade yourself by loading the file into the SA-10's buffer and selecting the menu item that writes the upgrade to the SA-10's Flash EPROM.

For files that are too large to fit into one EPROM, the SA-10 supports set and split programming. Set programming fills EPROMs sequentially, programming one EPROM with the first portion of the file, the next EPROM with the next portion, etc.

Split programming is used when 16-bit-wide (or wider) data is stored

Why take chances in today's job market?

Graduate as a fully trained electronics professional.

To get ahead and stay ahead in today's economy, you need the electronics training CIE has been providing its 150,000-plus successful graduates with for nearly 60 years.

Meet the Electronics Specialists.

When you pick an electronics school, you're getting ready to invest time and money. And your whole future depends on the education you receive in return. That's why it makes so much sense to go with number one... with the specialists... with CIE!

There's no such thing as a bargain education.

If you talk to some of our graduates, and we recommend you do, chances are you'd find a lot of them shopped around for their training. Not for the lowest priced, but for the best training available. They pretty much knew what was available when they picked CIE as number one.

Because we're specialists we have to stay ahead.

At CIE we have a position of leadership to maintain. Here are just a few of the ways we hang onto it...

Programmed Learning.

That's exactly what happens with CIE's Auto-Programmed Lessons®. Each lesson uses famous "programmed learning" methods to teach you important electronics principles. You explore them, master them completely, before you start to apply them. You thoroughly understand each step before you go on to the next. You learn at your own pace.

And, beyond theory, some courses come fully equipped with electronics equipment to actually let you perform hundreds of hands-on experiments.

Experienced specialists work closely with you.

Even though you study at home, CIE's faculty and staff stand ready to assist via CIE's toll free number. And, each time you return a completed exam you can

be sure it will be reviewed, graded and returned with the appropriate instructional help, you get it fast and in writing from the faculty technical specialist best qualified to answer your question in terms you can understand.

Pick the pace that's right for you.

CIE understands people need to learn at their own pace. There's no pressure to keep up...no slow learners hold you back. If you're a beginner, you start with the basics. If you already know some electronics, you move ahead to your own level.

"Same Day" grading cycle.

When we receive your lesson, we grade it and mail it back the same day. You find out quickly how well you're doing!

State-of-the-art laboratory equipment.

Some courses feature the CIE Microprocessor

Training Laboratory. An integral part of computers, microprocessor technology is used in many phases of business, including service and manufacturing industries. The MTL gives you the opportunity to program it and interface it with LED displays, memory devices and switches. You'll gain all the experience

needed to work with state-of-the-art equipment of today and tomorrow.

New Courses!

CIE now offers two new career courses: Automotive Electronics and Computer Operation and Programming.

CIE offers you an Associate Degree.

One of the best credentials you can have in electronics — or any other career field — is a college degree. That's why CIE offers an Associate in Applied Science in Electronics Engineering Technology. And all CIE career courses earn credit toward your degrees.

Which CIE training fits you?

Beginner? Intermediate? Advanced? CIE home study courses are designed for ambitious people at all entry levels. People who have: No previous electronics knowledge, but do have an interest in it; Some basic knowledge or experience in electronics; In-depth working experience or prior training in electronics.

At CIE you start where you fit and feel comfortable where you start, then go on from there to your Diploma, Associate Degree and career!

Today is the day. Send now.

Fill in and return the postage-paid card attached. If some ambitious person has already removed it, cut out and mail the coupon below. You'll get a FREE CIE school catalog, plus complete information on independent home study. Mail in the coupon below or, if you prefer, call toll-free 1-800-321-2155 (in Ohio, 1-800-523-9109).

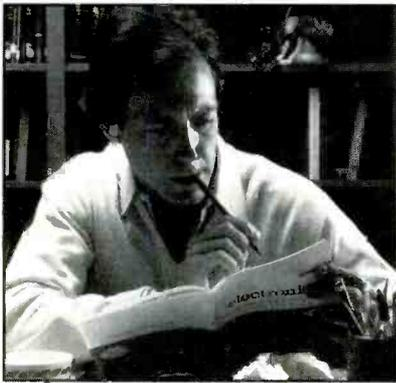

YES! I want to get started. Send me my CIE school catalog including details about the Associate Degree program. (For your convenience, CIE will have a representative contact you — there is no obligation.) AO19

Print Name _____

Address _____ Apt. _____

City _____ State _____ Zip _____

Age _____ Area Code/Phone No. (_____) _____

Check box for G.I. Bulletin on Educational Benefits Veteran Active Duty

 **CLEVELAND INSTITUTE OF ELECTRONICS, INC.**
1776 East 17th Street • Cleveland, Ohio 44114 • (216) 781-9400



A school of thousands.
A class of one.
Since 1934.

in ICs with eight-bit data buses. For a 16-bit split, the data at each address is divided into a higher and lower byte, with the higher byte stored in one EPROM and the lower in another. When split-programmed EPROMs are placed in a circuit, they share the same address and enable lines, but their data pins connect to different areas of the data bus—one to D0 through D7 and the other to D8 through D15, for example.

As a bonus, when the SA-10 isn't programming EPROMs, it can double as a printer buffer. This gives you a handy alternate use of its memory.

The SA-10 costs \$550. Its owner's manual includes a tutorial and other operating information. A 5¼" MS-DOS floppy diskette contains Needham's SA communications program for use with the SA-10 and MS-DOS computers. With other computers, you can use any standard communications program. Also on-disk are files that, when printed using an Epson MX80 or compatible printer, reveal schematic diagrams for the programmer. These show that the SA-10 contains a 65C02 microprocessor, 28F256 Flash memory and 27C64A EPROM.

A \$75 adapter allows you to use the SA-10 to program 40- and 50-pin EPROM and SRAM memory cards. For mass production, the SA-20 programmer (\$750) has an additional row of eight ZIF sockets across the top of the case.

Using The SA-10

As a stand-alone machine, the SA-10 is excellent. It allows you to select an amazing number of functions using its display and keypad. The manual lists over 100 supported EPROMs, EEPROMs and Flash EPROMs, plus a list of generic part numbers to use if an exact match isn't listed. Fifty-millisecond Intelligent and Quick Pulse programming are supported, along with Needham's Averaging algorithm, which provides fast programming for prototyping and other short-term, non-critical uses.

The first step after inserting an IC into the ZIF socket is to identify the device so that the programmer will know what algorithm and voltages to use. The easiest way to do this is to ask the SA-10 to read the IC's A9

identifier. If the code is one that the SA-10 recognizes, it will identify the device by manufacturer, size and recommended algorithm.

Be aware that not all devices are recognizable by the SA-10. When a part isn't listed, you're responsible for finding an equivalent. For example, the programmer wasn't able to identify a Samsung 28C65 EEPROM that I inserted. I looked for a match in the generic menu but found nothing close to it. I then scanned the devices listed under other manufacturers and eventually programmed the IC by identifying it as a Seeq 28C65.

Usually, an identical part number indicates a good match, even if the manufacturer is different, but there are no guarantees. Check the data sheets if possible.

One thing missing from the SA-10 is any documentation of the programming voltages used. You select programming algorithms only by name. A display of the voltages used would be reassuring, especially when you don't have an exact match and substituted a similar part number.

After using the SA-10 as a stand-alone device, I experimented with its computer interfaces. I first cabled the serial interface to my computer. Needham's SA program is supposed to find the SA-10 and set up all communication parameters automatically, but I had no luck with this. After much experimentation, I was able to send information from the SA-10 to my computer, but keystrokes from my computer's keyboard were still ignored by the SA-10. The parallel interface, worked fine, however; so I suspect that my programmer had a problem somewhere in its serial port's hardware or software. (Such failures are covered by a two-year warranty.)

The SA communications program expands the SA-10's 4-line display to a full screen. This allows you to view all 19 supported manufacturers at once, instead of just four at a time.

Some of SA's editing functions are a little awkward to use. To change a file name, I first had to cursor to the end of the current filename and then backspace repeatedly to erase. Sometimes, the cursor display didn't match the selected menu item, and I soon learned that when the display says "Press any key," it means any

key except the space bar—the one I hit instinctively.

In short, the SA-10 does a great job as a stand-alone, using its four-line display and keypad to full advantage. The computer interface allows you to transmit and receive files, but you're still pretty much limited to the same basic communications interface, with the addition of a larger display and keyboard for easier entering of file names and other text.

PC-Bus Programmer

If you own an IBM/compatible computer, Needham offers another option: its \$139.95 PB-10 programmer that plugs into an expansion slot in your computer's motherboard. A 2-foot cable that terminates in a 40-pin ZIF socket is routed through the back bracket of the PB-10's slot. The PB-10 requires an IBM/compatible equipped with at least 512K of memory. A hard disk is recommended but not required, and the card's port address is selectable.

The PB-10 costs just a quarter of the price of the SA-10 because it uses the microprocessor, memory, display, keyboard, enclosure and other resources of the computer it plugs into. All the EPROM programmer has to provide is the interface between the computer and the programming socket and the software to control it.

The PB-10 performs the same basic functions as the SA-10: selecting, reading, verifying and programming devices, loading and saving files, viewing, searching, filling and editing buffer memory. The PB-10's software displays 256 bytes of buffer memory, compared to the SA-10's 16-byte display. Split and set programming and macros are supported.

The PB-10 also allows programming of the encryption and security bits available on some EPROMs to prevent unauthorized reading of their contents. It supports Quick Pulse, Intelligent, Standard and Averaging algorithms. It allows you to view and change programming voltages, and it reads the full range of binary, ASCII hex, Intel hex and Motorola S-record files.

Figure 2 shows the PB-10's main menu. The user interface is intuitive and convenient. For example, the display allows you to scan supported

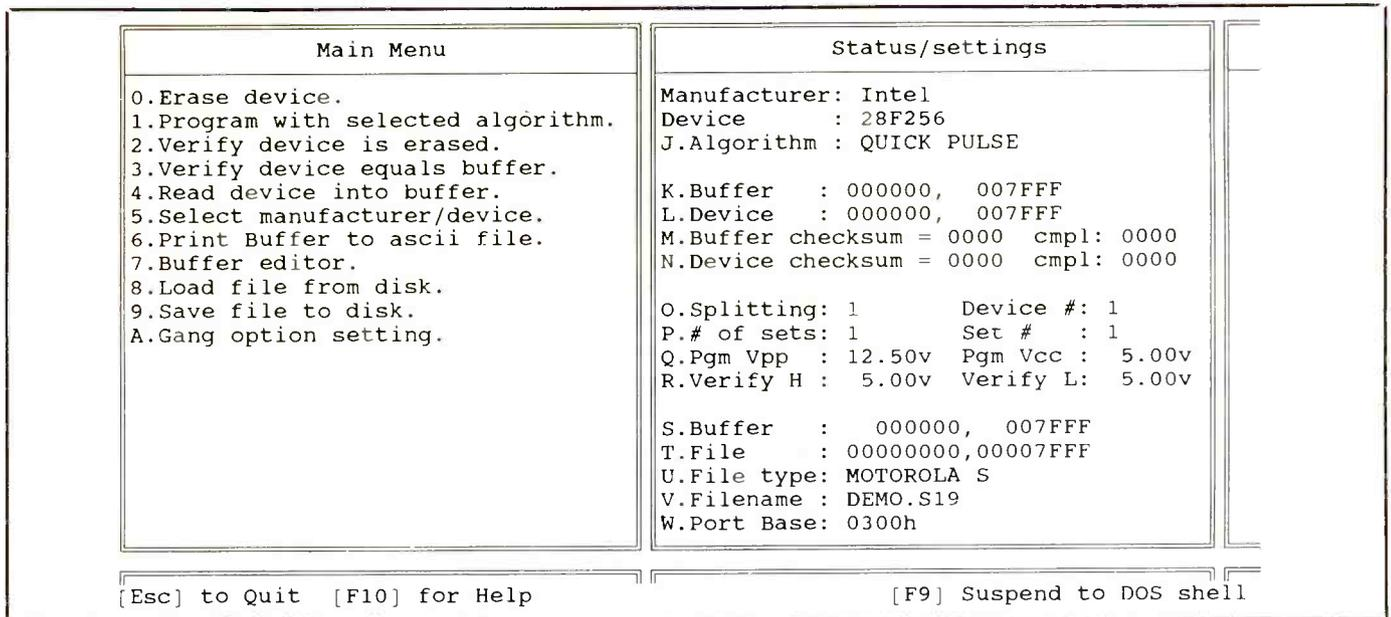

Fig. 2. The main menu of the PB-10's control program gives a complete list of available functions and settings.

Buyer's Checklist

The following are some general things you should take into consideration when selecting a particular EPROM programmer:

- (1) What devices does it program? (types, capacities and manufacturers)
- (2) What programming algorithms and voltages are available? (Quick Pulse, Intelligent, 50-millisecond, etc.)
- (3) What file formats can be used? (binary, ASCII Hex, Intel Hex, Motorola S-record)
- (4) How do I communicate with the programmer? (stand-alone operation, serial port, parallel port, bus interface)
- (5) How large is the memory buffer?
- (6) What functions are available? (read; copy; verify; verify erasure; read A9 identifier; send and receive files; view and edit buffer; set and split programming; macros)
- (7) How many programming sockets does it contain?
- (8) Is it upgradable to accommodate new device types?

devices by cursoring through the manufacturers displayed on the left side of the screen and viewing the part numbers for each on the right side. Simple text-mode graphics pop up automatically to show you how to insert devices into the programming socket on the device.

The PB-10's software creates a disk buffer file that's used to store

programming data, similar to the SA-10's buffer. The size of the file is user-selectable, from 64K to 16M.

In addition to EPROMs from 2716 to 27040 and EEPROMs, the PB-10 programs nonvolatile SRAMs from Dallas Semiconductor and Flash memory from Intel and others. Four adapters (\$50 each) expand capabilities by allowing programming of 8751 and other microcontrollers, 40- and 50-pin SRAM cards, 87C751 microcontrollers, and 27210 and other word-wide EPROMs. Also available is a four-socket adapter for \$65. The PB-10 carries a 1-year warranty.

The PB-10 doesn't read A9 identifiers—you must select device type manually. Schematics aren't included, and a printed manual (a printout of the extensive Help files) costs an additional \$5.

Buying Decisions

The PB-10's lower price makes it the better deal if you have an MS-DOS computer with a spare expansion slot. If you require a portable programmer or one that can communicate with a variety of computers, the SA-10 can do the job.

The box shown elsewhere in this article lists factors to take into consideration if you're in the market for a programmer. These should help you decide if one of the above pro-

grammers, or a different model, is the one for you.

Next time, I'll discuss Implementing a real-time clock.

If you have comments, suggestions or questions on topics relating to designing, building and programming with microcontrollers and other small, dedicated computers, send them to Jan Axelson, ComputerCraft, 76 North Broadway, Hicksville, NY 11801. If you'd like a personal reply, please include a self-addressed, stamped envelope. ■

Sources

SA-10 and PB-10 EPROM programmers
Needham's Electronics
 4539 Orange Grove Ave.
 Sacramento, CA 95841
 Tel.: 916-924-8037
 FAX: 916-972-9960



Jan Axelson

Computers At The Dayton Hamvention

Some 35,000 attendees at the biggest ham-radio convention in the US were treated to a large contingent of computer and software vendors with flea-market prices

Before the MIS people discovered personal computers, before Lotus and IBM made personal computers truly respectable in business settings, before "hacker" became a dirty word, there were computer swap meets. Frequently, they were associated with a ham-radio "hamfest," since many early computer hackers were also ham radio operators.

There were no carpets or three-piece suits. Signs offering merchandise were as apt to be crudely drawn by hand as typeset. But there were bargains, and there were shoppers looking for those bargains. And those early computer swap meets were just plain fun, too.

The 1991 Dayton (Ohio) Hamvention, in its fortieth year, carried on that tradition. It's the premier US hamfest, drawing a bigger crowd than any other ham show in the country and placing second in the world. Even though the main thrust of the weekend-long show was ham radio equipment, computers had a strong showing, as they've had for the last 10 years or more. Forty percent of the 350-plus vendors present inside Dayton's Hara Arena offered computer-related items. Outside, in the 25-acre flea market area, you could find virtually anything related to electronics and components in the 2,200 designated selling spaces.

This year, more than 35,000 people made the trek up and down the aisles searching for that special bargain, renewing friendships and making new friends. The official paid attendance was 32,716, but the sponsor, Dayton Amateur Radio Association, opened the gates to youngsters for free, pushing the attendance well above the 35,000 mark.

Attendees represented every state in the Union and numerous foreign countries. Several Japanese CEOs flew in for the event, including Shunsaku Inoue, president of Alinco Electronics, Inc. Joe Rudy, retired baseball player, drove from his Oregon ranch in a pick-up truck so that he would have a convenient way of transporting home his anticipated "finds."

Although most of the computer dealers were from the East Coast and Midwest, JDR (CA) brought in a "slick" dis-



So many computers, so little time.

play occupying six booth spaces with 15 sales reps, a tradition begun several years ago. JDR offered a full range of upgrade boards and parts, as well as complete systems at special "show prices." At the other end of the spectrum, specialty ven-

dors like Memory World provided greater depth in a narrow range of products in a single booth space.

The majority of the computer dealers, though, fell in the middle, offering some of just about everything in two or three

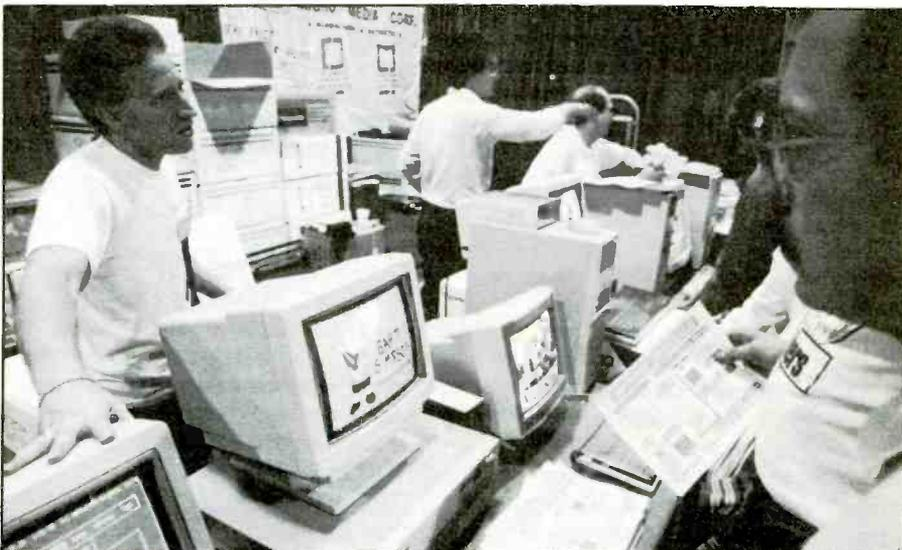

That's right folks, when you buy our computer, Bart Simpson comes to your house and personally installs Windows.



Boards, boards and more boards.

spaces. XT systems were offered for as low \$250, but even at such a "fire-sale" price, they seemed to attract relatively little attention.

MAX systems, with stores in Winter Garden, FL, and West Harwich, MA, offered its MAX 33-C 33-MHz system for only \$2,695, \$600 off the regular retail price. The MAX 330-C includes 4M of 80-ns RAM, a 64K cache, eight expansion slots, a tower case, 230-watt power supply, 5¼" and 3½" floppies, 106M 18-ms hard drive, 1,024 × 768 super VGA with 1M controller, 130-key keyboard (includes a calculator) and the usual assortment of I/O ports. This is hardly a second rate system!

Debco, a Cincinnati-based computer retailer, simply used its standard catalog and offered a 10% discount on any item purchased at the show. The Heath Company was selling kits and factory-assembled units at a much deeper discount, sometimes as much as 75% off list price. Most of the items Heath brought were products that had been returned and factory refurbished. Other items were new off the truck, but presumably overstocked. As the Heath employees began unloading their truck Thursday afternoon (set-up day), a crowd gathered around. Although many of the "choice" items were sold before the show opened to the public on Friday afternoon, enough bargains were left to draw a crowd and keep it until the entire stock was gone by Saturday afternoon. At times, the booth resembled a Wall Street trading pit.

The scene at the Radio Shack booth was less frenetic, but the bargains were



Quick! Let me buy this before you change your mind.

choice. External disk drives for the 1000 series were priced under \$50, down from \$170 list. Discontinued products were selling at distress prices, while current items were more modestly discounted.

Numerous vendors offered shareware. Typically, a 5¼" disk sold for around \$2 in small quantities. Some dealers, like Computer Companion, offered discounts based on the number of disks sold. Had you purchased 75 or more disks from this vendor, the price would have been 75 cents per disk! Disks in the 3½" format were somewhat higher in price, and there were far fewer dealers offering this format. Of course, software on the disks covered the complete gamut from ham-radio-specific offerings to utilities to business applications to "adult-oriented" graphics and games. Software for *Windows* was particularly popular.

Sometimes, the vendor names were quite deceptive. For instance, Shareware-To-Go did offer shareware, but it had several low-end commercial packages, such as Mosaic's *Integrated 7* package, for around \$30. These people also had an extensive collection of current computer-related books from Que. Pricing was at 25% off list.

Blank disks and other peripherals were also available in abundance at excellent prices. ERM offered 1.2M 5¼" bulk-erased floppies, including labels and Tyvek sleeves for \$38 per hundred. The company also had stackable disk drawers of various sizes and formats at competitive prices.

Pricing was more aggressive in the outdoor flea market. Outmoded hard disks, for instance, could be had for as little as

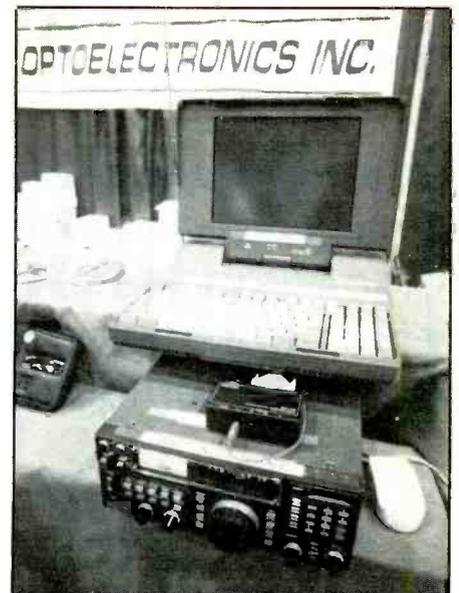

A 2.4-GHz frequency counter inside a laptop computer.

\$10—for those willing to take a chance. Shareware disks were often priced around \$1 each in small quantities. Ribbons, paper and other peripherals abounded. The size of the flea market, though, made comparison shopping difficult. "Now, where did I see the 360K disks for \$19 per hundred?"

Inside, comparison shopping was possible. Posted prices on items often showed signs of having been hastily altered. It was obvious that people were buying, but it was difficult to gauge just what was moving best during the weekend by watching people parade by with their heavy load of shipping cartons.

"What's selling? High end stuff mostly. 33-MHz 386s and 486s. That's what these guys are looking for this year. They ignore the XT and 286 stuff," said Joe Chang. Chang owns Greentree Computers, a retail storefront operation located in Marlton, NJ.

"Quality. That's what's selling here this year. That's the focus of our business. We specialize in name-brand equipment, and we are doing very well," said Northway Computers president, Ciro D'Angelo. This was the first year for the Philadelphia retailer to make the odyssey to Dayton.

These sentiments were echoed over and over again from the vendors. High-end systems, laptops and printers were the hot movers at Dayton this year. Even at the hobbyist level, the XT seems to be on its last gasp, and the 286-based boxes aren't far behind.

If Dayton was any indication, the hobbyist and MIS people are in agreement on one thing: bigger and faster is better. ■

Build an ELF Monitor

This milligauss meter lets you check extremely-low-frequency electromagnetic emissions from electrical equipment so that you can take remedial action

There is growing concern over possible health hazards from low-frequency electromagnetic emissions, which includes 60-Hz fields. At first, this related to electromagnetic fields given off by overhead power-line transformers. This has since been extended to computer video display monitors, where apprehensions about the effect of ELF (extremely-low-frequency electromagnetic fields) have been voiced. Sweden has long had stringent regulation relating to limiting ELF in video monitors, for example. Now, U.S. companies, including IBM, make available computer monitors that emit less ELF than do standard ones. The ELF Monitor described here allows you to check and modify your environment to reduce ELF emissions.

About the Circuit

Shown in Fig. 1 is the complete schematic diagram of the circuitry that makes up the ELF Monitor. The heart of this circuit is the ELF sensor shown at top-left. This device detects the 60-Hz field generated by ac-line-powered equipment and, in turn, generates an output voltage whose magnitude is proportional to the magnetic field strength detected. The sensor outputs 1 millivolt ac for each milligauss of field strength detected.

Our ELF Monitor is basically a simple ac millivoltmeter that connects to the sensor. If you own a digital multimeter, you might be able to connect the sensor directly to the meter and use it as the metering device. Of course, this depends on the resolution and accuracy of the meter. Although my DMM worked after a

fashion, it lacked the accuracy I desired because it dropped about 2 millivolts off my readings. In any case, if you have a meter set to the ac-volts mode, you might give it a try. You can also try calibrating your meter using the same procedure outlined later for the ELF Monitor.

Three measuring ranges are provided in the ELF monitor: 10 milligauss, 100 milligauss and 1 gauss. Operational amplifier *IC1* is configured in Fig. 1 as a non-inverting amplifier. Germanium diode *D1* provides nonlinear feedback from the output at pin 6 to the input at pin 3 of *IC1*. This diode allows the op amp to amplify and rectify millivolt signals.

When no electromagnetic signal is sensed by the sensor, insufficient output voltage is available from *IC1* to force *D1* into conduction. Thus, the feedback appears to *IC1* as an open-circuit, with the result that the op amp operates at full voltage gain. At this point, only a small voltage from the ELF sensor is required to produce a large output.

When an electromagnetic field is sensed, the sensor outputs a signal that drives *D1* into conduction. When this occurs, *R1* sets a lower closed-loop gain for the input signal. In practice, the millivolt-level ac signal from the sensor is passed through a half-wave rectifying op-amp arrangement in which *D1* in the feedback loop compensates for the voltage dropped across *D2*.

Germanium diodes were used for *D1* and *D2* because they have a lower voltage drop (approximately 0.3 volt) than do silicon diodes (approximately 0.7 volt). Furthermore, germanium diodes provide superior per-



formance from the op amp. Pc mounted potentiometer *R7* allows calibration of the meter.

Capacitor *C1* between the + output of the ELF Sensor and input pin 2 of *IC1* blocks any dc component from entering the op amp. Resistors *R1* through *R4* make up a three-step attenuator that gives a 10-milligauss range in position 1 of switch *S2*, 100-milligauss range in position 2 and 1-gauss range in position 3.

For complete portability, you can power this hand-held project from a single 9-volt battery, as shown at the lower-right in Fig. 1.

Construction

Owing to its basic simplicity, you can assemble and wire this project by any traditional means that suits you. For example, if you feel ambitious, you might want to design and fabricate a printed-circuit board. Alternatively, you can use perforated board that has holes on 0.1-inch centers and suitable Wire Wrap or soldering hardware. Whichever way you go, though, it is a good idea to use a socket for the integrated circuit.

All components, except the sensor, meter movement, battery and two switches mount on the circuit board. Plan your component layout so that all wire or conductor runs are as short as possible to minimize pickup

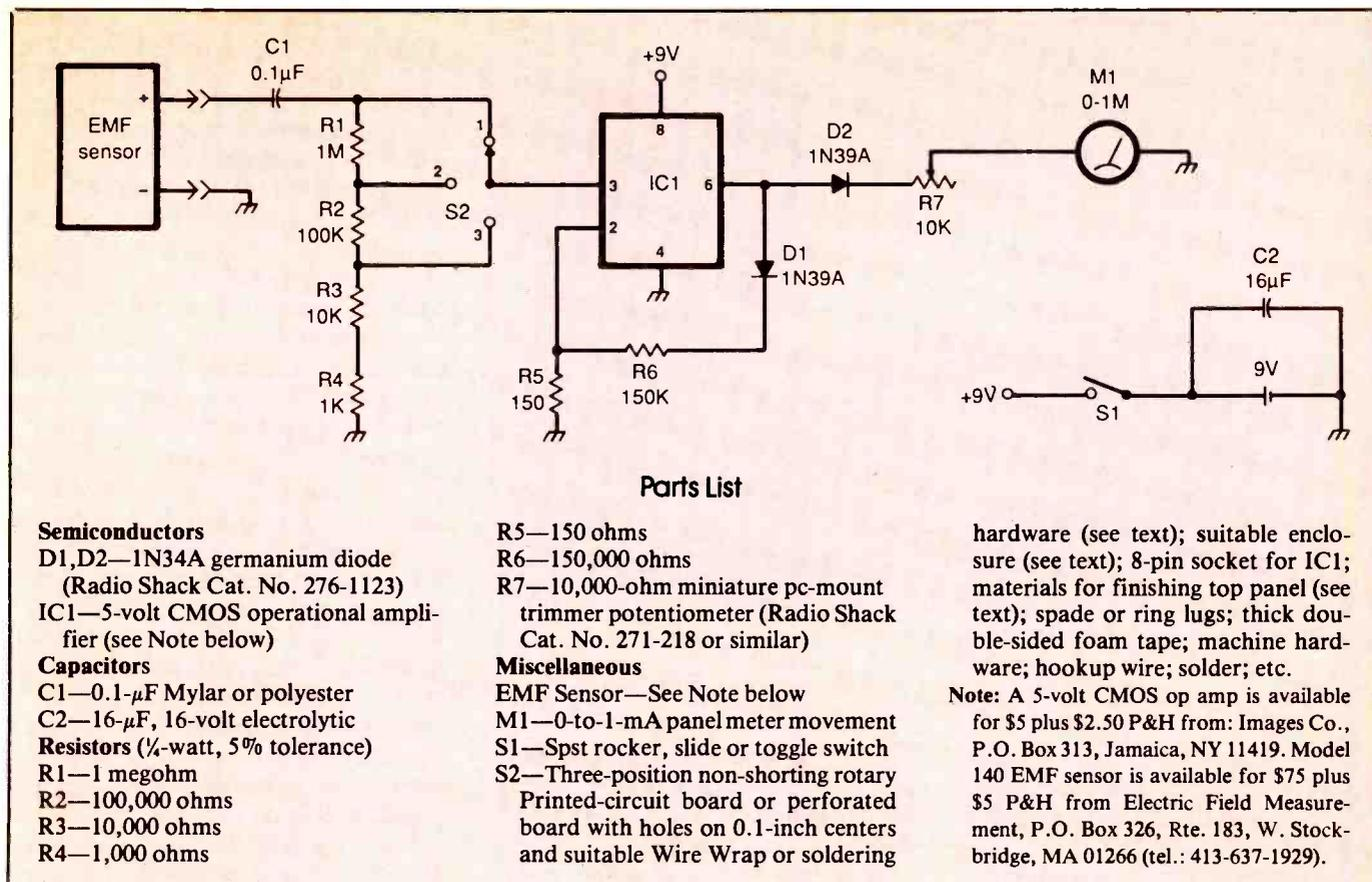

Fig. 1. Complete schematic diagram of circuitry used in ELF Monitor.

of stray electromagnetic fields.

Begin assembling the project by mounting the IC socket in place. Do *not* plug the IC into the socket until after you have conducted preliminary tests and are certain that your wiring is correct. Next, mount the resistors, trimmer control *R7*, capacitors and diodes. Make sure you properly polarize the two diodes.

Strip $\frac{1}{4}$ inch of insulation from both ends of five 5-inch lengths and five 3-inch lengths of hookup wire. If you are using stranded wire, tightly twist together the exposed fine conductors at all ends and sparingly tin with solder. Plug one end of the 6-inch-long wires into the holes for the meter movement and solder into place. Do the same for the +9-volt and sensor lines. Then plug one end of the remaining wires into the holes for the lines that go to the RANGE switch and ground line to the power source. The other ends of these wires will be connected later.

You can use any all-plastic enclosure that is sufficiently large to accommodate the circuit-board assembly

and sensor unit on the floor panel and all other components on the top panel. Do *not* use a metal enclosure. If you do, the circuit will not sense electromagnetic fields. A typical enclosure is pictured in the lead photo.

Machine the enclosure as needed. Drill mounting holes through the top panel for mounting the POWER and RANGE switches and the battery holder. This done, nibble or cut the large hole in this panel in which to mount the meter movement.

Before you mount any components on the top panel, use dry-transfer lettering kit or plastic-strip labeler to label the control panel. If you use dry-transfer lettering, spray two or more light coats of clear acrylic over the entire panel to protect the legends. Allow each coat to dry before spraying on the next. When the acrylic coating has completely dried, mount the battery holder, meter movement and POWER and RANGE switches in their respective locations.

Use thick double-sided foam tape to mount the circuit-board assembly and sensor unit to the floor of the en-

closure. The correct arrangement for this is shown in Fig. 2. With these items in place, wire together the remainder of the circuit. Begin by crimping and soldering the four shorter wires coming from the circuit board to the appropriate lugs on the rotary RANGE switch and the negative (-) lug of the battery holder.

Crimp and solder spade or ring lugs to the ends of the two meter-movement wires. This done, secure these wires to the meter screw terminals of the meter movement. Make certain that you properly polarize these connections. The wire that comes from the wiper terminal of trimmer control *R7* on the circuit-board assembly must go to the + terminal, the other wire coming from circuit ground to the - terminal on the movement.

Crimp and solder the free end of the + wire coming from the circuit-board assembly to one lug of the POWER switch. Then strip $\frac{1}{4}$ inch of insulation from both ends of a 2-inch-long hookup wire and crimp and solder this between the other lug

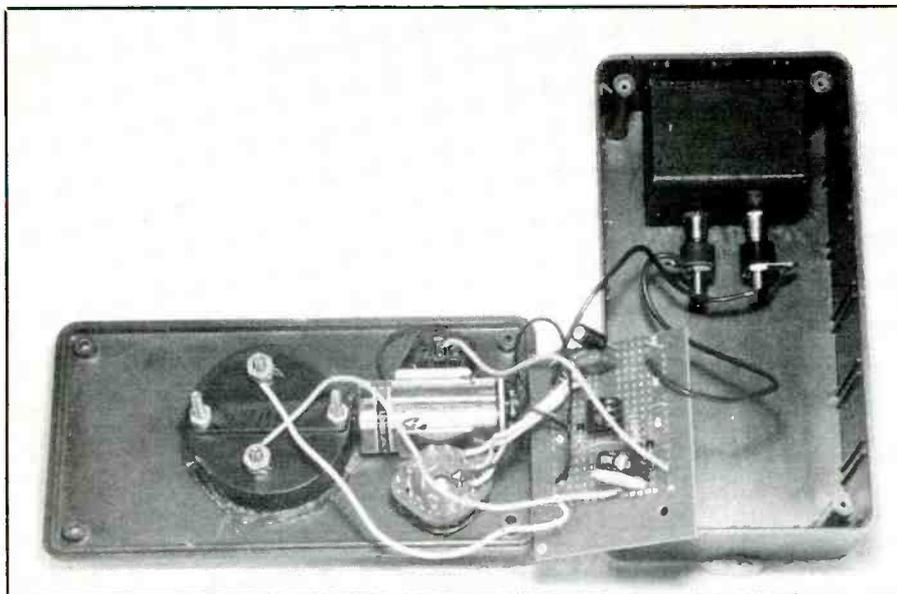

Fig. 2. Interior view of author's prototype.

of the POWER switch and the + lug of the battery holder. Crimp and solder the free end of the ground wire to the - lug of the battery holder.

Two wires remain to be connected. These go to the sensor unit. Terminate both wires in spade or ring lugs, but do not connect them just yet.

Checkout & Calibration

There should be no IC plugged into the *IC1* socket on the circuit-board assembly. Place a fresh 9-volt battery in the battery holder. Clip the common lead of a dc voltmeter or multimeter set to the dc-volts function to the - lug on the battery holder. Turn on your meter and set the project's POWER switch to ON.

Touch the "hot" probe of the meter to pin 8 of the IC socket. You should obtain a reading of approximately +5 volts. If not, power down and check your wiring. Do *not* proceed until you are sure you have corrected the problem.

Once you are certain that your project has been correctly wired, power down and disconnect the meter. Plug the IC into the socket on the circuit-board assembly. Make certain you properly orient it and that no pins overhang the socket or fold under between IC and socket.

Before you connect the circuit to the ELF sensor, calibrate the circuit.

To do this, you need a 60-Hz millivolt source of known power. A simple to obtain such a source is to wire the circuit shown in Fig. 3.

With the 6.3 secondary wired across the 100,000- and 100-ohm resistors and the output taken across the latter resistor as shown, the voltage obtained should be roughly 6.3 millivolts. Because a very-low-amplitude voltage is required, it is a good idea to measure the values of the two resistors and secondary voltage of the transformer to assure tight accuracy. Select resistors that have values (preferably with a specified tolerance of 1%) that are as close as possible to the specified 100,000 and 100 ohms.

Use Ohm's law to calculate the voltage across *R2*. It should be close

to 6.3 millivolts. Use this calculated millivolt number to calibrate the your meter. Connect the input of the two sensor wires coming from the circuit-board assembly in the ELF Monitor across the 100-ohm resistor in the Fig. 3 circuit and set the Monitor's RANGE switch to the 10-milligauss position. Adjust the setting of trimmer control *R7* on the circuit-board assembly in the project until the reading indicated on the meter movement matches as closely as possible the voltage you calculated above.

With your ELF Monitor calibrated, you can now connect the ELF sensor into the circuit. Examination of the sensor module will reveal that it has two banana plugs protruding from one end. One plug is identified with a "G," identifying it as the ground or - plug, to which you must connect the free end of the ground wire coming from the circuit-board assembly. Finish up by connecting the free end of the remaining wire to the other plug on the sensor module.

Using the ELF Monitor is as simple setting the RANGE switch to the 1-gauss position and setting the POWER switch to ON, positioning the project near the line-powered electrical device you wish to check out and taking a reading. If you observe no up-scale movement of the meter pointer, switch to the 100-milligauss or even 10-milligauss position until you do obtain a reading.

When switching to a higher position of the RANGE switch, if you obtain a meter reading that seems to be too high, you probably have stray pickup in the circuit leads. To rectify this, try shortening the wires from

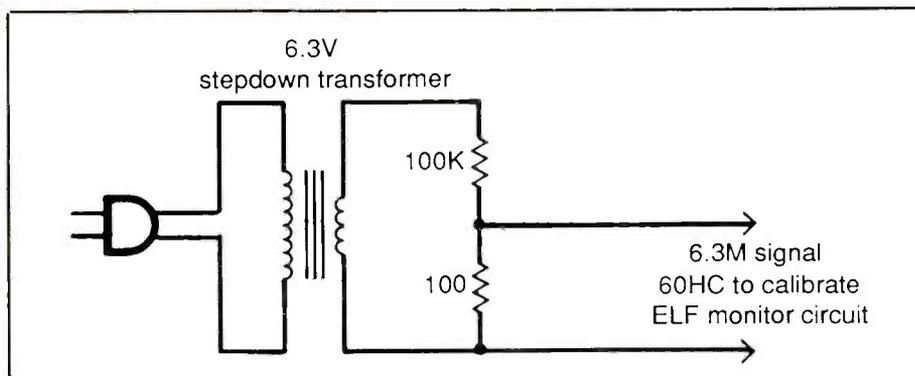

Fig. 3. Circuit arrangement for obtaining a millivolt-level signal with which to calibrate the project.

ELF Radiation and You

The concern that exists over possible health hazards from low-frequency electromagnetic emissions, much of it from computer video display monitors, has prompted a number of agencies to initiate on-going research in this area to set standards. In the forefront is Sweden, which limits ELF to a maximum of 2.5 milligauss at a distance of 50 centimeters from a video monitor. Closer to home, the EPA has begun to study possible biological implications due to ELF. With a growing body of evidence, even though no solid conclusions have come of the studies, some manufacturers are beginning to offer video monitors with reduced ELF radiation.

Whether or not hard evidence exists, it is a good idea check 60-Hz equipment and compare ELF readings obtained to the Swedish standard. The ELF Monitor project detailed in the main article is an ideal instrument to use for this purpose.

Most ac-line-operated devices are generally operated with the user at a distance from them. A major exception in the modern workplace is the computer video monitor, which requires the user to sit close enough to read data displayed on-screen. With the user positioned well within the sphere of any low-frequency magnetic field the monitor radiates, if a hazard does exist, it is

here that its effect is most likely to be encountered.

Results of ELF tests on 10 popular computer monitors published last year revealed that all emitted "excessive" ELF at close range. These monitors constitute the bulk of those in current use. Because it was shown that effects of ELF dropped off dramatically with increasing distance between monitor and user, the logical conclusion is: put more distance between user and monitor. Having run tests of my own (see the accompanying Table), the results obtained reveal that a reasonable working distance should be 24 or so inches.

Keep in mind that an ELF field, like radio waves, propagates omnidirectionally around a video monitor, not just from the screen area. Consequently, wherever monitors are close to each other, users can be exposed to ELF effects from another nearby monitor, multiplying the possible risk.

Measurements listed in the Table are of 60-Hz ELF fields radiated by a 1084 Amiga video monitor. The distance column entries are in inches. As you can see, ELF field strength drops off dramatically with increasing distance between monitor and measuring device. Data in the Table is not meant to be representative of all video monitors. If you were to check another model moni-

ELF Measurements
From a Computer Monitor

Distance	Front	Left	Right	Rear	Top
0	78	97	90	125	270
4	24	14	16	37	65
12	5	1.5	1.5	8	9
24	<1	<1	<1	3	1.5

tor, you would almost certainly discover that it emits different levels of ELF radiation from those listed.

The ideal solution to this problem would be to use an ELF shield. Unfortunately no such shields exist. Antiglare screens that do block electric and magnetic fields emitted by video monitors are effective for only high-frequency fields generated by CRTs and, thus, are not effective for low-frequency (60 Hz) magnetic fields.

Whether or not ELF radiation is, indeed, a real health hazard, sufficient evidence already exists for you to at least consider reducing your exposure to it. If you are a typical user, you spend a considerable amount of time at your computer. Prudence dictates that you practice some precautionary measures—like limiting your long-term exposure to 1 milligauss or less.

the RANGE switch to circuit-board assembly. These wires are particularly sensitive to stray-field pickup.

The ELF Monitor accurately measures the 60-Hz magnetic field from any appliance or other ac-line-powered device. To test project operation, turn on your video monitor. Starting from approximately 2 feet away, turn on the ELF Monitor and slowly advance toward the video monitor. As you close the distance, the pointer of the project's meter should jump off-scale. When this occurs, switch to a higher range and continue closing the gap.

When measuring ELF from a computer monitor, you may notice that the reading varies by a few milligauss, changing from low to high to low on a slow-moving sine curve.

This is likely caused by phase interaction of the electromagnetic coils on the CRT tube. This effect is not observed for transformer coils, electric motors or anything else I have checked. It also was not observed when using the 1-gauss setting of the RANGE switch.

Before powering up the ELF Monitor, you should always set the RANGE switch to the 1-gauss position and work downward as needed. As you move around checking various appliances, you may discover that simply by rearranging your appliances you can considerably reduce ELF effects. For example, one of my computers has an external power supply that emits strong ELF. Simply by moving the power supply farther from my work area to a more discrete location considerably reduced my exposure to the ELF radiation from it as I work.

Simple fixes, like changing from a fluorescent desk lamp to an incandescent desk lamp, can provide a similar benefit.

Bear in mind that the ELF Monitor will not measure a static magnetic field, such as one generated by a permanent magnet.

Though the biological effects of ELF on humans or even animals is not yet conclusive, it pays to err on the side of caution. If you wish to learn more on this subject, as well as on other types of electromagnetic energy effects, I refer you to *Biological Effects and Medical Applications of Electromagnetic Energy* Edited by Om P. Gandhi (Prentice Hall). Dr. Gandhi is a professor of Electrical Engineering at the University of Utah, a Fellow of the IEEE and past Chairman of the IEEE Committee on Man and Radiation. ■

On Line With Computer Graphics

A fast tour of graphics available by modem

Graphics have become an important part of information retrieval and display. Anyone with a modem can join in the fun of creating, viewing, and trading images by phone. We'll look at some graphics tools and sources that are widely available.

CompuServe & GIF

CompuServe Information Service has done much to encourage disseminating digital images. Some years ago it promoted Graphics Interchange Format (GIF). That acronym is pronounced "jif," and it has several very good points. One outstanding feature is its portability from one computer platform to another.

IBM and Mac users alike can view the same GIF file. All it takes is a GIF viewer made for the particular operating system. GIF format was received enthusiastically by users across the country. Accordingly, the format gathered wide support and remains popular on CompuServe itself, as well as many private bulletin-board systems.

Another feature of the GIF format is an efficient data format that makes the file take up less space than is normal. It has a sort of built in data compression. For users who are interested in details of GIF structure, the GIF standard is explained in the document GIFSTD.ASC. The document resides on CompuServe in library 17 of the Graphsupport forum.

One of the more abundant sources for GIF files is, as one might expect, CompuServe. To get on CompuServe requires a modem, of course. Although 1,200 baud is supported, 2,400 baud is much preferred, and 9,600 baud is in the works. The mail-order price of a typical 2,400-baud internal modem with error correction is less than \$200. Besides that cost, there's the additional money that must be paid for becoming a CompuServe subscriber. There's a one-time

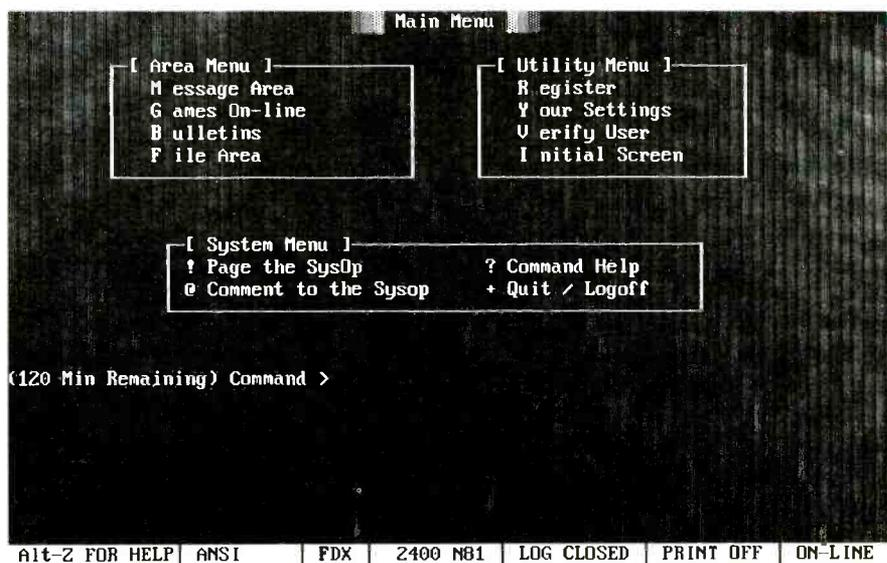

set-up fee, which buys a start-up kit that includes a user ID and temporary password. At this writing, the rates for actual hourly connect time are \$6 for 300 baud and \$12.50 for 1,200 and 2,400 baud.

For users who can afford the potentially expensive use of CompuServe, the benefits are clear. It provides user discussion forums for all types of interests, including graphics. Topics discussed on the graphics forums range from format conversion to video hardware. Subscribers of CompuServe can freely join any forum. They can then ask questions or download graphic viewers and images to be viewed. CompuServe contains a wide selection of images that include nature, astronomy, contemporary art, science and technology.

There are other commercial on-line information services. Some of them charge by connect time. Others have a flat rate that covers basic services. It shouldn't be difficult to find an on-line service that suits your preferences and pocketbook. But the home of the GIF is undoubtedly CompuServe.

There are other ways to get at graphic images, utilities and related

information. Local bulletin boards can be found in every large (and many small) cities.

Some of these bulletin boards deal exclusively in graphics. The System Operators (Sysops) and members of these bulletin boards can be very helpful. Keep in mind that such private boards are kept operational at the expense of the owner. It's common to meet up with membership fees. First-time callers to these boards are given limited access to look around. If you like what you see and want to become a member, you fill out an on-line application. The Sysop takes it from there.

When becoming a member of a private board, system rules must be obeyed. Violation of rules may result in termination of membership. It may take some looking around to find a board that suits your phone bill and tastes. But the end results are worth the time spent.

Hidden Costs

There's another cost that some users don't think about at first: long-distance connect charges. If a favorite bulletin board lies across the coun-

try, repeated lengthy calls can run up the phone bill. However, a good high-speed modem and efficient telecommunication practices will minimize phone costs. For example, a large number of private bulletin boards use the Courier HST modem from U.S. Robotics. HST is a proprietary protocol that enables two HST modems to have a high data throughput as compared to more standard protocols. The faster throughput means less time spent downloading.

Fairly recently, better communication protocols have arisen. We now witness the settling in of V.42bis and MNP5. Each protocol is a little different and has assumed its own position for usage. Very quickly, though, private boards latch onto new communications technologies. U.S. Robotics' newer dual-standard modem handles most, if not all, modern protocols. Modems that have the new protocols are higher in price, but higher throughput and data compression can make a difference in long-distance and on-line costs. The HST is a good buy for serious bulletin-board "junkies" simply because of its widespread use on private bulletin boards.

Phone time can be further minimized by practicing some sensible rules. One rule is to know what you want to download before you begin the transfer. Log onto your favorite board and capture a list of available files. Hang up and then browse the file list at your leisure, deciding which files you want. Use your telecommunication software to help you to estimate how long the download might take. The next time you log on to your bulletin board, no time is wasted wading through menus or trying to remember file names.

Automatic Downloads

Some users have been successful at automating download sessions. Most modem software has a kind of loose programming capability that's sometimes called a script language. Essentially, the script language allows the modem to take a series of special commands and act on them, line by line. Phone call, log-in and download session all can be automated. With a little practice, script programming produces results that are quite useful.

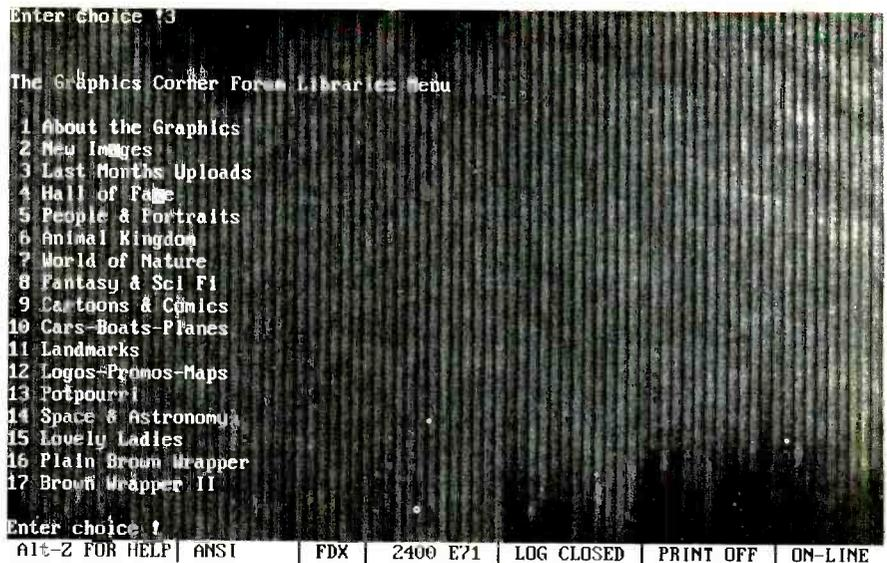

Many bulletin-board systems have a provision for downloading multiple files without entering the name of each individual file. The files are marked as they're browsed from menu. All tagged files will be transferred. When finished downloading, a modem software with a script language can automatically terminate the phone connection. This is a good feature to use for late-night batch mode downloading. A download session can run unattended. This batch method of downloading is a time saver but care should be taken not to become a "download hog."

Hogging can greatly affect private boards that normally have a limited number of phone lines. Smaller boards have only one or two. The Sysop of your bulletin board may have download limits or time limits. You must observe those limits. Some boards, though, simply sell connect time. In that case, it doesn't matter how long you stay connected, as long as your membership is paid. An excellent modem program is *Procomm* from Datastorm Technologies, Inc. It's easy to use, has extensive terminal emulation, supports several popular protocols and has a script language. Its latest release, Version 2, finally supports the prevalent Zmodem protocol.

Basic Tools

For those who plan to get strongly involved in graphics, a VGA graphics system is highly recommended. GIF

images come in resolutions to match VGA and Super VGA. The more ambitious images get as high as 1,024 × 768 in 256 colors. Some go even higher. That kind of resolution on a good monitor is nothing short of stunning.

A fast 16-bit VGA card is advantageous for viewing GIFs. They cost more than slower eight-bit cards but are undoubtedly worth the extra money. If you already have an eight-bit VGA card and can't afford to upgrade, there's something you can do. Normally, a video card comes with software utilities that help get maximum performance out of the card. One of the utilities is used to copy the video card BIOS into system RAM. System memory is much faster than an EPROM on a video card. Therefore, copying video BIOS into system RAM can dramatically speed up video execution.

Graphic files tend to take up a large amount of disk space. Even with its efficient method of data compression, a high-resolution GIF can easily approach half a meg. Considering that figure, it doesn't take long for a library of graphics to crowd a 40-meg hard-disk drive. Accordingly, quantity of disk space should rule over access speed of the hard drive. A very fast hard drive is nice to have, but the price tag of quick, large storage media is often prohibitive for the home user.

A graphics file viewer is needed to look at the images. CompuServe members can download from many

different kinds of viewers that have been provided by members. Most of them are distributed under the "shareware" concept. A shareware product is one that the author offers free access to on a trial basis. Anyone can download and use it. Those who like it, send in a specified fee to become registered. Registration entitles one to detailed documentation, technical support and updates. Shareware is a common item on boards.

One shareware GIF file viewer is *CompuShow* from Canyon State Systems and Software. It features hardware-specific drivers for various video cards, support for graphics resolution from Hercules to Super VGA and support for graphics formats other than GIF.

Another viewer is *Vuimage* from Offe Enterprises. Some of its features include zoom and automatic scaling that fits the image to the monitor screen, no matter what the image's original size. That's quite handy for users who have graphics sys-

tems that can't handle the higher resolutions. The entire image can still be seen without panning it across the screen. *CompuShow*, *Vuimage* and other shareware viewers are available from CompuServe and private bulletin boards. They exist for many kinds of computers, even some older models that have been orphaned.

Other Formats

GIF is a popular graphics format, but it isn't the only one. Since paint programs, desktop publishing and computer animation have become routine, varying graphics formats have turned up. Some of them are *MacPaint*, *Amiga*, *Targa*, *PC Paintbrush*, *PC Paint*, *Deluxe Paint*, *Dr. Halo*, *Autocad*, *Tiff* and *ColorRix*. And that's not all of them. A typical graphics viewer will support more than one format. Some viewers try to keep up with all formats and do a pretty good job of it. The important thing is to get a viewer that supports whatever graphics format you like to

use. Otherwise, you'll have to convert the graphic from one format to another. Some graphics viewers can do that, too.

One particular conversion program isn't a graphics viewer. It's called *Hijaak* from Inset Systems, Inc. and it exists to convert graphics formats. It handles a wide variety of formats and is simple to install and use. Unusual graphics formats that may not be supported by *Hijaak* can be adapted for use by capturing the screen image. This is done by loading *Hijaak*'s image capture program into memory. Then run the graphic you want captured. Press a hot-key combination and the graphic image is stored in *Hijaak* format. *Hijaak* itself can then be used to further transform the graphic image into GIF or other supported format.

Paint programs have screen-capture utilities, too. They all work pretty much the same. There are enough viewers, paint programs and conversion utilities that you're almost certain to find something that will work for you.

A Few Good Boards

Private boards, in some sense, reflect the personalities of their owners. The on-line atmospheres of bulletin boards range from very strict and businesslike to the informal. One of the best ways to get phone numbers of bulletin boards is to call a bulletin board. Here are some numbers that will help get you started:

Event Horizons (503-697-5100) is run strictly as a business. Subscribers pay for access time at a fairly steep rate. However, it has enough phone lines that a busy signal is rarely, if ever, encountered. It has a large listing of GIFs of all types that are of excellent quality. Users who can afford this board aren't disappointed. **JPix** (219-267-2188) has a free public-access section and a restricted pay access. First-time callers are required to register before looking around. After the Sysop checks you out, you can use the free-access section. Byte limits and time limits are enforced. Sysop: Jim Priser.

The Blue Star (214-234-1647) is an example of a dying breed of bulletin boards. This one is run by a hacker type who does it just for fun. It has an assorted variety of public-domain material, shareware and graphics. There are few rules and, best of all, it's free. Sysop: Paul Sloan.

LEARN VCR

CLEANING/MAINTENANCE/REPAIR

EARN UP TO \$1000 A WEEK, WORKING PART TIME FROM YOUR OWN HOME!



Secrets Revealed!

NO Special Tools or Equipment Needed.

EARN UP TO \$60 AN HOUR AND MORE!

THE MONEY MAKING OPPORTUNITY OF THE 1990'S

IF you are able to work with common small hand tools, and are familiar with basic electronics (i.e. able to use voltmeter, understand DC electronics) . . .

IF you possess average mechanical ability, and have a VCR on which to practice and learn . . . then we can teach YOU VCR maintenance and repair!

FACT: up to 90% of ALL VCR malfunctions are due to simple MECHANICAL or ELECTRO-MECHANICAL breakdowns!

FACT: over 77 million VCRs in use today nationwide! Average VCR needs service or repair every 12 to 18 months!

Viejo's 400 PAGE TRAINING MANUAL (over 500 photos and illustrations) and AWARD-WINNING VIDEO TRAINING TAPE reveals the SECRETS of VCR maintenance and repair—"real-world" information that is NOT available elsewhere!

Also includes all the info you'll need regarding the BUSINESS-SIDE of running a successful service operation!

FREE INFORMATION
CALL TOLL-FREE 1-800-537-0589
Or write to:
Viejo Publications
5329 Fountain Ave., Dept. CC
Los Angeles, CA 90029

CIRCLE NO. 130 ON FREE INFORMATION CARD

Laser Printer Toner Cartridge Recharging

- Earn up to \$125/hr at home - P/T
- \$32K - \$65K Annual Income - P/T
- **Low-Cost**, high-quality, videotape and "hands-on" training available

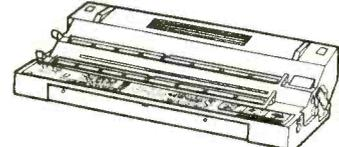

- **Huge Market** - less than 5 in 100 cartridges recharged last year
- **100% Money-Back Guarantee!**
- Call **NOW** for complete details

1-815-748-5823

The Laser Group, Inc.

223 Palmer Court • Suite 100 • De Kalb, IL 60115

CIRCLE NO. 115 ON FREE INFORMATION CARD

- Confused by today's electronics?
- Looking to learn and develop your building skills?
- Want to explore beyond Amateur communications?

**CALL
TOLL FREE
(800) 457-7373**

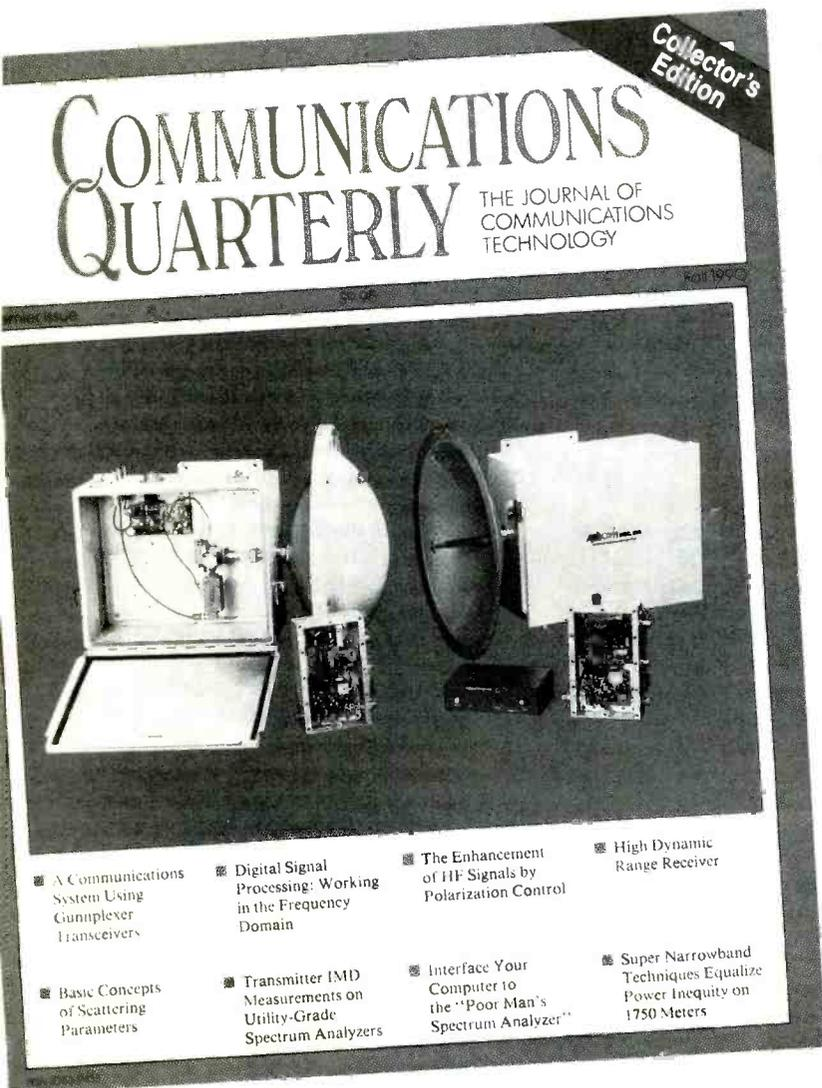

COMMUNICATIONS QUARTERLY

a publication of CQ Communications Inc., 76 North Broadway, Hicksville, NY 11801 USA



Hewlett-Packard's New LaserJet IIIP

With its introduction of the LaserJet IIIP, Hewlett-Packard has given new meaning to the phrase "low-cost laser printer." At a suggested list price of \$1,595 and a street price nearer to \$1,000, Hewlett-Packard has unleashed a veritable typesetting machine for the rest of us. Packing the features made famous by the LaserJet III, namely resolution enhancement technology, scaleable typefaces and the ability to create special typographical effects, Hewlett-Packard's new smaller-size personal model is a low-cost solution with just one problem—how to tap the printer's power.

Designed for use with IBM, IBM-compatible and (with optional enhancements) Apple Macintosh computers, the LaserJet IIIP comes standard with a 16-MHz microprocessor, 1M of RAM and parallel and serial interfaces. The review unit also included an additional 2M RAM and a PostScript cartridge.

IIIP Features

The Hewlett-Packard IIIP boasts features pioneered by the LaserJet III. Built into the LaserJet IIIP is the HP PCL 5 page description language (which includes HP-GL/2 for vector graphics). This makes it possible to scale fonts and perform other kinds of text manipulations. The IIIP also includes HP's proprietary Resolution Enhancement Technology (see the "Understanding Resolution Enhancement Technology" box). This technology improves print quality in both text and graphics.

The LaserJet IIIP comes standard with eight scaleable fonts from two type families: CG Times and Univers. There are also 14 bit-mapped fonts (see the "Scaleable Versus Bit-Mapped Fonts" box). A selection of internal scaleable and bit-mapped fonts is shown in Fig. 1. Additionally, you can use cartridge fonts and downloadable fonts with the printer.

In addition to type scaling, the IIIP can work with some application software to create advanced special effects with type. The special effects are:

- Printing at any angle in 1° increments
- White letters on a black background (reverse printing)
- Multiple print directions appearing on the same page
- Mirrored text
- Spirals, curves, outlines, and shadows
- Outlined letters filled with gray shades or patterns

CG Times
CG Times Italic
CG Times Bold
CG Times Bold Italic
 Univers Medium
Univers Medium Italic
Univers Bold
Univers Bold Italic

Line Printer 16.67 pitch, 8.5 point
 Courier 12 pitch, 10 point
Courier Italic 12 pitch, 10 point
Courier Bold 12 pitch, 10 point
 Courier 10 pitch, 12 point
Courier Italic 10 pitch, 12 point
Courier Bold 10 pitch, 12 point

Fig. 1. Shown here are (A) LaserJet IIIP internal scaleable fonts and (B) sample of LaserJet IIIP internal bitmapped fonts.

- Type condensed, expanded or slanted
 Samples are shown in Fig. 2.

Rated at four pages per minute, the IIIP's engine is about as slow as a laser printer gets. But Hewlett-Packard provides three other features that enhance the speed of the printer: a 16 MHz microprocessor, PCL 5 and improved input/output. These help the IIIP process type and images faster.

A Tour

The LaserJet IIIP is compact, with dimensions of 16"D × 13.2"W × 8"H. The front of the printer is actually a door with a hinge along the bottom. When opened, the door becomes a tray for inserting paper and envelopes. In addition to this built-in tray, the review unit had an optional tray attached to the bottom

of the printer (this tray adds about 2½" to the total height of the unit). In contrast to the built-in tray, which holds 50 sheets or 5 envelopes, the optional tray holds 250 sheets or 20 envelopes.

When the door at the front of the printer is down, pressing a button at the right side releases another door, called the paper path door, which gives access to the interior of the printer. You need to open the paper path door to insert the toner cartridge and adjust the print density.

Inserting a cartridge is easy—you just slide it in. With dimensions of 11.5"W × 4"D × 3"H, IIIP toner cartridges are about two-thirds the size of those used in the LaserJet II model. Cost of a cartridge is \$95. You adjust print density (lighter or darker) by moving a slide control.

At the top front of the printer is the control panel. Six buttons (in two rows of

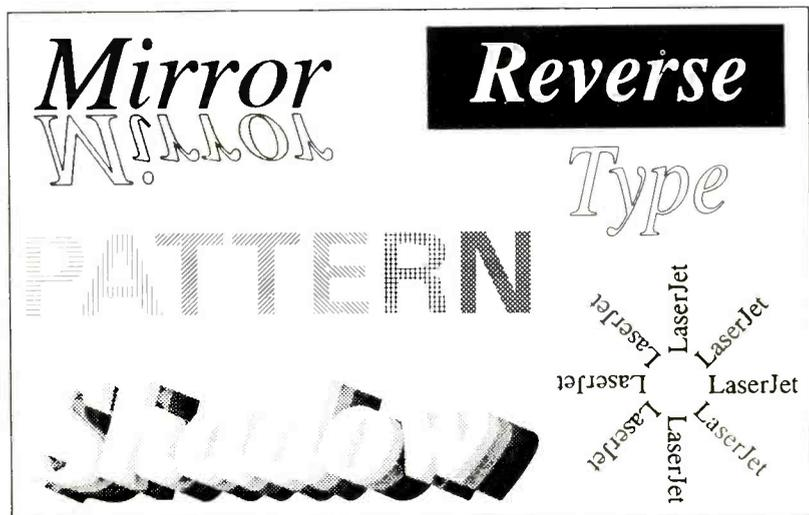

Fig. 2. Sample of typographical effects created with the LaserJet IIIP.

three) are labeled ONLINE/Reset, MENU/Print Fonts, ENTER/Test, FORM FEED/Continue, Alt and + / - . A liquid-crystal display conveys messages to the user. A MENU key gives access to the Printing Menu and the Configuration Menu. The Printing Menu lets you select user default job and page formatting choices from the control panel when these choices can't be specified through software. For example, you can use this menu to change character height (point size) of a font. The Configuration Menu lets you make selections to configure your printer so it will communicate with your computer.

Paper ejects at the top of the printer. This built-in output tray accommodates about 70 sheets of paper. Three plastic hinged tabs built into the tray serve as paper stops. You raise the tab that corresponds to the paper size (letter, legal or A4). When using heavier paper, transparencies and envelopes, you can have

the pages exit at the front of the printer onto a plastic extension tray that attaches to the unit. A lever inside the front door of the printer lets you choose between output trays. Using the front tray helps reduce paper curl.

On the right side of the printer is the slot for plugging in a cartridge, such as the PostScript Cartridge or another font cartridge. Cartridges slip into the slot easily. Also on the right is the power switch.

On the left side of the printer is the vent for the fan. This vent juts out and adds about 1/2" to the width of the printer.

At the rear of the printer are the connectors that access the parallel and serial ports that come standard with the printer. The back of the printer also gives access to the memory expansion slots. Removing two screws allows the back panel to be opened. Removal of three more screws allows a metal plate to be dislodged. This gives access to two memory-

expansion slots. When adding a memory card, you have to push hard on the card to seat it firmly. When replacing the metal plate, you have to make sure that the connector for the I/O ports is seated correctly.

Setup & Use

Setup of the LaserJet IIIP is a straightforward procedure, though we did encounter some difficulties. The first occurred when we tried to insert the toner cartridge. Although this is usually a simple matter, the toner cartridge wouldn't slide into its bay. After trying without success to seat the cartridge, we found that a metal bar inside the printer had dislodged during shipment. As soon as we discovered and corrected this, we inserted the toner cartridge without a hitch.

A second problem occurred when we tried to install additional memory in the printer. After removing the rear panel of



PC SOFTWARE

<p style="text-align: center;">\$1.69 per disk 10 disks or more</p> <p style="background-color: black; color: black; height: 15px; width: 100%; margin: 5px 0;"> </p> <p>WP01 PC-Write v3.02--Latest version of this all-powerful package with mail-merge and spell checking.</p> <p>(A) ^s WordPerfect Macros--</p>	<p style="text-align: center;">Shareware and Public Domain Software for IBM and Compatibles, DOS 2.1 or higher.</p> <p>DB07 Home Movie Librarian (v.1.0)--A menu-driven database for cataloging videotapes and film information.</p> <p style="background-color: black; color: black; height: 15px; width: 100%; margin: 5px 0;"> </p> <p>bar, and scatter charts from data files or data entered directly from the keyboard.</p> <p style="background-color: black; color: black; height: 15px; width: 100%; margin: 5px 0;"> </p> <p>BU02 Painless Accounting (v.</p>	<p style="text-align: center;">\$2.29 per disk 1-9 disks</p> <p style="background-color: black; color: black; height: 15px; width: 100%; margin: 5px 0;"> </p> <p>but no graphics. PC has 2-D graphics.</p> <p>GA03 Cyrus Chess--High-res 3-D chess game. (EGA)</p> <p>GA09 Striker (v.1.2)--A helicopter attack game. Your task: to navigate various tunnels in order to complete</p>
---	---	---



PC SOFTWARE

<p style="text-align: center;">\$1.69 per disk 10 disks or more</p> <p style="background-color: black; color: black; height: 15px; width: 100%; margin: 5px 0;"> </p> <p>WP01 PC-Write v3.02--Latest version of this all-powerful package with mail-merge and spell checking. (3 disks)</p> <p>(B) WordPerfect Macros-- 80 macros for WordPerfect</p>	<p style="text-align: center;">Shareware and Public Domain Software for IBM and Compatibles, DOS 2.1 or higher.</p> <p>DB07 Home Movie Librarian (v.1.0)--A menu-driven database for cataloging videotapes and film information.</p> <p style="background-color: black; color: black; height: 15px; width: 100%; margin: 5px 0;"> </p> <p>bar, and scatter charts from data files or data entered directly from the keyboard.</p> <p style="background-color: black; color: black; height: 15px; width: 100%; margin: 5px 0;"> </p> <p>BU02 Painless Accounting (v. 4.0)--A superb easy-to-use 9-</p> <p>CO01 Procomm 2.42--Advanced</p>	<p style="text-align: center;">\$2.29 per disk 1-9 disks</p> <p style="background-color: black; color: black; height: 15px; width: 100%; margin: 5px 0;"> </p> <p>but no graphics. PC has 2-D graphics.</p> <p>GA03 Cyrus Chess--High-res 3-D chess game. (EGA)</p> <p>GA09 Striker (v.1.2)--A helicopter attack game. Your task: to navigate various tunnels in order to complete five separate missions. Requires</p>
--	--	--

Fig. 3. Shown here are (A) a sample printout from the LaserJet IIIP and (B) a sample printout from the LJ II.

Understanding Resolution Enhancement Technology

Resolution enhancement technology, a major feature of the LaserJet IIIP printer, provides smooth text and graphics printing. Sharper point and line intersections are printed by intelligently adjusting dot size and position in relation to neighboring dots.

The HP LaserJet IIIP's laser beam scans the photosensitive drum from left to right. This makes it possible to shift dot placement on the grid to the left or right by adjusting on/off timing of the laser beam—the beam is turned on either sooner or later. The resulting edge of a nearly vertical line or curve looks smoother because the dot's position has been shifted closer to neighboring dots.

Smoothing nearly horizontal lines and curves is technically more complicated than the process described for vertical enhancements. Horizontal smoothing is achieved by varying dot size.

Shown below is a nearly horizontal line printed without benefit of resolution enhancement.

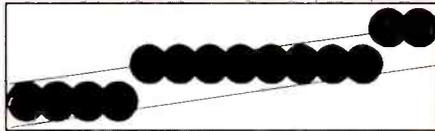

This same jagged effect occurs on horizontally oriented curves, such as the lower-case CG Times "r."

Resolution enhancement modulates the intensity of the laser beam to address the problem. This modulation causes smaller-than-normal amounts of energy to be deposited on the photosensitive drum. The drum, in turn, attracts a smaller amount of toner and produces smaller dots. The smoothing effect is created by placing dots that have been

divided in 20% increments into corollary relationships. For example, the 20% smaller dot is placed opposite the 80% smaller dot, and the 40% smaller dot is opposite the 60% smaller dot. This creates a line that appears uniform in width. This smoothing is apparent on the enhanced nearly horizontal line shown below.

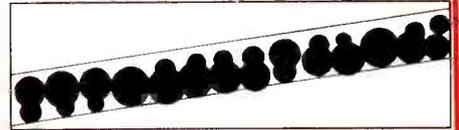

Use of resolution enhancement technology creates sharper character points and cleaner line intersections. The result is better looking text and graphics and more professional looking printed documents.

the printer and an interior plate, we slid the memory card into a connector. The card appeared to seat correctly. We found out, however, that you have to give the card a very strong push before it connects properly.

Installing an optional paper cassette to the bottom of the printer was a snap. The \$195 price tag on this item may seem high, but it provides two major benefits. You can load 250 sheets at a time, and you don't have to allow room for a paper tray to extend out from the printer.

After we got the printer up and running, we tested it with applications programs like *WordPerfect 5.1*, *Windows Write* and *Pagemaker 3.0*. Immediately evident was the LaserJet IIIP's superb text output—a result of resolution enhancement technology. Also evident was the printer's excellence at printing solid black areas. We printed a page composed in *PageMaker* on the standard LaserJet IIIP and compared it to the same page printed with a standard LaserJet Series II printer. The results are shown in Fig. 3.

Notice how resolution enhancement technology sharpens both text and graphics.

The biggest problem we encountered with the LaserJet IIIP was taking advantage of all its features. For example, features like type scaling, reverse type, rotated type and shadow type must be supported by the application you're using or you can't take advantage of them. Furthermore, *Windows* applications rely on *Windows* to provide a printer driver for the IIIP. When we tried to print reverse type, a feature supported by *PageMaker 3.0*, a solid black bar printed instead.

We discovered that the problem was in the *Windows* driver. We used the LaserJet III driver supplied with our original copy of *Windows 3.0*. Although *Windows* has not been updated, the driver for the LaserJet III series of printers has been. A note we found in one of the LaserJet IIIP manuals states "... check your *Windows* driver to insure that you are running at least version 3.6 of the *Windows* printer driver."

We ran a time test that compared the LaserJet IIIP to the LaserJet II. We composed a page in *PageMaker* that consisted of a graphic at the top of the page (created in *Arts & Letters*) and text for the remainder of the page. Time to print the page on the IIIP was 1 minute 32 seconds; time for the II was 1 minute. In its promotional material, Hewlett-Packard includes a chart that compares the LaserJet IIIP to the IIP. This chart is shown in Fig. 4.

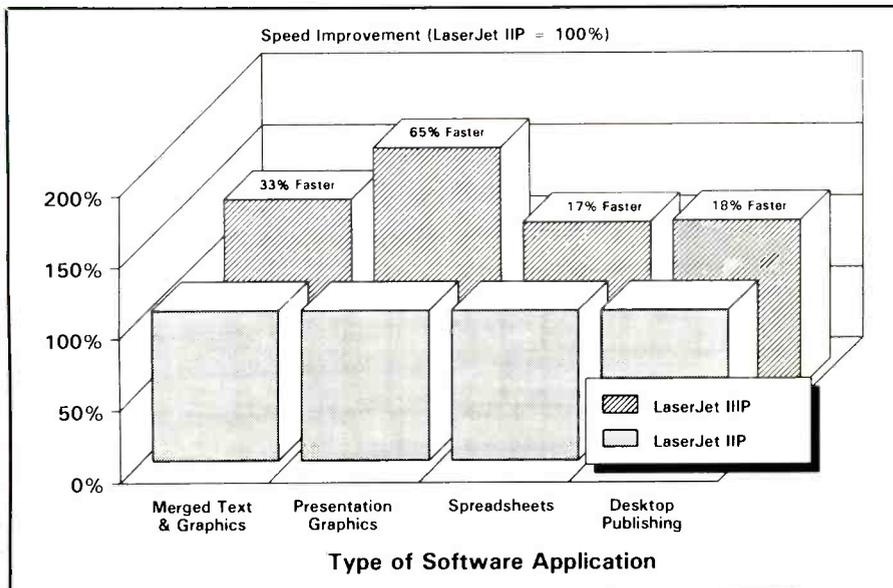

Fig. 4. Speed comparison between the LaserJet IIIP and IIP.

PostScript Advantage

To convert the LaserJet IIIP from a PCL

Scaleable Versus Bitmapped Fonts

ITC Avant Garde Gothic Book
 ITC Avant Garde Gothic Book Oblique
 ITC Avant Garde Gothic Demi
 ITC Avant Garde Gothic Demi Oblique

ITC Bookman* Demi
 ITC Bookman Demi Italic
 ITC Bookman Light
 ITC Bookman Light Italic

Courier
 Courier Bold
 Courier Bold Oblique
 Courier Oblique

Helvetica*
 Helvetica Bold
 Helvetica Bold Oblique
 Helvetica Oblique

Helvetica Narrow
 Helvetica Narrow Bold
 Helvetica Narrow Bold Oblique
 Helvetica Narrow Oblique

New Century Schoolbook Bold
 New Century Schoolbook Bold Italic
 New Century Schoolbook Italic
 New Century Schoolbook Roman

Palatino*
 Palatino Bold
 Palatino Bold Italic
 Palatino Italic

Symbol Σμυβολ

Times Bold
 Times Bold Italic
 Times Italic
 Times Roman*

ITC Zapf Chancery* Medium Italic

ITC Zapf Dingbats* +*■*◎▼▲

The main difference between scaleable and bitmapped fonts is the number of different character sizes the printer can generate. Bitmapped printer fonts consist of dot-by-dot patterns in pre-defined sizes. Bitmapped fonts have a fixed point size (height), style (normal, condensed, italic, wide) and weight (light, medium, bold). For example, 10-point Courier is one font and 12-point Courier Bold is another. An example of a bitmapped font follows:



Scaleable fonts are described by a unique mathematical formula within the printer. Characters made from scaleable fonts are created within the printer on a character-by-character basis. Fonts can be scaled up to 999.75 points (1 point = 1/72") in quarter-point increments. Scaleable fonts can vary in point size but have a fixed style and

weight. An example of a scaleable font follows:

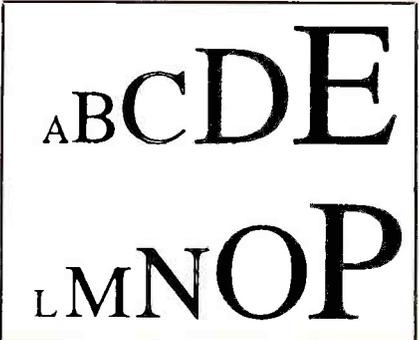

For bitmapped fonts, each change in point size requires a separate font. This can take up more printer memory than scaleable fonts. If you use a wide variety of point sizes, one scaleable font can replace the need for many discrete-size bitmapped fonts. On the other hand, scaleable fonts use more processing power, since the printer is always performing mathematical routines to create fonts on the fly.

Fig. 5. The Hewlett-Packard PostScript cartridge contains 35 typefaces licensed from Adobe Systems.

5 printer into a PostScript printer, all you need do is slip the Hewlett-Packard PostScript Cartridge into the slot on the right side of the printer. The cartridge, which has a suggested list price of \$695, features true Adobe PostScript. (This is the same cartridge that fits into II series and other III series printers.)

Contained inside the PostScript cartridge are 35 Adobe typefaces (see Fig. 5), which can be scaled to any size. The PostScript language also lets you bend, clip, rotate, shape and stretch typefaces. As with PCL 5, the software must support these features in order to use them. (An alternative is to write a PostScript program to access these features.) For optimum performance with the IIP, Hewlett-Packard recommends an additional 2M of RAM for the printer when using the PostScript cartridge.

After you insert a PostScript cartridge into the IIP and turn on the printer, the control panel displays a self-test message. Following a delay of about 3 minutes, a start-up page ejects from the printer. Thankfully, this feature can be turned off with appropriate menu selection. To leave PostScript mode and revert to PCL

5 mode, you turn off the printer and remove the cartridge.

We tested the PostScript cartridge with PageMaker 3.0 running under Windows 3.0. We first installed the Windows Apple Laser Writer IINT driver as suggested in the HP PostScript cartridge manual. With this driver, the IIP produced our test document perfectly, including reverse type. The printer needed 1 minute 35 seconds to produce the document. This was 3 seconds slower than the time in PCL 5 mode.

Documentation

The LaserJet IIP comes with two manuals: the *LaserJet IIP User's Manual* and the *LaserJet III/IIID/IIP Printer Software Application Notes*. Both are well-written and well-illustrated. One knock against the *User's Manual* is its sparse information on the Hewlett-Packard graphics language, HP-GL/2. Instead, the manual refers you to another manual—which isn't included with the printer—called the *PCL 5 Printer Technical Reference Manual*.

Comments & Conclusions

The LaserJet IIP is a relatively low-cost laser printer with advanced features like resolution enhancement technology, type

scaling and special type effects. The text and graphics produced by the standard LaserJet IIP are superb. You couldn't ask for sharper text or blacker blacks at this price.

Although the LaserJet IIP has the powerful PCL 5 language built in, another powerful page-description language, PostScript, is only a cartridge away. Keep in mind, though, that you have to factor in the \$695 cost of the cartridge and the suggested \$390 for the 2M of additional memory. If you're interested mostly in PostScript, you may want to check out the competition.

Whether using PCL 5 or PostScript, you may be disappointed in your software's ability to harness the power of this printer. If you want to exploit certain features of the printer, make sure your software supports them.

The only knock against the IIP is raw speed. With an engine rated at 4 ppm, the printer may not be fast enough for every taste. If speed isn't an issue, though, you'll be hard pressed to find a better printer at the price.

The IIP represents an awesome engineering accomplishment for Hewlett-Packard. The company has delivered super features at an unbeatable price and has truly created a laser printer for the rest of us. ■

Publishing the Old Fashioned Way

About 15 years ago, when I worked for a daily newspaper, I often found myself in the production department surrounded by computer terminals. Whenever I looked at a terminal, the screen was always filled with text—all the same size characters—like you see on many IBM and compatible computer screens today. But operators would insert control codes into the text so that the printed result was a newspaper with captions in italic type, a variety of column widths and so on.

Today, most electronic publishing packages display a facsimile of the page to be printed, rather than use text with embedded codes. These software packages give you the ability to display and manipulate a page on-screen, a feature of desktop publishing programs such as Aldus *PageMaker* and Xerox *Ventura Publisher*. These programs deliver much in the way of publishing power, but they demand a great deal in the way of computing power, too.

With such programs, desktop publishing on an XT-class computer is out of the question. Thus, people who have low-end computers are shut out of using powerful desktop publishing for the most part. There is, however, a powerful desktop publishing program that can be used with an XT, 286 or more-powerful computer. It's called *LePrint*, and it does the job the old-fashioned way—it uses codes embedded in text.

LePrint requires an IBM PC, XT, AT, PS/2 or compatible computer and MS/PC-DOS 2.1 or later. The computer must have a minimum of 384K of RAM. *LePrint* will operate on a single 3½" or 5¼" floppy-disk system, but dual floppy drives or a floppy/hard-disk drive system (the latter with 1M to 2M of free space) is highly recommended. To print documents, you must have a dot-matrix or laser printer directly supported by *LePrint* (or a printer that emulates a directly supported make/model). If you want to preview your documents, you must have a graphics display adapter that's supported by the program, but this isn't necessary for printing.

To use *LePrint*, you create documents using your own word processor, spreadsheet, database or other program. *LePrint* supports all major word processors and any others that can create ASCII files. In addition to conventional memory, *LePrint* automatically uses any LIM expanded memory installed in the system.

The Standard version of *LePrint* 4.0 B comes on a single 5¼" high-density floppy

disk (the program also is supplied on 5¼" 360K and 3½" 720K disks) and is accompanied by a 350-page manual and quick-reference card. This package has a suggested retail price of \$149. The Extended version of *LePrint* 4.0 B (reviewed here) is the same as the Standard package plus two extra high-density disks that include six type-style packages. Cost of the Extended version is \$495. Type-style packages cost \$75 each.

About the Program

LePrint uses commands to format a document. These commands (there are more than 50 of them) are placed directly in text that has been typed into a word processor. The commands generally consist of a period followed by a two- or three-letter code. In some cases, you must also include additional parameters. There are two ways to insert a command into a body of text. One is the line command. A line command is placed on a line by itself with the period in the first column. It might look like this:

```
.FA Dutch
```

The second kind of *LePrint* command is an embedded command. This is placed in the text and is surrounded by braces. An embedded command might look like this:

```
... text { .FA Dutch } more text ...
```

In each case, the command affects any text that follows it.

In addition to commands, *LePrint* can store commands and other text in variables and reference those variables later in the document. Variables are given names and are referenced by surrounding the names with ampersands (&). Several predefined variables contain *LePrint* commands. For example, predefined variable "c" causes the text following it to be centered. You enter this command by typing &c& into the text.

These commands let you control type on a page in every imaginable way. You can select typeface, point size, margins, justification and so on. Additionally, you can make the type do fancy things, such as sit at an angle or turn in a circle.

The program offers graphics commands for adding borders, boxes and rules. Commands are also available to create special effects, such as reverses and screens. *LePrint* can integrate graphic files from other programs and then scale the image or change the aspect ratio and

place it anywhere on the page. Graphic file formats that *LePrint* supports are .PCX, .PCC, .IMG, .MSP and .TIF.

After you format text in your word processor, you exit the word processor and start *LePrint*. At this point, *LePrint* lets you preview a document on-screen and print it, among other things.

The Standard version of *LePrint* comes with five type styles: Courier, Pica, Prestige Elite, Dutch and Dutch Italic. Seven additional type packages are available optionally. Each includes three or four type styles. Keep in mind that these are typefaces, not fonts. A font is limited to a particular size, while a typeface includes a variety of sizes.

Fonts range in size from less than four points (a point is 1/24") to more than 10". *LePrint* uses outline fonts, which means that characters stay crisp and clean, regardless of how large or small they are. Type can be varied in the following ways: bold, italics, expanded, condensed, outline and any combination of these. Documents can be printed in portrait (normal) or landscape (sideways) mode.

LePrint type styles can be used in other software packages by saving its output as a graphics file. The file can then be imported into programs like *Ventura Publisher* and *PageMaker*. This is one way to overcome type size or design limitations in these programs.

Installation & Use

To install *LePrint*, you first copy all files from the *LePrint* floppy disks to the hard disk. Then you type an install command and answer questions about your printer, display adapter and word processor.

After installing it, the first thing we tried with *LePrint* was to run a sample file included with the program. This file produces camera-ready copy for a business card. Figure 1 shows a printout of the text file necessary to produce the business card. Figure 2 shows the business card as it was printed out on a Juki 5510 (Epson FX-80-compatible) printer. Obviously, this isn't camera-ready copy, but it would have been had it been printed on a Hewlett-Packard LaserJet III or just about any other laser printer.

The next thing we did was "typeset" a rough draft of text of this review. We tried to make it appear just as it does in *ComputerCraft*. To do this, we needed to create a headline, use different kinds of type styles, divide the copy into three columns and so on. To accomplish all this,

```

.. horizontal trim marks
.ru 0.2in, 0.5pt, -0.25in, 0.25in
.ru 0.2in, 0.5pt, -0.25in, 2.25in
.ru 0.2in, 0.5pt, 4.55in, 0.25in
.ru 0.2in, 0.5pt, 4.55in, 2.25in
.. vertical trim marks
.ru 0.5pt, 0.2in, 1in, 0in
.ru 0.5pt, 0.2in, 4.5in, 0in
.ru 0.5pt, 0.2in, 1in, 2.3in
.ru 0.5pt, 0.2in, 4.5in, 2.3in
.. decorative rule
.ru 3.1in, 1pt, 1.2in, 0.4in
.. text boundaries

.. monogram

..fa times italic
.ch 70 pt
                                YNH

.. screen with box
.ro 9
.. Raster Operation for
.. screening
..bx 3in, 1in, 0.5, 1.2in, 0.7in
.ro 15
.. normal Raster Operation
.. type style and size
..fa times
.ch 12 pt
.. format and starting position
                                Your Name Here
.. change type size and slant
.ch 9 pt
.it on
                                YOUR OCCUPATION

.. reset slant and format
.it off
123 Your Street
Your City, State 12345(.fr on)
555-1212
.fr off

```

Fig. 1. Text file used to create a sample business card. File can be used over and over again with minor changes.

we embedded appropriate codes into the document with *WordPerfect 5.1*. Then we brought up the document with *LePrint* to preview it on-screen. *LePrint* commands are then selected from pull-down menus.

LePrint caught the first mistake we made and gave an error message detailing the cause of the error (we neglected to include the dimension when changing character height). This was corrected by quitting *LePrint*, restarting *WordPerfect*, making the change, quitting *WordPerfect*, starting *LePrint* and previewing the document again.

We needed to go back and forth between *LePrint* and *WordPerfect 5.1* several times before we got the page to look right. This part of the task was an annoyance. Overall, though, it was relatively easy to lay out the page as we wanted it. If we had to lay out pages on a regular basis, the codes used for this document could be used over and over again.

We used *LePrint* on an ALR PowerFlex with an 80486 processor card installed. Even with this kind of power, the preview mode took several seconds to write the screen. This wait would be multiplied many times on an XT-class computer. Keep in mind, though, that a preview of the document isn't required to print a page. If you're fairly certain that all coding is correct, you can skip the preview operation.

We found no need to adjust the kerning of the headline, although we could have done so with a *LePrint* command.

We did, however, use indent and line-spacing commands to get the text to lay out just the way we wanted it.

We printed the document on a nine-pin dot-matrix printer, which produced the rather poor looking page shown in Fig. 3. As with most desktop publishing programs, a laser printer is recommended for high-quality output.

Documentation & Support

LePrint documentation is excellent. It gives a thorough explanation of typesetting terms and includes many examples to help in learning the program quickly. Illustrations provide help to guide the user in understanding the elements of type design and terms like kerning.

Technical support is available from the company. You have to pay for the call, unless you pay for an extended support plan, which costs \$95 per year. However, this plan covers only 4 hours of toll-free support. The program comes with a 30-day refund guarantee.

Comments & Conclusions

Although you might expect a desktop-publishing program to let you create and manipulate layouts on-screen, *LePrint* uses the older method of embedding codes into text. This may seem a cumbersome way to do electronic publishing, but we found it to be not so bad. We were able to create a layout fairly quickly and could make changes quite easily.

(Continued on page 89)

Publishing the Old Fashioned Way

LePrint's command method works with any PC

About 15 years ago, when I worked for a daily newspaper, I often found myself in the production department surrounded by computer terminals. The people who operated these terminals would type stories given to them by the editors. Whenever I looked at a terminal, the screen was always filled with text—all the same size characters—like you see on many IBM and compatible computer screens today. But the operators would insert codes into the text, and the eventual result

single 3.5" or 5.25" floppy disk system, but dual floppy drives and/or a hard disk drive (with 1 to 2 MB of free space) is highly recommended. To print documents, you must have a dot-matrix or laser printer directly supported by *LePrint* (or a printer that emulates a directly supported printer). If you want to preview your documents, you must have a graphics display adapter supported by the program, but this is not necessary for printing. To use *LePrint*, you must create your

braces. An embedded command might look like this:

```
...text (:FA Dutch) more
text...
```

In each case, the command affects any text that follows it.

In addition to commands, *LePrint* has the capability to store commands and other text in variables, and reference those variables later in the document. Variables are given names and are referenced by surrounding the

Fig. 2. Sample file printed on a nine-pin dot-matrix printer. For high-quality output, a laser printer is recommended.

Ring Director II

Upgraded microcontrolled telephone accessory adds modes that greatly improve upon the original design

The Ring Director that appeared in the August 1990 issue was a popular project. However, Ring Director II, described here, offers a considerably expanded list of modes from which to choose. The original Ring Director used an Intel 8748 microcontroller and ran under a short operating program, but it used only about an eighth of the on-board program storage memory and didn't use a single byte of the available 64 bytes of RAM. Ring Director II, in contrast, provides four jumper-selectable modes of operation—which is three more than were available with the original project.

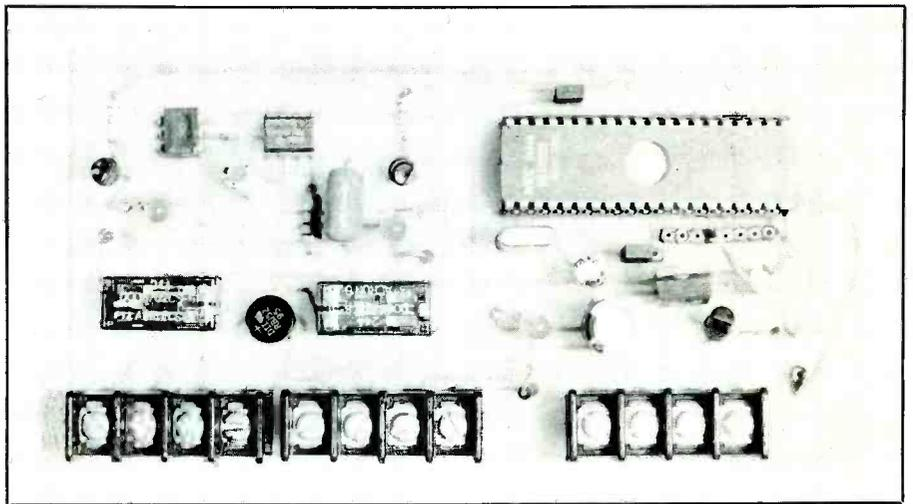

Operating Modes

Repeating the single mode provided by the original project, Ring Director II provides a Ring Back mode that permits two or more answering devices to share the same phone line. With it, normal calls are answered by the primary answering device. By calling, ringing once or twice, hanging up and calling back within 60 seconds, the project disconnects the primary device from the line and allows the secondary device to answer.

The second mode, Ring Mate, works with the Ringmate service provided by most telephone companies for about \$5 per month. It allows a second telephone number to be added to your primary telephone line, with the two numbers sharing the same line. Using this service, calls to the primary number ring normally once per pulse and calls to the secondary (Ringmate) number ring twice per ring-signal pulse.

Under normal operating conditions, all telephone instruments connected to the common line ring when either number is called. Using Ring

Director II's Ring Mate mode, you can select which instrument(s) will ring for each number. Thus, each instrument will ring for only one number but not both.

Ring Alert, the second of the new modes, lets you know when an answering device has failed to answer by sounding an alarm whenever an answering device fails to answer. If your phone continues to ring and the number of rings exceeds the selected number programmed into Ring Director II, the built-in alarm output latches and a normally silent backup ringing device is given a direct phone line connection to allow the ring to sound. To silence the alarm and reset the project to "armed" condition, you must press a RESET button.

Finally, Ring Delay mode prohibits the phone line output from ringing until the preset number of rings is exceeded. It also activates the alarm output when the number is exceeded. Unlike Ring Alert mode, the circuit for Ring Delay mode resets as soon as the line stops ringing.

About the Circuit

As shown in Fig. 1, three paired phone line connections are provided—input T_{in}/R_{in} and outputs $T1_{out}/R1_{out}$ and $T2_{out}/R2_{out}$. The outputs are controlled by relays $K1$ and $K2$. When the relays aren't energized, the outputs are directly connected to the T_{in}/R_{in} incoming line. When energized, the outputs are ring filtered through bridge rectifier $BR1$, which rectifies the incoming ac ring signal and converts it to dc. Because they're looking for an ac ring voltage, telephone devices connected to the outputs won't ring.

Note that the phone line input is also tied to TCM-1520 ring detector $IC2$ through $C1$ and $R3$. The output of $IC2$ is coupled to the microcontroller through MCT-2 isolator $IC1$. This input to the microcontroller signals when the phone line has a ring signal on it.

Relays $K1$ and $K2$ are controlled by 8748 microcontroller $IC3$ and are driven by $Q1$ and $Q2$, respectively. The microcontroller decides when to

PARTS LIST

Semiconductors

- BR1—200-PIV round full-wave bridge rectifier assembly
- D1,D2,D3—1N4002 or equivalent silicon rectifier diode
- IC1—MCT-2 optical isolator
- IC2—TCM-1520 ring detector
- IC3—8748 microcontroller (see text)
- IC4—7805 fixed +5-volt regulator

ComputerCraft

FREE READER SERVICE CARD

ENTER MONTH AND YEAR OF THIS ISSUE:

Month _____ Year _____

(REQUESTS CANNOT BE PROCESSED WITHOUT DATES)

1	2	3	4	5	6	7	8	9	10	11	12
13	14	15	16	17	18	19	20	21	22	23	24
25	26	27	28	29	30	31	32	33	34	35	36
37	38	39	40	41	42	43	44	45	46	47	48
49	50	51	52	53	54	55	56	57	58	59	60
61	62	63	64	65	66	67	68	69	70	71	72
73	74	75	76	77	78	79	80	81	82	83	84
85	86	87	88	89	90	91	92	93	94	95	96
97	98	99	100	101	102	103	104	105	106	107	108
109	110	111	112	113	114	115	116	117	118	119	120
121	122	123	124	125	126	127	128	129	130	131	132
133	134	135	136	137	138	139	140	141	142	143	144
145	146	147	148	149	150	151	152	153	154	155	156
157	158	159	160	161	162	163	164	165	166	167	168
169	170	171	172	173	174	175	176	177	178	179	180

Did you purchase this issue of ComputerCraft from either a newsstand or magazine store? Yes
No

Name _____
 Company Name _____
 Address _____
 City _____ State _____ Zip _____

(Please note: This card expires 3 months from cover date.)

calling 800-538-5000 and All Electronics Corp. by calling 800-826-5432. The following items are available from M. Lucas, P.O. Box 777, Glenham, NY 12527: Complete Ring Director II assembled and tested \$65; complete kit of parts, including power supply, \$45; programmed 8748 with Ring Director I, Ring Director II and Ring Alert programs with pc board only, \$25; 8748 Microcontroller, \$13; TCM-1520 ring detector, \$4.50. Add \$2.50 P&H per order. New York residents, please include state sales tax.

Fig. 1. Complete schematic diagram of Ring Director II circuitry.

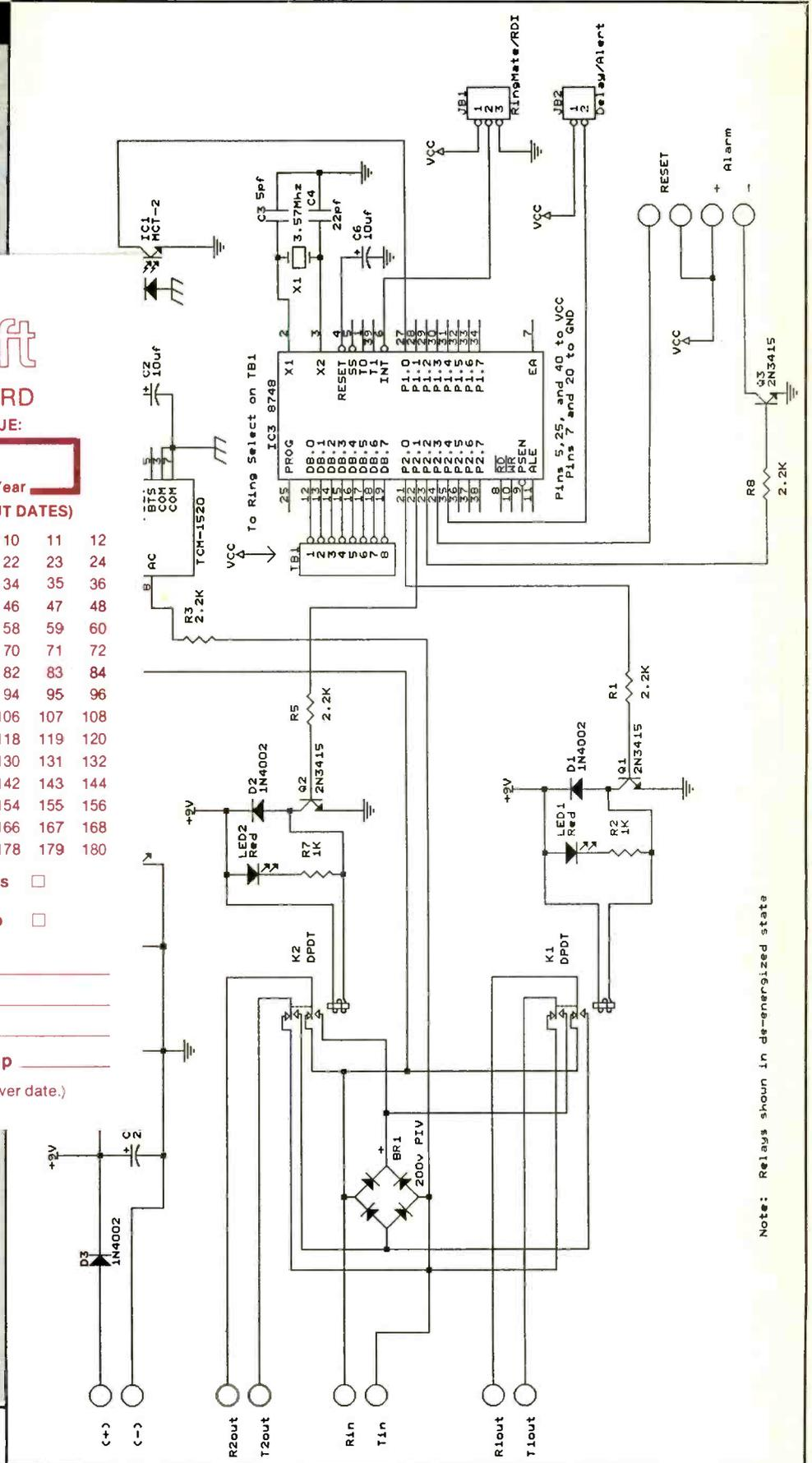

Note: Relays shown in de-energized state

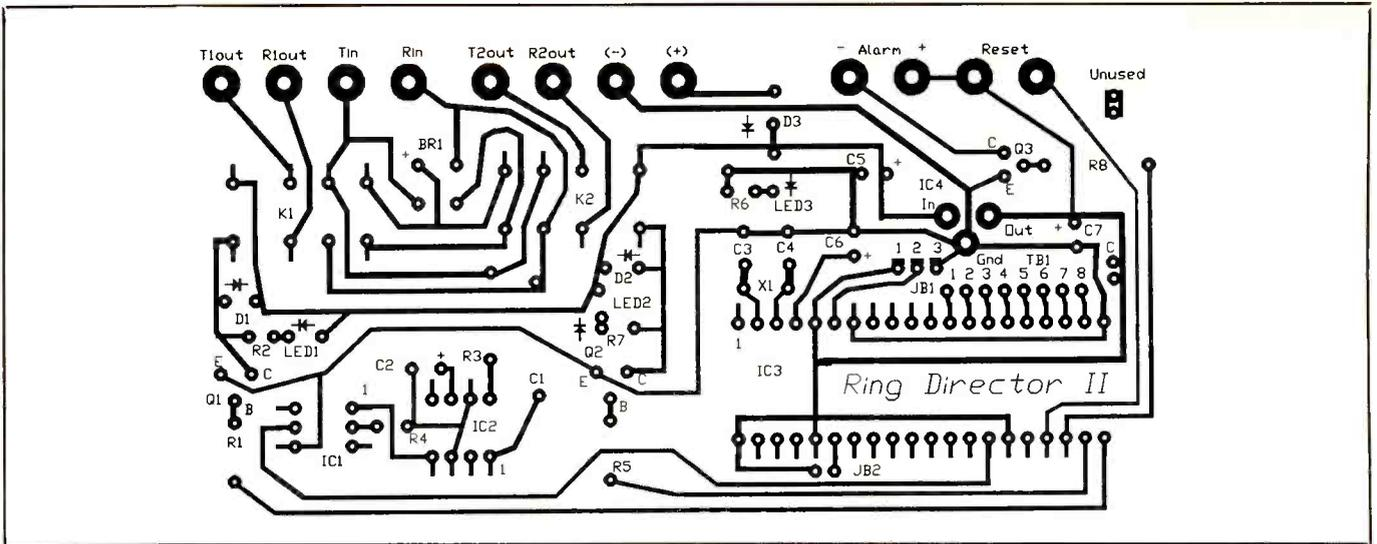

Fig. 2. Actual-size etching-and-drilling guide for fabricating printed-circuit board for project. Note that component-installation details are etched into copper pattern. Mount components on reverse side of board, where there are no copper traces.

activate either relay, based on the ring signal received from IC2 and mode selected via jumpers JB1 and JB2 and terminal block TB1.

The microcontroller itself is an eight-bit device that contains 64 bytes of RAM, 1K of EPROM program storage memory and three I/O ports (P1, P2 and DB). It also has two test inputs (T0 and T1), and its INT line can be used as a testable input or to generate an interrupt.

Port 2 is used to control the relays and alarm output and to sense the RESET terminals. Only one bit on Port 1 is used to sense the ring signal on the telephone line. The INT line is used as a test input to choose between the Ring Back and Ring Mate modes.

Clock speed of the microcontroller can be as fast as 11 MHz. However, because of its ready availability, a 3.579-MHz crystal is used in this circuit. Because internal timing is based on the 3.579-MHz speed, don't substitute for a different speed.

Terminal Block TB1 is tied to the data bus port and supplies the microcontroller with the user-selected number of rings to be used in Ring Alert and Ring Delay modes. Bringing any pin on TB1 to V_{cc} selects the number of desired rings.

Ring Alert and Ring Delay are the only modes that use the RESET and ALARM terminals shown at the lower-right in Fig. 1. The open-collector ALARM output provides a 5-volt output when the alarm function is trig-

gered. Loads on this output should draw less than 100 milliamperes of current. The RESET terminals signal the microcontroller when to reset the alarm. A normally-open pushbutton switch should be wired across these terminals.

If you plan to use the Ring Director II in Ring Back or Ring Mate modes only, you can eliminate the RESET and ALARM terminals, Q3, R8, TB1 and JB2, which aren't used when operating in either of these modes. Likewise, if you plan to use only Ring Delay or Ring Alert mode, you need not install K1, D1, R1, Q1, R2 and LED1 as these components are not used in either of these two modes.

• **Ring Back Mode.** To activate Ring Back mode, the following conditions must be met:

JB2	Open
JB1	Jumper pins 2 & 3
TB1	Doesn't matter
RESET	Doesn't matter

On power-up, both LEDs light, and then both should extinguish.

Ring Back mode has two operating conditions: Mode A, where the output is active until a ring-back condition, and Mode B, where the output is ring-filtered until a ring-back condition occurs, at which point it becomes active. To create a ring-back condition, you place a call, ringing once or twice, hang up and call back within 60 seconds. Because Ring Di-

rector II has two dpdt relays (K1 and K2), both modes are available concurrently. Mode A operation is available on the T1_{out}/R1_{out} outputs, Mode B on T2_{out}/R2_{out} outputs.

When a call is received, K2 energizes to permit filtering the ring signal on the T2_{out}/R2_{out} terminals, prohibiting the answering device wired to this output from responding to the ring. The answering device on the T1_{out}/R1_{out} terminals is allowed to ring because K1 is kept deenergized. On a ring-back, K2 deenergizes and allows the ring signal to appear on the T2_{out}/R2_{out} output terminals. Now K1 energizes so that the ring signal on the T1_{out}/R1_{out} output terminals is filtered.

The outputs aren't disconnected from the phone line, as was the case with the original Ring Director. In Ring Director II, they're just *ring-filtered*. If you wish to completely remove the phone line from the outputs to the answering devices, eliminate bridge rectifier BR1.

Connecting the circuit in Ring Back mode requires the telephone line normally going to the answering device(s) to be brought to the T_{in}/R_{in} terminals. Connect the primary answering device to the T1_{out}/R1_{out} terminals and wire the secondary answering device to T2_{out}/R2_{out}.

When a call is received, LED2 lights at the start of the first ring-signal pulse, indicating that K2 is energized. This filters the ring output

to the devices connected to the T2_{out}/R2_{out} terminals. Relay K2 remains energized for the duration of rings on the first call.

If the line rings only once or twice and the caller hangs up and calls a second time within 60 seconds, LED2 extinguishes and K2 deenergizes to provide a direct connection to the T2_{out}/R2_{out} terminals to allow them to see the ring. When this occurs, LED1 lights and the ring to the devices connected to the T1_{out}/R1_{out} terminals is filtered.

For as long as the line continues to ring on the second call, devices connected to the T2_{out}/R2_{out} terminals are allowed to ring. About 5 seconds after ringing ceases, regardless of whether the caller hangs up or the line is answered, LED1 extinguishes again and the circuit resets.

If the line rings once or twice and a second call isn't received within the specified 60 seconds, LED2 extinguishes and the circuit resets. If the line rings more than twice on the first call, LED2 extinguishes 5 seconds after the last ring and the circuit resets.

• **Ring Mate Mode.** To activate Ring Mate mode, the following conditions must be met:

JB2	Open
JB1	Jumper 1 & 2
TB1	Doesn't matter
RESET	Doesn't matter

On power-up, LED1 and LED2 light. Ringmate service from the telephone company provides a second telephone number to your existing telephone line. Although it isn't a second line and you can't conduct two simultaneous conversations, it's well suited as a low-volume fax or business number. This service rings all phones either normally, when the primary number is called, or twice for each normal ring when the Ringmate number is called. With the Ring Director operating in Ring Mate mode, you can connect the primary telephones to the T1_{out}/R1_{out} terminals and Ringmate telephones to the T2_{out}/R2_{out} terminals.

When the primary number is called, K1 deenergizes after the first ring and only the phones connected across T1_{out}/R1_{out} ring. When an incoming call is received on the Ringmate number, K2 deenergizes after the first ring and only the phones connected

Shortcuts to Repair PC's Down to the Chip Level in Under 10 Minutes

MANAGERS

NAC PROGRAMS CAN:

- Help your department drastically reduce down time and increase efficiency.
- Increase productivity of staff and users.
- Saves your department valuable dollars on computer support and repair.
- Reduce computer spare parts inventory.
- Safeguard valuable data from hardware failure.
- Provide immediate response to customer and/or department needs.
- Make your department more self sufficient.
- Increase quality and knowledge of technicians.
- Offer your staff opportunities for self-improvement.

TECHNICIANS

NAC TRAINING OFFERS:

- The most comprehensive hands-on training classes available.
- New tools add information to shorten troubleshooting and repair time.
- The latest schematics not available from IBM and other manufacturers.
- Vital Novell/LAN skills that will make you more knowledgeable and more valuable at your job.
- Nuts and bolts training from Analog Signal to Zero Wait State.
- PC Repair, PS/2, Printers, Networking, PS/2 Monitors, and Front-Line Support Courses.

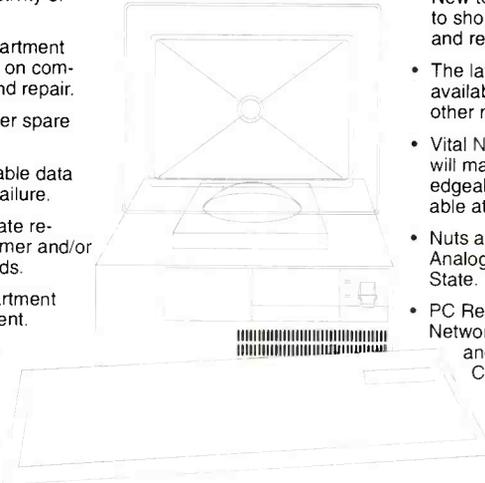

CALL (800) 832-4787 - in calif. (800) 443-3384

2730-J South Harbor • Santa Ana, CA 92704 • (714) 754-7110

CIRCLE NO. 118 ON FREE INFORMATION CARD

NOW DOUBLED IN LIBRARY SIZE

DC/CAD

CAD Showdown Results!!

HIGH DENSITY EXPERTS!

Schematic Capture • PCB Layout • Autorouting

Top-rated DC/CAD out-routed the competition in the 1990 CAD Show-down. Routing the challenging benchmark on a double-sided board while competing routers used four to six layers, DC/CAD displayed the power and flexibility needed in a top-notch design package to tackle high density board jobs. This non-copy protected package with surface mount support includes:

- High capacity schematic capture
- Multi-strategy 1-mil parts autoplacer
- "1-mil" autorouting with rip up & retry
- Through annotating design rule checker
- Full 2-way GERBER and DXF support
- Optional autoground plane support with cross-hatching
- Optional protected-mode version for 386 Users and much more!

CALL TODAY FOR DC/CAD
Priced at \$595
(Priced from \$395).

30-Day Money Back Guarantee.



DESIGN
COMPUTATION

Rt. 33, Sherman Square, Farmingdale, NJ 07727
(908) 938-6661 • (908) 938-6662 (FAX)

Smart Software for Tough Board Design.

CIRCLE NO. 149 ON FREE INFORMATION CARD

NOW - THE ALL NEW URDA®, INC.

SDK-386™*

*386 is a trademark of Intel Corporation. Used by permission.

32 BIT MICROPROCESSOR TRAINER AND DEVELOPMENT SYSTEM

With optional 80387 Floating Point Coprocessor, 16 Kbytes of EPROM for Monitor, Utilities and User Expansion, 32 Kbytes of Static RAM, 5x8 Matrix Keypad, 40 Character x 2 Line Dot Matrix Liquid Crystal Display with Optional Accessories.

Also available:

the 8 Bit SDK-85 and the 16 Bit SDK-86

Coming in 1992:

the 8 Bit SDK-51 Microcontroller

CALL URDA®, INC.

1-800-338-0517 or (412) 683-8732

URDA®, Inc. Has Additional Single Board Products:

8086 68000 68020 68030 32010 DSP

With Cross Assemblers for MS-DOS Computers

CIRCLE NO. 127 ON FREE INFORMATION CARD

Satellite-TV

SAVE 40% - 60%
48 Page Catalog; it's loaded with All Major Brands, Systems, Upgrades, Components & Accessories. Huge Savings, Easy Installation and Complete Instructions.

FREE Catalog

800-334-6455
218-739-5231 Int'l

SKYVISION INC.
1018 FRONTIER DRIVE
FERGUS FALLS, MN 56537

INSTALL OR UPDATE YOURSELF!

LEARN TO CLEAN/MAINTAIN/REPAIR FAX MACHINES

HUGE NEW UNTAPPED MARKET!



Over 8 million Fax machines in homes/offices - predictions are for over 25 million by 1992!

- Work from your home/van
- Home study program gets you started servicing fax machines in 2 weeks!
- No special tools/equipment needed
- Earn additional profits selling fax supplies!
- Fax machines are not cheap - therefore, you can get good \$\$ for the repair
- Average Fax machine requires professional service every 18 months
- Home study training program includes full instructions on EVERY ASPECT of Fax maintenance/repair. FULL COVERAGE of how to set up your home-based service business

FREE DETAILS

CALL 1-800-537-0589

Or Write To: Viejo Publications, Inc.

5329 Fountain Ave., Dept. CC/FX

Los Angeles, CA 90029

CIRCLE NO. 132 ON FREE INFORMATION CARD

across T2_{out}/R2_{out} ring.

The first ring must be suppressed for the circuit to identify which number is called. Once the first ring is over, the circuit deenergizes the appropriate relay only during each individual ring and returns it to energized condition when the ring is over.

The incoming telephone line connects across the T_{in}/R_{in} terminals before all other telephone devices. All telephone devices must connect to either of the two phone-line outputs on the project. Any phones connected before the Ring Director II will ring when either number is called. Connect all primary phones across T1_{out}/R1_{out}, all Ringmate phones across T2_{out}/R2_{out}.

Although the outputs are normally ring filtered, they don't prohibit outgoing calls. Also, because they share the same physical line, if the Ringmate number is called, the phone can be answered at any primary telephone, even though the primary phone isn't ringing.

• **Ring Delay Mode.** To activate Ring Delay mode, the following conditions must be met:

JB2	Shorted
JB1	Doesn't matter
TB1	Jumper to selected ring
RESET	Jumper

On power-up, LED1 and LED2 light. Then, if there's no jumper to TB1, LED2 extinguishes and LED1 remains on and the ALARM output is active to serve as an indication of an error condition. A pin must be jumpered for the circuit to operate. If TB1 is jumpered during power-up, LED1 and LED2 light and then LED1 extinguishes.

Ring Delay mode suppresses the ring signal to a telephone device until the preset number of rings is exceeded. The number of rings is set by connecting leads from V_{cc} to the appropriate pin(s) on TB1. It can be set for any number between 1 and 15 rings. For one through eight rings, jumper the appropriate pin. For nine through 15 rings, jumper pin 8 and any pin 1 through 7. The sum of both pin counts determines the number of rings. For example, to set the unit for 15 rings, jumper pins 8 and 7 to V_{cc}. Only pin 8 plus a second pin can be jumpered for ring counts greater than eight. For example, jumpering pins 6 and 7

will set the circuit for six rings.

Connect the telephone line, which normally feeds the telephone device(s), to T_{in}/R_{in}. Connect the telephone device(s) that you wish to be ring-delayed to T2_{out}/R2_{out}.

When the number of rings exceeds those selected by jumper settings, T2_{out}/R2_{out} deenergizes, allowing the telephone device(s) to ring. Also, the ALARM output becomes active. Five seconds after the last ring-signal pulse occurs, the ALARM output resets, relay K2 re-energizes and the circuit resets.

At any time when the circuit is idle, the jumper on TB1 can be changed. When jumpers are removed, LED2 extinguishes and LED1 lights to indicate an error condition exists. This returns to normal as soon as a jumper selection is made. This also occurs when the circuit is powered up without making a jumper selection. Placing a jumper on TB1 resets the error condition, and the circuit loads the new selection.

Primary use for this mode is to operate as the Ring Alert mode does but without the latching alarm. The ALARM output and K2 will reset when the phone stops ringing.

• **Ring Alert Mode.** To activate the Ring Alert Mode, the following conditions must be met:

JB2	Shorted
JB1	Doesn't matter
TB1	Jumper to selected ring
RESET	Wire to RESET switch

On power-up, LED1 and LED2 light. Then, if there's no jumper to TB1, LED2 extinguishes and LED1 remains on and the ALARM output will be active, indicating an error condition exists. A pin must be jumpered for the circuit to operate. If TB1 is jumpered during power-up, LED1 and LED2 light, and then LED1 extinguishes.

Ring Alert mode operates the same as Ring Delay mode, with one exception. When the number of rings exceeds the selected number, the unit must be manually reset. A normally-open switch must be wired across the RESET terminals. The ALARM output becomes active and K2 deenergizes until the RESET button is pressed.

Telephone line connections can be made anywhere on the phone line.

All the circuit does is count the number of rings on a single call. If the line has fewer ring-signal pulses than the number selected on *TBI*, the circuit resets the counter and waits for the next call. A back-up ring device can be wired across *T2_{out}/R2_{out}*. That output is ring filtered until the selected number of rings is exceeded.

In some applications where phone lines are connected directly to an answering device without ringers, it may be imperative that the device be functioning. Without a ringer, there's no verification that the device is, in fact, answering.

A typical configuration using Ring Director II would have an answering machine connected across the *T1_{out}/R1_{out}* terminals and a fax, modem or other secondary answering device connected across the *T2_{out}/R2_{out}* terminals. Normally, the caller will ring until the answering machine picks up the line. As soon as the phone rings, the *T2_{out}/R2_{out}* terminals filter the ring so the secondary device won't see it and, consequently, won't answer.

To access the secondary device, a caller must call, ring once or twice, hang up and call back within 60 seconds. When this occurs, *K1* and *K2* will switch states, where *T1_{out}/R1_{out}* become ring filtered and *T2_{out}/R2_{out}* allow the ring to reach the secondary device, which then answers.

Power for the project is supplied by a standard plug-in 9-volt dc supply. The output from the supply connects to the + and - terminals shown at the upper-left in Fig. 1. This incoming 9 volts dc is regulated by *IC4* and filtered to stable +5 volts for delivery to most of the rest of the project. When power is applied to the circuit, green *LED3* lights to provide a visual indication of this.

Construction

Though you can assemble Ring Director II on perforated board that has holes on 0.1" centers using suitable Wire Wrap or soldering hardware, printed-circuit construction is recommended. You can fabricate your own pc board using the actual-size etching-and-drilling guide shown in Fig. 2. Alternatively, you can purchase a ready-to-wire pc board from the source given in the Note at the end of the Parts List.

Whichever way you go, though, it's a good idea to use sockets for all DIP ICs, especially *IC3*.

Placing and soldering the appropriate components on the board should be fairly easy. Simply adhere to the details shown in Fig. 2.

Start populating the board by installing and soldering into place the IC sockets. Do *not* plug the ICs into the sockets until after you've conducted preliminary voltage checks and are certain that all wiring is okay. Proceed to the resistors, capacitors, diodes, transistors and crystal. Make certain that the electrolytic capacitors and diodes are properly oriented and that the transistors are properly based before soldering their leads into place.

Next, install and solder into place *BR1* and *IC4*. Again, make sure both components are properly oriented before soldering their pins into place.

For *JB1* and *JB2*, you need three- and two-pin headers (see Parts List). Plug the three-pin header into the *JB1* location and solder into place. Similarly, plug the two-pin header in the *JB2* location and solder this into place. Then plug the eight-pin SIP socket into the *TBI* location and solder this into place.

Plug a two-pin header into the UNUSED location on the circuit board and solder it into place. You'll use this header for storing the free end of any wire coming from *JB2*.

Strip $\frac{1}{8}$ " of insulation from both ends of two $2\frac{1}{2}$ " lengths of stranded hookup wire. Tightly twist together the fine conductors at both ends and sparingly tin with solder. Plug one end of each wire into the C holes on the right side of the board, as shown in Fig. 2. For now, plug the free ends of these wires into the sockets of the header at the UNUSED location.

Strip $\frac{1}{4}$ " of insulation from both ends of eight 3" lengths of hookup wire. Again, if you use stranded wire, prepare the ends as above. Plug one end of these wires into the holes for the LEDs and RESET switch. Clip the cathode lead of the green POWER LED (*LED3*) to $\frac{1}{2}$ " long and form a small hook in the stub. Slide a 1" length of small-diameter heat-shrinkable tubing over the ends of all LED wires coming from the circuit board.

Crimp and solder the free end of the wire coming from the cathode

hole for *LED3* to the cathode lead of the LED. Trim the anode lead of the LED to $\frac{1}{2}$ " and crimp and solder the anode wire coming from the other *LED3* hole on the board to it. When the connections cool, slide the tubing over them until it touches the bottom of the LED case and shrink into place. Repeat the entire operation for the remaining two LEDs. Make certain you observe proper polarity for all three LEDs!

Crimp and solder the free ends of the wires coming from the RESET switch holes in the board to the lugs of a miniature normally-open push-button switch.

You can use any type of enclosure that will conveniently accommodate the circuit-board assembly (and audible alarm device, if used) inside it and has panel space on which to mount

ATTENTION! ELECTRONICS TECHNICIANS



EARN YOUR
**B.S.E.E.
DEGREE**

THROUGH HOME STUDY

Our New and Highly Effective Advanced-Placement Program for experienced Electronic Technicians grants credit for previous Schooling and Professional Experience, and can greatly reduce the time required to complete Program and reach graduation. No residence schooling required for qualified Electronic Technicians. Through this Special Program you can pull all of the loose ends of your electronics background together and earn your B.S.E.E. Degree. Upgrade your status and pay to the Engineering Level. Advance Rapidly! Many finish in 12 months or less. Students and graduates in all 50 States and throughout the World. Established Over 40 Years! Write for free Descriptive Literature.

COOK'S INSTITUTE OF ELECTRONICS ENGINEERING

 4251 CYPRESS DRIVE
JACKSON, MISSISSIPPI 39212

CIRCLE NO. 109 ON FREE INFORMATION CARD

the two modular phone sockets that connect to the relay contacts, the jack into which to plug the power supply and the RESET switch. Also, make sure the selected enclosure has panel space for drilling the entry holes for the telephone extension cord that plugs into the telephone line and the cable to the external alarm device.

Machine the enclosure as needed. If you use a metal enclosure, deburr all holes to remove sharp edges and line the entry holes for the cables with small rubber grommets. If you wish to economize, you can eliminate the plug/jack connection for the power-supply cord, wiring the power supply directly to the circuit board. If you do this, make the entry hole just large enough for this cord. Finally, if you incorporate the audible alarm into the project, drill a few small holes where its sound-generating element will mount for the sound to escape.

When the enclosure is ready, use a dry-transfer lettering kit to label the LED, jack and switch positions with appropriate legends. Protect the legends with two or more light coats of clear acrylic spray. Allow each coat to dry before spraying on the next.

Route the free end of the telephone line cord into the enclosure through its entry hole and tie a strain-relieving knot in it about 3" from the unfinished end inside the enclosure. Plug the free ends of the red- and green-insulated conductors into the appropriate T_{in} and R_{in} holes in the board. Clip away and discard any other conductors in the cord.

Mount the modular jacks in their cutouts and plug the free ends of the wires on them into the appropriate $T1_{out}$, $T2_{out}$, $R1_{out}$ and $R2_{out}$ holes in the board, referring back to Fig. 1 for details. Again, use only the red- and green-insulated wires and clip away and discard any other wires.

If use a jack/plug arrangement for the power-supply connection, mount the jack in its hole in the enclosure and use suitable length hookup wires to bridge from its lugs to the appropriate holes in the circuit board. If you direct-wire the supply into place, clip off and discard the plug on the end of its output cable and separate the conductors a distance of 1½". Strip ¼" insulation from both con-

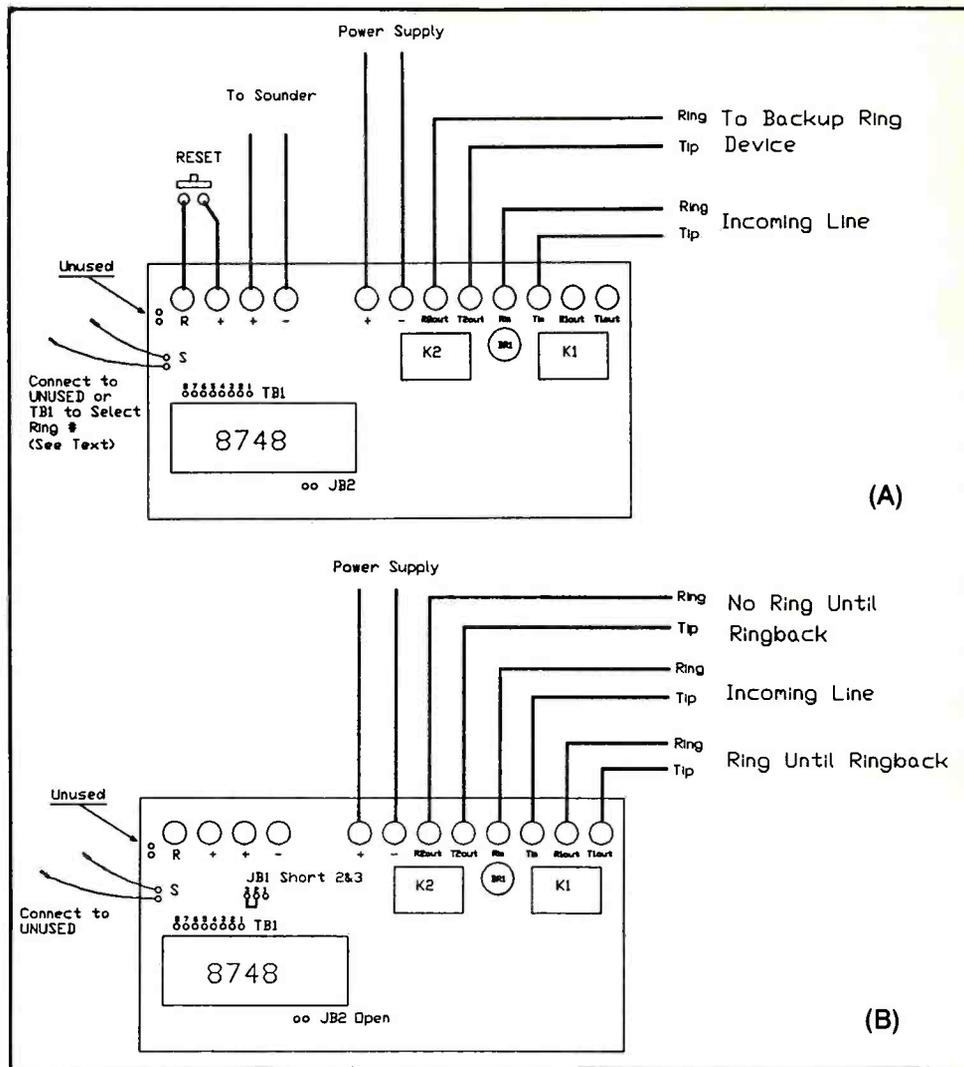

Fig. 3. Configuration details for different modes of operation: (A) Ring Alert; (B) Ring Delay; (C) Ringmate; and (D) Ring Back.

ductors, tightly twist together the fine wires in each and sparingly tin with solder.

Plug the power supply into an ac outlet and use a meter to determine and mark the polarity of each conductor. Route the cable through its entry hole into the enclosure and tie a knot in it about 3" from its free end inside the enclosure. Carefully match conductor polarity with the (+) and (-) holes in the circuit board and solder into place.

If you use an audible alarm device, such as a piezoelectric sounder or buzzer, with the project, mount it in its selected location. Then use suitable length hookup wires to bridge from it to the ALARM + and - holes on the circuit board.

Testing

Place the project on a nonconducting surface and plug its power supply into an ac outlet. Check to see if green LED3 is on. If it isn't, check to make sure that the LED isn't installed in reverse polarity. If it isn't and it's still not lit, use a dc voltmeter or multimeter set to the dc-volts function to check for the presence of approximately 9 volts dc at pads + and -. Do not proceed until you've rectified any problem anywhere along the line.

Clip the common lead of your meter to any convenient circuit ground, such as the negative (-) lead of C5 or C7. With power applied to the circuit, touch the "hot" probe of the meter to pins 5, 25 and 40 of the IC3

also hear the relay click as it energizes. Unplug the project again from the ac line and place one of the jumpers onto any pin on *TB1*. When you plug in the power supply and again, both LEDs should light at first. This time, *LED1* should extinguish.

If everything works as described, the microcontroller is running. If not, check the orientation of reset capacitor *C6*, and check for any bent leads on *IC3*. If everything looks okay, carefully remove from the circuit *C3* and *C4* and try again.

Unplug the power supply again and plug in *IC1* and *IC2*. Connect the extension cord coming from the *T_{in}/R_{in}* terminals to the telephone line. Remove any jumpers on *JB2* and jumper pins 1 and 2 on *JB1* to select the Ring Mate mode.

Power up the circuit again and observe that both relays energize and both LEDs light. Have a friend call your number. The first ring of the incoming call should do nothing. On the second ring, *LED1* should extinguish and *K1* should deenergize. When the ring stops, *K1* should reenergize and *LED1* should re-light. If this doesn't happen and *LED1* remains on, try briefly shorting together pins 4 and 5 of *IC1*, waiting 4 seconds and shorting again. The relay LED should go out. If this works, use a larger value capacitance for *C1* or a lesser value for *R3* and try ringing the phone line again.

If the relay buzzes during the ring cycle, check the value of *C2*. It should be 10 μ F at 50 volts or greater. If it's the correct part, increase the value of *C1* and try again.

Once you have your Ring Director II up and running, configure it for the type of operation you wish by referring to the appropriate drawing in Fig. 3. Also refer back to the detailed descriptions of each mode of operation under About the Circuit.

Once you have your Ring Director II up and running, you'll soon discover its advantages. At the very least, having the rings separated with Ring Director II, you can assign a separate telephone number to your fax machine at a significantly lower cost than would be a dedicated line. Just connect the fax machine to the appropriate phone line output on the Ring Director II. ■

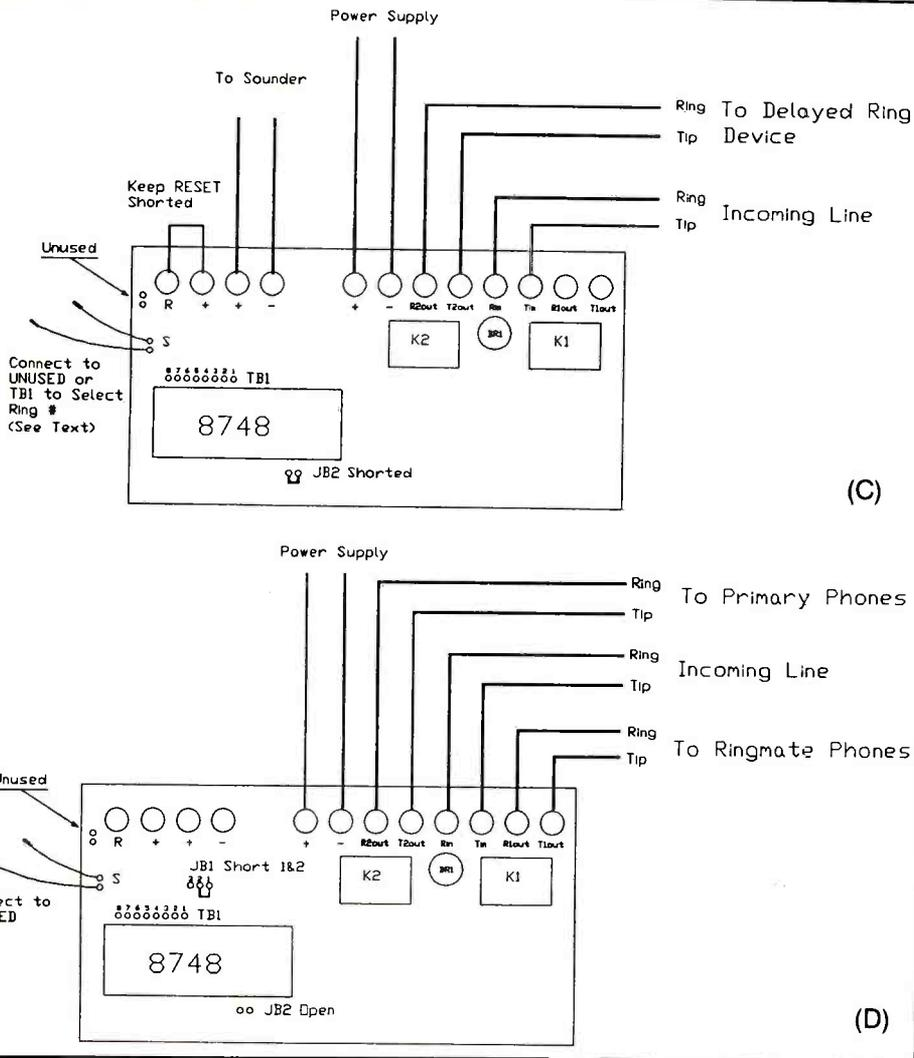

socket. You should obtain a reading of +5 volts at all three pins.

When the circuit is powered up without the ICs, neither relay should be energized. Test *K1*, *Q1*, *R1*, *R2*, *LED1* and *D1* by jumpering together pins 40 and 21 of the *IC3* socket. The relay should energize and *LED1* should light. Do the same with *K2*, *Q2*, *R5*, *R7*, *LED2* and *D2* by jumpering together pins 40 and 22 on the *IC3* socket.

If a relay fails to energize, check the orientation of the transistor and the diode across the coil of that particular relay. If they are inserted properly, you can suspect a bad component. Test each component individually out-of-circuit or try a known good one. If the LED lights but the

relay doesn't energize, the relay may be bad. If the relay energizes but the LED fails to light, the LED is likely oriented incorrectly or is bad.

When you obtain the proper indications, power down the circuit. Mount the circuit-board assembly inside the enclosure and then plug *IC3* into its socket. Make sure the IC is properly oriented and that no pins overhang the socket or fold under between device and socket.

Remove any jumper wires on *TB1* and jumper the pins on *JB2*. This selects the Ring Alert and Ring Delay modes. Plug the power supply back into the ac outlet and observe *LED1* and *LED2*. When the project is first powered, both LEDs will light and then *LED2* extinguishes. You should



An Optical Output Port for Your Computer

There are many methods for connecting a personal computer to an external device so that the latter can be controlled by the former. The most common methods use the computer's serial port or parallel printer port. The computer's bus can also be used for this purpose. All these methods require that wires be connected between the computer and what is to be controlled. They also require that a port or expansion slot, which might be needed for more important purposes, be dedicated to a simple control application.

Some time ago, I designed an optical output interface for a PC that requires no wire connections between the computer and device being controlled. My original intent was to develop a commercial product or a project book based on this interface. In the meantime, various other projects have interrupted these plans. Rather than delay this project longer, it seems only fitting to publish it here.

Instead of wires, the interface I'll discuss here is implemented by attaching one

or more light sensors directly to the computer's screen. The sensors are activated by causing pixels under them to be illuminated. Simple instructions can cause the pixel(s) to stay on continuously or flash in any imaginable pattern or sequence.

Analog control is possible by varying the number of pixels that are illuminated under a single detector. Multiple output channels can be made available by attaching a row of sensors to the screen and selectively activating the pixels under each of them.

An important advantage of this form of output interfacing is that a continuous range of analog output values can be delivered to an external circuit simply by changing the number and/or color of the pixels that are illuminated under the sensor. Therefore, this form of optical interfacing can be used to implement digital-to-analog (D/A) conversion without use of conventional D/A circuits or complicated software. Thus, a tiny spot of light in one corner of a computer's monitor

can control, for example, the volume and frequency of a tone or speed of a motor.

Finally, optical interfacing makes it possible to control output devices with a high degree of electrical isolation between computer and device being controlled. This method doesn't use an expansion slot and preserves serial and parallel ports for other applications.

Designing an Optical Output Port

If you're familiar with the light pen, you already know what an optical output port is. The pen contains a photosensor that's triggered when it's placed over a glowing pixel on a computer's monitor screen. The resulting signal doesn't control an output device. Instead, it's fed back to the computer so that the computer can determine where on the screen the pen is pointed. This permits the operator to control the computer merely by moving the light-sensitive point of the pen to dif-

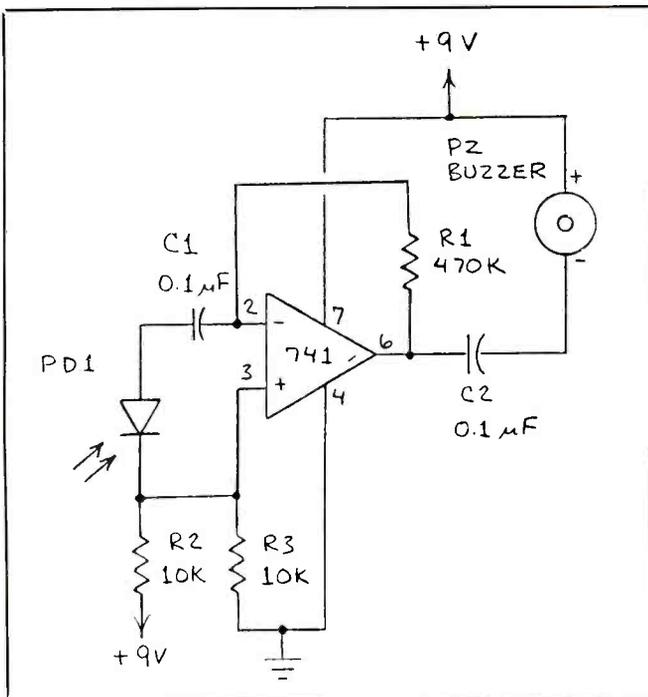

Fig. 1. Schematic of a simple pixel-to-sound converter circuit.

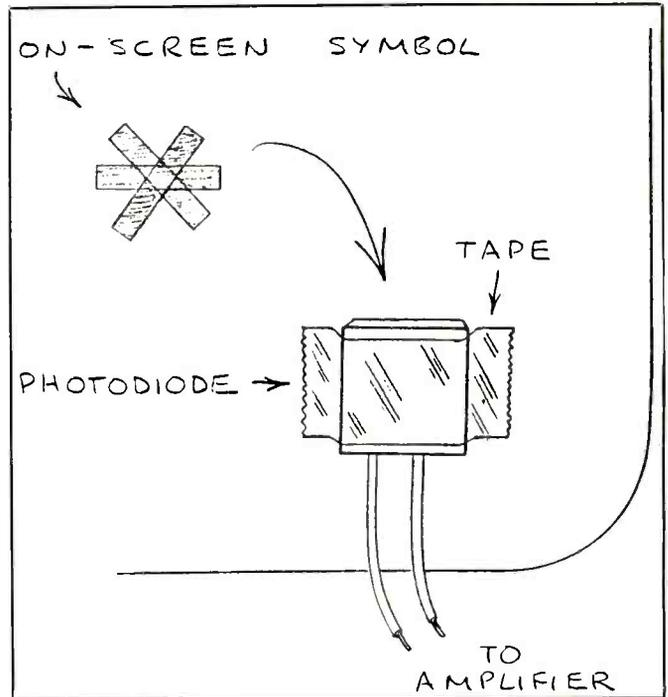

Fig. 2. How to attach a photodiode to the screen of a computer's video display monitor screen.

ferent areas of the screen.

A basic optical output port requires a light sensor and a circuit to amplify the signal from the sensor so that a switching device, such as a relay or power MOSFET transistor, can be triggered. Many kinds of light detectors can be used, ranging from cadmium-sulfide (CdS) photoresistors and miniature silicon solar cells to phototransistors and detectors with built-in amplifiers or Schmitt triggers.

Since glowing pixels are scanned by a moving electron beam, they don't glow continuously. Instead, they flash on and off at a rate determined by the sweeping electron beam. Because the entire screen is scanned at a faster rate than the eye can respond to, the pixels appear to glow continuously.

You can transform the flashing of the pixels into an audible sound by connecting a photodiode or phototransistor to the input of an amplifier and pointing the detector at any glowing spot on a computer monitor. By doing this, you'll hear a buzzing sound that coincides with the rate at which the screen is being scanned.

Figure 1 shows the circuitry for a simple optical port that will trigger a piezoelectric buzzer when a cluster of pixels is actuated adjacent to a light sensor. Instead of a continuous tone, the buzzer will emit a buzz. Though the sound from the buzzer won't be very loud, it can be easily heard.

In operation, photodiode *PDI* generates a small photocurrent when it's illuminated by light from a glowing array of pixels. This photocurrent is coupled into an operational amplifier through *C1*, which blocks any signal from ambient daylight that might strike *PDI*. The photocurrent from *PDI* is transformed into a voltage by the op amp. The gain of the op amp is approximately equal to the resistance of feedback resistor *R1*.

The prototype circuit I built and tested used a Siemens photodiode for *PDI*. Many other photodiodes will also work. For example, a miniature silicon solar cell can be used. The only photodiodes you should avoid are those with built-in near-infrared filters designed to block visible light. You can recognize these photodiodes by the black appearance of their epoxy encapsulation.

Almost any op amp will work with this circuit. I used a 741 since it's so commonly available and inexpensive. I'd probably use a newer low-current op amp for a permanent version of the circuit.

You can attach *PDI* to the video display screen with tape, using transparent double-sided tape applied directly to the face of the photodiode or any single-sided tape applied over the back of the photodiode, as shown in Fig. 2. I used trans-

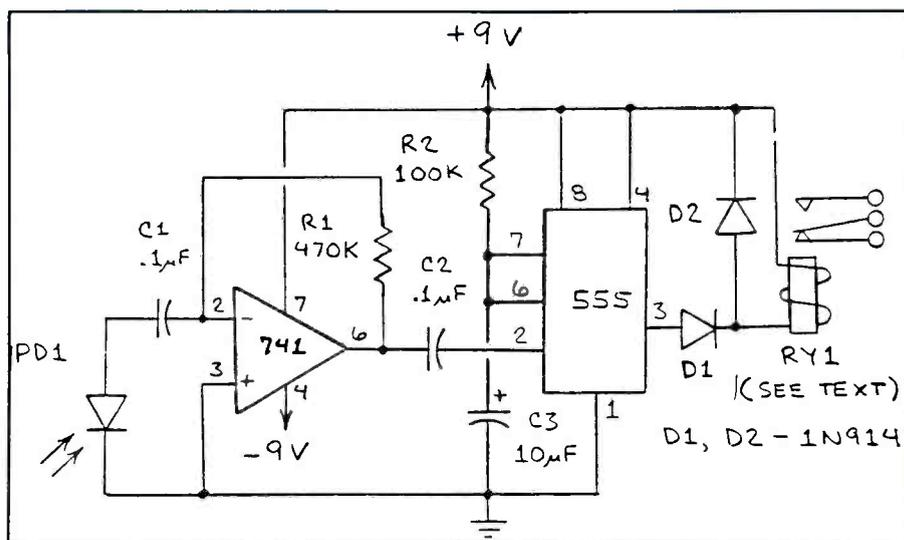

Fig. 3. Schematic details for a computer video monitor optical interface circuit.

parent tape to attach the photodiode of the prototype circuit to the screen of my monitor. In some cases, it might be necessary to use black tape to keep external light away from the sensitive surface of the detector.

Though I used a miniature photodiode, you can experiment with other kinds of light sensors. If the buzzer is actuated when the pixels beneath the sensor are switched off, ambient room lighting is too bright or your computer screen should be adjusted for as dark a background as possible.

Simple Driver Routines

You can trigger the Fig. 2 circuit with any set of instructions that will illuminate a sufficient number of pixels to activate the buzzer. For example, here is a simple BASIC routine I've used with various MS-DOS-compatible computers:

```
10 CLS
20 SCREEN 1
30 LOCATE 25,40
40 PRINT "*"
50 END
```

This routine, which can be easily modified for other versions of BASIC, prints an asterisk in the lower-right corner of your monitor screen. If the asterisk is printed at center-bottom of the screen, then your computer doesn't respond to the SCREEN 1 command. If this is the case, replacing line 30 with LOCATE 25,80 will cause the asterisk to appear in the lower-right corner of the screen when you run the routine.

You can experiment with the size and shape of the character printed on the screen to change the loudness of the sig-

nal emitted by the buzzer. For example, to reduce sound level, replace the asterisk with colon or, especially, a period. This nicely illustrates how a simple optical port can be used to derive an analog output from a computer without using a conventional D/A converter circuit.

Incidentally, if your computer responds with "Illegal function call in 30," your function key index is illuminated on line 25. Press the F9 function key and type "OFF" to switch off the index. The routine will now run.

It's interesting to experiment with the effect of various colors on the detector. For example, if your computer can process EGA or VGA graphics, you can try this simple routine:

```
10 CLS
20 SCREEN 7
30 FOR C=1 TO 9
40 COLOR C
50 LOCATE 25,40
60 PRINT "*"
70 FOR X=1 TO 1000:NEXT X
80 NEXT C
90 GOTO 10
```

This routine prints an asterisk in a specific series of colors in a continuous loop. Line 70 determines how long each color is displayed. It's interesting to hear how the various colors change the level of the sound from the buzzer.

For the widest range of illumination, you can experiment with the BASIC command PSET. A single pixel can be illuminated with a command like PSET(100,100). You can specify different colors if you like. Replace the coordinates in parentheses with characters, and you can then write various routines to vary the number of pixels that are PSET. You can use

PRESET to switch off any or all the pixels that are illuminated. For details, see the manual for your version of BASIC. Be sure to read the section on SCREEN commands to ascertain whether or not the computer can respond to your instructions.

Optical Port Relay Driver

Figure 3 is a schematic diagram of the circuitry for an optical port that triggers a relay when a cluster of pixels is actuated. This circuit follows the amplifier in Fig. 1 with a 555 timer configured as a monostable or one-shot.

When *PDI* is illuminated by a cluster of pixels, the output of the 741 swings low to generate a negative spike that triggers the one-shot. When this occurs, the one-shot's output goes high for a period determined by the values of *R2* and *C3*.

The actual length of the output pulse is approximated by the product of the values of *R2* and *C3*. For example, the values in Fig. 3 should give an output pulse duration of about 1 second. (The actual duration in the prototype circuit I assembled and tested for this column was slightly more than 1 second).

The circuit shown in Fig. 3 will drive a small relay such, as a Radio Shack

Cat. No. 275-005. If the relay doesn't energize, check to make sure the batteries are fresh. Incidentally, don't be tempted to operate the circuit without *D1* and *D2*. These diodes protect the 555 from the high-reverse voltage that occurs when current through the energized relay coil is switched off.

Some Software Ideas

There's a virtually unlimited number of ways to actuate optically-triggered circuits. For example, assume you want to trigger a loud buzzer connected to the relay in Fig. 3 when a program detects a specific condition. Just direct your program to a subroutine like this:

```

100 CLS
110 SCREEN 1
120 LOCATE 25,40
130 PRINT "***"
140 FOR X = 1 TO 1000:NEXT X
150 LOCATE 25,40
160 PRINT ""
170 FOR X = 1 TO 1000:NEXT X
[180 IF ...GOTO ...]
190 GOTO 120
    
```

This routine cycles the relay back and forth continuously. During each cycle,

the program checks to see if a predetermined change has occurred (line 180) so the loop can be exited. The length of time the relay is energized and released is determined by the timer loops in lines 140 and 170. If your computer has a fast clock speed, you may want to increase the number of counts in these two loops.

You can easily modify the program to produce odd-sounding buzzer patterns that might be more attention-getting. One way to do this is to make the timer loop that switches on the buzzer two or three times longer than the one that switches it off. You can use mathematical functions to generate fancy on/off pattern sequences or random-number generators to generate unpredictable sequences.

A single computer can control dozens, even hundreds of optical output ports. Here, for example, is a rough outline of how you might implement a row of several ports along the bottom margin of your computer screen:

```

10 INPUT VOLTS
100 IF VOLTS = 1 THEN N = 10
110 IF VOLTS = 2 THEN N = 20
120 IF VOLTS = 3 THEN N = 30
130 IF VOLTS = 4 THEN N = 40
    
```

COMPUTER SHOW SCHEDULE

PRODUCED BY KGP PRODUCTIONS

- | | |
|-----------|--|
| Oct. 5 | MARLBOROUGH, MA - NEAR BOSTON |
| Sat. | Royal Plaza Trade Center - 400 Tables |
| 10am-4pm | I-495 Exit # 24-B - 1/2 mile on right |
| | |
| Oct. 19 | HEMPSTEAD, NY - HOFSTRA UNIV. |
| Sat. | Just past Nassau Coliseum - 400 Tables |
| 10am-4pm | in the Physical Fitness Center - Swim Ctr. |
| | |
| Oct. 20 | NORTHERN JERSEY-PARSIPPANY, NJ |
| Sunday | Aspen Manor - Route 46 Westbound |
| 10am-3pm | 400 Tables - off I-80 Westbound Exit #47 |
| | |
| Nov. 2 | GREENBELT SHERATON (DC Area) |
| Sat. | New Carrollton, MD - 250 Tables |
| 10am-3pm | I-95 Exit #20-B off Capital Beltway |
| | |
| Nov. 9-10 | EDISON, NJ - RARITAN EXPO HALL |
| Sat 10-4 | 800 Tables - Largest Show Ever! |
| Sun. 10-3 | Off NJ Turnpike Exit #10 on Rte. 514 |

a ken gordon show

**SHOW OFFICE: (908) 297-2526
OR FAX US AT (908) 422-0076**

CIRCLE NO. 111 ON FREE INFORMATION CARD

8031 CONTROLLER BOARDS

- 11.0592 MHz clock
- 16 K EPROM, 8 K RAM sockets
- 8255 parallel I/O
- ULN2803 outputs, 16 lines
- MC1489 inputs, 20 lines
- MAX232 serial I/O
- Screw terminals
- Support software included
- Monitor & PLC EPROMS & accessories available

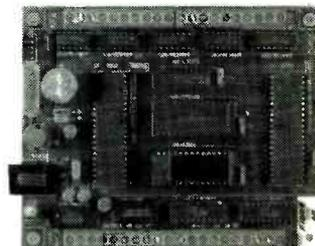

DG31 Board (4½" x 5½")

A&T: \$129 — Partial kit: \$70 — PCB Board kit: \$25

- 11.0592 MHz clock
- 8/16 K EPROM socket
- 8/32 K RAM socket
- MAX232 serial I/O
- Two 20-pin expansion headers
- Monitor, application notes & support software included
- Accessories available

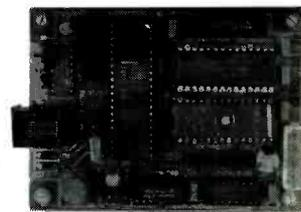

EMC32 Board (3" x 4")

A&T: \$80 — Full kit: \$62 — Partial kit: \$38

L.S. ELECTRONIC SYSTEMS DESIGN

2280 Camilla Rd., Mississauga, Ont. L5A 2J8 Canada
Phone/Fax: (416) 277-4893

Terms: Shipping US/Canada \$6. Check or Money Order please.

```

140 IF N>0 AND IF N<THEN GOTO
200
.
.
.
200 CLS
210 SCREEN 1
220 LOCATE 25,N
230 PRINT "*"

```

Of course, this isn't intended to be a functional program. It's purpose is merely to show how a computer can check for a specified input condition and then actuate one of several optical output ports. Thousands of variations on this basic theme can be implemented.

Optical Port Applications

Though the concept presented here is very basic, it has many possible variations and practical applications. Here are a few that come to mind:

- (1) Attach an optical port to the light that indicates when a disk is spinning in its drive. Whenever the light comes on, a gentle tone could sound. This would be a good way for a blind user to tell when a drive is operating if ambient noise level is so high the drive can't be heard.
- (2) Use an optical port to indicate when a stream of characters reaches the right side of a monitor screen.
- (3) Use a series of optical ports along the bottom or right side of a display screen to control a series of light-sensitive oscillators to produce electronic music.
- (4) Devise various kinds of D/A conversion methods by using one or more optical ports. You can do this by changing the number or color of illuminated pixels in a cluster to implement changes in the voltage from the port.
- (5) Use an optical port as a dedicated light pen by feeding its output back to an input circuit connected to a computer.
- (6) If your optical port(s) is electronically connected to your computer, write a routine that automatically checks for presence of the port(s) and verifies its operation. This routine should be implemented each time the program is run.

Going Further

Remember that the concepts presented here only hint at the hundreds of possible applications for an optical output port. There are many ways you can improve on the basic concept. For example, you can detect the presence of individual pixels or small clusters of pixels using one or more optical fibers if you increase the gain of the amplifier (by increasing the resistance of feedback resistor *R_f*). For best results, use an operational amplifier that has a lower noise figure than the 741.

With care, you should be able to trigger an optical port with a back- or side-illuminated liquid-crystal screen. If so, you'll be able to use optical ports with laptop computers.

Be sure to experiment with various kinds of detectors and ways to mount them. Although I've used tape to attach optical ports to a display screen, they can also be attached with small suction cups and various kinds of removable adhesives and putties.

Finally, as much as I'd like to help individual readers design optical ports for

specific applications, there simply isn't sufficient time for me to undertake such designs. For help with programming in BASIC, pay close attention to the SCREEN and COLOR commands in your BASIC manual. Be sure the parameters you select match those available to your computer. If you need help with the electronics, many books on optoelectronics are available. Two Radio Shack books I wrote that offer some assistance include *Getting Started in Electronics* and *Engineer's Mini-Notebook: Optoelectronics Circuits*.

**A HARD
DRIVE IS A
TERRIBLE
THING TO
WASTE.**

Join DELPHI for FREE and you can download onto your hard disk from a library of over 10,000 programs. You can also chat with other members in Conference, participate in multi-player games, read up-to-the-minute news, and much more. Basic membership is just \$5.95 per month and includes your first hour online —additional use is \$6 per hour. Or choose the 20/20 Advantage Plan, and enjoy 20 hours of usage each month for only \$20!

JOIN DELPHI NOW FOR FREE

- Dial by modem, 1-800-695-4002
- When connected, press RETURN
- At Password: type CRAFT

DELPHI

THE WORLD'S PREMIER ONLINE SERVICE

800-695-4005 • 617-491-3393

CIRCLE NO. 110 ON FREE INFORMATION CARD



More On Digital Imaging For Computers

This month, we continue with the digital imaging topic started several months back and interrupted last issue for a brief look at MS-DOS 5.0. In the previous two columns on imaging, I discussed the basics of how an image is converted into a digital representation and stored with grayscale information to approximate a continuous-tone photograph or video image. This time around and next month, I'll take a look at the two most popular methods of digitizing images: scanning and video frame grabbing.

Scanners have come quite a way in just a few years. Early scanners could generate only black-and-white line-art. Their sensor arrays were set to differentiate only extremes—light (white) or the absence of light (black). Many of these scanners could extrapolate grayscale information by analyzing a matrix of sensor findings and reproduce an approximation of the continuous-tone image being scanned using patterns of dots in a process called dithering. Dithering is still used extensively today, even with grayscale scanners, to allow images to be printed on dot-oriented printers. Though a laser printer is a dot-oriented printer, it just uses the very high 300-dot-per-inch (dpi) density.

As economies of scale were reached in scanner manufacturing and the electronics became cheaper to manufacture, true grayscale scanners have become common. In fact, it's no longer the ability to discriminate between levels of grayscale that's the limiting factor.

With modern sensors and inexpensive electronics, it's just about as easy to produce 512 or even 1,024 levels of gray from a scan as it is to generate 256 levels. But remember that the higher the grayscale scanning level, the larger the file it creates (for the same size scanned area). For example, the small color scan shown in Fig. 1 (as a black-and-white printout) was scanned at 4,096 colors, which is equivalent to the same number of levels of gray. It's not much different in quality from the scan performed with the 256-level ScanMan 256.

File sizes are a different story, though. The color .TIF file takes up almost 2M of space, while the grayscale .TIF file takes up only 258K. When you consider this,

along with the limited ability of most output devices (video and print) to display or reproduce more than 256 levels of gray, it appears as though this figure represents a barrier that will remain with us for at least a short while.

The above figures are for black-and-white (or gray) image files. Color, though, is a very different story. With Super VGA displays, 24-bit color display cards and wide-bandwidth displays, and color printers all becoming at least somewhat affordable, there's a very noticeable difference between 256 and 4,096 colors on a scan. Most newer color scanners, whether handheld or flatbed, offer the ability to capture 4,096 different colors. Depending on the software and display and print equipment available, you may be able to obtain color resolution even greater than that.

Color scanners work somewhat differently from black-and-white (grayscale) scanners. Most color flatbed scanners either scan the same area three times with red, green and blue light sources or have three different sensor arrays, each covered by a primary color filter. When the red, green and blue scans are combined, you wind up with a full-color picture.

I recently had the opportunity to use a well-known grayscale hand scanner, color hand scanner and very nice pixel-editing program for use by people who already have non-grayscale scanners.

Migraph Color Hand Scanner

I have to admit that I'm not quite sure how the folks at Migraph did it. In a unit that's just a bit larger than a standard grayscale hand scanner, the company packed a complete color scanner that can capture a color image in a single pass. This is a pretty neat trick, considering that flatbed scanners usually have to make three passes over the same area to accomplish the same thing. If I had to hazard a guess, I'd say it was accomplished with mirrors, splitting the scan into three parts that are channeled into separate sensors covered with red, green and blue filters.

The Migraph CS-4096 is unique among the hand scanners I've seen in that it uses a fluorescent light source, rather than the

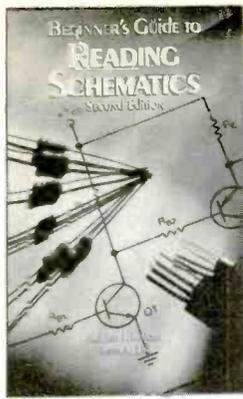

Fig. 1. Color photo scanned with a Migraph CS-4096 as a 4,096-color .TIFF file and reproduced as a black-and-white printout on an H-P LaserJet printer.

more common red or yellow-green LEDs that other hand scanners use. This white light source is necessary with a color scanner, but it also requires that the light source stabilize for up to a minute before a scan is performed. The Migraph scanner indicates this by flashing all its LED indicators until the fluorescent light has come up to operating temperature. The documentation supplied with the scanner also states that if you have a lot of scanning to do, you should turn off the unit after about 45 minutes to let it cool for a while to assure a consistent color range in the scans.

The unit comes with three software packages. The CS-4096 Scan Utility is the package actually used to perform the scan, and is a *Windows* 3.0-based application. It's very simple to operate. Once the configuration of the video display is set and interface board settings are made, you just go into the Scan menu and choose the desired scan options. These include setting: a 4,096 or 256 color, grayscale or line-art scan; the length of the scan (up to about 7" for a 4,096-color scan); and the file format in which you want the scan saved.

The CS-4096 Utility lets you save files in several .TIF formats (and compressed or uncompressed form), .PCX for use with *PC-Paintbrush* and compatible pro-



3632 \$18.95



3278 \$34.95
Counts as 2



2925P \$9.95



2875 \$17.95



3828 \$29.95
Counts as 2



3414 \$39.95
Counts as 2

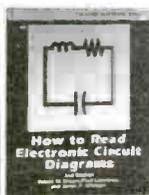

2880P \$14.95



3738 \$26.95
Counts as 2



2995 \$25.95



3672 \$24.95
Counts as 2



3275 \$22.95

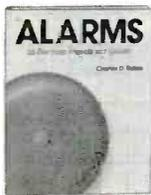

2986P \$14.95



2613P \$17.95

SELECT 5 BOOKS for only \$4.95

(values to \$124.70)
and get a **FREE Gift!**

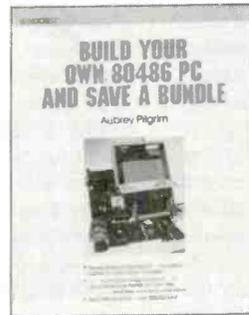
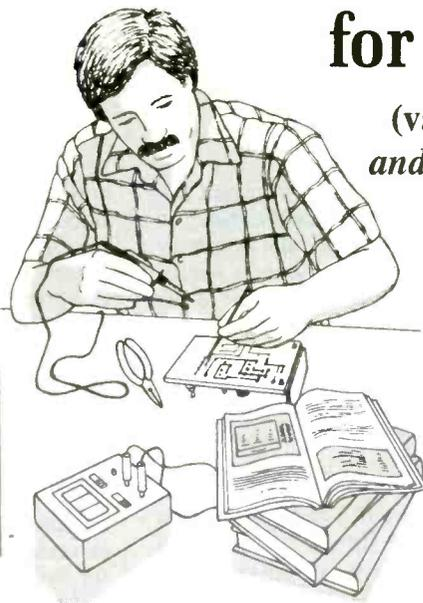

3628 \$26.95
Counts as 2

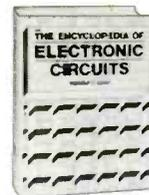

1938 \$60.00
Counts as 3



3258 \$28.95
Counts as 2



3679P \$22.95



2867P \$18.95

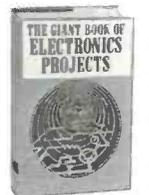

1367P \$24.95



3627 \$29.95
Counts as 2

Your most complete source for electronics books for over 25 years.



1604P \$17.95



3540 \$26.95
Counts as 2



3241P \$16.95



881715-3P \$14.95



3374P \$16.95

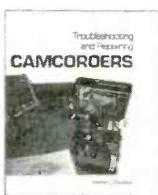

3337 \$35.95
Counts as 2



2947P \$13.95



2887 \$16.95

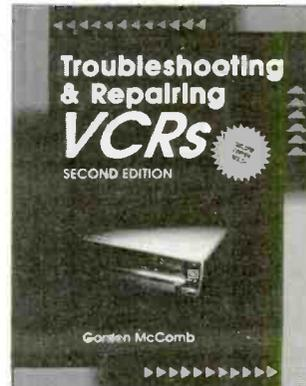

3777 \$32.95
Counts as 2

FREE when you join!

15 Easy Electronic Projects From Delton T. Horn
Projects you can build—some unique, some old favorites—from the author's vast treasury of electronics know-how.



Membership Benefits • Big Savings. In addition to this introductory offer, you keep saving substantially with members' prices of up to 50% off the publishers' prices. • **Bonus Books.** Starting immediately, you will be eligible for our Bonus Book Plan, with savings of up to 80% off publishers' prices. • **Club News Bulletins.** 15 times per year you will receive the Book Club News, describing all the current selections—mains, alternates, extras—plus bonus offers and special sales, with scores of titles to choose from. • **Automatic Order.** If you want the Main Selection, do nothing and it will be sent to you automatically. If you prefer another selection, or no book at all, simply indicate your choice on the reply form provided. You will have at least 10 days to decide. As a member, you agree to purchase at least 3 books within the next 12 months and may resign at any time thereafter. • **Ironclad No-Risk Guarantee.** If not satisfied with your books, return them within 10 days without obligation! • **Exceptional Quality.** All books are quality publishers' editions especially selected by our Editorial Board. MDNE1091



3475 \$27.95
Counts as 2



2865P \$14.95



3072P \$16.95



9417P \$24.95
Counts as 2

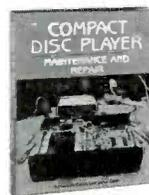

2790P \$14.95



2883P \$18.95

A shipping/handling charge and sales tax will be added to all orders.

If card is missing, use this address to join:
ELECTRONICS BOOK CLUB, Blue Ridge Summit, PA 17294-0810

(Publishers' Prices Shown)
©1991 ELECTRONICS BOOK CLUB

All books are hardcover unless number followed by a "P" for paperback.

grams, or *Windows*' own .BMP (bitmap) format. For more sophisticated file format conversions, Migraph includes Computer Presentations, Inc.'s *Image-Prep* package. *Image-Prep* lets you convert images stored in one file format into another. In addition to the formats offered by Migraph's own utility, *Image-Prep* offers .GIF, .TGA (Targa), .CPI (Color-Lab), and .EPS (PostScript) formats. *Image-Prep* also offers such additional capabilities as color reduction (for example, it lets you convert a 4,096-color image into a 256-color image), color to grayscale conversion, dithering options for printing on lower-resolution printers and color-correction functions. Even an excellent screen-capture function is included in the package.

Image Prep is a very useful utility for anyone who performs color scans, but neither it nor the CS-4096 Utility have the kind of capabilities that true image editing and manipulation packages offer. To make up for this lack, Migraph also includes *Picture Publisher Plus*, the color version of Astral Development's well-known image editing software. *Picture Publisher* has become pretty much the standard in image manipulation, and now that Astral Development has been acquired by Micrografx (developers of *Designer* and *Charisma*), you can expect Version 3.0, which should be out about the time you're reading this, to set even higher standards.

Picture Publisher gives the ability to adjust contrast, brightness, color balance, hues and tints. It also gives the ability to cut, paste and duplicate parts of the image you're working on. Its major shortcoming is its documentation. Although very comprehensive, the documentation assumes you already have a high level of understanding about the image-manipulation process.

I was up and running with the CS-4096 scanner in about 20 minutes after starting installation.

The CS-4096 isn't perfect for everyone. At \$895 it's certainly not inexpensive (though it's among the least-expensive color scanners you can buy). And it's limited to a scan width of about 4.5". This is too narrow for some applications, and stitching together scans is tedious and doesn't work very well. However, if your need is to produce a high-quality scan within the scan-width limits, this Migraph scanner does an excellent job.

To use the Migraph CS-4096 color scanner, you need *Windows* 3.0, a 16-bit expansion slot and a lot of memory. Because of the 16-bit interface card, 8088-based PCs can't use the scanner. Though the system will run on an AT-class machine, I recommend at least a

386SX with plenty of RAM and a large hard disk. I don't know if I would call anything costing almost \$900 a bargain, but the CS-4096 is certainly a good value if it fits your needs.

Touch-Up

Another of Migraph's products, and one with a bit more universal applicability, is *Touch-Up*. This package was originally developed for another vendor's system and ported several years ago over to the PC. Operating under Digital Research's GEM/3 Graphical Operating Environment (included with the package), it offers much of the same functionality as better-known pixel editing packages like *PC-Paintbrush*.

Touch-Up is for use with only black-and-white images. It doesn't work with grayscale or color files, and if you load such a file into *Touch-Up*, it will be converted into a monochrome file. For users with grayscale or color scanners (or frame grabbers), this is a severe limitation. But if you're currently using an older hand scanner or page scanner, *Touch-Up* has several advantages over the software you're probably using. One is that it's very easy to use. While the GEM/3 GUI has never become as popular as *Windows*, it's still an excellent and very intuitive environment to work under, and *Touch-Up* makes excellent use of it.

Touch-Up also offers a feature many other monochrome editing packages lack: the ability to work with very large files. With files larger than available RAM, *Touch-Up* buffers the image file between memory and disk. This slows things a bit when it happens, but it's a tradeoff that lets you work with image files that might not be able to fit with other vendors' packages.

I didn't find using *Touch-Up* that much different from other "paint" programs, like Z-Soft's *PC-Paintbrush*. *Touch-Up* does, however, have a few tricks up its sleeve that *Paintbrush* lacks. One major difference is its ability to work with B-Spline and Bezier curves. B-Splines and Bezier curves are similar in that they both create a connecting curve between a number of points you define.

With *Touch-Up*, B-Splines can have up to 32 control points, while *Touch-Up*'s Bezier curves are limited to four control points. Curve functions like these are more often found in the high-end graphics packages, like *Corel Draw* and *Arts & Letters*, rather than "paint" type packages.

Touch-Up also gives you scalable fonts, the ability to stretch, tilt and rotate images, and standard paint features like airbrush, lasso and FatBit editing. *Touch-Up* directly supports a number of non-

grayscale scanners, including the HP ScanJet and Canon page scanners and the Logitech ScanMan hand scanner.

As with Migraph's color hand scanner, *Touch-Up* is really a specialty product. With a list price of \$495, it's competing with some much better known software, and it's a few hundred dollars less costly than the very high-powered graphics packages like *Corel Draw*. Yet I liked *Touch-Up* a lot, and I think it's great for fixing scanned-in signatures and logos. If you have an older scanner and have frequently become frustrated with the capabilities of the software that came with it, it's definitely worth taking a look at *Touch-Up*.

Grayscale Scanner

As much fun as they are to play with, color scanners still aren't all that practical for many users. For one thing, they're still very expensive when compared to grayscale scanners. For another, they require expensive output devices to take advantage of the color. I've had the luxury of having a number of 300-dpi color printers to play with for the last few months, but few users will shell out the \$7,000 or more that these printers run just to generate a few color images.

At the same time, lots of people are finding that they like having the capability of dropping a photo into desktop published newsletters, brochures and even greeting cards. For many such applications, grayscale images work just fine. Laser-printed grayscale images work well for casual applications, and if your needs are such that you need a higher quality, many typesetting houses can output your image file on a high-resolution phototypesetter for a reasonable price. This makes a grayscale scanner or video frame grabber a logical choice for even light-use professional tasks.



Fig. 2. Image obtained with Logitech's ScanMan 256 hand scanner as a 256-level grayscale .TIFF file and printed with Aldus Pagemaker on an H-P LaserJet printer.

Products Mentioned

CS-4096 Color Hand Scanner, \$895
Touch-Up, \$199.

Migraph, Inc.
200 S. 333, Ste. 220
Federal Way, WA
206-838-4677

ScanMan 256, \$499.00

Logitech, Inc.
6505 Kaiser Dr.
Fremont, CA 94555
415-795-8500
Info: 800-231-7717, ext. 2602

Among the best-known grayscale hand scanner manufacturers is Logitech, which makes the ScanMan 256, a black-and-white hand scanner that offers 256-level grayscale capability. The scanner itself is pretty much a standard unit. It comes with an interface card that can be plugged into either an 8-bit or 16-bit expansion slot. The 16-bit slot is preferable because it allows the card to make use of interrupts 11 and 12, which are infrequently used by other peripherals.

I had the ScanMan 256 up and running (on my kid's PC; I'd learned my lesson well) in about 10 minutes with no problems. ScanMan 256 offers a 4" scan width, red scanning light (which can cause some red drop outs in color images and a true eight-bit-per-pixel 256 levels of gray. It tracks well for a hand-held unit, and it's scan button is conveniently located on the left side of the unit, just under where your thumb rests. The unit is of good quality, but there's nothing about it that stands out very much when compared to similar units.

One thing that does set the ScanMan 256 apart from the crowd is its software. This package comes with two pieces of software that let you operate the scanner. The DOS scan utility must be installed first, as this software disk contains the scanner driver that both packages use. As scanning programs go, it's pretty generic, letting you capture and save an image. The second package, named ANSEL, runs under *Windows 3.0* and provides a scanner control utility and a fairly sophisticated image-editing functions in an easy-to-use format.

Of course, ANSEL isn't quite as powerful as *Picture Publisher*. But, at the same time, it's a whole lot easier to use for the majority of tasks most users will attempt, such as retouching a scan. ANSEL also has image-stitching abilities, letting you scan a large image or document (for

use with OCR software) in several passes, then stitching them together.

It may not be apparent from Fig. 2, but the scan obtained from the ScanMan 256 was the best I've ever gotten from a hand scanner straight out of the box, with no fiddling with the controls and the software. Some vendors are now supplying *Picture Publisher* along with their hand scanners. This is fine if you want the cap-

abilities that Astral's software offers and are willing to put in the time learning the software and experimenting. Sometimes, though, simpler is better. If all you want is to get great scans easily, and you're not interested in doing extensive trick photography with your hand scanner, buy the ScanMan 256. The ANSEL software makes it an excellent choice for someone who just wants to get the image. ■

The Electronics Lab in a Computer!

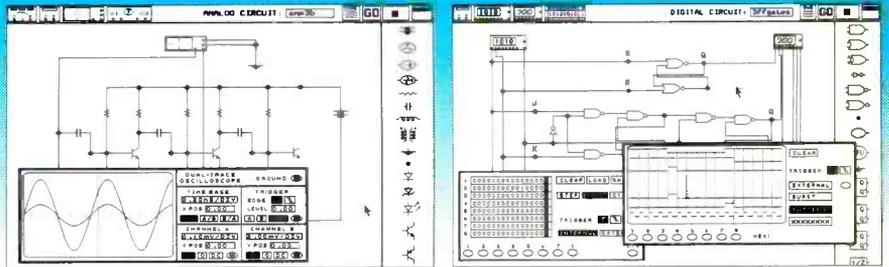

Build and simulate both Analog and Digital circuits.

Electronics Workbench®

"Electronics Workbench is pretty amazing."

Jerry Pournelle, Ph.D., InfoWorld

"...a marvellous learning and teaching tool..."

Art Salsberg, Editor-in-chief, Modern Electronics

"Building a circuit is simple and intuitive."

Jeff Holtzman, Computer Editor, Radio-Electronics Magazine

Yes, I want Electronics Workbench® in my computer!

Check the version you want:

<input type="checkbox"/> MS-DOS 5.25"	<input type="checkbox"/> MS-DOS 3.5"
Personal	\$ 99.00
Personal Plus	\$199.00
Professional	\$299.00

ORDER INFORMATION: Canadian residents please add 7% GST (Ontario residents add 8% PST plus 7% GST). All orders please add \$10.00 shipping and handling.

Return to:

Interactive Image Technologies Ltd.
Computer Craft Offer
908 Niagara Falls Boulevard
North Tonawanda, NY 14120-2060
Tel: (416) 361-0333
Fax: (416) 368-5799

Name: _____

Address: _____

City: _____ State: _____ Zip: _____

Tel: () _____ Fax: () _____

MC/VISA/AMEX# _____

Signature: _____ Exp. _____

REQUIREMENTS ■ Personal/Personal Plus Versions: IBM PC/XT/AT or PS/2 or true compatible with 512 kB RAM; Microsoft-compatible mouse; graphics display; two floppy drives or hard disk; MS-DOS 3.0 or later.
■ Professional Version: 640 kB RAM; EGA/VGA graphics; hard disk.
■ Personal Plus also available for the Macintosh.

FEATURES ■ Personal Version: builds circuits containing 20 components or less. ■ Personal Plus Version: builds circuits containing an unlimited* number of components. ■ Professional Version: uses color coding for circuit tracing with an unlimited* number of components; EGA/VGA support.
*limited only by the amount of memory available.

INTERACTIVE IMAGE TECHNOLOGIES



CIRCLE NO. 112 ON FREE INFORMATION CARD



Flash Memory, a Flip-Stik and a New Kind of Battery

This month's column covers a product that makes it easier to change software in a chip, a product that makes it simpler to put software into a chip at the last minute, and a product that helps keep software in a chip for a longer period of time.

"Flip Stik" Microcontroller

A new miniature microcontroller from Dallas Semiconductor (4401 S. Beltwood Pkwy., Dallas, TX 75244) accepts software updates via its serial port while it's in the system, with no component removal required. The DS2340 Flip Stik supports DOS-equivalent operating systems for diskless embedded systems, enabling application development using standard DOS function calls.

The Flip Stik is so named because it functions as an expandable microprocessor when plugged in one way and a single-board microcontroller when plugged in the other way.

Due to the Flip Stik's in-system reconfigurability, an embedded system incorporating it can be pulled from a stockroom shelf and configured with customized software just prior to shipment, without opening its enclosure. Software upgrades can even be downloaded over the telephone line from a remote PC.

The Flip Stik incorporates a V40 microprocessor (software-compatible with the 8088), up to 256K of nonvolatile RAM and a recently introduced Dallas chip called the DS5340 Softener. This chip crash-proofs the microprocessor to safeguard critical data against power failure. A version of the Flip Stik features a clock/calendar for time and date stamping of data in the nonvolatile RAM.

Because the V40 executes the native instruction set of the PC, the world's largest installed software base can be used in developing code for the Flip Stik. Programmers can write software for the Flip Stik on the same computer that sits on their desks and later port it to the embedded system. Rather than having to learn a new language or buy special development systems, programmers can simply use the software base with which they're already familiar.

To increase flexibility, Dallas Semiconductor used the top of the Flip Stik—

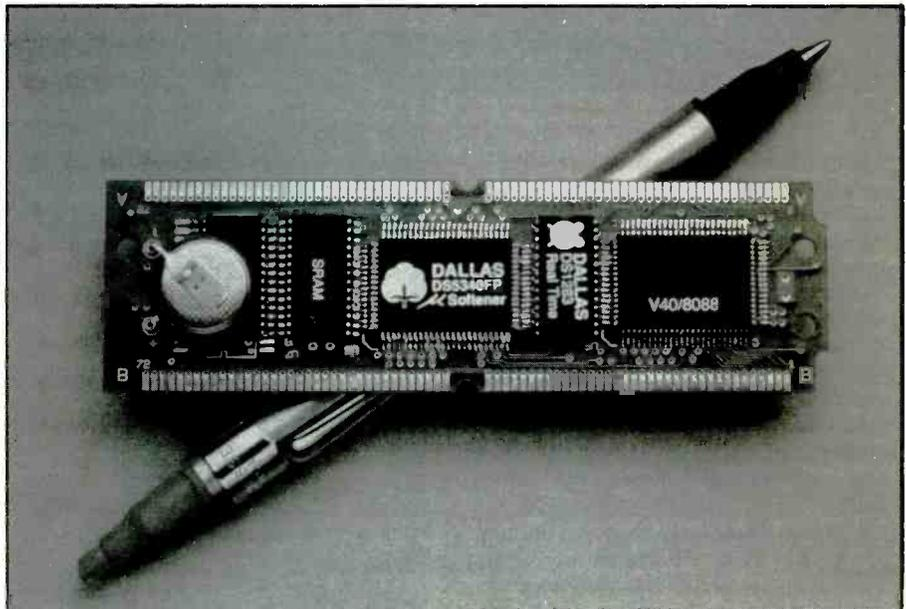

The DS2340 Flip Stik from Dallas Semiconductor is a miniature embedded control system designed for in-system software updates.

space that is normally wasted on SIMMs—to give dual functionality. Plugged in one way, the Stik is a complete microcontroller. Plugged in the other way, the Flip Stik serves applications that require additional memory and I/O. It then functions as a building block and provides all the hooks necessary for expansion.

The Flip Stik has many functions required in embedded applications. The V40 processor provides a serial port, interrupt controller, timer/counters and a DMA controller. The DS5340 Softener chip complements these functions with a clock oscillator, power monitor, watchdog timer, programmable address decoder, dual port register file and parallel input/output ports.

Measuring only 4.25" × 1.25", the Stik is roughly the size of a stick of chewing gum. Thus, it conserves valuable PCB space. Due to Dallas Semiconductor's CMOS and lithium technologies, the board consumes very little power—about 100 mA typical.

Prices of the DS2340 16A Soft V40 Flip Stik running at 8.0 MHz is \$54.30; the DS2301V 08 Soft 6301 Stik running at 1.0

MHz is \$29.80 (prices are for 1,000-piece quantity).

Block-Erase Flash Memory

A flash memory device with block-erase capability is available from Intel Corp. (3065 Bowers Ave., P.O. Box 58065, Santa Clara, CA 95052). This device, the 28F001BX, is designed for updatable BIOS (basic input/output system) in personal computers and updatable firmware in minimum-chip embedded applications.

The 1-megabit "Boot Block" flash-memory device features an 8K boot block section with a hardware lock-out feature to ensure data security and reliability within that block. Other memory segmentation includes two 4K parameter blocks and one 112K main block. The chip is available in two configurations, making it compatible with microprocessors and microcontrollers that boot from either high or low memory.

The 28F001BX helps simplify system design by merging the functions of several chips into one. This makes the device

an innovative alternative to EPROM (erasable programmable read-only memory), EEPROM (electrically erasable programmable read-only memory) or battery-backed SRAM (static random-access memory).

As with all Intel Flash Memory devices, the 28F001BX is manufactured using the company's 1-micron ETOX II (EPROM tunnel oxide) process, thus assuring the highest levels of quality, reliability, performance and production.

Many new and existing designs can take advantage of the chip's integration of blocked architecture, automated electrical reprogramming and standard processor interface. Along with these integrated features, the 28F001BX provides a "deep power-down" mode. This lowers power consumption to 10 microwatts (typical) when the device isn't in direct use and is crucial in laptop, hand-held instrumentation and other low-power applications.

As PCs—including high-end desktops, engineering workstations and portable systems—increase in complexity, so does associated BIOS code. Combined with the open nature of microcomputer systems, the need for a flexible BIOS increases. With an "updatable ROM," operating system kernels and utility programs can now be stored in BIOS instead of on-disk. A flexible BIOS also allows for multiple operating system support, new peripheral upgrades and improved power-management routines in computer systems already released. With BIOS traditionally stored in EPROM or ROM, any revision requires costly and impractical system disassembly.

The blocking scheme of the 28F001BX allows BIOS updates in the main and parameter blocks. The parameter blocks can be used to back-up configuration data stored in SRAM to avoid loss of set-up data when the battery fails. A boot section is provided for recovery code storage and can also be protected or locked to prevent inadvertent writes or tampering. Additionally, the fully automated erase and write capability simplifies device interface and frees the microprocessor to perform other tasks while the 28F001BX is being programmed with data or erased.

In embedded applications, integration of chip functions is a main design concern. Here, it's critical to keep chip count, board space, power consumption and product cost as low as possible. With the 28F001BX's four memory blocks, logical segmentation of the entire embedded software program can be achieved, thus providing the needed integration. For example, the 8K block could be used

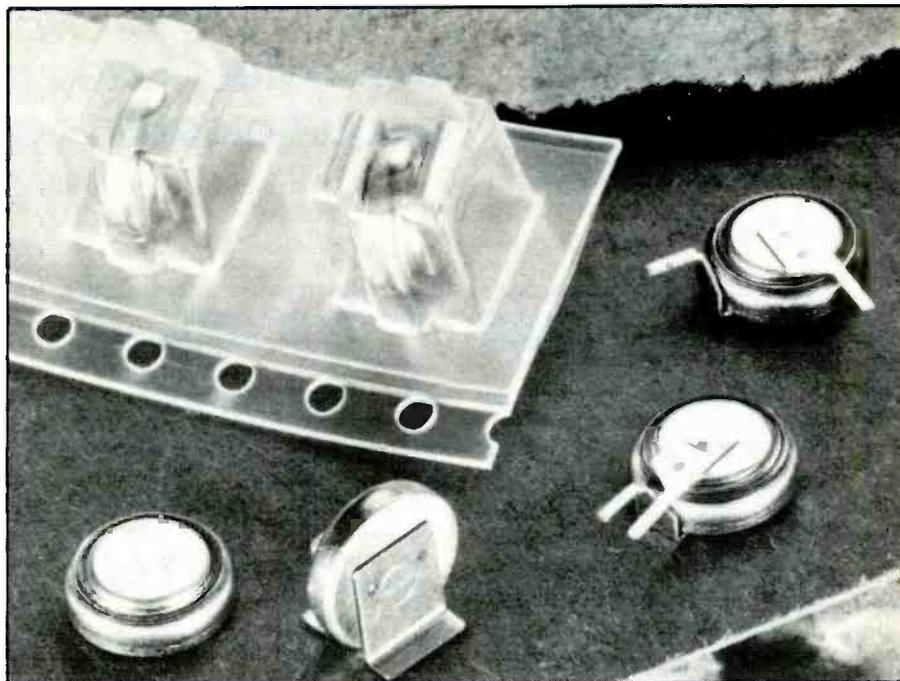

Seiko Instruments' new rechargeable polymer-lithium battery is designed for CMOS and RAM memory backup use.

for the boot code, the 112K block for the main program code and the two 4K blocks for updatable parametric data storage, diagnostic messages and data or extensions of either the boot code or program code.

Specific embedded applications include embedded DOS designs, disk drive controllers, portable equipment, copiers/printers and automotive engine control, to mention just a few.

Organized as 128K \times 8, the 28F001BX is offered in both 120- and 150-ns access speeds. Its three packaging types—32-pin PDIP (plastic dual in-line pinout), 32-lead TSOP (thin small-outline package) and 32-lead PLCC (plastic leaded chip carrier)—are all JEDEC compatible, backward-compatible with Intel's 1M-, 512K and 256K flash memory footprints and EPROM and ROM devices.

The 28F001BX is available in either top-boot or bottom-boot configuration. The top-boot device is designed for systems using microprocessors or microcontrollers that boot from high memory, including Intel's i386, i486, i860 and i960A microprocessors and the MCS-186 microcontroller family.

With a blocking scheme reversed from the top-boot device, the bottom-boot chip is compatible with microprocessors or microcontrollers that boot from low memory, such as Intel's i960KA/KB and i960SA/SB microprocessors and MCS-51 and MCS-196 microcontrollers, as

well as Motorola's 68000 family.

Price for the 150ns 28F001BX is \$17.20 for PDIP and PLCC packages and \$20.60 for the TSOP package, all in 1,000-piece quantity.

Rechargeable Polymer Lithium Battery

Seiko Instruments USA Inc. (2990 West Lomita Blvd., Torrance, CA 90505) announced its new Model AL Series rechargeable, polymer lithium battery, the most recent addition to the company's extensive line of lithium coin batteries. This new battery uses a proprietary electric conductive polymer as cathode and a lithium alloy as anode and organic electrolyte, which provide an operating potential as high as 3 volts, compared to the 1.2 operating volts of conventional rechargeable Ni-Cd cells. It's available in several sizes and has a temperature range of -10° to $+60^{\circ}$.

The AL Series has a long life cycle and long-term reliability and storage life, ensured by use of organic electrolytes. These electrolytes provide low self-discharge and are essentially leakproof.

Recommended for CMOS and RAM memory backup, as well as other applications requiring high-capacity memory backup, the AL Series is available in tape and reel packaging with typical 1,000-piece pricing of \$2.25 each.



Free and nearly-free software; computer viruses; and compression/decompression packages

The reason many on-line computer users prowl the networks and BBSs is to locate and download public-domain and shareware software. There's an almost endless supply of software available just for the time it takes to download it from the network service or BBS. The excellent quality of these programs is surprising, and some of them are equal or superior to many commercial packages. In future columns, we'll try to review as many programs here as our space permits and bring exceptional ones to your attention. We'll also answer your requests for information sent care of this magazine (please enclose a SASE).

The place to start looking on-line for public-domain programs and shareware is a local BBS near where you live and where you can access software libraries without making toll calls. Major public networks, such as CompuServe and GENie, have the largest collection of this software. In some cases, this may be the only place to download what you're looking for. Just keep in mind that this may also be a very expensive way to get "free" programs because you have to pay on-line connect charges to the networks plus telephone charges. With local BBSs, both of these are usually free or carry a nominal membership fee.

Some commercial software-distribution companies that make a business of supplying shareware often prove to be the cheapest and most reliable way of getting programs that have been around for some time. The best known of these companies are PC-SIG, PBS (Public Brand Software) and PSL (Public Software Library). Other shareware distribution companies also advertise in magazines. PC-SIG also publishes the *Encyclopedia of Shareware*, a very important reference book to have. It's regularly updated to keep current with new software releases.

Keep in mind that these shareware companies don't always distribute programs that are brand new. Instead, they pick up software that's most popular and most often downloaded by users. In addition, they seldom distribute public-domain or "freeware" programs. You have to get these from bulletin boards and major on-line services. Most Forums on CompuServe and Roundtables on GENie

announce when new software listings are available in their libraries.

Downloading software is a simple procedure that's usually described in the documentation for your particular communications program. Receiving the software takes time and patience. When you select software for downloading, the source will give you a short description of the program. In addition, they often tell you how many blocks comprise the program and approximately how long it will take, according to the modem you have and protocol (method) you select, for transmission.

Don't start downloading unless you have the time to hang around to complete the job. Nothing is more annoying than to start a lengthy download and have to go for supper or leave for some other reason that can't be delayed. What happens then is the same thing that occurs when you leave your printer to print a long document—something goes wrong. However, in the case of downloading, you're paying for something you don't get.

A new network called "America On Line" has one of the easiest ways to download software. It uses a proprietary method that's very simple and very fast. Its library isn't very large now, but it's growing by the day. America On Line has reduced the process of downloading software to its simplest form. I'll be reporting on this new network in my next column.

People ask me if there's danger in downloading software because of the possibility of virus infection. At one time, you could rely on the BBS Sysop to ensure clean code for all programs in his libraries. Those days are long past. Be careful because viruses are real! Don't receive and load any downloaded programs on to your hard disk. Route all downloads to a floppy-disk drive. Use a fresh, formatted floppy diskette, and immediately after completion of the download, scan the drive for virus before moving the downloaded program to your hard-disk directory.

Lately, I notice many virus protection programs selling for large sums of money. You don't have to spend a lot of money for virus protection. *Viruscan* and *Clean-Up* from McAufe Associates are among the very best protection you can

get and cost only a small registration fee to use. The latest versions of this software are available on most BBSs and networks and from all shareware distributors.

If you find you're infected, clean and disinfect your computer with *Clean-Up* and then turn off the computer. Follow the instructions in the README.1ST file that comes on the disk and your trouble will be over. Though the libraries on the major networks are continually scanned for virus infestation and are clean, be careful anyway. The disks you get from PC Sig and other major distributors are clean and can be used without fear if you get them directly from a reliable source.

The first thing you'll notice when you start to download software is that most programs have been archived (compressed) to save space and transmission time. You can detect a compressed program because it has the extension .ARC or .ZIP, such as Program_title.ARC or Program_title.Zip. To decompress them, you need suitable de-compression software. You will know which compression software you need by the title extension, that is, PROGRAM.ARC or PROGRAM.ZIP.

The ARC format from System Enhancements Associates Inc. was the standard compression technique used for a long time. Now you'll find most new programs have been compressed with ZIP from PKWARE Inc. Both programs are available on most BBSs and networks. Both also have very reasonable registration fees; so you should have both of them. I suggest that you get them from a friend or your club library or a shareware distributor because you'll need them to decompress almost every program you get from a library.

You might want to get *ZipMaster* from New-Ware, too, which will work with most formats and is very easy to use. However, if you get only one such program, make it *PKZIP/PKUNZIP* from PKWARE Inc.

Recently, a new archiver has appeared, this is *LHarc* by Haruyasu Yoshzaki from Japan. While *LHarc* isn't as well known as ARC or ZIP, it's becoming more popular since it's distributed as freeware and requires no registration fees for either personal, or commercial use. In

spite of this free policy, however, it isn't public domain software but is copyrighted by the author.

Software is often compressed by its author using a self-decompressing version of the compression software. In this case, all you do is enter the name of the program and it automatically does its job. An important consideration with this type of software is to have enough room on your disk or directory to accommodate both the compressed version and the

decompressed files. You can erase the compressed version after decompression to save disk space. Lately, many commercial programs are using this same system.

A word of warning here. Many people, upon discovering this treasure house of software, go overboard and try to download everything that even faintly appeals to them. They become "Software Junkies." Before long, they run up big bills on the networks and with the telephone company. They also fill up their hard disks with software they seldom use. You'd be amazed at how fast even large-capacity hard drives fill up! "Software expands to fill the space available to it." This is Veit's Law No. 2: What's law number one? "Nothing ever works right until Revision 3."

If you become a sensible on-line software collector, you might want to join the

largest BBS in the country, which is one huge software library that contains more than 90,000 program files for PC, MAC and Amiga computers. This is EXEC-PC in Elm Grove, WI. The fee to join is only \$60 per year, and you can try it for three months for only \$20, one of the on-line world's greatest software bargains.

It's much more practical to learn something from books before going software hunting. Books to read for more information: *Dr. File Finder's Guide To ShareWare* by Mike Callahan and Nick Anis (Osborne-McGraw Hill); *The Complete Handbook of Personal Computer Communications* by Alfred Glossbrenner (St. Martin's Press). Mike Banks has also written a number of good books on the subject. Get the latest revision of *The Encyclopedia of Shareware*, Third Edition, by PC Sig.

Additional Information

CompuServe
P.O. Box 20212
Columbus, OH 43220
800-848-8199

GENie
401 N. Washington St.
Rockville, MD 20850
800-638-9636

EXEC-PC
P.O. Box 57
Elm Grove, WI 53122
414-789-4200 (voice)
414-789-4210 (modem)

PC-SIG
1030-D E. Duane Ave.
Sunnyvale, CA 94066
808-245-6717

Public Library
P.O. Box 35705
Houston, TX 77235
800-2424-PSL

Public Brand Software
P.O. Box 51315
Indianapolis, IN 46251
800-426-DISK

ARC
System Enhancement Assoc.
21 New St.
Wayne, NJ, 07407

PKWARE Inc.
7545 N. Port Washington Rd.
Lendale, WI 53217

New Ware
8050 Camino Kiosco
San Diego, CA 92122
619-455-6225

LHarc
Available from PLS, PBS, PLS
CompuServe (IBM Forum); GENie
(IBM Roundtable)

Subscribe Now and Save

**CABLE TV DESCRAMBLERS
★ CONVERTERS ★
and ACCESSORIES.**

**SAVE MONEY.
DON'T RENT!**

PANASONIC, JERROLD, OAK,
PIONEER, SCIENTIFIC ATLANTA
AND MORE. LOWEST PRICES. FREE CATALOG.
CABLE READY COMPANY (800) 234-1006

CIRCLE NO. 106 ON FREE INFORMATION CARD

K.D. VIDEO

**FOR ALL YOUR CABLE TV NEEDS
WE SPECIALIZE IN DEALER PRICING**

QTY	1	10	20
Jerrold (Type) SB-3	89.00	56.00	48.00
Jerrold (Type) Tri-Bi	119.00	69.00	65.00
Scientific Atlanta SA-3	129.00	80.00	75.00
Hamlin MLD-1200	99.00	59.00	45.00
Oak N-12 Vari-Sync	99.00	59.00	58.00
Jerrold 550 Converter	99.00	75.00	68.00
Jerrold 400 DRX-3DIC (With Built in SB-3)	169.00	109.00	100.00

1-800-327-3407

Call us for prices on large quantities
K.D. Video PO Box 29538, Mpls., MN 55429

**SUPER
LONG PLAY
TAPE RECORDERS**
12 Hour Model —
USES 120 TAPE
\$119.00*

Modified Panasonic Slimline,
high quality AC-DC provide 6
continuous hours of quality
recording & playback on each
side of cassette for 12 hours
total. Includes • Voice level
control • Digital counter,
etc. TDK - 120 Cassette
Furnished.



PHONE RECORDING ADAPTER
Records calls automatically. All Solid
state connects to your telephone
jack and tape recorder. Starts
recording when phone is lifted.
Stops when you hang up. **\$28.50***
FCC APPROV.



VOX VOICE ACTIVATED CONTROL SWITCH
Solid state. Self contained. Adjust-
able sensitivity. Voices or other
sounds automatically activate and
control recorder. Uses either re-
corder or remote mike. **\$28.50***



* Add for ship. & handling Phone Adapter & Vox \$2.00 each
Recorders \$5.00 each Calif. Res. add tax. Mail order. VISA,
MIC, COD's OK. Money Back Guarantee. Quantity discounts
available. Dealer inquiries invited. Free data.
AMC SALES INC. Dept. M 9335 Lubec Street
Box 928, Downey, CA 90241
Phones (213) 869-8519 1-800-926-2488
FAX (213) 923-1478
Mon-Fri 8-5 PAC. TIME

CIRCLE NO. 135 ON FREE INFORMATION CARD

vantage. Right decisions at key times can turn the tide of an investigation.

The importance of making correct decisions may be illustrated with something as simple as choosing a car to drive when following a suspect. One's initial temptation may be to hop into a fiery Italian sports model and get on with the chase. Flashy vehicles are impressive to just about everyone, including your suspect. For following, it's much better to choose an inconspicuous vehicle, even though its handling or speed might not be tops.

An interesting item has turned up with *Covert Action*. You'll recall that when equipping for breaking and entering, Remington may choose an Uzi Submachine Gun as his weapon. The game manual goes out of its way to mention that Uzi rounds are non-lethal, causing human targets to sleep for a while. The same is true of hand guns and the three different kinds of grenades.

These comments concerning non-lethal bearing of weapons is interesting in that, to my recollection, MicroProse has never done such a thing before. One of the game maker's previous releases, *Airborne Ranger*, is surely as violent a concept for a game as *Covert Action*; yet it's

understood during game play that an enemy who's shot is out of game play; dead in other words. I mention this item because forcing players to use non-lethal weapons seems to deny the dangerous nature of international espionage and covert action. The life-threatening occupation of a super-spy is undoubtedly the point of the game.

If MicroProse is concerned about customer perception of its corporate image in our modern ultra-violent times, that's perfectly understandable. However, it isn't unreasonable to think that anyone who purchases this kind of game might be somewhat aware of its potential contents and be able to remember that it's only make-believe. The game itself focuses more on data collection, use of resources and one's ability to put it all together. It doesn't glorify violence and wouldn't do so even if lethal weapons were used.

MicroProse has remained true to its reputation for making quality simulations that force intelligent involvement without getting mired in tedium. *Covert Action* successfully gives players an entertaining look at international espionage and the high-level world of the super-spy.

CIRCLE NO. 140 ON FREE INFORMATION CARD

Bird's Eye View

Covert Action, \$59.95
MicroProse
 180 Lakefront Dr.
 Hunt Valley, MD 21030
 301-771-1151

Requirements

Memory 640K
Graphics VGA, MCGA, EGA, CGA, Tandy
Sound Roland, AdLib, Tandy
Controllers Joystick

Evaluation

Documentation Good
Graphics Good
Learning Curve Medium
Complexity Medium
Playability Good
In Brief: Enjoyable espionage with all the trimmings. Requires analytical thought, full attention and some earnest practice.

**THE PERFORMANCE LEADER
 IN EASY TO USE CAD TOOLS
 From Labcenter Electronics**

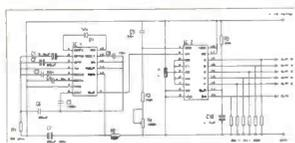

SCHMATIC CAPTURE

PCB LAYOUT

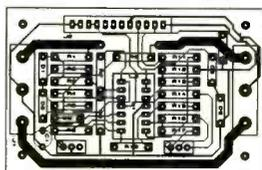

Easy to Use PC Software - ICON Based
 Ultra Fast Performance - Mouse Driven
 Complete With Advanced Editing Tools
 Output to Printers, Plotters & Lasers

PCB BOARD DESIGN

Full range of products available from entry level through to autorouting.

SCHMATIC CAPTURE

A family of products that feature modern graphical user interface & an intelligent diagram editor.

Products as low as \$149^{us} !!!

R4 SYSTEMS Inc.
 P.O.Box 451
 West Hill, Ontario
 Canada M1E 4Y9

Free DEMO Package
 Write or Call Today

(416) 439-9302

Download DEMO from BBS at 416 289-4554 (2400/8/N/1)

CIRCLE NO. 125 ON FREE INFORMATION CARD

Cross-Assemblers from \$50.00

Simulators from \$100.00

Cross-Disassemblers from \$100.00

Developer Packages

from \$200.00(a \$50.00 Savings)

Make Programming Easy

Our Macro Cross-assemblers are easy to use. With powerful conditional assembly and unlimited include files.

Get It Debugged--FAST

Don't wait until the hardware is finished. Debug your software with our Simulators.

Recover Lost Source!

Our line of disassemblers can help you re-create the original assembly language source.

**Thousands Of Satisfied Customers
 Worldwide**

PseudoCorp has been providing quality solutions for microprocessor problems since 1985.

Processors

- | | | | |
|-----------------|---------------|-----------------|------------------|
| Intel 8048 | RCA 1802,05 | Intel 8051 | Intel 8096,196kc |
| Motorola 6800 | Motorola 6801 | Motorola 68HC11 | Motorola 6805 |
| Hitachi 6301 | Motorola 6809 | MOS Tech 6502 | WDC 65C02 |
| Rockwell 65C02 | Intel 8080,85 | Zilog Z80 | NSC 800 |
| Hitachi HD64180 | Mot. 68k,8,10 | Zilog Z8 | Zilog Super 8 |

• All products require an IBM PC or compatible.

For Information Or To Order Call:

PseudoCorp

716 Thimble Shoals Blvd, Suite E
 Newport News, VA 23606

(804) 873-1947

FAX:(804)873-2154

CIRCLE NO. 121 ON FREE INFORMATION CARD

Classified Commercial Rates: \$1 per word, 15-word minimum (\$15.00) prepaid. (Word count includes name and address; ZIP code and abbreviation each count as one word; P.O. Box number and telephone number count as two words each.) Indicate free category heading (**Computers, Communications, Electronics, Video or Miscellaneous**). A special heading is available for a \$6 surcharge. First word only is set boldface caps at no charge. Add 20% for additional boldface words.

Non-Commercial Rates: FREE to subscribers, as space permits; maximum 15 words. A recent **COMPUTERCRAFT** mailing label must accompany ad.

(All advertisers with P.O. Box addresses must supply permanent address and telephone number. Copy is subject to publisher approval.)

Mailing Information: Copy must be received by the publisher by the 25th of the third month preceding the cover date. Send Advertising material with check or money order or credit card information (Visa or MasterCard only) with number and expiration date to: **COMPUTERCRAFT**, Classified Department, 76 N. Broadway, Hicksville, NY 11801.

VIDEO

VHS-VCR Repair Solutions Sets I, II, III, IV, V, VI. Each contains 150 symptoms and cures, updated cross reference chart, free assistance, \$11.95 each all six \$59.95. Eagle Electronics Box A, 52053 Locks Lane, Granger, IN 46530.

TV NOTCH FILTERS PHONE RECORDING EQUIPMENT, BROCHURE \$1.00. MICRO THinc. BOX 63/6025, MARGATE, FL 33063. 1-305-752-9202.

VCR Cleaning Step by Step instructions Send \$5.00. Shauri Enterprises, P.O. Box 986, Plaiston, NH 03865.

T.V. NOTCH FILTERS PHONE RECORDING EQUIPMENT, BROCHURE \$1.00. MICRO THinc. BOX 63/6025, MARGATE, FL 33063, 1-305-752-9202.

CABLE T.V. DESCRAMBLERS, Converters, Guaranteed, **LOWEST PRICES,** CNC Concepts Inc., P.O. Box 34503, Minneapolis, MN 55434, 1-800-535-1843.

ELECTRONICS

KINETIKITS from **KINETICO:** electronic kits outputting light or sound. Free catalog: **KINETICO**, P.O. Box 1634, NY, NY 10114-0508.

MINIATURE FM TRANSMITTERS! Tracking Transmitters! Voice Disguisers! Bug Detectors! Phone Devices! More! Available in kits or assembled and tested! Catalog \$2.00: **XANDI ELECTRONICS**, Box 25647, "B16", Tempe, AZ 85285-5647.

SURVEILLANCE / COUNTERSURVEILLANCE devices catalog. Cameras, bug detectors, video camera detectors, transmitters, communications, and much more. Catalog \$3.00. DSP, P.O. Box 1275-ME, Redondo Beach, CA 90278.

DAZER Personal Protection Devices! Lasers! AM/FM/Infrared Transmitters! Detectors! More! Kits/Assembled. Catalog \$2.00. **QUANTUM RESEARCH** 16645-113 Ave., Edmonton, Alberta T5M 2X2.

PRIVACY Device Detects Hardwire Taps On Modular Plug-In Telephones, (Most Common). \$69. Check, VISA, M/C, AMEX, Disc. Twilight Enterprises, 1-800-833-2681.

BUILD AND SELL electronic bug and rodent chasers. Plans: \$1.00 SASE, HUNTER, 1802 Cook, Duncan, OK 73533.

EZ LEARN DIGITAL SIGNAL PROCESSING IBMPC based TMS320 board \$199 plus utilities, software development tools -299 1409 West 14 Mile Road, Madison Heights, MI 48071.

SATELLITE TV DESCRAMBLER. Build your own. Easy instructions. parts list. Circuit board. Wiring diagram. \$9.95. **ABG ENTERPRISES:** 27081B Halifax, NS. Canada, B3H-4M8.

EPROM EMULATOR (32K) 8 bit with SIMULATOR. Simulates popular microprocessors. \$135 only. JSM Inc., 83 Seaman Road, West Orange, NJ 07052, 201-325-1892.

8031 MICROCONTROLLER SYSTEMS. Assembled and Tested systems from \$49.95. Cross-assemblers and C cross-compilers from \$50.00. Quantity discounts make our products the ideal platform for educational use and short production runs. Cottage Resources Corporation, Suite 3-672, 1405 Stevenson Drive, Springfield, IL 62703. 217-529-7679.

SAMS books and Photofacts, TV, VCR, and Computer, new and surplus, ARRL books. Aim audio and video accessories and connectors, EKI Kits, NTE replacement parts, Surplus tubes. **ATKINSON & SMITH, INC.,** 17 Lewis St., Eatontown, NJ 07724 1-800-542-2447.

PAN-COMM INT'L CATALOG. Over 350 Kits, Plans, Books about Licensed/unlicensed AM/FM broadcasting, Ham/CB/SW/DX electronics amplifiers, 1750M transmitters, Surveillance devices, Computers/Software, Science Projects, MORE. \$1.00 refundable. Box 130-ME8, Paradise, CA 95967.

SURVEILLANCE - COUNTERSURVEILLANCE. Guaranteed lowest prices! Unbelievable, Detectors, Jammers, Transmitters, Phone Security, Cameras, Personal Protection, Books, More! Huge catalog \$5.00 (Refundable) **PROTECTOR** P.O. Box 520294-B, Salt Lake City, UT 84152.

MINIATURE Electronic Surveillance Devices, Catalog \$5.00, refundable. F & P Enterprises, Box 51272, Palo Alto, CA 94303-H

BIOS Upgrades

For The IBM PC, XT, AT & 386 Or Compatible.

AMI, Phoenix & Award Latest Versions

- 1.2 & 1.44 Floppy Support
- Complete Set Up In ROM
- Supports VGA
- Novell & Netware Compatible
- User Defined, Hard Drive Support
- 101 & 102, Keyboard Support
- Complete Documentation
- 30-Day Money Back Guarantee

CALL FOR PRICE

1-800-TEL-BIOS
1-800-835-2467 Good In Both U.S. & Canada
603-432-1532 In N.H.

ADVANCED SOFTWARE

CIRCLE NO. 102 ON FREE INFORMATION CARD

AC/DC VOLTAGE AC/DC CURRENT DIODE TEST LOGIC TEST LED TEST GOOD/BAD 5 FREQ RANGES 5 CAPACITANCE RANGES LOW BATTERY Warning CONTINUITY TEST/BUZZER TRANSISTOR CHECKER 20 MHZ FREQ COUNTER	PRO 400 Stock No. 990092 \$69.95 30 DAY MONEY BACK GUARANTEE! VISA M/C	
KELVIN Electronics 7 Fairchild Ave. Plainview, NY 11803 (516) 349-7620 1(800) 645-9212 FAX (516) 349-7830		

	CABLE TV	
DESCRAMBLERS		
ALL TYPES 800-582-1114		
FREE CATALOG		
M.K. ELECTRONICS • 7958 Pines Blvd Suite 276 • Pembroke Pines, FL 33024		

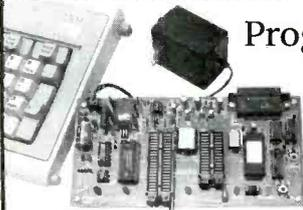
	Program
	6805 Chips
Design & Test on your PC . . . From \$349	
TECI's MCGM-1 system allows your IBM PC and Compatibles to be used as a complete development system for the Motorola 6805 family of single chip microcomputers. Many time saving features at an affordable price.	
Also available - Programmer for 68HC05, in-circuit emulators, "How-to" Primer, and many software tools to help you.	
Call Toll Free 1-800-336-8321	
TECI	
The Engineers Collaborative, Inc. Rt. #3 Box 8C Barton, VT 05822 USA TEL: (802) 525-3458 FAX: (802) 525-3451	

CIRCLE NO. 45 ON FREE INFORMATION CARD

B.S. & M.S. In Computer Science

- ALL COURSES BY CORRESPONDENCE
 - Increase your earning power
 - Join students from leading computer companies
 - Ada course available
- For free information call
1-800-767-2427

AMERICAN
INSTITUTE
COMPUTER
SCIENCES

B.S. & M.B.A. In Business Administration

▲ Chadwick University degree program can help you achieve a more successful future:

- B.S. and M.B.A. programs in Business Administration.
- ALL COURSES BY CORRESPONDENCE
- Join students from Fortune 500 companies.
- Increase your earning power.

Call for our free bulletin:
1-800-767-2423

CHADWICK
UNIVERSITY

© 1991 Chadwick University

CABLE-MATE, INC. Are You Tired of Paying Outrageous Fees?

All makes and models of cable equipment shipped within 24 hrs. Quantity discounts. For free catalog send S.A.S.E. to:

Cable-Mate, Inc., 450 Shag Bark
Algonquin, IL 60102

C.O.D. orders accepted
CALL FOR PRICES TODAY!!
800-422-0525

(708) 658-2121



*No Illinois orders



Hours—8:00 am-5:00 pm central time

Order Back Issues of ComputerCraft

REMOVE HARDWARE LOCKS

PROTECT YOUR INVESTMENT! MAINTAIN PRODUCTIVITY!

Software utility that allows for the removal of hardware locks.

Available for most major
CAD/CAM and PCB
software programs

Easy - Simple - Guaranteed

Programs start at \$99.00 U.S.

Visa and Mastercard Welcome
Call or Fax for more Information

SafeSoft Systems Inc.

202-1100 Concordia Ave.
Winnipeg, Mb. R2K 4B8
Canada

Phone (204) 669-4639
FAX (204) 668-3566

CIRCLE NO. 124 ON FREE INFORMATION CARD

MAKE \$75,000 TO \$250,000 YEARLY OR MORE FIXING IBM COLOR MONITORS, (AND MOST BRANDS). NO INVESTMENT, RECESSION PROOF. START DOING IT FROM YOUR HOME (A TELEPHONE REQUIRED) BASIC ELECTRONICS OK. INFORMATION: USA, CANADA \$2.00 CASH FOR BROCHURE, OTHER COUNTRIES \$15.00 US FUNDS. RANDALL DATA DISPLAY, BOX 2168-M, VAN NUYS, CA 91404, USA. FAX: 818-990-7803.

COMPUTERS

LOTUS 1-2-3/v3.1/3.5", Usually \$596! 66% Discount! Limited Stock! Send \$197.50, to: Network Media, P.O. Box 7849, Redlands, CA 92373.

X-10 Everything included to Send and Receive with C-64 \$69.96 Free Info Taurus Automation, 7423 Tacoma Avenue, Dept CC, Tacoma, WA 98408.

CONTROL your world with your computer! Interface your computer with robotics projects, radio control, home security and more. Unlimited potential! Complete plans, schematics, programs, only \$12.95 check/m.o. ICDS, P.O. Box 265, Plainwell, MI 49080.

ANTI-STAT neutralizes static discharges which cause malfunctions, loss of data and files, 8-02. \$9.95. PRO-Q 7369 Idamor Street, Louis, MO 63123.

LOGTROLLER, Temperature logger and controller. 8052BASIC microcontroller. Plans, \$9.00. TENSOR, Box 2543, Thunder Bay, Ontario, P7B 5G1.

BARCODES Get in on an industry that is growing by 20% each year with THE BARCODE COURSE. THE BARCODE COURSE comes complete with a detailed barcode textbook, a portable barcode reader, RS-232 interface and barcode printing software for only \$149.95. OBR Inc., RR3 BOX 47-7, Carbondale, IL 62901. 618-549-7100.

80C52-BASIC microcontroller board. BASIC interpreter, 32K RAM, 16K EPROM, EPROM programmer, RS232, expansion connector. Bare board with manual, schematics \$19.95 + \$3 P&H. 80C52-BASIC microprocessor chip \$24.95 + \$1 P&H. Assembled and tested \$119.95 + \$5 P&H. MD residents include sales tax. SASE for info. Prologic Designs, P.O. Box 19026, Baltimore, MD 21204.

ROBOT Mind Software. Turn your PC into a Robot Friend. Learns. Converses. Extrapolates. Requires PC Compatible 640K. Specify Disk. "Sleeper" "Fascinating" \$39 + \$2 S/H. ARTIFICIAL MIND MACHINES, 1105 CENTRAL AVENUE, FARIBAULT, MINN 55021.

COMPUTERS AT/XT COMPATIBLE SYSTEMS and components at discount prices. Catalog \$2.00, refunded with first order. MPS ENTERPRISES Box 1048, Lemon Grove, CA 91946.

FREE SOFTWARE 24 useful programs for IBM and compatibles including anti-virus, DOS utility, games and more. Free catalog: 200+ quality programs. \$6.00 for shipping. TDS 12 Audubon Avenue, Apt 308, Jersey City, NJ 07305.

COMMUNICATIONS

MORSE Code? No Problem. You can increase your speed, no matter how many times you've failed before. Results guaranteed when you follow the instructions. PASS Publishing's CW Mental-Block Buster program helps you explode mental blocks that hold you back. Based on 40 years of research, the CW Mental-Block Buster uses guided meditation, dynamic visualizations, and powerful affirmations to blast through mental blocks. You can do code! That means new bands, more contacts, more fun! (This is not a CW practice tape.) The CW Mental-Block Buster audio cassette and practice booklet are only \$24.95 ppd. in the US (NY residents add \$1.87 sales tax). (Quantity discounts available for classes.) PASS Publishing, P.O. Box 570, Stony Brook, NY 11780.

DISTRIBUTORS NEEDED

NEW Mini Satellite antenna. Tremendous demand. 100% profit. No Experience necessary. Serious inquiries only. (800)762-7952 Ex 774 24 Hours.

BUSINESS OPPORTUNITIES

MAKE \$\$\$ Become an American Electronics Dealer! Profit opportunities since 1965. Call Jerry Norville, 1-800-872-1373.

FOR SALE

DESCRAMBLER KITS Complete cable kit \$44.95. Complete Satellite kit \$49.95. Add \$5 shipping. Free Brochure. Summit MO, Box 489, Bronx, NY 10465.

CABLE TV EQUIPMENT

CABLE TV converters and descramblers discount center. Jerrold, Tocom, Hamlin, Scientific, Atlanta, Oak, Zenith. Order your today 800-962-6836.

FOR SALE

DESCRAMBLER KITS Complete cable kit \$44.95. Complete Satellite kit \$49.95. Add \$5 shipping. Free Brochure. Summit MO, Box 489, Bronx, NY 10465.

IDEAS WANTED

CABLE INVENTORS! Can you patent and profit from your idea? Call AMERICAN INVENTORS CORP. for free information. Serving inventors since 1975. 1-800-338-5656.

MISCELLANEOUS

AMATEUR RADIO no Morse code requirement license approved by FCC effective Feb. 14, '91. Complete details with question and answer pools, rules & regulations. Send \$15.00 for everything you need to obtain Amateur license to Dan Mobley, 1800 Williams St., Valdosta, GA 31602.

ASIAN LADIES want correspondence for friendship, marriage. SUNSHINE INTERNATIONAL-Dept. TW, Box 5500, Kailua-Kona, Hawaii 96745. (808) 325-7707.

THAILAND Women seek Marriage, Correspondence. Photographs, Brochure \$2., Escorted Tours. Club Thai, Miami, Florida 33233-0974.



123 Your Street
Your City, State 12345 555-1212

Fig. 3. This finished DTP output of a sample rough draft of this review was printed on a nine-pin dot-matrix printer.

LePrint's commands provide control over every aspect of publishing, including kerning and line spacing. The drawback is that if you don't like the way the layout looks the first time, you have to spend time switching between *LePrint* and your word processor. And although *LePrint* can be used with an XT-class computer, using Preview mode entails a rather long wait.

A case could be made that *WordPerfect 5.1* (or a word processor with similar power) is itself a fairly sophisticated desktop publishing program that will run on any kind of PC. This is true enough, but in my opinion, *LePrint* is an easier to use program and is more powerful than *WordPerfect 5.1*.

In the year 1991, it seems silly to recommend a desktop-publishing program that uses embedded codes to do the job. However, *LePrint* is actually a smart choice for people who have a laser printer connected to an 8088, 8086 or 80286 computer. The program is fairly easy to learn, and the results are surprisingly good. ■

FACT BOX

LePrint 4.0 B, \$195 Standard Package; \$495 Extended Package; \$75 per Type Package
LeBaugh Software Corp.
11145 Mockingbird Dr.
Omaha, NE 68137
402-593-0590
Requires: IBM PC, XT, AT, PS/2 or compatible computer; 384K RAM

Ratings

Documentation	Excellent
Graphics	Text based; has preview mode only
Learning Curve	Fairly easy to learn
Complexity	Has powerful features

CIRCLE NO. 141 ON FREE INFORMATION CARD

ADVERTISERS' INDEX

RS#		Page #
135	AMC Sales	85
168	Advanced Computer Prod. Cov. II	
102	Advanced Software	87
103	Altex Electronics	21
-	Amer. Inst. for Comp. Sci.	88
104	BG Micro	25
-	Brunelle Instruments	89
-	CIE	43, Cov. III
105	C&S Sales	6
-	Cable-Mate Inc.	88
106	Cable Ready Company	85
-	Communications Quarterly	55
107	Consolidated Electronics	34
92	Consumertronics	35
108	Contact East	39
109	Cook's Institute	69
149	Design Computation	67
-	Electronic Book Club	79
110	General Video Corp.	75
111	Gordon, Ken	74
-	Grantham	33
112	Interactive Image Tech.	81
113	JDR Microdevices	Cov. IV
-	KD Video	85
-	Kelvin Electronics	87
114	Komputerwerk	34
-	L.S. Elec. Systems Design	74
115	Laser Group	54
-	M.K. Electronics	87
116	Merrimak Valley	89
151	Microtech	9
117	Minotau Systems	89
-	NRI Schools	14, 17
118, 119	National Adv. Corp.	13, 67
120	Netronics	39
121	Pseudo Corporation	86
125	R4	86
123	Radio Shack	7
124	Safesoft Systems	88
-	Skyvision, Inc.	68
-	Smith Design	89
45	TECI	87
127	URDA	68
129	U.S. Cyberlabs	24
128	Unicorn Electronics	5
130, 131,	Viejo Publications	39, 54,
132		68

We'd like to see your company listed here too. Contact Eric Teitelbaum or Margaret Milanse at 516-681-2922 to work out an advertising program tailored to suit your needs.

If you really want to learn Microcontrollers...

BUILD ONE.

Try our experimenter kits based on Motorola's best 8-bit microcontroller:

68HC11

E2-KIT With 68HC811E2, 2Kbytes of internal EEPROM and 256 bytes of internal ram. \$84

F1-KIT With 68HC11F1, 32Kbytes of external 'Flash' eeprom and 8Kbytes of ram. \$109

Both kits include HC11 with 8-bit A/D, 16-bit timer, serial ports, PCB with 5 volt only RS-232, status LEDs, reset button, interrupt button, generous user-design area, IBM PC downloader software with freeware assembler and excellent Motorola HC11 documentation. No eeprom programmer is needed for these kits.

Please send check or money order (with \$3 S&H) to
Minotaur Systems
4241B Valley Rd., Drexel Hill PA 19026
(KS and PA residents please include sales tax)

CIRCLE NO. 117 ON FREE INFORMATION CARD

107 SPECTRUM PROBE™ \$249.

converts any scope into a
100MHz spectrum analyzer
60dB display dynamic range

SMITH DESIGN 30 day refund, VISA/MC
1324 Harris, Dresher, PA 19025 (215) 643-6340

TEST EQUIPMENT
Oscilloscopes • Multimeters
Function Generators • Frequency Counters
Power Supplies • Video Head Testers • Etc.
CALL OR WRITE FOR OUR FREE CATALOG
BRUNELLE INSTRUMENTS INC.
P.O. Box 1223 • Newport Vermont 05855
Tel: 1-800-567-3506 Fax: 1-819-569-1408

DOS IN ROM!

Tired of waiting for the Prompt? Speed up with an MVS ROM Drive. Boot instantly! Also used for Diskless Workstations and Embedded control. Easy to install half-size card.
64k \$95
360k \$200
1.44m \$300
PROM Programmer \$95



Merrimak Valley Systems
Box 850 Merrimack, NH
Phone: (508) 792 9507



WORLDS SMALLEST PC!
robots-alarms-datalog
3 Easy Steps:
1. Develop, debug on PC
2. Download, test in SBC
3. Burn PROM, stand alone
-LCD port -3 ser 2 par
-Keyboard In -PC bus
-Battery or 5v -BIOS option
-Real Tm Clk -LED display
Use Turbo C, BASIC, MASM



8088 SBC \$95

CIRCLE NO. 116 ON FREE INFORMATION CARD



Covert Action From the Files of a Super-Spy

Espionage has been a source of intrigue almost as long as there have been novels and movies. High technology and political unrest of modern times have lifted the spy genre to new levels of appeal. If you've ever wanted to be a super-spy but were afraid of getting shot at, Micro-Prose has a game for you. *Covert Action* is a graphic role-play game that simulates the danger and excitement of international espionage.

Game players take the role of Max (or female Maxine) Remington, a free-lance spy who takes assignments by special request from the President. Remington's true identity, background and training are a closely-guarded secret. Working independently, Remington has full access to various agency facilities and maintains a good working relationship with other nations, even Interpol. The agent is rumored to use local CIA assets as home base and for support, though no retired agency personnel will comment on the possibility.

When game players create a Remington character for the first time, they're briefed by CIA personnel and offered meager clues. Player task is to track those clues and eventually foil the 26 different masterminds of various international criminal organizations.

To achieve mission goals, Remington must use covert action, which means working beyond the law in acts of wire

tapping, breaking and entering, electronic bugging, code-breaking and physical combat. These sanctioned illegal methods are directed against enemy organizations like drug lords of the Colombian Cartel, Death Squads of South and Central America, French terrorists of Direct Action and the Iraqi Secret Police.

Clues usually lead first to relative minions of a particular crime organization. It's up to the player to be skillful enough in covert action to uncover more substantial information, eventually leading to an arrest. Key arrests, along with expert covert action, might make a trail to a criminal mastermind. Once the mastermind is arrested, his particular organization is put out of business.

Performing well at covert action is what the game is all about. Fortunately, players can practice covert skills before actually entering the espionage arena. The four practicing skills are Combat, Driving, Cryptography and Electronics. Combat skills may be needed when breaking into and entering a suspected enemy hideout. Sometimes, even the stealthiest of spies gets caught by guards. That's when gas grenades, Kevlar body armor and an Uzi Submachine Gun come in handy. Before making a break-in, whether to search for clues or plant electronic bugs, players must make sure that Remington picks the right tools for the job. The difference can be wasted time

and effort, which gives the bad guys a better chance to realize their evil plans.

Driving is another precious skill, used in car chases and when tailing a suspect. As in real life, following closely and obviously frightens the quarry, who may then lead you on a "wild goose chase." But alert driving and judicious switching between vehicles can lead a spy to a secret enemy hideout.

Cryptography is yet another skill that's important to Remington's success. Intercepted enemy communiques may reveal information unavailable elsewhere. Using the cryptography computer and a player's own wit, coded messages can be broken. This yields a decided advantage because the enemy may not be aware of the security breach.

Finally, electronics skills enable Remington to defeat alarm systems long enough to place a wiretap. Tapping the right phone at the right time can yield a wealth of information.

Perhaps the best feature of *Covert Action* is its successful integration of all its parts into a controllable and enjoyable playing experience. Therefore, all game aspects are important, from reviewing news bulletins to breaking and entering. Each player is left to his own intelligence as to how and when any piece of information should be used. Making poor decisions wastes time and can create a disad-

(Continued on page 86)



Preparing for a break-in.

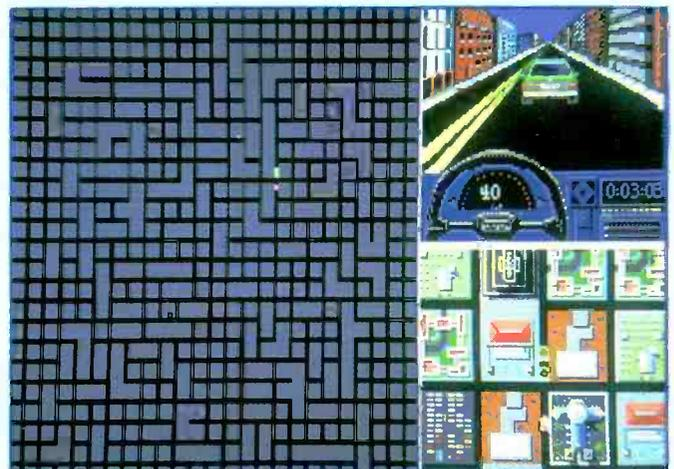

Tailing a suspect.

Learn to Use Your Computer's Full Potential.

New Career Course from CIE!

If you've been hesitating about upgrading your computer skills because you couldn't find the time or locate the right program to teach you everything you need to know to be successful in today's world of computers, you'll be happy to hear that CIE's new career course can provide you with the computer technology curriculum you seek in an independent study program you can afford to invest your time in.

CIE's COMPUTER OPERATION and PROGRAMMING course was designed and developed by CIE to provide a complete overall understanding of the unlimited potential today's computers offer, once you learn and discover their full capabilities, in today's high tech environment. CIE's new computer course quickly provides you with the electronics fundamentals essential to fully understand and master the computer's technological potentials for your personal and professional advancement. Upon mastering the fundamentals you will move into high level language programming such as BASIC and C-Language and then use that programming in order to relate the interfacing of electronic hardware circuitry to programming software. As a graduate of the Computer Operation and Programming course, you will be able to successfully understand, analyze, install, troubleshoot, program and maintain the various types of electronic equipment used in business, manufacturing, and service industries.

Since 1934, CIE has been the world leader in home study electronics by providing our 150,000-plus graduates with the curriculum and hands-on training they've needed to become successful in



today's highly competitive and computer oriented society. As a CIE student you'll receive a first rate education from a faculty and staff with only one desire. Your future success!

We encourage you to look, but you won't find a more comprehensive computer course anywhere!

And it's a course designed to fit around your lifestyle and commitments today, so you can be assured of professional successes and financial gains tomorrow.

Please, do yourself a favor and send the attached card or fill out and mail the coupon below for more information about CIE's

Computer Operation and Programming course. Do It Today!

Computer not included with course



YES! I want to get started. Send me my CIE school catalog including details about the Associate Degree program (for your convenience, CIE will have a representative contact you - there is no obligation).

Print Name _____

Address _____ Apt. _____

City _____ State _____ Zip _____

Age _____ Area Code/Phone No. _____

Check box for G.I. Bulletin on Educational Benefits Veteran Active Duty

CIE CLEVELAND INSTITUTE OF ELECTRONICS, INC.

1776 East 17th Street • Cleveland, Ohio 44114 • (216) 781-9400



*A school of thousands.
A class of one.
Since 1934.*

AO20



JDR Microdevices®

2233 Samaritan Drive, San Jose, CA 95124

Serving you since 1979

BUY WITH CONFIDENCE FROM JDR!

- 30-DAY MONEY BACK GUARANTEE
- 1 YEAR WARRANTY
- TOLL-FREE TECH SUPPORT



MOTHERBOARDS

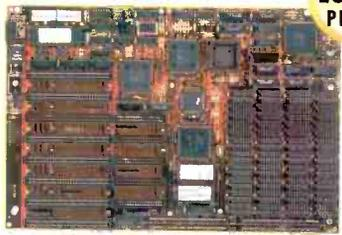

NEW LOWER PRICES

16MHz MINI 386-SX \$349⁹⁵

• NORTON SI 15.3 • LANDMARK AT SPEED 20.8

• EXPANDABLE TO 8MB ON-BOARD • AMI BIOS • CHOOSE 0 OR 1 WAIT STATE FOR USE WITH SLOWER RAM • FIVE 16-BIT AND THREE 8-BIT SLOTS • CHIPS & TECHNOLOGY "NEAT" CHIPSET • SOCKET FOR 80387-SX CO-PROCESSOR • 8.5" X 13" SIZE FITS MINI-286 & FULL-SIZE 286 CASES

MCT-386SX		\$349.95
MCT-386SX-20	20MHZ MINI 386-SX	\$399.95
MCT-M386-25	25MHZ MINI 386	\$699.00
MCT-386MBC-33	FULL-SIZE 33MHZ CACHE 386	\$949.00
MCT-386MBC-25	25MHZ VERSION	\$899.00
MCT-486MB33	33MHZ CACHE 486	\$1895.00
MCT-486MB25	25MHZ CACHE 486	\$1495.00
MCT-M286-20N	20MHZ 286 W/NEAT	\$389.95
MCT-M286-16N	16MHZ 286 W/NEAT	\$289.95
MCT-M286-16	16MHZ 286	\$199.95
MCT-M286-12	12MHZ 286	\$179.95

INTERFACE CARDS

16-BIT IDE MULTI I/O \$69⁹⁵

- 286/386/486 COMPATIBLE
- SUPPORTS 2 IDE HARD DRIVES & 2 FLOPPIES (360K, 720K, 1.2MB & 1.44MB)
- TWO SERIAL, ONE PARALLEL & ONE GAME PORT
- SUPPORTS COM1 THRU 4, LPT1, 2, & 3
- ALL FUNCTIONS CAN BE INDIVIDUALLY DISABLED

MCT-IDEIO		\$69.95
MCT-FDC-HD	1.44MB FLOPPY(2X) CARD	\$49.95
MCT-FDC-HD4	4 FLOPPY VERSION	\$59.95
MCT-HDC	HARD DISK CARD	\$79.95
MCT-RLL	RLL HARD DISK CARD	\$89.95
MCT-FAFH	16-BIT 1:1 MFM F/H CARD	\$149.95
MCT-AFH-RLL	16-BIT 1:1 RLL F/H CARD	\$199.95
MCT-ESDI	16-BIT 1:1 ESDI CARD	\$149.95
MCT-IDEFH	IDE FLOPPY/HARD CARD	\$29.95
MCT-IO	MULTI I/O CARD FOR 8088 SYSTEMS	\$59.95
MCT-AIO	286/386/486 MULTI I/O CARD	\$49.95
MCT-AEMS	16-BIT EMS CARD	\$129.95
MCT-EEMS	16-BIT EEMS CARD	\$149.95
MCT-VGA	8/16-BIT VGA CARD	\$149.95
MCT-VGA-1024	1024 X 768 VGA	\$169.95
MCT-VGA-1024+	1024 X 768/256 COLORS	\$199.95



CALL FOR OUR FREE 100 PG CATALOG!

FOR PC'S, MONITORS, DISK DRIVES, KEYBOARDS, MODEMS, LAPTOPS, CABLES, CONNECTORS, SOFTWARE, PROGRAMMING PRODUCTS, TEST EQUIPMENT, ICS & MORE!



DISPLAY CARD \$49⁹⁵ DIAGNOSES SYSTEM ERRORS

PLUG INTO SLOT, READ DISPLAY AND CHECK MANUAL FOR POWER-ON SELF-TEST CODE

- 286/386/486 COMPATIBLE
- WORKS WHEN SOFTWARE WON'T EVEN BOOT PC
- PLACE DISPLAYS ON-BOARD OR ON BACK PANEL

PCODE		\$49.95
PCODE+	WITH QA PLUS VERSION 3.12	\$69.95



UNIVERSAL PROGRAMMER/TESTER

• PROGRAMS EPROMS, EEPROMS, PALS, BI-POLAR PROMS, 8748 & 8751 SERIES, 16V8 & 20V8 GALS • TESTS TTL, CMOS, DYNAMIC & STATIC RAMS • LOAD DISK, SAVE DISK, EDIT, BLANKCHECK, PROGRAM, AUTO, READ MASTER, VERIFY & COMPARE • ACCEPTS .3" TO 6" WIDE IC'S (8-40 PINS) MOD-MUP REQUIRES HOST ADAPTOR CARD \$499.95



EPROM PROGRAMMING MODULES

• PROGRAMS 24-32 PIN EPROMS, CMOS EPROMS & EEPROMS, 16K TO 1024K • HEX TO OBJ CONVERTER

MOD-MEP		\$119.95
MOD-MEP-4	4-EPROM UNIT	\$169.95
MOD-MAC	COMMON HOST ADAPTOR CARD	\$29.95

UPRIGHT CASE

\$249⁹⁵

- FOR STANDARD, FULL SIZE AND MINI-MOTHERBOARDS
- 250 WATT POWER SUPPLY (110/220V)
- MOUNTS FOR 3 FLOPPY AND 4 HARD DRIVES
- TURBO AND RESET SWITCHES
- SPEED DISPLAY, POWER, DISK LEADS
- MOUNTING HARDWARE, FACEPLATES AND SPEAKER INCL



CASE-100		\$249.95
----------	--	----------

MORE CASES...

CASE-200	UPRIGHT HOLDS 11 DRIVES	\$499.95
CASE-120	MINI-UPRIGHT W/200 WATT PS	\$199.95
CASE-70	FULL-SIZE 286 STYLE CASE	\$89.95
CASE-50	MINI-SIZE 286 STYLE CASE	\$59.95



101-KEY \$49⁹⁵

101-KEY WITH 12 FUNCTION KEYS • 286/386/486 COMPATIBLE	
BTC-5339	\$49.95
FC-3001	101-KEY, 12 F-KEYS & CALCULATOR \$69.95
BTC-5060	84-KEY WITH 10 FUNCTION KEYS \$59.95

DYNAMIC RAM

PART #	SIZE	SPEED	PINS	PRICE
TMS4464-10	65536x4	120ns	18	3.49
41256-100	262144x1	100ns	16	1.99
41256-80	262144x1	80ns	16	2.19
414256-100	262144x4	100ns	20	6.95
414256-80	262144x4	80ns	20	7.95
1MB-100	1048576x1	100ns	18	6.95
1MB-80	1048576x1	80ns	18	7.95
1MB-60	1048576x1	60ns	18	9.95

SIMMS

PART #	SIZE	SPEED	FOR	PRICE
41256A9B-80	256K x 9	80ns	SIMM/PC	21.95
421000A9B-10	1MB x 8	100ns	SIMM/MAC	64.95
421000A9B-10	1MB x 9	100ns	SIMM/PC	64.95
421000A9B-80	1MB x 9	80ns	SIMM/PC	69.95
421000A9B-60	1MB x 9	60ns	SIMM/PC	69.95

MATH CO-PROCESSORS

MANUAL, SOFTWARE GUIDE & 5 YEAR WARRANTY

NEW LOWER PRICES

	PART #	SPEED	PRICE	PART #	SPEED	PRICE
INTEL	8087	5 MHz	89.95	80387-20	20 MHz	209.95
	8087-2	8 MHz	129.95	80387-25	25 MHz	219.95
	8087-1	10 MHz	169.95	80387-33	33 MHz	229.95
	80287-XL	12 MHz	94.95	80387-SX	16 MHz	129.95
	80387-16	16 MHz	199.95	80387-SX20	20 MHz	149.95
CYRIX	83D87-16	16 MHz	199.95	83D87-40	40 MHz	239.95
	83D87-20	20 MHz	209.95	83S87-16(SX)	16 MHz	129.95
	83D87-25	25 MHz	219.95	83S87-20(SX)	20 MHz	149.95
	83D87-33	33 MHz	229.95	83S87-25(SX)	25 MHz	159.95
IIT	2C87-8	8 MHz	79.95	2C87-12	12 MHz	99.95
	2C87-10	10 MHz	89.95	2C87-20	20 MHz	139.95

MAXIMIZE CO-PROCESSOR SPEED

OUR "2ND STAGE" ALLOWS 20MHZ CO-PROCESSORS TO RUN AT FULL SPEED IN THE SLOWEST 286 SYSTEMS

2ND-STAGE FOR 10/20 MHZ 80287'S \$49.95

OTHER VERSIONS FOR 8, 12 OR 16 MHZ 80287'S

POWER SUPPLIES

PS-135	8088 135 WATT	\$59.95
PS-150	8088 150 WATT	\$69.95
PS-200X	8088 200 WATT	\$89.95
PS-200	286/386/486 200 WATT	\$89.95
PS-250	286/386/486 250 WATT	\$129.95



1024 x 768 \$499⁹⁵ VGA PACKAGE

- 8088 & 286/386/486 COMPATIBLE CARD & 1024 X 768 INTERLACED MONITOR
- 1:1 ASPECT RATIO; 0.28 DOT PITCH
- 256 COLORS FROM 262,000
- 8/16-BIT CARD HAS 512K VIDEO RAM EXPANDABLE TO 1MB



VGA-PKG-1024+		\$499.95
VGA-PKG 640 X 480 VGA PACKAGE		\$399.95

MORE MONITORS...

NEG-MULTI-3D	14" MULTISYNCH MONITOR	\$649.00
VGA-MONITOR	VGA MONITOR	\$379.95
MONO-VGA	PAPERWHITE VGA MONITOR	\$139.95

2400 BAUD MODEM \$79⁹⁵

• 2400/1200/300 BPS INTERNAL DATA MODEM • FULL HAYES AT COMPATIBILITY • INCLUDES PROCOMM SOFTWARE

MCT-24I		\$79.95
MCT-FAXM	AS ABOVE W/4800 BPS FAX SEND	\$89.95
PC6M7296	INTEL 9600 BPS EXTERNAL	\$549.00
PCCB6201	INTEL SATISFACTION FAX/MODEM	\$449.95
VIVA-24MNP	2400 BPS EXT MODEM W/MNP	\$149.95

BREADBOARD ON-A-CARD

• INCLUDES ADDRESS DECODING LOGIC, DATA BUFFERING, 2 LSI CIRCUITS FOR PROGRAMMABLE DIGITAL I/O & COUNTER/TIMING FUNCTIONS • ACCEPTS UP TO 24 14-PIN IC'S • ACCEPTS 9, 15, 25, OR 37-PIN D-SUBS

PDS-601	8-BIT CARD	\$79.95
PDS-611	16-BIT CARD WITH I/O DECODE	\$89.95

PROTOTYPE CARDS

JDR'S CARDS INCLUDE FR-4 EPOXY LAMINATE WITH GOLD-PLATED EDGE CARD FINGERS & SILK-SCREENED LEGENDS

JDR-PR2	8-BIT WITH I/O DECODE LAYOUT	\$89.95
JDR-PR10	16-BIT WITH I/O DECODE LAYOUT	\$79.95

3-BUTTON MOUSE \$14⁹⁵

- SELECTABLE ACCURACY 290-1450 DPI
- SWITCH SELECTABLE MICROSOFT OR MOUSE SYSTEMS COMPATIBILITY MODE
- OPTO-MECHANICAL DESIGN
- WINDOWS 3.0 COMPATIBLE

JDR-MOUSE-3 \$14.95

HARD DRIVES

45MB \$219

5-1/4"	ST-251-1	42.8 MB	MFM	28MS	\$249
3-1/2"	ST-157A	44.7 MB	IDE	28MS	\$219
5-1/4"	ST-277-1	65.5 MB	RLL	28MS	\$289
3-1/2"	ST-1102A	89.1 MB	IDE	19MS	\$399
3-1/2"	ST-1144A	131 MB	IDE	19MS	\$499
3-1/2"	ST-1201A	177 MB	IDE	15MS	\$749
5-1/4"	ST-2283A	338 MB	IDE	16MS	\$1295
5-1/4"	1654	161 MB	ESDI	16MS	\$899
5-1/4"	1664	345 MB	ESDI	14MS	\$1449
5-1/4" FH	1568	676 MB	ESDI	16MS	\$2195

FLOPPY DRIVES

FDD-1.44X	1.44MB 3.5" FLOPPY - BLACK	\$79.95
FDD-1.44A	1.44MB 3.5" FLOPPY - BEIGE	\$79.95
FD-55GFV	5.25" TEAC DOUBLE-SIDED HD 1.2MB	\$99.95
FDD-1.2	5.25" DOUBLE-SIDED HD 1.2MB	\$89.95
FD-55B	5.25" TEAC DOUBLE-SIDED DD 360K	\$89.95
FDD-360	5.25" DOUBLE-SIDED DD 360K	\$69.95



SALES 800-538-5000

Customer Service 800-538-5001 Local/Int'l 408-559-1200
 Technical Support 800-538-5002 Fax 408-559-0250

TERMS: For shipping & handling include \$5.00 for ground and \$7.50 for air. Orders over 1 lb. and foreign orders may require additional shipping charges—contact our Sales Dept. for the amount. CA residents must include applicable sales tax. Prices subject to change without notice. We are not responsible for typographical errors. We reserve the right to limit quantities and to substitute manufacturer. All merchandise subject to prior sales. A full copy of our terms is available upon request. Items pictured may only be representative. JDR, the JDR logo, JDR Microdevices, and the MCT logo are registered trademarks of JDR MICRODEVICES, INC. Modular Circuit Technology, are trademarks of JDR MICRODEVICES, INC. Copyright 1991 JDR MICRODEVICES.

KEY CODE 1803

CIRCLE NO. 113 ON FREE INFORMATION CARD