

# Proceedings



of the

# I · R · E

## A JOURNAL of the Theory, Practice, and Applications of Electronics and Electrical Communication

- Radio Communication • Sound Broadcasting • Television • Marine and Aerial Guidance •
- Tubes • Radio-Frequency Measurements • Engineering Education • Electron Optics •
- Sound and Picture Electrical Recording and Reproduction •
- Power and Manufacturing Applications of Radio-and-Electronic Technique •
- Industrial Electronic Control and Processes • Medical Electrical Research and Applications •

### I.R.E. BUILDING FUND CAMPAIGN

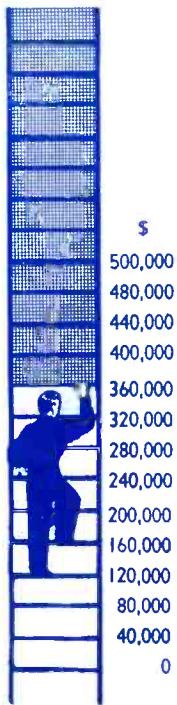

HELP HIM  
CLIMB

## MAY, 1945

VOLUME 33 NUMBER 5

Engineer in Modern World

Engineer in Scheme of Things

Navy Electronics Program

Mould and Humidity

Compensated-Loop Direction Finder

Tuned-Circuit F-M Distortion

Standard-Frequency Broadcast Service

# The Institute of Radio Engineers

Available through Leading Radio Equipment Distributors!



# AMPEREX

## WATER AND AIR COOLED TRANSMITTING AND RECTIFYING TUBES

The more popular AMPEREX tubes are available through leading radio equipment distributors. Thus, engineers may now obtain many of our standard tube types with minimum delay. The AMPEREX line, especially for industrial and electro-medical applications, is probably the most com-

plete in the industry. AMPEREX engineers pioneered in the design and development of these types, and our name stamped on a "bottle" designates longer life with corresponding economy. If we can be of service to you, on present or peacetime assignments, we will be very glad to oblige.

**AMPEREX**

*... the high  
performance  
tube*



## AMPEREX ELECTRONIC CORPORATION

79 WASHINGTON ST., BROOKLYN 1, N. Y. . . . Export Div.: 13 E. 40th St., N. Y. 16, N. Y., Cables: "ARLAB"

WASTEPAPER IS A CRITICAL WAR REQUIREMENT... SAVE EVERY SCRAP

BOARD OF DIRECTORS

1945

William L. Everitt  
President

Hendrik J. van der Bijl  
Vice-President

Raymond A. Heising  
Treasurer

Haraden Pratt  
Secretary

Alfred N. Goldsmith  
Editor

Lynde P. Wheeler  
Senior Past President

Hubert M. Turner  
Junior Past President

1943-1945

Wilmer L. Barrow

F. B. Llewellyn

Harold A. Wheeler  
1944-1946

Raymond F. Guy

Lawrence C. F. Horle

William C. White

1945-1947

Stuart L. Bailey

Keith Henney

Benjamin E. Shackelford

1945

E. Finley Carter

Lewis M. Clement

Ralph A. Hackbusch

Donald B. Sinclair

William O. Swinyard

Harold R. Zeamans  
General Counsel

BOARD OF EDITORS

Alfred N. Goldsmith  
Editor

Ralph R. Batcher

Robert S. Burnap

Philip S. Carter

Lewis M. Clement

William G. Dow

Elmer W. Engstrom

William L. Everitt

William G. H. Finch

George W. Gilman

Peter C. Goldmark

Frederick W. Grover

Lewis B. Headrick

C. M. Jansky, Jr.

Hugh S. Knowles

John D. Kraus

Donald G. Little

Frederick B. Llewellyn

Samuel S. Mackeown

Edward L. Nelson

Harry F. Olson

Harold O. Peterson

Greenleaf W. Pickard

Ralph A. Powers

Haraden Pratt

Conan A. Priest

Herbert J. Reich

Peter C. Sandretto

Vernon W. Sherman

Lynne C. Smeby

E. C. Wente

Harold A. Wheeler

William C. White

Laurens E. Whittemore

Gerald W. Willard

William Wilson

Charles J. Young

Vladimir K. Zworykin

# Proceedings of the I.R.E

Published Monthly by

The Institute of Radio Engineers, Inc.

VOLUME 33

May, 1945

NUMBER 5

Section Meetings.....	Next Page
The Engineer Goes to War and Prepares for Peace... Paul W. Kesten	281
Stuart L. Bailey—Board of Directors, 1945.....	282
The Engineer's Place in the Modern World..... Ivan S. Coggeshall	283
The Engineer and His Future..... C. A. Powel	284
The Engineer's Place in the Scheme of Things.....	
Round Table Discussion by R. H. Herrick, J. E. Hobson, J. E. Brown, and A. B. Bronwell.....	286
Correction: Birth Date of Browder J. Thompson.....	290
The Navy Electronics Program and Some of Its Past, Present, and Future Problems..... J. B. Dow	291
Mould and Humidity in Radio and Signals Equipment..... C. P. Healy and J. C. Niven	300
The Compensated-Loop Direction Finder..... Frederick Emmons Terman and Joseph M. Pettit	307
A Theoretical and Experimental Investigation of Tuned-Circuit Distortion in Frequency-Modulation Systems... David Lawrence Jaffe	318
Standard-Frequency Broadcast Service of National Bureau of Standards.....	334
Institute News and Radio Notes.....	335
Board of Directors.....	335
Executive Committee.....	335
Browder J. Thompson Memorial.....	336
Timely Inventive Problems.....	338
Membership Transfers.....	339
Increase in Rebates to Sections.....	339
Transcription of Frequency-Modulation Discussion.....	
I.R.E. Winter Technical Meeting.....	339
Building-Fund Program.....	340
Constitutional Amendments.....	342
Correspondence:	
"Equivalent-Plate-Circuit Theorem"..... Harry Stockman	344
"A Stabilized Frequency-Modulation System"..... A. St. C. G. Grant and D. L. Jaffe	344
I.R.E. People.....	345
Wartime Radio Progress.....	348
Books:	
"An Introduction to Electronics," by Ralph G. Hudson..... Keith Henney	349
"Electrical Drafting," by D. Walter Van Gieson..... B. E. Shackelford	349
Contributors.....	349
Section Meetings.....	36A
Membership.....	38A
Positions Open.....	50A

Helen M. Stote, Associate Editor • William C. Copp, Advertising Manager

Responsibility for the contents of papers published in the PROCEEDINGS rests upon the authors. Statements made in papers are not binding on the Institute or its members.



Entered as second-class matter October 26, 1927, at the post office at Menasha, Wisconsin, under the Act of February 28, 1925, embodied in Paragraph 4, Section 538 of the Postal Laws and Regulations. Publication office, 430 Ahnapp Street, Menasha, Wisconsin. Executive, editorial, and advertising offices, 330 West 42nd Street, New York 18, N. Y. Price, \$1.00 a copy. Subscriptions: United States and Canada, \$10.00 a year; foreign countries, \$11.00 a year. Changes of address (with advance notice of fifteen days) and communications regarding subscriptions and payments should be mailed to the Secretary of the Institute, at 330 West 42nd Street, New York 18, N. Y. All rights of republication, including translation into foreign languages, are reserved by the Institute. Abstracts of papers, with mention of their source, may be printed. Requests for republication privileges should be addressed to The Institute of Radio Engineers.

Copyright, 1945, by The Institute of Radio Engineers, Inc.

PAPERS COMMITTEE

Frederick B. Llewellyn  
Chairman

Herman A. Affel  
Wilmer L. Barrow  
Howard A. Chinn  
James K. Clapp  
Ivan S. Coggeshall  
Edward J. Content  
Clifford W. Corbett  
Murray G. Crosby

Frederick W. Cunningham

Robert B. Dome  
Enoch B. Ferrell  
Donald G. Fink  
Howard S. Frazier  
Robert L. Freeman  
Stanford Goldman  
Frederick W. Grover  
O. B. Hanson

Thomas J. Henry  
Edward W. Herold  
John V. L. Hogan  
Frederick V. Hunt  
Harley Iams  
Loren F. Jones  
John G. Kreer, Jr.  
Emil Labin

Frederick R. Lack  
Hugo C. Leuteritz  
Charles V. Litton  
Knox McIlwain  
Harry R. Mimno  
Ilia E. Mourontseff  
G. G. Muller

Albert F. Murray  
Dwight O. North  
Allen F. Pomeroy  
Jack R. Poppele  
Simon Ramo  
Francis X. Rettenmeyer

Sergei A. Schelkunoff  
Donald B. Sinclair  
Dayton Ulrey  
A. P. Upton  
Karl S. Van Dyke  
E. K. Van Tassel  
John R. Whinnery  
Irving Wolf  
J. Warren Wright  
Harold R. Zeamans

PAPERS  
PROCUREMENT  
COMMITTEE

Dorman D. Israel  
General Chairman  
Edward T. Dickey  
Vice General Chairman

GROUP CHAIRMEN

Arthur B. Bronwell  
Nelson P. Case  
Madison Cawein  
Ivan S. Coggeshall  
Murray G. Crosby  
Alfred Crossley  
Harry Diamond  
Arthur E. Harrison  
Theodore A. Hunter

James R. Nelson  
Harry F. Olson  
Donald B. Sinclair  
Howard J. Tyzzer  
Wilbur L. Webb  
William C. White  
Karl S. Van Dyke

George W. Bailey  
Executive Secretary

William B. Cowilich  
Assistant Secretary



# THE INSTITUTE OF RADIO ENGINEERS

INCORPORATED



## SECTIONS MEETINGS

<b>ATLANTA</b> May 18	<b>CHICAGO</b> May 18	<b>CLEVELAND</b> May 24	<b>DETROIT</b> May 18	<b>LOS ANGELES</b> May 15
<b>NEW YORK</b> June 6	<b>PHILADELPHIA</b> June 7	<b>PITTSBURGH</b> June 11	<b>PORTLAND</b> June 11	<b>WASHINGTON</b> June 11

## SECTIONS

- |   |   |
|---|---|
| <p><b>ATLANTA</b>—Chairman, R. A. Holbrook; Secretary, J. P. Lenkerd, 1154 Hancock Dr., N.E., Atlanta, Ga.</p> <p><b>BALTIMORE</b>—Chairman, W. L. Webb; Secretary, H. L. Spencer, Box 6760, Towson 4, Md.</p> <p><b>BOSTON</b>—Chairman, C. C. Harris; Secretary, Corwin Crosby, 16 Chauncy St., Cambridge, Mass.</p> <p><b>BUENOS AIRES</b>—Chairman, A. DiMarco; Secretary, H. Krahenbuhl, Trans-radio Internacional, San Martin 379, Buenos Aires, Argentina</p> <p><b>BUFFALO-NIAGARA</b>—Chairman, A. J. Dybowski; Secretary, H. G. Korts, 51 Kinsey Ave., Kenmore, N. Y.</p> <p><b>CEDAR RAPIDS</b>—Chairman, F. M. Davis; Secretary, J. A. Green, Collins Radio Co., 855-35th St., N.E., Cedar Rapids, Iowa</p> <p><b>CHICAGO</b>—Chairman, W. O. Swinyard; Secretary, A. W. Graf, 135 S. LaSalle St., Chicago 3, Ill.</p> <p><b>CINCINNATI</b>—Chairman, L. M. Clement; Secretary, J. F. Jordan, The Baldwin Co., 1801 Gilbert Ave., Cincinnati 2, Ohio</p> <p><b>CLEVELAND</b>—Chairman, H. B. Okeson; Secretary, A. J. Kres, 16911 Valleyview Ave., Cleveland 11, Ohio</p> <p><b>CONNECTICUT VALLEY</b>—Chairman, R. E. Shea; Secretary, L. A. Reilly, 989 Roosevelt Ave., Springfield, Mass.</p> <p><b>DALLAS-FORT WORTH</b>—Chairman, J. D. Mathis; Secretary, B. B. Honeycutt, 9025 Roanoak, Dallas 18, Texas</p> <p><b>DAYTON</b>—Chairman, G. L. Hallman; Secretary, Joseph General, 411 E. Bruce Ave., Dayton 5, Ohio</p> <p><b>DETROIT</b>—Chairman, R. A. Powers; Secretary, R. R. Barnes, 1411 Harvard Ave., Berkley, Mich.</p> <p><b>EMPORIUM</b>—Chairman, W. A. Dickinson; Secretary, H. E. Ackman, West Creek, R. D. 2, Emporium, Pa.</p> <p><b>INDIANAPOLIS</b>—Chairman, H. I. Metz; Secretary, J. D. Colvin, 328 E. 47 St., Indianapolis 5, Ind.</p> <p><b>KANSAS CITY</b>—Chairman, A. P. Stuhrman; Secretary, R. N. White, 4800 Jefferson St., Kansas City, Mo.</p> <p><b>LONDON</b>—Chairman, G. A. Wootton; Secretary, Robert Wilton, No. 5-Radio School-Royal Canadian Air Force, Clinton, Ont., Canada</p> | <p><b>LOS ANGELES</b>—Chairman, R. C. Moody; Secretary, R. G. Denechaud, Blue Network Co., 6285 Sunset Blvd., Hollywood 28, Calif.</p> <p><b>MONTREAL</b>—Chairman, F. S. Howes; Secretary, J. A. Campbell, Northern Electric Co., Ltd., 1261 Shearer St., Montreal, Que., Canada</p> <p><b>NEW YORK</b>—Chairman, G. B. Hoadley; Secretary, J. T. Cimorelli, RCA Manufacturing Co., 415 S. Fifth St., Harrison, N. J.</p> <p><b>OTTAWA</b>—Acting Chairman, F. R. Parks; Acting Secretary, L. F. Millett, 33 Regent St., Ottawa, Ont., Canada</p> <p><b>PHILADELPHIA</b>—Chairman, T. A. Smith; Secretary, P. M. Craig, Philco Corp., Philadelphia 34, Pa.</p> <p><b>PITTSBURGH</b>—Chairman, T. C. Kenny; Secretary, R. K. Crooks, Box 2038, Pittsburgh 30, Pa.</p> <p><b>PORTLAND</b>—Chairman, Kenneth Johnson; Secretary, C. W. Lund, Route 4, Box 858, Portland, Ore.</p> <p><b>ROCHESTER</b>—Chairman, G. R. Town; Secretary, A. E. Newlon, Research Dept., Stromberg-Carlson Co., Rochester 3, N. Y.</p> <p><b>ST. LOUIS</b>—Chairman, B. B. Miller; Secretary, C. H. Meyer, KFUV, 801 DeMun Ave., St. Louis, Mo.</p> <p><b>SAN DIEGO</b>—Chairman, F. A. Everest; Secretary, Clyde Tirrell, United States Navy Radio and Sound Laboratory, San Diego 52, Calif.</p> <p><b>SAN FRANCISCO</b>—Chairman, David Packard; Secretary, William Barclay, Stanford University, Palo Alto, Calif.</p> <p><b>SEATTLE</b>—Chairman, G. L. Hoard; Secretary, K. A. Moore, 5102 Findlay St., Seattle 8, Wash.</p> <p><b>TORONTO</b>—Chairman, E. O. Swan; Secretary, Alexander Bow, Copper Wire Products, Ltd., 137 Roncesvalles Ave., Toronto, Ont., Canada</p> <p><b>TWIN CITIES</b>—Chairman, H. S. McCartney; Secretary, C. W. Engelman, 4648 Chowen Ave. S., Minneapolis 10, Minn.</p> <p><b>WASHINGTON</b>—Chairman, H. A. Burroughs; Secretary, L. C. Smeby, 4801 Connecticut Ave., N.W., Washington, D. C.</p> <p><b>WILLIAMSPORT</b>—Chairman, L. E. West; Secretary, Frank Burroughs, 2030 Reed St., Williamsport, Pa.</p> |
|---|---|

Presenting

# A NEW 75 MEGACYCLE MARKER RECEIVER

Improved Indication at Low Battery Voltage—A new minimum in unwanted lamp operation— $\frac{1}{2}$  A.T.R. Size Case—Reduced Weight

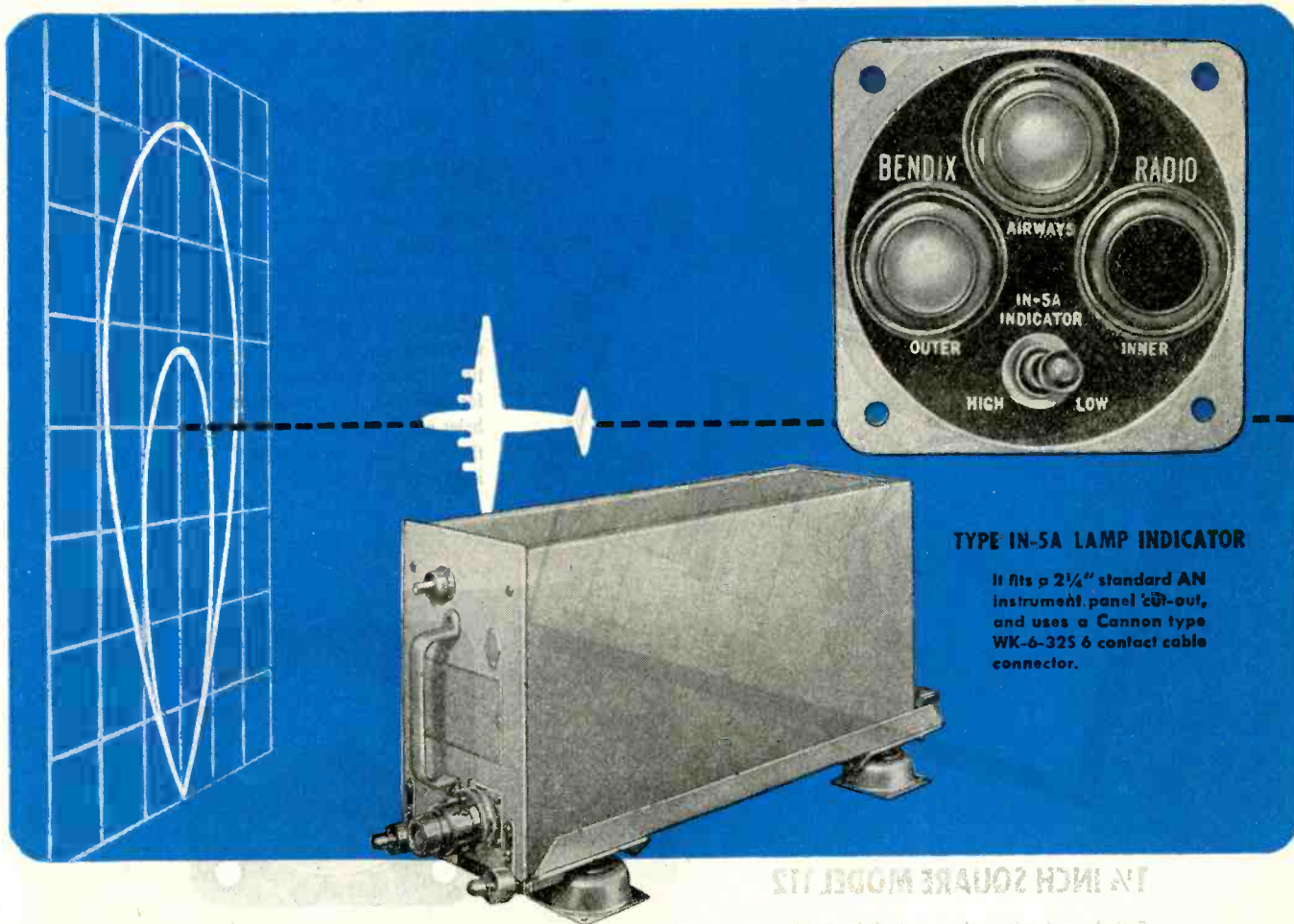

TYPE IN-5A LAMP INDICATOR

It fits a 2 1/4" standard AN instrument panel cut-out, and uses a Cannon type WK-6-325 6 contact cable connector.

Does your marker receiver give good indications when battery voltage drops to eleven (or twenty-two) volts? Does unwanted lamp operation confuse the pilot during instrument approaches? These difficulties have been eliminated in the design of the new Bendix Radio MN-53 marker receiver; and, in addition, valuable weight and mounting space have been saved.

This receiver is available in a number of different types. This same unit may be used with either twelve or twenty-four volt systems. A centralized radio power supply may be used, or an individual dynamotor may

be plugged right into the unit. In addition there is a model that is both mechanically and electrically interchangeable with existing airline marker equipment.

Another feature of this new marker receiver is variable coupling of the intermediate frequency transformers. IF adjustment is thus greatly simplified and the desired band pass characteristic can be easily obtained.

For further information on this latest product of Creative Engineering, write direct to the Sales Department, Bendix Radio.

BENDIX IS A TRADE-MARK OF BENDIX AVIATION CORPORATION

# Bendix

**RADIO DIVISION**

BENDIX AVIATION CORPORATION, BALTIMORE 4, MARYLAND

STANDARD FOR THE AVIATION INDUSTRY

# DeJUR HERMETICALLY SEALED MINIATURE 1 1/2" METERS

**Designed to aid in the development of small equipment for present or postwar applications**

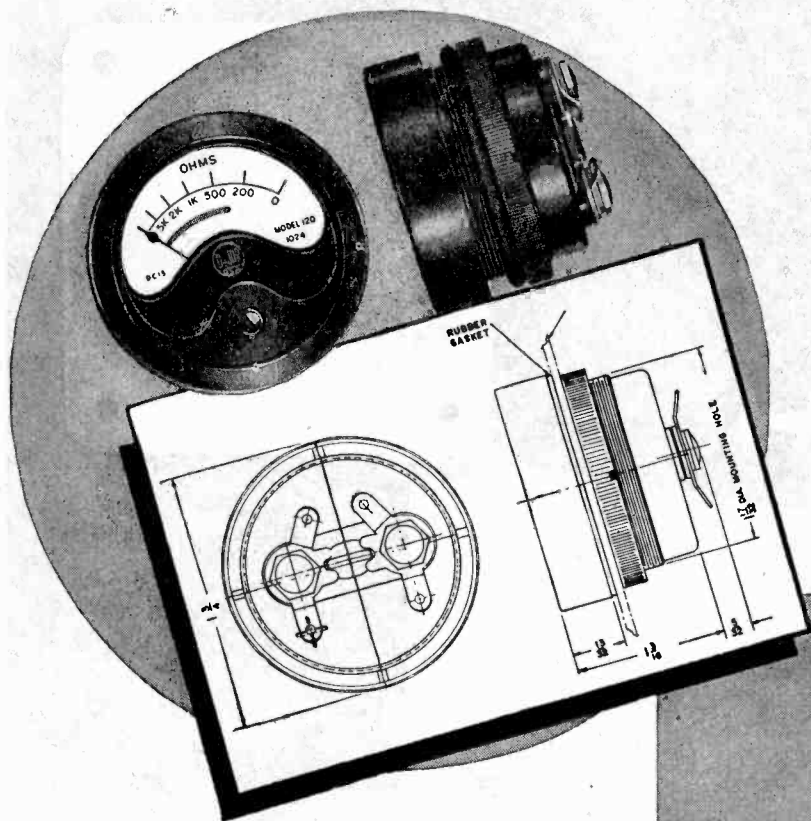

## 1 1/2 INCH ROUND MODEL 120

The smallest meter of its kind, built with the care and precision of all DeJur larger instruments. Sealed to sustain immersion in 30 feet of water for as many as 7 days without harm to the mechanism. If the glass breaks, the meter case is designed to seal the equipment against water seepage. Terminal studs are also waterproof sealed. Another advanced construction feature is the ring mounting which makes for quick and easy installation—no mounting holes or screws necessary, just tighten on with the ring. A.S.A. type movement. Built to exacting specifications.

## 1 1/2 INCH SQUARE MODEL 112

Entirely self-contained with built-in resistors and shunts. Available in wide variety of ranges. This model, too, may be immersed in 30 feet of water for 7 days without harm to the movement. In addition, it incorporates all other waterproof features of the Model 120. Though compact in size, no sacrifice has been made in quality of materials or construction details. It performs with high efficiency in a variety of applications. A.S.A. type movement. Built to exacting specifications.

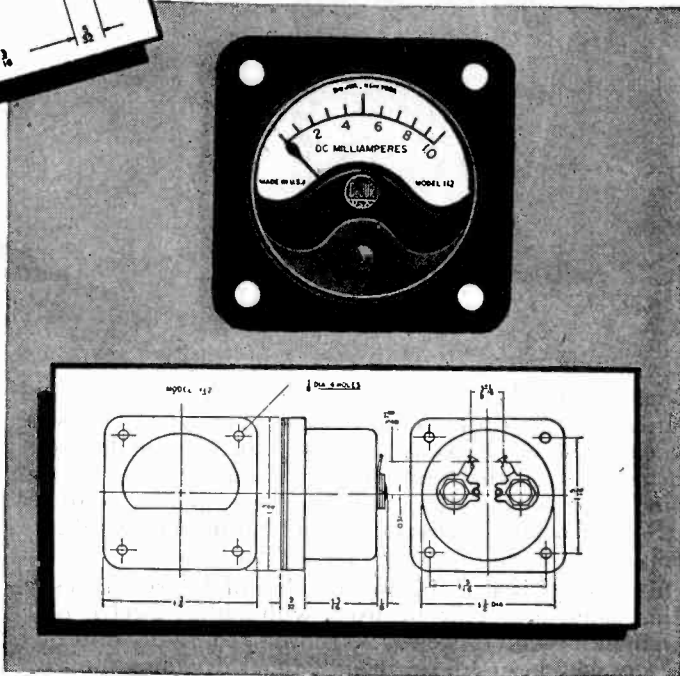

Additional information supplied upon request... Write for the new DeJUR catalog

GIVE FULL SUPPORT  
TO THE SEVENTH  
WAR LOAN DRIVE

**DeJUR** AMSCO CORPORATION

GENERAL OFFICE: NORTHERN BLVD. AT 45th STREET, LONG ISLAND CITY 1, N. Y.  
IN CANADA: - ATLAS RADIO CORP. LTD., 560 KING ST. WEST - TORONTO, CANADA



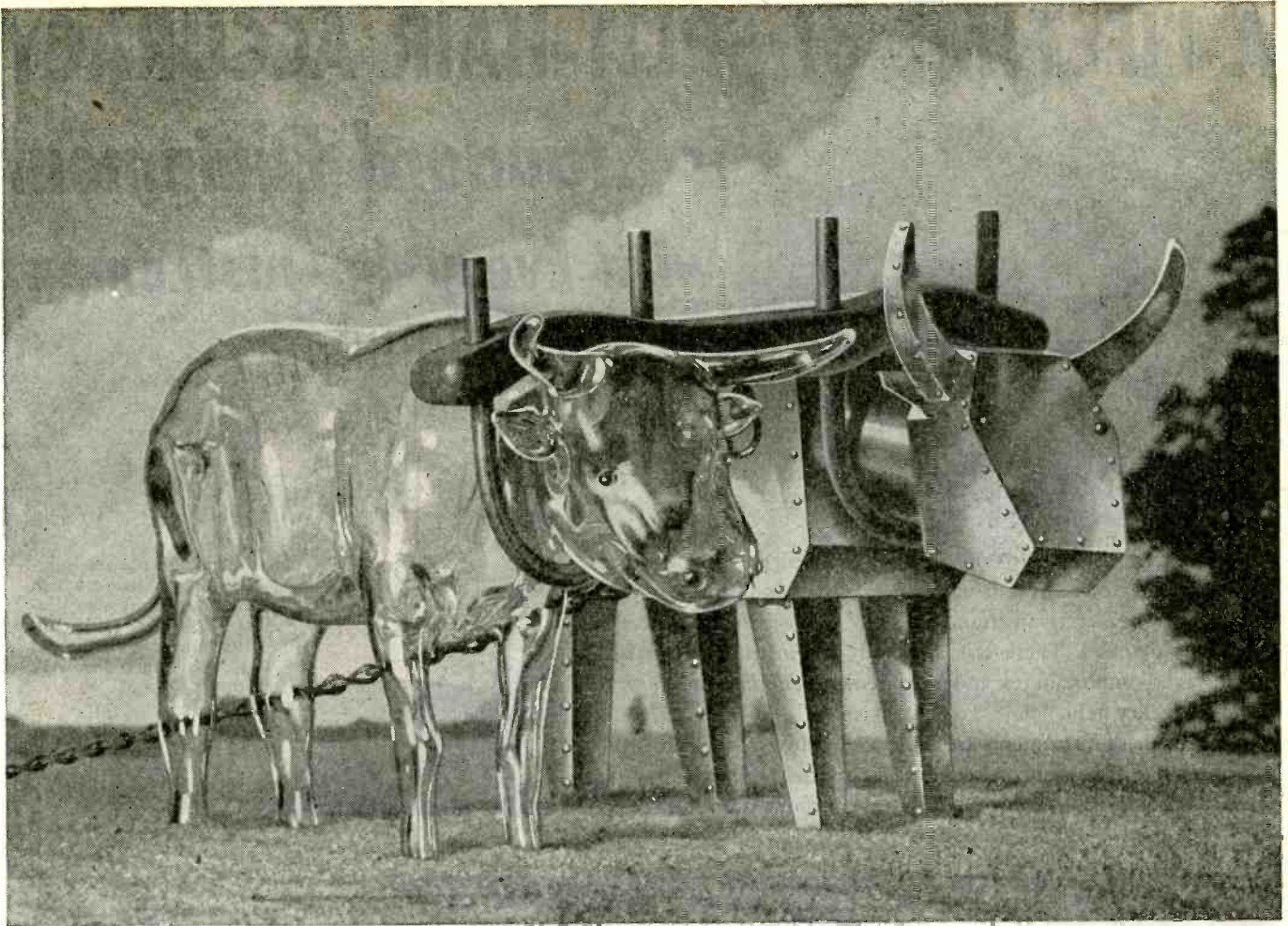

## TOGETHER THEY FORM A GREAT TEAM...

*thanks to Corning Metalizing!*

**G**LASS and metal work together for the electronics industry under a yoke fashioned by Corning Research in Glass.

Metalized glass has been used for many years, mainly for decorative purposes. But Corning Research developed a metalizing process which can be accurately controlled and which is permanent under severe industrial service conditions.

The superior electrical properties of glass are well known in the electronics field. Low power factor, high dielectric strength, extremely high resistance, wide range of dielectric constants —

coupled with fine mechanical properties — make glass invaluable in electronic applications. The addition of metalized areas permits hermetic seals between glass and metal by ordinary soldering methods. Corning's metalizing process, particularly when applied to low expansion glasses, also produces accurate and fixed inductances, capacitances or shielding.

Perhaps our team of glass and metal can help you. Write us about your problem. Address Electronic Sales Department P-5, Bulb and Tubing Division, Corning Glass Works, Corning, N. Y.

**CORNING**  
— means —  
Research in Glass

*Electronic Glassware*



"PYREX", "VYCOR" and "CORNING" are registered trade-marks and indicate manufacture by Corning Glass Works, Corning, N. Y.

# A LIFETIME of SPLIT-HAIR ACCURACY is Standard Equipment with Every-hp-Instrument

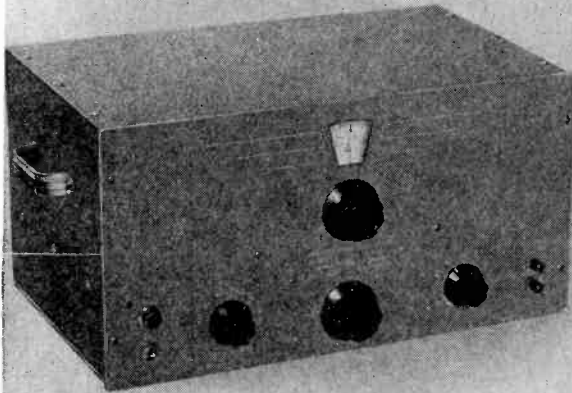

MODEL  
200-I

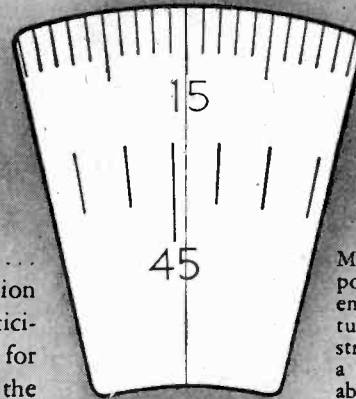

Model 200-I is a new interpolation oscillator which embodies many new features. New, rugged construction, new circuit and a new accurate dial. Ask about it.

"Guess-testing" belongs to the era of crystal sets and silent pictures... Radio and electronics of today *and tomorrow* demand the use of precision testing and measuring instruments. Hewlett-Packard engineers anticipated this demand. There is a standard *-hp-* instrument available for making every important test and measurement *with insured accuracy* in the audio frequency field.

A few of these instruments are illustrated below... complete technical information will be sent on request. For special applications, a note or sketch outlining your problem will receive prompt attention.

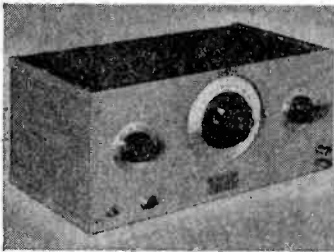

#### RESISTANCE-TUNED AUDIO OSCILLATORS

Require no zero setting...several models available to cover frequency ranges from 2 cps to 200 kc.

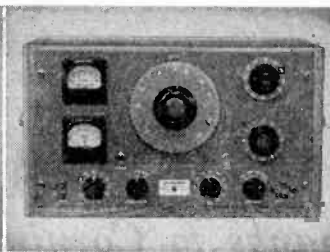

#### AUDIO SIGNAL GENERATORS

Three models—205-A, 205-AG, 205-AH—provide frequency ranges from 20 cps to 100 kc.

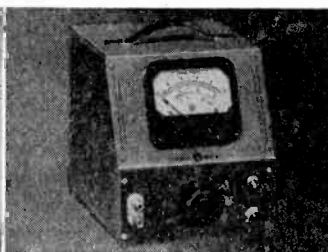

#### VACUUM TUBE VOLTMETERS

Make accurate voltage measurements from 1 cycle to 1 megacycle, cover nine ranges, (.03 volts to 300 volts) with full scale sensitivity.

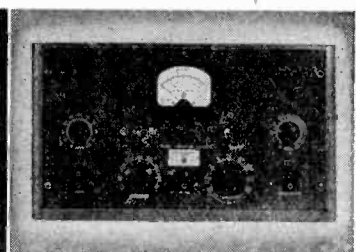

#### DISTORTION ANALYZERS

Three models available—320-A, 320-B and 325-B—to provide frequency coverage from 30 cps to 15 kc. Model 325-B incorporates a vacuum tube voltmeter.

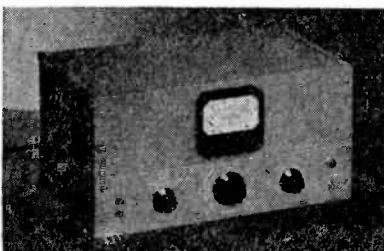

#### ELECTRONIC FREQUENCY METER

The Model 500-A is designed to measure the frequency of an alternating voltage from 10 cps to 50 kc. Overall accuracy is  $\pm 2\%$  of full scale value.

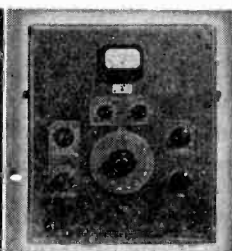

#### HARMONIC WAVE ANALYZER

Measures individual components of a complex wave over a frequency range of 30 to 16,000 cps. The selectivity can be varied continuously, making the analyzer adaptable to a wide variety of measurements.

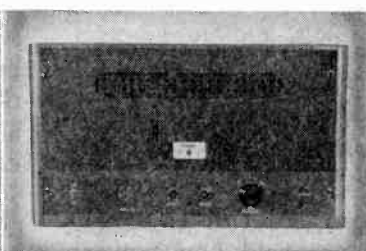

#### FREQUENCY STANDARDS

The Model 100-B supplies standard frequencies of 100, 1,000, 10,000 and 100,000 cps, all of which are available simultaneously.



#### ATTENUATOR AND VOLTAGE DIVIDERS

The Model 350-A consists of a 10 db and a 100 db bridged-T attenuator, providing a total of 110 db attenuation, variable in 1 db steps. Other attenuators and voltage dividers can be quickly supplied.

## HEWLETT-PACKARD COMPANY

BOX 990 D, STATION A

PALO ALTO, CALIFORNIA

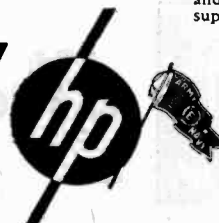

CANADIAN OFFICE:  
560 KING STREET WEST  
TORONTO 2, CANADA



# Another FIRST for Federal Selenium Rectifiers



## FEDERAL'S INVERTER FAILURE RELAY

In a B-29 high over Tokyo . . . or a Clipper winging across the Atlantic—an instrument panel lamp flashes timely warning of a-c power failure.

This is the job done by Federal's Inverter Failure Relay . . . always on the alert, providing a constant check on inverter operation. Highly sensitive, this compact unit responds to line variations as low as *one volt*.

Here the specific need was for an accurate relay to operate on an a-c line. Federal engineers supplied the answer with a Federal Selenium Rectifier and a sensitive d-c relay.

This is another example of Federal engineering ingenuity, the kind of ingenuity you need to solve your rectification problems—particularly in the new higher frequency aircraft a-c power systems.

Look to Federal for the best in Selenium Rectifier equipment, *first in the field and standard for industry.*

Federal's Inverter Failure Relay, shown actual size, operates on 115-volts, 400 cycles a-c, the relay contacts carrying approximately one ampere at 28 volts.

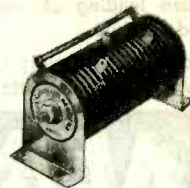
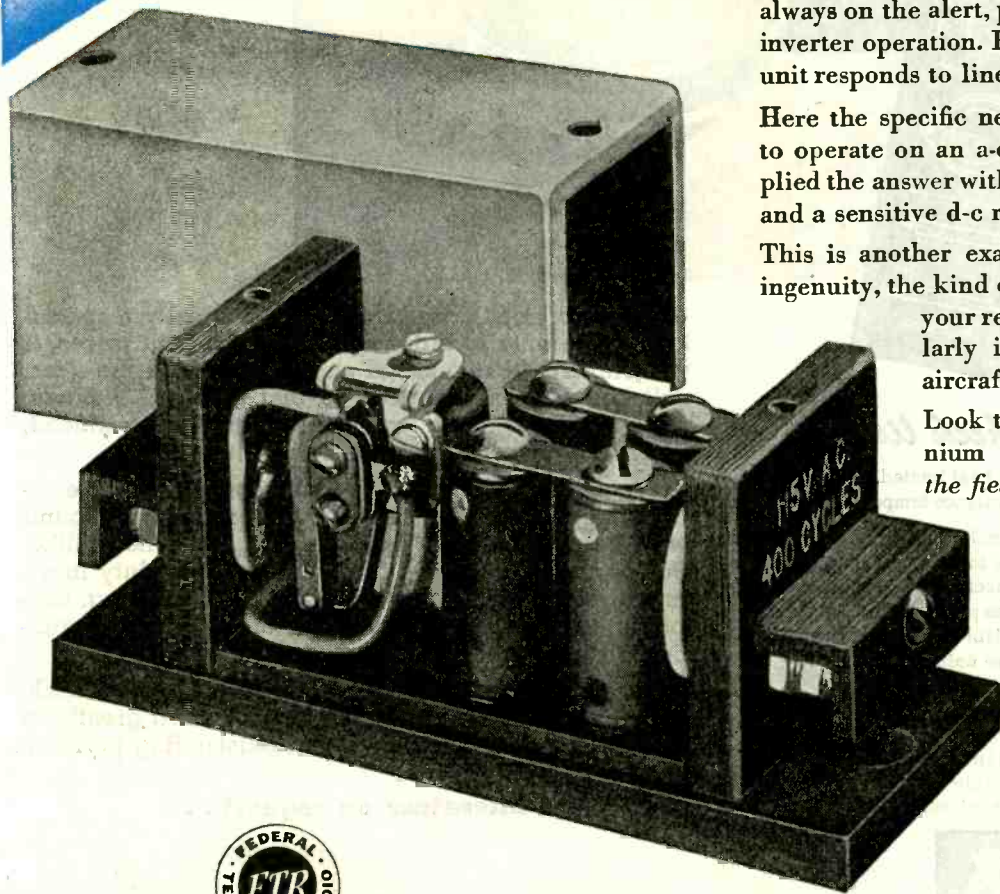

## Federal Telephone and Radio Corporation



Newark 1,  
New Jersey

# STACK MOUNTING CAPACITORS

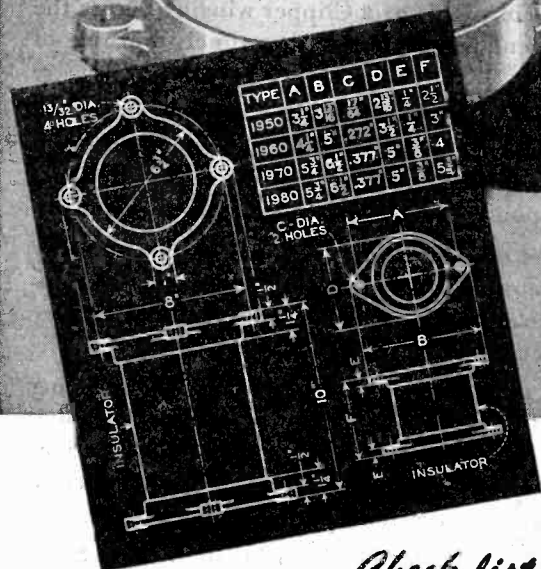

## Check list...

- ✓ Low-loss glazed ceramic case for long creepage path between terminals.
- ✓ Corona losses eliminated on inside and outside alike.
- ✓ Cast-aluminum terminal ends for low contact resistance between stacked units.
- ✓ Close-tolerance mica units equalize loading of series-connected sections
- ✓ Mica sections rigidly clamped in low-loss non-magnetic clamps

- and heat-treated for maximum capacitance-temperature stability.
- ✓ Mechanical design permits units to be stacked and thereby connected in series, parallel and series-parallel. Dummy units are available to support and insulate active units.
- ✓ Units may be bolted together through holes in aluminum caps.
- ✓ Standard listings; normally available without delay; at the right prices.

● Aerovox popularized this type. Originally a special item made only to order and at custom-built prices, it was Aerovox that selected and standardized the sizes, voltages and capacitances so that standard Aerovox stack-mounting units could be regularly produced, listed and properly priced. The rest is history.

Especially intended for various transmitting and electronic applications, these heavy-duty micas have found wide usage in military and peaceful applications alike. Such units are especially popular in heavy-duty transmitting applications such as grid, plate blocking, coupling, tank and by-pass functions. Also in carrier-current applications.

Special yesterday, standard today, Aerovox stack-mounting mica capacitors have contributed greatly to available quality equipment and outstanding performance.

● Literature on request ...



# Capacitors

INDIVIDUALLY TESTED

AEROVOX CORPORATION, NEW BEDFORD, MASS., U. S. A.

SALES OFFICES IN ALL PRINCIPAL CITIES

Export: 13 E. 40 St., NEW YORK 16, N. Y. • Cable: 'ARLAB' • In Canada: AEROVOX CANADA LTD., HAMILTON, ONT.

# THE ALSIMAG CERAMICS

ALSiMAG is the trade name of a wide variety of ceramic bodies, each with its own particular physical and electrical characteristics. Among those finding widest applications are the following:

**ALSiMAG 35 and 196** Possessing high mechanical strength combined with low electrical loss at high frequencies, these bodies are ideally suited to most electrical and electronic applications.

**ALSiMAG 197** Good mechanical strength and resistance to high temperatures for sustained periods make ALSiMAG 197 especially valuable in the field of electrical heating devices.

**ALSiMAG 72 and 202** Low coefficients of expansion, coupled with ability to withstand thermal shock, make these materials desirable in combustion tips and thermo-couple insulation.

Whatever you are planning in the electronic or electrical field, we believe our specialized knowledge, experience, constant research and development will be helpful. Let's work together.

**AMERICAN LAVA CORPORATION**

Chattanooga 5, Tennessee

43RD YEAR OF CERAMIC LEADERSHIP

# ALSiMAG

TRADE MARK REG. U.S. PAT. OFFICE

## CERAMICS



ALCO has been awarded for the fifth time the Army-Navy "E" Award for continued excellence in quantity and quality of essential war production.

35 and 196

197

72 and 202

# Why are Carbonyl Iron Powders better?



**I**N ILLUSTRATION, note regularity of pattern. This is due to uniform shape, density, size, and purity of each particle.

These factors account for high "Q" value—the combination of maximum magnetic permeability and minimum power loss. This is why carbonyl iron powders are better.

The following text gives a brief, complete outline of G.A.F. Carbonyl Iron Powders for those desiring more information.

G.A.F. Carbonyl Iron Powders are obtained by thermal decomposition of iron penta-carbonyl. There are

five different grades in production, which are designated as "L," "C," "E," "TH," and "SF" Powder. Each of these five types of iron powder is obtained by special process methods and has its special field of application.

The particles making up the powders "E," "TH," and "SF" are spherical with a characteristic structure of increasingly larger shells. The particles of "L" and "C" are made up of homogenous spheres and agglomerates.

The chemical analysis, the weight-average particle size, the "tap density" and the apparent density are given in the following table for the five different grades:

TABLE 1

Carbonyl Iron Grade	Chemical Analysis		% Nitrogen	Wt. Ave. diameter microns	Tap Density g/cm <sup>3</sup>	Apparent Density g/cm <sup>3</sup>
	% Carbon	% Oxygen				
L	0.005—0.03	0.1 —0.2	0.005—0.05	20	3.5—4.0	1.8—3.0
C	0.03 —0.12	0.1 —0.3	0.01 —0.1	10	4.4—4.7	2.5—3.0
E	0.65 —0.80	0.45—0.6	0.6 —0.7	8	4.4—4.7	2.5—3.5
TH	0.5 —0.6	0.5 —0.7	0.5 —0.6	5	4.4—4.7	2.5—3.5
SF	0.5 —0.6	0.7 —0.8	0.5 —0.6	3	4.7—4.8	2.5—3.5

With reference to the chemical analysis shown above it should be noted that spectroscopic analysis shows the rest to be iron with other elements present in traces only.

Carbonyl Iron Powders are primarily useful as electromagnetic material over the entire communication frequency spectrum.

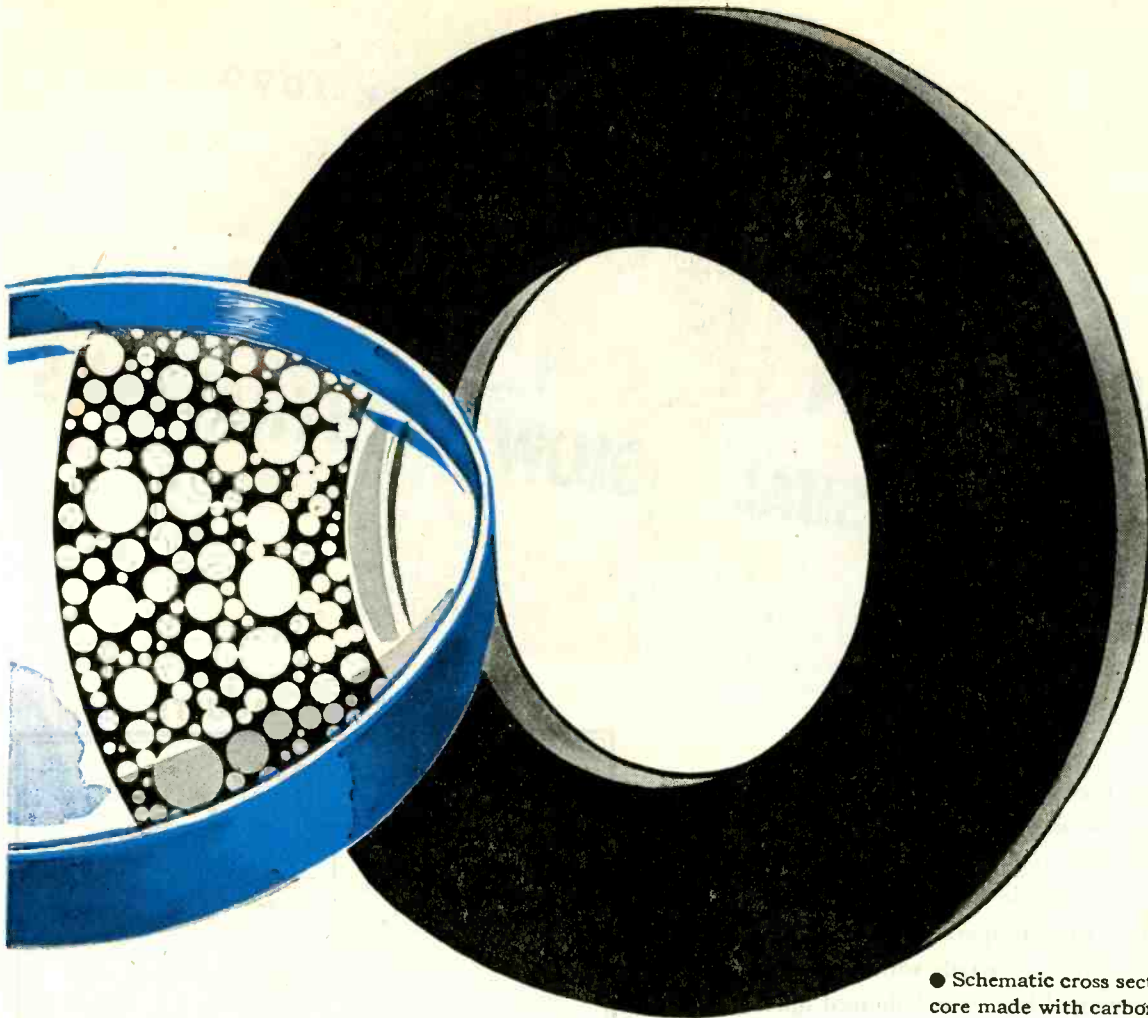

● Schematic cross section of powdered iron core made with carbonyl iron powder.

Table 2 below gives relative Q values (quality factors) and effective permeabilities for the different grades of carbonyl iron powder. The values given in the table are derived from measurements on straight cylindrical cores placed in simple solenoidal coils. Although the

data were not obtained at optimum conditions, the Q values as expressed in percentage of the best core give an indication of the useful frequency ranges for the different powder grades.

**TABLE 2**

Carbonyl Iron Grade	Effective Permeability at 1 kc	Relative Quality Factor at				
		10 kc	150 kc	200 kc	1 Mc	100 Mc
L	4.16	100	96	90	43	1
C	3.65	94	100	98	72	3
E	3.09	81	94	100	97	30
TH	2.97	81	93	98	100	54
SF	2.17	62	71	78	84	100

(Note: The actually measured Q values can be obtained by multiplying the rows respectively with: 0.78, 1.09, 1.25, 2.63, and 1.62.)

"L" and "C" powders are also used as powder metallurgical material because of their low sintering temperatures, high tensile strengths and other very desirable qualities. (Sintering begins below 500° C and tensile

strengths reach 150,000 psi.)

Further information can be obtained from the Special Products Sales Dept., General Aniline & Film Corporation, 437 Hudson Street, New York 14, N. Y.

# G.A.F. CARBONYL IRON POWDERS

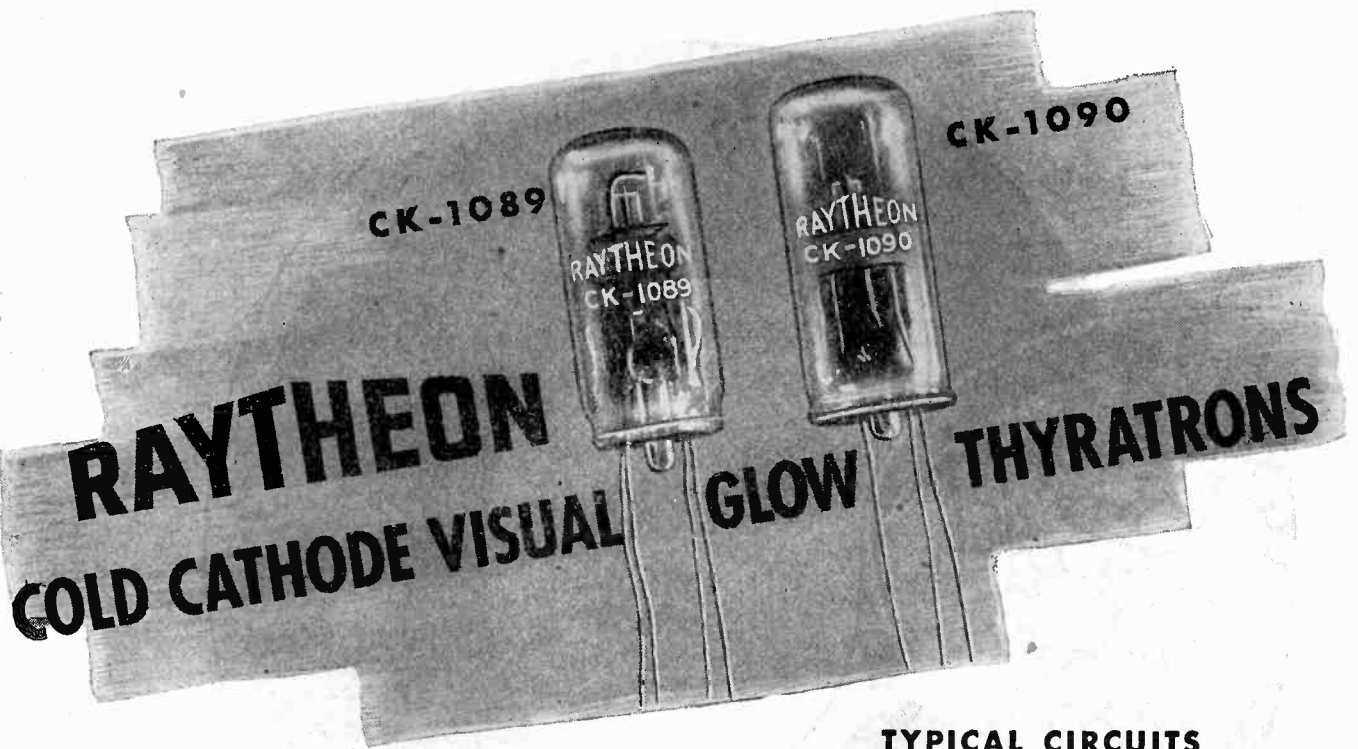

● Outstanding recent developments by Raytheon's research laboratories are two visual-glow cold cathode thyratrons, types CK-1089 and CK-1090.

The former is a tetrode incorporating two starter electrodes and so can be operated from a balanced line, whereas the latter is a triode with a single starter electrode for grounded line or unbalanced operation. In addition to normal grid controlled thyatron performance, these neon-filled tubes are engineered to produce a good visual glow near the top of the bulb.

This characteristic, and their small size, make them admirably adaptable to telephone switchboard applications where they can be wired directly as a combined relay and indicator lamp. It is also possible to actuate a separate relay in the anode circuit by the initiation of plate current, which, of course, is coincident with the glow. The resulting simplicity and the reduction in weight and size are highly desirable. Thousands of Raytheon CK-1089 and CK-1090 tubes are now giving dependable service in just such an application—even under the worst climatic conditions. Convincing proof, indeed, that Raytheon builds fine tubes . . . tubes that you should consider for your postwar products!

### TYPICAL CIRCUITS

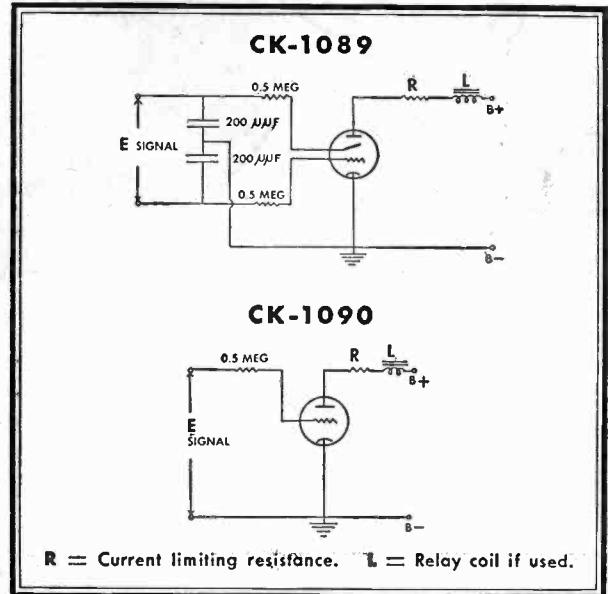

### SPECIFICATIONS OF CK-1089 AND CK-1090

Minimum Peak Anode Breakdown Voltage (No Signal)	225 volts
Peak Positive Starter-Anode Breakdown Voltage	75 min. volts 170 max. volts
Across Starter Electrodes on CK-1089	
Starter Electrode to Cathode on CK-1090	
Approximate Starter Electrode Voltage Drop	90 volts
Maximum Peak Cathode Current	20 ma
Maximum Average Cathode Current	15 ma

# RAYTHEON

RADIO RECEIVING TUBE DIVISION

Newton, Mass. · Los Angeles · New York · Chicago · Atlanta



All Four Divisions  
Have Been Awarded  
Army-Navy "E"  
with Stars

Listen to  
"MEET YOUR NAVY"  
Every Saturday Night  
ENTIRE BLUE NETWORK  
Coast-to-Coast  
161 Stations

DEVOTED TO RESEARCH AND THE MANUFACTURE OF TUBES FOR THE NEW ERA OF ELECTRONICS



## **I**very tower... with a view!

**Aireon** engineers are not in any sense prima donnas. But

we *do* provide them with the sort of seclusion that promotes constructive thinking...an isolated building of 22,000 square feet, equipped with the latest and finest scientific apparatus, given over exclusively to research and development. A place where you can hear a kitten pound its feet. ▀ This partly accounts for the fact that, of twenty-eight *major* electronic products, turned out by our Electronic Division, *twenty-four* were largely designed from the ground up and converted into production realities by **Aireon** engineers. ▀ The regenerative force of research is responsible for the steady progress of **Aireon** in the electronics field. Supporting it are manufacturing facilities groomed for the mass production of precision products. ▀ Our executives are ready to discuss your plans for today and tomorrow—our engineers and plants to carry them out. A call to any one of our offices will bring results.

# **Aireon**

**MANUFACTURING CORPORATION**

Formerly AIRCRAFT ACCESSORIES CORPORATION

Radio and Electronics • Engineered Power Controls

NEW YORK • CHICAGO • KANSAS CITY • BURBANK

*Attention*  
EQUIPMENT  
MANUFACTURERS

# HEINTZ and KAUFMAN

takes the lead in solving  
a problem which has plagued  
the equipment designer

**H**eintz and Kaufman is establishing a standardization policy which will be heartily welcomed by all who design and service electronic equipment.

From now on, whenever you engineer your equipment around Gammatron tubes you can be sure that *identical* replacement tubes will be readily available throughout the life of that equipment!

Thus while Heintz and Kaufman will continue to develop new and improved Gammatrons, these advancements will never embarrass the equipment manufacturer since they will not result in the discontinuance of any Gammatron type.

We are starting this program off by standardizing the specifications for 22 Gammatron types, the outstanding products of our 17 years of tube research and development.

The electrical and physical uniformity and quality of these 22 types will be maintained at the level of Joint Army and Navy specifications. We feel that these specifications are sufficiently high to serve as a sound basis for our standardization policy.

With the establishment of this progressive policy, Heintz and Kaufman Ltd. is taking the

lead to end the problem you have always faced of redesigning equipment in production because of variations in type characteristics, and to prevent the premature obsolescence of equipment from the same cause.

Here are the 22 types of Gammatrons which we pledge will be available during the years ahead, always conforming to the same high specifications:

14 TRIODES: HK-24, 24G, 54, 254, 354C and E, 454L and H, 654, 854L and H, 1054L, 1554, 3054.

1 PENTODE: HK-257B.

4 HIGH VACUUM RECTIFIERS: HK-253, 953B, D, and E.

3 IONIZATION GAUGES: VG-2, VG-24G, VG-54.

Our advertisement next month will contain additional data on the above types, and will also include a list of Gammatrons available primarily for replacement use.

Have you written for  
the specification sheet on the  
HK-1054 Gammatron?



## HEINTZ AND KAUFMAN LTD.

SOUTH ASAN FRANCISCO CALIFORNIA

AS099L

*Gammatron Tubes*

Export Agents: M. Simons & Son Co., Inc. 25 Warren Street, New York City, N. Y., U. S. A.

  
BUY WAR  
BONDS



# "Line Production" Experience IN RADIO MANUFACTURING

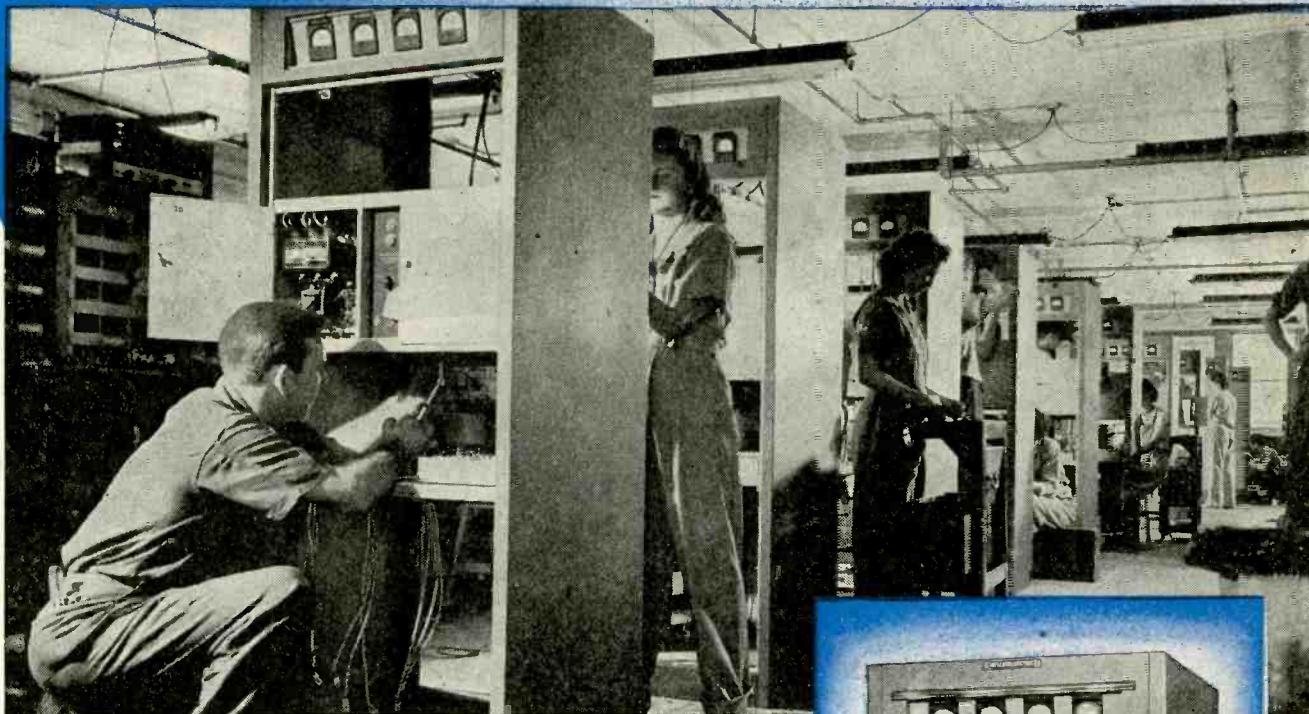

From Wilcox's war experience, as one of the largest manufacturers of radio communications equipment, has come many new products... a completely modern mass production factory... a trained engineering staff... plans and the knowledge needed for both war and peacetime products of highest quality. Look to Wilcox for leadership in radio communications equipment!



**Model 50A Modulator** — The 1600 watt 50A Modulator, shown at right, may be used for transmitter modulation, or high-powered audio needs.

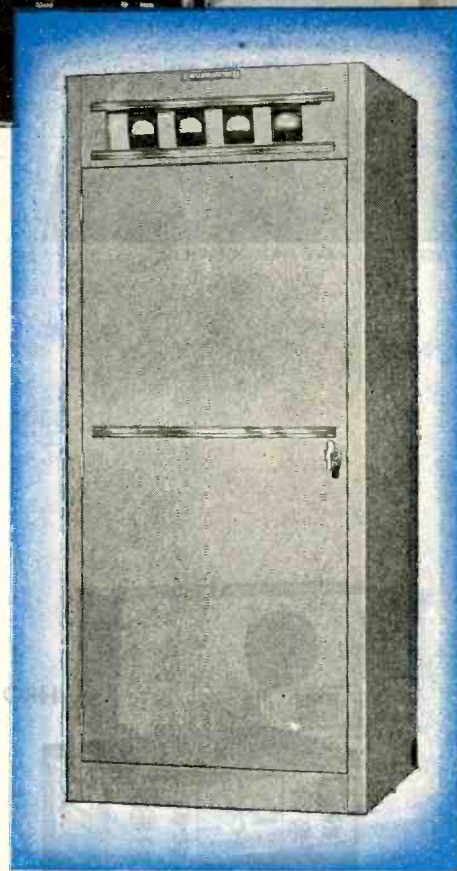

## WILCOX ELECTRIC COMPANY, INC.

*Manufacturers of Radio Equipment*

FOURTEENTH AND CHESTNUT

KANSAS CITY, MISSOURI

NATIONAL RECEIVERS ARE THE EARS OF THE FLEET



OFFICIAL U. S. NAVY PHOTOGRAPH

3 out of 4 of the Navy's ships—  
landing craft and larger—are equipped  
with receivers designed by National

This is a small part of mighty Task Force 58. It is  
more than a lot of ships and a lot of men, it is an  
integrated striking force of terrific power. Radio  
communications have played a vital role in the  
operations for which Task Force 58 has become  
famous.

We are proud that National radio receivers are a  
part of this Force.

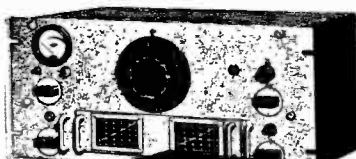

HRO

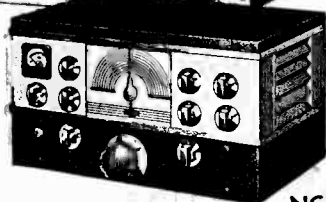

NC-200

**NATIONAL COMPANY**

**MALDEN**



**MASS, U. S. A.**

NATIONAL RECEIVERS ARE IN SERVICE THROUGHOUT THE WORLD

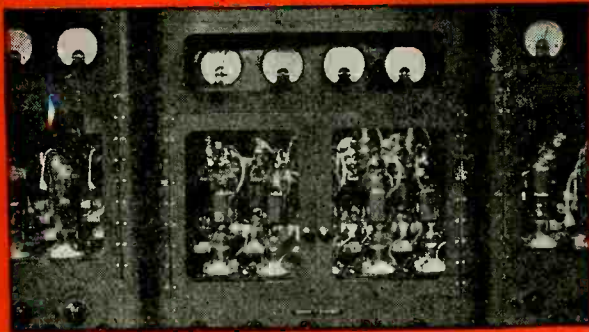

QST-1—Life testing is an important Quality Standard test at United. It is a strictly observed procedure whereby life expectancy is controlled in "run-of-production" tubes.



QST-2—A unique test is applied to every United tube to assure noise-free operation.

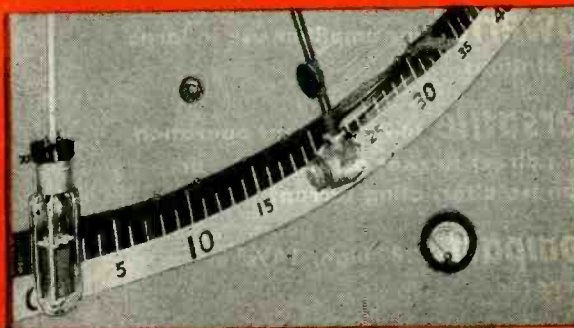

QST-3—United tubes designed for very rough service have extra, built-in shock resistance proved by the severe Bump Test each tube must pass.

**Quality Standard Test.**

# Who sets the *Quality Standard* FOR TRANSMITTING TUBES

Brilliant United craftsmanship is steadfastly verified and maintained by skillful and vigilant testing—truly representative of daily production. For this reason every United tube must pass through a series of critical examinations that do not permit any defects, no matter how minute they may be, to escape unnoticed.

By maintaining Quality Standard Tests of the highest order United engineers and technicians have

achieved recognition for leadership. To engineers everywhere, the name United is the *trusted* standard by which other transmitting tubes are judged and measured.

For every electronic application including radio communication, physiotherapy, industrial control and electronic heating, standardize with tubes that are the Quality Standard. "Tube up" with United.

Order direct or from your electronic parts jobber.

*Masterpiece of  
Skilled Hands*

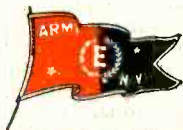

# UNITED

**ELECTRONICS COMPANY**

NEWARK, 2



NEW JERSEY

Transmitting Tubes **EXCLUSIVELY** Since 1934

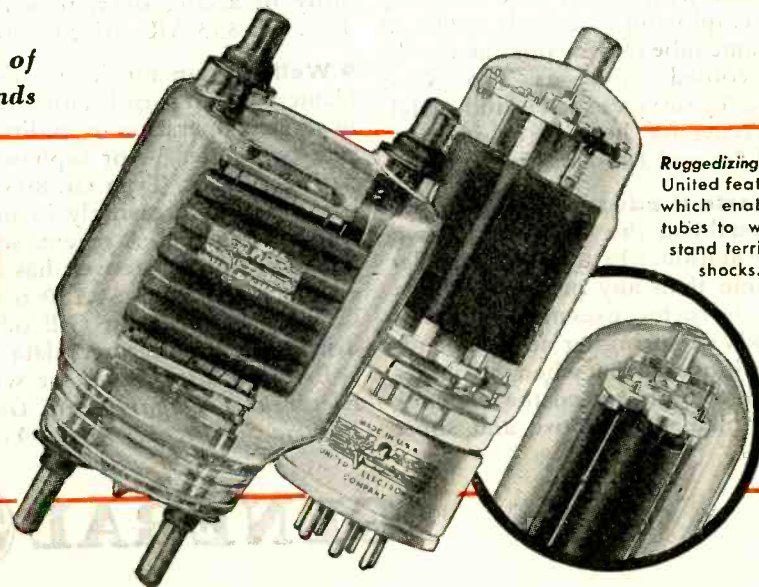

**Ruggedizing:** A United feature which enables tubes to withstand terrific shocks.

# Designed for the modern 50-kw transmitter!

a G-E high-vacuum, forced-air-cooled tube

**Up-to-the-minute** in its design characteristics and performance

**Powerful** for amplifier use in large AM stations

**Versatile** in its filament operation from direct current or single, 3-, or 6-phase alternating current

**Compact**—28" high, 14 $\frac{1}{8}$ " in diameter

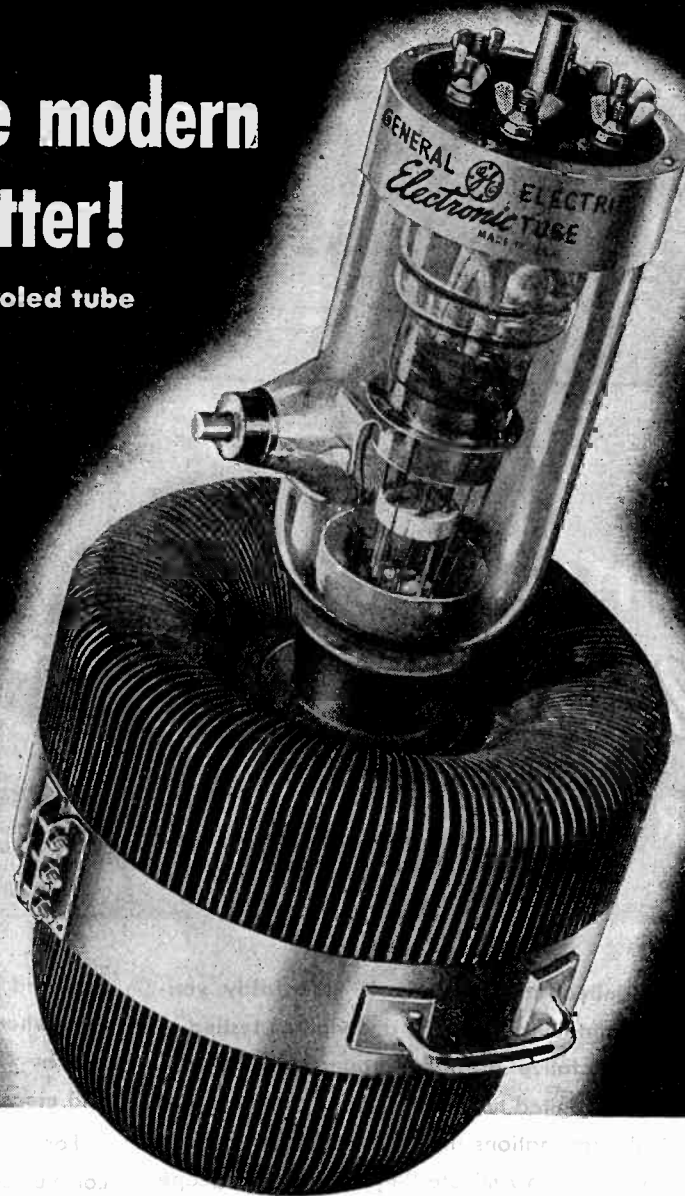

● **Type GL-893-AR** was created for the newer 50-kw transmitters which broadcast at standard frequencies, and with power-tube installations employing forced-air cooling. The same tube may be obtained with water-cooled anode as Type GL-893-A, for services such as industrial high-frequency heating or international 50- and 100-kw broadcasting.

● **Important advancements** in design establish the GL-893-AR as a power amplifier better and more dependable than any predecessor. Its filament structure uses new, improved methods of springing and suspending the loops, so that when the phase-voltages are unbalanced, the tendency of the filament to move and short

with the grid is minimized. Improvements in grid construction also have been introduced to reduce the possibility of arcing over, thus making Type GL-893-AR easier to break in.

● **Well-known** for its multi-strand filament which permits, for all classes of service, operation from direct current or single, 3-, or 6-phase alternating current, Type GL-893-AR is being used increasingly in modern transmitting sets. A recent, substantial reduction, moreover, has lowered the price from \$1,150 to \$800. Consult your nearest G-E office or distributor for further data about G-E transmitting tubes, or write to *Electronics Department, General Electric, Schenectady 5, New York.*

## TYPE GL-893-AR. PRICE \$800.

A 3-electrode, forced-air-cooled vacuum tube for use as a r-f amplifier, oscillator, or Class B modulator. Operates from direct current or single, 3-, or 6-phase alternating current. In Class B a-f service, with a signal plate output for two tubes up to 70 kw, the maximum ratings per tube are: plate voltage 20,000 v, signal plate current 4.0 amp; signal plate input 60 kw, dissipation 20 kw. In Class C plate-modulated service, with a power output up to 18 kw, the maximum ratings per tube are: plate voltage 12,000 v, current 2.0 amp; plate input 24 kw, dissipation 12 kw. Highest frequency at full ratings is 5 megacycles; at reduced ratings, 25 megacycles.

Type GL-893-A also is available with the same design and ratings, but with water-cooled anode. Price \$450.

Hear the G-E radio programs: "The World Today" news, Monday through Friday 6:45 p. m., EWT, CBS. "The G-E All-Girl Orchestra," Sunday 10 p. m., EWT, NBC. "The G-E House Party," Monday through Friday, 4 p. m., EWT, CBS.

**GENERAL**  **ELECTRIC**

161-DE-9880

# T IS FOR "TROPICALIZED"



... which means that **STANDARD** Sprague Koolohms now have the same **EXTRA HUMIDITY PROTECTION** formerly obtainable only on special order.

All Sprague Koolohm Resistors are now supplied with glazed ceramic shells and a *new type of end seal* as standard construction.

These features provide maximum protection against the most severe tropical humidity and corrosive conditions. Extensive tests in the laboratories of the armed forces and prime contractors have proven the ability of the "KT" construction to "take it" under the most brutal air thermal shock, humidity, and corrosive conditions.

Type "KT" Koolohms correspond to characteristic "J" of resistor specification JAN-R-26.

All previous catalog designations remain the same except for the addition of the letter "T" to the old type numbers to designate the new standard construction.

Thus "T" is for "Tropicalized"—and all Sprague Koolohms have it. One type of Koolohm, the *standard* type, does the job—under any climatic condition, anywhere in the world.

**SPRAGUE ELECTRIC CO., Resistor Division, North Adams, Mass.**  
(Formerly Sprague Specialties Co.)



# SPRAGUE

## KOOLOHM RESISTORS



TRADEMARK REG. U. S. PAT. OFF.

**FOR THE TOUGH JOBS**

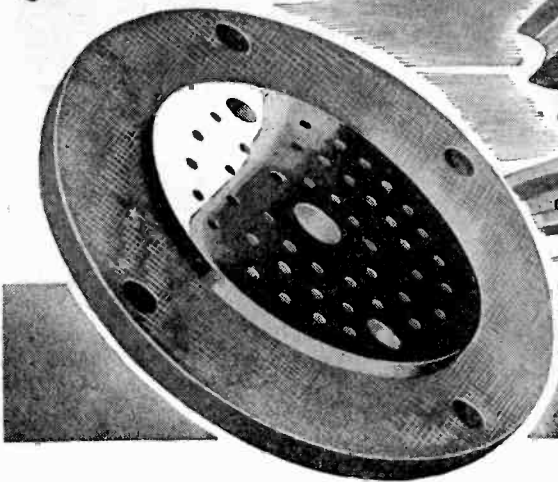

**Continental-Diamond**  
*Engineered Dielectric Materials*

*A grade LE DILECTO laminated plastic insulating part used in rocket controls. Its insulating properties and dimensional accuracy must remain stable under terrific impact and vibration and regardless of temperature extremes.*

**T**HE ability of C-D DILECTO Electrical Insulation to take all a rocket can give . . . and still function perfectly . . . is good evidence that C-D DILECTO will serve well as electrical insulation in your present and future products.

C-D DILECTO is made in many standard grades to meet specific electrical, physical and thermal problems. Special grades can be developed to meet unusually exacting conditions. C-D DILECTO may be the solution to your "What Material?" problem.

**DISTRICT OFFICES**

NEW YORK 17 • CLEVELAND 14 • CHICAGO 11  
SPARTANBURG, S. C. • SALES OFFICES IN PRINCIPAL CITIES

WEST COAST REPRESENTATIVES  
MARWOOD LTD., SAN FRANCISCO 3

IN CANADA:  
DIAMOND STATE FIBRE CO. OF CANADA, LTD., TORONTO 8

KR-45

**C-D PRODUCTS**

**The Plastics**

DILECTO—A Laminated Phenolic.

CELORON—A Molded Phenolic.

DILECTENE—A Pure Resin Plastic Especially Suited to U-H-F Insulation.

HAVEG—Plastic Chemical Equipment, Pipe, Valves and Fittings.

**The NON-Metallics**

DIAMOND Vulcanized FIBRE

VULCOID—Resin Impregnated Vulcanized Fibre.

MICABOND—Built-Up Mica Electrical Insulation.

**Standard and Special Forms**

Available in Standard Sheets, Rods and Tubes; and Parts Fabricated, Formed or Molded to Specifications.

**Descriptive Literature**

Bulletin GF gives Comprehensive Data on all C-D Products. Individual Catalogs are also Available.

**Continental - Diamond** FIBRE COMPANY

Established 1895.. Manufacturers of Laminated Plastics since 1911—NEWARK 48 • DELAWARE

# The Picture with Ten Billion Parts!

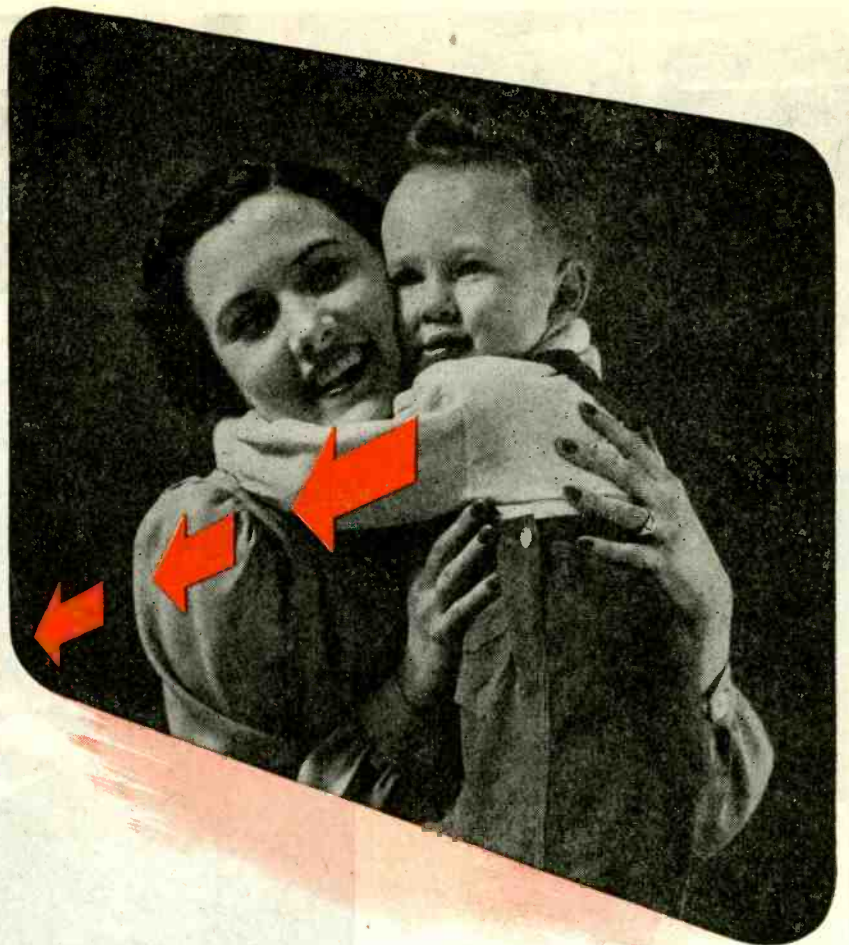
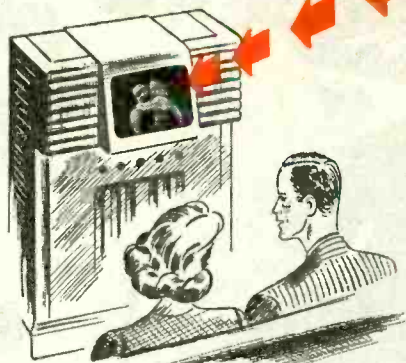

● You see a clearer, more detailed picture on a National Union Television Tube, because of the ultrafine grain screen, developed by N. U. research engineers. It is calculated that the 10" television picture appearing on the screen of a National Union cathode-ray tube is reproduced on 10 billion crystals.

With this development National Union scientists have demonstrated that the quality of the screen—its uniformity, smoothness, depth and fine-grain texture are just as vital to high definition television pictures as is the number of lines received. When projected on

the fine grain N. U. screen, any television picture, of any number of lines, looks more life-like, because of its superior halftones and gradations of light and shadow.

As a leading producer of cathode-ray tubes, National Union is engaged in one of the most extensive CRT research programs ever undertaken. Today, this N. U. research is helping to deliver superior radio and communications equipment for war. Tomorrow, it will contribute its part to the peacetime needs of our homes and industries. For progress through research—count on National Union.

**NATIONAL UNION  
RADIO AND ELECTRON TUBES**

NATIONAL UNION RADIO CORPORATION • NEWARK 2, N. J.



# SALT WATER MIKES

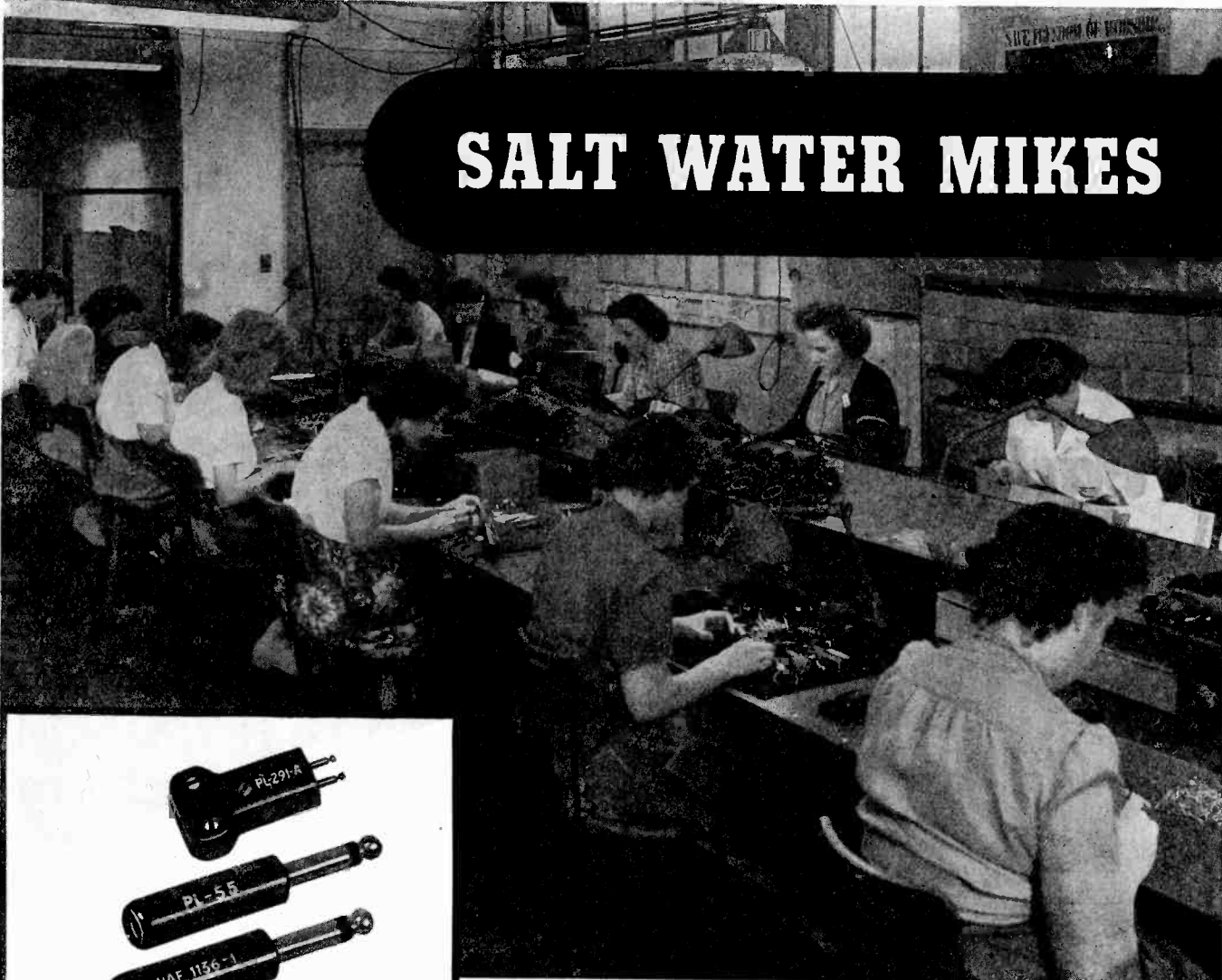

Marine microphone assembly. Plastic and metal parts designed, made and assembled by Remler to meet Navy and Merchant Marine specifications.

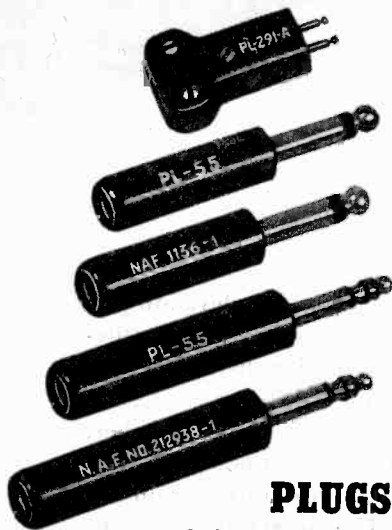

## PLUGS & CONNECTORS

Signal Corps - Navy Specifications

Types:	PL				NAF
50-A	61	74	114	150	1136-1
54	62	76	119	159	
55	63	77	120	160	
56	64	104	124	291-A	
58	65	108	125	354	No.
59	67	109	127		212938-1
60	68	112	149		

PLP		PLQ		PLS	
56	65	56	65	56	64
59	67	59	67	59	65
60	74	60	74	60	74
61	76	61	76	61	76
62	77	62	77	62	77
63	104	63	104	63	104
64		64			

OTHER DESIGNS TO ORDER

**ONE REMLER ASSIGNMENT** is the production of amplifying and transmitting systems for our Navy and Merchant Marine. Systems are complete—from shock-proof microphones, built to resist the corrosive action of salt air and water to transmitters and bull-horn speakers for baby Flat Tops. • Remler was organized in 1918 to manufacture ship wireless. Present activities in marine communications are a logical development of early activities in this field. The facilities and experience of this organization are at your disposal.

Further assignments in radio and electronics invited. Consult—

REMLER COMPANY, LTD. • 2101 Bryant St. • San Francisco, 10, Calif.

# REMLER

SINCE 1918

*Announcing & Communication Equipment*



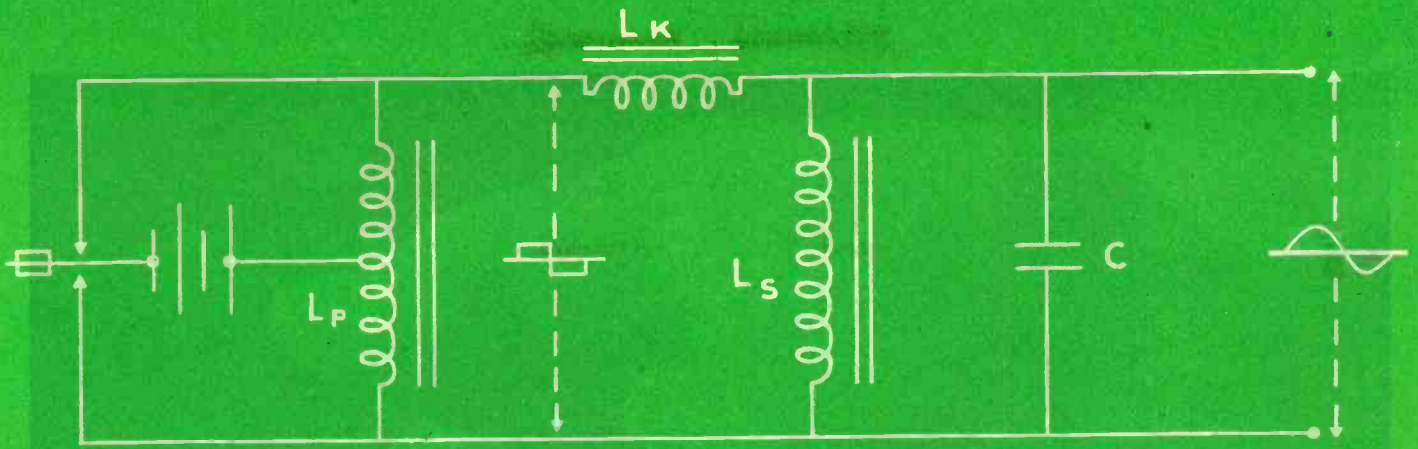

## NOW, A VIBRATOR POWER SUPPLY WITH A SINE WAVE OUTPUT

● For years, it has been taken for granted that the output wave form of a Vibrator Power Supply necessarily must be a rectangular wave with its characteristic "swingback" or commutation lines. With the development of very sensitive radio equipment this, of course, caused shock excitation of the audio and RF tuned circuits. In equipment designed for sine wave, operation on square wave resulted in the wrong ratio of A and B voltages applied to the tubes.

Realizing the need for eliminating the difficulties arising from square wave operation, Electronic Laboratories research department has perfected a Vibrator Power Supply which can supply a sine wave at powers up to several hundred watts from any DC source. In addition, this output is stable and has excellent regulation characteristics with load and input voltage.

Referring to the diagram at the top of this page,  $L_k$  (leakage reactance) and the condenser, "C", form a series resonant circuit. This circuit establishes a voltage across the secondary inductance,  $L_s$ . This voltage rises as  $L_k$  is varied until it is established by the saturation of the secondary inductance,  $L_s$ . The saturation characteristic of the inductance,  $L_s$ , is such as to sustain sinusoidal voltage across the condenser, "C". This results in a smooth sine wave output voltage, substantially independent of the input voltage.

An elementary form of this system is shown in figure 1. The power transformer consists of a primary winding, "P", energized from the battery through the vibrator. The secondary winding, "S", is separated from the primary by magnetic shunts, and the tank condenser, "C", is across the secondary winding.

Since the reactive energy stored in the system is large, compared to the actual energy dissipated by the

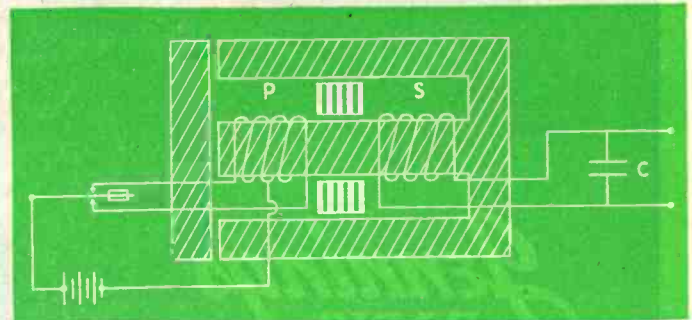

Figure 1

load, this system is also independent of load changes.

Careful design of the primary circuit insures proper commutation for long life and reliability. Any number of voltages can be had from the system by properly tapping the tank circuit.

\* \* \* \* \*

**EL** Vibrator Power Supplies have wide application in many fields: radio, electrical, electronic, marine, aviation and railroad. Their high efficiency and versatility with multiple inputs and outputs, enable them to meet many power supply needs. They may be designed to provide any wave form required for specific equipment. . . . Economy is assured because of long, efficient service with minimum maintenance. **EL** Engineering Service is available to discuss your power supply problem and to design a vibrator power supply to meet specific voltage, power, size and weight requirements.

Model illustrated is a typical **EL** Vibrator Power Supply with sine wave output and voltage regulation.



**Electronic**  
LABORATORIES INC.  
INDIANAPOLIS





*Jennings*  
RADIO

VACUUM ELECTRONIC COMPONENTS

# "WALNUT" CAPACITORS

REVOLUTIONARY IN DESIGN, SIZE, WEIGHT

PATENT APPLIED FOR.— PHOTOGRAPH SHOWS SIZE OF JENNINGS' "WALNUT" CAPACITOR IN RELATION TO HAND.

The latest and most highly successful electronic component is the Jennings "Walnut" size Capacitor, now in full production.

## **WALNUT VC, SERIES M — AMPERE SERIES 20**

### CHARACTERISTICS

Capacity Range 6-50 mmfd.

Maximum Current 20 Amperes Peak

Maximum Voltage 30KV Peak

Specially designed for high frequency operation

Self-healing in case of overload

We can now accept orders for early delivery of this greatly improved, compact, plug-in type capacitor.

WRITE FOR BULLETIN IR

**JENNINGS RADIO MANUFACTURING COMPANY • 1098 E. WILLIAM ST. • SAN JOSE 12, CALIFORNIA**

VERI  
GRAIT

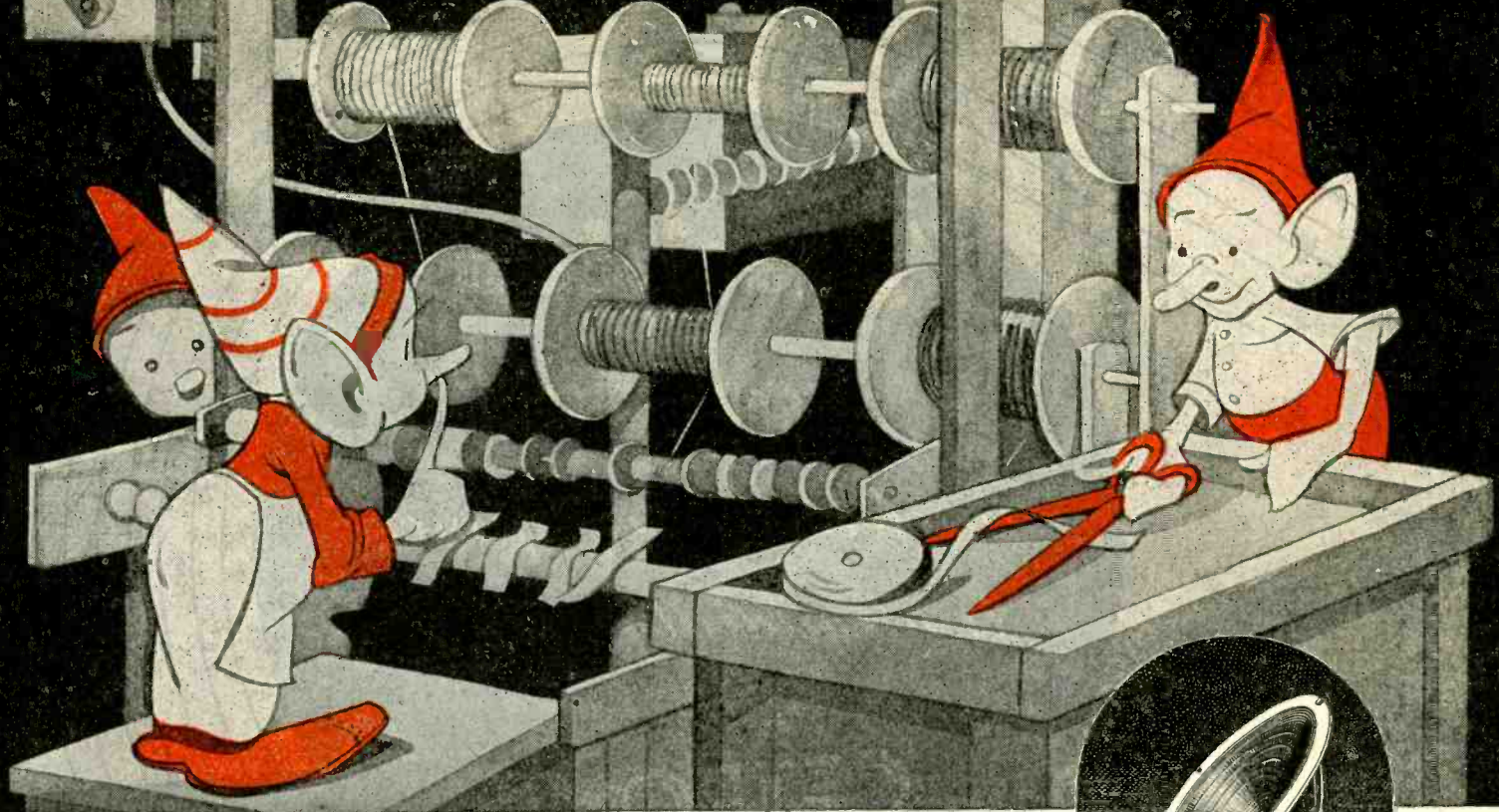

★ Utah Speakers: More than 20 million Utah speakers have been made for radio, and public address systems.

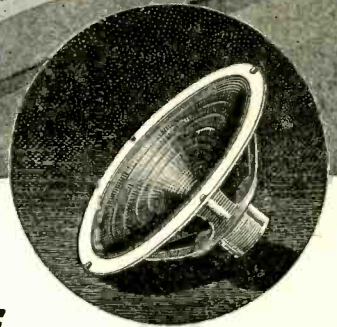

## PRECISION PLUS . . . THAT'S UTAH PERFORMANCE

When it comes to coil winding, Utalins\* are past masters. They operate machines, built by Utah engineers, that produce finished products to a greater accuracy than ever possible by human hands alone.

This, and every manufacturing step, is part of a comprehensive process carried through

in Utah's own factory . . . tooling, welding, plating, winding . . . to unexcelled standards of accuracy. Then comes checking, rechecking, supervising, testing . . . till every step of production has been thoroughly approved. In fact, there's not one moment from the original buying of raw materials to the final delivery, that Utalins\* relax their efforts. This is the Utah perfection that guarantees performance.

\*Utah's Helpers

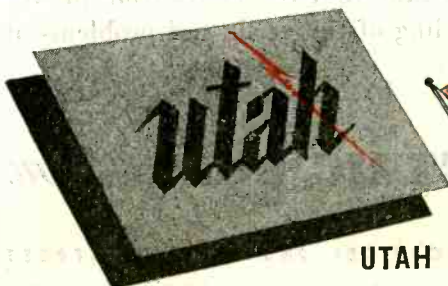

UTAH RADIO PRODUCTS COMPANY, 820 ORLEANS ST., CHICAGO 10, ILL.

Utah Electronics (Canada) Ltd., 300 Chambly Road, Longueuil, Montreal (23) P.Q. • Ucoa Radio, S.A., Misiones 48, Buenos Aires

**"precision  
control"**

*in electronic equipment  
is a certainty with the*

**CETRON CE-309 TUBE**



Write for catalog of our  
**COMPLETE LINE** of  
Rectifiers . . . Phototubes  
. . . Electronic Tubes

Wherever precision control is of prime importance in electronic devices, this CE-309 Thyatron will serve capably and efficiently. It is a mercury vapor filled rectifier designed especially for exceptional service in such operations as handling primary currents of small resistance welders, motor control, etc. It is quick starting, averaging 5 seconds heating time . . . conservatively rated for 2000 hours . . . in every way a tube that reflects Cetron quality engineering and our thorough understanding of the needs and problems of tubes for industrial use.

**CONTINENTAL ELECTRIC CO.** *Geneva, Ill.*

CHICAGO OFFICE: 903 MERCHANDISE MART • NEW YORK OFFICE: 265 W. 14TH STREET



This equipment is designed to operate at  
**115 V-AC**  
 60 cycles

As a protection against voltage fluctuations a **CONSTANT VOLTAGE TRANSFORMER** has been built-in as a component part of this equipment. Rated performance will therefore be maintained at all times, regardless of input voltage fluctuations as great as  $\pm 15\%$ .

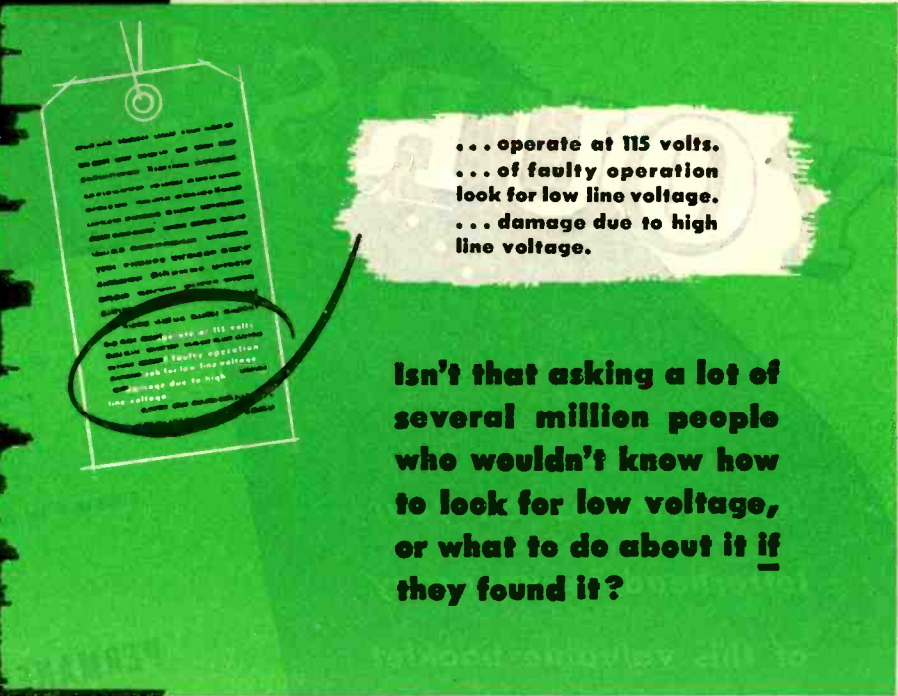

... operate at 115 volts.  
 ... of faulty operation look for low line voltage.  
 ... damage due to high line voltage.

Isn't that asking a lot of several million people who wouldn't know how to look for low voltage, or what to do about it if they found it?

**Warnings against unstable voltages are unnecessary on equipment protected with built-in**  
**CONSTANT VOLTAGE**

Unstable voltage on commercial power lines is so prevalent that many manufacturers of electrical and electronic equipment have found it necessary to warn their customers of its existence and its possible effects on the operation and efficiency of the equipment.

There is an easy and inexpensive solution to this important problem—specify a **SOLA CONSTANT VOLTAGE TRANSFORMER** as a component

part of your equipment. There are several types of **SOLA CONSTANT VOLTAGE TRANSFORMERS** specially designed for this purpose—small, compact units in capacities ranging from 10VA to several KVA. Other capacities and designs can be custom built to your specifications.

Once installed in your equipment they require no pampering or supervision. They are fully automatic, instantly correcting voltage fluctua-

tions as great as  $\pm 15\%$ . They are self-protecting against short circuit.

No sales manager will overlook the added salability of a product that features this guarantee of performance, low maintenance cost and satisfaction to the user.

**SOLA** engineers with wide experience in the application of the **SOLA CONSTANT VOLTAGE** principle are available for consultation on details of design specifications.

**SOLA**  
**Constant Voltage Transformers**

**To Design Engineers:**  
 Complete, new hand-book of Constant Voltage Transformers available on request.  
 Ask for Bulletin **KCV-102**

Transformers for: Constant Voltage • Cold Cathode Lighting • Mercury Lamps • Series Lighting • Fluorescent Lighting • X-Ray Equipment • Luminous Tube Signs  
 Oil Burner Ignition • Radio • Power • Controls • Signal Systems • Door Bells and Chimes • etc. **SOLA ELECTRIC CO., 2525 Clybourn Ave., Chicago 14, Ill.**

# YOURS!

*Just write us, on your letterhead, for your copy of this valuable booklet on permanent magnets*

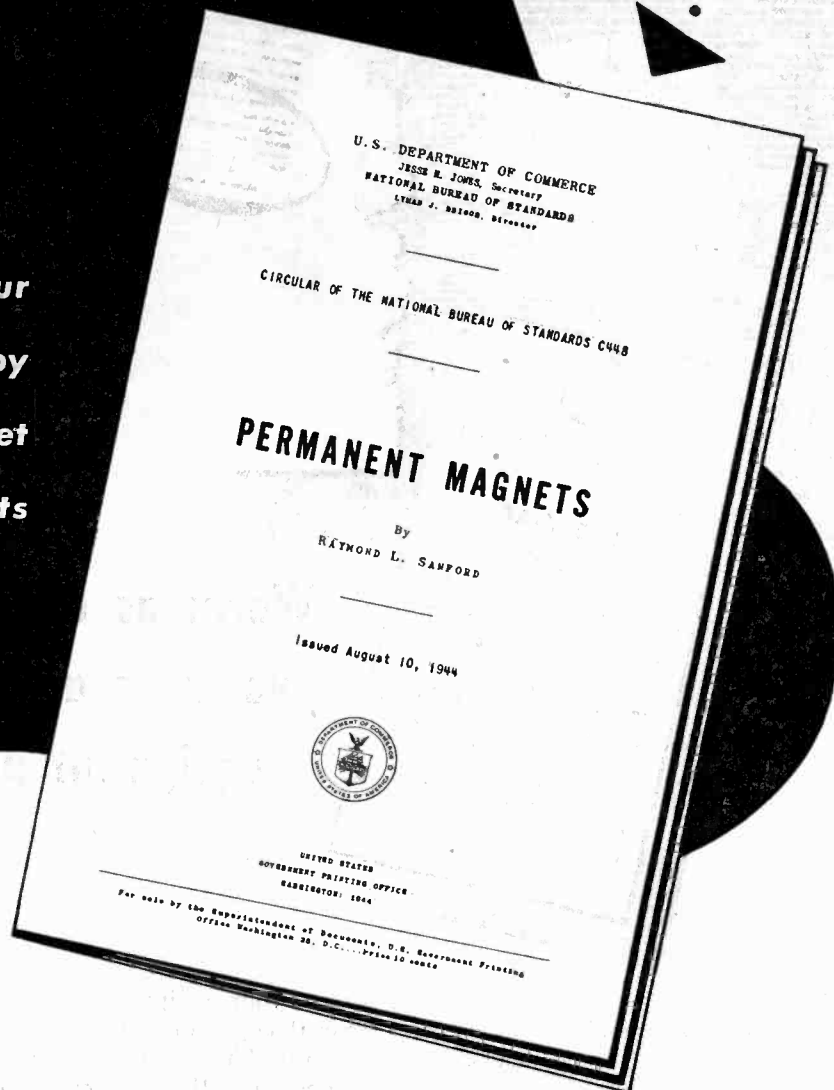

● As a service to industry, The Arnold Engineering Company is "lending a hand" in the distribution of what Arnold engineers believe to be a very informative study on the subject of permanent magnets.

This 39-page book of permanent magnet theory, design data and references was published by the government. Arnold is pleased to make it available to you free of charge and without obligation. Write for it today!



## **THE ARNOLD ENGINEERING COMPANY**

147 EAST ONTARIO STREET, CHICAGO 11, ILLINOIS

*Specialists in the Manufacture of ALNICO PERMANENT MAGNETS*

# THE WESTINGHOUSE

# IGNITRON

...the electronic tube that revolutionized the use of D-C power is the key to many more electronic applications.

In 1932 Westinghouse created the sealed ignitron, making possible compact portable equipment to supply the heavy and precisely timed d-c currents required in resistance welding. High-speed welding of aluminum and stainless steel became possible, and volume production of uniformly welded products became economically practical.

Today there are two basic types of Westinghouse sealed ignitrons: One for resistance welding; the other for power conversion.

There are four Westinghouse welding ignitrons, rated up to 2400-kva capacity. While they are now used mainly for joining light metals, they are capable of handling heavy metals. The wartime experience gained in resistance welding similar and dissimilar metals is opening new opportunities in the field of fabrication.

There are two Westinghouse ignitrons for power rectifier applications: a 100-ampere and a 150-ampere tube at d-c-output voltages up to 600-volts. Ignitron rectifiers often can be used profitably to replace conventional rectifying equipment. The high capacity of the ignitron opens a new field in motor speed control where motors of greater than usual horsepower must be controlled within very close limits.

Westinghouse ignitrons are now available in your Westinghouse distributors stock for immediate delivery.

Westinghouse engineers will be glad to advise you on problems of application of the ignitron. Write Westinghouse Electric & Manufacturing Company, Lamp Division, Bloomfield, N. J.

## Westinghouse

PLANTS IN 25 CITIES OFFICES EVERYWHERE

*Quality Controlled Electronic Tubes*



WL 655/658 For Welding Service  
 Maximum Welder Demand 2400 kva  
 Maximum Average Current per tube 355.0 amp  
 Maximum RMS Supply Voltage 600 volts

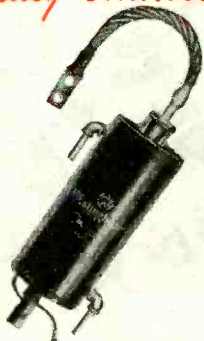

WL 651/656 For Welding Service  
 Maximum Welder Demand 1200 kva  
 Maximum Average Current per tube 140.0 amp  
 Maximum RMS Supply Voltage 600 volts



WL 681/686 For Welding Service  
 Maximum Welder Demand 300 kva  
 Maximum Average Current per tube 22.4 amp  
 Maximum RMS Supply Voltage 600 volts



WL 679 For Rectifier Service  
 D-C Output Average Current per tube  
 Voltage Continuous 2 hours 1 minute  
 300 100 amp 150 amp 200 amp  
 600 75 amp 112.5 amp 150 amp

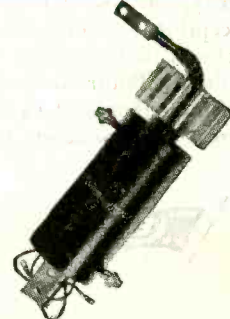

WL 653-B For Rectifier Service  
 D-C Output Average Current per tube  
 Voltage Continuous 2 hours 1 minute  
 300 200 amp 300 amp 400 amp  
 600 150 amp 225 amp 300 amp



# HOW hallicrafters EQUIPMENT COVERS THE SPECTRUM

## *Model S-37*

**FM-AM**  
for very high frequency work  
130 to 210 Mc.

**T**HE new Model S-37 FM-AM receiver is an outstanding example of Hallicrafters pioneering work in the upper regions of the spectrum. Covering the frequencies between 130 and 210 megacycles, the S-37 provides VHF performance which is in every way comparable to that of the finest communications receivers operating in the medium and high frequency bands. The average over-all sensitivity of the S-37 is approximately 5 microvolts. The image ratio of at least 1000 times is achieved through the use of two pre-selector stages and an intermediate frequency of 16 megacycles. No band switching is necessary and exceptional ease of tuning is provided by mechanical band-spread with 2300 dial divisions between 130 and 210 megacycles. The pre-loaded gear train is completely enclosed and is equipped with a positive stop at each end of the tuning range. Hermetically sealed transformers and capacitors, moisture proof wiring, and extra heavy plating, all contribute to the long life and reliability of the S-37 . . . the only commercially built receiver covering this frequency range.

The amazing performance of the Model S-37 is largely due to the RF section shown at right. It is mounted as a unit on a brass plate  $\frac{1}{4}$  inch thick. The two type 954 RF amplifiers and the type 954 mixer are placed in the heavy shields which separate the stages. The type 955 oscillator is mounted directly on its tuning condenser. Exceptional stability is assured by the use of individually selected enclosed ball bearings, extra-heavy end plates, and wide spacing in the oscillator condenser - rigid mounting of all components - and inductances of  $\frac{1}{8}$  inch copper tubing wound on polystyrene forms. All conducting parts are heavily silver plated.

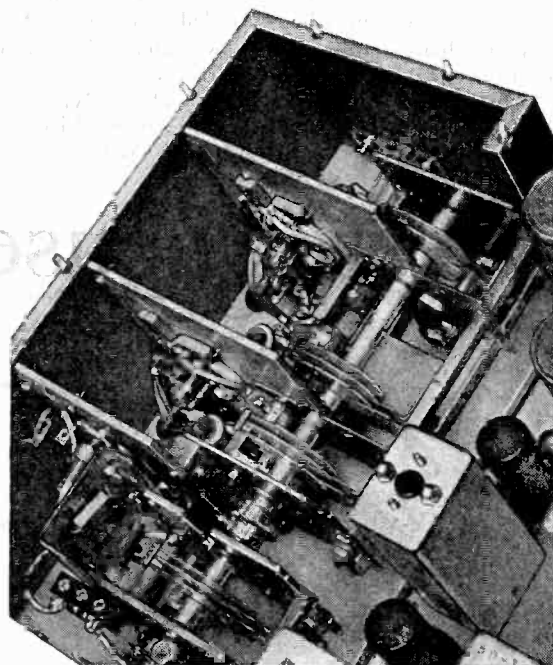

Write for Catalog No. 36F, describing Hallicrafters complete line of high frequency receivers and transmitters.

BUY A WAR  
BOND TODAY!

# hallicrafters RADIO



THE HALLICRAFTERS CO., MANUFACTURERS OF RADIO AND ELECTRONIC EQUIPMENT, CHICAGO 16, U.S.A.



# WEAVING COMMUNICATION HIGHWAYS

**RESEARCH**

*FINDS THE IDEA*

**DESIGN**

*GIVES IT FORM*

**DEVELOPMENT**

*MAKES IT WORK*

**SPECIFICATIONS**

*TELL THE FACTORY*

## **BELL TELEPHONE LABORATORIES**

brings together the efforts of 2000 specialists in telephone and radio communication. Their wartime work has produced more than 1000 projects for the Armed Forces, ranging from carrier telephone systems, packaged for the battle-front, to the electrical gun director which helped shoot down robots above the White Cliffs of Dover. In normal times, Bell Laboratories' work in the Bell System is to insure continuous improvement and economies in telephone service.



# PREVIEW OF A STARTLING NEW FARM TYPE BATTERY



**OLD**

The present No. 748 1½-volt "A," 90-volt "B" A-B Pack  
Dimensions, 15 13/16" x 6 15/16" x 4 15/32"  
Weight, 23 lbs., 11 oz.



**NEW**

The New No. 758 1½-volt "A," 90-volt "B" A-B Pack  
Dimensions, 10 11/16" x 6 13/16" x 4 1/8"  
Weight, 16 lbs., 13 oz.

## 30% SMALLER, LIGHTER -BUT SAME CAPACITY!

**T**HIS GIVES YOU an advance-look at the latest "farm-type" radio battery to be developed by National Carbon Company. A revolutionary construction makes this smaller, lighter "Eveready" "Mini-Max" battery a reality. Actually it is a good 30% more compact than the present No. 748 A-B Pack. Yet not one bit of capacity has been sacrificed in achieving a valuable reduction in size and weight.

The advantages of this more compact battery will be obvious to you. The way is paved for smaller, less expensive battery-operated radio sets. And these sets will have the advantage of being far easier to move about from room to room. The way is likewise paved for sets of the present size utilizing the space saved by the new battery to use larger speakers giving improved receptivity and tonal qualities. Both add up to a greater demand for farm-type radios and an important increase in business for you.

This newcomer, known as the "Eveready" No. 758 A-B Pack, is only one of many improved types of "Eveready" bat-

teries which will appear after the war. Look to National Carbon's exclusive construction, used in the "Mini-Max" battery, for more and equally important news to the trade.

**"EVEREADY"**

**MINI-MAX**  
TRADE-MARK

**RADIO "B" BATTERIES**  
**NATIONAL CARBON COMPANY, INC.**  
*Unit of Union Carbide and Carbon Corporation*

**UCC**  
General Offices: NEW YORK, N. Y.

The trade-marks "Eveready" and "Mini-Max" distinguish products of National Carbon Company, Inc.

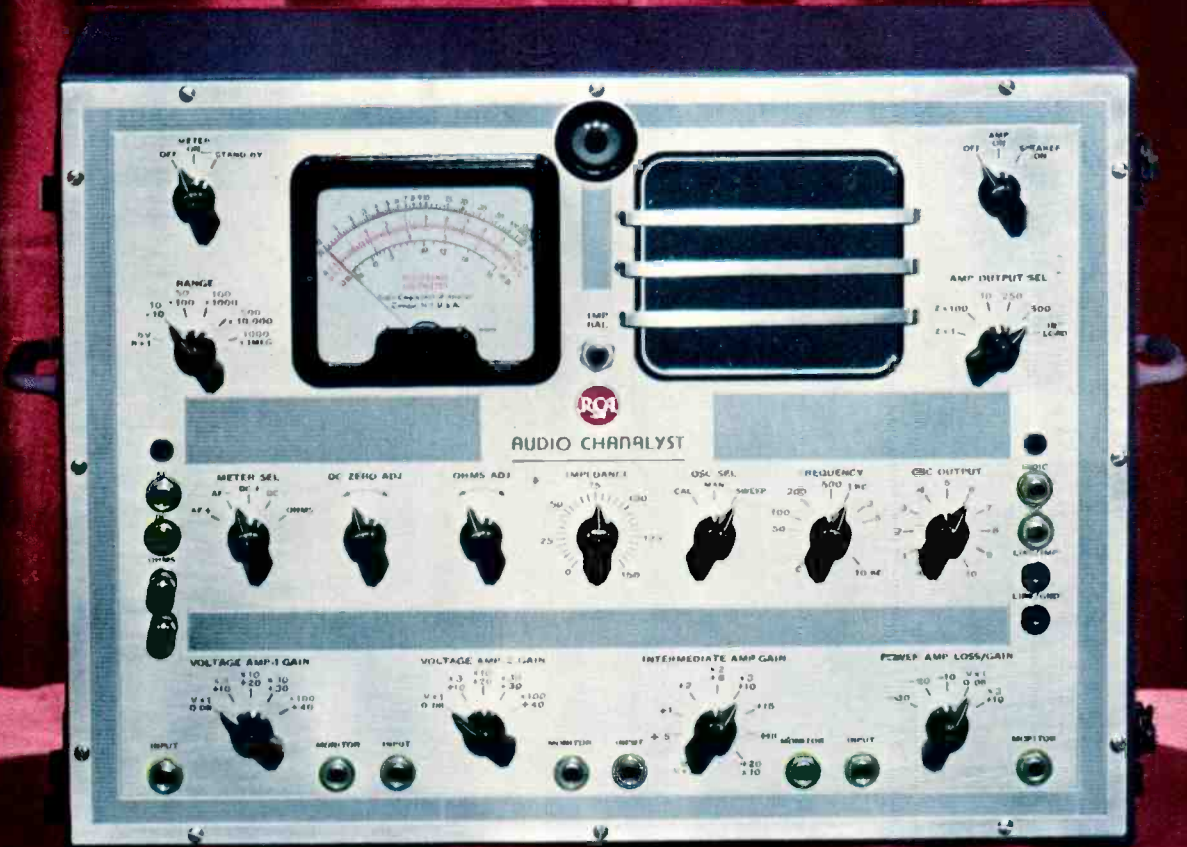

## THE NEW AUDIO CHANALYST

Here is a complete test bench for sound-system servicing — a test bench which is self-contained, easily carried where needed.

Includes a calibrated high-gain amplifier for signal tracing, tube checking and gain measurement; a beat frequency oscillator with automatic sweep for testing multiple-speaker installations; a built-in Volt Ohmyst modified for linear audio measurements, an impedance tester, a high-speed Electronic Indicator, a loudspeaker, and other features.

Use this new instrument in checking microphones, amplifiers, loudspeakers, audio distribution systems, theatre sound systems, public-address systems, industrial music and announce systems.

For bulletin describing the new 170-A Audio Chanalyst write: Test Equipment Section, Dept. 255, RCA, Camden, New Jersey.

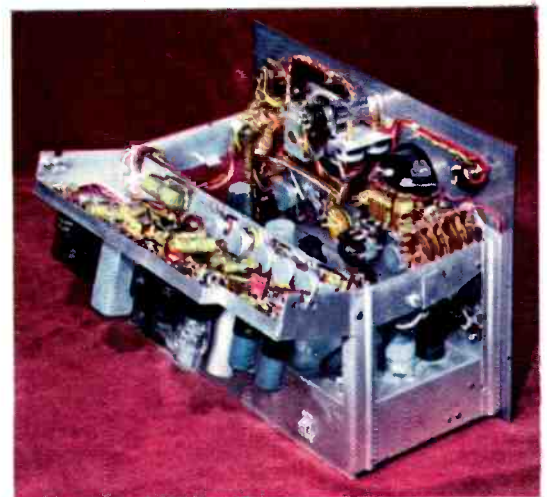

BUY MORE WAR BONDS



# RADIO CORPORATION OF AMERICA

RCA VICTOR DIVISION • CAMDEN, N. J.

In Canada, RCA VICTOR COMPANY LIMITED, Montreal

DESIGNING TELEVISION, FM,  
OR SHORT-WAVE EQUIPMENT?

# RCA PREFERRED-TYPE METAL TUBES CAN BE A BIG HELP TO YOU



THE FOUNTAINHEAD OF MODERN TUBE  
DEVELOPMENT IS RCA

BUY MORE WAR BONDS

● Intrinsic features of RCA Preferred-Type Metal Tubes offer many advantages to set-designers.

Because metal tubes are little affected by stray fields, you get greater flexibility in mechanical layout, resulting in compact, stable circuits, which are economical to manufacture and easy to service.

Other features are simplified grounding through the No. 1 socket terminal, standard octal base, sturdy appearance, and wide acceptance among designers and servicemen. And there are 55 types from which to choose. A substantial number of these were on the prewar RCA Preferred-Type list, and many are sure to be retained on the postwar list.

First to manufacture metal tubes, RCA has introduced over 90% of the metal types now available — and has built more than 150,000,000 metal tubes since 1935.

If you have a design problem involving receiving tubes, investigate RCA Preferred Types — metal, glass, or miniature. RCA tube-application engineers will be glad to help. Write to RCA, Commercial Engineering Section, Dept. 62-30P, Harrison, N. J.



62-6136-30

**RADIO CORPORATION OF AMERICA**

RCA VICTOR DIVISION • CAMDEN, N. J.

Communication and electronic engineers are profoundly interested in, and influenced by the thoughts of the industrial leaders in their field. Accordingly there are presented in the PROCEEDINGS expressions of the viewpoints of such men, in the form in which they are received. There follows a guest editorial from the Executive Vice President of the Columbia Broadcasting System.

*The Editor*

## The Engineer Goes to War and Prepares for Peace

PAUL W. KESTEN

The part which radio- and electronic-engineers have played in this war adds up to a major contribution towards our victory. It is true that radio engineering made its influence felt on the outcome of World War I, but the real mass of its applied skills, as one of our most powerful arms in this war, bases on developments between both wars.

These developments in turn were largely encouraged and implemented by the radio broadcast industry. Within the past 25 years of radio's youth, competitive enterprise has built a system of communication not only to the whole people of our own nation, but one which carried round the world. The engineers did this job. Starting with comparatively crude equipment and methods, the engineers have built step by step, at a rapid pace, a remarkable physical structure. The public has given its service loyal support, and realistic incentive to constant improvement.

When war came to us, it brought with it an interesting division of the forces within radio. The civilian service was so sound that it could continue to offer essential broadcasting to the mass of the people and to the armed forces, and to perform an enormous new service in fortifying the morale of the home front. The diversion of many technicians to the Armed Forces put an extra burden upon those charged with maintaining the home-front plant. They have carried this extra burden superbly. Meanwhile, radio research for military purposes marched into military silence and locked the door, and went to work. There the lessons of radio in peace were applied to war, and it is no military secret to state that they have added incalculable strength to each of our military arms.

When the guns cease fire, the nations of the world will require every resource of technology for the repair of damage, and the building of new services. They must to a considerable extent pattern after our own. They must rely at first largely on our earned leadership not only in military electronics, but in the manifold improvements and discoveries within American civilian radio: standard-wave broadcasting, frequency modulation, short wave, television, and facsimile. Ships at sea, cars on the road, trains on the right of way and planes in flight will depend increasingly on radio. Radio broadcasting and television face the task of facilitating the distribution throughout the world of increased quantities of useful goods and services, in order to support healthy peacetime economy, and the jobs that make such an economy.

Today our eyes must be kept focused directly upon the line of battle. But it is impossible not to foresee that the application of the skills of the radio engineer in the subsequent reconstruction of the world imposes a constantly widening opportunity and responsibility upon the radio engineering profession. My long and intimate association with the engineers of radio, and my deep respect for the stability and imagination and accomplishment of their profession, leaves no doubt whatever in my mind that they will meet this new challenge fearlessly, and that their victories in peace will be even more renowned than their magnificent contribution to victory.



Harris and Ewing

## Stuart L. Bailey

### BOARD OF DIRECTORS—1945

Stuart L. Bailey was born in Minneapolis, Minnesota, on October 7, 1905. He received the degree of Bachelor of Science in electrical engineering from the University of Minnesota in 1927, and the Master of Science degree from the same institution in 1928. During his undergraduate years he was active on the staff of W9XI, an experimental station run by the University; while taking his graduate work, he was chief engineer of WLB, owned and operated by the University of Minnesota. His Master's thesis was on the subject of radio field-intensity measurement.

In the summer of 1928, Mr. Bailey accepted a position as assistant radio engineer with the airways division of the United States Department of Commerce. His experience there included work on radio aids to marine and air navigation. He initiated and supervised the early work of the Lighthouse Service on radio-controlled fog signals, and participated in the development of the visual radio range for use on the airways of the United States.

In the summer of 1929 Mr. Bailey went to Panama, where he installed two automatic marine radio beacons, one at the entrance to Cristobal Harbor, and the other at Cape Mala, 120 miles south of Balboa.

In September, 1930, he joined with C. M. Jansky, Jr., to form the consulting engineering firm of Jansky and

Bailey. Mr. Bailey's activities in the consulting field have been on both general allocation problems and specific engineering guidance for broadcast stations and commercial operating companies. He has had charge of all of the laboratory activities of the firm, including the development of field-intensity-measuring equipment and other devices used by the firm in evaluating radio-station effectiveness.

In the fall of 1941, Jansky and Bailey entered into a prime contract with the Office of Scientific Research and Development; and all of the work under this contract as well as subsequent contracts, has been under Mr. Bailey's direct supervision. At present he is in charge of a laboratory working full time on Office of Scientific Research and Development contracts of a secret nature.

He became an Associate Member of the Institute of Radio Engineers in 1928, a Member in 1936, Senior Member in 1943, and was advanced to the grade of Fellow in 1943. He has been a member of the Committee on Wave Propagation since 1939, and was a member of the Admissions Committee in 1943 and 1944. He was appointed a member of the Board of Directors of the Institute in 1943 and 1944, and was elected to the Board for a three-year term beginning in 1945. He is a member of Sigma Xi, Theta Tau, and Eta Kappa Nu.

The positions of the engineer in his local community, the life of the nation, and the planning activities for world future have properly engaged increasing attention among thoughtful leaders of the profession. An ever-larger number of constructive contributions to thought in these fields has of late been presented. On some following pages, there are printed extracts from an article by C. A. Powel, President of the American Institute of Electrical Engineers, stating his reasons for urging engineers, through their professional societies, to join in carrying out their public responsibilities. We are indebted to Mr. Powel, the American Institute of Electrical Engineers, and its publication, *Electrical Engineering*, for their courtesy in permitting the use of this material.

The professional and civic significance of Mr. Powel's comments, considered together with his concomitant activity in association with the presidents of other engineering societies, has been analyzed in an accompanying presentation by Ivan S. Coggeshall, a former Director of The Institute of Radio Engineers and one of its earnest planners and supporters. Mr. Powel's views and Mr. Coggeshall's comments are commended to the attention of the thoughtful readers of the PROCEEDINGS by the Board of Directors of The Institute of Radio Engineers.

*The Editor*

## The Engineer's Place in the Modern World\*

IVAN S. COGGESHALL†, FELLOW, I.R.E.

WHILE THE president of the American Institute of Electrical Engineers, in his article "The Engineer and His Future," deplores present lack of an eminent organic council to determine and express the collective viewpoint of engineers, he has not let its non-existence stand in the way of employing another more available means of expression, by joining with the presidents of the American Society of Civil Engineers, the American Institute of Mining and Metallurgical Engineers, the American Society of Mechanical Engineers, and the American Institute of Chemical Engineers to publicize a protest against the Morgenthau plan of reducing Germany to agricultural-nation status by removing or destroying her industries. This protest was published in full in the November, 1944, issue of *Electrical Engineering* and in the organs of the other participating societies. It is of considerable interest to engineers to note that one of the reported results of the Crimea conference made public at the White House on February 12, 1945, was that the three leaders of the United Nations are determined to eliminate or control all German industry that could be used for military production, yet determined not to destroy the people of Germany, their hope for a decent life, nor to deny them a place in the comity of nations.

The engineers' recommendations may be epitomized as follows:

In general, the Morgenthau proposal is indefensible

\* Decimal classification: R060. Original manuscript received by the Institute, February 8, 1945; revised manuscript received, February 21, 1945.

† Western Union Telegraph Company, New York, N. Y.

because destruction of the machines, utilities, tools, materials, and other essentials for peacetime living penalizes not only the owners of the materials destroyed, but the world as a whole.

On the contrary, a clear defensible objective would be to institute effective industrial means to keep Germany from starting another war, but to give Germany its chance for recovery along peaceful lines after the war.

This is farthest from any suggestion of a so-called "soft peace." The proposal is not for indiscriminate destruction but selective restriction and control of German industry by elimination of the following:

1. All synthetic coal-distillation plants which have been used to produce 50 to 60 per cent of the German war-soil and gasoline requirements.
2. 75 per cent of synthetic-nitrogen plant capacity, which accounts for 80 per cent of German nitrogen production used as the principal ingredient of explosives.
3. 50 per cent of Germany's steel-making capacity producing heavy forgings, electrolytic and high-alloy steels.
4. Aircraft plants and equipment.

Accompanying the discontinuance of these manufacturing activities would be effective control or prohibition of imports of manganese, chromium, nickel, tungsten, iron ore, flux material, steel, steel products, bauxite, aluminum, petroleum, pyrites, chromium ore, and nitrogen compounds.

It is felt that taking these precautions would afford ample insurance against war without preventing the

re-establishment of a productive German economy for nonmilitary purposes.

It will be noted that heavy industry dominates the list of German industrial activities which should be prohibited or controlled, in the opinion of the spokesmen for the 75,000 engineering members of their societies. By that standard, The Institute of Radio Engineers is concerned but little in the subject matter of this particular protest. The important point for I.R.E. members is that other engineers are here expressing themselves politically (in the best sense of the word); they are seeking to discharge a social responsibility and give voice to a conscience which transcends belligerency and sees the future clearly through the fog of war.

The document referred to is, therefore, something new in over-all engineering expression. The trend will bear watching by I.R.E. members. Our Institute is more and more broadening its horizons by co-operating with other organizations: the American Institute of Electrical Engineers, American Standards Association, International Scientific Radio Union, Radio Technical Planning Board, Radio Manufacturers Association, National Association of Broadcasters, National Electronics Conference, to name but a few. We have taken

formal legislative positions on induction of engineers, nationalization of research and patents, and postwar planning. Special committees are watching such developments as state licensing of engineers, collective bargaining for engineers, codification of engineering ethics, and certification of colleges. Recently, the subject of engineering education engaged the attention of the Sections meetings as a nationwide forum. Our conventions, of late, have featured speakers bringing broad-gauge engineering messages. The pages of the PROCEEDINGS have carried feature articles and guest editorials of similar content. Yet the possibilities have hardly been explored.

In its plans to utilize effectively its present place as one of the world's great engineering societies, the Institute must generate momentous actions. Some of these will, naturally, be excited by the Board of Directors. More of them should come from Institute committees, from letters from members to the Editor, and from letters from Section officers to the President of the Institute. Like the radio-and-electronic art, our society is young, virile, and imaginative enough to be a thoughtful leader, not a follower, in the engineering world.

## The Engineer and His Future\*

C. A. POWEL†

WAR is a tremendous stimulant. It brings about not only enormous physical production, but also mental achievements, such as scientific inventions, art in the form of stirring posters, and literature in the form of moving books and articles dealing with various phases of the conflict. One result of this mental effort is a searching analysis of the position of the engineer in world affairs. It was evident during the last war and has come very much to the fore again during the last four or five years.

A frequent criticism is that the engineer does not carry enough weight in community and civic affairs and that he does not enjoy the public prestige and regard that his professional brothers in medicine and law enjoy. Another is that his occupation is not as continuous and secure as it should be. This is true particularly of civil and construction engineers. Another is that his remuneration is not as high as in other professions.

Whether these criticisms are well founded or not will remain pretty much a matter of opinion. It is impossible

to establish the facts in the matter, because one can set up premises and definitions to prove one's case, just as in the present controversy regarding the increase in the cost of living one can prove anything from 10 to 100 per cent, depending upon what is included in the cost of living.

Nevertheless, because one cannot expect an exact answer may not be sufficient cause for ignoring the subject.

That the engineer in the early days did not get much public esteem is explained by the fact that most of them were essentially practical men with little theoretical training, whereas the physician, the lawyer, and the pastor were all university trained. The relatively few scientists who devoted themselves to technical developments never came in direct contact with the public, as did doctors and lawyers, and their work was consequently not appreciated outside of their own small circle. Up to the beginning of this century, theoretical training in an engineer was looked on by old timers with suspicion as likely to lead to errors in design and performance, particularly because the application of theory invariably led to marked savings in materials, which was tantamount, they argued, to removal of the margins of safety. The older professions likewise did not give the college-trained engineers a warm welcome, and

\* Decimal classification: R060. An address delivered at the A.I.E.E. Los Angeles technical meeting, Los Angeles, Calif., August 29-September 1, 1944. Reprinted, in part, from *Electrical Engineering*, pages 14-16, January, 1945, with permission of the author and the American Institute of Electrical Engineers.

† President, A.I.E.E.; manager, headquarters engineering departments, Westinghouse Electric and Manufacturing Company, East Pittsburgh, Pa.



attempted to establish a difference by referring to the "technical professions" as distinct from the "learned professions." The difference is real and engineers must recognize it. Today there is still no minimum standard requirement for the practice of engineering and even no satisfactory definition of what constitutes an engineer. In medicine, on the other hand, the minimum standard is not only well defined but also requires more than the bachelor's degree that satisfies most engineers. In law the situation is similar. While the general scheme of legal education differs in various localities and is not as uniform as in medicine, admission to the bar requires at least seven years of study.

However, criticism by the old die-hards did not retard progress of the theoretically trained engineer who became firmly entrenched in all branches of engineering to the exclusion of the rule-of-thumb type of man.

As the profession developed, more and more of these intellectuals began to realize that while scientific knowledge and engineering achievement were shaping the world and establishing the habits of thought and life the engineer got scant recognition in the councils of government. Attempts were made to remedy this situation, notably by the establishment during the last war of Engineering Council. This association was formed under a broad charter of what is now the United Engineering Trustees to provide for closer co-operation among the four Founder Societies on matters of general interest to engineers and to the public, and to serve as an agency for united action upon questions of common concern to engineers.

In 1920 it was enlarged to include a much larger group of engineering societies, and the name changed to Federated American Engineering Societies. A joint committee drafted the principles for a nation-wide engineering organization to be composed of representatives of local state, regional, and national societies. The conference met in Washington with 132 delegates representing 66 societies having a total membership of 130,000. After an intensive debate, a constitution was adopted containing the following objective: "To further the interests of the public through the use of technical knowledge and engineering experience, and to consider and act upon matters common to the engineering and allied technical professions."

In 1924 the name of the organization was changed to American Engineering Council, and it functioned until the end of 1940 when it went out of existence due to lack of interest and lack of funds.

We need such an overriding engineering society as American Engineering Council that can speak for all engineers with some authority. Legislation of vital importance to industry is enacted but much of it shows no evidence that industry was ever consulted. Even the soundness of such a fundamental law as the Sherman antitrust law can be debated. Unrestricted competition

does not necessarily produce the best results. We recognize this when dealing internationally by putting up tariff barriers to keep out those who can undersell us, but we close our eyes to it in our national affairs. In industries where the prices and wages are the same for all, those concerns are the most prosperous and successful that work with the highest efficiency.

Serious attacks are made on our patent system and on organized research for their alleged contribution to antisocial monopoly. Some of our socialist friends would have the product of organized research, both industrial and academic, become common property. In other words, they propose to kill the very thing that has put us in a leading position in scientific progress and has made possible our tremendous contribution to the winning of the war.

Tax policies and legislation are already such as to penalize thrift and make difficult financial protection against business recessions. These are all problems in which the engineer should interest himself because the engineer, more than anyone else, is shaping our present civilization. It was hoped that he would be able to express himself effectively through American Engineering Council, but that organization died for lack of support chiefly, I think, because it had insufficient contact with the rank and file of engineers, to most of whom it was totally unknown.

Engineering councils on a smaller scale are numerous throughout the United States in the form of local engineering organizations comprising all classes of engineers. Unlike American Engineering Council, they provide support of the engineering profession at the base of the pyramid, so to speak, instead of at the apex. They substitute a large cross section of opinion for a small one. These councils should be encouraged, expanded, and also co-ordinated. They should include among their committees one made up of the most competent men in the district to follow legislation affecting industry and science to relay to the membership any steps by the governing bodies that adversely affect their interests. The individual members through letters to their representatives could then take appropriate action, if they so desired. The better these local associations are financed, the more effective they can become. One of the difficulties is that too many engineers fail to realize that the money they devote to such societies comes back to them many fold in benefits affecting the whole profession.

I believe our need is for some overriding association of engineers whose purpose is to represent all branches of the profession in civic and state affairs, and which also is capable of watching over the welfare of its individual members in broad issues. It must first set up a definition of what constitutes an engineer, and it must have constant and intimate contact with its local branches to keep the rank and file of engineers informed and interested.

# The Engineer's Place in the Scheme of Things\*

BASED ON A FORUM AND ROUND-TABLE DISCUSSION BY  
R. H. HERRICK,<sup>1</sup> J. E. HOBSON,<sup>2</sup> J. E. BROWN,<sup>3</sup> AND A. B. BRONWELL<sup>4</sup>

MR. HERRICK introduced the subject of "The Engineer's Place in the Scheme of Things" by pointing out that engineering requires so high a degree of concentrated effort that it tends to discourage the engineer from giving thought to any problems outside of his immediate work. This lack of consideration for other problems, he continued, results in a lag of engineering education behind the technical demands of engineering, a lowering of the position of the engineer, a lack of protection against his exploitation without a fair return, a negligible participation in civic and governmental activities, and an erroneous view widely held that an engineer makes a poor executive.

Competition among engineers is increasing because of the training of war workers and service men in technological fields. Men so trained may feel that when the war is over, they should be classified as professional engineers.

Mr. Herrick further pointed out that there is a need for an increased and more widespread recognition of the engineer's potentialities and worth. To meet the public-relation needs of the engineering profession, he suggested publicity concerning what engineers have done, what they are doing, and what they intend to do; or, in other words, a plan to create in the public mind a more vivid and human picture of the profession.

In keeping with this need, Dr. Hobson discussed the "Engineer's Academic Education"; Mr. Brown "The Technical and Economic Status of the Engineer"; and Professor Bronwell "The Engineer's Social Status."

Dr. Hobson stated that the broad aspects of the engineer's academic education included the selection of the engineer, a basic training program (for the undergraduate), and the postgraduate training of the engineer.

With respect to the selection of the engineer, Dr. Hobson contended that educators have done an inadequate job of explaining what engineering is. However, neither have the engineers explained clearly what engineering is. One result is that the high-school student has a very inadequate idea of the nature and scope of the engineering profession. He has a good idea of the characteristics of the medical and legal professions, but he does not clearly visualize the activities involved in engineering. His idea of an engineer may even be largely based on the irrelevant concept of a locomotive engineer

or the like, and not at all on what engineers themselves consider to be the professional type of engineer.

Therefore educators should in the future do a better job of explaining to high-school students the character of the engineering profession, of stating the obligations of the profession, and of showing the opportunities awaiting engineers in their profession.

In addition to the duty of explaining the sphere of engineering, Dr. Hobson believed, educators have the obligation of providing for the careful selection of students permitted to enter college for the study of engineering. The engineering college should not take every applicant since not everyone can become a good engineer. It is necessary for colleges to set up some type of standard, possibly in the form of entrance tests. Some way must be found of detecting within the high school boy or girl that creative instinct which is peculiar to the engineer. A method must also be found to separate the technicians from the truly creative engineers.

The undergraduate or basic-training program often has been discussed and at great length, but no definite decision as to its content has as yet been reached. Dr. Hobson suggested that the undergraduate program should include more of the humanities, more basic-science training, more applications of basic science to engineering, and some knowledge of modern equipment. The present undergraduate engineering education is not sufficiently functional, thereby creating an illogical educational situation. In order to teach functionally, more than four years of undergraduate work are required.

This therefore suggests a five- or six-year college course as compared to the usual four-year undergraduate course.

The aims of the undergraduate school should include trying to develop that creative ability which is an essential characteristic of engineering, to inculcate the proper professional attitude, and to provide adequate curriculum subject matter to develop reasoning habits in the engineer.

Dr. Hobson suggested that after the first two years of college work, the curriculum should branch into two divisions, the creative branch and the administrative branch. The first-named branch would involve industrial engineering, research, development, and design, and the second branch would deal with the application of engineering principles, sales activities, and executive work. He felt that at present curricula now being offered are excessively crowded and not correctly subdivided in proper proportion. The laboratory work in the college should not serve merely to prove the correctness of textbook statements but should be experimental in nature so as to stimulate creative ability. The

\* Decimal classification: R070. Original manuscript received by the Institute, February 23, 1945. This Symposium was held by the Chicago Section of The Institute of Radio Engineers on November 17, 1944. The original draft report was prepared by Alois W. Graf, Secretary of the Chicago Section.

<sup>1</sup> Automatic Electric Company, Chicago, Ill.

<sup>2</sup> Formerly, Illinois Institute of Technology, Chicago, Ill.; now director of Armour Research Foundation, Chicago, Ill.

<sup>3</sup> Zenith Radio Corporation, Chicago, Ill.

<sup>4</sup> Northwestern University, Evanston, Ill.

amount of time devoted to laboratory work (which is now from thirty to forty-five semester hours), should be modified accordingly in proper proportion to the amount of class time.

The colleges should also present the truly professional attitude and a suitable respect for engineering. He told of an instance of an improper attitude displayed by a student who entered the electrical engineering department and inquired flippantly if this was the "juice" department.

The training of the engineer must continue after he leaves college. The engineer is not a finished product after four years of undergraduate work in his technical training, nor in his understanding of professional engineering, nor indeed in any other sense. Dr. Hobson felt that the most ideal training after college is that experience which is co-operative between the school and industry. This would correspond to a form of internship which should be served. This training should advance the engineer in his knowledge of basic engineering and stimulate his creative ability. Postgraduate training must be directed primarily toward creative work since the whole function of postgraduate work is to bring out further the originality of thought of the engineer which has been partly developed in the undergraduate school. The engineer also needs added education in management, industrial engineering, and even in social engineering. Research scholarships appear to be one form through which these objectives of postgraduate training may be achieved!

In the round-table discussion which followed Dr. Hobson's remarks, the question was asked as to whether any testing of the engineering student should be done during his college career to determine his fitness for the course which he has selected. It was agreed by the round-table group that it is desirable to provide some testing ground to enable the student engineer to decide which branch of work he is qualified to enter; possibly some co-operative program between industry and the schools would greatly help the student to decide on this point. It was questioned as to whether testing of the type offered by the Human Engineering Laboratory, which is a branch of the Illinois Institute of Technology, might be of any value in classifying engineering students. It was mentioned that where such tests have been used they have in general been successful; but as yet no school or college has used such type of test on all of the students. It was felt that some such tests are needed to help weed out the students who are unfitted for engineering work. In the past some engineers have not been weeded out until their senior year. It has been observed that freshmen must meet a so-called "B" average to have a good chance of becoming good engineers; and that the best point to erect barriers against unqualified engineering candidates is at the beginning of the junior year. The biggest problem is to counsel the student properly since as yet no fully dependable tests have been advanced.

The question was also raised as to the desirability of separating power engineering from communication engineering. As a general rule, the teaching profession is opposed to this plan while the industrialists take the opposite view. Both groups, however, agree that physical and technical training and cultivation of creative ability are common factors in both courses. While certain common elements are found in all types of engineering, there might be a possibility of giving a greater meaning to the subjects taught by demonstrating their application to different fields or types of engineering as for example, by showing how particular divisions of mathematics can be definitely applied to engineering problems. In this respect the high schools seem to have been more successful. Students should be made to do more original and intensive work to get the maximum benefits from their training since education is essentially an internal process.

It was agreed that the task to be done is the broad training of an engineer, and not merely the production of particular forms of specialists. Certain fundamentals underlie all engineering. The medical profession seems to have accomplished more along this line of teaching fundamentals. It would appear that the general approach made to the teaching of engineering is of prime importance, rather than a segregation of methods of specialization in certain fields.

Mr. Brown treated the technical and economic status of the engineer. The engineer, said Mr. Brown, should be trained in a logical mode of thinking. The training which gives him a logical attitude should be an advantage to him in his profession and in his sphere of activities. It should fit him broadly for handling other problems arising in political, community, and domestic fields.

In view of this it is proper to examine some of the things which concern the engineer and which affect his economic status. One of these is the matter of state licensing and its value. An observation of the operation of the New York State law for many years by Mr. Brown resulted in his conclusion that the law does not have the proper effect since it appears to limit and hamper rather than to advance and elevate the profession. He admitted that the state law might give some dignity to the profession, but he believed it did not accomplish much more than distinguish slightly between a profession and a trade. The engineer, he stressed, must think of himself as being a member of a profession and not a practitioner of a trade. He should, accordingly, think in terms of what advances the profession as a whole.

Mr. Brown felt that professional societies could do more in this field than could legislation. Thus far, many professional societies have been primarily organizations for the presentation of technical papers. Professional societies, he thought, might well become more active in some of the broader aspects of the profession which they represent, and to plan to do what they can do to

improve their profession. As an example of what can be accomplished, he believed the architects seem to have done more than the engineers, and it seems definite that the doctors and lawyers have done even more.

Another factor to be considered, observed Mr. Brown, is the value of unions to engineering. The engineer is a creative man. He is a person who has to figure things out for himself and then to do them in his own way. The union fetters and ties down the professional man.

Another interesting matter considered by him was the comparison of government work with industrial work, and correlatively the likely future of an engineer in a government organization. The danger of government-laboratory work, he felt, is that future important developments might never spread out into private industry and would thus be immured in the governmentally organized laboratories. Industry can envisage better peacetime applications of research than can government organizations. Competent men, he feared, might be taken from private industries and placed in government work which would not advance the development of industry and engineering as effectively as if they were in private industries. Thus many engineers might be frozen in their present status and not serve to advance peaceful progress. A government laboratory engineer cannot, in general, be industrially active after the war unless he goes into industry.

Mr. Brown suggested careful consideration of what could be done to broaden the outlook of the engineer. He said that the engineer has an unfortunate tendency to become wrapped up in his own specific problems whereas he should do other and broader thinking. It is an obligation to himself and his community occasionally to think constructively in some other fields.

Mr. Brown was of the opinion that the professional status of the engineer appears to have been appreciably affected by the unfortunate and misleading term "engineer." The problem appears to be how to get away from the misuse of the term "engineer," and how to differentiate clearly between professional engineers and, on the other hand, such "engineers" as the locomotive engineer.

The salary status of the engineer certainly is not in the best condition. Often a salesman of equivalent ability and application is far better compensated than the engineer. The problem of raising the economic status of the engineer is now with us and shows some promise of being improved. The engineer must have a rise in his status. Perhaps this can best be assisted by the engineer's interest in community affairs and by his development of a broad viewpoint along lines of interest to the general public and industrial executives.

The round-table discussion following Mr. Brown's remarks emphasized that the term "engineer" is indefinite, and this is a matter of concern to the engineer. The question arose as to whether a part of the indefiniteness might not be caused by the use of "engineer" in nonengineering jobs where a so-called engineer is

asked to do routine work not properly within the sphere of a professional engineer's position. The answer would appear to be partly in a sharp differentiation between technical assistants and engineers, and in raising the standards for the professional engineer.

In foreign countries, the group discussion further brought out, technical training schools constitute the largest educational group, and the universities are an important, smaller, and more evolved group. In the United States the contrary conditions prevail and it might be to our advantage to follow the foreign example. The Engineering Science and Management War Training program has shown the need for the highest type of technical training in the United States. As to the future of technical training when compared to engineering training, this perhaps can be learned from an observation of the radio industry where its complexity and the correspondingly complicated profession of radio engineering will illustrate the complexity of the matter. Technical training should be a definite process leading to a particular goal and not merely a stepping stone to engineering training, since there is clearly a need for both types of workers.

Professor Bronwell discussed the effect of university training on the engineer's social status. The social responsibility of the university is to provide a complete and integrated undergraduate training program covering both technical and social studies. The principal objective of the university is to train men suitably and to provide a proper program for such training. There is considerable difference of opinion as to what the training program should contain. Thus, some educators advocate a highly analytical training while others propose to broaden the engineering program. Thus there is disagreement among the experts, which, while probably a healthy condition, presents the need for two types of training programs as originally suggested by Dr. Hobson.

The basic elements of an engineering course, according to Professor Bronwell, include the fundamental sciences integrated with mathematics. This sequence should be properly co-ordinated with not too much stress on specialization. Adequate provision should be made for humanistic and social courses presenting broader outlines of social, political, economic, and industrial problems. The university should also provide a comprehensive and intensive graduate program, to train engineers for professional leadership in science, engineering, and administration, and to prepare them to contribute creatively to the advancement of the art. Evening graduate training programs are seriously needed in many cities and some of the Engineering Colleges have instituted evening graduate courses to satisfy this need. The university's social responsibility lies in the direction of the fields of fundamental knowledge and the developmental of research. The need for creative research to extend our frontiers of knowledge and expand the industrial horizons has been repeatedly emphasized

by such eminent men as Mr. Kettering and others.

Professor Bronwell expressed the further opinion that there seems to be a need for a broad-scale type of research, of more socialized character than at present carried out by the highly specialized research organizations in industry. There is also the need for such research organizations to make their research efforts available to smaller industries and to society as a whole.

Part of this proposed expansion of research can be handled by the universities, many of which are planning on extending their research activities after the war.

The engineer's social responsibilities, contended Professor Bronwell, may require a change in his attitude toward social improvement which, at present, is often predicated on the assumption that what is not economically profitable is not socially desirable. The government projects seem, at times, to take the absolute opposite of this attitude. An intelligent compromise is necessary, together with the awakening of management and engineering to the importance of a new philosophy of management, government, and labor. Management may rightfully be accused of having been unduly stubborn on many issues as, for example, on the rural-electrification issue where the government approach resulted in a social benefit. Obviously, concluded Professor Bronwell, there is a need for a more intelligent meeting of the minds between government and management.

Management needs the stimulation of creative ideas and accordingly industry should not fail to promote the development of creative thinking among its employees. Professor Bronwell again pointed out that relatively few people do original thinking, and perhaps one reason for this among engineers is that they are usually given a particular job to do and are then kept so busy along that particular line that their thinking becomes channelized. Part of this proposed expansion of industrial research may be had through the expanded research efforts in universities.

Professor Bronwell pointed out that, in general, the engineer avoided social responsibility. This he contrasted with the interest in civic affairs displayed by doctors and lawyers (whose financial income, incidentally, bears a direct relation to such interest). He has found that senior students of engineering are not interested in obtaining government positions since apparently some social stigma is attached by them to working for the government. He admitted that there is no incentive for responsible people to go into certain government positions of the routine or "dead-end" type.

The subsequent round-table discussion mentioned the present tendency to apply the brakes to any monopolistic tendency or action by industry. The question was then raised as to whether research of the fundamental type should be carried on in college or whether it might be preferable for the college to encourage research of the developmental type. The research accomplishments in the university laboratories have played a

vital role in winning the war. The discussion also indicated that there seemed to be some factor in government organizations which tended toward a degeneration of the activities, enterprise, or opportunities in such organizations, which fact might account for the lack of interest of students in government engineering positions.

The forum discussion brought forth various views which supplemented the discussion by the principal speakers and their round-table conferences. The following is a summary of the discussion in which S. J. Bartha, J. M. Cage, C. A. Christensen, Edward Classen, Alfred Crossley, Beverly Dudley, Dr. H. C. Fruth, Alois W. Graf, J. B. Hershmann, Earle Kent, Cullen Moore, C. A. Petry, Paul Smith, and W. O. Swinyard participated.

It was pointed out that if the engineering profession is to maintain a high standard of excellence, the increased scope of engineering which must be taught requires more effective and powerful teaching methods to provide the student with a sound foundation of general engineering principles. Further, the length of training required for professional proficiency must be increased. Undoubtedly there are many opportunities for enhancing the effectiveness of teaching methods, particularly in mathematical subjects. Mathematics must constitute a compact method of quantitative thinking and must largely express the physical relation between those engineering quantities in which the engineer is vitally interested. Therefore the physical interpretation of mathematics should be particularly emphasized and taught by those who can apply it, instead of being taught by those whose interest in mathematics bears no relation to its practical utility. This does not mean any opposition to the study of pure mathematics, but it does suggest the desirability of teaching mathematics in a fashion more helpful to engineering by correlating symbolic modes and operation with factual and physical problems of engineering.

To illustrate what is intended to be suggested, much more could be accomplished in the physical interpretation of mathematics through the judicious use of animated motion pictures, models, and more effective textbook illustrations. If the fundamental processes, such as modulation or detection of electromagnetic waves (which require mathematics for their detailed comprehension), were illustrated by accurately drawn and clearly produced animated drawings, these drawings could be properly co-ordinated with the mathematics of the problem they represent so that no engineering student could fail to grasp the fundamentals of a problem the first time he is introduced to it.

It was also pointed out that perhaps the public measure of an engineer depends somewhat on his activities. The medical doctors, for example, are in wide and repeated contact with individuals in their community. An engineer is not so close to the members of his community since he is essentially concerned with industry

and manufacturers. Any attempt to gain the same kind of respect by personal contacts is a step in the wrong direction. The engineers might rather try to make the public conscious of the quality of their leaders and of their own work, and thus to gain more recognition by educating the public to the value of engineering and occasionally dramatizing their profession.

The education of the engineer should begin at high-school level since creative ability begins at this level shortly after adolescence. At present creative ability is not given encouragement until after the sophomore year in college when it may somewhat have deteriorated through lack of encouragement. Creative ability should not be stifled; and high schools should encourage it by arranging for their students to spend some time working in industry on activities requiring originality.

The Armed Forces training program indicates that many of the things which the older engineers learned after their college training were far more valuable than much of the theory presented in the usual engineering courses. It appears that there is a need for concentration on basic training, and that the high school might to advantage train students to solve actual, practical, and difficult problems so as to develop their creative ability.

One suggestion for an improvement in the status of the radio engineer was that he might work for himself rather than for a member of the industry. This procedure might avoid the inefficient use of an engineer in a field for which he is not fitted. Too often engineers have been used where technicians should be employed, and often technicians have been used in place of engineers. Such misplacement is to the detriment of the economic status and professional standing of the engineer, and at the same time constitutes a loss to management which thus fails to make the best possible use of the available engineers. Management has an investment in each employee, and consequently it should not indiscriminately use its employees so as to waste their efforts and ultimately discourage them any more than it would indiscriminately misuse and finally wreck its machinery.

Engineers may be well trained technically, but as a rule they do not know how to get along readily with other people. Social studies bearing on this point should be stressed in an engineering curriculum since the approach to this subject in the past has been much too indirect or even missing. Better social adaptation would considerably assist in the establishment of the social

and economic status of the engineer on a higher plane.

Teaching would be greatly improved if college professors were expected or required to keep up with new developments in industry. In fact before a college professor obtains any promotion in his position, it is reasonable to expect that he should be able to prove that he can get an equivalent salary in industry.

It was then mentioned that some industries are now providing teachers for employees within their organization since improvement of the worth of an individual to the organization is deemed to be a paramount necessity. The administrative practices of industry are of importance to engineering students and should be brought to their attention.

Engineering education courses might well be lengthened, and the teaching made more efficient. The marks or grades received in school should not be as important as the actual knowledge and thinking habits acquired by the student. Courses should be better planned, coordinated, and integrated to teach the engineer to think logically. An increased efficiency in effective presentation of ideas may stimulate the student's ability to think straight. The human engineering side of engineering courses should be emphasized, so as to explain the psychological traits of the introverts, and their peculiar adaptability in some instances and for certain functions in the engineering profession. To improve teaching further, higher pay should be offered to the instructors.

The discussion further indicated that it is almost impossible to introduce new curricula in colleges to bring their courses up to date. It also is difficult to prove to the colleges that there is a greater need for more technicians than for more engineers. It was suggested that the length of the engineering course be increased and that its content be modified to include some form of "co-operative engineering." Such a co-operative course might be devoted to developing the ability of the engineer to get along with other people, and to stimulate the trait of introspection or self-examination so that, subsequently, the engineer will know how to accommodate himself to various conditions and how to adopt the proper attitude toward his fellow engineer and management. He may improve his social status and professional repute by rubbing elbows with those people who might aid his advancement. Joining in activities outside of those of his engineering group, together with some measure of well-assimilated business training, may improve his general place in the community and in the industry for which he works.

### Correction

"In the February, 1945, issue of the PROCEEDINGS, on page 71, the date of birth of Browder J. Thompson was given as August 14, 1903. To correct this inadvertent error, it is here stated that the date of Mr. Thompson's birth was August 14, 1904."

# The Navy Electronics Program and Some of Its Past, Present, and Future Problems\*

J. B. DOW†, FELLOW, I.R.E.

*Summary*—The decisive factor in determining the outcome of the present world conflict may well be the wide and intelligent use of the latest products in the field of electronics. Certainly when it is possible to tell the whole story of the effectiveness in combat of many new electronic devices, all those who have made significant contributions in this field will have reason to be proud of the part they have played. This paper emphasizes the significant part played by the men and women of science and industry who have assisted our country in maintaining the lead which the United Nations now hold in electronic equipment used by the Army, Navy, and Marine Corps in modern warfare. Comparisons are presented which indicate the amount of money appropriated for electronic research and development in the Navy prior to the war, with the amounts being currently expended for the same purpose. The paper presents in its broad outlines the author's ideas of what he considers to be a forward-looking research and development program of adequate scope. The magnitude of the production and installation problem which has faced the Navy in equipping its vast fleet and air arm is reviewed, with a brief description of the organization required to accomplish the program. Some of the unusual climatic and atmospheric conditions which must be met by electronic equipment in service are outlined to give emphasis to the need for high performance standards in specifications. The standardization work now being carried on by the Army-Navy Electronics Standards Agency established in December, 1943, is described and specific recommendations made for participation by design engineers and manufacturers in a comprehensive component standardization plan. The paper gives considerable attention to the possibility of establishing a postwar radar patent pool, with specific suggestions on how such a pool might be operated. It is pointed out that, unless there is a reasonable adjustment of the patent situation, the public will not be able to purchase the most suitable designs of radar equipment because of adversely held patents, pyramiding of royalty rates with consequent excessive equipment costs, and costly, time-consuming litigation which will follow issuance of patents.

OFFICERS and Members of the American Institute of Electrical Engineers, The Institute of Radio Engineers, and Guests:

When I was first approached by Dr. Kelly, of your Joint Sessions Committee, in the matter of addressing you this evening, my response was not as enthusiastic, I am sure, as he would like to have seen it. The fact is, for several days preceding Doctor Kelly's call I had been engaged in a series of discussions concerning the security classification of electronic equipment. With these discussions freshly in mind, I accepted the invitation to make this address with a certain feeling of trepidation, not knowing exactly what I could talk about that would be of interest to this distinguished audience.

Electronics, as you all know, is playing a leading role in this great war in which substantially the entire world is engaged. Because it is the newest of the arts used in

\* Decimal classification: R565. Original manuscript received by the Institute, January 29, 1945. Presented, Joint Meeting, I.R.E.-A.I.E.E., New York, N. Y., January 24, 1945.

† Captain, United States Navy, Bureau of Ships, Washington, D. C.

warfare on a large scale, because it has become the very heart of so many tools and weapons, and because its field of usefulness and art itself are developing so fast, the outcome of the present war may very well be decided in favor of that nation which maintains the greatest lead.

I wish to state here that the Navy, the Army, and the Nation are depending upon you distinguished men and women of science and industry assembled here this evening, and upon your associates, to maintain the lead which the United Nations now hold. From your minds and hands have come equipments and devices so important and so widely used that they take second place only to the personnel of our armed forces who utilize them, and without these tools they would be at a hopeless disadvantage in the face of enemies such as we are dealing with today.

I regret that the peace has not yet been won so that I might have the pleasure of telling you in the language of action reports by fleet and force commanders, and commanding officers of ships, some of the many narratives in which the outcome in battle is attributed directly by those officers to our superiority in the utilization of equipment which you have provided. When the hundreds of thrilling action narratives involving electronic equipment are unfolded to you in the days to come, I can assure you that you will be proud of the part which you have contributed to the success of these battle actions.

This evening I should like to have you members of the American Institute of Electrical Engineers and The Institute of Radio Engineers take with me a retrospective glance at the Navy's electronics program, follow it through today, and delve a little into the future.

The Navy has always recognized the importance of radio communication to the operation of ships and aircraft, and for many years prior to the present conflict, had not been unaware of the equally or even more important part which other types of electronic equipment might play in a future war. Many of you here tonight have been engaged in endeavors to meet the Navy's requirements for communication and other electronic material over a period of a great many years, and I am sure you will agree that we have continuously sought equipment, components, and materials just a little better than you thought possible to produce at the time, and when you developed or produced something that met our needs, we almost invariably tightened our specifications or otherwise asked for more the next time.

As a result of your co-operation, your ingenuity, skill, and resources, Navy communication equipment was

well designed for the big job ahead at the time of our entrance into the war.

A long period of research and development by the Naval Research Laboratory with the assistance of the tube laboratories, and later, the leading equipment manufacturers, had produced some very satisfactory types of radar, and by December 7, 1941, these were coming off the production lines in considerable numbers.

Much of what is done in research and development depends upon funds available for the purpose. Prior to the Navy fiscal year 1942 there was made available to the Naval Research Laboratory, for electronic research and development, an average annual sum of approximately \$300,000 to cover the salaries of scientific personnel and project material. Funds for labor and the overhead connected with the laboratory were provided in addition to this. In 1942, the above figure was increased to approximately \$600,000. For the fiscal year 1945, a figure of approximately \$8,855,000 will have been reached.

While the Navy depends upon its own research and development facilities for much of this work, particularly where developments require the highest degree of security, or which, by their nature, are of little interest to commercial laboratories, much of the work is contracted to commercial electronic-research and engineering organizations. The funds being spent during the fiscal year 1945 on such commercial contracts for research and development work will amount to approximately \$38,000,000, which is exclusive of an estimated \$25,000,000 being expended for development work under production contracts. These latter two figures total \$63,000,000. The corresponding figure prior to the fiscal year 1942 was approximately \$3,800,000.

Since the establishment of the Office of Scientific Research and Development, the Navy has drawn heavily upon the directly administered or contracted laboratory services of that office. I do not have a figure to indicate, in terms of dollars, the very substantial contribution of these laboratories to Navy research and development, but it would probably be at least equal to the \$8,855,000 previously indicated for the Naval Research Laboratory with certain overhead and labor similarly not included.

In summarizing the above figures, it will be seen that in the fiscal year 1945 a total of approximately \$80,000,000 will have been contributed to Navy research and development in the electronic fields of radio, radar, and sonar, in comparison with a corresponding figure of roughly \$3,800,000 prior to 1942.

The spread between these wartime and peacetime figures is so great that, even with full recognition of the fact that a war greatly accelerates the demand for research and development, the only sound conclusion which can be drawn is that we don't do enough such work in peacetime properly to prepare for war. When we again emerge from the present world catastrophe, I sincerely hope the need for an adequate peacetime research and development program will not be forgotten, and

that a minimum of \$25,000,000 per year can be made available to the Navy for this work in the fields of radio, radar, and sonar. All chiefs of bureaus concerned recognize the need for an adequate program, and the Secretary of the Navy is, as you know, an enthusiastic supporter of research and development. What is needed is an everlasting inscription of that need in some suitable place so that it will not be lost from sight in the march of time to come, when those who now recognize the need are gone. Machinery for this purpose is now being set up and I trust it will meet the aims to which it is directed.

A forward-looking, well-organized and directed research program of adequate scope is admittedly costly, but it is nowhere near as costly in dollars and lives as a research program which is undertaken too late or after war begins, because, following research, comes the long design, development, and testing period necessary before new discoveries and modifications can be translated in terms of equipments installed and ready to use.

It is true, of course, that intense wartime research such as has been conducted by the Navy through the Naval Research Laboratory, the National Defense Research Committee, and a great many commercial agencies, has advanced the art of electronics by many years. I doubt that the bulk of electronic weapons which are now in large-scale production and use would have been available in their present forms for another ten years without that intense research. I am convinced, however, that many would have been available before December 7, 1941, had the importance of research and development been recognized to the extent which this war of science has taught us, and had funds been available to carry out vigorously a well-planned program.

To say that any nation is ahead of any other in a scientific art is likely to be misleading unless the comparison is based upon identical needs. Except in the case of submarines, Germany no longer has a navy of any considerable importance. Japan has one of considerable size, but it is not required to operate 8000 miles from its prime supply sources and repair bases. From such observations as we have been able to make, it is safe to state that, from the Navy point of view, American science and industry have met our needs as well as the Germans have met theirs. We have good reason to believe these needs of our Navy have been considerably better met than the corresponding needs of Japan.

We must at least maintain our present position, and to shorten the war we must improve it. To do either requires that we move ahead with all possible speed and effort. A static position rapidly will put us behind. You men in this auditorium tonight are, in effect, the controlling stockholders of those great assets to the Navy and the nation, comprising the ingenuity and effort of American science and industry in research and development in the electronic field. What is done in the days to come is up to you. I have no doubt that you will provide what is needed to accomplish the job.



Now, a few words concerning procurement, production, and installation of equipment since December 7, 1941. At the end of December, 1941, the Navy comprised a total of 2,082 vessels and landing craft in each of which at least one transmitter and two receivers were installed. As of December 1, 1944, this figure had risen as a result of the shipbuilding program to 37,981. A large carrier has installed in it 101 complete equipments. By a complete equipment I mean a complete receiver, transmitter, etc. A battleship has 78 such equipments. A small motor torpedo boat has 7. Certain of the smaller types of landing craft have as many as 13 complete equipments, others have as few as 3. It is estimated that since December 7, 1941, some 300,000 complete equipments, each comprising 2 to 15 major units of equipment, have been installed in these 38,000 vessels and landing craft. Some idea of the complexity of these equipments can be gained when I say that they vary in cost from a few hundred dollars for a simple receiver to \$250,000 for the most complex item. This installation task, accomplished by the Navy Yards, private shipbuilders, repair ships, and other activities is, in my opinion, one of the outstanding large-scale accomplishments of the war, and second only to that of industry in producing the enormous amount of high-quality complex equipment required for the program.

The program covering aircraft electronic equipment is equally worthy of note, and in dollar value is almost identical with the ship program. In December, 1941, the Navy had 5200 service airplanes. By January 1, 1945, this figure had grown to be in excess of 38,000. These had to be equipped with transmitters, receivers, altimeters, direction finders, homing devices, radars, and other related equipment varying from a minimum of three complete equipments for the smallest planes to ten in the case of the largest.

I have said nothing regarding the other programs involving equipment for the Marine Corps and shore and advanced-base activities. These are by no means small ones, as you may imagine.

Delivery of electronic equipment under the administration of the radio division, Bureau of Ships, has grown in dollar value from approximately \$4,000,000 per month in 1941 to considerably over \$100,000,000 per month in 1944. During the calendar year 1944 there was delivered to the Navy in excess of \$1,300,000,000 worth of radio, radar, and sonar equipment, exclusive of a very large amount of equipment purchased directly from the Army.

I mention these figures only to give you a yardstick by which to measure the vastness of the Navy's electronic program, and to permit you to visualize the magnificent mobilization of this country's scientists, engineers, and other personnel, its tremendous manufacturing facilities, and to give you an indication by inference of the astronomical size of the manpower both in and outside the Navy which has been necessary to do the job. When we try to visualize this effort, which is only a part of the

whole panorama of our fighting strength now arrayed against the enemy, it is easy to understand Emperor Hirohito's recent somber warning to his millions of subjects, "The future of the war situation permits absolutely no optimism."

You may be inquiring at this point as to what is the Navy's organization for handling such a program. I will cover this very briefly.

The allowances of equipment for the various types of ships, planes, shore stations, advanced bases, etc., are specified by the Chief of Naval Operations. His organization works directly with the commanders in chief and the operating forces in establishing operational needs. His is the agency which also establishes the requirements of equipment as to desired performance, that is, the military characteristics of equipment. His instructions are transmitted to the Bureau of Aeronautics for airborne equipment, the Bureau of Ordnance for ordnance equipment, and the Bureau of Ships for ship and shore-station equipment. These bureaus are each concerned with their own technical problems involving the installation of material and, in turn, transmit amplified instructions to the Bureau of Ships for the use of the radio division (now the electronics division), in preparing detailed equipment specifications. These specifications are prepared in close collaboration with the other Bureaus concerned. Contract-and-production administration is handled by the Bureau of Ships, except in the case of certain equipment handled by the Bureau of Ordnance.

The installation and maintenance of the latter is handled jointly by the Bureau of Ordnance and the Bureau of Ships through the radio material field organization of the Navy. All other radio, radar, sonar, and related electronic material installed aboard ship and ashore is handled by the Bureau of Ships through the same field organization.

In the case of airborne equipment, installation and maintenance are handled by a field organization of the Bureau of Aeronautics after initial distribution by the Bureau of Ships from contractors' plants.

The electronics division of the Bureau of Ships is organized along functional lines into three main branches; namely, design branch, equipment branch and installation-and-maintenance branch. The design branch administers the research, development, and design work conducted in government and commercial laboratories and plants, prepares technical specifications for materials, components, and equipment, and handles matters of a technical nature involving production, inspection, and standardization. The equipment branch is charged with the translation of directives into procurement requests upon the contracting authorities of the Navy, the selection of qualified contractors, the establishment of delivery schedules in co-operation with contractors, the supervision of production through the inspectors of naval material, and the distribution of material after its production. The installation-and-maintenance branch

administers the electronic field organizations of Navy Yards and shipbuilding activities, and works with fleet and shore-station activities concerned with installation and maintenance problems. It also works in close collaboration with the shipbuilding and ship-maintenance divisions of the Bureau of Ships in the preparation of ship plans and the handling of a vast amount of technical work relating to installation and maintenance.

I would like now to address you concerning a subject of importance to both the war and postwar programs of the Navy. This concerns standardization of component parts of electronic equipment.

The successful prosecution of the Navy's electronics program is contingent upon, among other factors, the expeditious solution of many component-part problems which are both urgent and difficult. It is beyond the allotted time for this address to attempt to cover the many phases of these problems. Instead, it is intended to mention some of the conditions under which component parts are required to operate in the naval service, to indicate the standardization procedures now followed, to point out the value of standardization to the solution of some of the Navy's problems, and to mention some influences which are retarding standardization. The magnitude of the problems to be solved is great enough to require an understanding by, and the concerted and co-ordinated efforts, to some degree, of practically every person associated with the Navy's electronics program.

Navy electronic equipment is presently being used in every theater of war, where climatic and other conditions encountered are so severe that the establishment of simulating laboratory tests is an extremely difficult problem. A few of the general severe conditions are as follows: High temperature combined with high humidity is encountered in countries such as Malaya, Burma, the East Indies, and the Philippines, where the rainfall is constantly heavy on most days during the wet season. The air temperature may rise by day to 40 degrees centigrade and normally falls to about 25 degrees centigrade at night, but is never less than 20 degrees centigrade. Consequently, the relative humidity is very high and frequently reaches saturation for considerable periods.

High-temperature and low-humidity conditions prevail in many regions, and air temperatures as high as 58 degrees centigrade occur during the day and a drop to freezing occurs at night. The relative humidity in these regions may be as low as 5 per cent.

Sub-zero temperatures are encountered in Siberia, Alaska, Northeastern Europe and the northern parts of Canada. Temperatures as low as -40 degrees centigrade are frequently experienced. Temperatures of -55 degrees centigrade are relatively common and -70 degrees centigrade may occur in isolated regions. Equipment is not generally required by specifications to work below -40 degrees centigrade, but must not suffer any permanent ill effects through transport or storage at the lowest temperature met.

Components may be exposed to an air pressure of 120 millimeters of mercury at an altitude of 42,000 feet. The rate of change of air pressure may be as high as 10 millimeters of mercury per second. It should be remembered that equipment not designed for operation when airborne may have to be transported by air freight at high altitudes.

Air temperature at 42,000 feet is reasonably constant at about -55 degrees centigrade. The rate of temperature change experienced by descending aircraft may be as high as 5 degrees centigrade per minute, but the actual rate of temperature change of apparatus will be lower, possibly 2 to 3 degrees centigrade per minute.

Equipment is liable to suffer prolonged exposure to salt-laden atmosphere and spray from sea water.

Dust may be encountered as a cloud created a few feet above ground level by moving vehicles, or as a dust storm created by strong winds which drive the particles to considerable heights and in all directions. The dust particles may be abrasive or hygroscopic.

In an atmosphere near saturation and other favorable tropical conditions, fungus will start to form within a few days. Many destructive insects are also encountered in jungle regions. The effects of fungi and insects are very serious and call for much additional work on "tropicalization" of components and equipment.

All equipment must withstand, without serious reduction in performance or reliability, severe mechanical vibration, shocks, and rough handling.

The experience gained in this war has shown that a high percentage of those components designed for domestic commercial service cannot withstand the extremely severe climatic and other conditions to which they are exposed either out of doors or under inadequate shelter during shipment, storage, and operation in forward areas. In addition, many refinements and advances in radio, radar, and sonar design during the present war have imposed heavier demands upon the component designers and manufacturers for smaller, lighter, and more dependable types of components whose need was not entirely realized even a few years ago. In fact, it is believed in many instances that improvements in the designs of components have not been carried out quickly enough to keep pace with equipment advances and, as a result, the problem of improving the usefulness, dependability, and ease of maintenance of equipment in the field is largely contingent upon improving the quality and performance of various necessary components rather than upon further refinements in the basic-equipment designs.

It is felt that improvement of the dependability of components and hence, of complete equipments, is largely contingent upon more thoroughgoing and extensive qualification testing of components "per se." In many instances, misapplication of components with attendant high failure within equipment can be traced directly to the fact that the limitations, of the component with respect to electrical ratings, temperature,

vibration, pressure, etc., had never been accurately established for the guidance of the equipment design engineer. In this connection, the Navy is establishing at the naval research laboratory a \$1,000,000 component-testing laboratory supplied with the necessary measuring apparatus and technical personnel to pursue an active and continuing program for the improvement of components required in radio, radar, and sonar equipments. It is intended that this activity shall be maintained in peacetime on a large scale in order that the types of components suitable for naval usage can be ascertained and made the subject of continuous improvement. The present qualification testing of components, under Joint Army-Navy standard specifications is being done on an appreciable scale at this laboratory and will increase as additional types of components are covered by approved Joint Army-Navy specifications.

The actual work of joint standardization of components has been carried on for over 2½ years by the Bureau of Ships and Signal Corps, in collaboration with the American Standards Association, War Production Board, and representatives of industry, and has resulted in about 40 published standard specifications with many more to follow in the future.

To facilitate the work of component-part standardization the Army-Navy Electronics Standards Agency, now quite generally known by its brief title ANESA, was established in December, 1943, and was given the responsibility and authority for co-ordinating electronic-equipment-component specifications to be used by both services. After drafting, the co-ordinated specifications are processed independently by the Bureau of Ships and Signal Corps through approved channels, and after Industry and the War Production Board have offered comments for consideration, a final approved draft is submitted to the Joint Army and Navy Committee on specifications for approval as a Joint Army-Navy specification.

Following issuance of the approved Joint Army-Navy specification, the laboratory facilities of the Signal Corps and of the Navy are pooled to carry out the qualification testing of components and materials submitted by prospective suppliers. Test reports resulting from qualification tests are reviewed by both services, regardless of which service laboratory conducted the tests. Following review of the test reports, independent action is taken by each service to establish listings of approved manufacturers of standard components and materials. Action is presently being taken to work out a procedure by which Joint Army-Navy approval certificates can be issued.

It is felt that the following urgent needs of the Navy flow directly from standardization:

1. Replacement components in Navy Yards and depots and in the field are more readily identified and, therefore, more readily usable among various types of Navy electronic equipments since the standard components can be identified by standard markings,

nomenclature, color coding, etc. In this connection, a very major maintenance problem exists in the Navy at the present time, because the present nonstandardized systems of marking components do not permit relatively inexperienced personnel to identify usable substitutes, or often even identical items, supplied by the many equipment manufacturers.

2. The workload imposed on field-maintenance personnel, especially those inexperienced in maintaining equipment, is made less burdensome by virtue of the relatively smaller number of noninterchangeable components of each particular type which must be stocked, properly packed, housed, and correlated with the proper Navy electronic equipment.

3. The expanded use of standard components will minimize the vast numbers of components with respect to types, sizes, and ratings which must be dealt with in respect to improvement, testing, inspection, procurement, stock-upkeep, issue, and cataloging, and hence reduce the man hours required for preparing necessary drawings, specifications, stock-catalog numbers, and other clerical work.

4. The co-ordination of production among the various plants of equipment and component manufacturers, and control and scheduling of component deliveries to equipment manufacturers, can be accomplished on a far better basis through the availability of standardized and co-ordinated components. During the past three years one of the most difficult problems has been that of co-ordinating the production of Navy electronics equipment among the many prime equipment contractors to make maximum use of facilities for the production of components, the availability of which too often has limited and seriously delayed the production of equipment. The magnitude of this problem can be appreciated when I tell you that some thousand different plants and laboratories have been working under Army or Navy contracts in supplying electronic components and equipment. Component standardization will go a long way toward the solution of problems resulting from this cause.

In pointing out some of the shortcomings and difficulties of the component-standardization program to date, there is no intention to lessen the appreciation of the work accomplished to date or to overlook the many impeding conditions imposed on such a program by the extremely heavy demands for components resulting by the wartime requirements of the Armed Services. The intent is rather to review the difficulties to date from the viewpoint of suggesting ways and means by which this initial start can be strengthened, expanded, and established on a more effective, firm, and continuing basis as soon as possible.

One of the more general difficulties has been the disinclination of many engineers, both within the Government and within Industry, to become involved in the tedious, detailed, and relatively uninteresting work associated with the preparation of standards, with the result that a heavy workload has been imposed on a restricted

group. It is felt that there should be a greater realization that the responsibility for component standardization must be assumed by a greater number of engineers who have a combined knowledge of the needs of the industry and Armed Services and of standardizing procedures.

Another difficulty experienced in that phase of component standardization having to do with the establishment of performance requirements, is the tendency on the part of a relatively small portion of industry to question and discount heavily the necessity for some of the stringent and detailed requirements stipulated by the Armed Services. It is not claimed that the Services are in every case 100 per cent correct in asking for certain tight and detailed requirements. However, by virtue of living with and having the responsibility for correcting failures in the field under conditions in the field, the Armed Services do have knowledge of the need for special performance requirements.

In the past and even at present, the advantages of standard Joint Army-Navy specifications are being mitigated by requests for waivers from the required tests. Such waivers in whatever form granted, and if allowed to grow, rapidly reduce the value of standard specifications to an ineffectual level. In the last analysis, the effectiveness of any good standard is largely contingent upon all interested activities voluntarily making every effort toward its adoption and application as a desirable instrument to implement mass production and simplify maintenance problems. Requests for waivers should be made only in cases of the highest urgency.

The production of dependable and easily maintained equipments with the least component complexity is greatly contingent upon the early selection and application by the equipment-design engineer of standard approved items for the various required components during the conception, research, and development phases. Research personnel and development engineers working on the early stages of equipment development are far too prone to use nonstandard components in their early experiments and far too often, the resulting mechanical and electrical problems left to the final design engineers are so formidable that many nonstandard components are left in the equipment as it is finally delivered, and the great benefits of component standardization are lost.

Another important consideration in overcoming a past weakness in the standardization program is that of selecting three or more geographical locations where adequate accommodations can be established for standardization meetings in order that participating members can minimize the required traveling, and that whatever traveling is necessary will be more equably shared among the participating members.

While the prime effort of component standardization must be directed toward the problems of immediate urgency in advancing the present and future activities of this global war, it is also important that we start plans for a postwar standardization program.

The Armed Services sincerely hope that the component standardization achieved during the war will not be shelved in the postwar period, but will be expanded and improved. A restricted but significant start has been made.

It is not my intent here to attempt to outline the structure for a postwar standardization association, but rather, to emphasize from the experience gained in this war the importance to the Armed Services and Industry of jointly realizing, together with the engineering societies, the need of, and the assumption of, the responsibility for a co-operative program of component standardization. The reorderings, delays, waste of material, waste of shipping and storage space, excessive purchases of spare parts, added costs, and many other undesirable conditions arising from the use of nonstandardized items must be vastly reduced. Taken collectively, these undesirable conditions have probably already cost the Navy \$100,000,000 in this war. What has been accomplished in standardization under war conditions will be lost again in the years of peace to follow unless Industry continues to understand and give full support to the solution of the problems of the Services. If financial help is needed, I feel that the Navy alone should and would contribute \$1,000,000 per year, or whatever amount was needed to support a virile and effective electronics-standardization association which, in co-operation with the Services during the years of peace, would anticipate and remedy the conditions which I have mentioned.

A second subject concerning which I take this opportunity to address you is that involving the postwar radar-patent situation.

This new and important art was born only a few years preceding this war, and probably 95 per cent of the so-called radar inventions upon which patent applications have been filed or are in process, have been made since January 1, 1941. Because of the restrictions which have been placed on the dissemination of information concerning radar developments, little information is known concerning the number, nature and scope of patent applications on file and in process except to a relatively few officers of the government. I can assure you that a large number of inventions of importance to the production and use of well-designed radar equipments have been made the subject of patent applications. The United States patents resulting from these applications will be widely held in industry, by foreign interests, by individuals, and by the government. It is expected that a considerable block of radar patents, now held in a secret status in the form of applications in the Patent Office, will issue upon relaxing the present security restrictions following the war.

Pending a reasonable adjustment of the patent situation, which may require as long as 10 years, it is expected that the following undesirable conditions will exist unless appropriate steps are taken now to avoid them:

1. Contractors will not be able to supply the Services

and the public with the most suitable designs of radar equipment because of adversely held patents.

2. A pyramiding of royalty rates will contribute to excessive costs of equipment.

3. A great amount of litigation will follow the issuance of patents.

With a view to overcoming these undesirable conditions to the maximum degree, it is recommended that the electronics industry undertake now a full exchange of views in the matter of either establishing a radar-patent pool for a period of 10 years following the war, or working out some other satisfactory solution in the premises. I am urging that Industry give this matter its serious attention. In view of the nature and use of radar, I am sure you will agree that the Services and the public are entitled to the best-designed equipment that the state of the technical art is capable of providing. Moreover, it is my belief that the government will not long acquiesce to the payment of pyramided royalty rates which represent a substantial portion of the cost of equipment, especially since practically all of this development has resulted directly or indirectly from the expenditure of public funds.

In order to look at the picture in proper perspective it is desirable, first, to consider just what dollar value of business is probably involved. I have solicited the opinions of persons who have pertinent information and have obtained a figure of \$75,000,000 per year for several years following the war as representative of the volume of sales in the United States for radar equipment for government and commercial purposes. All equipment utilizing radar techniques is included in this estimate.

The problem which is presented to industry is not simple in its solution. Whether it can be solved by negotiated agreements, I do not know. Whether it can be solved by a single pool comprising all of industry, or two pools, one including patents held by the larger holders, and the second including patents held by the smaller holders, I do not know.

Having heard from several sources the suggestion that a pool of radar patents be established and never having seen anything in the form of a concrete proposal to shoot at, either literally or from the point of view of its attainment, I submit the following as one suggestion.

A pool, operating as a corporation, initially financed by a government loan and organized by all of the electronics industry, is visualized.

The corporate structure of such a pool would conceivably comprise a board of directors, a corporation president selected by the board of directors, and a patent department, legal department, and accounting department, together with such officer, staff, and other assistance as may be needed. The Board of Directors should be elected by pool members, the votes which any member exercises being determined by the profit-sharing value of the patents contributed by each such member to the pool. Membership would be limited to companies, agencies, or individuals who contribute patents essential

to the operation of the pool and would continue during the useful life of such patents. United States citizenship should be a qualification for membership on the board of directors and for all officers of the company. To insure full representation by all the industry on the board of directors, it would probably be desirable to devise a plan for electing members of the Board every two or three years.

The successful establishment and operation of such an agency will require the full co-operation of all holders of major blocks of pertinent patents. This co-operation would have to be extended to a degree which would enable the management to make the enterprise attractive to the many holders of small blocks of patents whose enrollment as members is mandatory if all the benefits of pool operations are to be obtained. Foreign holders of United States patents essential to radar, of which there may be a considerable number, should also be admitted to membership under conditions to be determined.

It is contemplated that the corporation will, insofar as practicable, obtain licenses under all radar patents considered essential to the manufacture, sale, and use of radar, all nonradar patents essential to such manufacture, sale and use, and the right to grant sublicenses under such patents in that field.

If the past policies of the government in patent matters are any criteria of the future, I feel that the government will license the pool upon a royalty-free basis under its considerable block of pending radar patents, but will wish to retain any voting rights given members.

As previously indicated, membership in the pool would be limited to companies, agencies, and individuals holding rights under patents essential to the manufacture, sale, and use of radar, and who agree to extend to the corporation a suitable license under which it may grant sublicenses.

The corporation should itself determine the essentiality of any patent to the pool's operation. For carrying out this responsibility, it is proposed that an essentiality board be set up within the patent department. Provision should be made to permit any patent holder to present his case to this board, and if a satisfactory showing of use by any licensee of the pool is made, the corporation may accept such patent holder as a member of the pool. Decisions of courts favorable to patent holders in infringement suits against licensees of the corporation should also be accepted as a showing of essentiality if, in the opinion of this board, such decision applies to the radar art.

The license granted the corporation by a member should provide that all essential patents held or acquired by such member be made available to the pool. It is contemplated that each member may himself become a licensee of the corporation upon his own request.

It is contemplated, also, that the corporation will grant licenses only on condition that such licensees holding or acquiring patents essential to the art will themselves become members of the pool.

The proceeds from operations would be distributed to each pool member in proportion to the value of patent rights which he contributes.

Infringement suits between pool members and licensees should be nonexistent, since if any member can make a satisfactory showing of use of a patented invention in radar equipment manufactured, sold or used by a licensee, such patent is itself available to the corporation and to its licensees. The same applies in the case of suits by licensees against pool members and by licensees who may not be registered as members, in the case of suits by such licensees against other licensees of the corporation. Exceptions to these cases might conceivably arise, should the corporation decline to recognize the essentiality of a patent.

It is thought desirable to establish a legal department of the corporation independent of the patent department to provide legal services at no cost to members and licensees upon request in bona fide radar-patent matters, such as infringement suits by patent holders who are not pool members or licensees. In extending such legal services it is contemplated that members or licensees may prosecute their cases with legal assistance of the corporation, or may request the corporation to prosecute their cases with such assistance as the member or licensee may give. While these legal services may be provided at no cost to the member or licensee, it is contemplated that the member or licensee will pay any damages assessed by an adverse decision in such a suit.

Except in the case of a contest between a member or licensee and a nonmember, it is considered undesirable for the corporation to render legal assistance or otherwise engaged in radar-patent matters involving validity.

The articles covering the operation of the corporation should provide that it take all necessary legal action against infringers of pool patents. Since such actions will be against nonmembers and nonlicensees, matters involving validity in such cases may be engaged in by the corporation.

It is proposed that a uniform royalty of 6 per cent of the selling price of radar equipment be paid to the corporation by all licensees. This is considered not excessive from the point of view of licensees since, through the operation of a pool system, they will be relieved of the need for paying pyramided royalties. This figure is considered adequate to provide a reasonable financial return to members of the pool, since the pool system will have greatly reduced expenditures by members which would otherwise have to be made for legal services, license management, and defending infringement suits, especially in the case of those members who are themselves radar manufacturers.

The matter of how to distribute among members the profit from operations presents the most difficult problem to be faced in the operation of such a pool. Anyone who has had experience in appraising patents can appreciate this fact. I estimate that the corporation would have to concern itself with between 2000 and 3000 essential patents, but under the plan which I am proposing only about one half of this number need be considered

in the distribution of profits for any one accounting year. Because the number of models of equipment which must be studied during each accounting year is quite large, perhaps in the order of 100, and because some 1000 to 1500 patents will have to be studied in connection with each of these models, a reasonably simple method of appraisal must be adopted. It is important, however, that each patent be given the recognition which its extent of use and importance merits.

It is proposed that the corporation place patents in the following classes with reference to extent of use:

- Class 5 Used in more than 75 per cent of the equipments sold by licensees in the preceding year.
- Class 4 Used in 50 to 75 per cent of the equipments sold.
- Class 3 Used in 25 to 50 per cent of the equipments sold.
- Class 2 Used in 10 to 25 per cent of the equipments sold.
- Class 1 Used in less than 10 per cent of the equipments sold.

The above "use classification" is made for the purpose of informing the corporation and its members of the relative evaluation of their patents from the point of view of use. This classification is to be made by a patent-classification board. It is visualized that the staff operating under this board will study continuously designs of radar equipment made by licensees. To permit necessary studies of confidential military radars, it is proposed that the classification board and certain staff members be cleared by the War and Navy Departments for the purpose. Each licensee will necessarily have to make available, to the board and its staff, all designs and essential data concerning his commercial radar equipment at the time it is released for sale. A member may request reconsideration of the classification of any patent at any time, and if in his opinion an injustice has been done, he should be entitled to a hearing before the board.

Although the initial classification of all patents involved will be a laborious process, it is expected that the operation will become considerably simplified as the staff becomes familiar with both the patents and the general features of radar design. It is doubtful if there will be more than 100 different models on the market in one calendar year, and these can probably be broken down into a relatively few basic designs.

The preceding classification assigns a figure of merit based upon extent of use, which figure is numerically equal to the classification number. While the most widely used inventions are generally the more basic and important ones, this is not invariably the case. Certain inventions may be widely used for convenience only and may be circumvented at some sacrifice to convenience. On the other hand, certain inventions enjoying restricted use may be of the greatest importance in their particular field of application and may not be circumvented by any known means.

To satisfy the need for this kind of distinction, it is

proposed that a "weight factor" be assigned to each patent. These weight factors would also be assigned by the patent-classification board upon the recommendation of its staff. "Weight factors" are also made known to the pool member concerned, and are subject to review upon his request in the same manner as the "use classification."

Weight factors of 1.0, 1.25, 1.5, 1.75 and 2.0 are suggested. Except in the case of a small percentage of the patents, the largest weight factors will be associated with those patents having the highest "use classification."

By the evaluation system proposed, the product of the classification number and the weight factor gives a rough figure of merit for the profit-sharing value of the patent. For example, a class-5 patent is one used in 75 to 100 per cent of all radar equipments sold by licensees of the corporation. Most class-5 patents will be important ones and therefore entitled to a weight factor of 2.0. This indicates that such a patent has at least 15 to 20 times the profit-sharing value of a class-1 patent with a weight factor of 1.0.

I mentioned earlier that only about half of the pooled patents need be considered in the distribution of profits in any one calendar year. In order to keep the total number of patents which need be considered for accounting purposes in any year within reasonable bounds, it is proposed to establish a maximum for that member having the greatest number of patents accepted for the pool by the essentiality board, and to establish a proportionate maximum for each other member. To illustrate this by a simple example, assume that the largest member of the pool contributed 500 essential patents, and that other members contributed 400, 300, 200, 100, 50, and 10 patents, respectively. If for accounting purposes it were decided to limit those of the largest member to 250 patents, the other members cited would be limited to 200, 150, 100, 50, 25, and 5, respectively.

To satisfy the interests of the smaller pool members, it is probable that the distribution of maxima among the membership cannot follow a strictly linear law. In the case of a member having only one or two patents it would probably be desirable to establish no such maximum, although even a fraction of a patent may be evaluated for accounting purposes under the method proposed.

Each member so limited as to the number of patents allowed for profit-distribution purposes would be permitted to designate those which he desired the corporation to use. With knowledge of the "use classification" and "weight factor" in each case, any error due to his choice should not be large.

An alternate method to that just proposed might be used to simplify the work and profit distribution of the corporation. The Radio Corporation of America, American Telephone and Telegraph Company, General Electric Company, and Westinghouse Electric and Manufacturing Company together would probably control about one half, or perhaps more, of the essential patents. It might be possible to reach an agreement with all other

members whereby 3 per cent of the profits each year would be turned over to the above group of major companies for distribution among themselves and the remaining 3 per cent distributed by the method which I have proposed. This alternate method would make it unnecessary to consider anything but essentiality in the case of patents held by the Radio Corporation of America, American Telephone and Telegraph Company, General Electric Company, and Westinghouse Electric and Manufacturing Company to determine the equitability of the 3 per cent division of profits and perhaps even this may be made unnecessary by agreement among members of the pool.

The accounting procedure connected with the distribution of profits should not be too difficult. To cite a very simple case, assume \$60,000 were available for distribution from royalties paid to the corporation by a licensee in connection with a certain production run of radars. Assuming the involvement of 10 class-5, weight-2 patents, 10 class-3, weight-1.5 patents, and 5 class-1, weight 1.0 patents, simple arithmetic will show that the \$60,000 should be distributed in the amount of \$4,000 for each class-5 patent. At first glance it may appear that the class-5 patents do not receive shares of profit commensurate with their values relative to the class-1 patents. Further reflection will show that since class-5 patents are involved in 75 to 100 per cent of equipments sold, and the class-1 patents in less than 10 per cent of such equipments, this apparent discrepancy will be corrected when the whole year's business is accounted for.

As previously mentioned, I do not know what, in the final analysis, will comprise a solution to the radar-patent situation. The matter is one which merits Industry's full attention, and I leave the subject in the hope that steps leading to a solution will be taken.

In closing my address, I wish again to express, through you of the engineering societies here assembled, the appreciation of the Navy for the magnificent job which American science and industry have done in meeting the requirements of the Navy for the development and production of electronic equipment. This has been done under many difficult conditions imposed by large and often conflicting demands.

I wish also to express the Navy's appreciation for the co-operation and great contributions of those laboratories administered by the Office of Scientific Research and Development and the National Defense Research Committee. The educational institutions of the country have also contributed directly and greatly to the Navy program, in addition to making large numbers of their staffs available to industry and the government. Finally, I wish to acknowledge the fine co-operation and assistance rendered by the Signal Corps Army Air Forces, and War Production Board.

What has been accomplished, has been done through the co-operation and efforts of all, and each of you has good reason to be proud of the job which has been done to date. The Navy looks forward with confidence to the future.

# Mould and Humidity in Radio and Signals Equipment\*

C. P. HEALY† AND J. C. NIVEN†

**Summary**—Radio equipment constructed by prewar methods and used in areas north of Australia, where the temperature is 75 to 90 degrees Fahrenheit and the average humidity is 90 per cent, does not operate satisfactorily. Mould grows on some parts, while the insulation resistance of others is lowered to unusable values. Fungicides may be used to combat mould growth, but a variety of methods must be adopted to eliminate the effect of humidity on insulation. Methods of test for mould and humidity are dealt with.

**C**ONDITIONS in the present fighting zones north of Australia have necessitated considerable departures from standard practice in the design of radio and signals equipment. It is the aim of this paper to set out briefly some of the precautions that must be taken so that the equipment will operate satisfactorily under these conditions. In the land areas at present concerned, records show that the rainfall is between 40 inches and 250 inches per year, while, in most areas, the temperature varies over the range of 75 to 90 degrees Fahrenheit. The atmospheric humidity is rarely less than 70 per cent, sometimes rising to 100 per cent, and having an average value of 90 per cent. (Fig. 1).

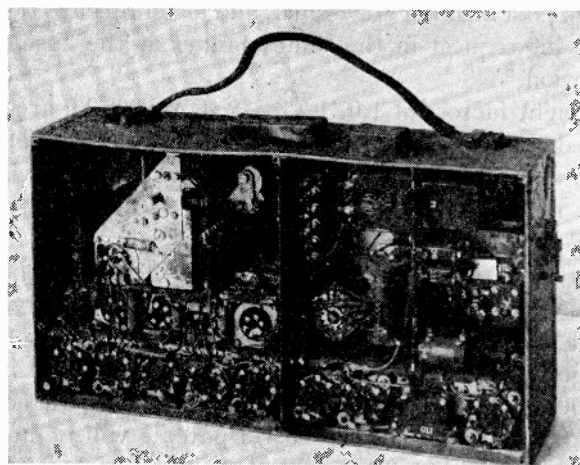

Fig. 2—Radio set constructed before the war for temperate climates. This set was sent to New Guinea after several years service in the Middle East. Results of a few months exposure to tropical climate can be seen.

and condensation takes place on most nights. The equipment may be taken into dripping jungles, and may suffer damage from falling into mud and rivers.

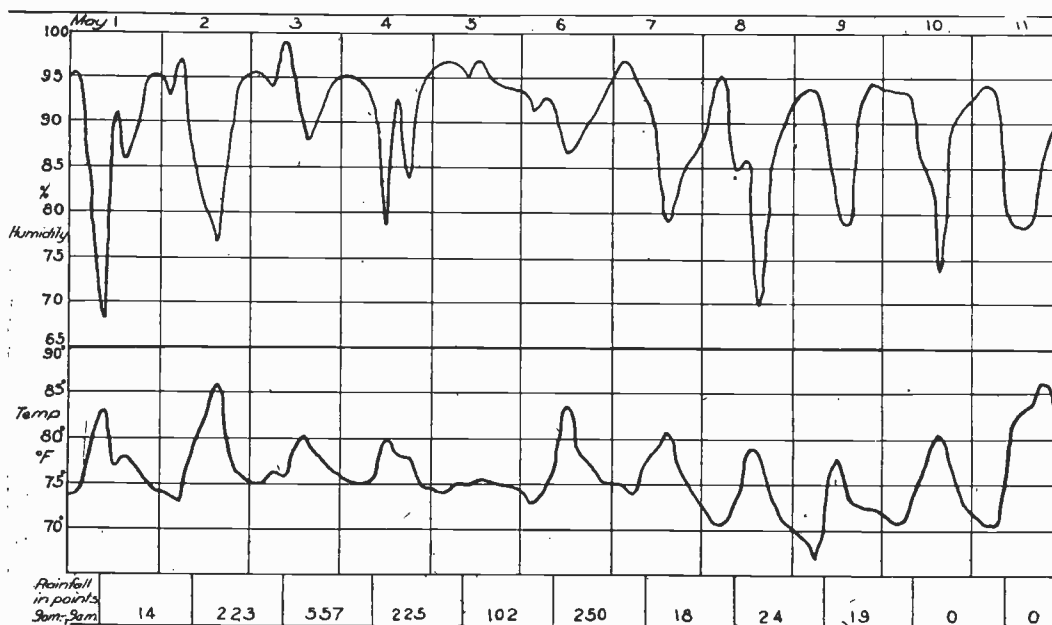

Fig. 1—Conditions in Milne Bay.

Field equipment, in addition to withstanding these conditions of temperature and humidity, must be capable of being stored in cases on the ground covered with tarpaulins, and inside Armco sheds where the temperature may reach 130 degrees Fahrenheit during the day

Under these conditions mould growth is severe in the average type of radio equipment and this, in addition to the effect of humidity on the components, may render the equipment inoperative within a short time of arrival in the fighting zones (Fig. 2).

## MOULD IN RADIO AND SIGNALS EQUIPMENT

Moulds are minute fungi which grow from spores blown by the wind. The mould grows when the spores

\* Decimal classification: R281. Original manuscript received by the Institute, November 21, 1944.

† Amalgamated Wireless (Australasia) Ltd., Ashfield, N.S.W., Australia.



lodge on a suitable medium for their growth and have sufficient moisture, together with the requisite warmth for germination. These conditions of warmth and moisture are found in most of the fighting zones north of Australia.

Mould consists of cobweb-like threads (mycelia) bearing membranous spore cases. The mycelia of moulds may penetrate the surface layers of a material, or may grow only on the surface. Sometimes, although appearing to grow outwards from the surface, considerable penetration of the material takes place.

Moulds grow in colonies where spores are lodged, and may develop to full growth in a few days. Mould can grow on debris consisting of organic dust, and consequently can appear to grow profusely on material that would not support growth without the debris. The mould in such cases, once established, can injure the adjacent material through the action of by-products of its growth.

Some materials on which mould is known to grow are set out as follows.

Timber and plywood	Emery cloth
Casein and gelatine glues	Sandpaper
Cotton, canvas	Hessian
Linen	Felt
Paper and cardboard	Adhesive tapes
Other cellulose materials	Blankets
Cellulose acetate tape and sleeving	Rope and string
Leather	Canvas base synthetic resin bonded material and in some cases on synthetic-resin bonded-paper materials
Cork	
Varnished cambric cloth and sleeving	

Other materials have been reported to grow mould in New Guinea, but this has not been confirmed and the growth noted may be due to debris growth. Such materials are shown below.

Optical glass	Artificial silk
Paraffin, fats, organic oils, waxes	Flax, jute, ramie sisal
Beeswax	Some lubricants containing oleic acid

#### GROWTH ON DEBRIS

Metal surfaces have been seen with healthy growth on them, but it is not likely that the metal could provide the necessary nutrient. Organic dust collected on the surface is probably the source of the nutrient.

Even so, the surfaces of the metal may be etched and damaged by the by-products of mould growth. Growth on debris has been confirmed in the laboratory.

Moulds may grow on some materials without causing mechanical weakening of the base materials; for instance, the nutrient of the mould may be obtained from organic matter that does not contribute to the strength of the material. On other materials such as cotton, fabric, paper, wood, etc., mould growth breaks down the cellulose and the material is rotted to disintegration. Moulds such as stachybotrys are said to have this effect on canvas of tents; aspergillus glaucus rots leather rapidly.

Apart from mechanical weakness, moulds can seriously affect electrical insulation. This action takes

place in three ways: (1) Mould becomes saturated with water and can cause surface leakage. (2) Mould rots the surface of some materials, thus changing the material from its original form. (3) The mycelia of moulds are conducting.

In addition to this it is reported that troops in the field will not handle certain equipment which has a profuse mould growth, although no serious damage to the equipment is apparent.

#### PREVENTION OF MOULD GROWTH

There are two methods by which mould growth can be prevented in radio and signals equipment. The first is by the elimination of materials that support mould growth and their replacement by materials that are not affected. The second method is the treatment of materials that support mould growth with suitable fungicides. It is not possible at present to provide a simple cure-all for mould in radio equipment but some individual problems will be considered.

#### CONNECTING WIRES

The growth on cotton-braided rubber-covered wire that is thinly lacquered is prolific. Cases encountered have not been sufficiently long in the damp conditions to cause obvious disintegration of the cotton, but, as the mould holds water in a saturated atmosphere, the surface insulation drops to a few ohms per yard. Samples of this wire treated by immersion with the following fungicides and tested in the laboratory mould chamber for a period of several months showed immunity from mould growth.

Copper naphthenate	1 per cent in kerosene
Trichlorphenol	1 per cent in kerosene
Salicylanilide	1 per cent in methylated spirits

For use in damp tropical areas it would be necessary to waterproof the cotton braid to prevent surface leakage when damp. Several lacquers have been tested. Some are ineffective, others merely delay the absorption of water.

The connecting wire problem has been solved by the use of wires having polyvinyl-chloride or vulcanized-rubber covering without additional braids. Reports have been received from the field stating that both of these wires, and some types of wire using a covering of polyvinyl-chloride with a fiberglass braid, are satisfactory. We have had very little experience with the fiberglass-braided wire due to the lack of supplies, but the tests that we have carried out indicate that it is satisfactory.

#### VARNISHED-CAMBRIC SLEEVING

Varnished-cambric sleeving rots in damp tropical conditions and, although the cotton may be fungicided, it is considered more satisfactory to use a plastic sleeving to replace this material.

### PAPER LABELS

A solution of latex in ammonium hydroxide is used in some cases as an adhesive for affixing labels onto smooth surfaces such as phenolic mouldings. Mould grows anywhere this latex spreads. The latex solution is now poisoned with salicylanilide, using 20 grams per gallon of latex solution in which it is soluble. This has proved satisfactory as far as the latex solution is concerned.

Paper labels are covered with a thick film of cellulose-nitrate lacquer, which has proved effective in prevention of mould. A thin film is not effective and only retards mould growth.

Paper labels should be avoided if possible, as apart from the obliteration of the printing, the paper is rotted to disintegration by the mould. At the same time, labels treated as above have proved effective for as long as 12 months.

### SYNTHETIC-RESIN BONDED-PAPER SHEET

This material in its various forms has proved unsatisfactory for use in tropical climates unless specially treated. Mould has been seen growing on the edges of high-grade synthetic-resin bonded-paper sheets such as XXXP and XPLW, but in these cases growth has been small and is due, possibly, to debris collected on the rough surfaces, which has provided the nutrient. More vigorous growth takes place on canvas or linen base sheet, and mould growth in a number of cases has caused severe damage on these types.

Fabric sheet is not recommended for electrical insulation as its high water absorption lowers its insulation resistance in tropical climates. Where this material must be used, it should be treated with the highest available grade of alkyd-resin baking varnish. The material so-treated has not been known to grow mould, such that any damage may be caused thereby, but its insulation resistance properties are still poor.

Synthetic-resin bonded-paper sheet of even the best grades does deteriorate in the damp tropical areas. Mould growth on the better grades of material is only slight, but the insulation-resistance properties of the paper are affected seriously by high humidity. Treatment of the material with a high-grade oleo-resin or alkyd-resin varnish does not prevent deterioration on exposure, but laboratory measurements indicate that a considerable improvement is effected initially. Synthetic-resin bonded-paper sheet is inferior to ceramics, polystyrene, mica, or similar materials, and wherever possible these materials have been used as a replacement.

It is interesting to note that measurement of insulation resistance versus time of exposure to high humidity gives a continuously dropping curve. If the material is dried out until the initial insulation resistance is regained, and then exposed a second time to the humid atmosphere, the drop in insulation resistance takes

place more rapidly, indicating that the material has been damaged by its first exposure due to swelling of the fibers bursting the resin bond.

### MOULDED PHENOLIC MATERIALS

Similar remarks apply to these materials as to synthetic-resin bonded-paper materials; fabric-filled phenolics are subject to mould growth and rapid deterioration of insulation resistance with humidity. Wood-flour-filled materials, while not generally suffering from mould growth, are still affected by humid conditions; the insulation resistance drops and the material swells on exposure. Mica-filled phenolic-moulding materials have much superior performance to wood-flour-filled phenolics, and good grades such as Micanol or English XMB262 appear satisfactory, although their performance does not compare with ceramics or polystyrene.

### CERAMICS

Good-grade ceramics have not been known to give trouble under tropical conditions where they have been designed so that no continuous film of moisture can form on the surface. Surface leakage of unglazed ceramics depends on the type of ceramic, and an appreciable improvement of the surface characteristics of this material can be affected by drying and treating with a thin coating of polystyrene lacquer.

### LEATHER

Leather is one of the materials most likely to be attacked by mould. Reports from New Guinea state that leather, in any form, grows mould and disintegrates in a few weeks. There does not appear to be any known method of prevention applicable to leather, so its use should be avoided as far as possible, and webbing or some other fabric that can be treated should be used in its place. Experiments conducted here with substances such as neat's-foot oil on military boots have shown that none of these materials improve the resistance of the leather to mould. Leather could be protected from mould during storage by spraying with a fungicide, such as trichlorophenol applied as a 0.2 per cent solution, but this does not penetrate the leather and when disturbed the leather will be exposed to mould growth.

### CELLULOSE-ACETATE SLEEVING AND TUBING

Cellulose acetate supplied to us has grown mould rapidly in the laboratory, and reports indicate that it is unsatisfactory in tropical areas such as New Guinea. Its use has been discontinued, and it has been replaced by polyvinyl chloride.

### CORDS AND FABRICS

Canvas and duck from various sources have been tested for mould growth in the laboratory. All except a specimen of birkmyre (English) canvas, which was treated by the manufacturers, grew mould in a few

days. We have found that treatment of the material with copper naphthenate salicylanilide, or trichlorophenol each used as a 1 per cent solution, the first by weight of copper and the others by weight of compound, has rendered the material resistant to mould. It has been said that copper naphthenate weakens the canvas, but we have never had any experience of this effect, which is possibly due to acid impurities in some types of copper naphthenate used.

Cords for cable tying and aerial guy ropes can be treated in the same way.

#### WOODWORK

Treatment of woodwork with copper naphthenate solution is effective in the prevention of mould growth and termite attack.

Plywoods bonded with casein or gelatine glues are most unsatisfactory, even when treated with copper naphthenate. The glues mentioned are water soluble, and the ply disintegrates after a few weeks in a tropical climate (Figs. 3 and 4). Urea-formaldehyde or phenol-

resin glues are satisfactory as bonding materials, although fungicidal treatment of the wood is still necessary.

#### DRY BATTERIES

Quantities of dry batteries made with untreated-cardboard containers have been sent to tropical areas with bad consequences. Cardboard treated with paraffin has been tested in the laboratory and has been found unsatisfactory, as mould grows rapidly on the waxed cardboard. Moisture is absorbed, the adhesive dissolves, the case becomes wet and disintegrates. The zinc cells corrode. It is recommended that dry batteries for tropical areas be sealed in metal cases filled with a plastic petroleum asphalt with a ball-and-ring test of 95 degrees centigrade. Cardboard as insulating material between terminals is useless but is commonly used. The highest grade of synthetic-resin bonded-paper sheet treated with the best available insulating varnish and baked should prove satisfactory, provided adequate terminal spacing is allowed.

#### POWER TRANSFORMERS

Open-coil types of power transformers are unsatisfactory for use in tropical conditions. Water is absorbed through voids in the varnish impregnation, lowering the insulating resistance, and condensation takes place on the unit, forming water paths around barriers on the open ends. Although the wire itself may be protected by a layer of insulating varnish, there remains after condensation only a few thousandths of an inch separation between high-voltage windings that will break down easily, forming a carbon track and permanently damaging the units. It is quite common for the insulation resistance between windings of this type of transformer to be reduced from thousands of megohms to a few thousand ohms after a week's exposure. In some cases complete breakdown of the units has taken place after the set has been left exposed to a tropical thunderstorm.

Power transformers for tropical service are now being impregnated by a vacuum process using petroleum asphalt with a ball-and-ring test American Society for Testing Materials of 85 degrees centigrade. Each is then tanked in a welded sheet-iron can and filled with a plastic petroleum asphalt with a ball-and-ring test of 120 degrees centigrade, leaving an air space for expansion at the top. The can is sealed by soldering the flanged lid in place. Terminals of porcelain fitted in the base extend into the filling compound to reduce surface leakage. The terminals are compound filled.

Transformers constructed by this method can be operated safely after immersion in water and, as the sealing compound fills the space around the transformer, condensation in tropical climates cannot have any effect on the transformer's internal insulation. (Fig. 5). The danger of undried varnish in the transformer with its effect on insulation is eliminated. The

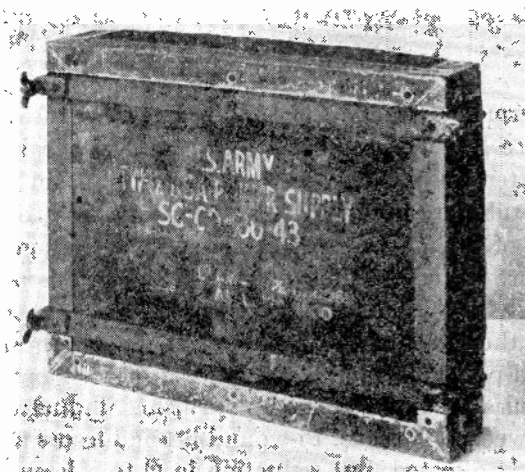

Fig. 3—Carrying-case lid constructed with casein-bonded plywood treated in any way. The damage seen took place after one month in the static-humidity-test atmosphere set out in the report.

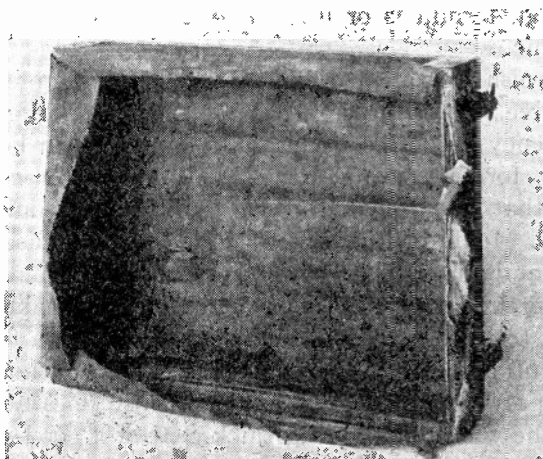

Fig. 4—Interior view of carrying-case lid shown in Fig. 3.

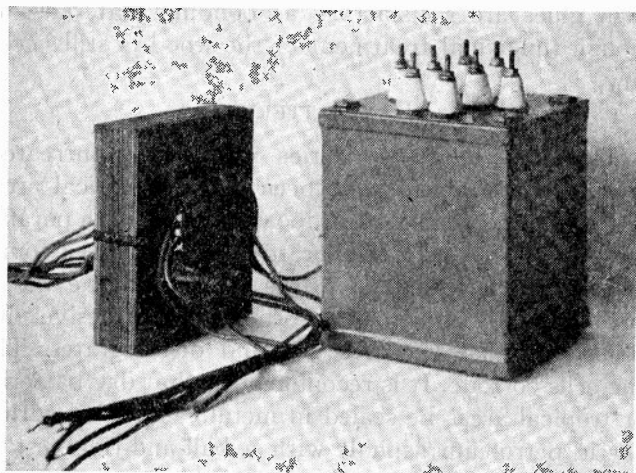

Fig. 5—Example of old open-type construction of power transformers compared with the "potted" hermetically sealed type.

effect on increase in size and weight and elimination of air cooling are disadvantages and, for some applications, open transformers still have to be used.

It has been found practicable to vacuum impregnate coils for open transformers with petroleum asphalt instead of the usual varnish without any danger of running of the impregnating material, even up to 100 degrees centigrade. A measure of protection better than that afforded by available insulating varnishes is provided. A series of tests with a wide variety of insulating varnishes showed that the ordinary paper-interleaved coil cannot be waterproofed with varnish.

While oil immersion is perhaps the ideal method, this cannot be applied readily to the average service equipment on account of the difficulty of sealing and providing a reliable expansion device. Canning with suitable petroleum asphalt is thus considered the most satisfactory method of tropic proofing of transformers for ordinary service equipment. Oil-filled transformers give trouble due to moisture contaminating the oil if a breather is used; however, as far as is known, the sealed type gives no trouble.

The same remarks apply to audio transformers as for power transformers. Bitumen-impregnated potted types have given excellent service.

#### FOIL PAPER CAPACITORS

Wax-coated, tubular paper capacitors are unsatisfactory for tropical conditions, insulation resistance being lowered very rapidly. Insulation resistances of the order of 100,000 ohms per microfarad are very common with this type after a few weeks service. Phenolic and wax-moulded types have given similar trouble, but to a lesser degree. Laboratory measurements have been carried out on the leakage of air along leads of wax and phenolic-moulded types. This leakage was found to be appreciable and was made worse by heat treatment. Phenolic-moulded types have been improved by treating with a good alkyd-resin varnish, but

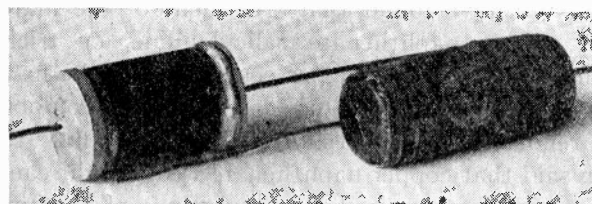

Fig. 6—Wax-moulded paper capacitor with mould on the label. The new glass-cased type is shown for comparison.

this improvement is only temporary. The only satisfactory method of sealing paper dielectric capacitors known to date has been achieved by placing the unit in a metallized glass tube and soldering on metal end caps (Fig. 6). Insulation resistance of units manufactured by this method has not deteriorated after being subjected to a saturated atmosphere for 3 months. Metal-cased types using neoprene seals are not resistant to tropical conditions, and although not as severely affected as other types, the insulation resistance falls to approximately  $\frac{1}{4}$  of its initial value after one month in a saturated atmosphere.

#### HIGH-FREQUENCY INDUCTORS

Intermediate-frequency and radio-frequency inductors are badly affected by humidity, and leakage between terminals develops when synthetic-resin bonded-paper tube or sheet is used to support these terminals. The  $Q$  of the inductors drops due to this leakage and to moisture entering the winding. Surface resistances as low as 40,000 ohms between terminals are common when the terminals are mounted on synthetic-resin bonded-paper parts and reduction in  $Q$  of from 200 to 15 occurs in unprotected or varnished inductors after a few weeks exposure. Pi-wound litz inductors are most seriously affected, but reduction in  $Q$  to a lesser extent takes place in solenoids. Coils wound on ceramic or polystyrene formers and impregnated with polystyrene lacquer or a plastic wax are satisfactory under tropical conditions, providing connections are brought out through terminals or lugs mounted on polystyrene or ceramic.

Varnish treatment of high-frequency inductors is not effective. Cases have been noted where large high-frequency inductors wound on synthetic-resin bonded-paper formers, using artificial-silk- or cotton-covered wire that has been varnished have grown mould profusely. Mould on this type of inductor has caused permanent damage. The  $Q$  of the inductor has been reduced to approximately  $\frac{1}{3}$  of its original value and baking has failed to restore the  $Q$ . Fungiciding the cotton for this type of inductor is not satisfactory for, although it does prevent mould growth, the varnish does not protect the winding. Use of a thick coat of a good wax or polystyrene lacquer has given better results on this type of inductor.

## RESISTORS

Reports have been received from forward areas of open circuits of both carbon and wire-wound resistors. To date, these faults have not been reproduced in the laboratory with wire-wound resistors, but further work is proceeding. It is known that wire-wound resistors with vitreous-enamel coatings are satisfactory under tropical conditions.

Carbon resistors have been a source of trouble and, although laboratory tests have not revealed the cause of this trouble, it is apparently due to faulty carbon coatings. Of large numbers of resistors put through the humidity and life tests, only a small percentage has failed in each case. We have been unable to trace the cause of these failures.

## INSULATING VARNISHES AND LACQUERS

Laboratory tests of insulating varnish and lacquers have been carried out under conditions similar to those set out in American Society for Testing Materials D115-41. Variations of this test have been made in that moisture-permeability tests are carried out in a tropical atmosphere instead of at the lower humidity recommended by the American Society for Testing Materials.

Probably the most important characteristic of an insulating varnish or lacquer used for sealing purposes is its moisture permeability. Values of moisture permeability greater than  $3 \times 10^{-8}$  gram per hour per centimeter per millimeter of mercury do not provide satisfactory protection under tropical conditions. Impregnating varnishes, while having been tested, have not been used to any great extent as it has been preferable to use some solid compound such as bitumen for the impregnation of power-transformer coils, etc. Varnish impregnation of radio-frequency coils has been unsatisfactory.

The incorporation of fungicides in paints, varnishes or lacquers has not achieved the results expected. Fungicides, while rendering the varnish or lacquer immune to mould growth, do not necessarily prevent the mould from growing on the base material where that base material will provide nutrient for mould growth. Fungiciding of the base material has been a superior method of preventing mould growth.

## EFFECTS OF SOME FUNGICIDES ON METALS

Tests have been carried out to determine the effect of some common fungicides on metals. Felt treated with the fungicide to be tested is clamped between two metal plates and exposed to a temperature of 70 degrees centigrade and 95 per cent relative humidity for two days and then to seven days in a saturated atmosphere at 86 degrees Fahrenheit.

The stains caused by the copper naphthenate on the cadmium and silver seemed to be due rather to the felt, which contained a brown dye, than to the fungicide, as the impression of the felt was clearly marked. This may

TABLE I

Metal	Fungicide		
	Copper Naphthenate	Trichlorphenol	Dowicide No. 6
Cadmium	Marked by felt	Heavy white powder on surface	No effect
Silver	Brown stain	Brown stain	Brown stain
Chromium	No effect	No effect	No effect
Nickel	No effect	No effect	No effect
Zinc	Silver-grey stain	Dark-grey stain	Slight stain
Tin	Dark-grey stain	No effect	No effect

also have been the case with the zinc and tin, although there the marking was more continuous. The corrosion with the trichlorphenol on cadmium was definite, but the zinc was so corroded by moisture that the effect of the fungicide was masked.

## PACKING EQUIPMENT

Reports indicate that the majority of casualties to electrical equipment take place during storage and transport. Packing is thus of great importance. Containers for equipment and spares must be such that they are not damaged by surface condensation, moulds, termites, or spray. Airtight, waterproof containers that are dry internally are essential. Packing cases must be strong enough not to be damaged by dropping, and the wood in the packing cases should be treated with copper naphthenate to prevent termite and mould attack.

## CONCLUSIONS

In general, it is preferable to use materials that are not affected by mould and humidity, rather than to treat poorer grades of materials in an attempt to render them "tropic proof." Materials such as vinyl plastics, mica, ceramics, and others of a similar nature are quite satisfactory in tropical conditions, whereas untreated papers, paper board, fabric, varnished cloth, and varnished-cambric sleeving, are unsatisfactory even when treated.

It would be better if the equipment supplied to tropical areas could be hermetically sealed in containers rather than manufactured by standard methods.

## TEST PROCEDURE

Two test atmospheres have been used to determine the resistance of materials and components to mould and humidity. The atmospheres are as follows:

*High-Temperature-and-Humidity Cycle:*

Materials and components are subjected to 70 degrees centigrade for eight hours, cooling to ambient over a period of 16 hours. The same materials and components are then placed in a chamber maintained at 60 degrees centigrade  $\pm 2$  degrees centigrade and 95 per cent  $\pm 5$  per cent relative humidity for six hours. The closed chamber is cooled over a period of 16 hours. The above cycle is repeated once.

This method of test has been used widely to obtain rapid results of corrosion of metals and lowering of the

insulation resistance of materials. However, the shortcomings of this method of test led us to develop the static humidity test in which the time element is taken into account. The results obtained in this latter test are more consistent and approach more closely to natural tropical conditions.

#### *Static-Humidity Test:*

The static-humidity-test atmosphere is based on conditions met with in some parts of New Guinea, where the average temperature is approximately 86 degrees Fahrenheit and humidity 70 to 100 per cent. The test chamber itself maintains a temperature of 86 degrees Fahrenheit  $\pm$  2 degrees Fahrenheit and a relative humidity of 95 to 100 per cent with condensation predominating. This chamber is used both for static-humidity and mould testing. The normal duration of test is 28 days. In some development work this period is extended to as long as six months, depending on the time available.

Material and components are placed in the test atmosphere and left undisturbed for 28 days. They are then removed and left in free air at a temperature of 25 to 30 degrees centigrade and atmospheric humidity of 40 to 60 per cent for  $\frac{1}{2}$  hour before measurements are taken. This recovery period is to enable free moisture on the surface of materials and components to dry out sufficiently so as not to affect measurements.

#### *Mould Test:*

Materials and components before exposure in the static-humidity atmosphere are sprayed by means of an atomizer with a suspension of mixed spores of selected mould species isolated from electrical components returned from New Guinea. The moulds used for inoculation include the following species:

- |                                |                                 |
|--------------------------------|---------------------------------|
| (1) <i>Aspergillus glaucus</i> | (4) <i>Penicillium</i> No. 40   |
| (2) <i>Aspergillus niger</i>   | (5) <i>Memnoniella echinata</i> |
| (3) <i>Penicillium luteum</i>  | (6) <i>Rhizopus nigricans</i>   |

The materials and components are then subjected to the saturated atmosphere for 28 days, or until mould growth takes place, observations being made every few days.

#### *Preparation of Cultures:*

Potato-dextrose agar used for cultures is prepared as follows: 200 grams of peeled and sliced potato is boiled in a liter of water for one hour. The liquid is filtered through cotton wool; 200 grams of dextrose and 25 grams of agar are added. The material is tubed and autoclaved for 20 minutes at 15 pounds per square inch pressure. Slopes are used for ordinary culture work.

Test tubes are quarter-filled with the agar medium, sterilized, and while still hot, inclined at 20 degrees to the horizontal and allowed to cool.

Tubes are inoculated with spores of the required mould growth by drawing a loop of sterile wire first across the surface of the mould to be cultivated and then across the fresh agar surface. During this operation, precautions are taken against contamination by flaming the mouths of the tubes and sterilizing the wire by heating to redness in a Bunsen flame (Figs. 7 and 8). Cultures are incubated at a temperature of 26 to 30 degrees centigrade.

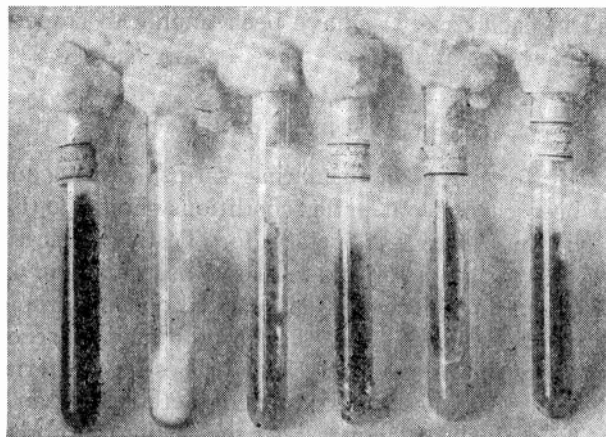

Fig. 7—Examples of mould cultures grown on potato dextrose agar and used to obtain spores for inoculation.

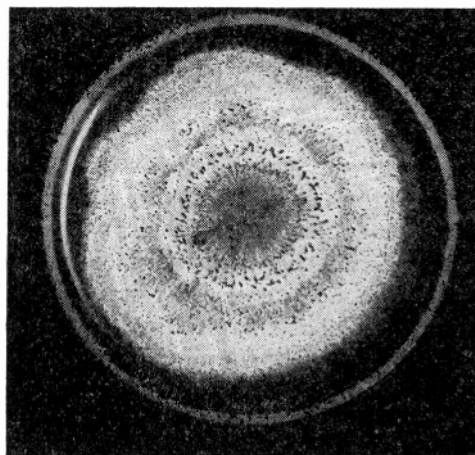

Fig. 8—Example of *Pestalozzia* specimen.

Components which satisfy the conditions of the static humidity test have been found to operate satisfactorily in tropical climates for periods up to six months, while materials and components that are damaged in any way by this test condition break down after a few weeks of tropical service.

# The Compensated-Loop Direction Finder\*

FREDERICK EMMONS TERMAN†, FELLOW, I.R.E., AND  
JOSEPH M. PETTIT†, MEMBER, I.R.E.

**Summary**—One of the serious limitations of the null-type radio direction finder has been the “night-effect” error caused by the horizontally polarized component of the downcoming sky wave, which is picked up in the horizontal elements of the loop. Two types of attack on this problem are represented by the “Adcock antenna” and the “compensated loop.” The Adcock antenna is effective because of its construction *without* horizontal elements, but suffers from low pickup of the desired vertically polarized components. On the other hand, the compensated loop consists of a standard loop plus an auxiliary horizontal antenna mounted on the loop, from which is obtained a voltage for neutralizing the undesired loop pickup. The latter system offers the greater advantages in terms of good pickup and compactness of structure, but has not received adequate consideration by previous investigators. This paper presents an analysis of the compensated loop in the general case, together with the results of detailed calculations for direction finders covering a wide range of wavelengths, with two specific examples for 550 and 1100 meters. The analysis shows that when the earth has a high reflection coefficient the system is capable of providing complete or nearly complete neutralization with no tuning required other than an initial adjustment, and even with poor earth conditions, substantial reduction in errors is obtainable.

## INTRODUCTION

**E**RRORS due to abnormal polarization of the received wave constitute one of the serious limitations of radio direction finding. Of these polarization phenomena the two most familiar are “night effect” and “airplane effect,” the former being present under night conditions when ionospheric reflections produce the abnormal polarization, and the latter occurring when bearing measurements are made from the ground upon an airplane transmitter having a trailing antenna inclined at an angle from the vertical. According to the amount and variability of the abnormal polarization, the phenomena may present any of the following symptoms: (1) a sharply defined bearing but on an incorrect azimuth; (2) a blurred, indefinite bearing indication; or (3) a sharp but shifting bearing. Since these undesirable effects have been known for over twenty years they have received considerable study,<sup>1-2</sup> but it is believed that the solution represented by the compensated loop has not heretofore been adequately presented.

## MECHANISM OF POLARIZATION ERRORS

In order to assist in the understanding of this problem and its solution, it will be desirable first to review briefly

\* Decimal classification: R325.31. Original manuscript received by the Institute, March 13, 1941; revised manuscript received December 9, 1944.

† Radio Research Laboratory, Harvard University, Cambridge, Massachusetts. Work reported in this paper was done in the main while the authors were at Stanford University.

<sup>1</sup> A good review of the problem, together with a complete bibliography to 1938, is given in R. Keen, “Wireless Direction Finding,” Iliffe and Sons, Ltd., London, Third Edition, 1938, Chapter 6.

<sup>2</sup> F. S. Howes and F. M. Wood, “Note on the bearing error and sensitivity of a loop antenna in an abnormally polarized field,” Proc. I.R.E., vol. 32, pp. 231-233; April, 1944.

the cause of polarization errors in direction-finding systems.

The normal action of the null-type direction finder using a loop antenna is so well known as to need only brief discussion. With a vertical loop as in Fig. 1, a vertically polarized wave will induce in the two side elements the voltages  $E_1$  and  $E_2$ , which are of equal magnitude but whose phase difference varies as the loop is rotated. The two voltages balance each other when the phase difference is zero, and thus give zero loop output. The mathematical expression for this behavior is obtained quite simply. The phase angle between  $E_1$  and  $E_2$  can be expressed as:  $2\pi a \cos \alpha / \lambda$  (radians)

where  $a$  = width of loop, meters

$\alpha$  = angle between plane of loop and direction of signal arrival (see Fig. 2)

$\lambda$  = wavelength, meters.

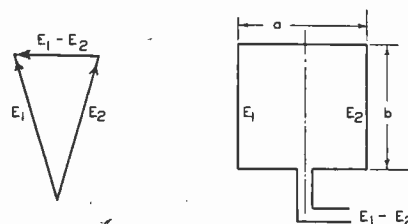

Fig. 1—Simple case of voltages induced in-loop by vertically polarized wave traveling along the ground.

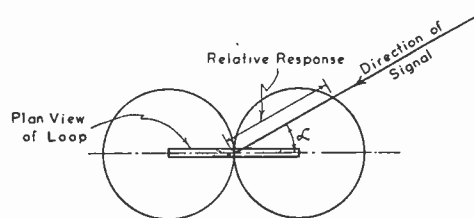

Fig. 2—Plan view of loop, showing polar diagram of response to vertically polarized wave.

It is apparent from Fig. 1 that since  $E_1$  and  $E_2$  are equal in magnitude

$$E_1 - E_2 = 2E_1 \sin \frac{1}{2}((2\pi a \cos \alpha) / \lambda) \quad (1)$$

and since the width of the usual direction finder is very small compared to a wavelength, we can simplify (1) by replacing the sine by the angle itself:

$$E_1 - E_2 = 2E_1(\pi a \cos \alpha) / \lambda. \quad (2)$$

The magnitude of  $E_1$  can be written in terms of the field strength  $E$ , giving:

$$|E_1| = |E_2| = EbN \quad (3)$$

where  $E$  = field strength, volts per meter

$b$  = vertical loop width, meters

$N$  = number of loop turns.

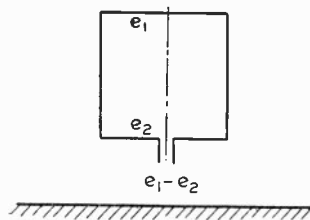

Fig. 3—Voltages induced in loop by horizontally polarized wave.

Hence, the final expression for the loop voltage is

$$E_1 - E_2 = (2\pi abN/\lambda)E \cos \alpha. \quad (4)$$

Assume now that, in addition to the vertically polarized wave just discussed, there is also present a horizontally polarized downcoming component. As illustrated in Fig. 3, there are two voltages  $e_1$  and  $e_2$  induced in the horizontal-loop elements. These voltages are zero when the plane of the loop is at right angles to the wave front (this is the *maximum* position of the loop for the normal case previously described), and they are maximum when 90 degrees from this position (the normal *minimum* or null position). Because of the angle of arrival of the wave, there is always a phase difference between  $e_1$  and  $e_2$ , and therefore, the net loop voltage is zero only when both  $e_1$  and  $e_2$  are themselves zero. It can thus be seen that the horizontally polarized component produces voltage when there should be a null, and hence the operator turns the loop past the true null position until the voltages due to the horizontal and vertical components are equal and opposite, thereby giving a null, but an erroneous bearing indication. Furthermore, if the horizontal and vertical components are not in time-phase; i.e., elliptical polarization of the wave, there will be no position of the loop for which the voltages will cancel exactly, and thus, only a blurred minimum will be obtained. The apparent shifting of the observed bearing described above comes from variations in relative magnitude of the horizontal and vertical components. It should be pointed out that the vertical component comprises both the ground wave and the vertical component of the sky wave, and therefore, variations in *phase* between these two changes the resultant magnitude of the combination. Thus, rapid changes in the ionospheric reflection characteristics can produce corresponding variations in observed bearings.

Two possible modes of attack suggest themselves. Since the undesired horizontal pickup comes from the horizontal wires of the loop, some form of antenna having only vertical elements would provide a solution. This procedure has been successfully followed in the Adcock antenna. Unfortunately, by using an antenna with only vertical members, the advantage of the multi-turn loop in high signal pickup must be sacrificed. This requires an antenna of very large dimensions to provide adequate pickup of the desired signal components, which renders this type of structure impossible for compact mobile installations. Another approach to the problem is the employment of the standard loop antenna,

with all its undesired pickup of the horizontal component, and then by means of additional horizontal pickup from an auxiliary antenna mounted on the loop *neutralize* the unwanted component by proper coupling into the output circuit of the main loop. Achievement of this solution requires the designing of the system in such a way as to obtain from the auxiliary antenna, by means of a simple coupling network, a small, horizontally polarized voltage which will neutralize the undesired loop pickup for the desired range of frequency, signal bearing, and angle of incidence of the sky wave.

The compensated loop has been previously discussed in the literature<sup>3-4</sup> and several patents have been granted.<sup>5-7</sup> The principal conclusion that seems to have been reached, however, is that, while under certain specialized and greatly limited conditions the forms of compensated loop proposed are immune to night effect, they have not seemed practicable under general conditions. It is these authors' belief that the shortcomings of these types of compensated loop have resulted from basic analyses and proposals that were too specialized and which failed to bring out the full potentialities of the idea in general. The difference between the proposal of this paper and those of the previous systems will be presented later.

In the analysis that will follow there are several phases of the problem that will be considered. First, it is desirable to provide an analysis of the loop without compensation, in order to calculate the bearing errors introduced by certain selected night-effect conditions. Second, it is necessary to determine what sort of requirements must be placed upon a coupling network for neutralizing the undesired component of loop voltage by means of an auxiliary horizontal antenna. Third, it is important to calculate the extent to which the network would fail to neutralize as the various operating conditions (such as angle of wave incidence) are changed, and finally, to translate this into actual bearing errors. Thus we wish to be able to compute the bearing errors for any polarization of the signal for both the uncompensated and the compensated loops.

#### POLARIZATION ERROR IN THE UNCOMPENSATED LOOP<sup>8</sup>

In order first to calculate the polarization errors of the uncompensated loop it will be necessary to examine the behavior of a loop in the presence of a downcoming wave (in contrast to one traveling horizontally along the surface of the earth), having both vertical and horizontal components of polarization. It will be convenient to consider the two components separately; i.e.,

<sup>3</sup> See pp. 219-220 of footnote reference 1.

<sup>4</sup> R. H. Barfield, "The performance and limitations of the compensated loop direction finder," *Jour. I.E.E.* (London), vol. 86, pp. 396-398; April, 1940.

<sup>5</sup> Lorenz: German Patent No. 624,706; 1934.

<sup>6</sup> Hell: German Patent No. 601,904; 1933.

<sup>7</sup> Telefunken: British Patent No. 464,075; 1937.

<sup>8</sup> The analysis of Howes and Wood (footnote reference 2), is comparable to that herein, except that the authors did not include the effect of the ground.



as two distinct waves, one vertically and the other horizontally polarized.

**Effect of Ground**

For any antenna situated in the vicinity of the semi-conducting earth's surface, it is necessary to consider not only the direct, downcoming wave, but also a reflected wave as shown in Fig. 4. This reflected wave will

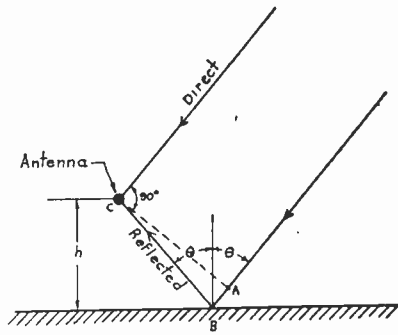

Fig. 4—Geometrical arrangement of wave paths for downcoming wave.

lag in phase by an angle<sup>9</sup>  $\beta = (4\pi h \cos \theta) / \lambda$  because of the longer path traveled. Further complication is introduced by the nature of the reflection. The angle of reflection is equal to the angle of incidence, but the field strength undergoes an attenuation in magnitude and a shift in phase at the point of reflection. In other words, the reflected wave generally has a smaller field strength and differs in phase from the incident wave. In general, the relationship between the direct and reflected waves is represented by a reflection coefficient which contains both the magnitude ratio and the phase difference. These are,<sup>10</sup> for vertical polarization ( $E$  vector in plane of incidence),

$$r_v e^{-i\gamma_v} = \frac{K' \cos \theta - \sqrt{K' - \sin^2 \theta}}{K' \cos \theta + \sqrt{K' - \sin^2 \theta}}; \quad (5)$$

for horizontal polarization ( $E$  perpendicular to plane of incidence)

<sup>9</sup> The reflected wave travels a greater distance than the direct wave by an amount equal to the length  $\overline{AB}$  plus  $\overline{BC}$  in Fig. 4.

$$\begin{aligned} \overline{BC} &= (h / \cos \theta) = h \sec \theta \\ \overline{AB} &= \overline{BC} \cos 2\theta = \overline{BC} (2 \cos^2 \theta - 1) \\ &= h (2 \cos^2 \theta - \sec \theta) \\ \overline{AB} + \overline{BC} &= 2h \cos \theta. \end{aligned}$$

Phase difference  $\beta$  due to this path length is  $(2\pi/\lambda)(2h \cos \theta)$ , or  $(4\pi h/\lambda) \cos \theta$ .

<sup>10</sup> This form was adapted from C. B. Feldman, "The optical behavior of the ground for short radio waves," *PROC. I.R.E.*, vol. 21, pp. 764-801; June, 1933. Derivations of these may be found in the literature, for instance: P. O. Pedersen, "Propagation of Radio Waves," G. E. C. Gad, Copenhagen, 1927. For charts of values see C. R. Burrows, "Radio propagation over plane earth—field strength curves," *Bell Sys. Tech. Jour.*, vol. 16, pp. 45-75; January, 1937; and J. S. McPetrie, "The reflection coefficient of the earth's surface for radio waves," *Jour. I.E.E.* (London), vol. 82, pp. 214-218; February, 1938. These charts do not give great enough precision for some work, and it was found necessary to make detailed calculations of the reflection coefficients for the conditions of interest in this paper.

It should be mentioned that these equations do not hold for angles approaching grazing incidence, where the situation blends into the ground-wave propagation equations. As will be shown later, the interest here is primarily in higher-angle waves.

$$r_H e^{-i\gamma_H} = \frac{\sqrt{K' - \sin^2 \theta} - \cos \theta}{\sqrt{K' - \sin^2 \theta} + \cos \theta} \quad (6)$$

where  $r_v, r_H$  = magnitude ratios (reflected to direct)

$\gamma_v, \gamma_H$  = phase lag at reflection (referred to phase of reflected wave for reflection from perfect conductor)

$$K' = k - j2\sigma\lambda c$$

$k$  = dielectric constant of the surface (assuming  $k$  for air = 1)

$j$  = 90 degrees vector operator

$\sigma$  = conductivity of the surface in electromagnetic units (for air  $\sigma = 0$ )

$\lambda$  = wavelength, meters

$$c = 3 \times 10^8$$

$\theta$  = angle of incidence (measured from vertical).

Thus, referring back to Fig. 4, we can write for the sum of the direct and reflected waves at an antenna of height  $h$

$$\left. \begin{aligned} \text{vertically polarized: } & E_v (1 + r_v e^{-i(\gamma_v + \beta)}) \\ \text{horizontally polarized: } & E_H (1 + r_H e^{-i(\gamma_H + \beta)}) \end{aligned} \right\} \quad (7)$$

where  $E_v$  and  $E_H$  are the vertical and horizontal components, respectively, of the field strength of the wave in the absence of the earth. The voltage induced in any horizontal or vertical antenna element is simply the product of the component (parallel to the wire) of the appropriate field strength according to (7), times the effective length of the element.

**Vertical Polarization**

Take first the case of a downcoming wave whose electric vector is in the vertical plane of incidence (i.e. the vertical plane containing the incident and reflected wave paths, and thus perpendicular to both the horizontal earth plane and the plane of the wave front). This is illustrated in Fig. 5. It will be noted that  $E_v$  actually has a horizontal component lying in the plane of incidence,

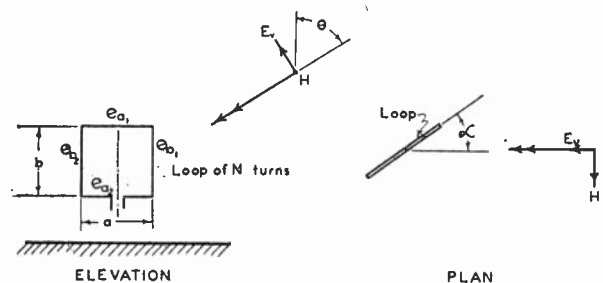

Fig. 5—Voltages induced in loop by downcoming wave with vertical polarization.

but this is not to be confused with what is usually called the horizontal component, namely, the electric vector perpendicular to the vertical plane of incidence. Nevertheless,  $E_v$  will in general induce voltages in the two horizontal elements of the loop, and these are indicated as  $e_{a1}$  and  $e_{a2}$ . The vertical component of  $E_v$  induces voltages in the vertical loop elements designated as  $e_{b1}$  and  $e_{b2}$ , as indicated in Fig. 5. To calculate the loop

voltage one needs only to add up these voltages induced in the vertical and horizontal elements, using the field strengths of (7).

The analysis can be achieved a little more neatly by considering the direct and reflected waves as two separate waves, and obtaining the net loop voltage for each of them exactly as in (1), (2), (3), and (4). This becomes especially expedient in view of the fact that it is necessary to refer the phase of all voltages to the same point in space (the phase of the resultant fields given in (7) refers only to the direct wave at each different wire being considered). For this analysis the reference to be taken is the phase of the direct wave at the center of the loop.

Consider now the vector diagram of Fig. 6; here are pictured the loop voltages  $e_{b_1}$  and  $e_{b_2}$  indicated in Fig. 5, induced by a downcoming wave with vertical polarization. The voltages induced by the direct wave are indicated as  $e_{b_1}'$  and  $e_{b_2}'$ , and by the reflected components as  $e_{b_1}''$  and  $e_{b_2}''$ . Several important characteristics can be noted by careful examination of this vector diagram. First, the phase of the reflected wave at the center of the loop is seen to lag that of the direct wave by an angle  $\gamma_v + \beta_0$  (where  $\beta_0$  is calculated for the height of the center of the loop; thus  $\beta_0 = (4\pi h_0 \cos \theta) / \lambda$ ). Also, the magnitudes of the voltages induced by the reflected component are smaller than those induced by the direct wave by the factor  $r_v$ .

The net loop voltage resulting from each pair,  $e_{b_1}'$  and  $e_{b_2}'$  and  $e_{b_1}''$  and  $e_{b_2}''$ , can be expressed in both magnitude and phase by multiplying the magnitude of one of the pair by the factor  $j2 \sin \frac{1}{2}((2\pi a \cos \alpha \sin \theta) / \lambda)$ . This operation is essentially the same as that of (1),

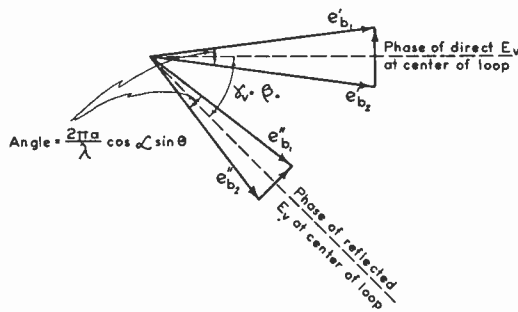

Fig. 6—Vector diagram for voltages in vertical-loop elements due to vertically polarized downcoming wave as in Fig. 5.

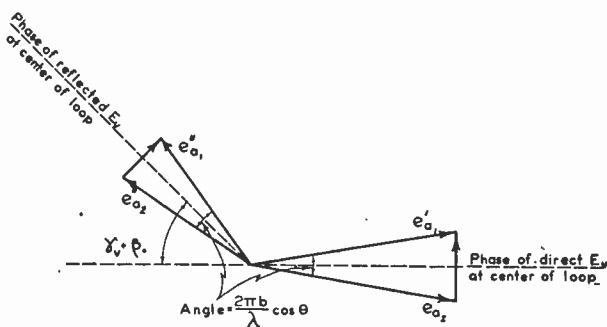

Fig. 7—Vector diagram for voltages in horizontal-loop elements due to vertically polarized downcoming wave as in Fig. 5.

with the factor  $j$  included to refer the phase angle of the difference voltage to the reference phase at the center of the loop. The component of the field strength which is parallel to the vertical-loop wires is  $E_v \sin \theta$  and the effective length of the wires is  $bN$  where  $N$  is the number of turns on the loop. We can, therefore, write for the resultant voltage

$$e_{b_1} - e_{b_2} = (E_v \sin \theta)(bN)(1 + r_v \epsilon^{-i(\gamma_v + \beta_0)}) \cdot (j2 \sin)(\pi a \cos \alpha \sin \theta) / \lambda. \quad (8)$$

By a similar process we can obtain the voltage  $e_{a_1} - e_{a_2}$ . The vector diagram for these voltages is given in Fig. 7. It will be seen to differ from Fig. 6 in that the reflected wave has an additional 180 degrees phase difference; this is due to a geometrical reversal of the direction of the horizontal component of  $E_v$  in the reflected wave. The net voltage is

$$e_{a_1} - e_{a_2} = (E_v \cos \theta \cos \alpha)(aN)(1 + r_v \epsilon^{-i(\gamma_v + \beta_0)}) \cdot (j2 \sin)(\pi b \cos \theta) / \lambda. \quad (9)$$

The total loop voltage is the sum of (8) and (9). If the loop dimensions  $a$  and  $b$  are small compared to a wavelength, a simplification can be made by replacing, in the last parenthesis in the two equations, the sine of the angle by the angle itself. Then, letting  $e_v$  designate the combined voltage due the vertically polarized component, we can write for the combination, (noting that  $\sin^2 \theta + \cos^2 \theta = 1$ )

$$e_v = j(2\pi abN/\lambda)E_v(1 + r_v \epsilon^{-i(\gamma_v + \beta_0)}) \cos \alpha. \quad (10)$$

This equation reduces to (4) if the term representing the reflected wave ( $r_v \epsilon^{-i(\gamma_v + \beta_0)}$ ) is omitted, as would be the case for a wave traveling along the earth's surface. The phase operator  $j$  was not included in (4), because there the emphasis was on only the magnitude of the resultant voltage.

It can be noted from (10) that the bearing observed on a downcoming signal whose polarization is in the vertical plane should be just as accurate as for a wave traveling horizontally along the ground, for the behavior with respect to the angle  $\alpha$  is identical for either case.

### Horizontal Polarization

Fig. 8 shows the loop in the presence of a downcoming wave whose electric vector is horizontal; i.e., perpendicular to the vertical plane of incidence. It will be noted that voltage is induced in only the horizontal elements of the loop, regardless of the angle of incidence; these

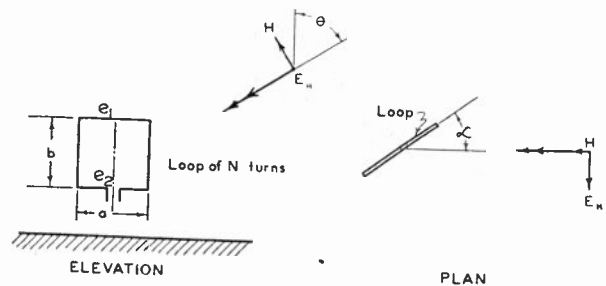

Fig. 8—Voltages induced in loop by downcoming wave with horizontal polarization.

two voltages are indicated as  $e_1$  and  $e_2$ . As before, it will be advantageous to consider the direct and reflected

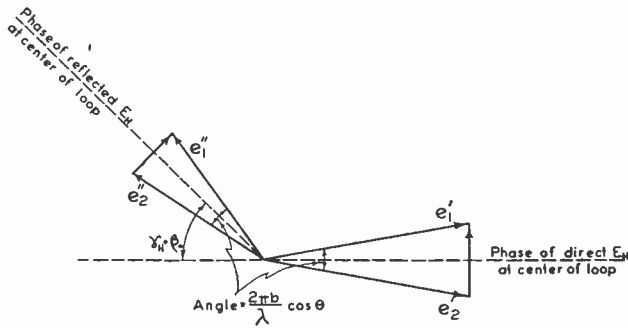

Fig. 9—Vector diagram for voltages in loop due to horizontally polarized downcoming wave as in Fig. 8.

waves as two separate waves. The vector diagram appears in Fig. 9, and the equation for the net voltage is

$$e_1 - e_2 = (E_H \sin \alpha)(aN)(1 + r_H e^{-i(\gamma_H + \beta_0)}) \cdot (j2 \sin \frac{1}{2}) (2\pi b \cos \theta) / \lambda. \quad (11)$$

Letting  $e_H$  indicate this loop voltage due to the horizontally polarized component, and making the same assumption as previously that the loop dimensions are small compared to a wavelength, (11) can be rewritten

$$e_H = j(2\pi ab N \cos \theta / \lambda) E_H (1 + r_H e^{-i(\gamma_H + \beta_0)}) \sin \alpha. \quad (12)$$

It will be noted that  $e_H$  varies according to  $\sin \alpha$  as the loop is rotated, while  $e_v$  varies according to  $\cos \alpha$ . This means, then, that the zero, or null point for the horizontally polarized component occurs at bearings displaced 90 degrees in azimuth from the correct ones; (i.e., for vertical polarization). Hence, if only a horizontal component is present, the direction finder will have an error of 90 degrees in bearing. This represents the extreme case, of course, but it can happen in practice when the vertically polarized component comprises a ground wave and a sky wave which are equal and 180 degrees

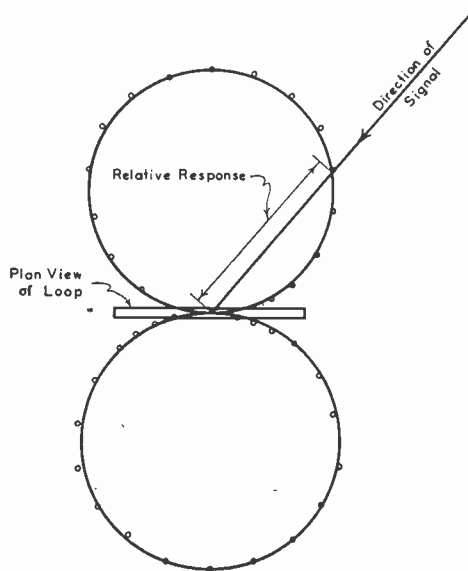

Fig. 10—Plan view of loop, showing polar diagram of response to downcoming, horizontally polarized wave. Test values were obtained with the elevated transmitter used in later field tests. Solid curve is theoretical response pattern.

out of phase. This behavior of the loop in the presence of only a horizontally polarized component can be demonstrated readily in the field by using an elevated transmitter with a horizontal dipole antenna. An actual field pattern obtained in this manner is shown in Fig. 10, which may be contrasted with Fig. 2.

### Combination of Horizontal and Vertical Polarization

In the usual occurrence of polarization errors, there are both horizontally and vertically polarized components present, and all the symptoms of night effect now can be demonstrated with the aid of the equations for  $e_v$  and  $e_H$ .

First let us assume that  $e_v$  and  $e_H$  are in phase. Then for some particular orientation of the loop they will be equal and opposite and a null will be obtained. Depending upon the relative magnitudes of the vertical and horizontal components of the wave, this null point may be anywhere between the correct bearing and  $\pm 90$  degrees. This accounts for one symptom previously mentioned as a result of abnormal polarization.

If  $e_v$  and  $e_H$  are in phase but varying in relative magnitude, due perhaps to changes in ionosphere reflection conditions, the observed bearing will change over a period of time.

If  $e_v$  and  $e_H$  are not in phase (a more general situation), no sharp null can be obtained, but instead, an indefinite minimum is observed. This can be illustrated by the vector diagram of Fig. 11. The locus of  $e_v$  shown

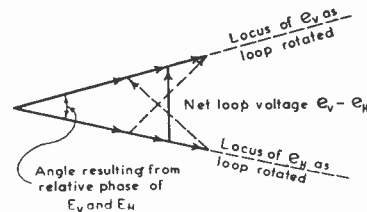

Fig. 11—Vector diagram demonstrating incomplete null resulting from mixed polarization of downcoming wave.

in the figure is the line along which  $e_v$  varies in length according to  $\cos \alpha$  as the angle of rotation  $\alpha$  of the loop is varied. Similarly the locus of  $e_H$  shows the line along which  $e_H$  varies in length according to  $\sin \alpha$ . These two vectors maintain a constant phase difference as indicated by their angular separation. The resultant difference voltage is shown for three positions of loop rotation, 1, 2, and 3. The vector numbered 2 corresponds to the minimum voltage. It can be seen that the difference voltage never becomes zero, the residual amount depending upon the phase angle between the two voltages. This is the explanation for the blurred, indefinite bearing indication previously mentioned. The most common cause of this is elliptical polarization of the downcoming wave; i.e., a phase angle between the field strengths  $E_v$  and  $E_H$  introduced in the ionosphere reflection. Of course, the angle between the induced voltages  $e_v$  and  $e_H$  depends not only upon the relative phase of  $E_v$  and  $E_H$ , but also upon the combination of the direct and

reflected waves at the ground reflection, involving the reflection coefficients for vertical and horizontal polarization.

### Bearing Error

With the aid of the equations for  $e_v$  and  $e_H$  it is now desirable to derive a relationship for calculating the actual error that would be observed for any arbitrary condition of polarization. Having this, the reduction in the errors afforded by the compensating system can then be computed.

A convention established by Barfield,<sup>11</sup> known as the "standard wave," will be adopted. This concept was introduced to provide a convenient set of reference conditions whereby the relative accuracies of different types of direction finders might be readily compared. There are two essential features to the standard wave. The first stipulates that the angle of incidence shall be 45 degrees and the angle of polarization shall be 45 degrees; i.e.,  $E_v = E_H$ . The second condition is that  $E_v$  and  $E_H$  shall have suitable phase relationship so that the induced voltages in the loop ( $e_v$  and  $e_H$ ) shall be in phase, regardless of ground conditions. This second condition simply assures that a sharp null will be obtained. In this paper the second condition will always be kept plus that part of the first condition that stipulates polarization at 45 degrees; but the errors will be investigated for all angles of incidence, rather than just 45 degrees.

If  $e_v$  and  $e_H$  are exactly in phase, the condition for the null point can be expressed by the simple relationship

$$|e_v| = |e_H| \quad (13)$$

with the inference that the two voltages are in opposition. Then the expressions of (10) and (12) can be substituted:

$$\begin{aligned} j(2\pi abN/\lambda)E_v(1 + r_v\epsilon^{-i(\gamma_v+\beta_0)}) \cos \alpha \\ = j(2\pi abN/\lambda)E_H(1 + r_H\epsilon^{-i(\gamma_H+\beta_0)}) \cos \theta \sin \alpha \\ \cot \alpha = (E_H(1 + r_H\epsilon^{-i(\gamma_H+\beta_0)}) \cos \theta / (E_v(1 + r_v\epsilon^{-i(\gamma_v+\beta_0)}))). \end{aligned} \quad (14)$$

The ratio  $E_H/E_v$  is the tangent of the angle of polarization  $\psi$ . Also it will be recalled that, for vertical polarization alone, the true bearing would be obtained with a null point at  $\alpha = 90$  degrees ( $\cos 90^\circ = 0$ ); thus it follows that the error  $\epsilon$  in the observed bearing is

$$\tan \epsilon = \cot \alpha. \quad (15)$$

Thus, the complete expression for the error in bearing is<sup>12</sup>

$$\tan \epsilon = (\tan \psi (1 + r_H\epsilon^{-i(\gamma_H+\beta_0)}) \cos \theta / (1 + r_v\epsilon^{-i(\gamma_v+\beta_0)})). \quad (16)$$

In this equation it is implied that only the magnitudes of the quantities in parentheses are sought for; i.e., the vector relations are computed in the regular way, but the resulting angle for the combination is disregarded because the standard wave presumes that  $E_v$  and  $E_H$  are so phased as to make this angle zero.

<sup>11</sup> R. H. Barfield, "Some principles underlying the design of spaced aerial direction finders," *Jour. I.E.E.* (London), vol. 76, pp. 423-447; April, 1935.

<sup>12</sup> This equation has been derived from a different approach by Barfield, footnote reference 11.

It is often quoted in the literature that the standard-wave error for the loop is 35.3 degrees. This derives from the fact that, for soil of high conductivity, the reflection coefficients for vertical and horizontal polarization are practically equal; and hence  $\tan \epsilon = \tan \psi \cos \theta$ . And since  $\psi$  and  $\theta$  for the standard wave are defined as 45 degrees, it follows that  $\tan \epsilon = (1.00)(0.707)$ ;  $\epsilon = 35.3$  degrees.

In the general case, of course, it is not permissible to assume equality of the reflection coefficients, and (16) must be used with the actual calculated values of the coefficients.

## POLARIZATION ERROR IN THE COMPENSATED LOOP

### Basic Analysis

As described previously, the basic idea of the compensated loop is the obtaining from an auxiliary horizontal antenna a voltage which can be introduced into the loop circuit in such a manner as to neutralize the loop voltage due to horizontal polarization, namely  $e_H$ . It is, therefore, necessary to examine the behavior of such an auxiliary antenna.

It is obvious that the antenna must be mounted on, and rotate with the loop structure. For convenience only, let us first assume the antenna to be mounted at a height  $h_0$ , the center of the loop. It can be shown that some advantage is gained by mounting the antenna higher, but it is not an important one, and structural difficulties might outweigh it. The vector diagram for the antenna voltage, which shall be designated as  $e_a$ , is

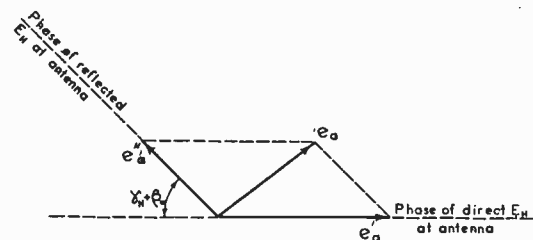

Fig. 12—Vector diagram for voltage induced in compensating antenna due to downcoming, horizontally polarized wave.

shown in Fig. 12, and it may be expressed in equation form as follows:

$$e_a = l_a E_H (1 - r_H \epsilon^{-i(\gamma_H + \beta_0)}) \sin \alpha \quad (17)$$

where  $l_a$  = effective length of the antenna.

In order that this voltage  $e_a$  be coupled into the loop circuit in such manner as to neutralize  $e_H$ , the coupling network must have a characteristic defined by

$$\begin{aligned} (R_N \epsilon^{j\delta_N}) &= (e_a / e_H) \\ &\text{(for neutralization)} \end{aligned} \quad (18)$$

where  $R_N$  is the magnitude ratio (or attenuation) of the network, and hence the magnitude ratio of  $e_a$  and  $e_H$  for the condition of neutralization. Likewise,  $\delta_n$  is the corresponding phase angle of the network, and thus the angle between  $e_a$  and  $e_H$  at neutralization.

Now, since the network must be composed of conventional circuit elements, it will be unable to change

its characteristics to accommodate changes in the nature of the wave arriving at the loop and antenna, such as angle of incidence. Thus, since the actual ratio of  $e_a$  and  $e_H$  depends upon angle of incidence, the neutralization will become imperfect when this change takes place. The question is, how imperfect will the neutralization become under practical conditions, and what will be the resulting error in observed bearing? Let  $R$  and  $\delta$  be the magnitude ratio and phase difference of  $e_a$  and  $e_H$  in the general case (other than at the condition of neutralization); then the residual voltage due to horizontal polarization which is present in the loop circuit is

$$e_H [1 - R e^{j(\delta - \delta_N)} / R_N]. \quad (19)$$

It will be noted that this residual voltage will not, in general, have the same phase as  $e_H$  itself. Hence, if  $e_v$  and  $e_H$  are initially in phase as stipulated by the standard-wave specifications, the voltage determined by (19) will differ in phase by an angle  $\zeta$ , defined as the phase angle resulting from the quantity in brackets. This, of course, is a situation similar to the one previously described for elliptical polarization; namely, there is a tendency toward a broad minimum rather than a sharp null as the loop is rotated. However, if the neutralization remains nearly complete; i.e., the residual voltage small compared to  $e_v$ , the observed bearing will be quite sharp regardless of the slight phase difference. Let us rewrite (19) as follows:

$$\text{Residual voltage} = e_H \mathcal{R} e^{j\zeta} \quad (20)$$

where  $\mathcal{R}$  is the magnitude of the quantity in parentheses in (19), and  $\zeta$  the angle, as mentioned above.

With the aid of the relationships just derived, we are able to compute the residual voltage that will exist in the circuit of the compensated loop for any desired set of practical operating conditions. It should be pointed out that the degree of perfection attainable does not depend upon the actual values of  $R_N$  and  $\delta_N$  at the condition of neutralization (assuming one is capable of designing and constructing the necessary network), but depends rather upon the extent to which  $e_a$  and  $e_H$  maintain a constant ratio and phase difference as the operating conditions are varied from this condition of neutralization. Regarding angle of incidence of the wave, for instance, if  $R$  and  $\delta$  for the two voltages remain approximately constant for the entire range from 0 degrees to 90 degrees, then it is to be expected that one could make the neutralization adjustment at say 45 degrees, and have the compensation remain nearly perfect for all other angles.

At this point, it will be well to contrast this approach to a compensated-loop system with the proposals which are discussed in Barfield's paper.<sup>4</sup> These depend upon a well-known fact that, where a horizontally polarized plane wave is reflected from a plane surface of infinite conductivity, a standing-wave pattern is set up in the vertical direction (in a manner similar to voltage on a short-circuited transmission line), and that the voltages induced in horizontal antennas at any height will there-

fore be in phase. Thus, the voltages induced in both a loop and horizontal antenna by such a wave would be in phase,<sup>13</sup> and hence, the output of an antenna could be used to compensate the loop voltage  $e_H$  by direct coupling, with only a magnitude adjustment necessary. This latter adjustment can even be obtained by simply cutting the auxiliary antenna to the required length. Difficulty at once arises in the practical application of the idea, for only ocean water has a high enough conductivity adequately to approach the ideal case. Barfield has made some calculations for soil with a conductivity of  $1.5 \times 10^8$  electrostatic units, corresponding to wet soil, and reports residual errors of from 4.5 to 20 degrees. Briefly, the difference between the previous system and the one herein proposed is that in the former the residual error arises from failure to approach perfect ground reflection (and hence if the ground is poor, there is no possibility of complete compensation), while in the latter system the requirement is that the relation between  $e_a$  and  $e_H$  should not vary too much within a desired range of deviation in operating conditions from the condition at which neutralization was made.

To reiterate the distinction between the two systems, it can be stated that Barfield assumes that the loop and antenna voltages have the same phase (correct only in the ideal case), calculates their magnitude ratio for perfect reflection, and then combines the voltages in direct opposition. If, for soil conditions other than perfect conductivity, the magnitude ratio and phase difference are different from those assumed, the neutralization is imperfect and a residual bearing error results. Barfield's only suggestion on this point is artificial increase of the soil conductivity in the vicinity of the direction finder. In contrast, the system presented here calls for a coupling network which will couple the loop and antenna voltages in such manner as to neutralize for the magnitude ratio and phase difference as dictated by the actual soil conditions to be encountered. Then, if this ratio and phase difference do not vary greatly over the specified operating range, the neutralization will remain adequate.

#### Bearing Error

It is possible to compute the residual error remaining in the loop when the neutralization becomes imperfect. The vector diagram is shown in Fig. 13. The desired voltage  $e_v$ , due to the vertically polarized component, is the same as before, and the residual voltage due to the horizontal component is that defined by (20). The net voltage in the loop is then  $e_x$ , and the observed bearing will occur where  $e_x$  is a minimum. To locate this bearing it is necessary to express  $e_x$  as a function of loop rotation angle  $\alpha$ , differentiate the expression with respect to  $\alpha$ , set the derivative equal to zero, and solve

<sup>13</sup> This can also be demonstrated by (12) and (17), the expressions for  $e_H$  and  $e_a$ , respectively. For a surface of infinite conductivity,  $\gamma_H = 1.0$  and  $\gamma_H = 0$ . The demonstration can be made with the vector diagrams corresponding to the equations.

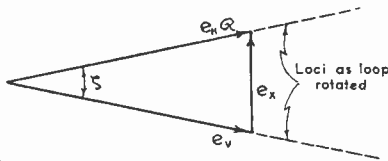

Fig. 13—Vector diagram showing residual voltage  $e_x$  resulting when neutralization is incomplete.

for  $\alpha$ . For this purpose it is convenient to write (10) and (20) as  $e_H R = A \sin \alpha$ ;  $e_v = B \cos \alpha$ . Then, by the cosine law,  $e_x^2 = A^2 \sin^2 \alpha + B^2 \cos^2 \alpha - 2AB \sin \alpha \cos \alpha \cos \zeta$ ,  $d(e_x^2)/d\alpha = 2A^2 \sin \alpha \cos \alpha - 2B^2 \sin \alpha \cos \alpha - 2AB(\cos^2 \alpha - \sin^2 \alpha) \cos \zeta$ . The observed bearing, which will now be designated as  $\alpha'$ , is that for which this derivative is equal to zero; hence,

$$(A^2 - B^2)(\sin \alpha' \cos \alpha') = AB(\cos^2 \alpha' - \sin^2 \alpha') \cos \zeta \cot 2\alpha'$$

$$= \frac{A^2 - B^2}{2AB \cos \zeta} = \frac{(A/B)^2 - 1}{2(A/B) \cos \zeta}$$

By examination of (10) and (20), and comparing with (16) for  $\tan \epsilon$  (the error of the uncompensated loop), we can see that  $A/B = R \tan \epsilon$ . Therefore, the observed bearing  $\alpha'$  for the compensated loop is obtained from

$$\cot 2\alpha' = \frac{R^2 \tan^2 \epsilon - 1}{2R \tan \epsilon \cos \zeta} \quad (21)$$

Finally, the residual error  $\epsilon'$  for the compensated loop is found by

$$\epsilon' = 90^\circ - \alpha' \quad (22)$$

EXAMPLES

In order to show what the proposed system of compensation should be able to do in a few selected situations, two example direction finders have been calculated. Because of the great number of variables involved in the problem, it is almost imperative to limit these to conditions having practical significance. We shall use, for instance, the following soil conditions which were accepted at the Madrid Conference as representative types.

TABLE I

Type of Ground	Dielectric Constant	Conductivity
Ocean Water	80	$10^{-11}$ electromagnetic unit
Wet Soil	8-10	$5 \times 10^{-14}$
Dry Soil	4	$10^{-15}$

While no example will be presented for dry-soil conditions, the values are included in Table I because they have been employed in exploratory calculations to determine the situations in which the compensating system may be expected to work.

The concept of the standard wave is brought out in the examples, for this provides a good method of standardizing the variables involved in (1) amount of polarization; (2) angle of incidence of the wave; and (3) the relative phase of the horizontal and vertical components.

Finally, geometrical dimensions are chosen to typify practical installations on shore or ship. No aircraft in-

stallations are considered, as it will be explained later that, when the height above ground is variable over extreme ranges, this version of the compensating system is not applicable.

Example Number 1

This direction finder is considered to be located over ocean water at a height of about 50 feet. For mathematical convenience only, the loop is taken to be 1 meter square, with one turn ( $N=1$ ), and the auxiliary compensating antenna having a length of 1 meter. The operating wavelength is 550 meters. The downcoming wave is polarized at 45 degrees, and there is no ground wave present.

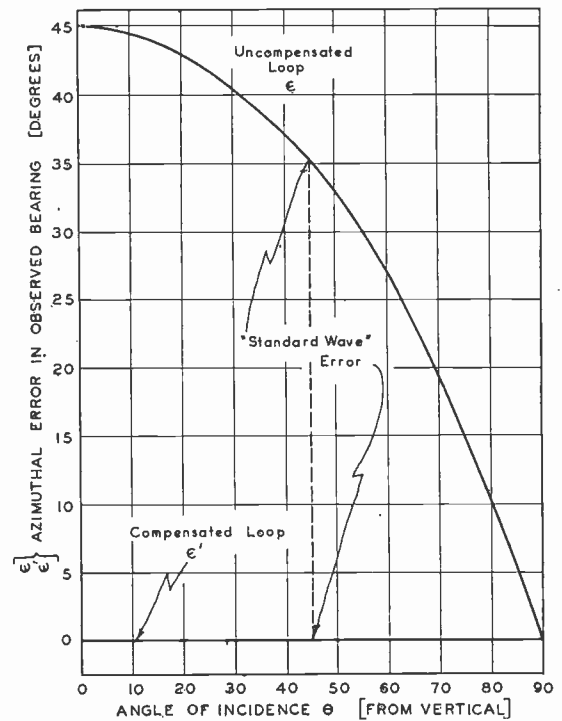

Fig. 14—Bearing errors for example number 1.  $\lambda = 550$  meters  $k = 80$   $\delta = 10^{-11}$  electromagnetic unit

The curves of Fig. 14 show the bearing errors that would exist for waves arriving at any angle of incidence for both the uncompensated and the compensated loops. It is seen that the elimination of the error by means of the compensation is practically complete. The effectiveness of the compensation is traceable to the behavior of the voltage ratio  $R$  and phase difference  $\delta$  of the loop and antenna voltages for horizontal polarization as shown<sup>14</sup> in Fig. 15. Here it will be observed that  $R$  and  $\delta$  are virtually constant, and hence, if the horizontal component of the loop voltage is neutralized at one

<sup>14</sup> It will be noted that the calculations for  $R$  and  $\delta$  are not carried to values of  $\theta$  near 90 degrees, for as it was pointed out in the development of the mathematical analysis, the equations for reflection at the earth's surface do not hold as the wave approaches grazing incidence. This is really no sacrifice in completeness, however, for waves approaching at such low incidence would have to originate at transmitters so distant as to be beyond the range of normal direction-finding activities. Furthermore, even the uncompensated loop has virtually no error at this angle of incidence, so the compensation problem is minimized.

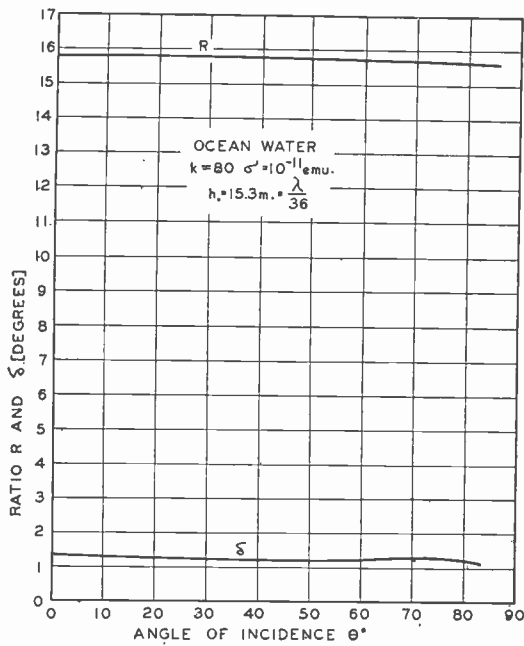

Fig. 15—Variation of loop-versus-antenna voltage ratio  $R$  and phase difference  $\delta$  for example number 1.

angle of incidence (in this case 45 degrees) the cancellation will remain effective at other angles.

It should be mentioned that, although the compensation for this first case is extremely effective, the ocean-water reflecting surface is so nearly a perfect conductor that the earlier system of compensation analyzed by Barfield would probably be equally effective. The second example, involving poorer earth surface, will provide a better demonstration of the advantages of the newer approach.

*Example Number 2*

This direction finder is identical to number 1, except that a wet-soil reflecting surface is employed. The errors, with and without compensation, are presented in Fig. 16. It can be seen that the compensation is not quite so perfect over the entire range of angle of incidence as it was in the previous case, but the residual bearing error is still less than 1 degree. This is quite good considering the errors up to 45 degrees that would be present in the uncompensated loop. The behavior of  $R$  and  $\delta$  is shown in Fig. 17, where it can be seen that their variation with respect to angle of incidence is somewhat greater than in example number 1, thus accounting for the failure to neutralize perfectly over the entire range.

It is here that the first contrast in results becomes apparent between this system of compensation and that described by Barfield. For wet-soil conditions similar to those considered here, Barfield calculates errors of 4.5 degrees and 12 degrees at 300 meters, and 8 to 20 degrees at 1000 meters. As discussed previously, this results from his system depending upon how closely the ground conditions approximate those of a perfect conductor; i.e., upon the voltage ratio  $R$  and the phase difference  $\delta$  having *particular* values, rather than upon  $R$

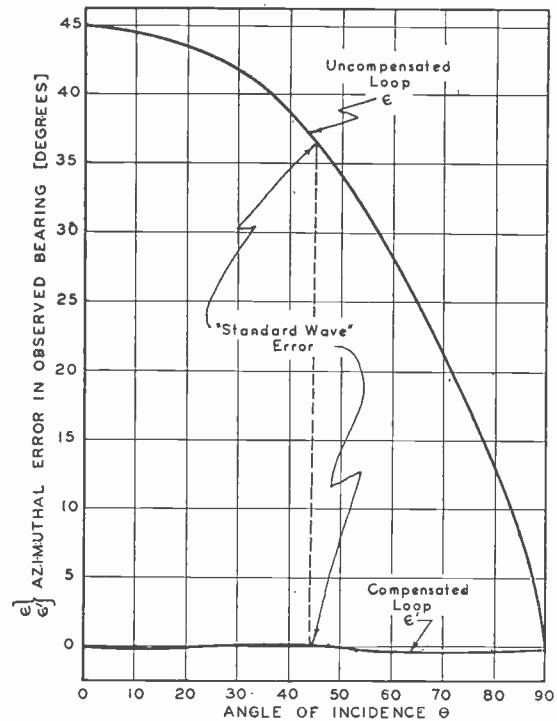

Fig. 16—Bearing errors for example number 2.  $\lambda = 550$  meters  $k = 8$   $\delta = 5 \times 10^{-14}$  electromagnetic unit

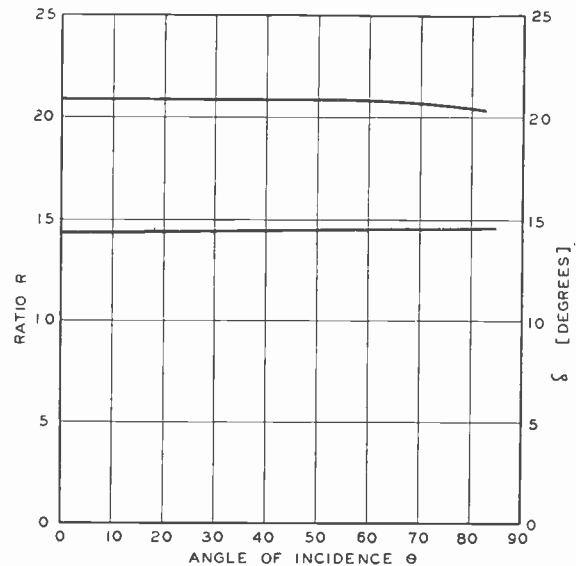

Fig. 17—Variation of loop-versus-antenna voltage ratio  $R$  and phase  $\delta$  as a function of angle of incidence for example number 2.  $k = 8$   $\delta = 5 \times 10^{-14}$  electromagnetic unit  $h_0 = \lambda/36$   $b = \lambda/55$   $\lambda = 550$  meters

and  $\delta$  merely maintaining *any* values with reasonable constancy.

In Fig. 18 are shown the resulting bearing errors when the angle of incidence is left at 45 degrees and the wavelength varied instead. The assumption is that the characteristics of the coupling network do not change with frequency, while  $R$  and  $\delta$  vary as shown in Fig. 19; hence, the neutralization becomes imperfect. This is a somewhat unfair test, for it is usually possible to make a coupling network change its characteristics with change in frequency. Nevertheless, the curves indicate

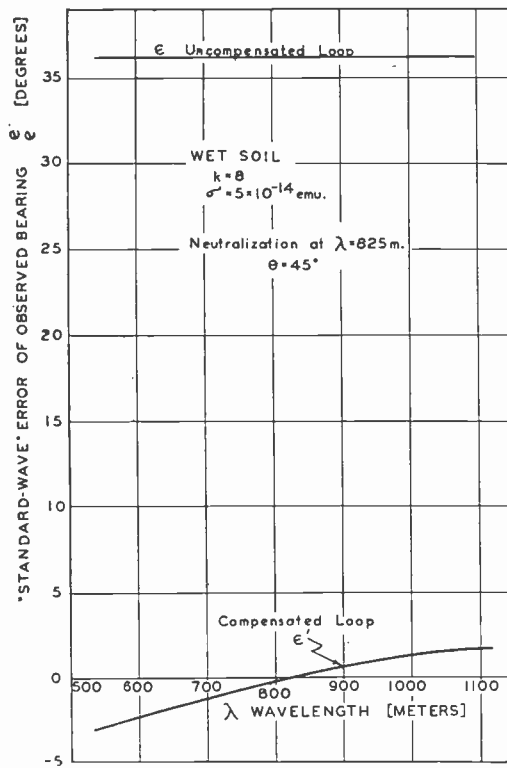

Fig. 18—Standard-wave bearing error for example number 2 as a function of wavelength for constant neutralization coupling.

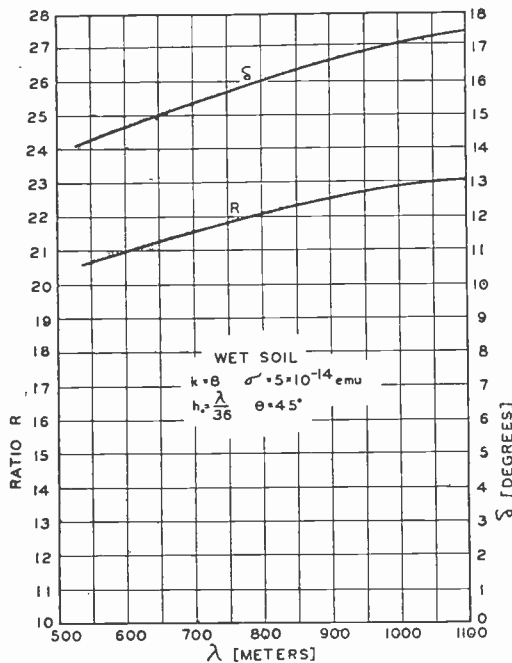

Fig. 19—Variation of loop-versus-antenna voltage ratio as a function of wavelength for example number 2.

that the incompleteness of the compensation introduces errors of only 2 or 3 degrees, whereas without compensation the error is over 35 degrees. This is enough improvement to make the difference between a usable and an unusable direction finder.

EXPERIMENTAL VERIFICATION

Extensive tests have been conducted for the purpose of checking the mathematical analysis and demonstrat-

ing the technique of compensation. Their complete description would be too bulky to include here, but briefly, they consisted of observing the relative behavior of voltages induced in loops and horizontal antennas by abnormally polarized signals from an elevated transmitter located at a distance of between two and three wavelengths away. A fairly high frequency, about 15 megacycles, was used in order to limit the distances required. A photograph of the site is shown in Fig. 20. The comparison observations were made with two radio-frequency amplifiers, adjusted for equal gain and phase shift, and whose outputs were connected to opposite pairs of deflecting plates on a cathode-ray oscilloscope.

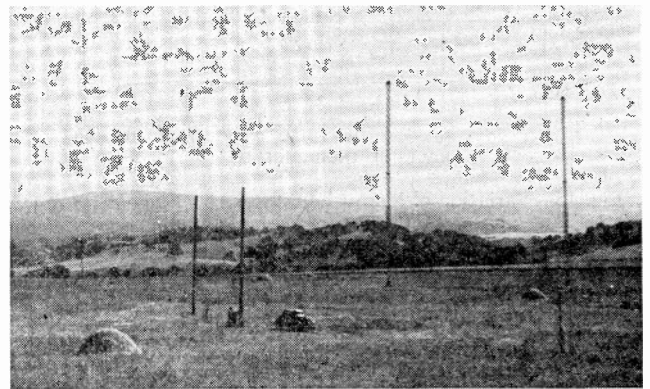

Fig. 20—Site of field tests. Receiving location at left center. Elevated transmitter at upper right.

The resulting elliptical Lissajous figure provided a measure of the relative amplitude and phase of the two voltages.

A sample result for a one-turn loop at a height of 2 meters is shown in Fig. 21. It will be noted that there is good correlation between the measured values and the curves calculated on the basis of the theoretical analysis. Although the measurements provide only relative values, and thus do not provide exact proof of the equations, they do show that the variation in R and  $\delta$  is small, which is the basic requirement of the compensated-loop system.

A demonstration of compensation possibilities in a commercial direction finder was tried at 1200 kilocycles on a Sperry aircraft type unit by means of a 30-inch horizontal antenna attached to the loop as shown in Fig. 22. The antenna was coupled into the loop circuit through an auxiliary amplifier as in the diagram of Fig. 23. Adjustment of grid tuning varied the phase; this, of course, varied the amplitude also, but an independent control of amplitude was provided by the gain control in the cathode circuit. The initial compensating adjustment was performed with the aid of an elevated transmitter, whose 5-foot dipole antenna was horizontal. The loop was turned to the normal null position; i.e., maximum pickup for horizontal polarization, and then the coupling network adjusted until an output meter on the receiver read zero. This adjustment can be performed at



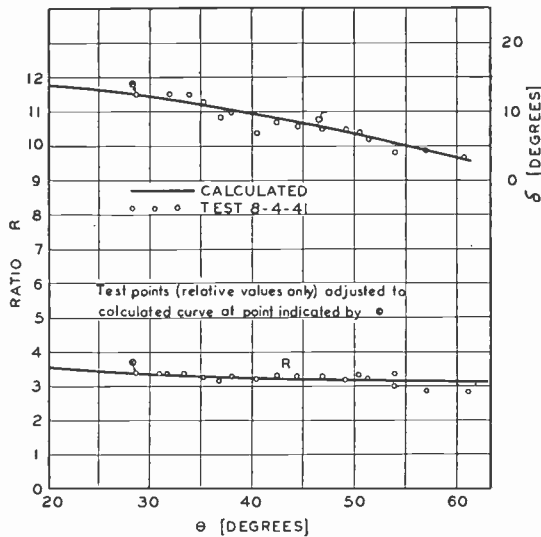

Fig. 21—Sample field-test results. Ground constants.  $k=4$   $\delta=2.9 \times 10^{-18}$  electromagnetic unit  $f=14.7$  megacycles

any desired angle of incidence. The following results were obtained with a downcoming wave at 65 degrees:

1. Uncompensated:
  - Vertical polarization—0 degrees bearing error
  - Moderate horizontal component—28 degrees error
  - Horizontal component only—90 degrees error.
2. Compensated:
  - All polarizations—essentially 0 degrees error.

LIMITS OF USEFULNESS

The theoretical analysis has been extended in order to predict what limitations there may be in terms of

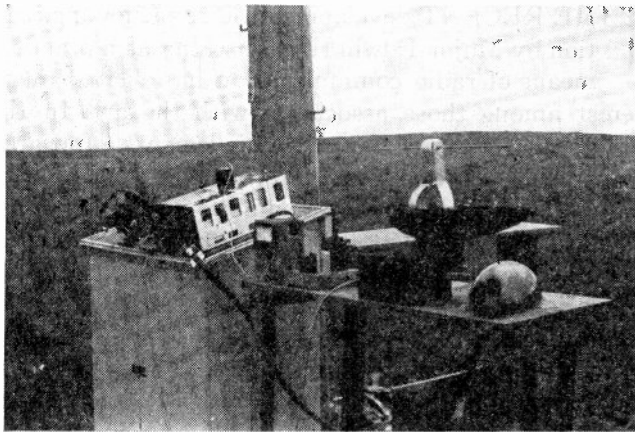

Fig. 22—Compensating antenna mounted on airborne-type direction finder for trial demonstration. Coupling amplifier is in small box in front of loop assembly. Receiver and output meter at left.

practical application of the compensated-loop system. Without going into detail on explanations, some general statements may be made.

Effect of Wavelength

It was found that the magnitudes of  $R$  and  $\delta$  increase as the wavelength becomes shorter, although their variation as a function of angle of incidence for any given installation and wavelength does not become much

worse as the wavelength decreases. In other words, once the initial compensating adjustment is made, it appears that the compensation should be effective whether the wavelength is 1000 meters or 10 meters.

Effect of Height Above Ground

For operation at fixed heights above ground the principal requirement is that the height be small compared to a wavelength. At large heights the variation of compensating conditions with angle of wave incidence becomes extreme. The reason for this can be seen in the equations for loop voltage  $e_H$  due to the horizontal component and antenna voltage  $e_a$ ; the phase angle  $\beta_0$  appears as with a plus sign in one, and with a negative sign in the other. It will be recalled that  $\beta_0$  changes with angle of incidence according to  $\cos \theta$ , and is proportional to  $h_0/\lambda$ . Thus, when  $\beta_0$  is small, it has little influence on

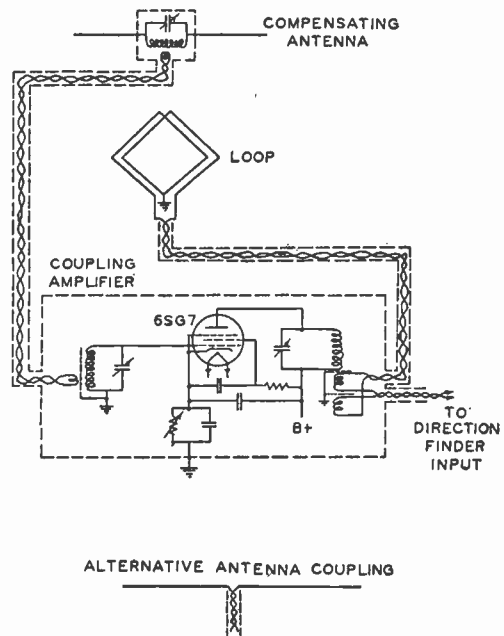

Fig. 23—Circuit diagram for coupling of compensating antenna to direction finder for demonstration.

the relative behavior of the voltages in loop and compensating antenna. But when, due to increased  $h_0/\lambda$ ,  $\beta_0$  becomes larger, there results a greater deviation between  $e_H$  and  $e_a$ . Calculations indicate that if the height is kept to  $\lambda/10$  or less the bearing errors can be held to 2 or 3 degrees for variations in angle of incidence.

For operation at varying heights above ground, as in aircraft application, compensation with a single horizontal antenna becomes impossible. The difficulty is traceable to the standing-wave pattern set up above the earth in a vertical direction by the horizontally polarized field component. The compensating antenna responds to the actual magnitude of the field strength at its given height, whereas the loop, acting to give a difference voltage, responds effectively to the rate of change of field strength with respect to height. Thus, extremely large variations occur between  $e_H$  and  $e_a$  as a function of altitude. An escape from this difficulty lies

in using a pair of spaced horizontal antennas connected in opposition to provide the compensating voltage. Their resultant pickup would be small, however, and it is questionable whether any net advantage over an Adcock system would result.

The relative height of the loop and the compensating antenna is not important. A reduction in the phase difference  $\delta$  between  $e_H$  and  $e_a$  does result, however, by increasing the height of the compensating antenna. In fact, for a system situated over a perfectly conducting surface (closely approximated by sea water),  $\delta$  reduces to zero for all angles of wave incidence when the antenna height is twice that of the loop, thus requiring the compensating network to provide only the necessary voltage ratio  $R$ .

#### *Effect of Ground-Reflection Conditions*

In general, it appears that the system will function with direction finders situated over almost any type of ground, ranging from high-conductivity ocean water to

dry soil, provided only that the proper initial compensating adjustment is made for each installation. The degree of failure to maintain compensation is worse, however, for the more poorly reflecting soil.

The system does not appear applicable where there are large variations in reflecting conditions, as with an airplane flying over extremes of sea water to dry soil.

#### CONCLUSION

From the analysis and the indicated results it may be concluded that the compensated-loop system of elimination of polarization errors can, by proper design, be made to give a high degree of neutralization. For numerous applications the system will give virtually complete neutralization without complicated equipment and with fixed tuning adjustment for a wide range of operating conditions. With poor earth conditions or shorter wavelengths, the neutralization will be not quite so complete, and the operating range will tend to be more restricted.

# A Theoretical and Experimental Investigation of Tuned-Circuit Distortion in Frequency-Modulation Systems\*

DAVID LAWRENCE JAFFE†, ASSOCIATE, I.R.E.

**Summary**—The problem of distortion introduced into the modulation intelligence by tuned circuits is considered both theoretically and experimentally. Complex equations result when the effect of the intelligence modulation is considered. These equations, while not readily amenable to Fourier analysis, disclose that the distortion parameters are  $\Delta W/BW$  and  $\lambda/BW$  where,

$\Delta W/2\pi$  = peak-frequency swing

$\lambda/2\pi$  = modulation frequency

$BW$  = bandwidth in kilocycles measured at 3 decibels down. Double-tuned circuits critically coupled.

If the effect of the modulation frequency is neglected, the equations resulting from a theoretical analysis are somewhat simplified and the distortion due to single- and double-tuned circuits can be formulated. Close agreement between calculated and measured distortion was obtained up to approximately a 5000-cycle-per-second modulation frequency. At this frequency the departure of the observed from calculated values was quite noticeable.

Theoretical maximum-distortion limits for the single- and double-tuned circuits are derived. For the single-tuned circuit the theoretical maximum distortion is

$$D_n \text{ max (single-tuned circuit) } = 2\lambda/\Delta W \cdot 100.$$

For the double-tuned circuit it is

$$D_n \text{ max (double-tuned circuit) } = 4\lambda/\Delta W \cdot 100$$

A conservative design figure relating bandwidth to frequency swing in order to insure distortion-free transmission to 15,000 cycles per second was experimentally found to be,  $\Delta W/BW = 1/4$ .

\* Decimal classification: R148 1×R414. Original manuscript received by the Institute, November 21, 1944. Submitted (1940) in partial fulfillment of the requirements for the degree of Doctor of Philosophy, in the Faculty of Pure Science, Columbia University, New York, N. Y.

† Templeton Radio Manufacturing Corporation, New London, Conn.

#### INTRODUCTION

THE RECENT development of frequency modulation by Major Edwin H. Armstrong as a practical means of radio communication has elicited much interest among those associated with the art. In the van of these experimental achievements appeared papers which have given theoretical substantiation to the superiority of frequency modulation over amplitude modulation. This superiority is due to two characteristics which distinguish the new system from amplitude modulation: (a) improved signal-to-noise ratio; and (b) elimination of static.

The reason for the greatly improved signal-to-noise ratio has been treated both theoretically and experimentally by Armstrong,<sup>1</sup> Crosby,<sup>2</sup> Roder,<sup>3</sup> and Carson and Fry.<sup>4</sup> It is understood that the elimination of static in frequency-modulation systems is due to the operating characteristics of the current limiter<sup>1</sup> and balanced detector.<sup>1</sup> A study of the behavior of these circuits under transient conditions has not as yet been made.

<sup>1</sup> E. H. Armstrong, "A method of reducing disturbances in radio signaling by a system of frequency modulation," *Proc. I.R.E.*, vol. 24, pp. 689-740; May, 1936.

<sup>2</sup> M. G. Crosby, "Frequency-modulation noise characteristics," *Proc. I.R.E.*, vol. 25, pp. 472-514; April, 1937.

<sup>3</sup> H. Roder, "Noise in frequency modulation," *Electronics*, vol. 10, p. 22; May, 1937.

<sup>4</sup> J. R. Carson and T. C. Fry, "Variable electric circuit theory," *Bell Sys. Tech. Jour.*, vol. 16, p. 513; October, 1937.

The unusually high fidelity possible is, of course, first due to the high signal-to-noise ratio, second to the low transmitter distortion,<sup>5</sup> and third to the relative simplicity with which the receiver can be designed so that the over all root-mean-square distortion, transmitter to voice coil, is less than 2 per cent.

It was found experimentally that, unless the tuned circuits associated with the radio-frequency amplifiers were sufficiently broad, amplitude distortion would result in the demodulated intelligence. The distortion due to tuned circuits was first treated theoretically by Roder,<sup>6</sup> who approached the problem from the side-band-theory point of view. The complexity of the equations involved necessitated the use of a mechanical differential analyzer for solution. The results obtained were for the most part qualitative, and it was felt that an analysis of the problem along the lines of Carson and Fry's "Variable Frequency Circuit Theory," together with an experimental investigation of the problem, would not be amiss at this time. We are thus led to the purpose of the paper.

PURPOSE

The purpose of this paper will be to investigate the phenomenon of tuned-circuit distortion in frequency-modulation systems by means of conventional theory, and to verify experimentally the theoretical results.

GENERAL THEORY

In developing the theory fundamental to frequency-modulation-network analysis let us start with the generalized differential equation applicable to problems in communications where the excitation function can be either modulated in amplitude, phase, or frequency.

The generalized differential equation to be studied can be written as

$$Z(D)i = Ef(t) \exp(j\omega t) \tag{1}$$

where

$i$  = complex current

$i(t) = \text{Re}(i)$

$D = d/dt$

$Z(D) = \Delta(D)/M(D)$  where  $\Delta(D)$  and  $M(D)$  are polynomials in  $D$

$f(t)$  = a time function

$E$  = a constant

$\omega = 2\pi f$  = a constant frequency.

The solution to (1) is<sup>7</sup>

$$i(t) = \sum_1^n \underbrace{A_i \exp(m_i t)}_{I_T} + \underbrace{1/Z(D) \cdot Ef(t) \exp(j\omega t)}_{I_{ss}} \tag{2}$$

where

$I_{ss}$  = steady-state solution

$I_T$  = transient solution

<sup>5</sup> D. L. Jaffe, "Armstrong's frequency modulator," Proc. I.R.E., vol. 26, pp. 475-481; April, 1938.

<sup>6</sup> H. Roder, "Effects of tuned circuits upon a frequency modulated signal," Proc. I.R.E., vol. 25, pp. 1617-1647; December, 1937.

<sup>7</sup> D. A. Murray, "Differential Equations," Longmans Green Publishing Co., New York, 1932, p. 63.

$A_i$  = constant depending upon initial conditions

$m_i$  = distinct root of  $Z(D)$ .

The solution for the steady-state current can be obtained by methods well known in the theory of differential equations.<sup>8</sup> Let  $1/Z(D) = Y(D)$  then

$$I_{ss} = EY(D)f(t) \exp(j\omega t). \tag{3}$$

By the shifting theorem<sup>9</sup>

$$I_{ss} = E \exp(j\omega t)Y(D + j\omega)f(t). \tag{4}$$

Expanding  $Y(D + j\omega)$  about  $j\omega$  and remembering  $Y = Y(j\omega)$

$$Y(D + j\omega) = Y + \sum_1^\infty \frac{1}{j^n n!} \frac{d^n Y}{d\omega^n} D^n \tag{5}$$

$$I_{ss} = E \exp(j\omega t) \left[ Y + \sum_1^\infty \frac{1}{j^n n!} \frac{d^n Y}{d\omega^n} D^n \right] f(t) \tag{6}$$

whence

$$I_{ss} = E \exp(j\omega t) \left[ Yf(t) + \sum_1^\infty \frac{1}{j^n n!} \frac{d^n Y}{d\omega^n} f^n(t) \right] \tag{7}$$

where

$$f^n(t) = d^n f(t)/dt^n.$$

Equation (2) can now be written in its final form as

$$i(t) = \sum_1^n A_i \exp(m_i t) + E \exp(j\omega t) \left[ Yf(t) + \sum_1^\infty \frac{1}{j^n n!} \frac{d^n Y}{d\omega^n} f^n(t) \right]. \tag{8}$$

For practical purposes we need only consider the steady-state solution of (2) which is given by (7).

When amplitude modulation is to be considered the type of exciting function is

$$e_{a.m.} = E(1 + m_a \sin \lambda t) \exp(j\omega t) \tag{9}$$

where

$\lambda/2\pi$  = modulating frequency

$100m_a$  = per cent modulation

$\omega/2\pi$  = carrier frequency.

Thus, for amplitude modulation.

$$f(t) = (1 + m_a \sin \lambda t). \tag{10}$$

When (10) is substituted in (8) the generalized-network solution for amplitude-modulation systems results.

Equation (8) can be simplified for phase- and frequency-modulation systems.<sup>11</sup> For if we let

$$f(t) = \exp(j\phi(t)) \tag{11}$$

then we can write, letting  $\phi = \phi(t)$

$$I_{ss} = E \exp(j\omega t) \left[ Y \exp(j\phi) + \sum_1^\infty \frac{1}{j^n n!} \frac{d^n Y}{d\omega^n} \frac{d^n}{dt^n} \exp(j\phi) \right]. \tag{12}$$

In Appendix I it is shown that (12) reduces to

$$I_{ss} = E \exp(j\omega t + \phi) \left[ Y + \sum_1^\infty \frac{1}{n!} \frac{d^n Y}{d\omega^n} M_n(t) \right] \tag{13}$$

<sup>8</sup> See p. 70 of footnote reference 7.

<sup>9</sup> See p. 78 of footnote reference 8.

<sup>10</sup> This expansion is valid providing the series resulting from the operation by  $Y(D + j\omega)$  on  $f(t)$  converges.

<sup>11</sup> H. Roder, "Amplitude, phase and frequency modulation," Proc. I.R.E., vol. 19, pp. 2145-2176; December, 1931.

where

$$\begin{aligned} M_1 &= \phi \\ M_2 &= (\dot{\phi} - jD)\dot{\phi} \\ M_3 &= (\dot{\phi} - jD)(\dot{\phi} - jD)\dot{\phi} \\ &\vdots \\ M_n &= (\dot{\phi} - jD)(\dot{\phi} - jD) \cdots (\dot{\phi} - jD)^{n-1}\dot{\phi} \\ M_n &= M_n(t) \\ \dot{\phi} &= d\phi/dt. \end{aligned}$$

In a frequency-modulation system the instantaneous frequency  $\Omega$  can, for sinusoidal modulation, be written as<sup>11</sup>

$$\Omega = \omega + \Delta\omega \sin \lambda t \quad (14)$$

where

$$\begin{aligned} \omega/2\pi &= \text{carrier frequency} \\ \Delta\omega/2\pi &= \text{frequency swing} \\ \lambda/2\pi &= \text{modulating frequency.} \end{aligned}$$

Since the instantaneous frequency is the time rate of change of phase angle we have

$$\begin{aligned} \Omega &= d\psi/dt \\ \psi &= \int \Omega dt \end{aligned} \quad (15)$$

where  $\psi$  is the instantaneous phase angle. Substituting (14) in (15) we have

$$\psi = \omega t - \Delta\omega/\lambda \cos \lambda t. \quad (16)$$

The constant resulting from the integration is considered zero. Note that  $\phi$  in (13) for frequency modulation becomes

$$\phi = -\Delta\omega/\lambda \cos \lambda t = \int u(t) dt \quad (17)$$

where

$$\begin{aligned} u(t) &= \Delta\omega \sin \lambda t \\ \Omega &= \omega + u(t). \end{aligned}$$

With these considerations in mind it is shown in Appendix II that (13) for practical frequency-modulation systems becomes

$$I_{ss} = E \exp j \left( \omega t + \int u(t) dt \right) \left[ Y(j\Omega) + j \frac{\dot{u}}{2} \frac{d^2 Y(j\Omega)}{dY(j\Omega)^2} \right] \quad (18)$$

where  $\dot{u} = \lambda \Delta\omega \cos \lambda t$ . This is the quasi-steady-state equation of Carson and Fry.<sup>4</sup>

#### APPLICATION OF GENERAL THEORY

Suppose it is desired to find the output voltage from a four-terminal network in frequency-modulation systems. If the input voltage is of the form

$$e_i = E \exp j \left( \int \Omega dt \right) \quad (19)$$

the output voltage will then be according to (18)

$$e_o = E \exp j \left( \int \Omega dt \right) [Y(j\Omega) + j\dot{u}/2Y^{(2)}(j\Omega)] \quad (20)$$

where  $e_i$  and  $e_o$  are the real parts of the vector voltages  $E_i$  and  $E_o$  respectively and

$$\begin{aligned} Y(j\Omega) &= \text{steady-state transfer ratio.} \\ Y^{(2)}(j\Omega) &= d^2 Y(j\Omega)/dY(j\Omega)^2. \end{aligned}$$

Now let us make the following substitutions in (20).

$$\begin{aligned} Y(j\Omega) &= R(\Omega) + jX(\Omega) \\ Y^{(2)}(j\Omega) &= R^{(2)}(\Omega) + jX^{(2)}(\Omega). \end{aligned} \quad (21)$$

Considering  $E=1$  we obtain

$$\begin{aligned} e_o &= \exp j \left( \int \Omega dt \right) [R(\Omega) + jX(\Omega) \\ &\quad + j\dot{u}/2(R^{(2)}(\Omega) + jX^{(2)}(\Omega))]. \end{aligned} \quad (22)$$

Equation (22) reduces to

$$E_o(t) = E(t) \exp j \left[ \int \Omega dt + \frac{X(\Omega) + \dot{u}/2R^{(2)}(\Omega)}{R(\Omega) - \dot{u}/2X^{(2)}(\Omega)} \right] \quad (23)$$

where

$$E(t) = \sqrt{(X(\Omega) + \dot{u}/2R^{(2)}(\Omega))^2 + (R(\Omega) - \dot{u}/2X^{(2)}(\Omega))^2}.$$

Since in frequency-modulation systems the transmitted intelligence is proportional to the time derivative of the instantaneous phase angle, the total transmitted signal, including the distortion introduced by the network will be

$$\Omega_0 = d/dt \left[ \int \Omega dt + \arctan \frac{X(\Omega) + \dot{u}/2R^{(2)}(\Omega)}{R(\Omega) - \dot{u}/2X^{(2)}(\Omega)} \right]. \quad (24)$$

Here  $\Omega_0$  is the instantaneous output frequency. The phase-angle distortion introduced by the network will be

$$\phi_{\text{dist.}} = \arctan \frac{X(\Omega) + \dot{u}/2R^{(2)}(\Omega)}{R(\Omega) - \dot{u}/2X^{(2)}(\Omega)}. \quad (25)$$

It should be noted at this point that (24) and (25) have been derived from the generalized equations with the only assumption that  $\Delta\omega > \lambda$ . This is the case for practical frequency-modulation systems.

Since  $\Omega = \omega + \Delta\omega \sin \lambda t$  and  $\dot{u} = \lambda \Delta\omega \cos \lambda t$  we can see from (25) that the distortion will be a function of the particular network, frequency swing, and modulating frequency.

If we choose as our particular networks the single- and double-tuned circuits, we can arrive at the parameters which determine the magnitude of the phase and frequency distortion. It is shown in Appendix III that per cent distortion (single-tuned circuit) =  $f(\Delta\omega/BW, \lambda/BW)$

per cent distortion (critically coupled double-tuned circuit) =  $F(\Delta\omega/BW, \lambda/BW)$

where  $BW$  denotes the total bandwidth at 3.0 decibels down. This is illustrated in Fig. 1. Thus, the distortion

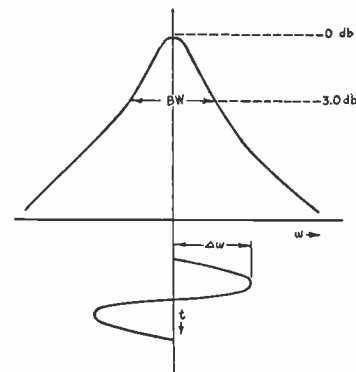

Fig. 1

due to tuned circuits in frequency-modulation systems is a function of the ratio of peak frequency swing and modulating frequency to bandwidth.

Because of the complex nature of the equations which must be used to evaluate the distortion, (12) or (25), formulation of the distortion in terms of the parameters for numerical computation is extremely difficult. It is shown later that, for practical purposes, the distortion can be formulated readily for reasonably low modulating frequencies, and that these formulae can be used to predict rather closely the resulting distortion.

An engineering approach to the problem of distortion due to tuned circuits in frequency-modulation systems can be made by steady-state theoretical considerations. By steady-state theory is meant the analysis which results by neglecting the modulating frequency in (24). This procedure is valid, as will be shown later by experimental verification, insofar as the modulating frequency is sufficiently low. While this solution does not admit of distortion due to high modulating frequencies, and only takes into account the distortion due to the peak frequency swing for a given circuit, it allows one to formulate the distortion due to the tuned circuits under consideration.

When the effect of the modulating frequency is neglected (24) becomes

$$\Omega_0 = d/dt \left( \int \Omega dt + \arctan P(\Omega) \right) \quad (26)$$

where  $P(\Omega) = X(\Omega)/R(\Omega)$ .  $R(\Omega)$  and  $X(\Omega)$  are the real and imaginary parts of the complex transfer ratio  $Y(\Omega)$ .

Physically (26) might be interpreted as follows. The output instantaneous frequency is determined by the original instantaneous phase angle plus the phase angle introduced by the frequency sweeping the network-phase-shift characteristic.

It is shown in Appendix IV that in general

$$P(\Omega) = -\rho \sin \lambda t \quad (27)$$

where

$$\rho = 2\Delta w/BW \text{ for the single-tuned circuit}$$

$$\rho = 2\sqrt{2}\Delta w/BW \text{ for the critically coupled double-tuned circuit.}$$

Substituting (27) in (26) and carrying out the differentiation we obtain

$$= w_0 + \Delta w \sin t - \rho \lambda \frac{\cos \lambda t}{1 + \rho^2 \sin^2 t} \quad (28)$$

After a Fourier analysis has been made of the distortion term<sup>5</sup> the demodulated signal will be

$$w_s = \Delta w \sin \lambda t - \sum_1^n 2\lambda/\rho^n (\sqrt{1 + \rho^2} - 1)^n \cos n\lambda t \quad (29)$$

where  $n$  is always odd. Odd harmonics only appear because of the symmetry of the phase-shift characteristic. The per-cent distortion is

$$D_n = \frac{2\lambda(\sqrt{1 + \rho^2} - 1)^n \cdot 100}{\rho^n \sqrt{(\Delta w)^2 + 4\lambda^2(\sqrt{1 + \rho^2} - 1)^2}} \quad (30)$$

where  $D_n$  is the per-cent  $n$ th-harmonic distortion. Since in practice

$$\Delta w > 2\lambda(\sqrt{1 + \rho^2} - 1)$$

we have

$$D_n = (2(\sqrt{1 + \rho^2} - 1)^n \cdot 100) / \rho^n (\Delta w / \lambda). \quad (31)$$

It should be noted that, for the same value of bandwidth and  $\Delta w/\lambda$ , we might expect the distortion due to the double-tuned circuit to be higher than that due to the single-tuned circuit, since  $\rho$  is greater in the former case.

An approximate distortion limit can be determined from purely physical considerations. After the original frequency-modulated signal has been passed through a tuned circuit, the recovered intelligence will be, assuming linear demodulation, directly proportional to the rate of change of the instantaneous phase angle. That is,

$$\Omega_0 = d/dt(wt + \Delta w/\lambda \sin \lambda t + \psi) \quad (32)$$

where  $\psi$  is some phase-shift function. In general  $\psi$  can be defined by the Fourier series

$$\psi = \sum_1^\infty A_n \sin n\lambda t + \sum_1^\infty B_n \cos n\lambda t$$

where  $A_n$  and  $B_n$  are real constants.

For the single-tuned circuit the maximum phase change due to the variable frequency can only be  $\pm\pi/2$  radians. Thus the absolute value of the upper limit of  $\psi$  is known. That is

$$|\psi| \leq \pi/2. \quad (33)$$

If we now choose a functional form for  $\psi$  such that  $|\psi| = \pi/2$  at all times, then the distortion determined by this function will define the maximum possible distortion. A square wave of fundamental frequency equal to  $\pi/2$  radians satisfies this condition. This wave is illustrated in Fig. 2.

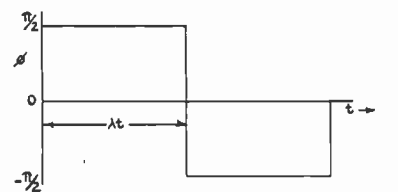

Fig. 2—The function  $\psi(t)$ .

The function  $\psi$  is odd and hence contains only sine terms. Thus,

$$\begin{aligned} A_n &= 2/n \\ B_n &= 0. \end{aligned} \quad (34)$$

The limiting distortion function  $\psi_L$  is written as

$$\psi_L = \sum_1^\infty 2/n \sin n\lambda t \quad (35)$$

where  $n$  is odd. Substituting (35) in (32) and differentiating with respect to time,

$$\Omega_0 = w + \Delta w \sin \lambda t + 2\lambda \sum_1^\infty \cos n\lambda t. \quad (36)$$

Thus in the limit, all the harmonics have the same

magnitude. The maximum per-cent distortion due to any harmonic will be

$$D_{n-\max} = 2/\sqrt{(\Delta w/\lambda)^2 + 1}. \quad (37)$$

For practical systems where  $\Delta w \cong 75$  kilocycles and the modulating frequency ranges from 30 to 15,000 cycles per second, the parameter  $\Delta w/\lambda$  is greater than unity, so that

$$D_{n-\max}(\text{single-tuned circuit}) = 2\lambda/\Delta w \cdot 100. \quad (38)$$

For the double-tuned circuit  $|\psi| = \pm \pi$  so that

$$D_{n-\max}(\text{double-tuned circuit}) = 4\lambda/\Delta w \cdot 100. \quad (39)$$

The approximate maximum possible distortion as a function of  $m_f = \Delta w/\lambda$  has been plotted for both the single- and double-tuned circuits in Fig. 3.

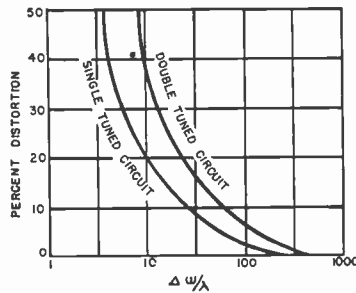

Fig. 3—Maximum *n*th harmonic distortion due to single- and double-tuned circuits. Steady-state theory.

In the following paragraphs the theory developed above will be correlated with the experimental results.

EXPERIMENT

The apparatus used for this section of the investigation essentially consisted of a frequency-modulation transmitter and receiver. Provision was made in the design of the receiver for the incorporation of either a

single- or double-tuned circuit in the radio-frequency-amplifier section. A block diagram of the apparatus arrangement is shown in Fig. 4.

*Transmitter:* The transmitter was a General Electric

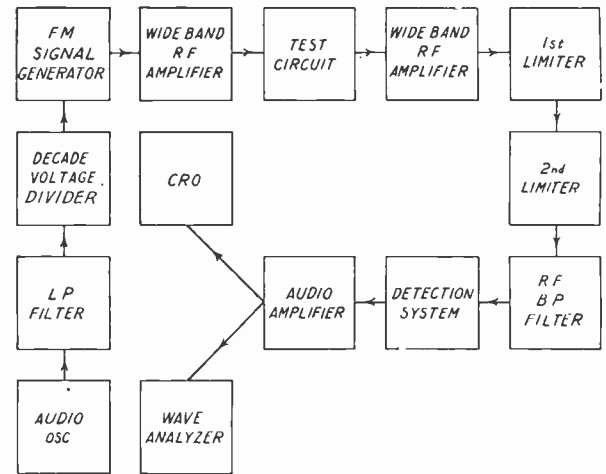

Fig. 4

frequency-modulation visual-alignment signal generator whose modulator was redesigned to suit the purposes of the test. A wiring diagram of the circuits is shown in Fig. 5. The modulator<sup>12</sup> in principle was a reactance tube arranged to present a variable capacitance to the tank circuit of the 30-megacycle oscillator. Modulation was effected by varying the voltage in the grid circuit of the modulator tube. A magnetic feedback arrangement maintained constant oscillator output during modulation. The oscillator output was

<sup>12</sup> D. E. Foster and S. W. Seeley, "Automatic tuning, simplified circuits, and design practice," Proc. I.R.E., vol. 25, pp. 289-313; March, 1937.

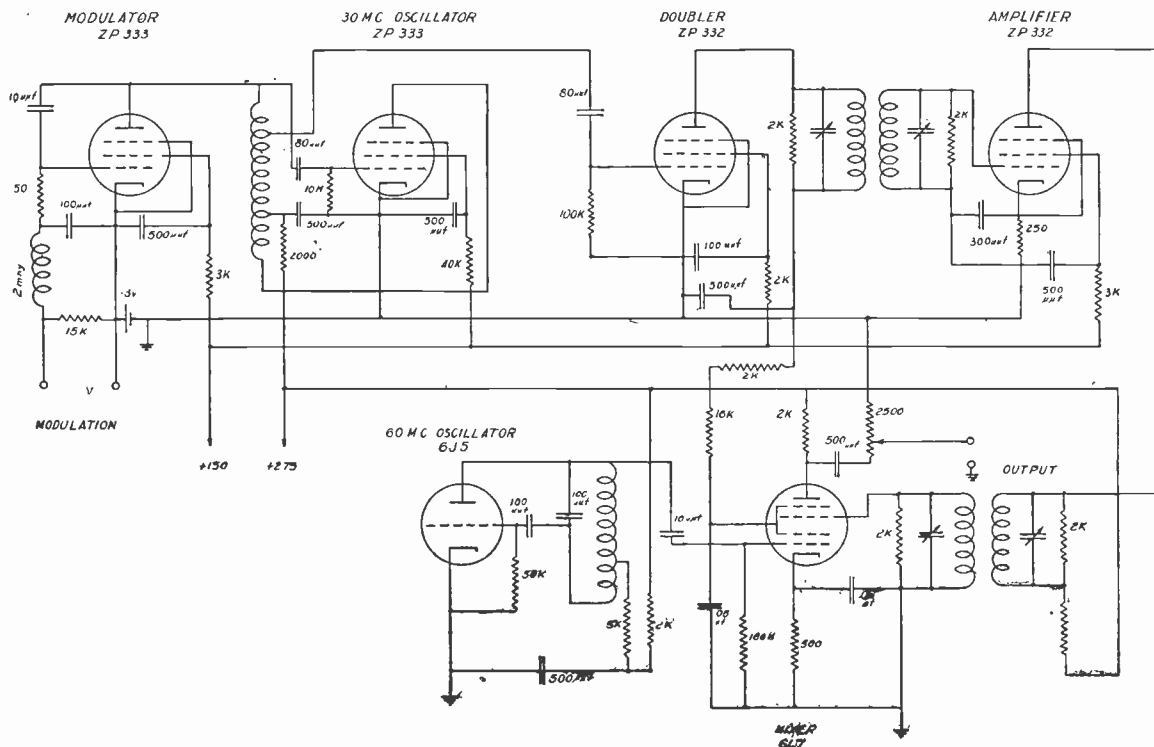

Fig. 5

passed through a frequency doubler, amplified and heterodyned with a 31.7-megacycle local oscillator to give 1700 kilocycles, at which frequency the tests were made. All circuits were heavily damped to minimize tuned-circuit distortion.

The signal generator was calibrated statically by placing a direct voltage of known magnitude across the 15,000-ohm resistor in the input circuit of the modulator. The frequency deviation was measured with a General Radio 615-A heterodyne frequency meter. The frequency of the signal generator was maintained to within  $\pm 5.0$  kilocycles by means of a differential tuning meter in the receiver. A calibration chart of the generator is shown in Fig. 6.

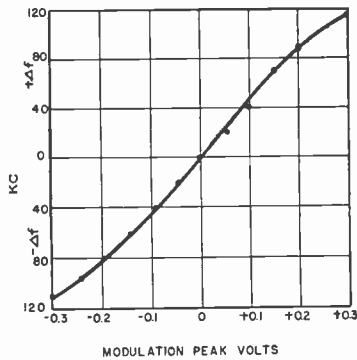

Fig. 6—Frequency-modulation signal-generator calibration.

Two methods were used to check the calibration under dynamic conditions. For low modulation frequencies the sidebands generated produce a spectrum which is closely equal to twice the peak frequency swing.<sup>13</sup> The signal generator was modulated at 10 cycles per second, and the total bandwidth measured. Table I shows the values of frequency deviation obtained statically and by beats with the 10 cycles per second modulated carrier. The average deviation of the dynamic from the static calibration was 2.14 per cent.

TABLE I  
DYNAMIC CHECK OF STATIC FREQUENCY CALIBRATION

Peak Modulation Volts	$\Delta f$ in kilocycles	
	Static	Dynamic
0.00	0.0	0.0
0.05	20.5	22.0
0.10	43.0	43.0
0.15	64.5	65.0
0.20	83.0	80.0
0.25	101.0	100.0
0.30	116.0	116.0

The second method used to check the dynamic calibration involved a count of sidebands generated by a 20,000 cycles per second signal. The peak frequency swing was varied to obtain different values of the parameter  $m_f = \Delta f / f_a$ , where  $f_a$  is the modulating frequency.

It can be shown that the magnitude of the sidebands generated are proportional to  $E_c J_n(m_f)$  where<sup>11</sup>

$$E_c = \text{carrier voltage}$$

<sup>13</sup> B. van der Pol, "Frequency modulation," Proc. I.R.E., vol. 18, pp. 1194-1205; July, 1930.

$J_n(m_f)$  = Bessel function of the  $n$ th order—first kind.<sup>14</sup> With this in mind, the heterodyne frequency meter was calibrated for sensitivity. It was found that the beat note became inaudible when the input signal was 80 decibels below one volt. One volt of carrier with 20,000 cycles per second modulation was applied to the hetero-

TABLE II  
THEORETICAL AND EXPERIMENTAL SIDEBAND COUNT. MODULATION FREQUENCY = 20,000 CYCLES PER SECOND,  $\Delta w$  = VARIABLE. HETERODYNE-FREQUENCY-METER SENSITIVITY = 80 DECIBELS BELOW ONE VOLT

$m_f$	Total Sidebands	
	Theoretical	Measured
1.1	10.0	11.0
2.1	14.0	15.0
3.1	16.0	19.0
4.1	20.0	21.0
5.1	22.0	24.0
6.1	26.0	27.0

dyne-frequency-meter circuit. For a given frequency swing  $m_f$  will be constant. Bessel-function tables are available which give the relative values of the  $n$ th order sidebands for fixed argument  $m_f$ . Thus, if we assume the calibration of the signal generator to be correct, we should be able to predict the number of sidebands from the Bessel-function tables by means of the heterodyne frequency meter whose sensitivity is already known. Table II shows the theoretical and experimental sidebands counted.

*Receiver:* The receiver consisted of a radio-frequency stage followed by an arrangement which allowed inclusion of either a single- or double-tuned transformer stage, in the radio-frequency circuit. This was followed

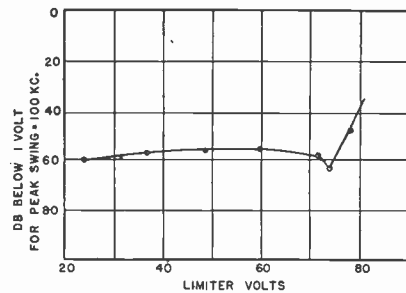

Fig. 7—Limiter effect for 80 per cent amplitude modulation.

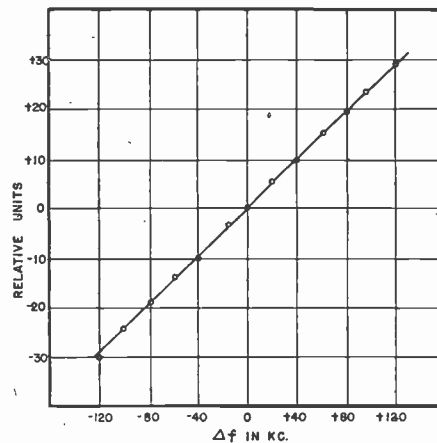

Fig. 8—Receiver detector characteristic.

<sup>14</sup> Eugene Jahnke and Fritz Emde, "Funktionentafeln," Leipzig, Germany, 1933.





by another radio-frequency stage which fed two current limiters in cascade. The limiters were cascaded to minimize as much as possible the resultant amplitude modulation due to the tuned circuits. Their effectiveness in reducing 80 per cent amplitude modulation is shown in Fig. 7. During the test the amplitude modulation on the first limiter never exceeded 50 per cent. After limiting, the voltage was fed to a class A stage and then demodulated by a Seeley-Foster type detection system.<sup>12</sup> The demodulation characteristic is shown in Fig. 8. A two-stage negative-feedback amplifier was used for audio amplification. The complete receiver diagram is shown in Fig. 9.

For the distortion measurements a General Radio 636-A wave analyzer was used. The modulator oscillator was an RCA type 68-B whose output at 2800 cycles per second was fed to a low-pass filter before modulating the signal generator. The input signal

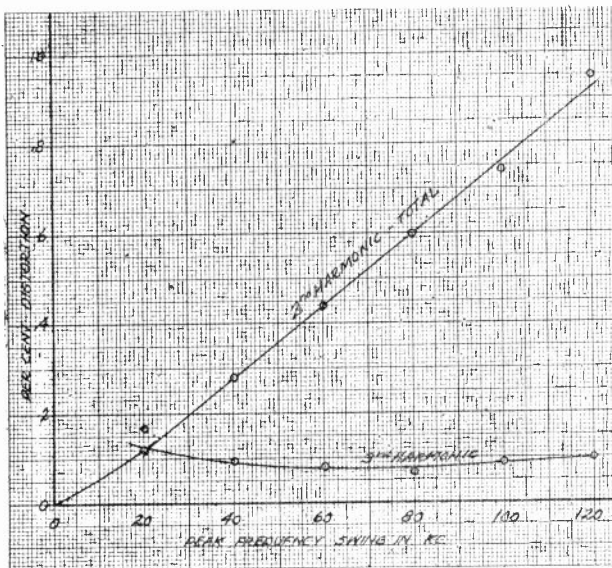

Fig. 10—System distortion as a function of frequency swing.  $f_m = 2800$  cycles per second without tuned circuits.

distortion for 2800 cycles per second at modulation level was

- 2nd harmonic = 0.061 per cent
- 3rd harmonic = 0.120 per cent
- 4th harmonic = 0.000 per cent
- 5th harmonic = 0.092 per cent.

At 5000 cycles per second the third-harmonic distortion into the system (without low-pass filter) was 0.025 per cent. The over-all-system distortion when the tuned circuits were omitted is shown in Fig. 10. The over-all root-mean-square distortion for a frequency swing of 120 kilocycles is less than 1.0 per cent, and is approximately linear with frequency swing. This distortion is practically all second harmonic and is due to the asymmetry of the modulator and demodulator characteristics.

EXPERIMENTAL RESULTS

The variation of the fundamental with frequency

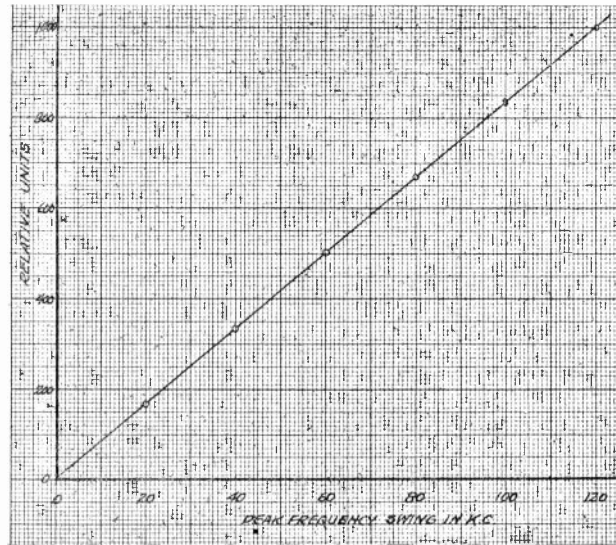

Fig. 11—Experimental determination of variation of fundamental with frequency swing.  $f_m = 2800$  cycles per second. Single-tuned circuit, critically coupled,  $BW = 50$  kilocycles. Bandwidth at 1700 kilocycles.

swing at 2800 cycles per second is shown in Fig. 11 for both the single- and double-tuned circuits. The bandwidth measured at 3.0 decibels down was 50 kilocycles (double-tuned transformer critically coupled). The fundamental output is proportional to the frequency swing plus the product of the modulating frequency by the time rate of change of the phase angle introduced by the tuned circuit. For low modulating frequencies the tuned-circuit-fundamental contribution is small compared with the signal fundamental, so that the output should be linearly proportional to frequency swing. Fig. 11 shows that this is the case for  $f_m = 2800$  cycles per second.

Fig. 12 shows the third-harmonic distortion as a

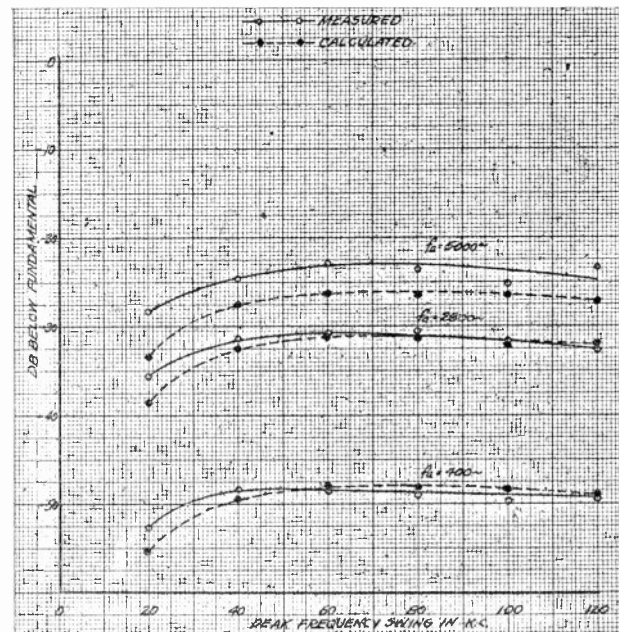

Fig. 12—Third-harmonic distortion as a function of frequency swing. Single-tuned circuit.  $BW = 50$  kilocycles at 1700 kilocycles.

function of frequency swing. Calculations were made with (31). For modulating frequencies of 400 and 2800 cycles per second, the calculated and measured curves show close agreement. However, at 5000 cycles per second the agreement becomes somewhat poorer because of

above, that increasing the bandwidth will reduce the distortion introduced by the tuned circuit. Fig. 13 illustrates this phenomenon quantitatively.

Fig. 14 is an experimental run to show the effect of tuning capacitance of the single-tuned transformer on the fundamental and harmonic distortion. The magnitude of the fundamental is seen to be independent of the tuning capacitance. It is shown that the even harmonics

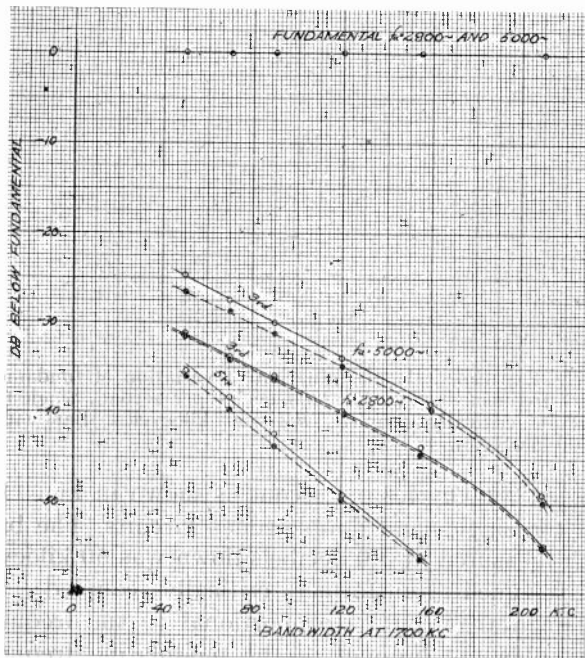

Fig. 13—Harmonic distortion as a function of bandwidth at 1700 kilocycles. Single-tuned circuit. Peak frequency swing = 100 kilocycles.

the effect of the modulation frequency. It is interesting to note that the distortion is practically constant when the frequency swing is greater than 40 kilocycles.

It is qualitatively known, and has been shown

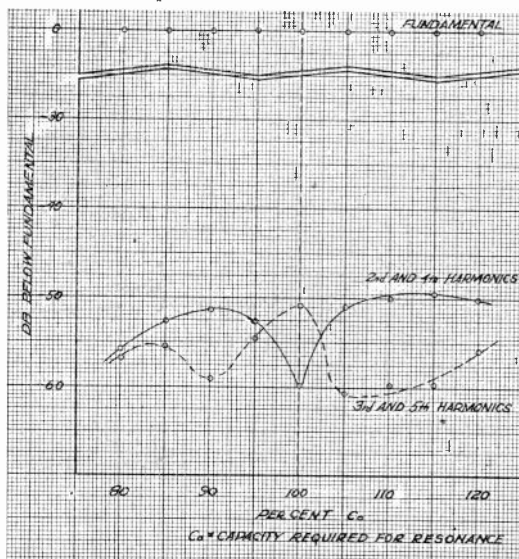
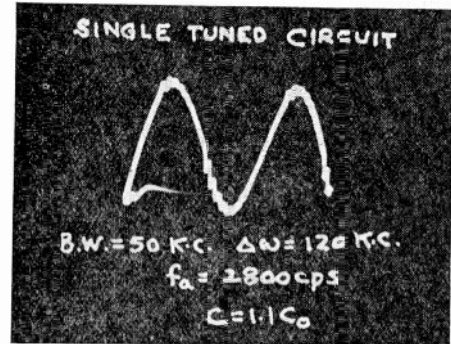
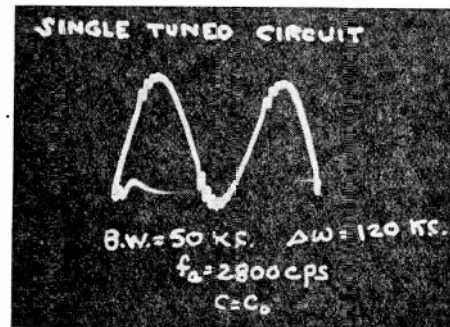

Fig. 14—Experimental determination of distortion as a function of tuning capacitance. Single-tuned circuit.  $BW=50$  kilocycles at 1700 kilocycles. Peak frequency swing = 120 kilocycles.  $F_a=2800$  cycles per second.



(a)



(b)

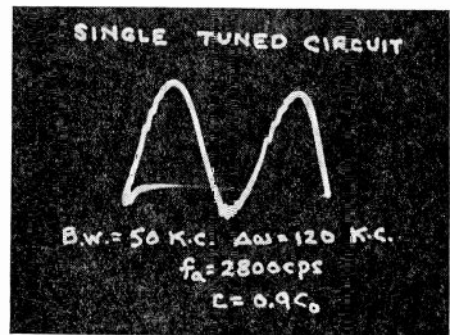

(c)

Fig. 15—The effect of tuning capacitance on the output wave form for the single-tuned circuit is shown in (a), (b), and (c).

are minimized as the capacitance tunes the transformer to resonance. This is to be expected, since at resonance the phase-shift characteristic is symmetrical. The odd harmonics, on the other hand, reach a maximum which illustrates the introduction of odd-order harmonics by the tuned circuit. The total root-mean-square distortion remains substantially constant with capacitance change

at 30 decibels below the fundamental, which is equivalent to 3.4 per cent of the fundamental.

Figs. 15(a), 15(b), and 15(c) illustrate the effect of changing the tuning capacitance on the output wave form. Note the symmetrical displacement of the transient ripple for equal changes of capacitance above and below the resonance value. These transients are initiated

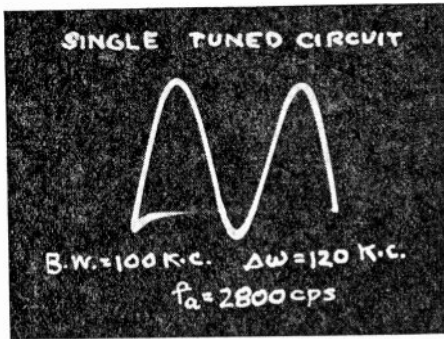

Fig. 16—The effect of doubling the bandwidth for the same parameters as in Fig. 15(a).

where the frequency rate of change of phase angle is greatest, namely the point on the phase-shift characteristic where the slope is a maximum. Fig. 16 shows that the transient character of the wave is removed when the bandwidth is doubled, the other parameters being kept constant.

When the voltage on the limiter is dropped below that necessary for effective limiting, the wave form in Fig. 15(a) becomes, as is shown in Fig. 17, a very distorted signal.

Figs. 18 and 19 show the audio and carrier envelope wave shapes for  $BW = 50$  kilocycles,  $\Delta w / 2\pi = 120$  kilocycles and  $f_a = 8000$  cycles per second. Here the audio distortion is particularly bad.

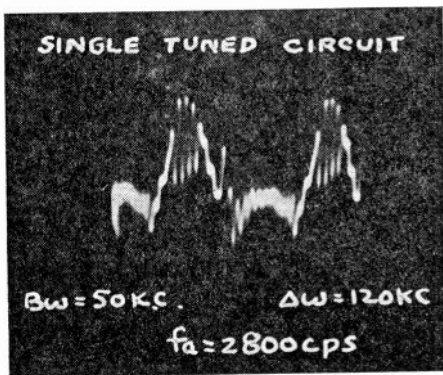

Fig. 17—Output wave form for insufficient voltage on limiter grid.

For a given bandwidth the distortion introduced by a tuned circuit is a function of the frequency swing and modulating frequency. The curves in Fig. 20 show the maximum audio frequency which can be used for a given bandwidth and frequency swing before the signal output appears distorted on the oscillograph screen. This criterion is qualitative, but a quantitative distortion limit would require rather elaborate equipment. It will

be seen that, for design purposes, to transmit the entire audio range to 15,000 cycles per second, the bandwidth should be roughly four times the peak frequency swing. Fig. 21 illustrates the type of distortion used as a criterion. In no case was the wave form seriously distorted. The above design figure therefore is quite conservative.

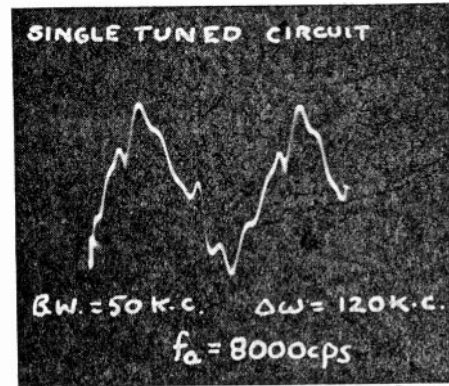

Fig. 18—Output wave form for conditions given on oscillogram.

For the double-tuned circuit, the variation in third-harmonic distortion with frequency swing is shown in Fig. 22. The calculated curve predicts a maximum in the neighborhood of  $\Delta w / 2\pi = 50$  kilocycles. Theoretically this is reasonable, in that we know as the swing increases, the distortion, according to steady-state theory, has an upper limit. Thus, as the swing is increased, the distortion will go through a maximum. Actually, in practice it was found that the distortion tended toward a maximum at a swing greater than 50 kilocycles.

A comparison of the odd-harmonic distortion introduced by the single- and double-tuned transformers is

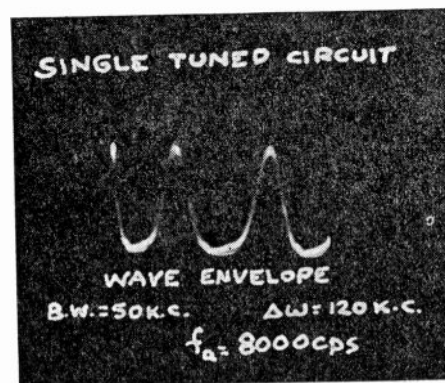

Fig. 19—Carrier envelope for conditions given on oscillogram.

shown in Fig. 23. It will be seen that the double-tuned circuit introduces the greater distortion. This is to be expected, since analysis reveals that the effective frequency swing for a double-tuned transformer is  $\sqrt{2}$  times the frequency swing of the single-tuned transformer. Inspection of (27) will show this to be the case.

When the coupling of a double-tuned transformer is

varied, the distortion is minimized in the neighborhood of critical coupling as is shown in Fig. 24. The experimental results show the minimum distortion to occur when  $k = 1.4$  kilocycles.

The effect of detuning the coils of a double-tuned transformer is shown in Fig. 25. The fundamental remained constant at all times, while the even harmonics tended toward a minimum when the coils were correctly aligned. The odd harmonics, it is interesting to note, remained practically constant.

Fig. 26 shows the maximum audio frequency which can be used for a given bandwidth and frequency swing for the double-tuned critically coupled transformer before the distortion becomes visible on the oscillograph screen. These curves are practically identical with those of the single-tuned circuit in Fig. 20. It will be seen that the design figure  $BW = 4\Delta w$ , also applies to the double-tuned circuit, where transmission to 15,000 cycles per second is desired. Fig. 27(a) and Fig. 27(b) are typical wave forms of the distortion criteria.

Fig. 28(a) is an oscillogram of the wave form for the critically coupled double-tuned transformer whose  $BW = 50$  kilocycles,  $\Delta w/2\pi = 120$  kilocycles,  $f_a = 2800$  cycles per second. The transient ripple is practically the same as that for the single-tuned circuit for the same parameters. (See Fig. 15(b)). Reducing the fre-

quency swing eliminates the transients, as is shown in Fig. 28(b). The same result could have been achieved by increasing the bandwidth.

CONCLUSIONS

An analysis of tuned-circuit distortion in frequency-modulation systems by variable electric-circuit theory reveals that the resultant signal output is the sum of the original modulation and the distortion products introduced by the tuned circuit. These distortion products are a function of the frequency swing and the signal frequency for a particular network. The equations derived by this method are rather complex, and while they are not readily amenable to Fourier analysis, disclose that the distortion parameters are  $\Delta w/BW$  and  $\lambda/BW$  where

$\Delta w/2\pi =$  peak frequency swing

$\lambda/2\pi =$  modulation frequency

$BW =$  bandwidth in kilocycles measured at 3 decibels down. Double-tuned circuits critically coupled.

If the effect of the modulation frequency is neglected, the equations are somewhat simplified and the distortion due to the single- and double-tuned circuits can be formulated. Thus the per-cent  $n$ th odd-harmonic

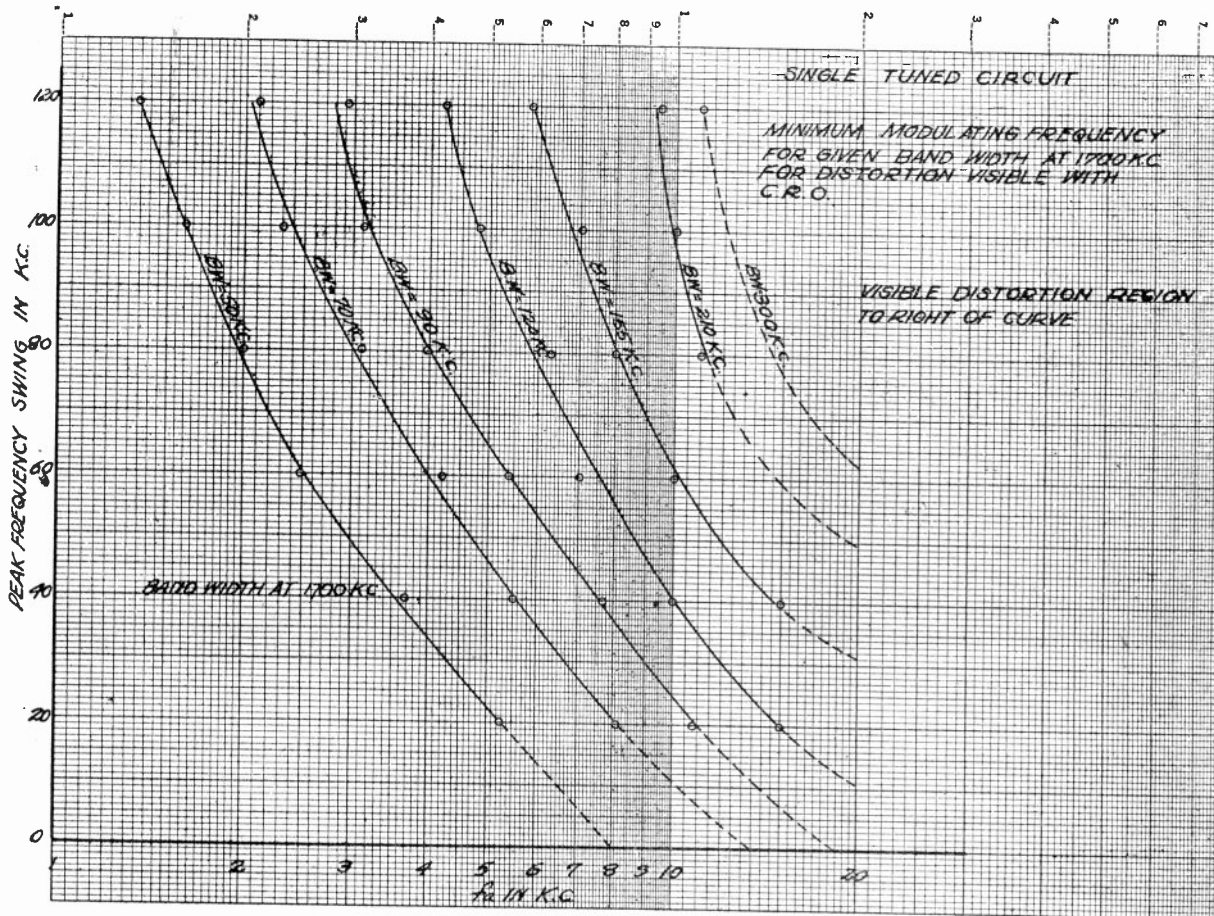

Fig. 20—Single-tuned circuit. Minimum modulating frequency for given bandwidth at 1700 kilocycles for distortion visible with cathode-ray oscilloscope.

distortion introduced by the tuned circuit is

$$D_n = [(2(\sqrt{1 + \rho^2} - 1)^n) / (\rho^n (\Delta w / \lambda))] \cdot 100$$

where

- $D_n$  = per cent  $n$ th odd-harmonic distortion
- $\rho = 2\Delta w / BW$  for single-tuned circuits
- $\rho = \sqrt{2} \cdot 2\Delta w / BW$  for critically coupled double-tuned circuits.

Inspection of this equation will show that effectively the peak frequency swing for a double-tuned circuit is  $\sqrt{2}$

times as great as that for a single-tuned circuit for the same bandwidth. Hence, for equal bandwidths the double-tuned-circuit distortion should be greater. This conclusion was checked experimentally for  $\lambda/2\pi = 2800$  cycles per second.

An approximate distortion limit has been derived for the distortion due to the single- and double-tuned circuits. It has been shown that, in the limit, the distortion harmonics will all have the same magnitude. For the single-tuned circuit it is  $2\lambda$  while for the double-tuned circuit it is  $4\lambda$ , where  $\lambda/2\pi$  is the modulating

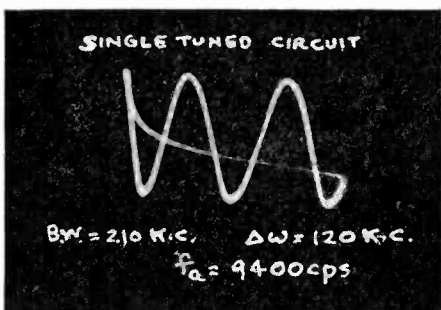
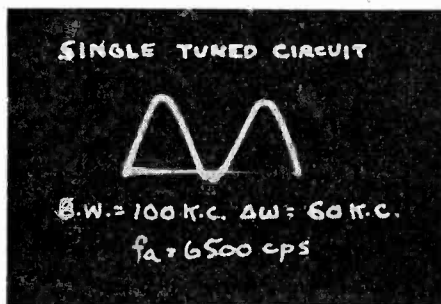
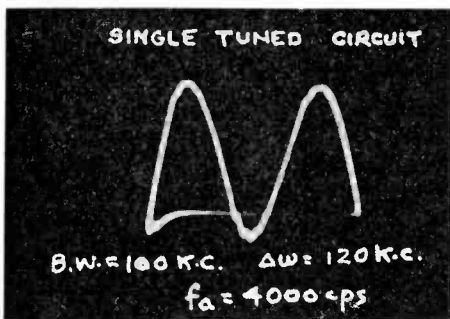
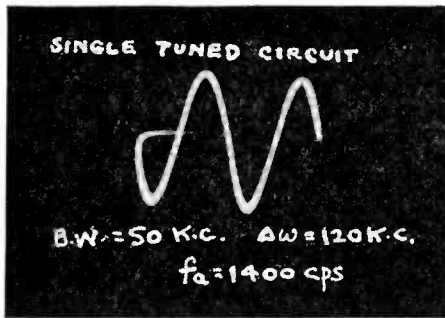

Fig. 21—Wave forms used as criteria for curves of minimum modulating frequency for given bandwidth at 1700 kilocycles for distortion visible with cathode-ray oscilloscope.

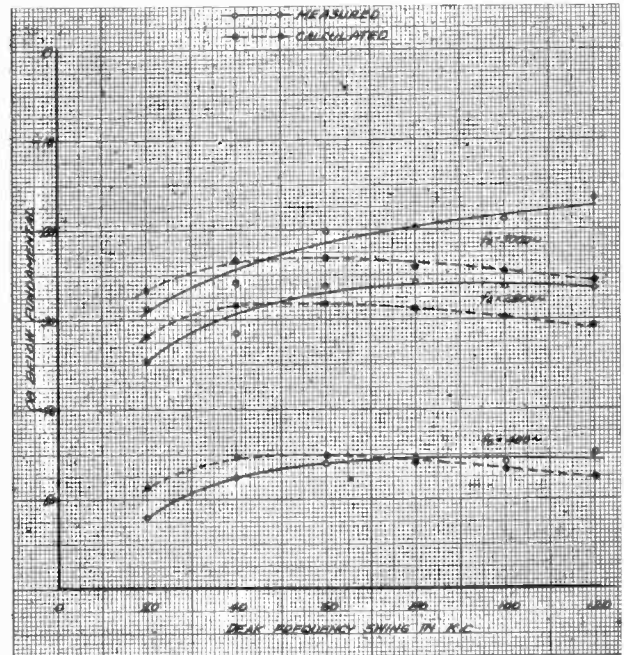

Fig. 22—Third-harmonic distortion as a function of frequency swing. Double-tuned circuit critically coupled.  $BW = 50$  kilocycles at 1700 kilocycles.

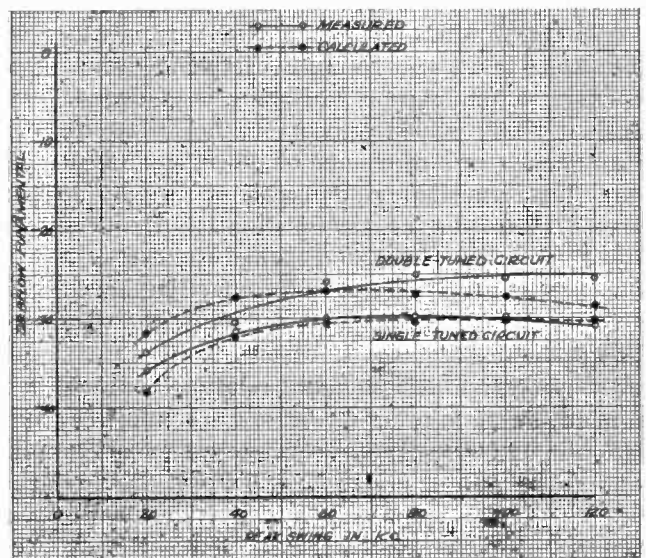

Fig. 23—Root-mean-square third- and fifth-harmonic distortion as a function of peak frequency swing for single- and double-tuned circuits. Double-tuned circuit critically coupled.  $F_o = 2800$  cycles per second.  $BW = 50$  kilocycles at 1700 kilocycles.

frequency. The maximum distortion in per cent will be

$$D_n \text{ max (single-tuned circuit) } = 2\lambda/\Delta w \cdot 100$$

$$D_n \text{ max (double-tuned circuit) } = 4\lambda/\Delta w \cdot 100.$$

Where oscillator stability can be manually controlled, a frequency-modulation signal generator based on the automatic-frequency-control circuit can be designed to be practically distortion-free.

Experiment shows that variation in the tuning capacitance of a single-tuned transformer does not affect the fundamental output. The odd harmonics,

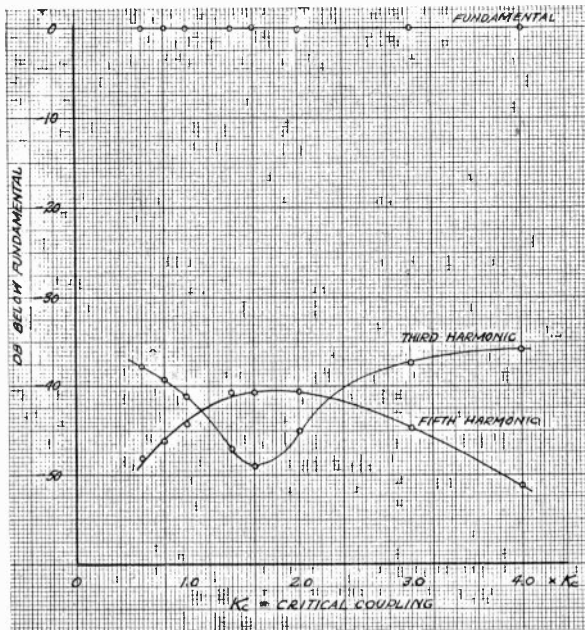

Fig. 24—Harmonic distortion as a function of coupling. Double-tuned circuit. For critical coupling.  $BW=125$  kilocycles,  $F_a=2800$  cycles per second. Peak frequency swing = 120 kilocycles.

however, reach a maximum for the value of capacitance required for resonance. The even harmonics are minimized at this point. The total root-mean-square distortion remains practically constant.

For  $\Delta w/BW=2.4$ , as the audio frequency is increased, the effect of modulation frequency is evidenced by a transient ripple which appears to be initiated where the frequency rate of change of phase angle is a maximum. This transient ripple soon gives way to pronounced distortion as the modulation frequency exceeds 2800 cycles per second. When the carrier level is reduced below that necessary for effective limiting, the above parameters being kept constant, the distortion is greatly increased.

A conservative design figure relating bandwidth to frequency swing in order to insure distortion-free transmission to 15,000 cycles per second, was experimentally found to be approximately  $\Delta w/BW=1/4$ . This relation holds for both the single- and double-tuned transformers.

The distortion introduced by a double-tuned circuit will be minimized in the neighborhood of critical coupling. It was found experimentally that the distortion was a minimum when  $k=1.4$  kilocycles.

Detuning either the primary or secondary capacitance of a double-tuned transformer will not affect the fundamental output. The odd harmonics remain practically constant, while the even harmonics are minimized for the value of capacitance which tunes the coils to the intermediate frequency.

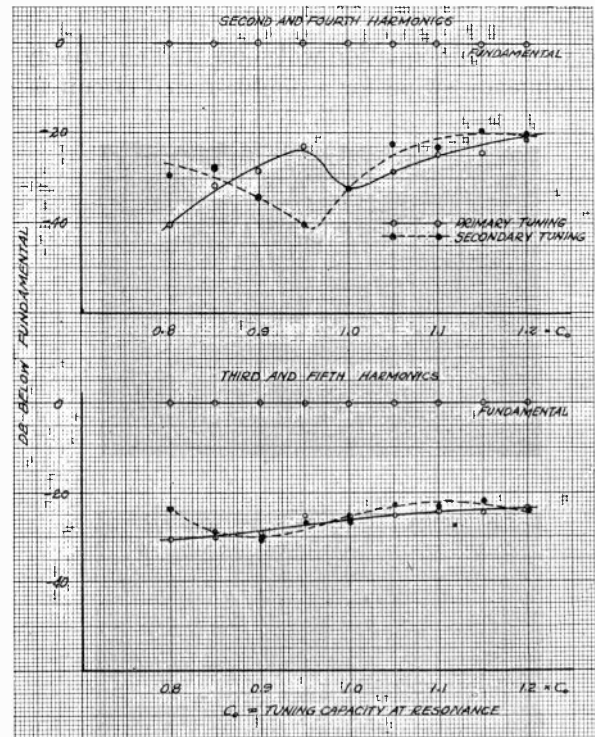

Fig. 25—Experimental determination of distortion as a function of primary and secondary tuning capacitance for a double-tuned circuit, critically coupled.  $BW=50$  at 1700 kilocycles.  $F_a=2800$  cycles per second. Peak frequency swing = 120 kilocycles.

ACKNOWLEDGMENT

To the School of Engineering of Columbia University the writer wishes to express his appreciation for the Samuel Willard Bridgham Fellowship which made possible this study. To Professors Edwin H. Armstrong and John B. Russell, Jr., for their guidance and helpful suggestions in the preparation of this paper; to the members of Professor Armstrong's staff, particularly Mr. J. R. Day, for his help in the design of the experimental receivers; and to Mr. Anthony Orłowsky, for his help in constructing the experimental apparatus.

APPENDIX I

The steady-state-current equation for phase and frequency modulation is given as<sup>15</sup>

$$I_{ss} = E \exp(j\omega t) \left[ Y \exp j\phi + \sum_1^{\infty} \frac{1}{j^n n!} \frac{d^n Y}{d\omega^n} \frac{d^n}{dt^n} \exp j\phi \right] \quad (40)$$

where

$$Y = Y(j\omega)$$

$$\phi = \phi(t).$$

<sup>15</sup> Equation (12).

APPENDIX II

Performing the indicated operations on  $\exp(j\phi)$

$$I_{ss} = E \exp(j\omega t) [Y \exp(j\phi) + ((1/j) \cdot (dY/d\omega)) j\dot{\phi} \exp(j\phi) + ((1/2!j^2) \cdot (d^2Y/d\omega^2)) [j^2\dot{\phi}^2 \exp(j\phi) + \ddot{\phi} \exp(j\phi)] + ((1/3!j^3) \cdot (d^3Y/d\omega^3)) [j^3\dot{\phi}^3 \exp(j\phi) + 2j^2\dot{\phi}\ddot{\phi} \exp(j\phi) + j\ddot{\phi}\dot{\phi} \exp(j\phi) + \ddot{\phi} \exp(j\phi)] + \dots] \quad (41)$$

$$I_{ss} = E \exp(j\omega t) [Y \exp(j\phi) + (dY/d\omega)\dot{\phi} \exp(j\phi) + (1d^2Y/2d\omega^2) [\exp(j\phi)(\dot{\phi} - jD)\dot{\phi}] + (1d^3Y/3d\omega^3) [\exp(j\phi)(\dot{\phi} - jD)(\dot{\phi} - jD)\dot{\phi}] + \dots] \quad (42)$$

$\dot{\phi} = d\phi/dt \quad \ddot{\phi} = d^2\phi/dt^2$  etc.

Writing (42) in shorthand form we obtain

$$I_{ss} = E \exp(j\omega t + j\phi) \left[ Y(j\omega) + \sum_1^{\infty} \frac{d^n Y(j\omega)}{d\omega^n} M_n(t) \right] \quad (43)$$

where  $M_n(t)$  is defined in the following manner

$$\begin{aligned} M_1(t) &= \dot{\phi} \\ M_2(t) &= (\dot{\phi} - jD)\dot{\phi} \\ M_3(t) &= (\dot{\phi} - jD)(\dot{\phi} - jD)\dot{\phi} \\ &\vdots \\ M_n(t) &= (\dot{\phi} - jD)(\dot{\phi} - jD) \dots (\dot{\phi} - jD)_{n-1}\dot{\phi} \\ &= (\dot{\phi} - jD)^{n-1}\dot{\phi} \end{aligned}$$

The generalized steady-state equation for phase and frequency modulation has been derived in Appendix I and is written as

$$I_{ss} = E \exp(j\omega t + j\phi) \cdot \left[ Y(j\omega) + \sum_1^{\infty} \frac{1}{n!} \frac{d^n Y(j\omega)}{d\omega^n} M_n(t) \right]. \quad (44)$$

For frequency-modulation systems,  $\phi = \int u(t) dt$ ,  $\dot{\phi} = u(t)$ , so that

$$\begin{aligned} M_1(t) &= u \\ M_2(t) &= u^2 - j\dot{u} \\ M_3(t) &= u^3 - 3j\dot{u}u - \ddot{u} \\ M_4(t) &= u^4 - \dot{u}u^2 - j(6u^2\dot{u} + 3u\ddot{u} + 3\dot{u}^2 - \ddot{u}) \text{ etc.} \end{aligned} \quad (45)$$

where

$$\begin{aligned} u &= \Delta\omega \sin \lambda t = \phi \\ \dot{u} &= d\phi/dt. \end{aligned}$$

Substituting for  $u$  and its time derivatives in (45)

$$\begin{aligned} M_1(t) &= \Delta\omega \sin \lambda t \\ M_2(t) &= \Delta\omega^2 \sin^2 \lambda t - j\lambda\Delta\omega \cos \lambda t \\ M_3(t) &= \Delta\omega^3 \sin^3 \lambda t + \lambda^2\Delta\omega \sin \lambda t - j3\lambda\Delta\omega^2 \sin \lambda t \cos \lambda t \\ M_4(t) &= \Delta\omega^4 \sin^4 \lambda t + \lambda^2\Delta\omega^2 \sin^2 \lambda t - j(6\lambda\Delta\omega^3 \sin^2 \lambda t \cos \lambda t - 3\lambda^2\Delta\omega^2 \sin^2 \lambda t + 3\lambda^2\Delta\omega^2 \cos^2 \lambda t - \lambda^3\Delta\omega \cos \lambda t). \end{aligned} \quad (46)$$

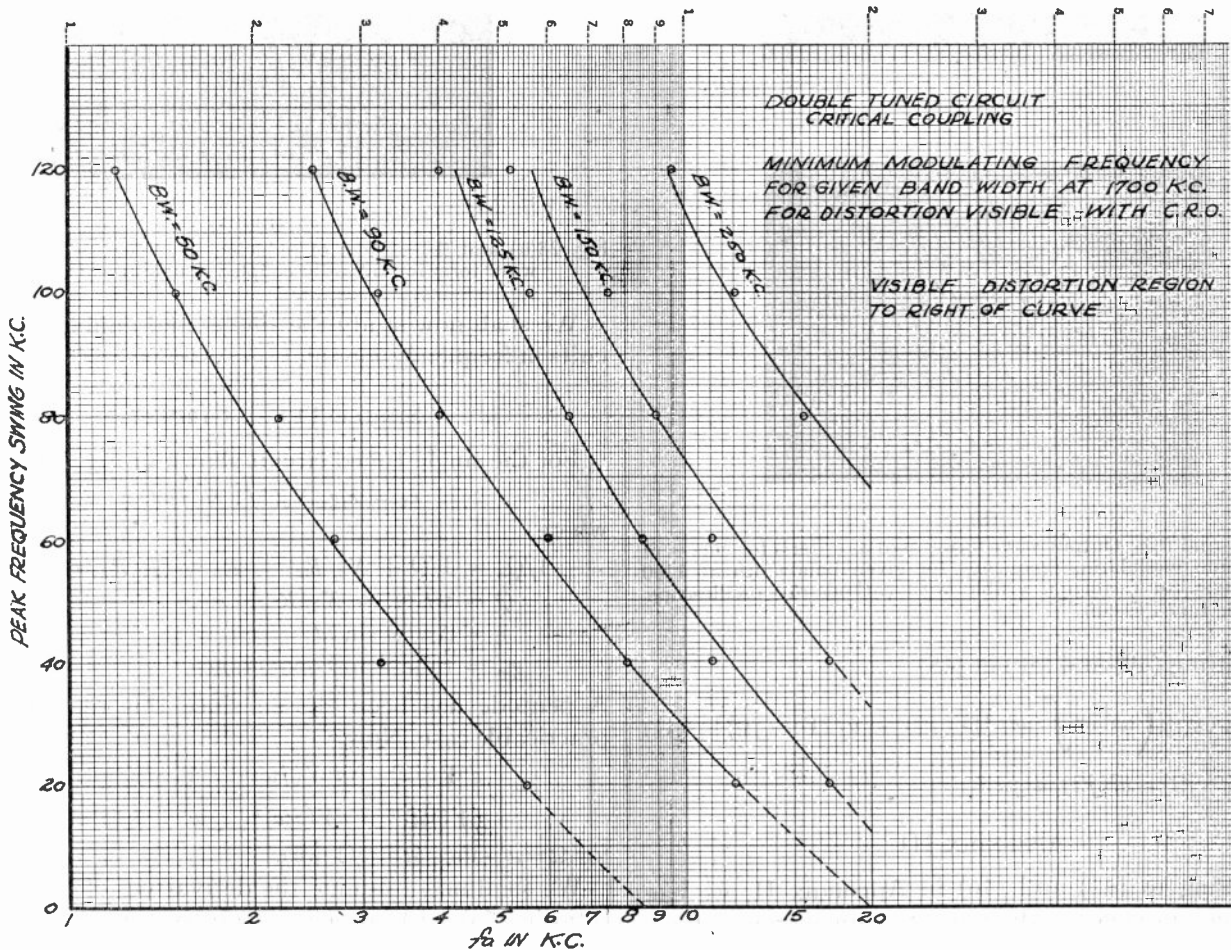

Fig. 26—Double-tuned circuit. Minimum modulating frequency for given bandwidth at 1700 kilocycles for distortion visible with cathode-ray oscilloscope.

In practical systems  $\Delta w \gg \lambda$  so that the series  $M_n(t)$  can be approximated by

$$M_n(t) = \sum_2^{\infty} u^n(t) - j \frac{n(n-1)}{2} u^{n-2} \dot{u}. \quad (47)$$

Substituting (47) in (44) we obtain

$$I_{ss} = E \exp j \left( wt + \int u dt \right) \left[ Y(jw) + \sum_1^{\infty} \frac{u^n}{n!} \frac{d^n Y(jw)}{dw^n} - \sum_2^{\infty} -j \frac{n(n-1)}{2n!} \frac{d^n Y(jw)}{dw^n} u^{n-2} \dot{u} \right]. \quad (48)$$

Now

$$Y(j\Omega) = Y(jw) + \sum_1^{\infty} \frac{u^n}{n!} \frac{d^n Y(jw)}{d(jw)^n} \quad (49)$$

$$\frac{d^2 Y(j\Omega)}{d(j\Omega)^2} = \sum_2^{\infty} \frac{-n(n-1)}{n!} u^{n-2} \frac{d^n Y(jw)}{d(jw)^n} \quad (50)$$

since  $\Omega = w + u$ ,  $d\Omega = du$ .

$$E_o = E \exp j\Omega \left[ Y + \frac{dY}{jd(jw)\Delta w} \sin \lambda t + \frac{d^2 Y}{j^2 2! d(jw)^2} (\Delta w^2 \sin^2 \lambda t - j\lambda \Delta w \cos \lambda t) + \frac{d^3 Y}{j^3 3! d(jw)^3} (\Delta w^3 \sin^3 \lambda t + \lambda \Delta w^2 \sin \lambda t - j3\lambda \Delta w^2 \sin \lambda t \cos \lambda t) + \frac{d^4 Y}{j^4 4! d(jw)^4} (\Delta w^4 \sin^4 \lambda t + \lambda^2 \Delta w^2 \sin^2 \lambda t - j(6\lambda \Delta w^3 \sin^2 \lambda t \cos \lambda t + 3\lambda^2 \Delta w^2 \cos^2 \lambda t - 3\lambda^2 \Delta w^2 \sin^2 \lambda t - \lambda^3 \Delta w \cos \lambda t) + \dots \text{etc.} \right] \quad (52)$$

where  $Y = Y(jw)$  and  $w$  is the carrier frequency.

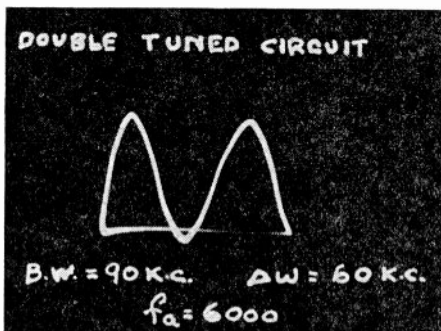

(a)

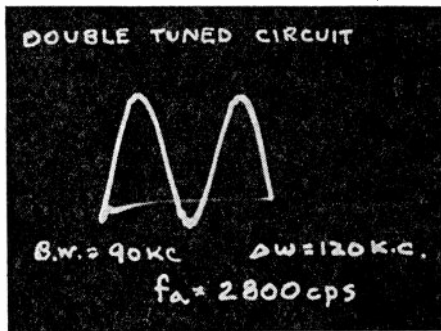

(b)

Fig. 27(a) and (b)—Output wave forms used as criteria for curves of minimum modulating frequency for given bandwidth at 1700 kilocycles for distortion visible with cathode-ray oscilloscope. Double-tuned circuit.

Substituting (49) and (50) in (48)

$$I_{ss} = E \exp j \left( wt + \int u dt \right) [Y(j\Omega) + \dot{u}/2Y^{(2)}(j\Omega)] \quad (51)$$

where  $Y^{(2)}(j\Omega) = d^2(j\Omega)/d(j\Omega)^2$ .

APPENDIX III

Referring to (44) and (46) in Appendix II, we can write that, in general, the output voltage from a four-terminal network in a frequency-modulation system will be

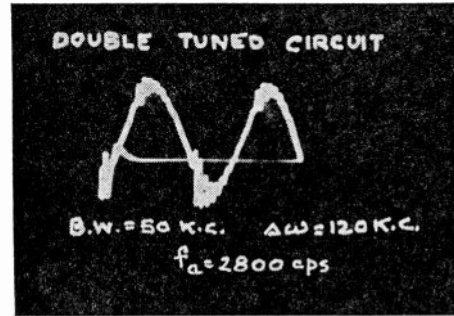

(a)

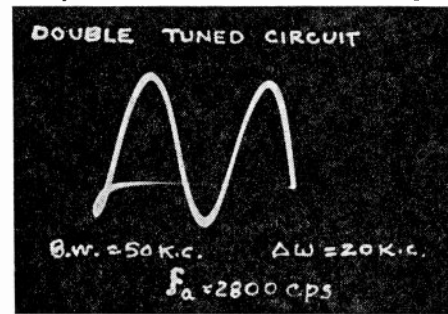

(b)

Fig. 28(a) and (b)—Effect of reducing frequency swing on output wave form for critically coupled double-tuned circuit.

We shall now study the single- and double-tuned circuits in frequency-modulation systems.

SINGLE-TUNED CIRCUITS

For the single-tuned circuit shown in Fig. 29

$$e_o = e_{ig_m} X_o / (1 + j2\delta Q_o) \quad (53)$$

where

$$1/Q_o = 1/Q + X_o/R_o \quad R_o = (R_p R_L / R_p + R_L) \\ Q = wL/R = X_o/R \\ \delta = \Delta w / w \sin \lambda t \\ g_m = \text{tube transconductance.}$$

A pentode has been chosen since this represents the practicable case. Now

$$\frac{d^n Y(j\Omega)}{dY(j\Omega)^n} = \frac{d^n Y(jw)}{dY(jw)^n} = \frac{1}{w^n} \frac{d^n Y^n(j\Omega)}{d(j\delta)^n} \quad (54)$$

for  $\Omega = w$ , since  $\Omega = w(1 + \delta)$ .

We shall now examine the derivatives of the transfer ratio in (53) with a view to substituting them in (52).

From (53) the transfer ratio is

$$Y(j\Omega) = g_m X_o / (1 + j2\delta Q_o) \quad (55)$$



The successive frequency derivatives of  $Y(j\Omega)$  at carrier frequency turn out to be

$$(d^n Y(jw)/d(jw)^n) = (g_m X_0 (-1)^n (2Q_e)^n n! / w^n). \quad (56)$$

Now  $Q_e = w/BW$ , where  $BW/2\pi$  is the total bandwidth in cycles when the gain falls to 70.7 per cent of its value at resonance. This follows from the fact that at resonance  $2\delta Q_e = 1$ , referring to (53), whence  $Q_e = 1/2 = w/2\Delta w$ . Here  $\Delta w$  is the frequency deviation when the gain is down 70.7 per cent or 3 decibels. Substituting for  $Q_e$  in (56) we have

$$(d^n Y(jw)/d(jw)^n) = g_m X_0 (-1)^n (2/BW_{stc})^n n!. \quad (57)$$

The subscripts *stc* and *dte* refer to the single- and double-tuned circuits, respectively.

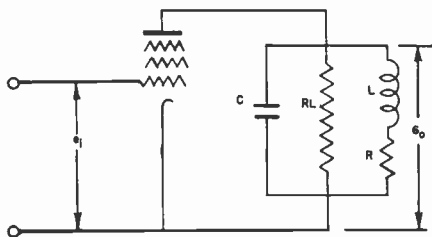

Fig. 29

When the derivatives given by (57) are substituted in (52) we obtain

$$e_o = e_i g_m X_0 \exp j\Omega (1 - 2a/j \sin \lambda t + 4/j^2 (a^2 \sin^2 \lambda t + ab \cos \lambda t) - 8/j^3 (a^3 \sin^3 \lambda t + ab^2 \sin^2 \lambda t - j3a^2 b \sin \lambda t \cos \lambda t) + 16/j^4 (a^4 \sin^4 \lambda t + a^2 b^2 \sin^2 \lambda t - j(6a^3 b \sin^2 \lambda t \cos \lambda t - 3a^2 b^2 \sin^2 \lambda t + 3a^2 b^2 \cos^2 \lambda t - ab^3 \cos \lambda t)) + \dots) \quad (58)$$

where  $a = \Delta w/BW_{stc}$   $b = \lambda/BW_{stc}$ .

It is seen that, for the single-tuned circuit the distortion products will be a function of the parameters  $a$  and  $b$ . Thus

$$D_{stc} = f(\Delta w/BW_{stc}, \lambda/BW_{stc})$$

where  $D_{stc}$  is the distortion due to the single-tuned circuit.

### DOUBLE-TUNED CIRCUIT

For the double-tuned circuit it is preferable to write the gain in terms of the primary and secondary power factors.<sup>16</sup> Referring to Fig. 30 the output voltage can be written as

$$e_o = j e_i g_m X_{m0} / (p_1 + j2\delta)(p_2 + j2\delta) + k^2 \quad (59)$$

where

$$X_{m0} = wM$$

$$p_1 = 1/Q_1 + X_{10}; R_{01} = R_p R_{L1} / R_{L1} + R_p; X_{10} = wL_1 = Q_1 R_1;$$

$$p_2 = 1/Q_2 + X_{20}; R_{02} = R_{in} R_{L2} / R_{L2} + R_{in}; X_{20} = wL_2 = Q_2 R_2;$$

$k$  = coefficient of coupling

$k_c$  = coefficient of critical coupling

$$k_c^2 = 1/2(p_1^2 + p_2^2)$$

$$BW_{dte} = 1/2\sqrt{2}(p_1 + p_2)w \text{ for } k = k_c.$$

In practical circuits,  $p_1$  is very closely equal to  $p_2$ . The double-tuned circuits are critically coupled so that the transfer ratio in this case (assuming  $p_1 = p_2$ ) becomes

$$Y(j\Omega) = g_m X_{m0} / (p + j2\delta)^2 + p^2. \quad (60)$$

<sup>16</sup> H. Roder, "Theory of the discriminator circuit for automatic frequency control," Proc. I.R.E., vol. 26, pp. 590-611; May, 1938.

The derivatives of  $Y(j\Omega)$  with respect to frequency are

$$Y^{(1)} = -1/p^2 \cdot 1/pw \quad Y^{(2)} = 2/p^2 (1/pw)^2$$

$$Y^{(3)} = 0 \quad Y^{(4)} = -48/p^2 (pw)^4.$$

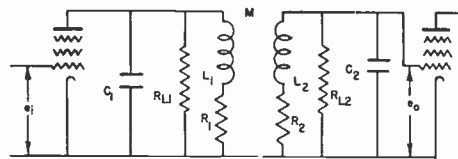

Fig. 30

Now for the double-tuned circuit the bandwidth at 3 decibels down for a critically tuned transformer is  $BW_{dte} = \sqrt{2}pw$ . Thus the derivatives can be written

$$Y^{(1)} = -1/p^2 \cdot \sqrt{2}/BW_{dte}$$

$$Y^{(2)} = 1/p^2 (\sqrt{2}/BW_{dte})^2$$

$$Y^{(3)} = 0$$

$$Y^{(4)} = -48/p^2 (\sqrt{2}/BW_{dte})^4.$$

When these derivatives are substituted in (52) an expression similar to (58) results where the parameters now become  $\Delta w/BW$  and  $\lambda/BW$ . Thus the distortion products for the critically coupled double-tuned transformer of equal primary and secondary power factors will be  $D_{dte} = F(\Delta w/BW_{dte}, \lambda/BW_{dte})$  where  $D_{dte}$  is the distortion due to the double-tuned circuit.

### APPENDIX IV

The function  $P(\Omega)$  has been defined in the text as

$$P(\Omega) = X(\Omega)/R(\Omega) \quad (61)$$

where  $R(\Omega)$  and  $X(\Omega)$  are the real and imaginary parts of the complex transfer ratio  $Y(j\Omega)$ .

Now for the single-tuned circuit it will be seen from Appendix III that

$$P(\Omega) = -2\delta Q_e = -2(\Delta w/BW_{stc}) \sin \lambda t. \quad (62)$$

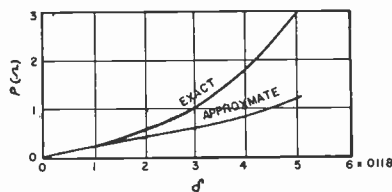

Fig. 31—The function  $P(\Omega)$  vs.  $\delta$ . Critically coupled double-tuned circuit.  $w = 2\pi \cdot 1.7 \cdot 10^6$ ,  $R_p = 10^6$ ,  $R_{L1} = R_{L2} = 10^4$ ,  $X_{10} = 980$ ,  $Q_1 = Q_2 = 50$ ,  $p_1 = p_2 = 0.1$ .

For the critically coupled double-tuned circuit with equal primary and secondary power factors  $P(\Omega) = -4\delta p/2p^2 - 4\delta^2$ . The problem is considerably simplified if  $4\delta^2$  is small compared to  $2p^2$ . This will be the case for heavily damped circuits. Fig. 31 illustrates the effect on  $P(\Omega)$  of neglecting  $4\delta^2$  for a typical frequency-modulation intermediate-frequency transformer. For these conditions  $P(\Omega)$  then becomes

$$P(\Omega) = -2\delta/p = -2\sqrt{2}(\Delta w/BW_{dte}) \sin \lambda t. \quad (63)$$

We can then write that in general

$$P(\Omega) = -\rho \sin t \quad (64)$$

where

$$\rho = 2\Delta w/BW_{stc}$$

$$\rho = 2\sqrt{2}\Delta w/BW_{dte}.$$

The following statement is a revision of the material appearing on pages 175 and 176 of the March, 1944, and on pages 493 and 494 of the August, 1944, issues of the PROCEEDINGS. The attention of the reader is accordingly directed to the corresponding changes.

*The Editor*

## Standard-Frequency Broadcast Service of National Bureau of Standards\*

THIS service comprises the broadcasting of standard frequencies and standard time intervals from the Bureau's radio station WWV near Washington, D. C. Starting in February, 1945, the service has been slightly extended by broadcasting 15 megacycles at night as well as in the daytime.

The service is continuous at all times day and night, from 10-kilowatt radio transmitters except on 2500 kilocycles per second where 1 kilowatt is used. The services include: (1) standard radio frequencies, (2) standard time intervals accurately synchronized with basic time signals, (3) standard audio frequencies, (4) standard musical pitch, 440 cycles per second, corresponding to A above middle C.

The standard-frequency broadcast service makes widely available the national standard of frequency, which is of value in scientific and other measurements requiring an accurate frequency. Any desired frequency may be measured in terms of the standard frequencies. This may be done by the aid of harmonics and beats, with one or more auxiliary oscillators.

Four radio carrier frequencies are used; three are on the air at all times, to insure reliable coverage of the United States and other parts of the world. The radio frequencies are:

2.5 megacycles (= 2500 kilocycles = 2,500,000 cycles) per second, broadcast from 7:00 P.M. to 9:00 A.M., Eastern War Time (2300 to 1300 Greenwich Mean Time).

5 megacycles (= 5000 kilocycles = 5,000,000 cycles) per second, broadcast continuously day and night.

10 megacycles (= 10,000 kilocycles = 10,000,000 cycles) per second, broadcast continuously day and night.

15 megacycles (= 15,000 kilocycles = 15,000,000 cycles) per second, broadcast continuously day and night.

Two standard audio frequencies, 440 cycles per second and 4000 cycles per second, are broadcast on the radio carrier frequencies. Both are broadcast continuously on 10 and 15 megacycles. Both are on the 5 megacycles in the daytime, but only the 440 is on the 5 megacycles from 7:00 P.M. to 7:00 A.M., Eastern War Time. Only the 440 is on the 2.5 megacycles.

The 440 cycles per second is the standard musical pitch, A above middle C; the 4000 cycles per second is a useful standard audio frequency for laboratory measurements.

\* Decimal classification: R555. Original manuscript received by the Institute, January 24, 1944.

In addition there is on all carrier frequencies a pulse of 0.005-second duration which occurs at intervals of precisely 1 second. The pulse consists of 5 cycles, each of 0.001-second duration, and is heard as a faint tick when listening to the broadcast; it provides a useful standard time interval, for purposes of physical measurements, and may be used as an accurate time signal. On the 59th second of every minute the pulse is omitted.

The audio frequencies are interrupted precisely on the hour and each 5 minutes thereafter; after an interval of precisely 1 minute they are resumed. This 1-minute interval is provided in order to give the station announcement and to afford an interval for the checking of radio-frequency measurements free from the presence of the audio frequencies. The announcement is the station call letters (WWV) in telegraphic code (dots and dashes), except at the hour and half hour when a detailed announcement is given by voice.

The accuracy of all the frequencies, radio and audio, as transmitted, is better than 1 part in 10,000,000. Transmission effects in the medium (Doppler effect, etc.) may result at times in slight fluctuations in the audio frequencies as received; the average frequency received is however as accurate as that transmitted. The time interval marked by the pulse every second is accurate to better than 10 microseconds (= 0.00001 second). The 1-minute, 4-minute, and 5-minute intervals, synchronized with the seconds pulses and marked by the beginning or ending of the periods when the audio frequencies are off, are accurate to 1 part in 10,000,000.

The beginnings of the periods when the audio frequencies are off are so synchronized with the basic time service of the United States Naval Observatory that they mark accurately the hour and the successive 5-minute periods.

Of the radio frequencies on the air at a given time, the lowest provides service to short distances, and the highest to great distances. Reliable reception is in general possible at all times throughout the United States and the North Atlantic Ocean, and fair reception throughout the world.

Information on how to receive and utilize the service is given in the Bureau's Letter Circular, "Methods of using standard frequencies broadcast by radio," obtainable on request. The Bureau welcomes reports of difficulties, methods of use, or special applications of the service. Correspondence should be addressed to the National Bureau of Standards, Washington, D. C.

# Institute News and Radio Notes

## Board of Directors

**March 7 Meeting:** At the regular meeting of the Board of Directors, which was held on March 7, 1945, the following were present: W. L. Everitt, president; G. W. Bailey, executive secretary; S. L. Bailey, W. L. Barrow, Alfred N. Goldsmith, editor; R. F. Guy, R. A. Hackbusch, R. A. Heising, treasurer; Keith Henney, L. C. F. Horle, F. B. Llewellyn, Haraden Pratt, secretary; B. E. Shackelford, D. B. Sinclair, W. O. Swinyard, H. M. Turner, H. A. Wheeler, W. C. White, and W. B. Cowilich, assistant secretary.

**Executive Committee:** The actions of the Executive Committee, taken at its February 6 and 7, 1945, meetings were ratified and the following Executive Committee recommendation approved:

**Date of Election to Senior Member Grade:** Authorization was given to using the date of election to the old Member grade (that is, only in case of those of Member-grade status prior to October, 1943), as the date of election to the Senior-member grade, and to having the election dates on that basis shown in the YEARBOOK.

### Committees and Appointments

**ADMISSIONS:** The appointment of F. A. Polkinghorn to the vice-chairmanship of this committee was unanimously approved.

**BOARD OF EDITORS, PAPERS, AND PAPERS PROCUREMENT:** The members listed in the April issue of the PROCEEDINGS were appointed to the 1945 Board of Editors, Papers Committee, and Papers Procurement Committee.

**EDUCATION:** The appointment of G. A. Wootton as a member of this committee for the current year was given unanimous approval.

**TELLERS:** By a unanimous vote, Edward DeNike was named to this committee.

**INSTITUTE REPRESENTATIVE:** Dr. C. S. Royce was appointed Institute Representative at the Illinois Institute of Technology.

**RMA-IRE CO-ORDINATION:** Upon recommendation of the Executive Committee, these members were named to the RMA-IRE Co-ordinating Committee:

W. L. Barrow, *chairman*  
D. D. Israel      F. R. Lack  
W. L. Everitt, *ex-officio*

President Everitt explained that the purpose of this committee is to improve the coordination between IRE and RMA and to attempt to define, so far as possible, the relative sphere of each organization, with appropriate recommendations to each body. The group is intended to be a continuing committee. It was also stated that, as a matter of policy, the chairman of this committee would be that member of the Executive Committee responsible for the technical-committee activities of the Institute, referred to in the organization plan as "Mr. A" in which capacity Dr. Barrow is serving this year.

It was understood that President Everitt

would address a letter to the RMA Engineering Department relative to the appointment of the foregoing committee and to having a similar committee appointed within the RMA group.

### Constitution and Bylaws

**BYLAW SECTION 41:** Attention was called to the notices, mailed to the Board members on February 5 and March 2, 1945, relative to the proposed amendment of this Bylaw (Section 41 in the November 29, 1944, edition of the Constitution in the process of being printed, or Section 40 in the preceding edition.)

Following the discussion, the proposed amendment of Bylaw Section 41, quoted below, was unanimously adopted:

"Sec. 41. For Section maintenance, the Institute shall pay to each Section for each calendar year the greater of the following sums:

"(a) Seventy-five cents per member plus ten dollars per meeting for not more than ten meetings, or

"(b) Ninety cents per member less ten dollars for each meeting under ten. Member means Fellows, Senior Members, Members, and Associates with mailing addresses within the territory of the Section on December 31 of the calendar year for which payment is made, and Meeting means meetings of the Section within the calendar year."

**PETITIONED AMENDMENT OF ARTICLE IV:** This proposed amendment, submitted by a petition initiated by H. P. Westman and representing a second plan to increase membership dues, was reviewed. It was noted that this amendment includes the three quoted sections to replace Sec. 1 of Article IV of the present Constitution:

### PROPOSED AMENDMENT OF ARTICLE IV

"Sec. 1—The entrance fee for all grades shall be \$3.00 except that there shall be no entrance fee for Student grade.

"Sec. 2—There shall be no transfer fees.

"Sec. 3—The annual dues for all grades shall be \$10.00 except for Student which shall be \$3.00 and except for Associate which shall be \$7.00 for each year that is within the first five years of membership in any grade or grades other than Student. Thereafter, the annual Associate dues shall be \$10.00 beginning the January First following. The clause increasing Associate dues from \$7.00 to \$10.00 shall take effect on January 1, 1946."

Unanimous approval was given to interpreting the foregoing Sec. 3 of Article IV to mean the first five years or any part of the fifth year.

**PROPOSED AMENDMENTS OF BYLAW SECTIONS 3 AND 10:** The Constitution and Laws Committee was instructed to prepare and submit amendments of the indicated Bylaw Sections (given as Sections 3 and 10 in the

new edition of the Constitution, or as Sections 3 and 12 in the preceding edition) to the extent explained below:

**Sec. 3:** The proposed amendment to consist of the substitution of the word "references" for the word "sponsors."

**Sec. 10:** The proposed amendment to consist of the substitution of the word "references" for the word "sponsors" in the fourth line.

**B. J. Thompson Memorial:** Secretary Pratt, chairman of the Special committee on the B. J. Thompson Memorial, outlined the plan developed at the recent meeting of his group. Among those plans were the letter, to be sent to the friends of the late Mr. Thompson and the two-page PROCEEDINGS material describing the memorial.

The discussion resulted in the motion that the Board authorize the use of two pages in the May, 1945, issue of the PROCEEDINGS for the indicated text material, to be worded substantially as reported and to contain the signature of Dr. Law as secretary of the Memorial Advisory Committee (and not that of Secretary Pratt).

## Executive Committee

**March 7 Meeting:** The Executive Committee meeting, held on March 7, 1945, was attended by W. L. Everitt, president; G. W. Bailey, executive secretary; S. L. Bailey, W. L. Barrow, Alfred N. Goldsmith, editor; R. A. Heising, treasurer; Haraden Pratt, secretary; G. T. Royden (guest), and W. B. Cowilich, assistant secretary.



**W. C. Hahn:** The application of W. C. Hahn, as shown on page 269 of the April PROCEEDINGS, should be indicated as a transfer and not as an admission to this grade, thereby reducing the number of admissions to six and increasing that of transfers to 19.

**Membership:** The following transfers and applications for membership were unanimously approved:

### (Admissions Committee Meeting on February 7, 1945)

For transfer to Senior Member grade, A. Barco, G. T. Bennett, H. E. Bernstein, C. W. Carnahan, H. A. Chinn, K. H. Emerson, L. K. Findley, G. B. Hoadley, K. Kramer, R. Lee, C. J. Madsen, I. E. Mourontseff, F. L. Pampel, W. H. Radford, E. W. Schafer, W. A. Schwalm, B. R. Teare, Jr., C. T. Weibler, and R. S. Yoder; for admission to Senior Member grade, C. A. W. Grierson and H. R. Yeager; for transfer to Member grade, N. W. Aram, H. K. Bradford, W. Brown, E. Collins, C. W. Engelman, O. F. Foin, Jr., F. N. Gruwell, G. D. Hulst, Jr., G. M. Kirkpatrick, J. J. Krakora, Jr., R. S. Mautner, C. M. Morris, J. H. Pratt, L. G. Sands, E. H. Smith, T. H. Walker, G. S. Watson, and J. J. Wellendorf; for admission to Member grade, L. Biederman,

(Continued on page 338)



Tribute to  
**Browder J. Thompson**  
By  
**The War Department**

In the fall of 1943 Browder J. Thompson, Associate Research Director of RCA Laboratories was called upon by Edward L. Bowles, Expert Consultant to the Secretary of War, to serve as a special consultant and advisor on his staff on certain urgent problems in the electronics field then confronting the Army. Thompson, recognizing the importance of these problems and believing that he could contribute substantially to the solution of them, accepted this post. During the ensuing months he did much to assist the Army on these matters.

Early in 1944 the need arose for a suitably qualified individual to undertake a special study of another and somewhat broader problem which General Marshall, himself, had declared to be one of the utmost urgency and importance. In view of the outstanding success achieved by Thompson in his initial assignment with the War Department, his experience with Army matters gained in this work, his unusual background and high technical and over-all competence, he was selected as the one best qualified to undertake and supervise this study.

As a first step in this task, he concluded that it would be essential for him to visit active military theaters in order to become familiar with the problems presented. Accordingly, in June of 1944 he proceeded overseas and, after a short time spent in the United Kingdom, went on to the Mediterranean in pursuance of this objective. There, shortly after arriving at the headquarters of an air unit, and after having discussed his mission briefly with the commanding officer, he expressed his desire to participate in an operational mission to acquire firsthand knowledge of the matters with which he was concerned. He was fully informed of the danger involved but insisted that this was the only way in which he could secure the information he needed satisfactorily to complete the work he had undertaken and was permitted to participate in a mission over enemy territory on the night of 4-5 July.

From this mission he never returned. Later the wreckage of the airplane, together with his remains and those of the crew, were found in what had been, at the time of the mission, enemy territory.

In commenting on this most unfortunate loss, the Secretary of War has said:

"It is a great tribute to him that, under no other compulsion than his own great desire to do all in his power to aid in the solution of a most urgent problem facing our own Army and those of our Allies, and thereby to assist in bringing the war to an early conclusion, he deemed it necessary to do as he did. I know of no instance of an individual having given more freely of his talents and having more deliberately and willingly accepted the risks of war to give service to his country."

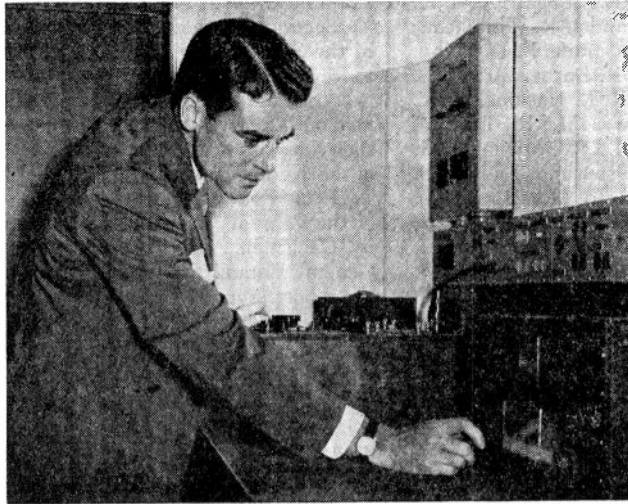

## Browder J. Thompson Memorial Prize

. Contributions of friends of the late B. J. Thompson will be turned over to The Institute of Radio Engineers to establish an annual prize for outstanding papers in Radio and Electronics.

Undoubtedly many friends of the late Browder J. Thompson will favor the establishment of a memorial commemorating his interest in science and his many contributions in the field of radio and electronics. In recognition of this fact, a committee has been formed to carry out this objective.

In view of B.J.'s long and intimate association with The Institute of Radio Engineers, it has seemed fitting to co-operate with that organization in this matter. This has been accomplished in the following way. Through a small group of friends acting as an Advisory Committee, arrangements have been made to receive contributions for the establishment of a memorial fund. This fund will subsequently be turned over to the Institute which has gladly agreed to administer it and to employ the income therefrom to provide an annual award.

This award shall be known as the Browder J. Thompson Memorial Prize. Its purpose shall be to stimulate research in the field of radio and electronics and to provide incentive for the careful preparation of papers describing such research. This award shall be made annually to the author or joint authors under thirty years of age for that paper of sound merit recently published in the Technical Publications of The Institute of Radio Engineers which, in the opinion of the Awards Committee of the Institute, constitutes the greatest contribution to the field of radio and electronics and the best presentation of the subject.

As far as possible, the Advisory Committee will communicate with individual friends and invite them to send contributions to the Browder J. Thompson Memorial Fund. Unfortunately many friends or acquaintances may not receive such an individual invitation, either because they were unwittingly omitted, or because their addresses were unknown. Others who recognize the significance of this memorial in the advancement of the radio and electronic fields may also wish to contribute. Such individuals may contribute directly. All contributions should be made to the order of the Browder J. Thompson Memorial Fund and addressed to The Princeton Bank and Trust Company, Princeton, New Jersey. Contributions will be acknowledged upon receipt. Inasmuch as independent arrangements have been made to defray the expenses of collection, the entire amount contributed will be applied to the fund.

### Browder J. Thompson Memorial

#### Advisory Committee

E. L. BOWLES  
A. V. EASTMAN  
F. R. LACK  
R. R. LAW  
F. B. LLEWELLYN

J. M. MILLER  
W. B. NOTTINGHAM  
E. W. RITTER  
W. C. WHITE  
V. K. ZWORYKIN

(Continued from page 335)

E. G. Bond, J. S. Boyers, L. W. Butler, R. J. Christensen, A. F. Coleman, L. M. Craft, J. Deitz, C. L. Frederick, K. N. Fromm, H. L. Jackson, G. W. James, R. L. Kahn, A. R. J. Leary, S. B. Lieben, B. Shmurak, J. Simpson, R. O. Swartz, and P. G. Taylor.

(Admissions Committee Meeting on  
March 6, 1945)

For transfer to Senior Member grade, A. P. Chesney, J. T. Cimorelli, P. M. Craig, D. G. Haines, W. D. Hershberger, J. B. Hershman, H. J. Kayner, F. J. Moles, J. G.

Prentiss, L. W. Sepmeyer, and P. S. Smith; for admission to Senior Member grade, W. P. Maginnis, R. R. Stoddart, W. H. Teare, W. H. Timble, and J. R. Whitehead; for transfer to Member grade, F. D. Clapp, M. J. A. Contreras, R. R. Darden, Jr., E. L. Fredine, J. A. Green, R. L. Haskins, K. K. Jensen, W. R. Lindsay, M. R. Ludwig, R. Mayer, H. R. Meahl, L. V. Michal, J. H. Mulligan, Jr., S. G. Osterlund, and H. S. Overby; for admission to Member grade, J. Babillus, D. V. Carroll, M. L. Doelz, L. M. Harris, J. P. Hocker, M. R. Hubbard, L. L'Allier, J. Leighton, P. N. Librizzi, A. Liebscher, B. A. McKendry, J. E. Pauch, R. P. Raynsford, M. R. Saslaw, W. T.

Stephen, W. T. Strenger, J. G. Todds, I. D. Volpe, and E. S. Watters; Associate grade, 152; and Student grade, 56.

**Sections:** Treasurer Heising as chairman of the Sections Committee called attention to revisions in the Sections Constitution, proposed at the Sections Committee meeting held on January 24, 1945, and suggested that such revisions be included in the next edition of the Section Manual.

**1945 Winter Technical Meeting:** Copies of the February 26, 1945, report, submitted by Chairman Austin Bailey of the WTM General Committee, were distributed and the report favorably received.

## Timely Inventive Problems

A new list of problems, in the solution of which the Navy Department of the United States is interested, has been released. There have been selected from them the following which seem of special interest to communication and electronic engineers, and in which the methods of their field might prove useful. Any suggested solutions should be prepared in sketch and description form and sent to the National Inventors Council, Department of Commerce, Washington 25, D. C., for consideration and report.

The Editor

### 1. Device for transmitting rotary motion through a moisture-proof barrier.

**Applications:** Shafts for control knobs on radio equipment provided with immersion-proof case; generator shaft for field telephones equipped with immersion-proof cases; generator shafts for hand-cranked power supplies for field radio equipment.

**Characteristics:** Should prevent entrance of water or moisture vapor when immersed to a depth of ten feet; should offer a minimum of frictional opposition to rotary motion; should be small in relation to the equipments to which applied; should have ample power-transmission capability; should be applicable to existing equipment with a minimum of modification.

### 2. Waterproof jack.

**Applications:** Microphone, headphone, and key jacks for telephone equipment.

**Characteristics:** Should prevent water or moisture vapor from penetrating equipment, even when immersed to a depth of ten feet; should be capable of cleaning and drying without tools; should accommodate standard plugs.

3. A small portable field-strength meter about the size and weight of a walkie-talkie for rapid checking of radio field intensities in the vicinity of radio transmitting stations. The instrument must be simple to use and accurate within plus or minus 10 per cent. Frequency range desired is 100 kilocycles to 20,000 kilocycles. The range of field intensities desired is from 10 to 1000 millivolts per meter.

## Important Notice

Because of severely overcrowded conditions at I.R.E. Headquarters, it became necessary to move the Editorial Department. All mail, intended for the Editorial Department, should be addressed to

I.R.E. Editorial Department  
Fourth Floor  
26 West 58th Street  
New York 19, New York

Mail for the Secretarial Department should be addressed as heretofore to  
I.R.E. Headquarters  
Room 2000  
330 West 42d Street  
New York 18, New York

Mail for the Advertising Department should be addressed to  
I.R.E. Advertising Department  
Room 707  
303 West 42d Street  
New York 18, New York

4. Radio antennas up to 300 feet in height that can be set up by unskilled ground crews. The efficiency of radio devices is often limited by the extreme difficulty of obtaining reasonable antenna heights quickly in the field. Very light alloys and special rigs for rapid erection by a ground crew without climbing are desired, in addition to ability to dismantle or collapse into packages not exceeding 20 feet in length. Insulated-base vertical antennas are preferable, but grounded-base type could be used if the device had enough other advantages in the way of ease of erection and ruggedness.

5. A cheap and effective barrier to prevent the propagation of cracks in steel structures, without making use of riveted seams and the caulking, etc., incidental thereto.

6. A method of welding high-pressure piping without the aid of backing straps or with back straps which would be soluble in a harmless solution which could be introduced in the pipe before putting same into service.

7. A method of measuring the elastic stresses locked up in steel or other metallic structures at and beneath the surface of the material without having to dissect the structure in order to record the elastic recovery which results from isolating various segments.

8. A method of welding light-gauge aluminum (This is of particular interest since aluminum lifeboats and life rafts are currently of riveted construction due to the lack of a satisfactory method of welding.)

9. Small aircraft-type direct-current motors without commutators, slip rings, or any other moving contact arrangements, so as to eliminate service difficulties with commutators and electrical noise produced thereby.

10. A small Hooke's joint or universal joint for instrument use, the efficiency of which is sensibly constant with angularity of output shaft axis up to 10 degrees. For above shaft-axis angularity units, the Hooke's joint should have an angular-velocity ratio of input to output shafts constant and equal to unity over the cycle with as high an efficiency as possible.

11. A precision twin-triode vacuum tube with general characteristics of the current 6SN7 type, having the following additional precision features:

1. After a fifteen minute warm-up, the  $g_m$  of the two sides shall be equal over the normal operating range to within +1 per cent.

2. The tube shall be completely nonmicrophonic.

3. The above characteristics to be maintained over an ambient temperature range +80 degrees centigrade to -40 degrees centigrade.

4. It would be possible to produce this tube by mass-production methods with not more than 10 per cent rejects. NOTE—Tubes presently available in production permit excessive variation in grid-plate conductance in the separate halves of the tube.

12. An expendable, compact, lightweight, rugged, mechanical device to permit successive closures of up to eight electrical circuits with a time interval between closures of about 0.2 to 0.3 second.

13. A small, fast-acting, double-action solenoid to operate on 28 volts direct current, with a stroke of about 0.5 with a 20-pound pull (or push) at condition of maximum air gap. The plunger should "seat" at each end of travel and would very probably have to be an electromagnet whose polarity would reverse at each end of travel.

## Membership Transfers

The Chairman of the Institute Membership Committee, in addressing Mr. E. Finley Carter of the Board of Directors by letter, on March 14, 1945, has correctly emphasized a matter of interest to the entire membership of the Institute. It involves the obligation of each member to transfer to that grade of membership in the Institute to which he is justly entitled. Dr. E. D. Cook's communication follows.

A large number of I.R.E. members qualify, but have not applied for, a higher membership grade. Some of these members intend to make application some day, but never seem to find the occasion. The Associate grade is particularly filled with such cases, some as a consequence of the constitutional change in grade structure. It is of course to their advantage to make the change as soon as possible, particularly since there is no added expense. These members are definitely realizing less than they should on their investment, since not even an admission fee is charged.

Those who are now members, and could qualify as Senior Members should also be taken under advisement. Very few would study and pass all tests for a Master's degree, and then fail to attend graduation because he had to rent a cap and gown. Senior Membership in the I.R.E., in fact any higher grade, is in a very real sense the same sort of a diploma for worth. It is much more, in that through the Admissions Committee, it is a public announcement that The Institute of Radio Engineers finds the qualities and abilities in the individual which the modern radio industry needs for leadership.

When this is the case, why do so many fail to avail themselves of this opportunity? Frankly, some feel that it is an added expense. Those now in the higher grades must have found it was worth the few dollars involved, and they had reason to be proud of the status and the Institute is proud of them.

To those who have planned to make application for a higher grade of membership, but have failed to do so, the Membership Committee would like to point out that it takes only a letter to settle this matter, and to write that letter requires only the belief in the desirability of the step.

It is my personal belief that the best service the Section Membership Committee can render the man and the Institute, is to apply itself energetically to this matter of transfers. But the member, who has everything to gain, should not wait for a personal invitation to transfer. If he cannot think of sponsors, he can tell his story to the Admissions Committee, and let it make some pertinent suggestions.

ELLSWORTH D. COOK  
Chairman, Membership Committee

## Increase in Rebates to Sections

By unanimous vote of the Board of Directors at the March meeting, Institute Bylaw Section 41 was modified to increase rebates to Sections approximately 25 cents per member effective retroactively to January 1, 1945. The modified Bylaw is as follows:

"For Section maintenance, the Institute shall pay to each Section for each calendar year the greater of the following sums:

- (a) Seventy-five cents per member plus ten dollars per meeting for not more than ten meetings, or
- (b) Ninety cents per member less ten dollars for each meeting under ten. Member means Fellows, Senior Members, Members, and Associates with mailing addresses within the territory of the Section on December 31st of the calendar year for which payment is made, and Meeting means meetings of the Section within the calendar year."

At the April 4 meeting of the Board of Directors, the November 29, 1944, Bylaws, Sections 3 and 10, were modified.

The modification of Section 3 consisted of the substitution of the word "references" by the word "sponsors."

The modification of Section 12 consisted of the substitution of the word "references" for the word "sponsors" in line four.

The modified Bylaw Sections are as follows:

"Section 3: Applicants for membership shall furnish names of references as follows:

"For Senior Member—Five Fellows or Senior Members.

"For Member—Four Fellows, Senior Members, or Members.

"For Associate—Three Fellows, Senior Members, Members, Associates or other responsible individuals.

"For Student—A member of the faculty of his school."

"Section 10: Admission or transfer to any grade except Fellow may be proposed by any member acting as sponsor, or by the Membership Committee, by supplying to the Admissions Committee sufficient information and testimonials from the required number of references to satisfy the Admissions Committee as to qualifications. Such proposals shall be acted upon by the Admissions Committee, and, if approved, transmitted to the Board of Directors for their action. If approved by the Board of Directors, an Invitation Blank shall be sent to the proposed member inviting him to accept the grade of membership proposed, which membership grade shall become effective automatically and immediately upon his supplying the biographical and professional information required, and paying the necessary dues and fees. The name of an invitee shall be placed on the mailing list for the PROCEEDINGS immediately upon receipt of dues and fees. The proposal and invitation blanks shall be drawn up by the Membership Committee so as to avoid unconstitutional action due to the sponsor supplying incorrect information."

At the April 4 meeting of the Board of Directors, the November 29, 1944, Bylaw, Section 47 was modified.

The old Section 47 of the Bylaws was:

"Section 47—The Membership Committee shall include the Secretary of each Sec-

## Transcription of Frequency-Modulation Discussion, I.R.E. Winter Technical Meeting

The discussion of the position of frequency modulation in the radio spectrum, which took place on January 27, 1945, at a special session of the four-day I.R.E. Winter Technical Meeting terminating on that date, has been transcribed and, as a result of the many requests for the information, additional copies of the transcription were made by the Institute of Radio Engineers for general distribution.

The transcription, containing thirty mimeographed pages and bound in a durable cover, is available at three dollars a copy, postage prepaid, and requests for it should be addressed to The Institute of Radio Engineers, 330 W. 42 St., New York 18, N. Y.

Those participating in the discussion include Dr. W. L. Everitt, I.E.R. President, as meeting-chairman; K. A. Norton, formerly, Federal Communications Commission; E. W. Allen, Jr., Federal Communications Commission; Major E. H. Armstrong, professor of electrical engineering, Columbia University; R. A. Hackbusch, vice-president, Canadian Radio Technical Planning Board and vice-president and managing director, Stromberg-Carlson Company, Ltd.; Dr. H. H. Beverage, RTPB Panel 8 vice-chairman and associate research director, Radio Corporation of America; D. E. Noble, RTPB Panel 13 chairman and director of research, Galvin Manufacturing Corporation; Dr. C. R. Burrows, technical staff, Bell Telephone Laboratories, Inc.; J. R. Poppele, chief engineer of WOR and president, Television Broadcasters Association; D. D. Israel, vice-president, Emerson Radio and Phonograph Corporation; J. R. Reid, research director, The Crosley Corporation; Dr. T. T. Goldsmith, Jr., director of research, Allen B. DuMont Laboratories, Inc.; D. L. Jaffe, chief research engineer, Templetone Radio Manufacturing Corporation; Dr. Allen B. DuMont, president, Allen B. DuMont Laboratories, Inc.; C. M. Jansky, Jr., RTPB Panel 5 chairman and Jansky and Bailey, consulting radio engineers; Dr. J. H. Dellinger, radio section chief, National Bureau of Standards; Dale Pollack, director of engineering, Templetone Radio Manufacturing Corporation; D. G. Fink, McGraw-Hill Publishing Company (on leave); J. R. Popkin-Clurman, assistant chief engineer, Panoramic Radio Corporation; and Dr. H. T. Stetson, Massachusetts Institute of Technology.

tion, ex-officio."

This Section, as modified, is:

"Section 47—The Membership Committee shall include the Chairman of the Membership Committee of each Section, ex-officio."

# "Every Member a Subscriber"

Contributions to the Building Fund are being received at such a great rate that progress can be recorded only on a stop-press basis. See the cover of this issue of the PROCEEDINGS for the latest information just before publication date.

The Initial Gifts Committee work is now in advanced stages. The first 58 corporation subscriptions averaged \$2733 each.

The first three Sections to complete organization for the Building Fund campaign were Rochester, Emporium, and Williamsport.

Organization for the Building Fund was under way in all except four sections on April 1. Not only is the Building Fund meeting with enthusiasm in the Sections, but many members at large are also subscribing generously. Before the start of active Section solicitation, the first 50 subscriptions received from members averaged \$222.00 and ranged from \$25.00 to \$1000.00.

Diversification of interest in the I.R.E. is shown by the fact that the first 100 subscrip-

tions came from 23 different States, the District of Columbia, and Canada.

Many engineers, after their companies subscribe to the Building Fund, are asking how they can join the I.R.E.

Much additional good has already come from this effort; additional groups of executives have become aware of the I.R.E. and its program, and are joining its rolls; many engineers holding important posts, who have been content with an associate grade of membership for years are asking to be up-graded to where they belong, and closer relations are being established between those associated with the I.R.E. management and the industrial leaders in the radio and electronic fields.

Don't stop when you have given a contribution to the fund. Get others to attend meetings with you and to join up; investigate as to how the Institute can help you. Much greater advantages of membership are in the offing because of this program. Take advantage of it.

"Every member a subscriber" is the I.R.E. Building-Fund Victory slogan.

## Administrators of the I.R.E. Building Fund



MELVILLE EASTHAM

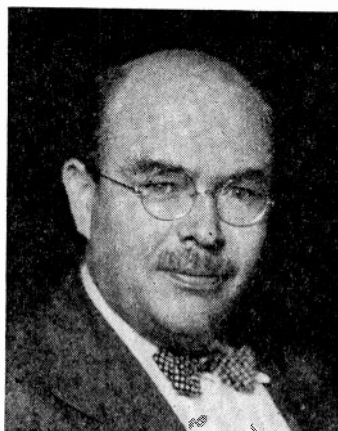

*Blackstone Studios*  
L. C. F. HORLE



*©Underwood & Underwood*  
E. A. NICHOLAS



# The Building-Fund Program IS Going to Succeed!

THE MEMBERS of The Institute of Radio Engineers and hundreds of corporations in the radio—electronic field are following the “Blueprint for Progress” by investing in a Greater Institute.

FOR STABILITY, for prestige, for efficiency—the Building-Fund program must succeed. You need it! Industry needs the work of engineers! And the Building-Fund program needs you!

PROBABLY you have given already. If not, please do so now. Get in touch with your Section leaders or make out your check to I. R. E. BUILDING FUND, and send to ROOM 930, 55 West 42nd Street, New York 18, New York.

# Constitutional Amendments

Dear Fellow Member:

The Institute of Radio Engineers is presented with the greatest opportunity ever offered to an engineering society. The expansion of wartime radio-and-electronic activities under the guidance of military groups has been phenomenal. The post-war developments and trends are up to the profession and the industry. The Institute as the natural leader can and must meet the challenge.

If we are to meet our responsibilities, we must do more than we have in the past. Your Board of Directors has developed plans to go ahead. But such activities require money, which must be furnished by the membership.

Recognizing this problem a group of the members has submitted a petition proposing a raise in dues to ten dollars for all grades of membership. The Board and I personally ask for its support.

In considering this problem of how he should vote, the member must consider not only the extent to which he will directly contact such expanded activities but also the effect of such activities upon the profession and the industry, which will react to the benefit of us all.

Sincerely yours,  
W. L. EVERITT  
*President, I.R.E.*

LATE in May of this year voting members of the Institute will receive a ballot by which they may vote for or against a change in the Institute's Constitution. The following is being presented in advance of the ballots in order that members may become familiar with the proposed amendment, the reason for it and the fact that the Board of the Institute endorses it.

Last year a Constitutional Amendment to increase dues was proposed by the Board of Directors and its submission to the membership by ballot was voted by the Board on June 7, 1944. While this amendment was being prepared for submission another Constitutional Amendment to increase dues was proposed in the form of a petition submitted by Mr. H. P. Westman. This petition was signed by one hundred and eight voting members in good standing and complied with Article X of the Constitution. Upon advice of Counsel, submission of the Petitioners' amendment was postponed until after the membership had voted on the amendment proposed by the Board of Directors. The latter amendment received a large majority of favorable votes but lacked the 75 per cent required for adoption.

The Westman amendment proposes to accomplish the following:

1. Equalize the entrance fees for all membership grades at \$3 except for Students for which there will continue to be none.
2. Eliminate transfer fees for all membership grades. Under the present Constitution there is no transfer fee when transferring immediately from Student to Associate, there is none when transferring from Associate to Member, there is a fee of \$4 when transferring from Member to Senior member and there is none when transferring from Senior Member to Fellow.
3. Equalize the dues for Fellows, Senior Members, and Members by increasing dues for Members from \$6 to \$10.
4. Increase the dues for Associates from \$6 to \$7 per year for the first 5 years, and thereafter increase them to \$10. The five-year clause would apply retroactively from January 1, 1946.
5. Encourage applications for increasing grade on the part of properly qualified members by eliminating any cost differential.

If the Westman amendment is approved, the Board will make its provisions effective on January 1, 1946.

Lack of adequate income has created many hardships and prevented the Management from enlarging the scope of Institute activities and extending the services to the membership. An increase in dues has been needed for some time to correct these conditions. The amendment proposed by the Board last year was to provide the funds but, while it received a majority, it failed by a small margin of the necessary 75 per cent. This proposed amendment recognizes the need but differs in details. It is hoped that the membership disapproval of the Board amendment was based upon the details of the plan and not upon lack of recognition of the need for augmented income.

The Board, by a resolution at the February, 1945, meeting, endorsed this proposed amendment. The Sections Committee in 1944 recommended to the Board that dues be increased moderately to cover advances in costs and provide additional services to the membership, and that dues for all grades be equalized with the exception that lower dues be paid by Students and for a reasonable period by new Associates. This amendment was designed to accomplish exactly that result. At the 1945 meeting the Sections Committee again went on record favoring an increase in dues.

The Board had hoped for passage of its amendment so that funds would be available before augmenting the office staff and otherwise committing additional funds for operations. But despite failure of the amendment, certain steps were too important to be delayed further.

## *Increase in Rebates to Sections*

Many Sections have not received rebates sufficient to enable them to operate without deficits. They have been unable to take their proper places among Sections of other national engineering societies, particularly in regard to membership in local engineering groups. The need for correction has been a matter of concern to the Board and at the March, 1945, meeting, it increased rebates to Sections twenty-five cents per member\* (excepting Students), retroactive to January 1, 1945. This

\* See modified Bylaw on page 339.

will result in an annual budget increase of \$2575. It was the second increase in rebates in one year. The Board's budget forecast for 1945 operations anticipated a net deficit of over \$8000 under the former scale of rebates. That deficit and the increase in rebates, a total of \$10,643, will have to be taken from the accumulated surplus of past years. This situation calls for prompt correction by an increase in dues.

#### *Increase in Office Staff*

The membership has trebled since 1934 but there has been no corresponding increase in the office staff. It has been necessary for the officers of the Institute to devote to its affairs a highly disproportionate amount of time and to use extensively the facilities and personnel maintained for the conduct of their private businesses. The Editor has devoted 120 working days per year and other officers have devoted forty or more working days per year to Institute affairs, at the expense of their personal interests and private businesses. It is not believed that the membership is aware of the extent to which this has been carried nor the degree to which they are indebted to their officers for their devotion to the interests of the Institute. These efforts have been necessary to carry on only our present activities. Relief is necessary.

The situation existed for so long and became so acute that forthright action had to be taken. By Board action on November 29, 1944, the addition of three officials to the full-time office staff was authorized. The new office of Executive Secretary was created and has been assumed by Mr. George W. Bailey. The Executive Secretary will be responsible for the management of office affairs and will greatly relieve the burden of the Institute officers in other respects. The office of Technical Secretary was created to guide the expanded technical program. The office of Technical Editor was created to provide a permanent staff officer capable of technically editing the publications and expanding their engineering scope to meet the needs of the members.

In addition there has been a growing need for expanded services to members which could not be provided without an increase in the office staff and a corresponding increase in dues to keep the budget balanced. The new and expanded services consist of (a) more liaison work with other societies, engineering bodies, and the Government, (b) assistance in placement and employment of members, (c) full-time supervision and guidance of standards activities, (d) more program aid to Sections, (e) relief in handling correspondence, which is acutely needed, (f) publication of handbooks and yearbooks, (g) creation of a technical library and an accompanying service both direct and by correspondence, (h) organization of educational activities, (i) formulation of a conference program far beyond the scope of any past effort, (j) creation and maintenance of a book department, (k) activity in the advancement of professional recognition and engineering ethics, (l) guidance

and direction in adequate publication of papers in the subdivisions of radio and electronics, (m) information of an economic or industrial nature and of other developments not warranting publication of papers, (n) publication of abstracts from other journals, (o) more traveling to the Sections and other groups by the President and other officers in the furtherance of the program described, (p) creation and maintenance of a traveling-lecture series which will bring to the Sections outstanding figures and the latest information in their fields, (q) creation and maintenance of centralized information services on technical matters of wide application such as radio propagation.

#### *Advertising Revenue*

In the latter part of 1941 the Institute was in financial difficulties. The Board believed it should exhaust all possible channels of relief before asking for an increase in dues and entered into an agreement with an advertising specialist to solicit advertising for the PROCEEDINGS and to manage an advertising department. This produced a substantial improvement in income in 1942. Subsequently there has existed a favorable advertising situation. It does not appear possible to expand this source any further in the immediate future so support for expanded services must depend upon the membership.

#### *Increased Dues Will Benefit all Members*

It might appear superficially that the increased income from expanding membership would provide funds needed for operation. However, office expense and correspondence climb in proportion to membership so there is no surplus resulting to provide additional services. The PROCEEDINGS are printed in volume far beyond the point where volume discounts are significant. Student membership has multiplied but pays dues which cover only incremental printing and mailing costs. The Board is most desirous of respecting the expressed wishes of the members that new and helpful activities be undertaken. Enlarged service is of special concern to the Board in connection with members at remote points who cannot reach the large Sections. Many of the proposed benefits are directed to those members who have not been active participants in Institute affairs because of geographical separation. Institute membership in the large sections offers many obvious advantages which are not always available to others. The Board desires to expand the scope of Section activities, tangibly and soon. It especially desires to create a closer bond with the isolated members, equalize the benefits to a greater degree, and make I.R.E. membership indispensable to all.

#### *Present and Proposed Dues Are Low*

The average dues of nine other leading engineering societies with whom we and our activities are constantly compared are almost exactly double those proposed for

the Institute. The dues of the other individual societies range from one and one half to three and one half times those proposed by this amendment. Attention is directed to the fact that there has been no increase in I.R.E. dues during the last fourteen years. There have, however, been increases in all normal operating expenses such as wages, salaries, paper, rent, printing and other items, and these increases are continuing with no indication of a reversal of trend.

The financial operations for 1945 are expected to result in a deficit of \$10,643. The increase in dues which would result from passage of the Westman amendment would be about \$25,000 in 1946, increasing to about \$40,000 in 1950. Passage would insure that services to the members may be increased and also that the 1945 deficit would not be repeated in 1946 and the years to follow. The creation of the offices of Executive Secre-

tary, Technical Secretary, and Technical Editor in the full-time office staff is a progressive and necessary step toward the proper conduct of the Institute's affairs. The result will be reflected in increased service to and for the members.

The Board hopes that the membership, after carefully considering the need for increased dues, will vote affirmatively on this amendment. The need has been evident and pressing for so long a time and the Institute membership has grown so rapidly that these expanded services must be undertaken without further delay. They are consistent with the nature and stature of the Institute and must be undertaken if we are to continue to progress, carry on the activities, and make the contributions to which our membership is entitled.

RAYMOND F. GUY, *Chairman*  
Constitution and Laws Committee

## Correspondence

Correspondence on both technical and nontechnical subjects from readers of the PROCEEDINGS OF THE I.R.E. is invited subject to the following conditions: All rights are reserved by the Institute. Statements in letters are expressly understood to be the individual opinion of the writer, and endorsement or recognition by the I.R.E. is not implied by publication. All letters are to be submitted as typewritten, double-spaced, original copies. Any illustrations are to be submitted as inked drawings. Captions are to be supplied for all illustrations.

### Equivalent-Plate-Circuit Theorem<sup>1</sup>

When writing my original letter, I did not expect that it would lead to important contributions by other writers,<sup>2,3</sup> but I am happy that this has been the case. Although these contributions deal partly with added questions of great importance, they seem to indicate that, except for questions of terminology, Mr. A. Preisman and Dr. H. J. Reich are in agreement with my fundamental statements and equations. I feel certain that future textbook writers will make use of the information in Mr. Preisman's and Dr. Reich's letters, and, maybe, also pay some attention to my efforts by avoiding misleading statements regarding the power distribution in the equivalent tube circuit.

There are two small points in Dr. Reich's interesting letter on which I should like to comment. One is the criticism of the usefulness of my diagram in Fig. 2. I am sure Dr. Reich has a good point here, as in cases like this many people, including myself, prefer an

analytical approach to a graphical one. Thus, Fig. 2 with explanation was given as added material after the conclusion of the analytical proof. The other point refers to my equation (4). Dr. Reich's derivation and equation (b) are, of course, fully correct, but I somehow hesitate to agree with him regarding the necessity of making the statement that equation (4) is not valid for all cases. Most certainly it is not! It is developed for the particular circuit shown in my Fig. 1, which, by the way, is the frequently used fundamental circuit in textbooks. Actually, my suggested term equivalent-plate-circuit equation hints agreement with Dr. Reich's correct and important statement, that (4) is one application of the general theorem, which he formulates in the latter part of his letter.

If we denote the grid voltage in equation (4) by  $e_g$ , this equation reads

$$I_p = \mu e_g / (r_p + Z_L) \quad (4)$$

If we transfer the reactance tube circuit to fit my Fig. 1, however useless such a transformation may be, we obtain  $e_g = E_g + (1/\mu)V_p$ , so (4) yields the correct result

$$I_p = \mu(E_g + (1/\mu)V_p) / (r_p + Z_L)$$

which is identical with Dr. Reich's equation (b). There are no disagreements regarding our equations, although there may still be some disagreement regarding their interpretation and, certainly, regarding the terminology. It would be an additional achievement if this series of letters would stimulate the proper authorities towards an improved terminology.

HARRY STOCKMAN  
Cruft Laboratory  
Harvard University  
Cambridge 38, Massachusetts

### A Stabilized Frequency-Modulation System

In the communication by D. L. Jaffe,<sup>1</sup> an error has been made in the approximation for  $\Delta\phi$ .

Equation (5) follows from

$$\tan x = \frac{\sin x}{\cos x} = x \frac{1 - \frac{x^2}{6} + \frac{x^4}{120} - \dots}{1 - \frac{x^2}{2} + \frac{x^4}{24} - \dots}$$

and becomes

$$\tan x \cong x \frac{1}{1 - \frac{x^2}{3}} \quad (5')$$

upon neglecting terms higher than the third order, which by the way introduces an error of the order of 5 per cent for  $x=1$ . Substituting  $x = p \sin \lambda t$  in (5') yields

$$p \sin \lambda t \cong \tan^{-1} \frac{p \sin \lambda t}{1 - \frac{1}{3}p^2 + \frac{1}{3}p^2 \cos 2\lambda t} \quad (7')$$

If now, a suitable value of  $p$  is substituted in (7') to give a maximum phase displacement of 60 degrees, an expression for  $\Delta\phi$  that is in better agreement with Pieracci's equation will result.

A. ST. C. G. GRANT  
98 Inglis St.  
Halifax, Nova Scotia

I should like to thank Mr. St. C. G. Grant, for his letter of January 23, 1944, in which he points out an error in an approximation for  $\Delta\phi$  in my communications which appeared in the PROCEEDINGS for January, 1944. The expression for  $\Delta\phi$  should read

$$\Delta\phi = \arctan \frac{p \sin \lambda t}{(1 - \frac{1}{3}p^2) + \frac{1}{3}p^2 \cos 2\lambda t}$$

It is of interest to note that after Mr. Grant's correction is included, equation (8) becomes

$$\Delta\Phi = \tan^{-1} \frac{\sin \lambda t}{0.756 - 0.178 \cos 2\lambda t}$$

D. L. JAFFE  
Templeton Radio  
Manufacturing Corporation  
New London, Connecticut

<sup>1</sup> R. J. Pieracci, "A stabilized frequency-modulation system," *Proc. I.R.E.*, vol. 30, pp. 76-81; February, 1942.

<sup>1</sup> *Proc. I.R.E.*, vol. 32, p. 373; June, 1944.  
<sup>2</sup> *Proc. I.R.E.*, vol. 32, p. 642; October, 1944.  
<sup>3</sup> *Proc. I.R.E.*, vol. 33, pp. 136-138; February, 1945.

<sup>1</sup> *Proc. I.R.E.*, vol. 32, p. 54; January, 1944.

If in equation (7') we put  $\lambda = \pi/2$  and  $\Delta\phi = 60$  degrees, then solve the resulting quadratic for  $p$  and substitute the positive root obtained back in (7') the result is,

$$\Delta\phi = \tan^{-1} \frac{\sin \lambda}{0.756 + 0.178 \cos 2\lambda}$$

This corresponds to Mr. Jaffe's new equation (8) except for the sign of the coefficient of  $\cos 2\lambda$ .

It should be noted that due to the fact that the approximation

$$\tan p \sin \lambda \cong \frac{p \sin \lambda}{1 - (1/6)p^2 + (1/6)p^2 \cos 2\lambda}$$

becomes increasingly inaccurate as  $p$  increases (the discrepancy being about 3 per cent when  $p=1$ ) the above method of choosing the coefficients causes a certain feeling of discomfort since the value of  $p$  used was even greater than 1. Even so, at most the two expressions

$$\frac{1}{0.756 + 0.178 \cos 2\lambda} \quad \text{and} \quad \frac{1}{0.765 + 0.188 \cos 2\lambda}$$

differ by only slightly more than 1 per cent.

It may be possible to choose the coefficients by some other method which would yield an expression in still closer agreement with Pieracci's equation.

A. ST. C. G. GRANT



Appreciation is expressed for Mr. Grant's communication of January, 1944, in which he has pointed out an error made in the approximation  $\Delta\phi$ .

It is of interest to note that after Mr. Grant's correction is made equation (8) becomes

$$\Delta\phi = \arctan \frac{\sin \lambda}{0.756 + 0.178 \cos \lambda}$$

D. L. JAFFE



#### AMERICAN BROADCASTING COMPANY APPOINTMENTS

To implement its engineering plan to erect new buildings in New York and Hollywood and new studios in Chicago, Mark Woods, president of the American Broadcasting Company, announced the appointments, effective on March 8, 1945, of Frank Marx (A'41), who has been heading the technical advisory group of that company, as director of general engineering, and George Milne (SM'43), who has been chief engineer, as director of technical operations. Milne will continue in charge of all technical operating functions of the network.

Reporting to Marx will be the following: Benjamin Adler (A'28), facilities engineer, and Frank G. Kear (A'24-M'31-SM'43), consulting electronic development engineer. Studio and broadcasting engineers report to Mr. Milne.

The two departments, general engineering and technical operations, will work in close co-operation with one another in order to co-ordinate fully all engineering development as well as operations.

## I.R.E. People



STANFORD CALDWELL HOOPER

### STANFORD CALDWELL HOOPER

Selection of Stanford Caldwell Hooper (F'28-A'33), Rear Admiral, United States Navy (retired), as a winner of the Elliott Cresson Gold Medal in 1945 was announced on March 10, 1945, by Dr. Henry Butler Allen, secretary and director of the Franklin Institute, Philadelphia. The medal was presented on April 18, 1945.

Since the founding of the Cresson Medal award in 1848, it has been presented by the Institute "for discovery or original research, adding to the sum of human knowledge, irrespective of commercial value" to such scientists as Professor and Madame Curie, Rudolf Diesel, Tolbert E. Lanston, Nikola Tesla, Tinius Olsen, and Roger Adams.

Admiral Hooper receives the award this year "in consideration of his pioneering leadership and practical utilization of discovery in the field of radio for the United States Navy." He was born at Colton, California, in 1884, and showed an interest in communications at a very early age. He is credited with being on the rolls of the Southern Pacific Railway as relief ticket agent at the age of nine with the responsibility of receiving train orders by telegraph.

Following his graduation from Annapolis



N. F. SHOFSTALL

in 1905, he spent five years on sea duty. He then obtained an appointment as instructor at Annapolis so that he could keep in touch with the infant art of "wireless" by working at the laboratory of the Bureau of Standards on weekends, where he worked all day and almost all night, sleeping on a table under a borrowed blanket for a few hours before he began work again early next morning.

Admiral Hooper's long career in Navy radio really dates from 1912 when he was appointed Fleet Radio Officer, a post he himself had suggested as necessary for the proper administration of this new method of communication. With his accession to this position he began the building up of the radio system of the United States Navy and was so successful that, in 1915, at the completion of his tour of duty, he was made head of the radio division of the Bureau of Ships. He commanded a destroyer for a few months in 1918, but was soon returned to a second tour as head of the radio division which lasted until 1923, followed by a third tour from 1926 to 1928—a reappointment without precedent in naval annals. Between 1915 and 1928, Admiral Hooper was the guiding spirit in developing naval radio from little more than a toy to the essential communications medium it had become by that latter date.

In 1925, between his second and third tours as head of the radio division, he again served as Fleet Radio Officer on the cruise to Australia and carried out the Navy's pioneer tests of what were then very-high-frequency waves.

In 1927 and 1928 he was chief engineer of the Federal Radio Commission, (now the Federal Communications Commission).

In 1928 he became director of Naval Communications, and in 1934 chairman of the Naval Research Committee, and director of the Technical Division of Naval Operations. Since 1940 and until his recent retirement he has been director of the Radio Liaison Division.

### N. F. SHOFSTALL

N. F. Shofstall (A'41) has been appointed designing engineer of the receiver division of the General Electric Company's electronics department.

In this capacity, Mr. Shofstall will be responsible for the technical design of the products of the receiver division, with headquarters at Bridgeport, Connecticut. Since August, 1942, he has been acting designing engineer of the West Lynn, Massachusetts, branch of the division.

A native of Houston, Texas, and a graduate of Rice Institute with B.S. and M.S. degrees in electrical engineering in 1928 and 1929, respectively, Mr. Shofstall has been associated with General Electric in various engineering capacities since July, 1929. He has held positions as section leader in charge of the design of all International General Electric export receivers and as chief broadcast-receiver engineer responsible for technical designs of all broadcast domestic and export receivers.

During 1939, Mr. Shofstall visited Argentina, Brazil, Uruguay, and Chile as a consultant on the receiver-manufacturing requirements of these countries.



OTTO S. SCHAIRER

❖

C. B. JOLLIFFE and  
OTTO S. SCHAIRER

C. B. Jolliffe (M'25-F'30), chief engineer of the RCA Victor Division, was elected vice-president of the Radio Corporation of America in charge of RCA Laboratories on March 2, 1945, Brigadier General David Sarnoff (A'12-M'14-F'17), president, announced following a meeting of the Board of Directors. Dr. Jolliffe will succeed Otto S. Schairer (M'43-SM'43), who was elected staff vice-president of RCA at the Board meeting. Mr. Schairer will be consultant and advisor on matters pertaining to research, development, patents, trademarks, and licenses.

Dr. Jolliffe, born in Mannington, West Virginia, was graduated from West Virginia University with a B.Sc. degree in 1915 and received the M.S. degree in 1920. He was awarded the degree of Ph.D. in 1922 at Cornell University, where he was instructor in physics from 1920 to 1922. His Alma Mater conferred the honorary degree of LL.D. in 1942.

❖

From 1922 to 1930, Dr. Jolliffe served as physicist in the radio section of the Bureau of Standards, resigning to become chief engineer of the Federal Radio Commission. He remained for five years with the FRC and its successor, the Federal Communications Commission, and then joined the Radio Corporation of America as engineer-in-charge of the RCA Frequency Bureau. In 1941, he was appointed chief engineer of RCA Laboratories, and early in 1942 he was made assistant to the president of RCA Victor. In September, 1942, he was appointed chief engineer of the RCA Victor Division, Camden, New Jersey.

While with the Bureau of Standards, the FRC, the FCC, and later with RCA, Dr. Jolliffe attended most of the international radio conferences as technical advisor or delegate. During the war he has been active on several government wartime committees including Division 13 of the National Defense Research Committee of the Office of Scientific Research and Development, which he served as chairman from 1940-1944; as

secretary of the Industry Advisory Committee of the Board of War Communications, and as a member of the Engineers Defense Board. He is a member of Phi Beta Kappa and Sigma Xi. Dr. Jolliffe was chairman of the 1929 Convention Committee of the Institute, elected to the Board in 1944, and has also contributed to the PROCEEDINGS.

Mr. Schairer joined RCA in 1929 as director of patent development following twenty-seven years with the Westinghouse Electric and Manufacturing Company, which he entered in 1902 after graduation from the University of Michigan with an E.E. degree.

Soon after affiliation with RCA, Mr. Schairer was placed in charge of the combined patent and license departments. In 1930, he was elected a vice-president of the company.

Plans for a major research center in radio and electronics, which he had fostered for many years, materialized in 1941, when the Radio Corporation of America built the RCA Laboratories at Princeton, New Jersey. Mr. Schairer, as vice president in charge of RCA Laboratories, supervised the plans and construction, and since the dedication in September, 1942, has directed extensive research and developments concerned almost exclusively with war projects.

❖

JENNINGS B. DOW

Recognizing the increasingly important part played by electronic devices in the fields of Naval Communication, navigation, ordnance and gunnery tactics, and in the general battle efficiency of the Navy's planes and surface ships, the Bureau of Ships of the United States Navy recently created an electronics division (which supersedes the older radio division). Captain J. B. Dow (M'26-F'42) United States Navy has been appointed as director of electronics. Captain Dow, who is well known both in and out of the Naval Service for his technical ability, has been responsible for the design, production, and installation of the Navy's electronic equipment for several years.

The electronics division counts among its personnel of 1200 employees, some of the foremost electronic authorities and engineers in the country, and their work has been reflected in the excellent, up-to-the-minute equipment supplied to the fleet and its air arm. The research organizations of government and industry have fully collaborated with the division's engineers in producing radio, radar, and sonar equipment which is believed definitely superior to that possessed by our enemies. One of the objectives of the electronics division is to maintain a clear technical superiority over the enemies equipment.

Captain Dow recently stated "that the research work in the electronic field started before the war and carried on at an accelerated rate since hostilities commenced, has resulted in advancing the electronic art by at least ten years."

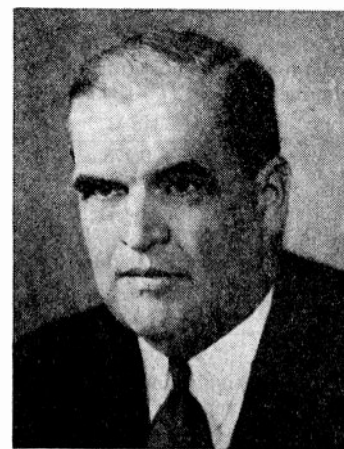

C. B. JOLLIFFE

❖

ARTHUR H. HALLORAN

Arthur H. Halloran, (M'26-SM'43) has been appointed Western Editor of *Electronic Industries*. Mr. Halloran was for many years editor and publisher of *Radio*, and previously had served as vice-president and managing editor of the *Journal of Electricity* published in San Francisco.

In recent years Mr. Halloran has specialized in research on cathode-ray equipment and television. He was chief of electrical exhibits for the Golden Gate Electrical Exposition of 1937, and is the author of the book "Television with Cathode Rays" besides making numerous contributions to radio journals.

During the war period he has served as United States Signal Corps preradator instructor at the University of California, Berkeley, and for the past 18 months has been research associate in ultra-high frequencies at the Harvard University, Radio Research Laboratory, Cambridge, Massachusetts.

❖

C. J. BURNSIDE

C. J. Burnside (A'32-M'38-SM'43), for the past three years manager of the radio division of the Westinghouse Electric and Manufacturing Company, will head the newly organized industrial electronics division, according to an announcement by Walter Evans (M'36-SM'43), vice-president in charge of the company's radio, radar, and electronics activities. The industrial electronics division, in its radio section, will continue to build commercial transmitting and receiving equipment for the radio industry.

❖

CHARLES V. STROMEYER

On March 2, 1945, Charles V. Stromeier (A'29), was elected vice-president and director of engineering of the Hytron Radio and Electronics Corporation of Salem, Massachusetts.

F. P. BARNES AND  
C. G. PIERCE

Frank P. Barnes (A'43-M'44) and Cameron G. Pierce (S'41-A'43) have been appointed Western District representatives of the General Electric Company's electronics department, with headquarters in San Francisco and Los Angeles, respectively. They will be responsible for the sale of products of the transmitter division.

A graduate of Stanford University, Mr. Barnes joined General Electric in 1937, taking the engineering test course in Schenectady, N. Y. Before receiving his present promotion, he spent a number of years in Seattle, where he specialized in industrial electronics and radio communications for that company. He is well known in radio-and-electronic circles on the west coast, and taught courses in industrial electronic engineering and radio engineering at the University of Washington.

Mr. Pierce, also a graduate of Stanford University, joined General Electric in 1941 as an industrial sales specialist in the company's San Francisco office. Later he went to headquarters in Schenectady, N. Y., during which time he taught radio theory to night classes at Union College.

Mr. Pierce has been active in electronic and radio fields for a number of years. He did amateur radio work for 12 years and during his college career, acted as short-wave broadcast propaganda recording engineer for the Rockefeller Foundation. He saw active duty with the United States Naval Reserve as a radio operator, during his summers while in college, and later did post-graduate work on the development of a cyclotron at Stanford, for which he received a degree of engineer in communications. In his present position, Mr. Pierce has been engaged in considerable work of secret military nature for the Navy, Army, and Marine Corps in radar development and communication transmitter and antenna engineering work.

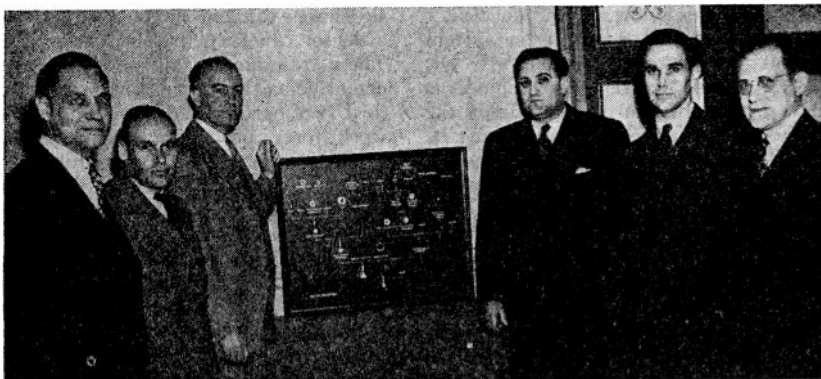

Pictured at a recent Washington Section I.R.E. meeting are left to right: J. W. Greer (A'41), tube division, Navy Dept.; F. W. Albertson (A'33-M'44), vice-chairman, Washington Section I.R.E.; T. B. Jacocks (A'36), General Electric, Washington; E. F. Peterson (M'44), General Electric tube engineer; H. A. Burroughs (A'41-M'44), chairman, Washington Section, I.R.E.; and H. H. Lyon (A'14), chief engineer, Station WOL, Washington, D. C.

Mr. Peterson discussed the development of General Electric's "lighthouse" tube at the meeting and showed a breakdown of component parts pictured in the photograph. The new tube development provides the basis for a multitude of new public services in the frequency-modulation, radio, television and other electronics fields after the war.

McMURDO SILVER  
COMPANY ESTABLISHED

An engineering and manufacturing organization known as the McMurdo Silver Company and headed by McMurdo Silver (SM'43) was established recently in Hartford, Connecticut. This company will devote its efforts primarily to the amateur parts, kit, and special-equipment market, and to consulting engineering for a small group of selected and noncompeting clients in the radio-and-electronic field. A number of nonduplicating items of test equipment will be announced shortly.

Mr. Silver has long been active in engineering circles here and abroad. His technical papers have appeared in numerous engineering periodicals.

During the past six years, Mr. Silver has devoted his energies and experience to the conversion of three manufacturers to high-volume war radio production. He successively reorganized the Airplane and Marine Direction-Finder Corporation and was its general manager from 1939 to 1941; as executive vice-president, he directed the conversion of Fada Radio and Electric Company to complete war output from 1941 to 1943; and in 1943-1944 he aided the conversion of Grenby Manufacturing Company to radar production as its vice-president in charge of radio and electronics. Mr. Silver was formerly president of Silver-Marshall of Chicago.

JOHN G. RUCKELSHAUS

John G. Ruckelshaus (A'42-M'43) has recently been promoted from vice-president to president of the Madison Electrical Products Corporation, of Madison, New Jersey.



JACK DAVIS

JACK DAVIS

The Galvin Manufacturing (Motorola Radio) Corporation of Chicago has announced the appointment of Jack Davis (A'44) as chief engineer of the auto radio division. Mr. Davis has been associated with the Galvin Corporation for over ten years, and has been engaged in all phases of auto radio engineering; research, design, experiment, and production.

D. F. SCHMIT AND  
GEORGE L. BEERS

Appointment of D. F. Schmit (A'25-M'38-SM'43) as director of engineering and of George L. Beers (A'27-M'29-SM'43) as assistant director of engineering in charge of advance development, was announced by Frank M. Folsom, vice president in charge of the RCA Victor Division. Mr. Schmit, who was formerly chief engineer, will fill the post vacated by Dr. J. B. Jolliffe (M'25-F'30) who recently was elected vice-president of the Radio Corporation of America in charge of RCA Laboratories.

Mr. Schmit has held important engineering posts in the RCA Victor organization and its predecessor companies for more than fifteen years. He joined the RCA Radiotron Company in Harrison, New Jersey, in 1930. Later he was placed in charge of tube design and application, and then became manager of research and engineering at the Harrison plant. In 1939, Mr. Schmit was named manager of the new products division of the company, and in 1943 became assistant chief engineer of the RCA Victor Division. A native of Port Washington, Wisconsin, Mr. Schmit was graduated from the University of Wisconsin with an electrical engineering degree.

Mr. Beers has been associated with RCA Victor and its predecessor companies since 1921. He was a section engineer of the RCA Manufacturing Company's research department in 1930. Ten years later he was placed in charge of advance development. Since 1943 Mr. Beers has been on the engineering administration staff of RCA Victor at Camden. He has presented papers before the Institute, including a recent contribution describing a circuit for frequency-modulation reception.

## LESLIE BALTER

The awarding of the "Commendation for Meritorious Civilian Services" to civilian employees of the Signal Corps ground signal agency, Bradley Beach, New Jersey, was announced on January 4, 1945, by Colonel Victor A. Conrad, commanding officer. Among these was Leslie Balter (S'41-A'43), who "displayed unusual initiative during bombing attacks while on temporary duty in England for the purpose of suppressing radio noise interference and installing suppression equipment on United States army vehicles for use in the North African campaign."



## MIDLAND RADIO AND TELEVISION SCHOOLS

Ownership of Midland Radio and Television Schools, Inc., was acquired by Gerald L. Taylor, (A'37-M'41-SM'43), president and active head of the Schools, on February 22, 1945. Under the new ownership, the school name will be changed to Central Radio and Television Schools, Inc.

Mr. Taylor has filed his resignation from his former position with Station KMBC of Kansas City as its vice-president in charge of technical development.



## Wartime Radio Progress

Reminiscent of conditions which existed at the end of World War I when sound broadcasting came into being as a revolutionary medium of progress, a new radio-frequency spectrum opened by scientific developments in this war promises even greater advances, embodying the formation of vast new industries and services for the American people, Dr. C. B. Jolliffe, vice-president in charge of RCA Laboratories, declared at Indianapolis, Indiana, on March 23, 1945 in an address before a joint meeting of the American Institute of Electrical Engineers and The Institute of Radio Engineers.

"At the end of this world war we shall have all of the conditions necessary for an explosive mixture," Dr. Jolliffe said. "If the spark of public demand for new things is struck, we shall be in on a much larger explosion than that which occurred with the start of sound broadcasting."

Asserting that the impending allocation by the Federal Communications Commission of all frequencies from 10 kilocycles to 30,000 megacycles will be "one of the important milestones in radio history," Dr. Jolliffe said it will determine the future of many possible uses of radio, including applications of radio-frequency power which do not require Federal Communications Commission allocations or authorization.

"Sound broadcasting revolutionized our ideas of entertainment and altered our way of living," Dr. Jolliffe declared. "Television can provide a second revolution of entertainment and affect our mode of living to an even greater degree. The application of electronics can revolutionize manufacturing.

In air transportation the use of new developments in radio aids to navigation and communications will change our conception of the reliability of air transportation and make it a really true competitor to surface transportation. 'Citizens' radio' is an entirely new concept of the use of radio communications in everyday life and it may extend enormously the use of radio equipment.

"Each of these applications of radio may create a new industry which may affect other industries. The men who have made radar useful for the complicated business of war certainly can be relied upon to conceive of many uses of the new radio techniques used in this field."

Dr. Jolliffe, declaring that radio manufacturers are now able to build transmitters, receivers, and antennas which "will give a very satisfactory television performance for the home," emphasized the necessity of having definite frequency assignments and a well-organized system of distribution of programs.

"With frequency allocations definitely set, with program sources organized, and with networks in operation—in other words, with a system organized—this one industry can completely revolutionize our way of life," Dr. Jolliffe said. "It does not take much imagination to see this industry as a possible five- or even ten-billion dollar enterprise, employing thousands of men, either directly or indirectly."

Expressing a desire to avoid controversy as to the merits of whether television should be below 300 megacycles or above 500 megacycles, Dr. Jolliffe remarked that the question which needs to be answered is "whether we want television or not." He said that if the public wants it, technically it can be produced below 300 megacycles. He added that, on the other hand, if the belief prevails that the public does not want television "then let us honestly postpone its inauguration and not hide behind the probability of possible new developments."

Extensive field tests in several large metropolitan areas have established the fact that "very satisfactory entertainment" can be provided by television broadcasting service using 6-megacycle channels and carrier frequencies below 300 megacycles.

"Having obtained a television system with this degree of performance," Dr. Jolliffe continued, "the television engineer is faced with the problem of determining the extent to which television images must be improved before the public will be conscious of the improvement and be willing to pay a higher price for television receivers."

"What is the nature of the improvement which will be most acceptable to the television audience?" Dr. Jolliffe asked. "Should some new broadcast service be added, for example, the transmission of odors, good and bad? All of these additions may be desired by the public, but each improvement represents an increase in the cost of the receiving instrument and also requires an additional cost in terms of valuable space in the frequency spectrum."

Dr. Jolliffe emphasized that as the television industry develops, engineers have the obligation to see that the public gets better and better service and that the new developments which would be brought about by the

stimulation of use are integrated into an over-all system.

"Engineers should not be satisfied that their television job is done," Dr. Jolliffe asserted, "until they have made it possible to project in the home pictures of adequate size in color, and also for anyone to attend, by television, all major happenings wherever they occur, in the United States or in any other part of the world. These objectives may be accomplished in a few years, or many years may be required."

Another important field of radio development is in aviation, Dr. Jolliffe pointed out, stressing the necessity of continuing advances in this work after the war to insure the safety and expansion of the great air-transportation service for public and private use. He added: "Radar has been publicized chiefly for its use as an instrument for increasing the destructive power of aircraft. It can be and is used, however, to guide and land planes under the poorest visibility conditions. Radio instruments can look ahead and warn the pilot of obstacles in the path of the plane and tell the pilot at all times the height of the plane above the ground. Vacuum tubes (electronics) can make the operation of flight instruments more accurate and dependable. Radio communications, of course, can keep the pilot and passengers in touch with persons on the ground and in other planes. Radio then can make flying a safe and reliable service; therefore, it can be an important part of another big industry."

Dr. Jolliffe in his address foresaw the day when "citizens' radio"—personal radio communication—will have a prominent role in our lives. He recalled how the walkie-talkies and other portable radio apparatus have demonstrated their usefulness in the war, and reminded his listeners that the Federal Communications Commission has already planned frequencies for their peacetime counterparts.

"Regulations for this service," he said, "will be so simple that anyone can use the apparatus without restriction; only simple licenses will be required. A farmer's wife can talk to her husband while he is riding his tractor; a construction superintendent on a skyscraper can give direction to his workers; a doctor can keep in touch with his office. These are examples; the possible uses are as extensive as the human mind can imagine."

Use of portable radio equipment in police work, forest protection, and in new public service communications, Dr. Jolliffe stated are all due for rapid expansion. But he added that two new applications of radio deserve special mention.

"We are accustomed to think of telephone and telegraph traffic being carried by wires," he said. "Recent developments in ultra-high-frequency radio have shown that radio relays can also do the job. Directive beams in the ether can carry messages as well as wires. Using frequencies of 1000 megacycles or more, it is possible to use the technique of wire communications without many of its limitations."

"It is not fantastic to imagine long telephone and telegraph lines being replaced by lines of towers spaced 25 to 40 miles apart with small automatic radio transmitters and receivers carrying many messages simul-



taneously through the ether from coast to coast. A single communications channel may carry telegraph, telephone, and television messages or programs simultaneously with less maintenance or service than simple wire lines."

The second application, which Dr. Jolliffe said promises "great impact on industry," is the use of radio frequencies for heating. He reported that the development of radio heating has gone forward rapidly in recent years and is being used to speed and improve the efficiency of many industrial processes.

In conclusion, Dr. Jolliffe said: "I want to emphasize again that we, as engineers, have a responsibility not only for the creation of the apparatus that is useful in new industries but also for the organization of this apparatus into systems and services that can be the basis for new industries and new employment. Also, we must continue to recognize our responsibility to the Government in peace as well as in war, and do our part to provide adequate technical preparedness as a practical measure to insure the permanence of peace."

## Books

### An Introduction to Electronics, by Ralph G. Hudson

Published (1945) by The Macmillan Company, 60 Fifth Avenue, New York 11, New York. 94 pages + 3-page index + xii pages. 72 illustrations.  $8\frac{1}{2} \times 5\frac{1}{2}$  inches. Price, \$3.00.

Professor Hudson's book aims to explain the "science of electronics and its modern applications in terms that will be understandable and useful to those with only an elementary knowledge of mathematics and physics." Thus, the author has set himself down to a most difficult task which cannot help but increase the more he knows about his subject and the less his audience knows. Whether he has done a good job or not must be for a layman, and not a technician, to say.

The part that interested this reviewer

most dealt with atomic disintegrations and the prospects of putting atomic energy to work. Probably this is because the reviewer is a layman on these subjects, and if so, the remainder of the book should take equally well with a novice in electronics.

The processes of radio communication, reproduction of sound and picture, flow of electricity, the electron microscope, and electronic applications to industrial problems occupy most of the 100-page book.

There is, of course, danger in oversimplification and when the author makes the flat statement that the cathode rays pass down through a cathode-ray "tube in a concentrated line of light," or that the direction of flow of current is "always" taken as the direction of the flow of the positively charged particles, a technician's eyebrows cannot be blamed if they rise just a little bit.

KEITH HENNEY  
McGraw-Hill Publishing Company  
New York 18, N. Y.

### Electrical Drafting by D. Walter Van Gieson

Published (1945) by the McGraw-Hill Book Company, Inc., 330 W. 42 Street, New York 18, N. Y. 136 pages + 4-page index + viii pages. 82 illustrations.  $8\frac{1}{2} \times 5\frac{1}{2}$  inches. Price, \$1.50.

This small volume treats of certain electrical drafting fundamentals such as symbols and schematic diagrams, and then gives some information about circuit diagrams in a number of different branches of the electrical field.

In most of the branches, an elementary circuit is given in detail, after which more complicated circuits are shown as examples. Unfortunately, many of the symbols and items of equipment shown in some of the drawings are neither labeled nor explained.

In each branch of the field, there is some background discussion. Whether this is sufficient to be of use to a draftsman in that particular line of work is doubtful.

B. E. SHACKELFORD  
Radio Corporation of America  
New York 19, N. Y.

### THOMAS JAMES GUILFOYLE

Thomas James Guilfoyle (M'35-SM'43) died on October 2, 1944, at his home in Jamaica, BWI. He was a chartered electrical engineer, serving at the time of his death as engineer in chief of the Post and Telegraphs Department, and acting officer in charge of broadcasting.

Born at Hampshire, England, on March 11, 1886, Mr. Guilfoyle went to Jamaica in his youth and made it his permanent home. In 1932 he received the Wireless Engineering Certificate from Marconi College at Chelmsford, and later qualified as a chartered electrical engineer, and for the degrees of M.I.E.E. and M.I.R.E.

His first post with the government of the British West Indies was that of train dispatcher, to which he was appointed in 1902. In 1906 he became operator and acting station electrician with the All America Cable Company, and in the following year joined the Panama Railroad, as train dispatcher. He remained in this position until 1913, when he went to Brazil to serve with the Maderia Mamore Railway Company, returning to Jamaica later in the same year, to accept appointment as inspector of trains and stations.

During the First World War, Mr. Guilfoyle was cable censor at Kingston and Holland Bay; and in 1917 became associated with the Post and Telegraphs Department as first-class clerk in the telegraphs branch, succeeding to the position of superintendent of telegraphs in April, 1921, and later to the post of engineer-in-chief.

He served the government in various technical capacities in connection with telecommunications, as electrical inspector; as representative at the opening of the Wireless Meteorological Station in Georgetown; as chairman of the Wireless Board; as Competent Authority on Wireless Equipment; and in the outfitting and maintenance of the government broadcast station. In 1935, he was awarded the King's Jubilee Medal, and in 1937, the King George VI Coronation Medal.

## Contributors



IVAN S. COGGESHALL

Ivan S. Coggeshall (A'26-M'29-F'43) was born at Newport, Rhode Island, on September 30, 1896, and attended Worcester Polytechnic Institute. Since 1917 he has been employed by the Western Union Telegraph Company in New York, having been appointed, in 1927, general traffic supervisor of the company's submarine cable system. Mr. Coggeshall is a Lieutenant Commander in the United States Naval Reserve, and serves on the Cable Committee of the Board of War Communications. He is a director of the Mexican Telegraph Company, a director of the Institute of Radio Engineers, and a member of Tau Beta Pi and the American Institute of Electrical Engineers.



Jennings B. Dow (M'26-F'42) was born at Bowling Green, Ohio, on January 2, 1897.

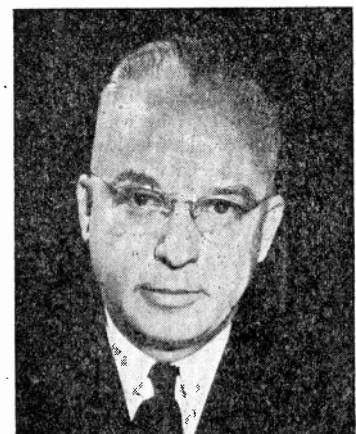

JENNINGS B. DOW

He was graduated from the United States Naval Academy in 1919, and received the M.S. degree in electrical communication engineering from Harvard University, in 1926.

Captain Dow has served with the United Navy since 1919, when he began his service



DAVID LAWRENCE JAFFE

as radio and communication officer, and was later transferred to the staff of the commander of battleship divisions, serving as radio officer. He was Asiatic Fleet radio officer during 1926 and 1927, and was stationed in Cavite, P.I., as radio material officer in the Navy Yard, from 1927 to 1929.

From 1930 to 1932, Captain Dow was with the Bureau of Engineering in the radio division, serving as head of that division from 1938 to 1939. During the winter and spring of 1940 and 1941 he was on special duty as observer of radio and radar in Great Britain, returning to this country in 1941 to become head of the radio division of the Bureau of Ships. He held this post until January, 1945, when the electronics division of the Bureau of Ships was established, with Captain Dow as its director.

David Lawrence Jaffe (A'31) was born on July 6, 1913, in Brooklyn, N. Y. He received the B.S. degree in engineering from the College of the City of New York in 1935, the M.S. degree in electrical engineering from Columbia University in 1936, and the Ph.D. degree in electrical engineering in 1940, also from Columbia University.

From 1935 to 1937 he was instructor in the department of electrical engineering at The College of the City of New York. He

was a Bridgman Fellow in electrical engineering at Columbia University from 1937 to 1939, associated with Major E. H. Armstrong in frequency-modulation research problems.

In 1939 Dr. Jaffe became a member of the television engineering department of Columbia Broadcasting System, in New York City, a post which he held until 1942, together with that of lecturer in frequency modulation and television engineer at Columbia University, from 1941 to 1942. At that time he became staff engineer for Raytheon Manufacturing Company, assigned to the radiation laboratory at the Massachusetts Institute of Technology. Since 1944 Dr. Jaffe has been chief research engineer for Templetone Radio Manufacturing Corporation, at New London, Connecticut.

He is a member of the American Institute of Electrical Engineers and Sigma Xi.

Joseph M. Pettit (S'39-A'40-M'45) was born on July 15, 1916, at Rochester, Minnesota. He received the B.S. degree in 1938 from the University of California, the degree of Engineer in 1940 from Stanford University, and the Ph.D. degree in 1942 from the same institution. From 1939 to 1940, Dr. Pettit was teaching and research assistant in electrical engineering at Stanford University. Since 1940 he has been instructor in electrical engineering at the University of



JOSEPH M. PETTIT

California. During 1941 and 1942, he was a research associate in electrical engineering at Stanford University, in charge of a project under the National Defense Research Committee. In May, 1942, Dr. Pettit was given

a leave of absence by the University of California to join the staff of the Radio Research Laboratory, which operates under Harvard University in co-operation with the Office of Scientific Research and Development. For several months during 1944 Dr. Pettit



FREDERICK EMMONS TERMAN

served overseas with the Army Air Forces as a technical observer, and is now associate technical director of ABL-15, a laboratory in England associated with the Radio Research Laboratory.

Frederick Emmons Terman (A'25-F'37) was born on June 7, 1900, at English, Indiana. He received the A.B. degree in 1920 and the degree of Engineer in 1922 from Stanford University, and the Sc.D. degree from Massachusetts Institute of Technology in 1924. From 1925 to 1937 Dr. Terman was an instructor, assistant professor, and associate professor of electrical engineering at Stanford University. Since 1937 he has been professor and head of the electrical engineering department at Stanford. In February, 1942, Dr. Terman was given a leave of absence by Stanford to assume the directorship of the Radio Research Laboratory which operates under Harvard University, Cambridge, Massachusetts, in co-operation with the Office of Scientific Research and Development. At the present time he is also a member of Divisions 14 and 15 of the Office of Scientific Research and Development and was recently appointed Dean of Engineering at Stanford University. Dr. Terman was Vice-President of the Institute of Radio Engineers in 1940 and President in 1941.

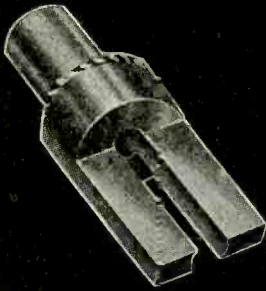
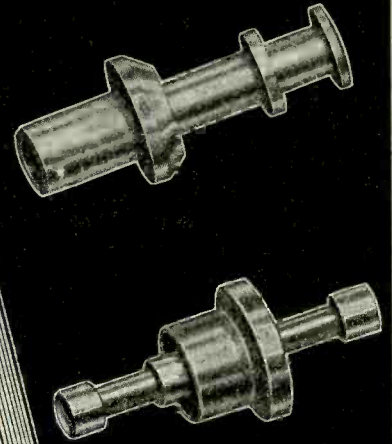

**YOU NEED THIS BOOK!**

It contains complete information on recent C. T. C. radio and electronic components designed to speed production and improve the performance of precision equipment.

You'll discover how the new line of C. T. C. Terminal Lugs and Swaging Tools saves time and money through faster, cleaner assembly. It contains specifications for C.T.C. Crystals and facts about a thumb-size I-F Ultra-High Frequency Transformer.

*You need this book for your files. Write for your copy today.*



**CAMBRIDGE THERMIONIC CORPORATION**  
456 CONCORD AVENUE · CAMBRIDGE 38, MASSACHUSETTS

# RCA

1. Pilot sets optimum height by turning knob or altitude-limit switch

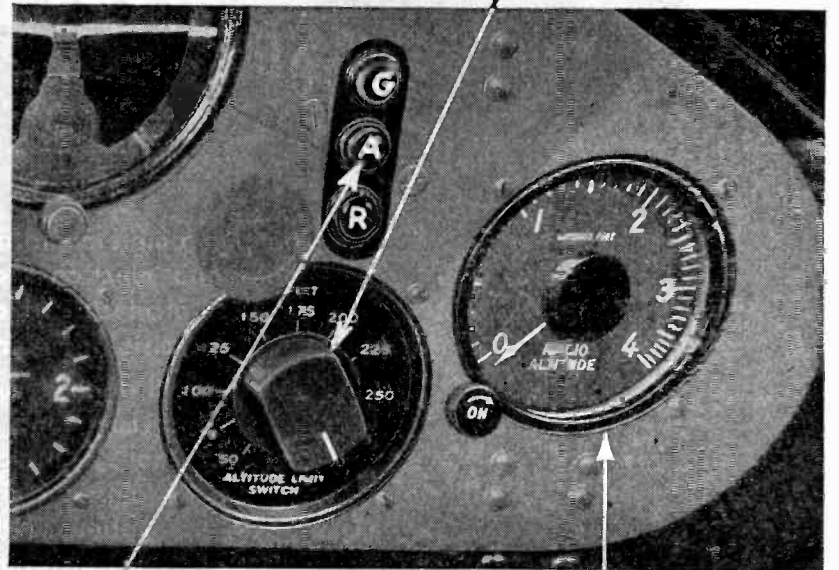

2. Amber light indicates maintenance of correct height; red indicates too low; green too high.

3. Dial provides reading of height in feet.

# *Radio Altimeters* *in the AVENGER*

**T**HE HEIGHT from which a torpedo bomber drops its torpedoes is critically important... too high and the "tin fish" will "dive"... too low and it will "porpoise." With an RCA Radio Altimeter, the problem of holding correct height has been simplified. The provision of pre-set, altitude-controlled

warning lights makes it possible for the pilot to concentrate on flying toward his objective without the necessity for constantly watching the usual altimeter indicator needle.

The RCA Radio Altimeter used in the Avenger is a type designed especially to read accurately at low levels. Its ability to do this, plus the feature of indicating immediately any deviation from optimum height, has contributed substantially to the high percentage of successful hits on the Japanese Fleet by Navy Avenger pilots.

There are other models of the RCA Radio Altimeter for other requirements. In fact, ALL of the radio altimeters used today by the Army, the Navy and the British were designed and first produced by RCA. Moreover, these altimeters are but one of the wartime contributions of RCA research and engineering. Others will be disclosed when security permits.

After the war, these RCA developments will find their place in commercial and private aircraft—to help make peacetime aviation safer, more reliable and more economical.

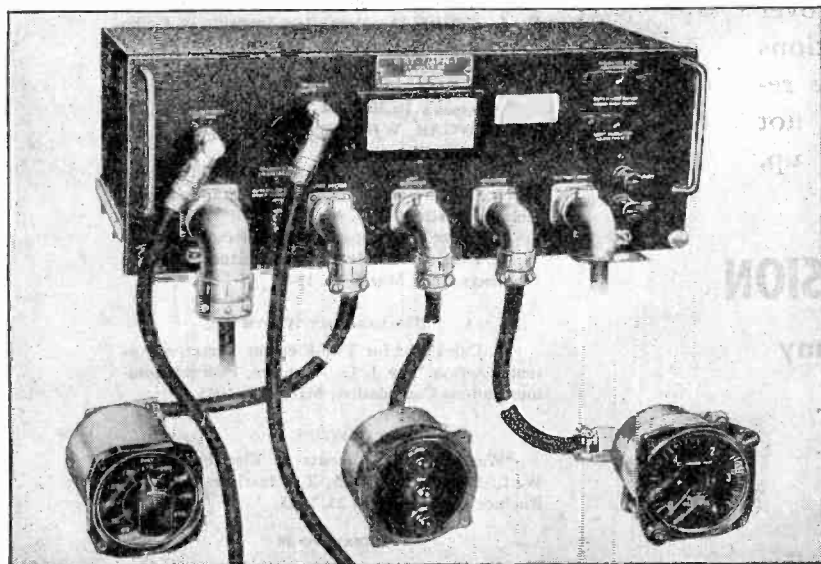

BUY MORE WAR BONDS



**RADIO CORPORATION OF AMERICA**

RCA VICTOR DIVISION • CAMDEN, N. J.

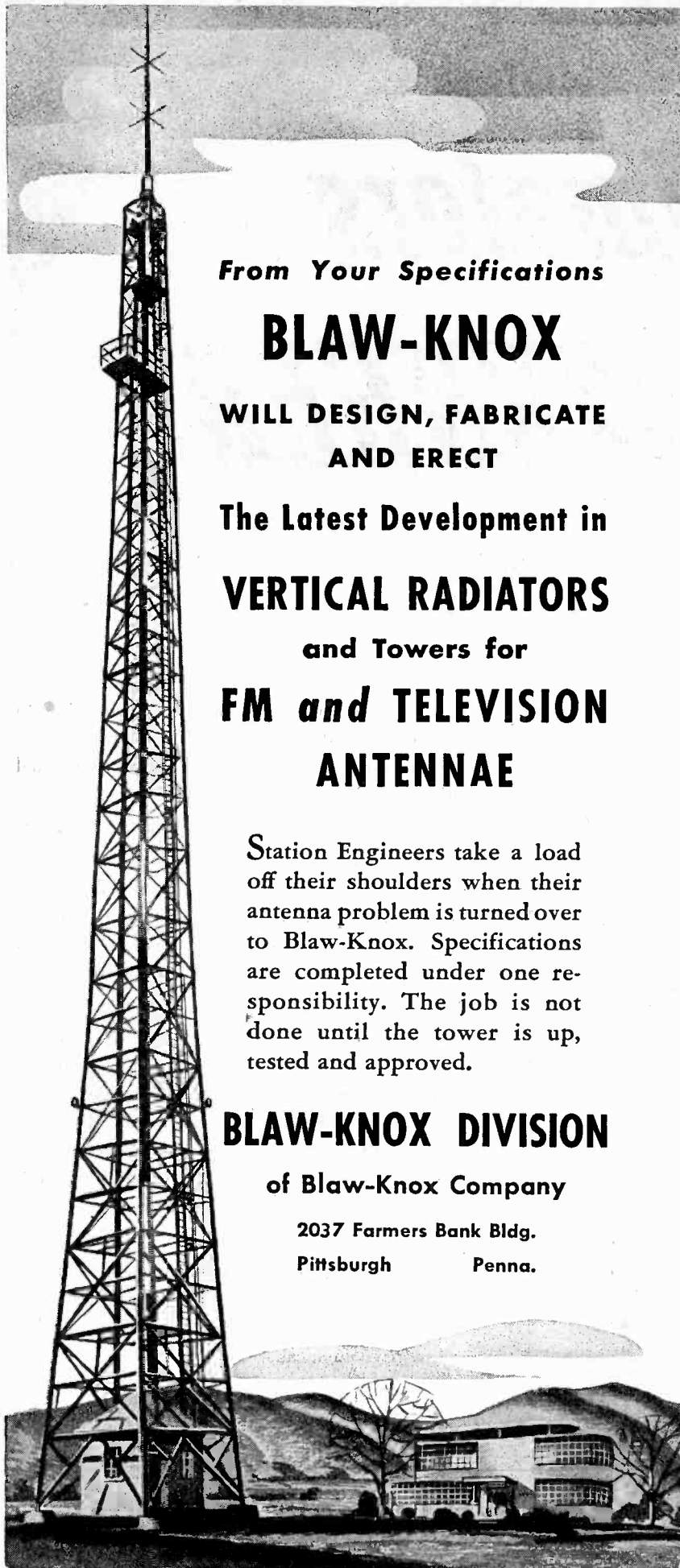

*From Your Specifications*

# BLAW-KNOX

**WILL DESIGN, FABRICATE  
AND ERECT**

**The Latest Development in  
VERTICAL RADIATORS  
and Towers for  
FM and TELEVISION  
ANTENNAE**

Station Engineers take a load off their shoulders when their antenna problem is turned over to Blaw-Knox. Specifications are completed under one responsibility. The job is not done until the tower is up, tested and approved.

## BLAW-KNOX DIVISION

of Blaw-Knox Company

2037 Farmers Bank Bldg.

Pittsburgh Penna.



### ATLANTA

"Engineering Aspects of the New Frequency Allocations," by R. N. Harmon, Westinghouse Electric and Manufacturing Company; February 23, 1945.

Panel Discussion—"Pulse Time Modulation," by M. A. Honnell, Georgia School of Technology; March 23, 1945.

### BOSTON

"Railroad Communications Systems," by George Phelps, Westinghouse Electric and Manufacturing Company; March 23, 1945.

### BUENOS AIRES

"Frequency-Modulation Broadcasting," by L. C. Simpson, RCA-Victor Argentina; December 15, 1944.

Election of Officers, December 15, 1944.

### BUFFALO-NIAGARA

"Communications in Aeronautics," by J. G. Petrierson, Airways Communications; February 21, 1945.

"Television," by A. B. Dumont, Allen B. Dumont Laboratories, Inc.; March 8, 1945.

### CEDAR RAPIDS

"Wartime Developments in Electronics," by W. L. Everitt, President, The Institute of Radio Engineers, Inc.; March 19, 1945.

### CHICAGO

"Instrumentation in Medical Electronics," by W. E. Gilson, University of Wisconsin; March 16, 1945.

"Wartime Developments in Electronics," by W. L. Everitt, President, The Institute of Radio Engineers, Inc.; March 16, 1945.

### CINCINNATI

"Air Power For Peace," by E. E. Wilson, United Aircraft Corporation; February 28, 1945.

"Wartime Developments in Electronics," by W. L. Everitt, President, The Institute of Radio Engineers, Inc.; March 22, 1945.

### CLEVELAND

"European Radio and The War," by O. M. Pierce, WGAR, WJR, and KMPC; February 22, 1945.

"Utilization of Polyphase High-Frequency Power for Aircraft," by Ralph Heintz, Jack and Heintz; March 6, 1945.

"Wartime Developments in Electronics," by W. L. Everitt, President, The Institute of Radio Engineers, Inc.; March 13, 1945.

### DALLAS-FORT WORTH

"A Calculator for Two-Element Directive Antenna Arrays," by J. G. Rountree, Federal Communications Commission; March 21, 1945.

### DAYTON

"Wartime Developments of Electronics," by W. L. Everitt, President, The Institute of Radio Engineers, Inc.; March 23, 1945.

### INDIANAPOLIS

"Significant Aspect of Magnetic Recording," by S. J. Begun, The Brush Development Company; February 21, 1945.

### KANSAS CITY

"The Analysis of Train Communications Systems," by W. T. Bishop, Aireon Corporation; February 26, 1945.

### LONDON

"Transcription Recordings," by E. O. Swan, Radio Station CKEY; February 27, 1945.

(Continued on page 38A)

# COMPACT!

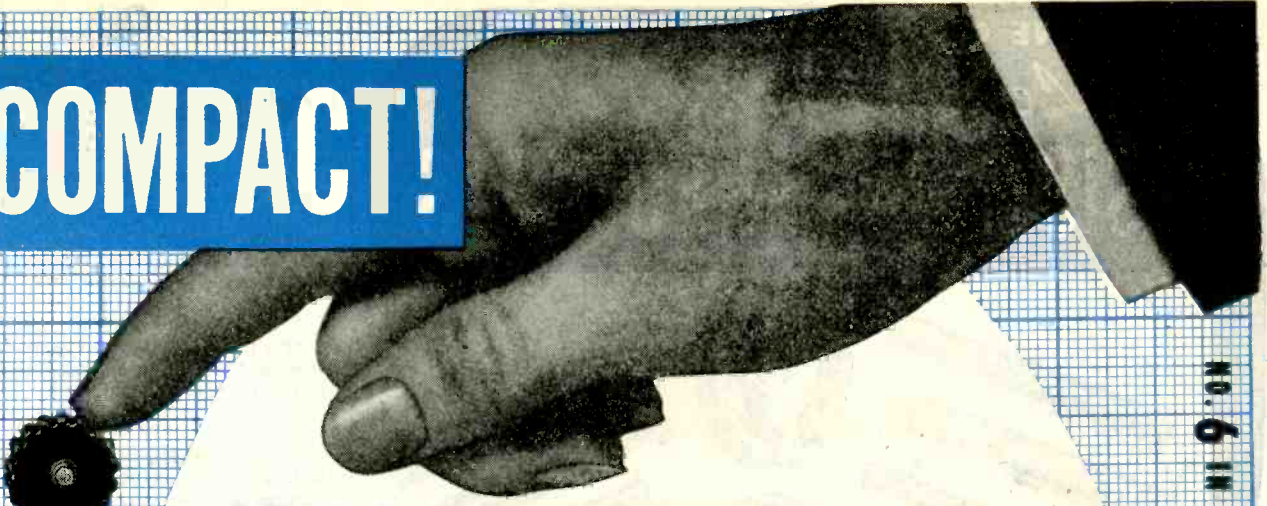

## IRC's NEW FINGERTIP CONTROL ANSWERS SPACE-SAVING PROBLEMS

No bigger 'round than a nickel and wafer thin, this new Fingertip Control will find many important applications in miniature electronic devices. An all-inclusive unit, its unique design eliminates the usual bulky knob, shaft and bushing without any impairment of functional operation.

Of neat appearance and available in either black or colors, this Type H control is intended for edgewise installation. A light-pressure, fingertip rotation of the knurled edge of the cover permits ready resistance adjustment.

Embodying suitable mechanical strength and many of IRC's famous features as found in Type CS and D controls, the Fingertip Control has a rotation of 290°, a power rating of 0.25 watts and 500 ohms to 3 megohms, as standard resistance values. Fingertip Control may be had with linear taper or with standard audio tapers.

Inquiries are invited from interested manufacturers of hearing aids and other miniature equipment. Engineering Bulletin on the Type H control is now in preparation.

**OCCUPIES LESS THAN HALF CUBIC SPACE REQUIRED FOR CONVENTIONAL TYPES**

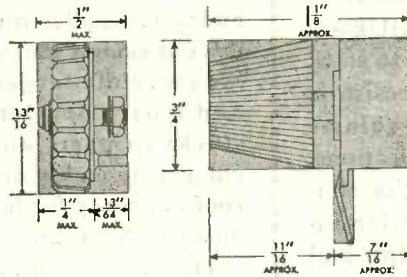

NO. 6 IN THE NEW IRC PRODUCT PARADE

## INTERNATIONAL RESISTANCE CO.

Dept. 10-E

401 NORTH BROAD STREET • PHILADELPHIA 8, PA.



IRC makes more types of resistance units, in more shapes, for more applications than any other manufacturer in the world.



AN 3155  
Rheostat



BTR—1/4 watt  
Insulated Resistor



BTA—1 watt  
Insulated Resistor



Grade 1—Class 1  
Resistors



Type FRW  
Resistor



Fingertip  
Control

COMING...COMING...

ONE CENTRAL SOURCE FOR  
*Leading Makes of*  
**RESISTORS & RHEOSTATS**

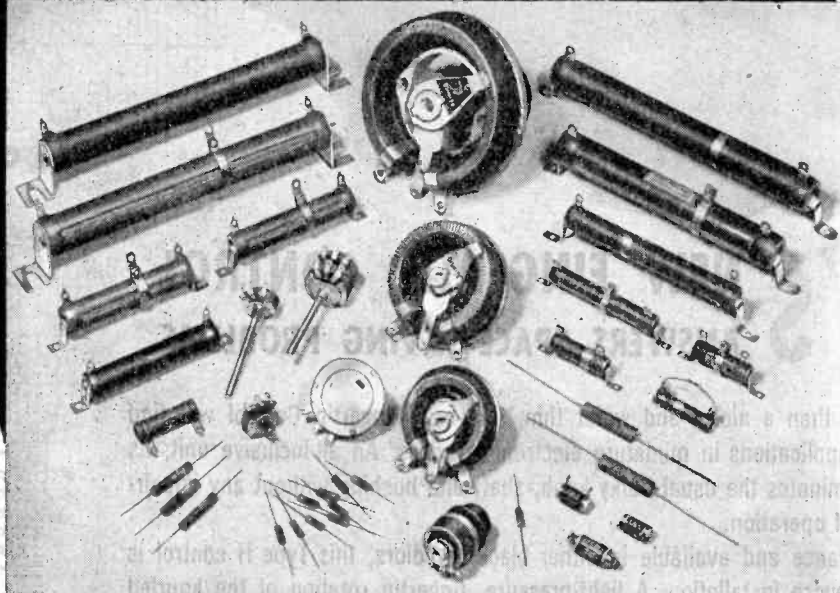

**STOCKS ON HAND FOR**  
*Immediate Delivery*

**YOU** get the very type of units you require . . . *in the shortest time possible* . . . from Allied. All the well-known makes such as OHMITE, MALLORY, IRC, CENTRALAB, and SPRAGUE are concentrated here *under one roof*. In stock are fixed, adjustable, precision resistors—rheostats—potentiometers—volume controls—for all kinds of applications. This complete, centralized service simplifies and speeds procurement for industry, government and laboratories. You save hours, days and effort.

**Helpful  
BUYING  
GUIDE**  
Available  
on Request  
Write for it!

*Thousands Call ALLIED First  
Write, Wire or Phone  
HAYmarket 6800*

**EVERYTHING IN  
ELECTRONICS & RADIO**  
It's faster, simpler to get all your electronic and radio supplies from this one central source. We carry the largest and most complete stocks of parts and equipment under one roof . . . ready for immediate shipment.

Our close contact with all leading manufacturers aids procurement. *Engineering service* is available.

**ALLIED RADIO**

CORPORATION

833 W. Jackson Blvd. Dept. 3-E-5 Chicago 7, Illinois

**SUPPLIERS OF ELECTRONIC PARTS AND EQUIPMENT TO INDUSTRIAL AMERICA**

Electronic Tubes, Rectifiers, Power Supplies, Intercommunicating Systems, Sound Systems, Photo-Cell Equipment, Batteries, Chargers, Converters, Generators, Supplies for Resistance Welders, Fuses, Test Instruments, Meters, Broadcast Station Equipment, Relays, Condensers, Capacitors, Resistors, Rheostats, Transformers, Switches, Coaxial Cable, Wire, Soldering Irons, Microphones, Speakers, Technical Books, etc.

**SECTION MEETINGS**

(Continued from page 36A)

LOS ANGELES

"Radio-Frequency Induction Heating," by E. H. Hulse, Westinghouse Electric and Manufacturing Company; February 20, 1945.

MONTREAL

"The Electrical Director's Conquest of the Flying Bomb," by C. A. Lovell, Bell Telephone Laboratories, Inc.; February 23, 1945.

PITTSBURGH

"Wartime Developments of Electronics," by W. L. Everitt, President, The Institute of Radio Engineers, Inc.; March 12, 1945.

"The World-Wide Communication System of the Signal Corps," by G. B. Meyers, United States Army Signal Corps; March 13, 1945.

PORTLAND

Review of a Published Paper on "Time Pulse Modulation," by R. W. Deardorff, Pacific Telephone and Telegraph Company; March 14, 1945.

ROCHESTER

"How Bats Use Supersonics for Navigation," by Robert Galambos, University of Rochester; March 15, 1945.

SAN DIEGO

"Technique of Crystal Cutting," by W. A. Burnett, United States Naval Repair Base; March 14, 1945.

"Piezoelectric Crystals as Circuit Elements," by D. C. Kalbfell, University of California; March 14, 1945.

TWIN CITIES

"Wartime Developments in Electronics," by W. L. Everitt, President, The Institute of Radio Engineers, Inc.; March 15, 1945.

WILLIAMSPORT

"Radio-Frequency Generators for Induction Heating," by T. P. Kinn, Westinghouse Electric and Manufacturing Company; March 2, 1945.  
Election of Officers, March 2, 1945.

**MEMBERSHIP**

The following transfers and admissions were approved on April 4, 1945:

**Transfer to Senior Member**

Blahna, C., 3351 N. Rutherford Ave., Chicago, Ill.  
Brothers, J. T., Philco Radio and Television Corp., Tioga and "C" Sts., Philadelphia, Pa.

Brown, Jr., W. N., 747 S. Monroe St., Xenia, Ohio  
Daniell, C. M., 5 Craigie Cir., Cambridge, Mass.  
Freeman, R. L., Hazeltine Corp., Little Neck, L. I., N. Y.

Fyler, G. W., 174 Plymouth St., Stratford, Conn.  
Harmon, R. N., 1920 South Rd., Baltimore, Md.  
Hickson, W. P., Seale, Nr. Farnham, Surrey, England

Jordan, E. C., Dept. of Electrical Engineering, Ohio State University, Columbus, Ohio  
Matthews, A. C., 108 Seminole Ave., Philadelphia, Pa.

Pezopoulos, K. N., 2221 Massachusetts Ave., N.W., Washington, D. C.

Prince, D. C., General Electric Co., Schenectady, N. Y.

Ruckelshaus, J. G., 11 Pomeroy Rd., Madison, N. J.

(Continued on page 40A)



# For Low Power Voltage Control . . . these NEW AUTOMATIC REGULATORS by SECO

RACK OR CABINET MODELS —  
NO WAVE-FORM DISTORTION —  
LOW COST PER KVA —  
COMPACT — LIGHT WEIGHT

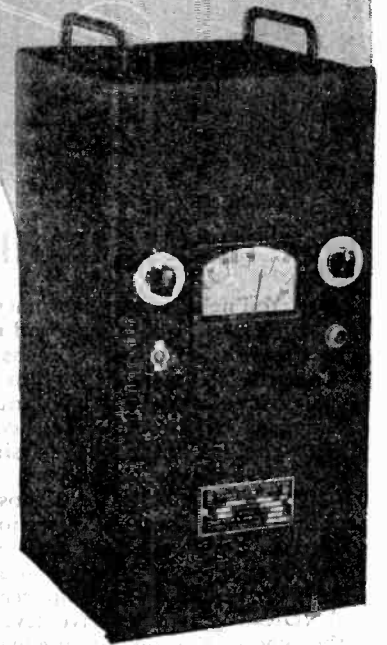
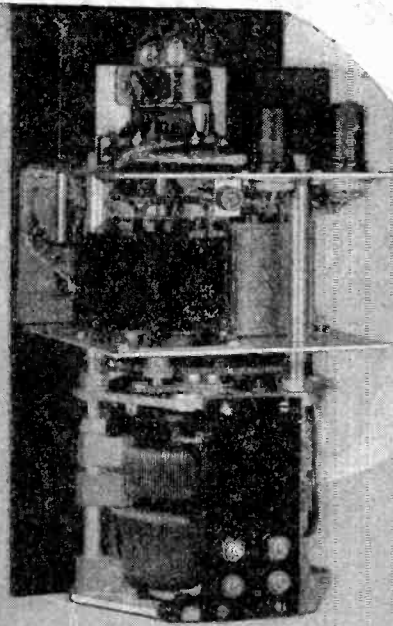
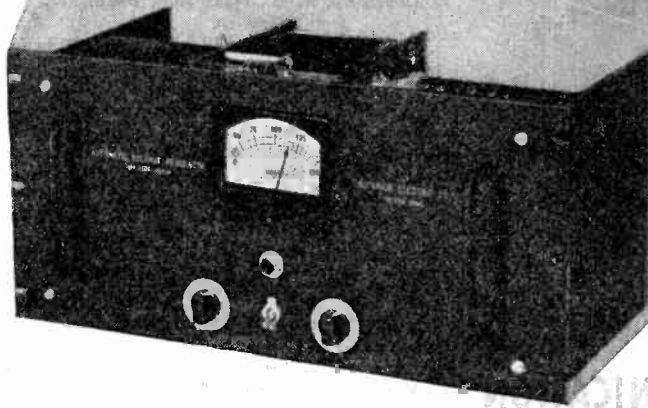

In the past, SECO Automatic Voltage Regulators have found wide use in maintaining constant voltage to equipment of 6 KVA capacity and greater. The introduction of SVR 4101 and SVR 4102 provides the SECO type of electronic voltage control for 1 and 2 KVA applications.

These new models possess many notable improvements to supplement the remarkable characteristics of larger SECO regulators. In addition to such features as zero wave-form distortion, high efficiency and adjustable output voltage, the SVR 4101 and SVR 4102 are compact and light weight. As illustrated, these models are available in self-contained cabinets and in rack units for installation as a component part of existing equipment.

## SPECIFICATIONS

*Type	Input Voltage Range	Nominal Output Voltage	Output Voltage Range	Phase	Output Current	Output KVA	Over-all Dimensions
SVR 4101	95-135	115	100-120	1	10	1	9 1/2" x 10" x 19 5/8"
SVR 4102	95-135	115	100-120	1	20	2	9 1/2" x 10" x 21 1/2"
SVR 4106	95-135	115	100-120	1	52	6	9 1/2" x 10" x 26 1/2"

\*When the regulator is used for mounting in customer's rack, add the letter "R" to the type number. For table or wall mounting add the letter "H".

Detailed information is gladly given by SECO engineers upon request.

Send for Bulletins 149 ER and 163 ER

**SUPERIOR ELECTRIC COMPANY**  
482 LAUREL STREET BRISTOL, CONNECTICUT

# ANDREW

## Rhombic Transformers

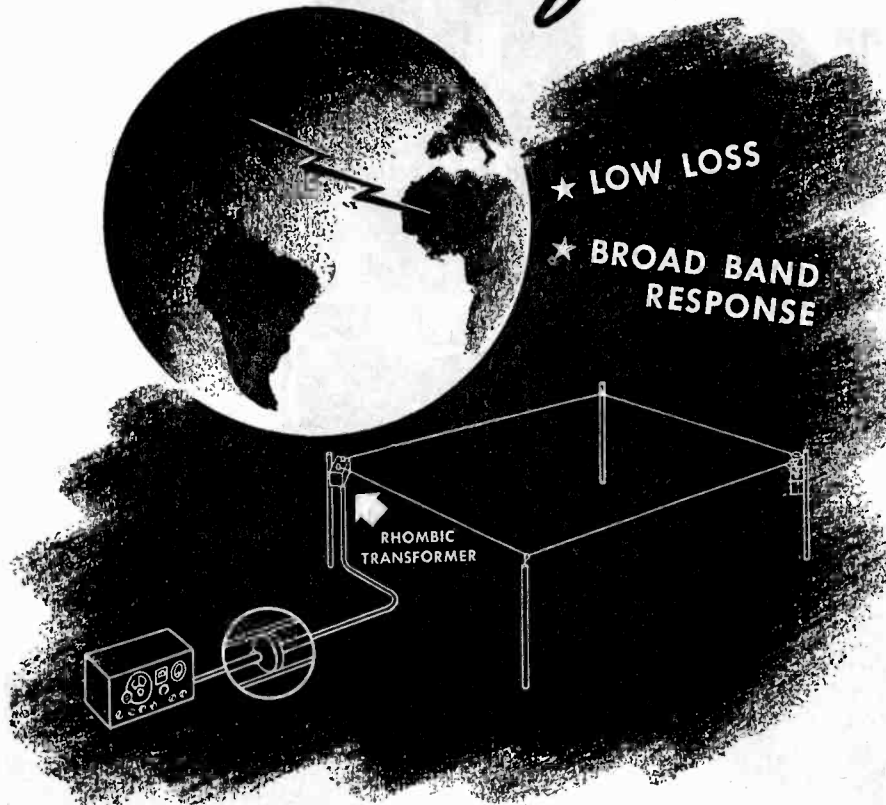

### FOR TRANSOCEANIC RADIO COMMUNICATION

★ You need *quality* equipment for reliable, uninterrupted radio communication across oceans and continents. That is why radio engineers specify ANDREW antenna coupling transformers and coaxial transmission lines when designing rhombic antenna systems.

For highest efficiency and most successful rhombic antenna operation, the antenna coupling circuit must have a broad frequency response and low loss. To meet these requirements, ANDREW engineers have developed the type 8646 rhombic antenna coupling transformer, illustrated below, to assure fullest utilization of the advantages of the rhombic type an-

tenna. Losses are less than 2 decibels over a frequency range from 4 to 22 megacycles.

Type 8646 unit transforms the 700 ohm balanced impedance of the antenna to match the 70 ohm unbalanced impedance of the line. Unusually broad band response is achieved by using tightly coupled transformer elements with powdered iron cores of high permeability. This unit is contained in a weatherproof housing which may be mounted close to antenna terminals.

Transformer unit 8646 is another expression of the superior design and careful engineering that has made ANDREW CO. the leader in the field of radio transmission equipment.

WRITE FOR BULLETIN NO. 31 giving complete information on this new radio communication unit.

**ANDREW CO.**  
363 EAST 75th STREET  
CHICAGO 19, ILLINOIS

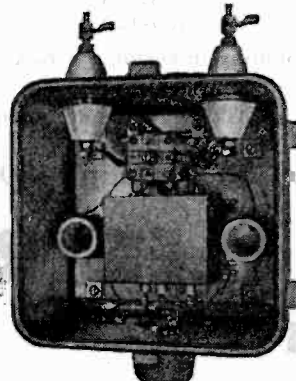

## Membership

(Continued from page 38A)

Swedlund, L. E., RCA Victor Division, Lancaster, Pa.  
van Spankeren, G. H., Herrera 527, Buenos Aires, Argentina  
Wintringham, W. T., 463 West St., New York, N. Y.  
Wright, S. B., 463 West St., New York, N. Y.

### Admission to Senior Member

Fett, G. H., Dept. of Electrical Engineering, University of Illinois, Urbana, Ill.  
Lozier, J. C., 463 West St., New York, N. Y.  
Marsolan, V. C., 4014 Mountain View Dr., Bremerton, Wash.  
Thomas, H. A., National Physical Laboratory, Teddington, Middlesex, England

### Transfer to Member

Bonness, Q. L., 1418 Union St., Schenectady, N. Y.  
Brown, J. S., 1658 W. 101 Pl., Chicago, Ill.  
Caudle, Jr., L. L., 1925 N. Tryon St., Charlotte, N. C.  
Chamberlain, P. E., 201 Marilyn Dr., O'Fallon, Ill.  
Chien, F. C., 227 N. Third St., Camden, N. J.  
Ciscel, B. H., 54 Hancock St., Dorchester, Mass.  
Colvin, J. D., 328 E. 47 St., Indianapolis, Ind.  
Daugherty, R. M., 14433 Mark Twain Ave., Detroit, Mich.  
Dean, W. W. H., RCA Victor Co., Ltd., 4001 Lenoir St., Montreal, Quebec, Canada  
Feyerherm, M. P., RCA Victor Division, Lancaster, Pa.  
Fitch, J. A., 229 N. Barton St., Arlington, Va.  
Fonger, C. I., Y.M.C.A., 18th and G Sts., Washington, D. C.  
Fox, F. J., 201 Plymouth St., Stratford, Conn.  
Freund, W. H., 147 E. Chestnut St., Lancaster, Pa.  
General, J., 1319 Superior Ave., Dayton, Ohio  
Kenworth, W., 1235 E. Ranchito St., El Monte, Calif.  
Kimzey, T. I., 1201 W. Lancaster St., Fort Worth, Texas  
Lippert, H. B., 164 Alpine Ave., Bridgeport, Conn.  
Markus, J., 31 Crescent Place, Hohokus, N. J.  
Nekut, A. G., RCA Victor Division, Lancaster, Pa.  
Olson, F. A., 105 Hickory St., Bridgeport, Conn.  
Peet, E. C., 534 N. Maple Ave., East Orange, N. J.  
Pugsley, D. W., 216 Ridgefield Ave., Bridgeport, Conn.  
Rado, J. A., 58-25 Little Neck Pkwy., Little Neck, L. I., N. Y.  
Renne, H. S., 14745 Main St., Harvey, Ill.  
Reynolds, M. T., 1614 Becker St., Schenectady, N. Y.  
Root, C. S., 1285 Boston Ave., Bridgeport, Conn.  
Sabaroff, S., 5003 C St., Philadelphia, Pa.  
Schick, N. E., 1567 Union St., Schenectady, N. Y.  
Shaw, R. F., 3504 Baring St., Philadelphia, Pa.  
Sheppard, G. E., R.F.D. 5, Lancaster, Pa.  
Snedeker, M. L., 5300 Archmerę Ave., Cleveland, Ohio  
Spangenberg, L. F., 55 Monroe Place, Bloomfield, N. J.  
Thompson, R. R., 48 Schley Blvd., Bremerton, Wash.  
Tuttle, R. W., Tuttle RD., Wallingford, Conn.  
Vergeichik, J., 1912 Avenue H, Brooklyn, N. Y.  
Vladimir, L. O., Box 1565, Bridgeport, Conn.  
Wagner, R. W., 81 Irving St., Cambridge, Mass.  
Weiss, L., 906 W. California Ave., Urbana, Ill.  
Wilson, C. C., 125-33 St., Newport News, Va.  
Worcester, Jr., J. A., 415 Clinton Ave., Bridgeport, Conn.  
Zimmermann, H. J., 45 Lockeland Ave., Arlington, Mass.

### Admission to Member

Berry, G. R., St. Joe, Ind.  
Bierwirth, R. A., RFD 2, Princeton, N. J.  
Blackmon, H., 322 Edgewood Rd., Forest Hills, Pittsburgh, Pa.  
Brown, R. H., 189-30-37 Ave., Flushing, L. I., N. Y.  
Cook, H. A., 8702-D Raven Dr., Towson, Md.  
Cooper, N. J., 4617 N. Damen Ave., Chicago, Ill.

(Continued on page 42A)

*Assembling the filament stem  
of a 50 kilowatt vacuum tube  
at the Federal Telephone and  
Radio Corporation plant at  
Clifton, New Jersey. Ten fire,  
seven jet Litton burners.*

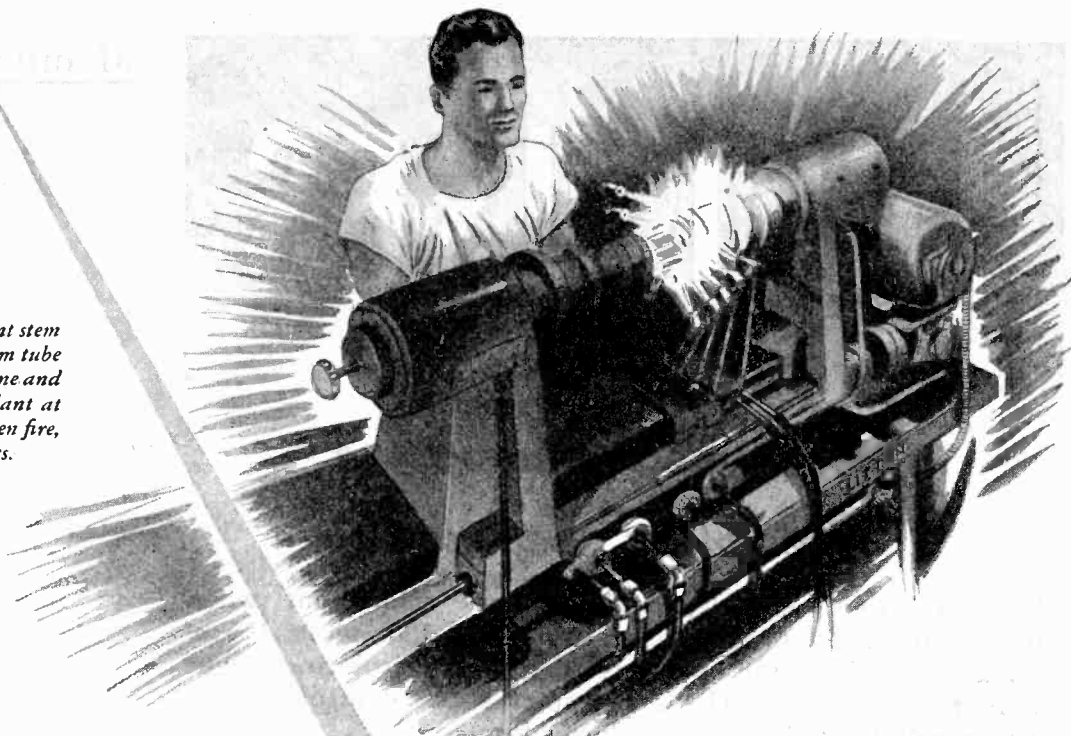

## What you may expect from LITTON

**JET MIX BURNERS.** Litton engineered Jet Mix Burners, proved by 13 years of practical industrial performance, have stepped up production in a number of urgent war industry operations—spectacularly so in vital vacuum tube output.

Compact in size, Litton burners are designed to achieve almost complete carburetion thus eliminating the intense light so injurious to eyes, while permitting low volume operation with complete absence of pop outs—explosions due to rapid change of fire size. Other features of Litton burners include low cost, use of oxygen-gas or oxygen-hydrogen at low and non-critical pressures, uniform size of high temperature flame. They articulate at both head and base, are quickly replaceable, and maintain oxidizing conditions permitting work close to burner tips. Models available are: single jet, two to twelve fire assemblies; large size, seven jet, six or ten fire assemblies; Annealing Burner for bench mounting or with handle. Also hand torches with single or seven jet burners. Complete catalog listings may be had on request.



# Litton

**ENGINEERING LABORATORIES**

**REDWOOD CITY, CALIFORNIA, U. S. A.**

# 1,001 USES

## Condensed Power for Years of Service

VERSATILITY and dependability were paramount when *Alliance* designed these efficient motors — *Multum in Parvulo* . . . They are ideal for operating fans, movie projectors, light home appliances, toys, switches, motion displays, control systems and many other applications . . . providing economical condensed power for years of service.

### Alliance Precision

Our long established standards of precision manufacturing from highest grade materials are strictly adhered to in these models to insure long life without breakdowns.

#### EFFICIENT

Both the new Model "K" Motor and the Model "MS" are the shaded pole induction type — the last word in efficient small motor design. They can be produced in all standard voltages and frequencies with actual measured power outputs ranging upwards to 1/100 H. P. . . Alliance motors also can be furnished, in quantity, with variations to adapt them to specific applications.

#### DEPENDABLE

Both these models uphold the *Alliance* reputation for all round dependability. In the busy post-war period, there will be many "spots" where these Miniature Power Plants will fit requirements . . . Write now for further information.

# A

Remember Alliance!  
—YOUR ALLY IN WAR AS IN PEACE

# ALLIANCE

# MANUFACTURING CO.

# ALLIANCE . OHIO

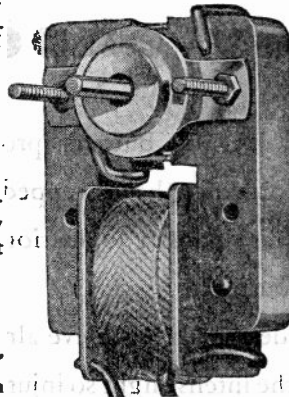

Model "MS" — Full Size  
Motor Measures  
1 1/4" x 2 x 3 1/2"

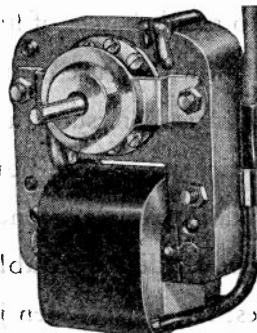

New Model "K" — Full Size  
Motor Measures  
2 1/8" x 2 3/8" x 3 1/2"

## Membership

(Continued from page 40A)

- Diem, G. W., 4748 Hartel Ave., Philadelphia, Pa.  
Goldsmith, J., 48 Eldredge St., Newton, Mass.  
Howe, C. E., Oberlin College, Oberlin, Ohio  
Johnson, Nels, 222 Harrogate Rd., Philadelphia, Pa.  
Lorch, J., 62 Guelph Wood Rd., Southbridge, Mass.  
Marthens, A. S., 218 Metoxet St., Ridgway, Pa.  
Olson, R. H., 30 St. Dr., S.E., Cedar Rapids, Iowa  
Pearce, W. B., 21 Chestnut St., Sharon, Mass.  
Reynolds, J. H., 1901 N. Emerson Ave., Indianapolis, Ind.  
Rodgers, L. M., 8124 Eastern Ave., Philadelphia, Pa.  
Rubin, L., Herrera 527, Buenos Aires, Argentina  
Ruiter, J. H., Jr., 123—17 Ave., East Paterson, N. J.  
Santos, P. J., C. A. Apartado No. 168, Caracas, Venezuela, S. A.  
Schiffmayer, G. F., 186 Maple Ave., Metuchen, N. J.  
Shank, C. A., 32-20—93 St., Jackson Heights, L. I., N. Y.  
Smith, C. P., 998 Center Ave., Lancaster, Pa.  
Stewart, W. F., 2730 Second Ave., S.E., Cedar Rapids, Iowa  
Thompson, W. S., 95 Cumberland Ave., Verona, N. J.

### Admission to Associate

- Adams, W. A., 6405 Corsini Pl., San Pedro, Calif.  
Agren, R., 16145 Pierson St., Detroit 19, Mich.  
Albert, D., 25 Prospect Pl., New York, N. Y.  
Albright, W. G., Box 46, Blacksburg, Va.  
Allen, F. C., 544 Winston Ave., Baltimore 12, Md.  
Amsterdam, C. F., 86 Perth Ave., New Rochelle, N. Y.  
Andreasen, I., 508 Maple Ave., LaPorte, Ind.  
Ascione, R., 8848 Stone Ave., Seattle 3, Wash.  
Barreto, J. M., 196 Stockton St., Brooklyn 6, N. Y.  
Bartolini, E., General Alvarado 550, Ramos Mejia —F.C.O., Buenos Aires, Argentina  
Bawden, M. R., 101 Fordham Rd., West Newton 65, Mass.  
Bell, M. B., 95 Alleghany Rd., Hampton, Va.  
Birdsong, O. J., 1521 Eighth Ave., S.E., Cedar Rapids, Iowa  
Bischoff, C. W., 378 Maplewood Ave., Columbus 9, Ohio  
Bishop, H. M., c/o Postmaster, New York, N. Y.  
Blackwell, E. L., 302 1/2 LaReine Ave., Bradley Beach, N. J.  
Borner, R. C., 495 W. 187 St., New York 33, N. Y.  
Bower, R. S., G.C.A., 3-45, N.A.T.C., Gainesville, Ga.  
Brink, W. H., 7034 S. Artesian Ave., Chicago 29, Ill.  
Brown, R. M., 2 W. 16 St., New York 11, N. Y.  
Brown, C. H., U. S. Naval Mine Warfare Test Station, Solomons, Md.  
Bullock, W. W., 4232 W. 167 St., Lawndale, Calif.  
Burrell, M. W., Collins Radio Co., Cedar Rapids, Iowa  
Carman, F. C., Station KUTA, Salt Lake City, Utah  
Charles, W., 327 E. Walnut St., Marion, Ind.  
Ciardelli, O., Matienzo 58, Quilmes F.C.S., Prov. of Buenos Aires, Argentina  
Converse, L. R., Ward 37-B, McCloskey General Hospital, Temple, Tex.  
Cooke, R. B., 4306 E. 23 St., Kansas City 1, Mo.  
Csensich, J. E., Broadview Rd., Breckville, Ohio  
Custidero, S. D., 223 N. Thomas St., Arlington, Va.  
Davis, H. H., J. P. Seeburg Corp., 1500 Dayton St., Chicago 22, Ill.  
Deiss, E. W., 503 Sunset Ter., Ridgefield, N. J.  
Dilks, C. F., 2 Lynes Pl., Norwalk, Conn.  
Dunefsky, M., 1061 Intervale Ave., Bronx 59, N. Y.  
Easum, C. M., 3020 N.W. 14 St., Oklahoma City, Okla.  
Edleman, V. W., 1404 Florida Ave., West Palm Beach, Fla.  
Edmonds, W. H., Building 509, N.T.C., Bainbridge, Md.

(Continued on page 48A)

# These U. S. Navy Planes Carry Collins Autotune Transmitters



GRUMMAN TBF AVENGER



PB2Y-3 CORONADO

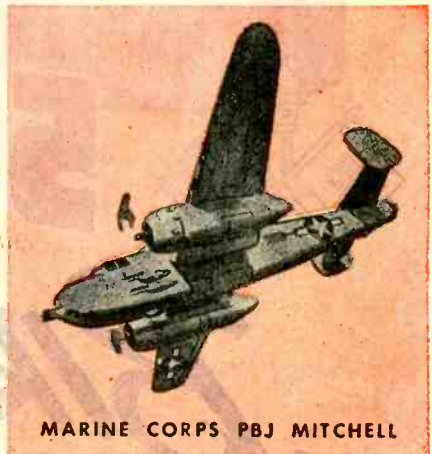

MARINE CORPS PBJ MITCHELL

## The voice of thousands of Navy fliers



THE COLLINS ATC Autotune transmitter is regulation equipment for most two-place-and-larger types of Navy aircraft. It is the military successor of Collins airborne Autotune transmitters which were adopted by several of the great commercial airlines years before the war. Since Japan struck, the Navy has ordered many thousands. In advanced design and rugged construction, today's ATC reflects the lessons of war learned in every quarter of the world. It is a foretaste of the reliability and efficiency to be expected of Collins by commercial and private users after victory. Collins Radio Company, Cedar Rapids, Iowa; 11 West 42nd Street, New York 18, N. Y.

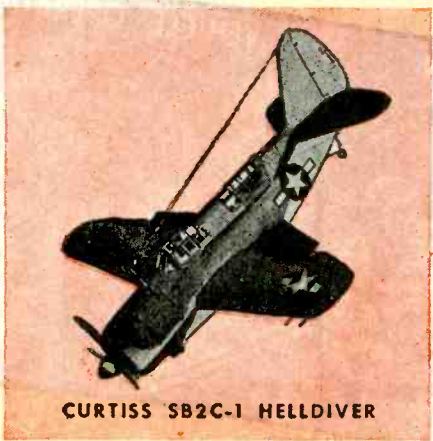

CURTISS SB2C-1 HELLDIVER



PB4Y-2 PRIVATEER



MARTIN PBM-3D MARINER



IN RADIO COMMUNICATIONS, IT'S . . .



Comp Coles Signal Laboratories  
Red Bank, N. J.

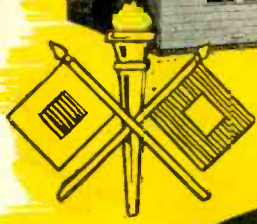

# SCGSA

(SIGNAL CORPS GROUND SIGNAL AGENCY)

# ... BIRTHPLACE OF

The Laboratory . . . here are born electronic weapons that are making history. Our American systems of army communications have proved mighty factors in our fighting successes, due primarily to the remarkable achievements of the Signal Corps Laboratories, known as SCGSA, comprising a chain of research units under one centralized supervision. At one of these Laboratory Units, Camp Coles (pictured above), was conceived the SCR-694, a compact, lightweight, highly versatile and efficient two-way radio telephone and telegraph outfit, for use in vehicles, as a portable ground station or front line command post.

It is a pleasure to give full recognition to the creative genius and organization of SCGSA and the really vital work it accomplishes, necessarily without public attention.

President, The Rauland Corporation



Photos courtesy U. S. Army Signal Corps

**RADIO • • RADAR • • COMMUNICATIONS • •**

*Rauland esteems it a high honor to have been*

# THE SCR-694

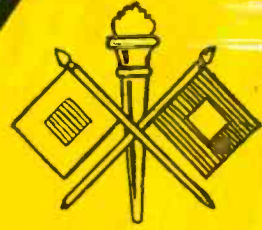

Whether in a foxhole or jeep, in jungle or on the beach, in a tropical downpour, blizzard or surf, the SCR-694 can "take it." When its switch is pressed, this radio is ON THE AIR.

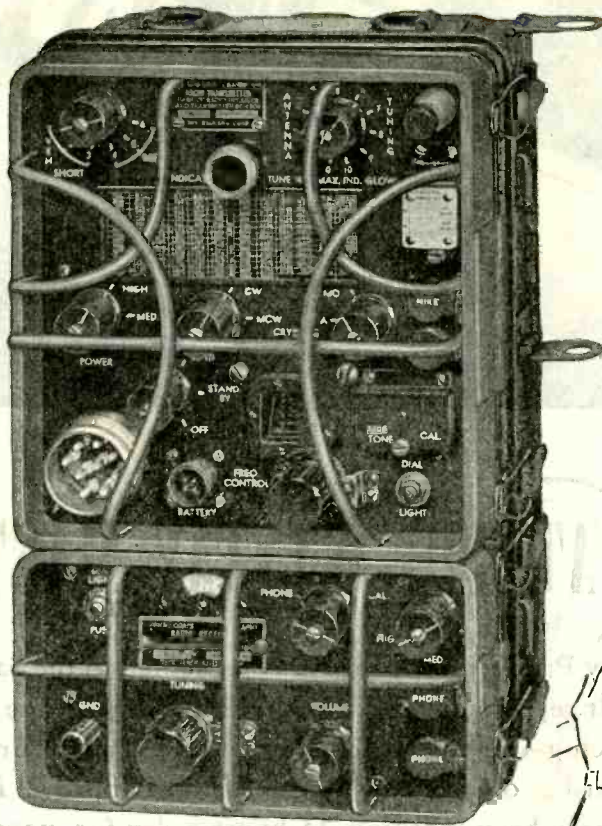

Quotes from field reports  
— from the Pacific:

"During a rainstorm the 694's were the only sets in one section that remained operative."

"The weight of the set, its construction, its features such as crystal control, etc., make it ideal for use in amphibious operations."

— From airborne source:

"One set (SCR-694) landed in a stream of water and although completely submerged (time undetermined) worked normally."



**WATERPROOF**

## SCR-694 TRANSMITTER-RECEIVER

Weight 22 lbs. ★ range sufficient for vehicle use ★ waterproof and fungus proof ★ ideally adapted to jungle or sub-zero operation ★ powered by hand generator, gasoline engine or vehicular vibrator power supply ★ converted from vehicle to field use immediately.

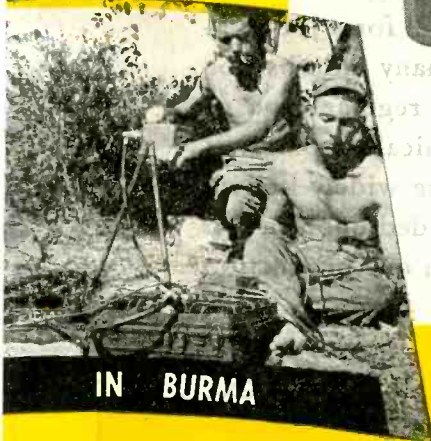

**IN BURMA**

SCR-694 in operation with America's newest fighting unit in Central Burma.

*Electroneering is our business*

# Rauland

**SOUND**

**TELEVISION**

THE RAULAND CORPORATION • CHICAGO 41, ILLINOIS

*selected by SCGSA for the development of SCR-694*

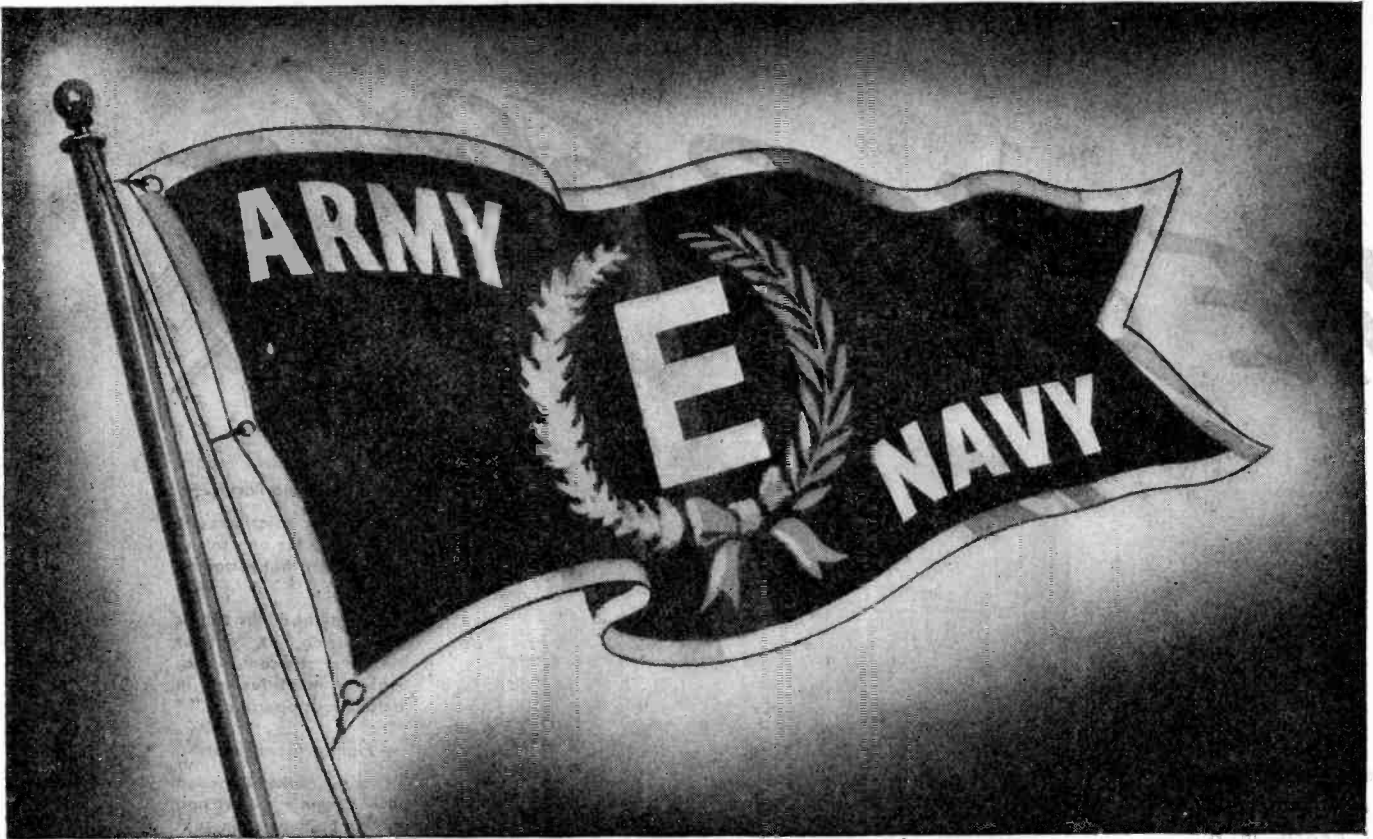

## NOW FLYING AT THE SANTAY MASTHEAD

★ The coveted Army-Navy Production Award was presented to the Santay Corporation on March 24, 1945! It represents official recognition for the fine record established by Santay in producing war equipment. The entire Santay organization is justifiably proud of this award . . . our country's expression of approval for a job well done. All of our facilities have been working 24 hours a day for many months, for VICTORY! Santay's war production has concentrated upon our regular type of products . . . injection molding, metal stamping and electro-mechanical assemblies. The skill and precision craftsmanship for which Santay workers are widely known are indicated in this award. These same fine qualities can be depended upon in *post* war production in equal or surpassing measure to that employed in our production *before* and *during* the war.

INJECTION MOLDING • METAL STAMPING • ELECTRO-MECHANICAL ASSEMBLIES



**SANTAY CORPORATION 358 NORTH CRAWFORD AVE., CHICAGO 24, ILLINOIS**

FORMERLY S NKO TOOL & MANUFACTURING CO.

REPRESENTATIVES: POTTER & DUGAN, INC., 29 WILKESON STREET, BUFFALO 2, NEW YORK • PAUL SEILER, 7779 CORTLAND AVENUE, DETROIT 4, MICHIGAN • QUEISSER BROS., 708 E. NINTH STREET, INDIANAPOLIS 2, INDIANA



# Combining

1. SPECIAL PURPOSE ENGINEERING
2. RECEIVING TUBE TECHNIQUES

The 2C26A exemplifies Hytron's ability to build in soft glass, at high speed, and for economical prices, special purpose tubes. Hytron solved a tough problem for the Services by designing in the 2C26A a tube capable of performance and high ratings never before — or since — achieved in soft glass. This small tube — approximately the same size as the 50L6GT Bantam — is capable of delivering 2 KW of useful r.f. power at 400 megacycles. It replaces larger and much more expensive hard glass transmitting tubes which must be operated at much higher potentials.

## HYTRON TYPE 2C26A VERY-HIGH-FREQUENCY TRIODE PULSE OSCILLATOR

The Hytron type 2C26A is a special triode for use as a grid or plate pulse oscillator up to 300 megacycles. Its cathode is designed and processed to provide the extremely high peak plate currents required in pulse operation. Special top cap design permits use of the maximum potentials, without external voltage breakdown, at the higher altitudes. Other notable features are: convenient size, standard octal base, high-voltage internal ceramic insulators, and extremely rugged construction.



### ELECTRICAL

Coated Unipotential Cathode	6.3 volts
Heater Voltage	1.1 amps.
Heater Current	10 max. watts
Plate Dissipation	2.5 max. watts
Grid Dissipation	3500 max. peak volts
Plate Potential (plate pulsed)	2500 max. dc volts
Plate Potential (grid pulsed)	- 700 max. dc volts
Grid Bias	Eb:400V; Ec:-15V; Eh:6.3V
Average Characteristics for Plate Current	16 ma.
Amplification Factor	16.3
Transconductance	2250 micromhos
Average Direct Interelectrode Capacitances	
Grid-to-Plate	2.8 mmf.
Grid-to-Cathode	2.6 mmf.
Plate-to-Cathode	1.1 mmf.
Frequency for Maximum Rating	300 MC

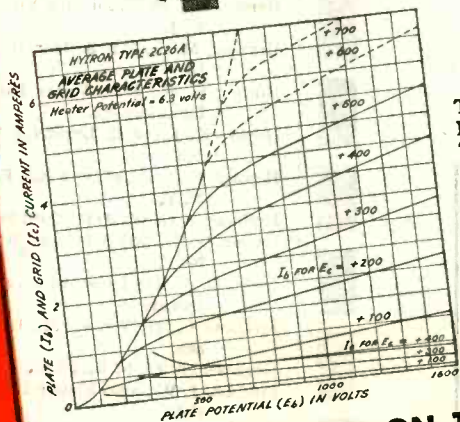

### MECHANICAL

Type of cooling	Convection
Base	Intermediate shell octal 8-pin phenolic
Top Caps	Skirted miniature with insulating bushing
Bulb	T-9
Maximum overall dimensions	
Length	3 11/16 inches
Seated Height	3 3/8 inches
Diameter	1 5/16 inches
Net Weight	1 1/2 ounces

**2C26A IS ON THE ARMY-NAVY PREFERRED LIST**

OLDEST EXCLUSIVE MANUFACTURER OF RADIO RECEIVING TUBES

# HYTRON

RADIO AND ELECTRONICS CORP.



MAIN OFFICE: SALEM, MASSACHUSETTS  
PLANTS: SALEM, NEWBURYPORT, BEVERLY & LAWRENCE

FORMERLY HYTRON CORPORATION

**MOTOR DATA**  
No. 129

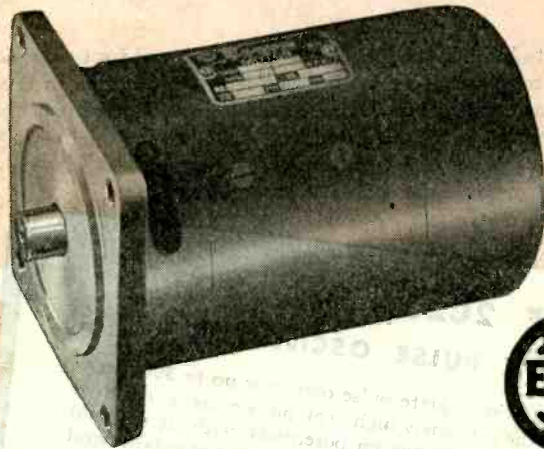

**4000 FRAME MOTOR**  
1/2 HP at 3900 RPM

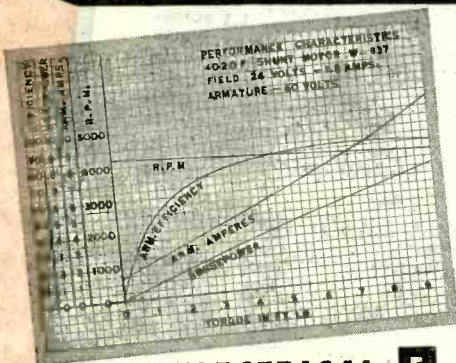

The output—the weight—the size—of these 4000 Frame Motors are features well worth remembering. Every adaptation of the standard design is engineered for the precise requirements of an aircraft, portable, or industrial application.

**ELECTRICAL**  
Series, shunt, or compound-wound  
Unidirectional or reversible  
Optional torque  
Optional speed  
Optimum efficiency  
For control circuits  
Electric braking optional

**MECHANICAL**  
Ventilated or enclosed types  
Base or flange mounting  
Operation in any position  
Low space factor  
Ball bearing equipped  
Optional shaft details  
Rugged construction

4000 FRAME MOTORS		4020	4020
		Shunt	Series
Watts, Output, Con.	(Max.)	375	746
Torque at 3900 RPM	(ft. lbs.)	.65	1.4
Torque at 6000 RPM	(ft. lbs.)		.88
Speed Regulation		8%	
Lock Torque	(ft. lbs.)	2.5	4
Volts Input	(min.)	12	24
Volts Input	(max.)	110	110
Diameter		4"	4"
Length Less Shaft		7 1/8"	7 1/8"
Shaft Dia.	(max.)	.625"	.625"
Weight	(lbs.)	9.2	9.2

**EICOR INC.** 1501 W. Congress St., Chicago, U. S. A.  
DYNAMOTORS • D. C. MOTORS • POWER PLANTS • CONVERTERS  
Export Ad Auricma, 89 Broad. T., New York, U. S. A. Cable Auricma, New York

**Membership**

(Continued from page 42A)

- Ellermann, K. E., 328—13 St., S.E., Washington 3, D. C.
- Ellis, F. W., 3821 Troost Ave., Kansas City 3, Mo.
- Enslin, K., 5501 W. Washington Blvd., Chicago, Ill.
- Fallot, G. W., 135 Charles Ave., Massapequa, L. I., N. Y.
- Faris, J. J., West Beach, Md.
- Faust, A. C., Driftwood, Pa.
- Franco, M., 114, Lordship Lane, Tottenham, London, N. 17, England
- Frank, V. J., R.F.D. 2, St. Mary's, Pa.
- Frantz, N., 2325 N. Springfield Ave., Chicago 47, Ill.
- Frear, G. C., 9901 S. San Pedro St., Los Angeles 3, Calif.
- Friedman, H., 21 Pennsylvania Ave., Brooklyn 7, N. Y.
- Gage, W. M., 7 Newport Rd., Cambridge 40, Mass.
- Gallagher, F. H., Western Electric Co., Radio Division, 165 Broadway, New York, N. Y.
- Garcia Servidio, L. R., Pergamino 178, Buenos Aires, Argentina
- Garrettson, T. M., Box 222, Brightwaters, L. I., N. Y.
- Gates, R. S., Collins Radio Co., Cedar Rapids, Iowa
- Glynn, L. A., 723—34 St., N.E., Cedar Rapids, Iowa
- Goodman, D. H., 4112 First Ave., San Diego 3, Calif.
- Graf, P., 7021 S. Benton St., Kansas City 5, Mo.
- Greenwood, W. R., c/o Fleet Post Office, San Francisco, Calif.
- Gregg, P. E., Squadron B., Flight Two, Boca Raton Field, Fla.
- Gruber, J. R., 2245 Shannon Pl., Washington 20, D. C.
- Haberman, H. M., Staff, Radio Materiel School, Naval Research Laboratory, Washington 20, D. C.
- Harring, D. M., S-26, 15 Royce Rd., Allston 34, Mass.
- Hash, E. F., Radio Laboratory, Building 37, N.N.Y., Portsmouth, Va.
- Heath, D. W., 3417 Hutchison St., Apt. 8, Montreal 18, P.Q., Canada
- Henning, R. W., Radio W-A-R, Box 30, Fort Myer, Va.
- Herman, C. L., 824 Park Ave., Williamsport 14, Pa.
- Hersh, S. H., 49 Washington Village, Asbury Park, N. J.
- Heyman, M. G., 7457 S. Bennett Ave., Chicago 49, Ill.
- Horton, C. E., RCA Victor Division, Dept. 97, Lancaster, Pa.
- Hovey, K. J., 18 E. Lexington St., Baltimore 2, Md.
- Howard, E. P., 25 Jefferson Rd., Farmingdale, L. I., N. Y.
- Huffmaster, G. W., 3147 Third St., Detroit, Mich.
- Immen, G. H., 2835 Bainbridge Ave., New York 58, N. Y.
- Irwin, D. A., 118 Lansdowne Ave., Toronto, Ont., Canada
- Jarvis, G. C., 453 Victoria St., London, Ont., Canada
- Jorgensen, A. C., 67 Broad St., New York 4, N. Y.
- Jamison, J. W., 3906 Flower Dr., Los Angeles 37, Calif.
- Juni, E., Co. 14-45, Section 3, Room 351, N.T.S., Cordell Hall, Stillwater, Okla.
- Joshi, C. P., 11 Hamilton Rd., George Town, Allahabad, India
- Karcher, E. R., 9125 Bradford Rd., Silver Spring, Md.
- Kantrowitz, P., 203 E. 174th St., Bronx 57, N. Y.
- Kelvin, W., c/o Federal Telephone and Radio Corp., Dept. R-3, 67 Broad St., New York 4, N. Y.
- Kihn, A., 98 Grant St., Passaic, N. J.
- Kinnett, C. M., 409 Residence Ave., Albany, Ga.
- Kirby, T. H., 707 S. Oakland Ave., Villa Park, Ill.
- Kirschner, L., 1026 Burton Ave., Apt. 205, Cincinnati, Ohio

(Continued on page 60A)

# POWER TUBE ANODES

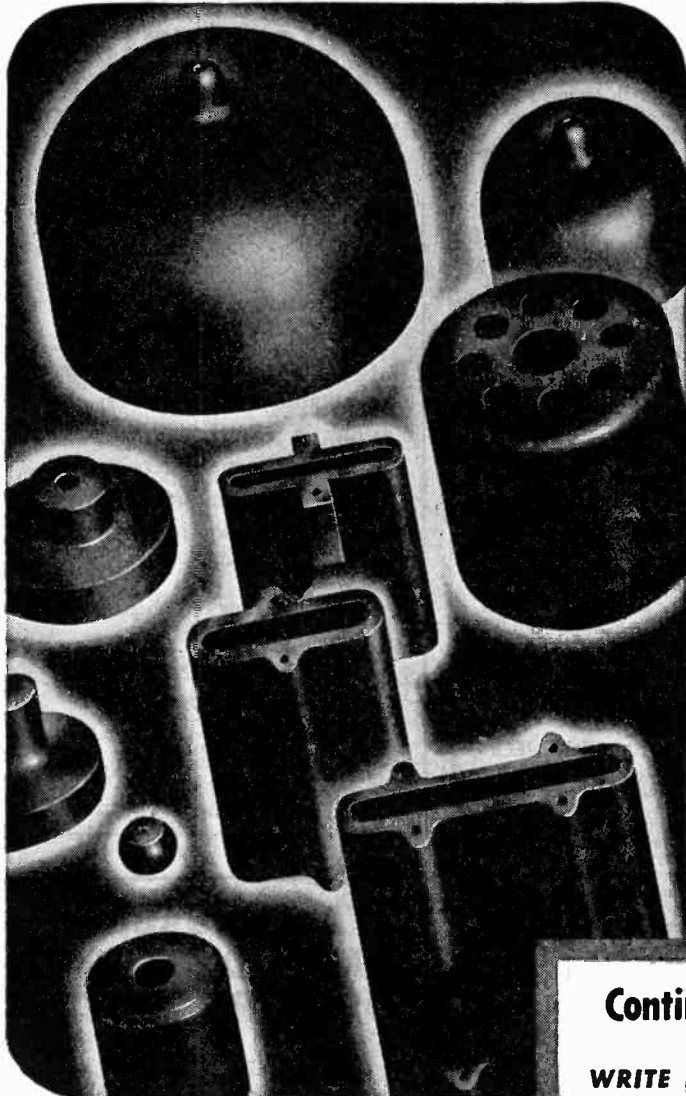

## Standard or Special Types



Stackpole Power Tube Anodes are "tailor-made" for the specific tube type involved. Whether your need is for a standard type or something new for a tube type that has never been made before, Stackpole engineering is well equipped to serve you. Years of experience throughout the entire and highly ramified power tube field are your assurance of the closest possible match to your specifications—or samples which may enable you to set a new, higher standard for your present anode specifications.

## STACKPOLE CARBON COMPANY

St. Marys, Pa.

## STACKPOLE

**ELECTRICAL BRUSHES and CONTACTS**  
(All carbon, graphite, metal, and composition types)

**RARE METAL CONTACTS**

**WELDING RODS, ELECTRODES and PLATES**

**BRAZING BLOCKS**

**RHEOSTAT PLATES and DISCS**  
**PACKING, PISTON and SEAL RINGS**

**CARBON REGULATOR DISCS**

**SINTERED IRON COMPONENTS**

**CARBON PIPE, etc.**

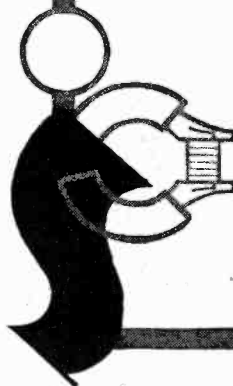

## Continuously Adjustable Carbon Rheostats

(CARBON PILES)

**WRITE FOR  
THIS NEW  
BOOKLET**

Stackpole Engineering has developed the Continuously Adjustable Rheostat formed of piles of carbon discs to a state of efficiency where it is now being used and considered for applications heretofore reserved for rheostats of other, but less satisfactory types. Write for new Bulletin, just off press, describing this development in detail.



# STACKPOLE

"EVERYTHING IN CARBON BUT DIAMONDS"

## OPPORTUNITY NOW FOR TECHNICAL ENGINEERS

In Expanding Organization  
with Post War Future

Progressive company located near San Francisco has splendid openings for Engineers with a degree from a recognized college in physics, electrical or mechanical engineering who have specialized in electronics or allied fields.

Write, stating qualifications, education, draft status and salary requirements. Applicants now employed should submit a detailed resume of their experience together with an evaluation of their present duties.

**DALMO VICTOR**

1414 El Camino Real  
San Carlos, California

## Wanted ENGINEERS

Radio

\*Electrical

Electronic

\*Mechanical

\*Factory Planning

Materials Handling

Manufacturing Planning

Work in connection with the manufacture of a wide variety of new and advanced types of communications equipment and special electronic products.

Apply (or write), giving  
full qualifications, to:

R.L.D.  
EMPLOYMENT DEPT.

**Western Electric Co.**

100 CENTRAL AVE., KEARNY, N.J.

\*Also: C.A.L.  
Locust St., Haverhill, Mass.

Applicants must comply with WMC regulations

## POSITIONS OPEN

The following positions of interest to I.R.E. members have been reported as open. Apply in writing, addressing reply to company mentioned or to Box No. ....

The Institute reserves the right to refuse any announcement without giving a reason for the refusal.

### PROCEEDINGS of the I.R.E.

330 West 42nd Street, New York 18, N.Y.

#### PHYSICIST AND ELECTRICAL ENGINEER OR ENGINEERING PHYSICIST

Physicist qualified to supervise industrial and fundamental research in acoustics. Ph.D. with industrial experience preferred.

Also an electrical engineer or engineering physicist for research position in fundamental and applied electronics. Some industrial experience preferred. Essential work with excellent post-war prospects. Write Armour Research Foundation, 35 West 33rd Street, Chicago 16, Illinois.

#### COMMUNICATION OR RADIO ENGINEERS AND PHYSICISTS

A leading Eastern University is in immediate need of several communication or radio engineers and physicists for a war research project, the importance of which is certified by the armed services. This is an opportunity to make a real contribution to the successful and rapid completion of the Pacific War. The location is on an attractive campus and satisfactory salary arrangements can be made. Write to Box 370.

#### ELECTRONIC AND AUDIO ENGINEER

Electronic and audio engineer for key position in established manufacturing concern with its own laboratories and wide range of facilities. Liberal salary. Post-war opportunities assured by civilian markets. Design and production experience in audio frequency and R. F. fields desired. For confidential interview address Box 371 stating background and qualifications.

#### TRANSFORMER DESIGN ENGINEER

Transformer design engineer for one of the leading transformer manufacturers. Located in New York metropolitan area. If you are E.E. graduate and interested in becoming associated with a company which has real post-war possibilities write to Box 372 giving detailed information about yourself.

#### SALES MANAGER—PARTS JOBBER

Somewhere there is a radio parts salesman or sales engineer now working for a manufacturer's agent, jobber, or manufacturer of radio parts who has cut his eye teeth and is ready for a bigger job.

To such a man we offer a real post-war opportunity, with a hard hitting aggressive organization located in metropolitan area of New York. This company will have a quality line of parts and test equipment to be merchandised and sold through the electronic jobber. Salary and participating basis. If you have the necessary qualifications we want to hear from you. Write fully, in confidence to Box 373.

#### RESEARCH ENGINEERS

Several positions for Physicists, Analysts, and Electronic Engineers are open with the University of California Division of War Research. For further details write, giving personal history, education and qualifications, to Personnel Manager, University of California Division of War Research, U. S. Navy Radio & Sound Laboratory, San Diego 52, California.

#### ELECTRONIC ENGINEERS AND TECHNICIANS

These war jobs, with peace-time opportunities, are open in research laboratory and two manufacturing plants in Newark, N.J., and plant near Philadelphia, Pa.

ENGINEERS: SENIOR TUBE, COMMERCIAL, QUALITY CONTROL MEN AND WOMEN, TEST EQUIPMENT.

JUNIOR ENGINEERS: Men and women with degrees in physics, electrical engineering, chemical engineering, mechanical engineering, mathematics, or chemistry.

(Continued on page 52A)

## RADIO ENGINEERS

Medium - sized, progressive, Midwest manufacturer has openings for one senior and two junior engineers. Desire men for work on military projects now who will be adaptable later to postwar engineering. Prefer men with experience in radio receiver or television laboratory, and with college education in communication engineering.

Our staff knows of this advertisement.

Box No. 355  
PROCEEDINGS OF THE  
I.R.E.  
330 West 42nd Street  
New York 18, N.Y.

## An Unusual EMPLOYMENT OPPORTUNITY

The world wide demand for Seismic Crews provided by Seismograph Service Corporation requires an immediate expansion of its technical personnel.

Men with training and experience particularly in Geology, Physics, Mathematics or Electronics, who will enter foreign service are offered an opportunity leading to responsible positions in petroleum exploration.

Applicants who qualify will be given training in SSC methods, and those who show promise may be sent to South America for further field experience, and when proved competent will be considered for assignments on Seismic crews throughout the world.

Applicants in the U. S. A. must comply with the regulations of the War Manpower Commission.

In writing for details as to training, salary, living allowances, etc., please state your qualifications and age.

## SEISMOGRAPH SERVICE CORPORATION

Kennedy Building  
TULSA, OKLAHOMA, U.S.A.

# HERMASEAL

## HERMETICALLY SEALED TRANSFORMERS —DEPENDABLE IN JUNGLE WARFARE

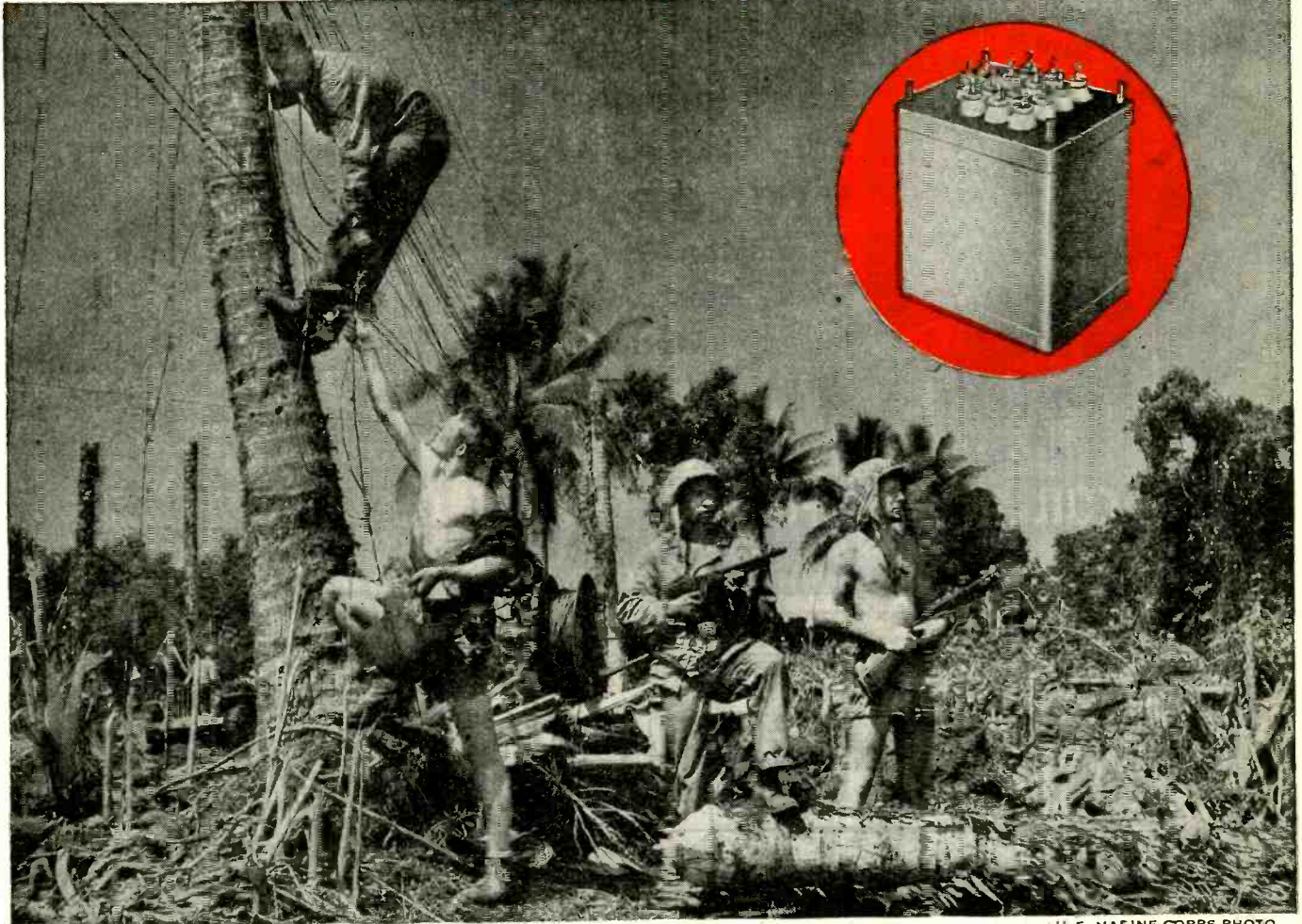

U. S. MARINE CORPS PHOTO

AmerTran has always adhered rigidly to high quality standards. For this reason, Hermaseal Hermetically Sealed Transformers had no difficulty in meeting the strict requirements of government procurement officers for "tropicalization" of these components.

Precautions include vacuum varnish impregnation of core and coil, infra-red pre-heating before compound filling, induction soldering of case seams. Ceramic terminals are protected by torque gauging and resilient gaskets. To insure thorough hermetic sealing, each unit is subjected to a vacuum immersion test. Write for details.



**HERMASEAL**

THE AMERICAN TRANSFORMER CO., 178 Emmet St., Newark 5, N. J.

Pioneers Manufacturers of Transformers, Reactors and Rectifiers for Electronics and Power Transmission

### AMERTRAN ASSIGNED "APPROVED" QUALITY CONTROL RATING BY AIR FORCES

On March 14, 1945, the Air Technical Service Command of the Army Air Forces delegated to the American Transformer Company full responsibility for meeting contract requirements. This assignment of an "Approved" Quality Control Rating which eliminates duplicate inspection during fabrication was awarded on the basis of AmerTran's record in adhering to quality standards.

# AMERTRAN

MANUFACTURING AND ENGINEERING NEWARK, N. J.

**MERIT**  
C.T.C.  
Since 1924  
FINE  
RADIO  
PARTS

CONTRIBUTING  
to  
**VICTORY**  
—and the New  
Electronic  
World—

**MERIT COIL & TRANSFORMER CORP.**  
TELEPHONE  
4427 North Clark St. Long Beach 6311 CHICAGO 40, ILL.

## LOOKING FOR ENGINEERS

An unusual opportunity to undertake engineering activities in design and development of ultra-high frequency electronic products.

Prior to the war, this Corporation was among the leading producers of Electronic equipment for Industrial application.

Now engaged as Prime Contractors on urgent War Contracts, involving interesting research and development. We need engineers with experience in designing and engineering VHF-UHF Electronic products, and with ambition.

Large projects in the field of Ultra-high Frequency and advanced Electronic applications are scheduled to follow in the post-war period, insuring security and fine environments to all our co-workers.

Write to L. R. Ripley, President, explaining your experience in detail. Your communication will be treated in complete confidence and no further investigation will be made without your express permission.

**United Cinephone Corporation**  
Torrington, Connecticut

## POSITIONS OPEN

(Continued from page 50A)

**FOREMEN AND ASSISTANT FOREMEN, experienced in radio or radio tube manufacture. TECHNICIANS, CIRCUIT MEN, to do wiring and construction.**

Address replies to National Union Radio Corporation, Plane St. at Raymond Blvd., Newark 2, N.J. (WMC rules apply.)

### RADIO AND RADAR ENGINEERS

Your services are vitally needed by the Army Air Forces for the development of ground communication systems peculiar to the Air Forces. These projects are now under development at the newly activated AAF, Watson Laboratories, Red Bank, N.J.

These are Civil Service positions and the pay scale ranges from \$2600 to \$5600 per annum.

Application may be made to the Civil Service Commission, 641 Washington St., New York, N.Y. or by contacting the Personnel Officer of the Watson Laboratories, Red Bank, N.J.

### RADIO, ELECTRICAL AND MECHANICAL ENGINEERS

Opportunity for men with experience in design of receivers and allied equipment. Extensive post-war program. Write fully outlining experience, salary desired, etc. Address Bernard Fein, Electronic Corporation of America, 45 West 18th St., New York, N.Y.

### RADIO ENGINEERS

Southern California manufacturer has openings for senior radio engineers with design experience in home receivers, communication receivers, and phono play-backs. Communicate with A. O. Williams, 703 West Ivy St., Glendale 4, Calif.

### ELECTRONIC ENGINEERS, PRODUCTION MANAGER

New York corporation is interested in adding Junior and Senior Engineers with design and development experience, and a Production Manager with electronic and mechanical experience.

Salaries, based on experience and capacity, range up to \$100 a week for Junior Engineers, and \$10,000 a year for Senior Engineers and Production Manager. Address reply to Box 368.

### ACOUSTICAL ENGINEER

Acoustical and electronic engineer for development work on electronic musical instruments.

Also electronic technician and an electronic draftsman. Permanent positions in a research and development laboratory. Write Supersonics, Inc., 231 East 47th Street, New York 17, N.Y.

### SALES ENGINEER

Manufacturers-representatives' company in New England needs a sales engineer, preferably one residing in Connecticut, with good technical background, pleasant personality, and keen judgment in appraising and working out technical details. Past experience in selling not necessary.

Work involved includes calling on industrial accounts in New England, and discussing engineering matters and working out solutions of technical problems between customers and manufacturers.

Position represents an immediate opportunity with postwar future and pays well. Send replies to Box 369.

### OPPORTUNITIES IN PRESENT AND POST-WAR WORK

Senior and Junior graduate engineers with one or more years radio experience wanted by an expanding manufacturing division of an established communication company.

Present activities include high- and medium-power transmitters, frequency shifters, other communication products for the Navy and designs and models for post-war use.

Engineers with practical experience also required for radio communication plant installation and test in foreign countries.

Phone, call or write stating experience, education, present salary, etc. Press Wireless, Inc., Hicksville, L.I., N.Y.; Attention of S. A. Barone, Chief Mfg. Engr.

### TELEVISION TECHNICIANS

The Television Laboratories of the Columbia Broadcasting System, in New York, need television technicians. Men having had definite experience in the television field, transmitters, or

(Continued on page 54A)

ONE OF A SERIES OF ELECTRO-VOICE ADVERTISEMENTS EXPLAINING IN DETAIL  
THE APPLICATIONS AND SPECIFICATIONS OF ELECTRO-VOICE MICROPHONES

# INDOOR . . . . OUTDOOR

## IN ALL KINDS OF WEATHER

### HIGHER ARTICULATION WITH LESS FATIGUE

# Electro-Voice MODEL 600-D

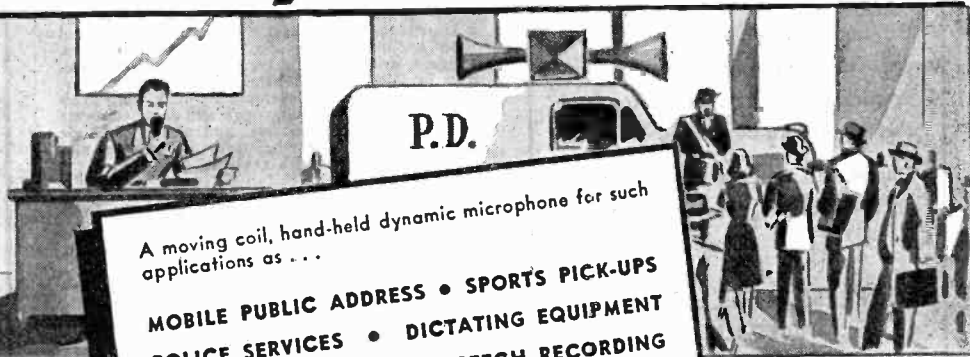
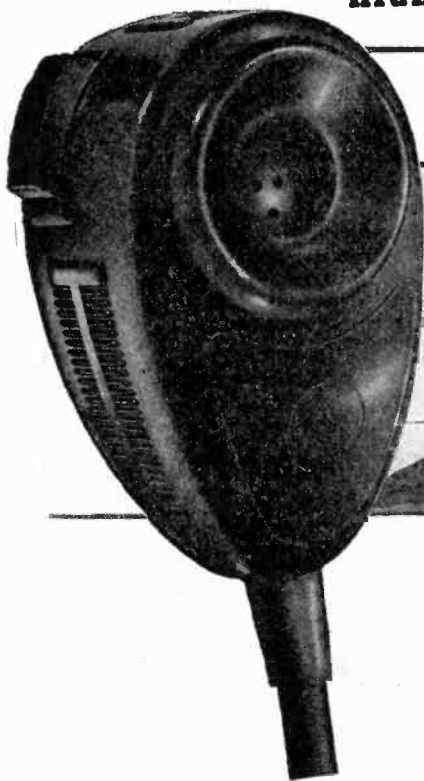

A moving coil, hand-held dynamic microphone for such applications as . . .

- MOBILE PUBLIC ADDRESS • SPORTS PICK-UPS
- POLICE SERVICES • DICTATING EQUIPMENT
- MARINE SERVICES • SPEECH RECORDING

Exhaustive tests have proved that a uniform response to all frequencies between 200-4000 c.p.s. will give higher articulation, provide more usable power level, and be less fatiguing to the listener than one which is peaked. These advantages are assured in the Electro-Voice Model 600-D because the frequency response is unweighted and substantially flat. Where ambient noise does not interfere or distract, high fidelity speech transmission is provided, indoors or outdoors . . . in any kind of weather.

**OUTPUT LEVEL RATING:** Power: 56 db below 6 milliwatts for 10 dynes/cm pressure. Voltage (high impedance): 5 db above .001 volt/dyne/cm<sup>2</sup>, open circuit. Voltage developed by normal speech (100 dynes/cm<sup>2</sup>): .177 volt.

**FREQUENCY RESPONSE:** 100-6000 c.p.s.

**WEIGHT:** 9 ounces.

**HARMONIC CONTENT:** Less than 2% at all frequencies.

**DIAPHRAGM:** Made of heat-treated duralumin, corrosion inhibited.

**VOICE COIL:** Made of pure aluminum, high-Q design.

**CASE:** Constructed of finest quality, high impact phenolic.

**PRESS-TO-TALK SWITCH:** Sliding contact, self cleaning type, standard circuit opens microphone and closes relay simultaneously. Other combinations optional.

**TRANSFORMER CORE:** Made of nickel alloy, hydrogen annealed metal; low capacity windings.

**MAGNETIC CIRCUIT:** Employs Alnico V and Armco magnetic iron.

**IMPEDANCES:** Hi-Z (Direct-to-Grid), 50, 200, 250, or 500 ohms.

Equipped with 6 feet of two conductor and shielded synthetic rubber jacketed cable.

Model 600-D, List Price \_\_\_\_\_ \$27.50      Model 600-DL, with switch lock, List Price \_\_\_\_\_ \$29.00

See your nearest radio parts distributor today. His knowledge of Electro-Voice microphones may aid you in selecting the appropriate type for your specific needs. He may also be an important factor in speeding your order.

SUPPORT  
THE SEVENTH  
WAR LOAN  
DRIVE

# Electro-Voice MICROPHONES

ELECTRO-VOICE CORPORATION • 1239 SOUTH BEND AVENUE • SOUTH BEND 24, INDIANA  
Export Division: 13 East 40th Street, New York 16, N. Y., U. S. A. Cables: Arlab



## OPPORTUNITIES In Present and Postwar Work

Senior and Junior graduate engineers with one or more years radio experience wanted by an expanding manufacturing division of an established communication company.

Present activities include high and medium power transmitters, frequency shifters, other communication products for the Navy and designs and models for postwar use.

Engineers with practical experience also required for radio communication plant installation and test in foreign countries.

Phone, call or write stating experience, education, present salary, etc.

TO  
PRESS WIRELESS, INC.  
HICKSVILLE, L.I.

ATT: S. A. BARONE CHIEF MFG. ENGR.

## ENGINEERS NEEDED

**ELECTRONIC ENGINEER**, with laboratory experience and familiarity with circuit design and development work. Job will be in connection with high frequency heating generators and other industrial applications of electronics. Graduate—Electrical or Radio Engineering.

**JUNIOR ENGINEER**, preferably Engineering graduate, with experience in Radio Engineering laboratory, factory or engineering department. Job will be in connection with H.F. and A.F. measurements, and general development work.

**JUNIOR RADIO ENGINEER OR PHYSICIST**, with good mathematical background.

In replying give complete information as to experience, education, marital, draft status, and salary expected.

**ILLINOIS TOOL WORKS**  
Employment Manager  
2501 North Keeler Avenue  
Chicago 39, Illinois



(Continued from page 52A)

receivers, preferred. Excellent opportunity for well qualified applicants. Our staff knows of this advertisement and replies will be kept confidential. Write, giving all details, to CBS Television Engineering Department, 485 Madison Avenue, New York 22, New York.

### ENGINEERS

A Midwestern manufacturer of radio transmitters and associated equipment has openings for several junior project engineers qualified to supervise or assist development of transmitters, speech input systems, control apparatus, and similar items. Salary average \$2500 per year. Give full details first letter. Address Box 365.

### ELECTRICAL ENGINEER FOR ELECTRONIC RESEARCH

An unusual opportunity for a man who has a knowledge of hot and cold cathode tubes and tube applications in amplifiers, multivibrators, triggers, and switching circuits. Permanent position in laboratory of established manufacturer, doing research and development work, both present and post war. Salary open and commensurate with experience, initiative, and ability. Include complete details of education, experience, and WMC availability with reply to Box 366.

### THE OHIO STATE UNIVERSITY

Announces Westinghouse Educational Fellowships in Electron Optics

A post-doctoral fellowship—\$3600 per year. Two pre-doctoral fellowships—\$1000 per year.

Open to graduates in Physics, Mathematics or Electrical Engineering.

Application forms may be secured from the Dean of the Graduate School, Ohio State University, Columbus 10, Ohio

## ELECTRONIC AND RADIO EQUIPMENT

*Customized*

### For Dependable Performance

Designed and built by seasoned engineers and skilled craftsmen, Comco Electronic Equipment is rigidly restricted in volume to permit highest *custom* standards.

### A VERSATILE LINE

- ★ Aeronautical Ground Stations
- ★ Airport Traffic Control Towers
- ★ Commercial and Private Aircraft
- ★ Police, Fire and Public Safety
- ★ Marine Communications

WRITE! Complete details on request.

MANUFACTURERS OF RADIO & ELECTRONIC EQUIPMENT  
**COMCO**  
COMMUNICATIONS COMPANY, Inc.  
CORAL GABLES 34, FLORIDA

## Microwave Research and Development Engineers

Engineers or Physicists who have had experience in the development or design of microwave equipment, or experience in television or non-linear circuits are needed to work on a long-range government development project.

## Radio Product Design Engineers

Engineers experienced in designing radio communication, radio broadcast, or television equipment are needed to assume responsibility for designing radio equipment for factory production.

• While these openings are primarily for senior men, we also have opportunities for several junior engineers in these fields. Interested persons are invited to write, giving full qualifications, to the Engineering Personnel Manager.

War Manpower Commission rules will be observed.

**STROMBERG-CARLSON CO.**  
ROCHESTER, 3, N. Y.

## Electronic Circuit Engineers

Graduate or non-graduate Engineers, with at least two years experience, needed for application of hearing aid type tubes to present and post war small electronic devices. Interviews can be arranged in New York and Chicago after application is submitted. Applicants must comply with all necessary W.M.C. regulations.

**Raytheon Manufacturing Co.**  
55 Chapel Street  
Newton, Massachusetts



HERE'S ONE OF THE SECRETS OF HIGHER FIDELITY

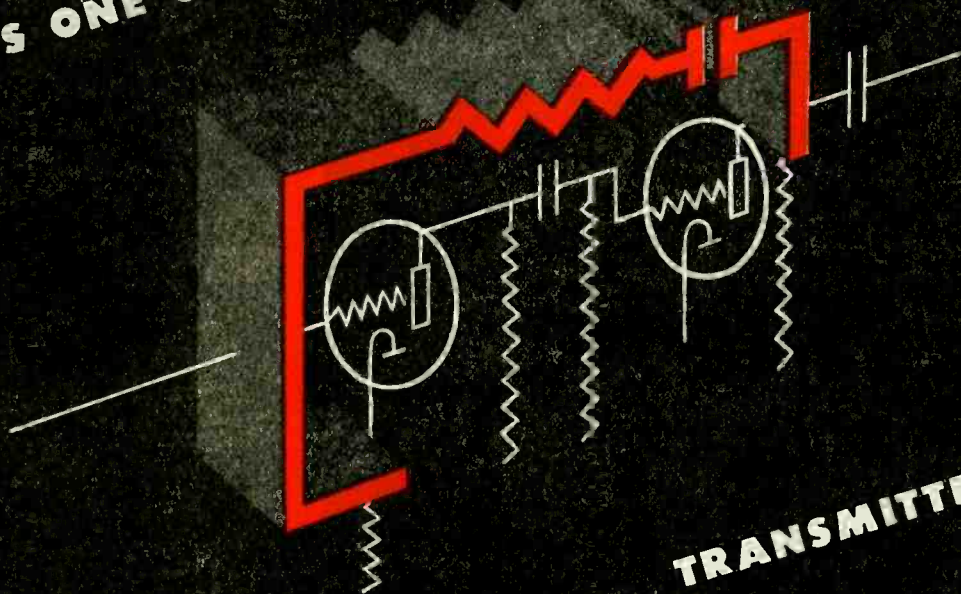

IN WESTINGHOUSE

TRANSMITTERS

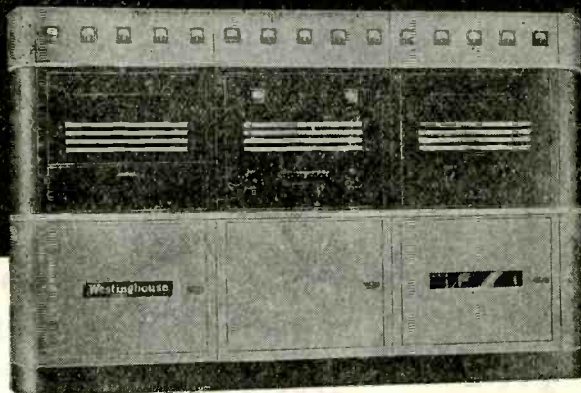

Easy operation is another keynote of the smartly-styled Westinghouse 5kw transmitter . . . one master switch puts the transmitter on the air and cuts off power at close of broadcast day. Controls reset automatically whenever overloads occur in any circuit for any reason.

Here's one of the secrets of the higher fidelity in Westinghouse 5 and 10kw transmitters: it's called equalized audio feedback (see drawing) and it's an outstanding contribution to higher signal fidelity.

Equalized audio feedback strengthens the already high fidelity of the audio and modulation circuits in Westinghouse transmitters, and reduces audio distortion to even lower limits. The system is independent of any variation in rectified antenna output.

Control simplicity, economy and high fidelity are natural partners of the solid dependability you find in the complete line of Westinghouse transmitters . . . 5, 10 and 50kw AM and 1, 3, 10 and 50kw FM. Your nearest Westinghouse office has all the facts on these newest achievements in faithful transmitter operation designed by Westinghouse . . . the oldest name in broadcasting. Westinghouse Electric & Manufacturing Company, P. O. Box 868, Pittsburgh 30, Pa. J-08110

XXV—RADIO'S 25TH ANNIVERSARY—KDKA

Proceedings of the I.R.E. May, 1945



**Westinghouse**  
PLANTS IN 23 CITIES . . . OFFICES EVERYWHERE

*Electronics at Work*

YOUR BLUE PRINT  
IS READY...

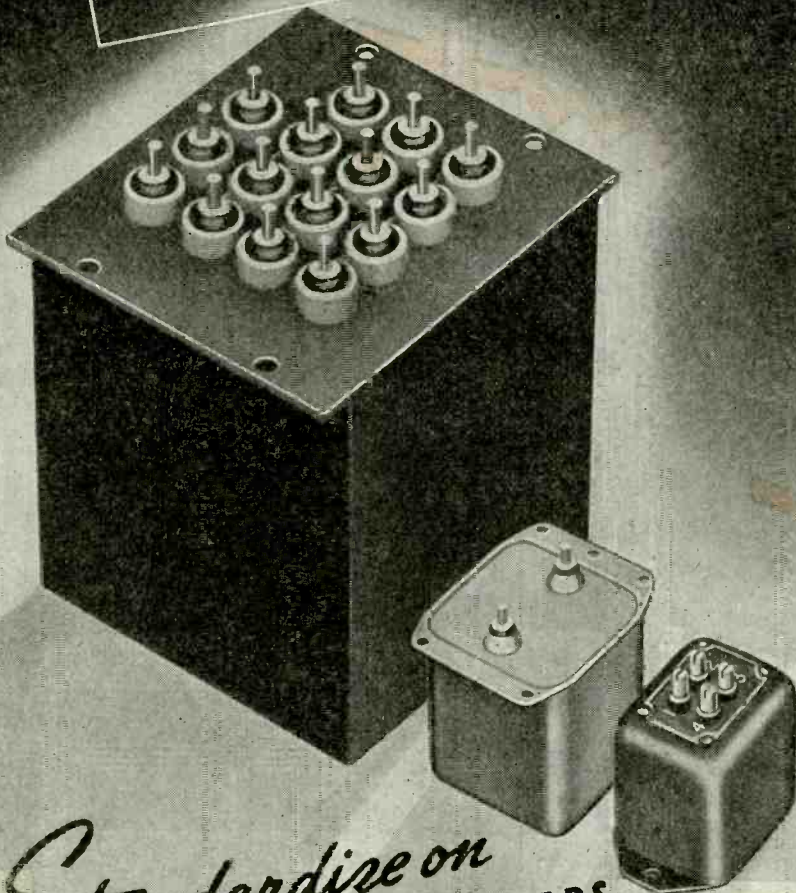

*Standardize on*  
**STANCOR TRANSFORMERS**  
...the precision-built line!

Many startling improvements have come out of our broad war communications experience, which will distinguish Stancor transformers for the future, PLUS a wide expansion into diversified peace-time uses... We are sure that your individual specifications for your post-war designs are present today, in Stancor engineering... May we be of aid in drawing the transformer part of your industrial blue print?

STANDARD TRANSFORMER CORPORATION  
1500 N. HALSTED ST., CHICAGO 22, ILLINOIS



KEEP OFF  
THE

*Beam*

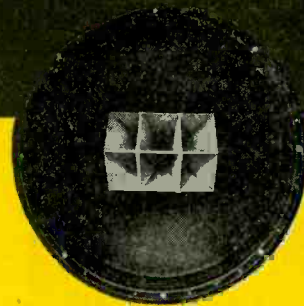

WITH THE  
**DUPLEX SPEAKER**

The very objectionable concentrated beam at high frequencies in sound reproduction is eliminated by the Duplex Speaker. Even at 15,000 cycles plus, the DUPLEX speaker distributes high quality sound 60 degrees horizontally and 40 degrees vertically as compared to the 5 degrees of single unit speakers of comparable size. Another reason why the DUPLEX is the SPEAKER that REVOLUTIONIZES the methods of sound REPRODUCTION.

SEND FOR BULLETINS

**ALTEC**  
LANSING CORPORATION

1210 TAFT BLDG., HOLLYWOOD 28, CALIF.  
250 WEST 57 STREET, NEW YORK 19, N. Y.  
IN CANADA: NORTHERN ELECTRIC CO.

Proceedings of the I.R.E. May, 1945

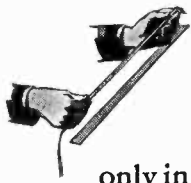

## WHY WE MEASURE OUR OWN "YARDSTICKS"

Complex, sensitive instruments are a commonplace not only in the engineering laboratories but on the production lines of Connecticut Telephone & Electric Division. These instruments enable us to maintain the extreme precision in telephone equipment and electronic devices called for by Signal Corps standards. So important is this high precision that we

have special apparatus for measuring the accuracy of the test instruments themselves.

The result of this constant testing and retesting is *better products*... better telephones, headsets, switchboards and other devices, for our armed forces, a better, brighter future for your communicating systems, electrical and electronic equipment for tomorrow.

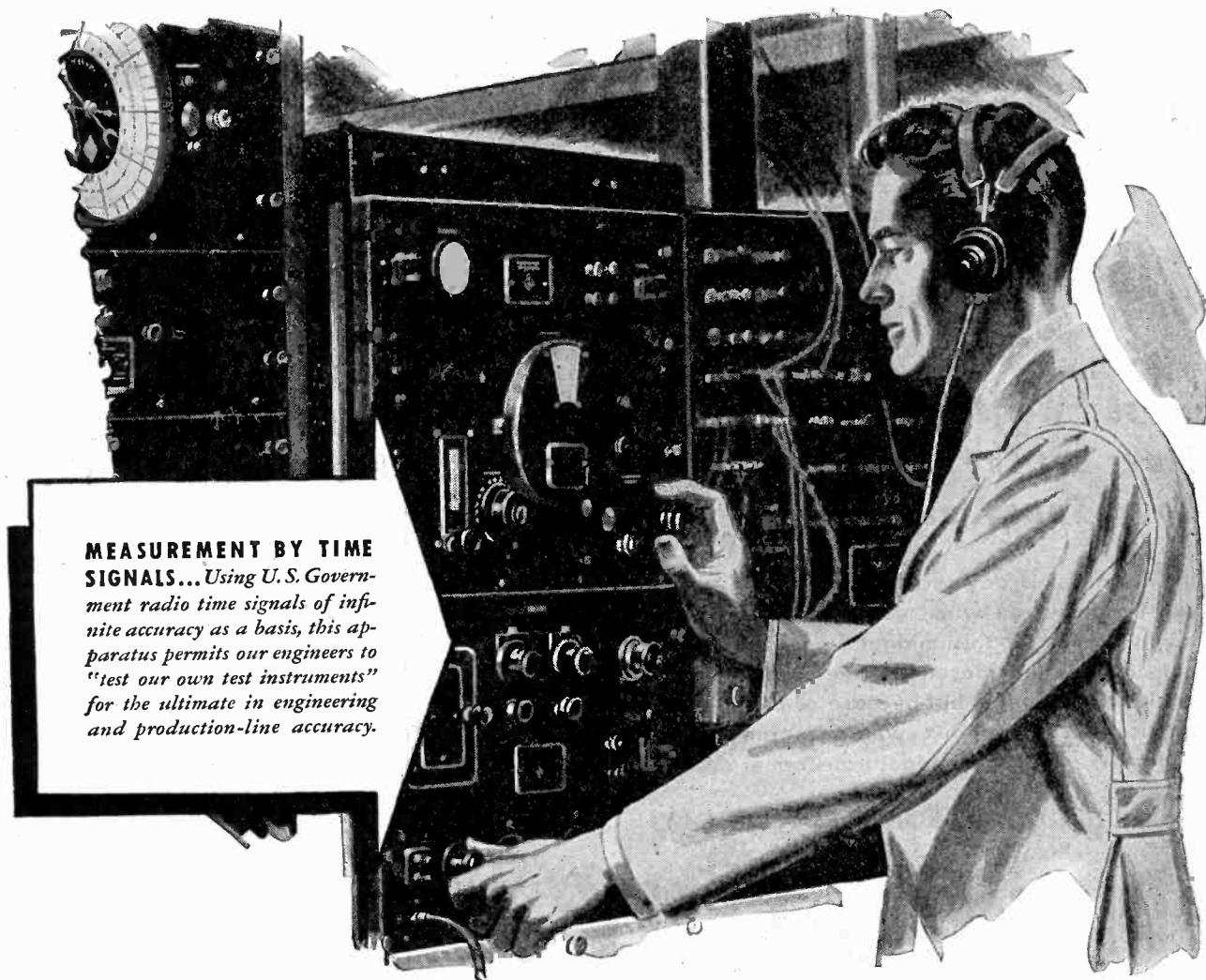

**MEASUREMENT BY TIME SIGNALS...** Using U. S. Government radio time signals of infinite accuracy as a basis, this apparatus permits our engineers to "test our own test instruments" for the ultimate in engineering and production-line accuracy.



## CONNECTICUT TELEPHONE & ELECTRIC DIVISION

GREAT AMERICAN INDUSTRIES, INC. • MERIDEN, CONNECTICUT

TELEPHONIC SYSTEMS • SIGNALLING EQUIPMENT • ELECTRICAL EQUIPMENT • HOSPITAL AND SCHOOL COMMUNICATIONS AND SIGNALLING SYSTEMS • IGNITION SYSTEMS

**Permoflux**

*Triumphs!*

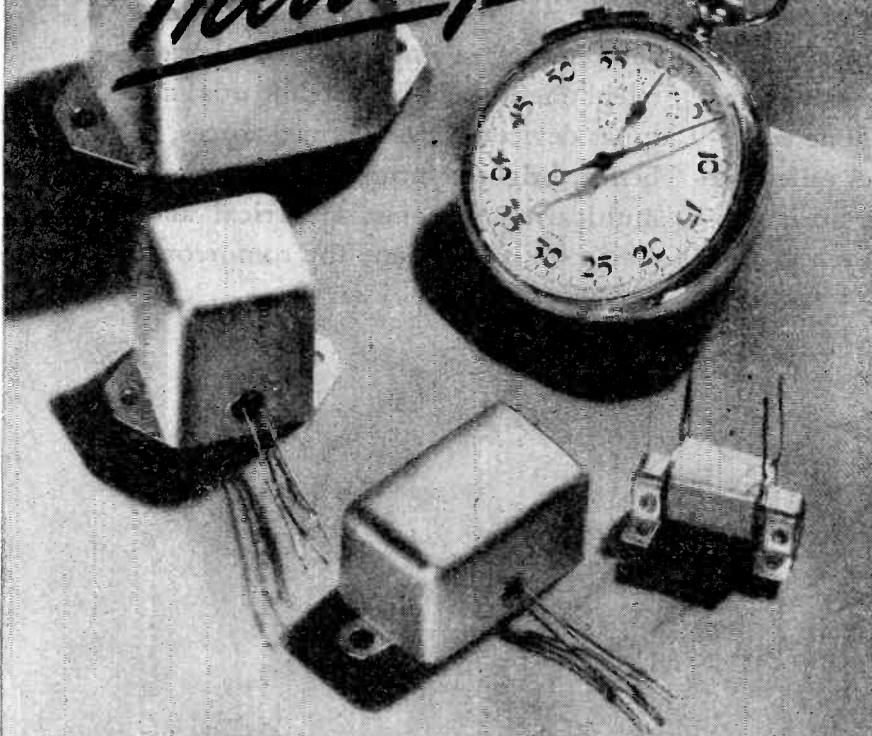

**These "World's Smallest Transformers" May Be The Complete Answer to Your Space and Weight Problems!**

It's not an everyday occurrence when so large a problem can be answered with such a small unit. In fact, we're mighty proud of this midget transformer achievement—not only for the reason that Permoflux engineers met a vital war challenge, but because of its numerous practical applications. Permoflux welcomes inquiry from design engineers about this midget transformer development.

**BUY WAR BONDS FOR VICTORY!**

TRADE MARK  
**PERMOFLUX**

**PERMOFLUX CORPORATION**  
4900 WEST GRAND AVE., CHICAGO 39, ILL.



**PIONEER MANUFACTURERS OF PERMANENT MAGNET DYNAMIC TRANSDUCERS**

**A FAMOUS PAIR—**

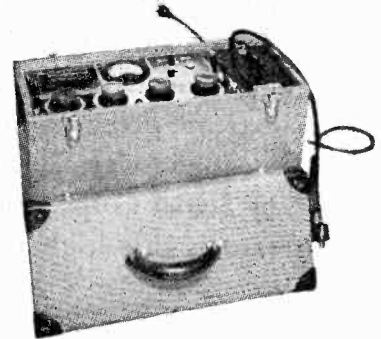

● THE GATES 3 CHANNEL PORTABLE REMOTE AMPLIFIER FOR ALTERNATING CURRENT OR BATTERIES



● THE GATES REMOTE CONDITIONER FOR SINGLE MICROPHONE REMOTE PICK UPS, A.C. OPERATED

**GATES REMOTE PICK-UP AMPLIFIERS**

This famous pair is truly "a Jack of all trades" . . . for more than a decade they have been "Aces" in doing an outstanding job of remote broadcasting from Maine to Pango Pango—from Macy's windows to Montana's mountains—from Sandlot ball games to World Series. The fact that Gates Remote Conditioners are used in nearly every U. S. broadcast station for single mike pickups, is proof that this famous pair has been engineered for efficiency and economy.

*Ask About Our Priority Plan for Prompt Delivery When Gates Equipment is Again Available.*



**RADIO COMPANY**  
QUINCY, ILLINOIS, U.S.A.

MANUFACTURERS OF RADIO BROADCAST TRANSMITTERS, SPEECH EQUIPMENT, ANTENNA TUNING AND PHASER UNITS, AMPLIFIERS, REMOTE EQUIPMENT, BROADCAST STATION AND TRANSMITTER ACCESSORIES.

# When insulator design calls for Quick Action

DEPEND ON

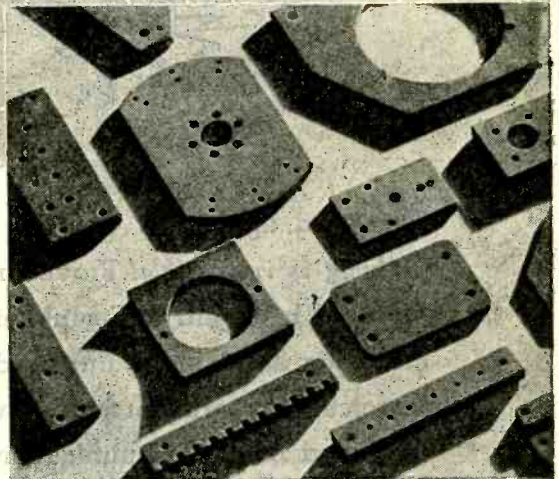
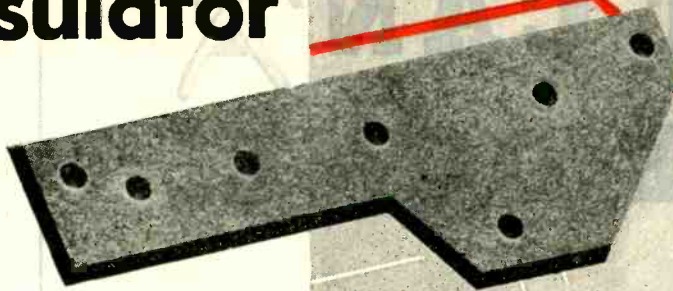

When time is of the utmost importance the ease and precision with which Mykroy can be fabricated into insulator parts makes it exceptionally useful to electronic and electrical engineers. Make those design changes on the spot . . . make them quickly and economically with Mykroy, for, here is a ceramic which can be worked in your own shop. Just transfer your design to the Mykroy sheet . . . then using conventional shop tools . . . produce the desired part by simple cutting, grinding, drilling, tapping and polishing techniques.

Because it has high structural strength and physical stability Mykroy can be machined to critical tolerances more readily than other types of ceramics. In addition, its electrical characteristics are of the highest order and do not shift under any conditions short of actual destruction of the insulation itself. This, plus excellent chemical and physical properties, makes it one of the best insulating materials ever developed for general and high frequency applications.

Get the full facts about this versatile dielectric now. Ask for a copy of the new MYKROY BULLETIN 102 which describes the new larger (19 1/4" x 29 3/4") sheet now available and call upon our engineers to help with your problems.



A representative group of parts fabricated in Mykroy to customer's specifications in our own plant. We have complete facilities to produce such parts in any quantities on rapid delivery schedules. Send us your specifications.

#### MECHANICAL PROPERTIES\*

MODULUS OF RUPTURE.....	18000-21000psi
HARDNESS	
Mohs Scale 3-4 BHN. BHN 500 K9 Load. 63-74	
IMPACT STRENGTH.....	ASTM Charpy .34-.41 ft. lbs.
COMPRESSION STRENGTH.....	42000 psi
SPECIFIC GRAVITY.....	2.75-3.8
THERMAL EXPANSION.....	.000006 per Degree Fahr.
APPEARANCE.....	Brownish Grey to Light Tan

#### ELECTRICAL PROPERTIES\*

DIELECTRIC CONSTANT.....	6.5-7
DIELECTRIC STRENGTH (1/4").....	630 Volts per Mil
POWER FACTOR.....	.001-.002 (Meets AWS L-4)

#### \*THESE VALUES COVER THE VARIOUS GRADES OF MYKROY

- GRADE 8. Best for low loss requirements.
  - GRADE 38. Best for low loss combined with high mechanical strength.
  - GRADE 51. Best for molding applications.
- Special formulas compounded for special requirements.

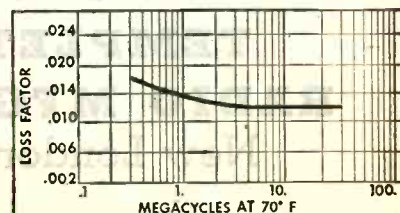

Based on Power Factor Measurements made by Boonton Radio Corp. on a standard Mykroy stock.

MADE EXCLUSIVELY BY

**ELECTRONIC MECHANICS INC.**

70 CLIFTON BLVD., CLIFTON, N. J.  
CHICAGO 47: 1917 N. Springfield Ave., Tel. Albany 4310  
EXPORT OFFICE: 85 Broad Street, New York 4, New York

MYKROY IS SUPPLIED IN SHEETS AND RODS — MACHINED OR MOLDED TO SPECIFICATIONS

# IT CAN'T BE DONE!



Time and again this war has proved that *nothing is impossible!* Proved right here in our own backyard, as Temple engineers and craftsmen delve along unblazed trails of research and experiment to design and produce more and better communications equipment for the battle fronts.

This ability to both design and deliver the seemingly impossible, under stress of war, has bred an unfailing inventive capacity that should prove invaluable in meeting the vast commercial requirements of peace.



*Electronics Division*

**TEMPLE TONE**  
**RADIO MFG. CORP.**  
New London, Conn.

## Membership

(Continued from page 48A)

- Knoblock, E. C., 711 J.M.S. Building, South Bend 5, Ind.
- Kowch, S. D., 66 Bolton St., Ottawa, Ont., Canada
- Lapham, R. R., AP176 (Detail) U.S.C.G. Rec. Station, Ellis Island, New York
- Lawrence, C., Base Co., U.S.N.A.S., Alameda, Calif.
- Loeber, C. W., Federal Communications Commission, Washington 25, D. C.
- Leemon, W., 25 Wilmer St., Apt. 1-E3, Madison, N. J.
- Levis, O. C., Jr., 2432 Oregon Ave., Long Beach 6, Calif.
- Lizotte, O. A., 8003 Roxboro Rd., Montecello Village, Norfolk 5, Va.
- Longtine, E. J., 29, Melville St., Springfield, Mass.
- Lindsay, J. C., 84 Mokema Ave., Waltham, Mass.
- MacKay, J. G., R.C.A.F. Station, Clinton, Ont., Canada
- Macnee, D. H., c/o Standard Telephones and Cables, Ltd., Dowlish Ford Mills, Ilminster, Somerset, England
- Mangiameli, V. S., 39 Cedar Ave., Long Branch, N. J.
- Marsa, A. R., 1407 S.E. Knapp St., Portland 2, Ore.
- Mayer, A. L., 1437-18 Ave., San Francisco 22, Calif.
- Mayer, B., 66 Rigby Rd., Sydney, Nova Scotia, Canada
- Mayhew, M. B., 1190 St. Matthew St., Montreal 25, P. Q., Canada
- McLaughlin, C. J., Squadron T-1, Box 329, 815 AAF BU., Malden, Mo.
- Menneken, C. E., 23 State Cir., Annapolis, Md.
- Metzner, P. E., 424 W. LaSalle Ave., Mishawaka, Ind.
- Miller, R. C., Box 20, Falmouth, Hants County, Nova Scotia, Canada
- Monod, C. P., Puerto Rico Water Resources Authority, Santurce Stop 16½, Puerto Rico
- Namaroff, J. H., 5427 Belmar Ter., Philadelphia 43, Pa.
- Nechemias, M., 332 Rogers Ave., Brooklyn 25, N. Y.
- Nevins, I., 53 Park Pl., New York 7, N. Y.
- Newton, W. A., 37 Fairfield, Greenfield Park P. Q., Canada
- Nowicki, J. J., 166 Straley St., Buffalo 11, N. Y.
- Nye, W. H., Towers Hotel, Room 807, Brooklyn 2, N. Y.
- O'Donnell, T. J., 218 N. Craig St., Pittsburgh 13, Pa.
- O'Gara, J. J., 10710 Grandview Ave., Cleveland 4, Ohio
- Oulton, G. R., M.P.O. No. 111, Clinton, Ont., Canada
- Owen, E. R., E. I. duPont de Nemours and Co., Towanda, Pa.
- Paddison, L. J., Applied Physics Laboratory, Johns Hopkins University, 8621 Georgia Ave., Silver Spring, Md.
- Parant, N., 23-73 Crescent St., Astoria, L. I., N. Y.
- Parkhurst, D. D., 4194 First Ave., San Diego 3, Calif.
- Perez-Romero, M., c/o Postmaster, Miami, Fla.
- Perkins, M. G., 3603 S. Alaska St., Tacoma 8, Wash.
- Phillips, F. G., Jr., 209 Sherman St., Boonton, N. J.
- Pinney, E. M., Collins Radio Co., Cedar Rapids, Iowa
- Prodger, A., Pall Mall No. 575, London, Ont., Canada
- Rajopadhye, V. Y., 148 Hindu Colony, Dadar Bombay, India
- Randall, E. F., 1947 Broadway, Studio 532, New York, N. Y.
- Rappaport, H., 106 Stuart Ave., Downingtown, Pa.
- Rauf, R. H., 502 W. Sixth St., Covington, Ky.
- Reis da Silva, S., Av. Almirante Barroso 91, Room 1101 Rio de Janeiro, Brazil
- Ridley, W. H., Jr., 171 Atlantic Ave., Rochester 7, N. Y.
- Rissi, T. L., 1112 W. Warren Ave., Detroit 1, Mich.

(Continued on page 66A)

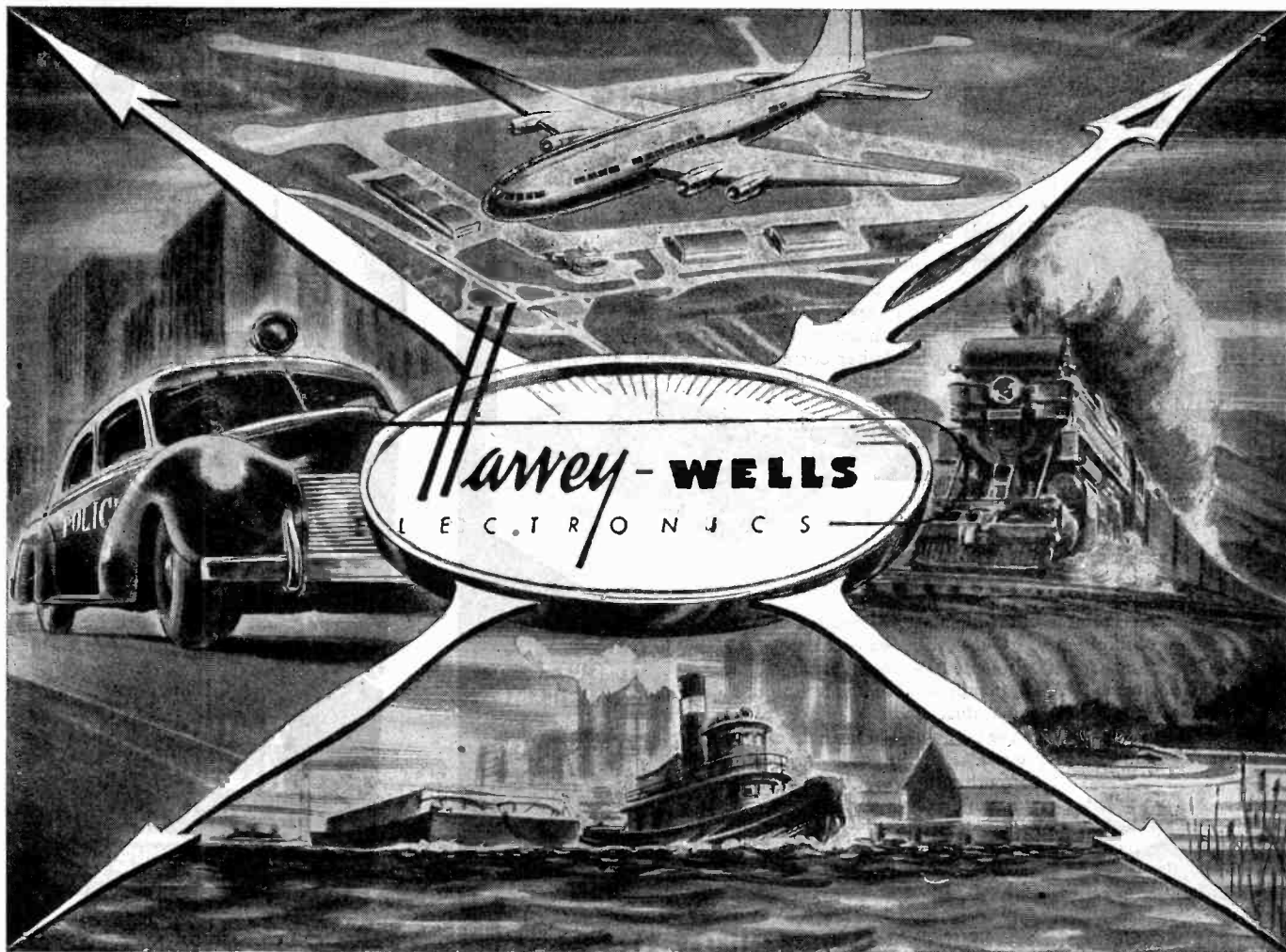

## ENCOMPASSING ALL FIELDS

*wherein communications contribute to*

**SPEED  
SAFETY  
EFFICIENCY**

On all points, Harvey-Wells communications equipment meets the need for high fidelity in transmission and reception.

Through intensive testing methods and exclusive engineering techniques, Harvey-Wells systems have made important contributions to communications in vital war operations. Their wide use

by the armed forces is "proof positive" of their ability to deliver completely dependable service.

The unusually high standards fulfilled by Harvey-Wells receivers and transmitters are your guarantee of maximum efficiency in peacetime communications.

SETTING THE PACE FOR PROGRESS IN COMMUNICATIONS

  
**Harvey-Wells**  
 ELECTRONICS  
 SOUTHBRIDGE, MASSACHUSETTS

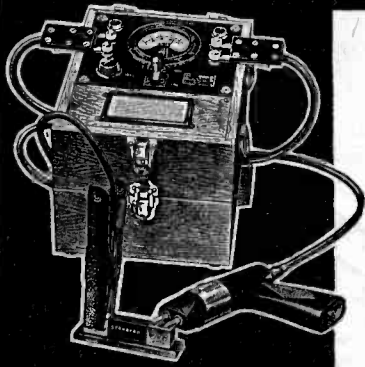

SHALLCROSS PORTABLE  
TYPE 645 FOR FIELD  
INSPECTION WORK

### STREAMLINING LOW RESISTANCE MEASUREMENTS

Are you required to make hundreds of accurate "Go, No-Go" low resistance measurements? The Shallcross Portable Low-Resistance Test Sets are ideal for making rapid measurements in bond testing, switch and relay contact resistance testing, bar-to-bar commutator readings, etc. Write for Bulletin LRT.

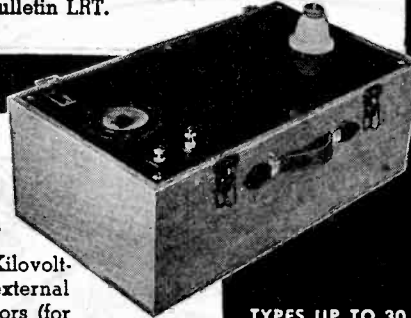

TYPES UP TO 30  
KV AVAILABLE  
FOR  
RAPID DELIVERY!

### HIGH-VOLTAGE MEASUREMENT PROBLEMS SOLVED

Shallcross Portable Kilovoltmeters, Kilovoltmeter Multipliers (for use with external meters) and Corona Protected Resistors (for voltages up to 200 KV) comprise a complete line of high-voltage measuring apparatus. Over a period of years Shallcross engineers have pioneered in the field of modern high-voltage measurements. They will welcome an opportunity to put their experience to work on your problem.

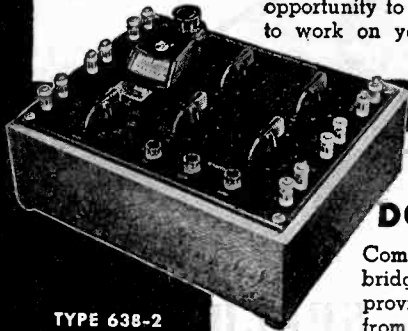

TYPE 638-2  
COMBINED KELVIN  
AND WHEATSTONE  
BRIDGE

### ONE BRIDGE THAT DOES THE WORK OF TWO

Combining both Kelvin, and Wheatstone bridges, this popular Shallcross instrument provides a resistance measurement range from 0.0001 to 11.11 megohms in a single portable instrument. Just the thing for maintenance, production line tests, field investigations, school and laboratory work, etc.

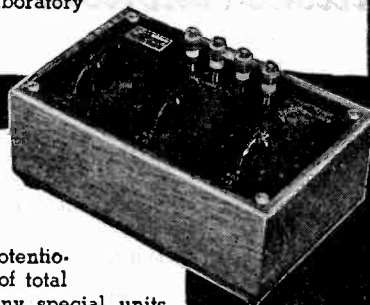

### ACCURATE VOLTAGE DIVIDERS

Shallcross Voltage Dividers (Decade Potentiometers) are available in a wide range of total resistance and voltage increments. Many special units regularly produced for special applications. Write for latest data bulletins on any Shallcross instrument type.

TYPE NO. 845  
POPULAR  
3-DECADE UNIT

# Shallcross

## MANUFACTURING COMPANY

DEPT. IR-55 COLLINGDALE, PA.

ENGINEERING • DESIGNING • MANUFACTURING

# PREMAX

## In the Commercial Services

*Premax  
Antennas*

Tested in War...  
Ready for Peace

PREMAX PRODUCTS  
DIVISION OF CHISHOLM-RYDER CO., INC.  
NIAGARA FALLS, N. Y.

### The Story of Premax In Action

Twenty-four pages — forty photographs — nineteen diagrams of antennas — nine sketches of police installations — thirty-one amateur hookups — twenty-one diagrams of mountings. The complete story of Premax Antennas in every field of activity.

*A request on your  
letterhead will  
bring a copy.*

# RADIO ANTENNA

*Premax Products*

Division Chisholm-Ryder Co., Inc.  
4503 Highland Ave. Niagara Falls, N.Y.

Proceedings of the I.R.E. May, 1945



# JOHNSON *for* HIGH POWER COMPONENTS

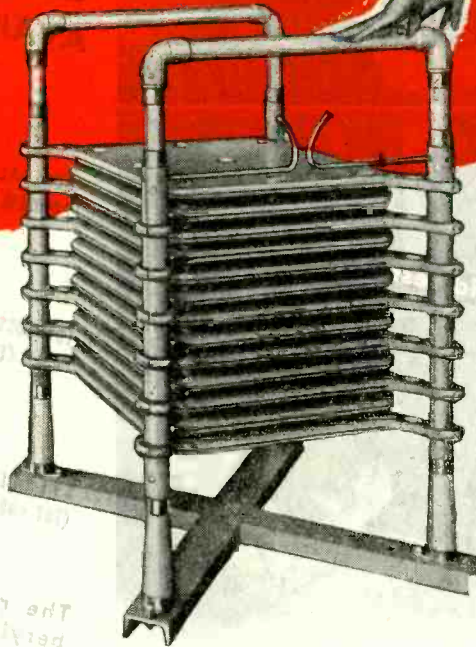

To meet the need for a light-weight, high-capacity, high-voltage tank condenser for transmitter applications, Johnson engineers developed a new type of condenser. The unit illustrated has a capacity of 1200 mmf. at a peak voltage of 40,000 volts at 2 megacycles. Nearly any combination of capacity and voltage ratings may be had. The capacity may be varied in the field by removing plates or altering spacing.

The plates are made of fabricated sheet steel, heavily copper plated and enamelled. Rounded edges increase the breakdown voltages. Vertical tie rods of copper tubing furnish good conductivity between plates. Plates are secured to the upright supports with aluminum castings.

A protective gap is incorporated in the condenser to protect the plates from damage in case of excessive voltages or surges. The mounting base is welded channel iron, which forms a strong support. A very convenient mounting for the tank inductance is formed by the two cross beams at the top of the condenser.

This condenser will find wide application in high power equipment because of its compact and efficient construction.

Ask for Catalog No. 968S

- Other JOHNSON Products  
for High Power . . . . .
- INDUCTORS, variable & fixed
  - TRANSMISSION LINE EQUIPMENT
  - SOCKETS
  - SWITCHES
  - COUPLINGS
  - CHOKES
  - ANTENNA PHASING UNITS
  - GAS-FILLED CONDENSERS
  - CONTACTORS
  - INSULATORS

# JOHNSON



*a famous name in Radio*

E. F. JOHNSON COMPANY • WASECA • MINNESOTA



## QUALITY CONTROL The Case Tests

Careful control of quality in essential parts is good insurance for smooth flowing production and for a high calibre product.

Thus Deep Drawn, Seamless Steel Cases, an essential part of many Chicago Transformers, are subjected to precision checks for case dimensions, pull tests for strength of spot welds in internal mounting structures, and inspection for electro-plating thickness with carefully timed acid erosion.

By this type of Quality Control, applied in every phase of manufacture, uniformity of parts is maintained and high standards of quality in finished Chicago Transformers is assured.

# CHICAGO TRANSFORMER



DIVISION OF ESSEX WIRE CORPORATION  
3501 WEST ADDISON STREET  
CHICAGO, 18



TRADE MARK REG.

# EBY SADDLE TYPE MINIATURE TUBE SOCKETS

AVAILABLE IN

GENERAL PURPOSE  
PHENOLIC (EBY #8100) →

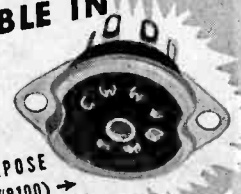

LOW LOSS PHENOLIC  
(EBY #8082) →

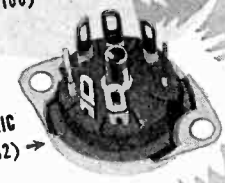

STEATITE  
(EBY #8083) →

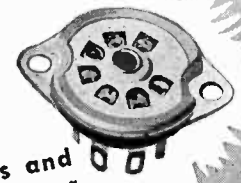

The castings and beryllium copper contacts are identical with JAN 5-28 Types SO 10M and SO 10C except that the shield base is replaced with a saddle. These EBY sockets meet the need for quality replacement of sockets of the saddle type. Write today for prices and samples.

### LONG LIFE CONTACTS

The self-aligning beryllium copper contacts have been especially designed and Micro-processed to assure constant, even pressure on all parts of the socket pin without fatigue in contacts after continuous use.

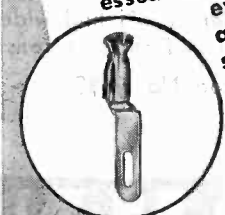

IF IT'S IN A CIRCUIT  
... EBY COMPONENTS  
AND SERVICES WILL  
HELP YOU DO IT BETTER

HUGH H.  
**EBY**  
INCORPORATED  
18 W. CHELTON AVE.  
PHILADELPHIA, PA.



## THE JACK WITH THE CHANNEL-BEAM FRAME... BY FEDERAL

You can swing forty pounds from the free end of this jack without bending it from the horizontal.

Because . . . Federal has taken sturdy stainless-steel and die-drawn it to form a rigid channel-beam jack frame, instead of the bend and spot weld method of construction normally used.

This rigidity is all-important in a jack — not only in supporting heavy cable harnesses, but allowing the spring nests to provide positive tension on the plug . . . even though worn from years of constant service.

Jack springs are of nickel silver and the palladium crossbars assure positive contact at all times.

**DESIGN FEATURES:**  
Rigid Construction, Positive Spring Tension, Stainless Steel Channel-Beam Frame, Plain or Threaded Bushings, 15 Standard Spring Combinations, Phenol Fiber Insulation.

Federal's jacks are available with either plain or threaded bushings in 15 different spring combinations, including all of the more commonly used arrangements. Additional combinations can be provided where needed.

When required Federal's jacks can be supplied fungus and moisture proofed.

Another superior communications component by Federal, and another reason to see Federal first.



**Federal Telephone and Radio Corporation**



Newark 1, New Jersey

# Unsurpassed QUALITY

• The Industrial Condenser Corporation manufactures a complete line of Oil-filled, Electrolytic, Wax and Special Mica Capacitors for all industrial, communications and signalling applications up to 250,000 volts working. Complete laboratory and engineering facilities available for solution and design of capacitor problems for special applications.

**An Industrial Condenser for every industrial application.**

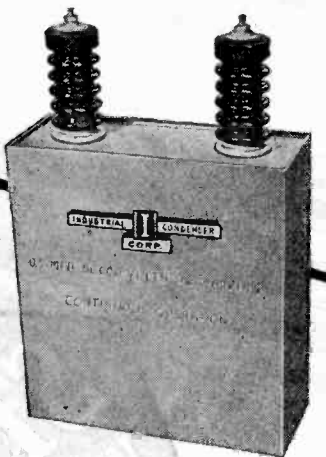

**.5 MFD. 50,000 VOLTS  
DC WORKING**

(Illustrated above)...28 inches high, weight 175 pounds, built by Industrial Condenser Corporation to meet Navy specifications. Oil-filled, oil impregnated. Built for 24 hour continuous operation and total submersion in salt water.

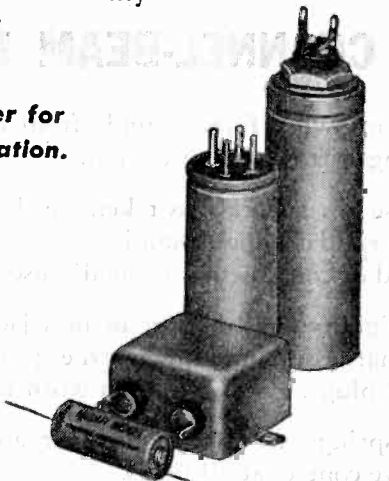
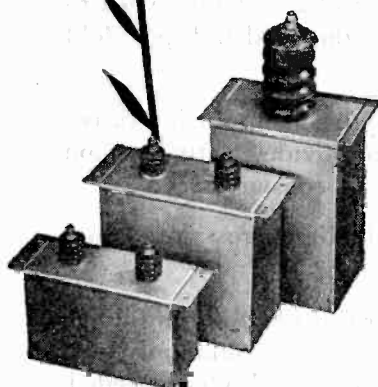

PAPER, OIL AND ELECTROLYTIC CAPACITORS

**INDUSTRIAL  
CONDENSER  
CORPORATION**

3243-65 NORTH CALIFORNIA AVE., CHICAGO 18, U.S.A.

DISTRICT OFFICES IN PRINCIPAL CITIES

## Membership

(Continued from page 60A)

- Roberts, D. E., 1405 Seventh Ave. S.E., Cedar Rapids, Iowa
- Rosene, K., c/o Panagra, Santiago de Chile, S. A.
- Rossi, G. B., 717 Cabrillo St., San Francisco, Calif.
- Sachs, S., 617 W. 169 St., New York 32, N. Y.
- Schiller, J., 198-39—32 Ave., Flushing, L. I., N. Y.
- Schrand, E. J., 860 S. Clinton St., Charlotte, Mich.
- Schreiner, E. D., 3825 Woodley Rd., N.W., Washington, 16, D. C.
- Schueler, J. J., 10206 Ridgemoor Dr., Silver Spring, Md.
- Shatto, L. E., Station KERN, Elks Building, Bakersfield, Calif.
- Shaw, S. J., 207 Empire Building, Pittsburgh 22, Pa.
- Shepard, F. H., Jr., 31 Union Pl., Summit, N. J.
- Sickels, W. H., Jr., 32 N. Main St., Dayton 2, Ohio
- Smallwood, S. G., 8 Krug St., Kitchener, Ont., Canada
- Spearman, E. L., Jr., 12809 Kling St., North Hollywood, Calif.
- Sperling, P., c/o Majestic Radio and Television Corp., St. Charles, Ill.
- Voss, H. R., 390 G St., Chula Vista, Calif.
- Staniforth, A., No. 1, 240 Gilmour, Ottawa, Ont., Canada
- Stauder, L. F., 802 St. Vincent St., South Bend, Ind.
- Stein, L. F., 4800 N. Springfield Ave., Chicago 25, Ill.
- Stoner, J. W., 845 Edgewood Rd., Redwood City, Calif.
- Stovall, H. E., 1909 G St., N. W., Washington, D. C.
- Taeschner, L., 930 West End Ave., New York 25, N. Y.
- Thaxton, H. A., 622 East Garfield St., Belleville, Ill.
- Trim, D. P., 245 Los Alamos Dr., San Diego 2, Calif.
- Walton, H. E., 2111 Woodward Ave., Detroit 1, Mich.
- Ward, B. G., 4583 Oregon St., San Diego 4, Calif.
- Warner, H. V., 406 W. Joppa Rd., Towson 4, Md.
- Washabaugh, D. G., 808 W. Kings Highway, Haddon Heights, N. J.
- Waterton, P. J., 245a Magdalen Rd., Earlsfield, London S.W. 18, England
- Wazlo, C. J., 2501 Haste St., Berkeley, Calif.
- Webster, J. C., 601 S. Third St., Elkhart, Ind.
- Weir, E. J., 801 Orange St., New Haven, Conn.
- Westerberg, O. D., 1901 N. New England Ave., Chicago, Ill.
- White, D. E., 2191 Knapp St., St. Paul 8, Minn.
- White, R. A., 41 Park Pl., Bloomfield, N. J.
- Whiting, S. V., Electric Equipment Shop No. 4, Fort Bliss, Tex.
- Winchester, J. L., 6009 Edmondson Ave., Catonsville, Md.
- Winkler, E. H., 102 McLaren St., Red Bank, N. J.
- Williams, J. A., 6325 McCallum St., Philadelphia, Pa.
- Wisman, F. O., 2705 Prast Blvd., South Bend 19, Ind.
- Wright, P. M., West Branch, Iowa
- Yoldi, D., Salta 2193, Buenos Aires, Argentina
- Zayac, F. R., Boonton Lakes Rd., Boonton, N. J.

### M. F. M. Osborne Associates Consulting Physicists

Fluid Dynamics, Mechanics, Electronic Design, Electromagnetic and Acoustic Wave Propagation, Mathematical Analysis.

703 Albee Bldg., Washington 5, D.C.  
Atlantic 9084

### FRANK MASSA

Electro-Acoustic Consultant

DEVELOPMENT PRODUCTION DESIGN  
PATENT ADVISOR

ELECTRO-ACOUSTIC & ELECTRO-MECHANICAL  
VIBRATING SYSTEMS

SUPERSONIC GENERATORS & RECEIVERS

3393 Dellwood Rd., Cleveland Heights 18, Ohio



## Cathode Ray Tubes For War and Post-War

**A**MONG the many types of tubes produced by North American Philips for war purposes is the 5-inch cathode ray tube illustrated here. The problem with this type tube was to produce it in volume with evenly coated screens having no pinholes or other defects.

The ability to produce, in volume, NORELCO cathode ray tubes that meet rigid specifications, is the result of experience gained by an organization with a background of over half a century of research and development in the electrical field.

Although NORELCO tubes now go to our armed forces, a list of tube types we are especially equipped to produce will be sent on request.

North American Philips will have post-war facilities available for the development and production of tubes for projection television; also amplifier, transmitting, rectifier and special purpose tubes.

Write today for interesting booklet on "How and Why Cathode Ray Tubes Work" and the brochure describing the background of North American Philips in the science of electronics.

• When in New York, be sure to visit our Industrial Electronics Showroom.

**Norelco** Electronic Products by

**NORTH AMERICAN PHILIPS COMPANY, INC.**

Dept. F5, 100 East 42nd Street, New York 17, N. Y.

Factories in Dobbs Ferry, N. Y.; Mount Vernon, N. Y. (Metalix Div.); Lewiston, Me. (Elmet Div.)

*\* Again Available!*

# LINGO

## VERTICAL TUBULAR STEEL RADIATORS

**\*AVAILABLE NOW ONLY TO THOSE WITH PROPER PRIORITY—READY FOR QUICK SHIPMENT TO ALL, THE MOMENT PRIORITY RESTRICTION ARE LIFTED. . .**

There's a Lingo Radiator and supporting pole for every need and purpose in standard heights—100 to 500 feet—for AM, FM, Television and other UHF uses. Immediate shipment to those with necessary priority. We invite your inquiries, whether your installation is large or small—for today or tomorrow.

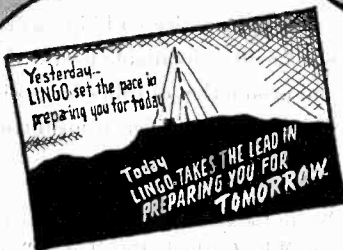

Send for Your **FREE** Copy of Our New Brochure, Full of Detailed Information on Standard and Special Types of Lingo Radiators

**JOHN E. LINGO & SON, INC.**  
Est. 1897  
CAMDEN, NEW JERSEY

## WIRE, RIBBON and Other Metal Products

★ Smaller than Commercial Sizes; closer than Commercial Tolerances

An organization devoted to the research, development and production of wire and ribbon and similar products of Platinum and other Precious Metals, as well as Rare and Base Metals . . . This metallurgical plant is completely equipped with alloying, melting and working facilities for precision production. Equipment and staff permit specialization in smaller than commercial sizes and closer than commercial tolerances for the most exacting technical requirements.



**SIGMUND COHN & CO.**  
44 Gold Street • New York 7, N. Y.

## BLUE PRINT to SERVICE

ON URGENTLY REQUIRED  
RADIO PARTS · TUBES  
ELECTRONIC EQUIPMENT

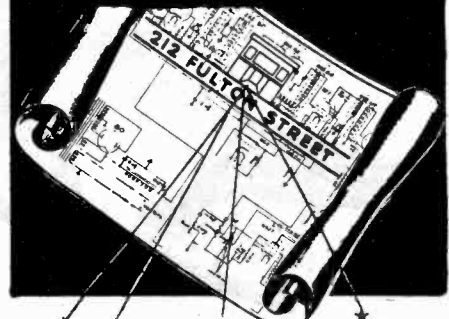

★ **PHONE**  
Barclay 7  
1840

★ **TELETYPE**  
Direct fast wire service to our premises.  
Code: RBY-New York

★ **Free 800 Page Catalog**  
Available to purchasing agents and engineers who write on company letterhead.  
Address Box 1M

★ **OVER 10,000 ITEMS IN STOCK FOR IMMEDIATE DELIVERY!**

America's most complete  
Radio • Electronic Supply House

**SUN RADIO  
& ELECTRONICS CO.**  
212 Fulton Street, New York 7, N. Y.



**NO REJECTS WITH COMPONENTS BY AVIOMETER**

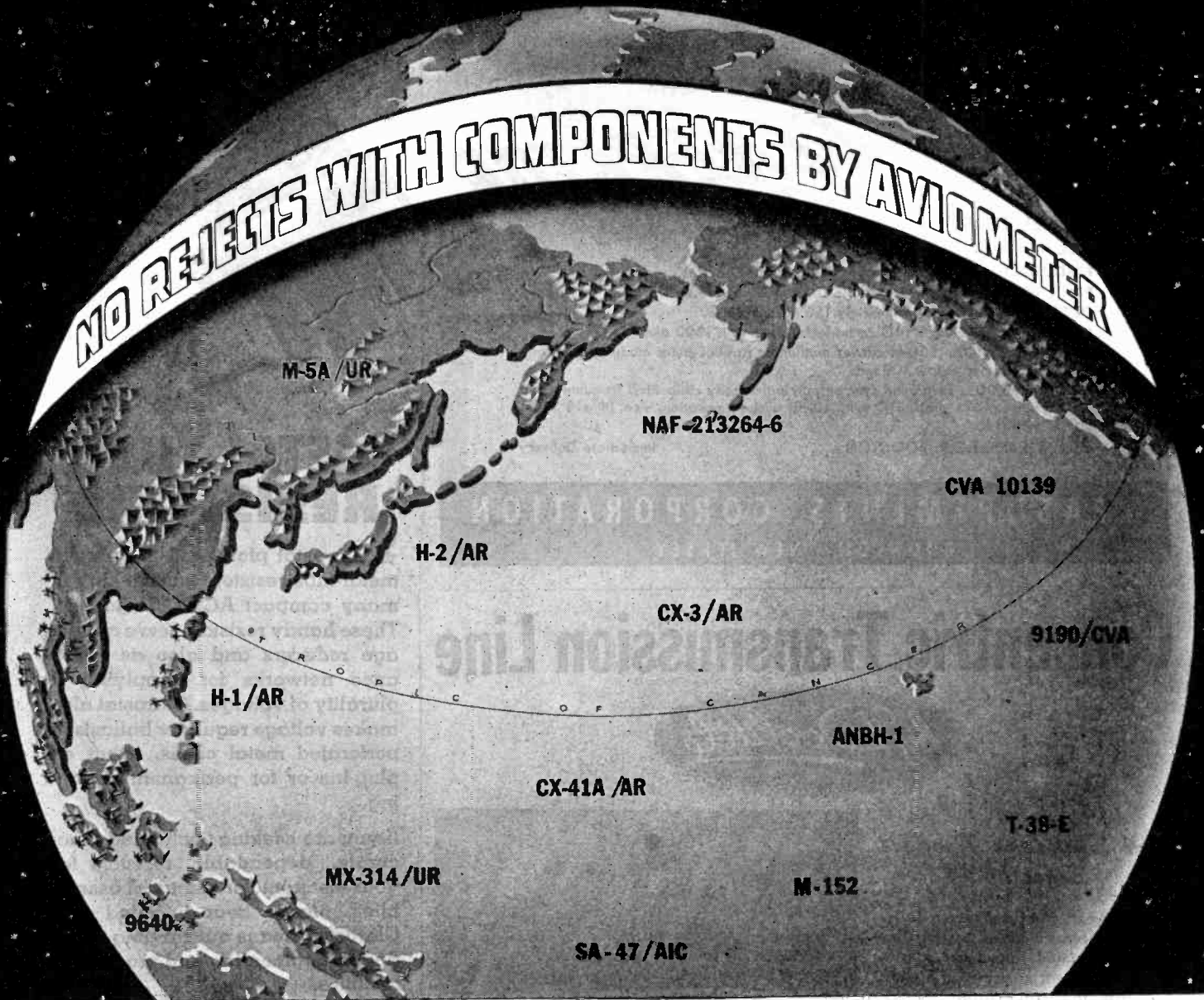

# **AVIOMETER**

**COMMUNICATION AND CONTROL INSTRUMENTS**

**370 WEST 35TH STREET NEW YORK 1, N. Y.**

Laboratory  
Standards

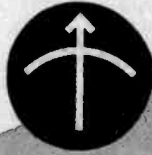

# PULSE GENERATOR

**MODEL 79-B**

**SPECIFICATIONS:**

**FREQUENCY:** continuously variable 60 to 100,000 cycles.

**PULSE WIDTH:** continuously variable 0.5 to 40 microseconds.

**OUTPUT VOLTAGE:** Approximately 150 volts positive.

**OUTPUT IMPEDANCE:** 6Y6G cathode follower with 1030 ohm load.

**R. F. MODULATOR:** Built-in carrier modulator applies pulse modulation to any r.f. carrier below 100 mc.

**MISCELLANEOUS:** Displaced sync output, individually calibrated frequency and pulse width dials, 117 volt, 40-60 cycles operation, size 14"x10"x10", wt. 31 lbs.

Price: \$295.00 F.O.B. BOONTON

Immediate Delivery

**MEASUREMENTS CORPORATION**  
BOONTON • NEW JERSEY



*Plug in*

## METAL TUBE RESISTORS

★ Clarostat pioneered the plug-in metal tube resistors found today in many compact AC-DC radio sets. These handy resistors serve as voltage reducers and also as resistance networks for supplying a plurality of voltages. Clarostat also makes voltage regulator ballasts in perforated metal cases, either as plug-ins or for permanent mounting.

If you are seeking such handy, accurate, dependable resistors for your electronic or electrical assemblies, please bear in mind that Clarostat means outstanding experience, engineering and production facilities.

★ Consult Us . . .



# Concentric Transmission Line



*A Standard Product  
Since 1934*

• Ten years of experience in building concentric transmission line and associated impedance matching equipment assures you highest quality and workmanship.

Doolittle lines are made in seven standard sizes. Each line uses seamless copper tubing for the outer and inner conductor, except Types C-1 and C-6 which use solid inner conductors. The insulating heads are made of low loss ceramic—impervious to moisture—spaced and fastened securely for maintaining proper electrical and mechanical characteristics.

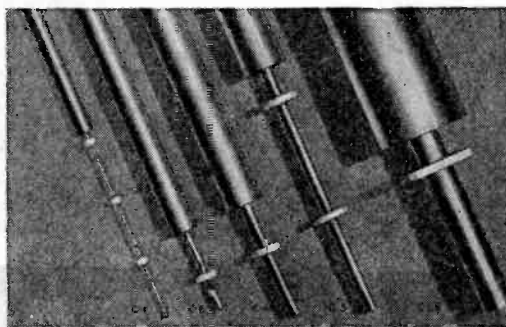

Carefully designed fittings and accessories for any requirements are also available.

Special sizes are made to order. For engineering information concerning installation and use, feel free to consult our engineering staff.

**WRITE  
FOR  
CATALOG  
AND  
PRICES**

**QUICK DELIVERY**  
On All Standard  
Sizes Upon  
Suitable Priority

**Doolittle RADIO, INC.**

Builders of Precision Communications Equipment  
7421 SOUTH LOOMIS BLVD., CHICAGO 36, ILLINOIS



CLAROSTAT MFG. CO., Inc. • 285-7 N. 6th St., Brooklyn, N. Y.



# ANOTHER QUALITY PRODUCT



## CD-604, CD-605 TRANSFORMER-CORD SETS

UTC production facilities for these Signal Corps headset adapters permit acceptance of additional quantity orders for quick delivery. Also available in hermetic construction.



*May we cooperate with you on Design savings for your applications...war or postwar?*

*United Transformer Corp.*

150 VARICK STREET NEW YORK 13, N. Y.  
EXPORT DIVISION: 13 EAST 40th STREET, NEW YORK 16, N. Y. CABLES: "ARLAB"

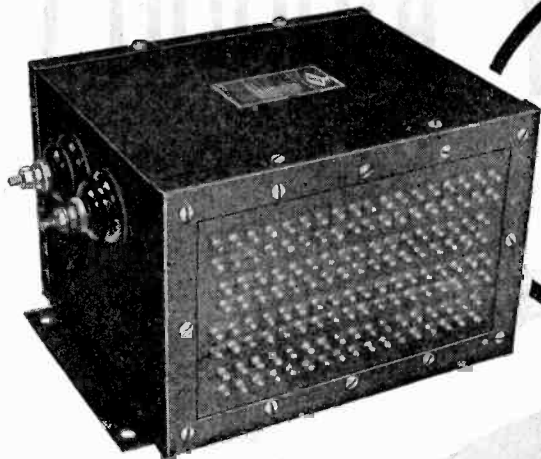

*More  
Examples of*  
**ACME  
TRANSFORMER  
ENGINEERING**

▲ The specially designed testing unit (illustrated above) has 140 terminals providing 70 individual secondary circuits of 2 volts each.

This radio power transformer is designed with a standard 115 volt, 60 cycle primary winding and provides a high voltage secondary winding and filament winding. Manufactured in quantity to high performance standards.



**THE ACME ELECTRIC & MFG CO.**  
Cuba, N. Y.                      Clyde, N. Y.



## INDEX

Section Meetings .....	36A
Membership .....	38A
Positions Open .....	50A

### DISPLAY ADVERTISERS

Acme Electric & Manufacturing Co. ....	72A
Aerovox Corporation .....	8A
Aireon Manufacturing Corp. ....	13A
Alliance Manufacturing Company .....	42A
Allied Radio Corporation .....	38A
Altec Lansing Corporation .....	56A
American Lava Corporation .....	9A
American Telephone & Telegraph Co. ....	31A
American Transformer Company .....	51A
Amperex Electronic Corporation .....	Cover II
Andrew Company .....	40A
Arnold Engineering Company .....	28A
Aviometer Corp. ....	69A
Bendix Radio Division, Bendix Aviation Corp. ....	3A
Blaw-Knox Company .....	36A
Boonton Radio Corporation .....	72A
Cambridge Thermionic Corporation .....	33A
Chicago Transformer Corporation .....	64A
Clarostat Manufacturing Co., Inc. ....	70A
Sigmund Cohn & Company .....	68A
Collins Radio Company .....	43A
Communications Company, Inc. ....	54A
Connecticut Telephone & Electric Div. ....	57A
Continental Diamond Fibre Company .....	20A
Continental Electric Company .....	26A
Cornell-Dublier Electric Corp. ....	Cover III
Corning Glass Works .....	5A
Dalmo Victor .....	50A
DeJur AmSCO Corporation .....	4A
Tobe Deutschmann Corporation .....	73A
Doolittle Radio, Inc. ....	70A
Hugh H. Eby, Inc. ....	64A
Eicor, Inc. ....	48A
Eitel-McCullough, Inc. ....	74A
Electronic Laboratories, Inc. ....	23A
Electronic Mechanics, Inc. ....	59A
Electro-Voice Corporation .....	53A
Federal Telephone & Radio Corporation ..	7A, 75A
Gates Radio & Supply Corp. ....	58A
General Aniline & Film Corp. ....	10A, 11A
General Electric Company .....	18A
General Radio Company .....	Cover IV
Hallicrafters Company .....	30A
Harvey-Wells Communications, Inc. ....	61A
Heintz & Kaufman, Ltd. ....	14A
Hewlett-Packard Company .....	6A
Hytron Radio & Electronics Corp. ....	47A
Illinois Tool Works .....	54A
Industrial Condenser Corp. ....	66A
International Resistance Company .....	37A
International Telephone & Telegraph Corp. ....	7A, 65A
Jennings Radio Manufacturing Company .....	24A
E. F. Johnson Company .....	63A
John E. Lingo & Son, Inc. ....	68A
Litton Engineering Laboratories .....	41A
Frank Massa .....	66A
Measurements Corporation .....	70A
Merit Coil & Transformer Corp. ....	52A
National Carbon Company, Inc. ....	32A
National Company .....	16A
National Union Radio Corp. ....	21A
North American Philips Company .....	67A
M. F. M. Osborne & Associates .....	66A
Permoflux Corp. ....	58A
Premax Products .....	62A
Press Wireless .....	54A
Radio Corporation of America .....	Facing 32A, Facing 281, 34A, 35A
Rauland Corp. ....	44A, 45A
Raytheon Manufacturing Company .....	12A, 54A
Remler Company, Ltd. ....	22A
Santay Corporation .....	46A
Seismograph Service Corp. ....	50A
Shallcross Manufacturing Company .....	62A
Sola Electric Company .....	27A
Sprague Electric Company .....	19A
Stackpole Carbon Company .....	49A
Standard Transformer Corporation .....	56A
Stromberg-Carlson Telephone Manufacturing Co. ....	54A
Sun Radio & Electronics Company .....	68A
Superior Electric Company .....	39A
Templetone Radio Company .....	60A
United Cinephone Corp. ....	52A
United Electronics Company .....	17A
United Transformer Company .....	71A
Utah Radio Products Company .....	25A
Western Electric Company .....	50A
Westinghouse Electric & Manufacturing Company .....	29A, 55A
Wilcox Electric Company .....	15A

# *There's no substitute for* **ACCURACY**

B. R. C. instruments are designed and manufactured to give accurate and precise direct reading measurements with simplicity of operation.

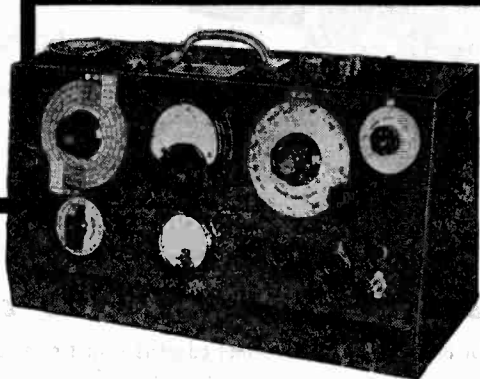

**Q METER**  
TYPE 160-A

A Standard for "Q" Measurements with a reputation for accurate and dependable service. Has a Frequency Range of 50 kc to 75 mc which may be extended with external oscillator down to 1 kc.



**BOONTON RADIO**  
Corporation  
BOONTON, N. J.



DESIGNERS AND MANUFACTURERS OF THE "Q" METER . . . QX-CHECKER . . . FREQUENCY MODULATED SIGNAL GENERATOR . . . BEAT FREQUENCY GENERATOR . . . AND OTHER DIRECT READING TEST INSTRUMENTS

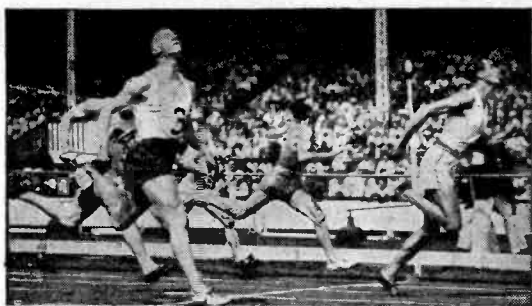

# AWAY AHEAD!

## TOBE LEADS IN NOISE ELIMINATION

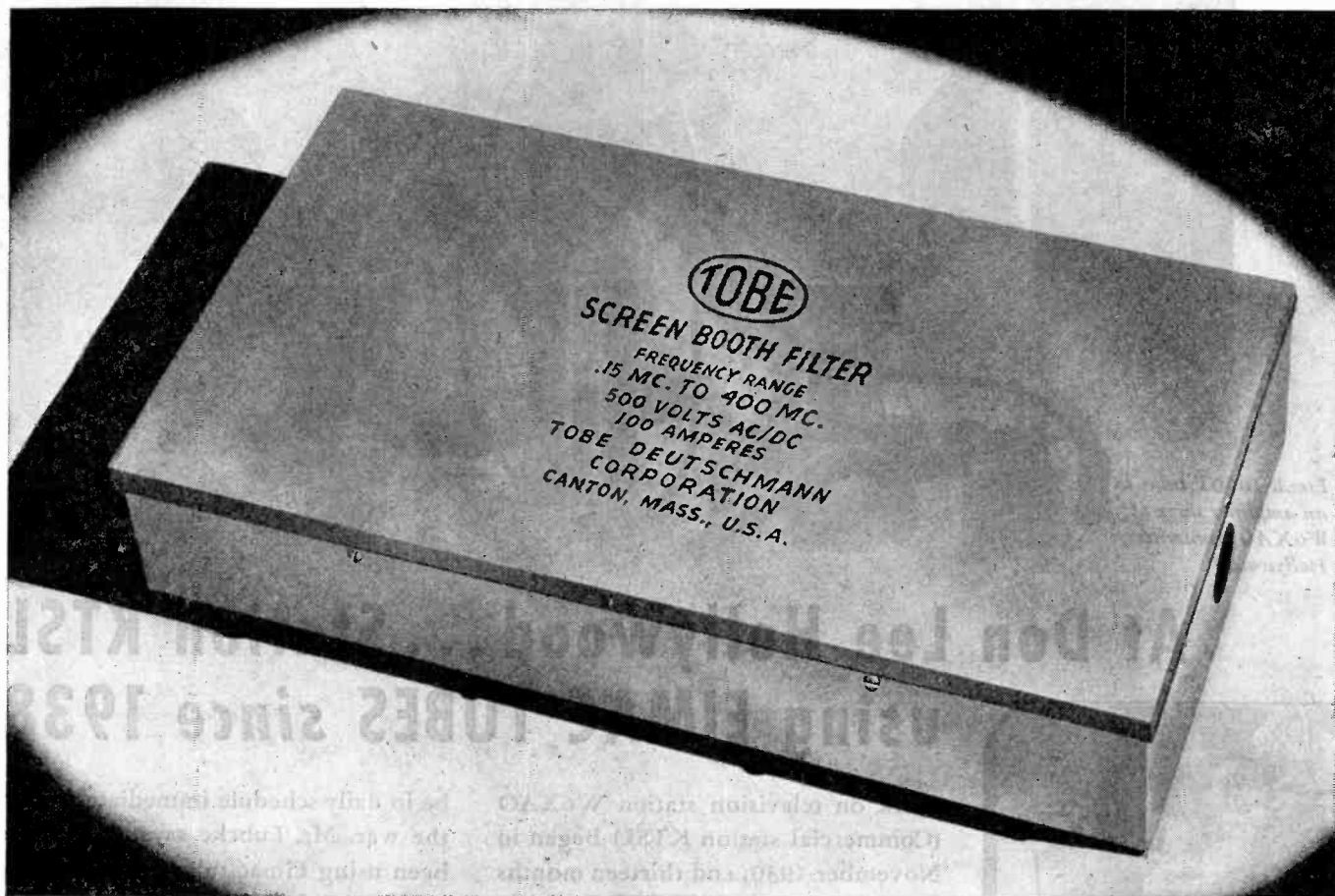

## NEW SCREEN BOOTH FILTER

**H**ERE is more evidence of Tobe's Leadership in the noise elimination field. This remarkable SCREEN BOOTH FILTER is designed for use in laboratory testing rooms, including those already shielded to prevent outside electrical interference. It is attached to the power line at the point of entrance into the booth, and is designed to eliminate troublesome interference which might upset vital testing work. *Note the exceptional frequency range, from .15 MC to 400 MC.*

#### CONTAINER DIMENSIONS

Length . . .	20 1/16"	Height . . .	4 1/8"
Width . . .	7 15/16"	Weight . . .	35 lbs.

Whenever your problem is connected with eliminating electrical interference, the name to remember is

. . . TOBE! We have a great inventory of knowledge on this subject, backed by 17 years' experience. Your inquiries are welcome at any of our offices. Investigate the applications you can make of TOBE Filters, including the unusual SCREEN BOOTH FILTER described on this page.

**TOBE DEUTSCHMANN CORP., CANTON, MASS.**



GRAND CENTRAL TERMINAL BUILDING  
NEW YORK 17, N. Y.  
•  
110 WEST BROADWAY  
GAIENDALE 4, CAL.  
•  
230 NORTH MICHIGAN AVE.  
CHICAGO 1, ILL.  
•  
2-159 GENERAL MOTORS BLDG.  
DETROIT 2, MICH.

# TELEVISION IS HERE!

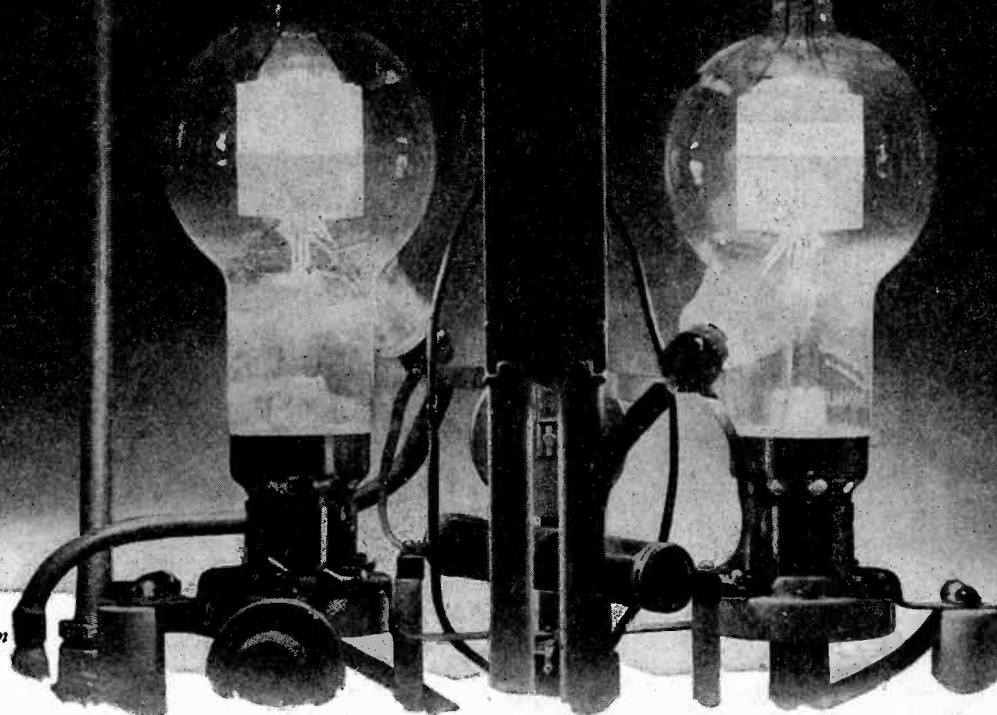

*Eimac 1000T tubes in an amplifier stage of W6XAO transmitter, Hollywood*

## At Don Lee Hollywood... Station KTSL using EIMAC TUBES since 1938



*Julia Lee Wright, noted Home Economics Director of "The Family Circle" magazine being interviewed, and telecast, revealing tricks of her trade.*



*Two young comedians, Robert Sweeney and Hal March, currently on transcontinental radio show, give a preview of their talents for television broadcast over W6XAO.*

Write for your copy of *Electronic Telesis*—a 64 page booklet fully illustrated—covering the fundamentals of Electronics and many of its important applications. In layman's language.

Work on television station W6XAO (Commercial station KTSL) began in November 1930; and thirteen months later, Dec. 23, 1931, it was on the air on the ultra high frequencies, the first present day television to operate on schedule. Today the station occupies elaborate copper sheathed studios which stand 1700 feet above Hollywood with an antenna on a 300-foot tower.

The program log shows almost every type of presentation. Highest in interest and achievement are the remote pick-ups and special event broadcasts made simultaneously or recorded on film for release later. Studio presentations, especially those directed to war activities, have become a duration standard.

Under the direction of Harry R. Lubcke, television station KTSL will

be in daily schedule immediately after the war. Mr. Lubcke says: "We have been using Eimac tubes in our television transmitter since about 1938... We have found them good and reliable performers... their design is such that a favorable ratio of power output to tube and circuit capacitance is obtained... we look forward to using new Eimac tubes which may be forthcoming."

Here again is a statement from a leader in the field, which offers clear evidence that Eimac tubes are first choice of leading electronic engineers throughout the world.

Follow the leaders to



EITEL-McCULLOUGH, Inc. 991 San Mateo Avenue, San Bruno, Calif.  
Plants located at: San Bruno, California and Salt Lake City, Utah  
Export Agents: Frazer & Hanson, 301 Clay St., San Francisco 11, Calif., U. S. A.

# **creative capacitor engineering**



**C-D TYPE 6K MEDIUM POWER MICA CAPACITOR**

Ideal for high stability tuned circuits where constant capacity is required. A compensated unit which can be made having any temperature coefficient between the limits of  $+0.003\%$  to  $-0.005\%$  per degree C. (tolerance  $\pm 0.001\%$  per degree C) over a temperature range from  $-40^{\circ}$  C to  $+70^{\circ}$  C, made in a wide range of capacity and voltage ratings.

## **CORNELL-DUBILIER CAPACITORS**

1910  1945

MICA • DYKANOL • PAPER • WET AND DRY ELECTROLYTICS

The name Cornell-Dubilier on capacitors is more than a 35-year old symbol of dependability.

It stands for creative capacitor engineering—the technical ingenuity capable of designing and building peak-efficiency capacitors for every application. C-D's engineering ability acknowledged today, was already recognized when Secretary of the Navy, Josephus Daniels, wrote on March 8, 1919:

"Mr. Dubilier's improved condenser has been of value in increasing the compactness and reliability of radio transmitters."

William Dubilier, pioneer of modern capacitors, set a high precedent for Cornell-Dubilier engineers.

Today, he works with them—counsels them with the wisdom of a lifetime devoted to capacitor engineering. He has inspired them to further creative efforts.

The result: Basic innovations in capacitor design, engineering and manufacture—such as the first series-stack mica capacitor.

*We welcome the opportunity to demonstrate to you our ability to design and build any type capacitor for your needs. Cornell-Dubilier Electric Corporation, South Plainfield, N. J. Other Plants: New Bedford, Brookline, Worcester, Mass. and Providence, R. I.*



# When You Don't Want to Draw Power

## USE THIS

# NEW D-C VACUUM-TUBE VOLTMETER



- WIDE RANGE
- HIGH INPUT RESISTANCE
- GOOD ACCURACY
- NO A-C EFFECT
- PORTABLE
- BATTERY OPERATION



HAVING the very wide d-c voltage range of 0.05 to 3,000 volts with exceptionally high input resistance, this new d-c v-t voltmeter is very useful in radio and electronic circuit design and testing.

Small, portable, lightweight, self-contained and accurate the new Type 728-A Voltmeter is especially useful when voltage measurements have to be made without drawing power from the circuit.

### FEATURES

**WIDE RANGE** — 0.05 to 3,000 volts, in 7 full-scale values of 3, 10, 30, 100, 300, 1000 and 3000 volts, d-c

**HIGH INPUT RESISTANCE** — Over 5000 megohms on ranges below 100 volts; 1000 megohms above

**GOOD ACCURACY** — within  $\pm 3\%$  of full-scale on low ranges to 30 volts; within  $\pm 5\%$  on higher ranges

**NEGLIGIBLE A-C EFFECT** — superimposed a-c voltage up to 200 has negligible effect on meter indication

**REVERSING SWITCH** — switch on panel to ground either positive or negative terminal of source being measured

**BATTERY OPERATED** — instrument supplied complete with batteries

**PORTABLE** — weighs only  $9\frac{3}{4}$  pounds with batteries; dimensions (length) 11 x (width)  $6\frac{3}{8}$  x (height)  $5\frac{3}{8}$  inches with cover closed

**TYPE 728-A D-C VACUUM-TUBE VOLTMETER \$110**

At present this instrument is available only for high priority war orders; reservation orders for later deliveries are being accepted.

Write for a copy of the G-R Experimenter for December 1944 for complete description of this instrument.

**GENERAL RADIO COMPANY** Cambridge 39, Massachusetts  
NEW YORK CHICAGO LOS ANGELES