

# Proceedings

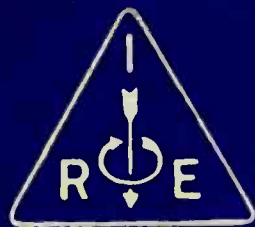

*of the*

# I · R · E

J U L Y                      1 9 3 9

VOLUME 27                      NUMBER 7

CBS Hollywood Studios  
Wide-Band Amplifiers for Television  
Line Microphones  
Fractional-Frequency Generators  
Single-Sideband Filter Theory  
Ionosphere Characteristics

Institute of Radio Engineers



Fourteenth Annual Convention  
New York, N. Y., September 20-23, 1939



Rochester Fall Meeting  
November 13, 14, and 15, 1939

SECTION MEETINGS

CLEVELAND  
September 28

LOS ANGELES  
September 19

PITTSBURGH  
September 19

DETROIT  
September 15

PHILADELPHIA  
September 7

WASHINGTON  
September 11

SECTIONS

- ATLANTA—Chairman, Ben Akerman; Secretary, J. G. Preston, 230 Ansley St., Decatur, Ga.  
BOSTON—Chairman, H. W. Lamson; Secretary, E. B. Dallin, 64 Oakland Ave., Arlington, Mass.  
BUFFALO-NIAGARA—Chairman, H. C. Tittle; Secretary, E. C. Waud, 235 Huntington Ave., Buffalo, N. Y.  
CHICAGO—Chairman, V. J. Andrew; Secretary, G. I. Martin, RCA Institutes, 1154 Merchandise Mart, Chicago, Ill.  
CINCINNATI—Chairman, H. J. Tyzzer; Secretary, J. M. McDonald, Crosley Radio Corp., 1329 Arlington, Cincinnati, Ohio.  
CLEVELAND—Chairman, S. E. Leonard; Secretary, H. C. Williams, Rm. 1932, 750 Huron Rd., Cleveland, Ohio.  
CONNECTICUT VALLEY—Chairman, E. R. Sanders; Secretary, W. R. G. Baker, General Electric Co., Bridgeport, Conn.  
DETROIT—Chairman, H. D. Seielstad; Secretary, R. J. Schaefer, 9753 N. Martindale, Detroit, Mich.  
EMPORIUM—Chairman, R. K. McClintock; Secretary, D. R. Kiser, Hygrade Sylvania Corp., Emporium, Penna.  
INDIANAPOLIS—Chairman, I. M. Slater; Secretary, B. V. K. French, P. R. Mallory & Co., E. Washington St., Indianapolis, Ind.  
LOS ANGELES—Chairman, F. C. Albin; Secretary, M. T. Smith, General Radio Co., 1000 N. Seward St., Hollywood, Calif.  
MONTREAL—Chairman, A. B. Oxley; Secretary, W. A. Nichols, Canadian Broadcasting Corp., 1012 Keefer Bldg., Montreal, Que.  
NEW ORLEANS—Chairman, G. H. Peirce; Secretary, D. W. Bowman, 8327 Sycamore St., New Orleans, La.  
PHILADELPHIA—Chairman, R. S. Hayes; Secretary, R. L. Snyder, 103 Franklin Rd., Glassboro, N. J.  
PITTSBURGH—Chairman, W. P. Place; Secretary, R. E. Stark, 90 Pilgrim Rd., Rosslyn Farms, Carnegie, Penna.  
PORTLAND—Chairman, H. C. Singleton; Secretary, E. R. Meissner, United Radio Supply, Inc., 203 S. W. Ninth Ave., Portland, Ore.  
ROCHESTER—Chairman, W. F. Cotter; Secretary, H. C. Sheve, Stromberg-Carlson Telephone Manufacturing Co., Rochester, N. Y.  
SAN FRANCISCO—Chairman, F. E. Terman; Secretary, L. J. Black, 243-30th St., Oakland, Calif.  
SEATTLE—Chairman, R. O. Bach; Secretary, Karl Ellerbeck, Pacific Telephone and Telegraph Co., 612 Northern Life Tower, Seattle, Wash.  
TORONTO—Chairman, R. C. Poulter; Secretary, N. Potter, Canadian National Carbon Co., Ltd., 805 Davenport Rd., Toronto, Ont.  
WASHINGTON—Chairman, Gerald C. Gross; Secretary, M. H. Biser, 3224-16th St., N. W., Washington, D. C.

# Proceedings

## of the I·R·E

*Published Monthly by*

The Institute of Radio Engineers, Inc.

VOLUME 27 *July, 1939* NUMBER 7

CBS Hollywood Studios.....	H. A. Chinn and R. A. Bradley	421
Wide-Band Amplifiers for Television.....	Harold A. Wheeler	429
Line Microphones.....	Harry F. Olson	438
Fractional-Frequency Generators Utilizing Regenerative Modulation.....	R. L. Miller	446
Single-Sideband Filter Theory with Television Applications.....	John M. Hollywood	457
Characteristics of the Ionosphere at Washington, D.C., May, 1939.....	T. R. Gilliland, S. S. Kirby, and N. Smith	472
Discussion on "A Bearing-Type High-Frequency Electrodynamic Ammeter," by Harry R. Meahl.....	John H. Miller and Harry R. Meahl	474
Institute News and Radio Notes.....		475
Board of Directors.....		475
New ASA Standards.....		476
Committees.....		476
Sections.....		477
Membership.....		481
Contributors.....		482

### BOARD OF DIRECTORS

- Raymond A. Heising, *President*
- Peder O. Pedersen, *Vice President*
- Melville Eastham, *Treasurer*
- Harold P. Westman, *Secretary*
- Harold H. Beverage
- Ralph Bown
- Frederick W. Cunningham
- Alfred N. Goldsmith
- Virgil M. Graham
- O. B. Hanson
- Alan Hazeltine
- Lawrence C. F. Horle
- C. M. Jansky, Jr.
- Ira J. Kaar
- Frederick B. Llewellyn
- Albert F. Murray
- Haraden Pratt
- Browder J. Thompson
- Hubert M. Turner
- Arthur F. Van Dyck



### BOARD OF EDITORS

- Alfred N. Goldsmith, *Chairman*
- Ralph R. Batcher
- Philip S. Carter
- Frederick W. Grover
- J. Warren Horton
- Greenleaf W. Pickard
- Benjamin E. Shackelford
- Karl S. Van Dyke
- Harold P. Westman, *ex officio*
- Lynde P. Wheeler
- Laurens E. Whittemore
- William Wilson



### PAPERS COMMITTEE

- William Wilson, *Chairman*
- Herman A. Affel
- Edmond Bruce
- Howard A. Chinn
- James K. Clapp
- Tunis A. M. Craven
- Paul O. Farnham
- Enoch B. Ferrell
- Elmer L. Hall
- Loren F. Jones
- Frederick B. Llewellyn
- De Loss K. Martin
- Harry R. Mimno
- Albert F. Murray
- Harold O. Peterson
- Ralph K. Potter
- Hubert M. Turner
- Paul T. Weeks
- Harold A. Wheeler
- William C. White
- Irving Wolff



- Helen M. Stote, *Assistant Editor*
- John D. Crawford,  
*Advertising Manager*

## THE INSTITUTE

The Institute of Radio Engineers serves those interested in radio and allied electrical-communication fields through the presentation and publication of technical material. In 1913 the first issue of the PROCEEDINGS appeared; it has been published uninterruptedly since then. Over 1500 technical papers have been included in its pages and portray a currently written history of developments in both theory and practice.

### STANDARDS

In addition to the publication of submitted papers, many thousands of man-hours have been devoted to the preparation of standards useful to engineers. These comprise the general fields of terminology, graphical and literal symbols, and methods of testing and rating apparatus. Members receive a copy of each report. A list of the current issues of these reports follows:

Standards on Electroacoustics, 1938  
Standards on Electronics, 1938  
Standards on Radio Receivers, 1938  
Standards on Radio Transmitters and Antennas, 1938.

### MEETINGS

Meetings at which technical papers are presented are held in the twenty-one cities in the United States and Canada listed on the inside front cover of this issue. A number of special meetings are held annually and include one in Washington, D. C., in co-operation with the American Section of the International Scientific Radio Union (U.R.S.I.) in April, which is devoted to the general problems of wave propagation and measurement technique, the Rochester Fall Meeting in co-operation with the Radio Manufacturers Association in November, which is devoted chiefly to the problems of broadcast-receiver design, and the Annual Convention, the location and date of which are not fixed.

### MEMBERSHIP

Membership has grown from a few dozen in 1912 to more than five thousand. Practically every country in the world in which radio engineers may be found is represented in our membership roster. Approximately a quarter of the membership is located outside of the United States. There are several grades of membership, depending on the qualifications of the applicant. Dues range between \$3.00 per year for Students and \$10.00 per year for Members. PROCEEDINGS are sent to each member without further payment.

### PROCEEDINGS

The contents of each paper published in the PROCEEDINGS are the responsibility of the author and are not binding on the Institute or its members. Material appearing in the PROCEEDINGS may be reprinted or abstracted in other publications on the express condition that specific reference shall be made to its original appearance in the PROCEEDINGS. Illustrations of any variety may not be reproduced, however, without specific permission from the Institute.

Papers submitted to the Institute for publication shall be regarded as no longer confidential. They will be examined by the Papers Committee and Board of Editors to determine their suitability for publication. Suggestions on the mechanical form in which manuscripts should be prepared may be obtained from the Secretary.

### SUBSCRIPTIONS

Annual subscription rates for the United States of America, its possessions, and Canada, \$10.00; to college and public libraries when ordering direct, \$5.00. Other countries, \$1.00 additional.

The Institute of Radio Engineers, Inc.

Harold P. Westman, Secretary

330 West 42nd Street

New York, N.Y.



*Copyright, 1939, by The Institute of Radio Engineers, Inc.*



# CBS Hollywood Studios\*

H. A. CHINN†, MEMBER, I.R.E., AND R. A. BRADLEY†, ASSOCIATE MEMBER, I.R.E.

*Summary*—The CBS Hollywood broadcast studios, which incorporate many new features and engineering developments, are described. The studio and master-control audio-frequency facilities are detailed and system designs presented. A number of constructional features, new to broadcast plant design, are outlined.

## INTRODUCTION

THE dedication, by the Columbia Broadcasting System, on April 30, 1938, of its new studios in Hollywood, California, marked another milestone in the development of broadcast facilities. Serving as the network's west-coast headquarters and as the new home of station KNX, this project embodies practically all of the latest developments known to the art.

The increasing importance of Hollywood as a source of transcontinental radio programs and the growing broadcast audience in the western part of the country, resulted in the building of elaborate studio and office facilities. Nevertheless, should the need arise, the design of the new buildings and the utilization of the tract of ground at Columbia Square is such that even the new extensive accommodations may be approximately doubled.

It is believed that a description of this latest broadcast center will be of interest because of the many new features and engineering developments involved.

## BUILDING GROUP

The principal building, Fig. 1, is a five-story structure which contains an auditorium studio, seven regular studios (three with visitor observation rooms), a master-control room, two audition rooms, a display and demonstration room, two reverberation chambers, a recording room, an ultra-high-frequency transmitter room, an engineering laboratory and 70 offices. Another building, two stories in height, at present, houses a bank, a restaurant, 3 stores, and 20 business offices. A patio, Fig. 2, with a circuitous driveway separates the two buildings. The canopied entrance to the auditorium studio is at the head of this driveway, while a branch road leads to a convenient parking space.

The entire patio side of the first-floor reception hall is paneled with glass. The centrally located master-control room is also glass-enclosed and can be seen, not only from the main entrance hall, but also from the patio sidewalk and from the lobby of the auditorium studio.

The structures are of reinforced concrete especially designed for the intended purpose and for the locality in which they are situated. The interiors are sound-insulated, acoustically treated, and air-conditioned

in accordance with best present-day practices. The entire plan was co-ordinated in the most efficient functional manner since the activities to be undertaken were accurately known and since it was unnecessary to provide for any applications other than broadcasting. The utilitarian features of the resulting buildings are convincing evidence of the soundness of modern architectural design.



Fig. 1—Main building of CBS Studios at Columbia Square, Hollywood, California.

## AUDITORIUM STUDIO

Access to the auditorium studio, which is one of the largest of its kind ever built, is gained through its entrance lobby without the need for passing through the main reception hall. This auditorium, Figs. 2 and 4, can accommodate 1050 visitors in an orchestra and mezzanine section. Special chairs, wider and deeper than usual, having both the seats and backs heavily upholstered, are used. Thus the size of the audience present has little effect upon the studio acoustics.

The broadcast stage has a depth of 38 feet and a proscenium opening 50 feet wide and 27 feet high. The usual theater footlights have been omitted since they would seriously interfere with the reading of scripts and scores by the performers. Special illumination, designed for the application in hand, is used.

Movable "flats" or reflecting surfaces, Fig. 2, section 7, are available to form the effective sides and rear of the stage in order to provide an orchestra shell of adjustable size. These may be arranged to form a stage of the desired dimensions for the production involved.

The control room for the auditorium studio is located to the left of the stage while an observation room is to the right. The latter room is provided in order to accommodate persons who are especially interested in the opportunity of viewing the actions on the stage while hearing the performance from a loud speaker.

\* Decimal classification: R550. Original manuscript received by the Institute, July 27, 1938.

† Columbia Broadcasting System, New York, N. Y.

The location of the control room to the left is a small but very important detail. It is usually easier for a musical conductor, facing the orchestra, to turn to the left than to the right. This results from his right arm being raised for conducting with a baton, and thereby partially obstructing movement and vision to the right.

A loud speaker has been located backstage for rehearsal-break purposes; that is, for communication from the control room to the studio, during the course of rehearsals. In the auditorium, sound-reinforcing loud speakers have been installed for the benefit of the audience present during regular broadcast programs.

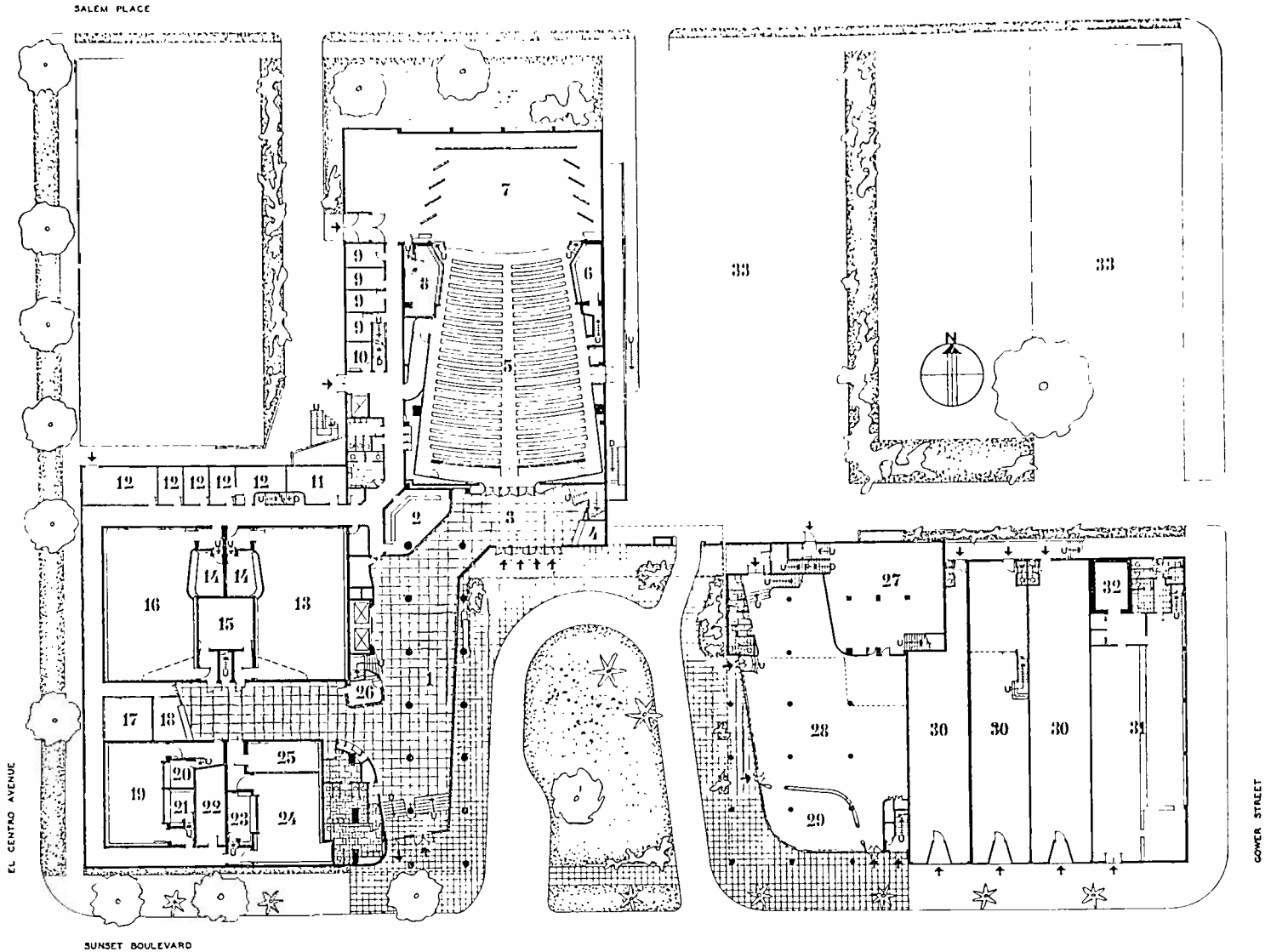

Fig. 2--First-floor plan of CBS Hollywood studio building showing auditorium studio, larger studio units, master-control room, offices, and business-building arrangement.

- |                         |                              |                      |                    |
|-------------------------|------------------------------|----------------------|--------------------|
| 1. Entrance hall.       | 9. Dressing room.            | 17. Artists' lounge. | 25. Organ chamber. |
| 2. Master-control room. | 10. Building Superintendent. | 18. Checkroom.       | 26. Information.   |
| 3. Foyer—Studio A.      | 11. Musicians' lockers.      | 19. Studio No. 3.    | 27. Kitchen.       |
| 4. Checkroom.           | 12. Engineering Department.  | 20. Clients' room.   | 28. Restaurant.    |
| 5. Studio A.            | 13. Studio No. 1.            | 21. Control room.    | 29. Cocktail bar.  |
| 6. Clients' room.       | 14. Control room.            | 22. Storage room.    | 30. Stores.        |
| 7. Platform.            | 15. Storage room.            | 23. Control room.    | 31. Bank.          |
| 8. Control room.        | 16. Studio No. 2.            | 24. Studio No. 4.    | 32. Vault.         |
|                         |                              | 33. Parking.         |                    |

STUDIOS

Twelve microphone and sixteen utility outlets have been installed in special floor boxes on the stage. Still another microphone outlet is located in the ceiling of the auditorium for a microphone suspended over the front orchestra rows. The liberal distribution of outlets facilitates the location of microphones wherever desired without long cables on the stage floor. The utility outlets provide headphone monitoring facilities, volume-indicator extensions, private-line telephone extensions, and spare circuits for any unusual requirements,

In addition to the auditorium studio, four regular broadcast studios are located on the first floor while three others are on the second floor of the main building. The two largest studios, Nos. 1 and 2, are two stories in height and are identical in size and arrangement except that one is the reverse of the other. Both of these studios have glass-enclosed observation galleries on the second-floor level, Fig. 3, area 20, and Fig. 5. Studio 3 is a general-purpose unit that has an observation room adjacent to the control room while Studio 4 is an organ studio,

Public access to the studios on the first floor is obtained directly from the main reception hall. On the other hand, artists, technicians, and other staff members reach the studios by means of a staff corridor.

Studios 5 and 6 are small units located on the second floor together with Studio 7. This latter studio is used expressly for local KNX announcements, news broadcasts, and transcription purposes.

A great many special features are incorporated in the construction of the studios to insure the realization of the desired degree of sound insulation and isolation. For example, the studios themselves are of the room-within-a-room construction. The walls, ceiling, and floor are suspended from the main concrete structure by means of flexible supports. Carefully designed flexible supports were also used for the isolation of all machinery that might contribute

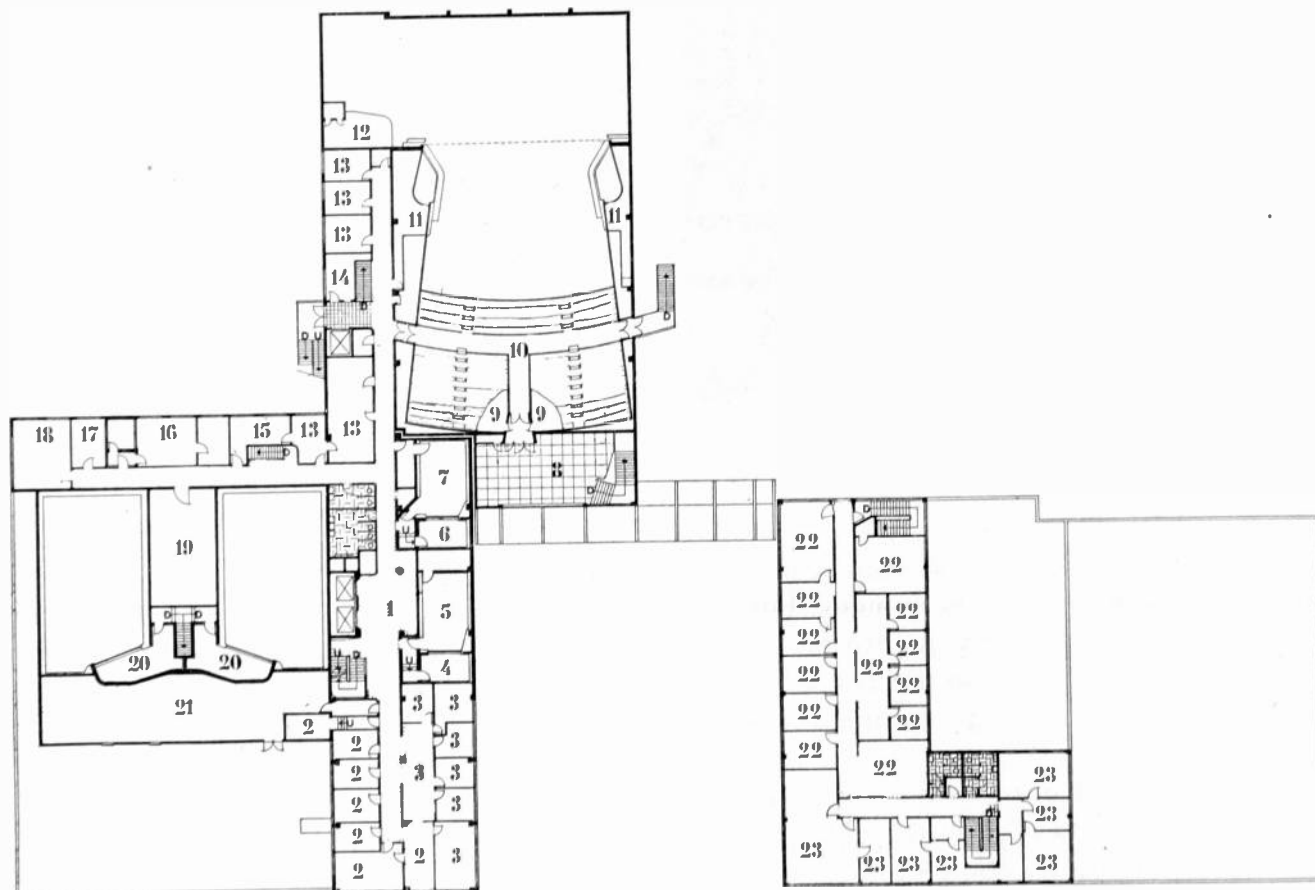

Fig. 3—Second-floor plan of CBS Hollywood studio building showing the mezzanine section of the auditorium studio, the smaller studio units, the studio observation rooms, and smaller offices.

- |                                       |                           |                          |
|---------------------------------------|---------------------------|--------------------------|
| 1. Reception room.                    | 8. Balcony foyer.         | 16. Transcription rooms. |
| 2. Program and continuity department. | 9. Plenum.                | 17. Head announcer.      |
| 3. Production department.             | 10. Studio A balcony.     | 18. Announcers' lounge.  |
| 4. Control room.                      | 11. Spotlight booths.     | 19. Unassigned.          |
| 5. Studio No. 6.                      | 12. Switchboard platform. | 20. Clients' room.       |
| 6. Control room.                      | 13. Music department.     | 21. Fan room.            |
| 7. Studio No. 5.                      | 14. Mail room.            | 22. Artists' bureau.     |
|                                       | 15. Unassigned.           | 23. Rentable area.       |

The size of the various studios is shown in Table I.

TABLE I  
CBS HOLLYWOOD STUDIOS

Studio	Length in feet	Width in feet	Height in feet
A	108	48	33
A*	50	38	45
1	50	30	20
2	50	30	20
3	34	21	13
4	30	21	13
5	22	12	11
6	22	12	11
7	9	8	9

\* Stage on'y.

An unusual feature of the studio design is the inclined walls illustrated in Figs. 5 and 6. The absence of parallel walls and the judicious distribution of the acoustical materials effectively eliminates the possibilities of room "flutter" or echoes.

noise or vibration. All studio groups, including the auditorium, are equipped with sound locks and special sound-isolation doors. Acoustical plaster is used



Fig. 4—Stage and control room of KNX Studio A, the auditorium studio which accommodates an audience of 1050 persons in an orchestra and mezzanine.

in all corridors and public spaces adjacent to the studios. All air-conditioning ducts have honeycomb type absorption cells of new design to prevent the transmission of sound from one area to another and to isolate any noise from associated machinery.



Fig. 5—A view from the microphone end of KNX Studio 2 showing the observation room and the new sloping-wall treatment.

#### CONTROL ROOMS

The studio control rooms were designed, not only to accommodate the necessary equipment, but also to provide the best possible vision into the studio and vice versa. In order to achieve the desired results a number of new construction features were developed.

The height of the control-room floor is chosen so that the seated occupants of this room are on the same eye level as an orchestra conductor on a podium in the studio. Thus, both parties can readily see each other without looking either upwards or downwards.

The control room is extended slightly out into the studio which, combined with the seating of the occupants as close to the windows as practical, makes it possible to see the entire studio area. For all practical purposes, there are no "blind spots" for the control room occupants.

The control-room windows are double-glazed for greater sound insulation, and are set at the critical angle that eliminates all reflections under normal lighting conditions. The design of observation windows that avoid all reflections requires close co-ordination of such factors as studio and control-room illumination, ceiling, floor and wall decoration, the sill height, the angle with the vertical and allied factors. So complex is this design, in fact, that a number of full-scale control-room models were built in New York, together with a full-scale model of Studios 1 and 2, in order to study this, the acoustical, and other problems.

#### STUDIO AUDIO-FREQUENCY FACILITIES

The audio-frequency equipment in each studio consists, basically, of a six- or eight-position mixing con-

sole (depending upon the studio size) supplemented by associated amplifying and monitoring apparatus. Complete unity and independence are achieved by including, in each studio control room, all the apparatus necessary for transmission of the program at normal outgoing-line levels. In addition, regular and emergency power supplies are provided for the 110-volt alternating-current primary power and the low- and high-voltage direct-current power requirements. These latter supplies are obtained from rectifier-filter units and, consequently, no batteries whatsoever are employed in the installation. In addition to obtaining primary alternating-current power from two separate mains an emergency gasoline-engine-driven alternator is available.

The studio audio-frequency facilities provide for two incoming-line and four or six microphone channels. The monitoring facilities consist of an especially designed volume-indicator<sup>1</sup> instrument and a loud speaker. Rehearsal-break and cuing facilities are also included. The circuit arrangement is, essentially, in accordance with the system design already outlined.<sup>2</sup>

The premixing amplifiers may be connected for the accommodation of microphones having from 30- to 250-ohm output impedances. This permits the use of any present-day dynamic- or velocity-type microphones, as desired.

The mixer and master gain controls are bridged-T attenuators having no insertion loss and providing volume control in approximately 0.75-decibel steps,<sup>3</sup> linearly over a range of 45 decibels. Thereafter, the attenuation increases rapidly and in the "off" position substantially infinite attenuation is obtained for all audio frequencies.

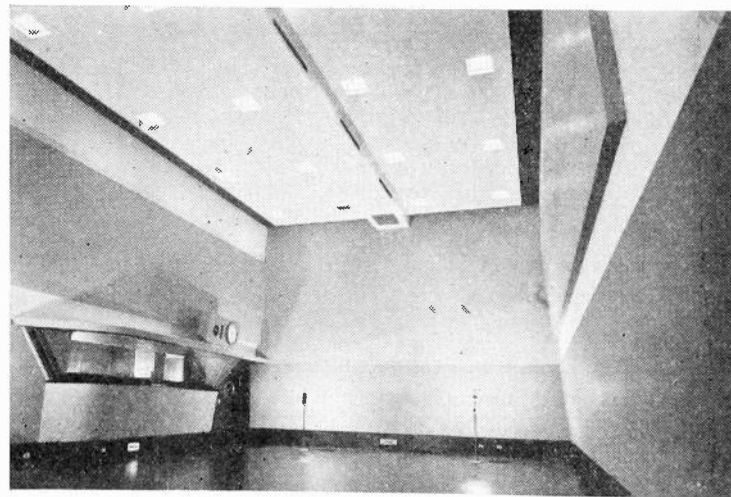

Fig. 6—The control room and microphone area of KNX Studio 2. The projection of the control room into the studio and the critical angle of the observation windows provides an unobstructed view of the entire studio from the control room.

<sup>1</sup> H. A. Chinn, H. A. Affel, and R. M. Morris, "A new "VI" and reference level," *Electronics*, vol. 12, pp. 28-29; February, (1939).

<sup>2</sup> H. A. Chinn, "Broadcast studio audio-frequency system design," *Proc. I.R.E.*, vol. 27, pp. 83-87; February, (1939).

<sup>3</sup> Actually 1.5 decibels per contact but bridging between adjacent contacts results in intermediate attenuation values.



The channel key switches are of the one-way, locking type. The circuit arrangement is such that in the "off" position, the output of the mixer control and the input to the mixer matching network are both properly terminated. Moreover, the contacts are of the make-before-break type so that upon operation of the key the circuits are completed before the terminating resistors are disconnected.

In the case of the incoming-line channels, these design details assure the proper circuit load irrespective of the channel key position. In the case of the microphone channels, it obviates the possibility of cross talk caused by an excessive voltage being developed across amplifier output terminals which would otherwise be open-circuited. Furthermore, the arrangement insures that the mixer matching network source impedances remain constant for either position of the microphone key.

Another small but important detail is the circuit sequence of mixer control and key switch. The arrangement is such that in the event a control becomes defective during operations, it may be isolated from the circuit and adjusted without affecting the remainder of the system.

Most of the remaining features of the studio audio-frequency system design have been mentioned heretofore.<sup>2</sup> One item that has not been described, however, is the operation of the outgoing-line key. This key, which is of the two-way, locking type, has three functions. In its up or "rehearsal" position, it arranges the circuits so that the studio performance may be "mixed" and monitored by the control-room occupants, but it is not transmitted on the outgoing-line. The rehearsal-break facilities are available for communication from the control room to the studio for the direction of the performers by the program producer.

With the line key in its neutral or "stand-by" position, the occupants of both the control room *and* the studio are able to hear the "cue" program, that is, the one being broadcast at the moment and from which, presumably, the starting cue is obtained.

In the down, or "on-air" position of the line key, the system is again aligned for transmission but in this case the output of the studio is connected to the outgoing line. The rehearsal-break equipment is, however locked out of the circuit so that it cannot be inadvertently operated while the studio is originating a program.

The response-versus-frequency characteristic of a complete studio channel is uniform, within 1.5 decibels of the 1000-cycle value, over the frequency spectrum from 40 to 10,000 cycles. The harmonic distortion at 400 cycles is less than 0.2 per cent, root-mean-square, for any output level up to the "normal" level of 10 milliwatts. At a level of 100 milliwatts, that is, 10 decibels above normal, the distortion is less than 0.6 per cent, root-mean-square.

The signal-to-noise ratio of the complete channel approaches 60 decibels.

In addition to the regular transmission and monitoring apparatus, there are a number of associated facilities which contribute greatly to the flexibility of the studio equipment. For example, there are adjustable low- and high-pass filters for "sound-effect" purposes. Various cutoff frequencies may be selected or the filters removed from the circuit by means of a rotary switch on each unit. Since the filters are connected in tandem, a band-pass effect is also available. A total of eighteen useful filter characteristics may be obtained. The function of other apparatus, for general utility use, has been outlined heretofore.

The apparatus in the studio control rooms is contained in a mixer console and an associated cabinet-type equipment rack. In designing the control console, its height and depth were kept at a minimum in order that the technician's view into the studio would be as unobstructed as possible. The angle of the control panel was chosen so that its plane would be perpendicular to the technician's line of sight. This affords a clear view of the volume-indicator instrument and of every control knob and associated graduated scale. The position of the signal lights and of each control was carefully determined to facilitate operation of the equipment. Likewise, careful consideration was given to the table height and width and to the panel finish, in order to provide the most convenient arrangement.

The cabinet-type equipment rack is, in most instances, located directly at the right of the control console. It contains the pre-mixer, booster, channel, and monitoring-loud-speaker amplifiers, together with the jack fields, relays, transformers, attenuator pads, sound-effect filters, regular, emergency, and master power switches, and terminal blocks. All power necessary for the operation of this equipment is obtained from the alternating-current power mains.

In the wall behind the equipment rack in each studio control room, there is an especially designed wall box. This box is divided into four compartments which contain (a) the terminal blocks for the audio-frequency circuits, (b) relays for controlling the alternating-current to the equipment rack and to the "on-air" sign, (c) alternating-current switch and fuse panel, and (d) 12-volt, direct-current rectifier-type power-supply unit.

All external audio-frequency wiring is in a rigid conduit which terminates in the wall box. Where the rigid conduit enters the sound-isolated studio, a length of flexible conduit is employed to guard against any sound transmission through this medium. The control-room audio-frequency circuits are contained in a steel duct which extends from the wall box, under the floor, to the equipment rack, and

thence to the control console. Signal circuits and low- and high-voltage direct- and alternating-current power circuits are in a conduit separate from the audio-frequency circuits.

Two separate conduit runs connect each studio control room with the master control room. Of the twenty-four pairs of shielded cable contained therein, only ten were used initially, leaving ample spare circuits for future use.

All interconnecting audio-frequency circuits (except microphone circuits) employ enamel-covered,

lation of the microphone receptacles, in the studio, to avoid unintentional grounding of the microphone-cable shield at this point.

An interesting feature of the installation is the location of the electrical ground for the audio-frequency facilities underneath the main building, at the very bottom of the foundation. It consists of a 100-square-foot copper mat to which there are bolted and brazed a number of heavy copper conductors. These, in turn, are insulated and distributed throughout the building in rigid conduit.

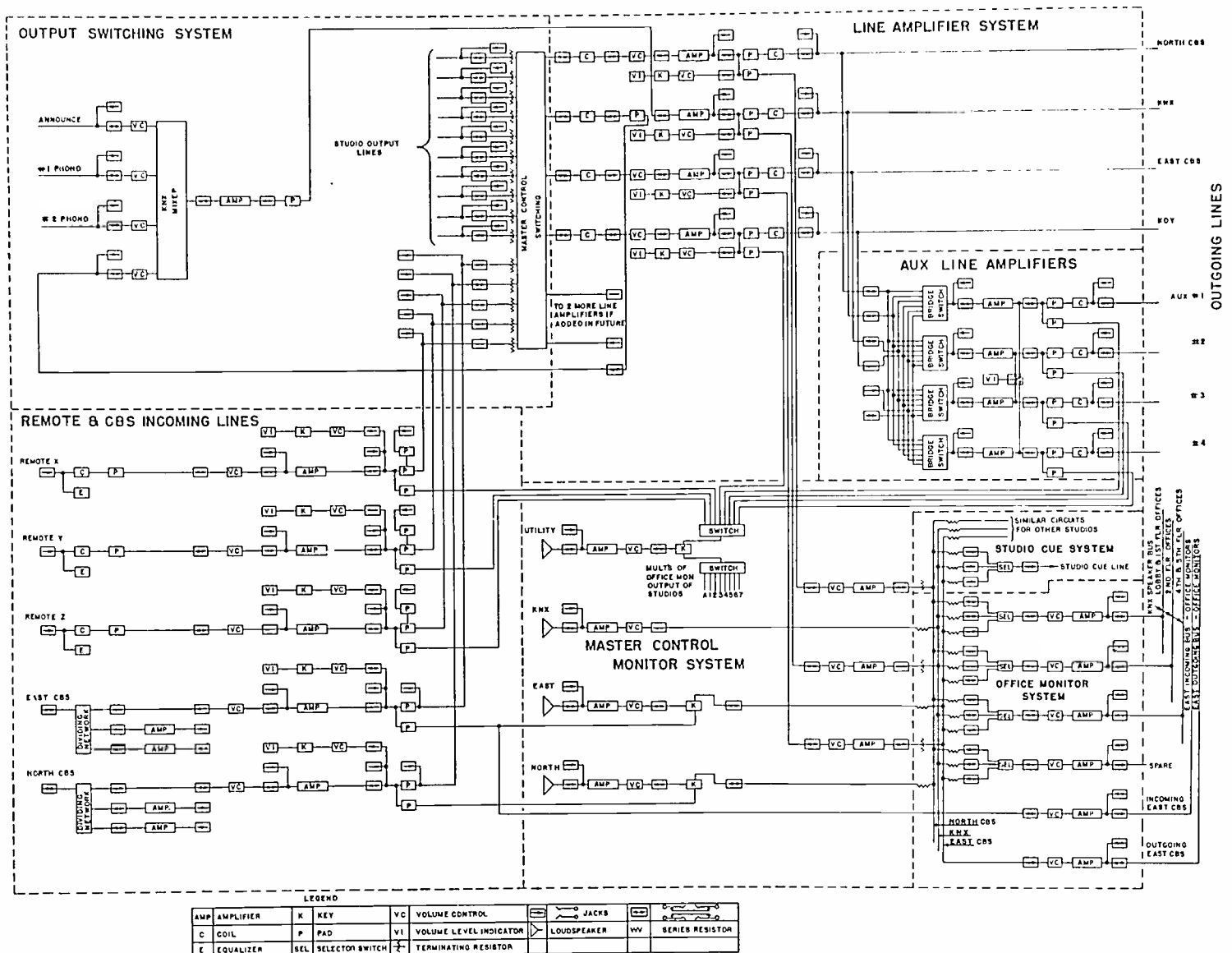

Fig. 7—Schematic block diagram of the KNX master-control room audio-frequency facilities.

copper-wire pairs, silk- and cotton-insulated, twisted and shielded with an outer braid of copper. In the case of the very low-level microphone circuits, a similarly shielded cable is employed, except rubber insulation is used in place of cotton and an outer covering of rubber is added over the braided-copper shield. This prevents the shields on adjacent microphone circuits from rubbing against each other and creating noise in the circuit. Furthermore, it insures against multiple grounding of the microphone-cable shield which, normally, is connected to ground only at the equipment end of the circuit. In this connection, special precautions must be taken in the instal-

### MASTER-CONTROL FACILITIES

Fundamentally, the function of the equipment installed in the master-control room is to distribute program material simultaneously to any one or more of eight outgoing program lines from any one or more of eighteen program sources. These basic facilities are supplemented by equipment for (a) the incoming network and remote-program lines, (b) visual- and aural-monitoring purposes, (c) the operation of the loud speakers located throughout the building, (d) testing and measuring purposes, and (e) telephone communication to all points to which programs are

distributed or from which they originate, whether in the building or at a remote location.

The master-control audio-frequency facilities, which are outlined in the block schematic diagram, Fig. 7, are designed to accommodate an ultimate of 18 program sources. Provisions are made for three auditorium studios, ten regular studios, three "remote" channels, and two incoming network lines. The three remote channels, in turn, may be connected to any one of an initial installation of forty-eight program lines from points scattered throughout the Los Angeles area. Included in these are two Radio Playhouses which are regularly used, supplementary to the studios being described, for the origination of large, nation-wide programs from Hollywood.

Each remote channel consists of a variable line equalizer, a volume control, a channel amplifier, a volume-indicator instrument, and a means for aurally monitoring the channel. This equipment provides for the equalization of the remote lines in use, for amplifying the incoming program material to a power level comparable to the output of a studio channel, and for monitoring the quality of the program prior to and during the broadcast.

The program lines from the studios, together with the remote and incoming network lines are terminated in resistive loads of the proper value and constitute the program busses. All outgoing-line amplifiers are connected to these busses by means of "bridging" transformers which have relatively high input impedances. This arrangement permits the connection of any reasonable number of outgoing channels to a given program bus without appreciably affecting the circuit impedance or the level on the program bus.

Each of the outgoing line channels consists of the afore-mentioned bridging transformer, a volume control, a line amplifier, a volume indicator, an isolation

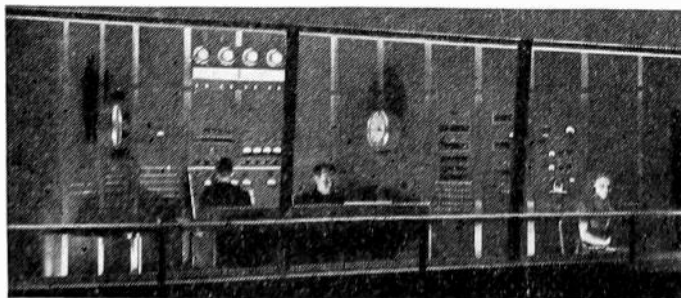

*Bulotti-Denton*

Fig. 8—Center section and left wing of KNX master-control room as seen from the lobby.

pad, and a line transformer. These channels are connected to the program busses by means of relays which, in turn, are operated by selector switches and associated controls. The desired program distribution is obtained by presetting the selector switches for each outgoing channel, Fig. 9, and then operating a master "on" button. The "on" button operates the selected relays which "lock in" by means of auxiliary

contacts, whereupon the preselection of the ensuing distribution can be made without disturbing the existing circuits.

Individual "on" and "off" buttons are provided for the control of each outgoing channel separately,

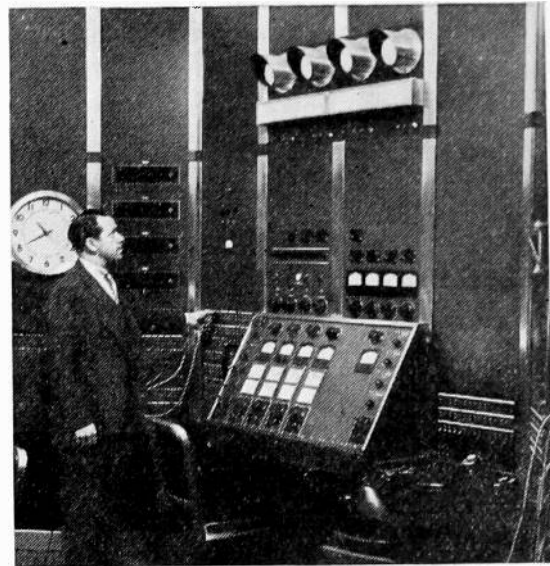

*Bulotti-Denton*

Fig. 9—Close-up of KNX master-control room central operating position where the complex network switching operations are undertaken.

in the event that the timing of a channel does not coincide with that of the entire group. By-pass switches are also provided to omit any studio from group operation. This permits a studio to transmit to a given line or lines without interruption, if desired, when the master button is operated. By-pass action and individual "on" and "off" control of each channel takes care of programs that do not end in unison with the others. It also provides for multiple network operations, as well as split announcements in group distribution.

The following example illustrates the flexibility of the output switching system: Three studios may be transmitting programs to the eight outgoing lines. If the program in one studio terminates while the others continue, operation of the individual "on-off" buttons on the channel or channels to which this studio was connected will permit the termination of the program; permit a local announcement to be made on the KNX transmitter channel, if involved; and by preselection, permit still another studio to transmit to the lines involved. All this may be done without disturbing the program distribution to the remaining outgoing lines.

If the reverse operation should be necessary, that is, the termination of a group program while a single studio continues, this operation may be undertaken by the use of the by-pass key.

The arrangement affords, in every case, ample time to preset the selector switches and since the selection arrived at is visible at all times, switching errors are reduced to a minimum.

The preselection and selection of the master-control switching are indicated, respectively, on two

opalescent glass panels placed one above the other, Fig. 9. Beneath the glass in each case is a stencil or mask through which light passes from one of a bank of eighteen signal lamps. Thus the number or letter of the selected studio appears in the opalescent glass. On the upper panel, the preset number or letter appears in green and corresponds with the setting of the selector switch. As soon as the relays are operated connecting the studio through to that channel the figure appears in red on the lower panel indicating that the studio is on the air. A glance at these indicating panels shows at all times which studios are on the air, and which studios are selected for the next program.

The equipment in the master control is mounted in fifteen cabinet-type racks, each of which is ten feet in height. For efficient operation, the racks have been arranged as three sides of an octagon. This arrangement, which is believed to be new, provides a center section in which the master switching console is located convenient to all other apparatus. All controls used during routine operations are grouped, in the center section of the assembly, within easy reach of the technicians on duty. In addition, this section contains the outgoing line amplifiers, the volume-indicator instruments, and the switching relays.

The left wing, which is only partially visible in the photograph, contains the monitoring amplifiers for the four loud speakers in the master control. The arrangement is such that any four of the incoming or the outgoing program lines may be monitored simultaneously. Also included in this wing are the monitoring amplifiers for the loud speakers located throughout the lobbies and offices. Four separate programs (transcontinental network, Pacific coast network, KNX, and an audition selector) are distributed for executive monitoring and other purposes. Additional amplifiers are provided for the transmission of the "cue" program to the studios and to the remote points in the field.

The right wing contains the remote and incoming-line terminations, the line equalizers and amplifiers, and the measuring equipment. The grouping of these facilities provides a very convenient arrangement for line equalization and other measurement work.

An especially constructed telephone switchboard is located partly in the center section and partly in the right wing. This location was chosen because of proximity to both the master switching console and the incoming line and the measuring equipment. This switchboard provides private-line telephone communication to all program sources such as the studios, the Radio Playhouses, the remote origination locations, and to all local-program transmission points such as the KNX transmitter, the telephone office handling the network lines, and recording companies.

A steel duct runs above the master-control equipment racks for the entire length of the assembly. On

top of the duct are the wall boxes, in which all conduits for the audio-frequency circuits throughout the building are terminated. The boxes, conduit, and duct above the racks are contained in a "curtain" wall which extends down from the ceiling and meets the top of the cabinet racks.

The terminal blocks are located at the top, rather than at the bottom, of the cabinet racks. This is contrary to past broadcast-plant practice but it greatly facilitates the interwiring between the terminal blocks in the equipment racks and those in the wall boxes which are directly overhead. This is evident when it is considered that there are ten wall boxes which connect to the wiring duct by very short lengths of conduit. Contrasting this to the former method of locating the terminal boxes in the walls back of the racks and then connecting them to a floor duct, indicates the great saving in conduit, wire, and labor that results from the new method.

The alternating-current power-supply lines are carried in a rigid conduit from a switch and fuse panel located in the wall back of the racks (but near one end of the assembly for easy access) to a steel duct running under the racks. Lead-covered cable with twisted insulated pairs is used for this purpose. Each rack of equipment is separately fused at the switchboard end; in many instances, a fuse is incorporated as a part of the individual apparatus units in the rack.

#### CONCLUSION

Throughout the planning of the KNX studios and master-control audio-frequency facilities, an effort was made to simplify the design as much as possible consistent with providing means for undertaking the complex operations encountered in a major broadcast center. This procedure, which is in line with the functional design of the entire project, resulted in a system that is relatively straightforward in its operation and as trouble-free as practicable.

Continuity of service throughout the broadcast day is one of the foremost requisites of all broadcast facilities. Consequently, many precautionary measures were taken to insure against program interruptions and to provide for the immediate restoration of service in the event that any piece of equipment does become defective.

Experience gained from daily operation of the CBS Hollywood studios since the spring of 1938 indicates that the new plant fulfills expectations and requirements from all standpoints. The system designs and the equipment components have proved themselves to be in accordance with requirements and entirely satisfactory in operation.

This project, which was carried out under the general direction of E. K. Cohan, Director of Engineering and A. B. Chamberlain, Chief Engineer of the Columbia Broadcasting System, provides Hollywood with the most advanced broadcast facilities in existence at the present time.

# Wide-Band Amplifiers for Television\*

HAROLD A. WHEELER†, FELLOW, I.R.E.

**Summary**—The maximum uniform amplification that can be secured over a wide frequency band by means of a single vacuum tube is much greater than that of the usual simple circuits. It can be secured by either of two arrangements, one using an individual filter coupling each tube to the next, and the other using degenerative feedback in each stage to make the stage behave as a section of a confluent filter. In either case, the shunt capacitance on each side of each tube is included in an individual full-shunt arm of a band-pass or low-pass filter. One end of each interstage filter, or of each filter including one or more feedback stages, is extended to a dead-end termination with resistance approximately matching the image impedance. The other end is terminated at one of the tubes in a full-shunt arm, where the filter presents the maximum uniform impedance that can be built up across the tube capacitance. These concepts in terms of wave filters lead to practical wide-band circuits adapted to meet any given requirements.

The following general formula is shown to express the maximum uniform amplification that can be secured in one tube:

$$A = \frac{g_m}{\pi f_w \sqrt{C_g C_p}}$$

in which

$A$  is the voltage ratio between input and output circuits of equal impedance,

$g_m$  is the transconductance of the tube,

$C_g$  and  $C_p$  are the grid and plate capacitance of the tube, and

$f_w$  is the width of the frequency band.

## I. INTRODUCTION

FOR more than twenty years, the design of amplifiers to cover a wide band of frequencies has been a major problem. The severe requirements of television have forced the solution of this problem. Even now, there has not been published either a treatment of the fundamental limitations or an outline of the basic methods of design. The purpose of this treatment is to give both as concisely as possible.

The problem dates from the "untuned radio-frequency amplifiers" of the World War. It was discovered that the amplification in a wide-band amplifier was limited not only by the amplifying ability of the vacuum tube at low frequencies, but also by its shunt capacitance. Later, we tried to design amplifiers to cover the broadcast band without tuning. We met with failure until the advent of screen-grid tubes, and by that time the need for selectivity in radio receivers had quenched the demand for wide-band amplifiers.

As soon as radio receivers no longer wanted wide-band amplifiers, television appeared on the horizon. Television came to demand wide-band amplifiers such as never before had been conceived. They must not only amplify over megacycles of band width, but they must do that with unusual fidelity. They must amplify megacycles more faithfully than the sound receivers amplify kilocycles.

For fifteen or twenty years, the development of wide-band amplifiers was casual and sluggish. Only

\* Decimal classification: R363.1×R583. Original manuscript received by the Institute, July 12, 1938. Presented, Thirteenth Annual Convention, New York, N. Y., June 18, 1938.

† Hazeltine Service Corporation, Little Neck, L. I., N. Y.

during the past few years have the fundamental limitations been appreciated. The British publications of W. S. Percival, which appeared last year, do show this appreciation. Only recently have we learned of independent work in this country, but this has not been published.

Our problem is to secure the maximum product of the band width and the amplification ratio of one stage. The product is the logical criterion, because either can be increased at the expense of the other. The product is limited by the quotient of the transconductance over the shunt capacitance. The shunt capacitance is involved because it limits the wide-band coupling impedance that can be built up across the input and output circuits of a vacuum tube. The real problem is merely building up the impedance across a shunt condenser, effective over a wide band of frequencies.

There are many forms of networks which can be employed to maintain nearly uniform impedance across a shunt condenser. The condenser is regarded as one element of the network. These networks all have in common some filter properties, the total width of the frequency band being limited by the shunt capacitance. Therefore it is logical to take the wave filter as a basis for the study of this subject.

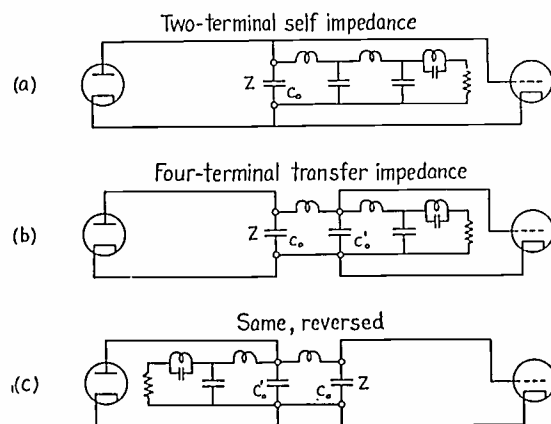

Fig. 1—A low-pass coupling impedance obtained by means of a dead-end filter.

Fig. 1 shows three ways in which a low-pass filter may be connected as a coupling impedance between successive tubes of an amplifier. In each case, there is included shunt capacitance across each tube. There is no obvious reason for choosing a configuration such as that shown. There is no obvious way of assigning circuit values to obtain the maximum product of coupling impedance and band width.

The configuration is chosen and the elements are evaluated by an unusual application of the theory of wave filters. The coupling impedance  $Z$  is the input impedance of a low-pass filter. The filter is a dead-end filter, employed only to secure the desired im-

pedance. It is possible to design the filter to secure nearly uniform impedance, to any degree of approximation, by the simple methods to be described.

In Fig. 1(a), the impedance  $Z$  is employed as a two-terminal self-impedance coupling the two tubes. The network includes  $C_0$ , the total shunt capacitance of both tubes. The product of the impedance and the band width is limited by the total shunt capacitance. The amplification is proportional to the impedance, so greater impedance is desirable.

Greater impedance can be secured by separating the capacitance of the preceding tube from that of the succeeding tube, so only one of these is lumped across the impedance terminals. This separation is shown in Figs. 1(b) and (c).

In Fig. 1(b), the uniform impedance  $Z$  is developed in the output circuit of the first tube, across its

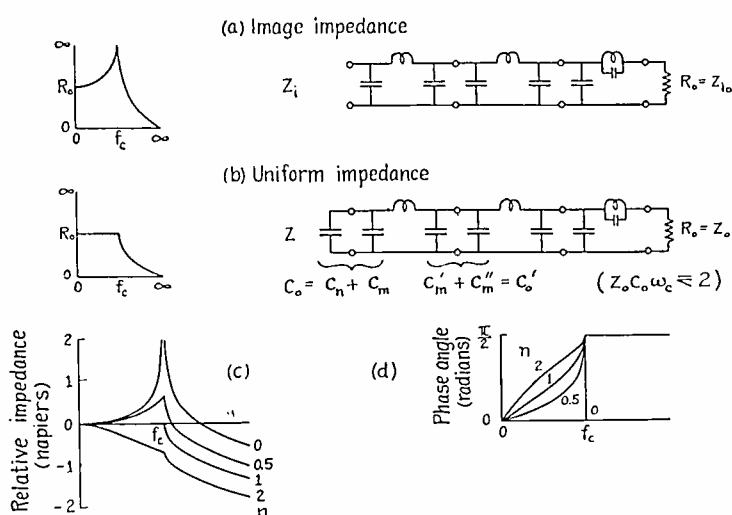

Fig. 2—The derivation of a low-pass coupling impedance from the filter theory.

shunt capacitance  $C_0$ . Therefore the amplification (voltage ratio) from grid to plate is uniform. The filter offers no attenuation from the first plate to the second grid, in the pass band. Therefore the amplification is uniform from the first tube to the second tube.

In Fig. 1(a) the two-terminal self-impedance  $Z$  is the coupling impedance. In Fig. 1(b), the coupling of the four-terminal network is measured by its transfer impedance. The transfer impedance is the quotient of the output voltage over the input current. In this case, it is the quotient of the second grid voltage over the first plate current. In the absence of filter attenuation, the transfer impedance has the same magnitude as the self-impedance. In the pass band, they differ only by the phase angle of the intervening filter.

Since the transfer impedance is the same in both directions, the four-terminal network of Fig. 1(b) may be reversed end for end, as in Fig. 1(c), without changing its coupling properties. The dead-end filter is backward instead of forward. The advantage is the location of the dead-end resistor on the plate side for carrying the plate current.

With Fig. 1 as an introduction, the theory of uniform coupling impedance and the filter method of design are to be described.

## II. UNIFORM COUPLING IMPEDANCE OBTAINED BY MEANS OF A DEAD-END FILTER

In the usual applications of wave filters, uniform impedance is found only in the form of image impedance which is approximately uniform resistance over the pass band. Relatively small shunt capacitance is found to be associated with such image impedance, as compared with other arms of the same filter. Therefore a more favorable arrangement has been found. This is to be derived with reference to Fig. 2.

A low-pass filter is shown in Fig. 2(a). It contains several constant- $k$  sections with mid-shunt termination. The far end is concluded with an  $m$ -derived half section to secure image impedance nearly matching the terminal resistor  $R_o$  over the pass band.

The image impedance  $Z_i$  at the near end is of the constant- $k$  mid-shunt form, as shown in the impedance diagram. The image impedance is the actual impedance of an infinitely long filter. The actual impedance of the filter shown is nearly the same, because image impedance matching is followed through the filter to the terminal resistor. It can be made the same, to any degree of approximation, by multiple  $m$ -derivations at the far end.

The input impedance is purely resistive over the pass band, which is desirable, but it is not uniform. It can be made uniform by adding more shunt capacitance across the impedance terminals, as shown in Fig. 2(b). The added capacitance  $C_n$  should be equal to the constant- $k$  mid-shunt arm  $C_m$  within the filter, across the impedance terminals. These together comprise a full-shunt arm  $C_o$ . The resulting impedance  $Z$  is uniform over the pass band, as shown in the impedance diagram.

The curves of Fig. 2(c) show the variety of impedance characteristics available from this combination.\* The parameter  $n$  is the number of mid-shunt arms added in parallel with the image impedance  $Z_i$ . That is,  $n$  is the ratio of the added capacitance  $C_n$  to the constant- $k$  mid-shunt capacitance  $C_m$ .

The image impedance  $Z_i$  in Fig. 2(a) has the form

$$Z_i = \frac{R_o}{\sqrt{1 - \omega^2/\omega_c^2}} \quad (1)$$

It is modified by adding more capacitance  $C_n$  in parallel

$$C_n = \frac{n}{R_o\omega_c} \quad (2)$$

\* Relative impedance as a ratio is expressed in nepiers, one napier being equal to 8.7 decibels. A small fraction of one napier represents an equal departure from unity ratio; for example,  $\pm 0.01$  napier represents a ratio of 1.01 or 0.99. The corresponding unit of angular measure is the radian, equal to 57.3 degrees. This comparison enables angles to be expressed in decibels if desired, one radian being 8.7 decibels, or one decibel being 6.6 degrees.

The resultant impedance is

$$Z = \frac{1}{\frac{1}{Z_i} + j\omega C_n} = \frac{R_o}{\sqrt{1 - \omega^2/\omega_c^2 + nj\omega/\omega_c}} \quad (3)$$

In the pass band,  $\omega < \omega_c$ , the magnitude of this impedance is

$$|Z| = \frac{R_o}{\sqrt{1 - (1 - n^2)\omega^2/\omega_c^2}} \quad (4)$$

If  $n=1$ , the variable term disappears so the impedance is uniform over the pass band.

The corresponding phase curves are shown in Fig. 2(d). The phase angle of the impedance, in the pass band, has the form

$$b = \text{antitan} \frac{n\omega/\omega_c}{\sqrt{1 - \omega^2/\omega_c^2}} \quad (5)$$

This is the same as the phase angle of an  $m$ -derived half section of a low-pass filter, but with  $n$  in place of  $m$  in the formula.

In the special case of  $n=1$ , the impedance  $Z$  is developed across a full-shunt arm of the filter. The amplitude and phase characteristics of this self-impedance are identical with the transfer characteristics of a constant- $k$  half-section filter.

The phase characteristic corresponding to uniform impedance is curved, causing some phase distortion. Uniform (zero) phase slope is secured by  $n=0$ , but with an abrupt change at the cutoff frequency. Nearly uniform phase slope is secured with  $n$  slightly greater than one. There is no value of  $n$  corresponding to uniform impedance and uniform phase slope, both at once. This result can be approximated by combining in different stages, self-impedance coupling with different values of  $n$ .

If this network is used as a four-terminal coupling impedance, as in Fig. 1(b) or (c), the attenuation and phase are merely increased by the amount of the intervening sections of the filter. Therefore any desired characteristics can be obtained by proper choice of the intervening filter sections. Great attenuation outside the pass band, and phase correction in the band, are the properties most likely to be desired. Either or both can be secured at will.

This derivation is equally applicable to band-pass filters having any set of cutoff frequencies. The essential requirements are merely that  $Z_i$  is a mid-shunt image impedance of the constant- $k$  form and that the added shunt arm is a corresponding constant- $k$  mid-shunt arm. The impedance is then uniform over all pass bands.

Uniform impedance  $Z_o$  equal to  $R_o$  is developed in Fig. 2(b) across the total shunt capacitance equal to a full-shunt arm of a constant- $k$  filter:

$$C_o = \frac{2}{R_o\omega_c} \quad (6)$$

This is the greatest shunt capacitance across which this uniform impedance can be developed over a frequency band of this width. The level impedance  $Z_o$  is double the reactance of the shunt capacitance  $C_o$  at the cutoff frequency  $\omega_c$ .

This relation leads to the ultimate theoretical limitation on the wide-band performance of this coupling impedance

$$Z_o C_o \omega_w \leq 2 \quad (7)$$

in which  $\omega_w$  is the band width in terms of angular frequency. This formula is valid not only for low-pass

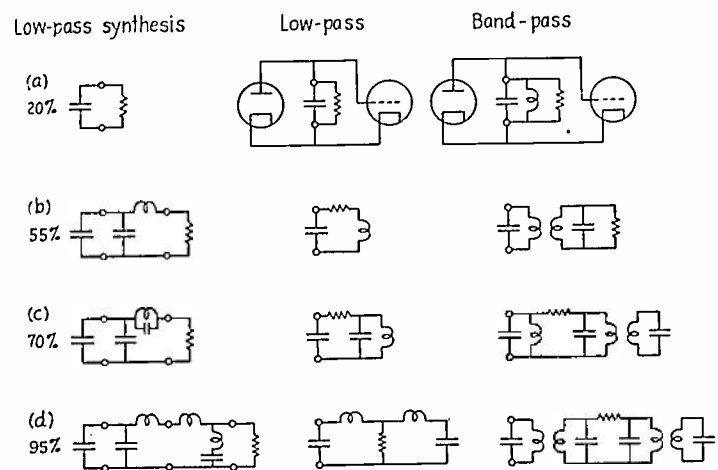

Fig. 3—Two-terminal self-impedance coupling networks, low-pass and band-pass.

filters, but also for band-pass filters of the same total band width. This product is the figure of merit by which any wide-band uniform impedance should be judged. Its theoretical upper limit is two. Its practical value depends not only on the theoretical factors but also on the tolerance of departure from uniformity.

The theoretical limit is based on an infinite number of circuit elements, and cannot be exceeded in any passive network. The very simple practical circuits in common use are makeshifts and fall far short of the limit. The addition of a few circuit elements in a preferred arrangement is sufficient to obtain a very close approximation to the theoretical performance.

The design of a wide-band coupling impedance by this method is best accomplished by working from the simple to the complex, until a sufficiently good figure of merit is realized. Fig 3 is an example of this procedure. The low-pass filter components are shown in the first column. The first example (a) includes no filter sections, only the shunt capacitance with a resistor in parallel. The second example (b) includes a constant- $k$  half-section. This turns out to be the ordinary video-frequency coupling impedance with series inductance and resistance in the parallel path. The third example (c) has instead an  $m$ -derived half section. The fourth example (d) has first a constant- $k$  half section and then an  $m$ -derived half section. The constant- $k$  half section provides for maximum capacitance directly across the impedance terminals on

the left-hand side. The  $m$ -derived half section provides for matching the image impedance with the resistor at the dead end on the right-hand side.

The percentage notations give an approximate indication of the figure of merit of these networks, relative to the ideal. They are based on a tolerance of  $\pm 0.03$  radian or  $\pm \frac{1}{4}$  decibel over the useful band (with reference to the curves of Fig. 5). There is an improvement from 20 to 95 per cent by the addition of three more circuit elements in the low-pass filter.

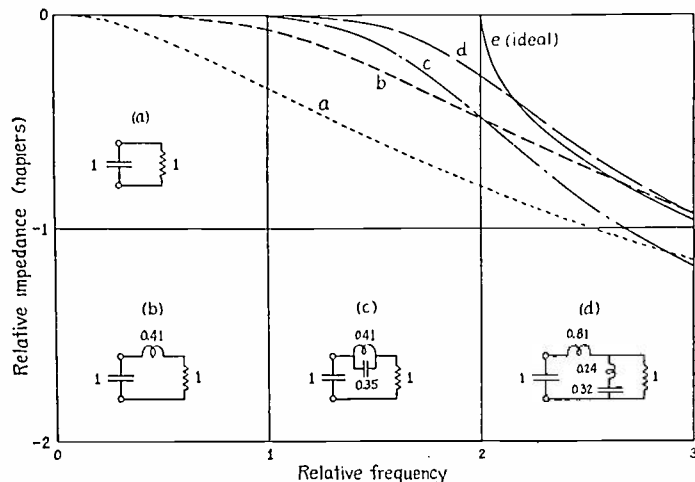

Fig. 4—Low-pass self-impedance characteristics for the critical values of the added circuit elements.

The second column of Fig. 3 shows the practical low-pass circuits. The resistor and reactors are rearranged in ladder networks, in the most convenient order. One to three circuit elements are added to the shunt capacitance and the essential resistor.

The third column shows the band-pass networks exactly analogous to the low-pass networks of the second column. The band-pass dead-end filters are reduced to a chain of coupled circuits, each resonant within the pass band. Each reactance element of the low-pass filter becomes a tuned circuit in the band-pass analogue.

The practical circuits, especially the band-pass examples, are arranged to include shunt capacitance to ground wherever the circuit permits. Such capacitance may be a disturbing factor if neglected. This is the reason for deriving the band-pass analogues in terms of parallel-tuned circuits instead of the obvious combination of parallel-tuned and series-tuned circuits to replace shunt capacitors and series inductors.

The performance of the simpler low-pass networks can be checked by computation. Also they can be designed by different methods, without reference to filter theory. The method commonly used involves expanding the impedance formula into a power series in terms of frequency. The added circuit elements are so evaluated as to cancel the same number of frequency terms in the power series. With reference to the familiar Taylor series, this means cancellation of a number of the lower-order derivatives. This method involves too much labor when the number of circuit

elements becomes large. Experience with this method and the filter method serves to demonstrate the advantages of the latter, which is equally useful for any number of circuit elements.

Fig. 4 shows the impedance curves of the low-pass networks of Fig. 3, the circuit elements having their critical values determined by the series method. All the peaks are merged into a single peak. The ideal curve (e) is that of Fig. 2, for  $n=1$ .

This and the following figure are plotted in such a manner as to show directly the figure of merit in terms of the useful band width. There are three quantities involved, the impedance, the shunt capacitance, and the frequency band width. Two of these have definite values while the third is indefinite in practical cases. The mid-band or zero-frequency impedance has a definite value, and the impedance varies but little over the useful band. The shunt capacitance has a fixed value. The useful band width, however, depends on the tolerance of departure from uniform impedance. The curves are plotted for unit impedance and unit capacitance, so the figure of merit is equal to the useful band width on the frequency scale. The figure of merit of the ideal curve is two, the maximum theoretically possible.

If the same low-pass impedance networks have their circuit elements evaluated by the filter method instead of the series method, the resulting impedance curves are those of Fig. 5. The computations are simple and direct. The  $m$ -derived half sections are based on the usual value,  $m=0.6$ . Curve (d), for three added elements, approaches the ideal so closely that the difference has no practical significance.

The question arises why curve (c), based on Fig. 3(c), should fall so far short of curve (d), based on Fig. 3(d). Both have an  $m$ -derived image impedance facing the resistor, with equal approximation of matching. In (c), however, the total capacitance across the impedance terminals is a constant- $k$  mid-shunt arm plus an  $m$ -derived mid-shunt arm, the total being only  $(1+m)$  constant- $k$  mid-shunt arms. In (d), the total shunt capacitance has the maximum value, two constant- $k$  mid-shunt arms. When these networks are reduced to unit impedance and unit shunt capacitance, the filter cutoff frequency of (c) is only 1.6 while that of (d) has the maximum value two. It is noted that (d) includes no shunt capacitance directly across the coils and the resistor. If such incidental capacitance is appreciable, it may be taken into account, but it always reduces the cutoff frequency. The method of plotting used in Fig. 5 shows clearly the result of these factors.

Referring back to Figs. 1(b) and 2(b), greater coupling impedance between two tubes may be obtained by separating their shunt capacitance in a four-terminal network. The self-impedance then has to be developed across the shunt capacitance of only one of the tubes. Double the impedance is possible



over the same frequency band. In Fig. 2(b), the self-impedance is developed across the shunt capacitance of one tube  $C_o$ . That of the other tube  $C_o'$ , is displaced along the filter, so it does not limit the self-impedance. The transfer impedance from one tube to the other, over the pass band of the filter, has the same magnitude as the self-impedance  $Z$ . Therefore the four-terminal transfer-impedance network has a higher standard of performance than the two-terminal self-impedance.

Several examples of four-terminal networks are shown in Fig. 6. The simple examples of (a) and (b) are simple filters without the dead-end extension of the filter. They are makeshifts in view of the present theory of design. Symmetrical damping by resistors on both sides is shown in the first row (a). The more effective unsymmetrical damping by a resistor on only one side is shown in the second row (b). The latter is the first step toward the dead-end filter, which is further unsymmetrical. Good practical embodiments of the dead-end filter are shown in the third and fourth rows (c) and (d). They have the same dead-end termination as (c) and (d) of Fig. 3. The low-pass examples have the dead-end filter reversed as in Fig. 1(c).

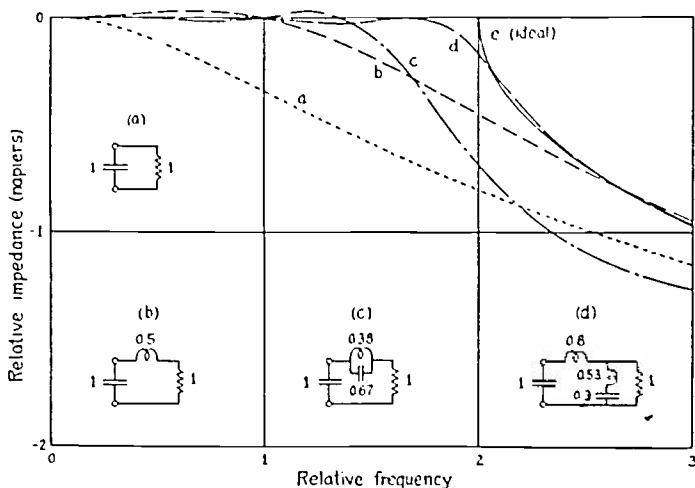

Fig. 5—Low-pass self-impedance characteristics for the filter values of the added circuit elements.

In the band-pass examples of Fig. 6, the part of the filter between the two pairs of terminals is not an exact analogue of the corresponding low-pass example. The low-pass section requires three reactors, that is, two capacitors and an inductor, whereas the band-pass section requires only two tuned circuits. The result is less attenuation and phase shift than would be found in the exact band-pass analogue.

It is interesting to compare, for the various examples, the phase shift within the pass band. That is the change of phase angle over the band. It is one right angle for the two-terminal low-pass case and two right angles for the band-pass. For the four-terminal cases, it increases to three and four right angles, respectively. The attenuation outside the band compares in the same ratios.

The phase shift may be detrimental in two ways. The phase slope represents delay of the signal, which may be undesirable, but usually does no harm if uniform over the pass band. The phase angle also includes departure from uniform phase slope. This is phase distortion and is always detrimental. In comparing the two-terminal and four-terminal cases, the relative phase distortion affects the choice of which yields the optimum compromise between maximum coupling impedance and minimum phase distortion.

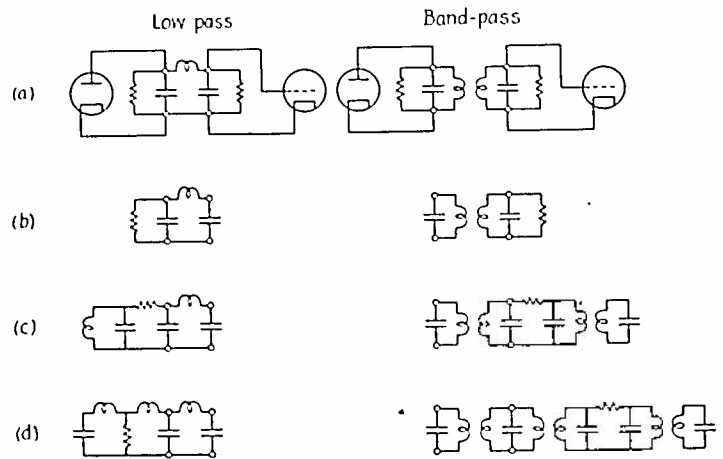

Fig. 6—Four-terminal transfer-impedance coupling networks, low-pass and band-pass.

The impedance is about twice as great in the four-terminal cases. The low-pass phase shift is three times as great, while the band-pass is twice as great. Therefore the four-terminal coupling has less advantage in a low-pass case than in a band-pass case.

Without the aid of filter theory, the study of phase characteristics is even more difficult than the study of amplitude characteristics illustrated in Figs. 4 and 5. Neither is practical for the more complicated networks.

Phase correction, with nearly uniform amplitude, may be obtained among two-terminal networks by designing the different ones of a group to be complementary. In a four-terminal dead-end filter, phase correction may be obtained without affecting the amplitude characteristics. All that is needed is the insertion of a phase-correcting filter between the two pairs of terminals. Such a filter is the  $m$ -derived section with  $m$  greater than one, obtained by negative mutual inductance. The availability of systematic phase correction is a great advantage of this method of design.

Before summarizing the theoretical limitations on wide-band amplifiers, the use of feedback deserves attention. It is interesting, not only because it is a useful extension of the method of dead-end filters, but also because it proves to be subject to the same theoretical limitations.

### III. A FILTER SECTION INCLUDING A FEEDBACK AMPLIFIER

Feedback of a degenerative or stabilizing nature has the effect of decreasing the amplification in an

amplifier. It also increases the width of the frequency band over which the amplification is uniform. Therefore, it is useful in a wide-band amplifier.

The feedback amplifier has usually been treated in terms of its forward amplification and backward attenuation. The amplitude and phase characteristics of both have been required, and are usually difficult to handle, especially if there are several stages involved.

A much simpler method of design can be used if the feedback is associated individually with each

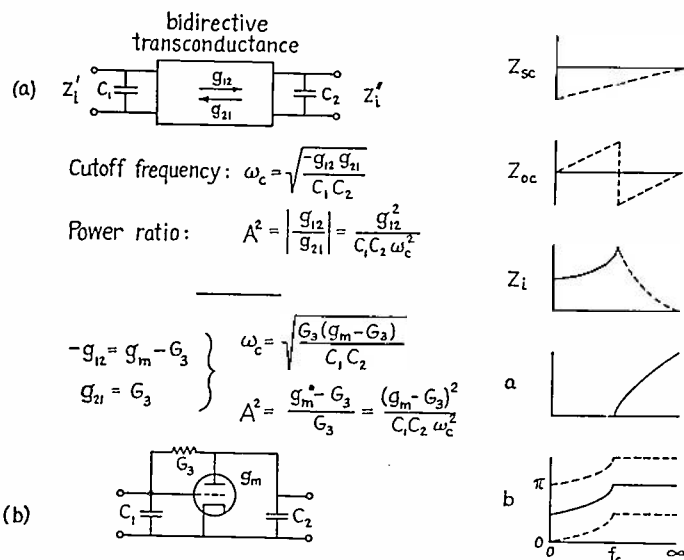

Fig. 7—The derivation of a feedback amplifier operating as a low-pass filter section.

stage. This is one of the best arrangements for a wide-band amplifier, as well as one of the simplest.

Each stage of the amplifier, with its feedback, is designed as a section of a wave filter. It can then be combined with other stages and other filter sections, in accordance with filter theory. This gives greater insight into the behavior of the feedback amplifier, and facilitates the design of circuits to obtain any characteristics available in wave filters.

The essential elements of such a filter section are a pair of reactance arms with forward and backward coupling. The forward coupling is the transconductance of the amplifier tube.

A low-pass filter section including a feedback amplifier stage is shown in Fig. 7(a). It comprises shunt capacitance across input and output terminals,  $C_1$  and  $C_2$ , coupled by forward and backward transconductance,  $g_{12}$  and  $g_{21}$ . This combination is termed bidirectional transconductance. Each transconductance may be positive or negative. Each may be obtained in a screen-grid tube having negligible input or output self-conductance. The usual transconductance of a vacuum tube is called negative, because the signal polarity is reversed by coupling through the tube. Two such tubes resistance-coupled in cascade, or some special types of tube, can be used to secure the opposite polarity of transconductance, called positive. The absence of self-conductance is necessary if dissipation in the filter is to be avoided. This

condition is met in screen-grid tubes. The transconductance property by itself does not involve dissipation.

In order to derive the filter properties of this network, the usual method is followed, based on short-circuit and open-circuit impedance. Looking into one end of the network, the impedance with the other end on short circuit is simply that of the shunt arm:

$$Z_{sc}' = \frac{1}{j\omega C_1} \quad (8)$$

The feedback comes into play when the other end is on open circuit:

$$Z_{oc}' = \frac{1}{j\omega C_1 - \frac{g_{12}g_{21}}{j\omega C_2}} = \frac{j\omega C_2}{-g_{12}g_{21} \left(1 - \frac{\omega^2 C_1 C_2}{-g_{12}g_{21}}\right)} \quad (9)$$

The image impedance is the geometric mean of these two:

$$Z_i' = \sqrt{Z_{sc}' Z_{oc}'} = \frac{1}{\sqrt{-g_{12}g_{21}}} \cdot \frac{1}{\sqrt{1 - \frac{\omega^2 C_1 C_2}{-g_{12}g_{21}}}} \cdot \sqrt{\frac{C_2}{C_1}} \quad (10)$$

This has the same form as the mid-shunt image impedance of a constant- $k$  low-pass filter:

$$Z_i' = \frac{R'}{\sqrt{1 - \omega^2/\omega_c^2}} \quad (11)$$

The nominal image impedance, or that at zero frequency, is

$$R' = \frac{1}{\sqrt{-g_{12}g_{21}}} \sqrt{\frac{C_2}{C_1}} \quad (12)$$

The cutoff frequency is

$$\omega_c = \sqrt{\frac{-g_{12}g_{21}}{C_1 C_2}} = \frac{1}{C_1 R'} \quad (13)$$

It is noted that similar expressions are obtained looking into the input end or the output end. The only difference is the interchange of the subscripts. This has no effect on the cutoff frequency. The image impedance is the same at both ends if the shunt capacitance is the same across both ends.

The nominal image impedance and the cutoff frequency are real only if the forward and backward values of transconductance are of opposite polarity. This is the condition for degenerative feedback at zero frequency. The total phase angle of input and output capacitance causes the feedback to become regenerative to the point of oscillation at the cutoff frequency. This corresponds to the free oscillation which would occur in a nondissipative filter section at its cutoff frequency. In either case the oscillation is damped by the resistance termination of the filter.

The graphs of Fig. 7 summarize the filter properties of the low-pass feedback amplifier. The attenuation  $a$  and the phase angle  $b$  of a wave filter are given by the relation

$$\tanh (a + jb) = \sqrt{\frac{Z_{sc}}{Z_{oc}}} = \frac{\sqrt{\omega^2/\omega_c^2 - 1}}{\omega/\omega_c} \quad (14)$$

Simplifying this expression,

$$\cosh (a + jb) = \pm \omega/\omega_c. \quad (15)$$

In the attenuation band,  $\omega > \omega_c$ ,

$$a = \operatorname{anticoth} \omega/\omega_c; \quad b = 0 \text{ or } \pi. \quad (16)$$

In the pass band,  $\omega < \omega_c$ ,

$$a = 0, \quad b = \operatorname{anticoth} \pm \omega/\omega_c = \operatorname{arcsin} \omega/\omega_c \pm \pi/2. \quad (17)$$

The choice between the two values of  $b$  is not determined by the filter characteristics but rather by those properties yet to be discussed, which are not found in passive wave filters.

The forward amplification and the backward attenuation through the feedback amplifier filter can be described separately from the filter characteristics. They arise from the inequality of the forward and backward transconductance. The filter properties alone would be secured if the transconductance were the same in both directions. But the product of the forward and backward values must be negative, so each value would have to be imaginary. Also their values are assumed constant in this treatment. This set of conditions cannot be realized, so the filter characteristics have to be supplemented by the effect of unequal transconductance. This would have to take care of the phase angle of  $\pm \pi/2$  at zero frequency, given by the filter analysis but not possible in a physical network.

Just as the transconductance product  $g_{12}g_{21}$  determines the filter characteristics, the transconductance ratio  $g_{12}/g_{21}$  determines independently the amplification. This is uniform over the entire frequency range, because the ratio is constant. The uniform amplification is regarded as superimposed on the filter properties. The amplification must be expressed in terms of power, because the zero attenuation of a filter in the pass band is based on equal power input and output. The power ratio of amplification can be shown to have the value

$$A^2 = \left| \frac{g_{12}}{g_{21}} \right| = \frac{-g_{12}}{g_{21}} = \frac{g_{12}^2}{C_1 C_2 \omega_c^2} = g_{12}^2 R' R''. \quad (18)$$

If the filter is terminated by its image impedance, the actual voltage ratio at zero frequency is

$$A \sqrt{\frac{R''}{R'}} = \sqrt{\frac{-g_{12} C_1}{g_{21} C_2}} = g_{12} R''. \quad (19)$$

This result is inevitable because the output impedance is  $R''$  under these conditions. The voltage ratio

and power ratio are uniform in the pass band, and are subject to the filter attenuation at higher frequencies.

The transconductance ratio simply causes the current or voltage ratio of the filter to be multiplied by the "directive factor"

$$q = \sqrt{\frac{g_{12}}{g_{21}}} \quad (20)$$

which is imaginary so it has a phase angle of  $\pm \pi/2$ . Taken with the filter phase angle  $b$ , this gives 0 or  $\pi$  as the net phase angle at zero frequency. Either is physically possible. The dotted phase curves in Fig. 7 show these conditions. The usual vacuum tube as the forward transconductance gives a negative value, representing a reversal of polarity, that is, a phase angle of  $\pi$ .

The backward directive factor is the reciprocal of the forward, while the filter properties are the same in both directions. These together determine the backward attenuation. This distinguishes the feedback amplifier from the unidirectional amplifier having no coupling in the backward direction.

The attenuation and phase characteristics of the filter are those of a half-section constant- $k$  low-pass filter. The image impedance, however, has the mid-shunt form at both ends of the filter. Such a low-pass filter has not previously existed. It is the low-pass analogue of the band-pass filter comprising a symmetrical coupled pair of tuned circuits. The analogy is complete as far as the filter characteristics, but not the amplification, are concerned.

This filter can be designed for any set of cutoff frequencies. A constant- $k$  mid-shunt arm, designed for these cutoff frequencies, is included at each end of the section. It is arranged to include directly in parallel, the maximum capacitance consistent with the band width and the nominal image impedance. Then this capacitance is embodied in the inherent capacitance of the vacuum tube and associated circuit elements.

Separate forward and backward tubes would be required to meet the conditions in the theoretical feedback amplifier filter of Fig. 7(a). This is neither desirable nor essential for practical purposes. Large amplification requires that the forward transconductance  $g_{12}$  be much greater than the backward  $g_{21}$ . Therefore the latter can be replaced by a resistor without departing too much from the ideal conditions of zero self-conductance.

This expedient is shown in Fig. 7(b). The negative forward transconductance is furnished by the vacuum tube  $g_m$ , with slight opposition from the smaller self-conductance  $G_3$  of the feedback resistor. The latter furnishes the backward transconductance:

$$-g_{12} = g_m - G_3; \quad g_{21} = G_3. \quad (21)$$

The self-conductance  $G_3$  has the undesired effect of

introducing dissipation just as if an equal conductance were in parallel with  $C_1$  and another with  $C_2$ . This effect is small if the amplification is large. The resulting cutoff frequency, power ratio, and voltage ratio are

$$\omega_c = \sqrt{\frac{G_3(g_m - G_3)}{C_1 C_2}} \quad (22)$$

$$A^2 = \frac{g_m - G_3}{G_3} = \frac{(g_m - G_3)^2}{C_1 C_2 \omega_c^2} = (g_m - G_3)^2 R' R'' \quad (23)$$

$$A \sqrt{\frac{R''}{R'}} = (g_m - G_3) R'' \quad (24)$$

The treatment of a feedback amplifier as a filter involves an undue amount of work for a single simple

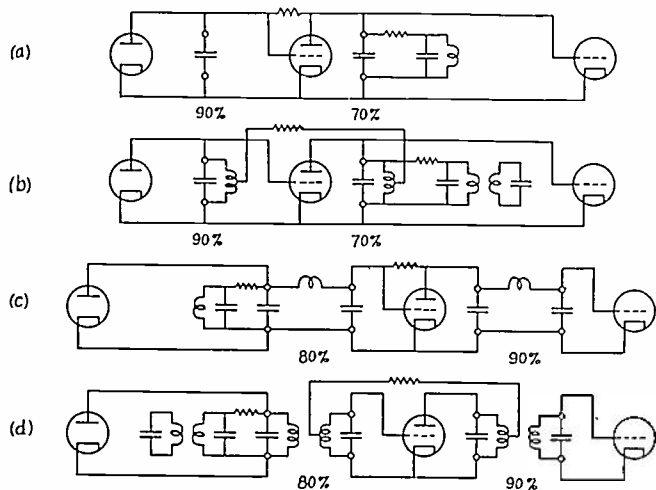

Fig. 8—The insertion of a feedback amplifier as a section of a dead-end filter, low-pass and band-pass, two-terminal and four-terminal interstage coupling impedance.

example such as that of Fig. 7. (The same would have been true of a single-section low-pass filter in the evolution of wave filters.) Its benefits are found in its general application. It introduces a new concept in the co-operation of amplifiers and filters. Feedback amplifiers and filter sections can now be designed individually and joined in succession with image-impedance matching at the junctions. They behave like an ordinary filter plus an amplifier, with the added advantage of distributing the filter attenuation among the amplifier stages. It is now possible to design a feedback amplifier with complex circuits which could not be computed directly. Its performance can be predicted with very close approximation.

In designing a wide-band amplifier with feedback, the feedback filter stage is inserted as a section of a dead-end filter. All of its properties described above are retained, while adding the amplification of the feedback stage. Several examples are shown in Fig. 8. The first two, (a) and (b), have two-terminal interstage coupling networks. The second two examples have four-terminal networks to secure the advantage of separating the shunt capacitance of one tube from that of the next.

A simple low-pass example is shown in Fig. 8(a).

The middle tube is in the feedback stage. This section is included in a filter which is extended on the output end to a dead-end termination with uniform image impedance matching a resistor. The termination is like that of Figs. 3(c) and 6(c). Uniform impedance is developed at the input end, in the output circuit of the preceding tube. The amplification is uniform over the pass band. The percentage notations have the same meaning as those of Fig. 3.

The principal advantage of using feedback is the reduction of the number of circuit elements. Only one dead-end termination is required for several interstage circuits, instead of one for each. An incidental advantage is the greater percentage of the ideal figure of merit, for a small number of circuit elements in the dead-end filter. Another is the reduction of distortion from nonlinear amplification, such as overloading. A disadvantage is the interdependence of the filter properties with the amplifying properties of the tube. The cutoff frequency depends on the transconductance, so this must remain constant. Some of the interstage circuits include no resistance, relying entirely on the feedback for their damping. The cutoff frequency must be the same for all stages in a single filter.

The band-pass analogue is shown in Fig. 8(b). Here the feedback resistor is tapped down on the input and output coils to permit the use of the most convenient value of resistance. This is a value small enough to minimize the disturbance of parallel capacitance but large enough to minimize that of series inductance.

The examples of Figs. 8(c) and (d) are the corresponding examples with four-terminal instead of two-terminal interstage coupling impedance. The percentage notations are relative to the higher standard of performance of the four-terminal networks. The comparison is about the same as between the dead-end filters of Fig. 3 and those of Fig. 6. The dead-end termination is shown toward the input. This places the resistor ahead of the amplification, so it has to dissipate less power and a smaller unit can be used. Only the feedback is required to damp the higher-power coupling networks, following the amplification. This minimizes the power output required from the tube in each feedback stage, especially from the last stage in the filter.

The maximum amplification obtainable by the use of a given tube in a feedback amplifier filter is subject to the same limitations as if an individual dead-end filter were used in each interstage network. The two alternatives are comparable in most respects.

#### IV. THE THEORETICAL LIMITATIONS ON THE WIDE-BAND PERFORMANCE OF AN AMPLIFIER

There is a maximum uniform amplification that can be obtained over a wide band of frequencies

from a single tube in the systems described. It depends on the grid and plate capacitance of the tube,  $C_g$  and  $C_p$ , as well as its transconductance  $g_m$ . If it is measured between input and output circuits of equal impedance, the voltage ratio has the value

$$A = \frac{2g_m}{\omega_w \sqrt{C_g C_p}} = \frac{g_m}{\pi f_w \sqrt{C_g C_p}} = \frac{f_o}{f_w} \quad (25)$$

The total frequency band width is  $f_w$ , or  $\omega_w$  in terms of angular frequency.

This formula is based on a band-pass dead-end filter of ideal properties, that is, freedom from dissipation and exact matching of image impedance with the terminal resistor over the pass band. It is based on a band-pass rather than a low-pass case, to permit the use of transformers to match capacitance in different shunt arms of the same filter. Also this permits of measuring the amplification between input and output circuits of equal impedance. This is the only fair measure of amplification if expressed in terms of voltage ratio.

The formula may be derived in any of several circuit arrangements with four-terminal coupling networks, with or without feedback. The simplest is the band-pass circuit of Fig. 6(d). Like tubes are assumed and the voltage ratio from one grid to the next is computed. The uniform impedance developed in the plate circuit of the first tube, across  $C_p$ , is

$$Z_o = \frac{2}{C_p \omega_w} = \frac{1}{\pi f_w C_p} \quad (26)$$

The gain from grid to plate of the first tube is this impedance multiplied by the transconductance  $g_m$ . This is multiplied by the voltage ratio from plate to grid, which is the transformer ratio needed to match the plate and grid capacitance,  $C_p$  and  $C_g$ . The amplification is then found to be

$$A = g_m Z_o \sqrt{\frac{C_p}{C_g}} = \frac{g_m}{\pi f_w \sqrt{C_g C_p}} \quad (27)$$

This formula contains the grid and plate capacitance, only in terms of the geometric mean value. In the case of a low-pass coupling filter, a transformer is not available, so not quite as much amplification can be secured between unequal values. The same theoretical limit is still valid, however, and can be approximated in low-pass networks designed to operate between unequal values of shunt capacitance. They are designed to secure the effect of a transformer over all of the pass-band, except near zero frequency where there is no difficulty in building up the amplification to its level value.

There is a certain band width over which the theoretical maximum voltage ratio is unity, corresponding to neither gain nor loss. This band width is called the "band-width index"\*

\* This term was suggested by my associate, Mr. L. F. Curtis.

$$f_o = \frac{g_m}{\pi \sqrt{C_g C_p}}; \quad A = \frac{f_o}{f_w} \quad (28)$$

The amplification is easily computed as the ratio of the band-width index over the required band width. The band-width index is an interesting property of a vacuum tube, to express its relative merit as a wide-band amplifier. The practical value of the band-width index is about half as great, being reduced by the added circuit capacitance and by the failure to realize exactly the ideal dead-end filter.

It is recommended that the band-width index be included in the specifications of vacuum tubes, especially of those for use in wide-band amplifiers. The following table includes its value for various types of pentode amplifier tubes.

Type	$g_m$ ( $\mu$ mhos)	$C_g$ ( $\mu\mu$ f)	$C_p$ ( $\mu\mu$ f)	$f_o$ (Mc)
6K7 (metal)	1600	8	12	52
6D6 (glass)	1600	6	6	85
954 (acorn)	1400	3	3	150
1851 (metal)	9000	15	5	330

The formula given for the band-width index is valid only for tubes having the grid-plate coupling shielded to such a degree that neutralization is not required. If push-pull neutralization is to be used, the grid and plate total capacitance should each be increased by the amount of the neutralizing capacitance, which is equal to the grid-plate capacitance.

Another band-width index, useful with reference to power tubes, would be the maximum band width over which the optimum load impedance could be developed across the plate capacitance by the use of a dead-end filter.

#### CONCLUSION

We have derived the theoretical limitations on the performance of a wide-band amplifier. We have shown how circuits can be devised to approximate this performance as closely as required. The methods of design are simple and direct. They involve no laborious computations because they draw from the wealth of information available in the art of wave filters. Examples have been given to show how the methods lead to practical designs which meet any reasonable demands. These methods are the connecting link between amplifiers and wave filters.

#### Bibliography

- The references are classified as follows, in terms of the subject matter to which they relate.
- (1, 2, 4, 6) The general theory of filters and methods of design.
  - (3, 16) Wide-band amplifiers using the dead-end filter.
  - (5, 7, 8, 9, 10, 14, 18, 20) Wide-band amplifiers using series inductance and resistance across the shunt capacitance.
  - (3, 4, 5, 15, 17, 18) Wide-band amplifiers using other forms of interstage coupling networks.
  - (11, 12, 13, 19, 31) Degenerative feedback associated with a pair of tuned circuits in an amplifier.

- (1) G. A. Campbell, "Physical theory of the electric wave filter," *Bell Sys. Tech. Jour.*, vol. 1, pp. 1-32; November, (1922).
- (2) O. J. Zobel, "Theory and design of uniform and composite electric wave filters," *Bell Sys. Tech. Jour.*, vol. 2, pp. 1-46, January, (1923).
- (3) W. van B. Roberts, "Resistance-coupled amplifier," U. S. Patent 1,925,340, March 29, 1929, to September 5, 1933.
- (4) E. L. Norton, "Filtering circuits," U. S. Patent 1,788,538, April 16, 1929, to January 13, 1931; British Patent 353,066, April 16, 1929, to October 14, 1931.
- (5) H. E. Ives, British Patent 386,296, April 8, 1930, to about 1932.
- (6) O. J. Zobel, "Extensions to the theory and design of electric wave filters," *Bell Sys. Tech. Jour.*, vol. 10, pp. 284-341; April, (1931).
- (7) J. P. Smith, U. S. Patent 2,045,315, May 23, 1932, to June 23, 1936.
- (8) Loewe, British Patent 437,641, February 25, 1933, to February 7, 1936.
- (9) G. D. Robinson, "Theoretical notes on certain features of television receiving circuits," *Proc. I.R.E.*, vol. 21, pp. 833-843; June, (1933).
- (10) G. L. Beers, "Description of experimental television receivers," *Proc. I.R.E.*, vol. 21, pp. 1692-1706; December, (1933).
- (11) French patent 790,833, June 12, 1934, to November 28, 1935; British patent 454,435, June 12, 1934, to about 1936.
- (12) L. F. Curtis, "Selectivity control for radio," U. S. Patent 2,033,330, September 21, 1934, to March 10, 1936.
- (13) H. D. Ellis, "Variable coupling of electrical oscillatory circuits," British Patent 442,685, October 11, 1934, to May 7, 1936.
- (14) R. S. Holmes, W. L. Carlson, and W. A. Tolson, "An experimental television system. Part III—the receivers," *Proc. I.R.E.*, vol. 22, pp. 1266-1285; November, (1934).
- (15) J. Hardwick and E. L. White, British Patent 459,581, July 9, 1935, to April 1, 1937.
- (16) W. S. Percival, British patent 460562, July 24, 1935, to April 22, 1937; also 475,490, February 21, 1936, to February 10, 1938.
- (17) British Patent 465,030, November 11, 1935, to July 22, 1937.
- (18) British Patent 469,791, November 11, 1935, to October 28, 1937.
- (19) H. F. Mayer, "Automatic selectivity control," *Electronics*, vol. 9, pp. 32-34; December, (1936).
- (20) S. W. Seeley and C. N. Kimball, "Analysis and design of video amplifiers," *RCA Rev.*, vol. 2, pp. 171-183; October, (1937).
- (21) J. F. Farrington, "Receiver with automatic selectivity control responsive to interference," *Proc. I.R.E.*, vol. 27, pp. 299-245; April, (1939).

## Line Microphones\*

HARRY F. OLSON†, ASSOCIATE MEMBER, I.R.E.

*Summary*—A line microphone with useful directivity normal to the line axis is described. Several types of line microphones with useful directivity along the line axis are described as follows: A simple line, a line with progressive delay, two simple lines and a pressure-gradient element, two lines with progressive delay, and a pressure-gradient element. An ultra-directional microphone employing line elements exhibits uniform directional characteristics over the range from 85 to 8000 cycles.

### INTRODUCTION

THE solid angle over which sound is received without appreciable attenuation characterizes a directive sound-collecting system. The effective solid angle of the directional characteristic determines the ratio of direct to generally reflected sound or other undesirable sounds. The shape and solid angle of the directional characteristic determines the complexion of the action which can be effectively received. One important requirement is a directional characteristic that is independent of the frequency. A system that does not possess this characteristic will introduce frequency discrimination in both the desired and undesired sounds. In general, the particular directional characteristic will depend upon the pickup problem. For example, the bidirectional velocity microphone has been found to be very useful for overcoming excessive reverberation and other undesirable sounds, and as a tool for attaining a "correct balance" of the received sound. The unidirectional microphone has been found to be very useful in sound-motion-picture recording, radio-broadcast, and sound-re-enforcing systems in which the desired sounds originate in front and the un-

desired sounds to the rear of the microphone. It has been found that directional sound-collecting systems are more effective than nondirectional systems in problems connected with sound collection such as balance and reverberation in music, long-distance pickup of speech, and feedback difficulties in sound re-enforcing. In view of this demonstrated usefulness, it seems logical to give further consideration to directional sound-collecting systems. It is the purpose of this paper to consider a number of directional sound-collecting systems and to describe a highly directional sound-collecting system in which the directional characteristic is independent of frequency.

### ACOUSTIC LINE SYSTEMS

In the line systems to be considered, the microphone consists of a large number of small tubes connected to a large pipe at a common point; this pipe in turn is connected to the ribbon element terminated in a resistance equal to the combined surge resistance of the small pipes. It is the purpose of this section to consider the action of line systems as applied to line microphones.

Consider two pipes  $S_1$  and  $S_2$  of length  $l_1$  and  $l_2$  and the same cross-sectional area  $S$  connected to a single infinite pipe of cross-sectional area equal to the combined cross-sectional area of the two pipes as shown in Fig. 1.

Let  $A_1$  and  $B_1$  be the amplitude of the waves to the right and left in  $S_1$ , and  $A_2$  and  $B_2$  be the amplitude of the waves to the right and left in  $S_2$ .

At  $X_1=0$

$$S(A_1 - B_1) = U_1 \quad (1)$$

\* Decimal classification: R385.5. Original manuscript received by the Institute, July 22, 1938.

† RCA Manufacturing Company, Inc., Camden, N. J.

where,

$S$  = cross-sectional area of pipe  $S_1$  and  
 $U_1$  = volume current at  $X_1=0$ .

At  $X_2=0$ .

$$S(A_2 - B_2) = U_2 \tag{2}$$

where,

$S$  = cross-sectional area of pipe  $S_2$  and  
 $U_2$  = volume current at  $X_2=0$ .

At  $X_1=0$

$$U_1 = \frac{p_1 - p_{01}}{Z} \tag{3}$$

where,

$p_1$  = pressure in the incident sound wave,  
 $p_{01}$  = pressure in the pipe  $S_1$  at  $X=0$ , and  
 $Z$  = impedance of the opening of the pipe.

At  $X_2=0$

$$U_2 = \frac{p_2 - p_{02}}{Z} \tag{4}$$

where,

$p_2$  = pressure in the incident sound wave,  
 $p_{02}$  = pressure in the pipe  $S_2$  at  $X=0$ , and  
 $Z$  = impedance of the opening of the pipe.

The pressure in the pipe  $S_1$  at  $X_1=0$  is

$$p_{01} = \rho c(A_1 + B_1) \tag{5}$$

where,

$\rho$  = density of air and  
 $c$  = velocity of sound.

The pressure in the pipe  $S_2$  at  $X_2=0$  is

$$p_{02} = \rho c(A_2 + B_2). \tag{6}$$

At the junction of the three pipes we can apply the principle of continuity of pressure and volume current

$$\text{at } X_1 = l_1 \text{ and } X_2 = l_2.$$

For continuity of pressure

$$A_1 e^{-jkl_1} + B_1 e^{jkl_1} = A_2 e^{-jkl_2} + B_2 e^{jkl_2} = A_3 \tag{7}$$

where,

$$K = 2\pi/\lambda \text{ and } \lambda = \text{wavelength.}$$

For continuity of volume current

$$A_1 e^{-jkl_1} - B_1 e^{jkl_1} + A_2 e^{-jkl_2} - B_2 e^{jkl_2} = 2A_3 \tag{8}$$

where,

$$A_3 = \text{amplitude of the transmitted wave in } S_3.$$

From (1), (2), (3), (4), (5), (6), (7), and (8) we can obtain  $A_3$  in terms of  $p_1$  and  $p_2$  as follows:

$$A_3 = \frac{p_1(X_1 e^{-jkl_1} + X_2 e^{jkl_2}) + p_2(X_1 e^{-jkl_1} + X_2 e^{jkl_2})}{X_1 X_2 [\epsilon^{jk(l_2-l_1)} + \epsilon^{-jk(l_2-l_1)}] + 2X_2 \epsilon^{jk(l_1 l_2)}} \tag{9}$$

where,

$$X_1 = SZ - \rho c \text{ and}$$

$$X_2 = SZ + \rho c.$$

Equation (9) may be simplified when applied to actual microphone structures. For example, assume that pipes  $S_1$  and  $S_2$  are equal in length and that the

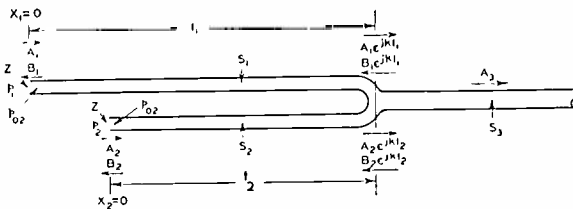

Fig. 1

incident sound pressures upon  $S_1$  and  $S_2$  differ by any phase angle. Substituting  $l_1=l_2=l$  in (9), the pressure  $p_3$  in pipe  $S_3$  becomes

$$p_3 = \rho c A_3 = \frac{\rho c(p_1 + p_2)\epsilon^{-jkl}}{2X_2}. \tag{10}$$

Assume that the phase of the pressures  $p_1$  and  $p_2$  differs by an angle  $K(l_1-l_2)$  and that the amplitudes are the same. This is the condition of a plane wave traveling from left to right in a direction parallel to the axes of the pipes. Substituting  $p_1 = p_2 \epsilon^{jk(l_1-l_2)}$  in (9) the pressure  $p_3$  in pipe  $S_3$  becomes

$$p_3 = \rho c A_3 = \frac{\rho c p_1}{X_2} \epsilon^{-jkl_1} = \frac{\rho c p_2}{X_2} \epsilon^{-jkl_2}. \tag{11}$$

Assume that the difference between the lengths of the two pipes  $S_1$  and  $S_2$  is small compared to the wavelength, that the diameter of the pipes is very small compared to the wavelength, and a plane wave of pressure  $p_1$  with the line of propagation making an angle  $\theta$  with the axes of the pipes (Fig. 1). Substituting  $p_1 = p_2 \epsilon^{jk(l_1-l_2) \cos \theta}$  in (9) the pressure in pipe  $S_3$  becomes

$$p_3 = \frac{\rho c p_2}{2X_2} \epsilon^{-jkl_1} (1 + \epsilon^{-jk(l_1-l_2)(1-\cos \theta)}). \tag{12}$$

Equation (12) shows that  $p_3$  is made up of two vectors differing in phase by  $k(l_1-l_2)(1-\cos \theta)$ .

Damping due to viscosity in the pipes has been neglected in the above considerations. Analysis including damping, in the small pipes used in line microphones, shows that the resonances in the pipes are highly damped.

The above analysis may be extended to any number of pipes by considering two at a time. Of course, there is interaction between the pipes which must be considered. The addition of damping reduces the effects of interaction between the pipes. In the microphones to be considered it has been found that for all practical purposes the outputs of the pipes may be added vectorially.

## LINE MICROPHONE

## Useful Directivity Normal to the Line

This microphone consists of a large number of small pipes with the open ends, as pickup points, where,

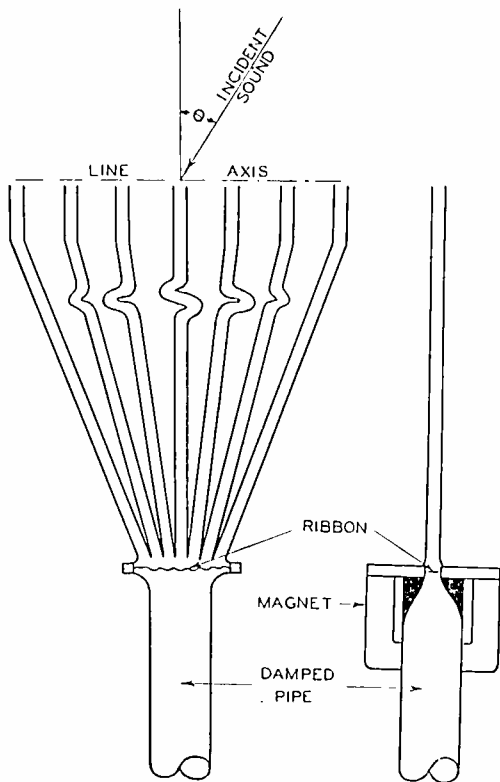

Fig. 2—Line microphone. Useful directivity normal to the line axis.

equally spaced along a straight line and the other ends connected at a common junction to a ribbon element terminated in an acoustic resistance in the form of a long damped pipe (Fig. 2). The vibration of

The velocity of the ribbon is given by

$$\dot{X} = \frac{pS_r}{r + j\omega m_r} \quad (13)$$

$p$  = pressure at the common junction of the small pipes,  
 $S_r$  = area of the ribbon,  
 $r$  = mechanical resistance of the ribbon termination, and  
 $m_r$  = mass of the ribbon.

If the terminating resistance is large compared to the ribbon mass reactance, the ribbon velocity and the resultant generated voltage for constant pressure is independent of the frequency.

In the theory it will be assumed that there are a large number of small pipes and that the separation between pipes is a small fraction of the wavelength, in other words, a continuous line. It will also be assumed that the outputs of the small pipes may be added as shown in the preceding section. For all practical purposes the actual systems satisfy these conditions.

The output as a function of the angle of a line source<sup>1</sup> is given by

$$R_\theta = \frac{\sin Z}{Z} \quad (14)$$

where,

$$Z = \frac{\pi l}{\lambda} \sin \theta,$$

$l$  = length of the line, and

$\lambda$  = wavelength.

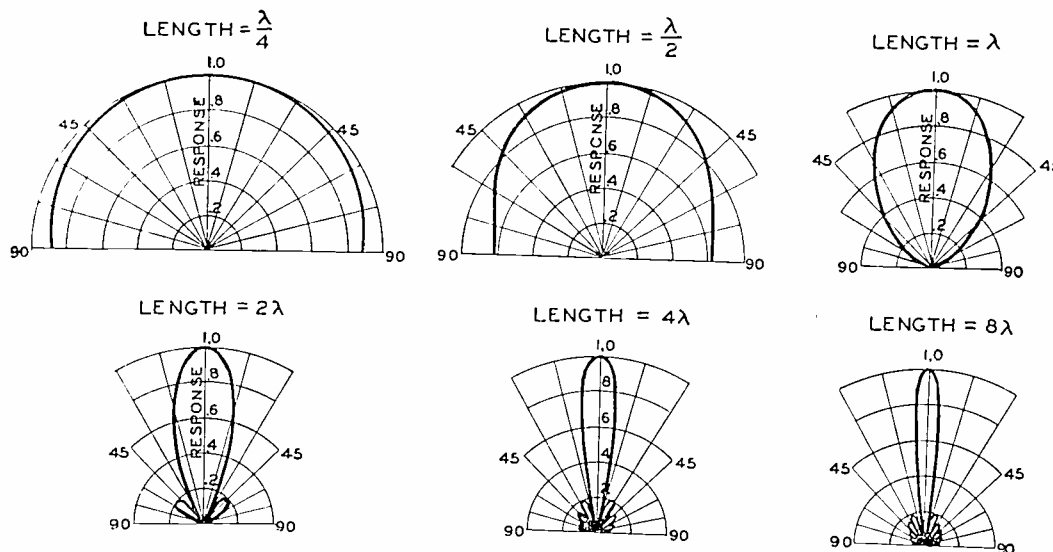

Fig. 3—The directional characteristic of the microphone shown in Fig. 2 as a function of the ratio of the length of the line to the wavelength.

the ribbon in a magnetic field transforms the acoustical vibrations into the corresponding electrical variations. The combined area of the small pipes is equal to the area of the large damped pipe. The acoustic path from the opening of each pipe to the ribbon is made the same by inserting appropriate bends to compensate for the unequal lengths.

The directional characteristics of a microphone of the type shown in Fig. 2 for various ratios of the length to the wavelength are shown in Fig. 3. These

<sup>1</sup> Wolff and Malter, *Jour. Acous. Soc. Amer.*, vol. 2, no. 2, pp. 201-241; October, (1930), have derived the directional characteristics of a line source having uniform intensity and the same phase for all points on the line. The equation for the directional characteristics of a line source is applicable to the microphone shown in Fig. 2.



characteristics are actually surfaces of revolution with the microphone line as the axis. Fig. 4 illustrates the directional characteristic in three dimensions for a line length of  $2\lambda$ . The small secondary lobes have been omitted. This type of characteristic is useful for the collection of sources of sound in a plane normal to the axis of the line. For example, the microphone could be built in the form of a vertical stand for picking up sounds over 360 degrees in a horizontal plane.

*Useful Directivity on the Line Axis*

*Simple Line.* This microphone consists of a large number of small pipes with the open ends, as pickup points, equally spaced on a line and the other ends joined at a common junction with the distance from the opening of each pipe to the junction decreasing in equal steps (Fig. 5). A ribbon element, connected to the common junction and terminated in an acoustic resistance in the form of a long damped pipe, is used for transforming the acoustical vibrations into the corresponding electrical variations.

The contribution by any element  $n$  at the common junction of the microphone may be expressed as

$$P_n = B_n \cos 2\pi \left( ft - \frac{X_n - X_n \cos \theta}{\lambda} \right) \quad (15)$$

$$+ jB_n \sin \pi \left( ft - \frac{X_n - X_n \cos \theta}{\lambda} \right)$$

$$P_n = B_n \epsilon^{2\pi i f t} \epsilon^{-2\pi i} \left( \frac{X_n - X_n \cos \theta}{\lambda} \right) \quad (16)$$

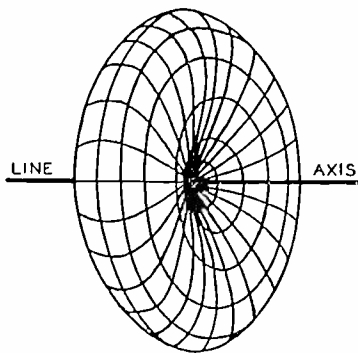

Fig. 4—The directional characteristic of Fig. 3 in three dimensions for a line length of  $2\lambda$ .

where,

- $f$  = frequency,
- $t$  = time,
- $X_n$  = distance of the element  $n$  from the center of the line,
- $\lambda$  = wavelength,
- $\theta$  = angle between axis of the line and the incident sound, and
- $B_n$  = amplitude of the pressure due to element  $n$ .

In the case of a uniform line, with the strength a

constant, the resultant when all the vectors are in phase is  $B_n l$ , where  $l$  is the length of the line.

The ratio of the response for the angle  $\theta$  to the response for  $\theta = 0$  is

$$R_\theta = \frac{1}{B_n l} \left| \int_{-l/2}^{l/2} B_n \epsilon^{2\pi i} \left( ft - \frac{X - X \cos \theta}{\lambda} \right) dX \right| \quad (17)$$

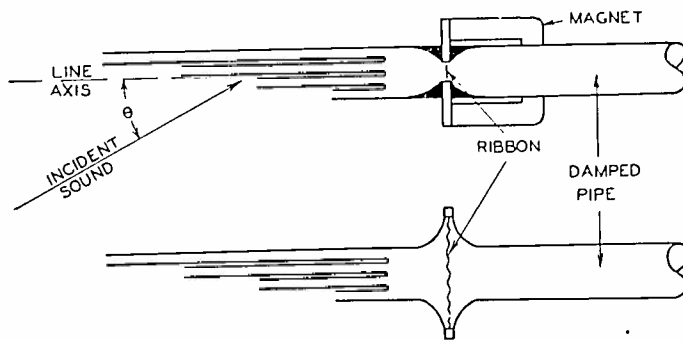

Fig. 5—Line microphone. Useful directivity on the line axis.

The absolute value of the term on the right is given by

$$R_\theta = \frac{1}{l} \left| \int_{-l/2}^{l/2} \epsilon^{2\pi i} \left( \frac{X - X \cos \theta}{\lambda} \right) dX \right| \quad (18)$$

$$R_\theta = \frac{\sin \frac{\pi}{\lambda} (l - l \cos \theta)}{\frac{\pi}{\lambda} (l - l \cos \theta)} \quad (19)$$

The directional characteristics of the microphone of Fig. 5 for various ratios of length of the line to the wavelength are shown in Fig. 6. These characteristics are surfaces of revolution about the line as an axis. Fig. 7 illustrates the directional characteristic in three dimensions for a line length of  $4\lambda$ . This microphone is useful for collecting sounds arriving from directions making small angles with the microphone axis.

*Line with Progressive Delay.* As in the case of Fig. 5, this microphone consists of a large number of small pipes with the open ends, as pickup points, equally spaced on a line and the other ends joined at a common junction. In addition, there is inserted a delay which is proportional to the distance from the end of the line or the pickup point nearest the common junction (Fig. 8).

In this case

$$R_\theta = \frac{1}{B_n l} \left| \int_{-l/2}^{l/2} B_n \epsilon^{2\pi i} \left( \frac{X - X \cos \theta}{\lambda} + \frac{d}{\lambda} \right) dX \right| \quad (20)$$

where  $d$  is the path length of the delay introduced for the point farthest removed from the common junction.

$$R_\theta = \frac{\sin \frac{\pi}{\lambda} (l - l \cos \theta + d)}{\frac{\pi}{\lambda} (l - l \cos \theta + d)} \quad (21)$$

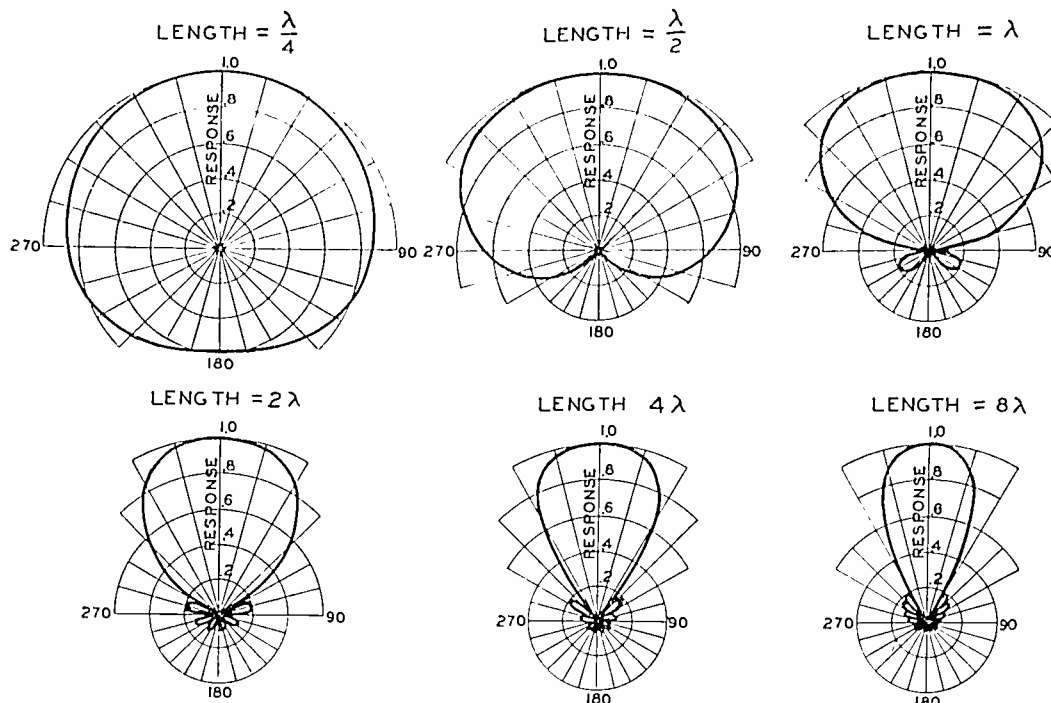

Fig. 6—The directional characteristics of the microphone shown in Fig. 5 as a function of the ratio of the length of the line to the wavelength.

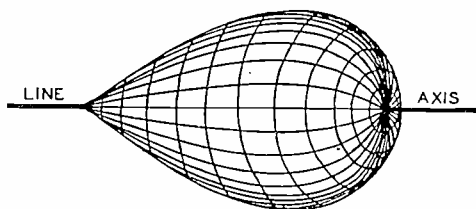

Fig. 7—The directional characteristic of Fig. 6 in three dimensions for a line length of  $4\lambda$ .

The directional characteristics of the microphone of Fig. 8 for various ratios of the length of the line to the wavelength, and for delay paths of  $\frac{1}{4}$ ,  $\frac{1}{2}$ , and

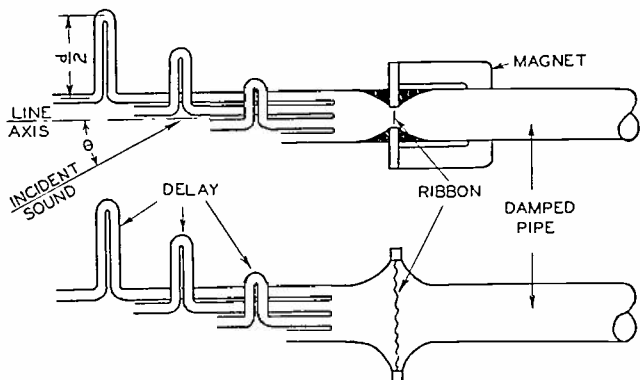

Fig. 8—Line microphone. Useful directivity on the line axis. This microphone differs from Fig. 5 in that a delay is inserted in each small pipe.

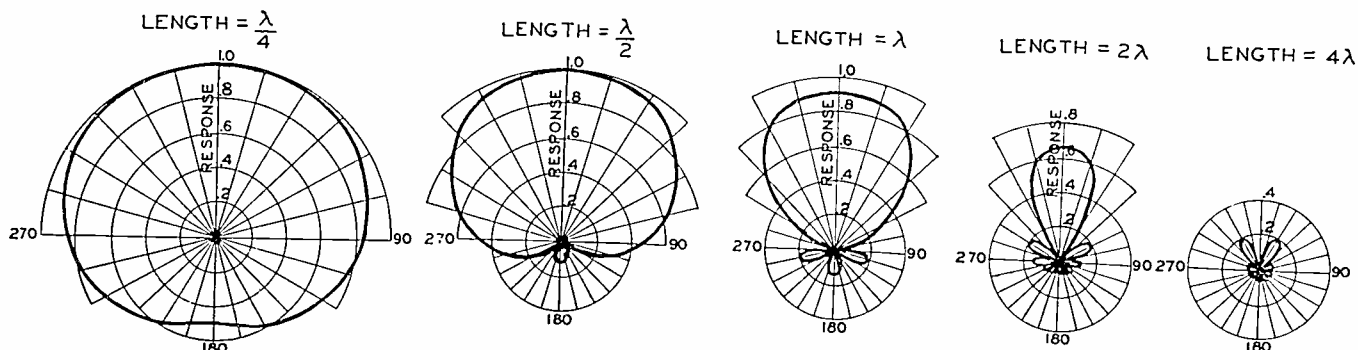

Fig. 9—The directional characteristics of the microphone shown in Fig. 8 for a time delay equivalent to one fourth of the length of the line as a function of the ratio of the length of the line to the wavelength.

1 times the length of the line are shown in Figs. 9, 10, and 11. Comparing Figs. 9, 10, and 11 with Fig. 6, it will be seen that the same directional characteristic can be obtained with a line of shorter length by introducing appropriate delay. In the case of a delay path comparable to the wavelength, loss in sensitivity occurs.

*Two Simple Lines and a Pressure-Gradient Element.* This microphone consists of two lines of the type shown in Fig. 5, arranged so that the ribbon element measures the difference in pressure generated in the two lines. (Fig. 12.) The centers of the two lines are displaced by a distance  $D$ . In the line nearest the element a bend of length  $D$  is inserted between the junction and the ribbon element.

To show the action of the pressure-gradient system, assume that the length of all the small pipes is the same and the opening between the two sets is separated by a distance  $D$ . Under these conditions the line systems are nondirectional.

The difference between the forces on the two sides of the ribbon, assuming the mass reactance of the ribbon system is large compared to the resistance of the damped pipes, may be expressed as

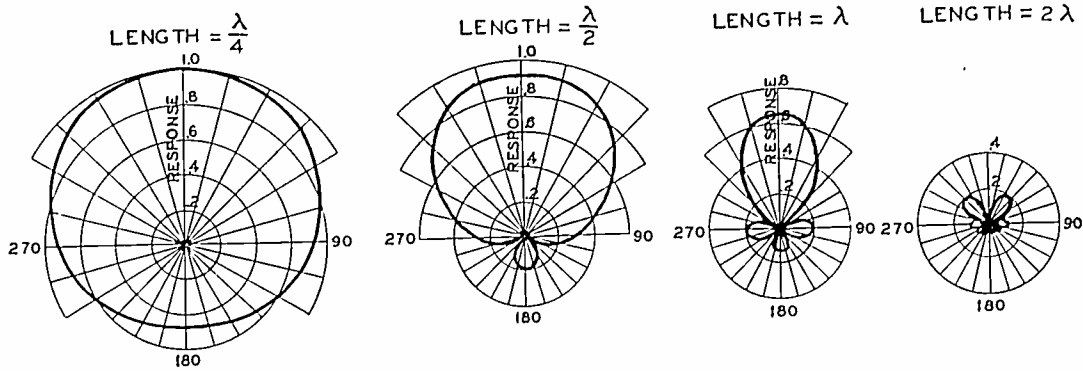

Fig. 10—The directional characteristics of the microphone shown in Fig. 8 for a time delay equivalent to one half of the length of the line as a function of the ratio of the length of the line to the wavelength.

$$F_M = Af \cos(2\pi ft) \sin\left(\frac{\pi D \cos \theta}{\lambda}\right) \quad (22)$$

where,

$A$  = constant including the pressure of the impinging sound wave and dimensions of the microphone.

If  $D$  is small compared to the wavelength, (22) becomes

$$F_M = A \frac{\pi D}{\lambda} f \cos(2\pi ft) \cos \theta. \quad (23)$$

Equation (23) shows that the force available for driving the ribbon is proportional to the frequency and the cosine of the angle  $\theta$ .

Employing a mass-controlled ribbon of mass  $m_r$ , the velocity is given by

$$\begin{aligned} \dot{X} &= \frac{Af}{j2\pi f m_r} \left(\frac{\pi D}{\lambda}\right) \cos(2\pi ft) \cos \theta \\ &= \frac{A}{2\pi m_r} \left(\frac{\pi D}{\lambda}\right) \sin(2\pi ft) \cos \theta. \end{aligned} \quad (24)$$

This quantity is independent of the frequency and as a consequence, the ratio of the generated electro-

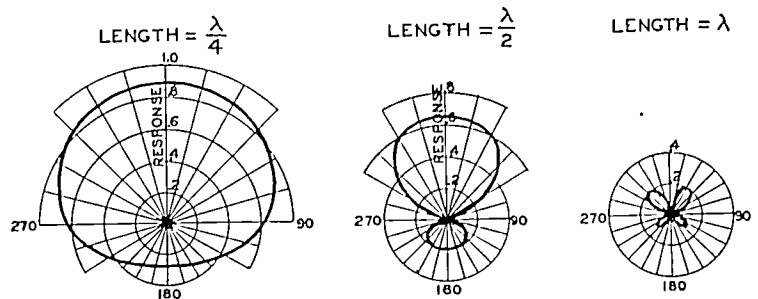

Fig. 11—The directional characteristics of the microphone shown in Fig. 8 for a time delay equivalent to the length of the line as a function of the ratio of the length of the line to the wavelength.

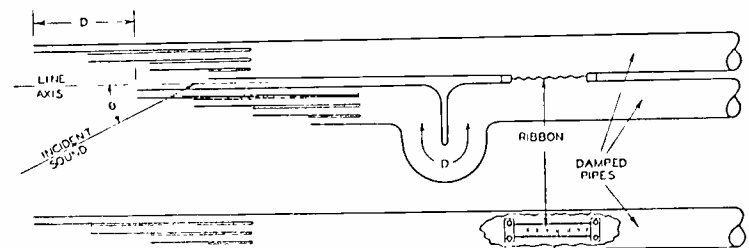

Fig. 12—Line microphone. Useful directivity on the line axis. This microphone consists of two lines of the type shown in Fig. 5 displaced by a distance  $D$  along the axis. In the line nearest the ribbon element a bend is inserted which introduces a path length  $D$ . The ribbon element measures the difference in pressure in the two lines.

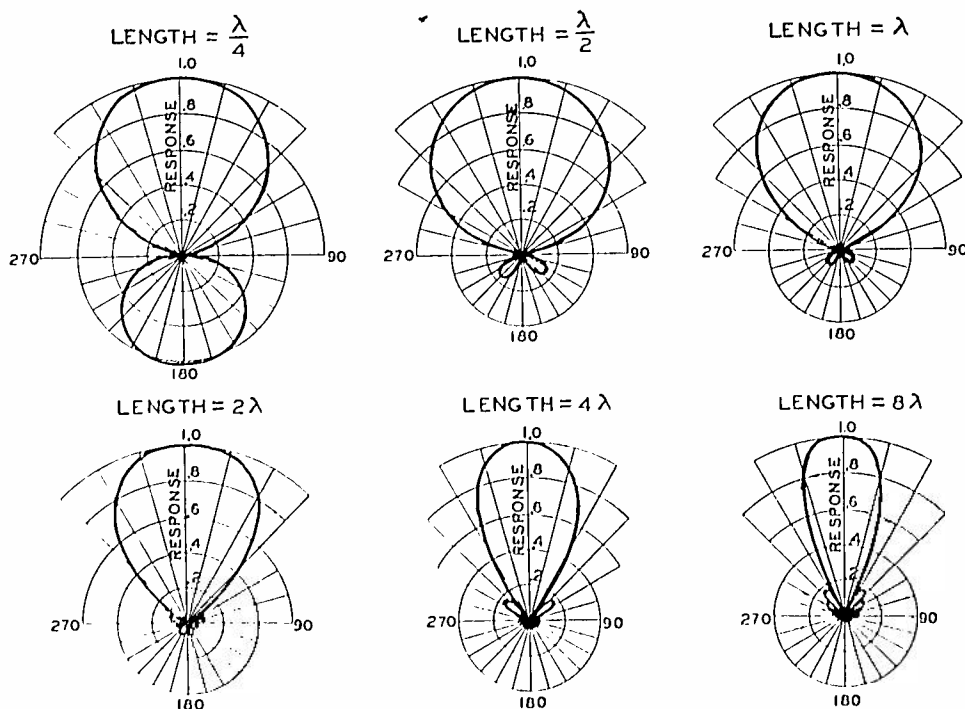

Fig. 13—The directional characteristics of the microphone shown in Fig. 12 as a function of the ratio of the length of the lines to the wavelength.

motive force to the pressure in the sound wave will be independent of the frequency.

The above discussion assumes that the lines are nondirectional. The directional characteristics of the

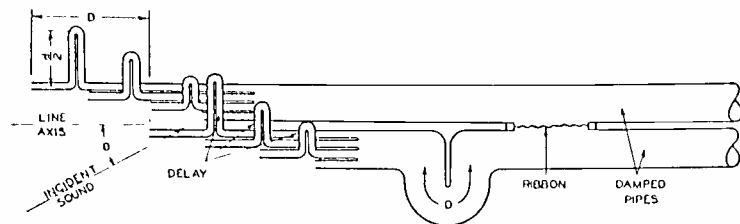

Fig. 14—Line microphone. Useful directivity on the line axis. This microphone consists of two lines of the type shown in Fig. 8 displaced by a distance  $D$  along the axis. In the line nearest the ribbon element a bend is inserted which introduces a path length  $D$ . The ribbon element measures the difference in pressure in the two lines.

individual lines of Fig. 12 are given by (21). The directional characteristics of the microphone shown in Fig. 12, for  $D$  small compared to the wavelength, is the product of (21) and (24). The directional characteristic may be written as

$$R_{\theta} = \frac{\sin \frac{\pi}{\lambda} (l - l \cos \theta)}{\frac{\pi}{\lambda} (l - l \cos \theta)} \cos \theta. \quad (25)$$

The directional characteristics of the microphone shown in Fig. 12, for various ratios of the length of the line to the wavelength are shown in Fig. 13. A measure of the value of a pressure-gradient element for improving the directivity of a line microphone may be obtained by comparing Figs. 6 and 13. In

addition to sharpening the directional characteristic, the amplitude of the lobes is reduced except at 0 and 180 degrees.

*Two Lines, Progressive Delay, and a Pressure-Gradient Element.* This microphone consists of two lines of the type shown in Fig. 8 displaced by a distance  $D$  along the axis and arranged so that the ribbon element measures the difference in pressure generated in the two lines (Fig. 14.)

The directional characteristic is given by

$$R_{\theta} = \frac{\sin \frac{\pi}{\lambda} (l - l \cos \theta + d)}{\frac{\pi}{\lambda} (l - l \cos \theta + d)} \cos \theta. \quad (26)$$

The directional characteristics of the microphone shown in Fig. 14 for various ratios of the length of the line to the wavelength for delays of  $\frac{1}{4}$ ,  $\frac{1}{2}$ , and 1 times the length of the line are shown in Figs. 15, 16, and 17. A measure of the value of a line with progressive delay and a pressure-gradient element for improving the directivity may be obtained by comparing Figs. 15, 16, and 17 with Fig. 6. Employing these expedients approximately the same directivity can be obtained with a line of a quarter of the length of the simple line shown in Fig. 6.

#### DIRECTIONAL EFFICIENCY OF A DIRECTIONAL SOUND-COLLECTING SYSTEM

The ratio of energy response of a nondirectional microphone as compared to a directional microphone for sounds originating in random directions, all di-

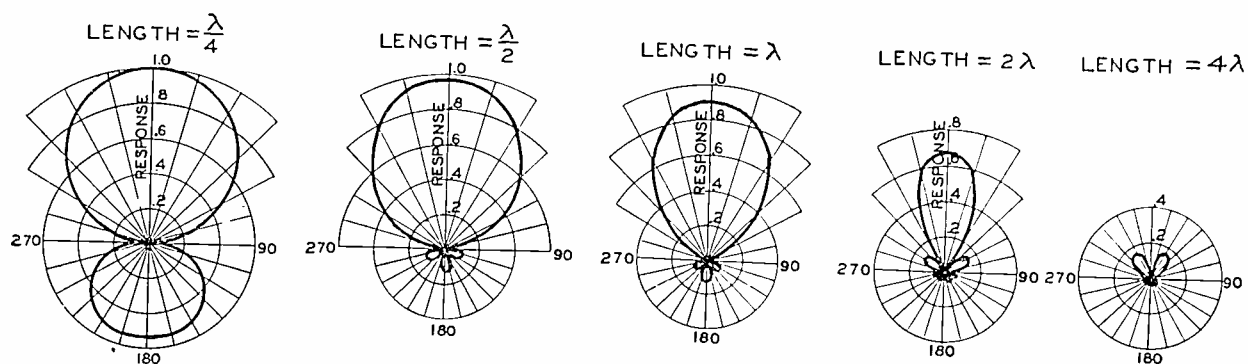

Fig. 15—The directional characteristics of the microphone shown in Fig. 14 for a time delay of one fourth the length of the line as a function of the ratio of the length of the lines to the wavelength.

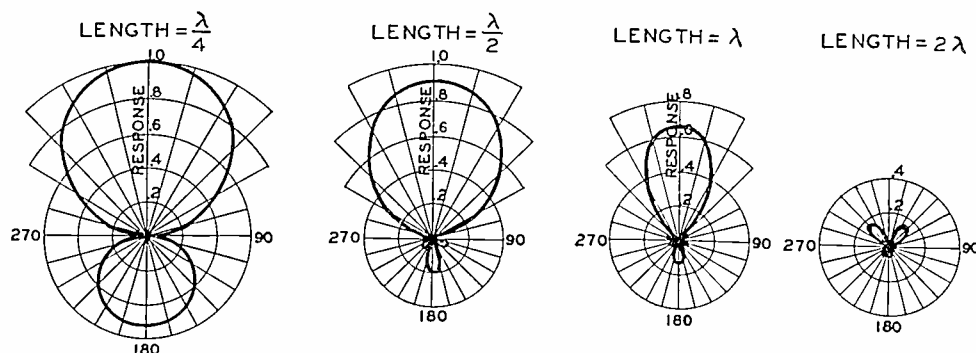

Fig. 16—The directional characteristics of the microphone shown in Fig. 14 for a time delay of one half the length of the line as a function of the ratio of the length of the lines to the wavelength.

rections being equally probable, is termed the directional efficiency of a directional microphone.

In many of the systems described above, determining the directional efficiency becomes a rather

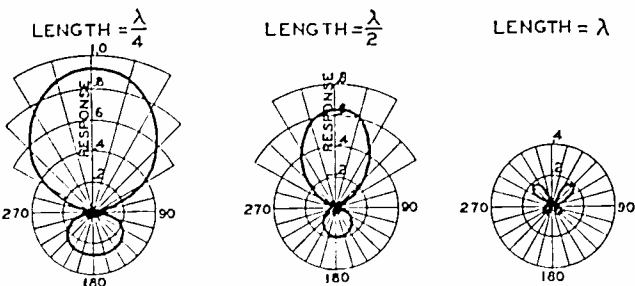

Fig. 17—The directional characteristics of the microphone shown in Fig. 14 for a time delay equal to the length of the line as a function of the ratio of the length of the line to the wavelength.

cumbersome job. However, the directional efficiencies of the cosine functions are easily determined. A few of these functions are plotted in Fig. 18. The directional efficiency as outlined above is also given. For the same ratio of signal to noise, reverberation,

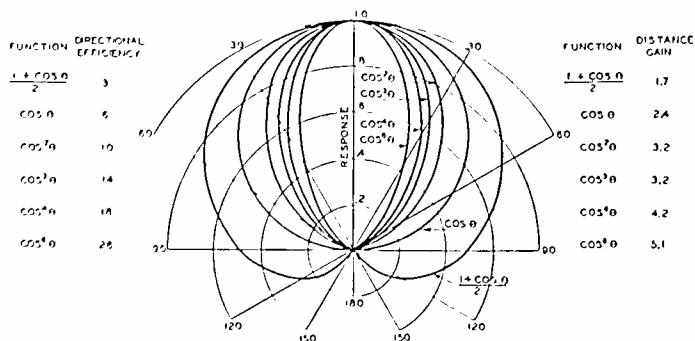
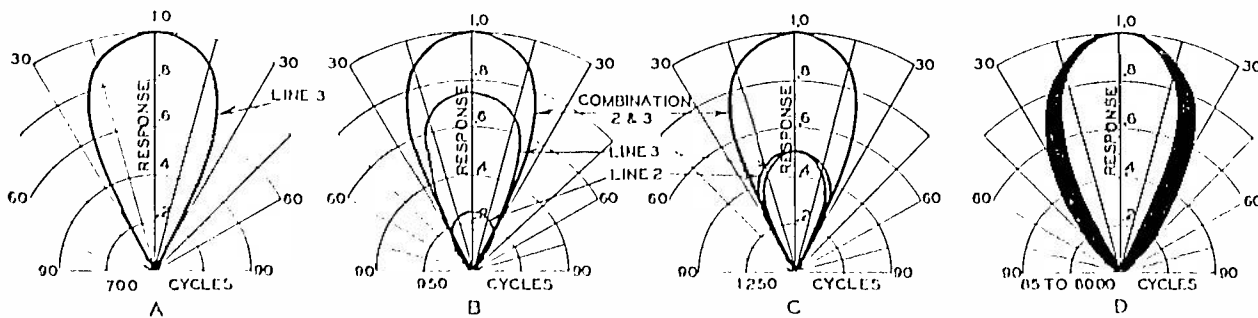

Fig. 18—The directional efficiency of microphones having directional characteristics which are various cosine functions.

etc., the directional microphone may be operated at  $\sqrt{\text{directional efficiency}}$  times distance of a nondirectional microphone. By means of the characteristics shown in Fig. 18, the efficiency of other characteristics may be obtained by comparing characteristics which have approximately the same shape and spread.

ULTRA-DIRECTIONAL MICROPHONE

Directional microphones employing lines of various types have been considered in the preceding section.



A. The directional characteristics of line 3 at 700 cycles.  
 B. The directional characteristics of lines 2 and 3 and the resultant at 950 cycles.  
 C. The directional characteristics of lines 2 and 3 and the resultant at 1250 cycles.  
 D. The directional characteristics of the microphone shown in Fig. 19 for the range from 85 to 8000 cycles falls within the shaded area.

These directional characteristics indicated considerable variation with frequency. Experience gained from work on reflectors a few years ago indicated that a directional characteristic which varies with

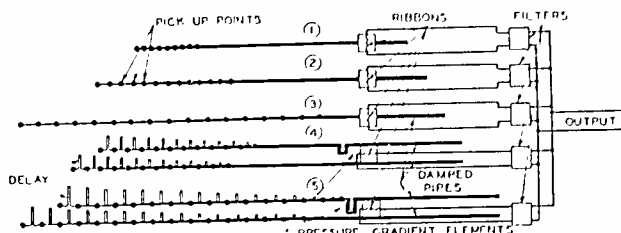

Fig. 19—Ultra-directional microphone consisting of five units. Units 1, 2, and 3 are of the type shown in Fig. 5. Units 4 and 5 are of the type shown in Fig. 14.

frequency is undesirable, principally due to the introduction of frequency discrimination for points removed from the axis. In addition, the response to reflected sound is a function of the frequency which alters the reverberation characteristics of received sound.

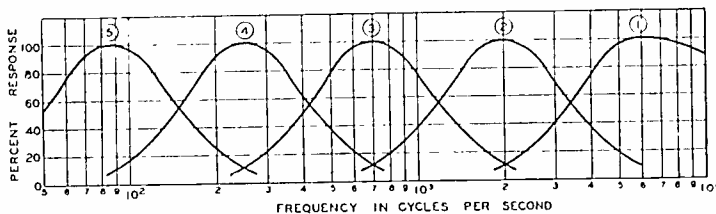

Fig. 20—Response-frequency characteristics of the units and filter systems shown in Fig. 19.

From the results of experiments upon directional systems, it appears that a microphone with a small solid angle of pickup would be extremely useful in recording sound motion pictures, in television pickup, in certain types of sound broadcast, as for example, symphony and stage productions, and in many applications of sound re-enforcing. The acoustic lines referred to above seem to be the logical solution of the problem from the standpoint of size and portability. However, the directional characteristics must be independent of the frequency. This can be accomplished by employing a number of separate lines, each covering a certain portion of the frequency range. It is the purpose of this section to describe

an ultra-directional microphone consisting of five separate lines.

The ultra-directional microphone shown schematically in Fig. 19 consists of five units. Units 1, 2,

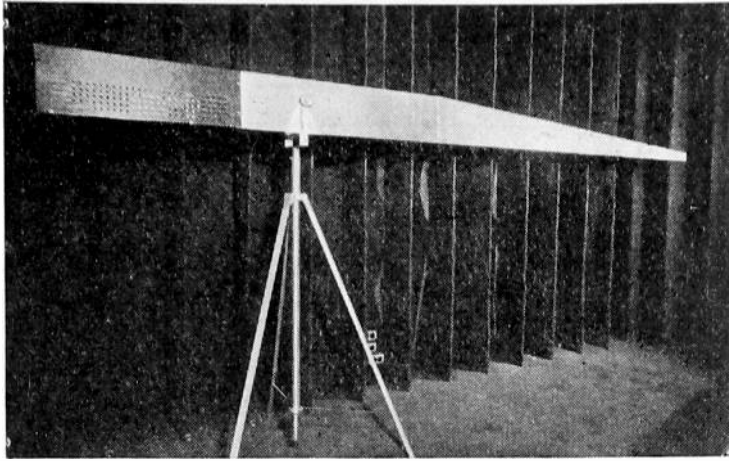

Fig. 22—Ultra-directional microphone.

and 3 are of the type shown in Fig. 5. Units 4 and 5 are of the type shown in Fig. 14. An electrical filter system is used to allocate the outputs of the units

to their respective ranges. The response characteristics of the units with the filter systems is shown in Fig. 20. Fig. 21 illustrates the principles used in obtaining uniform directional characteristics. Fig. 21A is the directional characteristic of line 3 at 700 cycles. Fig. 21B shows the directional characteristics of lines 2 and 3 at 950 cycles. The resultant of these characteristics is also shown in Fig. 21B. The same is shown in Fig. 21C for 1250 cycles. In Figs. 21B and 21C the directional characteristic of line 2 is broader than Fig. 21A, while the characteristic of line 3 is narrower. The resultant of lines 2 and 3 is a directional characteristic very close to Fig. 21A. The directional characteristic of the microphone shown in Fig. 20 for the range from 85 to 8000 cycles, except for the small lobes for angles greater than 90 degrees, falls within the shaded area of Fig. 21D. Considering that this microphone has a frequency range of  $6\frac{1}{2}$  octaves, it is a remarkably uniform directional characteristic. A photograph of the ultra-directional microphone is shown in Fig. 22. The over-all length is 10 feet.

## Fractional-Frequency Generators Utilizing Regenerative Modulation\*

R. L. MILLER†, NONMEMBER, I.R.E.

**Summary**—By the application of the principle of regeneration to certain modulation systems, a generator of submultiple or other fractional frequency ratio may be obtained.

A simple example is obtained by considering a second-order modulator whose output is connected back to a conjugate input by means of a feedback loop including an amplifier and a selective network. If an input frequency  $f_0$  is applied, it is found that a frequency component  $f_0/2$  appearing in the feedback path will modulate with the applied frequency to produce sidebands of  $f_0/2$  and  $3f_0/2$ . The network and amplifier, being especially efficient for the frequency  $f_0/2$  and having a gain higher than the modulator loss, will reinforce this component causing it to build up to some steady-state value. Similar processes are possible by which greater submultiple ratios may be obtained.

Since the output wave is obtained by a modulation process involving the input wave, it will appear only when an input is applied and then bears a fixed frequency ratio with respect to it. Experiments show that the ability of the generator to produce a fractional frequency is independent of phase shift in the feedback path. Circuits are possible in which the amplitude of the fractional-frequency wave will bear a linear relation to the input wave over a reasonable range and at the same time maintain a constant phase angle between the two waves. Typical circuits are discussed which make use of copper oxide as the modulator elements.

### I. INTRODUCTION

WITH the recent developments in precision standards of frequency and time, radio synchronization, carrier telephony, television, and other allied fields of communication, the need for an extremely reliable fractional-frequency generator has become increasingly important.

\* Decimal classification: R146.2×R355.9. Original manuscript received by the Institute, January 6, 1939.

† Bell Telephone Laboratories, Inc., New York, N. Y.

One method of obtaining fractional frequencies, which is widely used and about which there has been a considerable amount of published information, is to synchronize an oscillator of the relaxation or similar type at the proper submultiple ratio by means of an applied wave of the higher frequency. In a number of applications, this method of obtaining fractional frequencies has some inherent disadvantages. Since the circuit is an oscillator of its own accord, variations of the control voltage, circuit elements, or battery voltages may cause it to produce an uncontrolled or incorrect frequency ratio.

By the application of the principle of regeneration to certain modulation systems it is possible to obtain a fractional-frequency generator having a number of desirable characteristics. The more important of these are:

1. The output wave, since it is obtained through a modulation process involving the input wave, will appear only when the input is applied and then bears a fixed frequency ratio with respect to it.
2. The shape of the output wave is essentially sinusoidal.
3. By proper design the amplitude of the output wave will approach a linear relation with that of the input wave and at the same time maintain a constant phase angle between the two waves.

4. Experimentally, it has been found that the ability of the generator to produce the proper fractional frequency is not affected by considerable amounts of distortion of the input wave or extraneous frequencies such as noise.

5. The principle is applicable over the entire frequency range in which it is possible to amplify and modulate.

The basic ideas which are utilized in regenerative modulation were described as early as 1922 by J. W. Horton.<sup>1</sup> However, this type of circuit was never very widely used nor were its merits generally recognized. This has undoubtedly been due to the rather complex nature of the original circuits. In recent years, aided by the great advances in modulation and feedback systems, it has been possible to obtain considerable simplification of the circuits as well as improved operation.

In the present discussion general circuit relations are obtained which may be applied to the more common types of circuits. The theory has also been extended to include circuits which utilize modulation systems of a higher order than the second. Circuits which have been described previously have been confined to the use of multielement vacuum tubes entirely. Here examples are given illustrating the use of copper oxide, silicon carbide, and diodes.

## II. GENERAL THEORY

The principle of regenerative modulation may well be explained with reference to the diagram of Fig. 1. In this generalized diagram a modulator  $K$  is shown having its output fed back to the balanced or conjugate input of the modulator. The feedback path contains an amplifier  $\mu$  and a filter network  $N_1$ .

If the modulator is of the second-order<sup>2</sup> type and has an input frequency  $f_0$  applied, then any frequency  $f_1$  applied in the conjugate branch will originate two sidebands whose frequencies are  $f_0 \pm f_1$ , and whose amplitudes have a certain loss with respect to  $f_1$ . If the amplification is greater than the sideband loss plus the network loss, the sideband frequencies will be reapplied to the modulator having a greater amplitude than the original component of  $f_1$ . Likewise, if the component  $f_1$  is to maintain itself in the feedback path it must satisfy the relation

$$f_0 \pm f_1 = f_1.$$

As long as the frequency  $f_0$  has a finite value this relation can only be satisfied by

$$f_1 = \frac{f_0}{2}.$$

<sup>1</sup> U. S. Patent No. 1,690,299.

<sup>2</sup> The new frequencies created by modulation may be expressed as  $F = |nf_0 \pm mf_1|$  where  $f_0$  and  $f_1$  are the applied frequencies and  $n$  and  $m$  are positive integers or zero. The order of modulation is the sum of  $n$  and  $m$ .

With no input wave applied to the modulator, this circuit will remain inactive as long as Nyquist's criterion<sup>3</sup> for stability of feedback systems is not violated. A rule for stability applicable to the present system which falls well within the above criterion is to make the loss due to the network and modulator balance greater than the gain of the amplifier.

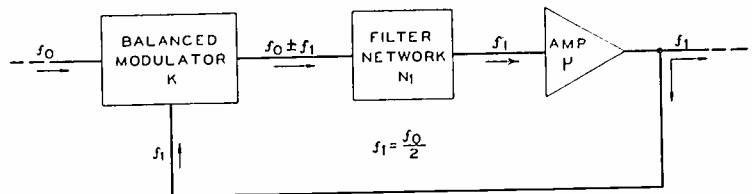

Fig. 1—Schematic diagram of a second-order regenerative modulator.

In the most general case for this type of circuit depending upon the order of modulation used, we may have

$$nf_0 - mf_1 = f_1, \quad (nf_0 > mf_1)$$

or

$$mf_1 - nf_0 = f_1, \quad (mf_1 > nf_0).$$

Simplifying we find that the possible frequency relations are

$$f_1 = \frac{n}{m \pm 1} f_0. \quad (1)$$

In the case of a third-order modulator where  $n = 1$ ,  $m = 2$ , a possible frequency relation is

$$f_1 = \frac{f_0}{3}.$$

Although in the original case it has been assumed that the network  $N_1$  and the amplifier  $\mu$  do not create

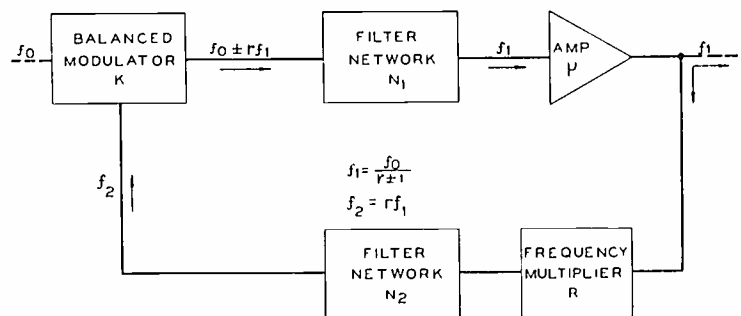

Fig. 2—Schematic diagram of a multiplier—second-order regenerative modulator.

any new frequencies in themselves, an important result arises when this part of the circuit is deliberately designed to create multiples or harmonics of the frequency  $f_1$  in the feedback circuit as illustrated in Fig. 2. Setting  $r$  as the integer denoting the harmonic created in this circuit, we have as the possible frequency relations when the modulator is of the second order

$$f_1 = \frac{1}{r \pm 1} f_0. \quad (2)$$

<sup>3</sup> H. Nyquist, "Regeneration theory," *Bell Sys. Tech. Jour.*, vol. 11, p. 236; January, (1932).

This indicates that greater submultiple ratios than one half may be obtained by the use of a second-order modulator and harmonic generator, as well as by the use of a high-order modulator.

A more general case is obtained when both a high-order modulator and a multiplier are used. The resulting relation for this case is

$$f_1 = \frac{n}{rm \pm 1} f_0. \quad (3)$$

So far only general terms denoting frequency relations have been considered. However, in order to determine whether the circuits are possible of realization the actual amplitude and phase relations of the various parts of the circuits must also be considered.

Due to the nonlinear nature of the modulator elements it is extremely difficult to obtain a single quantitative expression which will represent this unit for all values of voltages which may be applied to it. In the regenerative modulators described hereafter it has been found more desirable to consider the modulator under two important conditions which are encountered in its operation. The first condition with which we are usually concerned is that of starting, in which a fixed amplitude of input wave is applied, and where the amplitude of feedback wave is extremely small. The second condition is that of the final steady-state relation in which the feedback amplitude usually exceeds that of the input wave. The transition from one condition to another may be demonstrated to involve no discontinuities.

The practical application of regenerative modulation results in at least three useful types of circuits; second-order, second-order—multiplier, and third-order. Since each of these types exhibits different characteristics, they will be described individually.

### III. SECOND-ORDER REGENERATIVE MODULATOR

#### *Starting Condition*

One of the first questions that arises is "Where does the frequency  $f_1$  originate?", because in our general relations we have assumed that it is present and then proceeded to determine what its actual relation to  $f_0$  is. Consider the original case of a second-order modulator as shown in Fig. 1. If we represent the input wave by

$$e_0 = A \cos \omega t \quad (4)$$

and the component of frequency  $f_1$  at the input of the modulator by

$$e_1 = B \cos \left( \frac{\omega t}{2} + \theta \right), \quad (5)$$

in which the amplitude coefficient  $B$  may approach zero, then the two sideband outputs which are obtained in a second-order modulator are given by the expression

$$e_{sb} = KAB \left[ \cos \left( \frac{\omega t}{2} - \theta \right) + \cos \left( \frac{3\omega t}{2} + \theta \right) \right]. \quad (6)$$

In general the component  $3\omega/2$  is attenuated by the network  $N_1$  and we need be concerned with only the other term. For a given amplitude of the input wave  $e_0$ , the product  $KA$  is a constant and will represent the loss of the modulator on a feedback-signal-to-sideband-output basis. Now if the gain of the amplifier is greater than the loss of the modulator plus the loss of the network  $N_1$ , the frequency component  $\omega/2$  will be reapplied to the modulator having a greater amplitude than the original component regardless of how small it may be at the beginning of the process. Thus whether the original component of  $\omega/2$  is present as a component of thermal noise, battery noise, or the transient caused by the application of the input wave, the starting of the circuit is analogous to the starting of an oscillator. However, it should not be implied from this that the circuit is a controlled oscillator in the same sense that the term is applied to certain relaxation-oscillator circuits, since the component  $\omega/2$  can only be present as long as the input is applied. If the input wave vanishes or becomes too small, the loss of the modulator becomes large causing the term  $\omega/2$  to vanish.

Since each element of regenerative modulators may be constructed in a large number of ways, it is desirable that only general terms be used in discussing the various parts of the circuit. This allows the basic principles of the circuit to be clearly demonstrated without being confused by a large number of circuit details.

For this purpose it is convenient to make use of the transfer factor of the particular section in question. The transfer factor may be defined as the vector ratio of the output voltage to the input voltage when measured in the normal direction of transmission and with the section terminated as it appears in the circuit. It is also desirable from an analytical standpoint to associate the proper phase shift with a given element. For this reason it is convenient to assume that input and output impedances of the different elements are resistive for the frequency in question. Even if such were not the case our results would not be invalidated since the resulting change in the phase shift and amplitude coefficients may properly be assigned to one of the circuit elements.

In the present circuit, since the network  $N_1$  is normally a part of the amplifier, the net gain and phase shift of these two units will be denoted by the transfer factor  $\mu \angle \phi$ ,  $\phi$  being the phase shift for  $\omega/2$ .

We can now establish the relation between the feedback wave given by (5) and the lower sideband output given by (6). This will be

$$B \cos \left( \frac{\omega t}{2} + \theta \right) = \mu KA B \cos \left( \frac{\omega t}{2} - \theta + \phi \right). \quad (7)$$

Separating the phase and the amplitude components gives



$$\theta = \frac{\phi}{2}, \quad (8)$$

and

$$\mu = \frac{1}{KA}. \quad (9)$$

A question which often arises concerns the necessity of having a certain phase relation between the output of the modulator and the feedback input, as is the case in oscillators and other types of feedback circuits. If we inspect (8) it will be found that regardless of the phase shift in the feedback circuit the frequency component  $\omega/2$  may always adjust itself with respect to the input wave so that the above relation will hold, and the ability of the circuit to produce the component  $\omega/2$  is independent of the phase shift in the feedback circuit. Equation (9) gives the condition for which a possible steady-state operation will result. As we have stated before, in order for the circuit to build up  $\mu KA$  must be greater than unity, therefore, in order for the circuit to reach equilibrium either  $\mu$  or  $KA$  must decrease. One method by which this may be accomplished is for the gain of the amplifier to decrease as the amplitude increases, overload being a common example. In general it will be found that the coefficient  $K$  will be the one which decreases. However, as this condition takes place in an overloaded region of the modulator characteristic it will be found that the relation given in (6) is no longer valid. We shall consider this as a special case.

#### Steady-State Condition

The solution of the steady-state condition is a very important one, since it represents the usual operating condition. There are two courses open in solving this relation: one is to formulate a mathematical relation between the input voltages and the output sideband which will be valid in this particular region, the other to obtain a solution by graphical means. Both of these methods will be described since each has its particular field of usefulness, the former method clearly illustrating the principles involved and general circuit relations; the latter being especially suitable to the design and operation of actual circuits.

A method which very closely represents the actual condition is to consider the modulator as one of the "commutator" type.<sup>4</sup> The general procedure is to obtain some function of the feedback wave by which the input wave may be multiplied in order to obtain the modulator output wave. In the present case, since the feedback wave is of a periodic nature, this function may be represented by means of a Fourier series. The solution to the steady-state condition which is given in the Appendix is similar to that obtained for the starting condition except for the different treat-

ment of the modulator. The resulting amplitude and phase relations are as follows:

$$B_1 = \frac{4}{3} \frac{AK_1\mu}{\pi} \frac{1}{\sqrt{1+3\cos^2\phi}} \quad (10)$$

and

$$\theta_1 = \frac{1}{2} \tan^{-1} \left( \frac{1}{2} \tan \phi \right). \quad (11)$$

Two interesting features concerning the steady-state condition can be observed by inspection of (10).

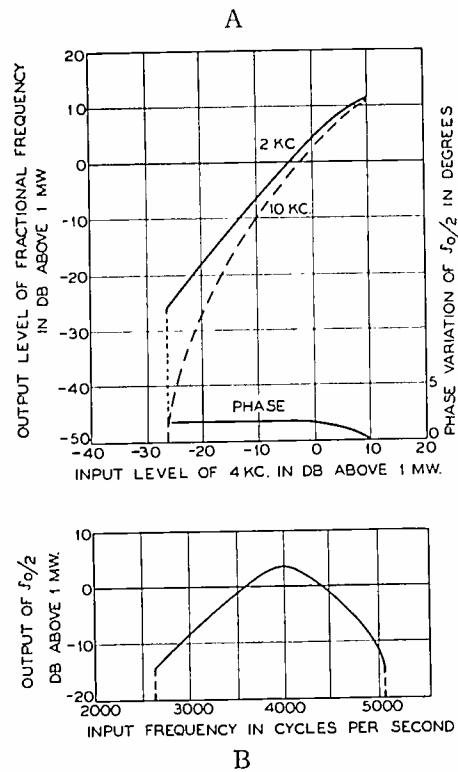

Fig. 3—Operating characteristics of fractional-frequency generator illustrated in Fig. 6. (A) Output levels and phase angle plotted as a function of input level; (B) output level of  $f_0/2$  plotted as a function of input frequency.

First, the feedback voltage is proportional to the input voltage, and since the output voltage can usually be considered a part of the feedback voltage the output is likewise proportional to the input. Second, the amplitude of the feedback and output currents will vary depending upon the phase shift of the feedback circuit. This variation can be as much as 2:1, having a maximum value when  $\phi$  is an odd multiple of  $\pi/2$  and a minimum when it is an even multiple.

Another interesting effect may be noted with reference to (11). This expression indicates that the phase angle between the input wave and the output wave is independent of the input amplitude.

Experimental curves demonstrating these characteristics are given in Figs. 3 and 4. The solid curves in Fig. 3A show both the relative phase angle and the output amplitude with respect to input amplitude. These curves were obtained from a circuit of the type shown in Fig. 6, the only alteration being that the 10-kilocycle tuned transformer is omitted. The total variation in phase over a 35-decibel range of input amplitude is only two degrees. Nearly all of this phase shift occurs at the very high levels

<sup>4</sup> E. C. Blessing, "Modulation in the G-1 carrier system," *Bell Lab. Rec.*, vol. 15, pp. 210-215; March, (1937).

and might easily be accounted for by the slight overloading occurring in the amplifier as shown by the amplitude curve or by a slight variation of transformer constants due to large amplitudes.

Fig. 3B demonstrates the operation of the circuit with variation of input frequency, the input ampli-

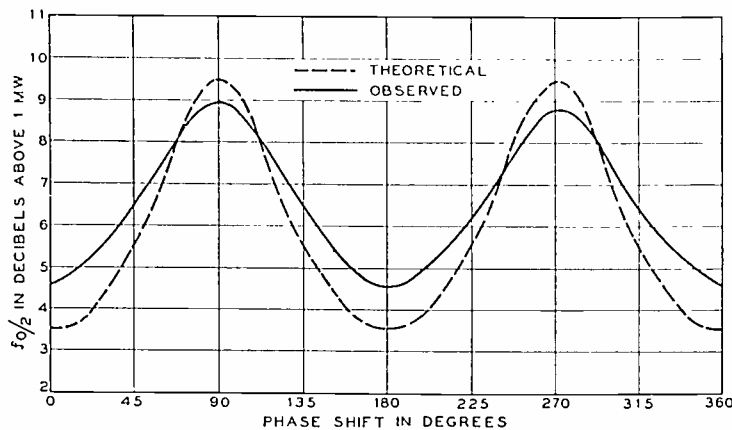

Fig. 4—Comparison of calculated and observed output levels of a second-order regenerative modulator plotted as a function of phase shift to  $f_0/2$  in the feedback path.

tude remaining fixed. This curve shows that as the frequency is increased or decreased beyond a certain point the increasing network loss causes the circuit to stop operating. An experimental curve demonstrating the variation of amplitude with phase shift in the feedback circuit is shown in Fig. 4. This curve which was obtained from a similar circuit indicates a variation of five decibels as compared to the theoretical amount of six decibels.

#### Graphical Method

Since the real difficulty in obtaining a solution to the steady-state condition is due to the fact that the operation of the modulator can be approximated only over certain regions, it is desirable in practical applications to obtain a method of accurately portraying its characteristic.

A good method of accomplishing this is to make actual measurements on the modulator over the regions in which it may operate and in such a manner that the results may be easily used in obtaining a graphical solution. A basis for such a graphical construction may readily be derived with reference to (9). If the input impedances of the modulator (feedback) and amplifier are denoted as  $R_M$  and  $R_A$ , this expression may also be written

$$10 \log_{10} K^2 A^2 \frac{R_M}{R_A} = -10 \log_{10} \mu^2 \frac{R_A}{R_M} \quad (12)$$

Since the term  $KA$  represents the transfer factor of the modulator the left-hand term of (12) will represent the energy loss expressed in decibels while the right-hand term represents the negative of the amplifier gain. A similar relation may also be obtained for (10). In this case the transfer factor of the modulator will be more complicated as it involves the phase angle of the feedback path. Thus a

graphical solution may be obtained by finding the point on the modulator characteristic where the energy loss through the modulator is equal in magnitude to the gain of the amplifier.

In Fig. 5 a family of experimental curves is given showing the operation of the modulator which is used in the practical circuits illustrated in Figs. 6, 7, and 9. The particular type of modulator<sup>5</sup> which is shown is especially suited to the regenerative modulation process since both the main input wave and the feedback wave are balanced out in the output making the filtering requirements of the network less severe. Referring to Fig. 5, the output of the wanted sideband has been plotted as a function of the energy level of the feedback wave, separate curves being obtained for different amplitudes of the input wave.

The solid curves in Fig. 5 have been obtained by using two input frequencies which are incommensurate, the output level being that of the lower sideband. By this means a reference curve can be obtained with which the curves for different phase angles may be associated. It is also desirable for purposes which will be indicated later under the second-order—multiplier type, where the phase angle does not enter into the amplitude relations. It will be noticed that the solid and broken curves for a given input amplitude coincide at low values of feedback input. This corresponds with the original conclusions which were drawn from the solution of the starting condition as given in (8) and (9).

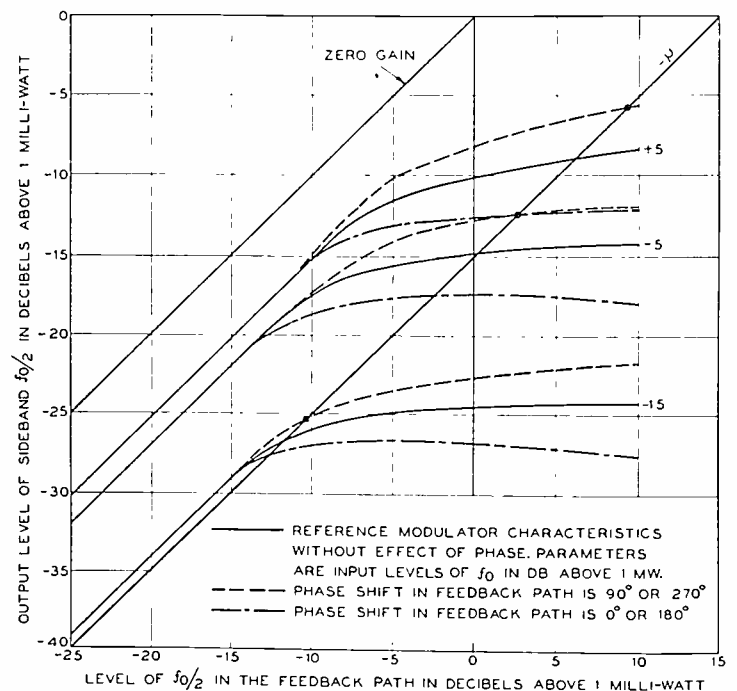

Fig. 5—Characteristics of second-order modulator plotted to demonstrate a graphical method of obtaining the steady-state solution.

If a straight line is drawn through the points of equal energy level, we find that it represents the points of zero gain between the feedback input and the sideband output. Since the modulator of the

<sup>5</sup> F. A. Cowan, U. S. Patent No. 2,025,158, December 24, 1935.

type indicated will always have a loss, it will be found that the curves all fall below this line, the vertical displacement of a given curve representing the loss of the modulator. Now, if a second line is constructed below the line of unity gain by a vertical displacement representing the net gain of the amplifier, the intersection of this line with a particular modulator characteristic will give the final steady-state operating point of the circuit. The modulator characteristic should be chosen which represents the phase shift present in the amplifier and the network. The points given by the intersection of the amplifier gain line with the various modulator curves will represent an operating characteristic of the circuit with a variable input.

### Practical Applications

There are two particularly interesting types of circuits which arise from the principles which have been outlined for the simple second-order type of regenerative modulator.

In the output of the modulator under the steady-state condition (equation (34)) it will be found that the fractional frequency terms,  $3\omega/2$ ,  $5\omega/2$ ,  $7\omega/2$ , . . . , appear with decreasing amplitude. In the simple circuit these terms were removed by the network. However, it is quite often desirable to obtain these components rather than  $\omega/2$ . As long as the characteristics of the feedback path are not materially altered we may design the amplifier circuit to be especially efficient for each desired fraction and thus obtain the fractional frequencies at even larger amplitudes than the original component  $\omega/2$ .

A circuit illustrating this principle is given in Fig. 6. This particular circuit has been designed to produce 10,000 cycles from a 4000-cycle source. The tuned transformer utilized in the plate circuit to obtain 10,000 cycles offers only a low impedance to

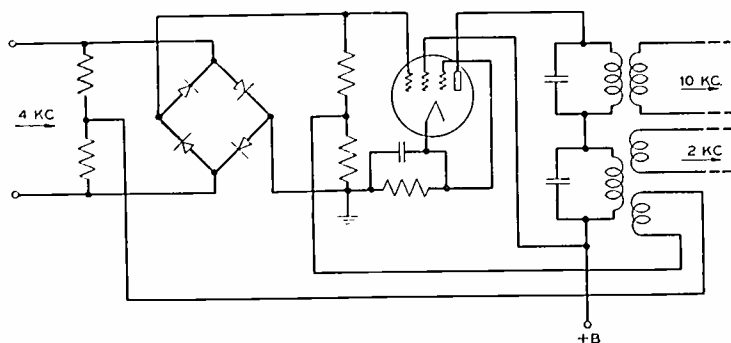

Fig. 6—Circuit diagram of second-order regenerative modulator for obtaining 2 kilocycles and 10 kilocycles from 4 kilocycles.

2000 cycles and thus does not appreciably affect the regenerative action. An operating characteristic for 10 kilocycles of this particular circuit is given in Fig. 3A. The addition of the transformer for obtaining 10 kilocycles does not materially alter the characteristics which are indicated in Figs. 3A and 3B for the two-kilohertz output.

Another particularly interesting type of circuit

made possible because the amplifier is normally used in class A operation, is one that has been called the reflex type. In each succeeding stage of a cascaded group of frequency converters a lower frequency will be found when compared with the preceding stage,

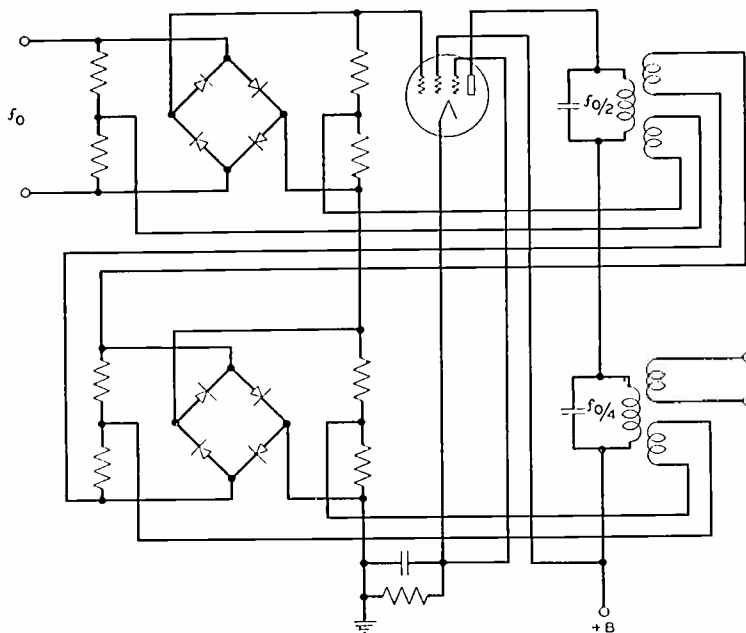

Fig. 7—Circuit diagram of reflex type of a second-order regenerative modulator.

this ratio being 2:1 for the second-order type. It is possible then for the same amplifier to be used for more than one stage. A circuit illustrating this principle is shown in Fig. 7. The number of stages which may be utilized this way is limited practically by the actual load and gain capacity of the amplifier and by the fact that with each succeeding feedback path more care is needed to insure that Nyquist's rule for stable operation is not violated. Ratios of 8:1 have been obtained in this manner.

### IV. SECOND-ORDER—MULTIPLIER REGENERATIVE MODULATOR

In the preliminary discussion on regenerative modulators it has been demonstrated that a possible method for obtaining greater subharmonic ratios than  $1/2$  is to make use of a frequency multiplier in the feedback circuit.

Referring to (2) it will be found that the largest submultiple ratio will be obtained for a given harmonic produced in the multiplier if

$$f_1 = \frac{f_0}{1+r}$$

Assuming that the networks are so designed that these relations can be fulfilled then we may take as the input waves to the modulator

$$e_0 = A \cos \omega t \quad (13)$$

and

$$e_2 = B \cos \left( \frac{r}{1+r} \omega t + \theta \right) \quad (14)$$

### Starting Condition

The transfer factor of the amplifier and network  $N_1$  may be designated by  $\mu\angle\phi$  for the frequency  $\omega/(1+r)$ , and of the network  $N_2$  associated with the multiplier by  $L\angle\Psi$  for the frequency  $r\omega/(1+r)$ . The multiplier is assumed to have no phase shift and therefore the output wave is obtained by multiplying the input amplitude by an amplitude factor  $R$ , analogous to the transfer factor, and by multiplying the frequency and phase of the input wave by a factor  $r$ .

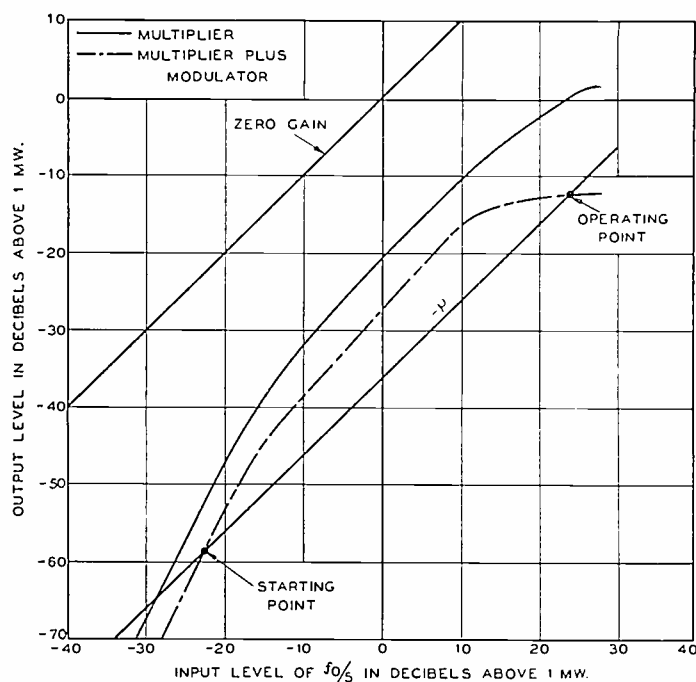

Fig. 8—Typical characteristics of multiplier—second-order regenerative modulator illustrated in Fig. 9. Curves are plotted to demonstrate graphical solution.

The output of the modulator will be given by the expression

$$e_{sb} = KAB \left[ \cos \left( \frac{1+2r}{1+r} \omega t + \theta \right) + \cos \left( \frac{1}{1+r} \omega t - \theta \right) \right] \quad (15)$$

and the relation between the modulator output and the feedback wave by

$$KABL\mu R \cos \left[ r \left( \frac{\omega t}{1+r} - \theta + \phi \right) + \Psi \right] = B \cos \left( \frac{r}{r+1} \omega t + \theta \right). \quad (16)$$

Solution of this expression gives

$$\mu = \frac{1}{AKRL} \quad (17)$$

and

$$\theta = \frac{r\phi + \Psi}{r+1}. \quad (18)$$

The term  $R$  enters into the above relations as a part of the loss of the circuit which must be overcome by the gain of the amplifier. However, the term  $R$  is not necessarily a constant but is in all practical circuits a function of the feedback voltage. In general the value of the factor  $R$  for the low values of voltage which are present under the starting condition follows the relation

$$R = \frac{e_2}{e_1} = C_r e_1^{r-1}. \quad (19)$$

This relation indicates that when the voltage in the feedback circuit is small the value of  $R$  becomes very small. It is evident then that with a fixed value of gain in the circuit a definite minimum value of the fractional frequency must exist in the feedback circuit in order for the circuit to start. If the gain is increased the amount of necessary feedback voltage becomes smaller. In actual circuits this small feedback wave is usually supplied by an external starting circuit.

### Steady-State Condition

A solution to the steady-state condition of the second-order—multiplier has been included in the Appendix. The resulting amplitude and phase relations are

$$B_1 = \frac{AK_1\mu RL}{\pi} \quad (20)$$

and

$$\theta_1 = \frac{r\phi + \Psi}{r+1}. \quad (21)$$

Referring to (20) and (21) it will be noticed that the amplitude of feedback current is not a function of either of the phase angles in the feedback path. Also that the phase angle  $\theta_1$  is identical to that found in (18). The reason that the phase angle does not enter into the amplitude term as it did in the case of the second-order type can be readily seen by inspection of the components obtained in the output of the modulator (Appendix). In this relation only a single term of the Fourier expansion contributes to the component  $\omega/(1+r)$ . This is not an undesirable feature since it does not require any consideration in the design of the circuits.

Another fact which can be observed from (20) is that the amplitude of the feedback current bears a linear response to the input amplitude  $A$ .

### Graphical Solution

In order to obtain a graphical solution of the second-order—multiplier type it is necessary to obtain an operating characteristic of the multiplier as well as the modulator. In Fig. 8 is given a multiplier characteristic which was obtained from a 5:1 frequency converter of the type shown in Fig. 9. In this diagram the output level of the fourth harmonic is plotted as a function of the input level to the multi-

plier of the frequency  $f_0/5$ . The nonlinear nature of the multiplier for low levels is clearly demonstrated.

Since the output of the multiplier is connected to the feedback input of the modulator, a composite loss curve of the two units in tandem may be obtained by referring these levels to a characteristic of the modulator as shown in Fig. 5. The solid curves should be utilized since the phase shift does not enter in. Now by constructing the line representing the gain of the amplifier, we can obtain the intersection representing the final steady-state output of the modulator.

It will also be found that there is a second intersection at a low input level which represents the feedback amplitude required for the fractional wave to start the building-up process.

### Practical Applications

In a manner similar to that described for the second-order type, it is possible to obtain fractional frequencies other than the frequencies necessary for regeneration. Another source of fractional frequencies in this particular type of circuit is from the output of the multiplier, since nearly all types of harmonic producers give a series of harmonics rather than the single one which is selected by the network.

### V. THIRD-ORDER REGENERATIVE MODULATOR

We have demonstrated by (1) the possibility of using a high-order modulator for obtaining fractional ratios greater than  $1/2$ . Assuming that  $m = 1$  and  $n = 2$ , which is a common case for a third-order modulator, we find that it is possible to obtain  $1/3 f_0$ . If we let the two input waves to the modulator be represented by the relations

$$e_0 = A \cos \omega t \quad (22)$$

and

$$e_1 = B \cos \left( \frac{\omega t}{3} + \theta \right), \quad (23)$$

the output sidebands for the condition that  $e_1$  is small compared to  $e_0$  will be given by the relation

$$e_{nb} = K A B^2 \left[ \cos \left( \frac{\omega t}{3} - 2\theta \right) + \cos \left( \frac{5\omega t}{3} + 2\theta \right) \right] \quad (24)$$

and since  $e_1$  is to be obtained from the sideband outputs

$$B \cos \left( \frac{\omega t}{3} + \theta \right) = \mu K A B^2 \cos \left( \frac{\omega t}{3} - 2\theta + \phi \right). \quad (25)$$

Separating amplitude and phase components gives

$$\mu = \frac{1}{A K B} \quad (26)$$

and

$$\theta = \frac{\phi}{3}. \quad (27)$$

Referring to (26) we find that the amplitude term  $B$  enters into the equation for the necessary gain; i.e., when  $B$  is small  $\mu$  must be larger in order to satisfy the equation. It is evident from this that under conditions of starting  $\mu$  would have to be infinite since  $B$  approaches zero. The third-order modulator is then similar to the multiplier type, in that a finite value of feedback wave is necessary in order that the submultiple may build up to a steady-state condition.

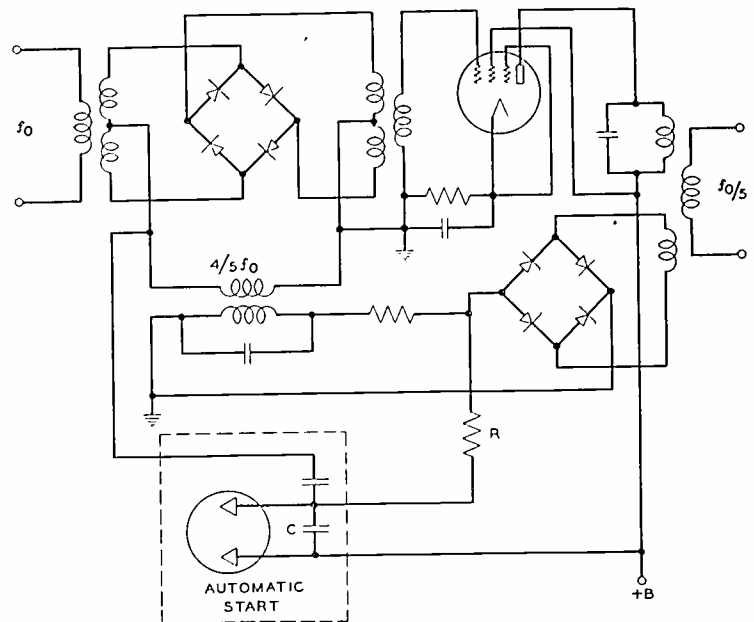

Fig. 9—Circuit diagram of multiplier—second-order regenerative modulator constructed to give a fractional-frequency ratio of  $1/5$ .

### Steady-State Condition

A solution to the steady-state condition for the third-order type can be obtained in a manner much the same as in the case of the second-order. The resulting phase and amplitude relations are as follows:

$$B_1 = \frac{A \mu}{2} \frac{(C_2 + C_4)(C_2 - C_4)}{\sqrt{(C_2 + C_4)^2 - 4(C_2 C_4) \cos^2 \phi}} \quad (28)$$

and

$$\theta_1 = \frac{1}{3} \tan^{-1} \left[ \left( \frac{C_2 + C_4}{C_2 - C_4} \right) \tan \phi \right]. \quad (29)$$

These expressions, if compared to the ones obtained for the second-order type, will be found to have a very close similarity in form. However, it is much more difficult to obtain actual quantitative results for the third-order type. This is due to the fact that in the usual third-order modulator the two coefficients,  $C_2$  and  $C_4$ , both approach zero as the amplitude of the feedback wave increases, while in the second-order type the corresponding coefficients approach constant values. For this reason the graphical method becomes a more accurate method.

### Graphical Method

The graphical method as applied to the third-order type of circuit is very similar to the second-

order type. In Fig. 10 there is shown a family of operating characteristics which was obtained from a modulator employing silicon-carbide varistors similar to the type illustrated in Fig. 11. Broken curves which represent conditions for  $\phi = \pi/2$  and  $\phi = 0$  have also been plotted for one of the characteristics. A

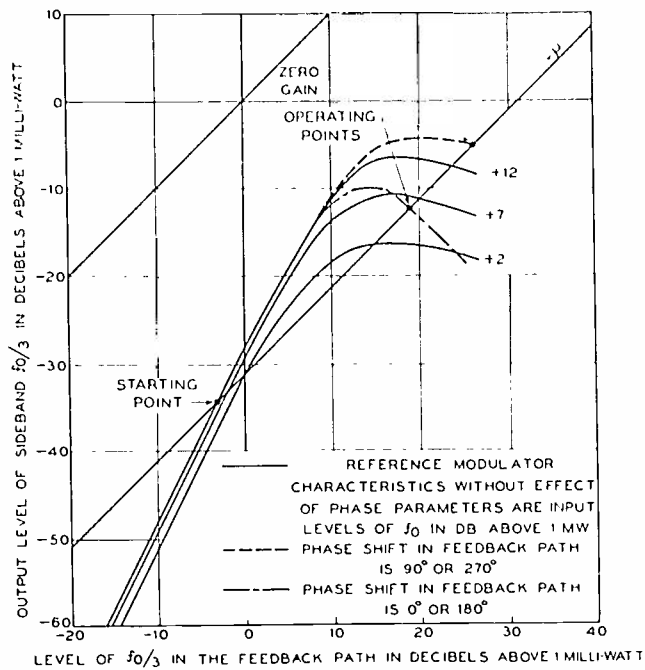

Fig. 10—Characteristics of typical third-order modulator plotted to illustrate the graphical method of solution.

representative amplifier-gain line has been constructed which represents an excess gain of ten decibels. The intersection of this line with the two curves representing the extremes caused by possible phase shift of amplifier and network indicate a variation of seven decibels. The intersection at lower feedback levels represent the initial amplitude necessary for starting.

#### VI. STARTING OF HIGH-ORDER REGENERATIVE MODULATORS

It has been demonstrated under the theoretical consideration of both the multiplier second-order and third-order type that it is necessary to have a finite value of feedback wave in order that these circuits may build up to a steady-state condition. The amplitude of the required feedback wave is usually quite small when compared to the final steady-state amplitude. While this value can be decreased by an increase in gain or as in the case of the multiplier type by the use of a harmonic producer which is linear for small amplitudes, it is usually more desirable to accept the simplest type of circuit which has the desired margins of operation and then provide some means of starting the circuit.

The starting circuits may be made either manual or automatic. An example of the latter type is shown in Fig. 9. In this circuit a bias, which is obtained from a rectifier type of multiplier, is used to control a gaseous type of discharge tube. As long as there is no

feedback wave, the bias voltage developed by the multiplier is zero and allows the voltage across the gaseous tube to build up to the ionization potential. As the tube breaks down a transient impulse is applied to the feedback circuit, the interval at which the impulse circuit operates depending upon the constants  $R$  and  $C$ . If an input is present on the modulator, the transient which will be at the natural frequency of the circuit will start the building-up process. As the feedback wave builds up, a bias is developed by the multiplier circuit which opposes the potential applied to the gaseous-discharge tube thus preventing it from operating.

Quite often it may be desirable to have the circuit remain inoperative after a failure has occurred at some point in the system. In this case the gaseous-discharge tube could have been omitted and the condenser discharged by a manually operated switch to start the circuit.

#### VII. EFFECT OF NOISE OR DISTORTED INPUT WAVE

In the description of the various type of circuits it has been demonstrated that the input wave acts very much as a carrier input to an ordinary modulator. As might be expected from this the only effect obtained by applying a badly distorted input wave is to change the modulator loss and thereby a possible change in the output level. In the case of noise we have a somewhat similar action except the extraneous frequencies do not bear any harmonic relation to the input wave. The most serious interference of random noise or single-frequency wave is obtained whenever the frequency is close to that of the main input frequency. However, it has been found in experimental work that the amplitude of the noise wave may be increased to within approximately 80 per cent of the input wave without impairing the frequency-division action, although the noise wave must necessarily produce other modulation products in the modulator.

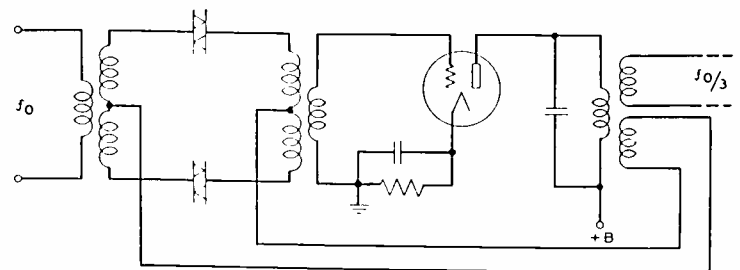

Fig. 11—Circuit diagram of a third-order regenerative modulator.

#### VIII. CONCLUSION

The operation of the regenerative modulator may be likened to that of an amplifier which performs the dual function of frequency conversion and amplification. The comparison to an amplifier is particularly suitable since a conversion gain equal approximately

to the gain of the amplifier less the loss of the modulator is obtained.

If elements which act essentially as linear rectifiers are utilized for the modulator and multiplier in the case of either the second-order or the second-order-multiplier types, it is also possible to obtain a linear output response with respect to input amplitude, and at the same time maintain a constant phase angle between the two waves.

A marked difference between the regenerative modulator and the usual type of controlled relaxation oscillator is found in the behavior of the circuit with variations of vacuum-tube characteristics. In the regenerative modulator the variation of tubes due to

voltage changes or aging can only change the gain of the feedback path. Thus, if the gain increases or decreases the only change is an increase in output or vice versa. If the gain becomes too low the circuit simply ceases to operate. Vacuum tubes having widely different characteristics can be substituted in the same circuit, the only requirement being that they have sufficient gain.

#### ACKNOWLEDGMENT

The author is indebted to Mr. W. R. Bennett for the methods which are utilized in obtaining the steady-state solutions for the different types of regenerative modulators.

#### APPENDIX

##### *Analysis of Steady-State Condition*

A desirable method of treating the operation of a modulator under the steady-state condition is to consider it as one of the "commutator" type. By this is meant that the feedback wave, being large compared to the main input wave, will act merely

$$e_{sb} = \frac{A}{2} \left\{ 2C_0 \cos \omega t + C_1 \left[ \cos \left( \frac{\omega t}{2} - \theta_1 \right) + \cos \left( \frac{3\omega t}{2} + \theta_1 \right) \right] + C_2 [\cos 2\theta_1 + \cos (2\omega t + 2\theta_1)] \right. \\ \left. + C_3 \left[ \cos \left( \frac{5\omega t}{2} + 3\theta_1 \right) + \cos \left( \frac{\omega t}{2} + 3\theta_1 \right) \right] + C_4 [\cos (3\omega t + 4\theta_1) + \cos (\omega t - 4\theta_1)] + \dots \right\} \quad (34)$$

as a switch in alternately changing the transmission of the input wave through the modulator from one value to another. This is in effect the modulation of the input wave by essentially a rectangular-shaped wave.

Such an approximation will be a very close approach to the actual operation of a modulator, particularly if either of the following conditions are fulfilled: One, if the impedance of the nonlinear element has a constant value in the conducting direction; two, if the impedance of the nonlinear element in the conducting direction is small compared to the load impedances of the modulator. A good example of an element which complies with the former condition is a linear rectifier such as a diode, with the latter, a copper-oxide rectifier.

A general expression for the switching function is

$$F(e_{FB}) = C_0 + C_1 \cos (p\theta + \theta_1) + C_2 \cos 2(p\theta + \theta_1) \\ + \dots + C_n \cos n(p\theta + \theta_1) \quad (30)$$

where  $p$  is the frequency and  $\theta_1$  is the phase angle of the feedback wave.

If the input wave is represented by

$$e_0 = A \cos \omega t \quad (31)$$

then the output wave of the modulator will be

$$e_{sb} = F(e_{FB})A \cos \omega t. \quad (32)$$

Solutions for the different types of regenerative modulators may now be obtained.

##### *Second-Order Type*

If the feedback wave is represented by

$$e_1 = B_1 \cos \left( \frac{\omega t}{2} + \theta_1 \right) \quad (33)$$

then the output wave of the modulator may be obtained by expanding (32) by means of the series given in (30).

If we represent the amplification factor and phase shift of the combined network and amplifier by  $\mu \angle \phi$  the relation between the feedback wave and the components of the same frequency present in the output wave of the modulator will be

$$B_1 \cos \left( \frac{\omega t}{2} + \theta_1 \right) = \frac{A\mu}{2} \left[ C_1 \cos \left( \frac{\omega t}{2} - \theta_1 + \phi \right) \right. \\ \left. + C_3 \cos \left( \frac{\omega t}{2} + 3\theta_1 + \phi \right) \right]. \quad (35)$$

Simplifying this equation we find that

$$B_1 = \frac{A\mu}{2} \frac{(C_1 + C_3)(C_1 - C_3)}{\sqrt{(C_1 + C_3)^2 - 4C_1C_3 \cos^2 \phi}} \quad (36)$$

and

$$\theta_1 = \frac{1}{2} \tan^{-1} \left( \frac{C_1 + C_3}{C_1 - C_3} \tan \phi \right). \quad (37)$$

In the second-order modulators of the type shown in the present paper, it will be found that the commutation process occurs as the feedback wave passes through zero. This type of switching function may be represented by an ordinary square wave which is symmetrical about the zero axis and whose amplitude is  $K_1$ . Substitution of the appropriate coefficients in (36) and (37) gives

$$B_1 = \frac{4}{3} \frac{AK_1\mu}{\pi} \frac{1}{\sqrt{1 + 3 \cos^2 \phi}} \quad (38)$$

and

$$\theta_1 = \frac{1}{2} \tan^{-1} \left( \frac{1}{2} \tan \phi \right). \quad (39)$$

### Second-Order—Multiplier Type

The feedback wave may be represented by

$$e_2 = B_1 \cos \left( \frac{r}{1+r} \omega t + \theta_1 \right). \quad (40)$$

As the modulator is of the same type which is found in the second-order case the values of the coefficients

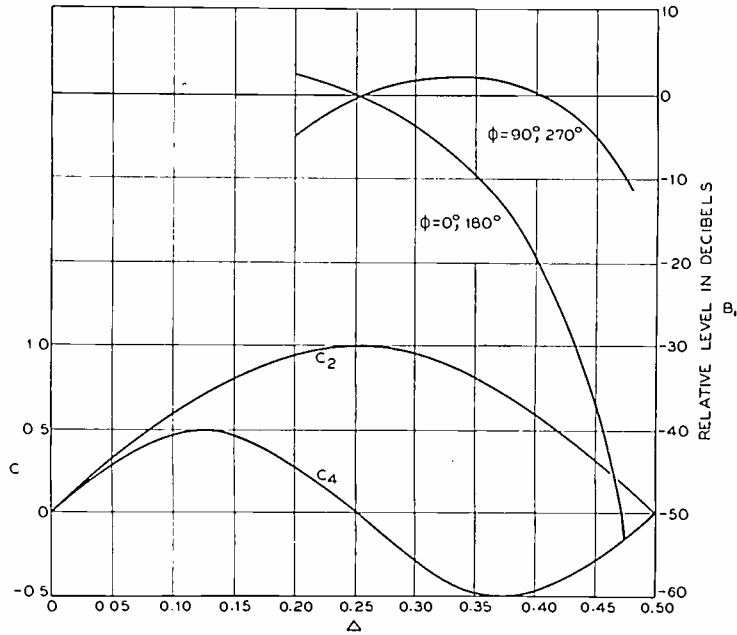

Fig. 12—Computed values of coefficients  $C_2$ ,  $C_4$ , and the resulting feedback amplitude  $B_1$  plotted as a function of  $\Delta$ .

may be substituted directly in the expansion of (32) which gives as a result

$$e_{sb} = \frac{AK_1}{\pi} \left\{ \left[ \cos \left( \frac{1}{1+r} \omega t - \theta_1 \right) + \cos \left( \frac{1+2r}{1+r} \omega t + \theta_1 \right) \right] - \frac{1}{3} \left[ \cos \left( \frac{1-2r}{1+r} \omega t - 3\theta_1 \right) + \cos \left( \frac{1+4r}{1+r} \omega t + 3\theta_1 \right) \right] + \frac{1}{5} \left[ \cos \left( \frac{1-4r}{1+r} \omega t - 5\theta_1 \right) + \cos \left( \frac{1+6r}{1+r} \omega t + 5\theta_1 \right) \right] + \dots \right\}. \quad (41)$$

If the transfer factor of the amplifier and network  $N_1$  is designated by  $\mu\angle\phi$  for a frequency  $\omega/(1+r)$ , the network  $N_2$  by  $L\angle\Psi$  for  $r\omega/(1+r)$ , and of the multiplier by  $R$  the relation between the feedback wave and the output of the modulator will be

$$B_1 \cos \left( \frac{r}{1+r} \omega t + \theta_1 \right) = \frac{AK_1\mu RL}{\pi} \left[ \cos r \left( \frac{\omega t}{1+r} - \theta_1 + \phi \right) + \Psi \right]. \quad (42)$$

Simplifying this expression we find that

$$B_1 = \frac{AK_1\mu RL}{\pi} \quad (43)$$

and

$$\theta_1 = \frac{r\phi + \Psi}{r+1}. \quad (44)$$

### Third-Order Type

The solution to the third-order type follows the same procedure as in the second-order case. Solving the circuit relations gives the following amplitude and phase relations:

$$B_1 = \frac{A\mu}{2} \frac{(C_2 + C_4)(C_2 - C_4)}{\sqrt{(C_2 + C_4)^2 - 4(C_2C_4)} \cos^2 \phi} \quad (45)$$

and

$$\theta_1 = \frac{1}{3} \tan^{-1} \left[ \left( \frac{C_2 + C_4}{C_2 - C_4} \right) \tan \phi \right]. \quad (46)$$

The above relations when compared to (36) and (37) display a very close similarity. However, the evaluation of the coefficients  $C_2$  and  $C_4$  in the third-order case is not a simple matter.

If we inspect a third-order modulator of the type shown in Fig. 11, it will be found that, regardless of the polarity of the voltage applied at the feedback input, an increasing voltage will cause a decrease in impedance of the nonlinear element. It follows from this characteristic that for each half cycle of the feedback wave a pulse of the input wave will be obtained in the modulator output. The length of this pulse will approach a half cycle as a limit when the feedback wave becomes very large, and its shape will be essentially rectangular. If we denote the fraction of the feedback cycle occupied by the pulse as  $\Delta$  and its amplitude by  $K_1$  then the values of the coefficients will be given by

$$C_n = \frac{2K_1}{n\pi} \sin n\Delta\pi. \quad (47)$$

In Fig. 12 there are plotted the resulting coefficient values which are obtained when  $\Delta$  is varied between 0 and 0.5. Since the feedback wave will cause the impedance of the nonlinear elements to be low over the major part of a half cycle, only the values of  $\Delta$  between 0.25 and 0.5 are of immediate interest. It is interesting to note that the values of both coefficients approach zero as  $\Delta$  approaches 0.5 instead of fixed values as in the case of the second order. By substituting the values of  $C_2$  and  $C_4$  in (45) and assuming different values for  $\phi$  we can obtain characteristics which will depict the operation of the circuit for the steady-state condition. Two curves have been plotted in Fig. 12 showing the relative values of  $B_1$  over this region for phase angles of 0 and 90 degrees in the feedback circuit.

Since the term  $\Delta$  approaches 0.5 as the amplitude



of the feedback wave is increased it will be found that there is a close similarity between the curves for  $B_1$  as given in Fig. 12 and the experimental curves showing the relation between the feedback amplitude and the sideband output as indicated by the broken lines in Fig. 10.

#### Bibliography

- (1) Balth. van der Pol, "On relaxation oscillations—Part I," *Phil. Mag.* vol. 2, pp. 978–992; November, (1926).
- (2) I. Koga, "A new frequency transformer or frequency changer," *PROC. I.R.E.*, vol. 15, pp. 669–678; August, (1927).
- (3) Balth. van der Pol and M. van der Mark, "Frequency de-

multiplication," *Nature*, vol. 120, pp. 363–364; September 10, (1927).

(4) Yasusi Watanabe, "Some remarks on the multivibrator," *PROC. I.R.E.*, vol. 18, pp. 327–335; February, (1930).

(5) J. Groszkowski, "Frequency division," *PROC. I.R.E.*, vol. 18, pp. 1960–1970; November, (1930).

(6) G. Longo, "Multiplication of a frequency by simple fractional numbers," *L'Onde Elec.*, vol. 13, pp. 97–100; February, (1934).

(7) Balth. van der Pol, "The nonlinear theory of electric oscillations," *PROC. I.R.E.*, vol. 22, pp. 1051–1086; September, (1934).

(8) Ph. le Corbeiller, "The non-linear theory of the maintenance of oscillations," *Jour. I.E.E.* (London), vol. 79, pp. 361–378; September, (1936).

(9) H. Sterky, "Frequency multiplication and division," *PROC. I.R.E.*, vol. 25, pp. 1153–1173; September, (1937).

## Single-Sideband Filter Theory with Television Applications\*

JOHN M. HOLLYWOOD†, ASSOCIATE MEMBER, I.R.E.

*Summary*—Given the phase and amplitude characteristics of a filter, a graphical method is presented for deriving the phase and amplitude characteristics of the modulation envelope or video-frequency response when a modulated carrier is impressed. Sources of distortion are briefly discussed.

Several filter structures are considered as to their suitability for use in attenuating one side band of a television signal. Radio-frequency phase and amplitude characteristics are given, with notes as to the physical realizability of the structures. Resulting video-frequency phase and amplitude characteristics are derived after demodulation, and in some cases the video-frequency transient response resulting from a suddenly impressed carrier is given.

Design formulas are given for a filter using transmission lines as circuit elements. Some problems in the application of a filter to the transmitter are considered.

The gain of amplifier stages is treated for many types of video- and radio-frequency amplifiers, for single- and double-sideband use, and for one- and ten-stage amplifiers, when meeting certain tolerances to a fixed maximum modulation frequency.

#### PROBLEM INVOLVED

SINCE gain varies inversely with band width in television reception, many receivers attenuate one sideband thus allowing the tuned circuits to have smaller band widths. It is highly desirable to know what the resulting distortion will be in the signal after demodulation.

In television transmission, for a given maximum video frequency the channel width can be reduced by removing one sideband. Again it is necessary to know what distortion will occur in the demodulated signal.

Design formulas are needed for practical filters for the transmitter that will meet the requirements of sufficiently flat amplitude and sufficiently linear phase of the demodulated signal at the receiver, and sufficiently great attenuation of the undesired sideband.

Much experimental and theoretical work has been published on single-sideband transmission. In particular, the graphical analysis given here may be

used alternatively with a mathematical analysis given by Poch and Epstein.<sup>1</sup> The transmission-line filter structures to be dealt with here are based largely on the work of Mason and Sykes.<sup>2</sup>

#### GRAPHICAL TRANSFORMATION FROM RADIO- TO DETECTED VIDEO-FREQUENCY RESPONSE OF A SELECTIVE STRUCTURE

A modulated carrier may be represented as a fixed vector plus two oppositely rotating vectors. The instantaneous amplitude of the modulation envelope is the length of the vector sum.

On passage through a filter for which the phase and amplitude characteristics are known, the carrier vector is shifted in phase angle by a known amount, and in the same way the shifts in the phase angles of the upper and lower sideband vectors can be obtained from the filter phase characteristics. The new amplitudes of each vector can be found from the amplitude curve of the filter. The new vector sum can then be found graphically, and plotted as a function of time to investigate distortion, or as a function of modulation frequency.

If the amplitude of modulation is small, the vector sum is approximately the sum of the projections of the two small vectors on the large vector  $C$  and the work can be simplified by replacing one rotating vector by an oppositely rotating one symmetrically disposed with respect to the carrier vector; this leaves the projection unchanged. Now both small vectors rotate in the same direction and at the same speed and may be replaced by a single vector sum  $V$ . The total vector sum as a function of time has

<sup>1</sup> Poch and Epstein, "Partial suppression of one side band in television reception," *PROC. I.R.E.*, vol. 25, pp. 15–31; January, (1937); *RCA Rev.*, vol. 1, pp. 19–35; January, (1937).

<sup>2</sup> Mason and Sykes, "Transmission lines in filters and transformers," *Bell Sys. Tech., Jour.*, vol. 16, pp. 275–302; July, (1937).

\* Decimal classification: R386×R583. Original manuscript received by the Institute, July 1, 1938.

† Columbia Broadcasting System, New York, N. Y.

maximum and minimum limits (corresponding to maximum and minimum modulation envelope heights) of  $|C| + |V|$ ;  $|C| - |V|$ ; and the video-frequency output from a linear detector would have amplitude at this modulation frequency of peak-to-peak value  $2V$ . The angle between  $V$  and  $C$  is to be drawn zero at zero modulation frequency, and at other modulation frequencies the angle between  $V$  and  $C$  becomes the phase angle of the detector output.

The graphical process of transforming the radio-frequency phase and amplitude curves into video-frequency phase and amplitude curves is therefore accomplished by the following procedure: (See Fig. 3 for an example.)

(1) From the radio-frequency curves find the phase angles  $\phi_U$ ,  $\phi_0$ ,  $\phi_L$  and amplitudes  $A_U$ ,  $A_0$ ,  $A_L$  for the upper sideband, carrier, and lower sideband frequencies respectively, for a given modulation frequency.

(2) Take an axis as representing the carrier vector phase  $\phi_0$ . At any point  $P$  on this line, draw a line at the angle  $(\phi_0 - \phi_L)$  and of length  $A_L$ , and from its extremity draw a line of length  $A_U$  and at an angle  $(\phi_U - \phi_0)$  with respect to the carrier axis  $\phi_0$ . Calling  $Q$  the extremity of  $A_U$ , draw  $PQ$ .

(3) The distance  $PQ$  represents the video-frequency amplitude; the angle between the line  $PQ$  and the axis  $\phi_0$  represents the video-frequency phase angle; at the given modulation frequency.

To find the phase delay  $PD$  in seconds at any modulation frequency  $f$ ,  $PD = \theta / 2\pi f$  where  $\theta$  is the video-frequency phase angle in radians. The envelope delay  $ED$  in seconds is  $ED = (1/2\pi)d\theta/df$ .

The time of build-up of a transient sent through a filter depends upon the envelope delay. If  $ED$  is kept within certain tolerable limits,  $PD$  will fall well within the same limits as it is the average of  $ED$  over a frequency range of zero to  $f$ .

A television signal is more nearly a periodic function so that the phase delay is the important factor.

Phase angles are plotted with leading angles considered negative. This gives a positive slope in most cases, so that the delay becomes positive. The vector patterns are drawn in their true relative locations, however, and are "backwards" with respect to the phase characteristics of the filter structures.

#### DISTORTION AT LARGE MODULATION PERCENTAGE

If the original vector diagram is sketched for the carrier and the oppositely rotating sideband vectors, after passage through a network which treats one sideband differently from the other, it will be noticed that the time variation of the vector sum is not sinusoidal unless the modulation percentage is small.

Poch and Epstein<sup>1</sup> showed this mathematically, and also brought out that a square-law detector gives

linear output when one sideband is completely suppressed, but no known detector gives linear output for all degrees of suppression of one sideband. In practical use, the degree of suppression becomes negligible as the modulation frequency approaches zero, so that many degrees of suppression are involved and a linear detector and small modulation percentage seems the best compromise.

This distortion effect, which is worst when the sideband and carrier vectors tend to cancel, that is, when the modulation envelope is at minimum height, is an argument in favor of that polarity of transmitting television signals which results in having all picture components at high carrier levels, and the synchronizing pulses in the direction of zero carrier (positive transmission). Distortion of square pulses is of no consequence as they will remain square.

#### REQUIREMENTS FOR SELECTIVE CIRCUITS IN TELEVISION

Some information has been published on bandwidth requirements for television, but very little as to what tolerances are allowable over the desired band width. The tolerances as given here are somewhat arbitrary and not necessarily the optimum values; experience, theory, and psychological factors were involved in the choice.

(1) Video-frequency amplitudes are to fall within the limits of 0.8 to 1.25 of the value at low frequency, up to video frequencies of 4 megacycles.

(2) Phase delay is not to vary by more than 0.05 microsecond in the range of video frequencies from 100 kilocycles to 4 megacycles. (It may exceed this considerably at lower frequencies so long as the departure from a linear phase characteristic does not exceed a few degrees.)

(3) Envelope of transient response to a suddenly impressed carrier to be reasonably similar to an exponential rise of not more than a 0.05-microsecond time constant.

(4) In single-sideband transmitter use, attenuation is to exceed 40 decibels at frequencies more than 1 megacycle to the undesired side of the carrier.

(5) Structural elements must be physically realizable and capable of handling the voltages and currents involved.

(6) If used on the output of a transmitter, the filter must not dissipate more than 20 per cent of the output.

The requirements above are for an entire system from pickup device to reproducing device. Individual stages must have correspondingly smaller deviation from ideal response.

#### TYPES OF FILTERS CONSIDERED

Among the filter types considered were usual band-pass structures, single and coupled tuned circuits, lattice structures, and filters using transmis-

sion lines as circuit elements. The object was to find a design meeting the above requirements, which could be applied to an ultra-high-frequency transmitter on about 50 megacycles.

The first step is to estimate the constants required in the circuit for a 4-megacycle band width and a 50-megacycle central frequency. These must be obtainable practically. Then the radio-frequency phase and amplitude characteristics are calculated, and converted to video-frequency characteristics by the graphical method. It will usually be found that the filter meets its requirements over a wider or smaller range than the nominal band width. A revised value of nominal band width must then be used in obtaining the final data.

### CONVENTIONAL BAND-PASS FILTER

The first filter structure to be treated is the conventional band-pass structure of Fig. 1.

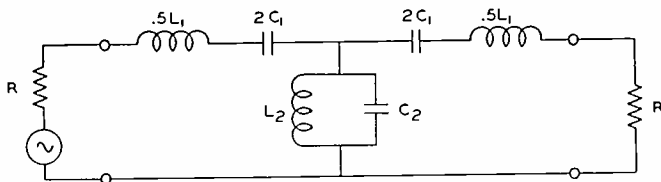

Fig. 1—Conventional band-pass filter.

$$L_1 = \frac{R}{\pi(f_2 - f_1)} \quad L_2 = \frac{(f_2 - f_1)R}{4\pi f_2 f_1}$$

$$C_1 = \frac{f_2 - f_1}{4\pi f_2 f_1 R} \quad C_2 = \frac{1}{\pi(f_2 - f_1)R}$$

where  $f_1$  and  $f_2$  are the frequencies at the edges of the pass band. If the series resistance in  $L_1$  and  $C_1$  is not to exceed  $0.1R$ , the value of  $Q$  for the series resonant circuit must exceed  $20\sqrt{f_1 f_2}/(f_2 - f_1)$ , or 250 for the band width and central frequency 4 and 50 megacycles, respectively. Similarly, if the equivalent parallel resistance across  $L_2$  and  $C_2$  is to exceed  $10R$ , a  $Q$  of 250 is required for the parallel resonant circuit.

At 50 megacycles this  $Q$  value is difficult to obtain with no specifications for the reactances. From the design data, the reactance for each series resonant component must be  $25R$ , and for the parallel resonant components,  $R/25$ . The required  $Q$  becomes impossible to obtain practically and the power loss therefore excessive.

The filter is impractical for this use for another reason. Values of capacitance and inductance are required which are impossible to obtain practically at the 50-megacycle frequency, because of excessive inductive reactance in connecting leads and capacitive admittance due to stray capacitance.

If an attempt is made to duplicate the structure by using transmission lines in place of the resonant circuits, making the rate of change of reactance with frequency the same as in the original circuit in the pass-band region, it will be found that the surge

impedances required are  $25R$  and  $R/25$ , a ratio of 625:1. Such transmission lines are not available practically.

It is worth noting that most of the difficulties are proportional to the ratio of central frequency to band width.

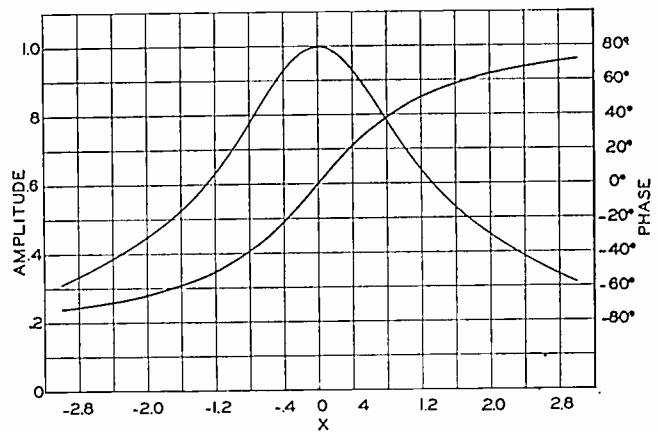

Fig. 2—Radio-frequency characteristics of a simple tuned circuit.

### TUNED CIRCUITS

Consider a simple tuned circuit consisting of  $L$ ,  $C$ , and  $R$  in parallel connected to a relatively high impedance source, as in a pentode amplifier coupling circuit. The output voltage is then proportional to the load impedance and current from the source, or

$$E = \frac{I}{\frac{1}{R} + j\left(\omega C - \frac{1}{\omega L}\right)}$$

which is similar to a series  $LCR$  circuit with a constant voltage source, admittances replacing impedances.

Using a notation and method of approximation as used by Guillemin,<sup>3</sup> with appropriate modifications, substitute

$$\alpha = \frac{1}{2CR}; \quad X = \frac{1}{\alpha} \left( \omega - \frac{1}{\sqrt{LC}} \right).$$

We then obtain

$$E = IR \left\{ \frac{1 - jX}{1 + X^2} \right\}; \quad |E| = \frac{IR}{\sqrt{1 + X^2}};$$

$$\phi = -\tan^{-1} X.$$

The new variable  $X$  allows plotting one general curve for all tuned circuits, which takes the form of the usual resonance curve centered at  $X=0$ , with nominal band width  $BW$  (radians per second) extending from  $X=-1$  to  $X=1$ .  $X$  is therefore a measure of "amount by which the applied frequency differs from the central frequency" divided by "half the band width."

The radio-frequency phase and amplitude curves are plotted against this variable in Fig. 2. For a

<sup>3</sup> Guillemin, "Communication Networks," vol. 1, John Wiley and Sons, New York, (1931).

carrier impressed at the half-amplitude point or  $X = 1.732$ , the corresponding loci of the video-frequency vectors are given in Fig. 3, where  $Z = \omega_m/\alpha$  ( $\omega_m =$  modulation frequency in radians) is the modulation frequency divided by half the band width. Fig. 4 shows the resulting video-frequency phase and amplitude plotted against  $Z$  (curves  $C$ ), also similar curves for the case where the carrier is impressed at  $X = 0.8$  (curves  $B$ ).

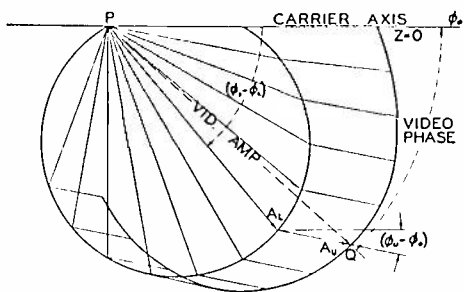

Fig. 3—Loci of video-frequency vectors for a simple tuned circuit, when the carrier is impressed at  $X = 1.732$ .

The transient solution when a carrier is suddenly and asymmetrically applied has been given by Guillemín<sup>3</sup> and is

$$e(t) = IR \left( \cos \omega t - \epsilon^{-\alpha t} \cos \frac{1}{\sqrt{LC}} t \right).$$

This may be represented as a fixed vector plus a vector initially equal and opposite to it and rotating about its terminus at an angular velocity of  $(1/\sqrt{LC} - \omega)$  radians per second, and at the same time dying out exponentially according to the factor  $\epsilon^{-\alpha t}$ . The envelope of the function  $e(t)$ , or output of a linear detector, is given by the length of the vector sum at any time. By geometrical construction this envelope function, or video-frequency transient response is

$$E(t) = IR \sqrt{1 + \epsilon^{-2\alpha t} - 2\epsilon^{-\alpha t} \cos \left( \frac{1}{\sqrt{LC}} - \omega \right) t}.$$

The transient  $e(t)$  is shown in Fig. 5 for carriers suddenly impressed at  $X, 0, 0.8, 1.732$ , curves  $A, B,$

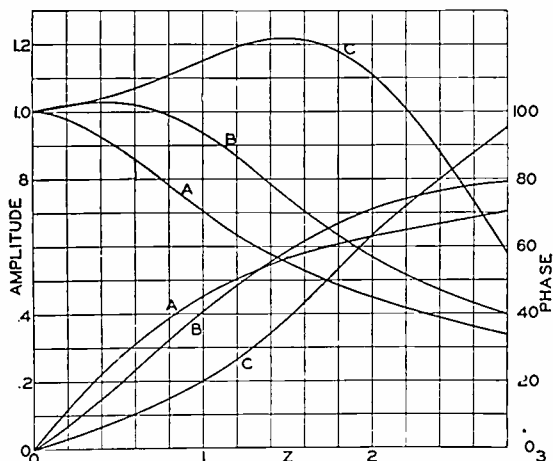

Fig. 4—Video-frequency characteristics of a simple tuned circuit. The carrier is impressed at  $X = 0$  for curves  $A$ , at  $X = 0.8$  for curves  $B$ , and at  $X = 1.732$  for curves  $C$ .

and  $C$ , respectively. These curves are drawn to approach a common final amplitude, although the final

value is actually given by the corresponding point on the resonance curve and is half as large for curve  $C$  as for curve  $A$ .

A more practical comparison with curve  $C$  is given by curve  $D$ , which is curve  $A$  redrawn to the same time scale under the assumption that  $R$  has been reduced to make the gain equal for both curves. Then the initial slopes and final values are identical, and there is little choice between the two curves. On this basis there is little if any advantage in tuning to one side of the carrier when using a single tuned circuit.

It will be seen that the shape of the transient response is reasonable if the carrier is impressed at  $X = 1.732$ , and its initial rate of change corresponds to that of an exponential rise of 0.05 microsecond if  $RC$  is 0.05. The nominal band width is then  $20 \times 10^6$  radians or 3.2 megacycles.

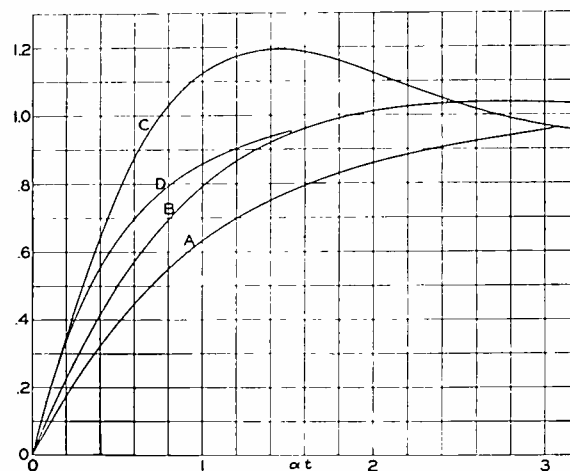

Fig. 5—Video-frequency transient response of a simple tuned circuit. The carrier is suddenly impressed at  $X = 0$  for curve  $A$ , at 0.8 for curve  $B$ , and at 1.732 for curve  $C$ . Curve  $D$  is the same as  $A$  but on a different horizontal scale.

The video-frequency amplitude curve is within the required limits to a 4-megacycle frequency if the nominal band width is 3.2 megacycles and the carrier is impressed at  $X = 1.732$ . The phase delay then varies by 0.03 microsecond up to 4 megacycles. Phase-delay variation exceeds 0.05 microsecond if on the video-frequency phase curve lines are drawn from the origin through points on the useful range of the curve; a vertical line representing a 4-megacycle frequency is drawn; and the intersections of these lines range over more than 72 degrees on the phase axis.

It is interesting to compare the above situation with the case of a carrier impressed at  $X = 0$ . Then the video-frequency amplitude is within the prescribed limits to a 4-megacycle frequency if the nominal band width is  $67 \times 10^6$  radians or 10.6 megacycles. The resulting phase delay then varies by 0.005 microsecond up to 4 megacycles. The gain in a receiver stage is doubled due to the point used on the resonance curve, but also multiplied by 20/67 due to the necessity of reducing  $R$  in order to increase the band width, assuming constant  $C$ . Therefore the net gain

resulting is 1.67 times larger when the carrier is impressed at  $X=1.732$  instead of at resonance, for an equivalent video-frequency band width. This is a very reasonable way to compare the merit of the two points of carrier impression, from a receiver standpoint. The figure of merit depends upon the tolerances chosen, however.

When the carrier is impressed at  $X=0.8$ , a nominal band width of 5.85 megacycles is needed. The resulting phase-delay variation is 0.005 microsecond, and the gain is 1.4 times larger than for the resonance case.

The  $Q$  of the circuit is  $\omega CR = (\omega/BW)$ . For a 50-megacycle carrier and 3.2-megacycle band width,  $Q$  should be 16, which is easily obtained, still more so if the circuit operates at a lower frequency. If however, we had specified that 1/11 of the power loss should occur in the  $LC$  circuit proper and 10/11 in an external load, the  $Q$  of the  $LC$  circuit would have to be 160. This would best be obtained by replacing it with a transmission-line system.

The attenuation of the undesired sideband is not great enough to be of use in transmission systems. The simple tuned circuit has been considered at length only because it occurs so generally in networks.

#### TUNED COUPLED CIRCUITS

Tuned coupled circuits may take a variety of forms, such as those usually found in receiver circuits with parallel  $L$  and  $C$ , or the types often found in filters with series  $L$  and  $C$ . The mutual coupling may be inductive, resistive, or capacitive or a combination of these, but in any case an impedance which does not vary greatly over the pass band. The response for all of these is nearly the same. The type to be dealt with here, because of its similarity to conventional band-pass filters and certain types to be considered later, is a structure shown in Fig. 6. This looks like a conventional band-pass filter except for mutual coupling  $C_M$  instead of a parallel resonant circuit.

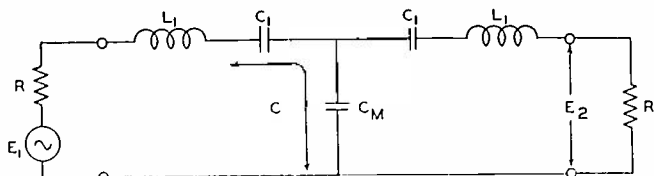

Fig. 6—One form of a tuned-coupled-circuit system.

The steady-state solution for the input to output ratio of this network is

$$\frac{E_2}{E_1} = \left( \frac{j\omega C_M}{R} \right) \left\{ R - j \left[ \left( \frac{1}{C} + \frac{1}{C_M} \right) \frac{1}{\omega} - \omega L \right] \right\} \cdot \left\{ R - j \left[ \left( \frac{1}{C} - \frac{1}{C_M} \right) \frac{1}{\omega} - \omega L \right] \right\}. \quad (1)$$

Again using a notation and method of approximation as used by Guillemin,<sup>3</sup> let

$$\alpha = \frac{R}{2L}; \quad X = \frac{1}{\alpha} \left( \omega - \frac{1}{\sqrt{LC}} \right); \quad y = \frac{\sqrt{LC}}{C_M R}.$$

Substituting, and considering the factor  $j\omega C_M/R$  practically equal to its value at resonance at any

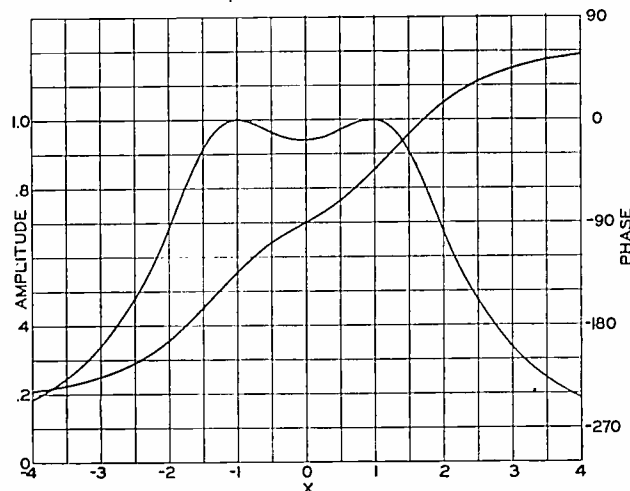

Fig. 7—Radio-frequency characteristics of the tuned-coupled-circuit system of Fig. 6.

frequency near the pass band, this equation becomes

$$\frac{E_2}{E_1} = \frac{\{1 + j(X + y)\} \{1 + j(X - y)\}}{-jy}. \quad (2)$$

Here  $X$  has the same general significance as in the simple tuned circuit, and  $y$  is an additional parameter which depends upon the coupling and determines the shape of the response curve.

$$\frac{E_2}{E_1} = -2 \frac{X}{y} + j \left( \frac{1 - X^2 + y^2}{y} \right) \quad (3)$$

$$\left| \frac{E_2}{E_1} \right| = \frac{y}{\sqrt{\{1 + (X + y)^2\} \{1 + (X - y)^2\}}} \quad (4)$$

$$\phi = -\tan^{-1} \left( \frac{1 - X^2 + y^2}{-2X} \right). \quad (5)$$

We cannot plot one general curve for each function as in the simple tuned circuit, because by choosing various values of  $y$  we get a whole family of general curves.

In order to pick the best value of  $y$  we should plot general curves for several values of  $y$ , and from these find the video-frequency phase and amplitude response when the carrier is impressed at several values of  $X$ . It will merely be assumed here that 1.414 is near enough to the ideal value of  $y$ , for a single-stage arrangement. Then

$$\left| \frac{E_2}{E_1} \right| = \frac{\sqrt{2}}{\sqrt{X^4 - 2X^2 + 9}} \quad (6)$$

$$\phi = -\tan^{-1} \left( \frac{3 - X^2}{-2X} \right). \quad (7)$$

This gives the radio-frequency phase and amplitude responses shown in Fig. 7. (Leading angles are

considered negative.) The vector loci patterns of Figs. 8 and 9 are used in deriving the video-frequency phase and amplitude curves plotted against  $Z$  and shown in Figs. 10 and 11. The point of carrier impression is  $X=2$  and  $X=2.42$ , respectively, and  $Z=\omega_m/\alpha$ , where  $\omega_m$  is the modulation frequency in radians.

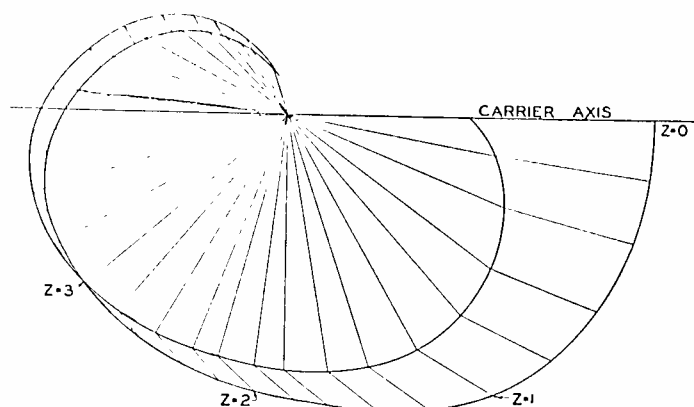

Fig. 8—Loci of video-frequency vectors for a tuned coupled circuit, when the carrier is impressed at  $X=2$ .

The parameter  $X$  is not particularly suitable in this case as a measure of "amount by which the applied frequency differs from the central frequency" divided by "half the band width," because the band width varies with  $\gamma$ . The parameter  $X/Y$  would more nearly correspond to this definition. However,  $X$  is used here for convenience in the mathematical work, the only difference being in the scale of the curves.

Fig. 10 shows that the video-frequency amplitude requirements are met up to modulation frequency  $Z=1.65$  when the carrier is impressed at  $X=2$ . To have this correspond to a required limit of 4 megacycles,  $Z=2\pi \times 4 \times 10^6/\alpha$ , or  $\alpha$  must be  $15.2 \times 10^6$ . The nominal band width  $2\gamma\alpha$  is then  $43 \times 10^6$  radians or 6.9 megacycles. The scales for  $X$  and  $Z$  may be converted to frequency scales in radians by multiplying by  $\alpha$ . The phase delay varies over a range of 0.01 microsecond up to  $Z$  of 1.65.

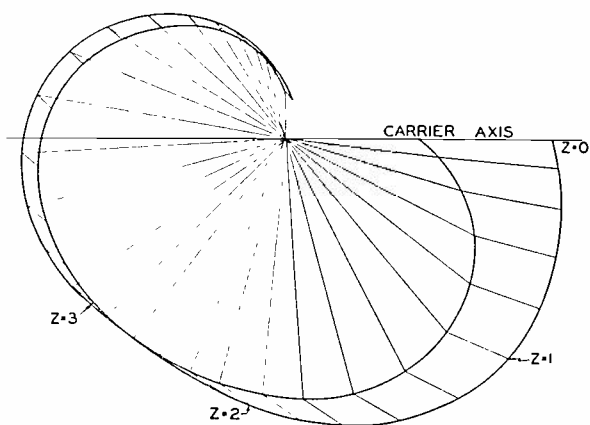

Fig. 9—Loci of video-frequency vectors for a tuned coupled circuit, when the carrier is impressed at  $X=2.42$ .

For the case where the carrier is impressed at the mid-band, the video-frequency curves are the same as one side of the radio-frequency curves of Fig. 7. Amplitude requirements are met up to  $Z$  of 1.75. The

nominal band width should then be 6.5 megacycles. Phase delay varies over a range of 0.02 microsecond up to  $Z$  of 1.75.

For the case when the carrier is impressed at  $X$  of 2.42, the video-frequency amplitude curve of Fig. 11 meets requirements up to  $Z$  of 4.0. The nominal band width should be  $18 \times 10^6$  radians or 2.8 megacycles. Phase delay varies over a range of 0.05 microsecond up to  $Z$  of 4.0. This is still acceptable.

The gain in a single stage for the three cases above will be inversely proportional to the required band width and directly to the amplitude given by the curve of Fig. 7. Considering the gain as 1.0 for the case of the carrier at mid-band, it becomes 0.69 for

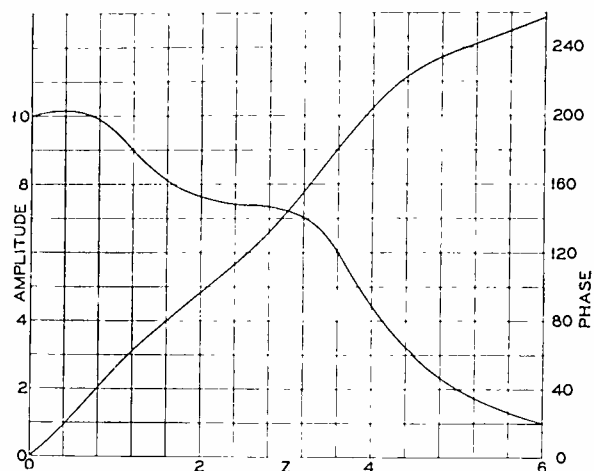

Fig. 10—Video-frequency characteristics of a tuned coupled circuit, when the carrier is impressed at  $X=2$ .

carrier impression at  $X$  of 2, and 1.23 for carrier impression at  $X$  of 2.42. (The poor showing of the second case is due to the shape of the amplitude curve of Fig. 10, which barely misses coming within the allowable limits up to a much higher frequency.) Tuning to one side of the pass band is therefore a 23 per cent improvement from the gain standpoint.

From the standpoint of reduction of noise external to a receiver, this is actually detrimental. Comparing the cases of carrier impression at mid-band and at  $X$  of 2.42, the band width may be reduced in the latter case by the ratio of 2.31:1. The noise voltage for

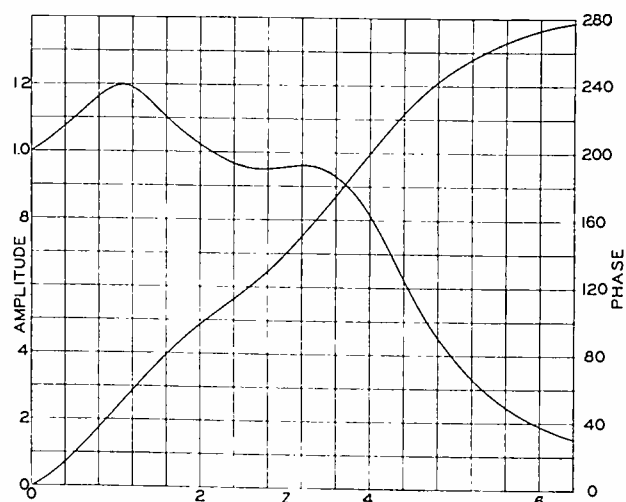

Fig. 11—Video-frequency characteristics of a tuned coupled circuit, when the carrier is impressed at  $X=2.42$ .

constant mid-band gain varies as the square root of the band width; but the mid-band gain is increased inversely to the band width; therefore the noise voltage is greater by the square root of 2.31 or 1.52. But the signal level was improved by a factor of only 1.23, so that the signal-to-noise ratio drops to 81 per cent of its value for the mid-band case.

Noise voltage developed internally in the input tuned circuit of the receiver should not change in the two cases, so that tuning to one side would be of advantage here. But this case is not of much consequence because the input circuit is usually broadly tuned, and moreover the noise contributed from this source is usually a minor item in television reception.

To sum up the receiver situation, it seems that the improvement resulting from tuning to one side of the pass band is not very great when all factors are considered.

The power losses in a tuned coupled circuit are of the same general magnitude as for a single tuned circuit, and as in that case the constants required can be obtained with conventional circuit elements, but the resistive components of those elements constitute a large part of the total circuit resistance, so that transmission lines or other low-loss elements should be used if the application is in a transmitter.

The transient response of tuned coupled circuits when a carrier is suddenly impressed may be found by the following method: Substitute  $\lambda$  for  $j\omega$  in (1) and set the left-hand side of the equation equal to zero. Then

$$0 = \left( \frac{\lambda C_M}{R} \right) \left\{ R + \left( \frac{1}{C} + \frac{1}{C_M} \right) \frac{1}{\lambda} + L\lambda \right\} \cdot \left\{ R + \left( \frac{1}{C} - \frac{1}{C_M} \right) \frac{1}{\lambda} + L\lambda \right\}. \quad (8)$$

There are five roots of this equation. The first,  $\lambda_0 = 0$ , is of no consequence and means merely that a voltage may exist permanently in the output due to the condenser coupling network. The other four determine the force-free behavior of the system. These are

$$\lambda_{1,2,3,4} = -\frac{R}{2L} \pm \frac{j}{2} \sqrt{\frac{4}{L} \left( \frac{1}{C} \pm \frac{1}{C_M} \right) - \frac{R^2}{L^2}}.$$

This becomes simpler if the following substitutions are made:

$$\alpha = \frac{R}{2L}; \quad \omega_0 = \frac{1}{\sqrt{LC}}; \quad k = \frac{C}{C_M}$$

$$\lambda_{1,2,3,4} = [-\alpha \pm j\sqrt{\omega_0^2(1 \pm k) - \alpha^2}] \cong \left[ -\alpha \pm j\omega_0 \left( \sqrt{1 - \frac{\alpha^2}{\omega_0^2}} \pm \frac{k}{2} \right) \right]. \quad (9)$$

It is worth noting that the approximate expression (2) cannot be used to find the roots, as it leads to only two solutions. In fact, no perfectly symmetrical

response curves can be used to derive the roots for the transient solution inasmuch as the symmetry is the result of an approximation which loses some of the roots. This is a curious situation because the video-frequency phase and amplitude curves can be derived accurately enough from such curves and they should therefore contain the information necessary for the video-frequency transient solution. The translation from video-frequency phase and amplitude curves to the video-frequency transient is possible by Fourier-integral methods.<sup>4,5</sup> The integral expression for the transient is not difficult to set up, but very difficult to evaluate.

From (9) the complete transient may be found by using Carson's form of the Heaviside expansion theorem for suddenly impressed voltage  $E\epsilon^{j\omega t}$ .

$$E_2(t) = \frac{E\epsilon^{j\omega t}}{Z(j\omega_i)} + \sum_{k=1}^{k=4} \frac{E\epsilon^{\lambda_k t}}{(j\omega_i - \lambda_k)Z'(\lambda_k)} \quad (10)$$

$$Z(\lambda) = \left( \frac{\lambda C_M}{R} \right) \left\{ R + \left( \frac{1}{C} + \frac{1}{C_M} \right) \frac{1}{\lambda} + L\lambda \right\} \cdot \left\{ R + \left( \frac{1}{C} - \frac{1}{C_M} \right) \frac{1}{\lambda} + L\lambda \right\}.$$

Or if preferred the coefficients of the terms may be found from initial conditions in the network.

The complete solution is too laborious to be attempted here. However, from (8) and (9) the general nature of the transient can be appreciated even though not worked out in detail. The response is of the form

$$\frac{E\epsilon^{j\omega t}}{Z(j\omega_i)} + E\epsilon^{-\alpha t} \left\{ a\epsilon^{j[\sqrt{\omega_0^2 - \alpha^2} + (k/2)\omega_0]t} + b\epsilon^{-j[\sqrt{\omega_0^2 - \alpha^2} + (k/2)\omega_0]t} + c\epsilon^{j[\sqrt{\omega_0^2 - \alpha^2} - (k/2)\omega_0]t} + d\epsilon^{-j[\sqrt{\omega_0^2 - \alpha^2} - (k/2)\omega_0]t} \right\} \quad (11)$$

which is the steady-state carrier plus frequencies at each edge of the pass band damped by a time constant  $1/\alpha$ . ( $k\omega_0$  is proportional to the band width, and equals  $2y\alpha$ .) The demodulated output will contain beat frequencies between the carrier and each band edge, and between the two edge frequencies, damped with a time constant  $1/\alpha$ .

To supply a numerical case, if  $y$  is 1.414, the carrier is impressed at  $X$  of 2.42, and if  $\alpha = 6.2 \times 10^6$ , then  $k\omega_0/2\pi$  is 2.8 megacycles, and the carrier differs from resonance by  $\alpha X/2\pi$  cycles or 2.4 megacycles. The beat frequencies present in the video-frequency transient output will then be 2.8, (2.4 - 1.4), and (2.4 + 1.4) megacycles or 1.0, 2.8, and 3.8 megacycles, damped with a time constant  $1/\alpha$  or 0.16 microsecond. The resultant effect is rather complicated, but it would seem that the slope halfway up the edge of the transient would be somewhat better than

<sup>4</sup> Bush, "Operational Circuit Analysis," p. 180, John Wiley and Sons, New York, N. Y., (1929).

<sup>5</sup> Guillemin, "Communication Networks," vol. II, John Wiley and Sons, New York, N. Y., (1935).

for a 0.16-microsecond time constant, and that the transient will overshoot its final value, but not by a large amount because of rapid damping.

SINGLE AND COUPLED TUNED CIRCUITS IN CASCADE

Loh<sup>6</sup> has shown that the amplitude response of tuned coupled circuits may be made much flatter with little loss in band width by using in cascade a single

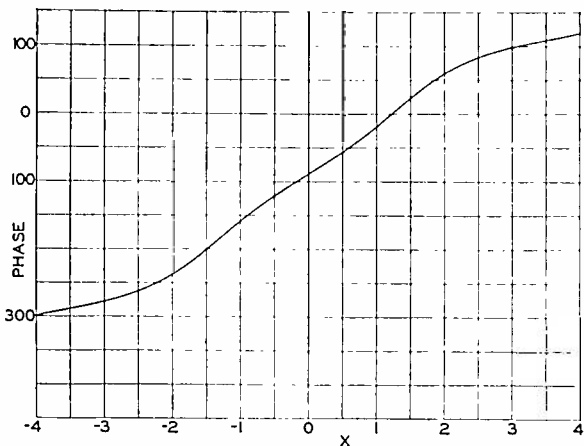

Fig. 12—Radio-frequency phase characteristic of a simple tuned circuit and a tuned coupled circuit in cascade.

tuned circuit. Where the two coupled circuits are identical, the  $Q$  of the single circuit should be half the  $Q$  of the coupled circuits. His chosen condition that  $\omega M/\sqrt{R_1 R_2} = 3$  corresponds in the circuit just discussed to the condition that  $y$  should equal 3.

An important matter is the phase characteristic of the over-all system. Rather than solve for the case  $y = 3$ , we shall consider here the previous case of  $y$  equal to 1.414, when to the radio-frequency phase characteristic given in Fig. 7 we add the phase characteristic of a single tuned circuit given in Fig. 2, but made twice as broad to correspond to the  $Q$  ratio desired. The over-all radio-frequency phase characteristic is given in Fig. 12, and is seen to be appreciably flatter than either of the individual phase characteristics. Since the curve shape is flatter than necessary when  $y$  is 1.414, it is likely that when  $y$  equals 3 the linearity will still be sufficiently good and a wider band width will be obtained.

This kind of curve correction should find considerable use, particularly in receivers.

FILTERS USING TRANSMISSION LINES AS CIRCUIT ELEMENTS

Mason and Sykes<sup>2</sup> have given design data on a number of interesting filters and transformers containing transmission lines as elements. One in particular is very similar in its action to tuned coupled circuits, and is shown in Fig. 13. The equations given for input and output voltages and currents are in the form

<sup>6</sup> Ho-Shou Loh, "Single and coupled circuits having constant response band characteristics," PROC. I.R.E., vol. 26, pp. 469-474; April, (1938).

$$e_0 = A e_1 - j B i_1$$

$$i_0 = C i_1 - j D e_1$$

$$e_0 = R i_0$$

where, in the case  $Z_{01} = 2Z_{02}$ ,  $v = 1/\sqrt{LC}$ ,  $Z_0 = \sqrt{L/C}$ ,

$$A = \left[ \begin{array}{cc} \cos \frac{2\omega l_1}{v} + \frac{\sin \frac{2\omega l_1}{v}}{v} & \frac{\sin \frac{2\omega l_1}{v}}{v} \\ \sin \frac{2\omega l_1}{v} & \tan \frac{\omega l_2}{v} \end{array} \right]$$

$$B = Z_{01} \left[ \begin{array}{cc} \sin \frac{2\omega l_1}{v} + 2 \frac{\sin^2 \frac{\omega l_1}{v}}{v} & \frac{\sin^2 \frac{\omega l_1}{v}}{v} \\ \sin \frac{2\omega l_1}{v} & \tan \frac{\omega l_2}{v} \end{array} \right]$$

$$C = A$$

$$D = \frac{1}{Z_{01}} \left[ \begin{array}{cc} \sin \frac{2\omega l_1}{v} - 2 \frac{\cos^2 \frac{\omega l_1}{v}}{v} & \frac{\cos^2 \frac{\omega l_1}{v}}{v} \\ \sin \frac{2\omega l_1}{v} & \tan \frac{\omega l_2}{v} \end{array} \right]$$

Characteristic impedance

$$K = Z_{01} \sqrt{-\{\tan(\omega l_1/v)\} \tan[\omega(l_1 + l_2)/v]}$$

At the mid-band frequency, for narrow bands,  $K$  is approximately equal to  $Z_{01} \times 4l_1/\pi l_2$ . The frequency limits of the first pass band are

$$f_1 = \frac{v}{4(l_1 + l_2)}; \quad f_2 = \frac{v}{4l_1}$$

and the mid-band frequency is  $f_m = v/(4l_1 + 2l_2)$ . Solving for  $e_s/e_0$ ,

$$\frac{e_s}{e_0} = \left( \frac{C + A}{AC + BD} \right) + j \left( \frac{B + R^2 D}{R[AC + BD]} \right)$$

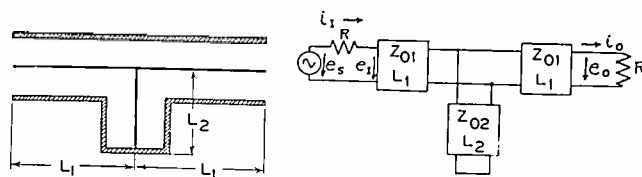

Fig. 13—A band-pass filter using transmission lines as circuit elements.

Substituting, letting  $\tan(\omega l_2/v) = m$ , and simplifying,

$$\frac{e_s}{e_0} = 2 \left[ \cos \frac{2\omega l_1}{v} + \frac{1}{m} \sin \frac{2\omega l_1}{v} \right] + j \left[ \left( \frac{Z_{01}}{R} + \frac{R}{Z_{01}} \right) \left( \sin \frac{2\omega l_1}{v} - \frac{1}{m} \cos \frac{2\omega l_1}{v} \right) + \left( \frac{Z_{01}}{R} - \frac{R}{Z_{01}} \right) \frac{1}{m} \right]$$



Narrow band width is obtained when  $l_2$  is small; for this case

$$m \cong \omega l_2/v \cong 2\pi f_2 l_2/v \cong (\pi l_2/2l_1).$$

Let  $y = R/K$ , so that  $R/Z_{01} = 2y/m$ .

Let  $q = (1/m)[(2\omega l_1/v) + m - \pi]$

so that

$$(2\omega l_1/v) = (\pi + mq - m).$$

This substitution will make  $q=0$  correspond to frequency  $f_m$ ,  $q=1$  to  $f_2$ , and  $q=-1$  to  $f_1$ . The shape factor  $y$  modifies the shape of the resulting curves according to the degree of impedance match.

$$\frac{c_s}{c_0} = 2 \left[ -\cos(mq - m) - \frac{1}{m} \sin(mq - m) \right] + j \left[ \left( \frac{m}{2y} + \frac{2y}{m} \right) \left\{ -\sin(mq - m) + \frac{1}{m} \cos(mq - m) \right\} + \frac{1}{m} \left( \frac{m}{2y} - \frac{2y}{m} \right) \right].$$

By series expansion of the terms, neglecting all terms with a positive power of  $m$  on the assumption that the band width is small,

$$\frac{c_s}{c_0} \cong -2q + j \left( \left[ \frac{1 + y^2}{y} \right] - yq^2 \right).$$

Now introduce the new variable  $X = qy$ . Then

$$\frac{c_s}{c_0} \cong -2 \frac{X}{y} + j \left( \frac{1 - X^2 + y^2}{y} \right). \quad (12)$$

This is identical to (3) for the tuned coupled circuit. Therefore the radio- and video-frequency characteristics and transient response for the tuned coupled circuit also apply to this type of transmission-line filter. Table I showing equivalent

TABLE I  
TABLE OF EQUIVALENT QUANTITIES

In General Terminology	In Tuned-Coupled-Circuit Terminology		In Transmission-Line Filter Terminology	Definition
	Mutual Coupling $M$	Mutual Coupling $C_m$		
$\omega_0$	$\frac{1}{\sqrt{LC}}$	$\frac{1}{\sqrt{LC}}$	$\frac{2\pi v}{4l_1 + 2l_2}$	Mid-band frequency radians per second
$BW = k\omega_0 = 2y\alpha$	$\frac{M}{L\omega_0}$	$\frac{C}{C_m\omega_0}$	$\frac{l_2}{l_1\omega_0}$	Nominal band width radians per second
$R$	$R$	$R$	$R$	Terminal resistance
$y$	$\frac{\omega_0 M}{R}$	$\frac{1}{R\omega_0 C_m}$	$\frac{\pi l_2 R}{4l_1 Z_{01}} = \frac{R}{K}$	Shape factor
$\alpha$	$\frac{R}{2L}$	$\frac{R}{2L}$	$\frac{2\omega_0 Z_{01}}{\pi R}$	Damping factor
$k$	$\frac{M}{L}$	$\frac{C}{C_m}$	$\frac{l_2}{l_1}$	Coupling coefficient
$X$	$X$	$X$	$X$	Frequency parameter $(\omega - \omega_0)/\alpha$
$q$	$q$	$q$	$q$	Alternative frequency parameter $X/y$
$\lambda_0$			$4l_1 + 2l_2$	Wavelength on line for $\omega_0$

quantities will help in making translations from one system to the other. Guillemin<sup>7</sup> gives some interesting data on tuned coupled circuits as band-pass filters which is related to the present subject matter.

It should be noticed that the parameter  $q$  is really more suitable than  $X$ , since from the manner in which it was formulated it expresses "amount applied frequency differs from resonance" divided by "half the band width." Band width  $BW$  extends from  $q$  of  $-1$  to  $q$  of  $1$ .

In regard to physical realizability of the transmission-line structures, the characteristic impedances required in the elements are quite reasonable for terminal impedances ranging upward from 300 ohms, and the losses should be small. Further design data will be given later.

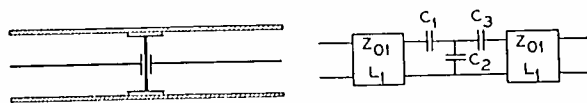

Fig. 14—A band-pass filter using transmission lines and condensers as circuit elements.

Mason and Sykes<sup>2</sup> have also shown another filter structure that should be applicable in television circuits. This has low losses, and the characteristic impedances of the transmission-line elements are reasonable if the terminations are of low impedance. With wide-band transformers, also shown by the same authors, many other terminal-resistance magnitudes are made possible for this and the preceding structure. Fig. 14 shows the second arrangement. The performance of this structure will not be worked out here, but is believed to be similar to that of the previous structure or tuned coupled circuits, because its mutual coupling is in the form of a small impedance which does not vary appreciably over the pass band, which is also the case in the other structures; and its resonant circuits lie between lumped constant circuits as in tuned coupled circuits, and purely distributed constant circuits as in the previous transmission-line filter.

## LATTICE FILTERS

Lattice filter structures, unlike ladder structures, permit the propagation function and characteristic impedance to be treated independently. The phase characteristic may be made more nearly linear in the pass band by using a method of design given by Bode.<sup>8,9</sup> The phase characteristic is far from linear at the edge of the pass band, which introduces serious difficulty if the carrier frequency is located there as in single-sideband applications.

The filter structure is also more complicated, one of the simplest arrangements for band pass being

<sup>7</sup> See pages 372-375 of footnote reference 5.

<sup>8</sup> H. W. Bode, U.S. Patent, No. 1,825,454, October 20, 1931.

<sup>9</sup> H. W. Bode, "A general theory of electric wave filter," *Jour. Math. and Phys.*, vol. 13, pp. 275-362; November, (1934).

given in Fig. 15. Pairs of elements resonant near the carrier frequency are involved, while one element of each pair has a value typical of a low-pass filter of the same band width. (This is true of most band-pass filters in general.) This leads to values that are impractical with lumped constant circuits for a 4-megacycle band width at 50 megacycles. Lattice structures are too complicated to permit easy use of

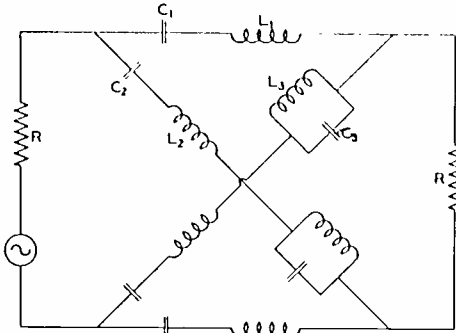

Fig. 15—Simple form of a lattice band-pass filter.

transmission lines as circuit elements. For these reasons they were considered unsuitable for the present application.

#### IMPROVEMENT OF FILTER PERFORMANCE

The performance of a single-section filter may not be sufficiently good in regard to its phase or amplitude characteristics, or attenuation of the undesired sideband.

A simple method of improvement is to add more sections of the same type of structure. The attenuation of the undesired sideband is of course greater. The slope of the amplitude characteristic becomes greater, so that the carrier must be impressed somewhat closer to the edge of the band in order to fall near the half-amplitude point for the over-all system. This requires designing the structure for a slightly greater nominal band width in order to pass the same video-frequency band.

The phase and amplitude characteristics of each section approach the ideal characteristics that one of an infinite series of such structures would have. The ideal characteristics of a band-pass filter (including tuned coupled circuits and transmission-line filters) are unfortunately not well suited for single-sideband applications. The radio-frequency amplitude characteristic results in a tolerable video-frequency curve, but the radio-frequency phase characteristic has a sudden change in slope at each edge of the pass band, which results in a very poor video-frequency phase curve.

There are no artifices by which a given number of independent reactive elements can be rearranged or revalued in a simple filter section to improve the steepness of cutoff, and still retain their original functions. A finite number of reactive elements can give only a finite order of polynomials in an expression such as (6) determining the response shape.

The same conclusion is reached by arguing backwards from Foster's reactance theorem<sup>10</sup> as applied to a four-terminal network.

The most promising method of improving the attenuation of the undesired sideband is to add band-elimination filters. These have a nonlinear phase characteristic near each edge of the band-elimination region, but if the band eliminated is removed a reasonable distance to one side of the pass-band region of the main filter, its phase characteristic will be nearly linear in the pass region of the latter. Moreover, the linearity in that region becomes better the smaller the elimination band is made. By using a series of band-elimination filters, each very narrow, and eliminating successive bands in the undesired spectrum, the over-all phase characteristic will be quite satisfactory in the pass region of the main filter. Narrow band-elimination filters require very high  $Q$  circuits, so that transmission-line elements would be necessary.

A band-pass filter may be converted into a band-elimination filter by interchanging its shunt and series branches. When this method is applied to the filter structures given by Mason and Sykes<sup>2</sup> the resulting structures are not very useful or convenient. More work needs to be done in this field.

#### DESIGN DATA FOR BAND-PASS FILTERS USING TRANSMISSION LINES

The design data given by Mason and Sykes for the structure of Fig. 13 is given here in somewhat different form. A more detailed sketch of the structure is given in Fig. 16. The data normally given is

$R$  = terminal resistance

$y$  = shape factor for response curves

$\lambda_0$  = wavelength along transmission line corresponding to the mid-band frequency

$(BW/\omega_0)$  = nominal band width divided by the mid-band frequency in the same units.

The nominal band width for any specific case can be obtained from the video-frequency response curves, such as those of Fig. 11. If these meet all

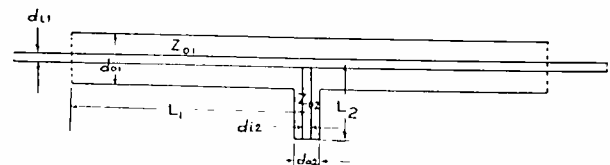

Fig. 16—Band-pass filter of Fig. 13 in more detail.

requirements up to an upper limit of  $Z_0$ , whereas the nominal band-width limit corresponds to  $Z = 2y$  (for single-sideband use), the nominal band width  $BW$  needed will be  $2y/Z_0 \times$  maximum modulation frequency needed. For example, in Fig. 11,  $Z_0$  is 4.05 for the tolerances given earlier in this article, and  $2y$

<sup>10</sup> See p. 216 of footnote reference 5.

is 2.828; therefore for a maximum video frequency of 4 megacycles,  $BW$  required is 2.8 megacycles for a single-stage arrangement.

The design figures are then as follows:

$$L_1 = \frac{\lambda_0}{4 + 2 \left( \frac{BW}{\omega_0} \right)}$$

$$L_2 = L_1 \times \left( \frac{BW}{\omega_0} \right)$$

$$Z_{01} = \frac{\pi}{4} \times \frac{R}{y} \times \left( \frac{BW}{\omega_0} \right)$$

$$Z_{02} = \frac{Z_{01}}{2}$$

$$\frac{d_{01}}{d_{i1}} = \log_{10}^{-1} \frac{Z_{01}}{138.5}$$

$$\frac{d_{02}}{d_{i2}} = \log_{10}^{-1} \frac{Z_{01}}{277}$$

The magnitude of the diameters will be fixed by the power to be handled, and will be considerably larger than for a coaxial line under matched impedance conditions.

The most effective tuning means is to adjust  $L_1$ , but if this is impractical it may be done by making  $L_1$  a bit too short and shunting an equivalent variable condenser across the terminals. The shunt stub need not be tuned as it merely determines the band width. For the same reason its surge impedance is not critical.

From Fig. 7, the attenuation 1 megacycle to the side of the carrier will be only 6 decibels. Methods of improving this situation have been discussed. A series of narrow-band elimination filters is recommended. An alternative is to add more band-pass sections, with  $BW$  approaching the top video frequency and  $y$  approaching unity rather than the values given for the single-section case. The over-all response is not easy to calculate for an extended chain of this sort, but becomes rather poor as the idealized band-pass phase characteristic is approached.

The reader is referred to the article by Mason and Sykes<sup>2</sup> for variations in this type of filter to match different impedances on the two ends, for wide-band transformers, and for other types of filters using transmission lines.

#### PROBLEMS IN APPLYING A SINGLE-SIDEBAND FILTER TO A TELEVISION TRANSMITTER

In this discussion it has so far been assumed that the single-sideband filter is to be located somewhere between the final stage of the transmitter and the antenna, and therefore will operate at the carrier frequency.

Another method which greatly simplifies filter design and permits use of normal circuit elements is to

operate the filter at an intermediate frequency and obtain the final carrier frequency with one side band by impressing both the filtered output and a local high-frequency source on a frequency converter. This frequency converter may itself act as the final stage, or its output may be amplified by class B stages. This system is very convenient but has several disadvantages. The efficiency in the final stage is low; and there is danger of reinjecting to some extent the undesired sideband if at any point a circuit is encountered in which the output-versus-the-input characteristic has an appreciable third-power term. There is also the problem of eliminating from the output the frequency of the local high-frequency source, which differs from the carrier by the amount of the intermediate frequency.

Inserting the single-sideband filter between the final stage and the antenna overcomes these difficulties, but restricts the form which the filter may take, and also may have a harmful effect on the efficiency of the final stage. An exact analysis of this effect is very complicated. If the final stage is class C and plate-modulated (which is rarely the case in television practice) the analysis would involve obtaining, for any particular modulation frequency and amplitude, the radio-frequency phase and amplitude of the voltage on the plate circuit for each point on the modulation cycle, determining the resulting tube dissipation and output, and averaging these over the modulation cycle.

Systems using modulator tubes in conjunction with transmission lines to furnish a varying radio-frequency impedance and so modulating the output of a high-efficiency stage have recently become of importance. A single-sideband filter in conjunction with these offers good possibilities, but a mathematical treatment would become very involved.

In order to form a rough idea of the effect of a filter upon the final stage, let us investigate the input impedance of the transmission-line filter of Fig. 13. Going back to the original equations for the currents and voltages, and solving for  $e_I/i_I$  we find

$$Z_I = \frac{e_I}{i_I} = \frac{R(AC + BD)}{A^2 + R^2D^2} + j \left( \frac{AB - R^2CD}{A^2 + R^2D^2} \right).$$

Taking the same case as before and making the same substitutions this can eventually be simplified to

$$\frac{Z_I}{R} = \frac{y^2 - jX(X^2 + 1 - y^2)}{X^2 + (X^2 - y^2)^2}. \quad (13)$$

This incidentally is the inverse of the same quantity for a series-resonant tuned-coupled-circuit filter. When  $y$  is 1.414, (13) becomes

$$\frac{Z_I}{R} = \left( \frac{2 - jX(X^2 - 1)}{X^4 - 3X^2 + 4} \right)$$

$$\left| \frac{Z_I}{R} \right| = \left( \frac{\sqrt{X^6 - 2X^4 + X^2 + 4}}{X^4 - 3X^2 + 4} \right).$$

The efficiency of a class A amplifier operating at maximum output in each case based on the same argument as used by Morecroft<sup>11</sup> is approximately given by

$$\text{eff.} = (X^6 - 2X^4 + X^2 + 4)^{-1/2}.$$

This incidentally is the same as for a series-resonant tuned-coupled-circuit filter even though its input impedance is the inverse of the filter now under discussion.

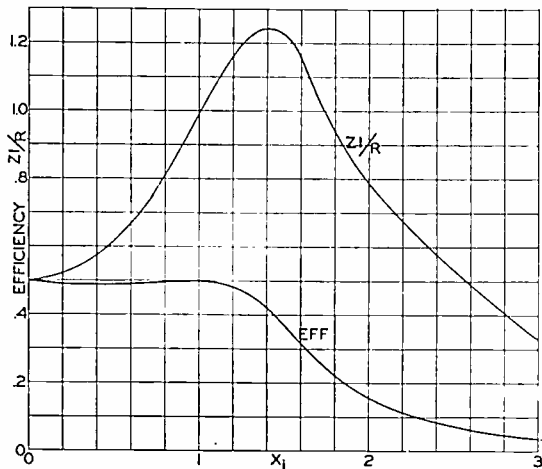

Fig. 17—Input impedance of the circuit of Fig. 13, and efficiency of the circuits of Figs. 13 and 6 when used as the output load of a class A amplifier, as a function of the point of carrier impression.

Fig. 17 shows the scalar value of input impedance and the efficiency is given above as a function of  $X$  (the point at which the carrier is impressed on the response curve). The severe drop in efficiency at for example the half-amplitude point where  $X$  is 2.42 is largely due to the large phase angle of the impedance. This causes the amplifier input, which is proportional to the volt-ampere product at the filter input, to become large compared to the power delivered to the filter input.

These efficiency values of course are not applicable to the more commonly used types of output stages, and have been given merely to emphasize that when the carrier frequency is to one side of the pass band of a filter, the reactive component resulting will cause serious difficulty. This would be particularly true of a class C amplifier, where high efficiency can only be obtained with a resistive load. There is some possibility that with a multisection filter the input reactance can be canceled without upsetting too much of the filter system.

Another difficulty lies in finding a suitable compromise between making the filter-input impedance that value which gives maximum efficiency for the final stage, and making the equivalent internal resistance of the final stage that value which is required for the filter-input termination.

When applying a filter to the transmission-line

<sup>11</sup> John H. Morecroft, "Principles of Radio Communication," second edition, pp. 551-553, John Wiley and Sons, New York, N. Y., (1927).

modulator systems, it is probable that some of these difficulties can be reduced by inserting a corrective network between the final stage and the point where the modulation is introduced. Undesirable reactions upon the modulator system are still probable.

In view of these difficulties, it would appear that the use of a filter at an intermediate frequency and an output stage acting as a frequency converter with or without class B amplification is not unreasonably inefficient. There is then more freedom in filter design. The filter may take the form of cascaded vacuum-tube amplifier stages using single and coupled tuned circuits, sufficiently great in number to give the desired attenuation, and the phase characteristic will be much more nearly linear than for a many-section filter without vacuum-tube isolation between stages. The disadvantages of such a system have already been discussed and may not prove too serious.

#### GAIN IN AMPLIFIER STAGES

The circuits to be compared are the radio- or intermediate-frequency amplifiers (A) and (B), and the video-frequency amplifiers (C) and (D) of Fig. 18.

In each case it will be assumed that the input current  $I$  is of fixed magnitude, equal to  $e_0 S_m$ , and that  $C_0$  is also fixed and equal to the input and output tube capacitance plus minimum stray capacitance obtainable. The gain will then be found for each circuit when the values are arranged so that video-frequency phase and amplitude requirements are met up to a fixed video frequency  $\omega_0$ . The figure of merit for each case will be of the form  $|E/I|(C_0\omega_0)$ . Gain per stage will be this figure of merit multiplied by  $S_m/C_0\omega_0$ .

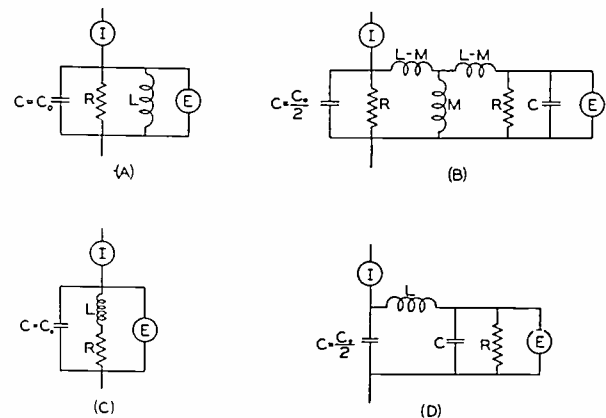

Fig. 18

- (A) Simple tuned circuit.
- (B) Tuned coupled circuit.
- (C) Compensated video-frequency amplifier.
- (D) One form of split video-frequency amplifier.

The figure of merit for cases (A) and (B) will be compared for several points of impression of the carrier with respect to the radio-frequency response curve.

At this point the objection might well be raised that the figure of merit will be dependent upon the tolerances chosen, which were arbitrary; and upon

the number of stages between the pickup device and reproducing device, since the shape of curve needed and the range usable on it for each stage will vary with the number of stages. The first difficulty is not too serious as a change in the tolerances will affect all figures of merit in more or less the same way, without greatly changing the comparative figures.

The second objection is of importance. The design of individual stages is conditioned by the number of stages in the over-all system, so that one cannot lay down fixed rules for design. However, the design for typical cases may still be a very useful guide. In order to overcome this difficulty partially, the figures of merit will be obtained for one stage (rather unlikely in practice!) and for ten stages.

The single tuned circuit (A) has already been discussed. It meets video-frequency requirements for a carrier impressed at  $X=0$  (mid-band) to a video frequency  $Z=0.75$ . But  $Z=2CR\omega_m$ , therefore the value of  $R$  meeting requirements is  $0.75/2C_0\omega_0$ . At mid-band,  $|E/I|=R$ ; therefore, the figure of merit is  $|E/I|C_0\omega_0=0.375$ . For single-side-band use, if the carrier is impressed at  $X=1.732$ , it was pointed out earlier that the gain is improved 1.67 times, so the figure of merit becomes 0.625 in this case.

Ten stages using single tuned circuits have an overall radio-frequency response shown in Fig. 19, from which the video-frequency curves of Fig. 20 may be obtained for a carrier impressed at  $X=0.4$  (half-amplitude point). The video-frequency response for a carrier impressed at resonance is identical to half of the radio-frequency response curve. The curve for

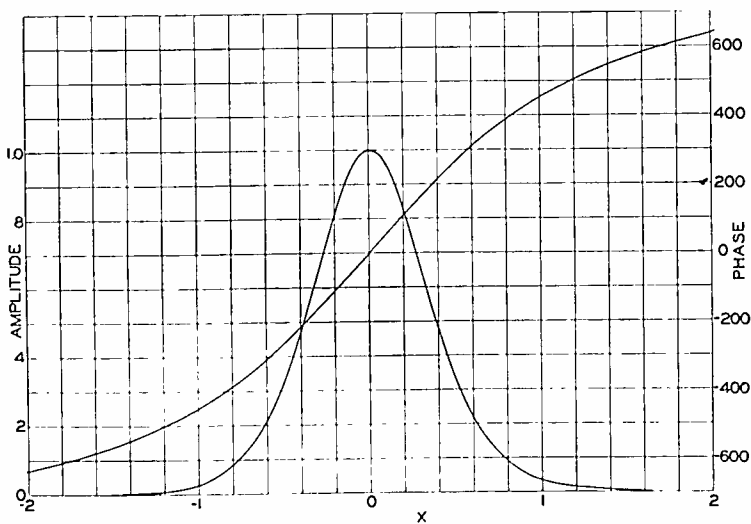

Fig. 19—Radio-frequency characteristics of ten stages using single tuned circuits.

$X=0$  meets requirements to  $Z=0.21$  and the figure of merit is 0.105. For  $X=0.4$  requirements are met up to  $Z=0.63$  and taking into account the point where the carrier falls on the response curve, the figure of merit is  $0.315 \times 0.925$  or 0.291.

It is important to emphasize that the video-frequency response curves for ten stages are not those for one stage multiplied by ten. The entire derivation must be repeated whenever anything is

done that changes the radio-frequency curve shapes.

The derivation of video-frequency curves from radio-frequency ones may be greatly simplified in cases where the phase characteristic is practically linear over a range of frequencies to each side of the carrier broad enough to cover the point where one sideband becomes negligible. Then, approximately, the video-frequency amplitude is the arithmetical sum of the two sidebands, and the video-frequency phase angle, the phase of the main sideband less

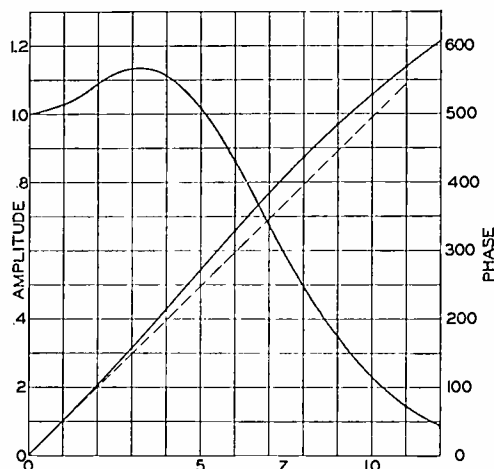

Fig. 20—Video-frequency characteristics of ten stages using single tuned circuits, when the carrier is impressed at  $X=0.4$ .

that of the carrier. This approximation applies to many multistage arrangements.

For the tuned coupled circuit (B) of Fig. 18

$$|E| = \frac{yIR}{\sqrt{\{1 + (X + y)^2\} \{1 + (X - y)^2\}}}$$

where  $y = \omega_0 MCR/L$

$$X = (\omega - \omega_0)/\alpha$$

$$\alpha = 1/2CR.$$

For the one-stage case, and for  $y=1.414$ , and for a carrier impressed at mid-band, video-frequency requirements are met to  $Z=1.75$ . But  $Z=2CR\omega_m = C_0R\omega_m$ , therefore  $R=1.75/C_0\omega_0$ . At mid-band,  $|E/I|=0.471R$ ; therefore, the figure of merit is  $0.471 \times 1.75$  or 0.825. When the carrier is impressed at  $X=2.42$ , an improvement of 1.23 times results as shown previously, so that the figure of merit becomes 1.015.

For ten stages of tuned coupled circuits, and for  $y=1.22$ , the radio-frequency characteristics are given in Fig. 21. When the carrier is impressed at mid-band, video-frequency requirements are met to  $Z=1.03$ . The figure of merit for a tuned-coupled-circuit system of any number of stages may be expressed as

$$\frac{Z_0 y}{\sqrt{\{1 + (X + y)^2\} \{1 + (X - y)^2\}}} \quad (14)$$

where  $Z_0$  is the maximum value of  $Z$  meeting requirements, and  $X$  is the point of carrier impression. Solving, the figure of merit becomes 0.50.

For ten stages of tuned coupled circuits and for  $y=1.22$ , and for a carrier impressed at  $X=1.2$ , the video-frequency phase requirement is met up to  $Z=1.0$ , although the amplitude is satisfactory up to  $Z=2.3$ . The video-frequency characteristics are shown in Fig. 22. From (14), the figure of merit be-

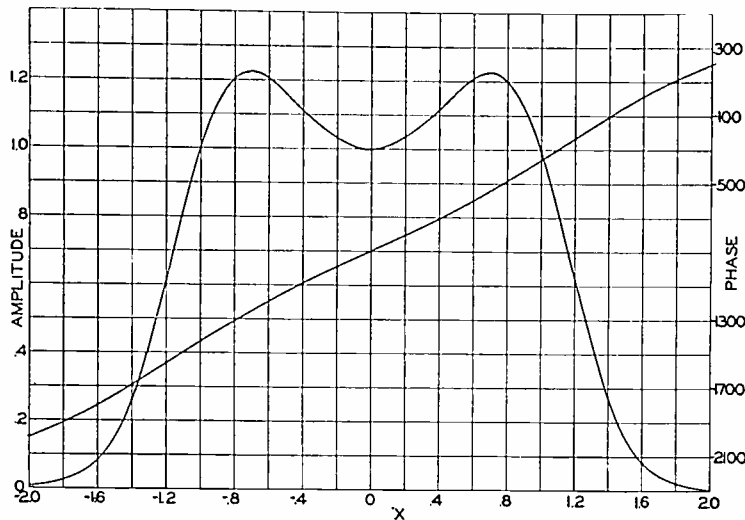

Fig. 21—Radio-frequency characteristics of ten stages using tuned coupled circuits, where  $y$  is 1.22.

comes 1.08 if the phase could be compensated, but 0.47 if this cannot be done. Here another situation arises; if such an arrangement is used within the latter limits it satisfies the requirements but in addition to passing the required range of video frequencies it will also pass higher frequencies for which its phase characteristic is not satisfactory. If appreciable signal or noise components of these higher frequencies are fed into the system or originate in it, there will be harmful effects. It is possible that there might be cases where this is of no consequence, or might even be desired for frequency compensation reasons.

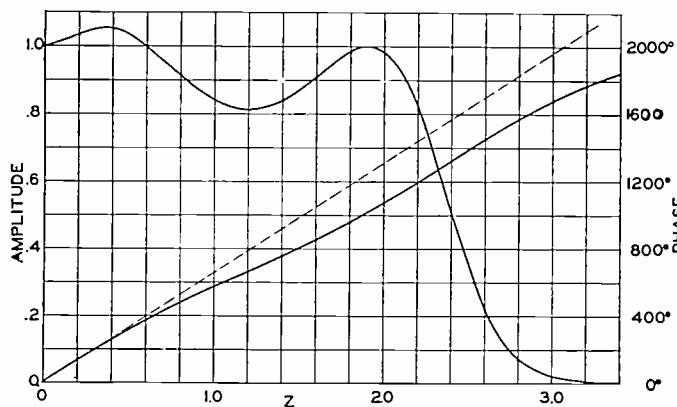

Fig. 22—Video-frequency characteristics of ten stages using tuned coupled circuits, where  $y$  is 1.22 and the carrier is impressed at  $X=1.2$ .

Since the above case is not generally satisfactory, results are also given for a similar case in which the amplitude drops off at video frequencies above the upper limit meeting requirements. Here ten stages are taken, but with  $y=1.0$  and the carrier impressed at  $X=0.88$ . Radio-frequency characteristics are

given in Fig. 23 and the derived video-frequency curves in Fig. 24. Maximum  $Z$  usable is 1.05, and by (14) the figure of merit becomes 0.49. This is the best of the ten-stage arrangements shown because of its exceptionally flat response, fair figure of merit, and no unused "humps" on the amplitude curve.

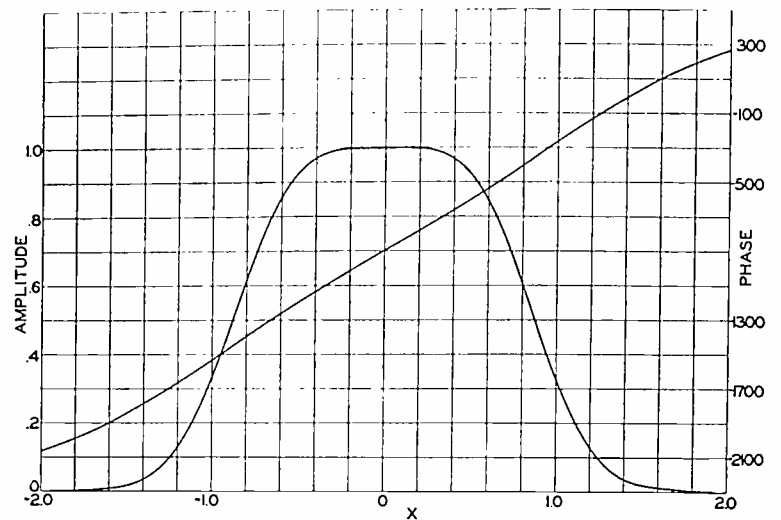

Fig. 23—Radio-frequency characteristics of ten stages using tuned coupled circuits, where  $y$  is 1.0.

A matter to be stressed is that in single-side-band applications, tuning becomes extremely critical. A little experimentation with different points of carrier impression for some of the ten-stage cases will show that the video-frequency response is quite unsuitable except for carrier impression at the point where the amplitude is about 0.4 to 0.6 maximum; and this corresponds to a very restricted frequency range for the steep-sided curves.

Some video-frequency amplifiers will now be given for comparison, of particular interest in regard to the relative effectiveness of carrier-frequency amplification as compared to video-frequency amplification.

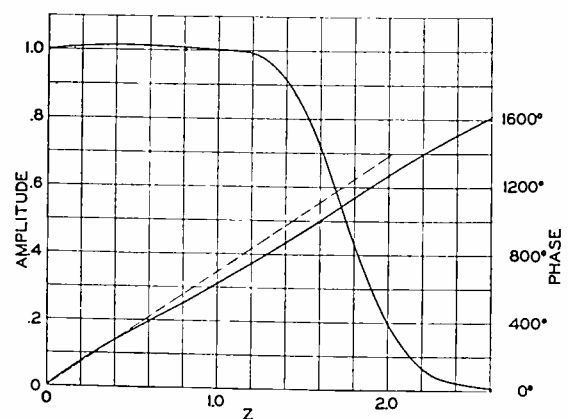

Fig. 24—Video-frequency characteristics of ten stages using tuned coupled circuits, where  $y$  is 1.0 and the carrier is impressed at  $X=0.88$ .

For the simple compensated circuit (C) of Fig. 18,

$$\theta = -\tan^{-1} Z(1-\gamma+\gamma^2 Z^2)$$

$$\left| \frac{E}{I} \right| = R \sqrt{\frac{1+\gamma^2 Z^2}{1+(1-2\gamma)Z^2+\gamma^2 Z^4}} \quad \text{where} \quad \begin{cases} Z = \omega CR \\ \gamma = \frac{L}{R^2 C} \end{cases}$$

The video-frequency phase and amplitude characteristics are given in Fig. 25 for  $\gamma=0.8$  and  $0.5$ . The latter figure is one commonly used. The figure of merit becomes simply  $Z_0$  and is 1.60 for one stage with  $\gamma=0.5$ ; and 0.75 for one stage with  $\gamma=0$  (uncompensated).

When ten stages of the same sort are used, and  $\gamma=0.5$ , the figure of merit becomes 1.05.

The situation can be improved somewhat for one stage by splitting the capacitance into two parts as in (D), Fig. 18. This is not the best such arrangement but is shown here for simplicity. For this

$$\theta = - \tan^{-1} \left[ \frac{Z(4 - \gamma Z^2)}{2(2 - \gamma Z^2)} \right]$$

$$\left| \frac{E}{I} \right| = R \left\{ 1 + (1 - \gamma)Z^2 + \left( -\frac{\gamma}{2} + \frac{\gamma^2}{4} \right) Z^4 + \left( \frac{\gamma^2}{16} \right) Z^6 \right\}^{-1/2}$$

where

$$\gamma = L/(R^2 C_0); \quad Z = \omega C_0 R.$$

The video-frequency phase and amplitude characteristics for circuit (D) are given in Fig. 26. For one stage,  $\gamma=0.5$ , requirements are met up to  $Z=3.0$  which is also the figure of merit. For ten stages, the case  $\gamma=0.8$  is more suitable and is flat to  $Z=1.05$  which is the figure of merit; unfortunately an unusable peak of large amplitude at higher frequencies is left over, so that this arrangement is not generally useful except where no higher-frequency noise or signal components can occur, or where the arrange-

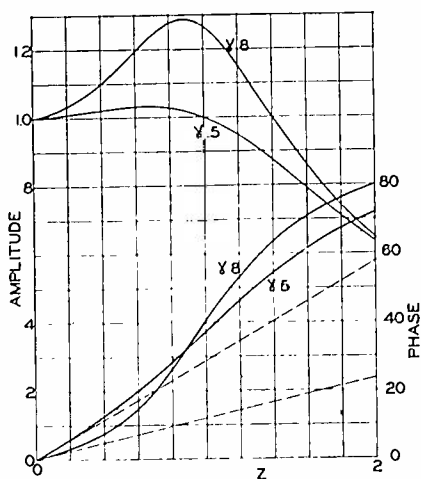

Fig. 25—Video-frequency characteristics of the compensated video-frequency amplifier of Fig. 18(C).

ment is to serve as a compensating device. (For example, the curve for  $\gamma=0.8$ , Fig. 26, is almost complementary to that of  $\gamma=0.5$ , Fig. 25, over a considerable range; these two circuits might well be used in cascade.)

The gain situation is conveniently summarized in

Table II. The actual gain per stage is the figure of merit multiplied by  $S_m/C_0\omega_0$ .

One may conclude that from the gain standpoint video-frequency amplification is superior to carrier-frequency amplification; tuned coupled circuits to single tuned circuits; single-side-band reception to

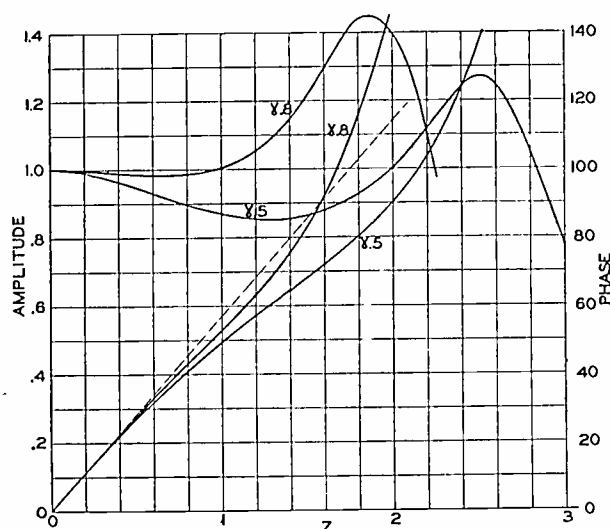

Fig. 26—Video-frequency characteristics of the split video-frequency amplifier of Fig. 18(D).

double-sideband reception but only slightly; and that for some cases video-frequency amplifiers may be improved by special artifices such as the circuit (D), Fig. 18.

TABLE II  
GAIN COMPARISON SUMMARY

Arrangement	Single or Double Sideband	Figure of Merit	Remarks
Single tuned circuit X 0	DSB	0.375	
Single tuned circuit X 1.732	SSB	0.625	
10 stages Single tuned circuit X 0	DSB	0.105	
10 stages Single tuned circuit X 0.4	SSB	0.291	
Tuned coupled circuit X 0 y 1.414	DSB	0.825	
Tuned coupled circuit X 2.42 y 1.414	SSB	1.015	Best of the 1-stage tuned coupled circuits
10 stages Tuned coupled circuit X 0 y 1.225	DSB	0.50	
10 stages Tuned coupled circuit X 1.2 y 1.225	SSB	0.47	Unused peak at higher frequency
10 stages Tuned coupled circuit X 1.2 y 1.225	SSB	1.03	Phase not satisfactory
10 stages Tuned coupled circuit X 0.88 y 1.0	SSB	0.49	Best of the 10-stage tuned coupled circuits
Video-frequency amplifier, uncompensated		0.75	
Video-frequency amplifier $\gamma 0.5$		1.60	
10 stages Video-frequency amplifier $\gamma 0.5$		1.05	Best 10-stage video-frequency amplifier
Split video-frequency $\gamma 0.5$		3.0	Best 1-stage video-frequency amplifier
Split video-frequency $\gamma 0.8$		1.05	Unused peak at higher frequencies

## CONCLUSIONS

Phase delay and amplitude response for the video-frequency signal may be found relatively easily by the graphical method given, when the corresponding radio-frequency characteristics of a system are known. Some typical cases involving single and tuned coupled circuits and a transmission-line filter have been treated, and the results show that these may be constructed to give satisfactory fidelity in television transmission and reception. Transient analysis checks this insofar as it has been carried out.

Experimental work is most likely to show whether reasonable efficiency and fidelity may be obtained in television transmission by the employment of single-sideband filters using transmission lines as elements and operating at the carrier frequency, or whether better efficiency can be obtained with a frequency-

conversion system and filters operating at an intermediate frequency.

If the filtering is done before the final transmitter stage, cascaded amplifier stages using single and coupled tuned circuits are very suitable and have more desirable phase characteristics than a structure approaching "ideal" band-pass characteristics.

Conclusions on the relative gain of a large number of circuits applicable to receivers have been given at the close of the preceding section.

## ACKNOWLEDGMENT

Grateful acknowledgment is made of the helpful suggestions and encouragement of all members of the staff of the Columbia Broadcasting System; and of the assistance of Mr. John A. Rado in the preparation of graphs, drawings, and data.

## Characteristics of the Ionosphere at Washington, D. C., May, 1939\*

T. R. GILLILAND †, ASSOCIATE MEMBER, I.R.E., S. S. KIRBY †, ASSOCIATE MEMBER, I.R.E.  
AND N. SMITH †, NONMEMBER, I.R.E.

DATA on the critical frequencies and virtual heights of the ionosphere layers during May are given in Fig. 1. Fig. 2 gives the monthly average values of the maximum usable frequencies which could be used for radio sky-wave communication by way of the regular layers during undisturbed periods. Fig. 3 gives the distribution of the hourly values of F- and F<sub>2</sub>-layer critical frequencies about the average for the month. Fig. 4 gives the expected values of the maximum usable frequencies for transmission by way of the regular layers, average for August, 1939. The ionosphere storms and sudden ionosphere disturbances are listed in Tables I and II, respectively. Table III gives the approximate upper limit of frequency of the stronger sporadic-E reflections at vertical incidence. It shows the hours of the day for the days of May, 1939, during which strong sporadic-E reflections were most prevalent at Washington.

Ionosphere storms during May were numerous but not as severe as during April. Out of the 744 hours of the month 284 hours were disturbed.

Prolonged periods of low-layer absorption were especially pronounced on May 4, 12, and 28.

In these reports the E-layer critical frequency in the early morning has usually been indicated as constant until about one-half hour before sunrise, when

it rises sharply. The data for the flat part of the graph indicate a layer of the nature of sporadic E rather than a true refractive layer. It is believed that

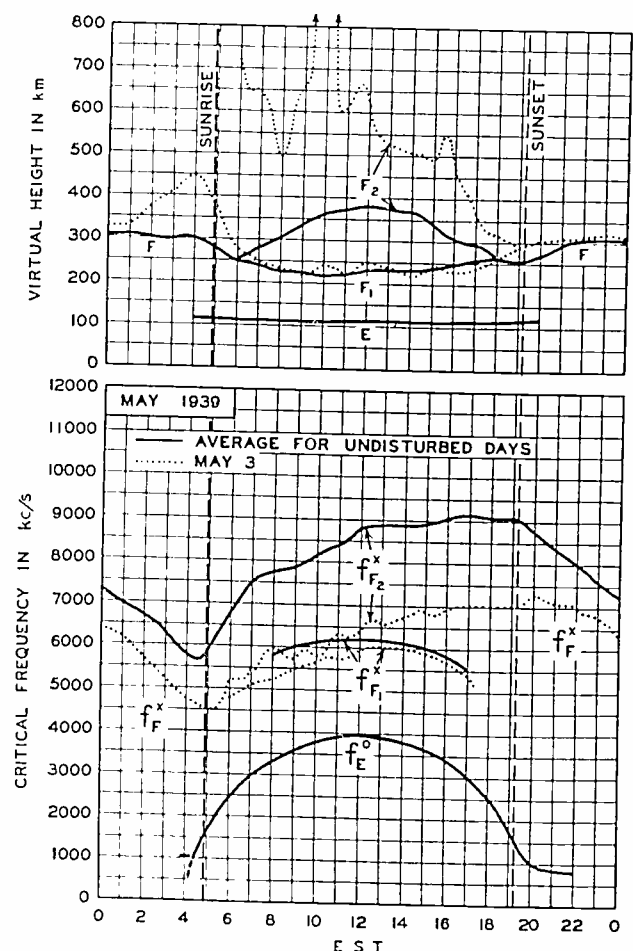

Fig. 1—Virtual heights and critical frequencies of the ionosphere layers, May, 1939. The solid-line graphs are the averages for the undisturbed days; the dotted-line graphs are for the ionosphere storm day of May 3.

\* Decimal classification: R113.61. Original manuscript received by the Institute, June 10, 1939. These reports have appeared monthly in the PROCEEDINGS starting in vol. 25, September, (1937). See also vol. 25, pp. 823-840; July, (1937). Publication approved by the Director of the National Bureau of Standards of the U. S. Department of Commerce.

† National Bureau of Standards, Washington, D. C.



TABLE I  
IONOSPHERE STORMS (APPROXIMATELY IN ORDER OF SEVERITY)

Date and hour E.S.T. 1939 May	$h_F$ before sunrise (km)	Minimum $f_{p2}$ before sunrise (kc)	Noon $f_{p2}$ (kc)	Magnetic character <sup>1</sup>		Ionosphere character <sup>2</sup>
				00-12 G.M.T.	12-24 G.M.T.	
6 (after 0800)	—	—	6000	0.7	1.1	1.4
7	426	3500	6200	1.4	0.9	1.5
8 (until 1200)	390	3800	6700	1.1	0.7	1.0
1 (after 2000)	—	—	—	0.6	1.5	0.8
2	412	3400	7000	1.6	1.1	1.2
3	380	4500	6400	0.9	0.6	1.4
4 (until 0500)	318	5700	—	0.2	0.3	0.5
25 (after 1600)	—	—	—	0.6	0.6	1.0
26 (until 1700)	336	4500	6350	0.5	0.5	1.0
23 (after 2100)	—	—	—	0.9	0.6	0.7
24	318	4650	6600	0.7	0.6	0.9
20 (after 0100)	324	4600	6200	0.5	0.1	1.0
21 (until 1200)	326	4950	7000	0.1	0.8	0.5
28 (after 0300)	332	4700	6600	1.0	0.4	0.7
29 (until 0500)	388	3800	—	1.1	0.7	0.7
8 (after 2200)	—	—	—	1.1	0.7	0.3
9 (until 0800)	328	4400	—	0.9	0.5	0.7
19 (0100 to 1800)	324	5300	7000	0.4	0.1	0.3
22 (0100 to 0800)	338	4050	—	1.0	0.6	0.3
15 (after 2200)	—	—	—	0.4	0.4	0.2
16 (until 0500)	352	5100	—	1.0	0.4	0.2
13 (0700 to 1700)	—	—	7000	0.2	0.1	0.2
For comparison: average for undisturbed days	303	5700	8700	0.2	0.3	0.0

<sup>1</sup> American magnetic character figure, based on observations of seven observatories.  
<sup>2</sup> An estimate of the severity of the ionosphere storm at Washington on an arbitrary scale of 0 to 2, the character 2 representing the most severe disturbance.

TABLE II  
SUDDEN IONOSPHERE DISTURBANCES

Date 1939	G.M.T.		Locations of transmitters	Relative intensity at minimum <sup>1</sup>	Remarks
	Beginning	End			
May 3	1625	1650	Ohio, Ont., Mass., D.C.	0.1	Sporadic E failed
3	1826	1850	Ohio, Ont., Mass., D.C.	0.05	
4	1352	1400	Ohio, Mass., D.C.	0.1	
7	2321	2330	Ohio, Ont., Mass., D.C.	0.1	
8	1942	2010	Ohio, Mass., D.C.	0.0	
9	1706	1750	Ohio, Ont., Mass., D.C.	0.05	
21	1806	1920	Ohio, Ont., D.C.	0.05	
29	1444	1510	Ohio, Ont., Mass., D.C.	0.05	
30	1939	2005	Ohio, Ont., Mass., D.C.	0.05	

<sup>1</sup> Ratio of received field intensity during fade-out to average field intensity before and after: for station W8XAL, 6060 kilocycles, 650 kilometers distant.

TABLE III  
SPORADIC E  
Approximate upper limit of frequency of the stronger sporadic-E reflections at vertical incidence.

Midnight to noon

Date	00	01	02	03	04	05	06	07	08	09	10	11
May 6							6	8	4.5			
12		8	6	6								4.5
14					4.5	4.5	4.5	4.5	4.5	6	6	6
15							6	6	8	4.5	4.5	8
28									4.5	8	4.5	4.5

Noon to midnight

Date	12	13	14	15	16	17	18	19	20	21	22	23
May 4	4.5	8	4.5									
8	4.5	6	8	8						4.5	8	
11				8				4.5	6	6	6	
15	8		4.5	4.5	6	8	8	4.5	8			
16						8	8	4.5	8		4.5	
18			4.5	8	6							
28	4.5	4.5	6	6	8							

the true refractive critical frequencies rise from quite low values up through the sporadic-E values as shown in Fig. 1. The reverse sequence occurs in the evening except that the rate of decrease of the refractive critical frequencies after sunset is much less than the rate of rise in the morning.

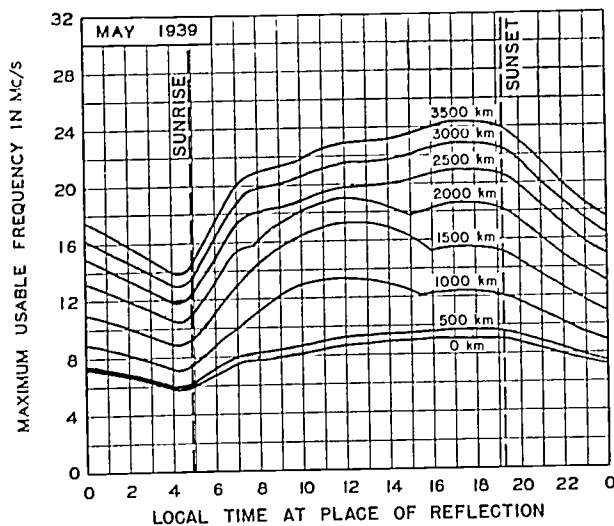

Fig. 2—Maximum usable frequencies for radio sky-wave transmission. Average for May, 1939, for undisturbed days for dependable transmission by the regular E, F, and F<sub>2</sub> layers. The values shown were considerably exceeded during irregular periods by reflections from clouds of sporadic-E layer.

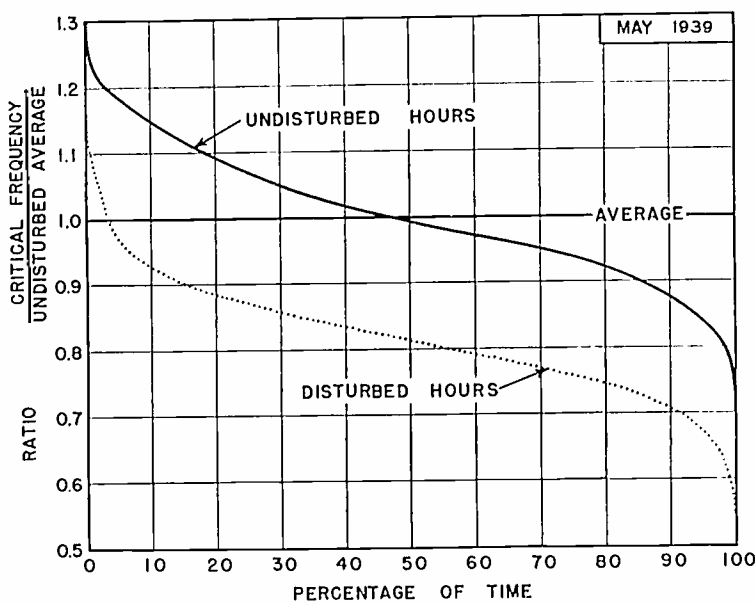

Fig. 3—Distribution of F- and F<sub>2</sub>-layer critical frequencies (and approximately of maximum usable frequencies) about monthly average. Abscissas show percentage of time for which the ratio of the critical frequency to the undisturbed average exceeded the values given by the ordinates. The graphs give data as follows: solid line, 460 undisturbed hours; dotted line, 284 disturbed hours listed in Table I.

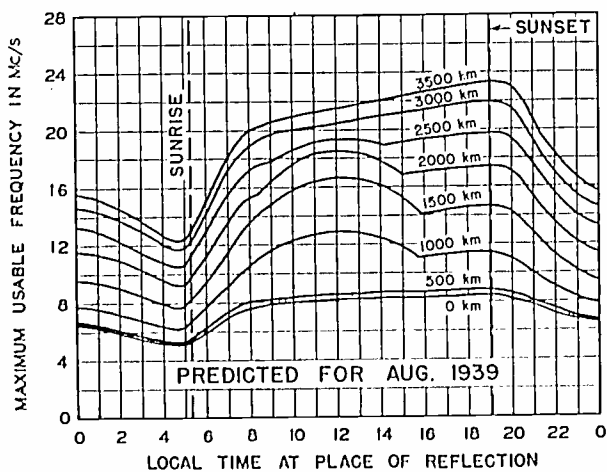

Fig. 4—Predicted maximum usable frequencies for dependable radio sky-wave transmission by way of the regular E, F, F<sub>1</sub>, and F<sub>2</sub> layers, for August, 1939. The F layer will ordinarily determine the maximum usable frequencies at night. The effect of the E and F<sub>1</sub> layers is shown by the humps on the graphs during the middle of the day. The values shown will be considerably exceeded during irregular periods by reflections from clouds of sporadic-E layer.

Discussion on

## "A Bearing-Type High-Frequency Electrodynamic Ammeter"\*

HARRY R. MEAHL

John H. Miller:<sup>1</sup> Mr. Meahl's paper on the latest design of the oscillating-type electrodynamic ammeter indicates an interesting future for this instrument. It is believed, however, that it will find its greatest usefulness as an additional laboratory check of the more practical and useful thermocouple instruments for field work.

In the first paragraph Meahl states that it is not evident in the literature that the frequency limitation of the heating effect of the current, presumably in lamps, used with the photoelectric method was appreciated. Reference is made to page 1569 of the writer's paper,<sup>2</sup> where it is stated, "The five-ampere instrument having a heater with an  $R_{HF}/R$  ratio of 2.57 may be checked with a tungsten filament lamp having a similar ratio of 1.065." The ratio of 1.065 mentioned is the skin effect in the tungsten filament, which was not only appreciated but very definitely calculated throughout this entire study. Further, it was checked for a number of different sizes of filaments in rather complete fashion. It should be noted further that the skin-effect factor in a tungsten filament worked at white heat at a given current, is far less than that in the heater of a thermal converter worked at the same current where maximum temperature rise is of the order of 200 degrees centigrade.

In the paper by Wallace and Moore,<sup>3</sup> on page 300, there is a very complete discussion of the frequency limitation of lamps due to skin effect, and it is rather obvious that very complete consideration was given to this factor. The curves shown on Figs. 5 and 6, pertaining to the frequency errors of thermocouple instruments, are indicative of the state of the art up to the year 1938 and represent the best practice using solid heaters for the thermal converters in such instruments.

Attention should be called to a new design and manufacturing technique in such instruments, wherein the heater takes the form of a tube.<sup>4</sup> Using tubular heaters of 1 mil platinum-alloy foil, the errors are reduced to such an extent that even at 50 megacycles the inherent skin effect results in errors of the order of approximately 1.5 per cent and much less at lower frequencies. Such instruments have been checked by numerous laboratories, and the results are surprisingly consistent and quite universally accurate even at frequencies up to 150 megacycles.

Such instruments are now commercially available and it is believed that this new type should be considered as the basic criterion of a correctly designed thermocouple converter-type of high-frequency ammeter, rather than the prior type using solid wire or strip and designed for use up to several megacycles.

Certainly this extension of good accuracy at the higher frequencies makes it necessary for other systems to be advanced very

materially beyond their present status for them to be considered as even comparable. Neither are the figures given the ultimate, since by following through this system using a tubular heater wherein the high-frequency resistance is maintained very close to the low-frequency resistance through the use of still thinner tubes, there seems to be no practical limit to the frequency to which the basic design may be carried. The limit is rather one of introducing the system into the circuit properly, and this portion of the problem would appear to be a common one to all systems.

Harry R. Meahl:<sup>5</sup> Mr. Miller attributes to me a statement I did not intend to make. I actually said "This (the photoelectric) method is not fully satisfactory because it also depends upon the heating effect of the current and is therefore frequency limited as to accuracy in the same way as the thermocouples are." The meaning is that the lamp and the thermocouple heater are alike in frequency characteristic. It is true that the lamp filament can be so chosen that the skin effect is about one third that of the thermocouple heater being calibrated, but this advantage is accompanied by three inherent disadvantages:

1. Higher reactance and resistance with resulting circuit effects at high frequencies.
2. A difficult measuring technique resulting from:
  - a. The narrow useful current range of the lamp.
  - b. The compromise necessary when locating the light-sensitive indicator. To use the light generated to best advantage it should be close to the lamp and extraneous light should be excluded. To prevent response to electromagnetic and electroacoustic high-frequency fields it should be far from the lamp carrying the high-frequency current.
3. An uncertainty of from one to two per cent in the skin effect resulting from the combination of the high temperature coefficient of resistivity of tungsten at high temperatures and the difficulty of determining the operating temperature of the filament.

In addition there are the special precautions necessary in using any high-frequency calibrating circuit.

Wallace and Moore stated on page 337 of March, 1937, PROCEEDINGS that, "The accuracy of the calibrations is probably within five per cent at fifteen megacycles and within twelve per cent at one hundred megacycles, the accuracy at intermediate frequencies falling between these estimated percentages."

Item (3) above was rightly neglected in the work of Wallace and Moore. It could not be in work of the accuracy inferred in Miller's discussion. I cannot reconcile these two statements of probable accuracy. All of the above is interesting, but it is outside the scope of this paper.

Since data are not available on the design to which Miller calls attention, I cannot comment upon it. It is presumed that these data will be published soon.

<sup>5</sup> General Electric Company, Schenectady, N. Y.

\* Proc. I.R.E., vol. 26, pp. 734-744; June, (1938).

<sup>1</sup> Weston Electrical Instrument Corporation, Newark, N. J.

<sup>2</sup> John H. Miller, "Thermocouple ammeters," Proc. I.R.E., vol. 24, pp. 1567-1572; December, (1936).

<sup>3</sup> J. D. Wallace and A. H. Moore, "Frequency errors in radio-frequency ammeters," Proc. I.R.E., vol. 25, pp. 327-339; March, (1937).

<sup>4</sup> U. S. Patent No. 2,100,260, November 23, 1937.



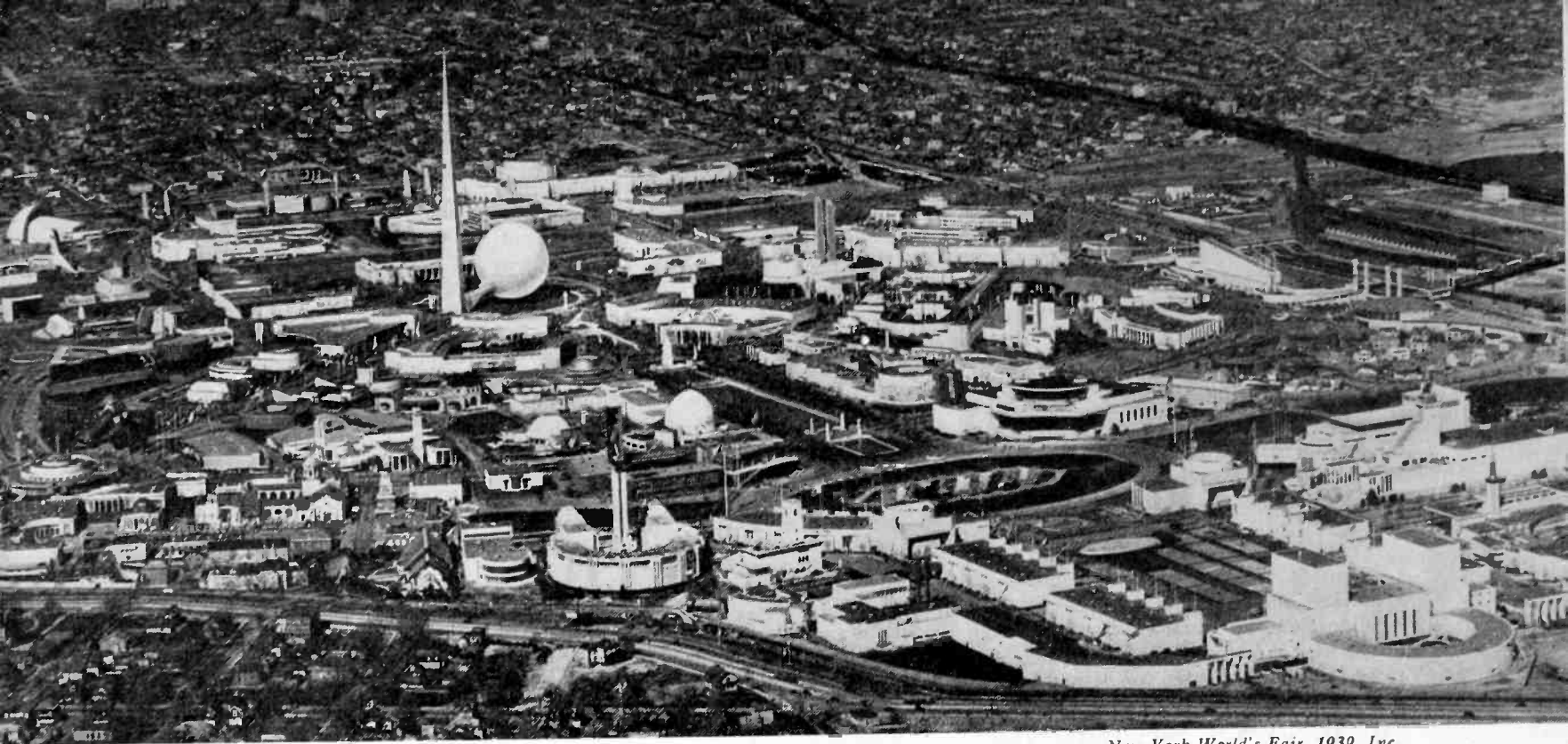

New York World's Fair, 1939, Inc.

Air view of the New York World's Fair. Visitors to the I.R.E. Convention will have an opportunity of visiting the Fair from September 20-23. All persons interested in presenting papers should submit them to the Secretary of the Institute not later than July 15, 1939.

## Institute News and Radio Notes

### Board of Directors

A meeting of the Board of Directors was held on May 3 and attended by R. A. Heising, president; Ralph Bown, F. W. Cunningham, Alfred N. Goldsmith, Virgil M. Graham, L. C. F. Horle, C. M. Jansky, Jr., I. J. Kaar, F. B. Llewellyn, Haraden Pratt, B. J. Thompson, H. M. Turner, A. F. Van Dyck, and H. P. Westman, secretary.

Sixty-eight applications for Associate, two for Junior, and forty-nine for Student membership were approved.

The Secretary reported that in accordance with authority previously issued, a five-year renewal of the lease on the present Institute office space had been signed.

On recommendation of the Awards Committee the Institute Medal of Honor for 1939 will be given to Sir George Lee for his accomplishments in promoting international radio services and in fostering advances in the art and science of radio communication.

The Morris Liebmann Memorial Prize was awarded to Harold Trap Friis for his investigations in radio transmission including the development of methods of measuring signals and noise and the creation of a receiving system for mitigating selective fading and noise interference.

The nomination for candidates for office to be balloted on this fall was made. These nominations were published in the June PROCEEDINGS.

A meeting of the Board of Directors was held on June 7. Those present were R. A. Heising, president; Melville East-

ham, treasurer, Ralph Bown, F. W. Cunningham, Alfred N. Goldsmith, Virgil M. Graham, L. C. F. Horle, C. M. Jansky, Jr., I. J. Kaar, F. B. Llewellyn, B. J. Thompson, H. M. Turner, and H. P. Westman, secretary.

R. F. Guy was transferred to Fellow grade. This is the last pending application for Fellow grade and future transfers will be made by invitation by the Board of Directors.

C. H. Bond, M. M. Eells, A. W. Friend, E. E. George, G. M. Giannini, Ferdinand Hamburger, G. J. Irwin, E. W. Jacker, R. B. Janes, G. I. Jones, E. E. Kapus, S. R. Khastgir, P. L. Narayanan, F. E. Nimmcke, W. C. Osterbrock, H. J. Tyzzer, and J. M. Wells were transferred to Member grade. J. B. Bishop, W. G. Dow, and L. M. Hershey were elected to Member grade.

There were thirty-six Associates, three Juniors, and twenty-one Students elected.

Dr. Goldsmith reported that the Board of Editors had made a thorough investigation of the abnormal delay which papers accepted for publication are now suffering. Approximately twelve months elapse between the receipt of a manuscript and its publication in the PROCEEDINGS. The rate at which papers are being approved and published indicates the situation will not improve unless special action is taken.

Several methods of increasing income were examined and it was felt that little relief could be expected from that source.

The greatest improvement appears possible through the application of more rigorous editing. The Board of Directors agreed that this procedure should be ap-

plied not only to new papers but that all existing papers which had been accepted for publication would be again reviewed to see whether any material could be deleted without seriously impairing their usefulness. In order to assure reasonably uniform editorial standards, a subcommittee of the Board of Editors (known as the Co-ordinating Committee) was appointed to examine and make a final decision on every paper accepted for publication.

Under the previous editing system, some papers were given preferential publication because it was felt that their contents were of great immediate usefulness. This method will, in general, be discontinued and only in rare instances will any paper be published in advance of others which have been received before it.

The present policy of giving fifty free reprints to the author will be discontinued.

Printing economies will be effected through a slight expansion of the area of the page on which printing appears and by starting a new paper in general immediately after the previous paper and not on the next page.

An additional appropriation of \$2000 was made to be expended in increasing the contents of the next four or five issues of the PROCEEDINGS which have not yet been made up. The increase will start with the September issue.

As Austin Bailey has been asked to serve as a candidate for Director, his resignation as chairman of the Tellers Committee was accepted. F. R. Lack and O. W. Pike were appointed to the Technical Committee on Electronics.

The resignation of Irving Wolff as the Institute's representative on the ASA Sectional Committee on Acoustical Measurements and Terminology was accepted and H. F. Olson designated as our new representative.

The Convention Committee was instructed to avoid the scheduling of any banquets or boat trips during the Fourteenth Annual Convention in view of the great interest which will undoubtedly be shown in the World's Fair. It is probable an official luncheon will be held.

President Heising submitted a preliminary report to the Board of Directors on his visits to thirteen of the Institute's Sections.

A draft by the Constitution and Laws Committee of a new set of Bylaws was examined and tentatively approved after modification. The final vote will be taken at the next meeting of the Board of Directors which is scheduled for September.

## New ASA Standards

On May 31, 1939, two existing American Standards of radio equipment were revised. One of these revisions is entitled "Standard Vacuum-Tube Base and Socket Dimensions—C16.2-1939." This standard includes dimensions for the small 4-, 5-, and 6-pin bases, the tapered small 4-pin bases, the small 4-nub base, the WD4-base, the medium 4-pin bases, both plain and bayonet, the medium 5-, 6-, and 7-pin bases, the small 7-pin bases, the small and large terminal caps used on receiving-type tubes, the 4-pin transmitting-tube base, and the bases used on double-ended radiation-cooled transmitting tubes.

The other standard is entitled "Manufacturing Standards Applying to Broadcast Receivers—C16.3-1939." This standard includes a number of commercial definitions, dimensional standards on cord tips, binding posts, cable terminals, plugs and jacks, panel lamps, and bases. It includes also a color code for resistors and dimensional and operating standards on on-off switches, adjustable resistance units, and rotary circuit switches.

All of the above standards were taken from existing ones adopted originally by the Radio Manufacturers Association.

It is anticipated that copies of these standards will be made available and those interested in receiving them should forward their requests to the Institute which is the sponsor of the Sectional Committee on Radio through which the standards were presented to the American Standards Association.

## Committees

### Admission

The Admissions Committee met in the Institute office on June 7 and those present were F. W. Cunningham, chairman; Melville Eastham, L. C. F. Horle, C. M. Jansky, Jr., F. M. Ryan, C. E. Scholz, H. M. Turner, and H. P. Westman, secretary.

Five applications for transfer to

Member grade were considered. Two of these were approved, two were rejected, and one was tabled pending the obtaining of additional data. Of five applications for admission to Member, three were approved, one was rejected, and one was tabled for further information.

### Awards

The Awards Committee met on May 3 and completed its work in the preparation of citations to accompany the awarding of the Institute Medal of Honor to Sir George Lee and the Morris Liebmann Memorial Prize to Harold Trap Friis. Those at the meeting were Haraden Pratt, chairman; Ralph Bown, H. M. Turner, and H. P. Westman, secretary.

### Board of Editors

At the May 23 meeting of the Board of Editors to consider the problem of reducing the delay between the time a manuscript is submitted and its publication in the PROCEEDINGS, the following were present: Alfred N. Goldsmith, chairman; R. R. Batcher, P. S. Carter, J. D. Crawford, advertising manager; B. E. Shackelford, Helen M. Stote, assistant editor; B. J. Thompson, L. E. Whittemore, William Wilson, and H. P. Westman, secretary.

The decisions reached at this meeting were approved by the Board of Directors and are given in detail in the report of the June 7 meeting which appears in this issue.

Two meetings of the Co-ordinating Committee of the Board of Editors were held on June 2 and June 7. Both were attended by Alfred N. Goldsmith, chairman; B. E. Shackelford, Helen M. Stote, assistant editor; William Wilson, and H. P. Westman, secretary. At these meetings approximately thirty papers which have already been approved for publication were carefully studied and recommendations were made for reducing a number of them in length in order to conserve space in the PROCEEDINGS. The authors are being asked to co-operate with the Institute by observing these recommendations.

### Constitution and Laws

The Constitution and Laws Committee met on April 20 and those present were H. M. Turner, chairman; Ralph Bown, B. J. Thompson, and H. P. Westman, secretary.

Final action was taken on the draft of Bylaws to supplement the new Constitution. This draft will go to the Board of Directors for action.

### Convention

The committee in charge of arrangements for the Fourteenth Annual Convention to be held in New York City on September 20-23 met on June 5. Those present were H. P. Westman, chairman and secretary; Austin Bailey, E. K. Cohan, J. D. Crawford, J. R. Poppele, C. E. Scholz, E. R. Shute, Helen M. Stote, and William Wilson.

Preliminary preparations were made for the convention program.

### Nominations

The Nominations Committee met in Washington, D. C., on April 20 and those present were C. M. Jansky, Jr.; chairman, F. W. Cunningham Melville Eastham, B. J. Thompson, L. P. Wheeler, and H. P. Westman, secretary.

A slate of candidates to run for President, Vice President, and Directors of the Institute was prepared for submission to the Board of Directors.

### Technical Committees

#### Electroacoustics

The Technical Committee on Electroacoustics met in the Institute office on May 18. Those in attendance were H. S. Knowles, chairman; V. L. Chrisler (guest), R. P. Glover, G. G. Muller (representing J. T. L. Brown), G. M. Nixon, H. F. Olson, L. J. Sivian, and H. P. Westman, secretary.

The preparation of a report for the Annual Review Committee was discussed and the need for preparing notes on the important developments in the field throughout the year stressed.

A discussion on methods of calibrating microphones was held in anticipation of preparing a standards report on this subject.

The definitions appearing in the 1938 Standards Report were reviewed and arrangements made for the drafting of definitions of several terms not included in it.

Three representatives of the committee were appointed to serve on the newly established Technical Committee on Letter and Graphical Symbols.

### Electronics

A meeting of the Technical Committee on Electronics was held in the Institute office on April 19. Those present were P. T. Weeks, chairman; R. S. Burnap, E. C. Homer (representing H. P. Corwith), Ben Kievit, Jr., George Lewis, B. J. Thompson, J. R. Wilson, and H. P. Westman, secretary.

Subcommittees on Cathode-Ray and Television Tubes, Gas-Filled Tubes, High-Frequency Tubes, Large High-Vacuum Tubes, Photoelectric Tubes, and Small High-Vacuum Tubes were appointed. These committees were instructed to hold early meetings looking toward the preparation of reports on developments in their fields during 1939 for submission to the Annual Review Committee and the preparation of revisions and supplements to the 1938 Standards Report.

A report on the Electronics Conference held on January 13 and 14 was discussed. A special committee to make arrangements for a second conference to be held later in 1939 was appointed.

A meeting to review the reports of the several subcommittees was held on June 2 in the Institute office and attended by P. T. Weeks, chairman; R. S. Burnap, E. L. Chaffee, Ben Kievit, Jr., F. R. Lack, George Lewis, F. B. Llewellyn, H. W. Parker, J. R. Wilson, and H. P. Westman, secretary.

## Electronics Subcommittees

Five of the subcommittees of the Electronics Committee held meetings to arrange for the preparation of the reports to be submitted to the Annual Review Committee and to review the material contained in the 1938 Standards Report with the thought of outlining a program for the revision of material which is considered to require modification and the drafting of new material to be considered for inclusion in the next report. These meetings were as follows:

### Cathode-Ray and Television Tubes

This meeting was held in the Institute office on June 1, and attended by Ben Kievit, Jr., acting chairman; P. S. Christaldi (representing A. B. DuMont), M. S. Glass, R. C. Hergenrother, Harley Iams, R. T. McKenzie, and H. P. Westman, secretary.

### High-Frequency Tubes

The Subcommittee on High-Frequency Tubes met on May 18 in the Institute office and those present were F. B. Llewellyn, chairman; R. L. Freeman, L. S. Nergaard, J. D. Schantz, A. L. Samuel, and H. P. Westman, secretary.

### Large High-Vacuum Tubes

This subcommittee met in the Institute office on May 27. The meeting was attended by E. L. Chaffee, chairman; K. C. DeWalt, H. E. Hergenrother, I. E. Mourmtseff, Alexander Senauke, C. M. Wheeler, and H. P. Westman, secretary.

### Photoelectric Devices

Ben Kievit, Jr., chairman; M. S. Glass, A. M. Glover, J. H. Miller, and H. P. Westman, secretary, attended a meeting of the Subcommittee on Photoelectric Devices which was held on June 1 in the Institute office.

### Small High-Vacuum Tubes

The Subcommittee on Small High-Vacuum Tubes met on May 19 in the Institute office. Those in attendance were R. S. Burnap, chairman; G. W. Bain, R. H. Fidler, E. C. Homer (representing H. P. Corwith), G. D. O'Neill, E. A. Veazie (representing H. A. Pidgeon), and H. P. Westman, secretary.

## Television

The Technical Committee on Television met in the Institute office on June 6. Those present were H. P. Westman, acting chairman and secretary; H. S. Baird, P. S. Christaldi (representing T. T. Goldsmith), G. L. Fernsler (representing P. T. Farnsworth), D. E. Foster, G. W. Fyler (representing I. J. Kaar), R. S. Holmes (representing E. W. Engstrom), A. G. Jensen, and George Lewis.

A method of gathering data for and preparing the annual review report was adopted.

Three representatives on the new Technical Committee on Letter and Graphical Symbols were appointed.

The standards material on television

which has been developed to date by the Institute and other groups was discussed and preparations made for the drafting of a new report on this subject.

## Sloan Fellow



RICHARD T. ORTH

An Alfred P. Sloan Foundation Fellowship has been awarded to Richard T. Orth, (A '31), head of the receiving-tube design section of the RCA Manufacturing Company of Harrison, N. J. This fellowship is for a year of advanced study of industrial problems at the Massachusetts Institute of Technology.

In addition to formal study intended to expand executive ability and understanding of the social and economic implications of industrial responsibilities, Mr. Orth will make an extended investigation of some topic of significance to industry and will confer with thirty government officials and industrial and labor leaders.

Mr. Orth was graduated from Purdue University in 1930 with a Bachelor of Science degree in Electrical Engineering. He has since been employed by the RCA Manufacturing Company.

## Sections

### President's Tour

During April and May, President Heising visited the following Institute sections: Buffalo-Niagara, Chicago, Cincinnati, Cleveland, Detroit, Indianapolis, Montreal, Pittsburgh, and Toronto.

On these visits, he spoke first of Institute affairs, outlining the significance of the changes which recently were made in the Institute Constitution and discussing the desirability of all members being of the highest grade of membership for which they are qualified. The advantage to the Institute and those active in radio in participating in Institute affairs was stressed.

He then presented a paper on "Radio Extension Links to the Telephone System." He outlined first the historical development of radio and wire telephony. Radiotelephony is only about thirty-five years old. Transcontinental wire telephony

was established in 1914 and transoceanic telephone service in 1927.

He then described various equipments used in the radio extension links to the wire telephone system. The vodas is a "voice-operated device anti-singing" which suppresses feedback or singing by permitting the speech currents of the subscriber to operate switching devices which connect the radio transmitter to the wire line and disconnect the receiver during the time the subscriber is speaking.

The vogad is a "voice-operated gain-adjusting device." It adjusts the gain of amplifiers in accordance with the input signal to permit maximum utilization of the transmitter. This compensates for the different levels at which the speech of the subscriber is impressed on the microphone.

The compandor, "compressor-expandor," first compresses the volume range by reducing the peaks and increasing the weaker signals. After transmission, the expander operates to restore the signals to their original range. This increases the signal-to-noise ratio by permitting better loading of the transmitter.

The codan, which is a "carrier-operated device anti-noise," introduces a high loss into the audio-frequency operation of the receiver during intervals when there is no incoming carrier and insures relatively quiet conditions on the receiving line. When the carrier is impressed on the receiver, this high loss is removed and the receiver operates normally.

The codan is especially useful for marine radiotelephone service to small harbor and coastal craft. The vogad is also used in this service.

A short-wave single-sideband system used for transoceanic service was described. Its modification to permit the use of two channels each occupying one of the sideband positions was described. This twin-channel system requires three steps of modulation to reach the final frequency.

The musa, which is the name of the "multiple-unit steerable antenna," was then described. It permits the vertical angle of reception to be adjusted over a wide range by electrical means, improves the signal-to-noise ratio, and also decreases the distortion commonly caused by selective fading.

### Atlanta

O. W. Towner, chief engineer of WHAS, presented a paper on "The Doherty 50-Kilowatt Transmitter at WHAS."

The speaker described and showed photographs of the shunt-fed vertical radiator, transmitter building, outdoor power equipment, final amplifier plate-voltage rectifier, filter equipment, pumps and porcelain pipes for the cooling of water, six-inch coaxial transmission lines with their expansion junctions and end seals, and the four-wire antenna feed line.

A simplified circuit diagram of the Doherty amplifier was shown and its method of operation described. The author then discussed the adjustment methods which have been found to be

most satisfactory. A method of remotely monitoring the phase adjustment of the circuit was covered.

The paper was closed with a discussion of the radiation pattern of the antenna.

April 20, 1939, Ben Akerman, chairman, presiding.

## Chicago

E. L. Plotts, engineer for the Columbia Broadcasting System, presented a paper on "Synchronous Operation of Broadcast Stations WBBM and KFAB."

In it he presented the results of synchronous operation which started in January, 1934. The stations are separated by 475 miles and utilize 50 and 10 kilowatts, respectively. The carrier frequency is 770 kilocycles.

The various engineering problems which such operation presents were discussed in detail and the advances which have been made in the methods of synchronization were described and their effects indicated by measurements and reports on services rendered.

March 24, 1939, V. J. Andrew, chairman, presiding.

## Cincinnati

A "Symposium on the Use of Ultra-High Frequencies in Airplane Radio" was presented and was composed of five papers from authors associated with the War Department Aircraft Radio Laboratory at Wright Field.

The first paper on the "Propagation of High-Frequency Waves from an Airplane" was by George Haller. It described methods of measuring the propagation of high-frequency waves from aircraft antennas by the use of scale models. In this work, models one tenth the size of the equipment to be studied were operated at a frequency which was ten times that which would be used.

The second paper was by A. S. Brown and discussed the "Sonic Altimeter." He included a description of several types of sonic altimeters which were used chiefly for the measurement of altitudes of less than 1000 feet.

J. E. Keto described the "Western Electric Radio Altimeter." This instrument transmits a 450-megacycle wave which is swept eighty times per second by a modulating frequency of up to twenty-five megacycles. The beat between the direct and reflected wave is measured by a frequency meter which is calibrated directly in altitude.

"Horn-Type Ultra-High-Frequency Beam Projector" was the subject of a paper by S. Lavoie. These radiators are operated at frequencies corresponding to a wavelength of about ten centimeters and are used to obtain straight-line glide paths for the blind landing of aircraft.

J. Woodyard presented a paper on the "Klystron Ultra-High-Frequency Tube." The electrical and mechanical structure of the tube permits exceedingly low circuit losses at ultra-high frequencies. Its performance at ten centimeters was stated to

be comparable with the performance of normal triodes at 300 meters. From 200 to 500 watts output may be obtained at a wavelength of 43 centimeters and an efficiency of about 30 per cent.

April 14, 1939, P. B. Taylor, vice chairman, presiding.

## Cleveland

C. J. Young, research engineer of the RCA Manufacturing Company, presented a paper on "RCA Radio Facsimile." The operation of scanning, synchronization, and reproduction was described and the characteristics of the scanning equipment, compensating amplifier, and reproduction process were illustrated graphically. An interesting feature was the method used to compensate for the nonlinearity of the pressure-density characteristic of the carbon-paper transfer.

Framing of the picture by use of signals generated by the scanning of the clamp area on the scanning drum was described and the effects of incorrect framing and lack of synchronization illustrated.

Utilization of standard broadcast transmitters permits satisfactory operation in their original service areas. With ultra-high-frequency transmission, automobile interference was found to be detrimental where the traffic was heavy and the signals weak. Facsimile reception tolerates a higher interference ratio than is permissible with sound broadcasting.

At the close of the paper, the system was demonstrated through the use of the 41.5-megacycle transmitter at WBOE.

February 23, 1939, S. E. Leonard, chairman, presiding.

"Recent Developments of Radiotelephony on the Great Lakes" was the subject of a paper by H. P. Boswau, chief engineer of the Lorain County Radio Corporation and the Lorain Telephone Company.

The problem of supplying radiotelephone service to Great Lakes shipping was only partly one of equipment. The allocation of channels for this service required the co-ordination of the United States and Canadian Governments and when the first transmitter was installed in 1933, three frequencies were assigned. The service increased both in the number of units in operation and the geographical range over which they were required to operate, and by 1938 frequencies in the 6-, 11-, and 13-megacycle range were added to those in the neighborhood of two megacycles which were originally assigned. Experimental work is progressing and the utilization of additional channels being sought. Proposals for a standard calling and distress frequency were described.

In discussing the relative merits of telegraph and telephone communication for safety purposes, it was stated that during the period of operation, there have only been twelve times when ships were out of communication and twelve hours has been the maximum time required to restore service.

A description was given of the WMI

shore station and the method used in handling calls to and from vessels. A log of the positions of the various ships is maintained and enables the operator to select the most favorable frequency for transmission. As an indication of the usefulness of this service, the 1939 season was expected to open with over 100 ships equipped.

The paper was closed with an inspection tour of WMI and of the Central Office of the Lorain Telephone Company where ship transmitting and receiving equipment was on display.

March 30, 1939, S. E. Leonard, chairman, presiding.

## Detroit

"Cold-Cathode Discharge Tubes" was the subject of a paper by M. A. Acheson of the Hygrade Sylvania Corporation. The structure and theory of operation of cold-cathode discharge tubes were described. Circuits in which they are employed were discussed and the considerations which must be made in their design were outlined.

D. E. Foster of the RCA License Division Laboratory, presented a paper on "Television Reception Problems." An outline of the problems was first presented and followed by a description of the circuits generally used today for television receivers.

Various types of cathode-ray tubes were described. Methods of deflecting the electron beams were covered.

A description was given of the various standards used in present-day television transmission. The necessity of wide frequency bands was indicated.

April 21, 1939, L. C. Smeby, chairman, presiding.

## Emporium

"Vacuum Tubes and Some Application Problems" were discussed by W. R. Jones of the sales division of the Hygrade Sylvania Corporation. The subject was introduced by an outline of the relationship of the sales engineer to the factory, the sales department, and the consumer. He then described various problems met in the field and their solutions both as regard modification of circuits and tubes. An interesting case cited was one in which a tube was operated at a grid bias less than the contact potential. This caused the bias to be positive on a strong signal and thus prevented the set from operating. Another complaint was of poor quality in a resistance-coupled amplifier which was caused by the cathode-biasing resistor being too small. Difficulties arising from using a grid resistor of too high a value were discussed.

April 26, 1939, R. K. McClintock, chairman, presiding.

R. M. Wise, chief engineer of the Hygrade Sylvania Corporation, presented a report on "Some Aspects of the Vacuum-Tube Industry in Europe." It was composed of his observations on a trip which he just completed through the principal

cities of western Europe. Special emphasis was placed on the rapid advance of television.

May 23, 1939, R. K. McClintock, chairman, presiding.

## Indianapolis

"The Chromatic Stroboscope" was the subject of a paper by O. H. Schuck, an engineer for C. G. Conn, Ltd. This device permits the accurate measurement of the frequency of a musical note as it is being played by a musician. It is calibrated in units which are one hundredth of a musical interval on the chromatic scale. This unit has been called the "cent." An adjustable calibrated tuning fork controls the speed of a synchronous motor which drives a series of disks by means of a system of gears. The speeds of the disks are such that the individual notes of an octave are represented. By means of a microphone and amplifier, a neon lamp illuminates the disk and permits the frequency of the actuating signal to be determined.

The device was demonstrated by being actuated by a piano, violin, and several other musical instruments.

October 14, 1938, I. M. Slater, vice chairman, presiding.

J. V. Fill, field engineer for the Ferrocart Corporation of America, presented a paper on "Iron Cores in Radio." He described various uses of finely divided iron cores in modern radio design. The design of movable-core inductors for both push-button and continuous tuning was discussed. The use of iron cores for inductance trimming in intermediate-frequency transformers, radio-frequency tuning circuits, and oscillators was covered in detail.

November 30, 1938, I. M. Slater, vice chairman, presiding.

W. R. Jones of the Hygrade Sylvania Corporation, presented a paper on "A High-Frequency Tube of New Design." This tube is a high-transconductance television pentode, 1231. Its characteristics when operated as a triode, tetrode, and pentode were given and general utilization described. Its unusual mechanical construction was described and its advantages, both mechanical and electrical, pointed out. The paper was closed with a general discussion of tube circuits and applications in which other recent developments were described.

January 27, 1939, I. M. Slater, chairman pro tem, presiding.

"Facsimile Transmission and Reception" was presented by J. F. Silver of the Crosley Radio Corporation. The subject was introduced with an historical outline of the development of facsimile transmission from the nineteenth century to date. The underlying principles were described and mechanical, photographic, and chemical methods of recording discussed. Synchronization methods were described.

A description was then given of the system employed in the transmissions from WLW. A commercial facsimile receiver and recorder were demonstrated and were actuated by phonograph records of

transmissions. The results of field tests, at both broadcast and ultra-high frequencies, were described.

March 3, 1939, I. M. Slater, chairman pro tem, presiding.

Five papers were presented by students of Purdue University at this meeting. The first by R. B. Koehler was on "A Plate-Resistance Measuring Set." S. T. Novak described "A Photoelectric Timer." "A Model Modulated Transmitter" was the subject of a paper by J. A. Dale. F. J. Hickman described a "Color Organ." The "Companor" was the subject of a paper by G. L. McClanathan.

Mr. Novak's paper was adjudged the best presented and he will receive a membership in the Institute as a prize.

April 27, 1939, I. M. Slater, chairman pro tem, presiding.

## Los Angeles

"The Telephone Company's Part in Giving Service" was the subject of a paper by H. Crawford who is engineer-in-charge of program service transmission design for the Southern California Telephone Company.

The paper was introduced by W. C. Thomas who described briefly the relationship between the American Telephone and Telegraph Company, Bell Telephone Laboratories, and the various associated telephone companies. The broadcast system in this country relies upon the telephone companies to link together the various transmitters by telephone circuits and deliver at the far end a signal which does not differ materially from that impressed on the sending end of the circuit.

Mr. Crawford described the equipment and circuits necessary to handle these broadcast programs and insure uninterrupted service. He described some new receiver amplifiers and control networks which enable programs to be transmitted in either direction over a given toll circuit.

The paper was followed by an inspection tour of the toll facilities in Los Angeles.

April 18, 1939, F. G. Albin, chairman, presiding.

## Montreal

E. L. Plotts, transmission engineer of the Columbia Broadcasting System, presented a paper on "Synchronous Operation of WBBM and KFAB" which is described in the report on the Chicago Section meeting in this issue.

March 8, 1939, Sydney Sillitoe, chairman, presiding.

## New Orleans

"Principles of Directional Antennas with Particular Reference to the WWL Installation" was the subject of a paper by C. H. Bond of the staff of Glenn D. Gillett, consultant. The subject was introduced with a discussion of the principles of directional antennas and the problems encountered in tuning them. The installa-

tion at WWL was then described. Two identical sectional loaded towers comprise a directional array. The towers are 400 feet high with "hats" sixty feet from the top.

Measured results departed considerably from calculated values when compared with directional arrays using conventional radiators. The towers are spaced 135 degrees apart and are so fed that the current in one lags that in the other by 67.5 degrees. The maximum decrease in signal is about 38 per cent above that when using one of the two radiators with 50-kilowatt input, and the minimum signal is about equal to that of a ten-kilowatt station.

April 18, 1939, G. H. Peirce, chairman, presiding.

## New York

"A New Television Pickup Tube" was the subject of a paper by Albert Rose and Harley Iams of the RCA Manufacturing Company (Harrison). In it the authors pointed out that the iconoscope, as it is known today, is capable of transmitting clear, sharp pictures, even under unfavorable conditions of illumination. Previous workers with the tube have shown that the good sensitivity is obtained in spite of an efficiency only 5 to 10 per cent of that which is theoretically attainable. An analysis of the operation of the iconoscope suggests that improved efficiency and freedom from spurious signals should result from operating the mosaic at the potential of the thermionic cathode, rather than near anode voltage. The beam electrons then approach the target with low velocity and the number of electrons which land depends upon the illumination.

Special designs were developed to make sure that the beam of low-velocity electrons was brought to the cathode-potential target in a well-focused state, that the scanning pattern was undistorted, and that the focus of the beam was not materially altered by the scanning process. A strong magnetic field perpendicular to the target was found useful in focusing and guiding the beam. In some of the earlier tubes which were tested, the scanning beam was released by a flying light spot moving over a photocathode. These experiments led to the present form which uses a thermionic cathode to develop the electron beam. A new type of deflection plate was developed too so that the beam could be deflected in the presence of a strong axial magnetic field.

The new pickup tube, which has been called an Orthiconoscope (or Orthicon), has an output signal over 300 times the noise of a typical television amplifier. The signal is proportional to light intensity. There is no observable spurious signal. Within the accuracy of measurement, the efficiency of conversion of possible photo-emission into light is 100 per cent. In its present developmental form, the Orthiconoscope gives promise of becoming a useful television pickup tube.

June 7, 1939—President Heising, presiding.

## Philadelphia

The "American Television System" was described by R. S. Holmes, engineer in charge of television receiver research of the RCA Manufacturing Company. A general review of the American system soon to be available to the public was presented. It was pointed out that various important details of transmission had to be agreed upon by the industry in order to prevent unreasonable obsolescence of equipment sold to the public. These details included such matters as the number of scanning lines, synchronizing methods, transmission frequencies, and selectivity characteristics.

This meeting was held jointly with the local section of the American Institute of Electrical Engineers and included also a showing of motion pictures of the damage done to the telephone system of New England during the hurricane of 1938.

April 10, 1939, Howard Phelps (A.I.E.E.), and H. J. Schrader (I.R.E.), chairmen, presiding.

President Heising attended this meeting and discussed various Institute matters.

J. G. Brainerd of the University of Pennsylvania, presented a paper on "Some Nonlinear Circuit Problems." Professor Brainerd selected four typical equations representing functions of alternating currents and showed that, by the use of the differential analyzer, curves can be drawn to represent their values with respect to time.

A. E. Thiessen of the General Radio Company, showed some high-speed motion pictures and demonstrated some of the latest types of stroboscopes. The use of these instruments in the analysis of machine operation has grown rapidly during recent years.

As this was the annual meeting, officers for the next year were elected. R. S. Hayes of the Bell Telephone Company of Pennsylvania, was named chairman; C. M. Burrill of the RCA Manufacturing Company, was elected vice chairman; and R. L. Snyder was re-elected secretary-treasurer.

May 4, 1939, H. J. Schrader, chairman, presiding.

## Pittsburgh

F. A. Lennberg, sales engineer for the Bliley Electric Company, presented a paper on "Crystals and Crystal-Oscillator Circuits." In it he explained the mechanism of oscillation of crystals. It was pointed out that Rochelle-salt crystals exhibited very great activity but are not considered as being sufficiently stable to be used to control the frequency of an oscillator.

Quartz crystals appear to be most suitable for this purpose and most of the raw crystals are obtained from Brazil.

The grinding and use of quartz crystals for oscillator control was then discussed in detail. Precautions on their use to avoid damage to the crystal were outlined. The various types of crystals were exhibited.

April 18, 1939, R. T. Griffiths, past chairman, presiding.

F. R. Brick, engineer for Finch Telecommunications Laboratories, presented a paper on "Facsimile Transmission and Reception." He described the theory of operation and construction of equipment used in the Finch system.

May 16, 1939, W. P. Place, chairman, presiding.

## Portland

A convention type of program occupied the time from 3:00 P.M. to 9:30 P.M. for this meeting. The afternoon was devoted to organized inspection trips of Oregon State College and its campus.

In the late afternoon, a technical session was held at which two papers were presented. They were "Recent Television Developments," by F. A. Everest, and "Measurements of Ionosphere Heights," by William Barclay. A dinner was held in the Memorial Union Dining Room and was followed by a second technical session at which three papers were presented. W. Weniger presented some "Reminiscences in Radio," G. S. Feikert discussed some "Interesting Features of the Eugene Studio Equipment," and A. L. Albert outlined "Some Fundamental Concepts in Communication."

W. R. Jones of the Hygrade Sylvania Corporation presented a paper on "Vacuum Tubes and Some Application Problems" which is described in the report on the Emporium Section meeting in this issue.

May 15, 1939, H. C. Singleton, chairman, presiding.

## San Francisco

This seminar meeting was devoted to a discussion of two papers. The first, "An Ultra-High-Frequency Power Amplifier of Novel Design," by A. V. Haeff, which appeared in *Electronics* for February, 1939, was reviewed by Karl Spangenberg of Stanford University. The second paper, "Communication by Phase Modulation," by M. G. Crosby, appeared in the PROCEEDINGS for February, 1939, and was reviewed by H. S. Julian of the University of California.

March 29, 1939, J. Sharp, seminar chairman, presiding.

The two papers presented at this meeting were by students. The first, "A Direct-Reading Vacuum-Tube Voltmeter for Audio Frequencies," was by H. M. Stearns of Stanford University. The second on an "Analytical and Experimental Investigation of Superregeneration," was presented by J. B. Berkley of the University of California. The award of a year's Institute membership was given to Mr. Stearns.

April 19, 1939, F. E. Terman, chairman, presiding.

H. E. Held of the Weston Electrical Instrument Corporation, presented a paper on "The New VU Reference Level and Indicator." An historical sketch of the development and characteristics of volume indicators was presented first. Tests have shown that the most desirable type of pointer action is one wherein the pointer speed is as uniform as possible. Instruments having a high degree of damping,

including those critically damped, move quite rapidly at the beginning, and slow down as they approach the final deflected position. A group of instruments having different degrees of damping were tested under operating conditions and it was agreed that the most useful one reached 2/3 scale deflection in 0.3 second with an overthrow of about 1 per cent. The action of various types of indicators was demonstrated under operating conditions at the studios of KSFQ.

After the presentation of the paper, an inspection visit was made to the laboratories of the Farnsworth Television Corporation where a demonstration was given of their television pickup and receiving equipment.

May 3, 1939, Carl Penther, vice chairman, presiding.

"Vacuum Tubes and Some Application Problems" were discussed by W. R. Jones of the Hygrade Sylvania Corporation. The phenomenon of contact potential was described and it was pointed out that this potential had been reduced to about one volt in present-day tubes. How this phenomenon influences the characteristics of various types of tubes was described.

Hot-cathode-tube rectifiers were then described. Among their advantages were improved regulation and the reduction of stresses on condensers because of the fact that the output voltage builds up with the load. Cold-cathode gas-discharge tubes were also discussed.

May 11, 1939, Carl Penther, vice chairman, presiding.

## Seattle

W. R. Jones of the Hygrade Sylvania Corporation presented his paper on "Vacuum Tubes and Some Application Problems." This paper is summarized in the immediately preceding report of the San Francisco Section.

May 18, 1939, R. O. Bach, chairman, presiding.

## Toronto

"An Automatic Audio-Frequency Response Recorder and Some of its Applications" was the subject of a paper by Benjamin Olney, director of research of the Stromberg-Carlson Telephone Manufacturing Company.

Because the response of a loud speaker varies markedly even though over small frequency ranges, it is necessary to make a complete response-frequency measurement as one may not depend on measurements made at only a few points in the range of operation.

With a recorder constructed for this purpose, a complete examination of the frequency range from 30 to 10,000 cycles may be covered in approximately three minutes. As the frequency is varied continuously, there is no chance of missing any sharp irregularities in the curve.

The device was demonstrated using a loud speaker with a small microphone located directly in front of it and then with much greater separation between the two units; the two curves indicated a substantial difference in the response caused by the characteristics of the room.



It was pointed out that in high-fidelity systems where a small horn is used for the higher frequencies, difficulty is encountered at the crossover point where the large low-frequency speaker drops off and the tweeter becomes effective.

As much of the design work on speakers continues to be of the cut-and-try variety, an advantage of the recording system is that the graph is plotted on standard paper rather than of the rolled type. This permits the operator to watch the plotting and stop the measurement if it is evident that an undesirable result is being obtained.

April 24, 1939, R. C. Poulter, chairman, presiding.

A paper on "Modern Radio Range Equipment" was presented by F. A. A. Baily, an engineer of the Canadian Marconi Company. The theory of operation of aircraft radio range beacons was first presented. It was pointed out that large course errors caused by reflections from the ionosphere required that the closed-loop radiators be supplanted by vertical towers.

The ability to adjust the phase relation of the currents in the towers makes it unnecessary to construct the towers in the precise orientation in relation to the courses to be provided. Also, it is possible by unequal loading to shift the four courses in relation to each other so that they do not occur ninety degrees apart.

Weather conditions affect the resistance and reactance of the towers. Changes in resistance have little effect on the courses as observed at a distance but small changes in reactance produces considerable phase shift and wide variations in the observed courses. By arranging the reactance of the goniometer which couples the radiators to the source so that it exactly equals the short-circuited reactance of the transmission line, small changes in tower reactance have almost no effect on the phase relation of the currents in the towers.

The paper was closed with a discussion of the new ultra-high-frequency marker beacons. These produce a cone-shaped field pattern directly above the transmitter and give the pilot a positive indication of his location. This avoids the necessity of depending on the cone of silence which occurs directly above the regular range antenna which may be in error if the transmitter is interrupted in its operation.

May 8, 1939, G. J. Irwin, chairman, presiding.

## Washington

L. N. Chatterton, superintendent of the radio division of the Department of Public Safety of Cleveland, Ohio, presented a paper under the title of "Communications Modernize Police Administration." In it he presented a comprehensive picture of the operation of a modern police radio system. The Cleveland installation was described and included an extensive telephone network with an automatic exchange, teletype, public-address call systems, two-way radio communication between cars and the cen-

tralized transmitters, and an interstate radio network.

These facilities permit much greater police protection for a given personnel than could otherwise be obtained. It was pointed out that since the installation of this extensive system a reduction of over a million dollars has been made in insurance rates on automobiles and accessories in the city of Cleveland alone.

May 8, 1939, Gerald C. Gross, chairman, presiding.

## Membership

The following indicated admissions to membership have been approved by the Admissions Committee. Objections to any of these should reach the Institute office by not later than July 31, 1939.

### Transfer to Member

- Betts, P. H., Western Electric Co., 180 Varick St., New York, N. Y.  
 Platts, G. F., 3140 Epworth Ave., Cincinnati, Ohio.  
 Schlaack, N. F., Bell Telephone Labs., Inc., Deal, N. J.

### Admission to Member

- Edwards, B. J., 24 Gilbert Rd., Cambridge, England.  
 Preston, J. L., 936 N.E. Floral Pl., Portland, Ore.  
 Saliba, G. J., 172 Hudson Ave., Englewood, N. J.

### Admission to Associate (A), Junior (J), and Student (S)

- Acevedo, J., (A) Calle 60 No. 7-48, Bogota, Colombia.  
 Berkheiser, H. A., (S) 1024 N. 12th St., Lafayette, Ind.  
 Blumberg, M., (S) 2915 S. Broad St., Philadelphia, Pa.  
 Boyle, K. R., (A) 310 N. Mesquite, Arlington, Tex.  
 Brewster, F. C., (S) 1401 S. Washington St., Joliet, Ill.  
 Bronwell, A. B., (A) Northwestern University, Evanston, Ill.  
 Bryan, F. E., (A) 12906 Venice Blvd., Venice, Calif.  
 Buttschardt, C. C., (A) 29 Kingsbury Rd., Garden City, N. Y.  
 Cansick, N. V., (A) Amalgamated Wireless Valve Co. Pty., Ltd., 47 York St., Sydney, N.S.W., Australia.  
 Carlson, E. V., (J) White Cloud, Mich.  
 Christian, D. R., (S) 691 W. Main St., Geneva, Ohio.  
 Clark, J. R., (S) Box 244, Carmel, Ind.  
 Coales, J. F., (A) H. M. Signal School, R. N. Barracks, Portsmouth, England.  
 Cook, C., (A) 925 N. Wilson Ave., Rice Lake, Wis.  
 Cox, R. T., (S) 534 Bingham Ave., Sault Ste. Marie, Mich.  
 Dailey, H. J., (A) 81 Floyd Ave., Bloomfield, N. J.  
 Daniel, E., (S) 2100 W. 50th Pl., Chicago, Ill.  
 Decker, F. W., (S) 1653 S.E. Clatsop St., Portland, Ore.

- Eitel, W. W., (A) San Bruno, Calif.  
 Exner, D. W., (A) 238 Avenue A, Forest Hills, Wilkesburg, Pa.  
 Exner, W. L., (S) 1914 E. Roy St., Seattle, Wash.  
 Field, L. M., (S) 1505 S. Central Park Ave., Chicago, Ill.  
 Finch, H. D., (A) 5923—48th Ave., S.W., Seattle, Wash.  
 Gander, M. G., (A) 158 W. 101st St., New York, N. Y.  
 Gordon, H., Jr., (S) 601 W. 44th St., Richmond, Va.  
 Gostyn, E., (A) 71 Clifton Ave., Springfield, Mass.  
 Gowdey, M. V., (A) 1537—7th St., Bremerton, Wash.  
 Gradws, L., (A) Zelazna Str., 64, Warsaw, Poland.  
 Gray, R. I., (A) 3 Pratt St., Nashua, N. H.  
 Green, J. A., (S) 411 W. Stadium, West Lafayette, Ind.  
 Hansen, E. B., (A) 602 Northern Life Bldg., Seattle, Wash.  
 Hawk, R. R., (A) 6533 S. Sangamon St., Chicago, Ill.  
 Hebson, J. D., (S) 7943 Union Ave., Chicago, Ill.  
 Hess, H. A., (A) Bozener Str. 8/1, Berlin-Schöneberg, Germany.  
 Hoisington, D. B., (S) 95 Lorraine Ave., Upper Montclair, N. J.  
 Homewood, C., (A) CASOC, Bahrein Island, Persian Gulf.  
 Hooker, H. H., (S) 418 N. Kensington Ave., LaGrange, Ill.  
 Howard, R. R., (S) 304 N. Grove Ave., Oak Park, Ill.  
 Ingraham, J. S., (A) Burton, Wash.  
 Irons, A., (A) 34-40—100th St., Corona, L. I., N. Y.  
 Kozub, L. J., Jr., (J) 311 Elysian St., Pittsburgh, Pa.  
 Lampkin, R. J., (A) 470 Convent Ave., New York, N. Y.  
 Lorenzen, B. R., (S) 5519 Kenwood Ave., Chicago, Ill.  
 Marchand, N., (A) 104 Martense St., Brooklyn, N. Y.  
 Marik, E. F., (S) 1120 S. 22nd Ave., Bellwood, Ill.  
 McCann, B., (A) H.M.S. *Warspite*, c/o G.P.O., London, England.  
 McCullough, J. A., (A) 340 Hazel Ave., Millbrae, Calif.  
 Miffin, R. C., (A) Radio Station KXII, S.W. 11th & Washington, Portland Ore.  
 Miller, M. L., (S) 121 W. Lutz, West Lafayette, Ind.  
 Mohan, M. R., (A) "Vasant," Pachiapas Hostel Rd., Kilpauk Post, Madras, India.  
 Morgan, H. G., (S) 430 Techwood Dr., Atlanta, Ga.  
 Mundt, C. H., (A) 185 S. Elmwood Ave., Buffalo, N. Y.  
 Nanda, I. N., (A) c/o L. S. Nanda Srinager Kashmir, India.  
 Novics, B., (A) Guise 1956, Buenos Aires, Argentina.  
 Nuckolls, R. G., (A) Physicists Research Co., 343 S. Main St., Ann Arbor, Mich.  
 Nyquist, H., (A) Bell Telephone Labs., Inc., 463 West St., New York, N. Y.

- Orrell, D. B., (A) 3321 S.E. Lincoln St., Portland, Ore.
- Pacini, H. P., (S) 909 Rutger St., Utica, N. Y.
- Peter, B. K., (J) Washington St., Algonquin, Ill.
- Peterson, S., (A) 5937 N. Talman Ave., Chicago, Ill.
- Pike, D. A., (A) "Avalon," 74 W. Park Ave., Northfield, Birmingham 31, England.
- Polanco, G., (A) Apartado 65, Havana, Cuba.
- Redmond, J., (A) 12 Grove Cres., London N.W.9, England.
- Rempt, H. F., (A) 142-12—231st St., Rosedale, L. I., N. Y.
- Richardson, W. E., (A) Pacific Highway, Tigard, Ore.
- Robinson, E. F. V., (S) 11719—89th St., Edmonton, Alta., Canada.
- Salcedo, A., (S) Box 2365, Georgia Tech., Atlanta, Ga.
- Sasaki, K., (A) c/o Furukawa Phisico-Chemical Lab., 520 Shimoshinmeicho, Ebaraku, Tokyo, Japan.
- Schram, S. M., Jr., (A) 402 S. Brown St., Jackson, Mich.
- Shoaf, H. K., (S) Physics Dept., West Virginia University, Morgantown, W. Va.
- Simpson, J. A., Jr., (S) 2828 N.E. 30th Ave., Portland, Ore.
- Stewart, A. C., (A) Box 479, Council Bluffs, Iowa.
- Streeter, E. C., Jr., (S) 9A Ware St., Cambridge, Mass.
- Thorkelsson, S., (A) Norre Farimagsgade 65 II-V, Copenhagen K, Denmark.
- Trout, J. L., (A) 40 N. Bradley St., Indianapolis, Ind.
- Van Horn, J. H., (S) 244 Pierce St., West Lafayette, Ind.
- Vollum, H., (A) 1115 S.E. Lambert St., Portland, Ore.
- Whitney, M. G., (S) 249 Paine Ave., New Rochelle, N. Y.
- Williamson, A. F., (A) 1320 Main St., Kansas City, Mo.

## Contributors



R. A. BRADLEY

R. A. Bradley (A'37) was born on March 5, 1904, at Fort Wayne, Indiana. He attended Columbia University from 1920 to 1924. From 1924 to 1926 Mr. Bradley was a marine operator for the Radio Corporation of America; from 1926 to 1927, technical editor of *Wireless Age*; 1927 to 1928, assistant chief inspector of the Wireless Specialty Apparatus Company; 1928 to 1934, engineer-in-charge, station WNBZ; and from 1934 to date, in the audio-frequency division of the General Engineering Department of the Columbia Broadcasting System.



John M. Hollywood (J'30, A'32) was born at Red Bank, New Jersey, on February 4, 1910. He received the B.S. degree in communications in 1931 and the M.S. degree in electrical engineering in 1932 from Massachusetts Institute of Technology. From 1933 to 1935 Mr. Hollywood was with the Electron Research Laboratories; from 1935 to 1936 with the Ken-Rad Tube Corporation engaged in cathode-ray-tube development; and from 1936 to the present time, with the Columbia Broadcasting System working on television development.



H. F. OLSON

H. F. Olson (A'37) was born at Mt. Pleasant, Iowa, on December 28, 1902. He received the B.S. degree in 1924, the M.S. degree in 1925, the Ph.D. degree in 1928, and the E.E. degree in 1932 from the University of Iowa. Dr. Olson was a research assistant at the University of Iowa from 1925 to 1928. From 1928 to 1930 he was in the Research Department of the Radio Corporation of America; from 1930 to 1932, in the Engineering Department of RCA Photophone; and since 1932 he has



J. M. HOLLYWOOD



R. A. MILLER

been in the Research Division of the RCA Manufacturing Company. He is a member of Tau Beta Pi, Sigma Xi, the American Physical Society, and a Fellow of the Acoustical Society of America.



Ralph A. Miller was born on March 11, 1907, at Agra, Kansas. He received the B.S. degree in electrical engineering from Kansas State College in 1929. Since that date Mr. Miller has been engaged in research work on the derivation of precision frequencies and more recently on studies of speech analysis and speech synthesis at the Bell Telephone Laboratories.



H. A. CHINN

Howard A. Chinn, (A'27—M'36) whose photograph and biographical sketch appeared in the February, 1939, issue of the PROCEEDINGS, has brought to the attention of the editors an error in the latter. During the period from 1932 to 1933 he was employed as a research associate at Massachusetts Institute of Technology rather than at the Columbia Broadcasting System.



For biographical sketches of T. R. Gilliland, S. S. Kirby, Newbern Smith, and H. A. Wheeler see the PROCEEDINGS for January, 1939.

# Pennies For Wings

THE voice of a friend. Reassuring words from father, mother, son or daughter. A hurried call for aid in the night. You cannot set a price on such things as these.

Yet this is true—telephone service is cheap in this country. No other people get so much service, and such good and courteous service, at such low cost.



## BELL TELEPHONE SYSTEM

The Bell System cordially invites you to visit its exhibits at the New York World's Fair and the Golden Gate International Exposition, San Francisco



# Commercial Engineering Developments

These reports on engineering developments in the commercial field have been prepared solely on the basis of information received from the firms referred to in each item.

Sponsors of new developments are invited to submit descriptions on which future reports may be based. To be of greatest usefulness, these should summarize, with as much detail as is practical, the novel engineering features of the design. Address: Editor, Proceedings of the I.R.E., 330 West 42nd Street, New York, New York.

## Radio Beacon

The H.B.1 500/135-watt Tone Modulated Radio Beacon expressly developed for marine or air navigation purposes by Standard Telephones and Cables, Limited,\* in conjunction with the International Marine Radio Company, Limited, is capable of automatically sending out coded transmissions at predetermined intervals. The transmitter has a power rating of 500 watts continuous wave, or 135 watts modulated continuous wave, or telephone carrier and a frequency range of 240 to 350 kilocycles.

To ensure absolute reliability under all circumstances and at all times the components have ample operating margins and the equipment itself is tropically finished.

The transmitter is capable of continu-

\* Standard Telephones and Cables, Limited, Oakleigh Road, New Southgate, London N., England.

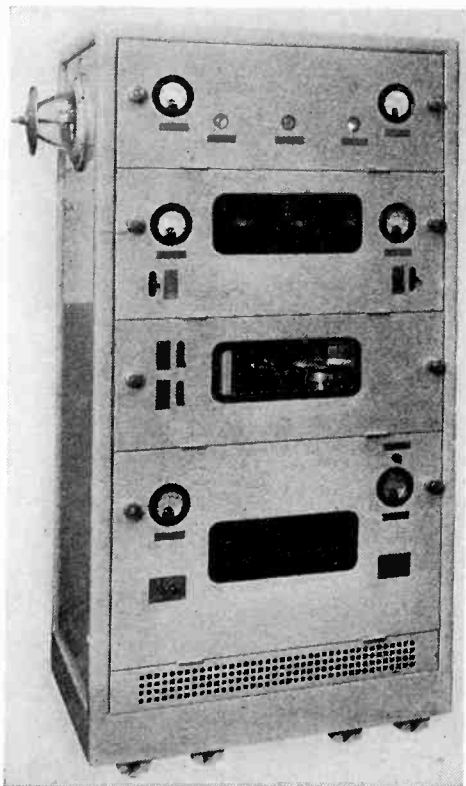

H. B. 1 Tone-Modulated Radio Beacon

ous, unattended operation and a small wall mounting fault indicator gives audible and visual alarm of carrier failure, modulation failure, code sender failure, or mains failure.

To maintain an uninterrupted service a second transmitter can be provided in duplicate. A changeover unit common to both transmitters immediately switches the aerial and power supplies from the operating transmitter to the standby transmitter in the event of a failure.

Control of the transmitter and code sender is effected by a chronometer accurate to within one half second per day. The code sender is motor driven and can be easily set up to transmit any desired sequence of signals.

The performance of the beacon conforms to the exacting requirements of this type of service. Modulated continuous wave or telephone carrier may be modulated 80 percent and the non-linear distortion under this condition is not more than 5 per cent. The radio frequency stability is better than 0.005 per cent with crystal control and 0.05 per cent with auto-oscillator control. Harmonic radiation conforms to the C.C.I.R. requirements. The power consumption is approximately 1.5 kilowatts for modulated continuous wave and 2.0 kilowatts for continuous wave.

Trials of the H.B.1 have been conducted in the radio laboratories of Standard Telephones and Cables, Limited, over a lengthy period with the transmitter operating under fog conditions, i.e., transmission every six minutes. The equipment was subject to these tests under extreme humidity and temperature conditions to ensure satisfactory working in tropical countries.

The transmitter complete with rectifier, power unit, clock control and code sender unit, and radio frequency apparatus is housed in a single standard cabinet 5 feet high, 2 feet 8 inches wide, and 1 foot 10½ inches deep, weighing approximately 900 pounds.

## Wax-Molded Paper Condensers

By developing a method of molding a paper-condenser in wax—much as though the section were imbedded at the center of a tallow candle—a manufacturer\* claims to have materially improved the life expectancy of the tubular by-pass condenser. Accelerated life tests are said to indicate a probable life 2 to 5 times greater than units built by other methods.

Recent efforts by condenser designers have been directed primarily at reducing the size of the unit to meet the restricted space allotment in a modern compact receiver. The problem of keeping out moisture—and moisture is one of the principal causes of bypass condenser failure—has been attacked at various times and slightly improved performance obtained by such expedients as wax dipping of the

\* Solar Manufacturing Company, 599 Broadway New York, New York.

section prior to its assembly in the cardboard tube and subsequent wax dipping of the condenser after end filling has been done. Failure would sometimes occur, however, at the joint between the end fill and the cardboard tube or at the joint in the end fill where the connector leads enter. Moulding the entire unit in wax, thus completely encasing the section with a uniform wax coating, seals the condenser element against moisture and, tests are said to show, materially improves life characteristics. Accelerated life tests conducted at twice the rated voltage and at 40 degrees centigrade with a relative humidity in excess of 95 per cent, have shown results of from 2 to 5 times greater than the same tests on standard wax end-filled units of the same rating.

Details of the manufacturing methods employed have not been disclosed, but they are said to depend for their success as much upon the choice of the type of wax as upon the molding technique employed.

## Current Literature

New books of interest to engineers in radio and allied fields—from the publishers' announcements.

A copy of each book marked with an asterisk (\*) has been submitted to the Editors for possible review in a future issue of the Proceedings of the I. R. E.

\* NEMA MANUFACTURED ELECTRICAL MICA STANDARDS. New York: National Electrical Manufacturers Association, March, 1939. 14 pages, 8×10½ inches, paper. \$0.25.

\* ELECTRON OPTICS: THEORETICAL AND PRACTICAL. By L. M. MYERS, Research Department, Marconi's Wireless Telegraph Company, Ltd. New York: D. Van Nostrand Company, Inc., 1939. 618 pages, 6×9 inches, cloth. \$15.00.

\* PRINCIPLES AND PRACTICE OF RADIO SERVICING. By H. J. HICKS, Radio Instructor, Hadley Vocational School. New York: McGraw-Hill Book Company, Inc. 1939. x+273+17 appendix+13 index pages, illustrated, 6×9 inches, cloth. \$3.00.

\* TEST CODE FOR APPARATUS NOISE MEASUREMENT. By Subcommittee on Sound, A.I.E.E. New York: The American Institute of Electrical Engineers, March, 1939. 9 pages, 8×10½ inches, paper. \$0.30.

\* APPLIED ACOUSTICS, Second Edition. By HARRY F. OLSON, Acoustic Research Director, Research Laboratories, RCA Manufacturing Company, Inc. and FRANK MASSA, Sound Engineering Division, RCA Manufacturing Company, Inc. Philadelphia, Pa.: P. Blakiston's Son & Company, Inc., 1939. xviii+494 pages, illustrated, 5½×8½ inches, cloth. \$5.50.

\* COMPLEX VARIABLE AND OPERATIONAL CALCULUS with Technical Applica-

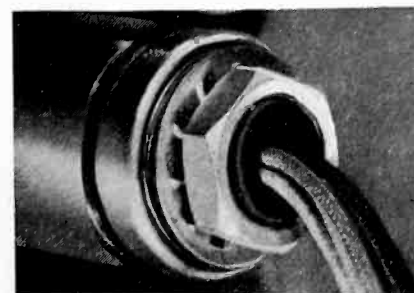
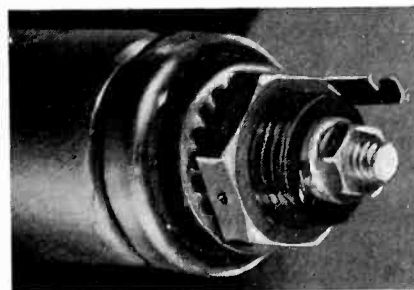
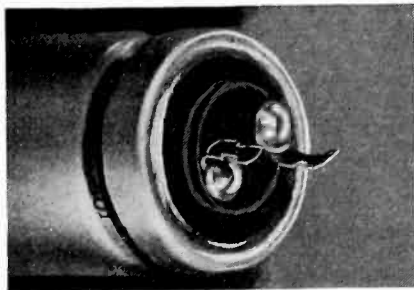
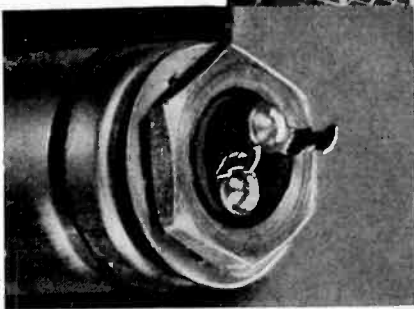
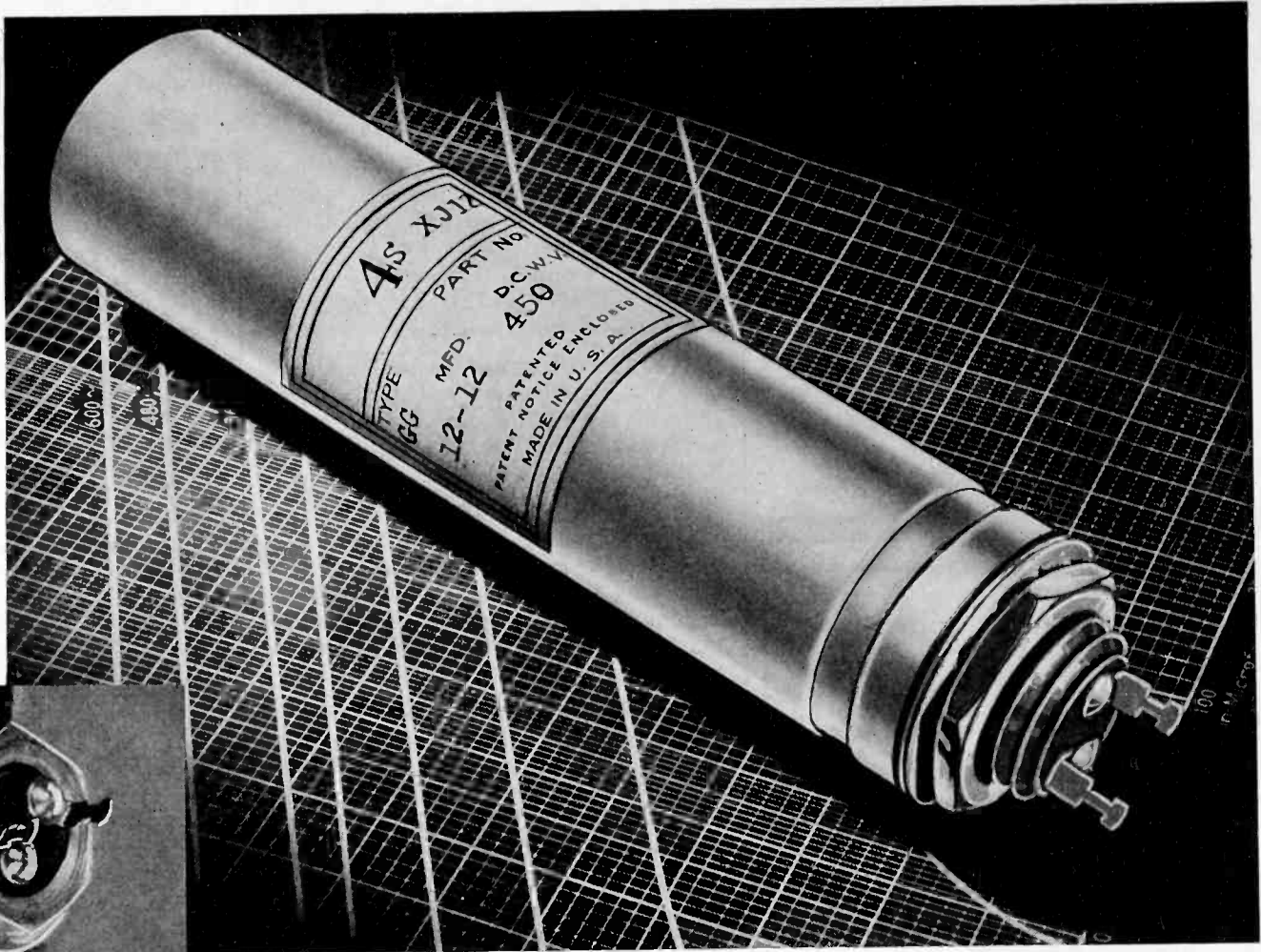

# Mountings *and* Terminals...

•Mechanically as well as electrically, AEROVOX electrolytic condensers can be precisely fitted to your assembly requirements. No need to improvise or shift things about, when dealing with the largest choice of cans, mountings and terminals extant.

Consider the matter of mountings: AEROVOX offers upright or inverted ring mounting, inverted threaded stud with lock nut mounting, flat strap mounting, and others.

Likewise with terminals. You can have leads or soldering lugs, grounded cans or insulated cans, ground contact lugs or insulating mounting washers for use with otherwise grounded cans, etc.

So wide a choice of cans, mountings and terminals, in addition to meeting any electrical considerations, is certainly in keeping with the spirit of A.A.E. (Aerovox Application Engineering) service, which strives to provide you with a still better assembly at a lowered cost.

## Submit Your Condenser Problems...

- It costs you nothing to get A.A.E. Just place your tuner, amplifier, power supply or other circuits before our engineers for suggestions, samples, specifications, quotations.



# AEROVOX CORPORATION

*New Bedford, Mass.*



Sales Offices in All Principal Cities

# DEPENDABLE HIGH FREQUENCY CRYSTAL CONTROL



Bliley High Frequency Quartz Crystal Units are designed to provide accurate, dependable frequency control under the adverse operating conditions encountered with mobile and portable transmitters. Both the rugged type MO2 holder and the compact MO3 temperature controlled mounting are widely employed for U.H.F. services where reliability counts. Catalog G-10 contains complete information on these and other Bliley Crystal Units for frequencies from 20kc. to 30mc.

Write for your copy.

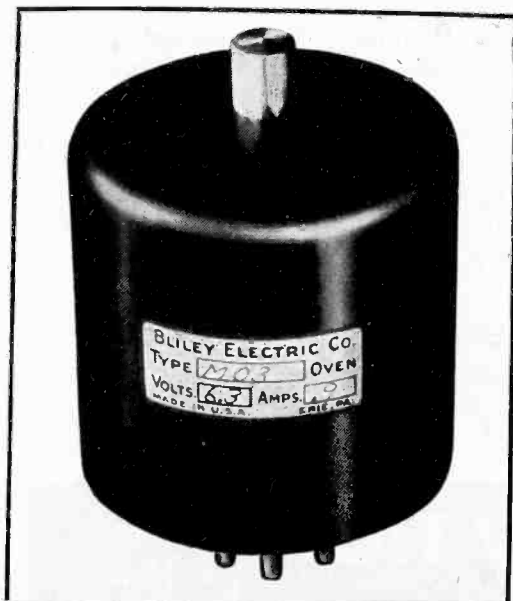

**BLILEY ELECTRIC CO.**  
UNION STATION BUILDING ERIE, PA.

tions. By N. W. Mc LACHLAN. Cambridge: at The University Press; New York: The Macmillan Company, June 27, 1939. xi+293+45 appendix +13 index pages, illustrated, 6×9 inches, cloth. \$6.50.

\* DER KONDENSATOR IN DER FERNMELDETECHNIK (The Condenser in the Communication Art). By DR. ING GEORG STRAIMER, Oberkommando des Heeres (Heereswaffenamt). Leipzig: S. Hirzel, February, 1939. x+224+5 index pages, illustrated, 6×9 inches, paper.

\* ELEKTROTECHNIK für den Rundfunk- und Verstärkerfachmann (Electrical Engineering for the Broadcasting and Amplifier Specialist). By DR. ING. F. BERGTOLD. Berlin: Weidmannsche Verlagsbuchhandlung, 1939. 294+3 index pages, illustrated, cloth.

\* ENGINEERING OPPORTUNITIES. Edited by R. W. CLYNE. New York and London: D. Appleton-Century Company, 1939. xxv+387+9 index pages, illustrated 6×8½ inches, cloth. \$3.00.

\* PRODUCTION AND DIRECTION OF RADIO PROGRAMS. By JOHN S. CARLILE, Production Manager, Columbia Broadcasting System. New York: Prentice-Hall, Inc., June, 1939. xx+383+11 index pages, illustrated, cloth. \$3.75.

\* THE ABC OF RADIO. Washington, D. C.: National Association of Broadcasters, 1938. 37 pages, illustrated, paper.

\* DISTRIBUTION OF WEATHER INFORMATION, FORECASTS, AND WARNINGS BY RADIO FOR THE BENEFIT OF NAVIGATION ON THE GREAT LAKES. Washington: U.S. Department of Agriculture, Weather Bureau, April 15, 1939. 9 pages, 7½×10½ inches, pamphlet.

## Booklets, Catalogs and Pamphlets

The following commercial literature has been received by the Institute.

ADJUSTABLE TRANSFORMERS \* \* \* *General Radio Company, 30 State Street, Cambridge, Massachusetts. Bulletin 424-C, 4 pages, 8½×11 inches.* Specifications and application data on the variac in a variety of models.

AIRCRAFT ANTENNA \* \* \* *RCA Manufacturing Company, Inc., Camden, N. J. Bulletin 1A612, 4 pages 8½×11 inches.* Description of the AVA41 Antenna System for aircraft.

BROADCASTING \* \* \* *National Broadcasting Company, 30 Rockefeller Plaza, New York, New York.* "Broadcasting in the Public Interest" 80 pages+cover, 6×9 inches. A comprehensive description of NBC's history, policies, etc.

CABLE-TEST SET \* \* \* *Leeds & Northrup Company, 4907 Stenton Avenue, Philadelphia, Pennsylvania. Catalog E-53-441(1), 6 pages, 7½×10½ inches.* Description of the recently revised Type U Test Set for locating line and cable faults in communication circuits.

CERAMIC INSULATION \* \* \* *American Lava Corporation, Chattanooga, Tennessee. Bulletin 39, 36 pages+cover, 8½×10½ inches.* Data on the properties of the alsimag ma-

## New circuit CONDENSER BRIDGE covers all range requirements

Model 1640



Dealer Net \$90.00

- ★ Red Dot Lifetime Guaranteed Meters.
- ★ 110 Volt 60 Cycle A.C. Operation.
- ★ Range .00025 to 250 mfd. Paper, Mica or Electrolytic Condensers.
- ★ Two-Color GOOD-BAD scale for Electrolytics from 2 to 250 Mfd.
- ★ Voltmeter and Milliammeter in Circuit at Same Time for Leakage Test.
- ★ Capacity Measured at 60 Cycles.

By means of this new circuit perfected by Triplet, paper or electrolytic condensers can be measured on direct reading scales, including accurate measurements on condensers with high leakage. Capacity is measured at 60 cycles. Leakage tests can be made up to 600 volts. The six direct reading scales have a total length of 36 inches. The red dot on the dial of the meter assures you a lifetime service and is a guarantee against defective material or workmanship in the measuring instrument. Model 1640 in Metal Case with black suede finish. . . . Dealer Net Price . . . \$90.00.

COMPLETE TECHNICAL  
DATA ON REQUEST

**TRIPLET**  
Precision  
ELECTRICAL INSTRUMENTS

THE TRIPLET ELECTRICAL  
INSTRUMENT CO.  
217 Harmon Ave., Bluffton, Ohio  
Please send me more information on  Model  
1640;  I am also interested in . . . . .  
Name . . . . .  
Address . . . . .  
City . . . . . State . . . . .

The background of the entire page is a dense, overlapping collage of various vacuum tubes. The tubes are of different shapes and sizes, some with labels like 'AMPEREX 801', 'AMPEREX 203A', 'AMPEREX 849H', and 'AMPEREX HE-100'. They are arranged in a way that creates a sense of depth and technical complexity.

# KVGB

Technical Department  
GREAT BEND, KANSAS

LEO LEGLEITER  
*Chief Engineer*  
DAVE WILSON  
*Production Manager*  
JUSTIN BRADSHAW  
*Traffic Manager*  
VERN MINOR  
*Business Manager*

May 16, 1939

Gentlemen:-

...Going back over the transmitter logs of KVGB, I find that two 872's and two 838's were installed in the transmitter on March 4th, 1937. These tubes have never been removed from their respective sockets, except, of course, for the routine prong and socket polishing jobs, and the periodic emission tests.

These four Amperex tubes have seen every day, every hour of broadcasting from this station, and are, according to the last tests, in "as good as new" condition.

Two Amperex 203A's were placed in service at the same time, but were removed after successfully and satisfactorily passing 6,094 hours. Two other tubes of a well known make were then installed. The last of these competitive tubes gassed out of service at the end of 2,586 hours. The Original Amperex tubes were then restored to service and at the last accounting had 7,571 hours of interrupted service behind them.

The initial tube installation of 872's and 838's are, as I stated above, still in service, and have passed 10,157 hours of perfect performance. Some of these hours, by the way, were hard ones, in which line voltage fluctuations, and extremely high powerline peaks would raise the filament voltage to the eleven and twelve volt levels. Thought you might like to know.

With this perfect record to serve as a basis of comparison, it's not hard to guess the name our replacement tubes will carry.

Yours enthusiastically,

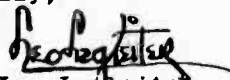
  
Leo Legleiter,  
Chief Engineer, KVGB

*Thank You KVGB*

**AMPEREX ELECTRONIC PRODUCTS, Inc.**  
79 WASHINGTON STREET

**BROOKLYN, NEW YORK**

Export Division: 100 Varick Street, New York, U. S. A. Cables: "ARLAB"

# Undeniably "TOPS"

We proudly submit any of our attenuators as an example of DAVEN craftsmanship . . . and on its all-round quality and dependability in most exacting service. We base our claim to a standard of excellence that is associated with the leaders in the field of broadcasting.

You will find DAVEN ATTENUATORS used extensively in the Columbia Broadcasting System . . . the National Broadcasting Company and key stations of the Mutual Broadcasting System . . . in fact, in practically all networks and major station installations. . . .

## TYPE LA-350 ★

**CIRCUIT:** Ladder Network. Twenty steps of attenuation, 2 db. steps tapered to infinity or complete cut-off. Minimum attenuation, 6 db. for 1:1 impedance ratio and 2 db. for 1:2 impedance ratio.

**FREQUENCY ERROR:** None over the range from 0 to 20,000 cycles. Noise level below microphonics. Wire wound resistors used exclusively. Knob, Alumilite dial and shield supplied.

**DIMENSIONS:** 1 3/4" diameter x 1 3/4" depth.

TERMINAL IMPEDANCES:		
30/30	50/50	125/125
30/60	50/100	200/200
	250/250	500/500
	250/500	600/600

Price . . . . . \$7.50

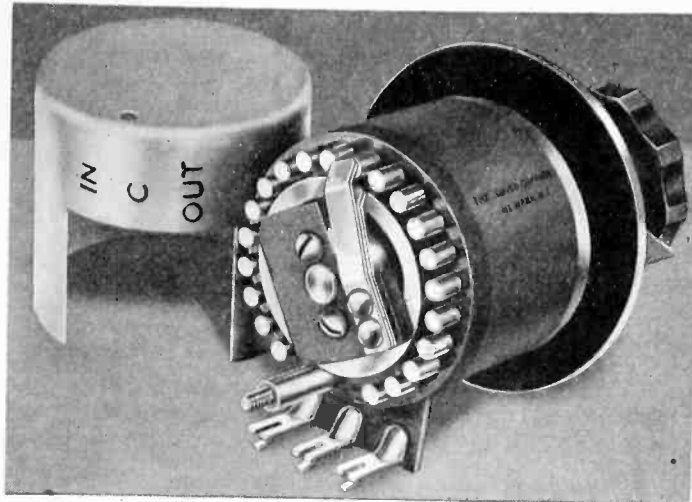

Patent Applied For

## TYPE 321 ★

**CIRCUIT:** "TEE" Network. Twenty steps of attenuation, 2 db. steps tapered to infinity or complete cut-off. Zero insertion loss for 1:1 impedance ratio and minimum loss for unequal impedances.

**FREQUENCY ERROR:** None over the range from 0 to 20,000 cycles. Noise level below microphonics. Wire wound resistors used exclusively. Knob, alumilite dial and shield supplied.

**DIMENSIONS:** 2 3/4" diameter x 2-1/16" depth.

TERMINAL IMPEDANCES:		
30/30	200/200	500/500
50/50	250/250	600/600

Price . . . . . \$15.00

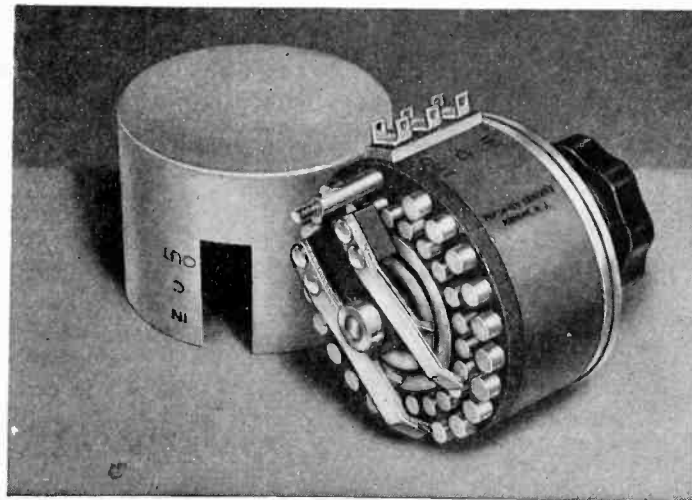

Patent Applied For

## TYPE 154

Type 154 pads are fixed type attenuator networks for use where a definite and constant loss must be introduced without upsetting the impedance characteristics of the system. They are also used for changing from one impedance to another. Most popular terminal impedances and decibel loss available in stock for immediately delivery. Any terminal impedance or loss may be secured at no additional cost.

Balanced "H" network, \$4.00 "TEE" network, \$3.00

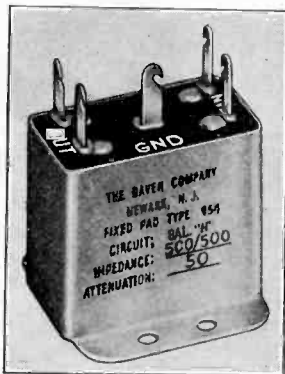

materials and a description of some of the forms in which it can be manufactured.

**COILS** . . . *Meissner Manufacturing Company, Mt. Carmel, Illinois. Catalog J-87, 48 pages, 8 1/2 x 10 1/2 inches.* Coils, intermediate-frequency-amplifier transformers, and kits for the construction of receivers.

**CONDENSERS** . . . *Aerovox Corporation, New Bedford, Massachusetts. "The Aerovox Research Worker," 4 pages, 8 1/2 x 11 inches.* Information on methods of testing motor-starting condensers.

**COMPONENTS** . . . *American Phenolic Corporation, 1250 Van Buren Street, Chicago, Illinois. Catalog 57-J, 32 pages, 8 1/2 x 11 1/2 inches.* A listing of sockets, cable connectors, insulators, coil forms, etc., including the new Amphenol Polystyrene-Base insulating material.

**CONSTANT-VOLTAGE TRANSFORMERS** . . . *Sola Electric Company, 2525 Clybourn Avenue, Chicago, Illinois. Bulletin SM-22, 12 pages + cover, 8 1/2 x 11 inches.* Basic engineering notes on the design, construction, and application of a new voltage-regulating power transformer.

**CRYSTAL CALIBRATOR** . . . *Bliley Electric Company, Erie, Pennsylvania, Bulletin E-7, 8 pages, 6 1/2 x 9 1/2 inches.* Description of a crystal calibrator unit for indicating 100-kilocycle and 1000-kilocycle points, primarily intended for amateur and radio-service use.

**CRYSTAL-TYPE ELECTRO-ACOUSTIC TRANSDUCERS** . . . *The Brush Development Company, 3333 Perkins Avenue, Cleveland, Ohio.* A set of three catalog folders, 20 pages, 8 1/2 x 11 inches. Data on Brush crystal headphones, microphones, and phonograph pickups.

**INSTRUMENTS** . . . *Cornell-Dubilier Electric Corporation, South Plainfield, New Jersey. Catalog 167-A, 8 pages, 8 1/2 x 11 inches.* Description of two capacitance bridges and a new line of direct-reading decade condensers.

**INSTRUMENTS** . . . *General Radio Company, 30 State Street, Cambridge, Massachusetts. June, 1939, 8 pages, 6 x 9 1/2 inches.* Describes a new 500-volt megohm bridge for measuring insulation resistance. Also contains a 2-page table listing the principal mechanical and electrical properties of 29 different solid insulating materials.

**INSTRUMENTS** . . . *The Triplett Electrical Instrument Company, 217 Harmon Ave., Bluffton, Ohio. Catalog 6439-T, 12 pages, 8 1/2 x 11 inches.* Circuit analyzers, test oscillators, condenser bridges, etc.

**NOISE FILTERS** . . . *Cornell-Dubilier Electric Corporation, South Plainfield, New Jersey. Catalog 166-A, 8 pages, 8 1/2 x 11 inches.* Line of radio-noise interference filters for home and industrial applications.

**TELEVISION-SIGNAL GENERATOR** . . . *Allen B. DuMont Laboratories, Inc., 2 Main Avenue, Passaic, New Jersey. "DuMont Oscilloscoper," April-May, 1939, 4 pages, 6 x 9 1/2 inches.* Contains a description of the Type 203 synchronizing-signal generator for use in television-transmitting-station applications.

# THE DAVEN COMPANY

158-160 SUMMIT STREET

NEWARK, N.J.



# IRE membership offers many services to the radio engineer

**Proceedings**—An outstanding publication in the radio engineering field. Over a quarter of a century of service to the world in publishing important radio engineering discoveries and developments, the PROCEEDINGS presents exhaustive engineering data of use to the specialist and general engineer. A list of its authors is a "Who's Who" of the leaders in radio science, research, and engineering.

**Standards**—Since 1914 our standards reports have stabilized and clarified engineering language, mathematics, graphical presentations, and the testing and rating of equipment. They are always in the process of revision and thus remain up to date

**Meetings**—In twenty-two cities in the United States and Canada, meetings of the Institute and its sections are held regularly. Scores of papers on practically every branch of the field are presented and discussed. Several convention meetings are sponsored by the Institute and add materially to its effectiveness in distributing data of value to engineers.

## The Institute of Radio Engineers

Incorporated

330 West 42nd Street, New York, N.Y.

To the Board of Directors

Gentlemen:

I hereby make application for ASSOCIATE membership in the Institute of Radio Engineers on the basis of my training and professional experience given herewith, and refer to the sponsors named below who are personally familiar with my work.

I certify that the statements made in the record of my training and professional experience are correct, and agree if elected, that I shall be governed by the Constitution of the Institute as long as I continue a member. Furthermore I agree to promote the objects of the Institute so far as shall be in my power.

.....  
(Sign with pen)

.....  
(Address for mail)

.....  
(City and State)

.....  
(Date)

### SPONSORS

(Signatures not required here)

Mr. ....

Address .....

City and State .....

Mr. ....

Address .....

City and State .....

Mr. ....

Address .....

City and State .....

# Associate membership affiliates you with the Institute and brings you the PROCEEDINGS each month as well as notices of meetings held near you.

(Typewriting preferred in filling in this form) No.....  
**RECORD OF TRAINING AND PROFESSIONAL EXPERIENCE**

Name .....  
 (Give full name, last name first)

Present Occupation .....  
 (Title and name of concern)

Business Address .....

Home Address .....

Place of Birth ..... Date of Birth ..... Age .....

Education .....

Degree .....  
 (College) (Date received)

**TRAINING AND PROFESSIONAL EXPERIENCE**  
 (Give dates and type of work, including details of present activities)

---

---

---

---

---

---

---

---

---

---

---

---

---

---

---

---

---

---

---

---

---

---

---

---

Record may be continued on other sheets of this size if space is insufficient.

Receipt Acknowledged ..... Elected ..... Notified .....

**Requirements**—For Associate membership, an applicant must be at least twenty-one years of age, of good character, and be interested in or connected with the study or application of radio science or the radio arts.

**Sponsors**—Three sponsors who are familiar with the work of the applicant must be named. Preferably these should be Associates, Members, or Fellows of the Institute. In cases where the applicant is so located as not to be known to the required number of member sponsors, the names of responsible nonmember sponsors may be given.

**Dues**—Dues for Associate membership are six dollars per year. The entrance fee for this grade is three dollars and should accompany the application.

**Other Grades**—Those who are between the ages of eighteen and twenty-one may apply for Junior grade. Student membership is available to full-time students in engineering or science courses in colleges granting degrees as a result of four-year courses. Member grade is open to older engineers with several years of experience. Information on these grades may be obtained from the Institute.

---

# COMPLETE YOUR FILES OF

## PROCEEDINGS of The Institute of Radio Engineers

### WHILE BACK ISSUES ARE STILL AVAILABLE

Now is the time to fill out the gaps on your *Proceedings* shelf and replace lost or borrowed copies. Already, more than 25% of all back numbers are no longer available. Ten numbers went on the "out-of-print" list during 1938. Order from the following list :

**1913-1915**                      **Volumes 1-3**                      **Quarterly**                      **\$1.50 per copy**  
1913 Vol. 1 Jan. (a reprint), July, Dec.

**1916-1926**                      **Volumes 4-14**                      **Bi-monthly**                      **\$1.50 per copy**

1917	Vol. 5	Apr., June, Aug., Oct., Dec.	1922	Vol. 10	All 6 issues
1918	Vol. 6	All 6 issues	1923	Vol. 11	All 6 issues
1919	Vol. 7	Feb., Apr., Aug., Dec.	1924	Vol. 12	Aug., Oct., Dec.
1920	Vol. 8	Apr., June, Aug., Oct., Dec.	1925	Vol. 13	Apr., June, Aug., Oct., Dec.
1921	Vol. 9	All 6 issues	1926	Vol. 14	All 6 issues

**1927-1939**                      **Volumes 15-27**                      **Monthly**                      **\$1.00 per copy**

1927	Vol. 15	Apr. to July, Oct. to Dec.	1933	Vol. 21	All 12 issues*
1928	Vol. 16	Feb. to Dec., inc.	1934	Vol. 22	All 12 issues*
1929	Vol. 17	Apr. to June, inc., Nov.	1935	Vol. 23	All 12 issues*
1930	Vol. 18	Jan., Feb., Apr. to Dec., inc.†	1936	Vol. 24	Jan. to June, inc.
1931	Vol. 19	All 12 issues* †	1937	Vol. 25	All 12 issues*
1932	Vol. 20	Jan., Mch. to Dec., inc.	1938	Vol. 26	All 12 issues*
			1939	Vol. 27	Jan. to date

\* Price for the set of 12 issues, \$10.00

† Complete sets, bound in buckram, are available, \$12.00

#### I.R.E. MEMBERS . . . PUBLIC AND COLLEGE LIBRARIES

I.R.E. members in good standing are entitled to a discount of 25% from the above prices. Information about discounts to accredited public and college libraries will be supplied on request.

#### POSTAGE

Prices include postage in the United States and Canada. Postage to other countries: 10 cents per copy, \$1.00 for bound volumes and complete sets of unbound 12-issue volumes.

**Remittance should accompany your order**

**THE INSTITUTE OF RADIO ENGINEERS, Inc.**  
**330 WEST 42nd STREET, NEW YORK, N. Y.**

# ENGINEERING DIRECTORY

Consultants, Patent Attorneys,  
Laboratory Services

BRUNSON S. McCUTCHEN and  
CHARLES B. AIKEN  
Consulting Engineers

Technical cooperation with Attorneys in  
connection with patent litigation—De-  
sign and Development work—Audio and  
radio frequency measurements—Equip-  
ment studies—Receiver and transmitter  
problems—A well equipped laboratory.  
75 West Street Telephone  
New York City Whitehall 4-7275

W. J. POLYDOROFF  
CONSULTING ENGINEER

Design and complete tests of dust core  
inductors, all frequencies and applications.  
Research and patent problems in com-  
munication art, including television.

2020 ENGINEERING BUILDING  
CHICAGO, U.S.A.

## Use this directory . . .

when you need consulting serv-  
ices

when you are asked to suggest  
the name of a specialist on an en-  
gineering or patent problem

Consulting Engineers, Patent Attor-  
neys, Laboratory Services . . . Applica-  
tions for card space in the Engineering  
Directory are invited. Complete data  
will be sent on request to

PROCEEDINGS of the I.R.E.

330 West 42nd Street New York, N.Y.

# INDEX

BOOKLETS, CATALOGS AND PAMPHLETS . . . . .	iv
COMMERCIAL ENGINEERING DEVELOPMENTS . . . . .	ii
CURRENT LITERATURE . . . . .	ii
ENGINEERING DIRECTORY . . . . .	x
POSITIONS OPEN . . . . .	x

## DISPLAY ADVERTISERS

### A

Aerovox Corporation . . . . .	iii
American Telephone & Telegraph Company . . . . .	i
Amperex Electronic Products, Inc. . . . .	v

### B

Bliley Electric Company . . . . .	iv
-----------------------------------	----

### C

Cornell-Dubilier Electric Corporation . . . . .	xii
---	-----

### D

Daven Company . . . . .	vi
-------------------------	----

### G

General Radio Company . . . . .	Cover IV
---------------------------------	----------

### R

RCA Manufacturing Company, Inc. . . . . .	Cover III
--	-----------

### T

Triplett Electrical Instrument Com- pany . . . . .	iv
---	----

### W

Western Electric Company . . . . .	xi
------------------------------------	----

# POSITIONS OPEN

The following positions of interest to  
I.R.E. members have been reported as  
open on June 26. Make your application  
in writing and address it to

Box No. . . . .

PROCEEDINGS of the I.R.E.  
330 West 42nd Street, New York, N.Y.

*Please be sure that the envelope  
carries your name and address*

## DESIGN ENGINEERS

The Proceedings is receiving an  
increasing number of requests from  
employers for engineers with *com-  
mercial—design experience* on va-  
rious specialized types of radio-  
communication equipment: receivers  
and transmitters, audio and video,  
for the broadcast, police, and air-  
craft services.

If you are qualified and are inter-  
ested in openings of this type, we  
suggest that you file a statement of  
your education and experience rec-  
ord with I.R.E. headquarters. Write  
to Box 200 and request a copy of the  
"I.R.E. Employment Record Form."

## TELEVISION RECEIVER ENGINEER

not over 35, with wide background  
of laboratory experience in modern  
radio receiver testing and construc-  
tion. Must possess skill in mechani-  
cal layout and know electrical wir-  
ing technic at high frequencies as  
well as at high voltage. Must be able  
to calculate coils and circuit con-  
stants for practical application to  
television broad band amplifiers.  
Should be familiar with sweep cir-  
cuits and synchronizing equipment.  
Enclose picture and state salary. Box  
198.



## Attention Employers . . .

Announcements for "Positions Open" are  
accepted without charge from employers  
offering salaried employment of engineer-  
ing grade to I.R.E. members. Please sup-  
ply complete information and indicate  
which details should be treated as confi-  
dential. Address: "POSITIONS OPEN,"  
Institute of Radio Engineers, 330 West  
42nd Street, New York, N.Y.

The Institute reserves the right to refuse any  
announcement without giving a reason for  
the refusal

# Enjoy maximum Studio Control Flexibility

... with this new and modern  
Speech Input Bay and Control Console

## ASK YOUR ENGINEER about these features

**Inputs** (Equipment as stocked): 3 studio microphones, 1 booth microphone, 2 transcriptions, 2 remote lines or networks, 1 spare.

**Overall Gain:** Approximately 86 db.

**Overall Frequency Response:** Uniform within  $\pm 1$  db from 30 to 10,000 cycles.

**Output:** 600 ohms.

**Output Level:**  $\pm 12$  vu.

**System Noise Below Program at Output:** (as measured in laboratory with 70 db net system gain)—

Weighted (as the ear would hear it) . . . 69 db.  
Unweighted . . . 56 to 60 db.

**Distortion:** Less than 1% under normal operating conditions.

**Power Required:** 105 to 125 volts, 50 to 60 cycles with a power consumption of approximately 160 watts.

**Bay Cabinet Dimensions:** Approximately 83 $\frac{3}{4}$ " high (77" panel mounting space) x 21 $\frac{1}{2}$ " wide x 13 $\frac{1}{8}$ " deep.

**Control Cabinet Dimensions:** Approximately 8" high x 20" long x 7 $\frac{3}{8}$ " deep at the base (sloping panel).

*You've got something extra when you can tell your prospects and sponsors that your station is*

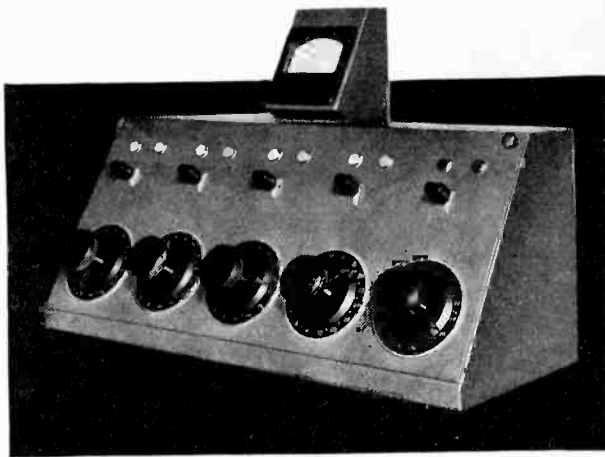

The Western Electric 704A Speech Input Bay—plus the 721A Control Cabinet—gives you a convenient and compact, AC operated, single program channel assembly—with space for adding a second program channel for stand-by, audition or dual program operation.

This equipment provides maximum control flexibility—circuit and equipment adaptability to varied operating requirements, with highest quality performance.

For booklet giving full details, write Graybar Electric Co., Graybar Building, New York City. In Canada and Newfoundland: Northern Electric Co., Ltd. In other countries: International Standard Electric Corp.

**Western Electric**  
EQUIPPED FOR  
BETTER BROADCASTING

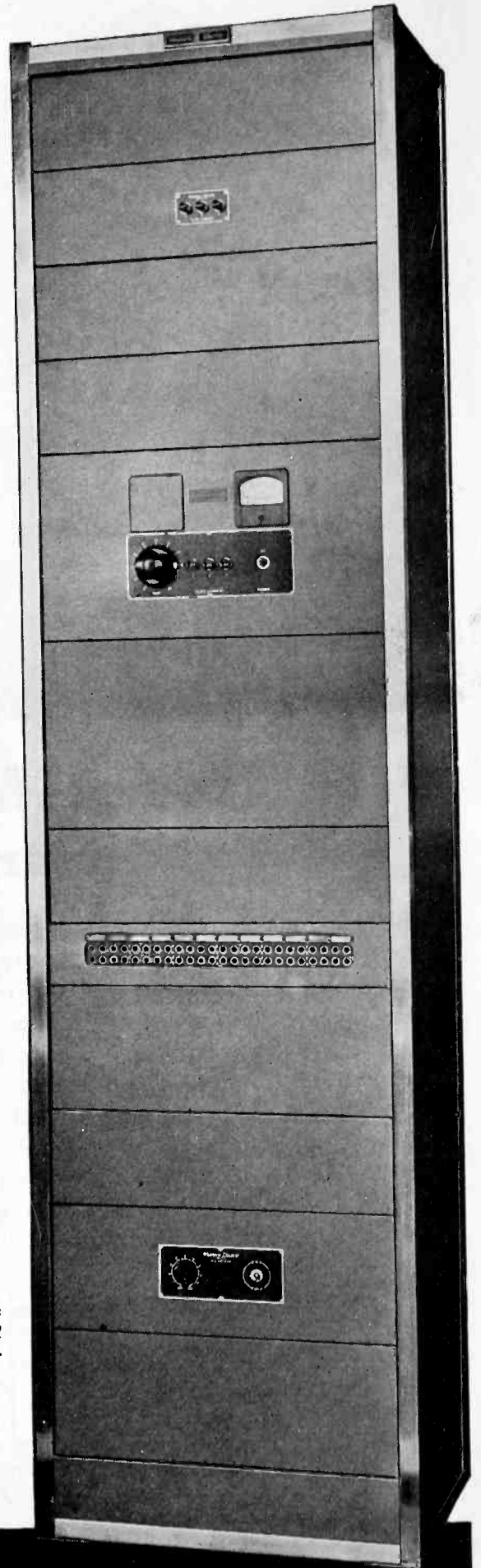

# Western Electric

RADIO TELEPHONE BROADCASTING EQUIPMENT

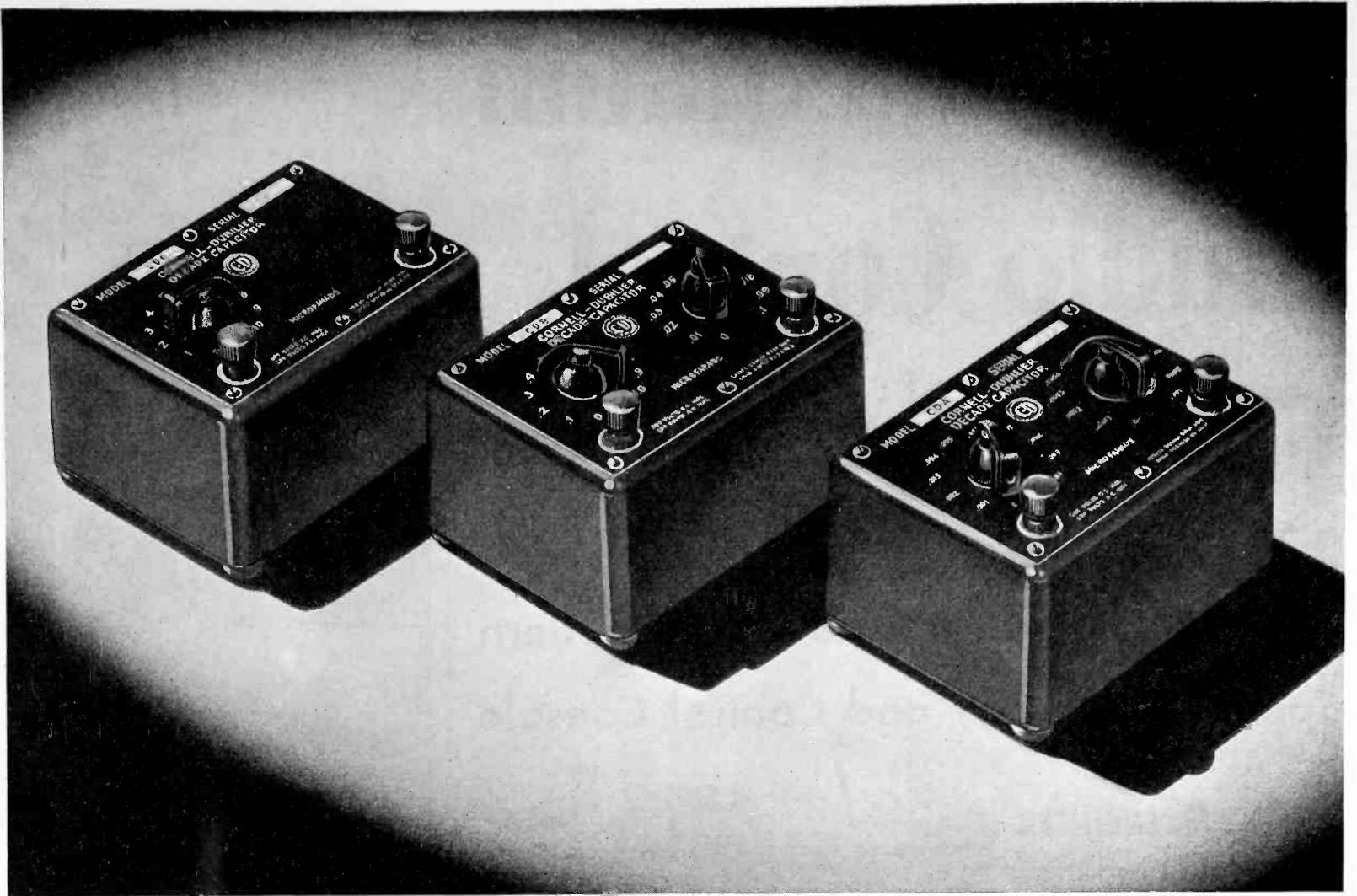

## DIRECT READING CAPACITOR DECADES For General Purpose Measurements

C-D Capacitor Decades provide accurate standards over a wide capacity range. Ideally suited for test circuits, filter design, bridge measurements and many other experimental applications. C-D Decades may be used in groups of three, or individually for maximum flexibility. They employ high quality capacitor standards, accurate to within 5%, (special units available at a slightly higher cost, accurate to within 3%). Decades of other capacity ranges, close-tolerances or higher voltage ratings can be furnished on special order.

MODEL	CAPACITY	TOLERANCE	DIELECTRIC	LIST PRICE
CDA-5	.011 mfd in .0001 mfd steps	5%	Mica	9.00
CDB-5	1.1 mfd in .01 mfd steps.	5%	Oil-Paper	9.00
CDC-5	10. mfd in 1. mfd steps	5%	Oil-Paper	16.00

For complete information on C-D Capacitor Decades, Analyzer and Bridge write for catalog No. 167-A today.

**CORNELL-DUBILIER  
ELECTRIC CORPORATION**

1012 Hamilton Boulevard, South Plainfield, New Jersey  
Cable Address: CORDU

### FEATURES OF CORNELL-DUBILIER CAPACITOR DECADES

**COMPLETE CAPACITY RANGE.** A complete capacity range from .0001 to 11.1 mfd. offered by grouping of three decades.

**DESIGNED FOR CONTINUOUS DUTY.** Capacitor decades can be used continuously in circuits where voltages do not exceed 220 V.A.C. or 600 V.D.C.

**HIGH QUALITY STANDARDS USED.** Decades employ high quality mica and oil paper dielectric capacitors. Losses and capacity variation with frequency reduced to a minimum.

**ACCURATE CALIBRATION.** Chart furnished with decades gives exact capacity values for all dial settings, extending use to more precise measurements.

**DIRECT READING.** Calibration markings are indicated directly in microfarads for simplified readings.

**EXTREMELY COMPACT.** Size of Decades only 3<sup>5</sup>/<sub>8</sub> x 5 x 3 inches.

**COMPLETELY INSULATED.** Decades are housed in attractive walnut Bakelite casings completely insulated.

**PRODUCT OF THE WORLD'S  
LARGEST AND OLDEST MANU-  
FACTURER OF CAPACITORS.**

Have you received your copy of the new C-D Radio Transmitter Capacitor Catalog No. 160-T? Copy free on request.

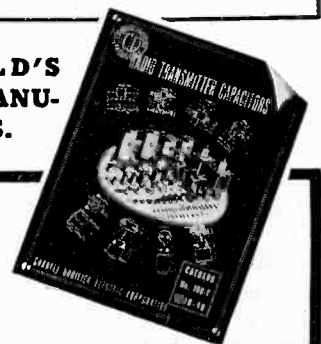

# RCA ICONOSCOPES

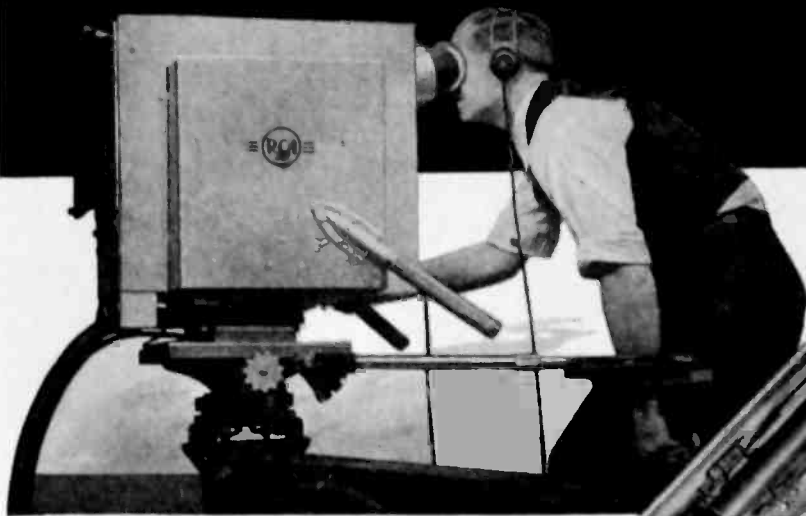

Television transmission with the RCA 1850 Iconoscope under studio conditions. A lens in the "camera" focuses the scene on the photo-sensitive mosaic of the "Ike".

## *Paving the Way to* **HIGH-DEFINITION TELEVISION**

Not since the development of the electronic tube itself, has there been an event of such tremendous significance to the fields of entertainment, communications and education as the introduction of the RCA Iconoscope. A tribute to modern engineering genius, the Iconoscope is literally the "heart" of Television in its most practical, most modern form. It is the Iconoscope which made possible the public advent of High-Definition Television in New York City over both the CBS and NBC Broadcasting Systems. The Iconoscope is truly the Aladdin's lamp of the most amazing system of communication ever devised by man!

By providing a means of electronic scanning at the transmitter, the Iconoscope affords a practical solution to such all-important problems as those of flexibility and definition. Its construction permits the storing up of effects from a light image between successive scanings. The resulting high sensitivity permits its use under a wide range of lighting conditions.

Two Iconoscope types, RCA 1849, designed for pick-up from movie film, and RCA 1850, for direct pick-up of scenes, are now ready for delivery. These are described in detail in an RCA Technical Bulletin now available from RCA Commercial Engineering Section, Harrison, New Jersey.

*Visit the RCA Television Exhibits at the Golden Gate International Exposition and the New York World's Fair*

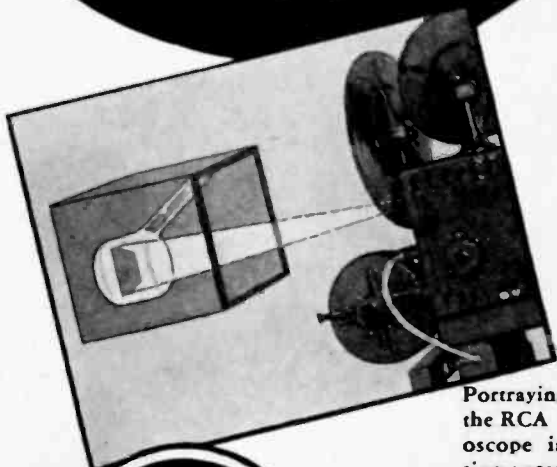
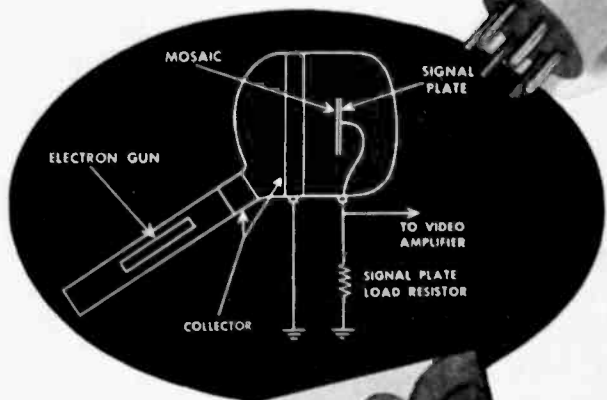

Portraying the use of the RCA 1849 Iconoscope in transmitting a scene from film.



*for*

# TELEVISION

**IN RADIO AND TELEVISION . . . It's RCA ALL THE WAY**

RCA MANUFACTURING COMPANY, INC., Camden, N. J. A Service of the Radio Corporation of America

# FOR MAKING RAPID MEASUREMENTS

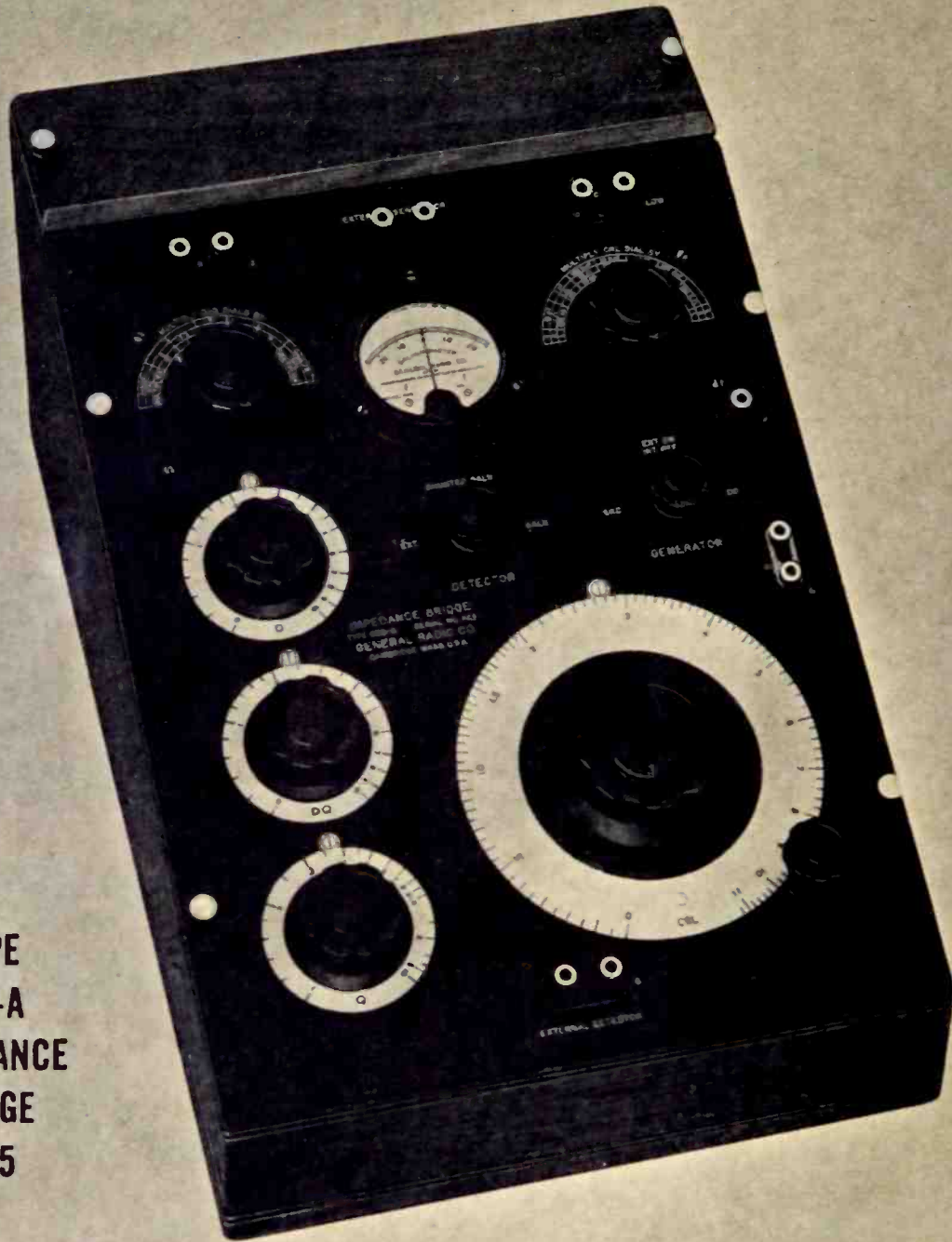

TYPE  
650-A  
IMPEDANCE  
BRIDGE  
\$175

## RESISTANCE • INDUCTANCE • CAPACITANCE

● THIS bridge—completely self-contained with built-in 1,000 cycle and d-c power supplies—is proving very valuable in hundreds of laboratories and factories for routine measurements of inductance, capacitance, resistance, dissipation factor and

energy factor. Its very wide ranges . . . its portability . . . its direct reading feature and its simplicity of operation contribute to the continued popularity of this instrument as one of General Radio Company's most widely used bridges.

● *\*Write for Bulletin 450 for Complete Information*

### GENERAL RADIO COMPANY

Cambridge, Massachusetts

BRANCHES: NEW YORK AND LOS ANGELES

---

MANUFACTURERS of PRECISION ELECTRICAL LABORATORY APPARATUS

---