

VOLUME 21

SEPTEMBER, 1933

NUMBER 9

PROCEEDINGS
of
The Institute of Radio
Engineers



Form for Change of Mailing Address or Business Title on Page X

The Institute of Radio Engineers

GENERAL INFORMATION

INSTITUTE. The Institute of Radio Engineers was formed in 1912 through the amalgamation of the Society of Wireless Telegraph Engineers and the Wireless Institute. Its headquarters were established in New York City and the membership has grown from less than fifty members at the start to almost six thousand by the end of 1932.

AIMS AND OBJECTS. The Institute functions solely to advance the theory and practice of radio and allied branches of engineering and of the related arts and sciences, their application to human needs, and the maintenance of a high professional standing among its members. Among the methods of accomplishing this need is the publication of papers, discussions, and communications of interest to the membership.

PROCEEDINGS. The PROCEEDINGS is the official publication of the Institute and in it are published all of the papers, discussions, and communications received from the membership which are accepted for publication by the Board of Editors. Copies are sent without additional charge to all members of the Institute. The subscription price to nonmembers is \$10.00 per year, with an additional charge for postage where such is necessary.

RESPONSIBILITY. It is understood that the statements and opinions given in the PROCEEDINGS are views of the individual members to whom they are credited, and are not binding on the membership of the Institute as a whole. Papers submitted to the Institute for publication shall be regarded as no longer confidential.

REPRINTING PROCEEDINGS MATERIAL. The right to reprint portions or abstracts of the papers, discussions, or editorial notes in the PROCEEDINGS is granted on the express condition that specific reference shall be made to the source of such material. Diagrams and photographs published in the PROCEEDINGS may not be reproduced without making specific arrangements with the Institute through the Secretary.

MANUSCRIPTS. All manuscripts should be addressed to the Institute of Radio Engineers, 33 West 39th Street, New York City. They will be examined by the Papers Committee and the Board of Editors to determine their suitability for publication in the PROCEEDINGS. Authors are advised as promptly as possible of the action taken, usually within two or three months. Manuscripts and illustrations will be destroyed immediately after publication of the paper unless the author requests their return. Information on the mechanical form in which manuscripts should be prepared may be obtained by addressing the secretary.

MAILING. Entered as second-class matter at the post office at Menasha, Wisconsin. Acceptance for mailing at special rate of postage is provided for in the act of February 28, 1925, embodied in Paragraph 4, Section 412, P. L. and R., and authorization was granted on October 26, 1927.

Published monthly by

THE INSTITUTE OF RADIO ENGINEERS, INC.

Publication office, 450-454 Ahnaip St., Menasha, Wis.

BUSINESS, EDITORIAL, AND ADVERTISING OFFICES

Harold P. Westman, *Secretary*

33 West 39th Street, New York, N. Y.

INSTITUTE SECTIONS

- ATLANTA—Chairman, H. L. Wills; Secretary, Philip C. Bangs, 23 Kensington Road, Avondale Estates, Ga.
- BOSTON—Chairman, E. L. Chaffee; Secretary, G. W. Kenrick, Tufts College, Mass.
- BUFFALO-NIAGARA—Chairman, L. Grant Hector; Secretary, E. C. Waud, 235 Huntington Avenue, Buffalo, N. Y.
- CHICAGO—Chairman, R. M. Arnold; Secretary, Donald H. Miller, McGraw-Hill Publishing Company, 520 N. Michigan Ave., Chicago, Ill.
- CINCINNATI—Chairman, W. C. Osterbrock; Secretary, Helen Klein, Crosley Radio Corporation, Cincinnati, Ohio.
- CLEVELAND—Chairman, P. A. Marsal; Secretary, R. P. Worden, 1629 Cordova Ave., Cleveland, Ohio.
- CONNECTICUT VALLEY—Chairman, H. W. Holt; Secretary, C. B. De Soto American Radio Relay League, 38 La Salle Rd., W. Hartford, Conn.
- DETROIT—Chairman, G. W. Carter; Secretary, E. C. Denstaedt, Detroit Police Department, Detroit, Mich.
- LOS ANGELES—Chairman, J. K. Hilliard; Secretary, N. B. Neely, 1569 Munson Ave., Los Angeles, Calif.
- NEW ORLEANS—Chairman, J. A. Courtenay; Secretary, C. B. Reynolds, Radiomarine Corporation, 512 St. Peter St., New Orleans, La.
- PHILADELPHIA—Chairman, W. F. Diehl; Secretary, G. C. Blackwood, 243 E. Upsal St., Mt. Airy, Philadelphia, Pa.
- PITTSBURGH—Chairman, Lee Sutherlin; Secretary, A. P. Sunnergren, West Penn Power Company, 14 Wood St., Pittsburgh, Pa.
- ROCHESTER—Chairman, A. E. Soderholm; Secretary, John J. Long, Radio Station WHAM, Sagamore Hotel, Rochester, N. Y.
- SAN FRANCISCO—Chairman, G. T. Royden; Secretary, R. C. Shermund, 2300-16th Ave., San Francisco, Calif.
- SEATTLE—Chairman, H. H. Bouson; Secretary, Howard Mason, 2709-4th West, Seattle, Wash.
- TORONTO—Chairman, W. F. Choat; Secretary, G. E. Pipe, Rogers-Majestic Corporation, Toronto, Ont., Canada.
- WASHINGTON—Chairman, H. G. Dorsey; Secretary, C. L. Davis, Washington Building, 15th and G Sts., Washington, D. C.

OFFICERS AND BOARD OF DIRECTORS, 1933

(Terms expire January 1, 1934, except as otherwise noted)

President

L. M. HULL

Vice President

JONATHAN ZENNECK

Treasurer

MELVILLE EASTHAM

Secretary

HAROLD P. WESTMAN

Editor

ALFRED N. GOLDSMITH

Directors

M. C. BATSEL

J. V. L. HOGAN

C. M. JANSKY, JR.

R. H. MANSON, *Junior Past President*

E. R. SHUTE

A. F. VAN DYCK

WILLIAM WILSON

Serving until January 1, 1935

W. G. CADY, *Junior Past President*

O. H. CALDWELL

C. W. HORN

E. L. NELSON

Serving until January 1, 1936

R. A. HEISING

H. M. TURNER

F. A. KOLSTER

INSTITUTE NEWS AND RADIO NOTES

The Relation of Engineering to the Radio Industrial Code

American radio manufacturers are now operating under a "Code of Fair Competition for the Electrical Industry" which was approved by President Roosevelt on August 4. In the necessarily broad regulations thereby established for this highly ramified industry there is no formal recognition of that select class of professional laborers to whose creative effort the principal commodities of every radio manufacturer owe their origin. There exists, nevertheless, a vital connection between the corporate welfare of every radio manufacturer and the productivity of his engineering employees. Unless the teachings of industrial history are mockery, the radio industry will be distinguished for years to come by an essential dependence upon inventive thought, both technical and artistic. Periods in which this industry has provided large employment for labor and legitimate return on invested capital have always been preceded by exceptionally productive engineering activity. The recurrence of this sequence has been too consistent to suggest anything but a causal relation.

A choice is now presented squarely to all radio engineers and their employers: whether to revive conditions favorable to *inventive* engineering effort or to continue with price-lowering as the main objective of engineering thought. Such a revival would provide sufficient centrifugal force to throw the industry out of the vicious competitive circle in which it is now spinning. Competition in ideas, rather than competition in prices, is still a sane and profitable activity. Furthermore, this revival of creative engineering is the most direct means of reconciling the Government's requirement of sustained highly-paid employment with that renewed effectiveness of invested capital which is vital to the industry. Recognition of this principle is an obligation to be shared alike by engineers and by their employers, in striving toward that rehabilitation of the industry which we all confidently anticipate.

Lewis M. Hull
President

Institute Meetings

ATLANTA SECTION

The Atlanta Athletic Club was the place of the April 13 meeting of the Atlanta Section. H. L. Wills, chairman, presided.

"Class B and C Radio-Frequency Amplifiers" was the subject of a paper by I. H. Gerks of the Georgia School of Technology.

In his paper, Professor Gerks presented, in an interesting and concise fashion, a considerable amount of data concerning the theoretical and practical operation of the two types of radio-frequency amplification which have been standardized as Class B and Class C.

The paper was discussed by Messrs. Akerman, Bangs, Etheredge, Fowler, Goldwasser, and Petterson. The attendance was twenty-six and a number were present at the informal dinner which preceded the meeting.

CINCINNATI SECTION

The Cincinnati Section held a meeting on May 23 at the University of Cincinnati. W. C. Osterbrock presided, and the attendance totaled seventy.

R. J. Rockwell of the Crosley Radio Corporation presented a paper on "B supply for Automobile Radio Receivers." In introducing his paper, the author pointed out that automobile radio receivers first employed batteries for obtaining plate voltages but that short life and high initial cost made these undesirable. Later developments replaced them with dynamos, generators which include wind-driven types for aircraft purposes, and similar machines. The cost of operating and constructing these devices was then considered which, together with low operating efficiency, indicated the necessity of improvement. The next introduction was the vibrator type of interrupter combined with a step-up transformer and a mercury-vapor rectifier in the high voltage circuits. Tube failure indicated desirability of improvement and the use of the vibrator interrupter in the primary circuit of the transformer, and an additional set of contacts on the same reed to rectify the output of the secondary of the transformer was then considered.

A discussion of the theory of this type of mechanism, the necessary synchronization of primary and secondary to permit both to be operated on the same reed, and the filter systems necessary for quiet operation formed the main topic of the paper.

The general discussion which followed was participated in among others by Messrs. Austin, Barbulesco, Boyle, Kentner, Kesheimer, and Platts.

LOS ANGELES SECTION

A meeting of the Los Angeles Section was held on May 16 in the Hotel Arcady, and was presided over by J. K. Hilliard, chairman.

Two papers were presented, the first by H. R. Lubcke on "General Aspects of the Don Lee 1000-Watt Television Transmitter." Mr.

Lubeke, who is director of television of the Don Lee Broadcasting System, discussed the general aspects of their television transmitter and described its construction, appearance, and operation. Data were submitted on the results obtained in the experimental operation of the transmitter and reception of a complete program in Maine announced. A brief outline was given of the requirements for reception of signals from this transmitter. The paper was closed with a discussion of the effects of fading on the received signals.

The second speaker of the evening, F. M. Kennedy, development engineer for the Don Lee Broadcasting System, delivered a paper on "The Technical Features of the Don Lee 1000-watt Television Transmitter." In it he presented a general description of the transmitter by the use of block diagrams. He then proceeded with a discussion of the construction and operation of the various parts of the transmitter. More technical features of the station and specifications of several of the important components were discussed. Particular emphasis was placed on the piezo-electric oscillator and methods employed in checking its stability.

The meeting was attended by 140 of whom sixteen were present at the informal dinner which preceded it.

The June meeting of the Los Angeles Section was held on the 20th at the Los Angeles Junior College. Chairman Hilliard presided, and the attendance totaled 150.

Two papers were presented, the first by J. F. Blackburn, consulting physicist, on "Theoretical Considerations of Thermionic Vacuum Tubes" and the second by C. R. Daily of Electrical Research Products, Inc., on "Power Output Considerations of Vacuum Tube Circuits."

Dr. Blackburn presented a brief history of the theory of thermionics. By the use of hypothetical cases the speaker gave a clear conception of the action inside tubes of the high vacuum type. After discussing the elementary theory of the thermionic tubes, the speaker took up the temperature and work functions of diodes. By the use of graphs, saturation factors of tubes were shown and explained. The plate resistance in vacuum tubes and the method of deriving its value were discussed at length and various basic laws and formulas for diodes were given. The paper was closed with a brief consideration of the function of the grid in a vacuum tube and the principal tube characteristics were defined.

In his paper Dr. Daily treated principally the calculations for power output of vacuum tubes as both audio- and radio-frequency amplifiers. Fundamental considerations in the calculation of the gain of amplifiers were discussed. The relation of the decibel rating to the power output in watts as concern amplifying circuits was considered.

Static and dynamic curves for various tubes were compared and methods of selecting proper grid bias explained. Maximum undistorted power output for Class A amplifiers and formulas for computing this were given. In addition, formulas were presented for determining plate efficiency, and a chart giving the plate efficiency and the harmonic content of various tubes as Class A and Class B amplifiers was presented. It was pointed out that the harmonic content in radio-frequency Class B amplifiers was not particularly important.

Personal Mention

H. C. Behner, Lieutenant, U.S.N., has been transferred from the U.S.S. Langley to the Fleet Air Base, Coco Solo, C. Z.

E. B. Boise formerly with the DeForest Radio Company has become a commercial engineer for the Hygrade Sylvania Corporation of New York City.

J. J. Cummings is now technical director of WCAM, Camden, N. J.

Formerly with the Colin B. Kennedy Corporation, P. B. Gebhardt has become an engineer for the International Radio Corporation, Ann Arbor, Mich.

M. R. Jones, Jr. formerly at Stanford University has joined the engineering staff of the Jenson Manufacturing Company of Chicago, Ill.

Previously with Wells-Gardner Company, Walter Lyons has become chief engineer of the Emerson Radio and Television Company of New York City.

D. P. Mason, Lieutenant, U.S.A., has been transferred from the War Department transmitting station in Washington to the Aircraft Radio Laboratories at Wright Field, Dayton, Ohio.

W. T. Guest, Lieutenant, U.S.A. has been transferred from Washington, D. C. to Patterson Field, Fairfield, Ohio.

Previously with the Department of Communications, T. Nakagami has become chief engineer of the International Telephone Company, Ltd., of Tokio, Japan.

Leon Podolsky formerly with RCA Victor Company is now a research engineer for the Wirt Company of Philadelphia, Pa.

K. H. Thow previously with Standard Telephones and Cables of Wellington, New Zealand, has joined the research department of Ultra Electric, Ltd., of London, England.

I. J. Ball has been advanced to radio inspector for the Federal Radio Commission at the Frequency Monitoring Station, Great Lakes, Ill.

D. P. Bennett formerly with Warner Brothers Industrial Films, is now instructing in photography and sound recording at the New York Institute of Photography, New York City.

R. M. Booth, Jr., on leaving Purdue University, joined the staff of Crosley Radio Corporation, Cincinnati, Ohio.

Previously with Ufonic Radio Corporation, L. B. Brittain is now a radio engineer for H. H. Hoin, Los Angeles, Calif.

Formerly with the Bell Telephone Laboratories, Ansel Challenor is radio engineer for the Television Laboratory of Oklahoma City, Okla.

C. J. Dow previously with the Robert Dollar Steamship Company, has become chief engineer for Radio Engineering Company of Shanghai, China.

W. B. Larew, Lieutenant, U.S.A., has been transferred from Fort Monmouth for post graduate work at Cornell University.

E. H. I. Lee has been transferred from Detroit, Mich., to become assistant to the chief of the division of field operations of the Federal Radio Commission and is located at Washington, D. C.

T. G. Lo has left Hunan University to join the electrical engineering department of Nankai University in Tientsin, China.

A. E. Lyle now chief engineer of the Johnsonburg Radio Corporation, Johnsonburg, Pa., was previously with the Cable Radio Tube Corporation.

L. J. McKesson of R.C.A. Communications has been transferred from Manila to Rocky Point.

Formerly at the University of Minnesota, L. S. Nergaard has joined the engineering staff of RCA Radiotron Company of Harrison, N. J.

Previously with the Mackay Radio and Telegraph Company, C. R. Rowe has joined the staff of the Jensen Radio Manufacturing Company with headquarters in New York City.

E. W. Rector has been advanced to chief engineer of WKZO, Kalamazoo, Mich.

A. E. Reoch has left the RCA Victor Company and is now located with the Radio Corporation of America in New York City.

Formerly with the China Radio Corporation, H. L. Tsia has become manager of the Shanghai office of the West China Development Corporation.

ERRATA

S. J. Model has brought to the attention of the editors the following errors which occurred in his paper, "Transmission Curves of High-Frequency Networks," which was published in the January, 1933, issue of the PROCEEDINGS.

	Printed	Should be
p. 122 (16)	$+ \frac{2\Omega}{\omega_0} \frac{\delta_1' - \delta_2}{\delta_1'}$	$+ \frac{2\Omega}{\omega_0} \frac{\delta_1' - \delta_1}{\delta_1'}$
p. 122 (18)	$\mu = \operatorname{arctg} \dots$	$\varphi = \operatorname{arctg} \dots$
p. 123 (19) $\mu_2 =$	$\frac{1}{\sqrt{1 + \left[\frac{m_2}{\delta_1' \delta_2 (1 + \beta)} \right]^2}} - \dots$	$\mu_2 = \frac{1}{\sqrt{1 + \left[\frac{m^2}{\delta_1' \delta_2 (1 + \beta)} \right]^2}} - \dots$
p. 130 (31) $m =$	$\delta_2 \sqrt{A \sqrt{A^2(1 + 2\beta) + 2} - 1}$	$m = \delta_2 \sqrt{A \sqrt{A^2(1 + 2\beta) + 2} - 1}$
p. 138 (39) $\mu_3' =$	$\frac{1}{\sqrt{\left[1 + m^2 \frac{(\delta_1 + \delta_2 + \delta_3)}{\delta_1' \delta_2' \delta_3'} \right]^2}} + \dots$	$\mu_3' = \frac{1}{\sqrt{\left[1 - m^2 \frac{(\delta_1 + \delta_2 + \delta_3)}{\delta_1' \delta_2' \delta_3} \right]^2}} + \dots$
p. 139	five points of maximum values:	five points of extreme values:
p. 139	$B^2 = \frac{A\sqrt{b} - 1 - A^2}{A^4}$	$B^2 = \frac{A\sqrt{6} - 1 - A^2}{A^4}$

TECHNICAL PAPERS

THE RADIO PATROL SYSTEM OF THE
CITY OF NEW YORK*

BY

F. W. CUNNINGHAM

(Bell Telephone Laboratories, Inc., New York City)

AND

T. W. ROCHESTER

(Police Department, New York City)

Summary—The application of radiotelephony to municipal police work in New York City is described from the organization viewpoint. Brief references are made to historical backgrounds and description of apparatus, and the steps taken to select a receiver suitable for local conditions are outlined. The method of controlling the patrol force by radio is described at some length with examples, and a summary of results during the first year is given to show the value of this means of communication to police work.

WHEN radiotelephony is mentioned, most of us probably think first of broadcasting. There are, however, other important applications of this art, one of them being its use as an aid to police work. Since this weapon in the war against crime is relatively new and its use is growing rapidly, it may be interesting to discuss its application in a specific case which is representative of good practice in this field.

The New York Police Department obtained a license for its first station (KUVS) in 1916. This station was used for transmitting radiotelegraph messages to ships at sea and for carrying on two-way communication with one of the police boats (station KUSM) used at that time in patrolling the waters adjacent to New York. On February 27, 1924, station WLAW was established with a view to supplementing the regular wire telephone service by radiotelephone. In 1929, a new tube transmitter, operating on interrupted continuous wave and continuous wave with the call letters WPY, was erected to replace the old spark station KUVS.

While New York was the pioneer, it remained for the City of Detroit to initiate the service commonly referred to as Radio Patrol. Early experiments in 1921 were abandoned after a short period of

* Decimal classification: R566. Original manuscript received by the Institute, April 21, 1933. Presented before Eighth Annual Convention, Chicago, Ill., June 26, 1933.

operation only to be revived again about 1927, and the service was placed on a substantial basis in 1929 when a standard 400-watt transmitter was installed and approximately 50 cars equipped with radio receivers. The success of this system resulted in other cities rapidly following the lead of Detroit and there are now about 100 transmitters licensed for municipal police service in the United States.

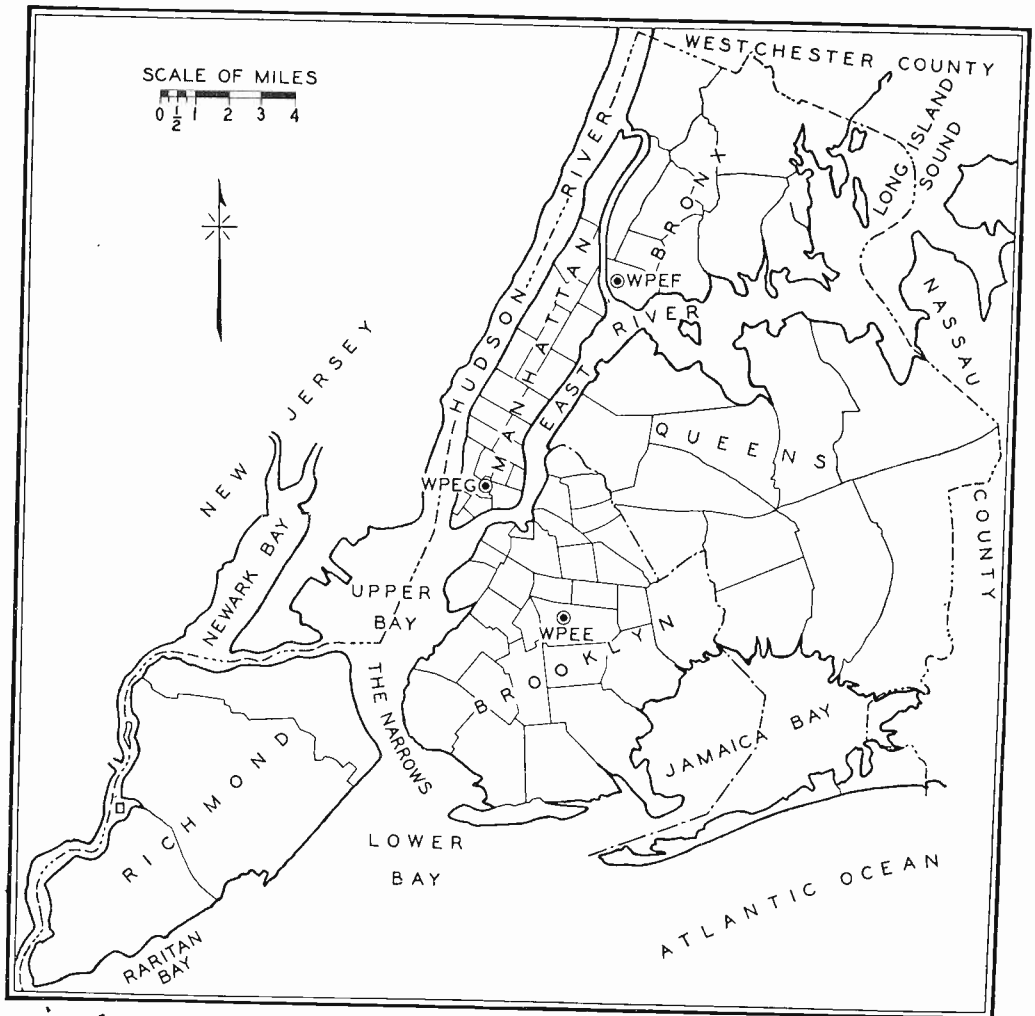

Fig. 1—Precinct map of New York City showing transmitter locations.

New York again began active experimentation with radiotelephony during the summer of 1929 under Police Commissioner Grover A. Whalen, and on August 17, 1931, Police Commissioner Edward P. Mulrooney obtained an appropriation of \$100,000 to carry out the installation of the system described in this paper.

Eight frequencies between 1500 and 3000 kilocycles are available for municipal police service. Since these frequencies are shared by a large number of stations operated simultaneously the power of the transmitters is restricted to avoid interference. Power assignments,

based on the population of the area to be served, are authorized up to 500 watts maximum. When it is impossible to maintain reasonably good service throughout this area with a single transmitter of the maximum power, permission may be given to install additional units of the same or smaller output.

A single 500-watt transmitter would be hopelessly inadequate for New York because of the absorbing effects of the many tall steel

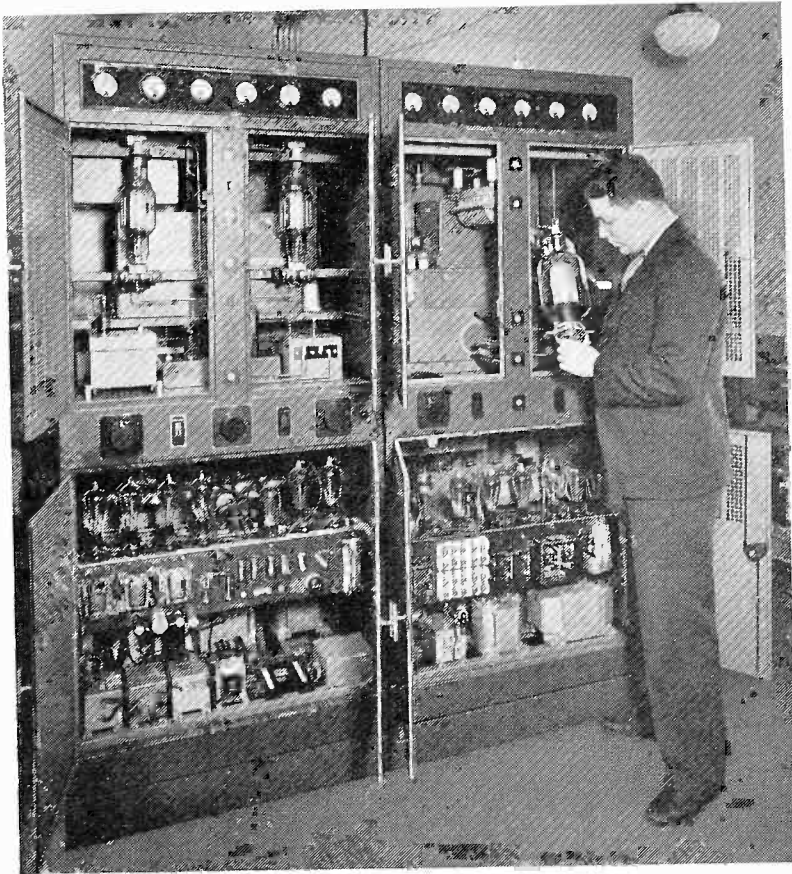

Fig. 2—Headquarters transmitter.

framed buildings, elevated railways, and bridges, and because of the extent and configuration of the area to be served. The interference caused by electrical systems and devices adds to the difficulty, and greater signal strength is required for adequate coverage than would be the case without these handicaps.

After careful study, it was decided to install a 500-watt unit at Police Headquarters on Center Street and a 400-watt unit in Brooklyn and another in the Bronx, all using the same frequency. This arrangement required careful selection of transmitting sites but is far simpler to operate and more economical of personnel than an earlier proposal

to use seven transmitters. Synchronous operation of the transmitters was also suggested but discarded as impractical. At the present state of the art there is little doubt that in many parts of the city the signal distortion resulting from synchronous operation would reduce or entirely prevent intelligibility of the transmitted messages. It is therefore customary to transmit all signals from Headquarters and to repeat them from the other stations. This arrangement has proved entirely satisfactory.

The equipment at Headquarters is a Western Electric No. 305A radio transmitting equipment and a Western Electric No. 9A speech input equipment. The transmitting equipment consists of a 100-watt transmitter with a 1000-watt power amplifier which is operated at 500 watts output. The transmitter unit contains a crystal oscillator, two stages of radio-frequency amplification, and a wo-tube balanced modulating amplifier, the grid voltage of which is varied by the audio-frequency voltage supplied by the speech input equipment. The power amplifier has a single push-pull stage, harmonic suppression circuits, antenna coupling and tuning circuits, and a monitoring circuit. Each unit also contains its own complete power equipment, such as the grid and plate rectifiers and filters, and control and protective apparatus. The required 4.5 kilowatts for the two units is taken directly from the public service 3-phase, 60-cycle mains at 220 volts. Equipment similar except for the changes required for operation at police frequencies was described more fully before the New York meeting of the Institute of Radio Engineers, December 2, 1931.¹

The No. 9A speech input equipment is a standard alternating-current operated single-channel broadcast outfit with three moving coil microphones, one for the dispatcher, who normally issues instructions to the patrol cars, and one each in the offices of the Police Commissioner and the Chief Inspector. The loud-speaking monitor permits the dispatcher to check all messages from his own or the other stations except those through his own microphone. The speech input equipment, except for the microphones, is entirely contained in the cabinet shown at the left in Fig. 5 and, like the transmitter, it takes its power directly from the local service mains at 220 volts, 60 cycles, drawing about 150 watts from a single phase circuit. A more detailed description was given before the New York meeting of the Institute of Radio Engineers, December 2, 1931, by W. L. Black under the title "A compact alternating-current operated speech input equipment."²

¹ A. W. Kishpaugh and R. E. Coram, "Low power radio transmitters for broadcasting," *Proc. I.R.E.*, vol. 21, pp. 212-227; February, (1933).

² To be published in the *PROCEEDINGS*

Structural limitations prevented the erection of towers or poles for the antenna on the Police Headquarters building but it was found possible to erect on the Police Academy across the street a mast of the same elevation as the cupola on the Headquarters building. Between these supports an inconspicuous but effective single wire inverted 'L' type antenna of No. 2 hard-drawn copper concentric cable was sus-

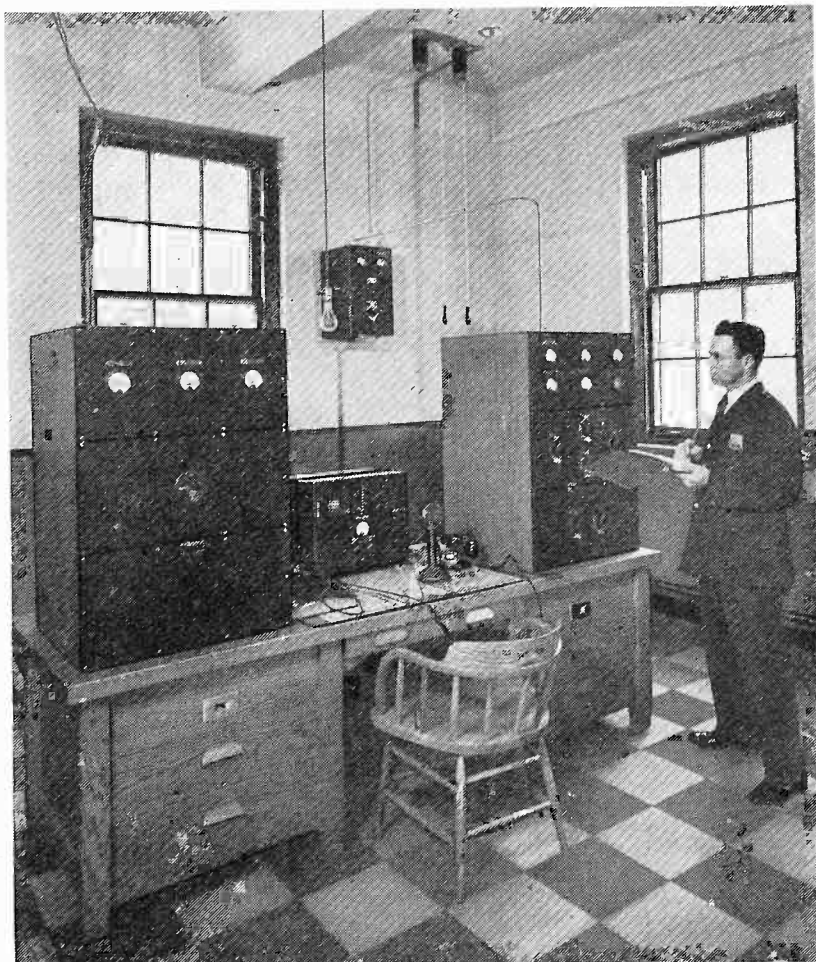

Fig. 3—Radio room in Precinct 71, Brooklyn.

ended directly over the transmitter. The vertical section is 60 feet long, and the 39-foot horizontal section is 148 feet above the street.

The equipment in the Bronx and Brooklyn stations are similar and consist in each case of a No. 9 type radio transmitter, a No. 2B rectifier, a No. 3A tuning unit, and a modified No. 10A speech input equipment, all made by the Western Electric Company.

The transmitter consists of a quartz crystal controlled oscillator, a frequency doubler, a modulating amplifier, an audio-frequency amplifier, and a power amplifier. Two crystals are provided, each with

its own heater which is kept energized at all times, and an artificial antenna is included to facilitate testing.

The power supply unit, shown at the left in Fig. 3, draws 4 kilowatts from the 3-phase, 60-cycle public service mains at 220 volts. It consists of two 3-phase rectifiers, one single phase rectifier, and two transformers, and supplies potentials of 2500, 1000, 200, and 60 volts direct current and 10 volts alternating current. Its relays automatically apply the voltages in proper sequence when the master switch is operated and protect the equipment in case of failure of apparatus or improper adjustments.

The tuning unit mounted on the wall consists of an inductance and series condensers for tuning the antenna which is similar to that at Headquarters but supported by two 65-foot wood poles on the roof of the precinct station building. The speech input equipment includes a No. 57A amplifier for raising the level of the messages over telephone lines from Headquarters to the input level of the transmitter, and a No. 6061A telephone set for use when the message is originated by the local operator. The amplifier contains its own rectifier and draws all its power from the local 110-volt alternating-current lighting circuit.

An operator is constantly on duty at each of these stations, but the normal method of operation is for the dispatcher at Headquarters to start the Bronx and Brooklyn transmitters by remote control and feed his message to them over the telephone circuit and through the No. 57A amplifier. In case of emergency both stations may be operated independently and each is equipped with a monitoring receiver to avoid the danger of breaking in on a message from the other.

The filaments are kept constantly lighted at all three stations and the carrier is started by closing the plate circuit.

When the system was laid out, the department had in operation 1100 automobile units, 10 boats, and 4 planes. It was decided to equip 400 automobiles, 3 boats, and 1 plane with receiving apparatus. Field and laboratory tests were made on all available makes of police radio receivers before making a selection. For the field tests a 50-watt transmitter on the Municipal building was used as the signal source and the sample receivers were all in turn installed in a seven-passenger test car which ran over a fixed route, introducing all kinds of conditions expected in actual service. The tests were started each day at 2 P.M. and ended at 5 P.M., the direction of the run always being the same. Three trained observers always in the same positions in the car independently rated the performance of each set at twenty standard points on the run. All car windows were kept open. The route selected was through the skyscraper canyon of Broadway, along the Miller (ele-

vated express) Highway, through the garment center, theatrical district, and Central Park. It also included streets having subways and elevated structures and those near the East River bridges and the New York Central and Pennsylvania electrified railway systems. The effects of stray fields from the ignition systems of the test and other cars, sign flashers, motor equipment, etc., upon the received signal were studied as well as the absorption caused by bridges, elevated structures, and steel framed buildings.

The bench tests included comparisons of receiver sensitivity and selectivity, volume and quality from the loud speaker, filament and plate battery consumption, and studies of the effects of vibration and temperature changes.

The receiver selected was a special American Bosch seven-tube superheterodyne outfit equipped with automatic volume control and a manual sensitivity control between the limits of 1 and 100 microvolts. The receivers are mounted under the instrument board and the controls on the steering column of the automobile units.

The standard car batteries and generators are used to supply the 2.2 amperes drawn by the filaments and have been generally satisfactory. In a few cars low cruising speed or light duty prevented adequate charging, and the generator pulley size was reduced to start charging at a lower car speed and so supply more ampere hours per day.

Plate power at 135 volts, 13 to 20 milliamperes, is drawn from heavy duty dry B batteries mounted under the floor in sedans and in the rear compartment of the smaller cars. These batteries require renewal in five weeks and will soon be replaced by eliminator units capable of delivering 25 milliamperes at 135 volts with a 6-volt, 1-ampere input.

Magnetic cone type loud speakers specially impregnated against moisture are mounted under the right end of the instrument board of runabouts and on the ceiling in other cars.

The antenna consists of 12 square feet of copper screen in the car roof, except in the runabout model which has about 40 feet of No. 16 rubber-covered wire sewed in the top.

Four-cylinder Ford runabouts and coupes are used by the Patrol and eight-cylinder Cadillac, Chrysler, Ford, and Packard sedans are used as detective squad and division cars and for the higher officials. A folding writing shelf with its own light is attached to the instrument panel in front of the observer's seat of all cars. Two windshield wipers are provided, and the windshields open wider than on stock cars to permit the use of revolvers. The ceiling lights are mounted

at the rear of the top to keep their wiring away from the antenna. All sedans are equipped with tear gas bombs and those used by division detectives also have short rifles.

In addition, there are five repair cars on 24-hour service, each equipped with eight spare receivers, loud speakers, pilot signal lamps, batteries, fuses, and a full complement of instruments including a dynatron oscillator set for 2450 kilocycles so that the receiver adjustment can be checked without waiting for the next call from the transmitting station. With this mobile repair squad it is rarely necessary to take a patrol car to the shop for radio servicing.

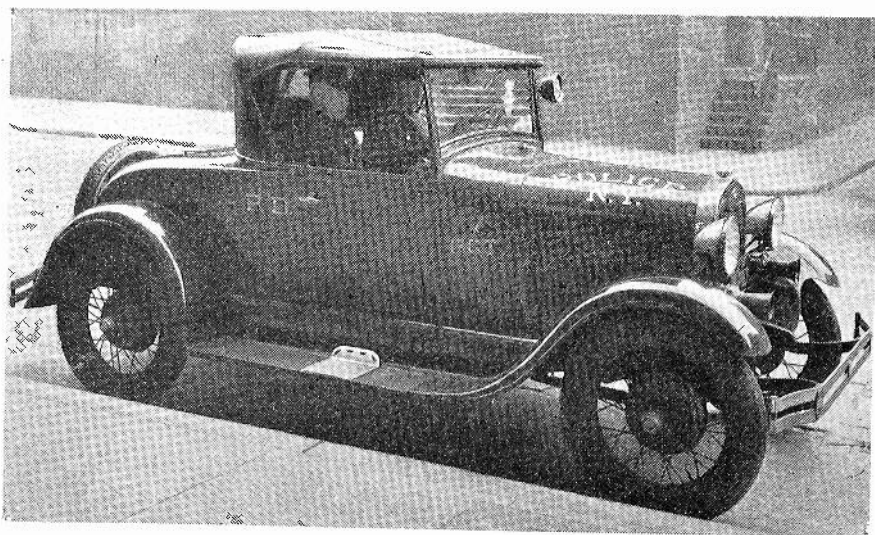

Fig. 4—Radio patrol car.

In all cars the driver operates and is responsible for the radio equipment while the observer who sits beside him transcribes all alarms, keeps the log and telephones the dispatcher as required.

As the city has an area of 316 square miles the area covered by each of the 400 patrol cars is on the average about three-quarters of a square mile. Three patrol cars and a captain's car are assigned to each precinct. The area assigned to each patrol car is known as a sector and is shown on the dispatcher's map at Headquarters. (Fig. 5.)

The dispatcher's control map is mounted in 14 sections under glass on a large "U" shaped table in the transmitter room which adjoins the telephone exchange. The dispatcher sits at the center with the maps of Manhattan and the Bronx before him, those of Brooklyn and Richmond at his left and Queens at his right. Each car is represented by a numbered brass disk which is placed over the sector to which the car is assigned. Any map section may be withdrawn from under the glass for alteration without disturbing the disks or the other

map sections. The disks are numbered on both sides, with black numerals on one side and white on the other to indicate, respectively, that the car is on routine patrol duty or has been assigned to cover a specific call. In addition there are paint-filled depressions, one above and one below the numerals, indicating by color the type of car and branch of service to which it is assigned, as follows: Patrol cars and captains' cars have white dots, detective squad cars have black dots, detective division cars have red dots, and executive cars have green dots. A



Fig. 5—Radio room at Police Headquarters showing dispatchers control map.

brass ring is slipped over the disk corresponding to any car that needs radio servicing. The disk is left with black number up until the service man is sent to the car and is then turned over to show the white number until the trouble has been cleared and so reported, after which the ring is removed. If a car must leave its sector for gasoline, oil, or grease, its crew telephones the dispatcher who places the car disk on edge within the ring until its return, but such a car is considered still available for assignment. The disk is moved to the margin of the map and replaced by the ring if the car is out of service for mechanical repairs.

The Headquarters telephone switchboard routes the incoming alarm to the dispatcher's desk. He notes the location of the trouble,

selects the cars to be assigned and passes instructions to the announcer-operator, who has meantime sent the 1000-cycle "Attention" signal which precedes all calls. The frequency of the "Attention" signal was selected as being particularly effective with the loud speakers used. When the alarm is issued, the disks corresponding to the cars assigned are turned over and left with the white numerals up until their crews report the assignment completed. The report ordinarily made by the crew of the first car on the scene, includes the rank and name of the officer reporting, the numbers of the radio equipped cars that responded to the alarm, the number of the telephone used for the report, the location of the assignment, what police action was taken and whether the car and its crew are still required by the officer in charge at the scene. The crew or crews no longer required are directed to resume patrol duty at once.

Every hour and half hour, unless a message is being transmitted a time signal is sent out. Any crew that fails to receive one of these messages or time signals notifies the dispatcher and a radio service car is sent to clear the trouble. The receiver is immediately replaced if it is not functioning properly. While the exchange is being made, the patrol car crew uses the service car receiver to listen for calls and, if necessary, interrupts the service work to respond to an assignment. When the service man has completed his work the receiver in the patrol car is checked on the next signal and the service man and the car crew report by telephone to the dispatcher who returns the car to patrol duty and the service man to the shop or another assignment. Receiver repairs are made in the shop while the service men are awaiting calls.

The station personnel consists at Headquarters of a dispatcher and an announcer-operator and at the auxiliary stations of one operator for each 8-hour tour. All of these men, together with a relief man for each station, hold first class commercial radio operators' licenses. There are also twenty service men, one for each 8-hour tour and one relief man for each of the five service districts. Some of these men also have first class operators' licenses and the others are expected to qualify. Instructions on the characteristics, operation, and maintenance of the equipment were given the men while the equipment was being installed so that they would be prepared for their duties when the stations were completed.

Only messages of prime importance are sent over the radio system, the teletype and telephone systems being used where immediate action is not essential. For the sake of brevity, code calls are used for several types of assignment, such as "Signal 30" which means that "All cars

designated are to investigate reported robbery, shooting, stabbing, assault, etc., at address given; to arrest perpetrators, detain witnesses, preserve evidence and take other police action as required, pending arrival of precinct detectives." On the average, the Radio Patrol cars reach the scene of their assignments about 45 seconds after the transmission of their instructions and one arrest is made for every 12 assignments. During the year the system has been in operation all calls have been received by the cars and all assignments have been filled and reported within the 15 minutes allowed for this purpose, except in a few cases where the machines were wrecked on the assignment or some similar reason delayed the report.

It has been found that the new system improves the morale of the patrol force and the coöperation between them and other branches of the service, particularly the detective branch. Also that to be most effective, the training of candidates for Radio Patrol duty must be modified since the necessary qualifications are much more like those for detective service than for patrol duty as it was before the introduction of radio control. The officer is likely to reach the scene while the crime is in progress or as the criminal is making his escape. Alertness is more than ever called for and he must approach, gun in hand, to meet the criminal on an equal footing. He must be able to size up the situation at a glance, preserve evidence, and detain material witnesses until the arrival of the detectives, whose greater cruising range may delay them a few moments at most. The men respond to the new opportunity to distinguish themselves and there is a waiting list for the Radio Patrol assignment in every precinct. They are more eager than ever to get into action even though it may be their last ride.

Another result of the new service is additional opportunity for the law-abiding citizen to thwart the criminal. Many crimes costing lives and thousands of dollars might be prevented by the police and the criminals caught if the citizen would immediately telephone the police of any suspicious action or crime he observes. To this end the Police Commissioner has distributed a booklet describing the new system and asking the coöperation of the public. Posters have also been widely displayed. The resultant help has far outweighed the inconvenience of the unnecessary alarms turned in.

The following are cited as typical examples of the cases handled by the Radio Patrol.

The crew of Patrol Car No. 1074 noticed a dishevelled man running on Third Avenue early one evening in April. When he refused to stop they pursued and caught him. Failing to get a satisfactory explanation of his behavior, they put him in the car intending to investigate

his connection with some street brawl in the neighborhood. Just then they received a "Signal 30" call for their car and two others to investigate a reported hold-up at 34 Great Jones Street, Brooklyn. On arrival the officers took their suspect into the restaurant at that address where he was identified as the man who had shot one of the employees a few minutes before during an attempted holdup.

One evening in May the radio dispatcher received a telephone message that a man was in the East River off Third Street. Three radio cars were dispatched to the scene. Thirteen minutes later the crew from a fourth car reported that Detective Norton of Car No. 29, the first car to arrive, jumped into the river, swam for the man and after subduing him brought him to the dock where both were hauled to safety. Both men were removed to the hospital suffering from submersion and the effect of their fight in the water, but both recovered.

Recently two colored men attacked a driver of a mail truck in Brooklyn. A citizen in an apartment house heard his calls for help, and telephoned the Police Department. Two cars were assigned to the case. On their approach, the bandits ran into a near-by apartment house, where one was captured in the cellar and the other under the bed in one of the apartments.

Three patrol cars were assigned to investigate a holdup in a Chinese laundry in Brooklyn. The third crew to arrive, finding that the three holdup men had escaped into the subway for New York bound trains, left the first two crews to collect the necessary information at the scene of the holdup and raced the train to Union Street. There one man went down on the platform and the other proceeded to the next station, at Pacific Street. The patrolman at Union Street had the subway guards delay opening the train doors until he could locate the men, whom he found and took off at the next station where his partner was waiting for him.

In another case, all patrol crews were ordered to look for two men reported to be in a Hudson sedan, license number uncertain except for the first two figures, last seen near Spencer and Willoughby Streets, Brooklyn, in the 79th Precinct, after leaving a fight during which they shot and seriously wounded three other men who were removed to a hospital. In 17 minutes the crew of Car No. 698 in the 102nd Precinct reported that they had captured the men who still had the revolvers used in the fight.

These cases are probably sufficient to illustrate the excellent results obtained under difficult circumstances and the alertness, clear thinking and initiative shown by the Radio Patrol officers in handling the assignments. The serious nature of the offences handled is shown by the

following summary of arrests for the first 12 months the station was in operation. In most of these cases it is unlikely that the offenders would have been caught without the aid of radio communication.

SUMMARY OF ARRESTS

Arson.....	3	Juvenile delinquency.....	134
Assault, simple.....	24	Larceny, grand.....	152
Assault, felonious.....	84	Larceny, petty.....	100
Assault, robbery.....	165	Malicious mischief.....	17
Auto, drunken driver.....	19	Possession of burglar's tools.....	14
Auto, leaving scene of accident.....	7	Possession of narcotics.....	5
Auto, reckless driving.....	4	Possession of revolvers.....	145
Burglary.....	305	Rape.....	7
Counterfeiting.....	24	Robbery.....	47
Disorderly conduct.....	122	Transportation of alcohol.....	5
Escaped prisoner.....	4	Unlawful entry.....	9
Homicide.....	12	TOTAL.....	1408

During the first year's operation the Radio Patrol cars recovered stolen property worth over \$250,000, which is greatly in excess of the combined expenditures for station and car equipment and for their operation and maintenance, including the salaries of the station operators and the service men.



AN OUTLINE OF THE ACTION OF A TONE CORRECTED HIGHLY SELECTIVE RECEIVER*

BY

E. B. MOULLIN

(Engineering Laboratory, Oxford University, Oxford, England)

Summary—The action of a highly selective simple tuned circuit located between a source of radio-frequency energy and the terminals of a detector is discussed. Next, the effect of linear and of square-law detection together with an audio-frequency tone correction system is described. Various interference conditions are analyzed with the aid of graphical construction.

I. INTRODUCTION

IF A continuous wave is to carry intelligible information its amplitude must be modulated according to some prearranged system which, for example, may be speech or Morse signs. The simplest form of such modulation is expressed by the equation

$$e = E(1 + M \cos nt) \cos pt.$$

Since in practice the modulation frequency n is very small compared with the radio frequency p , it is customary to think of a sine wave whose height varies at a slow rate. But the modulation does not occur in jumps affecting only the height of the wave but is continuous during any half cycle: consequently the shape of any half cycle is not that of a true sine curve. The difference becomes noticeable only when n is comparable with p : by way of illustration Fig. 1 shows four quarter-cycles when n is equal to $1/2p$. It may be seen that each half cycle differs considerably in shape from a sine curve and the maxima do not occur at 180 degrees and at 360 degrees.

The modulation does not alter the frequency of crossing the zero line; but it alters the height of each half cycle and also it alters the wave form of each half cycle. Hence we are concerned with an electromotive force whose frequency is constant but whose amplitude is not constant and whose wave form is not sinusoidal. If this electromotive force acts on a tuned circuit it cannot produce a simple harmonic current whose amplitude follows the height of the voltage peaks. But this electromotive force can be written in the form

$$e = E \left(\cos pt + \frac{M}{2} \cos \overline{p - nt} + \frac{M}{2} \cos \overline{p + nt} \right)$$

* Decimal classification: R161 × R361. Original manuscript received by the Institute, April 12, 1933.

which shows that it is the graphical addition of three sine curves of constant amplitude and constant frequency. Thus the modulation of a sine curve converts it into three unmodulated sine curves and these are commonly described as a carrier and two side bands.

The resultant current in a circuit is the sum of the three components: each component is the current which would be due to a component electromotive force in the absence of the other two component electromotive forces.

Sometimes it is convenient to retain the resultant current in three separate components and sometimes it is convenient to recombine them.

II. THE EFFECT OF A MODULATED ELECTROMOTIVE FORCE ON A HIGHLY SELECTIVE RECEIVER

Consider a simple *LCR* circuit acted on by a sinusoidal electromotive force: we shall not consider compound circuits but only the attainment of selectivity by reducing the resistance of a simple circuit.

First suppose the circuit has no resistance and consider the potential difference v across the condenser: we have,

$$\begin{aligned}
 I &= \frac{E}{pL - 1/pC} \\
 \therefore v &= \frac{I}{pC} = \frac{E}{p^2LC - 1} \\
 &= \frac{E}{\frac{p^2}{p_0^2} - 1} = \frac{p_0^2}{(p - p_0)(p + p_0)} E \\
 &= \frac{E}{2\alpha \left(1 + \frac{\alpha}{2}\right)}, \quad \text{where } \alpha = \left| \frac{p - p_0}{p_0} \right| \\
 &\doteq \frac{E}{2\alpha}, \quad \text{when } \alpha \ll 1.
 \end{aligned}$$

If the resonance curve is plotted so that the frequency is expressed as a fractional change from the resonant value, then the two sides of the resonance curve are rectangular hyperbolas. The resonance curve for a circuit of zero resistance is shown in Fig. 2. Every circuit has some resistance, and hence the peak has a finite height.

If we define the circuit power factor F from the equation $F = R/pL$, then the height of the peak is E/F . Within the hyperbolic branches of

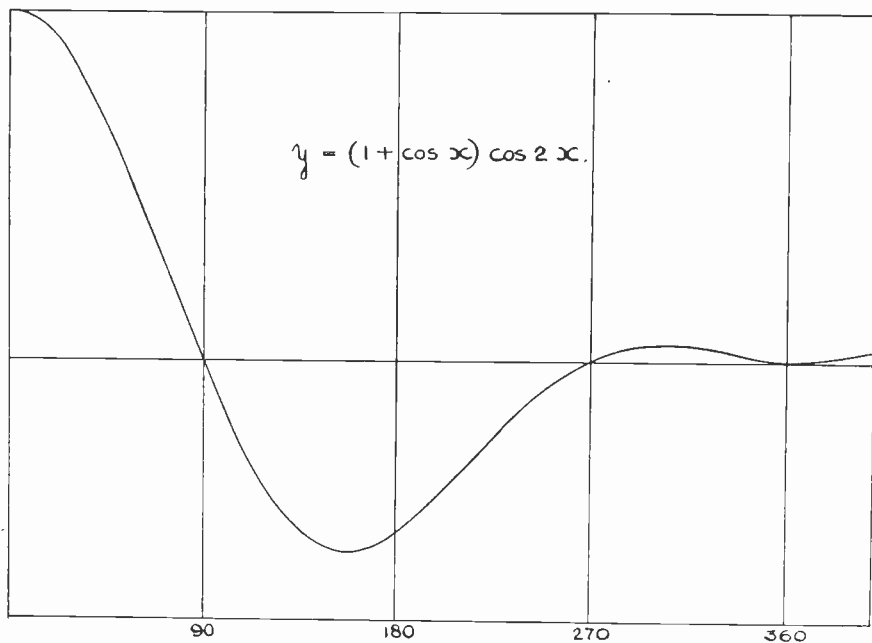

Fig. 1

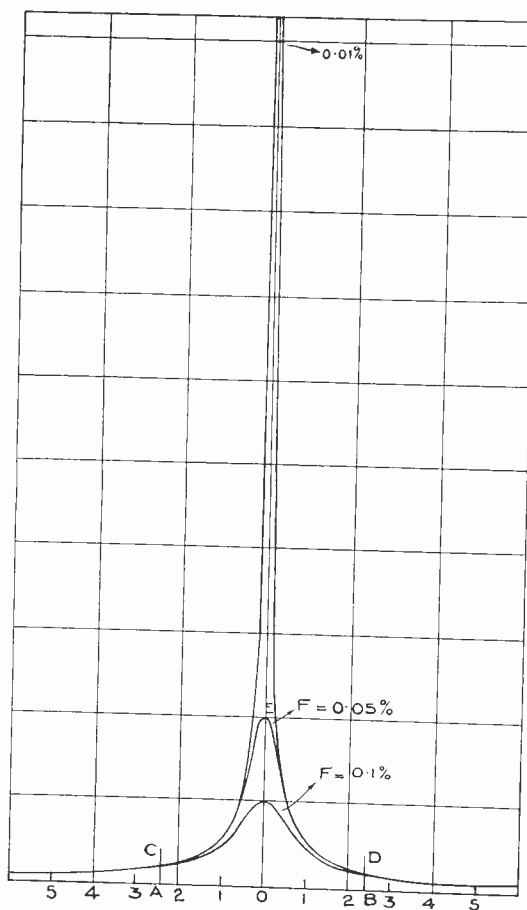

Fig. 2

Fig. 2 are drawn the resonance curves for $F = 0.01$, 0.05 , and 0.1 per cent respectively. It will be seen that these curves lie everywhere below the hyperbolic branches and that they all approach very rapidly to these limiting curves: this means that if the frequency is appreciably displaced from resonance, the effect of resistance is negligible.

To assist in the interpretation of Fig. 2, it is supposed that the resonance frequency is 1000 kilocycles, and the frequency displacements from resonance are shown in kilocycles.

It will be seen that if F is less than 0.05 per cent, then the response is sensibly independent of F for all modulation frequencies greater than, say, 500 cycles.

For present purposes the term highly selective is used of a circuit when an electromotive force acting on it has a frequency sufficiently displaced from resonance to make the response sensibly independent of F .

Thus in Fig. 2, the circuit whose power factor is 0.05 per cent is considered to be highly selective for all modulation frequencies greater than say, 500 cycles.

Now use Fig. 2 to consider the response of a highly selective circuit tuned to the carrier frequency of a modulated electromotive force. The response to the carrier frequency depends on F , but the response to the side bands does not depend appreciably on F . The resultant current has three components, one whose amplitude is OE , one whose amplitude is $\frac{1}{2}M \cdot AC$ and one whose amplitude is $\frac{1}{2}M \cdot BD$. The voltage AC is in phase with its electromotive force and the voltage BD is in antiphase with its electromotive force, while the voltage OE is in phase quadrature with its electromotive force.

Since the "side" component amplitudes are independent of F and the carrier amplitude varies inversely as F , it follows that the modulation depth of the resultant voltage will vary inversely as F . Expressing the resultant voltage in trigonometrical form we have

$$v = \frac{E}{F} \left(1 - \frac{M}{2\alpha} F \sin nt \right) \sin pt.$$

Hence for a given value of F the modulation depth varies inversely as the fractional width of the modulation.

If the response of the detector is proportional to the modulation depth, then a tone correcting amplifier must be applied which amplifies in direct proportion to the acoustic frequency.

If a highly selective receiver, a suitable detector and such a tone correcting amplifier are combined, then all modulation frequencies will be reproduced with the relative intensity which they had in the original electromotive force.

It is useful to estimate the probable size of the factor $F/2\alpha$, by which the circuit reduces the depth of modulation. By means of valve retroaction, F may be reduced to 0.01 per cent, then if $\alpha = 5 \times 10^{-3}$ (5-kilocycle modulation on a carrier of 1000 kilocycles), $F/2\alpha = 1/100$: hence the highly selective receiver reduces the modulation depth to some 2 per cent of its intrinsic value.

III. THE EFFECT ON THE DETECTOR

Having found that the modulation depth of the detector voltage is very small and since in practice the fractional modulation frequency is very small, we shall picture the detector with a sinusoidal voltage applied to it whose amplitude varies very slowly and sinusoidally. We know that this voltage is really the sum of three simple harmonic terms but our simplification is extremely close when the circuit is highly selective. In other words we now find it convenient to put aside the true description of a carrier and two side bands and to visualize an inexact description which is very closely correct.

(a) Square-Law Detector.

We shall suppose the rectified current J is proportional to the square of the rectifier voltage: this voltage varies slowly between the values $(A + B)$ and $(A - B)$.

Hence,

$$\begin{aligned} \frac{J}{k} &= (A + B)^2 - (A - B)^2 \\ &= 4AB. \end{aligned}$$

Referring now to Fig. 2, we remember that the quantity A is represented by OE and the quantity B by $\frac{1}{2}M(AC + BD) = M \cdot AC$. Therefore,

$$\begin{aligned} \frac{J}{k} &= 4 \frac{E}{F} \cdot \frac{ME}{2\alpha} \\ &= \frac{2M}{\alpha F} E^2. \end{aligned}$$

The acoustic output is thus proportional to M and inversely proportional to F : if this passes through a tone correcting amplifier, as described above, the final acoustic output will repeat the intrinsic modulation and the intensity of all notes will increase in inverse proportion to the power factor.

Exact treatment by carrier and side band voltages shows that the rectifier produces also the octave note, but its fractional amplitude

is negligible when the modulation depth is small. With highly selective receivers this is inevitable and inherent to them and consequently the output of a square-law detector is more pure when operated by a highly selective circuit than it would be if it were operated by a circuit of moderate selectivity.

(b) *Linear Rectifier.*

But if F has a value such as 0.01 per cent, the mean voltage applied to the rectifier will probably be sufficient to make it depart from the square law: or high-frequency amplification may be provided before the highly selective circuit in order to make this voltage sufficient to obtain linear rectification. In these circumstances the acoustic output is proportional to the amount by which the amplitude of the detector voltage rises above and falls below the mean value, which is represented by OE in Fig. 2. Hence the acoustic output is proportional to

$$\begin{aligned} \frac{M}{2}(AC + BD) &= M \cdot AC \\ &= \frac{ME}{2\alpha} \end{aligned}$$

We now have an acoustic output which is independent of the circuit power factor: when the circuit power factor has been reduced to a value sufficient to produce linear detection further reduction will not produce any increment of acoustic output, nor does it affect the requisite adjustment of the system used to produce the necessary tone correction.

We may here regard a reduction of power factor as a device to produce linear detection. Once this has been achieved there is no object in going further unless the intrinsic strength of the signals was insufficient to produce linear detection when the power factor had been reduced to a value which makes the circuit "highly selective," as defined in section II above.

IV. THE PROBLEM OF INTERFERENCE

Before considering the problem of interference it is first necessary to consider the rectified current due to a detector voltage consisting of two unmodulated sine curves: let these be $A \sin pt$ and $B \sin(p+n)t$.

(a) *Square-Law Detector.*

If the rectified current is proportional to the square of the detector voltage, the acoustic output is proportional to $AB \sin nt$. Here there is no restriction on the relative values of A and B ; the acoustic output is pure and does not contain an octave note.

(b) *Linear Detector.*

To understand the behavior of this form of detector we must study the envelope of the resultant voltage. It is not uncommonly supposed that the envelope is the same as that of a true modulated voltage; this is incorrect, but the difference is appreciable only when A and B are of comparable size.

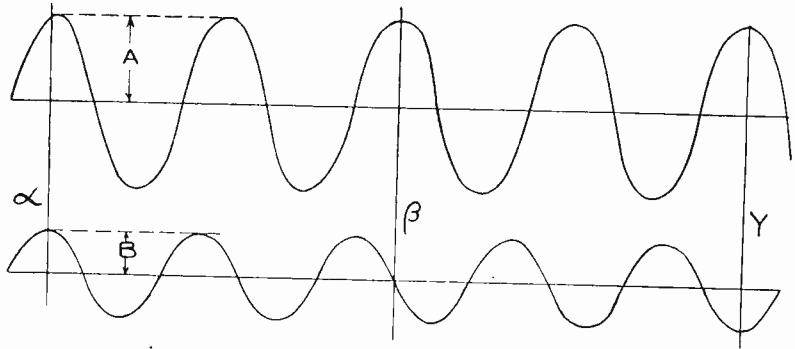

Fig. 3

Consider Fig. 3 which shows two sine curves of slightly different frequency. At time α the two are in phase and the resultant is a sine curve of height $A+B$: at time γ they are in antiphase and give a resultant height $A-B$. But at time β , which is half way between α and γ , they are in phase quadrature and the resultant sine curve has a height $\sqrt{A^2+B^2}$. The height of the resultant sine curve does not fall to A , until an epoch later than β : it does not occur until curve B has an appreciable component in antiphase with A .

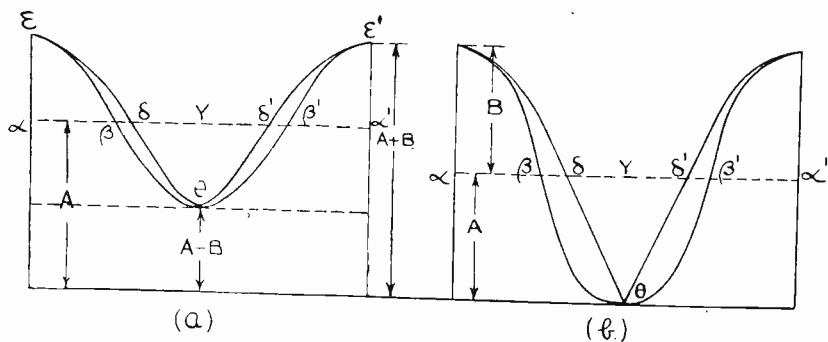

Fig. 4

The envelope is shown in Fig. 4 (a): in this the curve $\epsilon\beta\theta\beta'\epsilon'$ is the envelope for a modulated voltage and $\epsilon\delta\theta\delta'\epsilon'$ is the envelope we are considering. The detector voltage does not fall to A until the point δ : and it remains greater than A for longer than it is less than A . Since it rises to $A+B$ and falls to $A-B$, the area above the line $\alpha\beta\delta\gamma$ is greater than the area below the line. Therefore, the mean rectified

current (direct) is increased by the presence of B , whereas with true modulation it is independent of the presence of B . Further the shape of the curve $\epsilon\delta\theta$ is not sinusoidal, and therefore the output is not pure but contains all the overtones. The envelope for the limiting case of $A = B$ is shown in Fig. 4 (b); there the increase of mean current and the acoustic distortion is very noticeable. We may summarise these effects as shown in the table below.

	Square Law		Linear	
	Mean current	Acoustic output	Mean current	Acoustic output
Modulated voltage	increase	note and its octave	no change	note and no octave
Heterodyne voltage	increase	note and no octave	increase	note and all overtones

The increase of mean current and the overtones from a linear rectifier are appreciable only when A and B are comparable. If A is, say, greater than 4 B they are so small that for practical purposes they may be considered nonexistent. This is a very important point in considering the relative behavior to interference of highly selective and moderately selective receivers and must always be kept in mind. We shall suppose A is the desired signal (for the moment supposed unmodulated) and B is the undesired signal (also supposed unmodulated for the moment). If the receiver is not highly selective then A and B will be of comparable strength and a linear rectifier will show an increase of mean current.

If the receiver is highly selective then A will be at least ten times B and the increase of mean current is sensibly nonexistent.

Now let A be modulated: referring to Fig. 3 we have to add the small sine curve B to the now modulated larger sine curve A , whose frequency of modulation is much less than the frequency difference between A and B . During one cycle of difference frequency, the amplitude of A will change very little and conditions will differ inappreciably from those shown in Fig. 4 (a). If the circuit is highly selective, B is inevitably much smaller than A and the modulation depth of A is only some 5 per cent. But during the cycle shown in Fig. 4(a) the mean current is in reality changing: this change is due to the modulation of A and any change of mean current due to the presence of B is a second order effect because of the essential disparity between B and A . We may visualize the complete cycle of changes by drawing cycles such as 4(a) about a base line (of which $\alpha\beta\beta'\alpha'$ is a small piece) which follows the modulation of A . The modulation of A is unimpaired and the output due to the unmodulated B is the same as it would be if A were unmodulated.

(c) Interference Due to a Modulated Signal.

Consider a modulated signal $B(1 + M \cos nt) \cos pt$ acting on a highly selective circuit tuned to p_0 the carrier frequency of the desired station A. Fig. 5 shows the hyperbolic side of the resonance curve of the circuit tuned to p_0 . The carrier and side frequencies of B are indicated by B , B_1 , and B_2 , respectively, in Fig. 5, and these have electromotive forces E , $EM/2$, and $EM/2$, respectively: for simplicity we shall take $M = \text{unity}$ and so have E , $E/2$, and $E/2$. The current due to B is CD , that due to B_1 is $\frac{1}{2}GH$ and that due to B_2 is $\frac{1}{2}EF$. We shall divide the

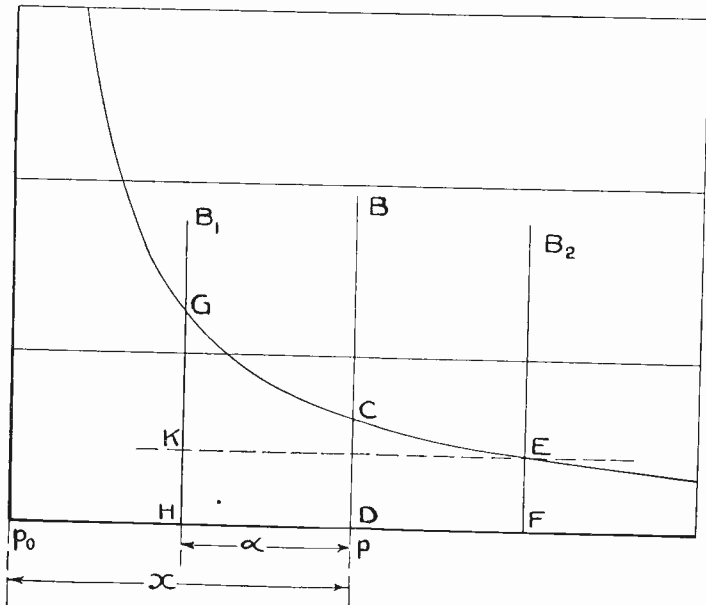

Fig. 5

current GH into two portions, GK and $KH = EF$. Then the resultant voltage is a component CD with side bands $\frac{1}{2}KH$ and $\frac{1}{2}EF$, giving a voltage CD with sensibly the full modulation M and also an unmodulated component of amplitude $\frac{1}{2}GK$.

Calling the carrier separation κ and the modulation width α (see Fig. 5), it follows that

$$\frac{\frac{1}{2}GK}{CD} = \frac{\alpha}{\kappa \left(1 - \frac{\alpha^2}{\kappa^2} \right)}$$

We shall consider separately the effect of the modulated voltage CD and the unmodulated voltage $\frac{1}{2}GK$.

Refer again to Figs. 3 and 4(a) and consider the effect of modulating B : we shall have cycles such as 4(a) in which the voltage B is modulated

up to 100 per cent superposed on a base line $\alpha\alpha'$ which is modulated perhaps 5 per cent.

The total effect is shown in Fig. 6. The base line $\alpha\beta\gamma\delta\lambda$ is modulated by the original wanted signal A . The envelope $\epsilon\theta\kappa\lambda$ is the 100 per cent modulation of the unwanted signal B , but this is a modulation of the difference frequency, which is shown by the modulated sine curve superposed on the wavy base line $\alpha\beta\gamma\epsilon$.

The total acoustic output is now the modulation frequency of A plus the difference frequency modulated with the modulation frequency of B .

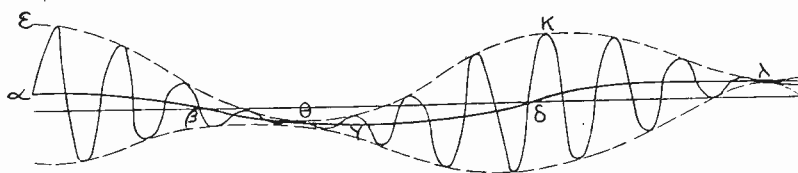

Fig. 6

The linear rectifier has the very important property of preventing the modulation note of the interfering station from appearing in the output. It is true that due to the displacement between the points β and δ in Figs. 4(a) and 4(b), there is a trace of the modulation frequency of B , but this trace depends on the ratio between the carrier voltage of B and the carrier voltage of A . In a highly selective receiver this ratio is of the order of 50 to 1, and the trace may be ignored entirely.

It may be shown that the modulation of the weak station W is reduced by the strong station in S the ratio $\frac{1}{2}WS$ (Appleton and Boohariwalla)¹ and since $W/S \gg 1$ in a highly selective receiver, this residual trace is negligible. With a linear rectifier a strong station S is sometimes said to demodulate a weak station W . An alternative statement is, that with a linear rectifier the modulation of W becomes a modulation of the heterodyne note, but in addition there is a small current of modulation frequency having an amplitude proportional to $\frac{1}{2}WS$.

The circumstances are exactly the same as in the superheterodyne system of reception where the original modulation is handed on as a modulation of the difference frequency.

If the circuit is not highly selective then the ratio W/S is not necessarily much less than unity and the interfering modulation is reproduced to a considerable extent.

A highly selective circuit combined with a linear rectifier acts as a frequency changer of the modulation. It is so essential to understand this effect that it will be illustrated by a numerical example. Stations

¹ *Wireless Engineer*, March, (1932).

A and B are separated by 12 kilocycles; and both are modulated with 1 kilocycle.

(In the notation of Fig. 5, $\alpha/\kappa = 1/12$ and therefore $\frac{1}{2}GK = 1/12CD$ and the presence of $\frac{1}{2}GK$ will be ignored.)

The acoustic output is the 1 kilocycle modulation of A , which is restored to its proper relative strength by the tone corrector.

The disturbance due to B is a modulated note of 12 kilocycles, which the tone corrector elevates to the same strength as if it had been a 12-kilocycle note of A 's transmission. This modulated note of 12-kilocycles may be decomposed into a note of 12 kilocycles and half strength notes of 11 and 13 kilocycles: after tone connection these come out in the ratio 1, 0.42, and 0.54, respectively. Owing to the disabilities of acoustic apparatus these notes would generally be almost inaudible and the presence of B would not be suspected.

There is an inversion of the acoustic spectrum: a low note of interference will appear as a high note and vice versa.

(d) *Two Types of Interference.*

It is convenient to divide interference into two rather arbitrary categories.

- (a) Interference by a station whose carrier is so far separated from the desired station that there is no appreciable overlapping of the side bands.
- (b) Interference by a station whose carrier is separated from the desired station by an amount which permits considerable overlap of side bands.

Type (a) has already been considered and we find that a highly selective receiver and linear rectifier confers much more immunity from interference than would have been expected from consideration of the resonance curve alone.

To consider interference of category (b), we shall refer to Fig. 7 which is supposed to represent two stations A and B , having carrier frequencies separated by 5 kilocycles and each station is modulated with about 2.5 kilocycles: then A_2 , the upper side band of A is sensibly coincident with B_1 the lower side band of B . We may choose to split B_1 into the components GK and KH of Fig. 5. Then we shall say that the heterodyning of A and B produces a 5-kilocycle note which is modulated with 2.5 kilocycles, and has sensibly the intrinsic modulation of B : this is equivalent to notes of 2.5, 5, and 7 kilocycles. Also we must say that a portion $\frac{1}{2}GK$ of B_1 heterodynes with A and produces a note of 2.5 kilocycles. Being now clear that we are combining a modulated sine curve B and an unmodulated sine curve $\frac{1}{2}GK$ with the car-

rier sine curve A , we see what notes are produced and can drop the rather fictitious division of B_1 into two portions. But the process is useful because it stops us from supposing that A_1 will beat with B or B_2 , A_2 with B_1 , and B and B_2 . Exact analysis would show that some or all of these frequencies do exist but the magnitude of these terms is vanishingly small.

We wish to compare the note of 2.5 kilocycles due to the modulation of A with the note of 2.5 kilocycles which results from the modulation of B .

The acoustic output due to A 's modulation is proportional to $M/2(B_1H + G_1H_1) = MGH$. The note of 2.5 kilocycles due to B_1 is proportional to $\frac{1}{2}MGH$.

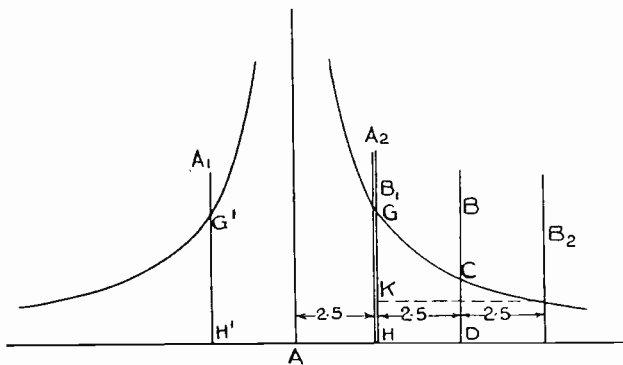

Fig. 7

Hence the modulation note which is half way between the carrier frequencies will be twice as strong from the wanted station as from the unwanted station. This ratio is nearly independent of the detector and is independent of the sensitivity of the receiver: with a linear detector the ratio may be slightly greater than 2:1 if the circuit is not highly selective, but the advantage is insignificant.

A proper tone correcting device exactly compensates for the fall of the resonance curve and the combination of highly selective circuit, linear detector, and tone corrector has the effect of displacing the audio spectrum without altering the relative modulation depths. If an interfering station whose carrier is separated h kilocycles from the desired station is modulated with frequency m , it will produce an acoustic note κ of frequency h , a note $\frac{1}{2}\kappa$ of frequency $h - m$ and a note $\frac{1}{2}\kappa$ of frequency $(h + m)$.

If two equal and equally modulated stations are separated by 10 kilocycles, and if the desired station is modulated at 2 kilocycles, and the undesired station is modulated at 8 kilocycles, then the desired station will produce a 2-kilocycle note of strength κ , and the undesired

station will produce a 2-kilocycle note of strength $\frac{1}{2}\kappa$. It will also produce a 10-kilocycle note of strength κ , and an 18-kilocycle note of strength $\frac{1}{2}\kappa$.

If an acoustic reproducer is faithful up to frequency n and then cuts off abruptly, two stations separated by $2n$ will produce no interference if their modulation width is also restricted to n . If a telegraph station signals a Morse dot by a modulation of 200 cycles and a dash by a modulation of 500 cycles, then one aerial could be used to operate any number of channels separated by one kilocycle: it could operate 500 channels in the wave band between 300 and 600 meters.

Since we find ultimately that the permissible difference of frequency between stations depends only on the acoustic reproducer we might suspect that the highly selective circuit and tone corrector are not necessary. But this is not so, because the whole effect depends on the action of a linear detector in shifting the acoustic spectrum: the detector has this property only if the desired radio-frequency voltage dominates the undesired voltage. This automatic domination can be secured only by means of a receiver which has a very narrow band width to radio frequency. This narrow band width will necessitate a tone correcting system: this system is simplest when it has to correct the resonance curve of a simple resonant circuit.



A STUDY OF RECEPTION FROM SYNCHRONIZED BROADCAST STATIONS*

BY

CHARLES B. AIKEN

(Bell Telephone Laboratories, Inc., New York City)

Summary—The present paper gives the practical results of an extensive analysis of the detection of two modulated waves of identical carrier frequency. It is shown that the total effects of time delay in the program distribution circuits, differences in circuit elements in the two transmitters, and differences in path lengths of the two signals in traveling from their respective transmitters to the receiving point, may all be expressed in terms of two fundamental angles, γ and β . γ is the phase angle between the two carriers at the receiving point, and β is an angle determining the relation between the side frequencies received from the two stations. At any given point there will be a different value of β for each modulation frequency.

Analyses in terms of β and γ yield quantitative descriptions of the distortions present in the rectified wave. From these results it is possible to determine how the distortions vary from point to point in space and upon what significant quantities they are dependent:

Experimental work has been carried out in the laboratory which confirms the results of the theoretical analysis and which shows in a striking manner the effects of small time delays on the quality of the received signal. This work agrees with theory in showing that time delays, of the order of 200 microseconds, may be responsible for serious distortion, and that a delay as small as 50 microseconds requires a 2:1 carrier ratio to prevent distortion.

It is shown that if two synchronized broadcast stations are far enough apart and are of such powers that there are places where the signals from the two stations are of approximately the same strength and have traversed paths differing in length by more than about ten miles, then distortion is at times bound to occur at these points. At places where the path difference is greatly in excess of ten miles, very serious distortions may occur. It is not possible to reduce the distortion at such points appreciably by equalizing the times of voice-frequency transmission of the program over the wire circuits from the studio to the two stations, nor is there much advantage in making the voice-frequency and modulating circuits at the stations identical.

On the other hand it is shown that if the two broadcast stations with synchronized carriers are fairly close together, that is, within about twenty-five miles of each other, there is no distortion in the middle zone between them if the modulated waves radiated from the two stations are identical. There may, however, be variations in resultant field strength. The effect of such variations may usually be eliminated by the use of automatic volume control in the receiving set. An exception must be noted at points where the resultant field strength falls below the noise level. At such points the use of a receiving antenna having slightly directive properties will eliminate this difficulty.

The results of the analysis suggest an interesting possibility for supplying service to urban areas. Instead of employing one high power transmitter at a distance from the region to be covered, it may be possible to distribute a number of low power

* Decimal classification: R550. Original manuscript received by the Institute, April 1, 1933. Presented before American Association for the Advancement of Science, Atlantic City, N.J., December 28, 1932.

transmitters throughout this area and to supply each of them with identically the same modulated wave from a central point by means of appropriate transmission circuits. The total radiated power required for adequate coverage should be far less than that required when a single high power transmitter is used. On this account there would be a great reduction in the total sky wave and consequently a great reduction of interference at distant points. For this reason several station groups of this kind could be operated on one channel with the same geographical separations that would be required by several individual low power stations.

If, within station groups, the program were to be distributed to the various transmitters at audio frequencies, the requirements on transmission time, frequency-transmission characteristic, and modulation characteristic would have to be very severe in order to meet the necessity of identical radiated waves from all stations in the group. This technical difficulty would be avoided if the modulation of a carrier were effected at a central point and the resulting modulated wave distributed to the several transmitters over high-frequency transmission lines of equal lengths, or distributed directly by radiation through the ether.

INTRODUCTION

RADIO broadcast systems involving the operation of two or more stations on the same carrier frequency, and with the same program used for modulation, have been put to considerable practical use, both in this country and abroad, and the list of such systems is now a long one.^{9,10} The experience which has been gathered during the course of the operation of these systems has done much to establish the limitations and possibilities of common frequency broadcasting of certain types. It has been observed that the quality of reception is good where the field from one station predominates, but is usually unsatisfactory in the middle zone between two stations where the field strengths are approximately equal. Experimental observations of these regions of distortion, both in the field and in the laboratory, have led to the conclusion that, if reception is to be of good quality, the voltage induced in the receiving antenna by the weaker of the two stations must not exceed K times the voltage induced by the stronger station. Estimates of the value of K , which have been made by various investigators, range from 0.2 to 0.5. These figures both refer to the case in which the difference in carrier frequency is zero, or is so small that it may be regarded as a slowly changing phase difference between the carriers.

The theoretical treatments of the distortions which may be expected to result from the reception of two synchronous* carrier trans-

^{9,10} Numbers refer to bibliography.

* It has been pointed out¹⁰ that the term "synchronous" suggests identity of phase as well as frequency and that hence "isochronous" is preferable. This is, of course, strictly correct but as synchronous is a somewhat less clumsy term, and as it seems to have taken on a perfectly well-understood meaning in its application to common frequency broadcasting, it will here be used interchangeably with isochronous.

missions have been based largely upon a consideration of the standing wave patterns formed in the space field by the carriers and by the side frequencies. The variation of the carrier amplitude, distortion of the received side bands, alteration of the effective degree of modulation, etc., have been thus indicated. But the results of this type of analysis are somewhat qualitative in character and cannot be readily interpreted in terms of the distortion components present in the output of the detector. In fact, many such analyses have not dealt with the rectifying action at all. Consequently, there has not thus far been brought to bear upon the problem the full power of a theoretical investigation, with the result that a complete comprehension of the significance of the various physical quantities involved has not been achieved. It has not been possible to say whether the recorded experimental observations were made under optimum conditions, nor to specify what these conditions are. This state of affairs has resulted in the temporary acceptance of certain misconceptions, such as the early thought that if exact identity of frequency could be achieved the zones of distortion would vanish; and has prevented the realization of all of the possibilities of common frequency systems.

The present paper gives the results of an extensive theoretical analysis** of the problem, together with the results of experimental work which has been suggested by the theory. An attempt is made to point out certain as yet unrealized possibilities of common frequency broadcasting, and to establish limitations involving path length, program circuit delay, etc. The results set forth do not abrogate in any essential manner the majority of those obtained by others with regard to the synchronous operation of fairly widely spaced stations employing the usual program circuits, but it is hoped that they will place on a firm theoretical foundation the limitations of such systems and will serve to extend the range of useful practice beyond that which has so far been established.

The mathematical processes underlying the results which are to be given have been largely developed, for the linear detector, in a recent paper.¹² The analysis for the case of a square-law detector is a straightforward matter and will be briefly considered in an appendix of the present paper. Mathematical details will be avoided in the body of the text.

It is assumed that the transmitters are not guilty of appreciable

** When Mr. Gillett presented his paper¹⁰ on "Some developments in common frequency broadcasting" the analysis which forms the basis of the present paper was in a very incomplete state. However, it was possible to furnish him with a limited number of curves, which were included in his paper, from which were drawn certain conclusions which will here be restated and enlarged upon.

phase or frequency modulation and that the receiver is properly tuned so that there is no unsymmetrical response of the tuned circuits.

PHASE RELATIONS AND THE SPACE FIELD†

The parameters which are significant in quantitatively determining the characteristics of the reception of two isochronous waves carrying the same modulation are: the ratio of the field strengths, the two modulation factors, and certain phase relations between the carriers and their accompanying side frequencies. In order to avoid unmanageable complexity we shall deal chiefly with the case of a single modulation frequency of $P/2\pi$ cycles per second. The total phase relationships between the two modulated waves may then be described by means of two angles, γ and β , both of which are dependent upon the course of events at one transmitting station relative to that at the other, and also upon the difference in the lengths of the paths traversed by the two waves in traveling from their respective transmitters to the receiving point. These two angles, γ and β , play an important rôle in the greater part of our discussion and their significance must be clearly set forth.

Let the wave radiated from one transmitter be taken as a reference. Then the expression for this wave need contain no arbitrary phase angles and may be represented by

$$E[1 + M \cos Pt] \cos \omega t, \quad (1)$$

$P/2\pi$ being the modulating frequency and $\omega/2\pi$ the carrier frequency. Now at a given instant of time the phase of the carrier leaving transmitter No. 2 will differ from that of the carrier leaving transmitter No. 1 by a certain angle. We shall assume that the second carrier leads the first by an angle γ_0 . At a receiving point which is equidistant from the two transmitters, the carriers will be observed to have this same phase difference. If the modulating frequency is furnished to the two transmitters in identical phase, which might theoretically be managed by feeding it from a common point over identical circuits to the two stations or by phase equalization of dissimilar circuits, then the envelopes of the two waves will have a zero phase difference between them, and the wave leaving the second station may be represented by

$$e[1 + m \cos Pt] \cos (\omega t + \gamma_0). \quad (2)$$

However, if the modulating frequency at the second transmitter leads that at the first by the angle β_0 , then the wave leaving the second antenna is represented by

† This matter is discussed in a slightly different way in Appendix A of No. 12 of the bibliography.

$$e[1 + m \cos (Pt + \beta_0)] \cos (\omega t + \gamma_0). \tag{3}$$

The waves from the two stations will require identical times to travel to an equidistant receiving point, and hence the phase relations between them will be unaltered and the expressions (1) and (3) may be used to represent the waves received at such a point.

Suppose, however, that the waves are received at a point which is d_1 meters from the first transmitter and d_2 meters from the second. Then, if the first wave is still taken as having zero phase, the relation of the second wave to it may be described by the quantities γ and β which are such that

$$\gamma = \gamma_0 - \frac{\omega D}{c} \tag{4}$$

$$\beta = \beta_0 - \frac{PD}{c}, \tag{5}$$

in which $D = d_2 - d_1$ and $c = 3 \times 10^8$ meters per second, the velocity of propagation. The two waves impressed upon the receiver at this point may then be represented, in a very general manner, by

and,
$$\left. \begin{aligned} E[1 + M \cos Pt] \cos \omega t \\ e[1 + m \cos (Pt + \beta)] \cos (\omega t + \gamma). \end{aligned} \right\} \tag{6}$$

The significance of γ and β may be shown graphically by employing the conventional vector diagrams representing a modulated wave. In Fig. 1, E represents the carrier of the stronger signal and e that of the weaker. The angle between them is γ . The diagram represents the

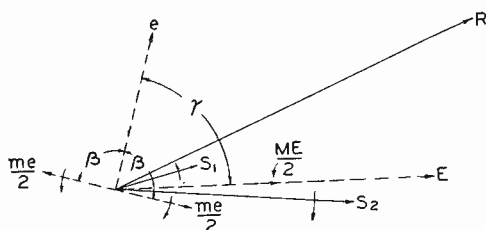

Fig. 1—Vector diagram of two modulated waves. The trigonometric expressions for these two waves are $E[1 + M \cos Pt] \cos \omega t$ and $e[1 + m \cos (Pt + \beta)] \cos (\omega t + \gamma)$. The diagram shows the state of affairs at time $t=0$, when the two side frequency vectors $EM/2$ are both coincident with the carrier vector E . Each side vector $em/2$ then makes an angle β with the carrier e . γ is the angle between the carriers.

state of affairs at time $t=0$, that is, when the vectors representing the two side frequencies of the stronger wave are coincident with their carrier. At this instant each side vector of the weaker wave makes an angle with its carrier which is equal to β . R is the resultant carrier and

S_1 and S_2 are the resultant side frequencies. From the inequality in the sizes of these side frequencies and their lack of symmetry with respect to their carrier, it is evident that the detection of this particular combination of waves will yield distortion products of considerable magnitude.

The foregoing discussion shows that if an analysis of the reception of the waves indicated in (6) is made with γ and β as parameters, it is possible to translate this into terms of space relations for any given values of ω and P by employing (4) and (5). This use of γ and β results in much simpler and more readily handled results than does the direct insertion of path lengths at the outset, and we shall deal chiefly with the phase angles and refer to space parameters only when specific use of them is desirable. But it should be observed that this procedure is not restrictive, or lacking in generality, and that it is adaptable to a description of areas of distorted reception, etc.

When the modulating program contains a number of frequencies, a different value of β must in general be assigned to each frequency, with the result that at a given instant the audio output of the detector may be of a materially different character for one portion of the voice spectrum from what it is for another. Since β is a simple function of the modulating frequency, as indicated by (5), it is evident that distribution of distortion of various types throughout the voice-frequency spectrum may be estimated from the results of the analysis in terms of β .

Time delay due to difference in time of wire circuit transmission of the program will affect β but not γ . Differences in the circuits of the equipment employed at the two stations may affect γ or β or both, and if these differences are quantitatively known the magnitude of the effect on γ and β may be predicted.

COMMENTS ON THE ANALYSIS EMPLOYED

The results which are recorded in the next section of this paper have been obtained by an analytical determination of the audio-frequency output of a detector when two waves of the type indicated in (6) are impressed upon its input terminals. The problem has been solved for the square-law and linear rectifiers, both of which are of common practical occurrence. Any rectifier having a single valued, continuous characteristic, that is, any ordinary nonionizing rectifier, will give a square-law response when worked at low input levels. Rectifiers which approximate quite closely to the ideal linear form are readily constructed and are in common use; and such devices are highly important because of their property of giving essentially distortionless detection, or, as it is frequently called, demodulation, of the usual

type of modulated wave. In a sense these two detectors represent practical extremes, and all detectors commonly met with in practice which have characteristics not conforming closely to either type will be in between them. Consequently, the results obtained from the use of such units in the reception of either one or two transmissions may be expected to be intermediate, in a general way, between the results obtained when the square-law and the linear rectifiers are employed.

The method of analysis which has been developed for the linear rectifier has been fully discussed in another paper.¹² Certain minor extensions of this analysis have been found to be necessary in computing the desired curves and these extensions are discussed in Appendix A. A point to be observed here is that the amplitudes of the various audio-frequency components of the rectifier output (which will here be considered as voltages, although an equivalent description in terms of current is readily made) are conveniently expressed as ratios to the carrier amplitude, thus removing any bother about the absolute magnitudes of the impressed and output voltages. It happens that the solutions for the linear rectifier contain the factor $1/\pi$, and it has been found convenient to remove this by calculating such quantities as $\pi E_P/E$, $\pi E_{2P}/E$, etc., in which E is the amplitude of the larger of the two impressed carriers, E_P is the amplitude of the voltage of frequency $P/2\pi$, acting in the output circuit, and E_{2P} is the amplitude of twice this frequency.

In the case of the square-law detector, we are dealing with a non-linear device possessing a characteristic which is not necessarily of pure parabolic form, and we merely assume that the low level operating portion of this characteristic may be represented by an equation involving terms up to and including the second degree in the impressed voltage. The absolute magnitude of the rectified output voltages will depend upon the coefficient of the second-degree terms, i.e., upon the curvature of the characteristic at the operating point. This curvature will vary from one detector to the next, and from one point to another on the characteristic of a given detector. When studies are made of efficiency of detection the curvature must be evaluated. Here, however, we are not interested in efficiency or absolute magnitude of output for a given input, but in quality, or the interrelation of the output components. Such relations do not depend upon the magnitude of the curvature, and we shall therefore refrain from encumbering the discussion by including the second-order coefficient in our results, and shall merely calculate values of such quantities as E_P/E^2 , E_{2P}/E^2 , etc. Such quantities are of the dimensions $1/E$, but this should cause us no trouble.

In many cases a desired quantity will contain a factor such as M , the degree of modulation of the stronger station. Instead of plotting a different curve for each of several values of M , it is more convenient to plot a single curve, the ordinates of which contain $1/M$. Thus in Fig. 3 we have plotted E_P/E^2M as ordinate and can use this same figure to examine the results for various values of M .

In view of the foregoing, it should be evident that the form in which the results are stated will not permit a comparison of the absolute magnitudes of the outputs of the linear and square-law detectors, but

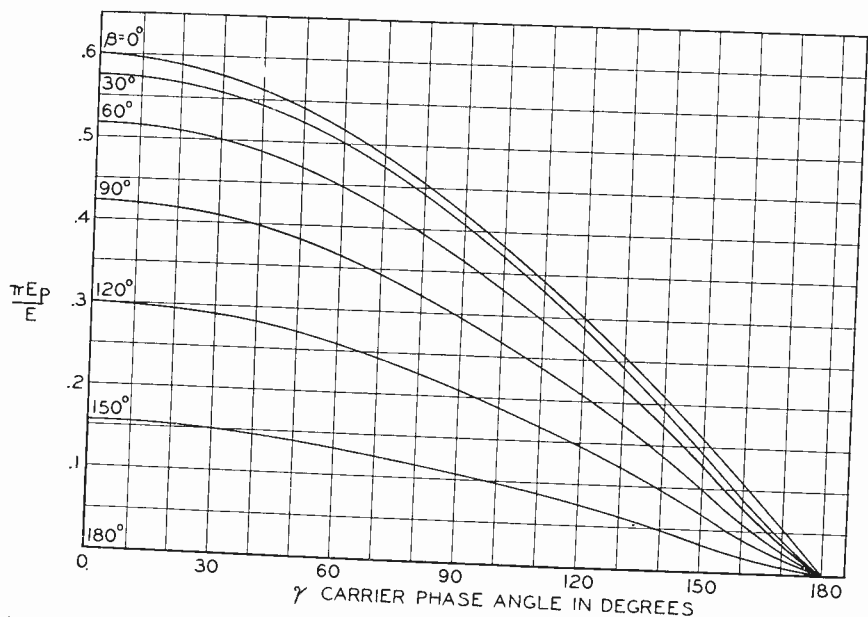

Fig. 2—Fundamental audio-frequency output of linear detector when two waves of the type illustrated in Fig. 1 are impressed upon the input. The carrier ratio $K = e/E$ is unity. Both stations are modulated 30 per cent ($M = m = 0.3$).

that the interrelations of the components of the output of one detector may be compared with those of the other.

A brief discussion of the square-law analysis is given in Appendix B.

DISCUSSION OF RESULTS OF THE ANALYSIS

It has been pointed out that the phase angles γ and β are significant quantities which vary from point to point in space. There will now be discussed a number of curves showing the output components of the square-law and linear rectifiers, these curves having γ or β as the independent variable.

Fig. 2 shows the amplitude of the fundamental component of the audio-frequency output of a linear rectifier when there are impressed upon the input two waves of equal carrier strength ($K = e/E = 1.0$) both

of which are modulated 30 per cent. The quantity actually plotted is π/E times this amplitude. When γ , the phase angle between the carriers, is 180 degrees, the fundamental component of the output is zero

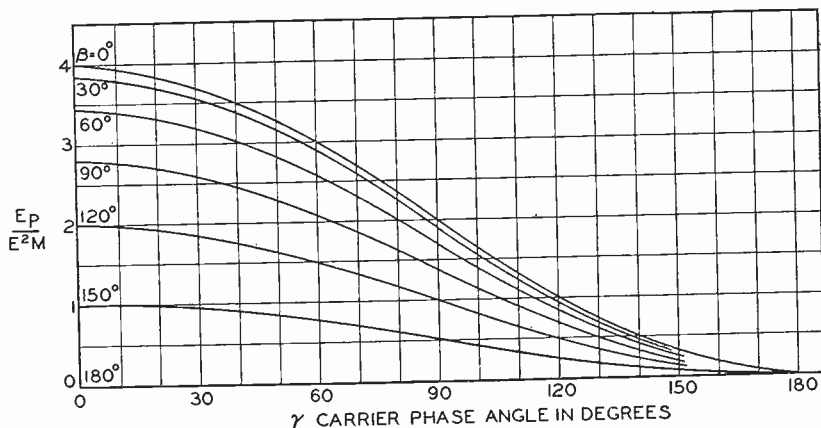

Fig. 3—Fundamental audio-frequency output of square-law detector under the conditions of Fig. 2.

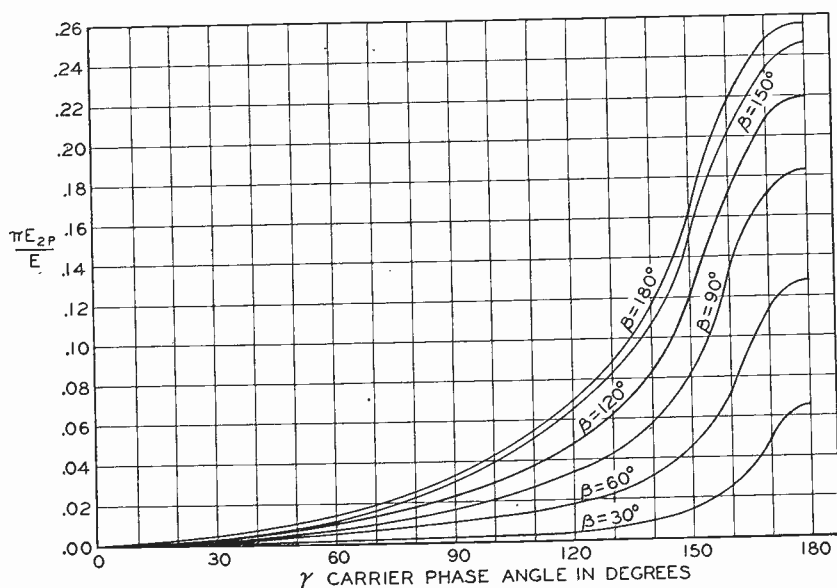

Fig. 4—Second harmonic audio-frequency output of linear detector under the conditions of Fig. 2.

for all values of β , since the carriers annul each other and the beats between the side bands will give only harmonics. It will be noted that the magnitude of the fundamental depends radically upon β and vanishes when $\beta = 180$ degrees.

The curves of Fig. 2 are symmetrical about the vertical line through $\gamma = 0$ and about that through $\gamma = 180$ degrees. This is true of all the curves shown in this paper in which either γ or β is plotted as abscissa.

In Fig. 3 is shown a similar set of curves for the case of the square-

law detector. The shapes of these curves are strikingly similar to those of Fig. 2. The quantity plotted in Fig. 3 is E_P/E^2M , and it is evident that if E_P/E^2 were plotted the ordinates of the resulting curves would be proportional to M . The ordinates of the linear rectifier curves are approximately proportional to M when the modulation is less than 50 per cent, but the relation becomes more complex for M near unity.

Figs. 4 and 5 show the second harmonic outputs of the linear and quadratic rectifiers, respectively, for the conditions of Fig. 2. The difference between these curves is very interesting. The harmonic output of the square-law detector may be considerable for any value of γ , if β

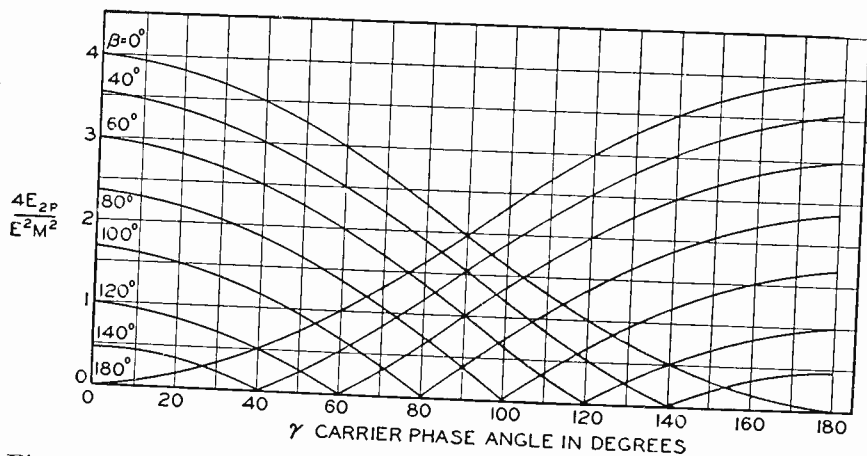

Fig. 5—Second harmonic audio-frequency output of square-law detector under the conditions of Fig. 2.

has the proper value. On the other hand, the linear rectifier gives appreciable harmonic output only when the carriers are near phase opposition and the side frequencies are near phase equality, i.e., when the resultant wave is nearly or actually overmodulated. However, this difference between the two types of detectors is not as great as the curves might lead us to believe. This may be made evident by plotting the ratio of second harmonic to fundamental. The result is shown in Fig. 6, † where the solid lines represent the linear and the dashed lines the square-law rectifier. For every value of β there is a value of γ that makes the second harmonic output of the square-law detector vanish. This fact makes the quadratic detector curves of Fig. 5 lie below the curves for the linear rectifier over a good portion of the range, but for values of E_{2P}/E_P near unity there is little to choose between the two types of detector. Later curves for which K , the carrier ratio, is less than unity, show that a definite superiority may be attributed to the linear rectifier.

† Two of the curves of this figure, namely, those for $\beta = 0$ and $\beta = \pi/2$ have already been given in Fig. 15 of Gillett's paper,¹⁰ while the corresponding curves of Fig. 10 of the present paper have been shown in Fig. 17 of his paper.

From Fig. 6 it will be noted that the distortion due to the generation of harmonics is slight when γ is small, but Figs. 2 and 3 indicate that if β is large and γ is small, there is a large reduction in the amplitude of the fundamental audio output. This will cause a loss of certain frequency bands in the output. Thus, suppose that β_0 , of (5), is zero and the time of travel of the two signals through space differs by 100 microseconds, corresponding to a path difference of 18.6 miles. Then, if both stations are modulated to an equal degree, the frequency of 5000 cycles

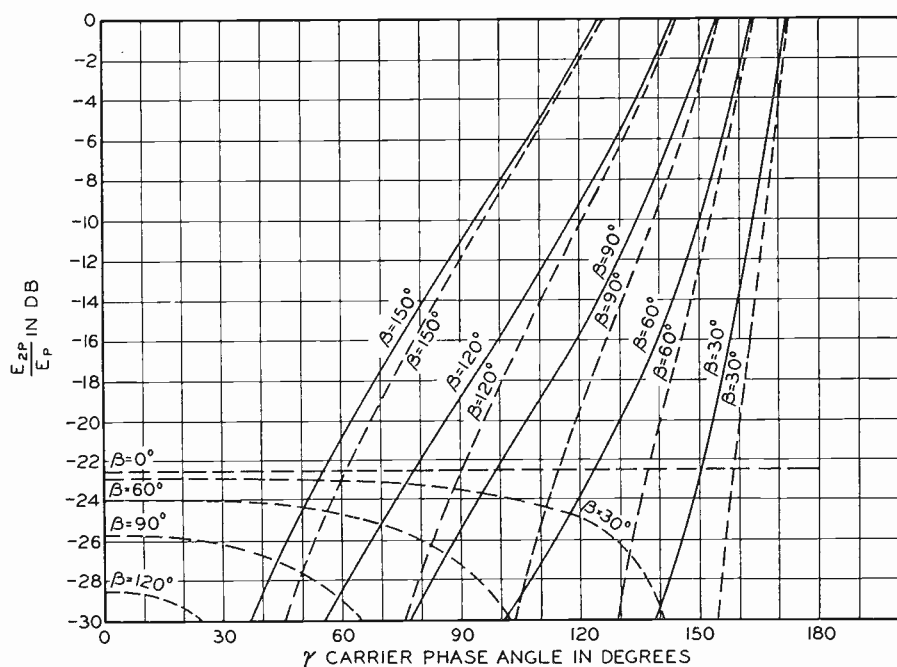

Fig. 6—Ratio of second harmonic to fundamental audio-frequency output under the conditions of Fig. 2. The full lines are for the linear detector and the dashed lines are for the square-law detector.

will vanish from the rectified output at those points in space for which $\gamma = 0$. If the path difference is 93.0 miles, there will be no 1000-cycle output when $\gamma = 0$, and frequencies near to this value will be greatly attenuated. These examples make it evident that even when the phase relation of the received carriers is such as to produce little or no harmonic distortion, there may still be a serious impairment of the fidelity of the rectified signal.

This impairment of fidelity may also be caused by unequal time of wire line transmission of the programs, or by unequal phase shifts in the audio-frequency circuits embodied in the two transmitters, since such inequalities will affect the magnitude of β . They will also produce harmonic distortion when γ is near 180 degrees. It is interesting to note that a time delay of a small fraction of a millisecond in one wire line, as

compared with the other, is capable of causing seriously distorted reception in an otherwise ideal system (i.e., identical transmitters and equal wave paths in the ether), while several hundred times as large a delay may be tolerated before "echo" effects become appreciable.

When β is not zero the field strength will be zero at a carrier node ($\gamma = 180$ degrees) only when the modulation is absent. At such points the received signal will be tremendously distorted but will not vanish.

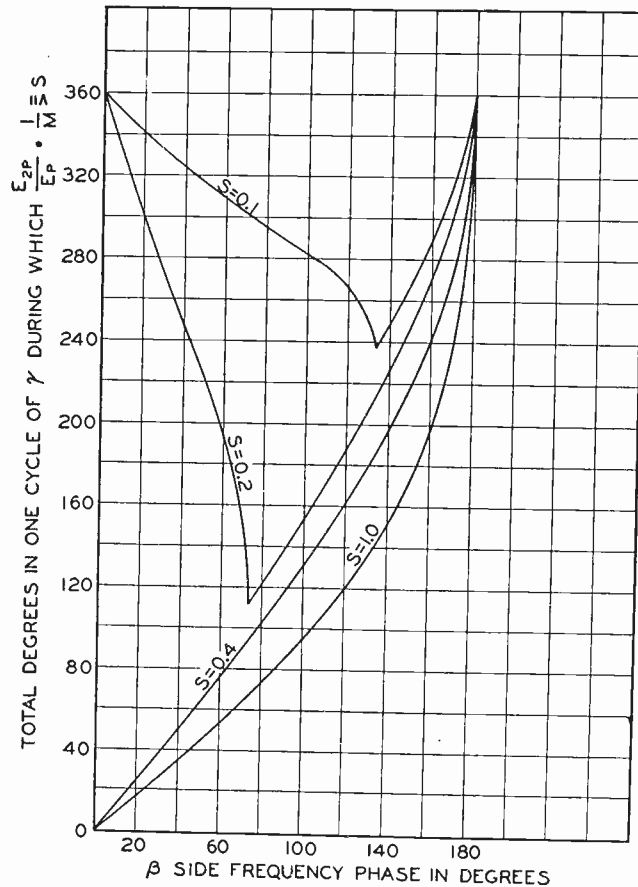

Fig. 7—Curves showing the portion of a cycle of γ during which the ratio of second harmonic to fundamental output of a square-law detector equals or exceeds a certain value. $K = 1.0$, $M = m$.

In Fig. 7 are shown a group of curves, for the quadratic detector, and for $K = 1$, each of which indicates the number of degrees in a cycle of γ for which $E_{2P}/E_P M$ will be equal to or greater than a specified value. This number of degrees is a function of β which here serves as abscissa. When $M = 1$ the value of E_{2P}/E is 0.25 when a single wave is received. In the reception of two equal waves it will exceed this value for a large fraction of the range of γ , if β is large. Since γ goes through a complete cycle when the receiving point is moved a half wavelength along the line joining the transmitting stations, the curves

of Fig. 7 may be interpreted as showing the fraction of the area, included in a band one-half wavelength wide, for which the distortion exceeds a specified value.

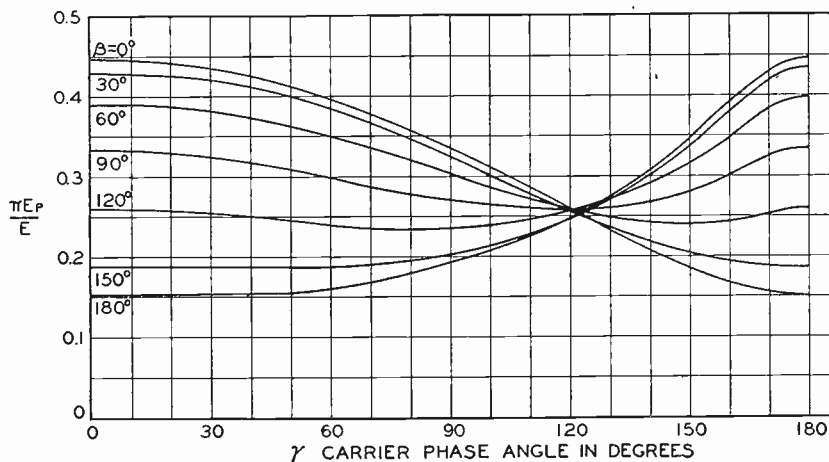

Fig. 8—Fundamental audio-frequency output of a linear detector under the action of two waves of the type shown in Fig. 1. $K = 0.5$, $M = m = 0.3$.

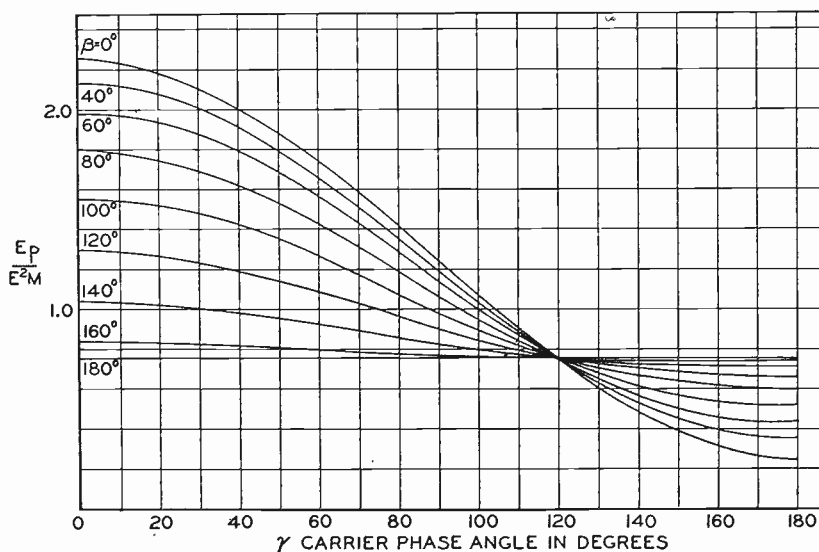

Fig. 9—Fundamental audio-frequency output of a square-law detector under the conditions of Fig. 8.

Fig. 8 to 10, inclusive, show curves for the case in which the amplitude of one received carrier is twice that of the other ($K = e/E = 0.5$) and the modulations are both 30 per cent. The harmonic distortion produced by the linear rectifier is less serious than that produced by the quadratic device, as may be seen by reference to Fig. 10. When the carriers are directly in or out of phase the distortion from the former detector vanishes. At such times the resultant side frequencies are sym-

metrical with respect to the carrier, and no harmonic distortion can result. However, when higher modulations are employed the resultant side frequencies may add to a magnitude greater than the resultant carrier, in which case the resultant wave form will be effectively over-modulated. Serious distortion may then occur. Consequently higher degrees of modulation of the original waves will call for higher carrier ratios if reception is to be satisfactory.

The variation, with β and γ , of the amplitude of the fundamental audio-frequency output, which is evident from Figs. 8 and 9, shows

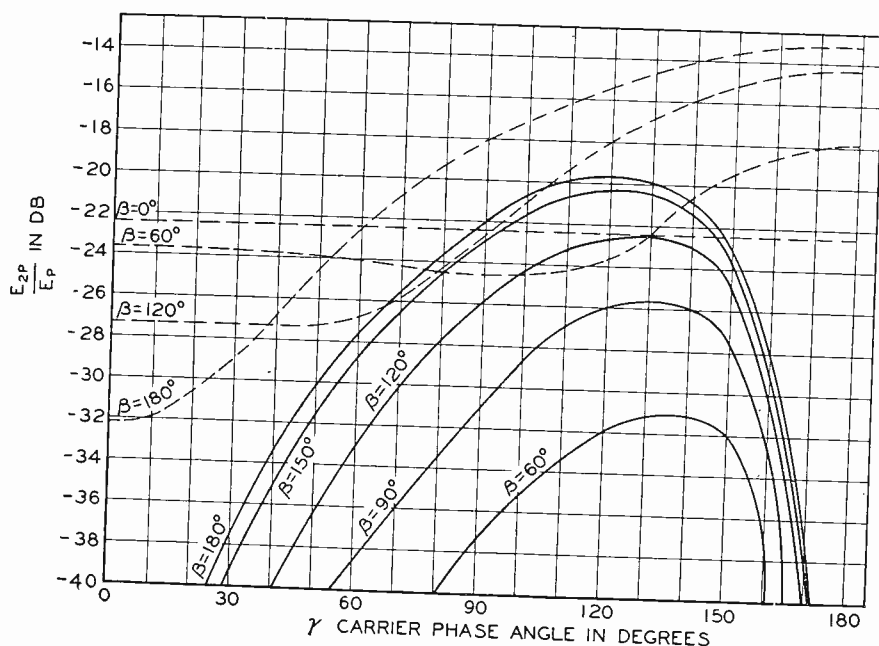

Fig. 10—Ratio of second harmonic to fundamental audio-frequency output under the conditions of Fig. 8. The full lines are for a linear detector, the dashed lines are for a square-law detector.

that considerable modifications of fidelity may still occur when $K = 0.5$. Such variations will be reported in an account of the experimental results which is given further on. The dependence of the fundamental output on β , when γ is fixed, is of sufficient importance to be shown, for a typical case, in the form of curves having β as abscissa. Fig. 11 shows the fundamental output of a linear rectifier for $K = 0.5$, $M = m = 0.3$, while Fig. 12 shows a similar set of curves for the quadratic detector.

A great many more curves might be given showing other combinations of the various parameters involved, but the foregoing are typical and are sufficient to give a quantitative picture of the distortions which are encountered in the reception of two equally modulated waves. The curves given are for 30 per cent modulation of both stations. For higher

modulations, the distortions will be greater and, in the case of the square-law detector, may be determined directly from the figures already given. Thus if $M = m = 0.6$, the value of E_{2P}/E may be obtained from Figs. 6 and 10 by raising the dashed line curves 6 decibels. The same is approximately true in the case of the linear rectifier for the

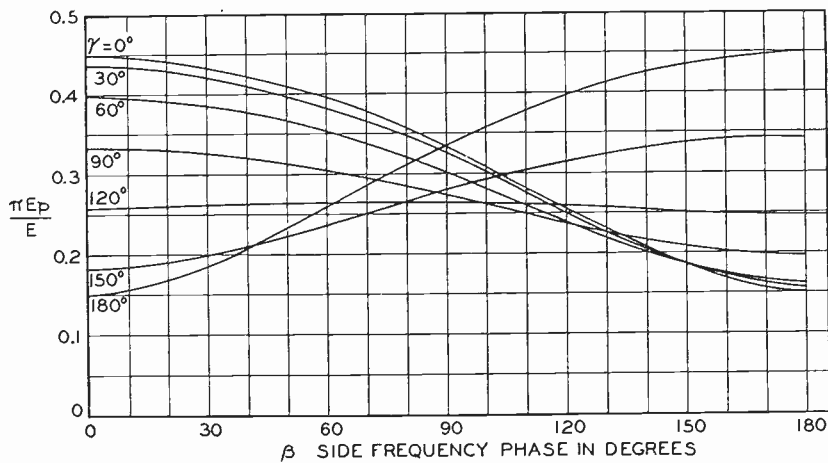

Fig. 11—The data of Fig. 8 plotted with β , the side frequency phase angle, as abscissa.

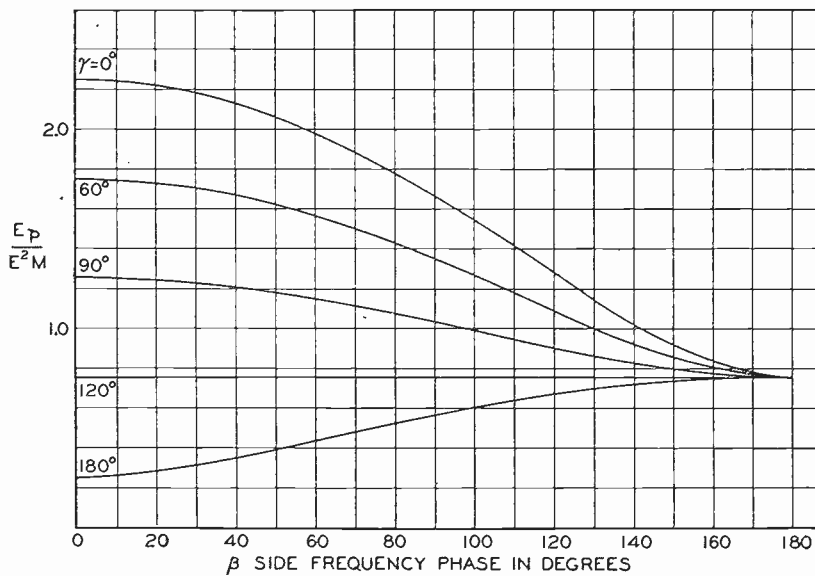

Fig. 12—The data of Fig. 9 plotted with β as abscissa.

lower modulations, although when M and m are near unity the relations are very complex.

Modulations Unequal

The effect of unequal modulations is interesting. It might be expected that when one station is modulated to a greater degree than the

other, the general result would be a decrease in the distortion in the regions where the field strength of the more deeply modulated station predominates, and an increase where the weakly modulated station has the higher intensity. This is indeed true for certain pairs of values of γ and β but, in general, the phenomena are not so simple. Under many conditions a decrease in the modulation of the weaker of the two waves will actually cause an increase in the distortion. A physical picture of

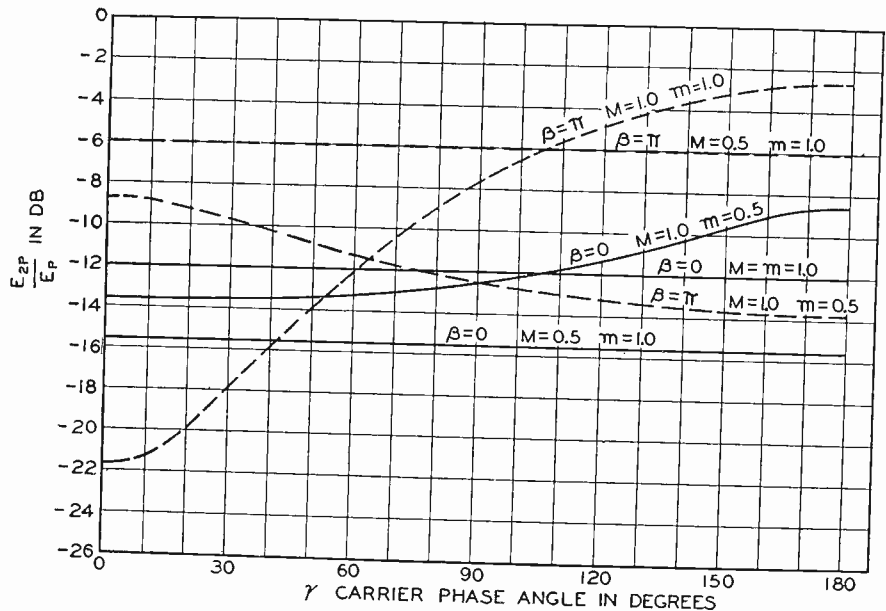

Fig. 13—Typical curves showing the effect of unequal degrees of modulation. $K = 0.5$.

this may be gained by considering the case of $\gamma = \pi$, $\beta = 0$. In this case the two carriers will be in phase opposition, as will the side frequencies also. If $M = m$, the effective modulation of the resultant wave will be the same as that of either component. But if the modulations M and m are unequal, the side frequencies may cancel to a lesser degree than do the carriers, with the consequence that the resultant wave is modulated to a greater degree, or is even overmodulated. This may cause a marked increase in distortion.

Fig. 13 illustrates the case of $K = 0.5$ for the quadratic detector. The horizontal line at -12 decibels shows the distortion which occurs when both stations are modulated 100 per cent and $\beta = 0$. This distortion is the same as that which results when only a single 100-per cent modulated wave is received. If the modulation of the weaker station is dropped to 50 per cent, β being maintained at zero, the distortion will decrease if $\gamma < 106$ degrees, but will increase for larger values of γ . On the other hand, if the stronger signal is modulated only 50 per cent

and the weaker 100 per cent, the distortion is less than when the modulations are equal, and is constant for all values of γ . Of course, this independence of γ will occur only for certain combinations of K , m/M , and β . In the last case cited, the modulation of the resultant wave is less than 100 per cent.

When $\beta = \pi$, it will be noted that the condition $M = m = 1$ results in a greater maximum distortion than does that of either $M = 1.0$, $m = 0.5$, or $M = 0.5$, $m = 1.0$. However, in the latter case the distortion ratio is large over the whole range of γ .

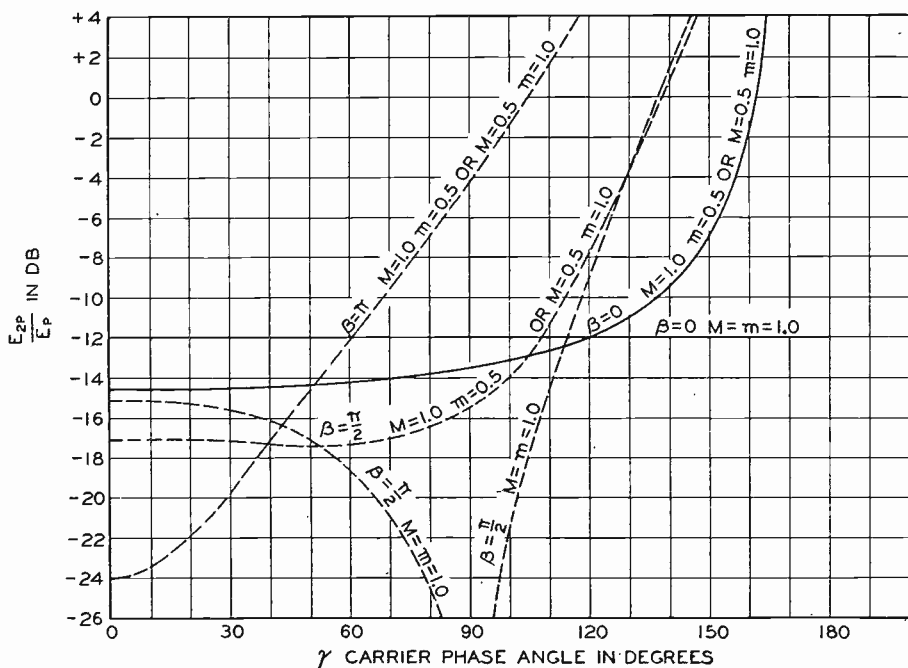

Fig. 14—Typical curves showing the effect of unequal degrees of modulation. $K = 1.0$.

In Fig. 14 are shown a few curves for the case of equal carrier ratios. When $\beta = \pi$, unequal modulation reduces the distortion ratio from an infinite value independent of β for $M = m$, to the range of values shown by the dashed curve. On the other hand, when $\beta = 0$ a change in the degrees of modulation from equal to unequal causes a great increase in the distortion for the larger values of γ . When $\beta = \pi/2$, the distortion is not different, to an important extent, when $M = m = 1$ or when $M = 0.5$, $m = 1.0$, or $M = 1.0$, $m = 0.5$.

From the foregoing remarks it is evident that a detailed consideration of the effects due to unequal modulations, as compared with those due to equal, is a very complex matter. However, from the results obtained, it may be concluded that, if the physical constants of the synchronized system are such that β may have all sorts of random values,

moderate inequalities in the modulations of the two stations are not violently detrimental. This is true even though the region in which the field strength of the more weakly modulated station predominates may suffer a slight additional reduction in quality. On the other hand, if the physical set-up of the system is such that β can be held near zero in regions where the field strengths from the two stations are of the same order of magnitude, then there is a great deal to be gained by employing equal modulations. Probably all existing stations fall into the first category. Systems which are so arranged as to keep β small in important regions will be discussed presently.

Case of $\beta = 0$ and $M = m$

In the curves which have been given for the condition of equal modulation, it will be noted that the quality of detection is particularly satisfactory when $\beta = 0$. Thus, in Figs. 4 and 10 it may be seen that there is no second harmonic output from the linear rectifier under such conditions, while Figs. 6 and 10 indicate a distortion ratio for the square-law rectifier which is the same as that encountered when only one wave is received. Moreover, when β is constant for all of the modulation frequencies, there will be no impairment of fidelity, since they will all be equally affected by changes in γ .

It is a simple matter to prove that if $\beta = 0$ and $M = m \leq 1$, then the resultant modulated wave is of the same form as either of its two component modulated waves and differs from them only in magnitude. To establish this theorem, we note that the two impressed waves will be

$$\text{and, } \left. \begin{aligned} E(1 + M \cos Pt) \cos \omega t \\ e(1 + M \cos Pt) \cos (\omega t + \gamma) \end{aligned} \right\}. \quad (7)$$

The sum of these two waves is

$$\begin{aligned} & E(1 + M \cos Pt) [\cos \omega t + K \cos (\omega t + \gamma)] \\ &= E(1 + M \cos Pt) \sqrt{(1 + K \cos \gamma)^2 + K^2 \sin^2 \gamma} \\ & \quad \cos \left[\omega t + \tan^{-1} \left(\frac{K \sin \gamma}{1 + K \cos \gamma} \right) \right] \\ &= E \sqrt{1 + 2K \cos \gamma + K^2} (1 + M \cos Pt) \cos (\omega t + \epsilon). \end{aligned} \quad (8)$$

Now this is an ordinary modulated wave of amplitude

$$E \sqrt{1 + 2K \cos \gamma + K^2}$$

and of degree of modulation M , and hence the distortion attendant upon its rectification will be the same as that encountered in the detection of any ordinary wave, of the same degree of modulation,

which might be received from a single station. It is evident that if in a given region the value of β could be kept small for all of the frequencies present in the program (or modulation) spectrum, high quality reception would be possible even when the field strengths of the two received waves were nearly equal and this would be true regardless of the phase angle between the carriers. Further, if β could be made to have a value identically zero for all of the modulating frequencies, then the quality of the rectified signal would not be impaired for any value of the field strength ratio, except in so far as noise background might appear when the resultant amplitude was very small. A discussion of practical systems for realizing such advantages will be given in a later section.

Action of Automatic Volume Control

When the resultant wave is heavily overmodulated the gain of a receiver which is equipped with automatic volume control will fluctuate violently with the modulation. However, as overmodulation alone will cause serious distortion, the antics of the gain control cannot do much additional harm. Under some conditions the resultant wave may have a low modulation, as will occur when γ is near zero and β is near π . The gain of the receiver will then be reduced by the action of the carriers, and the audio output will be low. In the intermediate condition, when the effective modulation of the resultant is high but not sufficient to cause serious distortion, the carrier may be somewhat reduced, thus raising the gain of the receiver, and the output level will be high. γ may often drift in value and β will usually vary rapidly with the modulating frequency. If K is near unity, the audio output may be of fair quality at one instant, while at the next it may be affected by extreme non-linear distortion; at one moment it may become very loud and an instant later nearly vanish; or some frequencies present in the modulation may practically vanish while others are greatly exaggerated.

However, if we suppose that $\beta = 0$ and $M = m$ at all times, the variations in the intensity of the resultant, as γ varies, will be taken up by the action of the automatic volume control, and the output will not vary unless there is a noise background which swings in and out. If $K = 1$, when γ passes through 180 degrees the resultant signal will vanish for an instant, but if E and e are reasonably large the resultant will stay below the range of action of the gain control for only a very small interval of γ .

Review of Significant Points

The important quantities with which we have to deal in considering reception of two synchronized transmissions are K , the carrier ra-

tio; M and m , the respective modulation factors of the two waves; γ , the phase angle between the carriers at the point of reception; and β , the angle, also at the point of reception, which a side frequency vector in one wave makes with its carrier vector at the instant of time at which the analogous side frequency in the other wave is coincident with its carrier.

γ will vary from point to point in space even if the phases at the transmitters are constant. If the receiving point is moved one-quarter wavelength along the line joining the stations, γ will change by 180 degrees. At a fixed point γ will vary only if there is a change in the relative phase of the carriers leaving the two transmitters, or in the difference in path length from the two stations to the receiving point. Variations in γ will be accompanied by variations in amplitude of the resultant wave and usually by changes in quality of the rectified signal, although if β is small the latter may not occur.

β is dependent upon the phase and time delay inequalities which occur in the two complete electrical paths from the studio microphone to the receiving point, and upon the frequency of modulation as well. A difference of one-half millisecond in the total time of propagation will give β a value of 180 degrees at the receiving point when the modulating frequency is 1000 cycles, of 540 degrees when the frequency is 3000 cycles, etc. Even a time difference of only 100 microseconds will give β a value of 90 degrees at 2500 cycles. Not only will these time delays tend to give β a random value, but also unequal phase shifts in the audio amplifiers and similar equipment used at the two transmitters will add to the variety of values which β may take on.

When the carrier ratio is not small, distortion is bound to occur if β departs from zero. Hence, it is evident that when two stations are widely spaced, the variations in β with the position of the receiver will result in distortions at many points, even if the time of propagation over all wire circuits could be made equal to within well under 100 microseconds, and the phase shifts in all equipment involved in the two paths could be made identical. Even ideal circuits would not eliminate distortion except at certain points. Add to this the facts that differences as small as, let us say, 50 microseconds in the time of transmission over long voice-frequency circuits can hardly be hoped for under any circumstances, and that identical phase shifts in the numerous pieces of equipment involved in the two paths could never be attained in practice, and it becomes evident that β must be regarded as a completely and incurably random quantity. This being the case, there is nothing to be gained by efforts to equalize lines or equipment as long as the inequalities are not so great as to give rise to echo effects.

Even the modulations of the two stations need be only approximately equal.

The only factor tending toward improvement in reception of signals from widely spaced stations is the averaging effect which appears when waves are received over multiple paths. Both P. P. Eckersley and Gillett have concluded that this may result in a very important reduction of distortion in regions where both stations are received about equally well. Changes in polarization of the waves may also improve the quality of the resultant.

It has been pointed out that the ideal conditions of $\beta = 0$ and $M = m$ permit of distortionless reception practically regardless of the value of K and γ . In view of the above, the only hope of achieving these conditions is to place the synchronized stations close together and to supply them both with the same modulated wave over short, equalized, high-frequency circuits. But before going into the details of such a system it will be well to discuss the experimental work which has been performed.

EXPERIMENTAL OBSERVATIONS ON THE RECEPTION OF TWO ISOCHRONOUS CARRIER MODULATED WAVES

The theoretical work has shown the importance of γ and β and has indicated that experimental work on the reception of isochronous carrier waves should be of such a nature as to take these quantities into account. Curves have been discussed which show the effect of γ and β on the distortion when a single modulating frequency is used, and from these it has been possible to draw a number of interesting conclusions. In an actual transmission there will be present in the modulation, frequencies covering the whole of the usual program spectrum, and for each such frequency there will be a different value of β . The total distortion occurring in the detection of a complex wave can be described, in a general way, by inference from the single frequency results. But the carrier ratio which can be tolerated for various values of γ , when β is random, must be determined experimentally.

A practically random character can best be bestowed upon β by introducing time delay into one of the two electrical paths at a convenient point, for by making this delay large enough β will take on a wide range of values, and will vary very rapidly with the modulating frequency. By progressively reducing the time delay, the random character of β will begin to disappear, and the carrier ratio which is tolerable for a given value of γ should begin to rise. This procedure will give practical data on the effect of γ and on the effect of difference in time delay in the two paths.

It has already been estimated that relative delays of less than 100 microseconds in an otherwise ideal system should give rise to serious distortion, and hence it is evident that large values of delay should not be necessary in the experimental work. There was constructed an audio-frequency network giving a nearly constant delay in the range from 0 to 5000 cycles. The delay obtainable could be varied in steps of 32 microseconds up to a maximum of 480. This network was introduced into the audio-frequency feed to one of two modulators, the other being supplied directly. The effect of time delay introduced at this point is

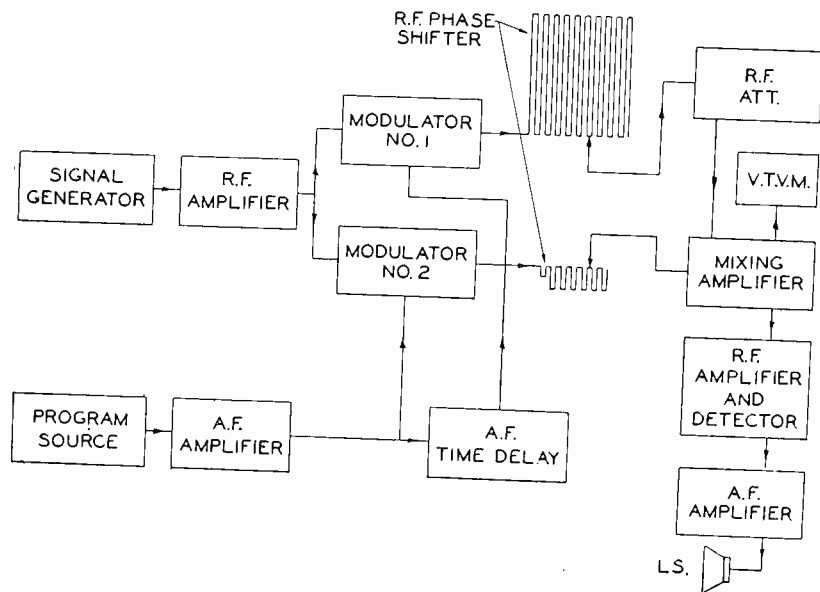

Fig. 15—Block schematic diagram of equipment used in experimental study of detection of two isochronous carrier modulated waves.

the same as that of delay due to difference in the length of the ether path. It is total relative delay which is significant.

In order to control the value of γ there was employed a high-frequency, concentric conductor, transmission line, variable lengths of which could be included in one or the other paths. At 1100 kilocycles a length of 225 feet of this line included in one path caused a shift in relative phase of 180 degrees. This is 0.80 degree per foot.

A block schematic of the circuits is shown in Fig. 15 and is largely self-explanatory. The two modulators were made as nearly identical as possible. The output of each was fed into a 50-ohm line terminated in its characteristic impedance. One line was laid out in a long grid and was tapped at intervals of 29 feet 4 inches. Contact could be made to any tap by means of a circuit having an input impedance of 3500 ohms. This high impedance prevented any disturbance of the voltage distribution along the line.

The high impedance circuit included a radio-frequency attenuator, the output of which was fed to the grid of a shield-grid amplifier tube. The amplifier output circuit impedance was common to the plate circuit of this tube and that of a similar tube which was fed by energy from the other modulator.

Across this output circuit was connected a vacuum tube voltmeter. By cutting off one voltage supply the carrier amplitude of the other could be measured, and the process then reversed. In making measurements the carriers were first adjusted to equality at the terminals of the voltmeter. Any desired ratio could then be obtained by manipulation of the radio-frequency attenuator.

The output of the second modulator was fed to a length of cable adjustable in steps of 5 feet, or 4 degrees of phase shift. Further means were provided for cutting in or out of circuit a piece of cable 2 1/2 feet in length which represented a phase shift of 2 degrees. It was thus possible to make adjustments of the carrier phase to within ± 1 degree of any desired value.

The total path difference which could be obtained by adjusting both output lines amounted to 291.3 feet of cable, or approximately 233 degrees. As γ only need be varied from 0 to 180 degrees, this allowed ample margin. A complete reversal of phase of one carrier could be obtained by a transformer with interwinding shield and a polarity changing switch (not shown in the diagram).

A suitable portion of the output of the mixing amplifier could be fed to either of two radio receivers. One receiver was equipped with a square-law and the other with a linear detector. Both had fidelity characteristics which were essentially flat to 5000 cycles, and both were carefully tuned to the carrier frequency. All observations were made on a frequency of 1100 kilocycles.

Check of Distortionless Case

As the first observational step, a check was made on the validity of the theorem which has been established, to the effect that when $M = m$ and $\beta = 0$ there is no distortion with a linear rectifier, but only variations in intensity of the resultant signal as K or γ are varied. To this end, the radio-frequency output from a single modulator was divided into two parts which were fed to the phase adjusting circuits of Fig. 15. The two signals thus derived were adjusted to equal amplitude and to various carrier phase relations. The output of the mixer amplifier was monitored on the receiver incorporating the linear rectifier.

No difference in quality could be noted between the resultant signal and one signal alone. When phase opposition was nearly attained, so

that the resultant carrier was 44.7 decibels below either carrier alone, no distortion could be detected, although the background noise was unpleasant, on account of the high noise field in the vicinity. However, a change in the carrier ratio of 0.1 decibel raised the resultant signal by a fairly large amount so that the noise was no longer objectionable.

It should be noted that the introduction of a greater length of cable in one path than in the other will not leave β entirely unaffected. A phase shift of 180 degrees at 1100 kilocycles will cause a change in β of 0.18 degree, or 0.00314 radian, for a modulating frequency of 1100 cycles. Such extremely small changes may be safely neglected in the present work.

Similarity of the Modulators

The case of $\beta=0$ and $M=m$ may be used as a check on the similarity of the two modulators and their associated circuits. The carrier frequency amplitudes were adjusted to equality of magnitude in the mixer output circuit. A 1000-cycle tone was then supplied to the modulators without time delay in either circuit, and the degrees of modulation carefully adjusted to equality. This was done by noting the output of the radio receiver when first one signal and then the other was supplied to it, and adjusting the 1000-cycle level supplied to one or the other modulators as required. It was found that after such an adjustment had been made at one level the modulation remained equal from a point of definite overmodulation down to low levels.

A speech program was then supplied to both modulators, and the peaks of modulation were adjusted to about 80 per cent. γ was adjusted to within 1 degree of 180 degrees and the equality of the carriers again checked. The combined wave gave fairly serious distortion, showing that the modulators were not identical. After every effort had been made to improve the similarity of the circuits the distortion was not entirely eliminated for the condition of $K=0$ decibels and $\gamma=180$ degrees ± 1 degree. However, a change of 0.5 decibel in one carrier amplitude resulted in a very great improvement in quality, and 1.0 decibel reduced the distortion to a mere trace. This indicated an equality in form of the two waves which was sufficient for the present purposes.

The trouble encountered in making two physically adjacent laboratory modulators identical is indicative of the tremendous practical difficulties which would be met in attempting to make two separate radio transmitters so similar that β_0 would be very small.

Determination of Tolerable Carrier Ratio as a Function of γ

A time delay of 480 microseconds was introduced into the program feed circuit of one modulator. There was then determined the carrier

ratio at which the distortion was slightly, but definitely, perceptible. Tests were made in the open laboratory where listening conditions were about average. The distortion noted would hardly be perceptible to the average observer, although entirely appreciable to the engineer. A higher standard of quality could have been employed, but it is felt that the results so obtained would have been of less value in their application to the problems of isochronous frequency broadcasting.

The upper curve of Fig. 16 represents the average of a number of observations, and indicates the carrier ratio, as a function of γ , at which perceptible distortion sets in when a linear detector is employed and the program consists of speech, with peak modulations running about 80 per cent. Programs were derived from two sources, a phonograph record and a high quality microphone with a 5000-cycle low-pass filter in the amplifier circuit.

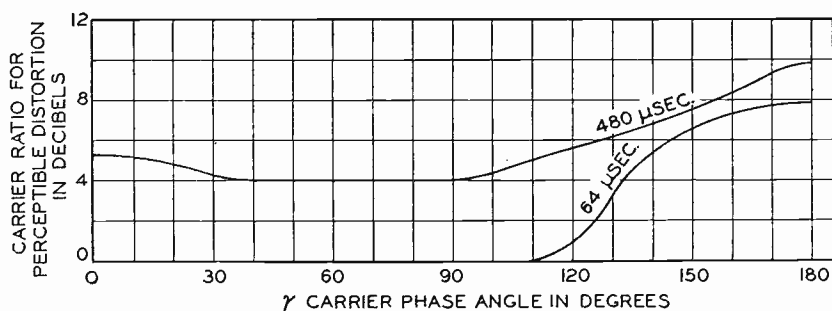

Fig. 16—Effect of carrier phase angle on the field strength ratio at which distortion is just perceptible in the output of a linear detector. The relative time delay is constant for each curve, as indicated. Both stations are modulated 80 per cent at peaks of speech program.

The character of the distortion observed near $\gamma = 180$ degrees was very different from that noted when γ was near 0 degrees. With approximate phase opposition, a value of K less than that indicated by the curve resulted in nonlinear distortion of an extremely unpleasant type. When $K = 0$ decibels and $\gamma = 180$ degrees the resulting uproar was frightful. On the other hand, when γ was near zero the distortion showed chiefly as a reduction in fidelity, certain frequencies being badly attenuated. This was to be expected, since, with equal carrier amplitudes and a delay of 480 microseconds, the frequency of 1031 cycles should vanish and the band of frequencies in the immediate vicinity of 1031 cycles should suffer badly. However, impairment of fidelity is not nearly so unpleasant as nonlinear distortion. Even with a unity field strength ratio the quality noted when γ was near zero might be considered as being very nearly within the usable range, if a rather low standard of quality is assumed.

The point of perceptible distortion is much less sharply defined when the question is one of fidelity than when it is one of nonlinear distortion, and the relation between the standards of judgment employed in the two cases must necessarily be rather indefinite. Consequently, the left-hand portions of the upper curve of Fig. 16, and the curve of Fig. 17, cannot be considered as being as definitely established as are their right-hand portions.

Fig. 17 is for the square-law detector and differs only slightly from the upper curve of Fig. 16. The quality of the performance of a square-law device is very appreciably inferior to that of the linear when only a single modulated wave is received. Judgments based on a perception of additional distortions, due to the presence of a second wave, yield curves which are hardly different for the two types of rectifiers. How-

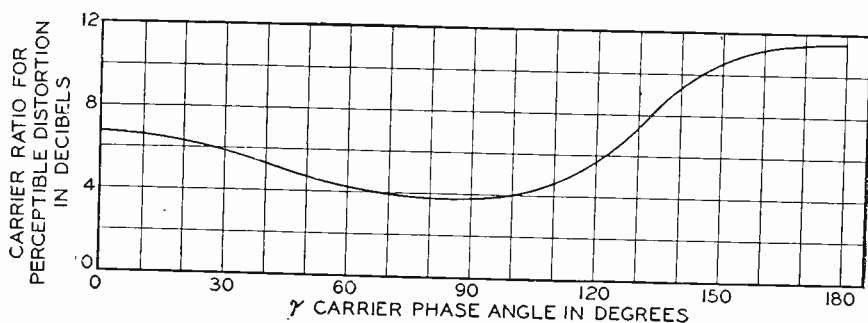

Fig. 17—Effect of carrier phase angle on the field strength ratio at which distortion is just perceptible in the output of a square-law detector. Relative time delay 480 microseconds. Modulation 80 per cent for both stations.

ever, the absolute magnitudes of the distortion products are greater, on the average, for the quadratic type.

Effect of Variation in Time Delay

The lower curve of Fig. 16 is for a relative time delay of 64 microseconds. Appreciable distortion occurs only when γ is greater than 120 degrees and the maximum number of decibels required is less than when a larger delay is used.

Fig. 18 shows a curve of the carrier ratio which yields perceptible distortion when the time delay is varied, γ being maintained within ± 1 degree of 180 degrees. These data were taken with a linear rectifier. The dotted curve represents values actually obtained with the system employing two separate modulators, while the solid curve is corrected to pass through zero at zero time delay. The lack of identity of the modulators calls for a correction in this part of the curve, but its effect is almost certainly negligible elsewhere. When β begins to take on all sorts of values, due to increasing time delay, a slight difference in the modulators will be of no conceivable consequence.

With a relative delay of 200 microseconds the carrier ratio necessary to eliminate distortion is practically as great as that required for larger delays. The curve has been studied to only 480 microseconds, but it is very unlikely that any appreciable rise occurs after that point.

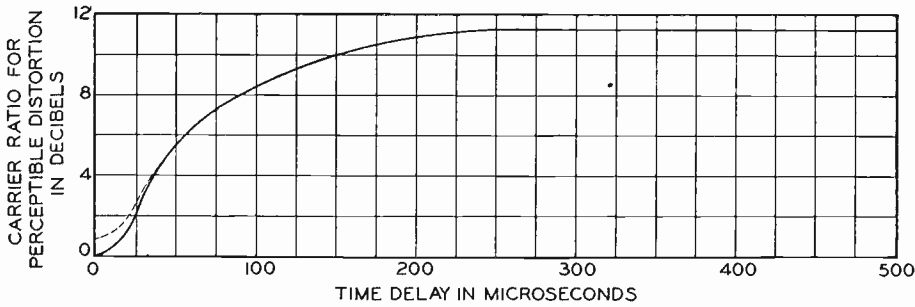

Fig. 18—Effect of relative time delay on field strength ratio at which distortion becomes just perceptible in output of linear detector. Carrier phase angle, $\gamma = 180$ degrees ± 1 degree. Both stations are modulated 80 per cent on peaks.

A field strength ratio of 2:1 will allow a relative delay of about 50 microseconds, corresponding to a space path difference of 9.3 miles.

Effect of Degree of Modulation

If the modulation of the two transmitters is increased appreciably over that employed in the foregoing work, overmodulation will set in.

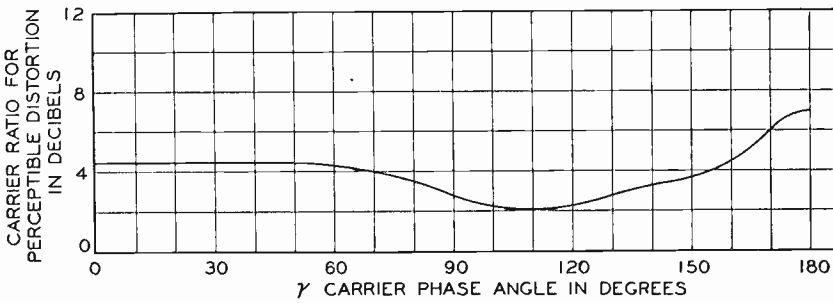

Fig. 19—Same as upper curve of Fig. 16 except that both stations are modulated about 27 per cent on peaks.

This will cause an increase in the distortion arising in the reception of two waves and will also damage the quality of the signal received from only one station. Overmodulation should of course be avoided.

When the degree of modulation is decreased, the carrier ratio necessary to prevent distortion will be reduced. This can, of course, be readily predicted from the theoretical curves, but some experimental observations are in order. In Fig. 19 is shown a curve taken under condi-

tions identical to those of the upper curve of Fig. 16, except that the modulation of both waves is here 10 decibels lower. This means that the peaks were approximately 27 per cent. As before, the distortion occurring when γ is small appears largely as a fidelity change and the left-hand portion of the curve is not as definitely established as is the right.

A reduction in modulation gives rise to a reduction in the effective service area of a station. In the case examined, a decrease in modulation of 10 decibels improves the permissible carrier ratio under the worst conditions ($\gamma = 180$ degrees) by only 4 decibels. It is possible that the correct figure is 5 decibels, or one half the decrease in modulation. One decibel is a small amount in a judgment of this kind. At any rate

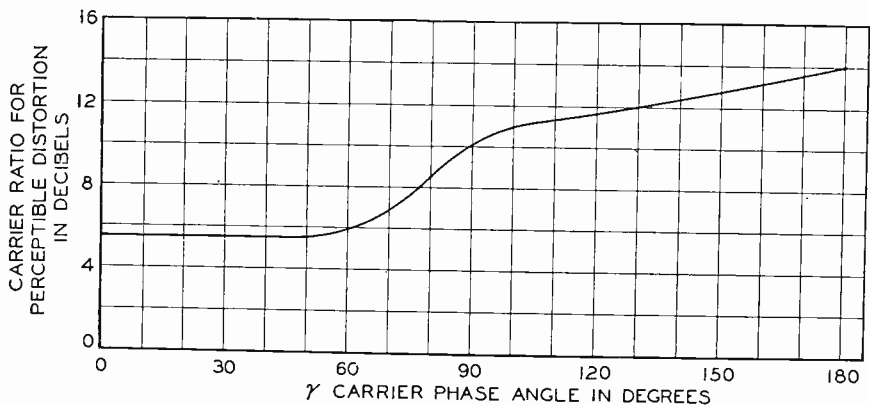

Fig. 20—Effect of carrier phase angle on field strength ratio at which distortion becomes perceptible in the output of a linear rectifier. $\beta = 180$ degrees for all of the modulation frequencies; i.e., there is no relative time delay but the polarity of the program frequency supply to one modulator is reversed. Both stations are modulated 80 per cent on peaks.

the improvement in the permissible carrier ratio is not sufficient to justify the reduction in modulation.

A Specially Unfavorable Case

By employing no time delay and reversing the phase of the program frequency feed to one of the modulators, it is possible to make β approximately 180 degrees for all of the program frequencies. In Fig. 20 is shown a curve of carrier ratio for perceptible distortion taken under these conditions, a straight-line rectifier being used in the monitoring receiver. When γ is small the effective modulation is reduced, and if K is set equal to zero decibels this reduction is very great. Mere changes in level were discounted in taking this curve, and an attempt was made to base judgments on degradation of quality alone. As before, the left-hand portion of the curve is less definitely established than is the right.

Perhaps the most interesting fact to be noted in connection with this curve is that its height at $\gamma = 180$ degrees is only about 2 decibels above

that of the upper curve of Fig. 16. A uniform value of $\beta = 180$ degrees throughout the audio-frequency range may be considered as more unfavorable to good quality than the variety of values caused by a large relative time delay. Hence we have experimental support for the statement which has been made, that the curve of Fig. 18 will show no appreciable rise beyond 480 microseconds.

Carrier Ratio for Other Types of Program

Speech programs were used in obtaining the experimental data which have been discussed. This was done for two reasons: first, because distortion of speech is usually more readily detected than is that of music; and second, because the important distortion occurs when the modulation is high, and by using a reader it is possible to obtain a rapid sequence of peaks which fall just short of overmodulation. If a musical program had been used it would have been necessary to adjust the level so that overmodulation would not occur on the peaks. Considerable portions of the program would then be of too low a level to produce distortion, and in a long piece of music there would occur only a limited number of passages which are suitable for the determination of the limiting carrier ratio. For these reasons, then, speech programs seemed much better adapted to experimental work of the character which has been reported.

However, it was desirable to have enough data on musical programs to enable us to say what carrier ratio will be necessary to reduce distortion to a just perceptible amount under the worst conditions; i.e., when the modulation and time delay are high and $\gamma = 180$ degrees. Observations on several types of music showed that a ratio of 11 to 12 decibels was necessary, and that hence a ratio which will protect speech from distortion under the worst conditions will also be about right for music.

Conclusions to be Drawn from Experimental Work

A number of interesting conclusions may be drawn from the experimental results which have been obtained. They are in agreement with the theoretical work from which many of them have already been predicted. The conclusions may be listed as follows:

Distortion is most serious, both in magnitude and in type, when $\gamma = 180$ degrees; i.e., when the carriers are in phase opposition.

When γ is near 180 degrees the distortion is of a very unpleasant nonlinear character, while when γ is near zero degrees the distortion is largely a matter of impaired fidelity and is not nearly as unpleasant.

When the time delay is zero and the circuits of the two transmissions are identical to a high order, i.e., when $\gamma = 0$ and $M = m$ for all of the frequencies present in the modulation spectrum, there is no distor-

tion when a linear rectifier is used, while with a square-law device the distortion is the same as that which appears in the rectification of a single wave of the same degree of modulation.

The advantage, from a standpoint of quality, which is to be gained by using a linear rectifier, is about the same as that realized when only one transmission is received. The carrier ratio at which additional distortion becomes perceptible as the weaker wave is increased in amplitude is about the same for either type of detector, although the absolute quality of the output of the linear device is better.

A carrier ratio of about 12 decibels is sufficient to reduce distortion to a just perceptible amount even under the worst practical conditions, provided the stations are not guilty of overmodulation. This figure is applicable to programs of both speech and music.

The distortion caused by the presence of two waves will be decreased if the modulation of both stations is reduced, but the reduction in distortion is not sufficiently great to compensate for the reduction in the effective service area of each station, which is a consequence of the use of low modulation.

What may be regarded as very small time delays are capable of producing serious distortion in an otherwise ideal system. This is due to a disturbance of desirable phase relations and not to anything in the nature of echo effects. Delays hundreds of times as large are required to produce the latter.

A relative time delay of 200 microseconds will be responsible for distortions which are essentially as serious as those produced by much larger delays.

A relative delay of only 50 microseconds between two otherwise identical transmissions will produce a distortion, when the carriers are out of phase, which is of sufficient magnitude to require a carrier ratio of about 6 decibels for its elimination. Fifty microseconds corresponds to a difference in path length in the ether of only 9.3 miles.

THE PRACTICAL POSSIBILITIES OF THE DISTORTIONLESS CASE

It has been shown that if at a given receiving point $\beta = 0$ for all of the frequencies present in the modulation, and if the degrees of modulation of the two stations are identical, then detection by a linear rectifier will be free from distortion. This is true regardless of the carrier ratio which may exist at the receiving antenna. It has been further pointed out that almost insuperable difficulties are involved in making the two transmitters and their associated circuits nearly enough identical to fulfill these conditions. Even could such identity be achieved with the usual types of synchronized transmitters, distortionless reception with

a carrier ratio of less than two to one could occur only where the difference in the length of path from the two transmitting stations to the receiver was less than about nine or ten miles. Hence it is evident that when synchronized stations are separated by considerable distances, distortion is bound to occur in the mid-zone. The only known factor which may tend to reduce this distortion is the averaging of a number of waves arriving by different paths. The distortionless case, of the present paper, cannot be realized for such systems. This does not mean, of course, that they are to be discarded. On the contrary they are capable of the most successful operation, as has been shown in Gillett's interesting paper. But their limitations are definite and are now well established. This being the case, the question naturally arises as to whether there may possibly be other practical systems of synchronous operation which will meet the essential requirements of the distortionless case, and which might extend the range of applicability of isochronous carrier broadcasting. The present section will contain a discussion of this question.

The operating requirements which must be fulfilled are, first, practical identity of the radiated waves and, second, small geographical separation of the two transmitting antennas. The latter condition will insure that the area between the stations, where the carrier ratio is near unity, will be served over ether paths of nearly the same length. If both stations are of low power, the service area will be small, and regions a considerable distance from both stations will not be served at all. Hence there will be no areas of distorted reception which are of appreciable importance.

As an example, let us suppose that two stations are placed ten miles apart and that both radiate identical waves. The means of accomplishing this will be discussed presently. At any point on a line halfway between the stations, which is perpendicular to the line joining them, the field strengths will be equal, if we neglect nonuniform attenuation, and β will be zero. At a point on the line of centers which is $3\frac{1}{3}$ miles from one station and $6\frac{2}{3}$ miles from the other there will exist a field strength ratio of two to one, if attenuation is neglected. At this point the path difference is $3\frac{1}{3}$ miles which corresponds to a difference in time of wave travel of only 17.9 microseconds. The data of Fig. 18 show that under such conditions no distortion will be experienced. At points which are closer to the near station the relative time delay will be larger, but so will the carrier ratio. At points nearer the center the carrier ratio will be near unity, but the relative delay will be small.

There will be no distortion anywhere along the line of centers, although, where the carrier ratio is near unity, there will be large varia-

tions in signal strength of the resultant wave as the phase relation of the two carriers changes. As long as the resultant signal is not down in the noise level this will be a matter of no consequence. If the wave pattern is fixed in space the listener will adjust his gain to the proper value when he tunes in. If the pattern moves, automatic volume control will take care of the variations in intensity.

When a receiver is located at a point where the carrier ratio is so near unity that the resultant signal drops below the noise field, it will be necessary to use a slightly directive receiving antenna, in the manner which has been suggested by Gillett.¹⁰ Since a very small inequality in the carriers will bring the resultant signal up to a satisfactory level, a directive effect of about 1 decibel should be sufficient. At such short ranges the sky wave will be negligible, and hence, when the antenna is once adjusted to the necessary degree of directivity, the adjustment will be adequate for both day and night service. Thus the use of directive receiving antennas at the few points at which they might be necessary becomes a very simple matter.

A little consideration shows that favorable receiving conditions would occur over a considerable zone, extending on either side of the line of centers. In addition there would be areas of high grade reception immediately around each station. Thus high quality service to the local community would be assured. At considerable distances from the transmitters it would be possible to find points where the carrier ratio was near unity and the path difference sufficient to cause distortion, especially if the sky waves were of appreciable intensity. In order to avoid delivering unsatisfactory service to such regions the power radiated by the two stations should be very small so that the field strengths at a distance would be negligible.

If a fair-sized region were to be served, more than two synchronized stations would be employed.* All of these would radiate identical waves, all would be of low power, and the spacing between adjacent stations would be small. In this way a large local area could be furnished high quality service with only a small total power radiated into the ether, and the total sky wave would be accordingly reduced. Interference at distant points would thus be greatly decreased, and it should be possible to set up a number of such groups on the same nominal frequency. The stations of each group would be carefully synchronized among themselves, but each group would be reasonably independent of all the others. It would, of course, be advisable to control the carriers

* It may be readily proved that when more than two isochronous carrier modulated waves are received at a point the detection will be distortionless if all of the waves are identically modulated, and $\beta = 0$ for each and every pair of the received waves.

of separated groups to within a few cycles, and in some instances control by land line might even be advantageous. Such points would have to be settled in accordance with the total power assigned to each group and the distance between them. Under favorable conditions each group might transmit a different program.

In the example chosen above we assumed a spacing of ten miles between two stations. When several stations are included in a group it is probable that larger spacings should be avoided. Otherwise a point midway between two stations might have poor reception caused by the combination of a low intensity resultant wave from two of the stations, with a wave from a third station which had too large a time delay relative to the first two. Numerous station arrangements might be worked out which were especially well suited to various types of service requirements, but a reasonably complete development of this kind would be too long to include in the present paper.

When only two stations are to be synchronized it may be desirable to employ a spacing of more than ten miles. Just how widely they might be spaced, without creating areas of poor service, would depend upon the nature of the region to be served, its attenuation characteristics, and the distribution of populated and unpopulated areas. With a spacing of thirty miles, the points of two-to-one carrier ratio would divide the line of centers into three ten-mile intervals if there were no attenuation. The effect of attenuation would be to make these points fall nearer the mid-point of the system. There would be little or no distortion near the line of centers with such a configuration, but if the powers of the stations were sufficient to serve the whole area between them there might be regions of bad service well off to either side of the system. In certain localities this might be of no importance while in others it would be objectionable. It is evident that no definite limit can be set to the spacing which may be considered desirable, but it is suggested that about twenty-five miles or less would usually result in the best sort of service conditions.

Radiation of Identical Waves

In view of the difficulties already pointed out, in obtaining practical identity of the waves radiated from two stations of the usual type, it would seem to be desirable that modulation of a carrier wave be effected at a central point and that the modulated wave be distributed, over circuits of equal electrical length, to the radiating points. From a purely technical standpoint high-frequency transmission lines suggest themselves as being ideal for this purpose. Distribution might be made at low power, with amplification at each radiating point, or the full power

required for radiation might be transmitted directly. We have supposed that the power radiated would be small, probably a few hundred watts or less, and consequently the power lost in transmission over a high efficiency line a few miles long would constitute no serious economic loss. In fact such an arrangement would probably be cheaper than one requiring amplifying equipment at each radiator.

It would be necessary to equalize the time of propagation over the various paths to within a few microseconds, but this would be a simple matter at radio frequencies, and would allow considerable phase shifts in one path as compared with another. When necessary, delay corrections of a few microseconds could easily be made by including in the short path a coil of high efficiency cable.

As an alternative, distribution at high frequencies could be made through the ether, although amplifying equipment at each radiator would then be essential. The chief difficulty in such an arrangement would probably be that of arranging for the auxiliary frequency or frequencies required.

One method of distribution through the ether would involve transmitting the control wave at a submultiple of the carrier frequency which was to be broadcast. A linear rectifier might be used to give distortionless multiplication of a modulated wave, but the output of such a rectifier would contain only even multiples of the original carrier frequency. If an odd multiple were required, it would be necessary to separate a portion of the original carrier from its side bands by means of very sharp filters, and to beat the single frequency thus obtained with the appropriate modulated harmonic of the rectifier output.

In many cases it would no doubt be more practicable to transmit control frequencies in a range above the broadcast band. It would then be necessary to radiate two waves from the control point, one modulated and one unmodulated. Their difference frequency would then be broadcast. An extraordinarily close control of these two frequencies would not be necessary, since any variation in their difference would affect all of the radiating stations in the same way. Therefore, the conditions requisite to distortionless broadcasting of the type we have been discussing would not be upset. By using two auxiliary frequencies, whether they were located above or below the broadcast band, it would be possible to employ a sum or difference frequency for radiation and would remove the restriction imposed by a harmonic relation between the control and broadcast waves.

ACKNOWLEDGMENT

In conclusion I wish to express my indebtedness to Mr. R. J. Jones for his calculation of a large number of curves for the square-law rectifier and to Messrs. C. B. McKennie and J. E. Corbin for their assistance in the experimental work.

APPENDIX A

Note on Calculations for the Linear Detector

The audio-frequency output voltage components obtained from a linear rectifier have been calculated from equations derived in an earlier paper.¹² These equations are rather lengthy and will not be repeated here. It is merely necessary to discuss their application to the calculation of the present results.

In the paper mentioned, the method of derivation was such as to establish the solution only when

$$K < \frac{1 - M}{1 + m}, \quad (\text{A1})$$

$K = e/E$, being less than unity. This condition was introduced by the use of expansions in terms of zonal harmonics which require it. It can be shown that in the isochronous case (A1) may be replaced by a less restrictive condition which depends upon β . If $\beta = 0$, K may have any positive value less than unity, while if $\beta = \pi$, K is limited by (A1). For intermediate values of β the limiting value of K is between unity and $(1 - M)/(1 + m)$.

As was pointed out at the time, an expansion by a double Taylor's series is an alternative method of solution. When this is employed the condition (A1) does not appear, although convergence does not occur for all relations of M , m , and K .

When $K = 1$ the condition (A1) would preclude the possibility of dealing with modulated waves. Actually, the formulas are sufficiently accurate for M and m small (e.g., $M = m = 0.3$), and for ranges of γ and β such that the calculated value of $E_P/E_{2P} \leq 1.0$. This has been checked by making a graphical Fourier analysis of points on the border of this region.

Still further points can be obtained by calculating the case of $K = 1$, $\gamma = \pi$. The resultant carrier is zero in this case and the side frequency vectors combine into a single pair, the components of which are of equal amplitude and rotate with a relative velocity of $2P$ radians per second. The detection by a linear rectifier of two equal amplitude continuous waves has been treated by Colebrook.¹³ His results applied to the present case give

$$V = \frac{2EM}{\pi} \sqrt{(1 - \cos \beta)^2 + \sin^2 \beta} \left[1 + \frac{2}{1.3} \cos 2Pt - \frac{2}{3.5} \cos 4Pt \dots \right]. \quad (\text{A2})$$

V is the amplitude of the resultant wave composed of the two modulated waves of the type of (6). (See reference 12.)

The fundamental output component is zero. The second harmonic is

$$E_{2F} = \frac{4ME}{3\pi^2} \sqrt{(1 - \cos \beta)^2 + \sin^2 \beta}. \quad (\text{A3})$$

In a similar manner it can be shown that when $\gamma = 0$,

$$V = \frac{2EM}{\pi} \sqrt{(1 + \cos \beta)^2 + \sin^2 \beta} \left[1 + \frac{2}{1.3} \cos 2Pt - \frac{2}{3.5} \cos 4Pt \dots \right]. \quad (\text{A4})$$

(A2) and (A4) are for equal modulations but expressions for unequal modulations may be readily derived.

The extensions discussed in this appendix, together with the original analysis,¹² give data for a range of values of K , M , m , γ , and β which is sufficient for the present work.

APPENDIX B

Analysis of the Square-Law Detection of Two Isochronous Carrier Modulated Waves

It will be assumed that the current-voltage characteristic of the rectifier and load together may be represented by

$$i = a_0 + a_1v + a_2v^2. \quad (\text{B1})$$

The load will be taken to be a pure resistance r . When two isochronous carrier modulated waves of the form of (6) are impressed upon the input, the only audio-frequency voltages which appear across r will be derived solely from the term in v^2 of (B1). Every component of audio-frequency output voltage will contain ra_2 as a simple factor. For the sake of convenience and simplicity this factor will be dropped from the discussion. The output voltage components are then obtained by simply squaring the expression

$$v = E[1 + M \cos Pt] \cos \omega t + e[1 + m \cos (Pt + \beta)] \cos (\omega t + \gamma) \quad (\text{B2})$$

and extracting the audio frequencies from the result. The only such frequencies present are $P/2\pi$ and $2P/2\pi$.

The result of the foregoing operations gives, for the fundamental audio-frequency output voltage,

$$E_P = E^2 M$$

$$\sqrt{(1 + K \cos \gamma)^2 + K^2 \mu^2 (K + \cos \gamma)^2 + 2K\mu(1 + K \cos \gamma)(K + \cos \gamma) \cos \beta} \quad (B3)$$

in which,

$$K = \frac{e}{E} \text{ and } \mu = \frac{m}{M} \quad (B4)$$

In the simple case of equal carrier amplitudes ($K = 1$), (B3) reduces to

$$\frac{E_P}{E^2 M} = (1 + \cos \gamma) \sqrt{1 + 2\mu \cos \beta + \mu^2} \quad (B5)$$

The second harmonic output voltage is

$$E_{2P} = \frac{E^2 M^2}{4} \sqrt{[1 + 2K\mu \cos(\beta + \gamma) + K^2 \mu^2][1 + 2K\mu \cos(\beta - \gamma) + K^2 \mu^2]} \quad (B6)$$

From (B3) and (B5) there may be readily calculated a large number of curves for various combinations of K , M , μ , β , and γ . Typical cases have been reported in the body of the paper.

Bibliography

1. D. K. Martin, G. D. Gillett, and I. S. Bemis, "Some possibilities and limitations in common frequency broadcasting," *Proc. I.R.E.*, vol. 15, pp. 213-223; March, (1927).
2. F. Eppen, "Über Empfangsbeobachtungen beim Gleichwellenrundfunk" *Elek. Nach. Tech.*, vol. 4, pp. 385-387; September, (1927).
3. W. Hahn, "Die Technik des deutschen Gleichwellenrundfunks," *Funk*, no. 35, pp. 247-248, (1928).
4. W. Hahn, "Versuche auf dem Gebiet des Gleichwellenrundfunks," *Sendung*, vol. 5, pp. 430-432, (1928).
5. P. P. Eckersley and A. B. Howe, "The operation of several broadcasting stations on the same wavelength," *Jour. I.E.E.*, (London) vol. 67, pp. 772-785, (1929).
6. F. Gerth, "A German common frequency broadcast system," *Proc. I.R.E.*, vol. 18, pp. 510-512; March, (1930).
7. C. B. Aiken, "The detection of two modulated waves which differ slightly in carrier frequency," *Proc. I.R.E.*, vol. 19, pp. 120-137; January, (1931); and *B.S.T.J.*, vol. 10, pp. 1-19; January, (1931).
8. P. P. Eckersley, "The simultaneous operation of different broadcast stations on the same channel," *Proc. I.R.E.*, vol. 19, pp. 175-194; February, (1931).
9. F. B. Falknor, "A history of synchronization," *Citizens Radio Call Book Magazine and Technical Review*, vol. 12, pp. 38-40; March, (1931).
10. G. D. Gillett, "Some developments in common frequency broadcasting," *Proc. I.R.E.*, vol. 19, pp. 1347-1369; August, (1931).
11. Walter Hubner, "Beitrag zur Theorie der Storzonen bei Gleichwellensendern," *Arch. fur Elek.*, vol. 26, pp. 381-396; June 17, (1932).
12. C. B. Aiken, "Theory of the detection of two modulated waves by a linear rectifier," *Proc. I.R.E.*, vol. 21, pp. 601-629; April, (1933).
13. F. M. Colebrook, "The frequency analysis of the heterodyne envelope," *Wireless Eng.*, vol. 9, pp. 195-201; April, (1932).

SOME CHARACTERISTICS OF ULTRA-HIGH-FREQUENCY TRANSMISSION*

BY

HENRY MUYSKENS AND JOHN D. KRAUS

(University of Michigan, Ann Arbor, Michigan)

Summary—A receiving equipment and calibration method is described for the measurement in absolute units of 5.1-meter (58.8-megacycle) field strengths. A transmitter of low power is used. The attenuation of the waves is discussed, and a field strength contour map of Ann Arbor, Michigan, and vicinity is presented. The attenuation constant is found to be 0.36.

Experiments on receiving antenna lengths show the importance of a properly resonant receiving antenna. The field distribution around the transmitting antenna is investigated by rotations of the antenna with the receiver at a fixed location. The polarization of the waves is studied, and results indicate that horizontally polarized radiation is more rapidly attenuated than is the vertically polarized.

INTRODUCTION

IT HAS become customary to speak of waves between 10 and 100 meters in length as "short waves" and of the corresponding frequencies as "high frequencies." Likewise, the region between one and ten meters is generally designated as that of the "ultra-short waves" or "ultra-high frequencies." The term "microwaves" has been applied to those waves less than one meter in length which may still be considered as belonging to the radio spectrum.

The high-frequency region has for about a decade been the subject of much investigation, and is used at the present by numerous services. Studies of ultra-high-frequency transmission are, however, of more recent date, and it is only within the last year that extensive quantitative measurements have been made.^{1,2,3,4} The use of the ultra-high frequencies for communication purposes is, however, still in the early stages of development. The study of this region forms a logical continuation of the transmission studies of the short waves, and presents numerous opportunities for investigation. It is the purpose of this paper to describe some experiments conducted at the University of Michigan on the propagation of 5.1-meter waves (58.8 megacycles).

* Decimal classification: R270×R113. Original manuscript received by the Institute, May 9, 1933. Presented before Detroit Section, June 15, 1933.

¹ L. F. Jones, "A study of the propagation of wavelengths between three and eight meters, Proc. I.R.E., vol. 21, no. 3, pp. 349-386; March, (1933).

² B. Trevor and P. S. Carter, "Notes on propagation of waves below ten meters in length," Proc. I.R.E., vol. 21, no. 3, pp. 387-426; March, (1933).

³ J. C. Schelleng, C. R. Burrows, and E. B. Ferrell, "Ultra-short-wave propagation," Proc. I.R.E., vol. 21, no. 3, pp. 427-463; March, (1933).

⁴ C. R. Englund, A. B. Crawford, and W. M. Mumford, "Results of a study of ultra-short-wave transmission phenomena," Proc. I.R.E., vol. 21, no. 3, pp. 464-492; March, (1933).

EQUIPMENT

Transmitter. Since the receiver used was highly sensitive, it was possible to employ a transmitter of low power. A very satisfactory transmitter was constructed using two type '10 tubes in push-pull. It was found that if the tubes were not modulated and were operated under constant load with the same input the frequency was very stable. This stability was improved by a "high-C" plate tank circuit in the transmitter and relatively loose coupling to the antenna circuit. This loose antenna coupling as well as the relatively low efficiency of such

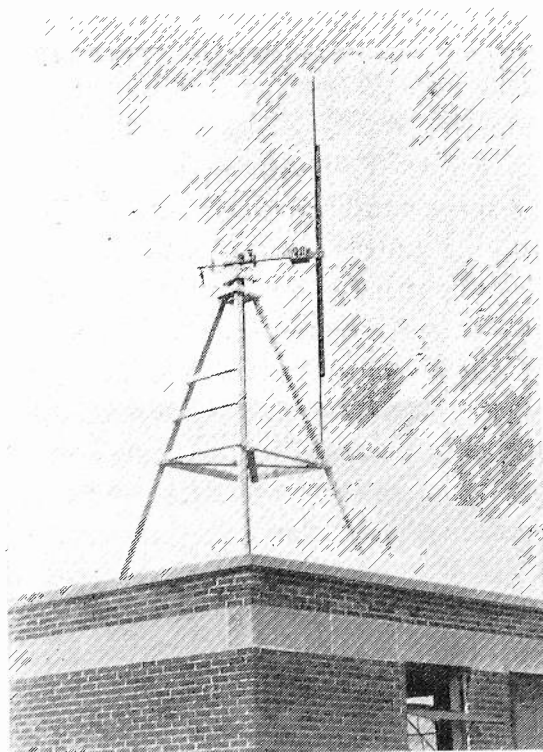

Fig. 1—Tower on roof of elevator house on the Physics building, showing transmitter with cover removed and the antenna in vertical position.

an oscillator at these frequencies combined to give an antenna power which was small compared to the input. However, a transmitter input of 15 watts was found to be sufficient.

The transmitter proper was located on a tower on the roof of the Physics laboratories on the University of Michigan campus. The power supplies were housed in the building. The transmitter together with the antenna formed a dirigible unit, which could be turned in any direction desired. The center of the antenna was 27 meters above the ground. Fig. 1 gives a view of the tower and the transmitter-antenna system. The antenna was a full wave in length, so constructed that the

currents in the two halves were in phase. It should be noted that the transmitter was located at the middle of this antenna and formed an integral part of it.

Receiver. A superheterodyne receiver was chosen as the basis for the field measuring equipment. The set used was a modified National type H.F.R. The indicating meter was placed in the plate circuit of the second detector. The input to the receiver was made through a one-micromicrofarad fixed condenser. For the field intensity work the set was suspended in the tonneau of a Studebaker touring car. The receiving antenna was a 2.75-meter aluminum tube with one end secured in a ball-and-socket joint in the roof of the car directly above the receiver. From the inside of the car it was possible to orient the antenna in any direction. When vertical, the top of the receiving antenna was 4.8 meters above the ground.

Calibrating equipment. This consisted of (1) a shielded 5.1-meter oscillator; (2) a variable coupling unit to the oscillator carrying energy to (3) a fixed coupling unit with primary and secondary coupled inductively; (4) an attenuator system; and (5) a shielded receiving booth. For purposes of calibration the receiver was removed from the car and placed in the booth both before and after a set of field measurements.

The input to the attenuator was made from the secondary of the fixed coupling unit. The attenuator unit consisted of a twisted pair of insulated copper wires running down the center of a long brass tube four centimeters in diameter. This tube furnished a shielded path for the attenuator system between the oscillator and its associated coupling units, and the receiver inside the booth. The pair was grounded at the end in the receiving booth, and a tap was brought out radially from one of the wires at a distance of seven centimeters from the grounded end. The potential difference between this tap and the ground constituted the output of the attenuator and was coupled to the receiver. A radio-frequency current indicating device was introduced between the variable and fixed coupling units. It can be shown that the current measured at this point was at all times proportional to the output of the attenuator.

To measure radio-frequency voltages one frequently resorts to the vacuum tube voltmeter, calibrating this instrument at commercial frequencies. At the higher radio frequencies, however, the shunt admittance of the tube is of sufficient magnitude so that appreciable current passes and a serious error is introduced. This source of error can be materially reduced provided the impedance of the branch, across which the voltage is measured, is small compared to the input impedance of the voltmeter. This fact was utilized in the calibration method, since

the output impedance of the attenuator was very small compared to the input impedance of the receiver. Accordingly, a vacuum tube voltmeter, also of a high impedance, could be used to measure the same voltages that operated the receiver by coupling the vacuum tube voltmeter to the attenuator in place of the receiver. The vacuum tube voltmeter was calibrated over a range of somewhat lower radio frequencies by the use of an inductance potentiometer.⁵ As this calibration disclosed no marked trend of voltmeter sensitivity with frequency, the calibration was used with assurance at the ultra-high frequencies.

Since the radio-frequency current meter between the variable and fixed coupling units indicated the attenuator output or receiver input within a constant factor, the measurement of a single attenuator output voltage sufficed to permit the receiver calibration to be made in absolute units, i.e. microvolts. In order to give field strengths in microvolts per meter when the receiver was used in the automobile, the receiver input voltages were divided by a factor involving the effective length of the car antenna.

ATTENUATION CURVE

The equipment described was used for a field strength survey of the 5.1-meter transmitter in Ann Arbor, Michigan, and vicinity. The results of part of this work are shown in Fig. 2. Readings were made in all directions from the transmitter, and in order to reduce the effect of the topographical variations it was attempted to make readings at points having as little shielding as possible and with intervening territory of about the same elevation. It can readily be seen that such points are limited. There are two extremes: (1) points in a direct line of observation were sometimes much higher than the intervening territory, and consequently at these points the magnitude of the electric vector approaches the theoretical inverse distance relationship, a value higher than the same point would give if the intervening territory were of the same elevation. Such points will be somewhat above the curve. Points with intervening territory of the same elevation were very few, most points being partially shielded by land of higher elevation. (2) Points thus shielded, which are in the majority, will give a field strength somewhat too low in value. For these reasons, the final attenuation curve must be between these two extremes. The second group mentioned above predominates, hence, the curve must be drawn so as to cover the higher values of this last mentioned group of points.

⁵ A. W. Hull and N. H. Williams, "Determination of elementary charge E from measurements of shot effect," *Phys. Rev.*, vol. 25, no. 2, p. 160; February, (1925).

SOME CHARACTERISTICS OF ULTRA-HIGH-FREQUENCY TRANSMISSION*

BY

HENRY MUYSKENS AND JOHN D. KRAUS

(University of Michigan, Ann Arbor, Michigan)

Summary—A receiving equipment and calibration method is described for the measurement in absolute units of 5.1-meter (58.8-megacycle) field strengths. A transmitter of low power is used. The attenuation of the waves is discussed, and a field strength contour map of Ann Arbor, Michigan, and vicinity is presented. The attenuation constant is found to be 0.36.

Experiments on receiving antenna lengths show the importance of a properly resonant receiving antenna. The field distribution around the transmitting antenna is investigated by rotations of the antenna with the receiver at a fixed location. The polarization of the waves is studied, and results indicate that horizontally polarized radiation is more rapidly attenuated than is the vertically polarized.

INTRODUCTION

IT HAS become customary to speak of waves between 10 and 100 meters in length as "short waves" and of the corresponding frequencies as "high frequencies." Likewise, the region between one and ten meters is generally designated as that of the "ultra-short waves" or "ultra-high frequencies." The term "microwaves" has been applied to those waves less than one meter in length which may still be considered as belonging to the radio spectrum.

The high-frequency region has for about a decade been the subject of much investigation, and is used at the present by numerous services. Studies of ultra-high-frequency transmission are, however, of more recent date, and it is only within the last year that extensive quantitative measurements have been made.^{1,2,3,4} The use of the ultra-high frequencies for communication purposes is, however, still in the early stages of development. The study of this region forms a logical continuation of the transmission studies of the short waves, and presents numerous opportunities for investigation. It is the purpose of this paper to describe some experiments conducted at the University of Michigan on the propagation of 5.1-meter waves (58.8 megacycles).

* Decimal classification: R270×R113. Original manuscript received by the Institute, May 9, 1933. Presented before Detroit Section, June 15, 1933.

¹ L. F. Jones, "A study of the propagation of wavelengths between three and eight meters, Proc. I.R.E., vol. 21, no. 3, pp. 349-386; March, (1933).

² B. Trevor and P. S. Carter, "Notes on propagation of waves below ten meters in length," Proc. I.R.E., vol. 21, no. 3, pp. 387-426; March, (1933).

³ J. C. Schelleng, C. R. Burrows, and E. B. Ferrell, "Ultra-short-wave propagation," Proc. I.R.E., vol. 21, no. 3, pp. 427-463; March, (1933).

⁴ C. R. Englund, A. B. Crawford, and W. M. Mumford, "Results of a study of ultra-short-wave transmission phenomena," Proc. I.R.E., vol. 21, no. 3, pp. 464-492; March, (1933).

EQUIPMENT

Transmitter. Since the receiver used was highly sensitive, it was possible to employ a transmitter of low power. A very satisfactory transmitter was constructed using two type '10 tubes in push-pull. It was found that if the tubes were not modulated and were operated under constant load with the same input the frequency was very stable. This stability was improved by a "high-C" plate tank circuit in the transmitter and relatively loose coupling to the antenna circuit. This loose antenna coupling as well as the relatively low efficiency of such

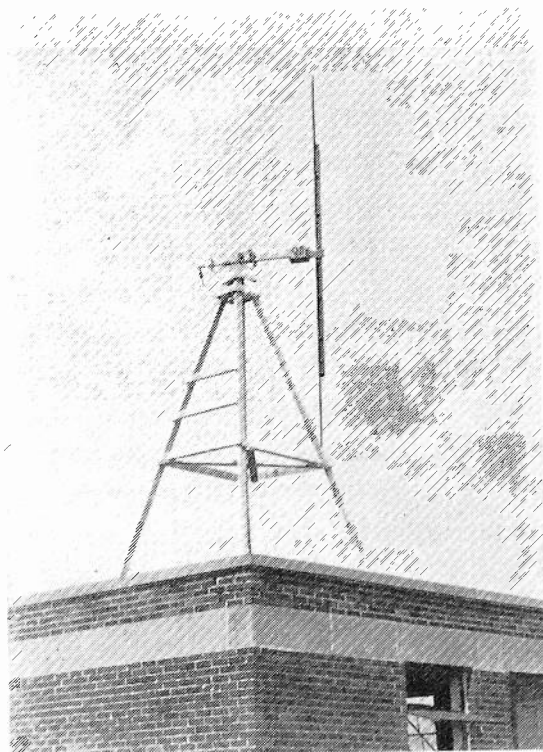

Fig. 1—Tower on roof of elevator house on the Physics building, showing transmitter with cover removed and the antenna in vertical position.

an oscillator at these frequencies combined to give an antenna power which was small compared to the input. However, a transmitter input of 15 watts was found to be sufficient.

The transmitter proper was located on a tower on the roof of the Physics laboratories on the University of Michigan campus. The power supplies were housed in the building. The transmitter together with the antenna formed a dirigible unit, which could be turned in any direction desired. The center of the antenna was 27 meters above the ground. Fig. 1 gives a view of the tower and the transmitter-antenna system. The antenna was a full wave in length, so constructed that the

currents in the two halves were in phase. It should be noted that the transmitter was located at the middle of this antenna and formed an integral part of it.

Receiver. A superheterodyne receiver was chosen as the basis for the field measuring equipment. The set used was a modified National type H.F.R. The indicating meter was placed in the plate circuit of the second detector. The input to the receiver was made through a one-micromicrofarad fixed condenser. For the field intensity work the set was suspended in the tonneau of a Studebaker touring car. The receiving antenna was a 2.75-meter aluminum tube with one end secured in a ball-and-socket joint in the roof of the car directly above the receiver. From the inside of the car it was possible to orient the antenna in any direction. When vertical, the top of the receiving antenna was 4.8 meters above the ground.

Calibrating equipment. This consisted of (1) a shielded 5.1-meter oscillator; (2) a variable coupling unit to the oscillator carrying energy to (3) a fixed coupling unit with primary and secondary coupled inductively; (4) an attenuator system; and (5) a shielded receiving booth. For purposes of calibration the receiver was removed from the car and placed in the booth both before and after a set of field measurements.

The input to the attenuator was made from the secondary of the fixed coupling unit. The attenuator unit consisted of a twisted pair of insulated copper wires running down the center of a long brass tube four centimeters in diameter. This tube furnished a shielded path for the attenuator system between the oscillator and its associated coupling units, and the receiver inside the booth. The pair was grounded at the end in the receiving booth, and a tap was brought out radially from one of the wires at a distance of seven centimeters from the grounded end. The potential difference between this tap and the ground constituted the output of the attenuator and was coupled to the receiver. A radio-frequency current indicating device was introduced between the variable and fixed coupling units. It can be shown that the current measured at this point was at all times proportional to the output of the attenuator.

To measure radio-frequency voltages one frequently resorts to the vacuum tube voltmeter, calibrating this instrument at commercial frequencies. At the higher radio frequencies, however, the shunt admittance of the tube is of sufficient magnitude so that appreciable current passes and a serious error is introduced. This source of error can be materially reduced provided the impedance of the branch, across which the voltage is measured, is small compared to the input impedance of the voltmeter. This fact was utilized in the calibration method, since

the output impedance of the attenuator was very small compared to the input impedance of the receiver. Accordingly, a vacuum tube voltmeter, also of a high impedance, could be used to measure the same voltages that operated the receiver by coupling the vacuum tube voltmeter to the attenuator in place of the receiver. The vacuum tube voltmeter was calibrated over a range of somewhat lower radio frequencies by the use of an inductance potentiometer.⁵ As this calibration disclosed no marked trend of voltmeter sensitivity with frequency, the calibration was used with assurance at the ultra-high frequencies.

Since the radio-frequency current meter between the variable and fixed coupling units indicated the attenuator output or receiver input within a constant factor, the measurement of a single attenuator output voltage sufficed to permit the receiver calibration to be made in absolute units, i.e. microvolts. In order to give field strengths in microvolts per meter when the receiver was used in the automobile, the receiver input voltages were divided by a factor involving the effective length of the car antenna.

ATTENUATION CURVE

The equipment described was used for a field strength survey of the 5.1-meter transmitter in Ann Arbor, Michigan, and vicinity. The results of part of this work are shown in Fig. 2. Readings were made in all directions from the transmitter, and in order to reduce the effect of the topographical variations it was attempted to make readings at points having as little shielding as possible and with intervening territory of about the same elevation. It can readily be seen that such points are limited. There are two extremes: (1) points in a direct line of observation were sometimes much higher than the intervening territory, and consequently at these points the magnitude of the electric vector approaches the theoretical inverse distance relationship, a value higher than the same point would give if the intervening territory were of the same elevation. Such points will be somewhat above the curve. Points with intervening territory of the same elevation were very few, most points being partially shielded by land of higher elevation. (2) Points thus shielded, which are in the majority, will give a field strength somewhat too low in value. For these reasons, the final attenuation curve must be between these two extremes. The second group mentioned above predominates, hence, the curve must be drawn so as to cover the higher values of this last mentioned group of points.

⁵ A. W. Hull and N. H. Williams, "Determination of elementary charge E from measurements of shot effect," *Phys. Rev.*, vol. 25, no. 2, p. 160; February, (1925).

Due to reflections and the arrival of waves by different paths, interference effects were noted at certain locations. The signal passed from a maximum to a minimum value at intervals of a few meters along the ground. Such patterns were observed only at a few locations and here an average value was taken to represent the field strength. The values of field strength are uniformly low within about one kilometer of the transmitter, since within this radius the presence of steel frame buildings furnished considerable shielding for the receiver at ground level.

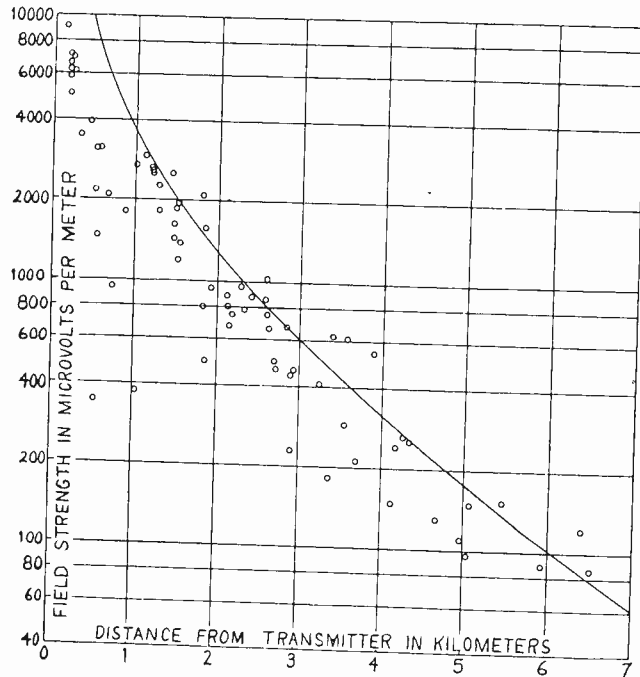

Fig. 2—Attenuation curve for 5.1-meter radiation. $\alpha = 0.36$.

ATTENUATION CONSTANT

Using points on the experimental attenuation curve, it is possible to obtain the law connecting the variables involved. The equation is of the type

$$E = \frac{K}{r} e^{-\alpha r} \sin \theta$$

where,

E = field strength in microvolts per meter

K = constant dependent on antenna height, antenna current, etc.

r = radial distance from transmitter

α = attenuation constant, dependent on nature of the terrain and on the wavelength

θ = angle that the radius vector makes with the transmitting antenna.

It should be pointed out that this equation applies to a spherical mode of radiation from an antenna and is the one best suited for the conditions encountered; i.e. the inverse distance term times the additional attenuation factor $e^{-\alpha r}$ approaches more closely to the actual conditions than would either an inverse square root or an inverse square of the distance term multiplied by the same additional attenuation factor.

Choosing any two points on the curve one can obtain the corresponding values of E and r . Then,

$$E_1 = \frac{K}{r_1} e^{-\alpha r_1} \sin \theta_1$$

$$E_2 = \frac{K}{r_2} e^{-\alpha r_2} \sin \theta_2.$$

Provided both points are at a sufficient distance from the transmitter so that $\sin \theta_1$ and $\sin \theta_2$ may be considered as unity, a solution for α reduces to,

$$\alpha = \frac{\log_e \frac{E_1 r_1}{E_2 r_2}}{r_2 - r_1}.$$

The value of α from the experimental curve is 0.36. K. Sohnemann⁶ stated that α had a value between 0.3 and 0.5 for different sections of Berlin and vicinity. F. Schröter⁷ proposed an attenuation factor of the type $e^{-\alpha r(d-h)/(H-h)}$.

Here,

r = radial distance from transmitter

d = height of absorbing layer such as is produced by buildings and trees

H = height of transmitting antenna

h = height of receiving antenna.

This form of attenuation factor would permit an inverse distance propagation between a transmitting and a receiving antenna located above the absorbing layer. The height of the absorbing layer is essentially the height of the surrounding obstacles. In the case of the transmitting antenna employed at the University of Michigan, d and H were essentially equal and therefore $(d-h)/(H-h)$ was equal to unity. Hence, the attenuation factor as proposed by Schröter becomes the

⁶ K. Sohnemann, "Feldstärkemessungen in Ultrakurzwellengebeit," *Elek. Nach. Tech.*, vol. 8, no. 10, pp. 462-467; October, (1931).

⁷ F. Schröter, "Zur Frage des Ultrakurzwellen-Runkfunks," *Elek. Nach. Tech.*, vol. 8, no. 10, pp. 431-436; October, (1931).

same as the one employed in this experimental study. It should also be noted that the attenuation constant, α , as used in this investigation

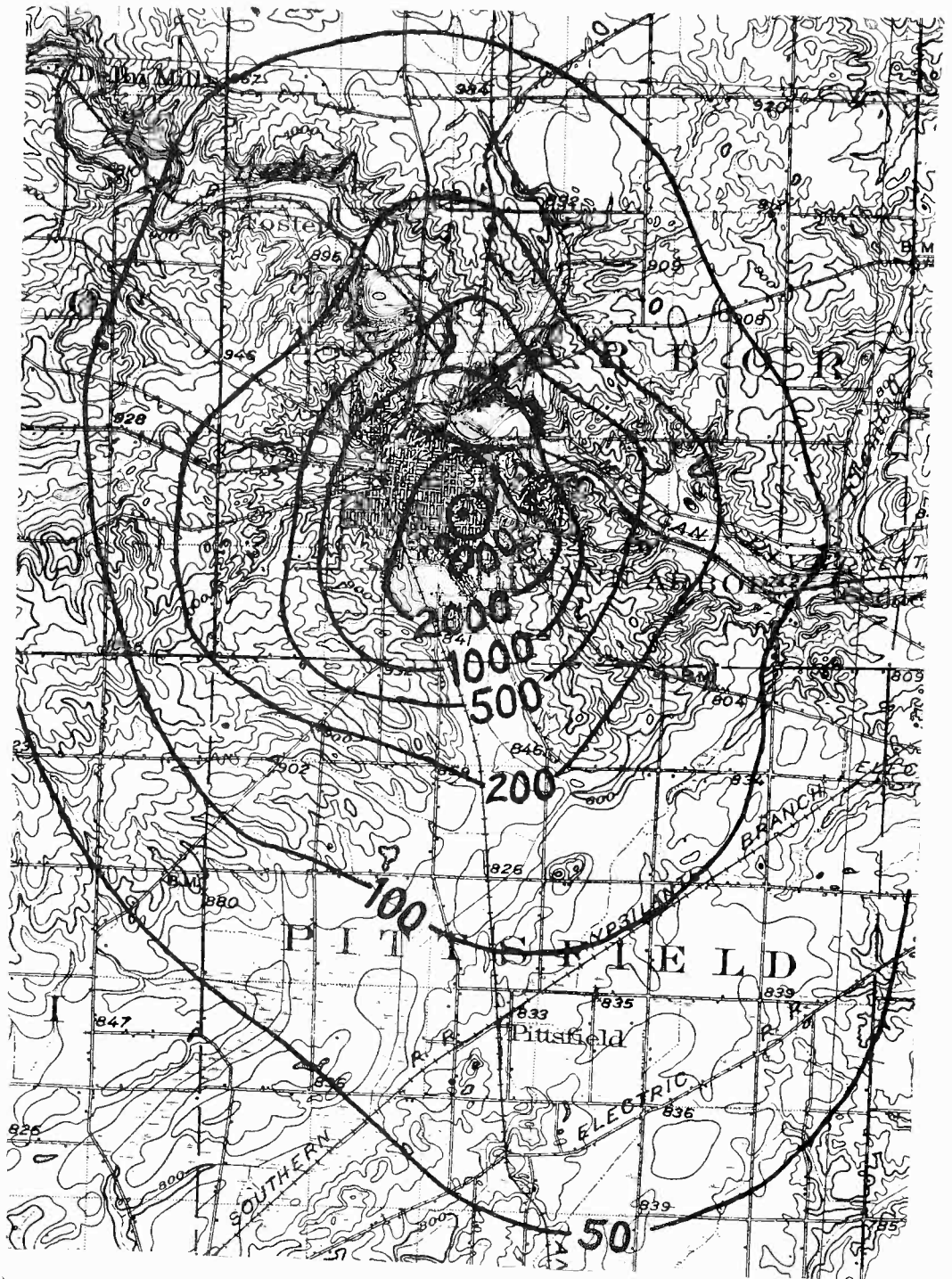

Fig. 3—Field strength contour map of Ann Arbor, Michigan, and vicinity. (58.8 megacycles.) Field strengths given in microvolts per meter. Scale 1: 125,000 or one inch equals two miles. Elevation contour interval 20 feet.

differs from that employed by Jones,¹ who used an α which was essentially independent of the wavelength.

FIELD CONTOUR MAP

In addition to the readings for the attenuation curve, field strength data were taken over a period of several weeks for the purpose of obtaining a field strength contour map. The map of Fig. 3 shows the field strength contours for the area over which measurements were made. The numerals in the contour lines indicate the field strength in microvolts per meter.

The contour lines show the general trend of the field strength. It is to be noted that the transmission appears more favorable where valleys run radially to the transmitter. At locations in the vicinity of Ann Arbor the field strength shows increased values on elevated points which have intervening territory of a lower elevation between them and the transmitter. The shielding effect of ranges of hills is also shown, although considerable filling-in behind such obstructions does take place.

In addition to the above quantitative measurements, numerous headphone observations were conducted at greater distances, with the transmitter audible as far as Toledo, Ohio, a distance of more than 80 kilometers south of Ann Arbor. In this case, the receiver was 200 meters below the line of sight from the transmitter. For both the contour map and the attenuation curve data, the transmitter antenna was maintained in a vertical position.

VARIATION OF RECEIVER INPUT WITH ANTENNA LENGTH

Fig. 4 gives the results of an experiment in which the receiver input was measured for a vertical receiving antenna shortened by successive steps. For a nonresonant condition the input voltage varies nearly linearly with antenna length. This is seen to be the case where the antenna length is small compared to the wavelength. For a resonant condition the input voltage rises beyond that which one would expect for a linear performance. In other words, an antenna approaching a resonant condition performs as if it were a nonresonant antenna of much greater length.

It should be noted that the section F to J is essentially a duplicate of A to F . The upward trend of the points A , F , J is due to the increased pick-up of the antenna as it was raised clear of the earth. This experiment was conducted with the receiver below the line of sight from the transmitter.

The curve shows that the resonant points occur at half-wave intervals; the best length, however, appears to be $n\lambda/2$, where n is odd. The

¹ *Loc. cit.*, pp. 360-361.

fact that n must be odd for maximum resonant effect is due to nodes and loops along the antenna which tend to cancel effects for n even.

An inspection of Fig. 4 reveals the fact that the distance between successive corresponding maxima is 5.1 meters. That is, the distance between the odd half wavelength maxima, C and G , is 5.1 meters as is also the distance between the even half-wave resonant points, E and I . The distance of 5.1 meters is the same as the wavelength of the received radiation. The first half-wave maximum, C , does not occur at a wire length equal to one half of the wavelength used, since there is an

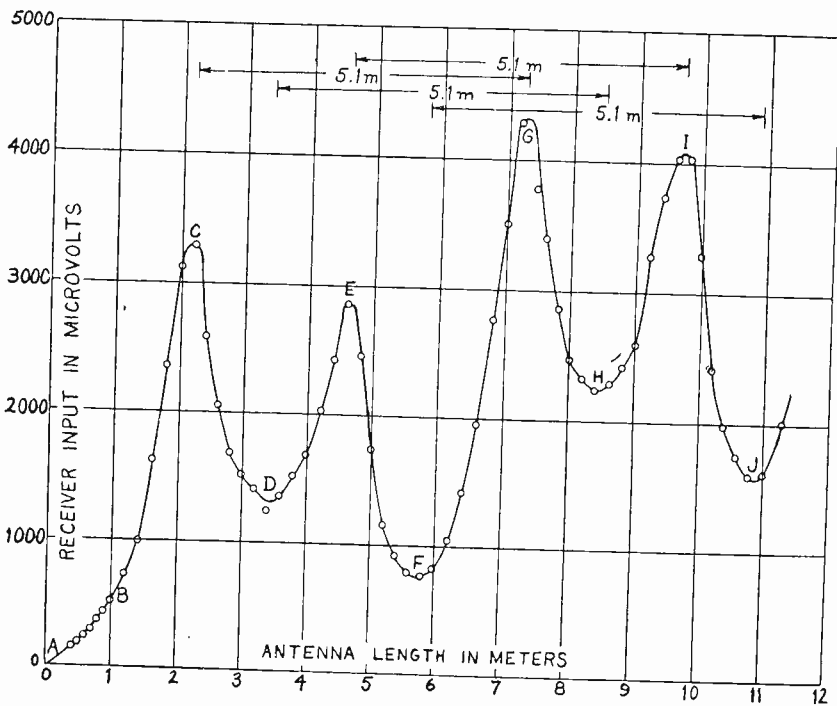

Fig. 4—Curve showing effect of antenna length on receiver input. Wavelength of received radiation 5.1 meters. Receiving antenna vertical and located 2.7 kilometers distant from the transmitter.

end effect present on the antenna. This end effect is, however, present also for the higher half-wave resonant points and is eliminated by taking the difference of the wire length for two maxima. In order to obtain the wavelength of the received radiation it is important, however, that the two maxima chosen for this difference be of the same type, i.e. odd or even half-wave resonant points. This indicates the presence of another end effect which is not the same except for maxima of the same type. By choosing the proper maxima, the end effects will be constant for both of the maxima, and when their difference is taken the end effect error is eliminated.

For example, the distance between the two maxima, C and E , is not one-half wavelength. Neither is the distance from E to G , since C and G are at odd half-wave maxima, and E is at an even half-wave max-

imum. The distance between C and G , however, is one wavelength to a high degree of approximation. The same statements hold true for the minima, the distance between successive corresponding minima being 5.1 meters.

The insertion of small tuned traps or "phase shifters" at the half-wave intervals produced a marked increase in voltage available to the receiver. A system of this type has been called a Franklin antenna.⁸ As an example, a uniform wire antenna 7.3 meters long gave an input to the receiver of 3800 microvolts. When two phase shifters were inserted at the proper points, the receiver input was increased to 7450 microvolts.

TRANSMITTING ANTENNA ROTATIONS

The rotation tests were conducted for the purpose of making measurements of the field distribution around a dipole antenna of the type used. In investigations of this nature which have been conducted at longer wavelengths, it was customary to use a fixed transmitting antenna and to measure the field distribution with a portable receiver. This method imposes limitations on the number of planes in which measurements can be made.

Owing to the shortness of the wavelength used in this investigation, it was possible to make the transmitting antenna assembly dirigible as was indicated in the description of the transmitter. In this way the receiving equipment could be located at a fixed point and the transmitting antenna given various orientations.

The types of antenna rotation divide themselves into three distinct groups: (1) rotations of the antenna in the horizontal plane, (2) rotations in a vertical plane perpendicular to the radius vector, and (3) rotations in a vertical plane parallel to the radius vector.

The equation giving the value of E at any point when the radiator is a doublet is⁹

$$E = \frac{120\pi hI}{r\lambda} \sin \theta \text{ volts per cm.}$$

For the case where h , I , λ , and r are each constant,

$$E = K \sin \theta, \quad \text{where } K = 120\pi hI/r\lambda.$$

By variations of the antenna in a horizontal plane, θ could be varied, and in this way the receiver input could be obtained as a function of the transmitting antenna position.

⁸ P. P. Eckersley, "The calculation of the service area of broadcast stations," *Proc. I.R.E.*, vol. 18, no. 7, pp. 1181-1182; July, (1930).

⁹ L. B. Turner, "Wireless," Cambridge University Press, pp. 23-34, (1931).

The curve of Fig. 5 shows the effect of a horizontal antenna rotation in the horizontal plane on the receiver input. The car receiving antenna was maintained in a vertical position. The transmitting antenna was

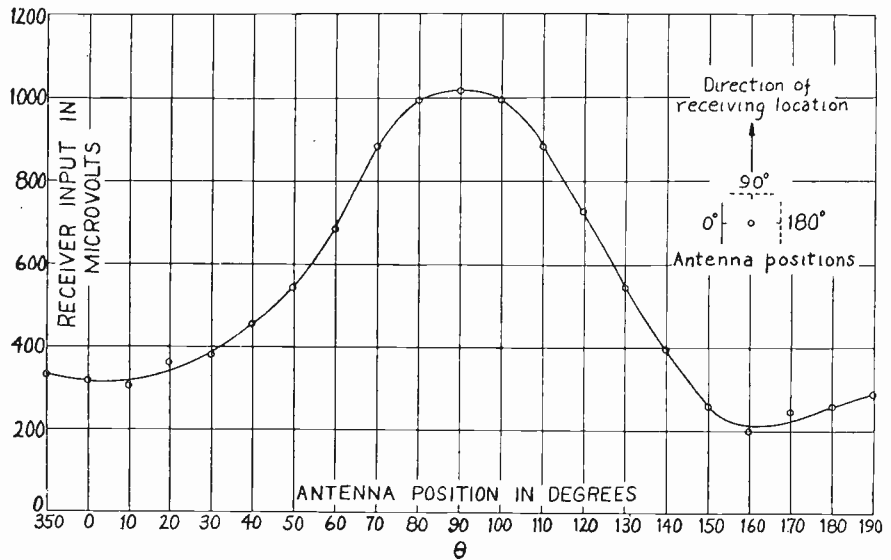

Fig. 5—Results of horizontal transmitting antenna rotation in horizontal plane. Distance of receiving location 4.28 kilometers (58.8 megacycles).

rotated through 200 degrees. At 90 degrees the transmitting antenna was perpendicular to the radius vector from the transmitter to the receiver and for this condition the received field strength was a max-

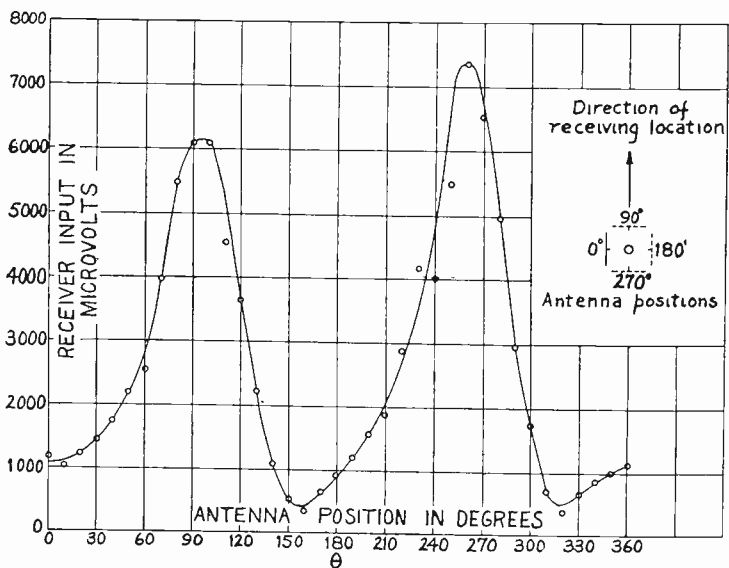

Fig. 6—Results of horizontal transmitting antenna rotation in horizontal plane. Distance of receiving location 1.82 kilometers (58.8 megacycles).

imum. Fig. 6 shows the results of a similar test conducted with the receiver at another location, and with the transmitting antenna rotated through 360 degrees. The maximum field strengths occurred at

approximately the 90-degree and 270-degree positions which correspond to a transmitting antenna position perpendicular to the radius vector.

Again using a fixed vertical receiving antenna, the transmitting antenna was rotated in a vertical plane perpendicular to the radius vector. Under these conditions the angle θ was a constant. However, the angle ϕ , which the transmitting antenna made with the horizontal, was varied through 180 degrees. The results of such a test are given in Fig. 7, in which the variation approaches closely to that expected for a sine relationship. This is to be anticipated since the vertical component of the electric vector for the various transmitting antenna posi-

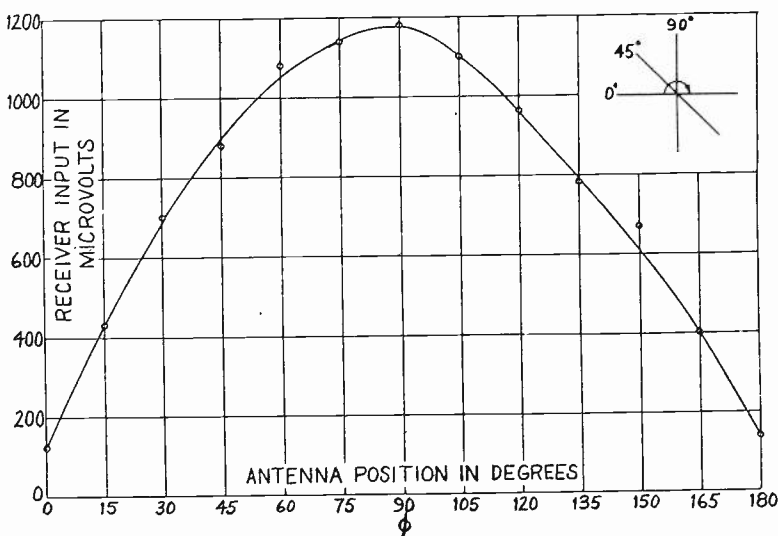

Fig. 7—Results of transmitting antenna rotation in a vertical plane perpendicular to the radius vector. Insert at upper right shows antenna rotation as “viewed” from receiving location. Receiving antenna vertical. Distance to receiving location 2.7 kilometers (58.8 megacycles).

tions is equal to the product of the maximum value, occurring with the antenna vertical, and the sine of the angle ϕ , which the antenna makes with the horizontal.

The results of another investigation of this nature are given in Fig. 8. The solid line *A* represents the part of the test made with the receiving antenna vertical at all times. When the direction of the receiving antenna was adjusted to give maximum receiver input the variation followed the dashed curve *B*. Although this latter curve exhibits less variation than curve *A*, it is evident that the horizontally polarized wave is not as effective at a distance. In other words, it is attenuated more rapidly than the vertical. This agrees with the results obtained by Trevor and Carter² in an experiment of a different nature.

² *Loc. cit.*, p. 396.

A study of the positions of the receiving antenna as compared to the transmitting antenna, as given at the bottom of Fig. 8, indicates that the electric vector was more nearly vertical, in most cases, by the time it reached the receiver at a distance of 3.4 kilometers than it was when it left the transmitting antenna. If one assumes that the receiving antenna was able to indicate the direction of the electric vector, it would appear that at sufficient distances from the transmitter the electric vector would be essentially vertical regardless of the orientation of the transmitting antenna in a vertical plane perpendicular to the radius vector. The same, to an even greater degree, was also found to

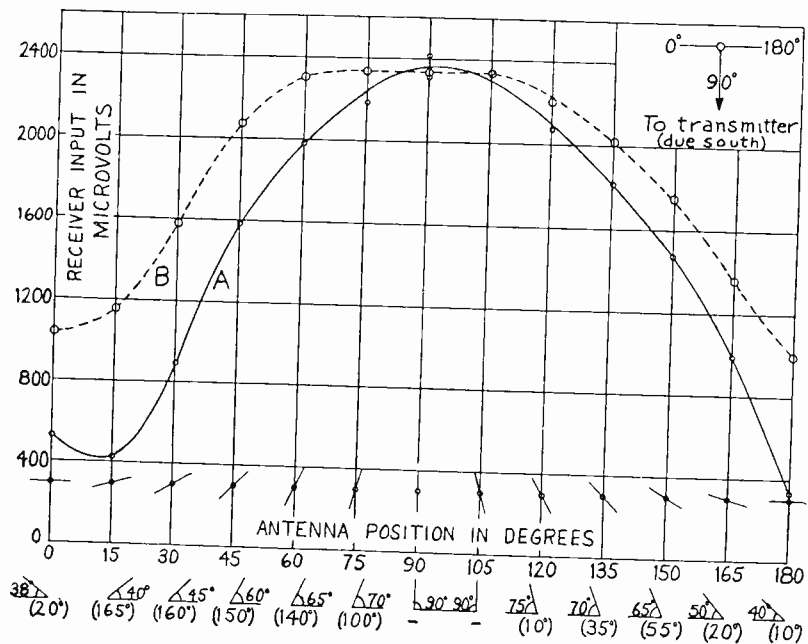

Fig. 8—Results of transmitting antenna rotation in a vertical plane perpendicular to the radius vector. For curve A (solid) receiving antenna maintained vertical. For curve B (dashed) receiving antenna position adjusted to give maximum receiver input. The figures along abscissa give transmitting antenna position in degrees (ϕ) and these positions are also indicated just above diagrammatically. The altitude of the corresponding receiving antenna positions, for part B, is indicated by the diagram at the bottom of the figure, "viewing" the receiving antenna from the same direction as the transmitting, i.e. from the south. The azimuthal angles of the receiving antenna positions are given by the figures in parentheses, and their meaning is explained by the insert in the upper-hand corner of the figure. Receiving location 3.4 kilometers due north of transmitter (58.8 megacycles).

be true for transmitting antenna positions in a vertical plane parallel to the radius vector. It is evident, however, that similar tests must be conducted at varying distances along a straight line from the transmitter before definite conclusions can be reached. Nevertheless, when one considers a wave having both a vertical and a horizontal component of the electric vector, it is reasonable to suppose that the wave tends to become more nearly vertical as it progresses along the ground in view

of the more rapid attenuation of the horizontal component. This discussion, of course, applies to the unreflected ground wave.

The solid curve *A* of Fig. 9 shows the effect of rotating the transmitting antenna in a vertical plane parallel to the radius vector with the receiving antenna at all times vertical. The results gave a curve in which the maximum occurred for θ , which is now the variable, equal to 90 degrees, or with the transmitting antenna vertical. The curve does not appear symmetrical due to some characteristics of the transmitter-antenna unit. When the receiving antenna was adjusted to give maximum receiver input the dashed curve *B* resulted, indicating again that

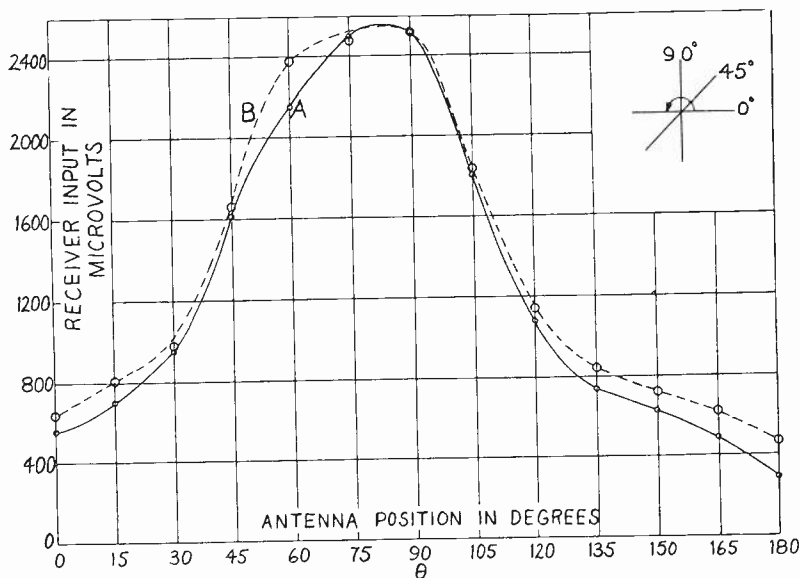

Fig. 9—Results of transmitting antenna rotation in a vertical plane parallel to the radius vector. For curve *A* (solid) receiving antenna maintained vertical, for curve *B* (dashed) receiving antenna adjusted to give maximum receiver input. Insert at upper right shows antenna rotation as “viewed” from the east of the transmitter. Receiving location 3.4 kilometers due north of transmitter (58.8 megacycles).

waves leaving the transmitting antenna horizontally polarized are attenuated more rapidly than the vertically polarized waves.

CONCLUSION

The type of field strength measuring equipment and the method of calibration as described in this paper have proved to be very effective. From the field strength surveys, and in particular the field contour map, a transmitter of low power with an input of about 15 watts is seen to be able to give a good coverage of Ann Arbor and environs. It was demonstrated that a vertical transmitting antenna has definite advantages, and, in general, for this case a vertical antenna proved best for reception.

A resonant receiving antenna was shown to be of considerable value. Using an antenna of this type good reception may be obtained for field strengths of about 50 microvolts per meter with even the comparatively simple superregenerative type of receiver. An area of about 150 square kilometers was covered with this as the minimum field strength. Such a low power coverage would be admirably suited for certain types of local services as broadcast, television, police, or local point-to-point communication. Likewise, due to the relatively small range under ordinary conditions, similar services in other cities could use the same frequencies without interference to each other.

ACKNOWLEDGMENT

We desire to express our deep appreciation to Professor Neil H. Williams for his encouragement and helpful suggestions during the course of this investigation. We are also indebted to Mr. Taintor Parkinson and Mr. Karl H. Martin for valuable assistance given in carrying out the experimental work.



NOTES ON TELEVISION DEFINITION*

By

WILLIAM H. WENSTROM

(Signal Corps, U.S.A., Fort Monmouth, N. J.)

Summary—This paper describes a qualitative study of the degrees of television definition required for the adequate portrayal of various scenes under various conditions. Still photographs transmitted by telephoto are examined. It is found that 60-line, 120-line and higher orders of television definition may be suitable for certain missions conditioned by general factors such as the comprehensiveness of the scene to be portrayed.

INTRODUCTION

IN THE television field many researches are directed towards the gradual improvement of various methods of sight transmission. Relatively rare¹ are inquiries into the limits which this improvement must reach before television can adequately perform the various functions for which it may be destined. The purpose of this paper is an inquiry of the latter sort.

Aside from screen size, and image color and brilliance, which are conditioned chiefly by the viewing circumstances and relatively easy of attainment in any given case, the major index of television development is definition—the clearness of the received image.

The considerations of this paper are based on the general scanning system invented by Bakewell in 1847, applied to continuous vision by Nipkow in 1884, and universally used in all television methods of the present day. The Bakewell-Nipkow analyzing-synthesizing system operates by (a) scanning elements of the scene or picture to be transmitted one at a time along successive parallel lines, (b) transmitting an electrical signal instantaneously proportionate to the shade of the element being scanned, and (c) painting the received picture in successive elements of light or shadow proportionate to the instantaneous signal. For continuous vision complete pictures must be formed at the rate of about 20 per second. As the scanning of two successive contrasting picture elements produces a complete cycle in the variation of signal current, the signal current frequency varies from some relatively low value up to 20 times half the number of picture elements.

The number of elements into which the scanner (or transmitting device) divides a scene is the measure of definition, and determines

* Decimal classification: R583. Original manuscript received by the Institute, March 6, 1933.

¹ D. K. Gannett—"Quality of television images," *Bell Lab. Record*, vol. 8, p. 358; April (1931).

the upper limit of picture clearness at the viewer (or receiving device). If this upper limit is to be even closely approached, the optical systems must clearly resolve the elements concerned and place them with exactness at any given instant; and the electrical systems, including the media of transmission, must faithfully transmit all frequencies involved.

Most present television methods scan a picture of optimum cinema proportions (about 4 units high by 5 units wide) along successive horizontal lines. In addition to "elements per picture," therefore, "lines per picture" (approximately the square root of the number of elements) is also a measure of television definition, equally quantitative and somewhat more convenient in practical use. Sixty-line television is the present visibroadcast standard; 120-line definition is said to have been reached in experimental work.

PROBLEM

The problem of this paper is: What degrees of definition (measured in lines per picture) must television attain for the suitable portrayal of various scenes under various conditions?

METHOD OF ANALYSIS

The method of analysis is in general that of D. K. Gannett¹ extended to higher orders of definition and to more comprehensive scenes. Still photographs of different degrees of comprehensiveness, transmitted by telephoto in various suitable sizes and reënlarged, represent the appearance of different scenes as viewed by television of various definition standards. The method has one serious disadvantage which may lead to underestimation of television possibilities: due to the integrating effect of eye and mind, a scene in motion always looks clearer than a still picture. In addition, sound accompaniment enhances realism. However, as these still pictures represent ideal definition of each given standard, which would seldom be attained in actual television due to the practical limitations of mechanical, optical, and electrical systems, it is not believed that estimates based on them are greatly in error.

Four photographs, for three of which the writer is indebted to Metro-Goldwyn-Mayer Pictures, were chosen to represent approximately equal gradations of scene comprehensiveness from the lowest to the highest. They are:

1. a single face
2. a small group (four people in three-fourths view)
3. a musical comedy stage, including three torpedo-shaped detached objects
4. general view of a football game.

These photographs were transmitted on telephoto machines, through the kindness of the American Telephone and Telegraph Company, so as to represent the performance of 60-line, 120-line, and 200-line television for each of the four scenes. Approximate representations of 400-line television² were obtained by means of suitable half-tone screens.



Fig. 1—Single face, musical comedy stage, small group, football game (60-line definition).

Original photographs courtesy of Metro-Goldwyn-Meyer Pictures.
Telephoto transmissions courtesy of American Telephone and Telegraph Company.

From a study of the final photographs, which are published with this paper, the reader can judge for himself the degrees of television likely to be required for the adequate portrayal of various scenes under various conditions. The conclusions of the writer, arrived at by this wholly qualitative method, are to be regarded as first approximations

² The writer had previously determined, by comparing Gannett's original photographs with home motion pictures, that the definition of the latter corresponds to approximately 400 lines. It is assumed that the definition of the standard cinema is about twice as good, corresponding to about 800 lines.

only, subject to any revision which later data and experience may suggest.

In studying the photographs it was found convenient to use a rating scale for television having six gradations, as follows:



Fig. 2—Single face, small group (120-line definition).

Perfect: equivalent to commercial cinema; no line structure noticeable.

Excellent: line structure barely noticeable; does not impair pictorial impression at all.

Good: line structure evident, impairing small details slightly.

Fair: line structure very evident, but does not impair general pictorial impression.

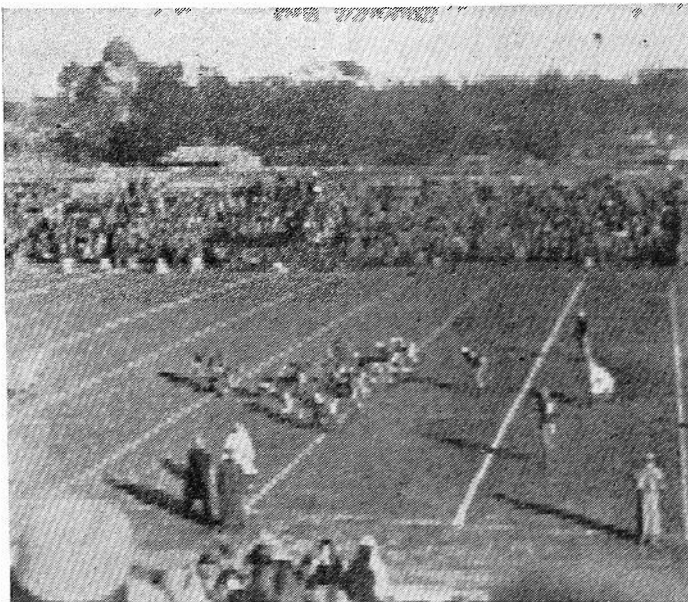

Fig. 3—Musical comedy stage, football game (120-line definition).

Poor: line structure impairs general pictorial impression.

Worthless: scene loses meaning.

CONCLUSIONS

The writer's estimate of the suitability of the several degrees of definition for the portrayal of various scenes is as follows:

(a) 60-line television: fair for a single face, poor for a small group or for detached objects such as a ship or airplane, poor to worthless for a full theater stage or for large outdoor spectacles.



Fig. 4—Single face, small group (200-line definition).

(b) 120-line television: good for a single face, fair for small group or detached objects, poor for full theater stage or outdoor spectacles.

(c) 200-line television: excellent for a single face, good for small

groups and detached objects, fair for full theater stage or outdoor spectacles.

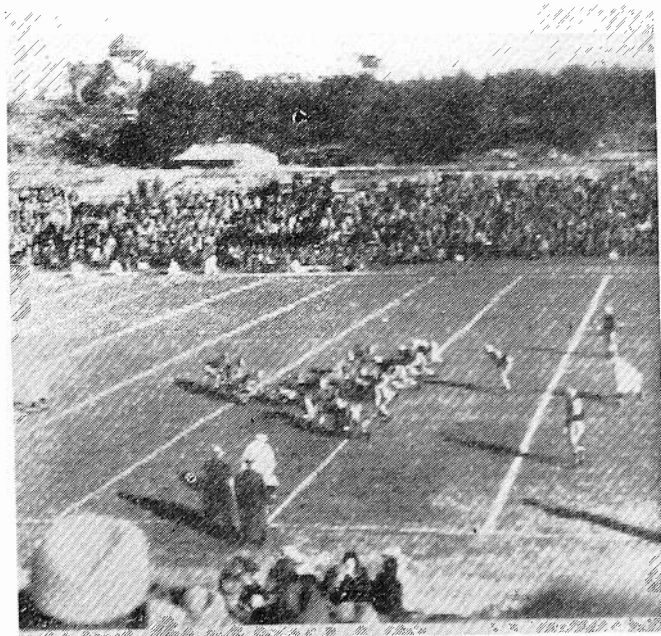

Fig. 5—Musical comedy stage, football game (200-line definition).

(d) 400-line television: perfect for single face, excellent for small group or detached objects, good for full theater stage or outdoor spectacles.

Reversing the above order of reasoning, it is possible to determine



Fig. 6—Single face, small group (400-line definition).

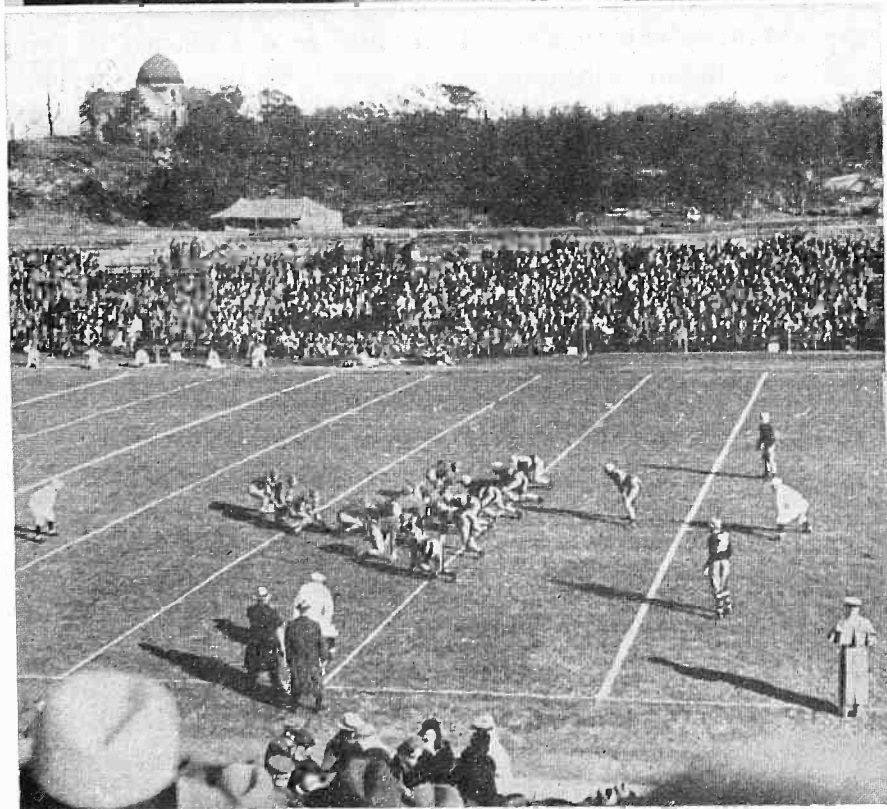

Fig. 7—Musical comedy stage, football game (400-line definition).

the degree of definition required for "fair-to-good" rendition of various scenes:

- (a) Single face: 60-120 line.
- (b) Small group: 120-200 line.
- (c) Detached objects such as ships, airplanes, etc.: 120-200 line.
- (e) Outdoor spectacles: 200-400 line.

From the foregoing analysis, and from observation of present television systems, certain general conclusions appear which, if verified, may have the force of basic laws governing the performance of television. These are:

(a) *The degree of definition required in any given television application is conditioned chiefly by the comprehensiveness of the scene to be portrayed.*

(b) *The higher the contrast in a given scene, the lower the order of definition required to portray it.*

(c) *While a lower order of definition may suffice for momentary presentation of certain scenes, a higher order of definition is required if the observer's continued attention is to be held.*

From these hypotheses and the foregoing conclusions it is possible to assume certain definition requirements for the classes of television service likely to be most in demand:

- (a) Two-way telephone television: 60-120 line, fair to good.
- (b) Theater television:
 - (1) Brief television projections of news events, faces, small groups, detached objects, etc.: 120 line, fair to good.
 - (2) Cinema projection of news events from films transmitted by telephoto methods: 120-200 line, fair to excellent.
 - (3) Continuous television entertainment equivalent to cinema: 400-800 line, good to excellent.
- (c) Home television, continuous:
 - (1) Faces, small groups, etc.: 120 line, fair to good.
 - (2) Full theater stage or outdoor spectacles: 200-400 line, fair to good.
- (d) Special purpose television:
 - (1) Where contrast is high and relative position of objects is more important than their exact size or shape (pilot landing airplane in fog by Hammond system, etc.): 60-120 line, fair to good.

(2) Where exact size and shape of objects is important (military commander viewing battlefield, etc.): 400-800 line, fair to good.

While generalized speculations about the future of television are somewhat beyond the scope of this paper, it is interesting to examine some practical possibilities in the light of the findings above:

(a) 80-120-line two-way telephone television appears to be now technically possible, adequate for the purpose, and limited in use only by economic factors.

(b) 120-line theater television suitable for brief news and other projections appears to be awaiting only a few electrical, optical, and mechanical refinements before it becomes technically possible.

(c) 120-200-line theater projection of electrically transmitted news films appears to be technically possible at the present time, and adequate for the purpose.

(d) 400-800-line theater television equivalent to the standard cinema appears to be a practical impossibility at the present time.

(e) 120-line home television appears to be now technically possible for short range transmission, and awaiting only economic support. It is perhaps good for the sale of several million receivers and considerable advertising income. Its future as a universal entertainment medium, similar to sound broadcasting today, appears to be doubtful.

(f) 200-400-line home television equivalent to home motion pictures would be suitable for continued universal entertainment, but appears to be a practical impossibility for the present. It is possible that the degree of definition which home television must reach for universal commercialization is in the neighborhood of 200 lines.

(g) Special purpose television: for certain limited uses the 60-120-line television available at the present day is adequate; for such uses as giving a military commander a complete view of the battlefield, neither present systems, nor those to be expected in the immediate future, fulfill the requirements.



A MAGNETOSTRICTION FILTER*

BY

HARRY H. HALL

(Harvard University, Cambridge, Mass.)

Summary—A rod of monel metal supported at its mid-point and fitted with two coils, one on each end, shielded from each other, and supplied with a polarizing magnetic field, resonates sharply at its natural longitudinal frequency to a voltage impressed on one coil, and induces a voltage in the other only while vibrating. It is thus a very selective band-pass filter. The attenuation is more than sixty decibels off resonance and about twenty at resonance. The band is about seventy cycles wide, thirty decibels up from the minimum, when the resonant frequency is 20,000 cycles. The effect of heat treatment and the design of the coils and shields are discussed. Actually two rods in series, coupled by a vacuum tube are used. This gives a curve only seventy cycles wide, as much as sixty decibels up from the minimum.

The attenuation is found to be low at frequencies below about 8,000 cycles and there is a rather sharp minimum at 16,000 cycles due to some mode of vibration other than the longitudinal one. These defects, however, may easily be remedied by the use of a high-pass filter of conventional design.

IN designing a new harmonic analyzer for Harvard University, it was desired to make use of a sharp band-pass filter of some sort which would be able to distinguish between two frequencies near 20,000 cycles, separated by not more than 100 cycles and differing by some fifty or sixty decibels in amplitude. To do this with an ordinary electric filter would obviously be difficult. A quartz filter was thought of but found impracticable at that frequency. A higher frequency might have been used with, however, a sacrifice of resolving power.

G. W. Pierce¹ then suggested the use of a magnetostrictive vibrator. At first a length of nickel tube, equal to a half wave at 20,000 cycles (12.5 centimeters), was supported at its mid-point in a cylindrical shield, which was divided into two parts by a central partition. Each half of the shield contained a coil which fitted loosely over the nickel tube. A polarizing field was provided by a horseshoe magnet placed near the shield. A diagram of the arrangement is shown in Fig. 1. When an alternating voltage was applied to one coil a similar voltage was found to be induced in the second due to the vibration of the nickel tube. If the ratio of input to output voltage be expressed in decibels and plotted against frequency, we have a typical attenuation curve of

* Decimal classification: R386 × 538.11. Original manuscript received by the Institute, May 17, 1933. Presented before U. R. S. I., April 27, 1933, Washington, D. C.

¹ Compare U. S. Patent 1,882,396, "Magnetostrictive Transformer," G. W. Pierce.

the device. The arrangement of measuring apparatus is shown in Fig. 2. The filter was found to have an impedance at resonance of approximately 20,000 ohms, and the 20,000-ohm series resistance was accordingly used for proper input termination. The curves of Figs. 3, 4, and 5, however, were taken without this series resistance.

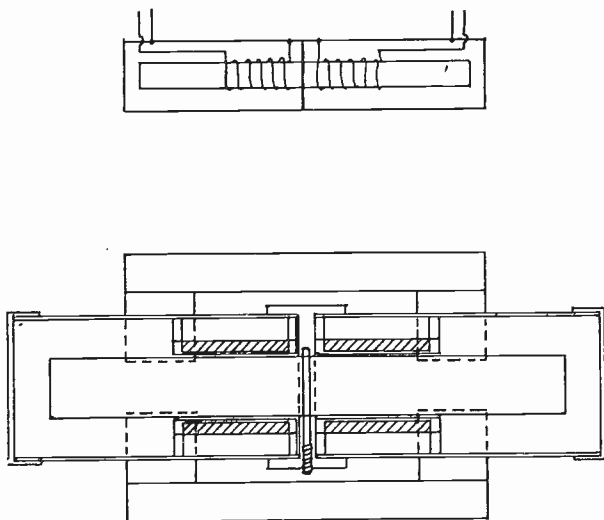

Fig. 1—Schematic diagram and cross section of the filter.

The purpose of the shield was to reduce direct magnetic coupling between the two coils. It proved to be surprisingly effective at 20,000 cycles. Tests for direct pick-up between the coils with the vibrator absent, gave attenuations greater than could be measured, that is, greater than seventy decibels. Later, the measuring apparatus was ex-

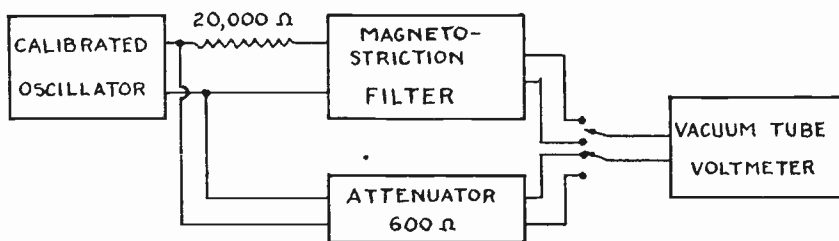

Fig. 2—Schematic arrangement of apparatus used to measure the attenuation. An amplifier having about sixty decibels gain was included in the block labelled Vacuum Tube Voltmeter.

tended to measure greater attenuations but these tests were not repeated. All the curves shown were taken with the shield open at its ends. But when the ends were closed by caps there was no appreciable increase in damping. Actually, the distance from the inside surfaces of the caps to the ends of the vibrators was very nearly one-half wavelength at 20,000 cycles in air. But as far as magnetic shielding is con-

cerned the caps are unnecessary and were used only for protection. The air damping might probably have been reduced by adjusting the distance from vibrator end to cap, to an odd number of quarter wavelengths in air. This was not tried, however.

Fig. 3 gives the attenuation curve for nickel tube. Resonance is seen to be not particularly sharp. It was therefore apparent that some vibrator having a much lower decrement should be used. J. M. Ide² gives a list of magnetostrictive vibrators and their decrements, and it appears that monel metal, a natural alloy of copper and nickel, has a

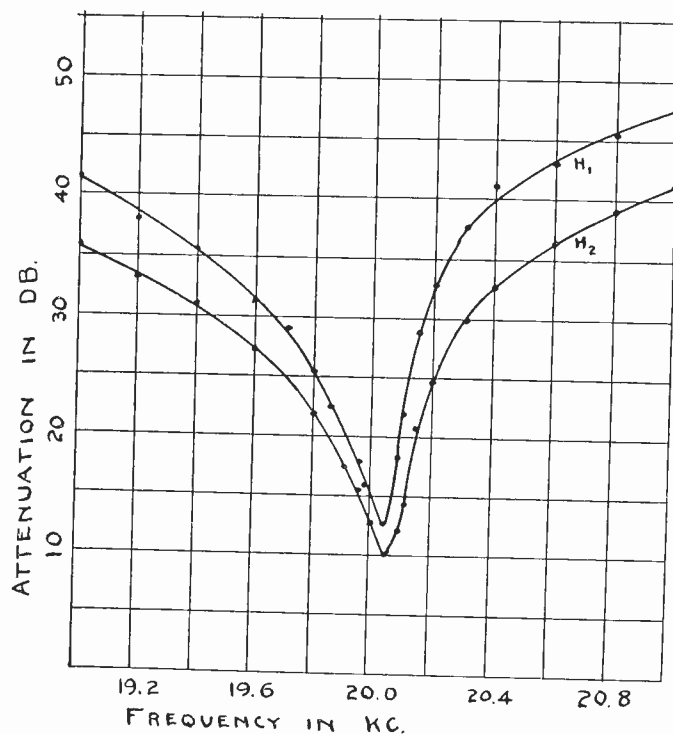

Fig. 3—Attenuation curves for nickel tube, 7/16 inch diameter, 1/64 inch wall. The curves are for two strengths of polarizing field, H_2 being stronger than H_1 .

decrement of but 14 radians per second as compared with 20 radians per second for nichrome and stainless steel, and about 600 radians per second for nickel tube. Accordingly, a sample of monel tube 1/2 inch in diameter, having a wall 35/1000 inch thick, was placed in the coils and gave the curves shown in Fig. 4. We see that resonance is very much more sharp than for the nickel tube but has much less symmetry. The asymmetry was thought to be due to the vibration of the tube in modes other than the longitudinal one. To test this the longitudinal mode was damped by inserting corks into the ends of the tube and allowing them to bear against the ends of the shield. This eliminated the principal minimum but left the others practically undisturbed.

² J. M. Ide, Proc. I. R. E., vol. 19, pp. 1216-1232; July, (1931).

The next thing tried was a solid monel rod in the hope that because of its greater rigidity it would be less likely to vibrate in any mode but the longitudinal one. It might be noted here that commercial monel varies considerably in magnetic properties. In fact one of the first bars of stock received was found to be almost nonmagnetic and a very poor vibrator, while another in the same lot had quite the opposite

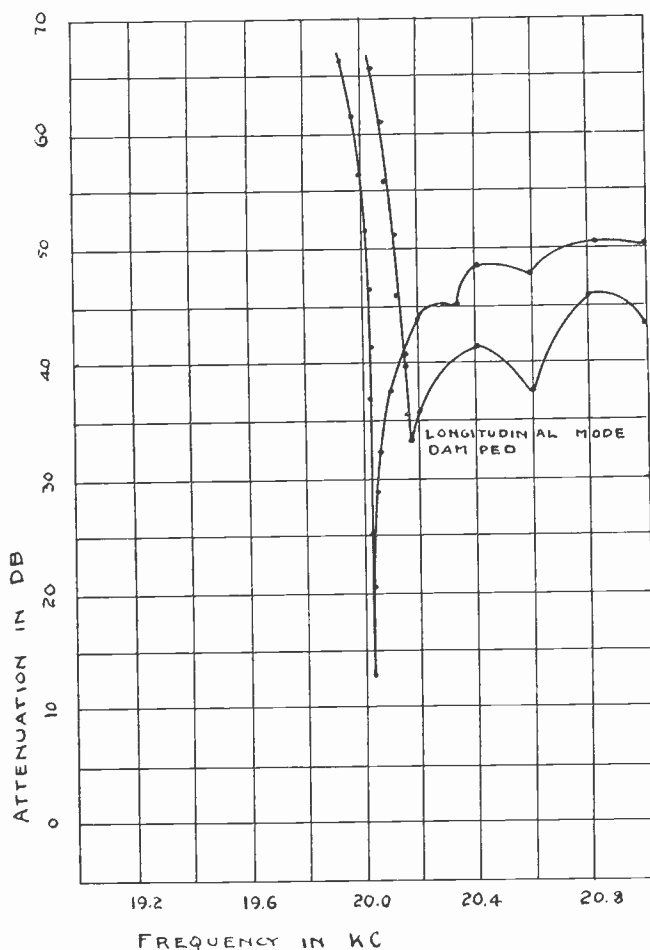

Fig. 4—Attenuation curves for monel tube, 1/2 inch diameter, 35/1000 inch wall. The longitudinal mode was damped by means of corks inserted into the ends of the tube and bearing against the ends of the shield.

properties. The dealer kindly allowed a selection to be made from his stock of the most magnetic bars, by testing with a horseshoe magnet, and the substitution of these for the first lot. These were, without exception, found to be very good vibrating stock. A piece of monel rod, 1/2 inch in diameter, and in length equal to a half wave at 20,000 cycles, was tested in the filter giving Fig. 5. The resonance is very sharp and is symmetrical as far up from the minimum as thirty-five or forty decibels, and is less than 100 cycles wide at that level. Vibration in

other modes is also seen to be practically nonexistent, though slightly apparent far up on the high-frequency side of the minimum. This was a much nearer approach to what was desired than anything previous to it.

Pierce³ has treated the electromechanical system involved in a way similar to the familiar treatment of telephone receivers by Kennelly

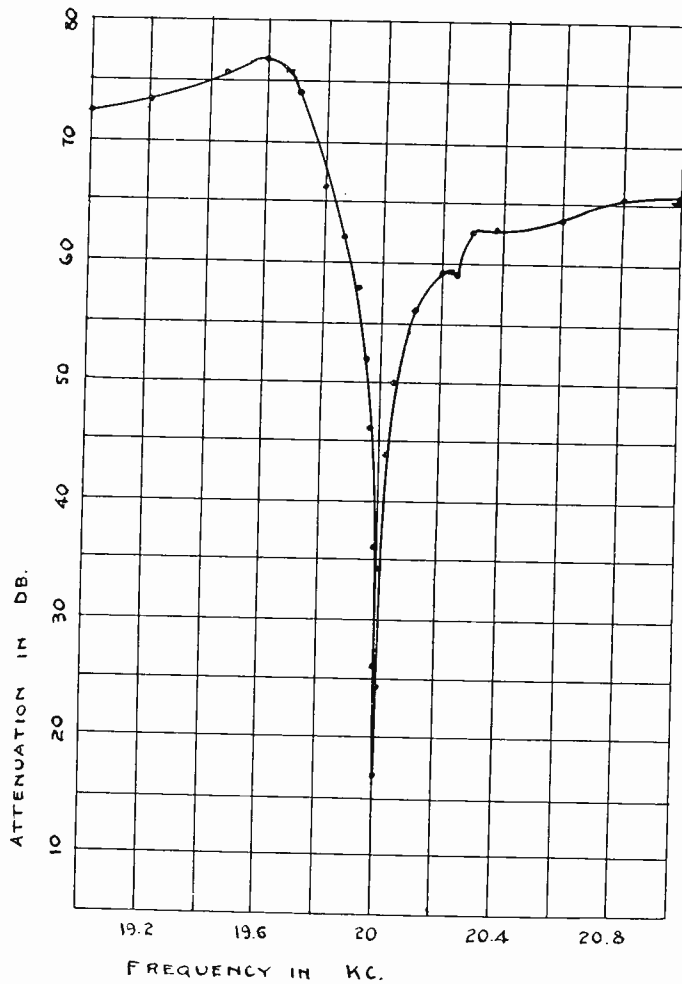

Fig. 5—Attenuation curve for monel rod, 1/2 inch diameter.

and Pierce.⁴ It is possible to deduce a motional impedance circle from impedance measurements on the system, which yields its dynamic characteristics, and the values given in the last paragraph were found in this way. The asymmetry of the curve of Fig. 5 corresponds to the "angle of dip," or "depression angle" of the motional impedance circle below the positive resistance axis. Since the voltage impressed by the filter upon the grid of a tube is very nearly proportional to the

³ G. W. Pierce, "Magnetostriction oscillators," *Proc. Amer. Acad.*, vol. 63, p. 1, (1928); *Proc. I. R. E.*, vol. 17, p. 42; January (1929).

⁴ Kennelly and Pierce, *Electrical World*, September, (1912).

reactance of the rod, the curve will be symmetrical if the depression angle is 90 degrees. It is actually 71 degrees in this case. The depression angle is considered to be due to hysteresis and eddy current effects producing a lag of the magnetic flux in the magnetostrictive core behind the magnetizing force in the coil. It was therefore thought possible to change the shape of the attenuation curve by milling slots in the rod or loading it with copper rings. So far, however, such attempts

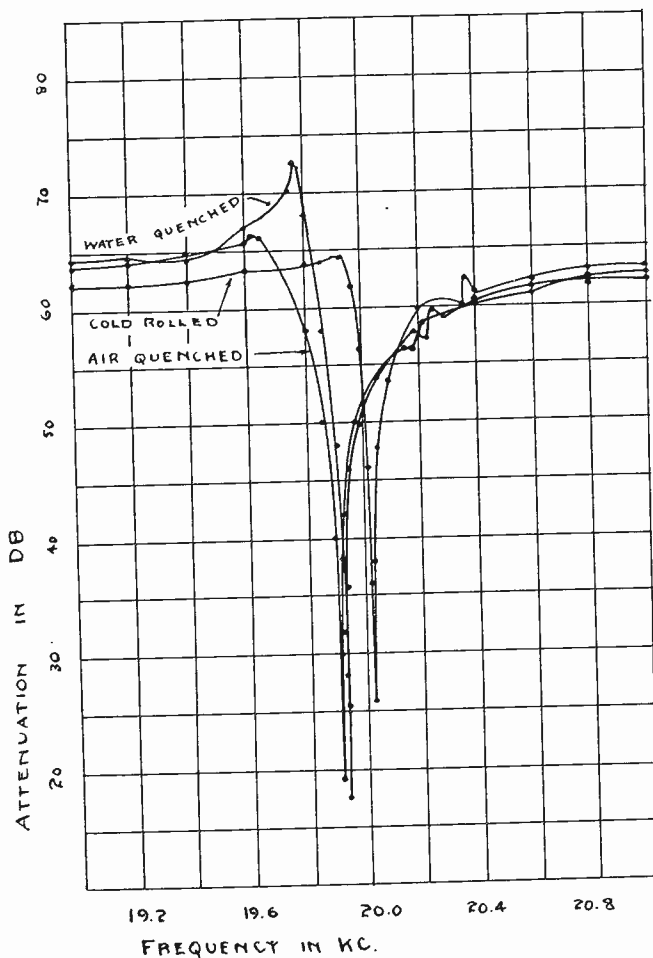

Fig. 6—Attenuation curves for 1/2-inch monel rod in coils which clear it by 3/32 inch, for various conditions of heat treatment.

have been unsuccessful in changing the depression angle without seriously impairing the efficiency and decrement of the system or introducing unwanted modes of vibration.

We must further note that since the rod is vibrating with a node at its middle the greatest stretch occurs at this point as well as the greatest magnetostrictive changes of flux. The coils must then be as near the center of the rod as possible. It has also been found by experiment that rather long, thin coils, with as little clearance between the

wire and the rod as necessary to allow the rod perfect freedom to vibrate, gave better efficiency than shorter, thicker coils.

The effect of heat treatment of the rod must also be discussed. A sample was tested after having been cut from cold-rolled stock and machined to fit the coils. The sample was then heated to a bright red, kept there for about five minutes, and air-quenched, or cooled in air on a piece of copper sheet three by eight inches in size, and tested

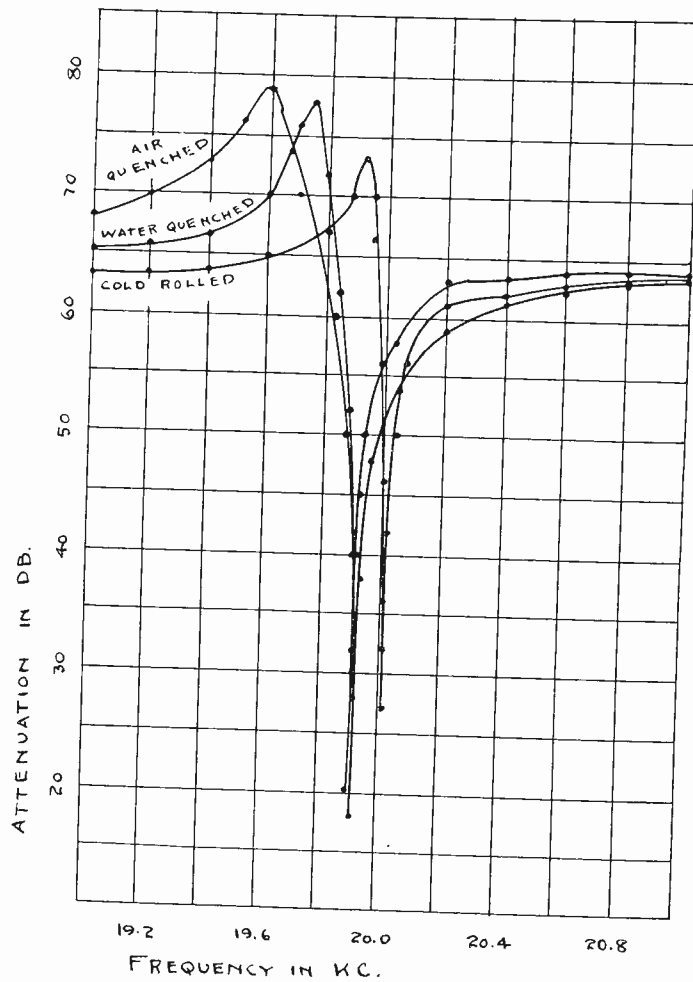

Fig. 7—Attenuation curves for the same rod and conditions as in Fig. 6, except that the coils clear it by $1/32$ inch.

again. Finally it was heated again as before and this time quenched in water. The results are shown in Fig. 6. The first condition gives very sharp resonance but small maximum motional impedance. Air quenching gave a large motional impedance but less sharp resonance, while water quenching gave motional impedance and sharpness of resonance about intermediate between the two other conditions.

The amount of clearance between the rod and the inside of the coil form has a definite effect on unwanted modes of vibration. For the

curves of Fig. 6 there was a clearance of more than $3/32$ inch. For the curves of Fig. 7 the same rod was tested in coils having a clearance of less than $1/32$ inch. In the former set a number of subsidiary modes are clearly present, while in the latter they are hardly detectable.

It should also be noted that all of these curves were taken at approximately optimum polarizing field. The fact that the motional impedance has a maximum value for a certain polarizing field was

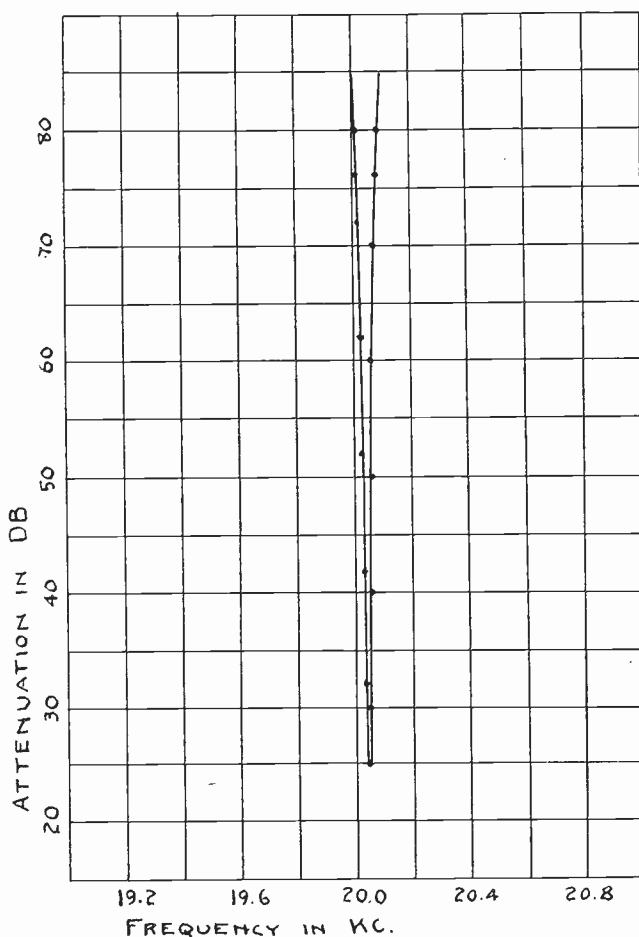

Fig. 8—Attenuation curves for two "water-quenched" monel rods in series coupled by a vacuum tube.

amply proved by observation of the output voltage when the polarizing magnets were moved with respect to the rod, and the frequency varied at the same time to keep the rod at resonance, for the natural frequency of the rod is also dependent on polarizing field.

The details of the design of the finally adopted system are as follows. Since a total variation in amplitude of at least sixty decibels was desired, two rod systems were used in series coupled by a vacuum tube, in order to avoid coupled circuit effects. The velocity of sound in monel

metal is given by Pierce² as 4549 meters per second and the lengths of the rods were then made about 11.4 cm for resonance at 20,000 cycles. They were turned to about 1/2 inch in diameter and drilled transversely at the center to allow the passage of a small steel pin on which each was suspended. The pin passed through holes drilled along a diameter of the central septum of the shield which was about 1/8 inch thick and which cleared the rod sufficiently to allow it perfect freedom. No effort was made to locate the exact node of vibration other than careful measurement of the central point of the rod. The coils used

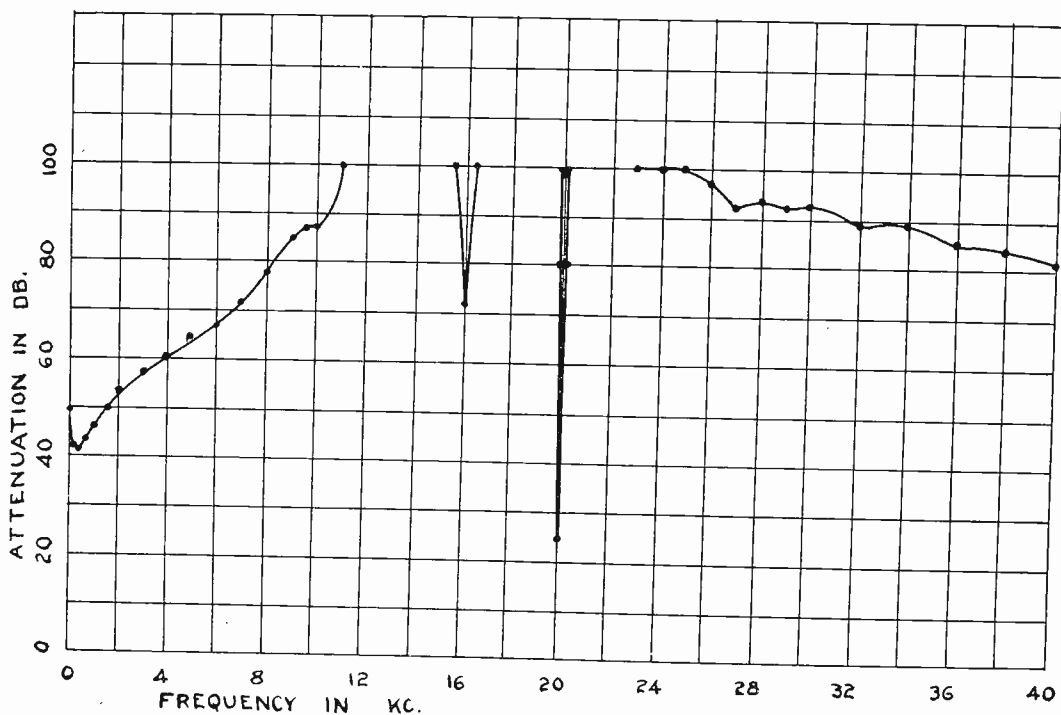

Fig. 9—Over-all attenuation curve for the two-section filter. The low attenuation at low frequencies and the unwanted response at 16,000 cycles can be eliminated by a high pass filter of conventional design.

were wound on bakelite forms with a winding space about 1 inch long and 3/32 inch deep and allowed a clearance between the wire and the rod of about 1/32 inch. 4000 to 5000 turns of No. 38 enamel wire were used with a turn ratio of about 1.2 to 1.0 of output coil to input. A larger turn ratio might be used with profit if the output is to go to a vacuum tube grid. The coils were mounted axially in cylindrical shields which fitted into recesses in the block containing the central partition in such a way that the coils butted directly against the latter. The shields and septum were made of brass. The polarizing field was furnished by a pair of permanent magnets made of 1 × 3/8-inch chrome steel strap, properly heat-treated, magnetized, and fitted with soft steel pole pieces which were milled to fit the shields. When first mag-

netized these magnets were found to give about optimum field. Over about a year's time, however, the effect of aging has been to reduce the

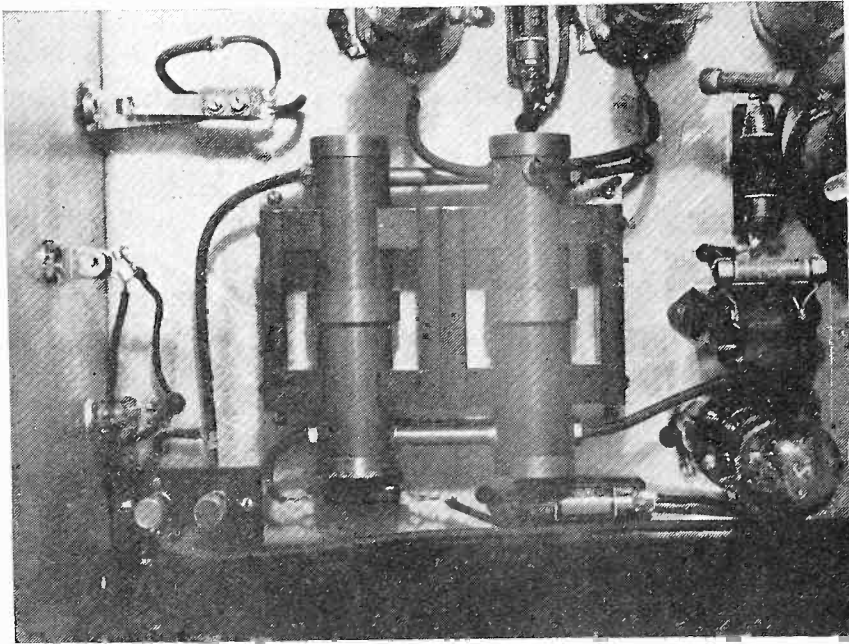

Fig. 10—Photograph of the two-section filter.

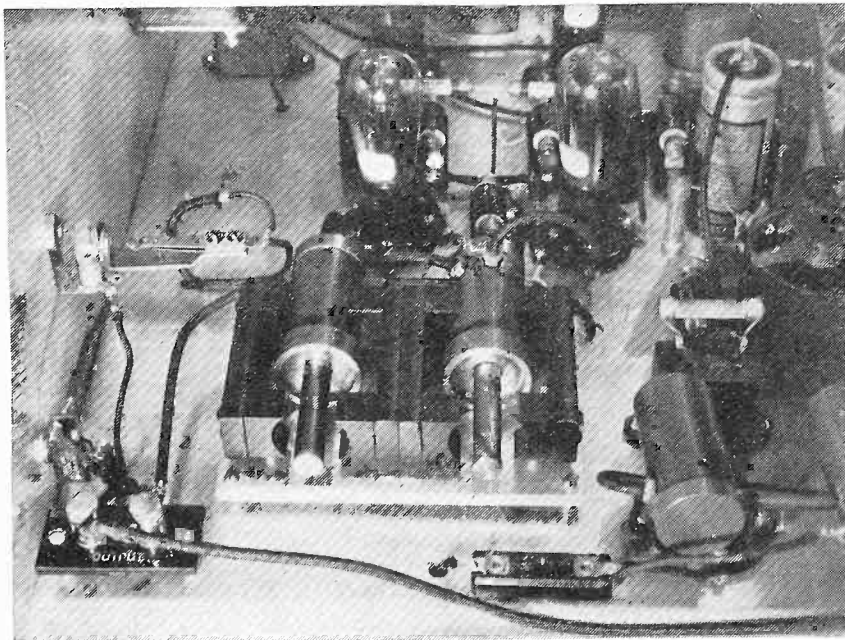

Fig. 11—Photograph of the two-section filter with one pair of coils removed to show the rods.

field somewhat below optimum value and reduce the efficiency of the system. Somewhat larger magnets or smaller air gap are therefore

recommended. The rods were carefully matched in frequency by cutting them as nearly as possible to the same length and then adjusting the frequency of the shorter one to the longer by filing it slightly around its middle.

Fig. 8 shows the attenuation curve of the double system near resonance, and Fig. 9 an over-all attenuation curve from 0 to 40,000 cycles. When these curves were measured the device was working between 20,000 ohms and a vacuum tube grid. Near the principal resonance the curve is seen to be only seventy cycles wide, as much as sixty decibels up from the minimum. Note that there is a rather strong mode of vibration at 16,000 cycles and that the attenuation falls down at low frequencies. Both of these defects may, however, be easily remedied by placing in series with the device a high-pass filter of conventional design.

Below are listed the various characteristics of one of the rods.

Input impedance	20,700 ohms
Maximum motional impedance	3,090 ohms
Logarithmic decrement	20.4 rad/sec
Depression angle	71 degrees



PROPERTIES OF MYCALEX*

BY

W. W. BROWN

(Radio Engineering Department, General Electric Company, Schenectady, N.Y.)

Summary—This paper presents data recently obtained on physical and electrical properties of Mycalex, a material having extensive and growing applications in the design of radio apparatus. The electrical data relate to the frequency range to 100,000 kilocycles.

PROPERTIES OF MYCALEX

SINCE the previous publication of information on the properties and applications of Mycalex to radio apparatus, considerable improvements have been made in manufacturing processes. In addition, physical and electrical properties have been more definitely established and larger sizes have become available.

The following tabulation indicates the physical properties determined in accordance with A.S.T.M. Standard Methods of Testing Molded Materials used for Electrical Insulation; Serial Designation D-48-30.

	Minimum Values, Except for Water Absorption Where Maximum Values Indicated	Average Values for Comparison with other Mate- rials
Density (lb. per cu. in.)	0.122	0.122 to 0.126
Specific gravity (C.G.S. units)	3.4	3.4 to 3.5
Water absorption		
24 hr.	0.06%	0.031%
48 hr.	0.07%	0.036%
Compressive strength (lb. per sq. in.)	20,000	25,000
Specimen: 1½ in. diameter 1½ in. long		
Resistance to impact (ft. lb.)		
Specimen: ¼ in.-diameter rod	1.0	1.16
Specimen: ½ in. by ½ in. by 5 in.		
Tested parallel to direction of molding	0.8	0.87
Tested at right angles to direction of molding	0.7	0.75
Transverse strength (modulus of rupture, lb. per sq. in.)	15,000	20,000

Figs. 1, and 2, and 3, indicate the relative losses through a range of frequencies much higher than previously measured. The data plotted in these curves were obtained in the following manner. Samples for testing were made up of insulating material 3/4 inch in diameter by 5

* Decimal classification: R281. Original manuscript received by the Institute, March 22, 1933.

¹ W. W. Brown, "Properties and applications of Mycalex to radio apparatus," Proc. I.R.E., vol. 18, p. 1307; August, (1930).

inches long. End caps of brass were attached with babbitt, leaving a clear length of 4 inches between the caps. High-frequency voltage ob-

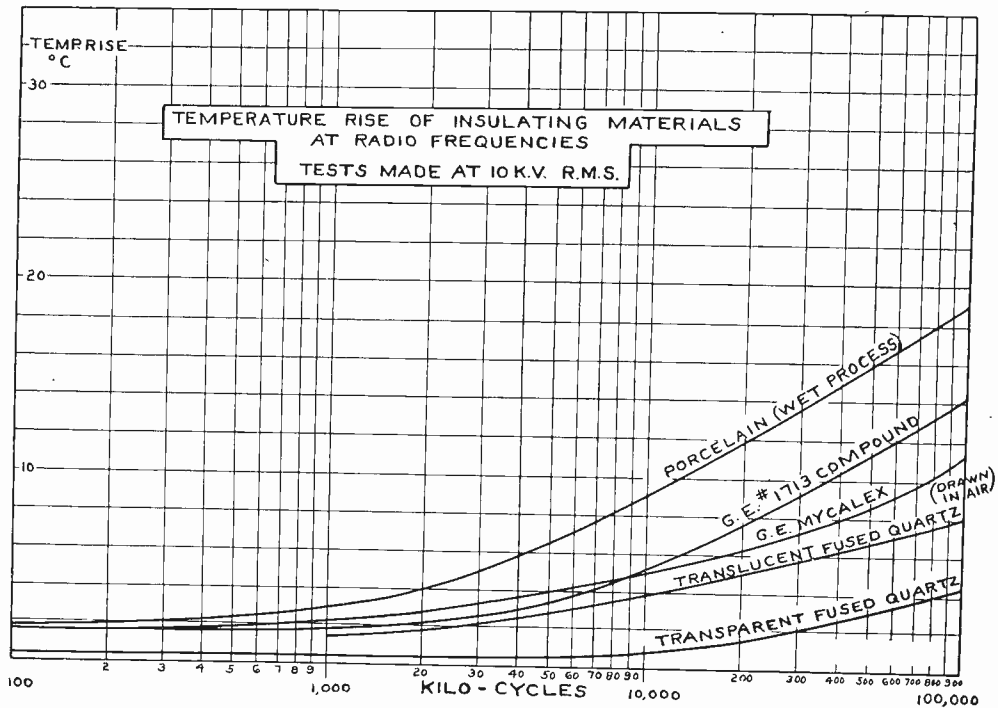

Fig. 1

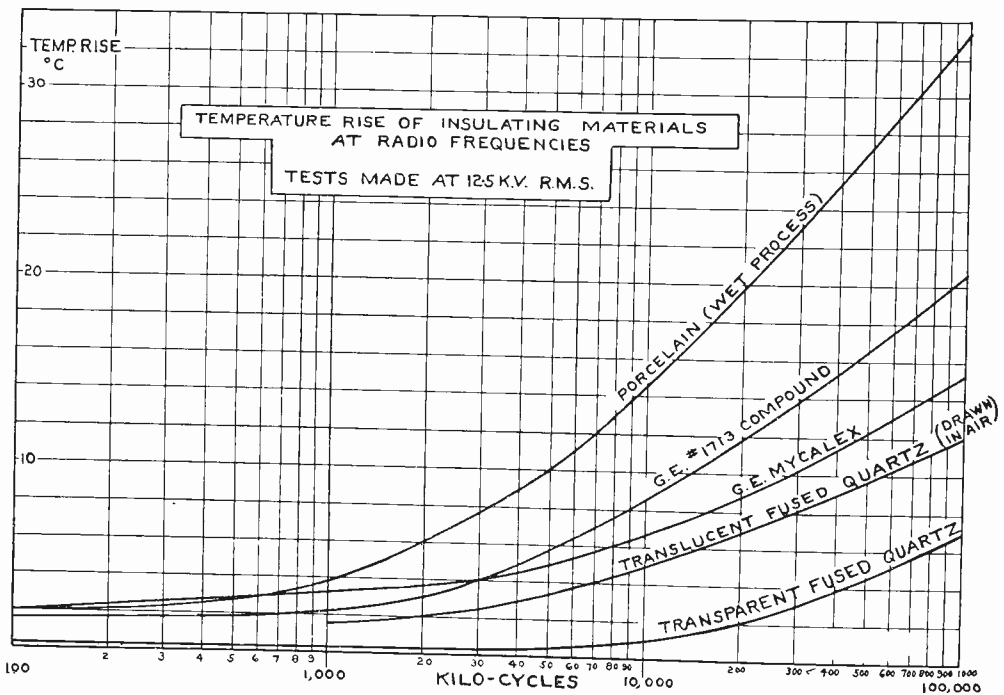

Fig. 2

tained from water-cooled tubes, Type RCA-846, operating in a self-oscillating circuit, was applied to the samples. After sufficient time had

elapsed to allow them to reach a constant temperature, the voltage was removed and the temperature was measured by contact thermocouples. The values of impressed voltage were obtained by calculation based upon a measured current through a known capacitance. A number of samples were tested simultaneously at all frequencies except the highest, at which each sample was tested separately. This was necessary to avoid excessive currents and the difficulties of measuring them accurately at these very high frequencies. The insulator temperature was measured at a point 1/2 inch below the bottom edge of the top end cap, the top being the high potential end. This point was very close to the

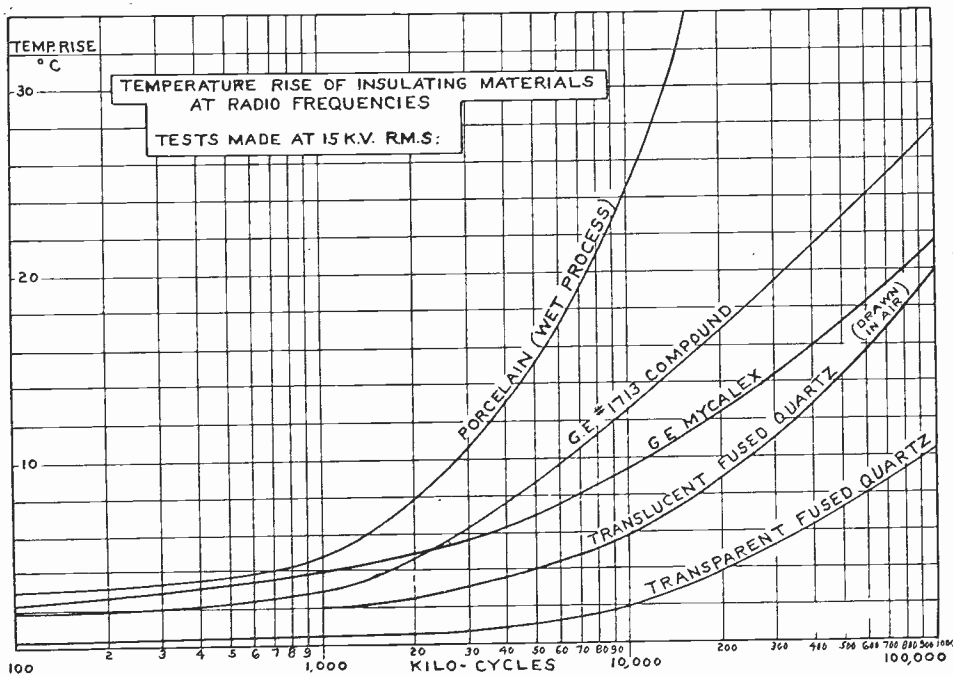

Fig. 3

highest temperature point, since no electrostatic shields were used. With the method and equipment used in measuring temperature, an accuracy of plus or minus 1/2 degree centigrade was assured.

Following is a list of sizes in which General Electric Mycalex is ordinarily molded:

Slabs—2 1/4 in wide, 12 in. long, any thickness between 1/4 in. and 1 in.

Slabs—1 in. wide, 12 in. long, any thickness between 1/8 in. and 1 in.

Rods—modified octagonal, 7/8 in. diameter by 12 in. long.

Rods—Octagonal, 1 3/8 in. diameter by 12 in. long.

Slabs—2 1/2 in. wide by 24 1/2 in. long, and thickness between 1/2 in. and 1 1/2 in.

Slabs—1 in. wide by 24 1/2 in. long, any thickness between 1/2 in. and 1 1/4 in.

Disks—3 in. diameter, any thickness between 1/4 in. and 1 in.

Disks—7 1/2 in diameter, any thickness between 1/4 in. and 1 in.

As previously stated, General Electric Mycalex can be sawed, turned, milled, drilled, ground, or polished. Carborundum wheels are recommended for sawing and grinding, and tungsten-carbide tools for turning, milling, and drilling. Although Mycalex can be machined by the methods used for machining marble, using ordinary steel tools, the machining operations are greatly facilitated by the use of tungsten-carbide tools as recommended above. High-speed twist drills are satisfactory for drilling thicknesses up to 3/8 inch. Deep-drilling operations are improved by the use of water lubricant. Water lubrication is generally recommended for all machining and grinding operations involving relatively large operations.



RADIATION RESISTANCE OF CONCENTRIC CONDUCTOR TRANSMISSION LINES*

BY

ROBERT WHITMER

(Department of Physics, Amherst College, Amherst, Massachusetts)

Summary—An expression for the radiation resistance of a cylinder is derived, following the "tangential field" or "induced electromotive force" method as adapted by Pistol Kors. The result is used to determine the radiation resistance of a segment of a concentric cylinder transmission line, as used in ultra-high-frequency oscillator circuits. A comparison is made with the more conventional parallel wire line segment. Numerical computations are made for the case of a line one-half wavelength long, with a radius (for the concentric line) and a spacing (for the open line) of one-twentieth of a wavelength. These are believed to be the largest dimensions to be encountered in practice. The resistances are, respectively, 0.086 ohm and 3.02 ohms, showing the concentric line to be definitely superior as far as radiation losses are concerned.

WHEN working with oscillators at frequencies above 300 megacycles it is customary to use a short segment of a transmission line in place of a tuned circuit. Tuned circuits have been constructed which resonate at 1500 megacycles, and they have been used in oscillators at 500 megacycles. However, the network resulting from the addition of a vacuum tube, with the distributed inductance and capacitance of its leads, is quite complex, and the efficiency of the combination as a source of high-frequency power is low. When a line segment is used there is a less abrupt change in the constants in passing from the tube to the external circuit, and better operation is obtained.

Both parallel wire and concentric cylinder lines have been used, although most investigators prefer the former because of the greater ease of construction and adjustment. The question of the relative radiation losses of the two systems has arisen, and the following paper gives an expression for the radiation resistance of the concentric line.

The method used is that of Pistol Kors.¹ He found the power radiated by two parallel wires, carrying equal sinusoidally distributed currents, when the wires are each an integral number of half wavelengths long. He did this by writing an expression for the tangential electric field at the surface of each wire, multiplying by the current with the proper phase angle, and then integrating over the length. This was later shown by Bechmann² to be equivalent to the usual procedure of integrating the flux of the Poynting vector over an infinite sphere.

* Decimal classification: R322 Original manuscript received by the Institute, March 23, 1933.

¹ A. A. Pistol Kors, Proc. I.R.E., vol. 17, page 562; March, (1929).

² R. Bechmann, Proc. I.R.E., vol. 19, page 1471; August, (1931).

I.

The general expression for the electric field is

$$E = -\frac{1}{c} \frac{\partial A}{\partial t} - \text{grad } \varphi, \quad (1)$$

where

$$\varphi = \frac{1}{\epsilon} \int \frac{[\sigma]}{r} dv, \quad \text{and} \quad A = \mu c \int \frac{[i]}{r} dv, \quad (2)$$

φ is the scalar potential, ϵ the dielectric constant of the medium, $[\sigma]$ the charge density at time $(t-r/c)$, A the vector potential, μ the permeability of the medium, c the velocity of light, and $[i]$ the vector current at time $(t-r/c)$.

For the particular case of the field at a point (d, ξ) parallel to a straight wire in free space, carrying a current $I = I_0 \sin \omega t \sin mz$, where $m = \omega/c = 2\pi/\lambda$, we have, dropping the vector notation,

$$e_d = -cI_0 \left[m \int_0^l \frac{\cos(\omega t - mr) \sin mx \, dx}{r} + \frac{\partial}{\partial \xi} \int_0^l \frac{\cos(\omega t - mr) \cos mx \, dx}{r} \right] \quad (3)$$

$$= cI_0 \left[\frac{\cos(\omega t - mr_{l-\xi}) \cos ml}{r_{l-\xi}} - \frac{\cos(\omega t - mr_\xi)}{r_\xi} \right] \quad (4)$$

where l is the length of the wire, and

$$r_{l-\xi} = \sqrt{d^2 + (l-\xi)^2}, \quad r_\xi = \sqrt{d^2 + \xi^2}.$$

In particular, when $d=0$, we have

$$e_0 = cI_0 \left[\frac{\cos(\omega t - ml + m\xi) \cos ml}{l-\xi} - \frac{\cos(\omega t - m\xi)}{\xi} \right]. \quad (5)$$

Suppose now a second wire of equal length, parallel to the first at a distance d , and also carrying a current $I_0 \sin \omega t \sin mz$. To obtain the power radiated by the current in the second wire due to the field from the first we multiply the current and field, with the proper phase angle, and integrate over the length of the wire. Changing now to practical units, the resulting expression is

$$P_d = -30I_0^2 \int_0^l \left[\frac{\sin mr_{l-z} \cos ml}{r_{l-z}} - \frac{\sin mr_z}{r_z} \right] \sin mz \, dz \quad (6)$$

where z now represents the distance from one end of the second wire, corresponding to the ξ of (4). (See Fig. 1.)

When the wires are an integral number of half wavelengths long, the integrated form of (6) is

$$P_d = 30I_0^2 [2Ci(md) - Ci(m\sqrt{d^2+l^2}+ml) - Ci(m\sqrt{d^2+l^2}-ml)] \quad (7)$$

where,

$$Ci(x) = - \int_x^\infty \frac{\cos n \, dn}{n}, \text{ called the cosine integral of } x,$$

$$= \gamma + \log x - \frac{x^2}{2 \cdot 2!} + \frac{x^4}{4 \cdot 4!} - \frac{x^6}{6 \cdot 6!} + \dots$$

[$\gamma = 0.577216 \dots$, known as Euler's constant.]

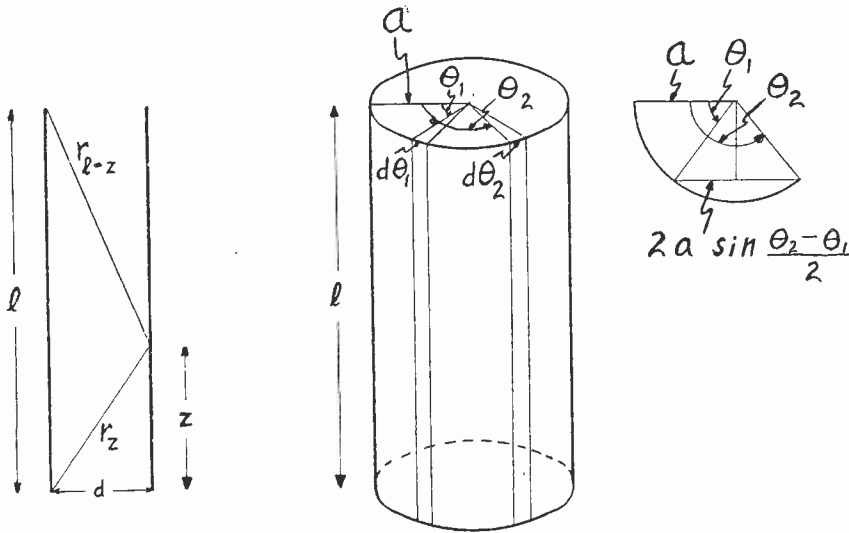

Fig. 1

Fig. 2

To find the power radiated by a current due to its own field, we use the expression for e_0 instead of e_a , and obtain

$$P_0 = 30I_0^2 [\gamma + \log 2ml - Ci(2ml)]. \quad (8)$$

If now we let R_s represent the self-resistance of one wire, and R_m its mutual resistance with the other wire, we have

$$R_s = \frac{P_0}{I_0^2} = 30 [\gamma + \log 2ml - Ci(2ml)] \quad (9)$$

$$R_m = \frac{P_d}{I_0^2} = 30 [2Ci(md) - Ci(m\sqrt{d^2+l^2}+ml) - Ci(m\sqrt{d^2+l^2}-ml)]. \quad (10)$$

If the two currents are 180 degrees out of phase, as would be the case if the line were used in an oscillator circuit, the radiation resistance of the pair would be

$$R = 2(R_s - R_m) = 60[\gamma + \log 2ml - Ci(2ml) - 2Ci(md) + Ci(m\sqrt{d^2 + l^2} + ml) + Ci(m\sqrt{d^2 + l^2} - ml)]. \quad (11)$$

Tables of $Ci(x)$ may be found in C. P. Steinmetz', "Theory and Calculation of Transient Electrical Phenomena and Oscillations." However, for small values of x , it is much better to compute $Ci(x)$ from the series. For a more detailed treatment of these developments, see Pistol Kors.¹

II.

We shall consider a concentric system in which the radius of the inner conductor is so small that we may neglect the phase difference between components of the field from different longitudinal elements. This, in effect, means that we consider the inner conductor to be a thin wire. Its self-resistance will be given by I, (9). Unless the radius of the outer cylinder is quite large, the currents in the inner and outer conductors will be equal and opposite, and the mutual resistance of either the cylinder or the wire will be given by I, (10), using the radius of the cylinder, a , in place of d . We have then to find the self-resistance of the cylinder.

We shall divide the cylinder into pairs of elements parallel to the axis, each pair being separated by a distance

$$2a \sin \frac{\theta_2 - \theta_1}{2} \quad (\text{see Fig. 2.})$$

We have from I, (7)

$$P_d = 30I_0^2 [2Ci(md) - Ci(m\sqrt{d^2 + l^2} + ml) - Ci(m\sqrt{d^2 + l^2} - ml)] \quad (1)$$

for the power radiated by one conductor due to the field from the second. If we substitute $2a \sin (\theta_2 - \theta_1)/2$ for d in (1) and integrate *both* angles from 0 to 2π , we shall obtain the power radiated by all *pairs* of elements of the cylinder, and hence the total power radiated by the cylinder itself.

If the cylinder is carrying a current whose peak value is I_0 , then the peak value of current in an element $d\theta$ is

$$dI_0 = \frac{I_0}{2\pi} d\theta. \quad (2)$$

Hence, rewriting (1),

$$\begin{aligned}
 P_a = & \frac{30I_0^2}{4\pi^2} \int_0^{2\pi} \int_0^{2\pi} \left[2Ci \left(2ma \sin \frac{\theta_2 - \theta_1}{2} \right) \right. \\
 & - Ci \left(m \sqrt{l^2 + 4a^2 \sin^2 \frac{\theta_2 - \theta_1}{2}} + ml \right) \\
 & \left. - Ci \left(m \sqrt{l^2 + 4a^2 \sin^2 \frac{\theta_2 - \theta_1}{2}} - ml \right) \right] d\theta_2 d\theta_1. \quad (3)
 \end{aligned}$$

The variables may be somewhat simplified by noting the following:

$$\begin{aligned}
 \int_{y=0}^a \int_{x=0}^a f \left(\frac{x-y}{2} \right) dx dy &= 4 \int_{y=0}^a \int_{x=0}^a f \left(\frac{x-y}{2} \right) d \left(\frac{x}{2} \right) d \left(\frac{y}{2} \right) \\
 &= 4 \int_{y'=0}^{a/2} \int_{x'=0}^{a/2} f(x'-y') dx' dy'. \quad (4)
 \end{aligned}$$

$$\begin{aligned}
 \therefore P_a = & \frac{30I_0^2}{\pi^2} \int_0^\pi \int_0^\pi \left(2Ci [2ma \sin (\theta_2 - \theta_1)] \right. \\
 & - Ci [m \sqrt{l^2 + 4a^2 \sin^2 (\theta_2 - \theta_1)} + ml] \\
 & \left. - Ci [m \sqrt{l^2 + 4a^2 \sin^2 (\theta_2 - \theta_1)} - ml] \right) d\theta_2 d\theta_1. \quad (3')
 \end{aligned}$$

Let us consider the first term in the brackets. If we expand it in the power series for the cosine integral, we have

$$\begin{aligned}
 & \int_0^\pi \int_0^\pi Ci [2ma \sin (\theta_2 - \theta_1)] d\theta_2 d\theta_1 \\
 = & \int_0^\pi \int_0^\pi \left(\gamma + \log 2ma \sin (\theta_2 - \theta_1) \right. \\
 & \left. - \frac{[2ma \sin (\theta_2 - \theta_1)]^2}{2 \cdot 2!} + \frac{[2ma \sin (\theta_2 - \theta_1)]^4}{4 \cdot 4!} - \dots \right) d\theta_2 d\theta_1. \quad (5)
 \end{aligned}$$

The first two terms of the expression on the right of (5) will later disappear, so we shall not trouble ourselves to integrate them, but proceed immediately to the power series. Applying a reduction formula to the general term we have, since n is even,

$$\begin{aligned}
 & \frac{(-1)^{n/2} (2ma)^n}{n \cdot n!} \int_0^\pi \int_0^\pi \sin^n (\theta_2 - \theta_1) d\theta_2 d\theta_1 \\
 = & \frac{(-1)^{n/2} (2ma)^n}{n \cdot n!} \int_0^\pi \left[- \frac{\sin^{n-1} (\theta_2 - \theta_1) \cos (\theta_2 - \theta_1)}{n} \right. \\
 & \left. + \frac{n-1}{n} \int_0^\pi \sin^{n-2} (\theta_2 - \theta_1) d\theta_2 \right] d\theta_1.
 \end{aligned}$$

The term which has been integrated once disappears upon applying the limits of θ_2 ; by successive applications of the reduction formula we obtain

$$\begin{aligned} & \frac{(-1)^{n/2}(2ma)^n}{n \cdot n!} \int_0^\pi \int_0^\pi \sin^n(\theta_2 - \theta_1) d\theta_2 d\theta_1 \\ &= \frac{(-1)^{n/2}(2ma)^n}{n \cdot n!} \frac{1 \cdot 3 \cdot 5 \cdots (n-1)}{2 \cdot 4 \cdot 6 \cdots n} \pi^2. \end{aligned} \quad (6)$$

Hence,

$$\begin{aligned} & \int_0^\pi \int_0^\pi Ci[2ma \sin(\theta_2 - \theta_1)] d\theta_2 d\theta_1 \\ &= \int_0^\pi \int_0^\pi [\gamma + \log 2ma \sin(\theta_2 - \theta_1)] d\theta_2 d\theta_1 \\ &+ \pi^2 \left[-\frac{(2ma)^2}{2 \cdot 2!} \frac{1}{2} + \frac{(2ma)^4}{4 \cdot 4!} \frac{1 \cdot 3}{2 \cdot 4} - \frac{(2ma)^6}{6 \cdot 6!} \frac{1 \cdot 3 \cdot 5}{2 \cdot 4 \cdot 6} + \cdots \right] \\ &= \int_0^\pi \int_0^\pi [\gamma + \log 2ma \sin(\theta_2 - \theta_1)] d\theta_2 d\theta_1 \\ &\quad + \pi^2 \sum_{n=2,4,6,\dots}^{\infty} \frac{(-1)^{n/2}(2ma)^n}{2^2 \cdot 4^2 \cdot 6^2 \cdots n^2 \cdot n} \\ &= \int_0^\pi \int_0^\pi [\gamma + \log 2ma \sin(\theta_2 - \theta_1)] d\theta_2 d\theta_1 + \pi^2 \sigma(2ma). \end{aligned} \quad (7)$$

Let us now consider the second and third terms of (3'):

$$\begin{aligned} & - \int_0^\pi \int_0^\pi Ci[m\sqrt{l^2 + 4a^2 \sin^2(\theta_2 - \theta_1)} + ml] d\theta_2 d\theta_1 \\ &= - \int_0^\pi \int_0^\pi \left(\gamma + \log [m\sqrt{l^2 + 4a^2 \sin^2(\theta_2 - \theta_1)} + ml] \right. \\ &\quad - \frac{[m\sqrt{l^2 + 4a^2 \sin^2(\theta_2 - \theta_1)} + ml]^2}{2 \cdot 2!} \\ &\quad \left. + \frac{[m\sqrt{l^2 + 4a^2 \sin^2(\theta_2 - \theta_1)} + ml]^4}{4 \cdot 4!} - \cdots \right) d\theta_2 d\theta_1 \end{aligned} \quad (8)$$

and

$$\begin{aligned}
& - \int_0^\pi \int_0^\pi Ci [m\sqrt{l^2 + 4a^2 \sin^2 (\theta_2 - \theta_1)} - ml] d\theta_2 d\theta_1 \\
& = - \int_0^\pi \int_0^\pi \left(\gamma + \log [m\sqrt{l^2 + 4a^2 \sin^2 (\theta_2 - \theta_1)} - ml] \right. \\
& \quad \left. - \frac{[m\sqrt{l^2 + 4a^2 \sin^2 (\theta_2 - \theta_1)} - ml]^2}{2 \cdot 2!} \right. \\
& \quad \left. + \frac{[m\sqrt{l^2 + 4a^2 \sin^2 (\theta_2 - \theta_1)} - ml]^4}{4 \cdot 4!} - \dots \right) d\theta_2 d\theta_1. \quad (9)
\end{aligned}$$

Let us add the first two terms of the expression involving $+ml$ to the corresponding terms in $-ml$:

$$\begin{aligned}
& \left(\gamma + \log [m\sqrt{l^2 + 4a^2 \sin^2 (\theta_2 - \theta_1)} + ml] + \gamma \right. \\
& \quad \left. + \log [m\sqrt{l^2 + 4a^2 \sin^2 (\theta_2 - \theta_1)} - ml] \right) \\
& = \left(2\gamma + \log [m\sqrt{l^2 + 4a^2 \sin^2 (\theta_2 - \theta_1)} + ml] \right. \\
& \quad \left. [m\sqrt{l^2 + 4a^2 \sin^2 (\theta_2 - \theta_1)} - ml] \right) \\
& = \left(2\gamma + \log [m^2(l^2 + 4a^2 \sin^2 (\theta_2 - \theta_1)) - m^2 l^2] \right) \\
& = 2\gamma + 2 \log 2ma \sin (\theta_2 - \theta_1). \quad (10)
\end{aligned}$$

We now turn to the power series of (8) and (9). If we add terms in $+ml$ to terms having the same exponents in $-ml$, the result is

$$\begin{aligned}
& \int_0^\pi \int_0^\pi \sum_{n=2,4,6,\dots}^{\infty} \frac{(-1)^{n/2} m^n}{n \cdot n!} [(\sqrt{l^2 + 4a^2 \sin^2 (\theta_2 - \theta_1)} + l)^n \\
& \quad + (\sqrt{l^2 + 4a^2 \sin^2 (\theta_2 - \theta_1)} - l)^n] d\theta_2 d\theta_1.
\end{aligned}$$

From the binomial expansion,

$$(u+v)^n = u^n + nu^{n-1}v + \frac{n(n-1)}{2!} u^{n-2}v^2 + \frac{n(n-1)(n-2)}{3!} u^{n-3}v^3 + \dots$$

also,

$$(u-v)^n = u^n - nu^{n-1}v + \frac{n(n-1)}{2!} u^{n-2}v^2 - \frac{n(n-1)(n-2)}{3!} u^{n-3}v^3 + \dots$$

Then,

$$\begin{aligned}
(u+v)^n + (u-v)^n & = 2 \left[u^n + \frac{n(n-1)}{2!} u^{n-2}v^2 \right. \\
& \quad \left. + \frac{n(n-1)(n-2)(n-3)}{4!} u^{n-4}v^4 + \dots \right].
\end{aligned}$$

We may apply this to the above integral.

$$\begin{aligned}
 & \sum_{n=2,4,6,\dots}^{\infty} \frac{(-1)^{n/2} m^n}{n \cdot n!} \int_0^\pi \int_0^\pi \left([\sqrt{l^2 + 4a^2 \sin^2(\theta_2 - \theta_1)} + l]^n + [\sqrt{l^2 + 4a^2 \sin^2(\theta_2 - \theta_1)} - l]^n \right) d\theta_2 d\theta_1 \\
 &= 2 \sum_{n=2,4,6,\dots}^{\infty} \frac{(-1)^{n/2} m^n}{n \cdot n!} \int_0^\pi \int_0^\pi \left([l^2 + 4a^2 \sin^2(\theta_2 - \theta_1)]^{n/2} + \frac{n(n-1)l^2}{2!} [l^2 + 4a^2 \sin^2(\theta_2 - \theta_1)]^{\frac{n-2}{2}} \right. \\
 & \quad \left. + \frac{n(n-1)(n-2)(n-3)}{4!} l^4 [l^2 + 4a^2 \sin^2(\theta_2 - \theta_1)]^{\frac{n-4}{2}} + \dots + l^n \right) d\theta_2 d\theta_1. \tag{11}
 \end{aligned}$$

It will be seen that by adding the two series we have eliminated all terms in which $[l^2 + 4a^2 \sin^2(\theta_2 - \theta_1)]$ appears under a radical.

We shall now perform the secondary expansions of (11).

$$\begin{aligned}
 & \sum_{n=2,4,6,\dots}^{\infty} \frac{(-1)^{n/2} m^n}{n \cdot n!} \int_0^\pi \int_0^\pi \{ [\sqrt{l^2 + 4a^2 \sin^2(\theta_2 - \theta_1)} + l]^n + [\sqrt{l^2 + 4a^2 \sin^2(\theta_2 - \theta_1)} - l] \} d\theta_2 d\theta_1 \\
 &= 2 \sum_{n=2,4,6,\dots}^{\infty} \frac{(-1)^{n/2} m^n}{n \cdot n!} \int_0^\pi \int_0^\pi \left\{ l^n + \frac{n}{2} l^{n-2} s^2 + \dots + \frac{n}{2} \left(\frac{n}{2} - 1 \right) \dots 2 \frac{l^{n-4} s^4 + \dots + l^{n-2} s^2 + s^n}{\left(\frac{n}{2} - 1 \right)!} \right. \\
 & \quad \left. + \frac{n(n-1)}{2!} l^n + \frac{n(n-1)(n/2-1)}{2!} l^{n-2} s^2 + \dots + \frac{n(n-1) \left(\frac{n}{2} - 1 \right) \left(\frac{n}{2} - 2 \right)}{2! 2!} l^{n-4} s^4 + \dots + \frac{n(n-1)}{2!} l^{n-2} s^2 \right. \\
 & \quad \left. + \frac{n(n-1)(n-2)(n-3)}{4!} l^n + \frac{n(n-1)(n-2)(n-3) \left(\frac{n}{2} - 2 \right)}{4!} l^{n-2} s^2 + \dots + \frac{n(n-1)(n-2)(n-3) \left(\frac{n}{2} - 2 \right) \left(\frac{n}{2} - 3 \right)}{4! 2!} l^{n-4} s^4 \right. \\
 & \quad \left. + l^n \right\} d\theta_2 d\theta_1 \tag{12}
 \end{aligned}$$

where $2a \sin(\theta_2 - \theta_1)$ has been replaced by s .

Integrating as in (6), this becomes

$$\begin{aligned}
 & 2\pi^2 \sum \frac{(-1)^{n/2} m^n}{n \cdot n!} \left[l^n + \frac{n}{3} l^{n-2} (2a)^2 \cdot \frac{1}{2} + \frac{n}{2} \left(\frac{n}{2} - 1\right) \frac{l^{n-4} (2a)^4 \cdot \frac{1 \cdot 3}{2 \cdot 4} + \dots}{2!} \right. \\
 & \quad + \frac{n}{2} \left(\frac{n}{2} - 1\right) \frac{l^{n-2} (2a)^2 \cdot \frac{1 \cdot 3 \cdot 5 \dots (n-2)}{2 \cdot 4 \dots (n-2)}}{\left(\frac{n}{2} - 1\right)!} + (2a)^n \frac{1 \cdot 3 \dots (n-1)}{2 \cdot 4 \dots n} \\
 & \quad + \frac{n(n-1)l^n}{2!} + \frac{n(n-1)\left(\frac{n}{2} - 1\right) \frac{l^{n-2} (2a)^2 \cdot \frac{1}{2} + \dots}{2!} + \frac{n(n-1)\left(\frac{n}{2} - 1\right)\left(\frac{n}{2} - 2\right) \frac{l^{n-4} (2a)^4 \cdot \frac{1 \cdot 3}{2 \cdot 4} + \dots}{2!2!}}{2!} \\
 & \quad + \frac{n(n-1)(n-2)(n-3)l^n}{4!} + \frac{n(n-1)(n-2)(n-3)\left(\frac{n}{2} - 2\right) \frac{l^{n-2} (2a)^2 \cdot \frac{1}{2} + \dots}{4!} + \frac{n(n-1)(n-2)(n-3)\left(\frac{n}{2} - 2\right)\left(\frac{n}{2} - 3\right) \frac{l^{n-4} (2a)^4 \cdot \frac{1 \cdot 3 \cdot 5 \dots (n-3)}{2 \cdot 4 \dots (n-2)}}{2!}}{4!2!} \\
 & \quad + \dots + 1l^n \left. \right]. \tag{13}
 \end{aligned}$$

Adding the terms in the first column of this summation, we find that

$$2\pi^2 \sum \frac{(-1)^{n/2} m^n}{n \cdot n!} \left[1 + \frac{n(n-1)}{2!} + \frac{n(n-1)(n-2)(n-3)}{4!} + \dots + 1 \right] l^n = \pi^2 [Ci(2ml) - \gamma - \log 2ml].$$

Also, taking the last term of the first row of (13),

$$2\pi^2 \sum \frac{(-1)^{n/2} m^n}{n \cdot n!} \frac{1 \cdot 3 \cdot 5 \cdot \dots \cdot (n-1)}{2 \cdot 4 \cdot 6 \cdot \dots \cdot n} = 2\pi^2 \sigma.$$

If now we write

$$\begin{aligned} \sum (ml, ma) = & \sum \frac{(-1)^{n/2} m^n}{n \cdot n!} \left[\frac{n}{2} l^{n-2} (2a)^2 \cdot \frac{1}{2} + \frac{n \left(\frac{n}{2} - 1\right)}{2!} \frac{l^{n-4} (2a)^4 \cdot \frac{1 \cdot 3}{2 \cdot 4} + \dots}{2} \right. \\ & + \frac{n(n-1) \left(\frac{n}{2} - 1\right)}{2!} \frac{l^{n-2} (2a)^2 \cdot \frac{1}{2} + \dots}{2!2!} + \frac{n(n-1) \left(\frac{n}{2} - 1\right) \left(\frac{n}{2} - 2\right)}{2!2!} \frac{l^{n-4} (2a)^4 \cdot \frac{1 \cdot 3}{2 \cdot 4} + \dots}{2} \\ & + \frac{n(n-1)(n-2)(n-3) \left(\frac{n}{2} - 2\right)}{4!} \frac{l^{n-2} (2a)^2 \cdot \frac{1}{2} + \dots}{4!2!} + \frac{n(n-1)(n-2)(n-3) \left(\frac{n}{2} - 2\right) \left(\frac{n}{2} - 3\right)}{2!} \frac{l^{n-4} (2a)^4 \cdot \frac{1 \cdot 3}{2 \cdot 4} + \dots}{2 \cdot 4 \cdot 6 \cdot \dots \cdot (n-2)} \\ & + \frac{n(n-1)(n-2) \dots \cdot 3 \cdot 1}{(n-2)!} \frac{l^{n-2} (2a)^2 \cdot \frac{1}{2}}{2!} \left. \right] \\ & + \frac{n(n-1)}{2} \frac{\left(\frac{n}{2} - 1\right) \dots \cdot 2}{\left(\frac{n}{2} - 1\right)!} \frac{l^2 (2a)^{n-2} \cdot \frac{1 \cdot 3 \cdot 5 \cdot \dots \cdot (n-3)}{2 \cdot 4 \cdot 6 \cdot \dots \cdot (n-2)}}{2} \end{aligned}$$

we have for the complete integral of (3')

$$\begin{aligned} P_a = & \frac{30I_0^2}{\pi^2} \int_0^\pi \int_0^\pi \{ 2Ci[2ma \sin(\theta_2 - \theta_1)] - Ci[m\sqrt{l^2 + 4a^2} \sin^2(\theta_2 - \theta_1)] + ml \} - Ci[m\sqrt{l^2 + 4a^2} \sin^2(\theta_2 - \theta_1)] - ml \} d\theta_2 d\theta_1 \\ = & 30I_0^2 [\gamma + \log 2ml - Ci(2ml) - 2 \sum]. \end{aligned} \tag{15}$$

Now $\Sigma(ml, 0) = 0$. Hence,

$$P_{a=0} = 30I_0^2[\gamma + \log 2ml - Ci(2ml)]$$

which is exactly the expression for the power radiated by a straight wire, of length l , obtained by Pistolkors.

From (15),

$$R_a = \frac{P_a}{I_0^2} = 30[\gamma + \log 2ml - Ci(2ml) - 2\Sigma]. \quad (16)$$

We now have, for the total radiation resistance of the concentric line,

$$\begin{aligned} R &= R_s + R_a - 2R_m \\ &= 30\left(2[\gamma + \log 2ml - Ci(2ml)] - 2\Sigma\right. \\ &\quad \left. - 2[2Ci(ma) - Ci(m\sqrt{l^2 + a^2} + ml) - Ci(m\sqrt{l^2 + a^2} - ml)]\right). \quad (17) \end{aligned}$$

The radiation resistances of the concentric and of the parallel wire lines have been computed for the case $l = \lambda/2$, and $a = \lambda/20$. Here "a" is the radius of the outer conductor and also the spacing of the open line. It is believed that this is the largest value of "a" likely to be encountered in practice. It was found necessary to compute all the Ci 's directly from the series expansion.

The resistance of the concentric line is 0.086 ohm, and of the open wires 3.02 ohms. From the method used, it is seen that this difference is due to the decreased self-resistance of the cylinder, from that of a straight wire. While these figures are for a half wavelength, it is to be expected that similar relations will hold for a quarter wavelength.



LOW-FREQUENCY RADIO RECEIVING MEASUREMENTS AT THE BUREAU OF STANDARDS IN 1931 AND 1932*

BY

E. B. JUDSON

(Bureau of Standards, Washington, D.C.)

Summary—This report gives the monthly and annual averages of field intensities of ten European and three American low-frequency transatlantic radio stations, between frequencies of 16 and 24 kilocycles, and the field intensity averages of atmospherics on 15 and 23 kilocycles, observed at the Bureau of Standards, for the years 1931 and 1932. Measurements were made by the telephone current comparison method. Annual average curves of daylight field intensities of European signals and afternoon atmospherics on 23 kilocycles are shown with the corresponding yearly averages of sun spot numbers. A monthly average field intensity curve of Tuckerton WCI, 18.4 kilocycles, shows a return from the high values obtained in 1930 and 1931 to the average value of previous years. Some correlations between polarization of the reflected wave and sun spot numbers derived from a year of continuous recording of Tuckerton WCI, on loop antennas, are shown. The possibility of obtaining an independent value for the ground wave from such a series of observations is suggested.

THE tables and curves in this paper are a continuation of the extended series of field intensity measurements on low-frequency American and European transatlantic radio signals, made by the late Dr. Austin at the Bureau of Standards in Washington. The tables show the annual averages of field intensities observed between 10 and 11 A.M., E.S.T., which represent an all-daylight transmission path, while those observed between 3 and 4 P.M., E.S.T., on the

TABLE I
 Transmission Data

Call	Location	Approximate Frequency and Wavelength		Approx. Antenna Current I (amp)	Effective Height h (m)	Distance from Washington d (kilometers)
		f (kc)	λ (m)			
FYL	Bordeaux, France	15.7	19100	500	180	6160
DFY	Nauen, Germany	16.6	18100	400	170	6650
DFW	Nauen, Germany	23.1	13000	400	130	6650
GBR	Rugby, England	16.0	18700	700	185	5930
IRB	Rome, Italy	20.8	14400	500	156	7160
ORU	Brussels, Belgium	16.2	18520	—	—	6270
SPL	Warsaw, Poland	16.4	18280	—	—	7240
SAQ	Gottenborg, Sweden	17.2	17440	—	—	6450
GMU	Carnarvon, Wales	21.3	14100	—	—	5840
LCM	Stavanger, Norway	24.8	12080	—	—	6100
FYN	Lyon, France	19.7	15200	270	110	6400
WCI	Tuckerton, N.J.	18.4	16300	900	96	251
WQK	Rocky Point, N.Y.	18.2	16465	500	83	435
WSS	Rocky Point, N.Y.	18.8	15960	700	83	435

* Decimal classification: R270×R113. Original manuscript received by the Institute, May 3, 1933. Publication Approved by the Acting Director of the Bureau of Standards of the U. S. Department of Commerce.

European stations represent a part-daylight, part-darkness path. All measurements were made by the telephone current comparator method.¹

During 1931 and 1932, several stations included in reports of previous years ceased continuous transmission and the scattered measure-

TABLE II
Average Field Intensities of Rome (IRB), Nauen (DFW), Carnarvon (GMU), Lyon (FYN), Stavanger (LCM), and Atmospherics in Microvolts per Meter

	10 A.M.						3 P.M.				
	IRB	DFW	GMU	FYN	LCM	Atmos. 23 kc	IRB	DFW	GMU	FYN	Atmos. 23 kc
1931											
Jan.	78	61	48	59	35	15	97	72	47	70	22
Feb.	67	46	38	55	27	17	70	51	38	58	28
Mar.	85	65	51	76	38	22	81	61	48	77	34
Apr.	91	64	45	65	33	19	61	42	32	49	44
May	83	60*	44	60	32	22	61*	—	30*	40	57
June	59*	—	34	48	27	28	—	—	—	39*	364
July	55*	37	31	46	—	32	—	—	—	—	350
Aug.	—	44	34	47	24*	24	—	—	—	23*	260
Sept.	55*	53*	30	42	20	18	—	—	17	26	134
Oct.	51*	40	32	38	24	16	49	36	27	34	37
Nov.	—	27	26	32	22	23	—	36	29	44	27
Dec.	—	19	12	14	—	21	—	37	25	34	29
Av.	69	47	35	49	28	21	70	48	33	45	116
1932											
Jan.	—	22	16	17	—	17	—	30	—	22	23
Feb.	—	25	20	19	—	18	—	39	—	23	35
Mar.	—	30	21	20	—	30	—	29	—	18	47
Apr.	—	24	15	16	—	26	—	21	—	14	48
May	—	26	19	20	—	21	—	—	—	13*	68
June	—	25	18	20	—	23	—	—	—	—	185
July	—	23	16	19	—	32	—	—	—	—	244
Aug.	—	30	18	23	—	18	—	—	—	—	180
Sept.	—	29	20	22	—	23	—	—	—	—	108
Oct.	—	23	16	19	—	20	—	—	—	20	39
Nov.	—	13	8	8	—	25	—	17*	—	14*	49
Dec.	—	18	13	14	—	27	—	28	—	22	42
Av.	—	24	17	18	—	23	—	27	—	18	89

* Less than ten observations.

ments on these particular stations rendered their annual averages of little value. These have been omitted from the tables.

Table I gives the transmission data for the stations measured. Tables II, III, and IV show the monthly and annual averages of field intensities for these stations and atmospherics at 15 and 23 kilocycles. In Tables II and III most of the 3 P.M. monthly means for the summer months are omitted, because of the difficulty in obtaining measurements through the heavy summer atmospherics. All monthly averages containing less than ten observations for the month are indicated by an asterisk, as these values are not considered as representing fair averages.

¹ Proc. I.R.E., vol. 12, p. 521, (1924).

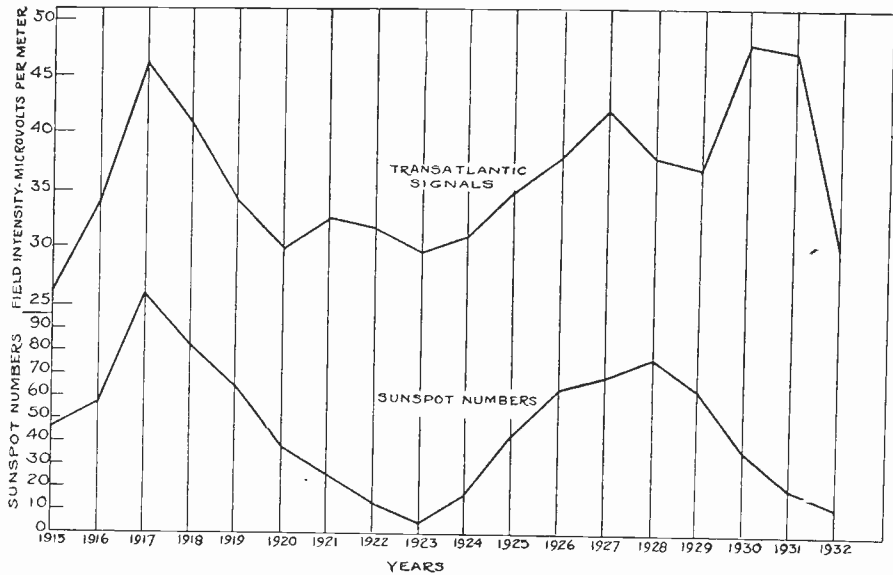

Fig. 1—Annual average field intensities of transatlantic daylight signals and sun spot numbers.

A continuation of the comparison of the annual averages of transatlantic, east-west daylight field intensities and sun spot numbers, is shown in Fig. 1. The field intensities in the signal curve were derived

TABLE III
Average Field Intensities of Rugby (GBR), Nauen (DFY), Brussels (ORU), Warsaw (SPL), Gottenborg (SAQ), Bordeaux (FYL), and Atmospherics in Microvolts per Meter

	10 A.M.						3 P.M.						
	GBR	DFY	ORU	SPL	SAQ	Atmos. 15 kc	FYL	GBR	DFY	ORU	SPL	SAQ	Atmos. 15kc
1931													
Jan.	187	90	89	63	48	18	198	228	127	129	100	56	25
Feb.	174	80	86	61	41	20	169	185	91	97	75	44	33
Mar.	208	104	110	78	63	25	180	219	98	111	81	56	40
Apr.	202	97	100	68	54	21	127	132	76	75	53	38	49
May	196	91	98	70	52	25	115	129	66	65*	46	36	59
June	138	67	70	48	38	31	103	91	49*	—	37*	27*	406
July	178	70	78	49	43	36	69*	88	—	—	—	—	379
Aug.	199	78	80	46	45	28	66	119	46	—	—	26*	310
Sept.	172	71	76	39	43	21	88	123	44	50	28*	22	156
Oct.	165	62	71	36	38	19	135	168	68	83	40	32	42
Nov.	143	55	64	32	30	29	150	166	75	84	43	42	38
Dec.	126	49	51	30	22	28	130	180	78	86	50	37	39
Av.	174	76	81	52	43	25	128	152	74	87	55	38	131
1932													
Jan.	131	39	51	28	23	22	117	157	63	68	44	30	29
Feb.	120	45	46	29	26	23	121	169	66	66	46	34	40
Mar.	131	51	51	35	29	40	111	140	54	55	34	29	53
Apr.	132	47	51	35	27	35	79	116	45	48	29	21	60
May	150	58	60	41	28	28	134*	113	41	45	34	20	92
June	146	56	57	37	30	33	56	86	29*	—	—	—	224
July	134	47	51	34	29	42	53*	71*	—	—	—	—	300
Aug.	148	53	60	36	32	25	42*	64*	—	—	—	—	213
Sept.	160	66	66	36	31	33	88*	115*	41*	48*	24*	—	128
Oct.	144	52	58	29	26	31	131	183	58	67	35	29*	55
Nov.	101	30	39	19	14	33	110	150	44	59	23	20	57
Dec.	141	43	52	28	19	39	144	175	68	82	44	31	58
Av.	137	49	53	32	26	32	99	128	51	60	35	27	109

* Less than ten observations.

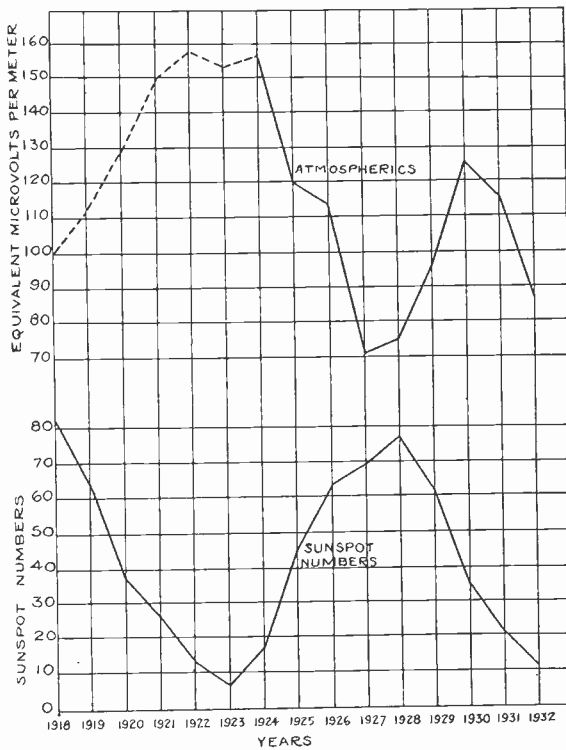

Fig. 2—Annual averages of atmospheric noise, 3 P.M., E.S.T., 23 kilocycles, and sun spot numbers.

TABLE IV
Average Field Intensity of Tuckerton (WCI), and Rocky Point (WSS and WQK), in Millivolts per Meter

	10 A.M.			3 P.M.		
	WCI	WSS	WQK	WCI	WSS	WQK
1931						
Jan.	6.4	2.8	2.6	6.2	2.7	2.3
Feb.	6.3	2.6	2.2*	6.3	2.5	2.2*
Mar.	5.5	2.4	2.7	5.5	—	2.3*
Apr.	5.8	3.0*	2.3	5.8	3.1*	2.2
May	4.8	3.1*	2.0*	4.5	2.7*	2.0*
June	4.2	—	—	4.2	—	—
July	3.3	—	—	3.4	—	—
Aug.	3.5	—	—	3.5	—	—
Sept.	3.5	1.3*	1.1*	3.5	1.2*	1.3*
Oct.	3.3	1.6	1.3	3.5	1.6*	1.5*
Nov.	3.3	1.5	1.2	3.7	—	1.4*
Dec.	3.4	—	1.6	3.7	—	1.9
Av.	4.4	2.3	1.9	4.5	2.3	1.9
1932						
Jan.	3.6	—	1.1	3.7	—	—
Feb.	3.6	—	1.6	3.9	—	—
Mar.	3.6	—	1.5	3.8	—	—
Apr.	3.1	—	1.3	3.2	—	—
May	3.2	—	1.2	3.3	—	—
June	3.0	—	—	3.1	—	—
July	3.1	—	—	3.2	—	—
Aug.	3.3	—	—	3.2	—	—
Sept.	3.4	—	—	3.8	—	—
Oct.	3.2	—	—	3.5	—	—
Nov.	3.3	—	1.6*	3.6	—	—
Dec.	3.4	—	—	4.0	—	—
Av.	3.3	—	1.4	3.5	—	—

* Less than ten observations.

by averaging the observed values of all stations after they had been reduced to a common base. Nauen, DFW, was used as the base station. This is in accordance with the method described by Austin.² The most interesting agreement between the two curves obviously occurs at the two maxima and minima of the sun spot cycles. In 1930, however, two years after the sun spot maximum of 1928 the field intensity increased to a value greater than previously obtained remained high through 1931 and decreased to a comparatively low value in 1932. A rise in

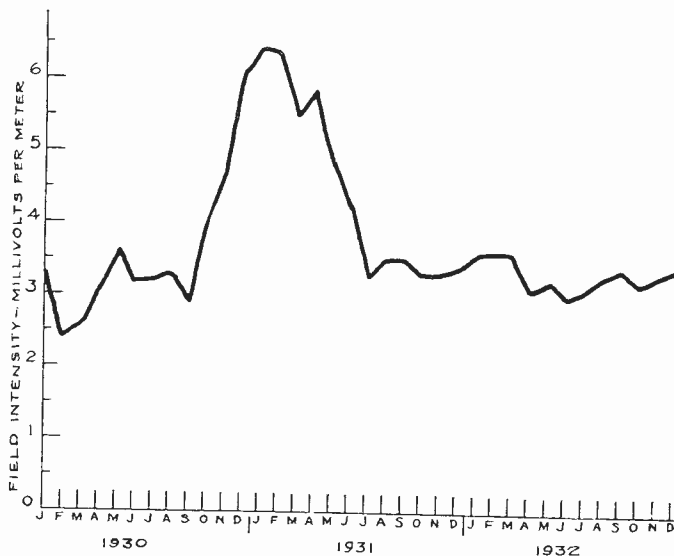

Fig. 3—Monthly averages of field intensities of Tuckerton, WCI, 10 A.M., E.S.T. 1930-1931-1932.

field intensity was also observed in 1921, four years after the sun spot maximum of 1917 but of considerably less magnitude. It is of interest to note that these phenomena occurred near the same phase in each sun spot cycle.

The curves of the annual averages of sun spot numbers and the strength of atmospherics observed at 3 P.M., E.S.T., on 23 kilocycles have been extended to include values for 1931 and 1932. These are shown in Fig. 2. The dotted part of the atmospherics curve between 1918 and 1924 was measured by the shunted telephone or audibility method, and are considered less precise than observations made in the following years. Atmospherics for 1931 and 1932 have decreased with the sun spot numbers contrary to the inverse relationship observed from 1918 to 1930.

Fig. 3 shows the monthly averages of Tuckerton, N.J., (WCI) 18.4 kilocycles for 1930, 1931, and 1932. The field intensities which were high during the latter part of 1930 and the early part of

² Proc. I.R.E., vol. 19, no. 9, p. 1615; September, (1931).

1931 have returned to the average value obtained for previous years.

The continuous recording of Tuckerton for a period of one year has shown some interesting correlations between the relative field intensity of the reflected wave and sun spots. A series of approximately 300 24-hour records were obtained for the year, May, 1931, to April, 1932 inclusive

Two loop antennas were used for reception. One which was placed in the plane of propagation received the ground and complete reflected wave when vertically polarized. The other placed at 90 degrees to the plane of propagation received only the horizontal component of the reflected wave when it was polarized at some angle to the vertical.

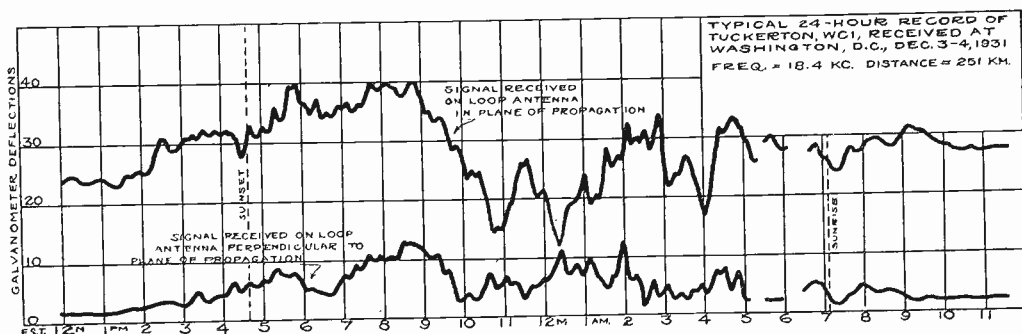

Fig. 4

An autodyne type receiver and an audio-frequency amplifier constituted the receiving set. The audio output was connected to a copper-oxide rectifier and the rectified current fed to a Cambridge thread recorder. The receiving set was connected alternately for five-minute periods to each loop antenna by means of a control clock and relay system. A typical 24-hour record of Tuckerton (WCI) obtained with this arrangement is shown in Fig. 4 where the upper curve was produced by the signal received on the loop antenna in the plane of propagation and the lower curve produced by the signal received on the loop antenna perpendicular to the plane of propagation. The latter represents the voltage induced in the loop antenna by the horizontal component of the reflected wave (perpendicular to the plane of propagation) caused by rotation of the electric vector at some angle with the vertical. Consideration will show that no voltage from the ground wave is produced in the loop antenna in this position.

No satisfactory method has been devised for separating the actual values of field intensity of the ground and reflected wave received from high power transmitters on low frequencies from comparatively short distances (in this case, 251 kilometers) The lower curves, or curves of

polarization, were selected as being a relative representation of the reflected wave free from ground wave interference. This, of course, would hold true only when the electric vector of the reflected wave was rotated from the vertical plane.

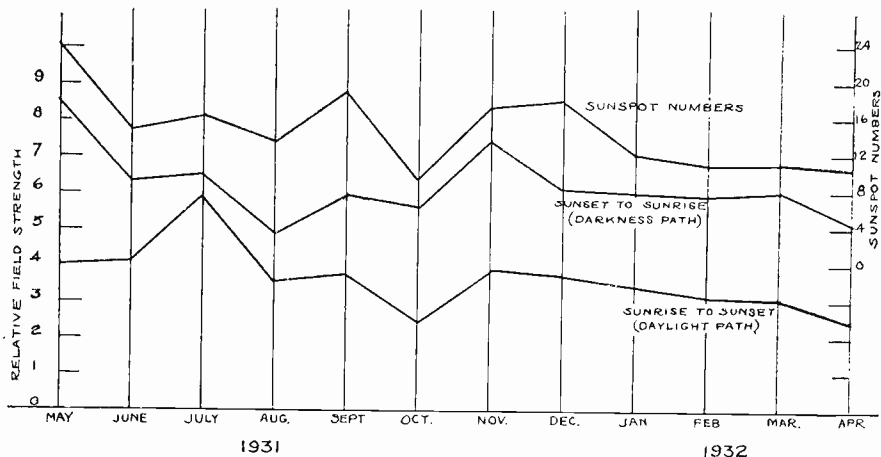

Fig. 5—Monthly means of average day and night field intensities of WCI received on loop antenna perpendicular to plane of propagation, and sun spot numbers.

For purpose of analysis these curves were divided into two sections; one being that portion between local sunset and sunrise, represented an all-darkness transmission path while the other between sunrise and sunset, represented an all-daylight transmission path. A mean value

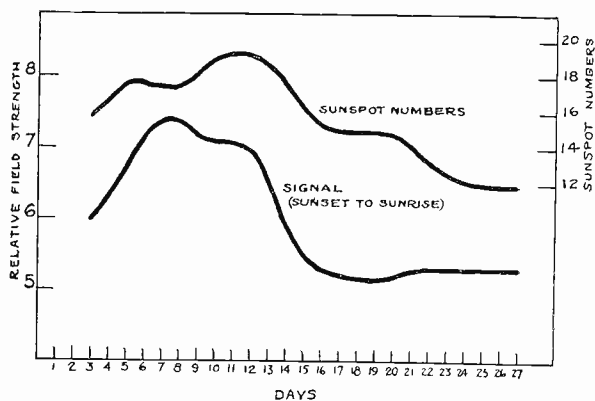

Fig. 6—Twenty-seven-day period, for one year (May, 1931–April, 1932, inclusive) of WCI received on loop antenna perpendicular to plane of propagation, and sun spot numbers. Smoothed by three-day moving averages.

of intensity for the sunset-to-sunrise period for each record was obtained by averaging the values of intensity for each half hour. Similarly, for each record, a mean value of intensity between sunrise and sunset was obtained. In Fig. 5, the monthly averages of these night and day means are shown with the monthly means of sun spot numbers. For the period of time considered (one year) the agreement

between the sunset-to-sunrise field intensity and sun spots is close. The curve for sunrise to sunset (daylight) is less in agreement with that of the sun spots, and considerably lower in intensity than the sunset-to-sunrise curve. Comparison of the two field intensity curves shows less rotation of the reflected wave for daylight than for night.

As a definite twenty-seven-day period of sun spot numbers is known to exist, a twenty-seven-day periodic average of the daily averages for the sunset-to-sunrise portion of the curves was computed, and the corresponding curves of field intensity and sun spots are shown in Fig. 6. The twenty-seven-day periodic averages of field strength measurements were obtained by averaging the values for the 1st, 28th, 55th

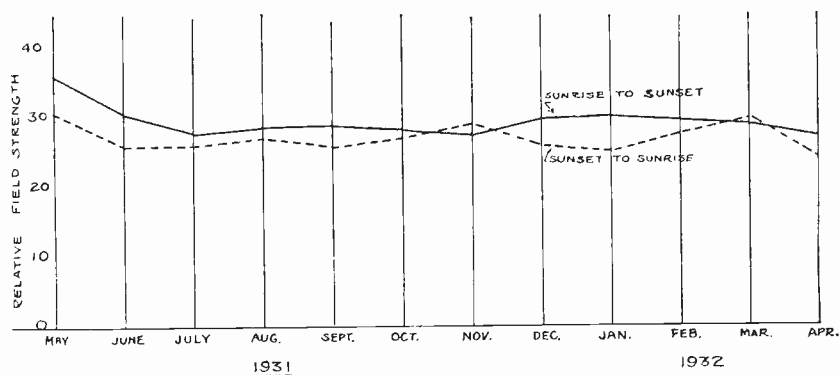

Fig. 7—Monthly means of average day and night field intensities of WCI received on loop antenna in plane of propagation.

days, etc. This mean constituted the first day of the period. The mean of the values for the 2nd, 29th, 56th, etc., days constituted the second day of the period, and so on. Each of the curves was smoothed by three-day moving averages. Again, the agreement between the sun spot numbers and the field intensity for the all-darkness transmission path is in evidence. Daylight intensity of the field produced by rotation showed no indication of a twenty-seven-day period.

No correspondence was found between daily variation in intensity of signal and daily sun spot numbers, nor for any shorter period than that of twenty-seven days.

Considering the observations made on the loop antenna in the plane of propagation, represented by the upper curve in Fig. 4, it will be seen that the greatest variations occurred between sunset and sunrise. These variations were assumed to be caused by phase interference between the ground and reflected waves, or perhaps at times produced by rotation of the electric vector or by absorption of the reflected wave.

The field intensity values from the curves represented by the

upper curve in Fig. 4 were first averaged in the same manner previously explained. The monthly means of the intensity for daylight and darkness paths are shown in Fig. 7. The all-daylight average curve agrees with the corresponding part of the curve from the same station in Fig. 3, which also represents the daylight monthly mean as measured at 10 A.M., E.S.T., by the telephone current comparison method.

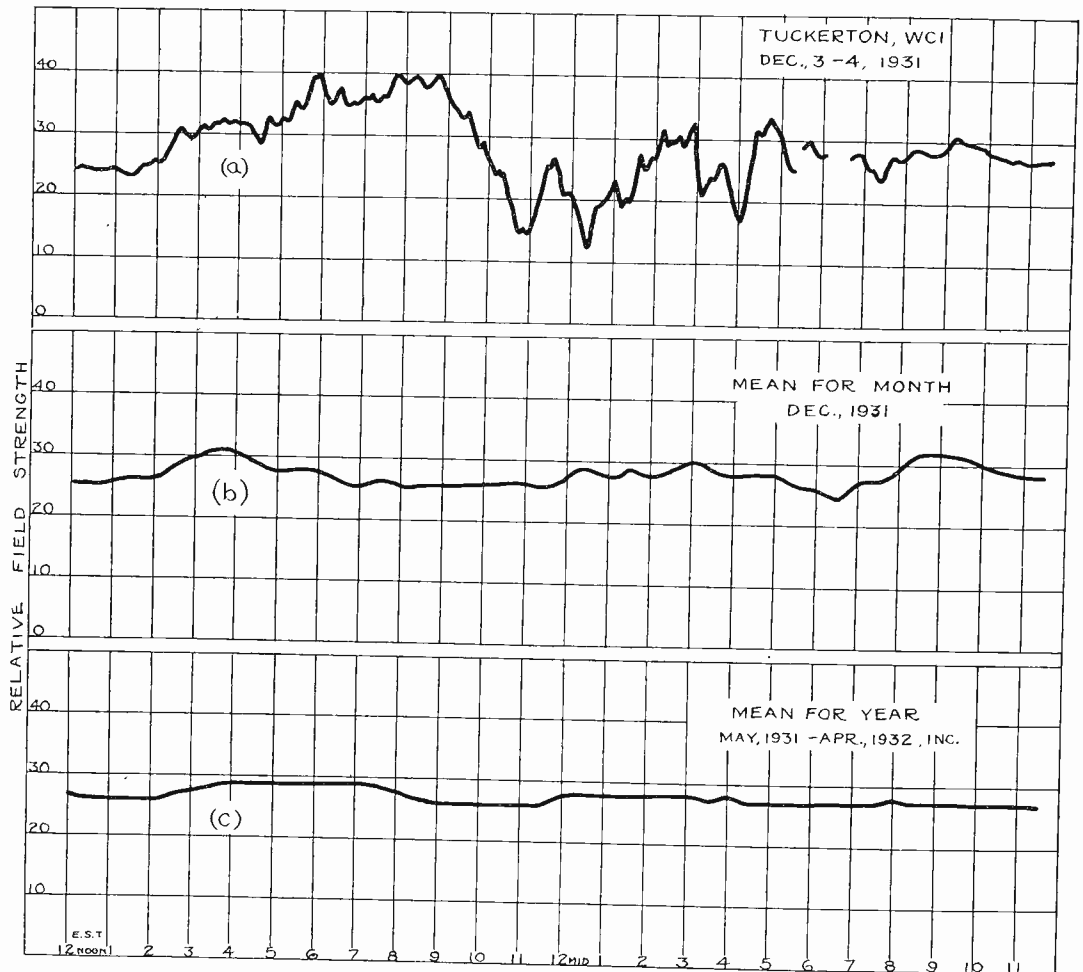

Fig. 8

The values from the recorder curves (for the loop antenna in the propagation plane) between 12 noon and 11:30 A.M. were next averaged in the following manner: For each month the values of field intensities occurring at 12 noon on each day were added and their mean obtained. Likewise, the means for 12:30 P.M., 1 P.M., 1:30 P.M., 2:00 P.M., etc., were computed. A typical monthly average curve thus obtained is shown in (b) of Fig. 8 while (a) is a curve for an individual day, shown for comparison. The yearly average curve (May, 1931, to April, 1932, inclusive) derived by the same method, and which is almost a

straight line, is given in (c), Fig. 8. Such a curve suggests a constant field intensity of the ground wave, remaining after the positive and negative effects caused by phase interference have been cancelled by averaging a large number of observations over a considerable period of time.

It is of interest, that out of the three hundred records no two patterns of the curves were found to be identical. However, some similarities were observed in two or more successive days.



NOTE ON A MODIFIED REACTANCE-FREQUENCY CHART*

BY

J. R. TOLMIE

(Pacific Telephone and Telegraph Company, Seattle, Washington)

A knowledge of the susceptances of coils and condensers together with the equivalent reactances of such elements in parallel is frequently required in many communication problems. These quantities may be readily obtained with the aid of a standard "Bell Laboratories, Reactance-Frequency Graph Sheet" (Keuffel and Esser No. 359H-47) to which an inverted scale of ordinates graduated in micromhos has been added.

This modification makes it possible to read directly the susceptances or reactances of any coil or condenser falling within the range of the chart. Thus, for example, suppose it is desired to find the susceptance of a one-millihenry coil at a frequency of 1000 cycles. Referring to Fig. 1 this may be accomplished by entering the chart on the right-hand margin at a point denoted by 0.001 henry and following the associated slant line until it intersects the vertical 1000-cycle line at Q . The projection of the point Q on the "B" scale then determines the desired value of susceptance which in this case is 1.6×10^5 micromhos. Conversely the corresponding value of reactance may be read on the "A" scale and is found to be 6.3 ohms. Likewise the susceptance or reactance of a condenser may be found by following the appropriate slant line to its point of intersection with the desired frequency line and then proceeding in the same manner as for a coil.

The possibility of solving circuits comprised of coils and condensers in parallel follows immediately from the fact that the resultant susceptances of such combinations is equal to the algebraic sum of the susceptances of the various branches. Thus having determined the branch susceptances and having performed the necessary additions or subtractions it is only necessary to enter the resultant susceptance on scale "B" and to read the desired value of reactance on scale "A." This may be simply illustrated by solving for the reactance of a parallel resonant circuit at frequencies both above and below resonance. For example, consider a circuit comprised of a 1.0-millihenry coil and a 0.01-microfarad condenser. The resonant frequency of such a combination may be readily determined by noting that the slant induc-

* Decimal classification: R220.1 \times R240. Original manuscript received by the Institute, May 18, 1933.

tance and capacity lines intersect at a frequency of approximately 50 kilocycles indicated by point *P*, Fig. 1, where the branch susceptances are equal. The resultant susceptance at 30 kilocycles is then found by

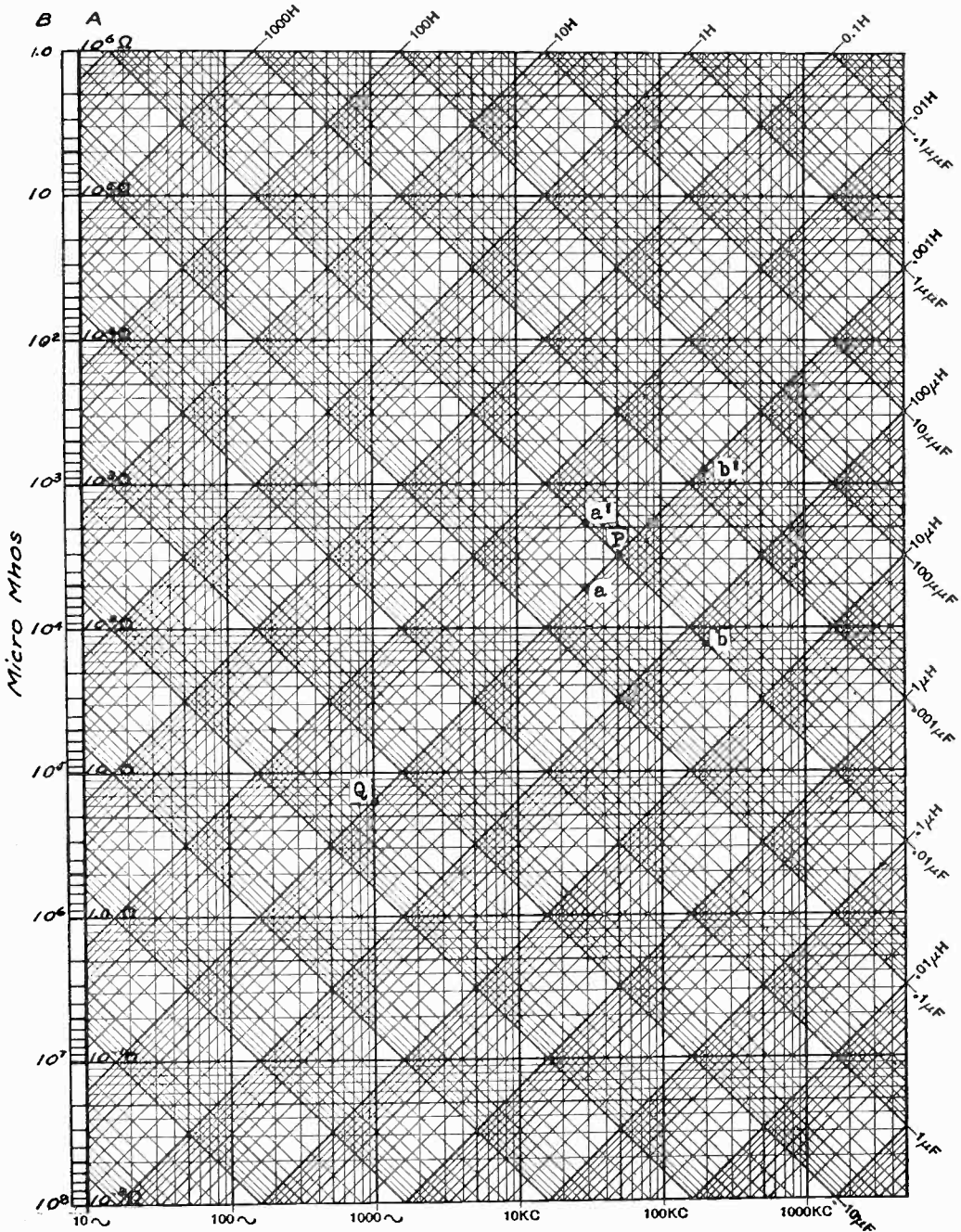

Fig. 1—Use scale A, main scale of ordinates, for reactances, and scale B, marginal scale of ordinates, for susceptances.

projecting points *a* and *a'* upon the “B” scale and taking the difference of the corresponding readings. Thus the resultant susceptance is $5300 - 1900 = 3400$ micromhos, which by referring to the “A” scale is found

to correspond to a reactance of 290 ohms which is the desired result. Likewise at 200 kilocycles the corresponding reactance may be obtained by projecting the points b and b' and proceeding as before. The combined reactance in this case is approximately -85 ohms.

Since this method is applicable to either series or parallel circuits, it is evident that it may be extended to any combination thereof, and that it may be applied to any reactance network provided that the latter is capable of resolution into series and parallel groups of elements.

Although the accuracy of this particular chart is rather low owing to the extreme range of the variables, this defect is more than compensated for in many problems by the ease with which the results may be attained. Where greater refinement is desired it is possible to construct charts of somewhat restricted range which will possess approximately slide-rule accuracy.



DISCUSSION ON "PITTSBURGH'S CONTRIBUTIONS TO RADIO"*

S. M. KINTNER

H. S. Gowan:¹ Attention is directed to the fact that, although Pittsburgh may claim the glory of contributing broadcasting as now constituted, Dr. Kintner neglects to appreciate properly the contribution of amateur radio operators in introducing broadcasting to the public.

Amateur radio communication as a hobby was well organized for many years before 8XK or KDKA were put into operation. For this reason, these stations were able to start program work with a listening body already in existence and in operation. Without these thousands of receiving stations manned by experienced operators, eager to demonstrate the new "miracle" to their fellow citizens, it might have been impossible to convince the layman that program reception was practical; it would certainly have taken many years of expensive salesmanship.

It might also be noted that a considerable number of the complaints of interference mentioned by Dr. Kintner resulted from the use of "single-circuit" tuners, which were kept on the market unduly by various manufacturers. Amateur operators were therefore not always responsible for interference caused by their signals.

* Proc. I.R.E., vol. 20, no. 12, pp. 1849-1863; December, (1932).

¹ Grimes Radio Corporation, Kitchener, Ont., Canada.

CORRECTION

There has been brought to the attention of the editors the following correction to the paper by Rudolph Bechmann, "On the Calculation of Radiation Resistance of Antennas and Antenna Combinations," which appeared in the August, 1931, issue of the PROCEEDINGS. On page 1480, the last line of equation (33) should read

$$+ 30 \left\{ \cos^2 \alpha \left(\frac{\sin 2\theta}{2\theta} - 1 \right) - Ci(2\theta) + \log 2\theta + C \right\}$$

instead of

$$+ 30 \left\{ \cos^2 \alpha \left(\frac{\sin 2\theta}{2\theta} - 1 \right) - Ci(2\theta) + 2 \log 2\theta + C \right\}$$

BOOK REVIEWS

Elements of Engineering Acoustics, by L. E. C. Hughes. Published by Ernest Benn, Ltd., London. 159 pages. Price 8/6d.

This is an excellent summary of the broad problem of sound reproduction. The introductory chapter deals with sounds and sound systems, a sound system being defined as a microphone and reproducer with intermediate apparatus. A concept here introduced is that the aesthetic value of a sound depends on its *acoustic-ratio*, that is, the ratio of its direct intensity to its reverberant intensity. In a later chapter the modification of this ratio by the acoustic surroundings at the originating and reproducing points and by the directivity of microphones and loud speakers is discussed under the topic of *acoustic distortion*.

Discussion of the nature and measurement of sound fields is followed by a general chapter on the reproduction of sound wherein the objective and subjective aspects of distortion are considered. The chapter on electro-acoustic measurements deals not only with loud speaker and microphone response, but also with the determination of frequency, power-level, gain and loss, nonlinear distortion, signal-to-noise ratios, and with the calculation of simple attenuation pads.

Typical frequency and directivity characteristics of carbon, condenser, moving coil, and ribbon microphones are shown and their construction briefly described. Amplifiers and their power supply are treated in a chapter which gives also an outline of the equivalent network method of transformer design. The book closes with a chapter on reproducers in which are presented, after a statement of the general requirements, performance curves and short descriptions of telephone receivers and the principal types of loud speakers.

The omission of much of interest to specialists is, of course, inevitable in covering such a broad subject in a single volume. Offsetting this, however, are references throughout the text to an appended list of sources in English and other languages. The reviewer feels that the inclusion in this list of the I.R.E. YEAR BOOK section on Performance Indexes and Tests of Electro-Acoustic Devices would have been helpful.

The treatment throughout is compact but clear, equations being introduced where necessary for definition. The decibel and logarithmic frequency axes are consistently used. There are 32 diagrams and 4 plates, some of the latter lacking in detail and contrast.

This book should prove interesting, helpful, and stimulating to anyone engaged in the operation or design of sound systems or their components.

*BENJAMIN OLNEY

Vector Analysis, by H. B. Phillips. Published by John Wiley and Sons, Inc., New York. 231 pages, 62 figures. Price \$2.50.

This book consists of two parts, the first covering the elementary principles and fundamental operations, including partial differentiation, integration, general coordinates, irrotational and solenoidal vectors.

*Stromberg-Carlson Telephone Manufacturing Company, Rochester, N. Y.

The remaining half of the book covers an analysis of fields, the properties of potentials, and linear vector functions. The style is clear and the treatment holds a good balance between the mathematical and physical aspects of the case. The book is thus of interest, not only as a text in mathematics, but as a text to be used collateral with a course in electromagnetic theory or hydrodynamics.

*F. W. GROVER

Wireless Receivers, by C. E. Oatley. Published by Methuen and Co., Ltd., London. 103 pages, 41 diagrams. Price 2s. 6d.

This book is a pocket monograph directed to the needs of a beginner. Nearly all of the information dates back of 1927. The major problems of simple receiver design are discussed in a few words. There are brief mathematical treatments of grid-plate capacitive coupling, antenna circuits, detection, and amplifier circuits. The superheterodyne and the more recent developments are omitted.

†HAROLD A. WHEELER

Mesures Radio-Electriques Elementaires, by F. Dacos and M. Rousseau. Preface by O. DeBast. Published by Dunod, 92 Rue Bonaparte (VI), Paris, 233 pp. 82 figures.

This book is a text on high-frequency electrical measurements, prepared for use at the Montefiore Electrotechnical Institute (Liège), and the preface is by the Director of the Institute. It is, in reality, two books—one on measuring instruments by the first author, and the other on the theory of resonance phenomena with brief applications to measurement methods, by the second.

The first part is in three chapters, covering instruments for measuring current, voltage, and power, respectively. The types of current-measuring instruments discussed are the oscillograph (electromagnetic, and cathode ray), galvanometer (permanent magnet and electro-dynamometer, unifilar, and bifilar) and the thermal types (hot-wire and thermoelectric). Instrument transformers are also treated in some detail. The voltmeters discussed are the electrometer (very briefly and inadequately), and the usual thermionic devices. The wattmeters described are those of Kipp (two-thermocouple method), and a Wheatstone bridge method.

In general, the theory of all these instruments is presented adequately, and in every case the discussion of the sensitivity attainable, and their limitations in actual practice is good. An admirable and unique feature is a graph giving the sensitivity of the various current measuring instruments as a function of frequency. But little space is devoted to descriptions of particular makes of instruments, practically all of which are by European manufacturers.

The first five chapters of the second part, together with an appendix giving a summary of the essentials of the symbolic operator method employed in the text, form an admirably lucid and compact presentation of the theory of resonance phenomena in both simple and complex circuits. Both the free and forced cases are treated. The most original matter in the book is that contained in chapters IV and V of the second part. In chapter IV the tuned triode amplifier is developed in a very illuminating manner from coupled circuit theory as a radio-

* Union College, Schenectady New York.

† Hazeltine Corporation, Bayside, L. I., New York.

frequency transformer with a unilateral coupling coefficient. In Chapter V the same device is developed to yield the theory of the triode oscillator with external (magnetic) coupling.

Chapter VI is the most disappointing portion of the book. It has to do with the measurement of frequency, and the resonance methods for measuring resistance, inductance, and capacity. The latter methods are dismissed with such brevity as to impair seriously their usefulness, while the discussion of frequency measurement is confined almost solely to the absorption type wavemeter, and the Amagnat modification to make it a null instrument. No mention of the much more accurate modern methods utilizing harmonics of precise piezo-oscillators is made, and the heterodyne frequency meter receives scant attention. The use of harmonics from an audio-frequency source (unspecified) through the intermediary of the multivibrator circuit is briefly treated. In one other respect, the book will disappoint American readers. The bibliography contains sixteen titles, of which one is in English! A book covering such similar ground with no reference to Bureau of Standards Circular No. 74, seems somewhat of an anomaly in our eyes.

However, within the limitations as to material set themselves (antennas, field strength measurements, transmission lines, filters, etc., are not treated) the authors have produced a very readable and valuable book.

*L. P. WHEELER

* Naval Research Laboratory, Bellevue, Anacostia, D. C.



BOOKLETS, CATALOGS, AND PAMPHLETS RECEIVED

Copies of the publications listed on this page may be obtained gratis by addressing a request to the publisher or manufacturer.

G. F. Lampkin Laboratories at 146 W. McMillan St., Cincinnati, Ohio, have issued Bulletin No. 6331 covering their station frequency meter.

RCA Radiotron and E. T. Cunningham of 415 S. 5th St., Harrison, N. J., have jointly made available the following reports: Application Note No. 16 on the Operation of the 2B7, or 6B7, as a Reflex Amplifier, No. 17 on Special Applications of the Type 53 Tube, and No. 18 on Operation Conditions for the Type 19 tube. Laboratory Series No. UL-6 and UL-7 discuss respectively Reflex Circuit Considerations and Methods for Conversion of a Tetrode or Pentode Plate Family. In addition data sheets are available on the 19, 2-Volt Class B Twin Amplifier; the 1-V, a Half-Wave Rectifier with 6.3-volt Heater; and the 12Z3, a Half-Wave Rectifier.

"How to Get Complete Reception Data" is the subject of a small pamphlet issued by the Westinghouse Electric and Manufacturing Company, East Pittsburgh, Pa.

Recent leaflets released by Shure Brothers Company of 337 W. Madison St., Chicago, Ill., cover their Model 40 Condenser Microphone and Model 41A Condenser Microphone Power Supply.

Ohmite Catalog No. 9 which gives data on rheostats and resistance units is available from Ohmite Manufacturing Company of 636 N. Albany Ave., Chicago, Ill.

Lumotron Vacuum Products Division of the General Scientific Corporation, 4829 South Kedzie Avenue, Chicago, Illinois, has issued a catalog covering a number of products in the photo-electric and allied fields.

Miles Reproducer Company of 244 W. 23rd St., New York City, has issued some leaflets covering their public address systems, microphones, and hearing aids.

Bulletin 220 of the Radio Engineering Laboratories, 100 Wilbur Ave., Long Island City, N. Y., covers portable radiotelephone equipment for ultra-high frequency transmission and reception.

A storage battery charger employing a tantalum rectifier is discussed in a leaflet issued by Fansteel Products Company of North Chicago, Ill.

Paper, mica, and electrolytic condensers are discussed in a booklet issued by Solar Manufacturing Corporation of 599 Broadway, New York City.

General Scientific Laboratories of Ridgefield Park, N. J., has issued leaflets covering their peak voltmeter, audio-frequency amplifier, and modulation meter.



RADIO ABSTRACTS AND REFERENCES

THIS is prepared monthly by the Bureau of Standards,* and is intended to cover the more important papers of interest to the professional radio engineer which have recently appeared in periodicals, books, etc. The number at the left of each reference classifies the reference by subject, in accordance with the "Classification of Radio Subjects: An Extension of the Dewey Decimal System," Bureau of Standards Circular No. 385, obtainable from the Superintendent of Documents, Government Printing Office, Washington, D. C., for 10 cents a copy. The classification also appeared in full on pp. 1433-1456 of the August, 1930, issue of the PROCEEDINGS of the Institute of Radio Engineers.

The articles listed are not obtainable from the Government or the Institute of Radio Engineers, except when publications thereof. The various periodicals can be secured from their publishers and can be consulted at large public libraries.

R000. RADIO (GENERAL)

- R005 R. F. Shea. Engineering organization. *Radio Eng.*, vol. 13, pp. 18-19; June, (1933).

"In this article the author presents his ideas as to economical and efficient organization of engineering staffs for radio manufacturing plants." A functional diagram of a large radio manufacturing engineering organization is given.

- R051 R. A. Watson Watt; J. F. Herd; L. H. Bainbridge-Bell. The Cathode-Ray Oscillograph in Radio Research (book). Published by H. M. Stationery Office, London, England. 1933. Price, 10 shillings.
×R388

This book is divided into six parts in which the following subjects are treated: (1) History, properties and operation of the oscillograph; (2) The variation of electromotive forces with time; (3) Special applications of various methods to the study of wave forms of atmospherics, and the continuous recording of echo pulses received from the ionized regions of the upper atmosphere; (4) Applications of cathode-ray tube as a radio polarimeter; (5) Use of oscillograph as a relay; (6) Photographic problems.

R100. RADIO PRINCIPLES

- R113 The Ionosphere. *Electrician* (London), vol. 110, p. 857; June 30, (1933).

This is a summary of Prof. Appleton's address to the Royal Society of London. The structure of the ionosphere, diurnal, seasonal and other regular variations, recurrence tendencies and irregularities, nature of ionization, ionizing agencies, and processes of electron capture are discussed. It is pointed out that four components of the ionosphere may be associated with ionization potentials of different atmospheric constituents, atomic and molecular.

- R113 E. V. Appleton; J. A. Ratcliffe; E. L. C. White. Fine structure of the ionosphere. *Nature* (London), vol. 132, pp. 872-873; July 17, (1933).

Evidence is presented to show that there are three or four layers or regions of ionization in the ionosphere.

- R113 R. A. Watson Watt. The ionosphere. *Nature* (London), vol. 132, pp. 13-17; July 1, (1933).

This article is a kind of résumé of the results obtained by the various experimenters studying the ionosphere. The existence of several layers is indicated by data of several different observers. The question of intensity of ionization does not seem to be one on which different observers agree. The views of several observers as to the cause of the ionization are reviewed.

* This list compiled by Mr. A. H. Hodge and Miss E. M. Zandonini.

- R113 J. A. Ratcliffe. The magneto-ionic theory. *Wireless Engineer & Experimental Wireless* (London), vol. 10, pp. 354-363; July, (1933).

The magneto-ionic theory is the name which has been given to the propagation of electromagnetic waves through an ionized medium in the presence of a steady imposed magnetic field. Without delving too deeply into mathematics, the theory is explained for the worker's use. The treatment first given neglects the "Lorentz term L ." Then the Lorentz term is included, and the alteration of the results observed. In a similar way collisional friction is neglected and later considered. Curves for the index of refraction and polarization which hold for wavelengths less than 1800 meters are given.

- R113.1 A. L. Green; W. G. Baker; R. O. Cherry; D. F. Martin. 1—A preliminary investigation of fading in New South Wales. 2—Studies of fading in Victoria—A preliminary study of fading on medium wavelengths at short distances. 3—Studies of fading in Victoria—Observations on distant stations in which no ground wave is received. Radio Research Board, Australia, Report No. 4, pp. 1-59, (1932).

Observations were on broadcast wavelengths and in directions at various angles to the magnetic meridian. Results are divided into two sections: (1) Results obtained at 65-200 kilometers. At these distances fading was found to appear anytime after half an hour before sunset and to disappear before the same length of time after sunrise. Slow, quick and periodic fading was observed. (2) Results obtained at 590-870 kilometers. Slow fading of irregular period, ranging from two to thirty minutes, and of amplitude varying from 0 to 0.5 millivolts per meter, and quick fading superposed on the slow of smaller amplitude and of period 5-30 seconds were observed.

- R113.5 K. G. Jansky. Radio waves from outside the solar system. *Nature* (London), vol. 132, p. 66; July 8, (1933).

Data taken on the direction of arrival of radio waves from outside the solar system indicates for the coordinates of the region from which the disturbance comes, a right ascension of 18 hours and declination of -10 degrees.

- R113.6 A. Esau and W. Köhler, Ausbreitungsversuche mit der 1.3-meter
 ×R423.4 Welle. (Propagation tests with the 1.3-meter wave.) *Hochfrequenz und Elektroakustik*, vol. 41, pp. 153-156; May, (1933).

Author's summary: "The propagation tests with 1.3-meter wave showed that even in conditions where an optical path did not exist, with 1.5 watts of high-frequency power distances of 10 kilometers could be covered. However, through absorption, reflection and scattering the field strength decreased very rapidly. The ranges obtained in the tests for equal field strengths over (a) optical paths, (b) flat land partly covered with trees, and (c) dense woods, were in the ratio of 25:4.1:1." The field strength increases with transmitter height and is a maximum on an optical path. When the transmitter is near the ground the vertical polarization is in general superior to the horizontal. The amplitude of the vertical polarization is on the average 100 per cent greater than the vertical polarization up to $d/\lambda = 1$ (where d = transmitter height). The field strength of the 1.3-meter wave is entirely independent of the time of day. Fading was in no case observed.

- R113.6 A. L. Green. State of polarization of sky waves. Radio Research Board, Australia, Report No. 2, pp. 11-36, (1932).

Polarization measurements were made in Australia under conditions very similar to those under which measurements were made in England, that is, for transmissions along the earth's magnetic field. Experiments are cited which are now being made with a view ultimately to control the fading of broadcast signals. It is shown that one property of a downcoming wave, namely, the phase difference between its normally and abnormally polarized components, shows a certain measure of constancy for different heights of the layer.

- R113.6 W. G. Baker and A. L. Green. The influence of the earth's magnetic field on the polarization of sky waves. Radio Research Board, Australia, Report No. 3, pp. 9-34, (1932).

This paper is a theoretical discussion of the influence of the earth's magnetic field on the propagation of sky waves of broadcast frequencies in the Heaviside layer. The calculation is not restricted to the case of propagation along lines of magnetic force. It is shown that the effect of the magnetic field is to make the direction of transmission of waves in the Heaviside layer oblique to the wave front. From data on the ratio of the components of a downcoming sky wave it is concluded that the errors in apparent bearing of a station should be large at night when the direction finder is south of the transmitter, and comparatively small when the direction finder is north of the transmitter and about 200 miles from it.

- R113.6 A. L. Green. Height measurements of the Heaviside layer in the early morning. Radio research Board, Australia, Report No. 2, pp. 37-80 (1932).

From author's summary: "Reflection coefficients of the layers were calculated in most cases and it was found that a mean value for the lower layer was about 15 per cent for the period preceding sunrise, and about 30 per cent for the upper layer in the early morning, when the lower layer had ceased to reflect. Reasons are given for supposing that the likely maximum value of the reflection coefficient for the Heaviside layer would be about 50 per cent, so that average values of about 15 per cent indicate imperfect reflection as well as extra attenuation of the sky wave at points along its path where it passes through the "D" region of absorbing ionization." Times in minutes after time of sunrise at ground level called "cut-off times" at which the intensities of sky waves fall below easily measurable values seem to depend on time of year and type of layer movements in the earlier morning.

- R113.62 R. A. Watson Watt and L. H. Bainbridge-Bell. Recording wireless echoes at the transmitting station. *Nature* (London), vol. 131, pp. 657-658; May 6, (1933).

S. L. Mitra and H. Rakshit have received echoes from the ionosphere on the same antenna used to emit the pulses. The authors of this letter suggest that the reduction of echo amplitude near the receiving antenna may be due to the receiver as a whole being rendered relatively insensitive, for periods of many milliseconds, by the incidence of the strong ground pulses.

- R113.62 T. L. Eckersley. Polarization of echoes from the Kennelly-Heaviside layer. *Nature* (London), vol. 131, pp. 512-513; April 8, (1933).

This is a letter which corrects an error made by the author in another letter in *Nature*, September 10, 1932, p. 398. The latter dealt with the subject of the polarization of echoes reflected from the Kennelly-Heaviside layer. According to the magneto-ionic theory, the left-hand circularly polarized ray should be less attenuated than the right-hand one and not vice versa.

- R113.7 B. van der Pol; T. L. Eckersley; J. H. Dellinger; P. le Corbeiller. Propagation of waves of 150 to 2000 kilocycles per second (2000 to 150 meters) at distances between 50 and 2000 kilometers. *Proc. I.R.E.*, vol. 21, pp. 996-1001; July, (1933).

Using eight graph sheets a condensed statement of the propagation characteristics of radio waves of 150 to 2000 kilocycles is made in terms of field intensities produced at distances between 50 and 2000 kilometers for both day and night.

- R114 G. H. Munro and L. G. H. Huxley. Atmospherics in Australia. Radio Research Board, Australia, Report No. 5, pp. 1-49, (1932).

The progress of an investigation of atmospherics which interfere with radio reception in Australia is described. Using two stations separated by 300 miles simultaneous observations were made on atmospherics and their origins determined. Practically all atmospherics observed have been associated with lightning flashes. The use of direction finders to locate low pressure areas and to observe their motion is considered. Automatic continuous directional recorders are being used to secure further information.

- R125 Operation of new antenna at KYW. *Radio Eng.*, vol. 13, p. 10; June, (1933).

A new quarter wave directional antenna supported by a wooden mast is described. The ground connection consists of copper sheets and radial wires.

- R133 E. W. B. Gill and R. H. Donaldson. Resonance in three-electrode valves. *Phil. Mag.* (London), vol. 15, pp. 1177-1181; June, (1933).

A large three-electrode vacuum tube is used to determine the resonance period of electrons vibrating about the grid between anode and cathode, the voltage on the grid being variable. The data show a distinct resonance for grid voltage = 24 volts approximately for 10-meter waves. This result remained practically constant for different filament emissions. This is said to confirm the theory that $\lambda^2 V = \text{constant}$.

- R134 R. DeCola. An analysis of power detection. *Proc. I.R.E.*, vol. 21, pp. 984-989; July, (1933).

The reasons for overloading of detectors as output devices is discussed. It is shown that in grid circuit rectification replacing the grid leak with a high impedance choke extends the overload point considerably. Using a 247-type pentode 800 milliwatts are obtained at the output circuit with seven per cent maximum distortion.

- R135 J. A. Hutcheson. Application of transformer-coupled modulators.
 ×R355.8 PROC. I.R.E., vol. 21, pp. 944-957; July, (1933).

A brief résumé of Heising's modulator theory is presented together with a discussion of the class B operation of tubes in a push-pull audio-frequency circuit. Several cases of commercial applications of class B audio amplifiers are mentioned. Several general problems involved in the use of a class B audio amplifier are discussed with the conclusion that such an amplifier will produce more audio power for a given tube complement, at higher efficiency, and with less distortion than amplifiers previously used in commercial applications.

- R140 J. G. Brainerd. Some general resonance relations and a discussion of Thevenin's theorem. PROC. I.R.E., vol. 21, pp. 1050-1054; July, (1933).

It is shown that the maximum possible current which can be obtained through an impedance joining two points of a linear network is in general greater than the short-circuit current between those points; the maximum possible voltage is in general greater than the open-circuit voltage; the ratio of open-circuit voltage to short-circuit current is equal to the ratio of the maximum possible voltage to the maximum possible current and both are equal to the magnitude of the input impedance of the network, etc. The condition for maximum voltage across a branch of a linear network is derived. As a preliminary, a form of Thevenin's theorem different from the usual one and of greater usefulness in the analytical solution of some circuit problems is obtained.

- R140 P. Caporale. A note on nonlinearity in transducers used in communication. PROC. I.R.E., vol. 21, pp. 1029-1038; July (1933).

For those cases where the characteristics of a nonlinear transducer can be expanded in a power series, a general law or equation is derived for the characteristic of a compensating transducer, that is, a transducer which in combination with the first transducer will produce over-all linearity. It is shown, moreover, that when the series for the distorting transducer is not sufficiently rapid in its convergence, it becomes impracticable to realize the necessary compensating transducer.

- R140 J. Groszkowski. The interdependence of frequency variation and harmonic content, and the problem of constant-frequency oscillators. PROC. I.R.E., vol. 21, pp. 958-981; July, (1933).

This paper represents the operation of nonlinear oscillating systems. The symbolic calculus has been used throughout in a complete and exact manner, by employing it for the fundamental frequency as well as for all harmonic frequencies which appear in the system. This could be done owing to the investigation of the negative resistance operation from the energy point of view. Formulas are obtained which allow the interdependence of the frequency variation and the content of harmonics to be determined. It appears that these harmonics, whose amount varies with the change of operative conditions (supply voltages, etc.) of the system, are just responsible for the frequency variation.

- R140 D. A. Bell. The optimum decrement of tuned circuits for the reception of telephony. *Wireless Engineer & Experimental Wireless* (London), vol. 10, pp. 371-374; July, (1933).

This article is a discussion of the factors that determine the optimum decrement of a receiving circuit. It is shown that there is an optimum degree of damping for a tuned circuit where the applied electromotive force is independent of the circuit. In a tuned-plate circuit it is especially desirable that the decrement of the circuit should not be unnecessarily reduced. Tables give values for R , where R represents all losses involved in the tuned circuit, and for the effective dynamic impedance of a circuit of negligible damping for various modulation frequencies.

- R148 E. A. Laport. A simplified method of modulator design. *Electronics*, vol. 6, pp. 184-185; July, (1933).

The procedure is to obtain the characteristics of the load which is to be modulated; to compute the current and voltage conditions existing in the load when it is modulated in the desired degree; to compute the current in the modulation reactor circuit to give the modulating voltage; to determine the modulator characteristics to give these conditions; and to apply these computations to the static characteristics of the type of tube to be used to obtain the dynamic characteristics, the excitation required, and associated information.

- R163 W. F. Floyd. A note on interference tones in superheterodyne receivers. *Proc. Phys. Soc.* (London), vol. 45, pp. 610-616; July 1, (1933).

"Briefly the problem involves: (1) The reception of at least three signals; (2) Double detection, and (3) A filter action between the two detectors. In the case of rectification by detectors with generalized characteristics, quantitative analysis is extremely complex. The form of the result, however, shows how large is the number of possible sources of interference tones. The specific case of square-law rectification is considered also."

R200. RADIO MEASUREMENTS AND STANDARDIZATION

- R230 F. W. Grover. Tables for the calculation of the mutual inductance of any two coaxial single-layer coils. *Proc. I.R.E.*, vol. 21, pp. 1039-1049; July, (1933).

The tables and formulas here presented enable the mutual conductance of any two coaxial solenoids whatever to be calculated from a single formula. Examples make clear that a five-figure accuracy may be attained with concentric coils and even with poorly coupled coils the error does not exceed a few parts in ten thousand.

- R241 L. Podolsky. Electronics in resistor manufacturing. *Electronics*, vol. 6, pp. 180-181; July, (1933).

Several methods of automatically testing resistors and ejecting the ones which fail in test are described. One method uses a bridge, two arms of which are vacuum tubes, another bridge method uses a light beam galvanometer and photo cells. A cathode-ray tube method of testing tapered volume controls is described. A thyatron actuated temperature control and a viscosity test device are also described.

- R265.2 N. W. McLachlan. On the amplitude of loudspeaker diaphragms at low frequencies. *Wireless Engineer & Experimental Wireless* (London), vol. 10, pp. 375-380; July, (1933).

The amplitude of vibration necessary for a 10-centimeter radius disk to radiate one watt of acoustic power is calculated. At low frequencies this amplitude is very large. Amplitude in an average case is then calculated. The resonance phenomena are treated. The relationship between amplitude and loudness is deduced.

- R270 W. G. Baker and L. G. H. Huxley. Corrections to field strength measurements. Radio Research Board, Australia, Report No. 1, pp. 7-22, (1931).

The theory of the loop antenna is considered on the assumption of uniformly distributed capacity, and the ordinary transmission line theory applied. Tables of correction factors are given.

- R270 W. G. Baker and O. O. Pulley. A radio field-strength survey within 100 miles of Sydney. Radio Research Board, Australia, Report No. 1, pp. 23-32, (1931).

This paper describes the development of a receiving set capable of measuring weak field strengths. Measurements were taken for roughly 100 miles around Sydney. The most important result is to show that 2BL, lying on the coast, has a great advantage over 2FC, several miles inland, for the service of the South Coast District.

- R270 S. Namba and T. Tsukada. A method of calculation of field strengths in high-frequency radio transmission. *Proc. I.R.E.*, vol. 21, pp. 1003-1028; July, (1933).

The theory on the transmission of high-frequency radio waves developed by one of the authors in a previous paper is applied to practical problems and a systematic method of calculating the field strengths of high-frequency waves is established. The property of the ionization chart is explained and the method of construction of the chart is given. From a number of measurements made on high-frequency transmission, it is shown that the coefficient of recombination in the *F* layer is about 1.5×10^{-10} (sec.⁻¹) this value being in fairly good coincidence with the theoretical value.

- R280 × R382 Ferrocart—Losses in radio-frequency magnet cores—Hans Voigt's latest invention. *Electrician* (London), vol. 110, pp. 849, 851; June 30, (1933).

The manufacture and use of Ferrocart, a special core material for high-frequency coils, is described.

R300. RADIO APPARATUS AND EQUIPMENT

- R320 C. F. Boeck. Radio distribution system for apartment buildings. *Radio Eng.*, vol. 13, pp. 20-21; June, (1933).

An amplifier and distribution system is described which accommodates up to 3000 receivers from one antenna. The system is alternating-current operated and requires only an occasional servicing. With this system, each receiver operates as though it were supplied from a separate and independent antenna.

- R322 G. Grammar. Twisted-pair feeders for transmitting antenna. *QST*, vol. 17, pp. 17-20; July, (1933).
Results of a group of tests with twisted-pair feeders are given.
- R325.31 A. Black. Direction finding for amateurs. *Wireless World* (London), vol. 32, pp. 456-457; June 30, (1933).
Some practical ideas for direction finding sets are given.
- R330 E. D. McArthur. Electronics and electron tubes—Part V. Plotron and screen-grid tube applications. *Gen. Elec. Rev.*, vol. 36, pp. 330-336; July, (1933).
The method of operation of class A, B, and C amplifiers is described. Methods of measuring power output are given. A general discussion of amplifiers and the various factors that effect their operation are given.
- R330 The Catkin tube. *Radio Eng.*, vol. 13, p. 11; June, (1933).
The metal-contained receiving tubes are described and illustrated. Operating characteristics of one vacuum tube are given.
- R331 M. A. Ausman. The processing of thoriated tungsten filaments. *Radio Eng.*, vol. 13, pp. 15-17; June, (1933).
The electron emission obtainable from oxide-coated, tungsten, and thorium filaments is given. A short table showing the emission of thoriated tungsten and of pure tungsten for different temperatures from 1000 degrees Kelvin to 2800 degrees Kelvin is also given. A method of preparing a thoriated filament is described.
- R331 J. J. Glauber and A. G. Campbell. A study of hum generation in vacuum tubes as affected by heater design. *Radio Eng.*, vol. 13, pp. 12-13; June, (1933).
Results of a study of the amount of hum produced by the various types of heater-type cathodes are given. It is found that the hum produced by the double hairpin type of 6.3-volt heater is less than for any other type of heater examined. It is suggested that the vacuum tube manufacturers might well standardize on the use of this type of heater and avoid the duplication of tube types now necessitated by the different voltages used on heaters.
- R332 C.E. Kilgour and J. M. Glessner. Diode detection analysis. *Proc. I.R.E.*, vol. 21, pp. 930-943; July, (1933).
NR134 This paper gives the current and output relations for the linear and square-law diode detector in terms of the detection efficiency and the detector and load resistances. The square-law case is shown to yield results similar to the linear for large input potentials and reasonable values of load. It is shown that the use of a small condenser across the load decreases the detection efficiency but increases the input impedance. The connection to the driving circuit of a second diode for the development of automatic volume control potential is shown to cause distortion when such a tube is used with a delay bias.
- R333 M. V. Callendar. A theory of available output and optimum operating conditions for triode valves. *Proc. I.R.E.*, vol. 21, pp. 909-929; July, (1933).
In this paper, the form of the triode curves is first investigated experimentally, and the allowable limits of dynamic swing thus determined for any given per cent harmonic; on this basis, a series of expressions are mathematically developed giving the required output characteristics in terms of an easily obtained valve constant. Curves are given for output and correct plate current with various values of resistive load and of per cent harmonic limit, with or without conditions of limited anode dissipation. The case of a practical load with low direct-current resistance is examined, and the results are checked with a harmonic analyzer; the paper concludes with a few practical rules.
- R355.9 F. E. Terman. Resistance stabilized oscillators. *Electronics*, vol. 6, pp. 190-191; July, (1933).
Resistance stabilized oscillator circuits are shown. Methods of construction and adjustment are given in detail.
- R357 V. J. Andrew. A simplified frequency dividing circuit. *Proc. I.R.E.*, vol. 21, pp. 982-983; July, (1933).
A circuit is described in which a type 57, three-grid tube functions as two triodes in two separate oscillator circuits. One of the circuits is a crystal oscillator, and the other is a self-excited circuit which is controlled by the crystal so that it oscillates at a subharmonic of the crystal frequency.

- R357 C. L. Lyons. The Pentagrid converter. *Wireless Engineer & Experimental Wireless* (London), vol. 10, pp. 364-369; July, (1933).
 ×R361.2 The vacuum tubes 2A7 and 6A7 (the same tube except for heater voltage) are five-grid tubes designed to take the place of the oscillator and detector in superheterodynes. The tube contains an oscillator grid, anode grid, two screen grids, a control or modulator grid, a cathode and anode. The tube has the following advantages: (1) higher translation gain; (2) oscillator system independent of radio-frequency system; (3) bias voltage can be used to control volume; (4) automatic volume control with a minimum number of tubes.
- R361 J. C. Haydock, Jr. An unusual 56-mc superregenerative receiver. *QST*, vol. 17, pp. 14-16; July, (1933).
 Details of a portable set with a self-quenching detector.
- R361.3 R. W. Tanner. Automatic regeneration. *Radio Eng.*, vol. 13, p. 10; June, (1933).
 A circuit arrangement is described in which automatic regeneration of a constant value over the entire tuning range is accomplished. This circuit arrangement should be very useful in high-frequency receivers.
- R363.1 W. Ure; E. J. Grainer; H. R. Contelo. The balancing and stabilizing of high-frequency amplifiers with special reference to power amplifiers for radio transmitters. *Jour. I.E.E.*, (London), vol. 72, pp. 528-543; June, (1933).
 Part I gives a brief sketch of the historical development of the high-frequency amplifier. Part II contains a discussion of the balanced bridge in relation to vacuum tube circuits, in which the effects of stray coupling, circuit unbalance and asymmetry of driving potentials upon the stability of bridge-circuit amplifiers, are considered. Part III gives an account of some experiences met within the experimental development of a two-stage power amplifier developed by H. M. Signal School, Portsmouth, for naval ships use as a wireless transmitter. The transmitter is described.
- R365.22 W. F. Cope. A method of tone control. *Wireless Engineer & Experimental Wireless* (London), vol. 10, p. 370; July, (1933).
 A method of tone control is described which depends for its effect upon a series resonant circuit consisting of a choke in the grid lead to a vacuum tube, its input capacity, and the alternating-current resistance of the preceding vacuum tube.
- R380 Parts and accessories for radio receivers. *Radio Eng.*, vol. 13, pp. 8-9; June, (1933).
 Briefly the improvements that have recently been made in available radio parts and materials are reviewed.
- R384 G. F. Lampkin. The micrometer frequency meter. *QST*, vol. 17, pp. 10-13, July, (1933).
 A frequency meter which is constructed about a micrometer condenser is described. The meter is compact, alternating-current operated, and at 3500 kilocycles, frequency can be determined to ± 500 cycles with an error of not more than 0.015 per cent.
- R387.5 P. D. Morgan and H. G. Taylor. The resistance of earth electrodes. *Jour. I.E.E.*, (London), vol. 72, pp. 515-518; June, (1933).
 The most important aspects of the resistance of electrodes used for earthing electrical installations and apparatus are treated. Electrodes must have a large area of surface in order to form low resistance grounds. Salting the ground around the electrode is suggested. The use of coke breeze is also discussed.
- R388 C. E. Holler. A linear timing axis for cathode-ray oscillographs. *Rev. Sci. Instr.*, vol. 4, pp. 385-386; July, (1933).
 By charging a condenser by means of the plate current of a constant current vacuum tube and discharging the condenser through a grid-glow tube a convenient timing axis is provided. The axis is linear, the circuit simple and the amplitude and frequency are controlled by potentiometers.
- R388 Zworykin's ionoscope (mosaic of 3,000,000 tiny photo cells scanned by cathode ray beam). *Electronics*, vol. 6, p. 188; July, (1933).
 A device which should greatly improve television pick-up is described. The image of the scene to be televised is focused on the 4×5-inch plate made up of 3,000,000 individual photo sensitive cells. Each cell, when illuminated, stores its photoelectric charge in its associated condenser. The cathode ray beam, sweeping the plate, discharges these condensers, producing impulses which are then amplified.

- R390 H. Piesch. Eine neue Kompensations-Messeinrichtung zur Bestimmung des Übertragungsmasses an Vierpolen. (A new compensated measuring device for determining the transmission equivalent of a four-pole network.) *Elek. Nach. Tech.*, vol. 10, pp. 251-257; June, (1933).

A measuring device for determining the transmission of a four-pole network is described, by means of which the damping and phase change of a network may be determined. The special feature of the circuit was to make the phase angle arbitrarily large so that positive and negative damping values may be determined and the result obtained quickly and without trouble.

R400. RADIO COMMUNICATION SYSTEMS

- R430 Radio interference. *Electrician* (London), vol. 110, p. 862; June 30, (1933).

The Institution of Electrical Engineers has set up a committee representative of all electrical interests for the purpose of considering and making recommendations on the question of interference with broadcast reception arising from the operation of other electrical apparatus.

- R430 Electrical interference. *Wireless World* (London), vol. 32, pp. 458-459; June 30, (1933).

A campaign is being conducted by the *Wireless World* and others to obtain legislation that will give the Post Office authority to demand the elimination of interference produced by electrical machinery. A questionnaire has been prepared and it is proposed to eliminate interference from Brighton and Howe districts as a preliminary experiment

- R430 A. L. J. Bernaert. Avoidable interference. *Wireless World* (London), vol. 33, pp. 4-5; July 7, (1933).

Types of apparatus causing radio interference and methods of eliminating it are discussed. Several types of filter arrangements are shown.

R500. APPLICATIONS OF RADIO

- R583 Reception of television. *Electrician* (London), vol. 110, pp. 854-855; June 30, (1933).

The cathode ray tube and its use in television reception are described.

R800. NONRADIO SUBJECTS

- 537.65 E. H. Reyner. The researches of the late Dr. D. W. Dye on the vibrations of quartz. *Jour. I.E.E.*, (London), vol. 72, pp. 519-527; June, (1933).

This article reviews briefly the physical properties of quartz as an introduction to a review of the work of Dr. Dye. The discoveries, dynamic analysis of vibrational motion, interference measurements, and application of quartz to control of time keeping devices are some of the things discussed. Fifty-three plates of vibrating quartz plates are shown. Most of these plates are taken with Dr. Dye's interference method.

- 537.65 N. H. Williams. Modes of vibration of piezo-electric crystals. *PROC. I.R.E.*, vol. 21, pp. 990-995; July, (1933).

(a) A crystal is made to oscillate by subjecting it to the action of an air wave produced at a considerable distance from the crystal by a jet of air escaping from a small tube. The piezo-electric charge developed on the surface of the crystal as a result of the oscillation is mapped out by means of a tuned amplifier, and the vibration is analyzed into a fundamental and many overtones. (b) Exciting the crystal electrically by means of two tubes and especially designed electrodes, any harmonic up to the tenth can be produced. The crystal usually has only one mode of vibration for each pair of electrodes.

- 621.375.1 E. Hughes. The measurement of peak values of alternating currents and voltages by means of a thyatron. *Jour. Sci. Instr.*, vol. 10, pp. 180-182; June, (1933).

"This paper deals with the use of a thyatron for measuring the maximum value of an alternating voltage such as the potential drop in a low resistance shunt, carrying an

alternating current. By this method, the maximum value of the potential difference can be determined within 0.02 volts. Reference is made to the various precautions necessary to ensure reliable and consistent readings.

- 621.375.1 W. H. Lord and O. W. Livingston. Thyatron control of welding in tube manufacture. *Electronics*, vol. 6, pp. 186-187; July, (1933).

The advantages of controlled welding are pointed out and a schematic circuit of a thyatron grid-controlled rectifier welding control is described.



CONTRIBUTORS TO THIS ISSUE

Aiken, Charles B.: See PROCEEDINGS for April, 1933.

Brown, W. Wilbur: Born November 11, 1889, at Hambleton, West Virginia. Received E.E. degree, I.C.S. Electrical construction, repair, and power station operation, Davis Coal and Coke Company, 1907-1910; electrical construction, repair, and power station operation, United Railways and Electric Company, 1910-1913. Test course, General Electric Company, 1913-1915. Radio development of Alexanderson high-frequency alternator system, and installation of 200-kilowatt equipments at New Brunswick, N. J., Tuckerton, N. J., Marion, Mass., and Rocky Point, L. I., 1915-1921; radio development and design engineering, 1921 to date. Member, American Institute of Electrical Engineers, 1926. Member, Institute of Radio Engineers, 1918.

Cunningham, F. W.: Born November 22, 1885, at Hamilton Square, New Jersey. Received B.S. degree, 1907; E.E. degree, 1911, Princeton University; Ph.D. degree, University of Wisconsin, 1911. Edison Lamp Works of General Electric Company, 1912-1916; Winchester Repeating Arms Company, 1917-1919; Edison Storage Battery Company, 1922-1925; radio development department, Bell Telephone Laboratories, 1925 to date. Associate member, Institute of Radio Engineers, 1926; Member, 1928.

Hall, Harry H.: Received B.S. degree, Union College, 1926. Instructor in physics, American University of Beirut, Syria, 1926-1929; graduate student of physics and research assistant, Harvard University, 1929 to date. Nonmember, Institute of Radio Engineers.

Judson, E. B.: Born December 3, 1898, at Washington, D.C. In Naval radio service, 1917-1919; laboratorian, U. S. Naval Radio research laboratory, 1919-1923; assistant to Dr. L. W. Austin, radio transmission research laboratory, Bureau of Standards, 1923-1932; with wave propagation group, Bureau of Standards, 1932 to date. Associate member, Institute of Radio Engineers, 1926.

Kraus, John D.: Born June 28, 1910, at Ann Arbor, Michigan. Received B.S. degree, 1930; M.S. degree, 1931; Ph.D. degree in physics, 1933, University of Michigan. Licensed amateur since 1926. Member, Sigma Xi. Associate member, Institute of Radio Engineers, 1932.

Moullin, E. B.: Born 1893. Graduated in engineering, Cambridge University, England, 1916. University lecturer, Cambridge University, 1920-1929; reader in engineering science, Oxford University, 1929 to date. Member, Radio Research Board of the Department of Scientific and Industrial Research of Great Britain, and of various subcommittees of the same Board. Author of "Radio Frequency Measurements," and "Principles of Electromagnetism." Member, Institute of Radio Engineers, 1927.

Muyskens, Henry: Born August 30, 1897, at Orange City, Iowa. Received B.S. degree, University of Washington, 1922; M.S. degree, 1925; D.Sc. degree in

physics, University of Michigan, 1933. Licensed amateur since 1925. High school principal at Harrington, Washington, 1922–1924; instructor in physics and mathematics at Puyallup, Washington, 1925–1928; instructor in physics and mathematics, Junior College, Centralia, Washington, 1928–1930; mathematics Fellow, University of Washington, 1930–1931. Member, Sigma Xi and Pi Mu Epsilon. Nonmember, Institute of Radio Engineers.

Rochester, Thomas W.: Born December 16, 1882, at Jersey City, New Jersey. Received E.E. degree, Columbia University, 1905; special courses, New York University, 1908–1910. Testing department, General Electric Company, 1905; equipment bureau, United States Navy, 1906. Engineer in Department of Water Supply, Gas and Electricity, Board of Estimate and Apportionment, Department of Plants and Structures, 1906–1929; chief engineer, Police Department, 1929 to date; instructor in electrical subjects, Evening High Schools, 1909–1924; special examiner for Board of Education, 1916–1917; New York City. Member, American Institute of Electrical Engineers. Member and Director, Municipal Engineers of the City of New York. Nonmember, Institute of Radio Engineers.

Tolmie, J. R.: Born March 19, 1897, at Seattle, Washington. Received B.S. degree in E.E., 1921; M.S. degree, 1923, University of Washington. Instructor in electrical engineering, University of Washington, 1921–1923. Pacific Telephone and Telegraph Company, 1923. Junior member, Institute of Radio Engineers, 1915; Associate, 1928; Member, 1932.

Wenstrom, William H.: Born July 28, 1898, at Sala, Sweden. Graduate, United States Military Academy, 1918; postgraduate course, 1919; Cavalry School, 1920; Signal School, 1924. Regimental and brigade communications officer, 1921–1923, 1924–1926. Instructor, United States Military Academy, 1926–1930. Graduate student, Yale University, 1930–1931; instructor, Army Signal School, 1931 to date. First Lieutenant, Signal Corps, United States Army. Associate member, Institute of Radio Engineers, 1925.

Whitmer, Robert M.: Born 1908, at Battle Creek, Michigan. Amateur radio since 1920. Marine operating experience. Received B.A. degree, University of Michigan, 1928. Member, technical staff, Bell Telephone Laboratories, 1928–1932. Member of faculty, department of physics, Amherst College, 1932–1933; graduate student, department of physics, University of Michigan, 1933. Associate member, Institute of Radio Engineers, 1929.



Two Critical Life Tests that "double check" Allen-Bradley Suppressors



Type W Suppressor



Type X Suppressor



Type Y Suppressor



Type Z Suppressor

The Allen-Bradley radio laboratories conduct two types of life tests. One test is the "road test" in which a large group of spark plug resistors are operated on motor cars continuously under all conditions of service and weather.

To "double check" the road tests, continuous life tests are made on hundreds of spark plug resistors day after day, week after week, with the test equipment illustrated below. Under conditions equivalent to motor speed of 50 miles per hour, these resistors are tested at various ambient temperatures and battery voltages. No road trial is more severe than this exacting ordeal.

These long and critical tests have enabled Allen-Bradley engineers to produce spark plug resistors that—

- 1—Do not "open circuit" in service and cripple the engine.
- 2—Do not "drap" in resistance and fail as suppressors.
- 3—Do not have a "high voltage characteristic" which sharply decreases the suppressor resistance during each spark discharge and thus defeats the purpose of the suppressor.
- 4—Do not foil from exposure to oil and water.
- 5—Do not break due to car or engine vibration. The resistors are enclosed in rugged, non-oring bakelite casings—not in brittle ceramic material.

The superiority of Allen-Bradley Spark Plug Resistors can be easily demonstrated. Our engineers will gladly supply data and performance curves on resistors for your requirements. Write us today.

Allen-Bradley Co.

116 W. Greenfield Ave., Milwaukee, Wis.

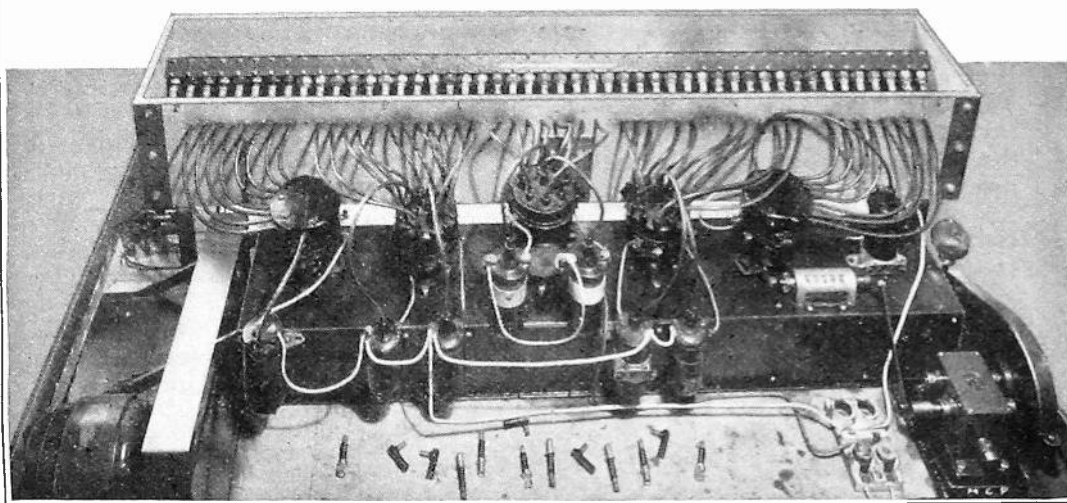

Allen-Bradley

SPARK PLUG RESISTORS

When writing to advertisers mention of the PROCEEDINGS will be mutually helpful.



STURDY

When you buy merchandise of a manufacturer, you automatically begin a partnership with him. Naturally, you want to know what kind of man you're taking into your business! Here is how the Hygrade Sylvania Corporation measures up:

You want a partner who is financially sound; Hygrade Sylvania has a credit rating of AaA1.

You want a partner who is loyal; Hygrade Sylvania is owned by the men who manage it. Its only goal is greater success for

their company and its customers.

You want a partner with experience; Hygrade Sylvania is an old-timer in the electrical field.

Last . . . you want a partner who will cooperate. Hygrade Sylvania offers dealers full sales support . . . gives manufacturers every assistance in solving circuit and design problems. When

you buy Sylvania Tubes you take a partner who helps build your profits! Hygrade Sylvania Corporation, Emporium, Pennsylvania.



Sylvania

(Reg. U. S. Pat. Off.)



THE SET-TESTED RADIO TUBE

When writing to advertisers mention of the PROCEEDINGS will be mutually helpful.

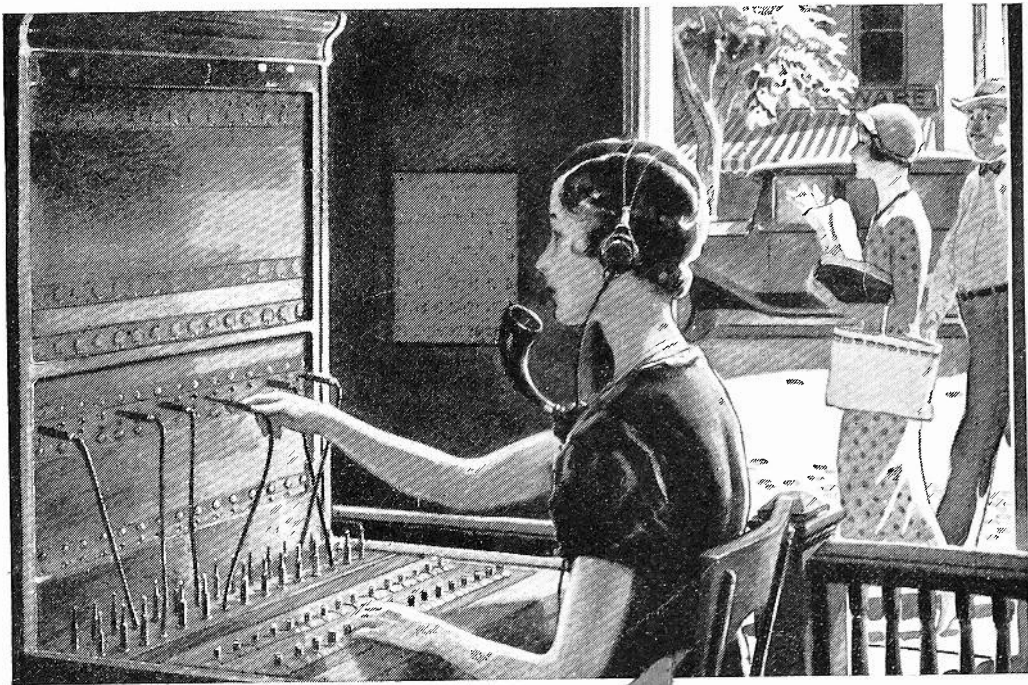

FRIEND AND NEIGHBOR

CLOSE to those who live in small towns, and farther out upon the farms, is the helpful service of the telephone operator.

Bright and early in the morning she puts through a call that helps a farmer locate a drill for sowing oats. Another connection finds out if Jim Thomas, "over near Bogard," is feeding a bunch of calves and needs any shelled corn. Another gets the latest price on heavy hogs for Bill Simpson, and helps him catch the market near the top.

Through the day she aids in calling a doctor for Mrs. Moore, whose baby is ill. Plugs in an emergency call that sends an ambulance east of town. Puts through

a long distance call for Bob Roberts, whose boy attends the state college. Then, through the night, stands ever ready to help those in need.

Constantly in her mind and activities is one guiding purpose . . . "Speed the call!" And the further thought that she serves best when she serves with courtesy and sympathetic understanding.

In the bustle of the city, as in town and country, that is the established creed of every employee of the Bell System. Its faithful observance in so large a percentage of cases is an important factor in the value of your telephone service.

AMERICAN TELEPHONE AND TELEGRAPH COMPANY



When writing to advertisers mention of the PROCEEDINGS will be mutually helpful.

CHANGE IN MAILING ADDRESS OR BUSINESS TITLE

Members of the Institute are asked to use this form for notifying the Institute office of a change in their mailing address or the listing of their company affiliation or title in the Year Book.

The Secretary,
THE INSTITUTE OF RADIO ENGINEERS,
33 West 39th Street,
New York, N.Y.

Dear Sir:

Effective please note change in my address
(date)
for mail as follows:

FROM

.....
(Name)

.....
(Street Address)

.....
(City and State)

TO NEW ADDRESS

.....
(Street Address)

.....
(City and State)

Please note following change in my Year Book listing.

.....
(Title)

.....
(Company Name)

.....
(Company Address)

The Institute of Radio Engineers

Incorporated

33 West 39th Street, New York, N. Y.

APPLICATION FOR ASSOCIATE MEMBERSHIP

(Application forms for other grades of membership are obtainable from the Institute)

To the Board of Direction

Gentlemen:

I hereby make application for Associate membership in the Institute of Radio Engineers on the basis of my training and professional experience given herewith, and refer to the members named below who are personally familiar with my work.

I certify that the statements made in the record of my training and professional experience are correct, and agree if elected, that I will be governed by the constitution of the Institute as long as I continue a member. Furthermore I agree to promote the objects of the Institute so far as shall be in my power, and if my membership shall be discontinued will return my membership badge.

.....
(Sign with pen)

.....
(Address for mail)

.....
(Date)

.....
(City and State)

References:

(Signature of references not required here)

Mr. Mr.

Address Address

City and State City and State

Mr.

Address

City and State

The following extracts from the Constitution govern applications for admission to the Institute in the Associate grade:

ARTICLE II—MEMBERSHIP

Sec. 1: The membership of the Institute shall consist of: * * * (c) Associates, who shall be entitled to all the rights and privileges of the Institute except the right to hold any elective office specified in Article V. * * *

Sec. 4: An Associate shall be not less than twenty-one years of age and shall be a person who is interested in and connected with the study or application of radio science or the radio arts.

ARTICLE III—ADMISSION AND EXPULSIONS

Sec. 2: * * * Applicants shall give references to members of the Institute as follows: * * * for the grade of Associate, to three Fellows, Members, or Associates; * * * Each application for admission * * * shall embody a full record of the general technical education of the applicant and of his professional career.

ENTRANCE FEE SHOULD ACCOMPANY APPLICATION

(Typewriting preferred in filling in this form) No.....

RECORD OF TRAINING AND PROFESSIONAL EXPERIENCE

Name
(Give full name, last name first)

Present Occupation
(Title and name of concern)

Business Address

Permanent Home Address

Place of Birth..... Date of Birth..... Age.....

Education

Degree
(college) (Date received)

TRAINING AND PROFESSIONAL EXPERIENCE

DATES	

Record may be continued on other sheets of this size if space is insufficient.

Receipt Acknowledged..... Elected..... Deferred.....
Grade Advised of Election..... This Record Filed.....

AGAIN OBSOLESCENCE TAKES IT ON THE CHIN!

Announcing A New Weston TUBE CHECKER



NO LONGER is there any need for worrying about tube checker obsolescence. Again Weston has supplied the solution; providing a design with 18 sockets, 11 of which are wired to test all of the present tubes, some 90 in number. The remaining 7 sockets are spares, and can be quickly wired in to test some fifty-odd additional tubes, when and if these tubes appear on the market.

Weston Model 674 Tube Checker is an "English Reading" tester—and is outstanding in its simplicity of operation. All reference to or knowledge of tube characteristics is avoided. The operator simply follows the few concise steps indicated on the tube limit chart and correct indication is obtained in minimum time.

Moreover, by means of the cathode leakage button the testing of all cathode type tubes for leakage between cathode and heater is readily accomplished—and in the same socket used for regular tests on the tube. Independent checking of the second plate in all double plate tubes also is accomplished simply by throwing a toggle switch.

And there are many more outstanding features—a few of them listed on the right. They will explain why Weston Model 674 is the outstanding value in tube checkers today. The coupon will bring descriptive circular RA . . . Weston Electrical Instrument Corporation, 589 Frelinghuysen Avenue, Newark, New Jersey.

OUTSTANDING FEATURES:

1. *Attractive appearance* — harmoniously finished in three tones of brown.
2. "English Reading". *Excellent readability.*
3. *Simplicity of operation* — no calculations necessary.
4. *Lowest obsolescence factor.*
5. *Tests second plates, all tubes* — diodes, duplex and rectifier.
6. *Tests cathode leakage by simply pushing a button.*
7. *Individual standard replaceable sockets.*
8. *Line voltage adjustment.*
9. *No adapters required.*

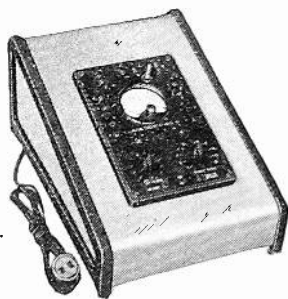

Also, the new Weston Model 673 Tube Checker. Combines attractive appearance, good testing ability, and low price. Send coupon for bulletin.

WESTON *Radio Instruments*

Weston Electrical Instrument Corporation,
589 Frelinghuysen Avenue, Newark, New Jersey
Please send circular RA containing full information on Model
674 Tube Checker and other radio instruments.

Name _____

Address _____

City _____ State _____

When writing to advertisers mention of the PROCEEDINGS will be mutually helpful.

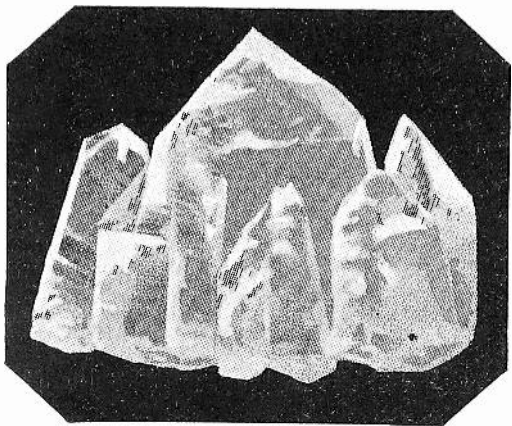

SINGLE-SIGNAL RECEPTION

with the
**COMET
"PRO"**

A New Model Uses an Improved **CRYSTAL FILTER**

HAMMARLUND'S interpretation of "Single-Signal" reception with a crystal filter is unique.

Characteristically thorough, Hammarlund has not rushed blindly into premature enthusiasm. It has required time and care to perfect the application of a quartz crystal to so excellent a receiver as the COMET "PRO", without losing more efficiency than is gained.

Now, it is here—the famous COMET "PRO", retaining all of its former desirable features—PLUS 100 PERCENT OF CRYSTAL SELECTIVITY.

A flip of a switch on the front panel instantly converts the *standard* "Pro" to the *crystal* "Pro". Another front-panel control varies the response characteristics of the crystal filter, without detuning the circuit or reducing efficiency in any respect.

These features are *exclusive*—have been accomplished only by Hammarlund.

HAMMARLUND MANUFACTURING CO.
424 W. 33rd St., New York

—Check here for new booklet describing the "PRO" in detail.—Check here for General Catalog.—Check here for folder on new Air-Tuned I.F. Transformers.

Name

Address

PE-9

Specially-tested quartz crystals are used, carefully selected for their low resistance and absence of spurious frequencies.

The COMET "PRO" thus reaffirms its leadership. It is a *complete* receiver, with built-in power supply. It provides band-spread tuning *at all frequencies*. Four sets of coils (*included*) cover all bands from 20,000 to 1,200 kc. *No extras to buy*.

The intermediate transformers are Litz-wound and are tuned by AIR-dielectric condensers. Peak I.F. selectivity is thus maintained regardless of weather or atmospheric conditions.

Built to *professional* standards, the COMET "PRO" is used all over the world by armies, navies, broadcasting networks, steamships, air-transport lines, police and news services. No finer recommendation could be made for any receiver. A.C., D.C. and Battery models.

**SPECIAL:—New 10-meter coils
now ready—\$5 a pair
MAIL COUPON FOR DETAILS**



When writing to advertisers mention of the PROCEEDINGS will be mutually helpful.

EMPLOYMENT PAGE

Advertisements on this page are available to members of the Institute of Radio Engineers and to manufacturing concerns who wish to secure trained men for positions. All material for publication on this page is subject to editing from the Institute office and must be sent in by the 15th of the month previous to the month of publication. (September 15th for October PROCEEDINGS IRE, etc.) Employment blanks and rates will be supplied by the Institute Office. Address requests for such forms to the Institute of Radio Engineers, 33 Wst 39th Street, New York City, N.Y.

MANUFACTURERS and others seeking radio engineers are invited to address replies to these advertisements at the Box Number indicated, care the Institute of Radio Engineers. All replies will be forwarded direct to the advertiser.

COLLEGE GRADUATE with B.S. degree. Has had three and one quarter years experience in building up inspection methods and engineering department at an electrical manufacturing concern, ten months experience in design and installation of power switchboards and theatre equipment, rapid cost estimating for purpose of bids. Three years experience in planning for manufacture and inspection of all types of transmission networks, including cost estimates, ordering of tools and testing equipment, clearing of manufacturing difficulties, manufacturing cost reduction and planning crystal filters. Desires work with any radio or electrical concern preferably New York or New England in the manufacturing branch. Age 29. Married. Would prefer not to travel. Box 148.

COLLEGE GRADUATE with B.S. degree in electrical engineering with two years experience in planning and specification of automatic telephone equipment, one year in development of broadcast receivers, two years on production and inspection of broadcast receivers, one year in design and development of factory test equipment and broadcast receivers. One year in development of oscillators and other laboratory equipment, one year in design of broadcast and short wave receivers for foreign and domestic trade. Age 32. Married. Will travel. Box 149.

Alphabetical Index to Advertisements

A

American Tel. & Tel. Co.....IX
Allen Bradley Co.....VII

H

Hammarlund Mfg. Co.....XIV
Hygrade Sylvania Corp.....VIII

C

Central Radio Laboratories.....XX
Cornell-Dubilier Corp.....XIX

I

I.R.E...X, XI, XII, Inside Back Cover

E

Employment Page.....XV
Erie Resistor Corp.....XVIII

P

Professional Eng. Directory.....XVII

G

General Radio Co..Outside Back Cover

W

Weston Elect. Inst. Corp.....XIII

PROCEEDINGS BOUND VOLUMES



Volume 20 (1932) of the Proceedings is now available in bound form to members of the Institute. It may be obtained in Buckram or Morocco leather for \$9.50 and \$11.00 respectively.

Bound copies of volumes 18 and 19 (1930 and 1931) are also available at the same price.

When writing to advertisers mention of the PROCEEDINGS will be mutually helpful.

PROFESSIONAL ENGINEERING DIRECTORY

For Consultants in Radio and Allied Engineering Fields

FOR ADVANCED TRAINING

in:

Practical Radio Engineering
Practical Television Engineering

write to

CAPITOL RADIO ENGI- NEERING INSTITUTE

Riggs Bank Bldg.
Washington, D.C.

Cathode Ray Tubes and Associated Equipment For All Purposes

*Write for Complete
Technical Data*

ALLEN B. DUMONT
LABORATORIES
UPPER MONTCLAIR, N.J.

FOR MANY YEARS

the Professional Engineering Directory has helped consulting engineers, designers, and laboratory men make the right contacts in the radio industry. Perhaps we can help you with your problems too. For further information write to

Advertising Department

INSTITUTE OF RADIO ENGINEERS

33 West 39th St.
NEW YORK CITY, N.Y.

LITTELFUSE LABORATORIES

Specialists in

Delicate Equipment Protection

INSTRUMENTS and METERS
RADIO RECEIVERS
RADIO AMPLIFIERS
RADIO TRANSMITTERS

Write for new Technical Bulletin No. 5
1764 Wilson Ave., Chicago, Ill.

For the Engineering Consultant

who can handle a little extra business this year

For the designer

who can manage some additional work

For the Patent Attorney

who is anxious to develop a larger clientele

we suggest the Professional Engineering Directory of the PROCEEDINGS I.R.E. Manufacturers and organizations with special problems who need services such as yours come to the Professional Engineering Directory for information. Your name and special services announced here will tell them what you do and where to find you. Further information will be furnished on request. Special rates to members of the Institute.

50,000 MILES

with little change in

RESISTANCE VALUE

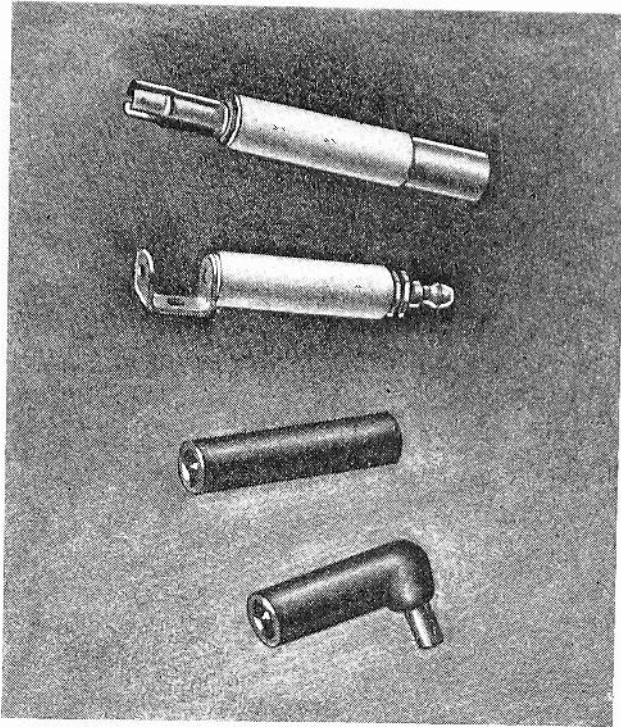

Repeated tests in actual use and in the laboratory have proved that ERIE SUPPRESSOR RESISTORS do not change more than 10% in resistance value in 50,000 miles of use — provided one suppressor resistor is used in each high tension lead.

Makers of automobile radio receiving sets have confidence in ERIE SUPPRESSOR RESISTORS because of their high suppression effectiveness and long life resistance value.

Resistance units are enclosed in both porcelain and Bakelite tubes, giving the best possible protection from oil, dirt, moisture and mechanical breakage.

In addition to the plug, screw and distributor types the new L type has been perfected recently. In this suppressor the resistance unit is a special "mix" which stands up in spite of the extremely short length used.

We will gladly give you charts and complete data showing performance of ERIE SUPPRESSOR RESISTORS and furnish you with any details needed on the particular type or types of suppressors needed for your requirements.

The Erie Resistor Corporation, Erie, Pa., Toronto, Canada and London, Eng.



When writing to advertisers mention of the PROCEEDINGS will be mutually helpful.



Pyranol Condensers

Cornell-Dubilier pyranol-impregnated condensers are available in three standard D.C. working voltages: 1000-volt, 1 to 10 mfd.; 1500-volt, 1 to 6 mfd.; 2000-volt, 1 and 2 mfd. These units feature:

- 50% reduction in cubic volume and weight over previous units, without sacrificing life.
- Non-inflammable impregnator, permitting use in hazardous locations.
- Operation at high ambient temperatures destructive to former ordinary types.

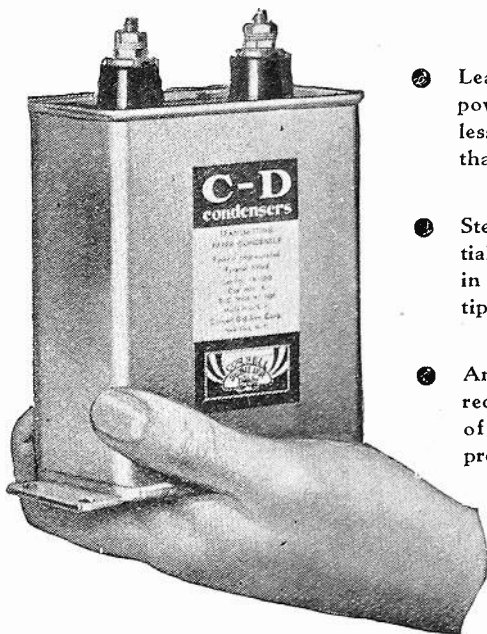

- Leakage resistance and power factor change far less at high temperatures than with other units.
- Steel containers, substantial, hermetically sealed, in standard sizes for multiple assemblies.
- And best of all, a marked reduction in price because of this newly patented impregnator!

Be sure to look further into the striking features and advantages of Cornell-Dubilier pyranol-impregnated condensers. They'll save you money and provide a better, more lasting and more economical assembly.

Write for data on pyranol-impregnated condensers as well as the new 1933 Cornell-Dubilier catalog covering entire line.

CORNELL-DUBILIER CORPORATION

4377 Bronx Boulevard - - - - New York City

1910



1933

When writing to advertisers mention of the PROCEEDINGS will be mutually helpful.

Seems like
1929 Again

*~ so enthusiastic
is the reception
of our New 1933*

**Centralab
RADIOHM**

Wires buzzing, cables calling for more Radiohms, phone calls with insistent voices on the other end . . . all bring back the good old hectic days.

Today—in 1933 Centralab is still producing the outstanding control—the standard by which all others are judged.

For original equipment or for replacements use CENTRALAB Radiohms.

**CENTRAL RADIO
LABORATORIES
MILWAUKEE**

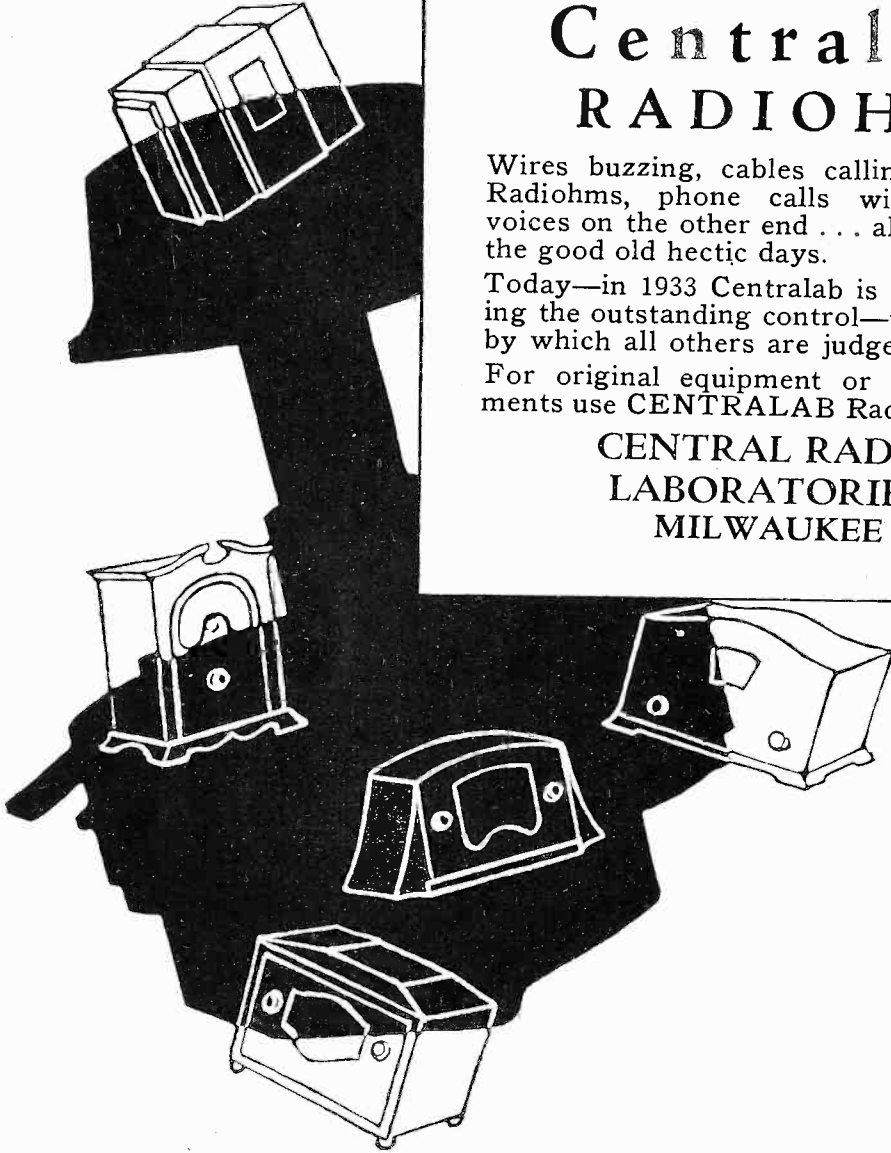

Centralab
CRL

When writing to advertisers mention of the PROCEEDINGS will be mutually helpful.

Don't Take Chances on Destroying Valuable Information!

Protect your back issues of the PROCEEDINGS with a binder that will stand abuse; a binder that will hold twelve issues and keep them all together for easy reference.

We can, to be sure, usually fill orders for back issues, but occasionally we may not have the one necessary to complete your reference work—this means unnecessary delay and delay means dollars.

Be sure—get a binder now and protect those back issues.

PROCEEDINGS BINDER

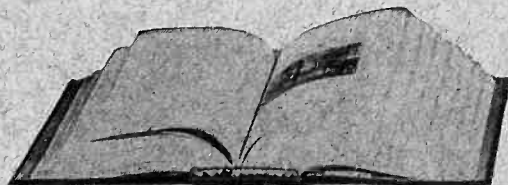

Binder of handsome Spanish Grain Fabrikoid in blue and gold. Can be used as temporary transfer binder or as a permanent cover. Wire fasteners hold each copy in place and permit removal of any issue from binder in a few seconds. All issues lie flat when binder is opened.

BINDER (holds complete 1931 or 1932 copies)\$1.75

(Name stamped on volume for \$.50 additional)

Send orders for binders, accompanied by remittance, to

INSTITUTE OF RADIO ENGINEERS

33 West 39th Street

New York City, New York

NOW READY . . .

A NEW BRIDGE FOR TESTING ELECTROLYTIC CONDENSERS

Leakage current
Power factor
Capacitance



Type 632-A Capacitance Bridge For Electrolytic Condensers—complete with 600-volt power supply for polarizing voltage and with tubes

\$300

HERE is a complete ready-to-operate test set for inspection testing of wet and dry electrolytic condensers. It measures capacitance, power factor, and leakage current for polarizing voltages up to 600 volts in the presence of 60-cycle a-c voltage. Write the General Radio Company, Cambridge, Massachusetts, for details.

GENERAL RADIO

GEORGE BANTA PUBLISHING COMPANY, MENASHA, WISCONSIN