

VOLUME 16

FEBRUARY, 1928

NUMBER 2

PROCEEDINGS
of
**The Institute of Radio
Engineers**



Published Monthly By
THE INSTITUTE OF RADIO ENGINEERS
Publication Office: 450-454 Ahnaip St., Menasha, Wis.

Editorial and Advertising Departments
37 West 39th Street, New York, N.Y.

Subscription \$10.00 per Annum in the United States
\$11.00 in all other Countries

General Information and Subscription Rates on Page 107.



THE CHOICE
of
LEADING
MANUFACTURERS

For over four years Thordarson transformers have predominated in the receivers and power units of leading radio manufacturers.

Such patronage is not an accident. It stands as a positive proof of a superiority of product. It demonstrates the effectiveness of a policy of service rendered to the n'th degree by an efficient and smooth running organization.

We are at present manufacturing over twelve hundred different types of transformers. Among our customers are more than a hundred radio manufacturers.

Thordarson engineers always stand ready to help you with your transformer problems.

PROMPT DELIVERY
RIGHT PRICES

THORDARSON
RADIO

Supreme in Musical Performance
TRANSFORMERS

THORDARSON ELECTRIC MANUFACTURING CO.
Transformer specialists since 1895
WORLD'S OLDEST AND LARGEST EXCLUSIVE TRANSFORMER MAKERS
Chicago, U.S.A. (3576)

When writing to advertisers mention of the Proceedings will be mutually helpful.

RADIO

*Whether socket power or battery operated
you'll find Faradon in the better sets*



Since 1907 Faradon experts have met electrostatic condenser needs with capacitors especially designed for each particular purpose.

There are several hundred types in routine production covering nearly all requirements. Write our engineering department for any detailed data desired for special applications.

*Electrostatic
Condensers
for all
purposes*

WIRELESS SPECIALTY APPARATUS CO.

Jamaica Plain

BOSTON, MASS., U. S. A.

Established 1907

Faradon

1604

When writing to advertisers mention of the Proceedings will be mutually helpful.

I

A Much Needed Instrument

ROLLER-SMITH

Type GSA

A. C. Portable Volt-Ammeter

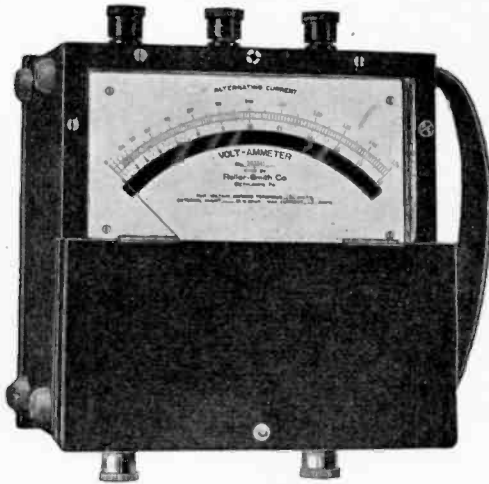

Bulletin No. K-160 describes the new ROLLER-SMITH Type GSA Volt-Ammeters and also Type GSA Ammeters, Voltmeters, Single and Polyphase Wattmeters, Frequency Meters, Power Factor Meters, Transformers, Resistors and "Y" Boxes, which represent a complete testing outfit for any shop or station.

Send for a copy of Bulletin K-160.

"Over thirty years experience is back of Roller-Smith"

ROLLER-SMITH COMPANY
Electrical Measuring and Protective Apparatus

Main Office
 2134 Woolworth Bldg.
 NEW YORK



Works
 BETHLEHEM,
 PENNA.

Bethlehem
 Birmingham
 Buffalo
 Boston
 Charlotte
 Chicago

Cleveland
 Dallas
 Detroit
 Los Angeles
 Montreal
 New Haven

New Orleans
 New York
 Omaha
 Pittsburgh
 Philadelphia
 San Francisco

Seattle
 St. Louis
 St. Paul
 Toronto
 Tulsa
 Washington

When writing to advertisers mention of the Proceedings will be mutually helpful.

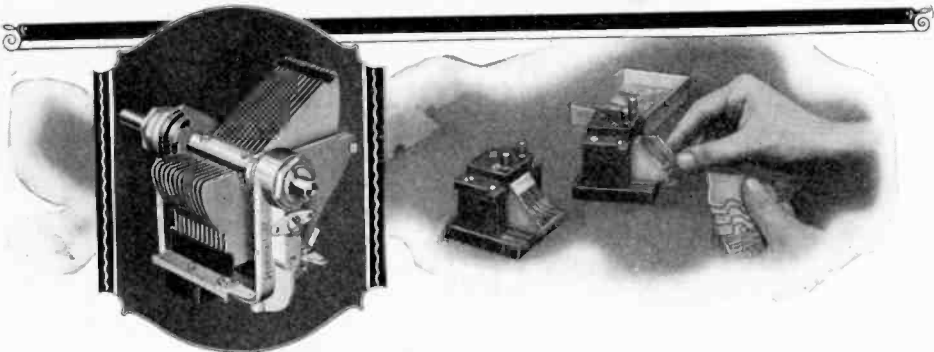

Above is shown how accurate alignment of Hammarlund Condenser plates is assured—firmly anchored in a metal holder, each plate in its own slot, while the tie-bars and solder are applied.

Hammarlund Products Are *Superior* Because Hammarlund Methods are *Better!*

There is a lot of loose talk about quality in radio, but you as engineers know that a radio receiver can be no better than the parts that go into it.

Does it mean anything to you when we tell you that Hammarlund Products are officially specified for more successful circuits than any other products of similar character?

Let Hammarlund engineers assist with *your* problems.

Send us your Specifications.

HAMMARLUND MANUFACTURING COMPANY
424-438 West 33rd Street, New York

More than a score of radio designers officially specify Hammarlund Precision Products for their newest circuits.

For Better Radio
Hammarlund
PRECISION
PRODUCTS

Trade inquiries invited concerning several new and appealing Hammarlund developments, having a wide sales demand.

When writing to advertisers mention of the Proceedings will be mutually helpful.

Finer Performance than you've ever enjoyed! Made available by complete AMERTRAN Units

The AMERTRAN A B C Hi-Power Box. List price \$102.50, east of the Rockies, complete with rectifying tube.



THESE are instruments that will appeal to the engineer or experimenter as they represent the highest standards for comparative purposes. Quality reproduction—limited only by the perfection of the speaker—noiseless reliable power without the nuisance of batteries or chargers—are available with these companion units. Cased in compact cabinets, they may be installed in a console, where your batteries used to be, or placed wherever convenient.

The A B C Hi-Power Box delivers uniform, dependable power from the house-current—supplying sufficient voltage and current for Push-Pull 210 tubes and all other A C tubes required in a modern receiver. The complete unit contains AmerTran designed equipment with a power transformer having separate windings to provide A C filament current for power tubes, the 281 rectifying tube, heater current for three or four UY-227 A C tubes, and current for four or five UX-226 raw A C tubes.

With either an A C power supplying system or batteries, the fidelity of reproduction brought by the AmerTran Push-Pull Power Amplifier is actually limited only by the perfection of the speaker. It

connects to the detector of any good receiver and may be entirely A C operated. The input to the speaker is free from distortion and objectionable A C hum—the energy output is increased especially at the lower musical frequencies bringing greater clarity at high or low volume. Furnished with cable and plug the amplifier connects directly with the A B C Hi-Power Box.

See these new AmerTran products on demonstration at any store displaying the sign, "Authorized AmerTran Dealer" or, if you cannot obtain them, write direct to this company. Both wired units are licensed under patents owned or controlled by R C A and must be sold complete with tubes.

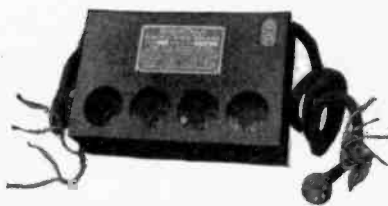

The AMERTRAN Push-Pull Power Amplifier. List price \$60, east of the Rockies. Price of Amplifier complete with tubes depends on tubes specified.

AMERICAN TRANSFORMER COMPANY

180 Emmet St.

Newark, N. J.

"Transformer Builders for Over 27 Years"



*A
Quality
Product*

*Pattern
No. 116
High
Resistance
Voltmeter*

*800 ohms
Per Volt*

Two Hundred Thousand Ohms

Two hundred thousand ohms is quite a lot of resistance. It is quite a lot of resistance, in wire wound form and of a type unaffected by temperature changes, to build into a voltmeter. Still, that is the actual amount required to establish a high resistance of 800 ohms per volt in the Jewell high resistance, portable voltmeter Pattern No. 116, which is used to check and adjust B-Eliminator voltages. A current draw of only one and one-fourth milliamperes at full scale reading, or one-tenth milliamperes at the 22½-volt scale reading gives an idea of the small amount of current required to deflect the pointer of this instrument.

The movement of the Pattern 116 is a high grade, D'Arsonal moving coil type having silvered movement parts. The scale is silver etched with black characters and the movement is provided with a zero adjuster.

Besides its adaptability for making B-eliminator adjustments, the Pattern 116 may be used for general test purposes as well.

Write for descriptive circular No. 1103

Jewell Electrical Instrument Co.

1650 Walnut St. - Chicago

"28 years making Good Instruments"

When writing to advertisers mention of the Proceedings will be mutually helpful.

Radio - Is - BETTER - With - Dry - Battery - Power



made to run
the *full* race!

ANY horse can make a good start. . . . But it takes real stamina to *finish!* ¶So it is with batteries. *Staying* power is the quality to look for—unfailing power over a long period of service. Millions prefer Burgess *Chrome* Batteries for just this reason. They hold up. . . . They *last.* ¶Next time, buy black and white striped Burgess *Chrome* Batteries. You are certain to get longer and better service for your money.

Chrome —the preserving element used in leather, metals, paints and other materials subject to wear, is also used in Burgess Batteries. It gives them unusual *staying* power. Burgess *Chrome* Batteries are patented.

Ask Any Radio Engineer

BURGESS BATTERY COMPANY

General Sales Office: CHICAGO

Canadian Factories and Offices: Niagara Falls and Winnipeg



BURGESS BATTERIES

When writing to advertisers mention of the Proceedings will be mutually helpful.

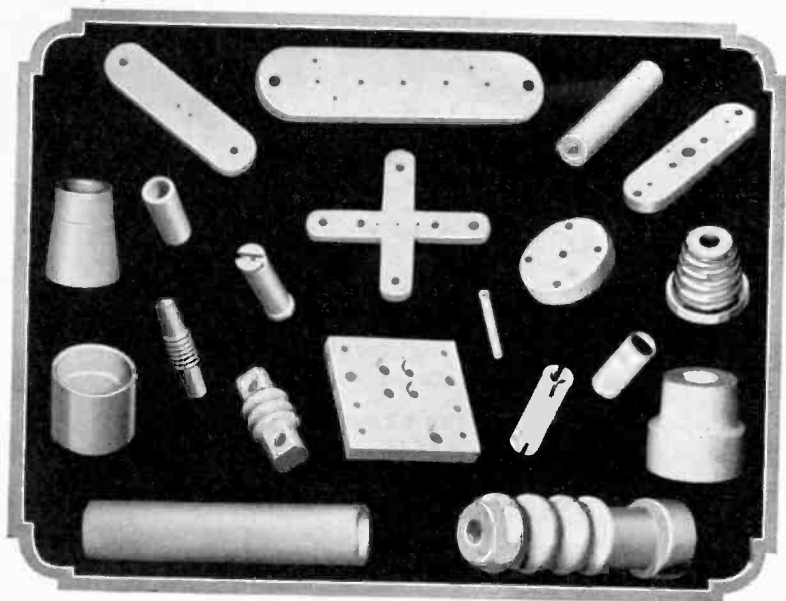

Typical
Isolantite
Radio Insulating Products

ISOLANTITE is a *logical* insulator for use in radio receivers and transmitters both electrically and mechanically. Get the facts on this scientifically processed and accurately fabricated ceramic. Send us your specifications for quotations.

Isolantite Company of America
(Incorporated)

New York Sales Office: 551 Fifth Avenue, NEW YORK

When writing to advertisers mention of the Proceedings will be mutually helpful.

VII

Nine Reasons Why Radiotrons UX-280 and UX-281 Are Most Economical Rectifiers

- 1 Fewer Condensers required in rectifying and filtering circuits (Buffer Condensers across transformer secondary not required).
- 2 Lower Capacity Condensers can be used (Wave form of UX-280 and UX-281 does not have jagged peaks, thus simplifying filter requirements).
- 3 Lower Voltage Condensers can be employed effecting further manufacturing economy.
- 4 High initial surge voltage from transformer not required as UX-280 and UX-281 start at any voltage. Thus design is simplified and possible failure of condensers due to erratic surge peak is eliminated.
- 5 Possibility of failure to operate due to insufficient breakdown voltage is eliminated.
- 6 Erratic and noisy operation is not experienced with highly evacuated tubes such as Radiotrons UX-280 and UX-281.
- 7 New Ribbon Filament makes tubes unusually rugged.
- 8 Long life.
- 9 The UX-280 will furnish adequate B and C voltage for a receiver using Radiotron UX-171A at maximum plate voltage.

RADIO CORPORATION OF AMERICA
New York Chicago San Francisco

RCA Radiotron

MADE BY THE MAKERS OF THE RADIOLA

When writing to advertisers mention of the Proceedings will be mutually helpful.

PROCEEDINGS OF
The Institute of Radio Engineers

Volume 16

February, 1928

Number 2

CONTENTS

	Page
Officers and Board of Direction	108
Committees	108
Institute Sections	110
Institute Activities	116
News of the Sections	118
Committee Work	120
Charles Bayne Aiken, "A Precision Method for the Measurement of High Frequencies"	125
J. W. Horton and W. A. Marrison, "Precision Determination of Frequency"	137
George Rodwin and Theodore A. Smith, "A Radio-Frequency Oscillator for Receiver Investigations"	155
L. W. Austin and Miss I. J. Wymore, "On the Influence of Solar Activity on Radio Transmission"	166
E. O. Hulburt, "Ionization in the Upper Atmosphere"	174
H. B. Maris, "A Theory of the Upper Atmosphere and Meteors"	177
Knox McLlwin and W. S. Thompson, "A Radio Field Strength Survey of Philadelphia"	181
Manfred von Ardenne, "On the Theory of Power Amplification"	193
Alexander Nyman, "Condenser Shunt for Measurement of High-Frequency Currents of Large Magnitude"	208
Book Reviews	218
Geographical List of Members Elected January 4, 1928	224

GENERAL INFORMATION

The PROCEEDINGS of the Institute are published monthly and contain the papers and the discussions thereon as presented at meetings.

Payment of the annual dues by a member entitles him to one copy of each number of the PROCEEDINGS issued during the period of his membership.

Subscriptions to the PROCEEDINGS are received from non-members at the rate of \$1.00 per copy or \$10.00 per year. To foreign countries the rates are \$1.10 per copy or \$11.00 per year. A discount of 25 per cent is allowed to libraries and booksellers.

The right to reprint limited portions or abstracts of the articles, discussions, or editorial notes in the PROCEEDINGS is granted on the express conditions that specific reference shall be made to the source of such material. Diagrams and photographs in the PROCEEDINGS may not be reproduced without securing permission to do so from the Institute through the Secretary.

It is understood that the statements and opinions given in the PROCEEDINGS are the views of the individual members to whom they are credited, and are not binding on the membership of the Institute as a whole.

Entered as second class matter at the Post Office at Menasha, Wisconsin.

Acceptance for mailing at special rate of postage provided for in the Act of February 28, 1925, embodied in paragraph 4, Section 412, P. L. and R. Authorized October 26, 1927.

Copyright, 1928, by

THE INSTITUTE OF RADIO ENGINEERS, Inc.

Publication Office 450-454 Ahnaip Street, Menasha, Wis.

Editorial and Advertising Departments, 37 West 39th St., New York, N.Y.

OFFICERS AND BOARD OF DIRECTION, 1928

(Terms expire January 1, 1929, except as otherwise noted)

President

ALFRED N. GOLDSMITH

Vice-President

L. E. WHITTEMORE

Treasurer

MELVILLE EASTHAM

Acting Secretary

JOHN M. CLAYTON

Managers

ARTHUR BATCHELLER

A. H. GREBE

R. H. MARRIOTT

W. G. CADY

L. A. HAZELTINE

R. A. HEISING
(Serving until Jan. 1, 1930)

J. V. L. HOGAN
(Serving until Jan. 1, 1930)

J. H. DELLINGER
(Serving until Jan. 1, 1931)

R. H. MANSON
(Serving until Jan. 1, 1931)

Junior Past Presidents

DONALD McNICOL

RALPH BOWN

Editor

ALFRED N. GOLDSMITH

Associate Editor

GEORGE R. METCALFE

Committees of the Institute of Radio Engineers, 1927

Committee on Meetings and Papers

R. H. MARRIOTT, *Chairman*

STUART BALLANTINE

R. R. BATCHER

CARL DREHER

W. G. H. FINCH

ERICH HAUSMANN

S. S. KIRBY

G. W. PICKARD

PAUL WEEKS

W. WILSON

L. M. HULL

F. H. KROGER

A. G. LEE

F. K. VREELAND

Committee on Revision of the Constitution

J. H. DELLINGER, *Chairman*

J. V. L. HOGAN

DONALD McNICOL

Committee on Publicity

W. G. H. FINCH, *Chairman*

C. E. BUTTERFIELD

DAVID CASEM

ORRIN E. DUNLAP

E. EHLERT

L. W. HATRY

E. H. HANSEN

LLOYD JACQUET

J. F. J. MAHER

Committee on Admissions

F. CONRAD, *Chairman*

ARTHUR BATCHELLER

HARRY F. DART

C. P. EDWARDS

A. H. GREBE

L. A. HAZELTINE

R. A. HEISING

Committees of the Institute—(Continued)

J. G. UZMANN
WILLIS K. WING
R. F. YATES

Committee on Membership

HARRY F. DART, *Chairman*
M. C. BATSEL
M. BERGER
F. R. BRICK
GEORGE BURGHARD
E. M. DELORAINÉ
DR. L. J. DUNN
C. P. EDWARDS
W. G. H. FINCH
C. M. JANSKY, JR.
ROBERT S. KRUSE
WILLIAM J. LEE
PENDLETON E. LEHDE
C. L. RICHARDSON
F. H. SCHNELL
E. R. SHUTE
G. S. TURNER
E. H. ULRICH

Committee on Institute Sections

DAVID H. GAGE, *Chairman*
M. BERGER
L. F. FULLER
D. HEPBURN
L. G. PACENT
M. C. RYPINSKI
E. R. SHUTE

All Section Secretaries ex-officio

Committee on Standardization

L. E. WHITTEMORE, *Chairman*
M. C. BATSEL
EDWARD BENNETT
E. L. CHAFFEE
J. H. DELLINGER
MELVILLE EASTHAM
C. P. EDWARDS
GENERAL FERRIE
A. N. GOLDSMITH
L. A. HAZELTINE
J. V. L. HOGAN
W. E. HOLLAND
L. M. HULL
F. A. KOLSTER
MAJOR J. O. MAUBORGNE
R. H. MANSON
DONALD MCNICOL
E. L. NELSON
H. S. OSBORNE
H. B. RICHMOND
LT. COMDR. W. J. RUBLE
E. H. SHAUGHNESSY
H. M. TURNER
C. A. WRIGHT
HIDETSUGU YAGI
J. ZENNECK

INSTITUTE SECTIONS

ATLANTA SECTION

Chairman
Walter Van Nostrand

Secretary-Treasurer
George Llewellyn, Room 524, Post Office
Bldg., Atlanta, Ga.

BOSTON SECTION

Chairman
George W. Pierce

Secretary-Treasurer
Melville Eastham, 30 State St.,
Cambridge, Mass.

BUFFALO—NIAGARA SECTION

Chairman
L. C. F. Horle

Secretary
C. J. Porter, 141 Milton Street,
Buffalo, New York

CANADIAN SECTION

Chairman
A. M. Patience

Secretary
C. C. Meredith, 110 Church St., Toronto, Ontario

CHICAGO SECTION

Chairman
John H. Miller

Secretary
H. E. Kranz, 4540 Armitage Ave., Chicago, Ill.

CLEVELAND SECTION

Chairman
John R. Martin

Secretary-Treasurer
B. W. David, 3223 Ormond Road,
Cleveland Heights, Ohio

CONNECTICUT VALLEY SECTION

Chairman
W. G. Cady

Secretary-Treasurer
George W. Pettengill Jr., P.O. Box 551
Ludlow, Mass.

DETROIT SECTION

Chairman
Thomas E. Clark

Secretary-Treasurer
W. R. Hoffman, 615 West Lafayette Blvd.,
Detroit, Mich.

LOS ANGELES SECTION

Chairman
L. Taufenbach

Secretary
W. W. Lindsay, Jr., 927 La Jolla Ave.,
Hollywood, Cal.

PHILADELPHIA SECTION

Chairman
J. C. Van Horn

Secretary
John C. Mevius, 1533 Pine St.,
Philadelphia, Pa.

ROCHESTER, N.Y. SECTION

Chairman
Harvey Klumb

Secretary
F. W. Reynolds, 1060 University Ave.,
Rochester, N. Y.

SAN FRANCISCO SECTION

Secretary-Treasurer
D. B. McGown, Custom House,
San Francisco, Cal.

SEATTLE SECTION

Chairman
Tyng Libby

Secretary-Treasurer
W. A. Kleist, 820 Dexter Horton Bldg.
Seattle, Wash.

WASHINGTON SECTION

Chairman
A. Hoyt Taylor

Secretary-Treasurer
F. P. Guthrie, 122 Conn. Ave., Washington, D.C.



A. HOYT TAYLOR

Recipient of the Morris Liebmann Memorial Prize, 1927.

A. Hoyt Taylor

RECIPIENT OF THE MORRIS LIEBMANN MEMORIAL PRIZE, 1927

A. Hoyt Taylor was born January 1, 1879 in Chicago, Illinois. He attended grammar school in Wilmette, Illinois, high school in Evanston, Illinois and graduated with the B. S. degree from Northwestern University. In 1900 he accepted a position as instructor at Michigan State College, teaching physics and electrical engineering. In 1903 he became instructor in electrical engineering at the University of Wisconsin and for some time specialized in electrical measurements with particular attention to alternating currents, and published one or two papers on high-frequency measurements, besides various publications on precision measurements with alternating currents.

In 1908 while assistant professor at the University of Wisconsin, he was granted a year's leave of absence to study in Germany, where he received the Ph. D. degree at the University of Gottingen, specializing in applied electricity, mathematics, and mathematical physics. Upon returning to the United States in the fall of 1909 he was appointed professor of physics and head of department at the State University of North Dakota.

Early in 1911 Dr. Taylor started his radio work at the University of North Dakota and constructed the station which was later known as 9XN. From the beginning of this work, particular attention was given to the study of wave propagation phenomena, fading, influence of weather conditions, studies of directional systems, etc. Various publications covering this work, prior to 1917, appeared in *The Electrical World*, *The Physical Review*, *Journal of the University of North Dakota*, and in the PROCEEDINGS of the Institute of Radio Engineers.

Dr. Taylor entered the Naval Reserve as Lieutenant in March of 1917, and was district communication officer at Great Lakes Naval Training Station until he was transferred to the east coast with headquarters at Belmar, New Jersey as transatlantic communication officer in the fall of 1917.

In the summer of 1918 he was promoted to Lieutenant Commander and sent to the Naval Operating Base at Hampton Roads, Virginia. While at Hampton Roads he acted as head of the Experimental Division of the Naval Air Station studying, particularly, aircraft radio development work.

Early in 1919 he was ordered to Washington, D. C. and was placed in charge of an aircraft radio laboratory with additional duties in a consulting capacity for other radio activities of the naval service. During this period he was promoted to the rank of Commander in the reserve force, remaining in active duty in this rank until July of 1922. Since then he has remained a reserve officer on inactive duty.

Dr. Taylor was made Superintendent of the Radio Division at the Naval Research Laboratory, Bellevue, Anacostia, D. C.

During the past few years his most important work has been the long series of experiments which led to the publication of papers dealing with the theory of short wave transmission. For his work in this connection the Board of Direction of the Institute awarded Dr. Taylor the Liebmann Memorial Prize for 1927.

Dr. Taylor has been a frequent contributor to the PROCEEDINGS of the Institute, and is a Fellow in the Institute.

CONTRIBUTORS TO THIS ISSUE

Aiken, Charles B.: Born at New Orleans, Louisiana, October 6, 1902. Marine radio operator, summers 1918-1921. Received B. S. degree in physics, Tulane University, 1923; M. S. degree, Harvard, 1924; M. A. degree, Harvard, 1925. Winner of Harvard Engineering School Prize Scholarship for 1924-1925. Whiting fellow in physics, 1924-1926. Research Engineer, Mason, Slichter and Hay, Consulting Engineers, 1926 to date. Associate member of the Institute.

Austin, L. W.: Born at Orwell, Vermont, October 30, 1867. Received A.B. degree, Middlebury College, 1889; Ph. D. degree, University of Strassburg, 1893. Instructor and assistant professor, University of Wisconsin, 1893-1901; research work, University of Berlin, 1901-1902; Bureau of Standards, Washington, D. C. since 1904; head of U. S. Naval Radio Research Laboratory, 1908-1923; chief of Radio Physics Laboratory, 1923 to date. Dr. Austin was President of the Institute in 1914 and served on its Board of Direction from 1915 to 1917. In 1927 he was awarded the Institute Medal of Honor. His contributions to the PROCEEDINGS have been frequent. He is a Fellow of the Institute.

Horton, J. H.: Born at Ipswich, Massachusetts, December 18, 1889. Received B.S. degree in electro-chemistry, Massachusetts Institute of Technology, 1914. Instructor, Massachusetts Institute of Technology, 1914-1916; Research engineer with Western Electric Company, 1916-1925 (on leave of absence 1917-1918 as technical expert with U. S. Navy working on methods for detection and location of submarines at experimental stations in this country). At present research engineer with Bell Telephone Laboratories, engaged in development of systems for the transmission of pictures and television; also in development of methods for the precision measurement of frequency. Associate member of the Institute.

Hulburt, E. O.: Born October 12, 1890. Received Ph. D. degree in physics, Johns Hopkins University, 1915. Taught undergraduate and graduate courses at Western Reserve University, Johns Hopkins University and University of Iowa. With American Expeditionary Force in France for two years as Lieutenant and later Captain in the Signal Corps. At present Dr. Hulburt is Superintendent of the Heat and Light Division, Naval Research Laboratory, Bellevue, D. C. He is the author of a number of papers on experimental and theoretical work in spectroscopy, physical optics and radio telegraphy.

McIlwain, Knox: Received B.S. degree, Princeton University, 1918; B.S. in E. E., University of Pennsylvania, 1921. U. S. Navy 1917-1919. Engineering department of Bell Telephone Company of Pennsylvania, 1921-1924. Instructor at Moore School of Electrical Engineering, University of Pennsylvania, 1924 to date.

Maris, H. B.: Born in 1885. Received A.B. degree, University of Michigan, 1909; M.S. degree, 1910; Ph.D. degree, Johns Hopkins University, 1927. Associate Professor of Physics at Birmingham-Southern College, 1922. Professor of physics, Emory and Henry College, 1923. Consulting physicist, Naval Research Laboratory, 1925 to date; researches, photo-elastic studies, and theoretical study of the upper atmosphere.

Marrison, W. A.: Served in Royal Flying Corps, later Royal Air Force, in Canada, 1917-1918; received B.S. degree in physics, Queens University, Canada, 1920; A.M. degree in physics and mathematics, Harvard University, 1921. Research engineer with Western Electric Company 1921-1925; research engineer with Bell Telephone Laboratories, engaged in the study of picture transmission and methods for the production of constant frequency, 1925 to date.

Nyman, Alexander: Born in Finland, December 29, 1893. Received B.S. degree, Manchester University, England, 1915. With Westinghouse Electric and Manufacturing Company, Pittsburgh, 1915-1923, with exception of brief period of service in U. S. Army. Associated with the Dubilier Condenser Corporation, 1923 to date, in capacity of technical manager, and later consulting engineer. Manager of Radio Patents Corporation, 1925 to date. Mr. Nyman is a member of the Institute.

Rodwin, George: Born at New York City, September 4, 1903. Received A.B. degree, Columbia University, 1923; E. E. degree, 1925. With Radio Corporation of America doing research work in connection with fading recorder equipment, standard receiver testing methods, receiver development, and general broadcast station equipment, 1925 to date. Associate member of the Institute.

Smith, Theodore A.: Born at Brooklyn, New York, February 17, 1905. Received M.E. degree, Stevens Institute of Technology, 1925. With Radio Corporation of America, Technical and Test Department, engaged in work on fading recording, short wave reception, field intensity measurements, and miscellaneous work on broadcast station engineering, 1925 to date. Associate member of the Institute.

Thompson, Walter S., Jr.: Received E. E. degree, Lehigh University, 1924. With Engineering Department, Bell Telephone Company of Pennsylvania, 1924-1925. Instructor, Moore School of Electrical Engineering, University of Pennsylvania, 1925.

von Ardenne, Manfred: Born at Hamburg, Germany, January 20, 1907. Educated at University of Berlin. Engaged in radio engineering since 1921; own research laboratory, 1923 to date, specializing in audio-frequency amplification and reproduction. Associate member of the Institute.

Wymore, Ivy Jane: Born in Mahaska County, Iowa. Received B.S. degree, Drake University, 1918; M.S. degree, George Washington University, 1925. With Division of Metallurgy, Bureau of Standards, 1919-1924; Laboratory for Special Radio Transmission Research, 1924 to date.

INSTITUTE ACTIVITIES

JANUARY MEETING OF THE BOARD OF DIRECTION

AT the meeting of the Board of Direction of the Institute held on January 4, 1928 the following were present: Ralph Bown, President, A. N. Goldsmith, Secretary, R. A. Heising, R. H. Marriott, L. E. Whittemore, A. H. Grebe and J. M. Clayton, Assistant Secretary.

The ballots for election of 1928 officers and managers of the Institute were counted, with the following results: President, A. N. Goldsmith; Vice President, L. E. Whittemore; Members of Board of Direction to serve until January 1, 1931: J. H. Dellinger and R. H. Manson.

To fill the unexpired term caused by the death of Colonel John F. Dillon, the Board appointed J. V. L. Hogan. The board appointed the following as managers with one year terms: Arthur Batcheller, W. G. Cady, A. H. Grebe and L. A. Hazeltine.

Commending the services of President Bown, the Board passed the following resolution:

"The Board of Direction expresses its earnest appreciation of the competent and sympathetic direction of its activities during the time Dr. Ralph Bown was President of the Institute."

The following were transferred or elected to the higher grades of membership in the Institute: transferred to the grade of Fellow: Joseph D. R. Freed. Transferred to the grade of Member: F. W. Cunningham and A. M. Patience. Elected to the grade of Member: E. K. Lippincott, G. Schottel and S. Siegel.

One hundred and twelve associate members and twelve junior members were elected.

1928 CONVENTION

On January 9th, 10th, and 11th the Third Annual Convention of the Institute was held in New York. The program opened with an address by the retiring president, Dr. Ralph Bown, followed by the presentation of the 1927 Morris Liebmann Prize to Dr. A. Hoyt Taylor. Dr. Bown next introduced President A. N. Goldsmith who, in turn, introduced Vice-President L. E. Whittemore. W. D. Terrell, of the Department of Commerce, read a paper on "The International Radiotelegraph Conference of Washington, 1927."

In the afternoon of January 9th a tour of inspection to the Bell Telephone Laboratories Experimental Station Group and the

National Broadcasting Station WJZ at Bound Brook was taken by over three hundred and fifty delegates to the convention.

In the evening papers by Dr. J. H. Dellinger, Dr. F. K. Vreeland, and E. H. Loftin and S. Y. White were read.

An inspection trip to Roxy's Theatre with a technical session on the making of talking moving pictures took place on the morning of January 10th. In the afternoon a trip was taken to the Talking Moving Picture Studio of the Radio Corporation of America and to the plant of the Polymet Manufacturing Company. That evening Captain Richard H. Ranger presented a paper with demonstrations on the transmission of photographs by radio.

The delegates, on Wednesday morning, inspected the studios of The National Broadcasting Company, the plant of F. A. D. Andrea and the plant of the Aerovox Wireless Corporation, luncheon being served by the Aerovox Corporation. In the afternoon a symposium relating largely to inter-electrode capacities in in tubes was presented, the following delivering papers: Lincoln Walsh, Harold A. Wheeler, E. T. Hoch, and J. C. Warner. Following the afternoon sessions a trip to the Paramount News Bureau was arranged.

On the final evening dinner was held at the Hotel Roosevelt. George C. Furness presided at this meeting. The program included short introductions of prominent Institute officials, an address by Dr. A. N. Goldsmith, entertainment by prominent radio broadcast stars, and music by the Vincent Lopez Orchestra. Following the dinner dancing was provided.

The total registration at the convention was over seven hundred. Over four hundred and fifty members of the Institute and their guests attended the dinner.

CONVENTION PAPERS AVAILABLE

The following papers presented at sessions of the convention are available free of charge to members of the Institute:

"The International Radiotelegraph Conference of Washington, 1927," by W. D. Terrell.

"On the Distortionless Reception of a Modulated Wave and Its Relation to Selectivity," by Frederick K. Vreeland.

"Some Characteristics and Applications of Four-Electrode Tubes," by J. C. Warner.

"Measurement of Vacuum-Tube Capacities by a Transformer Balance," by Harold A. Wheeler.

"A Direct Capacity Bridge for Vacuum-Tube Measurements," by Lincoln Walsh.

"Direct Coupled Detector and Amplifiers with Automatic Grid Bias," by Edward H. Loftin and S. Young White.

Upon application to the offices of the Institute a copy of any of the above papers in pamphlet form will be mailed to members.

MEETING OF SECTION REPRESENTATIVES

One meeting of the Institute was devoted to a conference of representatives of the sections of the Institute. Addresses were delivered by President Goldsmith, Past Presidents Ralph Bown and Donald McNicol, and by a number of the chairmen of sections.

The conference extended over a period of four hours during which time a vast amount of information relative to section operation and management, together with an account of the problems of individual sections, was summarized.

A summary of the activities of this conference will be available in the near future for members interested in the formation of a section.

It is planned that this very important feature of the Institute conventions will be held at future annual conventions.

Section Meetings

ATLANTA SECTION

R. M. Wise, chief engineer of the E. T. Cunningham Company, delivered a paper on "Shield Grid Tubes, AC Tubes and Oxide Filament Rectifier Tubes" at the meeting of the Atlanta Section, held on January 3rd in the Chamber of Commerce Building, Atlanta, Georgia.

Fourteen members of the Institute and twenty-two guests attended this meeting.

BUFFALO-NIAGARA SECTION

On December 14th a meeting of the Buffalo-Niagara Section was held in Foster Hall, University of Buffalo. L. C. F. Horle, chairman, presided.

W. R. Jones, research engineer of the Federal Radio Corporation presented a paper on "Notes on Design and Production of Uni-Control Broadcast Receivers."

Messrs. Horle, Henderson, Porter and others participated in the discussion which followed the presentation of the paper.

Forty-five members of the Section attended this meeting.

A meeting of the Section was held on January 18th in Foster Hall, University of Buffalo, at which time Dr. Leo Dana, chief physicist of the Linde Air Products Company read a paper entitled, "Application of Rare Gases to Radio."

Messrs. Horle, Lidbury, Porter, Hector and others discussed the paper.

Eighty-five members and guests attended.

The next meeting of the Section will be held on February 15th in the University of Buffalo. Carl Dreher, staff engineer of The National Broadcasting Company, will present a paper on "As the Broadcaster Sees It."

CANADIAN SECTION

The Canadian Section held a meeting on December 7th at which V. G. Smith delivered one of the junior lectures on "Series and Parallel Resonance." F. K. Dalton presented a paper entitled, "Marconi Beam Stations."

A. M. Patience, Chairman of the Section, presided.

In the discussion following the two papers, the following members took part: D. Hepburn, C. I. Soucy, V. G. Smith, C. C. Meredith and others.

The attendance at this meeting was fifty-six.

CHICAGO SECTION

On December 16th a meeting of the Chicago Section was held in the Auditorium of the Western Society of Engineers. Professor G. M. Wilcox presided.

Dr. Frederick W. Kranz, of Riverbank Laboratories, presented a paper on, "Some Characteristics of Speech and Hearing."

Following the discussion the annual election of officers was held, the result being that John H. Miller was elected Chairman, Harold L. Olesen, Vice-Chairman; H. E. Kranz, Secretary-Treasurer; and the Executive Committee with its membership as follows was appointed: G. M. Wilcox and E. L. Koch.

CLEVELAND SECTION

A meeting of the Cleveland Section was held on January 6th in the Ohio Bell Telephone Building. John R. Martin presided.

D. A. Leach, equipment engineer of the Ohio Bell Telephone Company, delivered a talk entitled "Automatic or Machine Switching." The talk included lantern slides, followed by an inspection of the new automatic equipment in the building.

Preceding the technical meeting, an informal dinner was held in the Hotel Winton.

Sixty-three members of the Section attended the meeting.

DETROIT SECTION

Dr. N. H. Williams presented a paper, "Some Characteristics of the Screen Grid Tube" at a meeting of the Detroit Section held on December 16th in the dining room of the Michigan Bell Telephone Company Building, Detroit.

Thomas E. Clark, Chairman of the Section, presided.

Over one hundred members of the Section and their guests attended the meeting.

Preceding the meeting a dinner, at which seventy-five persons were present, was held.

LOS ANGELES SECTION

On November 21st a meeting of the Los Angeles Section was held in the Elite Cafe, 633 South Flower Street, Los Angeles.

D. C. Wallace, Vice-Chairman, presided.

Dr. Leonard F. Fuller delivered a paper entitled "Vacuum Tubes and Their Application to the Power Field."

L. Elden Smith delivered a paper describing the short wave work accomplished on the Yacht *Ripple* through the South Seas, and also a description of radio beacons at Wheeling Field, Hawaiian Islands.

Seventy-two members of the Section were present.

Committee Work

I. R. E. SUBCOMMITTEE ON RECEIVING SETS

A meeting of the Subcommittee on Receiving Sets was held at the Institute Office on January 11th. Those present were: J. H. Dellinger (Chairman), E. E. Hiler (Secretary), E. Austin, I. G. Maloff, W. D. Kirschbaum, W. A. Diehl, C. A. Wright, A. H. Lynch, L. C. F. Horle, George Crom, H. B. Coxhead, and L. M. Hull.

The Subcommittee modified Section D of the printed May 20, 1927 preliminary report, by the adoption of an alternative method of measuring input field intensity, viz, the introduction of input voltage by a coupling resistor in the output circuit of the radio-frequency source. This was added because some laboratories have found this method to be convenient and to give results in agreement with those obtained by the use of a coupling coil.

The preparation of a section on Test Procedures was begun. This is a difficult undertaking and will require considerable more

work. It is expected that procedures will be worked out in sufficient detail to be applicable to the several types of receiving sets. The Committee is giving attention to correlation of its recommendations with those of the Subcommittee on Vacuum Tubes.

Extensions were made in the Bibliography. It has been found in listing references on receiving set testing that articles on other receiving apparatus must necessarily be included. This led to a recommendation that the Standardization Committee have a special subcommittee on Bibliography, in order that such work may be correlated for the whole field to which the Committee is giving attention.

I. R. E. SUBCOMMITTEE ON VACUUM TUBES

On December 6th a meeting of the Subcommittee on Vacuum Tubes, L. A. Hazeltine, Chairman, was held in the offices of the Institute. All members of the Committee were present or were represented.

All suggestions which had been received, for modification of the preliminary draft of May 20, 1927 were considered and some were adopted.

The connections of Fig. 4, a bridge method for measuring grid-plate capacity, were modified by interchanging the grid and plate and by substituting an adjustable resistance in series with the standard capacity for the adjustable capacity used for phase balance. This is the arrangement originally proposed by Lincoln Walsh, which was presented by him in the symposium on "Vacuum-Tube Capacity measurements" at the Convention. The main dimensions of a shielding plate, in which the vacuum tube is to be mounted, were specified, these being in accordance with the drawing appearing in the current "Nema Handbook of Radio Standards."

The subject of power rating of vacuum tubes used particularly to supply loudspeakers was discussed at length. It was decided to give, in a single section, specifications for "Maximum Undistorted Power Output" and "Conventional Power Output," the former to be essentially those given in the preliminary draft (Section 18), the latter to correspond with those for "Normal Output" in the report of the Subcommittee on Receiving Sets. The difference lies, essentially, in the value of resistance to be put in the external plate circuit: maximum undistorted power output calls for twice the plate resistance, or a higher value, if specified by the manufacturer, while conventional power output is a lower

value taken with an external resistance equal to the plate resistance, this giving the greatest output for a given input alternating voltage. In order to further bring the work of the two subcommittees into accord, Mr. Engel was asked to cooperate with Mr. Van Dyck on the Subcommittee on Receiving Sets in studying the desirability of directly measuring harmonics produced in the plate circuit, in place of inferring their magnitude by the change in the direct component of plate current, as specified in the preliminary draft.

It was voted unanimously to recommend to the main Committee on Standardization the use of the word "Capacitance" in place of "Capacity." This is in accord with the usage of the A. I. E. E. and of the N. E. M. A.

It was decided to define "screen-electrode vacuum tube," this being the name chosen for the new four-electrode tube in which the fourth electrode, or "screen," serves to screen the grid electrostatically from the plate.

Personal Mention

Ralph R. Batcher, formerly engineer with the A. H. Grebe Company, is now vice-president of the Decatur Manufacturing Company, Inc., of Brooklyn, New York.

B. R. Hubbard is now director of laboratory for the Submarine Signal Corporation of Boston, having returned from leave of absence at Massachusetts Institute of Technology, where he was an assistant instructor.

R. A. Hackbusch, formerly on the staff of the Canadian Westinghouse Company, Ltd., is now with Canadian Brandes, Ltd., of Toronto.

Charles C. Henry has resigned as radio sales engineer of the Sonora Phonograph Company, Inc. of Saginaw, Michigan, and has joined the staff of Grigsby-Grunow-Hinds Company of Chicago, in the same capacity.

William H. Fortington, late director of research of the Operadio Corporation, of Chicago, is now practicing as a consulting engineer in Chicago.

Lieutenant Leonard H. Bouchier, U. S. Marine Corps, has been transferred from the Radio Station, Belize, Honduras, to Radio Station, 2nd Brigade, U. S. Marines, at Managua, Nicaragua.

A. I. E. E. 1928 Winter Convention

With headquarters in the Engineering Societies Building, 33 West 39th Street, New York, the A. I. E. E. Winter Convention will be held February 13-17.

The "Communications" portion of the technical sessions will take place on Thursday, February 16th and will include two papers on "Transatlantic Telephony," followed by an exchange of greetings over the New York-London radiotelephone circuit between the President of the American Institute of Electrical Engineers and the President of the British Institution of Electrical Engineers. Arrangements have been made for these and other exchanges of greetings to be heard by those present at the sessions of the A. I. E. E. in New York, and also by members of the Institution of Electrical Engineers who will have a regular meeting simultaneous with the New York meeting.

A paper by C. R. Hanna on "A New Horn Type of Loudspeaker" will be presented, followed by a paper by H. B. Nyquist on "Certain Topics in Telegraph Transmission Theory."

A PRECISION METHOD FOR THE MEASUREMENT OF HIGH FREQUENCIES

BY

CHARLES BAYNE AIKEN

Summary—A precision method for the measurement of the frequency of an oscillating circuit is discussed. The theory on which the method is based is discussed and there is developed an equation which relates the frequency of the beat note between two oscillators to the natural frequency of a circuit which is loosely coupled to one of them. This equation is considered in some detail and certain of its properties are deduced. Curves are drawn for three typical cases. The cause and avoidance of certain errors are considered. The method is extended to the case of a non-oscillating circuit. Finally there is suggested a method for the measurement of small values of mutual inductance.

FOR a number of years there has been employed in the Craft Laboratory of Harvard University a zero beat method of frequency measurement which is susceptible of great precision. A brief mention of this method has been made by Professor G. W. Pierce in his paper, "Piezo-Electric Crystal Resonators and Crystal Oscillators Applied to the Precision Calibration of Wave Meters."¹ In the present paper a more detailed consideration of the method is given, together with a development of the theory involved. Suggestions are made for the application of the results of this development to the measurement of very small values of mutual inductance.

PART I—DESCRIPTION OF THE METHOD

There will first be described the measurement of the frequency of a source of sustained oscillations. We shall, as a matter of custom, speak of the meter which is to be used as a wavemeter, but shall call the quantity under measurement a frequency since the equations have been developed in terms of 2π times the frequency.

A vacuum-tube generator will oscillate at such a frequency as to make the total effective reactance of the oscillating circuit zero. This reactance is determined not only by the constants of the oscillating circuit proper, but also by the constants of the tube and of whatever circuits may be coupled to the oscillating system, including the plate circuit. In the present method a wavemeter is coupled to the oscillating circuit and advantage is taken of the effect which the tuning of this added circuit has upon the frequency of the

Original Manuscript Received by the Institute August 1, 1927.

Revised Manuscript Received by the Institute November 1, 1927.

¹ *Proc. Amer. Acad.*, 59-4, 1923.

oscillator. It is well-known that resonance effects in coupled circuits depend upon the constants of both circuits and that if the coupling is sufficiently loose the current in one circuit will follow a single peaked resonance curve when the other circuit is tuned. It is readily shown that this peak occurs when both circuits have the same period as either would have if the coupling were decreased to zero and that the total effective reactance of each circuit is equal to zero for this condition. If now one of the circuits is thrown out of resonance its effective reactance will no longer be zero nor will that of the other circuit. This is indicated by the fact that the currents in both circuits will decrease. If now the circuit which is arbitrarily thrown out of resonance is a wavemeter circuit and the other is the oscillating circuit of a vacuum-tube generator it follows that the frequency of oscillation will change in such a way as to keep the effective reactance of the oscillating circuit zero. In the neighborhood of mutual resonance this effect of the wavemeter tuning on the oscillating frequency may be large, but when the wavemeter is tuned to a frequency far removed from that which the oscillator would have alone, the effect of the wavemeter in altering the frequency will become vanishingly small. It is at once apparent that this phenomena furnishes us with a method for determining the frequency of the oscillator. This determination is made as follows:

With the wavemeter removed, or open circuited, zero beats are obtained between the fundamental or any convenient harmonic of the oscillator and some other source of high-frequency oscillations. This second source is to be used merely as a reference frequency which will be serviceable in making evident the variations in the frequency of the main oscillator, and it is assumed that the reaction of the oscillator on the auxiliary source is negligible. Instead of using another oscillator a distant transmitting station may be used and the oscillator tuned to zero beats with the signal brought in by a receiving set. After the zero beat adjustment has been made the wavemeter is loosely coupled to the oscillator and the tuning of the meter changed slowly. As resonance is approached the beat frequency will depart from zero and gradually rise to a maximum. As the tuning is continued, the beat frequency drops sharply off and passes through zero and then rises rapidly to another maximum after which it falls off gradually to zero. When the middle silent point occurs the oscillator and the wavemeter are both tuned to the frequency of the auxiliary signal, providing the fundamentals of both oscillations have been employed. If the wavemeter has

already been calibrated the frequency of the oscillator is determined as well as that of the auxiliary signal. If the last mentioned is a standard frequency broadcast then the oscillator frequency is again determined and a point is obtained for calibrating the wavemeter. By employing various harmonic ratios between the oscillator and the incoming signal several points can be obtained for the wavemeter calibration. If the harmonics of the incoming signal are too weak another oscillator may be tuned to zero beat with this signal, and the various harmonics of this oscillator made to beat with those of the first oscillator. The beat note is heard by inserting a pair of telephones in the output circuit of one or the other oscillators.

If the beat is adjusted to a value which is below the audible range of frequencies but is not at zero, the two maxima in the beat frequency which are obtained when the wavemeter is tuned through resonance will not be of equal magnitude. It will be shown later that the frequency read on the wavemeter scale when the meter is so adjusted as to split the silent interval in the beat note will not be the true reading if the maxima mentioned above are of unequal magnitude. If the frequencies under measurement are very high this error will be negligible, but at low frequencies it may be appreciable. It will also be shown that errors of this type are reduced if the wavemeter is coupled to the oscillator, the frequency of which is desired, rather than to the auxiliary oscillator.

If the coupling between the wavemeter and the oscillator is too close no silent mid-point in the beat note can be obtained but as the wavemeter is tuned through resonance the beat note will first increase to a maximum as before, and will then fall off slightly but instead of passing sharply through zero it will jump suddenly to another frequency and then fall gradually to zero. When the jump occurs resonance has been passed. This state of affairs should be avoided. The significance of this frequency jump is discussed in Part 2.

The resonant setting of the wavemeter can be determined with a degree of sharpness that is very great. It is superior in this respect to the *grid dip* method of resonance indication, in which a sensitive galvanometer is included in the grid circuit of the oscillator and is of course vastly superior to the methods which involve the actuation of an indicating device in the wavemeter circuit.

We shall now discuss the theory of the method from the point of view of the equations of a typical vacuum-tube oscillator.

PART 2—THEORY OF THE METHOD

We wish to study the variations of the beat frequency as the natural frequency of the wavemeter is altered. As a starting point we shall consider the conditions of oscillations of a typical vacuum-tube circuit, such as is shown in Fig. 1. The condition which determines the frequency of oscillation is that the effective reactance of the grid circuit shall be zero. This condition² is as follows:

$$X_2 + hX_p - \frac{M^2\omega^2 X_1}{R_1^2 + X_1^2} = 0 \quad (1)$$

$$\begin{aligned} \text{In which } X_1 &= \omega L_1 - 1/\omega C_1 & X_2 &= \omega L_2 - 1/\omega C_2 & X_p &= L\omega \\ h &= \frac{\mu m / C_2 - m^2 \omega^2}{Z_p^2} & Z_p^2 &= (R + R_p)^2 + L^2 \omega^2 \end{aligned}$$

If m and C_2 are kept constant, then h , the coefficient of regeneration, is practically constant, and will be so considered here. This

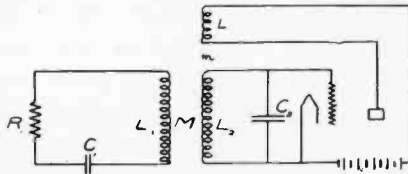

Fig. 1

amounts to assuming that $\mu/\omega C_2 \gg \omega m$ and that $\omega^2 L^2 / (R + R_p)^2 \ll 1$, which is usually the case in practice. Now we have

$$X_1 = (\omega^2 L_1 C_1 - 1) / \omega C_1 = L_1 (\omega^2 - \omega_1^2) / \omega$$

$$\omega_1 = 1 / \sqrt{L_1 C_1}$$

$$X_2 + hX_p = \omega(L_2 + hL_p) - 1/\omega C_2$$

$$= (\omega L_2' - 1/\omega C_2) = L_2' (\omega^2 - \Omega_2^2) / \omega$$

$$\Omega_2 = 1 / \sqrt{L_2' C_2}$$

Inserting these relations in (1), gives

$$\frac{L_2'}{\omega} (\omega^2 - \Omega_2^2) - \frac{M^2 \omega^2}{R_1^2 + \frac{L_1^2}{\omega^2} (\omega^2 - \omega_1^2)^2} \cdot \frac{L_1}{\omega} (\omega^2 - \omega_1^2) = 0 \quad (2)$$

² See p. 339 of "Regeneration in Coupled Circuits," by E. L. Chaffee. Proc. I. R. E., June 1924.

Since Ω_2 is a constant it is possible to obtain ω as a function of ω_1 and this relation would yield the desired information. However, the above equation is of the third degree in ω^2 and of the second degree in ω_1^2 and a direct treatment leads to extreme complications.

More convenient results can be obtained by solving for $(\omega - \Omega_2)$ as a function of $(\omega_1 - \Omega_2)$ and introducing certain well-justified approximations. Equation (2) can be written

$$\frac{L_2'}{\omega}(\omega - \Omega_2)(\omega + \Omega_2) - \frac{M^2\omega^2 \frac{L_1}{\omega}(\omega - \omega_1)(\omega + \omega_1)}{R_1^2 + \frac{L_1^2}{\omega^2}(\omega - \omega_1)^2(\omega + \omega_1)^2} = 0$$

Let $y = \omega - \Omega_2$ and $u = \omega - \omega_1$

$$yL_2' \left(1 + \frac{\Omega_2}{\omega}\right) - \frac{M^2\omega^2 L_1 u \left(1 + \frac{\omega_1}{\omega}\right)}{R_1^2 + L_1^2 u^2 \left(1 + \frac{\omega_1}{\omega}\right)^2} = 0 \quad (3)$$

Now assume that $\Omega_2/\omega = \omega_1/\omega = 1$ and call $\Omega_2 = \Omega = \omega$

Then
$$2L_2'y - \frac{2M^2\Omega^2 L_1 u}{R_1^2 + 4L_1^2 u^2} = 0 \quad (4)$$

Let $x = \omega_1 - \Omega = y - u$

Eliminating u from (4) gives

$$L_2'y - \frac{M^2\Omega^2 L_1(y-x)}{R_1^2 + 4L_1^2(y-x)^2} = 0 \quad (5)$$

or $4L_1^2 L_2^1 (y^3 - 2y^2x + yx^2) + (R_1^2 L_1^2 - M^2\Omega^2 L_1)y + M^2\Omega^2 L_1 x = 0$.

This can be written $y^3 - 2y^2x + yx^2 + Dy + Ex = 0$ (6)

In which

$$\left. \begin{aligned} D &= \frac{R_1^2 L_2' - M^2\Omega^2 L_1}{4L_1^2 L_2'} = \frac{(\eta_1^2 - \tau^2)\Omega^2}{4} \\ E &= \frac{M^2\Omega^2 L_1}{4L_1^2 L_2'} = \frac{\tau^2\Omega^2}{4} \end{aligned} \right\} \quad (7)$$

$$\left. \begin{aligned} D+E &= \frac{\eta_1^2 \Omega^2}{4} > 0 \\ \eta_1 &= \frac{R_1}{\Omega L_1} \quad \tau = \frac{M}{\sqrt{L_1 L_2'}} \end{aligned} \right\} \quad (8)$$

$y/2\pi = (\omega - \Omega)/2\pi$ is the beat frequency and $x/2\pi = (\omega_1 - \Omega)/2\pi$ is the frequency difference between the wavemeter setting and the resonant frequency. E cannot be less than zero but D may be positive, negative, or zero.

The obtaining of y as a function of x necessitates the solution of a cubic equation and involves calculations of considerable complication. We shall examine the equation and obtain all the information we desire without actually solving it.

Let us note that the substitution of $-x$ for x or of $-y$ for y in (6) reduces it to

$$y^3 + 2y^2x + yx^2 + Dy - Ex = 0 \quad (9)$$

Since (6) and (9) are not identical it follows that the curve $y=f(x)$ is not symmetrical with respect to either the x or y axes. However, the simultaneous substitution of $-x$ for x and $-y$ for y leaves (6) unchanged and hence $y=f(x)$ is symmetrical with respect to the origin. Equation (6) may be written

$$\frac{Ex}{y} = -[(y-x)^2 + D] \quad (10)$$

Now $(y-x)^2 \geq 0$. Hence if D is positive x/y is always negative and $y=f(x)$ lies entirely in the second and fourth quadrants and must either be discontinuous or pass through the origin. A detailed investigation shows that the curve is continuous at all points. If D is negative the curve lies in the first and third quadrant for small values of $(y-x)^2$ and in the second and fourth for values of $(y-x)^2$ which are larger than $-D$. When $x=0$ then $y^3 + Dy = 0$ by (6). Hence

$$y=0 \text{ or } y = \pm \sqrt{-D} \quad (11)$$

If $D \geq 0$ then $y=0$ is the only solution, while if $D < 0$ there are three possible values of y corresponding to $x=0$, that is, to the resonant setting of the wavemeter.

Solving (6) for $x=F(y)$ we obtain

$$x = y - E/2y \pm \sqrt{E^2/4y^2 - (E+D)} \quad (12)$$

If x is to be real there is imposed upon y the restriction that

$$y^2 \leq E^2/4(E+D) \quad (13)$$

$$\frac{dx}{dy} = 1 + \frac{E}{2y^2} \left(1 \mp \sqrt{1 - \frac{4y^2(E+D)}{E^2}} \right) \mp \frac{\frac{2(E+D)}{E}}{\sqrt{1 - \frac{4y^2(E+D)}{E^2}}} \quad (14)$$

If we choose the positive sign in the ambiguity then when $y=0$, $dx/dy = \infty$. This corresponds to $x = \pm \infty$. If we choose the negative sign, then when $y=0$, (14) is an indeterminate form, the evaluation of which gives $dx/dy = -D/E$. Hence the slope, at the origin, of $y=f(x)$ is negative when $D>0$, is infinite when $D=0$ and is positive when $D<0$. dx/dy is also infinite when $1 - 4y^2(E+D)/E^2 = 0$. This corresponds to a maximum value of y .

$$y_m = \pm \frac{E}{2\sqrt{E+D}} \quad (15)$$

Inserting (15) in (12) we obtain the value of x which corresponds to the maximum value of y

$$x_m = \mp \frac{2D+E}{2\sqrt{E+D}} \quad (16)$$

We are now in possession of the following information:

(a) $y=f(x)$ is not symmetrical with respect to either the x or the y axes but is symmetrical with respect to the origin.

(b) For $D>0$, f lies entirely in the second and fourth quadrants. For $D<0$, f lies in the first and third quadrants for $(y-x)^2 < |D|$ and in the second and fourth for $(y-x)^2 < |D|$.

(c) The curve passes through the origin.

(d) y is restricted in magnitude by the relation $y^2 \leq \frac{E^2}{4(E+D)}$

(e) Within the range of (d) there are two distinct values of x for every value of y except for $y = \pm E/2\sqrt{E+D}$ when the two values of x are identical.

(f) The maximum and minimum values of y are given by the relation of (d). The values of x corresponding to these values of y are

$$\text{given by } x_m = \mp \left(\frac{2D+E}{2\sqrt{E+D}} \right)$$

(g) The slope of the curve at the origin is given by

$$\frac{dy}{dx} = \frac{-E}{D} = -\frac{\tau^2}{(\eta_1^2 - \tau^2)}$$

In Fig. 2 are plotted three curves for $\Omega = 4 \times 10^6$ or $\lambda = 472$ meters, $\eta_1 = 0.004$ and $\tau = 0.002$, $\tau = 0.004$ and $\tau = 0.006$ for curves 1, 2, and 3 respectively.

As the resonant frequency of the wavemeter is increased from a value smaller than $\frac{\Omega}{2\pi}$, the beat frequency y , is seen to increase

slowly, reach a maximum, and then to drop off sharply as resonance is approached. This falling off of y will be the more rapid, the larg-

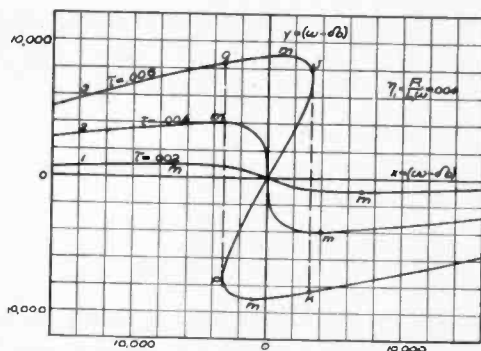

Fig. 2

er the value of τ , up to $\tau = \eta_1$. If $\tau > \eta_1$ then y will not pass through zero but after reaching its maximum value will decrease somewhat to a point such as J of curve 3. As ω_1 is further increased a jump to the point K takes place and a sudden change in the beat note results. If the order of tuning is reversed and ω_1 is decreased from a value larger than that corresponding to the point K then a jump again occurs but this time it is from P to Q and takes place at a value of ω_1 which is different from that which corresponded to the first jump. It is evident that this state of affairs is undesirable in making frequency measurements, although of course the interval in ω_1 may be split in order to obtain the resonant frequency. The ideal condition for precision measurements is the critical one, $\tau = \eta_1$. The middle region of inaudible beats is then as narrow as it is possible to have it and y_m will be larger than for any other curve

which does not give a discontinuity in the beat frequency. Calling the value of y_m corresponding to $\tau = \eta_1$, y_{mm} we have:

$$y_{mm} = \frac{\sqrt{E}}{2} = \frac{\eta_1 \Omega}{4} \quad (17)$$

This is directly proportional to the frequency. On the other hand

$\frac{y_{mm}}{\Omega}$ is dependent only on the quantity η_1 which is, for many

coils, almost independent of frequency over a considerable range.

In the case cited $\frac{y_{mm}}{\Omega} = 0.001$ or 0.1 per cent and the approximations

$\frac{\Omega}{\omega} = \frac{\omega_1}{\omega} = 1$ which were introduced into the original equations, are

well justified. It is evident that the method is better adapted to

the higher frequencies since the value of $\frac{y_m}{2\pi}$ must be in the audible

range, and if the frequency under measurement is low, y_m may be too large a fraction of Ω . However, the range of applicability may be extended several octaves by adjusting the auxiliary oscillator to zero beats with a harmonic of the oscillator which is being measured. If one of the higher harmonics is thus employed it may be necessary to insert the telephones in the circuit of the oscillator under measurement in order that the beat note may be audible without excessive amplification. Frequencies outside of the range of the wavemeter may also be determined by employing the harmonics of one or both oscillators.

If the two oscillators are not exactly in resonance a certain error will be introduced into the determination of the wavelength.

Suppose that the frequency $\frac{\Omega_3}{2\pi}$ of the auxiliary oscillator is slightly

lower than $\frac{\Omega}{2\pi}$, the frequency which is being determined. If the in-

terval ab , in Fig. 3, represents the magnitude of the minimum frequency of audibility, then when the wavemeter is absent the beat

note $\frac{\Omega_3 - \Omega}{2\pi}$ will be inaudible. When the wavemeter is coupled to the

oscillator which, when uncoupled to other circuits, has a frequency

of $\frac{\Omega}{2\pi}$ and the meter is tuned through resonance, the beats will

become audible at the points C and C' and the reading which is obtained will be too high by the amount $\Delta\omega = OS$, where S is the point which is judged to be the center of the interval CC' . The difference between the wavemeter reading and the frequency of

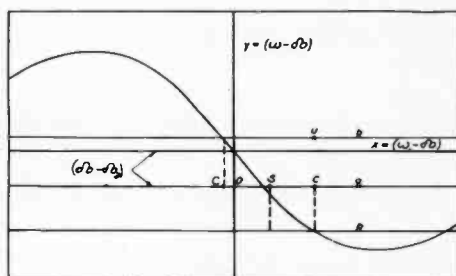

Fig. 3

the auxiliary oscillator is even greater, being $(\Omega_3 - \Omega) + OS$, and hence it is apparent that the wavemeter should be coupled to the oscillator, the frequency of which is to be measured. There is also evident the importance of having the two oscillators accurately adjusted to zero beat. When the beat note is inaudible but is not zero it will be noted that the maximum beat frequency will be greater when the wavemeter is tuned away from resonance in one direction, then in the other. By adjusting the auxiliary oscillator until these maxima are judged to be equal the errors from this source may be practically eliminated.

The frequency of a non-oscillating circuit can best be found by obtaining sufficient data for a calibration curve. The two oscillators are adjusted to zero beat at a frequency somewhere near that which the non-oscillating circuit is thought to have. The latter is then loosely coupled to one oscillator and its capacity varied until the silent mid-point is found. The circuit is then removed and a wavemeter put in its place. Without changing the adjustments of the oscillators the wavemeter is brought into resonance. The frequency of the wavemeter circuit is then the

same as that of the circuit under measurement. By obtaining several such points a calibration curve can be drawn and the frequency corresponding to any given condenser setting may be obtained by interpolation. If the circuit elements are invariable an auxiliary condenser may be added and two or three points obtained. If these points are properly chosen a fairly accurate extrapolation may be made to find the frequency which is associated with the circuit when the auxiliary condenser is removed.

$$\text{The relation } \tau = 2\sqrt{\frac{y_m \eta_1}{\Omega}} \text{ or } M = \frac{2}{\Omega} \sqrt{y_m R_1 L_2} \quad (15a)$$

suggests a possible method for the measurement of the coefficient of coupling or the mutual inductance. If the mutual inductance between two circuits is to be measured, one of them, the inductance of which is known, may be connected to a vacuum tube and made to function as one of the two oscillating circuits required to obtain zero beats while the other replaces the wavemeter circuit in the foregoing discussions. If the various circuit constants

are such that $\frac{y_m}{2\pi}$ lies within the audible range it may be measured

on a frequency meter of the resonance bridge or other suitable type. Then if R_1 , L_2 and Ω are known, M may be determined from (15a). The variation of y with x in the neighborhood of y_m is small and hence there should be no difficulty involved in setting x so as to obtain a value of y which is very near the maximum. R_1 can be found by any of the standard methods for the determination of resistance at high frequencies. Ω must be determined by means of a wavemeter as in the above. Since y_m , R_1 and L_2 enter under the radical sign the per cent error introduced into the value of M by a small error in any one of these quantities will be half the per cent error in that quantity.

In case a frequency meter is not available y_m may be adjusted to zero beat with a tuning fork by inserting a variable resistance in the circuit (1) and changing R_1 until y_m has the proper value.

Another method which might suggest itself as applicable in case there is no frequency meter to be had is that of bringing y into zero beat with a tuning fork by varying x . This adjustment is possible for four values of x provided that the frequency of the fork is less than y_m . Since y now differs from y_m the relation

between y and τ will contain x and (12) must be used. By substituting two pairs of corresponding values of x and y in (12) we obtain two simultaneous equations in x and y . If we choose two pairs that are symmetrical with respect to the origin the resulting equations are identical and cannot be solved. If we choose two pairs such that both values of x lie on the same side of the origin the sign of the ambiguity in (12) must be different in the two equations. On subtracting we obtain

$$x_2 - x_1 = 2 \sqrt{\frac{\tau^4 \Omega^4}{64 y^2} - \frac{\eta_1^2 \Omega^2}{4}} \quad (18)$$

or

$$\tau = \frac{2}{\Omega} \sqrt{y^2 (x_2 - x_1)^2 + y^2 \eta_1^2 \Omega^2} \quad (19)$$

In which x_1 and x_2 lie on opposite sides of y_m and are values of x which give identical values of y .

If we choose y sufficiently small $(x_2 - x_1)$ will be large and we may fulfil the condition

$$(x_2 - x_1)^2 > \eta_1^2 \Omega^2 = \left(\frac{R_1}{L_1}\right)^2 \quad (20)$$

In this case

$$\tau = \frac{2}{\Omega} \sqrt{y(x_2 - x_1)} \quad (21)$$

Because of the extreme flatness of the curve for large values of x there will be a large probable error in determining x_2 , the larger value of x . In order that the condition (21) may be fulfilled it is necessary that x_2 be extremely large. Because of the asymptotic approach of y to zero as x increases the difficulties involved in determining the value of x_2 , which corresponds to a given value of y , are considerable and consequently this method cannot be considered as a satisfactory one.

In conclusion I wish to acknowledge my indebtedness to Professor G. W. Pierce of Harvard University, under whose direction I first used this method of frequency measurement, for permission to work up and discuss the theory involved.

PRECISION DETERMINATION OF FREQUENCY*

By

J. W. HORTON AND W. A. MARRISON

(Bell Telephone Laboratories, New York City)

Summary—The relations between frequency and time are such that it is desirable to refer them to a common standard. Reference standards, both of time and of frequency, are characterized by the requirement that their rates shall be so constant that the total number of variations executed in a time of known duration may be taken as a measure of the rate over shorter intervals of time. Frequency standards have the further requirement that the form of their variations and the order of magnitude of their rates shall be suitable for comparison with the waves used in electrical communication.

Two different types of standard which meet these requirements are described. One consists of a regenerative vacuum-tube circuit, the frequency of which is determined by the mechanical properties of a tuning fork. The other is a regenerative circuit controlled by a piezo-active crystal. Means are provided, in the case of each standard, whereby the recurrent cycles may be counted by a mechanism having the form of a clock, the rate of which is a measure of the frequency of the reference standard.

Data taken over a period of several years with a fork-controlled circuit show that, under normal conditions, its rate may be relied upon to two parts in one million. Data taken over a much shorter time with crystal controlled oscillators indicate that they are about ten times as stable.

WHEN we speak of the frequency of a wave or, in fact, when we use the word frequency in any connection, we mean, in general, the number of times a periodic occurrence takes place within a given interval of time. Consequently the frequency of a recurrent phenomenon is the reciprocal of the time interval required for the variation to pass through one cycle provided the duration of any given cycle is identical with that of any other, or, in other words, that the variation has a constant frequency. Since, therefore, frequency may be expressed completely in terms of time, it is neither necessary nor desirable to have any fundamental standard of frequency other than the accepted standard time interval.

The present standard of time is, of course, the sidereal day, which is the time required for the earth to make one complete revolution in space. A succession of sidereal days, therefore, constitutes a recurrent phenomenon the duration of any cycle of which is, by definition, equal in time to the duration of any other

Original Manuscript Received by the Institute, December 6, 1927.

* Paper read at meeting of the International Union of Scientific Radio Telegraphy, Washington, Oct. 13, 1927.

cycle. In other words, the variation has the essential characteristics required of a standard of frequency. The mean solar day, in terms of which all measurements of time are expressed, must be considered as a practical standard the determination of which is made in terms of the sidereal day.

There is a unique difference between a standard of time—or frequency—and standards of most other quantities. For example, the standard unit of mass or the standard unit of length may be given physical embodiments and may be put in a safe where their identity will be preserved over extended periods. Unlike a mass or a length, an interval of time cannot of itself be preserved nor can it readily be given a physical embodiment which by virtue of its great constancy may be used as a fundamental standard. At present, therefore, all precision measurements of time must be referred directly to the rate of the earth's rotation.

Having once concluded that the fundamental standard of time is, *ex officio*, the fundamental standard of frequency, there remains simply the problem of comparing the rate of any periodic variation which is to be measured with the rate of the earth's rotation.

If there were available only the periodic phenomenon of unknown rate and the intervals defined by the earth's rotation, it would be necessary that the unknown phenomenon maintain its rate unchanged throughout an entire interval covered by one rotation of the earth. In this case the measurement would consist in counting the number of times the unknown variation repeated itself during the interval. Due, however, to the availability of means for accurately defining time intervals less than the sidereal day to the required precision, it is, of course, unnecessary to maintain the rate of the variation to be measured over the longer interval. When we recognize that any means used for evaluating the time of short intervals is itself executing periodic variations of equal duration, we realize that it is a secondary standard of frequency as well as a secondary standard of time. Thus the Riefler clocks at the National Bureau of Standards and at the U. S. Naval Observatory become our most practical working standards of frequency. In terms of the oscillations of their pendulums their frequency may be said to be unity when referred to the second.

A secondary standard such as a high grade seconds pendulum is unsuited to the actual determination of the frequency of such variations as are of interest in electrical communication, both

because of the excessively high ratio between the rates of the occurrences to be compared and because, in its usual form, the motion of a clock pendulum is not well suited for comparison with electrical variations. It is desirable, therefore, as the first step in the precision measurement of the frequencies of electric waves, to provide a suitable reference standard. The requirements of such a standard are that its rate should be of the same order of magnitude as the rates to be measured, that the form of the variation which it controls should be suitable for convenient comparison with the variations to be measured, and, finally, that its rate shall be sufficiently constant so that the total number of variations which it executes in a time of such duration that it may be defined with high precision may be taken as the rate of the variation over shorter intervals of time. This last requirement again emphasizes the inherent similarity between secondary standards of frequency and secondary standards of time. For convenience, it should also be possible to adjust the rate of the frequency standard to some prescribed value within such limits that the error may be neglected in the majority of measurements.

ORIGINAL EQUIPMENT

A secondary standard having the characteristics mentioned above was described several years ago by the authors of the present paper in collaboration with Mr. N. H. Ricker. This standard consists of a 100-cycle tuning fork maintained in vibration by an amplifier regeneratively connected through the fork by electromagnetic coupling. Means are provided for obtaining from the electrical portion of the resulting oscillating system a sinusoidal alternating current the frequency of which is constant to high precision. Standards of this general type are being extensively used, as will be seen by referring to the bibliography. A brief survey of the present status of this 100-cycle standard is of interest not only because of the improvement in its performance since the original report was presented, but also because the experience which has been gained from its use has been of value in the development of standards of still greater utility.

The fork which was described in the paper already referred to ran continuously from April, 1923, to May, 1927, except for four intervals totalling about three days. Of these interruptions two were from accidental causes and two for the purpose of making minor changes in the system. Throughout this entire period the

temperature of the fork, as maintained by its thermostatically controlled water bath, was held at approximately the value for which its rate is 100 cycles. Since the temperature coefficient of frequency for the particular fork in question is 0.0109 per cent per degree Centigrade, it is necessary to keep the temperature to within 0.01 deg. C. of the prescribed value in order that the rate shall be correct to one part in a million. It has been found that the temperature coefficient, instead of being a detriment,

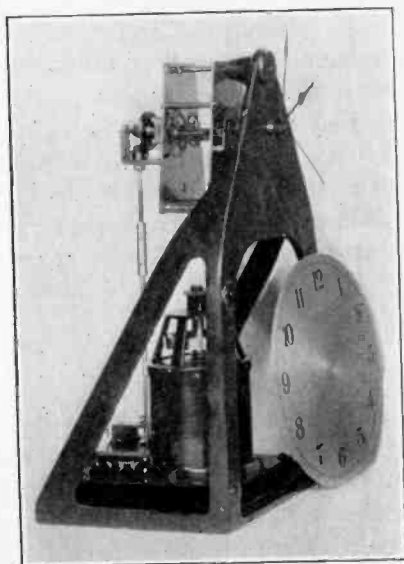

Fig. 1—100-cycle Synchronous Motor Geared to Clock Train.

has furnished an excellent means for adjusting the frequency, making possible small changes the amounts of which may be accurately predetermined. During the four years of operation, the change in the frequency of the entire system due to aging of the fork and to all other causes, as determined by the change in the temperature—indicated by a Beekman thermometer—at which the rate is exactly 100 cycles, has been less than 0.004 per cent.

The synchronous motor described in the previous paper has been replaced by an improved form shown in Fig. 1. The original motor was coupled to the clock by means of a gear reduction driving a commutator, from which seconds impulses were supplied to a clock train having an electromagnetic stepping device. The present motor is geared directly to the clock train, thus completely

avoiding errors due to the mechanism. In spite of the lack of confidence expressed by many people in the impulse type of synchronous motor, both of those mentioned have been found to give entirely satisfactory operation over long periods of time. In fact, the only occasions on which the motors have ever stopped in service have been those on which power was taken off some portion of the system.

During tests on this frequency standard, it was found that it constituted a far more reliable timekeeper than the electrically maintained pendulum clock which was used to obtain the data already published. The pendulum clock was, therefore, dispensed

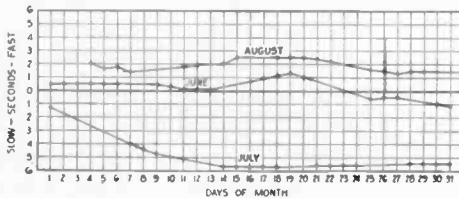

Fig. 2—Daily Error in Clock Controlled by 100-Cycle Frequency Standard. Mean rate for three month period 99.99991 cycles; average deviation from mean rate 0.00016 cycles; maximum deviation from mean rate 0.00067 cycles.

with and all measurements of the rate of the fork are now made by direct comparison with the mean solar day as defined by the radio time signals sent out from the U. S. Naval Observatory. By means of its second hand, which is concentric with the hour and minute hands and which rotates uniformly, the daily error in the fork-controlled clock may be determined to 0.2 second, giving its average rate for the day to approximately three parts in one million. For greater accuracy there is provided, in the gear train between the motor and the clock, a shaft rotating once per second and operating a contact by means of a cam. Pulses from this contact may be recorded simultaneously with the radio time pulses on a moving paper tape by means of a two-element siphon recorder. From the record thus obtained, the error of the clock may be determined to 0.01 second, increasing the accuracy of the determination about 20 times.

The data shown by the chart of Fig. 2 are typical of the performance of this system. On this chart the error in the clock reading is plotted against days. The rate is obtained from the slope of the curve; when it is straight the rate is constant; when

it is horizontal the rate is exactly 100 cycles. Attention is called not only to the constancy of the rate, which at no time during the period covered by this record departed more than 0.0007 per cent from the mean rate, but also to the precision with which the system was adjusted to the desired absolute value.

A method for the comparison of high frequencies with the 100-cycle standard is also outlined in the previous paper. This method involves the use of harmonic producers and of harmonic selecting networks. By repeated harmonic production and selection it is possible to obtain any multiple of the fundamental frequency to a limit determined by the care taken. Theoretically the process may be extended indefinitely, but practically there are difficulties in going beyond two or three stages. These difficulties arise from small irregularities in the frequency or in the amplitude of the current in the initial stages of the system, all of which result in frequency irregularities in the final wave. While these may be entirely negligible in the wave in which they originate, they are enormously magnified in subsequent stages. With ordinary care it is feasible to obtain from the 100-cycle standard current a current having a frequency of 100,000 cycles per second or even higher. By the use of a cathode ray oscillograph, an independent oscillator may be adjusted so that its frequency is an exact multiple of the frequency of the current thus obtained. This process may be repeated by successive stages up to the limit of the oscillograph tube.

The system, therefore, contains three essential elements: (1) The regeneratively driven fork constitutes a source of alternating current, the frequency of which is 100 cycles to a very high precision. (2) The synchronous motor and the gear train of the clock constitute a rate reducing mechanism having a ratio of approximately ten million to one. (3) The harmonic producer system and the cathode ray oscillographs may be operated so as to increase the frequency in the ratio of several thousand to one. It is, therefore, practicable by means of this system to determine the frequency of an electric wave, using the mean solar day as a standard, when the ratio between them does not exceed about 10^{11} .

PRESENT EQUIPMENT

At the time the development of the 100-cycle standard was undertaken, the frequency range over which measurements were required to high precision did not exceed several hundred thousand cycles per second. For this work the frequency chosen for the

secondary standard was quite satisfactory. Since then, however, more and more attention has been given to the higher frequencies until it has become necessary to make measurements to a very high degree of accuracy up to several million cycles per second. Any appreciable increase in the frequency of the reference standard is obtained at the expense of an increase in the ratio between its rate and the mean solar day. This is not particularly objectionable, however, since the comparison between these two rates may be made with permanently adjusted apparatus designed expressly for this fixed ratio, whereas comparisons between unknown rates and the reference standard must be made by carefully adjusting

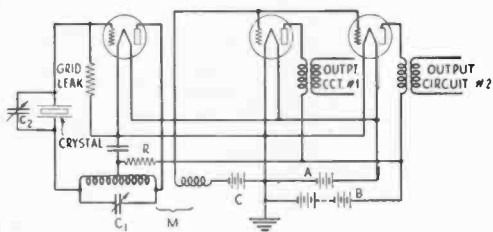

Fig. 3—Circuit of Oscillator for High Frequency Standard

apparatus capable of working over a wide range of ratios. More important still, it has been found that the frequency of a given current can be controlled by a current of higher frequency with much greater stability than by a current of lower frequency. Because of these various factors, therefore, there is need for a standard of the general type just described but having a fundamental frequency many times higher. Such a standard has been developed and some preliminary data as to its constancy of rate have been obtained.

The high-frequency generator of this standard is a 50,000-cycle quartz crystal-controlled oscillator having circuit elements and controls that give a high degree of stability. The circuit of this oscillator is shown in Fig. 3. It is of the Hartley type, differing from the usual form only in having a resonant piezo-electric crystal connected in the grid circuit. This type of circuit is used because it is convenient, by means of circuit adjustments, so to control the phase of the regenerative feedback that maximum stability is obtained. Being an efficient oscillating circuit it also permits of using the crystal loosely coupled to the electrical circuit, thus permitting full advantage to be taken of the very low decrement of the crystal.

The crystal is adjusted by lapping so that the frequency of the circuit controlled by it is 50,000 cycles exactly at a given operating temperature. Minute corrections that are subsequently required can be made by means of a small variable condenser in parallel with the crystal.

The crystal-controlled oscillator is coupled to two output circuits through vacuum tubes, having their grids in parallel, loosely coupled to the tuning coil. In this way considerable output

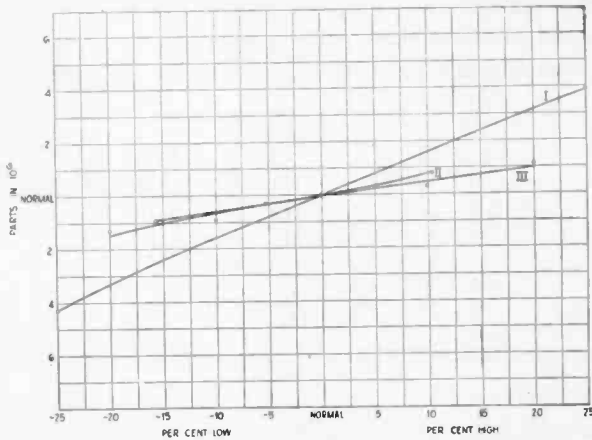

Fig. 4—Effect of Circuit Variations on Frequency of 50,000-cycle Standard Oscillator. I—Change in frequency vs. percentage change in the grid leak resistance; II—Change in frequency vs. percentage change in filament current; III—Change in frequency vs. percentage change in plate voltage.

current at 50,000 cycles can be obtained with no possibility of reaction on the oscillator from external circuits.

The three curves in Fig. 4 show the frequency stability of the oscillator under variations in filament current, plate voltage, and grid leak resistance. The departure from normal frequency in parts in a million is plotted against departure in per cent from normal filament current, plate voltage, and resistance.

The variation with grid leak resistance is greatest, but due to the use of a special type of resistance that is expected not to vary as much as 0.1 per cent in service, the variations in frequency due to this source are negligible.

The variation with battery voltage is the most serious factor, being in the same sense for both batteries. These voltages are controlled at present to about ± 2 per cent, therefore variations in frequency of about three parts in ten million may be expected

due to them. Of course, as has been done in other cases, it is possible to compensate the circuit for variations in voltage so that any tendency for a change in frequency in one direction is offset by an equal and opposite tendency.

The curves of Fig. 5 show the variations in frequency of the oscillator for changes in the condensers C_1 and C_2 . These curves show variations in frequency in parts in a million and are plotted, in the case of condenser C_2 , against dial settings, and in the case of condenser C_1 , against the capacity in micro-microfarads. Due

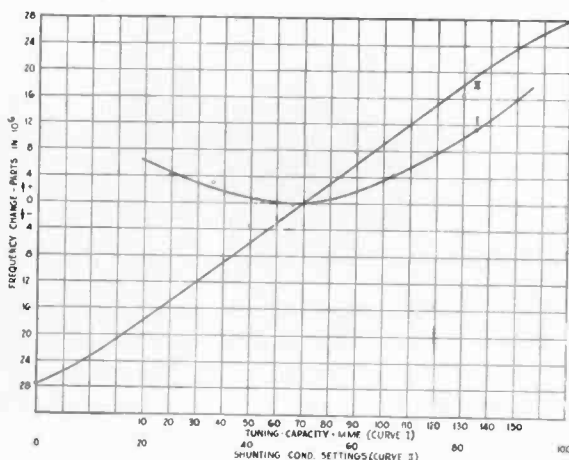

Fig. 5—Effect of Circuit Adjustments on Frequency of 50,000-Cycle Standard Oscillator. I—Change in frequency vs. capacity of tuned circuit of oscillator; II—Change in frequency vs. second of condenser shunting crystal.

to the linearity of the adjustment obtained by condenser C_2 it is possible to make predetermined minute changes in the operating frequency. The proper adjustment for condenser C_2 is very nearly that value for which the change in frequency with capacity is zero. Under this condition the small changes in the electrical circuit due to temperature variations have an entirely negligible effect on the frequency.

The quartz crystal in its mounting is shown in Fig. 6. It vibrates in the direction of its length and is supported on a short piece of felt at the center in order to allow free vibration. It is held in place and separated from the plates by silk threads. The logarithmic decrement of this crystal in its mounting, the whole being measured as an electric circuit, is about 0.00012. The conductor plates are made very rigid in order to keep the separation constant, since a variation in this spacing as small as 0.01 mm.

would cause an appreciable error in frequency. The temperature coefficient of frequency is about 0.00038 per cent per degree Centigrade, requiring a control of temperature constant to within 0.025 deg. C. in order to keep variations due to temperature change alone within one part in ten million. Measurements on the effect

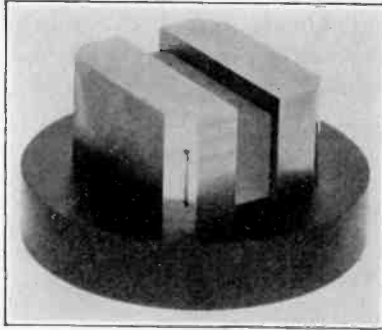

Fig. 6—Resonant Piezoelectric Quartz Plate in Mounting.

of atmospheric pressure, covering the range from 760 mm. to very low pressures, show the frequency to be approximately a linear function of the pressure. For the particular crystal measured, it was found that an increase in pressure of 140 mm. caused a decrease in frequency of 0.001 per cent.

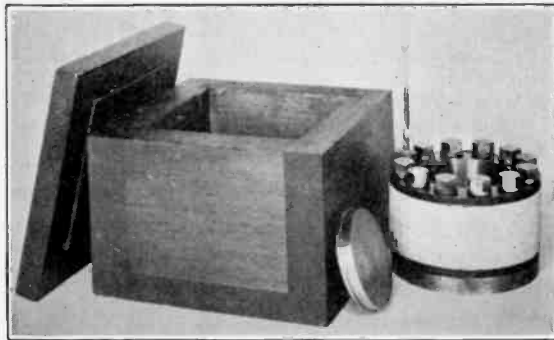

Fig. 7—Thermostat for Piezoelectric Plate.

The thermostat used at present to control the temperature of the crystal is shown in Fig. 7. It consists of a steel cylinder with hollow walls filled with mercury which expands when heated into a capillary tube, as in a thermometer. At a certain tempera-

ture contact is made on a pointed tungsten wire (not shown) which operates a mechanism for changing the rate of heating applied through a resistance coil wound on the outside of the steel cylinder. The crystal is mounted within the cylinder and the whole device is enclosed in a balsa-wood box for heat insulation. By means of this arrangement the temperature at a point within the cylinder may be kept at a prescribed value over long periods.

It is of interest to note that the temperature of the crystal when operating is not exactly that of the space surrounding it because some energy is dissipated within the crystal. For this

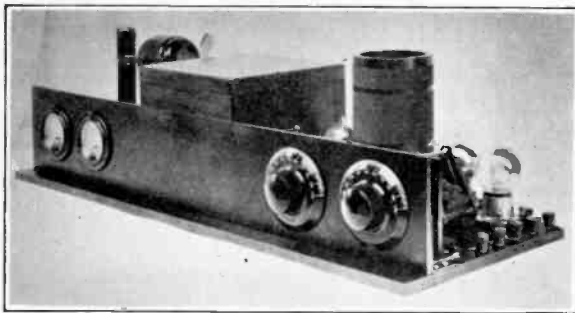

Fig. 8—Standard 50,000-cycle Oscillator.

reason, since the dissipation varies at least as the square of the applied plate voltage, that voltage is kept at a low value. The resistance R in the circuit of Fig. 3 is for this purpose.

The vacuum-tube circuit of the oscillator with the crystal and temperature control apparatus is shown in the photograph Fig. 8. This whole circuit is mounted in a closed cabinet which itself is temperature controlled by a commercial thermo-regulator.

An important element of this new frequency standard is the submultiple frequency generator which is used as the first element of the system for comparing the rate of the crystal-controlled oscillator with the time standard. This submultiple producer consists of an oscillator for generating the low frequency, a harmonic producer for obtaining a harmonic of the low frequency which corresponds to the high frequency by which it is controlled, and a modulator from which is obtained a direct current the amplitude of which is a function of the phase relation between the controlling high-frequency current and the harmonic of the controlled low-frequency current. The action of the direct current

on a control element in the low-frequency oscillator maintains the frequency at such a value that the current from the harmonic producer has exactly the same frequency as that from the standard oscillator. Fig. 9 shows the circuit arrangement. The tubes, from the left, are associated with the modulator, the oscillator, the harmonic producer and an output amplifier, respectively.

The control device consists of a core of magnetic material having two windings, one in the oscillating circuit proper and one in the plate circuit of the modulator tube. This coil is designed so that a variation in the direct current output of the modulator causes a variation in the inductance of the winding in the oscillating circuit by virtue of the magnetic saturation of the core.

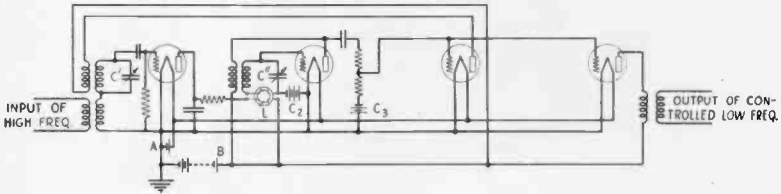

Fig. 9—Submultiple Controlled Frequency Generator

In operating, the low-frequency oscillator is adjusted so that the frequency is exactly some submultiple of the control frequency when the direct current into the control coil has a certain mean value. If, then, anything occurs that tends to change the low frequency, the resulting phase shift between the harmonic and the control current instantly causes a change in the direct current in the control coil that opposes that tendency. The result is that, in spite of large variations in the low-frequency circuit, the frequency is maintained at an exact submultiple of the high-frequency control, the only variation being a slight shift in phase with respect to the control current.

With a circuit operating in this fashion it is possible to control a current so that its frequency shall be maintained in an exact integral relationship to that of some other current, even when the latter is many times higher. A ratio of 50 to 1 may be readily secured with moderate care. It would thus be entirely feasible to secure, by repeated stages, a current having a frequency which was exactly one five-hundredth the frequency of the 50,000-cycle standard, or 100 cycles. This current could then be used to run the synchronous motor of the clock previously described. Actually

it has been found advantageous to secure a current having a frequency one-tenth that of the standard and to use this current to operate a 5000-cycle synchronous motor.

This high-frequency synchronous motor operates on the output of a single 5-watt tube. The rotor is mounted on a vertical steel shaft running on a single steel ball under oil. The motor is mounted under a bell jar and is operated in partial vacuum in order to reduce friction losses and to keep the bearings clean. It takes more than half an hour for the motor to come to rest from full speed when it is disconnected from the source of power.

The rotor is a flat disk having 100 teeth milled on one side for poles and having an annular recess in the upper side for the

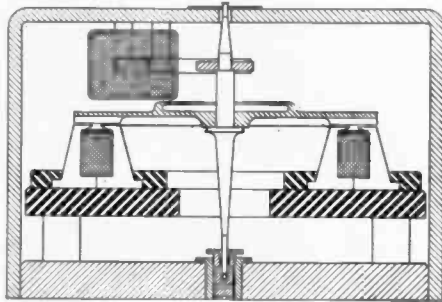

Fig. 10—Sectional View of 5,000-cycle Synchronous Motor.

mercury used to prevent hunting. The stator consists of 100 U-shaped pieces of silicon steel arranged in radial planes equally spaced around the axis. These form a ring of the same outside diameter as the rotor, and having an annular space in which is located a coil for magnetizing all the poles in parallel. A single U-shaped piece and a single fin on the rotor constitute one magnetic circuit around the coil. By this construction the minimum magnetic material is used and it is possible to laminate properly every part. Coils can be wound to match the electrical impedance of any suitable vacuum tube and can be exchanged easily. The spacing between the rotor and stator can be altered for any special case by adjusting the lower bearing. Figs. 10 and 11 show a sectional drawing and a photograph of the assembled motor.

The coil of the motor is connected in the plate circuit of the tube used to drive it so that both alternating and direct current flow in the winding. This produces 5000 magnetic pulses per second instead of 10,000 as would be the case if alternating current

alone were used. Thus the rotor moves one pole per complete cycle and revolves at 50 revolutions per second.

Maximum power is obtained in the motor if its impedance is conjugate to the impedance of the output circuit of the amplifier. The internal output impedance of a tube is nearly pure resistance, so the reactive component of the motor impedance is balanced by a series condenser between the motor winding and the filament. The space current is supplied through a choke coil connected to the junction of the motor winding and the condenser. A somewhat better arrangement would be to resonate the motor winding by



Fig. 11—5,000-cycle Synchronous Motor.

a parallel connected condenser and to connect the plate battery at a tap in the winding. In this way the choke coil can be dispensed with and the ratio of alternating to direct current in the winding can be adjusted so that the resultant goes to zero once during each cycle. At the same time the impedance of the tube can be matched exactly, as required for maximum power transfer.

It would be a simple matter to arrange a gear train so that this motor might operate the clock mechanism directly. Since, however, there were already available clocks designed to operate on a 100-cycle current, it was thought to be simpler to use these as they were. Consequently, the high-frequency motor drives a small generator, the two-pole rotor of which is mounted on the same shaft. Since the speed of the motor is 50 r.p.s., and since the generator is of the inductor type, the generated frequency is 100 cycles—or exactly $1/500$ th of the original high frequency.

The output of this generator is amplified by a single vacuum tube which supplies sufficient power to operate the motor of the 100-cycle clock, the rate of which, therefore, is an accurate measure of the frequency of the 50,000-cycle oscillator.

In the design of the electrical circuits, provision is made for supplying power from multiple amplifiers at 50,000, 5000 and 100 cycles, which frequencies are in exact harmonic relation. These are available continuously for making frequency comparisons in the three ranges.

In addition to this provision, circuits have been built that permit the control of any frequency which is a multiple or sub-

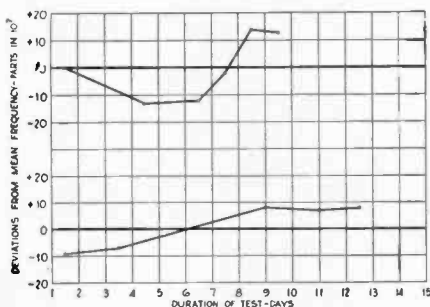

Fig. 12—Daily Variation in Average Frequency of 50-kilocycle Standard.

multiple up to the tenth order of any one of the three original frequencies. Also, many fractional multiples may be thus controlled. This considerably extends the usefulness of the new standard since it is possible to deliver alternating current at constant frequency over a range from 10 cycles to 500,000 cycles per second. These frequencies are not only constant but are known to the same accuracy as the 50,000-cycle control frequency, being some predetermined exact rational multiple or fraction of that frequency.

Because of the short time during which this standard has been in operation, and because of numerous interruptions for the purpose of making slight modifications, data covering a long continuous run are not available. Measurements made over several brief periods are, however, of interest as they indicate the performance which may be expected from the system. Fig. 12 gives the results of two brief runs. On this chart each point represents the deviation of the average rate for a single twenty-four hour interval from the mean rate for the entire period. It is

probable that variations in atmospheric pressure were responsible to a considerable extent for the variations in frequency. It is obviously desirable to provide means whereby the crystal may be operated under constant pressure as well as constant temperature.

The above data indicate a high degree of constancy of the average frequency of this standard over long time intervals. In view of the very great ratio between the rate of the standard and the mean solar day, it is desirable to obtain additional checks as to the constancy of frequency over shorter time intervals. For

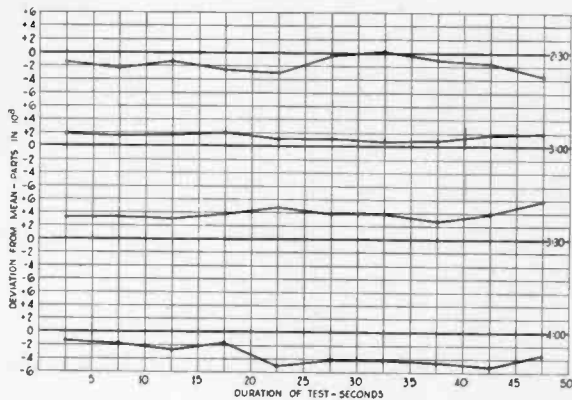

Fig. 13—A Relative Variation in Frequency of Similar Crystal-Controlled Oscillators.

this purpose a second oscillator, similar to that already described, was adjusted to approximately the same frequency, the actual difference being 0.2 cycles per second. Data taken by measuring the duration of ten consecutive periods at half-hour intervals show the relative variations. The results of these measurements are given in Fig. 13. Each point represents the difference between the ratio of the rates for any one interval from the average ratio of the rates for the entire two-hour interval. It will be noticed that for some of the runs, particularly that made at three o'clock the ratio of the rates remains practically constant. At other times, however, as at two-thirty and three-thirty, there is a marked periodicity to the variation. This may be accounted for in terms of temperature variation; the periodicity of the variation is practically the same as that of the operation of the thermostats. Whenever the two thermostats are operated out of phase, there

is a noticeable change in the ratio of the rates; whenever they are operated in phase, their rates remain practically constant.

In view of the fact that the accuracy to which a frequency may be defined depends on its constancy, on the precision of comparing its rate with the rate of the earth's rotation, and on the accuracy to which the latter rate can be determined, it seems reasonable, in view of the above data, to expect that in the near future it will be possible to define a frequency at any instant to an absolute accuracy of at least one part in ten million.

It has not been unusual to determine frequency in terms of some other quantity such as the acceleration due to gravity, the velocity of light, or the product of inductance and capacity. These are, of course, indirect measurements because each of the other quantities must first be defined in terms of time. In view of the present accuracy obtainable in the measurement of frequency, however, it is now possible to invert the procedure and measure some of these other physical quantities in terms of frequency with an accuracy heretofore unattainable.

BIBLIOGRAPHY

No attempt is made in this bibliography to mention all of the contributions relating to the art of frequency measurements. The attempt has been rather to pick out a few papers which describe in a broad way various important phases of the problem. In most cases each of these is accompanied by a fairly extensive bibliography.

Use of Tuning Forks in Constant Frequency Generators

D. W. Dye, The Valve Maintained Tuning Fork as a Precision Time Standard; Proc. Roy Soc. London, 103A, p. 241, May, 1923.

J. W. Horton, N. H. Ricker, W. A. Marrison; Frequency Measurement in Electrical Communication; Trans. A. I. E. E., 42, p. 730, 1923.

J. G. Ferguson, A Clock Controlled Tuning Fork as a Source of Constant Frequency; B. S. T. J., 3, p. 145, January, 1924.

A. B. Wood, J. M. Ford, The Phonic Chronometer; Jl. Sci. Inst., 1, p. 161, March, 1924.

A. B. Wood, Electrically Maintained Tuning Forks—Some Factors Affecting Frequency; Jl. Sci. Inst., 1, p. 335, August, 1924.

T. G. Hodgkinson, Valve Maintained Tuning Fork without Condensers; Phys. Soc. London Proc.; 38, p. 24, December, 1925.

Elias Klein, Glenn F. Rouse, Methods for Exciting and for Calibrating Tuning Forks; J.O.S.A. & R.S.I., 14, p. 263, March, 1927.

Use of Piezoelectric Plates as Frequency Standards

W. G. Cady, The Piezoelectric Resonator; Proc. I. R. E., 10, p. 83, April, 1922.

G. W. Pierce, Piezoelectric Crystal Resonators and Crystal Oscillators Applied to the Precision Calibration of Wavemeters; Proc. Am. Acad. of Arts and Sci. 59, p. 81, October, 1923.

J. W. Horton, Vacuum Tube Oscillators—A Graphical Method of Analysis; B. S. T. J., 3, p. 508, July, 1924.

D. W. Dye, Piezoelectric Quartz Resonator and Equivalent Electrical Circuit; Phys. Soc. Proc., 38, p. 399, August, 1926.

Correlation of Frequency Standards with Standard Time

E. A. Eckhardt, J. C. Karcher, M. Keiser; *Electron Tube Tuning-Fork Drive*; J.O.S.A. & R.S.I., 6, p. 949, November, 1922.

D. W. Dye. *The Valve Maintained Tuning Fork as a Precision Time Standard*; loc. cit.

M. Mercier, *New Method of Determination of Period of High Frequency Electric Oscillations*; *Ann. de phys.*, 19, p. 248, 1923.

J. W. Horton, N. H. Ricker, W. A. Marrison; *Frequency Measurement in Electrical Communication*; loc. cit.

J. G. Ferguson, *A Clock Controlled Tuning Fork as a Source of Constant Frequency*; loc. cit.

G. Ferrie, R. Jouaust, *The Use of Photoelectric Cells in the Observation and Maintenance of Astronomical Pendulums*; *Comptes Rendus*, 180, p. 1145, April, 1925.

Elias Klein, Glenn F. Rouse; *Methods for Exciting and for Calibrating Tuning Forks*; loc. cit.

R. H. Worrall, R. B. Owens, *The Navy's Primary Frequency Standard*; To appear shortly.

Frequency Comparison by Means of the Cathode Ray Oscillograph

J. B. Johnson, *A Low Voltage Cathode Ray Oscillograph*; J.O.S.A. & R. S.I., 6, p. 701, September, 1922.

Grace Hazen, Frieda Kennion. *Sci. Papers of the B. of S. No. 489*, May, 1924.

F. J. Rasmussen, *Frequency Measurements with the Cathode Ray Oscillograph*; *Jl. A. I. E. E.*, 46, p. 3, January, 1927.

Frequency Comparison by Means of Harmonic Generators

H. Abraham, E. Bloch; *Mesure en valeur absolue des periodes des oscillations electriques de haute frequence*; *Ann. de phys.*, 11, p. 237, 1919.

J. W. Horton, N. H. Ricker, W. A. Marrison; *Frequency Measurement in Electrical Communication*; loc. cit.

D. W. Dye. *A Self-Contained Standard Harmonic Wavemeter*; *Phil. Trans. of Roy. Soc.*, 224, p. 259, November, 1924.

C. B. Jolliffe, Grace Hazen; *Establishment of Radio Standards of Frequency by the Use of a Harmonic Amplifier*; *Sci. Papers of the B. of S.*, 21, p. 179, 1926.

A RADIO-FREQUENCY OSCILLATOR FOR RECEIVER INVESTIGATIONS

BY

GEORGE RODWIN AND THEODORE A. SMITH

(Technical and Test Department, Radio Corporation of America)

Summary—A modulated radio-frequency oscillator is described. This apparatus incorporates a means for obtaining radio-frequency outputs of widely varying range, a metering system, a means for changing the generated frequency in small steps to either side of a given frequency, and a modulation and indicating system.

A modulated radio-frequency oscillator forms a piece of apparatus which is extremely useful in an experimental laboratory. By incorporating a number of special features, such an oscillator can be made very flexible and its uses varied.

The equipment to be described was originally built in connection with work done in determining certain radio receiver characteristics.¹ The oscillator has also been used for providing known fields in the measurement of field intensities, determining coil resistance and inductance, lining up radio circuits, and for other general laboratory purposes.

The design was such as to satisfy as far as possible the following requirements:

1. The oscillator output should be widely variable without any appreciable change in frequency.
2. A means for reading the output should be provided.
3. The frequency should be variable over a given range (such as the broadcast band) and the calibration should be maintained.
4. At any frequency setting, it should be possible to vary the frequency in small continuous steps to either side of the setting with a fair degree of accuracy.
5. Modulation should be obtainable up to at least 70 per cent with means for indicating continuously the percentage of modulation.
6. The stray field from the apparatus should be low compared to the field produced by the known radiator used.
7. Mechanical details should be such as to enable the operator to take data quickly and easily.

Original Manuscript Received by the Institute September 13, 1927

¹ PROCEEDINGS of the Institute of Radio Engineers, Vol. 15, No. 5; May 1927, Page 389.

The apparatus to be described meets these requirements satisfactorily. Many details have been thoroughly developed and retained in this device, with the result that the oscillator may appear rather large and bulky. However, when it is considered to what varied use it may be put, its large size is justified.

Electrical Construction

The complete apparatus consists of a modulated oscillator-power amplifier arrangement, with an output and measuring circuit. A schematic diagram appears in Fig. 1.

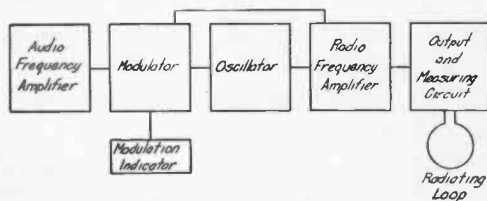

Fig. 1—Schematic Diagram of Modulated Oscillator Amplifier.

GENERAL CIRCUITS

It was found that the master-oscillator-power amplifier method for the generation of radio-frequency currents had several advantages over the use of a simple oscillator. The oscillator employs a UX-201-A tube in an ordinary Hartley circuit. A grid condenser of 500 micro-microfarads with a grid leak of 20,000 ohms gives sufficient constancy of frequency for small variations in filament and plate voltage, without greatly reducing the radio-frequency output. For the broadcast band, an inductance of 82 microhenrys with a variable condenser of 1,000 micro-microfarads maximum capacity forms the tuned circuit. The variable condenser, which is of the straight line frequency type, is purposely made large, so that only the really straight portion of its frequency calibration is normally used, while still maintaining a three-to-one range in frequency. In order to minimize the effect of tube capacity in different tubes on the frequency calibration, a small fixed condenser of about 60 micro-microfarads capacitance is placed in parallel with the main tuning condenser. This addition was found to improve the frequency-setting relation of the main control. Fig. 2 shows this relation for the apparatus constructed.

A mechanical arrangement is employed for varying the frequency in small steps. This device is explained in detail below.

Frequencies in steps of 1,000 cycles up to 8,000 cycles to either side of a given frequency can be obtained. The calibration of this adjustment was carried out as follows:

With the vernier control at its zero position, a zero beat was produced in a radio receiver with a separate external oscillator, the frequency of which is known to be constant over the period of the calibration. When the vernier is moved off its zero position,

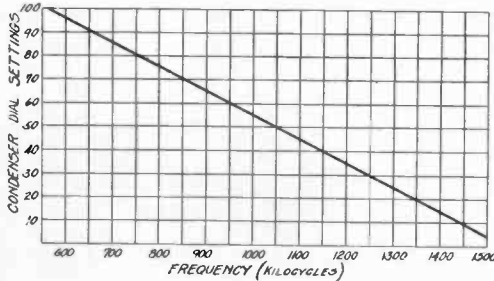

Fig. 2—Apparatus Frequency-Setting Relation.

a beat note will occur, which is compared with a calibrated audio-frequency source, adjusting the pitch of the beat-note so that it is equal to the known audio frequency. This operation was repeated for a number of frequencies up to 8,000 cycles to either side of the vernier zero position.

Since the vernier control is constructed so as to move the tuning condenser a constant amount, in angular motion, for a given rotation of the vernier, and since the variable tuning condenser has a straight line frequency characteristic, the calibration of the vernier will hold for all radio frequencies. This was checked by repeating the above beat-note comparisons for various condenser positions and the vernier calibration was found to be practically constant over the whole frequency range.

The radio-frequency power amplifier has its grid circuit coupled to the oscillator circuit by means of an untuned inductance. Two UX-112 tubes are employed in parallel and these are neutralized. The power amplifier is operated as a "proper amplifier" and its grid excitation is such as to obtain maximum output under these conditions. The amplifier plate circuit is tuned by a condenser placed on the main tuning condenser shaft.

The output circuit is coupled to the amplifier plate coil, its coupling being continuously variable for output control. It was

found desirable to have quite a large range of output—at least 5,000 to 1 in current. The combination of a radio-frequency current transformer, thermo-couple milliammeter and switching arrangement has been found satisfactory for providing and metering such a widely varying output.

CURRENT TRANSFORMER FOR PROVISION OF VARIOUS OUTPUT CURRENTS

The current transformer for radio frequencies,² in the form employed in this apparatus, has an iron core of 10 mil (0.0254

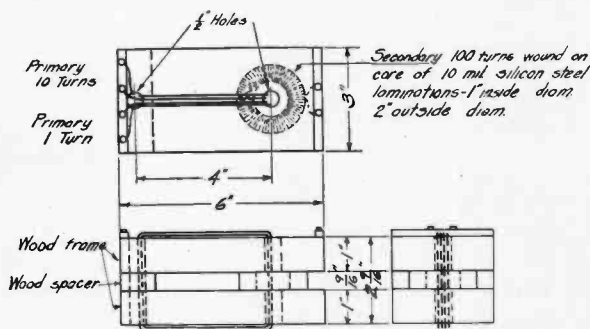

Fig. 3—Current Transformer for the Measurement of Output Currents.

centimeters) toroidal silicon steel laminations, $\frac{9}{16}$ inch (1.43 centimeters) thick, 2 inches (5.08 centimeters) outside diameter, and 1 inch (2.54 centimeters) inside diameter. The core is covered with insulating oiled silk and one winding of 100 turns is evenly spaced over this core. The other winding of either 1 or 10 turns is looped through the hole in the toroid. Wood blocks keep the windings well spaced from one another so as to reduce capacity effects between the windings and maintain the current ratio. The construction is shown in Fig. 3.

It can be shown that the current ratio for such a transformer is given by an expression of the form

$$\frac{I_1}{I_2} = \frac{n_2}{n_1} \left(1 + \frac{\alpha R_2}{\omega L_2} \right)$$

²"Measurement of Alternating Electric Currents of High Frequency"—D. W. Dye, *Proceedings of Royal Society (of Great Britain) A-1914*, Vol. 90, Page 621.

Bureau of Standards Circular No. 74, Page 153.

"Current Transformer Methods of Producing Small Voltages and Currents at Radio Frequencies for Calibrating Purposes"—D. W. Dye *Journal Institution of Electrical Engineers (London) June 1925*; Vol. 63, Page 597.

where I_1 and n_1 are the primary current and turns number respectively.

I_2 and n_2 are the secondary current and turns number respectively.

R_2 and L_2 are the secondary resistance and inductance respectively.

α is a coefficient depending on the iron losses, having a value usually less than 1.

When $\frac{\alpha R_2}{\omega L_2}$ is small compared to 1, this expression reduces to

$$\frac{I_1}{I_2} = \frac{n_2}{n_1}$$

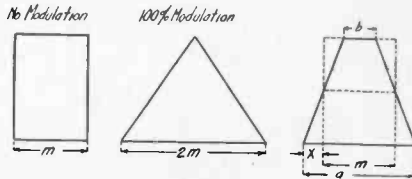

Fig. 5—Cathode-Ray Oscillograph Figures Used in Modulation Percentage Determination.

The secondary circuit contains the ammeter resistance and, for accuracy of transformation, this must be made low compared to the inductive reactance of the transformer secondary. For the transformer of the dimensions given used at frequencies in the broadcast spectrum, a 43-ohm thermo-milliammeter (0.8 milliamperes) has been found satisfactory. The ratio was checked by measuring the currents in both windings and an accuracy of better than 5 per cent was found throughout the range of currents and frequencies required.

Fig. 4 shows the complete wiring diagram of the apparatus and from it may be seen the method of using the current transformer. A six-pole, five-point switch allows the meter to be used in either the primary or secondary of the current transformer so that current ratios of 1-100, 1-10, 1-1, 10-1, or 100-1 may be obtained between the meter circuit and the load or radiating loop circuit. The capacity between various switch parts has been kept low. In addition, the effects due to any undesirable capacities are minimized by the use of low impedance load and metering circuits.

PROVISION OF KNOWN FIELDS

The radiating loop with a known current in it may be used to induce an easily calculated voltage in a second loop having a known mutual inductance between loops. Known field intensities in a plane x centimeters from the loop and parallel to the plane of the loop can be calculated from the field H which is

$$H = \frac{2\pi a^2 i n}{10} \times \frac{1}{(x^2 + a^2)^{3/2}} \text{ (gausses)}$$

The field intensity in microvolts per meter is $E = 300H \times 10^8$. Thus,

$$E = 18850 \frac{na^2i}{(x^2 + a^2)^{3/2}} \times 10^6 \text{ microvolts per meter}$$

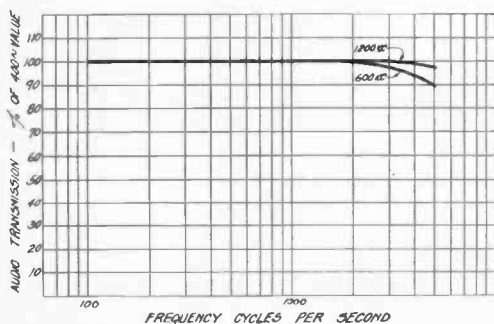

Fig. 6—Overall Audio-frequency Characteristics of the Apparatus.

where a is the radius of the loop in centimeters, i is the loop current in amperes, n is the number of turns on the loop.

If the plane in which it is desired to know E is at an angle to the plane of the loop, the field intensity may be calculated from the above expression, introducing a factor of the cosine of the angle between planes. Field intensities ranging from ten to one million microvolts per meter are readily obtained in this manner.

MODULATION

The conventional plate-circuit choke coil method is used for modulation, two UX-112 tubes controlling both master-oscillator and power amplifier. This system has been found satisfactory for the purpose. Fairly high degrees of modulation are obtainable. The relation between input voltage and percentage modulation has been found linear up to 70 per cent. For measuring the per-

centage of modulation, the ordinary method of measuring the audio-frequency voltage across the modulation reactor and comparing this value with the direct current plate voltage of the oscillator and modulator will not apply. This is due to the fact that both the oscillator and radio-frequency amplifier are being modulated. The cathode ray oscillograph has been used for modulation-percentage determination. One set of the oscillograph plates is excited from the voltage induced in a pick-up coil coupled to the radiating loop. The oscillator is modulated from an audio-frequency source. The other set of oscillograph plates is supplied with voltage from the same audio source. In general, the resulting oscillograph figure is a trapezoid. The various forms it may take are shown in Fig. 5.

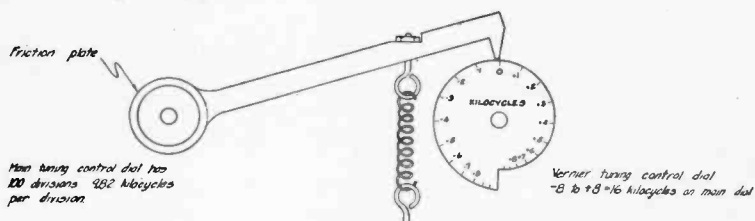

Fig. 7—Cam and Lever Used for Vernier Adjustment.

Using the symbols of Fig. 5, the modulation is given by $\frac{2x}{m} \times 100$

per cent. But $m = \frac{a+b}{2}$ and $x = \frac{a-b}{4}$, therefore modulation

$$m = \frac{a-b}{a+b} \times 100 \text{ per cent.}$$

As an indicating device, a UX-201A tube is employed with its normal plate current biased to practically zero and its grid excited from the audio voltage developed across the modulation reactor. The plate circuit of this tube contains a 0-2 milliamper meter, the scale of which has been calibrated directly in modulation percentages using the oscillograph method described. A radio-frequency choke and by-pass condenser prevent the radio-frequency voltage from affecting the indicator tube reading. With the radio-frequency amplifier tubes operating properly and the circuits equalized, the modulation indication is practically constant with varying radio frequency.

A two-stage resistance-coupled amplifier supplies sufficient voltage to the modulator grids. Its characteristic is practically flat over a wide range of audio frequencies.

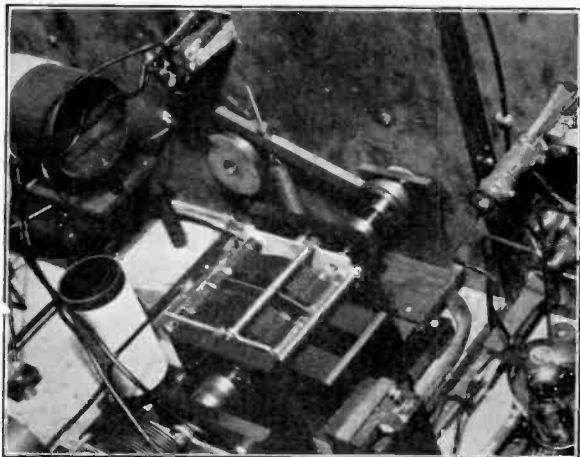

Fig. 8—View of Cam and Main Tuning Condenser

EQUALIZATION OF OUTPUT CURRENT

The radio-frequency output current was found to vary considerably with frequency and a constant output was believed to be desirable. A means for correcting this fault to a considerable extent was devised. This consisted of placing suitable fixed

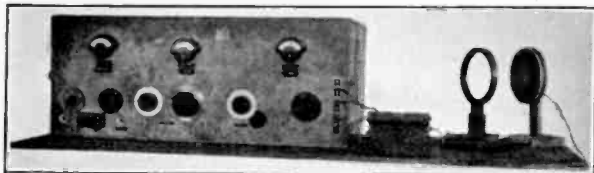

Fig. 9—External View of the Complete Apparatus.

resistances across both the radio-frequency amplifier coupling coil and its output coil. The variation of output current in the radiating loop was thus made less than 15 per cent for a constant output coupling setting over the frequency range. These resistances were also found to lessen the effect of the tuned circuit on the audio characteristics.

Overall audio-frequency characteristics from audio-amplifier input to modulated radio-frequency output are shown in Fig. 6. The data for these curves were taken by rectifying some of the voltage picked up with a biased detector tube and observing the audio-frequency output. A slight effect of resonant circuit selection still remains, but this is not of any considerable magnitude and can be allowed for in exact measurements.

Mechanical Construction

TUNING AND VERNIER CONTROLS

The oscillator and output tuning condensers are both mounted on the same shaft and are controlled from a single dial on the front

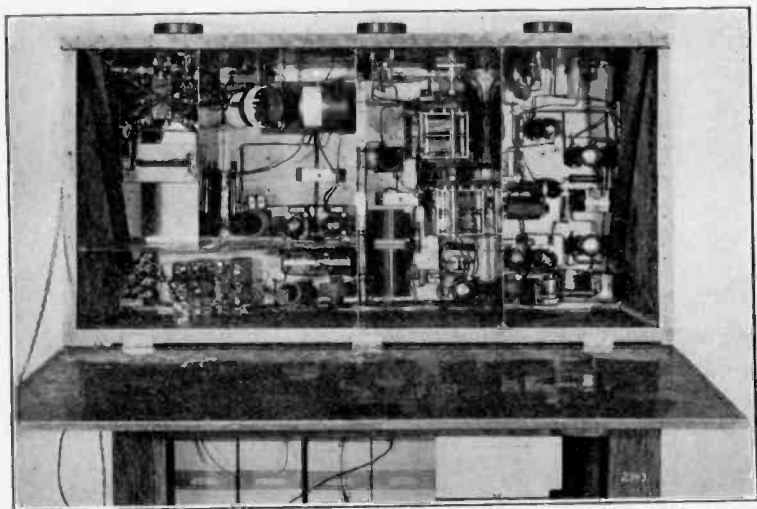

Fig. 10—Internal View of the Complete Apparatus.

panel. A friction cam arrangement has been found suitable for vernier adjustment. This consists of a lever and friction plate on the main shaft and a cam on a separate vernier shaft. The end of the lever arm bears on the cam and is held in position by a strong spring. Any movement of the vernier shaft will cause the lever to move either up or down a small amount and, since the friction plate is now bound to the main shaft, the main tuning condensers will move a small amount. The main tuning shaft can be moved without disturbing the vernier arrangement, since the friction plate will slip and the vernier lever arm will remain fixed due to

the combined action of the spring and the cam rest. The criterion of whether such a system will operate is that the force required to move the friction plate over its bearing should be greater than the bearing friction in the tuning condensers. In practice, this is easily accomplished. The details may be seen in Figs. 7 and 8.

The whole apparatus is mounted in a double copper shielded box. The front panel and base board have been made removable as a unit for convenience. The various units, such as audio-frequency amplifier, oscillator, radio-frequency amplifier, and output circuit, are shielded from one another. The details may be seen in Figs. 9 and 10. The grid batteries are located in a separate compartment, but the filament battery of six volts and the plate battery of 135 volts are located outside the shielded box. Radio-frequency filters in the battery leads prevent radiation from these.

The thermo-milliammeter for the measurement of output is placed externally near the apparatus, a twisted pair of leads of short length being used for connections.

In conclusion, we desire to mention that this design was carried out under the direction of Mr. Julius Weinberger, whose suggestions were very valuable in the development of the equipment.

ON THE INFLUENCE OF SOLAR ACTIVITY ON RADIO TRANSMISSION*

By

L. W. AUSTIN AND MISS I. J. WYMORE

(Laboratory for Special Radio Transmission Research, Bureau of Standards)

Summary—The paper describes further examination of the daylight long wave signal measurements of the Bureau of Standards for evidence of correlation with solar activity. It has already been shown that a probable correlation exists between signals and sunspots when the observations are continued for several years and are averaged in periods of a month or more. The present paper deals especially with observations averaged in shorter (5-day) periods. Here while the relationship is generally evident it is sometimes obscured by an apparent relative phase shift between the signal and sunspot curves.

AT the meeting of the American Section of the U.R.S.I. in April, 1927, some curves were shown¹ indicating a relationship between very long wave transatlantic radio reception and solar activity as measured by sunspot numbers and by the values of the solar constant. These curves represented annual averages from 1915 to 1926, and monthly averages from 1922 to 1926. These indicated without much question that there exists a direct correlation between solar activity and daylight signals, when averaged over long periods. Curves were also shown illustrating the correspondence of 27-day periodic averages of sunspots and reception.

G. W. Pickard² had previously published a paper using his own observations in the broadcasting band, as well as the observations of others, on very long as well as ultra short wavelengths, in which he produced striking evidence of the dependence of radio phenomena on solar activity. Mr. Pickard's own observations indicated quite positively an inverse relationship between the strength of night signals in the broadcasting band and sunspot numbers, while the ultra short wave night signal material treated by the same methods, indicated a direct correlation. This last conclusion is, however, seemingly not in agreement with a number

* Publication approved by the Director of the Bureau of Standards of the U. S. Department of Commerce.

Original Manuscript Received by the Institute, December 20, 1927.

Read at the International meeting of the Union of Scientific Radio Telegraphy in Washington, October 14, 1927.

¹ Proc. I. R. E. Vol. 15, p. 825, 1927.

² Proc. I. R. E. Vol. 15, p. 83, 1927. See also Vol. 15, p. 749, 1927.

of observations made by others of weakened ultra short wave night signals at times of great solar and magnetic disturbances.

During the past summer the examination of the long wave observational material at the Bureau of Standards, in connection with sun spots, has been continued. Especial attention is now being given to the correlation of the daily observations, or the averages of a few days at most, rather than to long time averages. It is found in general that daily comparisons of signals and sun spots give too complex curves to be of use. But when they are

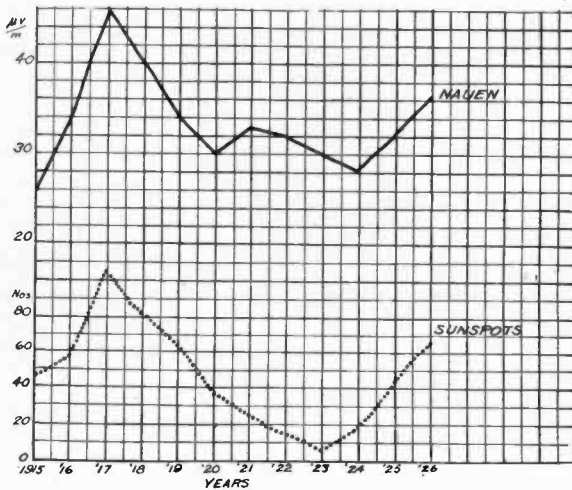

Fig. 1—Annual Average Signal Intensity of Nauen (AGS), 10 A.M. and Sunspot Numbers.

averaged in five-day periods good results begin to appear. It is also found in the examination of the material that the stations at moderate distances (less than 1000 km.) when treated in this way give on the whole better correlation with sun spots than more distant stations.

Since the signal and sunspot curves do not follow each other entirely in detail, it seems probable that there are other factors besides solar activity which contribute to the signal variations. One of these we believe to be temperature which has already been shown³ to have a strong influence especially in winter on the reception in Washington of the transatlantic stations at New Brunswick and Tuckerton, New Jersey.

³ Proc. I. R. E. Vol. 14, p. 781, 1926.

There also seems to be a tendency for the sunspot and signal curves to shift relatively back and forth in phase as though at times there might be a lag in the appearance of the sun spots in respect to the fundamental solar disturbance producing them, while on the other hand, there often seems to be a delay in the formation of the conditions in the earth's atmosphere which produce the changes in signal strength. At any rate there is no doubt that at times the increase in signal precedes the increase in sun spots, while at other times the reverse seems to be true.

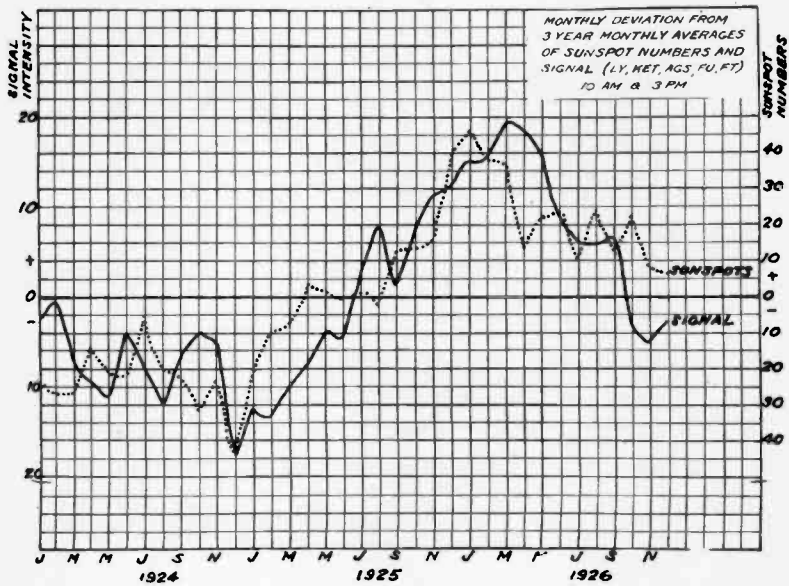

Fig. 2

Notwithstanding these phase shifts, the frequent similarity of the sunspot and signal curves renders it almost certain that we are dealing with a genuine relationship. On the whole there seems to be about the same degree of correlation between the signals and sun spots as between signals of similar wavelengths received at a given receiving station from two separate transmitting stations. In the following, Figs. 1, 2, and 3 deal with long time comparisons in which the connections between solar activity and radio transmission is believed to be fairly well established, while Figs. 4, 5, 6, and 7 deal with short period (5-day) averages in which the transmission curves are smoothed by the smoothing formula

$\frac{a+2b+c}{4}$. This last, without changing the positions of the main maxima and minima, renders the transmission curves more easily comparable with those of the sun spots.

Fig. 1 shows the annual averages of Nauen ($\lambda = 13000$ m.) as received at Washington at 10 A.M. from 1915 to 1926, and the corresponding annual averages of the Wolfer sunspot numbers covering the same period. The signals from 1915 to 1921 were taken by the shunted telephone method and are therefore less

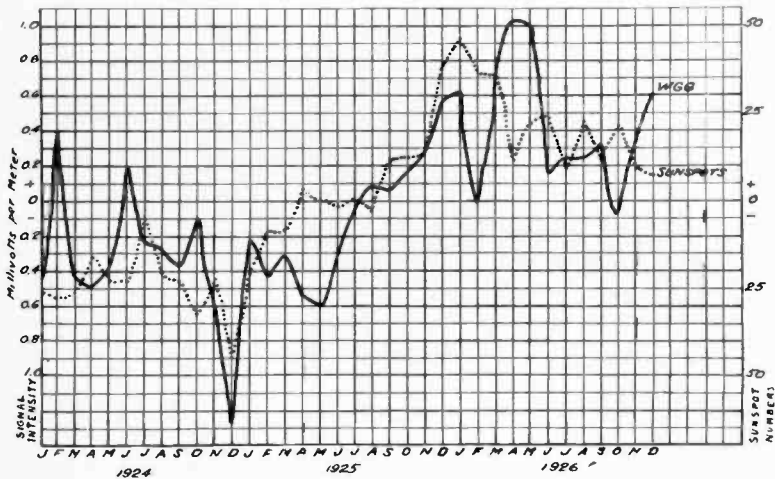

Fig. 3—Monthly Deviation from 3-Year Monthly Averages of Tuckerton (WGG), 10 A.M. and 3 P.M. (Corrected for Variations in Antenna Current) and Sunspot Numbers, 1924-1926.

accurate than those taken later, but we believe that there can be no doubt that the general course of the curve is correct.

Fig. 2⁴ shows the deviations of the individual monthly averages from the three-year monthly averages of five distant stations as compared with the sunspot numbers. It is seen that, while the two curves do not follow each other in detail, in general they rise together during the three years of increasing solar activity. The portion of the figure dealing with the rapid increase of sun spots in the autumn of 1925 is of especial interest.

Fig. 3 shows similar curves for the Radio Corporation of America transatlantic station at Tuckerton, N. J. (WGG), only 250 km. from Washington.

⁴ Figs. 1 and 2 are repeated from PROC. I. R. E., Vol. 15, p. 825, 1927.

As has been said, the degree of correlation between sun spots and signals is comparable with that between two signals received

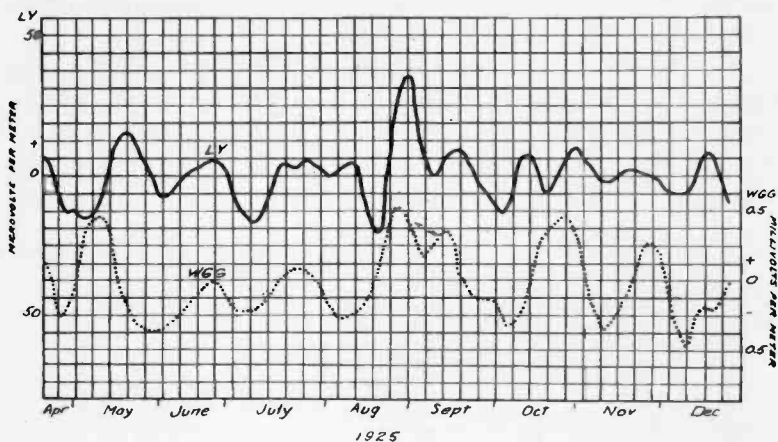

Fig. 4—Deviation of 5-Day Averages from Monthly Averages of Tuckerton (WGG), 10 A.M. and 3 P.M. and Lafayette (LY), 10 A.M. (1925).

at one point from different transmitting stations. For comparison with the following curves, therefore, Fig. 4 is shown giving the

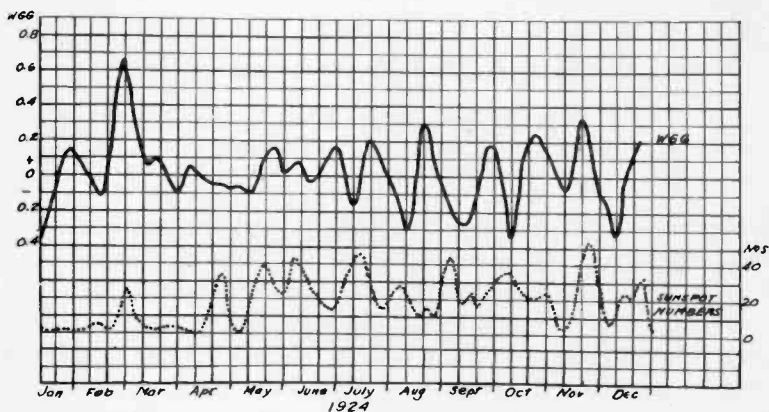

Fig. 5—Deviation of 5-Day Averages from Monthly Averages of Tuckerton (WGG), 10 A.M. and 3 P.M. and 5-Day Averages of Sunspot Numbers, 1924.

relationship of the five-day averages of Tuckerton, WGG, and Bordeaux LY as received at 10 A.M. during a portion of 1925 at the Bureau of Standards.

Fig. 5 shows the deviations of the five-day averages of Tucker-ton as compared with the five-day averages of the sun spots in 1924. The year 1924 was very near the sunspot minimum.

Fig. 6 shows the relationship between the sun spots and the same station between March, 1926 and March, 1927. Here the curves are drawn on a smaller scale than in 1924 on account of the much greater amplitude of the variations both of the sunspot numbers and of the signal intensity. It is at once seen that the degree of correlation of the sunspot numbers and signal seems much better in 1926 and 1927 than during the period of low solar activity in 1924.

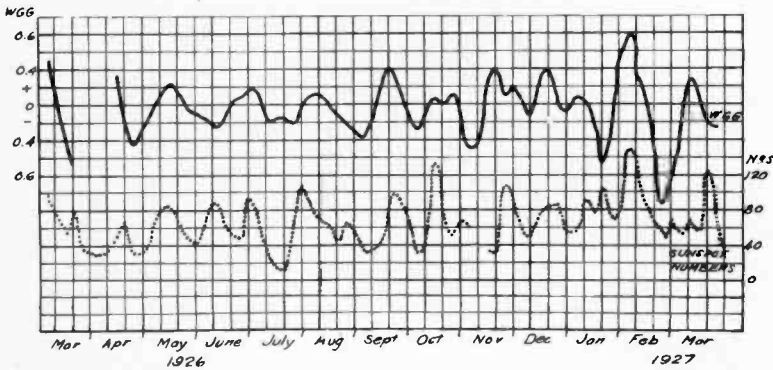

Fig. 6—Deviation of 5-Day Averages from Monthly Averages of Tuckerton (WGG) and 5-Day Averages of Sunspot Numbers, 1926-1927.

Fig. 7 shows similar curves for the R. C. A. station WSS at Rocky Point, L. I., at a distance of 435 km. from Washington in 1926-27. In addition to the signal and sunspot curves, a curve of the five-day averages of the range of the horizontal intensity of the earth's field as observed at Cheltenham, Maryland, is included. The resemblances between these curves are really striking, though we find here also the relative shifts in phase already mentioned between the sunspot numbers and the signal intensity. In some cases the signals evidently lead, while in other cases they lag.

In examining the curves of the five-day averages, it is evident that while there is little question of a connection between solar activity and radio signal intensity, yet there is a lack of any direct proportionality between the sunspot numbers and signal strength. For it is not by any means always the largest increase in sun spots

which corresponds to the largest increase in radio transmission.

Our present knowledge concerning the relation between solar activity and the strength of radio transmission may be briefly summarized as follows:

It seems reasonably certain that long wave daylight signal strength has increased in recent years with the increasing solar activity, when averaged in periods of a month or more, and there is fair evidence that the annual averages of signal intensity have roughly followed the sunspot curve since 1915.

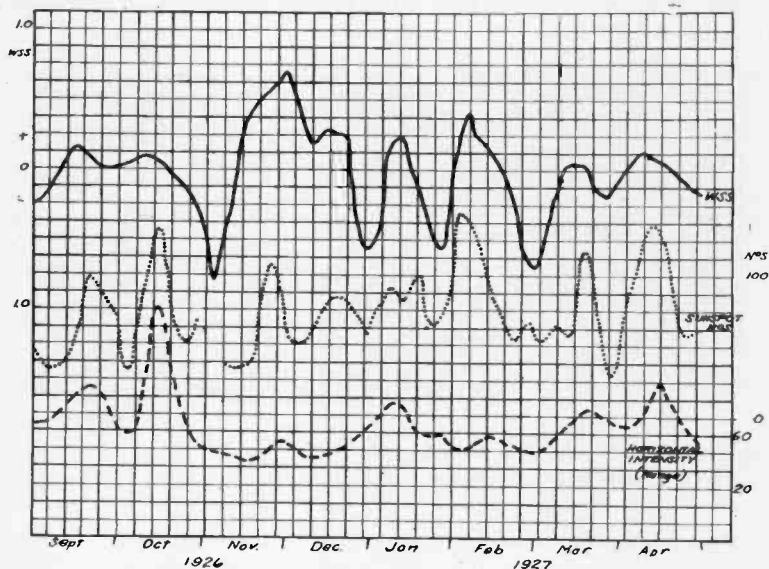

Fig. 7—Deviation of 5-Day Averages from Monthly Averages of Rocky Point (WSS), 10 A.M. and 3 P.M. and 5-Day Averages of Sunspot Numbers and Horizontal Intensity (Cheltenham), 1926-1927.

It is also reasonably certain that night transmission in the broadcasting range when averaged in periods of a few days is reduced at times of high sunspot numbers.

The information regarding the effects of the sun on long wave daylight transmission and ultra short wave night transmission averaged in periods of a few days, is somewhat discordant differing at different times and on different stations. These discrepancies may be due to the relative phase shifts in the transmission and sunspot curves already mentioned.

Very few observations have been published on long wave night transmission, on broadcasting day transmission, nor, so far as is known, have any been made on broadcasting night transmission extending over more than one year.

There is in general a rough resemblance observed in the reception curves of different long wave stations lying in different directions from Washington. This would seem to imply either that there are simultaneous changes in the electrical conditions in the upper atmosphere over very large areas or that the conditions in the immediate neighborhood of the receiving station form the chief controlling factor in signal strength. Occasionally, however, marked differences in reception from stations in different directions have been noted, a phenomenon which is much more common in the case of the broadcasting and ultra short waves at night.

While the sunspot numbers give a rough indication of the conditions governing transmission, it seems probable that they are only an imperfect index of the particular form of solar activity which apparently is the chief agent in controlling radio phenomena.

IONIZATION IN THE UPPER ATMOSPHERE*

By

E. O. HULBURT

(Naval Research Laboratory, Bellevue, Washington, D. C.)

THE more important agencies which may conceivably cause the ionization of the upper atmosphere of the earth are the ultra-violet light, α and β particles, all of solar origin, the penetrating radiation of cosmic origin, and the ionizing radiations from terrestrial sources. The last mentioned may perhaps be ruled out immediately because of the fact that the conductivity of the lower atmospheric strata increases rapidly with the height for the first few kilometers. The possible effects of these ionizing agencies have been considered in papers by Chapman and Milne, Benndorf, Elias, Lassen and others. Recently experiments with the electromagnetic waves of radio telegraphy together with theories of the propagation of these waves over the surface of the earth have led to information about the ionization in the upper atmosphere more definite than hitherto obtainable, and it has been of interest to examine again the causes of the ionization.

The experiments of Breit and Tuve with 70-meter waves, of Appleton with 400-meter waves, of Heising with 57- and 111-meter waves, of Wagner and Quack with 15- and 16-meter waves, of Hollingsworth and Eckersley with long waves, and the experiments of Taylor on the skip distances of waves below 50 meters and the theoretical considerations of Taylor and Hulburt on these skip distances, show that the electron density N increases with the height Z above the earth reaching a value of about 4×10^5 ; above the height where N has this value the electron density is not known except that it does not go on increasing. Although the radio data are none too extensive, it may be taken that in the day time (for the North Temperate Zone) the height where N is of the order 10^5 is roughly 150 to 200 km.

Because of the diurnal variation in the ionization, we choose the ultra-violet light of the sun as being the ionizing agency deserving first consideration. In order to make an explicit calculation

Original Manuscript Received by the Institute December 6, 1927.

* Abstract of a paper read at the open meeting of the U. R. S. I. at Washington, D. C., October 1927.

* Communication from the American Section of the International Union for Scientific Radiotelegraphy.

of the ionization the temperature, the pressure, and the constituent gases and their partial pressures must be known at each height in the upper atmosphere. These we may take as given completely in the classical thermodynamic isothermal equilibrium theory of Humphreys, Jeans, and others. There is a question as to the existence of hydrogen in the upper atmosphere, but the conclusions given later are much the same whether hydrogen is there or not. There is also the question of ozone, or oxygen, which may be of great importance. The law of the recombination of the electrons with the positive ions must be known. For this we have J. J. Thomson's theory of recombination, and complete formulas are available. We must also recognize the possibility of the electron attaching itself to a neutral molecule, for when it does this, thereby producing a negative ion, it is no longer an energetic refractor of the radio waves. The oxygen molecule is the only important one in this connection, and the values of the attachment coefficient measured in the laboratory for pressures of 10 mm. of mercury and above must be extrapolated to pressures below 10^{-2} mm., perhaps a questionable extrapolation. The diffusion of the electrons and ions must be considered; this is a very important influence. Using all these things and making entirely acceptable assumptions as to the amount of ultra-violet light from the sun in the spectral region useful for ionization the N, Z curve rises from $N \doteq 0$ at 50 km. to the order of 10^6 at $Z = 140$ km. in the winter time; above this height N falls off rapidly. In the summer time the electron bank is higher and denser than in the winter. The N, Z curve is in fair accord with the radio data for full daylight conditions, and its change at night is, as far as can be seen, in agreement with night time radio conditions. Below the electron bank there is an ion bank. The exact density of the ions is uncertain, but it seems possible that these may persist in sufficient quantities to play a part in the refraction of the longer radio waves. The uncertainty is due to the lack of exact knowledge of the formation and recombination of the positive and negative ions; the question seems to be inextricably bound up with and confused by the presence of ozone, the laws of ozone formation and destruction being quite unknown.

On the whole it seems that the ultra-violet light of the sun is a necessary and sufficient cause of the Kennelly-Heaviside layer. This means that it is not necessary to consider possible effects of other agencies of ionization, such as α and β particles etc.,

except as secondary, or unusual effects, which may of course be quite important, as the recent correlations between sun spots and radio transmission indicate. In conclusion we must emphasize the view that we can see no possibility of the existence of electron banks above the main one which has its maximum electronic density at a height around 150 to 200 km. and therefore that inferences from radio data which suggest the presence of such outlying layers must be examined with care before they can be accepted.

A THEORY OF THE UPPER ATMOSPHERE AND METEORS*

By

H. B. MARIS

(Naval Research Laboratory, Bellevue, Washington, D. C.)

Summary—A calculation of the rate of separation of gases of different density in the earth's atmosphere leads us to expect a uniform mixture of all gases below 100 km and densities of hydrogen and helium roughly a hundred thousandth of those previously calculated, for greater heights. Known absorption and radiation coefficients for gases of the upper atmosphere indicate that we should expect a daily temperature variation of about 140° during the summer and 30° during the winter for all heights greater than 80 km. Carbon dioxide is found to be more effective than water vapor in determining the final escape of radiation from the earth and the conclusion is drawn that variations in the carbon dioxide content of the air may explain the variation in climatic conditions of the earth indicated by the ice ages of the past. Frictional resistance offered by the upper atmosphere to the passage of meteors through it is not sufficient to account for the energy radiated by meteors and the conclusion is reached that the energy of the meteor is probably dissipated into the air by the escape of atoms and molecules driven from the meteor by the energies of impacts with molecules of the air.

THE force of gravity acting on the atmosphere of the earth causes the heavier gases to settle downward and the lighter gases to rise to higher altitudes by diffusion but winds unhindered by diffusion would by convection keep the composition of the air uniform at all elevations. The classical ideas of the change in atmospheric pressure with altitude (e.g., Humphrey, Jeans, Chapman and Milne, etc.) have been based on the assumption that convection is negligible, at least in the upper atmosphere, and that each gas is, through diffusion, in gravity equilibrium with its own partial pressure. Investigation has shown, however, that diffusion is of importance only at elevations greater than 100 km.

The ordinary equations of diffusion show at once that if the air were uniformly mixed at all altitudes and then left free from all convection currents, there would be a constant flow of lighter molecules upward and of heavier molecules downward, which would be independent of the altitude until a level was reached

* Communication from the American Section of the International Union for Scientific Radiotelegraphy.

Manuscript Received by the Institute, December 6, 1927.

* Abstract of a paper read at the meeting of the U. R. S. I., at Washington, D. C., October 13, 1927.

where the diffusing gas would be in gravity equilibrium. This *diffusion* level for hydrogen would move from infinity down to 142 km. in one day, at the end of five days it would be at a height of 127 km. and in 50 days it would be at 113 km. The corresponding levels for helium would be at 137, 120 and 106 km., respectively. The new calculations give hydrogen and helium densities above 150 km. roughly 1/100,000 of the values previously calculated.

Recent use of the upper atmosphere as a medium for transmitting electromagnetic radiation of wavelength 10 to 10,000 meters has emphasized the importance of knowledge, or at least of a theory, of changes which occur in the upper atmosphere between day and night conditions during different seasons of the year. Absorption of solar and terrestrial radiation by the air must determine any theory of temperature distribution in the upper atmosphere. Humphrey has discussed this problem and has suggested that it should have been worked out, but no attempt has been made previously to apply radiation and absorption coefficients and solve for the thermal condition of the upper atmosphere or to estimate probable temperatures at elevations greater than 20 km. for the radiation conditions of day and night or winter and summer.

Water vapor above 11 km. absorbs a little over 20 per cent of black body radiation from below at earth temperatures while carbon dioxide absorbs nearly 40 per cent. Ozone absorbs only about 2 per cent but its presence is important because it absorbs about 4 per cent of the solar radiation at an altitude where most of the re-radiation must be by the ozone itself. Temperature calculations based on these absorption coefficients show that for a 50 deg. latitude above a height of sixty kms. we should expect a temperature of about 250 deg. K during a winter day with a drop to 220 deg. during the night and a temperature of 370 deg. during a summer day with a corresponding drop to 230 deg. during the night. The atmosphere at the base of the stratosphere cannot be in radiation equilibrium, since its temperature varies from 205 deg. K over the equator to 230 deg. K over the poles but must receive more radiant energy than it loses both from above and below during a 24-hour day. The temperature condition of the earth's surface is in very unstable equilibrium. The loss in heat by radiation from the warm equator is much less than from the cooler polar regions. An increase in temperature at sea level near the equator would not result in an increase in the energy lost by radiation from these regions,

but would actually result in a decrease. Loss of heat by radiation from the earth depends, not on the condition of the surface, but on the temperature at the base of the stratosphere and absorption in the stratosphere. A slight change in the carbon dioxide of the air would have a tremendous influence on the climate of the earth. If the carbon dioxide content of the air were increased from the present 0.03 per cent to 0.1 per cent tropical plants would probably grow in the polar regions. On the other hand, if this protecting sheet decreased from 0.03 per cent to 0.01 per cent, ice would probably be found near the equator.

Since the present theory leads to low densities of the atmosphere above heights of 100 km., and densities one hundred thousandth of those of classical tables at 300 km. the facts about the appearances of meteors require explanation. It seems possible to do this following to a certain extent the ideas of Sparrow and to a certain extent those of Lindemann. When a high speed meteor strikes an air molecule, it is assumed that the energy of the impact violently ejects atoms, molecules and possibly small particles of molecular dimension from the body of the meteor. This ejected material by virtue of its velocity carries into the air the energy which eventually gives the light of the meteor trail. For example, when a nitrogen molecule strikes an iron meteor which has a velocity of 40 km. per second, the energy of the impact is sufficient to raise the temperature of 1800 molecules 1000 deg. C or to evaporate 56 molecules of iron, or to evaporate and ionize 24 molecules of iron. As a result of this impact a mass many times that of the nitrogen molecule is ejected from the meteor principally in the form of highly energized iron atoms which have velocities slightly greater than that of the meteor itself. The inelastic collisions of these iron atoms with the molecules of the air result in the visible trail. The excitation energy of these collisions may be as high as 155 volts for nitrogen or 280 volts for argon. Much of this energy may be radiated in the ultra-violet or even soft x-ray region, and it is probable that not more than one-tenth of the total radiation is in the visible part of the spectrum. Therefore, the total mass of the meteor must be much more than that derived by Lindemann and Dobson from their considerations of the relation between the mass of a meteor and its light. The temperature changes in the upper atmosphere from evening to morning, and from winter to summer, given by the present theory lead one to expect appearance of meteors at heights which are greater by perhaps 5 km.

in the evening than in the morning and in the summer than in the winter. It would be interesting to know whether this difference has been observed.

Recent studies of the propagation of electromagnetic waves over the earth's surface have emphasized the need of a theory and definite conclusions concerning diurnal and seasonal changes in temperature and composition of the atmosphere at heights greater than 50 km. It is the purpose of this discussion to take what steps are possible toward the meeting of this need.

A RADIO FIELD STRENGTH SURVEY OF PHILADELPHIA

BY

KNOX MCILWAIN AND W. S. THOMPSON

(Moore School of Electrical Engineering, University of Pennsylvania)

Summary—Measurements of the strength of the electromagnetic waves broadcast by station WFI were taken at representative locations throughout the city of Philadelphia and its environs. In the method used, measurements of the antenna loop resistance were used as a guide in determining when interference was sufficient to cause the rejection of a particular field strength reading. Lines of equal field strength were plotted on a map of the territory; these showed the location of several shadows and of one area in which the field strength was considerably higher than in the surrounding neighborhood. Conditions throughout the city remained virtually unchanged during the two years of the survey, with the exception of a considerable new shadow cast by a large building recently erected near the broadcasting station.

MEASUREMENTS of the electromagnetic field strength due to a particular radio transmitting station at a definite time and place are of importance in the study of the transmission of radio waves through space. At a point far from the transmitting station the field strength varies considerably with the period of the day (or night), the season of the year, and atmospheric conditions. Studies of such variations have been conducted by a number of agencies and now include the results of several years' work. Near the transmitting station the measurements do not vary greatly with time and atmospheric conditions, but within this area, where the field strength from the given station is comparatively great, there are great differences in the intensity of the electromagnetic field at different points. These variations were naturally suspected of being caused by the topography of the surrounding country, and by the presence of metallic materials in the immediate vicinity.

A study of the conditions existing in Washington, D. C., and in New York made in 1923¹ indicated the way hills, large building areas, rivers, and other local conditions affected field strength. It was considered worth while to extend these studies to other localities, particularly large cities, where the variations were found to be most marked. Philadelphia offered local conditions differing

Manuscript Received by the Institute, August 3, 1927.

¹ "Distribution of Radio Waves from Broadcasting Stations over City Districts," Bown and Gillett, I. R. E. Proc., Aug. 1924.

considerably from either of the cities previously studied. During the past two years the authors have been making measurements of the field strength produced by the transmitting station WFI in various parts of the Philadelphia area. Due to the congested condition of the air in the broadcasting frequency range, measurements were possible only during certain restricted periods each day. Those in charge of the station cooperated by carefully maintaining a constant power output and frequency.

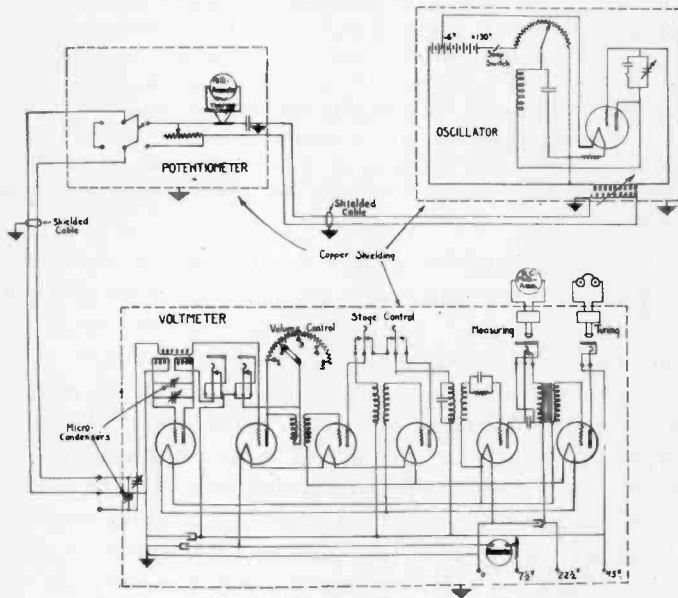

Fig. 1—Setup of Apparatus for Calibrating a Radio Receiving Set as a Voltmeter.

During the two years of the study certain readings were periodically rechecked; these readings proved to be practically constant throughout the investigation. Near the end of the study an entire recheck of the area was made. Conditions throughout the city and its environs proved to be unchanged with one very interesting exception. This exception, which showed the effect of a new steel skeleton building near the transmitting station, will be fully treated in the discussion of results.

METHOD AND APPARATUS

The method used in measuring the field strength was substantially the same as that described by Bown, England, and

Friis.² In the methods used by these investigators each reading was obtained by noting the change in direct-plate current of a detector tube caused by an incoming carrier wave. The incoming carrier was then eliminated, and a local oscillator used to impress a known variable voltage on the set. By adjusting the local voltage to cause the same variation in detector-plate current as given by the incoming carrier, the voltage, and by calculation the vertical component of the field intensity of the incoming signal was obtained. The voltage impressed across the input of a radio receiving

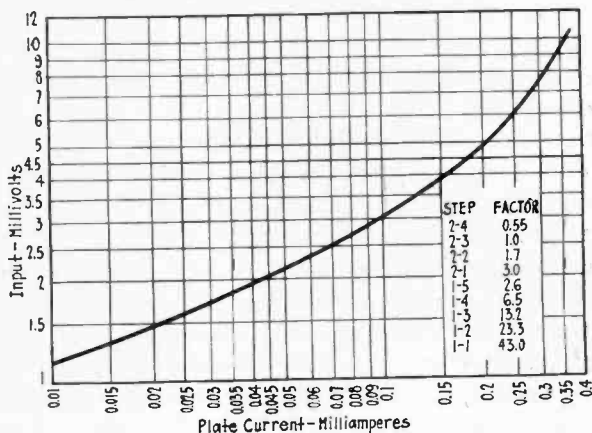

Fig. 2—Calibrating Curve of Receiving Set.

set by a given electromagnetic field depends on the effective height of the antenna used. The units of field intensity are volts, or fractions thereof, per meter.

The main difference in the method employed in the present investigation was that a set, consisting of a standard six tube superheterodyne receiver and loop antenna, was calibrated as a voltmeter in the laboratory before being used in the field (Fig. 1). The change in direct-plate current of the second detector tube due to a known voltage of a local oscillator was noted, and curves were plotted of plate current reading against impressed voltage (Fig. 2). Many calibrations were made at first to insure the reliability of the curves. It was soon found that the calibration was quite stable, changing only as the detector tube and plate batteries aged. From then on occasional check calibrations were made.

² "Radio Transmission Measurements," Bown, Englund, and Friis, I. R. E. Proc., April 1923.

In the calculation of the field intensity required to produce a given voltage on the input terminals of the set, the resistance of the loop circuit was required. This was obtained by the well-known reactance variation method of measuring circuit resistance, the calibrated set being used to indicate current differences due to the change in loop circuit reactance. The reactance change was caused by a calibrated micro-condenser connected permanently in parallel with the tuning condenser. In the field this micro-condenser permitted very accurate tuning. The method of measuring loop resistance was convenient in that it was very simple and capable of operation with no change in the setup of the apparatus; a fact which was utilized in determining when interference was present.

The reactance variation method of measuring circuit resistance depends on obtaining the ratio of the current in the circuit (or in this case the voltage across a particular fixed portion) at resonance, to the current in the circuit when a known reactance is introduced. When electromagnetic energy from sources other than the transmitting station is present, it will in general be made up of fields of other frequencies than that of the measured signal. In such a case it is impossible to adjust the loop circuit to resonance for all frequencies present, with the result that a greater reactance variation will be necessary to produce the desired ratio of currents. The loop circuit resistance is calculated from the following equation:

$$R = \frac{C_2 - C_1}{4\pi f C_1 C_2} \sqrt{\frac{I_1^2}{I_R^2 - I_1^2}}$$

where f is the frequency of the measuring current.

R is the loop circuit resistance.

I_R is the current at resonance.

I_1 is any other current.

C_2 and C_1 are the values of capacitance of the loop circuit for which the current is I_1 . (The inductance of the loop circuit is kept constant throughout.) Thus an increase in the capacitance variation required to reduce the current to a particular fraction of the resonant current (e.g., one-half) will cause an apparent increase in the loop circuit resistance.

In most cases the loop circuit resistance was constant within the accuracy of the method and the uniformity of conditions. Some variation was expected and experienced due to nearby

buildings, etc., increasing the losses in the loop circuit. Measurements of the resistance were made as a part of every field strength reading. Whenever the measurements indicated a resistance greater than a few per cent above normal, the reading was rejected since the energy input from the interference affected the accuracy of the reading. In almost all of these cases considerable interference could be observed by listening to the output of the set.

The procedure for a single measurement was as follows:

(1) The car in which the set was mounted was brought to the point chosen, and the motor stopped. The apparatus was set up,

Measurements of Field Strength:— Date: 5-17-26
 Plate Voltage:— 45 Filament Current:— 0.25 amp
 Weather:— Clear and Hot
 Remarks:— Calibration Factor 0.88

Location	Peak Volts, Bridge		
	East Bank of River	Avdleigh St.	Sprague St.
Direction of Loop	2 80	150	175
Gain Step	3 1-4	1-5	1-4
Loop off	4 74.5	70	69
Meter Loop on	5 39.5	40	54
Diff:	6 $\frac{35}{59.5}$	$\frac{39}{56}$	$\frac{15}{65}$
Reading of Vernier 1/2 I	7 51	62	63
Condenser 1/2 I	8 27	36	28
Loop Resistance	9 11.7	12.6	17
Input-Calibration Curve	10 8.27	7.45	
Amplification Factor	11 6.5	7.6	
Actual Input Volts	12 53.7	19.4	
Field Strength	13 $\frac{20,800}{11.0}$	$\frac{7,900}{4.6}$	

Fig. 3—Sample Data Sheet

the filament current adjusted, and the normal reading of the detector-plate current meter noted to insure that the set and batteries were in proper condition.

(2) The detector meter was removed (since the jack connecting the meter simultaneously disconnected the last stage) and the station tuned in roughly by ear. The meter was then reinserted and the set was carefully tuned by adjusting the loop condenser, the oscillator condenser, and the direction of the plane of the loop. The degree of amplification was at the same time adjusted to bring the meter reading to a convenient portion of the calibration curve.

(3) The reading of the meter was taken with the loop connected and disconnected. (Lines 5 and 4 of Fig. 3.) The difference between these readings was observed, and from the calibration curve of the set (Fig. 2) the reading to indicate one-half of the

resonant current was obtained, and both these readings were noted (Fig. 3, Line 6). The calibrated micro-condenser in parallel with the loop condenser was then varied (on each side of the resonance value) until one-half of the resonant current was indicated, and the readings taken.

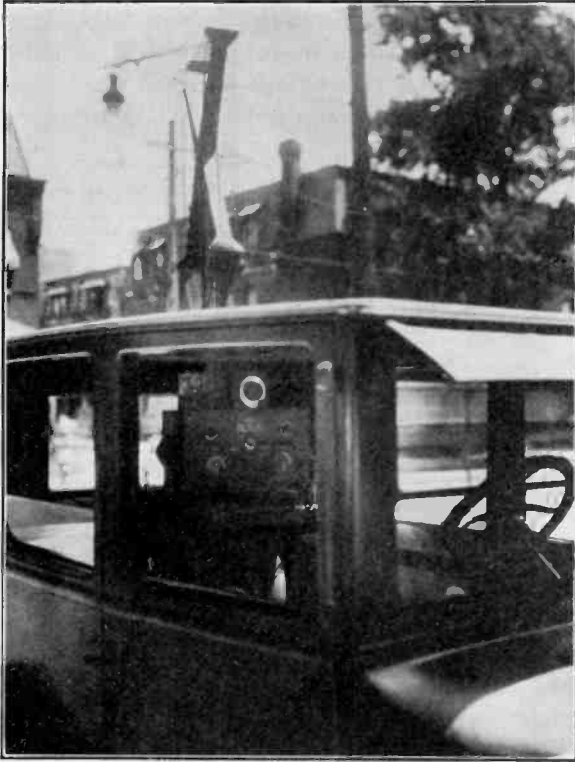

Fig. 4—Survey Car.

(4) The location, the direction of the loop with respect to the street and the amount of amplification were recorded. The delicate parts of the set such as the meters were then prepared for transportation.

A complete reading, depending on the skill of the operator, occupied from one to three minutes. Where interference was encountered, particularly of a transient nature, e.g., that due to trolley-cars, a longer period of time was required. Upon arrival

at the laboratory the loop resistance and the field strength were calculated.

DIFFICULTIES ENCOUNTERED IN THE FIELD

The set was carried in a Ford sedan upon a double spring suspension above the rear seat (Figs. 4 and 5). The loop was mounted in a hole cut in the roof, with directional control and indicator within the car. During transportation the meters were disconnected, taken off suspension, and placed on the cushions of the rear seat, but despite the care taken, open circuits, broken tubes, and other mechanical injuries were frequent.

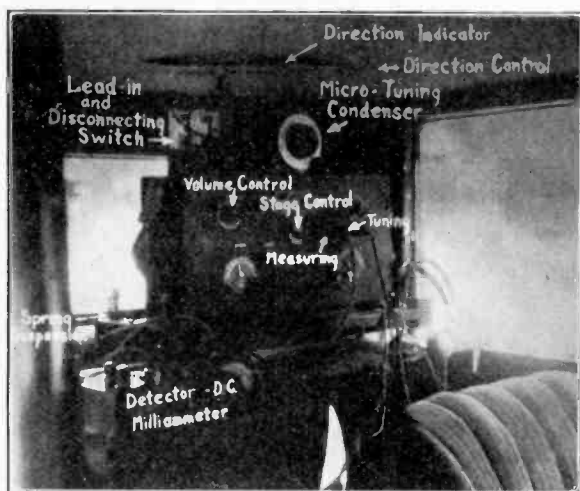

Fig. 5—Measuring Set Mounted in the Car.

Wherever possible measurements were taken in the center of open spaces or with some open space between the location and the nearest building in the direction of the transmitter. This was necessary since the shielding effect of even a two-story residence is considerable. On one occasion the transfer of the car to the opposite side of a seventy-foot street lined with two-story houses caused the field strength reading to double.

Field strength readings were spotted on a map of Philadelphia during the course of the field work. As the work progressed this afforded an opportunity of noting any unusual variations in an area and permitted the taking of check readings to determine the accuracy of such measurements. These local disturbances,

or shadows, were found to be due to such causes as the presence of large buildings, railways, elevated street car systems, or power lines. Since the object of the study was to get a general idea of

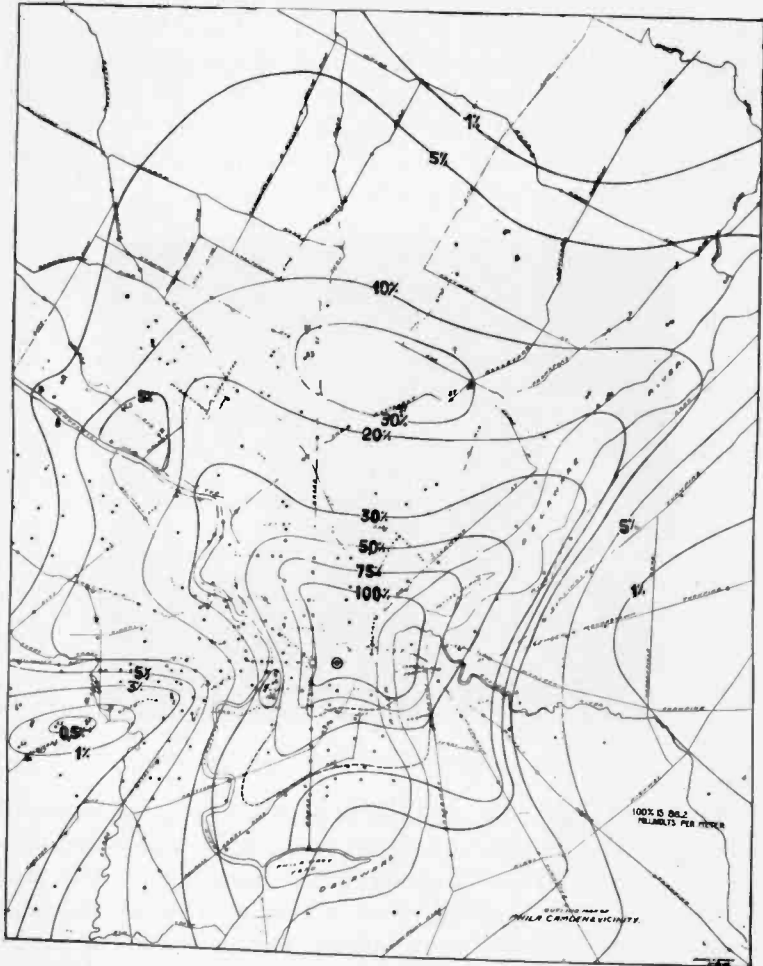

Fig. 6—Radio Field Strength Contour Map of Philadelphia

the distribution of radio waves over the city as a whole, and not to study conditions in a particular neighborhood, readings of this sort were discarded. In every case it was found possible to choose other locations in the immediate vicinity, which would not be subject to these local conditions.

It will be seen from the above discussion that, while a fair degree of accuracy was maintained, no great importance can be claimed for individual readings. Some interference was present at the majority of locations, there was always some effect from local buildings, and the readings taken on one side of the street would not necessarily hold for the other side. Readings taken at the street level would not be applicable to conditions on the roof of a three- or four-story building.



Fig. 7—Aerial Photograph of Philadelphia from Southeast of the Transmitting Station.

DISCUSSION OF RESULTS

The most reliable of the readings taken were plotted on an outline map of Philadelphia (Fig. 6). The dots represent locations where measurements were made. Arbitrarily assuming 86.2 milli-volts per meter as 100 per cent, contour lines were drawn for various percentages. While it was impossible to draw these lines so as to be in accord with every measurement taken, a surprisingly large percentage of the measurements were consistent with the lines as drawn.

It will be seen from the map that the high percentage contour lines assume roughly the form of a square (instead of the oblong shape to be expected from an *L* type antenna) whose center is far to the northeast of the station. From Fig. 7 it will be seen that a line drawn through the station from northwest to southeast

passes to the north and east of practically all of the larger buildings of the city. It would thus be expected that the heaviest losses would occur to the south and west of the station, accounting for the shift of the center of area of the contour lines to the northeast. The very noticeable bulge in these lines toward the northwest can only be accounted for by the directional effect of the *L* type antenna. In the northeast and southeast directions from the station there are less pronounced bulges in the contours due to the Delaware River and to the heavily built section of Camden which is located directly east of the transmitter.

The solid contour lines all represent conditions at the time of completion of the survey. There was no change during the course of the survey except in the area south of Market Street and between the Delaware River and the Schuylkill. The check measurements made throughout the city shortly before the completion of the survey indicated that in this area the field strength had decreased considerably from the values found during the early months of measuring. The 100 per cent and 50 per cent contours existing at the start of the survey are plotted in dotted lines on the map. These contours have a rectangular shape, with the center almost due east of the station. During the course of the survey a large steel skeleton building was constructed directly south of and just across the street from the station, the roof being several stories above the antenna of WFI. The effect of this one large building close to the transmitting antenna is thus very marked.

The lower percentage contour lines show several interesting conditions. The most pronounced of these is a very dense shadow covering the whole of the area south of Market Street and west of the Schuylkill, the lowest field strength being found in the middle of Lansdowne, six miles west-southwest of the transmitter. Beyond this point there is a definite increase in field strength, shown to some extent by the contour lines drawn on the map, and even more markedly by measurements taken at locations beyond the confines of the map. This increase in field strength, or so-called "healing" of the shadow, is due to the fact that energy is fed in from other portions of the wave front. This effect checks the results of measurements taken in New York and elsewhere.

Shadows due to locally congested areas were found in two places. Below Market Street and skirting the east bank of the Schuylkill there is an area of decreased field strength due to the

presence of a group of factory and business buildings. Northwest of the station, between the 10 and 20 per cent lines, there is a larger area of decreased field strength due to the congested building area of Manayunk.

East of the Delaware River the shadow of the heavily built area of Camden is quite well marked. This shadow is nearly as dense but not so clearly defined as that in West Philadelphia.

Directly north of the station in the vicinity of the Roosevelt Boulevard between the 10 and 20 per cent lines there is an area of increased field strength. This would be expected from the fact

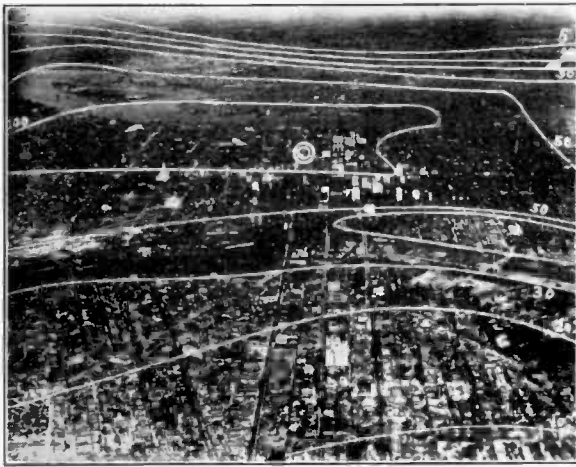

Fig. 8—Aerial Photograph of Philadelphia and Camden; West of Transmitting Station.

that in this vicinity there are only occasional groups of two-story houses, dotting a large area of open fields.

Whenever open country or rivers were encountered local bulges are found in the contour lines, indicating the decreased losses over such areas. This tendency of the lines is especially marked along the Delaware River northeast of the station; here the measurements taken as nearly on the river bank as possible indicate field strengths 50 to 100 per cent greater than those taken about a mile inshore. The percentages found at several of the locations in this area were noted on the map to illustrate this tendency.

All of the effects found above are consistent with existing theories of transmission. The pattern found for Philadelphia is

quite different from those of New York and Washington. While the New York pattern is characterized by its dumbbell shape and the Washington pattern by a circle, the Philadelphia pattern is roughly square, with its center far from the station. Other cities will undoubtedly exhibit equally interesting characteristic patterns.

ACKNOWLEDGMENT

The authors' thanks are due to the American Telephone and Telegraph Company not only for the loan of the equipment used in the measuring work, but also for advice and guidance received from its engineers. Thanks are also due to the Strawbridge and Clothier Company for cooperation in the actual measurements.

ON THE THEORY OF POWER AMPLIFICATION*

BY

MANFRED VON ARDENNE

(Berlin)

Summary—1. In order to supply a maximum output wattage to an inductive loudspeaker by means of high-power tubes, regardless of the necessary amplitude of E_g , it is necessary to calculate the plate battery and grid-biasing potentials required to ensure distortionless reproduction.

2. From the inductive load on the plate circuit of the tube an elliptical shape of the working characteristic follows, referring to the e_p, i_p diagram.

3. If the working ellipse is enclosed by a rectangular quadrangle, the sides of which are parallel to abscissa and ordinate axes respectively, then the slope or angle σ_{p_1} of the diagonal of this quadrangle means the dynamic slope or mutual conductance of the tube for the given plate-circuit load, for

$$\sigma_{p_1} = \frac{I_p}{E_g}$$

4. By means of σ_{p_1} and starting from the conditions of distortionless reproduction the position of the diagonal of the quadrangle and its useful part are determined and furthermore the following equations for the minimum necessary plate-battery potential as well as for the necessary grid-biasing potential are found:

$$\bar{E}_B = K + \bar{I}_p(r_p + R_b) + I_p \sqrt{(\omega L)^2 + (r_p + R_{bw})^2} = \bar{E}_g \cdot \mu$$

$$\bar{E}_C = \bar{E}_G - I_p / \mu \sqrt{(\omega L)^2 + (r_p + R_{bw})^2}$$

5. It is shown what conditions result if several loudspeakers are connected in series or in parallel with each other or if several tubes connected in parallel are employed to supply the loudspeaker.

6. Calculated and graphical solutions of the problem in question are given for practical examples and especially curves are shown illustrating the dependence of the effective output wattage of the loudspeaker on their internal plate resistance of the tube and on the operating frequency.

I. PROBLEM AND CONDITIONS

WHEN it becomes desirable to obtain a maximum distortionless output of sound from a system of loudspeakers by means of a power-tube, then the question of calculating the necessary d-c. plate- and grid-potentials arises.

The condition of freedom from distortion comprises:

First, that in no case should the effective grid-potential of the tube, that is the d-c. grid-bias plus the impressed a-c. potential, reach the region of either appreciable grid-current or appreciable

Original Manuscript Received by the Institute, November 2, 1927.

* Re-written in accordance with M. v. Ardenne, "Zur Theorie der Endverstärkung", *Jahrbuch*, Band 30, Heft 3.

curvature of the static tube characteristics; and, secondly, that the system of loudspeakers used should be capable of converting the impressed audio-frequency impulses into sound without distortion.

Furthermore, the condition is assumed to be fulfilled, as in practice is nearly always the case, that the preceding apparatus is capable of delivering any necessary amount of a-c. potential to the power-tube.

Roughly the load on the plate-circuit of the power-tube induced by the system of loudspeakers may be assumed to consist of an inductance L and an effective resistance R_{b_w} . This effective resistance R_{b_w} consists of the pure ohmic resistance R_b of the loudspeaker coils and the working resistance R_w , which itself again comprises both the losses resistance R_{w_v} and the useful acoustic radiation resistance R_{w_n} ¹.

II. THE PLATE-CURRENT

For the sake of simplicity it will be assumed that the power-tube is required to supply only a single loudspeaker.

The momentary plate-current then results from the steady direct plate-current and an a-c. value as indicated by:

$$i_p = I_p + \tilde{i}_p \quad (1)$$

The steady direct plate-current may be taken to be:

$$I_p = \sigma_{p_r} \cdot \left(\bar{E}_c + \frac{\bar{E}_B'}{\mu} \right) = \sigma_{p_r} \cdot \frac{r_p}{r_p + R_b} \cdot \left(\bar{E}_c + \frac{\bar{E}_B'}{\mu} \right) \quad (2)$$

In this formula σ_{p_r} designates the mutual conductance of the working characteristic, \bar{E}_c the d-c. grid-biasing potential and \bar{E}_B' the potential of the plate-potential battery, diminished by a correction potential K .

Furthermore

$$\tilde{i}_p = I_p \cdot \sin(\omega \cdot t - \psi) \quad (3)$$

can be written, if the impressed a-c. potential on the grid is sinusoidal, from which an also sinusoidal alternating plate-current follows. Since the tube may be looked upon as an a-c. generator

¹ R_{w_n} is in practice not absolutely constant, but changes according to the type of loudspeaker and is mainly dependent on the special resonance peaks of the latter. In the following R_{w_n} will be assumed to be constant, since for the usual loud-speaker-effectiveness its value may safely be disregarded.

with the e.m.f. or load-less potential $\mu \cdot E_g$, where E_g means the amplitude of the a-c. potential impressed on the grid,

$$I_p = \frac{\mu \cdot E_g}{\sqrt{(\omega \cdot L)^2 + (r_p + R_{bw})^2}} \quad (4)$$

follows; the denominator designates the impedance of the generator circuit. Finally the phase-angle between the plate-current and the grid-potential is given by

$$\psi = \text{arc tg} \left(\frac{\omega \cdot L}{r_p + R_{bw}} \right) \quad (5)$$

Thus the following final formula for the plate-current results:

$$i_p = \sigma_p \cdot \frac{r_p}{r_p + R_b} \cdot \left(\bar{E}_c + \frac{\bar{E}_{B'}}{\mu} \right) + \frac{\mu \cdot E_g}{\sqrt{(\omega \cdot L)^2 + (r_p + R_{bw})^2}} \cdot \sin \left[(\omega t) - \text{arc tg} \left(\frac{\omega \cdot L}{r_p + R_{bw}} \right) \right] \quad (6)$$

III. THE WORKING CHARACTERISTIC

By means of

$$lg = \bar{E}_c + E_g \cdot \sin (\omega t) \quad (7)$$

or

$$\sin (\omega t) = \frac{lg - \bar{E}_c}{E_g} \quad (8)$$

may be changed to define the relation between i_p and lg . For the sake of simplicity the letter α will be written instead of $\omega \cdot t$.

$$\sin (\alpha - \psi) = \sin \alpha \cdot \cos \psi - \sqrt{1 - \sin^2 \alpha} \cdot \sin \psi \quad (9)$$

$$= \cos \psi \cdot \frac{lg - \bar{E}_c}{E_g} - \sin \psi \sqrt{1 - \left(\frac{lg - \bar{E}_c}{E_g} \right)^2} \quad (10)$$

$$= \frac{r_p + R_{bw}}{\sqrt{(\omega \cdot L)^2 + (r_p + R_{bw})^2}} \cdot \frac{lg - \bar{E}_c}{E_g} - \frac{\omega \cdot L}{\sqrt{(\omega \cdot L)^2 + (r_p + R_{bw})^2}} \times \frac{\sqrt{E_g^2 - (lg - \bar{E}_c)^2}}{E_g} \quad (11)$$

From these equations the following results:

$$i_p = \sigma_{p_r} \cdot \left(\bar{E}_c + \frac{\bar{E}_{B'}}{\mu} \right) + \frac{\mu}{[(\omega L)^2 + (r_p + R_{b_w})^2]} \cdot [(r_p + R_{b_w}) \cdot (lg - \bar{E}_c) - \omega L \cdot \sqrt{E_g^2 - (lg - \bar{E}_c)^2}] \quad (12)$$

which may also be written thus:

$$y = A \cdot [a \cdot x - b \cdot \sqrt{E_g^2 - x^2}] \quad (13)$$

if the following substitutions are carried out:

$$\frac{u}{[(\omega \cdot L)^2 + (r_p + R_{b_w})^2]} = A; \quad \omega \cdot L = b;$$

$$r_p + R_{b_w} = a; \quad lg - \bar{E}_c = x; \quad i_p - \bar{I}_p = y. \quad (14)$$

Since equation (13) can be brought into the form of the central equation of an ellipse

$$a_{1_1} \cdot x^2 + 2 \cdot a_{1_2} \cdot x \cdot y + a_{2_2} \cdot y^2 = k \quad (15)$$

by means of the substitutions

$$a_{1_1} = A^2 \cdot (a^2 + b^2) = \frac{\mu^2}{[(\omega L)^2 + (r_p + R_{b_w})^2]};$$

$$a_{1_2} = -A \cdot a = \frac{-(r_p + R_{b_w}) \cdot \mu}{[(\omega L)^2 + (r_p + R_{b_w})^2]}; \quad a_{2_2} = 1; \quad (16)$$

and

$$R = A^2 \cdot b^2 \cdot E_g^2 = \frac{\mu^2 \cdot E_g^2 \cdot (\omega L)^2}{[(\omega L)^2 + (r_p + R_{b_w})^2]^2}$$

it becomes apparent that the working characteristic of the tube for an inductive and ohmic load of the plate circuit is not a straight line, but, according to equation (12), an ellipse the axes of which form angles with the abscissa lg and the ordinate i_p .

IV. THE RECTANGULAR QUADRANGLE ENCLOSING THE WORKING CHARACTERISTICS

This formula leads, as will be shown in the following, to the equations desired expressing the necessary d-c. plate and grid potentials, if it is brought into relation with the conditions of the problem here under discussion which were stated above.

The working ellipse of the tube may be assumed to be enclosed by a rectangular quadrangle the sides of which run parallel to the ordinate and abscissa axes respectively and touch the ellipse. If, for loudspeaker reproduction, the regions both of appreciable grid-current and of excessive curvature of the static tube characteristics are to be avoided, then it is clear that neither the ellipse itself nor the quadrangle enclosing it may encroach upon these regions.

If the region of appreciable grid-current begins at the line $l_g = \bar{E}_c$, which is at right angles to the abscissa l_g , then the one

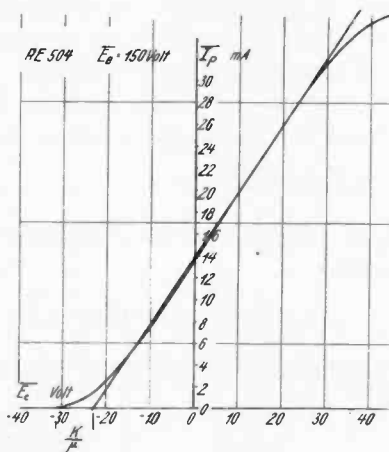

Fig. 1a

side of the quadrangle enclosing the ellipse must be identical with this line or, if considered necessary, correspond to even more negative grid-potentials.

The second side of the quadrangle running parallel to the first clearly lies at a distance of $2 \cdot E_g$ from the first. On the other hand, if the region in which the static characteristics are sufficiently straight reaches to I_{p1} and I_{p2} respectively, then the necessary position of the other two parallel sides of the quadrangle and their distance from each other is thereby defined.

V. THE DIAGONAL OF THE QUADRANGLE

Since the respective lengths of the sides of the quadrangle accordingly are

$$l_{g_{\max}} - l_{g_{\min}} = 2 \cdot E_g \tag{17}$$

and

$$\overline{I}_{p_1} - \overline{I}_{p_2} = i_{p_{\max}} - i_{p_{\min}} = \frac{2 \cdot \mu \cdot \overline{E}_g}{\sqrt{(\omega \cdot L)^2 + (r_p + R_{bw})^2}} \quad (18)$$

the diagonal of the quadrangle which passes through the point \overline{E}_G ; \overline{I}_{p_1} forms an angle with the abscissa lq , which may be expressed as follows:

$$\sigma_{p_2} = \frac{\mu}{\sqrt{(\omega L)^2 + (r_p + R_{bw})^2}} = \sigma_p \cdot \frac{r_p}{\sqrt{(\omega L)^2 + (r_p + R_{bw})^2}} = \frac{I_p}{E_g} \quad (19)$$

This angle here is expressed in the form of a mutual conductance, because, as will be shown later, the diagonal may with great advantage be assumed to be the working characteristic of the tube for an inductive and ohmic load on the plate-circuit, instead of the ellipse. The center of the ellipse and therefore also that of the enclosing quadrangle is the point $\overline{E}_c; \overline{I}_p = \frac{\overline{I}_{p_1} + \overline{I}_{p_2}}{2}$; therefore this point also lies on the diagonal, which therefore possesses the equation

$$i_p - I_p = \sigma_{p_2} \cdot (lq - \overline{E}_c) \quad (20)$$

By means of equation (2) this may be changed to the following form:

$$i_p - I_p = \sigma_{p_2} \cdot \left(lq - \frac{\overline{I}_p}{\sigma_{p_r}} + \frac{\overline{E}_B'}{\mu} \right) \quad (21)$$

VI. THE MATHEMATICAL SOLUTION OF THE PROBLEM

Now the point with the abscissa

$$lq = \overline{E}_g$$

and the ordinate

$$i_p = i_{p_{\max}} = \overline{I}_p + I_p$$

also belongs to the diagonal. If these values are substituted into equation (21), then after some operations the following formula results:

$$\overline{E}_B' = I_p \cdot (r_p + R_b) + I_p \cdot \sqrt{(\omega L)^2 + (r_p + R_{bw})^2} - \mu \cdot \overline{E}_G \quad (22)$$

Thus also:

$$\overline{E}_B = K + I_p(r_p + R_b) + I_p \cdot \sqrt{(\omega L)^2 + (r_p + R_{bw})^2} - \mu \cdot \overline{E}_G \quad (22a)$$

If the values $\bar{E}_G, \bar{I}_p = \frac{I_{p_1} + I_{p_2}}{2}$ and I_p together with those of $\mu,$

$r_p,$ and K are taken from the static tube characteristics and furthermore if the values $L_1 R_b$ and R_{bw} are known as the data of the loudspeaker in question, then the formula above supplies the desired value for the minimum amount of plate-battery potential necessary to meet the working conditions of the tube which were discussed above.

Furthermore, by means of

$$\bar{E}_c = \frac{\bar{I}_p}{\sigma_{pr}} - \frac{\bar{E}_B'}{\mu} \tag{23}$$

this equation for \bar{E}_B' leads to the following formula for the necessary d-c. grid-potential:

$$\bar{E}_c = \bar{E}_G - \frac{I_p}{\mu} \cdot \sqrt{(\omega L)^2 + (r_p + R_{bw})^2} \tag{25}$$

The a-c. potential impressed on the grid then must not exceed the value

$$\bar{E}_g = \frac{I_p}{\mu} \cdot \sqrt{(\omega L)^2 + (r_p + R_{bw})^2} \tag{26}$$

For ω a value of about $2\pi \cdot 800 = 5,000$ may be assumed, if the fact is taken into consideration that at the higher frequencies, with music as well as speech, the amplitudes of the impressed a-c. potentials are correspondingly smaller than at lower frequencies. The higher the frequency, the smaller the slope (mutual conductance) of the diagonal of the quadrangle which encloses the working ellipse becomes; and correspondingly smaller plate current variations are the result. If, as said above, the impressed a-c. potential amplitudes are greatest at a frequency of 800 Hertz, then in practice all those working curves for frequencies smaller than 800 must lie within the working ellipse for the frequency of 800 Hertz.

For the calculation of $\bar{E}_c,$ however, a value corresponding to the smallest frequency in question must be assumed for $\omega,$ about $\omega = 2\pi \cdot 16 = 100.$ Otherwise at these low frequencies the impressed a-c. potentials on the grid would reach the regions where the tube

characteristics are excessively bent. This will be shown by means of diagrams in section 13.

VII. LOUSPEAKERS IN SERIES AND IN PARALLEL

By connecting loudspeakers in parallel the impedance of the plate circuit is reduced, thus making smaller values of d-c. plate potential \bar{E}_B and d-c. grid potential \bar{E}_C sufficient; but at the same time the limit of a-c. potential which may be impressed on the grid is reduced.

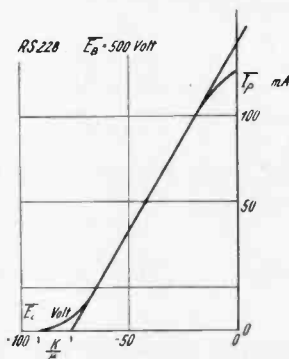

Fig. 1b

At the same time the acoustic wattage attainable is also reduced. This acoustic output wattage for a single loudspeaker corresponds to

$$W_{\sigma} = R_{w_p} \cdot \frac{I_p^2}{2} \quad (27)$$

while the attainable wattage with two loudspeakers of the same type in parallel is equal to:

$$W_{\sigma}' = 2 \cdot \left[R_{w_n} \cdot \frac{\left(\frac{I_p^2}{2} \right)}{2} \right] = \frac{1}{2} W_{\sigma} \quad (28)$$

If the loudspeakers are connected in series, then L and R_{δ} become larger. Thus under these conditions both the d-c. plate and grid potentials have to be increased and also the amplitude of the impressed a-c. potential has to be correspondingly larger. The effective acoustic output wattage then, for the case of two similar loudspeakers connected in series, is equal to

$$W_{\sigma}'' = (2 \cdot R_{w_n}) \cdot \frac{I_p^2}{2} = 2 \cdot W_{\sigma} \tag{29}$$

Thus the output wattage is doubled, but of course only if, as said above, the d-c. plate and grid potentials as well as the impressed a-c. grid potential are correspondingly increased.

VIII. PRACTICAL EXAMPLES

A loudspeaker of the following electrical dimensions will be assumed:

$$L = 2.35 \text{ henrys; } R_b = 2000 \text{ ohms; } R_{b_w} = 3000 \text{ ohms.}$$

In order to supply this loudspeaker with a maximum output wattage the tubes given in the table below will be considered; the values I_p , I_p and \bar{E}_G given in the table were taken from the static tube characteristics according to Figs. 1a-b.

TABLE I

Tube	E_f in volts	I_f in amps.	μ	r_p in Ohms	I_p in milli-amps.	I_p in milli-amps.	E_G in volts	K in volts
Telef. RE 504	3.5	0.5	4.5	7500	17	11	0	38.6
Telef. RS 228	7	1.1	5.5	3200	60	40	0	83.5

From these values follows:

TABLE II

Tube	$r_p + R_b$ in Ohms	Z_{b_w} in Ohms	Z_B in Ohms	\bar{E}_b in volts	\bar{E}_c in volts	E_G in volts
Telef. RE 504	9500	12130	15760	374	-38.2	25.4
Telef. RS 228	5200	12130	13300	927.5	-95.8	44.7
$\omega =$		5000	5000	5000	5000	100

In this table the different signs designate the data of the arrangement as follows:

$r_p + R_b$ = Internal plate resistance of the tube + pure ohmic resistance of the loudspeaker.

Z_{b_w} = Impedance of the loudspeaker system, $= \sqrt{(\omega \cdot L)^2 + (R_{b_w})^2}$

Z_B = Total impedance of the plate circuit, including the tube $= \sqrt{(\omega \cdot L)^2 + (r_p + R_{b_w})^2}$

\bar{E}_b = Minimum necessary plate-battery potential, chosen with regard to the higher frequencies, $\omega = 5,000$.

\bar{E}_c = Minimum necessary negative grid-biasing potential, chosen with regard to the higher frequencies, $\omega = 5,000$.

E_G = Maximum value of impressed a-c. grid-potential permissible, defined with regard to the lower frequencies, $\omega = 100$.

IX. THE USE OF SEVERAL POWER TUBES CONNECTED IN PARALLEL

According to the above calculations a clearly defined minimum plate-battery potential is necessary to obtain a maximum output wattage from a given power-tube to a given loudspeaker. This fact might lead to the false assumption that, in order to obtain an equal output wattage it would be possible to substitute a number of smaller tubes connected in parallel for a single but larger power-tube and at the same time using less plate-battery potential for the several smaller tubes.

If it is assumed that n similar, smaller tubes are connected in parallel, each one of which possesses the data $\bar{E}_f', I_f', \mu', r_p', I_p', I_p', K'$, then these tubes correspond to a single hypothetical tube of the following electrical dimensions:

$$\bar{E}_f = \bar{E}_f', I_f = n \cdot I_f', \mu = \mu', r_p = \frac{r_p'}{n}, I_p = n \cdot I_p', I_p = n \cdot I_p', K = K'$$

In this case the different electrode-systems may be assumed to be enclosed in a single evacuated glass tube.

The necessary plate-battery potential for the n power tubes connected in parallel then is

$$\bar{E}_B = K' + n \cdot I_p' \cdot \left(\frac{r_p'}{n} + R_b \right) + n \cdot I_p' \sqrt{(\omega L)^2 + \left(\frac{r_p'}{n} + R_{b_w} \right)^2} \quad (30)$$

For example, with four tubes RE 504 arranged in this manner and with the following electrical dimensions of the circuit

$$L = 2.35 \text{ henrys; } R_b = 2,000 \text{ ohms; } R_{b_w} = 3,000 \text{ ohms}$$

the necessary value of plate-battery potential resulting would be 861 volts. The output current of these four tubes is $I_p = 4.17 = 68 \text{ mA}$ and $I_p = 4.11 = 44 \text{ mA}$ for a filament wattage consumption of $4 \cdot 3.5 \cdot 0.5 = 7$ watts. About the same output current is supplied by a single tube of the type RS 228, namely $I_p = 60 \text{ mA}$ and $I_p = 40 \text{ mA}$, for a filament consumption of approximately the same value, namely $7 \cdot 1.1 = 7.7$ watts. This tube requires a minimum plate-battery potential of 927.5 volts according to Table II.

X. THE DEPENDENCE OF THE PLATE CURRENT AND USEFUL OUTPUT WATTAGE FROM THE INTERNAL PLATE RESISTANCE OF THE TUBE AND FROM THE OPERATING FREQUENCY

If the load on the plate circuit, that is the values L , R_b , and R_{b_w} of the loudspeaker system, is assumed to be constant and predetermined, then the plate-current is, if a certain amplitude

E_g of impressed a-c. grid-potential is predetermined, only dependent from the amplification factor μ of the tube, which may be regarded as a constant, from the internal plate resistance of the tube and from the operating circuit frequency ω . According to equation (19), in which σ_{p_2} is a dynamic mutual conductance,

$$I_p = E_g \cdot \sigma_{p_2} = \frac{\mu \cdot E_g}{Z_B} = \frac{\mu \cdot E_g}{\sqrt{(\omega L)^2 + (r_p + R_{bw})^2}}$$

$$= E_g \cdot \sigma_p \cdot \frac{r_p}{r_p + R_{bw}} \cdot \cos \psi \tag{31}$$

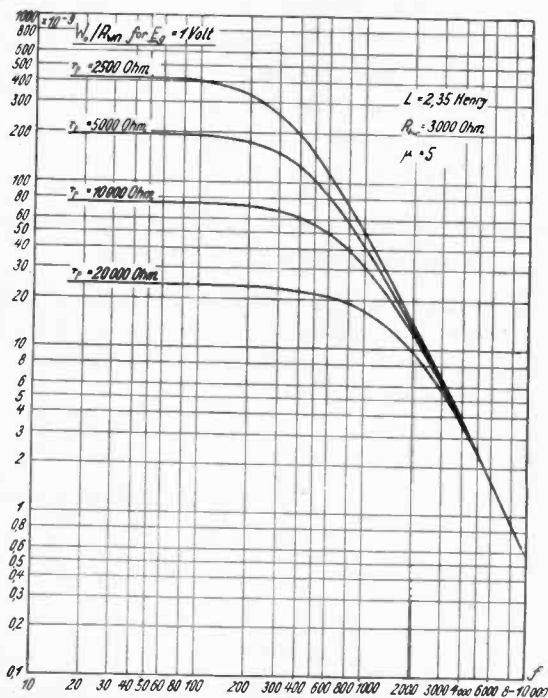

Fig. 2

By this means follows:

$$W_\sigma = \frac{1}{2} \cdot R_{w_p} \cdot I_p^2 = \frac{1}{2} \cdot R_{w_p} \cdot E_g^2 \cdot \left[\sigma_p^2 \cdot \left(\frac{r_p}{r_p + R_{bw}} \right)^2 \cdot \cos^2 \psi \right] \tag{32}$$

$$= \frac{1}{2} R_{w_p} \cdot E_g^2 \cdot \frac{\mu^2}{(\omega L)^2 + (r_p + R_{bw})^2}$$

This dependence of the output wattage supplied to the loud-speaker on the internal resistance of the tube and on the frequency

is shown for the values given in the above equations by a number of curves in Fig. 2.

In judging these curves it must be borne in mind that they only represent the electrical output wattage supplied to the loudspeaker, which the latter converts into sound, but not the actual acoustic air pressure amplitudes which are produced by the mechanical vibrations of the loudspeaker diaphragm at different frequencies. The actual radiated sound amplitudes, however, increase with the frequency in accordance with an approximately square law for equal amplitudes of mechanical vibration. This (if the losses are disregarded) practically square law approximately corresponds to the opposite incline of the curves shown above at higher frequencies and thus practically equal volume of sound is obtained at the higher frequencies. At the lower frequencies, however, matters become much more complicated and will therefore not be discussed here.

XI. A CONTRIBUTION TO THE DESIGNING OF TUBES FOR POWER-AMPLIFICATION PURPOSES

In order to design suitably a tube meant for power-amplification one may start with the condition that for a certain plate-battery potential \bar{E}_B a certain a-c. amplitude I_p is to be supplied to the loudspeaker. According to equation (22)

$$\bar{E}_B - K = I_p \cdot (r_p + R_b) + I_p \cdot \sqrt{(\omega L)^2 + (r_p + R_{bw})^2}$$

In this equation K is always defined with sufficient exactness for preliminary calculations (refer to Table I) as

$$K = 0.1 \cdot \bar{E}_b.$$

Furthermore

$$I_p = M \cdot I_p.$$

may be written and for M the value 1.5 may be substituted in the case of high-power tubes and 2 in the case of tubes of ordinary dimensions.

By this means

$$\frac{\bar{E}_B}{I_p} = \frac{M}{0.9} \cdot (r_p + R_b) + \frac{1}{0.9} \cdot \sqrt{(\omega L)^2 + (r_p + R_{bw})^2} \quad (33)$$

is found. Now if, as mentioned above, $\frac{E_B}{I_p}$ is predetermined, if a

suitable value is substituted for M (between 1.5 and 2) and if average values for L , R_b and R_{b_w} corresponding to a good loud-speaker available, are substituted, then the above equation will supply the desired optimum value for the internal plate resistance r_p of the tube. This (maximum) value of r_p the tube must have, if the desired output wattage defined by I_p is to be obtained at the plate battery potential \bar{E}_B without the regions of appreciable grid-current or excessive curvature of the static tube characteristics being entered into. As is apparent, r_p must be the smaller,

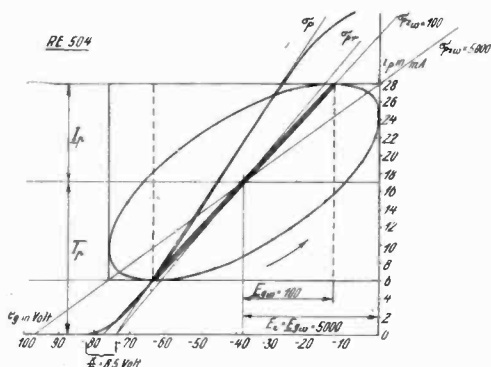

Fig. 3

the smaller the plate-battery potential and the greater the output wattage desired are.

If in equation (33) $\frac{\mu}{\sigma_p}$ is written instead of r_p as follows;

$$\frac{\bar{E}_B}{I_p} = \frac{M}{0.9} \left(\frac{\mu}{\sigma_p} + R_b \right) + \frac{1}{0.9} \sqrt{(\omega L)^2 + \left(\frac{\mu}{\sigma_p} + R_{b_w} \right)^2} \quad (34)$$

then this equation is the means of showing how the amplification factor μ of a certain tube must be changed, at the same time retaining the original mutual conductance, if the tube does not fulfil the conditions imposed regarding \bar{E}_B and I_p ; which latter is for example the case, if at the maximum plate-battery potential allowable a portion of the straight part of the static tube characteristic still runs into the region of positive grid-potentials. A small

value for $\frac{\bar{E}_B}{I_p}$, that is a high specific efficiency of the tube, is

obtained with low values of the amplification factor μ of the tube, which may be as small as 2.5.

The fact, however, must not be overlooked that the reduction of μ reduces the amplification of the tube and necessitates greater amplitudes of impressed a-c. grid-potential in order to retain the original output wattage required. For

$$W_o = \frac{1}{2} \cdot R_{w_p} \cdot (\mu \cdot E_o)^2 \cdot \frac{1}{(\omega L)^2 + (r_p + R_{b_w})^2} \quad (35)$$

Thus E_o must be changed in porportion with $\frac{1}{\mu}$, that means

that the e.m.f. must be constant if the output wattage is to remain unchanged.

XII. EXPLANATION OF THE PROBLEM BY MEANS OF DIAGRAMS

In Figs. 3 and 4 the practical cases corresponding to Tables I and II are diagrammatically reproduced. It is probably sufficient to explain one of these diagrams, because they are in principle exactly similar and only differ in certain values.

In Fig. 3, which refers to the tube RE 504, at first the diagonal of the rectangular quadrangle enclosing the working ellipse was drawn through the point $\bar{E}_c - E_{o_{\omega=5000}} = 0$; $I_p + I_p = 28m_A$ according to a calculation of $\sigma_{p_{z\omega=5000}}$ from equation (19). The crossing-point of this diagonal with the straight line $I_p = 17m_A$ results in the finding of the length $\bar{E}_c = E_{o_{\omega=5000}}$, which represents the necessary d-c. grid-biasing potential of 38.2 volts negative. Following this the rectangular quadrangle itself was drawn by means of $I_p - I_p = 6m_A$ and the known opposite corner of the quadrangle. Thus also, by means of equations (13) and (14) the working ellipse for the frequency of $\omega = 5000$ enclosed by the quadrangle could be drawn. The working direction of the ellipse is indicated by an arrow, for a capacitive load it would be in the opposite sense.

Thereupon a second diagonal was drawn with the angle or slope (mutual conductance) $\sigma_{p_{z\omega=100}}$; by means of this diagonal the second and smaller quadrangle drawn in broken lines was defined, which determines the value $E_{o_{\omega=100}} = 25.4$ volts and which encloses a shorter and much narrower ellipse corresponding to a frequency of $\omega = 100$. It is apparent from this narrow ellipse that if a-c. potentials of a frequency of $\omega = 100$ were impressed on the

grid exceeding the value $E_{g_{\omega=100}}$, then the narrow ellipse would be lengthened at both ends and would thus enter into the regions of excessively bent static tube characteristics determined by the plate-current limit values $I_p + I_p$ and $I_p - I_p$. This of course must be avoided if the fundamental conditions imposed are to be fulfilled. It is due to this fact of the tube being modulated up to the limit $I_p + I_p$ by small amplitudes of lower frequency in the same degree as by large amplitudes of higher frequency that there is an unequal frequency response of the plate-current and the output wattage, as shown by the curves reproduced.

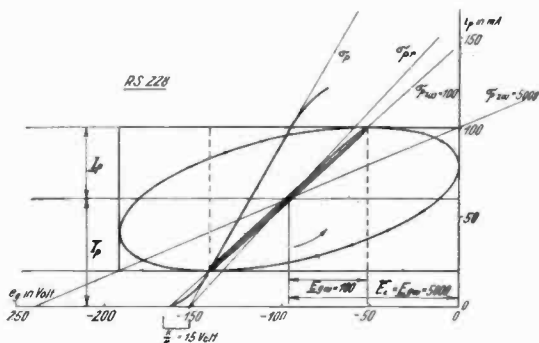

Fig. 4

Finally a third straight line is drawn through the point $\bar{E}_c; I_p$ this time with the angle σ_{p_n} , and through the crossing-point of this line with the abscissa a fourth straight line is drawn with the angle σ_p . In accordance with this last straight line a static tube characteristic is also drawn into the diagram. From this latter

curve $\frac{K}{\mu} = 8.5$ is found to be. If furthermore the tube character-

istic drawn for a plate battery potential of 150 volts shown in Fig. 1 is assumed to be included in Fig. 2, then the distance between the characteristic already present in this diagram from the characteristic just transferred, measured parallel to the

abscissa in volts, must be $\frac{\bar{E}_B - 150}{\mu}$. From this value a minimum

necessary plate battery potential of $\bar{E}_B = 374$ volts follows.

Author's Note: The nomenclature employed in this paper corresponds to that given by E. Leon Chaffee in his paper "Vacuum Tube Nomenclature."

CONDENSER SHUNT FOR MEASUREMENT OF HIGH-FREQUENCY CURRENTS OF LARGE MAGNITUDE

BY

ALEXANDER NYMAN*

(Consulting Engineer, Dubilier Condenser Corporation, New York City)

Summary—The necessity for an accurate ammeter for large high-frequency currents is pointed out. A new device consisting of a large condenser in parallel with a small condenser, and the latter carrying the current to a small thermocouple ammeter, is described.

A device of this nature can be made very accurate; in fact, comparable in accuracy to any available standards.

The construction of the device includes provisions for reducing and restricting the electrostatic and electromagnetic field, due to large current, the reduction of distributed inductance and capacity, and a provision to prevent the resonance effect of high harmonics of the operating current. Provisions are also made for locating the measuring instrument at a distance from the circuit. Large ratings are possible by connecting a number of condenser units in parallel.

THE use of large broadcasting stations and other continuous-wave, high-power installations has created a demand for accurate means of measuring high-frequency current of large magnitude.

The methods so far in use are all limited in one particular or another. The use of the hot-wire expansion type instruments is not feasible for values above 10 amperes, as the size of heating element becomes excessively large and the skin effect does not allow the subdivision of hot wire into parallel elements.

The direct thermocouple type has been used with satisfactory results up to currents of 100 amperes, but the heating element of the higher ranges becomes bulky and expensive to build on account of the large-sized conductors and careful workmanship required. Also the skin effect becomes appreciable at the higher frequencies.

An iron core transformer for reducing the high-frequency current so that it can be applied directly to a small instrument gives satisfactory results for frequencies up to 500 kc. For higher frequencies, the heating of the iron parts of the transformer becomes quite appreciable and is the greatest drawback. At 2,000 kc. and above, it is difficult to use such a transformer; the heating of parts, the influence of stray fields, and the distributed capacity of windings become quite objectionable.

* Original Manuscript Received by the Institute, August 10, 1927.

This article describes a novel arrangement which will permit the limits of operation to be extended as far as the present art of radio transmission requires.

The advantage of the new condenser type of ammeter for large currents lies in its accuracy and simplicity, combined with

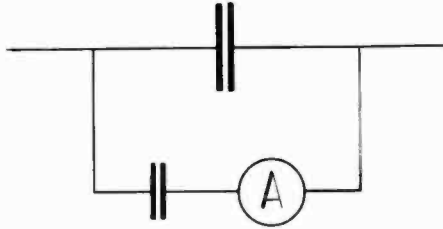

Fig. 1

its comparatively low cost, even for the highest of frequencies.

Fig. 1 illustrates the method by which currents of large magnitude and high frequency can be satisfactorily measured. It consists in general of two condensers in parallel; a large one

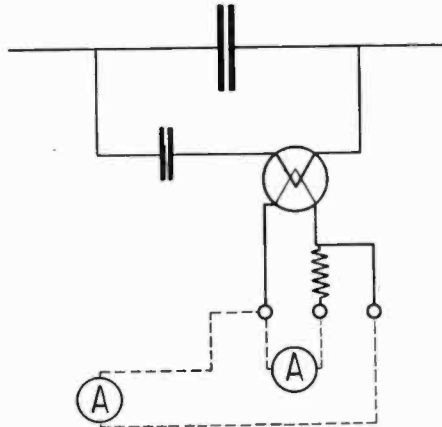

Fig. 2

which carries the greater portion of the current to be measured; without appreciable voltage drop, and so constructed that it can pass large current at high frequency without appreciable losses, and one considerably smaller, designed to shunt off a predetermined fraction of the total current through a small ammeter, either of the hot-wire or the thermocouple type. In the latter case, the meter may be located at a distance from the main circuit, as illustrated in Fig. 2.

A device of this nature, if properly designed, will give satisfactory measurements of current at frequencies as high as 60,000 kc., which is practically the limit of the present-day operations of radio stations. It can be designed for higher frequencies. The error due to the resistance of the thermocouple element is practically negligible, even at the highest frequencies used. Thus, if the condenser has a capacity of 0.001 μ fd. and the thermocouple element has a resistance of 2.6 ohms, the error becomes one-half of one per cent at 6,000 kc. (50-meter wavelength). For shorter waves, smaller capacity would be used.

The only source of error actually found in operation is due to the fact that the two condensers and the thermocouple form a

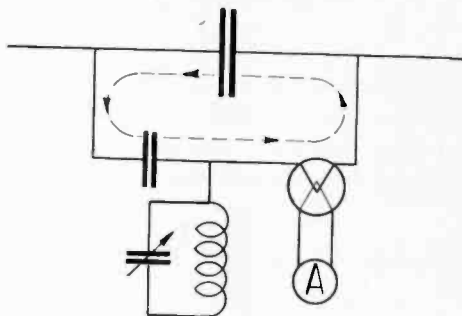

Fig. 3

closed circuit which has a resonant frequency that sometimes comes within the range of some harmonic of the frequency of operation of the instrument. The presence of such a condition becomes apparent in an obvious irregularity of the meter reading. Fig. 3 shows a very evident method to avoid this error due to the resonant frequency. An auxiliary circuit which is tuned to the resonant frequency of the closed circuit referred to is connected to some point of the condenser shunt and actually absorbs the power of the harmonic from this circuit and in this way eliminates this error. Since this tuned circuit is connected only at one point, its effect at all other frequencies is entirely negligible.

It is worthy of notice that the accuracy of this instrument cannot really be checked by any available standards of high-frequency current. Probably the most accurate fundamental method of measuring high-frequency current is by means of the calorimeter ammeter in which the heating due to the current registers the value of that current in terms of the resistance of

the heating element. Even this method, however, is subject to two errors which are difficult to eliminate. One is the actual value of resistance at the high frequency and the second is the distributed capacity of the heating elements and the calorimeter apparatus.

If it is remembered that the capacity values used in condenser shunt are considerably in excess of any distributed capacity, and moreover, with a properly constructed mica condenser, these values are constant at all frequencies, and if it is further realized

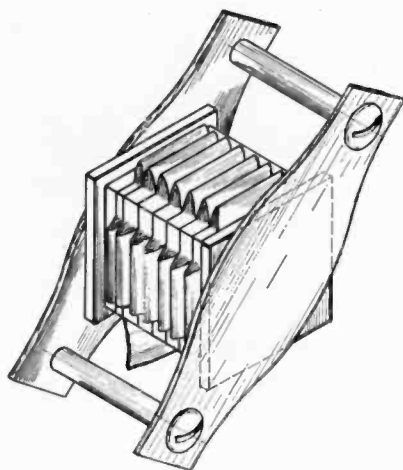

Fig. 4

that the distributed inductance and resistance of leads are really negligible, the accuracy of this method becomes self-evident; it establishes a standard of large high-frequency current measurement determined only by the accuracy of the meter element in series with the small condenser.

Fig. 4 illustrates an early design of condenser element which was found suitable for this apparatus. It is a unitary structure with a powerful clamp and two capacity elements, both within this clamp. One element consists of a number of metal foils in parallel, and gives the large capacity, while one extra foil brought out as a separate lead gives a small capacity. It is evident that the construction is made so symmetrical that there is no chance of one capacity changing relatively to the other. It will also be seen that the incoming and outgoing leads of this condenser are on the same side of the clamp. There is therefore no magnetic loop

around the path of the current, and consequently an important cause of the losses is eliminated.

Fig. 5 is an illustration of a meter of this type constructed for operating with a current of 100 amperes. It will be seen that there

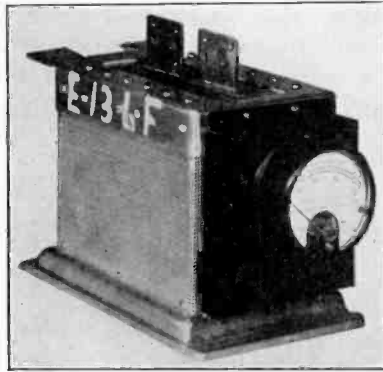

Fig. 5—External Appearance of an Early Model of Condenser Shunt.

are two leads coming out through the cover which can be connected in parallel or individually, depending on the current to be measured. There are two condenser elements corresponding to these leads. Only one of these condenser elements contains a small

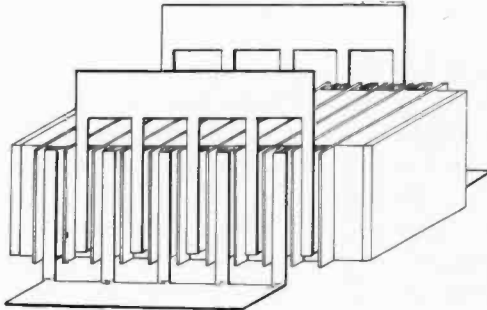

Fig. 6

capacity in series with the meter, that is, the element closest to the meter end. If this element alone is used, the reading is 50 amperes. If the second element is also connected, the reading becomes 100 amperes, and the meter readings must be multiplied by 2 without affecting the calibration of the instrument.

It is a well-known fact that a large current flowing at very high frequency causes considerable losses, and the heavier the current the more the relative losses. The cause of these losses was thoroughly analyzed and it was found that the probable reason for them is in the electro-magnetic field surrounding any path carrying large values of current. Such a magnetic field at very high frequency undoubtedly sets up an electro-static field through the body of the insulation and this electro-static field in turn causes dielectric losses. The problem therefore reduces to elimination of the magnetic field so as to eliminate the consequent electro-static field.

Fig. 6 shows diagrammatically a construction of a condenser where this electro-magnetic effect is practically entirely eliminated.

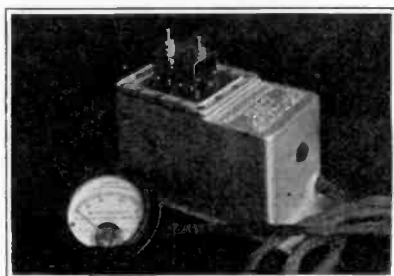

Fig. 7—Recent Model of Condenser Shunt with Shielded Lead and Panel Type Instrument

It will be seen that the condenser consists of a number of rather narrow sections interleaved with each other and so connected that the current through the body of the condenser has two opposite paths, each carrying an equal amount of current. Thus, the magnetic effects of the two paths cancel each other and the resulting electro-magnetic field is confined to the immediate vicinity of the conductors in each individual section. It was found by actual experiment that the losses by this construction were tremendously decreased so that a condenser which was previously giving a temperature rise of 15 or 20 deg. C. would with the new construction give an inappreciable temperature rise of 2 or 3 deg.

It will be further seen that this type of construction permits the use of a simple clamp surrounding the condenser, with leads coming out on both sides. Since the current now forms two loops in opposite directions, there will be no magnetizing effect on the

clamp. If, further, bronze springs and brass clamping rods are used, the losses in the clamp are practically eliminated. As before, the small capacity is introduced by an extra foil in the condenser. It was found desirable to split this condenser into two parallel sections so that when a smaller current rating is required from the condenser shunt, half of the capacity may be used, giving full scale rating on the meter at one-half the current.

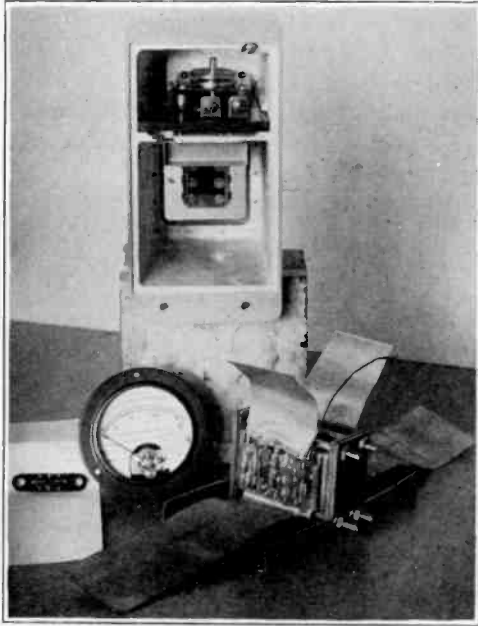

Fig. 8—Constructional Details of Condenser Shunt.

A typical example for a condenser to operate at 50 amperes is as follows. The shunt element is $0.199 \mu\text{fds.}$ and the part constituting the small condenser is $0.001 \mu\text{fd.}$ At 6,000 kc., the potential across this condenser will be only 6.6 volts. With this condenser a ratio of current is obtained of 200-to-1, so that with a 50-ampere condenser shunt the thermocouple will carry one-quarter of an ampere. If one-half of this condenser is used, as described above, to get the 25-ampere rating, the ratio is 100-to-1, giving again a current of one-quarter ampere for 25 ampere through the condenser shunt.

Fig. 7 illustrates a condenser of this type as it appears from the outside. In this case it was found more advantageous for commercial reasons to mount the instrument itself at a distance from

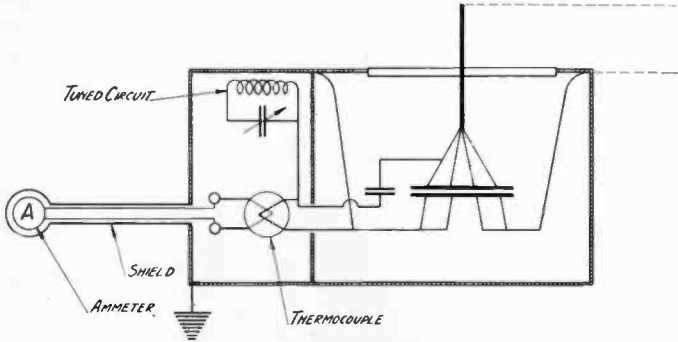

Fig. 9

the condenser shunt, and provide a shielded lead between the instrument and the condenser.

A split terminal is brought out on the top with a paralleling strap between the two halves. For currents more than 50 amperes,

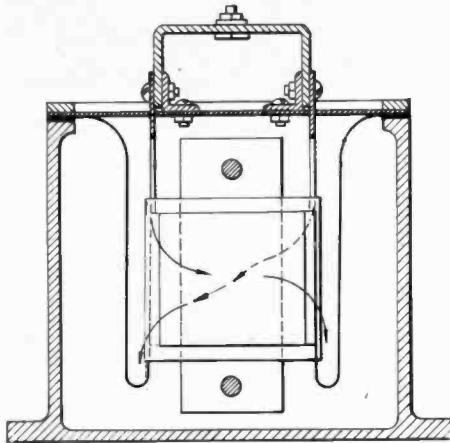

Fig. 10

a number of such condenser units may be paralleled, but of course only one instrument will be required. In that case it is evident that the ratio would be multiplied by the number of condenser units used.

Fig. 8 shows the inside appearance of this structure with a condenser element as described above in one compartment, and the small resonant circuit with the thermocouple in another compartment. A hole for bringing in a screw driver and adjusting the resonant circuit is sealed after the instrument is assembled, while a new thermocouple may be replaced by removing the lower cover.

Fig. 9 shows a diagram of connections inside of the condenser shunt. It will be seen that the lead from the small condenser to

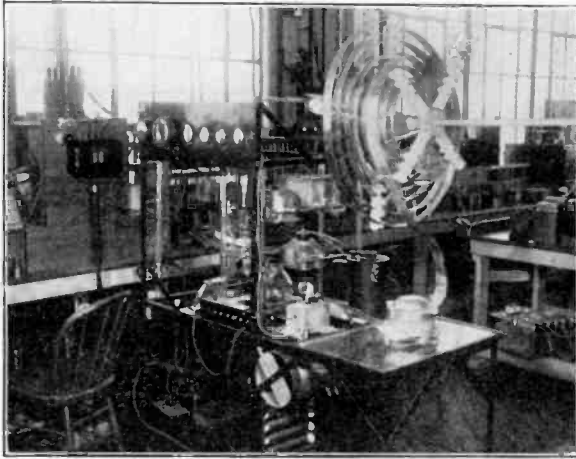

Fig. 11—Short Wave Radio Testing Set with Condenser Shunt Installed

the thermocouple is made as short as possible so as to avoid the inductive effect of this lead in the closed circuit consisting of two condensers and the thermocouple. This reduces one inductive effect and thereby increases the resonant frequency of that circuit until it is effective only at a very high harmonic of the operating current. This is then compensated by the tank effect of the compensating resonant circuit.

Fig. 10 shows the actual location of the main leads in the condenser element. Attention is drawn to the fact that by interlacing the condenser sections and by arranging ingoing and outgoing connections through two parallel leads the magnetic effect of the current outside of the condenser element is almost entirely eliminated and to further avoid this magnetic effect on the thermocouple the condenser element is enclosed in a metal partitioned compartment.

Fig. 11 illustrates the location of this instrument on a radio transmitting set. The condenser shunt is mounted in a convenient location next to the ground lead, while the instrument is located on the instrument panel, with a shielded lead between the instrument and the condenser. In this particular set, which was designed for the purpose of testing condensers, and is capable of operating on a wide range of frequencies from 1000 meters to 20 meters, the condenser shunt was found to give correct readings for the full range and for currents in excess of 50 amperes an additional parallel unit could be applied.

A meter similar to the one described above has been in continual use for over two years on a testing set where the frequencies have ranged from 100 kc. to 6,000 kc., and the current values have ranged up to 120 amperes. It has been found that the meter indications are consistent and reliable at all these values. In fact, its accuracy has been such that it was possible to measure the voltage in a circuit by connecting such an ammeter in series with a known condenser, and determining the voltage drop in the condenser by calculation.

For developing a special thermocouple ammeter used in connection with the condenser shunt, an acknowledgment is due the Weston Electrical Instrument Corporation of Newark, New Jersey.

BOOK REVIEWS

Dielectric Phenomena: Electrical Discharge in Gases, BY S. WHITEHEAD. D. VAN NOSTRAND COMPANY, INC., New York, N. Y. 176 pages. Price \$4.00.

The scope of this book is outlined in the preface by E. B. Wedmore. It is a scientific summary of what is known of electrical discharge in gases, as the sub-title indicates. The main title is to be justified by further publications dealing with liquids and solids.

The volume is written in three parts. The Introduction is a brief outline of the theory of ionic conduction through gases, such topics as "Mechanics of the Atom and Molecule," "Ionisation by Impact," "Radiations Emitted by the Discharge," and "Townsend's Continuity Theorem" being epitomized. In the second section the physics of electrical sparking is given, while the third portion of the book is concerned with corona phenomena. The term corona is taken as including dark, glow, and brush discharges. Mr. Whitehead's work is limited to "electrical discharges through gases at pressures for which the mean free path is small compared with the electrode dimensions," thus excluding discharges in vacua, and the electric arc. An arc is understood as an electrical breakdown between conductors in a gas, the electrodes themselves becoming sufficiently hot to contribute to the phenomena following the initial discharge.

The discussion is in the field of physics rather than engineering. The mathematical treatment of the various topics is adequate but not prohibitively difficult. For those readers who desire graphical results there are forty-two diagrams showing the variation of gradients and other effects. An engineer who picked up the book with the object of reading about horn gaps, the proportioning of the V-shaped sides, and the amount of energy which they may be depended on to break, would be disappointed in his search for specific engineering data, but he could learn how much the spark voltage of the sphere gap is reduced by rain or other water on the surfaces, and that humidity appears to have little effect, whereas the needle gap is markedly influenced by humidity. At the end of the book he would also find an alphabetically arranged bibliography covering the subject from 1860 to very recent publications. There is also a rather brief index.

Original Manuscript Received by the Institute, November 28, 1927.

While Mr. Whitehead's résumé is hardly of interest to radio engineers generally, it should be read by transmitter design specialists, who will find it to their advantage to substitute for isolated empiricisms a logical physical treatment of high voltage discharges.

CARL DREHER

The Propagation of Radio Waves Along the Surface of the Earth and in the Atmosphere, BY PROFESSOR P. O. PEDERSEN. 244 pages and appendix. Published by "Danmarks naturvidenskabelige Samfund" and sold by G. E. C. Gad, Vimmelskaftet 32, Copenhagen K. Denmark. Price 15 Kr. (about \$4.00).

In this book the author has attempted to give a connected physical theory of radio wave propagation—and it is no doubt the first case where really all the well-known facts of radio propagation have been assembled and brought into connection with the corresponding fields of physics.

It is first pointed out that only an ionization theory can satisfactorily explain the conditions of radio transmission, which is so extremely variable with the daytime, season, and wavelength. In the following chapters the physical basis of such a theory is worked out, and it is shown that radio experience throws light on many problems concerning the atmosphere, the laws of ionization and recombination, etc.

In chapter IV the pressure and composition of the atmosphere are treated. It is shown that no appreciable quantities of hydrogen can be present in the higher atmosphere, which therefore consists merely of helium—together with small percentages of nitrogen and oxygen; and that radio experience determines quite precisely the air pressure between 80 and 160 km. altitude. This determination would probably be in good agreement with the mass-density resulting from Lindemann and Dobson's investigations of meteors, if some errors in their theory are corrected.

Chapter V deals with the ionization of the atmosphere. The coefficient of recombination is shown to be proportional to the air pressure according to the theory of Langevin but for very low pressures will approach a constant value of about 10^{-5} times that at 760 mm Hg pressure, as shown in a theorem of the author. The different possible sources of ionization are now investigated. The ultra-violet radiation from the sun is the chief determining

Original Manuscript Received by the Institute, December 22, 1927.

factor though radiation from stars of very high temperature also has some influence on the propagation of very long waves. Formulas are developed for the numbers of free electrons and of mono-molecular and complex ions per cc. by day and by night.

In chapters VI and VII is determined the influence of electrons and ions on the dielectric constant and the conductivity of the atmosphere with or without the magnetic field of the earth acting, and taking into consideration the collisions between the different charged and uncharged particles. The reader will find several new and exact formulas set forth in this part of the book. In chapter VIII the dependency of the refractive index and the attenuation constant on the dielectric constant and the conductivity are treated. The approximate formula $n = \sqrt{\epsilon}$ is shown to be very unsatisfactory in many cases, and the exact formulas, taking into consideration the influence of both the dielectric constant and the conductivity, are given and represented in curves and charts.

For any set of values of the refractive index and the attenuation constant expressed as functions of the height over the earth and of the frequency we may determine the path and the attenuation of rays leaving the earth under a given earth angle according to the methods developed in chapter X. It is pointed out that the ray path will depend on both the earth angle and the frequency. This section of the book gives a very striking description of what happens to a ray penetrating into an ionized part of the atmosphere and indicates the average picture of radio propagation resulting from any ionization theory.—In other different theorems the influence of the refractive index and the attenuation constant on the rotation of the plane of polarization, on the phase- and group-velocity, etc., is treated.

In chapters IX and XI, the fundamental theories developed in the foregoing chapters are used for determining the actual state of ionization and for checking the theory against experience. Here are also used the old simplified theories of propagation listed in chapters I–III and the very useful formulas for reflection at the surface of the earth developed in chapter VIII. The ionization is shown to have its maximum value of about 10^6 electrons per cc. at an altitude of about 130 km. by day and 2×10^5 electrons per cc. at 155 km. at night, and to have its lower boundary at an altitude of 90–100 km. (mean values for summer). This ionization can just be produced by the energy of the ultra-violet in sunlight,

and the total conductivity due to this ionization will probably agree fairly well with the value determined from the daily variations of terrestrial magnetism, if Chapman's theory of this phenomenon is altered so as to take into consideration the much greater conductivity of the air in the direction of the magnetic field than perpendicular to it.

On the other hand, starting from this state of ionization all the well-known facts of radio wave propagation may be explained, at least qualitatively and in many cases even quantitatively. The outlines of the process of radio propagation are in general about as follows:

Long waves will be refracted without severe losses from a height of about 90-100 km. even for great earth angles. Both electrons and ions are effective in bending the rays. The direct earth wave is also of importance for distances up to about 1,000 km. and (during summer days) gives the interference pattern found by Hollingworth. At greater distance the refracted waves will predominate; still, the attenuation will not be so great as that found by Zenneck for propagation parallel to the earth because the multiple reflexions will distribute the energy almost uniformly over the space between the earth and the ionized "layer," while according to Zenneck the energy is propagated along the boundary surfaces and is nearly zero somewhere between them. The total energy is therefore actually much greater than that found by Zenneck, while the losses in the earth and in the ionized air are almost the same. Taking this into consideration, the author finds an attenuation for long waves which is in rather good agreement with the practical data as contained in Austin-Cohen's formula.

During summer days, the long waves will be refracted from a rather low height where the air pressure is so high and the number of heavy ions relatively so great that the magnetic field of the earth will have very little influence; the conditions of transmission will therefore be good and steady. During winter days, and during night time, the heights of refraction will be greater so that the magnetic field will be capable of rotating the plane of polarization and giving double refraction, and therefore will cause extremely variable conditions and poor (inaccurate) direction finding. This fact supplies a very good means for determining height of refraction of the very long waves.

For very short wavelengths the ground waves will be absorbed at very small distances from the transmitter. The rays will be

refracted at heights from 130 to 150 km. and by electrons only. Rays of wavelengths shorter than a certain limiting value cannot be refracted back to the earth; these limiting values are assumed to be 8.5 m. by day and 18.9 m. by night. These data determine the maximum numbers of electrons per cc. by day and by night and also a maximum value of the recombination constant at these heights. When the wavelength increases from these limiting values, the electrons will be able to refract a greater part of the radiated energy but at the same time they will give greater losses. For waves having a great part of their paths in or near to the height of maximum electron density there will therefore be a maximum of range for wavelengths of about 15-22 m. These waves are able to encircle the earth, propagated mostly at a height where their radius of curvature is nearly equal to the radius of the earth. When phase- and group-velocities are not confounded, the measurements of the time required by the signals to encircle the earth give average heights of transmission of the right order of magnitude, viz., about 150 km. The fact that it is just possible for a ray of 15 to 22 m. wavelength to be transmitted around the earth gives us rather good values of the number of collisions suffered by an electron per second in these heights and therefore also of the air pressure and assures us that no appreciable amounts of hydrogen can be present there.

Short waves of wavelengths greater than about 22 m. will be refracted from heights of 110 to 140 km. They are best transmitted during night time while the very short waves can only be bent down during day time, when the ionization is maximum. The "skip" phenomena are simply deduced from the shape of the curves of the refraction index and the fact that there is no ground wave except very near to the transmitter.

For waves of medium wavelength the refracted rays will be more attenuated than those of short wavelength and the ground wave will suffer a greater loss than that of a long wave. Therefore the day and night ranges will have minima for wavelengths of about 200 m. The magnetic field of the earth makes the drop even more pronounced, even if there is no real resonance effect because of the collisions between electrons and molecules and because of the influence of the heavy ions.

Those readers who are primarily interested in the practical results will find it most convenient to skip over the mathematical derivations in the first part of the book. They are advised to

start with chapter XI where the author's chief ideas of radio transmission are set forth and to go back to the earlier chapters only now and then for reference.

The book contains a comprehensive set of references to the literature of this field which is of great value in view of the huge number of papers presented on these subjects—in fact, it is hardly feasible to read even the more important of them.

And this bibliography in connection with the profound criticism and the valuable new ideas given in the book—which may really be said to supply us with the missing link between radio experiments and the corresponding fields of physics—strongly supports the hope expressed by the author that it will serve as a basis for the future development both of the physics of the higher atmosphere and of the theory of radio wave propagation.

J. C. F. RYBNER

GEOGRAPHICAL LOCATION OF MEMBERS ELECTED

January 4, 1928

	Transferred to the Fellow grade	
New York	New York City, 434 E. 141st St.	Fried, J. D.
	Transferred to the Member grade	
New Jersey	Maplewood, 5 Park Ave.	Cunningham, F. W.
Canada	Toronto, 62 Pleasant Blvd.	Patience, A. M.
	Elected to the Member grade	
California	San Francisco, 611 Crocker Bldg.	Lippincott, D. K.
New York	Brooklyn, 70 Washington St.	Siegel, Samuel
Holland	The Hague, Van Swietenstraat 16.	Schotel, Gerrit
	Elected to the Associate grade	
California	Glendale, 1246 Elm Avenue.	Minkler, L. D.
	Los Angeles, 703 W. 81st St.	Dalton, S. P.
	Sacramento, P. O. Box 632.	Barlow, Wm.
	San Bernardino, 831 Fifth St.	Beeson, K. H.
	San Diego, 1332 Bush Street.	Clement, J. D.
	San Diego, 4657 Oregon St.	Partch, Paul C.
	San Francisco, 812 Hobart Bldg.	Tuel, A. Y.
	San Francisco, 719 Scott St.	Patron, A. E.
Connecticut	Bridgeport, 200 Hazelwood Ave.	Mapes, H. T.
	Waterbury, 9 Burton St.	Greenblatt, Louis
Dist. of Columbia	Washington, Radio Bldg.	Hall, E. F.
Florida	St. Petersburg, 1127—12th St.	Wittstruck, H. H.
Illinois	Bloomington, 511 N. Mason St.	Goodfellow, E. D.
	Chicago, 349 East 59th St.	Cook, B. I.
	Chicago, 2600 Indiana Ave.	Mac Derrain, L. D.
	Chicago, 4912 1/2 Jackson Blvd.	Ewald, F. J., Jr.
	Chicago, 2011 Jarvis Ave.	Barlow, Wm. H.
	Chicago, 1815 Morse Ave.	John, K. B.
	Chicago, 940 West 55th St.	Noonan, J. C.
Indiana	Bloomington, 1000 South Lincoln St.	Hazel, H. C.
Kansas	Topeka, 230 Woodlawn Ave.	Jones, G. I.
Louisiana	New Orleans, 220 So. Johnson St.	Collins, J. F.
Maryland	Baltimore, 530 Richwood Ave.	Houston, G. P.
Massachusetts	Boston, 191 Friend St.	Krikorian, D. K.
	East Springfield, 94 Edendale St.	Kinsman, W. D.
	Malden, 21 Garland Ave.	Winchell, W. H.
Michigan	Detroit, 2914 Book-Cadillac Hotel.	Harper, J. K.
	Detroit, 3026 Lothrop Ave.	Byerlay, H. L.
	Detroit, 8037 Medbury Ave.	Friedenthal, A.
	Detroit, 2170 St. Clair Ave.	Ballbach, N. C.
Nebraska	Omaha, 2230 Jones St.	Cramer, W. R.
New Jersey	East Orange, 402 N. Grove St.	Beidleman, H. B.
	Ft. Monmouth, 15th Signal Ser. Co.	Wilson, L. E.
	Glen Ridge, 30 Edgewood Road.	Cunliffe, P. R.
	Ridgefield Park, 205 Preston St.	Pearee, Arthur
	West Orange, 7 Helen Avenue.	Tucker, M. E.
New York	Albany, 241 Quail St.	Ainsworth, R. I.
	Bronx, 494 Concord Ave.	Zyaman, Harry
	Brooklyn, 485 East 21st St.	Tucker, R. A.
	Brooklyn, 755 Gravesend Ave.	Kennedy, H. E.
	Brooklyn, 85 Montrose Ave.	Consoli, Vincent
	Buffalo, 555 East Amherst St.	Stevens, H. A.
	L. I., Elmhurst, 3714—92nd St.	Banks, A. C.
	L. I., Jamaica, 150-08—116th Drive.	Albert, M. M.
	New York City, 2022—233 Broadway.	Fisk, Wm. G.
	New York City, 771 East 180th St.	Pleasanton, A. W.
	New York City, 463 West St.	Delimel, R. C.
	New York City, 463 West St.	Freeman, R. H.
	New York City, 254 West 98th St.	Kanely, N. J.
	Orient.	Vail, L. G.
	Schenectady, 1719 Broadway.	Billins, J. H.
	Schenectady, 501 Campbell Ave.	Hoard, N. F.
	Schenectady, 318 Clinton St.	Selby, E. O.
	Schenectady, 143 Division St.	Dodge, A. O.
	Schenectady, 37 Eleanor St.	Stone, F. B.
	Schenectady, 806 Grant Ave.	Hoffer, G. M.
	Schenectady, 9 Park Place.	Priebe, Frank
	Schenectady, 606 Pleasant St.	Nickle, E. G.
	Schenectady, 205 Seward Place.	Frank, C. W.

	Schenectady, 231 Seward Place	Newbold, W. H.
	Schenectady, 929 State St.	Demmer, A. H.
	Schenectady, 962 State St.	Payne, J. H.
	Schenectady, 1452 State St.	Matthews, A. C., Jr.
	Schenectady, 1426 Sumner Ave.	Cottrell, M.
	Schenectady, 13 Swan St.	Schwartz, H. F.
	Schenectady, 8 Union St.	Serrell, Robert
	Schenectady, 900 Union St.	Witty, W. M.
	Schenectady, 1009 Union St.	Hitt, A. B.
	Schenectady, 802 Webster St.	Wallace, M. J.
	Scotia, 104 Collins St.	Gardiner, P. C.
	Scotia, 104 Collins St.	Romander, Hugo
	Scotia, 6 North Toll St.	Zuchter, Pieter
	Scotia, 12 Riverside Ave.	Norton, C. T.
	Wayland, 112 South Main St.	McCoy, J. C.
Ohio	Cleveland, 1130 B. of L. E. Bldg.	Schlesinger, B. R.
	Cleveland, 19400 Shoreland Ave.	Hannum, J. C.
	Columbus, 1940 Stanford Road.	Stocker, A. C.
	Columbus, 117 West Frambes Ave.	Shuler, J. H.
	Dayton, 216 Hartford St.	Bourne, G. E.
Oklahoma	Mansfield, North Main Road.	Kissel, M. M.
	Oklahoma City, 300 Grain Ex. Bldg.	Mier, C. W.
	Oklahoma City, 927 West 10th St.	Hirdler, F. C.
Pennsylvania	Allenwood	Schooley, Harold
	Avalon, 123 Harrison Ave.	Allen, J. G.
	Bethlehem, 39 East Wall St.	Davis, N. H.
	East Pittsburgh, Westinghouse Co.	Hitchcock, R. D.
	Essington, P. O. Box No. 66.	Geise, J. C., Jr.
	Philadelphia, 2445 East Huntingdon St.	Robinson, A. V.
	Philadelphia, 3650 N. 7th St.	Klenk, G. J.
	Philadelphia, Somerton	Dunn, J. C.
	Pottstown, 447 Chestnut St.	Fisher, C. H., Jr.
	Wilkinsburg, 2083 Chalfont St.	Amick, Wm. M.
	Wilkinsburg, 601 Ecker Way	Bohle, Wm. H.
South Dakota	Yankton, 907 W. Fourth St.	Mead, G. H.
Texas	Houston, 2407 Keene St.	Gower, S. G.
	Houston, 1843 Kipling Ave.	Crossland, H. A.
	Houston, 1211 Milam St.	McFarland, N. E.
Utah	Salt Lake City, 125 West Fifth South	Bird, C. R.
Virginia	Richmond, 914 West Broad St.	Wood, W. H.
Canada	Ontario, Ridgeway	Mann, G. F.
	Ont., Toronto 3, 34 Coomine Rd.	Ford, J. S.
England	Quebec, Grand Mere, 193 Laurentide	Purnell, C. F.
	London, S. W. 18 19 Earlsfield Rd.	Stanesby H.
	London, Herse Hill, S. E. 24 Winterbrook Rd.	Odel, L. F.
	Portsmouth, Hants, Southsea, 48 Lowcay Rd.	Kenedy, J. C.
Germany	Leipzig, Dresdner Bank	Wilder, M. P.
Holland	Hilversum, Neuweg 259	Breimer, S. W.
Japan	Tokyo, Marunouchi, Wireless Dept. N. Y. K.	Owada, Mankitsu
	Tokyo, 1500 Shimo-Shibuya	Hashimoto, Chuji
Phil. Islands	Manila, c/o Manila Electric Co.	Africano, Tiburdo
Strait S.	Singapore Collyer Quay Bank Chambers	Purdy, Leslie
Elected to the Junior grade		
California	Long Beach, 346 Molino Ave.	Hancock, J. W., Jr.
Connecticut	Bridgeport, 91 Columbia St.	Chopeky, P. A.
	East Hampton, P. O. Box 115	Carini, Louis
Massachusetts	Somerville, 21 Windsor Road	Grant, L. E.
Minnesota	Minneapolis, 1227—4th St. S. E.	Arthur, G. B., Jr.
New York	Brooklyn, 99 Snediker Ave.	Laford, Herbert
	New York City, 157 East 89th St.	Wald, A. H.
	New York City, 771 East 180th St.	Pleasanton, D. W.
Ohio	Marion, 639 Pearl St.	Houser, D. E.
Pennsylvania	Milton, 201 N. Front St.	Butler, W. M.
	Pottstown, 25 King St.	Mellon, R. E.
Canada	Ont. N. Hamilton 15 Huxley Ave.	Bailey, A. L.



To no other industry does this advice of Davy Crockett's apply with greater force than to Radio.

It is because they must be sure they are right that designing and production engineers of the foremost manufacturers consult with Polymet's engineers. This co-operation has been the means of solving the particular and individual condenser and resistance problems of these manufacturers.

Through this combination of en-

gineering experience Polymet meets the specific requirements of the individual manufacturer with condensers and resistors of accuracy and dependability, thus assuring the perfect performance of the manufacturer's unit.

You are now carrying on your experiments in anticipation of the coming season. Let us help you. Our entire staff is at your service. What we are doing for other manufacturers we can also do for you.

POLYMET MANUFACTURING CORPORATION
 591 Broadway, New York

To Dealers and Jobbers
 Polymet is one of the best known and most specified lines of radio essentials. You should stock Polymet parts to meet the popular demand. Write for catalog of complete line and full particulars.



Polymet Wire Wound Resistors

Polymet Wire Wound Resistors are high wattage type resistances designed for heavy work. They are equipped with special mounting lugs that save time in assembly. Built in all popular sizes and to your specifications.

POLYMET CONDENSERS

When writing to advertisers mention of the Proceedings will be mutually helpful.

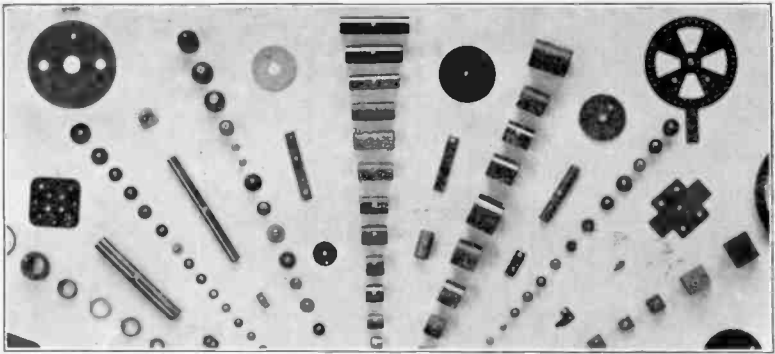

Parts of Great Variety for Radio!

Tubing, Rod, punched and machined parts in a great variety of shapes and sizes are made by Formica for the radio manufacturers of the country.

Uniform insulating qualities, good finish and accurate workmanship on parts made in large quantity are always available.

Since Laminated Phenolic insulating parts first began to be used, Formica has concentrated the efforts and resources of a large and competent organization on just this one product.

The plant and equipment are the largest and most modern in the business. The location makes possible prompt deliveries all over industrial America.

The Formica Insulation Company
4646 Spring Grove Avenue, Cincinnati, Ohio

FORMICA
Made from Anhydrous Bakelite Resins
SHEETS TUBES RODS

When writing to advertisers mention of the Proceedings will be mutually helpful

Efficiency

Economy

Uniformity

Select
your
Condensers
with
care.

The
Companies
to whom
we owe
our
Success
carefully
tested
our
product
before
purchasing.

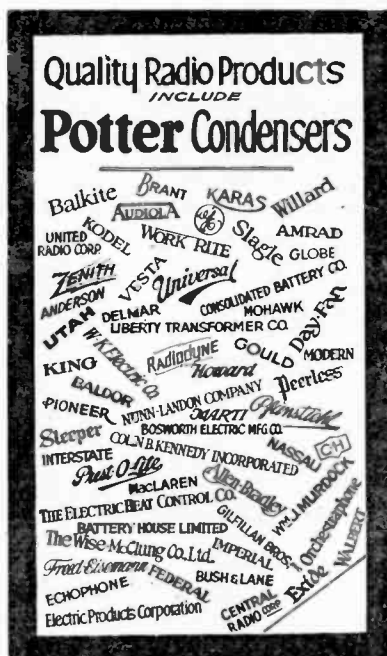

The
quality
of
these
Products
speak
of
the
Success
of
**POTTER
CON-
DENSERS**

Be Safe—Purchase a Proven Product
A Condenser Assembly for Every Use

POTTER MANUFACTURING COMPANY
NORTH CHICAGO, ILL.

When writing to advertisers mention of the Proceedings will be mutually helpful.

Always specify—
"ESCO" Maximum miles per watt
Power supplies for Transmission.

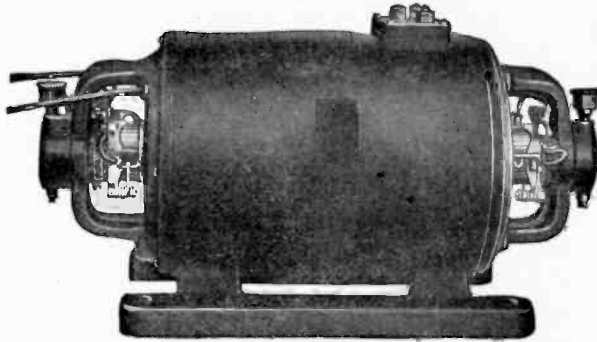

"ESCO" has developed a line of over 100 standard 2-bearing Motor-generators for plate or filament. These include D.C., A.C., single phase and polyphase motors.

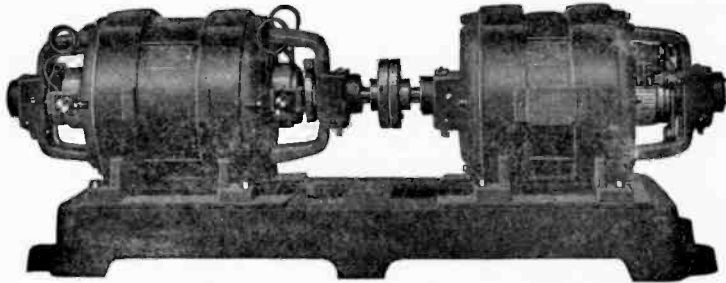

"ESCO" two and three unit sets have become the accepted standards for transmission. The "ESCO" line consists of over 200 combinations. These are covered by Bulletin 237C.

Our engineers are always willing to cooperate in the development of special sets.

"ESCO" is the pioneer in designing, developing and producing Generators, Motor-Generators, Dynamotors and Rotary Converters for all Radio purposes.

How can "ESCO" Serve You?

ELECTRIC SPECIALTY COMPANY

TRADE "ESCO" MARK

300 South Street

Stamford, Conn.

When writing to advertisers mention of the Proceedings will be mutually helpful.

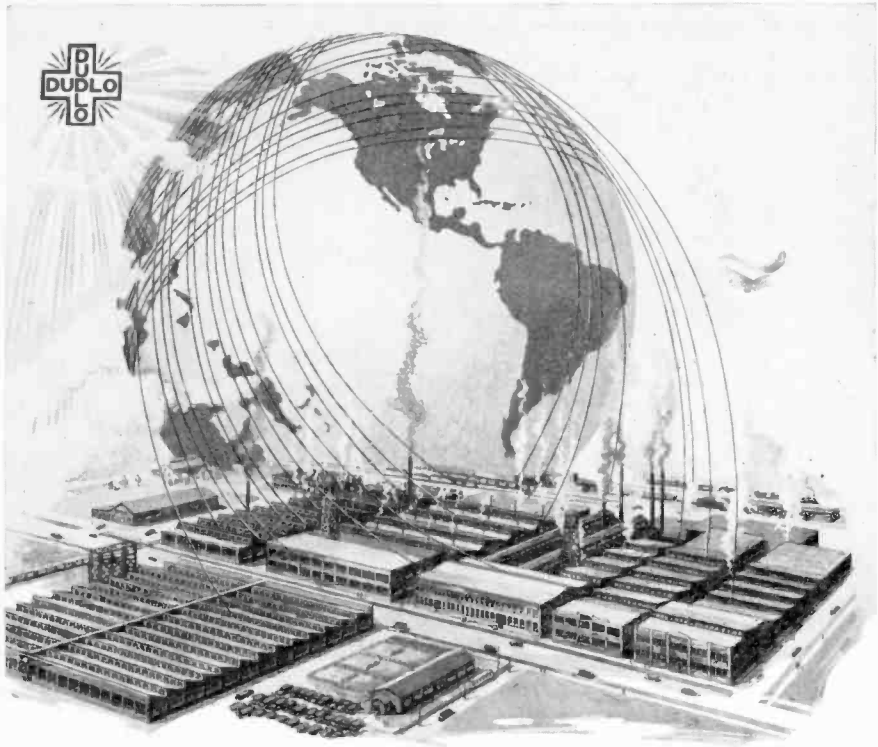

A World-wide Service

Every civilized nation in the world uses products from the Dudlo factories.

MAGNET WIRE *and* COILS

made in this plant at Fort Wayne, Indiana, are built into electrical units employed in all forms of communication and transportation as well as in the thousands of electrical conveniences in modern homes and commercial buildings everywhere. The Dudlo insulated magnet wire produced in a single month would encircle the globe a hundred times.

Electrical and Radio Manufacturers may draw upon the broad experience gained from this international service by coming to Dudlo engineers for assistance on their wire and coil problems.

DUDLO

DUDLO MANUFACTURING COMPANY, FORT WAYNE, INDIANA

Division of the General Cable Corporation

56 Earl Street
NEWARK, N. J.

160 North La Salle St.
CHICAGO, ILL.

4153 Bingham Ave.
ST. LOUIS, MO.

274 Brannan St.
SAN FRANCISCO, CALIF.

When writing to advertisers mention of the Proceedings will be mutually helpful.

PROFESSIONAL ENGINEERING DIRECTORY

For Consultants in Radio and Allied Engineering Fields

**The J. G. White
Engineering Corporation**
Engineers—Constructors
*Builders of New York Radio
Central*

Industrial, Steam Power, and Gas
Plants, Steam and Electric Rail-
roads, Transmission Systems.

43 Exchange Place New York

**Q R V
RADIO SERVICE, Inc.**

JOHN S. DUNHAM
J. F. B. MEACHAM

*Devoted to Servicing Broadcast
Receivers Exclusively*

1400 BROADWAY, NEW YORK
WISCONSIN 9780

Need Trained Radio Men?

Our Employment Department can supply thoroughly trained, experienced Radio Mechanics, Salesmen, Assemblers, Repairmen, Operators, etc.

No charge to employer or employee. If you need expert Radio help, let us recommend some one from our list. Bulletin of available men sent upon request.

National Radio Institute
Dept. I.R.E., Washington, D. C.

BRUNSON S. McCUTCHEN

Consulting Radio Engineer

17 State Street
NEW YORK

*Electrical Testing
Laboratories*
RADIO DEPARTMENT
also

**Electrical, Photometric,
Chemical and Mechanical
Laboratories**

80th Street and East End Ave.
NEW YORK, N. Y.

J. E. JENKINS and S. E. ADAIR
Engineers

Broadcasting Equipment
General Radio Telephone
Engineering

1500 N. DEARBORN PARKWAY
CHICAGO, ILLINOIS

RADIO ENGINEER WANTED

For Receiver design and laboratory work by an established Canadian Manufacturer. Supply full particulars of experience, age, salary, etc., to Box 222—
I.R.E. Proceedings.

John Minton I. G. Maloff

JOHN MINTON, Ph.D.

Consulting Engineer
for

Developing — Designing —
Manufacturing

of

Radio Receivers, Amplifiers, Transform-
ers, Rectifiers, Sound Recording and
Reproducing Apparatus.

Radio and Electro-Acoustical
Laboratory

8 Church St. White Plains, N. Y.

When writing to advertisers mention of the Proceedings will be mutually helpful.

Condenser Specialists

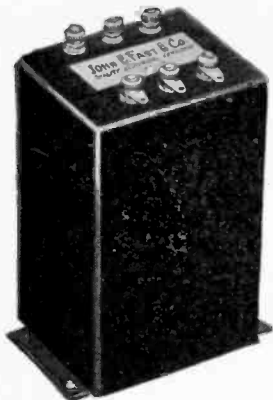

"B" Eliminator Units for AC and All-Electric Sets

Supplying the needs of set manufacturers is our specialty. Right now the trend is toward complete built-in power units in A-C operated sets. Let us show you how happily we can solve the condenser problem for your eliminator units as well as your other condenser needs.

WE make one thing and one thing only—wax impregnated paper condensers in medium and large capacities. We make no set hardware, no eliminators, no transformers, no parts, no sets. Our entire concentrated effort is on one product alone. Such specialization assures highest quality, economical production and real service.

Millions of Fast Condensers are in daily use in radio sets made by the leading set manufacturers. Fast condensers are renowned for their high insulation resistance and excellent and dependable electrical characteristics.

Manufacturers looking for a dependable source of supply will find here one of the largest organizations of its kind in the world.

Send us your specifications.

JOHN E. FAST & CO
Established 1919

3982 Barry Avenue
Dept. I.R.E.
Chicago, U. S. A.

When writing to advertisers mention of the Proceedings will be mutually helpful.

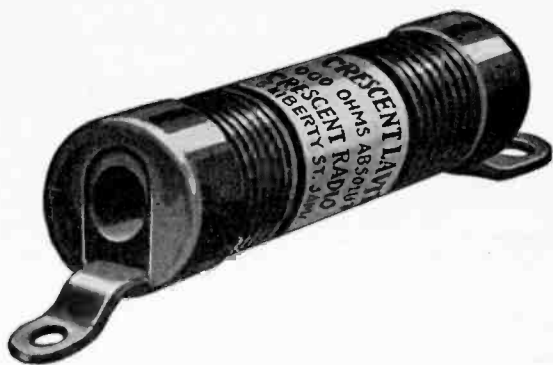

Crescent Lavite

is the pioneer resistance and still in the van. Economical in size but gluttons for punishment.

Used by U. S. Government, General Electric Co., Bell Telephone Laboratories, Westinghouse Electric and Manufacturing Co., and ninety broadcast stations.

Write for data which will be supplied on request.

Cresradio Corporation

166-32 Jamaica Ave., Jamaica, N. Y.

**CRESCENT
LAVITE
RESISTANCES**

When writing to advertisers mention of the Proceedings will be mutually helpful.

for that A-C Tube Job!

NEW PROBLEMS have appeared with A-C tubes. One is volume control. Another is filament and heater control. Still another is hum. And still another is tone control.

Ready solutions have been found in the application of proper resistance values—not mere approximations, but precise, micrometric, reliable resistance, instantly adjustable to any desired value and then held at that value for an indefinite period.

Once more the Clarostat has provided the necessary micrometric resistance. Thus the simplest solution of the A-C receiver volume control, is the Volume Control Clarostat placed across antenna and ground terminals. A-C tubes can be provided with proper heating current, despite line-voltage fluctuations, by means of a Power Clarostat in the input circuit of the transformer. A-C hum disappears through proper operating voltages in heating, plate and grid circuits, by means of Power and Standard Clarostats. Tone control, from the sharp, crisp words of the distant orator, to the soft, mellow, soothing slumber hour music, is obtained with the Volume Control Clarostat alone or in combination with a fixed condenser.

Four types of Clarostats, in four wattage ratings and any resistance ranges, will solve your A-C and socket power problems. And we can show you how, if you so desire.

Consult with us regarding your resistance problems. We shall be glad to co-operate in working out a solution. And when you specify Clarostats, be sure you get genuine Clarostats stamped with the name on the metal shell!

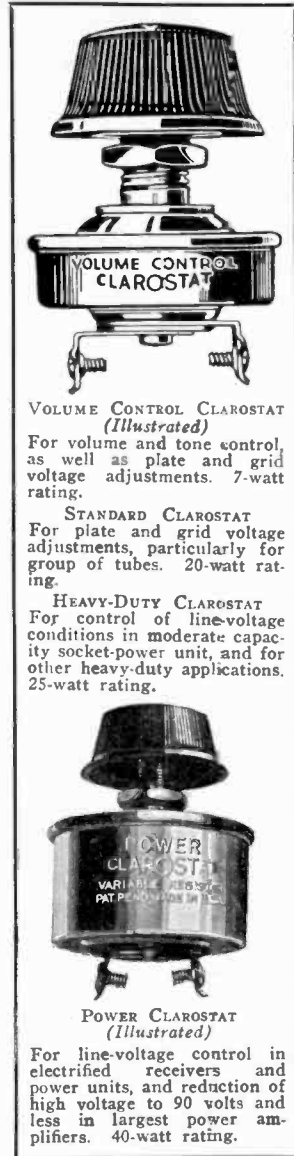

American Mechanical Laboratories, Inc.



Specialists in Variable Resistors

285 N. Sixth St. :: Brooklyn, N. Y.

—CLAROSTAT—

When writing to advertisers mention of the Proceedings will be mutually helpful.
XVII

WESTON

Announces

*A NEW
triple-range
voltmeter*



150 / 8 / 4 / volts

For Testing A. C. Supply and A. C. Tube Voltages

A new design of the Weston Model 528 A. C. Portable voltmeter, having three ranges to meet the requirements of A. C. receiver testing, is now available.

This new instrument has been eagerly awaited by the radio fraternity—manufacturers, laboratories, dealers, service men and set owners—all of whom have need for a small, compact and high grade A. C. meter for general testing work.

The electrical characteristics of this model are exceptional for instruments of this size. They are responsive and excellently damped, may be used continuously at full scale reading, and are accurate on any commercial frequency.

The Voltmeters are also made in double ranges up to 600 volts, with self-contained resistances of an exceptionally high value. Single range Ammeters, from 1 to 30 amps., are furnished in this same design. Write for the new Weston Radio Booklet as well as the new General Catalog—an indispensable reference for users of scientific instruments.

WESTON ELECTRICAL INSTRUMENT CORPORATION
73 Frelinghuysen Ave. Newark, N. J.

WESTON RADIO INSTRUMENTS

When writing to advertisers mention of the Proceedings will be mutually helpful.

XVIII

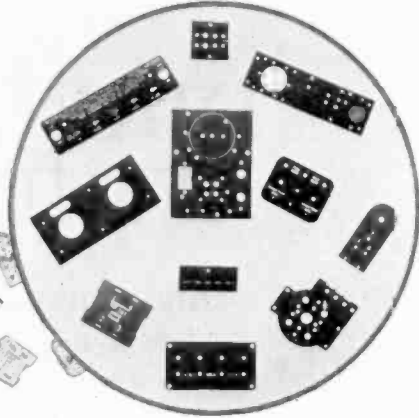

Here's a Radio Panel Material *that will really Punch!*

- easily
- quickly
- and clean

MICARTA is tough. It will take the punch with never a chip or crack around the holes. Use it for sub-panels, terminal strips, tube panels, or any other part requiring high insulating qualities and great strength.

The above radio parts illustrate a few of the innumerable sizes and shapes that can be punched from Micarta plate at a single stroke.

Micarta radio parts for volume production, punched and decorated to your specifications, can be obtained from—

Micarta Fabricators, Inc.

309 Canal St.
New York, N. Y.

500 South Peoria St.
Chicago, Ill.

Westinghouse Electric & Manufacturing Company
East Pittsburgh, Pennsylvania

Sales Offices in All Principal Cities of
the United States and Foreign Countries



Westinghouse

When writing to advertisers mention of the Proceedings will be mutually helpful.

An invaluable book for
Wireless Experimenters
and Radio Engineers!

WIRELESS

DIRECTION FINDING

and

DIRECTIONAL RECEPTION

By R. Keen, B.Eng. (Hons.)

Second Edition: Revised and Enlarged

THIS volume, written by an expert upon his subject, deals with the principles of Direction and Position Finding in such a way that the subject may be grasped easily by engineers tackling this field of wireless work for the first time. The entire matter has been carefully revised and in part rewritten, and further information, obtained subsequent to the first edition, has been incorporated. Numerous photographs and diagrams are included, together with some information concerning aircraft installations.

LIST OF CONTENTS:

DIRECTIONAL PROPERTIES OF AERIAL SYSTEMS: FRAME AERIAL RECEPTION: ROTATING FRAME D.F. INSTALLATIONS: THE BELLINI-TOSI SYSTEM: MAPS: POSITION FINDING AND WIRELESS NAVIGATION: BEACON TRANSMITTERS: NIGHT EFFECT AND OTHER FREAK PHENOMENA: THE SHORE D.F. INSTALLATION: THE SHIP D.F. INSTALLATION: THE AIRCRAFT D.F. INSTALLATION: FAULT CLEARING AND MAINTENANCE: NOTES ON FIELD AND NAUTICAL ASTRONOMY: BIBLIOGRAPHY: INDEX.

POST
FREE

21/9

Please send money order for 21/9 to cover the cost of the book and postage. The postal authorities will inform you as to the amount required in U.S.A. currency. Orders (with remittance) should be addressed to:

ILIFFE & SONS LIMITED

Dorset House, Tudor St., London, E.C. 4, England

When writing to advertisers mention of the Proceedings will be mutually helpful.

XX

"Liberty"

BRITISH MADE RADIO

SUPERHETERODYNE UNITS (Kits) 10 to 3000 METRES

comprising 3 matched intermediate transformers, filter, and combined pick up coil. Long wave oscillator (750/3000 metres) medium wave oscillator (250/800 metres) and short wave oscillator (10/150 metres).

NOTE—2 TUNING CONTROLS ONLY

PRICE Complete L=5/10/0-with full size wiring diagram instructions

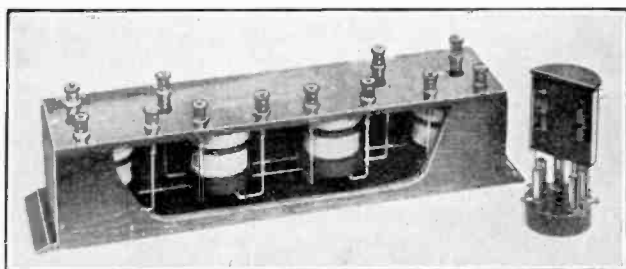

Sectional View of Unit and Oscillator

"WIRELESS WORLD," November 24, 1926

We have tested these units, first electrically before assembling, and finally on broadcasting, and the makers claims of range and selectivity are in no way exaggerated.

UNPRECEDENTED SUPERHET TEST

every unit tested in an actual Super Het Receiver over whole range of 10/3000 metres, and fully guaranteed.

Illustrated Catalogue Post Free

Sole Manufacturers—

RADI-ARC ELECTRICAL CO. (1927) Ltd.

Bennett Street, London, W. 4, England

Cables: Radiarc, London. ABC Code

When writing to advertisers mention of the Proceedings will be mutually helpful.

R A D I O P A R T S

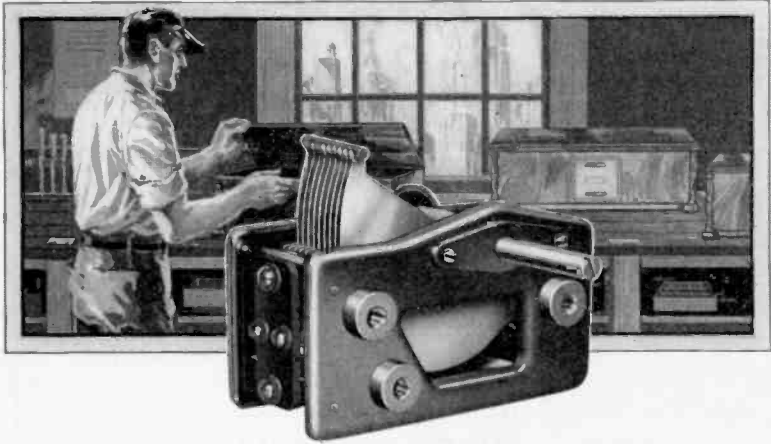

THE RADIO—magic of the modern age! In the design and construction of those hidden parts on which clearness and beauty of tone depend—Scovill is a leader. At Scovill, radio manufacturers find precision of workmanship and large volume production. A combination that aids them to forge ahead rapidly in this highly competitive field.

Scovill makes to order, in quantity—condensers, condenser parts, metal stampings, screw machine products, switches, decorated metal radio panels, etc. We work from your sample, blue print or suggestion. A wide variety of butts and hinges, continuous hinges and machine screws kept on hand.

Scovill means SERVICE to all who require parts or finished products of metal. Great factories equipped with the last word in laboratories, and modern machinery manned by skilled workmen, are at your disposal. Phone the nearest Scovill office.

SCOVILL

MANUFACTURING COMPANY

Waterbury

Connecticut

Atlanta

New York

Boston

Chicago

Detroit

Providence

Philadelphia

Cleveland

Los Angeles

San Francisco

Cincinnati

Member, Copper and Brass Research Association

When writing to advertisers mention of the Proceedings will be mutually helpful.

XXII

KOLSTER ELECTRIC



At the left is the six-tube full console electric (batteryless) Kolster Radio. Cabinet of walnut with special built-in cone speaker. Price (less tubes) \$250.

Below is the six-tube table model electric (batteryless) Kolster Radio, enclosed in attractive walnut cabinet. Price (less tubes) \$160.

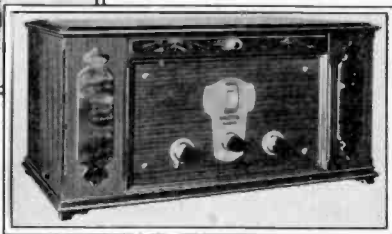

Kolster Electric Sets use the new A.C. tubes. No batteries of any kind required. Operated solely on A.C. house current (100-120 volts; 60 cycles). Indoor or outdoor antenna.

The Kolster Radio Compass, the use of which permits the safe navigation of vessels during thick or foggy weather, is also manufactured by this company.

FEDERAL-BRANDES, INC.

200 Mt. Pleasant Avenue

Newark, N. J.

© 1928, Federal Brandes, Inc.

When writing to advertisers mention of the Proceedings will be mutually helpful.

XXIII

An Announcement

Introducing a Line of Filter and By-Pass Condensers of Unimpeachable Quality

FOR thirty five years, Automatic Electric Inc., one of the largest manufacturers of communication equipment in the world, has been producing fixed condensers to meet the rigid specifications of large telephone companies. Thousands of these condensers, installed twenty or more years ago in connection with telephone exchange equipment where they are subjected continually to high voltages, are still giving satisfactory service.

The long life of the condensers produced by Automatic Electric Inc. is due to special and exclusive processes of fabrication which render them particularly fitted for the high voltages and other conditions peculiar to radio power devices.

To meet the growing demands of the radio business for better filter and by-pass condensers, arrangements have been made with Automatic Electric Inc. to supply condensers of the finest quality, both as to material and construction, to the radio trade and to manufacturers of radio apparatus. The company's condenser department has been enlarged and production increased to take care of these growing requirements.

The engineering and manufacturing organizations of Automatic Electric Inc. are devoted solely to the design and production of communication apparatus of the very highest quality. Its immense resources and its engineering personnel, under the leadership of electrical experts of world-wide reputation, guarantee a product beyond reproach. The company has placed its engineering and research facilities at the disposal of all interested parties, and assistance will gladly be given in designing condensers to meet particular specifications or for adaptation to particular products. Address all communications to:

A.G. BURT, JR.

1033 WEST VAN BUREN ST.
CHICAGO, U. S. A.

REPRESENTING

STROWGER  AUTOMATIC
CONDENSERS

MADE BY

Automatic Electric Inc.
CHICAGO, U. S. A.

Perfect Resistors

for B-Eliminator Manufacturers

Bradleyohm-E

PERFECT VARIABLE RESISTOR

Because of its unusually wide range and accuracy of control, the Bradleyohm-E is extensively used by B-eliminator manufacturers. The resistance of the scientifically-treated discs is not affected by use or atmospheric conditions. It does not vary in service. When once the correct value is selected, it remains fixed.

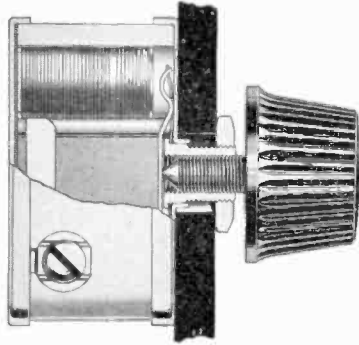

Bradleyunit-A

PERFECT FIXED RESISTOR



This molded resistor is baked under high pressure, and then accurately calibrated. Bradleyunits are guaranteed to be accurate within 5% of their ratings. Unaffected by temperature, moisture or age.

Bradleyunit-B

PERFECT FIXED RESISTOR



Has the characteristics of Bradleyunit-A, but is made especially for manufacturers. Made in an extremely wide range of accurately calibrated resistance values.

Write for data and prices

ALLEN-BRADLEY COMPANY
282 Greenfield Avenue, Milwaukee, Wisconsin

Allen-Bradley

PERFECT RADIO RESISTORS

When writing to advertisers mention of the Proceedings will be mutually helpful.

XXV

Alphabetical Index to Advertisements

A	
Allen-Bradley Co.	XXV
American Mechanical Laboratories, Inc.	XVII
American Transformer Co.	IV
Automatic Electric, Inc.	XXIV
B	
Burgess Battery Co.	VI
C	
Cambridge Instrument Co.	XXVIII
Cresradio Corporation	XVI
D	
Dudlo Manufacturing Corporation.	XIII
E	
Electric Specialty Co.	XII
F	
Fast, John E. & Co.	XV
Federal-Brandes, Inc.	XXIII
Formica Insulation Co.	X
G	
General Radio Co.	Back Cover
Grebe, A. H. and Co., Inc.	Inside Back Cover
H	
Hammarlund Manufacturing Company.	III
I	
Iliffe & Sons, Limited.	XX
Isolantite Company of America.	VII
J	
Jewell Electric Instrument Co.	V
P	
Polymet Manufacturing Corporation	IX
Potter Manufacturing Company.	XI
Professional Engineering Directory.	XIV
R	
Radi-Arc Electrical Co. (1927) Ltd.	XXI
Radio Corporation of America.	VIII
Radio Engineering Laboratories.	XXII
Roller-Smith Co.	II
S	
Scovill Manufacturing Company.	XXII
T	
Thordarson	Inside Front Cover
W	
Westinghouse Electric & Manufacturing Co.	XIX
Weston Electrical Instrument Corporation.	XVIII
Wireless Specialty Apparatus Co.	I

*When writing the advertisers please mention The Proceedings of
The Institute of Radio Engineers.*

VARIABLE CONDENSERS for TRANSMISSION

CAT. NO. 149

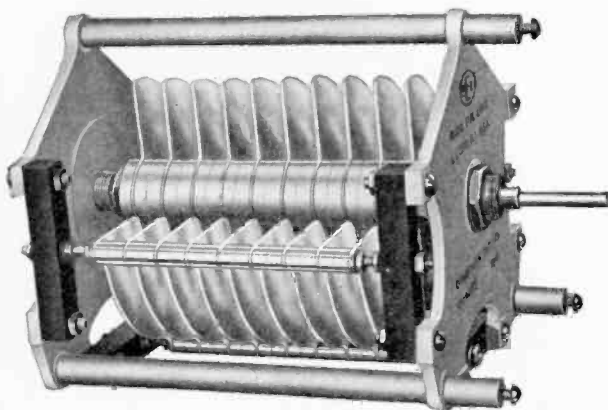

Super-Construction

Heavy Brass Plates . . . Substantial Cast Aluminum
End Plates . . . Steel Shaft Projecting Through Both
Ends . . . Cone Bearings with Locking Device . . .
Highly Polished Rubber Insulating Blocks.

The following table gives data on stock condensers:

Type No.	Breakdown Voltage	Number of Plates	Max. Cap. Mmfd.	Plate Spacing Inches	Overall Depth Inches	Wt. Lbs.	Price
K	3,000	19	200	.250	6.750	4.0	\$17.50
L	3,000	33	350	.250	9.100	8.0	21.00
M	3,000	59	650	.250	13.820	12.5	29.00
N	5,000	11	60	.500	8.750	3.5	17.25
O	5,000	19	100	.500	9.100	7.0	20.00
P	5,000	33	180	.500	13.820	10.5	28.00
R	10,000	7	25	1.000	6.750	3.0	17.00
S	10,000	11	45	1.000	9.100	6.0	19.00
T	10,000	19	80	1.000	13.820	9.5	27.00

Write for Bulletin 39



MANUFACTURES A COMPLETE LINE OF
APPARATUS FOR SHORT WAVE TRANS-
MISSION AND RECEPTION.

RADIO ENGINEERING LABORATORIES

100 Wilbur Ave. :-: Long Island City, N. Y., U.S.A.

When writing to advertisers mention of the Proceedings will be mutually helpful.

CAMBRIDGE INSTRUMENTS

5 Ranges
Max. 0-1000
milliamperes



Size
11¼" x 8" x 5½"
Weight 8½ lbs.

MULTI-RANGE THERMAL MILLIAMMETER

for Radio Frequency Currents

A precision instrument consisting of five separate vacuum thermo-couples, an extremely sensitive unipivot milli-voltmeter, and a six-way double pole switch, each position of which has a convenient scale factor.

The instrument data follows :

Switch Position	Scale Factor	Maximum Reading (Milliamperes)	Approximate Internal Resistance (Ohms)
E	0.1	10	30
D	0.5	50	4
C	1	100	1.2
B	5	500	0.24
A	10	1000	0.12

O—short, with air junction for trial indication, above 10 amperes

Fully described in List No. 162

This is only one of many Cambridge Precision Instruments, for use in the field of Radio Research. We invite your inquiries.

CAMBRIDGE
INSTRUMENT CO INC

3512 Grand Central Terminal, NEW YORK

When writing to advertisers mention of the Proceedings will be mutually helpful.

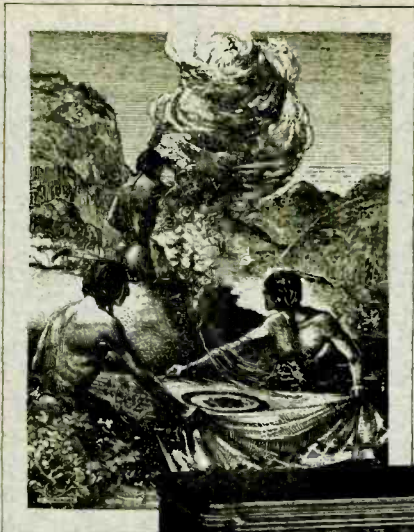

Signaling by smoke was a favorite method of the Indians. Messages were sent long distances by means of smoke released by a blanket held over a fire.



Distance—It is in the reception of distant stations that the superior qualities of the Grebe Synchronphase Seven are particularly evident.

It is then that the full, natural tone—which gives such enjoyment to local programs—makes it difficult to believe that you are listening to a distant station.

Easy tuning of these feeble signals, cleanly separated from strong local broadcasting and amplified

to satisfactory volume, enables you to enjoy programs from far away.

Nineteen years of making only quality radio has taught Grebe how to build a set that gives complete satisfaction for years to come.

Grebe Synchronphase Seven, \$135; Grebe Synchronphase Five, \$95; Grebe Natural Speaker, \$35.

Send for Booklet I. Then ask a Grebe dealer to demonstrate, in your home, that you can "get it better with a Grebe."



GREBE

SYNCHROPHASE

RADIO

A. H. Grebe & Co., Inc., 109 W. 57th St., New York City
 Factory: Richmond Hill, N. Y. Western Branch: 443 So. San Pedro St., Los Angeles, Cal.
 Makers of quality radio since 1909

When writing to advertisers mention of the Proceedings will be mutually helpful.

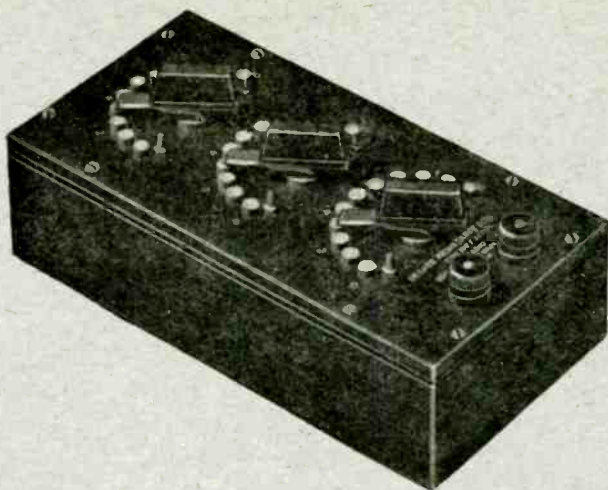

Decade Resistance

Type 102

The 102 Decade Resistance boxes present a convenient arrangement of standard resistances.

The resistances used are non-inductive and of extremely low capacity, the Ayrton Perry method of winding being employed.

The accuracy of adjustment is 0.1% on units above 5 ohms resistance.

Convenient two, three and four dial decade arrangements include a range of one tenth the one hundred thousand ohms.

The Type 102 boxes are particularly well suited for use in bridge set ups where an accurate and easily variable resistance is required.

Bulletin on request.

Prices, \$24.00 to \$85.00

Manufactured by

GENERAL RADIO COMPANY

*Manufacturers of Electrical and
Radio Laboratory Apparatus*

30 STATE STREET

CAMBRIDGE, MASS.