

PROCEEDINGS OF The Institute of Radio Engineers

Volume 14

APRIL, 1926

Number 2

CONTENTS

	PAGE
OFFICERS OF THE INSTITUTE OF RADIO ENGINEERS	154
COMMITTEES OF THE INSTITUTE OF RADIO ENGINEERS	155
INSTITUTE ACTIVITIES	156
RICHARD H. RANGER, "TRANSMISSION AND RECEPTION OF PHOTORADIO-GRAMS"	161
J. H. SHANNON, "SLEET REMOVAL FROM ANTENNAS"	181
T. M. STEVENS, "RECENT ADVANCES IN MARINE RADIO COMMUNICATION"	197
GREENLEAF W. PICKARD, "THE POLARIZATION OF RADIO WAVES"	205
SYLVAN HARRIS, "A METHOD OF CALIBRATING A LOW-FREQUENCY GENERATOR WITH A ONE-FREQUENCY SOURCE"	213
JOHN F. DREYER, JR., AND RAY H. MANSON, "THE SHIELDED NEUTRODYNE RECEIVER"	217
H. DE BELLESCIZE, "NEW METHOD PERTAINING TO THE REDUCTION OF INTERFERENCE IN THE RECEPTION OF WIRELESS TELEGRAPHY AND TELEPHONY"	249
JOHN B. BRADY, "DIGESTS OF UNITED STATES PATENTS RELATING TO RADIO TELEGRAPHY AND TELEPHONY, Issued January 5, 1926-March 2, 1926"	263

GENERAL INFORMATION

The PROCEEDINGS of the Institute are published every two months and contain the papers and the discussions thereon as presented at the meetings and at the Sections in the several cities listed on the following page.

Payment of the annual dues by a member entitles him to one copy of each number of the PROCEEDINGS issued during the period of his membership.

Subscriptions to the PROCEEDINGS are received from non-members at the rate of \$1.50 per copy or \$9.00 per year. To foreign countries the rates are \$1.60 per copy or \$9.60 per year. A discount of 25 per cent is allowed to libraries and booksellers.

The right to reprint limited portions or abstracts of the articles, discussions, or editorial notes in the PROCEEDINGS is granted on the express conditions that specific reference shall be made to the source of such material. Diagrams and photographs in the PROCEEDINGS may not be reproduced without securing permission to do so from the Institute thru the Editor.

It is understood that the statements and opinions given in the PROCEEDINGS are the views of the individual members to whom they are credited, and are not binding on the membership of the Institute as a whole.

PUBLISHED BY

THE INSTITUTE OF RADIO ENGINEERS, INC

37 WEST 39TH STREET, NEW YORK, N. Y.

OFFICERS AND BOARD OF DIRECTION, 1926

(Terms expire January 1, 1927; except as otherwise noted)

PRESIDENT

DONALD McNICOL

JUNIOR PAST-PRESIDENTS

J. H. DELLINGER

(Term expires January 1, 1928)

J. H. MORECROFT

VICE-PRESIDENT

RALPH BOWN

TREASURER

WARREN F. HUBLEY

SECRETARY

ALFRED N. GOLDSMITH

PUBLICATION OF "PROCEEDINGS"

ALFRED N. GOLDSMITH, editor

GEORGE R. METCALFE, assoc. editor

MANAGERS

(Serving until January 1, 1927)

LLOYD ESPENSCHIED

A. H. GREBE

L. A. HAZELTINE

J. V. L. HOGAN

GEORGE LEWIS

(Serving until January 1, 1928)

MELVILLE EASTHAM

A. E. REOCH

(Serving until January 1, 1929)

R. H. MARRIOTT

L. E. WHITTEMORE

WASHINGTON SECTION

CHAIRMAN

A. HOYT TAYLOR

SECRETARY-TREASURER

T. PARKINSON, Bureau of Standards,
Washington, D. C.

BOSTON SECTION

CHAIRMAN

GEORGE W. PIERCE

SECRETARY-TREASURER

MELVILLE EASTHAM, 11 Windsor St., Cambridge, Mass.

SEATTLE SECTION

CHAIRMAN

JOHN GREIG

SECRETARY-TREASURER

R. B. WILSON, 1132 Highland Ave., Bremerton,
Washington

SAN FRANCISCO SECTION

CHAIRMAN

J. F. DILLON

SECRETARY-TREASURER

D. B. MCGOWN, Custom House, San Francisco, Cal.

CHICAGO SECTION

CHAIRMAN

MONTFORD MORRISON

SECRETARY

L. R. SCHMITT, Morkrum Kleinschmidt Corporation,
Chicago, Illinois

CANADIAN SECTION

CHAIRMAN

C. L. RICHARDSON

SECRETARY

W. J. HEVEY, Radio News of Canada, 257 Adelaide St.
W., Toronto

PHILADELPHIA SECTION

CHAIRMAN

STUART BALLANTINE

SECRETARY

WM. G. ELLIS, 4549 Morris St., Philadelphia, Pa.

ROCHESTER, N.Y., SECTION

CHAIRMAN

V. M. GRAHAM

SECRETARY

JOS. HITCHCOCK, Rochester Gas & Electric Co

COMMITTEES OF THE INSTITUTE OF RADIO ENGINEERS, 1926

Committee on Meetings and Papers

R. H. MARRIOTT, Chairman
J. H. DELINGER
CARL DREHER
D. K. MARTIN
ERICH HAUSMANN
H. F. DART
A. N. GOLDSMITH
R. A. HEISING
W. R. G. BAKER

Committee on Institute Sections

M. B. SLEEPER, Chairman
L. F. FULLER
DAVID H. GAGE
L. G. PACENT
M. C. RYPINSKI
M. B. SLEEPER

Committee on Admissions

RALPH BOWN, Chairman
E. H. ARMSTRONG
A. H. GREBE
L. A. HAZELTINE
R. H. MARRIOTT

Committee on Revision of the Constitution

J. H. DELLINGER, Chairman
J. V. L. HOGAN
J. H. MORECROFT

Committee on Publicity

W. G. H. FINCH, Chairman
DAVID G. CASEM
EDGAR FELIX
ARTHUR LYNCH
R. F. YATES

Committee on Standardization

L. E. WHITTEMORE, Chairman
E. H. ARMSTRONG

R. BOWN
EDWARD BENNETT
A. J. CARTER
L. W. CHUBB
J. H. DELLINGER
A. N. GOLDSMITH
J. V. L. HOGAN
C. B. JOLIFFE
R. H. MANSON
LESLIE MCMICHAEL
R. H. LANGLEY
A. E. REOCH
T. R. ROSEBRUGH
H. M. TURNER
L. A. HAZELTINE
BOWDEN WASHINGTON

Committee on Membership

H. F. DART, Chairman
M. C. BATSEL
M. BERGER
STUART BALLANTINE
GEORGE BURGHARD
DAVID G. CASEM
FRANK CONRAD
F. A. CANAVACIOL
DR. L. J. DUNN
C. M. JANSKY, JR.
A. R. NILSON
C. L. RICHARDSON
COL. J. F. DILLON
W. G. H. FINCH
S. KRUSE
E. R. SHUTE
C. P. EDWARDS

Committee on Finance

E. B. MALLORY, Chairman
W. F. HUBLEY
M. C. RYPINSKI

COPYRIGHT, 1926, BY
THE INSTITUTE OF RADIO ENGINEERS, INC.
37 WEST 39TH STREET
NEW YORK, N. Y.

INSTITUTE ACTIVITIES

February Board Meeting

At the meeting of the Board of Direction, held on February 8, the following were present: Donald McNicol, president; Ralph Bown, vice-president; W. F. Hubley, treasurer; Lloyd Espenschied, A. H. Grebe, L. A. Hazeltine, R. H. Marriott and L. E. Whittemore, managers.

The Board reappointed Dr. A. N. Goldsmith secretary, and Mr. W. F. Hubley treasurer, for the year 1926.

Due to growth of the Institute it was decided to procure larger space for the headquarters offices. In place of the room heretofore occupied at 37 West 39th Street, a suite of five rooms was leased on the fifth floor of the same building, occupied on March 1, 1926.

Mr. H. M. Turner was appointed as the Institute's representative on the Dry Cell Committee, Radio Sectional Committee, A. E. S. C. Louis A. Hazeltine was appointed Institute representative on the Radio Advisory Committee, Bureau of Standards, Department of Commerce.

Mr. Whittemore presented a report summarizing the action taken at a Conference on Drawing and Drafting Room Practice, called by a joint committee of engineering societies on December 4, 1925.

Memorial to Dr. Goldsmith

At the first session of the 1926 annual convention in New York, an engrossed memorial was presented to Dr. Alfred N. Goldsmith, secretary of the Institute, and from the beginning, editor of the PROCEEDINGS. The memorial was signed by all of the officers and was presented to Dr. Goldsmith by retiring President J. H. Dellinger.

Applications For Membership

It is learned that applicants seeking entry into the Institute are in some instances deterred by the requirement that references must consist of five Fellows, Members or Associates, for the respective grades. In some instances applicants do not

personally know five members to whom they may refer. There is a clause in the Constitution which states that in such cases the applicant may give as references other engineers, employers, or business associates who are not members of the Institute, provided they state on their applications that they are not acquainted with the stipulated number of members. This refers particularly to those applying for the Associate grade. Those applying for transfer to Member or Fellow grade should be able to refer to the required number of Fellows or Members.

Membership Certificates

Engrossed Diplomas are now available for Fellows and Members of the Institute, and membership cards for Associates. The Diplomas will be signed by the President and Secretary, and the cards by the Secretary. In each case the certificate is issued without charge to those applying for it. As it is desired to have the Diplomas signed by the President in office at the time election or transfer was approved by the Board, there may in some cases be a little delay in forwarding the document. Where the delay or inconvenience would be considerable in procuring the signature of the past-president, the president in office at time request is received for the Diploma may sign the form.

San Francisco Section

Professor Louis A. Hazeltine, manager, was present at a dinner arranged by the San Francisco Section, in January. Chairman J. F. Dillon, of the San Francisco Section, is accomplishing commendable results in building up the activities of the Institute on the Pacific Coast.

Growth of Membership

At the February meeting of the Board of Direction 105 applications for Associate grade were approved, and at the March meeting 160 applications were favorably acted upon. It is anticipated by the end of the present year the Institute will have 4,000 members of the various grades. Six thousand copies of the PROCEEDINGS are now printed of each issue.

Advertising Pages

The support given the Institute by radio companies advertising in the pages of the PROCEEDINGS warrants due recognition by the membership. When writing to advertisers it is of advan-

tage to mention that the advertisement was noted as appearing in the Institute's periodical.

Washington, D.C., Section

Regular and enthusiastic meetings are being held by the Washington Section. At the annual meeting Dr. A. Hoyt Taylor was re-elected chairman and Mr. T. Parkinson, secretary-treasurer. The Meetings and Papers Committee consists of Messrs. F. P. Guthrie, Chairman; Capt. Guy Hill, C. Francis Jenkins, and, ex-officio, the secretary-treasurer. At a recent meeting an informal talk was given by Dr. L. W. Austin, on "Some Notes on Radio Development in Europe."

Radio Relics

In response to the call for radio relics, several communications have been received. Professor R. A. Fessenden has submitted for deposit in the Institute's archives a package of documents dealing with the early history of the radio telephone, and Dr. A. E. Kennelly has presented a file of documents and photostat copies of papers which record announcements of the theories of the Kennelly-Heaviside Layer.

Canadian Section

The Canadian Section (Toronto) held a meeting on the evening of February 19, at which the following papers were presented: "The Design of Modern Broadcast Receivers," by Prof. A. M. Pacent; "Stepping Stones in Radio History," by D. Hepburn, and "The Panatrobe," by C. L. Richardson. The meeting was held in the Auditorium of the Ward Street Works, Canadian General Electric Company.

On February 25, Messrs. C. L. Richardson and A. M. Pacent attended a meeting of the Radio Listeners' Association, Hamilton, Ont., where they delivered addresses on radio.

Rochester, N. Y., Section

A Section of the Institute has been organized at Rochester, N. Y., the first meeting being held on February 21.

The officers of the Section are: Chairman, Virgil M. Graham; Vice-Chairman, Joseph Hitchcock; Secretary-Treasurer, Harvey Klumb. The new Section started with a membership of forty, with additional applications to be passed upon.

A technical meeting was held on March 26.

Membership Committee

A meeting of the Membership Committee was held at Institute headquarters on the evening of February 23, the following being present: H. F. Dart, chairman, and Messrs. M. Berger, C. M. Jansky, Jr., W. G. H. Finch, Arthur Nilson, E. R. Shute and L. E. Whittemore. President McNicol was present, ex-officio.

The committee is perfecting plans for carrying on an active campaign looking to enrollment of all persons eligible to membership in the Institute who desire to avail themselves of the privileges and advantages of such membership.

Standardization Committee

For the purpose of avoiding duplication of effort, and to foster cooperation in the interests of radio engineering and radio manufacture, the following engineers have been made members of the Institute's Standardization Committee: A. J. Carter, as representative of the Radio Manufacturers' Association, Chicago, and R. H. Manson, as representative of the Associated Manufacturers of Electrical Supplies, New York.

Mr. L. E. Whittemore is chairman of the committee.

Elected to Member Grade

At the February and March meetings of the Board of Direction the following were elected to Member grade: Arthur H. Halloran, W. E. Garity, H. J. J. M. de R. Bellescize, Gerald M. Best, Leonard H. Bouchier, Archibald E. Hart, H. A. McIlvaine, J. P. McKenzie, James J. Nolan, W. L. Tierney, James E. Smith, E. Marks, Harrie King, Ira. F. Julian, W. W. Harper, J. M. Goodman, Charles S. Demarest, A. F. Bulgin, William Wilson, Arthur H. Lynch, Paul Kloke, H. F. Dart, L. J. Dunn, J. O. Smith, W. W. Lindsay, David H. Gage, John B. Ferguson and U. B. Ross.

American Association for the Advancement of Science

By virtue of the recent affiliation of the Institute with the American Association for the Advancement of Science, all Institute members may join the latter Association without payment of the usual entrance fee of \$5.00. This privilege is extended for all of this calendar year, after which the same privilege is available only to new members of the Institute and

is available to them any time within a year after their election to the Institute.

The American Association for the Advancement of Science is the leading general scientific organization in America. Its annual meeting, held in a different city in December each year, is a meeting place of all the sciences. Its members receive either "Science" (a weekly) or the "Scientific Monthly." "Science" is a good medium for the publication of short scientific contributions on the results of research in the radio field when of interest to workers in the broader fields of science.

Seattle Section

The Seattle Section, at a recent meeting, had a paper by Mr. J. R. Tolmie on the subject of "Modulation." Mr. John Greig described the method of carrier suppression in transatlantic radio telephony, and Mr. Libby gave an outline of the results of the 1925 radio conference at Washington.

Bound Volumes of PROCEEDINGS

Bound volumes of the Institute PROCEEDINGS are available for the year 1917 and all years to 1925 inclusive. The price to members is \$8.75 per volume; to non-members \$11.00 per volume.

ERRATA*

Corrections for February, 1926, issue of the PROCEEDINGS:
Page 87: Equation should read:

$$\Delta d = \sqrt{y^2 + 4h^2} - y.$$

Page 92: Equations (9), (10), (11) and (13) should read:

$$\theta_1 = 2\pi \int_0^t [F_o + f \sin r(t-d_1/V)] dt \quad (9)$$

$$\theta_2 = 2\pi \int_0^t [F_o + f \sin r(t-d_2/V)] dt \quad (10)$$

$$\begin{aligned} \Delta\theta = \theta_1 - \theta_2 = & 2\pi \int_0^t F_o dt + 2\pi \int_0^t f \sin r(t-d_1/V) dt \\ & - 2\pi \int_0^t F_o dt - 2\pi \int_0^t f \sin r(t-d_2/V) dt \end{aligned} \quad (11)$$

$$\begin{aligned} \Delta\theta = \frac{2\pi f}{r} [(\cos rt - 1)(\cos rd_2/V - \cos rd_1/V) + \\ \sin rt(\sin rd_2/V - \sin rd_1/V)]. \end{aligned} \quad (13)$$

Delete (12)

* Manuscript received by the Editor, November 15, 1925. Presented at a meeting of the INSTITUTE OF RADIO ENGINEERS, New York, November 4, 1925.

TRANSMISSION AND RECEPTION OF PHOTORADIOGRAMS*

By

RICHARD H. RANGER

(RADIO CORPORATION OF AMERICA)

INTRODUCTION

From recent announcements it may seem to many that the art of picture transmission has suddenly been born; but it is as old as the communication art itself. The transmission of pictures electrically had its inception almost at the same time as straight telegraphy, for in 1842 Alexander Bain, an English physicist, first proposed a device to send pictures from one place to another by electric wires. His plan is so basically correct that it is only right at the start to show the simplicity of his plan and how, generally, we are all following in his footsteps. He had, as is seen in Figure 1, two pendulums which were arranged electrically in

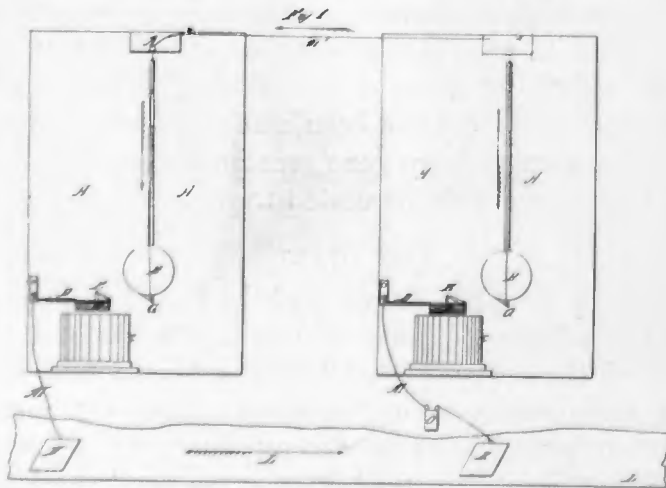

FIGURE 1—Copy of Bain's Original Patent

such a manner that if one preceded the other by a slight amount of the time of a stroke it was held until the other had reached the same position, when both then started a new stroke. These swinging pendulums were the basic synchronizers which

* Presented before THE INSTITUTE OF RADIO ENGINEERS, New York, June 3, 1925. Received by the Editor, October 5, 1925.

are necessary in any picture work. On each swing, a tablet descended a notch at a time at the side of the pendulum. At the transmitting station the swinging arcs of the pendulum carried a small contactor which rode over type faces making the appropriate electric contacts to be transmitted to the distant receiver where a similar swinging pendulum was tracing a path across a piece of paper. By chemical action, the electricity received from the transmitter would discolor the paper at the receiver to give an impression of the original.

We have here the basic elements of all picture transmission. First, the synchronous action covering a surface point-by-point at both transmitter and receiver, and the electrical identification of the point value to correspond between transmitter and receiver.

As it has taken more than eighty years from this initial step to anything approaching commercial reality, there must be something basically difficult in the process.

There have certainly been one thousand workers in the field, and surely it would seem that all of the fundamental conceptions of solving the problem had been realized by this time. However, it is safe to say that present successes are largely due to the wonderful strides that have been made in recent years in the production of more accurate instruments, which have given present-day workers in this field a far greater storehouse from which to draw upon in the accomplishment of the problem. Naturally many transmissions of pictures have been made and successfully, too. The fact that ours may have gone greater distances is only because that is what we were requested to do.

THE START

Mr. Owen D. Young, Chairman of the Board of Directors of the Radio Corporation of America stated, at a banquet, that he was tired of all the arduous effort behind a twenty-four-hour job of sending radio messages by telegraphy from a transmitting operator to a receiving operator who put down the letters one by one at a distant point. Instead of this, the new possibilities of radio should make it feasible for us to say: "ZIP, and a page of the *London Times* is in New York City." "Not being an engineer," he added, "I am not interested in the details; that is your job." If he had perhaps known, or if we had ourselves known, of all the griefs that others had gone through, perhaps we might have hesitated treading on such fearful ground. But, fortunately for us, our knowledge of the basic art developed apace with our study

of the problem, and we found ourselves living through all the past lines of thought of these many investigators, in rapid succession.

Figure 2 is a Denison facsimile of telegraph tape taken in 1901. Figure 3 is an example of the Korn system taken in 1922. Figure

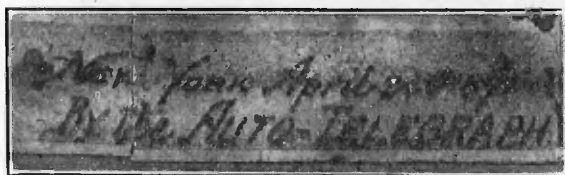

FIGURE 2—Denison Facsimiles of Telegraph Tape

4 shows the result of the Belin system transmitted in 1924, and Figure 5 is an example of the Jenkins process in the same year. Figure 6 represents the Ferree process in 1924, Figure 7 the Bart-Lane system in 1922, and Figure 8 the A. T. & T. Co. in 1925.



FIGURE 3—A Picture of Mr. Korn that was sent from Munich to Rome by the Korn System, 1922



FIGURE 4—A Picture of General Pershing that was sent by Belin's Asycerations

ECONOMICS

In view of the widely diversified attacks on the problem previously we soon realized that our main work was to produce an economic solution rather than essentially the purely mechanical problem of producing a machine that would work.

It has taken 80 years from the first inception to come to commercial operation due to the fact that it is inherently a more dif-

difficult proposition to send a picture than it is to send a telegraph message, or the voice.

Picture transmission requires exactly what these two other transmissions do, which is to depend on an intensity variation



FIGURE 5—A Picture of William Jennings Bryan that was Transmitted by the Jenkins' System in 1924

with time; but it must do the additional job of indicating the points on an area for which these values must be represented. Furthermore, whereas with the eye a whole picture is taken in at a glance,

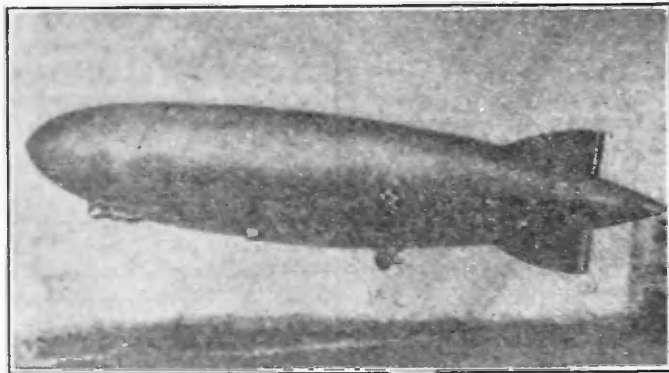

FIGURE 6—This Picture was Transmitted by the "Ferree" System in 1924

due to the fact that there are separate eye nerves for each portion of the area covered in the picture, in communication channels we are naturally restricted to taking a point at a time for each communication channel. If there happen to be more than one communica-

tion channel available, naturally more than one point can be taken at a time. But communication channels, that is, wires or radio circuits, are not available in such large numbers as to permit joint operation over several. Usually, it has seemed wiser to try to get the most out of one channel only. This means, therefore, that it takes a measurably greater time to cover a picture from point to point.

TWO LINES OF ATTACK

In order to keep a fresh viewpoint at all times and not to get into a cul de sac with any single one, it has always been our plan

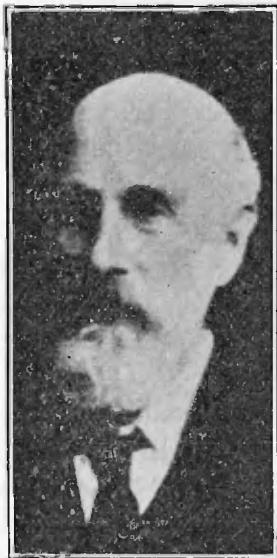

FIGURE 7—Sample of Cable Picture Transmission by the Bart-Lane System, 1922

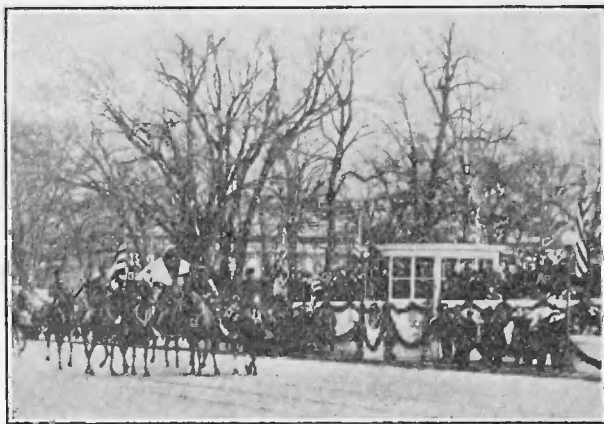

FIGURE 8—One of the Views of the Presidential Inauguration that was Transmitted from Washington to New York by the A. T. & T. System in 1925

to have two methods on trial for each essential of the picture development. It has been the old story of "the survival of the fittest." It takes will-power to throw away the results of months of work and time and money, when it is evident that a line of attack does not have the earmarks of success. But having two lines of attack at all times, we have realized this perhaps a little more readily, and as a result have built up quite a graveyard of dead ideas, and we trust a living survivor of merit.

PICTURE SHORTHAND

Morse's wonderful contribution to communication was not alone, as most seem to think, the development of a telegraphic

machinery or equipment, but largely the development of the telegraph code. Any number of telegraph devices had been constructed before Morse, but they did not have the economic practicability of an all-round system which would get words across in a short space of time.

How successful Morse was may be realized when, today, it is an established fact that the Morse code, representing letters by the dots and longer dashes, is still the most economical way of getting a given amount of words from one point to another, in the shortest time, with the least power, over the greatest distance, and through the greatest amount of interference.

Of course other means of sending words have been produced, typically, the telephone; but it requires, as you may all well realize, a higher quality of wire service and perfection in apparatus to accomplish the higher speeds realized in words transmitted by the voice. The same thing is true of many other systems proposed and in use wherever better facilities are available.

As soon as we realized the economic angle of our problem we began to look for a picture shorthand. It may well be mentioned at this time that our whole problem was largely one of realizing what confronted us and what our real aim was and then the answers began to come easily.

Practically every system to date has been, and still is, on the basis of dividing the picture up into small unit areas and to transmit their values one after the other. This is exactly the plan that would occur to any one knowing the success of the usual half-tone process of printing a picture as in a newspaper. Figure 9 shows this half-tone effect, and it will be seen that there is a regular grading in the proportionate size of the little squares to the surrounding area from the lightest portion to the darkest. Naturally a picture transmission system which would duplicate this would seem to be all that was necessary. But when we realize that the usual newspaper half-tone (and none too good a one at that) has at least 65 dots in a row for an inch, or more than 4,000 of them to a square inch, the size of the job becomes apparent. Let us assume that we wish five tone values to each of these dots, we may then describe this, arbitrarily, as requiring five photo units for each of these dots, or some 20,000 photo units to the square inch. In other words, it requires the ability to transmit from one point to another in identifiable shape 20,000 photo unit pulses per square inch. Naturally, this can be done on any circuit if you have time enough, and if it is a particularly good circuit it can be done in a very short time. The ratio between

the speed of transmission available and this quantity of units is the limiting factor.

On high-class telephone circuits we can readily send 200 such photo units in a second; but in the usual telegraph circuits such speeds are quite difficult, the fastest usual speeds being some 75 separate pulses a second, and normally around 30 or 40 impulses a second. The telegraph circuit, wire or radio, is a slower moving but further carrying message channel.

It is thus seen that, analyzing in this way, the usual method of picture transmission has found its serious drawbacks in the number of pulses that have to be put through; and the precision

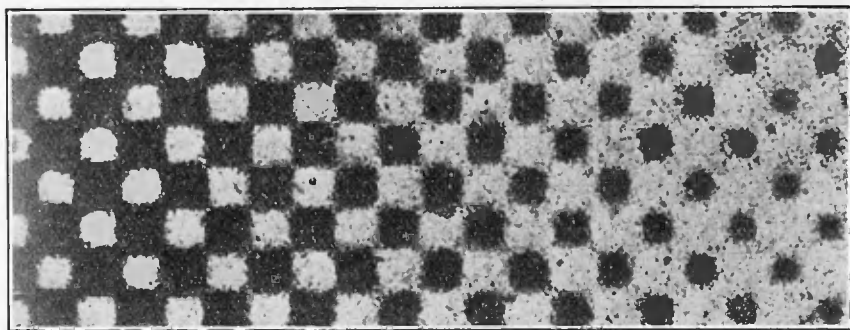

FIGURE 9—A Fundamental Specimen of "Korn's" Work in 1922

with which they have to be put through; and the time that it takes to put them through.

Search for a shorthand method of accomplishing the same results was then started. Our first effort in this direction consisted in the variable dot-spacing method. Obviously, if we place a group of dots on a piece of white paper and space them widely, we will get an impression of practically white. If we place them close, we approach black. This is what we did in our first shorthand attempt, making each dot of generally the same size; although it worked out practically such that the individual dots widely spaced were a little lighter than those grouped together. These dots by their grouping constituted the shades of the picture. The dots were so chosen that in size they would occupy a space of approximately one-fourth of the 64th of an inch as being the usual newspaper standard. One such dot per 64th of an inch would then give an impression of gray color. If they were spaced further apart, this gray color would give way to white. If they were spaced closer together, the gray would become darker up to almost black for the deepest portions. The spacing then was approximately two to each 64th of an inch.

Under these conditions it is realized that we have gone from the necessary five values for each 64th of an inch of the older systems to two values for each 64th of an inch, and have therefore realized a shorthand of a ratio of approximately five to two. Naturally we had the idea of what we wanted in the way of this dot concentration before we had the actual means for accomplishing it, but we were not long in finding a circuit which would give us this photographically and automatically.

DOT-DASH PLAN

Not satisfied with the shorthand already accomplished, we carried the process a step further. Now we start from separately grouped dots in the white end of the scale, and come up to the densely concentrated dots as before. But this time the receiver drum is given twice the speed of the movement, so that the spacing which formerly gave almost a black, now gives a middle gray. Then to accomplish the further deepening to the black, we lengthen out each of the dots grouped closely together so that they become heavier and heavier, and finally for solid black we have the transmitter held constantly. Many adaptations of our first plan could be suggested, but after trying many we came to a few, one of which consists of a balanced arrangement such as many are familiar with in the usual push-pull type of amplifier. In Figure 10 one side of the outfit works in the progression from white to gray and the other side works in the light progression from gray to black, with a slight overlap at the center.

The reduction that this shorthand accomplishes over the previous method is 2 to 1, so that, over all, a 5 to 1 improvement has been made. This means that with a fixed available speed for the transmission of individual units, by this process five times the area can be covered in the same length of time. Furthermore, a wide range of tones is secured without abrupt changes from one tone to the next. The individuality of the alignment of the sharp edges can be made very precise providing the synchronizing of the motors is sufficiently accurate.

And what interested us more than anything else was that we seemed to be entering on a new form of art. No doubt many will look on this as rather a bold expression, but it is the very boldness of our pictures which carries them across. While it is true that they leave considerable to the imagination, this is inherently true of art, and it is an interesting thing that the more that one sees of this type of picture the more one sees in any

given example. Naturally, when the pictures are reduced in size, the artistic effect is greatly enhanced.

PHOTOGRAPHY

In such a development it is natural that those who see only the general effects of the work may not appreciate the effort that must be expended on all the details involved. And if I may be allowed to mention one briefly, it is the production of a good film at the transmitter. We have found in our work that a film

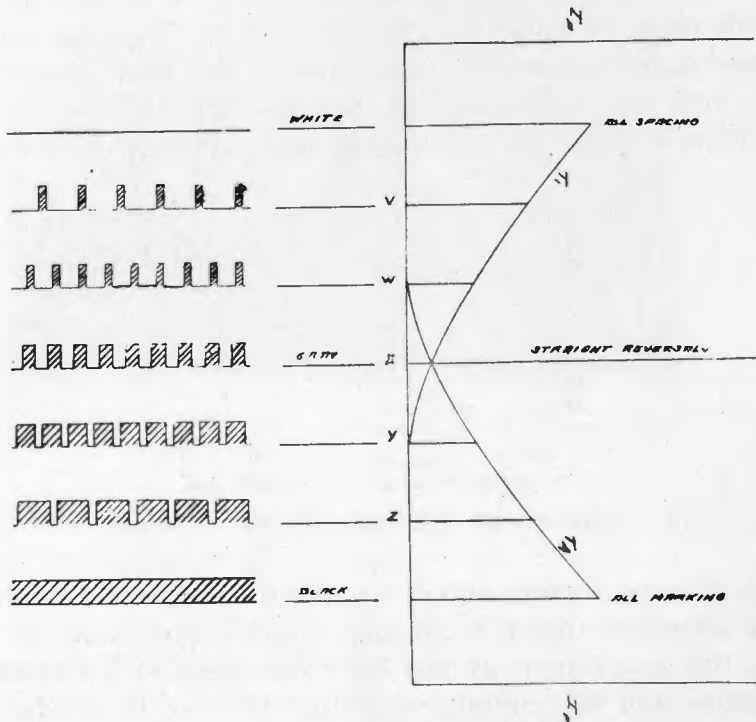

FIGURE 10

that would be normally classed as thin, is the best for our purposes. In actual measurements we have found that a film which varies in its ability to transmit light from 25 per cent. at the darkest portions, to 80 per cent. at the lightest portions, gives us best results. Naturally, it would be by chance that a film produced in the usual manner would be of a value best suited for transmission.

To organize our operations on a practical basis we have therefore made a very extensive study of photographic copying. We have found, for example, that with a given fixed original, it is possible to get a wide variation in the transparency of the copy from this original by changing either the exposure time in

our copying camera, or the development time. Also it is possible to get a still wider variation by using different types of films. These facts have, of course, been known, but mostly in a rule of thumb way. Curves have been developed which show the effect of changing the time of exposure in seconds, with a constant development; the effect of changing the time of development in minutes, with a given exposure; the effect of changing to a different film giving a very flat contrast; also other curves, accentuating the contrast.

From these curves as a starting point it is possible to obtain a wide range of values by proper selection. These have all been classed in the five sets of curves about a particular point to show just how the variations can be obtained, (Figure 11). For example, we will suppose that the original from which we are to

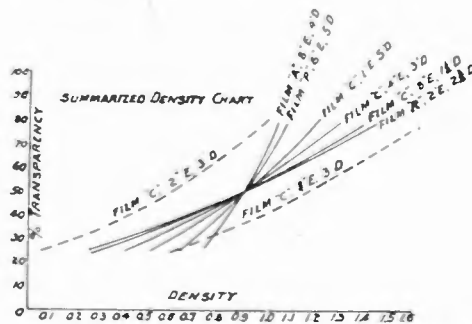

FIGURE 11—Summarized Density Chart

make a copy centers about a value of nine-tenths in density. It is then seen that if it already covers a wide range of values from this as a center, we can use a flat curve with a two-second exposure and $2\frac{3}{4}$ -minute development. If it covers a less range, we can use a different type of film with eight seconds of exposure and $1\frac{1}{2}$ -minute development. The same type of film can be modified by giving it a shorter exposure and in turn, a longer development, to make the curve take up different positions, and finally, by using a special slow-process film, we can obtain the required transparency with only a very slight density change available in the original. Naturally, it would not always be possible for the original film to center about a point such as nine-tenths, and we have therefore also shown on this curve how the whole process may be moved to the left or to the right by changing the exposure and using the same development. This information has been drawn up in a single table, so that the practical operator can obtain from any given original the copy which will have the exact range desired.

9. FIRST APPARATUS

We will now come to the concentration of the apparatus we use. Basically, we must start with a photograph. This photograph is conveniently in the form of a film such that it may be placed around a glass cylinder, as shown on the picture of the original transmitter, Figure 12. A powerful light is on the

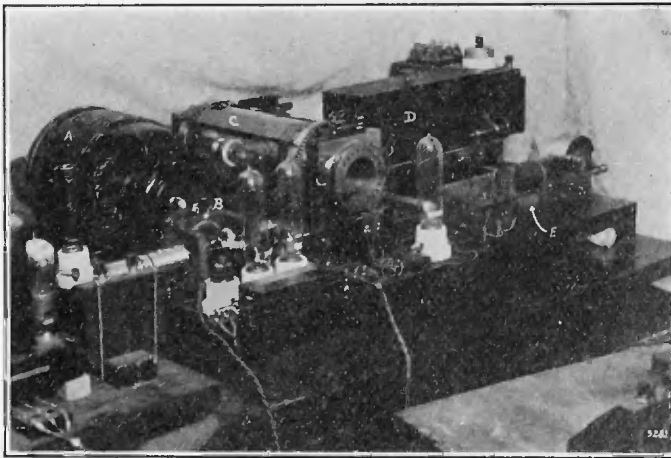

FIGURE 12—The First Photoradiogram Transmitter, 1924. This Unit is now in London

inside of this cylinder. To give an idea how powerful this light is, a few figures are cited:

The Incandescent Gas Mantel has	35 c.p. per square inch of surface.
The Carbon Filament Lamp has	400 c.p. per square inch of surface.
The Metallic Filament Lamp has	1200 c.p. per square inch of surface.
The Nernst Lamp has	2500 c.p. per square inch of surface.
The Gas Filled Lamp has	12000 c.p. per square inch of surface.
The Gas Arc has	15000 c.p. per square inch of surface.
The Sun	900000 c.p. per square inch of surface.

Naturally it has been one of our main problems to find the very best materials available for each and every part of the system. This has been made easy by the ready reception we have received from everyone, such as lamp manufacturers, ink manufacturers, fountain pen, paper, camera suppliers, etc., and others affiliated in this work. May I state what a pleasure it has been to have had such a wealth of material offered us in this work.

10. REVOLVING CYLINDER

This strong gas arc-light is in the inside of the glass cylinder and sends its ray by lenses through the film placed on the cylinder to a motion picture lens focused on the film which throws an image of the film onto the photo-cell, point by point. As the cylinder

revolves, each portion of the picture is shown progressively to the photo-cell. The photo-cell is then moved bodily down the cylinder length so that the whole picture is gradually built up line upon line.

Figure 13 is a view of the commercial type of transmitter of the present time.

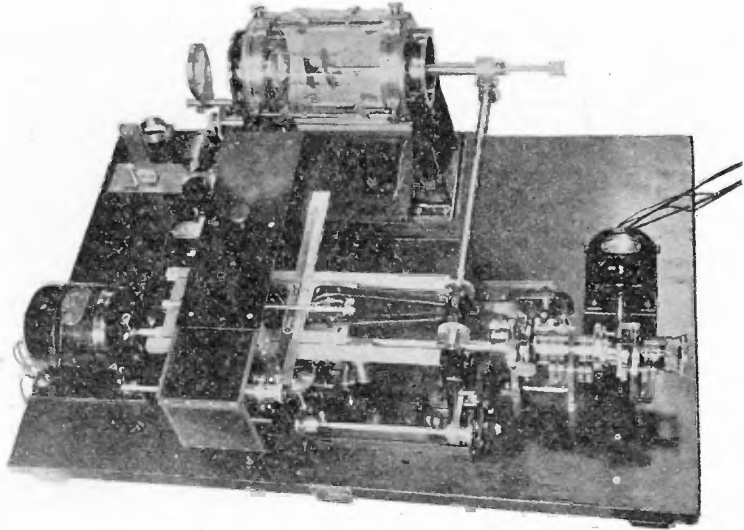

FIGURE 13—The First Commercial Type of Photoradiogram Transmitter, 1925

11. PHOTO CELL

In the camera box (Figure 14) is the electric eye, the photo-cell, which is a device for interpreting light values in terms of electric current. I believe it was Shelford Bidwell who first suggested the use of light sensitive electric valves for photo transmission work. Many others since then have contributed to this plan, notably, Elster and Geiter in Europe. We are indebted to the General Electric Company and to the Westinghouse Company for the excellent photo-cells they have developed for us in this work. Basically, the idea of the photo-cell is that a high voltage is applied to the cell, almost sufficient to ionize it. Photo-electric action is realized when light strikes a photo-cell such that the potassium hydride which lines the inside surface of the cell is ionized and electrons pass from the potassium hydride to the cathode in the center of the cell. Highly attenuated argon gas fills the inside of the cell which increased the ionizing effect materially, so that an appreciable current flows through the cell with the action of the light to the extent of some two micro-amperes. This current, of course, must be greatly amplified,

which is done by the use of the three-electrode vacuum tube. This is shown on the attached circuit, Figure 15, where the current is caused to pass through a high resistance, R , which causes voltage variations to be applied to the grid of the vacuum tube. This amplification might be carried on in further steps in the usual manner. However, for our first dot concentration plan this was quite sufficient in itself to give effective results. This is

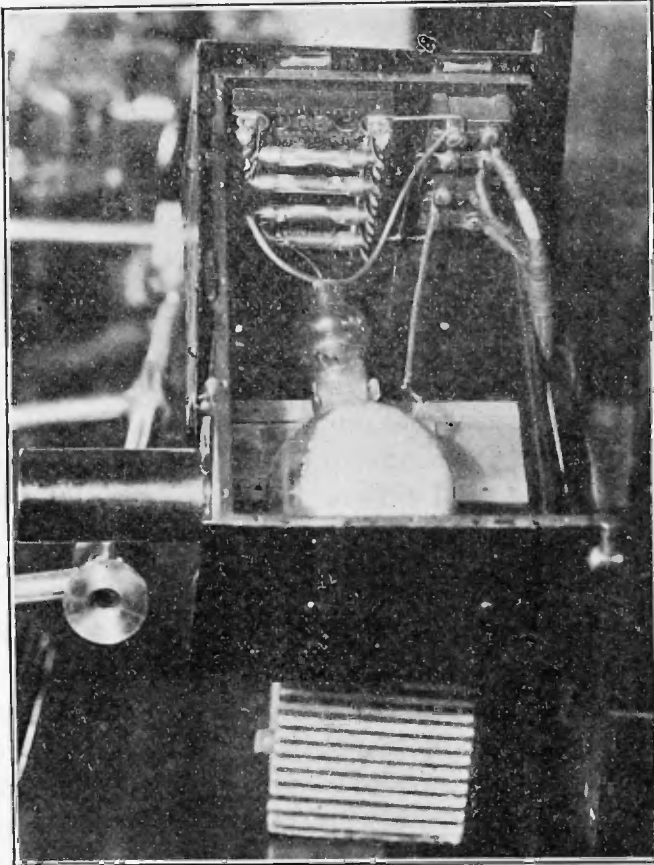

FIGURE 14—This View Shows the Photo-cell in the Photo-cell Box

arranged by having a vacuum tube with its grid thus controlled by the photo-cell, with its plate current supplied through a condenser charged at intervals. These intervals are determined by the rate at which the condenser discharges. In other words, a sort of low-pressure valve is arranged such that when the condenser discharges to a certain extent, the plate battery is again connected to the condenser to charge it up to the maximum value. This is accomplished by having a large C battery connected to the high side of the condenser so biased that the plate voltage

must fall below a given value before a second three-electrode tube stops drawing plate current through its plate. This second plate current is carried through a relay; while the relay coil is energized the contacts are open, but when the relay falls back against the contacts the charging *B* battery pulse is sent on to the condenser.

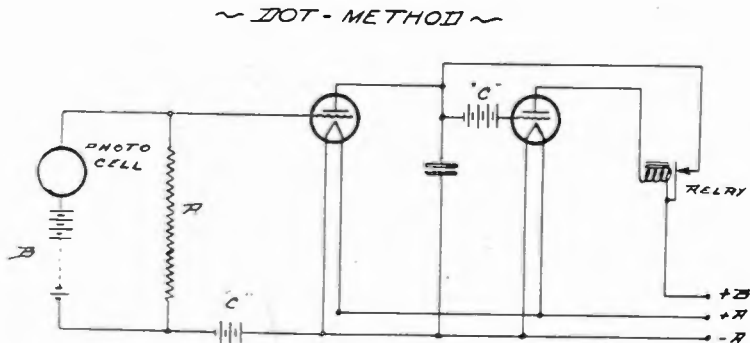

FIGURE 15

It is thus seen that the time interval between the successive charges of the condenser is determined by the rate of the plate-current flow in the first vacuum tube, and as this is in turn determined by the photo-cell current, we have a direct interpretation of the light action in terms of the relay closing. This relay closing can be used to activate telegraph lines or a telegraph radio circuit.

12. C LIGHT

As an interesting adjunct to our photo-cell operation we may mention the use of an additional light beyond the normal illumination obtained through the film to be transmitted; this we have termed the *C* light, Figure 16, corresponding in its action very much to the *C* battery used in grid amplification. The use of the *C* light makes it possible to operate the photo-cell itself more effectively, where it, in conjunction with the amplifiers, gives a more perfect straight line characteristic to the reproduction current values.

13. SYNCHRONISM

For synchronizing, we have adopted the tuning fork as giving us the appropriate constant rate of rotation to actuate our devices both at transmitter and receiver. By the addition of clock check control we have found it possible to obtain uniform speeds at each end, where the clock controls act as a check on the tuning fork. Aside from using clock control we have also used dashes

at the end of each stroke, which work very well to keep the receiving cylinder moving correctly with respect to the transmitting cylinder.

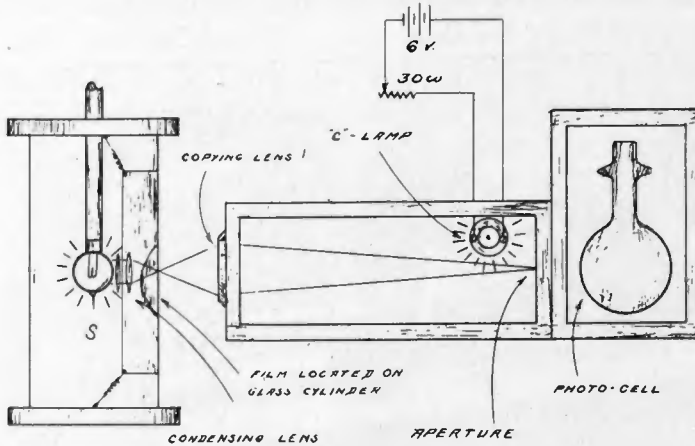

FIGURE 16

14. THE RECEIVER

For the receiver there are many available plans, but we have concentrated on the production of a daylight operation program which involves the use of something in the order of an ink record on paper. It is seen that this dot plan fits in very readily with an ink record. It is only necessary to have the recording pen mark on the paper whenever a charging pulse starts at the transmitter. The connection between the transmitter and receiver may be either by telegraph or by the regular radio telegraph.

Figure 17 is a close-up of the original receiver with most of the auxiliary apparatus excluded. *A* is the motor which is maintained at constant speed through the medium of the tuning fork *G* and associated apparatus. *B* is the reversing cam for changing the direction of rotation of the drum *C* upon which the recording paper is placed. *D* is the pen which is supplied with ink from the well, *E* for reproducing the picture as it is received, in the form of dots and dashes. *F* is the box for the film by means of which it is possible to obtain a photographic record at the same time the visible record is being made.

Figure 18 shows the modern type of photoradiogram receiver which is capable of making two pictures at the same time.

15. STATIC

The question of transmission to a distance is always one of obtaining sufficient desired signal strength to override the effects

of disturbances. This is true of all wire lines and cables, as well as radio. It is in this element that the telegraph wins, due to the fact that it is in a sense a trigger device, where the current is either on completely or off completely. Under these conditions

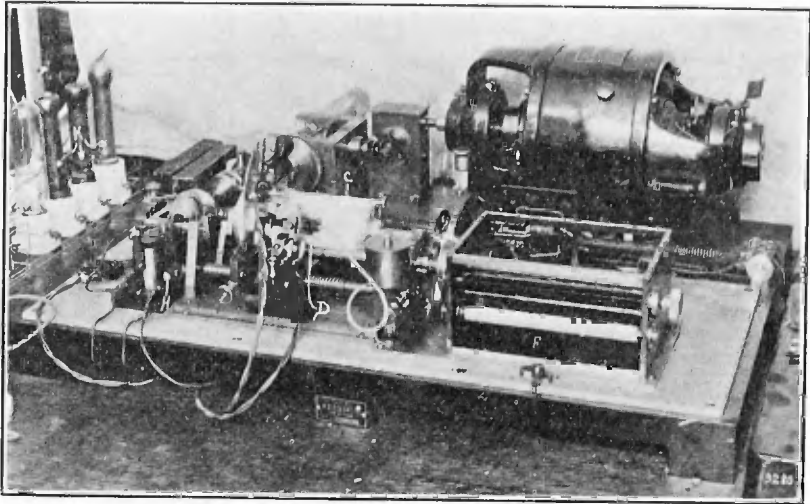

FIGURE 17—The First Photoradiogram Receiver which is still in the Design Laboratory of the Radio Corporation of America in New York, 1924

it becomes easier to identify electro-mechanically the times when the current is on and when it is off, than to attempt to analyze the variations in current strength. That is why it is

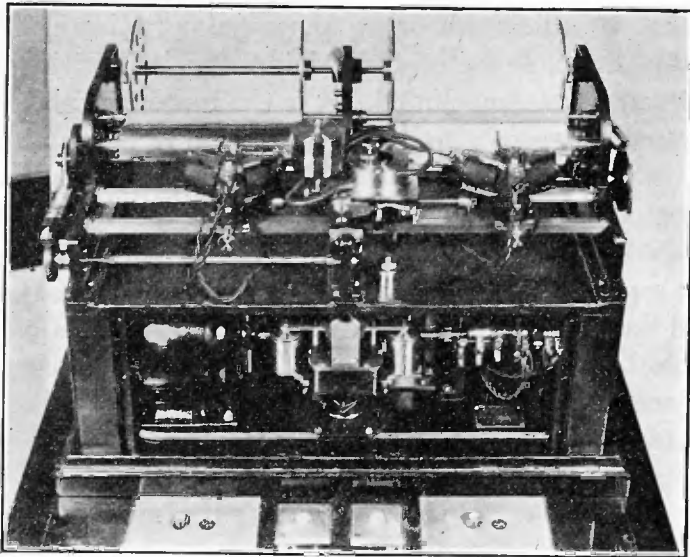

FIGURE 18—First Commercial Type of Photoradiogram Receiver, 1925

possible to get radio telegraph signals across the ocean at practically all times whereas even considering the smaller amount of power used, I am sure it is appreciated that broadcast telephony, for example, is badly interrupted by static and fading over much shorter distances. By interpreting picture values in dots and dashes, where the full current of the radio transmitter is on even for the shortest dot, we have taken full advantage of this telegraphic supremacy to carry a picture to the greatest distance. Furthermore, it fits in most readily with the relaying operation. This we first made use of on July 6th of last year when the following picture of Secretary Hughes, Figure 19, was sent from New York by wire line to New Brunswick, N. J., thence by radio to Brentwood, England, then into London and from there by wire line back to Carnarvon, Wales, thence back by radio to Riverhead, L. I., and back into New York City. This picture



FIGURE 19—First Photoradiogram,
New York to London, Back to New
York, July 6, 1924

is the result of this very involved journey. No picture was recorded in England, but it showed the effectiveness of our system at that time, so that when the apparatus for transmitting was sent to London the very first pictures came through successfully.

16. SOME EARLY PHOTORADIOGRAMS

The first public trans-Atlantic demonstration of the transmission and reception of pictures by radio took place in November,

1924. The photoradiogram transmitter was located in London. The signals from this apparatus were put on the 220-mile land line to Carnarvon, Wales, at which point they actuated the control relays of the high power radio transmitter there. These radio signals from Carnarvon were picked up at Riverhead, Long Island, amplified, heterodyned, detected and sent in to the New York office of the Radio Corporation of America as audio frequency dots and dashes. These tone signals were again amplified at the New York office, then rectified and applied to the photoradiogram receiving equipment.

In the spring of the following year (1925) a photoradiogram transmitter was installed in the offices of the Radio Corporation of America at Honolulu. On April 29th, 1925, pictures were successfully transmitted from Honolulu and reproduced in the New York office of the Radio Corporation of America.

17. COMMERCIAL USES

Naturally, all this work has a purpose in view, and, of course the news field is the most immediate. There are two angles, however, to the newspaper situation: first, is the unusual picture, and the other is the general news picture. Naturally, a business can not be built up around earthquakes. Therefore, it must be a case of supplying regular service to groups of papers that this service will become worthwhile. However, it is interesting to see to what extent the unusual picture will force news activities. I have received the following advice as to two particular instances of the unusual picture situation:

Some examples of the need for radio pictures are to be derived from news events of the past year. The earthquake in Japan was the cause of one of the greatest races between news-gathering agencies in modern times. The representative of one agency had flown from a Chinese port over the stricken area, taken several desirable photographs, and then returned in time to mail his results on a Pacific Mail steamer sailing from Shanghai. His competitor had been forced to make the trip to Japan by both air and water and arrived some twenty-four hours after the steamer had sailed. Chartering a seaplane he made a dangerous four-hundred-mile trip to sea in order to drop his package of film on the ship. Successful in this, the race was tied until Vancouver was reached, where two speedy planes awaited the ship's arrival. From there, across the continent it was a free-for-all race, one leading and now the other. Eventually, the pictures were delivered in New York with but a few hours' difference in time. Had a radio picture service been available, but a few hours would have transpired instead of the many days to transport the scenes of this disaster. The cost ran up into

thousands of dollars and many New York papers paid as high as five hundred dollars for pictures weeks old.

One picture-gathering agency sent a representative around the world with the Army fliers. Traveling in many different ways and even stowing himself away on one of the the planes, he was handicapped in keeping his service supplied with pictures from three to six weeks old. With a world-wide radio picture service it would have been but a matter of hours. With the public desire for pictorial news becoming more pronounced yearly, it is only natural that a demand for foreign pictures with foreign news items be met through radio pictures.

A very effective use to which photoradiograms will be put is distinctly in line with the original work of Alexander Bain, as emphasized in our particular development by Mr. Young, and that is, transmission of words—printed, typewritten or hand written. As an example of printed material may be mentioned a clipping taken from a Honolulu newspaper and transmitted all the way to New York by relay through California, in May, 1925. Tabulated material is particularly suited to such transmission and most difficult to accomplish by normal telegraphy. Drawings, signatures, fingerprints, and all such are a fruitful field for radio pictures.

Naturally, there remain many refinements necessary in this work, but it is largely a question of making the equipment continuously serviceable. To this end we have made both transmitter and receiver such that the operations may be continued without interruption between pictures, and with the equipment now set up and working both eastward across the Atlantic and westward to California and Honolulu, it is only a question of time when the mechanics of the operations will have been sufficiently worked out by the operators, who have to combine all that went before, in a way of radio technique with mechanical and artistic appreciation as well, to make photoradiograms of the highest service to everyone.

SUMMARY: This paper carries the art of electric picture transmission from its inception, over 80 years ago, to the results of present-day development.

It is pointed out that the seemingly rapid strides that have been made in the art during the last 10 years of its 83-year existence may be attributed to the larger storehouse of electrical and mechanical contrivances from which modern photo-transmission engineers may draw.

Picture transmission is not, as many think, a modern art. It is as old as the communication art itself and this paper carries us through the work, ancient and modern, of photo-transmission engineers, commencing with that of Alexander Bain in 1842.

A Denison facsimile of telegraph tape, taken in 1901, is shown, together with examples of the work of Korn taken in 1922; that of Bart-Lane in 1922; Belin, 1924; Ferree, 1924; Jenkins, 1924; and results of the A. T. & T. system in 1925.

The basic elements of all picture transmission systems are shown to consist of synchronously covering a surface, point-by-point, at both transmitter and receiver, and electrically identifying point values at the receiver so that any integral section of the received copy will have the same relative tonal value as the identical integral section on the transmitting surface.

Economics is as important a factor in the transmission of pictures as it was in the establishment of a telegraphic system of communication, and the reason that the Morse Code still exists is because it is the most economical means of getting a given amount of words from one point to another, in the shortest time, with the least power, over the greatest distance and through the greatest amount of interference.

The necessity of a picture shorthand was visualized and developed. Whereas the usual newspaper half-tone has 65 dots to the inch and 5 tonal values are desired per dot, making a total of 325 photo-pulses per inch, the picture shorthand developed in the "photoradiogram" system reduced this to 65 photo-pulses per inch giving a reduction or shorthand ratio of 5 to 1.

The photographic angle of the problem is touched on lightly and the 11,000,000-mile-a-minute flight of the picture pulses from the transmitter to the receiver are followed through their several transformations in "slow-motion."

The development of this system of picture transmission is shown graphically by examples of photoradiograms taken from epochal stages in the course of the development.

The commercial possibilities of this system are discussed, and in closing it is pointed out that one very immediate and effective use to which photoradiograms will be put is in the transmission of words, printed, typewritten or handwritten.

SLEET REMOVAL FROM ANTENNAS*

By

J. H. SHANNON

(RADIO CORPORATION OF AMERICA, NEW YORK)

The phenomenon of sleet forming on wires, which are exposed to the weather when the temperature is about freezing point and the atmosphere moist, is well known. It is a source of extreme annoyance to a great number of commercial enterprises, more particularly to power companies, in respect to their transmission lines; telegraph and telephone companies in regard to their overhead wire system; and radio companies in connection with their antenna systems.

With regard to the first two industries, the wire systems are so extensive that with the exception of one or two of the power companies, sleet melting is not resorted to; consequently interruptions, due to wires breaking, and towers and poles uprooting as a result of the heavy ice load, are frequent in districts where sleet is prevalent. Large sums of money are expended annually by these companies for maintenance and repair, as well as penalties for interruption to service of customers.

Fortunately for radio companies, the antenna systems are not so very extensive, and when sleet forms on the wires it is possible to pass a current of electricity thru the wires, thus raising their temperature to a point where the ice will melt and fall off, and in case the power supply at the station fails and it is impossible to melt the ice from the wires, a method of automatically dropping the wires when they have been loaded to a predetermined value has been devised. The method of melting ice and dropping the wires will be described.

If the antenna consisted of two wires, these wires being approximately two miles long and supported by means of insulators from towers spaced say twelve hundred feet apart, then it would be a simple matter to melt the sleet from these wires by connecting the far ends permanently together and applying a voltage across the wires at the station end.

The voltage can be so chosen that a current of the desired amount can be passed thru the circuit and thus insure that the wire will not be heated to such a temperature that the strength of the wire will be affected.

*Received by the Editor, June 6, 1925. Presented before THE INSTITUTE OF RADIO ENGINEERS, New York, September 2, 1925.

An antenna system is not usually as simple as this and may consist of anywhere from 12 wires up to 30 wires, each two miles in length, all of these wires being connected at a minimum of five points thru inductance coils to the ground, as represented diagrammatically in Figure 1. If we connect the wires together at

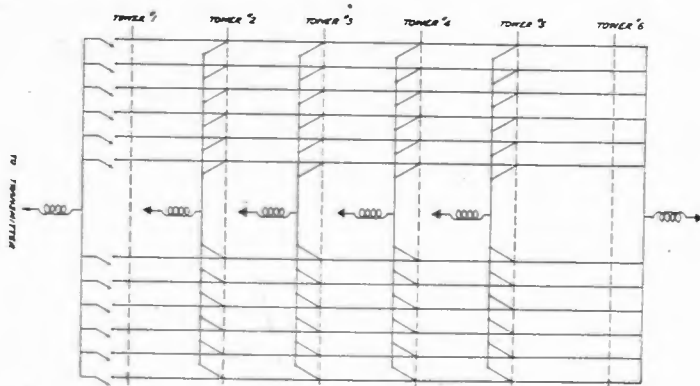

FIGURE 1—Schematic Wiring Diagram of Multiple Tuned Antenna.

the far end we have the same arrangement as our simple two-wire antenna before mentioned except that we have introduced several ground connections to each one of these wires. It can be seen that unless these ground connections are removed in some way we could not effectively pass current thru the whole length of the wires for sleet melting, and it would indeed be a difficult and inconvenient thing to disconnect each of the wires at the ground points when it is required to melt sleet. This, however, can be avoided by the insertion of a condenser between the wire and the ground connection (see Figure 2), this condenser being so designed that it offers a very high impedance path to the low-frequency sleet-melting current, allowing practically none of it to pass thru to ground, whilst offering very low impedance to the high frequency energy, allowing practically all of it to pass thru the coils to ground.

The mechanical and electrical design of a suitable condenser for this purpose was one which presented difficulties and required careful development. It was recognized that the best place for such a condenser to be installed was as close as possible to the point where the tap was made to the horizontal antenna wire at the suspension point, so that it would not be necessary to insulate the down lead wires from each other. Consequently a condenser which could be suspended aloft and carry the main horizontal antenna wire appeared to be the best solution, and such a

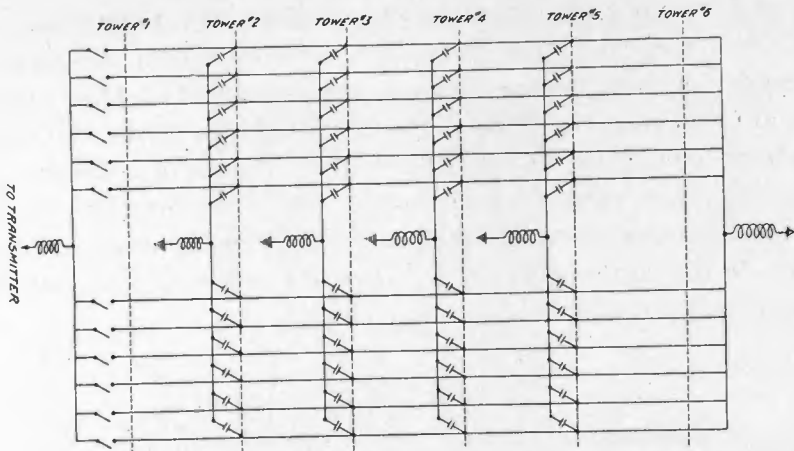

FIGURE 2—Schematic Wiring Diagram of Multiple Tuned Antenna Showing Where Condensers Are Inserted for Sleet-Melting Purposes

condenser was finally developed in co-operation with the General Electric Company at their West Lynn Works.

The plates of this condenser consist of aluminum foil and the dielectric consisted of waxed paper. The assembled condenser element is circular in form, being rolled on a brass mandrel.

The mandrel has an insulated coupling in the centre so that by attaching the plates to each end of the mandrel by suitable clamps, the ends can be used as the terminals of the condenser.

This condenser in its present form lends itself very readily for general use indoors, and with slight modifications could very conveniently be used for power factor correction, and similar purposes, as it can be mounted by simply clamping it between buses without any complicated mountings.

To make it serviceable for outdoor use, as we required, it was necessary to put some form of housing around it. If a metal housing had been adopted, trouble would have been experienced with insulating bushings, and other complications, so a hollow porcelain tube insulator, fitted with end caps and suspension lugs, was finally decided upon as the most practical solution. It was with the co-operation of the Locke Insulator Company, of Victor, New York, that this insulator was developed and produced.

The porcelain insulator as designed for this purpose is shown in Figure 3. One cap is permanently cemented to the insulator whilst the other cap is made in two parts; one part is in the form of a ring and threaded with a male thread, this part being permanently cemented to the other end of the tube. The other parts, or cap proper, with a female thread which can be unscrewed so as to allow for assembly of the condenser element. Should the condenser at any time break down, it is a simple mat-

ter to unscrew the cap, take out the element, and replace it.

By referring to Figure 3 it will be observed that the ends of the mandrel have been extended and threaded. One end is screwed down into the permanent insulator cap, whilst the other end makes contact with the other cap by means of a diaphragm plate, this plate being attached to the end of the mandrel by two nuts. The plates serve two purposes: (1st) for the electrical connection to the cap, and (2nd) to allow for longitudinal expansion of the mandrel due to temperature change.

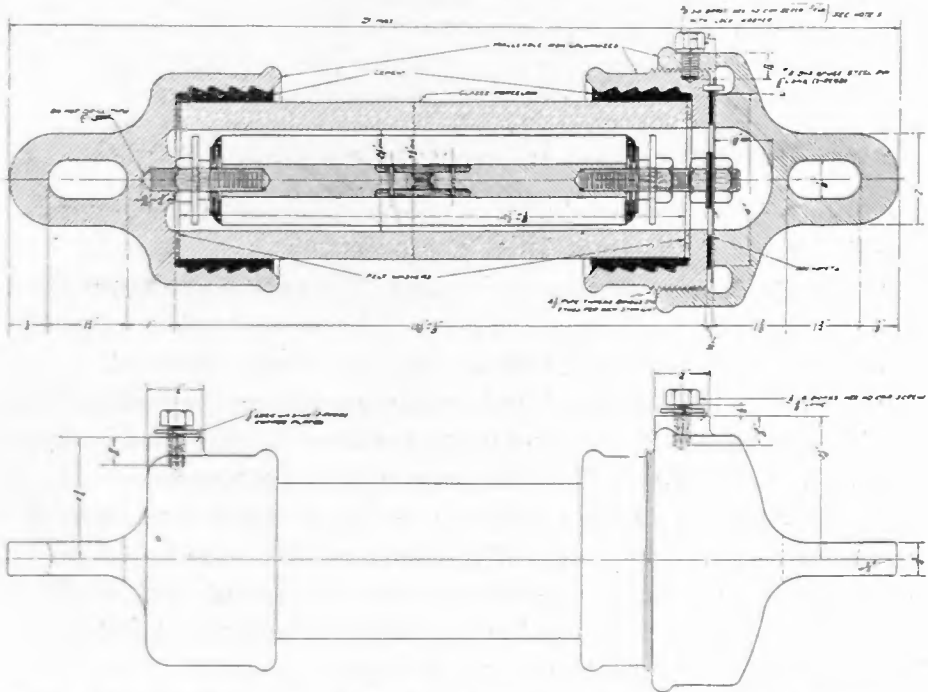

FIGURE 3—Combination of Condenser and Insulator for Sleet-Melting Purposes

The caps of the insulator now form the terminals of the condenser as well as acting as heat radiators for the unit. A special boss on the caps, finished with a flat surface and fitted with a $\frac{3}{8}$ -inch set screw and lock washer, forms the connection for copper connecting lugs.

The complete unit shown in Figure 4 makes a very neat arrangement, from a mechanical as well as electrical standpoint, as it can be suspended from the main antenna insulators and the antenna cable can in turn be suspended from the lower end of the condenser unit. The antenna wire can be connected to the lower cap and the top cap being connected to a common bus, the down-lead connection to the tuning coils which are erected on the ground, being taken from this bus. So long as power is available

and these condensers are in circuit, no danger from sleet need be feared.

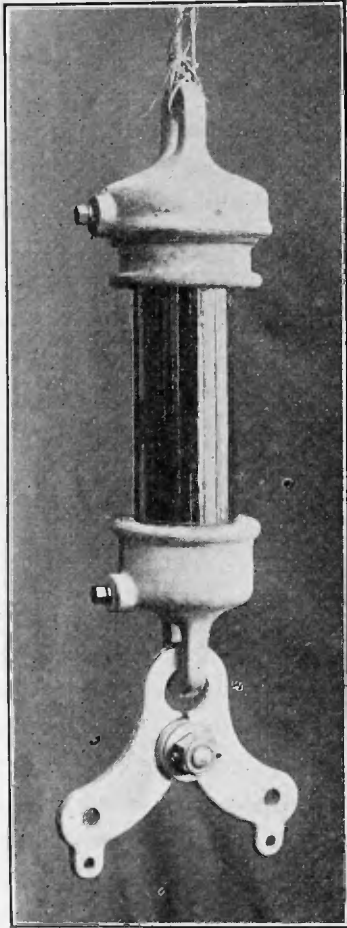

FIGURE 4—Condenser-Insulator Unit with Plyotrip Release Link

Unfortunately, as before stated, very few power companies are able to melt sleet from their transmission lines, and consequently their lines fail, due to wire breaks and uprooting of poles, thus cutting off the power supply to the radio station. Under such conditions it is to be expected that the antenna system will be crippled.

Where self-supporting towers with cross-arms are used for the suspension of the antenna cables, it would be a very serious problem if three or four of the outer wires broke in one span and the others remained intact. Under such conditions a big unbalanced torsional pull would act on the cross-arm, due to the ice and wind load, and unless the design of the tower was made to resist it, results would be disastrous. It would indeed have been very

uneconomical to have designed towers to withstand such conditions unless very low-breaking strength cables were used, but as this would have introduced many disadvantages, foremost among which would have been frequent interruptions to service, it was not practical to adopt such a method.

It was finally decided to install a cable that would have a high ultimate strength, in other words, a cable that would not break except under exceptional conditions. Then interruptions would be reduced to a minimum.

The use of a stranded medium-hard-drawn-copper or silicon bronze cable to give a high ultimate strength would not have been economically satisfactory, as the weight per foot of this cable would have been such as to make the sag on a twelve hundred and fifty foot span (this span having been adopted as it was considered the most economical) so great that the effective height of the antenna would have been low, thus reducing the radiating efficiency of the system, and again, the cost of such cable would have been very high.

The most nearly ideal cable for our purpose was one which had a diameter just large enough so that it did not show corona at 150 kilovolts of radio frequency; of maximum strength possible, and with a conductivity of 35 to 40 percent of pure copper. A cable which satisfied the foregoing characteristics was obtained from the Copperweld Company, of Rankin, Pennsylvania. This cable consisted of seven number-eight wires, formed into a strand of $\frac{3}{8}$ -inch diameter. Each wire had an exterior coating of pure copper with a high tensile strength steel core. The ultimate strength of this strand was 12,500 pounds and the yield point considerably in excess of 80 percent of this value. By the adoption of this cable the biggest percentage of trouble due to sleet was automatically eliminated.

In order to protect the towers against abnormal conditions which would exist if the power failed and sleet continued to form, it was necessary to devise some means by which the strain on the towers could be relieved before it got to dangerous proportions. The first thing that suggested itself was a weak link from which the antenna cables would be suspended, this link to break and allow the wires to drop at a predetermined load. This link is shown in Figure 5. By varying the cross section of metal in the link it can be made to break at any desired load. The specifications for this link were somewhat severe and it was indeed difficult to obtain a metal that would fulfil them in all respects. Amongst other things the specifications for this link called for

(1) The elastic limit to be at least 90% of the ultimate strength.

(2) Must be rust proof.

(3) Must not crystallize.

(4) Must break within 3% of estimated load.

After a number of experiments John A. Roebling Sons and Company produced a link, Figure 6, built up of straight pieces of wire, which proved very satisfactory. By varying the number of wires the strength can be adjusted to any desired amount. These links were installed on one of our stations and have been in service for over a year, but so far they have not been called upon to demonstrate their efficiency in case of emergency.

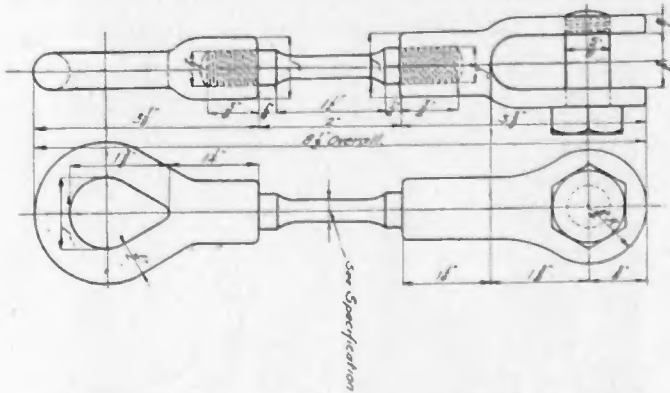

FIGURE 5—All-Metal Weak Link for Antenna Wire Suspension. (Allows Wire to Fall When Overloaded)

Whilst this link has proven satisfactory, it was thought that a mechanical device would be more convenient. A device that will relieve the strain at a pre-determined value and allow the antenna cable to drop for its whole length has been perfected. This device does away with the expense of renewals incurred by a breakable link, as it can be readjusted and put back into service after it has operated.

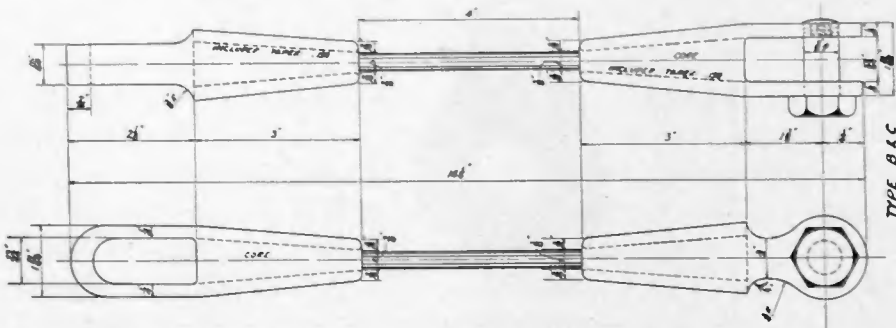

FIGURE 6—Weak Link Made Up of Straight Pieces of Wire for Antenna Wire Suspension. (Allows Wire to Fall When Overloaded)

The device is shown in Figure 7. It consists of a dynamometer spring *X* fitted with two jaws *A* and *B*. The jaw *A* is fixed whilst the jaw *B* is free to open. Attached to the end of the jaw *B* is a trigger *C*. An adjustable arm *D* is attached to the centre of the spring. At one end it is rigidly fastened by a lock nut to the spring at the point *E*, but can move through a guide *F* at the other end, the guide being rigidly fixed to the spring. Turned solid with the arm *D* is a hub *G* which serves to keep the trigger locked under normal load conditions. As the load comes on, the spring compresses, thus causing the arm, and consequently the hub, to move horizontally to the right. If the tension in the wire exceeds the amount for which the device has been adjusted, the spring will be compressed to such an extent that the hub will clear the trigger, allowing the latter to disengage

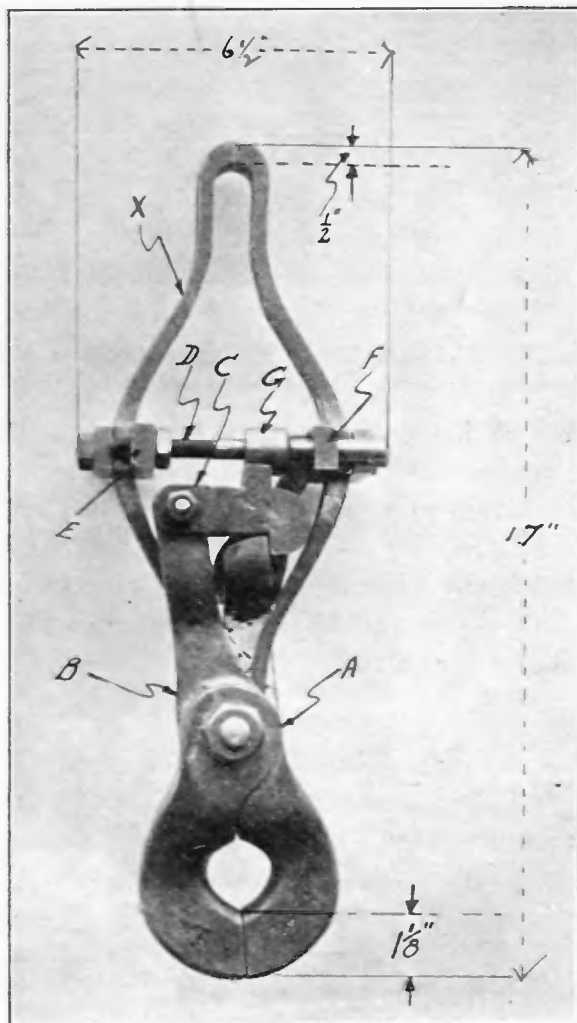

FIGURE 7—Device for Automatically Releasing Wire When Tension, Due to Sleet, Becomes Too Great.

itself from its locked position and thus allow the jaw *B* to open and release the cable. (The cable is attached to the device by means of a closed socket.) This automatically allows the cable to come adrift from its anchorage, thus relieving the tension.

For simplicity of description we will call this device the "Dynotrip." This device was developed in cooperation with the Kolbusch Company of Jersey City.

In order to allow the cable to drop from its suspension points on the towers when the tension has been relieved, a plier-like link, as shown in Figure 8, is used. For future reference we will

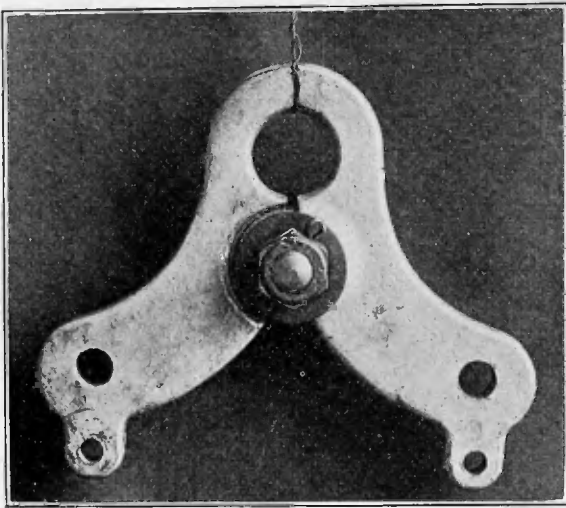

FIGURE 8—Device for Allowing a Wire that Has Been Automatically Released to, Fall from Several Suspension Points

call this link a "plyotrip." The angle of pull-off on this "plyotrip" is such as to keep the jaws tightly closed as long as the cable is in tension. As soon as the tension is relieved, and consequently the angle of pull changed, the jaws open allowing the cable to drop from its suspension points. As one of these "plyotrips" is used at each suspension point, they all release consecutively, allowing the whole cable to drop. In order to install the "plyotrips" it was necessary to have the antenna wires of each span attached to the "plyotrips" by means of open sockets; this broke up the continuity of the wire and introduced a possible source of trouble due to bad contact thru the plyotrip. This, however, was overcome by bridging the plyotrip by means of a piece of flexible braid attached to each socket lug. Also as each antenna wire had to be connected to the condenser to allow the current to pass to a common bus and thence to ground, it was necessary

to connect each antenna wire to the condenser at the point of suspension also. Figure 9 shows the details for the attachment of the antenna wires to the plyotrip and also the electrical connections, which connect the two cable spans together and which connect the cable to the sleet-melting condenser. It also shows the connection from the other terminal of the condenser to the "I" beam buses.

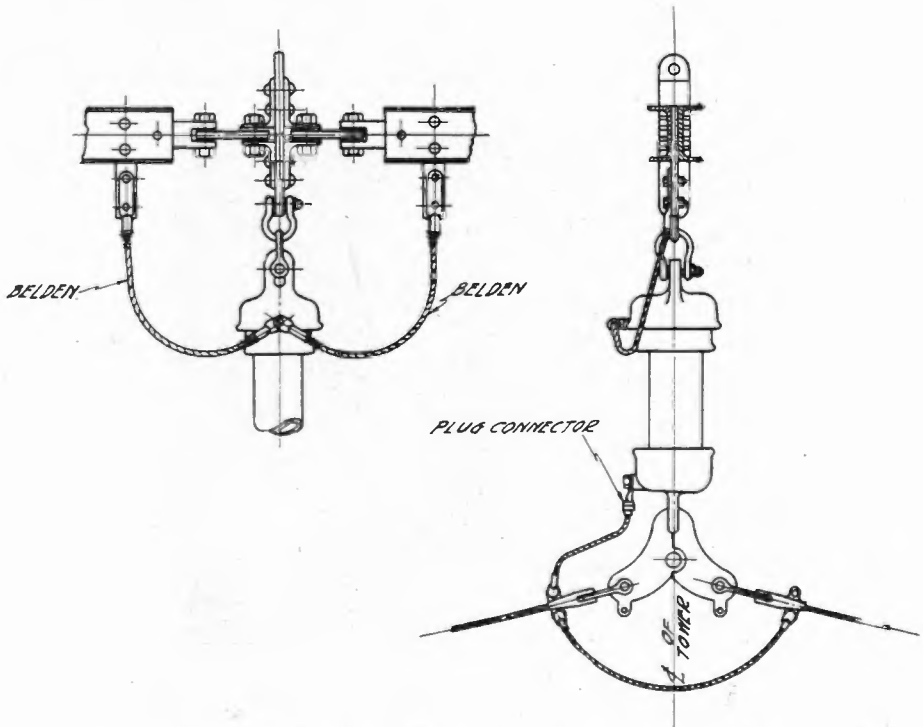

FIGURE 9—Shows Electrical and Mechanical Connections of Antenna Wires to Condenser-Insulator and Bus for Sleet-Melting Antennas.

The terminal which makes the connection to the condenser instead of being a lug is made in the form of a plug connector, shown in Figure 10. When the link releases, this plug pulls out and allows the cable to fall. If it were not for this plug connector it would be possible for the plyotrip to release and the braid connector take the weight, thus preventing the cable from falling. All these electrical connections are made of flexible copper braid and all lugs and terminal plugs are fitted with springs so as to prevent the braid breaking off at the point of attachment to the lugs due to vibration caused by wind.

Figure 11 shows the general assembly of six antenna cables on one-half of the bridge arm, and Figure 12 shows an actual photograph of the installation.

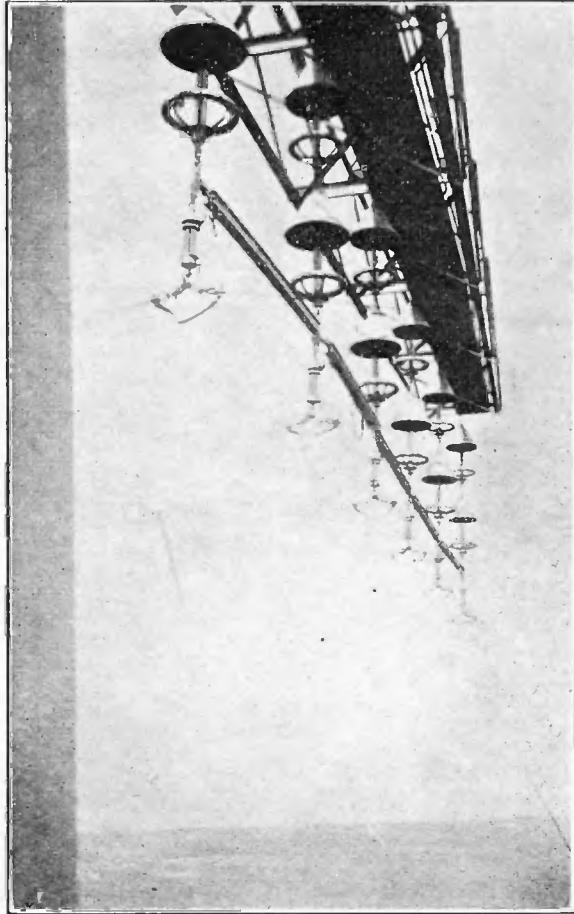

FIGURE 12—Photograph of the Assembly Shown in Figure 11 as Actually Installed.

Figure 13 shows the side elevation of the antenna and the points where the dynotrips and plyotrips are located in the system. It will be observed that the dynotrip is placed in the antenna cable at the far end of the antenna system. This is to facilitate operation. If an antenna cable drops, it is a simple matter to release this cable from its attachment at the power house end; retune the antenna by a variometer which is permanently installed in the antenna circuit to compensate for changes in antenna capacity due to heavy wind, decrease in sag, or reduction in number of wires, and continue operation, the whole procedure taking only a few minutes.

In order to protect the dynotrip from weather, it is enclosed in a canvas bag, a liberal coating of tallow being applied to the dynotrip and to the inside of the bag. This does not affect its operation as the canvas rips open when the "trip" operates.

Sleet melting is done from the 2300-volt, two-phase bus thru

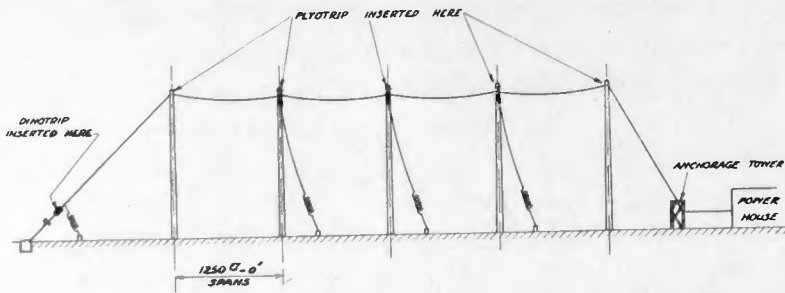

FIGURE 13—Elevation of Six-Tower Antenna System Showing Location of Dynotrip and Plyotrips.

auto-transformers which are used for controlling the voltage. A one-line diagram of the sleet-melting circuit is shown in Figure 15. By means of the push button switch on the control board the transformer switch at the sub-station is closed, putting the auto-transformers directly on the 2300-volt bus. The manually operated O. C. B. in the switch house is then closed, thus energiz-

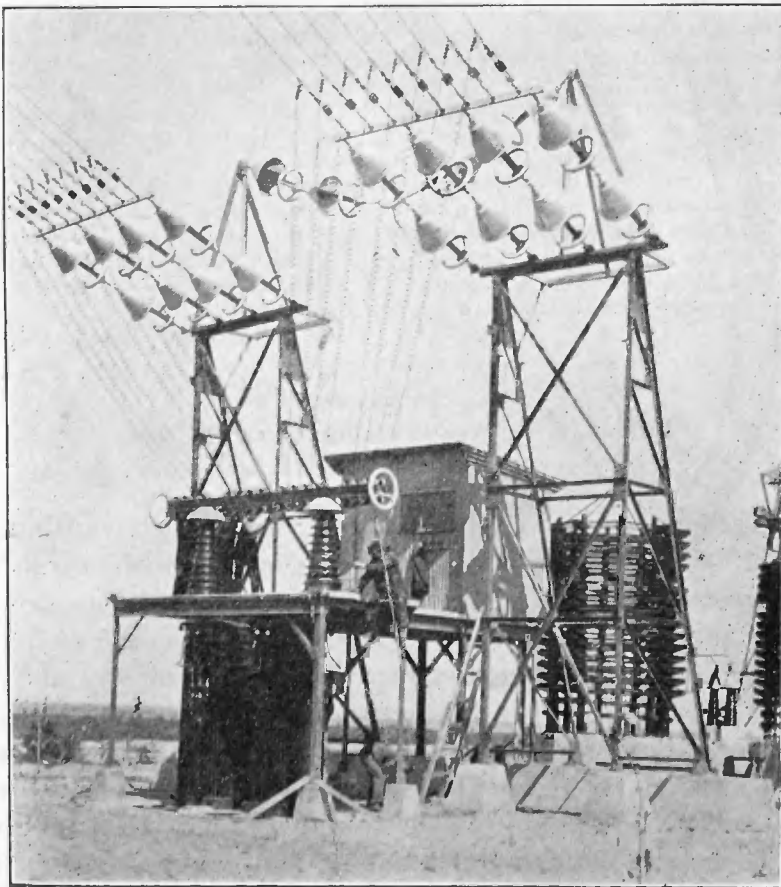

FIGURE 14—Antenna Dead End Structure, Showing Sleet-Melting Platform, Switch Rack, and Sleet-Melting Control House.

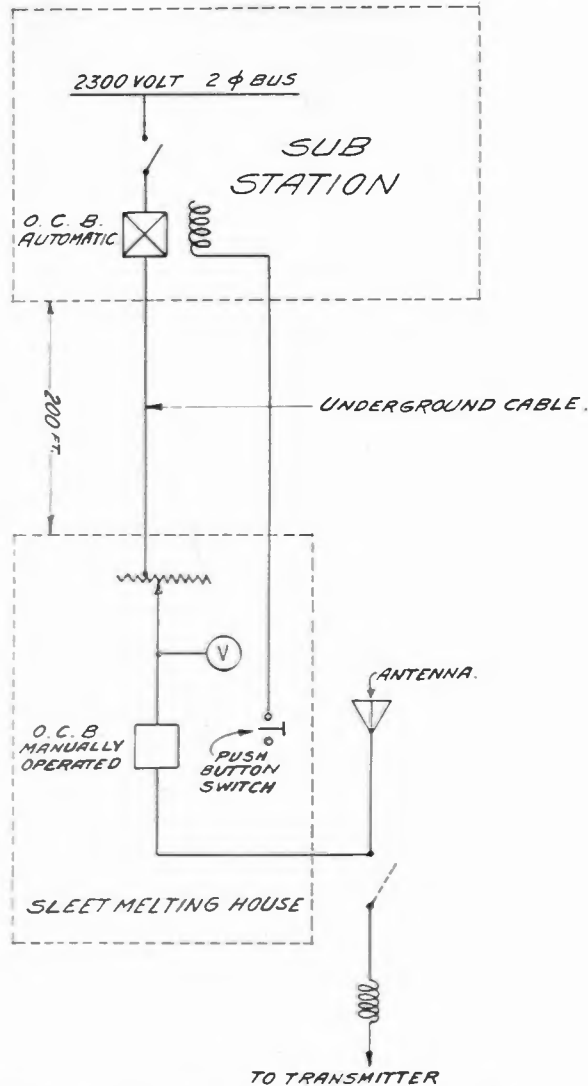

FIGURE 15—Schematic Wiring Diagram of Sleet-Melting Circuit.

ing the antenna wires. The transformer bank of two transformers is rated 500 kilovolt-amperes. They are provided with taps so that the secondary voltage can be varied from 1,000 volts up to 2,200 volts in steps of 200 volts. A total of four wires are melted at each operation. The current required is 300 amperes at 1,600 volts. Figure 14 shows the arrangement of the sleet-melting structure. The two steel towers are the dead-end anchorages for the antenna wires, eight wires being anchored to each tower. The wires are insulated from the towers by four sets of porcelain rods, each set comprising two hollow porcelain insulators, each fitted with rain and corona shields.

The two pedestal insulators on the platform support the sleet-

melting switches which are mounted on an "I" beam. Each wire is connected to a switch by means of a piece of wire formed into a spiral. This is to allow for movement due to wind so that no heavy strain will be put on the switches.

The auto-transformers can be seen underneath the platform. The small house on the platform houses the switching equipment and a telephone. The telephone giving communication to the power house is about 150 feet distant. When it is necessary to melt sleet the switches are opened up and the low frequency cables attached to the antenna side of the switch. One of the field tuning coils referred to earlier can be seen in the background.

It usually takes about five minutes to melt a $\frac{1}{4}$ -inch thickness of sleet from four wires so that on a twelve wire antenna the complete operation takes from twenty to twenty-five minutes from start to finish.

SUMMARY: A method is described for automatically releasing the antenna wires in case of excessive sleet load. Should the wires break under a heavy coating of ice, serious damage to the self-supporting towers would result, due to the unbalanced load. It also describes a new type of suspension condenser developed for the sole purpose of preventing the low frequency energy going to the ground and thus making it possible to melt sleet from the individual antenna wires of the multiple tuned antenna without the use and inconvenience of complicated switching at each ground point. The mechanical as well as the electrical design of this condenser is unique.

Further, it is believed that dynotrips and pliotrips can be adopted to power transmission lines in such a way as to prevent a big percentage of interruptions. These pieces of apparatus can be so arranged as automatically to introduce into the lines at intervals, additional lengths of conductor and thus increase the sag. It is expected that for long spans over canyons, these would be almost indispensable.

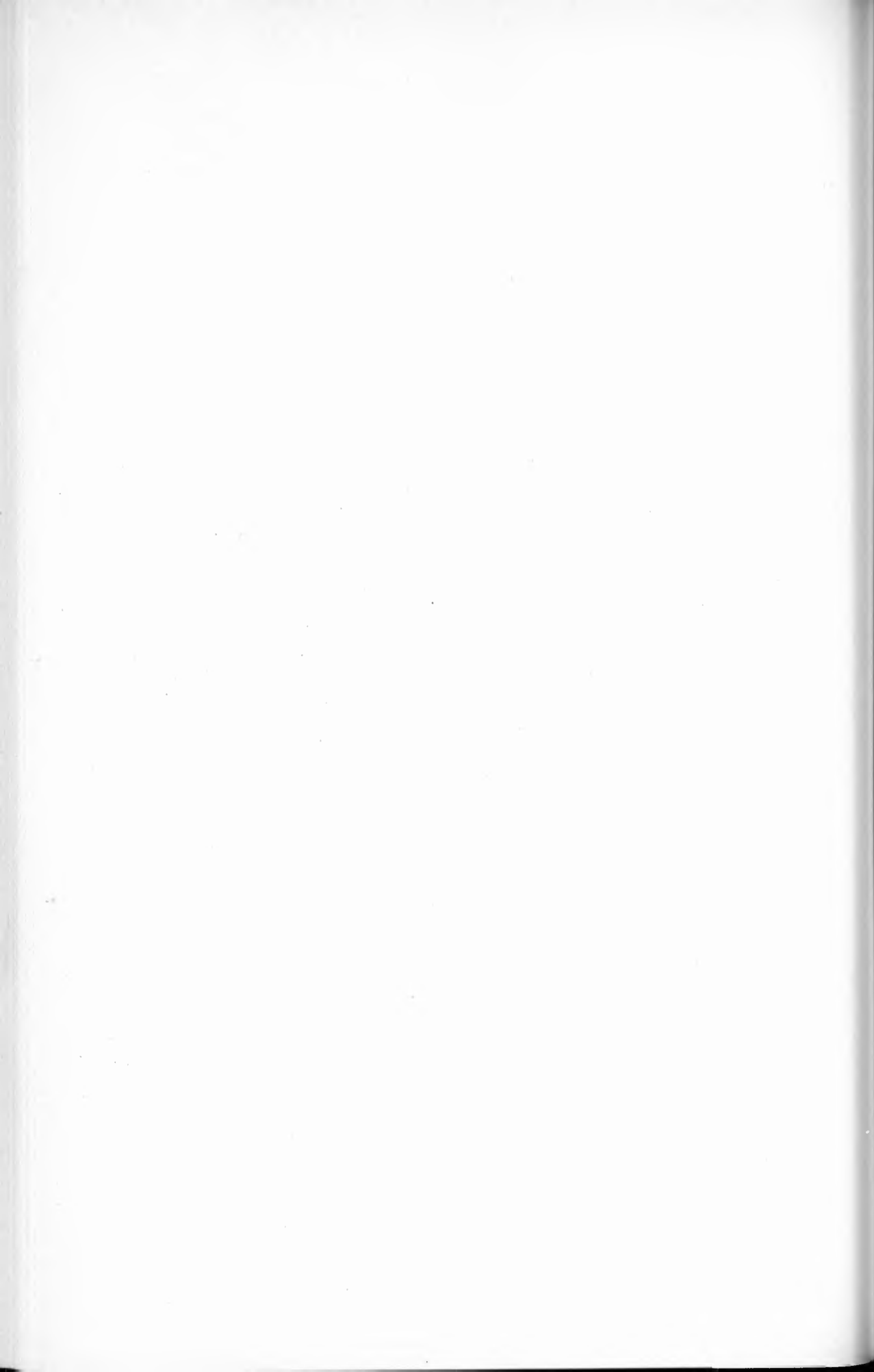

RECENT ADVANCES IN MARINE RADIO COMMUNICATION*

By

T. M. STEVENS

(RADIO CORPORATION OF AMERICA)

It is the purpose of this paper to outline, in a brief and non-technical manner, the progress made in Marine Radio Communication during the past few years.

It is not difficult for us to remember that only a short time ago the large passenger ships nearing our shores, or lying at quarantine, caused untold interference to radio telephone broadcasting while transmitting hundreds of radiograms to coastal stations. Indeed, the coastal stations themselves caused interference to almost the same extent in sending radiograms to ships, or in acknowledging those received.

After the termination of the World War, the Naval Communication Service, which at that time operated practically all coastal stations in the United States, was severely pressed for competent radio personnel due to demobilization. It was necessary to close many shore stations due to personnel shortage in order to man the fleets, compass stations, and, so far as the Navy was concerned, the more important strategical stations on land.

In the early summer of 1920 one of the larger radio companies found it necessary to establish a system of coastal stations in order to render prompt and efficient public radio telegraphic service. 2-kw. spark transmitters were installed at New York and Cape Cod. Other spark stations were then or about to be placed in service at Cape May, N. J., Babylon, L. I., Brooklyn, New London, Newport, Siasconset, Boston, and Bar Harbor. Shortly afterward, spark stations were established at East Hampton, L. I. and Rockland, Maine. Thus, we see there were no less than 12 spark stations in operation along the coast from Cape May to Bar Harbor. All were operating on only two wave-lengths, viz: 600 and 450 meters. Approximately 90 per cent of the traffic to and from ships was handled on these waves.

*Received by the Editor, November 16, 1925. Presented before THE INSTITUTE OF RADIO ENGINEERS, New York, November 4, 1925.

Imagine the interference to the marine radio telegraph service caused by so many stations.



Tuning House at End of Transmission Line, Located 1,400 Feet from the Transmitter in Power House, Tuckerton, N. J.

About this time broadcasting came to us. Fortunate, indeed, was it that vacuum tube radio telegraph transmitters made their appearance simultaneously. The first vacuum tube transmitter for commercial telegraph use in the United States was installed at Marion, Mass. (WCC). It was operated on 2,200 meters, distantly controlled from the receiving station at Chatham. A few of the transatlantic passenger vessels were by this time equipped with either arc or tube transmitting attachments. The shipboard operators, as well as those at Chatham, were astounded at the remarkable distances covered with the tube sets. The larger ships began to use the long wave channel almost exclusively for their traffic, and it became necessary to provide additional channels at the Chatham station. The shipboard transmitter could be quickly shifted from 2,100 meters (the

usual calling wave used by ships) to 2,000, 1,900, 1,800 meters, etc. Thus, Chatham could receive from three ships and transmit to a fourth vessel at one and the same time.

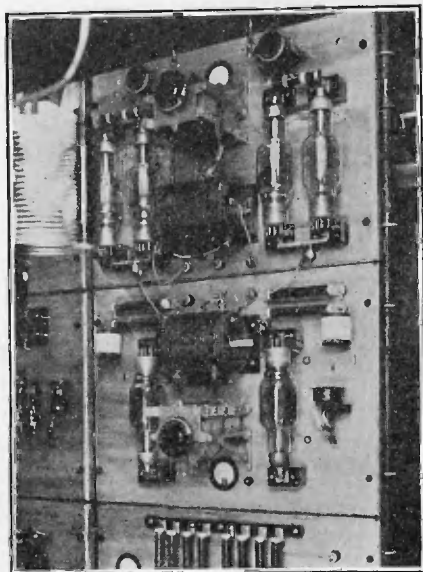

Master Oscillator and Intermediate Amplifier—Short Wave CW Set, San Francisco, Cal.

The use of CW vacuum tube transmitters not only increased the range of marine communication, but greatly facilitated the movement of traffic due to the possibilities of multiplex operation, and, by the removal of heavy loads from the shorter wave-lengths, aided the smaller ships in moving their traffic.

The increased range also resulted in making unnecessary the further operation of numerous stations along the Atlantic Coast. The Bar Harbor station practically ceased commercial activities; stations at Rockland, Me., Newport, Siasconset, New London, Babylon, and Cape May were closed.

As the radio broadcasting activities rapidly expanded, the elimination of spark stations on land was pushed with all possible speed. The Bush Terminal 5-kw spark gave way to a tube transmitter. To the Chatham station were added two 5-kw long wave transmitters and two short wave sets. The Tuckerton station, replacing Cape May, used a 5-kw transmitter. A 1-kw set replaced the 5-kw spark at Boston. The same type of set replaced spark equipment at Galveston. Apparatus similar to that at Chatham replaced spark sets at San Francisco, and a special CW set was installed at Los Angeles. The Chicago

coastal station has tube equipment similar to that at Galveston and New York. The company with which the writer is connected has no spark equipment in use at its coastal stations.

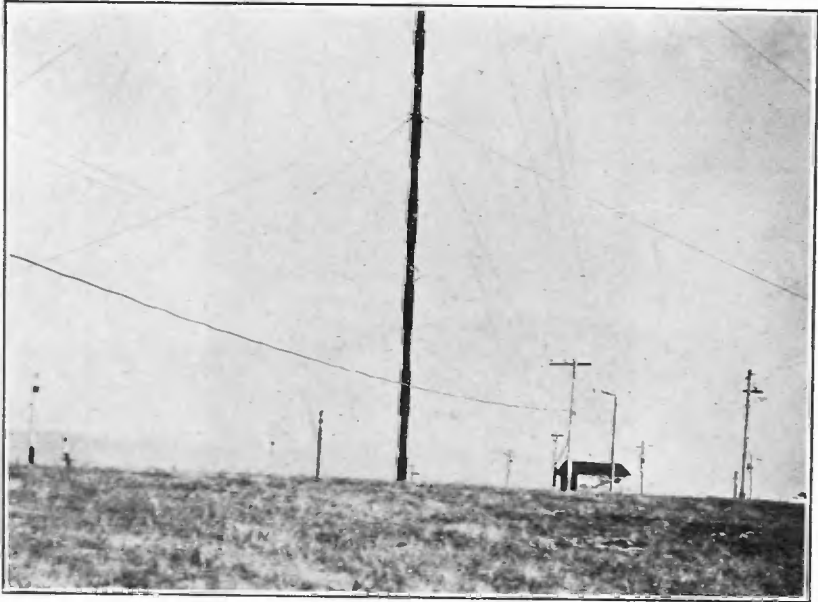

Tuning House and Transmission Line, San Francisco, Cal.

Although the apparatus used for transmitting was developed at the time of the Cape Cod installation, it was found that it suited the purpose without any changes. However, when the demand came to provide similar equipment at other stations, numerous improvements were made in the design tending toward simplicity and efficiency in operation. It was found feasible and advisable to use a power transmission line which made possible the installation of the transmitting apparatus in the main power house of the station, while at the same time erecting the antenna in the most desirable location. In the case of Chatham the antenna is about 800 feet distant from the transmitter. At Tuckerton the antenna and the transmitter are separated by about 1,400 feet. A novel control scheme was worked out whereby the operator at the receiving station could have complete and instant control of the transmitter through the use of only one control wire with ground return. The operator can start the transmitter, change wave-lengths, select CW or ICW signals, and carry on telegraphic transmission, all on this single wire control.

The operation of coastal stations using the vacuum tube type of CW and ICW transmitters does not cause interference to

broadcast reception. Therefore, the bulk of the nation's marine communication between ship and shore is now carried on without

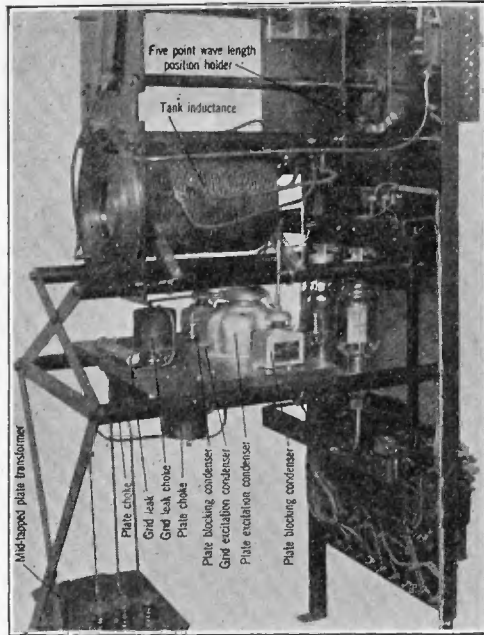
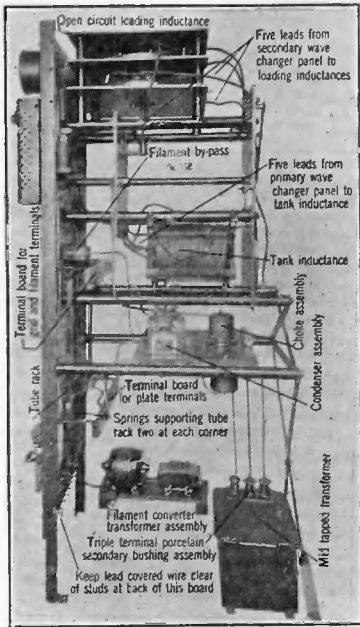

Views of Two-Kw., 500-Cycle Spark Set After Conversion into a Vacuum Tube Transmitter. Right Hand View Shows Condenser and Inductance Arrangement

Several hundred sets of this type of transmitter are being converted for shipboard use

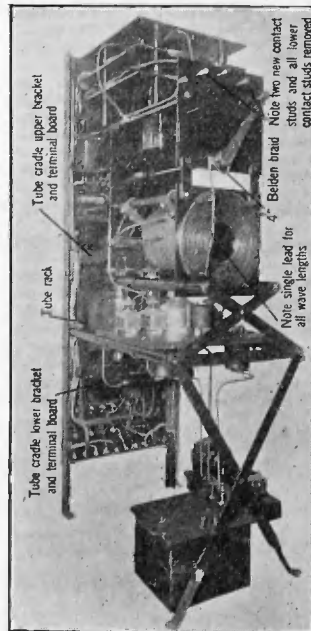
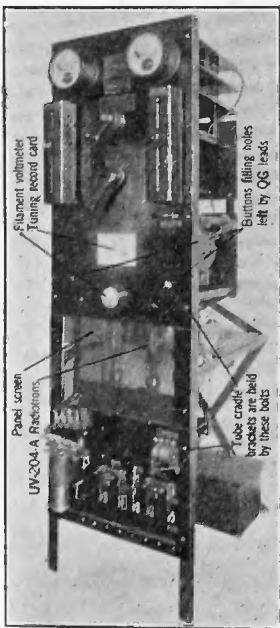

Front and Rear Views of 500-Cycle Spark Set After Conversion to a Vacuum Tube Transmitter

disturbing broadcast listeners. European countries are rapidly adopting vacuum tube equipment for coastal stations and a number of countries have sent their engineers and traffic experts to this country to get first-hand information on the type of equipment used in American stations, its general arrangement and operating procedure.

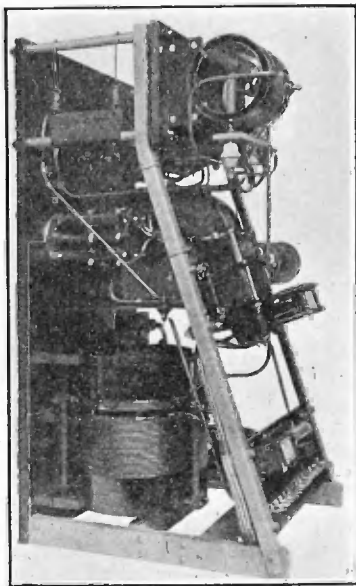
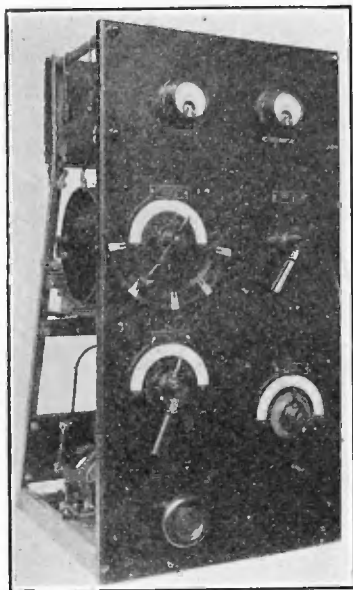

Front and Side Views of 200-Watt CW-ICW Transmitter, Model ET-3627—Wavelength Range 600-960 Meters

The vacuum tube type of apparatus having proven its superiority in the marine field, is now rapidly replacing sets of the spark type not only on land but aboard ship. Several types of tube transmitters have been designed specially for ship installations, ranging in power from 200 watts in the antenna to 6 kilowatts. A 200-watt set on a ship of average size has a daylight range of from 400 to 600 miles under normal conditions, with a night range of about 1,500 miles. Another type of transmitter delivers 500/750 watts to the antenna, giving a daylight range of at least 1,000 miles under normal circumstances, with much greater range during the hours of darkness.

The 200-watt set is usually adjusted to the following five wave-lengths: 600, 706, 750, 800 and 900 meters. The 750-watt set is usually adjusted to ten wave-lengths, including the five above mentioned and the following five wave-lengths: 1,800, 1,900, 2,000, 2,100, and 2,400 meters.

Radio telephone service is made readily available with appa-

ratus of the newer type through simple addition of a telephone attachment containing necessary modulating tubes, microphones, etc.

Another recent important development makes it possible to convert standard types of spark transmitters into ICW tube transmitters. It has been found that the waves emitted from such a transmitter compare favorably with pure CW. The range of the spark transmitter thus converted is improved practically 100 per cent.

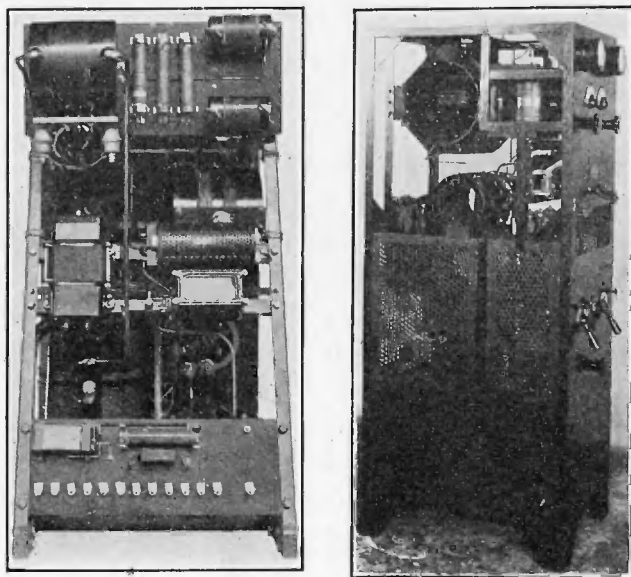

Left: Rear View of 200-Watt CW-ICW Transmitter.
Right: Side View of 500/700-Watt CW-ICW Transmitter, Model ET 3626—Wavelength Range 600-2500 Meters

The transmitters on approximately 300 American vessels are being rapidly converted in this manner. This is bound to have a beneficial effect in the elimination of spark interference, as well as in an economic way, for the reason that the spark transmitters now five or six years old are being modernized.

Needless to say, the progress in the reception of signals has kept pace with the developments of the transmitter. Coastal stations have been provided with wave antennas, super-selective and super-sensitive receivers, and with automatic high-speed recording devices.

During the past year, remarkable progress has been made in eliminating spark interference caused by marine radio communication, not only by commercial interests but by the Army, Navy, and Coast Guard.

SUMMARY: It will be seen that the development and use of vacuum tube apparatus by commercial and government stations has not only doubled the range of marine communications, but at the same time has made it possible to carry on a more extensive service with a far smaller number of corresponding stations on shore.

Due to the much sharper waves emitted by vacuum tube transmitters, a greater number of channels have been opened for marine communications, which has resulted in the development of multiplex stations where marine activities are concentrated.

Discontinuance of the use of spark apparatus at coast stations, and to a large extent on shipboard, has almost totally eliminated the interference formerly caused by spark stations.

THE POLARIZATION OF RADIO WAVES*

By

GREENLEAF W. PICKARD

(CONSULTING ENGINEER, THE WIRELESS SPECIALTY APPARATUS COMPANY,
BOSTON, MASSACHUSETTS)

(*Communication from the International Union of Scientific Radio
Telegraphy*)

In the ordinary practice of radio communication, vertical currents at the transmitter set up vertically plane polarized¹ waves, which are received at distant points on vertical conductors. It has been assumed from the inception of this art that if the wave was vertically plane polarized at its origin, it would remain so at all distances, and the measurements of Austin² confirmed this for the low frequencies employed in trans-oceanic working. Later, Smith-Rose and Barfield³ made similar measurements, extending the frequency range investigated up to 677 kilocycles, and finding, as did Austin at the lower frequencies, that the waves at the receiving point were always substantially vertically plane polarized.

These prior measurements did not cover the upper portion of the frequency band now used in radio communication, and dealt only with waves which were vertically plane polarized at their origin, so that two questions were left unanswered. If the waves left the transmitter vertically polarized, but if the transmission frequency were materially higher than any measured in the past, would they also remain vertical at all distances? And if the waves left the transmitter horizontally polarized, would they remain so at all distances?

The apparatus employed by my predecessors consisted of an ungrounded, linear Hertzian resonator, universally mounted and

*Received by the Editor, October 28, 1925. Presented at the Annual Convention, January 18, 1926, INSTITUTE OF RADIO ENGINEERS, New York;

¹In this paper the plane of polarization is taken as the direction of electric force in the wave-front; optical terminology is still disfigured by placing these at right-angles.

²L. W. Austin. "The Wave-Front Angle in Radio-telegraphy," Washington Acad. Sci., J. II. pp. 101-106, March 4, 1921.

³R. L. Smith-Rose and R. H. Barfield. "On the Determination of the Directions of the Forces in Wireless Waves at the Earth's Surface." Roy. Soc. Proc. 107, pp. 587-601, March 2, 1925.

with the receiving apparatus coupled to its center. For the measurements described in this paper, I used the same system, with the addition of a partial ground at the center of the resonator circuit, which not only determined a potential node at this point but made possible a second directional determination.

It must be borne in mind when such measurements are made near the surface of the earth, and a portion or all of the wave under investigation is coming slantingly down upon the receiving point, that some of the wave is reflected by the ground, particularly at the lower frequencies. Therefore, save for slight differential effects, such apparatus gives merely a measure of the resultant electric force from both the incident and the reflected rays. It is, therefore, difficult to determine whether the wave reaches the receiving point along a horizontal or an inclined path, and, equally, it is difficult to determine the true angle of polarization in the incident ray. For example, if an incident wave came down at an angle of 45 degrees, with the electric vector at 30 degrees with the vertical, the resultant observed by the resonator would be a maximum electric force along a true vertical, and a minimum along a horizontal line at right angles with the bearing of the distant transmitter, having an amplitude half that of the vertical. A true determination of the electric forces in the incident ray might be made at very high frequencies over high resistance ground, or, better still, the apparatus could be taken up a kilometer or two by an airship.

For the measurements about to be described, I selected a site on the flats back of Seabrook Beach, New Hampshire, well away from all obstructions, particularly overhead wires, which I assumed would absorb any horizontal component that might be present. Here a wooden tower was erected, and on top of this tower, at a height above ground of seven meters, was mounted a universal joint carrying a linear Hertzian resonator, consisting of a single wire eight meters long. This wire could be freely rotated about both horizontal and vertical axes, and was broken at its center by an insulator, with short leads running to an inductance with parallel connected condenser. The amplifier and observer were also placed near the center of the resonator, to avoid pick-ups other than by the resonator wire. The tower and the dispositions of apparatus on top is shown in Figures 1 and 2.

As with a direction-finding loop, I found it necessary to avoid the disturbing effects of unsymmetrical capacities from the wings of the resonator to surrounding objects, including, of course, the

amplifier and the observer. After some experiment I found a simple means of eliminating these undesired effects, which consisted in connecting the exact center of the resonator system to both the metal support on top of the tower and the filament battery of the amplifier. This is electrically similar to the grounding of the mid-point of a direction finder loop⁴ in that it determined a potential node at the center of the system, and greatly sharpened the indications. Another effect of this partial ground was to give the system marked directional properties in a hori-



FIGURE 1

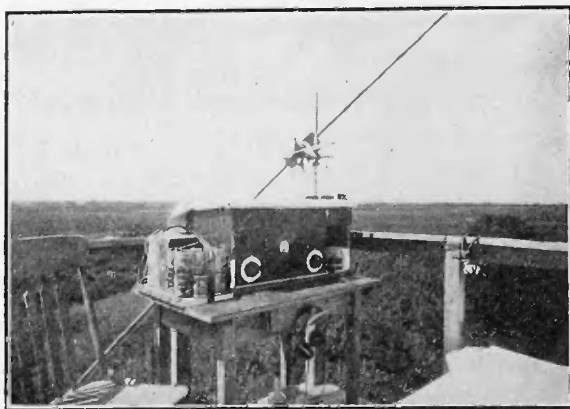

FIGURE 2

zontal plane. Unless the currents flowing to this ground are in phase, which can only be when the wire is parallel to the wave-front, a signal will be produced.

A superheterodyne amplifier, having two stages of intermediate (40 kilocycle) amplification, and one stage of audio frequency following the second detector, was employed in all of the measurements. In addition to the normal superheterodyne oscillator, which operated at input frequency plus or minus 40 kilocycles, a second oscillator was used, coupled into the second detector, and operating at a fixed frequency of 41 kilocycles. This produced an audio frequency beat with any intermediate frequency current which might be produced, and greatly increased the intensity of the signal. The voltage amplification of this receiver, from the grid of the first detector to the grid of the second, was 160, altho the measured amplification of the two intermediate frequency stages was 1,200. This appears to be the normal performance of the superheterodyne, in which a loss of from five to ten-fold occurs in the frequency conversion. The

⁴E. Bellini. "Un Nouveau Radiogoniometer avec Levée du Doute." *L'Onde Electrique*, No. 29, May, 1923, page 241.

elementary electrical circuit of the Seabrook Analyzer Station is shown in Figure 3.

As most of the stations measured were working in code, galvanometer readings could not be taken, and audibility measurements were used thruout. These readings are very nearly proportional to the squares of the electric fields involved, so that in reducing my observations I simply took the square root of the audibility ratios.

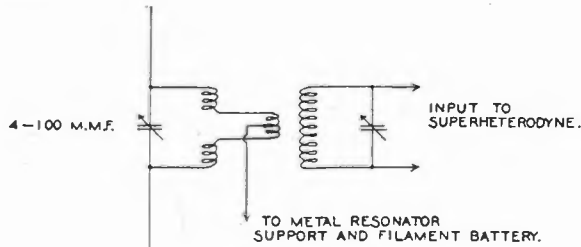

FIGURE 3

In the day time, and for all frequencies under one or two megacycles, the maximum signal was obtained with the resonator vertical. Rotating the resonator about a horizontal axis, the signal decreased, a minimum being obtained when the wire was horizontal. Rotating the now horizontal wire about a vertical axis, the signal passed thru two nulls, 180 degrees apart and with the wire exactly at right angles to the line of propagation. When the wire was set on either of these nulls, a rotation about the horizontal axis of less than one degree, and about the vertical axis of about four degrees, sufficed to bring the signal in again.

In the middle of the day, similar readings were obtained from station 2XK at Schenectady, operating at 2.75 megacycles, altho the null was obtained when the wire was placed in a N-S line, and 24 degrees from the horizontal. Schenectady lies nearly due west from Seabrook, at a distance of 250 kilometers, so this measurement indicates that altho the waves arrived at Seabrook with their front at right angles to the bearing of the transmitter, the electric force was inclined 24 degrees from the vertical. Altho several amateur stations at approximately the same distance and time of day were measured, operating at frequencies from two to four megacycles, no such tilt of the electric force was found, the nulls occurring within a few degrees of the horizontal in all cases; this effect, so far as my observations went, seems to be peculiar to reception from Schenectady.

During the month of August, 1925, and principally in the period from one hour before to two hours after sunset at the

receiving point, over 1,300 measurements of 379 stations were made. Most of these stations were operating on the two amateur bands of 3.5 to 4.0 and 7 to 8 megacycles, and the majority were within a 2,000-kilometer radius of Seabrook, altho a few European stations, and one South African amateur, were picked up and measured. All of these stations (with the exception of some special transmission from Schenectady) were of the antenna-ground or antenna-counterpoise type, operating either at the fundamental or a harmonic, so that the wave left the transmitter vertically plane polarized. In the tabulation following the more important results of this measurement are given.

It will be seen from the following table that the principal factors affecting the ratio of horizontal to vertical electric force are time of day, transmission frequency and distance. For frequencies over about three megacycles, night conditions begin over an hour before receiving point sunset, and altho my data on this point are rather meagre, last until over an hour after sunrise. In the two large groups of amateur stations working in the frequency bands of 3.5-4.0 and 7-8 megacycles, a marked maximum of horizontal force occurs between 200 and 300 kilometers. An ill-defined minimum is then found between 500 and 1,000 kilometers, and following this a slight rise begins. My few measurements of European stations working in these bands gave horizontal-vertical ratios of two and three, respectively.

The amateur stations measured in the United States and Canada subtended at Seabrook an angle of 210 degrees, and if the Cuban and Porto Rican stations are included, an angle of 240 degrees. This gives abundant material for an analysis with respect to direction, that is, with respect to the magnetic meridian. I have made this analysis for the frequency bands of 3.5-4 and 7-8 megacycles, but with entirely negative results; transmission direction with respect to the magnetic meridian does not appear to be a factor determining the ratio of horizontal to vertical electric force.

The answer to the first question is, therefore, that transmission frequencies measured in megacycles do not, like the lower frequencies, arrive at a distant receiving point vertically plane polarized.

A partial answer to the second question came early in 1925, when I found that radiation at 790 kilocycles from an elevated horizontal doublet at Schenectady was received on a symmetrical T antenna and ground at Newton Centre, with approximately the same intensity as if it had proceeded from a conventional

vertical antenna. Measurements made by me in September, 1925, with a more precise apparatus than a T antenna and ground have confirmed this observation, and will be described below.

Station	Place	Distance Kilo- meters	Time of Day 75th Mer.	Frequency Megacycles	Horiz- ontal Electric Force	Vertical Electric Force	Number of Measure- ments
WEEI	Boston, Mass.	50	9 A.M.—3 P.M.	0.62	0.0	100.0	3
WEEI	Boston, Mass.	50	5 P.M.—9 P.M.	0.62	1.0	50.0	11
WGY	Schenectady, N. Y.	250	9 A.M.—3 P.M.	0.79	0.0	100.0	5
WGY	Schenectady, N. Y.	250	5 P.M.—9 P.M.	0.79	1.0	30.0	8
WNAC	Boston, Mass.	50	9 A.M.—3 P.M.	1.07	0.0	100.0	10
WNAC	Boston, Mass.	50	5 P.M.—9 P.M.	1.07	1.0	20.0	134
Coast Guard Ships (1)		?	5 P.M.—9 P.M.	2.1	1.0	10.0	7
2XK	Schenectady, N. Y. (2) ...	250	9 A.M.—3 P.M.	2.75	0.0	100.0	8
2XK	Schenectady, N. Y. (2) ...	250	5 P.M.—9 P.M.	2.75	1.0	1.1	14
Amateur Stations (3).....		30	5 P.M.—9 P.M.	3.5—4.0	1.0	1.3	13
Amateur Stations (3).....		62	5 P.M.—9 P.M.	3.5—4.0	2.0	1.0	32
Amateur Stations (3).....		90	5 P.M.—9 P.M.	3.5—4.0	2.1	1.0	27
Amateur Stations (3).....		154	5 P.M.—9 P.M.	3.5—4.0	2.3	1.0	38
Amateur Stations (3).....		205	5 P.M.—9 P.M.	3.5—4.0	2.3	1.0	32
Amateur Stations (3).....		290	5 P.M.—9 P.M.	3.5—4.0	2.4	1.0	14
Amateur Stations (3).....		350	5 P.M.—9 P.M.	3.5—4.0	1.6	1.0	84
Amateur Stations (3).....		542	5 P.M.—9 P.M.	3.5—4.0	1.4	1.0	65
Amateur Stations (3).....		1050	5 P.M.—9 P.M.	3.5—4.0	1.5	1.0	12
WBZ	Springfield, Mass. (4)....	170	5 P.M.—9 P.M.	3.6	2.7	1.0	13
WIR	New Brunswick, N. J.	450	5 P.M.—9 P.M.	4.1	1.3	1.0	30
WQN	New Brunswick, N. J.	450	5 P.M.—9 P.M.	5.5	1.5	1.0	21
WIZ	New Brunswick, N. J.	450	5 P.M.—9 P.M.	7.0	3.0	1.0	29
Amateur Stations (3).....		58	5 P.M.—9 P.M.	7.0—8.0	4.0	1.0	12
Amateur Stations (3).....		115	5 P.M.—9 P.M.	7.0—8.0	4.5	1.0	19
Amateur Stations (3).....		219	5 P.M.—9 P.M.	7.0—8.0	5.0	1.0	18
Amateur Stations (3).....		337	5 P.M.—9 P.M.	7.0—8.0	3.9	1.0	103
Amateur Stations (3).....		547	5 P.M.—9 P.M.	7.0—8.0	3.1	1.0	115
Amateur Stations (3).....		1000	5 P.M.—9 P.M.	7.0—8.0	1.7	1.0	28
Amateur Stations (3).....		1610	5 P.M.—9 P.M.	7.0—8.0	1.8	1.0	35
2XAF	Schenectady, N. Y.	250	5 P.M.—9 P.M.	7.4	3.4	1.0	9
NKF	Washington, D. C.	700	5 P.M.—9 P.M.	7.5	2.4	1.0	7
WBBM	Chicago, Ill. (5)	1300	5 P.M.—9 P.M.	8.0	4.0	1.0	3
WIR	New Brunswick, N. J. (6) .	450	5 P.M.—9 P.M.	8.3	4.5	1.0	18
AGA	Nauen, Germany.....	6400	5 P.M.—9 P.M.	11.5	2.0	1.0	7

(1) Coast Guard stations rarely sign or give position.

(2) Electric vector not vertical, but tilted 24 degrees toward the south.

(3) United States and Canada only.

(4) Third harmonic radiation.

(5) Fifth harmonic radiation.

(6) First harmonic radiation.

On the morning of September 1, 1925, measurements of horizontally polarized radiation were made at the broadcasting frequency of 790 kilocycles. The transmitter was located at Schenectady, and consisted of a horizontal doublet running north 30 degrees west, at an elevation of 90 meters. Tone modulation was impressed upon the carrier wave, and the test covered the period from 12.01 to 1.00 A. M. As measured at Seabrook, with

readings taken every minute, the plane of polarization was predominantly vertical, the average vertical horizontal ratio for the entire period being 10.1. A very considerable variation in the ratio took place from minute to minute, as will be seen from a portion of the log for that period.

Time	Vertical	Horizontal	
12.32 A.M.	10	1	
12.33 A.M.	3	1	
12.34 A.M.	5	1	
12.35 A.M.	10	1	
12.36 A.M.	50	1	Maximum ratio obtained
12.37 A.M.	20	1	
12.38 A.M.	5	1	
12.39 A.M.	2	1	Minimum ratio obtained
12.40 A.M.	5	1	
12.41 A.M.	30	1	

The usual fading occurred during this transmission, but it was very noticeable that at times of low vertical intensity the horizontal component did not decrease in the same proportion; in other words, the amplitude of the fading fluctuations was distinctly less with horizontal than with vertical reception. The tone modulation, however, was less distorted at all times on vertical reception, being distinctly mushy when the resonator wire was horizontal.

With the resonator wire horizontal, rotation around the vertical axis would frequently—every three or four minutes—show nearly absolute nulls 180 degrees apart, and with the wire in a SW-NE line. The maximum horizontal signal was always obtained with the wire in a NW-SE line. As Schenectady is nearly due west from Seabrook, these results show a distortion of wave-front amounting to 45 degrees.

On the evening of September 2, 1925, a similar test was made with Schenectady, using a frequency of 3.75 megacycles. This schedule, which covered the period from 6 to 9 P. M., consisted of alternate ten-minute transmissions from vertical and horizontal doublets, and at Seabrook readings were taken every minute. The horizontal electric vector was found to be over twice as large as the vertical, regardless of whether the transmission was horizontally or vertically polarized. For the entire period, the aver-

age horizontal/vertical ratio for vertical transmission was 2.15:1, while for horizontal radiation the average ratio was 2.16:1; that is, they were substantially identical.

Measurements of static were also made every evening during August, 1925, at several frequencies. In the broadcasting band the static was from 90 to 95 per cent vertical. At three megacycles the vertical/horizontal ratio was about 3:1, while at 7.5 megacycles the vertical and horizontal intensities were nearly equal. A few measurements made at 15 megacycles showed no further increase in the horizontal component.

My findings at Seabrook may be summed up as follows: Under night conditions for frequencies above three megacycles, and for distances over 50 kilometers the electric field at the receiving point is predominantly horizontal. The ratio of the horizontal to the vertical electrical component is determined solely by the transmission frequency and the distance, and is independent of both the direction of transmission and whether the wave left the transmitter horizontally or vertically polarized.

For frequencies above three megacycles, there is a real advantage in horizontal reception. Not only is the electric field and hence the signal stronger, but the signal/stray ratio is markedly improved, because the horizontal component of the static does not increase so rapidly with frequency as does that of the signal. The advantage of horizontal reception is greatest for code working; for radiophone reception the increased audio frequency fading distortion partially offsets the gain in signal/stray ratio.

SUMMARY: Prior measurements of wave polarization made at the lower transmission frequencies have uniformly shown vertical electric force at all distances from the transmitter. The present work extends such measurements to the higher frequencies, where it was found that the electric force at any considerable distance from the transmitter was no longer vertical, but, instead, predominantly horizontal. Comparative measurements were also made of radiation alternately horizontally and vertically polarized at the source, which indicated that the ratio of horizontal to vertical electric field depended only upon the frequency, distance and time of day, being substantially independent of the plane of polarization at the transmitter.

A METHOD OF CALIBRATING A LOW-FREQUENCY GENERATOR WITH A ONE-FREQUENCY SOURCE*

BY
SYLVAN HARRIS

(MANAGING EDITOR, RADIO NEWS)

The object of this paper is to present a simple method of calibrating a generator of low-frequency oscillations with a single-frequency source of oscillations, such as a 1000-cycle carbon contact tuning-fork. It is often required to calibrate such a generator, or to check previous calibrations, so that the author believes that a simple and accurate method will be welcomed by the many who do not wish to invest in the special and expensive apparatus generally used for this purpose.

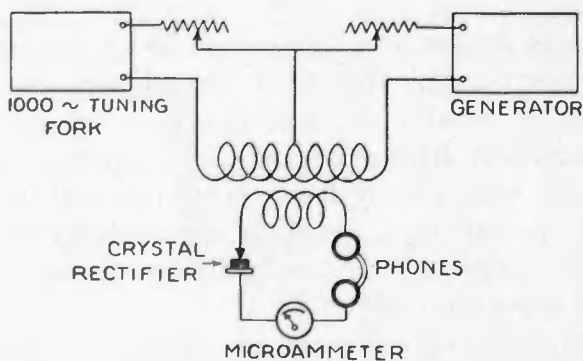

FIGURE 1

The tuning-fork and the low-frequency generator are both rich in harmonics, and the method makes direct use of these. The schematic set-up is shown in the illustration. The outputs of the generator and tuning-fork are combined in the transformer indicated (which is the ordinary transformer used in push-pull amplifiers), the secondary of which is in series with a crystal receiver, microammeter and telephone receivers. In the output leads of the generator and tuning-fork are resistances, which can be varied in order to adjust the outputs to the same order of magnitude. The reason for this is that, if the output

* Received by the Editor, December 30, 1925.

of the one is much greater than that of the other, the first is likely to mask the second, so that there will be no indication of beats in the microammeter or phones.

The presence of beats is indicated by a swaying of the microammeter needle, but, due to the sluggishness of the moving system of the meter, it is often difficult to detect the beats as they come into the audible range. For this reason the phones are included. It is not well to rely wholly on the phones, however, on account of aural fatigue.

Now let

a be the order of the tuning-fork harmonic

b be the order of the generator harmonic

f be the frequency of the generator, and

f_t be the frequency (fundamental) of the tuning-fork.

Then, the condition for exact resonance between the frequencies of the tuning-fork and the generator is expressed by

$$a f_t = b f$$

or,

$$f = \frac{a}{b} f_t$$

When the generator and tuning-fork are in operation, there will be, in general, a deflection of the microammeter needle, and two tones will be heard in the telephone receivers, corresponding to the fundamental frequencies of the generator and tuning-fork. No beats will be in evidence, however, until the condition expressed by the equation above is approached; the beat frequency will, in general, be above audibility, or too high for the needle of the meter to follow.

As the condition of resonance is approached, beats will be heard in the phones, and the meter needle will oscillate up and down, attaining its maximum amplitude of vibration, and greatest period, when exact syntony is attained. Theoretically, the needle should remain motionless at exact resonance, at a certain constant deflection which depends upon the phase relations, but such exact resonance is difficult to attain. It is often possible, however, to obtain a period of vibration of the needle of several minutes, and a very accurate adjustment can be obtained by noting the generator condenser values which give equal periods of vibration of the needle on either side of the position of zero beat. The value of the capacity for the zero beat condition can then be obtained as follows:

Let f_b be the beat frequency

c_0 be the capacity corresponding to zero beat condition,

c_1 be the capacity corresponding to the beat frequency, f_b , when $af_t > bf$,

c_2 be the capacity corresponding to the beat frequency, f_b , when $bf > af_t$,

$$af_t - bf = f_b$$

Substituting in this the relations for exact resonance, i.e.,

$$f_t = \frac{b}{a}f = \frac{b}{a} \frac{k}{\sqrt{c_o}}$$

we obtain

$$\frac{1}{\sqrt{c_o}} - \frac{1}{\sqrt{c_1}} = f_b$$

This relation holds when af_t is greater than bf . If the capacity is for an equal beat frequency on the other side of zero beat, we have

$$\frac{1}{\sqrt{c_2}} - \frac{1}{\sqrt{c_o}} = f_b$$

Equating these two expressions and reducing, we obtain

$$c_o = \frac{4 c_1 c_2}{(\sqrt{c_1} + \sqrt{c_2})^2}$$

This expression is rather cumbersome for ordinary use; a simpler expression is obtained by expressing the numerator as $2(c_1 + c_2)^2 - 2(c_2^2 + c_1^2)$. Then substitute $(c_1 + x)$ for c_2 in the last term of this expression, expand the latter and drop the second power of x . Then

$$4 c_1 c_2 = 2(c_2 + c_2)^2 - 4 c_1 c_2,$$

whence

$$4 c_1 c_2 = (c_1 + c_2^2).$$

Substitute this back in the original expression for c_o thus:

$$c_o = \frac{(c_1 + c_2)^2}{(\sqrt{c_1} + \sqrt{c_2})^2} = (c_1 + c_2) \left[\frac{(c_1 + c_2)}{(\sqrt{c_1} + \sqrt{c_2})^2} \right].$$

Since c_1 and c_2 are always very nearly equal, the bracketed term is very nearly equal to $\frac{1}{2}$. The final expression then gives for c_o the arithmetical mean of the two other values, viz.,

$$c_o = \frac{c_1 + c_2}{2}$$

It is evident that a great many combinations of fundamental and harmonics may be obtained, and several combinations may be used for checking a particular frequency of the generator. It is often difficult to locate the beats when the harmonics are used, so for that reason it is well to anticipate their approximate location.

For instance, the beats resulting from the combination of the two fundamentals are easily detected on account of their great strength. The capacity of the condenser in the generator is

then noted. If it is desired to calibrate the generator at say, 857 cycles, with a tuning-fork whose fundamental is 1000 cycles, the approximate capacity required in the generator will be obtained by noting that the capacity required varies inversely as the square of the frequency. Upon setting the condenser at this value the beats will readily be detected by the meter or in the phones, with only very slight capacity change from this value.

The seventh harmonic of the generator will then be in resonance with the sixth harmonic of the tuning, for obviously,

$$857 \times 7 = 1000 \times 6$$

The table below gives the various frequencies at which the generator can be calibrated with a 1000-cycle tuning-fork using the harmonics up to the tenth. The spaces left blank indicate duplications; for instance, the same frequency can be checked for either $a=3$ and $b=4$ or $a=6$ and $b=8$, for obviously

$$\frac{a}{b} = \frac{3}{4} = \frac{6}{8}$$

One of the main advantages of the method is shown in the table—that using harmonics up to the tenth, 63 points can be determined on the calibration curve using only one constant frequency source, the tuning-fork. Another advantage of the method is that due to the fact that harmonics are *exact* multiples of the fundamentals, very accurate results can be obtained by this method without much trouble.

b	1	2	3	4	5	6	7	8	9	10
1	1000	2000	3000	4000	5000	6000	7000	8000	9000	10000
2	500		1500		2500		3500		4500	
3	333	667		1333	1167		2333	2667		3333
4	250		750		1250		1750		2250	
5	200	400	600	800		1200	1400	1600	1800	
6	166.6				883		1167			
7	143	286	428	573	713	857		1143	1286	1430
8	125		375		625		875		1125	
9	111	222		444	556		778	889		1111
10	100		300				700		900	

SUMMARY: A simple method of calibrating an audio-frequency generator is described, a standard single-frequency source of oscillation being employed. The method makes use of the harmonics of the standard source and of the generator being calibrated.

THE SHIELDED NEUTRODYNE RECEIVER*

BY

JOHN F. DREYER, JR.

HAZELTINE CORPORATION LABORATORIES, HOBOKEN, N. J.

AND

RAY H. MANSON

OF STROMBERG CARLSON TEL. MFG. CO., ROCHESTER, N. Y.

Since this is the first paper before the Institute of Radio Engineers dealing with the "Neutrodyne" receiver, it is thought advisable to include a brief historical outline of the development of this device.

In 1918, L. A. Hazeltine, then Professor of Electrical Engineering at Stevens Institute of Technology, and also serving in a consulting capacity to the Navy Department, was requested by the Navy Department to design a radio receiver. Among other things it was desired that there be no capacitive coupling between antenna and secondary circuits; for such coupling had been found to result in serious interference from nearby 600-meter transmitters when reception of signals from weak, higher wavelength stations was attempted. To accomplish the desired result—that of eliminating the capacitive coupling—the antenna tuning coil and condenser first were isolated from the secondary circuit by enclosing each in a separate compartment of heavy sheet copper. But a coupling coil, in series with the secondary, was needed in the compartment containing the antenna coil to give various degrees of inductive coupling, and the inherent capacity between these coils left a certain amount of capacitive coupling between their circuits. To eliminate this, Prof. Hazeltine wound another coil in close proximity to the coupling coil with one end free and the other connected to coupling coil. In addition to providing a shielding action, this coil was so proportioned as to number of turns and polarity that capacitive currents flowing from the antenna coil to it produced a magnetic effect equal and opposite to the effect produced by

* Presented at New York meeting, INSTITUTE OF RADIO ENGINEERS, February 3, 1926.

the capacitive currents which flowed from the antenna coil to the coupling coil directly. The result obtained was then the neutralization of an undesirable coupling capacity by another, or neutralizing capacity.

Late in 1922, Prof. Hazeltine designed, had built and successfully operated a radio-broadcast receiver. This experimental model employed two stages of tuned radio-frequency amplification, detector and two stages of reflexed audio-frequency amplification. The novel feature of this receiver was the neutralization of the capacity coupling between the successive tuned circuits by a method similar to the one employed in the Navy receiver. Since then many such receivers have been built and except for the abandonment of the reflex arrangement, no major changes have been found necessary. This is a most significant indication of the fundamental soundness of the original design.

The neutralization of capacity coupling in vacuum-tube amplifiers was first made public in a lecture before the Radio Club of America on March 2, 1923.¹ This was the advent of the Neutrodyne. It entirely changed the situation with regard to radio broadcast receivers. Prior to this time most of the receivers in use were the three-tube regenerative type. These receivers were sensitive and selective, but were objectionable because their adjustments were interdependent and therefore required skill to operate them. They also had the serious disadvantage of being able to produce oscillations annoying to the user, which also fed into the antenna and caused disturbance to others. Another objection is that of the distortion introduced, if regeneration is depended upon to secure maximum amplification and selectivity. The circuits then become too sharply tuned, which results in the elimination of the higher audio frequencies in the modulated wave. (The possibility of the occurrence of this same effect in tuned radio-frequency amplifiers in which regeneration is not used will be discussed later.) The Neutrodyne, however, possesses none of these disadvantages. The tuning adjustments are independent and, therefore, after a station has once been heard, the settings of the dials may be recorded for future use. No oscillations are employed and the receiver may be designed to have the right degree of selectivity without causing distortion due to cutting of the side bands.

Receivers of today of the better sort may be grouped into

¹L. A. Hazeltine, "Proceedings of the Radio Club of America," Vol. 2, No. 8, March, 1923.

two main classifications: the tuned radio-frequency receiver, in which the signal is amplified at the frequency of transmission; and the super-heterodyne, in which the signal is first changed to a lower frequency and is then amplified. Regenerative receivers are still used, but in the better forms are provided with a tube or tubes whose internal grid-plate capacity has been neutralized to reduce the radiation. The tuned radio-frequency group includes the Neutrodyne and various other forms, which latter are known generally as "T. R. F. Receivers." In the latter attempts have been made to suppress undesirable oscillation due to regeneration, often by loss methods.

FUNCTIONS OF A BROADCAST RECEIVER. The broadcast receiver of the Neutrodyne type must perform the following functions:

The first function is to collect the signal on a suitable antenna.

The second function is to amplify the signal at radio frequency. In this process selectivity is obtained. That is, the amplifier, being a *tuned* radio-frequency amplifier, is selective against signals of different frequency from the desired one. The amount of amplification necessary is determined by the type of antenna used. In general, for best results, it should be sufficient, when adjusted to a maximum, to amplify signals which are only slightly stronger than the background level up to a point where the detector gives its normal output.

The third function is to rectify the amplified signal current—that is, to change it from modulated radio-frequency current to audio-frequency current.

The fourth function is to amplify the detector output current, which is at audio frequency, sufficiently to produce the normal output voltage at the loudspeaker. In general, it may be said that the maximum desirable audio-frequency amplification would be that which would amplify a normal detector output to a normal loudspeaker requirement. More than this is undesirable since tube noises and microphonic effects then become troublesome. Less than this is undesirable since the desired loudspeaker signal could then be attained only with an overloading of the detector tube.

The final process in reception, the conversion of the amplified electrical energy into sound energy, is accomplished by the loudspeaker. This process will be considered here only in its relation to the design of the receiver.

THE UNSHIELDED NEUTRODYNE

In obtaining the necessary radio-frequency amplification and selectivity for the receiver, cascade amplifiers employing the Neutrodyne principle are used. Cascade amplification requires several successive tuned circuits to be coupled together through vacuum tubes. To avoid regeneration and the resulting disturbing oscillation, it is necessary to eliminate all couplings between the successive circuits except the unilateral coupling of the vacuum tube itself. All other couplings are reciprocal, that is, may transfer energy in either direction. Any coupling which is capable of transmitting energy from one stage to a preceding one gives regeneration and results in undesirable sharpening of the tuning, or, if present in sufficient degree, results in the production of sustained oscillations which interfere with the signal being received, and also causes disturbances to others by radiation.

Prior to Professor Hazeltine's development of the Neutrodyne, the one coupling which stood in the way of successful cascade amplification was the coupling introduced in the vacuum tube itself by the capacity between grid and plate. His method of neutralization, when properly applied to a radio-frequency amplifier, eliminates the undesirable effects of this coupling.

Figure 1 illustrates the fundamental circuit.² If the inductances L_1 and L_2 are very closely coupled, a voltage devel-

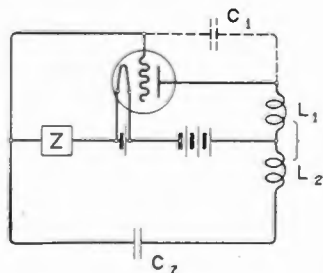

FIGURE 1—Fundamental Neutrodyne Circuit

oped in the plate circuit of the vacuum tube cannot produce an effect in the preceding grid circuit Z , provided the condenser C_2 is properly adjusted. This neutralization is independent of frequency. Some other forms of neutralization give the desired effect at the frequency to which the circuits are tuned, but are highly regenerative either in a positive or negative sense at other frequencies. This often results in the production of parasitic

²U. S. Patents 1,489,228 and 1,533,858.

oscillations which are very undesirable and prevent the cascading of units of this type into a multi-stage amplifier.

There are many other forms of coupling which must be eliminated in a successful multi-stage amplifier. It has been found that unless complete shielding is resorted to, only two stages of Neutrodyne amplification may be successfully used. However, two-stage amplifiers give a degree of amplification which is quite satisfactory if a good capacitive antenna is used. Selectivity also is sufficient without at the same time being so great as to cause distortion due to the elimination of the side bands of the modulated wave.

Let us consider what other couplings may exist and have been eliminated in these unshielded receivers. There are three resonant circuits: one for the antenna and one for each of the stages of radio-frequency amplification. It is necessary that no magnetic coupling exist between any two of the three coils.

In Professor Hazeltine's design, he resorted to a novel arrangement. He developed mathematically the theorem that magnetic coupling between any number of symmetrical coils may be eliminated by placing them, with their axes parallel and at a certain angle³ to a common line of centers. The mathematical assumptions made were not quite ideal, so that the true angle is not exactly the theoretical one, but it may be found readily. This arrangement of the coils has given a distinctive appearance to the unshielded type of neutrodyne receivers. It allows the use of single-layer cylindrical coils, which have proven to be the most efficient type of high-frequency inductance that can be put in a given space.

Magnetic coupling between stages may also be eliminated by placing the three coils mutually at right angles or by the use of some special form of coil which has a confined magnetic field. Arrangements of this kind have certain advantages in that they do not pick up, magnetically, signals from strong local stations.

If the second or third coils in the customary Neutrodyne do pick up from strong local stations, it may, in some instances, cause interference because of the fact that a signal picked up in this way is not subjected to the highly selective action of all three of the tuned circuits. However, all inductances of the last mentioned type, if of the same physical dimensions as the cylindrical coils, have, of necessity, higher electrical resistance. Their use, therefore, results either in less amplification or poorer selectivity or in both.

³ Angle whose tangent is $\sqrt{2} = 54.7^\circ$

Another coupling that may exist between the tuned circuits is that introduced by inherent capacity. Capacity between adjacent stages enters in the balance obtained with the neutralizing condenser. Capacity of this kind is less desirable than the ordinary neutralizing capacity, as is explained below in connection with Figures 2 and 3. The secondary coils themselves cannot be extremely closely coupled to the primaries, and therefore this capacity introduces neutralization of a less desirable kind.

Capacity between non-adjacent stages (between first and last coils in a three-circuit unshielded receiver) may result in appreciable regeneration and in oscillation when the total radio-frequency amplification is increased beyond a certain point. Many Neutrodyne receivers are supplied with a third neutralizing condenser which neutralizes this over-all capacity. These receivers may obtain a somewhat higher degree of amplification than receivers which are not so supplied.

It should be pointed out also that if a three-stage receiver is planned, four tuned circuits would have to be employed. In order to properly neutralize all capacitive couplings between such circuits, six neutralizations would be required. This becomes unwieldy and has led to the conclusion that if three or more stages are required, complete metallic shielding must be resorted to.

There are other incidental couplings which must be eliminated to produce a successful receiver. Couplings introduced by the use of common batteries and couplings introduced by poor arrangement of wiring and auxiliary apparatus, have all been discussed in detail before.⁴

As has been mentioned before with regard to Figure 1, it is desirable to have close magnetic coupling between the coils L_1 and L_2 . Figure 2 illustrates diagrammatically the effect of departure from this relation. In this figure, a vacuum tube employing a tuned grid circuit feeds an ideal transformer (transformer having unity coupling) through an inductance L_o , which represents the action of the leakage inductance which is present in an actual transformer. In this case the capacity C_2 , may be adjusted for a balance when the tube is unlighted. This balance, however, is not independent of frequency, because it is a balance between a pure capacity C_2 on one hand and the capacity plus the leakage inductance on the other hand.

⁴J. F. Dreyer, Jr. "Proceedings of the Radio Club of America," Vol. 3, No. 3, May, 1924.

This effect is not of serious import in the unshielded Neutrodyne since the leakage inductance, L_o , is always small. The capacity C_1 is also small and its reactance is always high compared to the reactance of the inductance L_o .

There is another effect, however, which causes the balance to be less than perfect. This is the effect of the plate impedance of

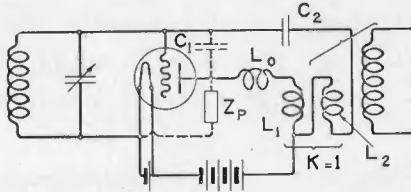

FIGURE 2—Effect of Lack of Unity Coupling

the tube which in effect is connected between the junction point of C_1 and L_o , and the ground potential terminal of inductance L_1 . Current flowing through this impedance is in nearly 90° phase relation to the current flowing through C_1 . This causes a voltage to be developed in L_o which cannot be neutralized by the capacity C_2 . This effect is also small in the customary Neutrodyne design and if L_o is minimized by close coupling between L_1 and L_2 , does not result in appreciable regeneration.

In the unshielded Neutrodyne, it is difficult to take full advantage of the principle of close magnetic coupling between the inductances L_1 and L_2 for the following reason: Consider Figure 3, which represents a customary arrangement. The primary of the trans-

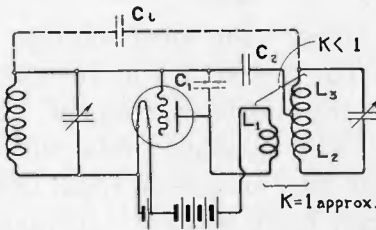

FIGURE 3—Effect of Inherent Capacity C_i

former L_1 may be very closely coupled to the neutralizing section of the secondary L_2 . However, L_1 cannot be so closely coupled to the entire secondary (L_2 plus L_3) without the introduction of undesirably high capacity and dielectric loss. There is, of necessity, a certain amount of inherent capacity (C_i) between the upper end of the secondary (L_2 plus L_3) and the preceding grid circuit. The fact that this capacity is present causes the neutralizing

capacity C_2 to be smaller than it would be otherwise. In other words, the inherent capacity C_i enters into the balance. The fact that it is present may be considered electrically as introducing additional leakage inductance in the plate circuit of tube. This is undesirable, as has been stated before.

USE OF SHIELDING

Figure 4⁵ illustrates diagrammatically the arrangement of one stage of a multi-stage amplifier, in which the metallic shield minimizes all other couplings and the neutralizing coil L_2 , to-

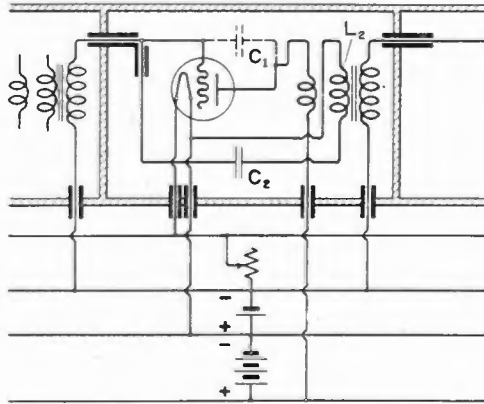

FIGURE 4—Shielded Stage of a Multi-stage Amplifier Proposed by Prof. Hazeltine in 1919

gether with the condenser C_2 eliminates the effect of the tube capacity.

Viewed broadly, this is the ideal solution of the multi-stage amplifier problem. The magnetic and dielectric fluxes associated with each stage are well isolated from all other stages by the metallic shielding. The magnetic flux which penetrates low-resistance shielding is very small—so small that it is unnecessary even in the compactly-built receivers, to take precautions such as placing the coils at critical angles. All capacities existing between adjacent stages or between non-adjacent stages are completely eliminated, except, of course, the capacity introduced by the elements of the vacuum tube, together with the capacity between the input and output circuit within the stage. This last is completely and properly neutralized by the condenser C_2 and the closely coupled inductance L_2 .

The use of metallic shielding in vacuum tube amplifiers and

⁵U. S. Patents Nos. 1,489,228 and 1,533,858.

that of a third or neutralizing coil were among the arrangements originally suggested by Prof. Hazeltine.

Referring back to Figure 3, it should be noted that the interposition of a metallic shield in the manner illustrated in Figure 4 eliminates the undesirable capacity C_i , so that all of the neutralization is accomplished by C_2 . The coil L_2 of Figure 4 may be closely coupled to the primary coil without introducing undesirable capacity. This results in almost complete elimination of the leakage inductance L_o , Figure 2, and, therefore, in the elimination of the undesirable effects which accompany this inductance.

It has sometimes been thought that metallic shielding placed in close proximity to the inductance coils would result in the introduction of serious losses. Measurements, however, indicate that this is not the case. Figure 5 illustrates how the losses

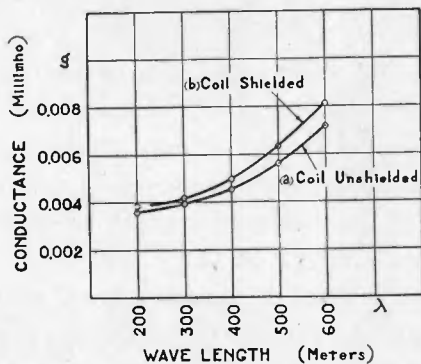

FIGURE 5—Losses of a Resonant Circuit

(given in terms of equivalent conductance at resonance) vary over the broadcast wavelength range.

Curve *a* represents the variation in loss of a resonant circuit consisting of a single-layer inductance, 80 turns of No. 24 A. W. G. double cotton-covered copper wire on a 2-inch diameter tube tuned with a 500-micromicrofarad air condenser.

Curve *b* shows the slight increase in loss caused by enclosing the inductance in a sheet copper box whose walls were 0.019 in. thick and separated by about 1 in. in all directions from the windings. The increase in loss is due mainly to the decrease in inductance, which necessitates the use of a higher capacity at a given wavelength. ($g = \frac{Cr}{L} = \omega^2 C^2 r = \frac{r}{\omega^2 L^2}$ where g is the conductance, C the capacity, L the inductance, r the effective series resistance and ω the angular frequency.)

Another argument advanced against the use of shielding, and which was quite pertinent, was the fact that the eddy current set up in the metal by the magnetic fields of the coils might circulate to the shielding of preceding stages and by their own magnetic effect cause undesirable coupling. It was this effect which caused the failure of partly shielded Neutrodynes. Such currents, however, are confined locally, if separate metallic containers are used for the separate stages or if the shielding is built into a single unit of low-resistance short-circuiting paths.

Many also were afraid of the prohibitive costs of metallic shielding. However, when it is considered that copper or brass, which are commonly used for this purpose, are excellent structural materials, on a strength basis, this cost argument loses its force.

DEVELOPMENT OF THE THREE-STAGE, COMPLETELY SHIELDED NEUTRODYNE

The above considerations and others point to the desirability of isolating the separate stages of the amplifier from one another by metallic shields. Having decided to do this, let us consider the design of a broadcast receiver of such a type.

First, the use of shielding makes it possible to increase the number of stages. The use of three stages of "Shielded Amplification" results in a total radio-frequency amplification which, when a small capacity antenna is employed, is sufficient to meet ordinary requirements. Three steps necessarily result in four tuned circuits which, if separately controlled, would be undesirable from the operator's standpoint. However, the last three tuned circuits may be made identical. A vacuum tube precedes each stage and follows each stage and, therefore, with proper care in the mechanical design and a slight change in the electrical design of the transformers, it becomes quite practicable to tune all three of these circuits with a single control.

The antenna circuit, however, is inherently different from the other circuits in that no tube precedes it. Also, it may be desirable to use a loop type antenna whose minimum capacity is likely to be variable. For this reason, it is most desirable to tune this circuit with a separate condenser. When this is done, all precautions may be taken in order that the antenna circuit may have a low a resistance as possible and thus contribute to the selectivity of the receiver as a whole.

The three other circuits, since they are controlled with a single adjustment, must be so designed as to have individually a

broader resonance curve than the circuits employed in the unshielded receiver. This can be done without serious sacrifice in amplification and with an actual gain in uniformity over the wavelength range by the use of a transformer designed as follows:

Figure 6 illustrates such a transformer. The primary and neutralizing windings are wound on an inner cylindrical tube which has been threaded with a double thread. The number of primary turns is considerably increased above that used in the unshielded type of receiver. The secondary coil is wound on a threaded tube which fits closely around the inner tube. It must be designed to have a lower inductance than would be required in an

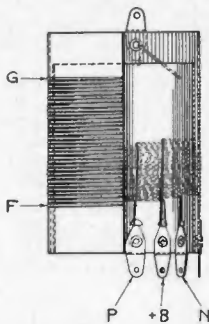

FIGURE 6--Arrangement of Inter-stage Transformer

unshielded transformer, because of the fact that relatively high number of primary turns and close proximity of these turns to those of the neutralizing winding result in a high minimum capacity of the circuit as a whole. This requires the use of a larger tuning capacity than would otherwise be required.

The high minimum capacity also introduces dielectric losses which are more important at the high-frequency end of the scale than at the low. This results in a flatter conductance curve, and, since the amplification is a function of the conductance, the amplification of the transformer, as a whole, is more nearly uniform.⁶ This arrangement of the primary and neutralizing winding results in a very high coefficient of magnetic coupling between these circuits; in this way the full advantage of the Neutrodyne method of capacity neutralization may be realized.

Figures 7 and 8 illustrate the performance of two types of transformers. Figures 7a and 8a illustrate the amplification per

⁶ Amplifications $\frac{\tau \mu g_p}{g_p + \tau^2 g}$, where τ is the effective turns ratio, secondary to primary; μ the amplification factor of the tube; g_p the plate conductance of the tube, and g the conductance of the tuned circuit at resonance.

stage and resonance curve of a transformer suitable for a two-stage unshielded receiver. Figures 7b and 8b illustrate the same properties of a transformer suitable for a three-stage shielded receiver. It should be noted that the three-stage transformer

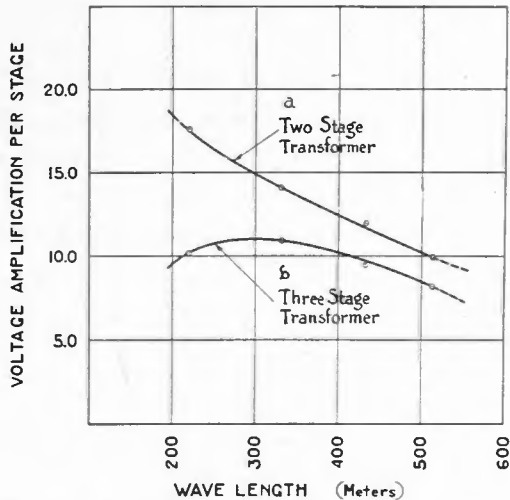

FIGURE 7—Voltage Amplification per Stage of Radio Frequency Transformers

has a considerably broader resonance curve and hence is more easily adaptable for use with "gang" controlled condensers. The

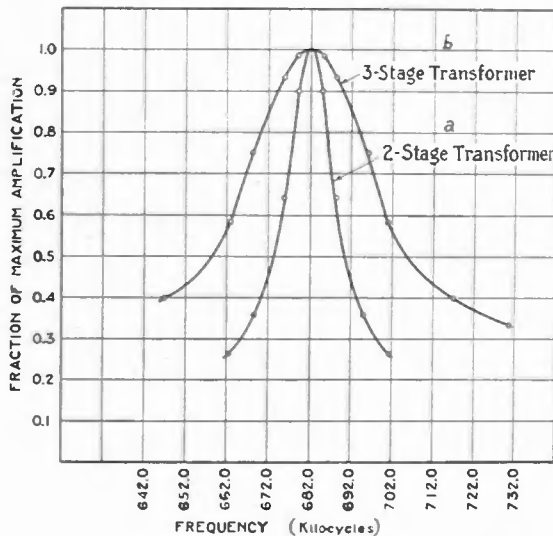

FIGURE 8—Resonance Curves, Tuned Radio Frequency Transformers

loss in amplification is more than made up by the additional stage.

In multi-stage amplifiers certain other precautions in the wiring and arrangement of circuits is necessary to prevent

incidental couplings of the type mentioned before when discussing the unshielded receiver. Figure 9 illustrates diagrammatically the ideal arrangement of two of the stages of a multi-stage amplifier showing the necessary by-passing and filtering

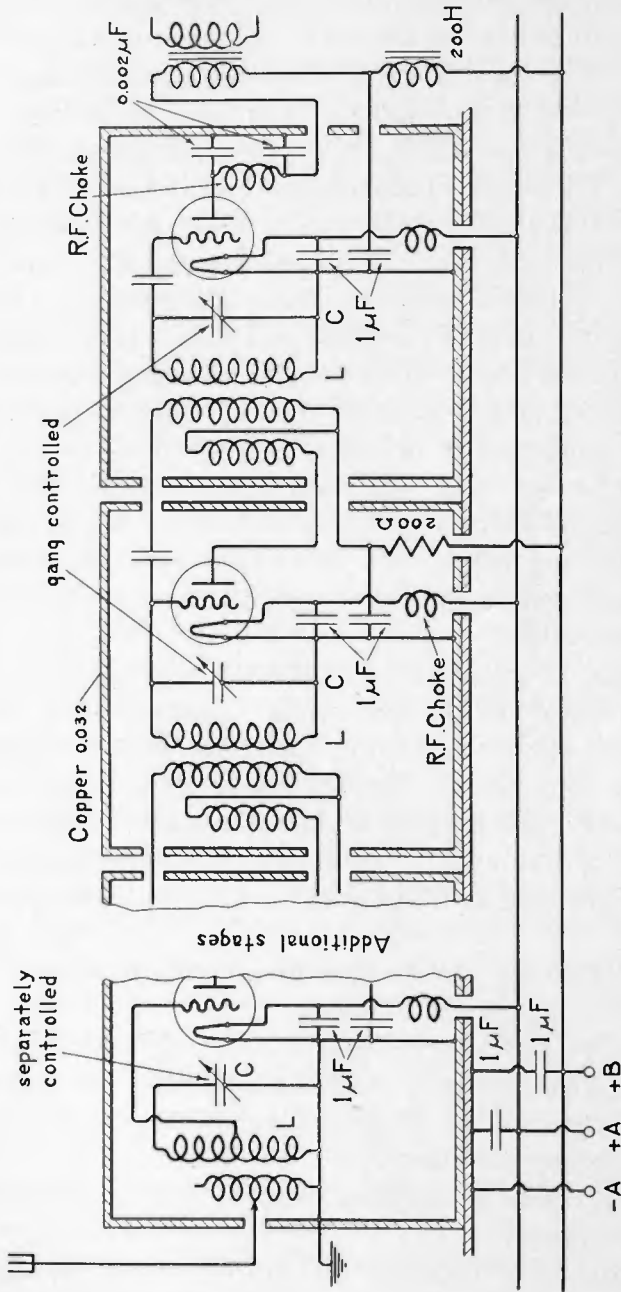

FIGURE 9—Arrangement of a Multi-stage Neutrodyne

that is required in the battery leads to prevent radio-frequency currents from passing out of the separate compartments and intermingling. This diagram illustrates the ideal arrangement

and some of the precautions illustrated here are not necessary in a three-stage receiver. They become of more and more importance the higher the total amplification, and all of them appear to be necessary in a four-stage receiver.

Even with precautions of this type there seems to be an upper limit to the amplification that may be obtained at the broadcast frequency. This limit is not reached with a three-stage receiver but may be with a four-stage. It appears to be due to radio-frequency potentials which build up upon the shielding of the last stage. These potentials are capable of feeding back energy to the antenna through the inherent capacity between these shields and the antenna. They are due to the capacitive and magnetically induced currents in the shielding. It is possible that this limitation may be removed by the use of double shielding. Fortunately, however, it occurs only when the total voltage amplification obtained is over 10,000. This is more than can be usefully employed in broadcast receivers.

Another limitation of considerable importance is that imposed by the variation in tube-coupling capacity. Receivers are balanced for normal tubes, but due to the lack of uniformity of tubes as delivered to the purchaser, allowances for such variation must be made.

Regeneration or oscillation, if present, due to inexact balance, is most noticeable in the first circuit, since no tube precedes it and since this circuit is of lower resistance than the others. It is desirable, therefore, to sacrifice somewhat the amplification of this stage, in order to gain stability against variation in tube capacity (tube tolerance). This may be done by connecting the grid of the first tube to a tap at the centre of the first inductance coil.⁷

Briefly, then, the advantages of shielding as applied to Neutrodyne receivers, are as follows:

- 1—Due to the removal of stray capacity and inductive couplings, the use of shielding makes possible the construction of three or four-stage tuned radio frequency amplifiers.
- 2—With complete shielding, perfect neutralization may be obtained.
- 3—Magnetic or capacity pick-up of interfering signals on intermediate circuits, is eliminated.
- 4—The number of tuning adjustments may readily be reduced to two.

⁷This arrangement is due to Mr. W. A. MacDonald.

AUDIO-FREQUENCY AMPLIFIER

In considering completely a radio receiver, some mention must be made of the audio-frequency amplifier employed with it. It is regrettable that in the past very little emphasis has been put upon the design of the audio-frequency portion of many receivers.

For satisfactory reproduction, audio-frequency amplifiers must satisfy two main requirements. First, they must be able to deliver to the loudspeaker as high an output as is desirable without the introduction of undesirable harmonics. In many amplifiers, undesirable harmonics are produced by overloading in the grid and plate circuits of the last tube even on moderate volume requirements. This limitation may be completely removed by the use of higher power vacuum tubes (tubes whose filaments have higher total emissions) together with the proper "B" and "C" voltages. If the user is content with moderate volume, an amplifier employing the 201-A and 112 type tubes may be made quite satisfactory.

The second main requirement of an audio-frequency amplifier is that it must have a proper amplification frequency characteristic curve, which when combined with the characteristic curve of the radio-frequency circuits and the loudspeaker, will result in a satisfactory over-all performance. It goes without saying that this frequency characteristic should be invariable and not dependent on circuit conditions. This is not always the case in conventionally designed amplifiers.

In transformer coupled audio-frequency amplifiers, the individual transformers must be carefully designed so as to have sufficient impedance at the lower audio frequencies to prevent a fall in amplification at these frequencies. Also, the distributed capacity and leakage inductance in the secondary must be considered, in order that the transformers shall not have a greatly exaggerated amplification at these higher speech frequencies (the resonant frequency of the secondary leakage inductance with the distributed capacity of the secondary). There are various methods of removing this "second peak." It is felt, however, that too much stress has been laid in the past on the frequency characteristic of the individual transformers. The characteristic of the amplifier, as a whole, may be much distorted by regeneration at audio-frequency. Figure 10 illustrates some of these effects. Curve (a) is the characteristic of an amplifier with all regenerative actions suppressed. Curves (b) and (c) show the characteristic of the same amplifier with distortion resulting from regeneration

due to impedance in the common "B" current supply. Impedances sufficient to cause this type of distortion may be found in dry "B" batteries after a few weeks' use or in "B" socket power devices from the start. This type of distortion is probably the most common source of dissatisfaction with amplifiers now on the market. It may be removed by the use of a separate detector

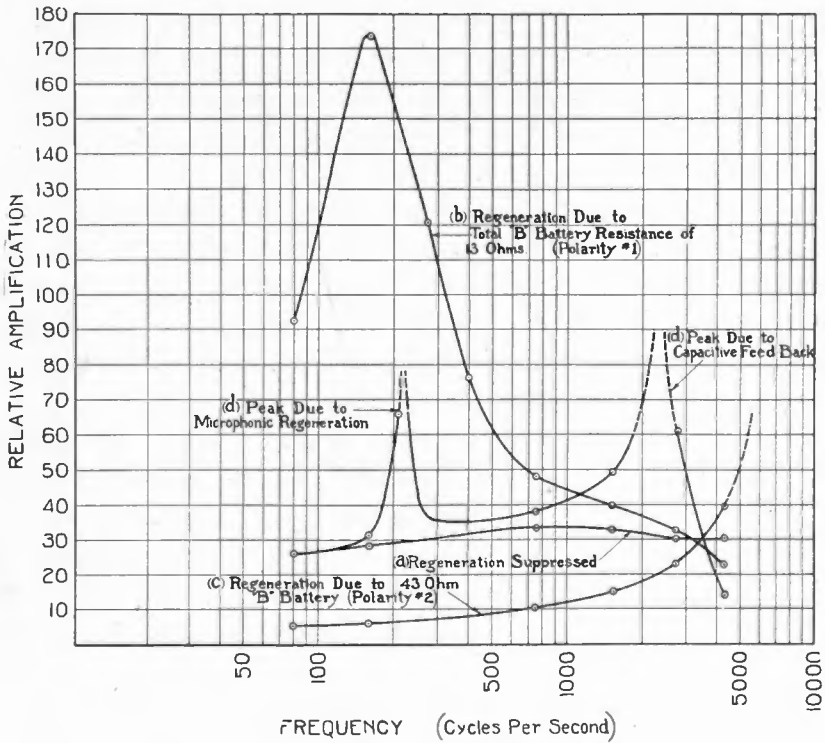

FIGURE 10

"B" unit or by proper filter arrangements which are now being investigated.

Curve (d) illustrates a distortion arising from capacity coupling between the output of the last tube and the detector grid, if grid-circuit detection is used. This may be entirely removed by shielding the detector tube in a metal compartment, or by the use of plate-circuit or mutual detection.

Curve (d) also illustrates a distortion arising from mechanical regeneration from the loudspeaker to the elements of the detector tube. The use of spring cushion sockets is helpful in preventing this type of distortion, but not wholly satisfactory since the vibration may sometimes be transmitted through the air. When springing is resorted to, the mechanical frequency of the device should be below the audible range. Felt-lined compartments for

detector tubes are helpful in minimizing this effect. In some cases rigid mounting of the tubes is desirable.

Distortion of this latter type may be caused by microphonic action of the radio-frequency tubes or even of the tuning condensers. The action is then a modulating one and only occurs when a carrier frequency is present.

If any of the above-mentioned effects are present to an extent slightly greater than illustrated, continuous howling takes place. When this occurs, it becomes at once apparent. It is desired to emphasize the fact, however, that distortion may occur from these effects even though no continuous oscillation or howl takes place.

The proper shape of the most desirable audio-frequency characteristic curve depends largely upon the loudspeaker. Those of the paper cone type are satisfactory, but even these seem to over-emphasize the higher frequencies. This is partially corrected by the radio-frequency circuits. It has been found necessary, however, for most pleasing results, to diminish the high frequencies to a still greater extent. This may most conveniently be done by the use of a condenser of the order of 0.01 microfarad in parallel with the loudspeaker. Suppression of the higher audio frequencies by this method is helpful in minimizing interference from stray disturbances since they appear principally as high audio frequencies.

COMMERCIAL DESIGN OF A SHIELDED NEUTRODYNE RECEIVER

One of the first designs of totally shielded Neutrodyne receivers to be manufactured was a six-tube model, which was first produced in quantities in the fall of 1925. It serves as a good example of the principles just enumerated for a three-stage shielded Neutrodyne receiver.

In general, this receiver consists of three stages of tuned radio-frequency amplification, a vacuum-tube detector and two stages of transformer-coupled audio-frequency amplification, the four tuned radio-frequency circuits and accompanying apparatus being enclosed in individual shields.

RECEIVER CIRCUIT. A simplified circuit diagram of this receiver is shown in Figure 11. It will be observed that each of the three radio-frequency tuning circuits is enclosed in a separate shielded compartment which contains the following apparatus:

(a) Radio transformer of the general design shown in

Figure 6.

(b) Variable tuning condenser (Figure 17).

- (c) Tube Socket and Vacuum Tube.
- (d) Neutralizing condenser of the design shown in Figure 22.

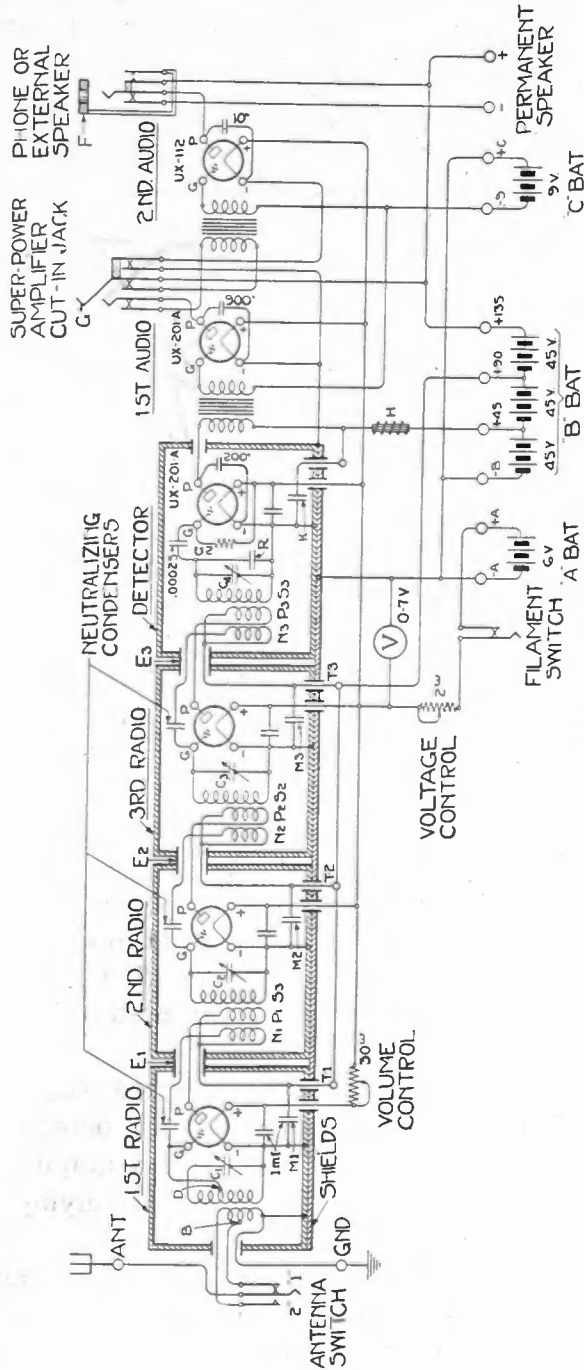

FIGURE 11

- (e) Fixed by-pass condenser (1 m.f.) for the "A" battery supply leads.

- (f) Fixed by-pass condenser (1 m.f.) for the "B" battery supply leads.

The detector-shielded compartment contains, in addition to the above apparatus, the following:

- (g) Condenser R of the type shown in Figure 22, connected across the variable condenser of the fourth tuning stage, to raise its capacity to that of the preceding three tuning stages, which already have in effect similar increase in capacity due to the neutralizing condensers, also of the type shown in Figure 22.
- (h) Fixed grid condenser of 0.00025 mf. capacity.
- (i) Fixed by-pass condenser of 0.002 mf. capacity.
- (j) Grid leak of 2 megohms resistance, connected between the grid and the "+F" terminal of the detector socket.

As previously explained, the use of the individual shields and the several by-pass condensers confines the action of each radio-frequency tuning and amplifying stage within its particular shield and thereby avoids inter-stage and over-all couplings. Additional precautions against these couplings are provided by shielding the three wires that inter-connect the shielded radio amplifier compartments, as shown at E_1 , E_2 , and E_3 in Figure 11.

No shielding is used for the audio amplifier system of this receiver, due to the fact that that portion of the circuit is sufficiently stable in itself and to the fact that the remainder of the receiver, including the detector circuit apparatus, is completely shielded.

Further consideration of the circuit, Figure 11, shows the following features:

- 1—A switch for connecting the antenna to the complete primary or to a tap "B" in the primary winding of the first radio transformer, so as to accommodate different sizes of antennas and provide increased latitude of sensitivity and selectivity in the operation of the receiver.
- 2—The use of the scheme, previously described, of connecting the grid of the first radio tube to a mid-tap D of the secondary winding of the first radio transformer, to gain stability against variation in tube capacity.
- 3—The provision of a by-pass condenser across the output circuits of each of the audio amplifier tubes, for

cutting down the higher audible frequencies to compensate for over-emphasis of these frequencies in some types of loudspeakers, as previously described.

4—The provision of three output connections for various types of reproducers, as follows:

- (a) Binding posts connecting to the output of the second audio tube for a permanently wired loudspeaker.
- (b) A cut-in jack *F* located on the front panel of the receiver, to which an external loudspeaker or a radio headset can be connected and at the same time cut off the circuit to the permanently-wired loudspeaker.
- (c) A cut-in jack *G* located on the terminal board at the rear of the receiver, to which any one of the various so-called "Super-Power" amplifier equipments can be attached. It will be noticed that the inserting of a radio plug into this jack cuts off the second audio tube and connects the external amplifier to the output of the first audio tube, thereby providing the one stage of audio amplification that is required between the detector and the super-power amplifier to prevent overloading of the detector tube.

5—A filament "voltage control" consisting of a rheostat connected in series with the "A" current supply to all six tubes, with a voltmeter *V* on the filament side of the rheostat. The voltmeter is provided with a red line at the 5-volt division and has printed on its face in large type the following wording, "*Keep pointer to left of red line.*" It has been found in service that the voltmeter serves several useful purposes, as follows:

- (a) Avoids over-voltage on tube filaments, giving longer active life for all tubes in the receiver.
- (b) Indicates condition of battery.
- (c) Serves as a visual indication that the receiver is connected for operation.

6—A "volume control" consisting of a rheostat for regulating the filament current supply to the first radio amplifier tube. By regulating the strength of signal at the first shielded compartment, it is possible to get a wide range of volume control and avoid the

detector tube overload distortion that is encountered when the voltage control is located at or after the detector tube. This type of volume control is made feasible by the shielding of the radio stages which prevents couplings of succeeding radio stages back to the antenna. Incidentally, the variation in current supply to the first tube filament, due to this volume control, does not change the voltage on the filaments of the remaining five tubes by a sufficient amount to require correction at the voltage-control rheostat.

- 7—The use of a third or neutralizing coil N_1 , N_2 and N_3 for each radio-frequency transformer, as previously described in connection with Figure 4.
- 8—The providing of an impedance coil H in the detector tube plate current feed, which, combined with the 1-mf. by-pass condenser connected between this coil and the primary of the first audio transformer and the shielding of the detector tube enclosure, serves to prevent audio regeneration, when the B current supply has a high impedance, as previously explained in connection with Figure 10. This arrangement is due to Mr. H. A. Wheeler.

STATION SELECTING SYSTEM. The wiring diagram, Figure 11, shows four tuning circuits, normally requiring four station selecting controls, one for each of the variable condensers C_1 , C_2 , C_3 and C_4 . A receiver made with these four controls would involve no special mechanical design or difficult manufacturing methods in its production. However, providing the three tuning condensers C_2 , C_3 and C_4 with a common drive, leaving the antenna tuning condenser on a separate control, so as to reduce the station selector controls to two, as previously described, introduces some mechanical problems that require special treatment. It is obvious that all three of the tuning coils used in the 2nd, 3rd and 4th tuning circuits must be alike in inductance and that three associated capacities also must be alike for each setting of the station selector throughout the complete scale.

The construction of the tuning system must be such that it will not be disturbed by rough handling during shipment or by subsequent wear of the driving mechanism or by mechanical displacement through temperature changes. The requirement that each of the three tuning condensers be enclosed in individual shields, also complicates the problem.

In this six-tube shielded Neutrodyne receiver, these problems have been solved by employing a chassis construction that is entirely new to radio receiver design. A heavy steel angle-iron framework, with suitable steel cross members, shown in Figure 12, serves as a base upon which all operating apparatus is

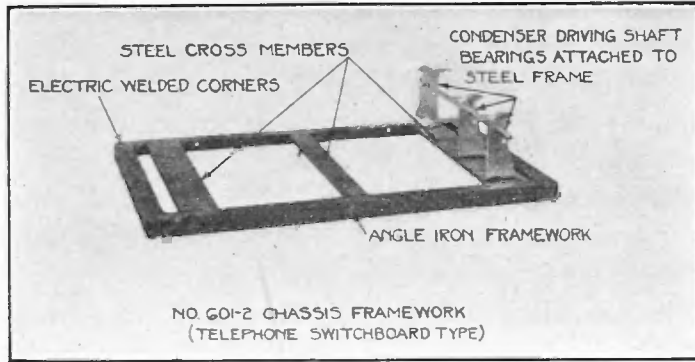

FIGURE 12

mounted. The complete chassis assembly, with tops of the shields removed, is shown in the two views, Figures 13 and 14.

The three tuning condensers C_2 , C_3 and C_4 are driven by a solid one-piece 5-16 inch diameter steel shaft, which extends

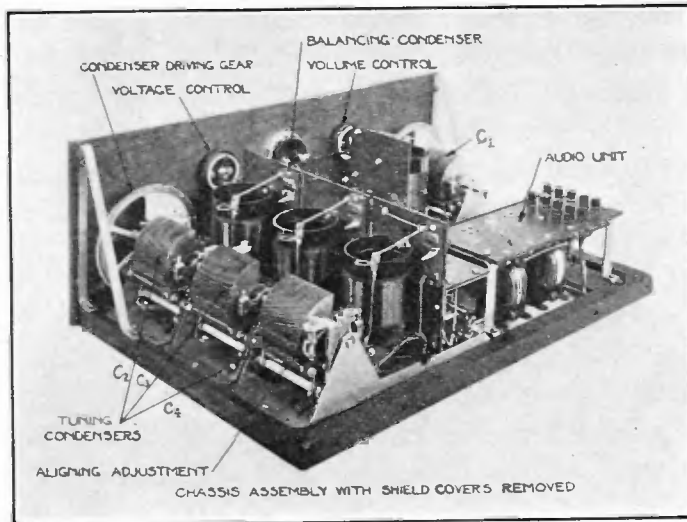

FIGURE 13

from the station selector dial pointer, through the hollow sleeve shafts of the separate condensers and the three main shaft supporting bearings, as illustrated in the cross-section diagram Figure 15.

A view of the main driving shaft and the three bearing brackets, which are assembled directly on the chassis, is shown in Figure 16. An adjustable, flexible, spring-type bearing is employed to provide against shaft looseness, due to wear. This type of bearing adjustment is shown more clearly in Figure 18.

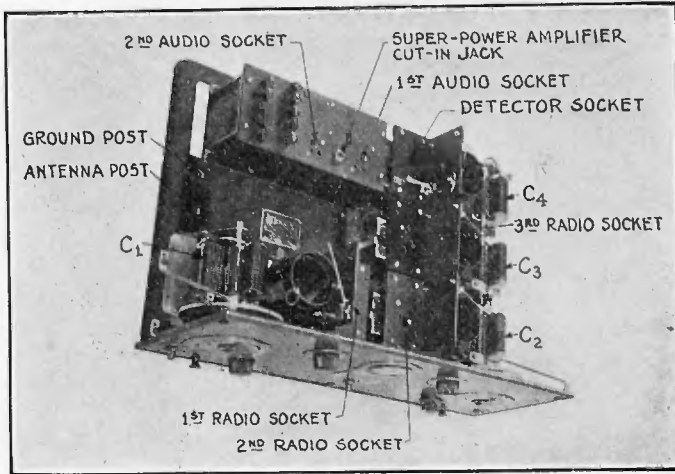

FIGURE 14

The one-piece driving shaft construction is made possible by using a hollow sleeve type of rotor shaft on each tuning condenser, as shown in Figure 17, and in the diagram, Figure 15. This allows individual condensers to be assembled and accurately

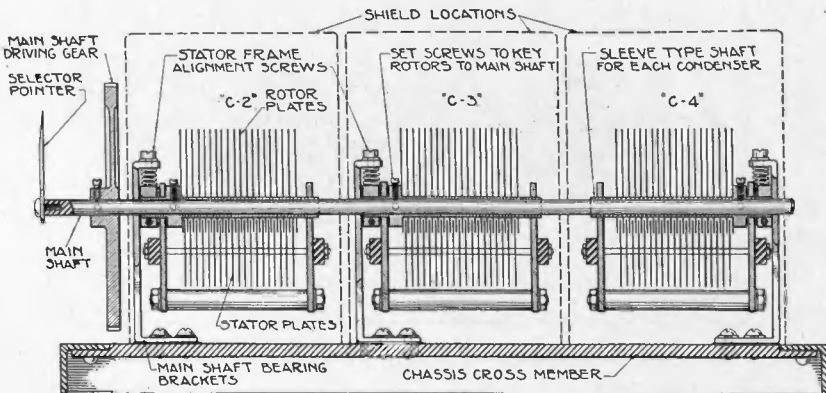

FIGURE 15

adjusted before mounting, the same as for any single-type variable condenser, and later slid on to the one-piece driving shaft and locked to the latter by two hardened steel set screws as shown in Figure 15. Thus, the one-piece shaft serves mainly as a means

for revolving the three condenser rotor plate assemblies, providing positive drive, not unlike that employed in the so-called "full floating rear axle" of a modern automobile. This construction also simplifies the mounting of the three variable condensers in separate shielded compartments.

While the construction just described provides for driving

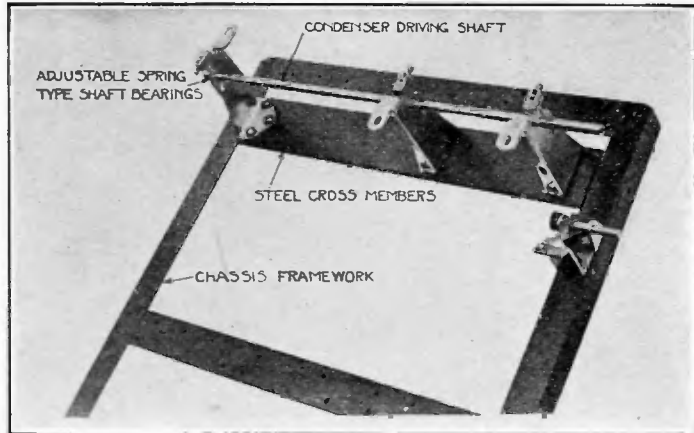

FIGURE 16

all three sets of rotor plates in unison, the scheme is made still more practical by adjustably fastening each condenser frame (stator assembly) to the main drive shaft-bearing bracket, as

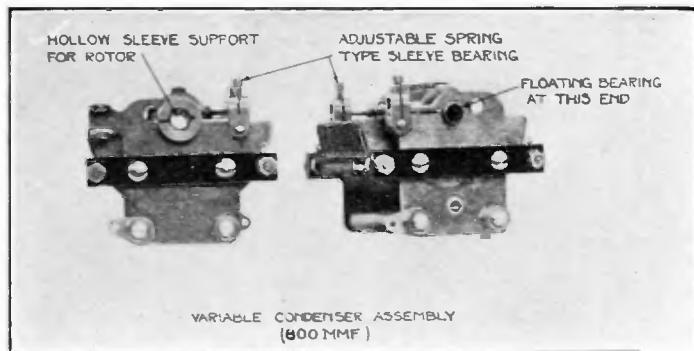

FIGURE 17

shown in Figure 18. An adjusting screw (A) passes through a clearance hole in the lug B of the main bearing bracket and threads into the lug D of the tuning condenser frame (stator assembly). A spiral spring C serves to swing the condenser assembly counter-clockwise, when the adjusting screw is turned in a counter-

clockwise direction and vice versa, as well as to maintain the adjustment against looseness. This adjustment provides a simple and accurate means for condenser alignment, as subsequently described.

CONSTRUCTION OF TUNING CONDENSERS. The mechanical accuracy in the construction of individual condensers to provide

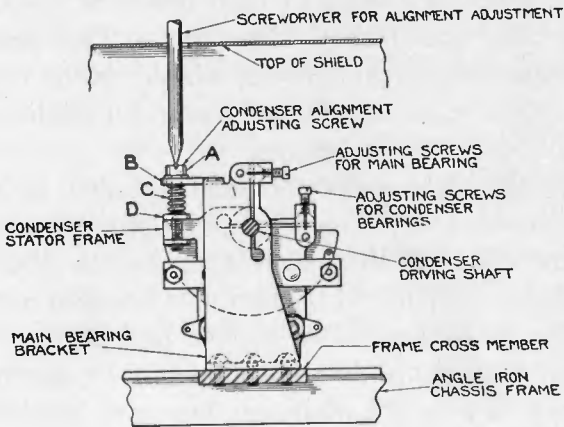

FIGURE 18.

for sharp tuning at each setting of the station selector control is attained as follows:

- (a) By the use of flat heavy-gage brass plates, assembled in accurate spacing fixtures and soldered together through overlapping lugs provided on the edges of the plates.
- (b) By employing wide spacing between plates.
- (c) By the use of a large number of plates, 19 stator and 20 rotor plates per condenser.
- (d) By adjusting for trueness of plates while rotating.
- (e) By the use of spring-type bearings as shown in Figure 18, to avoid looseness due to wear.
- (f) By taking all end-thrust of rotor shaft at one bracket of the condenser frame, the bearing at the other bracket being allowed to float.

These precautions in design and assembly of the variable condensers make it possible to pick, by suitable test methods, condensers for any one shaft assembly that have less than 0.4 per cent. total variation, this being found sufficient accuracy to provide a wide factor of safety for succeeding operations and for any changes that can occur, due to wear while in service.

The maximum capacity of these condensers is approximately 800 mmf., this being required, due to the high minimum capacity

of the circuit when the condenser rotor plates are out of mesh with the stator plates.

TYPE OF CONDENSER USED. It should be noted here that the type of condenser employed is the straight-line-capacity design, thereby giving equal changes in capacity in all three condensers on the common drive shaft for each division of the tuning scale, regardless of whether the stator and rotors of the three condensers are in exact mechanical alignment. This provides for an electrical alignment of condensers, which can be made after the shields are in place, so as to compensate for slight differences in the three shielded compartments.

The straight-line-capacity condenser also is desirable for completely-shielded type receivers, due to compactness. The present congestion of broadcast stations on the lower wave lengths makes it difficult to successfully bring in distant stations on the channels between 200 meters and 280 meters without interference. Usually, only a few powerful or nearby stations in this range can be selected with any degree of freedom from beating between transmitted carrier waves.

The tuning system of this receiver has been designed so that the broadcast range, 200 to 550 meters, just fills the station selector scale, allowing about 3 or 4 divisions at each end for manufacturing variations.

The station selector pointer is keyed and fastened directly on the end of the condenser driving shaft, avoiding lost motion that otherwise would cause inaccuracy in logging station settings. The operation of the station selector is made positive by use of a 10-to-1 reduction gear between the operating knob and the condenser driving shaft. It is felt that this arrangement results in a satisfactory spacing of the broadcast channels even with the use of a straight-line-capacity condenser.

CONSTRUCTION OF RADIO TRANSFORMERS. All four of the tuning coils used in this receiver are of the type described in the first part of this paper and shown in Figure 6.

The primary is wound on a cylindrical formica tube $2\frac{1}{2}$ inches in outside diameter with 20 double threads per inch cut in the outside surface to accurately locate the turns of the single-layer winding. As will be noticed from Figure 11, the antenna transformer has a single inner winding while the other three tuning stages have two inner windings. In these latter three transformers, the two wires of the two inner windings are wound together in adjacent grooves of the double thread, thereby giving a close coupling between the primary and the neutralizing winding. These

two windings are made with No. 29 A. W. G. double-silk-covered copper wire.

The secondary is wound on a cylindrical formica tube $2\frac{3}{4}$ in. in outside diameter with 24 threads per inch cut into the outside surface to accurately locate the turns of the single-layer secondary winding. This winding is made with No. 20 A. W. G. black-enamel copper wire.

By maintaining mechanical accuracy in the coil tubes and the winding, it is possible to keep the completed coils well within a 0.2 per cent. inductance variation.

The primary coil tube fits closely inside of the secondary coil tube and the assembly is mounted vertically within the shielded compartments as shown in Figure 13. The individual shields prevent any noticeable magnetic coupling between coils.

CONSTRUCTION OF SHIELDS. The individual shields of this receiver are made in three parts, the bottom, the rectangular box-shaped top, and the cylindrical-shaped tube cover, as illustrated in Figure 19.

The shield bottom is constructed of heavy gage brass (0.040 in. thick) and serves as a support for the tuning coil, tube socket

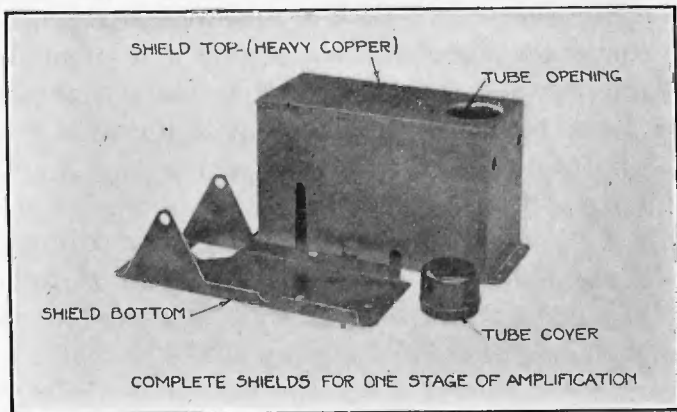

FIGURE 19

shelf, and two large fixed by-pass condensers, as illustrated in Figure 20.

The shield top is constructed of heavy gauge sheet copper (0.032 in. thick) with a polished copper surface inside and a tinned surface outside, the latter to facilitate soldering the seams when assembling this portion of the shield. The rectangular top shield fits closely over the bottom section with an overlap of $\frac{1}{2}$ in. all around.

The tube cover is drawn from one piece of heavy brass or copper and is designed to fit the tube opening in the rectangular shield top.

FACTORY TESTS AND ADJUSTMENTS. Besides the tests for accuracy of the variable condenser capacity and tests for the electrical constants of the tuning coils, it is necessary to electri-

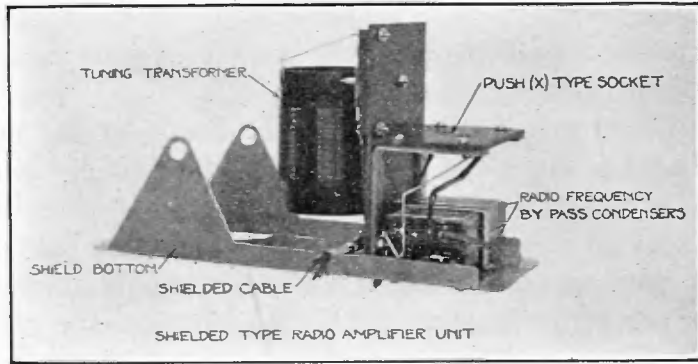

FIGURE 20

cally align the second, third and fourth tuning condensers, to neutralize the three radio amplifier stages, and to obtain readings for the calibration curve that is furnished with each receiver.

The condenser alignment is made by first tuning-in a signal at the high wavelength end of the station selector scale, then rotating the stators of the second and third condensers (the two nearest the front panel of the receiver) by means of a screwdriver inserted through a hole in the top of the shield, as shown in Figure 21. The screwdriver engages the adjusting screw, Figure 18, and allows for changing the stator with respect to the rotor. The output of the receiver is measured by a thermogalvanometer, the alignment for any one of the three condensers being considered correct when the maximum meter reading is obtained.

The fourth tuning stage, located in the detector shield, usually is adjusted first, by changing the capacity of the "padding" condenser, R, Figure 11, so as to give the proper top and bottom selector scale margins for the broadcast wavelength band.

After aligning at the high end of the scale, the accuracy of alignment at the other end of the scale is checked by the thermogalvanometer method just described.

The neutralizing operations follow the regular practice excepting that it is not convenient to block the filament connection in the new X-type of tube sockets, which are employed in this

receiver. Instead, the "+B 90-volt" current-supply wire is disconnected from a terminal, T_1 , T_2 or T_3 , Figure 11, provided on the bottom of each of the radio amplifier shields. By referring to the circuit, Figure 11, it will be noticed that the radio-frequency circuit is left intact when this B-battery circuit is opened, it then

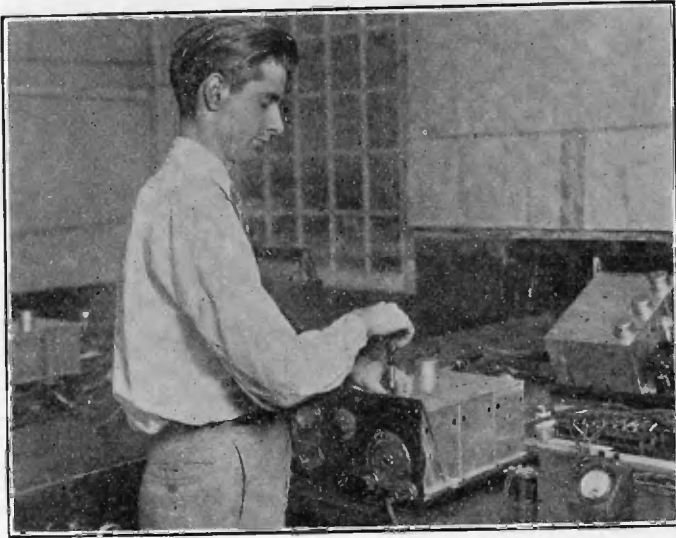

FIGURE 21

being maintained from the transformer primary windings, P_1 , P_2 and P_3 , through the 1 mf. by-pass condenser M_1 , M_2 and M_3 to "-F" terminals of the tubes.

The neutralizing condenser used in these receivers is of a simple design, as shown in Figure 22. A spring-type hexagonal

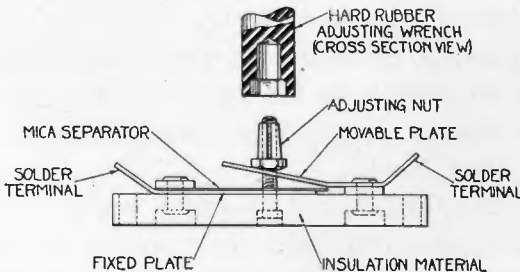

FIGURE 22

nut operates to change the position of a flat spring plate with respect to a similar stationary plate, when this nut is turned with a hard-rubber socket wrench as shown in Figure 23. The operator uses a radio headset, plugged into the output of the second

audio tube, to determine when the point of balance has been reached.

Following the alignment and neutralizing operations, a calibration curve of each receiver is hand-drawn from five points

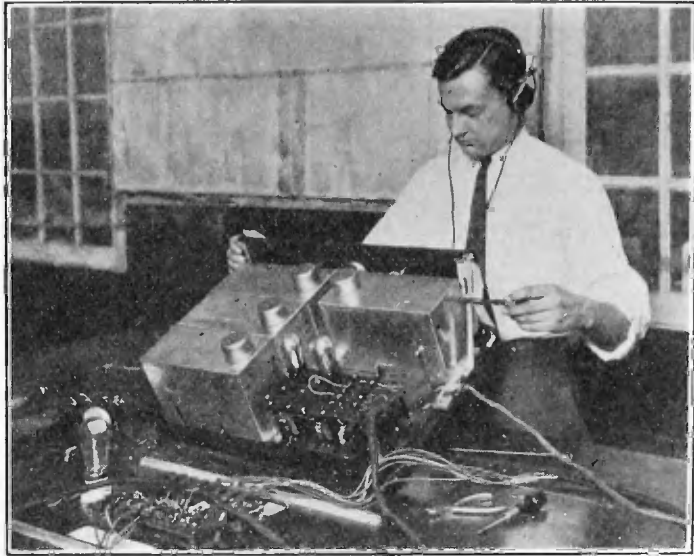

FIGURE 23

taken on the right hand station selector with the aid of a wave meter. These points can be made very accurate, as this selector control operates the three condensers of the second, third and fourth tuning stages and is extremely sharp when the volume control is turned down. The accuracy of this calibration curve, therefore, is not affected by changes in antenna conditions nor by slight differences in tube capacity.

AUDIO AMPLIFIER SYSTEM: As previously stated, the audio system of this receiver is of the two-stage transformer coupled type, with the second audio stage designed for a power output tube, such as the UX-112.

The audio transformers are specially designed to give a flat voltage-amplification curve over the range of audio frequencies that are considered essential to good quality reproduction. The usual "second peak" in the amplification curve, previously mentioned in this paper, is removed by the use of a short-circuiting band of copper applied around the outside of the secondary winding.

The turns ratio of these transformers, combined with the action of the short-circuit band, give a resulting voltage ampli-

cation for the transformers alone of approximately $3\frac{1}{2}$ to 1 for the first audio stage and 2 to 1 for the second audio stage.

As shown in the circuit Figure 11, both stages of the audio system are connected to the loudspeaker output binding posts and output "phone" jack at all times, thereby including sufficient audio amplification to insure ample volume of loudspeaker signal without the common tendency to overload the detector tube.

The complete receiver chassis is a self-contained unit that is designed to slide into an opening in a radio cabinet, similar to a desk drawer, and to be held in place with two 5-16 inch diameter automobile type cap screws, threaded directly into the rear member of the steel chassis framework. In some cabinets, these two screws need be used only for shipping purposes, and removed when the receiver is installed, thereby allowing the chassis to pull out like a drawer for inserting tubes, etc.

The individual shield covers are fastened securely to this chassis framework and therefore are sufficiently rigid to serve as a good mechanical protection for the variable condensers and other radio-frequency apparatus.

It has been found that this type of protection is advisable in a receiver that operates more than one tuning condenser with a common control, as the shields prevent accidental bending of condenser plates or changing of other elements that enter into the accuracy of the tuning circuits.

In conclusion, it will be noted that this manufactured design of totally shielded Neutrodyne receiver follows closely the principles outlined by Professor Hazeltine and his associates, and incorporates several mechanical features designed to insure reliability of operation when simplified controls are employed.



NEW METHOD PERTAINING TO THE REDUCTION OF INTERFERENCE IN THE RECEPTION OF WIRELESS TELEGRAPHY AND TELEPHONY*

BY

H. DE BELLESCIZE

(NEUILLY, FRANCE)

I—PRINCIPLES UNDER CONSIDERATION

The opinion of the great majority of the authorities relative to the possibility of reducing atmospheric interference in radio telegraphy and telephony, it seems to us, is summed up to-day, as follows:

Good results can be obtained by employing the differences of direction existing between parasitic currents (static or strays), and signals. To a less degree, phase differences can also be used to secure selectivity at the input of the receiving set. However, in so far as the oscillations created within the receiving set are concerned, no method can equal the judicious use of resonance; in certain cases, however, the devices do not take into account the independence of the oscillations and are, therefore, necessarily doomed to failure.

Even though this last conclusion is, in our judgment, very pessimistic, the impossibility of causing strong discharges superimposed on a continuous oscillation to disappear without at the same time suppressing this oscillation for a more or less prolonged period, seems to us to be axiomatic.

But the accuracy or exactness of this axiom can well be nullified by the method and devices hereafter described. Our point of departure* has been the hypothesis that a moving part retarded by constant friction cannot obey sinusoidal impulses of slight amplitude, even though the sinusoidal forces co-exist with other forces of no matter what form or shape and even if they are sufficiently intense to overcome the effect of friction.

By constant friction is meant that case in which the ampli-

Received by the Editor, October, 28, 1925.

*Differential device for the elimination of atmospheric disturbances by damping.

French Patent No. 587,625—December 28, 1923. 1st addition: July 22, 1924—Not granted as yet. 2nd addition: April 8, 1925—Not granted as yet.



NEW METHOD PERTAINING TO THE REDUCTION OF INTERFERENCE IN THE RECEPTION OF WIRELESS TELEGRAPHY AND TELEPHONY*

BY

H. DE BELLESCIZE

(NEUILLY, FRANCE)

I—PRINCIPLES UNDER CONSIDERATION

The opinion of the great majority of the authorities relative to the possibility of reducing atmospheric interference in radio telegraphy and telephony, it seems to us, is summed up to-day, as follows:

Good results can be obtained by employing the differences of direction existing between parasitic currents (static or strays), and signals. To a less degree, phase differences can also be used to secure selectivity at the input of the receiving set. However, in so far as the oscillations created within the receiving set are concerned, no method can equal the judicious use of resonance; in certain cases, however, the devices do not take into account the independence of the oscillations and are, therefore, necessarily doomed to failure.

Even though this last conclusion is, in our judgment, very pessimistic, the impossibility of causing strong discharges superimposed on a continuous oscillation to disappear without at the same time suppressing this oscillation for a more or less prolonged period, seems to us to be axiomatic.

But the accuracy or exactness of this axiom can well be nullified by the method and devices hereafter described. Our point of departure* has been the hypothesis that a moving part retarded by constant friction cannot obey sinusoidal impulses of slight amplitude, even though the sinusoidal forces co-exist with other forces of no matter what form or shape and even if they are sufficiently intense to overcome the effect of friction.

By constant friction is meant that case in which the ampli-

Received by the Editor, October, 28, 1925.

*Differential device for the elimination of atmospheric disturbances by damping.

French Patent No. 587,625—December 28, 1923. 1st addition: July 22, 1924—Not granted as yet. 2nd addition: April 8, 1925—Not granted as yet.

NEW METHOD PERTAINING TO THE REDUCTION OF INTERFERENCE IN THE RECEPTION OF WIRELESS TELEGRAPHY AND TELEPHONY*

BY

H. DE BELLESCIZE

(NEUILLY, FRANCE)

I—PRINCIPLES UNDER CONSIDERATION

The opinion of the great majority of the authorities relative to the possibility of reducing atmospheric interference in radio telegraphy and telephony, it seems to us, is summed up to-day, as follows:

Good results can be obtained by employing the differences of direction existing between parasitic currents (static or strays), and signals. To a less degree, phase differences can also be used to secure selectivity at the input of the receiving set. However, in so far as the oscillations created within the receiving set are concerned, no method can equal the judicious use of resonance; in certain cases, however, the devices do not take into account the independence of the oscillations and are, therefore, necessarily doomed to failure.

Even though this last conclusion is, in our judgment, very pessimistic, the impossibility of causing strong discharges superimposed on a continuous oscillation to disappear without at the same time suppressing this oscillation for a more or less prolonged period, seems to us to be axiomatic.

But the accuracy or exactness of this axiom can well be nullified by the method and devices hereafter described. Our point of departure* has been the hypothesis that a moving part retarded by constant friction cannot obey sinusoidal impulses of slight amplitude, even though the sinusoidal forces co-exist with other forces of no matter what form or shape and even if they are sufficiently intense to overcome the effect of friction.

By constant friction is meant that case in which the ampli-

Received by the Editor, October, 28, 1925.

*Differential device for the elimination of atmospheric disturbances by damping.

French Patent No. 587,625—December 28, 1923. 1st addition: July 22, 1924—Not granted as yet. 2nd addition: April 8, 1925—Not granted as yet.

tude is independent of the velocity of the moving part. Fundamentally, when there is motion, this friction maintains a constant absolute value F and has a tendency to stop the moving part; at rest, it can assume all the values included between plus F and minus F . The forces to which the moving part is subjected are related to the displacements which result from curves which take the form of closed cycles, the ascending and descending branches of which do not coincide (Figure 1). The width of the cycle is equal to $2 F$.

For a familiar example, we can cite the angular motion of a pendulum, the axis of which swings on its pivot. Neglecting the air resistance, the equation of the motion is:

$$G = K \theta'' + D\theta + f \tag{1}$$

G represents the starting couple applied to the pendulum; $K \theta''$ the couple due to inertia; $D\theta$ the couple due to gravity or to the spring; f the opposing couple due to the friction of the pivot. During motion, f maintains the value of F and its sign is that of velocity θ ; at rest, it can assume all values included between minus F and plus F , in such a manner as to maintain the equilibrium between the forces present during an interval of time which may or may not be infinitely small, the graph of the motion will, therefore, eventually have flat places such as aa , bb (Figure 2), even though the applied couple, G , varies continuously.

At the outset, it is evident that if during the course of one of these flat places, a small supplementary couple ΔG , less than F , is momentarily superposed on the main couple, the equilibrium will not necessarily be disturbed; ΔG will have no effect on this case.

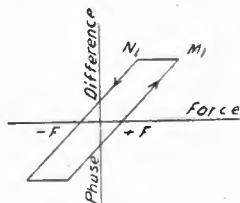

FIGURE 1



FIGURE 2

This idea can be extended. Let us suppose that for any reason whatsoever, which has disappeared, the moving part has passed from the position P_1 to the position P_2 and the equation of motion

$$G = K \theta_1'' + D \theta_1 + f_1 \tag{2}$$

which refers to the index curve (1), has changed to the equation

$$G = K \theta_2'' + D \theta + f_2 \tag{3}$$

which refers to the index curve (2).

The differential movement representing the free oscillation due to the cause which has disappeared is:

$$\theta = K (\theta_2 - \theta_1)'' + D (\theta_2 - \theta_1) + (f_2 - f_1) \tag{4}$$

As long as the velocities θ_1' and θ_2' are not zero, the friction f_2 and f_1 remain constant in absolute value, and equation 4 represents the ordinary sinusoidal oscillation; the peaks of the curves do not lead to any change, even when the maxima or minima of curve (1) do not coincide in time with those of curve (2); this is deduced from the appearance in equation (4) of couples having a definite amplitude ($2F$) and a short duration; therefore, their impulsive effect is negligible. This reasoning leads even further in the case of flat places. One of the two frictions remains constant, whereas the other varies progressively; the impulse now acquires a finite value susceptible of altering the free movement.

The expression for the impulses $\int_0^\infty (f_2 - f_1) dt$, shows that their influence will be proportionately greater as $(f_2 - f_1)_{max}$ —otherwise called F —is itself important in comparison with the elastic couple $D (\theta_2 - \theta_1)$, due to the free movement; and as the duration of the flat places becomes more considerable.

But, in order that there may be such a flat place, it is necessary, θ'' being now zero, that the expression

$$G = D \theta + f$$

be satisfied. That is to say, that the applied couple G balances the elastic couple $D \theta$ within a term included between $-F$ and $+F$.

Such states of equilibrium will occur more frequently and will be more prolonged when the couple G is less periodic and less regular (for aside, from resonance, G and $D \theta$ remain of the same order of magnitude) and when F becomes greater in proportion to the mean value of the couple G and $D \theta$. On the other hand, the instants when the presence of flat places interferes with the regularity of the free oscillation (4), depend upon the form of the couple applied at G . If this form is made non-periodic, there is a similar change on the variation in the free movement, which loses its sinusoidal character and its tendency to develop the resonance phenomena.

Since in such a system a free movement has a good probability of being rapidly destroyed, we are right in concluding that this system will not be susceptible to resonance under the action

tude is independent of the velocity of the moving part. Fundamentally, when there is motion, this friction maintains a constant absolute value F and has a tendency to stop the moving part; at rest, it can assume all the values included between plus F and minus F . The forces to which the moving part is subjected are related to the displacements which result from curves which take the form of closed cycles, the ascending and descending branches of which do not coincide (Figure 1). The width of the cycle is equal to $2F$.

For a familiar example, we can cite the angular motion of a pendulum, the axis of which swings on its pivot. Neglecting the air resistance, the equation of the motion is:

$$G = K \theta'' + D\theta + f \quad (1)$$

G represents the starting couple applied to the pendulum; $K \theta''$ the couple due to inertia; $D\theta$ the couple due to gravity or to the spring; f the opposing couple due to the friction of the pivot. During motion, f maintains the value of F and its sign is that of velocity θ ; at rest, it can assume all values included between minus F and plus F , in such a manner as to maintain the equilibrium between the forces present during an interval of time which may or may not be infinitely small, the graph of the motion will, therefore, eventually have flat places such as aa , bb (Figure 2), even though the applied couple, G , varies continuously.

At the outset, it is evident that if during the course of one of these flat places, a small supplementary couple ΔG , less than F , is momentarily superposed on the main couple, the equilibrium will not necessarily be disturbed; ΔG will have no effect on this case.

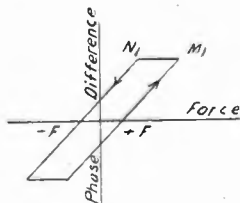

FIGURE 1

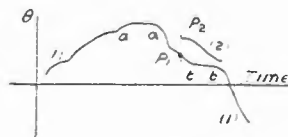

FIGURE 2

This idea can be extended. Let us suppose that for any reason whatsoever, which has disappeared, the moving part has passed from the position P_1 to the position P_2 and the equation of motion

$$G = K \theta_1'' + D \theta_1 + f_1 \quad (2)$$

which refers to the index curve (1), has changed to the equation

$$G = K \theta_2'' + D \theta + f_2 \tag{3}$$

which refers to the index curve (2).

The differential movement representing the free oscillation due to the cause which has disappeared is:

$$\theta = K (\theta_2 - \theta_1)'' + D (\theta_2 - \theta_1) + (f_2 - f_1) \tag{4}$$

As long as the velocities θ_1' and θ_2' are not zero, the friction f_2 and f_1 remain constant in absolute value, and equation 4 represents the ordinary sinusoidal oscillation; the peaks of the curves do not lead to any change, even when the maxima or minima of curve (1) do not coincide in time with those of curve (2); this is deduced from the appearance in equation (4) of couples having a definite amplitude ($2F$) and a short duration; therefore, their impulsive effect is negligible. This reasoning leads even further in the case of flat places. One of the two frictions remains constant, whereas the other varies progressively; the impulse now acquires a finite value susceptible of altering the free movement.

The expression for the impulses $\int_0^\infty (f_2 - f_1) dt$, shows that their influence will be proportionately greater as $(f_2 - f_1) \max.$ —otherwise called F —is itself important in comparison with the elastic couple $D (\theta_2 - \theta_1)$, due to the free movement; and as the duration of the flat places becomes more considerable.

But, in order that there may be such a flat place, it is necessary, θ'' being now zero, that the expression

$$G = D \theta + f$$

be satisfied. That is to say, that the applied couple G balances the elastic couple $D \theta$ within a term included between $-F$ and $+F$.

Such states of equilibrium will occur more frequently and will be more prolonged when the couple G is less periodic and less regular (for aside, from resonance, G and $D \theta$ remain of the same order of magnitude) and when F becomes greater in proportion to the mean value of the couple G and $D \theta$. On the other hand, the instants when the presence of flat places interferes with the regularity of the free oscillation (4), depend upon the form of the couple applied at G . If this form is made non-periodic, there is a similar change on the variation in the free movement, which loses its sinusoidal character and its tendency to develop the resonance phenomena.

Since in such a system a free movement has a good probability of being rapidly destroyed, we are right in concluding that this system will not be susceptible to resonance under the action

of weak sinusoidal couples $\Delta G = A G_0 \sin \omega t$ superposed upon the principle couple G . In fact, resonance signifies a movement produced by a present cause superposed on a movement freely damped due to previous causes.

Let us summarize the conclusions thus far:

In order that friction may stop the transmission of sinusoidal impulses (forces, couples, electromotive forces), superposed on other impulses of much greater amplitude which it is desired to allow to pass, it is necessary that: (1) the friction should be greater than the sinusoidal impulses and not too small in proportion to the others. (2) that these later impulses be as little periodic and as irregular as possible, which is precisely the case of atmospheric disturbances. To the properties, or rather the absence of those properties utilized heretofore for separating or picking out these interferences (absence of direction and regular phase), we add the absence of regularity and definite form. The new method, therefore, goes further into the mechanism of phenomena. Independently of the mechanical devices, it is possible to obtain hysteresis cycles by applying the properties of magnetic metals. The difference between the cycles in Figures 1 and 3 has been attributed** to the fact that as the molecule of the metal is subject to unequal frictions, its orientations require field variations of unequal values. Instead of being equal to unity, which would be the case with the horizontal flat places M_1N_1 of Figure 1, the mean permeability μ_0 of the cycles of small extent is less than those cycles of greater extent.

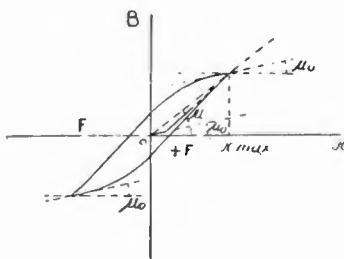

FIGURE 3

This progression in the friction is perhaps a very happy circumstance since it tends to add the width $-F + F$ of the cycle to its own length, which fact facilitates the formation of numerous flat places (or more accurately stated, regions corresponding to less permeability), in the curve of Figure 2.

**The energy losses in dielectrics. M. J. Granier, (Bulletin of the Society of French Electricians. August 1923, No. 28, page 463).

Let us substitute for the idea of friction those which occur relative to the changes or variations of period and permeability, on the strength of what has been stated above. We have thought that a resonance circuit LC (Figure 4 and following), in which the magnetic core acquires permeabilities, μ , greater than the initial permeability, μ_0 , under the influence of intense irregular fields, is no longer likely to resonate under the action of weak sinusoidal electromotive forces.

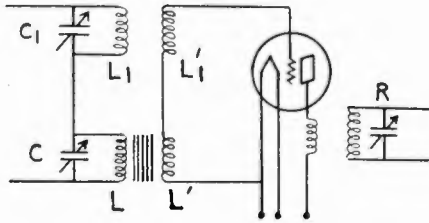

FIGURE 4

This principle defines the type of circuit intended to overcome the interference, and it indicates at the same time the main defect:

The signals being practically destroyed under the influence of the disturbances which is superposed upon them, recourse is made to a differential system. The resonant circuit, LC , having a magnetic core, will allow only the interference to pass; the other circuit L_1C_1 will transmit interference and signals. Superposition of these two outputs in opposite phases will leave the signals only remaining. The resonant circuit R is intended to eliminate the effect of inevitable differences of wave shape caused by parasitic currents from the differential resonant circuits.

The defect of the circuit is evident; as the permeability is a function of the field, each differential stage will stop only those disturbances whose amplitude is well defined or at least included between the rather restricted limits. This difficulty can be reduced, but it cannot be entirely overcome by the means under consideration. For example, one cannot hope to make the parasitic currents ineffective by the detuning eventually due to the variation of the permeability they provoke.

II—THE CONSTRUCTION OF A CIRCUIT

The first problem is so to construct a transformer that the ampere-turns which can be obtained from a receiving tube will appreciably modify the permeability of the magnetic circuit.

The frequency, nature of the metal, and manner of the construction, must be considered in this connection.

The frequency preferably should be fixed, which will permit adjustments (the super-heterodyne circuit is an example of this condition). Also, the frequency should be selected as low as possible in order to increase, at equal intensities, the number of windings of the coil L . The lower limit of the frequency depends, on the one hand, on the maxima time constant imposed on the resonant circuit R by the kind of service (telephony or telegraphy) and on the other hand, on the fact that the logarithmic decrement of this resonant circuit should be much less than that of the circuits LC , L_1C_1 , from which come parasitic currents probably quite dissimilar in forms.

The metal should be so chosen that μ , the permeability which can be attained with the vacuum tube, will be as large as possible in comparison with the initial permeability μ_0 .

Let n = the number of turns on the coil L .

K = its reactance in ohms, adapted to the plate resistance of the tube.

sl = the cross-section and the length of the magnetic circuit, in centimeters.

L_0 = the self-inductance for the permeability μ_0 , in henrys.

ω = the pulsation.

i = the maximum current furnished by the plate circuit, in amperes.

Then, as a first approximation, we can write:

$$L_0 = \frac{K}{\omega} = \frac{4\pi n^2 \mu_0 s}{l} \times 10^{-9}$$

$$H_{max} = \frac{4\pi n i}{10 l} \quad (5)$$

from which

$$H_{max} = 10^{-3} i \sqrt{40\pi \frac{K}{\mu_0 \omega \cdot sl}}$$

The suitability of the metal being determined by using the permeability curve in connection with the formula (5), the best procedure is to make various experiments and tests to determine the influence of the other factors; for instance, the form and period of the hysteresis cycle.

Formula (5) shows the necessity of reducing the cross-section and the length of the magnetic circuit. Although this reduction is limited by the necessity of maintaining the useful

flux which passes through the metal very great in proportion to that which follows other paths, it is possible to obtain dimensions much smaller than those of the ordinary transformers. Figure 5 represents in full size the profile of iron lamination used; almost all of the reluctance is in the branch s_1 which supports the coil, and whose cross-section is of the order of a square millimeter. Such a coil affords a very large number of windings.



FIGURE 5

Once they have been decided upon, the transformers can be used in many different ways. The simplest, if not from the point of view of handling, at least from the point of view of the number of parts and of the necessary tubes, is that shown in Figure 6.

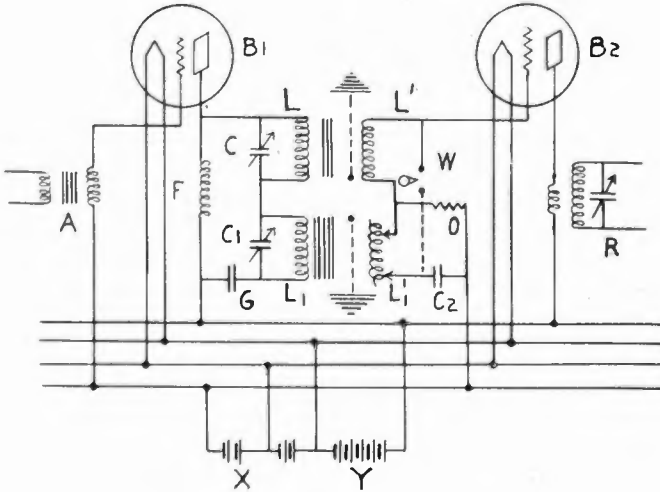

FIGURE 6

In the first place, experience shows the desirability of making the two opposing circuits as nearly identical as possible. With this in mind, we can equalize their own dampings and regulate the two by the same frequency as the rest of the circuit. It is understood that the value selected for the condenser C corresponds to the permeability transmitted to the iron of the coil LL' by the disturbances to be eliminated in that stage.

The presence of the metal introduces in this transformer a certain phase-displacement which can be compensated by winding the other transformer L_1L_1' on a magnetic core also. The core should have a much greater cross-section and length, thus requiring a slight number of windings. Signals and disturbances will then be equally incapable of changing the initial properties of the metal, and everything will pass in relative value as if the metal did not exist.

In order to oppose correctly the secondaries $L'L_1'$ in spite of the capacities distributed along the length of their windings, we have adopted the symmetrical circuit shown in the figure. The capacity C_2 balances that of the grid and the usual resistance O is connected to the middle of the circuit.

The switch W serves to short-circuit one or the other of the transformers for adjustments. The choke coil F and the blocking condenser G prevent the passage of the direct current of the plate through the primaries.

With such a circuit, opposition is obtained when the two resonant circuits are almost exactly tuned in respect to the oscillation to be eliminated, the relative value of the amplitudes are, on the other hand, adjusted by the variation of one of the secondaries L_1' . It is well understood that the batteries $X Y$ allow the tubes B_1B_2 to work in the rectilinear part of their characteristics. It is possible to reduce in many ways the inherent defect in the device, namely, that a stage such as that represented in Figure 6 only nullifies those disturbances the amplitude of which is near a certain value. In the first place several stages will be put in series and adjusted in such a manner as to eliminate oscillations of different intensities. If the abscissas in Figure 7 show the intensities at the input of the receiving device in the absence of any protective device, a certain straight line $O A_1$ will represent the intensities of the output.

A first stage designed to suppress the disturbances B_1 will yield at its output a curve such as that shown at $O A_2$.

If a second stage is added in series with the preceding and adjusted for the amplitudes B_2 , a curve $O A_3$ will result, and so on. From the initial value $O P_1$, the parasitic currents susceptible of confusing the signal S will assume the value $O P_2$.

An amplitude limiter stopping the oscillations of intensity greater than $O P_2$, can still precede the differential stages. The disadvantage of such a device, *i. e.*, that it suppresses simultaneously the signals and parasitic currents when the latter operate the limiter, is effectively reduced in the proportion $O P_2/O P_1$.

Finally, it is theoretically possible to make the transformers $L L'$ such that their cores will maintain a sensible and constant reluctance between two quite extended limits. As a result, there will be an increase of the undulations of the waves represented by the curves $A_2 A_3$ (Figure 7), and consequently an increase in the ratio $O P_2 / O P_1$.

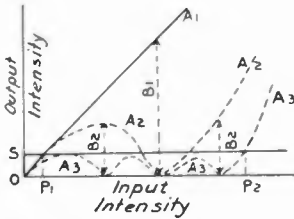

FIGURE 7

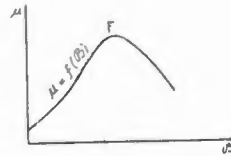

FIGURE 8

The magnetic circuit represented in Figure 5 has in series two branches cross-section and length $s_1 l_1$ and $s_2 l_2$ very unequal. Calling R the total reluctance, $\mu_1 \mu_2$ the permeabilities of the branches, $\mu = f(B)$ the equation of the curve represented in Figure 8, the flux, θ , can be written:

$$\Phi = \frac{4 \pi n i}{R} \quad R = \frac{l_1}{\mu_1 s_1} + \frac{l_2}{\mu_2 s_2} \quad \mu_1 = f\left\{\frac{\Phi}{s_1}\right\} \quad \mu_2 = f\left\{\frac{\Phi}{s_2}\right\}$$

Taking the flux as the independent variable, we deduce $\mu_1 \mu_2 R = i$. The relation between i and R will be valid up to the maximum current value furnished by the tube.

By revising the data $s_2 l_2$, it is possible to conclude by successive approximations that (the branch s_2 working in the ascending portion of the characteristic, whereas the other has gone beyond the elbow F), the increase of reluctance of one compensates within certain limits the decrease of reluctance of the other.

A complete circuit is schematically shown in Figure 9.

$A B$ represents the tuned input to the circuit.

Q_1 is a first detector, D_1 is the heterodyne transforming the high frequency to another, chosen once for all to achieve the desired result. $E_1 E_2$ are resonant circuits much more damped than the resonant circuit R placed after the differential stages. The latter, according to the description in Figure 6, are separated by an amplifier J to facilitate the operation of the second differential stage intended to operate on disturbances of less intensity. The heterodyne D_2 serves for telegraphic reception if the intermediate frequency is chosen in the inaudible range. The rest of the circuit offers nothing unusual.

The adjustment of the intermediate frequency is made once for all, the only adjustment which the operator has to make is that of the rheostat H which assures the necessary sensitiveness in the working of the iron.

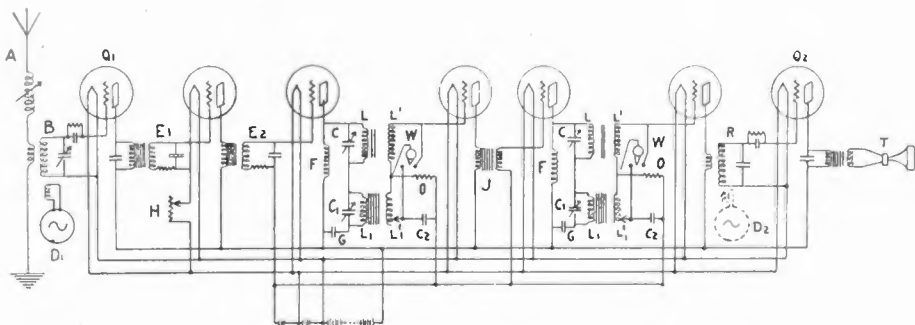

FIGURE 9

III—ADJUSTMENTS AND TESTS

The preliminary study of the transformers LL' consists chiefly in making certain that a strong emission causes an appreciable change in the permeability of the iron. One should use, for example, for this purpose the circuit shown in Figure 10, in which the phase variation and the amplitude changes corresponding to the different intensities read by the aid of a thermocouple S , are measured by an artificial line M half a wave-length long terminated without reflection in a resistance J . The current is supplied by a heterodyne H of which the frequency is that chosen for reception. For each value of the intensity, the sliding contacts P and Q , the first of which measures the phase variations, and the second the amplitudes, are adjusted so as to obtain the complete extinction of the signal. The currents that are too weak are detected by a shunted telephone receiver, taking as a basis of comparison the lowest reading of the thermocouple S . For wave-lengths of the order of 7,000 meters, we have obtained marked phase variations with many samples of steel, and when the plate current did not exceed one milliamper.

Before proceeding to the damped disturbances, it is convenient to study the adjustment of the differential stages with the aid of of continuous local signal of variable intensity and of a wave-length equal to that for which the receiving set is designed. We proceed one stage at a time, the others comprising but one transformer by operating the switch W (Figure 9). With regard to the differential stage under investigation, we must first tune the resonant circuit LC for a faint signal; then we find the point of

extinction of this signal by the operation of condenser C_1 and the secondary L_1' . If the circuit is correct, the adjustment thus found for C_1 should very nearly make the circuit L_1C_1 resonate, which is not to be touched upon in the following. Next, increasing the intensity of the signal, we can determine the values of $C_1'L_1'$, for which the extinctions are the best. The relation existing between these two parameters will be much more difficult to find by means of irregular disturbances.

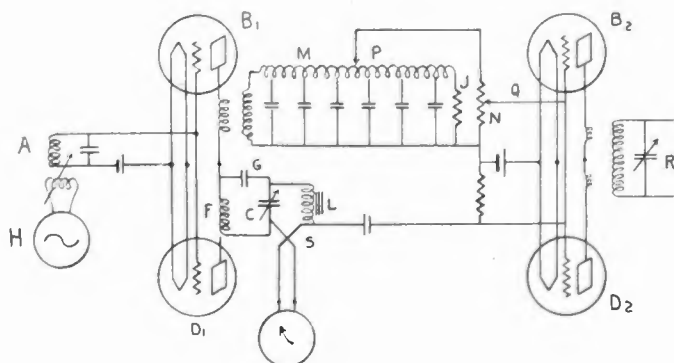

FIGURE 10

It is next easy to adjust simultaneously the two stages in such a manner as to extinguish two different intensities of emissions and to reproduce the curve A_3 of Figure 8. The stage on the left will first be adjusted so as to eliminate a very intense signal; and next the stage on the right to reduce the first undulation of curve A_2 which will appear clearly in continuously reducing the coupling with the local oscillator.

The adjustment obtained in this manner is capable of eliminating the damped disturbances produced, for example, by a musical tune acting on the antenna. With two protective stages, the reading of a signal remains clear under the action of artificial parasitic currents which, in the absence of this device, would necessitate the use of a power 80 times as great. One is especially struck by the impression of the continuity of the signal; this continuity is maintained when one modifies the frequency of the buzzer between the very extended limits, for example, from 50 to 1,000 impulses per second; or when one progressively increases its action upon the antenna up to the value OP_2 (Figure 8), for which the apparatus is adjusted. The presence of the disturbances does not modify in an appreciable manner the intensity of the signal.

Therefore one is led to believe that, no matter what the

continuity of the atmospheric disturbances, signals will pass through them all right just as if the power of the sending station had been effectively increased; the few tests that have been performed up to this date are encouraging, and the storms of the coming summer will suffice to determine this point.

These various results have been obtained for telegraphic signals, received with two heterodynes. In telephony, the adjustments are very much more delicate and the tests heretofore have been less successful. The obstacles encountered are due, it seems, to two principal causes. To improve the tuning, there is a tendency to exaggerate the constant time of the last tuned circuit, which can resonate unequally (and consequently cannot function correctly) even though the words and the music seem properly rendered. On the other hand, the quality of the signal requires a very weak modulation of the carrier wave, in accordance with the well-known expression:

$$S(1 + a \sin \Omega t) \cdot \sin \omega t$$

we have to operate on a signal of reduced power ($S \cdot a \sin \Omega t \cdot \sin \omega t$) which must be picked out from atmospheric disturbances despite the permanent disturbance of another oscillation ($S \sin \omega t$) which is much more intense.

Therefore, we shall see this problem adds further and new difficulties. Let us add that in the present case there is, without doubt, an excellent solution.

The influence of the disturbances originating from signals superposed on that to be received constitutes the weak point of the present device, and this fact has been examined with care. The working process consists in superposing on a signal of constant intensity and wave-lengths a disturbance (fog) of variable intensity and wave-length, the two signals being furnished by two sending stations. The intensities are measured by means of the shunted telephone receiver, before and after the differential stages. It includes the rheostat H (Figure 9), which assures the proper sensitiveness; these stages are adjusted, as it has been stated above, in order to assure the best elimination of the parasitic currents. The measurement of the wave-lengths in the intermediate frequency part of the receiving circuit is accomplished by the extinction of the musical note due to the interference of the calibrating heterodyne D_2 . Note (1) the wave-lengths $\lambda_B \lambda_s$ of the interference and of the signal; (2) the relation I_B/I_s of their intensities in the circuit preceding the differential circuits; (3) the weakening I_1/I_2 of the signal dis-

turbance; I_1 being the intensity with the disturbance, and I_2 that without disturbance.

There results a family of curves. The most interesting results are those of which Figure 11 gives an example; the wave-lengths of the disturbance are plotted as abscissa, the curve (X) gives the relative intensities I_B/I_s for which the disturbance begins to weaken the signal; the curve (B) the relative intensities for which the weakening of the signal is a maximum, the values of these reductions being written in parenthesis. For more energetic disturbances, the intensity of the signal increases rapidly, and it may even exceed that observed in the absence of the disturbance.

This example relates to a differential circuit adjusted once and for all in such a manner as to eliminate sustained oscillations of the same frequency as the signal and of intensities from 10 to 80 times greater, which conditions correspond very well to the attenuation of the parasitic currents, having given the respective constant time of the resonant circuits placed before and after the differential stages. This example is not absolute; the data are likely to vary with the adjustment of the apparatus. Nevertheless, one can deduce some observations.

The selective power of the circuits following the differential stages is limited to a certain maximum, about 10 in the example stated above; this however is not important in respect to the eliminations of the waves close to the signal in frequency, nor for the waves very different in frequency against which one can be protected by the aid of tuned circuits at the input, but there do exist on either side of λ_s , two narrow frequency bands inside of which the selectivity of the receiving set is practically diminished. We note this fact without having met any case where it has had any detrimental effect.

As a counter-measure, the circuit permits the elimination of certain disturbances against which we would otherwise be absolutely unable to cope. When, for example, a stage is very closely adjusted so as to extinguish completely a powerful disturbance which has nearly the same wave-length as the signal, the latter can still be received in the form of beats, marking, without doubt, its phase variations in respect to the disturbances; when there is coincidence or opposition, the signal being confused with the disturbance is stopped at the same time as the disturbance by the differential stage; in quadrature, on the contrary, it passes freely. The mean reduction of signal intensity is now about equal to 2. One therefore foresees the value of a

stage in which the parts can be adjusted by the operator, and especially intended for the elimination of the disturbances.

The weakening of a signal by a disturbance would have no great importance if in no case the value 2 were exceeded; this is what one would hope for. Figure 11 shows that unfortunately this is not the case. It can be seen, although not as yet explained,

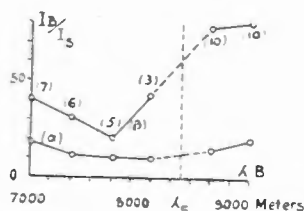

FIGURE 11

that the maxima in weakening seem to increase as one departs from λ_s . Besides, the curves I and II are not symmetrical in respect to this wave-length; which is caused without doubt by the fact that the circuits LC and $L_1 C_1$ not being identical at every point, a good position demands that one of them should be slightly out of tune.

SUMMARY: The usefulness of directional reception and of resonant circuit selectivity in reducing the effect of atmospheric disturbances of reception is first considered.

Assuming that sinusoidal forces coexist in a system with much larger impulses, it is shown that the sinusoidal forces will not pass through systems having internal frictional losses under certain definite conditions. The analogy between mechanical frictional systems and magnetic hysteretic systems is utilized in devising differential circuit arrangements whereby strong impulses, passing through two opposing circuits of controllable hysteric damping, are ultimately balanced out, whereas smaller sinusoidal currents are delivered at the output of the system. The application to radio reception is described in detail.

DIGESTS OF UNITED STATES PATENTS RELATING TO RADIO
TELEGRAPHY AND TELEPHONY*

Issued January 5, 1926—March 2, 1926

By
JOHN B. BRADY

(Patent Lawyer, Ouray Building, Washington, D. C.)

1,568,065—ROSS GUNN, filed June 9, 1923, issued January 5, 1926, resident of Dayton, Ohio.

CONSTANT FREQUENCY SOURCE, wherein a plurality of electron tubes are arranged in a common control circuit with impedances so disposed therein that the frequency of the generated oscillations is not dependent upon the plate voltage or filament currents in the system.

1,568,172—F. S. McCULLOUGH, filed May 6, 1925, issued January 5, 1926, resident of Wilkesburg, Pennsylvania.

THERMIONIC TUBE, in which an auxiliary heater is provided within the tube for raising the cathode element to an electron emitting temperature.

1,568,274—D. GRIMES, filed May 18, 1922, issued January 5, 1926, assigned to Grimes Radio Engineering Company, Incorporated.

CONDENSER where a set of stationary and movable plates is varied in position longitudinally with respect to each other for varying the effective capacity of the condenser.

1,568,632—L. Q. SLOCUMB, of Ferguson, Missouri, filed January 2, 1924, issued January 5, 1926.

RADIO RECEIVING APPARATUS having a single control for variation of both capacity and inductance in the tuning circuit of the receiver.

1,568,701—J. C. WARNER, filed March 5, 1925, issued January 5, 1926, assigned to General Electric Company of New York.

ELECTRON DISCHARGE DEVICE, in which a tube having two grids interposed between the anode and cathode is provided with a coupling between the grid circuits for facilitating the production of oscillations.

1,568,827—W. H. GERNS, filed June 21, 1924, issued January 5, 1926, assigned to Brandes Laboratories, Incorporated, of Newark, New Jersey.

APPARATUS FOR TESTING TELEPHONE RECEIVERS, for the production of telephone receivers or loud speaker units and the inspection of such devices for the rejection of defective units without loss of time on the part of the operator.

1,568,918—E. PFIFFNER, of Frybourg, Switzerland, filed March 19, 1923, issued January 5, 1926.

ELECTRIC CONDENSER, constructed of dielectric material having metal coatings thereon which are spacially related for building up a condenser structure.

1,568,939—E. E. CLEMENT, filed August 14, 1922, issued January 5, 1926, assigned to Edward F. Colladay, Washington, D. C.

SYSTEM FOR RADIO BROADCAST DISTRIBUTION, wherein a central station is provided for controlling the operation of a plurality of receivers in a community adjacent a broadcasting station.

1,568,979—V. O. KNUDSEN, filed September 3, 1921, issued January 12, 1926, assigned to Western Electric Company, Incorporated, New York.

OSCILLATION GENERATOR, where the input and output circuits

* Received by the Editor, March 11, 1926.

- are controlled through a common switching system for simultaneously varying the constants of the circuits.
- 1,569,095—C. A. LAISE, filed November 21, 1923, issued January 12, 1926, assigned to Electron Relay Company, of Ohio.
BODY OF HIGH ELECTRON AND LIGHT EMISSION AND PROCESS OF MAKING THE SAME, for use as electron emitting elements for electron tubes where tungsten, thorium and vanadium having the crystals thereof interspersed with grains of difficultly reducible refractory oxides, is provided.
- 1,569,211—E. W. SPENCER, of Hemple, Missouri, filed May 16, 1924, issued January 12, 1926.
VARIABLE CONDENSER, where the movable plates are adjusted longitudinally with respect to the stationary plates.
- 1,569,325—A. LEIB, filed August 8, 1922, issued January 12, 1926, assigned to Gesellschaft fur Drahtlose Telegraphie m.b.h. of Berlin, Germany.
RADIO DIRECTION FINDER for shipboard installation where the frame of the direction finder coil is supported in a rockable bearing with a counter-weight for maintaining the direction finder coil substantially in one plane at all times.
- 1,569,353—Q. A. BRACKETT, filed August 5, 1919, issued January 12, 1926. Assigned to Westinghouse Electric & Manufacturing Company.
RADIO RECEIVING SYSTEM, employing a construction of electron discharge tube in which the incoming signal receiving circuit is arranged to directly influence the electron discharge within the tube.
- 1,569,354—L. T. CARL, et al of Winona, Mississippi, filed January 21, 1924, issued January 12, 1926.
RADIO RECEIVING SET having parts arranged in such close relationship that bus wires are eliminated.
- 1,569,384—R. E. MARBURY, filed August 3, 1921, issued January 12, 1926, assigned to Westinghouse Electric & Manufacturing Company of Pennsylvania.
CONDENSER of stacked construction where the plates are secured under pressure by means of bowed spring clamps.
- 1,569,395—R. E. MARBURY, filed August 18, 1921, issued January 12, 1926, assigned to Westinghouse Electric & Manufacturing Company, of Pennsylvania.
CONDENSER CASING for enclosing a stacked condenser unit where telescopic parts are provided and welded together over the condenser stack.
- 1,569,446—T. E. ARUNDEL, filed March 12, 1925, issued January 12, 1926, assigned to G. D. Shipperd and W. H. Metcalf, of Omaha, Nebraska, 37½ percent and 25 percent respectively.
RADIO RECEPTION APPARATUS, including a crystal detector having a plurality of points engaged with the crystal surface forming the rectifier element in the receiving set.
- 1,569,630—T. R. GRIFFITH, filed December 12, 1923, issued January 12, 1926, assigned Western Electric Company, Incorporated, of New York.
ELECTRON DISCHARGE DEVICE of high power construction where the electrodes are carried on metallic rods spaced apart by an insulating block.
- 1,569,766—D. H. MOSS, filed February 27, 1925, issued January 12, 1926, assigned to Brandes Laboratories, Incorporated, of Newark, New Jersey.
TERMINAL FOR TELEPHONE RECEIVERS, where a locked stud is provided in the casing of the telephone receiver or loud speaker unit for establishing connection between the bobbins within the unit and the exterior of the unit.
- 1,569,835—E. W. KELLOGG, filed January 30, 1925, issued January 12, 1926, assigned to General Electric Company of New York.
RADIO TRANSMISSION SYSTEM, arranged with a distributed load whereby current may be supplied from a transmission line at a plurality of points along its length without producing any refractions.

- 1,570,261—A. J. KLONECK, of New York, N. Y., filed May 12, 1921, issued January 19, 1926.
SIMULTANEOUS SENDING AND RECEIVING SYSTEM, wherein switching means are provided for transferring the circuits of the apparatus to various types of antennae systems.
- 1,570,265—K. A. LEBBINK, filed July 5, 1923, issued January 19, 1926, assigned to Naamlooze Vennootschap Philips' Gloeilampenfabriken, of Eindhoven, Netherlands.
ELECTRODE FOR DISCHARGE TUBES, where successive turns of coiled electrode are supported in a slotted bar member, the slots of which are substantially closed for anchoring the turns therein.
- 1,570,444—A. MAVROGENIS, of Milwaukee, Wisconsin, filed December 26, 1923, issued January 19, 1926.
RADIO APPARATUS, in which an electron tube having a multiplicity of electrodes is connected in a circuit for simultaneous rectification of incoming signaling energy. The tube operates from the alternating current lighting source.
- 1,570,499—J. F. KEANE, of Bridgeport, Connecticut, filed February 28, 1924, issued January 19, 1926.
RADIO BATTERY CHARGING SWITCH MEANS for A and B batteries wherein a convenient circuit is provided for switching the battery units from a position of charge to a position for power consumption.
- 1,570,755—O. H. LOVNES, filed August 22, 1923, issued January 26, 1926, assigned to American Telephone & Telegraph Company of New York.
RADIO RINGING SYSTEM, wherein circuits are provided for interrupting a radio frequency at a ringing frequency for operating a vibrating polar relay at a radio receiver for actuating a call device.
- 1,570,959—J. O. GARGAN, filed January 16, 1924, issued January 26, 1926, assigned to Western Electric Company, Incorporated, of New York.
TUBE MOUNTING for high power operation where the tube is surrounded by a water jacket and cooling circulating water supplied therearound.
- Design 69,280—DAVID H. MOSS, filed August 21, 1925, issued January 19, 1926. Assigned to Brandes Laboratories, Incorporated, of Newark, New Jersey.
CASING FOR A PHONOGRAPH LOUD SPEAKER UNIT, which may be mounted directly upon the table of a phonograph adjacent the record support and attached to the tone arm for utilizing the phonograph as a radio reproducer.
- 1,571,011—B. W. KENDALL, filed December 3, 1920, issued January 26, 1926. Assigned to Western Electric Company, Incorporated, of New York.
SECRET SIGNALING, where a carrier wave modulated in accordance with speech is radiated and an inverted speech frequency band superimposed thereupon and properly distributed at the receiver.
- 1,571,020—W. D. MCGOWAN, of Jersey City, New Jersey, filed September 16, 1922, issued January 26, 1926.
CRYSTAL DETECTOR FOR RADIO TELEPHONY AND TELEGRAPHY, in which a rectifier element is supported between bristles which extend inwardly from opposite ends of a tube.
- 1,571,050—W. H. GERNS, filed April 29, 1925, issued January 26, 1926. Assigned to Brandes Laboratories, Incorporated, Newark, New Jersey.
ELECTROMAGNETIC DRIVING APPARATUS for operation of cone speakers or loud speakers, where a push-pull sound reproducer unit is provided for actuating a common armature member for the production of sound.
- 1,571,257—H. M. FREEMAN, filed August 18, 1921, issued February 2, 1926. Assigned to Westinghouse Electric & Manufacturing Company of Pennsylvania.
GRID LEAK formed by inside and outside metallic film coatings which are deposited upon the walls of an electron tube.

- 1,571,278—L. KUHN, filed August 26, 1921, issued February 2, 1926. Assigned to Westinghouse Electric & Manufacturing Company of Pennsylvania.
CONNECTION FOR PRODUCING OSCILLATIONS WITH VACUUM TUBES, where the input and output circuits of a tube each contain adjusting devices which may be simultaneously changed for controlling the oscillations.
- 1,571,370—G. H. CLARK, filed March 3, 1921, issued February 2, 1926. Assigned to Radio Corporation of America of Delaware.
VARIABLE CONDENSER, wherein the rotor plates of the condenser may be moved longitudinally with respect to the stator plates at the same time that rotative motion of the plates may be obtained.
- 1,571,371—G. H. CLARK, filed March 17, 1921, issued February 2, 1926. Assigned to Radio Corporation of America of Delaware.
RADIO SIGNALING APPARATUS, where a continuous wave transmitter is provided with an absorbing circuit for diverting portions of the signaling energy during non-signaling periods with means for super-imposing emf. of low frequency on the main emf. in the antenna circuit for the production of signals.
- 1,571,373—N. E. DAVIS, filed December 3, 1921, issued February 2, 1926. Assigned to Radio Corporation of America of Delaware.
RADIO TRANSMITTING APPARATUS, in which telegraphic signals are radiated by virtue of a key circuit which effectively shunts a portion of an inductance which is coupled to the antenna circuit while the radiated frequency remains constant.
- 1,571,463—V. K. ZWORYKIN, filed July 19, 1921, issued February 2, 1926. Assigned to Westinghouse Electric & Manufacturing Company of Pennsylvania.
OSCILLATION GENERATOR SYSTEM, in which a plurality of electrodes are arranged in an evacuated envelope in a position where the electrodes extend along radial lines from the center of the tube. Excitation of the tube may be obtained from single phase or polyphase sources of energy for the generation of high frequency current.
- 1,571,499—J. H. THOMPSON, of Hollidays Cove, West Virginia, filed November 17, 1924, issued February 2, 1926.
ELECTRON DISCHARGE DEVICE, wherein a pair of anodes and a pair of separate filament electrodes are arranged in the tube with separate terminals brought out from the tube base.
- 1,571,501—VANDEVENTER, filed June 25, 1923, issued February 2, 1926. Assigned to Dubilier Condenser & Radio Corporation of New York, N. Y.
ELECTRICAL CONDENSER, consisting of annular outwardly conductive and insulated plates which are secured together by a lead rivet passing through the center thereof.
- 1,571,512—W. DUBILIER, filed January 31, 1924, issued February 2, 1926. Assigned to Dubilier Condenser & Radio Corporation, of New York, N. Y.
ELECTRICAL CONDENSER of the stacked type where the terminals which provide connections for the opposite plates of the condenser also serve to exert pressure on the stack.
- 1,571,900—F. L. LORD, filed March 12, 1925, issued February 2, 1926. Assigned one-half to Harry J. Lucke, of New York, N. Y.
TUNED RADIO FREQUENCY RECEIVING SYSTEM, where the intervalve transformers have means for varying the capacity reactance therein and for varying the self-inductance of each primary winding and the mutual inductance of each transformer. The circuit is arranged for eliminating objectionable feedback oscillations.
- 1,571,907—T. G. McCLANAHAN, of Seattle, Washington, filed March 29, 1924, issued February 2, 1926.
DETECTOR of the crystal type where the entire rectifier is housed within an insulated body structure which may be readily mounted within the radio receiver.
- 1,571,948—W. G. HOUSEKEEPER, filed June 9, 1922, issued February 9, 1926. Assigned to Western Electric Company, Incorporated, of New York.

ELECTRON DISCHARGE DEVICE, in which connections are provided for passing a cooling fluid around the anode of a high power tube.

1,572,204—J. H. HAMMOND, JR., of Gloucester, Massachusetts, filed August 20, 1917, issued February 9, 1926.

MEANS FOR LIMITING THE EFFECT OF STATIC OR OTHER DISTURBANCES IN RADIO TELEGRAPHY, which consists of a magnetizing element placed in the grid circuit of an electron tube and arranged for preventing excessive currents due to static from detrimentally effecting the receiving circuit.

1,572,244—E. B. NOWOSIELSKI, filed April 12, 1922, issued February 9, 1926. Assigned to Splittdorf Electrical Company, of Newark, New Jersey. **CONDENSER**, which is substantially enclosed by insulating material which wholly clamps around the condenser stack.

1,572,504—H. PERLESZ, filed October 22, 1924, issued February 9, 1926. Assigned to Zenith Radio Corporation of Illinois.

ELECTROSTATIC CONDENSER of variable rotary plate construction, where the stator plates are mounted in a casting which also provides bearings for the shaft which carries the rotary plates.

1,572,530—W. F. HENDRY, filed December 28, 1918, issued February 9, 1926. Assigned to Western Electric Company of New York.

VACUUM TUBE, in which the terminals of the electron tube are supported in a plate of insulating material which is gripped in a metallic shell which surrounds the base of a vacuum tube.

1,572,604—C. HORTON, filed September 3, 1924, issued February 9, 1926. Assigned to Dubilier Condenser & Radio Corporation, New York.

RADIO CONDENSER of the stacked type where the stack may be secured in various positions by means of bent strip members which engage the terminals of the condenser and form supports therefor.

1,572,721—W. G. HOUSEKEEPER, filed December 11, 1920, issued February 9, 1926. Assigned to Western Electric Company, Incorporated, New York.

VACUUM TUBE, in which the elements are mounted from an insulated block by resilient members for taking up mechanical vibration to which the electrodes might otherwise be subjected.

1,572,726—M. J. KELLY, filed August 31, 1922, issued February 9, 1926. Assigned to Western Electric Company, Incorporated, of New York.

ELECTRON DISCHARGE DEVICE, where the cathode is prevented from vibrating by means of a pair of insulating members which grip the cathode intermediate its ends to prevent vibration thereof.

1,572,773—ALFRED CROSSLEY, of Washington, D. C., filed November 24, 1924, issued February 9, 1926. Assigned to Wired Radio, Incorporated, of New York, a corporation of Delaware.

PIEZO ELECTRIC CRYSTAL APPARATUS, where a piezo electric crystal for controlling the frequency of a transmitting station is mounted in such manner that the mechanical vibrations thereof may be utilized to control the frequency of an electron tube oscillator.

1,572,877—M. C. BATSEL, filed October 4, 1922, issued February 16, 1926. Assigned to Westinghouse Electric & Manufacturing Company of Pennsylvania.

RADIO RECEIVING APPARATUS, in which the electron tube support within the receiver is resiliently mounted from opposite ends and the movement of the electron tube socket support maintained within given lengths.

1,572,882—E. W. BREISCH, filed November 9, 1918, issued February 16, 1926. Assigned to Westinghouse Electric & Manufacturing Company of Pennsylvania.

HOT CATHODE APPARATUS, where the cathode is maintained in an electron emitting condition by energy which is supplied at separated points of the cathode and the relative amount of current passing through the cathode accurately governed.

- 1,572,897—R. E. MARBURY, filed December 14, 1920, issued February 16, 1926. Assigned to Westinghouse Electric & Manufacturing Company, of Pennsylvania.
VARIABLE CONDENSER, in which corrugated spacer washers are interposed between adjacent condenser plates for supporting the plates in fixed relationship.
- 1,572,910—A. L. WILSON, filed April 21, 1921, issued February 16, 1926. Assigned to Westinghouse Electric & Manufacturing Company of Pennsylvania.
THERMIONIC DEVICE, in which one electrode of the electron tube is embedded within the wall of the electron tube.
- 1,573,171—F. R. KRONFOTH, of Amsterdam, New York, filed February 12, 1925, issued February 16, 1926.
RADIO ANTENNA, having means for compensating for the contraction and expansion of the antenna under conditions of variable temperature.
- 1,573,303—E. H. COLPITTS, filed November 2, 1920, issued February 16, 1926. Assigned to Western Electric Company, Incorporated, of New York.
CARRIER WAVE TRANSMISSION, by which a plurality of messages are transmitted simultaneously and selectivity separated by tuned circuits at a receiver.
- 1,573,317—W. H. HOUSEKEEPER, filed June 2, 1922, issued February 16, 1926. Assigned to Western Electric Company, Incorporated, of New York.
MANUFACTURE OF VACUUM TUBES, where the tubes are sealed off while a space current is supplied to the tube circuits for releasing occluded gases from the electrodes of the tubes.
- 1,573,367—H. DEF. ARNOLD and J. P. MINTON, filed November 12, 1917, issued February 16, 1926. Assigned to Western Electric Company, Incorporated, of New York, N. Y.
METHOD OF GENERATING AN ALTERNATING CURRENT OF VARIABLE FREQUENCY, in which an oscillator has its constants cyclically and continuously varied for producing a variable frequency.
- 1,573,374—P. A. CHAMBERLAIN, filed July 2, 1924, issued February 16, 1926. Assigned to Electrical Dealers Supply House, Incorporated, of Chicago, Illinois.
RADIO CONDENSER, including a plurality of condenser units which are separated one from another by an intervening plate supported from the frame which carries the condenser units.
- 1,573,789—M. OSNOS, filed July 11, 1923, issued February 16, 1926. Assigned to Gesellschaft fur Drahtlose Telegraphie m.b.h. Hallesches, of Germany.
TRANSMITTING ARRANGEMENT FOR RADIO SIGNALING, including a static frequency changer which is modulated in accordance with speech or telegraphic signals for radiating signaling energy.
- 1,573,801—R. BOWN, filed October 5, 1923, issued February 23, 1926. Assigned to American Telephone & Telegraph Company of New York, N. Y.
TROUBLE ALARM SYSTEM FOR RADIO RECEIVING SETS, where local signal may be transmitted periodically to a receiving set for determining the operating condition of the receiver.
- 1,573,852—W. J. O'LEARY, of Montreal, Quebec, Canada, filed April 5, 1920, issued February 23, 1926.
HIGH FREQUENCY OSCILLATING DEVICE, where a condenser in the form of a primary and secondary coil is provided. The condenser is built up of primary and secondary elements in sheet formation spirally wound.
- 1,573,948—D. M. TERRY, filed November 21, 1925, issued February 23, 1926. Assigned to Western Electric Company, Incorporated, of New York, N. Y.
MEANS FOR PRODUCING OSCILLATIONS of constant frequency with means for stabilizing the oscillator circuit for rendering the oscillator insensitive to impedance changes.

- 1,573,983—R. C. MATHES, filed August 8, 1923, issued February 23, 1926. Assigned to Western Electric Company, Incorporated, of New York, N. Y. **SECRET SIGNALING**, where a plurality of transmission paths are arranged with a distributor and a storage element for simultaneously impressing on the paths successively produced message current components which are unscrambled at the receiver.
- 1,573,984—J. P. MAXFIELD, filed June 9, 1922, issued February 23, 1926. Assigned Western Electric Company, Incorporated, of New York, N. Y. **RADIO BROADCASTING EQUIPMENT**, where a distortionless air damped transmitter having a diaphragm whose natural period of vibration is not substantially less than 400 periods per second. The patent shows circuits for monitoring the audio frequency input power of a radio transmitter.
- 1,574,209—P. M. SMITH, filed June 4, 1924, issued February 23, 1926. Assigned to United States Tool Company, Incorporated, Newark, New Jersey. **STATOR FOR VARIABLE CONDENSERS**, where the stator plates are supported on screw-threaded posts with tubular insulated members supporting the posts.
- 1,574,268—B. R. WEBSTER, filed April 28, 1924, issued February 23, 1926. Assigned to Reliance Die & Stamping Company, of Chicago, Illinois. **ELECTRICAL CONDENSER**, in which an end thrust bearing is provided for supporting the rotor plates of a condenser in desired spacial relationship with respect to the stator plates.
- 1,574,424—H. A. HATCH, filed October 16, 1920, issued February 23, 1926. Assigned to Splittdorf Electrical Co., of Newark, New Jersey. **CONDENSER**, in which alternate layers of mica and conductive plates are secured under pressure in a stack by means of clamping terminals which exert pressure on the cover plate of the condenser stack.
- 1,574,472—H. F. Elliott, filed June 22, 1921, issued February 23, 1926. Assigned to Federal Telegraph Company, of California. **RADIO FREQUENCY ARC**, where means are provided for adjusting the arc electrodes so as to produce optimum value as regards the arc output. Mechanical means are provided responsive to vibrations beyond definite limits of the voltage drop across the electrodes for moving the electrodes relative to each other.
- 1,574,473—H. F. ELLIOTT and J. ARTHUR MILLER, filed January 9, 1922, issued February 23, 1926. Assigned to Federal Telegraph Company, of California. **RADIO FREQUENCY SYSTEM**, in which the frequency of an arc transmission system is maintained constant by providing a plurality of parallel paths for the current in the antenna circuit with means for insuring that there be no cross currents in the parallel paths.
- 1,574,715—C. E. WARNER, filed May 18, 1925, issued February 23, 1926. Assigned to Benjamin Electric Manufacturing Company, of Illinois. **CONDENSER**, where the rotor shaft which supports the rotor plates of a variable condenser is supported in a thrust bearing arranged in the frame from which the stator plates are supported.
- 1,575,013—J. SLEPIAN, filed August 18, 1921, issued March 2, 1926. Assigned to Westinghouse Electric & Manufacturing Company of Pennsylvania. **RADIO INTERFERENCE PREVENTION** means for application to flue-gas treaters or electromagnetic precipitating devices. A flue-gas treater is provided with a circuit for preventing high frequency radiation from the treater to prevent interference with local radio operations.
- 1,575,044—W. DUBILIER, filed May 24, 1921, issued March 2, 1926. Assigned to Dubilier Condenser & Radio Corporation, of New York, N. Y. **ELECTRICAL CONDENSER**, where the plates of a condenser stack are maintained under pressure by a clamping device which fits within the condenser casing.

- 1,575,045—W. DUBILIER, filed February 14, 1924, issued March 2, 1926. Assigned to Dubilier Condenser & Radio Corporation, of New York, N. Y. **ELECTRICAL CONDENSER** of the stacked type wherein a clamping device is provided for exerting pressure on the stack and for maintaining the stack in such position that electrical connections may be made with the terminals of the condenser independently of the clamp.
- 1,575,067—L. B. LAMBERT, filed February 17, 1925, issued March 2, 1926, resident of Wichita, Kansas. **FUNCTIONING PARTS OF MINERAL TYPE DETECTORS**, where the contact member for a crystal detector is provided with a weight for maintaining the contact member in position with respect to the crystal.
- 1,575,340—C. W. HOUGH, filed February 25, 1924, issued March 2, 1926. Assigned to Wired Radio, Incorporated, of New York, N. Y., a corporation of Delaware. **WIRED RADIO RECEIVING APPARATUS**, designed for protection of the receiving circuits against breakdown arising from the destructive effects of the power lighting circuit which extends into the receiver and over which the wired radio programs are broadcast. This patent covers the type of wired radio receiver installed in the wired radio installation on Staten Island.
- 1,560,505—ROBERT D. DUNCAN, JR., filed May 19, 1925, issued November 3, 1925. Assigned to Wired Radio, Incorporated, of New York, N. Y., a corporation of Delaware. **METHOD OF CARRIER FREQUENCY SUPPRESSION**, wherein a polyphase source of high frequency current is employed for transmission of signals and radiation secured by unbalancing one of the phases.