

features**29 Spectral lines: What could IEEE do as an economic-interest group?**

David DeWitt, Editor

When so much of the rest of the population is organized in economic-interest blocs, why should electrical engineers relinquish the same kind of protection? If such groups exist for some, presumably all must join in self-defense

30 The productive society

Patrick E. Haggerty

The apparent ease with which we have eliminated time and space gives the average citizen an exaggerated impression of the power of our technology and convinces him we could solve all our problems, if we but had the will to do so

40 Electricity in hospitals: elimination of lethal hazards

Gordon D. Friedlander

The danger of electric shock in hospitals, to both patients and staff, is becoming a matter of increasing concern to physicians, equipment manufacturers, and biomedical engineers

52 Statements from IEEE candidates

What the IEEE accomplishes in the near future depends very much on the men we elect this fall; to help our members vote effectively we have asked the various candidates to make statements concerning their beliefs about IEEE, their intentions, and their qualifications

63 Special applications report: Computer aids for IC design, artwork, and mask generation

Charles W. Beardsley

This special applications report surveys the automation services that minimize drudgery and reduce errors in the design, layout, and fabrication of semiconductor devices. Whether it's an interactive station, a digitizer, or a software package, CAD promises to make punched-card shuffling a thing of the past

80 Marketing as an engineering career

Myron Nichol, M. A. Cuevas

One man's view of marketing Charles W. Beardsley

Marketing engineers require not only technical competence, but an awareness of human relations. Industrial orientation programs can clear up many of the misconceptions held by undergraduate EEs about their role in this field



Copyright © 1971 by
THE INSTITUTE OF ELECTRICAL AND ELECTRONICS ENGINEERS, INC.

General Electric uses Collins MOS services for first-pass success



TermiNet 300 Teleprinter

GE's TermiNet 300 Teleprinter is whisper quiet and twice as fast as conventional printers. Advanced MOS circuitry minimizes size, maximizes versatility, reliability, and maintainability. Inset shows automated layout of GE's random logic MOS/LSI array.

General Electric engineers used Collins automated services to design a random logic chip for GE's new TermiNet® 300 Teleprinter.

After a two-week familiarization course, they followed the step-by-step computer transactions to translate their design logic into the digital data which directs the highly-automated teleprocessing and teleproduction operations.

Utilizing predesigned cells, Collins teleprocessing (design) services executed the logic simulation, automated layout and routing, and test generation programs. The teleproduction (build) services digitally generated the photomasks, controlled the wafer fabrication, produced the test tooling and characterization sequences, and packaged the MOS/LSI prototypes.

The 150- x 160-mil chip performed as predicted, and yielded 39 percent at wafer level in initial test. This first-pass success is typical of the fast turn-around time, low cost, and predictable results of Collins C-System automated MOS/LSI design and processing services.

*Trademark General Electric Company, U.S.A.



COMMUNICATION / COMPUTATION / CONTROL

Circle No. 3 on Reader Service Card



Spectral lines

What could IEEE do as an economic-interest group?

Times are hard and it has been proposed that the IEEE be transformed into an economic-interest group in the United States. The U.S. scene is well populated with such groups, some of them very successful. The American Medical Association, many unions, and the lobbies that have helped preserve depletion allowances and farm subsidies are conspicuous examples of success. When so much of the rest of the population is organized in economic-interest blocs, why should electrical engineers relinquish the same kind of group protection? The existing economic and legal practices make such groups legitimate and, if they exist for some, then presumably all must join in self-defense. Let us assume that IEEE is re-missioned as an economic-interest group and consider the ways in which it can function.

For 20 years electrical engineers were a favored economic group, eagerly wooed by employers in an environment of expanding opportunity. The reason lay in the rapid expansion of electronics in the '50s and '60s. That expansion was based on new technical competences that required a large engineering contribution for their rapid exploitation. The original IEEE mission was a significant contributor to that rapid development. The publications and meetings of those years were important in the widespread dissemination of the rapidly growing new arts. We have so many electrical engineers because of this basic ability to contribute. Any bargaining power we have with society rests on it. It is clear that IEEE must continue to foster the discovery of new ways in which we can contribute, and support our competence in those new ways. Another set of opportunities comparable to semiconductors and data processing could make the rest of this discussion of little interest to most of our members.

The improvement of pension schemes is a proposed activity for our new economic-interest group. There are two approaches—employer compulsion and new legislation. The pension schemes in the U.S. can be improved by legislation to make them like a Social Security System with options for larger pensions. The essential features are independence from employment history and protection against inflation. However, the need exists across many groups and those groups combined could represent a sufficiently potent force to get the legislation. We would be most effective by erecting a combination of all the well-salaried groups for this purpose.

One possible activity to improve the economic condition of IEEE members is patterned after the popular view of the AMA. On the basis of legislation that requires that electrical engineers receive a certification of competence by education and test, and by controlling the number of qualified schools, we will restrict the supply so that we are all employed and well paid. Historically the medical profession got the opportunity to control itself because incompetent practitioners were a menace to the public. Laws that require the certification and licensing of all engineers for work affecting public safety already exist. The U.S. is well equipped with good engineering schools capable of supplying qualified graduates. No equitable legal requirements could shut down or restrict most of them. It seems entirely unlikely that a small self-serving special group such as electrical engineers would get legislation permitting it to restrict its membership.

Economic dislocation insurance is an activity in which a new IEEE could engage. It could have the very desirable feature of dealing with the present problem in real time. Initially, those of us who are working could tithe ourselves to provide temporary employment for our unemployed members. Over time, permanent funds could be maintained on a much less painful basis.

There is a large group of possible activities based on compelling employers to pay us more and treat us better by threatening collectively to withhold our services. Labor unions have obtained better pay, fringe benefits, and seniority rules. Some successful unions are organized by particular skills, as we would be. For those who consider making the IEEE into a labor union, there are some practical considerations. Strikes are effective where there is a threat of immediate injury to the employer's business. Only engineers engaged in operating functions or working for employers whose product is engineering have that leverage.

Finally, there is the possible activity of lobbying for government expenditures on projects with a high engineering content. In most areas we would only be supplementing the funds already provided by the industries involved. They have already pledged our votes as happy beneficiaries of the employment created. The disclosure of new areas of public need and the potential for helping by engineering study is not lobbying and can be done by the present IEEE.

David DeWitt, Editor

The productive society

Criticism of our society is much in vogue today, but such criticism can help us to attain the wisdom necessary to make the choices that will allow us to improve the quality of our life without destroying the system that has made those choices feasible

Patrick E. Haggerty *Texas Instruments Incorporated*

Without question, the citizen of today's technologically oriented nation is much better off materially than his nonindustrialized neighbor, who in turn is struggling to become a part of that "better world." However, as an increasing number of our critics remind us, our productive society has its problems, many of which are by-products of the very system that has provided us our wealth and strength. By eliminating time and space, electronics has given modern man the capability to recognize these defects in his way of life. It is equally important that he recognize how truly far he has come—and, given the wisdom to do so, how much further he can go.

If the United States, the advanced nations of Western Europe, and Japan are to be considered as prime examples of what we mean when we speak of the contemporary industrial society, it takes only relatively limited travel to conclude that the average citizen in these nations is strikingly better off materially than is the average citizen in the underdeveloped nonindustrialized world. This is so obvious to the citizens of that other world that they are seeking to revolutionize their own societies so as to generate the capabilities necessary to be included in the industrial world.

Yet it is clear that the world we possess, and which they seek, is far from perfect. We fight wars; we drink alcohol to excess; we use drugs. The automobiles that have given us mobility jam our streets, kill and maim in accidents, pollute our air. The sanitation systems we proudly designed to meet another environmental problem—the disposal of human wastes—are contributing to

the pollution of our streams and lakes. The strengths of our cities as places where men could more readily participate and gain the additional material advantages offered by this industrial world have attracted so many people that their size and congestion threaten to destroy the very advantages that brought the people to them.

We all know about crime in the streets. We all know about the almost unbearable tension of the arms race. We all know about the turmoil on our campuses. We all know of the presence of racial prejudice and its consequences. Indeed, a growing minority of our citizens are finding the flaws in our system so abhorrent that they challenge not only the values but sometimes the existence of the system itself.

The critics

Let me illustrate the nature and the intensity of these criticisms by the words of a few of the critics themselves. For example, here is Lewis Mumford, writer, social critic, and sometime philosopher¹:

"Even those who see no personal threat from quantification must be prepared to recognize its statistically demonstrable results in the many forms of environmental degradation and ecological unbalance that have resulted from the by-products of our megatechnic economy. The ironic effect of quantification is that many of the most desirable gifts of modern technics disappear when distributed *en masse*, or when—as with television—they are used too constantly and too automatically. The productivity that could offer a wide margin of choice at every point, with greater respect for individual needs and preferences, becomes instead a system that limits its offerings to those for which a mass demand can be created. So, too, when ten thousand people converge by car on a wild scenic area in a single day 'to get close to nature' the wilderness disappears and megalopolis takes its place.

Essential text of the 42nd Steinmetz Memorial Lecture, presented at Union College, Schenectady, N.Y., on May 12, 1971.

“In short, megatechnics, so far from having solved the problem of scarcity, has only presented it in a new form even more difficult of solution. Results: a serious deficiency of life, directly stemming from unusable and unendurable abundance. But the scarcity remains: admittedly not of machine-fabricated material goods or of mechanical services, but of anything that suggests the possibility of a richer personal development based upon other values than productivity, speed, power, prestige, pecuniary profit. Neither in the environment as a whole, nor in the individual community or its typical personalities, is there any regard for the necessary conditions favoring balance, growth, and purposeful expression. The defects we have examined lie not in the individual products but in the system itself; it lacks the sensitive responses, the alert evaluations and adaptations, the built-in controls, the nice balance between action and reaction, expressions and inhibitions, that all organic systems display—above all man’s own nature.”

Here is another viewpoint, that of Charles Reich, professor of law at Yale²:

“What is the nature of the social order within which we all live? Why are we so powerless? Why does our state seem impervious to democratic or popular control? Why does it seem to be insane, destroying both self and environment for the sake of principles that remain obscure? Our present social order is so contrary to anything we have learned to expect about a government or a society that its structure is almost beyond comprehension. Most of us, including our political leaders and those who write about politics and economics, hold to a picture that is entirely false. Yet children are not entirely deceived, teen-agers understand some aspects of the society very well, and artists, writers, and especially moviemakers sometimes come quite close to the truth. The corporate state is an immensely powerful machine, ordered, legalistic, rational, yet utterly out of human control, wholly and perfectly indifferent to any human values.”

The protests are not restricted to words:

“Shortly after the hour of noon on May 17, 1968, seven men and two women walked into the Knights of Columbus Hall of Catonsville, Md., a suburb of Baltimore. They climbed the stairs to the second-floor room which houses the town’s Selective Service office and proceeded to empty the contents of several filing cabinets into large wire trash baskets. . . . It was startling, as were many other details of that afternoon, that several of the raiders wore Roman Catholic clerical attire. . . . Toward the end of the raid, which lasted 90 seconds, the youngest of the three clerks, with a desperation accentuated by her extreme surprise, threw a telephone clear through a closed window to attract the attention of passersby in the street

below. The raiders walked swiftly down the stairway and into the parking lot outside. They emptied their haul of papers into a single pile, doused it with home-made napalm, and ignited it with matches. As the fire blazed savagely, devouring the draft records of 378 young Catonsville residents, the nine men and women awaited arrest by joining hands and saying the Lord’s Prayer.”

Subsequently, at the trial of these Catonsville Nine, as they came to be called, there was an exchange between Judge Thomsen, who presided at the trial, and one of the nine, a Catholic priest, Father Philip Berrigan³:

“‘Your Honor,’ said Philip Berrigan, ‘I think that we would be less than honest with you if we did not say that, by and large, the attitude of all of us is that we have lost confidence in the institutions of this country, including our own bureaucratic Churches . . . we have no evidence that the institutions of this country, including our own Churches, are able to provide the type of change that justice calls for, not only in this country, but also around the world.’”

These are three statements of strong discontent with our society as it is constituted. I could have chosen any of a dozen or a hundred others—many more violent in both words and action. At the root of them all is loss of confidence in the ability of our institutions to provide a satisfactory life for our citizens. In a considerable proportion of these critical statements the critics equate science and technology and economic growth with the problems in our society that they decry.

One man’s reaction

Self-criticism in our society is nothing new. Indeed, criticism and reaction to criticism have been fundamental to its growth. Nevertheless, it would appear that not since the Civil War has there been so much and such a wide diversity of self-criticism as that in which we have been indulging ourselves this past decade, particularly since some of it has been expressed with so much hate in the form of assassinations and riots.

As have most of us, I have listened and reacted to the criticism, sometimes resentfully, sometimes with wonder, sometimes with understanding, often with compassion, often with agreement as to the criticism though usually not with the cure suggested—if any cure is suggested at all. Each of us reacts in terms of his own knowledge, of his background and biases. Certainly I have had my own pattern.

I am an engineer, and for most of my professional life have been involved in the management of Texas Instruments, an industrial organization emphasizing innovation in its products and services, innovation based heavily on science and technology. Among other extra-curricular activities, I am a member of the boards of

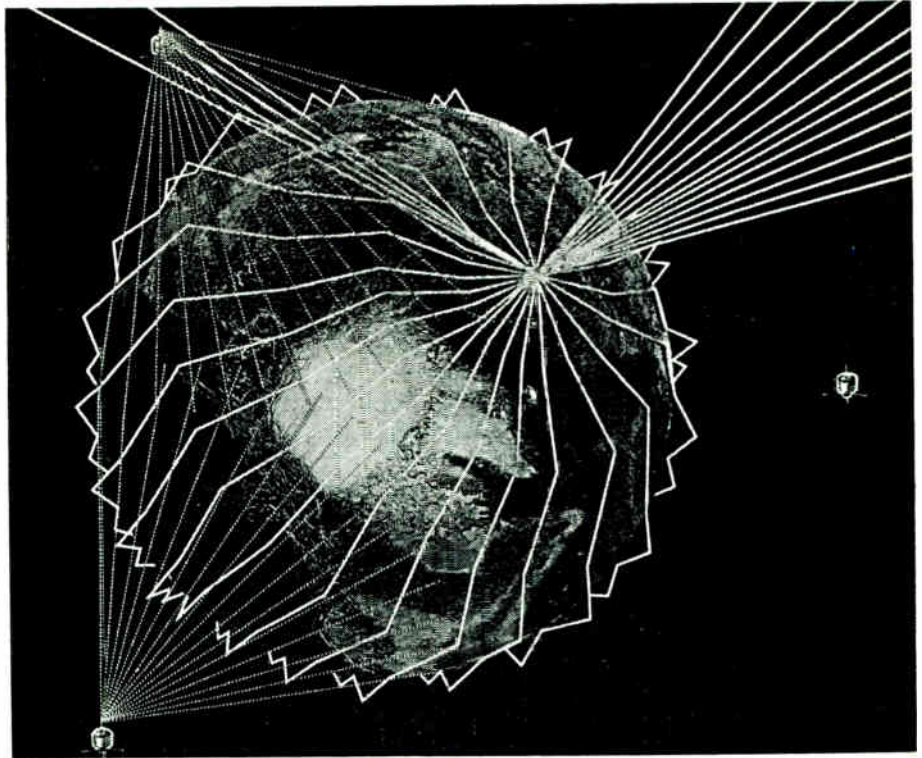

FIGURE 1. Electromagnetic fields blanket the earth.

trustees of two universities. I also have been involved in a variety of ways with our federal government. I was vice chairman of the Defense Science Board, a group of advisors to the Department of Defense, and have been a member of a Presidential Commission, the so-called Automation Commission. Presently, I am a member of the President's Science Advisory Committee and a Governor of the new Postal System. Clearly, I have spent a major proportion of my professional life, and with some considerable degree of responsibility, with the very institutions toward which these criticisms are directed; and to the extent they are justified, I must bear my share of the burden of those criticisms.

Although I believe that much of the criticism is destructive, especially when the mechanisms of expression have been violent, I also believe that both the personal and the national examinations of conscience that the criticisms have stimulated have been constructive.

In my own struggles to understand and to weigh the criticisms, I have come to the conclusion that those of us in science and engineering, and particularly those involved in electronics, are in a special way responsible for the consciousness that produces much of the criticism, and that hopefully over the coming decades the new tools we are providing to expand man's logic and his memory also will contribute to the solution of many of the problems that generate the criticism.

Man develops a culture, a civilization, in concert with other men. Until the 20th century that association was inevitably primarily local. Man inherited his own provincial culture. The men with whom we inherited, preserved, and slowly changed the culture were, by and large, those with whom we could physically come in contact over our lifetimes. The skin of the earth supported us,

and we lived on its plains and in its valleys and along its seashores, but its mountains and rivers and oceans divided us. Space and time contained us. We grew slowly, lived in villages, learned how to use the wheel to link village to village to make a state, and state to state to make a nation. Printing and the ship expanded our horizons, but the impact of man on man still was largely personal and limited by travel over the earth's surface. Man knew where he belonged. There was conflict. Men conquered other men, but even so, time and space limited us and the devastation was contained within relatively limited areas. Most men could identify with a particular community. They knew their place; they belonged.

In this 20th century man has begun to annihilate space and time as restrictions in his dealings with other men. This annihilation is based on a series of technical events, the consequences of which are responsible for the existence of our own IEEE as well. Just before 1900, Hertz demonstrated the existence of electromagnetic waves as predicted by Maxwell, and Marconi laid the foundations for what we call our electronics industry by demonstrating the practicality of wireless telegraphy. The vacuum-tube diode was invented by Fleming in 1904 and the vacuum-tube triode by De Forest in 1906. All of these were giant steps in learning how to harness the electron. And it is the harnessing of the electron that is gradually allowing man to overcome the limitations of space and time. It is electronics that has made possible radar, sonar, and satellite navigation, to say nothing of radio, television, sound movies, long-distance telephone calls, and computers. Many of us have spent our professional lives in bringing to original or improved fruition one or the other of these sophisticated expressions of electronics; because

of them, man is no longer limited in his impact on and association with other men by the skin of the earth.

As illustrated so dramatically in Fig. 1, man now can blanket the globe with electromagnetic fields, which, in a very real sense, let him touch every other man on the surface of the globe in a fraction of a second. This isn't just a fantasy. Not much more than 16 years ago, in October 1954, the first all-transistor pocket radio went into production. It was designed with Regency by Texas Instruments and was made possible by TI producing the first high-frequency germanium transistors in quantity. In 1971 it is estimated that, because of the introduction of the transistor radio, there are 900 million radio receiving sets in use in the world. Thus, if each set is available to but four people, it is theoretically possible for a single radio broadcast to reach the entire population of the earth. Indeed, it is estimated that 500 million persons were listening to astronauts Shepard, Mitchell, and Roosa when they landed Apollo 14 on the moon last February. With three synchronous communications satellites we can cover the entire earth with television and radio signals. Man's influence on other men is no longer limited by the speed with which he can crawl over the earth or fly through the air.

Is the medium the message?

Professor Marshall McLuhan of the University of Toronto says it this way⁴:

"The medium or process of our time—electric technology—is reshaping and restructuring patterns of social interdependence and every aspect of our personal life. It is forcing us to reconsider and reevaluate practically every thought, every action, and every institution formerly taken for granted. Everything is changing—you, your family, your neighborhood, your education, your job, your government, your relation to 'the others.' And they're changing dramatically.

"Electric circuitry has overthrown the regime of 'time' and 'space' and pours upon us instantly and continuously the concerns of all other men. It has reconstituted dialogue on a global scale. Its message is Total Change, ending psychic, social, economic, and political parochialism. The old civic, state, and national groupings have become unworkable. Nothing can be further from the spirit of the new technology than 'a place for everything and everything in its place.' You can't go home again."

McLuhan says, "All media are extensions of some human faculty—psychic or physical." Fiore's illustrations⁴ of the concepts include these legends: "The wheel. . . is an extension of the foot; clothing, an extension of the skin. . . ; the book. . . is an extension of the eye. . . ; electric circuitry, an extension of the central nervous system. The new electronic interdependence recreates the world in the image of a global village."

McLuhan continues: "Ours is a brand-new world of allatoceness. 'Time' has ceased, 'space' has vanished. We now live in a global village. . . ."

I think this conception of McLuhan's with respect to electronics eliminating space and time and creating a global village is fallacious. Things change slowly in a village and every man in it knows every other man—knows his place and his relationship to all of the others. There are dissatisfactions, but the relationships in a village are stable, because they are strong interpersonal relationships.

One needn't be a McLuhanite to agree that electronics has allowed man to reach across the globe and touch every other man in an instant. But in doing so it also has upset the stability of each man's village without substituting for that lost stability. Every man now can see wherein he has less than some other man. Citizens of Africa and India and South America can see and desire the material goods we seem to have in abundance. Our own citizens are forced to see that they do have much more of the world's material goods than does the bulk of its population, but at the same time they also are forced to examine, often in an exaggerated and isolated way, the price they have paid for it in the way of pollution or the problems of the cities.

Thus, man is exposed at any moment to things as they are, things that he can desire, other men whom he can envy, actions that are commendable—heroism, devotion; actions that are despicable—thievery, murder, rape, horrible deaths in war. But all of these are instantaneous vignettes of life, not connected to its other realities, not experienced as a part of a slow development and awakening, not tied to a foundation of tradition and knowledge. The nature of man and his curiosities being what they are, most of these instantaneous vignettes are related to the troubles of the world. Furthermore, the apparent ease with which these eliminations of time and space are accomplished gives the average citizen an exaggerated impression of the power and the competence of our science and technology and convinces him that we have both the knowledge and the affluence to solve all of our problems if we but had the will to do so. Little wonder then that so many conclude that since we have all of this knowledge and wealth, it must be either the malevolence of men—those who control the establishment—or the impersonal overwhelming clockwork of the functioning machines that keeps us from attacking and solving these problems.

One percent accomplished—or 99% to go?

Each of us can extrapolate only from his own experience and knowledge. From my own I have come to a view that seems to me to account for much of the frustration and of the impression that it is futile to attempt to change our institutions. I have come to that view from examination of that which I know best—my own company.

By all comparative standards, Texas Instruments must be considered among the better industrial organizations. We have grown from \$2 million per year total sales billed in 1946 to around \$800 million per year now. We have contributed a number of products and services of significance, including the silicon transistor, integrated circuits, key methods of oil exploration, and a variety of other products and services of sufficient worth that they have generated the growth we have enjoyed. We are an organization that emphasizes innovation based on science and technology, with a strong bias toward organized and institutional management techniques.

However, when I compare the programs where we have done best—the programs where our research and development have had a peculiarly effective insight, where the manufacturing processes have been developed and selected properly, where we truly comprehended and solved our customer's problems—with the way we perform on average, I am forced to conclude that in these

“best” areas we are at least 25 to 50 times more effective. Further, when I examine these best programs, it would appear that they, too, could have been carried out five to ten times more effectively if we had understood either the facts of nature, or one another, or our customers’ needs better. Thus, I conclude that, overall, Texas Instruments cannot be more than 1 percent effective as measured on any kind of theoretical scale as to what is possible for such a corporate institution, and yet I know that doing as well as we have has been an extraordinarily difficult task. It has required long hours of effort over decades by hundreds and thousands of key men and women who themselves have been more able than the average; who have understood their goals and objectives better than is common in most human institutions. Many of our most successful technical programs have taken longer and have cost more than we anticipated. Some of them have been dangerously close to failure—not once but several times—before final accomplishment. It would not be inaccurate to say that even with our best efforts, a number of effective programs have just barely attained satisfactory objectives.

My experience with other industrial organizations, with universities, and with government convince me that they, too, against any kind of similar theoretical standard, are 1 percent or less effective. In fact, my experience would suggest that universities and government have far more potential for improvement than today’s better industrial organizations.

This situation can produce optimism about science and technology and the industrial society, which was characteristic up to a decade or so ago, or the black pessimism that generates some of the criticism that I have mentioned. It all depends on the point of view. If the focus is on how much more effective today’s industrial societies are in satisfying man’s material wants than were the feudal and prefeudal societies, or are the societies of today’s underdeveloped world, then the optimism is justified. If, on the other hand, the concentration is on what yet remains to be done, on the potentials that exist, and on how far we are from attaining our ideals, either in satisfying material wants or in moving toward the ultimate in man’s spiritual development, then what we have accomplished seems inconsequential. Of even greater import, the rate at which we are moving toward such perfection will seem imperceptible.

Again, let me turn to Texas Instruments to attempt to

make the concept clearer. I believe that our company’s sales are a measure of the effectiveness of our products and services and that our profitability is a measure of how effectively we operate to create and market those products and services. On the average, TI attempts to make about 10 percent profit on its sales billed before taxes or about 5 percent after taxes. Thus, a 10 percent improvement in profits is attained by a 1 percent decrease in the costs we accumulate in generating our total sales billed. That kind of improvement ordinarily is the result of a large number of deliberate choices, the successful execution of a wide variety of programs, and extremely effective institutional operation over a considerable span of time. In other words, it is the result of a great deal of hard work to attain deliberately and carefully chosen objectives. Attainment of that kind of improvement ordinarily would and should result in a considerable degree of satisfaction. However, if TI is about 1 percent effective and if one is focusing not on improving the organization as it exists but on the 99 percent yet to be done, then that 10 percent improvement in effectiveness or that 1 percent decrease in overall cost is seen as a 1/100 percent gain against what yet remains as possible. In fact, concentrating on what could be done, it is highly probable that it will appear that no progress has been made and that all of this effort has been futile.

If I am evaluated as a professional and an executive on the basis of what Texas Instruments has accomplished in comparison with its competitors around the world, I must be given relatively good grades. On the other hand, if I am evaluated in terms of what could be done, measured on what I didn’t see, didn’t know, and didn’t do, I am a failure.

It seems to me that what the elimination of time and space by electronics has done so far for the average citizen of the world is to expose him to what could be and to what is wrong but to help him very little in measuring himself and his society as it is and is becoming by comparison with what it has been.

A nation in transition

As the most advanced industrial nation, the United States is in transition to what some are calling the post-industrial state. One of the characteristics of that transition is a shift in relative emphasis from the production of goods to the production of services. Interestingly enough, that shift is made possible only by the increasing effectiveness with which we have been able to produce goods in this society.

In 1890, according to the Committee for Economic Development, 42 percent of our working population was engaged in agriculture, 33 percent in industry, and only 25 percent in service (see Fig. 2).⁵ The service-producing sector includes transportation, communication, and public utilities; trade, finance, insurance, and real estate; such personal services as household employment, health, and education; and finally government. By 1929, agriculture was halved to 20 percent, and service had grown to equal industry, both at 40 percent. In 1967, agriculture was down to only 5 percent, industry at 39 percent, and service had gone to 56 percent. Although I haven’t put together a projected distribution in 1971, all projections suggest that the service sector will have increased its share of total employment still further.

Thus, you see that we now produce relatively far more

FIGURE 2. Relative employment in the economy, by economic sector.

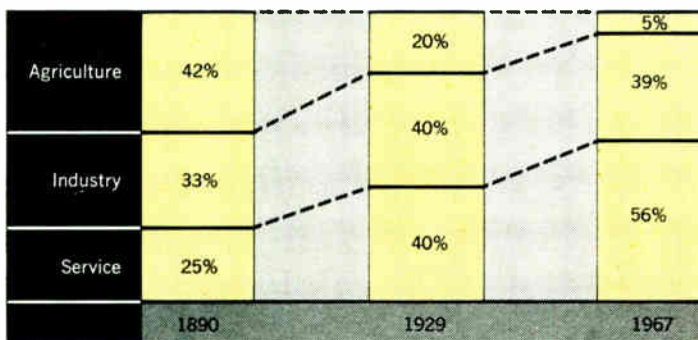

in the way of food with less than 5 percent of our working population than we did in 1890 when we employed 42 percent in that way. Further, the plenitude of industrial goods we now manufacture, including automobiles, airplanes, radio sets, television, all kinds of appliances, medicine and drugs, clothing, furniture, and recreational goods, requires only a very slightly larger percentage of our total workers than industry needed in 1890. Only because this is so has it been possible for us to increase those working in the service sector from 25 to 56 percent. That shift has been made because we could make it, and because we wanted to do so. We wanted more health services and more people in education. We wanted to move to the cities with all that implies in the way of government and governmental services. We wanted telephones and electricity in our homes and in our businesses.

Our standard of living depends upon our overall effectiveness as a nation, and the increases in productivity that have made this shift from goods to services possible have gone into improving our national standard of living. Our big gains in productivity have been in the agricultural and industrial areas, and the pay scales we have generated there in response to this increasing productivity have spread outward to all of the other work areas in our society, whether or not productivity was increasing there at an acceptable rate. This was a reasonable and natural development so long as the gains we were making in agriculture, industry, and the public utilities were sufficiently large to improve our overall effectiveness enough to justify our increasing rates of pay. Now that the services sector employs much more than half of the work force, we no longer can expect the rising productivity of agriculture and industry to be sufficient to carry the burden for all of our society. This shift from goods to services means that we are shifting employment from work areas that have had a record of high increases in productivity per person per year to others where the increases in productivity per person have been very much lower.

The productivity-per-person projections made by the U.S. Department of Labor in its projection of the economy through 1980 range from just under 6 percent for agriculture, forestry, and fisheries down to a little over 1 1/2 percent for such service areas as household employment and health and education; see Fig. 3.⁶ I have added government to this chart so that the 11 800 000 employed there can be compared with the employment levels of the other individual private sectors, and as a reminder that in calculating the productivity of the entire society, for government it is assumed that output equals input and hence no annual growth rate in productivity is applied.

The work areas in which we have enjoyed high annual productivity increases per person have been in the private sector where the profit system automatically forces management to recognize increasing costs either by increasing prices or improving productivity, or both. In general, competition limits severely the ability to increase prices; consequently, a constant effort is exerted to improve productivity, and we have been forced to learn how to use science and technology, capital, and management to improve effectiveness and reduce costs.

The existence of competition and the profit mechanism of the private enterprise sector have made of it a crude

but effective servo system that responds to these pressures by steadily increasing productivity per person. Thus, I feel that considerable part of the increasing feeling of frustration resulting from a seeming inability to improve our institutions at the rate we think we should is unconsciously related to this shift in effort from goods production to services production, and hence to the constantly increasing proportion of our total work force engaged in an area where we simply have not learned how to be as effective as we are in producing goods.

For example, according to Gilbert Burck,⁷ about five million educators were employed by state and local government in 1969, or more than half of all state and local government employees. There were only about 1 1/2 million in 1947. This means that the quantity of educators over these years has increased ten times as fast as the population and three times as fast as the number of students. That this extraordinary increase in cost is by no means restricted to our general-purpose primary and secondary schools is made clear by this quotation from a recent special report from the Carnegie Commission on "Higher Education and the Nation's Health":

"Expenditures of medical schools have gone up twice as fast in the past decade as expenditures in higher education generally, yet the number of students in medical schools has risen only half as fast as in the rest of higher education. It is high time to look more carefully at costs."

Hopefully, the higher costs generally, and the decrease in educator-student ratio, have improved education proportionately, but one can't help having a nagging feeling that, for a variety of reasons, not the least being the turmoil in our society, the quality of education has increased only marginally. But whatever the conclusion as to quality, surely the productivity per employee in education is sharply down, and I believe that the decrease in productivity is directly related to the increase in discontent among our student population.

There are any number of similar illustrations in the service sector where either satisfaction or dissatisfaction

FIGURE 3. Projected productivity, by major sector, for the private economy, 1968-80.

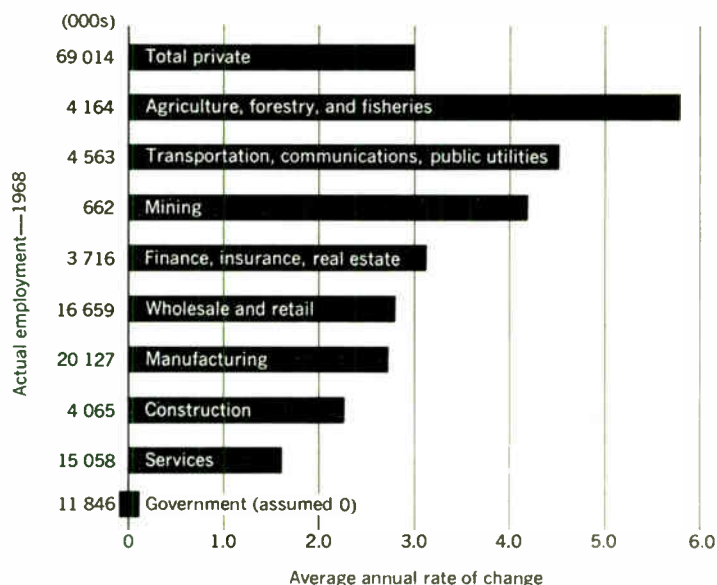

can result, depending upon our point of view. For example, one headline in the *New York Times* for Saturday, May 8, stated: "Poor in Nation Rise by 5%, Reversing 10-Year Trend." The news story went on to say there were 25.5 million poor persons in 1970, a rise of 1.2 million over 1969. This increase of 5 percent in one year follows a period of ten years in which the poverty population decreased by an average of 5 percent per year.

The federal government defines poverty by a sliding-dollar threshold—it was \$2973 in 1959, \$3743 in 1969, and \$3968 in 1970. This reversal has come about because of the efforts of the government to combat inflation while simultaneously decreasing our engagement in Vietnam and the overall expenditures of the Department of Defense, the Space Agency, and the Atomic Energy Commission, among others. Yet, the facts are that even on the increasing scale used by the government, there are 3 million fewer people below the poverty level now than there were five years ago and the percentage of the population in this category has decreased from 14.7 to 12.6 percent. It also is important to remember that "poverty" as defined in this category does not mean the same thing as destitution or serious want. Rather, the poor are characterized as "those who are not now maintaining a *decent* standard of living—those whose basic needs exceed their means to satisfy them."⁹ Certainly, moving the maximum number of our citizens above this line is a most desirable goal, but how we view the effort and the symbolism we attach to the word poverty can inspire us to proceed with satisfaction at the difficult task of gradual improvement or it can make us view the entire effort with frustration and dismay because progress is so slow!

Edward Banfield⁹ points out that:

"Many—perhaps most—of those with reported incomes below the official poverty line are not undergoing hardship (or if they are, it is not because of lack of income). About 40 percent own cars, a slightly higher per-

centage own their own homes, more than half have savings, and of those with savings about one third have more than \$500. According to Herman P. Miller, of those families with incomes below \$4000 and living in rented apartments in central cities in 1959, 95 percent of the whites and 90 percent of the Negroes had adequate housing, and the same percentages (not necessarily the same families) had a television set and access to a telephone for receiving calls. (Adequate housing in this context means an apartment free of defects that make it unsafe to live in, having hot piped water, direct access, a private kitchen with cooking equipment, a flush toilet and bath for the exclusive use of the occupants, and no more than one person per room.) Almost all the poor have some furniture and appliances, and many have more than enough of both for comfort and convenience....

"The discomfort and inconvenience experienced by most of those classified as poor are seldom acute and persistent. But it is not even discomfort and inconvenience that mainly constitute poverty in the city today. In our society a conspicuously low income is a mark of low status. It is this—appearing to others and to oneself as inferior or of 'no account'—that constitutes most poverty now. In short, the problem of poverty is not so much one of income *level* as of income *distribution*. As Victor R. Fuchs explains:

" 'By the standards that have prevailed over most of history, and still prevail over large areas of the world, there are very few poor in the United States today. Nevertheless, there are millions of American families who, both in their own eyes and in those of others, are poor. As our nation prospers, our judgment as to what constitutes poverty will inevitably change. When we talk about poverty in America, we are talking about families and individuals who have much less income than most of us. When we talk about reducing or eliminating poverty, we are really talking about changing the distribution of income.' "

In the sense that they do recognize the enormous potential for improvement in our society, such criticisms as those with which I began this discussion are justified, but rarely have the critics presented their arguments or their solutions in terms that suggest to me that they really understand how difficult it is to improve any complex institution.

Reich comes very close to describing the dilemma without, it seems to me, understanding it²:

"There is a great discovery awaiting those who choose a new set of values—a discovery comparable to the revelation that the Wizard of Oz was just a humbug. The discovery is simply this: there is nobody whatever on the other side. Nobody wants inadequate housing and medical care—only the machine. Nobody wants war except the machine. And even businessmen, once liberated, would like to roll in the grass and lie in the sun. There is no need, then, to fight any group of people in America. They are all fellow sufferers. There is no reason to fight the machine. It can be made the servant of man. Consciousness III can make a new society....

"The crucial fact to realize about all the powerful machinery of the Corporate State—its laws, structure, political system—is that it possesses no mind. All that is needed to bring about change is to capture its controls—and they are held by nobody. It is not a case for revolu-

FIGURE 4. Cost of transistor radios—1954-70.

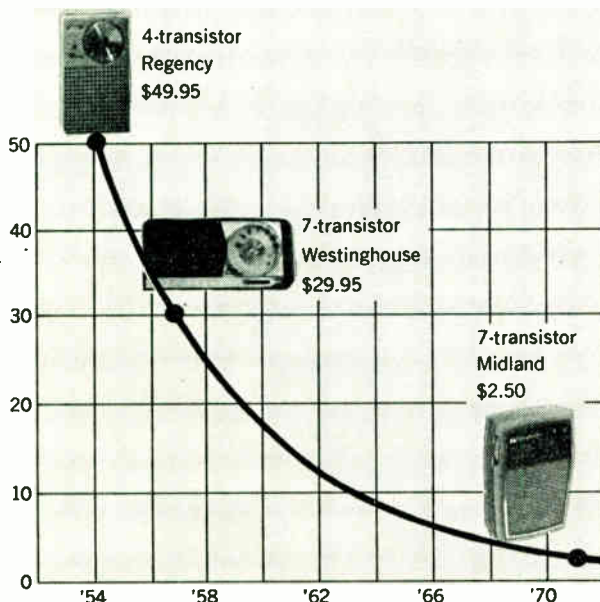

tion. It is a case for filling a void, for supplying a mind where none exists. No political revolution is possible in the United States right now, but no such revolution is needed.”

Clearly, Reich is looking at the 99 percent we still can accomplish but has not appreciated how difficult it has been to get this far and how much diligent effort it will require to continue to gain from where we are.

I am forced to conclude that, although criticisms such as those I have quoted are useful in making us think about where to apply our talents to attempt to improve our society, they are also dangerous if they are not understood and if the perspective of how well we have really done by comparison with the rest of the world is lost in the vistas of what can be.

Problems in pollution, opportunities in health care, improvements in meeting our transportation needs, improvements in the quality of education—these are the kinds of areas to which science and technology and improved management can make large contributions. Our commercial balance of payments has depended for years upon technologically intensive products and our technological advantage in the area of international trade seems to be eroding. The need for sustaining high annual rates of productivity increase in the sectors of our economy that now have them, and improving productivity sharply in those sectors of our economy where it is lagging, certainly calls for the application of increasing quantities and sophistication of technology and management.

I suggest that we need to keep on doing what we are doing, but more of it and better. We need to apply our science and technology more effectively to those areas of our society that need their help. We need to learn how to manage our industrial organizations still better; but even more, we need to learn how to bring our institutions in the nonindustrial sector—in education, in government, in health care—to something like the same level of effectiveness we already have attained in the private industrial sector. It won't be easy. Contrary to the impression so many have gained about our competence, it will take every skill we have applied over decades to continue to reach into that 99 percent still to be attained.

I have suggested that because electronics has annihilated time and space, it has exposed man to all of the problems of his time and the potentials for his develop-

ment without adding significantly to the stability of his institutions. I also suggest that the impact of electronics to date has been exceedingly limited by comparison with changes yet to come. Some of those changes are sufficiently large in scale to begin finally to improve man's capabilities to the extent that he will be able to cope with the problems of the complexities of his society well enough to gain slowly the kind of power over his surroundings necessary to add significantly to the stability of his institutions because he will be able to manage them better.

A new era for electronics

Electronics, even though more than 80 years old, has been plagued for most of that span of time by inherent limitations: limitations of cost, limitations of reliability, limitations of complexity, limitations imposed by the nature of the science and the art required of a practitioner before he could apply the tools of electronics intelligently to solve problems.

All of this really only began to change when, in December 1947, Bardeen and Brattain of the Bell Telephone Laboratories, with significant collaboration from several others, invented the transistor. This solid-state device made possible modern-day electronics by decreasing the cost of amplifying devices, increasing manifold their reliability, and making simpler and smaller the associated components required. It led directly to the first quantity production of high-frequency transistors at Texas Instruments in 1954 and the pocket radio previously mentioned.

To illustrate the impact of solid-state devices on the cost of electronics, note what has happened to the cost

FIGURE 5. The original integrated circuit, which was developed in 1958.

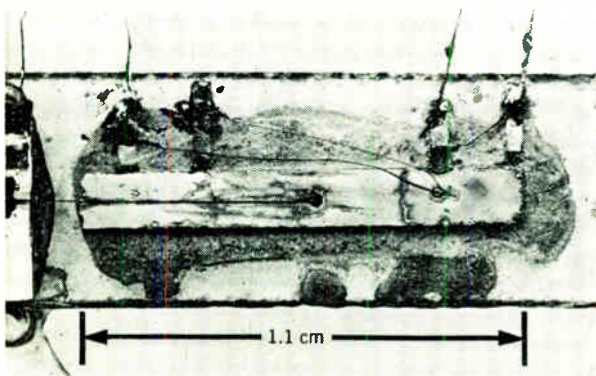
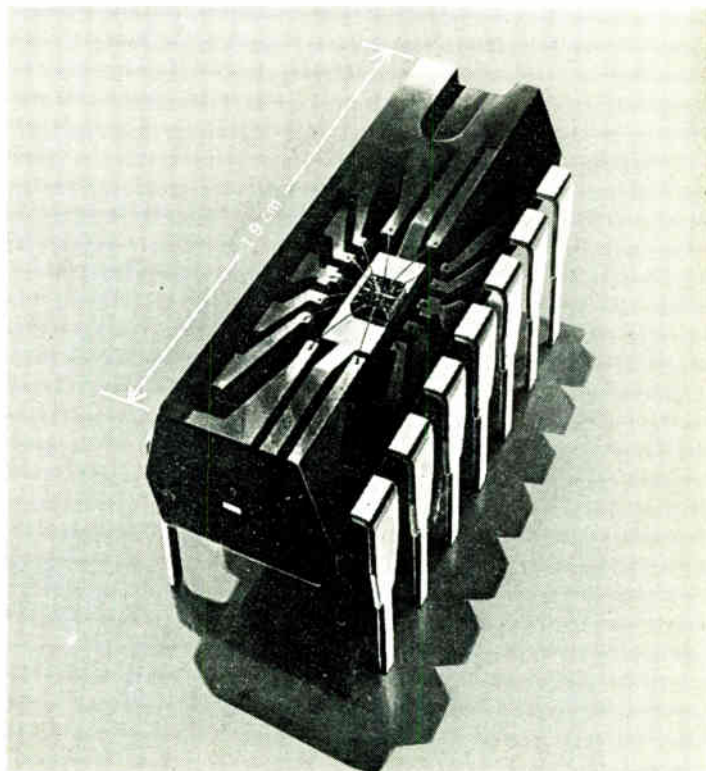

FIGURE 6. A contemporary integrated circuit.



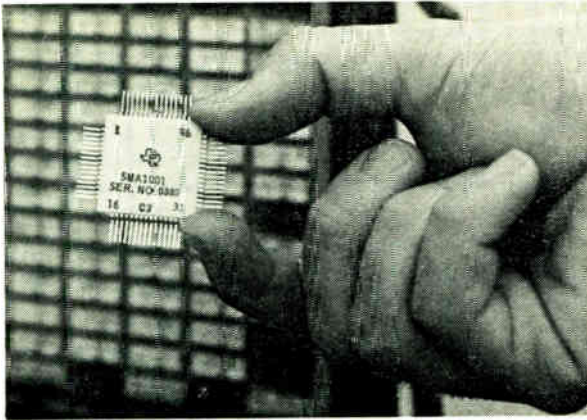

FIGURE 7. Semiconductor memory for the ASC.

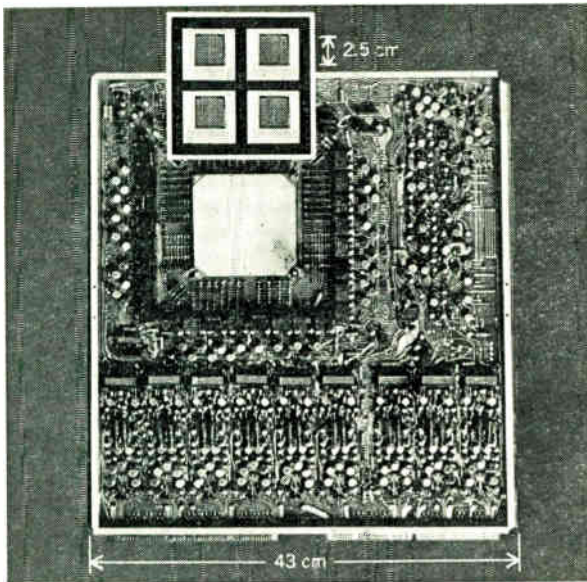
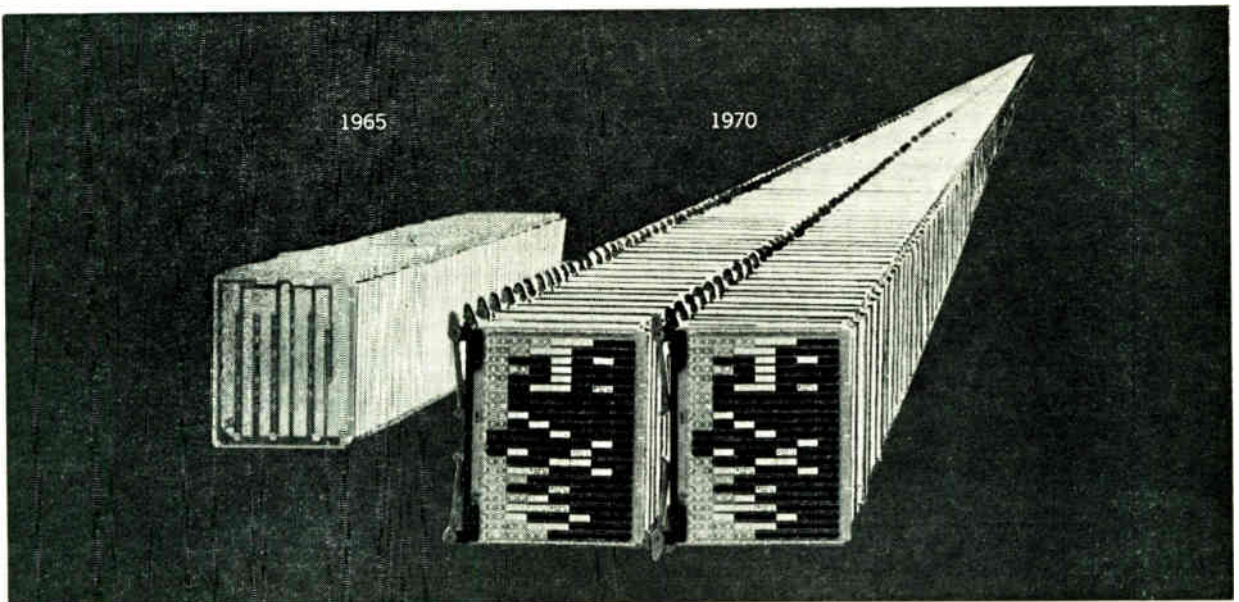

FIGURE 8. More complex semiconductor memory.

FIGURE 9. Increase in digital simulation capability between 1965 and 1970.



of transistor radios since 1954, as depicted in Fig. 4. The first Regency transistor set used just four transistors and a diode; it retailed for \$49.95 in 1954. The middle set is a Westinghouse seven-transistor set that retailed for \$29.95 in 1958; and the set at the bottom is a Midland, assembled in Hong Kong, and readily available at retail in the United States for \$2.50 this May. It is almost superfluous to point out that, in spite of its low price, its performance is far superior to that of the 1954 and 1958 sets.

But even the transistor was only a first step toward eliminating the inherent limitations on electronics that had been preventing its applications from pervading all of society. Next came the invention of the integrated circuit in 1958 by Jack Kilby of Texas Instruments. Figure 5 shows that first integrated circuit.

A great deal has happened since that time. Figure 6 shows a contemporary integrated circuit that is in volume production. The small silicon chip in the center of this plastic block contains the equivalent of 44 electronic components, such as transistors, diodes, and resistors. These components make up four circuits, called gates, which are the basic building blocks of digital computer circuitry. In large quantities this particular integrated circuit package sells for about 20 cents each or less than 0.5 cent per component. And around the world in 1971, it is estimated that more than 550 million integrated circuits will be manufactured for a total dollar volume of more than \$700 million.

This is an extraordinary accomplishment in just 13 years, but I suggest that those of us who have been in the middle of making it happen are only barely aware of the long-term consequences of this kind of massive extension of man's ability to hear, to see, to remember, and to think. It is these extensions of man's abilities through electronics that are making possible the development of tasks that will contribute in a major way to our ability to manage our institutions.

However, even the integrated circuit is not the last step in that almost headlong rush toward perfecting electronic circuitry so that it may be used more simply and more effectively to extend man's mind and nervous

system. For example, Fig. 7 shows a semiconductor memory produced by large-scale integration techniques for TI's Advanced Scientific Computer (ASC).

In this single package are 2048 memory cells. Each of the circuit boards in the background contains 16 of these packages—eight on each side of the board—making up more than 32 000 memory cells on a single circuit board. The cycle time of this memory system is 150 ns, or four times faster than conventional core memories.

Still further along the scale of complexity achieved by integrated circuit technology is the semiconductor memory illustrated in Fig. 8.¹¹ Each of the four white packages at the top contains a 2.5-cm-square silicon chip and, as the result of metal oxide semiconductor technology, each chip contains 16 000 bits of memory. Altogether, then, the four packages contain 64 000 bits, equivalent in function to the ferrite core memory and associated electronics shown on the larger 43-cm board. This kind of capability is in turn making possible completely new approaches to how we design our products.

With the increasing sophistication of computers, it has become a practical and an economic necessity to verify the functioning of the system before the actual hardware is built. This means that manual approaches to design with test by trial and error are no longer tenable. It takes a computer to design a computer—and even it must become better at the job. Look what has happened at TI since 1965 (see Fig. 9). At that time we used design automation to prove out the design of an advanced seismic computer, the TIAC 870. Six years ago our digital simulation capability was limited to 5000-gate subsystems on 40 two-layer boards. By 1970 we were able to simulate 200 000-gate subsystems on 220 17-layer boards. In addition, we were dealing with much faster circuits than in 1965.

In fact, our ASC could not have been built after it was designed were it not for this greater capability. We used design automation not only to simulate and prove out the logic design of the ASC arithmetic subsystem, but also to design manufacturing tooling and tests for the multilayer circuit boards and, finally, for the design tests for the boards after all their circuits were interconnected.

The ASC with its 80 000 integrated circuit packages can be classed as a "supercomputer." It was conceived to bring the full power of today's computational technology to solve problems of processing large arrays of data such as encountered in weather modeling, ballistic missile defense, and seismic surveys. On array-type data it will deliver more than 15 million computations per second.

No easy way

It is the enormous extensions of logic and memory that technical accomplishments such as these are just beginning to make possible that I believe will extend man sufficiently in his comprehension of his world and of his work so he will be able to improve significantly his control of his institutions. Of course, these new tools by themselves will not be sufficient. We are going to need to be a lot better than we are in all aspects of science and technology, especially those that relate to people. We need more knowledge of all kinds. We need especially to work on the structure and management of our educational and our government institutions.

There is no easy way, and even when our hard work and

our improved tools and our better management all combine to move us closer to fulfilling the material needs of all of our citizens adequately, it still will take something more to fulfill the "American dream." It will take a wise people. I believe that the great constructive part of the current criticism in our society is associated with our becoming a wiser people. We are learning that our standard of living is lower when we lose our forests and our streams and when the air in our cities is so polluted that we can no longer enjoy our surroundings. This is a large gain in wisdom. But it will take a very wise people indeed to make the choices that will allow us to improve the total quality of our life without simultaneously destroying the only system that thus far has made such choices feasible.

REFERENCES

1. Mumford, Lewis, *The Myth of the Machine: The Pentagon of Power*. New York: Harcourt, 1970.
2. Reich, C. A., *The Greening of America*. New York: Random House, 1970.
3. Gray, F. du P., *Divine Disobedience: Profiles in Catholic Radicalism*. New York: Knopf, 1970.
4. McLuhan, Marshall, and Fiore, Quentin, *The Medium Is the Massage*. New York: Bantam Books, Inc.
5. "Economic Growth in the United States," Committee for Economic Development, Oct. 1969.
6. "The U.S. economy in 1980: A preview of BLS projections," *Monthly Labor Rev.*, Dept. of Labor, vol. 93, p. 10, Apr. 1970.
7. Burck, Gilbert, "There'll be less leisure than you think," *Fortune*, vol. 81, p. 88, Mar. 1970.
8. Carnegie Commission on Higher Education, *Higher Education and the Nation's Health, Policies for Medical and Dental Education*. New York: McGraw-Hill, Oct. 1970.
9. Banfield, E. C., *The Unheavenly City*. Boston: Little, Brown, 1970.
11. Bylinsky, Gene, "Little chips invade the memory market," *Fortune*, vol. 83, p. 100, Apr. 1971.

Reprints of this article (X71-091) are available to readers. Please use the order form on page 8, which gives information and prices.



Patrick E. Haggerty (F) has been chairman of the board of directors of Texas Instruments Incorporated since 1966, having previously served as executive vice president (1950) and then president (1958). Following his graduation from Marquette University in 1936 with the B.S.E.E. degree, Mr.

Haggerty became an employee of Badger Carton Company. He left there in 1942 as assistant general manager to join the U.S. Naval Reserve as a lieutenant in the Bureau of Aeronautics. He served in the Navy until 1945, when he became general manager of the Laboratory and Manufacturing Division of Geophysical Service, Inc., which later became Texas Instruments Incorporated.

Mr. Haggerty, John Fritz Medalist for 1971, has received numerous other awards during his career, including EIA's Medal of Honor, the IEEE Founder's Award, and the Industrial Research Institute Medal. He served as IRE President in 1962 and is a former member of the IEEE Board of Directors.

Electricity in hospitals:

elimination of lethal hazards

The problems of macroshock and microshock in hospitals have received considerable coverage recently in the press, in symposiums sponsored by professional societies, and in technical publications. The general subject falls within a sensitive and controversial area in which proposals for upgrading the safety of medical–electric equipments are being studied and/or implemented

Gordon D. Friedlander Senior Staff Writer

The danger of patients being electrocuted in hospitals, particularly those who are “wired” to cardiac catheters, electronic pacemakers, and defibrillators—or connected to these and other devices simultaneously—has been the subject of numerous articles in leading newspapers, and in technical and professional publications. Physicians, engineers, and consumer-interest activists have offered statistics and opinions on the extent of these hazards. The range of concern involved among those either directly or peripherally involved with medical–electric equipments seems to run from consternation to minimal perturbation. Thus it is a controversial subject. Suggestions have been made that hospitals and medical-engineering staffs should adopt purchase-selection programs to evaluate the competing claims that equipment salesmen make for their products. Such programs might also include the testing and rating of medical devices and electronic apparatus. Proper maintenance of equipment and adequately trained operators of such devices in hospitals are equally important aspects of a comprehensive safety program.

Introduction to the problem

The problem of accidental electrocutions in U.S. hospitals has been the focus of increasing attention among physicians, surgeons, technicians, biomedical engineers—and a noted consumer protectionist—for at

least three years. At the 71st Annual Meeting of the American Hospital Association (AHA), held in Chicago in 1969, Dr. Carl W. Walter, a surgeon at Peter Bent Brigham Hospital, Boston, told the assemblage: “Electrocutions can happen. They happen very often. But hospital people do not suspect it because they’re so concerned in saving the life of an individual patient that they never unravel the maze of wires that fill up most intensive-care power receptacles. There’s no way of knowing how many such situations occur in hospitals.” The number of fatalities allegedly attributable to electrocution range downward from Ralph Nader’s claim of 5000 persons per year* to a very small figure over the same statistical period. As examples: in January 1969, Dr. Walter obtained a (now much-disputed) figure of 1200 annual deaths from an actuary of a national insurance company; but the Food and Drug Administration (FDA), after checking scores of articles published between 1963 and 1969, summed up about 115 deaths and more than 1600 injuries annually from “all medical equipment” (not medical–electric devices alone) during that six-year period.

Arnold S. J. Lee, director, Department of Electronics and Instrumentation, The Presbyterian Hospital, New York City, believes there has already been an “enormous overkill” in bringing the safety problem to the public’s

* Nader stated in 1970 that he based his estimate of the number of deaths on conversations with doctors and technicians during “recent meetings.”

attention in “a lurid manner.” According to Lee, the combined census of patients susceptible to microshock (inadvertent electrical leakage through an electrical conductor implanted directly in the heart, with leads extending out through the skin) is extremely small. He claims that not a single patient has been electrocuted in this manner during his association with The Presbyterian Hospital.

In paralleling Lee’s views, A. K. Dobbie, electrical safety engineer of the United Kingdom Department of Health, London, categorically stated in a paper to be presented at IEEE’s EUROCON ’71 convention in Lausanne, Switzerland, that “in the United Kingdom no patient has died from electrocution in the past 10 years . . .”

But Charles K. Spalding of New England Deaconess Hospital, Boston, who is also chairman of the Boston Patient Safety Committee, presented a paper at the annual meeting of the Association for the Advancement of Medical Instrumentation (AAMI) in Los Angeles last March, in which he said:

“Electrical safety, and more explicitly, patient shock hazards associated with the use of biomedical electronic equipment, has recently become the most written about, controversial and embarrassing subject those of us in hospital engineering have to contend with Electrical safety in our hospitals has been a continuously growing problem over the past ten years

“From available data, the problem of electrical hazards

I. Effects of 60-Hz electric current on an average human through the body trunk (macroshock)

Current Intensity, mA (1-second contact)	Physiological Effect
1	Threshold of perception
5	Accepted as maximum harmless current intensity
10-20	“Let-go” current before sustained muscular contraction
50	Pain, possible fainting, exhaustion, mechanical injury; heart and respiratory functions continue
100-300	Ventricular fibrillation will start, but respiratory center remains intact
6000	Sustained myocardial contraction, followed by normal heart rhythm. Temporary respiratory paralysis. Burns if current density is high

in hospitals is not unfounded but indeed real and serious. What is unreal is our inability to solve the problem.”

Proliferation of electric equipment—and hazards. Dr. H. M. Hochberg, of Roche Medical Electronics, put it this way during a radio interview last year on Station WFLN in Philadelphia:

“Not too many years ago, a doctor’s diagnostic tools consisted of his five senses and a conversation with the patient . . . today, he is assisted by a multiplicity of electrical and electronic devices . . . The ever-increasing battery of electronic devices does raise hazards. Not all medical and paramedical personnel are well trained to handle these ‘black boxes’ . . .”

Macroshock and microshock

There are two modes of electric shock in hospitals: macroshock and microshock. Macroshock is electric shock due to contacts applied to the exterior of the body. Here, currents in the range of 100 to 300 milliamperes (see Table I) can cause heart fibrillation. The lowest body resistance, with well-prepared electrodes, is in the range of 1000 to 1600 ohms, so that interelectrode voltages of the order of 75-120 volts (at dc or commercial power frequencies) could be dangerous.

All hospital patients are exposed to macroshock from defective electric devices such as lamps and bed-adjusting motors—just as they might be outside the hospital. But, in addition, macroshock may result from a defective electrocardiograph machine in operation after well-prepared electrodes are applied to the patient’s body.

Microshock is a much more serious hazard than macroshock. It applies to every patient who has a lead or electrical conductor from the interior of the heart extending out through the body’s surface; but the number of patients who are thus internally “wired” to pacemakers or cardiac catheters is very small indeed. Currents as little as 50 μ A caused by voltages as small as 5 mV can produce ventricular fibrillation of the human heart under these conditions.

From the currents and voltages required to cause fibrillation in the two modes of shock just described, it appears that minimization of macroshock can be accomplished by the effective application of conventional safety methods, but that the minimization of microshock requires a carefully designed and controlled electrical environment for the patient and a discipline to “keep him there.” These techniques will be discussed in this article.

Biological effects as a function of current

Dr. Marvin C. Ziskin of the Temple University Medical School (speaking at the “Update Medical Safety” seminar

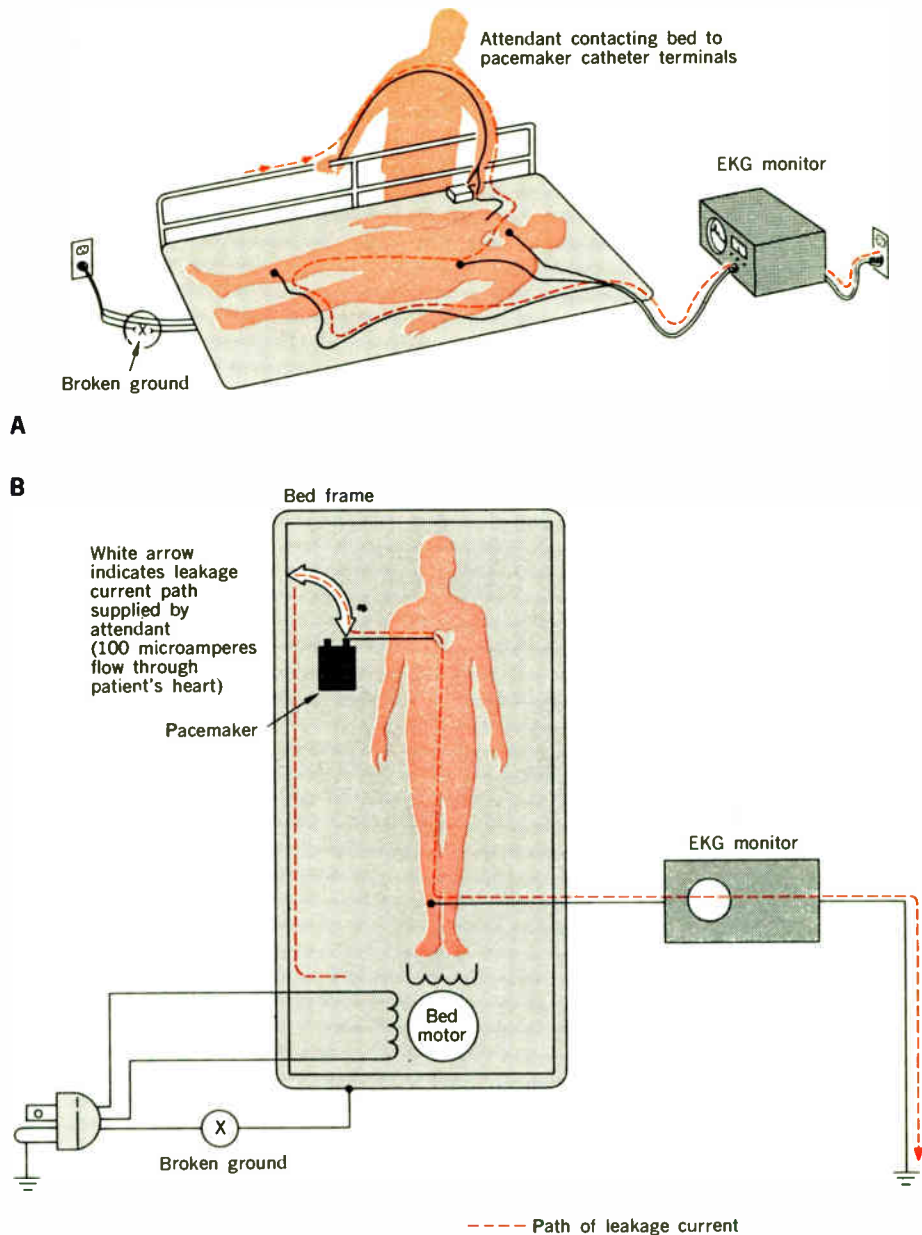
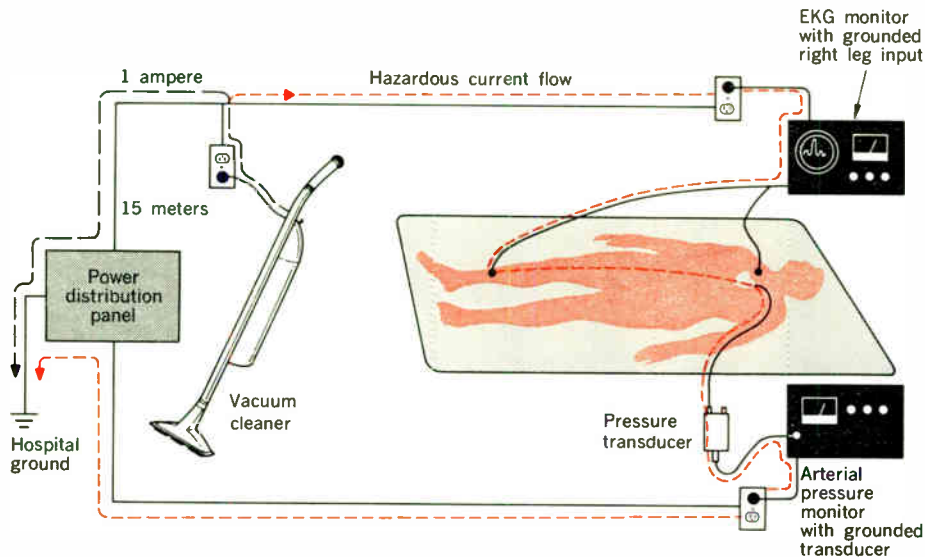

FIGURE 1. A—Anatomy of an accident: the faulty ground connection on the electric bed allows a voltage to exist on the bed frame due to capacitive coupling between the bed frame and the primary wiring in the bed. Here, the attendant unwittingly supplies the completion of the current path (from the source, through the pacemaker's wire, to the patient, to ground) when he touches the bed, thereby permitting the leakage current to flow through his body and that of the patient. B—Analysis of the mishap is shown in this block diagram of the leakage current's path.

sponsored by the IEEE Philadelphia Section's Group on Engineering in Medicine and Biology, in May 1970) related how the biological effects of electricity (both in instances of macroshock and microshock) are primarily a function of the amperage—not the voltage—applied. As indicated in Table I, approximately 1 mA applied externally is required before any physical sensation is noted. As the current is increased, pain is introduced as well as the involuntary contraction of muscles. In the average person, the muscular contractions reach the "can't let go" threshold at 11 to 16 mA. At about 100 mA, cardiac fibrillations can occur. It is interesting to note, however, that with currents greater than 100 mA, there is a tendency for muscular contraction to be so rapid and forceful that one is involuntarily jerked away from contact with the electrical source. Thus high currents are often not as lethal as moderate currents.

The primary factor causing improper stimulation of the heart muscle is the local current density. Since the human

body acts as a volume conductor, current flows from the point of contact (if the contact is made on the surface of the body) with the electrical source to the exit point—usually the soles of the feet—in a rather broad front. But tissues with the smallest specific resistivities will conduct the greatest amount of current and, hence, are the most adversely affected. Thus the introduction of metallic objects (catheters, pacemaker leads, etc.) or other conductors into the body drastically alters the electrical environment. With such conductors—essentially making a point contact on the heart's wall, and the possibility of concentrating all of the hazardous current at this point—the current density can become very high, even though the total current is very small. Therefore, if the current does succeed in setting up an episode of ventricular fibrillation, the loss of the heart's pumping action will lead to the patient's death—with no visible physical damage to the heart itself. A logical question is: will the sensitivity of the heart muscle be a function of frequency?



A
B

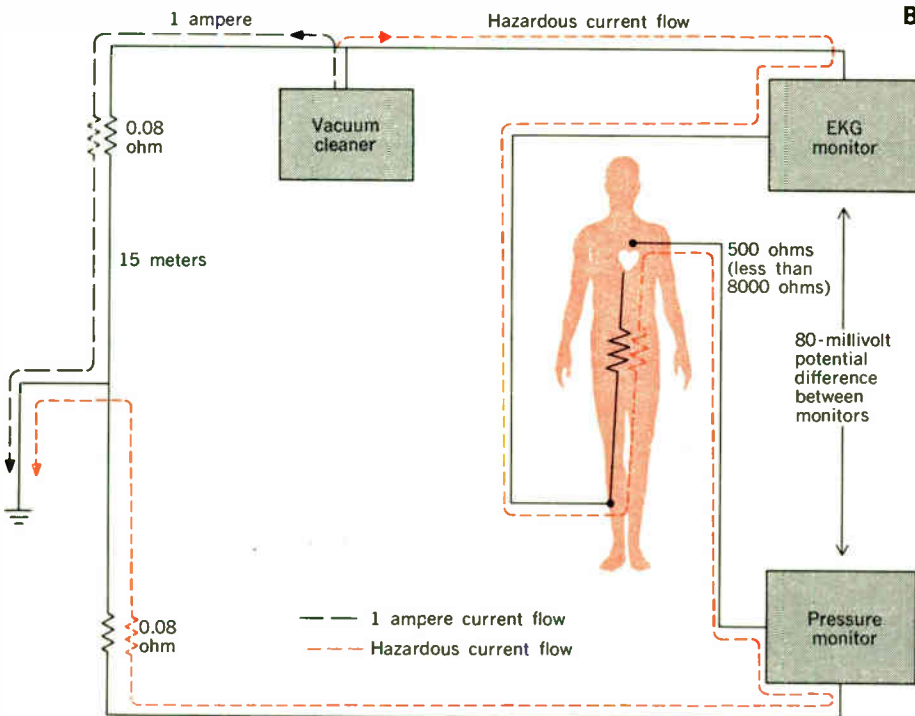

FIGURE 2. A—Case in which a vacuum cleaner is plugged into a wall outlet on same circuit as the EKG monitor. The cleaner has a three-wire power cord, with the third wire grounding its outer case. But the windings of the motor are exposed to dust (often damp), which provides a good path for an eventual “winding-to-outer-case” short circuit. Because this kind of short circuit makes the case rise to full line voltage, the case is grounded to protect the operator. In this example, the vacuum cleaner has not completely failed, but has developed a fault sufficient to permit 1 ampere to flow down the ground wire and back to the power distribution panel. **B**—In this analysis of the incident, if the power distribution panel is 15 meters distant and the power wiring is 12 gauge, the 15 meters of ground wire have 0.08 ohm of resistance. The hazard here is that the faulty appliance caused difference in ground potential between two devices and allows a possibly lethal current to flow through the patient.

Plotting a graph of current required to produce fibrillation versus frequency indicates that the greatest hazard occurs at the power-line frequency of 60 Hz.

Methods for reducing the hazard of microshock

Techniques for reducing microshock hazards will be described at length because they involve the solution of engineering problems even though, at present, very few hospital patients are exposed to this type of hazard. As we have already noted, shocks in the low-micro-ampere range, from as little as a 5-mV differential between electronic instrument probes, can be a potentially lethal problem. Figures 1 and 2 are illustrative examples of how such inadvertent situations can occur.

Isolated patient circuits. During the past few years,

it has become apparent that the patient in the typical intensive-care unit (ICU) and cardiac-care unit (CCU) is being exposed to the danger of microshock because of the increasing practice of using internal conductive electrodes or saline-filled catheters in the vicinity of the heart. With improvements in transistor circuits, however, there was no reason why the electrocardiograph (EKG) monitor, pressure monitor, or portable EKG had to have a direct ground path to the patient for proper operation.

In this approach, high patient circuit impedance must be maintained. This requires care by the medical personnel in their handling of an internal conductor that is passed into, or close to, the heart; it also requires the choice of instrumentation whose patient circuits are adequately isolated from *both* the power line and ground.

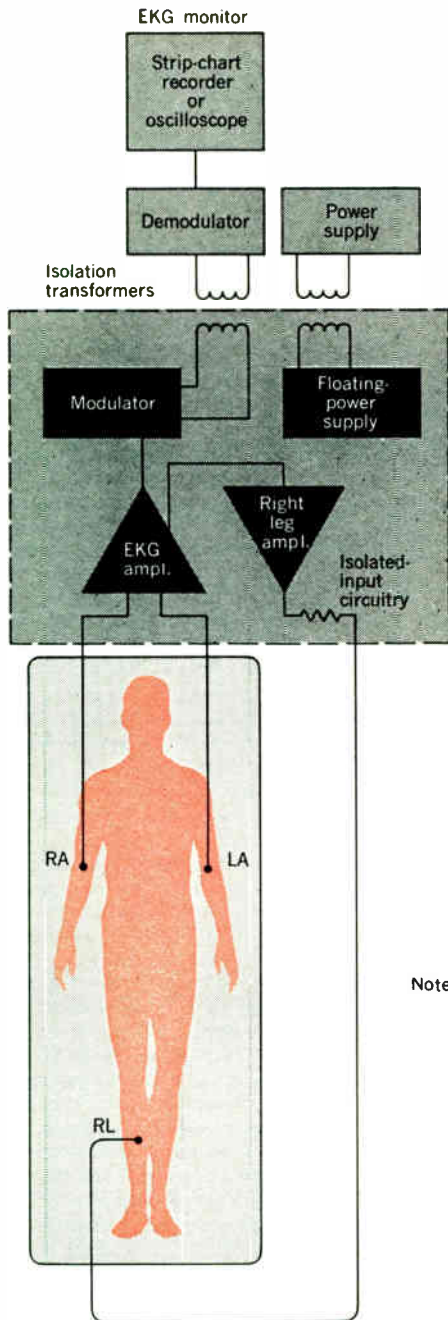

Note: RA = Right arm
 LA = Left arm
 RL = Right leg

FIGURE 3. Block diagram of isolated-input electrocardiograph-amplifier circuitry developed by Hewlett-Packard's Medical Electronics Division in 1967.

FIGURE 4. Electrical analysis of the situation illustrated in Fig. 1 when patient is protected by isolated input circuits, with 25-megohm isolated impedance.

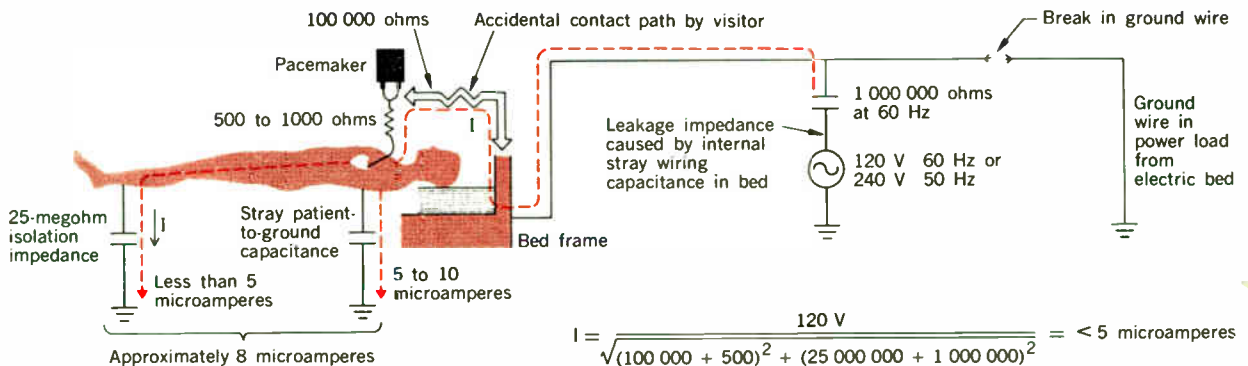

This can be accomplished by designing isolated input circuits into EKG instruments (as shown in the Fig. 3 block diagram), which are normally connected to patients with indwelling electrodes.

The isolated circuits, which connect directly to the patient, are physically insulated from ground and other portions of the EKG or patient monitor. One isolated circuit, for example, receives its power through a small isolation transformer (operating at high frequency) inside the instrument, and transmits the EKG signal through another isolation transformer (operating at the same high frequency) to the display and recording sections of the device. *No conductive path is present between isolated and other sections of the instrument.*

If it were possible to make the circuit infinitely small or to separate it by an infinite distance from other portions of the device, perfect isolation could be achieved. Since this is not possible, a small amount of capacitance remains between the isolated and grounded sections of the circuits. Yet, with present techniques, at 50 or 60 Hz more than 10 megohms of isolation impedance between input and terminals ground can be achieved.

Other monitoring devices that are connected to the patient can also be isolated. For instance, transducers for arterial and venous pressure measurement can be designed so that the saline column in the catheter is not connected to the chassis of the pressure monitor through the shield in the transducer cable. Also, sensors such as temperature probes, heart-sound microphones, and respiration transducers are available in isolated versions.

Value of patient isolation. The advantages of isolating the EKG leads from a patient in an ICU can be seen by referring back to Fig. 1. Here, the patient was connected to an EKG monitor that grounded his right leg, and this electrode became part of a hazardous current path when the attendant touched the electric bed (with its broken ground connection) and the pacemaker catheter terminals simultaneously. If we substitute a monitor, with isolated input circuits, and with 25-megohm isolated impedance, the quantity of current flowing through the monitor (Fig. 4) will be less than 5 μA —a considerable reduction when compared with the 100 μA shown in Fig. 1.

Power-isolation transformers—and patient safety. The power-isolation-transformer approach to a safe environment for the patient is based on eliminating low-voltage hazards (in contrast to the patient-isolation concept just discussed, which eliminates possible current paths through the patient). Although the concepts are different, they are complementary, and the combination of both can

produce the safe patient environment that will be discussed later. The objective of both concepts, however, is the same: the prevention of currents greater than $10\ \mu\text{A}$ from passing through the heart muscle from indwelling electrodes.

The power-isolation-transformer concept assumes that the externally exposed end of the electrode or catheter will be grounded, either intentionally or by accident. Further, if we assume that the resistance to current flow, measured from the catheter terminals to a point on the surface of the patient's skin, can be as low as 500 ohms, it then becomes necessary to limit the potential difference between the catheter terminals and any other surface or instrument in the vicinity of the patient to less than 5 mV—if the current is to be below $10\ \mu\text{A}$.

But the success of achieving and maintaining such low levels of potential difference in a patient is not an easy job. If the leakage current from a device near the patient exceeds 5 mA, and the grounding connection to it exceeds 1 ohm (not improbable conditions), then the potential on the outer case of the appliance will exceed the 5 mV defined as hazardous. Further, if an internal insulation failure occurs in the appliance, permitting a live power wire to touch a grounded part, the resulting fault-current flow can reach many amperes before the circuit breaker in the branch circuit supplying power to the appliance trips out. Larger fault currents will cause potential differences of several volts. This would be intolerable in the vicinity of a patient with a grounded internal catheter.

The power-line isolation transformer is proposed as a basic component in an electric power system to minimize voltages near the sensitive patient.

Protection by isolation transformers. To understand the operation of isolation transformers, we must consider the modern three-wire branch circuits in hospitals in which:

1. The current-carrying wire is at 110/120 volts above ground (in the U.S. and Canada).
2. The neutral wire, carrying the return load current, is near ground potential.
3. The grounding wire is at ground, or zero, potential.

The grounding wire provides a safe return path for any leakage currents from the appliances (or other devices supplied by the branch circuit). The assumption is that ground is connected to the outer case of these devices. The ground wire also serves to carry large fault currents if a current-carrying part in the appliance comes in contact with the case, thereby preventing the case from becoming "hot" with respect to ground. In this type of power circuit, the amount of current that would flow—if the hot wire contacts a grounded part of a device—is limited only by the branch-circuit fuse or circuit breaker.

In the power-isolation transformer, shown schematically in Fig. 5, note that both sides of the circuit are isolated from ground and that either line A or line B can be short-circuited to ground without a large current flowing through the connection. Actually, the current that will flow in a short circuit to ground is limited by the leakage capacitance in the transformer and associated wiring. It is generally no more than a few milliamperes.

The transformer also affords a high degree of protection against electric shock to medical personnel. Since an operating room staff and all conductive equipment are grounded to prevent static discharges (and possible fires

or explosions in the presence of anesthesia fumes), there is the possibility that such personnel could receive a serious shock if a live power wire were accidentally contacted. But, as we have already noted, line-to-ground faults are restricted to low milliamperage values; thus accidental contact with the power line may result in a painful, but not lethal, shock.

The line-isolation monitor. An additional protective feature, used in conjunction with the power-isolation transformer, is the line-isolation monitor (Fig. 6). It is connected to a detector that is set to trip an appropriate alarm if the impedance drops below a predetermined level (usually 60 000 ohms). Thus, as long as each power line is at least 60 000 ohms above ground, and if either line is short-circuited to ground, not more than

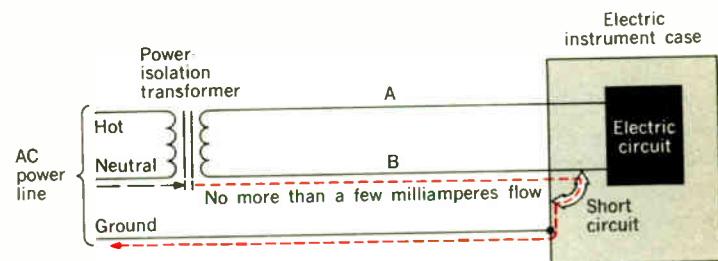

FIGURE 5. Schematic representation of power-isolation transformer. Note that either line A or line B can be short-circuited to ground without a large current flowing through the connection.

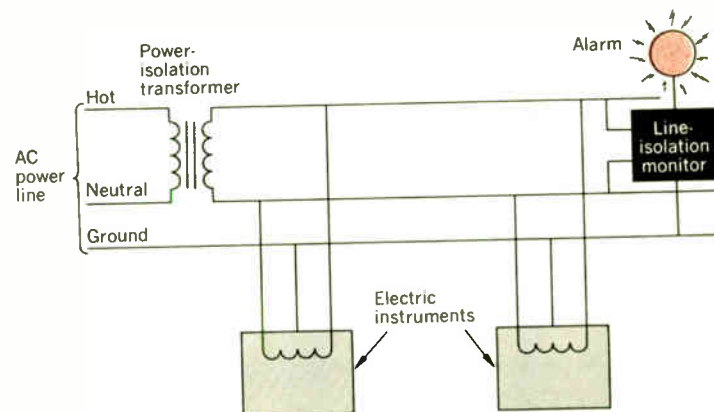
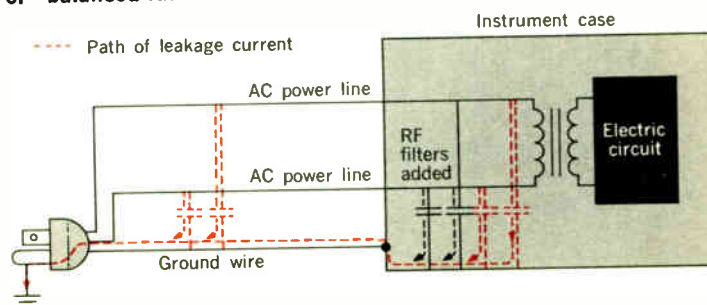

FIGURE 6. Diagram of a power-isolation transformer system equipped with a line-isolation monitor and alarm.

FIGURE 7. Schematic diagram of circuit in which RF filters have been added. The presence of the filters contributes to a higher leakage current—and the possibility of "balanced faults."



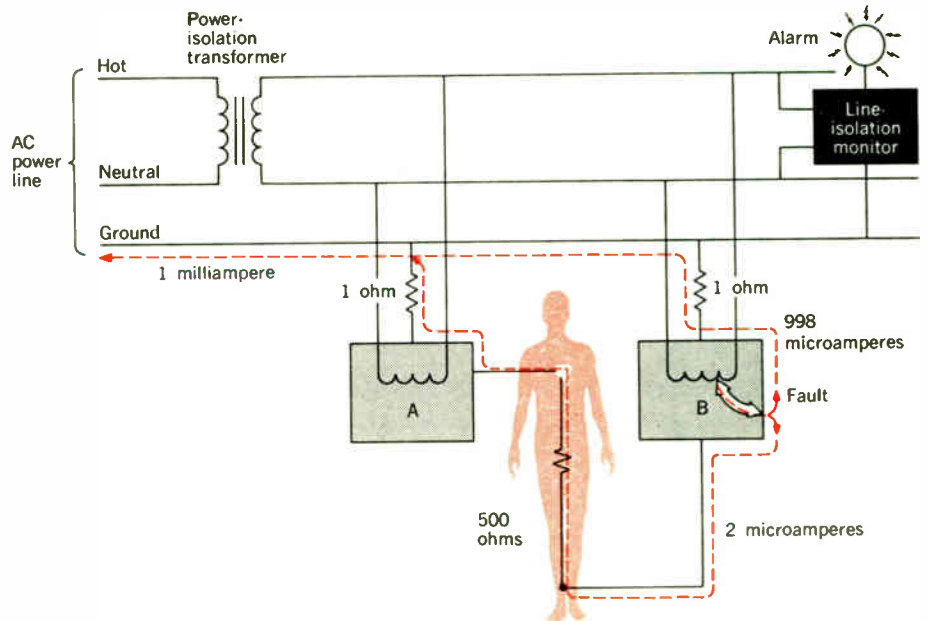
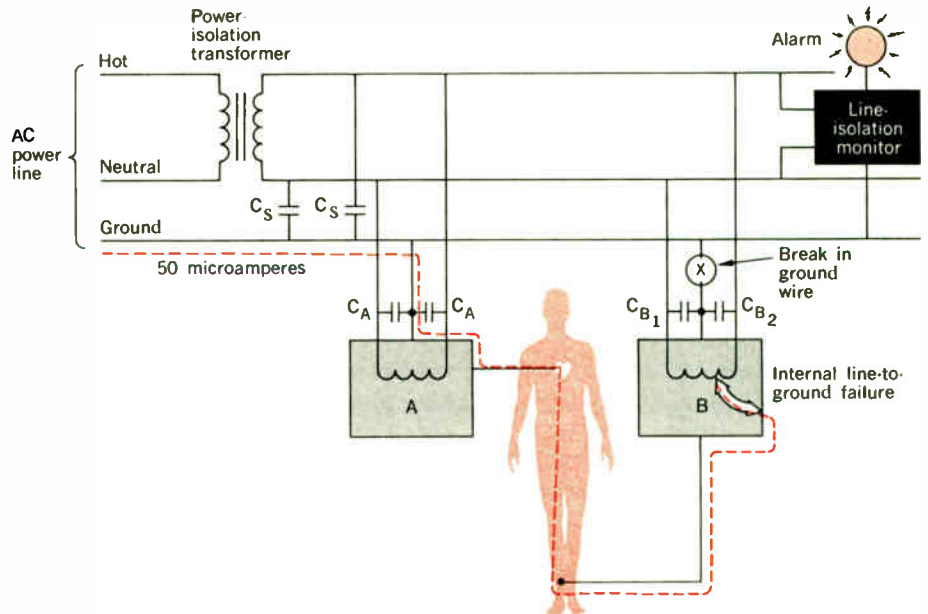

FIGURE 8. Situation in which a single insulation failure occurs in one device when a patient is electrically connected between two devices. Note the system is equipped, as in Fig. 6, with a power-isolation transformer and line-isolation monitor.

FIGURE 9. Grounding wire failure in isolation transformer system. This situation, compounded by an internal line-to-ground failure, can place patient in immediate danger.



2 mA will flow through the fault in a 120-volt, 60-Hz system. Until recently, the line-isolation monitors were mostly of the “static” type; that is, they depended upon detecting an unbalance in impedance to ground of either isolated power-line wire—but they *did not detect* balanced faults such as may occur in the use of equipment with balanced RF filters (Fig. 7).

The solution to this problem is in the “dynamic line-isolation monitor,” in which the impedance of each isolated power line to ground is measured alternately several times per second. In this way, the device can detect both balanced and unbalanced faults composed of the combination of resistive, inductive, or capacitive elements.

Isolation techniques permit a reduction of the inherent hazards of electrically powered equipment to a degree. Isolation transformers can help to protect

the patient if devices that ground the implanted electrode are used. The patient *is not protected*, however, if a grounding connection fails. Therefore, routine inspection and testing of the quality of these connections is an essential requirement to ensure the safety of the patient and medical personnel.

The isolation transformer in a case situation. Before leaving the subject of isolation transformers, the reader may get a better understanding of their performance in an actual operational situation. Figure 8 shows a patient electrically connected between two devices. Here, we assume that:

- The catheter leading to his heart is connected to the outer case of device *A*, while another part of his body is connected to the case of device *B*.

- Devices *A* and *B* are connected to a common ground point, with wires each having one ohm of resistance,

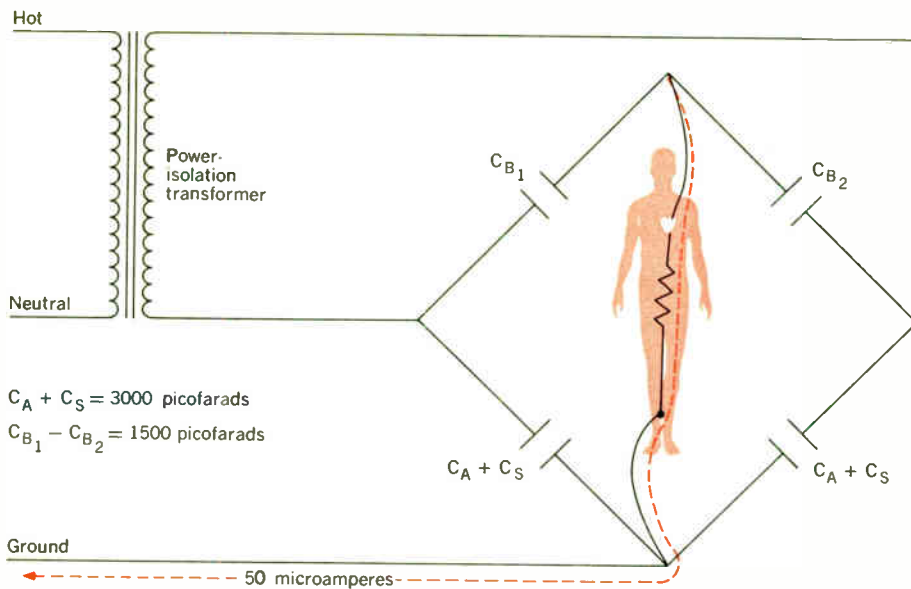

FIGURE 10. Grounding wire failure, shown in Fig. 9, redrawn to show hazardous current flow, in which patient becomes the “sensing element” in a four-arm bridge circuit.

and that the patient represents 500–1000 ohms of resistance (This is the range often assumed for patient safety calculations.)

The power for each device is supplied from an isolation transformer that, under single-fault conditions, will limit the current flowing in the fault to less than 1 mA. If a fault now occurs in device *B* (such as an insulation breakdown in the power transformer, which permits the live power line to touch the case), the isolation transformer limits the fault current flow to 1 mA. Because of the 500-to-1 ratio between the patient and ground-wire impedances, 998 μA will flow in the ground wire and only 2 μA will flow through the patient. Meanwhile, however, the isolation monitor would have triggered an alarm to indicate an equipment failure.

The open-ground problem. Despite its value in managing the fault-current problem, one very important class of failures is *not* eliminated by the isolation-transformer system: if a ground wire in a power cord breaks, it will not be detected by the isolation monitor; and if the patient is in the situation shown in Fig. 9, he can be in immediate danger. Therefore, it is necessary to consider the dual possibility of an internal line-to-ground failure in a device *and* a break in a ground wire. The insidious situation here is that the ground-wire break would not be detected by the staff since the equipment would probably continue to function.

In Fig. 9, as in Fig. 8, the patient is connected to two devices, with the indwelling electrode attached to the case of appliance *A*, and another point of his body connected to appliance *B*. It is usual for these devices to have RF interference-suppression filters connected from power line to case, as indicated by C_A and C_B in the diagram. Also, stray capacitance between building power wires and ground play an important part in total capacitance, and are indicated by C_S . If we assume that the grounding connection to device *B* breaks, the leakage current that normally flows from *B* to ground can now go through the patient.

If Fig. 9 is redrawn (Fig. 10), it can be seen that the patient becomes the “sensing element” in a four-arm

bridge circuit. The amount of current flowing through the patient is determined by the various capacitances; if C_A and C_S are of the order of 3000 pF, and the two capacitors C_B differ by 1500 pF (all reasonable levels), currents of the order of 50 μA will flow through the patient. This would be an intolerable condition.

The “safe patient” environment

Hewlett-Packard, for example, feels that the primary guideline for an electrically safe patient-monitoring

FIGURE 11. Schematic wiring installation of grounded-line outlet cluster for one-bed “safe patient” environment.

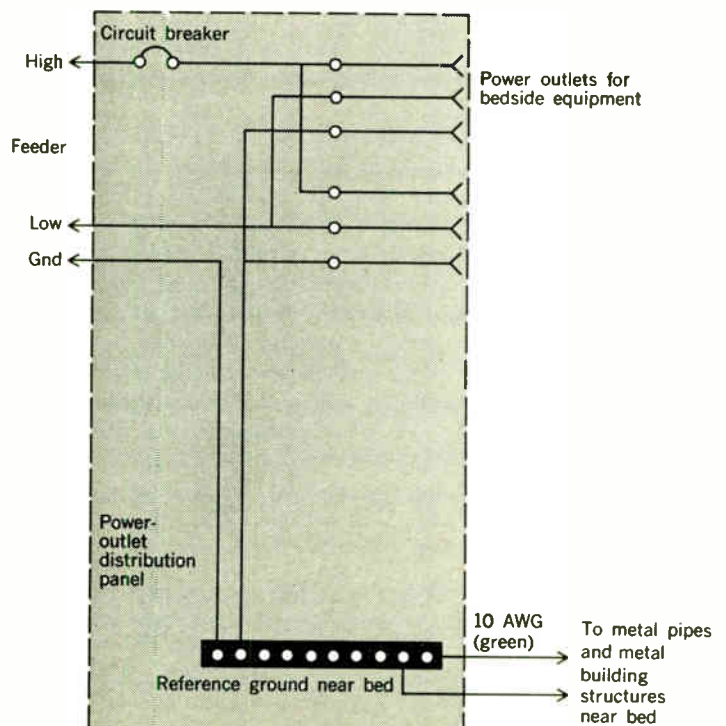

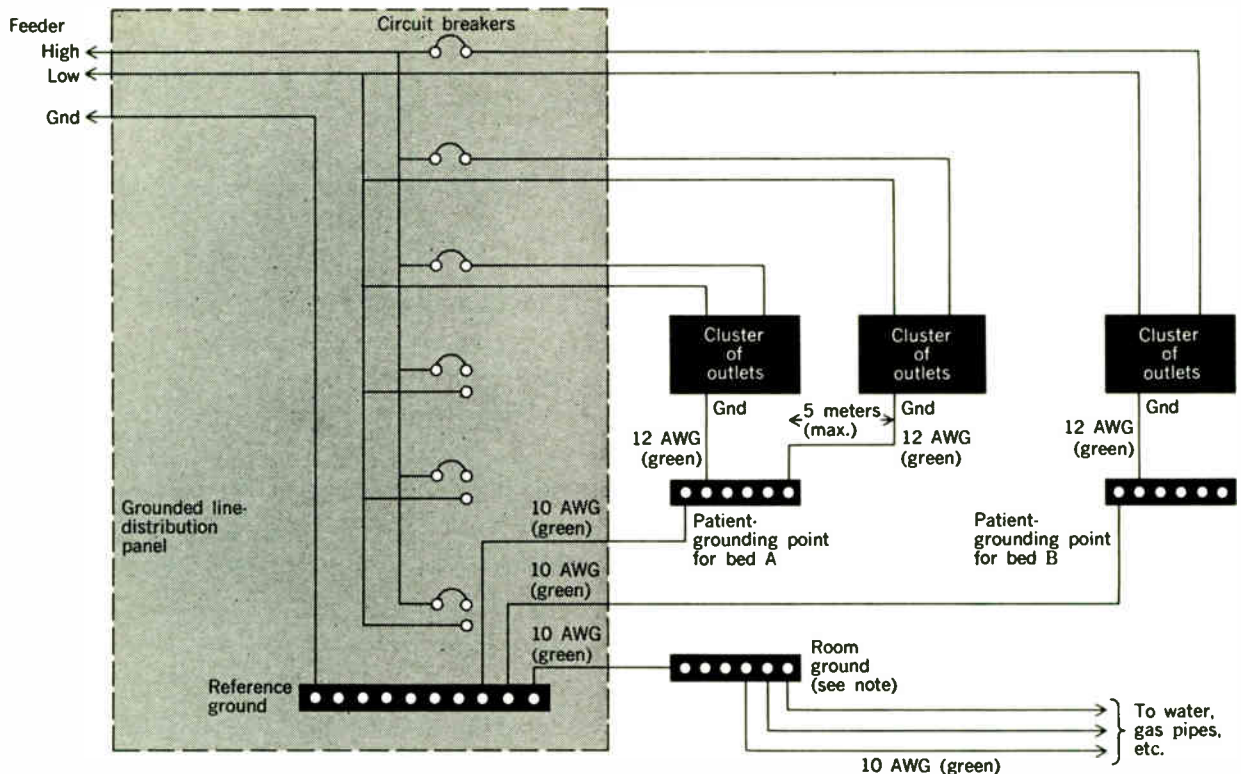

Note: If convenient, ground wires to building structures may be run directly to reference ground in distribution panel, omitting the separate room-grounding bus.

FIGURE 12. Schematic wiring installation for grounded-line outlets for multiple-bed situation in which beds are remote from distribution panel.

system starts with an adequate grounding plan, in which all metallic conductive surfaces within reach of the patient, and of any person touching the patient, are at the same potential.* In such an environment, all metallic surfaces within the room, the electric power outlet ground connections, and the metal furniture are tied to one common reference grounding point, which is, in turn, connected to the normal hospital electrical grounding system.

One such plan is shown in the Fig. 11 schematic. Here, the reference ground is a solid metal bar in the power distribution panel used for terminating ground wires from bedside furniture, plumbing, ducts, power outlet ground terminals, and the hospital's power grounding system. This power distribution panel is only for one patient and must be located close to his bed. However, if it is not practical to bring ground wires from all required points in the patient area to this one reference ground, the grounding system can be rearranged as indicated in Fig. 12. This arrangement is particularly beneficial when the beds are remotely located from the power distribution panel, and when more than one patient is in the same room. Each bed location is

equipped with a "patient grounding point." The ground terminals from electrical outlets for that bed and ground wires from furniture and the nonelectric bed are connected to the respective patient grounding point. The room ground serves to tie plumbing, partitions, window frames, and permanent metal building parts together electrically for the entire room. All patient grounding points and the room ground are, in turn, connected to the reference ground in the power distribution panel. The grounding system shown in Figs. 11 and 12 provides the primary safeguard against accidental shock to the patient and medical staff.

A note of caution. To ensure the safety of the patient in the event of failure with this kind of grounding system requires that *all* catheters and electrodes applied to the patient be connected only to *isolated input equipment* (under the isolated-patient-circuit concept we have already discussed). The hospital must establish disciplines and procedures to make certain that no equipment that provides a direct path to ground is brought into the patient area and connected to the patient. Further, the hospital should ensure that the external ends of catheter plumbing and indwelling electrodes are insulated so that accidental contact by the hospital staff will not result in a path to ground.

If the patient's indwelling electrodes and catheters *cannot* be protected from accidental contact with grounded objects, or if the patient might be grounded by the design of the devices attached to him, *power-line isolation transformers are justified.*

* Actually, this is the "equipotential grounding" concept in which, in each patient area, there is a single ground point to which is referenced any conductor with which the patient can come into contact. Thus there is no possibility, for example, that a wash basin will be at one potential and the case of a nearby instrument at another potential. We shall subsequently discuss Mr. Lee's alternative proposal to this concept.

A suggested alternative discipline. Arnold S. J. Lee, to whom we referred earlier, outlines two ways of protecting the patient from microshock caused by leakage currents coming from sources other than medical instrumentation and catheters:

1. The patient must be insulated from ground.
2. He must be insulated from contact with electrical conductors.

According to Lee, such protection is practical by the use of flexible plastic sheeting on floors, and by the use of tables, lamps, furniture, and instrumentation covered with plastic, wood, or glass on their outer surfaces. He states that “for instruments directly connected to the patient, modern electronic design is able to limit the maximum leakage currents in such instrumentation to values as little as a few microamperes, so that regardless of what faults may occur in the equipment itself, the patient cannot possibly be harmed.”

Is there a lack of adequate standards and regulations?

Dr. Joseph B. Davis, director of the Division of Clinical and Medical Devices in the Food and Drug Administration, states that, at the present time, FDA regulations apply to all medical devices on an “after the fact” basis, when they are misbranded. There is no requirement that any medical device be safe or effective before it is marketed; nor does the FDA have the authority to approve any medical device—electric or otherwise—at any time.

In the context of this subheading, Spalding, in his presentation at the March AAMI meeting, gave a rather gloomy review and forecast:

“After reviewing reports from several standards-writing organizations there appears to be but one logical solution: one standard, written and enforced by one recognized authority [commission] with the necessary prestige and legal backing. Therefore, I believe, it must be a function of a federal agency with the support of Congress. At present there are several governmental commissions studying and reporting on the subject. The prospect of final standards from any of these before the end of 1972 appears remote . . .”

Spalding then cited a statement by Dr. John Collins, president of AAMI, as published in the November 1970 issue of *Electronics in Medicine Newsletter*:

“There are already more than 50 nationally recognized organizations that are either directly or indirectly involved in standards for biomedical equipment, but none have the authority that a standards group must have, and some suffer from imbalance in their make-up.”

To this, Arnold Lee offers his rebuttal: “If there are more than 50 nationally recognized organizations involved in standards, that is because human beings like to get together and form groups. The point is that medical—electronic, and other esoteric, instrumentation has not arrived at so advanced a state that any of us can say we wish to have rigidly fixed standards. Not enough is known about either the human body or the interaction between the body and machines to stop development at this time and start rigid standardization.

“At some time in the future, when sufficient agreement concerning what it is we have to do to keep patients safe has been reached by experts in the field, we can then proceed to standardization.”

Other views: pro and con. However, Dr. F. A. Van Atta,¹ writing in *Electrical Hazards in Hospitals* (proceedings of a workshop sponsored by the National Academy of Sciences, April 4–5, 1968), published by the NAS in Washington (1970), made these interesting observations in regard to standards in other countries:

“I looked over these five sets of standards [British, Canadian, French, German, and Japanese] to see whether reduction by some common denominator would make them all look alike. If there is any common denominator, I could not find it. I think that, next to the United States, the Canadians take the prize for a care-free attitude about the whole thing. As we do, they prepare their standards in a private organization—the Canadian Standards Association. The standards take the form of regulations enforceable as law only if a provincial legislature passes an enabling act that permits their adoption by the localities immediately concerned with the regulation of the hospitals. This is comparable with our practice, which lets the standards become regulations upon adoption by any of the several hundred governmental units that are responsible for regulation of hospitals . . .

“The other contrast between practice in the U.S. and Canada and that in the other countries is that there seems to be no nonsense in the other countries about advisory standards. They are written to have the force and effect of legal regulations that are enforceable uniformly throughout the country by the central government. One difference among the other countries is that the British standards are apparently produced and promulgated directly by the Ministry of Health. The French, German, and Japanese standards are prepared wholly or in part by the electrical and technical societies for the use of the appropriate governmental agencies.”

A number of physicians in the United States are not wildly enthusiastic about all-out standardization of medical—electric equipment, or the governmental regulation that this might create. But there is a consensus that some degree of standardization would be beneficial. In Japan, for example, standards for EKGs have been established under government control; in West Germany, there are governmental standards covering the electrical safety of medical equipment.

Carl Berkley of New York’s Mt. Sinai Hospital, writing in the February 1970 issue of *Medical Research Engineering*, has some cogent observations on the problems of standardization in the U.S.:

“Part of the reason for the slow progress of standardization is that committees generally have a membership of individualistic delegates, responsible only to themselves or espousing . . . the views and self-interest of their employers. The result is that almost nothing is agreed upon and each manufacturer is free to go his own way. The demand and market for instruments and apparatus is therefore fractionated and uneconomical. There have been a number of suggestions . . . that the government should determine quantities and specifications and should award contracts for development and manufacture . . .

“In the U.S. it is rare that the government can impose such standards on a private industry such as the health industry. Although general standards are issued by the Public Health Service . . . it is noteworthy that the standards provide almost no guidance for the electrical or electronic equipment designer and manufacturer . . .”

Role of the NFPA

The National Fire Protection Association (NFPA) is a voluntary organization composed of representatives of a number of groups (including insurance companies, equipment manufacturers, professional societies, and government agencies) concerned with fire and other safety problems. Many city and state codes, however, are formulated, by reference, from NFPA standards. The NFPA's new manual, *76 BM—The Safe Use of Electricity in Hospitals*—has recently become available and, according to Dr. Saul Aronow, director of Medical Engineering, Massachusetts General Hospital, Boston, it is at present the most complete compendium of what constitutes an approach to safety in the hospital. But it must be stressed that *76 BM is only a manual* published for information and comment; it is, as of today, not a required code.

There are four parts to the manual:

1. The nature of the electrical hazards of macroshock and microshock, plus the heat and acoustical effects of some medical-electric equipments.

2. The wiring and electric power circuits within the hospital. (This section will also be included in the forthcoming revision of the National Electrical Code, so it will eventually become part of many building codes.)

3. Appliances, which is the Underwriters' Laboratories term for electric devices and instruments. (This section covers leakage currents, isolated design, etc.)

4. Maintenance and administration. (It recommends such things as the proper training of hospital personnel who use or handle medical-electric equipment, the establishment of in-house engineering staffs, the preparation of instruction manuals, etc.)

An engineer proposes some remedies

A suggested first step. David Lubin, administrative engineer at Sinai Hospital in Baltimore, believes that it would be most useful if hospitals took positive initial steps toward investigating, documenting, and detailing the problems of low-current shock. Such action, which could lead eventually to practical solutions, would entail

- The recognition that electrical faults resulting in accidents are usually the result of operator error or equipment defects.

- Better training programs for physicians, surgeons, technicians, and nurses who will handle and operate electric and electronic equipment.

- The installation of equipotential grounding systems *throughout* the hospital to provide a comprehensive and complete "yardstick of electrical safety."

- The establishment of a biomedical engineering department under the supervision of a competent biomedical engineer.

According to Mr. Lubin, proposals for the revised 1971 National Electrical Code include equipotential grounding systems. He admits, however, that "it may be a long time before standards can catch up with the pace set by ever-proliferating biomedical instrumentation."

Efforts of the Emergency Care Research Institute

The Emergency Care Research Institute, a nonprofit organization in Philadelphia, is primarily concerned with biomedical research but it also conducts a formal "Health Devices Evaluation Program." In this effort,

II. Procedure for electrical safety testing at the Emergency Care Research Institute

I. Physical examination

A. External:

1. Quality of line cord and plug cap.
2. Accessibility of fuses and circuit breakers.
3. Fault indicators or alarms.
4. Quality of switches, controls, connectors, and cables.
5. Appropriate choice and commonality of connectors for patient cables and transducers.

B. Internal:

1. Presence of balanced filter in primary of power circuit.
2. Strain relief on line cord and plug.
3. Voltage ratings of filter capacitors, lamps, switches, and other components.
4. Quality of components.
5. Construction practices—
 - a. Mechanical integrity.
 - b. Insulation to chassis where indicated.
 - c. Quality of assembly.
6. Presence of electrostatic shielding on power transformer.
7. Resistance between active components and patient-connected leads.
8. Design considerations that inhibit catastrophic failure.
9. Fire- and explosion-proofing.

II. Operational tests

A. Leakage (ac and dc):

1. Between patient leads.
2. Between patient leads and ground.
3. Between patient leads and case.
4. Between case and ground.

B. High-voltage test, input plug to chassis

C. Dangerous potentials on patient leads:

1. During operation.
2. Switching transients.

D. Ground-circuit resistance

E. Rating of fuses and other protective devices

F. Electromagnetic interference

it provides comparative evaluations of various classes of medical-electric and medical-electronic devices, hazard warnings, and technical guidance to the medical community. To preserve its objectivity and impartiality, the ECRI does not accept funds from the medical equipment industry, nor are its personnel permitted to engage in private consulting activities or to own stock in firms manufacturing medical devices.

According to Dr. Joel J. Nobel, ECRI director, the program's priority for evaluating a class of equipment is first established and then a five-step procedure is pursued:

1. A detailed test protocol is written and passed upon by experts in that particular field.

2. Units for evaluation testing are obtained from all significant manufacturers of the device.

3. Parallel testing of all units is conducted in which the manufacturer's specifications are confirmed, engineering tests of performance and safety are rated, and clinical tests in a real operating environment are performed.

4. A preliminary report on each device is written and sent to its manufacturer for comment and to encourage corrective action where needed.

5. A final composite report (containing data gleaned

from the four preceding steps) is prepared and issued.

Table II shows the generalized procedure for electrical safety testing that forms a part of the overall review of each electrically powered device that is evaluated by the Institute.

Results of the evaluation program are published in a monthly bulletin, which ECRI initiated recently. Its stated goal is to urge manufacturers to upgrade their equipment, to give potential purchasers of equipment objective data on which to base decisions, and to warn the user of the hazards involved in potentially dangerous equipment.

Dr. Nobel has urged hospitals and medical-engineering staffs to adopt "prepurchase selection programs" to evaluate the competing claims that equipment salesmen have for their products. He has also rejected "research by anecdote." Thus, if a failure or hazard in the equipment is noted, the supplier should be immediately informed for the purpose of consultation and comparison evaluation with his testing.

Economics involved in upgrading the hospital environment

Dr. Arthur Miller (F), a leading consultant on the design of medical-electric equipment and instrumentation, feels that it is difficult to estimate the relative costs of incorporating the two approaches to isolation design because of the variables involved; for example, whether the design is to be included in the plans for a new hospital as an incremental cost, or whether the improvement and upgrading is to be worked into the existing facilities of an old hospital. Arnold Lee, however, believes that about \$3000 per bed seems to be a reasonable cost for installing an isolated power system with ground-fault detection. But Dr. Aronow, in his presentation at the March AAMI meeting, stated that the components of an isolated power system "can be purchased for about \$300, or a packaged unit for about \$1000."

The Medical Electronics Division of the Hewlett-Packard Company estimates that power-line isolation transformers, and their associated accessories, can add from \$1000 to \$2000 to the cost per bed of a monitoring installation in an ICU or CCU. The company feels that, because of this cost, it is essential for hospital and building engineers to have a thorough understanding of isolated power systems in determining whether the expense of such a system is justified in their particular situations.

There seems to be no consensus on the number of beds in a given hospital that should be equipped with the shock-protection systems we have been discussing. One figure the writer obtained was 10 percent of the total beds in the medical facility.

Some thoughts and conclusions

We have discussed the medical-electric equipment evaluation program conducted by Dr. Nobel's Emergency Care Research Institute; thus it may be appropriate here to touch upon the logical extension of parallel efforts in this direction.

At the 1970 Update Medical Safety Conference, Dr. Nobel observed that "many defective devices have been designed and developed by physicians." Therefore, he feels they have a serious responsibility for this situation. He has suggested that a program analogous to that of Consumers Union (and similar to his own group's activities)

might be adopted for testing and rating medical devices and equipment. And he recommended that a pool of biomedical engineering talent be established for determining priorities in electromechanical device evaluation. Such a pool would:

1. Write up detailed testing protocols and specifications tailored to each class of equipment.

2. Obtain sample devices from appropriate manufacturers on an off-the-shelf basis in which no evidence of selective quality control by the manufacturer would be apparent.

But the highest quality medical-electric equipment is of little value if placed in the hands of untrained or poorly instructed personnel, and insufficient training programs often compound human ignorance and negligence factors. Hospitals, unlike most other institutions, operate on a 24-hour basis, seven days a week. Thus it is particularly urgent that qualified staffs, both medical and technical, be on hand at all times to use safe and reliable equipment in the many emergency situations that regularly occur.

The author wishes to thank the Medical Electronics Division of Hewlett-Packard for permission to reproduce Table I, the circuitry diagrams (Figs. 1 through 12), and the textual descriptions of the illustrations, which are contained in the H-P brochure, Patient Safety (© 1971); also Charles K. Spalding, chairman, Boston Patient Safety Committee; Dr. Joseph B. Davis, director, Division of Clinical and Medical Devices, FDA; and Arnold S. J. Lee, The Presbyterian Hospital, New York, for their cooperation and assistance in the preparation of this article.

REFERENCE

1. Van Atta, F. A., "Standards in other countries," *Electrical Hazards in Hospitals*. Washington: National Academy of Sciences, 1970, pp. 5-7.

Reprints of this article (No. X71-092) are available to readers. Please use the order form on page 8, which gives information and prices.



Gordon D. Friedlander (SM), senior staff writer for IEEE Spectrum, has written more than 35 major features for the core publication since he originally joined the staff in 1963. In 1968, he became assistant director of the Burndy Library, Norwalk, Conn. He rejoined Spectrum early in 1970.

Mr. Friedlander is a graduate civil engineer, with 15 years' experience as a structural and project engineer, and was engaged in the design of steam-electric and hydro power plants, and industrial and commercial buildings. Since 1959, his technical articles have been published in leading newspapers, encyclopedias, and trade and professional magazines in both the U.S. and abroad. Mr. Friedlander has lectured on engineering management at the University of Wisconsin, at IEEE Section Meetings, and at a symposium on the environment recently sponsored by the 3M Company. He moderated a panel discussion program series called "Science and Technology" for two years on a New York radio station. His biographical sketch is carried in "Who's Who in the East."

Statements from IEEE candidates

This year the IEEE elections are of special interest because some of our members believe we should be more than a medium for displaying, sharing, and teaching electrical science and technology. What the IEEE actually accomplishes in the near future depends very much on the men we elect this fall. To help each member vote effectively we have asked the candidates for President; Vice President; Regional Delegates/Directors for Regions 1, 3, 5, 7, and 9; and Divisional Delegates/Directors for Divisions I and V, to make statements of their beliefs about the IEEE, what their intentions are, and their own qualifications. Statements were received from all candidates except one.

David DeWitt, Editor

Robert H. Tanner— Candidate for President

Discussions with a considerable sampling of members at various IEEE meetings convince me that a vast majority wish to see the Institute develop steadily and rationally, rather than be swept into an upheaval which would change its nature entirely. I have heard much praise for the active program followed during 1971 by President Mulligan and the Board of Directors, whereby IEEE has led in urging the U.S. Government to act to correct the very serious unemployment situation among engineers. I intend to continue and broaden this program, encouraging joint action between major U.S. engineering societies, so that the profession may display a united front toward government, industry, and the public. From contacts I have had with U.S. Government officials, I am convinced that my Canadian nationality will be more help than hindrance, since it places me outside U.S. domestic politics.

While the unemployment situation is of obvious and paramount importance, IEEE must not neglect nor weaken its primary role as a medium for the exchange and propagation of high quality technical information. However, it must not equate "high quality" with "academic abstraction" and must ensure that its publications cover the whole of its field, not only by disciplines, but also by technical level, including papers and articles of interest and value to the engineer in the factory, as well as the researcher in the laboratory. We must remember too that we are human beings in a world desperately in need of the kind of technology which will help solve its problems rather than create new ones, and must open Institute channels to the discussion of the social impact of our work. At the same time we should develop the unique transnational character of IEEE which is making it a unifying force among electrical engineers all over the world.

Robert H. Tanner

Harold Chestnut— Candidate for Vice President

The IEEE and its members have an important mission in today's world. They have responsibilities for making more effective the processes of conceiving, defining, acquiring, operating, and maintaining technical and other equipment having a significant electrical or electronic content. They also have responsibilities for the education, standards, theory, and science associated with such equipment and its application.

The members of the IEEE have an opportunity to make the results of their efforts useful to society and their fellowmen. The IEEE must seek improved ways with which the skills of its members and other engineers and scientists are used effectively in solving those problems of society for which they are qualified. I believe the cooperative efforts of the IEEE, NSPE, and other engineering societies should be strengthened to help bring about such improvements.

The IEEE as a transnational institute serves as a unifying influence to enable engineers and scientists from all countries of the world to share their experiences and to improve their own abilities. This transnational role of the IEEE is a very useful one and should be strengthened.

Starting as a Student member, I have been associated with the IEEE in many Sectional and technical activities. I believe my background and experience on both the IEEE Board of Directors and the Executive Committee can be of benefit in the position of IEEE Vice President.

The record of the IEEE and its members is one of which they can be proud. But more can and must be done to serve our members more effectively. If elected, I shall be glad to work with the other officers to so serve the Institute and its members.

Harold Chestnut

Candidates for Regional Delegate/Director for Regions 1, 3, 5, 7, and 9

Richard C. Benoit, Jr.—Candidate for Regional Delegate/Director of Region 1

(No statement was received from Mr. Benoit because of the recent death of his wife.)

Harold S. Goldberg—Candidate for Regional Delegate/Director of Region 1

After over a year of intense personal involvement with our professional problems in New England, I am convinced we need a professional organization. I am less convinced that it should be the IEEE.

My background in this area includes being last year's Boston Section Chairman, Chairman of NEREM's "Brown Bag" meeting with Dr. Mulligan, Chairman of the IEEE Economic Analysis Committee, organizer of NEREM's Employment Opportunity Room, a member of the Massachusetts Engineers Council with MSPE and ASME, a founder and director of ATP, and a person very concerned about our basic problem.

In my opinion, we require an organization working on our behalf on the national, state, and local levels. It must be strong, aggressive, organized toward lobbying, self-help, and mutual well-being. I believe an organization like the IEEE with its complete technical bent may be a liability. IEEE is heterogeneous, internationally organized, and its only common bond is its technology. The IEEE also represents many who are not involved in this problem, either due to differences in field, or in position, or just indifference. As a volunteer technical organization depending on inexperienced subleaders, its procedures are adequate. But, when we have attempted to use IEEE structure for other purposes, we have been disappointed.

Moreover, the professional problems involve other specialties, such as mechanical engineers, chemical engineers, chemists, physicists, biologists, etc. A larger, more inclusive society should be able to have a greater impact than just the IEEE alone.

A restructured NSPE, coordinating with the other societies, could do the job. IEEE and ASME both recently affiliated with NSPE. Nonlicensed engineers can now become members of NSPE. With active participation of new members, with direction from society affiliates which are now forming, I believe we have the best opportunity to make an impact.

Harold S. Goldberg

Haroun Mahrous—Candidate for Regional Delegate/Director of Region 1

The engineer needs a strong advocate to promote his interests. This means the exercise of influence over industrial and government policy in areas which impact him both as a professional and as a citizen.

To achieve effective lobbying is costly. The larger the

common interest group, the lower the individual cost and the more powerful the influence. Therefore, there is a need for a single, new organization to represent the technical community of the nation, to speak for all the employed engineers and scientists.

The NSPE in its present form could not satisfy this requirement. Its membership base is too narrow and it is committed to goals not consistent with those of the entire technical community.

The most effective way to form such an organization would be to have the leadership of the existing technical societies take the initiative, with IEEE leading the way. IEEE and the other societies would be loosely affiliated with the new organization and need not change their present technical activities or their tax status. At the same time their membership lists and communication media would be available to enlist extended membership for the new organization.

If elected, I will:

1. Promote this purpose and the maximum possible role of the IEEE in behalf of the professional interests of the membership.

2. Encourage the Sections to hold forums to discuss important issues which affect the professional and economic status of IEEE members.

3. Promote cooperation of Section Chapters and of neighboring Sections to hold more effective technical meetings.

Haroun Mahrous

Grover F. Dausman—Candidate for Regional Delegate/Director of Region 3

IEEE's mission is well reflected in the Constitution: "advancement of the theory and practice of electrical engineering, electronics, radio, allied branches of engineering or the related arts and sciences." Although from a puritanical point of view it may be desirable, such advancement cannot be void of economic considerations, nor should there be geographical or political constraints.

Present policies of the IEEE seem aimed toward advancing the profession. However, unless continually reviewed, policies become archaic. In view of changing society, a review now seems imminent. This is not to advocate capricious change but serious assessment of policies and how they might be most responsive to our massive but diverse membership.

By comparison with a number of other technical and professional organizations in which I hold membership, IEEE's performance appears outstanding; I am proud to have been nominated to this responsible position.

If elected, I expect to advance our profession through:

1. Meetings, conferences, conventions, expositions, and seminars which promote greater knowledge among our members in the Southeast in their chosen field, as well as serve to enhance the profession in the minds of the general public and those persons and organizations which contribute most toward the advancement of the profes-

sion. In particular, the aim will be to give greater recognition to the engineer and the engineering profession.

2. Special attention to the employment problems of the Southeast, especially in the aerospace field and for the graduating engineer. Recognizing the profession's obligation to society, the profession should show greater responsiveness to society's needs. New opportunities will be sought where the engineering profession can make significant contributions.

3. Communications through newsletters or other media, so that members might be well informed as to what the Institute is doing in their behalf, and the services that are available to them.

4. Continuation of the Region's strong Student Activities Program.

Grover F. Dausman

Hugh S. Landes—Candidate for Regional Delegate/Director of Region 3

The mission of IEEE should be that stated in the Constitution; namely, the advancement of electrical engineering in theory and practice, but scientific and educational in purpose. I oppose any constitutional change that would give IEEE a trade union structure. I believe that IEEE should be concerned with the socio-economic aspects of the member, but should act only in an advisory capacity and in cooperation with other societies, such as NSPE, whose mission is chiefly oriented in this direction.

The future success of IEEE depends on a more intimate "grass roots" participation of the entire membership. For this reason, I maintain the concept of areas within a region, now in existence in Region 3, to be a vital part of the IEEE structure for the future. The success of this concept has been ably demonstrated in Region 3.

If elected, I intend working toward maintaining the present Constitution and mission of the IEEE, and to retaining, expanding if such is possible, the usefulness of the Area Chairman concept in Region 3.

I am associate professor of electrical engineering at the University of Virginia, Charlottesville, Va. I am currently Chairman of Area I, Region 3, and have also served on the IEEE Merger Committee for the State of Virginia (1962-63), as Chairman of the Central Virginia Section (1964-65), Chairman of the Blue Ridge Subsection of AIEE (1960-61) and the Piedmont Subsection of the IRE (1962-63), as well as Student Branch Counselor to the University of Virginia (1958-60 and 1971-72).

Hugh S. Landes

Lloyd B. Cherry—Candidate for Regional Delegate/Director of Region 5

A dormant idea does no one any good, for regardless of its merit an idea must be awakened and developed if it is to have value. The IEEE is uniquely equipped to bring to the attention of industry and governmental agencies ideas which, upon development, will provide employment for designers, analysts, test engineers, sales engineers, and others. Doubtless a number of ideas which

could contribute to industrial expansion have already been published and simply need to be evaluated and brought to the attention of those in a position to implement them.

At the Section level IEEE may well take a more active part in counseling with high school students who have demonstrated mathematical ability. A "protégé program," assigning one, two, or three students to each member of IEEE who expresses an interest, would redirect many students who would do better in other fields and attract others who have real potential but have never considered the study of electrical engineering. This program could result in a better "match" of ability and interest with an attendant increase in efficiencies in learning and, ultimately, in greater employment.

A stronger link is needed between the electrical engineering departments of the universities and current requirements of industry. The IEEE may provide this link by arranging for meetings of electrical engineering department heads and faculty with engineers from industry through the Groups and Societies. Besides, IEEE might take an active part in helping electrical engineering faculty members find meaningful work in industry during the summer months. In turn, the faculty will become aware of applied research projects in industry to suggest to graduate students.

My attention has been given to these endeavors in the past, and as president-elect of Eta Kappa Nu my energies will be given to the promotion of these activities.

Lloyd B. Cherry

William E. Cory—Candidate for Regional Delegate/Director of Region 5

Our IEEE stands at the crossroads of change. Some members are trying to push it toward a union, others a lobbying organization, while others desire to maintain a strict technical society. Look closely at our publications, conference programs, and TAB, RAB, and EAB activities; you will see that our elected officers and Directors and our appointed committeemen have made considerable progress toward (1) improved communications between members, Sections, Regions, and Headquarters; (2) improved cooperation between IEEE and other technical societies; (3) improved services to our members; (4) improved or established relationships between IEEE and other professional organizations; and (5) have made concerted effort to evaluate and solve our IEEE problems. You will be asked to choose among several candidates for most of the elected offices and to vote on proposed revisions to the IEEE Constitution and Bylaws. One of these revisions will completely alter the nature of our IEEE. For the first time in many years, it is very important that each IEEE member consider the candidates and proposals and then *vote*.

Where do I stand on major issues before our IEEE today? I am for maintaining a strong technical society within which the pros and cons of technological and sociotechnological issues are freely discussed in our publications and conferences; against IEEE becoming a union or lobbying organization; for expanding IEEE activities aimed at improving the professional well-being of our members, here providing technology assessments and

forecasts and expanded employment opportunity information may help; for expanding current efforts to improve communications between all members—professional cross-fertilization can lead the way to more effective use of today's technology for solution of today's and tomorrow's problems; for expanding communications between IEEE members and their national government organizations and international organizations; and for expanding the international aspects of our IEEE.

William E. Cory

Joel P. Kesler—Candidate for Regional Delegate/Director of Region 5

The IEEE must be more than a technical society. The reorientation required to better serve its members and society need not be radical; in fact, it is already under way. While the emphasis on the technical aspects must continue, the trend toward increasing the services to the individual illustrated by the actions to minimize unemployment and underemployment, and arrangements with NSPE for government liaison must continue. Like ASME, the Institute should consider acting directly to influence legislation, yet retain its tax-exempt status. We must look more toward the future and convince both government and private industry of the necessity for tremendously increasing our research and development efforts. Such a program will aid our maturing industries and especially help nurture new industries such as farming and mining the oceans. Our contribution in informing the layman on the technical aspects of our social problems must be increased so that better decisions can be made.

If elected, my efforts will conform to the philosophy above, but as a Delegate I would especially emphasize improvements at the local level. Greater enthusiasm should be created for group activity at the Section level as a means of providing the technical renewal of our local members. I would also solicit greater support by employers (including government) of member participation in Section activities. The feasibility of obtaining secretarial service for the Section activities by sharing the service and expense with other societies will be pursued. Implementation of such service in some Sections will permit the officers to better plan and direct the Section activities.

Joel P. Kesler

Douglas V. Carroll—Candidate for Regional Delegate/Director of Region 7

As a candidate for Director of Region 7 (Canada), I emphasize I am not soliciting votes for this position. If, however, the Canadian Region members feel that I can do a job for them as their Regional Director, then I am willing to serve on their behalf, as I have tried to serve the IRE/IEEE for the past twenty-odd years both in the Ottawa Section and on the International Sections Committee.

Yes, I have represented the Ottawa Section and IEEE on many committees and helped make important decisions on their behalf, on many occasions; but this is part

of being a member of a body that has in its constitution a purpose to which I fully subscribe. Section 2 of our Constitution reads, in part, "Its purposes are scientific, literary and educational directed toward the advancement of the theory and practice of electrical engineering, electronics, radio, allied branches of engineering or the related arts and sciences, etc."

To achieve this, the primary function of the Institute is to disseminate information in an effort to assist every member in the pursuit of his professional career. This is done through Regions, Councils, and Sections, along with the technical Group structures and the literature disseminated by Headquarters.

To continue this in Canada, augmented with Canadian ideas by close communications between the Canadian Councils and Sections while maintaining close liaison with the international body, will be my goal, if asked to serve the Canadian Region as your Director, by the members of our Region.

The urge to obtain national identity in all walks of life is becoming part of the Canadian scene. This too can be achieved by the Canadian IEEE Region but I hope not to the detriment of losing our international IEEE contacts.

Douglas V. Carroll

Douglas M. Hinton—Candidate for Regional Delegate/Director of Region 7

The Institute is a learned society which can only maintain its eminent worldwide position by the service it provides its members. That service is the provision of a forum where technical matters of concern to electrical and electronics engineers can be discussed and published. In essence, the Institute is a communication medium.

As a valid communication medium it has a parallel in a communication network, with inputs and outputs at the membership level. The elected officers exist to maintain the efficiency of the network or medium—they are not the medium. The medium serves its members and the officers maintain the medium with responsibilities delegated, on election, by the membership.

Elected officers must be sensitive to their members' needs or desires. In the Canadian Region (7) the need for greater identity is voiced—this must be examined and solutions decided. The solution may be the decentralization, on a regional basis, of some Headquarters functions and the establishment of a Canadian Region office. If this is the desire of the Canadian members then the Regional Director must respond with a critical appraisal of the cost and benefits to Canadian Region members and the IEEE.

If elected, it is my intention to serve the members of the Canadian Region in particular and the Institute in general. I will continue the programs of my two predecessors, R. H. Tanner and W. H. Thompson. I know the value of their programs, having served as Secretary-Treasurer with Mr. Tanner and as Council Chairman with Mr. Thompson. My most immediate goal will be the furtherance of the "Canadian identity," either by the creation of a Regional Office located in Canada, or the organization of a Canadian Society within IEEE. This must not detract from the aims of the Institute, but

enhance the Institute's function as a communication medium within the Canadian sphere of interest.

Douglas M. Hinton

Gilles A. Perron—Candidate for Regional Delegate/Director of Region 7

"A primary function of the IEEE is to disseminate information that will assist every member in solving the technical problems in the pursuit of his professional career." (President Mulligan)

There are other objectives, but I have doubts that welfare should be one. Professional associations should be better qualified, and even that is not too sure. However, the majority should define the options.

IEEE problems tend to illustrate that we are not reaching down to members. In any organic democracy, ideas should stem from the masses. Notwithstanding some efforts, members don't feel that IEEE is "their thing" and have not shown enough participation. Here I am willing to help.

Canada has 8000 members distributed over a vast country. The scattered region is now a more unified area through the Councils. There is a growing feeling for better identity and a need for increased exchanges within the country itself.

The need for identity is natural to any group. Canadian electrical engineers are looking for a common voice and their own publication.

Present diffusion is not satisfactory. The high quality of documentation is often beyond the average electrical engineer. Without decreasing the standard, more members could be reached.

To satisfy Canadian members, we may remain as we are: Region 7, part of a strong, centralized organization; or become exclusively Canadian and accept whatever losses that may result.

Or perhaps IEEE Canada remains bound to the international Institute with looser ties. It may be worth the extra cost. The majority will decide, but let's make sure the choice is right.

These are personal views. I offer simply willingness and some experience in the association field: over 25 years of involvement with AIEE and IEEE, and four years as responsible officer for the Corporation of Engineers of Quebec with some 15000 members—or maybe I should retire! Your vote is my decision.

Gilles A. Perron

Hector R. Ayllon—Candidate for Regional Delegate/Director of Region 9

It is my sincere belief that IEEE is one of the most efficient and best-organized technical societies at the service of its membership, which is kept excellently informed of the latest technical advances in its field, and also enjoys effective means of communication for the necessary exchange of technical knowledge.

However, considering its present status of international organization, certainly an evolution from its original formation as a national organization, I feel that there are some situations that should be taken into account in order to optimize the services rendered by the Institute.

For instance, there are those situations affecting the members of the Institute as a result of the different conditions and problems prevailing in the countries or zones where they perform their activities. Besides, it is important to give thought to the fact that, outside of the United States, there are in almost all countries local associations of engineers of our specialty, which pursue the same objectives aimed at by our Institute.

Consequently, I believe that IEEE should develop a policy to investigate the necessities of its members in the different zones where they work in order to implement the services most adequate to fill those needs. Also, contacts should be made with similar institutions so that, through mutual collaboration, a profitable relationship may be obtained and possibly result in an increase of the membership of the corresponding Section of the Institute.

This is, to me, the major task that Regional Directors should undertake and what I expect to do if I have the privilege of being elected by my colleagues of Region 9.

Hector R. Ayllon

Ernesto Obregon—Candidate for Regional Delegate/Director of Region 9

I believe the purpose of IEEE is not only the advancement of theory and practice of electrical engineering and electronics, but also the development of the individual, recognition of this development, and satisfaction of the needs of each one of the members and of the society in which they live. This is accomplished through conventions, seminars, meetings, and various technical publications.

IEEE is perhaps unique due to its transnational focus, which I feel is of great importance and could be emphasized more. Many engineering problems are universal and all of us can benefit from the exchange of ideas and solutions.

In the Latin American Region (Region 9) I hope it will be possible to organize new Sections. This is very important since Sections are the basic units of IEEE. By stressing the benefits, importance, and transnational scope of our organization many engineers in the Region would be encouraged to join IEEE; the potential is enormous.

There should be more contact between Sections. Since many of our situations are similar we could benefit from visits, lectures, and exchange of publications.

I feel it is possible to contribute much more in the field of publications not only for our own ELECTROLATINA but for other IEEE publications. The people in Region 9 are very capable; perhaps with more encouragement and facilities for publishing they will share their experience.

Special attention must be directed toward Student Branches. We should help orientate the student technically and professionally as well as members of our society. Engineers who are not members of IEEE can also benefit from lectures, conferences, etc., since IEEE should stress cooperation, not competition, with the local or national engineering societies.

I hope that by setting up goals, planning our efforts, and concentrating on cooperation and contribution, we can achieve more and the society and the individual member will benefit from this common effort.

Ernesto Obregon

Candidates for Divisional Delegate/Director for Divisions I and V

Arthur P. Stern—Candidate for Divisional Delegate/Director of Division I

The Director of Division I represents on the IEEE Board of Directors the Audio and Electroacoustics Group, the Circuit Theory Group, the Control Systems Society, and the Information Theory Group. These are sizable, successfully managed organizations, acknowledged internationally for their leadership, contributing significantly to expanding the theoretical and conceptual foundations of electronics and system engineering. The Division Director should not attempt to “manage” these organizations but should influence the Institute to continue providing a flexible environment in which these Groups can contribute responsively to our changing society and correspondingly changing profession. The principal future requirements include: to achieve closer academic-industrial coupling, to bring the primarily conceptual results of the Division’s Groups to other organizations that emphasize engineering practice and applications, to accelerate assimilation of new theory into practice, and to learn from the practitioners so that the Division’s Groups concentrate their endeavors in areas of greatest potential benefit to our science-technology-based society. While emphasizing financial responsibility, the Division Director must assure ample IEEE resources for theoretical and conceptual activities so that significant advances and information are not impeded by inadequate financial support.

Besides representing the constituent technical Groups on IEEE’s Board, the Division Director, as advisor to IEEE’s President and Officers, must strive to make IEEE more responsive to the social demands of our profession. IEEE must not become an ossified organization of old-timers—it must promote the ideals of our young colleagues and must accept the challenge to our profession caused by abruptly changed national priorities which jeopardize the contributing ability and livelihood of many, both young and experienced, professionals. IEEE must involve itself more actively in coping with the emerging crisis and must act to protect our fellow professionals and, through them, our society’s future.

The Institute should elect Directors who are most dedicated and effective in pursuing these objectives.

Arthur P. Stern

M. E. Van Valkenburg—Candidate for Divisional Delegate/Director of Division I

The primary responsibility of a Divisional Director is to the interests of the Groups he represents. These interests include technical activities such as conferences, Group Chapters, and publications. My own experience in IEEE has come through a variety of assignments in the Circuit Theory and Education Groups and in publication activities, including the Chairmanship of the Publications Board. This experience may be of value in influencing the deliberations of the Board of Directors.

I have had a long-term interest in the development of

the interface of professional engineering with economic and political problems of society. I have no doubt that the IEEE must assign more importance to these interfaces in the future. However, I believe that this can and should be done in the context of the historical IEEE role of professional and technical leadership.

We should continue to search for more efficient methods of information dissemination including printing, for more effective ways to involve the membership in technical meetings, and for improved techniques for continuing education. These objectives must have high priority, but they should be done after careful experimentation and step-by-step planning.

M. E. Van Valkenburg

John Zaborszky—Candidate for Divisional Delegate/Director of Division I

IEEE and other similar organizations are performing admirably in fostering, recording, and communicating technical progress. Yet many aspects of the professional life of the individual engineer and many necessary services to the membership are ignored.

Accordingly, I believe that:

1. The engineering profession must develop a strong voice that is heard and counted in decision making which affects our economic, legal, and professional affairs, specifically, *portable pensions, financial security, licensing, and policy on research and development*. IEEE, the largest and strongest engineering society, led by its Board of Directors, *must take the initiative*. This could mean direct action by IEEE or finding a solution to set the combined strength of the engineering profession into action at the levels of the public media, the corporation, and Congress. Only a strong “*esprit de corps*” can make either solution effective. Such seems to be developing now and this trend must be enhanced.

2. Broadening of national interests dictates that the engineering profession establish its rightful place in societal systems work, such as *transportation, pollution, economic, utility, and urban* systems. The engineer’s propensity for realistic, workable solutions enables him to make vast *contributions* here. This will require much learning and hard work by members and Directors alike, but it will substantially *benefit the profession* and serve the best interests of mankind.

3. Often the technical activities of IEEE lack immediate usefulness in the practical engineering pursuits of many members. This calls for *expanding the applicable content* of our general *technical activities* as well as expanding such *services* by IEEE as *continuing education, re-training, visiting lecturers for Chapters, and a library of “cassette” lectures*. I have been pursuing objectives 2 and 3 as Chairman of G-AC and of Joint Automatic Control Conference 1971 and in my other IEEE offices.

If elected, I will continue this work and will make a maximum effort toward furthering all the objectives described above.

John Zaborszky

Theodore H. Bonn—Candidate for Divisional Delegate/Director of Division V

The IEEE is meeting the technical needs of our profession, but has not effectively responded to the mounting economic and social needs. These needs differ from those of the rest of the society, and we bring a different and valuable perspective on technical-political problems.

The scientific, cultural, and educational excellence of the IEEE should be preserved and enhanced, and this should remain the primary purpose of the organization. But a significant proportion of the Institute's resources should be devoted to the other areas. How many of us want our sons to be engineers? A small percentage. The IEEE should have as a goal the improvement of the economic and social factors affecting the electrical and electronics engineering profession so that all of us find our careers more rewarding in terms of tangible and intangible satisfactions.

At the very least we should try to formulate the problems, quantify them, and develop possible solutions to them. We should provide the facts, alternative courses of action, and membership opinions to those in the political arena.

The first step is to provide staff at Headquarters reporting at the highest level, that would focus on economic, social, and technical-political problems only. The staff would organize committees of members to work on the problems and the staff would provide needed services, including factual research, membership surveys, and publicity for the results of the studies.

I have been involved in these issues for some time. As Technical Program Chairman of the 1969 SJCC I stimulated the organization of panels on "Computers and the Disadvantaged" and "Urgent—Increased Dialog with Society."

I am particularly proud of my work as Chairman of the Computer Group Publications Committee, and, with Harry Huskey and John Kirkly, in establishing the magazine *COMPUTER*, setting its tone, and starting the Computer Society Repository in that magazine.

Theodore H. Bonn

Linder Charlie Hobbs—Candidate for Divisional Delegate/Director of Division V

Three major problems face the IEEE management:

1. New technologies and markets are changing the scope and nature of our industry and spawning new technical societies. The IEEE must make organizational changes to adapt to rapidly changing technology and to give greater emphasis and flexibility to technical specialties, such as computers and digital systems. The technical Groups and Societies within the IEEE must exercise greater influence on policies and actions.

2. Technical communications must be improved to cover the ever-increasing scope of our technology while still meeting the needs of individual members. Conferences, symposia, publications, and new means of disseminating technical information must be developed, both to meet the needs of the young engineer to broaden his experience and knowledge and to meet the needs of the older engineer to keep abreast of new technical developments.

3. Our members face serious problems in the high un-

employment and lack of adequate professional status in engineering. The IEEE must give urgent attention to these problems that face both the new graduate and the 25-year veteran. We must stop encouraging an oversupply of engineering students and must work with government and industry leaders to stabilize requirements for engineers. Needs for technical manpower must be created and met on a long-range basis, rather than generating short-term peak demands with unemployment taking care of the valleys between. Most present transients are caused by government policies rather than by the normal working of an orderly marketplace.

During two terms as Chairman of the IEEE Computer Group and several additional years on the Administrative Committee, I have worked actively (and achieved some results) on restructuring the IEEE and improving our dissemination of technical information. While those areas are of continuing importance, the time has come when we must all place greater emphasis on creating a more stable environment for professional engineering employment.

Linder Charlie Hobbs

Samuel Levine—Candidate for Divisional Delegate/Director of Division V

The IEEE is facing a critical period with problems such as unemployment of members, financial problems in providing essential services to its members, and the need for applying technology to the solution of social problems and for greater interaction with government and society.

There is also pressure from a segment of the membership that the IEEE should change its role to also consider the economic problems of its membership.

The IEEE leadership is addressing all of these problems within the constraints of its charter.

There is a need for further discourse between the IEEE membership and its leadership on all of these matters. Only then can the IEEE leadership obtain the guidance necessary to meet the needs of its membership.

In the area of its clear responsibility, technical dissemination of information, the IEEE can do a more effective job. The IEEE Groups and Societies have been effective in providing high-quality Transactions for primarily theoretical articles of archival quality. There is greater need for its publications to provide an outlet for the practicing engineer on applications and hardware design subjects. There is also need for more aggressive action in continuing education and retraining programs.

As a past chairman of the Computer Group, as a member of TAB operating committee, and currently as Appointed Director of Division V (nonvoting), I have been in the forefront of action to change the structure of the IEEE to provide greater recognition for the Groups. I have been instrumental in the action to organize the Groups into six Divisions, each with representation on the Board of Directors, and, in particular, I played a major role in developing the concept of Society status—this status to provide greater recognition and autonomy to major professional Groups, such as the Computer Society.

As an elected member of the Board of Directors, I can be even more effective in addressing the problems of the IEEE and the Division (Computer Society).

Samuel Levine

An IEEE SPECTRUM applications report

Computer aids for IC design, artwork, and mask generation



APPLICON's Design Assistant/700.

Computer aids for semiconductor design, artwork, and mask generation have gone "public." No longer an expensive hobby, design automation for IC and LSI now permits layout and fabrication with a minimum of human intervention and invention

Charles W. Beardsley Associate Editor

A popular limerick of a few years ago told of a designer who dreamed "he was going mad, designing circuits pad by pad. He screamed, and woke, then thanked the dad, whose fertile mind had fathered CAD." This special report surveys the current revolution in computer-aided design systems and services for semiconductor design, layout, and fabrication. Recent breakthroughs in turnkey products—especially in low-cost terminal design—have permitted semiconductor houses that heretofore could not afford CAD to achieve error-free designs and eliminate much of the layout drudgery. Greater efficiency in design and better yields in production are just two of the benefits of these design aids.

Until two years ago, computer-aided design (CAD) for integrated-circuit layout and mask generation was a luxury available only to those semiconductor houses that could afford the multimillion dollar investment required for such a capability. Today, that's all changed. Breakthroughs in terminal design have brought CAD system costs below the \$100 000 mark. With the introduction of such products as Applicon's Design Assistant, Computervision's Interactgraphic I, Macrodata's FEDIS, Calma's GDS-ICM, System Science and Software's Mask, and Multi-Logic's AGS-200, CAD graphics can no longer be regarded solely as an in-house capability. The availability of these turnkey systems now means that any system or semiconductor manufacturer can automate most of the steps in laying out ICs and generating the circuit fabrication photomasks.

One supplier of CAD artwork services has even gone so far as to predict that lower hardware costs will eventually force the large semiconductor houses to buy or lease these available systems. According to him, it would be financial folly to order another \$200 000 computer when the same design results can be achieved with a CRT terminal, plotter, and minicomputer that are available as a complete system for \$60 000.

To the skeptics who still regard CAD as a gimmick, the suppliers of graphics services confidently quote examples of the dramatic increases in productivity and reductions in turnaround time that have been accomplished with their systems. Fontaine K. Richardson, vice president of Applicon, Inc., whose Design Assistant (page 63) has taken a big chunk of the market, tells of a complete quad 84-bit MOS shift register that was designed in 30 console-hours. The user started with only detailed bit and output buffer designs and finished with the complete photomask design for the entire chip. Fabrication photomasks were available one week after the design was started. A dual 100-bit MOS shift register was designed in 18 console-hours, and a 64-bit read-only MOS memory was designed in ten console-hours.

One satisfied owner of three Design Assistants, W. J. Laughton of General Electric's Integrated Circuit Department, describes a dual 100-bit dynamic shift register, the GER 2507, that took only 15 hours of console time. According to Laughton, this time is particularly impressive because it represents the first design effort of GE engineers on the Design Assistant. He does add, however, that the Design Assistant needs additional software to cope with problems of random logic. "The Design Assistant works very nicely for repetitive circuits," says Laughton, "but it's difficult to use when you're trying to interconnect 200 cells of 30 different types. The prime advantage of systems like the Design



TYPICAL interactive graphic IC layout at Texas Instruments uses two large interactive screens and a small storage screen. The large screen on the left shows the circuit schematic; the large screen on the right displays the area of the IC now being designed. The small screen shows a composite layout.

Assistant is that digitizing comes free—your digitized data are automatically fed to the computer."

Design engineers for the large semiconductor houses express additional reservations about the sudden proliferation of "bargain-basement" CAD. One manager of MOS design automation who was interviewed for this article maintains that giving the customer a toy is nice as long as he doesn't mind paying a 30 to 100 percent premium for providing his own artwork. This designer also emphasizes that layout and mask generation are only a small part of the total automation cycle for semiconductors. He stresses that the major houses have invested several million dollars in software alone for a design automation cycle that encompasses logic simulation and testing; circuit analysis; partitioning; layout, routing, and placement; mask generation; and test generation.

One satisfied user of turnkey CAD is National Semiconductor. National's Floyd Kvamme, director of marketing, emphasizes that "the likelihood of investing in a white elephant is extremely high in design automation." Kvamme likes to draw an analogy between the semiconductor and publishing industries. "Magazines are not in the business of printing cheaply; their business is communication. National's business is semiconductors, not CAD. That's why we've gone outside for our design automation."

The semiconductor design cycle

From CADIC to CAMP

CAD for IC design is nothing new. As early as 1966, a group of engineers working under a U.S. Air Force contract at the Norden Division of United Aircraft Corp. developed and implemented computer-aided design of integrated circuits (CADIC).¹ The system, one of the first to work on-line, employed a light pen and a

CRT display for circuit layout. About the same time, another government agency made a routing program available to its contractors, which is why the "cell" programs at Collins, Fairchild, Motorola, and Texas Instruments are so similar. This program automated the process of connecting standard cells and provided the user with digitized output for cutting masks. The program

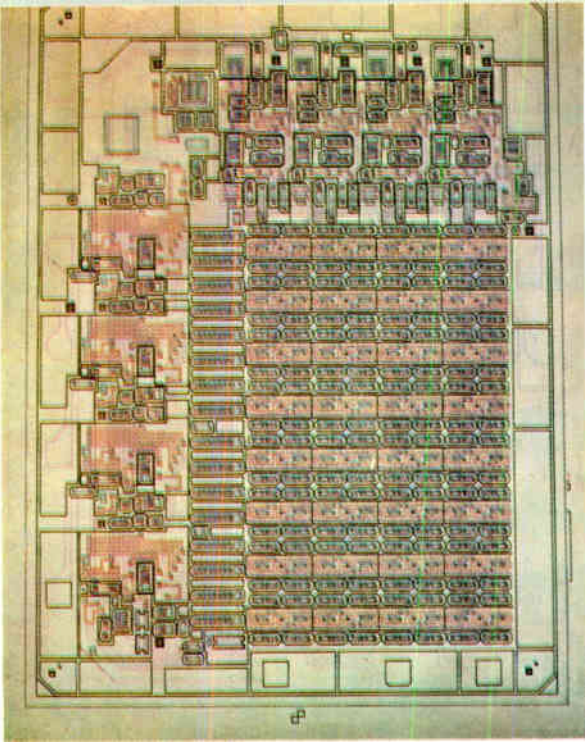

MULTILAYER COMPOSITE DRAWING (left) of a 64-bit random access memory circuit, which was produced by Monolithic Memories, Sunnyvale, Calif. The artwork and original masks for this circuit were generated by Micro-Mask, Inc. using the Calma system described in this article. Monolithic has introduced this circuit as its MM500 RAM, with 50-ns cycle time and 4.5- NW/bit dissipation.

THE CALMA COMPANY'S 485 system (below), part of a semiconductor photomask artwork generation system at Micro-Mask. In addition to the digitizer shown, the system includes an off-line CalComp flatbed plotter.



is still widely used—even though most houses won't, for security reasons, admit to a knowledge of such software.

Today, all the large semiconductor houses have developed their own variations of CAD software.²⁻⁸ At Motorola Semiconductor Products, entry into the system is by way of the Motorola automatically generated integrated circuits (MAGIC) deck, which indicates cell types and how they are interconnected; by computer-aided mask preparation (CAMP) source cards that have been prepared either by digitizer or hand; or by CRT/light pen, functional keyboard, and teletypewriter. The CAMP system handles graphical input data, stores it in a compact data base, and provides output to drive automatic drafting equipment. The CAMP data base contains all the layout information that has been generated for a particular circuit. It can be modified with further input information and used to generate tapes to drive either an ink plotter or artwork generator.

Placement and routing are achieved manually by CRT, digitizer, or card input; or, where appropriate, automatically by Motorola's automatic routing system (MARS). Figure 1 illustrates this design cycle for MOS logic—from developing the specifications to fabricating the final product.

Development of system specs and logic. In this initial working relationship in Fig. 1, the customer provides a system design and generates performance specifications. Logic design falls between the steps of equipment specification and the logic drawing, which is a preliminary synthesizing of the network that performs the specified functions. Logic design is usually done by the customer, but Motorola is capable of doing the synthesis if requested.

Logic simulation. The object of logic simulation is to verify the logic design prior to hardware implementation. Once designed, the logic system can be verified operationally by means of a Motorola-developed computer program, or with the customer's own logic simulation

program. Motorola accepts customer inputs in any form—such as logic diagrams, equation tables, or equipment logic specifications. Motorola engineers then analyze the logic and manually code the logic elements for entry into the simulation program.

System partitioning. Partitioning is the division of equipment logic into a number of chips, the complexity of which may range from the complete equipment logic to individual gates. For most equipment, optimum partitioning is somewhere between these two extremes. Depending on equipment performance requirements, complexity, reliability, and cost goals, various criteria may be given precedence in partitioning: number of package interconnections, number of unique chip types, and chip size.

Partitioning can be automated to a degree, but Motorola feels that there is no real substitute for a designer's decision. Because the customer is most knowledgeable about his own equipment assembly costs and goals, optimum partitioning is achieved through close vendor-customer cooperation.

Partitioning results in a set of chip logic drawings and an associated set of performance specifications. These comprise the minimum information necessary to implement design. Once the partitioned drawings are available, the next step is convert the drawings to a set of logic prints that employ Motorola's "polycells," members of a library of predesigned building-block

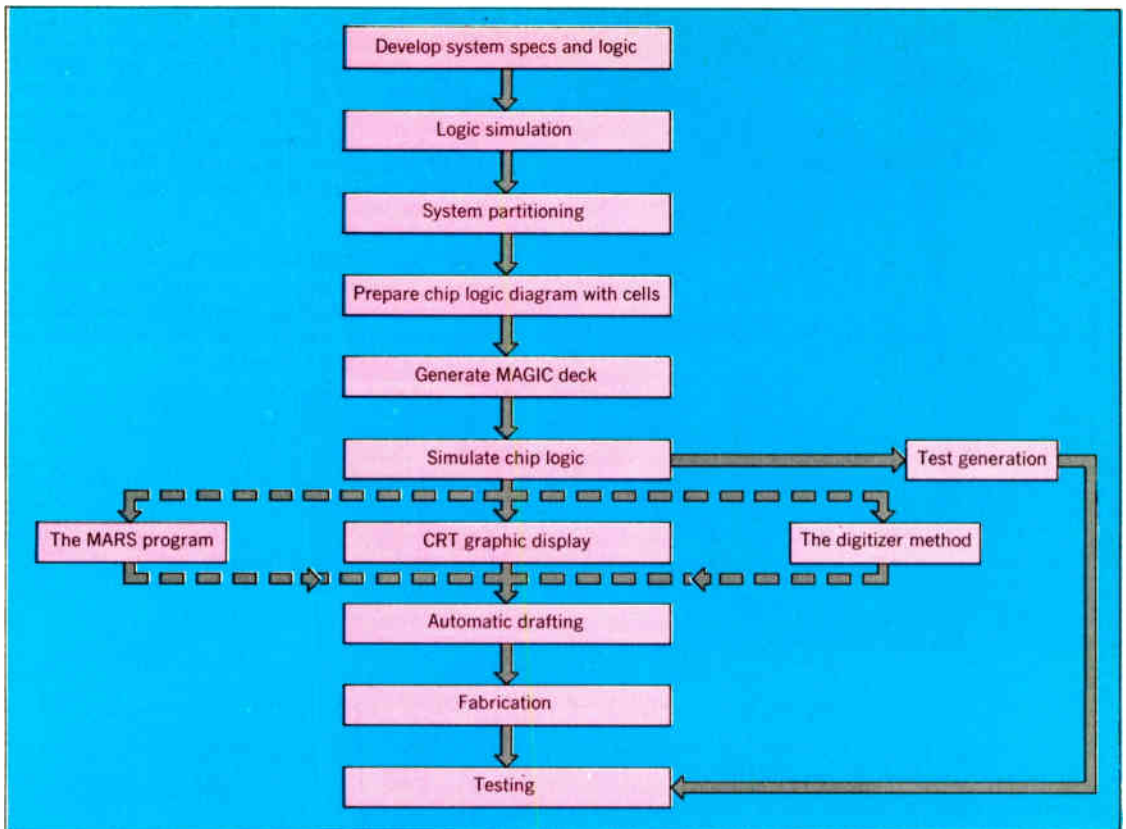

FIGURE 1 (above). Motorola's complete CAD program is shown in this flow chart. The main design route is through the ink plotter and coordinate digitizer, with the CRT console providing an alternative approach.

MASK SYSTEM, offered by Systems, Science, and Software, facilitates design optimization, reduces errors, and results in higher LSI yields.

circuits whose characteristics are stored in a computer.

Preparation of chip logic diagram with cells. Detailed descriptions of circuit elements are stored on disk in the polycell and device library and are available for either on-line or off-line use. The basic elements of the library are simple active devices such as transistors and diodes. Frequently, more complex structures—the polycells—are constructed of transistors, resistors, and metal interconnections to form, for example, gates or flip-flops. Each polycell is a combination of two basic circuit structures: (1) *the parallel structure*, in which all input devices have their drains connected in common to form the output node; and (2) *the serial structure*, in which an input device has its drain connected to the succeeding input device source, with the output node at the input device drain farthest from the ground.

Each basic gate in the library is labeled in terms of its number of inputs and its basic circuit structure. For example, the MH04PS is a parallel structure with four inputs, and the MH03SS is a serial structure with three inputs. Motorola provides a customer with a complete listing of the polycell library,⁹ which is updated with periodic supplements.

Generation of MAGIC deck. The MAGIC deck of



punched cards contains the set of equations that define the logic throughout a particular chip—the card equivalent of the logic diagram constructed of cells and polycells. Each statement gives the code number assigned to a cell on the logic diagram to which a connection is made (for example, B116), the nomenclature by which this cell exists in the library (MH01CL), and a list of the cells that provide an input signal to each terminal. The MAGIC deck must contain an expression for each element in the design, even if it is not a logic block. If



CALCOMP'S 745 flatbed plotter and model 900 controller is shown above. The model 745—with a drafting surface of polished granite and a recirculating-ball lead-screw drive system—uses model 900 software to cut rubylith, expose photographic film, or make multiple-line-width drawings.

FIGURE 2 (right). Process parameters displayed.

SPACINGS		EPI DOPING	
BASE TO BASE	0000.500	MINIMUM DOPING	0000.000
COLL TO BASE	0000.400	MAX RESISTIVITY	0000.300
BASE TO EMITTER	0000.400	MAXIMUM VOLTAGE	0020.000
BASE TO ISOL	0000.700	SHEET RESISTANCE	
ISOL TO ISOL	0000.400	DEVICE BASE	0200.000
RESIS TO RESIS	0000.500	RESISTOR BASE	0055.000
ISOL TO DEEP COL	0000.900	BURIED LAYER	0018.000
DEEP COL TO BASE	0000.500	DEEP N	0000.000
PHOTO RESIST SPACINGS		EMITTER	0010.000
DIODE OVERLAY	0000.200	HAUSER NUMBER	
PREDIODE WIDTH	0000.300	Z1 - SINGLE BASE	0000.000
PREDIODE LENGTH	0000.500	ZP - DOUBLE BASE	0000.000
METAL OVERLAP	0000.000	END EFFECT CONSTANTS	
P1 TO P2 OVERLAP	0000.000	DEVICE BASE	0001.079
METAL WIDTH	0000.500	RESISTOR BASE	0001.079
METAL SPACING	0000.400	GRID SPACINGS	
JUNCTION DEPTHS		X GRID SIZE	0000.000
EMITTER	0001.099	Y GRID SIZE	0000.000
DEVICE BASE	0002.000	X GRID OFFSET	0000.000
EPI	0006.000	Y GRID OFFSET	0000.000
BURIED LAYER	0003.130	PROCEED	
RESISTOR BASE	0001.760	SELECT PARAMETER TO BE CHANGED OR SELECT PROCEED BUTTON.	

such an element does not receive an input from elsewhere on the chip, it is noted on the MAGIC deck as a notation rather than an equation.

The MAGIC equations are intended primarily to describe the interconnections of a complex logic function designed with library polycells. Remaining to be defined are the physical placement of each cell and the actual route the interconnections are to take.

Simulation of chip logic. Because all subsequent steps are based on the MAGIC deck and related logic drawings, both must be verified. Chip designs are verified using Motorola's SIMUL8 program. When used in the simulation mode, SIMUL8 is capable of monitoring time-dependent states at any cell output node within the chip.

CRT graphic display. Motorola provides three methods of artwork generation: the CRT graphic display method, the automatic routing system (MARS), and the digitizer technique. The CRT graphic display system provides the designer with an interactive capability. He can place the cells on the CRT, or display or modify a placement that has already been generated. The interactive terminal also allows the designer to route or modify a route on the CRT. The example that follows is how David Lynn, Motorola's manager of CAD operations, describes a typical interactive design situation.³⁰

Placement and movement of devices on the CRT are done largely through the use of a tracking cross, which follows the movements of a light pen. The cross position can define, for instance, placement of a device, a point on a metal path, or the point at which to bend a resistor. When the on-line program is called in, the list of processes defined in the library is displayed. By picking the appropriate item with the light pen, the designer can restore a design from tape or disk or begin a new design by selecting the process he desires. Figure 2 shows an example of the process parameters that constrain element selection.

A parameter can be changed by selecting it with the light pen and entering the new value. The *grid spacings* shown in Fig. 2 are zero, which indicates the grid is not to be used. Ordinarily, these spacings would permit grid placement of cells and routing of metal on grid. In Fig. 2, a prompting message is displayed at the bottom of the CRT.

Figure 3A illustrates an early stage of MOS cell layout. A number of cells have been called up from the library; three cells have been placed, a fourth (indicated by the tracking cross) is about to be placed. The placement mode is entered when a device is selected from the device menu; it can also be entered at any time the main menu is displayed by selecting the device to be moved with the light pen. The placement menu is on the right in this figure. The device can be rotated, mirrored, deleted, moved with the light pen, or the placement can be accepted. In addition, the device can be positioned manually by entering the placement coordinates. The MOS cells of Fig. 3A have been designed so that their contacts fall on grid increments. Grid placement allows placement of devices only on grid locations; therefore, all cell contacts fall on metal grid locations. Then when grid routing is used, metal and cell contacts line up automatically and correct metal spacing is assured. The fourth cell in Fig. 3A is misaligned by one grid spacing in both the x and y directions. One increment of movement down and to the left will line up the cell with the row.

Only cell outlines and contacts are shown in Fig. 3A, which is all that is required for cell placement and routing. Other layers may be displayed if desired—Fig. 3B shows metal and p-diffusion of two cells at an expanded

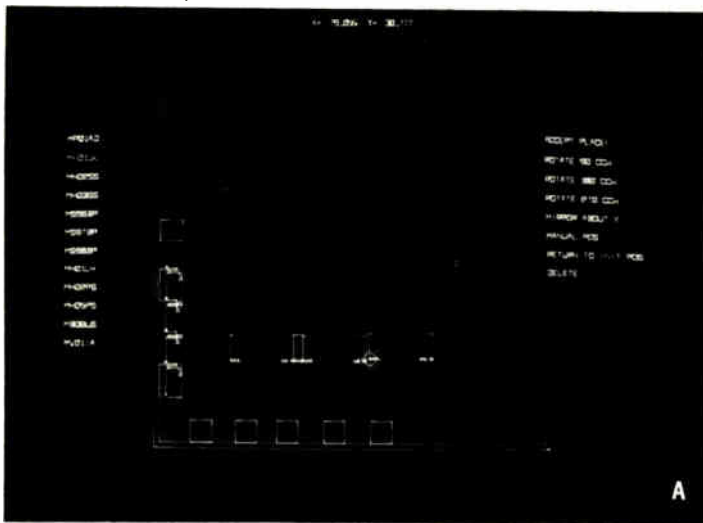
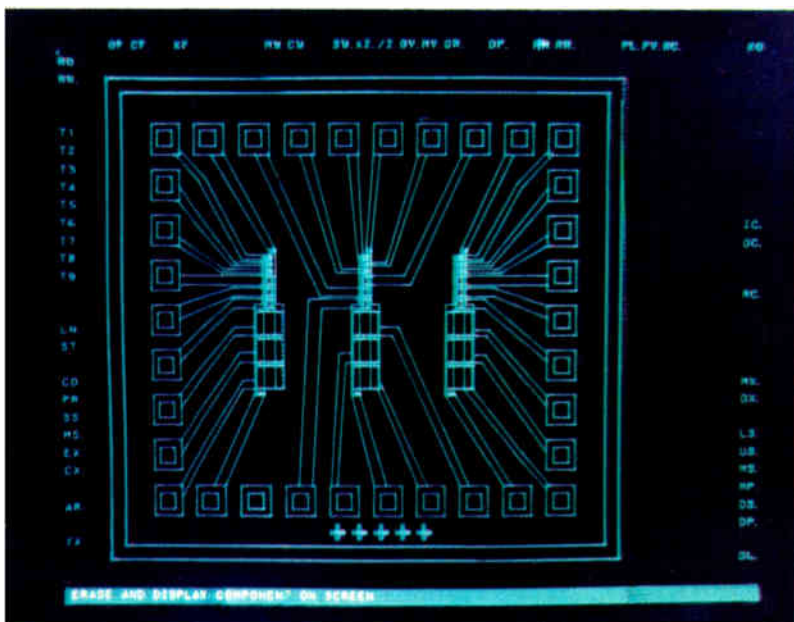

FIGURE 3. A—Grid placement of MOS cells. B—Metal and p diffusion of two cells at an expanded scale. C—Grid routing of an MOS layout. D—Completed layout.

scale. The “zoom” menu is shown in the upper-right-hand corner. The scale factors listed can be selected with the light pen or any other scale factor can be entered. “Normalize chip” displays the chip at 100× in the lower left area of the CRT screen.

Figure 3C shows the completed placement being routed. Rows of cells have been grouped into two polycells so that the rows can be moved to allow enough space for metal. The routing is done on grid, and the functional keyboard is used to change layers. Vias are

INTEGRATED-CIRCUIT test chip, designed interactively on the Multi-Logic AGS-200 system. The tracking cross may be observed over the RN (run) command. An explanation of this function appears on the communications band. Unused spaces around the periphery are reserved for custom-designed functions.



inserted automatically. Figure 3D illustrates the completed layout.

The MARS program. The MARS program can be used to place cells automatically or route interconnections automatically, or both. From the information in the MAGIC deck, this software program determines which cells should be close to each other—by virtue of their related inputs and outputs—and creates the appropriate interconnect pattern. The MARS program, however, is not ideal for MOS-LSI because it is designed for unrestricted two-layer-metal freedom, as practiced with bipolar arrays. In addition, as is common with most automatic systems, its utilization of chip space is relatively inefficient. Motorola has found that the most practical method of artwork generation employs an ink plotter and digitizer for MOS.

The digitizer method. Here, as in the MARS program, the MAGIC deck defines the basic cell types and their interconnections. Cell placement is manually specified with row cards, which define a row of cells, its origin, and its orientation. The designer decides where to insert these row cards by examining a computer-generated plot of lead density as a function of distance down the linear string of cells. A second and similar plot can then be obtained that accounts for row pairs—which provides the designer with an indication of how far apart to put the rows.

This deck is then fed to the computer, which uses the CAMP data base to drive an ink plotter. The CAMP source is essentially a card-input graphics language that allows layer-by-layer description of device geometry, placement of devices, and metal interconnection of devices. Instructions for driving the plotter are generated from this data base, the CRT display is generated from this data base, and a CAMP source deck can also be produced from the data base. This common data base permits the user to display and modify hand-coded or digitizer-coded layouts on the CRT, as well as generate CAMP source with a CRT layout, which can then be modified off-line.

With the layout drawing from the plotter, the designer determines the most efficient metal-routing pattern and manually draws it on the ink layout. This drawing is then taken to the digitizer, where the end points and

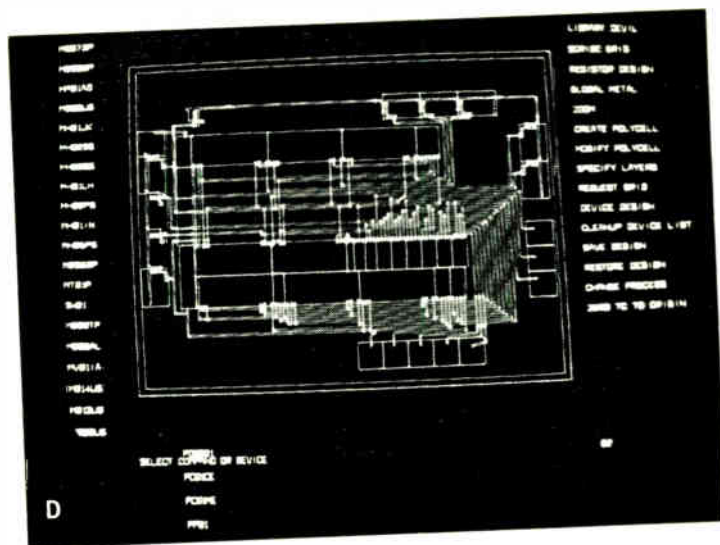
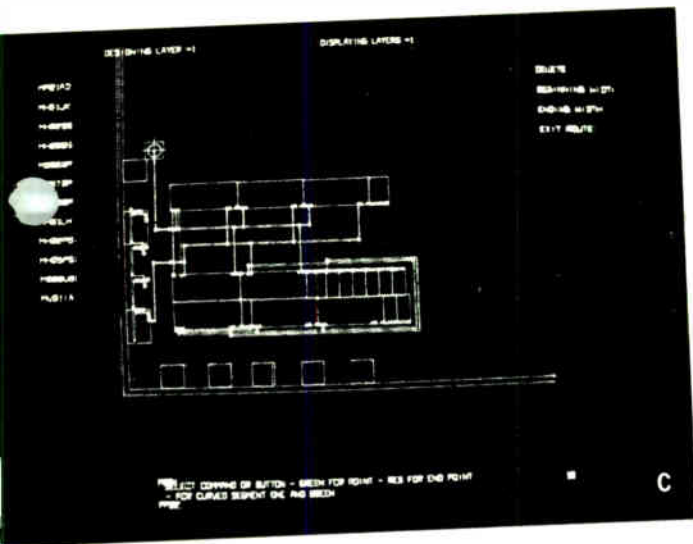

bends of all metal routing lines are manually converted into a corresponding set of routing cards compatible with the MAGIC deck. When these data are merged with information from the MAGIC deck, a complete description of the chip with all its cells interconnected is available in computer language. With this information, along with the CAMP data base, the computer can generate the required control tape for an automated drafting machine.

Test generation. Simple integrated circuits may be tested by driving the circuit into all possible combinations of input and internal states and comparing the expected results with those actually measured. With complex LSI circuits, exhaustive testing is not practical. From a cost point of view, it is necessary to devise a test sequence that will separate good and bad chips with a high probability of accuracy and a minimum of testing. Motorola has developed several programs to provide CAD test sequences for acceptance test specifications. One approach generates a near-minimal set of tests for entirely combinational networks. The other approach evaluates or grades the tests provided by the logic designer. This latter approach can be used with both sequential and combinational networks.

SIMUL8 in the test-grading mode generates a printout of the fault conditions detected by each input pattern in a test sequence. The SIMUL8 program grades submitted test sequences by comparing the output of the good network with the output of all possible single-fault networks. As a result of this simulation, the designer may reduce the level of testing or increase it, depending on whether the fault simulation has indicated test redundancy or the possibility of fault conditions escaping detection.

In test generation for LSI, the emphasis is on functional testing to insure that the test sequence generated is capable of detecting single fault conditions within the chip. In addition, parametric tests are considered; for example, dc parametric tests are primarily input/output leakage, and marginal-input high- and low-level tests, with associated output high and low levels being measured.

Automatic drafting. The automatic drafting machine used by Motorola for LSI is an x-y plotter that makes a 10X drawing from which the devices are produced. The

drafting head is moved on the table by stepping motors, and is accurate in position to $\pm 23 \mu\text{m}$ and repeatable to $\pm 13 \mu\text{m}$. The stepping motors are controlled by a computer that reads tapes and distributes the necessary pulses.

Two drafting heads are used, both of which draw on high-resolution photographic film. One has 24 program-selected apertures and is used primarily for line drawing. The other, a variable-aperture head, flashes rectangular shapes with sides that can vary in each direction from 0.2 mm to 50.8 mm in steps of 25.4 μm . It is used for drawing all rectilinear shapes. A detailed description of optical-pattern generators appears in the section of this article entitled "Mask making."

Fabrication. The manufacturing process consists of a series of diffusion, oxidation, and metalization steps—each with its associated photoresist pattern defining operation. When the wafer has completed the processing sequence and passed all process control inspections, it is sent to a computer-controlled probe station.

Testing. The test control tape generated during the design phase permits complete parametric and functional tests of the wafer. Functional tests exercise the circuits to demonstrate that they perform the logical function specified by the designer. At the same time, a series of parametric measurements checks the input and output terminals, the clock lines (if present), and the power supply buses for excessive leakage current and low breakdown voltage. When design permits, power consumption is measured to determine that it is within the design rating.

CAD for end users

Two years ago Collins Radio announced that it was selling customized MOS, but, unlike the other major semiconductor houses, that it would let the customer control design. The move surprised industry observers and has not proved to be a totally problem-free decision for Collins. Future history may, however, prove the house correct in its approach. This year American Micro-systems has offered to make parts of its CAD programs available to customers on an as-needed basis.

Collins' approach to design automation is also unique in that the design program is integrated with fabrication,

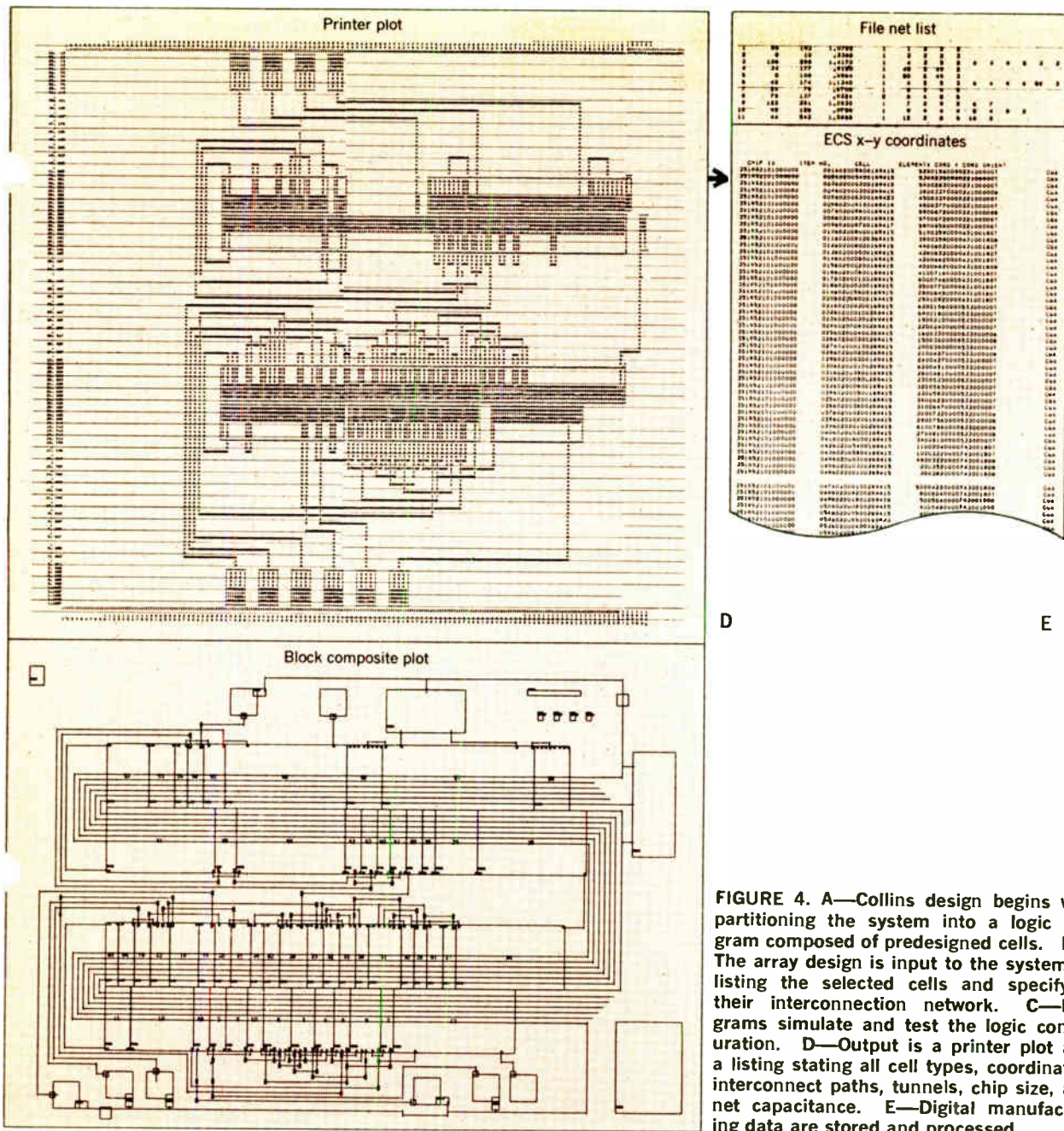

FIGURE 4. A—Collins design begins with partitioning the system into a logic diagram composed of predesigned cells. B—The array design is input to the system by listing the selected cells and specifying their interconnection network. C—Programs simulate and test the logic configuration. D—Output is a printer plot and a listing stating all cell types, coordinates, interconnect paths, tunnels, chip size, and net capacitance. E—Digital manufacturing data are stored and processed.

Teleprocessing and teleproduction. Teleprocessing is in the initiation and control of Collins' computer-oriented design processes. The services can be directed from a remote location—Collins data terminals in Newport Beach, Dallas, Cedar Rapids, Boston, and Toronto; from the customer's own data terminal; or by ordinary mail service. Teleproduction is the physical means of producing the MOS array.

At Collins the system design cycle follows a pattern that is initially similar to Motorola's—a logic diagram, simulation, and partitioning. Listing the selected cells from a library of more than a thousand, and specifying their interconnection by wiring equations, provide the entry of the array design into the system. From this point on, computer programs take over (Fig. 4).

The array definition file is run against the PRP (place-

ment, routing, and patch) program, which places and interconnects the cells in accord with the wiring list. The program outputs display the identity of the cell library used; the placement of cells; net list capacitance; and the coordinates of each cell, interconnect line, and unwired test device. The customer checks the data and makes changes by noting coordinates of lines or cells to be changed. These changes to the array geometry are performed using a defined patch transaction. A block composite linear plot permits final examination of the chip layout. Upon approval of the final plots, the digital manufacturing data are stored and processed in the ECS file to direct teleproduction, which begins with automated phototooling.

Some of Collins' potential customers have been reluctant to accept this new and total approach to design

automation. This fear of accepting the design responsibility apparently stems from abandoning such traditional tools as breadboarding and drafting. The design system just described eliminates the need for breadboards and drafting; nevertheless, Collins is still willing to continue to take on the design job for those customers who want merely to supply device specifications. The system can handle 100 designs a month, and the total design and fabrication cycle is typically only 60 days.

A complete turnkey system

Macrodata's front-end design-information system (FEDIS) relies on a digitizer that provides on-line editing and reproduces single- or multilayer-chip designs. With the exception of the fabrication step, the system cycle follows the pattern of Fig. 1—which makes FEDIS one of the only turnkey systems to provide automation for the entire semiconductor design cycle. The user can enter the system with logic equations, or he may choose to create his own composite of the chip for digitizing. Macrodata offers a library of software programs with the system—including programs for logic simulation and test sequence generation. FEDIS sells for a little more than \$100 000.

The basic parts of the system include a digitizer, cursor, digital readout, and menu board; a computer with a teletypewriter; a disk memory; magnetic tape; and a pen plotter. Options include additional digitizers, a printer, a card reader, and a CRT display system. This last can be used in the same manner as the digitizer in editing the composite drawing. The digital readout provides a visual x,y -coordinate of the cursor in user's units. This digital readout has been a great aid to a user digitizing composites having a grid of 50 divisions to the inch.

Any layer, or layers, can be drawn on the pen plotter in minutes or displayed on the CRT in seconds. By means of the floating cursor on the screen, the operator is able to locate and modify any element in the data bank. Scale changes, zooming, and window selections are all part of the CRT package.

A *topological design rule program* checks the composite digitized data for gross digitizing or format errors, the first step in Fig. 5. Once the user has corrected the errors on-line by placing the cursor over the image error of the invalid element, he may obtain a drum plot of the dimensional composite, or a plot that uses Macrodata's own shorthand symbols for such features as metal lines, transistors, feedthroughs, or output pads. In the next step of Fig. 5, the user feeds the digitized data to a *nodal artwork validation program*, which prints out all

nodes and their location. This node list pinpoints unconnected metal lines for correction. These are corrected via the edit mode using the digitizer, or CRT, to locate the elements in question. The output of the nodal program is used in the *equation-generation program* to produce a set of either circuit equations and/or time-dependent logic equations. Because these equations are derived from the data that were digitized, they represent the device to be manufactured.

The output of the equation-generation program is used as input to *logic simulation* to test whether or not the logic generated will perform as specified by the designer. Macrodata's logic simulator can also accept the designer's original set of logic equations as input. In this way, if the simulated results obtained from the manual input match those from the equation-generation program input, the designer has the assurance that what has been digitized represents his original specifications.

One more avenue must be followed to achieve the error-free design. Using the nodal validation output as input, the crosstalk analysis program calculates the capacitance present in each node and prepares input to be used in the *circuit analysis* program to analyze the characteristics of the circuit. Then, if the circuit characteristics are as required, the design can go to final artwork.

Macrodata has stressed the words "aided" and "information" in CAD and FEDIS. Its philosophy has been to leave the design aspects such as cell placement up to the designer and use the computer for the mundane tasks of checking. The tedious tasks of measuring spacing, areas of crossovers, the missing connections, and even missing cells, can best be done by computer. This philosophy lends itself to design of control logic as easily as it does to standard devices.

One of Macrodata's customers, National Semiconductor, devised a test before leasing FEDIS services last year. National engineers took a finished composite of what they thought was a perfect array and intentionally built in ten errors. Macrodata not only caught the original ten, but came up with an additional seven. The two firms have been working together ever since.

Macrodata's approach differs from other philosophies reviewed here in that it does not rely on a CRT, even though such an option is available. Customers like National aren't bothered by this fact. In fact, National's Dan Izumi notes that "when you're paying for an interactive terminal on a time basis, thinking can get expensive." As the next section points out, however, not everyone agrees with this view of interactive graphics. Applicon's Design Assistant is a good example of an alternate approach.

FIGURE 5. Macrodata's FEDIS design cycle.

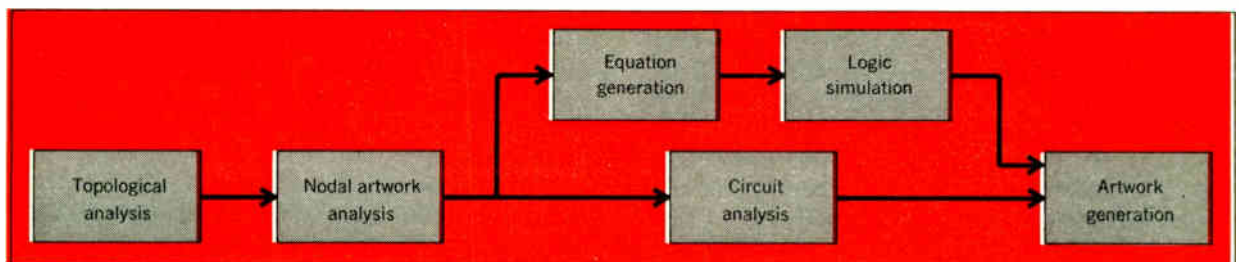

Layout and mask generation

Designing through a window

The initial research that resulted in Appicon's Design Assistant was performed by four staff members at the Massachusetts Institute of Technology's Lincoln Laboratory in 1968. Their scheme, called the Mask Program, was aimed at satisfying the Laboratory's need for fast-turnaround IC design. The present Design Assistant uses an edited version of that program to lay out IC photomasks and produced formatted data for plotters. Appicon leaves other design functions, such as circuit analysis, logic simulation, and test generation, up to the customer.

The designer interacts with the Design Assistant by using the CRT as a window through which he views a conceptual drawing table. He controls the system with commands typed on the keyboard or with commands drawn on the data tablet with a magnetic pen. The designer begins a layout by creating a library of components to be stored in the computer. The example that follows illustrates how this might be done for a basic component such as a resistor.

The CRT displays a tracking cursor, which follows the movement of the magnetic pen whenever it is within 1.27 cm of the tablet. By sketching various sets of rectangles, the designer can create a component library comprised of elements such as transistors, metal runs, gates, or flip-flops. With a component as elementary as a resistor, he would probably sketch a single rectangle. He then assigns this figure a name—such as RESIST—by typing in the appropriate characters on the keyboard. Then, by depressing the stylus onto the data tablet, he executes the STORE command. Once he has completed his geometric library of components, the designer can walk away from the terminal with his work in hand by removing the magnetic-tape cassette or disk file.

To add this resistor to his design, the operator must first place the system in the RESIST mode. He can do this either by typing in the command or by drawing a symbol on the data tablet. Figure 6 illustrates some of the other shorthand symbols for executing position, layout, and editing commands. The arrows indicate the direction of stylus movement; they are not part of the symbol.

In the case of the resistor, the designer can trace a "rho" (or any other symbol he elects to use) on the data entry tablet. He then notes the position and center line of the resistor by drawing a straight line with the stylus—with the length proportional to the resistance and the end points identifying the placement. To execute the actual drawing of the resistor, the designer makes a "dot" with the stylus; that is, he depresses the stylus, which is the standard action for a command execution. The line disappears from the screen and is replaced by a rectangle that represents the actual resistor. If, in this example, the resistor proved to be the wrong length—in other words, the wrong ohmic value—the designer could stretch or shrink the resistor by marking the right-hand end with a slash, the SELN command in Fig. 6. Then, by marking two dots on the screen (MOVE in Fig. 6), which indicate the new x - and y -coordinates and the revised length of the resistor, he can move and vary his

resistance, with the second dot representing both the execution command and the right-hand end of the resistor.

The TEACH mode of the system permits the user to choose symbols of his own design. Suppose, for example, the designer wants to substitute the letter "f" for the zig-zag "fit" symbol shown in Fig. 6. He first types the command TEACH on the keyboard, which

FIGURE 6. A partial listing of Appicon's suggested shorthand symbols for giving commands to the DA.

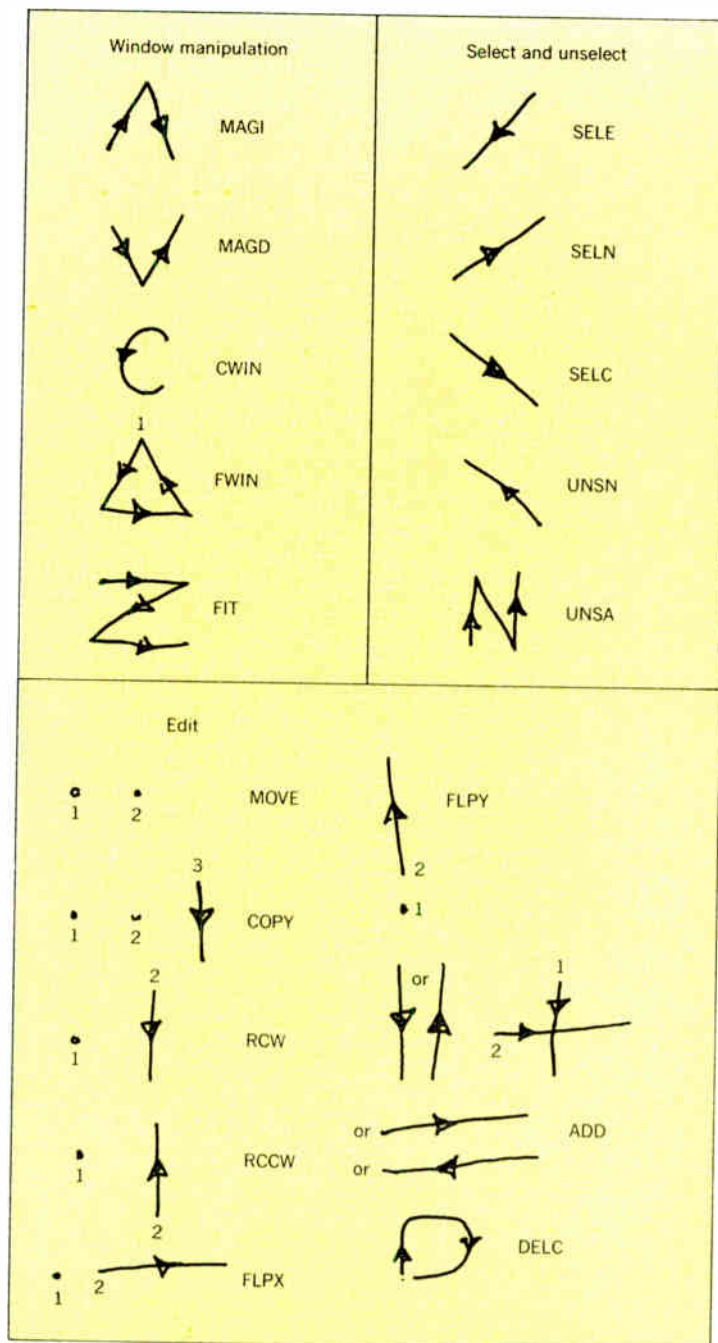

causes a menu of all possible commands to be displayed in the upper-left-hand corner of the CRT. The user draws the letter "f," moves the cursor to the fit command in the display listing, and executes the "dot" command. This command erases the data on the screen and generates the message "f = fit." If the "f" symbol had already been defined as a previous command, a message to this effect would appear on the display. The degree of accuracy of the symbol is a parameter that can be set by the user—the system recognizes characters ranging from a neatly drawn symbol to a "scrawl."

When a set of commands is executed, the display screen is erased and the "new view through the window" is redrawn in a matter of seconds. The user continues to make changes until he is satisfied with the results. Commands (Fig. 6) include directions for window position and magnification manipulation, composite specification, component manipulation, coordinate and distance information, and input/output. At any time; the user can save the photomask data to control a plotter to make the photomasks. The command OUTPUT generates a paper tape or punched cards that can be used as input to a plotter.

The system library feature allows the user to define photomask patterns for library components such as transistors, resistors, and isolation. A transistor, for example, is specified geometrically in terms of its base, emitter, collector, oxide cuts, and metalization photomasks. Any of these library components can be added, deleted, copied, stretched, shrunk, rotated, mirror-imaged, or stepped and repeated on a composite photomask layout in the system. The user can construct cells out of library components, store them in the library, and then use the cells in the layout.

A composite of an arbitrary set of up to 16 different masks can be displayed. The user can edit any portion of the layout at any desired magnification. Distances are measured with the "ruler" and grid commands.

Applicon now offers an advanced version, the system 700, of the Design Assistant, which incorporates many of the features critics found lacking in the original

configuration. Constructed from a series of modules, the DA/700 can be purchased in its simplest form as a single-terminal module that can be connected to the customer's existing computer or as building blocks that lead up to a system that includes a PDP-11 minicomputer, a hard-copy capability, two CRT displays per module, a digitizer, additional CRT terminals, punched-card input, paper tape input/output, a Fortran input/output interface, a bulk file storage system, and a plotter.

One criticism of the old hardware configuration for the Design Assistant was that it didn't permit the user to obtain an overview of his array while working on a detailed section. This has been corrected on the DA/702, a system option that adds a second display to the basic terminal module. With two CRT displays per module, the user simultaneously can examine different views of the same drawing. If the two displays overlap, or view the same area in the drawing, an outline of the position of the other window appears on each screen. Of these two windows, one must be *active* (the working window), the other *passive*. In most design situations, the active window produces a blown-up or detailed view of the artwork, whereas the passive window provides the overall view, for insight into routing, placement, and magnification problems.

Additional features of the new system include a magnetic-tape cassette file, a disk storage of 262 144 16-bit words, and 8192 words of 1.2- μ s core memory. The system, complete with minicomputer, interactive graphics terminal, plotter, and software license, sells for \$60 000. This system is also available on a service basis for rentals of: first four hours free, \$35 for each of the next 35 hours, and \$85 for each hour after that. In addition to the Burlington location, Menlo Park, Calif., also serves as a service center.

Electronic Arrays of Mountain View is one of Applicon's Menlo Park service-bureau users. Electronic Arrays did a shift register on the Design Assistant that took only 25 hours to lay out, but the firm does emphasize, however, that interactive graphics aren't needed for low-volume runs in which you can afford to waste chip real estate.

Another Applicon user, Western Digital of Newport Beach, has purchased a DA/700 system. Richard Serrine, vice president of research and development, observes that "in large chip MOS/LSI, hand coding is practically impossible." Western Digital is now offering customers its CAD system—consisting of the Design Assistant, a Gyrex pattern generator, and a David Mann step-and-repeat camera—for circuits that cost more than \$200 000 to develop.

The one-meter CRT

A stone's throw from Applicon in Burlington is Computervision, a firm that offers a terminal known as the Interactgraphic I (Fig. 7). According to Philippe Villers, senior vice president, the terminal was first exhibited at the Spring Joint Computer Conference in 1970, and is now being used for IC and LSI design at Bell Telephone Laboratories in Allentown, Pa. By using the Computervision terminal, Bell has cut its turnaround time for artwork on a bipolar device from two weeks to four days. The system is interfaced to Bell's software: XYMASK, a mask-making program.¹¹

Computervision solves the size barrier by providing

FIGURE 7. The Interactgraphic I terminal.

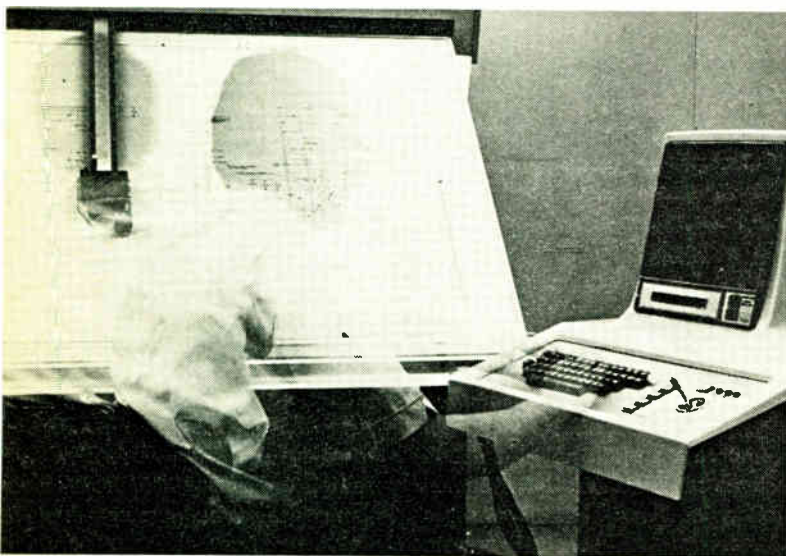

a 86-cm by 112-cm, 0.005-cm-resolution, hard-copy surface. An integral part of this "one-meter terminal" is an ARDS storage tube, manufactured by ADAGE, Inc., that provides a fast preview capability. The Interactgraphic I is, in effect, a single computer terminal that incorporates two operative interactive surfaces. Two distinct operations are involved: the creation of new and modified designs for ICs and the design of LSI, both of which use stored groupings of previously designed patterns of monolithic components in standard arrays.

In the design of ICs, the storage tube is used to call up these cells from the computer. The user selects a working scale and does the initial layout on the screen, usually working with device outlines. A keyboard and an arm-mounted joy-stick control with a digitize button allow the user to rotate, scale, or translate on the screen; or to modify the resistors by bending and folding to arrive at the desired resistance in the optimum space. After initial layout, he calls on his program to plot out the rough layout at larger scale on the hard-copy interactive surface. He then proceeds to make detailed changes and, with the aid of the computer, to lay out the interconnections. The Interactgraphic I's plotting arm can enter data by means of a digitizer mounted on the arm, in addition to plotting under computer command at speeds up to 36 cm per second.

In LSI design, the user displays the cells—usually at 200 \times —on the one-meter surface, and again works out the interconnections. The multipen capability of the plotter arm permits the user to differentiate between layers or to indicate deletions. When the layout interconnections are complete, the user can call upon another computer program to translate his layout into commands for an automated photoplotter, which produces final artwork at 10 \times to 500 \times , depending on the system used.

In the base configuration, the Interactgraphic I sells for \$47 000. Terminal rental, exclusive of computer time and telephone line costs, is \$8 per hour. The device can be supplemented with a larger drawing surface, a hard-copy printer for text, and an interactive graphics language program (the basic set only comes with Fortran-callable subroutines). The machine is not complete within itself—it requires a data link to a computer.

A keyboard and joy stick

Systems, Science, and Software, of La Jolla, Calif., also offers an interactive station for IC artwork. The S³ system, referred to as the Mask system, is operated by function buttons, keyboard, digitizer, and a joy stick (see p. 66). The buttons, stick, and digitizer can all issue the most frequently used general system commands—such as "operation complete" or "read cursor." The joy stick is capable of controlling the movement of a screen cursor in much the same manner as the systems that were previously described.

Instructions include the necessary graphical operations, such as scale control, window control, moves, rotation, and duplication, with single entities or groups of entities. Also, instructions have been added to maximize the amount of information that can be displayed on the screen while performing useful work.

The instructions allow the designer to construct lines, polygons, interconnects, and cells with simple operations. Working from the screen, the designer may modify or edit any instance of a cell in the drawing to optimize the

topography. The designer may work with all outlines in order to suppress the amount of clutter on the screen. The storage scope repaints only at the request of the designer.

Construction of geometric entities can be performed on any of 32 levels, defined by entering a level number from the keyboard. One or more levels can be displayed at any time.

The standard Mask hardware configuration consists of a minicomputer with 16K memory ($K = 1024$ words), a magnetic tape unit, a disk memory, and a CRT storage terminal and joy stick. The basic system, together with a software package, sells for \$70 000.

Mask making

Most of the design systems described so far offer the buyer hardware options such as plotters and pattern generators. For the firm that has developed its own design automation system in house, however, there are complete mask-generation systems available. One widely used mask-cutting package is offered by the Calma Co. The graphic-data-station integrated-circuit mask maker (GDS-ICM), p. 65, comprises a Nova 1200 minicomputer, a disk storage capacity of 1.25 million 16-bit words, a Calma digitizer with movable keyboard, a quick-look Tektronix CRT display, a Calcomp 563 incremental plotter, x - and y -coordinate displays, a read-write tape transport, and a teletypewriter printer. Various options, including on-line artwork generators, are available. The price of the complete system is \$99 500. The graphic input terminals can be expanded to a maximum of six at an additional price of \$32 000 each. The system is also available on a service basis from Micro-Mask Inc., Sunnyvale, Calif.

To generate a mask, the user places a gridded sketch of his layout on the digitizer table. He then enters significant coordinate points that describe cell locations by using the stylus and keyboard. Repetitive portions of a mask need only be digitized once. The system computer, using verification routines, monitors incoming source data to check conformance to design rules. It responds with *accept* or *reject* indications to the user. While entering data for the source drawing, the user has instant access to any of these data by use of the CRT display, which allows him to window-in on the desired area of the source drawing. He can also obtain a plot of the semi-completed drawing at any time if further intermediate verification is needed. When a mask layer or layers have been completed, a check plot can be generated to verify the validity of the masks prior to producing final artwork. Next, an output tape is generated in equipment language to drive the customer's mask-artwork-generating device. Intel, which has been doing its layouts manually and claiming higher yields than any other house for its LSI, recently purchased a Calma digitizing system, which it has found offers more flexibility than other automation aids on the market.

The hardware used for generating the actual mask depends on whether the customer prefers rubylith or phototools. With rubylith, the most common method of mask making, patterns for each layer are cut into a peelable plastic material. The mask for each layer is then "peeled" by removing the inner islands of strippable red film.

On page 67 the CalComp 745 flatbed plotter is shown

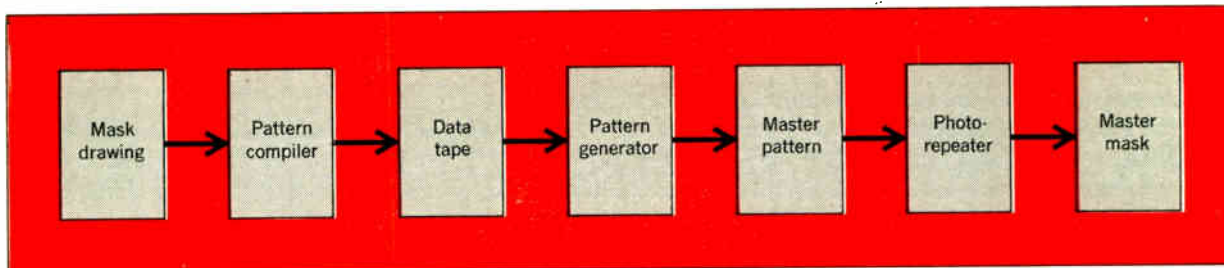

FIGURE 8. A typical photomask-making process.

in combination with a CalComp 900 controller. The plotter comes with interchangeable heads so that it can cut rubylith film, directly expose photographic film, scribe coated materials, or make multiple-line-width ink drawings on paper or synthetic materials. In a typical rubylith-mask-generation process, the designer would make an ink composite drawing of the mask to be cut, visually check the drawing, then replace the pens in the plotter cutting knives. In the CalComp plotter shown here, four sapphire spade-shaped cutting tools, each keyed to cut in a particular direction, cut the mask pattern in the rubylith. The cutting force and depth of penetration of each blade are adjustable, so they work equally well with any available film laminate. After cutting, the rubyliths are manually stripped and checked, then photo-reduced and stepped to produce a master.

In the second mask-making method—optical pattern generation—large cameras flash rectangles onto plates to turn out actual mask artwork. Figure 8 shows a typical photomask production cycle. The system described here incorporates a Hampshire Engineering pattern compiler, a Mann type 2600 pattern generator, and a Mann type 1795 dual-purpose photorepeater. The *pattern compiler* converts large-scale drawings or sketches to detailed input for the pattern generator. Major components are a control console, keyboard-printer, digitizing board, minicomputer, and a high-speed paper tape reader and punch. Because most of the artwork design systems previously mentioned already incorporate a digitizing capability, the *data tape* is ready for input to the *pattern generator*—that is to say, the pattern compiling hardware is already incorporated in systems surveyed here.

Under computer control the pattern generator assembles large images by combining several smaller rectangular ones into a single image. The master patterns so generated at 10 \times are further photoreduced and printed in a rectangular array to form photomasks using the *photorepeater*. The generator operates in the following manner. First, the operating program is loaded into the computer from paper tape. The tape or cards giving the size and placement of each rectangle is then put on the appropriate reader. When given the start command, the computer zeros the *x* and *y* counting registers in the computer and reads the data for a number of exposures from the tape or cards. The stepover stage then sets on the *y*-coordinate for the first rectangle, while the aperture is set to the required height, width, and angle. The scan stage then moves through the indicated *x* position and the flash lamp is triggered

at the appropriate time. When the first rectangle has been exposed, the aperture is set again, a new *y* setting is made, the scan stage moves through the next position, and the next exposure is made. Additional data are read from the tape or cards as needed. The process is repeated until all the indicated exposures have been made.

System or service bureau?

Two questions confronting the prospective CAD buyer are whether to buy or lease a system outright, or whether to put someone else in the designer's seat. This latter option—letting someone else provide your design automation on a fixed-cost or leased basis—is one that many houses are finding attractive. For the past year, Solid-State Scientific Corporation's MOS Division has been using the services of the Multi-Logic Corp. The hardware configuration at the Multi-Logic center comprises a large-scale Honeywell DDP-516 minicomputer with magnetic tape and disk storage, paper-tape equipment, a high-speed printer, a digitizer, a plotter, and an interactive display with a graphic tablet (p. 68). Although Multi-Logic markets the graphic artwork system as a separate product (prices for a basic interactive system start at \$55 000), most of the firm's customers use the system on a service basis.

Solid-State Scientific, which uses rubylith masks, claims that, by removing redundant lines due to cell overlap, Multi-Logic has cut peeling time in half. Solid-State still does the original layout. Then, Multi-Logic, working from 200 \times artwork, codes the drawings for Solid-State to review interactively. In a typical review situation, a Solid-State team of engineers flies to Boston from the firm's plant in Montgomeryville, Pa. As a Multi-Logic technician enters cells onto a CRT display, they direct him to zoom in on specific areas of the artwork for examination or correction. When all concerned are satisfied with the layout, Multi-Logic produces the pen plots for approval and magnetic or paper tape to drive an artwork generator. Simulation, circuit analysis, and testing software are not provided by Multi-Logic.

Most of the other service bureaus limit their design automation efforts to artwork for printed circuit boards. Nevertheless, many of those interviewed for this article expressed an interest in branching out into IC/LSI artwork in the near future. These include Algorex Data Corp., Hicksville, N.Y.; the AIDS Division of Automated Systems Inc., San Francisco, Calif.; Electronic Graphics Inc., Garland, Tex.; Photocircuits Corp., Glen Cove, N.Y.; and Autologic Inc., San Francisco, Calif. Service bureaus already active in the generation of IC artwork include Micromask Inc., Sunnyvale, Calif., and Concap Corp., Oakland, Calif.

```

1 20 20 12:A;
2 22 22 8 :B;
1 GAZE A B;
> GAZE 40,20 20,0 3;
3,20,50,10: NOZ;

> NOZ 30 70 10 20 2;
4,20,120, 40,8 : RECT;
RECT 80 120 5;
4 42 170 38 10 -22 38 -16 -48;
1 40 200 20;
2 42 202 16;
2,45,205,10;
*
```

A

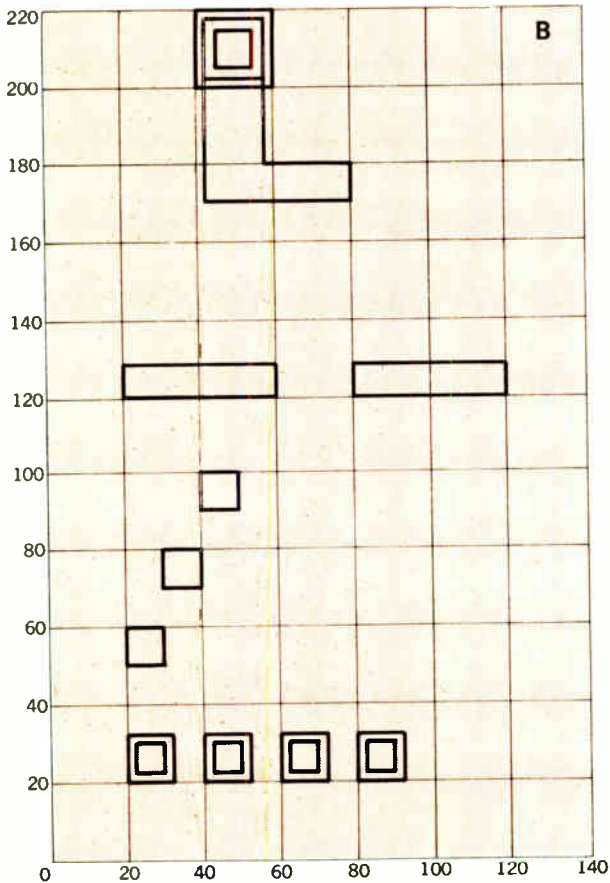

FIGURE 9. A—The input language for the Redal 4 layout program. B—The shapes created by this input.

Software packages

Software licenses are also available separately for those houses that don't have access to government-supplied programs. One such layout package that has found wide use in Europe and that is now available in the United States is offered by Redac Software Ltd. of England through Racal Communications Inc. of Silver Spring, Md. To make this software more readily available to an international market, Redac has translated it for use with the PDP-15 graphic display system produced by Digital Equipment Corp. of Maynard, Mass. For implementation on the PDP-15, the package is written in Fortran IV and assembler code.

Redal 1, the basic IC layout program of the Redac package, permits the designer to use the interactive graphical display to build up his design from a circuit diagram or rough layout sketches. He may also use Redal 4, an input language that enables him to define and name any closed rectangular shape. Redal 4 input is in the form of paper tape. Figure 9A illustrates how this program can be used to create these shapes and place them where required. The first line of instructions, for example, forms the outer square in the lower-left-hand corner of Fig. 9B; the second line of instructions provides the coordinates of the square formed within the first. The GAZE instruction identifies these coordinates as the square within a square, and the > symbol enables this group of shapes to be generated at different reference coordinates along the bottom of Fig. 9B. The fifth and sixth lines provide a similar set of instructions, except in this instance the NOZ command generates a succession of similar shapes equidistant from each other starting at the defined reference point 20, 50. The remaining instructions, including the RECT command, form the rectangles at the top of Fig. 9B.

If the designer elects to use the Redal 1 program, he enters these shapes with a light pen that enables him to move, rotate, delete, reproduce, merge, group, break, measure, mirror, and name the rectangles on the screen. The window can be moved over the layout, and the size of the window increased or decreased at a magnification range of 40:1. Each shape displayed has a layer associated with it—the program can handle up to 15 layers—and the different layers can be displayed bright, normal, dim, or invisible. A magnetic-tape, disk, or data-segmentation facility is available that permits only the required portions of a large layout to be in core storage. Output to paper or magnetic tape provides input for two other software programs: Redal 5, dimensional checking; and Redal 6, artwork generation.

Making the final choice

This article has reviewed the status of who and what are available in computer-aided design tools for semi-conductors. Prospective customers for such systems and services should keep in mind that it was neither the place or purpose of this article to evaluate or pass judgment upon any product or manufacturer. Such qualitative decisions shall be left to the user. Some questions, however, should be considered before opting for one brand of design automation over another. For example, does a system develop design data (synthesize) or does it simply store and organize design data (data management)? Does it provide analysis of input design? Are there peculiarities of each system that make it more favorable to particular IC artwork designs—such as MOS or bipolar devices? Or to particular products—such as ROMs, RAMs, or shift registers?

Table I provides a report card of sorts for evaluating CAD functions. As with any such tabular summary, these results are grossly oversimplified. They fail to take into account the *degree* of automation or *why* a particular firm has chosen to take the design route indicated. Also, because a survey like this can never be completely comprehensive, a number of companies and products have undoubtedly been omitted. To these firms, our apologies. The point of Table I is to illustrate that there

I. Summary of design automation capabilities

Company	Logic Simulation	Chip Layout			System Input Interface			
		Cell Inter-connect	Basic Circuit or Cell Placement	Test Program Generation	Punched Cards	CRT	Key-board	Digi-tizer
American Micro-systems Inc. 3800 Homestead Rd. Santa Clara, Calif. 95051	yes	automatic	automatic	yes	yes	(uses Computervision Interactgraphic I)		
Applicon Inc. 83 Second Ave. Burlington, Mass. 01803	no	manual	automatic	no	yes	yes	yes	yes
Calma Co. 707 Kifer Road Sunnyvale, Calif. 94086	no	manual	automatic	no	yes	no	yes	yes
Collins Radio Co. 19700 Jamboree Rd. Newport Beach, Calif. 92663	yes	automatic	automatic	yes	yes	no	yes	yes
Computervision Corp. Northwest Industrial Park Burlington, Mass. 08103	no	manual	automatic	no	yes	yes	yes	yes
CPS Inc. 722 E. Evelyn Sunnyvale, Calif. 94086	no	manual automatic (under development)		no	yes	yes	yes	yes
Fairchild Semiconductor 464 Ellis Ave. Mountain View, Calif.	yes	automatic	automatic	yes	yes	yes	yes	yes
Hewlett-Packard 5301 Stevens Creek Blvd. Santa Clara, Calif. 95050	yes	manual	automatic	yes	yes	no	yes	no
Hughes Aircraft Co. Fullerton, Calif. 92634	yes	under develop- ment	automatic (Applicon hardware)	under develop- ment	yes	yes	yes	yes
Integrated Circuit Engineering Corp. 4900 East Indian School Rd. Phoenix, Ariz. 84018	no	manual automatic (time-sharing)		no	no	no	yes	no
Intel Corp. 365 Middlefield Rd. Mountain View, Calif. 94040	yes	manual automatic (Calma hardware)		under develop- ment	yes	no	yes	yes
Macrodata 20440 Corisco St. Chatsworth, Calif. 91311	yes	manual automatic		yes	yes	yes	yes	yes
Motorola Semiconductor Products Inc. Phoenix, Ariz. 85036	yes	automatic	automatic	yes	yes	yes	yes	yes
Multi-Logic Corp. 179 Bedford St. Lexington, Mass. 02173	no	manual automatic		no	yes	yes	yes	yes
National Semiconductor Corp. 2900 Semiconductor Drive Santa Clara, Calif. 95051	uses Macrodata for almost all CAD functions							
North American Microelectronics Co. 3430 Miraloma Ave. Anaheim, Calif. 92803	yes	automatic	automatic	yes	yes	no	no	yes
Racal Communications Inc. 8440 Second Ave. Silver Spring, Md. 20910 (software only)	yes	manual automatic		yes	yes	yes	yes	yes
RCA Solid State Div. Somerville, N.J. 08876	yes	automatic automatic		yes	yes	yes	yes	yes
Signetics Corp. 811 E. Arques Ave. Sunnyvale, Calif. 94086	on a time- shared basis	manual automatic		yes	yes	yes	yes	yes
Systems, Science, and Software P.O. Box 1620 La Jolla, Calif. 92037	no	manual automatic		no	yes	yes	yes	yes
Texas Instruments Dallas, Tex. 75222	yes	automatic automatic		yes	yes	yes	yes	yes
Western Digital Corp. 19242 Red Hill Ave. Newport Beach, Calif. 92663	yes	manual automatic (Applicon hardware)		yes	yes	yes	yes	yes

System Output Interface		Device and Circuit Cell Design Analysis	Availability
CRT Display	Line Printer or Pen Plotter		
yes	yes	yes	in-house
yes	yes	no	turnkey
yes	yes	no	turnkey
no	yes	yes	in-house (customer may use)
yes	yes	no	turnkey
yes	yes	no	turnkey
yes	yes	yes	in-house
yes	yes	yes	in-house
yes	yes	yes	in-house
no	yes	no	turnkey
no	yes	yes	in-house
yes	yes	yes	turnkey
yes	yes	yes	in-house
yes	yes	no	turnkey
no	yes	yes	in-house
yes	yes	no	turnkey
yes	yes	yes	in-house
yes	yes	yes	in-house
yes	yes	no	turnkey
yes	yes	yes	in-house
yes	yes	yes	in-house

is a wide range of capabilities available in semiconductor CAD. Each service or system is designed to meet the needs of a specific type of user. The choice is up to you.

REFERENCES

1. Spitalny, A., and Goldberg, M. J., "On-line graphics applied to layout design of integrated circuits," *Proc. IEEE*, vol. 55, pp. 1982-1988, Nov. 1967.
2. Zucker, J. S., and Crawford, B. J., "Graphical layout system for IC mask design," *IEEE Trans. Circuit Theory*, vol. CT-18, pp. 163-173, Jan. 1971.
3. Mays, C. M., "A brief survey of computer-aided integrated circuit layout," *IEEE Trans. Circuit Theory*, vol. CT-18, pp. 10-13, Jan. 1971.
4. Hudson, P. W., "Interactive graphics for integrated circuit layout design," *1969 IEEE Internat'l Conv. Rec.*, pp. 384-385.
5. Larsen, R. P., "Computer-aided preliminary layout design of customized MOS arrays," *IEEE Trans. Computers*, vol. C-20, pp. 512-523, May 1971.
6. Markstein, H. W., "Are you ready for automated artwork?" *Electron. Packag. Production*, vol. 10, pp. 12-22, Dec. 1970.
7. Prince, D. W., *Interactive Graphics for Computer-Aided Design*. Reading, Mass.: Addison-Wesley, 1971.
8. *Semiconductor/IC East/West*. Chicago, Ill.: Industrial and Scientific Management, 1971.
9. *Polycell LSI*. Phoenix, Ariz.: Motorola Inc., 1971.
10. Lynn, D. K., "Computer-aided layout system for integrated circuits," *IEEE Trans. Circuit Theory*, vol. CT-18, pp. 128-139, Jan. 1971.
11. Fowler, B. R., "XYMASK," *Bell Lab. Rec.*, vol. 44, pp. 205-209, July 1969.

Reprints of this article (No. X71-093) are available to readers. Please use the order form on page 8, which gives information and prices.

Charles W. Beardsley (M) received the B.S. degree in mechanical engineering from Newark College of Engineering in 1961 and the M.S. degree in technical writing from Rensselaer Polytechnic Institute in 1962. He joined the General Electric Company in that year, where he helped to develop a computerized retrieval system for data from the Apollo Project. One of his major responsibilities during this period was the compilation of a thesaurus of aerospace terminology. In 1966, he transferred to GE's Aircraft Engine Group as a reliability engineer.

Mr. Beardsley joined the IEEE Headquarters staff in 1968. Since then he has served as Assistant Managing Editor and Managing Editor of the IEEE Student Journal. He is at present Associate Editor, IEEE Spectrum.

He is a member of Tau Beta Pi, Omicron Delta Kappa, Phi Eta Sigma, and Pi Delta Epsilon.

In the photograph, Mr. Beardsley (left) is shown with John C. Barrett, CAD Department Manager for Hewlett-Packard Co. in Santa Clara.

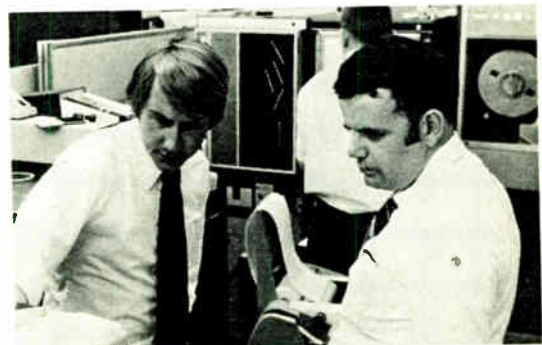



Marketing as an engineering career

Despite the current economic slump, industry is encouraging young graduates to enter marketing. Here, two students recount their experiences in a summer training program

Myron Nichol, M. A. Cuevas San Jose State College

When funds are tight, design and development are curtailed first; however, marketing is one of the last areas to go. That's the view of two recent electrical engineering graduates who spent last summer in a ten-week pilot program for junior marketing engineers. The marketing assistantship program described here was developed by the Hewlett-Packard Co. to acquaint engineering undergraduates with the job opportunities available in marketing. The authors soon realized that their initial impressions of this field were somewhat misleading.

Does the word *marketing* turn you off? We also had our doubts, until we saw a "marketing-assistantship" poster on the Electrical Engineering Department bulletin board. Such subtitles as systems engineering, applications engineering, and product management seemed more interesting. Both of us had several years of electronic experience before returning to school to obtain a B.S.E.E. degree. Consequently, we were familiar with engineering jobs available for new graduates, but had not associated marketing with engineering.

What are electrical engineers doing in marketing? We assumed that marketing was a part of the business field, and therefore belonged to the business students. However, this particular *marketing assistantship* was directed toward senior electrical engineering students only. With a little skepticism, we decided to apply for the program to see what job opportunities were available. Fortunately, we were selected from among several

students to participate in a ten-week one-afternoon-per-week program.

The managers of the several marketing departments talked with us, explaining their qualifications, duties, and responsibilities. They reviewed the various positions available in their departments for junior engineers. Usually each manager showed us through his department, so we could see firsthand what was going on.

Marketing needs young blood

Previously, most engineers entering the marketing field were experienced in other areas, such as research and development, or manufacturing. However, to satisfy a growing demand, industry is encouraging graduating engineers to enter marketing directly.

Broadly defined, marketing is the customer-oriented function of a company. A satisfied customer usually means a successful company! Marketing functions vary from company to company, or even from division to division within the same company, depending on the nature of the business. In general, engineering positions under marketing include service engineering, systems engineering, applications engineering, sales engineering, product management, and publications. Engineers in these areas work as a closely knit team. They assist the customer in solving technical problems such as updating or repairing a system, installing or interfacing one system to another, programming a computer, designing new products for the future, and selling the customer the most appropriate piece of equipment for his particular job.

Qualifications are general for each of these positions. Our purpose is to show the need for a strong technical

background in the marketing field. Normally a marketing engineer has the B.S.E.E. degree or equivalent; many companies encourage the pursuit of a higher degree. An M.S.E.E. is an advantage in systems and application engineering whereas an M.B.A. is very useful in sales and product management.

Service engineering provides technical and service support for division products and conducts customer training classes. This support includes installation, inspection, operation, and maintenance of equipment. This is a good starting job in a company for the new B.S.E.E., particularly if he has had no previous experience. Naturally, the company puts the new service engineer through an extensive training program before giving him all these responsibilities.

Systems engineering is responsible for the overall operation of a system. This usually includes the interfacing of many pieces of equipment to do a specific job. In a computer system, such a job requires a knowledge of both hardware and software. A few years of design or service experience is required before an engineer advances to systems work.

The *applications engineer* is usually a specialist in one area. He must be able to answer customer questions and solve problems concerning his particular product line. Very often he works closely with the sales engineer in determining equipment to satisfy a customer's particular needs. He is also responsible for writing literature on commonly asked questions, problems, and specifications.

Sales engineering is the art and science of selling products that demand engineering know-how in their selection, application, and use. In effect, a good sales engineer is a technical consultant. He must be technically competent and able to converse freely with his professional customers. Although he has the longest work week, he is also the most highly paid engineer in marketing.

Product management surveys industry for future product needs. This important job requires a mature engineer with a good business background. In researching the market and talking to people, he must be able to distinguish between marketable products and wishful thinking. He then recommends to top management the possible profitable product areas. There is little room for error.

Publications prepares technical manuals on the company's products. These manuals usually include a general description, operating instructions, theory of operation, maintenance, and list of replaceable parts. This job requires a person who can express his thoughts clearly.

Our impressions

At the end of the ten-week session, we were pleased to have been selected for this marketing assistantship. It

Career opportunities

This article is the first in a proposed series of features that will survey the various career options that are open to recent graduates in electrical and electronics engineering. Future articles will examine such areas as production and manufacturing, product engineering, systems engineering, and research and development. Reader comments and contributions are welcome.

gave us an insight into a previously unfamiliar area of engineering. We were impressed not only with the technical qualities of the marketing engineers, but also with their awareness of human relations.

With the literature of job descriptions and requirements—in addition to our own notes—we felt well prepared to inform our fellow electrical engineering students about marketing. We are not trying to convince everyone that he should go into marketing, although there are many opportunities to progress within a division and eventually get into top management. Rather, our purpose is to acquaint students with this field and its engineering jobs.

Successful companies are realizing that it is usually the work of marketing that determines whether their finances will end up in the black or red. Each year companies are allocating more money and manpower to this important division. The current economic slump puts even more demands on the marketing division, which is probably "carrying the company." Services to the customer become even more important. While sales might drop, some other services increase. When funds are tight, design and development are curtailed first, but marketing is one of the last areas to go.

What do you think? Is marketing your cup of tea? We now think it is ours. Do you measure up to the qualifications previously mentioned? Are you *people conscious*? Can you do engineering work under pressure when the customer wants fast results? If so, then probably some company has an engineering slot for you on its marketing team.

Reprints of this article (No. X71-094) are available to readers. Please use the order form on page 8, which gives information and prices.



Myron Nichol (M) received the B.S.E.E. degree from San Jose State College in January 1971. He was graduated from San Francisco City College in 1961 with the A.A. degree in electronic technology. From 1954 to 1959, Mr. Nichol served as an electronic technician with the U.S. Navy. His experience includes positions as test engineer and technical writer. He is presently employed by the Automated Measuring Division of the Hewlett-Packard Co.



Miguel A. Cuevas (M) received the B.S.E.E. degree from San Jose State College in June 1971. He was the recipient of the Dean's Scholar Commendation at San Jose and a member of Eta Kappa Nu. Mr. Cuevas holds a California vocational teaching credential in electronics, in addition to a first-class radio telephone license. He is employed by the Radio and Microwave Transmission Department of the Pacific Telephone Co.

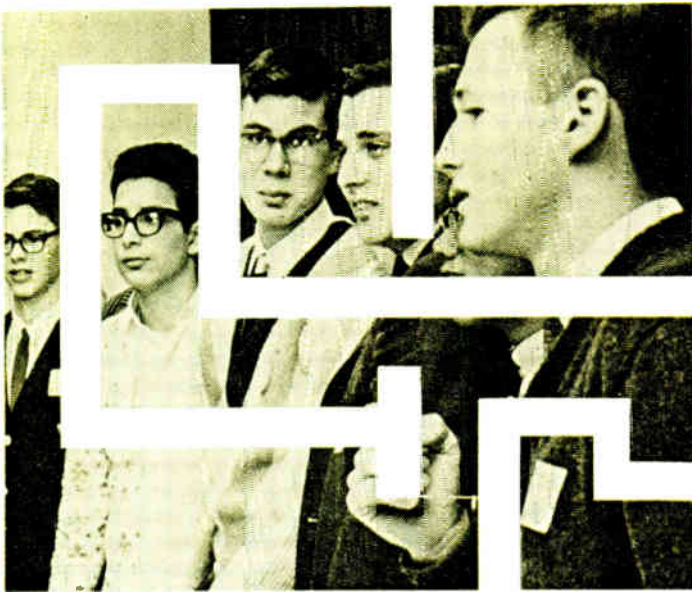

One man's view of marketing

"Marketing can be a real eye-opener for a recent engineering graduate—and a steppingstone to management at the same time," says Norman Gan, a field program engineer for the General Electric Company's Military Engine Division. For the past two years, Norm has served as GE's rep at Lockheed-California Co. in Burbank, where the Navy S-3A (VSX) antisubmarine aircraft is under development. Norm's prime responsibility is to answer Lockheed's questions about GE's TF-34 turbofan jet engine, which will power the S-3A. Although his degree from M.I.T. was in aeronautical engineering, Norm feels that his views on marketing are just as relevant to electrical and electronics engineering.

For Norm, *getting to know the product* is just one advantage of a marketing career. "You have to work with the real-life product back on the home front before you can represent your company to the rest of the world," Norm explains. "You have to establish your own technical credibility by being able to answer accurately the questions you'll be hit with in the field. I found that working as an engineer for a year or two was an asset for me. Marketing's a poor shot right out of college—you really don't know what you're talking about."

Norm was hired by GE as an engineering trainee in the aeronautical design area. After picking up a background in systems analysis and engine performance, he joined an applications engineering group, where he assumed responsibility for the applications side of the TF-34, then a "paper" engine. He administered that program until the submittal of a proposal to the Navy in 1968, when he was transferred to the West Coast to work with the airframe manufacturers who were bidding for the



NORMAN GAN

S-3A. When Lockheed won the contract, Norm took over field program management of the engine.

According to Norm, once a large contract is let and a rep is given the opportunity to conduct field liaison, marketing can open the door to further opportunities by providing *visibility* and *exposure*: "visibility to see who's running the show back at the home office and the personal exposure a young engineer needs if he's going to advance into the ranks of management." As Norm puts it, "When you're as remotely located as I am, no one from the home office can go directly to the customer. So I find myself part and parcel of negotiations, financial questions, contracts, and technical interfaces—pretty much the whole spectrum of the business."

"You can become a bit 'forest and trees' oriented working in the home office. Although you're great in your own area, you frequently have no idea what the guy down the hall is doing. As a field rep, I've had to become a fairly good generalist—which means being able to understand the product, but at the same time being sensitive to which way the wind's blowing. I've been hit with questions like 'What do we do now?' Because I wear two hats, both those of GE and Lockheed, I must play the diplomatic game of keeping both sides happy. In short, marketing is technical, yet it's also an excellent preparation for management."

Charles Beardsley